

SIR JOHN REITH WRITES IN THIS ISSUE

MODERN 1/- WIRELESS

Vol. XIII. No. 38

February 1930

THE "B.P."

*Short waves, 177
H. F. Baskin*

5



SIMPLE CONTROL
ALL WAVES
REMARKABLE POWER

"IS RADIO REALISM POSSIBLE?"
An Exclusive Article
By Our →

RADIO CONSULTANT-IN-CHIEF CAPT. P. PECKERSLEY M.I.E.E.

Purity

No matter what is being broadcast, a speech, an orchestral concert or a relay from the stadium, every little sound picked up by the microphone is faithfully reproduced through the Blue Spot Speaker.

Blue Spot has made its name as the world's leading Loudspeaker because of its purity of tone—purity that is almost incredible.

Here are three typical Blue Spot models, handsome and attractive. Listen to the *tone!* Your dealer will gladly demonstrate.

**F.A.HUGHES & CO.,
LIMITED**

204-6, Great Portland Street,
London, W.1. Museum 8630 (4 lines)

Distributors for Northern England, Scotland & North Wales: H. C. Rawson (Sheffield & London)-Ltd., 100, London Road, Sheffield (Tel.: Sheffield 26006); 22, St. Mary's Parsonage, Manchester (Tel.: Manchester City 3329).



**BLUE SPOT
101
£4. 4. 0.**



**BLUE SPOT
99
£4. 4. 0.**

**BLUE
SPOT**



**BLUE SPOT
GOLIATH
£6. 6. 0.**

CONTENTS

VOL. XIII. No. 38. MODERN WIRELESS. FEBRUARY, 1930.

Editorial	111	How Microphone Plays are Made ..	158
Leasing Out Britain's Ether	112	Electrical Echoes ..	158
A Revolution in Selectivity	115	What Readers Think ..	159
Radio in Australia	118	Points About Power ..	161
S.G.'s for Frames	119	My Broadcasting Diary ..	163
The "B.F." Five	122	Condenser Conductors ..	165
How Radio Has Helped	130	Battery v. Mains Valves ..	167
An American Short-Waver	132	Experiments with Resistance Reaction	169
Sets that Howl	133	Microphone Mannerisms ..	170
The "Eckersley" A.C. Three	134	In Our Test Room ..	173
Trouble Tracking	140	On the Short Waves ..	176
How Batteries Are Made	141	In Passing ..	178
Humour via Radio	144	Television in 1930? ..	180
Questions Answered	146	Wireless and Some Magnetic Mysteries	182
Is Radio Realism Possible?	147	Radio Abroad ..	184
A.C. versus D.C.	149	Radio Notes and News ..	202
The "Electric" Two	150		

SPECIAL SUPPLEMENT "RADIO AND THE GRAMOPHONE," PAGES 186-200

As some of the arrangements and specialities described in this Journal may be the subject of Letters Patent the amateur and trader would be well advised to obtain permission of the patentee to use the patents before doing so.

Edited by **NORMAN EDWARDS.**

Technical Editor: **G. V. DOWDING, Assoc., I.E.E.**

Radio Consultant-in-Chief: **Capt. P. P. ECKERSLEY, M.I.E.E.**

Scientific Adviser: **J. H. T. ROBERTS, D.Sc., F.Inst.P.**



KEEP YOUR SET AT ITS BEST



When reception is good, it is a pity if your speaker deprives you of its full beauty. Hear an Amplion A.B.6, the speaker that makes "pure" MEAN "pure." It even satisfies—nay, delights—the critical wireless experts whose work is to search for faults. Why? Because of the entirely new type movement. Because it brings out the personality of the voice or instrument. Because it handles unusually powerful volume before permitting distortion. Because its sensitivity is amazing. You will never regret saying:—"Amplion A.B.6."

AMPLION

IN OAK £4-10, MAHOGANY £4-17-6

GRAHAM AMPLION Ltd. 25/26, Savile Row, LONDON, W.1. WORKS, SLOUGH.

LOCKED for SAFETY!

LOCKED for RIGIDITY!

LOCKED for LONG LIFE!



THE NEW Cossor Screened Grid Valve is shock-proof, noise-proof and break-proof. Its Interlocked Construction makes it the strongest and most robust Screened Grid Valve ever produced. Its elements are immovably locked in position—vibration is impossible—all risk of microphonic noise is eliminated. And because of the girder-like rigidity of its elements the NEW Cossor has exceptional strength, even the hardest blow cannot mar its remarkable performance. Use the NEW Cossor Screened Grid in your Receiver—no other make has Interlocked Construction.

The NEW Cossor 220 S.G.
(2 volts, .2 amp.) Impedance
200,000. Amplification
Factor 200.
Anode Volts
120-150. Price **22/6**

Cossor 4- and 6-volt
Screened Grid Valves are
also obtainable from all
Wireless Dealers.

The **NEW**
COSSOR
Screened Grid
Valve

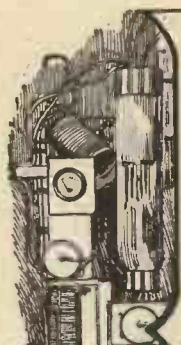

MODERN WIRELESS

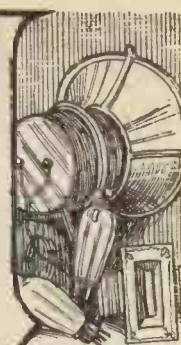

Vol. XIII. No. 38.

February, 1930.

The "B.P." Five Receiver—Eight Special Features—Two Sets for the Mains—Changes in 5 GB's Transmissions—Proposed Empire Broadcaster.

The "B.P." Five Receiver

THE receivers described in this month's MODERN WIRELESS include the "B.P." Five, and we should like to draw the very special attention of our readers to it.

The "B.P." Five was designed originally with the idea of completely satisfying all modern requirements, and, altogether, the receiver has been on the testing bench of the MODERN WIRELESS Research and Construction Department for nearly two months, because it was decided not to release the set for description in this journal until it had passed not only all the tests, but until it could safely be said to incorporate all the latest and most up-to-date features.

Eight Special Features

THERE are eight particular points about this receiver which we should like to enumerate:

1. It is extremely simple to control.
2. It is very powerful and, without exaggeration, can tune in dozens of distant stations on the loud speaker.
3. It is highly selective and employs a special H.F. band-pass filter scheme.
4. The L.F. stages are arranged to give a high-standard quality of reproduction.
5. A very simple but most effective wave-change system is incorporated in the set.
6. Provision is allowed for a gramophone pick-up.
7. It includes a special "fader" volume control, enabling the listener to "fade out" radio and bring in a gramophone record in the approved B.B.C. style.
8. It is not difficult or particularly expensive to construct.

Further details about this set will be found in another part of this issue.

Two Sets for the Mains

ABOUT the other two sets in this issue, the "Electric" Two and the "Eckersley" A.C. Three, little need be said here, as very full descriptions will be found elsewhere.

The "Electric" Two is an all-mains set which gives an excellent performance, and it will be found that its running costs are so low that they can hardly be measured.

The "Eckersley" A.C. Three is an electrified version of the popular "Eckersley" Three receiver described in a recent issue. This new version also provides for a gramophone pick-up.

Changes in 5GB's Transmissions

LISTENERS were startled the other day when the B.B.C. announced important changes in the programme hours of Daventry 5GB. Under the new arrangement the hours of transmission on Sundays are from 4.30 to 10.30 p.m., and a new departure—and one which will probably not widely be welcomed—is the inclusion of a series of talks.

The first series is by Dr. Waterhouse, the lecturer in Psychology and the Philosophy of Religion at the Wesleyan College, Richmond. The series will consist of twelve lectures on "Religion, in the Light of Philosophy."

Interesting as Dr. Waterhouse's lectures are, we feel that if the B.B.C. found it imperative to introduce talks into 5GB's programme they might have kept the talks more in line with the character of 5GB. In short, they might have had a little more entertainment value.

5GB has always been popular among a large section of listeners because of the freedom of its programmes from talks, and we seem to remember the B.B.C. definitely promising that talks would not be included in 5GB transmissions.

The Talks Department at Savoy Hill still seems to be gaining more and more power, and it is to be hoped that 5GB's programmes will not be unduly loaded with talks which could quite easily be incorporated in programmes from Brookmans Park.

Proposed Empire Broadcaster

IT is reported that the B.B.C. is to investigate the possibilities of a permanent short-wave Empire broadcaster, the idea being to supersede 5SW, the Chelmsford temporary Empire short-waver, and provide the Dominions and Colonies with an "all-time" station. An excellent idea, providing the Government pay for the station.

It would be grossly unjust if a new short-wave station were built out of the funds supplied by listeners in this country. Licence fees are paid on the distinct understanding that the money (apart from that portion "retained" by the Post Office) is spent on improving the B.B.C.

A short-wave Empire broadcaster would be excellent, but the cost of erection and maintenance is a matter for the Government and for the governments in our Dominions and Colonies. The Regional Scheme, the new B.B.C. offices, and better programmes, etc., cost all listeners subscribe. It is only fair that home broadcasting should come first.

Leasing Out Ether

CONSIDERABLE notice was recently given to the rumour that the B.B.C. proposed to permit advertising, and it was stated that influence was being brought to bear on the Corporation with this in view.

A denial was promptly issued, but, as usually happens, for one individual who saw and believed the latter, ten or more continue to believe the former. How difficult it is to kill a rumour, even though a denial be published in as many journals as set out the rumour. The same discrepancy is, of course, obvious in stories transmitted verbally in any line of life, from village gossip to high politics.

The Question of £ s. d.

"Selling time" by ether takes various forms. The advertising may be direct or indirect. The direct form consists, as the name implies, of a specific recital of the merits of products, special lines of stock, and so forth. Indirect advertising, on the other hand, implies the provision of a programme of entertainment, usually of half an hour or an hour's duration, in the course of which, on the lowest terms, an opening, closing, and possibly one or two intermediate announcements are permitted. These give the name of the concern providing the programme, but are sometimes extended to include brief puffs of the product.



The aerials of WRNY, a New York station that is owned and operated by a radio journal.

 * This is the first of a series of special and exclusive *
 * articles contributed to "Modern Wireless" by the *
 * Director-General of the British Broadcasting Cor- *
 * poration—Sir John Reith. Sir John does not often *
 * write articles, and we feel fortunate in having per- *
 * suaded him to contribute to "M.W." articles in *
 * connection with broadcasting matters which cannot *
 * fail to arouse widespread interest among our readers. *
 * —The Editor. *

Direct advertising entails a cash payment on some basis or another—number of words or minutes—and contracts may be made for a considerable period of time. Indirect advertising may or may not entail a cash payment in addition to the out-of-pocket expenses incurred by the "sponsors."

In the big American broadcasting organisations it usually does. In addition, therefore, to spending what is necessary for the provision of presumably first-class entertainment for half an hour or an hour, sponsors may pay anything up to £1,000 per hour where a big chain of stations is involved.

How Does Britain Compare?

The systems under which broadcasting is constituted, organised and conducted vary greatly in different countries. What may be permissible constitutionally in one country may not be permitted in another. So also with what is desirable; so also with what is necessary.

In Great Britain, as in other countries, the following questions have to be answered: (a) Is there anything in the constitution of the broadcasting organisation which prohibits advertising by some or by all methods? (b) If not, has the organisation put itself under any restriction in the matter, presumably for reasons which seemed right to it? (c) Assuming that the ground is more or less clear, is advertising desirable or necessary?

Clause 3 of the licence from the Postmaster-General to the British Broadcasting Corporation reads as follows:

"The Corporation shall not without the consent in writing of the Postmaster-General receive money or any valuable consideration from any person in respect of the transmission of messages by means of the stations or any of them.

"Provided that nothing in this clause shall be construed as precluding the Corporation from:

Britain's

By

SIR JOHN REITH

- "(1) Broadcasting matter provided gratuitously by any person with or without an acknowledgment of such provision by means of the broadcasting service.
- "(2) Receiving a consideration for broadcasting names of publishers and prices of matter which is broadcast.
- "(3) (So far only as the licence of the Postmaster-General is required) from using for broadcast purpose without payment concerts, theatrical entertainments, or other broadcast matter given in public in London or the provinces."

Cash Consideration

From the above it appears that the B.B.C. might permit direct advertising, so long as no money was taken, but this is, of course, improbable. It can, however, under (1) permit indirect advertising so long as no money passes; (2) does in effect permit indirect advertising for cash, but this is on narrow and specialised lines and has never been taken advantage of, although it might well be, either positively by receiving payment where a book is referred to in the course of a talk, or negatively by remission of copyright fees for literary, or even musical, extracts.

The permission in (1) has very occasionally been used by way of a provided concert and in the acceptance of appropriate programmes which are being prepared primarily for audiences in outside halls, and, of course, the eventuality in (3) happens almost daily.



Mr. Anderson, of Radio Publicity, Ltd., arranging advertising to reach listeners in this country by broadcasts from Radio Paris.



Sir John Reith, Director-General of the B.B.C.

To sum up, on the constitutional point the B.B.C. cannot, in general, accept money, but can permit indirect advertising in provided programmes.

Direct and Indirect Advertising

On the second question, it happens that the B.B.C. is under agreement with the Press not to broadcast paid advertising matter, preserving, however, the liberty indicated in the three provisos above. This was a bargaining point of value in negotiations for increased news facilities. The Corporation was not surrendering any right, as clearly, from Clause 3, no right existed. In that clause, however, is implicit liberty to make representations to the Postmaster-General to permit paid advertising, but he was not bound to accede. The B.B.C. in its Press agreement merely bound itself not to make such a request for a time.

There are, therefore, no constitutional or contractual obstacles to sponsored programmes without cash payment—that is, to sponsors deriving indirect advertising benefit from the provision of programmes of which they bear the expense. There are definite obstacles to direct advertising; and listeners can form their own judgment on whether or not, even did no such obstacles exist, valid and sufficient objections would not in any event be apparent to prevent its adoption save in case of dire financial need.

The B.B.C.'s Present Position

As to sponsored programmes, there are here three factors for consideration: financial, artistic, and (for want of a better term) political.

Is it desirable or necessary to save money by contracting out part of programme expenditure? Is it desirable or necessary artistically, i.e. is imagination running dry? Are there sources of entertainment only to be tapped in this way? Thirdly, is it unfair on potential advertisers to withhold etheric facilities? (One might have another point here: Would it be unfair to existing advertising media to permit them; or inexpedient?)

"HULLO, FOLKS!"



Here is the irrepressible Tommy Handley in front of the microphone. What a radio salesman he would make if advertising were allowed by the B.B.C.!

Obviously there is interaction between these factors. There might be no financial reason, but a strong artistic or political one. Or there might be financial justification and no artistic or political one.

The Corporation's Capital

The published B.B.C. financial statements and reports indicate that the service operates under a disadvantage in being unable, owing to the way in which it is financed, to accumulate a large reserve against essential capital development. The Corporation has, however, been able

to set aside the profits of its commercial activities year by year, against future capital requirements.

This is something, but not very much, and large borrowing is essential, with consequent interest and funding charges. These, however, can be met, and the loan wiped off in a reasonable period. Finances are carefully controlled, and it is not necessary to have recourse to sponsored programmes on this score.

Providing Sponsored Programmes

On the artistic point, no one suggests that the B.B.C. has a monopoly of programme building talent, or that the creative and imaginative reserves are limitless. An argument advanced is that it would be beneficial to contract out the provision of some programmes. At present, however, the position is simply that the Corporation does not believe that the task of building and presenting the additional number of programmes necessitated by the introduction of alternative programmes under the Regional Scheme presents a problem beyond its own powers of solution. And even did it cause concern, account would have to be taken of the embarrassments which might more than offset the advantages of such reinforcement.

On the "political" issue there has been practically no demand for advertising facilities. Occasional inquiries have certainly been made, but there is no evidence of desire from advertisers in general to use the broadcasting medium. Even if facilities were available, not everyone would face the indirect type with its stringent programme quality criterion.

Should Money Talk?

Reference was made above to embarrassments inherent in ether advertising. Many journals adopt a censorship of some kind on advertisements carried. These bear, in effect, some hall-mark of reliability by their inclusion. Wireless is a universal and powerful medium. Should the B.B.C. accept this responsibility? Should cash or the provision of an entertaining feature alone give access to the microphone? The B.B.C. is finally responsible for what is broadcast.

One does not deny that radio is an advertising medium of immense potentialities, nor that tangible results would accrue. Its exploitation in America has doubtless been of considerable importance; it has probably taught the advertiser more than ever to study the interests of the public; it can presumably create goodwill and make friends for a product among the listening public and encourage retailers to stock what is indirectly or even directly promoted through the microphone.

It is, however, the sole means of revenue in America; they have no licence system, so their practice cannot be taken as a guide. And in the opinion of the Corporation it is neither necessary nor desirable here.

Two Points to bear in mind when reading "M.W."

It is the considered policy of "Modern Wireless" to provide for its readers only THE BEST. There is only one Director-General of Broadcasting in this country—Sir John Reith—and he has written the above authoritative article exclusively for "Modern Wireless."

On the Technical side also this journal is in an unrivalled position, having secured the advisory services of Capt. P. P. Eckersley, M.I.E.E., late Chief Engineer of the B.B.C.

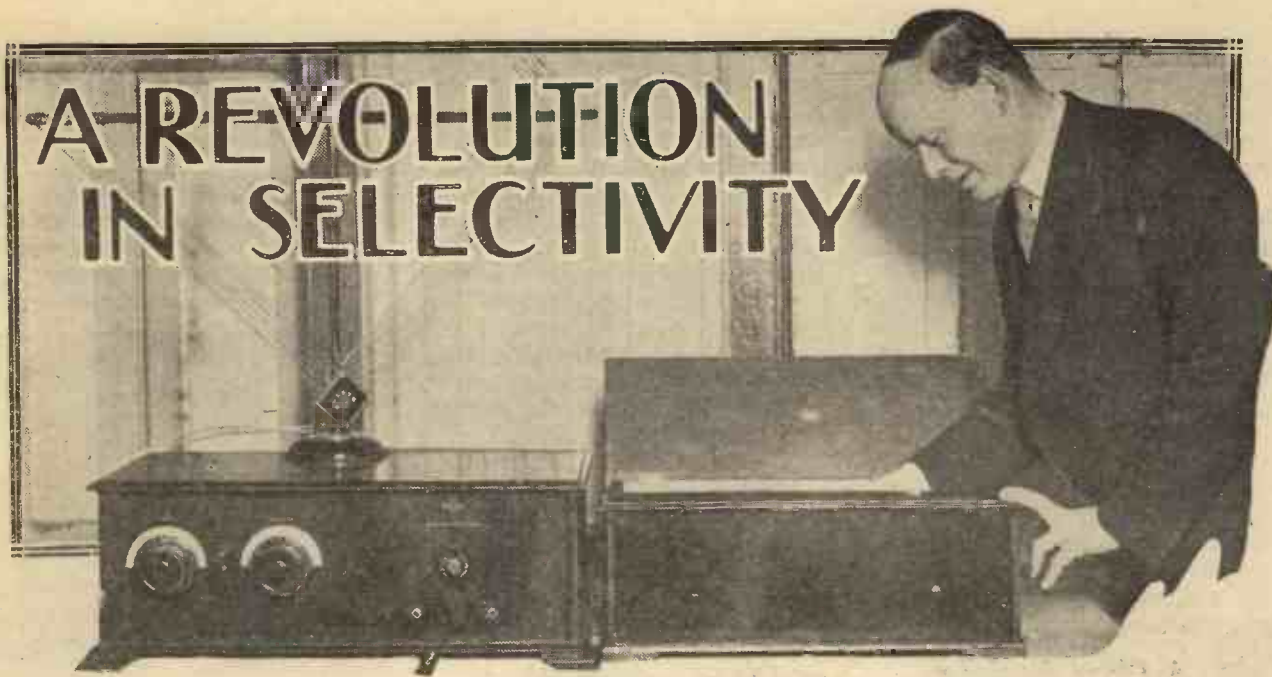

A REVOLUTION IN SELECTIVITY

IF the claims made for the new "Stenode" Radiostat receiver are found to hold good under all conditions we may have to abandon many of our previously-accepted notions concerning side-bands and the part they play in normal broadcast reception.

Dr. Robinson, the inventor of the new system of selective reception, has succeeded in completely cutting-out an interfering signal separated by only a few hundred cycles from the carrier-wave of 2 L. O. Not only does he cut out the interfering signal, but he does so without suffering any appreciable loss in the quality of the received programme.

Station Separation

This is where the mystery lies. Up to the present it has always been held that for good quality in reception the receiver must take in not only the carrier-wave, but also the so-called side-band frequencies, which are superposed on the carrier in the process of modulation.

The present system of separating the various broadcast transmitting stations by a minimum "frequency gap" of ten kilocycles—a system which is now enforced as far as possible by international agreement—is based upon the same consideration. A range of 5,000 cycles is allowed for the modulation frequencies on both sides of the carrier-wave, making a "band" of ten kilocycles (10,000 cycles) in all. Unless this minimum separation is maintained between adjacent stations in the frequency range they are found to overlap and "heterodyne" each other.

Is it still an open question whether the so-called side-bands actually exist? In this article the matter is concisely discussed.
By a Special Correspondent.

The same principle has also been accepted heretofore in the design of ultra-selective sets. Whilst sharp tuning is absolutely necessary for selectivity, the use of too-sharply tuned circuits has been deliberately avoided on the ground that this would result in cutting-out side-band frequencies which are essential to good quality reproduction.

We now have to face the extraordinary claim made on behalf of the "Stenode" Radiostat receiver that it is possible to receive a narrow band of frequencies limited to a couple of hundred cycles on each side of the carrier-wave, and at the same time to maintain a standard of reproduction equivalent to that given by a receiver handling side-band frequencies extending for 5,000 cycles on each side of the carrier-wave.

That Carrier-Wave

One is compelled to ask: "Is it still an open question whether the so-called side-bands actually exist? Is the wave sent out from the



It is claimed for the Radiostat that it makes possible the reception of a station in a band of 400 cycles, and that without any distortion!

transmitting aerial a single-frequency wave, or is it a complex wave comprising sum-and-difference (or side-band) frequencies due to the modulating signal as we have always been led to believe?"

As the case for the single frequency can be expressed more concisely and simply than that for the side-bands, it will be stated first.

A broadcast transmitter consists broadly of an oscillator, a modulator, and a series of amplifiers. The oscillator determines the carrier frequency, and great pains are taken by means of piezo-crystal or tuning-fork control to maintain the generated waves at absolutely constant frequency. The amplifiers certainly do not modify this frequency, their function being simply to introduce greater power into the oscillations and so give greater effective range.

A Clear Analogy

The modulator impresses the signal on this wave of constant frequency (say 1,000,000) by varying its amplitude in the rhythm of the musical note that is at the moment being picked up by the microphone. Suppose this to be a pure 1,000-cycle note, which

represents a pitch about two octaves above the middle C of the musical scale. Then the amplitude of the radiated oscillation rises to a maximum every one-thousandth of a second, and falls to a minimum half-way between two consecutive crests.

But there are still a million waves leaving the aerial in every second; during that second they are sometimes stronger, sometimes weaker, but their frequency remains unaltered. If one could watch the electrons in the aerial they would be seen surging upwards, coming to rest, and returning to earth, each cycle of movement occupying exactly one-millionth of a second.

In other words, the electronic excursions are alternately violent and feeble, and the cycle of violence and feebleness (the modulation frequency) is completed in every thousandth part of a second.

The fact that the electrons are too small to be seen, and that even if visible their movements would be too rapid to be followed by the eye, does not destroy the argument. An analogy which can be verified by the eye will perhaps assist in making this clear. If a child's swing is seen to pass the posts in the forward direction at

intervals one second apart, then its frequency must be admitted to be constant even though it may sometimes be swinging high and sometimes comparatively low.

In Your Aerial

When the modulated wave strikes a receiving aerial it induces currents similar in all respects (except that their power is enormously reduced) to



Dr. Robinson, the inventor of the Stenode Radiostat, with the apparatus for which such remarkable claims are made.

those in the transmitting aerial. If the aerial is tuned to the carrier frequency, or if it is coupled to tuned circuits adjusted to that frequency, these currents will be sufficiently strong to operate the detector and to give an audible signal.

There is certainly no need for any side-band theory to account for this. When the received wave is at peak strength the aerial current is also at peak strength, and the aerial current will follow accurately the modulations in the radio wave.

Three in One

So far, then, the theory of the single frequency might be held to explain intelligibly the mechanism of radio transmission and reception. It may also be added that so long as self-oscillation can be avoided there is no limit to the sharpness to which the circuits of the receiver can be tuned.

Supporters of the side-band theory will, however, probably refuse to be convinced by the above argument, and, whilst admitting its plausibility, will take refuge in trigonometrical equations to show to their own complete satisfaction that the modulated wave (which seems to be oscillating with such constant frequency) is really built up of three separate waves, one of the carrier frequency (say, one million), another of one million plus the modulation note of one thousand—i.e. 1,001,000—and a third of one million minus one thousand, or 999,000.

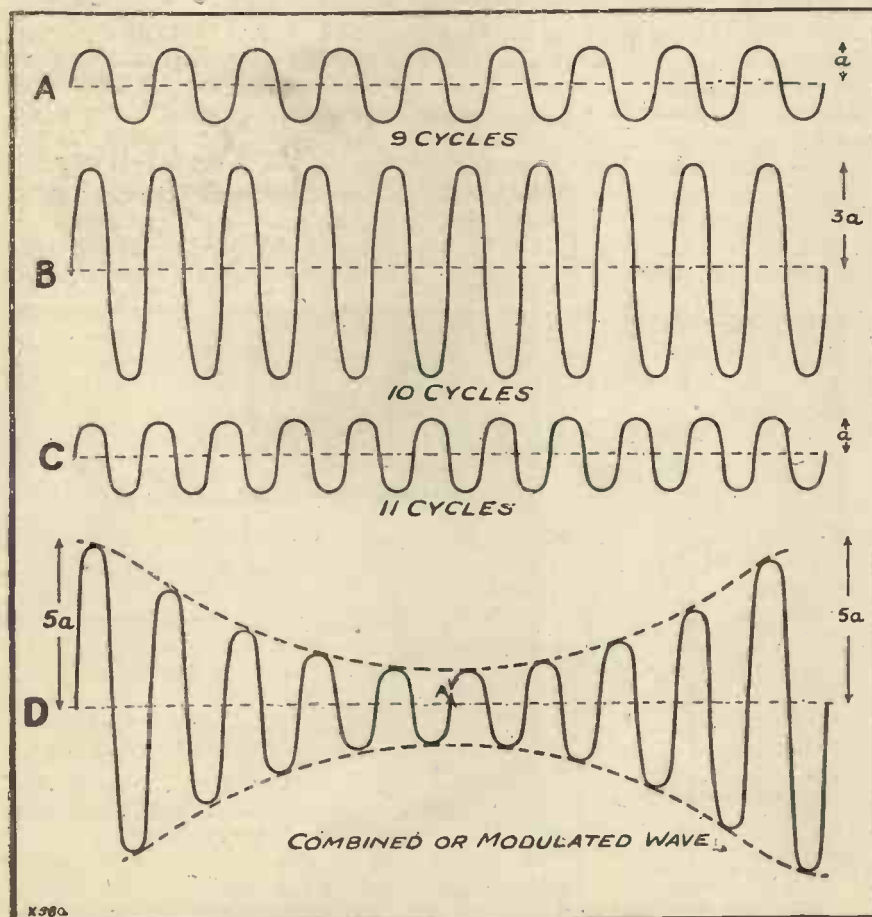

The existence of side-bands can be demonstrated very convincingly by a graphical representation. A full explanation of the above diagram is given in the text

Analysing Effects of Modulation

On the other hand, before the mathematician can show the existence of the side-bands he has to contrive some form of expression for a modulated wave. Having contrived this, he can manipulate it by unexceptionable logic into the form of a single carrier and several side-bands. But where he fails to be convincing is in the manner in which he translates the phenomenon of a modulated wave into an algebraical expression.

Adding Amplitudes

However, this mathematical argument cannot be further pursued here. It is too abstruse. Those who support the existence of side-bands have other strings to their bow.

For instance, the graphical method indicated in the figure will carry more conviction. The three curves A, B, C, drawn one above the other, represent respectively waves of 9, 10, and 11 cycles per second. The 10-cycle wave has treble the amplitude (3a) of the other two, but all the waves are of steady amplitude. If these waves are combined together by drawing a series of vertical lines and adding the respective amplitudes, the result is shown in the curve D, which clearly represents a wave of 10 cycles per second modulated in the rhythm of 1 cycle per second.

In other words, a carrier of 10 cycles and side-bands (or, rather, side frequencies) of 9 and 11 cycles, have been combined into a carrier of 10 cycles modulated by a wave of 1 cycle. If, therefore, side-bands and carrier can be combined into a single modulated wave, then the latter can with equal logic be analysed into a carrier-wave of 10 cycles, with attendant side-bands of 9 and 11 cycles respectively—i.e. the side-bands are "sum and difference" frequencies. These low figures have been chosen for the sake of simplicity, but the argument obviously applies with equal force to a carrier of a million cycles and a modulation note of a thousand cycles.

The Filter Test

But the graphical method is not the only one that can be used for analysing or breaking up a modulated wave into its component parts. If the signal or modulating wave is of comparatively high frequency, say, 10,000 cycles, and the carrier-wave is a long one, say, 100,000 cycles per

second, then the side frequencies, according to the side-band theory, would be 90,000 and 110,000.

When a wave modulated in this way is passed through a filter circuit, which cuts out all frequencies below 105,000, it is found that a wave having a definite frequency of 110,000 passes through the filter. This "sum" frequency can be built up into a powerful wave in a suitably tuned output circuit.

Similarly, another wave of 90,000 (the "difference frequency") can be isolated from the complex modulated wave. Each of these waves after its isolation can be amplified and radiated as a pure wave of the new frequency.

It is clear that they could not have been introduced by the filter circuit,

wave-length, ordinary sunlight being composed of a mixture of these waves. It is not practicable to split up complex wireless waves in quite the same way owing to their comparatively enormous dimensions. But the distortion which is frequently experienced when listening to short-wave wireless signals that have been reflected from the Heaviside layer affords a strong presumption that there are different frequency-components in a modulated wave, and that these have been differentially treated during the process of reflection or refraction.

Can You "Beat" It?

Finally, there can be no dispute regarding the well-known heterodyne

A special television transmitting station has been started in New Jersey (America) and very neat receivers are employed, as shown in this photograph. Incidentally, the Stenode Radiostat principle would prove very useful for television, which at present requires a very wide band of frequencies.

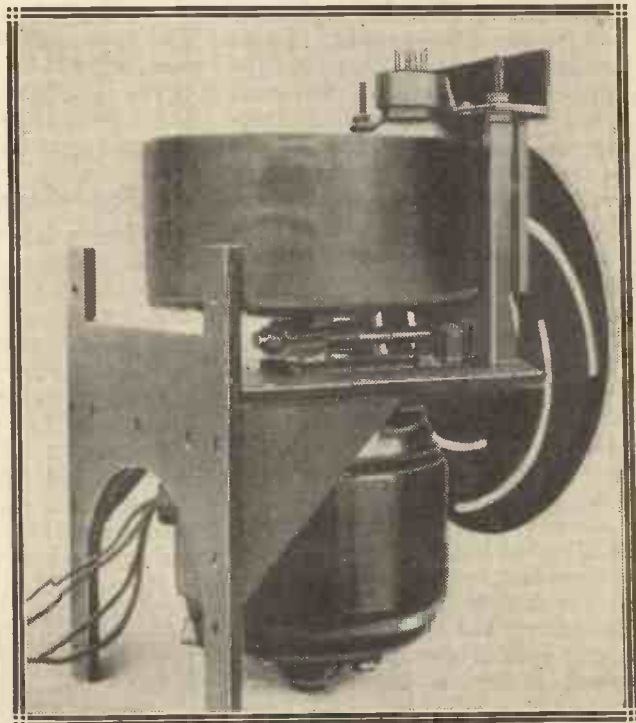

which is merely a complicated network of impedances, and contains no new sources of power. Evidently, therefore, they must have been present in a masked form in the original modulated wave.

There is still further evidence of the existence of side-bands in a complex modulated wave. Consider for a moment the action of a glass prism when breaking up ordinary white light into its rainbow-coloured components.

It is well known that each colour in the spectrum represents light-waves of a different frequency, or

action. When a local wave is superposed on a received wave of different frequency, a "beat" or difference frequency is at once obtained, which can be detected and heard in 'phones if the beat is of audible frequency.

Now, the apparatus and circuits employed in most forms of modulation are identical with those used in heterodyne reception. If one process produces a different frequency, why should not the other?

As a matter of fact, both produce a sum and a difference frequency; in modulation these are called the

(Continued on page 207.)

RADIO IN AUSTRALIA



Here is an absorbing account of real long-distance reception on ordinary broadcast wave-lengths. by an Australian reader.

Sir,—During the last two or three years much has been written on the subject of long-distance reception on ultra-short wave-lengths. Little, however, has been done on the ordinary broadcast band, and most people seem to think that long-distance reception on wave-lengths between 200 and 550 metres is only possible under very exceptional circumstances.

I have proved this to be otherwise, and that the most important feature in this regard is the conditions at the transmitting end.

Between the months of October and March, which are your winter and our summer months, European stations on the broadcast band can be heard on any efficient receiver until after sunrise.

Unfortunately, the English stations do not come in quite so well as some of the others, but the German stations, such as those at Langenberg, Breslau, Konigsberg, and Leipzig, come in at strong speaker strength on my receiver, which is an eight-valve, battery operated.

“2 L O—London ”

During these months, 5 G B can usually be heard here with much better strength than 2 L O, but this morning the reverse was the case, and 2 L O was a good deal stronger than 5 G B, and could be heard until some twenty minutes or so after sunrise.

I tuned into 2 L O at 5.35 a.m.—South Australian time—which corresponds to 8.5 p.m. G.M.T. At this time I heard a man singing the song “My Love for You,” with piano accompaniment, after which he spoke to his partner, a girl, and they both sang the duet “You, Just You.”

At 8.13 p.m. came the announcement “2 L O—London ” and that an orchestral number would follow. This item could be heard until 8.20 p.m., when the signal strength began to fall rapidly and fading increased, but I think that it was followed by a second orchestral item.

Four Stages of H.F.

Although 5.35 a.m. is some five or six minutes after sunrise at this period of the year here, the song and duet mentioned above came in at very good speaker strength, and almost every word could be heard.

It might be of interest to you to know that the receiver I use is an eight-tube T.R.F., built here in Australia, with four stages of R.F., detector, and three stages of transformer-coupled A.F., and that the set and valves, which are of the

ordinary three-electrode variety, have been in use for over 2½ years.

On this receiver I have had confirmed reception of 239 stations between 200 and 550 metres outside Australia, which include 137 in the United States and Canada, 19 in Germany, and 46 in other parts of Europe.

I have tried quite a number of receivers during the last two or three years, including some of the latest sets from America, using three and four stages of screen-grid R.F., but none of them have been as good as this Australian built “Udisco,” which, by the way, is a single-dial set.

Noisy Receivers

The American sets, of course, use the UX type of valve, including the UX222, and I have found them to be very noisy indeed, and so noisy, in fact, that the reception of the weaker stations is made quite impossible.

I have altered the wiring in some of these sets so that I could change the valves for the European and English valves, such as the Cossor and Philips, and have found these valves to be very much quieter than the UX type. However, the noise level in any set using more than three stages of screen-grid R.F. seems to be very high, and very much higher than in my old set with four three-electrode valves—A609’s—in the R.F. stages.

In conclusion, I must offer my apologies for the length of this letter, but I thought that a report on this long-distance reception and a few particulars of the set might be of interest.

Yours faithfully,

K. L. WILLIAMS.

South Australia.

OUTDOING EINSTEIN!



Prof. Richardson believes there is a fifth dimension which is largely a matter of electro-magnetism.

S.G.'s FOR FRAMES

The convenience of the frame aerial is never disputed, but it requires a sensitive receiver. Suitable methods of employing screen-grid valves are discussed in this article.



By J. ENGLISH.

ONE has only to think of the popularity of loud-speaker portables to visualise the great future that lies before the frame-aerial receiver specially designed for indoor use.

H.F. Essential

This can be used anywhere, even where any kind of elevated wire is out of the question, simply because it is not tied to a fixed aerial and earth like the ordinary set.

Moreover, with the frame-aerial receiver we obtain the much desired feature of high selectivity plus the directional properties of the frame, together with a compact and neat construction which adds to the appearance of the receiver.

Although we gain much in the way of convenience by using a frame aerial, the latter requires the backing of a powerful receiver if other than the local station's programmes are to be heard. At least one screen-grid H.F. stage must be used for satisfactory sensitivity, while for exceptional ranges there is a tendency to design receivers with two S.G. stages.

Interesting Results

During the summer months I have been working with different frame-aerial circuits, using S.G. valves in the H.F. stages, and although nothing radically new has been devised, I have been much interested by the results obtained, which indicate a very promising line of development for this type of receiver.

In this article I am going to set down a few notes on the various circuit arrangements and their operation, as this may suggest ideas for your own work on these lines or assist you in building your own frame-aerial receiver.

For the present I shall not include

THE FRAME-AERIAL VOGUE

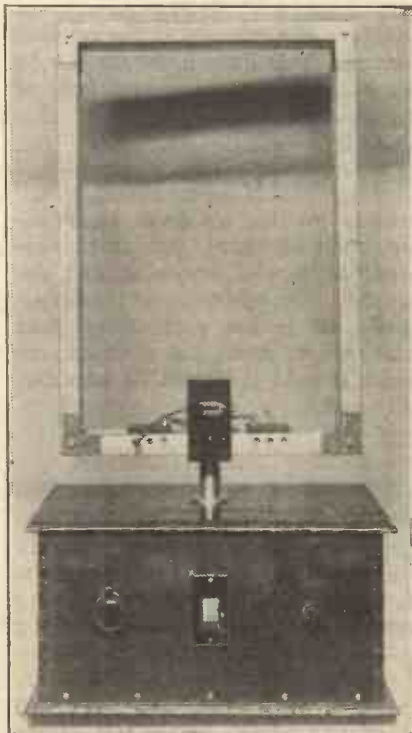

The "Flat-Dweller's" Four employs a screen-grid valve, and works from a small frame aerial mounted on the lid of the cabinet.

circuits with two S.G. stages, as these require considerable experience in handling. Receivers with only one screen-grid valve will provide you with ample material for experiment, and, although relatively simple, they can be made to give wonderfully good results.

The Simplest Circuit

The simplest and most trouble-free circuit, and the one with which I commenced investigations, incorporates a choke-coupled S.G. stage. Readers of "M.W." are sure to be familiar with this arrangement, which has been used successfully in several "M.W." transportables, and in the famous "Titan" receivers, so I need not deal with it here very fully.

The particular circuit arrangement which I found most suitable for frame reception is shown in Fig. 1, drawn as far as the detector valve only. Here few turns of the frame aerial are tapped off for the reaction winding, this arrangement having proved particularly successful in making the most of reaction build-up when working with ordinary detector circuits without H.F. amplification.

Tuning Condenser Values

With this circuit I use for medium-wave reception a 2-ft. frame of fourteen turns, the two innermost turns being the reaction winding, and this, with a .0001-mfd. maximum control condenser, provides ample reaction over the whole tuning scale.

The size of the tuning condenser is important in frame-aerial receivers,

because the loudest signals result from using the smallest amount of tuning capacity. The maximum capacity of the tuning condenser cannot be reduced too far, however, as this leads to loss of selectivity and a restricted wave-range.

A .00025-mfd. variable is about the minimum size you can use to cover some 250 to 550 metres, with adequate selectivity. With the circuit of Fig. 1, of course, selectivity depends entirely on the one tuned circuit, and where conditions are exceptionally bad we are forced to use more selective circuits of the type described further on.

The H.F. Choke

A vital factor in the performance of the choke-coupled S.G. stage is the H.F. choke, upon which depends entirely the degree of amplification obtainable. I have tried out a large number of chokes in the circuit of Fig. 1, and while there were not considerable differences in the control of reaction only relatively few of them provided satisfactory amplification. Therefore, if you use this circuit for your receiver, choose one of the new H.F. chokes specially designed for use with S.G. valves.

Although choke-coupling does not enable us to obtain as much amplification as other couplings, the circuit of Fig. 1, followed by two properly coupled L.F. stages, proved capable of receiving at excellent loud-speaker strength several of the stronger Continental stations, selectivity being quite pleasing.

Stable in Operation

On the long waves the impedance of the coupling-choke is several times greater than on medium wave-lengths, and this results in a considerable increase in amplification. This tends

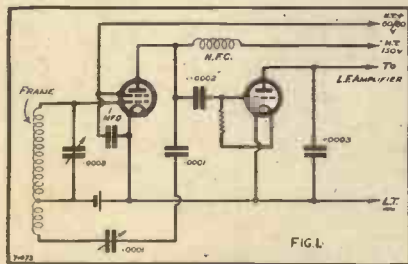

One of the most popular methods of coupling the S.G. valve to the detector is by means of an H.F. choke.

to counterbalance the decreased pick-up of the frame aerial on long waves, so that reception is distinctly good, particularly from such stations as Radio-Paris, Hilversum and Königswusterhausen.

The advantages of the choke-coupled S.G. circuit are its stability and easy operation combined with simple construction. Screening can be dispensed with if you use an H.F. choke with a small external field, and make your leads from S.G. anode to the choke and the coupling condenser as short as possible.

Preventing Feed-Back

The usual methods of keeping H.F. energy out of the L.F. amplifier must be adopted, as the frame aerial

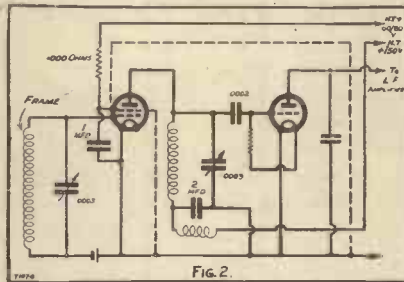

The direct-coupled tuned-anode circuit gives good amplification, but needs very careful screening.

is particularly susceptible to back-coupling from the loud-speaker leads unless this is done.

When using the maximum anode voltage with your screen-grid valve it is most desirable to apply a negative bias of 1 to 1½ volts, as in Fig. 1. Under these conditions for maximum amplification a certain amount of backlash was observed in the reaction control. This little difficulty can be got over by using a special form of reaction control which I shall describe presently.

Tuned-anode and parallel-feed couplings enable the maximum amplification to be obtained from the screened-grid valve, but at the expense of careful screening and decoupling. The selectivity of the tuned-anode set is not particularly good with an open aerial, but when a frame aerial is used it should be considerably better.

Better Amplification

This proved to be the case when the circuit of Fig. 2 was put into operation. Here the portion within the dotted lines was completely enclosed in a metal box, and it was found that stability could only be obtained with the S.G. valve inserted through a hole in the side of the box, nearly up to its base, that is, up to the flange of the screen-grid inside the bulb.

Even with very complete H.F. filtering, oscillation occurs if a low-

loss anode coil is used, due to the feed-back through the residual anode-grid capacity. However, this feed-back can be reduced with a slight gain in selectivity by tapping the S.G. anode on to the centre of the anode coil.

When receiving strong transmissions, such as 2 L O and 5 G B, a considerable gain in amplification over the circuit of Fig. 1 was observed, selectivity also being slightly better. In spite of these gains I was not particularly pleased with this circuit for frame reception.

The Question of Reaction

The two tuning controls do not make searching for distant stations particularly easy, and when the receiver is properly stabilised there is not that initial build-up of weak signals which we obtain when reacting direct into the frame, as in Fig. 1.

Under these conditions the frame aerial is peculiarly sensitive to weak signals, and I have often obtained extraordinary D.X. results by using a detector valve reacting direct into a frame aerial with the addition of only one L.F. stage.

Returning to the circuit of Fig. 1, one cannot help noticing that reaction feed-back from the anode is contrary to the purpose of the S.G. valve, which has been specially designed to reduce to a minimum such back-coupling. In this circuit we are using it solely as a high-magnification valve without taking advantage of the screening effect of the additional grid.

Separate Oscillator Valve

The series reaction circuit also diverts from the anode some of the H.F. voltage developed across the

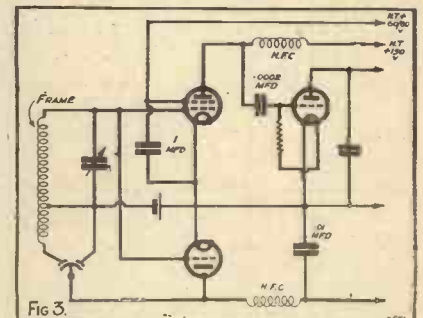

The use of a separate reactor valve is well worth trying, the correct connections for it being given in this diagram.

H.F. choke, all of which should be applied to the detector grid.

These considerations led me to try out the circuit of Fig. 3, where a separate valve is used to provide

Selectivity Obtained is all that can be Desired

reaction, which it does in a particularly effective manner. This is an old dodge, but it works extremely well with the S.G. valve.

Reaction control is exceptionally smooth, and very nearly constant

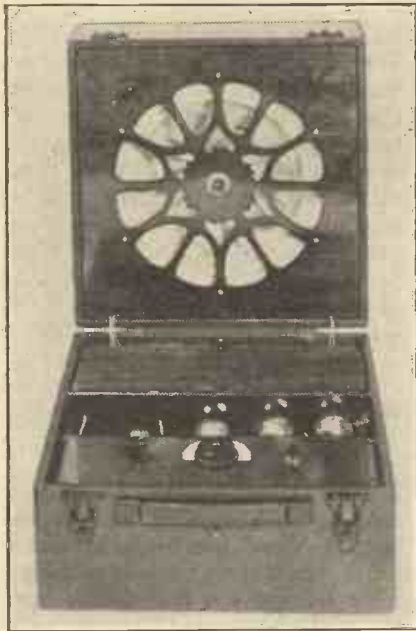

A portable "four" which employs a choke-coupled screen-grid H.F. stage is one of the most popular portable receivers. Such sets are quite easy to construct.

over the whole tuning range. Using another valve for regeneration is by no means an extravagance, because almost any type will do, so that you can make use of one of those old valves you are sure to have by you.

An H.F. valve is the best type to employ, but, whatever it is, between 30 and 45 volts H.T. is ample for full reaction, while the filament consumption of the extra valve is almost negligible. In fact, the separate reactor would be well worth while if it consumed even more filament current than it does.

Perfectly Smooth Reaction

You will notice that the grid of the separate reactor is connected in parallel with the control grid of the S.G. valve, incidentally deriving thereby a negative bias of $1\frac{1}{2}$ volts, which assists regeneration. For reaction control I use a .00015-mfd. differential condenser connected as shown in Fig. 3, whereby a remarkably efficient control is obtained, adjustment of this condenser having little, if any, effect on tuning. Consequently tuning is simplified, making the re-

ception of distant stations much easier.

Another interesting feature of the separate reactor is that the H.F. choke in its anode circuit can be replaced with advantage by a resistance, which for an H.F. or general-purpose valve can be anything between 20,000 and 100,000 ohms, without necessitating a higher anode-voltage than 45.

One of the first things I observed with this circuit was that volume was appreciable better, especially on weak signals. This is undoubtedly due to the absence of back-coupling from the anode of the S.G. valve, which is now used as a true screen-grid valve. On the whole the circuit is well worth investigation.

A.C. Receivers

When we begin to consider the possibilities of A.C. screen-grid valves the future of the frame-aerial receiver becomes quite rosy. As you know, the characteristics of the indirectly-heated valves are considerably better than those of the battery-operated types, so that even with choke-coupling the overall amplification is remarkably high.

Owing to the very high A.C. resistance of the A.C./S valve it is necessary to use a coupling of high impedance, such as tuned-anode or parallel-feed. The latter has the merits of simplicity, and lends it-

self to straightforward construction, especially where wave-change switching is to be incorporated.

High Efficiency

If we use in the detector and L.F. stages of the receiver valves of the mains-operated class, all of which are remarkably efficient, then we obtain a very powerful combination which has all the requirements of selectivity, sensitivity, and trouble-free operation. We can also obtain an extremely neat and compact installation by building the eliminator into the same cabinet as the receiver. This, however, requires careful attention to screening.

One of the most satisfactory circuits for A.C. valves is that shown in outline in Fig. 4. Here the screen-grid valve is coupled by means of a parallel-feed grid circuit to the detector, which is followed by a simple transformer-coupled L.F. stage. The usual standard component can be used, but for successful results the section in dotted lines must be built into a closed screening box, with the eliminator preferably totally screened in a separate box. If you use a commercial eliminator this will generally be fitted with a screening cover.

The necessity for very complete screening and decoupling is the only drawback in constructing a high-power receiver of this nature.

A.C. VALVES IN THEIR ELEMENT

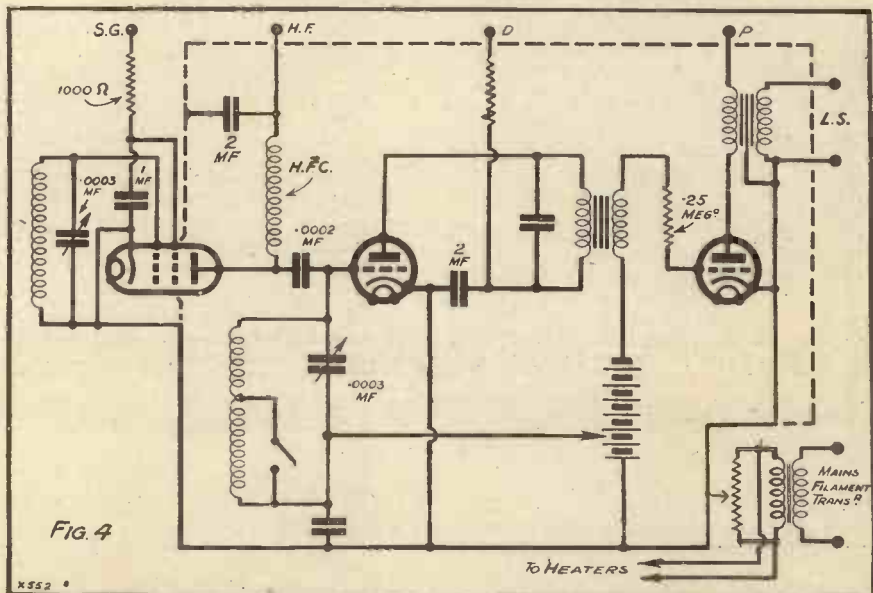

Outlined above is a typical transportable circuit employing A.C. valves, which are very suitable for such receivers, owing to their high efficiency.

THIS MONTH

The "M.W."

Research Department
PRESENTS—

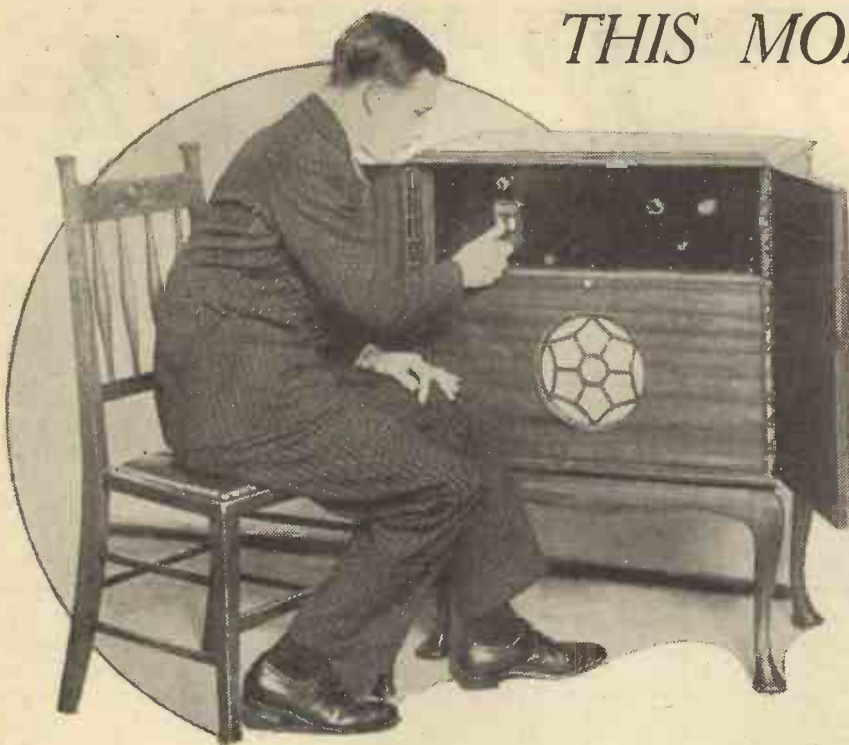

inclined to suggest that it is neither. For one thing, if you consider a set purely from the viewpoint of getting the maximum possible performance from a given number of valves, you are very apt to lose sight of many other important qualities, such as ease of handling, and refinement of performance generally, under which heading we would include the question of real fidelity of reproduction, which is rarely met with in sets in which the designer has tried to get the last ounce from each H.F. valve in the way of magnification and selectivity.

THERE are two ways of setting about the design of a wireless set. In the first you decide to build, say, a five-valver, and then you set to work to get the maximum possible sensitivity and selectivity from that number of valves.

Ease of Handling

If you are accustomed to treat sets in this way you will naturally be

in the habit of thinking entirely in terms of numbers of valves. As soon as, say, a five-valver is mentioned you will begin to compare the results to be expected from it with those you have heard from the most sensitive and selective "five" you have tried previously.

Is this necessarily the only, or even the best, way of looking at a set of the larger type? We are

Another Standpoint

There is undoubtedly a growing tendency nowadays to look at sets from a more commonsense standpoint. In this second way of designing a receiver you first decide upon the performance you require, make up your mind as to the standard of fidelity of reproduction you consider necessary, and decide upon the system of control. Then after all that you fix the number of valves and the type

COMPONENTS REQUIRED

- 1 Panel, 26 x 8 in. (Resiston, Trolite, "Kay Ray," Keystone, Becol, Trelleborg, etc.).
- 1 Cabinet, with baseboard 12 in. deep (Camco, Raymond, Pickett, Artcraft, etc.). (See also illustration of de luxe Pickett cabinet elsewhere.)
- 1 Double drum-drive with pair of .0005-mfd. condensers (J.B., Lotus, Cydon, Igranic, etc.).
- 1 .0004- or .0005-mfd. reaction condenser (J.B., Igranic, etc.).
- 1 20,000-ohm wire-wound potentiometer (Varley, Rothermel, etc.). (50,000 ohms also suitable, or any similar value.)
- 1 3-spring on-off switch (Wearite, Bulgin, Ready Radio, etc.).
- 1 ½- or 1-meg. "dissolver"-type volume control (Magnum).
- 5 Sprung valve holders (Benjamin, Lotus, Igranic, W.B., Lissen, Formo, Wearite, Bowyer-Lowe, Marconiphone, Burton, Precision, etc.).
- 1 D.B.A. coil unit (Lewcos).
- 1 D.B.P. ditto (Lewcos).
- 1 Baseboard-mounting neotrodyne type condenser, with rotary vanes (Bulgin, Magnum, Keystone, etc.).
- 1 "C.A.T. switch" unit (Wearite). (S₁ and C₁ on diagrams.)

- 4 1-mfd. condensers (Lissen, Dubilier, T.C.C., Mullard, Ferranti, Hydra, etc.).
- 2 2-mfd. condensers (Lissen, etc.).
- 2 H.F. chokes, suitable for H.F. inter-valve coupling (Varley and Lewcos in set). (Other pairs can be used, but the reader is warned that some may be unstable. A different natural wave-length is desirable in these two units.)
- 1 Standard H.F. choke (Lissen, R.I., Dubilier, Igranic, Wearite, Lotus, Ready Radio, Climax, Keystone, Bulgin, Lewcos, Varley, etc.).
- 4 600- or 500-ohm de-coupling resistances (Ready Radio and Bulgin in set). (Also supplied by Messrs. Wearite, Paroussi, etc.)
- 1 .0001-mfd. (max.) compression-type condenser (Formo type F, Igranic Pre-set, etc.).
- 1 H.T. fuse (Ready Radio, Bulgin, Magnum, etc.).
- 2 2-meg. grid leaks and holders (Dubilier, Ediswan, Igranic, Lissen, Pye, Mullard, etc.).
- 1 ½-meg. grid-leak, type with terminals or wires at ends (Lissen, Pye, etc.).

- 1 .0003-mfd. fixed condenser (T.C.C., Lissen, Dubilier, Goltone, or other edgewise-mounting type).
- 1 .001-mfd. fixed condenser (T.C.C., etc., as above).
- 1 .01-mfd. fixed condenser (T.C.C., Dubilier, Lissen, Mullard, Igranic, Clarke, Goltone, Graham-Farish, etc.).
- 1 100,000-ohm anode resistance and holder (Igranic, Lissen, Varley, Dubilier, R.I., Mullard, etc.).
- 1 20,000- or 25,000-ohm de-coupling resistance (Ready Radio, Ferranti, etc.).
- 1 Low-ratio L.F. transformer (Lissen, Ferranti, Telsen, Cossor, R.I., Brown, Varley, Mullard, Igranic, Lotus, Lewcos, Phillips, Marconiphone, etc.).
- 1 Output filter choke, about 20 henries (R.I., Ferranti, Varley, Wearite, etc.).
- 3 Standard "M.W." screens, 10x6 in. (Ready Radio, Paroussi, Magnum, Keystone, Wearite, etc.).
- 2 Screens, 4½ x 6 in. (see above).
- 1 Terminal strip, 3 x 2 in.
- 1 Ditto, 11 x 2 in.
- 12 Terminals (Eelox, Belling & Lee, Igranic, Burton, etc.).
- Wire, screws, flex, etc.

The "B.P." Five

of circuit accordingly, without laying too much stress upon the idea of making each valve work for its living as hard as possible.

This is very much the way set designs are regarded in America, where a "radio" is just an instrument giving a certain performance,

Another "M.W." Triumph!

This is a truly modern set for modern conditions. It is highly sensitive and selective, and sets a special standard of quality—in fact, it's everything that a set should be!

It helps to prevent us from being led by our enthusiasm for extreme sensitivity and power into thinking of a receiver as something which is primarily intended to perform well-nigh impossible feats of bringing in low-power relay stations at distances of thousands of miles.

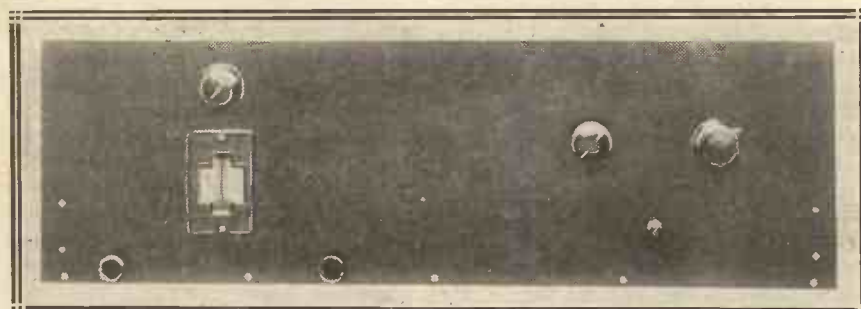
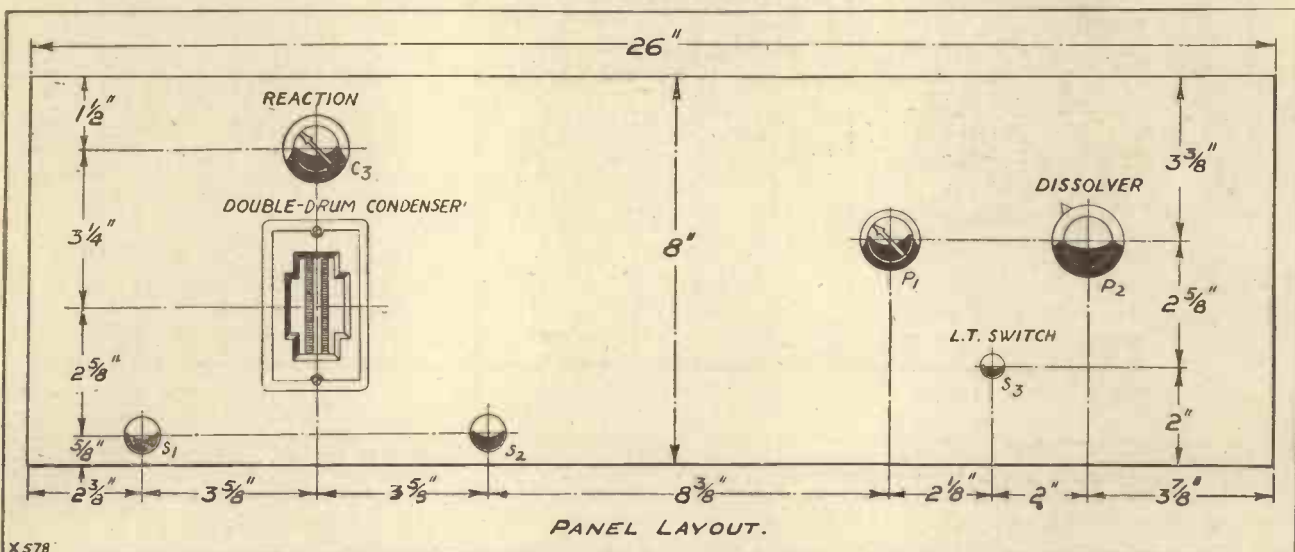

The tuning is simplicity itself, station after station coming in with perfect clarity as the drum-drive is revolved. If the volume is too great a touch on the volume control will regulate it perfectly.

the number of valves not being specified as a rule.

This way of looking at sets of the larger kind has much to commend it, although naturally it can be carried too far. Chiefly it leaves you free to concentrate upon the very important details which in the end decide whether the set will be a pleasant, reliable and serviceable instrument in use, and makes or mars it as a means of obtaining genuine entertainment from as many stations

as possible with the minimum of difficulty.

If you approach the task of designing a receiver from this angle you will find that you are automatically regarding the receiver far more as a means to an end than as an end in itself. The effect is really rather salutary, you know, because it keeps us reminded of the fact that, after all, a receiver is really simply a means of getting the best possible broadcast reception.

A set resulting from a design approached from what we have ventured to call this more common-sense point of view is apt to be a very different instrument from one of the "last ounce" type. Probably an example will be interesting. Readers may remember that last autumn we described a set under the title of the "Exhibition" Five, which was quite a good specimen of the type in which the designer first decides the number of valves and then sets to work to get a high performance from every one of them.

The Other Type

This receiver was one giving very excellent results, with a high degree of amplification and very good selectivity, and when used with an outdoor aerial it could be depended upon to bring in everything that was going—everything, indeed, which was above the level of atmospheric noise.

This receiver had many special attractions of its own, but was suitable for general domestic use.

Plenty of Programmes with Power and Purity

result of the use of band-pass filter tuning, a system of H.F. amplification which reduces risks of feed-back to an absolute minimum, and the addition to all this of two L.F. stages carefully designed to give really faithful amplification.

One-Thumb Tuning

As regards ease of operation, just take a look at the panel. You will see that the tuning control can almost be regarded as a matter for one thumb. It actually consists of a double-drum condenser, of one of those types which has the two drums placed so that their edges come close enough together to be operated simultaneously.

A great deal of the searching with this set, therefore, can be done by running the two drums together with your thumb, merely doing a little independent trimming up of the two when you tune in a rather weak station. Immediately above this unified tuning control is a reaction control which is only required on the weaker stations, and will normally be kept at minimum.

Other Controls

Below and to the right and left of the tuning control are two push-pull knobs which actuate the wave-change switches on the coil units and so can hardly be regarded as true operating controls. Away to the right

are two volume controls, one operating on the H.F. stages and one on the L.F., below these being the on-off switch. Those are all the controls, and you will realise what a strong contrast this arrangement presents to the average five-valver with its row of tuning dials, all requiring more or less simultaneous manipulation.

Now, as to the actual results you can obtain with this set. We have only made very mild claims for it so far, but as a matter of fact you will find that despite the fact that we have cut down the possible amplification perceptibly in order to obtain the special features we wanted, nevertheless it has still decidedly more power than you really need for general purposes.

Adjusting the Volume

On all the stronger European stations you will not find it necessary to run the set full out, and one or other of the volume controls will normally be in operation to some extent all the time. Only on the weaker stations will you need to turn up these volume controls to the maximum point, and possibly use just a trifle of reaction.

On test we found this receiver amply fulfilled our requirements and we were able to bring in every transmission worth listening to, and it did so with a fidelity and naturalness of reproduction exceedingly pleasing to

anyone who has become dissatisfied with the rather imperfect quality of the average super long-range set.

Now let us look at the design a little more in detail and see how all these desirable features have been obtained. First, there are the tuning arrangements, and these are rather interesting in themselves. There are two separate tuned circuits, coupled together in such a fashion that they constitute what is called a band-pass filter.

Coil Arrangements

That arrangement, as the reader may know, is simply such a combination of circuits as will ensure a comparatively even response to a comparatively narrow band of frequencies, with a sharp cut-off on either side, so ensuring both good quality and good selectivity. It can take a variety of forms, the simplest being just two separate tuned circuits with a suitable degree of coupling between them. (For an explanation of such circuits see MODERN WIRELESS for December, 1929, page 603.)

In the present case the two circuits are coupled together by means of an arrangement rather like a Reinartz reaction circuit. In this a little energy is withdrawn from the first tuned circuit and fed through a small winding which is coupled to the inductance in the second circuit. In series in this coupling circuit is a suitable small variable capacity, which

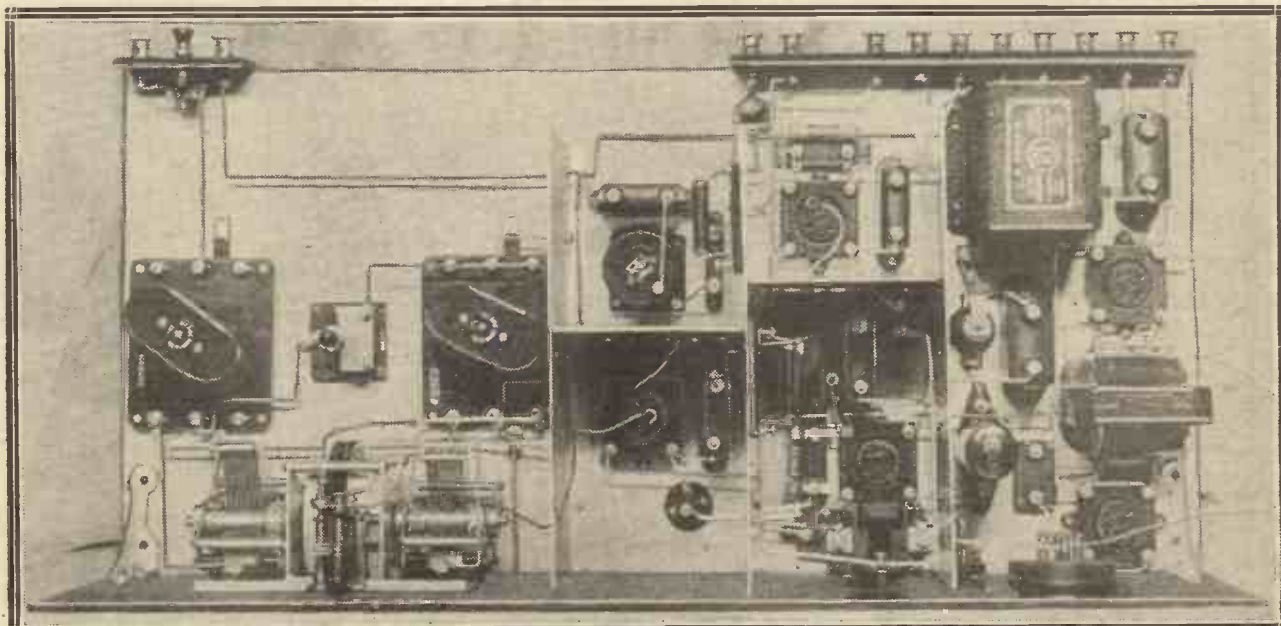

This plan view shows that the various stages have been grouped in such a way that the screening between them is easily and effectively carried out on standard lines.

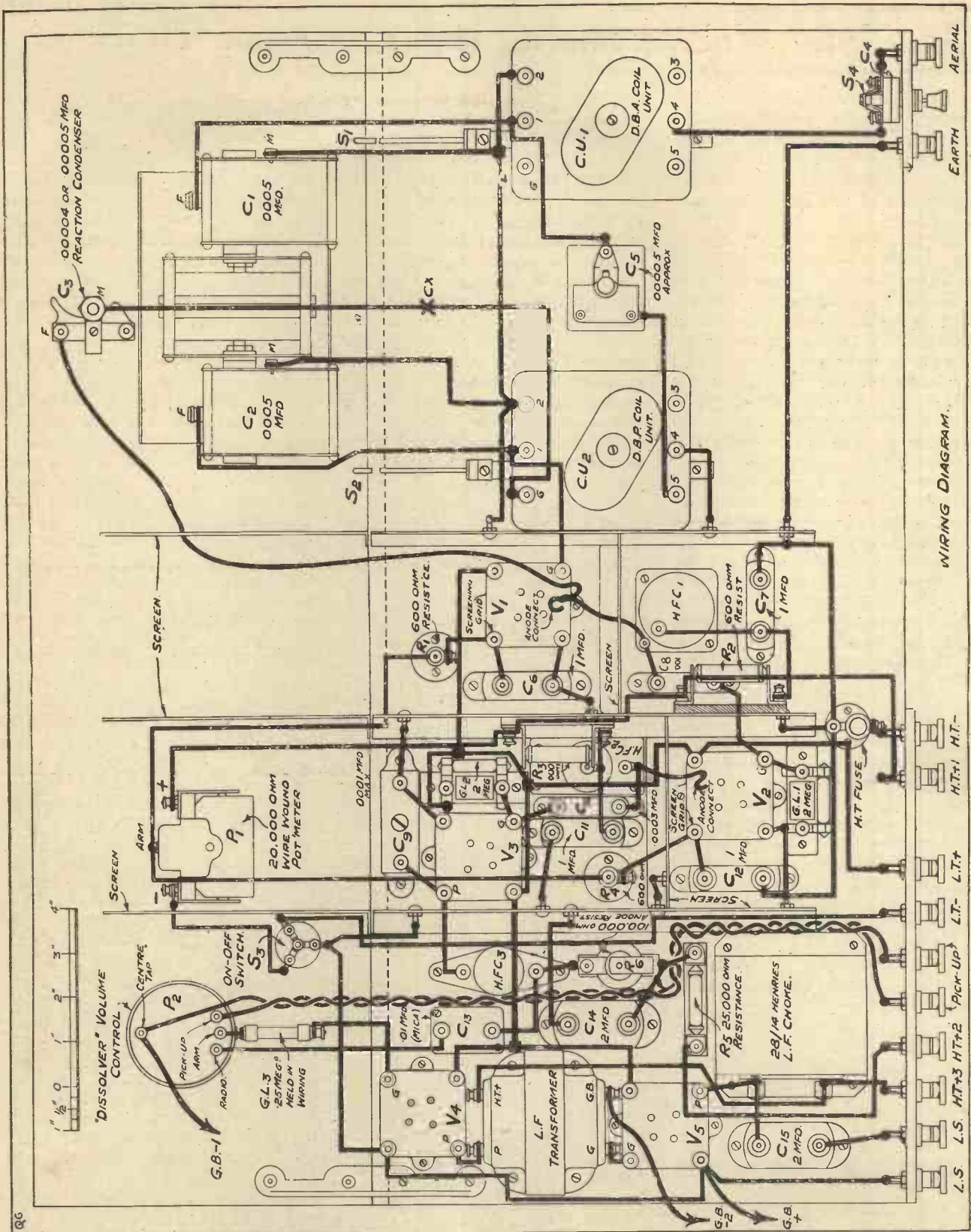

enables the operator to adjust the coupling within certain limits, very much as reaction is controlled in a Reinartz circuit.

Turning to the circuit diagram, you will be able to follow this out. Condenser C_5 is the one which controls

the coupling between the two circuits, and the adjusted amount of energy which flows through this from the first circuit is passed through a coupling winding on the second coil unit.

Condenser C_5 is actually of the base-board-mounting neodydyne type,

with a maximum of about .00005 mfd., and it will normally be kept set to its full capacity. Only when you require an abnormal degree of selectivity will you require to reduce it to some lower value.

There is another control of

The "B.P." Five is a "Band-Pass" Set

coupling on the second coil unit, giving you a further choice of two complete ranges of selectivity adjustments. This coil unit is actually a "split-primary" H.F. transformer, and the primary is used for coupling purposes.

Alternative Selectivity

Since the winding is in two parts there is an obvious choice of either the whole or only half of it. Probably the half alone will suit most users, and to set this connect the lead from C_5 to No. 5 on the unit, joining No. 4 terminal of the unit to the appropriate earthing point on the adjacent screen.

To get more coupling, with correspondingly slightly louder signals and reduced selectivity, connect C_5 to No. 5 as before, but join No. 3 on the coil to screen instead of No. 4. (This is only a preliminary test; future adjustments of selectivity can be made on C_5 .)

Wave Range of Set

Now a few notes about the coil units. They are of the wave-change type, covering something like 200 to 550 metres and 1,000 to 2,000 metres, according to the setting of their controlling switches (these latter are built into the units, and are operated by knobs on the panel through the medium of extension rods).

The second unit is, as we have already remarked, a split-primary H.F. transformer, and its secondary is tuned by one section of the double-drum condenser (C_2), forming the second tuned circuit of the band-pass filter. The first H.F. valve is connected across this circuit, and provision is made for applying a little reaction here on the rather rare occasions when it is required.

Obtaining Reaction

The normal reaction winding of the unit is used for this purpose, and reaction is taken from the anode of the first H.F. valve through the very small condenser C_3 on the panel. This is not an ideal method of obtaining reaction in theory, but it is the only one available in this circuit.

The main objection to it is that where there are two H.F. stages, as in the present receiver, it does not give the smooth and gradual control of a detector reaction circuit. That is quite immaterial in the case of this set, however, because you will never need to work it on the edge of oscillation.

It is only when reaction is used intensively like this that the niceties of control are of any importance, and you should never need to do so with the "B.P." Five. For all normal purposes you will only need to add just a spot of reaction for the weak stations, and for this purpose the method we have adopted is quite satisfactory.

Just one other point about the reaction arrangements before we leave them. You will see that the reaction circuit is in effect shunted across the H.T. supply, and if the vanes of the reaction condenser should chance to touch there will be a rather serious short-circuit.

This should not happen with a well-made component, but it is just worth bearing in mind. Examine your particular condenser, and if there seems to be the slightest risk of a short due to touching plates, put a blocking

"safety" condenser in series with the lead from the reaction condenser to the coil unit. The position for this condenser is marked "CX" on the diagrams, and a capacity of about .001 mfd. is suitable.

Aerial Coupling

The aerial and earth are coupled to the first tuned circuit in just the usual way, the coil unit being an ordinary "aerial coil." These units, of course, are provided with a terminal for the aerial lead which gives suitable coupling effects.

In connection with the aerial coupling arrangements there is a further control of selectivity consisting of an optional series condenser in the aerial lead. This is to be regarded as the main selectivity adjustment, giving two different degrees which will suit most purposes.

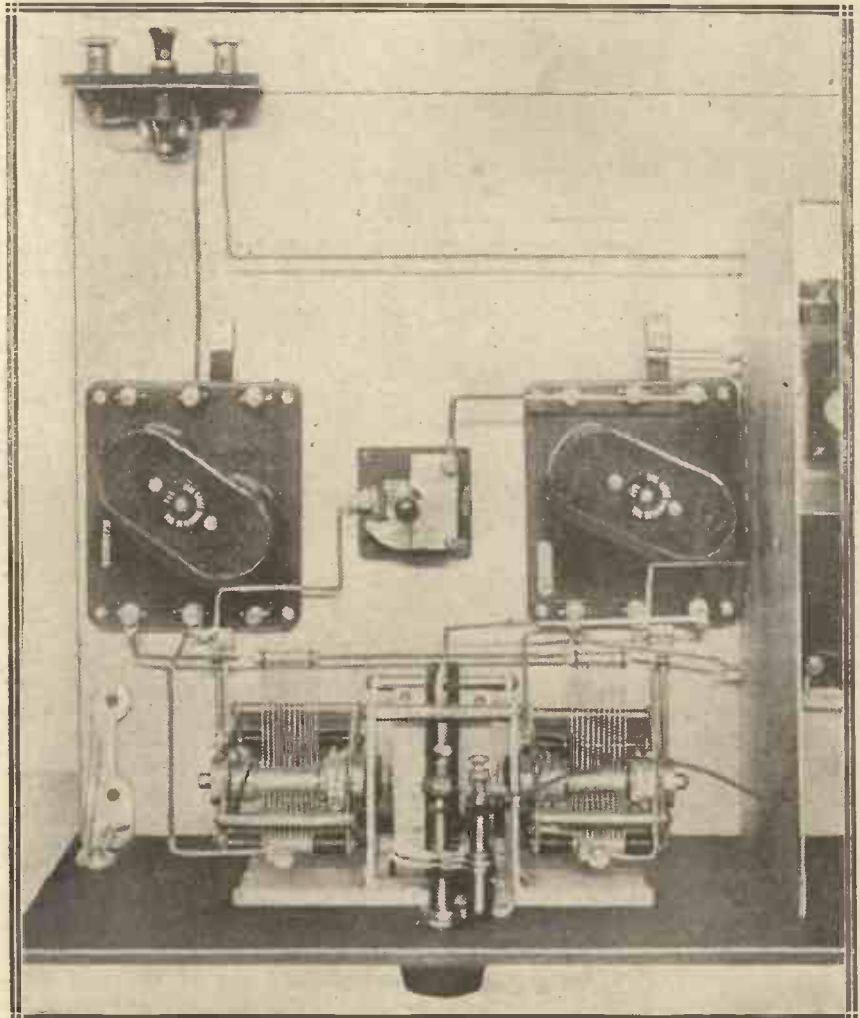

All the tuning is done in this section of the set, where two coil units are employed. Each has a control on the panel for low and high wave-lengths, and the degree of coupling between the circuits is regulated by the small condenser standing on the baseboard between them.

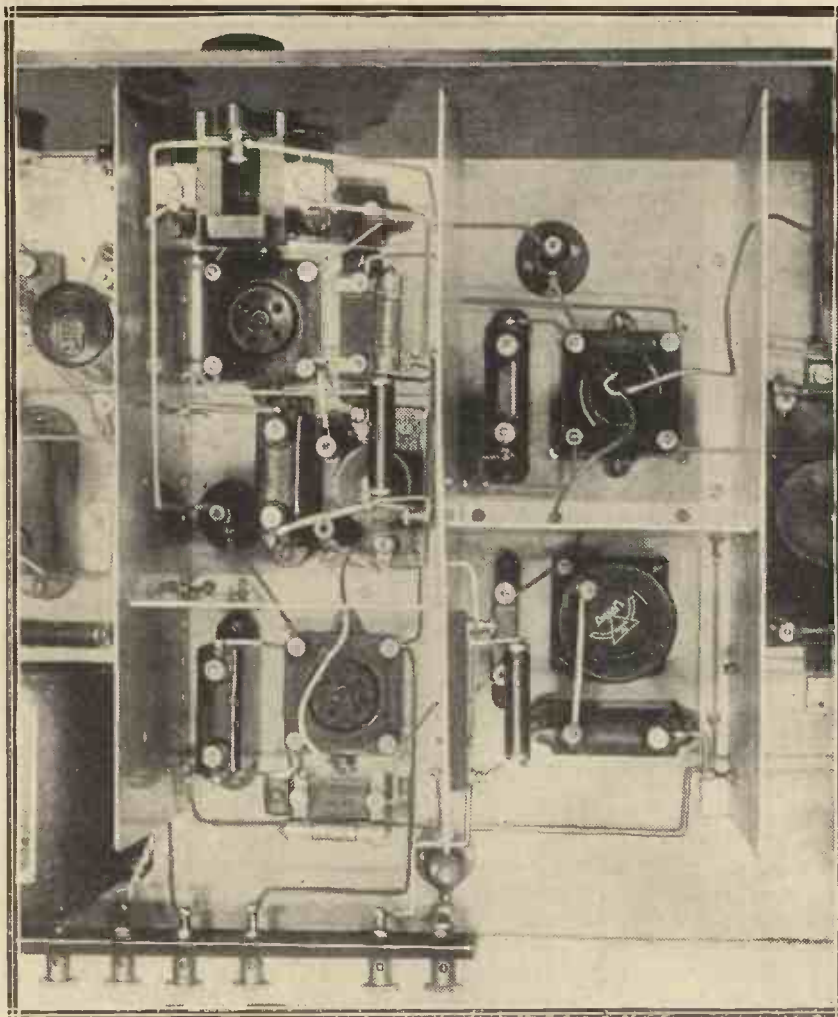

Here are the two aperiodic high-frequency amplifying stages.

The device takes the form of a little unit which incorporates the necessary fixed condenser and shorting switch in one component. It is mounted on the back terminal strip, between the aerial and earth terminals, and by operating the switch you can bring the condenser into operation or short it out of circuit as required. (Knob pushed inwards for condenser in, and pulled out for condenser shorted).

Following after the band-pass filter tuning circuits are the two H.F. stages, using S.G. valves with H.F. choke coupling. This, of course, is substantially aperiodic over the range of wave-lengths in which we are interested. Naturally, it gives less amplification than a tuned arrangement, but still ample for our purpose when two stages are used.

Aperiodic H.F. Stages

As a matter of fact, it does not give so much less amplification than the tuned system as you might think. You see, if the H.F. stages are tuned it is usually necessary to weaken the intervalve coupling by using H.F. transformers or some other scheme

in order to get selectivity, and so the mag. comes down. In the "B.P." Five, of course, we have already got our selectivity right at the beginning (from the band-pass filter).

An aperiodic H.F. amplifier has many solid advantages in the way of compactness, stability, and excellent quality of reproduction. In combination with a good band-pass filter it makes a most delightful outfit to handle.

Avoiding Coupling

Rather thorough precautions have been taken in each H.F. stage to prevent battery coupling, and you will see that each lead to screening electrode and plate circuit contains a separate stopping resistance, with the appropriate by-pass condenser down to the filament circuit.

As a further safeguard against battery coupling troubles there is an anti-coupling filter of the conventional type in the detector feed lead, and the last valve has an output filter for the loud speaker.

All this has been given particularly close attention, because such receivers

as this obviously call for a mains unit for the H.T. supply, and in such cases considerable care is needed to prevent motor-boating, when the overall magnification is high.

We would stress this point of the desirability of mains H.T. for a set of this class, since wherever two S.G. valves of the new and more greedy type are used, with two L.F. stages (presumably with a super-power valve), the total anode current is definitely high.

The H.T. Consumption

It may well be of the order of 20 or 25 milliamps, or even more, and this is scarcely an economical dry battery proposition. An accumulator H.T. battery could, of course, be used, but in this case we should advise that steps be taken to curtail the consumption of the S.G. valves by applying a little negative bias to the grid of each.

For this purpose you should use a separate 1½-volt dry cell for each valve, connected up as follows: First, break the lead from No. 2 on the second coil unit to screen, and instead wire No. 2 to the negative of one of the cells, the positive of the cell going to screen.

That completes the biasing of the first H.F. valve. The second can be biased through the grid leak, to do which proceed thus: Disconnect the grid leak G.L.1 from filament negative and take it instead to the negative of the other dry cell. Wire the positive of this cell to filament negative or a convenient point on the screening.

H.F. Volume Control

One other detail of the H.F. side calls for mention, and then we can pass on. You will see that the voltage on the screening electrodes of the two H.F. valves is adjusted by means of a high-resistance wire-wound potentiometer. The two ends of the potentiometer winding go across from H.T. +1 to the L.T. circuit, and the screening electrodes are fed from the slider.

You will find this device a very pleasant accessory in use. Not merely does it enable you to find the best setting in a few moments, but it is also a very effective pre-detector volume control.

You will probably find that you can set it to give a slightly lower voltage than that which gives the optimum results and keep it so for all normal purposes, only "turning up the wick" for very weak stations. In this way you not merely secure a quieter background, but economise H.T. current slightly.

Suitable for Radio or for Records

The remainder of the set is a very straightforward arrangement of detector and L.F. amplifying side. The latter consists of one resistance- and one transformer-coupled stage, with quite normal values.

Note that the detector is provided with an adjustable plate-to-filament by-pass condenser, C_6 . This will usually be set to about a mid-way position for best results, the method being to make the capacity as large as possible without injuring quality of reproduction.

Provision is made for the use of a gramophone pick-up when desired, and you will observe that the device for changing over from radio to records is a fader-type volume control. This is placed in the first L.F. stage, so that you have just two valves in use for pick-up work.

Economising L.T.

Where economy in L.T. current is a serious consideration, it is suggested that an extra switch be fitted to turn off the filaments of the two H.F. valves and the detector when the pick-up is being used. To do this you will have to re-arrange the filament wiring a trifle, but no doubt anyone who contemplates building a rather advanced design like this will be sufficiently experienced to do this for himself quite easily.

A constructional point arises concerning the pick-up connections, and

that is the method of wiring the pick-up terminals at the back of the set to the "fader." We decided to put the P.U. terminals at the back of the set because the more customary panel position struck us as being too untidy for a set of this class.

Avoiding Interaction Troubles

The only drawback about the rear-strip position is that rather long leads to the "fader" are required, and so there is a risk of interaction with other parts of the circuit. This risk we have dealt with by twisting the two leads together to form a pair, and running them along beside one of the screens in a position where they are well away from all danger points.

You will be able to follow this from the wiring diagram, bearing in mind that this lead runs quite high up along the side of the screen in question. The drawing shows it rather differently for the sake of clarity, but you will understand that it actually runs against the screen the whole way until it arrives close to the "fader."

Constructionally, the set is quite an undertaking, and will take you some time, but it is not unduly difficult to build, for there are no special parts to make, and it is just a matter of mounting up standard components and wiring. A little care and patience is needed, because

space is naturally limited in a set containing so many components, but there are only one or two special points about which you should be warned.

First, observe that the de-coupling resistances R_2 and R_3 are mounted on the screens, near the upper edges, to simplify their connections and save space. A couple of small brass screws and nuts will be needed for each.

Next, be careful to see that you do not miss out any of the connections to the screens themselves. This is most important, since the metal-work completes various circuits.

Now about the wiring. In any set where a good deal of screening is used, some sort of covered wire is most essential. Some such material as Glazite (used with great care to avoid scraping the covering against sharp edges) or tinned wire and Systoflex is therefore advised.

Voltage Figures

Finally, some condensed working data. Valves: two upright type S.G.'s for V_1 and V_2 , one H.F. type for V_3 , one L.F. or G.P. for V_4 , one super-power for V_5 . H.T. voltages: 120 volts on H.T. + 1, 60 to 70 volts on H.T. + 2, 120 volts or more on H.T. + 3.

One last point. Pull the wave-change knobs outwards for medium waves and push them inwards for long waves.

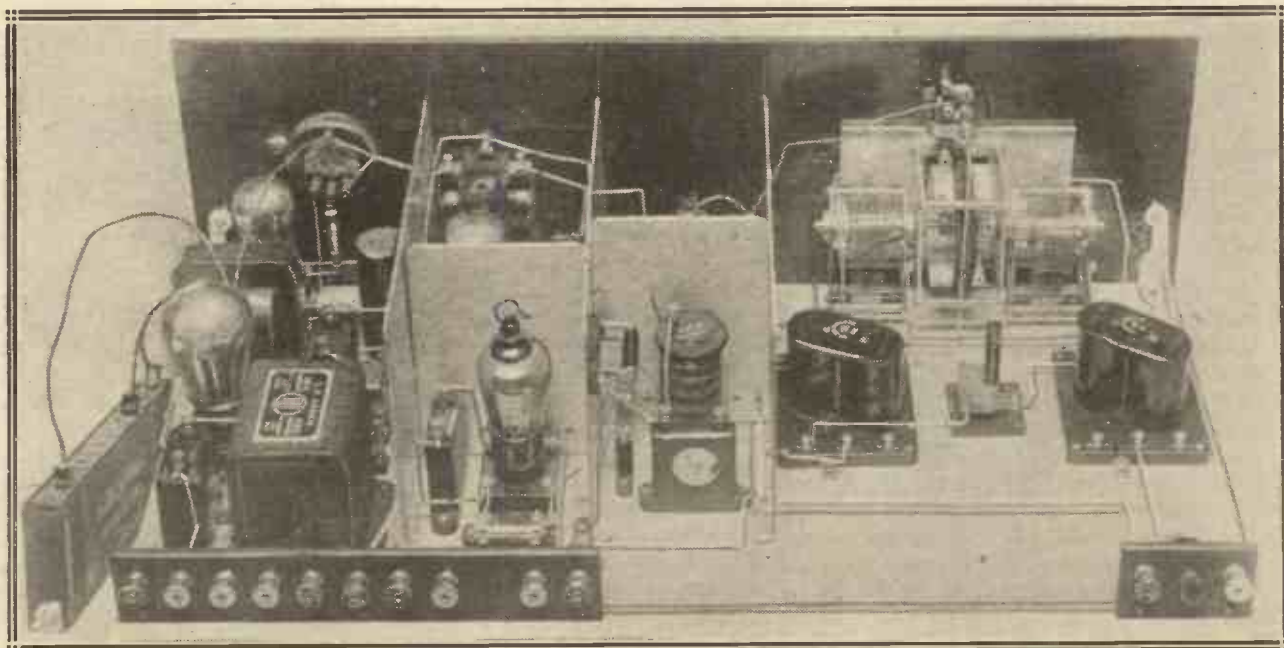

This view of the completed set shows the valves and coils in position, and it will be seen that there is ample spacing everywhere, yet the set presents a neat and compact appearance.

How Radio

—LITERATURE—EDUCATION—OPERA—



Feodore Chaliapine singing at 2 L O.

—**LITERATURE**, by *Rebecca West, the famous Novelist.*

IN my opinion, the B.B.C. is doing good work in giving us occasional readings from the works of the best modern writers, and in allowing writers to express their thoughts via the medium of the microphone.

Certain sections of the Press seem to under-estimate the public taste in literature, but the B.B.C. does well not to play down in this manner. Thus they give the ordinary man what he really wants.

Moreover, as with music, this policy is having the effect of fostering common taste and interest. Owing to broadcasting, we are all reading more than we used to do, and, what is more, reading better works.

The only fault I can find with the B.B.C. regarding the way in which it treats literature is that we have perhaps a little too much poetry, which, despite many different opinions, is, I believe, better seen upon the printed page than heard. This, however, is but a minor detail.

—**EDUCATION**, by *Dr. Cyril Norwood, Headmaster of Harrow School.*

I think that wireless has been very useful in elementary schools, where a studio lesson by an acknowledged expert can be broadcast to a hundred schools at once, and then followed up by a brief personal lesson from the teacher.

Many pupils tend to take more interest in facts and figures when they come via the loud speaker, and, of course, in the smaller country schools this method of teaching is invaluable.

Modern languages, for example,



Dr. Cyril Norwood.

when properly received by wireless, offer something which cannot be acquired in the smaller schools in the usual way.

For similar reasons, I believe that wireless will be of even greater educational value in the future. A broadcast from a foreign country will give greater interest to geography lessons, and a talk by a poet or author may brighten even such a subject as Grammar.

—**OPERA**, by *Feodore Chaliapine, the great singer.*

The microphone has saved the operatic art from itself, and in so doing has altered the whole future of this aspect of music. Eventually the microphone will become complete master of the operatic stage.

Witness the enjoyment of the wireless listener who, unhampered by the sight of comfortable prima donnas and insecure scenery, or by the petty annoyances of the Opera House, coughing, programme rustling, and so on, is free to enjoy the music and conjure up his own dreams.

I visualise a time when the stagey opera of to-day will be a thing of the past, and when the greatest music of this type will be heard only through the medium of the microphone allied to television or the talking pictures.

Then, by the aid of "Voice Doubles" and other skilful tricks, we shall be able to see a Siegfried or a Mimi such as we have always dreamed of.

—**THE THEATRE**, by *Philip Ridgeway, the well-known producer.*

When films first appeared it was prophesied that they would cause the death of the theatre, and when broadcasting was inaugurated there was a similar scare.

On the contrary, however, broadcasting has brought to the theatre a vast new public which otherwise it would never have had, not because of the outside broadcasts from



Philip Ridgeway represents the point of view of the theatrical producer.

Has Helped—

—THE THEATRE—ARTISTES—THE BLIND—DANCE MUSIC

Read the views of famous men and women—prominent in widely different walks in life—on the benefits of broadcasting.

By HAROLD A. ALBERT.

theatres, but simply because simple entertainment in the home has whetted the palate of the great public and made it cry for more.

Again, the wireless is proving an admirable training ground for both actors and dramatists. I can cite more than one well-known playwright who, but for the wireless, might never have been known to fame, and there are many other cases.

Also, the partial competition of the

To be brief, however, the advertisement and money the entertainer derives from wireless work is quite helpful enough, though it would sometimes be better to be both seen and heard.

—THE BLIND, by Ronald Gourley, the blind siffleur.

Everyone knows that broadcasting has enormously helped the blind. It

When broadcasting commenced, many prophesied that it would mean the death of the gramophone, the theatre and many branches of musical and dramatic art. That these prophecies were incorrect, is clearly shown in this symposium of the views of a number of well-known authorities.

programmes has caused the theatres to wake up. Consequently, we are now enjoying a period of prosperity unparalleled since the war.

—ARTISTES, by Helena Millais, the popular entertainer.

It has helped by giving entertainers a much wider public than concert hall or dinner work could provide, and people who never go to such functions hear them, so that wireless entertainers are "known" wherever they go.

Compared with singers and instrumentalists, however, entertainers and comedians are still at a disadvantage on the radio. The former can get pieces and songs for nothing, but entertainers have to find comedy material, and exclusive stuff costs a lot, even when one is lucky enough to find any.

This combined with the need of putting over one's personality makes wireless work rather worrying, but the big and warm-hearted public one acquires makes broadcasting worth while.

has brought us into touch with a multitude of activities which we could never have known save through Braille, and it has brought, too, a much easier method of entertainment.

Indeed, it has almost opened up a new world, not because it also lacks sight, but because it simply comprises sound. I do not think the coming of television will alter the position.

At one time, people sympathised with the blind. Now we have wireless such sympathy is wasted.

A charming study of the world-famed novelist, Miss Rebecca West.



To the left is Miss Helena Millais, the popular entertainer. The other photograph will be recognised as that of that great microphone favourite, Jack Payne.

—DANCE MUSIC, by Jack Payne, leader of the B.B.C. Dance Orchestra

Before the era of broadcasting, many people who were unable to visit ballrooms and hear dance music played by the best bands had a somewhat distorted view of dance music and did not know of what a good dance band was capable. Wireless has entirely altered this.

I find that the microphone enables me to endow dance music with a number of variations quite impossible in a ballroom, where it mainly appeals to the feet, instead of to the ear.



AN AMERICAN SHORT-WAVER

Some notes on the up-to-date amateur transmitter installed at the Clark University, at Worcester, Mass.

From Our Special Correspondent.



The short-wave transmitter of the Station I X Z.

THE "Clark" University, situated at Worcester, Massachusetts, U.S.A., has reason to be proud of its radio activities. Not only do complete courses in radio-technology and engineering feature in the University's Science curriculum, but the college boasts also of a long-established Radio Club of its own.

The history of the Clark University Radio Club goes back almost to the very beginnings of broadcasting activity in the States, and although since its inception the club has undergone many vicissitudes and changes of organisation, which have on more than one occasion resulted in the temporary closing down of the station's transmitter, these varied difficulties have been surmounted, and a long record of successful working has been the result.

Old-Established Station

Thus, as we have seen, the Clark University Radio Club's station—IXZ—is of no mushroom growth. Perhaps one ought to state that a large measure of its continued success is due to the good offices of the University authorities, and particularly to Professors E. C. Belknap and R. H. Goddard, who are responsible for the Chemical and Physics departments of the University respectively.

After working successfully for two or three years, station IXZ was completely reorganised in the September of 1923. In 1927, too, it was newly equipped with more efficient and up-to-date apparatus, and since that time

it has made many long-distance amateur records. I X Z now possesses several experimental transmitters, the features of the main one being depicted in the accompanying photographs. This transmitter is energised in the plate circuit of the transmitting valve by a 2-kw., 2,000-volt Westinghouse motor generator which is housed for convenience in the basement of the transmitter building.

The main transmitter of I X Z is of Western Electric design, and more or less normal in type. The circuit is tuned by means of copper strip inductances, and the output circuit of the transmitter is connected to a four-wire cage aerial, approximately 70 ft. long, which is suspended from adjacent buildings 75 ft. above the ground.

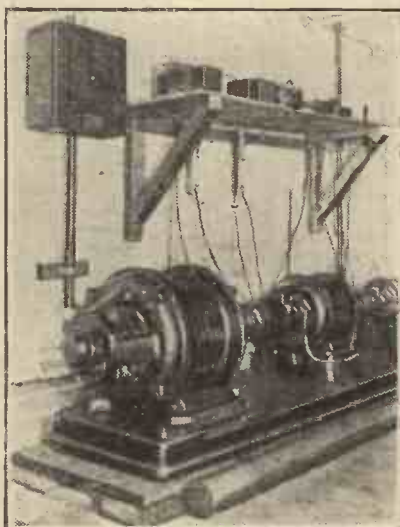

The 2-kw., 2,000-volt motor generator housed in the basement of the station building.

The Clark University station is capable of operating over a choice of wave-lengths, but for most purposes it confines its activities to wave-lengths between 25 and 200 metres. Working on a wave-length of 120 metres the transmitter develops an aerial current of 2.8 to 3 amps.

Station I X Z has for many years specialised in long-distance transmissions. It has been particularly successful in communicating with the Argentine and with New Zealand. Good reception of its signals has also been reported from Italy, France, Holland, and from time to time by a few enthusiastic DX fans in England.

Many DX Successes

However, the station's DX records have not all been confined to the sphere of radio short-wave transmission. In the matter of long-distance reception the Clark University Radio Club has accomplished many things of which it may well be proud. The station picks up all the well-known European transmitters, and it claims also to have received signals from nearly every country in the world.

In this connection it is of some interest to note that some three years ago the Clark University station was able to get into complete touch with, and to receive continuous messages from, a party of American explorers who had journeyed to within ten degrees of the North Pole.

Clark University Radio Club and its station, I X Z, is run on democratic and self-constitutional lines. It elects its own officers every year. The subscriptions of members go towards the operating expenses of the station, any surplus being devoted to a fund for the provision of additional equipment.



ONE of the most frequent ailments of modern sets is L.F. instability, and so often is this trouble encountered that I feel I am justified in summarising its treatments. Perhaps I can add little to that which has already been written about it, but, nevertheless, there must be many readers who are even now facing the problem and will welcome some advice.

The symptoms of L.F. instability are easily recognised. And I must mention that under the same heading I am including "motor-boating," which, after all, is a condition of instability. Likewise no apology is necessary for the inclusion of the microphonic valve.

Easily Recognisable Symptoms!

The commonest demonstration of "L.F. instability" is a loud howl which nearly drowns speech and music, a howl which varies neither in volume nor pitch as you adjust the tuning controls.

But quite often there is a high-pitched whistle, and, again, we sometimes get a slow "pop, pop, pop" that sounds like a machine-gun in action. It is a matter of pitch. If the pitch is very low the sound is deep and low, so low at times that it ceases to be a note and you get the

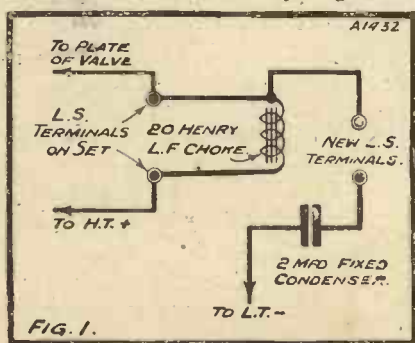

With the enormous amplification possible with efficient modern sets, certain troubles arise that did not prove so evident in the earlier days of radio. L.F. instability is one of them and here are some hints on how to overcome it.

By D. GLOVER.

pop-pop-pop of the separate "cycles."

On the other hand, the pitch may soar up to that of a piercing whistle verging upon inaudibility.

There is a "threshold" condition where no actual howl develops, but the speech and music develop a sort of hollowness and smudginess.

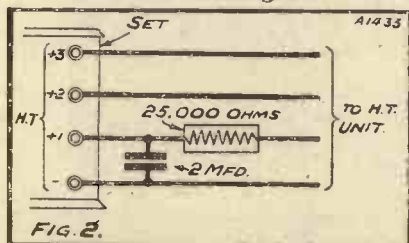

In the case of a howl that is not heard when the set is first switched on, but suddenly develops and builds up and up in volume until it nearly drowns everything, you can legitimately suspect one of the valves of being microphonic—probably the detector valve.

Curing "Ponging"

Air vibrations from the loud speaker cause the set to vibrate, and this gets the valve "ponging" and so away goes the dreadful howling.

Changing the loud-speaker's position might cure the trouble. Failing this, try sticking a penny with a lump of Plasticine on the top of the valve. If that doesn't work, you must suspect the set as well and experiment with the following general "cures."

Instability may be due to the use of faulty component values or valve types. But if you have wandered away from the specification and designer's operating details of the set anything might happen!

A very frequent cause is the coupling of a mains unit to a set not specially designed to take a unit having a meagre tapping separation arrangement.

Nothing can be done if the unit is incapable of providing the current that the valves of the set need. If you use three valves whose total current requirement is 15 milliamperes, a unit capable of providing 20 milliamperes at the right voltage is essential; the 5-milliamper margin is none too great.

Fitting a Filter

You will want a choke-filter output from the set, that is almost certain. And you can easily fit this to any set as shown in Fig. 1. You can mount the components in the set itself if there is room, or you can build them into a little box.

The choke must be of at least 20 henries and of low ohmic resistance (a few hundred ohms—not thousands), and capable of carrying the anode current taken by the last valve.

This filter arrangement safeguards

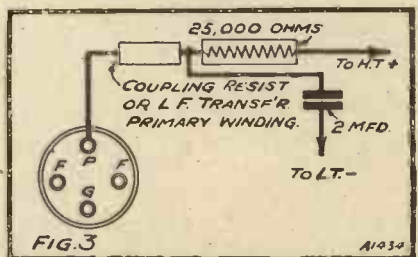

the loud speaker and makes it safe to run long leads to it and will probably greatly improve your results. (Continued on page 208.)

The "Eckersley"

WE seem to have "started something" recently when we produced a simple all-A.C. version of one of our standard receiver designs. The set in question was the "Brookman's" Three, and since it was of a rather specialised type we did not expect that it would appeal directly to a very large proportion of our readers.

However, when we produced the A.C. version it was at once evident that the idea was one which interested a very large number of readers, who were quick to realise that by proceeding on these lines it becomes quite a simple matter to produce an all-mains version of almost any receiver design.

So many readers have shown a keen interest in this method of producing a mains-driven outfit that we have

The tremendous popularity of the "Eckersley" Three, published in our December issue, has created a demand for an "electrified" version of this wonderful receiver. Below, the simple modifications necessary are outlined for the benefit of the listener with A.C. mains.

By The "M.W."
RESEARCH DEPARTMENT.

A.C. version of the "Eckersley" Three. The A.C. version of this set has pleased us immensely in the course of its tests, as you will readily understand when you remember that the original battery version was itself an unusually attractive receiver, with

that the selectivity of the design was unusually good, and stated that it might be expected to deal fairly easily with the new Brookmans Park transmitter at distances of the order of six or seven miles upwards, and it appears that certain of our readers imagined that this was rather faint praise. Well, if those readers were to enquire of their friends actually living within a six-mile radius of Brookmans Park we fancy that they would not need any further explanation from us!

Listeners who have not had actual experience of the situation which exists immediately around the new station can have little conception of the real difficulty of the problem.

High Praise

As a matter of fact, to say that a receiver can be expected to cut out this transmission with reasonable ease at distances of only six or seven miles is exceedingly high praise indeed, and indicates a very fine standard of selectivity.

Sets which will do this without the aid of a wave-trap or rejector at shorter distances still must definitely be regarded as possessing an absolutely phenomenal degree of selectivity, such a degree, indeed, as is quite unnecessary for all normal situations. It would almost render them unsuitable for general work.

The Power Supply

Fortunately, it would appear that a six or seven miles' radius round Brookmans Park does not include a very large population, so that not very many listeners are faced with the problem in its most acute form.

After which digression, let us return to the question of the conversion to all-mains working of the "Eckersley" Three, and see how simple a business it is. We have again used the scheme which we so strongly recommend for all general purposes, namely, a separate power unit giving the necessary high-tension current and also a supply of low-tension alternating current for the running of the mains valves, the set itself being merely modified very slightly from its original battery form. For the power unit we suggest the standard "M.W." A.C. unit described in our December number, which serves the purpose admirably.

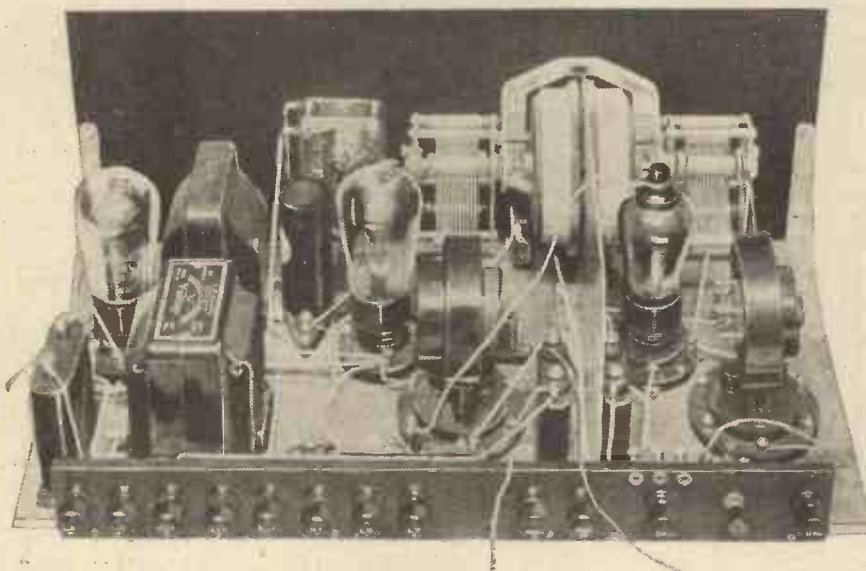

Here the coils and valves are shown in position, and the alignment of sockets above the switch on the terminal strip can be seen.

been confirmed in our estimate of its extremely practical nature, and have considered seriously whether we should not produce A.C. versions of quite a number of our more popular receivers. We propose to try out the idea a little further, still in a tentative manner, and if our readers indicate that the idea appeals to them as strongly as it does to us we will certainly extend it still further.

Even Better Performance

This month we are presenting another example of this method of "electrification" in the form of an

its special combination of superfine quality on the nearby transmissions and extra sensitivity and selectivity for long-range work. When you add to this again the extra power and sensitivity conferred by the superior characteristics of special mains valves, the result is naturally something quite out of the ordinary.

Mention of the selectivity of the original "Eckersley" Three design, by the way, reminds us of a little point which we should like to explain a trifle further before we go on with the description of the A.C. version. In the original article we mentioned

A.C. Three

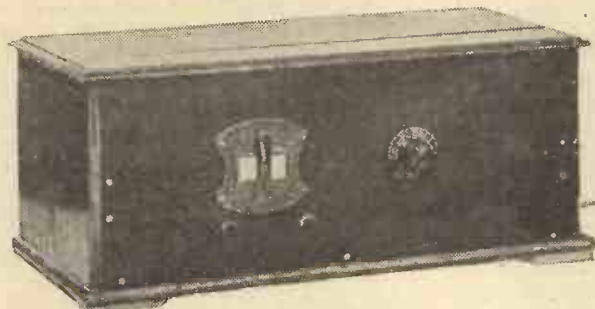

In this way you avoid the bulkiness of the type of all-mains set in which the power circuits are actually built into the main cabinet, the conversion of the receiver is an exceedingly simple matter, and you have further the assurance that if ever you decide to build yourself a bigger receiver, your existing power unit will almost certainly still serve your purpose

Choice of H.F. Valve

Even if for some reason your next set should chance to be one of the normal battery-valve type, the power unit will still serve, because you can use just the H.T. portion and ignore the L.T.A.C. output part of it.

Now let us go through the receiver in detail and see just what has to be

done to convert it for the use of A.C. mains valves. We must assume, by the way, that the reader has access to a copy of our December issue, which contains the main description of the "Eckersley" Three. Space will not permit us to repeat in full detail the explanation of all the special features of the set. The reader will no doubt remember that when the receiver first appeared we devoted a considerable amount of space to it, and he will find a very full account in the original article.

Taking first the H.F. stage, the reader will understand that we were faced with the choice of either a directly-heated or an indirectly-heated screened-grid valve. We decided after brief consideration in favour of the directly-heated type, for these reasons: The directly-heated

A.C. screened-grid valve is very much like its battery equivalent in characteristics, and so it can be fitted with the minimum of alteration.

The indirectly-heated type, on the contrary, has decidedly different characteristics, and really requires to be treated rather differently if its full potentialities are to be exploited. There is, indeed, little point in using it unless special provisions are made in order to obtain its higher magnification. Hence our decision in favour of the more amenable directly-heated type.

Filament Wiring

This is what you have to do to employ one of the directly-heated types of screened-grid A.C. valves in the H.F. stage. First of all, the ordinary filament wiring must be

COMPONENTS YOU WILL NEED

- 1 Panel, 18 in. x 7 in. (Resiston, "Kay-Ray," Paxolin, Goltone, Trolite, Becol, Ripault, etc.).
- 1 Cabinet to fit, with baseboard 10 in. deep (Raymond, Cameo, Pickett, Gilbert, Lock, etc.).
- 1 Double-drum condenser (Lotus, Cyldon, J.B., or similar type, in which the two driving drums come sufficiently close together to be revolved simultaneously with the operator's thumb). (Double, .0005 mfd.)
- 1 .0001-, .00013-, or .00015-mfd. differential reaction condenser (Utility, Ready Radio, Pye, Lissen, Magnum, Lotus, Polar, Ormond, etc.).
- 1 L.T. on-off switch (Lissen, Benjamin, Lotus, Wearite, Igranice, Magnum, Raymond, Burton, Bulgin, etc.).
- 1 Pair small panel brackets.
- 2 6-pin coil holders (plain un-screened type) (Formo, Leweos, Bowyer-Lowe, Magnum, Wearite, etc.).
- 1 Sprung valve holder (Lotus, W.B., Benjamin, Dario, Igranice, Wearite, Formo, Bowyer-Lowe, Pye, Precision, etc.).
- 2 Five-pin valve holders (replacing two of the ordinary type used in original set) (W.B., Lotus, Wearite, Junit, etc.).
- 1 200- or 400-ohm baseboard-mounting potentiometer (Igranice, Lissen, Ready Radio, etc.).
- 1 Combined series aerial condenser and switch unit (Wearite).
- 2 1-mfd. condensers (Dubilier, Lissen, Ferranti, T.C.C., Hydra, etc.).
- 1 2-mfd. condenser (Dubilier, Lissen, Ferranti, T.C.C., Hydra, etc.).
- 1 .0003-mfd. fixed condenser (T.C.C., Mullard, Goltone, Dubilier, Igranice, Clarke, Lissen, etc.).
- 1 .001-mfd. fixed condenser (Lissen, etc.).
- 1 2-meg. grid leak and holder (Dubilier, Igranice, Ediswan, Lissen, Mullard, Carborundum, Loewe, etc.).
- 1 H.F. choke (Ready Radio, Lissen, R.I., Leweos, Dubilier, Climax, Raymond, Keystone, Wearite, Varley, Colvern, Magnum, Lotus, etc.).
- 1 Low-ratio L.F. transformer (Lissen, Ferranti, R.I., Brown, Cossor, Lotus, Varley, Marconiphone, Mullard, Telsen, Philips, Igranice, etc.).
- 1 Output filter choke of about 20 henries (Varley, Igranice, Wearite, R.I., Pye, etc.).
- 1 H.T. fuse (Bulgin, Ready Radio, Magnum, etc.).
- 1 "M.W." standard screen, 7 in. x 6 in. (Ready Radio, Magnum, Wearite, Paroussi, Peto-Scott, etc.).
- 1 Terminal strip, 16 in. x 2 in.
- 12 Engraved or indicating terminals (Belling and Lee, Igranice, Eelex, Clix, Burton, etc.).
- Wire, screws, flex, plugs, etc.
- 1 Single-pole change-over switch of push-pull type (Lissen, Bulgin, Wearite, etc.).
- 1 Additional 400- or 200-ohm potentiometer (Ready Radio, Igranice, Lissen, Sovereign, etc.).
- 3 Small sockets (Eelex, Clix, etc.).

removed, and the filament terminals of the valve holder wired to an additional pair of connection points on the back terminal strip. In addition, we are suggesting that you should include in one of these new leads an extra switch on the panel for the purpose of turning off this H.F. valve when the receiver is being used for gramophone reproduction, the inclusion of a pick-up switch being a little modification we are providing in the present version of the design.

Neat Filament Wiring

As a practical point, the wiring of the filament circuit of the screened-grid valve should now be carried out with twisted leads, to minimise risks of induction from the A.C. wiring to other parts of the set.

of course, go to the two outside terminals of the '8-volt winding on the unit.

We explain these points rather in detail because it is not possible to show them very clearly on a plan-view wiring diagram, such as the one reproduced on these pages.

Mention of the on-off switch for the H.F. valve reminds us that we should perhaps explain that no ordinary on-off switch is required in the A.C. version of this receiver. If you already possess the battery version you can remove the battery switch, put it in the new position where it controls the H.F. valve, and fill in the hole with black wax, or you can just leave it in place without any connections. The A.C. version, of course, is turned on and off by means

now to be regarded as the four-volt A.C. terminals, to be connected up to the corresponding pair on the power unit. Directly across them you should also wire up another 400- or 200-ohm potentiometer, the connections going to those terminals on this component which represent the two ends of the winding. The slider terminal of the potentiometer should then be wired to a convenient point on the earth circuit, the one actually chosen being one of the terminals of the 1-mfd. condenser C_6 .

Altering the Grid Circuit

The two terminals of the five-pin holders representing the cathodes of the valves (usually marked C or K) should be connected together and also wired to some suitable point on the earth circuit (see wiring diagram). The rest of the wiring of the set remains exactly as before, with the exception of the grid circuit of the detector valve.

Some slight alterations are made here, partly to include the change-over switch for the pick-up arrangement, and partly to provide the necessary positive bias on the grid of the valve for rectification. Taking the latter point first, all that you have to do is to provide one terminal of the grid-leak holder with a flex lead bearing upon its end a battery plug for insertion in the grid-bias battery at a suitable point. (We will deal with the actual placing of this plug a little later on.)

For the gramophone change-over switch you require one of the single-pole change-over push-pull variety. This switch is mounted upon the panel in a position which balances that of the on-off switch for the H.F. valve, and the connections are shown on the wiring diagram.

Gramophone Switch Connections

We should just explain that the lead from the grid of the valve goes to that contact on the switch which represents the moving element. The contact marked "longest arm" should be the one with which the grid of the valve is brought into contact when the switch is pushed inwards. The one marked "small arm" should be the contact with which the grid of the valve comes into connection when the knob of the switch is pulled outwards.

This scheme is merely to ensure that when the two switch knobs are pushed inwards the H.F. valve is turned out and the grid of the detector valve is brought through to the pick-up. In

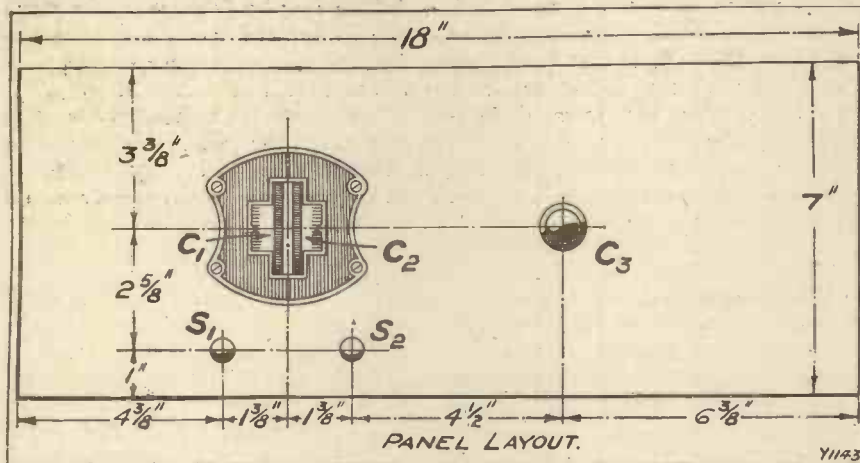

Ordinary twisted flex can be used, but we have found that a rather neater job is made by the use of ordinary tinned copper wire encased in Systoflex sleeving.

There is not very much room on the back terminal strip to fit extra terminals for the necessary A.C. supply to the screened-grid valve, and so we adopted the expedient of using some small sockets for the purpose. You require three of these, and one is placed on either side of the earth terminal. These are the ones actually wired to the filament terminals of the valve, one lead going thereto via the on-off switch, which we have already mentioned.

The On-Off Control

The third socket is placed on the strip immediately above the earth terminal and should be connected at the back to this terminal. This third socket should be connected by means of a flex lead to the centre-tap terminal on the '8-volt winding of the power unit. The other two should,

of the switch controlling the mains point from which you run the set.

The Indirectly-Heated Valves

In the detector and L.F. sockets we have used A.C. valves of the indirectly-heated type, since they present no particular problem in this part of the circuit, and their characteristics are definitely superior to the ordinary direct-heated type, and also to their battery equivalents. It is, indeed, upon the superior characteristics of these valves that the distinctly better performance of the A.C. version of the receiver is based.

All that you require to do to use these valves in the receiver is to replace the two valve holders of the detector and L.F. stages with a pair of the five-pin type, and make some slight alterations in the wiring. In the first place, the two pairs of filament terminals should be wired together with twisted connections, and also to the old low-tension terminals at the back of the set.

These low-tension terminals are

A Receiver for "Regional" Conditions

the other case (when the two switch knobs are pulled outwards) the H.F. valve is switched on, and the grid of the detector valve is switched through to the grid condenser and tuned circuits so that you are working on radio.

How Grid Bias is Applied

That completes our discussion of the actual practical modifications of the set, and now it just remains to give you a few practical hints about the working of the set in the new form. First of all, about the grid-bias arrangements. The power valves available in the indirectly-heated A.C. class are of fairly large type and can be regarded as super-powers, so you require a good deal of grid bias. A 16- or 18-volt battery is necessary, and it is suggested that this should be mounted in the usual position on the back of the cabinet inside.

The arrangement of the grid-bias plugs should be as follows. The plug marked G.B.+ on the wiring diagram should be inserted in a socket $1\frac{1}{2}$ volts away from the positive end of the battery. The plug marked "G.B.+ det." goes in the socket at the extreme positive end of the battery, while G.B.-1 goes in a socket $1\frac{1}{2}$ volts negative from the G.B.+ plug. In other words, it goes in a position 3 volts negative from the positive end of the battery.

Working Voltages

You will see that this gives you a positive bias of $1\frac{1}{2}$ volts on the detector valve when used for rectification and a similar negative bias when employed for gramophone reproduction. The power valve will require somewhere about $13\frac{1}{2}$ to 15 volts negative, and so the G.B.-2 plug should be placed in a socket somewhere near the negative end of the battery. The exact bias applied to the valve can be obtained by counting

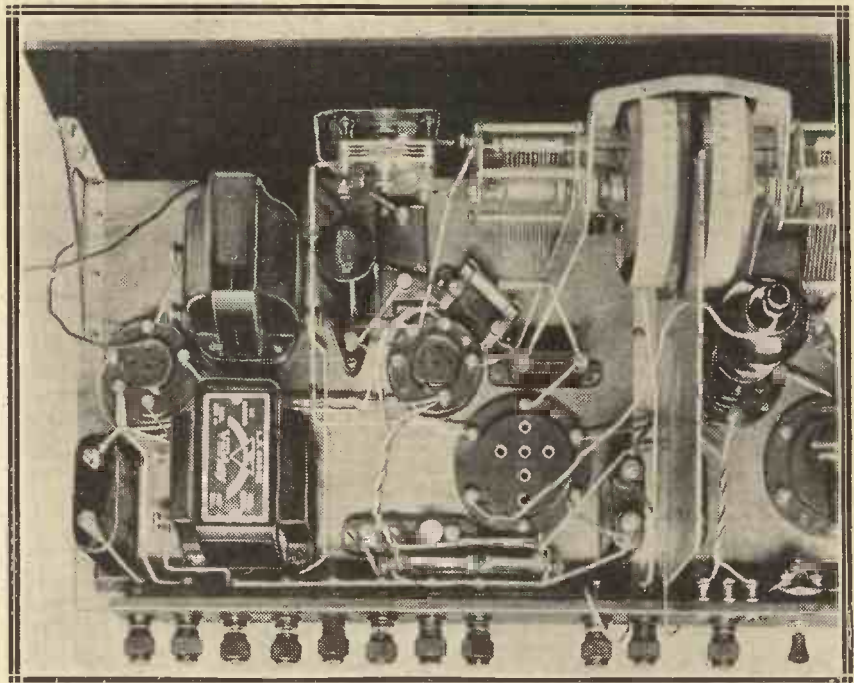

Note how the filament connections are made with twisted connections, thus reducing any possibility of humming due to A.C. induction.

up in a negative direction from the socket occupied by the G.B.+ plug.

The valves to employ will be one of the 8-volt screened-grid type for the H.F. stage, one of the 4-volt indirectly-heated H.F. type for the detector, and a similar power type for the L.F. stage. The valves originally employed in our tests were one Osram S. 8, one Marconi M.H.4 for the detector, and one M.L.4 for the L.F. stage.

The connections for the low-tension A.C. terminals have already been mentioned, and it just remains to add that the H.T.- terminal should naturally be connected up to the H.T.- point on the power unit, while H.T.+1 goes to the H.T.+1 terminal on the unit.

The wander plug from the inner side of this terminal on the power unit should be placed in the sixth or seventh socket of the 15,000-ohm potential divider therein, while the H.T.+2 terminal on the set should be wired to the H.T.+2 terminal on the unit, where the voltage is controlled by the right-hand potentiometer device. This should be adjusted in the usual manner to obtain a good combination of volume and smooth reaction.

Terminal H.T.+3 on the set feeds both the power valve and the anode of the screened grid, and this should be wired to the terminal H.T.+4 on the power unit, which should be

READY FOR ACTION!

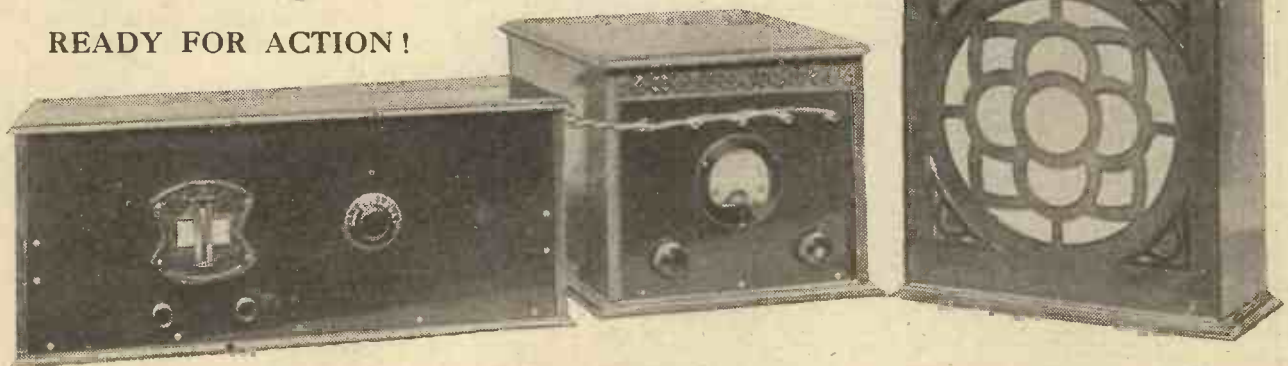

adjusted to give its maximum output by turning the left-hand voltage control device right round to the maximum setting as shown by the voltmeter.

There, that completes the job of conversion, and we think you will agree that it represents an exceedingly simple way of obtaining a completely mains-operated outfit, and we have no doubt that you will find when you have made these little alterations that not merely have you got rid of your battery troubles, but that you are now in possession of a receiver of even enhanced capabilities.

We have still a little space left, so we propose to use it to give a few general details of the set, repeated from our December issue.

The aerial and tuned secondary circuits are arranged so that a good

degree of selectivity is obtainable when desired, by virtue of the use of an efficient type of coil and widely adjustable aerial coupling. We have provided a rather unusually wide degree of coupling adjustment at this point. In the first place, there are three alternative tapping points on the coil itself (Nos. 3, 4 and 5).

Controlling Selectivity

These three tapping points give you quite a wide control and enable you to suit very different aerial conditions and selectivity requirements, but in addition to this control there is another in the form of an optional series condenser, giving you another and still higher range of selectivity adjustments.

Instead of providing the usual two alternative aerial terminals, one of

which brings in a fixed series condenser, we have adopted the rather more convenient method of incorporating a very neat little component which provides the necessary fixed condenser and a shorting switch all in one unit. Consequently, you have no need to fiddle round the back of the set, shifting the aerial lead from one terminal to another, but merely pull or push the knob on the switch according to whether the condenser is required out of circuit or in circuit.

The coupling of the high-frequency valve to the detector is done by means of an H.F. transformer, the particular type chosen being one with an interchangeable primary winding which can be adjusted as to size to suit all sorts of different conditions.

You have here a control of both selectivity and amplification. For

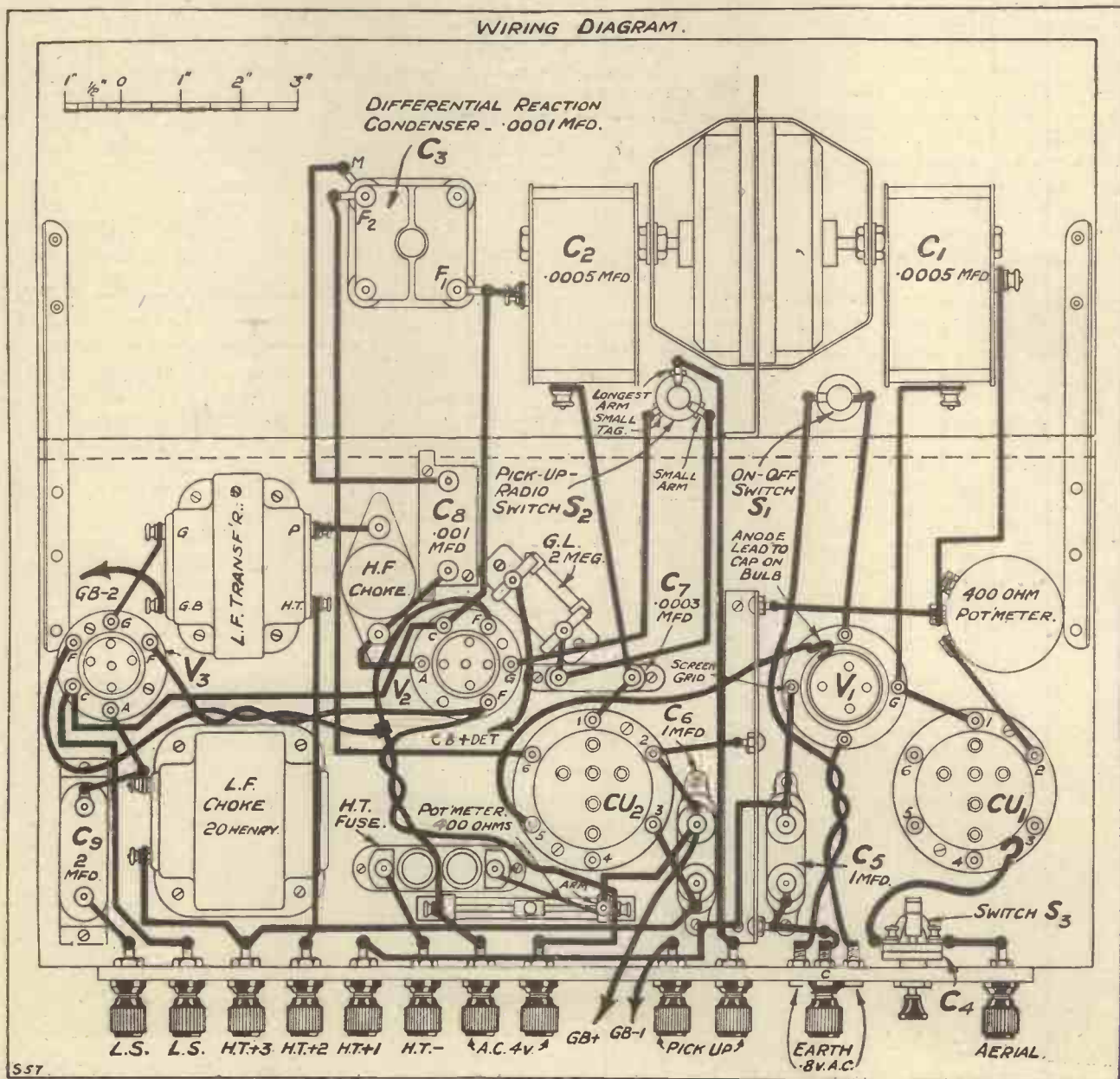

This Set Banishes your Bother with Batteries

example, by choosing a fairly large size of primary you obtain high amplification and only moderate selectivity, which is often a desirable state of things for obtaining powerful signals from, for example, 5 G B. Again, you can reduce the size of the primary and obtain distinctly higher selectivity at a slight sacrifice of amplification for the separation of weak distant stations from your more powerful local transmitter. As a rule, however, you will find it possible to decide upon one particular size of primary which gives good all-round results with moderate selectivity for the local programmes, and obtain your necessary high degree of selectivity for distant reception by bringing in the aerial series condenser C_4 .

Two Fuses ?

The remainder of the receiver you will find quite normal, but we should just explain a point about the safety fuse provided in the H.T. circuit. You will see that this appears to have two bulbs, and we would just explain that this is really an ordinary H.T. fuse of

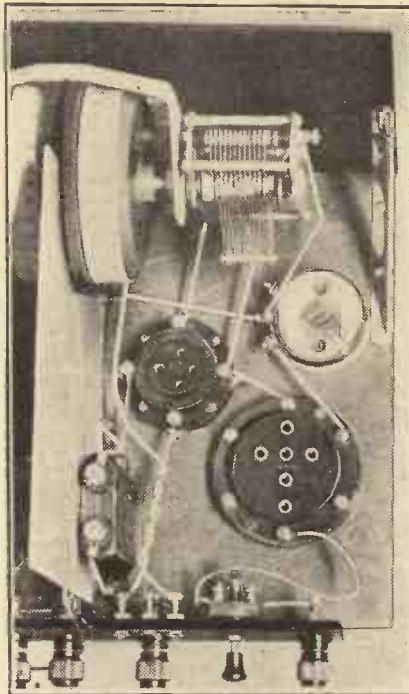

The simplicity of the H.F. screening arrangement will be apparent from this photograph.

broadcast band you will find that sizes P.6, P.8 and P.10 will cover most requirements. No. 8 is a good average adjustment, No. 6 gives you a definite increase in selectivity at a slight sacrifice of volume, while No. 10, although it usually increases volume again slightly above the No. 8 level, does not as a rule give you quite sufficient selectivity for cutting out a powerful local station.

A Word About Coils

For the long waves you should try primaries Nos. P.14, P.16 and P.18, these giving roughly similar results on the longer waves to those quoted for the lower-wave coils. By the by, we may as well state definitely, for the benefit of those who have not encountered these coils before, the actual types required in the set. They are the Lewcos "Super" type, and for the lower broadcast band you will require a C.A.C.5 for the aerial coil, and a C.S.P.5 for the H.F. transformer. For the long waves you want a C.A.C.20 for the aerial coil and a C.S.P.20 for the transformer.

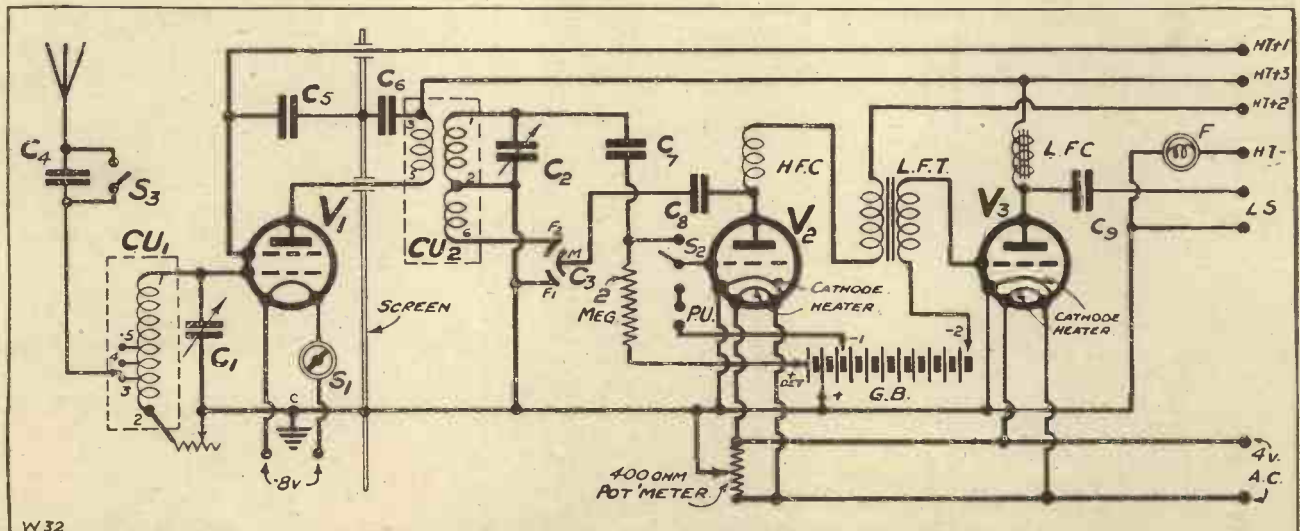

The screened-grid H.F. valve has a separate filament supply at .8 volt, whilst the detector and L.F. valves are wired in parallel across the 4-volt tappings. When the detector's grid is switched over to "pick-up" the filament supply of V_1 is unnecessary, and can be interrupted by means of the switch S_1 .

the single bulb type, with a separate holder for a spare fuse which can thus be kept ready for use when required.

An Important Point

The particular differential reaction condenser employed with the "Eckersley" Three, by the way, is of the ordinary air-dielectric type, and so we have provided the usual fixed condenser in the form of one marked

C_8 on the diagram. If you happen to choose one of the differential condensers having an interleaving of thin sheets of insulating material, of course, you can omit this condenser and wire the moving plates straight to the detector anode and so save a component.

An important adjustment in this receiver is naturally that of the primary winding on the H.F. transformer. For general work on the lower

In conclusion, there is one very important constructional point: note that connections are actually made to the screen itself at three places—one near the middle of the screen and two near the edges. For this purpose you should use small screws and nuts passed through and tightly clamped in the perforations in the lower edge of the screen, such screws and nuts being usually provided along with the screen.

TROUBLE TRACKING

On this page the Chief of "M.W." Queries Dept. discusses, month by month, some of those common difficulties and troubles which can be so perplexing. This time he deals

with the faults that a bad earth connection can cause, and explains how to overcome them.



It is a curious thing, but it would appear that the importance of a really good earth connection is very rarely realised by the average listener. Only the other day I happened to be reading a letter from a correspondent who stated that his three-valve set was not up to scratch.

Apparently he could receive signals at normal strength for days on end. Then, for no obvious reason, the volume would begin to decrease and moreover his L.F. stages would exhibit the usual symptoms of in-



One of the most convenient methods of making the earth connection is by means of copper tubes sold specially for the purpose.

stability. Thus not only was he getting poor signal strength, but the falling off in volume was accompanied by an objectionable distortion in which one of the symptoms was a loud "plop" when the grid terminal of the last valve holder was touched.

Now our correspondent had examined pretty nearly everything in the set itself, and he had tested the batteries also. He was quite frankly puzzled and enlisted our aid.

Apparent Instability

We asked for further details, and it was then he volunteered the information that he thought there was something wrong with the low-frequency stages, in spite of the fact that the H.T. and L.T. batteries were quite O.K. and that the correct grid bias was being used.

It was this falling off in signal strength, together with the apparent instability of his L.F. side, which made us suspect the earth. We then wrote for further particulars of the earth system itself. This, we found, consisted of a zinc plate buried about two feet in the ground underneath his window.

He had been unfortunate in his choice of a suitable position for the

earth. The spot in which the plate was buried was not good, and in consequence the earth system was poor. Sometimes the soil in the neighbourhood of the earth plate would be damp, in which case the receiver became stable and signal strength was normal.

Consistent Reception

When the soil in the vicinity of the plate dried up the earth resistance increased and signal strength decreased, while the L.F. stages tended to become unstable.

This type of fault can be very puzzling because the efficiency of the earth system depends so greatly upon the soil in which the earth plate or tube is buried. Many receivers which give poor results can be brought up to normal standard by

IS YOUR EARTH DRY?



Earthing plates should be buried in soil which is always damp, otherwise the efficiency of the earth will vary greatly.

an improvement in the earth. In the winter time perhaps these troubles are not so frequent, because usually the soil is moist. It is after a dry spell that the effect of an inefficient earth becomes so marked.

Those of you who desire absolutely consistent reception should pay as much attention to your earth system as you do to the maintenance of your L.T. batteries. Experience has already taught you that it is essential to keep the L.T. in a well-charged condition, otherwise you will be unable to get any results.

Water-Pipe Earths

It is not difficult to secure a good earth. Perhaps there is a convenient water pipe which runs into the ground close to the room in which your set is installed. If so, why not use this?

Procure one of the special earthing clips sold by wireless dealers, and priced at about sixpence or a shilling, and attach it tightly to the lead water pipe, after first having thoroughly cleaned the pipe itself so as to ensure a good contact.

A Buried Plate

If there is no convenient main water pipe, procure a couple of copper earth tubes, or a piece of copper sheet about three feet square. If you decide to use earth tubes place them in the ground fairly close together and join your earth lead to both of them. At regular intervals, if the soil is fairly dry, pour water down the centre of the tubes.

Instability on the L.F. side, crackling noises, periodic variation in signal strength, and poor results in general can all be caused by a faulty earth, so that a few minutes spent in inspecting this end of your broadcast receiver is not wasted.

HOW BATTERIES ARE MADE

OWING to the large number of inquiries which are received from time to time on various matters relating to the manufacture and use of dry batteries, the Editor has asked me to give you a general account of how the modern dry battery is made, and how it should be used in order to obtain the best possible results, at the same time indicating how constructors and those experimentally inclined can make up batteries for themselves.

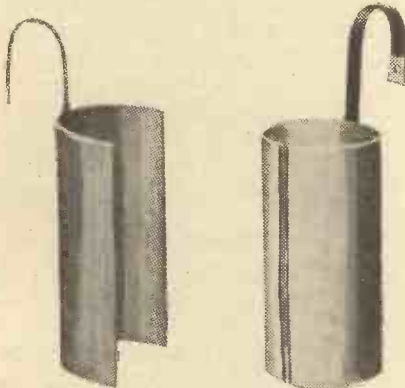

The half and cylindrical zinc plates as used in wet H.T. batteries.

Owing to the very wide field which is covered in the question of battery manufacture, and also to the advances which are constantly being made, I thought it important to bring this information right up to date by having a discussion with one of the leading manufacturers, who incidentally have prepared films showing the making up of dry batteries.

Value for Money

They very kindly gave me a private demonstration of these films, and also placed one of their experts at my disposal for a full discussion of every phase of modern battery making.

I can only say that, although I thought I knew something of the making of dry batteries, I was astonished at the extraordinary number of operations, samplings, tests, scientific experiments, and so on, which go to the making of a high-

An interesting article which takes you step by step through the intricate business of making the ordinary everyday H.T. battery.
 By J. H. T. ROBERTS,
 D.Sc., F.Inst.P.

class dry battery, and when I have told you something of what I myself learned I feel sure that you will not only take more pride in your batteries than hitherto, but that you will realise the value for money which a good dry battery represents and the wisdom of buying only the best

The Dry Cell

First of all, as you are all aware, the so-called dry cell (a collection of which cells go together to form the H.T. dry battery) is constructed on the Leclanché principle; the main elements being zinc for the negative electrode, carbon for the positive electrode, manganese dioxide for the depolariser, and some form of ammonium chloride (sal-ammoniac) for the excitant or electrolyte.

The first question which concerns the manufacturer is the purity of his elements and ingredients. The manganese arrives at the works in large casks filled with the familiar black powder.

Before these are taken into service every cask is drilled, and by means of a short tube inserted through the hole a sample of the powder is withdrawn. This is wrapped in a marked packet and sent to the research department for test.

Upon the depolariser, almost more than upon any other element in the cell, depends the steady working and long life which are essential to satisfactory service.

"Local Action"

The next item is the zinc for the negative electrodes. This zinc comes in large sheets about 8 ft. long by 4 ft. wide.

The zinc which is used must be of the highest purity, because any impurities in the zinc will cause what is known as "local action," or "parasitic currents"—that is to say, a little cell "on its own," as it were, will be set up by the electrolyte between the main body of the zinc and the impurities, which differ in electro-chemical characteristics.

Parasitic currents are one of the greatest enemies of long life in the cell, since clearly they use up the ingredients even when the cell is supposed to be idle. The greatest care, therefore, is necessary in the selection of the purest quality of zinc. Furthermore, the zinc sheets must be of uniform thickness, for if a cell is made up with a zinc container which is thin at one part, there will be a danger of this part being eaten through and so of the cell breaking down.

Testing the Zinc

Consequently, every sheet of zinc is carefully examined with a micrometer gauge to make sure that it is of uniform thickness. It is also examined, by means of an optical



A complete Standard wet battery cell, showing how the zinc pole is brought out, the positive carbon being in the centre of the cork top.

device, to ascertain that it does not contain any pinholes. The finished cell must be hermetically sealed, and this will not be possible if the zinc contains even minute holes.

In some types of dry cell the zinc container (as you know, the cell is enclosed in a zinc tube, and this

forms the negative electrode) is pressed out from the sheet, and is, therefore, seamless. In the larger types of cell, however, it is not practicable to press these out in the same way, and they are therefore formed by wrapping a piece of flat sheet zinc around a mandrel, to form the tube, and then inserting a circular disc of zinc for the bottom of the container. The seam along the length of the tube is then soldered by an automatic machine and the bottom of the container is also secured in position by solder.

Insulating the Seams

Before leaving this point I should mention that just as impurities in the zinc will cause parasitic currents when the excitant is introduced, so the solder (being of a different electrochemical character from the zinc) will act in the same way as an impurity.

It is necessary, therefore, to prevent the electrolyte from making contact with the solder, and for this reason the soldered seams are covered over with paraffin wax, or sometimes with a special pitch composition. This just covers the actual seams, but leaves all the rest of the zinc exposed.

Amalgamating the Zincs

There is a further refinement which has recently been introduced in the battery manufacture of the firm which I visited, and that is the amalgamation of the interior surface of the zinc containers. Those of you who have studied elementary science know that if the zinc rod in a Daniell cell is occasionally dipped in mercury this has the effect of preventing "local action."

This same principle is used in some of the zinc containers of the Siemens' batteries—the mercury is poured into one container and then from that container into a second, from the second to a third and so on, the time required for giving a mercury coating being merely a second or so.

Testing the Zinc Containers

Perhaps I should mention, in case some of you may not be aware of it, that "amalgamating" zinc means combining it or coating it with mercury.

The zinc containers are then subjected to various tests and again examined for pinholes and finally are tested by compressed air forced into them whilst they are held under water—exactly as you test a bicycle or motor-car inner-tube for punctures. You will see, therefore, the very great

care which is necessary in making even so simple a part as the zinc case or container for the cell.

Making the Carbons

I will now pass on to the making of the carbon electrodes. The raw carbon, as you probably know, is obtained from gas retorts. It comes in the form of irregular cakes roughly 1 ft. square and an inch or two in thickness. These cakes are thrown into a crushing machine which breaks them up into pieces somewhat smaller than a walnut.

The broken carbon is then passed through further machines until it is finally reduced to a powder. This powder is mixed into what is known as the "pudding," further ingredients (including pitch) being added. The "pudding" is then forced through hydraulic presses and extruded in the form of plastic carbon rod. The rod is broken off into lengths and is then sent to the furnace for baking.

The furnace is a large brick-built kiln, and as many as 50,000 to



A wet H.T. Leclanche type battery consisting of a large number of separate cells in a special containing box.

100,000 carbon rods will be baked in a single furnace at one operation. The carbon rods are arranged in special small wooden trays, and the trays filled with the rods are stacked closely together in the kiln, the wooden trays being subsequently destroyed during the furnacing operation. When the kiln is filled with the trays of carbon rods it is bricked up and the fire applied, the carbon being left about a week before the kiln is opened.

Fixing the Terminal Caps

We now have the carbon rods in the hard form with which you are familiar. A small notch is cut in the end of each rod, and this is filled with a low-melting-point alloy (in which bismuth is an important ingredient) which has the property of expanding as it solidifies.

In this way it makes a very firm mechanical joint with the carbon, and provides a metal surface to which the terminal pin may subsequently be soldered. Another method (with very small carbons) is simply to force on a brass cap which makes contact with the carbon purely by pressure.

The carbon rods are dipped in hot molten paraffin wax, so hot that only a very thin skin of the wax remains on the carbon. Curiously enough this does not prevent the electrolyte from making contact with the carbon, but it *does* prevent the electrolyte from creeping up the carbon rod and so attacking the terminal pin at the top.

"Sac" Elements

Now we come to the making of the "sac" elements, that is, the little bag which surrounds the carbon rod. This bag or sac is filled with a mixture of the depolarising ingredient (manganese dioxide) and the electrolyte.

There is no great secret about the depolariser, which consists of high-grade manganese dioxide mixed, in some cases, with a certain proportion of powdered graphite (carbon) in order to reduce the resistance, since manganese dioxide is itself a very poor conductor.

Secret Electrolyte

As to the electrolyte, however, which is mixed with the depolariser, this is a closely-guarded trade secret. The mixing of the electrolyte is carried out in a special department of the factory, under the control of operators who are trained to the work and who are not allowed to divulge the formula or the method of mixing.

When you remember that it has taken many years of practical experience and of research work to discover a highly efficient electrolyte, you will appreciate that the manufacturers are quite justified in maintaining great secrecy as to this part of the work.

The "Dollies"

The carbon rod, with the sac attached to it, is known in the trade as a "dolly," probably owing to its fancied resemblance to a tiny doll. The "dolly" is next inserted into the zinc container and the electrolyte is poured into the space between the two, this electrolyte being in such a form that it immediately "sets" into a moist, pasty condition.

The electrolyte which is added in this way is, of course, additional to the electrolyte powder, which is already mixed in the ingredients

Every Stage of Construction is Thoroughly Tested

inside the "dolly." Numerous tests are carried out in the research department to ensure the electrolyte being, both chemically and electrically, up to standard, and, in addition, complete cells are picked out at random as batches go through and are put through tests for voltage, internal resistance, short-circuit, and so on.

Assembling the Cells

Tests are also carried out upon cells which have been stored over varying periods of time. Mechanical tests are also made to find out if soldered connections are loose or faulty.

When the units are completed they then pass on to a department where they are assembled into the cardboard containers to make up the complete batteries. Inside the cardboard boxes are cross-work cardboard skeletons, similar to those which you sometimes see in cardboard egg-boxes, only, of course, smaller.

As internal insulation of every part of the containers is absolutely vital to the long life of the battery, special processes are used to ensure that every trace of moisture is expelled. The nest divisions and side-pieces and end-pieces are all boiled in very hot paraffin wax, which drives out all moisture, so that the battery, although contained in a cardboard box, is actually surrounded at every point inside by dry wax containers.

Sealing in Position

The cells are now inserted in the nest divisions until the battery is complete. One cell is then withdrawn, and into the hole which is thus left is poured moderately hot paraffin wax.

This flows over the whole of the bottom of the box and not only secures the cells firmly in position, but insulates the lower ends; the missing cell is immediately replaced before the wax sets.

Soldering Cells in Series

The battery then passes on to another department where the short wire connections are bent over and soldered from the zinc of one cell to the carbon of the next, and so on, joining all the cells together in series, with a special voltage tapping terminal every so often; this voltage tapping terminal stands up much higher than the rest of the cells.

When soldered connections have been made between all the cells some further tests are carried out, both

mechanically and electrically, and then the battery is covered over with another paraffin sheet, after which paraffin wax is poured over the whole of the top of the battery. To complete the insulation still further a special bitumen compound is poured over the top of the paraffin wax covering, making the battery finally complete so far as the mechanical and electrical requirements are concerned.

To give a finished appearance and a fine glossy surface a thin layer of a further special compound is poured on the top of the bitumen, this compound serving no purpose except, as I have indicated, to give a finished appearance and to be impressed with a warm die which imprints the maker's name as well as the voltageappings indelibly on the top of the battery.

Finishing Touches

At one time, as you probably remember, the cardboard box container of the battery used to be impregnated with paraffin wax, but as this made the box smeary and disagreeable to handle, this practice has been discontinued by the manufacturers

are printed on a long, broad band of paper which is unwound from a reel, so that the operator simply attaches the label, rotates the battery through one complete revolution, and the four labels are in position.

The batteries are now submitted to still further tests for voltage, internal resistance, correct marking of voltageappings, and so on, and are eventually wrapped and packed for despatch.

Radio Societies Please Note

Before concluding, I would like to refer again to the cinematograph films made by Messrs. Siemens Bros. and Co., Ltd. This firm are prepared to send a lecturer with a cinematograph projector to show these films, and give an accompanying lecture, to any Amateur Radio Society, or similar society or club, in any part of the country.

The film is extremely interesting, and the illustrated lecture should certainly form an excellent evening's meeting for such societies. I would suggest that any secretary who is interested should communicate direct with Messrs. Siemens in London.

AN AUSTRIAN RELAY STATION

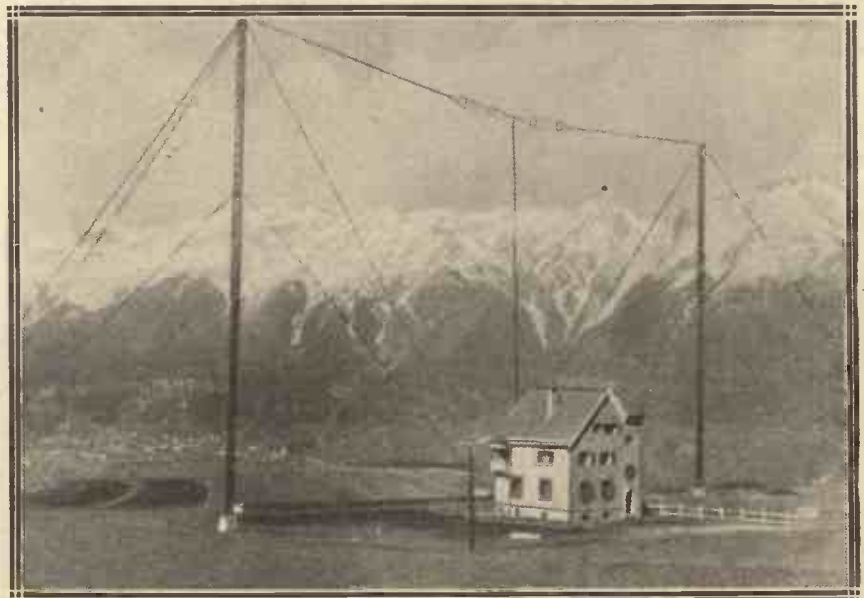

The Innsbruck relay station is situated outside the town which nestles beneath the snow-capped mountains.

mentioned above; it is quite unnecessary, inasmuch as the whole of the interior of the box, as I have already mentioned, is heavily insulated with waxed paper and waxed cardboard linings and separators.

The labels for the sides of the box

Apart from these films, however, enough has been written to emphasise the scientific nature of an H.T. battery, and you will realise that it is very desirable to keep the discharge rate within the prescribed limit.



The humour of Grock, the world-famous clown, would be lost on the loud speaker.

I HOPE that the comedians are the best paid of all broadcasters, for they have the hardest job, and all the bias of the thing is against them. There is a sense, of course, in which every public performer depends upon his audience. I clearly remember only one man who wasn't. He was our professor of Logic in far-off days. He never looked at us when he came into the lecture-room; he read his lecture, keeping his eye on his script all the time, and, when he had finished, he walked out again as if he had been leaving a room with nothing in it but glass cases and mummies.

An Audience is a Necessity

A distinguished man, and entirely self-sufficing, as a professor of logic ought to be. Most speakers, however, want (if they do not need) help. It is easier to teach an interested than an inattentive class. An auctioneer will rise to untold heights of pocket-squeezing if he has a keen crowd of buyers, and I have seen a preacher sweating agony because he felt that he had either the wrong people before him for the stuff he had to give them, or the wrong stuff for the people.

This, I suppose, is why they give comedians a small audience in the studio.

I take it they do not provide Sir Oliver Lodge with one. A lecturer does not need one so much. He is conversing with minds. So long as he gets his theories and his arguments across to us, that is all we ask of him.

If he gets himself across into the bargain, so much the better, but we do not require it of him, and he can succeed without it. Of the comedian, on the other hand, we do require it. For, when you come to think about it, the really funny thing about the comedian is himself, not his jokes.

Can you not recall innumerable times when, in a music-hall or some such place, you rocked and ached with

Humour

By "PHILEMON"

Whose talks in the early days of broadcasting were one of the B.B.C.'s most popular features.

laughter at jokes and antics which, if you could have considered them in cold blood, would have seemed very small beer, simply because the comedian had got you, and could do pretty well anything he liked with you?

I have only once been privileged to read privately a comedian's "book"; and I assure you that it was just as dull, flat, and unprofitable to read as it was bright, bubbling, and rich in humour when he clothed the skeleton with his own flesh and blood on the stage. If the comedian is going to succeed, he must be able somehow or other to project himself.

The Silent Comedian

And, on the wireless, he has nothing but words to help him. I recall a comedian, in pre-wireless days, who never spoke a word during the whole of his turn. He was first-rate. I think his name was Joe Jackson. Quite excruciatingly funny. But he would have been useless at the microphone. A comedian may make what grimaces he likes before the microphone, but they will be for his own comfort, not for our amusement.

Grock, in his white gloves, bringing the grand piano up to the stool, would make a cat laugh; but even if you brought in the studio of noises, the effect would be worse than dull in the loud speaker; the thing must be seen; vision or television.

I have behaved unpardonably at the sight of Leslie Henson swallowing a burning drink and recovering from it; but, until television comes to the rescue, you will have to get out of your slippers and your armchair and pay the best part of a year's licence to enjoy it.

So the wireless comedian stands at this disadvantage: he may have the drollest face, and the most engaging capers, but he cannot play on us with them. When he sets out for the studio he has to leave most of his kit behind. He is like a golfer who tackles the course with a single club. He comes to the microphone with nothing but his book of words and himself.

Creating the Right "Atmosphere"

His job is even harder than that. He has to create his atmosphere. In the music-hall the atmosphere is already created for him to a very considerable degree. I have always felt very deep sympathy for the unfortunate person who opens the programme at a music-hall, when the building is half empty, and a chilly feeling lies over the place, like a morning mist in a valley. But as the evening wears on the seats are filled, that queer thing which we call "crowd psychology" has had time to work, the whole place is warmed up, the audience has become expectant, and into this most favourable situation the comedian presents himself.

Joe Jackson—I do hope I have his name right, for I loved him—has only to put his face round the corner and a thousand hands are for him. Sir Harry Lauder,

via Radio

singing before he is seen, has only to come from the wings swinging his kilt, swaggering his curly stick, and smiling his bonny smile, and he walks straight into the heart of the audience, an open door hung with the bunting of welcome. This atmosphere is of immense importance.

Consider by contrast the wireless comedian who comes into the studio, which, even if it is a pleasant room and occupied for his sake with a few odds and ends of an audience—I beg their pardon!—with a genial little atmosphere of its own, is not the auditorium into which he is about to speak. There is no rattle of applause to greet him, no glare of lights, no jovial atmosphere, no crowd psychology, no amplitude of stage; he is pinned to the neighbourhood of a square box on a tripod; there are no adjuncts; his one hope is that heaven will help him if he helps himself. And somewhere, out of sight and knowledge, a listener, you perhaps, gentle reader, in a quiet room, tired and fractious after a long day, and a little bored with home company, suddenly says, "Oh, Tommy Handley is coming on in a minute!" and you switch on to hear him.

O.B. Vaudeville Turns

And it is between himself and you, between himself and an audience whose members, like you, are isolated from each other by brick walls and maybe by miles of space, that Tommy Handley, poor soul, has to establish rapport, create atmosphere, without previous preparation and, as it were, in the twinkling of an eye. He does it. But he has genius. And not all comedians have genius.

Sometimes a vaudeville programme includes among the performers at the microphone a relay from a music-hall; and it is interesting to note the difference between the two broadcasts. In the former you get more of the value of words and the savour of a voice and a personality; in the latter you get more atmosphere, more feeling of dash and snap and "business." And there are some who would counsel the B.B.C. to acquire a music-hall of its own, collar Mr. Cochran as they have collared Sir Henry



Mr. C. B. Cochran and Leonard Henry.

Wood, and relay vaudeville always from a stage before an audience.

I am not sure that the plan would work. The invisible audience would still be by far the greater, and there is a great difference between listening in a room and in a hall, between listening alone and in company. Music-hall relays always disappoint me, unless I happen to have seen the scene previously. I feel that I am getting the cake without the plums, or the plums without the cake. I am missing much. The audience roars with laughter, and I wonder why. "Business" and back-chat do not broadcast very well. To hear a fellow being smacked on the face is not nearly so funny as to see him being smacked on the face. And back-chat comes to me through the loud speaker always somewhat confused. It is a question of tempo and modulation.

Slower Tempo Necessary

The tempo of broadcast fun must be slower than that of fun on the open stage. In a crowded hall, full of excitement, one sees and hears more quickly; the very smell of the place seems to make one more sensitive and quicker in the uptake. Performers, therefore, can afford to go at speed; and speed itself is a distinct aid to hilarity. But as we sit and listen at the loud speaker we must hear all the words, have time to catch the accent and get the modulation; and for this, in the cooler atmosphere, we require slightly more time.

It is obvious, I think, that wit is better, as a matter of broadcasting, than humour; for, in a general way, wit

(Continued on page 208.)

THE GREAT LITTLE BROADCASTER



Sir Harry Lauder preparing to broadcast. He is one of our most successful microphone comedians, for the loud speaker can take little away from his personality and humour.

QUESTIONS ANSWERED

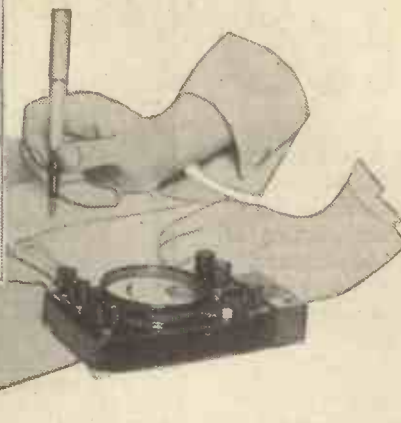

Microphonic Valves

C. L. (Mitcham) has three valve holders on hand, one of them being of the sprung type, while the other two are of the old-type rigid pattern. He asks whether it would be possible to make use of them in a three-valve set, and, if so, where he should use the sprung-type holder.

While we are in favour of using sprung-type valve holders throughout, it is generally admitted that it is the detector stage where this type of valve holder is most required. Most microphonic trouble emanates from the detector stage, and with normal valves there is a reasonable chance of satisfactory results if the rigid type holders are used in the two L.F. stages. Therefore, we think that the sprung valve holder should be used for the detector.

It is always a good plan, however, to place the cabinet on four little "Sorbo" rubber pads, thus insulating the set to a large extent from external vibration.

Anode Resistance Values

J. R. T. (Northampton).—"I am building a three-valve receiver consisting of a detector followed by one resistance-coupled L.F. stage and a transformer. I have several valves on hand, and I intend to use one of the D.E.L. type in the detector socket. What value of anode resistance shall I use?"

In your case, J. R. T., there will be no marked advantage in employing an anode resistance of high value, owing to the fact that your detector valve is one of comparatively low impedance. Therefore, we suggest that a suitable value would be 100,000 ohms.

An Unstable L.F. Amplifier

S. T. (Ilford) has an L.F. amplifier consisting of two transformer stages

which he believes is causing distortion. He asks us whether there are any particular symptoms to look for and, if so, what remedies he should apply.

THE TECHNICAL QUERIES DEPARTMENT

Are you in trouble with your set?

The MODERN WIRELESS Technical Queries Department is now in a position to give an unrivalled service. The aim of the department is to furnish really helpful advice in connection with any radio problem, theoretical or practical. Full details, including the revised and, in cases, considerably reduced scale of charges, can be obtained direct from the Technical Queries Department, MODERN WIRELESS, Fleetway House, Farringdon Street, London, E.C.4.

A postcard will do: on receipt of this all the necessary literature will be sent to you, free and post free, immediately. This application will place you under no obligation whatever. Every reader of MODERN WIRELESS should have these details by him. An application form is included which will enable you to ask your questions so that we can deal with them expeditiously and with the minimum of delay. Having this form you will know exactly what information we require to have before us in order to solve your problems.

London readers please note: Inquiries should not be made in person at Fleetway House or Tallis House.

Here are some of the symptoms which usually indicate L.F. troubles:

(1) Continuous howling, the howl taking the form of a low- or high-pitched musical note which does not vary with the tuning adjustment.

(2) Very bad distortion, frequently accompanied by a rushing and noisy background, which in many cases indicates that the L.F. stages are oscillating at a frequency above audibility.

(3) "Motor-boating," which takes the form of a steady pop, pop, pop.

In the majority of cases L.F. oscillation is due to a coupling effect in the H.T. supply circuit. If dry-cell H.T. is employed the voltage should be taken with the aid of a high-

resistance voltmeter after the set has been working for some time.

The fact that a battery is new does not always prove that it is in perfect condition, since dry cells deteriorate when they are kept in stock.

H.T. accumulators can cause trouble if they are in a partly run-down condition, or if the cells are sulphated, or there are poor connections between the cells.

In the case of H.T. eliminators it is necessary to see that the output is adequate. It is useless to expect a mains unit with a total output of 15/20 m.a. to supply a five-valve set of modern type, since such overloaded units cannot give their rated voltages. It is helpful to try reversing the secondary terminals of one of the transformers and also to earth the cores.

An output filter is a useful stabilising device, and an "anti-motor-boating" unit should always be employed when the instability is "acute."

A Transformer Hint

H. B. (Kidbrooke).—I am incorporating in my set a transformer with a high-permeability core. It is my intention to use a valve of the medium impedance type in conjunction with it in order to keep down the magnification and ensure perfect stability and high quality.

Is there any objection to this?

The chief objection, H. B., is the possibility of too much anode current passing through the primary winding.

There is a danger of core saturation and loss of inductance. It pays to keep down the anode current with these transformers or to use shunted H.T. supply.

Connecting a De-Coupling Unit

C. L. (Bexleyheath).—I have been advised to use an "anti-motor-boating" device with my det. and 2 L.F. receiver. Can I make the connections externally, since I do not wish to disturb the wiring?

You can try the external method. Break the H.T.+ lead which supplies the detector valve and insert a wire-wound resistance having a value of 20-40,000 ohms. One end of the resistance will be joined to the H.T.+ terminal on the baseboard terminal strip, and the other to the H.T.+ lead from the H.T. battery. Then join one side of a 2-mfd., or, better still, a 4-mfd., condenser to the H.T.+ terminal on the strip, and take the other side of this condenser to L.T.—, or to earth.



IS RADIO REALISM POSSIBLE?

by Capt. P.P. Eckersley, M.I.E.E.

WE have a system, the Editor and I; he offers me suggestions and I write. He's given me the above heading, but he's been careful to explain what he really means. He says: "Is there any defect in the broadcasting chain between microphone and the listener's speaker that will make it impossible to achieve anything like perfection in reproduction?"

Yes—and No

I take it it is asked, can we ever have a noise exactly like the noise made in the studio, in our room? Within limits I say we can, but those limits are fairly narrow. The discussion, in fact, can be taken along two paths: the technical, and, far more interesting, the artistic (for want of a better word, and oh, how I hate that one!).

The subject is not completely dealt with without following out each path, and it is logical to take the technical path first because only by learning how far we can get that way do we see how to pursue the other almost infinitely.

The Technical Side

Can we ever make a noise out of a loud speaker to sound exactly like the original noise it reproduces? Yes! But there are limits and conditions. Sound waves are made in the studio and these impinge upon the microphone, an armature vibrates, electrical vibrations are set up, amplified, and passed over long wires to wireless stations, electric waves are then modulated at the intensity and frequency of the original sounds, the waves energise the receiving aerial more and less as the intensity and frequency of the original sounds, the set does its own untying of the high-frequency parcel to reveal the low frequency again, and the loud-speaker diaphragm finally trembles to a copy of the original vibrations.

It is a long story, but there is nothing

We may often sigh for reality in our broadcast reception, and experience that annoying feeling that "something is lacking," but if we had full realism should we like it? As our Chief Radio Consultant says, in this fascinating article, "You could have the Berlioz Mass at full blast in your front parlour, but would you like it? . . . Would the house stand it?"

fundamental that stands in the way of making each and every transformation distortionless, both transiently and sinusoidally.

But there is one rather fundamental point. You are going to listen in a room with a certain reverberation. The player is going to perform in a

studio with a certain reverberation. Therefore there are two reverberations in series and, at once, by pure definition, a distortion. Before one can say that one is going to hear exactly the sound in the studio one has to either stick one's head down in the loud speaker to eliminate the influence of one's own room, or to eliminate any acoustical idiosyncracies in the studio itself.

Question of Intensity

Again, there is the question of intensity. There is nothing fundamentally impossible in getting the intensity right. You can have Berlioz Mass in your parlour if you will pay for the power and the last valves, but practicalities again enter into it, and suggest that the arrangement would be far from economic and most unpleasant.

RECORDING THE BLUES



Members of the Metropolitan Police Minstrels recording for one of the Gramophone Companies. It is a most difficult task to broadcast or record choirs and glee singers so that the result is realistic.

Capt. Eckersley Writes Exclusively for "M.W."

Then, again, there is the question of acoustics; would your room be always so free from acoustical influence that one can truly say that it is not super-imposed upon that of the cinema or concert hall? As a matter of fact, so predominant is the reverberation of a big hall that I think one can safely say that one does and can hear in an ordinary room exactly what one would sitting with the microphone.

"Can we ever make a noise out of a loud speaker to sound exactly like the original noise it reproduces? . . . Before one can say that one is going to hear exactly the sound in the studio one has either to stick one's head down the loud speaker or to eliminate any acoustical idiosyncracies in the studio itself."

Taking it all in all, and provided research shows that it is possible to transmit transients, to get a loud speaker and microphone faithfully aperiodic over the full gamut from 10 to 20,000 vibrations a second, to find room in the ether for a station transmitting up to 20 kilocycles, to design a receiver response curve as a square-shouldered cut-off 40,000 cycles wide (and transmitter, too), we could do it.

"Hopelessly Impractical"

But it is all hopelessly impractical to go to such lengths; and more, if one did so, one would find the result quite redundant. I have already hinted that you could have the Berlioz Mass at full blast in your front parlour, but would you like it, and, indeed, would your neighbours like it, and would the house stand it?—as a structure, I mean.

The point is that wireless reproduction is an art. So is painting, or stage decoration, or sculpture, or the cinema, and each and every art denies realism. Of course, wireless is only a creative thing where it diffuses plays and the spoken word; where it merely repeats music it is reproducing, and the more it does so faithfully the better it performs.

Why it Lacks Realism

We must accept its limitations as a musical instrument and realise that its lack of realism is its failure to be a musical instrument. Music is really a social entertainment and must be

heard first-hand to be true music. We must, when we use wireless, apart from music as a form of art, base our whole ideas of how to use it upon its limitations. We must, as always, adapt the art to the medium.

Because the silent film is the deaf man's entertainment we don't photograph Henry Ainley reading; in exactly the same way, because broadcasting is for the blind man we don't do an O.B. from Maskelyne and Devant's. But the very fact that each of these media has limitations which deny realism makes us the less fettered in our representation of realities.

Complete Freedom Required

We can call up the imagination to work for us instead of having to supply the extras in the original; our minds see the swirling seas through the gaps in the wireless dialogue, our minds hear the cry of the tortured cinema hero, as we watch the cinema property rack turned by the taut

DO YOU WANT THIS IN YOUR HOME?



If you had this jazz band in your own small room the noise would be unbearable, and so would the din from your loud speaker if true realism were your aim. A full-size military band in the drawing-room would drive you and your neighbours frantic.

muscles of the hideous-faced torturer (in three reels!).

It is important to see that we do not vainly seek for realism in reproduction, but rather ask the thinkers of Savoy Hill to use the necessary

limitations as the very essence of their freedom. There was never so great a restriction imposed upon art as the fetters of realism. Think of the embarrassment of scenery and the writings of Mr. Hannan Swaffer to the stage—all realism! Wireless can be as free as the air it agitates, but it will only gain the freedom as it turns its back upon the search for realism.

WIRELESS WISDOM

Do not pull your set half to pieces when looking for a mysterious fault until you have made sure that the loud speaker being used is not responsible for the failure.

When a crystal set suddenly "goes off" the trouble is usually due to a fault in the aerial or earth wiring, but failing these the wiring should be examined carefully to make sure that the connections are all tight and clean.

Breaking a piece of crystal in two and using the clean surface thus obtained will often improve the strength of reception greatly.

When a valve set is being examined for bad contacts, etc., be sure to disconnect all the batteries before any tests are made, or damage is certain to result.

"Safety First"

Remember that the proper way to disconnect a battery from a wireless set is to undo the leads at the battery end, and not at the set end. (Failure to remember this may result in serious damage.)

When drilling a hole in a panel for a fixing screw it is but the work of a second to finish off with two or three turns of a larger drill, to counter-sink the hole at the front of the panel in which the screw head may be sunk.

When wiring-up your first set do not forget occasionally to put the coils themselves into their holders, and to operate tuning controls, etc., as you go along, in case some of your wiring fouls the parts in action.

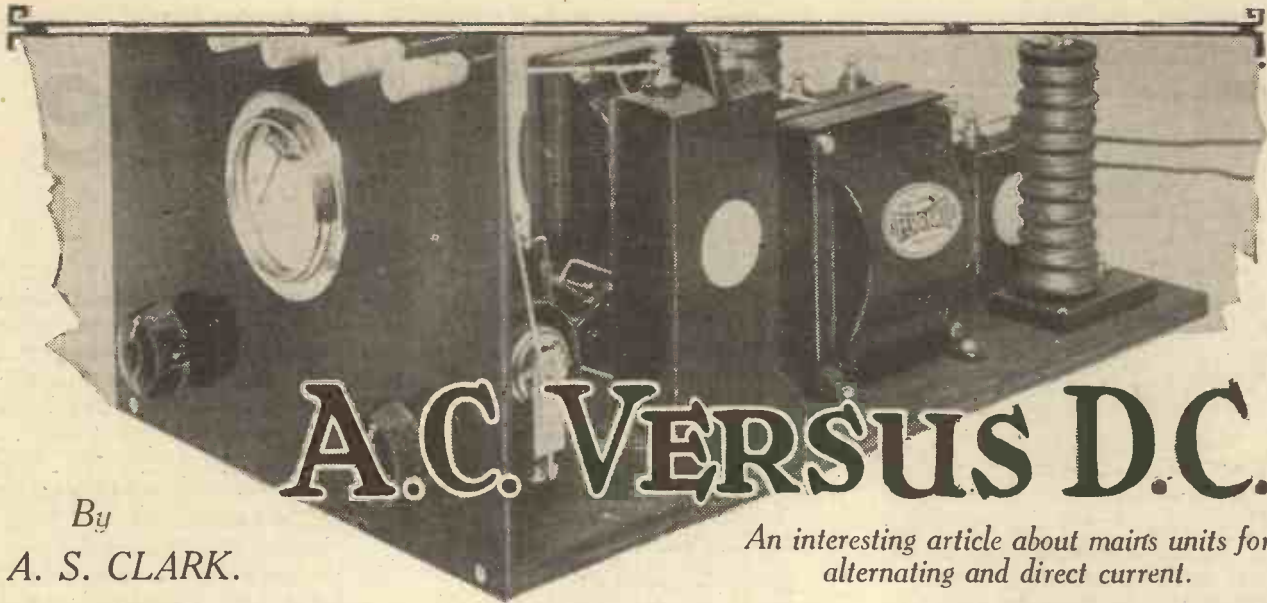

A.C. VERSUS D.C.

By

A. S. CLARK.

An interesting article about mairts units for alternating and direct current.

“CAN a D.C. eliminator be used on A.C. mains?” This query not infrequently arises now that many districts are changing over from D.C. to A.C. supply.

Similarly, one is sometimes asked whether an A.C. eliminator will work on D.C. Both these questions indicate a lack of familiarity with the main points concerning the working of eliminators, and the following facts should be of interest.

The chief difference between the two types of eliminators lies in the kind of current from which they work. In the case of direct current the flow is always in the same direction, namely, one lead is always positive and the other negative.

Two Functions

With alternating current, as its name indicates, the current flows first in one direction and then in the other; either lead therefore alternates between positive and negative. The number of times this change from positive to negative takes place in a second is called the frequency of the current and is stated in cycles.

A D.C. eliminator may be considered as carrying out two functions: first, smoothing out the ripples and variations in the current so that it is similar to that obtained from a dry battery; and, secondly, in reducing the voltage to that required by the various H.T. positive taps on the receiver.

Types of Rectification

Both these functions have also to be carried out by an A.C. eliminator, but first it has to change the alternating current into D.C. current. Consequently the A.C. eliminator has

three functions, two of which are similar to a D.C. eliminator, and the components that perform them would constitute a complete D.C. eliminator.

The process of changing A.C. to D.C. is called rectification, and may be one of two kinds—full-wave or half-wave.

We will not go into the various advantages of the two forms of rectification, but a consideration of

no current flowing, the rectifier has the effect of changing round the current every half-cycle so that the same wires are positive and negative the whole time and there are no gaps. The current still, of course, requires smoothing.

The Transformer

We may now turn our attention to the transformer which is part of the rectifying section of an A.C. eliminator. This component serves a very useful purpose, and accounts for one of the greatest advantages of an A.C. eliminator.

The point referred to is that the output voltage of an A.C. eliminator may be made as high as desired, whereas the voltage of a D.C. eliminator can never be more than approximately that of the mains themselves.

The reason for this is that if current from D.C. mains is passed through the primary of a transformer, no appreciable current will be obtained from the secondary; whereas if the A.C. mains are connected to the primary, A.C. current of a voltage determined by the ratio of the transformer windings will be obtained from the secondary.

Increasing Voltage

It will thus be appreciated that with A.C. mains of only 100 volts it is possible to obtain an H.T. supply of 200 volts or more. If the supply was D.C. the maximum H.T. obtainable would be about 90 volts since a certain voltage drop takes place in the smoothing circuit.

A number of schemes have been devised for breaking up D.C. current

(Continued on page 209.)

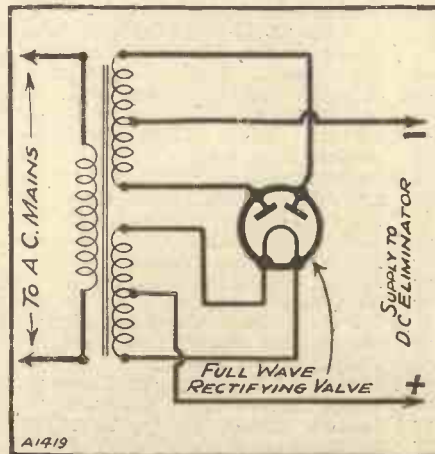

The circuit for a simple unit which, when added to a D.C. eliminator, will enable it to work on A.C. mains.

the difference between them will be useful. In effect this is what happens.

Half-wave rectification cuts out one half of each cycle, one lead becoming positive and the other negative, but with small gaps in between each pulse of current.

These gaps coincide with the reversal of polarity before the current is rectified, and it is the duty of the smoothing part of the eliminator to cover them up.

In the case of full-wave rectification, instead of there being gaps with

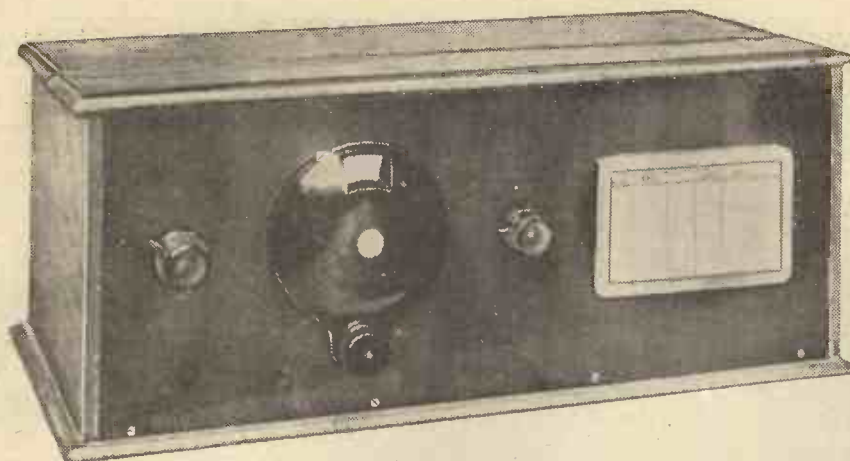

The

have thought it justifiable to assemble so elaborate an outfit with so relatively small a receiver as a two-valve set as its basis. The set may be small in size and in actual number of valves, but it is by no means small in performance.

IF you have had no previous experience of the indirectly-heated A.C. valve there is not much doubt about what your first thought will be when you see this receiver. It is pretty sure to strike you as being far too elaborate for two valves!

Those readers who have had experience of special mains valves will understand without being told that the special treatment we have given this set is amply justified by the results which it will give, but for the benefit of those to whom they may be new we had better explain matters.

Wonderful Results with A.C. Valves

Well, the point is really this. Some of these indirectly-heated mains valves give almost twice the amplification of the corresponding battery type, and so quite a small set can be made to put up a performance which amply justifies its being treated as something of a "de luxe" outfit.

The present set, for example, is only a Det. and 1 L.F., yet it actually gives a performance very nearly equal to that of the best three-valve battery circuit.

On test it gave very full volume loud-speaker signals from 5 G B in London on a decidedly inefficient aerial, the actual strength being such as one would have to use a pentode to obtain in a normal two-valve set. This was in the course of a test in the City.

Almost Like a "Three"

When tried out under normal suburban conditions it not merely gave extremely powerful signals from 5 G B, but also brought in at genuine loud-speaker strength quite a string of foreign stations, and, indeed, put up very much the kind of show one would expect from a three-valve receiver.

Now you will begin to see why we

- *****
LIST OF COMPONENTS.
 * 1 Panel, 18 in. x 7 in. (Resiston, Goltone, Paxolin, Kay-Ray, Becol, Trolite, Trelleborg, etc.).
 * 1 Cabinet (see text), and baseboard 10 in. deep (Pickett, Camco, Raymond, etc.).
 * 1 Terminal strip, 18 in. x 2 in. or 16 in. x 2 in.
 * 10 Engraved or indicating terminals (Eelex, Igranic, Belling & Lee, Burton, Clix, etc.).
 * 1 Panel-mounting log holder (Bulgin).
 * 1 '0005-mfd. tuning condenser (Lissen, J.B., Lotus, Cyldon, Igranic, Formo, Raymond, Ormond, Polar, Utility, Gecophone, Colvern, etc.).
 * 1 Slow-motion dial, if condenser not of slow-motion type (Lissen, Lotus, Igranic, Ormond, J.B., Utility, Formo, Brownie, etc.).
 * 1 '0001- or '00015-mfd. reaction condenser (Formo, Raymond, Lissen, J.B., Utility, Cyldon, Keystone, Ormond, Lotus, Bowyer-Lowe, Dubilier, Wearite, Magnum, etc.).
 * 2 Five-pin valve holders (W.B., Wearite, Lotus, etc.).
 * 3 Single baseboard-mounting coil sockets (Lotus, Ready Radio, Lissen, Igranic, Keystone, Raymond, etc.).
 * 1 H.F. choke (Ready Radio, R.I., Lissen, Dubilier, Varley, Lotus, Igranic, Climax, Raymond, Lewcos, Bowyer-Lowe, etc.).
 * 1 400- or 200-ohm baseboard-mounting potentiometer (Ready Radio, Lissen, Sovereign, Igranic, etc.).
 * 1 Low-ratio L.F. transformer (Cossor, Varley, Lissen, Brown, R.I., Ferranti, Mullard, Igranic, Philips, Telsen, Marconiphone, etc.).
 * 1 Output filter L.F. choke (Varley, Ferranti, R.I., Pye, Wearite, etc.).
 * 1 Double-pole change-over switch, panel-mounting type (Wearite, Utility, Dubilier, etc.).
 * 1 '0002-mfd. fixed condenser (T.C.C., Lissen, Goltone, Dubilier, Clarke, Igranic, Mullard, Graham-Farish, etc.).
 * 1 '0003-mfd. fixed condenser (Dubilier, etc.).
 * 1 '001-mfd. fixed condenser (Lissen, etc.).
 * 1 2-mfd. condenser (Dubilier, Ferranti, Lissen, etc.).
 * 1 2-meg. grid leak and holder (Dubilier, Lissen, etc.).
 * 1 Pair grid-bias battery clips (Bulgin, Ready Radio, Raymond, etc.).
 * 3 G.B. plugs (Belling & Lee, Clix, Eelex, etc.).

An Excellent General-Purpose Set

At the end of our usual series of tests we formed the opinion that it provides a very satisfactory outfit indeed for the man who chiefly wants really full volume loud-speaker programmes from his local station and 5 G B, with an occasional search for foreign stations.

We don't suggest it as an ideal outfit for anyone whose main interest is in foreign reception, because naturally for that purpose we should advise a receiver with at least one H.F. stage, such as perhaps the "Eckersley" Three. Incidentally, it may be mentioned that readers interested in this type of set will find an A.C. "Eckersley" Three elsewhere.

Reducing the Constructional Work

This receiver is another example of the type of all-mains design which, as we have explained more than once in recent issues, we believe is best adapted to meet the needs of the constructor who does not wish to undertake a very large task in producing a set for mains working.

In other words, it is another receiver on the two-unit system, in which we have the receiving set proper built very much like an ordinary battery set, but so arranged that it employs mains valves, and can be connected up to work with our standard A.C. power unit which was described in the December issue.

By adopting this system of construction the task is very much simplified, because the receiving set proper involves only very slightly more work than an ordinary battery set, and if ever the owner decides to scrap it and build a larger one his power unit remains a separate instrument which can be used with the new outfit.

The receiver proper is really simply an A.C. version of the "Two-Range"

“Electric” Two

Two, described in our November issue, which the reader may remember was a simple and straightforward little set of considerable merit, possessing the special advantage of a wave-change switching system which was singularly free from the usual defects of such arrangements.

Excellent performance from only two valves, completely trouble-free working, and running costs so low that they can scarcely be measured are the special features of this interesting all-mains receiver.

*Designed and described by the
“M.W.” RESEARCH DEPT.*

A Highly Efficient Circuit

Not merely is this wave-change switching arrangement particularly efficient and free from vices, but it is exceedingly simple, and calls for a very small number of coils, such coils as are required being of a perfectly standard type, namely, two “X” coils and one plain one, all of the plug-in variety.

To be a little more explicit, it is exactly the same circuit, but the L.T. arrangements are modified so that instead of the filaments of the valves being arranged for running in the usual way from an accumulator, five-pin valve holders are used, and the A.C. heater sockets for the indirectly-heated valves are wired up to a pair of terminals on the back strip which are to be supplied with 4-volt alternating

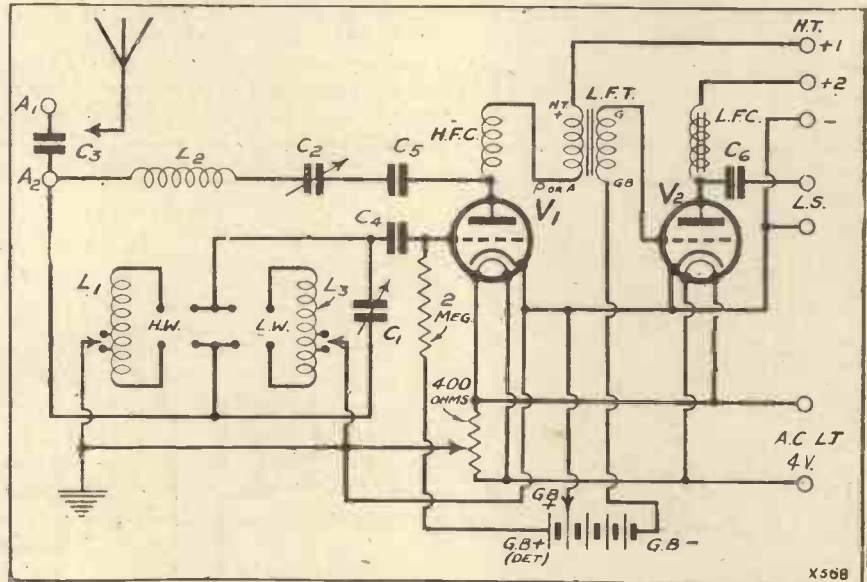

The only battery required for this set is the G.B. unit, which is fitted upon the baseboard. Note particularly the placing of the three coils.

Real Power With Only Two Valves

current from the standard power unit, and a potentiometer arrangement is provided for earthing the electrical centre point of this circuit.

One or two other minor points are arranged somewhat differently for A.C. working, as we shall see presently when we go through the receiver in detail.

Probably many readers who are attracted by this receiver in its all-mains form will not have seen the original version (the "Two-Range" Two) and they would probably be interested in a brief description of the arrangement of the circuit. We have mentioned that the circuit is one

which we have found specially efficient and satisfactory in operation, and it is therefore a little surprising to find that it is a particularly simple arrangement.

A Complete Change Over

Its essential feature can be explained very briefly. It is this: instead of employing any system of switching in loading coils for the long waves, paralleled windings or other more or less complicated schemes, we have employed two entirely separate tuning coils for long and medium waves, with a complete switching change-over from one to the other. In this way a number

of wave-change difficulties are overcome, and equal efficiency is obtained on both wave-bands.

The coils actually employed in the two sockets are of the "X" type, so that only a single unit is needed for each wave-length range, since both a tuned secondary winding and the necessary means of coupling the aerial thereto by means of a tapping scheme are provided on such inductances.

These coils, by the way, are not connected up in quite the usual manner, and we had perhaps best explain this point before we go any further. In the usual system of connection one side of the coil is wired to

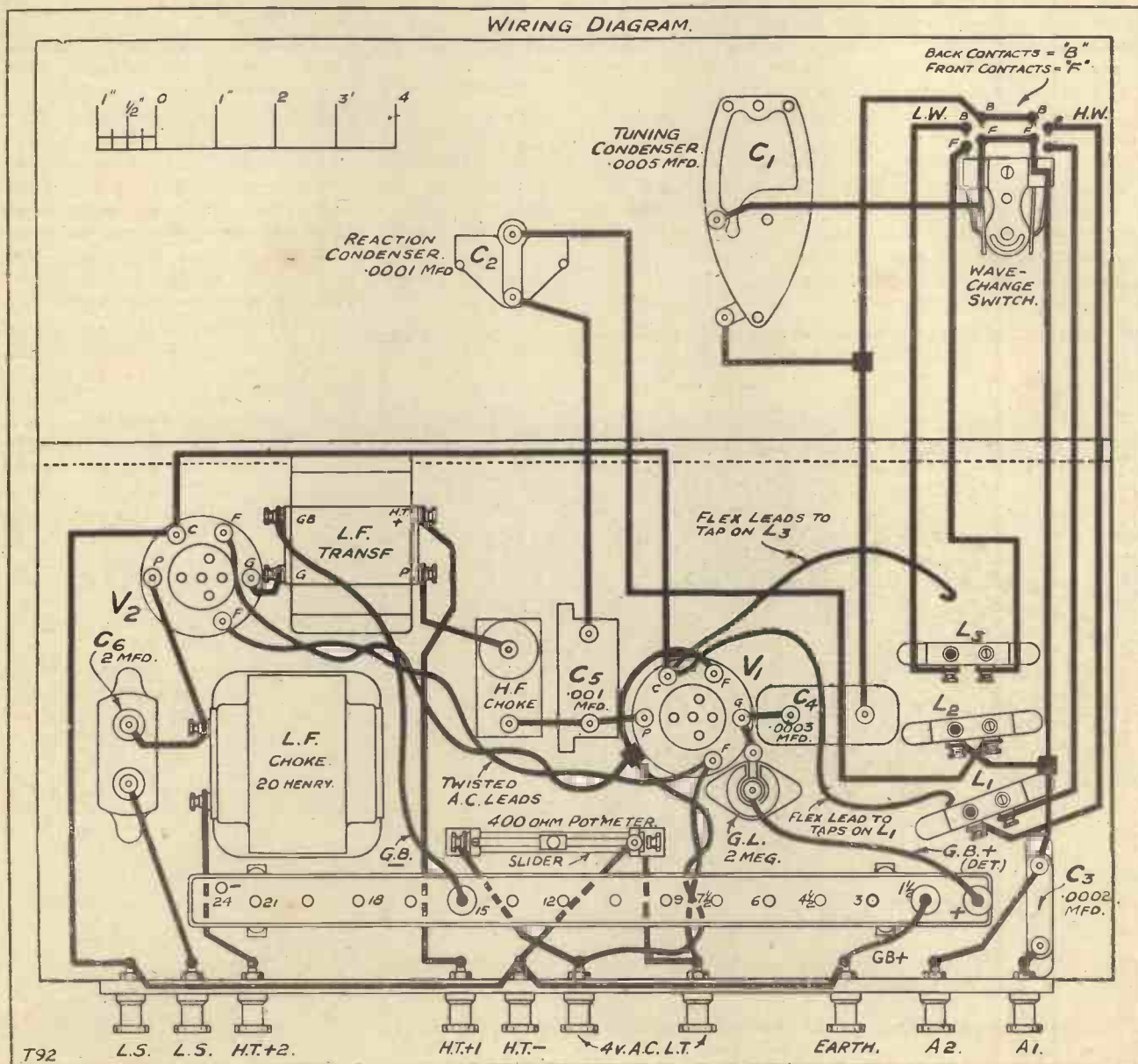

earth, while the aerial goes to one or other of the tapping points.

In the present instance, however, the tapping point is wired to earth, and the aerial goes to that side of the coil which would, in the normal way, be connected to earth.

This alteration makes little, if any, difference to the functioning of the aerial coupling arrangement, and was merely done in order that this portion of the winding might also be used for reaction, i.e. so that the direction should be correct for this purpose.

Simplifying the Reaction Circuit

The reaction scheme is also somewhat out of the ordinary, as you will observe upon inspecting the circuit diagram. We have already mentioned that the portion of each "X" coil used for aerial coupling also serves to give reaction, but these windings are not quite large enough to serve the purpose alone, and in order to simplify the switching arrangement it was decided not to provide a separate reaction coil for each wave-band.

If this had not been done we should obviously have had to use a switch considerably more complicated than the simple double-pole change-over type which was actually found adequate with the special scheme finally adopted.

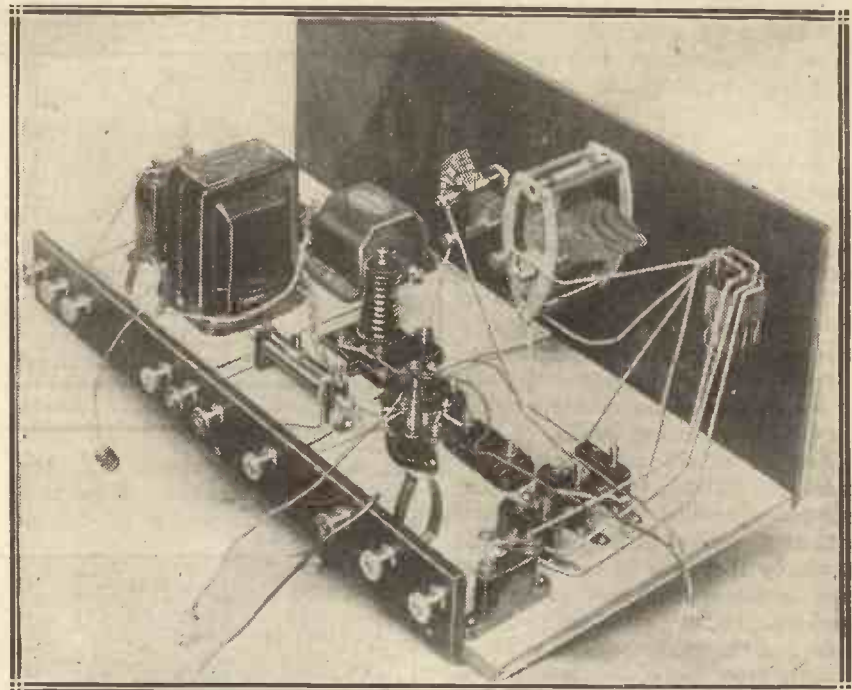

This view shows clearly how the three coil holders are fitted, with the reaction coil placed between the two tuning units.

We have found with this "X" coil scheme that it is quite possible to obtain entirely satisfactory results by using a common reaction winding for both the wave-bands, arranged so that it is always in the reaction circuit, no switching control being required. A larger reaction coupling winding is naturally required on the

long-wave range, but this is automatically obtained when changing over from one "X" coil to the other, because the coupling portion of the long-wave "X" coil is naturally larger than that of the low-wave one.

To obtain satisfactory results from this scheme we found that it was sufficient to place the common reaction coil between the two tuning coils, with a suitable degree of coupling between them. Usually it is satisfactory to arrange the reaction coil rather closer to the long-wave tuning coil than to the short. Then by choosing a suitable size of coil and making adjustments of the actual placing of the inductances it becomes fairly simple to hit upon a set of conditions which give satisfactory reaction effects on both wave-bands.

Placing Coils for Best Results

This is a point we had perhaps better pursue to its conclusion before we go on to the next feature of the set. If you will examine the wiring diagram on the third page of this article you will see that the two "X" coils are intended to be placed in the sockets L_1 and L_3 , and these are set at something of an angle to each other.

In between them is the holder for the reaction coil L_2 , and it is to be understood that this holder should at first be fastened down with only one screw, namely, the one nearest to the right-hand edge of the baseboard (looking at the wiring diagram).

When the set is first put on test

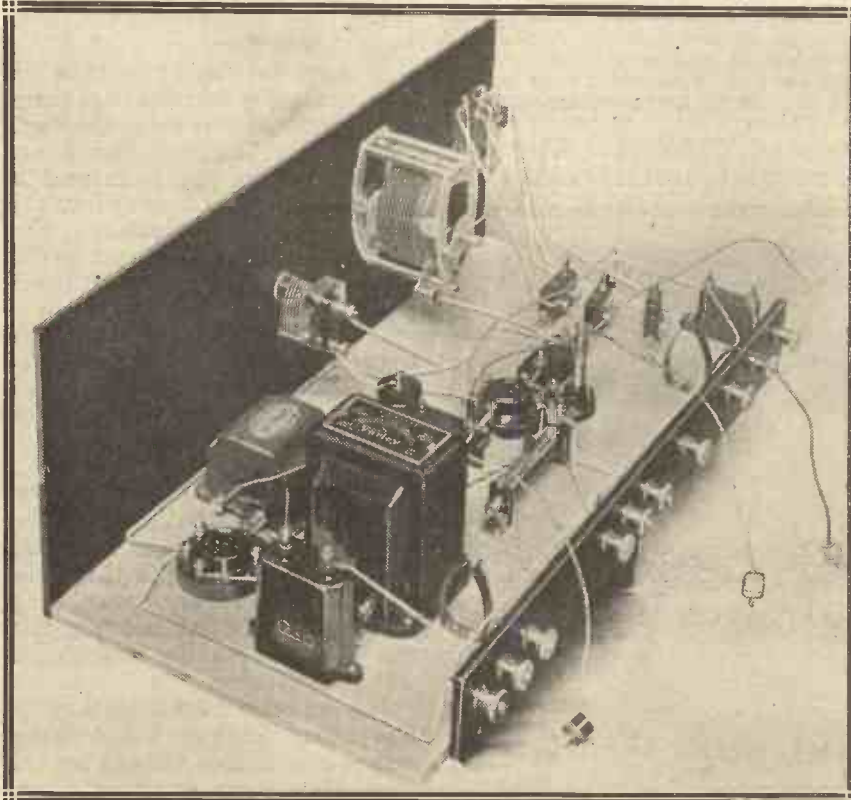

An output filter is provided for the loud-speaker circuit, a precaution which is very desirable in a mains outfit. Note also the space provided for the G.B. battery.

you should try setting the holder for L_2 at various angles, until you find that you are obtaining satisfactory reaction effects on both wave-bands with something like the same setting of the reaction condenser in each case. Having found this setting, you can insert the second screw for the coil holder L_2 and the adjustment is complete.

There is obviously a further control obtainable here by choice of a suitable size of coil for the reaction socket, a point which we will deal with later in the section of this article which is devoted to operating details.

Various details which make the receiver suitable for alternating current operation must claim our attention for a little while, since naturally they will be new to many readers accustomed only to battery working. In the first place, you will note that the valve sockets are of the five-pin type, two of the terminals on each being for the "heater element" of the indirectly-heated valve.

Avoiding Hum

These two terminals are to be wired in parallel with some form of twisted conductor, and connected up to the pair of A.C. terminals on the back terminal strip, which represents the usual low-tension point.

You can use ordinary twisted flex for these connections, but we ourselves have found that a rather neater-looking job results from the use of ordinary No. 18 or No. 19 gauge tinned copper wire enclosed in Systoflex sleeving and twisted together.

Wired in parallel across these heater elements, in other words across

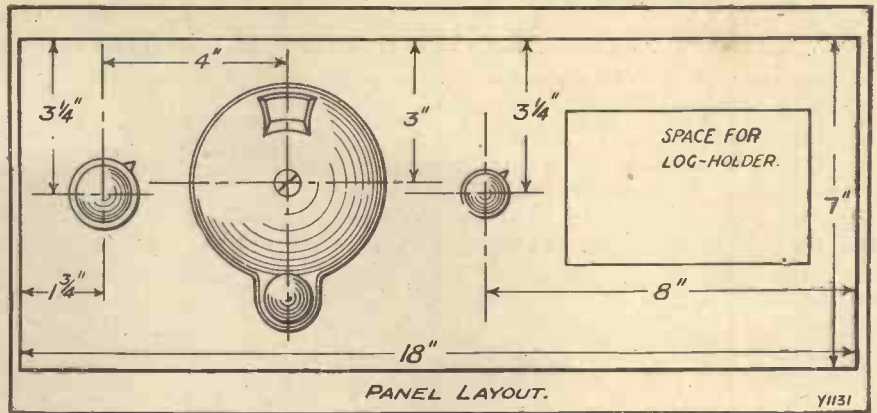

the alternating current L.T. terminals, is an ordinary baseboard-mounting potentiometer of 400 or



Quite an attractive piece of furniture. A view on the next page shows how the receiver and accessories can be installed in this type of cabinet.

200 ohms. The slider of this potentiometer is to be wired to the earth

circuit, and provides an earthing point for the heater circuit; by adjusting this suitably to a point somewhere near the middle of the travel of the arm or slider, you will find that the A.C. hum is cut down practically to inaudibility. As a matter of fact, unless your loud speaker possesses an exceptionally good low-note response you will find that you will hear no hum at all.

Grid-bias Arrangements

The only remaining point peculiar to the mains version of this set concerns the grid-biasing arrangement for the two valves. The detector valve requires a small positive bias to be applied to the end of the grid leak to obtain satisfactory rectification in the present circuit, while the power valve requires just the usual negative bias.

In order to simplify matters we have arranged so that these two biases can be obtained from a single battery, and this is how it is done. The normal grid-bias positive plug is inserted in a socket about $1\frac{1}{2}$ volts away from the positive end of the battery. The detector positive plug is then to be placed in the socket at the extreme positive end of the battery.

The grid-bias negative plug which controls the power valve should go in a negative socket about $13\frac{1}{2}$ or 15 volts removed from the grid-bias positive plug.

Voltage for the Power Valve

Thus to apply $13\frac{1}{2}$ volts negative to the grid of the power valve you should insert the plug in the minus 15 socket of the battery, remembering that there will be deducted from this the $1\frac{1}{4}$ volts positive bias tapped off for the detector.

Just one other point about the grid-bias battery. Since you will obviously require considerable voltages for the fairly large types of power valves available in the indirectly-heated range, we have made provision for

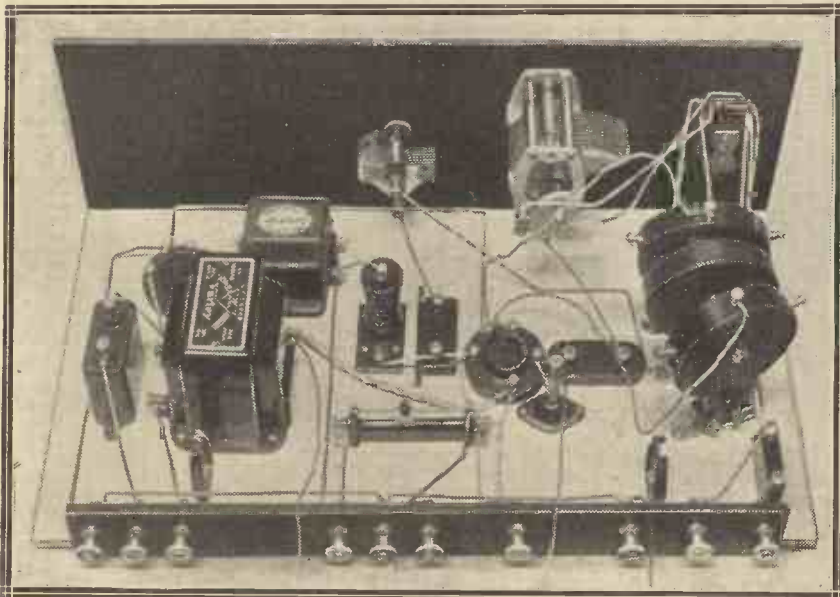

Note how the "heater" circuit of the valves is wired with twisted leads to prevent induction troubles from the alternating current flowing therein.

Trouble-Free Operation and Outstanding Performance

a 16- or 18-volt grid-bias strip on the baseboard. Two clips are provided for this, and you will note that it fits down over certain of the leads in the wiring. It is, therefore, obviously desirable that insulated wire should be used for the wiring-up process.

We do not propose to spend any more time on the general description of this receiver, because, as you will by now have gathered, it is really a very simple outfit, and all that you required was a general explanation of the special mains features.

Wiring the Switch

Before we begin upon this side of the question, however, there is just one constructional point we should explain. The general layout and wiring-up of the set is obviously very simple, partly the result of the rather open layout, but there is one point, namely, that of the connections to the wave-change switch, which we ought to explain just a little.

If you will examine the wiring diagram you will see that the contacts of this switch are marked with the letters "B" and "F". These refer to their position on the switch, and indicate back and front respectively. By "back" we mean the back of the switch as you look at it from the view-point of the wiring diagram.

In other words, the back contacts are those nearest to the panel, and the front contacts are those nearest to the eye of the observer when the switch is seen from the view-point of the photograph at the foot of the second page of this article.

Connecting Up the Auxiliaries

Now about the connections of the receiver to its various accessories. The aerial may be connected to terminal A_1 or A_2 ; the former point bringing in a fixed series condenser, giving the usual higher degree of selectivity at a slight sacrifice of volume. The earth goes on the usual point, and the loud-speaker connections are just the normal ones.

The low-tension A.C. terminals are to be wired up by means of a heavy twin-flex lead to the "3.5 to 4-volt" A.C. terminals of the "M.W." Standard A.C. power unit. H.T. negative should be wired to the corresponding point on the power unit, while H.T.+1 should go to the terminal H.T.+2 of the power unit, and

H.T.+2 should be connected to the H.T.+4 terminal thereon. (See also note in "Questions Answered.")

Getting Smooth Reaction

You will then have the normal maximum H.T. applied to the power valve, while the detector is run from the adjustable tapping controlled by the right-hand potentiometer on the power unit. The voltage here, of course, should be adjusted in the usual manner to give the smoothest possible reaction control, etc.

The coil sizes should be these: L_1 should be a No. 60 "X" type, L_2 a No. 250 of the same type, while L_3 should be a plain coil of about size No. 60. A little adjustment may be needed here to suit different valves, and a No. 50 and 75 may also require trial in some cases. With the valves we used in our own case, however, a No. 60 suited all requirements.

The valves may be of any of the well-known makes of 4-volt indirectly-heated varieties, one of the H.F. type being required for the detector and one of the power or super-power for the L.F. stage. In our tests we used the Marconi and Osram indirectly-heated type, the actual ones employed being the M.H.4 for the detector and the M.L.4 for the L.F. stage.

How the Switch Works

Working voltages for both H.T. and grid bias we have already dealt with, and there is just one final operating point to be covered before we leave you to try out the set for yourself.

The positions for the wave-change switch are these: With the knob turned towards the right the set is switched for the ordinary medium broadcast wave, while with the knob turned to the left the set goes over to long waves.



One method of assembling the set to form a handsome all-enclosed outfit is suggested here. The cabinet is one of Messrs. Pickett's standard lines, and the lower compartment houses the standard "M.W." A.C. power unit. Note how the latter is placed on its side to make room for a chassis-type loud speaker to be mounted on the detachable baffle board.

How Microphone

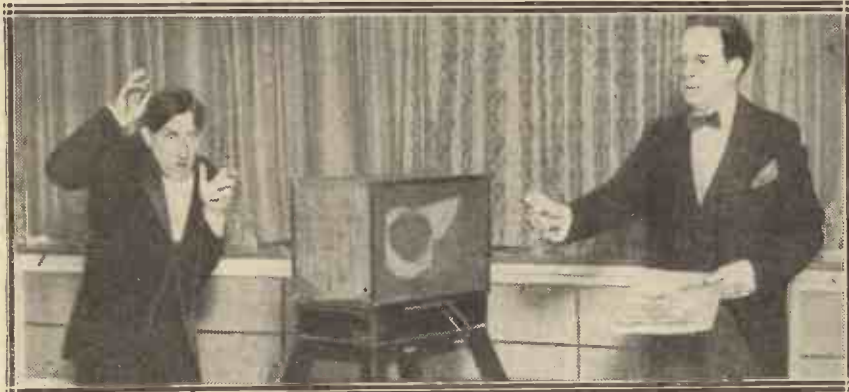

The part of the narrator is impersonal, supplying much that in stage performances would be visual.

THE best way of appreciating the new art of radio drama is to understand its possibilities, and these—as other articles in this series prove—are enormous. The following excerpts from plays written for the microphone show some of the methods which have been successfully adopted.

(1). Monologue Method

(a) Here is the method of "SHADOWS," a Radio Scene in One Act, by Valerie Harwood.

The scenic background is supplied by the playing of a barrel-organ in the far distance. Nearer than the music is heard the voice of a newsboy crying his papers and the chief item of news: "Chelsea Murder Clue," etc.

Then footsteps are heard crossing the floor, a window opening and the voice of a man buying a paper from the boy. The window closes, the newsboy's voice fades away and the man's voice begins to mumble as he reads the murder case.

Then silence, a suggestion of a chair being moved, then the report of a revolver, the clatter of the weapon as it falls to the floor, and again—silence. Suddenly a doorbell jangles, shortly afterwards comes the sound of a latchkey, the opening of a door, footsteps and then a woman's voice:

WOMAN: "I thought I left my key—so I rang. I thought you might come and let me in . . ." and so on. Throughout the scene, which you are given to understand is full of dark shadows, the woman is talking to the dead man. His silence she attributes to sulkiness until the dramatic crisis

is reached, when she discovers that he is dead.

It is indicated that she finds it impossible to go on without him and a revolver shot is heard. There is again a short silence, emphasised by the jangling of the bell and the cheery voices of visitors outside, who decide that the occupants must be out. They

Do you enjoy the radio thriller? Here are some vivid examples of form, showing how authors use the microphone as a new medium of expression.

depart joyously and there is again silence except for the distant playing of the barrel-organ.

Although in effect a monologue, this play gives the impression of dramatic action and conveys atmosphere. It is obvious, of course, that to be successful this objective form of monologue can be suitable only for certain themes. The touchstone is credibility.

Voice and Background

(b) "NURSE HENRIETTA," by Herman Kesser.

This begins as follows:

"Day at last. The morning star is gone, there is wind in the trees. They are opening the garden gates. A clock strikes a quarter to five. Terrible to

lie here between clammy sheets, wide awake, thoughts all awlirl . . ." and so on.

This gives the setting quite clearly. And then:

"Why am I so frightened? . . . I am only a minor witness. . . . I may not be called up at all . . . a young workman of twenty from a suburb is not the sort of man to invent the story of the watch. . . . No, that man must be acquitted. . . . But, then, I must keep quiet. . . . I shall say nothing, nothing. . . . I am a pencil and I write things down. . . ."

And so on, through a telephone conversation, a train journey, a visit to a shop, a taxi-ride to the law-courts and an enquiry into a man's death.

The Nurse lays bare her thoughts, her fears, her very soul, and through her reactions to the dramatic situation, made audible, we get the complete story.

Audible Atmosphere

A background of realism is supplied where practicable, such as music, street noises, sounds of train and taxi and the atmosphere of a court of law.

This form was very effective when broadcast, but it may be argued whether the microphone is the right medium for such a method. It is, after all, simply the first-person story uttered aloud by the supposed writer.

In a previous article we said that a variation of this form had been used with success—a form approximating to the Narrator Method, though different in this particular: that the narrative portions are really a Monologue (mostly descriptive) by a character in definite relation to the whole play. Cecil Lewis's adaptation of Conrad's "Lord Jim" is in this style.

Another Example

(c) "LORD JIM," adapted by Cecil Lewis.

This begins with a Prologue. It is heard coming through fading music as if it continued some story previously started.

PROLOGUE: . . . "And later on many times in distant parts of the world, Marlow showed himself willing to remember Jim, to remember him at length in detail and audibly. Perhaps it would be after dinner, on a

Plays Are Made

By R. E. JEFFREY (Late Dramatic Producer and B.B.C. Programme Research Director).

veranda . . . and with the very first word uttered, Marlow's body, at rest in the seat, would become very still, as though his spirit had winged its way back through the lapse of time and were speaking through his lips from the past. . . ."

The Prologue fades and immediately you hear Marlow's voice telling his story :

The Right Setting

" . . . Oh yes, it's easy enough to talk of Master Jim . . . he was the youngest son of a country parson. I believe he always had a passion for Nelson. Anyway . . . he went to sea. . . ."

And so on, giving sufficient information to make the first dramatic episode intelligible and to provide the right setting for it. As the voice of Marlow fades, you begin to hear the steady throb of engines, the hiss of foam, and, in the distance, an Arab intoning a prayer for travellers at sea. Follows the sound of a clear bell and of a man yawning, then dialogue :

SKIPPER : "Is she on her course, Jim ?"

JIM : "Yes, sir."

A dramatic scene follows, and it ends in an open boat :

SKIPPER (crying out) : "Don't—oh, don't . . . Help my . . ."

The wind and squall rise heavily again and the boat is lost in the storm. These sounds fade and, growing out of them, the voice of Marlow resuming the story :

" . . . Of course, the thing made a sensation. As you may imagine, the whole waterside talked of nothing else . . . etc."

And so on, throughout the whole play, dramatic episodes growing out of the narrator's words, from time to time until the finale is reached by Marlow who rounds it off.

This is an interesting form, but only perhaps as a means of adapting novels for use as radio plays.

(2). The Narrator Method

This is the best method for adapting existing stage plays. It bridges the gaps between Scenes and Acts by means of descriptive narrative, giving necessary indications of scene and

setting. One example will suffice.

"KING JOHN," Shakespeare.

NARRATOR : Picture to yourselves a room of state in King John's Palace at Northampton. The King is present with his mother Queen Elinor and several nobles. Chatillon, Ambassador from France, has brought a message from Philip of France to King John. Here follows Act 1, Scene 1.

Shortening Shakespeare

At once the Narrator resumes at the end of the Scene.

NARRATOR : "So is King John's right to the English throne disputed."

And so on, describing the events between the end of Act 1, Scene 1, and the beginning of Act 2, Scene 2.

Whether one approves or not of cutting Shakespeare, this method shows how to give a clear transmission of excerpts from dramatic masterpieces, which in their ordinary stage form might be too long for use by radio. The part of the Narrator is quite impersonal and is designed to supply much that in the stage performance would be visual.



Stage effects rely to a great extent on gesture—the pointed finger and the uplifted eyebrow—but the author of a microphone play has to convey all the action of the play by sound alone.

ELECTRICAL ECHOES

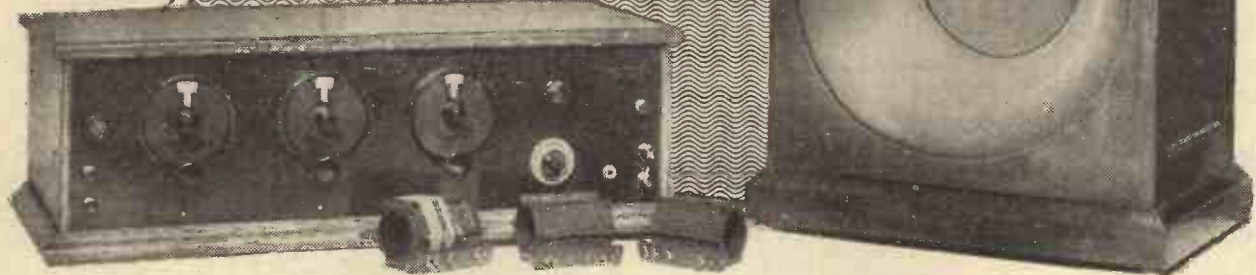

It is curious that there is practically nothing in electricity or radio that could be dispensed with entirely without occasioning serious loss. Resistance is frequently derated as a waster of energy, but without resistance where would be our R.C.C. amplifiers, potential dividers, voltage controls, and what not?

Then there is that "damping" which is presumed to interfere so badly with the operation of our H.F. circuits. But we want our H.F. circuits to have a reasonable damping. That may sound absurd, but it is quite correct.

If our sets had to receive only one frequency at a time, there would be no harm in allowing them to be responsive to only one frequency. As it is, they have to be sensitive to a band of frequencies.

Width of Broadcast

A broadcasting station operates on a wave-length core of so many metres. When it transmits speech or music this core is accompanied by a band of other frequencies which are so much plus and minus the central frequency according to the L.F. impulses to which they owe their presence.

Here is an interesting explanation of the effects caused by over-selective circuits and the exaggerated use of reaction.

By H. A. R. BAXTER

Supposing a broadcaster has a wavelength of 300 metres. This is a frequency of one million. When an instrument modulates at, say, 2,000 cycles, two more waves leave the transmitter, viz., 1,002,000 and 998,000.

Thus it is easy to see that when there is modulation by complex sound structures embodying a whole

gamut of frequencies between 10 and 10,000 the ether is pretty congested with waves between 990,000 and 1,010,000.

Now you have got to tune in all those waves at equal strength if you want to reconstruct the complex sound waves to which they owe their origin.

The selectivity of a circuit is inversely proportional to its damping.

The higher the selectivity the less the circuit will respond to any but one particular frequency, and the less the chance those side-band frequencies have of getting through.

You will see that the frequencies farthest removed from the "fundamental" will be the first to go. These correspond with the higher notes.

FLYING LESSONS BY RADIO

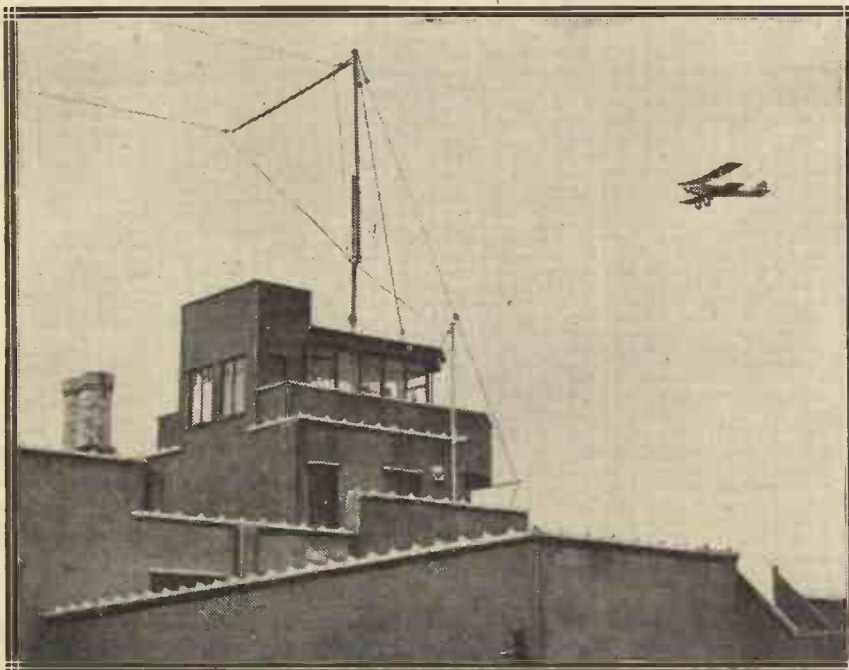

The radio control tower at Heston Air Park. Many of the aeroplanes are fitted with specially designed, simply-operated wireless receivers via which pupils receive instructions from instructors on the ground.

Reaction Effects

The closest we get to a tuning circuit having no resistance is when we apply reaction. And what is the result? Amplification, yes; but unless the reaction is used very carefully, away go those high notes and there is fearful distortion.

There are other things besides the decrease in circuit resistance that

(Continued on page 210.)

WHAT READERS THINK

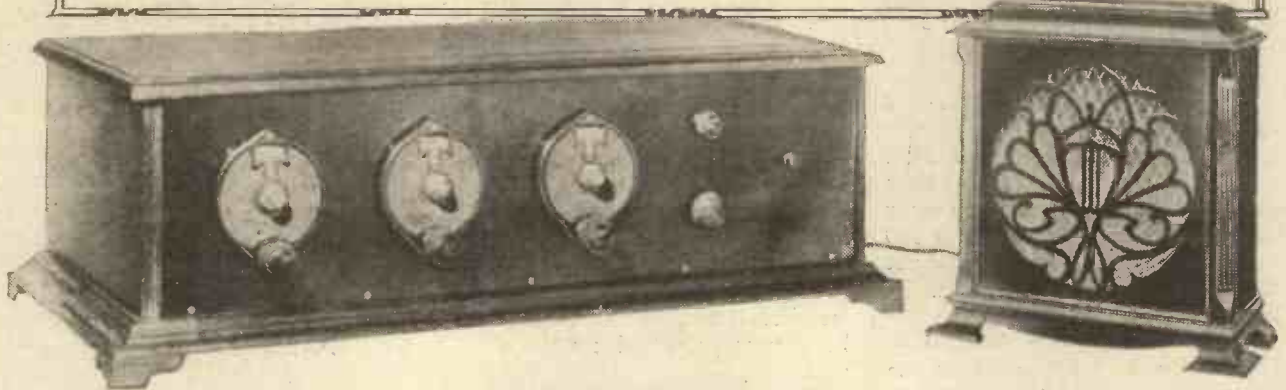

A Puzzler

Sir,—I feel I must write and congratulate you on the "Forte" Five. I have built this up and am delighted with the result. As you say, it will bring in practically anything that is going, and daylight reception—which is what I was out for—is excellent. Here is a very interesting little problem for your readers. I found when building the set that inserting the gramophone pick-up jack caused no loss at all in broadcast signal strength, but altered the L.S. tone so that it somewhat resembled a moving coil.

Investigation proved that two of the fingers of the D.P.D.T. switch for operating the P.U. jack were not making contact with the jack removed, so nothing apparently would be getting through to the grid of the detector valve. How did the set work? Which valve was doing duty as detector? Volume was well up to average four-valver. Wishing you every success.

Yours truly,
ROBERT AMES,
Comdr. R.N. (retired).
Monkton Combe,
Near Bath.

The "1928 Solodyne"

Sir,—I wish to congratulate you on that very fine set, the "1928 Solodyne." I built it in August, 1928, and had a bit of trouble in getting the ganging right, but after six months the set worked beautifully.

I have received about 86 stations and identified 56. One night, at about 11.15 p.m., I noticed that stations were coming in very well and that Milan came through with no reaction and the resistance just making contact, so I took out the aerial and

These letters, chosen from our large and varied post, give readers' results with "M.W." sets and their remarks on interesting subjects.

logged the stations. I received the stupendous number of 39 stations with only the earth; of these, 31 could be heard on the moving-coil loud speaker very well indeed, and the rest were poor at times. I will not bother you with a list of the stations, suffice to say that four Italians were amongst them and two Spanish, while Austria, Hungary, Poland, Sweden, Holland, Denmark figured in less degree, and France and Germany in very great quantity.

SING SING WIRELESS



A wireless set installed in one of the new cells of the famous American prison.

The set is situated about 18 miles from London at Virginia Water.

I am,
Yours truly,
A. R. PYE.

Bristol.

The "Long-Range" Five

Sir,—I built the "Long-Range" Five as described in the October issue of MODERN WIRELESS for 1927.

My aerial is of the indoor variety, and the house is badly screened by trees which overhang the roof. Yet I have no difficulty in obtaining twenty stations on the speaker, and on some occasions nearly forty, among them being Leeds and Swansea. All B.B.C. main stations are received at good strength, with the exception of Glasgow and Manchester.

Contrary to expectation, the set is more sensitive with anode-bend rectification than when using the orthodox leaky-grid, and I think you will agree that my list of stations received is pretty good.*

Yours faithfully,
E. J. T.

Plymouth.

* NOTE.—The list of foreign stations received enclosed is too long for reproduction here!—EDITOR.

H.F. on the Mains

Sir,—Which are we to believe, your Staff Technician at page 436, or your Research Department at page 460, of the November issue of MODERN WIRELESS? They give opposite ways of connecting up the H.F. filter and cannot both be correct.

I am interested in this because I have built the L.T.-D.C. Unit described in the September issue of your journal, and find it useless on account of hum. My H.T. eliminator is the "Universal" mains unit described in

"The Eliminator is Quite Forgotten"

the July, 1928, number, and works with practically no hum, so that there can be no doubt that the fault is in the L.T. unit.

I have tried the H.F. filter connected up in both ways, but without the least diminution of the hum. This may be due to the use of inefficient H.F. chokes. I find that the heavy-duty Wearite choke is only built to carry 250 m.a.; and as I require over 400 m.a. for my four-valve set it does not seem advisable to purchase them.

Searching for a Choke

I have therefore used instead (1) two 300 Igranic plug-in coils, these are 2½ centimetres broad and 3 centimetres radius, and with 300 turns I calculate that their inductance is somewhere in the neighbourhood of 120,000 m.h.; (2) two ordinary McMichael H.F. chokes. These have 30 S.W.G. wire, which is, of course, too fine, and they run hot, but for the short time required for a test they

as this one from readers who have been puzzled by this apparent discrepancy. The fact is that both methods ARE correct and effective. The one given by "Staff Technician" is slightly the better of the two, and so was recommended for general use with mains units of unknown characteristics.

The alternative scheme used in the "Standard D.C. Unit" proved sufficiently effective in combination with the other arrangements in this particular circuit, and was adopted therein because it permitted certain special earthing schemes to be used which will be discussed in the future in dealing with some unusual methods of earthing receivers working from the unit in question.

The L.T. Unit

Regarding the L.T. question, it is possible that the hum arises from using an earth connection. This is quite unnecessary, as an efficient earth

The instructions issued with the average H.T. eliminator contain the following warning: "Always switch on valves before switching on eliminator; and, finally, always switch off eliminator before switching off valves." It is as well to commit this golden rule to memory, and cultivate the habit; but usually there are others besides the owner who have occasion to use the set, and unless the drawing-room be placarded with instructions this is what may happen.

A Simple Remedy

At the end of the programme the customary "off" switch is operated and the loud speaker is silent; while the eliminator is quite forgotten and left to go on consuming its full share of the mains supply.

A very simple remedy which cannot fail to draw one's attention when this happens is to insert in parallel with the supply leads of the eliminator an Osglim lamp. The lamp will glow continuously so long as the eliminator is switched on, thus giving to the user a constant, though by no means an unpleasant, reminder.

The current consumption of the Osglim is so small that there need be no alarm as regards the quarterly light bills; in fact, it is questionable whether any difference would be noticed.

Actually, the Osglim lamp I am using for this purpose is placed (and so hidden) behind the fret of my loud speaker; and, perhaps more so because the design is in the form of a sunset across the water, the effect is delightfully pleasing.

F. S. HALL.

Bexleyheath,
Kent.

Try This Tip

Sir,—I wonder whether any of your other readers have been worried by a similar trouble to the following. When clamping wires under valve-holder terminals the whole terminal begins to go round, and it is necessary to remove the holder from the base-board before the terminal can be tightened. Personally, I now go over all terminals and screws on my components before mounting them, and think it is a tip worth following.

Yours faithfully,

A. L. R.

Broadstairs.

WIRELESS ON THE "DISCOVERY II"



Special Marconi wireless equipment is installed on the new Royal Research Ship. Above is a view in the chart room which contains the direction finder.

showed no improvement. I used 2-mfd. condensers in both tests.

An article on how to make suitable H.F. chokes would probably interest many of your readers who find themselves in the same position as myself.

Yours faithfully,

J. W. WALKER.

Guernsey.

Editorial Note.—We have received one or two letters in the same strain

can be found in the mains. An ordinary earth is liable to introduce hum and can well be entirely discarded.

A.C. H.T. Eliminators

Sir,—With the growing popularity of the H.T. eliminator the following idea may commend itself to many of your readers.

POINTS ABOUT POWER



A KNOWLEDGE of the fundamentals of electricity not only makes radio work much more interesting, but is decidedly useful—more especially when one is dabbling with mains units. Every radio enthusiast should know his Ohm's Law so well that its use becomes almost a matter of instinct. But there are other points almost as vital with which a really conscientious constructor acquires a very close acquaintance.

Before I proceed to describe these others, let me refresh your memory, should it need it, with regard to Ohm's Law. Ohm's Law concerns three factors—voltage, current and resistance. It shows that they bear very definite relations one with the other. For instance, voltage (in volts) equals current (in amperes) multiplied by resistance (in ohms).

Three Vital Factors

From this it follows that if you know any two of the above three factors you can discover the other one very easily. Current equals voltage divided by resistance, and resistance equals voltage divided by current. If you apply a pressure of 10 volts across a 10-ohm circuit, 1 ampere of current will flow through it. Likewise, if a current of 2 amperes is flowing through a circuit that is known to have 5 ohms of resistance, Ohm's Law tells you that there is a pressure of 10 volts.

Ohm's Law applies equally well to both D.C. and A.C. But in the case of A.C. the resistance is not the simple straightforward resistance encountered in direct-current work. Impedance takes the place of the resistance in the Ohm's Law Formula, and impedance is made up of resistance, inductance and capacity.

Alternating current first flows in one direction and then in the other, and it rises from zero to a maximum,

Every "M.W." reader who owns or intends to own a radio mains device should read this interesting and informative article.
By G. V. DOWDING, Assoc. I.E.E.

and then falls again to zero in each direction, the whole operation constituting what is known as a "cycle." Thus in a fifty-cycle supply the current changes its direction fifty times in a second. For practical purposes we calculate the voltage of an A.C. supply as being approximately 70 per cent of the maximum to which the voltage rises in each direction.

What are Watts?

Thus if you have A.C. mains which are rated at 140 volts, you must remember that the voltage actually rises to 200 at every half-cycle.

The term current indicates the amount of electricity that flows in certain time. In the case of half-wave rectification, such as you frequently meet in mains units, only that current which flows in the one direction is used, and the other half is suppressed. Theoretically, you should get double the current with full-wave rectification, although for

certain reasons it does not work out exactly like that in practice.

The watt is the unit of power. A kilowatt is a thousand watts. You work out the power consumed by a circuit or a piece of apparatus by multiplying the voltage developed across it by the current that passes through it. The result is the power in watts used.

A 6-volt valve that passes a quarter of an ampere consumes $1\frac{1}{2}$ watts of energy. If you know the watts rating of the device as well as the voltage that is applied across it, you can work out both its resistance and the current it passes.

Let us take for an example an electric lamp rated at 50 watts (this is quite a common rating) used in conjunction with 200-volt mains. You will remember that the watts are found by multiplying the voltage by current, so that all we have to do is to divide the 50 watts by the 200 volts to discover that the lamp passes a quarter of an ampere.

Useful Information

Knowing the voltage necessary to drive a quarter of an ampere through the lamp (200 volts), we can gain the additional information of the resistance of the bulb by dividing the two hundred volts by the quarter of an

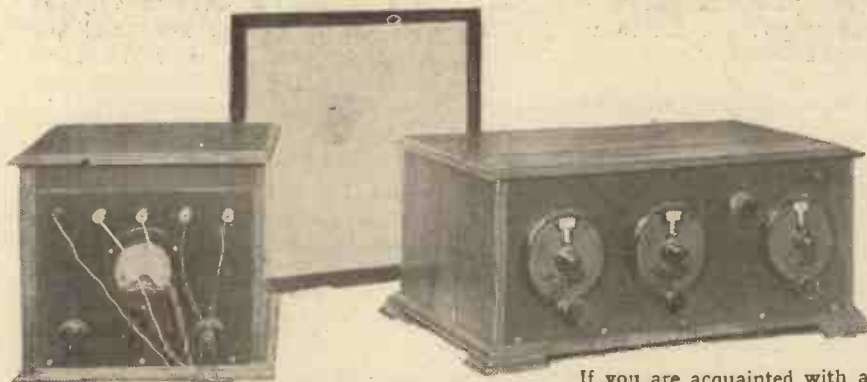

If you are acquainted with a few facts and rules concerning electrical power you will be able to use mains units more effectively and you also will find that they become more interesting to handle.

Working out your Electrical Running Expenses

ampere. That lamp, then, has a resistance of 800 ohms.

Sometimes gas-filled lamps are referred to as half-watt lamps, but this does not indicate the total power consumption of each of them, but refers only to the fact that the lamp gives one candle-power of light for every half watt of electrical power. That is, of course, somewhat confusing, but it is a term that is now seldom used.

The two main classes of lamps are the ordinary and the gas-filled.

type in parallel you have half the resistance, but twice the current can be passed.

Should the lamps be of a different type, it is rather harder to work out what the resistance will be. You have to take the reciprocal of each resistance, add these together and the result is the reciprocal of the resultant resistance.

Estimating Costs

In simpler language, you divide the resistance of one lamp into one, add

do so for a thousand hours before your unit is used up.

You divide the watts into a thousand to determine how many hours you can run a piece of apparatus before your unit is disposed of. Supposing you are paying 6d. per unit for your electricity, then a 25-watt electrical appliance can be operated for 40 hours for 6d. A 50-watt electrical lamp will give you 20 hours of light per unit.

In order to determine the total power consumption of a houseful of glowing lamps, all you have to do is to add the watts of each together. Eight 50-watters and two 60-watters give you a total of 520 watts.

Just plain addition, that is all. And plain addition and division and multiplication of the simplest kind are all that you come up against with regard to all the very important calculations I have described in this article.

AN ELIMINATOR FORTUNE

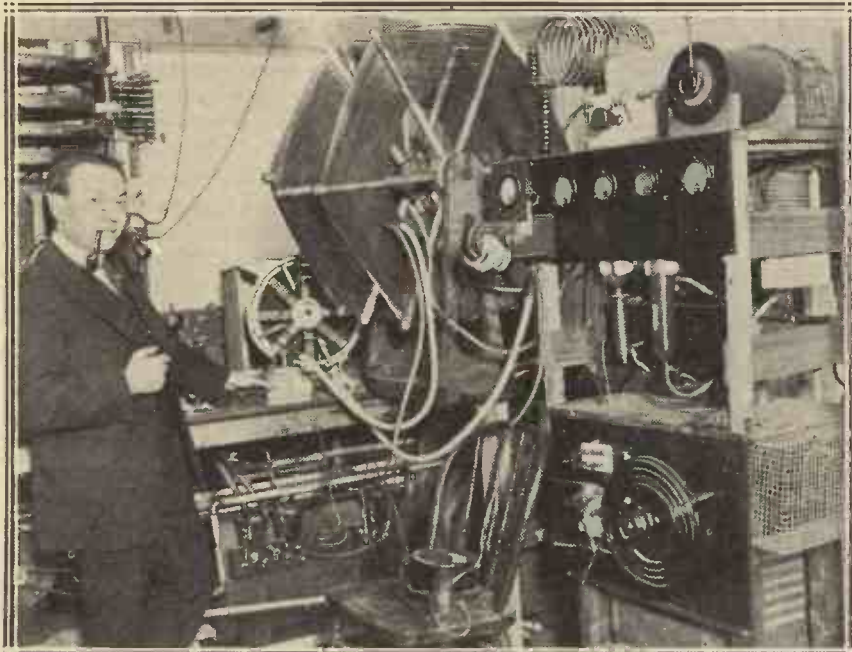

Mr. William Dubilier, who was recently awarded royalty rights worth millions of dollars from battery eliminators in America.

A knowledge of these simple characteristics of electric lamps is extremely useful, because lamps make cheap and reliable power resistances. If you work out the current they normally pass you know how much current you can ask them safely to handle.

Satisfactory Resistances

A wire-wound resistance capable of handling an ampere of current, and having a resistance of 500 or so ohms, will be a bulky and rather expensive article, but you have a device that will do the same work quite safely in the form of the electric lamp, or two or three or more of these joined in series or in parallel. And it is worth remembering that when you join two lamps of a similar

it to the resistance of the other lamp divided into one, and divide the result into one.

Supposing the resistance of the lamps were 500 and 1,000 ohms. First of all, you have to add one over 500 to one over 1,000, and this is three over a thousand. You invert this, and get a thousand over three, so that you arrive at 333.3 ohms.

If you have the mains laid on to your house you will know that you pay so much per unit for your electricity. Do you know what these units signify? One Board of Trade unit is a thousand-watt hours. That is to say, if you consume a thousand watts of power in one hour you have consumed one unit. Alternatively, if you only consume one watt you can

REMEMBER THESE TIPS

It is often recommended that a fixed condenser should be wired in series with the reaction condenser in order to reduce the risk of shorting the battery should the insulation break down; but remember that in such cases the fixed condenser's capacity should always be much larger than that of the reaction condenser.

* * *

A common cause of poor reception is the leakage of H.F. current from the aerial and lead-in tube, owing to these being placed too close to earthed objects.

* * *

For all simple sets, including crystal sets, it is impossible to over-estimate the importance of keeping the lead-in well spaced from damp walls, metal work, etc.

* * *

If you are constructing a big set do not attempt to save on it by buying cheap solder, as some of the inferior grades upon the market are not worth the low price asked for them.

* * *

If you want your accumulator to have a long life do not let it stand aside after it has been run down, but take it to the charging-station again as quickly as possible.

MY BROADCASTING DIARY

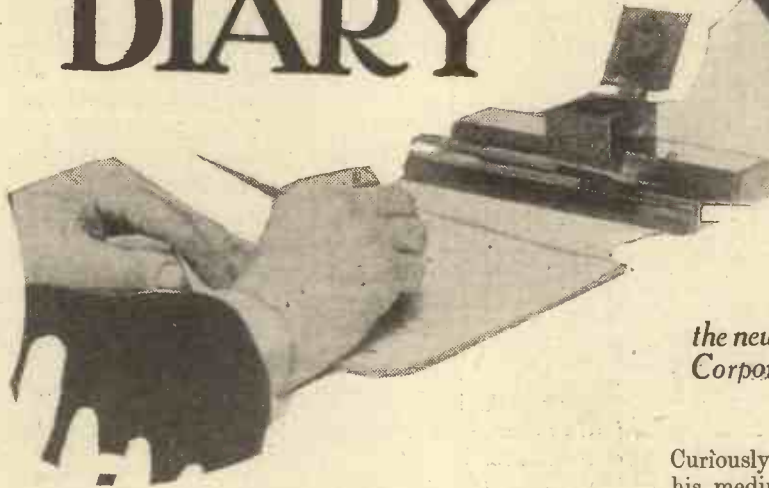

Under this heading month by month our Broadcasting Correspondent will record the news of the progress of the British Broadcasting Corporation, and will comment on the policies in force at B.B.C. headquarters.

Centralisation Gains Ground

THE prolonged struggle between the centralisers and the devolvers at Savoy Hill is experiencing a temporary lull with stocktaking on both sides. Recent engagements have gone badly for the devolvers, and it looks as if the honours of the campaign are to rest with the centralisers.

It seems practically certain that the Birmingham Studio Orchestra will come to an end next September. The negotiations between the Civic Society of Birmingham and the B.B.C. led to proposals for such substantial subsidies for the local orchestra that a good deal of the support for a continued B.B.C. orchestra was "sapped."

Manchester is the next objective. Demobilisation there will take place either this autumn or in the following March—that is, always allowing for contingencies.

Four Pianos for One Studio

During the last week of this month and the first few days of next rehearsals for the performance of "Les Noces" will take place in a studio provided with no less than four pianos. This is the first time that so many pianos have been provided for a studio rehearsal, and is a sign of developing technique in musical presentation.

Elena Gerhardt

The B.B.C. has taken a great fancy to this artiste, and she is to have a special performance before the microphone early in March.

Lord Clarendon Breaks Silence

Lord Clarendon's silence at the microphone is now firmly established. Apparently nothing can induce him to broadcast. This seems a pity, because there are many points he might deal with and many difficulties he might clear up if he appeared two or three times a year to take listeners into the confidence of the Board of Governors.

But apparently silence before the microphone does not mean silence in the Press. It is understood that the recent interview which the Chairman of the B.B.C. gave to Mr. Eric Dunstan is the beginning of a series in which Lord Clarendon will explain his policy and standpoint.

Curiously enough, no B.B.C. paper has been chosen for his medium.

Whether Lord Clarendon's Press activities will be paralleled by similar action on the part of other Governors remains to be seen. If, however, the Chairman of the B.B.C. gives voice to views with which Mrs. Philip Snowden is in disagreement, I for one would not be responsible for the task of muzzling the brilliant hostess at No. 11.

Parliament and Broadcasting

Mr. Lees-Smith, the Postmaster-General, is even more reluctant than was Sir William Mitchell-Thomson to satisfy the curiosity of members of Parliament on B.B.C.

SMILING AT SPACE



Irene Bordoni, a stage star, in front of the television set which was a feature of the World's Radio Fair in New York.

subjects. As a result there is growing uneasiness in the House as to the constitutional position of the B.B.C.

It is felt increasingly that although the Corporation was set up by Royal Charter, and its Governors appointed by the State, there is almost a dangerous absence of responsibility for its day-to-day operations. The fact that

All the Latest News for Listeners

under the administration of Sir John Reith the work goes on well does not provide an answer to the constitutional difficulty. There is no Minister who will answer for the B.B.C. in either House of Parliament.

It is on the cards that there will be some remedial action taken at the end of next year, when the first change over of Governors may provide a suitable opportunity. It is possible also that, at the same time, the Chairman may become Chief Executive, in which case it is likely that Sir John Reith would be invited to succeed Lord Clarendon on the latter's voluntary retirement.

With Sir John Reith as Executive Chairman the position of Director-General would go into abeyance; Admiral Carpendale continuing as Controller.

The National Chorus

The B.B.C. is arranging to produce in the spring, at the Queen's Hall, an elaborate presentation of "The Elijah," featuring the National Chorus.

Sir Thomas Beecham and the B.B.C.

Friends of Sir Thomas Beecham anticipate that his pent-up feelings about the B.B.C. will break forth in March. It is believed that there have been tremendous

conductor and his old *bête noire*, and that then they will settle down together as fast friends for another year or so. Anyway, this is the outcome for which all those who wish well for broadcasting will pray.

Shelving Old Favourites

Intelligent students of broadcasting will agree that it is not good policy to work willing horses to death, and that some of the big hits of early days were ruined by being left too long at a stretch in front of the microphone. But there is a lot of difference between giving people reasonable rests and shelving them.

There are several cases of shelving now puzzling the public. One is Sir Walford Davies. When it was announced that he was giving up most of his microphone work at the end of last year, the B.B.C. was asked to state whether there was any intention to have him back later on.

Savoy Hill had "nothing to say," from which it is fairly obvious that the musical junta at the head office of the B.B.C. is determined to exclude Sir Walford from the microphone.

Then there is the case of the sudden disappearance of Mr. G. A. Atkinson, who had been broadcasting film critic for six and a half years. I understand that one day Mr. Atkinson received a curt, written intimation telling him that his services would be required no longer.

There was no tribute of any kind to one of the most able and faithful of the pioneer broadcasters. The last case in point is that of Gerald Barry, who has been superseded at the microphone just as soon as his feature "The Week in London" had firmly established itself in the affections of millions of listeners. True, Mr. Barry is to be used in discussions and other microphone efforts, but these are no substitute for his real line.

The next thing we shall be hearing about is the ditching of Vernon Bartlett. Really, something should be done about all this. It is not fair to those concerned, and it is extremely bad for broadcasting.

The Identity of Holt Marvell

"Holt Marvell" has come to be a name to conjure with in British broadcasting. He has done a tremendous amount of successful dramatic production. But his real identity was kept secret until the other day, when a newspaper published "a write-up" with his photograph.

This reveals that Holt Marvell is none other than Mr. Eric Maschwitz. The author of the "write-up" revealing the identity of the editor-producer of the B.B.C. signed himself "Astyanax," which, I believe, cloaks the personality of Mr. Val Gielgud, Director of Productions for the B.B.C. These two make a very effective partnership in work, and no doubt their co-operation in mutual admiration is not devoid of advantage.

Work at Slaithwaite

There is feverish activity at Slaithwaite, the site of the twin-wave transmitter for the North of England under the Regional scheme. Results of the preliminary public tests at Brookmans Park have so encouraged the engineers of the B.B.C. that they have now no misgivings about the complete success of the new series of high-power transmitters. I expect Slaithwaite to be ready to transmit in December.

RADIO BEACON FOR AIRMEN

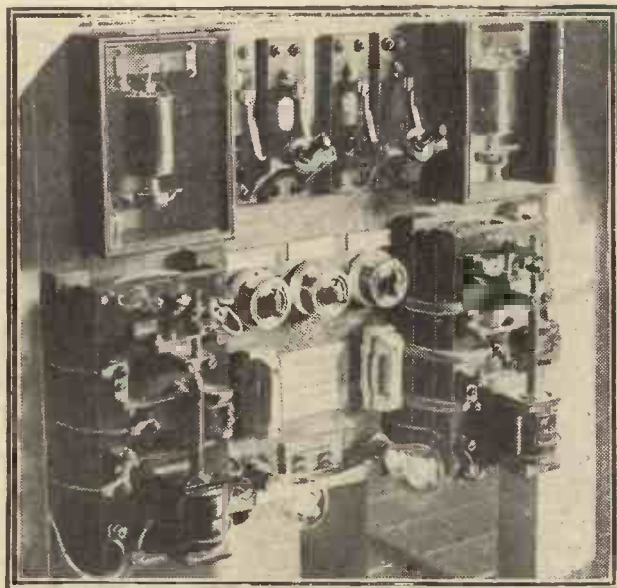

The control panel of the rotating wireless beacon erected in Suffolk as a guide to aeroplanes. The apparatus is quite automatic and transmits every alternate five minutes.

arguments and tussles behind the scenes of the National Orchestra scheme. Combined financial operations have not materialised in the way originally planned.

There has been a lot of delay. Meanwhile, the scheme has been hung up rather seriously, although the B.B.C. has managed to acquire a nucleus for the new orchestra. It remains to be seen whether the forthcoming breach will be so serious as to make it impossible for Sir Thomas to continue conducting for the B.B.C. My own view is that things will not get to that pass.

I believe there will be a big public outburst, with the time-honoured exchange of amenities between the brilliant

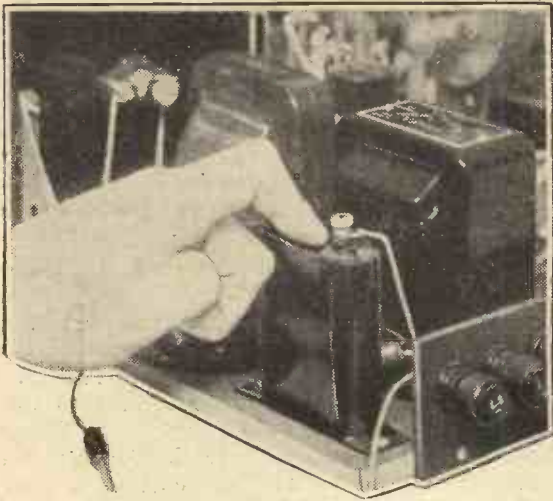

CONDENSER CONDUCTORS

An article about the oft-raised question of how musical programmes, with their low frequencies, can apparently "pass through" a small condenser in the aerial.

By P. R. BIRD.

QUITE apart from the programmes it provides, a wireless set is brim-full of interest.

Its methods of working are quite as fascinating as the final result, and, as in other forms of entertainment, the player is often just as interesting as the performance.

Foremost among the interest-compelling components is the ubiquitous condenser. Every set has at least one of them, whilst even a small valve set may have half a dozen or more—open or closed, large or small, fixed or variable. And whereas one condenser may be placed, for instance, in the aerial lead, right in the path of all the aerial currents, another, exactly similar, may be used for a blocking condenser because it stops currents!

High- and Low-Frequencies

Most listeners are familiar with the fact that the currents in question are of totally different types, and that a condenser can stop one kind of current ("direct") and pass the effects of "alternating" current.

They know, too, that an alternating current (A.C.) is one that does not flow steadily one way, but periodically reverses its direction at a given "frequency" per second; and that alternating currents can be of the "low-frequency" or the "high-frequency" type.

Some Curious Effects

Both kinds are full of interest. Low-frequency (L.F.) currents are those in which alternations occur at comparatively long intervals, such as only 50 times per second, or perhaps 500 times, or anything up to about 10,000 times in one second. They can be made to reproduce music and speech.

High-frequency (H.F.) currents, on the other hand, alternate at much

greater speeds, say in the neighbourhood of one million times every second. And these rapid alternations give rise to some very curious effects.

For instance, although low-frequency currents can be made to pass effects through a condenser, it must be a fairly large one or losses will be high. But high-frequency currents will "pass through" even a tiny condenser with astonishing ease. And a very interesting side-issue is often raised by the question: "How do the low-frequency impulses from a broadcasting programme get through a small fixed condenser in the aerial lead?"

High-frequency current would be able to tackle such a barrier without serious loss—but what about the

speech and music frequencies associated with it? If, for instance, the transmitting station is sending out an organ note with a frequency of about 50 per second, how can such an effect come down an aerial lead and get through a neutralising condenser which has enormous impedance except at high frequencies?

A Puzzling Point

As many readers have raised the point in one form or another, it is interesting to examine this apparent anomaly. "What enables low-frequency currents to pass easily through small condensers in the aerial circuit?" The answer is—they don't!

What really happens is this. The transmitting station sets up an aerial current with a frequency of generally

CROSSING THE BAR!

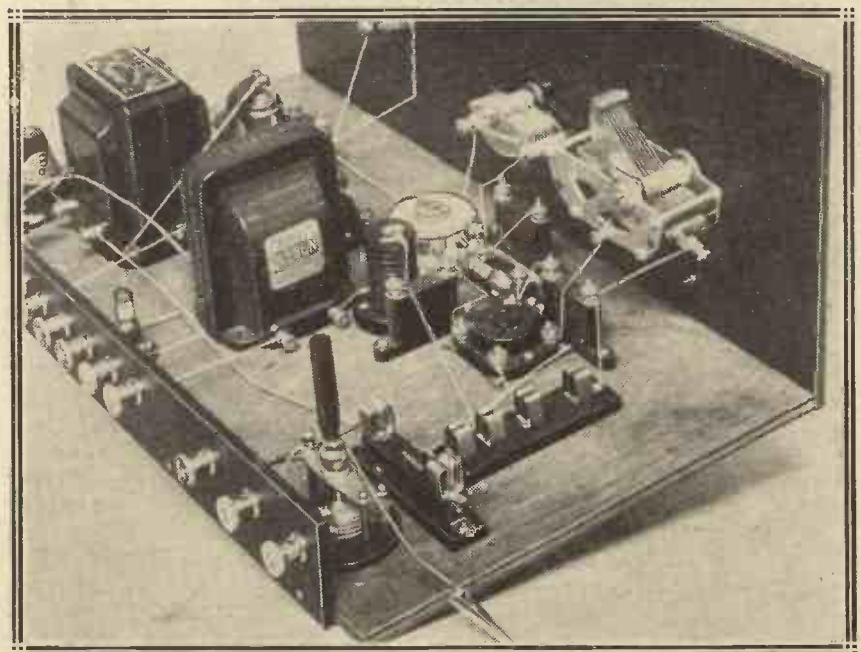

Here is an instance of all the aerial currents being led to a small condenser on their way to operate the set.

Carrying Currents that Continually Change

somewhere about a million a second—a really high-frequency current.

This is known as the carrier-wave, and if this station then sends out an organ note with a frequency of, say, 50 per second, that carrier-wave is "modulated" by this organ note fifty times per second; which simply means that the strength or amplitude of that carrier-wave is altered fifty times per second exactly to correspond with the note. The B.B.C. tries to make the music alter only the amplitude of the carrier, not its frequency.

Effect on Frequency

As a matter of uncompromising fact, the frequency does alter very slightly with the modulation, (as explained on another page in the article

they have not the slightest objection to alterations in amplitude, even if these alterations are at a low frequency. If they are handling a high-frequency current it is quite immaterial to them whether that current remains absolutely steady in strength, or whether it varies from one second to another.

Disentangling the L.F.

So long as it is a high-frequency current they will handle it, even though there are variations in the strength of it, say, 50 times every second. Where, then, does the low-frequency current that operates the speaker come from?

The production of L.F. from H.F.—the provision of speech and music currents from an H.F. input that is

or lurking on the line of the "anode bend," are the conditions which modulate that current at low frequency, regularly varying its amplitude as the organ note varies the amplitude of the original carrier-current.

Whilst the detector's reaction circuit is faithfully responding to all the vagaries of the input, its L.F. output circuit is paying attention to one factor only—to average size. If the average input to the detector varies in size fifty times a second, exactly like the rise and fall of an organ note, the input to the low-frequency transformer will vary in size fifty times a second also, exactly like an organ note.

The Final Form

If the input varies five thousand times a second, or a mixture of that and fifty times a second, or indeed at any low frequency, the detector's L.F. current will do the same, and can thus be made to work 'phones, or be passed through the primary of an L.F. transformer to operate the loud speaker.

Thus the "condenser-conductor" is not acting inconsistently in "passing low frequency"—it is merely being unexpectedly dexterous, and attending to amplitude as well

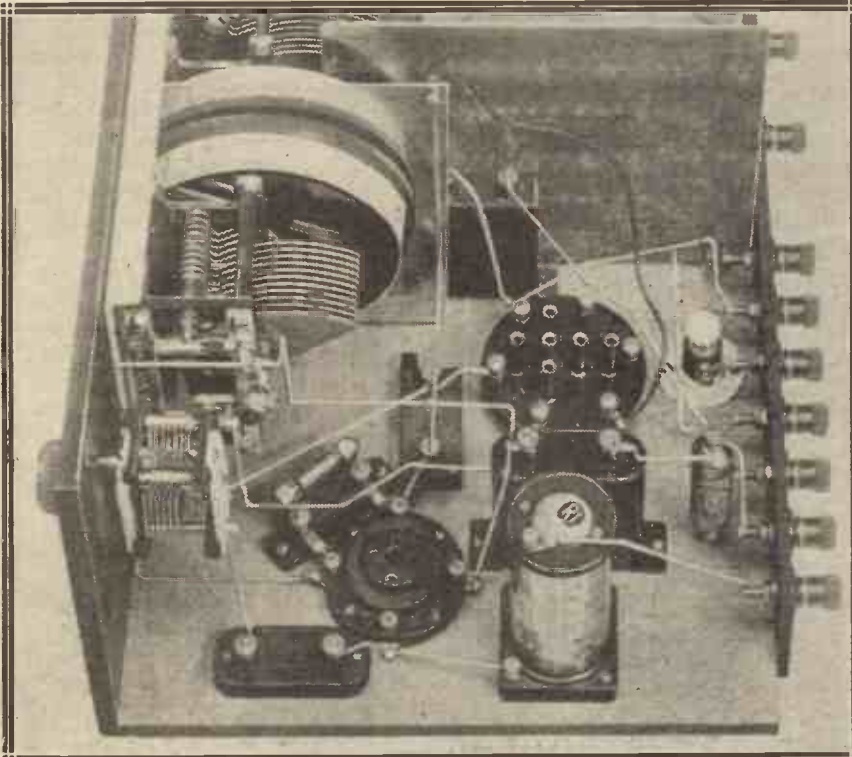

Its remarkable properties enable the condenser to be used for many purposes. All those shown in this illustration, for instance, are doing fundamentally different duties.

"A Revolution in Selectivity.") But side-bands are a side issue. Though the transmitted frequency may alter slightly, it is still right up in the neighbourhood of a million; a definitely high frequency that will act like high-frequency current in your aerial. It is the amplitude that is varying at lower frequency—the size of the signal, the strength of the received current.

Although small condensers object strongly to low-frequency currents,

altering in amplitude at low frequency—is the work of the detector.

When this is a valve, an H.F. choke in its plate circuit generally bars the way once and for all to high-frequency currents, whether they are steady or varying in amplitude at low frequency. But through that H.F. choke there flows a current, only a milliamp or two, that is normally steady and not varying when the original carrier is steady and unvarying. Artfully associated with condenser and grid leak,

HINTS FOR CONSTRUCTORS

When solder "sticks" and fails to run properly the trouble is usually that the soldering-iron is not sufficiently hot.

* * *

Do not forget when soldering two surfaces together that the metals must be heated equally by the iron if the solder is to run smoothly over the joint.

* * *

As both lead and sulphuric acid are poisons, remember that after an accumulator has been overhauled the hands should be cleaned very thoroughly.

* * *

Do not attempt to mix battery acid unless you wear a pair of goggles to protect the eyes.

* * *

An immediate bathing in clean warm water is the best treatment if a splash of battery acid should accidentally get into the eye.

BATTERY *v.* MAINS VALVES

If you have A.C. mains you are among the fortunate ones, for a mains-operated set, using indirectly-heated A.C. valves, should be much more efficient than a similar receiver employing battery valves. If you are on A.C., and still using batteries, you are missing a great opportunity to improve your results. The change over is not difficult, as is shown in this article.

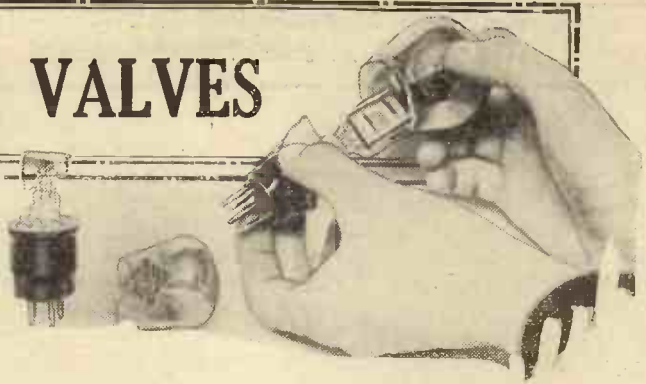

By KEITH D. ROGERS.

THIS month we are publishing an article describing the conversion of the "Eckersley" Three for use with mains valves, so that with the December and the February numbers of MODERN WIRELESS on hand the constructor has a choice between using either battery or mains valves in this particular set, and a large number of readers will probably be asking themselves "Which is the better system?"

Well Worth It

If you have D.C. mains, I am afraid there is nothing for it but to use battery valves. You can certainly run the filaments off the mains and you can get the H.T. from the mains, so that you need not be bothered with batteries, but the man who has A.C. mains has a complete choice between the two classes of valves.

It is only recently that mains valves have come into prominence, and, in fact, it is but a few years since the indirectly-heated type of valve was first designed, and so quite a number of constructors must be seriously considering the change over from batteries to mains—if not in their present set, when they build another receiver—and they must be asking themselves the questions: "Is it worth it?" or "Are there any snags in the change over?"

The answer to the first of these questions is decidedly "Yes," and the reply to the second is "No, provided that care is taken." The only snags that you are likely to meet in using an all-mains receiver are those generated in the H.T. section of the set, due either to a badly constructed eliminator or to the use of an eliminator which is not really capable of supplying the anode current which you desire to take from it.

Trouble-Free Operation

I refer, of course, to our old friends motor-boating and A.C. hum. The hum caused by the heater of the valve

is only very, very slight, even if it is present at all, and with a well-designed receiver, with potentiometer control of the cathodes, one can usually eliminate the hum altogether.

If, however, the constructor has been used to ordinary valves, and has never employed his mains for radio purposes, he may be a little diffident as to the advisability of making the change; but, at the same time, he will feel that he is missing something by not going over to the mains.

Let me assure anybody who is in that frame of mind that he is indeed missing something by not going over to the mains. There is no doubt that the indirectly-heated type of mains valve is far more efficient than the battery valve, and it is so simple and easy to run, for one does not have the slightest trouble with regard to the power of the set—no charging, no running down of H.T. batteries.

One can get far more out of a three-valve set with ordinary A.C. indirectly-heated valves than one can with the same set and battery valves. Both on the H.F. and on the L.F. sides the mains valves have got the battery

valves beaten, provided the set is built in a reasonably scientific manner.

So let all those who are hovering on the brink of the change over rest assured that it is certainly worth while, and the only questions which remain concern the possible expense and the best way to set about the necessary alterations.

Commencing the Change

If I were not too sure of myself and my ability to make a complete success of the change over from battery to mains, I would go about it in a fifty-fifty spirit—that is, I should continue using the ordinary battery valves and put in an H.T. unit first.

This, after all, is the biggest step that has to be taken, and once you have got the H.T. part right, you are not likely to have any trouble when you finally go right over to the mains. On the other hand, if you go right over to mains in the first place, and you have trouble with the set, it is rather difficult to find out where that trouble is coming from unless you are used to the type of valve and apparatus

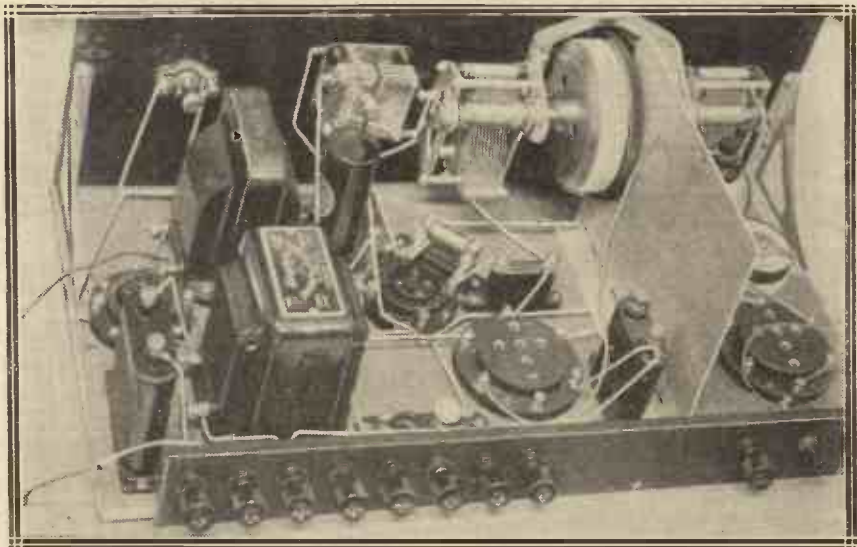

The "Eckersley" Three as originally wired for battery-operated valves. It has since been altered so that A.C. valves can be employed, greatly improving the set's efficiency.

Indirectly-Heated Valves are Extremely Efficient

you are employing—which, of course, will be quite strange to those who have always been on battery valves.

So, supposing I had decided to go over to mains valves, I should begin on the H.T. side. I should build or purchase a really reliable A.C. H.T. mains unit capable of giving at least 50 per cent more H.T. current at the highest voltage I would require than I should need for any set which I contemplated building.

The Safety Factor

That may sound a very high factor of safety; but, believe me, it is necessary. There are very few of our readers who have not experienced motor-boating; those who have not have been lucky, but if one wants to experience motor-boating at its very best (or worst!) one wants to use a mains unit which is not too well designed, and which is incapable of providing the necessary milliamps for the particular set with which it is being used. Then motor-boating in *excelsis* arrives, AND REMAINS until a new mains unit is constructed.

So when building a mains H.T. unit, bear in mind that a large factor of safety is required, and good heavy smoothing, and you will not go far wrong.

Then having got the H.T. side of

the set fixed up and working O.K. on the mains, one can turn attention to the filament side. A good plan here, if you are rebuilding your own set, is first just to change over the valve holders if you are going to decide to use five-pin mains valves, which are really more convenient than the four-pin with extra terminal type, and to rewire the filament portion with twisted flex, inserting, of course, across the filament leads a potentiometer of about 400 ohms, the slider of which is taken to all the points in the set which have to be earthed.

Use Twisted Flex

The new filament leads of twisted flex (which should be as short and as far away from other wiring as possible) are not taken to earth, but merely go to two terminals which lead to a special four-volt transformer, the other side of this transformer being connected to the mains.

So much for the filaments. Now the slider of the potentiometer will go to the fifth pin in every case, as well as to earth. That is to say, the cathodes of the valves are earthed and are tapped across the mains input on the four-volt side, the position of the potentiometer being somewhere about the middle and so adjusted as to cut out hum.

If you will have a look at the wiring diagram of the "Eckersley" A.C. Three, and compare it with the diagram which appeared in the December MODERN WIRELESS, you will see that it is different in its connections of the filament and the cathodes, for whereas in the ordinary battery valves the cathode is the filament, in the case of the indirectly-heated A.C. valves the cathode is a separate element and is completely insulated inside the valve from the heater or filament.

Mixed Mains Valves

In the "Eckersley" A.C. Three you will note that two of the valves—the detector and the L.F. valve—are of the indirectly-heated type and go to a four-volt transformer, while the screened-grid valve is of the .8 type which goes to a .8-volt tapping. This is because the indirectly-heated A.C. valves are so very lively that they require elaborate screening in order to ensure for stability.

When one does get the stability with these valves then they completely surpass the battery or the .8

types in magnification properties. As a matter of fact, a good A.C. screened-grid valve is worth about two ordinary battery valves, but, as I said just now, it requires very, very careful screening, and so when changing over from a

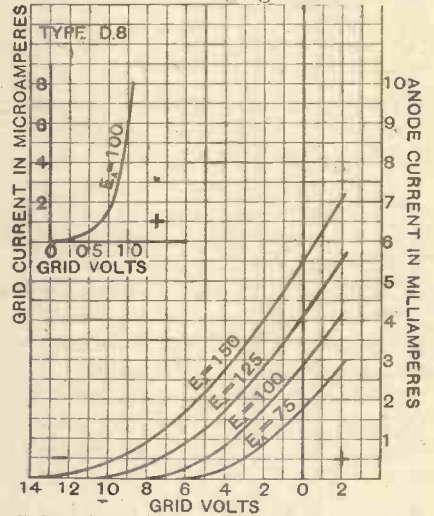

This point 8 detector valve has an impedance of 21,000 ohms, and a magnification factor of 14. Compare this valve's curves with those of the M.H.4 in column 1.

battery to a mains set it is not always advisable to use a screened-grid valve of the indirectly-heated type, but to use a .8 type which has characteristics like the battery valve although it is run off the mains.

A Magnificent "Power"

This then is the reason why a separate transformer and a separate potentiometer is used with that particular valve in the "Eckersley" A.C. Three. In the case of a detector and two L.F. valves one would use the indirectly-heated type of valve throughout, using perhaps an M.H.L.4, or A.C./H.L., for the detector, or possibly an M.H.4, and an M.H.L.4 for the first L.F. and an M.L.4 or A.C./P. or A.C./P.I. for the output valve.

The A.C./P. is rather a wonderful output valve, having an impedance of about 2,600 ohms and a magnification factor of 10. Although it will not carry a tremendous grid swing it will give tremendous output power for a small input and is a remarkably efficient valve. There is nothing, to compare with it among the battery valves, except the Mazda P.220 and P.240 two voltors.

Having changed over the filament wiring of the valve holders, it is hardly worth while for the average man to worry about getting his grid

(Continued on page 207.)

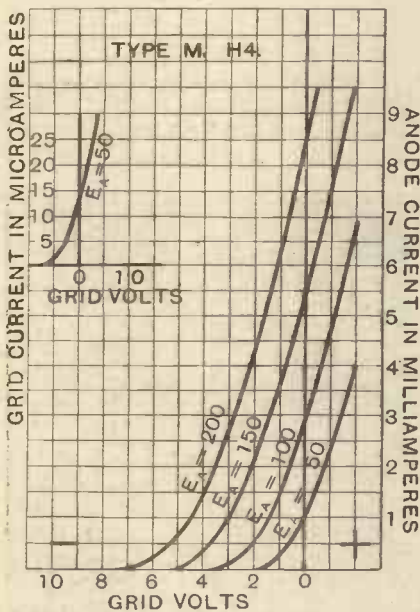

This indirectly-heated detector valve (the M.H.4) has much better characteristics than has its directly-heated brother, the D.8. Compare the two curves and you will notice how much steeper are those of the M.H.4, which has an impedance of 23,000 ohms, and an amplification factor of 35, against the D.8's 21,000 and 14.

EXPERIMENTS WITH RESISTANCE REACTION

This interesting letter from one of our readers abroad is the outcome of a recent article by "W.L.S." on controlling reaction by means of a variable resistance.

SIR,—In the September issue of MODERN WIRELESS your contributor, "W.L.S.," made some suggestions about the use of resistance reaction control on short-wave sets. This and the fact that you considered my previous letter about the performance of the "2.35 for Australia" of sufficient interest to merit its publication, has tempted me to write again about the latest edition of this set which I have made up for a friend. This set incorporates resistance reaction control. In fact, I adapted the original set I made up from the designs of the "2.35" to resistance control early this year, and I have been experimenting for the last eight months with this type of reaction control.

The Value to Use

As you are no doubt aware, the "2.35" has swinging coil reaction, with an auxiliary control consisting of a variable 300-ohm resistance in the detector H.T. lead. I found this very useful when the set was on the verge of oscillation, but the plate voltage on the detector valve had to be very carefully adjusted to get smooth control. I replaced the 300-ohm resistance with a variable 100,000-ohm resistance in conjunction with two 2 mfd. by-pass condensers, fitted up in the conventional "anti-mobo" manner, the only difference being that the resistance was variable at will, instead of being fixed.

Filament and H.T. Control

I then found that reaction difficulties had vanished as if by magic, the set had ceased to be "swinging coil," as the coil (reaction) had simply to be roughly adjusted in order to make the set oscillate freely with average detector voltage on the desired wave-band, and then left severely alone, tuning being effected by moving the tuning condenser until a carrier-wave was picked up. When the



resistance was brought into play the set ceased to oscillate; the filament rheostat, which I had mounted on the panel for greater convenience, being then adjusted until the set slid in and out of reaction simply by the manipulation of this control alone.

Many Advantages

Thus the set became a "single-dial short-waver" in the true sense of the word, there being only one wave-finding adjustment, the requisite reaction control being supplied by variations in the plate tension and filament. I have no hesitation in saying that this is the best short-wave reaction control I have yet used. Several of my friends have adopted this method and they are equally enthusiastic. The advantages of this type of control over the more usual capacity control may be summed up as follows:

Greater signal strength, easier manipulation of set, no interference with tuning, set may be brought in and

out of oscillation with silky smoothness, definite lessening of "mush" and background noise, no "threshold howling," H.F. choke obviated (incidentally I have found that the H.F. choke has a lot to do with "threshold howl" on capacity reaction control sets, a defective or unsuitable choke seems to have an uncanny knack of insinuating itself into an otherwise satisfactory set), and the fact that fewer parts are required in the H.F. part of the set is a great advantage on a short-waver.

On reading over this letter I find that I have made it much too long, so will close by wishing MODERN WIRELESS every success.

Yours faithfully,
T. W. POULTON (Buenos Aires).

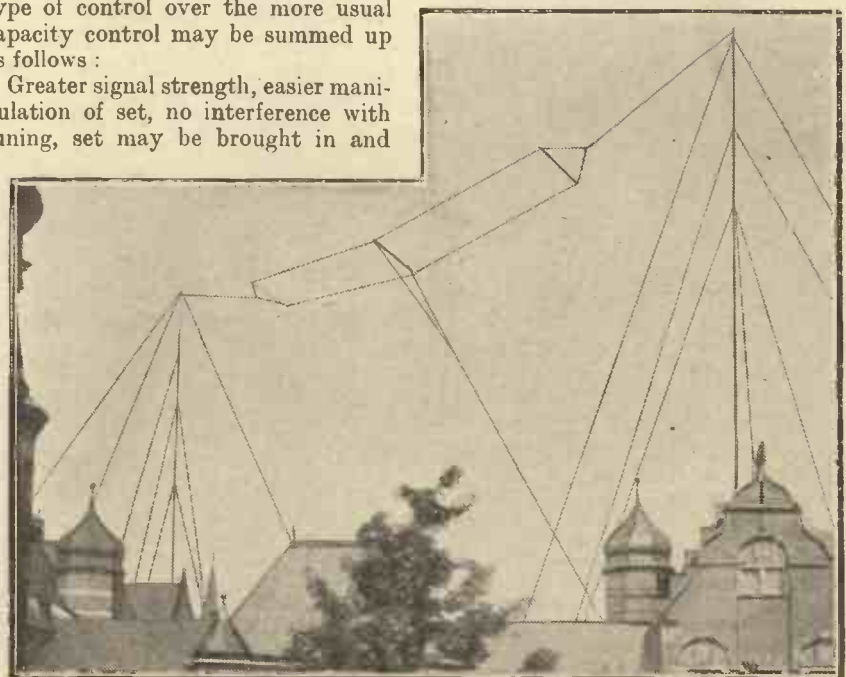

The aerial of the Cassel broadcasting station in Germany is a good example of the "T" type of antenna.

Microphone

By AN EX-ANNOUNCER



WILL it bite? Those few words briefly summarise the attitude adopted by most inexperienced broadcasters towards the microphone. The little object of vulcanite and wire seems to inspire an unholy fear in the heart of the would-be radio star. The reason for this could be better explained by a psychologist than by myself, but it seems extraordinary that even actors and actresses of world-wide repute should be amongst those who develop a decided inferiority complex in the studio.

The Prince a Natural Broadcaster

Of course, there are exceptions. Of these the Prince of Wales and Bernard Shaw are the most notable. Although they address the microphone in entirely different styles, both have grasped the fundamental secret of success in broadcasting—that of treating "Mr. Mike" as a human being and not merely as an inanimate chunk of wireless apparatus.

The Prince is a natural broadcaster. He speaks evenly and clearly, shows no trace of nerves, and his easy manner of address enables his whole personality, and the very spirit of his speech to "get over." He does not shout or declaim, but is anxious to impress on the microphone that he has come to talk very serious business with an equally serious audience.

Those who have heard the Prince's wireless speeches—and who has not?—must have been impressed by the fact that listening to him is a delightfully easy task. That is the acid test of a broadcasting artist. The Prince would make a splendid announcer.

G. B. S. Sure of Success

Bernard Shaw is one of the best wireless speakers, amateur or professional, in the world to-day. Even in broadcasting a serious speech he seems ready to poke fun at the microphone. His eyes twinkle with Shavian humour, and his manner is that of an elderly uncle chiding



Miss Lilian Harrison (above) is one of the most polished broadcasters, and has studied every mood and mannerism of the microphone, while Mr. Ramsay Macdonald has a naturalness that makes him always popular over the ether. To the right we see Sir Alfred Yarrow, for whom "Mike" has no terrors, however stony may be his silence.



Mannerisms

Microphone Fright is a malady that strikes at many broadcasters, and has been known completely to paralyse the tongues even of those most used to public speaking. This most interesting article deals with the way in which some of our best-known broadcasters face a "Mike," that solemn "poker-faced" sentinel who terrifies by his very silence.

a fractious schoolboy. The microphone enters eagerly into the spirit of quiet humour which prevails, and responds to Shaw's mood in a manner which, on the first occasion, astonished even the blasé experts of Savoy Hill.

Shaw is supremely confident of himself in the studio. He knows that he will be a success; he knows that thousands of listeners are waiting on his words, and is determined not to disappoint them. There is nothing forced or unnatural about his speeches. An unnatural Shaw would not be Shaw at all. Indeed, it is difficult to visualise any circumstances which could upset the equanimity and good humour of the great G. B. S. Perhaps that is the secret of his success.

Why Politicians Fail

Politicians as a rule do not make good broadcasters. The platform style is entirely unsuited to the studio, and it is for this reason that so many politicians who make wireless speeches are put down as rank bad speakers.

The Prime Minister has been good "over the ether," but Winston Churchill, wonderful orator though we know him to be, was not the success that was anticipated. On the other hand, Neville Chamberlain provided a pleasant surprise for the broadcasting authorities. The force of his strong personality was immediately "sensed" by the "mike," and transported into thousands of English homes. Mr. Chamberlain speaks quietly and confidently, as though addressing an old and valued friend. That is the attitude the microphone likes best.



Mr. Winston Churchill loses a great deal of his force when speaking over the ether, due no doubt to the fact that his audience is invisible.

The Prince of Wales is a natural broadcaster, and his easy manner of address enables his whole personality to "get over." Clapham and Dwyer invariably bring their mascot "Cissie" to the studio to help them in their quips and jests.

Helena Millais has the Perfect Radio Style

Sir Alfred Yarrow, the shipbuilder, was at home from the first minute he entered the studio. He removed his coat (not the first time a well-known personality has broadcast in shirt sleeves, by the way), seated himself



Tommy Handley and Helena Millais, two regular favourites.

comfortably, and poured himself some water from the bottle on the table before him. Between the sentences of his eighty-year life story he took an occasional drink, and he soon had the microphone in sympathy with the warm and friendly air which he extended.

The Regular Artists

All the regular radio artists are good broadcasters, but many of them are by no means ideal. Constant appearance before the "meat-safe" (as the microphone is affectionately called at Savoy Hill) is bound to produce a finished technique, and it is small wonder that the popular favourites have the best radio voices.

The profound silence of the studio and the sphinx-like imperturbability of the microphone make the first broadcast an ordeal that is not easily gone through. Many a well-known actor or actress has confessed to "fright" of the severest kind when faced with the uncanny procedure of being broadcast. It will be remembered that one well-known actress was completely overcome during the appeal that she was making from 2 L O one Sunday evening.

It has been said that all good actors and actresses are nervous before they perform, no matter whether they have been on the stage for six months or a lifetime. The same rule applies to wireless artists. Tommy Handley, who by this time may be considered one of the old school, confesses to a mild attack of nerves every time he appears before the microphone. It is interesting to note that Mr. Handley thinks out most of his ideas in the bath, and that he always rehearses his spoof lectures before a home-made "meat-safe" in the privacy of his home. This gives him the right manner when it comes to addressing "Mr. Mike" in person.

The Perfect Style

Helena Millais has the perfect radio style. When she is "putting across" one of her "Lizzie" talks she

addresses the microphone as one dear old Cockney lady to another. One can see many "Lizzies" in the Old Kent Road on a Saturday night; in the studio there is only one. But so appealing and intimate is Miss Millais when broadcasting that one almost expects the microphone pertly to reply, "Yus, dearie!"

Incredible as it may seem, Clapham and Dwyer, the most noted of wireless cross-talkers we have had so far, never enter the studio unless accompanied by "Cissie," their equally famous cow. Indeed, I believe "Cissie" is as necessary for the success of the performance as either of the two comedians! Needless to say, no life-size heifer is admitted to the studio, but a small wooden model on wheels, which occupies a proud position on the edge of the "meat-safe" during the turn. It would be difficult to say whether Clapham and Dwyer address their inane remarks to the microphone or to "Cissie," but whichever course they adopt there can be no doubt that the small model gives them added inspiration.

"Mike's" Dearest Friend

Lilian Harrison, the famous wireless "actress," is the most polished broadcaster we have at the present time. She has become a wireless specialist, and has studied every mood and mannerism of the microphone. She knows just what it will "take," what causes it to "blare," and what it will refuse. To her the "meat-safe" is a child which needs a careful and studied nursing. What the "mike" thinks of Miss Harrison we shall never know, but I am willing to wager that if it could speak it would point her out as its dearest and most understanding friend!



Mr. Bernard Shaw is so confident of his success that two or even a studio full of "mikes" could never daunt him.



Ekco Mains Units—Wates' Star Loud Speaker—Varley Nicore L.F. Transformer—Benjamin Battery Switch—New W.B. Cone Speaker—Climax Radio Earths, etc., etc.

Ekco Mains Units

IN a letter they recently circulated to the trade, Messrs. E. K. Cole, Ltd., stated that they are acquiring ten acres of land on which will be built by March one of the finest modern factories for the mass production of Ekco electric radio receivers and power supply units.

Wates' Star Loud Speaker

A month or two ago we reviewed on this page the Wates' Star Duplex loud-speaker unit. It is interesting to note that this is now available embodied in a complete cabinet loud speaker. This special loud speaker, a product of the Shaftesbury Radio Company, Ltd., also includes the Wates double-cone chassis. The two cones, which are of unequal sizes, are mounted back to back with very good effect.

The cabinet is a handsome well-made affair, and some idea of its appearance is given by the accompanying photograph. Probably due to its special cone construction, and the skilfully disposed apertures at

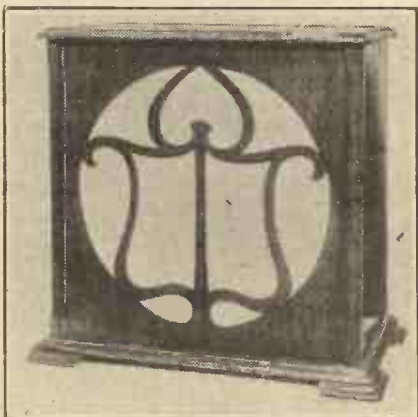

This is the Star loud speaker.

the back, this loud speaker is completely free from those boomy, box effects which mar some otherwise quite good instruments.

Speech, which is a crucial test for such a speaker, comes away crisply and clear, and with no trace of plumminess. The high notes are

Manufacturers and Traders are invited to submit for test purposes radio sets, components and accessories to the "Modern Wireless" Test Room at Tallis House, Tallis Street, London, E.C.4. Under the personal supervision of the Technical Editor all tests and examinations are carried out with the strictest impartiality. Readers can accept the Test Room reports published monthly under the above heading as reliable guides as to the merits and demerits of the various modern productions of the radio industry.

particularly good, and the violin sounds like a violin and not like a flute, and there is quite a fair proportion of bass.

It is a loud speaker "M.W." enthusiasts should hear, and after having heard it and remembering that the price is only £4, we are sure they will consider it as good a proposition as do we.

Varley Nicore L.F. Transformer

The Varley Nicore L.F. transformer is modelled on entirely modern lines. Moreover, it is built by people who are specialists at this sort of job. As its name indicates, the core is composed of a nickel-iron alloy. This material has a very high order of permeability, and this is the secret of the device's compact construction.

A special arrangement of windings

further contributes toward the very great efficiency achieved.

We have recently had the Nicore I, which is the senior model, on test. Used with shunt H.T. as an ordinary L.F. intervalve coupler remarkably even amplification is obtained. Between 40 and 5,000 cycles there is no appreciable falling-off at either end. If only we had a loud speaker that had an equally good response curve it would not be so difficult to achieve the perfect realism that is our ideal.

However, by using components such as the Varley Nicore I one can go a long way towards results that are above normal criticism.

Lotus Components

The new catalogue of Lotus components issued by Garnett, Whiteley &

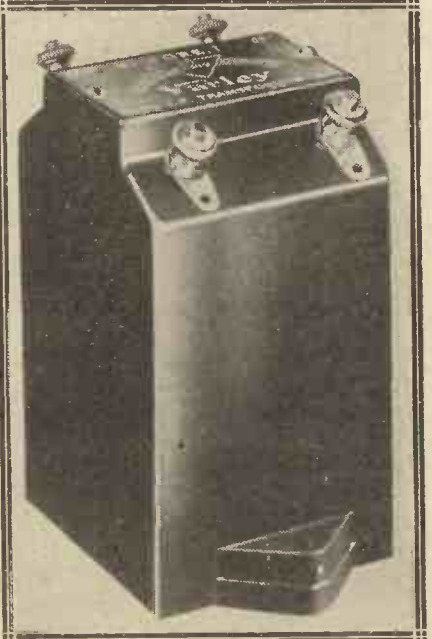

The Varley Nicore I L.F. transformer.

Co., Ltd., contains full details of the famous remote-control outfit, the Lotus all-mains unit, the Lotus L.F. power choke and H.F. choke, and other attractive and most useful productions.

Benjamin Battery Switch

The great attraction of the Benjamin battery switch is that it enables you to see at a glance whether the set is on or off. It is of a rotary type, and there is a nice knob and pointer which throws over between the plain markings "on" and "off" on a scale plate. The action of the switch is most definite; you go over with a click.

Point No. 2 in connection with this new switch is that it is a one-hole panel-mounting device, while a further advantage is that the spindle and mounting screws are completely isolated from the "live" parts of the device.

The price of this switch is 1s. 9d., which would seem to us to be remarkably reasonable because it is a high-class production. For instance, the terminals, though small, are provided with long screws, and they fit closely and not loosely, as is too often the case. It is decidedly the switch for a household set.

New W.B. Cone Speaker

In at least one way the new W.B. cone speaker, a production of Whiteley, Boneham & Co., Ltd., is unique. It is built into a bakelite casing which is one of the finest examples of bakelite moulding we have come across. We are quite mystified as to how it can be included in an instrument which retails at no more than two guineas. It is by no means a wafer moulding, but is really substantial, and there is adequate material throughout, while

the general design and finish are fine.

The instrument looks good from any angle. It is as clean in appearance from the back as from the front. The cone is gilt, and the symmetrical apertures at the back are covered with gilt meshing. An adjustable unit is employed, and the cone is semi-free-edge mounted.

On test the speaker gave good

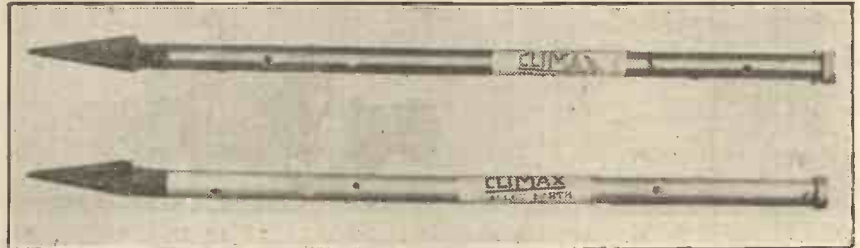

The two Climax Radio Earths described on this page.

results. It does not sound cheap any more than it looks cheap. Its response is, indeed, excellent for an instrument of its price. "M.W." readers would be well advised to search out, examine, and, if possible, listen to this new W.B. cone speaker.

The W.B. cone chassis is primarily designed for use with a W.B. balanced-armature cone unit, although it will fit any other unit on the market.

A special feature of this device is that it incorporates a stand so that, having fitted a unit to it, you have an instrument ready for use.

The chassis consists of a five-ply wood frame and a cone made of special process paper. Kid leather is employed to hold the cone to the frame. The stand is made of polished aluminium. The price of the assembly is 10s. 6d.

Climax Radio Earths

In these days of very efficient sets, sets in which every valve pulls its

weight, the aerial and earth equipment is apt to be neglected, but while there may be something to be said for an inefficient aerial (although very little!), there is this to remember in connection with the earth: an efficient earth is essential for adequate protection against lightning. If you try to use a bad earth for this all your trouble may be wasted.

A low-resistance, direct earth is what is needed. A very easy way to get this is to use a Climax Radio Earth. This is an earth tube of special construction. It is a product of people who are specialists in aerial and earth equipment. It is about three feet long and it has an armoured point which facilitates the task of driving it into the ground.

It is hollow, and holes are pierced in it so that water poured on from above percolates into the ground in its immediate vicinity. This is a simple way of ensuring that an efficient contact is achieved in dry weather. A screw for fixing the earth lead is provided at the top. The Climax copper earth retails at 5s. This is a model "for the connoisseur." "For the economist" there is the Climax Galloy earth at 2s. 6d.

C.A.V. Publications

We have also received copies of the latest radio accumulator catalogue published by C. A. Vandervell, Ltd., together with a folder dealing with an entirely new range of H.T. accumulators, and one describing the new jelly acid non-spillable accumulators. Copies of these are available to readers on application.

M.P.A. Wireless

We have also received a copy of an illustrated leaflet describing the new season's products of M.P.A. Wireless, Ltd. These include fine all-electric sets, and radio-gramophone outfits.

Igranic Publications

Recent Igranic publications include leaflets describing Igranic-Elkon Metallic Rectifiers, and the Igranic Neutrosomic Seven, which is a really noble long-distance receiver.

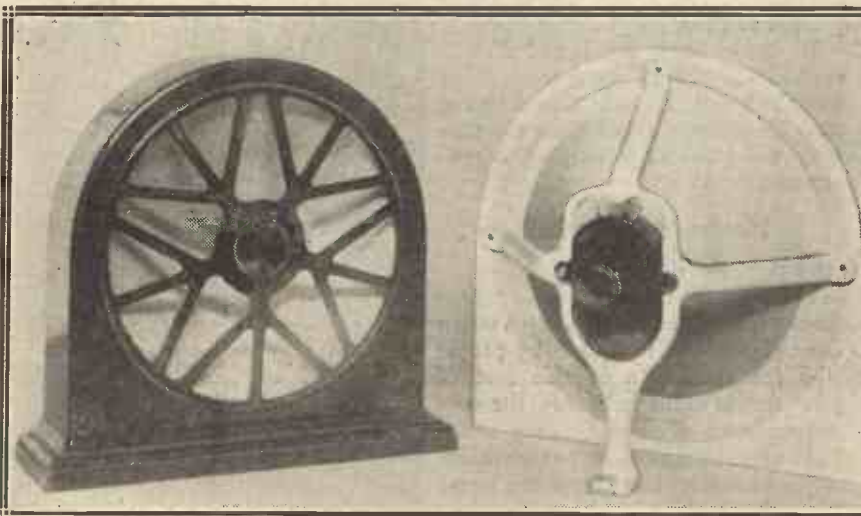

On the left is the new W.B. loud speaker, and on the right the W.B. chassis.

*It's like bringing into
the room the massed
orchestra —*

that was
previously
playing in
the distance

When you put this new Lissen Power Pentode Valve into any set with one stage only of L.F. amplification, what was previously a whisper becomes a great volume of sound. Yet this new Lissen Valve is battery driven—it takes only 7 milli-amps of current, and your existing batteries are therefore all it requires, and they will last you just as long as with ordinary valves. Put this new Lissen Power Pentode Valve into any set with one stage of L.F. amplification and the increase in volume will surprise you. You will get very big volume from your local station and fine loud-speaker strength from distant stations previously heard only on headphones. Ask for Lissen Power Pentode—the only Power Pentode Valve you can drive off batteries—and learn the difference this new valve makes to your set.

FOR ANY
SET WITH
ONE L.F.
STAGE USE

**LISSEN'S NEW
POWER
PENTODE**
THAT WORKS OFF
BATTERIES

2-VOLT
P. T. 17/6
225

OTHER TYPES
AND PRICES:

H.210—R.C. and
H.F. 10/6.
H.L.210—H.F. &
Detector 10/6.
L.210—L.F. Ampli-
fier 1st Stage
10/6.

P.220.—Power
Valve 12/6. All
other types
available shortly.

LISSEN LIMITED,

Worples Road, Isleworth, Middlesex.
(Managing Director: T. N. Cole).

Factories also at Richmond (Surrey)
and Edmonton.

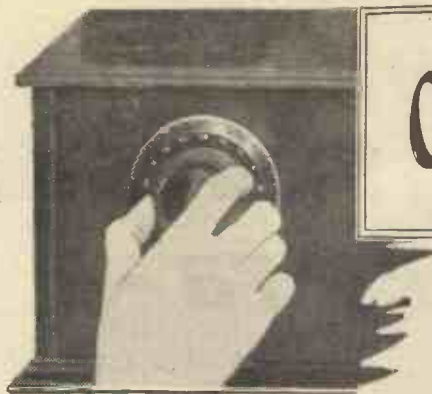

On the Short Waves

Short-wave enthusiasts will find the practical details concerning short-wave receivers given in this article extremely useful.

By W. L. S.

I AM afraid that the promised article on "Short-Wave Reaction Control" has, due to some important experiments, had to be postponed till next month. Meanwhile, however, there are sufficient points requiring explanation to fill the whole of this number!

Oscillation Difficulties

A large group of readers appears to be afflicted with the same trouble, namely, that they cannot make their receivers oscillate at all below about 30 metres. This is, of course, a trouble that might be due to "57 varieties" of faults in the receivers, and one that is quite impossible to diagnose with much certainty. Perhaps, however, a few general remarks on the subject will prove useful to the unfortunate ones.

First in order of importance is the way in which the general wiring of the set is carried out. Considerable thought should be given first of all to the layout of the components; they should be placed in such a way that the wiring, and particularly that of the grid and anode circuits of the detector, is all as short as possible.

Keep the grid condenser and leak right up against the grid terminal of the valve holder, and see that the lead from the far side of the grid condenser which goes to the coil and the tuning condenser is also as short as you can possibly make it.

Direct Wiring

Likewise take the lead from the other side of the coil and the tuning condenser straight to the correct filament terminal on the valve holder, and not merely to the nearest point of the wiring which appears to go to filament or earth.

Take the anode lead as directly as you can to the "live" end of the reaction coil, and the other side of the coil to the H.F. choke, L.F. transformer primary, reaction condenser, or whatever it is connected to, according to the type of circuit used.

If possible, mount the coils half an inch or so above the baseboard, and do not, unless for some particular reason, wind them on any kind of solid dielectric.

Practically all the commercially-made short-wave coils are exceedingly efficient, and even the standard plug and socket mounting does not have any appreciable effect upon the minimum wave-length to which one can tune.

The biggest "don't" of all is—Don't expect to tune in signals on 20 metres with a tuning condenser of .0005 capacity! It takes a superman to do it with a .0003 condenser, and, personally, I find a .0001 far too big to use with real convenience, although

coupled to the set. There is no reason whatever why you should not use a large outside aerial, but it will have to be very loosely coupled.

Probably the most convenient method is to attach it to the top of the detector grid coil, through a very small variable condenser. A neutralising condenser of the baseboard-mounting type is one of the most useful, and will generally have to be set about one-third in for work on 20 metres or so.

Reaction Coil Size

If you use inductive coupling, use a three- or four-turn coil and keep the coupling between this and the grid coil very loose.

*
A view of one of the giant arc transmitters at "Radio Malabar," which is situated in the Dutch East Indies. This station, which employs a maximum power of 2,400 kw., is employed for European services.
*

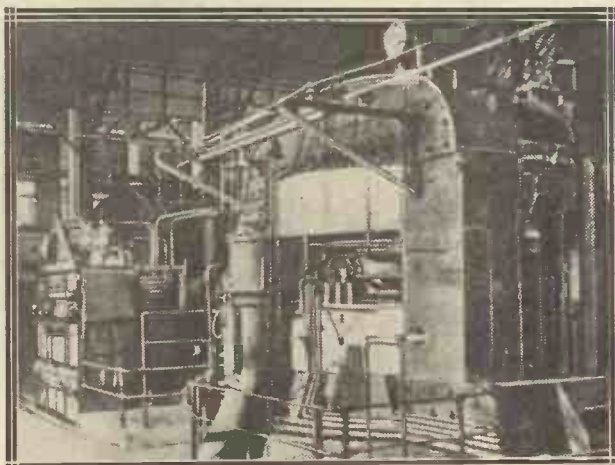

I imagine I am fairly well used to the handling of short-wavers by now.

As a compromise, however, the typical .0001 short-wave condenser sold nowadays, with a really good slow-motion dial, is perfectly satisfactory, and will tune over a reasonable range without changing coils.

Type of Aerial

Another factor, of course, which enters into the question of how low one can receive is the type of aerial used and the way in which it is

Yet another point is this: Don't use too large a reaction coil, or results will probably be just as unsatisfactory as with too small a coil. With a four-turn grid coil a four-turn reaction coil should normally be about right, but six turns should be quite satisfactory.

Don't expect much in the way of results, however, with four turns and fifteen turns, a combination that I once found to be the cause of much worry and anxiety that was soon ended by the provision of a smaller reaction winding.

Support the Set Above the Table

While on the subject of reaction coils it is as well to mention H.F. chokes. Where possible I believe in using series feed for short-wavers; that is to say, the H.T. is applied to the detector plate through the transformer primary, the H.F. choke (if any) and the reaction coil.

The efficiency of the H.F. choke is not then a matter of any importance.

THE TAPERING—

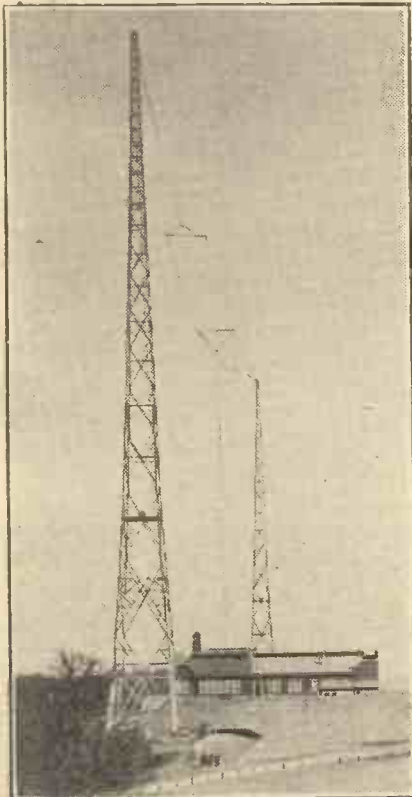

Langenberg's aerial is held by two masts of the self-supporting type, which are smaller at the top than at the foot.

In a shunt-fed circuit one needs only a defective or unsuitable H.F. choke and all sorts of troubles can set in.

Frequent Source of Trouble

With series feed this component does nothing but affect the reaction control, and, generally speaking, is unnecessary except when the transformer has a condenser across the primary incorporated, or when the self-capacity of the primary winding is very great.

Valves, of course, are a source of much trouble in short-wavers, particularly when old or unsuitable types are used. I really do not think it would ever have been possible to get

much below 70 metres or so with the old "R" type valves—I remember in my own early days what a hero a certain amateur transmitter seemed to me when he told someone that he was getting down to 75 metres with a receiver using ordinary plug-in coils without any modifications!

Suitable Valves

If things had been pushed ahead five years and someone had spoken of receiving 10-metre signals with plug-in coils there would have been some real excitement abroad!

A valve of the "H.L." type generally makes an excellent detector; this includes the Mazda and Marconi or Osram H.L. 210, 410 and 610; the Cossor H.F. and detector in similar types; and the Mullard P.M.2D.X., P.M.4D.X. and P.M.6D.

The P.M.3 and P.M.5X. are also eminently suitable.

With these types that I have outlined it is immaterial whether the detector is resistance or transformer coupled to the following valve. The choice of valves for the note-mags. is not a matter of any more importance than in the case of a normal broadcast receiver.

Interesting Refinements

And now regarding some smaller refinements that I have found worth while. Where possible set the coils well back from the panel, likewise the valves, and, of course, earth the moving plates of the condensers.

If possible use some scheme of reaction control that will allow the moving plates of the reaction condenser also to be earthed. Then everything in the way of wiring that is at all near the front panel will be earthed, and there will be no trouble with shifting signals on account of hand-capacity effects, and no need to resort to "broom-handle" tuning.

If convenient, support the receiver an inch or so above the table or bench, either by means of valve boxes (the simplest method!) or on small rubber feet such as are available from several firms.

Novel Vernier Tuning

It appears to be advisable to keep the H.T. as close to the set as possible, but to put the L.T. on the floor, provided that this does not entail the use of unreasonably long leads.

Incidentally, if you are one of the unfortunates that have perpetual trouble on account of a very long earth lead, very fine vernier tuning may sometimes be accomplished by slithering the feet to and from the accumulator, over the floor!

This method of fine tuning for short waves was first recommended in "Q.S.T." during 1923, and can be taken perfectly seriously.

It will very often be found that where only a long or high-resistance earth lead is possible it will be better to do without an earth altogether.

In no case does it appear to have any appreciable effect upon signal strength, but sometimes hand-capacity troubles that are experienced with an earth will disappear entirely when it is removed.

—AND THE STRAIGHT

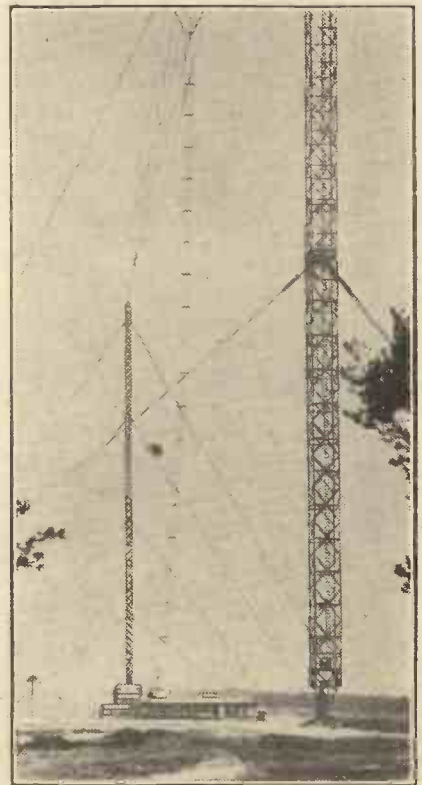

The aerial at Königswusterhausen employs straight masts which taper at the bottom and are held steady by numerous steel stays, as shown in this illustration.

Although a short-wave set is often curiously immune from atmospheric disturbances that may be troublesome on the long waves, any tendency to hum which is found on the ordinary broadcast receiver will probably be emphasised if short-wave reception is attempted with it.



FIFTY-NINE gallons of beer are consumed daily, exclusive of that put away by the management; or 0.9 fluid ounce per set, or 0.16 cubic centimetre per valve." This is a Stark Fact. Kindly take a good look at it so that you may recognise another like it.

Someone in authority came briskly into my room, wearing that offensively *alive* look characteristic of Smellmanism victims. You know! They wear business-like collars, rub their hands together and say: "We must alter all this," or equally offensive words.

More Stark Facts

A Business Expert was found battered to death in King's Road, Chelsea. (*Stark Fact.*)

Now this man told me that there was going to be an alteration. "Good lawks," I said, "have I got to shift my desk again?"



While he was waiting in the bathing queue.

"Oh, no! It's about these articles of yours. We want a New Outlook and a Different Angle. The January stuff can pass, because I know you wrote it in August while you were in the bathing-hut queue at Southendon-etcetera. But from now onward you have got to drop all this gentle

Jane stuff and get out into the Great Teeming World and make Contact with Stark Facts."

"Oh, quite."
"And another thing. Not so much meandering about before you get to the point. Begin your piece with a man-sized fact and plunge right into the subject. We want Vivid Portraiture—er—"

"Gripping Realism, doubtless," I suggested.

"*Ex-actly!* And—er—"
"Frightfully Naked Truth?"
"That's so! And Living Contact! You get the idea? Well, open up with a visit to Punglow and Quilper's factory."

That, gentlemen, is the reason why I began this piece with a Stark Fact, plunging right in without so much as a "By your leave!"

Really Modern Factory

The Modern Factory of Messieurs Punglow et Quilper (Proprietor: I. Steinburg), makers of the well-advertised "Harktuit" radio receivers, covers the deuce knows how many acres of Essex, cuts off most of the light from the village school and poisons most of the surrounding air and water with by-products. Stop me if I become too *Sterk*.

This Hive of Industry has four 800 feet chimney stacks, 1,000 "hands," a Costing Expert, a Pension Fund, a comic Foreman, a "hooter," a hospital and a safe. And one large Steinburg.

In a word, it is a Model Factory. I forgot to include one smaller Steinburg (P. & Q. type), known as "the Young Guv," who flits about the place like a dancing sunbeam in case any "hand" should momentarily lose interest in its job. Everybody loves Master Julius; he has such sharp, black eyes; yes, no?

Just inside the main entrance I found a large cupboard (with a glass front) containing a Field-Marshal who appeared to have a ribbon for every campaign except, possibly, Cæsar's little flop with the Belges. This caged Napoleon put down his spectacles upon his weathered neb, and inquired my business.

The name of a certain magazine made him "sit up," so he had evidently been well prepared by Mithter Juliuth. In two minutes I was in the fond clutches of the Works Manager and began my tour.

A Brief Biography

Stark facts: Works Manager, Geo. P. Lark. Bald and plays table-tennis. Formerly with B.S.A. Drooping moustache and permanently bagged trousers. Has an aunt named Mish, who once called for the station-master at Euston and told him his clock was fast. Vice-Pres. of R.M.A.P.Q.F.Z. Founder of "The Royal Society of Rixford Radio Scientists." Inventor of the Lark Low-loss Overtime Calculator.



In the fond clutches of the Works Manager.

The basement was mainly devoted to the clerical staff, which was arranged in neat rows and rustled papers assiduously. "In that room," said Mr. Lark, indicating a small sentry-box made of matchboarding, "is our Mathematician."

"Works out the discounts, I suppose?"

How Things Are Done

"Oh, no!" he replied in a hushed voice. "Mr. Julius does that in consultation with Mr. McBean, the Accountant. The Mathematician is responsible for each season's curves. No doubt you will recall our recent success, 'Has your Choke the P.Q. Line of Beauty?' Or last year's sensation, 'The transformer curve which inspired Epstein?' He is now working out a curve for cheese-headed screws, to fit our new slogan, 'Rigidity means Right Radio. Get the P.Q. Non-creaking Cabinet.'" "But how—" I began.

Facts, Stark Facts and Nothing but Facts!

Mr. Lark continued. "For the technical papers we are calculating a curve showing that the P.Q. Lead-in Insulator has a resistance five times greater than infinity, because the ohms are put in doubled up and brazed together. So far this curve is shaping excellently, but the Algebra to accompany it has come out rather sticky and we are re-boiling it with 2 per cent more *xy*. Now, before we proceed, just come here."

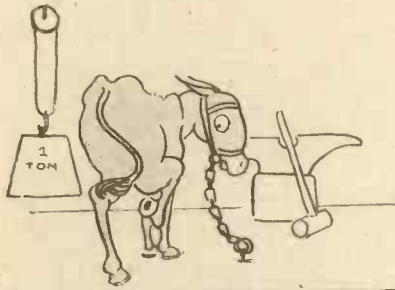

"A large Spanish mule."

Mr. Lark led me to a large room stacked with valves. Arranged down the middle line of the floor were certain objects which seemed to me to be irrelevant to the business. A large Spanish mule, for instance; an anvil, a ton weight hanging from a chain and pulley, a small steam-hammer, and electric furnace and so on.

Valve "Resistance" Tests

"Here we have the Valve Resistance Test Room," said Mr. Lark. "All P.Q. valves have to pass through our special durability trials. I expect you remember our front page ad. in the 'Daily Leader' last week. 'Kicked Twice by a Mule Yet Carries On.' Ah! there's one gone West. See that valve? It couldn't stand up to a rifle bullet! *Must have had a flaw!*"

"You will be interested to know that in the season we hire Huddersfield full-backs and make 'em shoot goals with our valves. And we are negotiating for the privilege of putting one of our new models—an S.G.—inside the ball to be used during the Cup-tie match."

Stark Facts: A "P.Q." Green Pip All-Purpose Valve was trodden on by the head elephant during a Durbar in Rajpipla. The elephant got the pip, but the valve now works better than ever.

Ascending to the ground floor, we came into a large machine-shop full of whirling wheels and honest artisans

all busily employed in the manufacture of brass filings, steel and copper turnings, ebonite chips and sawdust; the odd pieces of materials left over from this industry were turned into components.

As we passed along the ranks Mr. Lark dropped a kindly word of praise or encouragement here and there. "Hallo, Snootles, you here again? How that blind idgit of a foreman allowed an awkward, malingering, brass-waster like you to sneak back here beats me." Or, "Ha! Bunster, if you aren't the goat's bath-salts! Trying to do deep-breathing in the firm's time, are you? Fined a bob!"

Or, "Now, Willie Ramsbottomley, how many times am I to tell you not to fill up holes in panels with good glue? If you bore 'em wrong go and tell Mr. Julius and he will give you a chunk of used chewing-gum from the office."

Some Set Assembly

In an adjoining room stood rows of girls who were assembling sets so fast that they looked as if they were playing the piano. The first girl in the far corner was dealing baseboards on to a moving band with a facility equalled only by a commercial traveller dealing cards to a prospective victim of poker.

As the boards slid along, each wench jabbed a piece of radio receiver on to them and the completed layouts passed through a hole in the wall into the soldering shop. Here an army of ex-tinkers brandished their bolts; the atmosphere reeked of burning flux, molten solder ran like wine at a wedding-feast, and high up on a step-ladder sat an ex-R.B.C. announcer reading aloud "Hints on Soldering."

A Novel Scheme

"Just observe this little arrangement," said Mr. Lark. "You will see that the floor is not level. From each wall it slopes towards the centre. Now come here."

Then I noticed that in the centre of the floor there was a hole through which myriads of little balls of solder were tumbling, after having rolled off the benches.

"Under the hole," said Mr. Lark, "is a big cauldron. We melt the solder again, cast it into rods and up they come by this little conveyor. Isn't it beautiful?"

We then followed the completed sets up to the first floor and saw them being tested. The din was appalling, for two hundred loud speakers were in action.

"No instrument is passed unless it gets 2 L O loudly enough to shoot a bung out of the loud speaker," explained Mr. Lark.

Small boys nipped about in all directions, picking up and replacing the bungs as they hurtled from the horns.

"If a bung hits the opposite wall," said Mr. Lark, "the man who soldered the set gets a cigar. Last month a bung, operated by one of our 'Special Superman Musicmakers,' stunned a Welfare Worker." (Stark fact.)

"Hearing" the Output

After testing, the sets are run on a moving band into the packing shed, and as each one lands there it rings a bell in the Young Guv's private room. Mr. Julius loves to sit there and listen to the music. He has invented a device by means of which bells of various tones are rung by the sets as they fall on to the packing benches. One ring equals a case of champagne. A carillon equals a pair of new motor-car tyres. 'The Blue Bells of Scotland' means that enough profit has been made for a month at Cannes.

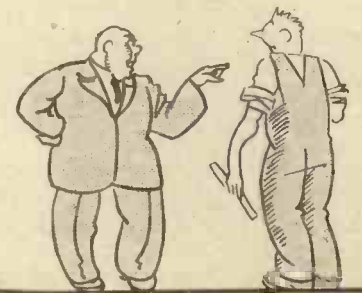

"Well, if you aren't the goat's bath-salts!"

On the top floor are the Rest Room and Canteen. These were full of lady typists—doubtless conveyed thereto on a moving band—and gave me an impression as of a bottle of scent spilt in the cockatoo house at the Zoo.

As we clumped downstairs Mr. Lark said:

"Fifty-nine gallons of beer are——"

"What!" I replied. "Not those girls?"

"Good lor, no!" he answered. "I was talking about the 'King's Arms' over the road."

It was fifty-nine and a quarter that day.

TELEVISION IN 1930?

When will the public be given a chance to judge the practicability of Television in its present state of development? Up to now no televisors have been placed on the market and the man-in-the-street is still completely in the dark as to the results of the B.B.C. tests.

IN our last issue of MODERN WIRELESS we referred to a communication we had received from a Mr. W. Barrie Abbott, who has recently come into public notice as a champion of television, and particularly the television system designed by Mr. Baird.

In his last letter, Mr. Abbott assumed that we were prejudiced in favour of German television, and that we had adverse opinions concerning British television.

Unmerited Enthusiasm

Now, rightly or wrongly, we have always assumed that our readers do not wish us to "lead them up the garden" by writing and describing in a high-falutin' manner any wireless invention purely because it is a British wireless invention.

Take an example. If somebody of British origin came forward and, with a good deal of propaganda in the Press and a good deal of advertisement generally, stated that he had written a Symphony for a large orchestra which left all other Symphonies—including those by Beethoven and Mozart—stone cold, should we be justified in acclaiming the composer of that Symphony as a heaven-born genius, as the sole inventor of Symphonies, and a lot of other things besides, just because he was of British nationality?

We venture to think that our readers are far too intelligent to agree with that sort of propaganda, which is really the worst kind of patriotism there is.

Up to Mr. Baird

Now, for all we know, Mr. Baird is a heaven-sent genius; but we do definitely know this—that he is not the sole inventor of television. He is the inventor of one particular television system, which may or may not be the best television system. It is up to Mr. Baird to prove to the general public that his system is the best system.

For some time past now he has been given facilities by the B.B.C. to conduct television experiments, but so far—at the moment of writing

—we are not aware of any member of the public who has been able to purchase a television receiver and thus to decide for himself whether the system of television devised by Mr. Baird may be regarded as worthy of all the laudatory accounts of it which he has heard.

The fact is that some propagandists often do their heroes more harm than good; and we are very sorry that Mr. Baird has allowed some of his well-meaning friends to overdo this business of acclaiming him and his television system in the way they have.

Let it be quite clear that we our-

the facts will acclaim Mr. Baird as the sole inventor of television, and we maintain that it is still a matter to be proved whether Mr. Baird's system is better than anybody else's.

And even if it is better than anybody else's, it has to be proved whether that degree of superiority entitles it to be regarded as a system which would justify the B.B.C. including it as a regular broadcast feature.

Will Television Appeal?

There is the unknown factor of how the public will respond. Mr. Baird's system can be judged in two ways—on its scientific merits, and on its merits as regards public appeal. That is to say, although scientifically his system may or may not be good, it may have, on the other hand, strong elements of fascination for the public.

For all we know, listeners may be quite satisfied with seeing a very small image not giving a great deal of detail, and certainly not comparable to an early cinematograph film. That is where the unknown element

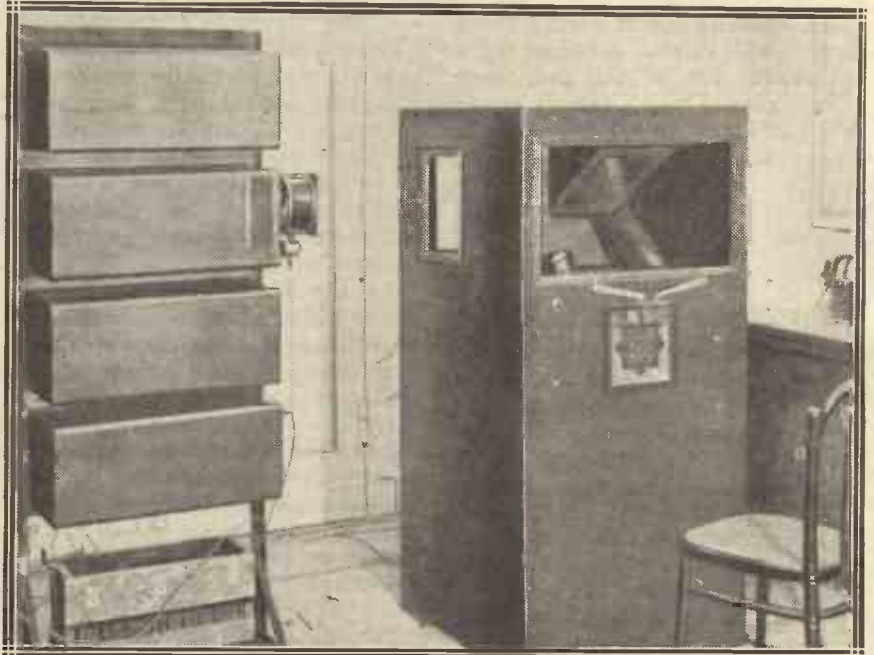

Compact television transmitting apparatus designed by Mihaly, the continental experimenter

selves have very great respect and admiration for the work done by Mr. Baird. We know him and we are acquainted with his work. We are also acquainted with the opinions of the greatest scientists in this country, and other countries concerning his work, and we know that, with every justification, his experimental research work has entitled him to be regarded as a *bona fide* experimenter who has done very meritorious work.

But nobody with any knowledge of

of popular appeal comes in. The Fultograph Picture System was extremely efficient technically, but it did not "catch on" with the public. Television might. If it does, congratulations to Mr. Baird. If it doesn't, then he must go on doing his best to improve his system.

If, as we believe, his system has definite limits, then he must invent another one—or if he can't, somebody else will; if not to-day, to-morrow;

(Continued on page 210.)

The BETTER SERVICE BATTERIES

They're BRITISH



Super Quality Only

Get an Ediswan H.T. battery and note the silent background—the perfect reception. It will give you good service, too — your Ediswan battery—and it will still be going strong long after another battery would have been relegated to the dust bin.

- W.L. 204P. 66v. 9/6.
- W.L. 205P. 66v. 17/6.
- W.L. 208P. 103v. 15/6.

IF IT'S **EDISWAN** IT'S BETTER

THE EDISON SWAN ELECTRIC CO., LTD.,
123/5, Queen Victoria Street, London, E.C.4.
Showrooms in all the Principal Towns. B.54.

a record achievement

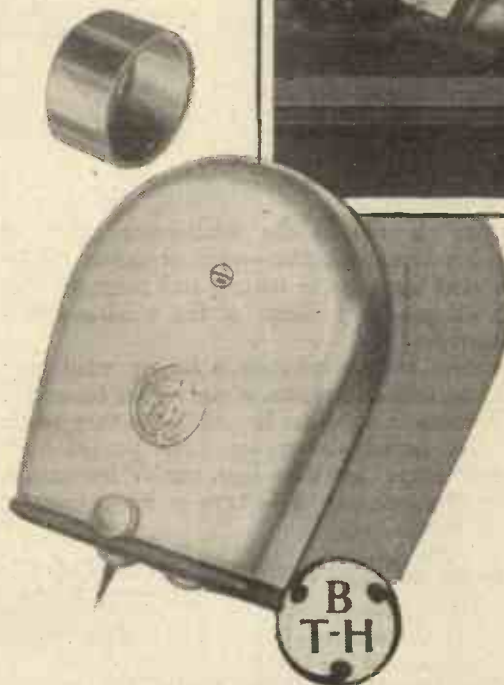

GRAMOPHONE PICK-UP

WITH ADAPTOR FOR COLUMBIA, H.M.V. AND OTHER STANDARD TONE ARMS.

An entirely new instrument designed to give the best possible output with a minimum of record wear—is very sensitive and renders perfect reproduction over a wide range of musical frequencies—ask for special catalogue which gives full particulars and circuit arrangements.

PRICE **27/6** COMPLETE



THE EDISON SWAN ELECTRIC CO., LTD.,
Radio Division,
1a, Newman Street, Oxford Street, W.1.
Branches in all the Principal Towns.

EDISWAN W.29

WIRELESS - AND SOME MAGNETIC MYSTERIES

The peculiar magnetic properties possessed by the earth are discussed in this fascinating article which brings to light many interesting but generally unknown facts.

By G. H. DALY.



MAGNETISM is one of the fundamental parts of wireless communication—wireless waves are 50 per cent magnetic in nature, and magnetism is embodied in almost every circuit of the wireless transmitter and receiver.

The magnetism used in wireless is largely what may be termed of an artificial nature, of natural or terrestrial magnetism wireless in the past has not been very much concerned. Yet recent discoveries have proved that terrestrial magnetism has also considerable connection with wireless phenomenon. This type of magnetism, in fact, is mixed up with such widely diversified subjects as wireless echoes, sunspots, the aurora, ionised layers, the condition of the atmosphere and the theory of the movements of continents, to mention a few.

Curious Facts

Why should the earth be magnetised? What is the reason for the magnetic field which causes the compass needle to point almost invariably to the magnetic pole? It is a complete mystery which has been puzzling men all through the ages, but we are gradually drawing nearer the solution of these problems as some recent investigations tend to show.

There are many curious facts concerning magnetism; sunspots, for instance, cause magnetic storms on the earth, yet the magnetism of the sun has no connection with the earth's magnetism. The magnetic field of the sun does not extend beyond the

sun's atmosphere, and although the earth's magnetic field extends for many thousands of miles beyond the earth's atmosphere, the two fields are separated clearly by many millions of miles of nothingness in empty space.

Then, again, we can discover no trace of magnetism on the moon or any of the other planets; for all we know, magnetism may be the prerogative of the earth and sun. These other bodies may possess magnetism, but as yet we can find no trace.

If the earth's magnetic field does not come from outside the earth it must come from the inside, and we may ask

DO SUNSPOTS AFFECT RADIO?

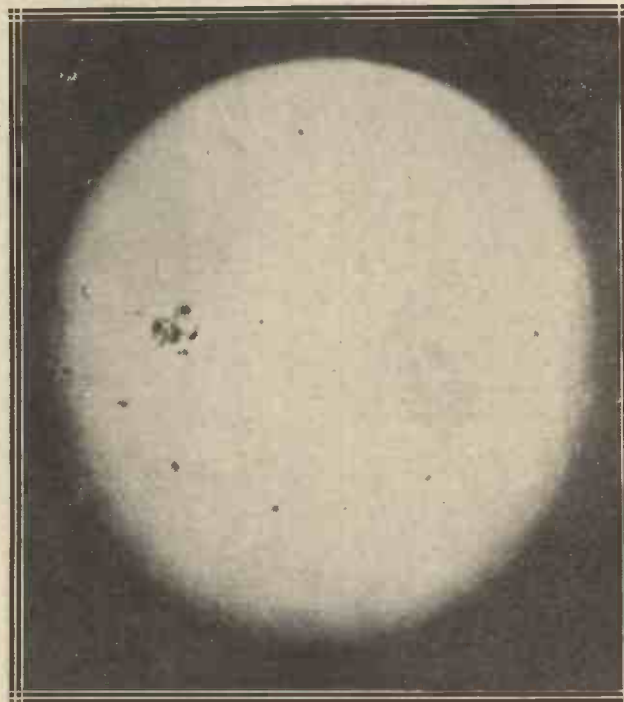

what is there inside the earth which is responsible for the intense magnetic field? Apparently the most likely answer would be the elements of which the interior of the earth is constructed; certain stones have magnetic properties and these one would say cause the earth's magnetic field. There is now, however, no foundation for this simple theory and it is something inside the earth which magnetises these magnetic stones.

Terrific Pressure

For example, the centre of the earth is very hot, and even the heat at 20 or 30 kilometres below the surface of the earth is sufficient to destroy the permanent magnetisation of such stones or metals. After this fact was discovered, the adherents to the above theory suggested that the terrific pressure on the centre of the earth might be sufficient to neutralise the damaging

Is the Earth a Giant Electro-Magnet?

effect of the intense heat and allow the earth's core to retain its magnetism.

The other day, however, this possibility with regard to pressure was proved to be non-existent by experiments carried out at the Carnegie Institute at Washington, and the only effects of the magnetic elements in the earth is to upset slightly the permanent magnetic field—a phenomenon well known to mariners.

Another theory to account for the field is that when the earth cooled down, electric currents were set up inside the earth, and these currents which are presumed to be gradually dying away are the cause of the earth's magnetic field.

The Compass Would be Useless

It has been calculated that it would take 20 million years for the complete decay of these electric currents to be accomplished, so that at the end of this time—whenever it is—terrestrial magnetism will disappear and the magnetic compass will be useless, and, incidentally, our wireless echoes would cease, although perhaps this would not be an unmixed blessing, as the prevention of echoes is one of the problems which will probably have to be solved later on.

However, just recently this theory has been modified, and it is now generally accepted that while internal electric currents are responsible for the earth's magnetic field, as well as that of the sun, these electric currents are not dying out, and the most recent theory is that these currents are kept alive, as it were, by the internal circulation of matter in the bowels of the earth.

RADIO MALABAR

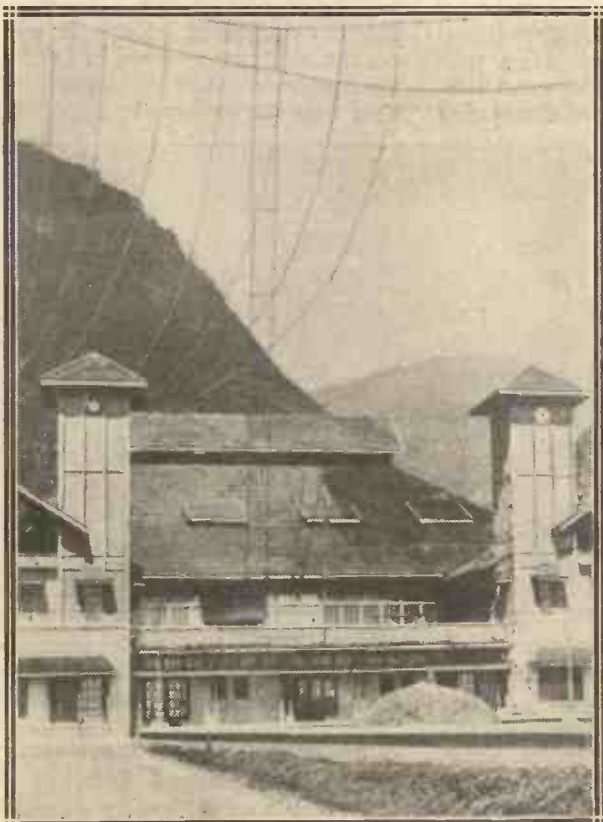

The peculiar aerial system of the Malabar C.W. station in the Dutch East Indies.

Incidentally this theory will also account for the movement of continents which some scientists believe is taking place, and so far this continental drift is the only evidence we possess in support of this internal circulation theory.

Why should the earth be magnetised? This diagram explains the latest theory concerning the origin of the powerful magnetic field which exists round the earth.

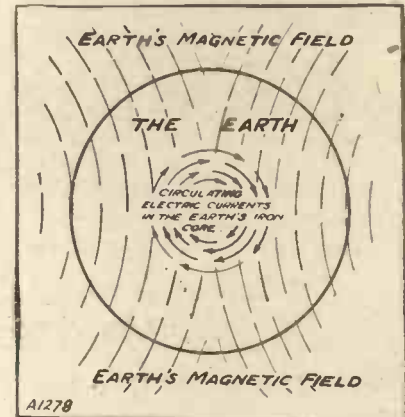

Electric currents will find no difficulty in circulating in the centre of the earth owing to the large amount of iron, and it appears to be an interesting fact that the nearer we draw to the centre of the earth the greater becomes the electrical conductivity, and a table has been prepared showing this increase in conductivity from the Heaviside layer downwards, with, of course, the exception of the lower atmosphere.

In many ways these internal electric currents must play an important part in the propagation of wireless waves about the earth, and may cause some varieties of atmospheric waves, for they resemble the output of a giant, but rather erratic, dynamo. Then, again, what effect has this changing magnetic field on our wireless transmission?

Reversal of the Earth's Magnetism

It should be added that the earth's magnetic field is not constant, but varies over a period of five centuries. In connection with this it is interesting to note that volcanic lava as it solidifies takes up magnetism along the direction the earth's magnetic field, and by investigating ancient lava it has been possible to find out to a certain extent the direction of the earth's magnetic field in remote times. It would appear that ages ago there was a complete reversal of magnetisation; the compass, if it had existed, would have pointed south and north, instead of north and south.

Cause of Wireless Echoes

The internal electric currents in the earth are also responsible for the formation of these large electron belts which exist far out in space and which give us the wireless echoes discovered by Hals. These electron belts are formed by electrons thrown off by the sun being drawn into belt formation around the earth by its magnetic field.

By further discoveries on these lines we shall possibly be able to find out exactly what effect, detrimental or otherwise, these factors connected with magnetism have upon our wireless waves, and undoubtedly the eventual solution of the mystery of magnetism will solve many wireless problems which puzzle us to-day.



RADIO ABROAD

*Notes and News of Wireless in Other Lands.
By Our Special Correspondents.*

New Television Development ?

I HAVE a report from Rochester, N.Y., of a television screen which can be viewed by a roomful of subscribers instead of merely one or two. This announcement was made recently by Dr. Vladimir Zworykin, a research engineer of the Westinghouse Electric and Manufacturing Company, to Members of the Institute of Radio Engineers. The use of a cathode-ray tube as a receiver is said to give this new type of television many advantages over the well-known scanning disc method of visual broadcasting.

The cathode-ray television receiver has no mechanical moving parts. It is stated to be quiet in operation, and the synchronisation of transmitter and receiver is accomplished easily, even when using a single radio channel.

Another advantage is that a fluorescent screen may be used, and the effect is assisted by the persistence of the image on the screen.

Trying It Out

The apparatus devised by Dr. Zworykin is now being used in experimental form in the Westinghouse Research Laboratories in East Pittsburgh, and a number of similar receivers are being constructed in order to give the set a thorough "field test" through station K D K A, Pittsburgh. This station, incidentally, is already operating a daily television broadcast schedule using the ordinary scanning disc type of transmission.

Another French Station

Paris Experimental Radio, a new French short-wave station, is now being heard on 31.6 metres several

days in the week. Transmissions so far consist of gramophone records and speech. The power of the station is 1 kw., and the transmissions take place between 10 and 11.30 a.m. Sundays, 9.30 p.m. Tuesdays, 6 to 7.15 p.m. Thursdays, and 7 p.m. on Fridays (G.M.T.). At the conclusion of the transmissions the military march "Entre Sambre et Meuse" is played.

Signal Strength Tests

An interesting series of test transmissions is now carried out regularly by the French National Meteorological Office, working in conjunction with the Administration of Posts and Telegraphs, for the purpose of discovering



Innovations are continually cropping up in television, and this American device is said to provide a reflected image so that many people can watch the broadcast pictures at the same time.



the relative signal strengths of different wave-length transmissions at different parts of the world

These transmissions are sent out twice a month on various wave-lengths from Lyons (F.Y.S.), Lyons (F.Y.R.), and Paris (F.L.E.). The aerial outputs of these stations are respectively ½ kw., 6 kw., and 1 kw.

Germans' Increased Power

I understand that most of the German transmitters are to operate on increased power since the recent Hague Conference has given permission for a power of 100 kilowatts the broadcasting band.

Bavarian Tests

When the Munich broadcasting studio closes down for the night, experiments are carried out with a transmitter which is located on the Herzogenstand, with a view to finding out the best position for a new station which is to be set up in Bavaria. At present these experimental transmissions are sent out with an aerial power of 1 kw. and on a wave-length of 535 metres.

Grenoble

The well-known station at Grenoble of the French P.T.T. is to have an increased power and is also to be moved to a better position outside the city.

Radio Explorers

When Major Court-Treath, the well-known explorer, went into the Sudanese jungle for the purpose of securing some exciting cinematograph films, he was in constant touch with London by means of a portable Marconi equipment. Not only were his transmissions received in London (on a wave-length of 30 metres), but they were also received by the official

station of the Sudan Government, and were even heard as far away as Massachusetts and Detroit.

An Interesting Transmission

The Decca Record Company is carrying out an interesting series of weekly programmes from Radio Paris on Sundays from 2 to 3 p.m.



Use an EVER READY
refill battery for your
Electric Hand Lamp.



BRITAIN'S BEST BATTERIES

Radio and the Gramophone

In this section of MODERN WIRELESS each month will be discussed both technical and other data of interest to the set owner who is also interested in gramophones.

Conducted by *KEITH D. ROGERS.*

CONTENTS

Recording the Bass	Page 2	Notes About Notes	Page 7
One of the most difficult problems with which the recording engineer has to contend is that of getting sufficient bass on to the record. This article explains why the problem is such an acute one, and why we have to compensate in the designs of our amplifiers for this lack of low notes.		Some interesting but too little known facts about the various sounds that your amplifier and loud speaker have to tackle.	
That G.B. Battery	3	Volume-Control Faders	8
The quality of electrical gramophone reproduction depends upon a large number of what are often considered minor points, and one of these is discussed in this article.		The radio-or-gramophone switch is a somewhat clumsy method of changing over from one to the other. This article describes a better and simpler scheme which is just as effective and gives more artistic results.	
Your Pick-Up Amplifier	4	A Novel Speed Tester	9
The design of a radio-gram receiver is not at all an easy task. It is one thing to build a set giving the required type of reproduction on radio or on the gramophone, but quite another story when it comes to combining the two and yet maintaining "perfection."		An easily made but accurate little device for checking up the speed of revolution of a gramophone turntable.	
Storing Records	6	Recent Record Releases	10
How do you keep your gramophone records? In a heap, a series of albums, or in boxes? A simple and effective method is described in this interesting article.		Our regular resumé of recent records written from the point of view of their suitability, or otherwise, for electrical reproduction by the average radio-gram receiver.	

The Quest for Quality

DURING the next few months we are not likely to see any outstanding advances in the radio-gram world, but a steady development towards a higher degree of realism will probably pave the way for some surprising revelations at the 1930 Radio Exhibition.

In the manufacture of radio and gramophone apparatus it is, of course, almost impossible, and certainly uneconomic, for manufacturers to bring out each little improvement immediately it has taken place. New components will appear on the market from time to time, but the main surprises are usually kept for the show.

The Road to Perfection

This commercial policy does not restrict the home constructor, however; for although he may not reap the immediate benefit of any improvement in, say, loud speaker or pick-up design, he can do a great deal in his apparatus towards the production of the perfect amplifier—as yet still too much of an ideal rather than an established fact.

Whether or not the "perfect" amplifier is to be one that has a straight-line characteristic is a very moot point, and one which is largely discussed in this month's Radio-Gram Supplement.

A straight-line amplifier would only be perfect if the input and the loud speaker also had straight-line characteristics. Without these two necessities the "perfect" amplifier, as denoted by a straight-line response curve, is of little avail.

Improvements in Pick-ups

In broadcasting we have a near approach to straight-line transmission, but we are very far from having a straight-line gramophone record, and it is only recently that pick-up manufacturers took to designing their products to counteract the failings in the record curve.

Then, finally, we have anything but straight-line speakers, and until this last important link is perfected we must of necessity compensate our apparatus in an attempt to provide a straight-line result—or, in other words, realism in reproduction.

This is the main theme of the articles in this month's supplement, and readers will do well to consider them in the light of the above remarks, for although we have advanced a great deal during the last two years, we have a long way still to go, and a consideration of the points brought forward in this section will do a great deal to further progress in the quest for quality and realism.



MAGNAVOX X-CORE

You can now purchase your MAGNAVOX X-CORE dynamic speaker unit complete with a handsome genuine walnut fire-screen baffle which will harmonise with any kind of furnishing. The Belvedere Fire-Screen Baffle has been correctly designed in order to give the very best results in conjunction with either a Magnavox Standard or special model X-Core moving coil unit. The combination of a Magnavox X-Core Unit and Belvedere Baffle will enable you to secure the finest reproduction possible.



Standard Model Unit 10 1/2" Cone Complete with Belvedere Baffle

No. 107.	110-180 volts D.C.	£12 5s. 0d.
" 109.	180-300 " D.C.	£12 5s. 0d.
" 201.	6-12 " D.C.	£12 0s. 0d.
" 401.	110 v. 50 cy. A.C.	£15 0s. 0d.
" 405.	200-240 v. 50 cy. A.C.	£15 0s. 0d.

Special Model Unit 7 3/4" Cone Complete with Belvedere Baffle

No. 106.	110-180 volts D.C.	£10 0s. 0d.
" 108.	180-300 " D.C.	£10 7s. 6d.
" 200.	6-12 " D.C.	£10 0s. 0d.
" 400.	110 v. 50 cy. A.C.	£12 5s. 0d.
" 404.	200-240 v. 50 cy. A.C.	£12 5s. 0d.



Write for the new 68-page "Great Voice" booklet. It tells you all about the operation of moving coil speakers, electrical gramophones, volume controls, eliminators, etc. This new enlarged edition should be in the hands of all "Modern Wireless" readers. Send 6d. in stamps for postage.

The Rothermel Corporation, Ltd.
24, Maddox St., London, W.1

'Phone: Mayfair 057819

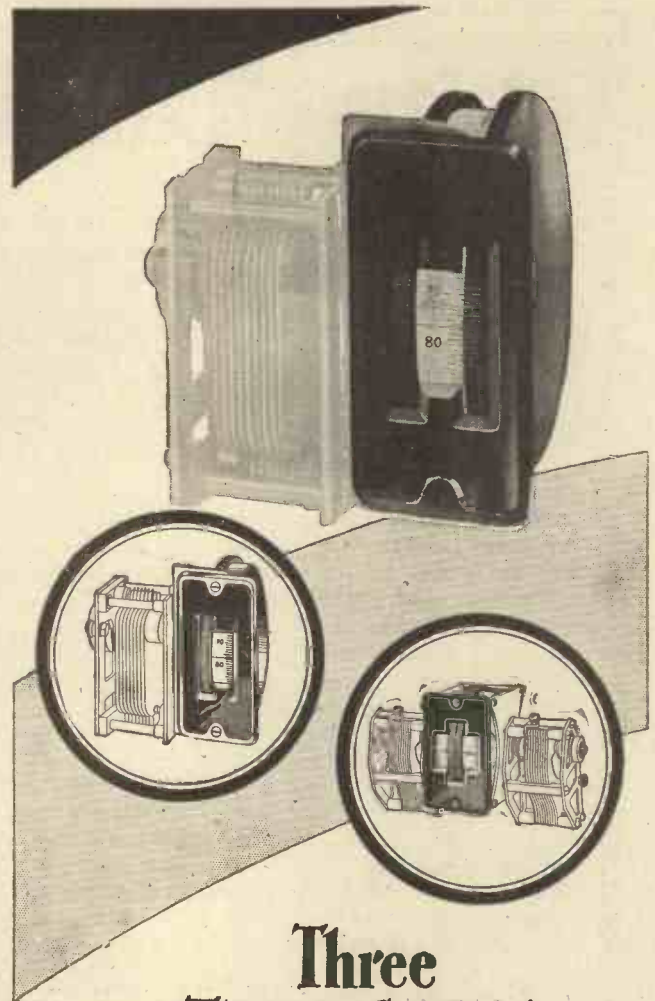

Three Thumb Control models

These latest examples of J.B. design and workmanship are typical of their many Precision Instruments. Each of the Thumb Control models is supplied with aluminium anti-capacity screen.

The Plain type allows any J.B. Condenser to be mounted on it. The Vernier type is similar, save that it has a second Thumb Rim to attach to Vernier Control Spindle of any J.B. Slow Motion Condenser. The Dual type may be used with two J.B. Universal Condensers, one mounted each side.

All three models provide the smoothest and most accurate tuning that could be desired, and are thoroughly well-finished in the very finest materials.

PRICES:

Plain Type, 4/6 Vernier Type, 6/-
Dual Type, 8/6

All models priced without condenser.



PRECISION INSTRUMENTS

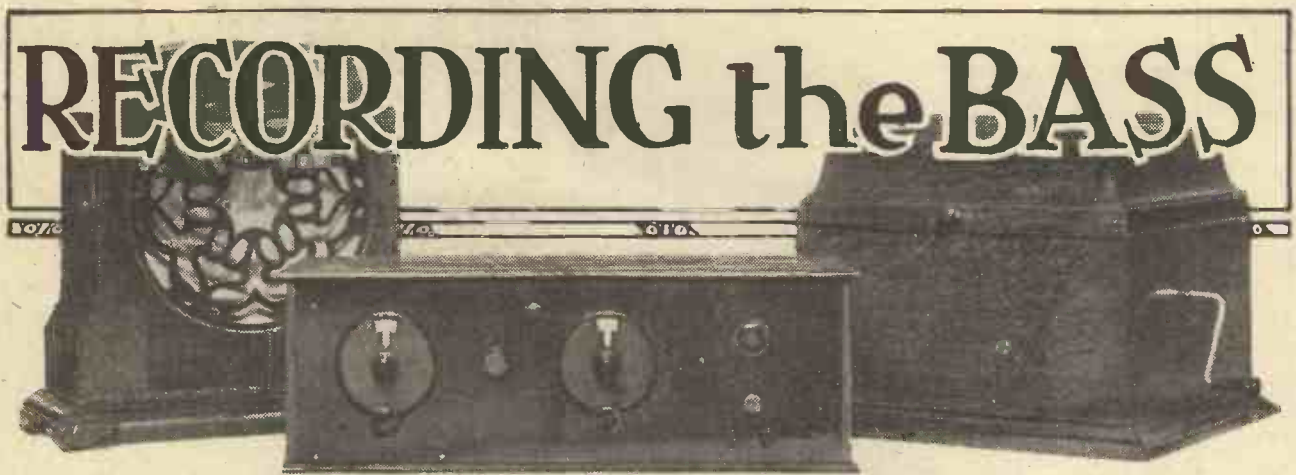

IT is some time since the constant-frequency records were placed on the market by the Gramophone Company and by the Parlophone Company, but the writer would advise all those who have not yet possessed themselves of these records, and who want to carry out really interesting experiments with pick-ups and loud speakers to get hold of some as soon as possible.

One of the most interesting facts about these records is that they do show up very plainly the tremendous difficulty in recording a very deep note. A glance at the two illustrations on this page will show how very different are the characters of the curves of pure fundamental notes round about 80 and 6,000 cycles.

Where the Trouble Lies

These are reproduced in the same scale and magnified about 16 times. If you compare these two photographs you will see the difference in the modulation of the grooves as well as the distance between them or the "pitch"

It is in the "pitch" of the groove that the main trouble comes in recording, because, although it is possible to get apparatus to work satisfactorily at 50 cycles, it would be impossible for

Why we get trouble with the reproducing of bass from gramophone records is briefly explained in this short article.
 By **FREDERICK LEWIS**

commercial purposes to provide a record giving a full-powered 50-cycle fundamental note. The grooves would take up far too much space, and instead of having a 12-in. record we should need one of about 24 or 30 in. in diameter in order to get anything like a reasonable length of playing from it.

In actual recording, in order to avoid the bass-note grooves from running into each other, the amplitude of the bass notes is reduced (and, incidentally, the high notes are also "doctored" so that the curvature of the grooves is not too acute for the reproducing needle to follow) to keep the grooves within reasonable limits.

The Recording Curve

What happens is that between about 300 and 4,000 cycles we get fairly straightforward recording; the amplitude, of course, being altered according to strength of the note; but

below 300 cycles, and right down to 50 or 60 cycles, where there is cut-off altogether (and also above 5,000 cycles), the recording curve falls away. Thus we get a falling-off in recorded strength, both of the high notes and of those notes lower than 300 cycles (middle "C" is 256 cycles).

As a matter of fact, of course, very few pick-ups and sound-boxes will respond properly to a frequency of 60, but a lot of them will go down to about 80 or 90, and it is for this reason (that the record manufacturers reduce their recording on the lower frequencies) that the modern pick-up designer endeavours to make his pick-up with a rising characteristic at the lower end.

Question of Proportion

It does not matter so much that the notes above 4,000 are reduced somewhat in strength on the record, though their presence in proper proportion is desirable, because with modern well-designed amplifiers we can reproduce up to 6,000 cycles without much trouble. But we require a fair amount of input power to the pick-up to reproduce the low notes in anything like their proper quality and proportion. A fundamental note

(Continued on page 190)

High notes and low notes are both difficult to record.

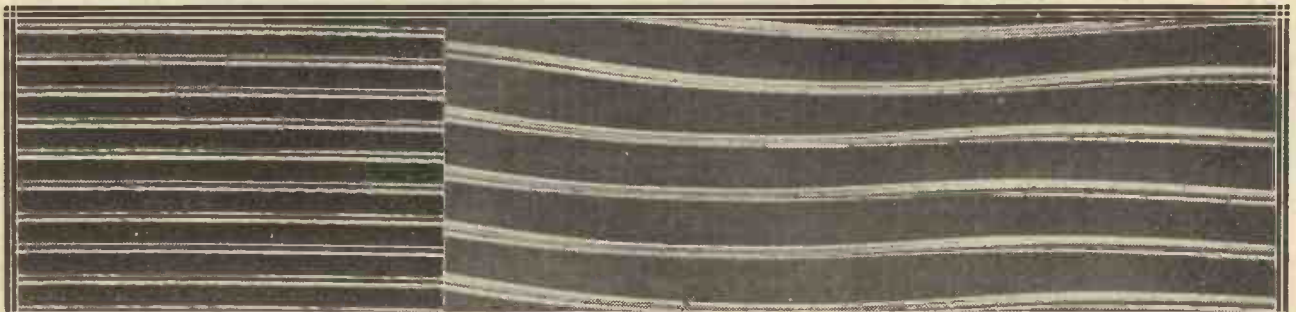

Compare these two micro-photographs, both taken on the same scale, of the tracks of a note of just under 6,000 cycles per second and that of one of 79 cycles. Note the relative distances between adjacent grooves and the amount of modulation required on the 79-cycle record in order that anything like proportional power be provided.

T.C.C.

acquire Sole
Selling Rights
in



THE Telegraph Condenser Co., Ltd.—the Makers of the world-famous T.C.C. Condensers—have pleasure in announcing that they have acquired sole selling rights in “Microfu,” product of Microfuses, Ltd.

The “Microfu” is made in various ratings, from 5 milliamperes to 1000 milliamperes, and is suitable for the protection of valves, wireless sets, eliminators and all instruments taking small currents. It remains constant and will carry a load within 80% of its blowing point. It blows to within 10% of its rated value and operates with the extreme rapidity of 1/1000 second.

The “Microfu” will now have behind it the backing of the whole T.C.C. organization, with its unrivalled and world-wide reputation.

PRICES:

Cartridge, 2/-

Complete with Holder, 2/9

The “Microfu” is made in a wide range of types to blow at from 5 m/a. to 1000 m/a. Obtainable from all dealers.



POLICY

The T.C.C. will continue as heretofore their policy of manufacturing Condensers only.

TELEGRAPH CONDENSER Co., Ltd., Wales Farm Road, NORTH ACTON, W.3.

VARLEY for SELECTIVITY

MULTI-CELLULAR H.F. CHOKE

The opening of the Brookmans Park Stations has brought into prominence one of the vital problems of the future and one that has been the subject of intensive Varley research. Apart from the striking success of our new Regional Coils, the Varley H.F. Choke is playing no small part in improving the selectivity of present-day radio receivers. The inability to separate stations and obtain the desired selectivity may be largely due to the lack of a really efficient H.F. Choke. This is equally important whether the H.F. Choke be used as a high-frequency coupling or for reaction control purposes.

In addition to incipient oscillation and coarse reaction control causing “plopping” reaction effects there is also that curious form of fault known as “wipe out.”

Eliminate all these disadvantages and secure a greater degree of selectivity by insisting on the Varley H.F. Choke. This component is recognised to-day as the “no peak” choke—the choke that is entirely free from subsidiary resonance—the best H.F. Choke on the British market for choking efficiency.

It's Specified for the Electric II



PRICE 9'6



Advertisement of Oliver Pell Control Ltd., Kingsway House, 103, Kingsway, London, W.C.2. Telephone: Holborn 5303.

THAT G.B. BATTERY

If you are to obtain perfect gramophone and radio reproduction you must have the valves properly biased, as any neglect in this regard will only spell distortion.

From a Correspondent.

It is impossible to over-emphasise the importance that the grid-bias battery plays in the provision of pure reproduction. Just let the grid bias be a little out, the battery faulty, or the plugs dirty, and all sorts of troubles, the most frequent of which is distortion, will make their appearance.

Most set owners know how to adjust their bias pretty well, but how many of my readers, having set the bias correctly, just leave it to "get on with it"? The battery should not be left over long periods unattended; its voltage should be checked up periodically to see that all is O.K.

When Voltage Drops

It may have dropped voltage and be working quite well, causing no trouble from the point of view of noise, but the moment it begins to drop voltage you must remember that this has the effect not only of decreasing the bias on your valves, but increasing the H.T. current.

Incidentally also, especially in an L. F. stage a decrease in grid-bias upsets the operating characteristics of the valve so that the grid swing available is not so great owing to the bias point coming along somewhat to the right of its proper position on the straight portion of the grid voltage-anode current curve of the valve.

And so, having set the grid bias in your set, do not go away with the idea that it can be completely forgotten. To a large extent it can be forgotten, but in all wireless receivers there should be a periodic overhaul of all portions likely to cause trouble, and during these overhauls, in which such things as H.T. batteries, L.T. batteries, battery connections, valve pins and sockets, coil pins and sockets, grid-leak clips and holders, etc., are examined, the grid-bias battery should also be overhauled.

The "Shelf" Life

It seems all wrong to say that although the battery is not giving out any current yet it will run down and "wear out," but actually, of course, there is always a slight leakage of current in the battery itself, and

probably a slight bias current every now and then, when strong positive signals are received, besides deterioration of the compounds inside the cells, as you will know if you have ever bought any batteries and kept them some time before using them.

Occasionally one gets a battery which only lasts a couple of months, and another time one gets a grid-bias battery which will last twelve months or more.

So do not forget to examine your grid-bias battery regularly. A great deal of the efficiency of the L.F. side of your set depends upon the condition of this battery.



A universal meter, such as the one illustrated, will give you a sure indication of the state of your batteries, enabling you to take the voltage and also to check the bias points of the valves by watching the kicking of the milliammeter needle.

RECORDING THE BASS

—continued from page 188

of 70 or 80 cycles takes some handling.

That is where a great number of reproducing systems fail. It is not an easy matter to get properly proportioned reproduction, and herein lies the reason why so many radio-gram users

employ a special input, such as a Novotone, in order to bring up the bass.

There is no doubt that a certain amount of bass, really deep bass, is present in many records, but it is very weak and requires a very good pick-up to bring it out. We do, however, have the advantage of the fact that if the fundamental, say, of the 64 cycle note is not present, we are quite likely to get a "ghost" fundamental from the harmonics at 128 and 192.

Ghost Fundamentals

This will give us the impression of the fundamental being present. It will not be produced in its correct proportion, but, since the ear is not at all critical, we may get the impression of quite a fair fundamental.

It is, however, essential for a pick-up to go well down to 100 if "ghost" fundamentals are to be generated, and we have to counteract the fact that the gramophone record response curve has been falling off ever since it passed the 300 mark in the downward direction.

We find that at about 100 cycles, the amplitude is very much smaller than it should be, while at 50 or 60 it usually ceases altogether, for the recording engineers arrange their circuits to have a complete cut-off at about those figures.

Though the photographs in this article are not those of musical notes, being pure sine curves, yet they serve to show the difficulty encountered in endeavouring to record both high and low notes, and especially the low notes. The high notes are difficult owing to the sharpness of the bend in the grooves, while the low notes are difficult owing to the fact that adjacent grooves tend to run into each other unless the pitch of the grooves is extremely wide.

"Straight Line" Impracticable

That is why "straight line" recording is at present an impossibility from a commercial point of view. I am afraid we shall have to put up with this falling characteristic at both ends, in order to get a reasonable amount of music on a confined space of reasonable size, and one which can be reproduced by a reasonably simple and inexpensive reproducing device. Very few pick-ups and sound-boxes would be sold that would successfully tackle the sharp curve of a 6,000 note if it were recorded while properly recorded bass notes would take up so much room that only short items would be available on the ordinary-sized record.

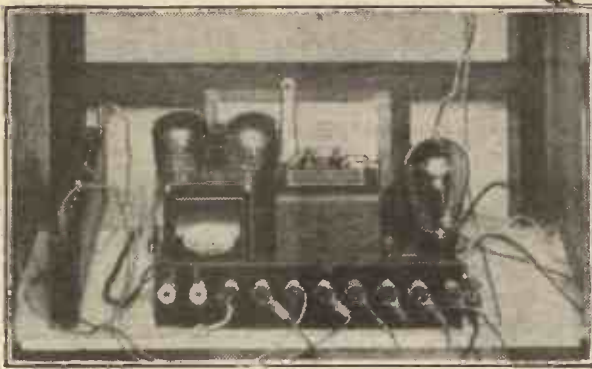

YOUR PICK-UP AMPLIFIER

This article on the question of the design of the L.F. section of radio-gram receivers should be considered in conjunction with two other articles published in this section. The first, "Recording the Bass," deals with a vital phase of gramophone reproduction, while the other, "Notes About Notes," brings to light some interesting facts which serve to amplify the remarks made in this article.

By K. D. ROGERS.

A RADIO-GRAM receiver, or an electrical gramophone, is only as good as the amplifier and loud speaker. That is obvious, but a great number of people seem to forget the point and to expect that because they have got a good pick-up and a set which "sounds all right" on radio they will get perfect gramophone reproduction.

They forget that even though their set may be O.K. for radio it may give far from satisfactory results with the particular pick-up which they are using.

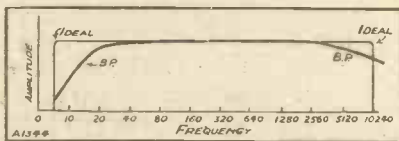

Fig. 1. The curve of the Brookmans Park 356-metre transmitter, showing how nearly it approaches the ideal.

You all know that an amplifier has a certain response curve, the set dealing with frequencies in the musical range more or less efficiently according to the frequency. For instance, it may have a curve showing that the bass is quite well reproduced, the middle range is quite O.K., but that the upper range is inadequately amplified and that the reproduction lacks brilliance.

The "Perfect" Amplifier

On the other hand, the amplifier may have a falling characteristic, the bass may not be properly reproduced, while the high notes may be over-emphasised, giving the reproduction a shrill tone. It will depend, of course, upon your loud speaker and its response characteristics in relation to those of the amplifier upon what type of reproduction you will get.

If you are near your local station and you have a set which gives absolutely straight-line amplification, and a straight-line reproduction loud speaker—a very unlikely state of affairs, but one which we will assume for the purpose of argument—you will

get a reproduction curve according to the transmitting curve of the local station, which, if the station happens to be Brookmans Park, is something like that shown in Fig. 1. That, you say, is quite good, and so it is.

Now supposing you go and put a pick-up on that amplifier, what sort of curve will you get? Obviously, if the amplifier has a straight-line characteristic you will get a curve exactly like that of the pick-up, which in the case of one may rise to a peak somewhere about 4,000, or in the case of another well-known pick-up will rise rapidly from about 2,000 downwards towards the bass, falling off in the treble.

Imperfect Pick-Ups

Now then, your set with its perfect amplifier is giving almost perfect results on the local transmission, but what sort of results will you get with those pick-ups?

In the first case your reproduction will be lacking in bass, and possibly a little shrill in the higher register, while in the case of the second pick-up you will have far too much bass and the results will be rather "boomy."

In actual practice we very rarely get an amplifier, combined with a loud speaker, that will give a straight-line characteristic. Instead, one gets humps and dips all over the place, and it is only after a lot of experimenting, and a great deal of correcting here and there, that one can get a response which gives a result anything like the original.

Now you must not forget that although Brookmans Park gives a curve which goes very well into the bass and well up into the treble, you do not get anything like that on a gramophone record. The falling off at the bass end begins at about 300 cycles and the falling off at the treble begins shortly after 3,500. Consequently, if you were to have a straight-

line pick-up and a straight-line amplifier you would get a very well reproduced middle register with poor bass and a lacking in harmonics and very high notes.

The Ideal System

This is more fully discussed by Mr. Lewis in "Recording the Bass" on another page of this supplement.

So obviously something has to be done in the way of "patching up" for gramophone reproduction. The treble must be boosted up, and the bass must be increased. In order to do that one can either use a pick-up with a tendency to emphasise the treble and increase the bass in the amplifier, or one can use a pick-up to increase the bass and raise the treble in the amplifier.

It is best to use an additional stage or system of transformers and chokes to give the added alteration in the final response curve, leaving the main amplifier O.K. for broadcasting. It is not fair either on the record or

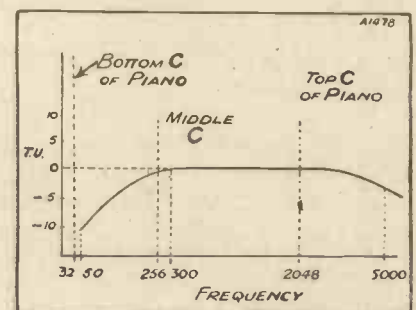

Fig. 2. This diagram shows how the curve of the average recording apparatus is arranged. Compare this with Fig. 1.

on broadcasting to expect one amplifier efficiently to do the job of reproducing radio music and record music equally well, until—and it is very unlikely that we shall ever get to that state of affairs—a record can be reproduced having a curve

Straight-Line Amplification is Not Always Desirable

something like that shown in Fig. 1.

Until then it will be impossible to get the same reproduction from broadcasting and from the records without correcting somewhere for either broadcast or the record.

The ideal, of course, is to have an amplifier for each of them—one for broadcasting and one for the pick-up, but this is not an economical method, and for general purposes it is best to

"While you cannot meddle with the broadcast transmission, you can play about with the input from your records. . . ."

design one's amplifier to suit the broadcasting, and to give the reproduction that one likes for broadcasting first, and then to readjust externally when we turn to records.

I am not insinuating that a straight-line amplifier is the best even for broadcasting, because one cannot get a straight-line speaker. Personally, I think that quite a deal of correcting is advisable even on broadcast music, and I like a little more brilliance in the reproduction than one gets even with what is termed a "good amplifier."

Boomy or Shrill ?

That, of course, is a matter of personal taste, and I would advise those of you who are designing radio-gram receivers to turn your attention to broadcasting, and work out your amplifier according to the requirements of your pet speaker on broadcasting. Then, when you have got it working to your liking, turn your attention to pick-up reproduction.

You will probably find that, having got the broadcast exactly as you like it, your pick-up reproduction will either be too woolly and lacking in brilliance or else too shrill, according to the pick-up you are employing.

When, however, you have your set working to your own satisfaction on broadcasting, it is advisable to study the curve in Fig. 1, and to get an idea of how much of that curve you are reproducing. You probably will not go down to 50 cycles in the same way that the Brookmans Park transmitter does, and you may not go quite so high. The bass reproduction and the treble reproduction of your amplifier can be increased if necessary, but we are assuming that the results are perfectly pleasant to you, and that you really do not want anything more realistic.

Now, from a comparison of the curve of broadcasting and the record curve reproduced in Fig. 2 you will be able to get a fair idea of what your amplifier will do on records, assuming you have a straight-line pick-up—which you have not.

Bass and Treble Fall-Off

Remember that the fundamental of the bottom C on the piano is 32 cycles, and the top note of the piano is something over 3,000, and you will get an idea of what your set is doing.

Now remember that a gramophone record has a curve very much like Fig. 2, so that you have not nearly so much bass supplied to you, and you have falling off in the treble much earlier than in the case of the music from the local station. Consequently, if you are going to get your reproduction like that of the broadcasting you will have to increase your bass and your treble.

In order to do that such instruments

"If your set gives perfect reproduction on radio, what sort of reproduction will you get with a pick-up?"

as the Novotone have been designed, but a simpler method is to use an input transformer for your pick-up. This will increase your overall amplification and will increase your treble. The bass, of course, will not be increased so much.

In the case of the Novotone the bass will probably be increased more than the treble, but if you use a pick-up which goes well down in the bass, and which has a reasonably good characteristic in the treble, you will very likely be able to correct the amplifier by means of the simple input transformer to give you a reproduction that will be just as pleasant as that obtained from radio.

Increased Brilliance

In fact, it is not unlikely that you will get a little added brilliance compared with the radio reproduction, and, although we have been inclined to make a lot of fuss about reproducing the bass, I think a large number of people will agree with me when I say that the high harmonics, or overtones, are even more important

than the bass notes, and that we can better do with a little less bass and more harmonics than a lot of bass and a lacking in harmonics.

So in designing your amplifier for a radio-gram receiver you must bear in mind the fact that while you cannot meddle about with the broadcast transmission, you can play about with the input from your records; so design your amplifier to give you your ideal in broadcast reception, and then turn your attention to the pick-up side.

Choose a pick-up which has a curve which will tend to correct the falling curve of the record to as large an extent as possible, and then, by means either of tone controls such as described by Mr. Kendall last month, cut down your high-frequencies if you are getting too much, or by means of an input transformer system boost them up if you are getting too little.

Simple Adjustments

Add something like the Novotone if you are getting too little bass or using a pick-up having a rapidly falling characteristic on the bass side. For average speakers a pick-up with a slightly rising characteristic in the treble fills the bill very well, provided it goes fairly well down into the bass.

I think if you experiment on the lines which I have indicated, remembering that transformer coupling will tend to increase the treble, that resistance coupling will tend to decrease the treble, but will give a fairly straight line down lower on the musical scale, and that by using such a system as shunt feeding a trans-

"Something has to be done in the way of 'patching up' for gramophone reproduction. The treble must be boosted up and the bass must be increased."

former, such as of the Hypermu, through a large condenser, and by altering the size of that condenser, one can vary the amount of bass (the bass response in this case increases as the size of the condenser is diminished between about 1 mfd. and .001 mfd.), then you will be able to arrange an amplifier which will give you just what you want.

Use

the



"MAJOR" Cabinet

FOR YOUR

RADIO-GRAM

Especially suitable for

**MULLARD ORGOLA,
OSRAM MUSIC
MAGNET,**

and for panels up to 18" x 8".

Loud Speaker compartment is
18" x 18" x 16½".

OAK - - - £7:10:0
MAHOGANY - £7:15:0

Call and see full range of "Camco"
cabinets at new London showrooms.

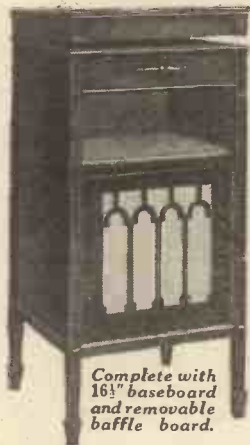

Complete with
16½" baseboard
and removable
baffle board.

CARRINGTON MANUFACTURING CO., Ltd.

New Showrooms, 24, Hatton Garden, London, E.C.1.

Telephone: HOLBORN 8202.

(CA) 3175

**MIDGET
BRITISH GENERAL
TRANSFORMER**

*The most
up to-date
Transformer!*



A transformer of Giant Performance and perfect, distortionless reproduction—but small, compact and neat. The illustration is the actual size, and the complete job weighs only 4 ozs. The secret is in the Special Metal Alloy—a recent discovery which enables us to guarantee performance the equal of a transformer of many times the weight or price.

From all dealers of repute, or direct from the manufacturers—
THE BRITISH GENERAL MANUFACTURING Co., Ltd.,
BROCKLEY WORKS, LONDON, S.E.4

Price



**Your set
deserves the best
Components**



CLEARERTONE.
The original anti-microphonic valve holder, often imitated, never duplicated.

2/-

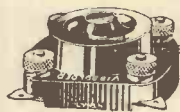

VIBROLIDER.
The self-aligning feature ensures positive contact with all 4-pin valves.

1/6



5-PIN HOLDER.
For 5-pin valves with centre leg. Can also be used with standard 4-pin valves.

1/9



ROTARY SWITCH.
An effective alternative to the push-pull type. All insulated and with indicating dial.

1/9

Whatever type of circuit you are building there are Benjamin components to suit your purpose. To those of you who are building portable sets, or gramophone amplifiers, Benjamin valve holders are essential, as the vibration and jolting in these two types of sets will not only give rise to unwanted noises, but may mean the complete breakdown of expensive valves. The patent anti-microphonic and self-aligning features ensure positive contact with all types of valves.

**THREE MORE
POPULAR COMPONENTS**

PUSH-PULL SWITCH.
Double-contact and with terminals. It's "off when it's in."

1/3

TURNTABLE.
Ball-bearing and equipped with hinged and folding legs, enabling set to be used either in or outdoors.

7/6

PENTODE HOLDER.
The standard Clearer-tone model, with flexible attachment for terminal on pentode valves.

2/3

Write for Illustrated Leaflets of
all Benjamin Radio Products.

Buy

BENJAMIN
the Best!



A simple record storing system for the radio-gram owner.

By J. F. CORRIGAN, M.Sc., A.I.C.

EVER since I came into possession of my *hundredth* record the problem of devising some suitable means of filing and storing these articles began to occupy my mind more urgently than it had done before. I suppose that every individual radio-gram enthusiast has his own method of storing his collection of records.

Still, when you come to think about the matter, there are far too many radio-gram owners who are content to keep their records in a flat pile in some convenient portion of the room, and in an order which can be described no more aptly than by the use of the term higgledy-piggledy.

The Easiest Way

I decided to adopt for my little collection the storage and filing system which is generally employed by the majority of the smaller dealers.

With this system the records are stored vertically on shelves, as shown in the accompanying photographs. If the records are packed together reasonably tightly they will be held in a perfectly flat and vertical position, and, therefore, no warping will occur.

Each record is put away on the shelf in its ordinary paper or card cover, and on the top corner of the cover an index number is placed. These numbers are given consecutively from (1) onwards. Thus with this filing system we have the records stored vertically on some convenient shelf, or series of shelves.

Each record cover bears a number, and any shelf space not at present occupied by records may be packed with books or polished wooden blocks in order to support the records in a truly vertical position. Thus it will be seen that there is no attempt at classifying the records on the shelves,

the latter providing merely an efficient means of storage and ready access.

The record classification is done in a loose-leaf notebook—such an article being procurable for sixpence from any departmental store in the country. In the notebook the record collection is divided up into as many different sections or classes as may be required, and, also, each main class may be subdivided further.

Classifying the Items

To make this matter clearer: Suppose a radio-gram owner divides his record collection up into a number of main classes, among which is "Instrumental Music." Naturally, he will have to subdivide his "Instru-

mental Music" category into smaller sections, such as "Orchestral Records," "Band Music," "String Orchestras," and so on.

Then, again, account will have to be taken of records which contain instrumental solos, such as piano records, violin selections, wind instruments, etc.

If the record owner is a specialist in any branch of musical or other recordings, his classification will naturally go much further. Still, the principle of the whole arrangement is the same, the records being stored in any order, but in consecutive numbers on the shelves, and the index or shelf number of each record being placed against it in the loose-leaf book classification.

Adding New Records

When new records are procured they are placed on the shelf with the others, and given the next available numbers, each record being entered under its required heading in the loose-leaf book index.

Thus it will be seen that this system can be worked with small or large collections of records. As the records are placed in consecutive numbers on the shelves, no gaps have to be left on the latter for records still to be obtained.

Consequently, a minimum of shelf-room is required, and if the shelves are provided with a draw-curtain, they can be placed very unobtrusively in almost any room.

SIMPLE AND VERY EFFECTIVE

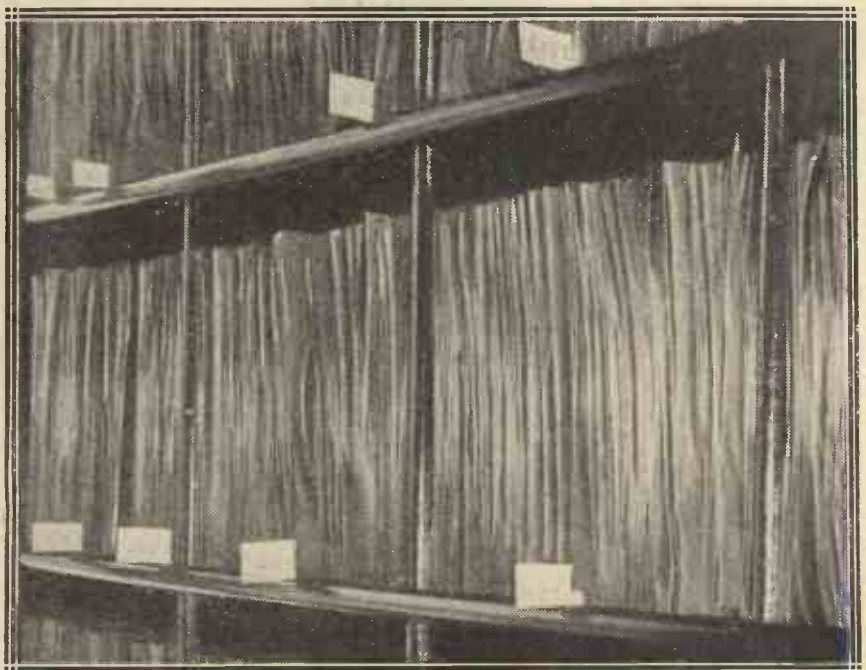

This photograph illustrates the method of storing discussed in the article. By this means records can be found very easily.

NOTES ABOUT NOTES

Do you realise how extremely complex are the sounds with which your radio-gram receiver has to deal? Some idea of the involved character of musical notes is given in this interesting article.

By G. W. EVANS

WE are all so familiar with musical notes and sounds in general that we rarely stop to think how one sound differs from another of the same pitch.

What is it that causes some notes coming from our loud speakers to sound like those from a violin, while others sound as if they originated in a flute? It is merely a question of the actual characters of the notes—m rely the harmonics and transients that accompany the fundamentals.

Fundamentals and Harmonics

Every musical note has a certain fundamental, and accompanying this fundamental are waves having frequencies which stand to one another in definite ratios of 1, 2, 3, 4, etc. It depends upon the proportion of these harmonics, as they are called, to the fundamental whether the note has the timbre of, say, a cello, organ, piano, violin, or saxophone, etc.

In other words, each instrument has its own peculiarities which cause it to emit fundamental notes with certain of the harmonics present, others missing, for the ratios of strengths between the harmonics and the fundamental depend upon the particular instrument and on the way it is played.

The Octave

For instance, a violin may have one of its notes played in the ordinary way, or as a "harmonic" as it is called, which latter, carried out by letting the finger touch the string very lightly instead of pressing on it, gives the note very similar qualities to those obtained from the flute.

Now the pitch of the note is that of the fundamental, which has a definite frequency and predominates in strength over the harmonics or

transients (about which more later) that accompany it.

For instance, the "middle C" of the ordinary piano has a frequency of about 264 per second, though for scientific calculations we usually take the frequency of 256 to be that of "middle C."

An octave is obtained by dividing or multiplying a note's frequency by 2. Thus the C's of the average piano have frequencies of 33, 66, 132, 264, 528, 1,056, and 2,112, or in the scientific scale they have frequencies of 32, 64, 128, 256, 512, 1,024, and 2,048.

The human voice usually ranges from about 60 as the limit for a low bass (Mr. Jetsam seems to reach down to 70 or thereabouts) to 1,200 for the top note of a very high soprano. Instruments, however, range from about 16 cycles where very deep

that true realism has not yet been accomplished.

In addition to the fact that to get realism in reproduction we must reproduce the fundamental and all the necessary harmonics in their proper proportions, our amplifiers and speakers must also be capable of reproducing what are known as transients.

A Further Complication

These are notes which are not harmonics to any fundamental, but are "inharmonic" and last only a short time, for a much less time than the ordinary fundamental and its harmonics. That is why they are called transients.

But these transients are very necessary in building up the quality of a note, and especially are they



The piano is the most difficult instrument to reproduce with an adequate degree of realism due not only to its harmonics and transients, but also to the fact that, being a percussion instrument, it is difficult to control modulation. The note emitted on the percussion is so strong that it cannot be recorded in its proper proportion to the "follow on" sounds when the strings are vibrating freely, and so we never get the true effect and quality of the piano on any record.

organ fundamentals are concerned, to above 10,000 for the high harmonics of violins and flutes.

So we see what a tremendously varied range our amplifiers, speakers, records, pick-ups and broadcasters have to deal with. It is small wonder

present in such instruments as the cymbals, drums, xylophone, triangle, and the piano—in fact, most percussion instruments. To reproduce notes from these instruments properly, therefore, we have to be sure that our

(Continued on page 196.)

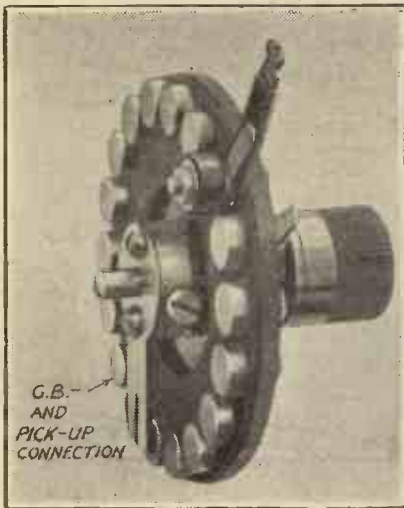

A G.E.C. volume control used as a "fader."

In this short article the writer wishes to draw the reader's attention to a system of volume controlling which, while enabling one to "fade" from one programme into another, also eliminates switching.

The modern receiver usually incorporates a volume control and sometimes a switch for "radio" or gramophone "pick-up," the latter being in the grid circuit of either the detector or first-stage L.F. valve, according to the number of amplifying stages it is desired to include for the purposes named. A "fader" control, however, is a better arrangement than a switch.

What It Is

Actually, the "fader" consists of a slider or roller engaging with a nearly complete circular graphite strip (or disc), the latter having an electrical connection at its centre

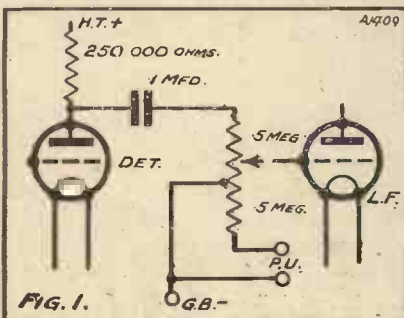

Using a fader with resistance coupling.

point and further connections from the ends of the graphite strip; a lead, of course, also being taken from the slider.

The point is the slider should be capable of passing over the graphite continuously from end to end, like an ordinary volume control.

When the volume control is joined

VOLUME-CONTROL FADERS

Switching over from radio to pick-up and vice versa is a somewhat clumsy method; here is a scheme which provides perfectly smooth transition from one programme to another.

By G. V. COLLE.

to two pick-ups, as in Fig. 3, it will be seen that the first can be faded out and the second faded in.

Applying the same volume control to circuit Fig. 1, it now acts as a "fader" from radio to pick-up, or vice-versa, with, of course, the action of a volume control in either position. In the case of Fig. 1, half the graphite resistance element acts as a grid leak for the L.F. valve, the remaining half

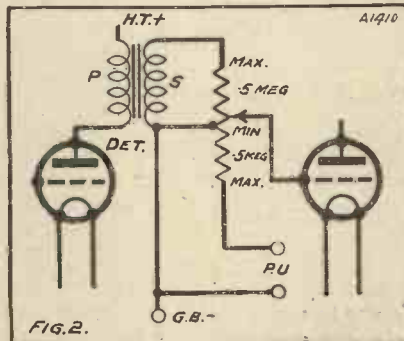

Where a transformer is employed the fader should be connected as shown above.

of the element being in parallel with the pick-up windings.

Referring to Fig. 2, the volume control acts in the same capacity across the pick-up, but the "radio" portion volume controls across the secondary of an L.F. transformer.

NOTES ABOUT NOTES

—continued from page 195.

sets will give us not only the harmonics, but also these transients. And what is more, that these transients shall last the right time.

If they linger too long they cause lack of detail in the reproduction—a common fault in cone speakers.

We are all familiar with the set that gives us good bass reproduction, though we may be assured by experts that the speaker "cuts off at 150 cycles." What is happening in such a case, for we feel sure we are hearing notes of lower frequency than 150?

We have learnt that a fundamental note is accompanied by its harmonics, which are 2f, 3f, 4f, etc., where "f" is the frequency of the fundamental.

Now odd multiples and even multiples can "beat" with each other, forming another note. For instance, 3f and 4f could heterodyne and form "f," also 2f and 3f could beat and form "f."

Thus if we had a speaker which failed to give us, say, a 64-cycle note, cutting off at 150 cycles, we could get that 64-cycle note very faintly by the heterodyne between 192 and 256. The second and third harmonics.

Harmonics Very Important

This "synthetic" fundamental would not be in its correct proportion, but it would give the ear a clue to the actual note transmitted, and the brain would have the sensation of the 64-cycle fundamental. It has been said that the ear "supplies the absent frequency," but surely this supply is merely a matter of heterodyne, and a purely physical process, and not at all one of "aural imagination," if one may use the term.

These remarks are a little sketchy, but they may serve to give some insight to the problems that beset the

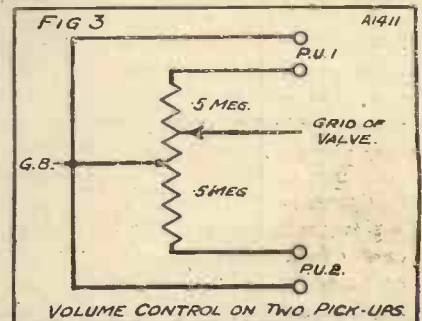

A useful circuit when two pick-ups are required.

radio-gram designer, and explain why on some speakers the violin sounds like a violin, and on others like a flute. We must watch these harmonics, for they are in every way as important as the fundamentals.

AN INDOOR AERIAL



The neatest and quickest way to fix an indoor aerial is to use these **ELECTRON INSULATOR PINS**

Fixed in a moment to your picture rail, skirting or any convenient place they hold the aerial so neatly that both the aerial and pins are practically invisible.

With Electron Indoor Aerial Insulator Pins a directional Aerial can be instantly removed and fixed at different angles at either end or across the room; simply pull out the Pins and fix in varying positions until the best results are obtained.

PRICE PER BOX
6^D
POST FREE

The NEW LONDON ELECTRON WORKS Ltd.

99, EAST HAM LONDON. E.6

For your aerial use Electron, 25 ft., 6d.; 50 ft., 1/-.
Superial, 50 ft., 1/6. On sale everywhere or direct.

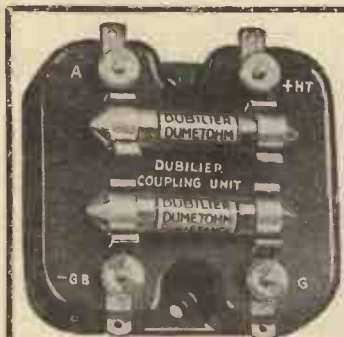

R.C. COUPLING UNIT

(With or without Valve Holder) Complete with Dumetohm. **7/-**



H.F. CHOKE

Four types to meet all uses. All types **4/6**



DUCON AERIAL

Does away with an outdoor aerial, as it has simply to be plugged into any standard electric lamp socket. Tested 2,500 volts — absolutely safe. **5/-**

If unobtainable from your dealer write direct giving his name and address.



DUBILIER

RADIO PRODUCTS

Free for the asking—
"A Bit about a Battery."
There's a copy for you
at your dealer's.

Dubilier Condenser Co. (1925), Ltd., Ducon Works,
Victoria Road, N. Acton, London, W.3. BC 279/C

MAZDA P.625A

EFFICIENCY
AND
ECONOMY

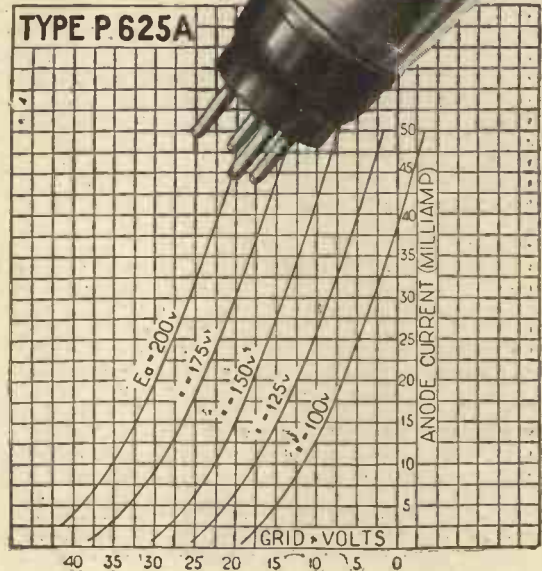
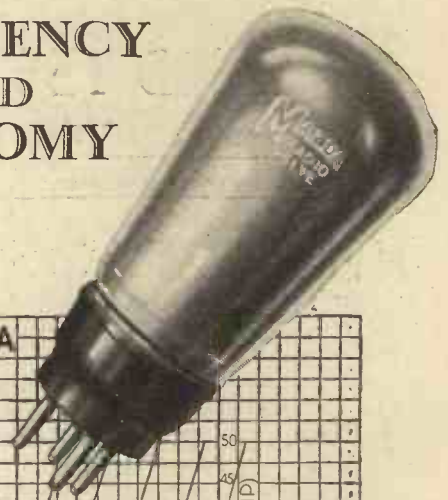

MAZDA P.625a

Type P625A is a super-power valve, and is capable of giving a high power output without distortion. It has been designed for operating cone and moving-coil type loud speakers. The volume obtained with this valve when used in the final L.F. stage is sufficient for most purposes, whilst the quality of reproduction over the whole of the musical range is bound to please all lovers of good music.

Those who desire a large volume of sound and better quality of reproduction should fit the valve in the final stage of their receivers.

These valves can be supplied matched for push-pull work.

PRICE 15/-
The AMAZING

MAZDA

RADIO VALVES

THE EDISON SWAN ELECTRIC CO., LTD.
Ediswan Radio Showrooms:
1a, NEWMAN STREET, OXFORD STREET, W.1.
(Phone: Museum 9801.)
Showrooms in all the Principal Towns. V.20.

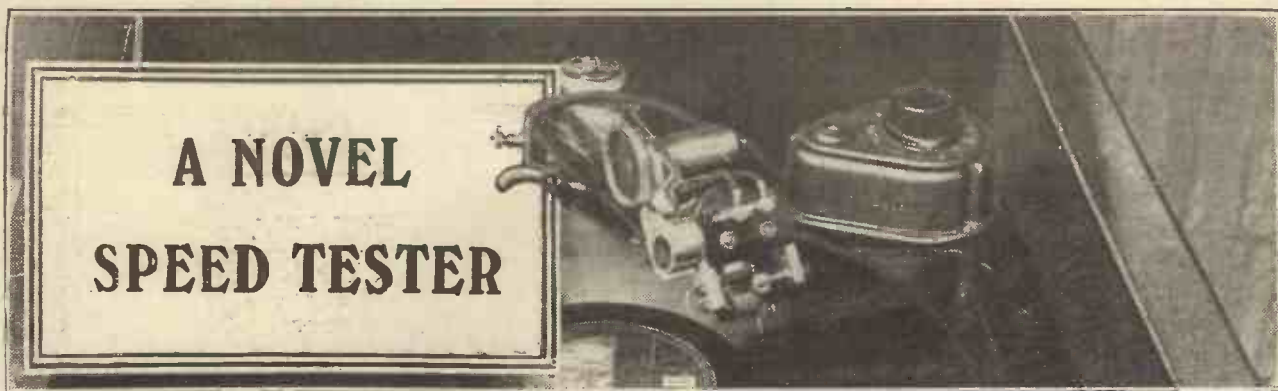

A NOVEL SPEED TESTER

A simple little gadget by which you can check up the speed of your gramophone turntable.
 By P. DUDLEY, Stud.I.E.E.

IT occurred to the writer recently that the "stroboscopic effect" could be utilised in a simple manner to check the playing speed of a gramophone. However, it should be clearly understood that the device to be described can be used only in conjunction with alternating current illumination, and not in daylight.

For the benefit of those readers who are not familiar with the stroboscope, it may be as well to give a brief explanation of the principle involved.

How it Works

When a regular body, such as a wheel, is in rotation, it will appear to be stationary if it be intermittently illuminated, the instants of illumination being such that the wheel turns through an angle equal to that between two consecutive spokes between successive illuminations. The same effect would, of course, be produced if the wheel were viewed intermittently.

An example of this effect, familiar to most of us, is furnished by the cinematograph. Sometimes, in the film of a moving car, or other vehicle, the wheels appear not to rotate. This phenomenon is due to the fact that the wheels turned through the angle between the taking of each successive picture. (Intermittent viewing.) If the wheels turn through two or three (or any other whole number) times the angle between the spokes, they will appear to move round slowly in the direction of rotation, and in the opposite direction if the angle turned through be less than that between the spokes.

Preparing the Disc

Obtain a piece of drawing paper and from it cut out a disc $3\frac{1}{2}$ in. in diameter (i.e. about the same size

as the label on a record), with a hole at its centre to take the driving spindle of the gramophone motor. Next it is necessary to mark out on the disc radial lines (see the accompanying diagram) of such a number that they appear to be stationary when the disc is placed on the gramophone turntable and the latter is revolving at the correct speed.

The method of arriving at the required number of lines is best shown by an example.

Let us suppose that the frequency of the mains supplying the lamp which we propose to use as our

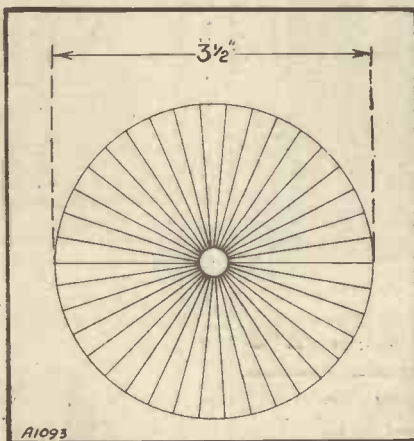

The home-made stroboscope speed tester.

source of illumination is 50 cycles per second. Then the lamp will be dimmed once every $\frac{1}{50}$ th of a second. (Intermittent illumination.) Further, let the speed at which the machine is to run be 78 r.p.m. Our disc would appear to be stationary at this speed if the number of lines marked upon it were such that the disc turned through the angle between

two consecutive lines in $\frac{1}{50}$ th of a second.

For a reason which will be apparent in a moment it is not possible to mark exactly this number of lines on the disc.

Simple Calculations

If in one minute the disc makes 78 revolutions, in one second the disc makes $\frac{78}{60}$ revolutions.

Then the number of lines required on the disc will be given by

$$50 \div \frac{78}{60} = \frac{60 \times 50}{78} = 38.46.$$

In general, $N = \frac{60f}{R}$

where N = number of lines on disc ; f = frequency of supply mains in cycles per second, and R = speed of gramophone turntable in revolutions per minute. Now we cannot mark 38.46 lines on the disc, so selecting the nearest whole number (i.e. 38), substituting this value in the above formula and solving for R, we get

$$38 = \frac{60 \times 50}{R}$$

Hence $R = \frac{60 \times 50}{38} = 78.95$

(or, for all practical purposes, 79 r.p.m.).

Accurate Measurements

When the disc is in motion, although the lines appear to be stationary, they are less clear than when the disc is actually at rest, since, on account of the time-lag of the filament, the lamp is not totally extinguished every $\frac{1}{50}$ th of a second.

If desired, it is, of course, possible to measure speeds other than that at which the lines appear to be stationary, by noting the *apparent* r.p.m. of the disc and adding or subtracting the figure so obtained to the speed indicated when the disc appears to be at rest.

"TWICE AS GOOD RESULTS"—

with **Lewcos** components

"I should like to say how pleased I am with your Super Coils, with my five-valve set I am getting twice as good results—"

The above testimonial gives ample proof of the superiority of Lewcos Super Coils.

Lewcos Super Coils with Interchangeable Primaries are the ideal coils for triodes and screened grid valves, and are specified for the A.C. "Eckersley" Three, as described on page 134 of this issue.

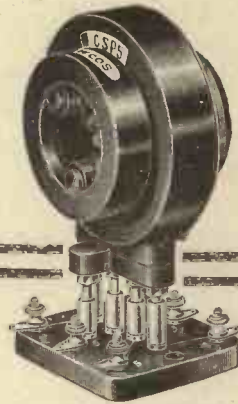

Patent No. 285,723

LEWCOS DUAL BINOCULAR COILS

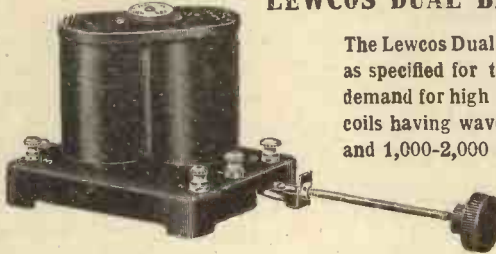

The Lewcos Dual Range Binocular Coils, as specified for the "B.P." 5, meet the demand for high efficiency astatic or fieldless coils having wavelength ranges of 235-550 m. and 1,000-2,000 m., the wavelength range being selected by a simple push-pull switch which protrudes through the receiver panel.



LEWCOS RADIO PRODUCTS

REGD.

THE LONDON ELECTRIC WIRE COMPANY AND SMITHS LIMITED, Church Road, Leyton, London, E.10
Trade Counter : 7, Playhouse Yard, Golden Lane, London, E.C.1

THE NEW CELESTION LOUDSPEAKER Z.20.

189

"Renowned for brilliancy and quality . . . speech and music particularly good . . . a handsome instrument."
PERCY HARRIS in "Wireless Constructor."

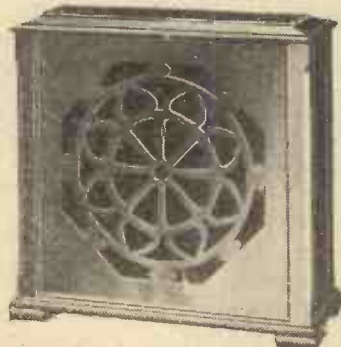

Designed specifically to give the finest possible results with any set from a Two-valver to a Power Amplifier. Crowned with the Celestion hall-mark—a beautifully designed and hand-polished cabinet.

In Oak £7 : 15 : 0.
Mahogany £8 : 5 : 0.
Walnut (to order) £9 : 0 : 0.
Other Celestion models from £3 : 15 : 0.

CELESTION
The Very Soul of Music!
LOUD-SPEAKERS

Write for an Absorbing Free Book on "SOUND RE-CREATION."

CELESTION, LTD.,
Dept. H., Kingston-on-Thames.



VERNIER DIAL

Tuning without irritating, uncomfortable crouch or stoop.

Black, **3/-** Walnut,
Brown, **3/-** Mahogany

(Black supplied unless otherwise stipulated).
Centre Knob Nickel Plated.

SMALL—EXTREMELY ELEGANT—EFFICIENT

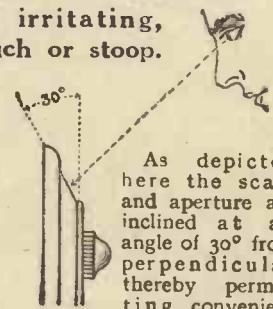

As depicted here the scale and aperture are inclined at an angle of 30° from perpendicular, thereby permitting convenient unobstructed view

of scale without need to crouch or stoop.

MECHANICALLY PERFECT. POSITIVE BRASS CONTACT drive on SOLID BRASS SCALE, ensuring SMOOTH MOVEMENT with absolutely NO BACKLASH. NO SLIP. ROBUST in Construction and TROUBLE-FREE.

3/- The DIAL you would Buy **3/-** even at DOUBLE THE PRICE

Full Catalogue sent post free on receipt of postcard.
CROWN WORKS, CRICKLEWOOD, LANE, LONDON, N.W.2

RECENT RECORD RELEASES



Some interesting records that have lately been placed on the market.

WE are often asked for details of records which will enable certain properties of pick-up and amplifier systems to be tested. For instance, many pick-up enthusiasts have asked for details of records—preferably light dance numbers—in which the brass is given a good run, and which are suitable for testing the “brilliance” of their reproduction.

Others require records which will give more on the bass side, while still others ask for good piano records. We therefore propose this month to discuss fewer records than usual, and to deal with them from a different viewpoint.

One of the best records we know for testing the brightness or brilliance of a pick-up outfit is Jack Hylton's *Tip-toe Through the Tulips*, H.M.V. 5722, which has some exceedingly valuable trumpet work. The selection from “*Dear Love*,” by the New Mayfair Orchestra, also contains some exceedingly high notes and any lacking in harmonic reproduction immediately ruins the record (H.M.V. C1792.)

Valuable Test Records

The Rounders and the Melody Three, two small male-voice organisations, give one a good chance to test for crispness in their *Singin' in the Rain* and *My Song of the Nile*, H.M.V. 3206; while Boyd Senter in *No More*, and Raie da Costa in *My Dream Melody* (Parlophone R501 and R521 respectively) form very fine harmonic tests.

The former record is a clarinet solo with piano and guitar—an ideal combination for test purposes where clear-cut reproduction is looked for; while Raie da Costa is a jazz pianiste whose records have a happy (or is it

unhappy?) knack of showing up any faults in one's radio-gram set.

By the way, Parlophones have brought out a series of three 2s. 6d. ten-inch records entitled *Talkieland Selection*. This is in five parts, the sixth side (second side of third record) being occupied by *What Can You Do Without Money?* a somewhat hackneyed song by the Pole Bros. These Talkieland records are well worth hearing, and are made by the Parlophone Variety Company (E6220, E6221, E6222).

More Talkie Hits

While talking about talkie hits it is worth while mentioning Jack Hylton's H.M.V. records, *Turn on the Heat*, and *If I Had a Talking Picture of You*, both from “*Sunny Side Up*” (B5741), and also his *Parisienne Doll* from “*Woman to Woman*” (B5730), and *Rio Rita*, from the film of that name (B5733).

One of the best general tests for a pick-up outfit is undoubtedly the vocal, and especially choral, record, and the H.M.V. *The Trumpet Shall Sound* (The Messiah), by Arthur Fear, gives one all that one can cope with, for the record is remarkably loud (H.M.V. C1786).

Another excellent record is the Zonophone *Vocal Gems from Merrie England* (A375), which again needs careful handling if the best is to be obtained from it. This is certainly one of the most popular of the English light operas, and lovers of this type of music—at which Edward German excels—should make certain they do not miss it.

Among the vocal records must also be mentioned a further excellent disc by a new tenor in gramophone circles, though he is well-known to the

concert and variety stages as the Phenomenal Boy Tenor.

We refer to Tommy Sandilands, who on Zonophone 5473 gives us a couple of real old favourites, *A Little Bit of Heaven* and *My Wild Irish Rose*. This is the first record by this artiste ever issued, and we should not be surprised if it commences one of those “vogues” which are a frequent occurrence in the gramophone world.

A Peculiar Vogue

And talking about “vogues,” we wonder why it is that yodelling is having such a long and vigorous turn round the various recording studios. We have people like Jimmy Rodgers, and various other artistes, but none of which has the real characteristics of the true Swiss yodeller. The Edelweiss Yodellers, however (Col. 5643), seem to be of different mettle, for they leave one with a feeling that there, at any rate, is the real stuff.

Those of our readers who are interested in records for records' sake, and are anxious not to miss anything new, should listen to the Decca and Vocalion concerts from Radio-Paris on Sundays; this latter is a follow-up of the Decca record hour (in the early afternoon) and usually takes place at 11 p.m.

The makers of the famous Broadcast records are nothing if not go-ahead, and have always been most ambitious and turn out a remarkable number of records each month. You can always be sure of getting what you want in their lists, whether it be a piano concerto, comedy number, orchestral selection, or the latest foxtrot.

Most Popular Foxtrot

We wonder what has been the most popular foxtrot of the last few months. It would not be surprising if *Ain't Misbehaving* carried off first prize. It has certainly enjoyed a most successful run, and from all appearance is still going strong.

One of the best records of this number that we have come across has been done by the Arcadians Dance Orchestra on Zonophone 5479.

This band, though it keeps to fairly “straight” orchestrations, certainly knows how to treat a number of this sort where melody and plain rhythm are more important than “hot” breaks and stunt playing.

For the latter the Rhythmic Eight are more noted, and this band, who also record for Zonophone, is composed of some of the finest instrumentalists in London.

ALL ELECTRIC - 2

A SET WORTH LISTENING TO

£13



£13

The Igranic All Mains 2 operates entirely from A.C. Mains. Compact design. One knob control. Dual wave switch to eliminate coil changing. Perfect reproduction.



Supplied in attractively designed oak or mahogany table cabinet. Price £13.0.0 complete with valves and royalties.

Please state exact mains voltage when ordering.

Write to Dept. J.996 for details.

Centralab

**Volume Controls
Rheostats
Potentiometers**

Centralab resistances are now used as standard by all leading radio receiver and electric gramophone manufacturers throughout the country. They are also used and recommended by technical editors of this and other radio magazines. The foregoing is proof of Centralab superiority.



Write for Centralab Circuits booklet—it's FREE on request. Our new 8-page Great Voice Booklet tells you all about Centralab Volume Controls, Pick-ups, Amplifiers and Dynamic Speakers. Write for your copy of this new issue today. Send 6d. in stamps for postage.

**CENTRALAB
POTENTIOMETERS AND
MODULATORS**

employ the famous rocking disc contact and pressure shoe. There is no sliding contact to wear out. All units have three terminals for potentiometer control, and are supplied complete with genuine black arrow knob.

TYPE P.109	200 ohms
.. P.110	400 ..
.. P.111	2,000 ..
.. P.112	10,000 ..
.. P.050	50,000 ..
.. P.100	100,000 ..
.. M.250	250,000 ..
.. M.500	500,000 ..

All the above 10/6 each

The Rothermel Corporation, Ltd.,
24/26, Maddox St., London, W.1.

Telephone: MAYFAIR 0578/9.

Fit the
DUBILIER
long-life
BATTERY

66 Volts

7/9

BRITISH MADE



and improve
the quality
of your
reception

Other
Voltages
Available.

Ask your dealer
for a copy of the
Dubilier Booklet
—"A Bit about
a Battery."

Dubilier Condenser Co. (1925), Ltd., Ducon Works, Victoria Road, North Acton, London, W.3.

RADIO NOTES AND NEWS OF THE MONTH

A feature in which our Contributor brings to your notice some of the more interesting and important Radio news items.

Conducted by "G.B."

The L.C.C. Wakes Up

IN reporting upon the use of wireless in elementary schools, the L.C.C. Education Committee says that it has been the general practice to decline applications for fixing wireless apparatus to electric light installations; but in view of the general tendency of manufacturers to construct sets which don't require batteries, the committee consider it desirable that facilities should be provided for the use of the most modern apparatus in the Council schools, provided that its chief engineer is satisfied about the suitability and safety of the apparatus.

Very Much Cheaper

The L.C.C. seems to have been a long time realising that the modern tendency in radio is to do away with

batteries. We are glad to note that at last this elementary fact in radio has dawned upon it, plus the fact that the cost of electricity used by wireless apparatus is practically negligible.

Another Television System

It was reported in the Press the other day that a patent has been taken out by Mr. Joseph Shinton, of Wolverhampton, for a system of television which he believes is ahead of any other yet devised, Baird's included. We understand that his experiments have been carried out as a hobby during the last six or seven years, and have now reached a stage when Mr. Shinton is convinced he is on the right track to produce a satisfactory television set as a marketable proposition at a reasonable figure.

A "Pre-Baird" Enthusiast

Mr. Shinton is a motor engineer, and is understood to have been interested in television before the war. Mr. Shinton claims that in his system the combination of mirrors and slots is different from other inventions, and by giving a greater division of the picture secures a sharper reproduction.

The receiver for his system, Mr. Shinton stated, would be somewhere about the size of an ordinary wireless set. The power unit would be a small electric motor of about one one-hundredth horse-power.

Well, we shall look forward to hearing more of Mr. Shinton's television invention.

Another B.B.C. Resignation

Mr. E. C. Henty, who has been in charge of the News Department at Savoy Hill for over two years, and has been responsible for the News Bulletins broadcast by the B.B.C., recently resigned his post. Once again resignation was clouded in some mystery. When questioned as to the reason for his resignation, Mr. Henty said:

"All that I can tell you is that I am leaving on my own account. The

(Continued on page 204.)

Build the "B.P." FIVE

	£	s.	d.
1 Oak Cabinet, with 12" Baseboard	2	2	0
1 Ebonite Panel, 26" x 8"	12	6	
1 Magnum Dissolver, as specified	10	0	
5 Magnum Valve Holders	7	8	
1 Magnum Neutrodyne Condenser	5	0	
2 Magnum Special H.F. Chokes	15	0	
1 Magnum Standard H.F. Choke	7	6	
1 Magnum Auto Fuse and Bulb	1	3	
1 Magnum .0005 Fixed Condenser	1	6	
1 Magnum .001 Fixed Condenser	1	6	
1 Magnum .01 Fixed Condenser	2	6	
1 Magnum 100,000-ohm Anode Resistance and Holder	5	6	
2 Magnum Screens, 10" x 6"	5	0	
2 Magnum Screens, 4 1/2" x 6"	2	0	
1 Lotus Dual Drum Dial, with 2 Condensers, .0005	1	9	6
1 J.B. Reaction Condenser, .00004	4	0	
1 Varley W/W Potentiometer	10	6	
1 3-spring On-Off Switch	1	6	
1 Lewcos D.B.A. Coil Unit	17	6	
1 Lewcos D.B.P. Coil Unit	17	6	
1 Wearite C.A.T. Switch Unit	2	3	
4 Dubilier Condensers, 1 mfd.	10	0	
2 Dubilier Condensers, 2 mfd.	7	0	
4 Decoupling Resistances, 600 ohms	6	0	
1 Formodensator, Type J	2	0	
2 Lissen 2-meg. Leaks and Holders	3	0	
1 Pye 1-meg. Leak	1	0	
1 Lissen Super L.F. Transformer	19	0	
1 R.I. Output Filter Choke	1	1	0
1 Terminal Strip, 3" x 2"	4	4	
1 Terminal Strip, 11" x 2"	1	3	
12 Elex Indicating Terminals	4	6	
Wire, Screws and Flex	3	5	
	£14	0	0

Any parts supplied separately as required. Pedestal Cabinet, as described, can be supplied if required. Price on application. The "B.P." FIVE, supplied ready wired and tested, including Table type Cabinet, Valves and Royalty paid, £21 10 0.

We specialise also in the "Eckersley" A.C.S., "Electric" Two, and all apparatus described in "Modern Wireless." Catalogue and Lists on application.

MAGNUM "UNIVERSAL" THREE



The set that cannot be improved!

15-2,000 metres.

The most perfect receiver yet designed for Ultra-Short Waves, Broadcast and Long-Wave reception.

Including valves, coils and royalty.

£18.

Full particulars, including a useful list of short-wave stations, on application.

MAGNUM SHORT-WAVE CONVERTOR



Attach this to your set and hear the whole wide world.

Price £4 : 10 : 0

Complete with coils and ready for use. Full particulars, including a list of short-wave stations, on application.

MAGNUM DISSOLVER

As specified for the "B.P." Five, "Connoisseur's" Five, "Exhibition" Five, etc., etc.



Price, 10/-

BURNE-JONES & CO. LTD.,
MAGNUM HOUSE

Telephone: HOY 6257.

296, BOROUGH HIGH STREET, LONDON, S.E.1.

**Invaluable to
EVERY Amateur
and Constructor.**

**"POPULAR" ^{THE} WIRELESS"
AND
"MODERN" ^{AND} WIRELESS"
BLUE PRINTS
OF
TESTED CIRCUITS
PRICE 6d. EACH**

The following is a list of the 6d. Blue Prints for Constructors in stock, showing the different circuits available:

"P.W." BLUE PRINT

- Number
1. DETECTOR VALVE WITH REACTION.
 3. 1-VALVE L.F. AMPLIFIER.
 4. CRYSTAL DETECTOR WITH L.F. AMPLIFIER.
 5. H.F. (Tuned Anode) AND CRYSTAL WITH REACTION.
 6. H.F. AND CRYSTAL (Transformer Coupled, without Reaction).
 7. 1-VALVE REFLEX AND CRYSTAL DETECTOR (Tuned Anode).
 8. 1-VALVE REFLEX AND CRYSTAL DETECTOR (Employing H.F. Transformer, without Reaction).
 9. H.F. AND DETECTOR (Tuned Anode Coupling, with Reaction on Anode).
 13. 2-VALVE REFLEX (Employing Valve Detector).
 16. H.F. (Tuned Anode), CRYSTAL DETECTOR AND L.F. (With Switch for Last Valve).
 17. CRYSTAL DETECTOR WITH TWO L.F. AMPLIFIERS (With Switching).
 18. 1-VALVE REFLEX AND CRYSTAL DETECTOR, with 1-VALVE L.F. AMPLIFIER, Controlled by Switch.
 21. THE 2-VALVE LODGE "N."
 22. "THE GUARANTEED REFLEX."
 23. THE 1-VALVE "CHITOS."
 24. THE "SPANSACE THREE." Three-Valve Receiver employing 1 Neutralised H.F. Valve, Detector with Non-Radiating Reaction Control, and 1 L.F. Valve.
 26. A "STRAIGHT" 4-VALVER (H.F., Det. and 2 L.F. with Switching).
 28. A "MODERN WIRELESS" 5-VALVER (H.F., Det. and 3 L.F.).
 29. AN H.T. UNIT FOR DIRECT CURRENT MAINS.
 30. A REINARTZ ONE-VALVER.
 32. THE "CUBE SCREEN" THREE (H.F., Det. and L.F.).
 33. A "KNIFE EDGE" CRYSTAL SET.
 34. AN H.F. AND DETECTOR TWO-VALVER.
 35. THE "UNIVERSAL THREE" (Det. and 2 L.F. stages resistance-coupled).
 36. THE "SPANSACE FOUR" (H.F., Det. and 2 L.F.).
 37. THE "LONG SHORT" CRYSTAL SET.
 38. A TWO-VALVE L.F. AMPLIFIER.
 39. THE "SYDNEY" TWO.
 40. THE "SUPER SCREEN" THREE.
 41. THIS YEAR'S "CHITOS" ONE-VALVER.
 42. THE "Q AND A" THREE. A simple set (Det. and 2 L.F.).
 43. THE "INEXPENSIVE FOUR."
 44. THE "ECONOMY FIVE." For long-range loud-speaker work.
 45. A SIMPLE A.C. H.T. UNIT.
 46. THE "REGIONAL" THREE.
 47. THE "WAVE-CHANGE" ONE.
 48. THE "REGIONAL" CRYSTAL SET.

"M.W." BLUE PRINT

- Number
2. A "HIGH POWER" FIVE (A powerful and selective five-valve set incorporating two high frequency stages).
 3. THE "SWITCH-OVER" ONE-VALVER (A little set intended for use in the Regional area. Can be changed over from one station to the other without retuning).
 4. THE "TITAN" TWO (A simple and straightforward wave-change Det. and L.F.).
 5. THE "FULL-TONE" TWO-STAGE AMPLIFIER (A powerful two-valve amplifier using two transformer coupled stages).
 6. A "SIMPLE CHANGE" THREE. (A simply made but highly efficient H.F., Det. and L.F. with wave-change switching).
 7. AN "EVERY PURPOSE" THREE (A powerful Det. and 2 L.F. receiver with wave-change switching).
 8. THE "SIMPLE SCREEN" FOUR (A straightforward general purpose four-valver).

Also THE "ECKERSLEY THREE" (A few blue prints of this famous circuit are available, price 1/-).

ALL BLUE PRINTS 6d. EACH.

All orders for these Blue Prints should be sent direct to the "Popular Wireless" Queries Department, Fleetway House, Farringdon Street, London, E.C.4, enclosing a stamped addressed envelope and a postal order for 6d. for each Blue Print ordered.

**Best way to
All Stations!**



The new Dario Valves will improve your radio set—at a lower price, because Dario Valves are made in large quantities by one of the biggest Valve Factories in the world and sold free from any price control. Dario Valves have the New Coated Filament—the New Super-Strength Grid and the New Large-Size Anode—points that mean greater all-round efficiency—points that prove Dario Supremacy.

	SCREENODION		SUPER POWER PENTODION	
15⁶	Universal 2-Volt 1 amp. .075 amp.	4-Volt .075 amp.	18⁶	Price
	Resistron 1 .075		5/6
	Super H.F. 15 .075		7/6
	Super Power 18 .1		9/6
	HyperPower 3		

2 v. .15 amp., 4 v. .075 amp.

2 v. .3 amp., 4 v. .15 amp.



Best way to all Stations

Ask your dealer for free Dario Folder or write direct to:
IMPEX ELECTRICAL LTD.,
Dept. H, 538, High Road, Leytonstone, London, E.11

RADIO NOTES AND NEWS OF THE MONTH
—continued from page 202

reason is, I feel, a question of confidence between the Director-General and myself."

A General Exodus

Mr. Henty thus joins the large band of well-known members of the B.B.C. who have in recent months resigned. Our readers will remember that they include Captain P. P. Eckersley, the chief engineer (who, after his resignation, joined our staff as Radio Consultant-in-Chief, but who, by the way, still is retained as a consultant by the B.B.C.); Mr. Eric Dunstan, the announcer; Captain A. G. D. West, assistant chief engineer; Mr. Rex Palmer, announcer and London station director; Mr. K. V. Wright; Mr. Cecil Lewis; Mr. R. E. Jeffrey, the Hon. David Tennant; Mr. C. E. Hodges, and a number of B.B.C.-trained engineers.

The Birmingham Orchestra

There still seems to be a good deal of uncertainty concerning the main-

tenance of an orchestra at the Birmingham Studio, although immediate anxiety is lessened by the announcement that the present contracts for the orchestra have been extended until next September.

There has been a lot of rumours that the B.B.C. had decided to

NEXT MONTH

there will be another article by

SIR JOHN REITH.

Exclusive to "M.W."

abolish the orchestra in the immediate future, but this extension of contracts seems to give the lie to these.

What is to Happen?

What will be the future of the orchestra no one can say, for the plans of the B.B.C. in connection with it are somewhat obscure. The matter is the subject of discussion by representatives of the B.B.C. and the members of a committee appointed to look after the Birmingham musical interests.

We understand that several meetings have already been held, at which a proposal was advanced for more substantial subsidising of the City Orchestra by the B.B.C. At the moment of writing, these plans have not assumed any definite shape.

Broadcasting "Museum" Wanted

It was suggested in the "Evening Standard" recently that a Broadcasting Museum should be established. It was pointed out that the great weakness of broadcasting is that its messages live but for an instant. In short, that there is no permanent record like that of the printed word or the gramophone. Famous people broadcast regularly, but directly they have finished speaking their message is lost. So it has been suggested that when they broadcast, a permanent record should be made by gramophone or telegraphone methods, and the copy kept for posterity.

Wireless Pictures Fail Again

Broadcasting of wireless pictures in Germany has not caught on, and the system has been abandoned because it was found it did not pay. In fact, only eighteen people in all Germany

(Continued on page 206.)

HAVE YOU NOTICED

138.

how consistently Wearite Components are specified and used in "Modern Wireless" Circuits?

Below are three specified Wearite Components.

WEARITE COMPONENTS



LL3. A real low-loss Coil Mount. Price 1/6.

G 23. Wave-change Switch. Price 1/6

Does your set look old and grey? Has your panel lost its bright appearance? PAXOLIN PANELS keep their beautiful appearance for all time and are not affected by air or light. Practically unbreakable and reasonable in price. A Paxolin panel, 7 in. by 21 in., by 1/2 in. costs 8/9.

Write for free illustrated lists.

WRIGHT & WEARE, Ltd.
740, High Road, Tottenham, N.17
Telephone: Tottenham 3847/8.

Non-inductive Decoupling Resistances from 100 to 600 ohms, within 5%. Price 1/6 each.

MINIMUM LOSS

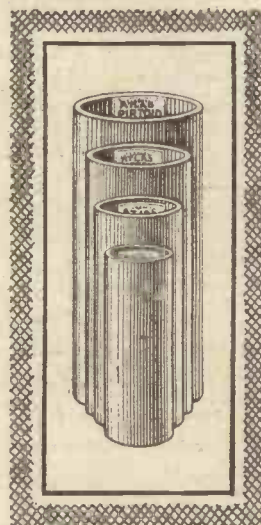

Hard and tough, almost unbreakable, "Atlas" Pirtoid Tubing is a unique and far superior material for High Frequency Transformers, Aerial Coils, etc. Drills and taps like hard wood or bone. "Atlas" Pirtoid Tubing can be obtained in any usual diameter, thickness of wall and length

CLARKE'S "ATLAS" PIRTOID TUBING

Write for full particulars to the Sole Makers:
H. CLARKE & CO. (M/CR) Ltd.
Atlas Works, Old Trafford, Manchester.

The Sets for RESULTS

“Best Way” TITAN SETS

- The Titan One
- The Titan Two
- The Titan Three
- The Titan Four

are profusely illustrated with full diagrams and instructions for building in the

“BEST WAY” BOOK No. 350.

The reader has the choice of anything from a simple one-valver to a de-luxe 4-valve set with built-in wave-trap and wonderful long-distance loud-speaker performance.



6^{D.}
Everywhere.



6^{D.}
Everywhere.

“Best Way” RADIO-GRAMAPHONE SETS

“BEST WAY” BOOK No. 349.

“BETTER THAN RADIO”

is the verdict of large numbers of radio-gramophone users.

In order to get the best out of your gramophone records—and an amazingly fine “best” it is, too—you must use an electrical reproducer.

This is not difficult, and the “Best Way” Radio-Gramophone Book tells you how to use your present set, your present gramophone, and your present loud speaker as an up-to-date electric gramophone.

The “Best Way” Radio-Gramophone Book is a mine of practical information on all phases of this latest branch of radio, and also includes full directions for building an up-to-date radio-gram. receiver, specially designed for the home constructor. It is amazingly simple to operate, and enables you to

CHOOSE YOUR OWN PROGRAMME.

You can easily build them

RADIO NOTES AND NEWS OF THE MONTH
—continued from page 204

had subscribed to the picture service. Yet it was generally admitted that the system worked excellently.

The system of broadcasting pictures, however, will be retained in order to send out weather maps to air 'planes and to send out pictures of criminals to all police authorities.

A Baird Television Demonstration

Writing in "The Times" recently, Mr. A. A. Campbell Swinton, the distinguished physicist and expert on television systems, described a visit he made to the offices of the Baird Company, where he was given a demonstration of television. Mr. Swinton described his visit as successful. But, he added, the picture was only a few inches in diameter and visible only to a small number of people; and for large pictures, such as would be able to be seen by a large number of spectators—as, for instance,

in a cinematograph theatre—very considerable improvements upon present methods would be necessary.

Practical Difficulties

As in present-day television, Mr. Campbell Swinton continued, the picture is divided into a number of parts or elements which are transmitted one after the other with sufficient rapidity to take advantage of visual persistence. The difficulty in the way of producing larger pictures is the dividing of the picture into a sufficient number of parts or elements to give reasonably close-grained results without interfering with other wireless transmissions.

Composers Praise Radio

Signor Mascagni, the famous composer of "Cavalleria Rusticana," recently gave his views on wireless to an Italian journal. "I am enthusiastic about wireless," said Signor Mascagni, "for in favourable circumstances it now affords perfect reproduction. I will say more. In my opinion, wireless should not merely reproduce music, but assist it."

He also referred to jazz as perverse, and as "cocaine to musical sensibilities."

Licences Nearing the Three-Million Mark

The number of wireless listeners holding licences in Great Britain is now close on three million. It is reported that in twelve months more than 300,000 new licences have been issued—a figure that is much greater than that for 1928. At the end of November the number of licence holders had reached a total of 2,914,521, and by the end of this month it is expected that the three-million mark will easily have been passed.

Death of Dr. Ferranti

Radio suffers a severe loss in the death of Dr. Sebastian Ziani de Ferranti, who was world-famed as an electrical engineer, and as "The Man Who Lit London." Born in Liverpool, he was educated at Hampstead, Ramsgate, and University College, London.

Dr. Ferranti had twice been President of the Institution of Electrical Engineers, and in 1924 was awarded their highest honour—the Faraday Medal.

He died after a very short illness at Zurich, on January 13th.

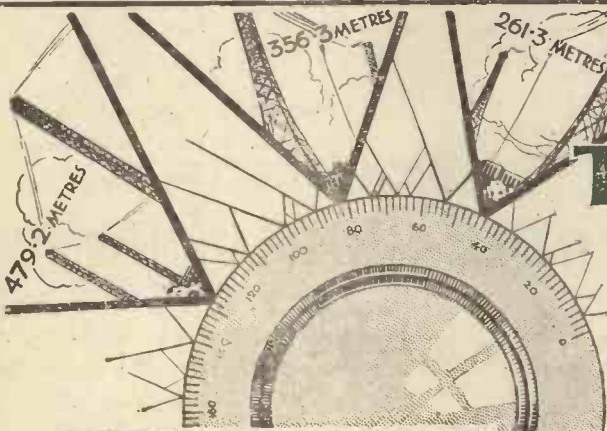

WIDE TUNING RANGE

Because Polar Condensers are scientifically designed—have accurately spaced vanes and low minimum self capacity—they give you a definitely wider range of tuning.

There is no need to sacrifice listening to 5 G B (479 metres) because you want Brookman's Park (261 metres) transmission. The Polar "Ideal" or Polar "No. 3" Condenser of '0005 capacity will tune them all in on any standard circuit receiver. Polar Condensers give velvet smooth control, and the "Ideal" with both Fast and Slow motion gives knife-edge selectivity. Both the Polar "Ideal" and "No. 3" will make a wonderful difference to your range of reception.

POLAR "IDEAL" '0005, 12/6. POLAR "No. 3" '0005, 5/9. '0003, 12/- (as illustrated). '0003, 5/6. (Dial 1/- extra).

POLAR CONDENSERS

Obtainable from all Dealers. Write for Free Copy of "Polar" Catalogue (M.W).

WINGROVE & ROGERS, LTD., 188-9, STRAND, LONDON, W.C.2.

Polar Works: Mill Lane, Old Swan, Liverpool.

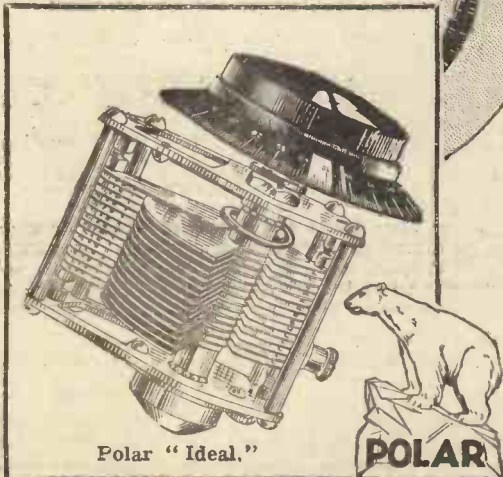

Polar "Ideal."

A REVOLUTION IN SELECTIVITY

—continued from page 117

side-bands or side frequencies; in heterodyne reception, one (the difference) is called the "beat" frequency, the other (which is about double the original carrier frequency) is too high to be audible and is therefore usually ignored.

To sum up, the evidence appears to be too strongly in favour of the side-band theory to allow of any reasonable alternative. The question, therefore, remains: how is it possible to secure high-quality reproduction by means of a circuit such as the Stenode Radiostat, which is so sharply tuned that it can cut out interference within a few hundred cycles of the received carrier-wave—i.e. by a circuit which must necessarily exclude practically all the side-band frequencies which extend for 5,000 cycles above and below that carrier-wave?

Whilst no specific information has so far been published of the details of the Stenode Radiostat receiver, it is possible that the solution of the mystery lies in the fact that the receiver picks up a frequency-modulated (as distinct from an amplitude-modulated) component of the radiated broadcast programme.

Frequency Variation

Ordinary choke-control modulation as used in broadcast transmission produces a radiated wave which is intended to be of constant frequency but varying amplitude. In spite of all precautions, however, it is impossible to prevent a slight variation from creeping into the carrier-wave frequency—due, for instance, to the variation in the plate potentials applied to the main oscillating valve.

These plate variations are created by the applied microphone currents, and whatever frequency changes do occur in the carrier frequency will accordingly transmit the microphone signals. They will, in fact, "duplicate" the ordinary amplitude modulations, though on a very much smaller scale. For instance, they may represent, say, from 2 to 5 per cent of the total energy of the radiated programme.

It is known that such frequency-modulated radiation can be received by means of a highly resonant circuit, tuned to admit only a few hundred cycles and to reject all frequencies

above and below this band—in fact, by a circuit having the same properties as that claimed by the new Stenode Radiostat.

BATTERY v. MAINS VALVES

—continued from page 168

bias off the mains, as a grid-bias battery lasts such a long time and it is very convenient to put a small dry battery in a set, rather than mess about with resistance controls in order to get the correct voltage from the mains, so I would advise those who are changing over to the mains to keep to the dry battery at first for grid bias, taking the H.T. and the L.T. from the mains.

The Detector Bias

It must be noticed that in using the indirectly-heated type of A.C. valves one has to use positive grid bias in the case of the detector valve. This is because there is no positive filament to which the grid-leak return can be made as in the case of the ordinary battery valves. The cathode is directly zero, and so one has to employ a positive potential for the grid of the detector valve in order to get the leaky-grid rectification in the proper manner. For anode bend, of course, one can carry out the anode-bend adjustments in exactly the same way as with battery valves.

That is all that has to be done. The new components necessary are the five-pin valve holders instead of the four, if you are going to use five-pin valves; and a four-volt transformer for the mains, with an additional 8-volt transformer if 8 S.G. valves are to be used, and the requisite potentiometers. The H.T. mains unit, of course, takes the place of the H.T. battery, but taking it all round, although one may have to expend a little extra money at the outset, this will very quickly be returned in convenience, and in the saving of money after the first few months.

The amount of power taken from the mains is remarkably small, certainly not more than that used by a good-sized lamp.

So to those who are hesitating I would say go right ahead and change. Start off with the H.T. and then change over the valves' filaments, and scrap that L.T. battery and all its attendant troubles.



NOW HERE IS THE SET YOU WANT!

"My advice—certainly, get a Lotus, because it's undoubtedly the easiest set to work and the cheapest to run."

Worked from any A.C. Mains light socket—no batteries needed—the Lotus 3-valve S.G.P. All-Electric Receiver is highly selective and covers a good range of British and Foreign stations. Cash Price (including Royalties and Valves), **£21.**

Where electric light is not available, get the Lotus 3-valve S.G.P. Battery Receiver. Cash Price, **£13.15.0.**

Home Constructors should get the Lotus 3-valve S.G.P. Battery Model Kit at **£7.12.6** cash.

All above Sets available on **Hire Purchase Terms.**

Ask your dealer for a demonstration or write for the Lotus Sets Catalogue and Hire Purchase Terms.

LOTUS

ALL ELECTRIC RECEIVER

Gets the Best Reception

Made by the makers of the famous Lotus Components in one of the most modern radio factories in Great Britain.

GARNETT, WHITELEY & CO., LTD.,
Dept. M.W.2, Lotus Works, Mill Lane, Liverpool

Cariston

Ready Radio

COMPONENTS

OF
PROVEN PERFORMANCE

USED IN THE "ECKERSLEY" A.C. THREE AND THE "ELECTRIC" TWO.

H.F. CHOKE

6/6



DIFFERENTIAL
REACTION
CONDENSER

5/-

NON-INDUCTIVE WIRE-
WOUND RESISTANCES



500 ohms	} 2/9	20,000 ohms	} 6/6
600 "		each.	
1,000 "	} each.	50,000 "	} each.
2,000 "		100,000 "	
3,000 "	} 4/6	150,000 "	} 8/6
4,000 "		200,000 "	
10,000 "	each.	250,000 "	each.

All complete with holders.

SPECIAL ANODE-FEED RESISTANCE
(Wire-wound), 25,000 ohms 2/5
(With Holder).



SLIDE POTENTIOMETER 2/9
Baseboard-mounting 400-ohm

Ready Radio

159, BOROUGH HIGH STREET,
LONDON BRIDGE, S.E.1.

Telephone:
Hop 5555
Private Exchange

Telegrams:
Ready, Hop 5555.
London

HUMOUR VIA RADIO

—continued from page 145

appeals more to the intelligence, humour to the emotions, and it is easier to get at our minds over the wireless than at our feelings. Wit depends more upon words, humour more upon situations. And since words are the only carriers between listeners and the microphone, wit makes the better parcel.

If because of sins in a previous incarnation I had been born into the hard labour of a broadcasting comedian, I should concentrate on words and the right choice of them; I should use every device known to elocutionists to give the fullest possible effect to

CAPT. ECKERSLEY

writes

TECHNICAL ARTICLES

only for the

BIG THREE—

“Modern Wireless”

“Popular Wireless”

“Wireless Constructor”

them; I should be very chary of “asides,” of snorts and giggles, of anything that would blunt the point or roughen the fine cutting edge of my jokes. I should aim at being drier than America and saltier than the depths of the sea; and although I would avoid dragging, for dragging fun is apt to be as frayed and as muddy as a dragging skirt, I would give my words time, I would not hurry them.

I would borrow the witty wisdom of the French professor who said to his young surgeons in the operating theatre: “Do not hurry, gentlemen, there is no time to lose”—“Do not hurry, O comedian, there is no fun to lose!”

FOUR HINTS

Moisture is essential for good connection at the earth plate.

High-resistance grid leaks are often of great assistance in improving the sensitivity of a short-wave set.

Bad contact at the 'phones, valves, coil sockets, rheostats, or in any of

SETS THAT HOWL

—continued from page 133

Therefore, if its introduction does not stop the howling, don't consider your money and time has been wasted.

The next thing to do is to insert one or two “anti-mobo” arrangements. This is quite a simple business. I would advise you to start at the detector valve. (A separate H.T. lead for each valve is strongly advisable, and the set should be altered for this if it is possible.)

Fixing Anti-Mobos

Supposing the detector is fed by H.T. plus 1 terminal, you connect up a resistance and fixed condenser as shown at Fig. 2. A wire-wound non-inductive resistance is required, and cheap ones especially designed for this job are obtainable.

It is no good putting in an anti-mobo if the same terminal feeds more than the one valve with H.T.—that is, unless the device is fixed up in the set as shown at Fig. 3. But aim at separate tappings for each valve.

When you have fixed up an anti-mobo you may have to increase slightly the H.T. voltage for the valve concerned. The last valve doesn't want an anti-mobo—the output filter does this job as well.

Anti-mobos may be just as badly wanted when an H.T. battery is used. And a run-down H.T. battery, by the way, can be an originator of L.F. instability.

Reversing Transformer Connections

In a set using two L.F. transformers, howling can quite often be stopped by reversing the connections to one or other or both of the primary windings of the transformers. Even when only one L.F. transformer is used, the expedient of reversing the primary winding connections should be tried.

Finally, never tolerate L.F. instability; even if this is not evinced until the volume control is over to maximum volume, or if the nuisance can be stopped by cutting down H.T. severely; don't leave it at that, because what you do get may not be the best the set can give you.

the leads will give rise to scraping and scratching noises.

The earth connection is really part of the aerial circuit, and it is impossible for the latter to be good if the earth connection is not.

CLIX 21 VARIETIES

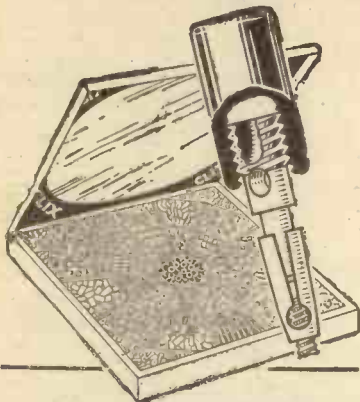

No. 10. CLIX-LOX WANDER PLUG

Adjustable to fit any socket. A turn of the insulator locks it. Special short insulator. Red, Black, and Green 2½d.

The above is one of the many useful lines displayed in the Clix Showcase.

Supplied with engraved insulators

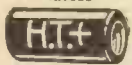

for ½d. extra. Full range of markings.

Look for the Clix Showcase on your dealer's counter. Write for descriptive leaflet: "A Matter of Connection."

LECTRO LINX LTD.,
254, Vauxhall Bridge Road, S.W.1



PUT HYDRA for safety BETWEEN YOUR MAINS AND SET

Build an eliminator with HYDRA Condensers and you are putting between the high voltage of your mains and your set the surest safeguard that science can provide.

Fit HYDRA for safety.

HYDRA Condensers are built to stand up to higher pressures than your mains supply—and every one is tested before it leaves the factory—tested far beyond its stated working voltage.

In all the best ELIMINATORS you'll find

HYDRA CONDENSERS

LOUIS HOLZMAN, 37, Newman St., London, W.1. Telephone: Museum 2641.

A.C. versus D.C.

—continued from page 149

so that it will work a transformer in a similar manner to A.C., but none of them have proved very satisfactory. They are really impracticable, a fact which is demonstrated by the absence of a popular commercial edition of any one of them.

We have seen how that a D.C. eliminator performs two main functions, which are similar to two of the three stages of an A.C. eliminator. Therefore a unit can be constructed for use in front of a D.C. eliminator which will make it suitable for use on A.C. mains.

It may be necessary to alter the values of the fixed resistances to keep the output voltages right, but this is only a minor detail.

A Converter Unit

A circuit diagram of such a unit is shown. It consists of a transformer and rectifier, the output from which is connected to the D.C. eliminator as though it were the mains supply. Either half- or full-wave rectification may be employed, and the rectifier may be either a valve or one of the modern dry metal rectifiers. In the latter case the filament winding of the transformer will not be necessary.

The output voltage from the transformer must be sufficiently high to give the same voltage as the D.C. mains, after allowance has been made for the voltage drop which will take place in the rectifier.

The transformer must be of the right voltage and frequency for the particular mains to be employed. Most mains have a frequency round about 50 cycles, but some have as low a value as 25 cycles.

Low-Frequency Mains

Mains of low frequency may require more smoothing to avoid hum com-

pletely, and if trouble of this nature is experienced it will be necessary to use more condensers or condensers of a larger capacity for smoothing. The use of another L.F. choke with shunt condensers will prove helpful as a last resource in obtaining absence from hum.

It is easy to use an A.C. eliminator on D.C. mains. All that has to be done is to remove the rectifier and feed the mains straight on to the smoothing circuit.

Do not forget, however, to insert a 2-mfd. condenser in the earth lead, to avoid possible short-circuits.

The Easy Way TO PERFECT RADIO

In addition to their own extensive range PETO SCOTT offer YOU every known Radio Receiver or Component on

EASY TERMS with SERVICE AFTER SALES

The following list is merely representative and we ask you to fill in the coupon below or send us a list of your requirements.

THE "ECKERLEY" THREE (see December issue). Complete kit of components, including panel, cabinet, valves and coils, Cash £12.1.6, or 12 monthly instalments of 22/-.
EXIDE 120-volt H.T. Accumulator TYPE W.J., in crates, Cash £3.15.0, or 12 monthly payments of 6/11. TYPE W.H., 120 volts, in crates, Cash £4.13.0, or 12 monthly payments of 8/6.
OSRAM MUSIC MAGNET, Cash £9, or 12 monthly payments of 16/8. Valves included.
CELESTION C.12 LOUD SPEAKER, in Oak, Cash £5.12.6, or 12 monthly payments of 10/4; in Mahogany, £5.17.6, or 12 monthly payments of 10/9.

PETO SCOTT CO., LTD.

Free Demonstrations and advice by Qualified Engineers at our Shops—

77, CITY ROAD, LONDON, E.C.1.

Telephone: CLERKENWELL 9406-7-8.

62, HIGH HOLBORN, LONDON, W.C.1.

Telephone: CHANCERY 8266.

4, Manchester Street, Liverpool.

33, Whitelaw Road, Chorlton-Cum-Hardy, Manchester.

Telephone: CHORLTON-CUM-HARDY 2028.

Mail coupon in unsealed envelope under ½d. stamp.

COUPON

Please send me your 48-page Illustrated Catalogue describing the 1929-30 products of all the leading makers.

NAME.....

ADDRESS.....

M.W., 2/30.

All Applications for Advertising Space in "Modern Wireless" must be made to the Sole Advertising Agents,
JOHN H. LILE, Ltd., 4, Ludgate Circus, London, E.C.4.

'Phone: City 7261.

HEAYBERD

ALL-MAINS TRANSFORMERS

Built to give long and satisfactory service. Use these free-from-breakdown Transformers—next time!

TYPE

21'-

W.14

21'-

135 volts 70 m.a. (H.T. Rectifier).
2-2 volts 4 amps. (L.T. A.C. Valves).
F. C. HEAYBERD & Co.,

10, Finsbury St., E.C.2.

Telephone: Clerkenwell 7216

BULGIN
RADIO PRODUCTS

COMPONENTS YOU WILL NEED FOR THE "ECKERSLEY" A.C. THREE

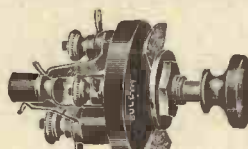

1 S.P.C.O. Switch, No. S33 - 2/3
1 Standard Switch, No. S22 - 1/6
1 H.T. Fuseholder, No. F4 - 1/3

or

THE "B.P." FIVE

1 3-Spring Switch, S39 - 1/3
1 N7 Condenser - 4/9
600-ohm Resistor, No. R55 - 1/6
1 H.T. Fuseholder, No. F5 - 9d.

or

THE "ELECTRIC" TWO

1 Station Log N.P. - 1/6
1 Pair No. 5 G.B. Clips - 4d.

AMPLE STOCKS ARE AVAILABLE.
REFUSE SUBSTITUTES.

Send 2d. for our 56-p. catalogue.

A. F. BULGIN & CO.
9-10-11, Cursitor Street, Chancery Lane,
LONDON, E.C.4.

ELECTRICAL ECHOES
—continued from page 158

can contribute to these bad results. The valve itself can handle properly only a certain amount of energy. You can feed-back so much for re-amplification, but if you increase the feed-back beyond a certain point you will overload the valve.

Additionally, a sort of continuance effect can occur. You read recently in "M.W." that if you reduce the resistance of a circuit very considerably an oscillating current will persist for a long time. An instance was given where a current continued in a ring of lead immersed in a liquid gas (this reduced its resistance enormously) for half an hour.

If the tuning circuit of our regenerative arrangement is reduced in resistance to zero the feed-back increases until the oscillations are maintained indefinitely.

Exit High Notes

But there will be a marked continuance long before this condition is reached. When the circuit resonates at only the one frequency, its selectivity has reached its highest degree, and it will deal only with the fundamental or carrier-wave of our broadcaster.

No speech or music gets through, but the slightest departure from zero resistance (optimum selectivity) brings in the nearest side-band frequencies, which are those representing the lowest notes.

A very narrow wave-band response gives you a preponderance of low notes, together with some incidental continuance of these, and there is a muffled, drummy result.

Very Misleading

Inasmuch as the lower audio-frequencies represent greater energy than the higher audio-frequencies, it frequently happens, even in a narrow band, that the former become less apparent than the latter, for the simple reason that the valve can give the higher frequencies more reasonable treatment before serious overloading occurs.

Thus there might not be a definitely boomy effect so much as a general muzziness forming a background to a modicum of clarity. This is very misleading, because when the low notes lose their individual character in this way one is apt to think that there is a less serious high-note loss.

TELEVISION IN 1930?
—continued from page 180

and if not to-morrow, in a hundred years time, or more—or less. Inventions can't be mapped out and definitely forecast to be ready as one can definitely forecast how long it will take to hatch an egg.

Mr. Abbott's Reply

However, to return to the subject of Mr. Barrie Abbott, who, as our readers know by now, has linked up with various other gentlemen who are out to boost the Baird system regardless of the fact that they themselves have not technical qualifications which entitle them to criticise the opinions of such men as Capt. P. P. Eckersley, Dr. J. H. T. Roberts, Sir Oliver Lodge, and other famous physicists.

In reply to our Editorial in January, Mr. Barrie Abbott writes as follows:

"I desire to thank you for your editorial reference in the January issue of MODERN WIRELESS, and for the tolerant attitude which you express to my article on the subject of television in Germany. It might have been fairer to me, however, if you had seen your way to publish my article, but in the absence of such publication I feel sure that you will allow me to reply through your columns."

(Ed. Note: We are dealing with this letter in detail because it is interesting. We did not publish Mr. Barrie Abbott's article in full because it contained a good deal of matter which we did not feel to be of general interest to our readers.)

Mr. Abbott continues in his letter to the Editor:

"As regards technical qualification, it by no means follows that if one has a sound knowledge of ordinary wireless (as I believe you and Captain Eckersley have) one must also have a technical knowledge of television. I honestly believe that neither you nor Captain Eckersley has had either the inclination or the opportunity to perform experiments in television. I doubt whether any of the experts to whom you refer have studied the whole problem of television as closely as I have done for at least two years; and probably none of them has gone through the Baird laboratories in London and seen the latest developments as I have done."

(Continued on page 211.)

A Bureau for Your Wireless!



For ALL SETS or RADIO-GRAM.
Nothing to touch! The snug way those untidy, dusty parts, trailing wires and batteries are compactly enclosed will delight you. As a beautiful piece of furniture, the "RADIOLA" will add pride to the home because it is modern and stylish.

Already over 3,000 delighted users. Highly recommended by the Radio Press and the leading experts.

"Radiola" de luxe, from £5 5 0 to £11 11 0
"Popular" Oak Model, from £3 15 0

Cash or Easy Payments.

A stately British-made Cabinet, trade-marked and guaranteed, sent on APPROVAL. (If you wish to part with it we will willingly refund FULL MONEY and pay return carriage, too!) Full particulars, Booklet and Photographs FREE.

PICKETT'S WIRELESS FURNITURE MAKERS.

"M.W." WORKS, BEXLEYHEATH, KENT.
Established since the beginning of Broadcasting.

For the Best in Radio

WILL-DAY LTD.

(THE BEST IN THE WEST)
10 LISIE STREET, LECHESTER SQUARE, LONDON, W.C.2.
Telephone: (Home) 4911; (Office) 4912. Telegrams: Willday Radio Ltd.

OPEN TILL 7 P.M.
WRITE FOR OUR CATALOGUE
POSTAGE 6d. FREE TO CALLERS

Make
The DAILY SKETCH
YOUR Picture Paper



The W.B. All-Bakelite Loud Speaker

This is the new model which has proved so popular. The mellow Tone and Full Volume of this Speaker are things to marvel at. It brings out the low and the high notes to exceptional advantage without overloading. The case is beautifully made and finished in mottled bakelite. At 42/- this new Whiteley Boneham Speaker is one of the big things in present-day speaker value.

42/-

Ask to hear it at your Dealer's
WHITELEY BONEHAM & CO., LTD.,
 Nottingham Road, Mansfield, Notts.
 Telephone: Mansfield 762. Telegrams: Whitebon, Mansfield
 London Office: 21, Bartlett's Buildings, Holborn Circus, E.C.4
 Telephone: Central 6669.

The W.B. 4-Fole Balanced Armature Cone Unit costs only 12/6. Mount it in the W.B. Cone Chassis, price 10/6, and you have an excellent loud speaker for only 23/-.

HIGH-GRADE QUEEN ANNE STYLE FIGURED OAK CABINET

Height 3 ft. 3 ins.
 Depth 1 ft. 3 ins.
 For Panels up to 21 ins
 X 7 ins.
 Baseboards up to 11 ins.
£5:5:0
 Carriage Paid.
 Prices of other size in proportion.

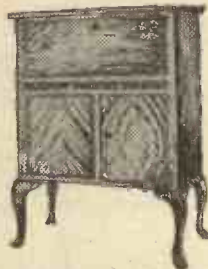

Manufacturer of all types of wireless cabinets and furniture of every description.

Illustrated lists free.
GILBERT, Cabinet Maker, SWINDON.
 Estimates Free. Estd. 1866.

CPAREX
 SCREENS & COMPONENTS
"ECKERSLEY" A.C. THREE
 Differential Reaction Condenser - 5/-
 Polished and Mottled Screen, 7" x 6" - 1/9
 On-Off Switch - 1/-
 Parex H.F. Choke - 3/6

THE "B.P." FIVE
 Polished (Trelleborg) Ebonite Panel, 28" x 8" (Drilled to Specification) - 17/6
 600-ohm De-Coupling Resistance - 2/-
 Standard Screen, 10" x 6" - 2/-
 Standard Screen, 4 1/2" x 6" - 1/-

DIRECT FROM
E. PAROUSSI, 10, Featherstone Buildings, High Holborn, London, W.C.1
 'Phone: Chancery 7010

The Picture Paper with the **MOST News**
SUNDAY GRAPHIC

TELEVISION IN 1930?
 —continued from page 210

Technical Qualifications

(Ed. Note: Our readers will note the above paragraph, no doubt, with some amusement, for it betrays in an exemplary manner Mr. Barrie Abbott's complete ignorance of any elementary curriculum of physics. Radio is a branch of physics, and so is television. Captain Eckersley is considered by Mr. Barrie Abbott to have no knowledge of television, although Mr. Abbott is good enough to consider that he has sound qualifications in wireless! Mr. Barrie Abbott seems to regard television as an entirely new branch of physics, whereas television, from the physicists' standpoint, is a problem as old as the hills and has been studied even more than the two years that Mr. Barrie Abbott has devoted to the subject! To suggest that Captain Eckersley, Sir Oliver Lodge, Dr. Roberts, etc., know nothing of the problems of television compared to the two years' study of the subject made by Mr. Barrie Abbott, is sufficiently indicative of the technical efficiency of the writer of the letter we are quoting.)

Mr. Barrie Abbott goes on to say: "The technical truth of the matter, so far as I know it, is that at present Baird television, which is synonymous with British television, is the only system in the world which has actually reached the commercial stage, because it alone has automatic synchronism (sic), and it alone gives real worth-while television within the existing wave-band."

(Ed. Note: We agree that the Baird television system has reached a commercial stage, but we are open to be convinced that it gives real worth-while television within the existing wave-band. We join with everybody else in hoping very sincerely that it does.)

Lack of Facilities

Mr. Abbott then continues: "There is no doubt whatever that had the British wireless authorities given long ago those broadcasting facilities, without which no system of television can function, British television would have been much more developed than it is. The fault does not lie with Baird, but with those who have withheld transmission facilities."

(Ed. Note: We wonder if Mr. Baird agrees with this.)

(Continued on page 212.)

DEPENDABLE
 MAINS UNITS, AC and DC
REGENTONE
 A.C. MAINS RECEIVERS
 and
 MAINS COMPONENTS

FOR RADIO from the MAINS

REGENT RADIO SUPPLY CO
 21, Bartlett's Buildings, Holborn Circus
 London, E.C.4. Telephone, Central, 9661

SOLVE ALL H.T. TROUBLES **WET BATTERIES**
TAYLEX
 SELF GENERATING

Per doz.	No.1	No.2
	s. d.	s. d.
Jars (waxed)	1 3	1 6
Sacs	1 2	1 9
Zincs	10	11
Rubber Bands (24)	4	4
Terminals	8	10

Special sizes for Pentodes.

LONG LIFE: SILENT: ECONOMICAL
 Sample doz. (18 volts), complete with bands and electrolyte. No. 1, 4/1; No. 2, 5/-; post 9d; terminals extra. No. 3, with terminals, 7/6 (10,000 milli-amps), sample unit 6d. Order: 10/- carr. paid. New illustrated catalogue post free.

FREE Bargain List of Receivers, Amplifiers and Components.
M. TAYLOR, 57, Studley Road, Stockwell, London.

ENGRAVED ON THE TOP
 —like the **Terminals**

The finishing touch that stamps Belling-Lee as the best. Completely insulated engraved top. The prongs, made of special spring metal, make a firm efficient connection. Entire flex—copper rubber and braiding—individually gripped without use of tools.

BELLING-LEE WANDER-PLUS
 Price 4d.

BELLING-LEE FOR EVERY RADIO CONNECTION

Ask your dealer, or send to us, for Belling-Lee Handbook, "Radio Connections" Advertisement of Belling & Lee, Ltd., Queensway Works, Ponders End, Middlesex.

PLEASE be sure to mention "MODE N WIRELESS" when communicating with Advertisers. THANKS!

TELEVISION IN 1930?
—continued from page 211

“ Even now, when your journal gives the information that television broadcasts in America, consisting merely of shadowgraphs, are being allowed from 3 to 4 p.m. and from 7 to 10 p.m., British television has not yet attained any time within programme hours, and the use of an additional line for speech or music as well as vision is still being withheld. The old story—other countries go ahead while Britain sleeps!”

(Ed. Note: One step at a time. Limited facilities have been granted the Baird Company, but what facilities have been given to the public so far? Why should the existing broadcasting arrangements, for which the public listener pays his licence fee, be completely upset in order to grant facilities to a television system which has yet failed to demonstrate to the public the claims made for it?

The authorities in this country have been quite right in not upsetting existing British broadcasting arrangements until definite proof has been obtained that a television system has been perfected sufficiently well enough to make its popularity with the British public assured.)

Mr. Abbott continues again: “Why should you, as the responsible Editor of a British wireless magazine, not do all you can to help Britain to win the race for television supremacy? Why should you and Captain Eckersley not press for greater facilities for British television, and also for revision of the wave-band allocation which, framed originally for ordinary wireless purposes only, has been rendered obsolete by the advent of television? Surely you would like to see Britain leading the world in this matter, if possible?”

(Ed. Note: The last two words of the above paragraph explain our attitude—*IF POSSIBLE*. We should be delighted—and we are getting rather tired of repeating that statement—to see Britain “win the race for television supremacy”; it is superfluous to drag in Captain Eckersley, because he, perhaps above all men, is more concerned with the leadership of Great Britain in all matters relating to radio. He has done so much himself and, knowing him as we do, we know that he would be overjoyed if a British wireless television system were to be definitely established as the leading system and fulfilling the service conditions he has so sensibly laid down.)

Justice and Encouragement

Mr. Barrie Abbott concludes his letter by saying: “I assure you that, while my efforts on behalf of British television are not contrary to technical realities, they derive any force they may have from a strong desire to see justice and encouragement meted out to a pioneer British industry instead of injustice and discouragement, as has been the case until now. If I could help to persuade you and Captain Eckersley to join those who are striving to help British television in the race for world supremacy, I should be very pleased indeed. My attitude is entirely friendly, and I would be delighted to try and arrange for both of you to visit the Baird laboratories at an early date, if you so desire.”

(Ed. Note: We quite believe that Mr. Barrie Abbott is sincere in assuming that his efforts on behalf of British television are not contrary to technical realities. Nevertheless, we disagree with him, and we can only assume that his knowledge of technical realities with regard to wireless and television are not quite so all-embracing as he appears to

think they are. That they derive any force they may have from strong desires Mr. Barrie Abbott holds to see justice and encouragement meted out to a pioneer British industry, we feel sure is true, but here again we fear he is a little prejudiced, and perhaps carried away by his own strong emotions about the matter, by stating that “injustice and discouragement” has been the case until now.

Impartiality seems to be a word not very clearly appreciated by Mr. Barrie Abbott. As for persuading Captain Eckersley and the Editor of this journal to join those who are striving to help British television in the race for world supremacy, Mr. Barrie Abbott will not have the slightest difficulty in doing that once we are assured that the Baird system is the system which will carry Britain forward to win the race for television supremacy, and once we are assured that the public like this system and regard it as worth while, and that it fulfils the service conditions necessary in any intelligent broadcasting system.

Still No Sets

Quite apart from any scientific merit or demerit of the Baird system, if the public wants his system that is the end of the matter. What the public wants, it must have. We advise Mr. Barrie Abbott and all those connected with him in this matter of television to exercise every effort they can in securing an early market delivery of television receivers. Nothing would settle the problem quicker than the delivery of television sets to the public. For two years or more now they have been promised; they were promised the last time for early delivery in January, but as we write these words there is not the slightest sign, for example, of our receiving the television instrument we ourselves ordered at the Radio Exhibition two years ago.

INDEX TO ADVERTISERS

	PAGE
Belling & Lee, Ltd.	211
Benjamin Electric, Ltd.	193
British General Manfg. Co., Ltd.	193
Bulgin, A. F., & Co.	210
Burne-Jones & Co., Ltd.	202
“Bestway” Wireless Books	205
Carrington Manfg. Co., Ltd.	193
Celestion, Ltd.	199
Cossor, A. C., Ltd.	110
Clarke, H., & Co. (M/c.), Ltd.	204
Dubilier Condenser Co. (1925), Ltd.	197, 201
Day, Will, Ltd.	210
Edison Swan Electric Co., Ltd.	181, 197
Ever-Ready Batteries	185

	PAGE
Ferranti, Ltd.	Cover iii
Forno Company	199
Garnett, Whiteley & Co., Ltd.	207
Gilbert, J. C. (Cabinets)	211
Graham Amplion, Ltd.	109
Holzman, Louis	209
Hughes, F. A., & Co., Ltd.	Cover ii
Hcayberd, F. C., & Co.	209
Igranic Electric Co., Ltd.	201
Impex Electrical, Ltd.	203
Jackson Bros.	187
Lectro Linx, Ltd.	209
Lissen, Ltd.	175
London Elec. Wire Co. & Smiths, Ltd.	199
New London Electron Works, Ltd.	197
Paroussi, E.	211
Peto-Scott Co., Ltd.	209

	PAGE
Pickett's Cabinet Works	210
“Popular Wireless” Blue Prints	203
Radio Instruments, Ltd.	Cover iv
Ready Radio	208
Regent Radio Supply Co.	211
Rothermel Corpn., Ltd. (Centralab)	201
Rothermel Corpn., Ltd. (Magnavox)	187
Taylor, M.	211
Telegraph Condenser Co., Ltd.	189
Varley Products	189
Wingrove & Rogers, Ltd.	206
Whiteley, Boneham & Co., Ltd.	211
Wright & Weaire, Ltd.	204

All communications concerning advertising in “Modern Wireless” must be made to John H. Lile, Ltd., 4, Ludgate Circus, London, E.C.4. Telephone: City 7261.

FERRANTI RADIO IN THE HOME



“That’s beautiful! don’t alter it, Betty—”

The Ferranti A.C. Mains Receiver is designed with recognition of the fact that Radio is now an accepted part of the equipment of the home. Beautiful in design and workmanship, it provides entertainment of very high quality. The cost of running—entirely from the mains—is negligible, and manipulation is the simplest possible.

Available for Alternating Current only, 200/250 volts, 40 cycles or over.

PRICE, including Valves:
 In Oak - - - £25
 In Mahogany - - £26
 In Walnut - - - £26
Royalty £1 extra.

Ready for immediate delivery.

FERRANTI LTD.
 HOLLINWOOD
 LANCASHIRE

The FERRANTI A.C. MAINS RECEIVER

AND NOW
The Price Right

HYPERMITE L.F. TRANSFORMER



12¹/₆

Little Bigger than a Matchbox
and weighs only 7 oz., yet its
**PRIMARY INDUCTANCE
EXCEEDS 50 HENRIES**

The Radio Marvel of 1930

The new L.F. Transformer weighs only 7 ozs., yet has a primary inductance of over 50 henries.

A CORE OF THE NEW NICKEL ALLOY

Here at last is a transformer built with a core of a new nickel alloy, of enormous permeability, yet sold at a price which places it within the reach of the average home constructor.

The "Hypermu," at 21/-, is, of course, the best Transformer it is possible to buy, but the "Hypermite" gives an opportunity of acquiring at the popular price of 12/6 a modern transformer with a high inductance, which guarantees the retention of the low frequencies without sacrificing the high.

The name of "R.I." in connection with radio products is a guarantee of excellence throughout the world, and a comparison of this transformer with any of the bulky, expensive transformers will definitely establish its value. It is an absolute boon to *set makers*, who are most enthusiastic with its performance. They have already placed contracts for the "Hypermite" for their 1930 Season for *Portable Sets*.

A "Hypermite" leaflet, with full diagrams, will tell you all about it. Ask your dealer for a free copy or send direct to the manufacturers. The "Hypermite" will be one of the outstanding features of progress in Radio during the 1930 season. Try it in your set.

Made by the Pioneers of
Transformer Production



Ask
for the
HYPERMITE
leaflet.

12, HYDE STREET, LONDON, W.C.1