

PORTABLES FOR EVERY PURPOSE

# MODERN WIRELESS

1 1/2 MONTHLY

Vol. XI. No. 30.

The Leading  
Radio Magazine.

Wave Trap missing  
JUNE, 1929. 660



MARCONIPHONE



LOTUS



PYE

## SPECIAL PORTABLE SET NUMBER



LISSEN



MULLARD



IGRANIC

# Free MULLARD'S Latest Greatest Circuit



Here's the Screened Grid Pentode set that you've been waiting for and what's more it's a Mullard Master circuit.

The new Mullard S.G.P. Master Three is designed round the wonderful Mullard "Pentone" and Screened Grid valves, and takes the fullest possible advantage of their amazing capabilities. It puts you right up alongside those distant stations—they become really enjoyable instead of being merely audible. Tuning is razor sharp, volume terrific.

This new Mullard set is as easy to build and operate as the original Master Three—need we say more?

Post the attached coupon to-day.

# Mullard

S · G · P 3  
MASTER 3

**CUT HERE AND POST TO-DAY.**

To the Publishers:  
"Radio for the Million," 63, Lincoln's Inn Fields, London, W.C.2.

Please send me Simplified Plan of Assembly of the new Mullard S.G.P. Master Three, and Free copy of "RADIO FOR THE MILLION" Vol. 3, No. 2.

Name.....  
(BLOCK LETTERS)

Address.....

M.W.

# CONTENTS

VOL. XI. No. 30.

MODERN WIRELESS.

JUNE, 1929.

	Page		Page
Editorial .....	583	The Mystery of the Ether .....	625
Buying a Portable .....	584	The "Auto Tune" One .....	628
Quality v. Quantity .....	587	Questions Answered .....	633
Radio on Railroads .....	589	The "Traveller's" Two .....	639
The "M.W." Portable Five .....	592	Illustrated Radio .....	652
Setting up Sound Waves .....	599	Radio Abroad .....	654
Pentodes and Portables .....	601	B.E.C. Finance .....	655
The Latest Wave-length Solution .....	603	In Our Test Room .....	658
My Broadcasting Diary .....	605	On the Short Waves .....	660
Short-Wave Schedules .....	607	How to Use Wave-Traps .....	662
Open-Air Radio .....	608	Permanent Sounds .....	663
Portable Fastimes .....	614	Radio Balance and Control .....	667
What Readers Think .....	616	In Passing .....	670
The S.G. Valve as a Rectifier .....	617	An Easily Made Milliammeter .....	672
Testing Telephones .....	619	Radio Notes and News .....	679
The "Kutemout" Three .....	620	The New Abbreviations .....	683
		Wireless Master Patents .....	683

SPECIAL SUPPLEMENT, "RADIO AND THE GRAMOPHONE," PAGES 643-650.

*As some of the arrangements and specialities described in this Journal may be the subject of Letters Patent the amateur and trader would be well advised to obtain permission of the patentee to use the patents before doing so.*

Edited by NORMAN EDWARDS.

Technical Editor: G. V. DOWDING, Grad.I.E.E.

Scientific Adviser: J. H. T. ROBERTS, D.Sc., F.Inst.P.

# MARCONI VALVES

## MARCONI 2-VOLT VALVES

- S215 Screen Grid - 22/6
- H210 H.F. and R.C. 10/6
- HL210 H.F. and G.P. 10/6
- L210 G.P. and L.F. 10/6
- P215 Power - 12/6
- P240 Super Power - 15/-

Write for new Marconi Valve catalogue No. 520. The best Marconi Valves for your receiver (portable or otherwise) will gladly be recommended on receipt of circuit details.

The Marconiphone Co. Ltd.,  
210-212, Tottenham Court Rd.,  
London, W.1.

For Portable Receivers Marconi 2-volt Valves are unexcelled. Their high efficiency builds up the microscopic voltages received by the frame aerial into full loud speaker strength. Clear, crisp speech and true toned music are obtainable with the lowest possible H.T. and L.T. consumption.

For screen grid stages use Marconi S215 and for aperiodic H.F., Marconi HL210. In the detector stage Marconi H210 or HL210 will give best results, followed by Marconi HL210 or L210 in the first L.F. socket. Finally, Marconi P215 for average power output and economy, or Marconi P240 where large capacity H.T. batteries are fitted.

For the M.W. "Portable Five" 3 Marconi HL210, 1 Marconi H210 and 1 Marconi P215 are recommended.



# INTERLOCKED ELECTRODES MAKE Cossor Screened Grid Valve—

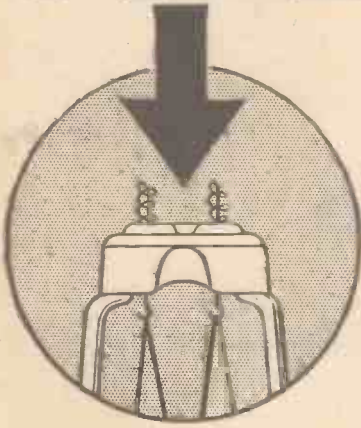

## SHOCK - PROOF !

These illustrations show why the Cossor Screened Grid Valve is the most robust—the most dependable—and the most uniform Screened Grid Valve made in Great Britain. This wonderful new system of interlocked construction is to be found only in the Cossor Screened Grid Valve.

## NOISE - PROOF !

Noises are generally due to loose elements in a valve. In the Cossor Screened Grid Valve the elements are interlocked. Every joint is scientifically welded to ensure long life and complete rigidity. Even under the heaviest shock individual movement is impossible.

## BREAK - PROOF !

Even the hardest blow cannot disturb the perfect alignment of the Electrodes which are rigidly braced at top and bottom. As a result, every Cossor Screened Grid Valve retains its characteristics throughout its abnormally long life. For any Screened Grid Receiver choose Cossor. Accept no substitute—for there is no adequate substitute for the Cossor system of Interlocked construction.



**1.** Here you see the double length of Cossor filament famed for its colossal emission. Note the neonite bridge holding it rigidly in position.



**2.** Around the two stout grid supports is wound the first grid, electrically welded at twenty-five points.



**3.** Note the enormous strength and rigidity of the screen. See how it is built on four stout supports and capped by a metal bridge-piece anchored to neonite insulator.



**4.** Finally, observe the construction of the anode. Actually two rectangular nickel plates are used and for greater rigidity each is diagonally ribbed.

**Only Cossor Screened Grid Valves have interlocked Electrodes**

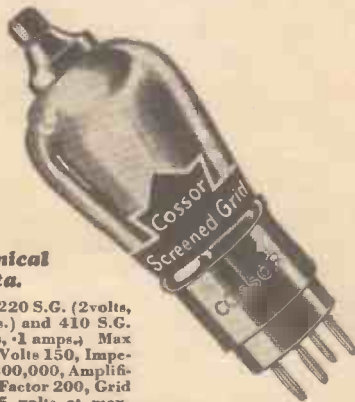

**Technical Data.**

Cossor 220 S.G. (2volts, .2 amps.) and 410 S.G. (4 volts, .1 amps.) Max Anode Volts 150, Impedance 200,000, Amplification Factor 200, Grid Bias 1.5 volts at max-anode Volts.

Price (each) **22/6**

A. C. Cossor Ltd., Highbury Grove, London, N.5.

# Cossor Screened Grid

**THE ONLY SCREENED GRID VALVE WITH INTERLOCKED CONSTRUCTION**



# MODERN WIRELESS

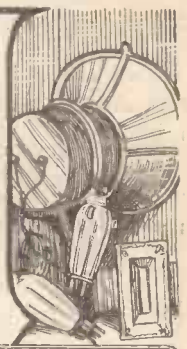

Vol. XI. No. 30.

JUNE, 1929.

*Portables for Constructors—Commercial Types—Ultra-Selectivity—The “Kuttemout” Three—The “Auto-Tune” One—Radio Politics.*

## *Portable Popularity*

**T**HERE is no gainsaying the fact that the Portable has now achieved tremendous popularity. In fact there are 116 various types of portable sets on the market to-day, and at least 37 radio manufacturers may be said to be specialists in the design, construction and sale of types of portable sets.

And so it is not surprising that a special number of MODERN WIRELESS should be produced dealing in reasonable detail with portable sets.

## *Rigorous Tests*

**N**OW there are two sets in this issue which are strictly portable. The designers have been working on them for a long time. Two others which they were working on did not pass that high standard test which is so essential before a description of the receiver appears in MODERN WIRELESS. We prefer, therefore, instead of describing four portable sets, to describe the two which have passed the most rigorous tests in our Test Department.

It is true that our readers have thus only the choice of two portables instead of four, but the M.W. “Portable” Five and the “Traveller’s” Two represent all that is best and soundest in portable set design.

## *A Powerful Portable*

**T**HE “Portable” Five has been designed and described by G. Van Colle, of the MODERN WIRELESS Research and Construction Department. It is a powerful, long-range loud-speaker set of the completely self-contained type, and no further eulogy of that set is required here. A glance at the editorial pages devoted to its description, and in particular a glance at the photographs and the theoretical diagram, will indicate to the technical reader that here is a multi-valve portable of the premier class.

## *The “Traveller’s” Two*

**T**HE “Traveller’s” Two is a lightweight set and, of course, is only suitable for telephone reception.

But it only weighs about 12 lb., frame aerial and all complete. It also incorporates a novel scheme of wave-change. In short, it is just the sort of set the radio tourist travelling light will find useful.

## *The Problem Reviewed*

**M**R. PERCY W. HARRIS, the Editor of our contemporary, the “Wireless Constructor,” also contributes a long article on portable sets. Mr. Harris’s articles need no further reference here: his judgment and experience in all matters relating to radio technique for the amateur are too well known to need recapitulation.

## *Real Selectivity*

**T**WO other sets are included in this issue of MODERN WIRELESS: one, the “Kuttemout” Three—the fancy title for this set probably being due to the Spring feeling, which exists even in our Technical Department. This set uses a special ultra-selectivity scheme which has been developed by the MODERN WIRELESS Research and Construction Department. It is a powerful loud-speaker receiver, and you can cut out your local station in a degree or two on the variable condenser.

This is not a suggestion; it is a fact. We are not in the habit of making casual statements about the selectivity of a set until it has been very carefully tested—and as the MODERN WIRELESS Research Department’s laboratory is situated within a mile or so of 2 L O’s transmitter, the conditions for testing are, in that sense, ideal.

## *Choice of Programme*

**T**HE “Auto-Tune” One, the last set which needs mention here, is another MODERN WIRELESS Research Department production. The constructor will find that he can set the tuning for two stations and change over from one to the other by the simple operation of a plug and socket. Simultaneously he can throw over the tuning of the wave-trap which is incorporated, in order to eliminate the station not required.

## *Radio Politics*

**W**HICH was the most successful of the pre-dissolution broadcasts? Quite apart from all questions of political sympathies, it seems to be the consensus of opinion that Mr. Lloyd George was the most interesting and entertaining broadcaster, although Mr. Churchill seems to have won much praise for the dramatic method of his delivery. But when all is said and done, politics by radio does not seem to have appealed to the majority of listeners as a suitable programme item!





# BUYING A

## A Selection from the Many

*This is the Marconiphone portable receiver. Note the accessible controls.*

THE chief charm of a portable receiver is not so much its actual portability, for, after all, the so-called non-portable is easily carried from place to place! What we all appreciate is the convenience of having everything—set, aerial, batteries, and loud speaker—in a small case which can be just as readily stood upon the sitting-room table in seaside apartments as on the drawing-room table or in the garden at home.

And speaking of holidays, does not the portable give us a happy deliverance from the dreadful gloom of a wet afternoon indoors? Who does not know those seaside apartments where the only reading matter seems to be a book of sermons, "Popular Recitations," and a bound volume of the "Strand Magazine" for 1896?

No further need to pull aside the lace curtains and gaze gloomily out of the window at the area railings and the shiny pavements beyond! Out comes the portable set, up goes the lid and there is always something to entertain us.

### Amazingly Cheap

Furthermore, portable receivers are now amazingly cheap, for in considering the prices one must remember that valves, batteries and loud speaker are all included, whereas with an ordinary set these are generally added as extras.

Among so many excellent sets the choice is almost embarrassing, but here are a few typical portables with which splendid results are obtainable. All are good and reliable, and though some must, in the nature of things, be mentioned before others, I am naming them in alphabetical order so as to avoid any invidious comparisons!

Take, for example, the Igranic Universal portable. Here we have a truly magnificent instrument where

no effort has been spared to give the best possible results. In this set two boxes are used, one to contain the set, loud speaker and valves, and the other the batteries. Separately the two cases are each lighter than a complete portable, and by keeping the batteries separate it is possible to provide a set the sensitivity of which is truly remarkable.

### Attractive Features

We have, for example, in this five-valve set two screened-grid high-frequency stages, a detector with one resistance-coupled and one transformer-coupled L.F. stages. An excellent balanced-armature cone loud speaker is a feature, while tuning is by vernier drum control.

A portable must not be too heavy!

And it should have a convenient carrying handle.

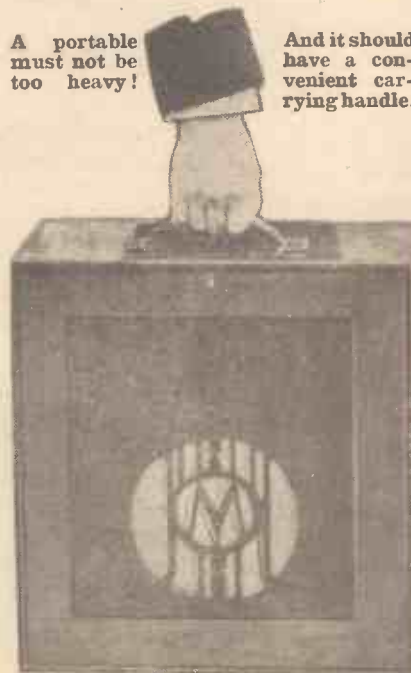

A good example of modern portable set design, the Mullard.

A gramophone pick-up can be used with this set, as provision is made for the insertion of such a device when required. As the batteries are kept separate there has been no need to restrict size, and two large-capacity H.T. units are fitted, together with an adequate accumulator. The whole outfit is most handsome and efficient, while the price (£33 4s. 6d.) is by no means high in view of what one gets for it!

### The "Lissenola"

For modest purses and the men who prefer a completely self-contained instrument in one box we have, as a good example, the Lissenola portable, again with five valves, made up of two stages of aperiodic high-frequency, a detector, and two transformer-coupled low-frequency stages.

As Messrs. Lissen are themselves manufacturers of many well-known wireless components, they have naturally combined these well-tried parts in their own portable, to the distinct advantage of the buyer; for obviously the manufacturer who makes practically everything himself is in a better position than one who has to assemble the parts of other manufacturers.

Thus we get the well-known Lissenola loud speaker, Lissen transformers, and the excellent Lissen 100-volt high-tension battery. This is one of the portables in which provision is made for the connection of an external aerial and earth, while a gramophone pick-up can also be attached.

### Excellent Value

The layout of the instrument is quite handsome, the valves being grouped neatly in the centre, and control for tuning being made very simple. At sixteen guineas this set is certainly excellent value.

Messrs. Garnett, Whiteley & Co., Ltd., whose Lotus components are world-famous, have also entered the portable set field. Lotus components are used very extensively in the set.

# PORTABLE

## Types of This Year's Sets

The Lotus portable has only three valves, but as one is a screened-grid high-frequency valve and another a pentode we get an effect strictly comparable with that obtained with that of five valves of the ordinary type, for one screened grid is practically equivalent to two ordinary high-frequency valves, while the pentode takes the place of two low-frequency stages, a detector being provided as usual.



A notable newcomer: the Lissen portable.

Readers who are acquainted with the excellent quality of the Lotus components will readily understand that the Lotus portable is also of very high quality. The same makers also sell the Lotus transportable, a similar instrument so far as the circuit is concerned, but instead of being of the suitcase type, with lift-up lid containing frame for loud speaker, this instrument stands on a table in a vertical position.

### The Transportable Type

The advantage of this type is that one is able to use a larger frame aerial and, therefore, get better distances, while there is more room for batteries. On the other hand, the set is really less portable, and cannot be taken about so easily. Its great advantage is, of course, that it can be removed

from room to room with little difficulty.

The price of both these instruments is the same, namely, £24 13s. 6d., with a slight increase in the case of the transportable instrument being made for walnut or mahogany case. Again, these represent excellent value.

The Marconiphone Company, Ltd., are well to the front in the portable lists, the Marconiphone portable having established itself in the very front rank. Five valves are used with two semi-aperiodic high-frequency stages, and the two transformer-coupled low-frequency stages.

### A Distinctive Model

The appearance of the Marconi five-valve portable is quite distinct, as will be seen from our illustration, and the inclusion of the Marconiphone cone loud speaker ensures excellent quality. A distinctive touch to this receiver is given by the edgewise tuning dials, while a convenient calibration chart is placed in the lid.

A useful feature of this set is that a plug is provided for the use of an external battery or mains unit, so

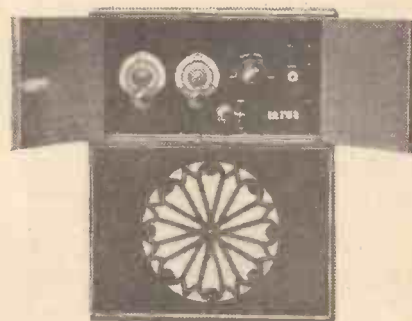

The "Lotus" transportable set.

that the internal battery can be economised and kept for outdoor use. A gramophone pick-up can be plugged in when required for the now popular electrical reproduction of gramophone records. The Marconiphone portable at £29 8s. can be purchased with full assurance of complete satisfaction and excellent value.

### A Design for Constructors

The name of Mullard, which is so intimately connected with valve history, is also well-known for the popular designs put out in the publication "Radio for the Million." Readers who like to build their own portables will find in this Mullard design much of interest, and the results obtainable when the set has been built well reward the listener for the small effort made. Five valves are used, and everything possible has been done to simplify the assembly.

The excellent appearance of the finished Mullard portable will be gathered from the photograph, and on all hands we hear the most gratifying reports of reception with this instrument.

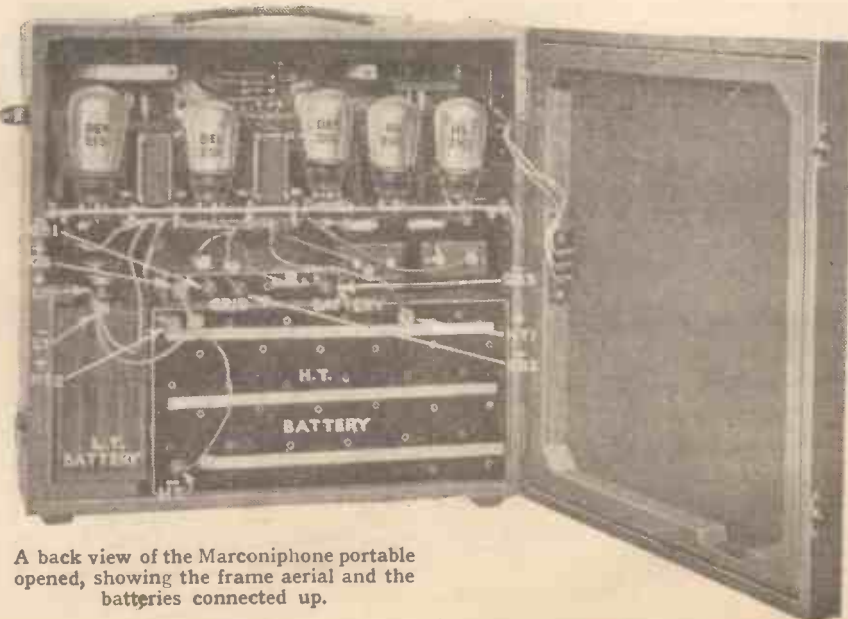

A back view of the Marconiphone portable opened, showing the frame aerial and the batteries connected up.

## A Review of the Leading Portables

Our notes on typical receivers would be incomplete without reference to the famous Pye portable, one of the first to be sold and one which still remains in the very front rank.

The Pye portable has always been distinguished for its excellent quality of reproduction, while its distinctive appearance will appeal to many. The artistic fret covering the loud speaker and the end control are two distinctive features, while so far as the circuit is concerned this, again, is distinctive, a special form of magnetic reaction being included.

### The "New Roadside" Four

Two stages of aperiodic high-frequency are used, and two transformer-coupled low-frequency stages, while either a Pye or a Celestion cone can be included as desired. A turntable is fitted to the base of this instrument to facilitate the location of a station by direction, and a good waterproof cover is also provided. The price of £23 10s. is certainly most reasonable for this type of instrument.

The Ready Radio Supply Company, who are already well known to readers of this journal as suppliers of components and kits for home constructors, are marketing Mr. Percy W. Harris's "New Roadside" Four—an excellent design, first published in

the "Wireless Constructor," and incorporating a screened-grid valve.

The receiver has four valves, a single tuning control, wave-change switching and a number of refinements, making for high-quality reproduction and not usually found in a portable set. The price complete is £15 10s., and the same company will supply a kit of parts for home constructors, if required.



When this excellent "Igranic" set is closed up it resembles a compact attaché case.

Among the excellent "portable" receivers—that is to say, completely self-contained sets of somewhat larger build than the "suitcase" variety, a word must certainly be given to the excellent "Ormond Five," the makers of which are very well known for their variable condensers and other components. The set has two choke-coupled H.F. stages, a detector, and one resistance, and one transformer-coupled L.F. valve, provision being made for use with an outdoor aerial when required. The price—£15—is remarkably low for the value given.

### Unusual Receivers

An interesting set which is adaptable not only for use with an outside aerial, but also for external batteries and loud speaker if required, is the "Peerless Suitcase." Five valves are used, with two transformer-coupled L.F. stages, and the weight complete, ready for working, is given as 25 lb.—an unusually low figure.

The "Rover," Messrs. Peto Scott's transportable receiver, can be obtained finished in either oak or mahogany, and is also adapted for use with an outside aerial and earth

if required, as well as an external loud speaker. Thus one can use either the built-in speaker or some favourite instrument which may be available. Among other refinements is a turntable for rapid searching, and a jack for use with an electrical gramophone pick-up.

Mr. C. S. Dunham's "Dunham Portable" is unusual, in that, instead of the more conventional choke-coupled H.F. stages, high-frequency transformers are used, the switching of these being automatically arranged on the wave-change. Adaptable for use with external aerial and earth, batteries, and speaker, if needed, the weight, complete with batteries, is but 25 lb. Another good feature is the wide wave-length range—250 to 600 metres, and 980 to 2000 metres.

### The G.E.C. "Portable Four"

Quite an unusual portable is the "Sifam Four," which includes a special form of super-heterodyne circuit and special valves with a pentode in the output. Unusual selectivity is claimed with a wave-length range of 180 to 2,800 metres. The weight complete is 30 lb., and the price complete £30.

A comparatively recent comer into the portable field, but one which has already made a host of friends owing to a combination of exceptional range and excellent quality, is the G.E.C. "Portable Four," using a screened-grid H.F. stage, a detector, and two transformer-coupled L.F. stages. The wave-length range is 230 to 550 and 900 to 1,850 metres respectively. It costs £27 10s. complete and represents excellent value for those who want a really first-class set.



The "Pye" portable has its controls on a small panel in the side of the case.



The "Lotus" portable uses an S.G. valve and has a fine range of reception.



# QUALITY v. QUANTITY

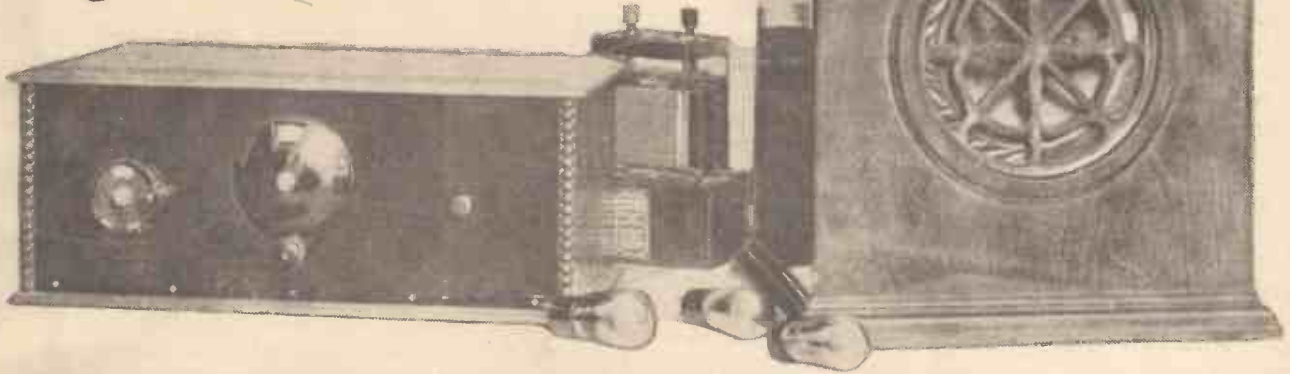

IT is the aim of most wireless experimenters to design their circuits in such a way that they make the best possible use of their components—and, in particular, that they obtain the best results from a given number of valves.

The excellent reproduction that can be obtained from a modern receiver makes it perfectly clear that very loud volumes can be produced without the quality of the reception being sacrificed in any way to mere noise; but, unfortunately, this result is not always achieved.

## The Aerial Circuit

Strange to say, one of the chief causes of the sacrifice of quality is the effort expended in obtaining the greatest volume with the simplest circuit and the smallest number of valves, and it is proposed here to outline briefly some of the reasons for this.

Let us take first the case of the aerial circuit, and the high-frequency amplifying portion of the receiver. If we wished to obtain the loudest results with the most economical

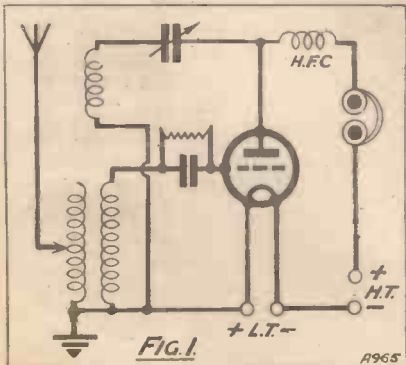

A selective one-valve circuit.

\*\*\*\*\*  
 \* In order to get the best out of a \*  
 \* wireless set we always have to \*  
 \* compromise between quality and \*  
 \* quantity, and the best way of \*  
 \* doing this is discussed in this \*  
 \* interesting article. \*  
 \* By C. E. FIELD, B.Sc. \*  
 \* \*\*\*\*\*

circuit, we might use a very low-loss aerial tuning circuit, working into a leaky-grid detector, with reaction back into the aerial coil, as shown in Fig. 1. A very high degree of sensi-

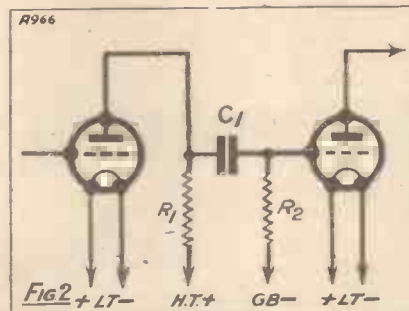

An example of resistance-coupled H.F. amplification.

tivity could be obtained by this arrangement, but in order to get the greatest possible signal strength from distant stations, while cutting out strong signals from local transmissions, the valve would need to be kept near to the oscillating point by the use of very tight reaction coupling.

## Side-bands Cut Off

The result of this would be that the band of wave-lengths received would be so narrow that the higher voice frequencies would be cut off.

You have probably noticed that when a detector valve is nearly oscilla-

ting, signals become very "woolly," and the announcer sounds as if he were speaking with a cloth tied over his mouth. This is an extreme case of the above effect, and indicates that the highest voice frequencies, i.e. the highest notes, are very weak or entirely absent.

The remedy is simple, for by utilizing a high-frequency amplifying valve, a greater degree of both sensitivity and selectivity can be obtained without the same loss of quality. This, then, is clearly a case where two valves are preferable to a single one being forced to do the same work.

## The Output Side

Now let us see what happens when it comes to making the most of the output of a detector or low-frequency amplifier, and passing on the maximum possible signal strength to the grid on the following valve.

Take first the case of a high-amplification valve of the resistance-capacity type, which might have an

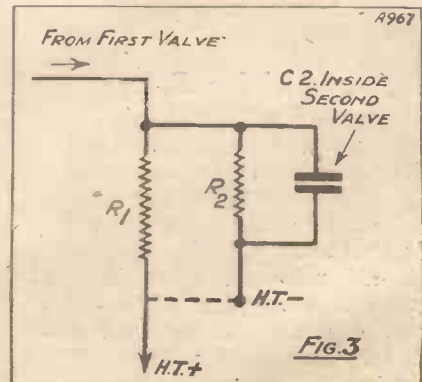

How the valve's internal capacity affects the circuit shown in Fig. 2.

## Selectivity Often Means Poor Quality

impedance of, perhaps, 70,000 ohms and an amplification factor of about 35, and would be followed by resistance coupling. Our circuit will be roughly as shown in Fig. 2, and we are concerned with the choice of suitable values for the anode resistance  $R_1$  and the grid leak  $R_2$ , for these are the components which determine the strength of signal which will be handed on to the second valve.

### Loss of High Notes

If there is ample high-tension voltage, then the higher the value of  $R_1$  the greater will be the signal strength, and so we might take a value of one megohm as being suitable.

Similarly, the grid leak would need to be high, and for use with the value of resistance which we have chosen for  $R_1$  should be about five-megohms. Under these conditions we are getting something like the maximum possible signal strength from the first valve. But what about the quality?

In order to understand how this may suffer we must remember that the second valve possesses capacity between its grid and filament, which means that the grid leak in reality is connected in parallel with a condenser, and these two, neglecting the coupling condenser  $C_1$ , may be regarded as being in parallel with the resistance  $R_1$ , as will be seen from the simplified diagram shown in Fig. 3.

Now, the valve capacity,  $C_2$ , is very small, but it is not small enough to be overlooked, for at frequencies corresponding to high notes it will behave as a much lower resistance than the grid leak, and will definitely reduce the strength of those notes below that of the lower ones. In short, distortion will be introduced, and the benefits of resistance-capacity coupling will be lost.

### Lower Value Better

If we were willing to sacrifice a little volume we could avoid this quite easily, and the improvement in quality would more than balance the loss in signal strength, which would not be very great.

A good value for  $R_1$  would be a quarter of a megohm, while for  $R_2$  about one megohm, or even half that value, would be suitable. The resistance of the alternative path offered by the valve capacity would

then be so high, compared with that of the grid leak, that the high-note loss would be negligible.

Take now the case of a transformer-coupled stage.

After being amplified by the first valve, signals are further amplified, or "stepped up," by the transformer. The extent of the stepping up depends upon the ratio of transformation of the transformer, which is the ratio between the numbers of turns of wire on the secondary and primary windings. Thus if there were 3,000 turns of wire upon the secondary and 1,000 upon the primary, the transformer would magnify the signals three times.

Obviously, therefore, if we desire the maximum signal strength from the stage, all we need to do is to make this transformation ratio as high as possible. This we may do either by

**"VOUS ALLEZ ENTENDRE..."**



A corner of the main studio at the Radio Paris station.

reducing the number of primary turns or increasing the number of turns on the secondary winding.

In the first case, however, we would soon spoil the quality of our results; for if a transformer has too few turns on the primary winding, it will not reproduce low notes. In fact, only the best transformers, operated under the correct conditions, give

a satisfactory reproduction of the lower notes of the musical range.

On the other hand, if we tried to increase our signal strength by increasing the number of turns upon the transformer secondary, we would soon find that our results were distorted by the cutting off of high notes produced by the self-capacity of the large winding, although before this became serious we should probably find that our transformer was becoming impossibly bulky.

### Effect of High Mag. Valve

In the case of transformer coupling, therefore, we should curb our ambitions and content ourselves with a medium step-up in voltage, a ratio of about 3 to 1 being generally a safe value for a reputable transformer.

Now, assuming that we agree to limit ourselves in this way, why should we not try to get something more out of the valves themselves?

Assuming that the second valve, is the last in the receiver, then this must be a power valve of low impedance and necessarily low amplification factor. But is there any reason why we should not double our signal strength by exchanging the first valve for one with an amplification factor twice as great?

We might, for instance, try in this position a valve with a voltage amplification of about 25. This high figure is all to the good, but, unfortunately, it is inseparable from a high impedance.

### Compromise Essential

In order to reproduce low notes faithfully, any increase in valve impedance should be accompanied by a corresponding increase in the size of the primary winding of the following transformer, so that we are faced with the alternatives of reducing our transformer ratio, and therefore our signal strength, or losing our bass notes.

Here again, therefore, an increase in the amplification per stage is obtained only at the expense of the quality of reproduction.

When employing transformer coupling, it is advisable that the impedance of the valve preceding the transformer should not exceed 12,000, or, at most, 15,000 ohms. It should, in fact, be kept as low as possible, without introducing core saturation troubles.



# RADIO ON RAILROADS

*Owing to the tremendous lengths of many of the long-distance American trains—which frequently are well*

*over a mile long—radio telephonic communication between guard and driver has been installed. Short waves are employed and the system has proved to be far more reliable than any other method.*

*The scheme is discussed in this special article by J. F. CORRIGAN, M.Sc., A.I.C.*

A GOODS train having a total length of, say, a quarter of a mile is considered in this country to comprise a fairly hefty assemblage of rolling stock, and trains having a total length of more than that distance are certainly very uncommon in England.

### **Driver and Guard**

In the United States, however, goods trains, or, as they call them over there, "freight trains," very frequently attain a total length of as much as a mile and a half, and sometimes even more than that. Consequently, as will be obvious to the reader, the unwieldy length of the American long-distance freight trains has for some very considerable time past brought with it the problem of devising a means of enabling communication to be established between the engine crew and the guard of the train in his van a mile and a half or so away from the engine. Particularly is this inter-communication needed for long-distance journeys.

### **Characteristic Curves**

For the above purpose, ordinary telephonic and telegraphic communication has, from time to time, been tried out, but many practical tests proved it to be unreliable. Any form of visual communication was, of course, obviously impossible, owing to the curves which the train would have to negotiate during its journeys, whilst mechanical forms of communication between guard and driver of a goods train proved almost equally futile.

Closely following upon their introduction of wireless receiving sets in all their long-distance passenger trains, the New York Central Railways Company attacked once again the old problem of inter-communication between guard and driver on long freight trains. This time, however, the attack upon the problem was made with the more efficient weapons which the advances in radio have forged.

In short, therefore, efforts were made to devise some system of radio communication between guard and driver. Radio-telephony had, of

course, to be employed, for the transmission and reception of Morse signals would bring about confusion. Then, again, all apparatus installed on the train had of necessity to be of as simple and as foolproof a type as possible, owing to the fact that the driver or guard of the train could not very well be expected to be an expert radio operator.

### **Jars and Jolts**

Furthermore, the apparatus had to be constructed in such a manner that it would withstand the extreme vibration and joltings of the train.

## **FULL SPEED AHEAD!**



The engine-driver is in direct touch with the guard at all times, by radio.

The tuning of the transmitting and receiving circuits had to be fixed, and arrangements made, also, to prevent any possible atmospheric interference.

After many protracted tests, however, the New York Central Railways have succeeded in perfecting a system of train communication on the above lines, and, as the illustrations reproduced herewith will show, the means taken to achieve the above end are of considerable interest to the English amateur to whom the term "railways" is not exactly synonymous with the most go-ahead policy of the age.

### Encased Aerial

The photograph comprising the heading of this article depicts a close-up view of one of the powerful locomotives ordinarily employed by the New York Central Railways Company for the hauling of long-distance goods trains.

Examination of the illustration will disclose the fact that a narrow tube runs outside the boiler, and almost its entire length. This contains the transmitting aerial of the locomotive, the transmitter itself being located in a steel box which is mounted on the rear tender of the engine, and is seen below. This box is securely locked, and it cannot be interfered with by the driver of the train.

Inside the box the locomotive transmitter and receiver is securely fitted. As will be seen from another photograph, the transmitter is slung within a steel frame in such a manner that it is proof against all excessive vibration and jolting. The

transmitter is of much interest. It comprises a turbine-driven generator which is also enclosed in a steel box, and is the smaller of the two boxes which are mounted on the engine tender. An interior view of this, showing the turbine generator, is seen on a following page. This generator is, of course, under the direct control of the engine man.

For the transmission of speech from the locomotive cab an ordinary carbon microphone is used, and by placing the mouth close to the microphone when speaking, most of the extraneous noise associated with the working of the locomotive can be cut out.

The type of microphone employed is clearly shown, while a loud

speaker at the end of the train, the transmitting and receiving aerials will be seen mounted above the guard's van in the photograph below. The microphone, switch, and control meter are seen mounted above a box containing the transmitter and receiver. This transmitting-receiving apparatus is identical with the apparatus employed by the driver of the train.

### How it Works

The rear transmitter, however, derives its electrical power from a 32-volt, 5-ampere accumulator which, in turn, is fed by an axle-driven generator situated below the floor of the van. The loud speaker employed by the guard of the train is shown on

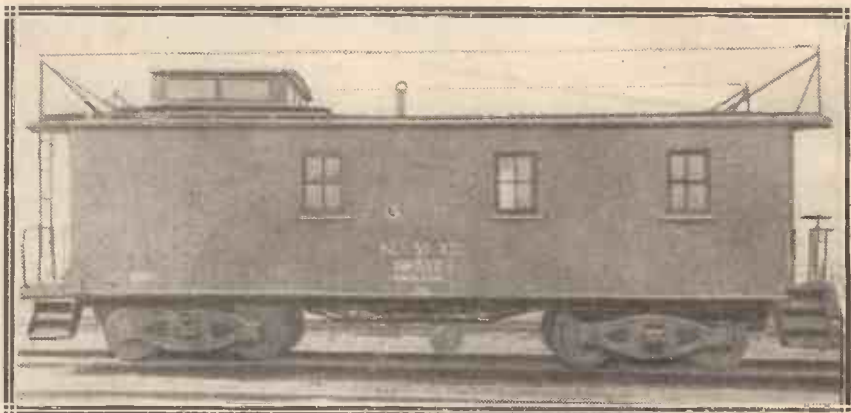

How the aerial on the guard's van is arranged is shown in the above photograph, while below we see the transmitter equipment (large box) and the turbine generator (small box) on the tender of the engine.

the next page, and is similar in principle to that used by the driver.

Now as to the mode of operation of this interesting radio installation. A small push-button, mounted on the microphone, is depressed whenever one desires to speak to the other installation. Upon releasing the button, the local apparatus is automatically connected in a receiving condition. Thus by means of such an arrangement, when the button is depressed the radio equipment transmits, whilst when the button is released, it receives only.

### No Knowledge Necessary

Thus the equipment at either end is always maintained when not in actual use at the "receiving" or "stand-by" condition. There are, of course, minor working details to be attended to, but it is claimed that the entire wireless installation of the train may be operated efficiently by a person possessing not the slightest knowledge of radio technique.

Finally, at various depots of the New York Central Railways system small stationary transmitters are

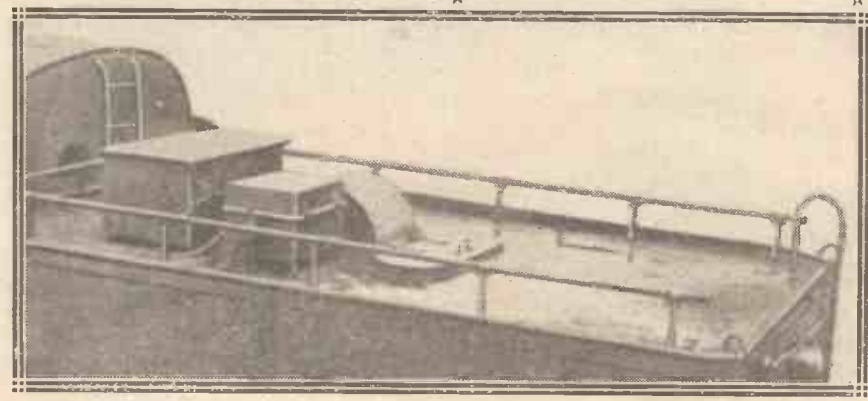

transmitter circuit is of a severely conventional type, and it is simplified to the utmost degree. It operates on a wave-length of 130 metres (2,300 kilocycles), and it delivers a power to the aerial of between 40 and 50 watts.

The power unit of the locomotive

speaker is fitted up in the cab of the locomotive in order to receive signals from the guard of the train. The speaker is very ruggedly built on the cone principle, and produces sufficient volume of sound to override the noises of the engine mechanism.

Turning now to the guard's equip-

# Trains Nearly Two Miles Long!

provided for the purpose of issuing instructions to drivers and guards of trains.

The power for transmitting is, in these cases, obtained locally, but, apart from this deviation, the design of the stationary transmitters is similar to those mounted on the engine tenders and in the guards' vans of the trains.

Such a system of signalling by means of radio between depots and trains is naturally an additional safeguard in foggy weather, and it is a system which is being greatly extended, not merely in the case of goods trains, but for passenger train communication also.

Radio, therefore, on the American railroads, besides comprising an additional convenience of working, may, indeed, well turn out at some

Not Achieving the Desired Happy Result by These Means, he Deemed it Advisable, as a Precautionary Measure, to Tighten All the Nuts on the Components.

Upon Tackling a Tricky One in the Vicinity of the Transformer, However,



Upon Seeking the Advice of a More Experienced Friend, he Learnt to his Great Dismay that his Precipitate Action Had Resulted in the Total Destruction of All his Valves.

*Moral:* Disconnect the battery leads first.

## The Fan and the Fault

A FAN was Once Requested to Examine a Set That Would Not Work. So he Removed it From its Cabinet, Tested the Batteries and Valves, and Cleaned the 'Phone Tags.

As this Did Not Have the Desired Effect, he Next Tried Altering the H.T. and G.B. Tappings and Testing the Connections for a Broken Wire.

The Correct Solution Still Evading him, he Took a Pair of 'Phones, and Tested the Transformer, the H.F.



\*\*\*\*\*  
\* A special form of loud speaker is \*  
\* installed in the guard's van on the \*  
\* ceiling, well out of way of any \*  
\* damage (see above). \*  
\* \* \* \* \*  
\* To the left is shown the micro- \*  
\* phone and control switch above \*  
\* the transmitter-receiver in the \*  
\* corner of the guard's van. \*  
\* \* \* \* \*  
\* A close-up of the turbine-gener- \*  
\* ator installed on the locomotive \*  
\* tender is shown in the right-hand \*  
\* illustration. \*  
\* \* \* \* \*  
\* The transmitting equipment of the \*  
\* locomotive is illustrated below. \*  
\* This is enclosed in a box placed \*  
\* near the generator on the tender. \*  
\*\*\*\*\*

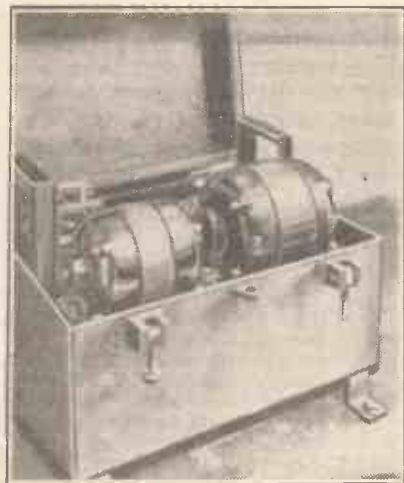

future time to constitute a life-saver of the very first order.

## TWO FABLES

Æsop's Radio — The Fan and the Fault

### Æsop's Radio

THERE Once Was an Amateur Whose Set Conked Out. Being Prompted by Experimental Leanings and a Natural Desire to See What Was Inside, he Decided to Put It Right Himself.

Having Borrowed a Screwdriver, a Pair of Pliers, and a Penknife, he Set To Work.

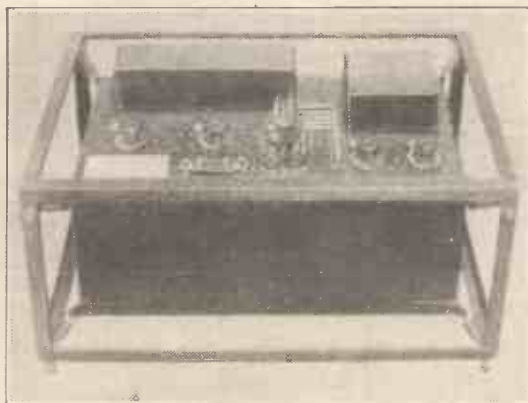

Great Was his Surprise to Observe a Bright Flash, Accompanied by an Unpleasant Noise. Nor Was This All.

Choke, and the Coils. Becoming Desperate, he Tried a New H.T. Fuse, Changed the Coils, Inspected the Aerial and Earth, and Slightly Modified the Circuit.

Following This, he Altered the Value of the Grid Leak and Tried the Effect of Varying the Aerial Tapping.

But it Was Not Until he had Thoroughly Examined the Input and Output Circuits, and Enquired Into the Power Arrangements that he Found that the H.T. Was Connected Up The Wrong Way Round.

*Moral:* It's the little things that count.

N. A. S.

By G. V. Colle.

# THE "M.W."



The completed receiver, showing how the speaker, panel and valves are arranged.

To begin with, this five-valve portable set costs approximately £14 5s., including every necessary part, such as loud speaker, batteries, valves, etc.

The advantages to be derived from the use of a metal chassis of the description used in the set, and shown in the various sketches and photos, are as follow :

- (1) Simplicity in construction. Bending the sheet metal in the form of a step enables the whole set to be built in one block.
- (2) Reduction in weight. (3) Greater space for components. (4) Screening. Aluminium sheet as used in this set acts as an electro-static screen between certain components. (5) Earthing.

The metal also acts as capacity earth, owing to its area, and therefore assists in stabilising the receiver. (6) Simplified connections. By taking connections from the various metal screws holding the components, L.T. negative connections can be dispensed with, thus eliminating a great deal of wiring. By screwing such components as metal-cased fixed condensers, L.F. transformers, variable condensers direct to the aluminium, the metal cases are "earthed" automatically, all assisting in stabilising the set.

### Pick-up Jack Provided

A gramophone pick-up jack is provided on the control panel, the output being controlled by the volume control on the set, as this automatically connects across it when the

## COMPONENTS REQUIRED

- 1 Special portable cabinet, complete with loud-speaker fret and wood frame for aerial; "Riverside" model (Carrington).
- 1 Aluminium chassis, to dimensions given elsewhere (Burne-Jones, Paroussi, Ready-Radio, etc.).
- 5 Sprung valve holders, small type, as shown (Benjamin, Formo, Magnum, Bowyer-Lowe, etc.). Note that chassis must be drilled to suit valve holders chosen.
- 1 .0005-mfd. variable condenser, of fairly small dimensions, such as Ormond, Formo.
- 1 Slow-motion drum dial, thumb type, for above Ormond condenser, or, alternatively, one ordinary slow-motion dial.
- 1 L.T. on-off switch, (Benjamin, Lissen, Lotus, etc.).
- 1 .0005-mfd. miniature reaction condenser, complete with insulating bushes, or latter separate if necessary (Cyldon, Igranic, J.B., Burton, etc.).
- 1 500,000-ohm potentiometer volume control, complete with bushes, as supplied (Gambrell, R.I., Igranic, etc.).
- 2 Special H.F. coupling units, Nos. 1 and 2 respectively (Peto-Scott).
- 1 Jack, Igranic No. P.66, known as five-spring automatic jack; or Lotus filament double-control No. 5, and complete with insulating bushes Igranic has insulated hexagon head, and requires further ebonite washer for underside of panel.
- 1 L.F. transformer of fairly small dimensions, such as the Marconi-

- phone universal intervalve type, as shown (Igranic type J, R.I. "Hypermu," Cossor, etc.).
- 2 2-mfd. condensers, usual test voltage (Hydra or other small type essential for one. Other can be any standard make, e.g., Lissen, T.C.C., Mullard, Dubilier, Ferranti, etc.).
- 2 Vertical grid-leak holders (Dubilier).
- 2 .25-meg. grid leaks (Dubilier, Lissen, Ediswan, Mullard, etc.).
- 1 .0003-mfd. fixed condenser, usual type (Dubilier, Lissen, T.C.C., Mullard, Clarke, Goltone, etc.).
- 1 .01-mfd. mica condenser (T.C.C., etc.).
- 1 .001-mfd. fixed condenser, vertical type (T.C.C., Lissen, Dubilier).
- 1 50,000-ohm wire-wound resistance of the power type (Edison Bell, Ferranti, etc.).
- 1 H.F. choke. (That shown is a Dubilier No. 40, though any of the following should prove suitable: Igranic, Wearite, Magnum, Bowyer-Lowe, etc.).
- 3 Black wander plugs and 2 red (Clix).
- 1 Red and 1 black fork connectors for L.T. (Clix).
- Quantity No. 19 or No. 20 S.W.G. tinned copper wire and 2 mm. Systoflex.
- Quantity of single red and single black flex of good quality.

### ACCESSORIES.

- 1 Portable loud-speaker frame, complete with diaphragm and parts (F. Squire).
- 1 Blue Spot adjustable unit for above loud speaker.
- 1/2 lb. No. 24 D.C.C. wire for frame aerial.

- 1 4-pole miniature change-over switch (Utility).
- 1 99-volt standard size H.T. battery (must be of dimensions suitable to cabinet).
- 1 2-volt non-spillable accumulator, 20 ampere hour (Exide USP7 type, size 3 3/8 in. x 4 1/2 in. x 4 3/8 in. overall height approx.).
- 1 9-volt G.B. battery, tapped every 1 1/2 volts.
- 1 Sheet of gauze for loud-speaker fret. In addition the constructor will require metal screws, etc., as given in a separate list. These can be obtained from any good radio dealer, who will procure them if so ordered; or from Burne-Jones, Ready-Radio, Paroussi and, alternatively, from any metal warehouse, such as Youngs, Smiths of Clerkenwell, London, etc.

### ODDS AND ENDS FOR THE FRAME AERIAL.

- 8 pieces of ebonite, 3/8 in. x 1/2 in. thick x 2 in. long, each having 17 saw-teeth spaced 3/32 in. apart on the 3/8-in. surface.
- 2 pieces of ebonite, 3/8 in. x 1/2 in. x 2 in. long, one for 3 screws and 6 nuts for the A., E., and R. connections from frame, and one for 2 screws and 4 nuts for the L.S. leads.
- 5 3/8-in. 4 B.A. countersunk brass metal screws.
- 10 4 B.A. standard nuts for above screws, or, alternatively, 5 small brass terminals with screws at their bases for terminal strips.
- 5 Soldering lugs to fit under the nuts or terminals.

# PORTABLE

# FIVE

*A really efficient five-valver for home or outdoor use. Two H.F. stages are employed, together with the detector and a couple of L.F. valves. The handling of the set is simplicity itself, while the total weight is only about 27 to 30 pounds.*

plug is inserted; the valves  $V_1$ ,  $V_2$ , and  $V_3$  having their filaments switched off.

Turning now to the theoretical circuit of the receiver, the various coupling devices make themselves at once apparent.

### Special H.F. Coupling

It will be seen, for instance, that special H.F. coupling units, each comprising an H.F. choke, fixed condenser and grid leak, are employed for joining the first H.F. valve to the succeeding one, and a further one for connecting the second H.F. to the detector.

By winding one of these H.F. chokes to a higher wave-length than the other, the problem of stabilising the H.F. valves is obviated, because the chokes cannot come into resonance. Then, tracing the wiring from the detector, we find this valve operates on the usual grid rectification principle and couples to the first L.F. by separate R.C.C. components, the grid leak being a .5-meg. potentiometer, for volume control.

Finally, we find the first L.F. is coupled to the second, or last, stage by an L.F. transformer, the output from the anode of  $V_5$  being fed through an H.F. choke by-passed

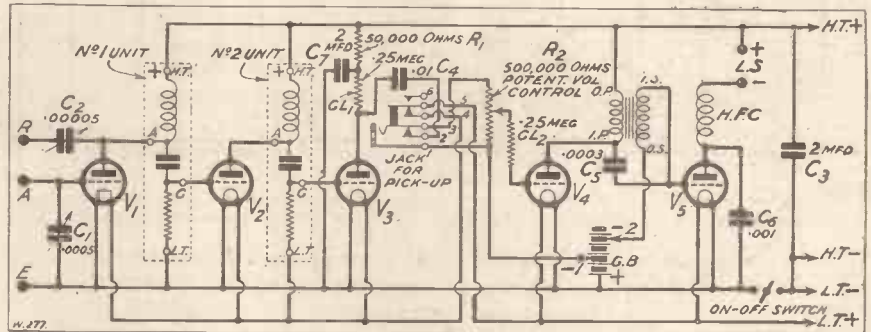

This diagram shows the circuit employed, the H.F. valves being choke coupled.

by a fixed condenser to prevent any H.F. currents from entering the loud-speaker windings, and so causing a feed-back through the frame aerial and grid of  $V_1$ .

The employment of a sensitive loud speaker in this receiver is one of the reasons why it is so successful, because, owing to the limitations of the last valve, a large output cannot be obtained without overloading it (the valve), and therefore the restricted output must be compensated for by other means—the loud speaker.

### Design of Frame

Our last theoretical discussion before we go on to the constructional details concerns the frame aerial and its connections. The frame is wound

on exactly the same principles as were laid down in the March issue of "M.W." under the title: "A Universal Frame Aerial."

Of course, readers will appreciate modifications had to be made to adapt the frame for the lid of the case used, though actually the method of constructing and wiring the frame is quite simple.

Three circuits are given with a sketch of the frame, and show the wiring of the aerial as actually carried out, when switched over to high waves and when switched to the broadcasting band, the latter two being simplified for purposes of comparison.

Complete lists of all the various screws and ebonite pieces and spacers are given elsewhere.

The first consideration in attempting the building of this set is the collection of the component parts, including the screws, nuts, washers, and spacers, and the whole should be laid out ready for selection as required.

### Commencing Construction

Naturally, construction will commence with the aluminium chassis, and it will be necessary to lay the components concerned on this, treating one surface at a time. Control panel drilling will come first, so procure the chassis and mark out (with a pencil first) the positions of the drum dial, reaction condenser, volume control, pick-up jack, and on-off switch, as given in the drilling layout shown elsewhere.

### ALL MOUNTED ON ONE SCREEN

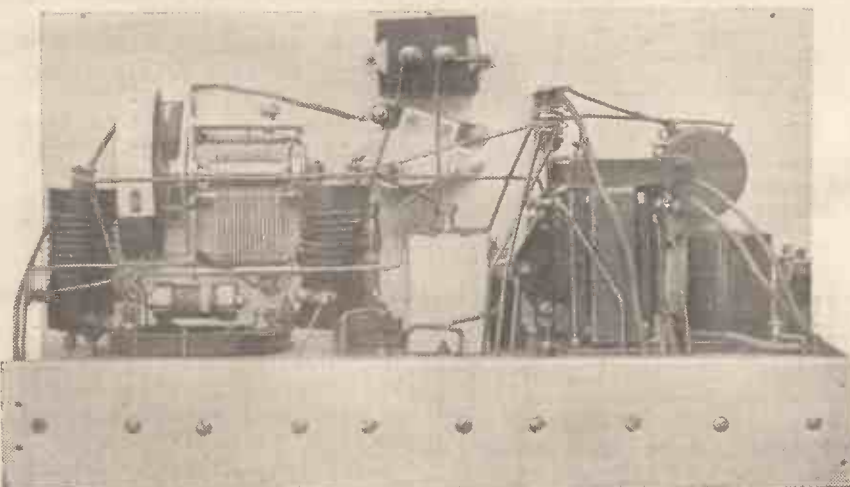

The bent metal screen is used also as a baseboard, and everything is mounted upon it as shown.

With the exception of that for the drum dial, the holes will be round, and can be carried out with an ordinary hand brace and twist drills. The size

marked, or else by a cold chisel, the former being preferable.

After removing the metal, file the edges square to shape, as denoted by

The remaining panel components are screwed direct to the panel, as in the case of the L.T. on-off switch, .0005-mfd. thumb-drive condenser, and all the inside components are either treated similarly or as mentioned later.

**Assembling the Components**

Having completed the panel drilling, that of the screw holes for the valve holders may next be undertaken, dimensions being given on the chassis sketch, with modifications if valve holders other than Benjamin (cheap type) are employed. Before clamping the valve holders to the metal ledge, do not forget to slip the fibre pieces under them, so as to prevent the springs on the holders from coming into accidental contact with the metal sheet.

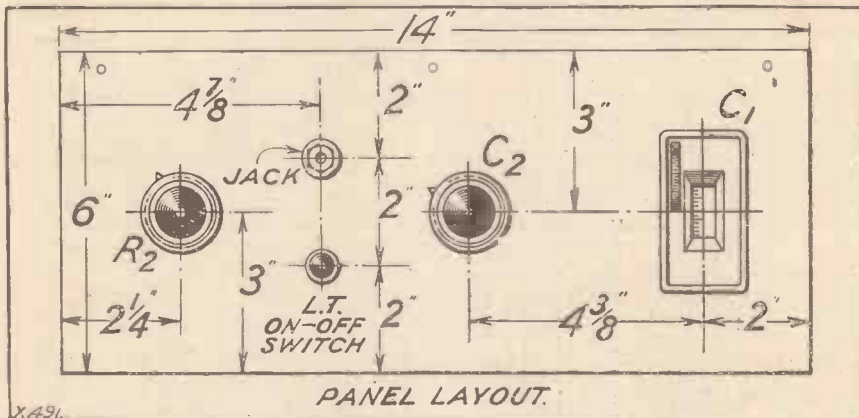

How the panel appears looking at it from the valve platform end of the screen.

of the irregular hole for the drum dial is given on a full-sized template supplied by the makers, and the piece of

the lines drawn. Ebonite bushes are necessary for the .00005-mfd. reaction condenser, the volume control, and

**THE VARIOUS WASHERS REQUIRED**

Component.	No.	Remarks.
.0005-mfd variable condenser	2	Extra brass washers for packing dial.
Valve holders	10	Brass washers, 4 B.A. clearance hole, for screws holding valve holders.
Valve holders	5	Fibre pieces to shape of valve holders to place under them to insulate from metal ledge.
Volume control	2	Ebonite bushes for insulating from panel (supplied with Voluvernier).
.00005-mfd. reaction condenser	2	Ebonite bushes for insulating from panel.
Pick-up jack	1	Extra ebonite bush to fit to underside of panel. Moulded hexagon head acts as top of panel insulation, otherwise further ebonite bush needed.

aluminium of this shape can be removed either by drilling a series of small holes around the inside line

pick-up jack, and small sheets of fibre (to the shape of the valve holders) to place under the valve holders.

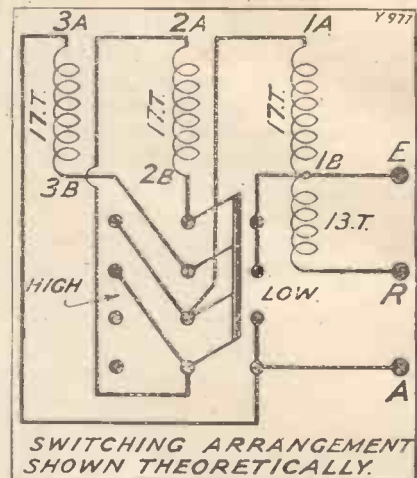

The wave-change switching is carried out on the series-parallel system.

Assembling the panel components may now be undertaken, the parts screwing through the various holes mentioned above, with ebonite bushes where mentioned on the wiring diagram and in the washer list.

There now only remain the layout of such components as the H.F. coupling units, L.F. transformer, R.C.C. parts, and the H.F. filter for the anode circuit of V<sub>3</sub>, all these screwing to the vertical aluminium wall of the chassis. This part of the proceedings is best undertaken when the panel components are in place, as then the exact position of each part may be determined.

**Use Insulated Wire**

Lay the components in the positions indicated on the wiring diagram, and mark with a steel scriber, or long, sharp nail, the points where screws have to be inserted through the chassis. Now remove the components and drill all the points so marked with a

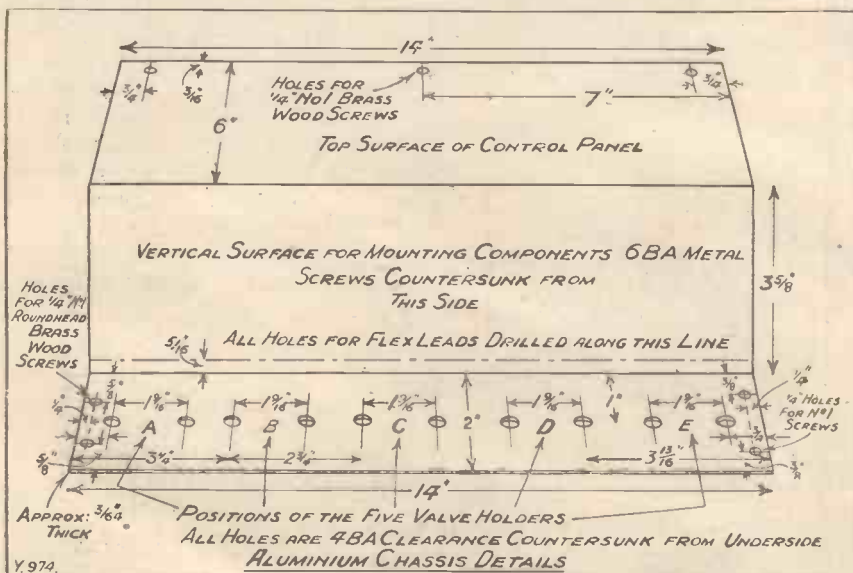

This diagram shows how the one metal screen is bent to provide panel, baseboard, and screen



## Receiver Built All In One

6 B.A. clearance drill, countersinking from the outside (side nearest valves) for 6 B.A. countersunk screws. Do not omit to drill the holes for the various leads to the valve holders at the same time, leaving these plain and not countersunk.

latter and the front wood fret for the former are already supplied with the cabinet.

An additional sketch of the front wood loud-speaker fret, shown on another page, gives the dimensions and positions of the holes for the wave-

change frame-aerial switch, and should have its corners removed diagonally to fit in the space inside the frame aerial, and against the back of the front fret.

### Order of Operation

The order in which the various processes should be carried out is as follows: (1) Drill the front wood fret; (2) remove the corners of the backboard diagonally with a saw; (3) fit the Blue Spot unit to the loud-speaker chassis and paper cone, if not already complete; (4) attach the loud-speaker frame (complete) to the back wood board, the magnet of the Blue Spot unit being downwards; (5) stick a square of tinsel cloth, or any suitable material of coarse, open texture, to back of front fret to cover openings constituting the fret. Finally, attach the back board, complete with loud speaker, to front wood fret, and screw the latter to the back board by the countersunk brass wood-screws from the front of the fret, making certain at the time that the knob on the Blue Spot unit takes a central position

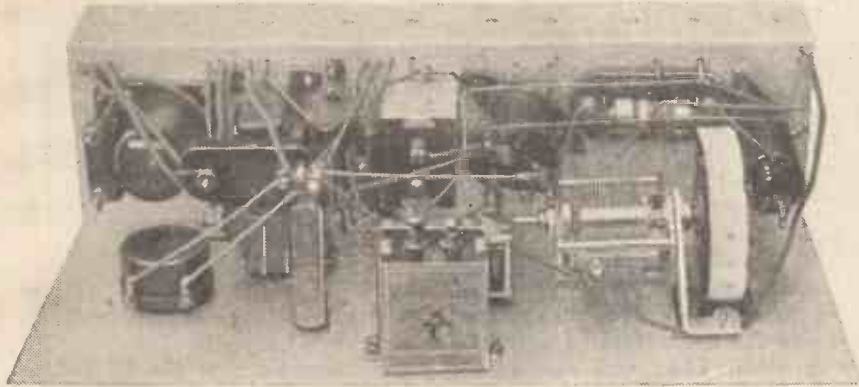

Some of the components are mounted behind the panel, thus allowing all the set to be taken out of the case in one piece.

To complete the assembly, fit the components with the various metal screws named in the screw list, not forgetting to raise the two H.F. coupling units away from the metal as far as the screws listed for them will allow.

Check over the components, and if everything is correct the wiring may then follow. Use No. 20 or 22 S.W.G. tinned copper wire and 2 m.m. Systoflex, because these give neat, simple wiring and are easy to use.

When attaching the flex leads, of which there are a number, the frayed cotton covering may be neatly bound with cotton thread and gummed to prevent it unwinding. The ends of the flex wires may also be tinned to avoid the strands fraying out when clamped under the respective nuts.

### Mounting the Loud Speaker

Finally, to complete the receiver unit, carefully check the wiring for errors, dry soldered joints, insulation, etc., and if O.K. fit the chassis in the cabinet after having removed the wooden partition supplied with it.

While in position in the cabinet, the lengths of the flex leads may be adjusted to suit the batteries, and suitable plugs and spade tags can be attached to the ends of the flex leads.

Our last constructional task brings us to the mounting of the loud speaker and the construction of the frame aerial, which will not prove difficult considering the wood frame for the

change frame-aerial switch, the knob controlling the Blue Spot unit and the screw holes for attaching the back plywood board holding the loud-speaker frame. This latter board is

### HOW THE LOUD SPEAKER IS MOUNTED

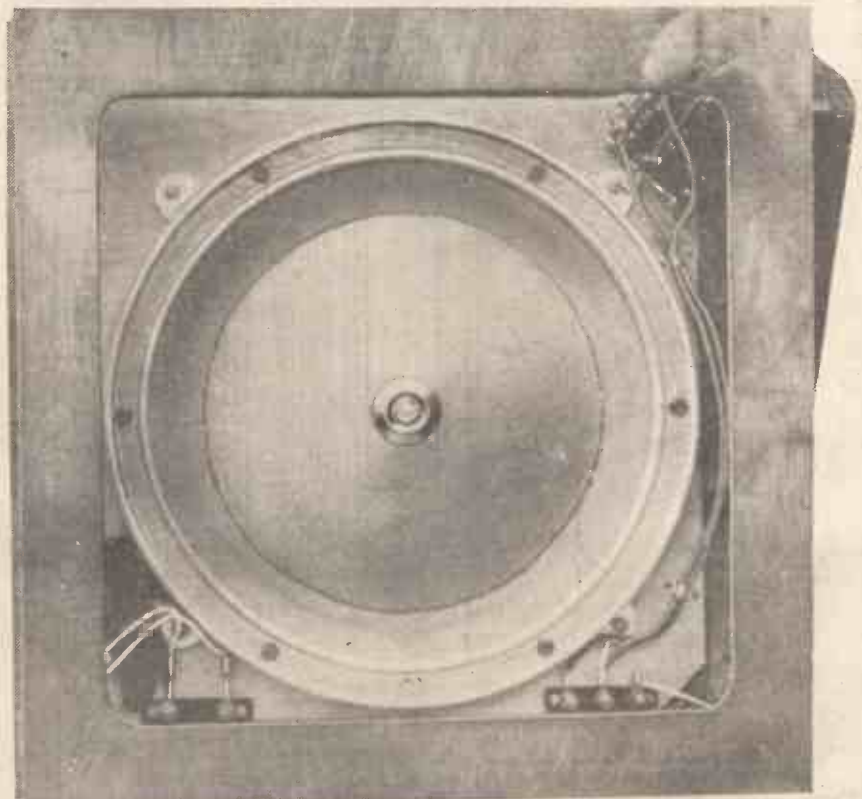

The loud-speaker unit is mounted inside the frame aerial. Note the wave-change switch in the top right-hand corner.

in the hole made for it in the front fret.

To complete the front fret mounting the slot and holes made for the switch must be carried through the back board, when the switch can be fitted in position.

If difficulties arise in fitting—that is, should the two round-head metal screws be found too short to hold the switch—one thickness of the back board, which is of plywood, can be removed from under the switch only, to reduce the overall thickness, failing the employment of two longer screws.

### Winding the Frame

Lastly, we have to wind the three layers for the frame aerial, wire it up, and fit the terminal blocks for the connections to this and the loud speaker.

Winding the frame aerial will not prove difficult if one point is borne in mind, namely, that the spacers for the second layer should be attached securely to the pieces of wood supporting the first before proceeding

with the winding, otherwise difficulties will be encountered in keeping the turns on the various layers taut during and after treatment.

To enable the fixing of the spacers

holes and hammer them gently into the wood.

Naturally, the fixing of the spacers can only be undertaken after the first layer and reaction turns have been

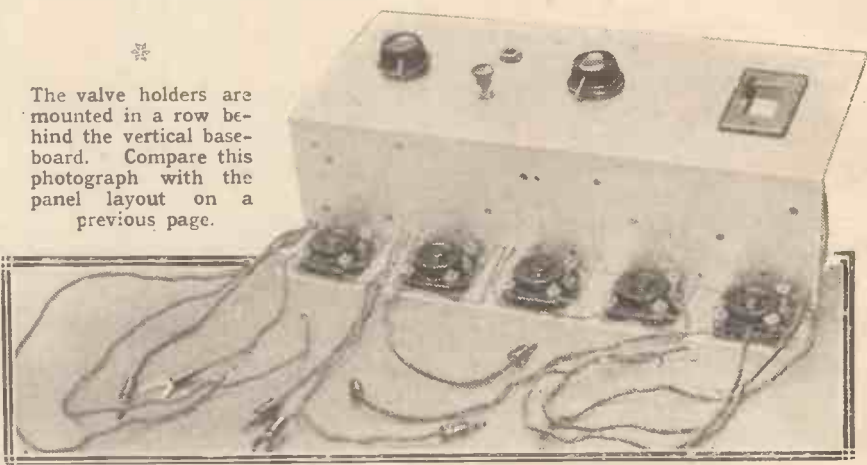

to be accomplished, drill very fine holes through the ends of the spacers and pass fine brads (such as supplied by Hobbies, Ltd., and sometimes called fine panel pins) through the

wound on, and these details will be found in the frame-aerial sketch of connections.

Seventeen turns of No. 24 D.C.C. wire are wound on each section of the frame aerial, with 10 turns for reaction wound alongside the bottom layer. The spacing between successive layers is  $\frac{1}{8}$  in., and between turns  $\frac{3}{32}$  in., while dimensions for the spacing pieces are not critical.

### Aerial and L.S. Terminals

When bringing the ends of the layers to the switch, make a point of covering the wire with the thin Systoflex

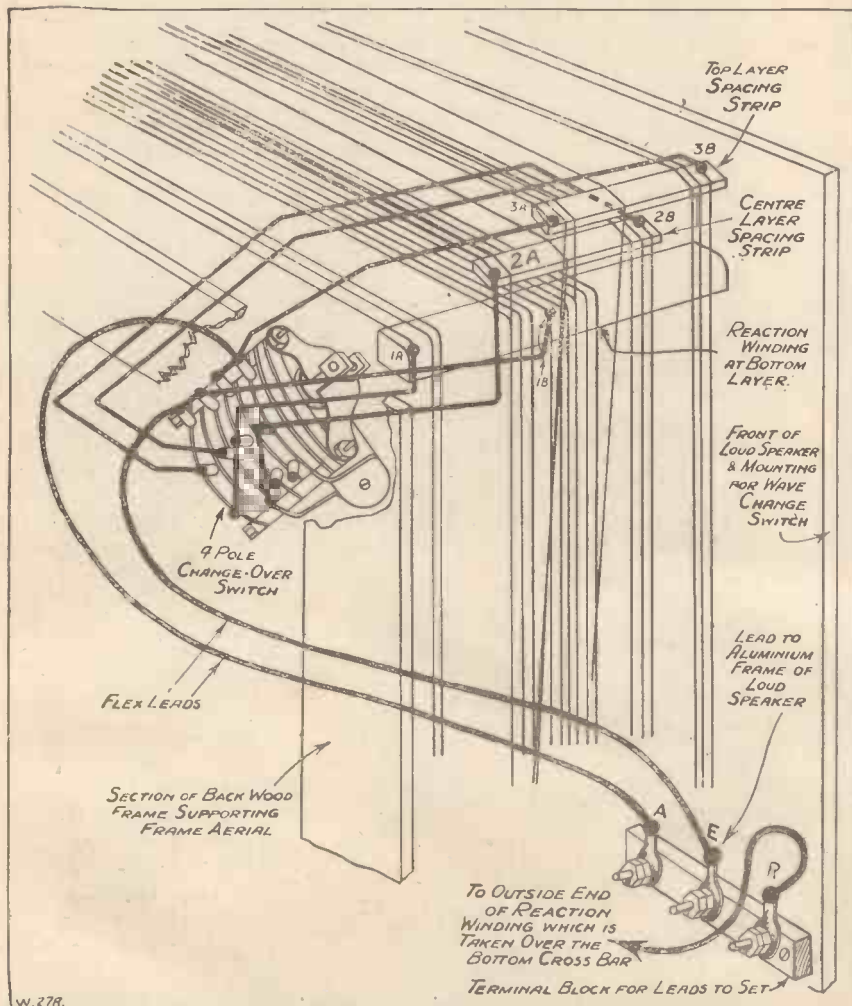

\*\*\*\*\*

LIST OF NUTS REQUIRED

Component.	No.	B.A.
Valve holders . . . .	15	4
H.F. coupling units . .	12	6
Rest of components given in metal screw list . . . . .	21	6

All nuts can be of lock type, if desired.

\*\*\*\*\*

as used in the set, and also very carefully recheck the connections when completed. Complete the construction by attaching the two terminal blocks—one for three connections, and the second for two (loud speaker)—to the back board by wood screws, and connect the leads from the frame aerial and loud speaker to them, not forgetting to take a further lead from the "E" terminal on block to the loud-speaker frame, the wire being twisted around one of the screws holding the frame to the back board. Make this connection carefully and thoroughly, otherwise there is a risk of crackling noises occurring.

This diagram shows how the frame aerial and wave-change switch are wired up, and should be followed very carefully when constructing the set.

## Receiver Costs Under Fifteen Pounds

With the completion of the frame aerial, construction, and loud-speaker mounting, our five-valve portable set

man's Park, the appearance of the station did not suggest that it would be in operation by June.

However, assuming that work is expedited and the station completed in time, listeners should soon be sampling the new station's transmissions.

### A Gradual Change

It is authoritatively understood that the change-over from the Oxford Street transmitter to the new Regional station plant will be a gradual one. To begin with there will no doubt be a series of test transmissions outside normal broadcasting hours; and later on the new station will probably deal with the latter portion of the old 2 L O's programme transmission—especially dance music between 11 and 12 p.m.

Gradually the new station will take over more and more of the programme, until, eventually, the transition will be complete and the Brookman's Park station will be in full-time operation.

The B.B.C. intends taking every care that listeners will be able to accustom

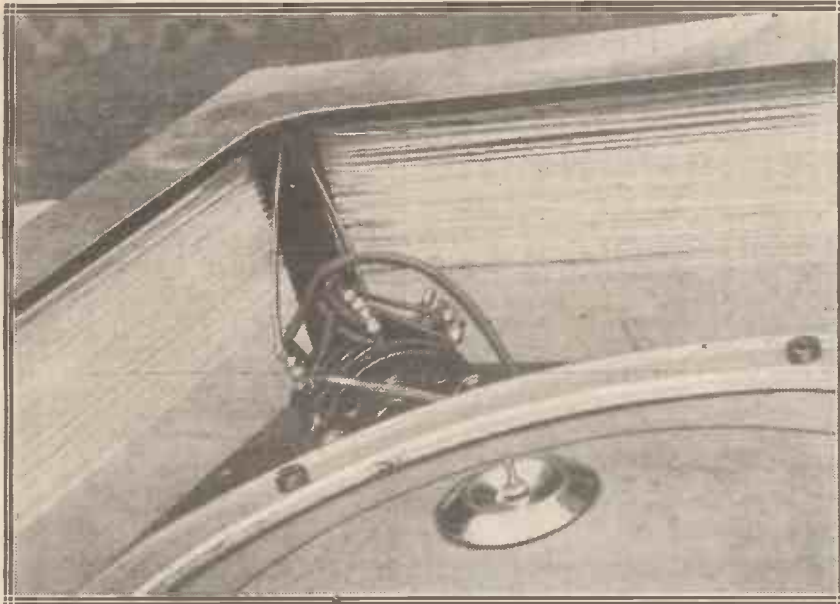

A close-up of the wave-change switch, and a section of the frame aerial.

is ready for testing and we can immediately connect it all together in the cabinet (temporarily), not forgetting to include an H.T. fuse in series with H.T.—lead for our initial tests.

### Directional Effect

If the receiver sounds "lively," with no tendency to shriek or whistle, it can be mounted on a turntable (such as the Ormond) and revolved to get the directional effects on the frame aerial; the volume of the stations increasing considerably.

Both Marconi and Six-Sixty valves have been successfully used in this receiver, which requires three H.F. valves (two for H.F. and one for detector), followed by an L.F. or general-purpose and a power valve such as the SS 215 P. for the last stage.

\*\*\*\*\*  
**THE NEW 2 L O**  
 \* A Regional Start this month ? \*  
 \*\*\*\*\*

If all goes according to plan, the first of the much-discussed Regional stations should begin tentative transmissions some time this month.

But when the writer passed through Potter's Bar, the new 2 L O at Brook-

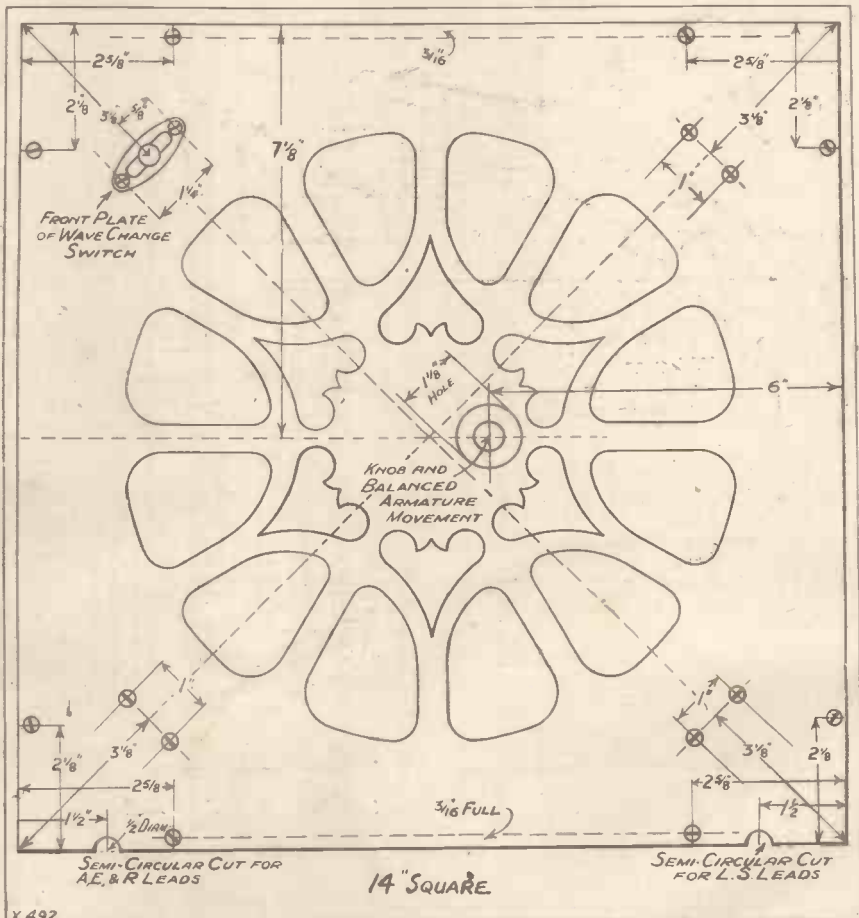

X.492.

The loud-speaker fret, which also carries the wave-change switch.

themselves to the change-over, and it is not anticipated that any serious inconvenience will be caused. In

north of London will probably find the present wipe-out area considerably modified.

The chief result anticipated when the new 2 L O starts working will be in connection with alternative programmes via the twin transmitter, and the possibility of an early start of television transmissions.

\*\*\*\*\*  
**METAL SCREW LIST FOR "MW" PORTABLE FIVE.**  
 \*\*\*\*\*

Component.	No.	Length	B.A.
Valve holders .. .. .	5	in.	4
Valve holders .. .. .	5	in.	4
.01 and .001 fixed condensers	4	in.	6
H.F. choke and 50,000-ohm resistance	4	in.	6
H.F. coupling units	4	in.	6
L.F. transformer, two 2-mfd. condensers, and two .25-meg. grid leaks	12	in.	6

\*\*\*\*\*

**Wave-length not yet Fixed**

The latter, however, are by no means certain, and in any case will only be experimental in character, and conducted after normal broadcasting hours.

The wave-length for the alternative transmission has not (at the time of writing) been definitely announced, but it is pretty certain to be separated as much as possible from the present wave-length used by the existing London station.

N. F.

fact, it is anticipated that listeners in the greater part of London served by 2 L O will hardly notice the change at all, and listeners in the

Listeners at Potter's Bar and the immediate surrounding district, however, must be prepared for more severe "wipe-out" effects.

**Wiring Diagram of the "MW" Portable Five**

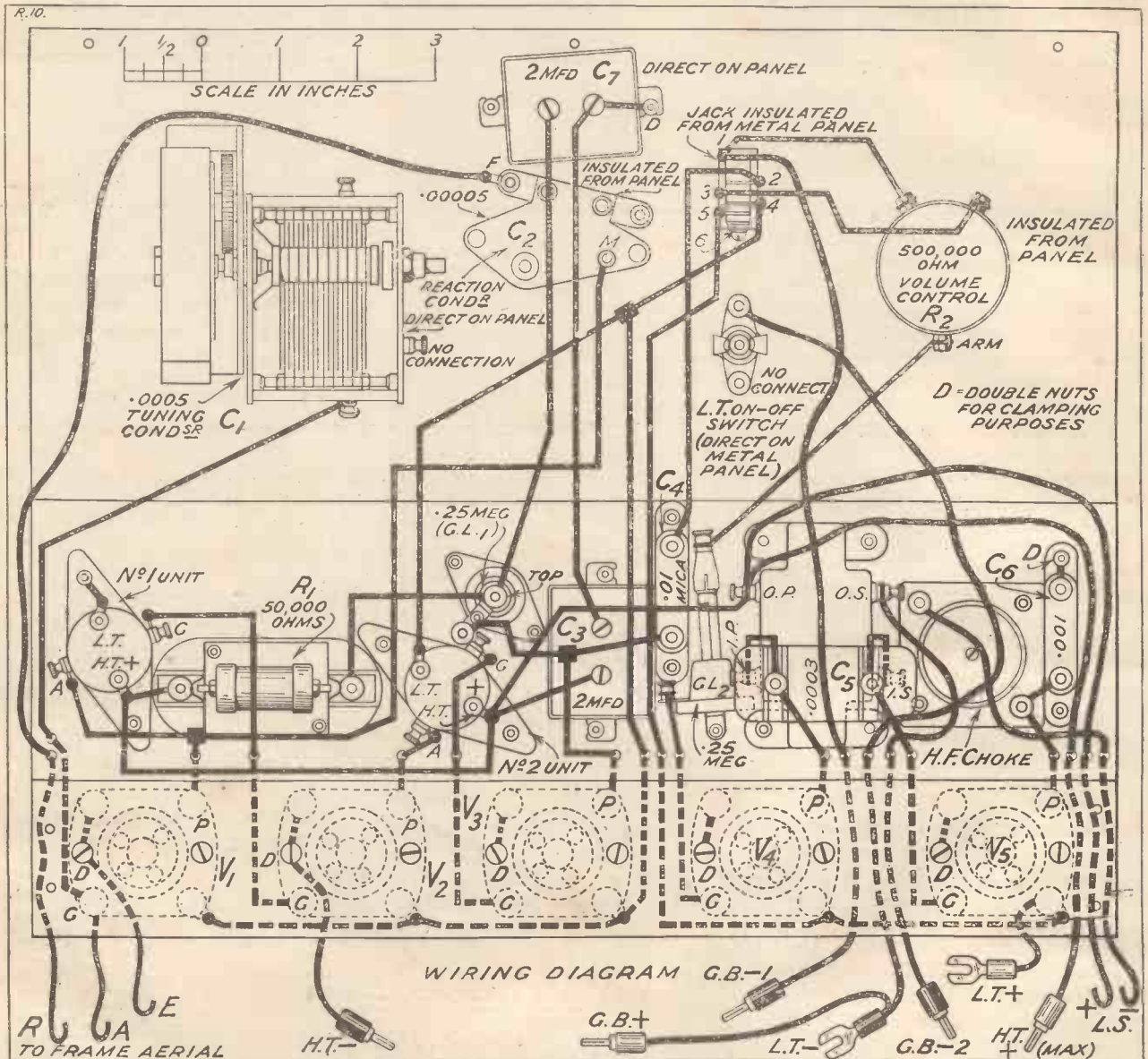

The valve holders are shown dotted in this diagram because they are actually mounted on the other side of the metal sheet, which is bent at right angles where the horizontal lines go across the above diagram. (See article in previous pages.)

*By P. R. BIRD*

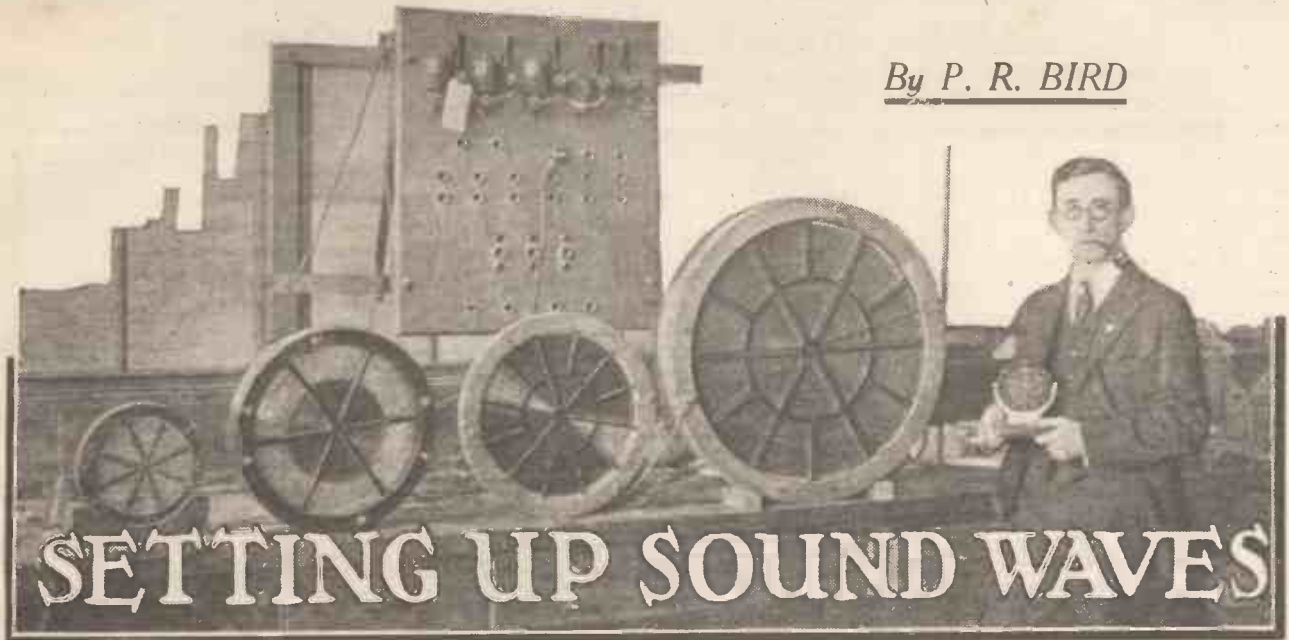

## SETTING UP SOUND WAVES

*An article about the realistic reproduction of Radio.*

As every burglar knows, from experience, it is very easy to set up sound! Almost any ordinary movement will do it, and, conversely, we instinctively feel that in order to obtain perfect silence we need perfect stillness.

From a practical point of view, the whole aim and object of radio is to set up sound. So interesting is the complicated action of a wireless set that we are apt to overlook the fact that all the amplifying, neutrodyning, coupling, and contriving are means to an end, this end being the reproduction of sound waves.

The working of the set, interesting as it is, is merely a preliminary operation in the driving of the diaphragm. And the telephones or loud speaker are not merely the last link in the chain between the broadcast studio and the listener, but these sound-reproducing instruments act as the bottle-neck through which flows all the energy obtained.

### *Defective Receivers*

Though the realistic reproduction of sound waves by means of a moving diaphragm is now commonplace, it is not generally realised how interesting is the action involved. In the last year or two there has been a vast improvement in the faithfulness of radio reproduction. The transmitting end, controlled by the B.B.C., is far in advance of the receiving end. It is an undisputed fact that, owing to defects in the apparatus employed by themselves, the great majority of

listeners are losing much of the beauty of the broadcasting programmes.

### *Where is the Bass?*

Sometimes the receiving set itself is to blame for this state of affairs. When an orchestral piece is being played at the studio the aerial picks up real music, including the boom of the drums and the deep notes of the bass viol, but unless the receiving set is a well-designed one the output from it will not be a faithful replica of the original.

In too many cases the low notes are suppressed, and consequently the

drums are missing, and there is no trace of the low piano notes or of the bass viol. Even if the set itself is capable of amplifying and reproducing the low notes, these may be still missing from the final reproduction, just because the loud speaker itself is incapable of bringing out these notes.

### *Where it Goes*

We can easily understand how it is that certain notes can be lost in this way if we try to understand the action of the original and simple type of loud speaker. In its essentials, such an instrument consists first of a thin

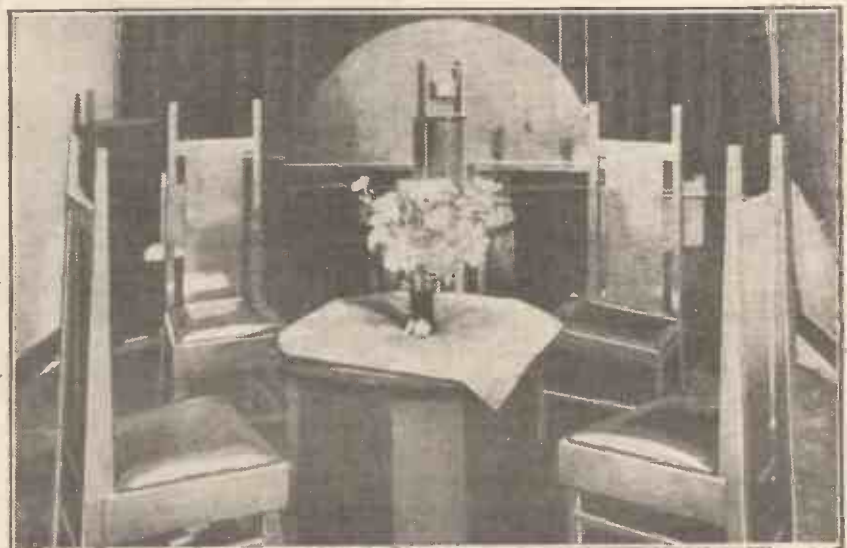

Here is the studio from which the announcements at Huizen (Holland) are made. The microphone that picks up the sound waves can be seen above the vase of flowers.

## Those High-Pitched Loud Speakers

iron diaphragm, an inch or two across, firmly supported at its outer edge. Secondly, there is a permanent magnet, placed very close to the centre of this diaphragm. Thirdly, there is the electrical part of the equipment, which consists of a winding of very fine wire round the magnet poles, through which all the currents fed to the loud speaker have to pass.

### Variations of Volume

Normally, and while no signals are being received, the diaphragm of such a loud speaker is slightly strained towards the permanent magnet. But if a tiny alternating current is fed into the instrument, the iron diaphragm will be displaced from its normal position by the magnetic effects of the successive impulses of current. The magnetism will make the diaphragm quiver at the exact frequency of the current which is causing the magnetism. And not only does the diaphragm have to quiver backwards and forwards 1,000 times per second when a current of a frequency of 1,000 per second is operating, but the extent of its movements must be great or small to correspond with the volume of the current.

Such a diaphragm must necessarily have a very small area, so in order to make the most of the sounds set up by the diaphragm it is usual to use it in conjunction with a horn. When mounted at the narrow end of a horn it is able to move the whole column of air inside the horn. As sound is caused by the movement of air, the electro-magnetic energy is able to create sound by alternatively pushing and pulling at the diaphragm.

### Complexity of Sound

An arrangement of this kind might be more effective if it were not for the fact that sound, either speech or music, is extraordinarily complex. If a piano, for instance, is being played note by note in the studio the frequency of the current handled by the receiver's detector varies with every note. Low notes are represented by low frequencies and high notes by high frequencies.

The lowest note on the piano represents a frequency of about 27 per second, but by the time middle C is reached the frequency has gone up to about 260. As the notes go higher the frequency increases, and by the

time the last note on the piano is reached the frequency has gone up to about 3,500.

In addition to this change in frequency there is, in ordinary playing, the change in amplitude. Some piano notes are played softly, some loudly, the loud ones being many times as loud as the soft ones. If the reproduction of the piano is to be realistic our currents operating the loud speaker must have not only variations in frequency from 27 to 3,500, but they must be capable at the same time of wide variations in strength.

If now we remember how the notes of the piano linger, how not merely one note is played at the time but whole chords are crashed down, we can realise that the current flowing in the loud-speaker winding is an extraordinarily complex one. It must

### "SOLID SOUND"



This photomicrograph shows a section of a gramophone record magnified 250 times, the indentations in the sides of the needle track representing the sound waves recorded thereon.

keep varying in frequency and amplitude, and continuously blending different frequencies and strengths to correspond with the variations in sound and tone.

Theoretically the diaphragm should faithfully follow all these movements. In practice it gets very much nearer to this condition than might be expected when we consider how exacting the task is, but, unfortunately, in the reproduction of sound both diaphragms and loud-speaker horns are greatly cramped by their own "personality."

For reasons connected with the

mass, the material of which it is made, etc., all loud speakers have a favourite frequency of their own. This frequency varies with the shape and size of the various parts, but in most loud speakers of the type we are discussing it is a fairly high frequency, round about 1,000.

### Frequency Favouritism

When a note that corresponds with this frequency is being received, it exactly suits the instrument, which responds more vigorously than it would to other notes. It is this "favouritism" effect that gives rise to the high-pitched quality of many loud speakers. And often they not only over-emphasise notes in the neighbourhood of their own frequency, but are incapable of responding to very low frequencies, owing to their own limitations of size, etc.

This partiality of the horn and diaphragm for high frequencies was largely overcome by the cone loud speaker, in which the horn was abolished altogether, and the area of the diaphragm was increased enormously, thus altering its characteristics considerably. But in all such types it is necessary to drive the diaphragm, and whatever mechanism is employed for this purpose it still has this certain "springiness" of its own, thus impressing its personality upon the reproduction.

Even the moving-coil loud speaker—hailed at the time of its introduction as being frequency-free—has proved in many instances to have a low-frequency characteristic which over-emphasised the reproduction of the low notes in the same way that the smaller diaphragm instruments had previously over-emphasised the high notes.

### Realistic Reproduction

If it were only a question of frequency-response, designers would be in a comparatively happy position, but as amplitude is constantly varying as well, a system which shall deal faithfully with all conditions of input to the receiver would seem to be well-nigh impossible. Yet the advances made in recent years go to show that there is no such thing as impossibility in radio, and just as at present our reproduction is incomparably superior to that of only a few years ago, so may the coming season show advances which at present appear impossible.

# PENTODES AND PORTABLES



*Some Notes on Valves that are suitable for Portable and Transportable Receivers.*

*By KEITH D. ROGERS.*

**D**URING the last year or so a large number of portable receivers have made their appearance on the British market, the majority of them employing pentode valves for the output stage. These have met with varied success as regards reproduction, but nearly all of them have been fairly expensive to run owing to the fact that the pentode valve takes a heavy H.T.

current when working at its full power, and therefore renewals of batteries have to be very frequent.

It is very difficult indeed to get a triple-size battery in a portable receiver, so smaller batteries have to be employed, and these rapidly run down, making the set rather an expensive one to work.

The problem of using the pentode in a portable set is not an easy one to solve, because it is obviously not an economical valve, and in order to keep the H.T. current down one has to use it in rather an inefficient manner. One can compromise by cutting down the H.T. voltage on the priming grid and giving the plate somewhat less than the maximum, but then one does not get the full magnification of the pentode valve.

### *Pentodes Very Convenient*

However, one gets a magnification (in a carefully designed set) greater than one would obtain with an ordinary output valve, and many portable receivers are now being placed on the market where the pentode is so used.

From the point of view of compactness the pentode valve is ideal, and very convenient for use in portables, but I must say that in the majority of cases I would prefer instead an

extra low-frequency stage, say resistance-coupled, or else coupled by one of the small transformers with a special type of core, followed by a power valve biased down reasonably so that it shall not take more than about 10 milliamps.

### *H.T. Current Problem*

After all, a wireless set, if it is to be portable, should not take more than 10 milliamps in H.T. current for the whole of the valves if economical running is to be ensured, though it is a difficult matter to get good volume



\*  
The screened-grid valve has proved exceptionally popular as a "portable" H.F. valve and enables a high degree of sensitivity to be obtained. This is the 2-volt S.G. Osram valve. It has a magnification factor of 170 with an impedance of 200,000 ohms.

\*  
A good valve for Portable Sets.

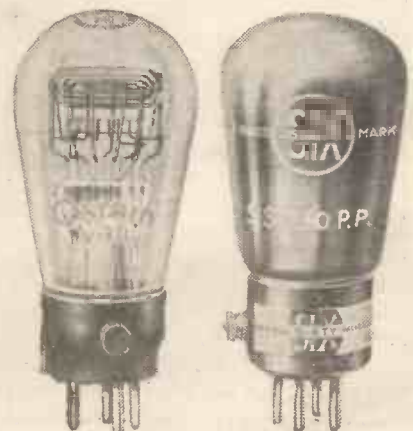

Two 2-volt Pentode Valves—the Osram and the Six-Sixty—both suitable for outdoor radio sets.

## Keep H.T. Current Down

and quality on a receiver if the H.T. current is to be limited to such a small milliamperage.

One or two quite well-known portable receivers have been so designed that in spite of the fact that they use two screened-grid valves, a detector, and a pentode, the total milliamperage is well under this figure. This is obtained, of course, by biasing the valves down carefully and also by keeping the pentode voltages down to the absolute minimum consistent with reasonable results.

### Choosing a Circuit

It is difficult to know what to do for the best in designing a portable set when the question of valves crops up, because one feels that one is being extravagant with the H.T. if a super-power valve is used, yet, at the same time, one realises that it is difficult to find any other valve for the output stage that will carry sufficient grid swing to allow good loud-speaker reproduction to be obtained.

Probably the best system is to use one or two stages of H.F. with a transformer-coupled detector valve,

is sometimes an advantage to use an R.C. valve (if resistance coupled) although I personally would prefer in practically every case the use of an H.F. valve to avoid those little snags, such as overloading and harshness, which so often accompany the use of an R.C. valve and also to ensure good reaction should it be applied on the detector stage.

In many portable set designs now, however, reaction is employed from the plate of one or other of the H.F. valves, and so gives the detector just the job of rectifying and amplifying, and without also the task of providing regeneration. This should make for better quality, and seems in no way to impair the sensitivity of the receiver.

### Two-Volters Best

Two-volt valves are practically essential for portable receivers, and I am of the opinion that, even in the case of small portable sets where two or three valves only are used, it is a decided advantage to use the small L.T. 2-volt *accumulator* rather than to use a dry battery of 3 volts and cut it down with a resistance, or else

but one also has the disadvantage that it is not always easy to choose valves which are going to work absolutely at their best when their filaments are placed in series.

The use of the screened-grid valve employing an untuned plate circuit coupled to the next stage is becoming popular, and forms a very easy method of obtaining good high-frequency amplification for portable receivers. It is difficult to decide whether the screened-grid valve or the neutralised stage forms the best type of amplification, because even with a portable set on a small frame aerial the screened-grid valve sometimes gives a rather disconcerting flatness of tuning which may be very serious if one is very near the local station.

Incidentally, it is usually worth the little extra weight (if a pentode is being employed) to include an output transformer in the set, as this certainly improves the quality of reproduction, and when all is said and done the quality of reproduction in most portable sets is a long way off the ideal.

By the way, to revert somewhat, if you are using a 2-volt screened-grid valve in a portable set and are troubled with ringing noises, do not be too ready to blame the trouble on to the *detector*, for it is quite likely to be due to the screened-grid valve.

### A Simple Cure

I have found quite a number of screened-grid valves to be very prone to provide microphonic noises, especially when they are boxed up in portable form, and the best remedy, apart from changing the valve altogether, appears to be to screen it in cotton-wool or Sorbo rubber to prevent the sounds from the loud speaker impinging on the valve and thus causing its electrodes to vibrate.

As magnification per stage has to be as high as possible in portable receivers, it is usually more advantageous to use a small transformer, such as now placed on the market for portable sets, rather than to go in for resistance coupling which, now that transformers are made so small, is very little lighter than the former method. The transformer certainly has it over the resistance method when it comes to amplification, while the quality of transformer coupling is really quite good provided a good quality loud speaker is employed.

## LONDON AND DAVENTRY CALLING!



Many a pleasant hour can be spent in the open air with a portable set.

using an H.F. valve in that stage, followed by either a pentode brought down to a small H.T. current, or else an L.F. valve followed by a power valve carefully biased to cut down H.T. and yet allow enough grid swing to enable satisfactory reproduction to be obtained.

In the case of the detector valve it

to use a 4½- or 6-volt battery of the dry variety and place the valves in series.

Dry batteries are often recommended, for by placing the filaments of the valves in series one gets a very small current of about 1 amp. (instead of the individual currents of the valve filaments put together),



# THE LATEST

As this article is being written it seems to be the general impression that the new Prague Plan, which comes into force on June 30th, will work much better than the old Plan de Bruxelles. The latter, as our readers know, came into force last January 13th, but in a very short time began to wear badly. In fact, so badly that a direct outcome of its inefficiency was the convening of the Prague Conference some weeks ago.

## A Practical Method

Judging from the reports we have had concerning the Prague Conference, and after a careful study of the recommendations made by the delegates, it seems at the moment to offer a more practical method of solution of the trouble than the old Plan de Bruxelles.

To start with, twenty-six European countries have co-operated in the new scheme, and although perhaps it is rather too much to hope that the ether will now be finally cleared of interference, it certainly looks as though listeners who are interested in reception on long waves will find the situation, in due course, much more satisfactory.

For instance, Scottish listeners should shortly be able to receive Daventry without interference, and the Eiffel Tower, which recently caused so much annoyance, will gradually reduce its programme service and, in the end, will be used chiefly for sending out weather reports to airmen. Hilversum will be closed altogether.

When considering the Prague Conference it is, incidentally, rather ironical to remember that its conception was due to the Czecho-Slovak Telegraph Administration; but it is gratifying to note that the Russian stations have now come into line and participated in the general share-out of wave-lengths.

## Third-Time Lucky?

Furthermore, the various European authorities represented at the Conference seem to have realised that they can't have it "all their own way." Consequently there was a fairly general unanimity at the Conference and a praiseworthy desire not to be selfish. Sacrifices have been made by various European broadcasting concerns which have made

# WAVE-LENGTH SOLUTION

*Sorting Out  
the Stations.*

*By  
THE  
EDITOR.*



the situation much easier as regards the sharing of wave-lengths.

The basic details of the Plan are due, of course, to the work of the Union Internationale de Radiophonie. The Plan extends the principle of nine kilocycles separation between stations—a difference between neighbouring stations of 9,000 oscillations per second—to all medium wave-lengths down to 216 metres. All the French stations have now come definitely into the scope of the Plan, as well as the Russian stations, and they have been sandwiched in between the wave-lengths shared by other European stations to cut down to a minimum the possibility of interference.

It is an old proverb that the third chance usually succeeds, and as the Prague Plan is the third effort to cope with the problem of ether congestion, perhaps luck has now turned and listeners will really benefit. The

Plan de Geneva and the Plan de Bruxelles worked all right on paper, but they certainly failed in practice.

The Prague Plan, however, has this great advantage: that it has been agreed upon in principle by Government representatives of the various countries concerned. And if only it were definite that the various Governments would impose penalties on the individual broadcasting authorities who fail to adhere to the Plan, it would be practically perfect.

## Effect in Britain

British listeners, of course, know by now that, with one exception, the changes to be made to the British exclusive or national wave-lengths are very small, ranging only from one kilocycle per second in the case of Daventry 5 X X to eight kilocycles per second in the case of Newcastle, and consequently changes in receiver

adjustments will be negligible and hardly necessitate in average sets any changing of condensers or coils.

The biggest change is that of Cardiff's wave-length, which will come down from 323 to 261 metres. In some sets, of course, this change may necessitate a smaller tuning coil. The Eiffel Tower is going to have a wave-length officially fixed at 1,444 metres, while Radio Paris will change from 1,744 to 1,725 metres. The principle of single wave-length working on a national wave-length for local stations has been strongly advocated by the delegates, and is certainly an important part of the Plan.

This is gratifying because, as our readers know, a lot of this detail work—in fact, the whole origin of the idea—has been demonstrated by the

LONG WAVES.

Station.	Country.	Wave-length in metres.
Huizen	Holland	1875
Lahiti	Finland	1800
Radio Paris	France	1725
Zeesen	Germany	1635
Daventry	Great Britain	1553
Moscow	U.R.S.S.	1481
Eiffel Tower	France	1444
Warsaw	(Also Poland reserved for Aviation work).	1411
(The wave-length of 1,380 metres is Motala	Sweden	1348
Kharkoff	U.R.S.S.	1304
Constantinople	Turkey	1200
Reykjavik	Iceland	1200
Kalundborg	Denmark	1153
Basle	Norway	1072
	Switzerland	1010

B.B.C. engineers with great success. On the 30th of this month the wave-length changes will take place, and we shall be pleased if as many of

our readers as possible will report in due course whether they note any sudden and radical improvement in receiving stations.

The long-wave stations under the Prague Plan have been briefly set forth in the table above.

It is suggested by the delegates to the Conference that the station at Kovno, in Lithuania, should seek an agreement with the British Government as to the future wave-length of the station, which has been working on 1,935 metres and 1,990 metres. On these two wave-lengths, however, it has been causing trouble to Scottish listeners, and its new wave-length will be a matter of early future adjustment.

The medium wave-length allocations are set out in the accompanying table.

MEDIUM WAVES.

Freq.	W.L.	Country.	Station.	Freq.	W.L.	Country.	Station.
320	930	U.R.S.S.	Moscow	923	325	Germany	
364	825	"	"	932	322	Sweden	
375	800	"	Kioff	941	318	Bulgaria	
385	778	"	Petrozavodsk	950	316	France	Marseilles
395	760	Switzerland	Geneva	959	313	Poland	
442	680	"	Lansanne	968	310	Great Britain	
527	572	{ Germany	Fribourg	977	307	Yugoslavia	
		{ Yugoslavia	Ljubliana	986	304	France	Bordeaux-Lafayette
531.5	565	U.R.S.S.	Smolensk				
536	560	Germany	Augsburg	995	301	Great Britain	
			Hanover	1,004	298	Holland	
			Budapest	1,013	295	Estonia	
545	550	Hungary		1,022	293	(France (Czechosl'v'k'a	Limoges
554	542	Sweden		1,031	291	Finland	
563	533	Germany		1,040	289	Great Britain	
572	525	Latvia		1,049	286	France	Rheims
581	517	Austria		1,058	283	Portugal	
585.5	511	U.R.S.S.	Archangel	1,067	281	Denmark	
590	507	Belgium		1,076	279	Czechoslovakia	
599	501	Italy		1,085	276	Germany	
603.5	497	U.R.S.S.	Moscow	1,094	274	Italy	
608	493	Norway		1,103	273	France	Rennes
617	487	Czechoslovakia	Gomel	1,112	270	Greece	
621.5	483	U.R.S.S.		1,121	268	Spain	
626	479	Great Britain	Simferopol	1,130	266	France	Lille
630.5	476	U.R.S.S.		1,139	263	Czechoslovakia	
635	473	Germany		1,148	261	Great Britain	
644	466	France	Lyon la Doua	1,157	259	Germany	
653	459	Switzerland		1,166	257	Sweden	
666.5	450	U.R.S.S.	Moscow	1,175	255	France	Toulouse P.T.T.
666	453	Common Wave	No. One				
671	447	France	Paris P.T.T.	1,184	253	Germany	
680	441	Italy		1,193	251	Spain	
689	436	Sweden		1,202	250	Czechoslovakia	
698	429	Yugoslavia		1,211	248	Italy	
702.5	427	U.R.S.S.	Kharkoff	1,220	246	Common Wave No. Two	
707	424	Spain		1,229	244	Albania	
716	418	Germany				(provisionally, Poland)	
725	413	Ireland		1,238	242	Great Britain	
729.5	411	U.R.S.S.	Odessa	1,247	240	Norway	
734	408	Poland		1,256	239	Germany	
743	403	Switzerland		1,265	237	Divided between Monaco, Nice and Corsica	
747.5	401	U.R.S.S.	Koursk	1,274	235	Norway	
753	399	Great Britain		1,301	231	Sweden	
761	394	Rumania		1,310	229	Spain	
770	390	Germany		1,319	227	Germany	
779	385	Poland & Italy		1,328	226	Rumania	
783.5	383	U.R.S.S.	Dnepro-petrovsk	1,337	225	Ireland	
				1,346	223	Luxembourg	
788	381	France		1,337	225	Ireland	
792.5	379	U.R.S.S.	Artemovsk	1,346	223	Luxembourg	
797	377	Great Britain		1,355	221	Finland	
806	372	Germany		1,364	220	France	
810.5	375	U.R.S.S.	Tver	1,373	218	Common Wave No. Three	
815	368	Spain		1,382	217	Common Wave No. Four	
819.5	366	U.R.S.S.	Mikolaieff	1,391	216	Common Wave No. Five	
824	364	Norway		1,400	214	Poland	
833	360	Germany		1,410	213	Italy	
842	353	Great Britain		1,420	211	Rumania	
851	352	Austria	Leningrad	1,430	210	Hungary	
855.5	351	U.R.S.S.		1,440	208	Belgium	
860	349	Spain		1,450	207	Common Wave No. Six	
869	345	France	Strasbourg	1,460	206	Common Wave No. Seven	
878	342	Czechoslovakia		1,470	204	Common Wave No. Eight	
887	339	Belgium		1,480	203	Common Wave No. Nine	
891.5	337	U.R.S.S.	Ivan-Voznesensk	1,490	202	Common Wave No. Ten	
				1,500	200	Free	
896	335	Poland					
905	332	Italy					
914	329	France	Montpelier				

RADIO ITEMS OF INTEREST.

Threshold howl in a short-wave set can sometimes be cured by connecting a large fixed condenser of 2 mfd. or more across the low-tension terminals.

The object of any high-frequency amplifying stage is to magnify the weak long-distance signals before they reach the detector, thus adding greatly to the range and sensitivity of the receiver.

Generally speaking, low-frequency amplifiers can easily be added to most sets. The addition of high-frequency stages is not so easy.

In addition to the British stations, both Berlin and Vienna are now sending regular picture programmes by the Fultograph method, and picture transmissions from Rome, Milan, Budapest, Brussels, Prague, and Hilversum are being arranged.

# MY BROADCASTING DIARY



*Under this heading month by month Our Broadcasting Correspondent will record the news of the progress of the British Broadcasting Corporation, and will comment on the policies in force at B.B.C. headquarters.*

## **B.B.C. Music Organisation**

I BELIEVE most regular listeners will agree that the opportunity of overhauling both the music policy and organisation of the B.B.C. has not arrived too early. In the last year or so there has been a singular absence of a sense of confident progressive policy with defined objectives.

The adhesion to broadcasting of Dr. Adrian Boulton would go a long way to putting things right provided he is vouchsafed adequate authority and freedom. In wishing him the maximum luck in his new venture I would give him the following "tips":

- (a) less "modern" distorted music,
- (b) more Gilbert and Sullivan and more early English light music,
- (c) less studio work,
- (d) ride rough-shod over the bureaucrats,
- (e) take in some fresh blood.

By the way, there is something mysterious concerning the way in which this change-over is being handled. Mr. Percy Pitt vehemently denies that he is to hand over the job of Music Director. Meanwhile, it is common knowledge that Mr. Adrian Boulton has fixed up with the B.B.C. Well—the future will decide.

## **A Schneider Cup Relay**

There is to be rather a special running commentary on the Schneider Cup Race. This will be given on two consecutive afternoons, that is, on the 6th and 7th September, from 2.30 to 4.30 p.m. Flight-Lieutenant Ragg and Squadron-Leader Helmore, who did the Hendon Air Pageant so well last year, will probably be the commentators, and will broadcast from the Control Point at Ryde Pier. It is proposed to utilise several reconnaissance aeroplanes, whose observers will communicate supplementary information to Control Point by wireless telephone.

## **Two Big Weeks this Year**

I hear the B.B.C. is planning two special weeks of programmes this year: the first during the Wireless Exhibi-

tion in September, and the second to mark the seventh birthday of broadcasting in Britain, which falls in the third week of November. Extra money is to be found, and the world searched for adequate talent to provide a whole series of "peaks." Sir Harry Lauder, John McCormack, George Bernard Shaw, Paderewski, Al Jolson, and George Robey are among those contemplated.

## **"THIS IS LONDON CALLING—"**

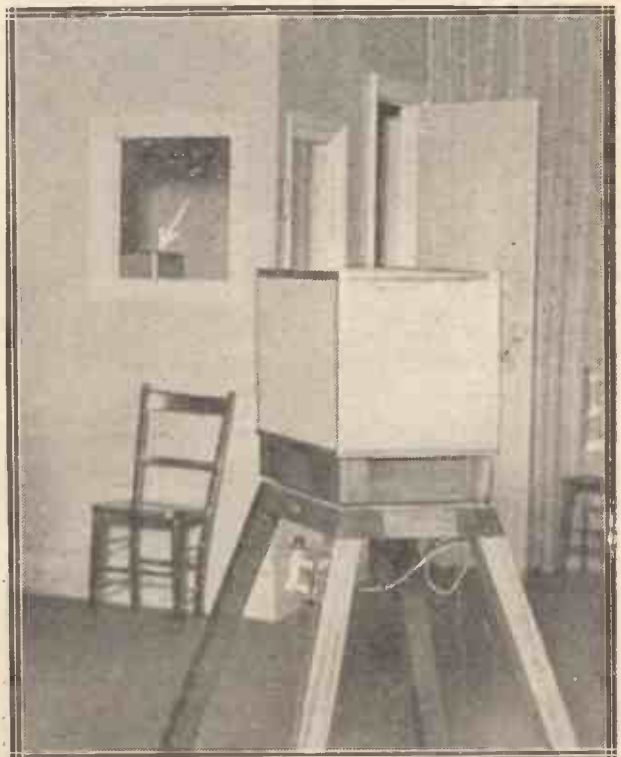

In the foreground is the microphone in one of the main studios at Savoy Hill. At the back can be seen the announcer's cabinet, wherein the activities of the studio are controlled. The arrow points to the microphone used by the announcer.

## All the Latest News for Listeners

### Early Curfew at Bournemouth

The B.B.C. has been anxious to arrange to take some of the excellent Sunday evening symphonies which are put on at Bournemouth this year. But a snag has occurred, because it appears that concert-goers at Bournemouth "pack-up" at ten; whereas the B.B.C. require another half-hour of symphony playing to complete their Sabbath entertainment.

It is not said whether the good people of Bournemouth are bound by local legislation to go to bed at ten; one explanation is that public conveyances are not available after this magic hour. Whatever the reason is, the difficulty for the B.B.C. is a real one.

### Favouring the Oddfellows?

The Oddfellows seem to stand in very well at Savoy Hill. Last year the B.B.C. gave them the Wireless Military Band, complete with conductor, for their big annual "do" at the Queen's Hall. The same thing is to be done this year on November 16th. I wonder what will happen if and when similar requests are received from other Ancient and equally reputable Order.

### Concerts from Central Hall, Westminster

The popular concerts occasionally relayed from the Central Hall have been so successful that the B.B.C. proposes to take these more or less regularly at intervals of about a month, beginning next September.

### THE DANZIG STATION

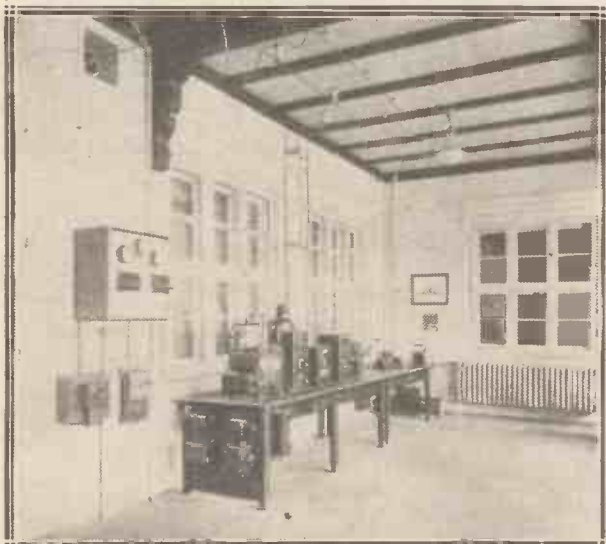

This is the 1-kw. transmitting apparatus at the Danzig station. Danzig operates on 456 metres, and relays Konigsberg.

### Dance Music from Exhibition

During the North-East Coast Exhibition, dance music will be taken from there regularly by the B.B.C. When the Wireless Military Bands are on leave, stations will draw on Newcastle for their dance music requirements. The period covered will be for the whole summer up to October 8th. I hear, also, that the B.B.C. is putting on a special "show" at this Exhibition.

### Contract Bridge

I hear the B.B.C. will start a course of instruction in Contract Bridge before midsummer. Mr. Grossmith and Mr. Filson Young are particularly interested in this development.

### Mr. Aylesworth's Mission

Mr. M. H. Aylesworth, the President of the National Broadcasting Company of the United States, recently paid a visit to Europe for the purpose of making a careful study of broadcasting on this side of the Atlantic.

Mr. Aylesworth's task corresponded on the programme side to that of Mr. David Sarnoff on the business side. United States' radio manufacturers, with the cognisance and approval of their Government, have embarked upon a great project to secure control of all radio and gramophone interests and services throughout the world. The merging of the gramophone and wireless industries in the States has already made considerable progress.

The invasion of foreign fields by American radio is going on apace. The original plan was to exercise control entirely from the manufacturing and marketing ends. But Canada's sudden move in the direction of a broadcasting system not unlike that in Britain has convinced the Americans that they cannot afford to stand out of radio service politics in other countries.

Mr. Aylesworth established pleasant personal relationships with Sir John Reith and others over here, and his published utterances were unexceptionable. It is known, however, that he returned to the States not only reassured of the superiority of private competitive enterprise even in the realm of idealism, but also convinced that if the British Empire is to come permanently within the orbit of American radio control there must be no renewal of the B.B.C. charter in 1936. It will be interesting to observe the sequel. Incidentally, he pointed out that it would be a great deal better not only for listeners, but also for competent B.B.C. officials, if the change he desires is brought about.

### B.B.C. to Reduce Staff

The policy of concentration (about which there has been so much discussion at Savoy Hill, and concerning which the first exclusive news was given on this page) is now accepted. It will be applied towards the end of next year, when a large proportion of the staff in the Provinces will part company with the B.B.C.

There was, of course, no logical alternative except in the case of Birmingham, where the application of the axe will yield a terrific uproar throughout the Midlands. I understand that octets will replace orchestras at Cardiff, Glasgow, Manchester, and Belfast. Part of the money thus saved will be spent in supporting agreed schemes for subsidising local orchestras which may be broadcast as required.

But so far as broadcasting is concerned, all effort of any consequence will originate in London after next year. It will be merely a matter of time before the provincial centres are closed down entirely. The B.B.C. can hardly be blamed in this, because at every extension of the London programme into provincial areas the average listener seems better pleased.

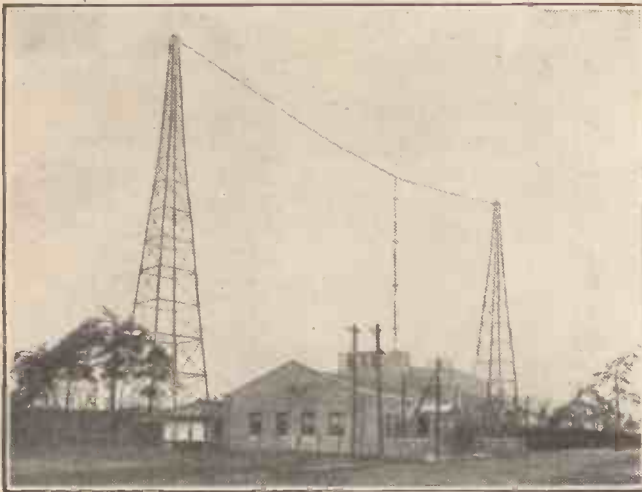

# SHORT-WAVE SCHEDULES

The number and quality of the short-wave programmes is continually advancing. Below are listed the principal stations that can be picked up in this country upon simple receivers provided with short-wave coils.

## STATIONS WORKING ON WAVE-LENGTHS BETWEEN 15 and 30 METRES.

Wave-length in Metres.	Name of Station.	Call-Sign and Remarks.	Wave-length in Metres.	Name of Station.	Call-Sign and Remarks.
15-5	Nancy (France) .. ..	Usual hours 9-10 p.m.	21-96	Schenectady (U.S.A.) ..	W 2 X O.
15-74	Bandoeng (Java) .. ..	P L E. Wed., 12.40 p.m. to 2.40 p.m.	22-2	Vienna .. ..	Power of .24 kw.
16-3	<b>KOOTWYK (HOLLAND)</b>	<b>P C K.</b> Works during morning from about 6 a.m.	22-48	<b>ROCKY POINT (U.S.A.)</b> ..	Transatlantic 'Phone station.
16-88	<b>HUIZEN (HOLLAND)</b> ..	<b>P H O H I.</b> Usually works from 3 p.m.-5 p.m. daily, on 40 kw.	24-5	St. Assize (France) ..	F W.
17-00	<b>BANDOENG (JAVA)</b> ..	<b>P L F.</b> "Radio Malabar." Power of 30 kw.	25-4	<b>PITTSBURGH EAST (U.S.A.)</b>	<b>W 8 X K.</b> Relays K D K A. Sun., 4.30-5.30 p.m. (Church Service) and Concert 6-8 p.m.
17-20	Nauen (Germany) ..	A G C	25-53	<b>CHELMSFORD (ESSEX)</b> ..	<b>5 S W.</b> Power of 15 kw. Mon. to Fri., 12.30 to 1.30 p.m., and 7 p.m. to 12.00.
19-56	<b>SCHENECTADY (U.S.A.)</b> ..	<b>W 2 X A D.</b> Relays W G Y. Sun., 8.30 p.m.-4 a.m. Mon., Wed. and Fri., 11 p.m. to 5 a.m.	25-6	Winnipeg (Canada) ..	<b>C J R X.</b> Power of 2 kw. Mon. to Sat., 10.30 p.m.-12.30 a.m. Also Sat., 6 a.m.-7 a.m.

When an ordinary set of short-wave plug-in coils is used, best results are generally obtained with the 2-turn coil in the aerial coil holder, for all the short wave-lengths.

With the 4-turn coil in the grid circuit, the 6-turn coil will generally be sufficient for reaction. Often these two coils may be reversed for the upper part of the wave-band, especially if H.T. is increased a little, or the aerial coupling slightly loosened.

As all short-wave working is more or less experimental, and fading and daylight effects introduce uncertain conditions, reception is less reliable upon short wave-lengths than upon medium or long waves, but is often more spectacular as regards distances covered, etc.

The more important stations are printed in heavier type. The Chelmsford station, though using high power, is not received strongly in most parts of Britain, owing to "skip-distance" effects.

## STATIONS WORKING ON WAVE-LENGTHS BETWEEN 30 and 60 METRES.

Wave-length in Metres.	Name of Station.	Call-Sign and Remarks.	Wave-length in Metres.	Name of Station.	Call-Sign and Remarks.
30-91	<b>NEW YORK (U.S.A.)</b> ..	<b>W 2 X A L.</b> Tues., midn't to 5 a.m.; Wed., midn't to 2 a.m.; Fri., midn't to 4 a.m.; Sat., midn't to 3 a.m. Pwr of .5 kw.	32-5	Sydney (Australia) ..	<b>2 B L.</b>
31	<b>NAIROBI (KENYA COLONY)</b>	<b>7 L O.</b> Daily, 4 p.m.-7 p.m. Sometimes relays 5 S W from 7 p.m. to 8 p.m.	37	Vienna (Austria) .. ..	<b>E A T H.</b> Mon. and Thurs., 10.30 p.m. to midnight. Now testing.
31-28	Sydney (Australia) ..	<b>2 F C.</b>	40	<b>PARIS (RADIO VITUS) (FRANCE)</b>	<b>Y R.</b> Mon. to Sat., 4.30 p.m.-5.30 p.m.
31-4	<b>HILVERSUM (HOLLAND)</b>	<b>P C J.</b> Power of 25 kw. Announces in English Thurs. and Fri., 7 p.m.-9 p.m. Sat. 2 a.m.-7 a.m. Also works (in other languages) 00.00 to 4 a.m. Fri. Also in Dutch, Sat., 1 a.m.-2 a.m.	40-2	Lyons (France) .. ..	<b>6 A G.</b> 10.30 a.m. and 3 p.m.
31-48	<b>SCHENECTADY (U.S.A.)</b>	<b>W 2 X A F.</b> Relays W G Y. Power of 10 kw. Mon., 11 p.m. to 5 a.m.; Tues., 11 p.m.-4.30 a.m.; Thurs., 11 p.m.-5.30 a.m.; Sat., 11 p.m.-5 a.m.; Sun., to 6 a.m.	42	Perth (Australia) .. ..	<b>E A R 110.</b> Tues. and Sat., 10.30 p.m. to midnight.
31-55	Melbourne (Australia) ..	<b>3 L O.</b> Sun., 8 p.m.-9 p.m.	43	Madrid (Spain) .. ..	<b>I M A.</b> Sun., 5 p.m.-7.30 p.m.
32-5	Paris (Eiffel Tower) (France)	<b>F L.</b> Time Sig. at 8.56 a.m. and 8.56 p.m.	43-5	Rome (Italy) .. ..	<b>X C 5 I.</b> 8 a.m. and 8 p.m. daily.
			44	San Lazaro (Mexico) ..	0-24 kw.
			44-4	Vienna (Austria) .. ..	<b>R F N.</b> 1 p.m.-2 p.m. Tu., Thurs., and Sat.
			50	Moscow (Russia) .. ..	<b>S A J.</b>
			50	Karlsborg (Sweden) ..	<b>W 8 X J.</b> Relays W E A O.
			54-02	Columbus (U.S.A.) ..	<b>W 2 X E.</b> Relays W A B C weekdays, 11 p.m. to 5 a.m., Sun. 3.50 p.m. to 5.30 p.m.
			58-5	Richmond Hill (U.S.A.) ..	Radio L L.
			60	Paris (France) .. ..	

# OP

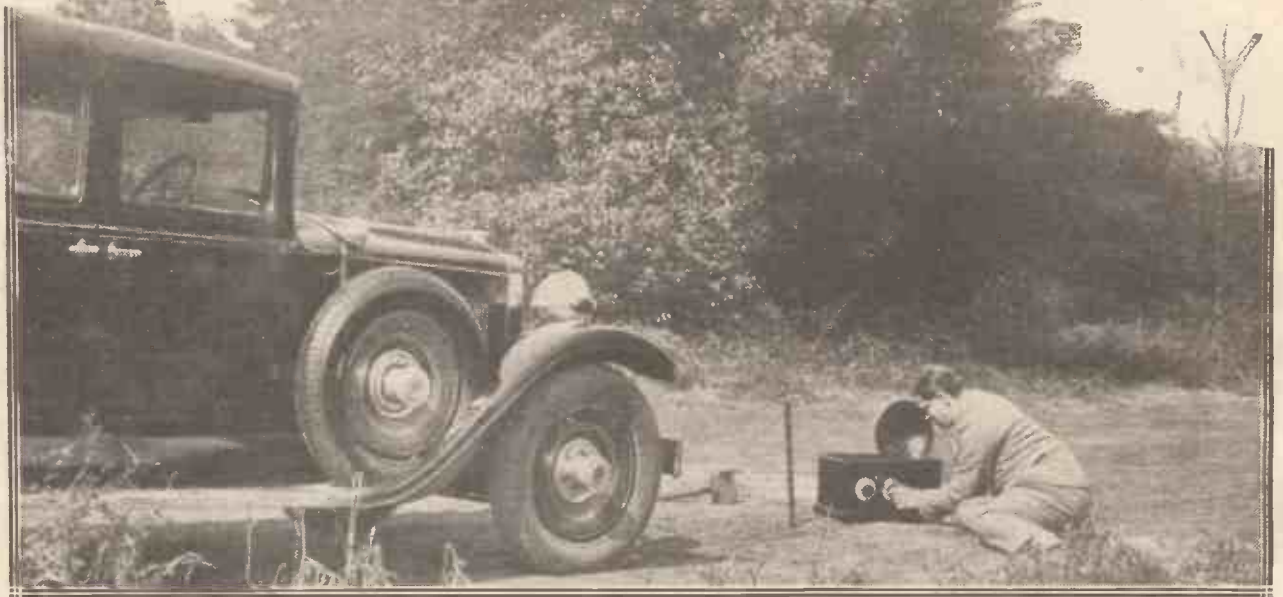

“**O**PEN-AIR RADIO” immediately conjures up a vision of grassy banks, shady trees, singing birds, and a good portable set. The optimist thinks at once of some delightful spot, miles away from the dust and roar of traffic, where he can sit, after a lunch enjoyed at some old-fashioned inn, and listen at leisure to the music of Europe.

The pessimist dwells on the hopelessness of trying to enjoy yourself with a portable set unless there is a car, or at least an L.G.O.C. bus, within a hundred yards in order to carry the “thing” home; the severely limited menu of the average country inn; and the obvious lack of amusement in a lesson on elementary French or volcanoes. He may also remark that if you have a good portable set you can get the French market prices from Radio-Paris as an alternative!

Joking apart, however, there is a good deal more in open-air radio than merely taking out a portable set

and listening to wireless programmes out-of-doors. The true wireless experimenter whose interest in the hobby lies in transmitting more than a desire to listen to programmes, will find outdoor radio presents a wide field of activity.

A great deal of valuable work still remains to be done in recording the variations in reception conditions at different places, and much useful information can be gathered regarding the efficiency of different types of aerials—data extremely hard to obtain in the restricted area of the average garden.

### Fixing the Aerial

Few modern listeners realise, for example, the amazing efficiency of a long horizontal wire supported only a few feet above the ground. Well-insulated wire, such as Electron or Negrolac, can be purchased very cheaply in 100-ft. rolls, and a single roll of this wire, an insulator or two, a copper earth tube with a wooden mallet to drive it into the ground, and a small wireless set will enable a group of listeners who are keen on experimental investigation to compile a good deal of interesting and useful data.

In experiments of this kind, where rapid changes of location or disposition of the aerial are necessary, I find the small device illustrated in the accompanying photograph of great use.

It consists of a large and strong spring clip secured by about two feet of cord to an insulator, which can be a porcelain rod or one of the many types sold for wireless aerials, the ends of the insulated aerial wire being attached to the other side of this insulator.

The particular merit of this device is that the end of the aerial can be quickly attached to any convenient point, while at the same time the end of the aerial is well insulated from the object to which it is attached—which may be a metal post. Because the wire itself is insulated it should not be imagined that this insulation *always* dispenses with the need of any separate insulator.



*Outward Bound for a car-picnic, with a set on board to provide some light music if required!*

# EN-AIR RADIO

By Percy W. Harris, M.I.R.E.

The insulation on the aerial wire, while excellent, is thin, and if this wire is bound round, for example, a metal post considerable leakage of wireless currents can occur from the wire to the post, the insulation here acting as a dielectric of quite a large condenser. By using a scheme such as I have just suggested this difficulty is overcome.

For general investigation of receiving positions, a portable set complete with frame aerial will enable you to do a great deal, but, of course, for experiments with aerials, and indeed for experiments in long-distance reception with any degree of certainty, a set which is designed for use with aerial and earth is indispensable.

The set should preferably have a stage of high-frequency preceding the detector, and if you have a car the starting and lighting accumulator can be used as the source of low tension. It should be remembered that a large number—if not the majority—of British cars have 12-volt accumulators, and the requisite 2, 4 or 6 volts will have to be obtained by tapping the accumulator.

American cars, on the other hand, always have 6-volt accumulators, so that owners of Ford, Essex, Buick, Chrysler, and other well-known American types need only plug-in to the most convenient lamp socket without lifting floor boards or whatever else is necessary to gain access to the car accumulator. This assumes, of course, that you are using 6-volt valves.

## The First Experiment

It is just as well to take, if you can, one or two fixed condensers of values varying from .0001 to .0005 mfd., or, better still, a variable condenser of .0005 mfd., which for convenience can be mounted in a box.

Many experimenters have found that an ordinary wire fence makes a wonderfully efficient aerial. To use it, connect one side of your fixed or variable condenser to the wire of the fence and the other to the aerial terminal of your set, adjusting the value of the condenser till the best results are obtained. Such an aerial is more truly aperiodic than many which bear the name, and owing to its very large size there are set up in it currents from a very large number of transmissions, the one required being filtered out, or selected by means of the tuning circuits of your receiving set.

In experiments of this kind I would strongly recommend the use of the older horn type of loud speaker, for sensitivity and not quality is required in the circumstances, and there is no question that the older horn types—at least many of them—are amazingly sensitive compared with most cones.

One of your first experiments should be with the insulated aerial wire laid out straight along the grass, with an

*There is a fascinating field for radio reception out-of-doors, for not only can the programmes be enjoyed under idyllic conditions, but much fun can be had from experiments with different aerials and earths. This article "puts you wise" to all the possibilities of outdoor wireless.*

ordinary earth connection such as can be obtained by using an earth tube.

You will find if you attach the aerial wire direct to the aerial terminal that the extremely large capacity between the wire and the ground will rather upset matters, but if you introduce the exterior variable condenser in series with this

wire, as suggested for the fence aerial, you will be very surprised to note the sensitiveness of such a scheme.

## Using Two "Earths"

Another interesting experiment is to use, instead of an earth connection a similar length of insulated wire connected to the earth terminal, the aerial wire going in one direction and the earth wire in the other. The variable condenser will then only be needed in the aerial lead. Experiments of this kind are by no means new—in fact, it is many years since certain German investigators carried out most important work of this kind in relation to long-wave signals from transatlantic transmitting stations.

Since the advent of broadcasting, however, we have heard little of this kind of aerial, and much new data can be accumulated in relation to the shorter wavelengths. In America a few years ago tests were made



To the left is shown the method of clipping the aerial in position, and the right-hand photograph shows the making of an efficient earth connection.

with insulated wires actually buried in the ground, and the name of Dr. J. Harris Rogers is prominent in this connection.

It is often thought that an aerial which goes from the receiving apparatus to the top of a mast and then down again, almost to ground level, is inefficient, but my experience is that such a type of aerial is often very good.

It is very easily reproduceable in an open-air excursion simply by attaching a weight such as a stone to the end of the insulated aerial wire and throwing it over the top of the tree so that the aerial goes up and then down the other side.

Beware, however, of drawing conclusions from too little data, as if you make comparisons with your home aerial without allowing for the difference in locality you may be considerably misled in favour of the "up and down" aerial just mentioned. It is here the ordinary portable set with self-contained frame aerial is useful for comparison purposes, for one can more accurately compare the reception conditions at home with those of the spot chosen for the experiment.

**Crystal Set Not Debarred**

The user of the humble crystal set is by no means debarred from useful experiments in open-air radio, and wave-change crystal sets easily switchable from the lower to the 5 X X range will often pick up signals of surprising strength in the open country, as I myself found many years ago when I took out a crystal set and experimented along the lines already discussed.

I remember, for example, just twenty years ago logging signals from a number of wireless stations on a temporary aerial consisting of a wire temporarily hooked to the upper window-sill of a house and dropped down the front into a lower room. I also remember sitting up all night at a farm with an aerial connected to a neighbouring church tower. There was no telephony, of course; telegraph signals in Morse being the only "source of supply."

These notes will have suggested a number of interesting experiments to the individual reader or to a group, such as

a few keen members of a wireless society, taking an outing together. A very large number of readers no doubt already possess a self-contained portable set, and the following notes on the use of such receivers in the open-air and in country districts may be found useful.

If you are using a portable set at the seaside, one of your biggest troubles will probably be Morse interference from ships and adjacent coast stations. Powerful coast stations working to ships at sea are situated very close indeed to



*Tea for Two—and a musical interlude!*

such resorts as Margate and Ramsgate, many places in the Isle of Wight, Land's End, and St. Ives districts, and so on round the coast.

If you are stopping at a place immediately adjacent to one of these Morse stations you are bound to get a good deal of interference on the lower band, and in such circumstances you will find the upper range much more satisfactory, as there will be a much wider wave-length difference between the interfering station and the station you wish to receive. In a few cases, however, you may have a long-wave station very close to you, and here you will have to choose the band with the lesser interference.

**Frame and Outdoor Aerial**

A few commercial portables are arranged with terminals for the connection of an external aerial and earth. In such cases it will be found decidedly preferable to use one of the improvised aerials already referred to in conjunction with an earth tube, or, better still, an earth plate thrown into a pond or stream.

In the case of a set which has no such provision a very considerable increase in the range of the set can be effected by erecting one of the temporary aerials in the manner already described and then wrapping a few turns round the lid in which the frame aerial is contained. The free end of the wire is then taken to an earth connection, or, if such is not convenient, to a length of wire approximately equal to that of the aerial itself.

Certain precautions need to be taken when a portable set is used in a motor-car. First of all the engine should be switched off, otherwise you will get an annoying noise due to the sparking of the ignition system, whether coil or magneto. I do not say that it is impossible to receive while the engine is running, or, indeed, while the car is in motion, for I have listened a good deal in this manner when testing reception conditions. Nevertheless, while in experimental work such noises are not too irritating, they completely spoil results if you desire to enjoy the programmes.

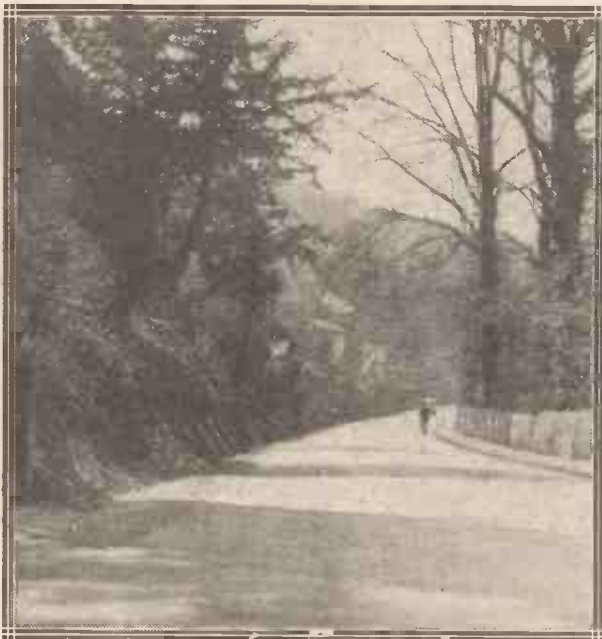

*The charm of the lanes, and of the countryside, can often be enhanced if radio music is available at the touch of a switch.*



## Your Licence Now Covers a Portable

There is a good deal of metalwork in every car, and some of the modern saloons, using what is known as "all-steel" construction, may act as a complete shield for reception, preventing the reception of a sound even from a nearby station. In most cases, however, something can be received inside the car, but usually if the portable set is placed on the back seat in such a position that its plane is parallel with the back panel, then the presence of metal in this panel will upset reception.

The best results will generally be obtained when the car is placed at such an angle that it points towards the station it is desired to receive. The portable set can then be placed at right-angles to the back seat and well clear of both sides, in which position its frame will be much less subject to screening effects.



*Interesting experiments can be carried out with crystal sets at various distances from the broadcasting stations within range.*

When the portable set is taken out of the car it should not be used too near it, as the large bulk of metal may act as a bad screening influence in that direction. The effect of the car diminishes rapidly with distance, and comparatively few yards away it will be found to have little effect.

### *Effect of Height on Reception*

When investigating receiving conditions vast differences will be found between conditions at spots comparatively few miles apart. Generally speaking (but not always), by far the best conditions obtain on high ground, particularly on top of a hill in rolling country. During the experiments for the preparation of this article a portable set was taken to the top of Ranmore Common, in Surrey, the spot being some fifteen or sixteen miles south-west of London.

Reception conditions with a portable set standing on the ground among the trees were extraordinarily good, the morning transmission from 5 X X and from Radio-Paris coming in at least twice the strength they are received in the "Wireless Constructor" laboratory.

Where the ground is gently undulating it will be found quite often that reception conditions on the lower ground are practically as good as on the upper, for the waves seem to slide along the surface of such undulating ground without serious loss. But where there is an abrupt change in altitude the high ground frequently acts as a screen. For example, at the foot of a cliff reception conditions are very poor as compared with those at the top (at least, from stations in the direction of the cliff).

In such cases much depends upon the actual soil, for occasionally an abrupt rise has brought an astonishingly small variation in reception conditions. Here experiments are extremely useful, particularly if the details are properly recorded and tabulated. It would be interesting to hear how reception conditions in, say, Dorking, are effected by the presence of Box Hill.

### *Using the Kite Aerial*

In all experiments for the comparisons of reception results be sure that, as far as possible, the experiments are repeated under the same conditions. With portable sets having frame aerials built into them the duplicating of receiving conditions is comparatively simple, but, when a temporary aerial is slung up, the earth conditions in two different spots may be totally unlike one another.

So far it will be observed that I have said nothing whatever about kite aerials. Marvellously good reception can be had by their aid, but the impossibility of predicting beforehand whether conditions will be suitable to kite flying, the difficulties connected with the attachment of such an aerial to a receiver, and a number of other problems which will occur to the reader, effectively prevent this being a really popular form of experimenting!

If the reader should try and experiment on these lines it is wise to make fast the lower end to a post or tree, and to take a long flexible lead from this point to the set. The

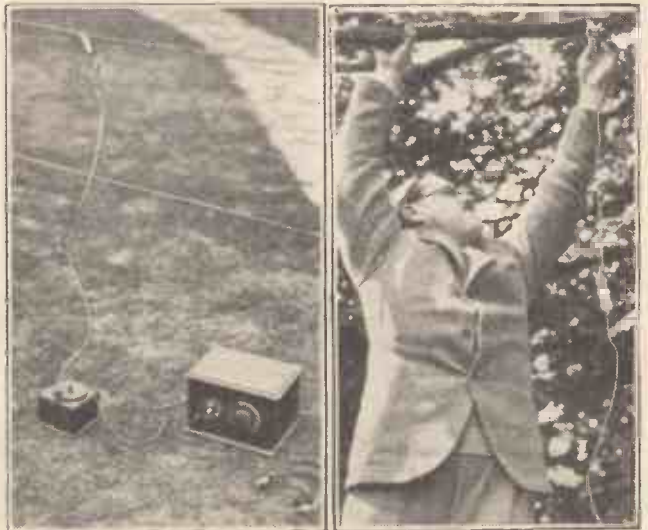

*The method of "commandeering" a wire fence to act as your aerial is shown to the left, and the other photograph illustrates one of open-air radio's most interesting little problems—that of fixing the aerial.*

man in charge of the kite can then concentrate his attention on keeping the aerial aloft, while the receiving operator will not be disconcerted by seeing his treasured portable set suddenly dragged into the air and flung over the top of the nearest farmhouse!

If you have a really sensitive set containing two stages of ordinary high-frequency or one stage of screened grid, and you have a fairly large garden or a field nearby, try the effect of receiving, not on an aerial and an earth, but on two different earths.

### An "Earth Mat" is Useful

A couple of earth tubes are the most convenient for this experiment because they can be driven in the ground and withdrawn without doing any serious injury to the ground. It might seem that when the aerial terminal of the set is joined to one earth connection and the earth terminal to another that the receiver will be effectively short-circuited.

Actually, however, it will be found that there is a difference in potential between the two different parts of the ground, and you will be able to pick up quite loud signals in this way, particularly when the two earth connections are in a line with the station you are receiving.

The set itself should be used as near as possible to the line between the two earths, otherwise if long leads are used there will be a considerable pick-up from these and you will not know what is due to earth reception and what to pick-up by the leads.

"Earth mats" (large sheets of copper or bronze gauze or netting) were largely used during the Great War, and



*Portable sets make interesting car-companions whether on the move or when the car is parked in a pleasant country lane.*

doubtless a number can be obtained very cheaply from the disposal firms, such as Leslie Dixon, Ltd., and Thompsons, Ltd. When these are unrolled upon the ground they can be used as counterpoises, and will often give a much better "earth effect" than a buried plate, particularly if the latter is small. An earth mat can easily be rolled up and tucked in the dickey of a car, and one should certainly be obtained if any serious work in outdoor reception is contemplated.

Altogether it will be seen that, as indicated at the beginning of this article, there is a wide field for experiment in outdoor radio, and that there is no need whatever to abandon the hobby during the summer months on the plea that we must get out-of-doors as much as possible.

The Editor tells me he will always be glad to hear from readers who have obtained results along the lines of the suggestions laid down in this article, and will be pleased to publish them for the benefit of other readers.

### Microphone Troubles

A trouble which often develops in connection with all portable sets is microphonic noise, that irritating ringing or humming sound which is something separate and distinct from an audio-frequency reaction howl. Unfortunately it is not confined to any one make of valve, as occasional specimens of all makes give it. The detector is the chief valve to watch, and if you have this trouble, change it first.

Some people talk glibly about microphonic electrodes, but any valve maker will admit, when questioned, that all of the causes of microphonic trouble are not understood. It is actually the case that with some valves the so-called anti-microphonic valve holder increases the trouble! However, whatever the cause, the effect is irritating enough, and you will want to know what to do to eliminate it.

If you are lucky enough to have several specimens of the same type, run through them, and you will probably



*It is quite an easy matter to mount an ordinary set on the running-board of a car, when a portion of the car-battery can be utilised for the low-tension supply.*

## Radio Provides Your Picnic Programmes!

find one which is quite free from noise. Do not be misled by a temporary silence, as it sometimes takes a loud signal to start the trouble, and some valves do not develop microphonic noises until they have been run for a few days. Put the valve in its socket, and tune-in the set to something quite loud. If no troubles occur then, and the valve is not quite new, it is probable you will have no further trouble.

### The Usual Sinner

If, as often happens, the microphonic valve is the only one available, the best cure I personally know of is to cover the whole of the glass with a thin covering of Plasticine, a small stock of which can be obtained for a penny or two from any toyshop. The valve will not look particularly attractive with its coat on, but in nearly all cases the microphonic trouble will be cured.

Remember that a valve in a portable set is particularly exposed to troubles of this kind, as the sound waves from the loud speaker impinge with greater strength upon it. A valve which is quite satisfactory in an ordinary cabinet receiver, where the cabinet itself shields it from sound waves, and where the loud speaker is many feet, or even yards off, may set up an appalling howl when placed a few inches from a cone.

Occasionally, one finds a faulty screened grid valve which is badly microphonic, but in the majority of cases the detector is the only sinner.

Do not confuse a true microphonic howl with the howl due to "chain effects" when radio-frequency signals get through into the audio-frequency side. An easy way to find whether the noise is due to a microphonic detector is to detune to some silent part of the scale (silent so far as signals are concerned!) and then tap the glass of the de-

detector and see whether the note exactly corresponds with that of the howl. If the set has been temporarily silent, this will probably start it off again.

Packing the valve compartment loosely with cotton wool or soft tissue will sometimes stop the trouble, and sometimes a revised layout will effect a complete cure, particularly in the "transportable" type of receiver where the valves are on a kind of shelf and rather boxed in. In this type of receiver, I have sometimes stopped the trouble by lining the interior walls of the valve compartment with a layer of wash-leather or thin cotton wool sheeting, so as to prevent too strong a reflection of sound waves back on to the glass.

And speaking of glass, it is probable that the design of the bulb has a good deal to do with whether a valve is inherently microphonic or not.

### An Interior Fault

Another type of valve noise, and one for which there is no cure, is a rushing and crackling on top of the signals, due to an interior fault. When heard it very closely resembles the noises due to a faulty anode resistance or partially broken down or faulty primary of a low-frequency transformer. A bad grid leak may also give the same noise. If the same sound occurs with any other similar valve, when placed in the same socket, the fault must obviously be sought elsewhere than in the valve, but if only one valve behaves in this fashion, then it should be returned to the dealer from whom it was purchased.

Before you start off on any expedition with radio, do not forget to check the battery voltages. Do not rely on somebody's statement that "It worked all right last night." That usually means trouble!



*There is a never-ending interest in reaching new surroundings and tuning-in old friends of the ether.*

# "PORTABLE"

RADIO ON THE ROAD,



When a car is available you can use a "transportable," and the car battery can supply L.T. ●



Happy Radio Ramblers.



"Further outlook—continuing fair in all districts."

# PASTIMES

Some pictorial suggestions of the many out-door entertainments in which radio plays a pleasurable part.

## RAIL AND RIVER.

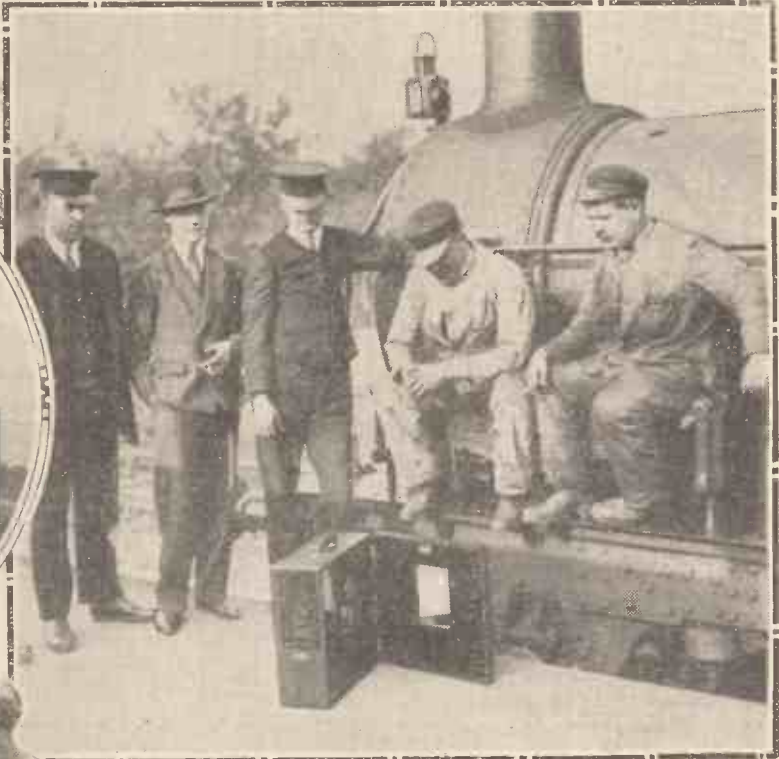

Was this railroad radio one of those "signal successes" that we read about?



Can you beat it?

Much better than "motor-boating!"



Don't forget to put the portable on board!



# WHAT READERS THINK

The P.G.F. Circuit—A Simple Charger—The "All-In" Two.

## The P.G.F. Circuit

SIR,—Some few months ago I designed and constructed an all-mains set using Cosmos indirectly-heated valves. In order to get real selectivity combined with great volume using only a frame aerial, my circuit was rather unusual, having three stages of H.F. followed by leaky-grid detection and two stages of L.F. amplification.  $V_1$  was aperiodic choke-coupled to  $V_2$ , which was transformer-coupled to  $V_3$  by the split-primary method.  $V_3$ , one of the new indirectly-heated screened-grid valves, was connected to  $V_4$  by parallel feed.  $V_5$  and  $V_6$  were resistance-capacity and transformer-coupled respectively.

## Dual-range Coils

Naturally the set was fully screened. Results were excellent, but I was unable to put more than 30-40 v. on the anodes of  $V_1$  and  $V_2$  without causing instability, and therefore I did not consider that the set was doing its best.

On seeing Mr. Allinson's "P.G.F." system of neutralising, described in the current number of MODERN WIRELESS, I decided to give it a trial. I cut out the choke-coupled stage of H.F. altogether, and neutralised the transformer stage as described. The result was that I was enabled to put the full rated voltage on, with absolute stability over the whole broadcast wave-band; consequently the valve could give its full amplification. The set now gave slightly better volume, than before, with one less stage of H.F., and selectivity was improved. There is no doubt that this system of balancing has got all the others beaten, and it should become deservedly popular. I imagine that my results will be interesting in so far as they prove that the "P.G.F." system is applicable to mains valves.

Perhaps some further details of my set may be of interest. Dual-range coils are used, and these are ganged on the one spindle for ease of wave-

band changing. Each valve is fully decoupled. The mains unit of the set is very carefully smoothed and has three variable feeds to the first three valves. A high-resistance voltmeter is incorporated with a switching scheme that gives the reading for each feed at a touch. Reaction is obtained by the usual capacity method and two volume controls are fitted: one across the primary of the transformer (L.F.), comprising a 50,000-ohm variable resistance, and the other, a 400-ohm variable resistance, in series with the frame-aerial windings. This latter also serves to flatten the tuning on the local and Daventry 5 XX, and thereby improves the quality. The frame aerial is designed along the lines of the one used in the Mullard Master Five Portable.

Yours sincerely,  
P. STEWART WATT.

Aberdeenshire.

## A Simple Charger

SIR,—I notice in the April issue of MODERN WIRELESS a letter, page 422, describing a change-over switch for a simple charger which I consider extremely dangerous. Even when fitted with a cover, as pointed out by the Editor, it is far from satisfactory,

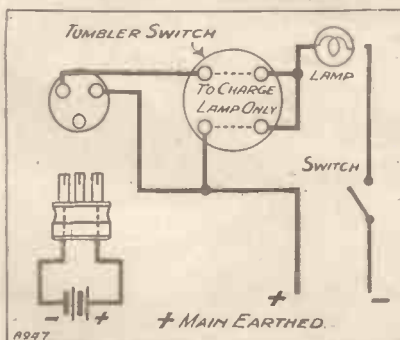

on account of having to remove the cover every time the battery has to be attached or removed.

It will be noted that one has to touch a live terminal when connecting or disconnecting the battery at night

when the light is on, a practice decidedly not to be recommended.

This circuit has another serious fault in that so long as the battery is connected to the switch, it is liable to be some 200 volts above earth potential, and consequently a great source of danger in certain cases to anyone touching it.

A very much safer and almost as cheap a method would be to have an electrician install an ordinary 5-amp. two-way tumbler switch, and to have the battery connected to the earthed main through a three-pin plug and socket. No connection is taken to the third pin, which is only used to make certain the plug is put in the same way every time.

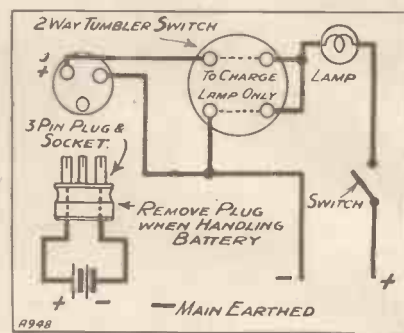

Enclosed are two sketches showing alternative connections depending on whether the positive or negative mains are at earth potential.

If neither pole is earthed, the battery should always be in a locked cupboard when connected to the mains.

Yours faithfully,  
C. GILES, A.C.G.I., A.M.I.E.E.  
Newcastle-upon-Tyne.

## The "All-In" Two

SIR,—It may be of interest to you to hear of my experiences in the working of the "All-In" Two portable, which was described in MODERN WIRELESS, May, 1928.

As the Philips 4-electrode valves are apparently unprocurable in England, I am using Aneloy A.P.412U, with anode battery of 9 volts (an Ever-Ready grid bias), and the grid connections altered as suggested in the article. The only difficulty I experienced was finding the correct winding, and the difficulty was enhanced by the fact that when the set was put into the case the tuning was altered.

A simple remedy was soon evolved; tappings have been taken at various points on the outside wiring, any of which can be connected with a wire attached to the fixed plates of the tuning condenser—to which also is

(Continued on page 682.)



The S.G. valve can make a very effective detector providing that it is used in the right way, and in this article a circuit of a particularly suitable nature for the purpose is described.

By C. P. ALLINSON, A.M.I.E.E., A.M.I.R.E., F.Inst.P.Inc.

**A** VERY useful function of the screen-grid valve which has so far received but little consideration is to use it as a detector valve. I know that it has one rather serious drawback—its high price—but to balance against this it has a number of advantages.

One of these is the fact that when working under the correct conditions it is extremely sensitive. This is to be expected, since it has such a high amplification factor.

### The Capacity Load

The other is that it places far less load across the tuned circuit connected to the grid of the detector valve than the usual three-electrode valve which has a high amplification factor. You will probably remember that the capacity load which is to be considered as being connected in parallel with the tuned circuit can be considered to be  $m+1$  times the grid-plate capacity of the valve.

In the case of a high- $\mu$  R.C. valve being used as a detector, let us see just what this value is. The amplification factor is 40, the grid-plate capacity is approximately 3–5 m./mfd. This gives a capacity of '00012 upwards.

### Hardly Surprising

When we consider this figure in conjunction with the minimum capacity of the tuning condenser, it is hardly surprising that one finds the tuning of the detector circuit getting extraordinarily flat at the bottom.

To help to make this quite clear I have drawn a diagram (Fig. 1) showing

two calibration curves. No. 1 shows the calibration of a tuned circuit with the usual incidental stray capacities in parallel with the tuning condenser, which has a minimum value below which, of course, it cannot go. This minimum capacity fixes the lowest wave-length to which the circuit will tune.

In the case of Curve No. 2 a fixed condenser of '0001 mfd. has been



The S.G. valve has a terminal situated on the top of its bulb, as shown by this photo. The additional terminal is the connection to the plate or anode of the valve, the pin in its base which is usually used for the plate is employed for the screening-grid. As valve-holder sockets are frequently marked, this re-arrangement sometimes causes confusion.

connected in parallel with the tuned circuit and a few turns taken off the coil so that the maximum wave-length reached will be the same as in the case of Curve No. 1. Actually in order to make sure that the curve shall be distinct from the first curve it has been kept a few metres higher at the top end.

But look what happens at the bottom. After the curve reaches a certain point it begins to flatten out rapidly, and instead of tuning three or four metres higher at the bottom, it tunes nearly 50 metres higher.

### Matching Tuned Circuits

Now let us see what happens in the case of the screen-grid valve. This has an amplification of 120 on the average, and the residual grid-plate capacity owing to the screening not being absolutely perfect is somewhere in the neighbourhood of 1 m./mfd.

The capacity load applied to the grid circuit is therefore only 12 m./mfd., as against 120 m./mfd. Not only does this enable us to cover a larger band of wave-lengths in the detector circuit, but it also enables two tuned circuits to be matched up much more accurately, so that the ganging of an H.F. and detector set will be far more successful and less of a compromise than with a three-electrode valve.

### Another Interesting Feature

The S.G. valve as a detector has another feature that some will regard as an advantage, and others as a disadvantage, and that is that owing to the screening within the valve there is practically no H.F. component in the output.

This, of course, makes it easy to keep H.F. out of the L.F. amplifier. But, on the other hand, it makes it very difficult, if not impossible in most cases, to get any reaction.

This is no disadvantage, however, in the case of a multi-stage H.F. set where reaction is not wanted for

## Some Suggestions for Experimenters

fear of spoiling the purity of reproduction. Further, owing to the high plate-filament capacity—for the plate is close to the screen, which is connected direct to L.T. through a large condenser—no shunting condenser in the anode circuit of the valve is required.

I estimate that with incidental stray capacities, when using an S.G. valve as detector, the anode-filament capacity lumps at .0001 to .00015 mfd., and this value in conjunction with the form of coupling which has to be used with an S.G. valve is ample to provide the necessary shunt capacity which is required in the plate circuit to relieve the load, which is otherwise imposed on the grid circuit, and which usually shows itself in the form of subnormal signal strength.

### Amazing Tone Purity

The practical use of the S.G. valve requires that certain simple rules be followed. Obviously it can only be used with resistance-capacity coupling. In view of the high impedance of this type of valve a high coupling resistance has to be used, not less than 1 megohm, and preferably 2. The coupling condenser should be about .006 mfd., and the grid leak 5 megohms, certainly not less

This arrangement gives amazing purity of tone, though I have found that anode-bend does not give quite such good signal strength on distant stations as leaky-grid rectification with the S.G. valve, as with ordinary valves.

### A Direct Comparison

A circuit that enables you to experiment with this valve as detector is shown in Fig. 2. The usual grid condenser  $C_2$  is included, either positive or negative bias being applied via the grid leak according to whether you want to get leaky-grid or anode-bend rectification.

In the ordinary way I do not care for this arrangement to give anode-bend, but with the S.G. valve I have found that it is perfectly satisfactory. I made a direct comparison of the grid leak against a high-frequency choke but could detect no difference at all.

The grid leak should have a higher value than usual, say 3 or 4 megohms, except for very powerful signals, when it may be reduced with advantage.

The H.F. choke  $L_2$  in the anode circuit is not really necessary, but I like to include it as an additional safeguard, and to make sure that

the clip-in type, different circuits and values can quickly be tried out, and the free-grid scheme experimented with.

### Adjusting the H.T.

I have shown a variable resistance  $R_4$  connected in the screen-grid lead, and I am inclined to think that this is almost essential, as I found that the screen potential was rather critical if the best results were to be obtained.

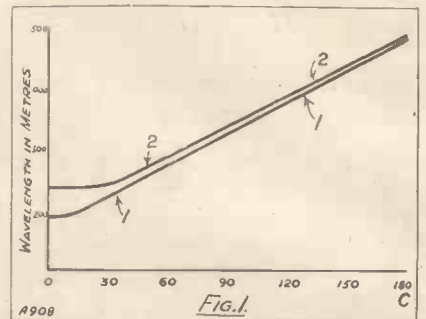

These curves illustrate how the tuning of the detector circuit flattens towards the bottom.

You will find when adjusting this that if you get it too low you may get a low-frequency growl. This is due to your getting the valve on its "negative characteristic" part of the working curve. You want to work the valve just above the point where it begins to growl.

With a fairly high potential for H.T.+2 I found that the correct grid bias for anode-bend rectification was between  $4\frac{1}{2}$  and 3 volts; either did very well for the value was not critical. On reducing the plate volts to 120 I found 3 volts as satisfactory as anything.

### The Grid Bias

You will find that the adjustment of grid bias will affect the correct setting for the screen potential, but a few minutes' experiment will soon show you the best adjustment.

The pure reproduction and faithfulness of tone that the S.G. valve gives is certainly beyond criticism and I have been impressed throughout my experiments with it as rectifier by what it would do in this way when working under suitable conditions, while its other peculiar advantages recommend it for use in many cases.

Readers will find that there is ample scope for research in the directions I have indicated.

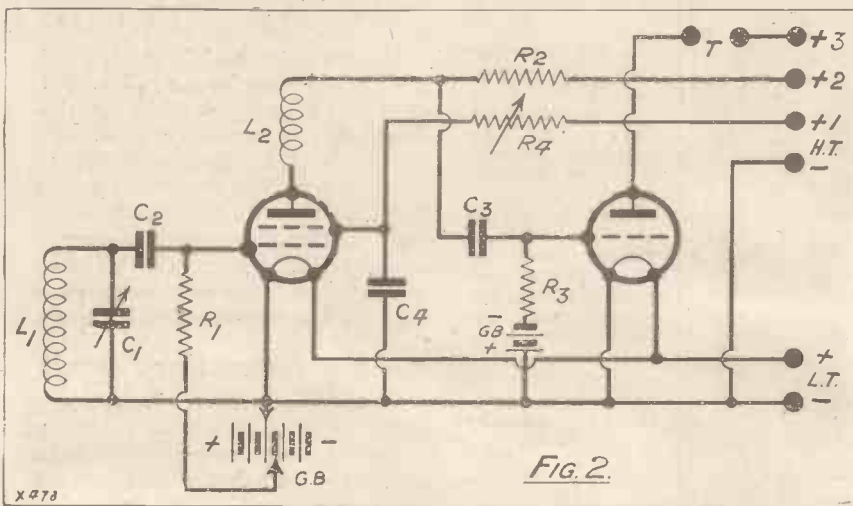

This circuit is a particularly suitable one with which to experiment with the screened-grid valve as a detector. Either anode-bend or grid-leak rectification can be arranged.

It also lends itself very well to the free grid arrangement. In this case the anode resistance may go as high as 5 megohms, providing always that anode-bend rectification is used. In this case the coupling condenser should be .001 to .002 mfd., and no grid leak used at all.

the anode-filament capacity does by-pass any residue of H.F. that may have got through the screening grid.

By having the L.F. grid leak  $R_3$  mounted in a handy position so that it can easily be removed, and by having the coupling condenser  $C_3$  of





# TESTING TELEPHONES

Some practical hints on an important subject.

By A. NIGHTINGALE.

THE usual method of testing a pair of telephones is clearly illustrated above. The phones are placed upon the head, and then one tag of the end of the leads is placed on one terminal of a battery, the remaining tag being placed on another of its sockets or terminals. The result is a very loud double click. But this is *not* the best way to test a pair of telephones.

The disadvantage of the method is that it is crude. Telephones are extremely sensitive instruments and to place them directly across a battery like this is rather like cracking a nut with a sledge hammer. A better test for 'phones, and one which does not even need a battery, is the following:

Place the earpieces over the ears in the ordinary manner, and then put one of the tags at the end of the cord into the mouth, holding it firmly between the lips. Now, in one hand take the other tag of the telephones, and in the other hand take a key, a nail, or a similar piece of metal, and rub this gently on the second tag. If the telephones are in good order you will hear noises corresponding with this rubbing in the telephones.

## The Human Battery

The noises, of course, will not be very loud, for in the absence of an external battery you are working the telephones by a kind of human electricity, generated in your own body. But so sensitive are a good pair of telephones that if they are O.K. the noises will be absolutely distinct and unmistakable.

If you wish to test each earpiece separately, you can do so by removing one of the earpieces from the ear and listening only with the other. Or, alternatively, you can place a pad between the ear itself and the

adjacent earpiece, so as to cut off the sound from the latter. In this way you can compare the loudness of the two sounds, but do not forget that most people hear better with one ear than the other, so before definitely pronouncing one earpiece less sensitive than the other, turn the telephones round and try both earpieces on one ear.

## Keeping in Condition

The great advantage of this method is that not only is there no risk of damage to the 'phones, because the currents dealt with are so small, but the very limitation of using a weak battery means that slight faults will be shown up which would not be

renewed, the plan of handling them carelessly and allowing them to twist and tangle is a bad one.

'Phones should be kept in dry place, leads neatly coiled out of harm's way, and if owing to constant use these become frayed, long life can be ensured by binding the affected place with cotton or silk so as to stiffen this and protect it. On no account throw the telephones on to a table, or drop them on to the floor, as a sudden sharp shock of this kind is sufficient to impair the efficiency of the permanent magnets, on which the 'phones depend in order to do their work.

Finally, it is a good plan to remember that after the 'phones have

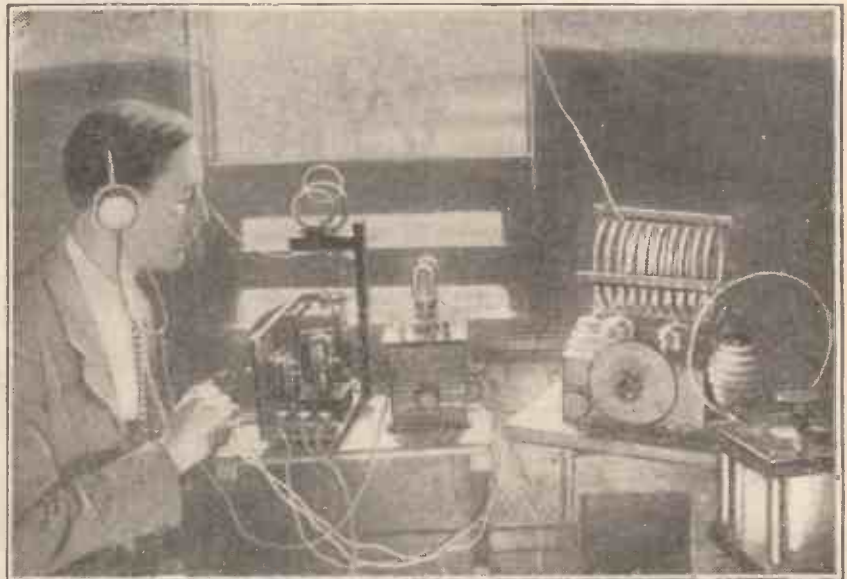

RUSSIA'S RAILROAD RADIO. This is the experimental short-wave gear fitted on a grad to Moscow train to test the possibilities of radio for railway communication.

noticeable when using higher power at the testing end.

The majority of telephone troubles are caused by faults in the flex leads, as it is here that most of the wear and tear of constant use is located. Although cords are cheap and easily

been worn for an hour or so they should be wiped carefully with a soft duster to remove perspiration, etc., from the diaphragms before being put away. Otherwise this may rust, and so put the 'phones out of action.

THE

# "Kut



The two large main dials give amazingly sharp tuning.

However, the problem is sufficiently imminent so far as London is concerned, and since a very large number of "M.W." readers live in that area, the "M.W." Research Department has been working seriously upon this special selectivity question for some months. The problem was considered to be important, not merely because of the impending difficulties in the London area, but because the same questions will possibly arise later in other places, and in any case, if methods of dealing with it can be devised they will probably be of great value in producing sets for use in the present broadcasting centres where there is only one transmission to contend with.

THAT long-delayed Regional Scheme may look mighty fine upon a casual inspection, but have you stopped to consider what the position is going to be in the actual broadcasting centres? We do a little grumbling even now about the difficulty of cutting out a powerful local station; but what is it going to be like when we have two of them to contend with?

### What About the Simple Sets?

How is the owner of a set of the ever-popular "detector and L.F." type

Even so, it seems pretty certain that things are going to be rather acutely difficult for the man who uses the average sort of set with only moderate selectivity. He is likely to find that so far as he is concerned the ether is completely filled by these two transmissions, his chances of receiving foreigners having evaporated. With some of the older and still less selective receivers it is only too probable that matters will be still worse, and the two "Regionals" will interfere with each other.

So far, of course, the only part of

### Where the Shoe Pinches

The real problem is obviously that of the comparatively simple set, since

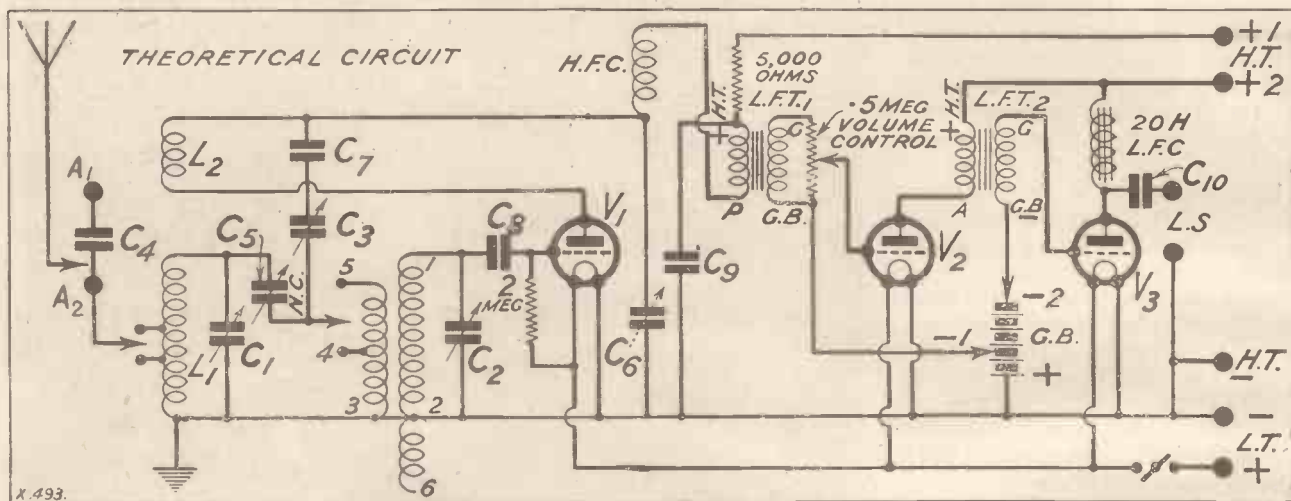

The extra selectivity circuit, formed by  $L_1$  and  $C_1$ , is coupled to the grid circuit by means of the condenser N.C.

going to find a bit of quiet ether in which to fish for foreigners? So far as can be judged at the time of writing, the answer is almost certainly that he won't be able to do it. It is a little dangerous to prophesy, because although the two transmissions from each regional station will be on very high power, the stations will be placed outside the towns and so will be farther from most of us than our present local stations.

the Regional Scheme which we can actually see developing is the station on the north side of London, now understood to be well advanced in construction, and it is the London area which we have chiefly in mind.

### Regional Uncertainties

How long it will be before the problem arises in other localities cannot be predicted, since the scheme appears to be in rather an uncertain state.

the larger and more sensitive type with H.F. stages and several tuned circuits may be expected to deal with the new conditions without much trouble. The most difficult type of all is probably the "detector and 2 L.F." receiver, since here there is normally only one tuned circuit, with a considerable degree of coupling to the aerial, and enough amplification to make the selectivity question really acute. Accordingly we chose

"M.W." RESEARCH DEPARTMENT PRESENTS THE—

# temout" Three

this type as the basis for our first experiments, feeling that if the problem could be solved here it would provide information which would render the same question easy to tackle in the case of other types.

Many avenues of approach have been tried, and one of the first conclusions reached was that the hitherto effective wave-trap method was not likely to be very successful in meeting the new conditions. The difficulty is obvious: A wave-trap would enable us to cut out either of the two transmissions when desiring to receive the other one, but would not, in all probability, give sufficient help when we wished to cut out *both* local transmissions in favour of a foreign station. (The method may still serve for certain rather different types of sets, of course.)

### Interesting Testing Method

It was evident that what was likely to be needed was a circuit of really high general selectivity for use in this particular type of receiver, and on these lines we worked. A special method of testing was evolved which approximated to the conditions likely to be met later, involving the use of a local "transmitter" consisting of a heterodyne wave-meter modulated by means of a gramophone and pick-up. With the aid of this transmission and that of 2 L O and 5 G B we produced a number of different combinations which enabled some very illuminating tests to be made.

### Two Circuits Needed

We soon came to the conclusion that with the coils ordinarily used it was a practically hopeless undertaking to obtain the necessary selectivity with only one tuned circuit. Accordingly, we turned our attention to the possibilities of two tuned circuits coupled together, with memories of the old-fashioned loose-coupled circuits.

We soon found that by using a tuned aerial circuit, either direct or auto-coupled, and another tuned circuit weakly coupled thereto, this latter forming the grid circuit of the detector valve, we could obtain extraordinarily high selectivity. The

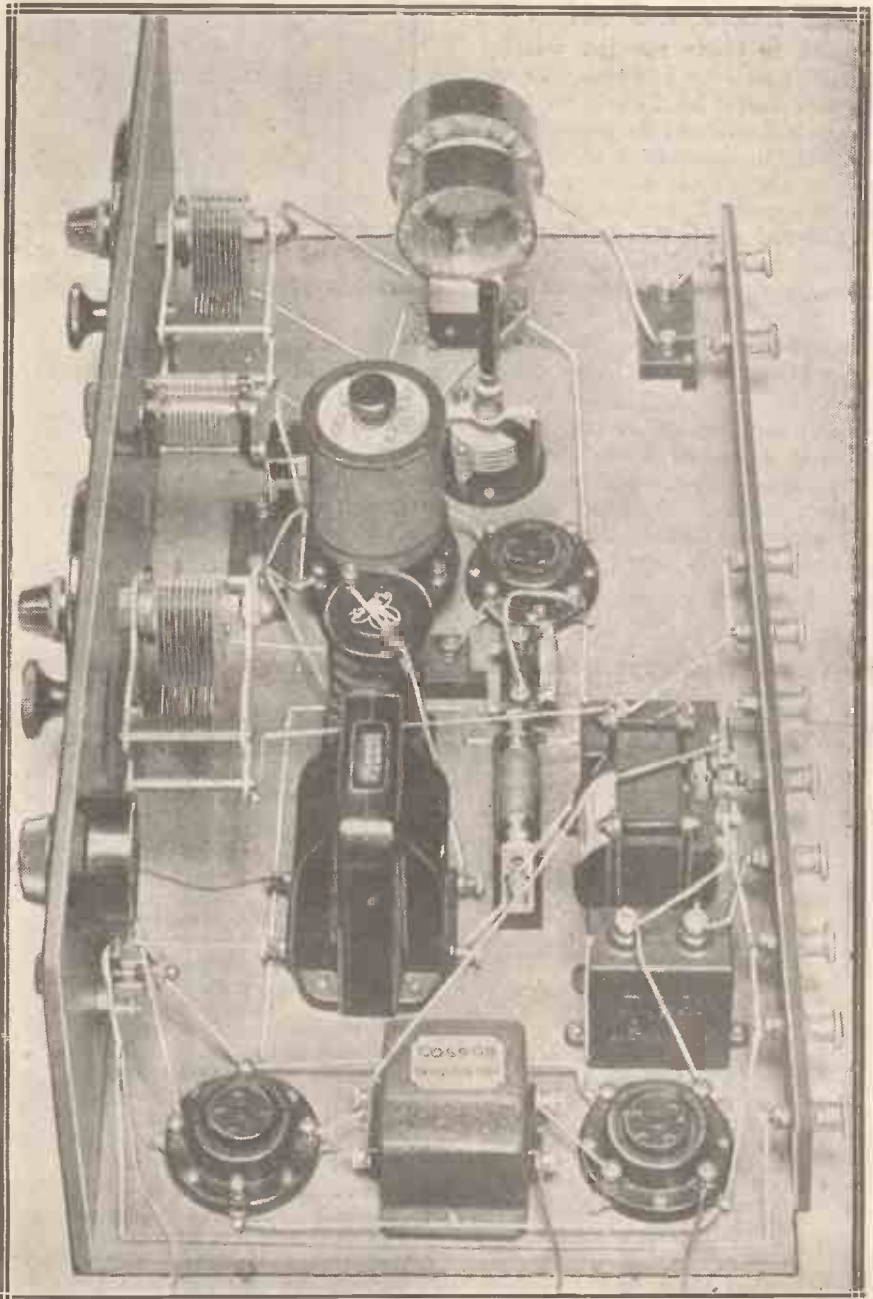

No complicated wiring is involved in the "Kuttemout," as this view of the set, taken from the L.F. end, clearly shows. Note the accessibility of all the parts.

selectivity given by the best of these arrangements was actually found to be higher than seemed likely to be needed. This remarkable selectivity, moreover, was obtainable with com-

paratively simple circuits and quite normal standard components, so it seemed that we were on the right line.

Merely getting high selectivity, however, is only part of the problem.

There remains the equally vital questions of sensitivity, and methods of applying reaction to the circuit. Here many of the schemes tried broke down, for to get selectivity in a large proportion of them it was necessary to weaken the coupling between the two circuits so much that sensitivity suffered heavily.

**The Reaction Problem**

Again, to apply reaction by no means an easy business. To see why this should be difficult we must refer to a diagram of the general type of circuit in question, and for this purpose the circuit diagram of the set which we finally evolved will serve. (It is reproduced in this article.) The essential feature of the circuit, you will see, is a pair of tuned circuits, the first being coupled in the usual manner to the aerial, and the second forming the grid circuit of the detector valve.

These two circuits are coupled together in a manner which we found much superior to the old purely inductive method. A condenser of very small capacity (actually a neutrodyne condenser) is used to adjust the

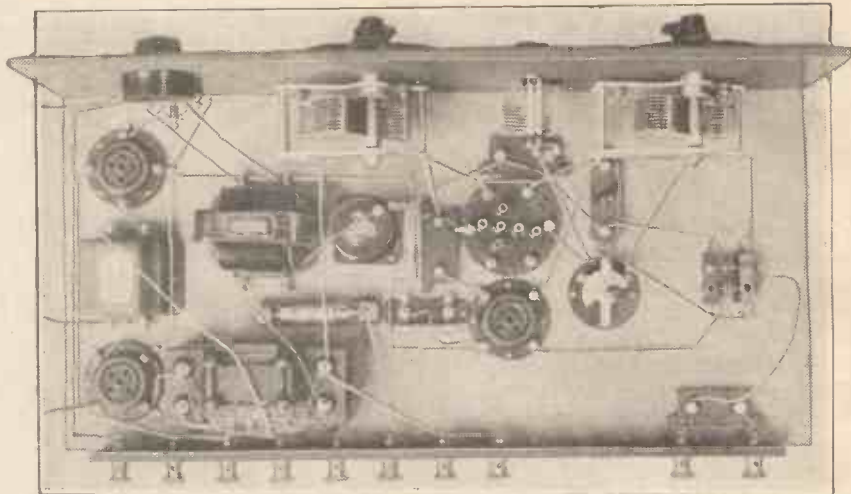

*If you compare this view of the wiring with the large wiring diagram the relative positions of the various leads can be copied very closely.*

coupling between them is the essential part of all the successful circuits we tried, and now we are in a position to appreciate the reaction difficulty. First of all we tried applying reaction in the ordinary way to the detector grid circuit, i.e. the second circuit, but this proved anything but good.

Strength was not very satisfactory,

would break into oscillation when one of them was detuned even a little. Tuning-in a weak signal was consequently very difficult.

We next attempted to apply reaction to the first tuned circuit instead of the second, and at once found that strength was considerably better. Also, the circuit became quite easy to handle, because its greatest tendency to oscillate was with the circuits in tune with each other. Still, however, there was a difficulty: if the coupling between the two circuits was weakened as much as was sometimes desirable it became impossible to get sufficient reaction with any normal arrangement.

**A Successful Solution**

Next we tried reacting into both circuits, and so hit upon the key to an arrangement which has given extraordinarily successful results in our hands, and will, we believe, be of great help to our readers.

The actual reaction scheme finally adopted is shown in the diagram, and you will see that throttle-controlled series reaction is applied to the first circuit, and Reinartz reaction to the second one, the latter by means of the same small winding used for coupling the two circuits together. A variety of other methods was tried, but this proved the only one which gave exactly the effects which we wanted.

**Easy to Operate**

Our object, you see, was to find a scheme which would enable one of the reaction condensers to be left set at a certain value, and all operating adjustments made on the other one. In the circuit chosen this can be done,

**LIST OF COMPONENTS**

- 1 Cabinet 21 in. x 7 in. x 10 in. deep (Cameo). (Lock, Pickett, Bond, Raymond, Gibert, Caxton, etc.).
- 1 Panel 21 in. x 7 in. (Radion). (Trolite, Ripault, "Kay-Ray," Becol, etc.).
- 2 .0005 variable condensers (Igranic). (Burton, Lissen, Lotus, J.B., Dubilier, Utility, Ormond, Formo, Gecophone, etc.).
- 1 .0001 variable condenser (Burton) (J.B., Cyldon, Igranic, Raymond, Utility, Dubilier, etc.).
- 1 Neutralising condenser, baseboard-mounting type (Magnum). (Peto-Scott, Bowyer-Lowe, etc.).
- 1 Semi-fixed condenser, .000035-.00015 (Formo, type F).
- 1 .001 fixed condenser (Lissen). (Igranic, Mullard, Clarke, Dubilier, T.C.C., Magnum, etc.).
- 1 .0002 fixed condenser (Lissen). (Goltone, T.C.C., etc.).
- 1 .0001 fixed condenser (Lissen). (Dubilier, Mullard, etc.).
- 2 2-mfd. fixed condensers (T.C.C.). (Hydra, Lissen, Ferranti, Dubilier, Mullard, etc.).
- 1 2-meg. grid leak and holder (Dubilier). (Pye, Igranic, Mullard, Ediswan, Lissen, etc.).
- 2 Baseboard-mounting single coil holders (Lotus) (Lissen, Magnum, Peto-Scott, etc.).
- 1 Six-pin coil holder (Magnum). (Lewcos, Bowyer-Lowe, Colvern, etc.).
- 1 5,000-ohm wire-wound resistance and holder (Ferranti). (R.I., Mullard, etc.).
- 3 Sprung valve holders (Magnum). (Formo, Lotus, W.B., Igranic, Benjamin, Pye, Marconiphone, B.T.H., etc.).
- 1 H.F. choke (R.I.). Bowyer-Lowe, Cosmos, Magnum, Lewcos, Lissen, Dubilier, Igranic, Climax, etc.).
- 2 Low-frequency transformers (Lissen and Cossor). (R.I., Marconiphone, Ferranti, Brown, Philips, etc.).
- 1 L.T. on-off switch (Lotus). (Bulgin, Lissen, Benjamin, Magnum, etc.).
- 1 Volume control, 500,000 ohm; (R.I.) (Magnum, Igranic, etc.).
- 1 Output filter choke (Magnum). (Pye, R.I., Wright & Weaire, etc.).
- 1 Terminal strip 19 in. x 2 in.
- 10 Engraved terminals (Eelex). (Igranic, Belling-Lee, etc.).
- 2 Vernier dials (Igranic). (Lotus, Utility, Lissen, etc.).

coupling effect, and the impulses passed through this are fed through a small winding coupled to the second tuned circuit. In this way the coupling between the circuits is brought under very close control.

This scheme of two tuned circuits with some form of capacity-controlled

as was perhaps natural in view of the fact that reaction was doing very little to reduce the damping in the first circuit. Further, the arrangement was decidedly unpleasant to handle, because with a given reaction setting it would be stable when the two circuits were in resonance, and

## Sensitivity, Selectivity and Power

the condenser  $C_6$  being set permanently and the operating control being provided by the condenser  $C_3$ , which is the usual small variable type mounted on the panel.  $C_6$ , on the other hand, is a semi-variable condenser of the compression type, and is placed inside the set. The actual handling of the receiver is thus per-

winding  $L_2$ , with  $C_6$  as the control. Since, however, there is a difficulty in getting the reaction effects to "come through" and reach the grid of the valve when we weaken the coupling between the two circuits—i.e. reduce the setting of  $C_5$ —we add the supplementary reaction circuit controlled by the condenser  $C_3$ ,

simultaneous tuning, it oscillates most easily when they are in step, and with the aid of this indication searching becomes comparatively simple. (It is probably a little easier to search with this set than with the average two-dial receiver incorporating an H.F. stage.)

### Remarkable Sensitivity

As a result of the effective use of reaction, sensitivity is extremely good, in spite of the weak coupling between the two circuits, and the set has very fine possibilities for long-distance work. Its selectivity is most impressive to anyone familiar with the ordinary standard of a "detector and L.F." receiver. As an indication of its powers in this direction we will give just one convincing example. We found on test that it would receive a transmission on 390 metres perfectly clear of 2 L O, which was only a mile away, and working on 359 metres, this being on a full-sized outdoor aerial.

The receiver, therefore, is one which we can strongly commend to the notice of anyone who has had a little practical experience (so that he can operate two dials successfully) and is looking

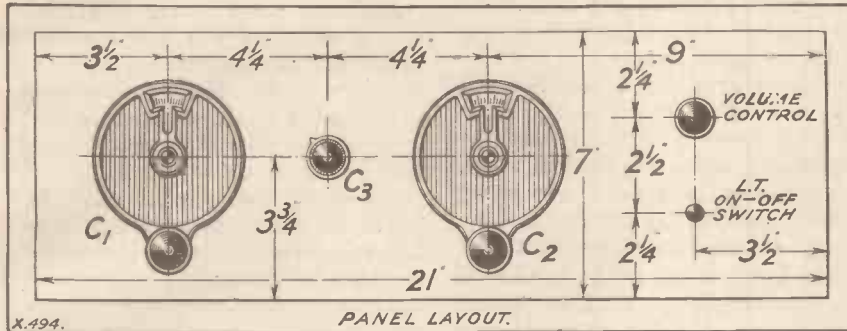

fectly normal, and is not rendered any more difficult by the fact that we are reacting into the circuit at two points.

### The Special Reaction Circuit

Let us be quite clear about this. The main reaction effect is into the first circuit,  $L_1 C_1$ , by means of the

which is made the actual operating control,  $C_6$  being set to a permanent value.

The results obtained with this arrangement have proved excellent. The preliminary adjustment of  $C_6$  is perfectly simple, and then the handling of the set is quite easy, since although it has two dials calling for

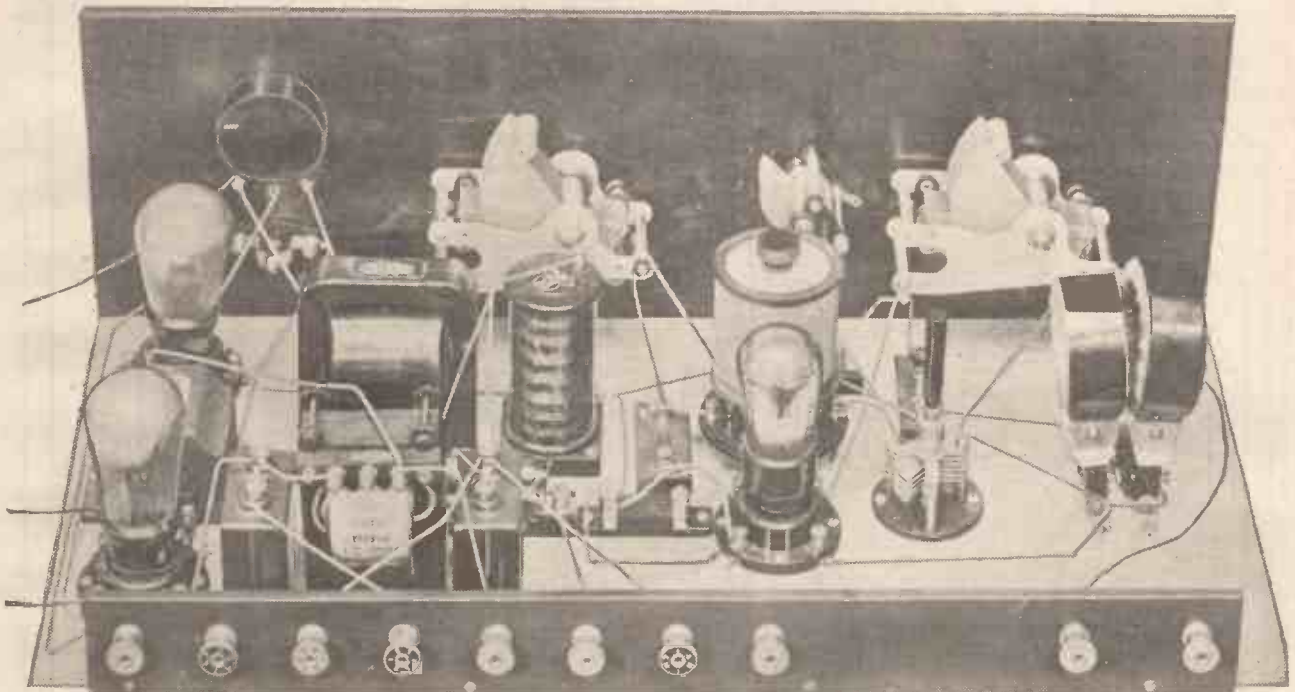

Here coils and valves are shown in position, and it will be seen that nowhere is there any tendency to overcrowding of components or wiring. The wiring at the high-frequency end of the receiver (right of picture) should be carried out with special care if the full selectivity given by this remarkable circuit is to be attained.

for something powerful, sensitive, and capable of disregarding the interference of a strong local station. We cannot recall a set in which we have felt greater confidence, or which pleased us better on test. Its combination of high sensitivity with really remarkable selectivity is extremely exceptional.

**Practical Data**

Now for some general practical details of its make-up. The two coils  $L_1$  and  $L_2$  are of the plug-in type, and  $L_1$  can be either a centre-tapped one or an "X" coil. For general purposes the centre-tapped form is good, in which case join the aerial to  $A_1$  and so bring in the series aerial condenser. Where a still higher degree of selectivity is wanted, use the "X" coil and cut out  $C_4$  by connecting the aerial to  $A_2$ . In this case, of course, try the flex lead on each tapping on the "X" coil in turn.

The second tuned circuit is made up of a six-pin coil of the split-primary

type, and the condenser  $C_2$ . The split-primary was chosen after considerable search for a suitable type, and it was found to provide just the windings needed. The primary and neutralising windings are used for coupling and reaction purposes, the actual reaction winding being too large for this circuit and is therefore left blank, as shown.

These are the correct coil sizes: For  $L_1$ , a No. 60;  $L_2$ , a No. 35 or 50 (250 and 75 or 100 for long waves). The split-primary should, of course, be of the correct size for the waveband to be received, and these units are usually marked 250-550 metres and 1,000-2,000 metres. By the way, by means of a flex connection you can use either the primary alone or the primary plus the neutralising winding in series for coupling. In the majority of cases the primary alone is best, so try the flex lead on No. 4 on the coil base for a start.

The L.F. portion of the receiver is of the extremely powerful transformer-coupled type, made "safe"

by modern methods of removing battery coupling. With proper stabilising devices such an L.F. amplifier is extraordinarily powerful and gives excellent quality. It is a very great help in getting loud-speaker reception of foreign stations without the aid of a stage of H.F. Stability is ensured by, first, a good layout, and then the use of a properly connected filter output circuit and an "anti-motor-boating" device at the detector stage.

**Anti-motor-boating**

Just one point about this last: in the diagrams you will see that 5,000 ohms is given as the value of the series resistance. The aim should be to use as low a value as possible here, to avoid upsetting the smoothness of reaction, and 5,000 ohms proved adequate in the original set. If, however, your particular pair of L.F. transformers (two different makes or types for preference, by the way, not two exactly similar ones) tend to

(Continued on page 679.)

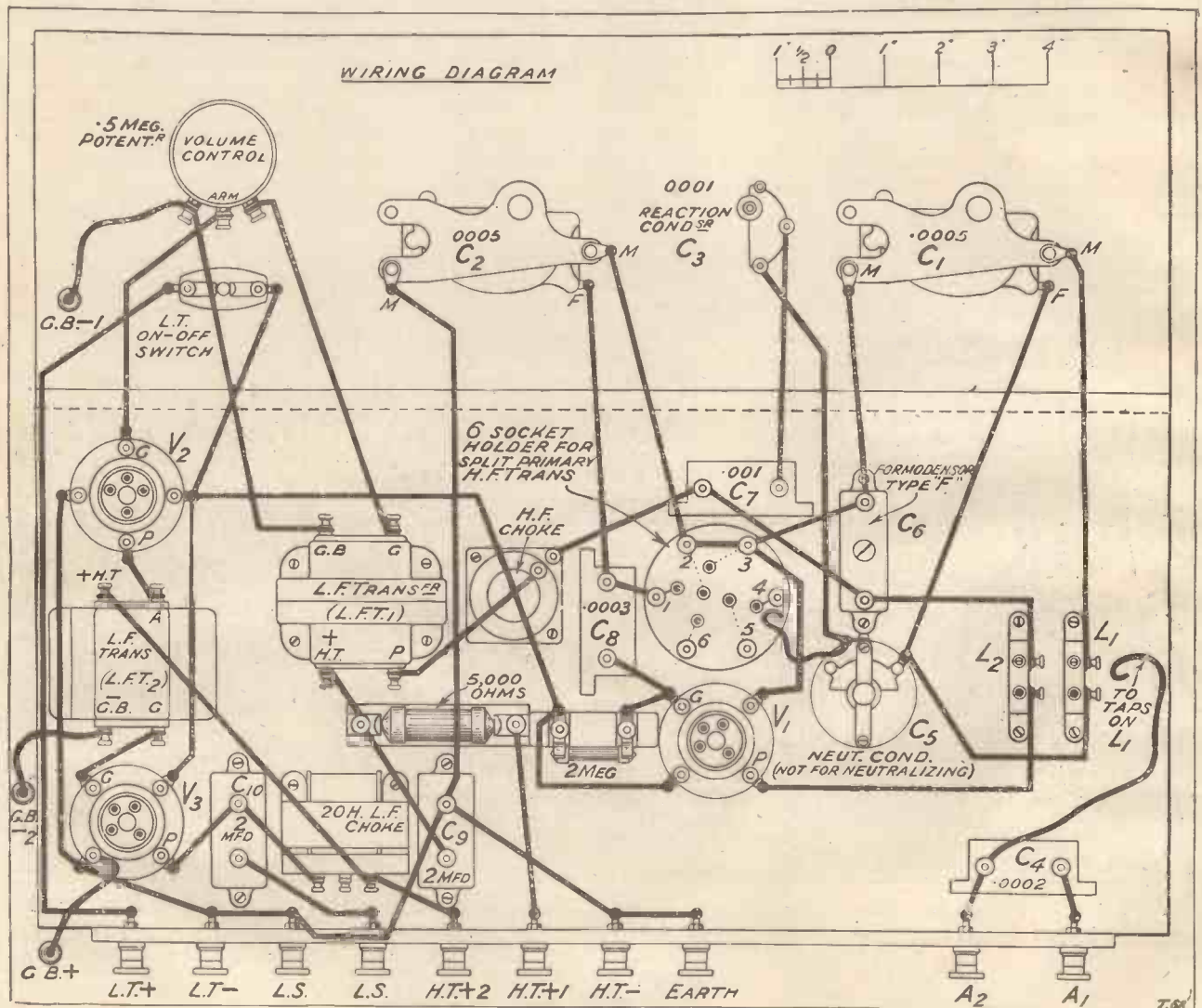

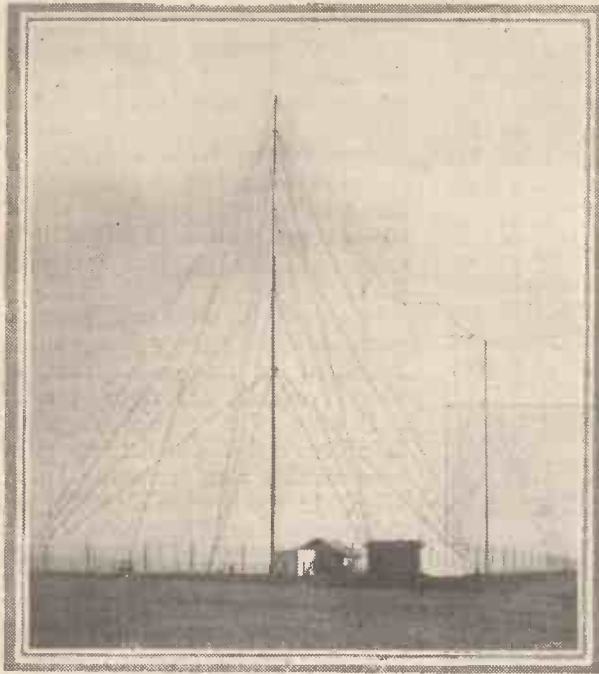

# The MYSTERY OF THE ETHER

*Is there such a medium as the ether?—which continues to occupy a most prominent part in modern scientific discussion and speculation. The latest arguments for and against this intangible "something" are laid out in this fascinating article.*

*By J. C. JEVONS.*

**T**HE wave theory of light built up by Young, Fresnel, and Huyghens, disputed by Newton, and re-established on a firmer foundation by Clerk Maxwell, postulates the existence of a tenuous medium, sometimes stated to possess specific mechanical properties such as density and elasticity. Actually it appears to be impossible to define its qualities in any strictly mechanical terms. Its nature is too fundamental to be compared consistently with any other known kind of matter. It is assumed to occupy all space, even inter-penetrating the molecules of the most compact material substance.

### **"Action at a Distance"**

The phenomena of attraction, repulsion, and induction demands

existence of an all-pervading medium to justify the otherwise inexplicable "action at a distance."

### **Clerk Maxwell's Theory**

It would obviously be too highly complicated and artificial to imagine that two such universal media should exist simultaneously and independently of each other. Nor is it necessary to do so, for Clerk Maxwell has shown on mathematical grounds that the properties necessary to explain the transmission, reflection, and diffraction of light rays are just those necessary to produce the known effects of magnetism and electricity. In short, he showed that the electro-magnetic medium must be identical with the luminiferous ether.

It is known that light vibrations

originate from the oscillations of charged particles (electrons) of incandescent matter, and so give rise to alternations of electric and magnetic fields. Similarly the rapid movement of the electrons constituting the oscillating current in a transmitting aerial set up wireless waves in the ether.

### **Matter and Ether**

The ultimate constitution of matter has been resolved into terms of protons and electrons, which are simply positive and negative charges of electricity. Since electricity and magnetism are both held to be different aspects of the same fundamental happening, namely, a definite stress or strain set up in the ether, the very existence of matter itself is



Two of the most prominent scientists who devoted the major portions of their researches to the electro-magnetic wave theories and especially the ether theory.

The late Dr. Steinmetz (left) opposed the idea of there being any such medium, which was first put forward as the solution to the problem of electro-magnetic wave propagation by Clerk Maxwell (right) whose theories have been strongly upheld by present-day scientists, including Sir Oliver Lodge, whose photograph appears on the next page.

Einstein has recently brought up the problem anew, while Sir Bampfylde Fuller, in a recent book, provides us with still further food for thought, and puts forward some very interesting speculations.



FOR AND AGAINST THE ETHER THEORY

thus made dependent upon this omnipotent medium.

From another point of view the development of wireless science in general, and broadcasting in particular, has brought the existence of the ether into common or everyday practical experience. In short, whichever way one turns, the question of etheric energy seems to be a focus of modern scientific interest and enquiry.

There are, of course, schools of thought which set up various alternatives to the ether. For instance, the quantum theory as developed by Planck, together with other recent discoveries connected with the study of radio-activity and molecular physics, appear to offer fresh evidence in favour of a corpuscular theory of radiation similar to that advocated long ago by Newton, and afterwards discarded in favour of the luminiferous ether.

According to another theory put forward by Thomson, the electro-static and electro-magnetic "lines of force" imagined by Faraday are actual realities, and consist of "strings" which are attached to the electric charges emitting radiation, and along which vibrations such as wireless waves are transmitted.

### Modern Speculations

Finally, Einstein proposes to replace the conventional "ether" by a four-dimensional space-time continuum in which space and time are inextricably mixed.

Here the known properties of the electro-magnetic and luminiferous ether are replaced by "fields" or "warpings" of space.

space relatively to an observer, possesses all the properties associated with static electricity. If, however, the same unit charge is moving relatively to the observer at the speed of light, it acquires all the known magnetic properties of an ordinary electric current.

### "Etheric Energies"

Professor Einstein has quite recently developed his "field" theory to cover the known laws of gravitation, thus fusing the mechanism of electro-



Sir Oliver Lodge, F.R.S., who is shortly contributing a series of special articles on radio waves, and who is a strong supporter of the ether theory.

magnetism with that of gravity in one comprehensive generalisation.

Sir Bampfylde Fuller now enters the arena to provide us with further provocative speculations. In his

theory and the results so often secured by practical experiment. In this connection he points out that the brothers Wright—the pioneers of aviation—having set out with absolute faith in existing scientific data, were driven to doubt first one maxim and then another until they finally cast it all aside and decided to rely entirely upon their own practical investigations.

In exactly the same way, practical electricians, particularly those who are interested in the development of wireless science, are realising more and more that precise dogmatic definitions and explanations are often irreconcilable with increasing knowledge. In short, when exploring the unknown one must learn to rely more upon experiment and less upon mere doctrine.

### Space and Time

Regarding the doctrine of Relativity, he says: If the movement of a thing is simply a change of place in relation to another thing, its measurement is not prejudiced by the movement of the latter. We are simply concerned with relative positions, and the two movements can be compounded.

On the other hand, if movement affects spacial dimensions, time must enter as a factor of space, combining with it to make a "space-time continuum." This the author states is in direct conflict with all experience. He cannot conceive of the mingling of space with time, and regards the uncomprehending acceptance of the doctrine of Relativity as one of the

## NEXT MONTH

In next month's issue of MODERN WIRELESS will commence a series of special articles by SIR OLIVER LODGE, F.R.S., entitled

### THE MYSTERY OF RADIO WAVES

Sir Oliver Lodge has for many years been investigating the Ether Theory, and these absorbing articles, written in his inimitable style and clarity of explanation, will be found of supreme interest to all our readers.

A "field" which gives rise to purely magnetic action when viewed from one set of co-ordinates appears as a purely electric field when viewed from another set of co-ordinates in relative motion to the first.

In other words, electricity and magnetism are identical in substance, but have different appearances according to the standpoint of the observer.

For instance, a unit charge of electricity, insulated and at rest in

book on "Etheric Energies" he investigates the significance and reactions of the medium, which he conceives to be the vehicle not only of radiant energy such as light and heat, magnetism and electricity, but also of gravity, movement, and sound.

The author draws an early distinction between text-book axioms or standard

\*"Etheric Energies," by Bampfylde Fuller, K.C.S.I., C.I.E., 264 pp. Published by Williams & Norgate, Ltd. Price 10s. 6d. net.

most disconcerting facts in the mental history of our time.

It is clear, he holds, that all substance is pervaded by ether—ether is present everywhere in the material world—for light and heat are transmitted terrestrially as well as celestially. Light and heat from a fire cross a room as those from the sun traverse inter-stella space. The method of transmission must be the same.

Etheric vibrations must be assumed to be devoid of thickness. They



## Matter Itself Depends on Ether!

radiate spherically, but, as they spread, their intensity diminishes only in accordance with an inverse square law, and not inversely as the cube of the distance. The sphere of distribution must therefore be composed of

Since electricity and magnetism are a definite strain set up in the ether, the very existence of matter itself is made dependent upon this omnipotent medium.

radiating lines which possess superficial area but not thickness. For if they did possess thickness, the diminution of the intensity would be greater than that given by the inverse square law. This conception is also in accord with the fact that etheric movements can cross one another without interference.

All ether energy is in the nature of a vortex. When a material object, such as a wheel, is in rotation, it produces a centrifugal force from its centre outwards, because its circumference moves more rapidly than its centre. A liquid in rotation may act in a contrary fashion, developing a centripetal or inward force. A whirlpool, for example, draws things strongly inwards towards its centre. This tendency increases as consistency of substance diminishes.

In a whirlwind the resultant force is violently inwards. It is justifiable, therefore, to assume that an etheric vortex would develop a very powerful indrawing force.

### Ether Vortices

Imagine that the rings of electrons and the central nuclei which form the ultimate basis of matter are ether vortices, one within the other, each extending its influence spirally across the surrounding ether so as to produce

an indraught. The extended overlapping influence of such ether vortices would then attract adjacent atomic systems, and so give matter its coherence.

The radiation of heat is due to an unbalancing of these vertical forces, created by friction, or electrical action, or other external agency, and a consequent streaming away of heat energy. Light radiation is treated on similar grounds, light being stated to differ from heat only in that its effects do not endure after the withdrawal of the etheric energy that causes them.

### Miniature Solar System

Coming to electricity, the author points out that matter is conceived by modern science as a miniature solar system in which variously grouped circles of electrons revolve around central nuclei, as planets

An electric current is the result of a disturbance in a balanced system of such vortices, leading to a rapid interchange of adjacent vortices and the final detachment of a core vortex at the end of the conductor.

Ether is too fundamental to be compared with any other known kind of matter. It is assumed to penetrate even the molecules of the most compact material substances.

When an electric discharge takes place across a spark gap, a series of very rapid oscillations occurs, the effect of which is to throw off a stream of broken spiral vortices alternately revolving in contrary directions, according to the direction of the momentary current which generated them. These fly off into space in all directions, and so form what we are accustomed to think of as electric waves.

### Polarisation

These spirals may travel outwards in loops progressing in a sidelong fashion, or after a time may change their mode of progress and advance face forwards like a screw. This corresponds to known alterations in the polarisation of transmitted wireless waves.

It is not possible to follow the author further in his conception of the manner in which electro-magnetic energy is propagated through space, nor to touch upon many other aspects of this fascinating volume. Sufficient has, however, been said to show that, although he may not always succeed in carrying conviction, the author has undoubtedly tackled his subject along original and thought-compelling lines.

His book is one that should be on every advanced radio student's bookshelf.

### A MODERN "ETHER-SHAKER" TESTING.



The latest British-built Chilean destroyer undergoing her radio tests in the English Channel. She is equipped with the most up-to-date wireless gear.

revolve around the sun. The nuclei differ in nature from the electrons; their essential element is a proton which possesses peculiar properties of its own.

He conceives both electrons and protons to be vortices, rotating in different directions, and the orbit around which the electrons move to constitute a third vortex. Positive electricity is then identified with the proton vortex, and negative electricity with the ring or orbit vortex of the electrons.

# THE "AUTO-

**W**HAT are the requirements of a thoroughly up-to-date one-valver?

Well, first of all we must have simplicity, otherwise the receiver will be tricky and difficult to operate. Hence it will lose much of its charm.

Secondly, some form of wave-changing must be included in the design to obviate the necessity for changing coils when going over to the long waves.

### Selectivity

Thirdly, the set must be selective. This is important, in view of the projected Regional Scheme, which, when completed, will provide two possible interfering transmissions in most localities. Thus some form of simple wave-trap capable of being pre-set to two stations is highly desirable.

Moreover, it is beneficial if the listener can instantaneously switch over to a second station on the medium wave-band when he wishes to receive an alternative programme. If all of these features can be incorporated in one compact set, it becomes a very attractive proposition.

### The Coil Unit

The "M.W." Research and Construction Dept. gave the matter a considerable amount of thought, and, as the result of experiments, were able to evolve the remarkably efficient design described in this article.

The work was simplified, perhaps, by previous research which had been carried out. Some months ago it became evident that an efficient coil unit, combining the medium and long wave-bands and readily lending itself

to easy wave-change switching, had to be produced to meet the needs of modern conditions.

The Research Staff. was finally able to produce a standardised unit which was first utilised in the successful "Titan" receiver (described in "Popular Wireless"). This unit is known as the "Titan" coil, and is obtainable in approved form from a number of manufacturers.

The second part of the unit comprises a loading coil which when switched into circuit provides a winding capable of being tuned to 2,000 metres approximately. This coil unit is the chief component in the set, and it is not possible to substitute for it any other type of dual-range coil. We mention this point in anticipation of queries from readers who may desire to employ their existing coils.

### COMPONENTS REQUIRED

- 1 Cabinet 12 in. x 7 in. x 9 in. deep (Raymond, Pickett, Camco, Bond, Caxton, Artercraft, etc.)
- 1 Panel 12 in. x 7 in. (Becol). (Resistor, "Kay-Ray," Trollite, Ripault, etc.)
- 1 .0005 variable condenser (Burton). (Utility, Lissen, J.B., Dubilier, Cyldon, Ormond, Raymond, Pye, Geophone, etc.)
- 1 .0001 reaction condenser (J.B.). (Raymond, Burton, Cyldon, Igranic, Ormond, Peto-Scott, Dubilier, Lissen, etc.)
- 3 Semi-fixed condensers, .0003-.00025 (Formo, type J).
- 1 .001 fixed condenser (Lissen). (T.C.C., Dubilier, Clarke, Goltone, Mullard, etc.)
- 1 .0002 fixed condenser (Dubilier). (Magnum, Lissen, Mullard, etc.)
- 1 2-meg. grid leak and holder (Dubilier). (Pye, Igranic, Lissen, etc.)
- 1 H.F. choke (Igranic). (R.I., Lissen, Climax, Cosmos, Wearite, Magnum, Bowyer-Lowe, Colvern, etc.)
- 1 Baseboard-mounting single coil holder (Peto-Scott). (Lotus, Magnum, Lissen, etc.)
- 1 Titan coil unit (Ready Radio). (Magnum, Paroussi, Peto-Scott, Simmonds Bros., St. Mary's Motor Co., Goltone, Wright & Weaire.)
- 1 3-point switch (Wright & Weaire). (Pioneer, Ormond.)
- 1 L.T. on-off switch (Benjamin). (Lissen, Magnum, Bulgin, Lotus, etc.)
- 1 Valve holder (Precision). (Formo, Ashley, W.B., Benjamin, B.T.H., Marconiphone, Magnum, etc.)
- 2 Clix plugs and sockets.
- 1 Terminal strip 10 in. x 2 in.
- 8 Engraved terminals (Igranic). (Bell-Ing-Lee, Burton, Eelex, etc.)

Those who may wish to construct this coil for themselves will find full details in "Popular Wireless," No. 352.

The unit consists of two portions. The first is a solenoid with three windings. These are a primary or aerial winding with four tappings, which is wound over a tuned grid coil having sufficient number of turns to cover the 250-500-metre medium wave-band. Below this grid winding is a reaction winding.

The "Titan" unit is normally tuned with a .0005-mfd. variable condenser. If you glance at the theoretical diagram of this set you will see that in parallel with the usual tuning condenser there is joined a condenser of the semi-variable type.

Now the object of this second condenser is to enable you to change

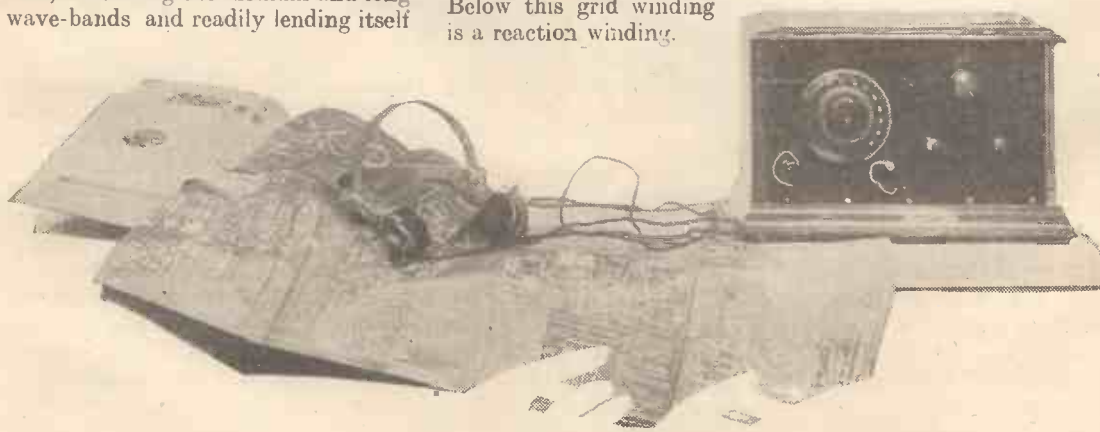

Although primarily for use with phones, the "Auto-Tune" One can easily have an L.F. amplifier added, and it then becomes a thoroughly efficient wave-change loud-speaker set.

# "TUNE" ONE

BY THE "M.W."  
RESEARCH  
DEPARTMENT.

straight over from your local station to 5 G B or your alternative Regional transmission. The dial setting for the local transmission will, of course, be known, and the .0005 variable condenser will be set accordingly. Consequently the semi-variable condenser can be adjusted so that the alternative station is tuned in when the two condensers are both switched into circuit. Thus if when the set is tuned to the local it becomes desirable to "go over" to 5 G B, the plug on the panel is inserted into the appropriate socket and the alternative programme is immediately received.

In certain districts there is a possibility of interference from the local station or 5 G B. For instance, at distances up to five or six miles, perhaps, the local transmission will break through and "jam" the programme from the alternative station. In other localities 5 G B may be the offender. In fact, it has been known for 5 G B to interfere on the long waves, although it is not clear why this should occur.

However, the trouble is easily overcome by the use of the wave-trap which forms part of the set. Two condensers of the semi-variable type are used. One of them is adjusted so as to eliminate the local station, whilst the second condenser is adjusted so that when it is brought into circuit the other interfering transmission, say 5 G B, is cut out.

## The Wave-trap

Now you will always have, one trap in circuit. Suppose you wish to listen to your local. Well, then, the trap in use will be that which cuts out the second interfering transmission. If you desire to go over to the alternative station, you will then change over the plug in its socket so that the trap is set to eliminate the local station. You will thus always have a clear signal free from an undesirable background of interference.

The tuning procedure will be as follows: For the local station the tuning condenser dial will be set

*A selective, sensitive, and simple one-valver which incorporates a novel system of wave-trapping, so that no matter where you live you need not fear your local station. Even when a twin-wave Regional starts up near you, this set will cut both programmes out, if desired.*

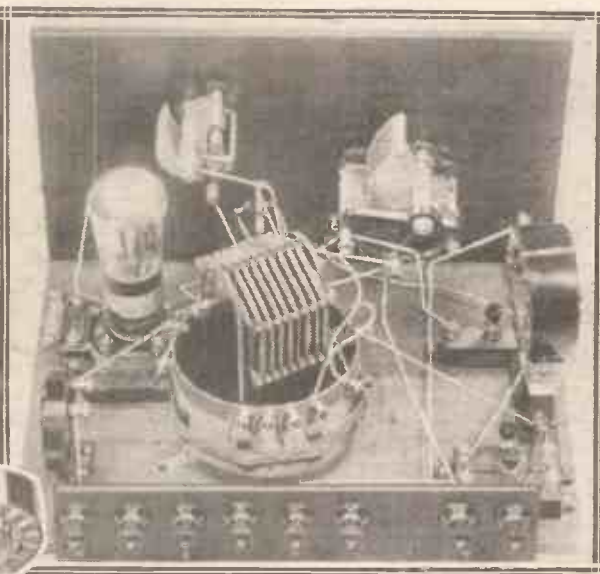

Two illustrations of the "Auto-Tune" One which show how the various components are arranged and which will help you when wiring up the set.

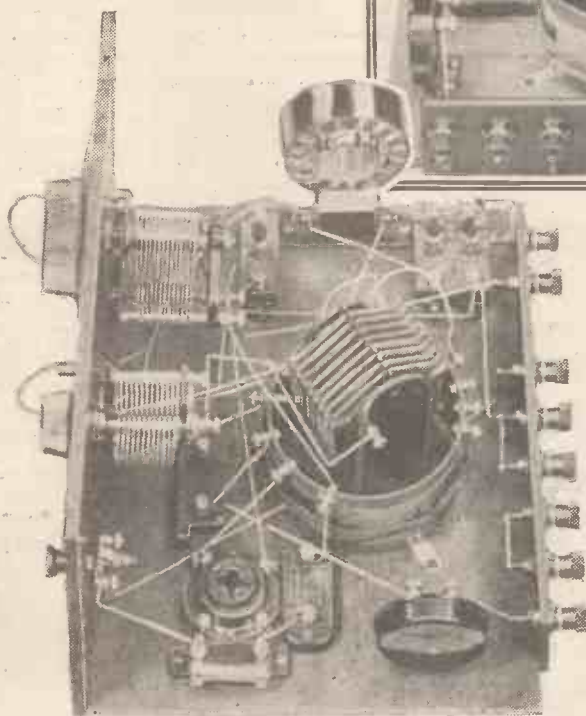

on-off switch, and to the left the wave-change switch.

Then below the tuning dial you will notice two plugs with flexible leads attached to them. The one on the right of the tuning dial brings in the semi-variable condenser which is connected across the .0005 tuning control. The plug and socket on the left are for the second trap condenser.

At the side of each socket is a blank hole into which the appropriate plug can be inserted when the semi-variable condensers are not required. In addition there are two holes to enable the flexible leads to pass through the panel.

## The Baseboard Layout

The drilling is quite straightforward if you carefully follow the dimensions given on the diagram.

The baseboard layout is not difficult. The approximate positions for the various components should be taken from the wiring diagram. The coil unit is a standard size, and so it does not matter which of the approved makes you obtain, since the space taken up will be the same in each case.

Take care when you place the valve holder in a position to allow adequate space for the valve to be inserted. Remember that it has to clear the reaction condenser.

accordingly and the trap will be adjusted to cut out the second powerful transmission. To change over to the alternative station the tuning condenser dial will be left "set" for the local, and the semi-variable condenser across it switched in. At the same time, the plug for the wave-trap will be inserted into the other socket in order to cut out the local station. Fuller operating details will be given later in the article.

Suppose we now turn to the construction of the set. If you examine the panel layout you will see that there is one large dial, on the left. That is the tuning condenser. On the right and slightly above it is a smaller knob for reaction control. Below this, on the right, is the L.T.

Then we come to the actual wiring-up. All leads nearest the baseboard should be connected first, then the wiring to the switches, the work being carried out from the panel towards the back of the baseboard.

If this scheme is followed the wiring task will be an easy one.

Be sure to purchase the correct type of wave-change switch. It is as well to state the name of the set when ordering, otherwise you may get the wrong pattern, and in consequence the set will not function properly.

When you have completed the wiring-up you will naturally wish to try out the receiver on actual broadcasting.

### Suitable Valve

You will require a valve of the "H.F." type, or alternatively you

can use one of those sold specially for detecting purposes. An "H.F." type is as good as any other, and will give very satisfactory results. You can use a 2-, 4-, or 6-volt valve, since the receiver will function equally well with any of them.

### Preliminary Tests

Connect up your L.T. and H.T. batteries to the terminals marked. Join a pair of high-resistance 'phones to the 'phones terminals and connect the aerial and earth leads. In the wave-trap socket insert a No. 60 "X" coil.

Switch on the on-off switch and pull out the wave-change switch.

Join the flexible lead from the aerial terminal to one of the tappings on the "X" coil. Place each of the small plugs on the panel in the blank holes, thus cutting out the second

trap condenser and the Formodensor across the tuning control.

Now rotate the tuning condenser until you hear your local station, and adjust the reaction condenser for maximum volume.

There are also four tappings on the "Titan" coil primary. Try the flexible connection on each of these until you find the tapping which gives you the best combination of sensitivity and selectivity.

Now, assuming that your alternative programme is on a higher wavelength than your local, as it probably would be in the case of 5 G B, leave your tuning condenser adjusted for the local transmission and switch in the Formodensor (not the wave-trap). Screw down the adjusting knob until you hear the alternative programme and lock the adjustment by means of the small locking nut.

### Local Interference

It is quite possible that interference from the local may take place. If so, the wave-trap should be adjusted to cut out this station. This is carried out by rotating the adjusting screw of the Formodensor nearest the coil holder, the second Formodensor being switched out of circuit. Both tappings on the 60 "X" coil should be tried.

If you switch back to your local station by cutting the alternative station tuning condenser out of circuit, you must change over on the trap by moving the appropriate plug on the panel so as to bring in the second Formodensor.

To cut out the alternative transmission you will have to adjust this second Formodensor so that the sum of the two capacities in parallel tunes the trap to the second interfering station. Thus when you are listening to your local your trap will be set to cut out the alternative programme, and vice versa.

### Receiving 5XX

When you wish to go over to the long waves for 5 X X you simply push in the wave-change switch and connect the flexible lead to the tapping on the loading coil which you find gives the best results.

Probably the 60 tapping will be as good as any of them, but try the 80 tapping as well.

You can use whichever wave-trap adjustment you find necessary, but it is quite possible that you will not suffer from medium wave-band interference when you are on the long waves. For long-wave reception you will not need the Formodensor

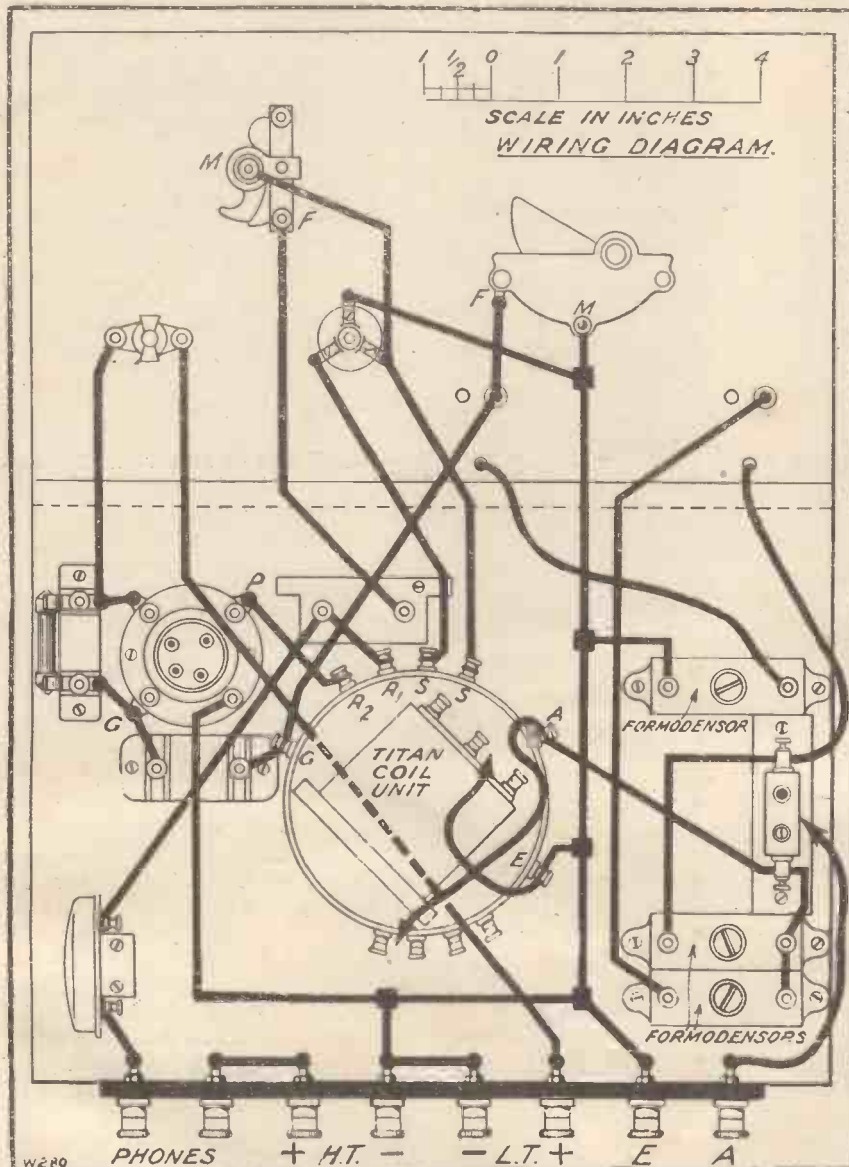

This diagram gives the layout of components and the various connecting leads. These should be followed as exactly as possible.

## Any Station—No Interference

which is joined across the .0005 tuning condenser. This should be switched out of circuit.

Try various values of H.T. on the detector valve until you obtain

rod is procured, and one end is fashioned after the style of a screwdriver blade. This rod can be a foot long if desired.

Thus, if the rod is used in a similar

When the set was first tested it was discovered that although the connections were quite in order, no reaction could be obtained on the medium wave-band. On the long waves, however, reaction seemed to be normal. An examination was carried out, and it was found that the reaction winding on the coil unit was the wrong way round. Upon the leads to  $R_1$  and  $R_2$  being reversed the set behaved in a normal manner.

This fault is mentioned in case a reader experiences similar symptoms, in which case it is advisable for him to check up the direction of the winding  $R_1$  and  $R_2$  on the coil unit.

### Reaction Control

It is very rare for faulty coils to be sent out by manufacturers, but there is always some possibility that one might get through in error. All the other coils tested in the receiver were found to be correct.

Do not use a larger capacity reaction condenser than that specified. If you do, there is every chance that you will be unable to obtain proper reaction control. Remember, also, that the reaction smoothness is largely dependent upon the value of H.T. which you apply to the detector valve.

Therefore it will pay you to vary the tapings on your H.T. battery until there is no sign of ploppiness.

The set should go into oscillation with a slight hiss, and when you reduce the value of the reaction condenser there should be no overlap.

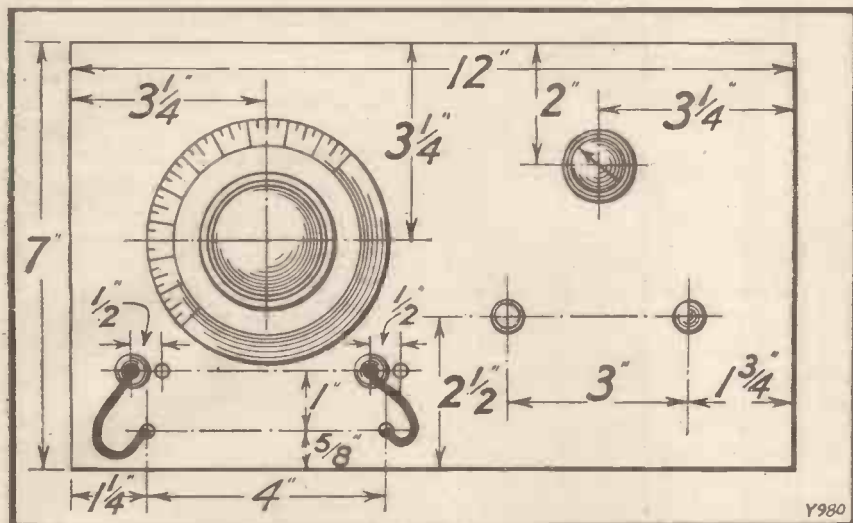

The drilling measurements of the panel are given in the above diagram.

perfectly smooth reaction. Usually about 60 volts is quite adequate.

In this article we have mentioned three condensers of the semi-variable type. Possibly this will lead to some doubt as to the particular Formodensor it is to which reference is being made. Well, you will notice in the photographs that one of these condensers is placed very near the .0005 tuning condenser. This is the Formodensor which is joined in parallel with the tuning condenser, and is switched into circuit when it is desired to change over to the alternative medium-wave station. The other two Formodensors (placed alongside of each other) are for the wave-trap. These semi-variable condensers have screw cuts in the adjusting knobs.

### A Useful Hint

Now it is very convenient to be able to carry out the necessary adjustments at some distance from the wiring of the set, because if the hand is too close to the various components, the tendency is to produce what is termed hand-capacity effects.

This frequently results in a false adjustment being obtained, and, one finds that the tuning is altered immediately the hand or body is removed. In order to obviate this trouble a form of "remote control" can be employed. A length of wooden

manner to a screwdriver it will be possible to make the necessary adjustments simply by engaging the sharpened end with the saw cut in the Formodensors. The hands and body will then be kept well away from the components and wiring.

When you are experimenting with the wave-trap do not forget to try both tapings on the X coil. One tapping includes a larger number of turns in circuit than the other, and may be more effective if the interference is very bad.

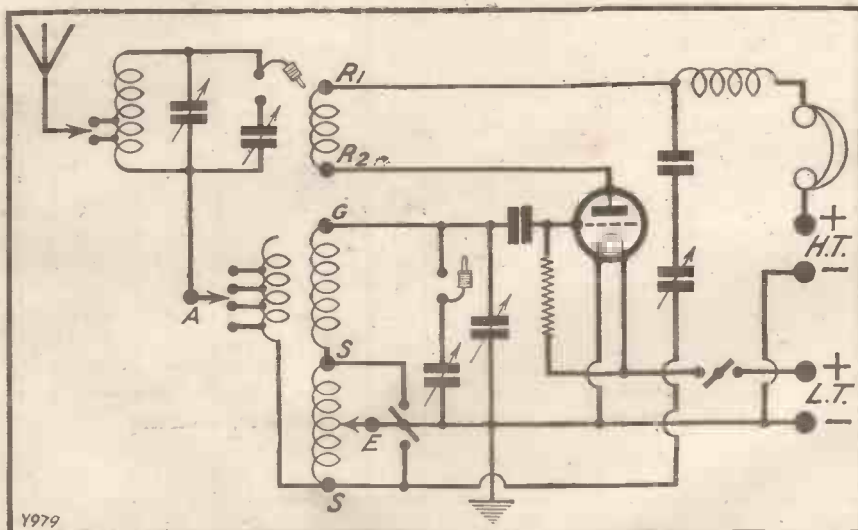

How the circuit operates may be seen from a study of this diagram. Note the wave-change coil unit and switch, as well as the double trap arrangement.

# QUESTIONS ANSWERED

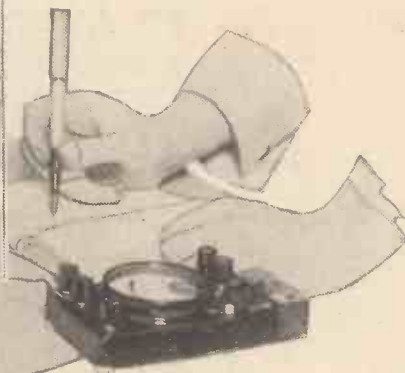

## Frame-Aerial Turns

A. R. (Eltham) wishes to utilise a cabinet 18 in. by 16 in. for a portable set. The receiver is to have a built-in frame aerial for reception on the medium wave-band. Our correspondent asks how many turns he will need and what gauge of wire is necessary.

The number of turns we suggest, A.R., is fourteen, and the gauge of wire, No. 24 D.C.C. The wire can be close-wound as a single-layer solenoid around the outside of the 18-in. by 16-in. frame, and with a .0005-mfd. variable condenser, should cover the medium wave-band. You could apply reaction by taking a tap at seven turns and using a .0001 reaction condenser.

## Portable Super-Hets.

S. C. E. (London).—"I wish to make a portable super-heterodyne for long-range reception; and I am told that the Tropadyne scheme has much to commend it, because it enables results to be obtained without the use of a separate oscillator. Do you agree with this?"

If the Tropadyne detector-oscillator is properly designed very good results can be obtained with a saving of one valve. Unfortunately, Tropadynes are apt to be rather critical and frequently need a considerable amount of experimental work with its consequent disappointments before the arrangement can be made to function correctly and consistently. On the whole we are in favour of the separate oscillator, which is more satisfactory in the majority of cases, and far more likely to give successful results in the hands of the average listener.

## L. F. Howling

H. D. (Gravesend) states that he is having considerable trouble with his three-valve portable. It consists of a

detector followed by two transformer-coupled L.F. stages, and he is unable to stop the set howling. He asks what steps he can take to remedy the trouble.

In the first place, H.D., there is always a big risk in using two transformer-coupled low-frequency stages in a portable set. The magnification which one can obtain from two stages of this type is very high, and since a frame aerial is used there is, of course,

## THE TECHNICAL QUERIES DEPARTMENT

Are you in trouble with your set?

The MODERN WIRELESS Technical Queries Department is now in a position to give an unrivalled service. The aim of the department is to furnish really helpful advice in connection with any radio problem, theoretical or practical.

Full details, including the revised and, in cases, considerably reduced scale of charges, can be obtained direct from the Technical Queries Department, MODERN WIRELESS, Fleetway House, Farringdon Street, London, E.C.4.

A postcard will do: on receipt of this all the necessary literature will be sent to you free and post free, immediately. This application will place you under no obligation whatever. Every reader of MODERN WIRELESS should have these details by him. An application form is included which will enable you to ask your questions, so that we can deal with them expeditiously and with the minimum of delay. Having this form you will know exactly what information we require to have before us in order to solve your problems.

London readers, please note: Inquiries should not be made in person at Fleetway House or Tallis House.

no earth to assist in holding the L.F. side down. In addition to this, the small H.T. batteries which are essential where space is a consideration, as in a portable, very rapidly develop a high internal resistance. Moreover, the components are somewhat crowded, all of which factors, when added together, often produce instability.

The remedy is to use low-ratio transformers and to include an "anti-motor-boating" device in series with the detector valve. The first L.F.

valve should be one of the medium or low magnification type and not the more usual "H.F." type, with an amplification factor of 20 or thereabouts. It is sometimes helpful to reverse the two leads to the primary of one of the transformers, and these instruments incidentally should be of different ratios and preferably not of the same make. In obstinate cases, connecting a resistance of 250,000 ohms, or even less, across the secondary of the second transformer frequently remedies matters, but, of course, magnification suffers.

## Tuned H.F. Stages

M. A. (Cardiff).—"Would it be possible to employ two tuned H.F. stages in a portable set without instability occurring?"

To use two fully-tuned H.F. stages in a portable is a most difficult matter. There is insufficient space to utilise proper screening and even with binocular coils the magnetic fields and stray capacitance couplings are usually sufficient to cause trouble.

Designers are very chary of attempting anything of such an ambitious nature, although the idea of obtaining high H.F. magnification is certainly attractive.

You will find, M. A., that where two stages are employed it is the usual procedure to employ H.F. choke coupling, thus avoiding the use of multi-tuned circuits.

This is much safer and also gives quite a respectable amplification.

## Directional Properties

T. D. C. (Glasgow) finds that the frame aerial of his portable four-valver is not as directional as he would like. This is particularly the case on the local station, which seems to come in an equal strength whatever the angle of the frame.

Frame aerials are rarely fully directive if there happens to be a mass of metal or electric wiring in the immediate vicinity.

Also, a neighbouring aerial can have an effect sufficient to destroy the directional properties of an aerial of this type. The user frequently finds that he receives most of his stations when the frame is pointing in one particular direction. Upon investigation it is observed that the direction is coincident with another aerial, or with a metal pipe.

The only way to secure the full benefits of a frame is to take the set into a field or into the country, where it is removed from these influences.

# The "TRAVELLERS" TWO



*A simple and really portable two-valver using a special wave-change scheme.  
Designed and described by J. ENGLISH.*

**H**APPY is the owner of a compact portable set, because it is one of the most fascinating receivers you can possibly have. I do not mean an expensive loud-speaker set, but just a light two-valve outfit for 'phone reception, which you can use anywhere and at any time. That is part of the fascination of the portable, you can listen-in wherever you please, even in such unusual places as the top of a 'bus or in a train going through a tunnel.

Apart from the wide field of experiment which the portable opens up for the keen amateur, the ordinary listener will find such a set a source of continual interest and enjoyment, while for the commercial traveller and the invalid a compact efficient portable is absolutely invaluable.

### *What to Expect*

Some of you may not be quite sure what to expect from a modern portable designed for 'phone reception. A really useful outfit should give clear signals up to 20 or 30 miles from the local station on a frame aerial built into the case. It should also be possible to use a temporary open aerial for reception on both medium and long wave-lengths. Other essential features are simple controls, easy operation and an outward appearance as unobtrusive as possible. No one likes to walk along the street with a case that is blatantly a wireless set.

When setting about the design of this two-valve portable, my intention was to incorporate as far as

possible all the above features, including up-to-date refinements such as wave-change switching; in other words, to get as much as possible into a small attaché case!

The performance of the completed receiver actually exceeded my expectations, so that I have no hesitation whatever in placing this design before you.

As you will see from the accom-

panying photographs, the complete receiver does not look in the least like a wireless set when ready for carrying about, as the only visible controls are two little knobs near the handle, where they are quite inconspicuous. With all accessories, the outfit weighs just over 12 pounds, and you can carry it for miles without

### **LIGHT AND EASY TO CARRY**



Only the size of a moderate sized attaché case The "Travellers" Two can be carried for miles without fatigue.

fatigue. Inside there is ample room for batteries, a reel of aerial wire, and two pairs of 'phones, not forgetting an earth spike!

### Continental Stations Heard

A built-in frame aerial is provided for medium-wave reception with the case closed, so that you can, if you like, carry it about while listening. At 15 miles from 2 L O, very strong signals are received, almost too loud for comfortable 'phone reception. Reception from 5 G B is also very clear and loud. The frame aerial also serves as the tuning coil when an outside aerial is used. On the

aerial and earth terminals, and the L.T. on-off and wave-change switches. The rest of the space is taken up by the batteries and accessories.

The receiver is quite stable when working on the frame or an outside aerial on both wave ranges. No hand-capacity effects are noticeable when tuning with the frame aerial, which is a valuable feature; frame-aerial receivers usually being particularly prone to such troubles.

The complete theoretical diagram of the receiver shows the usual regenerative detector followed by a transformer-coupled amplifier. Apart from the wave-change arrangements

the smoothest control with the least trouble from hand-capacity effects. Omitting the coil switching, the resulting circuit for frame reception is shown in Fig. 2,  $L_1$  and  $L_2$  being the frame windings and  $C_2$  the throttle-control condenser. You will notice in Fig. 1 that there is a tapping on the frame for an open aerial.

### On the Long Waves

For reception on the long waves, for which an aerial and earth are required, the loading coil  $L_3$  is brought into circuit by opening the switch  $S_2$ , as in the standard scheme employed in all "M.W." wave-

**COMPONENTS REQUIRED**

1 '00035 variable condenser, small S.L.F. (Ormond small type in set. Any good make in which a suitable small size is available.)

1 Midget '0002 variable condenser, small S. L. F. or miniature reaction type. (Ormond, J. B., Igranic, Cyl-don, Dubilier, Burton, Utillty, Raymond, etc.).

1 Transformer, ratio 6:1 (Igranic, type J).

1 H.F. choke (McMichael Junior Binocular, Burndept, Wearite, R.L., Igranic, Lew-cos, Lissen, Dubilier, Bow-yer-Lowe, Cos-mos, Burne-Jones, Climax, Colvern, etc.).

2 Valve holders (Benjamin "Vi-brolder," Lotus, W.B., Igranic, Burton, Pye, B.T.H., Marconi-

phone, Wearite, Burne-Jones, Formo, Bowyer-Lowe, etc.).

1 On-off switch (Benjamin, Lotus, mond, Wearite, Bulgin, Pioneer, etc.).

1 '0002 fixed condenser (Dubilier, Lissen, T. C. C., Mullard, Igranic, Burne-Jones, Goltone, Clarke, etc.).

1 5-meg. grid-leak (Dubilier, Pye, Mullard, Igranic, Lissen, Ediswan, etc.).

1 "M.W." loading coil (Wright and Weaire, Ready Radio, Paroussi, Lew-cos, Burne-Jones, etc.).

1 Rheostat (see text) 5 Terminals, 3 plugs, 2 spade terminals, screws, wire, and sundries.

Pieces of wood required for framework.

A—15½ in. × 4½ in. × ½ in.

B—15½ in. × 3½ in. × ½ in.

C—8½ in. × 3½ in. × ¾ in. (two pieces).

D—2½ in. × ½ in. × ¼ in. (four pieces).

E—9½ in. × 1 in. × ¼ in. (two pieces).

F—13½ in. × 1 in. × ¼ in.

FIG. 1.

The theoretical diagram of the "Traveller's" Two, showing how the wave-changing is carried out.

long waves, a standard "M.W." loading coil is brought into circuit, and on a small temporary aerial 5 X X comes in very strongly, while several long-wave foreigners are received at excellent strength.

You will see from the photographs of the set that the receiver proper is built on to a rectangular wooden framework, around which the frame aerial is wound. Most of the "works" are accommodated in a small compartment to the front of the framework, where you will recognise the two valves and the tuning condensers. On the left-hand side is a narrow panel on which are mounted the

and the wiring of the filaments the circuit is quite normal. For the benefit of those of you who would like to know how a receiver works, I will briefly describe the more interesting features of the tuning and reaction arrangements, which differ somewhat from standard practice.

### Smooth Reaction

On normal broadcasting wave-lengths reception on the self-contained frame aerial necessitates a very smooth control of reaction for the best results. For this reason I have incorporated throttle-controlled reaction in preference to the Reinartz method as giving

change receivers. As regards reaction, however, we now have a combination of the throttle and Reinartz systems, as you will see from Fig. 1, the condenser  $C_2$  being a throttle control for  $L_2$  and a feed control for the reaction winding of  $L_3$ .

This novel arrangement functions very satisfactorily. There is a second aerial terminal  $A_2$ , shown in Fig. 1, in order that greater selectivity may be obtained on long waves, although the terminal  $A_1$  is more suitable for the aerial connection when the aerial is a small one. The aerial connection can also be varied by tapping on to different sections of  $L_3$ ,



## Unobtrusive in Appearance

the lead from  $A_2$  terminating in a small spade terminal.

You may wonder why I have not provided for long-wave frame-aerial reception. Owing to the small area of the frame windings, the pick-up on long waves is so small and the

the filament connections. If you trace out carefully the filament wiring of Fig. 1 you will see that the automatic bias for the amplifier is 2 volts negative, which is just the value we require. The rheostat, R, is included for the purpose of dropping the voltage to 4 volts, or slightly less when a dry battery is used.

A 6-ohm rheostat is suitable for 1-amp. valves, but if you intend using valves of lower filament consumption, substitute a 30-ohm rheostat. As the voltage of the dry battery falls off, the rheostat is turned on a bit more, until it is all out, when you know that a new battery is wanted.

those which are readily obtainable, while possible alternatives are shown in the list of components.

If you use any others be very careful to see that they are of the right size to take the place of those I have used. Particularly is this the case with the

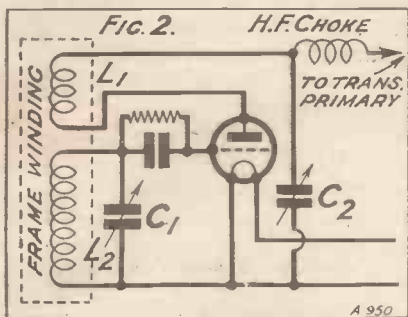

The detector stage simplified to show the basic circuit.

necessary switching so complicated that the results do not warrant the additional trouble of construction. It is much simpler and far easier to provide a small open aerial for long-wave reception, as even a short length of wire will give better results than a frame aerial, the pick-up efficiency of which falls off rapidly with an increase in wave-length.

You will now see that the tuning arrangements are very adaptable, giving frame-aerial reception on medium waves—the essential feature of a portable—and reception on both wave-bands on an open aerial. There is ample provision for varying degrees of selectivity and for adapting the set to various aeriels, short or long. We thus have a somewhat wider scope for reception than with the ordinary two-valver for indoor use, which is rather unusual in a portable.

### Automatic Grid-bias

Before we leave the theoretical circuit, I must explain the wiring of the filament circuit, which is somewhat unusual. The idea is that two 2-volt valves, with their filaments in series, shall be used with a 4-volt accumulator or a  $4\frac{1}{2}$ -volt dry battery. The total filament current is then the same as that for one valve, so that an L.T. battery of smaller capacity can be used.

Another advantage, perhaps even more useful, is that we can dispense with a grid-bias battery, as we can get an automatic negative grid bias for the second valve by juggling with

### Choosing Components

Choosing components for a compact portable of this description is not so easy as for an ordinary set. There is not such a wide choice of alternatives, as the set is more or less built up around components which have the required dimensions and characteristics. However, I have used only

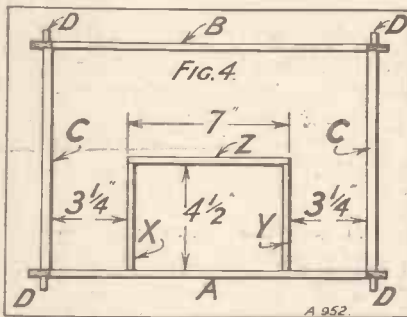

The dimensions for the framework are given in this diagram.

transformer, reaction condenser, and H.F. choke.

You will now no doubt be anxious at this stage for something definite in the way of constructional details. Building this portable is not difficult,

but a little more care than usual is required owing to the extra detail work peculiar to a portable receiver. The carrying case can be either an expensive leather or a cheap fibre one, according to your taste. The one used for the original set is a 16-in. fibre attaché case. The measurements of the top of the body of the case inside must be  $15\frac{1}{2}$  in. by  $9\frac{1}{2}$  in., and not less than  $4\frac{1}{2}$  in. deep.



This illustration shows how the batteries are housed and the relative positions of the components. The frame aerial is wound round the wooden frame.

### Skeleton Frame

Having obtained your case, the first step in construction is to build up the skeleton framework which is equivalent to the panel and base-board of an ordinary set. The sides are formed of two pieces of  $\frac{1}{2}$ -in.-thick wood, A and B (see Fig. 3), screwed to two pieces C,  $\frac{3}{8}$  in. thick. The front, A, is  $\frac{1}{2}$  in. deeper than B, but both pieces have slots at each end for the frame windings.

These slots you can cut out with a saw and chisel. The pieces A, B, and C may be made slightly longer or shorter to give a loose fit in the case, the dimensions of which may differ slightly from the original. Note the holes to be drilled in A for the two tuning condensers.

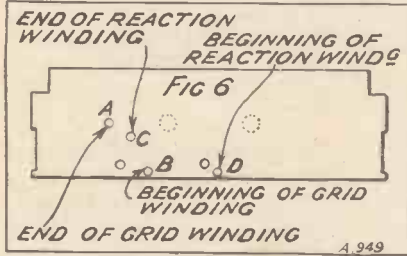

The lettering in this diagram corresponds with that in Fig. 5.

Next cut out four pieces D as in Fig. 3, and glue these down on A and B where shown in dotted lines. These pieces form additional supports for the frame corresponding to the ends of A and B. When the frame windings are put on they will be supported away from the wooden framework and from the inside of the case. This air-spacing of the frame accounts for its efficiency, and contributes largely to the success of the set, so that this little job of carpentry is well worth doing carefully.

**Completing the Frame**

To finish the wooden framework, cut out the three pieces X, Y, and Z. These are screwed together and to the

some of the components, and then re-assemble. Then cut out the strip E, drilling the necessary holes shown in Fig. 3. This strip can be ebonite, but dry 1/4-in. wood is quite satisfactory. The ends should be rounded off, so that when screwed to the framework the latter just slips into the case without forcing. You will also require a duplicate of E, without holes, and a piece F, the purpose of which I shall explain later.

The windings for the frame aerial can be put on either before or after the components are mounted. It is easier to do so before, as the framework is then lighter; but you must be careful not to damage the windings when mounting the components and wiring-up later on.

**Grid and Reaction Windings**

The grid-circuit winding consists of 24 turns of No. 26 or 24 D.C.C., starting at the bottom of the slots. The direction of winding does not matter, but wind the wire in groups of four turns close together, with a space of about 1/8 in. between each group. Note that a tapping must be taken at the 19th turn counting from the commencing of grid-ent.

The reaction winding, seven turns of No. 36 D.C.C., is wound in the same direction, but spaced 3/8 in. from the main winding. The ends of all windings are secured in place by passing through small holes drilled in A in the positions shown in Fig. 5, and the wire wedged in position by pieces of match-stick.

the H.F. choke on the front piece A. On the piece Z mount the transformer, and on the piece Y the two telephone terminals, heads inwards. The piece X supports most of the components, two valve holders, and the grid condenser and leak on the inner side, with the rheostat on the outer side.

Before again assembling the valve compartment, it will save you acrobatics with the soldering iron if you do part of the wiring first. This applies chiefly to the components on X, and also to the loading coil mounted on C. After wiring up these parts where they are inter-connected you can screw together the three sides X, Y, and Z, and then screw the whole assembly to the back of A in the position shown in Fig. 4.

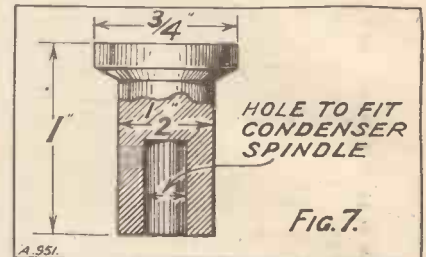

How to make the condenser control knobs.

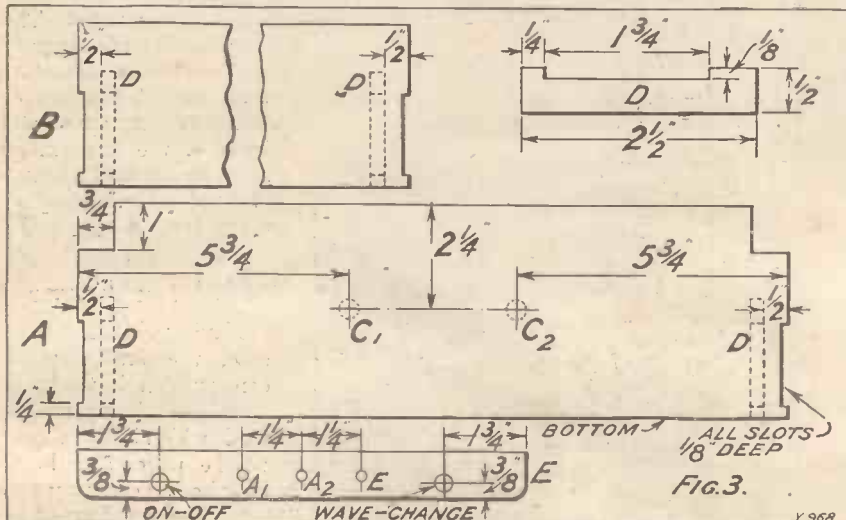

The various wooden supports and mounting frames are shown here.

back of A as in Fig. 4 to form a compartment for the receiver proper. Do not use wood thicker than 1/4 in. for these pieces.

After fitting together, unscrew the three pieces, as it is easier to mount

The mounting of components is quite simple, but it is essential to place them exactly as shown in the diagrams, as there is not much room to spare. First mount the tuning and reaction condensers and

The completed wiring of the receiver may appear somewhat complicated, but actually it is simple enough, as leads are fewer and shorter than in an ordinary set. I would advise you to use covered wire such as No. 20 Glazite, and if you have difficulty in fashioning any of the leads to the right shape, you can use rubber-covered flex. Keep all wiring close against the wooden partitions and sides, so that no leads foul the condenser vanes or valves.

**Wiring Up**

The easiest way to wire up, working to the diagram of Fig. 5, is to complete first the wiring of the strip E. Notice that a flex lead from one side of the on-off switch passes through a hole in the side piece C to the L.T. battery. Another flex lead passes through C from the terminal A<sub>2</sub> for the aerial connection to the loading coil. You will notice that an ordinary on-off switch is used for the wave-change switch, as there is not room for the usual three-pole component.

This switch must have the two contacts insulated from the centre rod. A flex lead is soldered to the moving contact, and this lead is connected to the earth terminal. I had to cut in half the moulded knob of this switch, as it could not be placed in the short-wave position with the

## Sensitive and Selective

lid of the case closed. The unwanted half of the knob can be cut off with a hacksaw, smoothing off the new top surface with fine sandpaper.

You can now commence the rest of the wiring, working carefully to Fig. 5. In this wiring diagram the separate wooden pieces on which the components are mounted are drawn as if laid out flat, showing both sides of the piece X. This makes some of the leads look much longer than they really are, but the photographs will help you here. The ends of the frame windings pass through holes in A, as shown in Fig. 6, and the letters correspond with these in Fig. 5, so that you should have no difficulty in tracing the connections to the frame windings.

### Battery Connections

The flex leads for the battery connections should be about six inches long, the connection for H.T. negative being secured under the same spade terminal as the end of the negative L.T. lead.

As regards plugs for the H.T. battery leads, there is not enough space for the usual wander plugs. This difficulty can be overcome by cutting down three Eelex plugs with a hacksaw, holding the wire in place with half the insulating sleeve, or simply by wedging the end of the wires in the battery sockets with pieces of match-stick.

Before the set can be operated you have to fit special control knobs, as those supplied with the condensers will not protrude outside the case. After marking the position of the two  $\frac{3}{4}$ -in. holes near the handle of the case, drill or cut them out with a sharp knife or half-round chisel, taking care that when the set assembly is inside the case the condenser spindles come immediately in the centre of these holes.

### The Control Knobs

The two control knobs of the original set were made very simply by cutting in half a small wire bobbin, plugging the centre hole with melted sealing-wax, and then drilling out to the diameter of the condenser spindles. This gives a nice tight fit, so that the knobs can be readily removed if you want to take the set out of the case (see Fig. 7).

Do not mount the set-assembly in the case until you have given it a preliminary test on the bench. Any

faults or mistakes in wiring can then be put right much easier than if the receiver were finally assembled.

For this receiver you will require two 2-volt valves, preferably of the '1 amp. variety, and for the best results you should use valves such as the H.L.210 or P.M.1 H.F. and D.E.L.210 or P.M.1 L.F. for the detector and amplifier respectively. General-purpose and H.F. type valves work well, a moderately high impedance detector giving the smoothest reaction control.

For the first test, place the set assembly upright, with the front piece A on top, and the plane of the frame aerial pointing towards the local

station. Pull out the wave-change switch and search for a strong carrier with the reaction condenser about half-way on. Reaction control should be quite smooth, but if it is at all jumpy, try reducing the detector anode voltage.

### Sharp Tuning

If the receiver will not oscillate the reaction winding may be incorrectly connected up. Provided you use the recommended valves and voltages you should have no trouble in getting a smooth control of reaction. A little practice with the controls may be necessary as you will find tuning quite sharp, the frame aerial

### THE MAIN SECTION OF THE SET

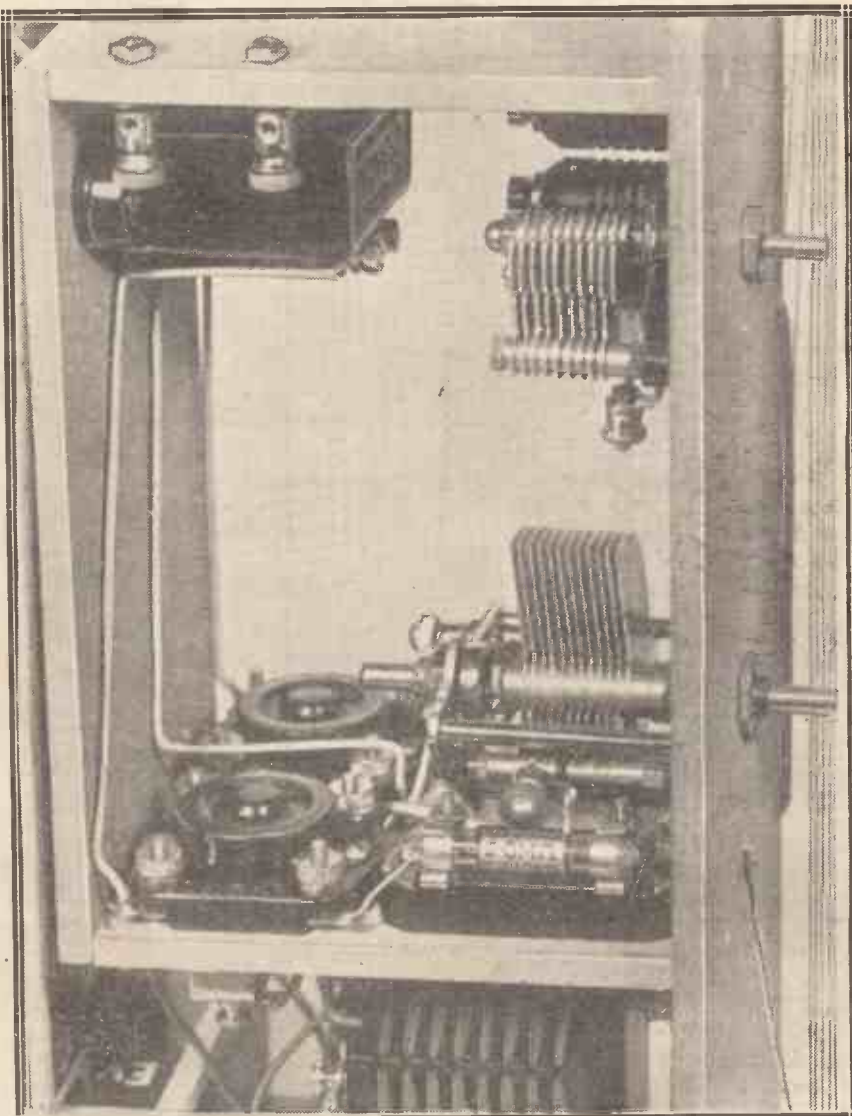

A close-up of the main "works" of the set, showing the tuning and reaction condensers, valve holders, L.F. transformer, grid leak, etc. The loading coil is seen below the platform.

being noted for selective tuning. Also the plane of the set should always point towards the station you want to hear when working on the frame aerial.

### Outdoor Aerial Test

Next try the receiver on a small outside aerial, using the aerial terminal  $A_1$  for medium waves and  $A_2$  for long waves.  $A_1$  may also be used with a rather short aerial for long-wave reception, for which the wave-change switch must be pushed in.

When you are satisfied with the working of the receiver on both frame and outside aerials, you can finally place it in the case. When in position the set assembly is held in place by screwing down the two wooden strips F and the duplicate of E. The dupli-

4½-volt No. 126, costing eighteen-pence. The dry battery is lighter than an accumulator, and has quite a useful life, while there is no bother of re-charging. If you prefer to use a non-spillable 4-volt accumulator, where, for instance, the receiver is to be used continuously, a suitable size is the Ever-Ready No. 898.

As regards the H.T. supply, you will not require more than 60 volts. (Even 30 volts will give good results.) The set is designed to take a 60-volt small capacity unit, such as the Ever-Ready "Winner," which has just the right dimensions for the available space.

With the batteries in position there is room for a reel of aerial wire, one or two metal rods about 15 inches long to which you have soldered a short

## RADIO REMINDERS

For successful short-wave work slow-motion dials are usually considered absolutely essential.

Tuning on a short-wave set is incomparably sharper than on an ordinary receiver, as owing to a peculiarity of the short waves it is possible to have half a dozen different transmissions on a space of only three or four degrees on the dial.

One of the causes of poor quality in a receiver is faulty emission of one of the valves.

## WIRING DIAGRAM OF THE "TRAVELLER'S" TWO

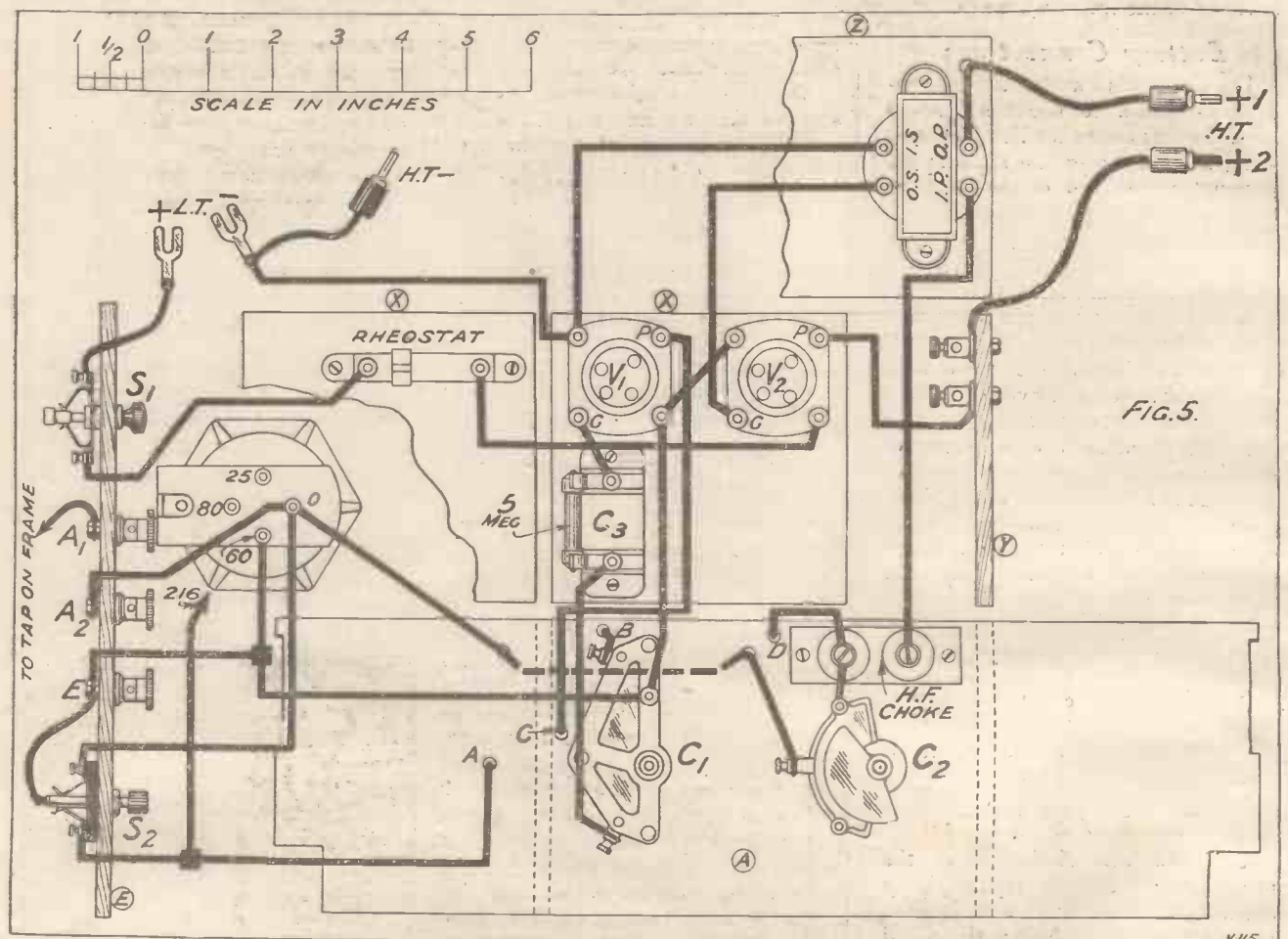

Used in conjunction with the photographs and smaller diagrams this full wiring diagram will enable you to build the set without any difficulty.

cate of E fits on the right-hand side, and F at the back of the framework, which is then securely held in position, so that there is no need to screw it to the case.

The most useful type of dry battery for the L.T. supply is an Ever-Ready

earth wire, and at least two pairs of 'phones. The set is now ready for anything, from a picnic in the country to a prolonged summer holiday tour. You will find it an excellent companion on all occasions, and it will rapidly become almost indispensable.

When a baseboard-mounting neutralising condenser is not provided with a slotted head at the adjusting knob, it is not a bad plan to cut a slot here with a hacksaw so that adjustments may be made by means of a screwdriver.



*An account of some fascinating Fultograph experiments*

*By H. R. A. BAXTER*

**H**AVE you heard the still pictures being transmitted from 2 L O, 5 G B or 5 X X? There is a series of piping noises interspersed with little high-pitched gurgles lasting about four minutes, and then a pause followed by a repetition of the sounds. Each parcel of pipings represents one picture, and when the transmission covers half an hour, generally five pictures are sent out.

**A Mistake**

We are rather apt to take wonderful things like this Fultograph very much for granted in this scientific age and to appraise them purely and simply upon their direct intrinsic values. But it is a great mistake to do this, and the listener who can capture a thrill

of wonder at hearing these pictures winging across the face of the night is very much to be envied.

**Hours of Enjoyment**

A voice coming from a funnel strung to a small box would have amazed our great-great-parents, (knock off a "great" or two if your years are heavy upon you!), but I

verily believe that this case-hardened, materialistic, blasé generation would hardly raise its eyebrows at the spectacle of a man slowly turning himself into a mousetrap by a new process of electronic rearrangement.

I have been operating one of those Fultograph outfits for some three or four weeks, and it has provided me with many fascinating hours of enjoyment. Right from the beginning I could get all the pictures Daventry or London liked to send me, and these with surprising clearness of definition.

**My "Bag"**

But I do not mind admitting that I have found the continental pictures rather harder to build up. And this has made it all the more enjoyable.

**THE COMPLETE PICTURE OUTFIT**

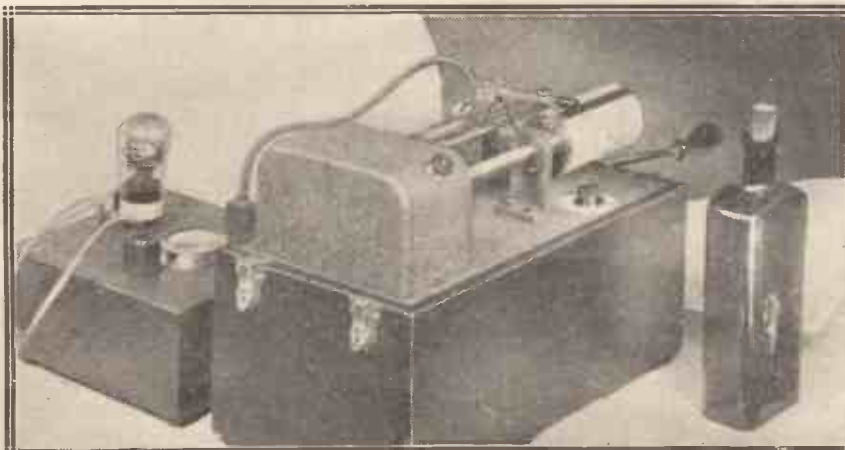

The Fultograph instrument consists of two sections which are linked together by a cable. The valve panel embodies the relay and milliammeter. The bottle that can be seen in the above photo contains the chemical solution into which the paper has to be dipped before it is placed in position on the cylinder.

Hunting for views from Vienna and pictures from Paris is more exciting than hunting big game and far less dangerous. Some of my "bag" I am reproducing with this article, and I must point out right away that they are not representative of the best that can be done with the Fultograph. But it is the best that I was able to do on the occasions of their reception, and I am not going to try and bamboozle you by saying that the faults were introduced deliberately.

If you have a Fultograph receiver, the following notes will give you the benefit of my personal experience, but even if you cannot afford the luxury of the instrument, it is my hope that you will find this article of some interest.

### The Paper and Solution

The Fultograph is supplied complete with everything that you will need to get the pictures. It can be connected to any set capable of providing fairly good loud-speaker strength reproduction. You merely connect the Fultograph input leads across the loud-speaker terminals of the set, leaving the loud speaker in position. You can use the existing



Half of this picture was received with too strong a signal, the other half being too weak. It is, of course, quite easy to arrive at the best strength after a trial or two.

H.T. and L.T. supplies, although a separate grid-bias battery is advisable. Special paper and solution is supplied by Wireless Pictures (1928), Ltd., although you can get both from other sources. For instance, I have found that ordinary "Cream

Wove Duplicator" paper is quite suitable for the job. As for the solution, this is a somewhat different matter. It took me quite a long time before I was able to make up a satisfactory solution, and I would advise other Fultograph enthusiasts not to attempt to do this unless they



This queer design was produced when the Fultograph was wrongly switched on in the middle of a transmission. The synchronising relay was kept working by the picture-making signals.

are prepared to spend some time experimenting.

The solution I make consists of one part of potassium iodide (1/9 per ounce from most chemists) to ten parts of boiling water in which a little starch has been "cooked." The measurements are by weight. Just sufficient starch, the ordinary household variety, should be added to make the water cloudy. And the solution must remain cloudy after it has been standing about for some time. If the starch tends to sink to the bottom and leave the fluid clear, then the mixture is a failure.

The fluid must be kept in a dark place or it will deteriorate.

### Altering the Colouring

The Fultograph people supply you with a booklet that concisely and clearly tells you how to handle the instrument, but, of course, there is a little technique attached to the operation of getting pictures that you can only acquire by experience.

Among other things that I have learnt are exactly how one can alter the depth of colouring of a picture and its definition by varying the strength of the received signal. One of the accompanying illustrations shows you a picture one half of which is rather over "modulated," while the other half is a trifle too light.

One must not get the idea that the louder the signals the better the picture, as this is very far from being the case. Regarding the paper, I have not found that it matters much whether this is fairly wet or well dried off. I generally soak the paper at the beginning of the tuning signal

and press it between blotting paper, just getting it in position before the start of the picture.

### An Exciting Business

By the way, our English stations do not give you much time to wind up the instrument, take off the picture and put on new paper. It is quite an exciting business trying to get everything done in time. And it is perhaps as well that there is this element of excitement, for I must admit that I am beginning to find the reception of English pictures a very dull business; to see the same sort of pictures at twelve midnight that one saw in the "late extra" tends to rob the whole thing of its wonder. I would strongly urge brother Fultograph to restrict the transmissions to non-topical pictures such as cartoons, and so on.



A "glad eye" from Vienna! This saucy picture did not seem to suffer from the slight fading that occurred!

By the way, another grouch of a similar vein occurs to mind. We don't get enough humorous stuff—everything is of the rather heavy order. A winning goal being kicked, horses at a race meeting, photo of a celebrity, etc., etc. This isn't the sort of thing we Fultographists want. Even Berlin has been rather stodgy of late, although in this case there is always the added interest of national characteristics, and, anyway, distance does lend enchantment you know!

### A Viennese Variation

The English stations tell you when to switch on your clockwork by sending three V's in Morse, and this is also the practice pursued by Konigswusterhausen. But Vienna has recently departed from this quondam universal rule. Instead, he stops his tuning note and then starts a series of relay releasing signals. If this stunt

You cannot get the  
**SECRET PROCESS**  
 in any battery  
 but  
**LISSEN**



You can only get this pure D.C. Current—this steady flow of noiseless power, from a Lissen Battery.

No mechanically generated power can equal the power that is produced by the Lissen secret process and chemical combination. It is pure, it is noiseless, it is steady flowing; there is never a sign of ripple in it, never a trace of hum. The power flows smoothly, sustainedly from the large cells throughout the longest programme and through months and months of use. And Lissen Battery power is the most economical source of power for radio.

Ask for Lissen New Process Battery and be sure to take no other. Obtainable at all good dealers.

**PRICES :**

60-volt (reads 66) .. .. .	7/11
100-volt (reads 108) .. .. .	12/11
36-volt .. .. .	4/6
60-volt Super Power.. .. .	13/6
9-volt Grid Bias .. .. .	1/6
4½-volt Pocket Battery (4/6 a dozen) each	5d.
Single Cell Torch Battery .. .. .	each 4½d.

**LISSEN LIMITED, 20-24, Friars Lane, Richmond, Surrey**

(Managing Director : THOS. N. COLE.)

## Pictorial Adventures Among the Continentals

happens to be new to you, as it was one time to me, you think he has forgotten his V's and, in a panic, you switch on.

Your cylinder revolves perfectly, but no picture appears. Suddenly the signals stop; there is a pause and then they go on again. The start of this new lot actually heralds the commencement of the picture.

### "Raddi-o Veen"

The Fultograph relay is a sensitive one and loud atmospherics will operate it. But neither Morse nor static upset



This 5 GB picture, which is very much reduced, clearly illustrates the sharpness of definition provided by the Fultograph.

the operation of the instrument quite as much as heterodyning. Vienna was at one time very badly heterodyned by Brussels, but of late I have found conditions much improved.

If you inadvertently let your set oscillate while the picture comes over you will find the relay failing to hold the cylinder to its speed, while the paper will register nothing but blackness. It is advisable to go as sparingly as possible with reaction.

I have already hinted that I fail to find much pictorial adventure among our own stations. My favourite is Vienna, and I struggle with this chap practically every night. "Raddi-o-Veen," as he calls himself, always concludes his nightly concerts with a couple of pictures. Sometimes these come over at eleven and sometimes not until eleven-thirty. I have to switch on at about ten to eleven and await the phrase (the only one I can catch from a welter of musical gutturals): "kong-sairt ist ended. Gute nart, mine darm anden herren, gu-u-ute nart."

### Coping with Fading

And the announcer always seems to be the same chap, and a very pleasant fellow he sounds. Seems to

enjoy his work very much and has a sort of Austrian "Uncle Arthur" intonation. I feel I know that announcer now, and hope I shall never meet him lest I be completely disillusioned!

You find Vienna some little way above 5 GB and just below Brussels. On an H.F.-Det.-2 L.F. I find him rather difficult to locate, although he is strong enough once I have tuned him in, except when he is fading; a practice to which he is somewhat addicted. I always get him as closely tuned as possible and then cut him down with a volume control so as to have something in hand against fading. At times, however, this is so bad that the Fultograph stops hopelessly.

### A Puzzle Picture!

I await the building up of every Viennese picture almost breathlessly, puzzling over every added line as to what the whole will be. If it is a portrait the mystery does not last long, but if the view is a more complex one, then sometimes I have to wait until the paper is peeled off before I can identify it.

On some occasions a trifle of fading or Morse renders the whole thing a mass of puzzlement which I look at from all angles and all ways without making anything at all of it. I remember receiving a medley of this nature which very suddenly assumed

the form of a railway accident. I reproduce it herewith. Perhaps seeing it for the first time the right way up you will fail to notice anything mysterious about it, but I assure you I spent a few seconds over it before enlightenment came. And I remember wondering quite a lot about that



Another picture received from Vienna. It shows some of the wreckage of a serious railway accident.

railway accident. It was probably the chief item of Viennese news for that day, but I could find no reference to it in our own papers either that day or any succeeding one.

### A Saucy Vision

Another Viennese night saw the arrival over hundreds of miles of land and sea of the saucy vision that forms the subject of another of the illustrations accompanying this article. The "glad-eye" aspect of this picture is cunningly emphasised by the fading to the left, which I assure you was completely due to "natural causes."

### THE INVENTOR AND HIS INVENTION



Captain Otto Fulton (centre), inventor of the famous Fultograph, is seen in this photograph with one of his instruments "hooked up" and ready for a demonstration.



# Radio and the Gramophone

*In this section of MODERN WIRELESS each month will be discussed both technical and other data of interest to the set owner who is also interested in gramophones.*

*Besides articles of a practical nature, a brief survey and critique of the latest gramophone records is included, making the section of vital interest to all music-lovers.*

Conducted by **KEITH D. ROGERS.**

## CONTENTS

	Page		Page
<b>Accurate Tracking</b> .. .. .	2	<b>Round the Turntable</b> .. .. .	7
Some details of a new pick-up carrier which enables remarkably accurate tracking to be obtained with very little trouble.		A page of odds and ends of interest and value to all radio or gramophone enthusiasts.	
<b>A Talk on Turntables</b> .. .. .	3	<b>Recent Record Releases</b> .. .. .	8
An interesting chat upon some of the vagaries of the gramophone turntable.		Our regular review of some of the records published during the month, written from the point of view of their suitability, or otherwise, for electrical reproduction.	
<b>Replies to Readers</b> .. .. .	4	<b>This Month's Pick-Up Programme</b> .. .	8
A selection of answers to queries from readers of the "Radio and the Gramophone" section of "Modern Wireless."		A representative collection of items specially chosen for the radio-gram listener.	
<b>Radio-Gram Portables</b> .. .. .	5		
When buying or building a portable wireless set do not forget your pick-up, for a portable set can also be a portable gramophone.			

## The Latest Gramophone Move

THIS issue of MODERN WIRELESS being a portable set number, readers will find the article on Radio-Gram Portables of special interest. It is easy to "kill two birds with one stone" when building a portable receiver; for the inclusion of a switch or adaptor for pick-up work will widen the sphere of usefulness of the set by a very large amount.

Many a useful portable can be altered with very little trouble so that it will take a pick-up, while such alteration requires little extra in components—just a switch—to enable radio or gramophone to be used at will.

### Another Surprise

The future of electrical reproduction appears to be becoming more and more vast, for the coming of the talkie bids fair to revolutionise the gramophone industry, and important developments in reproducing apparatus are almost bound to follow. Most recent among the "surprises" in the

electrical gramophone world is the alliance between H.M.V. and British and Dominion Films, Ltd. The Western Electric system of sound-recording and reproduction is employed (similar to the Vitaphone system) and radio has been linked to the enterprise, in that the services of Mr. Cecil Lewis and Mr. Rex Palmer (Uncle Rex) have been engaged by The Gramophone Company to look after the microphone technique.

### A Noted Trio

As readers will remember, Mr. Cecil Lewis used to be known as Uncle Caractacus before he left the B.B.C., some time ago, while Mr. Palmer—one of the best "voices" we have ever had—said good-bye to radio as recently as May 12th.

Another radio light, Albert de Courville, has also been engaged to produce the first British screen revue. It will be interesting to follow the activities of this trio, for we can undoubtedly expect great things of them.

# Accurate Tracking

*Details of the new B.T.-H. pick-up and carrier, by means of which excellent tracking can be obtained.*

**W**E recently had the opportunity of testing the new B.T.-H. pick-up and carrier arm, which has been specially designed to enable the home constructor to get the best results from his gramophone outfit.

The pick-up is the same as was placed on the market a little time ago, but the tone-arm is a greatly improved model giving an offsetting which enables tracking to be within three degrees over the whole of the path across the record.

This, of course, minimises record wear considerably, and it is a great feature of the outfit.

## Excellent Results

The results obtained leave little to be desired, and it speaks well for the pick-up that it is used by several commercial radio-gram outfits, and by several of the film talkie machines for the electrical reproduction of speech and music.

The pick-up is decidedly sensitive, and gives good reproduction of both the treble and the bass register, and is quite a reasonable price. We believe that the pick-up itself, which fits into the carrier arm by means of a jack switch arrangement, is obtainable alone, while with the carrier arm complete the price is 45s.

It must be remembered, also, that the carrier arm is specially designed for this pick-up, and is counter-balanced so that the correct weight with that particular pick-up is obtained, while the tracking is as near perfect as one could wish.

## An Important Point

We have one particular criticism to make about this pick-up and carrier, and that is the one which we have made several times before in discussing other models. It concerns a point which a large number of manufacturers and designers seem to miss: there is no method by which the pick-up, when lifted from the record, can be swung back and left at rest, either during the changing of a record or the changing of a needle, or at the cessation of a programme.

The pick-up and arm obviously

have to be swung round and either rested on the platform of the gramophone, away from the turntable, or else a special little rest has to be designed for it. We do not know whether Messrs. B.T.-H., Ltd., sell a special rest for it; but, if not, it is certainly worth their while to put one on the market, or else to alter the design of the carrier so that a portion can be swung back.

## To Assist Needle-Changing

Needle-changing would be facilitated, and there would be no difficulty in getting the pick-up and arm clear of the record when it is necessary to change the latter.

It is distinctly awkward to have to swing the pick-up right away from the record, especially when the arm is not constructed so that the pick-up can be self-supporting when swung

about pick-ups, is it not time that the makers of pick-ups published the curves of reproduction of those instruments?

So far, we have only seen one or two pick-up curves, and while these have been quite good, we are rather in the dark as regards the reproduction curves of the majority of the pick-ups on the market.

## Pick-up Curves Wanted

We believe the Gramophone Company have placed on the market a series of gramophone records which cover the whole of the piano scale, and which are so arranged that each note is given in octaves, so that on picking on a certain frequency or note we can go up and down the scale in multiples of that frequency, and thereby test the pick-ups and see how they respond to the various frequencies.

The records are arranged, we believe, so that a fixed power or energy output is provided. This does not mean to say that it is a fixed "noise" or "loudness," but a fixed energy output.

Could not the manufacturers of the various pick-ups use these records as standard testing records for their instruments and give

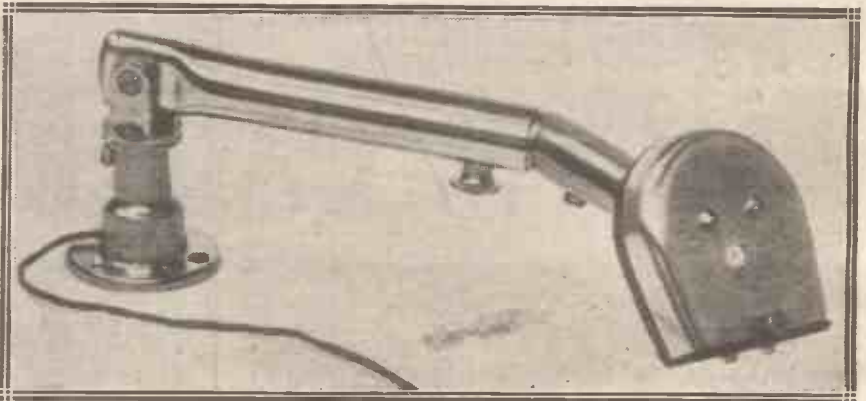

*The new B.T.-H. pick-up and balanced carrier.*

away. As it is, this merely drops down upon the platform of the gramophone, and it is not at all easy to change a needle when the pick-up and carrier are designed in this fashion.

Apart from this criticism, which we have made at rather great length, perhaps, because we feel that it is quite a serious point, there is nothing to be said against the pick-up and arm, and we are sure that readers, when wanting a pick-up, will have to look round a very long way before they find one which will beat the B.T.-H. equipment.

And, by the way, while talking

us curves of their reproduction?

It is true that loud speakers are not provided with curves, but modern transformers have their curves provided with them in all reputable makes, and it is only right that the pick-up should follow in their track and give a curve of its own.

It is difficult to judge a pick-up just by hearing it until it has been tried on all sorts of records and one has become thoroughly used to its reproduction, and it would be a great help to purchasers if curves were provided with the pick-ups sold by the various manufacturers.

# A TALK ON TURNTABLES

By  
**ALFRED  
PENN**



THE turntable is so common a part of the gramophone, be it of either the electrical or mechanical type, that one is apt almost to disregard its presence when attending to the points of maintenance of the machine. Yet so apparently simple a device as a gramophone turntable has its peculiar ills, like the majority of other things have, and it is to the credit of present-day gramophone and motor design that the average turntable performs its allotted functions so quietly and unobtrusively.

### *Rarely Perfect*

Still, however, what we may term the perfect turntable is a very rare article indeed.

\*\*\*\*\*  
\* An interesting article in which the \*  
\* vagaries of gramophone turntables \*  
\* are described, and hints for their \*  
\* proper care are given. \*  
\*\*\*\*\*

simple cardboard gauge be made and placed against the turntable, it will be seen that there is a slight periodic sway in the turntable as it revolves at normal speeds. The consequence is that unequal pressure between needle and record is liable to be set up, and a certain amount of record wear created.

Sometimes, however, a badly running turntable can be made to

kept for a long time in a damp atmosphere.

Now, baize which has even merely slightly become loosened at the edges should be stuck down immediately with a little hot glue solution, because in such a condition the turntable baize will present inequalities of surface and so will interfere with the correct playing of the record.

The tendency of modern gramophone design is to lighten weight wherever possible, and in some of the portable instruments which may be equipped for electrical playing the turntable may be on the light side. In such a case there may be a slight flattening of pitch on loud notes, due to the inability of the turntable to carry the record over these notes at constant speed.

### *The Rubber Mat*

An excellent remedy for light turntables is a rubber pad (obtainable from most gramophone and radio-gramophone specialists) placed over the turntable, as shown in the photograph. This acts as a non-skid device for the record and, used on a light turntable, or one of small diameter, it will enable the loudest record to be played without detriment to tonal quality.

The rubber turntable mat has other virtues as well. It insulates the record from the turntable, and so damps any extrinsic vibrations which may reach the record from below. It helps to reduce surface noise and pick-up chatter when it occurs is less noticeable, a valuable feature in a great many cases.



*A rubber pad over the turntable often prevents record slip.*

Strictly speaking, the majority of turntables do not preserve a perfectly true running plane. The plane is not a true horizontal one, and if the eye is lowered to the level of the turntable so that the revolutions of the latter can be viewed "edge on," or if, for more accurate measurements,

revolve more truly by the simple expedient of attending to the spacing washers on the bolts which hold the motor to the motor board.

Occasionally the baize or whatever material the turntable is covered with comes loose at the edges, especially if the machine has been

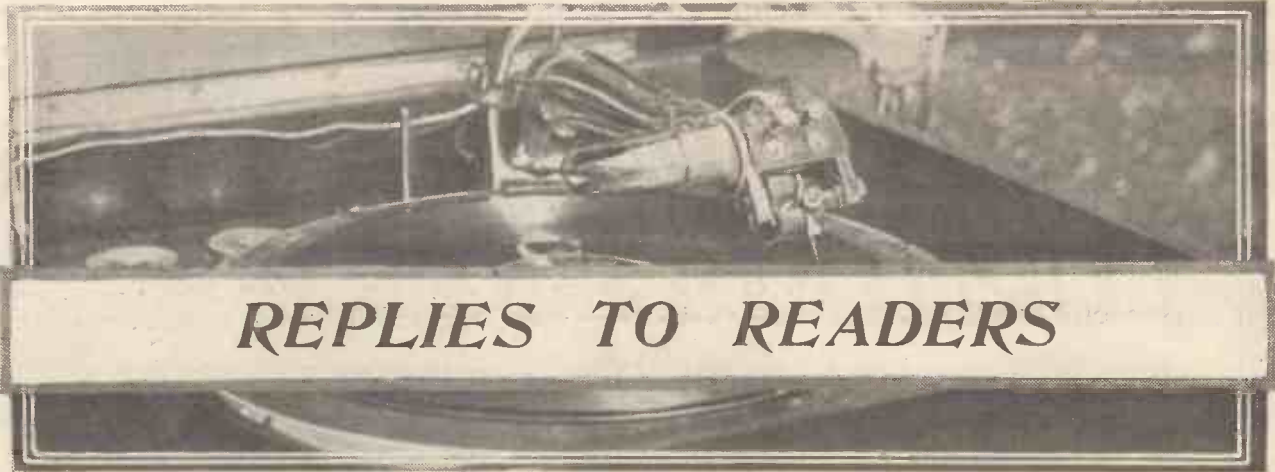

## REPLIES TO READERS

### Resonant Reproduction

D. T. T., of Leeds, has built a radio-gram receiver and has incorporated a moving-coil loud speaker, which is placed in the cabinet so that the baffle acts as part of the front of the cabinet. He complains of a boominess on low notes, and an apparent lack of brilliancy of the high notes, and inquires what the trouble is likely to be.

In all probability the trouble is caused by the position of the loud speaker. If the wood of the cabinet is not of really thick solid material then this is liable to give a resonance effect to the loud speaker which is quite undesirable. Furthermore, if the back of the loud speaker, that is, the side reversed from the front of the baffle, is fairly closely boxed in, then one gets a resonating vibration on many of the low notes due to the confined space of the air column at the back of the speaker.

In order to operate absolutely freely, the moving-coil speaker should have nothing behind the baffle except its own pot and diaphragm support. If it is totally boxed in, then an echo effect may react upon the speaker and give a most unnatural boominess.

### A Probable Cure

D. T. T. should try placing the loud speaker at the back of the cabinet so that the cabinet space itself acts as a sort of air chamber in front of the baffle. The ordinary baffle of the speaker should be fitted into the back of the cabinet and then the front of the cabinet left open or covered with gauze, when we think D. T. T. will find this will constitute a great improvement upon the present quality.

### Electric Gramophone Motors

F. D. W., of Bournemouth, has had trouble with his electric gramophone

motor, and states that when first placed in position everything was perfectly satisfactory, no sound being audible in the loud speaker, but after some use a crackling sound "appeared," and this has since got worse and worse.

In all probability, F. D. W., the brushes of your gramophone motor are sparking on the commutator, and it would be advisable to take the motor down and thoroughly clean the commutator, and also, if possible, fix slightly stronger springs to the brushes so that there is no chance of their being loose in their holders or of dancing on the commutator.

They should press fairly hard on

.....  
 ♦ A selection of readers' queries ♦  
 ♦ upon subjects relating to electrical ♦  
 ♦ gramophone reproduction. Let- ♦  
 ♦ ters containing gramophone ♦  
 ♦ queries should be addressed in ♦  
 ♦ the same way as those concerning ♦  
 ♦ other branches of radio. Such ♦  
 ♦ queries come under the general ♦  
 ♦ query rules as laid out elsewhere ♦  
 ♦ in this issue and should be ad- ♦  
 ♦ dressed to the Query Dept., ♦  
 ♦ "Modern Wireless," Fleetway ♦  
 ♦ House, Farringdon Street, London, ♦  
 ♦ E. C. 4. ♦  
 ♦.....

the commutator, but not too hard, and then you will find you have an increase of power and an absence of sparking which will give you freedom from the noise of which you complain.

With all gramophone motors (except the induction type) run on the electric principle it is advisable to clean the commutator at least once a month in order that sparking and burning shall not take place, for if this is allowed to go on it may easily ruin the commutator by causing pitting, and, as you have experienced, it completely spoils the reproduction when used with a pick-up and valve amplifier.

### H.T. from A.C. Mains

J. H. G., of Radlett, Herts, asks advice upon the building of a radio-gram receiver using the 50-cycle A.C. 230-volt mains for the H.T. He says he wants four stages of resistance-capacity coupling.

It is difficult to advise what sort of design you should use, but if you are going to have four stages of resistance coupling you will want plenty of H.T. and, of course, a large super-power valve in the last stage.

We assume you are going to use a moving-coil loud speaker or, at least, one of the better types of cone speakers, and would advise you to follow one of the amplifiers discussed in these columns during the last few months.

With regard to the eliminator, we would advise the use of a U.8 valve, or two R.H.1 valves, in preference to the U.5, and a transformer which will give you 400 volts from your mains. This will provide you with about 370 volts at your output valve, which should be of the D.F.A.7 or L.S.5A type, if you want really heavy loud-speaker strength.

### The Output Choke

Anti-motor-boating devices should be placed in the circuit, and grid bias can either be taken from the mains or from large-sized batteries. In any case, you will want about 100 volts grid bias available, in order that the L.S.5A or D.F.A.7 type of valves may be biased properly for use in the last stage.

Do not forget that the output filter choke of the set must be of the heavy duty variety, and must be capable of carrying at least 100 milliamps without serious loss of inductance. You want a fairly large margin of safety, as loss of inductance here will mean serious loss of bass and quality in the set.



# RADIO-GRAM PORTABLES

*Don't forget the pick-up when choosing or building your portable set this summer.*

*By KEITH D. ROGERS.*

I HAVE recently had a number of queries from readers asking what is the best type of receiver and circuit to employ for radio-gram "reception" out of doors. It sounds an easy question, but I am afraid most of my correspondents forget the point of weight when they start discussing portable radio-gram sets.

Unfortunately a really good portable receiver is bound to weigh so much that it makes it exceedingly difficult, or almost impossible, to carry it for any great distance. Hence the name "transportable" as applied to big receivers which are built up in compact form as against the portable receiver which is usually of the two- or three-valve type placed in an attaché case or in some other small container.

## General Requirements

When it comes to using a receiver for gramophone reproduction as well as for wireless, the difficulties of building it into portable form are very greatly increased, and the weight immediately goes up, for one has to consider then the turntable and gramophone motor and the records. These may or may not be included in the same case, but whether in the same

case or as a separate piece of luggage, they add to the total weight and make the whole outfit much less convenient than it was before.

Most portable receivers having two or more stages of low-frequency amplification (including the detector as the first stage) are suitable for radio-gram work if they are fitted with either a switch or an adaptor so that a pick-up may be applied fairly easily, but it is necessary that

at least two stages of low-frequency amplification be available for the pick-up, in order that sufficient "signal strength" from the records shall be obtained.

## Suitable Sets

The "M.W." "Transportable" Four is suitable for use with a pick-up, and so is the "M.W." "Portable" Five, described in this issue of MODERN WIRELESS, in fact, this latter has a switch arranged specially for pick-up purposes, and the low-frequency side is quite powerful enough to give amplification of any gramophone record. But it must be remembered that, in addition to the set itself, one has to take the turntable and motor in some portable form, and a supply of records besides the pick-up and carrier.

This, of course, makes another little parcel, and although it may not be particularly light, yet for anybody who has a car, or some easy means of transporting the apparatus, a transportable radio-gram outfit can be a sheer delight.

On a fortnight's holiday, where one takes one's luggage and leaves it more or less dumped in a particular spot at a hotel, or wherever it is one may be



*The Dubilier "Westminster" Radio-Gram Portable Receiver.*

## Set and Gramophone in One

staying, then the transportable radio-gram receiver has a large number of features in its favour.

After all, a great number of people take away a portable gramophone; also a large number take away, if not in addition to the gramophone, then by itself, a portable wireless set, so why not combine the two and take away a gramophone-cum-wireless set and plenty of records for electrical reproduction?

### Ingenious Design

There is no doubt that if the receiver is anything like a receiver, then the reproduction of the records will be quite as good, if not better, than that obtained from the ordinary gramophone. If the question of taking luggage is not an important one, then one can combine the whole outfit in one case, and as an example of what can be done I think perhaps the Dubilier "Westminster" radio-gram portable receiver is very good.

This set is more or less a standard design in that it has the usual mahogany case with a drop-front

self-contained gramophone as well as a wireless set.

The motor is inside, a very good single-spring motor being employed, and the pick-up and the handle clip are inside, while the turntable takes up its position on the back piece of the set, which fits in behind the frame aerial.

The circuit employed for radio consists of two screened-grid valves, followed by a detector and a pentode; while for the gramophone side the detector and pentode are used in low-frequency capacity. The pentode, of course, is not employed so as to give its maximum output, owing to the fact that it would take far too big an H.T. current, and would constitute a serious drain upon the battery. So it is biased carefully, and the priming grid is not given the maximum H.T. voltage.

### Good Gramophone Reproduction

On radio a large number of stations can be received and quality of reproduction is good. With gramophone the reproduction is also good, the bass

very neat panel it is. Drum-dial tuning is employed, and long and short waves are available by a turn of a switch on the panel front.

A three-way switch gives you either radio or gramophone or the "off" position.

### A Novel Feature

There is, of course, no space for records, and these would have to be carried separately in an attaché case, but the set represents one of the most ingenious methods of providing radio-gram reproduction in a single set.

The B.T.H. pick-up is employed, and this gives excellent reproduction, while a novel feature on the front of the set is the fret of the loud speaker, which is cut in the shape of a silhouette of Big Ben.

The clock of Big Ben is of transparent celluloid, and is lit up by a small lamp when the set is switched on, so that it is easy to tell at a glance whether the set is on or off.

Selling at £30 9s., the buyer is getting remarkable value for money, and it should appeal to the man who wants a luxury radio-gram portable set and does not want to build it himself.

For the home constructor, however, the writer rather fancies the separate arrangement, whereby an ordinary portable receiver of the four- or five-valve type, with a switch for pick-up, is employed, with a portable pick-up drive and records in another case. Such drives are available at the moment from several firms, and they form the easiest method of carrying such devices.

### Don't Forget the Pick-up

To construct a set of the description of the "Westminster" would be an exceedingly difficult job, and would hardly be within the average constructor's powers.

A portable radio-gram receiver can be the means of providing a considerable amount of pleasure and I would advise all who are considering building a portable receiver this summer to bear in mind the gramophone side, and to incorporate switches so that the gramophone pick-up may be employed if required. I am sure they will never regret the decision, and they will find that the added adjustability of the receiver will be well worth the little extra trouble which may be involved in the construction of the set.

### COMPLETELY SCREENED H.F. STAGES.

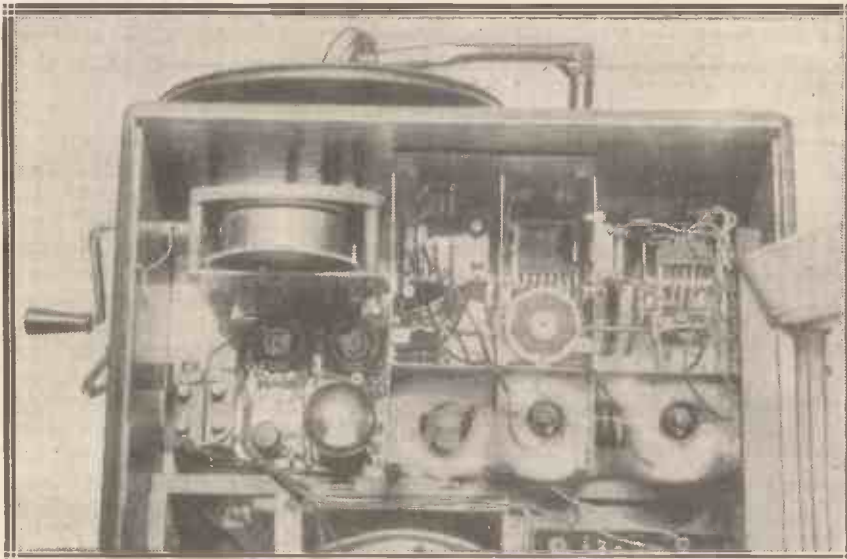

*The arrangement of the four valves (the H.F.'s and Det. being padded in cotton wool and screened) and the gramophone motor is clearly shown in this illustration of the "Westminster."*

section and loud speaker below it, but on top of the case can be fitted in a moment the pick-up and the turntable, while at the side is a place for the gramophone motor handle, so that the whole thing is a

being brought out remarkably well for a portable receiver, considering that limited power and space are available.

The gramophone control for speed and volume are on the front panel with the ordinary controls, and a

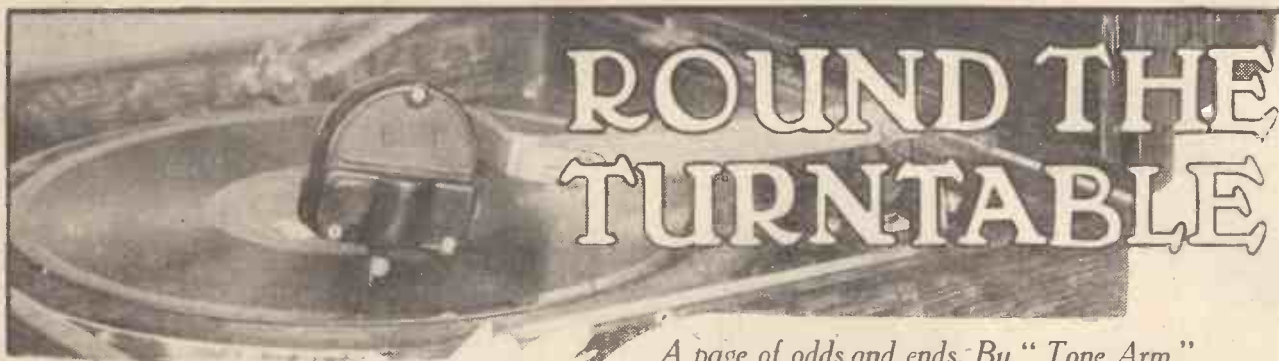

*A page of odds and ends, By "Tone Arm."*

### National "Records"

It is interesting to note that the British Museum has accepted an H.M.V. record of the speech by the Rt. Hon. Earl Balfour, delivered by him to the British Academy in November, 1927.

The copper matrix recording this speech is enclosed in an hermetically sealed brass container and preserved at the British Museum with other H.M.V. records made by various famous people.

These matrices, from which gramophone records can be made at any time should occasion arise, include the voices of H.M. the King (a speech at the opening of the British Empire Exhibition), the voice of the Queen, the Prince of Wales, Archbishop of Canterbury, Mr. Lloyd George, Sir Ernest Shackleton, The Earl of Oxford and Asquith, Mr. Winston Churchill, the Prime Minister of New Zealand, Sir Herbert Tree, Dame Melba, Chaliapin, Caruso, and others.

### Low H.T. Voltages

I have recently been trying out a number of experiments with different loud speakers, using a standard three-valve set consisting of detector and two resistance-coupled L.F. stages, employing D.E.L.610 as detector, another D.E.L.610 as first L.F., and a super-power valve of the B.T.H. Mazda 6-volt type for output. An ordinary output choke and condenser was employed, and only 100 volts H.T. was used throughout the tests to see what kind of reproduction could be obtained under difficult conditions.

The result was to prove that a sensitive moving-coil loud speaker is quite worth having even though the output be fairly small and only 100 volts H.T. be used. With a pick-up the results were certainly very good,

though hardly sufficiently good to warrant the substitution of electrical reproduction for an ordinary well-designed gramophone.

### Effect of Transformer

Substituting a good transformer instead of one of the resistance stages using a modern type of transformer, the results went up about 20 per cent in volume, and no loss of quality was apparent. I then substituted another good transformer and, using the same H.T., the moving coil began to show a certain loss of quality, which was eventually traced down to the fact that the last valve was being very badly overloaded on certain passages.

By the way, I should like to emphasise the importance of using heavy leads from the H.T. battery

to the receiver, especially if anything more than 60 volts is being employed. I recently came across an H.T. accumulator which had been completely run down in the space of a very short time, due to the fact that the positive H.T. lead and the negative H.T. lead were in contact with one another, and these leads consisted merely of 20 gauge D.C.C. wire.

### Completely Shorted

As well over 100 volts potential difference was between them, and the D.C.C. was not in too good a condition, a very short time sufficed to see the voltage succeed in breaking down the insulation, with the result that the battery was run down. If fairly heavy leads had been employed, this, of course, would not have occurred.

### NOT THE LATEST MODEL



*One of the very first phonographs, invented by Edison, and marketed in 1902. The records were cylindrical and were of fairly soft wax.*

# RECENT RECORD RELEASES



Our monthly review of gramophone records.

## Broadcast Records

**Q**UITE a novelty as regards records has been instituted by the Vocalion Gramophone Company, on their 1s. 3d. Broadcast records, in the special sports records made by Jack Hobbs and F. Gordon Lowe, the former being a double-sided disc on *How to Improve Your Cricket* (392), and the latter *Useful Hints to Lawn Tennis Players* (393).

The old time popular songs form an interesting record on 380, while the Band of H.M. Welsh Guards with male chorus do a concert hall recording, on 381, entitled *Military Church Parade*. Harry Hemsley, the well-known child impersonator, gives us a very interesting disc (384),



The "Trix" Portable Five is exceptionally suitable for pick-up work and represents excellent value at 17 guineas.

one side of which has *Winnie's Recitation* and the other side *The Pancake*.

Among the larger Broadcast records, the Broadcast Twelve, we must mention a couple of good band numbers, one on 5070, played by the City of London Band; *Polska* (from Slavonic Scenes by Gilmer) and *Étalog Militaire March* by

the same composer. The second record (5071) played by the band of H.M. Life Guards, gives *Here, There and Everywhere* and *Blaze Away*.

## H. M. V.

One of the outstanding records made by the Gramophone Co. is that by Mark Hambourg of Liszt's *Hungarian Rhapsody*, No. 14 (C1661). As a piece of piano recording this is a wonderful achievement, and requires a good pick-up and amplifier to do it full justice. We place it in the same rank as the Levitski record of *Rhapsody No. 6*—also an H.M.V. production.

Of lighter type we have *The National Game*, March (Sousa), played by Sousa's Band, and *Forge in the Forest*, by Pryor's Band, on B3010. Both excellent band pieces of the truly martial type.

A novelty among these recent releases is the Harpsichord cum orchestral accompaniment records by Wanda Landowska, on D.A.977. These consist of *Le Tambourin*, *Le Coucou* (Rondo) and *Don Giovanni* (minuet) forming a novel record.

And last, but not least, we have another of those superb records of Gracie Fields. This time she delights us with one of the sentimental solemn type *Sonny Boy* and one of the typical Gracie comedy type *Hot Pot*. Both are on the same disc (B3008), and once more Gracie Fields has shown us how marvellously versatile she is.

## Parlophone

It is very difficult to pick out outstanding numbers from the latest Parlophone list, as all the records we have heard have been of superb quality and excellent for reproduction purposes.

Those which stand out most are the novelty numbers, such as those provided by the Three Australian Boys on R347.

Leslie Hutchinson on the piano plays *Looking At You* and *Let's Fall In Love*, on R342, and *What Is That Thing Called Love* and *I'm a Gigolo*, on R343, all four being from "Wake Up and Dream."

Among the dance items, Joe Venuti's Concert Orchestra stands out above the others in their rendering of *Weary River*, on the reverse side of which is *A Precious Thing Called Love*, making a couple of fox trots, the latter being from the film "The Shopworn Angel." (R. 341.)

## Zonophone

The Zonophone people are still continuing their recording of Gilbert and Sullivan's operas, and this month have added two very bright records to their list. They are by the Zonophone Light Opera Company, and are recorded on one twelve-inch and one ten-inch record. The former is A.359, and carries Part 3 of *Vocal Gems from "H.M.S. Pinafore"* and Part 3 of *Vocal Gems from The Yeomen of The Guard*. The ten-inch record consists of two sides, Parts 1 and 2 of *Vocal Gems from The Gondoliers* (5294).

The Arcadians give us some lively dance numbers, including *Considerin'* and *Why?* a couple of fox trots on 5306. These are gems in their way and should certainly be heard by all lovers of dance music.

### THIS MONTH'S PICK-UP PROGRAMME

- ORCHESTRAL.  
Violin Concerto in D (Brahms) Col. L2265/9  
Szigeti and Hallé Orchestra.  
Dance of the Seven Veils (Strauss) H. M. V. D1633  
Berlin State Opera Orchestra.
- OPERATIC.  
Barcarolle from Tales of Hoffmann (Offenbach) Parlo E. 10836  
Emmy Bettendori and Karin Branzell.
- LIGHT ORCHESTRAL.  
The Sacred Hour Reverie (Ketylby) Col. 5289  
Ketylby's Concert Orchestra.  
Nell Gwynn Dances (German) H. M. V. B2987  
New Light Symphony Orchestra.
- POPULAR VOCAL.  
Dixie Dawn Col. 5289  
Layton and Johnstone.  
Cows and Fishes H. M. V. B2909  
Suzette Tarri.  
Ev'ry Little Moment Parlo R. 336  
Ord Hamilton.
- DANCE.  
Forget-me-not H. M. V. B5610  
Jack Hylton and His Orchestra.  
How about me Col. 5305  
Paul Whiteman's Orchestra.  
The Banjo Song Parlo. R.322  
Raia da Costa.



# STOP RECORD WEAR



The NEW  
**B.T.H.  
PICK-UP**  
takes care of  
the records

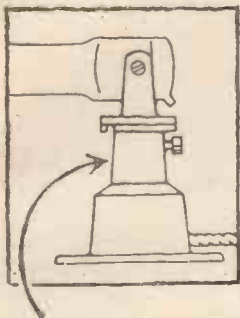

Here is the ball bearing swivel joint which reduces friction and consequently record wear.

The new B.T.H. Pick-up and Tone-arm incorporates two new features which reduce record wear to an absolute minimum.

- (1) An off-set tone arm reducing tracking error to no more than 3°
- (2) A perfectly balanced BALL-BEARING tone arm.

The result then, is a needle working centrally in the record groove, responding freely to all vibrations, and passing those vibrations—undistorted by mechanical error—to a really first-class pick-up with an acknowledged reputation. Under such conditions perfect reproduction and long record life are assured.

**PRICE £2. 5. 0.** This price is applicable in Great Britain and Northern Ireland only.



## PICK-UP & TONE-ARM

WITH BALL-BEARINGS AND IMPROVED TRACKING DEVICE



# RADIO ABROAD

*News and Views of Wireless in Other Lands.  
By Our Special Correspondents.*

## Radio in Sweden

**R**ADIO is making great strides in Sweden, and an order has recently been placed with an English Company for the supply of a broadcast transmitter for Stockholm. This is to be designed for 60 kw. in the aerial. The modulation system is to be of low power and similar to that which is at present used at Daventry 5 G B.

## A Giant Rectifier

You have probably seen reports lately of tests on the giant high-voltage rectifier made in the famous laboratories of the General Electric Company of Schenectady, New York. According to the "Wireless Age," this rectifier, which is now practically complete, has been sold to Russia. It gives a power output of 750 kw. at a voltage of 15,000, and works on the mercury-vapour principle. Eighteen rectifying valves are used to supply current to the anode of a radio transmitter.

A contract has been made for the supply of a large amount of radio equipment, of which the above-mentioned rectifier is part, and the other items include a 20-kw. short-wave telephony transmitter and several other high-power rectifiers.

## Radio Soviet

Radio developments are taking place very actively in Russia and, as evidence of this, a party of Soviet engineers have gone over to New York to engage in Technical Conference with the engineers of the Radio Corporation of America. It is anticipated that a similar return

visit will be made by American engineers to Russia in 1930.

## New York

Radio catering for flat-dwellers is a problem which is perhaps more acute in New York than in any other part of the world, and various systems for apartment houses (or what we would call "blocks of flats") have been introduced lately. In the new Kehaya apartment building in New York there are 118 flats, and these are all connected to a central radio distribution system, very much after the same manner as central heating arrangements. The plant has been installed by the Radio

Corporation of America, and all the tenant of a flat has to do is to plug his set to one of two single-wire aerials, when he can tune to any desired station.

## Czech Station

A new broadcasting station has been set up at Bratislava, in Czechoslovakia, with a power of 12 kw. and using a wave-length of 277.8 metres.

## New Italian Station

Broadcasting affairs in Italy are controlled by the Italian Broadcasting Company, and the latest addition to the system is a new short-wave broadcast transmitter for communication primarily with Italian Colonies. A contract for this station has been secured by the Marconi Company and the design will be generally similar to that of station 5 S W.

## Developments in Belgium

The Marconi Company has also secured the contract for short-wave telegraphy and telephony transmitters for the Societe Belge Radio-Electrique, on behalf of the Belgian Government. This station is intended for communication between Belgium and the Belgian Congo and also between Belgium and South America.

## Prague Conference

We have heard a great deal about the Prague wave-length scheme and about the recent Conference at which the B.B.C. Chief Engineer was present.

(Continued on page 682.)

## THE BROADCASTER AT BELLMORE

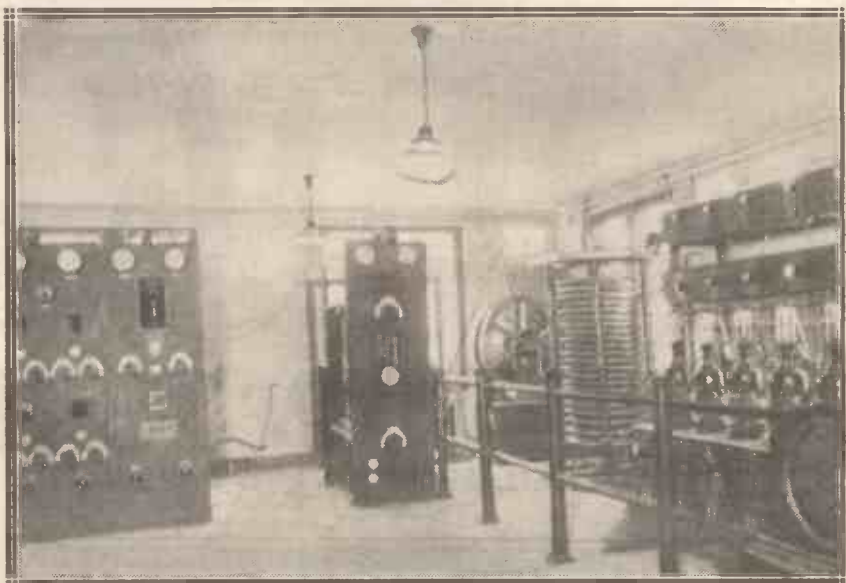

A section of the 50-kw. transmitter at W E A F, of Bellmore, Long Island, New York. The photo shows, on the right, the five-valve high-frequency unit. On the left is the crystal-control apparatus that is a special feature of this station.

# Lotus—the latest portable screened receiver—

—now *FOUR* valves!

Greater range, greater power, greater selectivity—all these are here in the new Lotus Screened 4. It is made with all the care and accuracy that has earned Lotus components their good reputation. These sets are constructed strongly, are handsome in appearance and entirely self-contained.

Portable or Transportable—if you want a really good set this summer get a Lotus.

**PRICES :**

4-valve Portable Screened Receiver in real hide case, 23½ gns.

4-valve Transportable Screened Receiver in cabinet, 24 gns.

SEND FOR DESCRIPTIVE LITERATURE

# LOTUS

## PORTABLE SETS

## B.B.C. FINANCE

*Some interesting information is contained in the Second Annual Report of the B.B.C., while there are one or two regrettable omissions.*

*By a Special Correspondent.*

**T**HE Second Annual Report of the B.B.C. has just been issued as a White Paper. It certainly makes interesting reading. It shows that the income for 1928 amounted to £1,002,505; and, of this sum, £879,324 was absorbed by expenditure, thus leaving a balance of £123,181, which will be carried to Revenue Appropriation Account.

### *Greater Expenditure Necessary*

The Report goes on to say that the development in broadcasting necessarily called for greater revenue expenditure in relation to both total income and licence income than was the case in the previous year. In 1927 against a licence revenue of £800,959, the total revenue expenditure was £773,289, leaving a balance of £27,669, apart from other income, towards the cost of current and contemplated capital expenditure. In 1928, however, the licence income fell short of the revenue expenditure total by £7,560.

In 1928 the number of licences taken out was 2,628,392, an increase of 233,218 licences over the previous year. 14,068 free licences were issued to the blind.

Another interesting item is that in 68,000 hours of transmission, the percentage of breakdowns was only .035, just a slight increase on the percentage for 1927. This increase is stated to have been due to the damage to aerials during the heavy gales of last November.

### *Talks More Popular*

The report goes on to say that Talks have improved technically, and become more popular. Exactly how the B.B.C. arrives at this judgment we fail to see. Possibly by the fallacious method of judging by letters. But the letters sent in from such a huge clientele can hardly be regarded as a clear indication of the popularity of the sort of talks which now appear so frequently in the B.B.C. programmes. However, the B.B.C. state that talks have increased in popularity, and our readers must judge for themselves whether they think this is really so.

It appears that the allocation of five minutes every Sunday evening for the Week's Good Cause broadcast has resulted in £60,000 being contributed by listeners for charities, and readers will learn with interest that the Prince of Wales' appeal on Christmas Day, probably one of the most moving appeals ever broadcast, and which has even earned praise from such an unlikely source as Mr. A. J. Cook—brought in the largest sum of the year, while Lord Knutsford's appeal on behalf of the London Hospital resulted in a contribution amounting to £19,000.

### *The Permanent Orchestra*

It is also good news to hear that the Governors state the negotiations with Sir Thomas Beecham regarding the formation of a large permanent orchestra in London are still progressing favourably. We hope, however, that very shortly some definite decision will be made. If the decision is favourable it will, of course, mean that the new scheme will entail some reduction in the constitution of provincial orchestras, but listeners

will benefit by hearing Symphonic work of the first order by the finest orchestra ever formed in this country.

The Report also states that satisfactory arrangements have been concluded for the building of the new 2 L O at Portland Place, where more suitable accommodation will be available for rehearsals and performances. According to the report, the financial position of the Corporation is satisfactory, the balance of capital account permitted just under £170,000 being devoted to the furtherance of the new Regional Scheme, while investments were increased by nearly £70,000 and the Depreciation Reserve increased by £31,150.

### *A Licence Income Increase*

The income from licences is increased by £71,000, and the increased revenue from the B.B.C.'s publications totals about £20,000. The total expenditure spent on programmes and programme staff shows a decrease of about 2 per cent. However, the actual amount spent on account of programmes, etc., has really been increased by over £50,000 during the year, while the sum of £538,990 has been spent on the provision of programmes, etc.

This is roughly a daily expenditure of £1,477.

The report, on the whole, is satisfactory;—and one cannot quibble very much with it. But, taken in conjunction with the fact that some of

*(Continued on page 682)*

### A DISTINGUISHED RADIO VISITOR



Mr. H. M. Aylesworth, President of the National Broadcasting Company of America, which controls 65 stations, serving 50,000,000 listeners, who recently paid a visit to this country. This photo was taken on the occasion of his broadcast from Savoy Hill



*The New R.I. L.F. Transformer—The Loewe Loud-Speaker Unit, etc., etc.*

**R.I. "Hypermu" Transformer**

MUCH more than in the case of a valve, good though the indications may be, the characteristic curve of an L.F. transformer does tell you what to expect from the component. If the "curve" be completely straight (paradoxically!), then there will be a completely even amplification of all notes at all frequencies.

Should there be peaks and slopes in the curve, then you will surely enough get peaks and slopes in your reproduction. Inasmuch as the curve is plotted against frequency and amplification, it would be strange if this were not the case.

The practice of publishing curves of transformers has now become fairly universal, and indicates the general high standard of these articles. At one time it would not have been wise for most manufacturers to show



The Loewe loud-speaker unit which is dealt with on the next page.

on paper exactly what their transformers were capable of, any more than it would for loud-speaker makers even to-day.

For some years the curves obtainable with efficiently arranged R.C.C. were exhibited as sorts of models

for the guidance of transformer makers, and to show how far ahead R.C.C. was for purity.

But the transformer is leaping up level with R.C.C. in that respect, while, as always, it leads vastly in point of amplification.

Manufacturers and Traders are invited to submit for test purposes radio sets, components and accessories to the "Modern Wireless" Test Room at Tallis House, Tallis Street, London, E.C.4. Under the personal supervision of the Technical Editor all tests and examinations are carried out with the strictest impartiality. Readers can accept the Test Room reports published monthly under the above heading as reliable guides as to the merits and demerits of the various modern productions of the radio industry.

The new "Hypermu" L.F. transformer, due to the R.I. people, puts the final seal on transformer coupling for at least ordinary receiving sets and home amplifying apparatus.

The N.P.L. curve for the "Hypermu" is an extraordinary curve; so extraordinary, in fact, that it is, in truth, no curve, but a straight line with a slight depression at one end and a slight rise at the higher frequencies. This latter is even advantageous in the majority of cases.

**Unorthodox Connections**

The line is quite straight down to as low as 35 cycles, and this is, of course, lower than the average moving-coil speaker (let alone an ordinary horn or cone speaker) can go.

In order to obtain this remarkable straightness of line the R.I. "Hypermu" must be connected up in a slightly different way than is usual, although this does not mean that any other transformer would equal its performance if so treated. Actually, we find that in a case chosen at

random from a stock of various other makes the results were much worsened.

Connected in the ordinary way, the "Hypermu" is still excellent, and the amplification is slightly greater; but there is no reason to depart from the special arrangement, as even then greater amplification than normal is possible.

**Special Core Design**

The efficiency of the "Hypermu" is mostly due to its very special design of core and windings. A special iron is used, and this enables the size and weight of the component to be kept down to surprising degrees.

The "Hypermu," for this reason, is ideal for portables, while its compactness will be appreciated in the layout of any set. It is contained within a handsome bakelite moulding, and this quite covers the metal



This is the new R.I. transformer. shrouding that is a feature of the article.

The price of this latest R.I. L.F. transformer is 21s., and it is undoubtedly an outstanding production,

both in this and all other respects. The R.I. people are to be congratulated on their achievement, one which cannot fail to enhance their already great reputation and endear them to the discriminating constructor of radio sets.

**Loewe Loud-Speaker Unit**

Surely the home-assembled loud speaker will soon begin to cause manufacturers of loud speakers a certain amount of trepidation, unless, of course, they early realise the probabilities of this serious encroachment into their reserves, and turn it to account by supplying the essential parts.

Some manufacturers are already doing this, and are no doubt reaping a rich reward. You can make a first-class loud speaker capable of giving results equal to those given by a four or five guinea model for a matter of twenty or thirty shillings.

The necessary elements are some sort of framework, a paper cone, and a loud-speaker unit. The framework can, it desired, be fashioned from a few pennyworth of wood, while the cost of a cone is merely a shilling or so. There remains, then, only the unit, and here we have

is cased in bakelite, and is rather original in form. It is sensitive, and its tone is bright and replete with bass.

**A London Address**

Messrs. Garnett, Whiteley & Co., Ltd., have taken offices at 125, High Holborn, W.C.1.



A novel method of demonstrating a loud speaker. The Celestion in view (and in hearing!) on the River Thames.



**Wireless Pictures**

Wireless Pictures (1928), Ltd., have prepared a leaflet for general distribution which contains excellent reproductions of Fultograph pictures received from 5 G B and Berlin.

**Radio for the Million**

No. 1 of Volume 3 of this excellent Mullard publication has just come to hand. It includes full details

**Radio Statistics**

P. C. Kullman & Co., a wireless brokerage house, of New York, have prepared an excellent radio statistical circular, a copy of which they recently sent us.

**Ferranti Screened Grid 3**

With reference to the above receiver, say Messrs. Ferranti in a

recent letter to us, we find that constructors are in some cases being advised to fit condensers of .0003 mfd. capacity under the impression that standard condensers, .00035 mfd., are not available.

We therefore draw your attention to this point, as the effect of using .0003-mfd. condensers in place of those specified is to make the receiver incapable of tuning to 5 G B.

The Ferranti people also state that in future all audio-frequency and output transformers manufactured by them will have their primary and secondary terminals reversed from what has hitherto been their standard positions.

Looking at the transformers from the primary side, the plate terminal will in future be on the right-hand side; and, in the same way, observed from the secondary side, the grid-bias terminal will be on the right-hand side. This alteration, whilst in no way affecting the performance of the component, will in future lead to an appreciable simplification of wiring

**"Trolitux" Panels**

F. A. Hughes & Co., Ltd., of 204-6, Great Portland Street, London, W.1, whose famous "Bluespot" loud speaker unit will be known to all readers, are now marketing a panel material styled "Trolitux."

It is a bakelised substance of a hard, close-grained material, and its electrical properties are decidedly high. In some instances there are artistic grained surfaces, while other styles include highly polished varieties of finish. "Trolitux" seems to be most admirable for panels, both in point of appearance and efficiency.

**THE AMPLION PEOPLE "GO RACING"**

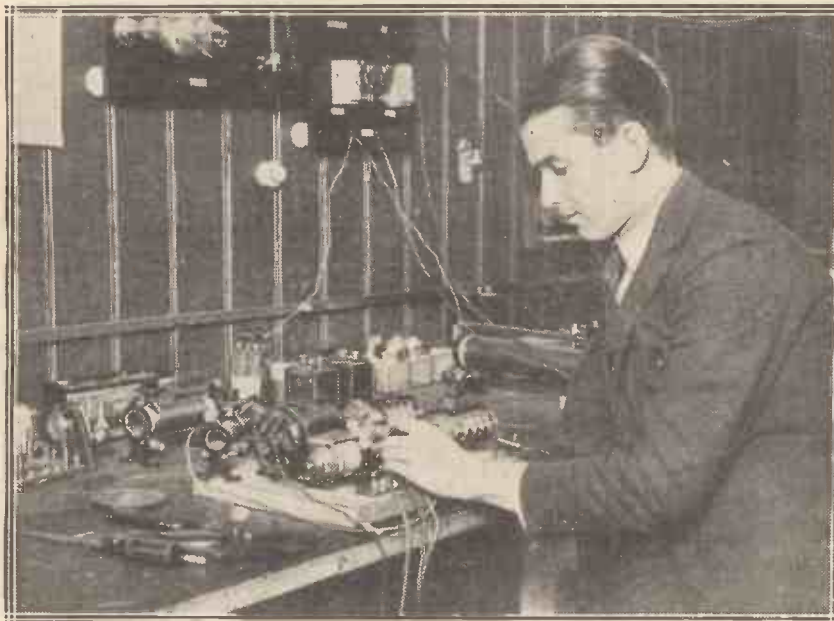

Mr. R. M. Hamilton, the English mathematical expert, under whose supervision a Totalisator installation is being built at the Amplion factory for the Racecourse Betting Control Board.

as an instance the Loewe, a new-comer, which retails at 13s. 6d.

And it is an excellent unit, both in appearance and performance. It

(and a fine chart is enclosed with the book) of the "S.G.P. Master Three." This set incorporates Mullard screened-grid and pentone valves.

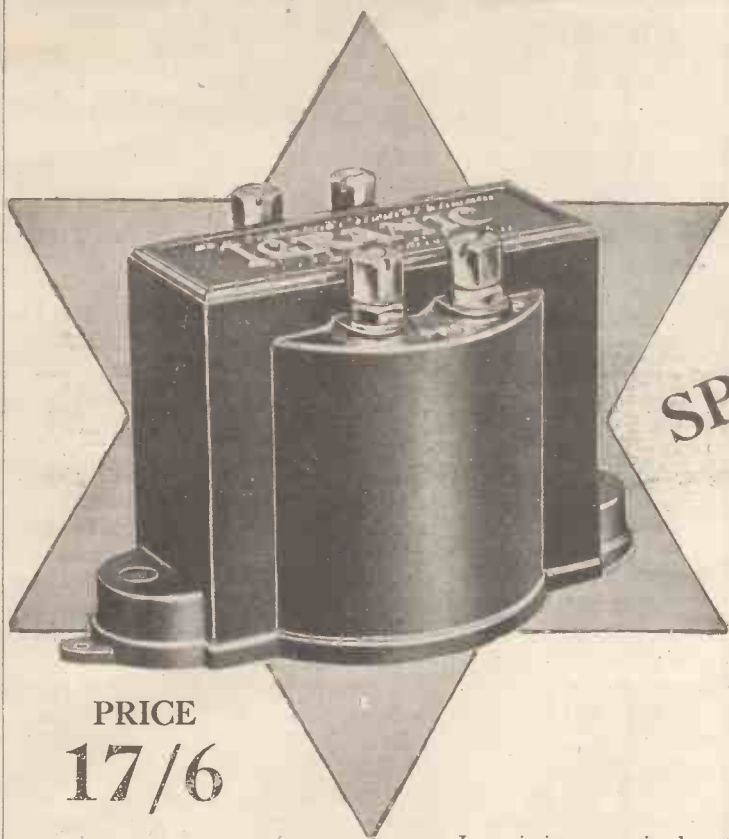

**SPECIFIED  
IN THIS ISSUE  
BECAUSE—**

PRICE  
**17/6**

Igranite is recognised as the hall mark of scientific radio instruments; because purchasers know that years of research, expert labour and continual tests combine to make Igranite components as good as they can be, therefore the Igranite "J" Type Transformer has been specified as more suitable than any other for inclusion in the Travellers Two. A particularly small, neat and robust transformer with published curves showing a straight line performance over practically the whole range of audible frequencies, incorporating special windings with an ultra-permeable iron core.

Ratios: 3:1 and 6:1 with primary winding current carrying capacities of respectively 5 and 10 milliamps.

*Write to Dept. J.876 for lists of Igranite Radio Devices.*



**IGRANITE UNIVERSAL PORTABLE  
5-VALVE RECEIVER**

A very handsome and powerful instrument with remarkable selectivity and sensitivity. Ample power due to battery room provided in separate case. Covered in selected hide. Price, inclusive of valves, batteries and Royalties.

**£33 4s. 6d.**

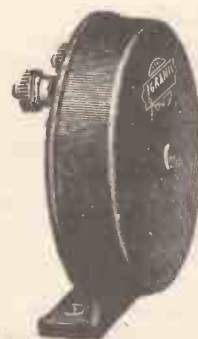

**IGRANITE H.F. CHOKE**

Specified for the Autotune One. Ensures satisfactory reaction control and total exclusion of unwanted H.F. current. Effective on wavelengths from the lowest up to 3,000 metres. Occupies little space. Coil winding protected by bakelite case.

Price 5s.

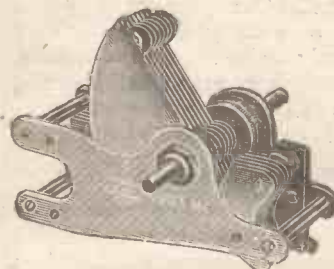

**IGRANITE LOKVANE SQUARE LAW  
VARIABLE CONDENSER**

Specially designed double self-aligning bearings and locking bar ensure smooth turning, prevent slip and provide sound electrical contact. No. 2231/25 specified for the Kuttemout Three, '0005 mfd.

**10s. 6d.**



Works **BEDFORD**

# ON THE SHORT WAVES

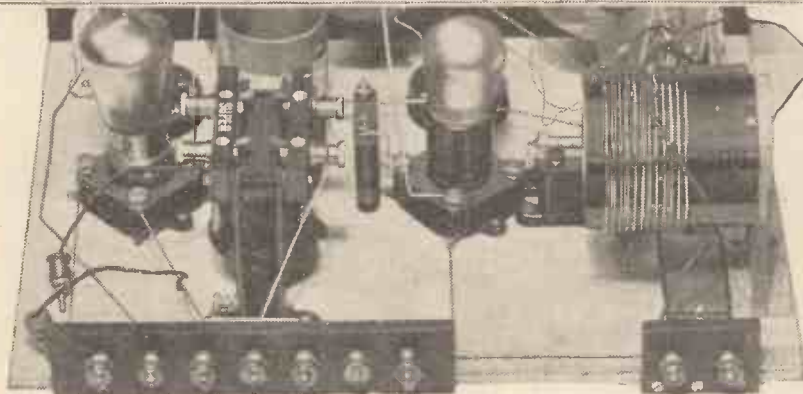

## Notes of Interest on Short-Wave Receivers and Reception By W. L. S.

WILL anyone ever be able to advance a satisfactory theory for some of the amazing variations and freaks noticed exclusively on the short waves? I could go on repeating instances of them until I had tired both myself and my reader, and I could spend years trying to tabulate them and bring some semblance of order into the happenings, but we should still be no nearer an understanding.

Why, for instance, are some of the most powerful American amateur stations only just audible on a night when W 2 X O is roaring through, while on another night they are rattling the 'phones over here when W 2 X O is a still, small, voice?

Why, on a morning when only the United States "6's and 7's" (down the Pacific Coast) are coming through, does a solitary "4" in Florida suddenly arrive at enormous strength, although there are hundreds of others in his district all working at the same time?

### An Extreme Case

I wonder whether a grand series of organised tests by all the enthusiastic short-wave receiving stations in the country (such as the R.S.G.B. "T.R.S.'s") would help to straighten matters out at all?

The most puzzling feature of all is the extraordinary way in which receiving conditions vary in a quarter of a mile or even less. I have come upon a most extreme case of that this month, in which one receiving station heard shoals of Australians and New Zealanders one morning, while the

other did not log a single one, but heard United States and *South America*, neither of which could be heard at the first station. The distance apart is about 150 yards! That is enough to make one sceptical about whether there is any rhyme or reason in the whole business.

### The 25/31m. Band

I am glad to note that the short-wave broadcasting stations appear to be grouping themselves together reasonably well, instead of being spread out over the whole band of

waves. The interesting parts of the band are, of course, 25 and 31 metres, as far as "broadcast fans" are concerned. Round about the former wave-length we have W 8 X K, who is, of course, the short-wave K D K A, on 25.4 metres; then 5 S W on 25.53 metres, and Winnipeg, C J R X, on 25.6 metres.

In the region of 31 metres we have W 2 X A L (New York City, 30.91), 7 L O (Nairobi, Kenya, 31.0 metres), 2 F C (Sydney, 31.28 metres), P C J (Hilversum, 31.4 metres), W 2 X A F (Schenectady, 31.48 metres), and 3 L O (Melbourne, 31.55 metres).

### A "Selectivity" Stunt

If anyone is really thrilled with the last-named little batch of stations, it is a good plan to connect across your ordinary tuning condenser another very small variable (such as a square-law type with all the plates removed except one fixed and one moving) and to equip it with a slow-motion dial. This gives a facility of searching and accurate tuning that is well worth while if one is really keen.

I generally use this scheme myself for covering the relatively narrow band of amateur wave-lengths; it is certainly a treat to have the band from, say, 20.5 metres to 22.5 metres spread over 180° of scale.

F Q - P M, a French mission in the Cameroons, has shifted down from 34 metres to about 21 metres, and may be heard almost any night. Two other stations in the Cameroons are F Q 8 W B and F Q 8 H P G.

### "A FALLING CHARACTERISTIC!"



Flying on his way to his sister's wedding, Mr. John Scott-Taggart had a crash. As you see, he did not miss the house by very many yards. Luckily, Mr. Scott-Taggart escaped with only a few bruises.



# Building Portable Sets ?

If you are, be careful in your choice of components. These Bowyer-Lowe components are widely recommended not only because they are ideal from the point of view of space and weight, but because they are instruments of precision and of the highest electrical efficiency.



Recognised by set builders as the highest standard of valve holder design and manufacture. One of the most popular holders ever sold. Scientific damping is quick and smooth and there is perfect insulation.  
List 282 . . . 1/9

**WHITELINE VALVE HOLDER**

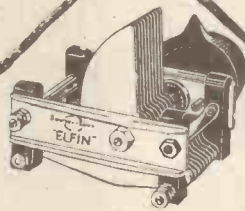

The pioneer and still the leader in miniature logarithmic condensers. A perfect precision instrument for reaction control and tuning in portable sets. The '00015 mfd measures only 2 3/4" x 1 3/4" when fully extended.  
List 311 '0001 mfd 5/9  
List 312 '00015 mfd 6/-  
List 313 '0002 mfd 6/3  
List 314 '00025 mfd 6/6

**'ELFIN' CONDENSER**

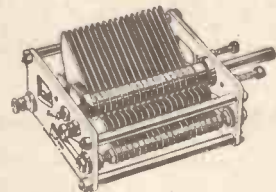

Weight under 3 ozs. Ebonite dielectric. Impossible for the plates to short circuit. Cast steel spindle on ball bearing. One piece pigtail. Length behind panel 1 1/2 ins.

List 338 '0005 mfd 11/-

**'LOG MINOR' CONDENSER**

## BOWYER-LOWE

IN ASSOCIATION WITH RECORD PHONES, LTD.

NEW LONDON SHOWROOMS

**ASTOR HOUSE ALDWYCH, W.C.2**

**HEAD OFFICE AND WORKS, RADIO WORKS LETCHWORTH, HERTS**

Every portable set builder should send for the Bowyer-Lowe component folder. Free on request.

Insist on Bowyer-Lowe Components at your dealers.

# HOW TO USE WAVE TRAPS



CONTRARY to the ideas of many, the tuning of a wave-trap can be very sharp and definite, and there is no reason why, providing it is properly used, another tuning position should be found for the local station once the trap is set. This is a point which brings disappointment to many when they use a wave-trap for the first time. To these the following details will be useful in helping them to get the best from this sometimes despised little unit.

## The "M.W." Standard Type

There are a large number of types of wave-traps, all of which are useful. The ease with which they can be adjusted varies, however, as also does their suitability for the modern kind of set. The type which is most commonly in use to-day may be described as a form of series rejector circuit. It is the scheme employed in the standard MODERN WIRELESS wave-trap.

A theoretical circuit of this type of trap is given in Fig. 1, from which it will immediately be apparent whence the wave-trap derives its name. It is connected in series with the aerial lead, and is so tuned that the unwanted transmission is rejected by the trap. The trap stops the signals causing the interference, but passes on all the others.

## Efficient Coil Essential

Two or three taps are made on the coil so that the aerial may be joined to the one that gives the best results. It is unnecessary to go into the practical details of the construction of the wave-trap, as these have been given in full in MODERN WIRELESS. It must suffice to say that the coil must be a fairly efficient one so that the tuning is made sharp. If the coil is inefficient it will have flat tuning, in the same way that a poor coil in a set will produce inselectivity. The

★  
★  
★ On the medium wave-band there are dozens of powerful stations jumbled together and selectivity is essential for successful D.X. work. This article tells you how to obtain this quality with simple sets.  
★  
★ By A. S. CLARK.  
★

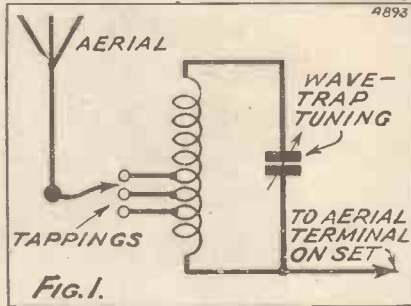

result of flat tuning in a wave-trap is twofold. Not only is it impossible to tune out the unwanted station completely, but the trap will cause a "cut out" over a fairly wide band, thus removing wanted transmissions.

The method of actually adjusting a wave-trap is as follows: Connect it up with the aerial joined to the lower tap on the coil. Now, with the reaction at zero, tune-in the inter-

fering station properly on the set. The next step is to vary the capacity of the condenser in the wave-trap until the interfering station vanishes completely, or nearly so.

## Adjusting the Condenser

The adjustment of the condenser must be made slowly, as very often the point at which the unwanted signals are cut out is very sharp and only covers a tiny wave-band. The signals will, of course, be considerably weakened on either side of this point, hence the need for careful tuning. If a variable condenser of the mica dielectric type is employed, it should be adjusted with a wooden-handled screwdriver, so that hand-capacity effects are avoided.

If the smallest tap does not cut down signals from the unwanted station sufficiently, a larger tap must be tried. Once the best adjustment is found, the station you desire to eliminate should not tune-in again at any position. If it does, it is probably because the set has got direct coupling to the aerial coil. (See A, Fig. 2.)

If this is the case, you must arrange an aperiodic aerial circuit either by means of a tap (B, Fig. 2), or a separate coil as at C, Fig. 2. The provision of an aperiodic aerial arrangement will in itself produce a sharpening of the tuning.

## When Screening is Desirable

A wave-trap of the type with which we have been dealing is not, as a rule, of much use on the higher broadcast wave-band. It is very difficult to find a wave-trap which is really efficient on the long waves.

Sometimes it is desirable to encase the wave-trap in a metal screen made of copper or aluminium. This only applies, however, when it is to be included in the actual set.

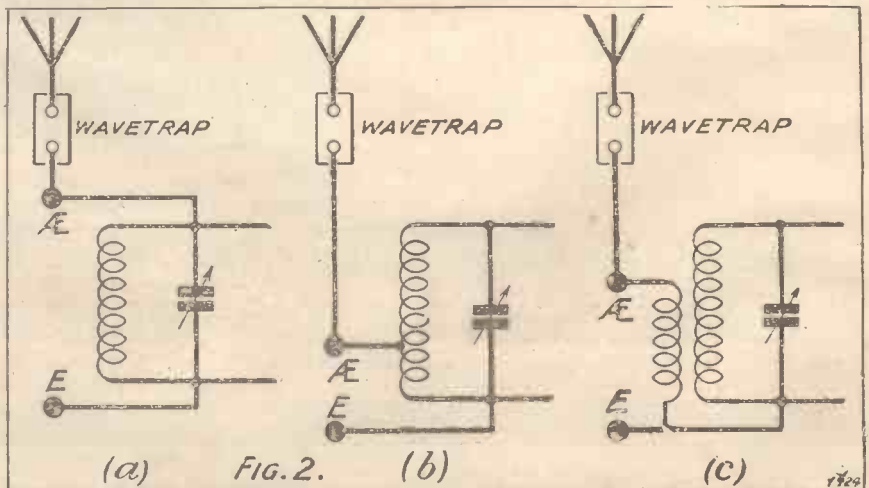

# Now

## The **BLUE SPOT** Electro-Magnetic Gramophone **PICK-UP**

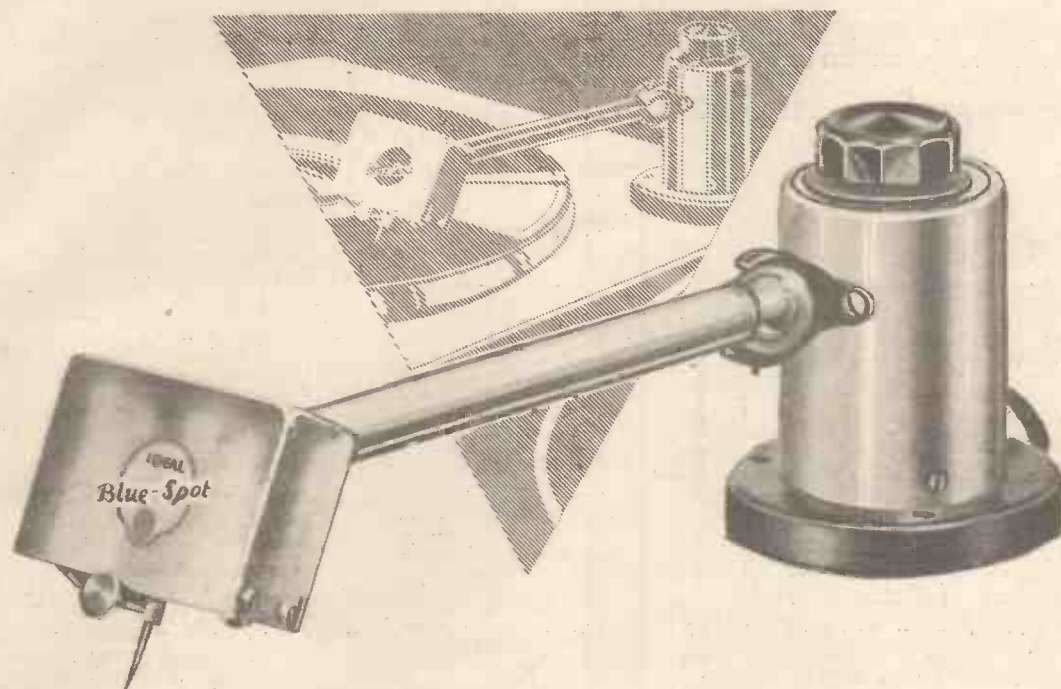

### *To satisfy exacting demands*

From a whisper to full orchestra strength—with the new Blue Spot Pick-up and Volume Control.

Designed in accordance with the accepted standard of Blue Spot—*Perfection*—the Blue Spot Pick-up is extremely light, so that there is no damage to the record, yet there is no chatter.

The Pick-up is complete with tone arm, which is attached to the base by means of a ball swivel—making tracking alignment exceptionally accurate.

The volume control is contained in the base and is absolutely silent and smooth in action.

The whole audio range is reproduced when the Blue Spot Pick-up is used—just listen for the bass!

Price complete, as illustrated, 39/6. Also supplied (Pick-up only) for attaching to existing tonearms, 25/-.

*The ideal loudspeaker to use with a Blue Spot Pick-up can be built up using the famous Blue Spot Unit. Write for full particulars.*

**F. A. HUGHES & CO., Limited., 204-6 Great Portland Street, London, W.1**  
Distributors for Northern England, Scotland and North Wales: H. C. RAWSON (SHEFFIELD & LONDON) LTD.,  
200 LONDON ROAD, SHEFFIELD; 185 PRINCESS STREET, MANCHESTER.

# PERMANENT "SOUNDS"



Here is the description of a new German invention by which hours of music and speech can be recorded on small, light apparatus.

By A. A. GULLILAND

EVERYBODY can, of course, have a gramophone record made of his or her voice. But this is a privilege of the comparatively rich.

There is, and always has been, a demand for spoken letters, even if the demand for an acoustic photograph of one's speech or singing is only now being awakened by broadcasting and talkies. Many people have tried to find a practical solution to the problem to find a piece of apparatus capable of recording acoustical effects and sound in general so that these records be small and light, that long speeches or theatre rehearsals of up to three hours' duration can be recorded on one record. Then everybody, even of small means, could at least reproduce the sounds recorded even if the recording apparatus were expensive.

## Acoustical Photographs

A few weeks ago I was able to assist at a demonstration in the laboratories of the South German Broadcasting Company in Stuttgart, where acoustical photographs fulfilling all the above demands were made.

The apparatus, which is to be on the market by this summer, is termed the "Literaphone." The fundamental patents were granted to Oberregierungsrat Rammelsberg, of Wernigerode. But this gentleman sold his rights to a Stuttgart consortium, who again passed on the invention to the laboratories of the broadcasting company with the request to see if the invention were of any practical use.

Dr. Formis, of these laboratories, set to work some time ago and has produced the practical "Literaphone," which even now is ready for manufacture. The underlying principle is that instead of impressions

being made on a given record by cutting or grinding, the impressions are made by pressing.

## Diamond "Needle"

If we intend making a cast for gramophone records, which, of course, can easily be made with the Literaphone, then metal, copper, or zinc is used as the material for the record. The finished cast looks just like a gramophone record, only that the grooves have been made by a diamond pressing into the material. The sound impressions are, as it were, "hammered" into the material. This diamond hammer is nothing but a pick-up device operated the wrong way round and using a diamond instead of a needle.

The main use of the Literaphone, however, will probably be in the spoken communication which will take the place of the written one. For this purpose a material known under the name of Cellon is used. This is non-inflammable celluloid, something

like the material for cinematograph films. For shorter records up to five minutes or so, round discs of Cellon are used. These discs are placed on a rubber plate revolving at usual gramophone speed, then the diamond hammer is set on and you speak or play into the microphone.

## Electrical Reproduction

When the record is full you can immediately play it by means of an electrical pick-up and a loud speaker. The only difference from a gramophone record is that you use fibre needles instead of steel. These Cellon records can be played from sixty to seventy times on any gramophone using an electrical pick-up, amplifier and loud speaker. And there are very few people who will not be playing their gramophones electrically in future. You can even play the Literaphone record on a common or garden acoustical gramophone, but here the wear is greater, and the reproduction not so good.

The Literaphone record can be rolled up and sent by post, or, if it is small enough, laid flat in a letter and sent. The receiver then places it on his electric gramophone and there you are.

The recording apparatus requires a "Reisz" microphone and elaborate amplifiers if one wishes to record music, but for speech our usual telephone microphone or even the ear-piece of a good pair of headphones and a home-built amplifier is all that is necessary.

You always, of course, require a gramophone or its works, with a revolving disc and the special hammer. But this simple recording Literaphone for speech only will not cost more than a good radio receiver, and at least every business office will have one.

## RECORDING ON THE LITERAPHONE



On the left can be seen Dr. Formis examining one of the pliable records, while on the right another scientist is recording via the microphone.



# RADIO BALANCE and CONTROL

*This is not the simple matter one might imagine. On the contrary, as is pointed out by the author in this article, elaborate amplifier circuits have to be employed and many control knobs "twiddled" before the music and speech are "fit" for public reception.*

By **BAYNHAM HONRI**  
(late B.B.C. engineer)

**T**HE B.B.C. transmits a large variety of musical (and unmusical) sounds from its aerials: loud, soft, high, low, sudden and swelling. If I were a musician I might be able to impress you with the correct musical terms for these various phenomena. The soft, lispings voice of a lady giving a gardening talk has to be as loud and clear on Mr. Listener's receiver as the piercing notes of a cornet solo.

The great variation in the strength of the original sounds of these typical broadcasters make it necessary to vary the "sensitivity" of the micro-

phone. In actual practice, the microphone sensitivity is not varied at all; instead, the magnification of the amplifiers between microphone and broadcast transmitter is adjusted so that the radiated strengths are approximately the same. This is the fundamental principle of broadcast "control."

### **Overloading the Transmitter**

If the magnification of the amplifiers were set for full modulation of the lispings lady, the broadcast of a military band without alteration of "control" would result in the over-

loading of the transmitter, and violent distortion on Mr. Listener's loud speaker. The "capacity" of a transmitter is the maximum strength of signal its modulation valves can handle without running into *grid current*.

A loud signal may momentarily "swing" the potential of the modulation valves right over until the grids become more positive than their filaments, giving an opportunity for some of the electrons to take the wrong turning in their journey from filament to plate. This question of grid current is bound up with that of control, and is so important that I



Mr. Percy Pitt conducting one of the rehearsals of the Wireless Symphony Orchestra at Savoy Hill.

think I ought to use a simile in order to clear the air of any doubt and depression.

If you imagine the valve to be a water-pipe, with the water rushing from filament to plate, and the grid to be a rapidly opening-and-closing tap in the middle of the pipe, you have it. A huge negative potential completely closes the tap and prevents the

\*\*\*\*\*  
 \* The transmitter must be controlled so that sudden loud bursts of sound can never take place, and, therefore the loud passages have to be controlled in relation to the soft.  
 \*\*\*\*\*

flow of electrons. If the tap is too far open, some of the "water" will escape at the actual tap—and this escaping flow is the equivalent of grid current. The tap, by the way, will have to open and close about five thousand times a second when the flute and piccolo are shaking up the electrons!

**Effect of Grid Current**

When grid current flows on the transmitter modulator valves, distortion is heard at the receiving end as a result of a whole bagful of troubles. First of all, the condenser coupling the previous valve to that in which the "leakage" is occurring will charge up. This charge is superimposed on the modulation for a moment or so, and until it discharges through a grid-leak transmission will be "whiskery."

Secondly, the extra-loud modulation will probably cause similar currents to flow in the grids of the amplifying valves of Mr. Listener's receiver. If he is using transformer coupling,

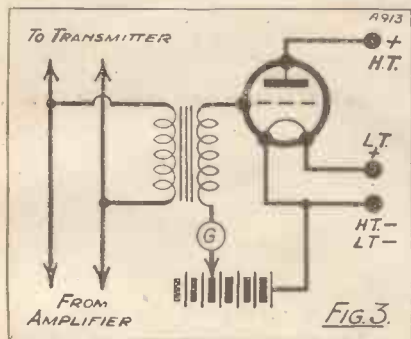

The "slide-back" galvanometer system devised by Capt. H. J. Round.

there will be an unwanted load on the transformer secondaries; if he is using resistance-capacity coupling, the coupling condensers may charge up in the same way as the one on the transmitter.

It is, therefore, quite obvious that over-modulation—and especially sudden over-modulation, must be avoided at all costs. That is the problem which confronts the broadcasting engineer. And his solution is to limit modulation of the transmitter to a certain percentage, giving a large margin of safety to take care of sudden bursts of sound.

**Loud and Soft Passages**

Referring to Fig. 2, he has to alter the relation of loud passages to soft, as represented by the line A to that represented by B. The controlling engineer remembers this as he turns the volume knobs of his amplifier. He is able to check his handiwork with an instrument which gives him a reading of the grid current at the transmitter. It does a little more than this, as a matter of fact; it gives him an *advance* reading of the galvanometer which registers grid current on the distant transmitter. This wonderful little instrument is called the "Slide Back."

The "slide back" is an ingenious invention of Capt. H. J. Round, and



Loud and soft sounds have to be balanced in relation to one another.

has been used by the B.B.C. for many years. The circuit, which is exceedingly simple, is shown in Fig. 3. A special transformer is connected across the line between the output of the control amplifier and the transmitter. The secondary of this transformer goes to the grid of a valve and to grid bias, via a galvanometer, and H.T. is applied direct on to the plate.

**How it is Done**

With a certain grid-bias adjustment, the galvanometer will flick at the same time as the grid galvo. in the transmitter modulation valve grid circuits. With a little less grid bias, the galvo. will flick when that on the transmitter is just not flicking. A common adjustment is to arrange that the slide-back galvo. shall flick five divisions when that on the transmitter is flicking only one, and for normal modulation of the transmitter the slide-back galvo. is not permitted to flick more than one division—with the transmitter, of course, registering nothing on its grid galvo.

Further check on control is obtained by means of an electro-static voltmeter across the main speech choke, the B.B.C. transmitters being of the "choke control" type. A

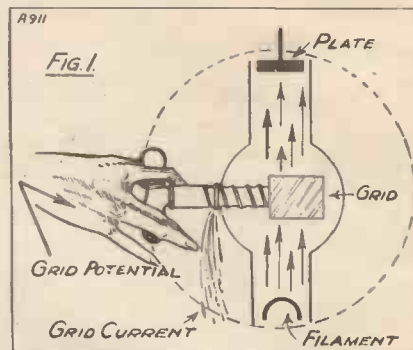

Showing how the grid controls the electron flow from filament to plate.

distant reading of this meter is obtained at a broadcasting station's control room by means of a specially calibrated measuring circuit attached to the "check receiver." Even if you don't quite follow all this, you should, at any rate, be convinced that the B.B.C. takes all kinds of precautions for the prevention of grid current, blasting and over-modulation of their amplifiers and transmitters.

**"Boomy" Announcers**

With a good quality receiver and loud speaker adjusted to give the best reproduction of the band, the announcer's voice may sound loud and boomy—quite unlike any human voice, and just as far from the "real thing" as it was years ago.

The reason for this is that the speech is "controlled" up until it is almost as loud as the band itself, as sent out from the transmitter. The announcer makes things worse by speaking confidentially into the microphone. When one speaks quietly, a considerable proportion of

\*\*\*\*\*  
 \* "The B.B.C. take all kinds of precautions for the prevention of grid current, blasting and over-modulation of their amplifiers and transmitters."  
 \*\*\*\*\*

sound is "radiated" from the chest in addition to that which comes from the mouth. When one speaks loudly, or shouts, these "chest tones" do not increase in strength to anything like the extent the "mouth tones" do.

"Chest tones" are low and boomy; test this for yourself by putting your ear to the chest of somebody who is talking. Consequently, a fully



# ALL READY



OUTSIDE VIEW OF PORTION OF WORKS



WINDING SHOP, OVER 100 GIRLS EMPLOYED IN THIS SHOP ALONE



A SECTION OF THE TESTING DEPT.



A CORNER OF THE MACHINE SHOP



ASSEMBLY SHOP



OUTSIDE VIEW OF PORTION OF WORKS

## for coming big radio developments

The Varley organisation—rich in radio experience and source of a score of well-known inventions—is on the threshold of big developments which will make the name VARLEY for ever famous in radio.

More than £10,000 has just recently been spent on the purchase of up-to-date plant and in enlarging our Factory in South-East London. The famous Bi-duplex winding, first invented by us some 30 years ago, has reached perfection, and this is only one of many spheres of Varley activity in which the valuable experience gained is being applied to the production of many other components. It is interesting to note that in 1922 the coils for many of the well-known L.F. Transformers of that day were Varley.

—And as in the past the new products of this Varley organisation will in a very few weeks' time be the admitted STANDARDS of efficiency and reliability throughout the length and breadth of the British Isles.



Advertisement of Oliver Pell Control Ltd., Kingsway House, 103 Kingsway, London, W.C.2. Telephone: Holborn 5303.

## Present System Not Good Enough

modulated version of a *sotto voce* results in false magnification of these low tones, and the introduction of "boom" to the loud reproduction of a soft voice.

### Two Remedies

There are two remedies for this boominess on speech. One is for the listener to cut down the volume of his set every time an announcement is made, and the other is for the B.B.C. to reduce considerably the modulation on announcements, particularly when they come between musical items. Another alternative would be for the announcers to speak loudly, as if they were addressing a meeting—a remedy which would probably be ruled out on artistic grounds!

There is yet another factor which has to be considered in this difficult matter of control. The bass notes of music modulate much more heavily than "middle" or treble. The drums, the double-bass and the pedal notes of an organ tend to flick over that slide-back meter needle even when modulation has been reduced.

### Low Notes

When a musical piece is being broadcast in which there are a lot of these very low frequencies, of the order of 50 and 100 cycles, the modulation has to be reduced to about half the "volume" which is normal for other broadcasts. Thus, a broadcasting station which consistently transmits good bass notes will make about half as much "noise" in the ether as a station of equal power that does not carry out this good work.

The "balancing" of an orchestra, the placing of the instrumentalists in relation to the microphone, is quite a problem in itself. Different types of headphones and loud speakers

sometimes give widely differing "versions" of the original balance of an orchestra in the broadcasting studio, some accentuating bass instruments and others favouring treble.

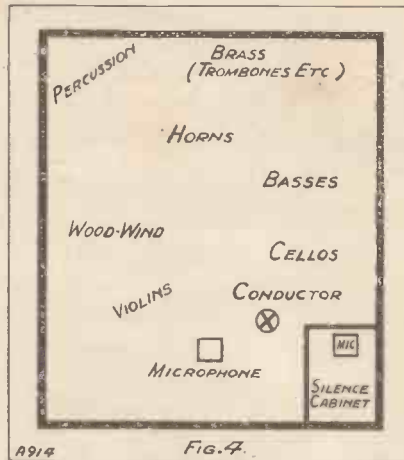

The positions of the various instruments in a broadcast orchestra.

The B.B.C. uses standard type moving-coil loud speakers or condenser 'phones for judging the main balance of an orchestra or band,

in Fig. 4. It will be noticed that the drums ("percussion"), the brass and the bass stringed instruments are kept well away from the microphone.

At one time the microphones were so insensitive to the bass that the stringed instruments, at any rate, had to be almost on top of it.

### The "Silence Cabinet"

The B.B.C. "silence cabinet" is one of the things that will be found written on my heart when I die!

I happened to be the "poor fish" called upon to design a silent switch-over, fool-proof in action (for the announcers' use, they added!), which would change over from the microphone in the studio to another in the silence cabinet.

I think I have indicated earlier in this article that the present system of control, good though it is in many ways, is not good enough. The general tendency is to magnify the weak passages too much so that the light and shade are "ironed out." The ideal gradation of control, shown in Fig. 2, is seldom achieved in actual practice.

The obvious suggestion is that an automatic control be used which will magnify the soft passages and cut down the loud, but at the same time retain a definite light and shade effect. Further, such a device should regulate things so that whisperings do not come out of the loud speaker at the same strength as a military band.

It would be extremely disconcerting for loud sounds to start with a burst and "die" with the

### BROADCASTING A BARCELONA BAND



An outside broadcast of a band at Barcelona. Note the two microphones hanging some feet above the musicians.

making slight variations if the result is unpleasing on ordinary 'phones or loud speakers. A rough idea of the placing of the instruments in the London Wireless Orchestra is given

rapidity of a punctured tyre. Several promising devices are already on the way to perfection, I understand, so that the troubles of balance and control may yet have a happy ending.



# IN PASSING

**H**EAR a plain tale! I have carved it for you, at the cost of many pints, from the gossip of the saloon bar of the Last Pot Inn, Great Turnipfold, Sussex. It's the greatest radio story in the world, though I get nothing extra for that, except the sense of having done my best for you.



Meet Harold Hickett, the Columbus of the 20th century.

World "talkie" rights are reserved to Chaplin, Lloyd and Fairbanks—but those gentlemen have not yet realised their colossal luck. I fear that I am like the poet's flower, born to blush unseen. However, I make up for that by wearing a big hat.

Without more ado, meet Harold; Harold Hickett, the Columbus of the 20th century, the obscure Sussex farmer who made space shrink, for all practical purposes, to the dimensions of an hotel dessert apple. You folk who get New Zealand with a hairpin and a leaky valve might as well put on black ties and go to your Band of Hope meeting for a nice game of rummy; for Harold Hickett is the only "ad" in radio.

## A Real Farmer

Harold was the tenant of Crabb's Farm, Great Turnipfold, called locally Nippold, and he was the farmerest farmer ever you saw. Everything you

imagine a farmer is, has and does, he was, had and did. He was a good bit of a sidesman at church, besides having ginger whiskers in a fringe round his map; and the back of his neck was coloured like a flower-pot and wrinkled like the old potato you find in the corner of the pantry behind the vinegar barrel.

Harold was ruined regularly each year, just as a proper farmer ought to be. He ate three square meat meals a day, used a red handkerchief which used to dangle from a sort of flapped pocket in his coat; the coat was of three-quarters length, and the pocket was a kind of side pocket which had shifted to the back. He slapped innocent horses and oxen resoundingly on their waistcoats, loved his ferrets as though they were eatable, and, as the landlord of the Last Pot expressed it, "That 'Arold cud tickle a pretty pig," meaning that his skill in that art was superlative. It is also to be understood that he subscribed to the dictum that "Roots ain't what they was."

## Lived a Simple Life

Harold lived a simple life, and never left the parish of Nippold, not even after he married that Gleeson woman to Uppet Seeddlings. "A right scold a was, her. Ay, and that jollopsome as you'd never— But I am lapsing in Turnipfoldery. That comes of living amongst them for a fortnight without a change of collars.

As I was saying, Harold's horizon was wholly Turnipfoldian. On the north a haystack, on the south the Last Pot, on the west a pig's home, and on the east fields stretching as far as Gubb's Coppice, where the Squire was found drunk in '93. A great year, that! Henery Seedums, aged 91, still

tells the story from between his two teeth, though strangers think he is whistling "Annie Laurie."

Here I am, writing a novel à la Sheila Kaye-Smith, instead of getting on with the grid leak and pentode stuff I'm paid for. But really, this simple life of Harold's is the key to the story. Because, for one thing, Harold went quite mad, and there may be some connection between that and living at Nippold with the Gleeson woman and "they pigs."

Don't imagine that Harold Hickett was a mere clod, please. He was very intelligent and weather-wise. He knew a wire-worm from a dewpond, as the saying is, and once explained rainbows to Henery Seedums. It took him six months, along of Henery's whistling. You see, every time Harold got to the part about light not being really white, but all manner of colours, and used the word "spectrum," Henery wanted to break him off to tell him about how he lost his spectacles in 1845. And then Harold used to get mad and say, "Dang ee," and the yarn was off till next Saturday.

## The Wonders of Wireless

When the wireless came to Nippold, and the Last Pot got a valve set and loud speaker, Harold used not to pay any attention to it because he took it for a gramophone worked by lack-tricity. He preferred to discuss the sins of cattle-dealers and the shortcomings of "roots." But one day he had occasion to visit the Squire, son of the roysterer of Gubb's Coppice, and there he heard that which started him on the downward path. Squire was very pleasant, gave him a strange drink and showed him a very fine four-valver. "Like to hear it?" he asked. You can't say no to a man over a small matter of no odds, specially

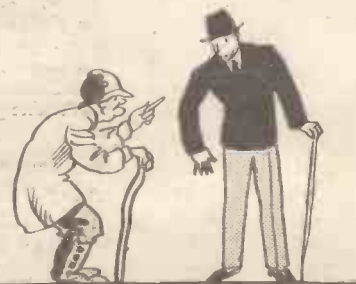

Henery Seedums, aged 91, still tells the story.

when you are drinking his liquor, with a cherry in it and all such fullishness, can ee? So Harold said, "Right well."

"That's what we call 'howling,'" quoth the Squire, busy with knobs.

## He Spent Four Months Listening for Mars

"Ar! tes they boys along of the school," replied Harold. The Squire tittered.

"Now this," he said, "is the Savoy Band."

"Reckon Jim Laws down to the Las' Pot has got his grammerfone tootlin' agin."

"No, no," persisted the Squire, "this is from London."

"Thik machine?"

"No, no! the music," said the Squire. "And this—" he turned two knobs, "this is—er—this is from Paris."

"Ar! Furrin! Ow'd it get 'ere?"

Here followed a brief lecture, during which Harold drank in the romance of radio like roots after a drought. The idea touched some chord in him which quivered and thrilled in his great simple soul, and he went home, drunk on something more potent than Jim Laws' ale.

### Harold's First Set

He cleared his attic, set up a work-bench and an aerial and cobbled together a crystal set, an unholy hotchpotch like a fishing-net struck by lightning. And when his hairy but keen ears heard the faint strains of 2 L O for the first time on his own set the virus of distance-getting



Harold's wife spoke a considerable piece.

entered and took possession of his mind. Roots came and went; his pigs pined for the touch of a vanished hand, and his wife railed as at the Sphinx. He was out after distance. Great Turnipfold no longer imprisoned his soul.

During the first year of his malady he worked steadily through the mill. He achieved the whole of Europe on the "Multum" Five; he conquered America with the "Columbus" Four, and roped in odds and ends like Nairobi with his own "Seedsman"

Six. Australia gave him a little relief—he got it with the "Down Under" Three—and his wife began to think that he would recover. And then the poor chap realised that he had got the globe just about harnessed and he began to think that he had been born on a deucedly miniature world. This notion so peeved him that he actually kicked Sylvia, the sow who once used to snork with pure joy whenever he leaned over the wall of her boudoir and called her "a dirty soshing girl."

### The World Too Small

Then, like a new doctor, came the news that radio signals can travel right round the world. This was like quinine to Harold. Straightway he produced his "Rounder" Six, and began to specialise. He would listen to nothing which had not been round once. Growing cunning—a bad sign—he learned to measure signal strength and knew at once whether a signal was trying to shirk the round trip. Once he followed "Ave Maria" (Schubert's) round the globe so many times that he became giddy and fell into a swoon. And on one memorable occasion he chased Handel's Largo in G so hotly that the thing declined into F and the band-conductor shot himself. But these are simply nothings.

After the merry-go-round craze died out, Harold grew mighty suspicious and began to read up geography, with the result that he became highly disgusted with a cosmogony of the order of 24,000 miles. There followed a period of doubt, during which he tried, without success, to convince the Royal Geographical Society that Earth has a diameter of 80,000,000 miles. They stuck to their old-fashioned notions and sent him home in a Daimler car, in company with a very kindly policeman who understood first-aid.

### A Message from Mars

When Harold left the nursing-home he heard of Mars. Reasoning from first principles he deduced that Mars would transmit on 23,962,384 (recurring) metres. Therefore he spent four months in listening for Mars, and as he heard only a choice selection of "atmospherics" he conceived the idea that we did not understand the

language of "atmospherics." Therefore he went into training, and by combining Egyptian hieroglyphics with tonic-sol-fa and shorthand evolved a new lingo. Then he waited for Mars again.

On January 18th, 1928, he got a message from Mars. Applying his



Heard the faint strains of 2 L O for the first time.

formula, and squaring the result, the message, as he read it, was as follows: "Beans isothermy Ard Patrick Dora making Casual De Lisle absolute cats."

This, of course, was most important, but clearly required confirmation from more remote sources. So poor Harold lit out for *Alpha Centauri*.

### The End of Harold

He announced, in January this year, that Alpha was a bit sticky, and that he proposed to stir her up a little. His idea was that if he set light to Great Turnipfold the conflagration would act much as the beacons did at the approach of the Spanish Armada. So he began with his haystacks. They lit beautifully and kept on burning without further encouragement. Harold's wife spoke a considerable piece at this juncture, but as Harold was apostrophising *Alpha Centauri*, clad only in a pair of dove-grey socks, he did not grasp the salient points of her oration.

Presently the pigstys caught the enthusiasm and burst into flame, much to the annoyance of Sylvia, who shortly afterwards became bacon. And then Hicket's Farmstead began to warm up, upon which the woman from Upper Scuddlings ran shrieking from the precincts and Harold was rid of her for ever. For Harold had received a message from *Alpha Centauri* and was dancing with joy when the roof of the house fell in and quietened him down.

Is your wireless  
reception  
clear and full  
of tone?



The  
**WINNER**

HIGH TENSION  
60 volts - - 7/-  
66 volts - - 7/6  
99 volts - - 11/6  
120 volts - - 14/-  
GRID BIAS  
9 volts - - 1/3

Satisfied users of  
**EVER READY** Regd

BRITAIN'S BEST BATTERIES

will assure you that their reception is perfect

TRY ONE AND TELL YOUR FRIENDS ABOUT IT!

**SCREENS** **PAREX** **COILS**

"M.W." PORTABLE F.V.E.  
Polished and mottled aluminium chassis drilled as specified (with screws) **9/6**

"AUTO-TUNE" ONE  
TITAN COIL **15/-**  
(as specified)

THE "TRAVELLER'S" TWO  
STANDARD LOADING COIL - - 7/6  
H.F. CHOKE BINOCULAR **6/6** SINGLE **3/6**

**E. PAROUSSI** 10, Featherstone Bldgs., High Holborn, W.C.1  
Phone: Chancery 7010.

A Ferranti  
at **17/6!**  
The **PROVED**  
TRANSFORMER  
Ideal for Portables

Type A F.4

**FERRANTI**  
FERRANTI LTD. HOLLINWOOD LANCASHIRE

THE **100% Broadcast Receiver**  
BUILD and OPERATE in ONE EVENING

FORMO  
*Screened 3 Grid*

BRITISH Components Throughout  
Send for Catalogue.

FAMOUS FORMO COMPONENTS as used in this Set and in ALL NOTABLE PUBLISHED CIRCUITS

TRANSFORMER-OUTPUT FILTER CHOKE **25/-**

"1928" LOG CONDENSER **5/-**  
'0005 '00035 '00025

"De Luxe" Model **6/-**  
'0005 '00035 '00025 '00015

COILS SG 1 & 2. **10/6** each

FORMO-DENSAR **2/-**  
In four variable capacities

VALVE HOLDER **1/3**

# AN EASILY MADE MILLIAMMETER

With a cheap compass, a small quantity of wire and a few pieces of wood you can make a meter that will measure currents over a range of about 1-50 milliamps—a most useful instrument for the radio enthusiast.

By J. E. WYNFIELD RHODES,  
B.Sc., M.I.Min.E., A.I.C.

MANY wireless amateurs would like to possess a milliammeter, and are unaware of the fact that quite a serviceable one can be made at home with very little trouble. The author has found that such an instrument can be made out of materials which are generally to hand, and, if not, are at any rate very inexpensive.

## Very Few Components

A piece of coil former (card will do, as ebonite is unnecessary for this purpose), 4 in. in diameter, a supply of wire (No. 28 is suitable, but the exact gauge is immaterial), a small magnetic compass such as is usually sold at from 1s. to 1s. 6d., two brass terminals, and a square foot of  $\frac{1}{4}$ -in. mahogany or satin walnut fretwork are all that we need.

A strip of the coil former about  $\frac{1}{2}$ -in. wide will be needed. Such a ring is easily cut off from the cardboard tubing of the wireless shops with a hacksaw. The compass should have its dial graduated in degrees instead of the conventional points of the compass.

## A Simple Coil

The instrument consists of a coil of insulated wire, No. 28 enamelled or No. 32 cotton-covered, wound on the 4-in. diameter former ring, having at its centre the compass needle so mounted that the centre of the needle is at the centre of the coil. The coil is most easily made if the experi-

menter has available a metallic former of the type having two rows of spokes.

Between these the cardboard ring is clamped, and as the turns are wound on the spokes effectively prevent them from slipping off. It will be gathered that the metal former, though convenient, is not really necessary. As 140 turns will

\*\*\*\*\*

\* **TABLE FOR CALIBRATING** \*  
\* **THE MILLIAMMETER** \*  
\* (140 turns on a 10 cm. former). \*

Reading in Degrees	Current in Milliamps
6	1
11	2
16 $\frac{1}{2}$	3
21 $\frac{1}{2}$	4
27	5
31	6
35	7
39	8
42	9
45	10
64	20
72	30
76	40
79	50

\*\*\*\*\*

be required, the coil will consist of several layers. These will not need any special method of winding as is usual in multi-layer tuning coils, because the instrument is used for direct and not high-frequency alternating currents.

## Keep Away from Iron

To construct the instrument four pieces of wood are cut to the sizes shown in the illustration. The coil is now placed on the long strip of wood and secured in place by means of a small strip of leather or card, and a few brass tacks or screws.

The side pieces and top are then glued in position and the ends of the coil brought to terminals bolted on to the side pieces. The little compass is

now mounted on the little platform so that the 0-deg. and 180-deg. marks are in the plane of the coil, and the 90-deg. and 270-deg. at right angles to it.

The compass may be fastened in position with cement or glue. No iron may be used in any part of the instrument, nor must it be used within two feet of any large iron object such as a pipe, gas stove, or electric fire.

## How it Works

The instrument is really a tangent galvanometer; that is to say, the current is proportional to the tangent of the angle of deflection when the instrument has been placed so that the needle is in the plane of the coil, i.e. on the 0- and 180-deg. marks, before the current is switched on.

The size of the compass needle is immaterial provided that it is not large compared with the coil. About one inch diameter is a suitable size, but there is no great error introduced if the needle is half as long again as this, and, of course, it will be then more easy to read its position accurately.

The current required to produce a given deflection varies directly as the diameter of the coil and inversely as the number of turns in it. It also depends on the strength of the earth's magnetic field, but this may be taken as constant.

## Scale of Readings

It varies to the extent of about 2 $\frac{1}{2}$  per cent with the locality, but for wireless purposes it is quite sufficient to know the current within 5 per cent of its true value.

If the coil is wound with 140 turns on a former 10 cm. (nearly 4 in.) in diameter, a deflection of 45 deg. corresponds to 10 milliamps, and the accompanying readings will indicate the currents set out in the table in column two.

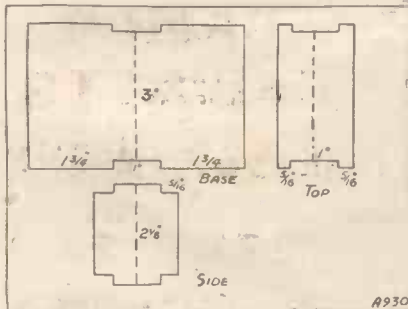

The dimensions of the four pieces of wood for the framework are given in this diagram.

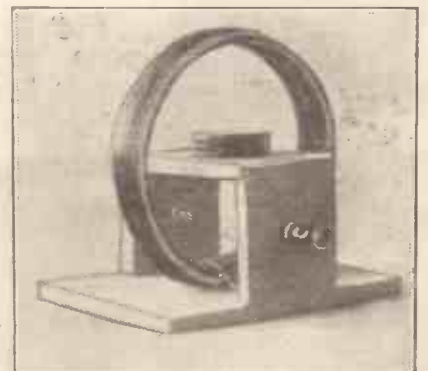

This photo shows you the remarkable simplicity of the instrument, which can be built in a very short time.

# How to increase selectivity!

**USE**

Greater selectivity and improved tone is the response of your receiver when you do it justice by fitting LEWCOS CENTRE TAPPED COILS.

The high standard of quality and skilled workmanship which are characteristics of all LEWCOS PRODUCTS is your guarantee of perfect service.

Leaflets, diagrams and full particulars will be sent free on request.

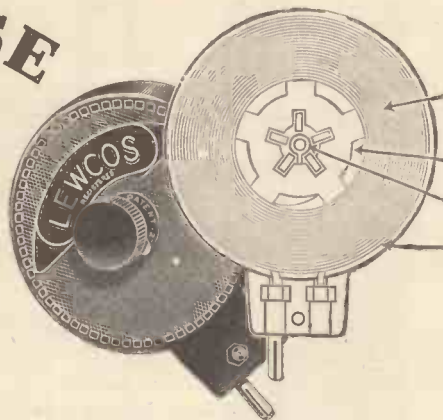

- 1 Maximum Inductance is ensured by close magnetic interlinkage between turns.
- 2 Minimum Self-capacity is ensured by scientifically spaced sectional windings.
- 3 Circuit Adaptability. Coils are interchangeable and you have an option of centre tapping.
- 4 Constant Magnetic Centre. All coils have the same external dimensions.

Patent 271,384

**LEWCOS**  
Regd.  
**CENTRE TAPPED COILS**

**The LONDON ELECTRIC WIRE COMPANY & SMITHS LIMITED**  
CHURCH RD., LEYTON, E.10

'Phone: Walthamstow 2531.  
'Grams: "LEWCOS, PHONE, LONDON."

Trade Counter and Cable Sales:

7 Playhouse Yard, Golden Lane, London, E.C.1

LEWCOS COILS are available for the **MULLARD S.G.P. MASTER 3.**  
235/550 metres. Ref. AM 5 10/-  
1000/2000 metres. Ref. AM 20 10/-  
Six Pin Bases. Ref. S.P.B. 2/9



Lewcos Radio Products For Better Reception!

## NOW ON SALE

Full constructional details of  
The "Radiano" Three  
and  
The "Concert" Four  
are obtainable in Envelope form in

**THE WIRELESS CONSTRUCTOR ENVELOPE SERIES, Price 1/6 ON SALE EVERYWHERE**

By post, 1/6, from Wireless Constructor Envelopes, The Amalgamated Press, Ltd., Bear Alley, Farringdon St., London, E.C.4

## FOR BEST RESULTS GOLSTONE "TITAN" COIL UNIT

Approved by POPULAR WIRELESS.

A super-efficient and High-grade Unit for "TITAN" Circuits. List No. T.C. 15. EACH 15/-

From all first-class Radio Stores. Refuse Substitutes. If any difficulty write direct.

Interesting Radio Catalogue FREE on request.

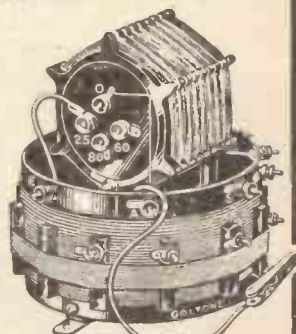

London Depot: 5 & 6, Eden St., Hampstead Rd., N.W.1  
Phone: Museum 4032/3.

**Ward & Goldstone**  
PENDLETON MANCHESTER

## The New W.B. VALVE HOLDER 5-PIN For A.C. Valves

The most scientifically designed 5-Pin Valve Holder on the market. Fitted with patent expanding leg sockets suitable either for resilient or solid valve legs. Already this new W.B. Valve Holder is in use in the laboratories of the leading Valve Manufacturers in this country.

Ask your Dealer to show you one to-day.

Price 1/6

**WHITELEY BONEHAM & CO., LTD.,**  
Nottingham Rd., Mansfield, Notts.

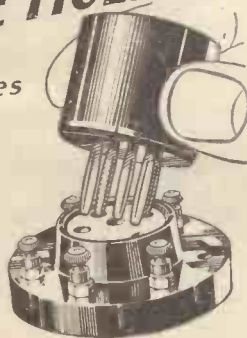

## CAMCO CABINETS

for the **MULLARD S.G.P. MASTER 3**

Latest List  
FREE on  
application to

OAK 22/- MAHOGANY 24/-

**DE LUXE CABINET**

OAK MAHOGANY  
49/- 55/-

Carrington Mfg. Co.,  
Ltd., Camco Works,  
Sanderstead Rd., South  
Croydon, Telephone:  
Croydon 0623.

## RADIO NOTES AND NEWS OF THE MONTH

A feature in which our Contributor brings to your notice some of the more interesting and important Radio news items.

Conducted by "G.B."

### Baird Beginnings

ACCORDING to the "Star," 4,000 television sets are now being manufactured by the Baird Television Company in preparation for the series of experimental broadcasts which may, with luck, begin in July, or, if not then, when the Potter's Bar regional station is complete.

### Percy Pitt's Post

The B.B.C. has come to the decision that its officials shall retire automatically at the age of 60. This is not, it is said, an implication that people of sixty are no good to the B.B.C., but it is just a red-tape rule which brings the B.B.C. into line with the similar red-tape rule existing in the Civil Service which insists on retirement at the age of 60. This probably accounts for the statement that Mr. Percy Pitt will retire at the

end of the year, for he will then be 60. As recently reported exclusively in "Popular Wireless," our contemporary, Mr. Percy Pitt's post will probably be taken by Dr. Adrian Boulton.

### Political Propaganda

The Soviet authorities, according to a message from Riga, have recently started a new propaganda wireless service in China from the station at Khabarovsk, which is situated on the Manchurian frontier. Any listeners who happened to pick up this station will probably have heard the propaganda broadcast, as the talks are usually sent out in Chinese, English and Korean.

### Radio in Russia

Reports suggest that quite a number of listeners in this country don't pay

enough attention to the Russian stations. These days you may hear many programmes from the U.S.S.R. which are well worth listening to. If any of our readers make a habit of picking up Russian broadcasts we shall be glad to hear from time to time any details as to wave-lengths, times of transmissions, etc., and general conditions.

### French Finance

France is going to institute state control of broadcasting stations in France other than those belonging to the Government. This new radio department will be under the Premier, and, according to the "Scotsman," users of crystal sets will pay a fee of 3s. 4d. a year, while 10s. will be charged to listeners in possession of valve sets. To-day there are about 800,000 listeners in France, of which 600,000, it is estimated, have crystal sets.

### Searching for Sites

Just before the Election the P.M.G. informed Mr. Day in the House of Commons that he had not yet received any report from the B.B.C. with reference to any increase in the building of high-power stations for the

(Continued on page 674.)

We specialise also in the "Kuttemout" Three, "Traveller's" Two, "Autotune" One and all apparatus described in MODERN WIRELESS and other publications.

### MAGNUM

### "TRANSPORTABLE" FIVE



Complete and ready for use - **18 Guineas.**

A really high-grade instrument.

Dutch representatives:

Messrs. A.B.C. RADIO,  
Singel 400,  
AMSTERDAM.

### BUILD THE

## "M.W." Portable Five

AS DESCRIBED IN THIS ISSUE.

	£	s.	d.
1 Special Portable Cabinet with Aerial Frame and Feet, as specified	2	5	0
1 Magnum Aluminium Chassis, as specified	10	0	0
5 Magnum Sprung Valve Holders	7	6	0
1 Ormond .0005 Var. Condenser	6	0	0
1 Ormond Slow Motion Drum Dial	5	0	0
1 On-and-Off Switch	1	6	0
1 Reaction Condenser, .00005, with bushes	5	0	0
1 Gambrell 500,000-ohm Volume Control, with bushes	6	9	0
2 Special H.F. Coupling Units, No. 1 and No. 2, as specified	1	1	0
1 Igranite Jack No. P.66	3	0	0
1 Igranite L.F. Transformer, Type J	17	6	0
2 Hydra Fixed Condensers, 2 mid.	7	0	0
2 Vertical Grid Leak Holders	2	0	0
2 Grid Leaks, .25 meg.	2	0	0
1 Magnum Fixed Condenser, .0003	1	6	0
1 Magnum Fixed Condenser, .001	1	6	0
1 T.C.O. Mica Condenser, .01	3	6	0
1 Ferranti Wire-Wound Resistance, 50,000 ohms, and Base	5	0	0
1 Dubilier H.F. Choke, No. 40	4	6	0
5 Clix Wandor Plugs (3 Black, 2 Red)	10	0	0
2 Clix L.T. Connectors (1 Black, 1 Red)	4	0	0
1 Squire Portable L.S. Frame, as described	18	6	0
1 Blue Spot Unit	1	5	0
1 Utility Miniature 4-Pole C.O. Switch	5	0	0
1 H.T. Battery, 99 Volts	16	6	0
1 Exide Accumulator, U.S.P.7	14	6	0
1 Grid Battery, 5-Volt	1	6	0
1 Quantity No. 20 T.O. Wire and 2 mm Systoflex	1	1	0
1 Quantity Single Red and Black Flex	2	0	0
1 lb. No. 24 B.C.C. Frame Aerial Wire	2	0	0
1 Sheet Gauze for fret	1	0	0
1 Sundry parts for Frame Aerial, as described	6	0	0
	<b>£12</b>	<b>9</b>	<b>0</b>

Any of the above parts supplied separately as required. Set of 5 Valves for the M.W.5 £2 14 6 The M.W.5, ready wired and tested, including Valves and Royalty £18 0 0

# BURNE-JONES & CO. LTD.

## MAGNUM HOUSE

Telephone: Hop 6257.

296, BOROUGH HIGH STREET, LONDON, S.E.1.

### MAGNUM

### "SUITCASE" FIVE



Complete and ready for use - **18 Guineas.**  
The ideal Portable for the motorist.

Magnum Products are on view and demonstrated at

Messrs. The Service Co., Ltd.,  
273/4, High Holborn,  
W.C.1.

Catalogue and lists on application.

**SAY**

**D**ON'T try to save money by buying unknown condensers. Experiment is costly. Say "T. C. C." and know you are getting utterly reliable condensers—because they are made by a firm that has made nothing but condensers for over 22 years. There is a T.C.C. Condenser for every purpose. This is the Upright Mica type. Capacities from .0001, 1/10 to .25, 18/-.

**T  
C  
C**



**WHENEVER  
YOU  
WANT**

**CONDENSERS!**

*Advt. Telegraph Condenser Co., Ltd., Wales Farm Rd., N. Acton, London, W.3.*

8712 

If you're going to build a set, don't forget the

**"BESTWAY" WIRELESS BOOKS**

*Two New Numbers for the Constructor have just been issued.*

**"BESTWAY" No. 328**

CONTAINS FULL DETAILS OF  
A Wave-Change One-Valver  
The "Bestway" Wave-Change Three  
A Two-Valve Amplifier  
The "Home-Circle" Four

**PRICE**

**6d.**

**EACH**

**"BESTWAY" No. 329**

CONTAINS FULL DETAILS OF  
A "Regional" Crystal Set  
An All-Wave Two-Valver  
A One-Valve Amplifier  
The S.G. and Pentode Three

**NOW ON SALE EVERYWHERE**

**RADIO NOTES AND NEWS OF THE MONTH**  
 —continued from page 672

purpose of providing alternative programmes in the northern and western sections of Great Britain. The Postmaster-General understood, however, that the B.B.C. was at present engaged in searching for suitable sites for those stations, but that it was not yet in a position to submit definite proposals for the Postmaster-General's approval.

**The London Symphony Orchestra**

It is announced that Mr. Albert Coates has been engaged to conduct the first concert in the autumn of the newly-constituted London Symphony Orchestra, which, as our readers know, is to become a permanent full-time orchestra. It is to be hoped that these new concerts will be broadcast. It is understood that the present B.B.C. Symphony Orchestra will be disbanded in the near future, and a small band of some fifteen players only retained.

**POPULAR WIRELESS**

is the

**LEADING RADIO WEEKLY**

Read by all discriminating radio enthusiasts, "P.W." keeps you informed of all the week-by-week developments worth watching.

All the leading set designers contribute to

**POPULAR WIRELESS**

Price 3d. Every Thursday

**The Master of Noises**

It is stated by the "Evening News" that Major Wright, the B.B.C.'s Master of Noises, is going to leave the B.B.C. to join his old chief, Mr. R.-E. Jeffrey, who recently left the B.B.C. to take up an appointment in connection with the talkies.

**Floods and Earthquakes**

Since Major Wright joined the B.B.C. in 1925, his task has been a heavy one. He has had to concoct all sorts of sounds, and some sounds which he has had to imitate include seagulls, earthquakes, floods, wind-mills, aeroplane crashes, trams, motor-cars, etc., etc. Major Wright does not give away the secrets of his imitations of sounds, because he thinks it would destroy realism if listeners knew how the trick was done.

**Keeping Daventry Dark**

Mr. Hannen Swaffer, who recently paid a visit to Germany, one evening had dinner in the Castle Wiesenberg. His hostess, the Princess Reuss, tuned in on a wireless set programmed from Frankfurt and Stuttgart and Hanover, and some other German stations. Suddenly she asked of Mr. Swaffer:

"Oh, where is Daventry? We

(Continued on page 676.)

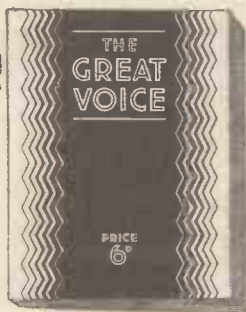

**MAGNAVOX**  
*The Originators of the Moving Coil Speaker*

The new and enlarged third edition of our Great Voice Booklet is now ready. It tells you all about electro dynamic speakers, pick-ups, amplifiers, and, in fact, everything you wish to know to enable you to obtain perfect radio or electrical phonograph reproduction. The "Great Voice" is packed full of useful diagrams and illustrations and should be in the hands of all enthusiastic amateurs, music lovers and managers of Theatres and Cinemas. Write for your copy to-day. Price 6d. post free.

THE

**ROTHERMEL CORPORATION**

LTD.

24, MADDOX ST., LONDON, W.1.

Phone: Mayfair 0578/9.

The Trade Mark on our components is your guarantee. All our components are the outcome of careful design, skilled labour and British made throughout. With this guarantee you are safe in using

**WEARITE COMPONENTS**

**"SUMMER TIME" FIVE**

LOW-WAVE COILS (3 to set) .. .. .	Each	13/9
HIGH-WAVE COILS (5 to set) Litz Wire .. .. .	"	18/9
BASES .. .. .	Per Set of 3	3/9

**FIVE-VALVE PORTABLE**

BATTERY SWITCH, G22, with terminals .. .. .	1/-
H.F. CHOKE .. .. .	6/6

**"AUTO-TUNE" ONE**

"TITAN" COIL .. .. .	15/-
WAVE-CHANGE SWITCH .. .. .	1/6

**DUAL-RANGE TUNER as USED IN FERRANTI CIRCUITS**

LOW-RANGE, 190-500 metres } .. .. .	15/-
HIGH-RANGE, 950-1900 " .. .. .	

WRITE FOR LISTS.

**WRIGHT & WEAIRE, LTD.,**  
 740, HIGH ROAD, TOTTENHAM, N.17.

Telephone: TOTTENHAM 3847-3848.



**WHAT  
WILL  
Brown  
DO ON  
JULY 1ST**

Watch the Wireless Shops for the answer—a range of Instruments which will upset all previous standards of Radio reproduction.

*Advt. S. G. Brown, Ltd., Western Avenue, N. Acton, W. 8662*

**12/6**  
Ratios  
5-1 or  
3-1



Entirely British.  
Standardised by all leading Set Manufacturers.

**“RADIOGRAND”**

**TELSEN**  
TRANSFORMERS

The recognised standard of Quality and Value throughout the Radio World.

**SOLD EVERYWHERE.**

Manufactured by  
THE TELSEN ELECTRIC CO., LTD.,  
Head Offices: Aston Rd., BIRMINGHAM.

Some prominent  
Portable Set Makers  
who use *Dubilier*  
Components . . . . .

- Aeonic Radio, Ltd.
- British Thomson-Houston Co., Ltd.
- Burgoyne Wireless, Ltd.
- Burndept Wireless (1928), Ltd.
- Celebritone, Ltd.
- Classic Radio, Ltd.
- Cliftophone & Records, Ltd.
- Gambrell Bros., Ltd.
- Halcyon Wireless Co., Ltd.
- Hart Collins, Ltd.
- Igranic Electric Co., Ltd.
- Langham Radio, Ltd.
- M.P.A. Wireless, Ltd.
- Rees-Mace Manufacturing Co., Ltd.
- Rialton Radio.
- R.I. & Varley, Ltd.
- The General Electric Co., Ltd.
- The Seraphone Co., Ltd.
- Triotone, Ltd.
- Truphonic Radio, Ltd.
- Whittingham, Smith & Co.
- Wingrove & Rogers, Ltd.

If unobtainable from your dealer, write direct to us giving his name and address

**“TOREADOR SCREEN-GRID FOUR”**  
This set incorporates the latest developments in Receiver design—full constructional details free on request.

**DUBILIER**  
RADIO PRODUCTS



Dubiler Condenser Co. (1925), Ltd., Ducon Works, Victoria Road, N. Acton, London, W.3. 253/6

**RADIO NOTES AND NEWS OF THE MONTH**  
 —continued from page 674

often wonder. And what does Daventry Experimental mean?"

"Princess," said Mr. Swaffer, "Daventry is a secret we keep even from ourselves. Sometimes, when we go near Rugby in a train, and we see wireless masts in the air, someone says, 'Oh, that's where the noises come from, is it?'"

According to Mr. Swaffer, Germany broadcasts the best music which we can pick up any night. And, according to him, for the credit of Great Britain he tried to lead the princess to think that Daventry was somewhere in Greenland.

**Behind the Scenes**

Although the B.B.C. engineers and the Baird Television Development Co.'s experts have recently been in conclave with a view to the planning of experimental television broadcasts, we understand on good authority, from an engineer who was present, that the best part of the time allotted for the discussion was taken up by Captain Eckersley telling in some

detail the experts present exactly what television could *not* do!

**A Sound Idea**

The B.B.C. has built a room at the Brixton experimental station for the sole purpose of measuring sound. This room is absolutely square, and has no windows or fireplace. Heavy felt and curtains of cotton waste drape the walls and ceiling. In fact, the room is dead in more senses than one.

**NEXT MONTH.**

The July issue of "M.W." will contain the first of a special and exclusive series of articles by

**SIR OLIVER LODGE, F.R.S.**

ORDER YOUR COPY NOW.

July issue :: Usual Price 1/-

**Wasted by Walls**

In an ordinary room, of course, 90 per cent of the sound is reflected by the walls; and, for example, when two people are talking to one another only 10 per cent of the sound the speaker is making travels direct to the listener, the other 90 per cent being reflected by the walls.

But in the new measuring room 90 per cent of any sound goes direct to the microphone, leaving only 10 per cent to be reflected by the walls. In this way the B.B.C. has been able to get accurate measurements of the volume of the various sounds.

**Vatican Radio**

It is understood that a Beam wireless station is to be erected in the new Vatican city, and that on great occasions the Pope himself will broadcast to the world. The Roman Catholic community is taking a great deal of interest in this new departure.

**Luxury Listening**

The Belgian Chamber has passed a measure for the foundation of a national broadcast institute. The Bill provides for annual licence fees of seven shillings for all kinds of receiving sets. An extra charge on valve sets will be made by adding a luxury tax to the cost of valves. The institute will be controlled by a council with a Minister of Posts as president, and transmissions will be made in French and Flemish on different wave-lengths.

(Continued on page 678.)



When your non-technical friends ask "Which is the best portable?"

**Recommend PYE**

Incomparable for appearance, performance—and reliability.

Very low H.T. current consumption.

Send a postcard for the new beautifully illustrated brochure "The Book of the Pye."

**PYE RADIO, LTD.,**  
 Paris House, (Dept. M.W.J.)  
 Oxford Circus,  
 London, W.1.



**PYE RADIO RECEIVERS**

**FOR PORTABLES**



The Squire Universal justifies its name! It has been accepted as the ideal portable speaker because although a "pocket edition" in size, its compactness has not led to any sacrifice in tone or volume.

The quality, finish and rigid construction are identical with the famous No. 97 and 99 models, and like them the Universal is supplied with a Croft Cone Kit made up and fitted.

Most units will fit it and it will fit all portables. Polished aluminium stand and set of four oxy-silver chains for suspension from ceiling can be supplied.

- The Squire "Universal" Cradle in girder section burnished and enamelled aluminium complete with Kraft Cone .. **18/6**
- Polished Aluminium Base for same **3/6**
- Set of 4 Oxy-Silver Chains .. **3/6**

**Fredk. SQUIRE,**

24, LESWIN ROAD, STOKE NEWINGTON, LONDON, N.16.



P & T

**THE CHANNEL TUNNEL-**



**May TAKE YOU  
TO THE CONTINENT**



**DARIO VALVES-**



**Will BRING THE CONTINENT  
TO YOU**



**VALVES**

A better Valve at a lower Price—Dario are the only valves at half-price which are **GUARANTEED LONG LIFE.**

Write for free Literature!

5/6 TWO VOLTS		FOUR VOLTS 7/6	
General Purpose, .05 amp. . . . .	0 6	General Purpose, .05 amp. . . . .	5/6
R.C.C., .06 amp. . . . .	5/6	R.C.C., .07 amp. . . . .	5/6
Super-Power, .12 amp. . . . .	7/6	Super-Power, .1 amp. . . . .	7/6
Super H.F. & R.C.C., .18 amp. . . . .	7/6	Super H.F. & R.C.C., .1 amp. . . . .	7/6
Pentodion, .3 amp. . . . .	21/-	Pentodion, .15 amp. . . . .	21/-

From your dealer or direct:

**IMPEX ELECTRICAL LTD.,**  
Dept. H, 538, High Road, Leytonstone,  
London, E.11.

**FOR THE  
PORTABLE  
FIVE**



**EXIDE UNSPILLABLE BATTERY**  
Type USP7  
2 volts. 18 amp. hrs. Price 14/6

Exide Unspillable Batteries are supplied as standard on practically all the leading portable sets on the market. And so the designers of the M.W. Portable Five have followed this great lead. They specify the Exide Unspillable Battery, Type USP7, and you would do well, if you would have absolute cleanliness and long trouble-free service, to follow this good advice to the letter.

**Exide**

**THE LONG LIFE BATTERY  
FOR WIRELESS**

Note the prices of Exide Trickle Chargers:

For H.T.—£3 . 7 . 6.

For H.T. and L.T. Combined—£5 . 0 . 0.

Obtainable from Exide Service Agents or any reputable dealer.

**EXIDE BATTERIES, CLIFTON JUNCTION, NR. MANCHESTER**  
London Sales & Service Depot: 215-229 Shaftesbury Avenue, W.C.2.

**RADIO NOTES AND NEWS OF THE MONTH**  
 —continued from page 676

**The Way the Money Goes!**

It is said that in the United States, where radio is in the hands of private enterprise, one particular concern spent a million pounds in a year on programmes. This compares rather curiously with the 1927 expenditure of the B.B.C., which was only £500,000. American listeners get their programmes for absolutely nothing, whereas listeners in this country provide the cash for everything connected with broadcasting.

**A Sensational Invention**

Again there has been a lot of publicity in connection with what, for example, the Newcastle Evening Chronicle calls a "sensational invention by Mr. Baird." According to this journal, the inventor now claims that one of his inventions will enable picture reproductions of actual events to be transmitted throughout the country by private wires, and relayed simultaneously to every cinema theatre in the land.

**Penalty of Progress?**

Mr. Baird is reported to have said that reproduction of actual events, like the marriage of a Prince, or the running of the Derby, could be transmitted to the Central Station and relayed from there to every theatre simultaneously. He says: "I have perfected an appliance for increasing the size of the image

so as to fill the largest screens in the cinemas. I am well aware that few people will believe me when I tell them this is possible. That, I suppose, is one of the penalties for being progressive."

**Those R's**

A Scotsman recently wrote to the "Daily Mail" giving voice to appreciation of what the B.B.C. has done for listeners, but stating that he becomes very irritated when announcers say: "Australia-r, Drama-r, Idea-r, India-r," etc., etc., as they frequently

Be sure to order your copy of "M.W." for

**NEXT MONTH**

In addition to a fine new series of articles by

**SIR OLIVER LODGE, F.R.S.,**

many special features have been arranged for the July number.

Every phase of radio is covered, and every article is reliable as well as readable.

**ORDER YOUR COPY NOW.**

do. The correspondent in the "Daily Mail" says that, being a Scot, he does not like: "Waw, Empiah, and Sir Samuel Hoa-ah, Ministah foh Ai-ah." In other words, he detests their final "r."

What about the Scot who persists in rolling his r's?

**Keston Goes West**

Listeners will be interested to know that the old B.B.C. experimental receiving station at Keston has now been scrapped. For some years it has been the centre of some of the

B.B.C.'s most important research work. Lately, however, the need for a more suitable site has been pronounced, and consequently another department for research work has been set up two or three miles away from Keston. The new station is at Tatsfield village, and the site is actually on Botley Hill.

**Communists and Broadcasting**

The B.B.C. had rather a strong letter from the Communist Party a little while ago. It seems that the Communists demanded that Sir John Reith should give them facilities for broadcasting similar to the facilities given to the Liberal-Conservative-Labour Parties.

The letter went on to state that the exclusion of the Communist Party from broadcasting means that the Board of the B.B.C. is "utilising funds provided in large measure by working-class taxpayers to convey only capitalist propaganda to wireless listeners. We protest against this open and arrogant class control of broadcasting, and demand that you should immediately review your decision and admit us to the same facilities as other Parties."

At the time of writing Sir John Reith's reply has not been made public.

Listeners noticed when Mr. Churchill was broadcasting that he spoke with a slight lisp. In the House of Commons, this is hardly noticeable, but before the "mike" those sibilant s's are accentuated, and were certainly accentuated when he broadcast recently.



**NEW "ROADSIDE" FOUR**  
DESIGNED BY MR. PERCY W. HARRIS.  
**A PORTABLE**  
**YOU WILL BE PROUD TO OWN**  
**Price £15'10'0 Complete**  
(Royalties Paid)  
**GUARANTEED TO STANDARD. TEST REPORT SUPPLIED.**

If you wish to build this set yourself, a complete kit of parts and all accessories can be supplied for £12 17s. 0d. Details in "Wireless Constructor" June, page 117.  
**IMMEDIATE DESPATCH**

Inland:—  
 All orders post free or by rail, carriage paid; crates 2/6, credited on return.

**A READY RADIO TITAN COIL UNIT**  
WAS USED IN THE ORIGINAL  
**AUTO-TUNE ONE**

PRICE  
**15/-**  
 Every Coil Guaranteed



Overseas:—  
 All orders carefully packed and insured. Charges forward.

**Ready Radio**  
**159, BOROUGH HIGH STREET, LONDON BRIDGE S.E.1.**  
(Telephone: Hop 5555 (Private Exchange). (Three minutes from London Bridge Station.)

**THE "KUTTEMOUT" THREE**  
 —continued from page 624

"motor-boat" or howl more easily than in our case, use a 10,000 or 20,000 resistance. In cases of unusual difficulty it is sometimes necessary to increase  $C_0$  to 4 mfd., but this is very exceptional. The rest of the L.F. circuit is quite normal, with the usual volume control of the high-resistance potentiometer type.

**Selectivity and Reaction**

Operating matters must be treated in some detail in the case of this set, since it is of a type quite new to our readers. Coil sizes we have already mentioned. The next point is the selectivity control by means of the coupling condenser  $C_5$ . This should be set at maximum for all general purposes, and only when very exceptionally high selectivity is needed will you require to reduce it to, say, half capacity.

The flex lead to the 6-pin coil base should be tried first on terminal No. 4, and will almost certainly prove best here. Next we come to the question of the adjustment of the reaction condenser  $C_6$ , and this is most important. There is only one right way to do it, and that is the one which follows; if you try any haphazard scheme you are liable to get into difficulties.

First set both reaction condensers to minimum, and both tuning condensers likewise. Now increase  $C_6$  gradually, and note when the set goes into oscillation. Then unscrew  $C_6$  until it just stops again, and lock up its clamping nut, for this is the correct setting. After this all operating adjustments of reaction can be made on the panel reaction condenser  $C_3$ . The next step is to adjust the voltage on H.T. +1 carefully to secure the smoothest possible reaction control, and when you are testing for smoothness remember to see that the two circuits are in tune. Probably somewhere about 40 volts will suit, but, of course, this depends on the detector valve.

**The Valves to Use**

Valves: For the detector, either an H.F. or R.C. type, the former being good for general work, but the latter giving slightly greater sensitivity for long-distance work. For the second valve, one of the "G.P." or "I.F." type, with an impedance of about

12,000 to 18,000 ohms is to be preferred, but the H.F. type (20,000 to 30,000 ohms) can be used. The former should be well biased to prevent a large anode current from passing through the transformer primary and upsetting its characteristics.

For the third valve you want something which can handle a good deal of power, for the set will produce really strong signals. With adequate H.T. supply available a super-power valve is very much to be desired, but remember that 120 volts at least is really essential to give such a valve a fair chance.

Just two final points. The volume of the local station is apt to be far too great for the valves in a circuit like this, so remember to detune the circuits (one up, and the other down) a little, as well as using the volume control.

The other point is this. The tuning of the two circuits is really sharp, so be prepared to spend just a little time getting the hang of the set. Once you have done so, we think you will be as delighted with it as we were.

**THE NEW ABBREVIATIONS**  
 By a Radio-Operator.

ONE result of the Radiotelegraphic Convention of Washington, is the re-shuffling and extension of the "Q" abbreviations used by all classes of radio operators.

Why it was considered necessary to change the meanings of the existing abbreviations is hard to understand, but the additions are welcome and help to make the exchange of commercial traffic even more efficient and "snappy" than it is at present. Anything which reduces the actual working in this respect is to be welcomed.

It is advisable, even necessary, for all amateurs who are handling a transmitter to make themselves familiar with these alterations made by the Convention and which are contained in the new edition of the Postmaster-General's Handbook for Wireless Operators. This is obtainable from any of H.M.'s Stationery Offices, at the moderate price of 6d.

The first alteration (in alphabetical order) is the abbreviation QRC? Originally, "What are your true bearings?" All queries and replies relating to bearings and such have

(Continued on page 680.)

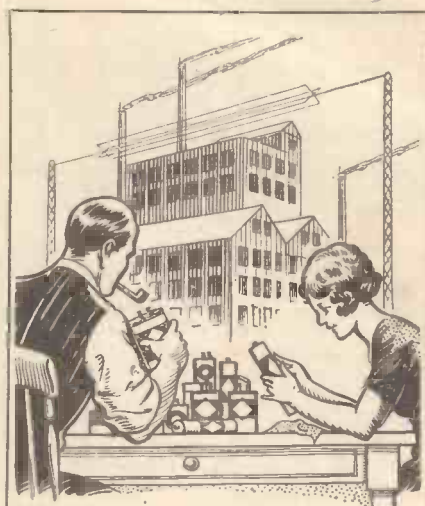

**Build a Business on your Kitchen Table!**

By the simple act of posting the Coupon below you can commence to "build a business on your Kitchen Table"! A Business that will provide a pleasant and interesting occupation for your spare time and anything up to £300 EXTRA a year for your pocket! So delightfully easy and simple is the work that even the children can help you!

**A BUSINESS THAT PAYS AND WILL PAY!**

The Business now opened to you is in the Wireless and Electrical Industry which, as you know, is going ahead by leaps and bounds. YOU can reap BIG PROFITS by manufacturing under our enormously successful Patents. Anybody can do it. No special knowledge or skill is required and no expensive "plant" or machinery is needed. The Kitchen can be your Factory and the Table your work-bench.

**WE GUARANTEE YOUR PROFITS!**

Anything up to £300 a year can be made—according to the amount of time you have to spare. Your profits are CERTAIN—WE GUARANTEE THEM and, if necessary, take the whole of your stock off your hands! The market can never be overcrowded, for only a limited number are licensed to manufacture!

**WE "BACK" YOU TO WIN!**

Become a Master Man! Take the first step now on the Road to Success by posting the Coupon below for FREE particulars of this HONEST, GENUINE AND BUSINESSLIKE PROPOSITION. The articles made are fully protected under Royal Letters Patent and we give you all instructions FREE! In all ways we back you to win, advise you and assist you. If you are an ambitious man and anxious to "get out of the rut," this is your opportunity! If you want to turn those leaden spare hours into GOLDEN interesting hours

SEND THIS "FIRST-STEP" COUPON.

**COUPON:**

To Mr. V. ENGLAND-RICHARDS,  
 The England-Richards Co., Ltd.,  
 1010, King's Lynn, Norfolk.

Sir,—Please send me at once, and FREE, full details as to how I can Make Money at Home in my spare time. I enclose 2d. stamp for postage.

Print your name and address boldly in capital letters on a plain sheet of paper and pin this Coupon to it. Modern Wireless, June, 1929.

# THERE MUST BE A REASON

Why the vast majority of the thousands who listen in prefer Celestion.

DESIGNED WITH MARKED DISTINCTION

# CELESTION

LOUD SPEAKERS

*The Very Soul of Music*

The only sure proof of our Statement is to hear Celestion yourself. You can do so without obligation at any good Wireless Dealer, or at our Showrooms. Models range from £5.10.0 in oak or mahogany. British throughout. Made under Licence.

The new Celestion Booklet is free and gives you briefly and interestingly all particulars. Mail the coupon below for your copy now!

CELESTION, LTD. (DEPT. H)  
KINGSTON - ON - THAMES.

Visit our Showrooms:  
**106, VICTORIA STREET,  
LONDON, S. W. 1**



Model C 12

WHEN A BETTER LOUD SPEAKER IS MADE—CELESTION WILL MAKE IT.

Please send me a copy of the New Celestion Booklet! Post to Celestion, Ltd. (Dept. H), Kingston-on-Thames.

NAME.....

ADDRESS.....

## THE NEW ABBREVIATIONS

—continued from page 679

been placed in the group QTE to QTN. QRC? now means, "What private enterprise (or Government administration) settles the accounts of your station?" The answer could be, of course, "QRC British Post Office," or, "QRC Alfred Holt, Ltd., Liverpool," or whatever particular organisation handles the accounts of the station making the reply.

### Question and Answer

It may be explained here, for the benefit of those who are not familiar with the use of these abbreviations, that when the abbreviation is followed by a note of interrogation it is understood to be a question and that the reply is prefixed by the abbreviation itself.

We now come to an addition, QRE? or, "What is the nationality of your

Another addition is QRI? "Is my note bad?" This question was originally conveyed by QSB? The answer to QRI? is in the affirmative, no provision being made in the abbreviations for the cheering information, "Your note is O.K." QRJ? (originally, "How many words have you to transmit?") now becomes, "Do you receive me badly. Are my signals weak?" The answer QRJ, is, "I cannot receive you, your signals are too weak." QRK has the opposite meaning to QRJ.

### Further Alterations

In the old code QRL? was "Are you receiving badly, shall I transmit 'V' 20 times for you to adjust your apparatus?" We now have QRL?—"Are you busy?" and QRV?—"Shall I send a series of V's?" QRV? was, originally, "Are you ready?"; "Are you busy?" was originally QRW? This now means, "Shall I inform... that you are calling him?" which under the old style was conveyed by QSP?

## Wireless Constructor Envelopes

are known everywhere as reliable and comprehensive guides to set builders.

- No. 1. THE "RADIANO" THREE
- No. 2. THE "CONCERT" FOUR

Obtainable at all Booksellers, price 1/6 each, or by post price 1/9, from Wireless Constructor Envelopes, The Amalgamated Press, Ltd., Bear Alley, Farringdon St., E.C.4

station?" The use for this abbreviation is obscure, for all stations, fixed or mobile, amateur or commercial, advertise their nationality by the letters comprising their call-signal. For example, "A" for German ships, "D" for German land stations and amateurs, "G" for British stations, "K" for American stations, and so on.

### Wave-length Queries

With the old code it was impossible to request information about the wave-length of your own station. QRH? meant, "What is the wave-length of your station?" Now we have QRG? "Will you tell me my exact wave-length in metres (or frequency in kilo-cycles)?" Originally QRG? asked; "To what company or line of navigation do you belong?" This has been washed out entirely.

It is interesting to note the adaptation of the frequency value of the wave as well as the older and more cumbersome metre measurement.

The question, "Are my signals weak?" (originally QRZ?) is now covered by QRJ? So QRZ? has taken the meaning, "Who was calling me?"; this was once QSQ? QSA? or, "Are my signals strong?" now becomes more definite with, "What is the strength of my signals (1 to 5)?" The old question as to quality of spark, QSB? is now used for "Do my signals vary?" The answer, QSB, is again in the affirmative.

QRC was originally somewhat of an insult, "Your spacing is bad." It now means, "Your signals disappear altogether at intervals."

### A Useful Addition

QSD, QSF, QSG and QSH have all been given new meanings, and QSE and QSI have been added to the happy band; QSI? being a useful one from the point of view of the operator, "Shall I send the telegrams in alternate order without repetition?"—an

(Continued on page 681.)

## The New Belling-Lee PLUG AND SOCKET

A new product by the famous firm whose terminals are known and used in every corner of the Globe. Both plug and socket are insulated—a unique feature, ensuring absolute safety in that it is impossible to touch metal parts. Further safety is ensured by the high and low voltage plugs being non-interchangeable to prevent the valves being burnt out. The loading device—both tray and copper—are gripped—is ahead of anything on the market. Both plug and socket are engraved—another unique feature—in fact it is the only really high class plug and socket obtainable to-day.

PRICE  
9d.

Ask for the new Belling-Lee insulated Wander Plug with the wonderful spring contact. Choice of 45 engravings.

1 Panel part in 3/6, each.  
A-Z portion 6/6 each.



Proc. Pat.

# BELLING-LEE

Advt. of Belling and Lee, Ltd., Queensway Works, Ponders End, Middlesex.

## THE NEW ABBREVIATIONS

— continued from page 680

abbreviation which saves a whole lot of superfluous working.

QSK? (originally, "Is the last radiotelegram cancelled?") is now, "Shall I suspend traffic?" while the cancellation is taken care of by QTA. QSL remains the same, "Can you give me acknowledgment of receipt?" but QSM? has been made supplementary to it with "Have you received my acknowledgment of receipt?" The original meaning of QSM? was "What is your true course?"—now QTI.

### A Bright Idea

The question, "Are you in communication with land?" (originally attached to QSN?) has been removed to make room for "Can you receive me now? Shall I remain on watch?"

QSP? (left vacant when its meaning moved to QRW?) now means "Will you retransmit to — free of charge?"—another abbreviation of real service to the operator. QSQ? (originally "Am I being called by —?"—the question now covered by QRZ?) now becomes "Shall I send each word or group once only?"

We now come to the brightest idea of the whole lot, the inclusion of the question, "Has the distress call been cleared?" This is taken care of by QSR?. The use of this abbreviation will reduce the chance of a call from a distressed vessel being missed through interference (QRM) from ships anxious to clear traffic and yet not sure that the SOS has been cleared.

### Four Wave Types

QSU was, under the old regulations, "Will call you later." It now becomes, "Shall I send on — metres or — kilo-cycles, using waves of type A1, A2, A3, or B?"

The inclusion of four different types of emissions is new, and demonstrates the extent of progress made in radiotelegraphy since the formulation of the original regulations in 1912.

According to the Handbook the waves are classified as follows:

Type A1—Unmodulated continuous waves, key controlled (C.W.).

Type A2—Continuous waves, modulated at audible frequency, key controlled (I.C.W.).

Type A3—Continuous waves, modulated by speech or music (telephony).

Type B—Damped waves (spark).

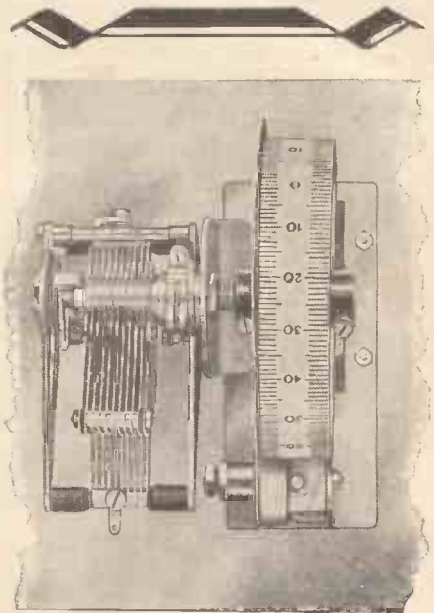

Illustration shows one of the two J.B. Condensers specified for the Mullard S.G.P. Master Three

# MULLARD SPECIFIES TWO NEW



# CONDENSERS for the S.G.P. MASTER THREE

Completely assembled, as illustrated, ready for fixing to panel in a few moments.

40/-  
THE PAIR

Advt. of JACKSON BROS., 72, St. Thomas' Street, London, S.E.1. Telephone: HO 1837



A  
Bureau  
for  
Your  
Wireless!

### ADAPTABLE TO ALL SETS!

Nothing to touch! The snug way those untidy, dusty parts, trailing wires and batteries are compactly enclosed will delight you. As a beautiful piece of furniture, the "RADIOLA" will add pride to the home because it is modern and stylish. Already over 3,000 delighted users. Highly recommended by the Radio Press and leading experts. "Radiola" de luxe, from £5.15 to £11.11. "Popular" Oak Model, from £3.15.

Cash or Easy Payments.

A stately British-made Cabinet, trade-marked and guaranteed, sent on APPROVAL (if you wish to part with it we will willingly refund FULL MONEY and pay return carriage too!)

Full particulars, booklet and Photographs FREE (they will interest you!) from the actual makers: **PICKETT'S, WIRELESS FURNITURE MAKERS,**

"M.W." WORKS, BEXLEY HEATH, KENT. Established since the beginning of Broadcasting.

For the Best in Radio

# WILL-DAY LTD

(THE BEST IN THE WEST)  
19 LISSE STREET, LEICESTER SQUARE, LONDON, W.C.2  
Telephone: 2400 (Night) 1091 and 0591. Telegrams: Willday, London  
OPEN TILL 7 P.M.  
WRITE FOR OUR CATALOGUE  
POSTAGE 6d. FREE TO CALLERS

Make  
**The DAILY SKETCH**  
YOUR Picture Paper

PLEASE MENTION "MODERN WIRELESS" WHEN REPLYING TO ADVERTISEMENTS

**Instantly Adaptable to work from the Mains or its own Internal Batteries.**

To convert the **TRIX** Portable Five to work from H.T. Eliminator, merely push in a plug which automatically disconnects the internal battery. That saves the batteries for outdoor occasions! In Walnut or Mahogany, 17 gns. Solid Leather Case model, 18 gns.  
Ask your dealer for full details, or write to the manufacturers.

**TRIX**  
**5 Valve PORTABLE**

Eric J. Lever (Trix) Ltd.,  
8/9, Clerkenwell Green, London, E.C.1.  
Phone: Clerkenwell 3014/5.



**17**  
**GNS.**

PLUS  
NEW  
ROYAL  
TIES.

The Picture Paper with the MOST News

**: SUNDAY GRAPHIC ::**

**FOR THE MULLARD S.G.P. MASTER 3**



*They're Specified Again!*

Type B  
td. each.

**BELLING-LEE**  
TERMINALS

BELLING & LEE, LTD., Queensway Works,  
Ponders End, Mdx.

**Advertisements**

As far as possible all advertisements appearing in "Modern Wireless" are subject to careful scrutiny before publication, but should any reader experience delay or difficulty in getting orders fulfilled, or should the goods supplied not be as advertised, information should be sent to the Advertisement Manager, "Modern Wireless," 4, Ludgate Circus, London, E.C.4.

**RADIO ABROAD**  
*—continued from page 652*

At this Conference, which ended on Saturday, April 13th, the agreement of various European Governments was obtained to a broadcast wave-length plan. This is known officially as the Prague Plan, and it follows upon the decisions at the previous Washington Convention. According to the latter, broadcast wave-lengths may be dealt with only by Government action.

**Vienna Concerts**

Short-wave experimenters will be interested to know that Vienna short-waves transmitter tests every Tuesday and Thursday on a wave-length of 49.4 metres. By the time these Notes are in print this experimental programme will probably have been extended to include also Wednesdays and Saturdays.

A scheme was arranged for the simultaneous broadcast of the Vienna evening concerts with Rosenhugel and the new short-wave station, but owing to the proximity of the high-power transmitter this scheme has so far proved impracticable.

**B.B.C. FINANCE**  
*—continued from page 654*

the B.B.C.'s leading experts have recently resigned to take up other positions, one wonders whether some of the huge income earned by the B.B.C. should not be more appropriately disbursed in the form of adequate salaries.

It is very disconcerting to find such men as Mr. Rex Palmer, Mr. Cecil Lewis, Mr. R. E. Jeffrey, and other popular and pioneer members of the B.B.C., leaving to take up more remunerative positions with talkies or with the gramophone companies. If the B.B.C. wishes to retain talent in the world to grumble at men such as we have mentioned receiving good salaries.

There has always been the criticism, and probably very well justified, that the B.B.C. is, to put it bluntly, a little stingy not only as regards salaries, but as regards payment to some of its artists. It is no good spending thousands and thousands of pounds on improving technical

developments if the quality of programmes is going to fall because the best people cannot and will not accept engagements with the B.B.C. on unsatisfactory terms. No doubt the B.B.C. believes in the old saying that no man is indispensable, but in the entertainment industry—and, after all the B.B.C. is essentially an entertainment industry—popularity in association with a well-known name is an essential ingredient of success.

No well-known music hall manager would dream of putting on an ordinary variety show by completely unknown people. Shakespeare says: "What's in a name?"—but, from the B.B.C.'s point of view, there's a good deal in a name, especially when it is backed up by ability, personality and tremendous popularity.

**A Veil of Mystery**

The loss of Mr. Palmer, for instance, is really a severe blow which the B.B.C. don't seem to appreciate. But if the leakage goes on, and more and more people leave Savoy Hill to take up positions elsewhere, it will certainly be time to make a thorough investigation into the methods in practise at Savoy Hill. A complete veil of mystery surrounds some of the financial aspects of broadcasting in this country.

We know Sir John Reith's salary, and we know the salaries earned by the Board of Governors, but if the B.B.C. is a Civil Service Department, which it claims to be, then it should publish the salaries of its leading members and let the public know how the public's money is being expended.

**WHAT READERS THINK**  
*—continued from page 616*

attached a connection for an outside aerial, passing through a .0001 fixed condenser, the earth being connected with the moving plates of the tuning condenser.

At 17 miles from 2 L O the set now works excellently as a portable. With an indoor aerial round a small room in a hotel (and also with a shilling spring aerial), with earth attached to radiator, 2 L O and 5 G B come in perfectly, and once a German station came through with considerable strength.

These results strike me as wonderful with an anode battery of 9 volts only.

I am,

Yours faithfully,

Caterham, Surrey. P. J. Rust.





**TREBLE DUTY TERMINALS**

are different and better. 40 indicating tops to the Terminal can be obtained, all different wording and six coloured tops for any special uses. The names will not rub off. The ideal "safety" system of connections. Hold securely spade, plug, pin, eye or just plain wires. (TZLC), 4½d. each. With plain top (TZLN), 3d. each.

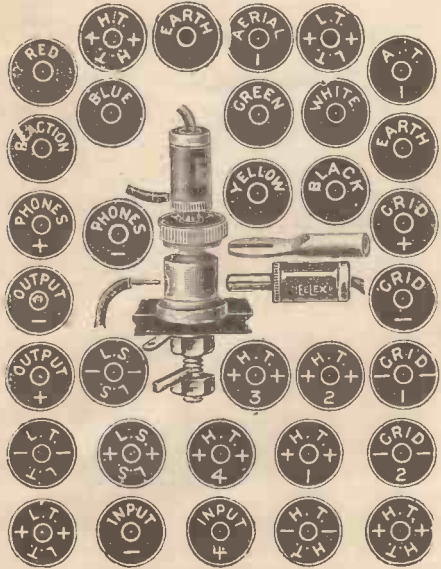

Write for Free Booklet S.69.

**J. J. EASTICK & SONS**  
Elex House, Bunhill Row, Chiswell Street, London, E.C.1. Phone: Clerkenwell 9282-3-4.

**WIRELESS MASTER PATENTS**  
A Report on the Marconi Appeal.  
BY OUR LEGAL CORRESPONDENT

THE Marconi Company have now appealed against the recent decision of the Comptroller of Patents reducing their scale of royalties from 12s. 6d. per valve holder to a minimum charge of 5s. on the first valve holder and 2s. 6d. on each additional valve.

The original decision was given in favour of the Brownie Wireless Company.

The appeal was heard in the Chancery Division of the High Court by Mr. Justice Luxmore, who, at the conclusion of the Proceedings, reserved judgment. In view of the wide interest attaching to the case the following summary is given of the arguments advanced by the various parties.

**A Unique Case**

Sir Duncan Kerly, K.C., Counsel for the Marconi Company, stated that the appeal involved points of the utmost importance to patent law and practice as it existed to-day. It was the first case of its kind to come before the Courts.

The Brownie Company had lately put on the market a two-valve amplifier which, when used with a crystal detector, did not infringe the Marconi Patents, but which, if used in combination with a valve detector or receiver might be an infringement of those patents.

The Marconi Co. had licensed some 2,200 manufacturers. There were also many private people who made their own sets. They were called home constructors, and it was complained that the Marconi Royalties were too high, with the result that the home constructor built up his own set, using the Marconi patents, but did not, because he was not able, pay any royalties.

**Marconi Licence Refused**

The Brownie Company applied for a license to the Marconi Company and were told that they could have one on the usual terms. They refused because, they said, the royalties were too high. Not a single other licensee had come forward to say that the licence was so unreasonable that they could not carry on their trade at a profit.

(Continued on page 684.)

**WORTH THEIR WEIGHT IN GOLD**

**HEAYBERD Power TRANSFORMERS**

Over 50 types available from stock for all methods of rectification.

The following for H.T. Eliminators—

200v 20ma, 4v 12/6	500v 100ma, 5v 32/6
400v 20ma, 4v 17/6	440v 120ma, 7.5v 32/6
300v 20ma, 5v 17/6	750v 60ma, 5v 40.-
440v 30ma, 4v 20/-	800v 120ma, 8v 55.-
400v 50ma, 5v 25/-	1000v 120ma, 8v 60.-
500v 50ma, 5v 28/-	2000v 120ma, — 85.-
440v 30ma, 4v and 4 volts 5 amps 28/6	

The following for Westinghouse Rectifiers—

230v 160ma 17/6	12v 1.5 amps 15/-
8.5v 1.5 amps 12/6	12v 3.2 amps 20.-
230 v 160ma, 12v 1.5 amps 45v 10ma 32/6	

The following for A.C. Valves, etc.—

4 volts 3 amps 8/4	2 volts 3.5 amps 10.-
4 volts 5 amps 12/6	7.5 volts 3 amps 12/6
5 volts 3 amps 12/6	6 volts 3.5 amps 12/6

The following Power Chokes—

50 henrys 25ma 12/6	50 henrys 100ma 20/-
100 .. 25ma 17/6 100 .. 100ma 25/-	
30 .. 50ma 12/6 17 .. 100ma 5/-	

Details with diagrams free on request.

**F. CHEYBERD & CO**  
10, FINSBURY ST EC2  
One Minute From Moorgate Station.

**BULGIN RADIO PRODUCTS**

FREE ON APPLICATION  
This 56 pp. Catalogue and Reference Book

Illustrating Hundreds of Original Components & Gadgets of the Highest Class.

**A. F. BULGIN & Co.**  
9, 10, 11, Cursitor St., Chancery Lane, London, E.C.4

**CLIX PLUGS & SOCKETS**

CLIX Parallel Plugs and Sockets constitute a perfect combination. The plug with its patented resilient principle fits into the socket easily yet firmly, while the method of wiring gives a positive grip and perfect connection with no risks of shorts.

Specified for "M.W." S.G. Unit in May Issue.

**CLIX PARALLEL PLUG.**  
2d.

**PARALLEL SOCKETS.**  
1d. and 1½d.

Write for the Cliz Catalogue  
**LECTRO LINX, LTD.,**  
254, Vauxhall Bridge Road, S.W.1.

PLEASE MENTION "MODERN WIRELESS" WHEN REPLYING TO ADVERTISEMENTS



**THE WORLD'S BEST STORIES**

Appear in the ARGOSY

An Argosy is always a good story. The policy of this brilliant magazine is to print only those stories which are indisputably great, and written by the acknowledged master writers of the past and the present day. Read it regularly.

*The* **ARGOSY** MAGAZINE

On Sale Everywhere, 1/-

**WIRELESS MASTER PATENTS**

—continued from page 683—

But one Company who wanted to compete with the existing 2,200 licencees hoped to do so successfully with a cheaper set. For this reason it was claimed that the terms of the licence were unreasonable. It was really a most extraordinary and even Gilbertian situation.

The decision of the Comptroller of Patents was largely based on two assumptions.

These were, first, that if a licence were granted at a low rate of royalty, this would ensure the sale of an enormous number of sets, and so reach a class of listeners who were now deprived of such sets because they could not afford them owing to the royalty charges.

**Question of Public Policy**

The second assumption was that the new cheaper sets would be bought by people who did not now buy at all, on which royalties had been paid, but, instead, made up their own sets at home from component parts; if they bought manufactured sets they would no longer infringe the Marconi patent rights.

No evidence had been brought forward in support of either of these assumptions.

The Comptroller held the Marconi Company to be super-monopolists, and said that "such an arbitrary exercise of monopoly rights seems contrary to public policy." That conclusion could not be upheld. One might conclude that there should be no royalty at all, that the patents should be put an end to, and the foreigner let in with his cheaper sets.

In his (Counsel's) opinion, there was no reason in law why a patentee should not select whom he pleased, but the Marconi Company had not done that. They had never yet refused a licence to any solid applicant.

There was no evidence whatever that if the royalty scale was reduced the price of receiving sets would fall to a more attractive figure. The retailers profit had been said to be 50 per cent. If there were a large number of persons who would not pay £7 5s. for a set, why did not the

The tendency of Parliament was to fetter more and more the power of the patentee.

Broadcasting had become a public service of vital national importance. Its educational value was such that it should be available to the poorest classes of the community at the earliest moment.

**Judgment Reserved**

The Brownie Company were in a position to supply receiving sets at such a price as would reach a vast new section of the public, who had never before been catered for. According to the avowed policy of the Government they desired all sections of the community to enjoy the advantages of the Broadcast service.

Continuing, Counsel said that the Comptroller has done his best in very difficult circumstances. If there was a manufacturer who was prepared, if granted a licence on reduced terms, to satisfy a large body of listeners with a two-valve set at 50s. it was obviously in the public interest that he should be put in a position to do so.

Sir Thomas Inskip (Attorney General), said that he appeared simply in order to help the Court so far as he could at the point of view of the public and to give whatever assistance he could on the interpretation of a somewhat difficult section of the Patents.

It had been clearly laid down by Parliament that the grant of Letters Patent was to enable ingenious inventors to make enormous profits at the expense of the public. The inventor was to use his monopoly rights on reasonable terms so as to enable as many as possible of the public to enjoy the advantages of his invention.

As previously stated, his Lordship reserved his final judgment on the Appeal.

**KEEP IN TUNE**

WITH RADIO WEEK BY WEEK.

- Get good how-to-make articles
- Get dependable designs
- Get red-hot news
- Get hints and tips
- Get busy

**GET POPULAR WIRELESS**

Every Thursday 10 Pence

manufacturers in the business reduce some of their profits in order to attract this enormous number of imaginary customers?

**Of National Importance**

Mr. Morison, K.C., Counsel for the Brownie Company, said the present appeal was important simply because it affected a large body of traders, and an industry which had grown up to be of national importance. The trade was struggling at the moment with difficult circumstances.

**INDEX TO ADVERTISERS**

Argosy Magazine	Page 683
Belling & Lee, Ltd.	681 & 682
"Best Way" Wireless Books	673
Bowyer-Lowe Co., Ltd.	659
British Thomson-Houston Co., Ltd.	651
Brown S. G., Ltd.	675
Bulgín A. F. & Co.	683
Burne-Jones & Co., Ltd.	672
Carrington Manfg. Co.	671
Celestion, Ltd.	680
Chloride Elec. Storage Co., Ltd.	677
Cossor, A. C., Ltd.	582
Day, Will, Ltd.	681
Dubilier Condenser Co., Ltd. (1925)	675

Eastick, J. J. & Sons	Page 683
England-Richards Co., Ltd.	679
Ever Ready Batteries	669
Ferranti, Ltd.	669
Formo Company, The	669
Garnett, Whiteley & Co., Ltd.	653
Hayberd F. C., & Co.	683
Hughes F. A., & Co., Ltd.	661
Igranic Electric Co., Ltd.	657
Impex Electrical, Ltd.	677
Jackson Bros.	681
Lectro Linx, Ltd.	683
Lever, Eric J.	682
Lissen, Ltd.	641
Londón Elec. Wire Co. & Smith's, Ltd.	671
Marconiphone Co., Ltd.	581
Metro-Vick Supplies	Cover iii
Mullard Wireless Service Co., Ltd.	Cover ii

Oliver Pell Control, Ltd.	Page 665
Paroussi, E.	669
Pickett's Cabinet Works	681
Pye Radio, Ltd.	676
Radio Instruments, Ltd.	Cover iv
Ready Radio Supply Co.	678
Rothermel Corpn., Ltd.	674
Squire, Fredk.	674
Telegraph Condenser Co., Ltd.	673
Telsen Electric Co., Ltd.	675
Ward & Goldstone, Ltd.	671
Whiteley Boneham & Co., Ltd.	671
Wireless Constructor Envelopes	671
Wright & Weaire, Ltd.	674

All communications concerning advertising in "Modern Wireless" must be made to John H. Lile, Ltd., 4, Ludgate Circus, London, E.C.4. Telephone: City 7261.

# THE WONDER VALVE IS HERE!

## Met-Vick AC/S Valves (Screened Grid) now available

This Valve with its independently heated filament has four times the amplification of any other valve. It is the valve all Constructors have been waiting for. Just think, amplification factor 1200, impedance 800,000!

Screening is so effective that even with 2 stages of H.F. there is no sign of reaction through the valves nor a trace of "mush." Far and away ahead of any other H.F. Valves on the market, leading Set Makers are standardising them for the coming season.

**YOUR DEALER CAN NOW SUPPLY**

# MET-VICK SCREENED GRID VALVES

For Mains Operation  
**AC/S 25/-**



Send for  
**CIRCUIT  
DIAGRAM  
(FREE)**  
which enables  
you to take  
the fullest ad-  
vantage of the  
remarkable  
characteristics  
of this valve.

**METRO-VICK SUPPLIES**

(Proprietors: Associated Electrical Industries Limited), Metro-Vick House, 155, Charing Cross Road, LONDON, W.C.2

# And the Greatest of these is THE **HYPERMU** L.F. INTERVALVE TRANSFORMER

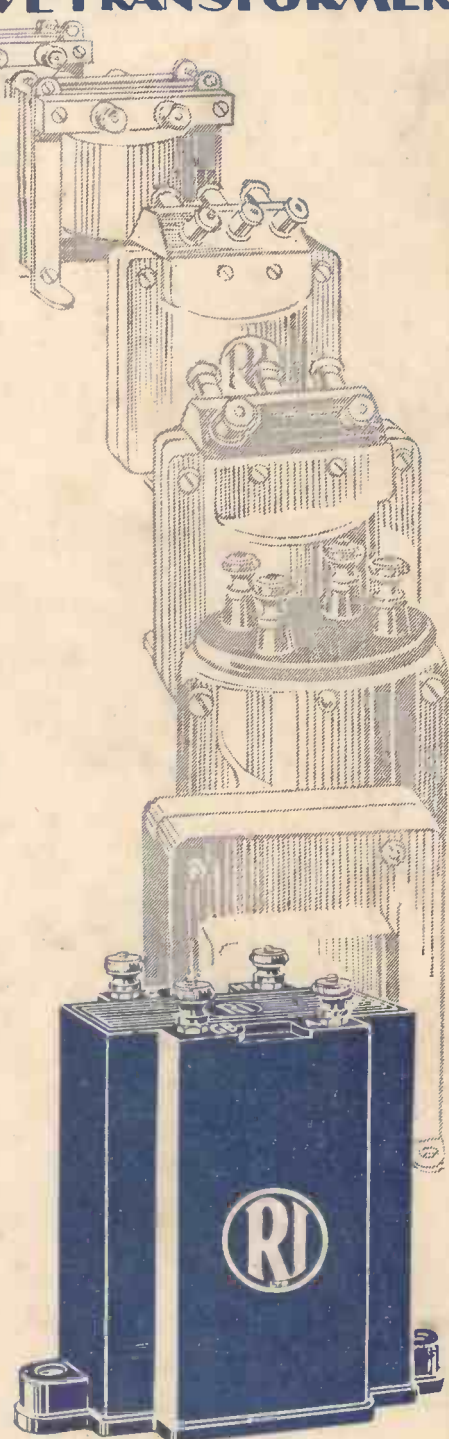
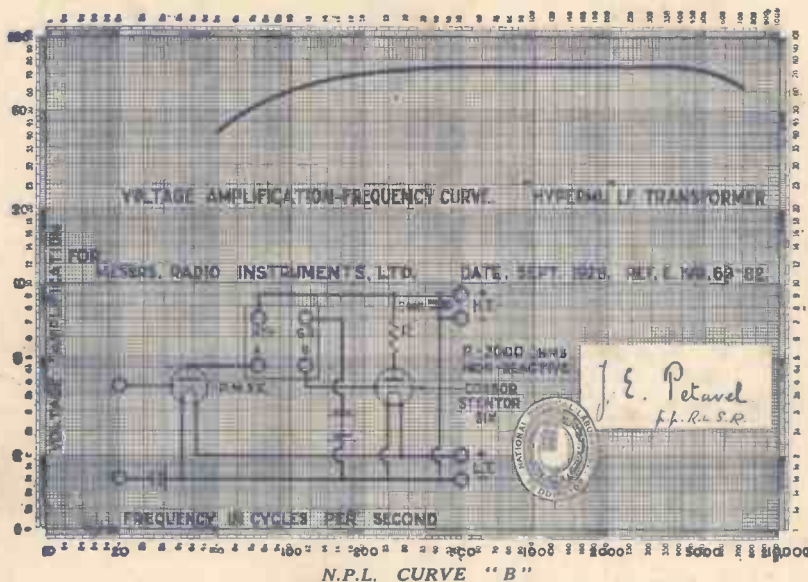

Yes, R.I. have produced another transformer—the "Hypermu," which heads an imposing list of British R.I. Transformer successes, from the pioneer model of 1922 to the famous straight line model of 1927-1928.

NO, it is NOT merely another gadget in wireless. YES, it does improve the efficiency of the set—NOT SLIGHTLY, BUT IMMENSELY.

You have seen curve "A" published in our last advertisement. Here is a still more remarkable curve in "B" illustrated above. The amplification at 50 cycles is 40 volts, which rises to 70 volts at 200 cycles, and maintains this enormous amplification up to 5,000 cycles.

"Hypermu" is the first metal-screened transformer. It is enclosed in a bakelite case of exquisite design and finish and weighs only 14 ozs.—a midget in size: 3 in. x 1½ in. x 3 in.



Sooner or later you will get the "Hypermu" in your set—why not investigate now—let us send you the "Hypermu" leaflet "M" together with the NEW R.I. CATALOGUE.

**21/-**

**RADIO INSTRUMENTS Ltd.**

Offices, Showrooms and Factories: Sole Address:

12M, HYDE ST., NEW OXFORD ST., LONDON, W.C.1

Phone: Regent 6214 (3 lines).

Wires: "Instradio, London."