

SPECIAL CHRISTMAS NUMBER

# MODERN 1/6 WIRELESS

Britain's Leading Radio Magazine

Vol. X. No. 24.

DECEMBER, 1928.



# FREE

In the history of wireless there has never been anything produced which can be compared with the new R.I. & Varley Instructional Book. This Volume is divided into 4 sections, one of which is given away FREE with each component purchased. Practically every use to which that particular component can be put is described in detail in that section, and a large number of efficient circuits opens up a new field of real interest for wireless enthusiasts. Actually these circuits are designed in a most ingenious manner—the L.F. side of one diagram can be linked up with the H.F. side of another—giving combinations of over 1,000 circuits altogether.

The complete Instructional Booklet can be purchased separately for 1/-. Our aim, however, is not to sell thousands of copies of this volume, but rather to give something really valuable to purchasers of R.I. & Varley products.



Section A.  
Complete  
Receivers.  
Eliminators.  
Gramophone  
Electrical  
Reproduction  
Apparatus.

Section B.  
Components.

Section C—D.  
Components.

Section E.  
Eliminator  
Components.



THE MARK OF

BETTER RADIO

Kingsway House, 103, Kingsway, London, W.C.2

Telephone: Holborn 5303

# CONTENTS

Vol. X. No. 24. MODERN WIRELESS DECEMBER, 1928

	Page		Page
Editorial .....	565	Broadcasting and the Next Election .....	627
Sounds We Do Not Hear .....	566	Why Not a Valve? .....	629
Choosing Your Radio Christmas Presents .....	567	Brighter Broadcasting .....	631
The "S.G.P." Three .....	569	The "M.G." Driver .....	633
The Future of the Valve .....	577	Questions Answered .....	636
Broadcasting in 1928 .....	581	The "R.G." Crystal Set .....	637
Radio Christmas Gifts .....	583	Rumours—and Some Facts .....	640
Striking the Right Note .....	587	Mr. Squeers Calling .....	641
The Extreme Penalty .....	593	In Passing .....	643
The "Shortadyne" .....	595	Lessening Leakage .....	645
Wireless in the Desert .....	601	My Broadcasting Diary .....	647
A "Moving Plate" Loud Speaker .....	603	Operating the "Rhapsody" Four .....	649
Further Adventures in Labrador .....	605	What Readers Think .....	650
The "Three-Band" Two .....	611	Radio Abroad .....	674
On the Short Waves .....	616	In Our Test-Room .....	676
Quality .....	617	The Oslo Echo .....	697
The Challenge to the B.B.C. ....	619	The Patent Question .....	690
Beam Beacons .....	621	The Paris Wireless Exhibition .....	702
Coil Comparisons .....	623	Notes and News .....	703
Grid-Leak Values .....	626		

**SPECIAL SUPPLEMENT, "RADIO AND THE GRAMOPHONE," PAGES 653-672**

As some of the arrangements and specialities described in this Journal may be the subject of Letters Patent, the amateur and trader would be well advised to obtain permission of the patentees to use the patents before doing so.

Edited by **NORMAN EDWARDS.**  
 Technical Editor: **G. V. DOWDING, Grad.I.E.E.**  
 Scientific Adviser: **J. H. T. ROBERTS, D.Sc., F.Inst.P.**



**"I am of the opinion that it reproduces sound better than any other loud speaker now on the market."**

This tribute from Dr. N. W. McLachlan, D.Sc., M.I.E.E., endorses the opinion of both Trade and Public on the New Amplion Speaker. Dr. McLachlan is the leading authority on loud speakers, whose moving coil speaker at the South Kensington Museum has hitherto been regarded as the standard. Unlike the moving coil speaker, the New Amplion requires no extra valves, batteries or mains connections. It is so sensitive that it reproduces the lightest

whisper; so flexible that it gives full-toned rendering of the heaviest orchestral selection. The Amplion is fundamentally different from all other types. Hear it at your dealer's.

\* \* \*

The New Amplion Speaker is obtainable in cabinets of Oak and Mahogany at prices varying from £9 to £42. Chassis only, £6 and £8. Amplion Standard & Junior Models, from 35/- to £5.



# AMPLION

Catalogues from Graham Amplion, Limited, 25/26, Savile Row, London, W.1.

Works : Slough. ®



# Give a Brown this Christmas

**G**IVE a BROWN Loud Speaker this Christmas. Let it express your Yuletide message in Music at its purest and best. Let it bring joy, as the chiming of the Christmas bells brought joy to the heart of Trotty Veck, Dickens' little old ticket-porter. Let it speak your good wishes, not only at this season of goodwill, but throughout the coming year.

When you give a BROWN Loud Speaker you not only say "A Merry Christmas," you *give* a merry Christmas. For who can be anything but merry when, with the blinds drawn and the fire blazing up the chimney, jolly music is filling the room? There is, too, an uncanny realism about the reproduction of the BROWN which so thrills all who hear it that they feel the artistes are in the very room.

There are many types of BROWN Loud Speakers. They are priced as low as 30/- and up to £15. 15s. We show a few here—any Wireless Dealer will show you the others as well.



The Mascot—£4. 10s.



The H.Q.—£6. 0. 0.



The Sphinx—£12. 10s.

LOUD SPEAKERS AND HEADPHONES



S. G. BROWN, LTD.,  
Western Avenue, North Acton, London, W.3.

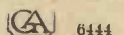

# R MAGNAVOX

*The Originators of the Moving Coil Speaker*

*And now read what others say:—*



R.4.

**The "Wireless Constructor."**

*The Magnavox Speaker gave a rendering of programmes which was a sheer delight to the discriminating ear.*

**The "Broadcaster."**

*Our tests convinced us that the Magnavox is the best moving coil speaker sold. The reproduction was as realistic as could be.*

**Mr. W. James in the "Morning Post."**

*Regardless of price the very best I have ever heard.*

**Radio Editor of a well-known Northern Newspaper.**

*No other speakers compare in the slightest degree with the Magnavox.*

To endeavour to publish all the testimonials which we have received from the leading Radio Engineers and amateurs in the country would necessitate our booking all the advertising space in this journal.

## Realism—

You can hear the bowing of the strings of the double bass and the beats of the drums in their true tone colour. There are no jarring sounds and the harp does not sound like a flute with Magnavox Speaker Units. There are models for A.C. or D.C.



D.80.

REMEMBER THAT ALL MAGNAVOX SPEAKER UNITS ARE EQUIPPED WITH INPUT TRANSFORMERS, 10-FT. INPUT AND FIELD CORDS AND FIELD SWITCH.

ALL MAGNAVOX MOVING COIL UNITS ARE GUARANTEED AGAINST MECHANICAL DEFECTS FOR A PERIOD OF ONE YEAR AFTER DATE OF PURCHASE.

### GOOD NEWS—Reduced Prices

TYPE R.4	6-volt D.C., ½ amp.	.. .. .	£8 0 0
" R.5	100/240-volt D.C.	.. .. .	£8 5 0
" D.80/1	100/120-volt 50/60-cycle A.C.	.. .. .	£11 0 0
" D.80/2	200/240-volt 50/60-cycle A.C.	.. .. .	£11 0 0
" M.7.K.	Magnetic Unit	.. .. .	£3 2 6

## THE GREAT VOICE



*Write for your copy of this new 32-page booklet to-day. It tells you all about moving coil speakers, power amplifiers for A.C. or D.C., pick-ups and volume controls, etc. Price 3d., post free.*

Telephone:  
Mayfair 0578-9

The  
**ROTHERMEL**  
CORPORATION . LTD.  
24-26, MADDOX ST, LONDON, W.1.

Telegrams:-  
Rothermel, Wesdo, London

**KNIFE EDGE**

**SELECTIVITY**  
NO OVERLAPPING OF STATIONS



**THE WONDERFUL NEW**

**COSSOR**  
**Melody Maker**

**BUILT BY ANYONE IN 90 MINUTES**

THE wonderful new Cossor Melody Maker has knife-edge selectivity. It will cut out your local station like magic. It is amazingly sensitive. You do not have to spend a long time searching for the desired programme. Just turn the dials a few degrees and the station you want comes in with enormous volume. It's as simple to work as a gramophone—to change your programme with the New Cossor Melody Maker is easier than changing a record. Anyone can build this remarkable Receiver in 90 minutes. It's as simple as Meccano. All the parts for the New Cossor Melody Maker—the valves, the wire and even the simple tools necessary are sold in a sealed box ready for you to start assembly. Get full particulars of this wonderful new Set

**Fill in the coupon NOW!**

Please send me free of charge one of your Constructor Envelopes which tells me how to build the new Cossor "Melody Maker."

Name.....

Address.....

M.W. Dec.



*Special Christmas Number Features—Four First-Class Sets—Sir Oliver Lodge's Article—"Wireless in the Desert"—Radio Picture Broadcasts.*

*By The EDITOR.*

ONCE again we present to our readers a special Christmas Number of MODERN WIRELESS, and take this opportunity of wishing all our friends a Happy Christmas and a Prosperous New Year.

We have provided in this Christmas Number many attractive features, not only for the skilled home constructor, but for the man who is more or less just beginning to indulge in the most delightful of all hobbies.

There is, for example, the "S.G.P." Three, probably an ideal de luxe of the most modern and up-to-date receiver of the year. The "S.G.P." Three is really two very modern receivers in one. There is an H.F. and detector unit using a screened-grid valve, and this can be used alone or with any low-frequency amplifier, while the second unit is a Pentode amplifier, which also can be used separately with any set.

The two units when used together make a magnificent up-to-date receiver, and easily equal in power to a last year's five-valve receiver.

The "Shortradyné" needs little description. It is in the "Big class," built on super-het. principles for short-wave reception, and is due to our well-known contributor on short-wave work, "W. L. S."

Our third receiver, the "Three-Band" Two, is a modern up-to-date wave-change receiver of the Det.-L.F. type. This is provided with simple front-of-panel switching, so that you can easily go from the ordinary waves to the 5 XX band, and again, by changing the plug-in coils, the set can then receive the short-wave stations. It is quite easy to build, and is an inexpensive set designed and described specially for the MODERN WIRELESS Christmas Number by Mr. A. S. Clark, of the Research and Construction Department.

The "R.G." crystal set should make a wide appeal to those who still find telephone reception to their liking, and who wish to build quickly and inexpensively a neat little receiver over the Christmas holidays. The "R.G." crystal set is a definite advance in crystal set design. Under-panel controls may be set to alternative programmes, and then switched from one to the other merely by a single push-pull switch.

This set, which incorporates many novel features, has been designed by our Technical Editor, Mr. G. V. Dowding.

#### Sir Oliver Lodge's Article

WE also present to our readers in this number several special articles, some of which will, perhaps, be regarded as unusual for inclusion in MODERN

WIRELESS. There is, for example, Sir Oliver Lodge's article on "The Extreme Penalty."

This article was sent in by Sir Oliver Lodge at the Editor's request for a Christmas contribution. The Editor suggested that Sir Oliver should choose his own subject.

It appears that Sir Oliver was extremely interested in listening recently to a debate on the question of Capital Punishment, and as many of our readers must have heard that debate, Sir Oliver suggested that, as the subject interested him greatly, he would write a sequel debate on that subject.

The result is an article which may be read with great interest by all, whether interested in wireless or not, and more especially by those who listened to the B.B.C.'s debate.

#### "Wireless in the Desert"

EVERY reader of MODERN WIRELESS has heard of Miss Rosita Forbes, the famous woman explorer.

To detail the adventures of this intrepid woman would take up many pages of MODERN WIRELESS, but we feel sure her article on "Wireless in the Desert" will be read with great interest.

Miss Rosita Forbes tells us in her article how wireless in the desert, both from the radio and from the native point of view, is effecting sweeping changes, and how, even in the most desolate spots in the world, where science had not yet manifested itself, there is always some natural form of communication, sometimes in its simplicity so puzzling that the European can never quite fathom it.

#### Radio Picture Broadcasts

ALTHOUGH the B.B.C. has now tentatively adopted the Fultograph still-picture system—and we say tentatively because it is by no means certain that a regular series of transmissions will be continued indefinitely—Fultograph receivers are still not ready in sufficient quantities to supply the public demand.

The demonstration which we attended at the Savoy Hotel last month, when Captain Otto Fulton, before a large and distinguished gathering, inaugurated the new service, and received in a space of three minutes a very fine wireless portrait of His Majesty the King, aroused universal interest and enthusiasm.

If the B.B.C. handle this new service on proper lines, and providing the receivers, when supplied in quantity to the public, are not too expensive, picture reception in one's own home should become extremely popular.

# SOUNDS WE DO NOT HEAR



*A new aspect on listening and the broadcasting of "noises."*

By ALFRED DUNNING.

ONE of the most useful results of broadcasting has been to make listeners more "sound-conscious." There are many sounds in everyday existence which we do not hear in the fullest sense of the word. Familiarity with them breeds deafness. A most striking example of this kind was afforded some time ago when "Up the River" was produced. In this broadcast, the familiar sound of lapping water was transmitted with a freshness and strangeness delightful to hear. Yet an almost identical sound passes unregarded and "unheard" every time one takes a bath.

The secret of experiencing the full "flavour" of any sound is largely a matter of giving it wholehearted and voluntary attention. A farmer I knew, whose house was built at the side of a waterfall, told me that he never noticed the roar which persisted day and night. If he had given conscious attention to the same sound being broadcast, he would probably not have recognised it for the same.

## Tally-ho and Yoicks!

There are many sounds with familiar names which one would like to attend to and enjoy in the isolation which wireless could give them. Some of them, moreover, if not broadcast, could only remain as names for many listeners.

There are, for example, the sounds of the hunting field. Everyone has read descriptions of these sounds which accompany the tragedy of Reynard. But few townspeople have had the opportunity of understanding the full meaning of "The horn of the hunter is heard on the hill." In the same way, if it were possible to broadcast a full-cry "Yoicks!" from the mouth of someone in genuine pink, it would probably prove a different matter from the musical-comedy-

revue cry which is the only one to penetrate the cities.

There are many other sounds of the countryside, more common than the song of the nightingale, which would be acceptable nevertheless to urban dwellers, and which, if they were broadcast, would provide them with "something rich and strange."

## Heard by City Children

A short time ago I asked a number of children whose homes are in the heart of the city to write me the names of sounds made by ten birds and ten animals, exclusive of foreign exhibits at the Zoo. In most cases their lists were sadly incomplete. The domestic animals, of course, had their places. Dogs barked, cows moo-ed, donkeys brayed and "hee-hawed." Similarly, the children wrote down the sounds made by such birds as the owl, the crow, the parrot and the barnyard family.

\*

A sound machine used at the German Langenberg station for imitating the noises made by a ship's propeller.

\*



It was startling to find that the calls and squeaks of creatures native to the wilder parts of Britain had never been heard. The children did not know of the bark which a fox will make, or the squeal of a frightened rabbit. They knew the poem which begins:

"I hear a sudden cry of pain,  
It is a rabbit in a snare!"  
But they themselves could not have written the second line based on an identification of the cry mentioned in the first line.

## "The Bittern's Boom"

The same inexperience was shown in their lists of bird sounds. The cackling of game birds, the rattle of the night-jarr and the call of peewit or curlew were unknown. How many listeners have heard as often as they have read, "The bittern's boom"?

Just as a broadcast of the sounds of the countryside would be very useful to town children, so would a transmission of city sounds educate children in remoter places. And for both there would be a great deal of interest in the noises to be heard at seaports.

As a rule, when inland dwellers go to the seaside they visit the pleasure resorts. Few, comparatively speaking, are aware of the strange and stirring noises which are to be heard in dockland. One of the most unforgettable noises of this type is, I think, the hooting of sirens of ships "speaking" outside a harbour; and on foggy nights, or nights when there is a "swell on," the lost souls which seem to cry through foghorns and bell-buoys are "thrillers" of the first degree.

The gramophone has done much to preserve for posterity the voices of celebrities in the musical and vocal world. While this art of "bottled sound" does not come within the province of broadcasting, yet the microphone could still give the younger generation a whisper of some sounds which are fast disappearing

with the changing times, and which may soon be silent for ever.

Of these, perhaps the best, both historically and artistically, are the street cries. "C.O.D." and the silent efficiency of modern shops are fast displacing the voice of the street vendor.



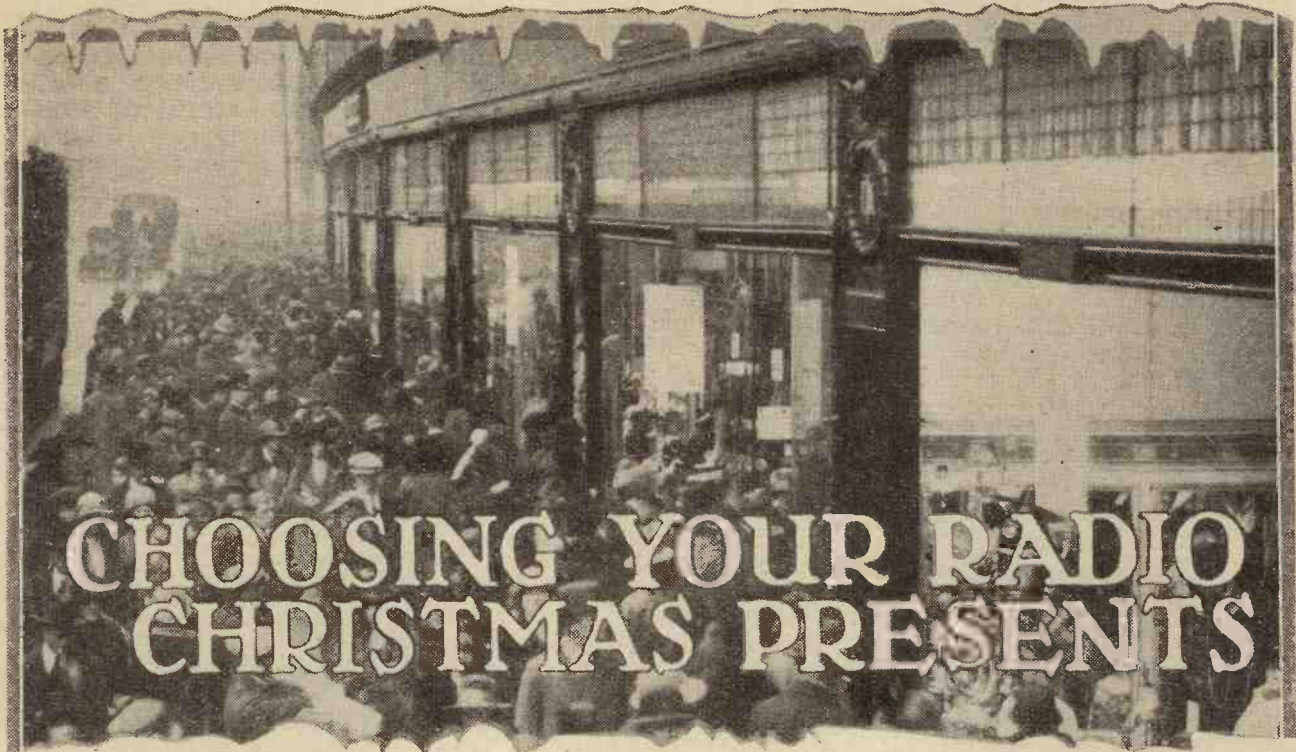

*No longer does radio savour of the laboratory, there are now some really beautiful and thoroughly artistic sets and accessories on sale; articles which, both for appearance and usefulness, make ideal Christmas gifts. But you must make your selection carefully, as there are dire "snags" to be encountered.*

*By G. V. DOWDING, Grad. I.E.E.*

**H**OWEVER tricky and full of pitfalls this business of selecting presents may be, it is a joyous one, one that should be tackled light-heartedly. And some of the happiest inspirations in the way of gift selections flash into one's mind when one's serious side is far away. Nevertheless, one cannot rely upon inspiration to come to one's aid whenever it is wanted.

For the most part, the present list will be the result of a certain amount of hard thinking, calculation and study—study, that is, of piles of catalogues, etc. However, we are in one respect much better off this year than we have ever been before. In radio there is a far wider field of choice; there are many new things, and prices, generally speaking, are lower than ever.

### A National Institution

It is safe to say that every house in the country, or at least every family, is interested in radio, and although perhaps at times the B.B.C. would lead us to believe otherwise, the fact remains that radio is a form of entertainment. And could two things go better together than entertainment and Christmas? The one is a part of

the other. Also we need not think of radio in the home as one complete instrument any more than we regard the furniture and ornaments in a room as a standard *ensemble*.

A rich man can give a relation the magnificent present of the complete domestic fittings for a house, but such a gift is not implied when one says for instance: "I will buy So-and-so something useful for the

home." Examining the question closer, let us endeavour to answer the direct question: What has radio to offer in the way of Christmas presents?

It frequently happens that the present-giver looks for artistry or grotesqueness of form. I am not sarcastically referring to some of the peculiar tie designs and slipper presents which provide our comic papers with such excellent copy at Christmas-time, but to the desire of the keen gift maker to select something out of the ordinary. Thus we find a run on ash trays, clocks, and inkstands, and so on, in the guise of polished brass or enamelled animals, etc.

### Secondary Considerations

You can be sure that the manufacturer who is ready at Christmas with something abnormal, but yet pleasing in appearance and moderately useful, such as a telephone cover that looks anything else but what it is, will be rewarded by meeting a brisk demand.

But with most pieces of radio apparatus, outward appearance must be regarded as only of secondary consideration. Right away it must be admitted that there are some most handsome productions as artistic as one could wish for, which are, at the

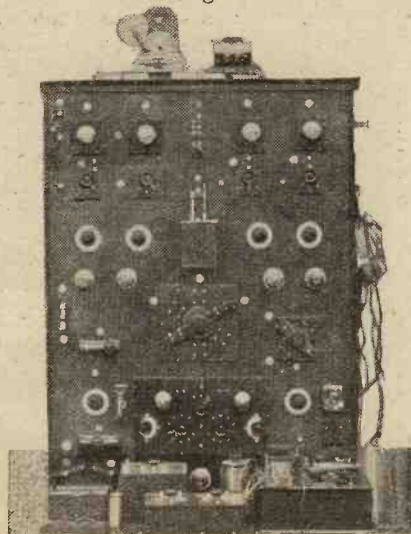

A typical radio set of four or five years ago. It was no doubt very efficient for its time, but hardly formed a drawing-room piece!

same time, very efficient radio articles. On the other hand, there are grotesque or, if you like, artistic looking wireless accessories to be found well to the fore in some shop windows round about Christmas-time, whose virtues are, unfortunately, only in their appearances.

You see, there is no reason at all why a loud speaker shaped like a fire-screen should not operate as well as any other. But, on the other hand, the man who has an instrument designed with this appearance which is capable of only very poor results could regard it and probably only use it as a fire-screen. It would have been cheaper to have forgotten about the radio side altogether and bought just an ordinary fire-screen.

### Getting to Work

Undoubtedly the very first step one must take in drawing up a list of radio presents is to narrow one's field of choice down to the catalogues, advertisements or displays of well-known manufacturers whose names alone will be guarantees of the high efficiency of the apparatus.

The few people, or householders perhaps I should say, who have not

### A CRYSTAL SET?



Senator Marconi, to whom we owe the development of wireless and, therefore, our broadcasting, listens in.

got radio sets, in this present year of British Broadcasting, will probably fall into two classes.

1. Those who feel they cannot afford to equip themselves with wireless, and
2. Those who are afraid to do so.

Let me amplify the latter category. The fear of some of those who are afraid will be that the apparatus required is either dangerous or too difficult for them to handle. The fear of the remainder will no doubt be that they will find it hard to get someone to fix up the gear for them or that it will prove unsightly.

You who are regular readers of MODERN WIRELESS can do valuable missionary work by dispelling such fears, and new readers will only have to have a few minutes' conversation with people who know more about the subject to arrive at the same conclusion. You can do a very good turn to anyone who has not got a radio set by fixing them up with one such as a Christmas present.

### Sets of To-day

To equip a house with a crystal receiver would cost only a pound or two, while you will find the labour of it amply rewarded by the pleasure it will give the recipient. When you go beyond a crystal set a complete set can become a moderately expensive affair. But those whose pockets are rather deeper than the average may like it drawn to their attention that there are sets on the market this season which are far in advance of those made even a few months ago.

There are, for instance, sets using screened-grid and pentode valves whose ranges of reception are vastly in excess of ordinary sets using the same numbers of valves. There are similar sets having additional apparatus enabling them to be worked directly from electric light mains, and it is worth noting that most of these sets are designed so that gramophone pick-ups can be used very easily with them.

And talking about gramophone pick-ups, the great increase of interest in these devices suggests a new field of exploration for present givers. Anyone owning a friend or relation who has a wireless set and a gramophone, and who uses both fairly frequently, would find here an opportunity of giving a very acceptable present. This is a gramophone pick-up by which the gramophone and radio receiver become linked and the electrical reproduction of records enjoyed.

### Gramophone Pick-ups

There are many gramophone pick-ups on the market at prices varying from fifteen shillings to four guineas, so it can be truly said that there are pick-ups for all pockets. Also you may have a friend who, having a radio outfit, tends rather to scoff at gramophones. But you will probably find that these people will have nothing but praise for the electrical reproduction of records, and to them a gramophone and a pick-up would prove a most useful gift.

But do not make the mistake of buying a very cheap, portable gramophone.

It is really essential that when electrical reproduction is going on the lid of the gramophone should be tightly shut down. Leaving the lid open completely spoils the results. You get a sharp metallic chattering direct from the best of pick-ups, which makes the loud speaker sound tiny and generally objectionable.

A loud speaker makes a very good Christmas present. Even if a listener has a loud speaker already he can always use another with advantage, but do not buy a loud speaker unless you are sure that the person to whom you are going to give it has apparatus capable of operating it. His set might only be a crystal or one-valve, and before he can place your loud speaker in operation he would have to add an amplifier, which might conceivably cost more than the speaker.

### Loud Speakers and Valves

I have said that a loud speaker makes a good gift, but to do so it must be a good loud speaker. You are doing a listener a bad turn if you

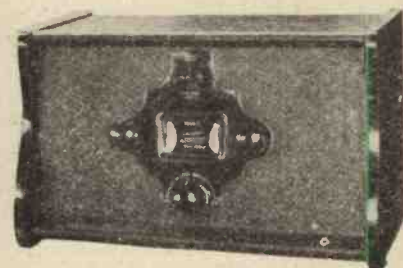

A set of to-day is a handsome, dignified article, one that makes an ideal Christmas present. The above is a Burndept receiver.

give him something that is going to give him bad radio results. If you cannot go to a pretty good type of speaker, think of something else.

Valves make good presents, but you should not indiscriminately distribute valves to people without consulting them beforehand, unless you want your gifts to be wasted. A man who has a Det.-2 L.F. set might appreciate the gift of a screened-grid valve; on the other hand, he might not. Before he could use this valve, he would have to add a stage of H.F. amplification to his set, and, at that, a stage of special design. He might not want to do this.

And do not be misled into thinking that a screened-grid valve can replace an ordinary high-frequency amplifying valve. Some sets have to be completely redesigned before these special valves can be used in them. Also, to some extent, the same applies to the pentode valve.

By judicious observation it is not

(Continued on page 688.)

# The "S.G.P."

## THREE

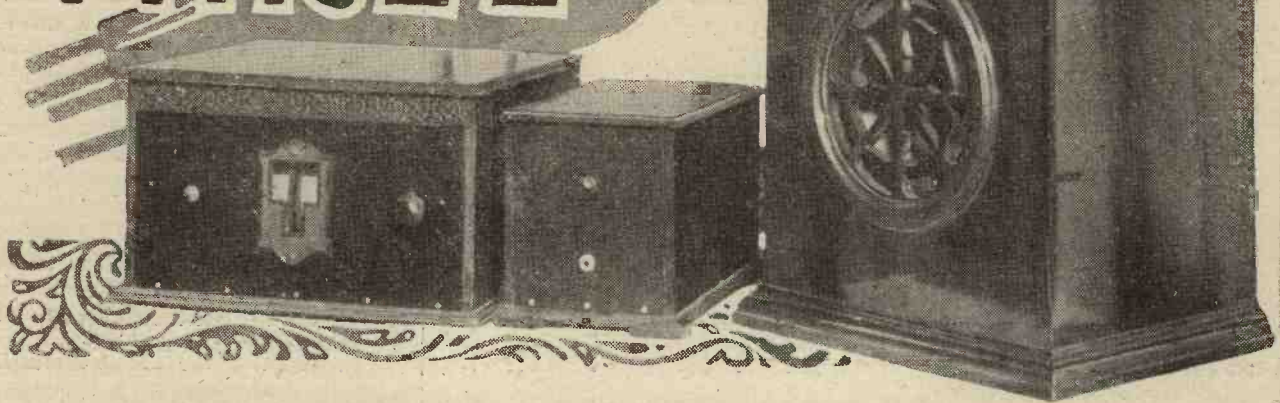

*A last-word receiver incorporating practically every modern refinement. A screened-grid valve, a Pentode and drum-control all figure in this "S.G.P." set, which comprises two units, either of which can be used independently.*

*Designed and Described by the "M.W." RESEARCH DEPT.*

**A** SMALL set with the performance of a big one has long been the dream of the enthusiast, and recent developments in screened-grid valves seem to be bringing the rosy vision nearer.

The fascination of a single H.F. stage giving almost the amplification previously only to be got from two stages of the normal type is a very real one, and it takes the operator a long time to get over the thrill of it.

When the screened-grid valve was first put upon the market it seemed that such a performance was to be brought within the easy reach of

everyone, without the difficulties of the neutralising adjustment necessary with previous types of high efficiency H.F. stages.

Actual experience, however, as distinct from theorising, has shown that matters are not really quite so ideal, and the valve is not the unmixed blessing which the over-optimistic at first thought it.

### Practical Difficulties

The fact is that to get in full measure the very high performance theoretically obtainable with this valve it is necessary to use circuits

of exceptionally low damping, and this involves us in considerable difficulties, for it means specially low-loss coils, weak coupling to the aerial, and care to avoid introducing appreciable detector damping.

Granted these things (and they are none too easy to provide in a home-construction design, where the use of standard parts is always a great advantage), the resulting receiver is apt to be a decidedly critical affair, demanding complete screening, careful layout and separation of H.T. feed circuits, etc., to ensure stability.

A set such as this is very decidedly

## COMPONENTS AND MATERIALS REQUIRED

### COMPONENTS FOR H.F. AND DETECTOR UNIT.

- 1 Panel, 14 in. × 7 in. ×  $\frac{1}{8}$  or  $\frac{1}{4}$  in. (Red Seal, Becol, "Kay Ray," Radion, Ebonart, Trelleborg, etc.).
- 1 Cabinet to fit, with baseboard 10 in. deep (Makerimport, Artercraft, Bond, Pickett, Raymond, Caxton, Gilbert, Lock, Camco, etc.).
- 1 Synchronatune double .0005-mfd. drum-drive condenser (Cylidon).
- 1 .0001- or .00015-mfd. reaction condenser (Bowyer-Lowe, Dubilier, J.B., Igranic, Peto-Scott, Ormond, etc.).
- 1 On-off switch (Lissen, Benjamin, Lotus, Igranic, Burne-Jones, Peto-Scott, etc.).

- 2 Sprung valve holders (Igranic, Lotus, Benjamin, W.B., B.T.H., Pye, Redfern, Bowyer-Lowe, Marconi-phone, Formo, Burne-Jones, Burndept, Ashley, etc.).
- 2 Six-pin coil sockets, unscreened type (Burne-Jones, Bowyer-Lowe, Peto-Scott, Colvern, Lewcos, etc.).
- 2 H.T. fuses and holders (Burne-Jones, Hunt, or similar type).
- 2 Mansbridge type condensers, any capacity between .2 and 1 mfd. (Lissen, Dubilier, T.C.C., Mullard, Hydra, Ferranti, etc.).
- 1 Mansbridge type condenser, 2 mfd. (Ferranti, Mullard, T.C.C., Lissen, Dubilier, Hydra). C, on diagram.)
- 1 Anode resistance, value about 100,000 ohms (See text as to

value, also holder). (Lissen, Mullard, Dubilier, Igranic, Ferranti, R.I.-Varley, etc.)

- 1 H.F. choke (R.I.-Varley, Lewcos, Lissen, Bowyer-Lowe, Dubilier, Peto-Scott, Climax, Burne-Jones, Colvern, Wearite, Cosmos, etc.).
  - 1 .0003- and one .001-mfd. fixed condensers (Dubilier, Lissen, Mullard, T.C.C., Igranic, Clarke, Burne-Jones, etc.).
  - 1 2-meg. grid leak and holder (Mullard, Lissen, Igranic, Dubilier, Pye, etc.).
  - 1 Terminal strip, 12 in. × 2 in. ×  $\frac{1}{4}$  in.
  - 9 Terminals (Igranic, Belling-Lee, Eelex, etc.).
  - 1 Standard screen, 7 in. × 6 in. (Paroussi, Burne-Jones, etc.).
- Wire, screws, flex, etc.

one for the very advanced constructor who does not object to an elaborate design, will wind his own coils, and can cope with the razor-edge tuning which usually results.

received a good deal of attention in the past, and various expedients have been adopted to meet the difficulty.

The H.F. and detector portion of the "S.G.P." Three provides a solu-

This, of course, was done in the 1928 "Solodyne," and resulted in a degree of selectivity much above that usually obtained with "S.G." sets, although even then not of the real knife-edge variety so beloved of some experimenters (actually it was quite high enough for all normal purposes, of course).

The weakening of coupling between the H.F. and detector stages introduced in this way also has a further very valuable effect in promoting stability, which is rendered considerably greater than when one of the more direct systems of coupling is used.

**Special Screening**

It might be expected on theoretical grounds that the amplification would fall off seriously when the intervalve coupling is weakened in this way, but experience shows that this is not the case with a well-designed transformer with a reasonably low H.F. resistance secondary winding.

The other important feature of the "S.G.P." outfit which makes it a receiver of such outstanding capabilities is the use of a method of coil placing and screening which really does give a highly effective separation of the circuits with the very minimum of metal and the easiest possible constructional work.

The scheme is exactly the same as that used in the three-valve

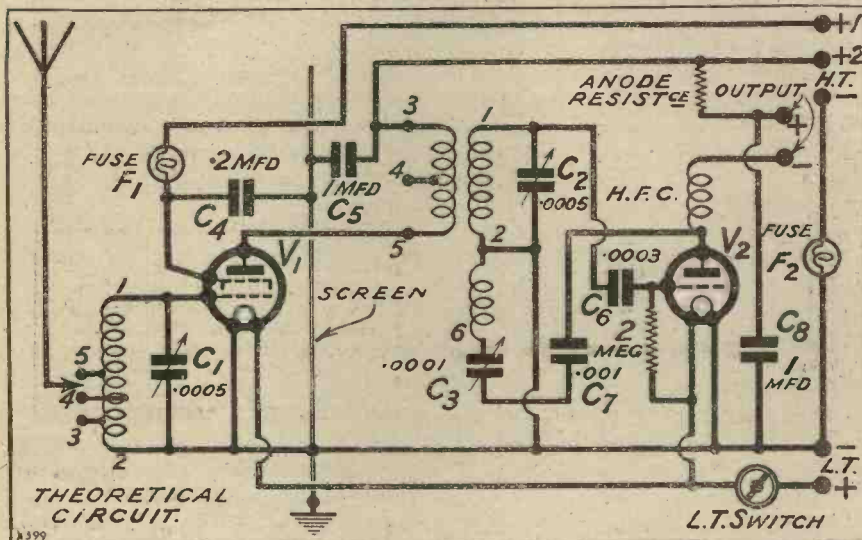

It has been generally realised, therefore, that a screened-grid design suitable for general home construction should be one with a greater margin of safety, capable of being assembled with reasonable ease with the aid of standard parts, although it follows that the amplification obtained will not be so great.

Such a set becomes "safe," in the sense that it can be built with an assurance of proper stability even if the constructional work is not very perfectly carried out, slight alterations made in the layout and wiring, and so on, a very important attribute from the point of view of the man who is meditating the spending of a considerable sum on a set of parts to build it.

**The Search for Selectivity**

Now, the difficulty which arises with a screened-grid receiver on these lines is the problem of selectivity. The type of intervalve circuit generally used with the S.G. valve is in its very nature less selective than that employed in the average neutralised set, and tuning is apt to become rather flat when ultra low damping circuits are not used for the reasons very briefly given above.

Some benefit can be obtained from weakening the coupling to the aerial, but this cannot be carried very far before signals are weakened seriously and we are driven to see what can be done in the intervalve coupling circuits themselves.

An examination of published designs will show that this problem has

tion which we have found to be unusually successful in practice, and enables an outfit of exceptional capabilities to be produced without any sacrifice of the important safety factor.

This desirable state of affairs results from the use of two special features, the first being H.F. transformer coupling between the screened-grid valve and the detector which follows it.

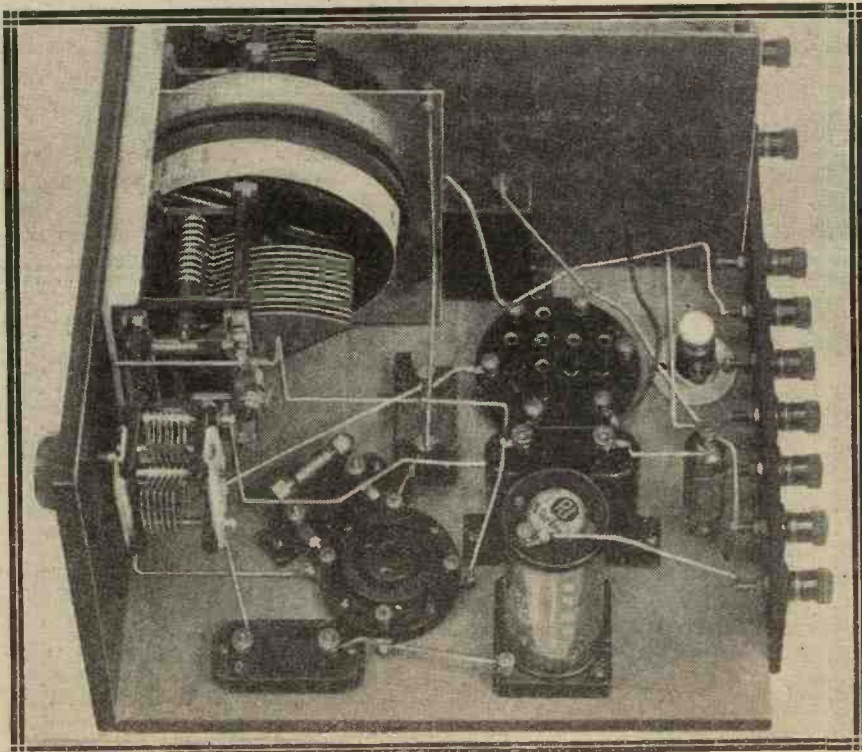

This view of the detector end shows the anti-motor-boating device in the H.T. positive lead. Note how the resistance is "hung" in the wiring.

"Solodyne," and the "Invincible" Five.

The method in question is very simple, and consists merely in the placing of the coils so that their axes are horizontal, and the insertion of a plain vertical screen so arranged that

you get maximum selectivity, and different degrees on the others. Signal strength is also usually different on each, and it is advisable to try each in turn.

The other unit is the H.F. transformer, and this is similar in general

combination of selectivity and amplification is available.

Naturally, the smaller the primary the greater the selectivity, but amplification suffers if the reduction is carried too far. A good size for all-round work is the P8, which gives much better selectivity than many people would think possible with the screened-grid valve.

For slightly louder signals and selectivity adequate for any situation

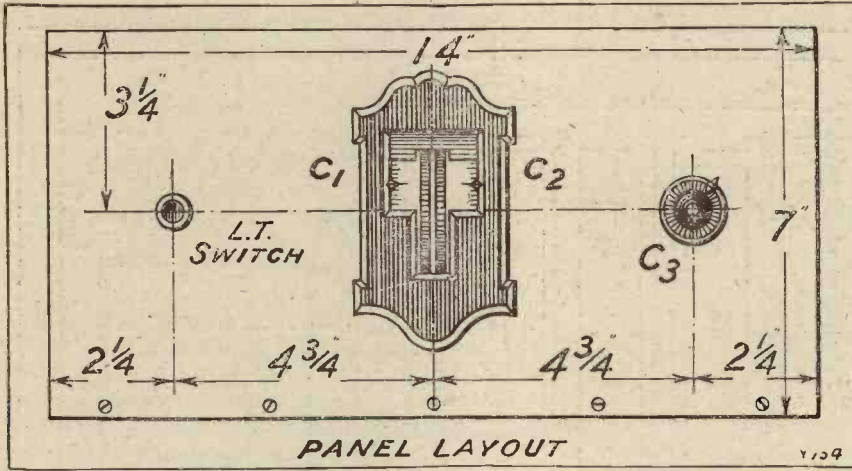

The "S.G.P." is the result of considerable research and experimenting; it embodies all the advantages of S.G. and Pentode valves with a minimum of their "snags."

it cuts off just those parts of the coil fields which would otherwise spread out and produce interaction.

The remainder of the field is not interfered with in any way, and hence the characteristics of the coils are modified as little as possible.

In the original sets we used the ordinary 6-pin H.F. transformer type of coil, and got it in a horizontal position by screwing the socket to the side of the screen, but for the "S.G.P." receiver we have been enabled to get the desired effect more easily still by using certain new coils just introduced by Messrs. The London Electric Wire Co., whose products are known by the name of "Lewcos."

### A New Standard Coil

These coils have the standard 6-pin fitting, but are actually of the flat disc type, so that they stand up edgewise exactly like the ordinary plug-in type. Consequently, the socket can be screwed down upon the baseboard of the set in the ordinary way, and the axis of the coil is then horizontal.

Two of these new coils are used in the "S.G.P." receiver, the first being an aerial coil, which differs slightly in its connections from the older type. Terminals 1 and 2 on the base are wired as usual, but the alternative aerial terminals are three in number instead of only two, as in the earlier form. Hence, a closer adjustment of aerial coupling can be obtained.

These terminals are Nos. 3, 4 and 5, and when the flex lead from the aerial terminal is placed under No. 3

construction to the aerial coil, the difference being that there is a fixed reaction winding on one side (to provide the usual Reinartz reaction on the secondary), and upon the three projecting pins on the other a small ring-shaped coil fits. This latter is the primary winding, and it is interchangeable by virtue of the pin fitting.

These interchangeable primaries are available in a complete range of graduated sizes, so that any desired

not too close to the local station the P10 size is suitable, while in very difficult areas close up to a main station the P6 should be used.

By the way, the interchangeable primaries are provided with a three-pin fitting because they actually contain two coils which can be used as primary and neutralising windings.

In the case of a screened-grid valve the two windings are connected in series and provide the equivalent of one large primary.

These coil units we have found of very satisfactory performance, the actual standard of selectivity and amplification obtained in the set as a

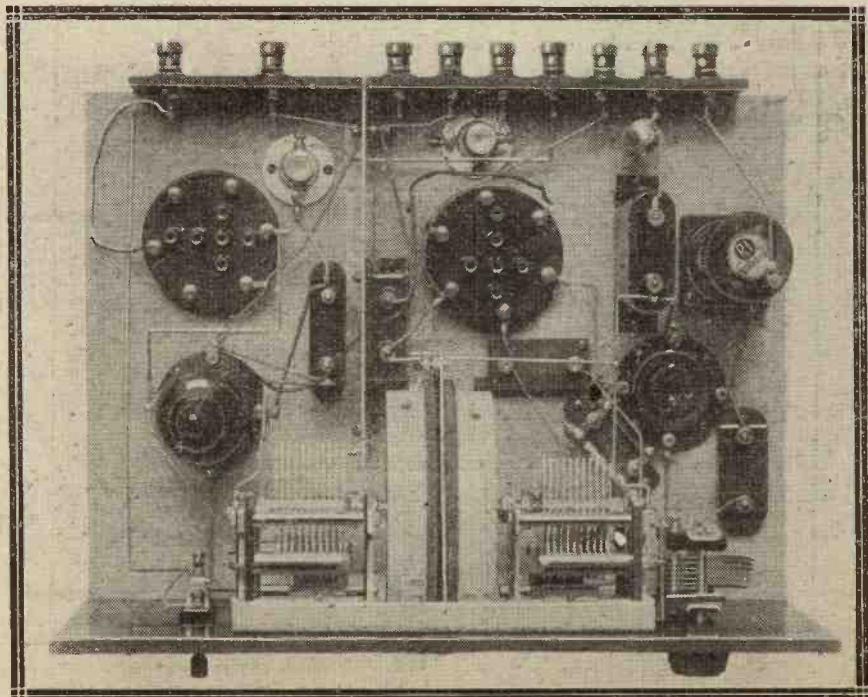

Note how the screening is arranged. The plate between the condenser drums is supplied with the "Synchrature" condenser all ready for screwing down.

whole being of a very high order indeed. The maker's reference numbers for these coils, by the way, are these: Aerial unit, C.A.C.5 (250-550 metres); and C.A.C.20 (1,000-2,000 metres). Transformer, C.S.P.5 and C.S.P.20. On the long waves primary No. 20 will suit most purposes.

Just two more general points before we start on constructional matters. First, you will observe that there are two H.T. fuses in the set, and it must be explained that the reason for this apparent prodigality is that when a screened-grid valve is used a single fuse in the H.T. negative

lead is not adequate protection, since there are possibilities of "shorts" between the screening grid and plate circuits of the valve.

The extra fuse in the H.T. lead to the screening grid guards against possible troubles of this sort. Just one tip in this connection: Fuse bulbs

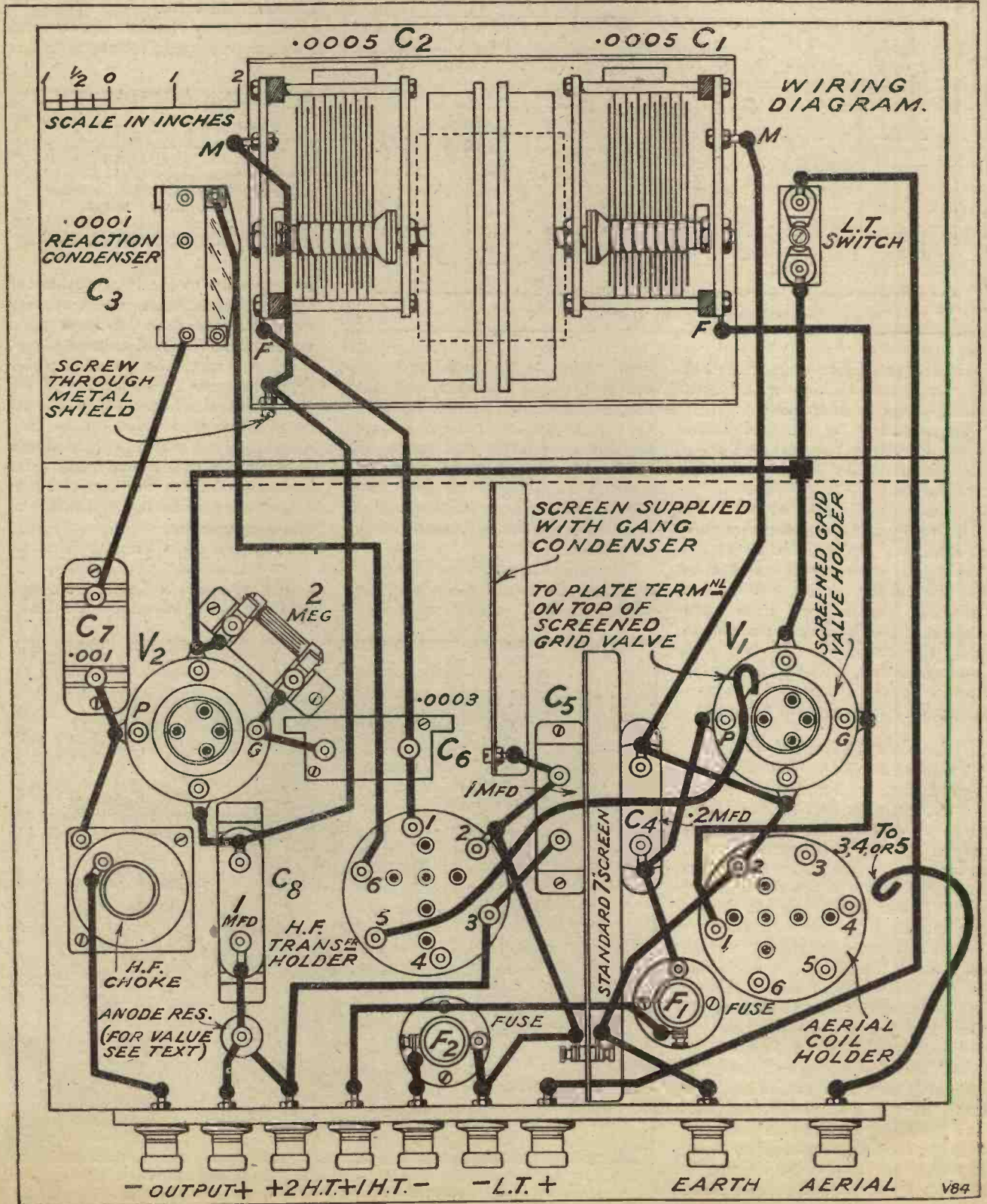

sometimes arrive with broken filaments, so test them with a pair of 'phones and a dry cell before you put them in, for a broken fuse can be a pretty puzzling fault.

other. In addition, a standard type screen is fixed in the position seen in the photos.

This screen is of the new standardised type which is provided with

By the way, when the wiring-up stage is reached note carefully the various connections made to the actual screens themselves, and also to the back plate of the condenser, and insert here a small brass screw and nut for the purpose of attaching the necessary wire.

Working the set you will find delightfully easy, since there is no neutralising adjustment to be made and tuning is rendered very simple by the double-drum condenser.

### Simple Tuning

Once you have got the two drums in step on one station you will find that you can run them together with your thumb, and pick up station after station, keeping the reaction just a little way below oscillation point. As each station is brought in you can adjust each drum a little separately, and make sure each is correct, but as a rule they keep step pretty closely except near the bottom of the scale.

Valve data you will find elsewhere in this issue, and it merely remains to give suitable voltages. The H.T. on the terminal for the H.F. and detector valve anode circuits should be from 100 to 120 volts, preferably the latter. On H.T.+1 (for the screening electrode) a voltage between 70 and 80 should be O.K., but this should be adjusted with some care on a distant station.

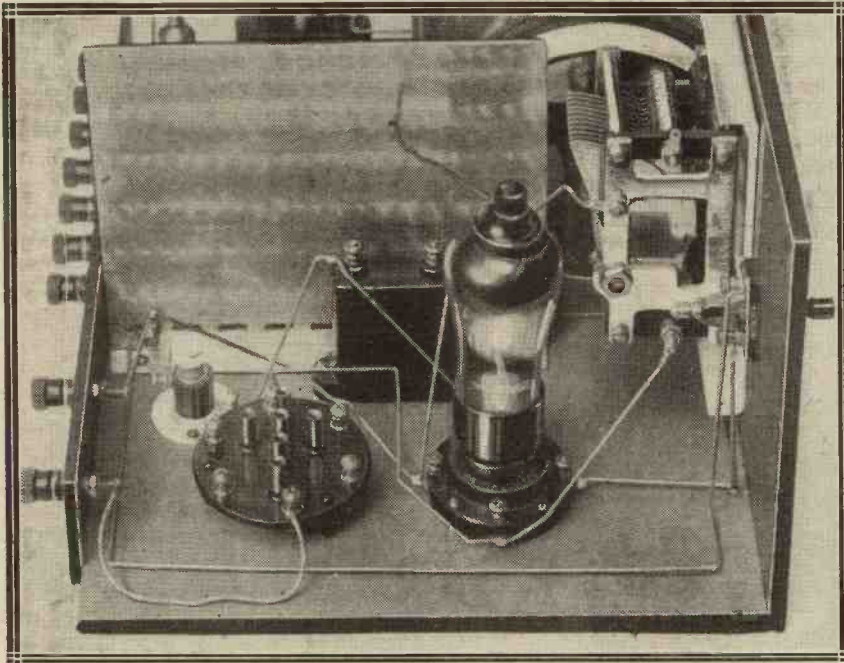

The set from the aerial end. Note the extra bulb type fuse in the H.T. lead to the screening electrode of the valve.

### Detector H.T. Adjustments

The other point concerns the anode resistance and 1-mfd. condenser you will see in the H.T. lead to the detector valve. This is what is called an anti-motor-boating device, and serves two purposes. First, it prevents motor-boating when the set (with amplifier) is used on a mains H.T. unit or high-resistance dry battery, and also automatically drops the voltage on the detector to a suitable value without providing a separate H.T. terminal.

A suitable value for this resistance with most valves is 100,000 ohms, but if the reaction control proves floppy (very unlikely) a higher value can be tried. In the original set, by the way, a Lissen resistance was used, and since this is provided with small terminals at the ends, it was fixed direct into the wiring without a holder. With other makes it will obviously be necessary to provide the usual holder.

The constructor should be warned that the placing of the coil sockets should be copied carefully.

Next, as to the screening arrangements. You will find that the drum-driven double condenser used in this set comes to you provided with a screening plate which is to be screwed down on the baseboard between the two drums, so as to screen the two halves of the condenser from each

a row of perforations across the lower edge through which the necessary leads can be passed without any drilling.

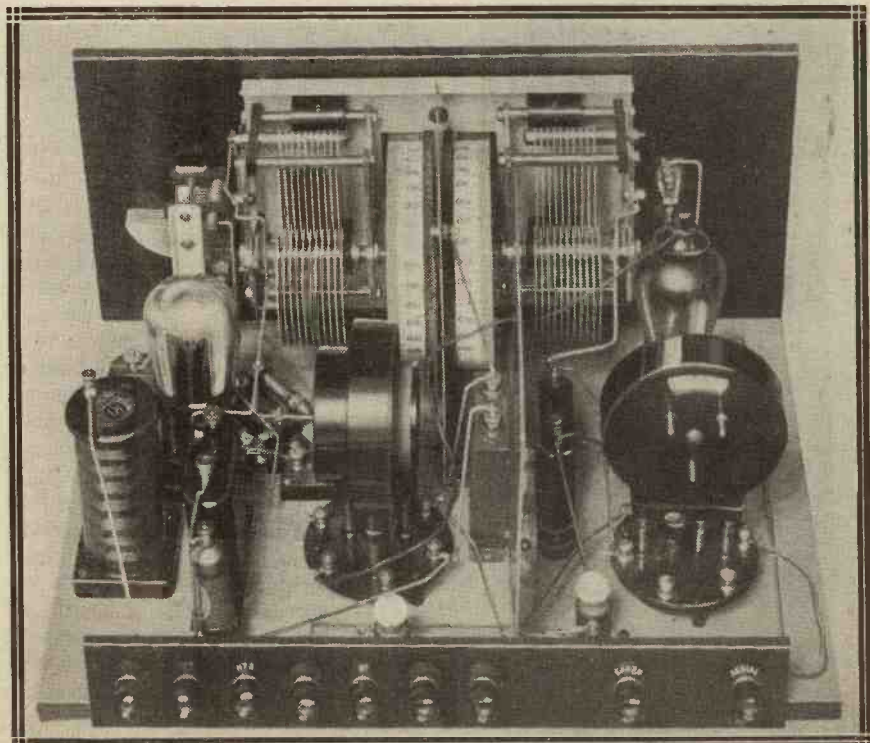

A general view. The three pins you see projecting from the aerial coil are not used in this set. Similar pins on the other coil unit carry the interchangeable primary which is seen in place.

# The "L.F." Unit

*This amplifier, which can be used independently with any set, makes use of the new Pentode valve, and is the result of a considerable amount of research.*

THREE months or so ago the Radio world was greatly interested to hear of a new L.F. amplifying valve which was shortly to be placed upon the market.

The evolution of this valve was a progressive step on the part of the valve manufacturers, because it aimed at the further simplification of wireless sets inasmuch as its use would enable one of the existing low-frequency valves to be dispensed with. One stage was considered to be quite adequate for all normal purposes when the new valve was used. Naturally radio enthusiasts have been eagerly awaiting the publication of sets utilising one of these new five-electrode, or, as they are called, Pentode, valves.

The "M.W." technical staff was quick to procure a number of Pentodes for experimental purposes

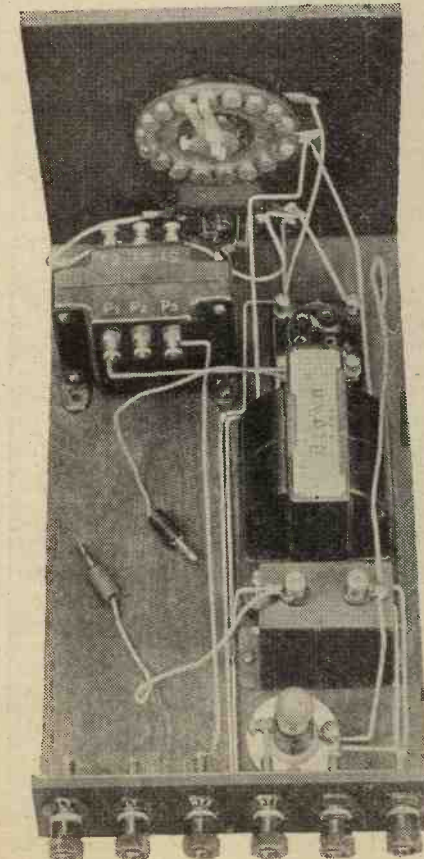

The layout is simple in the extreme. Note the volume control so desirable where Pentode amplifiers are concerned.

directly they became available. With the knowledge gathered from bitter experience, the technical staff realised that in common with most new devices the Pentode might contain certain little "snags" which ought to be searched for and overcome before incorporation into a published design.

So accordingly the "M.W." Research Dept., in the interests of MODERN WIRELESS readers, set to work to discover how best the Pentode might be employed in order

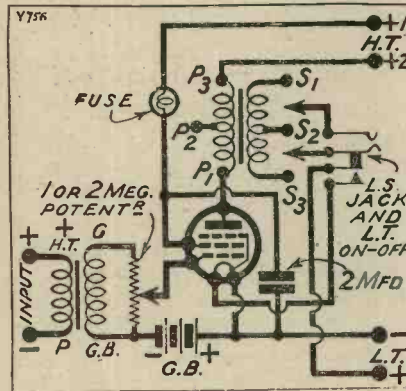

that its special properties as an amplifier should be made full use of. The "M.W." Pentode amplifier is the result of this work.

It is interesting to see how this new valve differs from those of the conventional three-electrode type. In the first place it has five electrodes. The usual filament, grid and anode pins are provided on the base, and in this respect the connections are identical with those of the normal three-electrode valve.

## High Magnification

The Pentode, however, has three grids as against one in the triode (three-electrode valve). The two additional grids play an important part in the operation of the valve. One of them is connected to the filament and the other is taken to a terminal on the side of the base of the valve. This grid is maintained at a potential equal to that applied to the anode.

The Pentode has an exceedingly high magnification factor, hence it is possible to obtain a large change in anode current for a relatively small grid swing. This, of course, is exactly what is wanted. A small grid swing is equivalent to a weak signal, and if for this small signal impulse we can get a very large impulse at the output end, or loud-speaker terminals, then we can use this one-valve stage when before we had to employ two stages in order to obtain the same results. So far, so good. Unfortu-

nately all good things have their little drawbacks. The Pentode certainly has a wonderfully high amplification factor, but with this desirable feature we are given a high impedance.

For instance, the magnification of the valve shown in the photographs (a P.M.22) is 82 and its impedance is 62,500 ohms. This was the first difficulty which the "M.W." Research Dept. had to contend with. A high impedance complicates the design of the output circuit and the technical staff realised that if a loud speaker were placed directly in the anode circuit of a Pentode the resulting reproduction would be high-pitched and therefore unfaithful.

## The Output Transformer

The obvious remedy was to employ some form of transformer output, but at the time the first batch of Pentodes came to hand there were no suitable transformers available.

Some of the leading radio manufacturers were quick to see that such components were necessary, and set about designing suitable output devices with the result that there is now a number of satisfactory transformers on the market.

### COMPONENTS REQUIRED.

- 1 Panel, size 7 ins. x 6 ins. x 3/8 in. or 1/2 in. (Becol, Radion, "Kay Ray," Ebonart, Red Seal, Trelleborg, etc.).
- 1 Cabinet with baseboard 10 ins. deep (Caxton, Gilbert, Camco, Lock, Pickett, Bond, Artercraft, Makerimport, etc.).
- 1 L.F. transformer, fairly low ratio (Brown "A" type in amplifier). (Any good make, Philips, R.I. Varley, Lissen, Igranic, Ferranti Mullard, Marconiphone, etc.)
- 1 Single filament control jack (Lotus No. 4 or equivalent type).
- 1 Volume-control potentiometer, 1 or 2 megohms (G.E.C., Gambrell, Burne-Jones, Centralab, etc.).
- 1 Special Pentode output transformer (Marconiphone universal type).
- 1 2-mfd. condenser (Lissen, T.C.C., Dubilier, Hydra, Mullard, Ferranti, etc.).
- 1 Fuse holder and lamp (Burne-Jones, Hunt, or similar type).
- 1 Valve holder (Benjamin, Igranic, Lotus, Pye, W.B., Burndep, Bowyer-Lowe, Marconiphone, B.T.-H., Redfern, Burne-Jones, etc.).
- 6 Terminals, and terminal strip, 6 ins. x 2 ins.
- Wire, screws, flex, G.B. plugs, etc.

One of these has been incorporated in the "M.W." Pentode amplifier.

Then there was another "snag." An examination of the Pentode characteristic curves showed that at



normal H.T. voltages the total anode current required was in the neighbourhood of 12 to 16 milliamperes. Now such a comparatively heavy current in addition to that taken by the remaining valves in the set would be too much for some H.T. batteries, notably dry batteries of the "Popular" type, which are only designed to give an economical output of 5 milliamps or so.

The "M.W." Research Dept., therefore, came to the conclusion that the Pentode could only be used in those cases where the listener was willing to employ dry batteries of the triple capacity type, H.T. accumulators, or a mains unit.

### An Important Point

It was decided that for the present the valve could not be utilised in small portable sets or in similar instances where space prohibits the use of dry batteries of the largest size.

The amplifier described in this article is therefore published with the warning that it is only suitable for use with sets where, if dry batteries are employed, the cells are of a size capable of standing up to a "super-power" valve load plus that of the remaining valves in the receiver.

Now for the details of the amplifier itself. You will see that it departs somewhat from normal practice by the inclusion of a lamp bulb fuse in the H.T. + lead which is joined to the extra terminal on the base of the Pentode. The object of this fuse is to prevent the H.T. battery from being short-circuited and possibly

ruined should by chance the third grid come into contact with the element which is joined to the filament. Valves are fragile things, and an accidental knock might produce a short-circuit with detrimental results to the H.T. battery. Of course, such a heavy shock would ruin the valve, and it must not be thought that the fuse is intended to protect the valve filament.

neighbourhood of between 2.5 and 3.5 to 1. Across the secondary terminals of the transformer is joined a high-resistance potentiometer for volume-control purposes. This is essential in order to avoid

Do not forget to leave space for the G.B. battery when laying out your components.

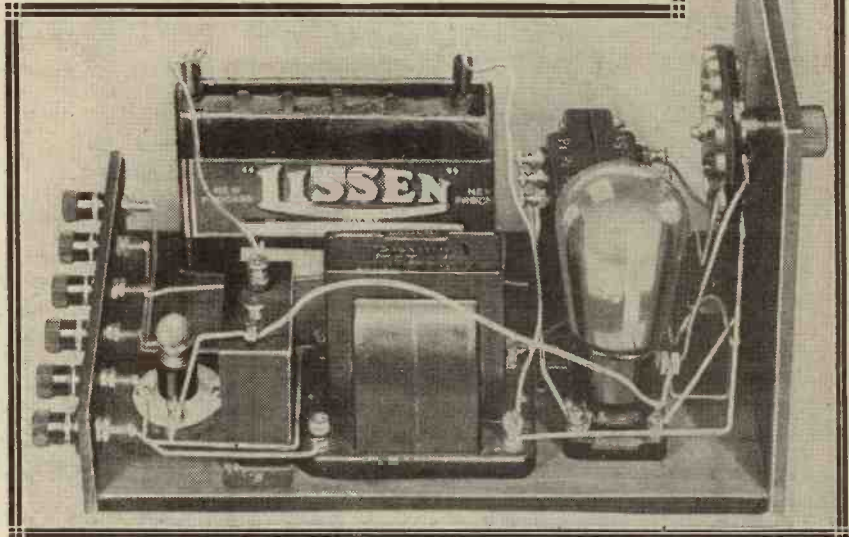

In order to reduce the possibility of the fuse introducing any coupling effects which might cause L.F. oscillation, a 2-mfd. Mansbridge condenser

The Pentode has an exceedingly high magnification factor and is capable of giving really loud signals.

is connected from the valve side of the lamp bulb to L.T. —

The L.F. transformer, which in the original design is a Brown type "A," should have a fairly low ratio in the

overloading the Pentode on very strong signals.

Then there is the special output transformer. The one in the amplifier is a Marconiphone with six terminals. The normal primary connections are  $P_1$  to the plate of the valve and  $P_3$  to H.T. +.

On the secondary or output side there is a choice of ratios, and exactly which terminals should be used is decided by the type of loud speaker employed.  $S_1$  and  $S_3$  are suitable for most high-resistance speakers, and  $S_2$  and  $S_3$  for those of 750 ohms resistance. Two flexible leads are provided from the jack so that the correct terminals may, if necessary, be found by experiment.

### The Flexible Leads

There are three other flex leads. That which goes to the side of the 2-mfd. condenser which is joined to one side of the fuse holder should be connected to the extra terminal on the Pentode. The remaining two are the usual grid-bias leads.

There is little to be said concerning the construction of this amplifier, because it is very straightforward and can be built in an hour or so.

Only two holes are required on the panel, viz., one for the volume control and the other for the loud speaker—filament jack.

The connections to the output transformer are clearly seen in this photograph.

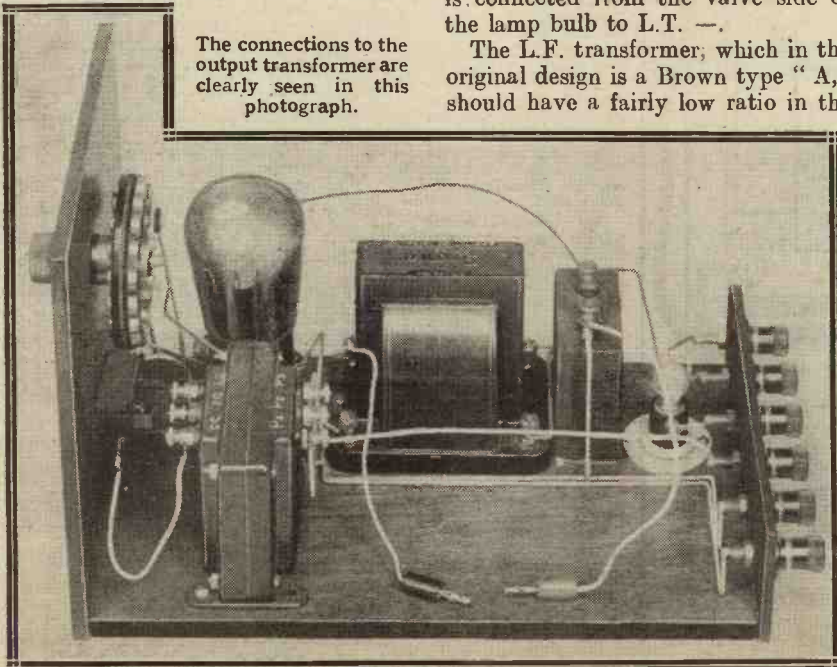

You will no doubt have noticed that the insertion of the loud-speaker plug into the jack automatically lights the filament of the valve.

Drill the panel and secure it to the baseboard with three wood screws along the bottom edge. Then mount

the various components on the baseboard as shown on the wiring diagram.

It will be as well not to screw down the output transformer at first, because of the wiring to the jack. Do this portion of the wiring and then proceed to screw down the output

transformer, otherwise you may have difficulty in placing the leads in position.

Do not forget to leave space for a grid-bias battery as shown in the photographs.

Carry out the wiring with insulation-covered wire in order to avoid short-circuits.

### Connecting Up

To connect the amplifier up to an existing set the procedure is as follows: Looking at the back of panel the various terminals are joined up in this way. Those two on the right go to the 'phone or output terminals of the receiver. H.T. + 1 is taken to a tapping on the H.T. battery, the voltage being the same or a little less than that applied to the anode via H.T. + 2.

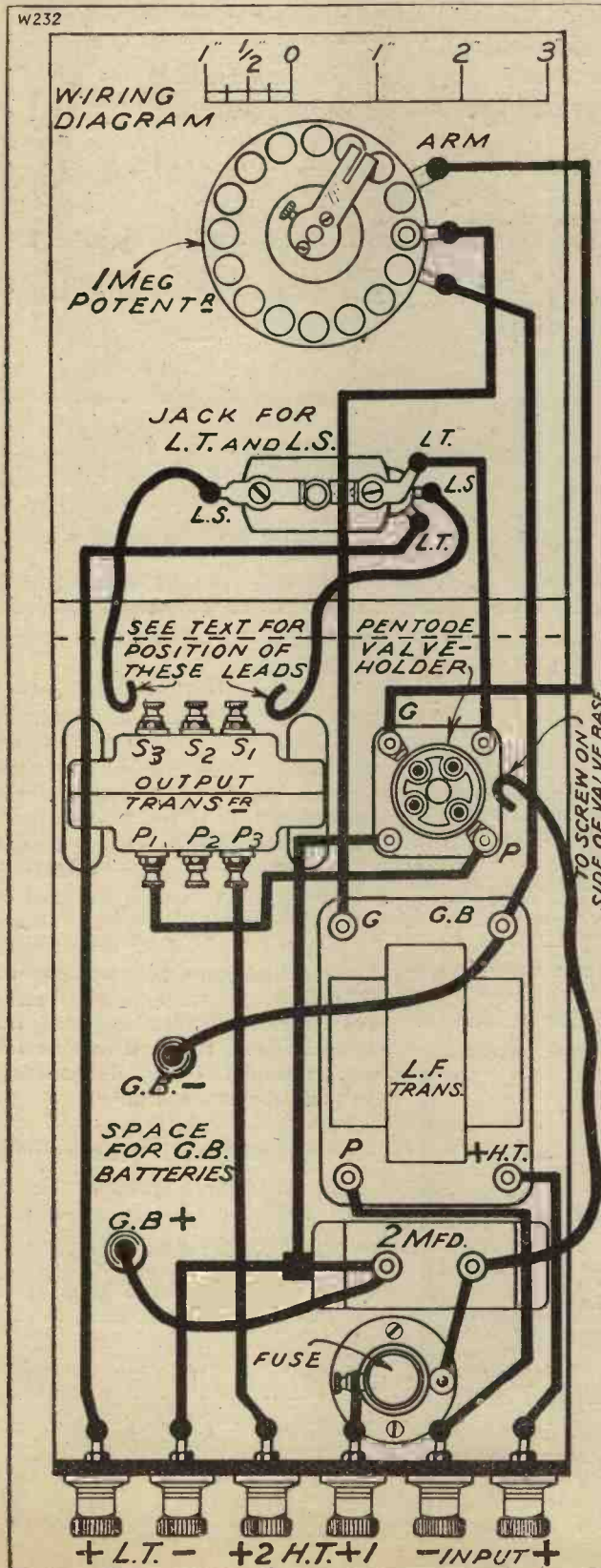

### POINT-TO-POINT WIRING.

Join "Input +" to H.T. + on L.F. transformer.

Join "Input -" to P on L.F. transformer.

Connect H.T. + 1 to one side of fuse, and other terminal of fuse to one side of 2-mfd. condenser.

Same side of 2-mfd. condenser to flexible lead which goes to terminal on side of Pentode.

Join L.T. - to other side of 2-mfd. condenser, to flex lead for G.B. +, and one filament terminal on valve holder.

Connect P terminal of valve holder to P<sub>1</sub> on output transformer.

Join H.T. + 2 to P<sub>3</sub> of output transformer.

Connect G on L.F. transformer to one end of resistance strip on potentiometer.

Join G.B. on L.F. transformer to other end of resistance strip, and to flex lead for G.B. -.

Looking at the jack from the rear, the top spring on the right goes to the L.T. + terminal on the valve holder.

The spring immediately beneath this is joined to a flex lead which is connected to the appropriate secondary terminal on the output transformer.

The bottom spring goes to the L.T. + terminal on the baseboard terminal strip.

The left-hand spring on the jack goes to a flex lead which is joined to the appropriate terminal on the secondary of the output transformer.

The arm of the potentiometer is connected to G on the valve holder.

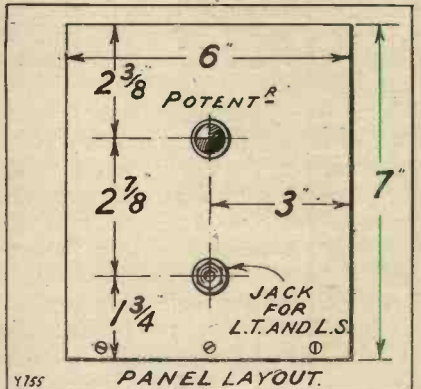

H.T. + 2 is taken to the usual 100 or 120-volt tapping on the H.T. battery, according to the voltage which the constructor has available. The next terminal goes to L.T. - and that on the extreme left to L.T. + on the L.T. accumulator.

There is no H.T. - terminal on the unit because it is assumed that a common H.T. battery will be used for both the receiver and the amplifier.

### Grid Bias

The existing H.T. - connection on the receiver will, of course, suffice. Insert the grid-bias plug in accordance with the maker's instructions which are supplied with the valve. You will need from 7½-9 volts at 120 volts H.T.

It is sometimes found that slightly more grid bias can be used with a Pentode valve than one would think from the maker's curve. It is therefore a good idea to try different valves with the object of finding the best grid bias by experiment. You will note that one of the "Input" terminals on the L.F. unit is marked +. This terminal should be joined to the 'phone terminal on the set which goes to H.T. +.

# The FUTURE of the VALVE

BY Dr J.A.FLEMING F.R.S.



IT is always a difficult matter to forecast the development of any invention. A safe rule to follow is, never to prophesy unless you know.

Any attempt to foretell the future, whether in history, politics or invention, is generally doomed to failure, and the only certainty is that the unexpected will happen.

Nevertheless, as the Editor has asked for some suggestions as to the future of the thermionic valve, the writer has endeavoured to let scientific speculation exercise itself for a few moments on that subject. First of all, casting a glance backward, we find five or six well-marked stages in the evolution of this truly remarkable invention—the thermionic valve. It is an invention which has required the ingenuity of many minds to bring it to its present state; but as an electrical appliance it holds its place for utility and importance in the front rank with the electromagnet and the voltaic cell.

## The First Step

The first step in the creation of the valve was taken in 1904, when the writer discovered that the emission of electrons from an incandescent conductor in vacuo could be used to convert high-frequency alternating currents into a direct current; in other words, could rectify an electric oscillation.

This was done by surrounding the carbon or metallic filament in an incandescent electric glow lamp by a cylinder of metal carried on a wire sealed through the glass bulb. The rectifying valves of the present day

are made in exactly this form, and chiefly used to rectify low-frequency high-voltage alternating currents to provide direct high voltage.

The second stage in the evolution came when it was found that the electronic current to this cylinder could be controlled by the interposition of a spiral of wire or metal gauze cylinder, which third electrode, when made to change slightly in electric potential, fluctuated the electron current in accordance with

John Ambrose Fleming was born in Lancaster on Nov. 29th, 1849. Educated at University College, London, Royal School of Mines and St. John's, Cambridge, he worked for some years under Clerk-Maxwell at Cambridge. In 1882 he joined the staff of the Edison Electric Light Co., and was made Professor of electrical engineering at University College, London, in 1885. It was following upon his researches into the mysterious "shadow" in the electric light bulb that Fleming made the epoch-making invention of the thermionic valve. He was elected Fellow of the Royal Society in 1892.

the electrostatic potential of this grid.

Thus the three-electrode valve or triode came into existence, and its theory and characteristics began to be studied. The third stage seems to have been reached when it was discovered that the fluctuation of grid potential of one valve could vary proportionately the anode current of that valve, and this again, either by the use of a two-coil transformer or resistance-capacity coupling, could be made to fluctuate the grid potential of a second valve, and

so on for several valves in series. It was thus found possible to construct an amplifying apparatus of enormous power to multiply very feeble high-frequency currents thousands of times.

This combined with the method of rectification called "anode-bend rectification" due to the form of the characteristic curve gave us the electric wave detectors of the present day of astonishing sensitivity. No other detectors—crystal, electrolytic, or magnetic—can thus be coupled in series so as to augment sensitivity. Without this power long-distance wireless and broadcasting, except on a small scale, would have been impossible.

## Discovery of Reaction

The fourth important step forward was taken in the discovery that by the inter-coupling of the grid and anode circuits of a triode in a certain way the valve could generate continuous electric oscillations, or convert the direct current from the high-tension anode battery into a high-frequency alternating current.

This was done about 1913, or before, and we thus became possessed of an appliance of enormous flexibility for creating pure sine-wave continuous electric oscillations, the frequency and amplitude of which, within limits, were under perfect control.

This solved the problem of wireless telephony for which the electric arc generator had only been an imperfect solution.

The inter-connection of grid and anode circuits or reactive coupling enabled a still more sensitive receiver

or amplifying detector to be constructed; a plan which had been suggested by Captain Round and Mr. C. S. Franklin even before the use of the valve as a generator of oscillation had been fully achieved.

Then the next or fifth stage of invention was the construction of valves with external water- or oil-cooled anodes. As long as the anode was inside a glass bulb and surrounding the filament it could only get rid of the heat produced in it by electronic bombardment by radiation.

### Powerful Generators

The discovery of a method of sealing metal to glass in the form of a tube or thimble of Invar, a nickel iron alloy having the same coefficient of thermal expansion as lead glass, rendered it possible to produce valves in which by water or oil cooling a jacketed anode could form part of the exhausted bulb. Hence, power to the extent of kilowatts could be expended on it without risk of overheating the anode.

This invention at one stroke gave us powerful generating thermionic

would at present be equipped with any other type of generator than this metal-glass bulb valve. Lastly, we may say that the shielded anode or four-electrode valve marks a definite and sixth stage of advance.

### The Screened-Grid Valve

In this valve there are two grids interposed between the filament or incandescent cathode and the metal cylinder or plate which forms the anode. One of these grids is placed very close to the filament and is the control grid. The other is placed in front of the anode plate and is kept at a certain positive potential.

The purpose of this last grid is to destroy the capacity which would

circuit and therefore the voltage magnification of the valve.

We have, therefore, in these shielded valves a great increase in the amplifying power, and can, therefore, dispense with reaction.

Turning, then, to possible improvements, the first thought which occurs is, naturally, whether we can do anything to increase the thermionic emission from the filament, or effect it at a much lower temperature; in other words, produce the desired cold valve.

### Electron Emission

The emission of electrons from hot bodies has been the subject of an immense number of researches, but, even yet, fundamental questions are not settled.

The source of these electrons is still in dispute. In the case of pure tungsten, heated by an electric current in a good vacuum, the conclusion of Professor O. W. Richardson is that these emitted electrons do not come from the break-up of tungsten atoms thrown out, but are brought into the filament from the filament-heating battery and escape from its surface in virtue of the great kinetic energy they acquire when the metal is heated, that is, when its atoms and electrons are in very rapid vibration or motion.

Certain substances, such as thorium and the oxides of barium, strontium or calcium, have the power of increasing this emission when placed in a layer over the heated tungsten, so that it is greater at a given temperature or equal at a lower temperature to that of uncoated tungsten.

### The "Cold Valve"

This has given us the so-called dull-emitter filament. The increased emission, due to a coating of the oxides of calcium, barium and strontium, was first observed by Wehnelt. Very much research has been expended on testing the emission from all kinds of salts of metals when electrically heated on a platinum strip, but the phenomena are very complicated and consist not only of the emission of electrons but of positive or negative ions.

It has not yet been shown that we can improve permanently the emission from a tungsten or metallic filament by the use of any other coating material than the oxides of the alkaline earthy metals. The only possibility of approaching the desired "cold valve" would be by the discovery of some material for coating a metallic filament or sheet which would

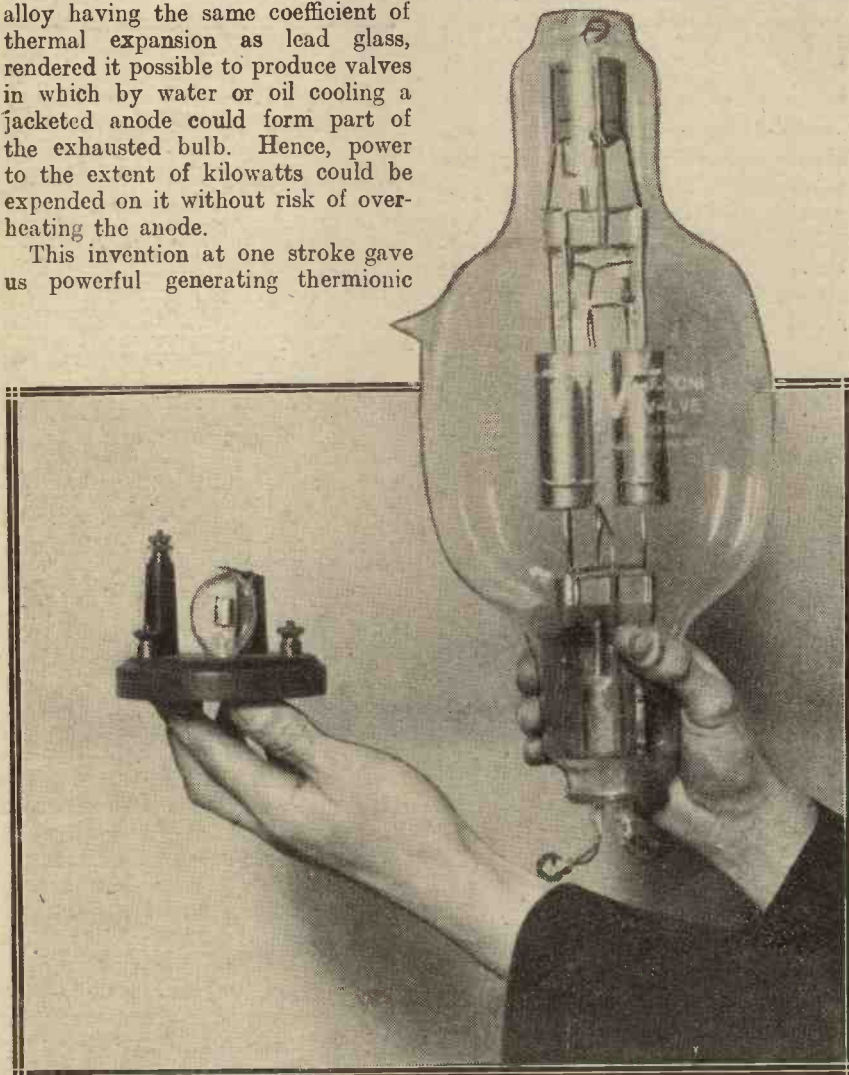

A modern transmitting "bottle" compared with one of the early Fleming valves, which were, of course, of the two-electrode variety and acted as rectifiers only.

valves which rendered antiquated all other methods of producing continuous oscillations, as by the Poulsen arc or high-frequency alternator.

No new large transmitting stations for wireless telegraphy or telephony

otherwise exist between the anode plate and control grid or plate and filament. Any such capacity as Captain Round shows in his book on this shielded valve tends to reduce the impedance of the external anode

increase the emission so much that the metal need not be even visibly hot.

But what is required in a valve is constancy of operation and manufacture. Thus it is possible to make a "soft" valve, that is, one with a not very high vacuum, extremely sensitive, but we cannot in general repeat the manufacture. The only satisfactory valve so far made is the "hard" valve with pure tungsten or thoriated tungsten filament, if we except the oxide-coated filaments of the Western Electric Company.

### Endless Possibilities

I have sometimes thought that the valve of the future might consist of a metallic thimble, welded to a glass extension, the thimble containing a small quantity of some material resembling barium iodide, which emits electrons at a low temperature below red heat, the heat being supplied, in this case, by a spirit-lamp flame so as to get rid of the filament-heating battery.

The possibilities of research in this direction are endless, and we may find some mixture, compound, or alloy, which, when slightly heated in a high vacuum, will emit a copious torrent of electrons and not merely atomic ions.

At present this copious emission of free electrons can only be obtained from tungsten at a high temperature, or from the oxides of earthly metals or thoriated tungsten at a red heat.

The great improvements made lately in photo-electric cells by the use of the hydrides of the alkali metals, and the discovery that a thin layer only a few atoms thick is just as effective as a thick one for photo-electric emission, indicates that perhaps the same may be true for thermionic emission, although the two phenomena are different in nature.

### Short-Wave Transmission

The combination of photo-electric emission and thermionic amplification is necessary for the construction of a light-sensitive cell for television purposes, and this is one very promising line of research.

Another very important direction in which investigation is and should be taking place is in the construction of valves for generation and reception of very short waves, 5 to 10 metres or less in length, but of great power.

The very remarkable qualities of these short waves for propagation round the earth, even more than once round, point out their great advan-

tages. It is well known that the flat-grid aerial of Mr. C. S. Franklin projects not only a main beam but certain lateral beams as well.

If, however, strong waves are used much shorter than the 16-metre wave at present in use in some beam stations, it may be possible to return to the use of skeleton parabolic mirrors at the transmitting and receiving stations which will employ a more defined beam of radiation focussed on a particular point, and so secure greater privacy and freedom from disturbances.

The high-power short-wave transmitting valve capable of making waves 5 to 10 metres or less in wavelength will no doubt be an article of

commerce in the future, even if not at present. There will be no departure from the usual construction, but great and minute attention to the relative capacities and impedances of the various paths and parts.

### "A Complete Revolution"

If we turn then to the uses of the valve we find that in addition to effecting a complete revolution in the arts of wireless telegraphy and telephony, replacing all other forms of generator and detector, rendering wireless telephony and therefore broadcasting practical and possible, the valve has rendered almost equal service to telegraphy and telephony with wire circuits. It gave us the

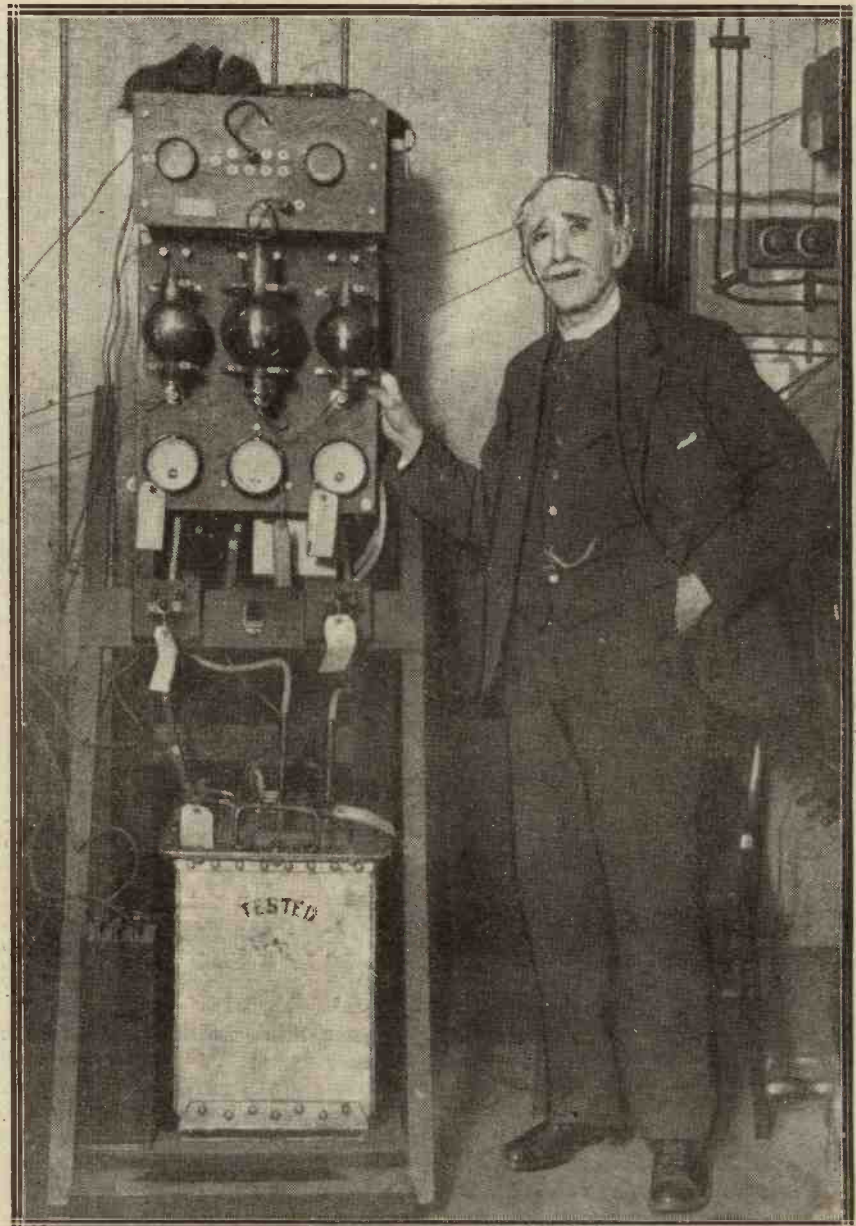

Dr. J. A. Fleming standing beside a modern valve-transmitting panel. It is due to Dr. Fleming's genius that broadcasting as we know it and picture transmission have been made possible.

only really useful telephone relay or repeater, thus enormously extending telephonic range, and in the form of carrier-wave telephony it created multiplex telephony.

But outside these arts of telephony and telegraphy, the rectifying valve, exactly in the form in which it was invented by the writer, has very numerous technical applications. By rectifying high-voltage low-frequency alternating currents we can provide high-tension direct voltages which are necessary in cable testing, and many manufacturing operations; one such application being the precipitation of solid particles from smoke.

It is possible it may yet have great uses in the dissipation of fogs, which are so disastrous to traffic in large cities.

**Application to Agriculture**

I have a strong conviction that the valve rectifier will yet have important applications in agriculture, in providing direct electric currents for stimulating plant growth or more rapid growth of cereals or greater return for a given seed expenditure.

In its three-electrode form the valve has given us a means of measuring changes of length or mechanical movements of extraordinary minuteness, and also small motions, such as the vibrations of bridges under traffic or earth tremors.

It can be used to maintain mechanical vibrations as of tuning forks and pendulums and to synchronise motions in distant appliances.

In its amplifying form it provides means of detecting extremely small changes of temperature and illumination, and has given the astronomer a new weapon of research.

**Measuring Minute Quantities**

In physics its applications are most numerous, in fact, wherever we can generate a very feeble and otherwise undetectable alternating electric current we can amplify it so as to make it possible to detect and measure it.

The valve enables us to measure the electric field or force due to radiation from a distant antenna, and in association with the cathode ray-tube has given us a large amount of information about "atmospherics" due to distant lightning, and also as to the electrical condition of our atmosphere at great heights.

When two oscillating valves having capacity and inductance in their external anode circuits are coupled together, any small change in the capacity of one circuit makes itself

evident by the change in the "beats" produced by the joint action of the two oscillations on a tertiary circuit containing a telephone receiver.

If the capacity of one valve circuit is formed of a pair of parallel metal plates, one of which is fixed and the other displaceable, we can construct in this way a means of measuring the most minute changes of length or small changes of pressure or a micro-balance capable of weighing small masses beyond the reach of any other form of balance.

**Wonderful Properties and Powers**

The valve has, in short, a perfectly endless number of applications in physics and engineering, and no experimentalist in any department of physical or biological science can afford to be ignorant of its wonderful properties and powers.

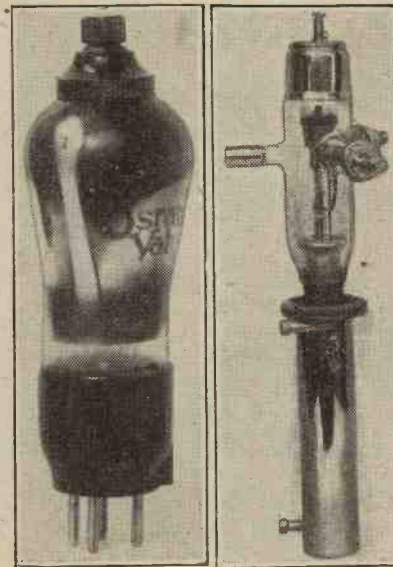

The latest in receiving valves—the famous screened-grid H.F., and a modern water-cooled transmitting valve.

**YOUR ACCUMULATOR**

When mixing distilled water with acid for making the electrolyte for an accumulator, the acid must be poured into the water very, very slowly. (On no account should the water be poured into the acid.)

If the level of the electrolyte in an accumulator falls owing to evaporation, do not replace this with tap water. Only distilled water should

be used for the purpose. Do not on any account add acid (the acid would make the electrolyte too strong).

When adding distilled water to an accumulator to replace losses by evaporation, remember that the battery should be charged immediately after the water is added, so as to "mix" the new electrolyte.

Failure to charge a battery regularly and efficiently is the cause of a large proportion of L.T. battery troubles.

On no account should the liquid from a cell be poured into any ordinary metal container, as the acid immediately attacks the metal, and both will be ruined.

If when charging a battery violent gassing starts, do not let this continue, but reduce the charging rate until the recharging is finished.

Although the separators in an accumulator may last longer than twelve months, it is often advisable to replenish them after they have been in use for about that period.

L.T. battery terminals should not only be kept clean but they should be covered occasionally with a good coating of petroleum jelly in order to protect them against the action of the acid.

**Causes "Local Action"**

Never shake an L.T. battery unnecessarily, as if sediment from the bottom of the cell settles on any of the plates, "local action" sets in and the battery may be ruined.

If distilled water is absolutely unobtainable and it is essential to replenish the electrolyte, as a temporary measure it is better to use clean rain water, thoroughly strained, for this purpose than ordinary tap water.

After a battery is discharged, it should never be stood aside for a few days, as in this condition the plates start to sulphate quickly, which is not the case if the battery is promptly recharged.

Be sure not to lose the little vent plugs on the top of an accumulator, as these play an important part in the maintenance of a cell in its correct condition.

# BROADCASTING IN 1928

by  
THE EDITOR

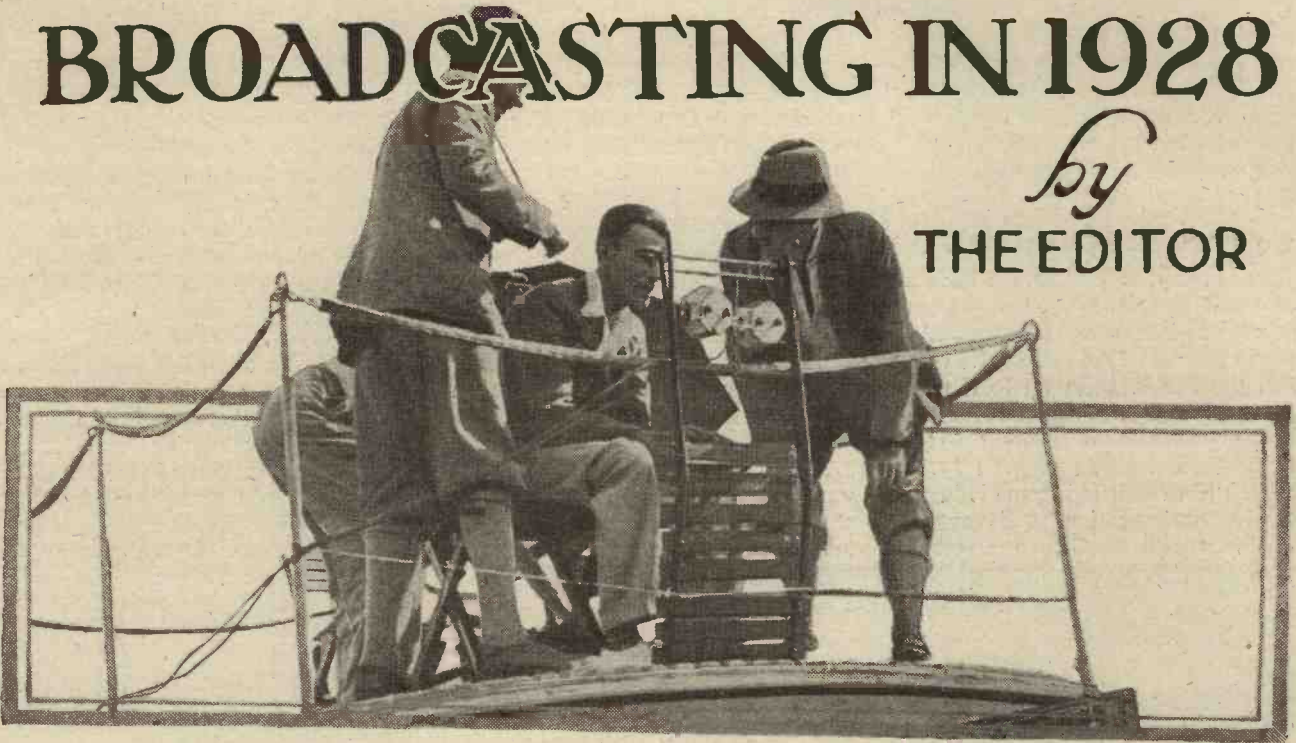

*A review of B.B.C. programme activities during the last twelve months from the listener's point of view.*

AT the end of each of the five years that have elapsed since broadcasting was seriously organised in this country it has fallen to me to survey the work of the preceding twelve months. It was my custom to seek for the big events in the programme year, and then deal with tendencies and averages. Experience told me that the "peaks" of the year provided a sure clue not only to progress, but also to the interesting treatment of the subject.

Imagine my surprise therefore when, in the course of my inquiries at Savoy Hill, I was informed by a competent programme builder that during 1928 there had been no "peaks," as in other years. He told me that this was due to the enormous improvement of the average standard and that it would be useless to try to pick out isolated programme efforts.

## Programme Peaks

While I was prepared to agree that B.B.C. programmes had improved considerably during the year, I was alarmed at the point of view which seemed to absorb consummate satisfaction from a mass-production thesis. Anyway, thrown back on my own resources, I consulted my listening diary and was relieved to discover that my friend had been building better than he knew. The year has not been devoid of superlative

episodes to console us for the terrific mechanical efficiency that holds Savoy Hill in its grip.

Schonberg's "Gurrelieder," conducted by the composer himself under B.B.C. auspices, on January 27th, was an artistic and organising triumph of a high order. Sir Thomas Beecham's symphony concert at Queen's Hall on October 13th, which

opened the new B.B.C. symphony season, was another conspicuous success.

## Outstanding Occasions

The Wireless Orchestra played vastly better than ever before, and the great conductor seemed specially inspired on the occasion of his microphone debut. Of the numerous operas



The past year has been noteworthy for the great interest aroused in television, although it has not yet borne a really practical proposition. The above photo shows an American television experiment in the course of progress at the G.E.C. laboratories at Schenectady.

performed during the year there is no doubt that "Pelleas and Melisande" (Debussy), given from the studios on October 22nd, directed by Mr. Percy Pitt, with Mr. Filson Young as counsellor, was an artistic "peak" in a very real sense.

**Waste of Time!**

The 1928 series of eight special Chamber Music Concerts contained so much "modern" music (sic) that it was no less of a "flop" than its predecessors in 1926 and 1927. When will the B.B.C. wake up to the fact that there is no demand for this exotic confusion of sound? It is worse than a waste of good broadcasting time. There is some influence in the music section at Savoy Hill which regards sanity as a crime!

Ansell has plodded away in the face of great difficulties, and has made substantial progress. But there is still lacking that element of real inspiration which distinguishes the work of the military band, for instance.

Then, again, Mr. Ansell has had the handicap of inadequate facilities for rehearsals, and the curse of chronic deputising. It was hoped that 1928 would see the merging of the chief orchestras of London into a new permanent national symphony orchestra, which might have taken the name of the London Philharmonic.

Although negotiations to this end were initiated and are continuing in a desultory fashion, there is no certainty that the plan will be realised in

dentally it would guarantee good music for Queen's Hall in perpetuity.

On the side of the spoken word, the B.B.C. has a mixed record for 1928. The conception of doing twelve of the World's Great Plays, specially adapted for broadcasting, was excellent in itself. Unfortunately, however, the plays were badly selected, and the production lacked the touch of original genius. Both the Maeterlinck play "The Betrothal," and the Ibsen play "The Pretenders," were wrong choices: neither being representative of the author's best work. Then, again, there was something distinctly unconvincing and amateurish in the actual production.

It is believed that later plays of the series will be better done. I sincerely hope so. It is all very well to strike upon a good and a big idea, but it needs to be carried out with enterprise and thoroughness. I sometimes wonder whether the productions' side of the work at Savoy Hill is as strong as it should be.

**The "Surprise" Items**

It is generally recognised that Mr. R. E. Jeffrey, its head, is a remarkably efficient producer of certain lines of radio plays and light entertainment. But he cannot manage the whole thing himself, and there is abroad the impression that the B.B.C. has starved him of competent professional staff in order to find jobs for officials displaced elsewhere in the business. No, in the matter of straight plays, there is not much to be said about the achievements of 1928 in broadcasting.

But Mr. Jeffrey is not to escape an encomium. His "surprise" items, introduced without announcement on occasional Friday nights after the set programme, have been unqualified successes. The "surprise" on August 4th showed real genius. None of these features has flopped. Touch wood! Go on, R. E. J., but for the love of Mike, don't make them so frequent. You are asking for trouble!

Of entertainment taken as "O.B.'s," of course, the top-notchers have been the relays from the Palladium under the arrangement which has broken the hostile front of music-hall management after five years' hostilities. Van and Schenk began a new era in British broadcasting.

Running commentaries, now absorbed into the fabric of programmes, have been efficiently carried out during the year. The Cup Final, the Boat Race, the Derby, the St. Leger, and

(Continued on page 698.)



Considerable rebuilding has recently taken place at the Radio-Paris station, which is one of the several continentals picked up by most British listeners. This photo shows the new studio which is situated in the heart of the aristocratic Champs-Elysees part of Paris. The call-sign of Radio-Paris is "S.F.R." and the station transmits on a wave-length of 1,780 metres.

This threatens to become a public nuisance, and I commend the scandal to the urgent and early attention of Mr. R. H. Eckersley.

From the standpoint of general public satisfaction there is no doubt at all in my mind that the palm should be given this year to Mr. Walton O'Donnell, who has built up a superb military band at Savoy Hill. The work of this band deserves every tribute it gets.

Hardly as much can be said for the wireless orchestra. True, Mr. John

1929. But the unknown factor is Sir Thomas Beecham, and he can be counted upon to put the deal through, if this is even remotely possible.

**A Mixed Record**

A permanent non-deputising orchestra, drawing inspiration from Sir Thomas Beecham, and handled from day to day by Sir Hamilton Harty, Mr. Pitt, and Mr. Ansell, is the only solution of the B.B.C. problem of finding a way to provide the best available music for listeners. Inci-



# RADIO CHRISTMAS GIFTS



Above is a three-stage B.T.H. receiver and to the right is illustrated the "Cabinet" model of the new Ampion "Lion" loud speaker.

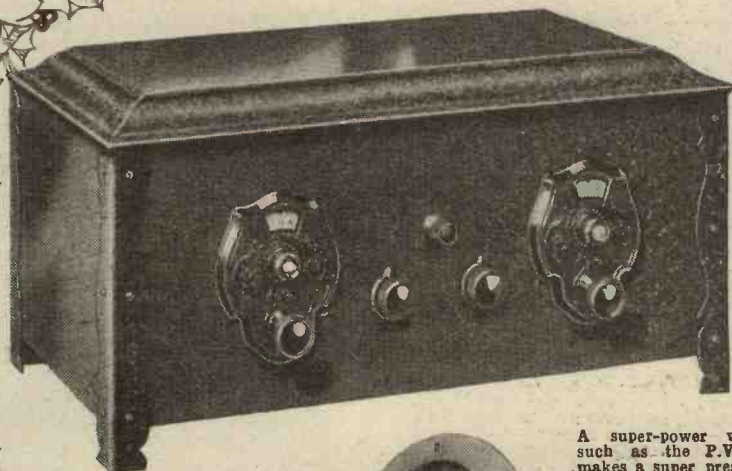

The new Cossor Melody Maker, introduced to the public a few months ago, and already a firm favourite, is shown above.

A super-power valve such as the P.V.225 makes a super present, and another sure-to-please gift is a Blue Spot loud-speaker unit (left).



The Igranic choke-coupling unit (left) incorporates a diagram showing how it is connected in circuit. To the right is a Lissen portable gramophone—just the thing for a lively evening.





Here is the "Cosmos" battery eliminator, whilst a Cameo loud-speaker cabinet is shown to the right. Below (left) is a Magnavox moving coil L.S. unit.

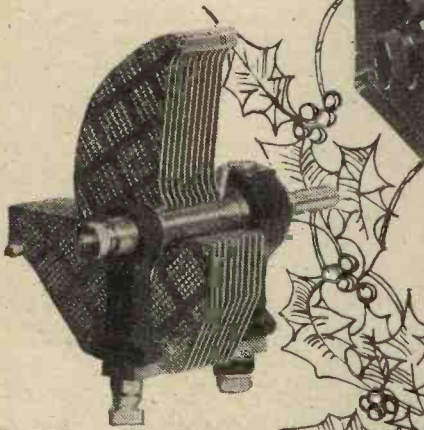

Above (to the right), is a Six-Sixty valve for "H.F." use, and beside it is the Philips "All Electric Three." The compact variable condenser (left) is a "Formo" product.

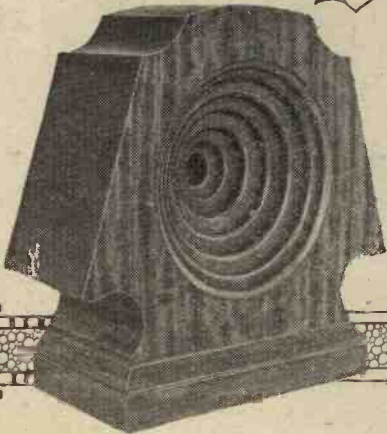

Here a Brown "Sphinx" loud speaker is depicted (left), whilst above is a Burne-Jones standard "P.W." loading coil. To the right is the new Lotus portable set, which is absolutely self-contained, and uses screened and Pentode valves.

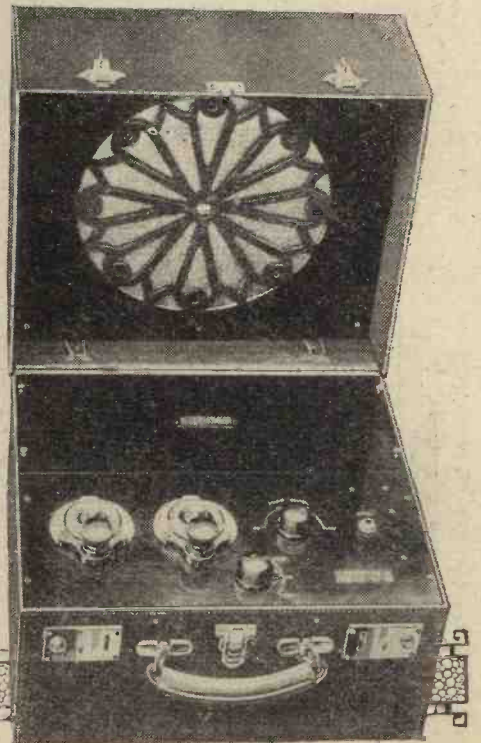

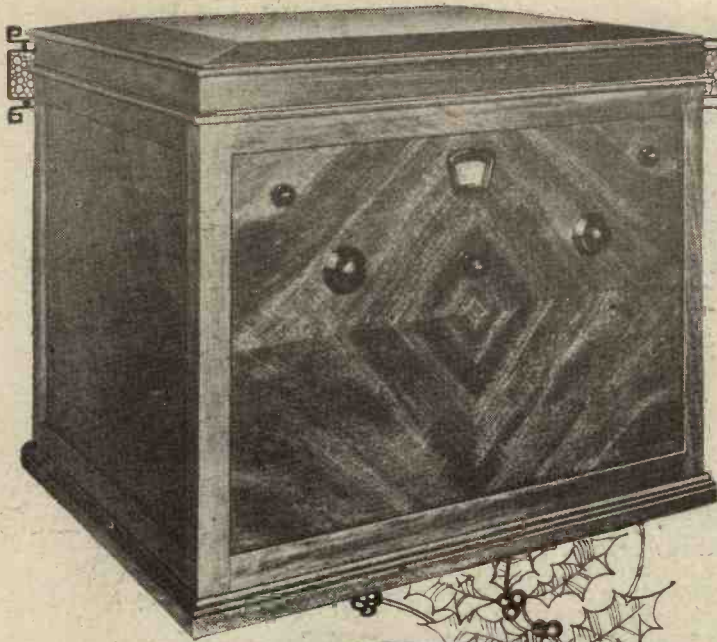

The "All-Mains Four" (left) is an R.I.-Varley product. To the right is a "Majestic" battery eliminator (Benjamin Electric Ltd.)



A "J.B." condenser (right) is a gift that will please any constructor. To the left is shown a Ferranti trickle charger, giving the very useful output of half an ampere.

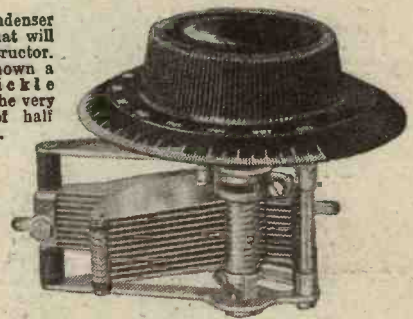

The loudspeaker, instead of being considered an eyesore, is now a handsome article of furniture, as a glance at these pages will show.



Mullard valves (left) and Ever-Ready batteries (below) need no introduction to purchasers. In the lower left-hand corner is an Atlas L.T. supply unit.

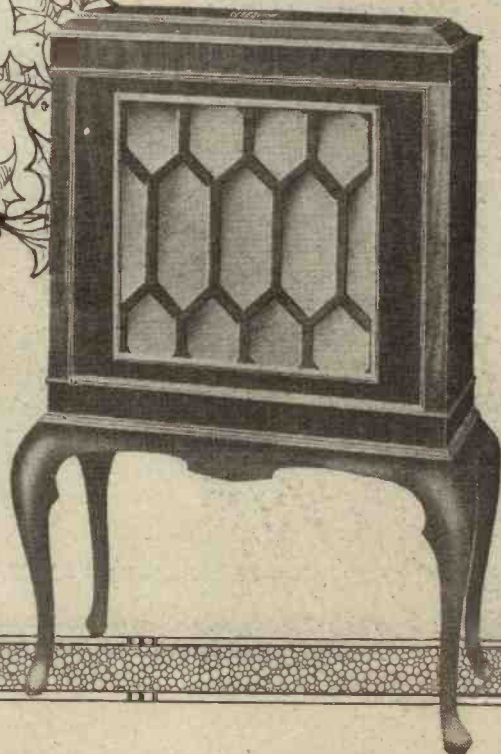

To the left is shown the largest of the popular Celestion loudspeakers.

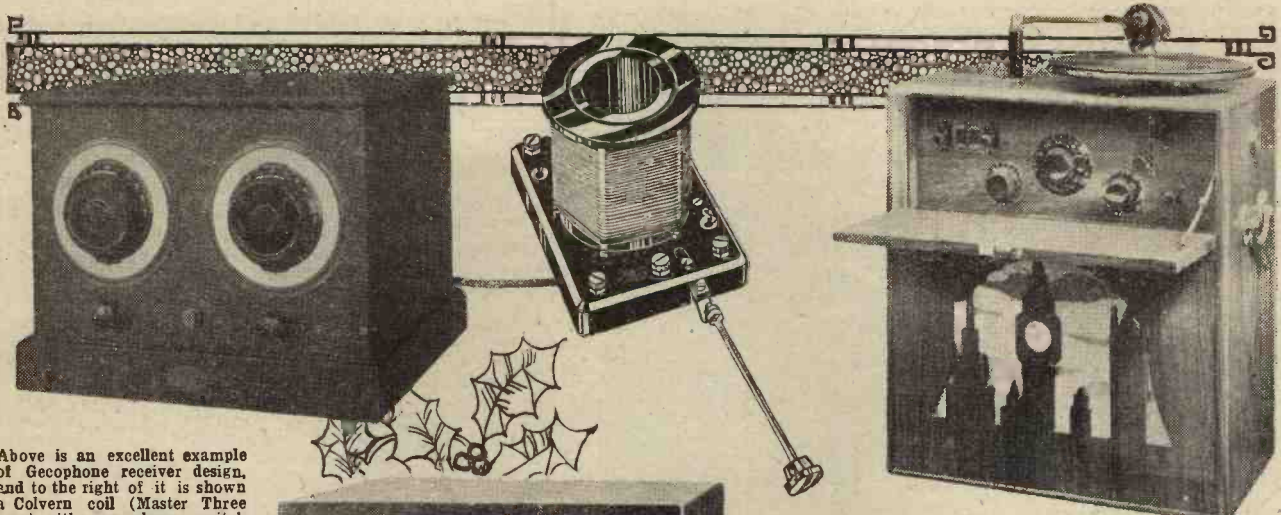

Above is an excellent example of Gecophone receiver design, and to the right of it is shown a Colvern coil (Master Three type) with wave-change switch incorporated in the base. The instrument below is a Westinghouse trickle-charging unit employing the dry rectifier principle which has been popularised by this famous firm. The mains outfit above it (right) is a Gambrell product, and provides grid bias as well as high-tension.



"Ormonds" are the makers of this robust and efficient variable condenser, which is of the S.L.F. type, with a liquid-like smoothness in operation.

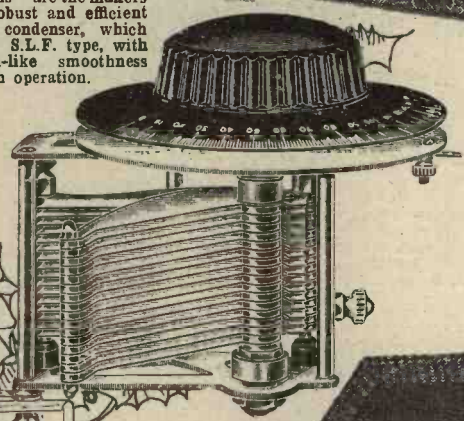

The top right-hand photograph on this page illustrates the "Westminster" portable radiogramophone outfit—a Dubilier product. Immediately below it we see the Peerless "Resonic" Two, which is a ready-to-make outfit requiring no soldering. (Bedford Electrical & Radio Co., Ltd.). At the bottom of the page (right) is shown an M.P.A. loud speaker of the mains-driven type, whilst beside it is one of the famous Lewcos plug-in coils with centre-tapping.

The handsome portable set shown below is an "Orphean" 3-valver (London Radio Manufacturing Co., Ltd.).

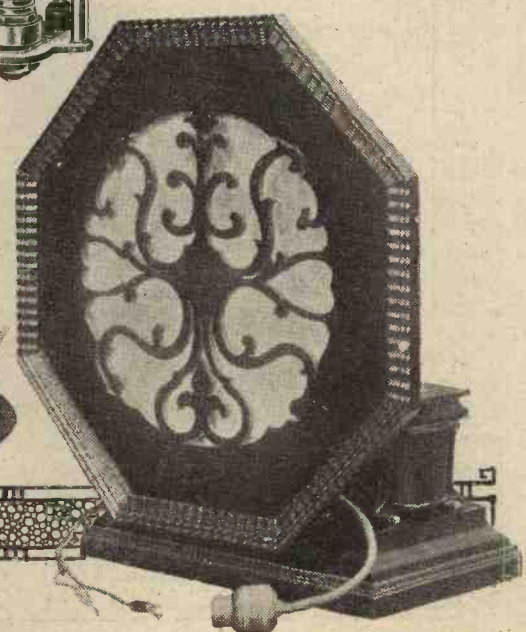
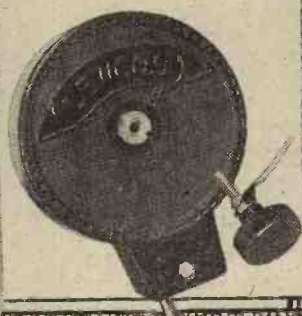
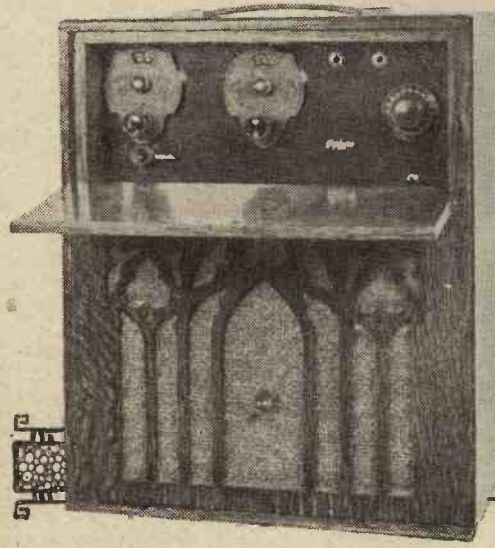

# STRIKING THE RIGHT NOTE!

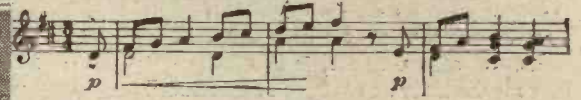

Full constructional and operating details of an easily-made audio-frequency oscillator, with which the amateur can carry out many valuable and interesting experiments.

Designed and described by  
**PERCY W. HARRIS, M.I.R.E.**

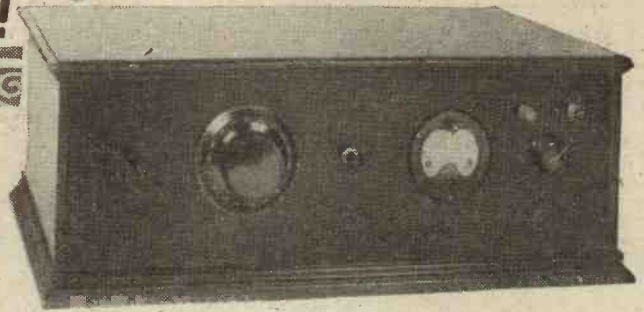

SEEING that the object of every wireless receiver is to produce sound waves, and that our judgment of the receiver will be based

to certain forms of reproduction, that many people entirely fail to notice the falsity of low-note reproduction in practically every speaker other than those of the moving coil type.

Our problems would be simplified if we could rely upon every receiver having a uniform frequency response, but, unfortunately, practically every set is unequal in its tone reproduction, tending to accentuate certain high frequencies and falling off in its response to the low. At the same time, there is scarcely a receiver, made with modern components, that will not reproduce, even if weakly, tones far lower than any but the finest loud speakers can render if only adequate anode voltage and grid bias is used with the correct types of valves.

Moving-coil loud speakers have come very prominently to the front during the last year or so, their remarkably good reproduction of the lower tones having imparted a naturalness to their performance which is

quite uncanny on the first hearing. Yet so easily do we seize upon the form of reproduction pleasing us, that we have rather overlooked the deficiencies of this type of speaker in the upper register. Whenever a loud speaker of any type sounds as if the speaker is addressing you from behind a blanket, the chances are that this speaker is deficient in high-note reproduction.

## Choosing Speakers

Many readers of this journal would probably like to study loud-speaker reproduction a little more carefully than is usually done, particularly when they want to compare various instruments, and to check up the performance against claims.

It may seem easy to have a change-over switch and a good receiver and to compare one speaker with the other by a flick of the wrist. Unless you have actually tried this method with a number of speakers and a number of auditors, you may think it very simple to choose.

### COMPONENTS REQUIRED.

- 1 Panel, 21 in. × 7 in.
- 1 Variable condenser.
- 1 Triple-scale meter.
- 1 Push-pull on-off switch.
- 1 10,000-ohm wire-wound potentiometer.
- 1 Panel-mounting neutralising condenser.
- 2 Standard "M.W." screening boxes.
- 4 Valve holders.
- 6 Cyl holders for baseboard mounting.
- 2 .0003 fixed condensers and clips.
- 2 2-megohm grid leaks.
- 1 .001 fixed condenser and clips.
- 1 1-megohm grid leak.
- 2 Adjustable condensers for baseboard mounting, .001 or .0015 max.
- 1 2-mfd. fixed condenser.
- 1 .5-mfd. " "
- 1 .0005 " "
- 1 Dial impedance coupler.
- 2 Terminals.
- 2 Panel brackets.

upon the degree of fidelity of these sound waves to the original, it is surprising that so many experimenters take the loud speaker for granted and concentrate almost exclusively upon the receiver itself.

### A Difficult Study

At the same time, any careful study of loud-speaker reproduction is fraught with no little difficulty, for, as no loud speaker is yet perfect, the choice of a loud speaker is frequently governed (disregarding for the moment the question of cost) by the chooser's tolerance of distortion. One person, for example, may be less irritated by the exaggeration of the high notes than by a booming or over-emphasis of certain lower frequencies. Again, so adaptable is the human ear

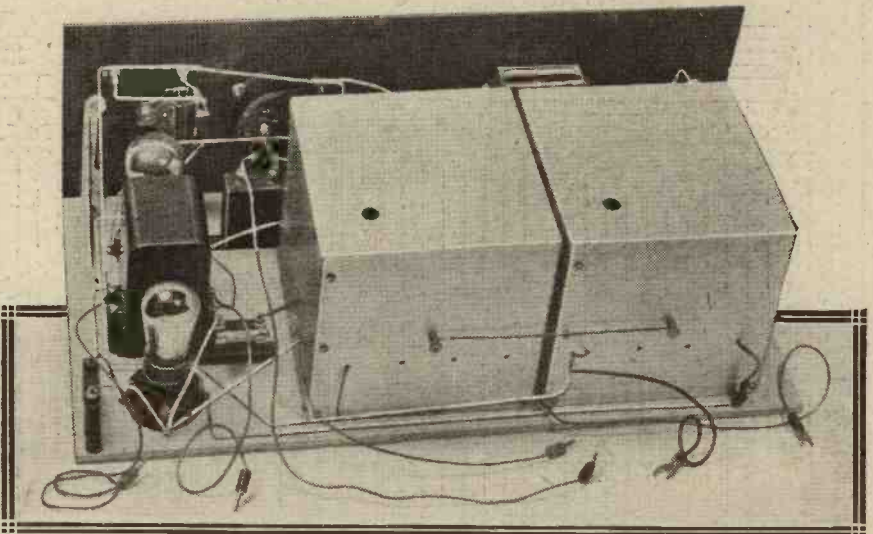

The low-frequency oscillator finally built, after many experiments, by the author. It comprises two single oscillators each contained in a standard screening box, a detector, and a stage of L.F. amplification.

Take half a dozen loud speakers of average quality, distribute them round a room, and by means of plugs and jacks, or any other simple change-over method, try an average orchestral programme on one after the other.

Make a note of which you consider the best and which the worst. Usually you will find that one will strike you as being particularly poor out of, say, half a dozen. Having checked and re-checked your opinion by personal tests, call in one or two other people and repeat the tests with them. Quite likely you will find that the one you picked out as the obvious worst is not placed at all badly in a scale of choice by your friends.

**Accurate Apparatus Wanted**

In the course of my tests and researches a large number of loud speakers come my way, and I long ago gave up any attempt to judge a loud speaker in this way. Firstly, it is rarely that one can pick up a suitable programme for testing at a time when the tests must be carried out; secondly, you may waste a good deal of time in hesitating between a couple of instruments; and, thirdly, an opinion should be made not upon individual preference but upon a genuine fidelity over the whole musical range.

What we want, then, is some piece of apparatus perfectly controllable by the operator which will give a pure musical note of any desired frequency over the musical scale which it is

desired the loud speaker should operate. This means, in effect, that we must have some apparatus which will vary its note from zero to about ten

is quite outside the province of ordinary home experimenting. The first practical alternative which suggests itself is a circuit with in-

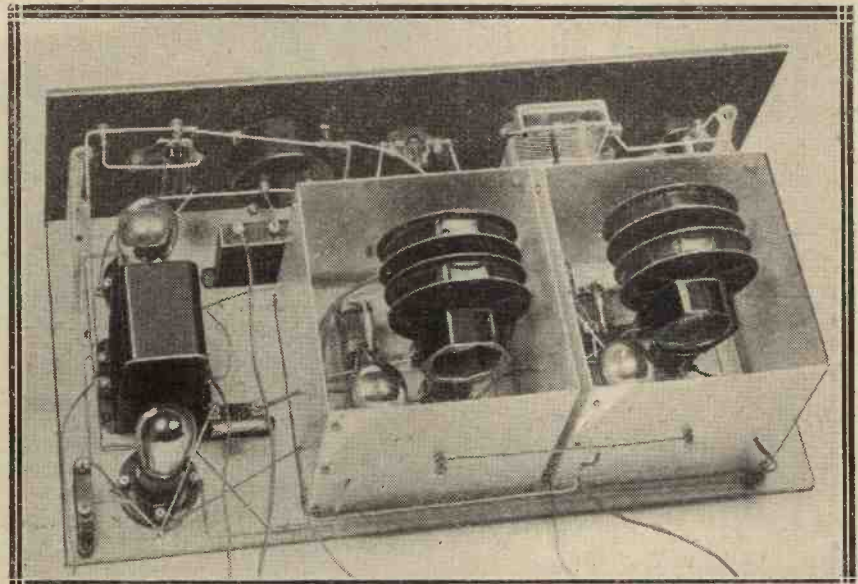

Another view of the oscillator with the lids of the screening boxes removed, showing the three coils used in each.

thousand cycles with, as far as possible, a uniform output, controllable in strength to suit the particular test. A carefully-designed low-frequency oscillator will serve the purpose, and this piece of apparatus can take several forms.

We might, for example, take a pure sine wave alternator of variable frequency over the whole range, but such an instrument, or rather machine,

ductance and capacity, the values of which are so chosen that its natural frequency is the note we wish to produce. Obviously, for a varying note one or the other or both of these values must be variable, but, unfortunately, for a given inductance the frequency range tunable with a practicable variable condenser is quite small, so to carry out our tests over practical range of frequencies for

**THE MOST IMPORTANT MUSICAL SCALE AS EXEMPLIFIED BY THE PIANO**

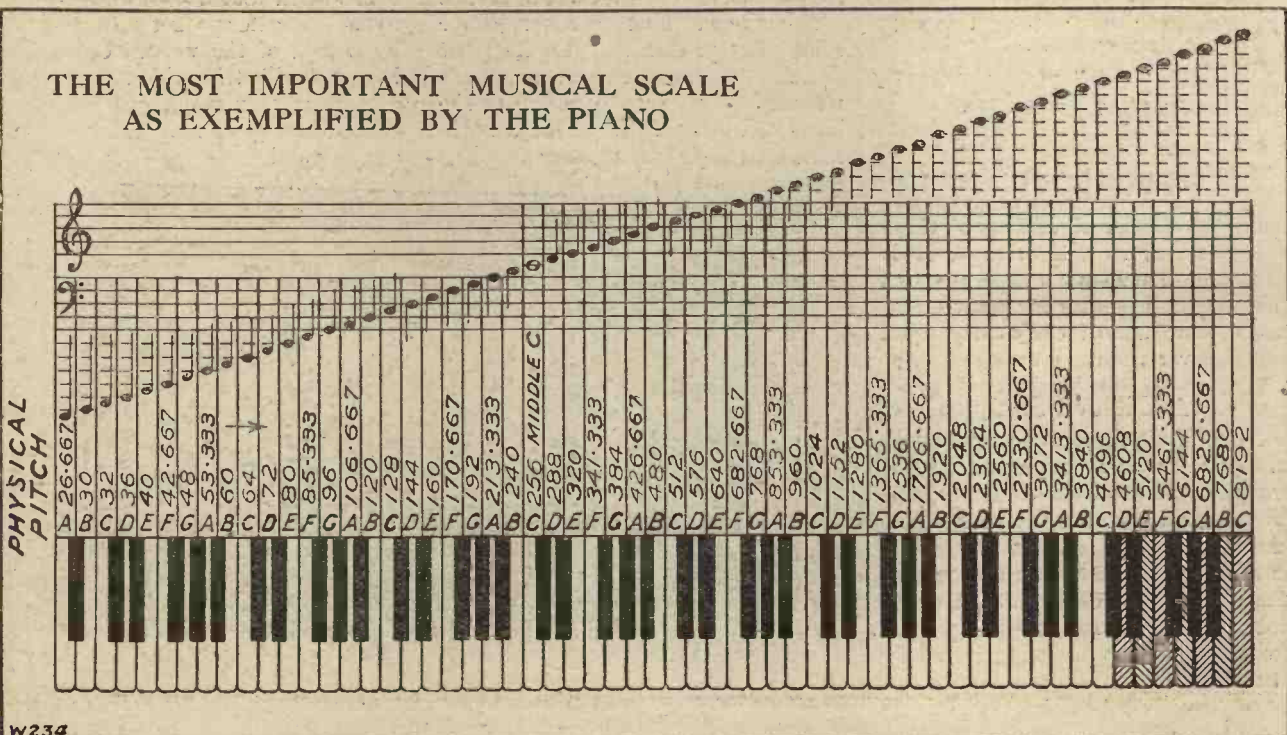

W234

A drawing the experimenter should keep by him for future reference. It shows the piano scale and its frequencies.

loud-speaker testing work we must have a large number of inductance tappings and a large number of condenser tappings. This means, in practice, a multiplicity of switches and a lack of convenience to run over the whole musical scale as continuously and as quickly as we desire.

A third and much more practical scheme is to use a beat-note oscillator, turning to good account the oscillatory howl which is so undesirable a feature in ordinary wireless reception. When I first began experimenting along this line I set up two valve circuits loosely coupled to one another, one of the circuits being that of a pure oscillator, the other of an oscillating detector, the output being taken from the plate circuit of the detector oscillator.

### A Number of Troubles

I soon came up against a number of troubles. Firstly, while quite a good beat-note was obtainable in the upper range, directly the beat-note came to lower frequencies (which meant in effect that the two oscillatory circuits were coming fairly closely into tune) the beat-note would suddenly cease, and one circuit would "pull the other" into resonance with itself with no really low-note reproduction at all.

Secondly, this arrangement is usually productive of a very large number of harmonics, and therefore wasted energy, but the chief trouble was that

mentioned above, namely, the impossibility to obtain a very low beat-note owing to the overpowering effect of one oscillator on the other. A careful study of existing laboratory apparatus, particularly that used in

valve with variable tuning oscillated uniformly over its whole scale.

This point might not occur to the reader at first thought, but any one who has experimented with valve oscillators knows that a set with

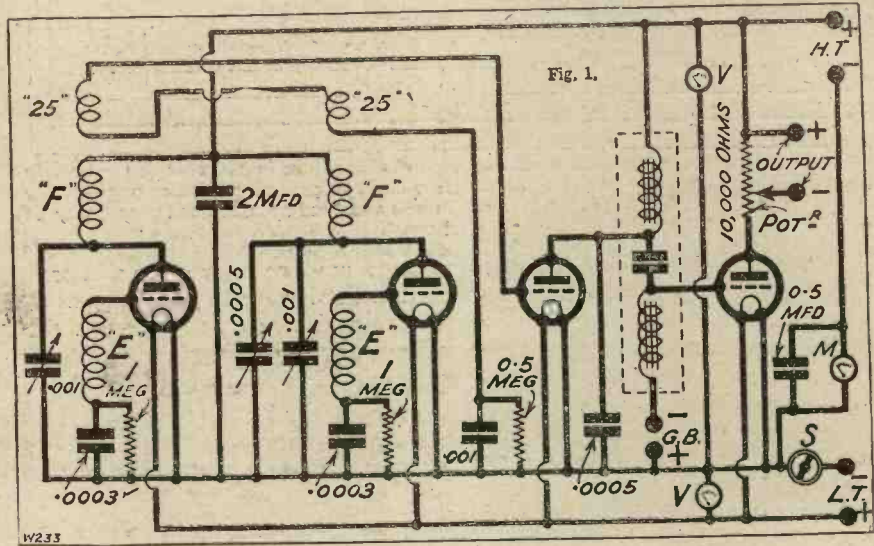

the United States, taught me that the really practical way of overcoming the difficulty was to make two oscillators as alike as possible, one having fixed tuning, and the other variable tuning of sufficient degree to allow the beat-note to go from zero (both circuits in tune) up to about ten thousand. It was also necessary to see that the

practically no capacity across its inductance oscillates far more freely than one with a good deal of capacity. Therefore, it was necessary to arrange the details of this circuit carefully.

Next it seemed wise and practical to let the oscillator valve oscillate alone and not to rectify, for if one introduces into one of the circuits

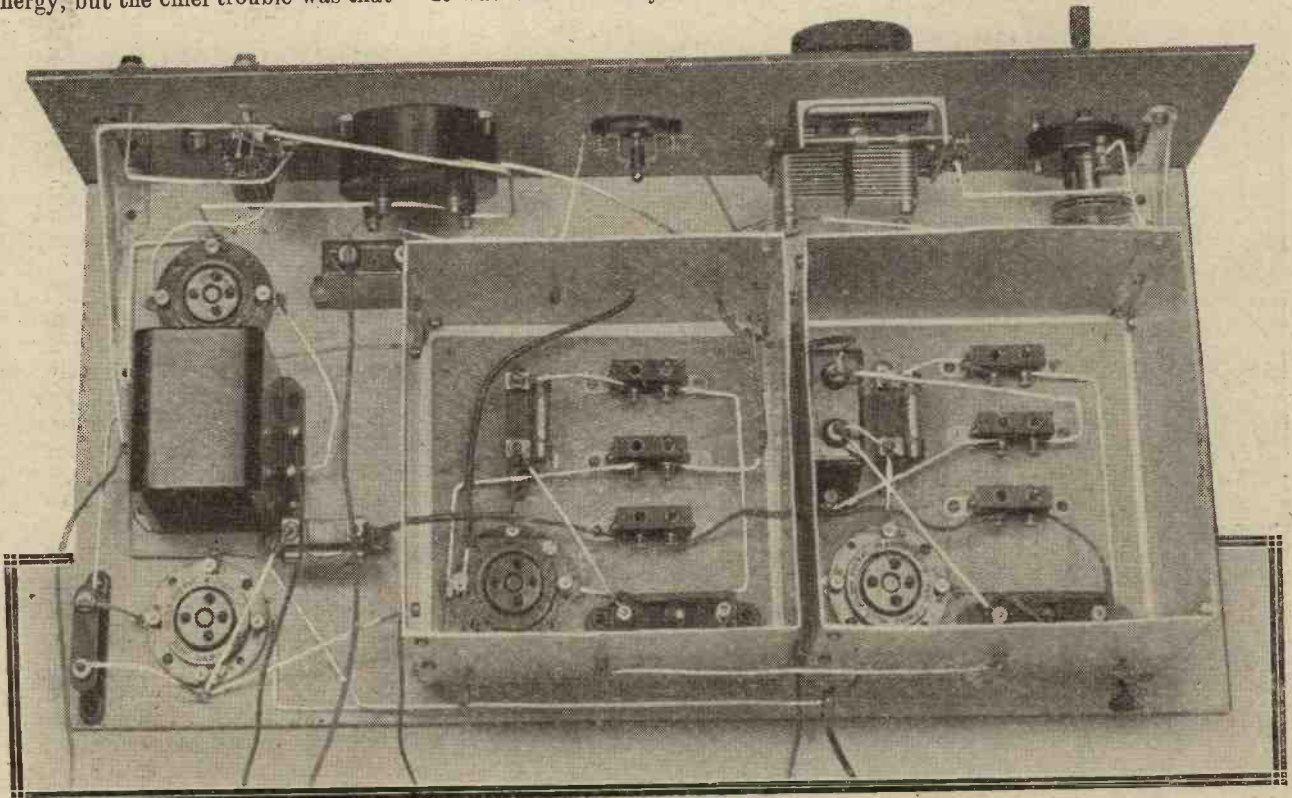

A photograph which will help you both when laying out the components, and when wiring them up. The wiring diagram, which appears in a subsequent page, is drawn to scale, a point well worth remembering when comparing it with the various photos.

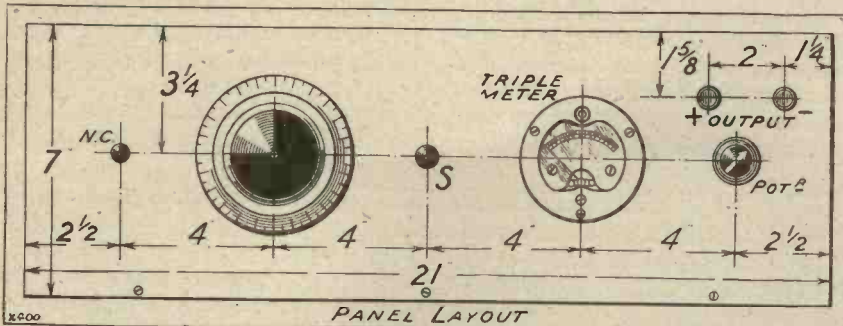

Every serious amateur should have an oscillator of this nature in his radio den. Used in conjunction with a piano—and the piano scale which appears in a preceding page—many interesting, and illuminative, experiments with sets and loud speakers can very easily be carried out.

means for rectifying; the set is not so easily controllable as it would otherwise be. The obvious step to take

was to use two separate oscillators, with a third valve to act purely as a detector. The output, however, of

this valve was not strong enough for practical use on loud speakers, and at least one stage of low-frequency is necessary to follow this. In many cases you will need more, but they are easily added as resistance-coupled stages.

### Excellent Design

The final low-frequency oscillator built up consists of two oscillating valves, a detector valve, and one low-frequency valve. The design is based to some extent upon the very excellent beat-note oscillator made by The General Radio Co. of America, but it has been modified in a number of ways to suit components which are very readily available, and are found—almost all of them—in the work-room of any serious student of radio.

Fig. 1 shows the theoretical circuit. The first valve on the left has an untuned grid circuit with a grid leak and condenser on the filament side, for the purpose of automatically

The oscillator is not really complicated, though care has to be taken in its construction.

This audio-frequency oscillator will very likely teach you more about loud speakers in half an hour than you would otherwise learn in a couple of years!

maintaining negative grid bias. The coil used here is a Gambrell E, and coupled to it by fixed coupling is a Gambrell F coil, with an adjustable condenser (Formodenspr) of .001 mfd. maximum connected between the plate and the filament. The other side of this coil is connected to a 2-mfd. condenser to the filament, and also to high-tension positive.

A moment's consideration of the circuit will show that the coil F is tuned by the .001 condenser in series with the 2 mfd. The second valve is made up with similar values, but in addition to the adjustable condenser a .0005 variable is paralleled with the adjustable condenser. Actually, in the finished instrument this .0005 variable has a small neutralising condenser as a vernier in parallel with it, although this is not shown in the theoretical diagram, and is not absolutely necessary.

### Practical Arrangement

The first oscillator and its coils and condenser are enclosed in a metal screening box, and the second oscillator is similarly screened, except for the .0005 mfd. variable and its vernier, which are kept outside of the box. The tuned plate coil of each oscillator has coupled to it a No. 25 coil, these two No. 25 coils being in series and taken to the grid and filament of the



detector valve, as shown. Practical trial fixed the value of the detector fixed condenser at .001, and a  $\frac{1}{2}$ -megohm leak, although readers may

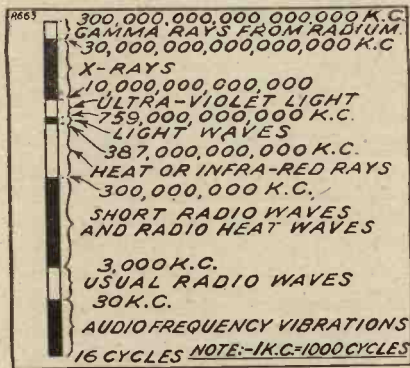

care to change these values when experimenting. Similarly, the grid return of the detector valve is taken to negative after comparison of results between the connections to positive and negative.

The detector valve is connected to the low-frequency valve by a special tuned impedance coupler made by the General Radio Co. of America. This type of coupling has a remarkably uniform response curve, and gives amplification down to frequencies as low as 50, at quite considerable strength. The output of the low-frequency valve is taken through a 10,000-ohm wire-wound Truvolt potentiometer. The actual output terminals are connected one to the positive high-tension and the other to the slider of this potentiometer. In this way the output strength can be controlled to a nicety without upsetting the functioning of the valve.

**Extremely Useful Meter**

For convenience (of course, it is not essential) a triple meter is fitted to read filament volts, plate volts and total milliamperes. This meter, which is of Ferranti make, cannot conveniently be shown as one instrument in the theoretical drawing, so that the three scales are shown as separate meters in their appropriate positions in the circuit.

The first oscillator circuit has a frequency of approximately 60 k.c. and the second is tunable from 50 to 60 k.c. with the .0005 variable condenser. I have chosen a Ripault variable for the tuning condenser as it has a 360-degree rotation, thus giving fine tuning when required, and yet not so fine that the whole range cannot be covered with one twist of the wrist.

Any variable condenser, of course, can be used in this position, but for

reasons just mentioned the pattern chosen has certain advantages.

The frequency response then is from 50,000 to 60,000 cycles, the maximum beat-note variation of 10,000 being thus obtained. It will be observed that the minimum capacity across either oscillator is .001 mfd., and in the variable oscillator the capacity varies from .001 to .0015 mfd. In this way an approximate uniformity of oscillation is

obtainable over the whole scale of the second valve, which would not be the case if one used a smaller plate coil and much larger variable capacity.

Incidentally, a good deal of experimenting was done before the most suitable coils were obtained. By choosing Gambrell E and F coils and a Lissen 25 coil as the pick-up, the reader will obtain a practical working instrument by following the exact spacing shown in the drawings. A list of the actual components used is given in this article, and a few words regarding choice of components

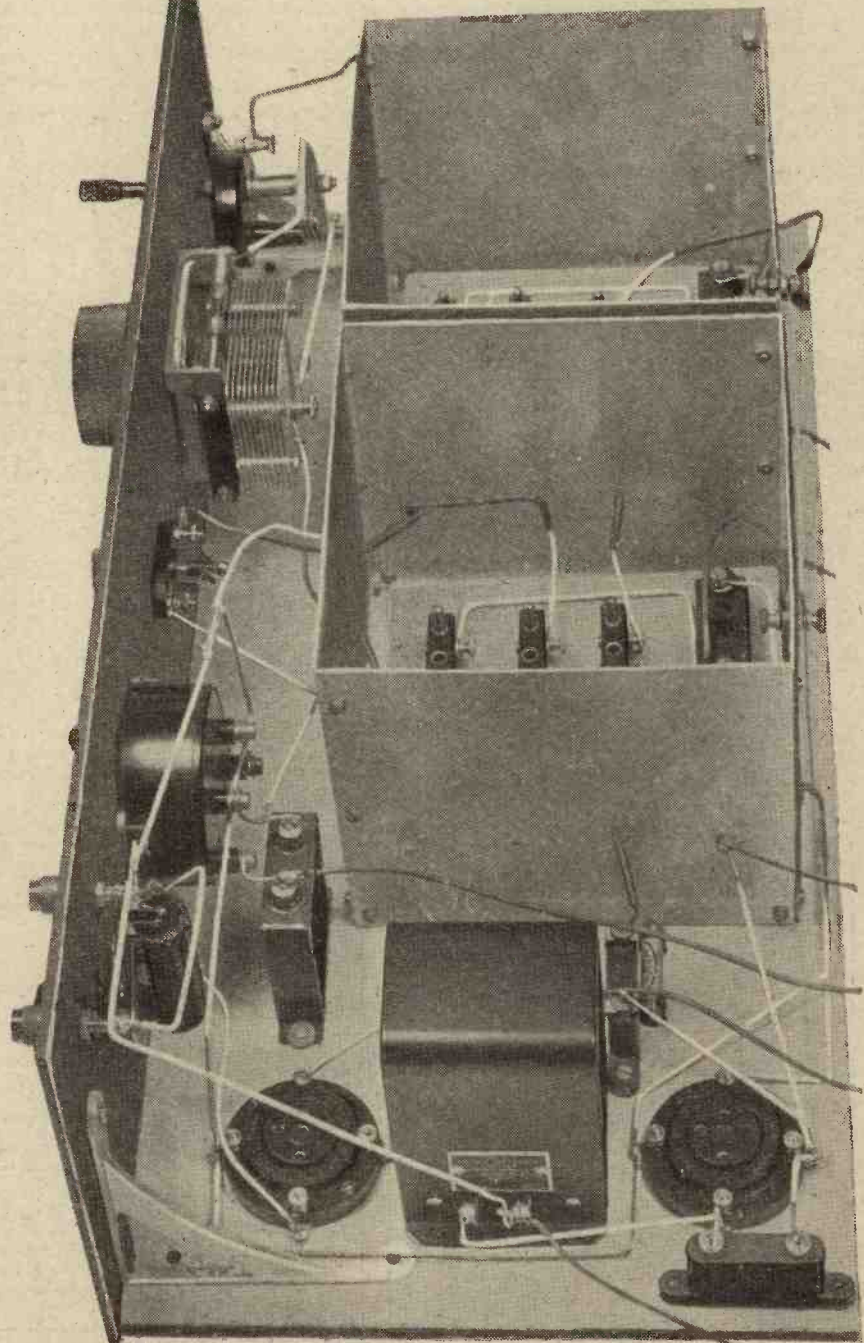

This photo of the Harris audio-frequency oscillator was taken from the L.F. amplifier end. It shows very clearly the triple meter and the potentiometer.

had best be made now. The panel is a standard size, and a standard size of baseboard is used. The metal screening boxes, which can be of copper or aluminium, are the standard "M.W." pattern.

Where leads are taken out of the boxes the standard holes are used, flexible rubber-covered wire being chosen for this purpose. The particular instrument shown is used in a

"over-size" cabinet in which a 2-volt accumulator and the necessary grid-bias and high-tension batteries are enclosed.

All "On Board"

For this reason a terminal strip is not provided, the six leads for low-tension, high-tension and grid bias being flexible rubber covered, but if the reader desires to use the oscil-

lator with external batteries the conventional strip can be used.

For convenience 2-volt valves are adopted throughout, as the small 2-volt accumulator takes very little room inside the cabinet. For the oscillator valve the high-frequency type is used, for the detector a low-frequency type (as this apparently suits the particular form of coupling),

(Continued on page 696.)

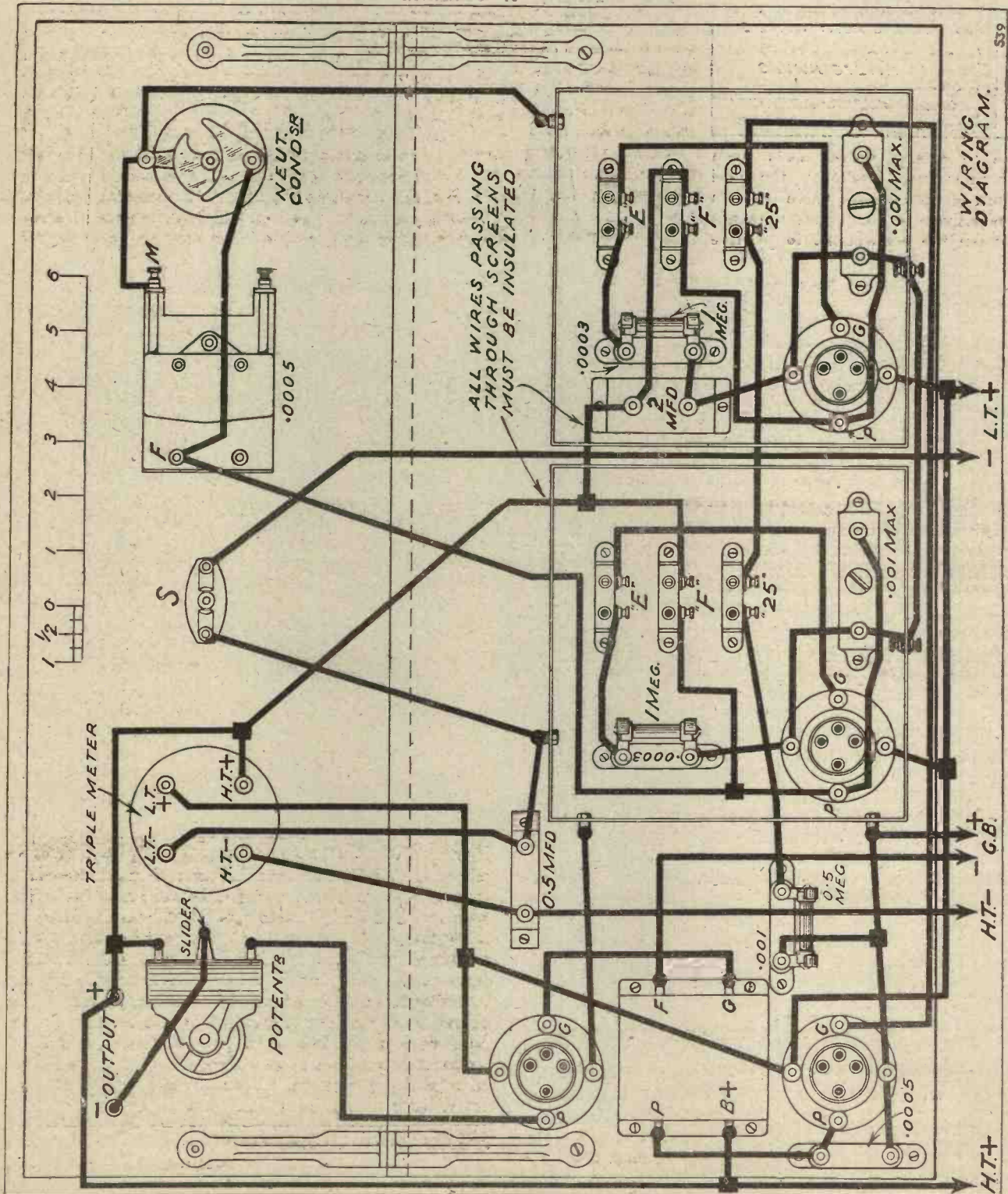

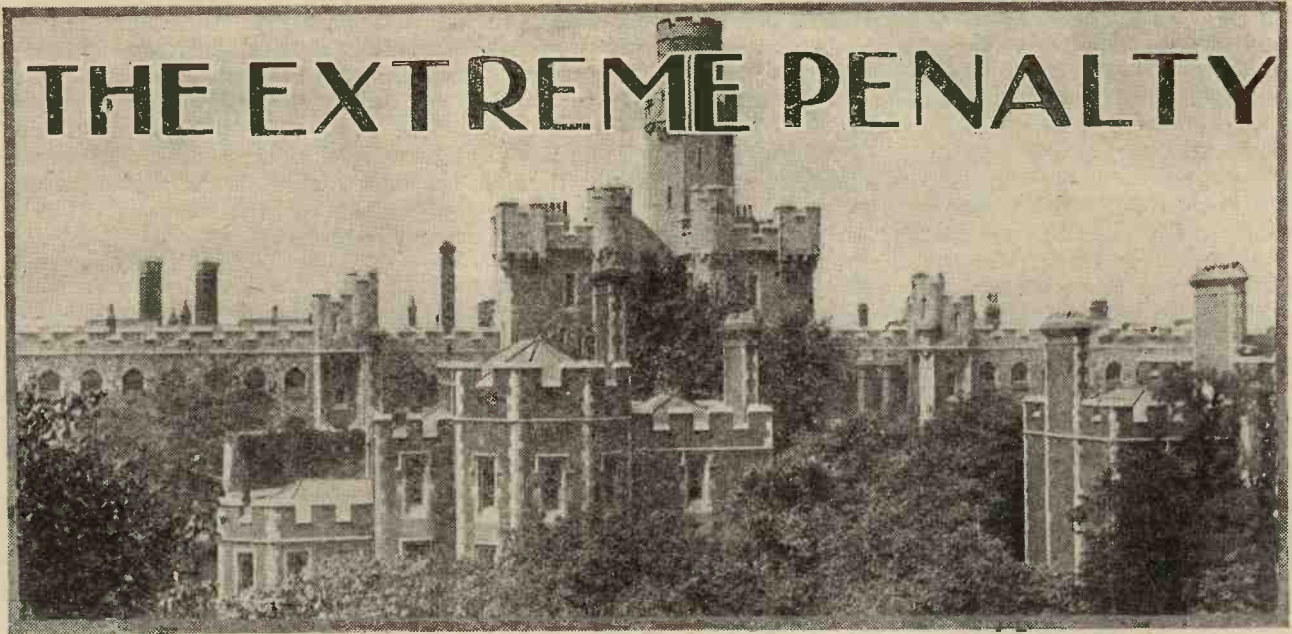

# THE EXTREME PENALTY

*A Sequel to a Recent Broadcast Debate.*

*By Sir Oliver Lodge, F.R.S.*

**T**HE crimes for which capital punishment is legally inflicted have been gradually reduced in number until now the penalty is attached only to what may be considered wilful murder.

That there are degrees in killing is obvious, since they shade off from self-defence, through manslaughter, and on through crimes of passion, to the most diabolical and cold-blooded murder, which sometimes is so inhuman that the criminal is liable to get off on the ground of insanity.

In considering the question of abolition, the different grades of murder ought to be taken into account. At present the law passes the sentence on a distracted mother who makes away with her recently born child; but the public conscience rebels against this, and the penalty is seldom inflicted.

But to take the opposite extreme. There are cases of murder with no motive but to escape the consequence of cold-blooded and prearranged crime. A burglar entering a house for purposes of plunder, or assaulting a peaceful citizen for the same end, must be often tempted to exterminate the victim in order to increase his own chance of escape, and leave no witnesses, in accordance with the proverb: "Dead men tell no tales."

## A Valuable Deterrent

A criminal of this type is often deterred from improving his chance of escape in that way because of the danger he runs if caught, and because of the extra energy that will be expended on the case in securing evidence if murder has actually been committed. In such cases therefore the punishment does act as a deterrent; and since the motive for the original crime is nothing but selfish greed, no mercy need be shown. It is an extreme case of robbery with violence, for which corporal punishment has already been found efficacious.

But in the case of crimes of passion, the thought of punishment hardly enters, and it is probably no deterrent at all. Indeed, how often does it not happen that the assailant turns his weapon upon himself and commits

suicide, showing that in certain violent cases, say, of jealousy, death is no evil, but rather to be welcomed.

Now the object of punishment is not only to deter others, but to furnish sufficient motive to an unbalanced and weak character to refrain from crime. There can be little doubt that theft and dishonesty are diminished by the fear of imprisonment, that robbery with violence has been diminished by the fear of the lash; and it may be expected that easy murder by violent criminals for the purpose of increasing their chances of escape would be liable to increase if they had nothing more to fear than the imprisonment which would inevitably follow their capture for burglary alone.

## Extenuating Circumstances

My view, therefore, is that the infliction of capital punishment should be retained where the motive is nothing but greed and selfishness, but that it is inappropriate where the murder is the outcome of intense human feeling—a feeling which often conduces to the most abject repentance on the part of the perpetrator of the crime.



An aerial view of the prison at Maidstone, Kent, and (above) Holloway Prison.

Offences of a human kind, which are not out of harmony with nature, often carry with them their own punishment, more severe than anything that society can inflict. Nor does society need to protect itself by law against excesses such as these, even if it were able.

The only way of combating them is by the spread of education, better discipline, and by social and enlightened progress generally. Preventive measures in such cases are more effective than penalties after the event.

But now there enter certain psychological considerations as to the state of mind in which crimes of violence are committed. It is often claimed that people are in an abnormal state of mind, or in a state of temporary insanity; and on this ground the attempt is sometimes made to mitigate the punishment. This I hold to be unfair and unwise.

### Fear of Punishment

In so far as the fear of punishment acts as a deterrent on a prospective criminal, the more weak-minded he is the more necessary is it that his motives against crime should be strengthened in every way; the idea of being able to get off on the ground of insanity is not only dangerous but unfair. There may be cases where such immunity is inevitable; but they must be very few.

A weak-minded person with murderous tendencies is no comfort to himself, no benefit to society, and is a blot on humanity; there is something wrong in his system which needs altering. If he can be treated medically, in accordance with the growing subject of psycho-therapy, well and good: that should certainly be tried to the



Crowds waiting outside Wandsworth gaol on the occasion of an execution.

uttermost. But if remedial measures all fail, then the individual thus afflicted is better dead; thereby he gets rid of his diseased body, and under other conditions may have a better chance.

To kill a sane man who has the potentiality of becoming a useful citizen, if the cause of his defect could be discovered and remedied, seems unwise and should be illegitimate. But to preserve a criminal lunatic, who can be no benefit to himself or anyone else, seems foolish; and no hope should be held out to such people, tacitly or otherwise, that they will escape the consequence of their acts. Their motives want strengthening rather than weakening; their inhibitions are defective; and anyone liable to give way to fits of violent temper should have the consequences clearly before him, and be helped to fight his own evil tendencies.

There seem to be a few strange instances where murder is committed through no defect of will or access of passion, nor yet even for the hope of escape, but in a cold-blooded, calculated and cruel manner, like the slow poisoning carried on continuously by a relative, or even by an attendant on an invalid. Such cases must surely be exceptional, and must involve an element of cruelty.

### Special Cases of Cruelty

There are other inhuman cases, as when a child is assaulted and murdered, for which no penalty can be too severe. It is these inhuman crimes, actuated by nothing but selfishness and cruelty, which should entail extirpation from the human family.

No punishment which society can inflict is adequate: the real penalty follows afterwards; and with that we have nothing to do. We can only decide that such persons are unfit to live; though we can bethink ourselves strenuously whether our social conditions are such as to breed people of this kind, and should take steps against the multiplication of the hopelessly unfit. A really cruel and perfectly selfish human being represents a failure of society somewhere. Their existence is lamentable, and their extirpation a regrettable necessity.

What we should work for, therefore, is not abolition of the power of legal extinction, but the infliction of it in only a limited class of cases, not for purposes of punishment, which is hardly our business, but to get rid of a useless danger, and to strengthen the inhibiting motives of those who are insufficiently provided with them, owing to the unfortunate condition of their lives.

It may be said that the present methods of appeal and reprieve already act somewhat in the direction indicated—though reprieve on the ground of insanity is too common. But surely it is desirable that the law itself should be amended, so as not to be out of harmony with the social conscience, and so as to throw the burden of a very difficult decision on some overworked servant of the State.

The duty of passing a sentence which a judge knows is unlikely to be carried out cannot be welcome or satisfactory. Even when accompanied by a recommendation to mercy, such a sentence must be an awful ordeal to all concerned; and, however difficult, it may be possible to secure the same result by other and better means.

### A Fault in Justice?

I feel that the present rather widespread demand for the total abolition of the death penalty is largely influenced by rebellion against this class of case; and that, unless a crime is of such a character as to enlist the genuine indignation of the jury as representative of the average citizen, an irrevocable penalty should not be even tentatively and temporarily pronounced; but that there are certain other cases, sufficiently indicated above, when extirpation of the criminal is the right and proper procedure.

It is sometimes urged, by those fully convinced of survival and continued activity, that criminals of this abominable type may be of more danger out of the body than in it. But that does not follow. We have to do the best we can here on earth.

We know too little of what is permitted elsewhere; and if we are careful not to exceed our rightful powers, then, as in other cases of self-protection, society may be content to leave the future of its mentally misshapen and unwholesome members to higher hands.



The "Shortradyne" is just what the name implies—a compact form of short-wave super-heterodyne. This instrument has been designed with particular attention to economy and simplicity, combined with the maximum efficiency obtainable in the reception of short-wave programmes from all over the world.

By W. L. S.

THERE has always been a certain amount of discussion as to whether the super-heterodyne is worth while for short-wave work, but it is now generally agreed that for telephony in particular it has very marked advantages over the ordinary receiver. In the writer's opinion the super-het has proved so conclusively that its advantages outweigh its disadvantages that there is no longer any room for argument on this score

The "battle" of the future will be not between the super-het and the straight "low-loss two-valver" or similar sets, but between the super-het and the screened-grid H.F. receiver, as far as short-wave work is concerned. Regarding the longer broadcast wavelengths, the screened-grid sets probably "have it" already.

**Not a Complicated Set**

The super-het has, however, a number of features all its own which

help to make it particularly suitable for short-wave work, and once the advocate of the "straight two" can get out of his head the idea that the super-het is something very fierce, complicated, and almost impossible to operate at all, it should become really popular.

The set described herewith has been boiled down to the very simplest form; all complications that have not been considered absolutely necessary have been omitted, and the

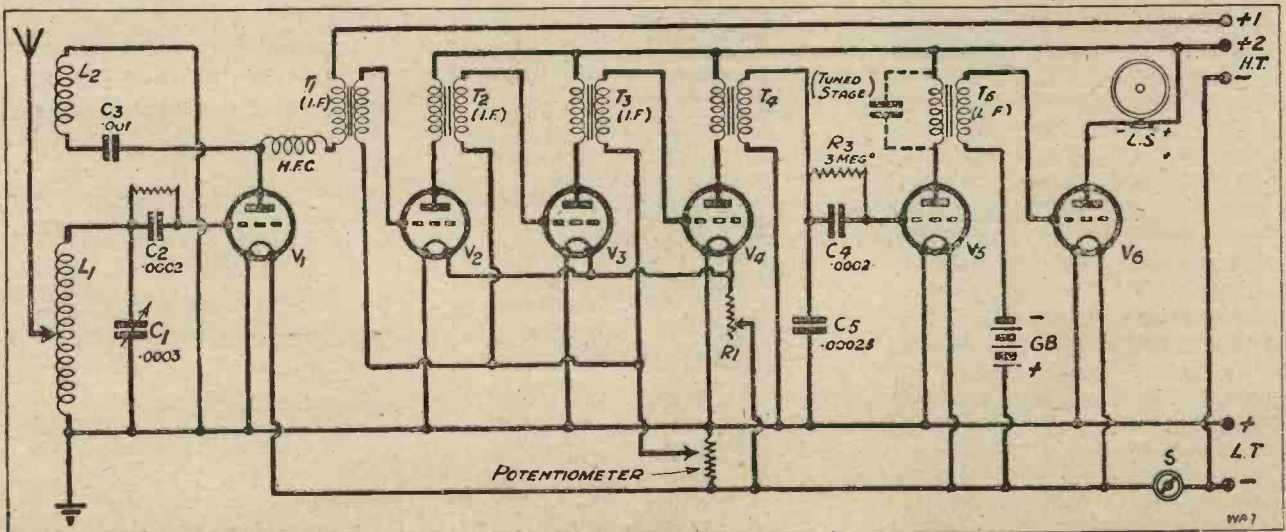

The circuit of the "Shortradyne" is as simple as a super-het can be, and the construction presents no difficulty whatever.

results obtained seem, if anything, to have benefited by this rather than suffering in any way.

It will be seen from the photographs that the baseboard layout is simple—all the wiring is easily carried out, and the components are, as far as possible, symmetrically placed. The panel is simpler still, only three components being mounted on it. These are the one and only tuning control, a potentiometer, and an on-off switch.

"The set has been 'boiled down' to the very simplest form. All complications that have not been considered absolutely necessary have been omitted."

The set may be divided, for the purposes of description, into three parts—the short-wave oscillator, the intermediate-frequency amplifier, and the second detector and note-magnifier.

For the benefit of those who are not thoroughly sure of the theory of the super-het one or two words may be said at the outset. It is well known that the average H.F. amplifier becomes less and less efficient as the wave-length at which it is operating is lowered.

In the bad old days the "experts" would pull long faces and tell us gravely that it was impossible to obtain any H.F. amplification on wave-lengths below about 500 metres. We know now that this was quite wrong, but there is no doubt whatever that, even now, H.F. amplification is far more easy and more efficient at wave-lengths of the order of 4,000 metres than it is in the neighbourhood of 400 metres.

### How it Heterodynes

The super-het makes use of this fact, and, instead of amplifying the signals actually being received from the aerial on a wave-length of 30 or 40 metres, creates an "artificial signal" with a wave-length of 4,000 or 5,000 metres, amplifies it up there to taste, and then detects it in the usual way and hands it on to the note-magnifier.

Most readers of MODERN WIRELESS will be familiar with the principle of the heterodyne, which is that two signals of different frequencies, if these frequencies are close enough together, will produce a "beat-note" with an audible frequency. Actually the frequency of the beat-note is equal to the difference between the frequencies of the two signals.

Thus, if we are receiving a signal on 20 metres, i.e. with a frequency of 15,000 kilocycles, and we create another signal of our own (with a local oscillator or something of the kind), with a frequency of 15,002 kilocycles, we shall produce a beat-note with a frequency of 2 kilocycles; 2,000 cycles is, of course, an audible note, and we shall accordingly hear our beat-note in the headphones without difficulty.

### The Intermediate Frequency

Now, if we move our artificial signal to a frequency of 15,060 cycles, the beat-note will still have a frequency equal to the difference between those of the two signals. We shall thus have a beat-note of 60 kilocycles, a frequency much too high to be

frequency, and that is just what is done here.

The amplifier we use for doing this is called, for want of a better name, the "intermediate frequency" amplifier. It may be regarded as a note-magnifier amplifying a "note" that is too high to be audible. Why it is not called a "high-frequency amplifier" is something of a mystery to many; presumably it was given the other name because a short-wave

The baseboard layout is simple, all the wiring is easily carried out, and there is only one tuning control.

super such as this "starts off" at the very high frequency of about 15,000 kilocycles, and ends up at audible frequencies in the telephones. Thus the frequency at which the amplification takes place is called the "intermediate."

Now, as regards the method of producing our artificial signal, so as to give a beat-note of suitable frequency. The usual method, as far as super-hets for broadcast work are concerned, is to use a separate oscillator, which is coupled to the first detector and always slightly detuned from it, giving a beat-note of 60 kilocycles, or whatever frequency is used for the amplifiers.

This method is undoubtedly efficient for broadcast work, but the separate oscillator seems quite unnecessary for short waves. Considering that we have only to detune from the signal by some 60 kilocycles, and we are receiving the signal at a frequency of 15,000 kilocycles or thereabouts (never at a lower frequency than about 5,000 kilocycles), the percentage of detuning quite obviously will not be very serious.

### A Short-Wave Simplification

For the lower frequencies of the broadcast band (365 metres is roughly 820 kilocycles) it will be seen that quite a severe loss of efficiency might take place if this method were used, and hence the separate oscillator is employed, so that the detector may remain exactly in tune with the signal.

For short waves we are enabled to simplify matters by cutting out this separate oscillator and using a combined detector and oscillator in the form of the ordinary reacting detector. We thus produce our own beat-note by detuning slightly from the signal, just as we produce our heterodyne note (of audible frequency) by

- LIST OF COMPONENTS NECESSARY.**
- 1 Ebonite panel, 21 in. x 7 in. x ¼ in. (Any good branded material).
  - Cabinet for same, with loose baseboard, 11 in. deep (Artcraft, Camco, Raymond, Pickett, Makerimport, Caxton, Bond, Gilbert, etc.).
  - 6 Sprung valve holders (Lotus, Benjamin, W.B., B.T.H., Burndept, Bowyer-Lowe, Igranic, Burne-Jones, Wearite, etc.).
  - 1 Set Intermediate-frequency transformers (Incorporating three "I.F." No. 600, and one "Tuned Stage," No. 610). (Remler.)
  - 1 .0003 variable condenser (Formo de Luxe model in set). (Any good make, .00025 will serve.)
  - 1 Slow-motion dial, if condenser not of slow-motion type (Igranic in set. Any good make).
  - 1 200- or 400-ohm potentiometer (Lissen, Igranic, etc.).
  - 2 Baseboard-mounting coil sockets (Lotus, Burne-Jones, etc.).
  - 1 .001, two .0002, and one .00025 fixed condensers (Dubilier, Lissen, T.C.C., Igranic, Mullard, Clarke, Burne-Jones, etc.).
  - 2 3-megohm leaks (Lissen, Igranic, Dubilier, Mullard, Ediswan, etc.).
  - 1 10-ohm baseboard-mounting rheostat (Lissen, Igranic, etc.).
  - 1 L.F. transformer (Lissen in original. Any good make, R.I.-Varley, Igranic, Mullard, Mareoniphone, Philips, etc.).
  - 1 Short-wave H.F. choke (Burne-Jones in original. Any good make).
  - 1 On-off switch (Lotus, Lissen, Benjamin, Igranic, etc.).
  - 1 Seven-terminal strip and one two-terminal strip.
  - 1 Grid-leak holder (Lissen, Dubilier, etc.).
  - Glazite for wiring, flex leads and plugs for G.B., flex lead and clip for aerial terminal, etc.

audible (10 kilocycles is about the upper limit of audibility). This beat-note of 60 kilocycles will, however, correspond to a signal on a wave-length of 5,000 metres, and, although we cannot hear it, there is no objection to amplifying it at this high

the same means when we are receiving a C.W. signal on an ordinary set.

Thus the "short-wave oscillator" section of the super-het is nothing more than a perfectly conventional single-valve short-waver. It is, if anything, more simple, since with a super-het it is not necessary, to obtain greatest selectivity, to keep the set just on the oscillation point, and we can dispense entirely with the reaction control. Fixed reaction is provided, of a suitable degree to keep the set oscillating over the whole range without allowing it at any point to oscillate hard enough to burst into a howl.

**Purpose of Potentiometer**

Now we come to section two—the "intermediate" amplifier. The only special point about this is the transformers that are used. Low-frequency transformers are designed to give amplification of an equal degree over a wide range of frequencies. These I.F. transformers are intended to do just the opposite—to give a strong peak at one particular frequency.

The last transformer is slightly different from the others, and is styled by the makers a "tuned stage" transformer. Tuning this transformer by means of a variable condenser across its secondary winding is sometimes beneficial, but the makers recommend the use of a .00025 fixed

condenser, and this was found perfectly satisfactory, and therefore adopted.

The circuit diagram will show in detail the arrangement of the transformers. It will be noticed that the bottom ends of the first three secondaries are taken to the slider of a potentiometer. The potentials on the grids of these three amplifying valves may thus be varied.

however, is this—that although the L.F. transformer follows the detector valve, the cheap types of transformer recommended for use as "first stage" will not be particularly satisfactory.

The voltage used on the second detector will be rather higher than usual for a detector valve on account of the large amount by which the incoming signals are amplified before they reach it, and the currents

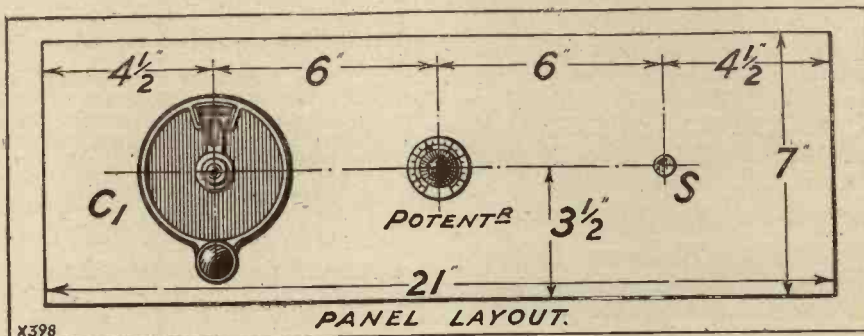

The last secondary, however, is taken down to positive L.T., since the valve to the grid of which the other end is taken is the second detector, and therefore needs a slightly positive potential for most efficient operation.

**A Point to Remember**

The third section of the set—the second detector and the L.F. amplifier—is also quite conventional, and need not be dealt with at any length. One point that should be remembered,

flowing in its plate circuit will be accordingly high. A good make of L.F. transformer is, therefore, essential.

It is interesting to note that a cheap type was incorporated in the set when it was first constructed, and on making the substitution for the transformer at present in the set an increase in volume of fully 100 per cent was obtained. Members of the technical staff were present at the time that this was done and can vouch for the extraordinary difference! The

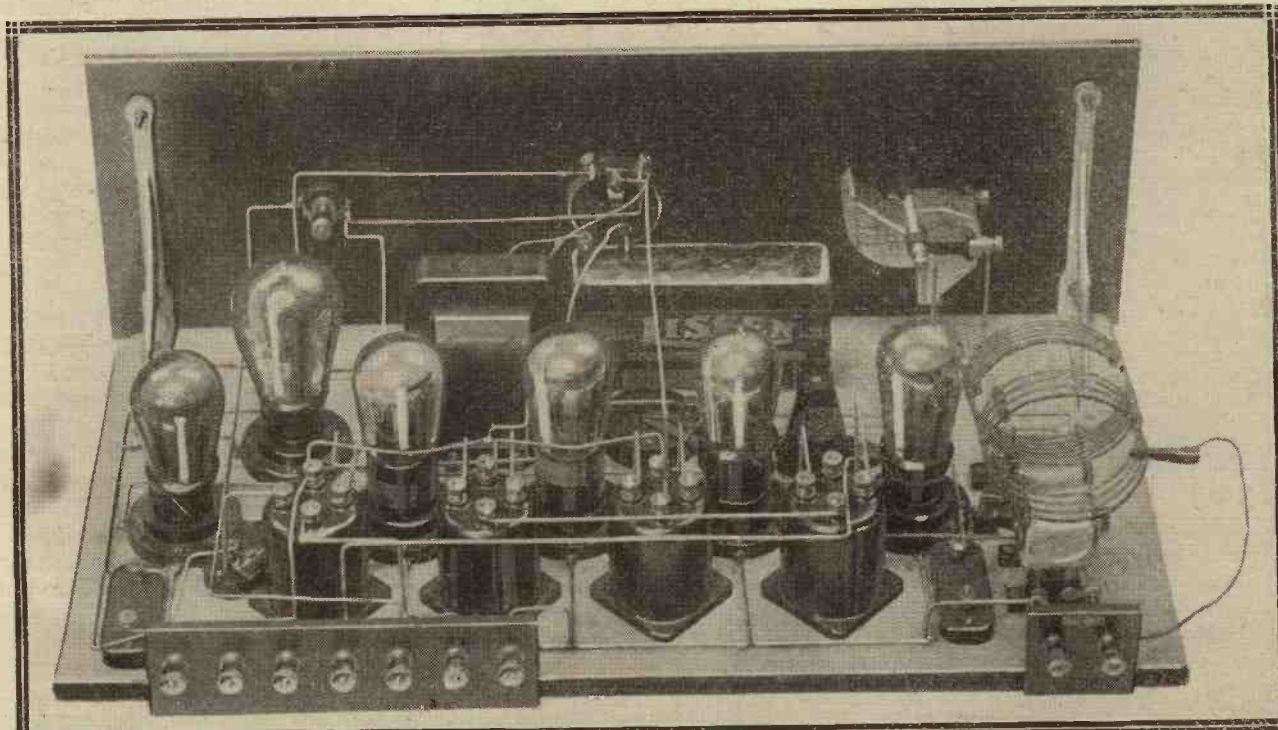

Considering the great amplification obtained the simplicity of the layout and wiring is extraordinary, and is, of course, a great advantage in construction.

two transformers gave almost identical results in a small two-valver.

With regard to voltage regulation, etc., the following few points should be noticed. In the first place, only two H.T. terminals are provided. One of these supplies the necessary potential to the plate of the short-wave oscillator, and as it is always as well to experiment considerably with the detector H.T. in a short-waver, it is not advisable to mention any particular value. This will be left to the reader's discretion. Generally speaking, however, the voltage should not exceed 75. The other terminal supplies the H.T. to all the I.F. amplifiers, the second detector and the note-magnifier.

### Constructional Considerations

One filament rheostat has been provided, and this is in the common lead to the filaments of the three I.F. amplifiers. The other three valves all operate direct from the accumulator, whether 2-, 4- or 6-volt valves are employed. It is sometimes useful to be able to control the filament voltage of the I.F. stages, however, and in the writer's case 6-volt valves were used for the other three, and 4-volt valves for the I.F. stages.

The potentiometer is connected across the full six volts (or whatever voltage is employed), but, of course, on the "set" side of the L.T. switch, so that it is not drawing current from the accumulator when the set is switched off.

it. The transformers are not provided with soldering tags, and it would probably pay to procure some of the right size and to fit them. If the original layout is not followed in every detail, take care that the transformers are mounted sufficiently far forward from the rear edge of the baseboard to allow room for all the battery wires from the terminal strip. Severe congestion is otherwise likely to occur.

"The 'short-wave oscillator' section of the super-het is nothing more than a perfectly conventional single-valve short-waver. It is, if anything, more simple, since with a super-het it is not necessary to keep the set just on the oscillation point, and we can dispense entirely with the reaction control."

Nearly all the wiring of the components on the baseboard can be completed before the panel is affixed at all. The latter, with its three components properly mounted, can be tackled after all the places that would otherwise be "awkward corners" have been finished.

### Tips on Tuning

When the receiver has been completed, go over the wiring with more than usual care, comparing it with the diagram from which you work and also, if you can, with the theoretical circuit. Remember that there are several components which are rather expensive to replace should there be a "burn-out," apart from the valves. The set being ready for test, insert

In short, any valve with a mag. of about 17 and an impedance between 17,000 and 30,000 ohms.

For the intermediate-frequency stages, almost any valves intended for high-frequency amplification or resistance-capacity coupling will be suitable. For the L.F. amplifier a good power or super-power valve is required, examples being the D.E.5a, Stentor Six, P.M.256, P.M.6, P.625, etc.

Now connect up the batteries,

giving the note-mag. about 9 volts negative grid bias and a plate voltage of the order of 100 or 120 volts. The first detector, as previously mentioned, should not receive more than about 70 volts or so.

Insert coils in the short-wave oscillator as follows, according to the wave-band you wish to cover.

Igranic or Atlas coils may be used, since similar turn numbers are employed.

40-80 metres. A.T.I. 9 turns, reaction 6 turns.

27-42 metres. A.T.I. 6 turns, reaction 4 turns or 9 turns.

19-30 metres. A.T.I. 4 turns, reaction 6 turns.

The clip on the end of the flex lead from the aerial terminal should be taken to a point about one turn up from the earthed end of the coil. With the potentiometer slider roughly at the mid-point of its travel, switch on the set.

Swinging round the oscillator condenser  $C_1$ , one should now hear signals of all kinds. There should be no whistles or shrieks of any kind, but C.W. signals will be received as a series of clicks, with any modulation that they possess "breaking them up," and telephony should sound just as it does on an ordinary receiver well below the point of oscillation.

Settle on a good steady signal of some sort, and gradually swing the potentiometer round towards the negative end of the scale. A fairly definite point should now be found at which the signal breaks into an audible beat-note as the I.F. stages commence to oscillate.

The general effect is very similar to that obtained when an ordinary receiver is tuned in to a signal while not oscillating and then brought up

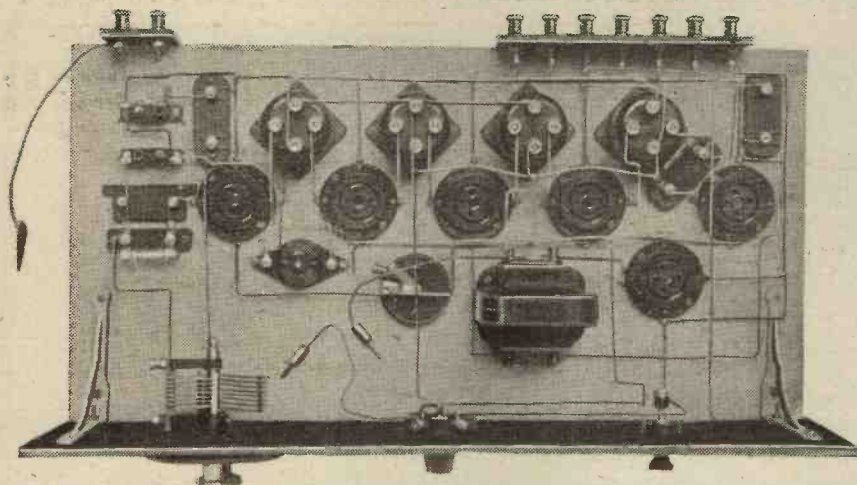

Here is a plan view of the set, and it will be noted that the intermediate stages are extremely easy to wire, the connections being symmetrically disposed throughout.

The constructional work, considering the size of the set, is very straightforward, and should offer no trouble to the average reader. The "I.F." portion of the set is notable for the simplicity of the wiring, short leads from the transformers to the valve holders forming the greater part of

valves of suitable types. Appropriate 6-volt types will be mentioned, and those who use other voltages will be able from these to determine the best valves for their own purpose. Probably the most satisfactory are as follows: First and second detectors, H.L.610 class, P.M.5X class, etc.



to oscillation point fairly gradually, except that in the case of the super-het the "slide-in" is rather more smooth.

Set the potentiometer just "behind" this point—i.e. so that the intermediate stages are just *not* oscillating, and there should be no need for further adjustment. Unless extensive C.W. reception is to be carried out it will be found preferable not to let the I.F. stages oscillate at all.

Should the set break into a squeal at either the top or bottom ends of the tuning scale, the first detector is oscillating too hard, and the H.T. voltage should be reduced or the degree of aerial coupling increased, which is to say that the tap should be moved higher up the coil, farther away from the earthed end.

### Keep Aerial Coupling Loose

This rough control of the damping effect of the aerial forms quite a useful control of reaction, and it may be found worth while, when you have the "feel" of the set thoroughly mastered, to insert a "Formodenser" or a small neutralising condenser between the clip and the aerial coil, as a more simple means of adjusting it than the movement of the tap.

It should be clearly understood that for the set to operate at all the short-wave detector *must*, of course, be oscillating. Even for the reception of telephony this is so, and for this reason the aerial coupling should be as loose as is consistent with good results, out of consideration for others in the immediate neighbourhood. In actual practice, the writer arranged for a friend to listen to 2 X A D on 22 metres at the same time as he was trying out the super-het on that station, and nothing was heard whatever of any interference from the super.

### Melbourne Too Loud!

Regarding results, as has already been said, the excellence of this type of set shows up chiefly on telephony. If a search is made with the I.F. stages oscillating, a carrier-wave modulated by telephony will probably be found.

If now the potentiometer is moved towards the positive end of its travel, thus stopping the oscillation of the intermediates, the telephony will be received at a strength some 200 or 300 per cent greater than was that of the carrier-wave originally. The effect is the reverse of that obtained with an ordinary detector with reaction.

3 L O, Melbourne, on his usual wave-length of 29 metres or so, has

been put on a moving-coil speaker on several occasions at sufficient strength to fill the whole house. As a rule, on a good night, he has to be detuned for comfort's sake, and late at night he has once awakened a protest from neighbours! 2 X A D is even louder, and can very seldom be tuned right in.

### Remarkable Reliability

The bunch of C.W. stations round 2 X A D sounds very peculiar with their unmodulated successions of "thumps," but they serve as a useful indication of conditions, since they are rather more constant than 2 X A D himself (most of them being nearer), and if they are all up to scratch

The various amateur transmissions of telephony in the neighbourhood of 45 metres come in at astounding strength at times. Several of the French amateurs are now putting out really excellent "phone" instead of the "raw A.C." which used to be their favourite method of transmission. German stations have also been heard

Six valves—  
but see how  
simple the  
wiring is.

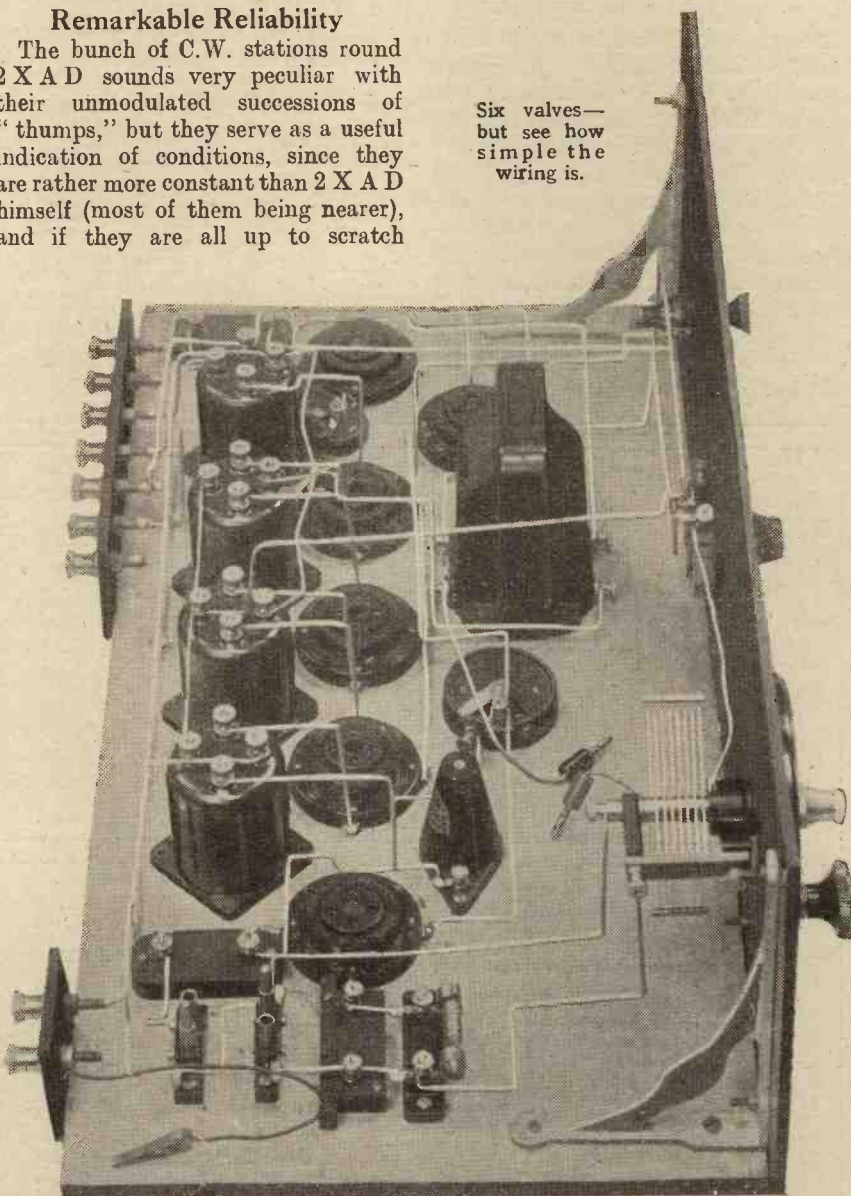

By arranging the components as shown the wiring can be made short and extremely easy to carry out.

and 2 X A D is not, it is safe to blame the weather conditions and not the set!

Actually one does not notice variations in conditions with a super-het to anything like such a great extent as with an ordinary two-valver. Where, on the latter set, 2 X A D or 2 X A F may be but half as strong one night as on the previous one, the super rarely shows a difference of more than 20 per cent or so.

in quite large numbers, and our own men are, of course, exceptionally numerous and loud.

It will, by the way, be noticed that every station comes in on two separate positions on the tuning control. This is an inevitable factor with the super-het, and is due to the fact that our 60-kilocycle beat-note is produced when the oscillator is either 60 k.c. above or below the signal. As a rule no interference will result from this,

since the two positions are sufficiently far apart to be quite clear of any other stations working close to the one to which the set is tuned.

If the set is required for the reception of C.W. it appears to be perfectly suitable for this without the need of making the intermediates oscillate—by reading "key-clicks" several Australian and South African amateurs have been read on the 20-metre band, and when a large number of stations are on and interference is bad, it seems easier to read C.W. in this way than by producing a heterodyne with the intermediate frequency.

Also one does not appear to receive atmospherics, mush, and general outside interference to such an extent with the set in this condition.

On the whole the super has proved itself well worth while. It gives one a very satisfying feeling that the station one is after will "be there

to time," and one can arrange receiving schedules with amateur stations and others, confident that there will be no difficulty in finding them when the time comes.

### SOME PRACTICAL TIPS.

If you are using a soldering paste which splutters a little, do not let this get on to the panel, but stick down a piece of paper over the terminal shanks or soldering tags, and tear it away when the operation is completed.

If you use a fairly large soldering-iron, remember that it is not necessary to tin all the sides of this, and

it is much easier to keep one side thoroughly clean.

If you are trying short-wave reception for the first time, remember that a swinging aerial may give trouble on short-wave work, although no fading effect was noticed when receiving ordinary broadcasting.

Variations in the volume of sound do not affect the ear so much as might be expected, and most people would be unable to detect a difference of even up to 25 per cent on certain notes.

When trying to drive a screw into a place where it cannot be held with the fingers, get a slip of paper or stiff cardboard, pass the screw through the end of it and hold it in position with one hand while you drive the screw with the other.

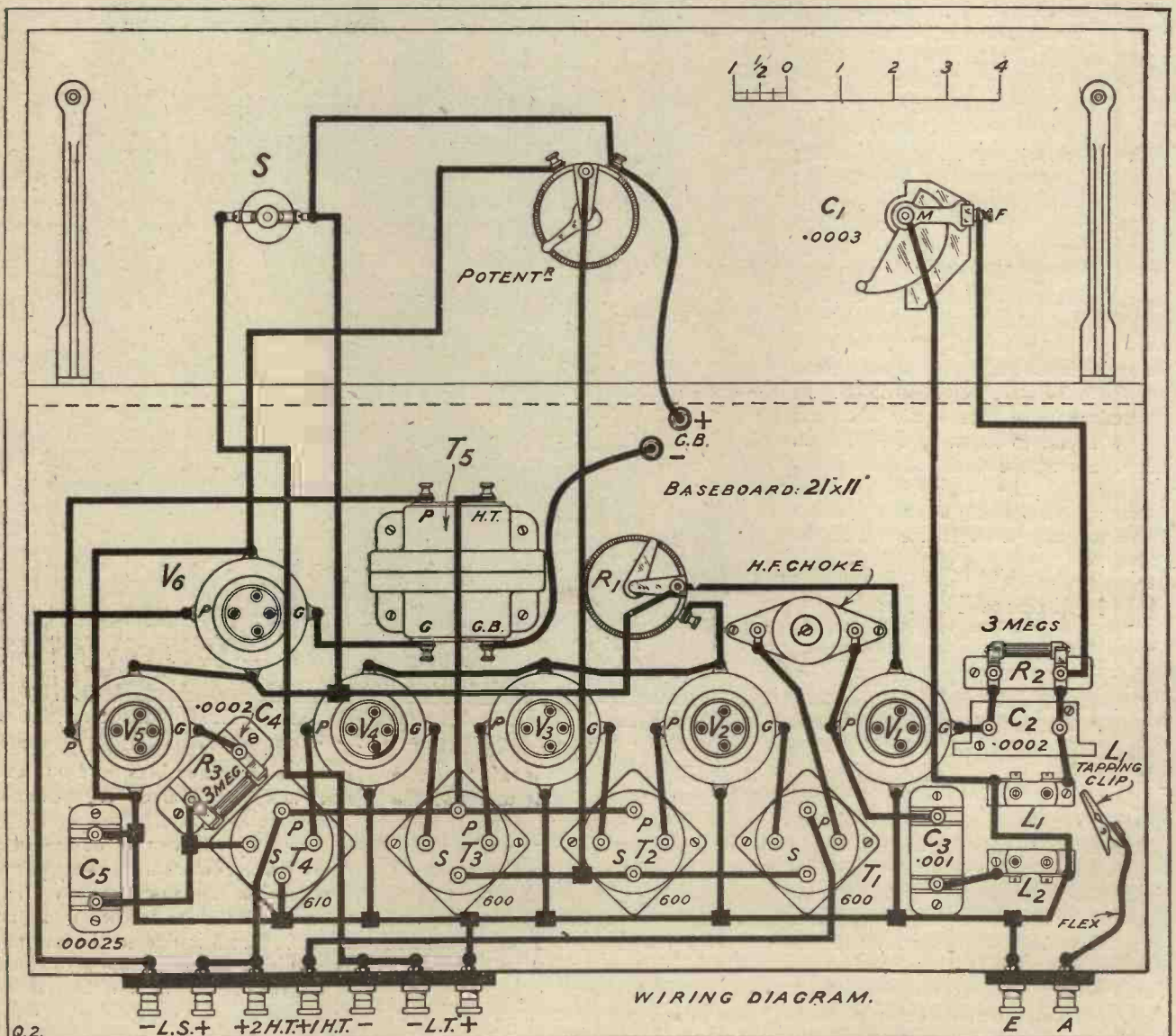

# WIRELESS IN THE DESERT

by  
ROSITA FORBES

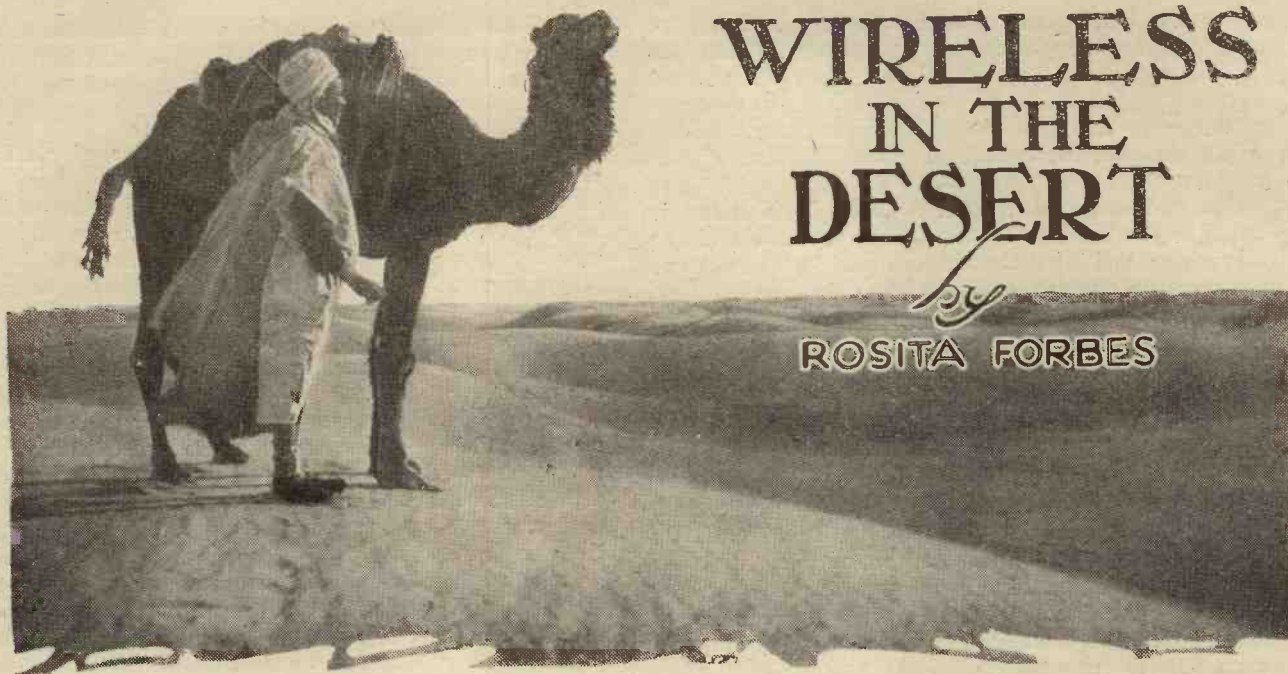

*In the following article a famous Woman Explorer writes, among other things, about the mysterious native "wireless" of the desert. Radio may beat desert forms of communication—yet desert news travels faster than an English Telegram!*

**A**T present the apparent rate of communication in the desert ranges from the two miles an hour of a baggage caravan to the six of a trotting camel. Yet news travels faster than an English telegram!

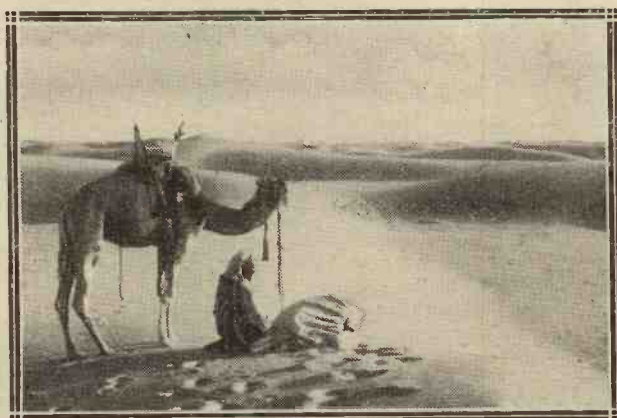

Wireless would be invaluable to the explorer of the desert as a means of fixing his position day by day.

Every African or Arabian traveller is aware of the "desert wireless," by which mysterious means information leaps from one isolated village to another.

### Uncanny "Transmission"

For instance, when Sir Lee Stack was killed in Cairo, a friend of his was shooting ibex in the Red Sea mountains, six hundred miles away. The journey had taken him twenty-four days by camel and there was no other means of doing it. His camp was in those spectacular hills inhabited by shock-headed Haddendowe, separated from Egypt and the nearest telegraph or telephone by the Eastern desert. Yet he received the news of the Sirdar's assassination three hours after it had happened! Further south, this particular miracle may be attributed

to bush fires, to smoke or sound signals. In Central Africa, if you want to warn a distant chieftain of your approach, the local drummer will beat out the message on a hollow tree-trunk. The next village will hear the signal and repeat it in the same way, so that through forests and along river banks the news reverberates from one mighty-muscled "telegraphist" to another.

### No Sign of Life

But there are no drums in the desert. Sometimes, for several hundred miles there is no human being. There is neither stick, nor bush, nor blade of grass with which to make a fire, yet all that happens on this sunburnt waste is known the same evening in the surrounding camps and villages.

When I travelled across the Libyan desert to Kufra, no caravan passed us for fifteen days. We saw no human

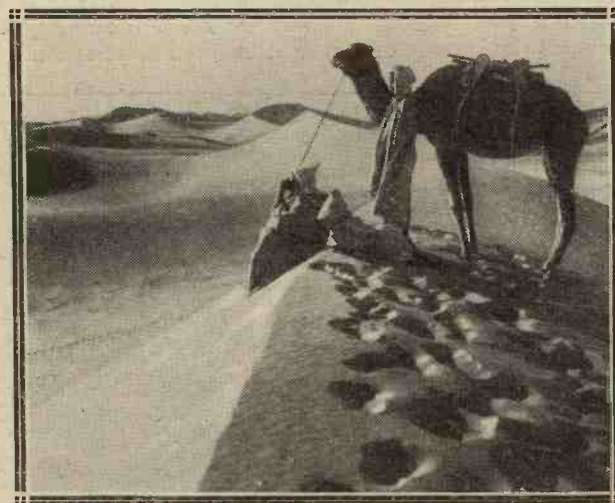

Radio is the worst enemy of lawlessness, and in time it will conquer the last desert stronghold.

being, let alone a fast rider to carry the news of our coming. We camped in hollows, lighting no fires, for fear of enemies. Our powerful field-glasses showed us, day after day, an uninhabited world as blank as a gramophone disc. Yet, when we left the desert, every hostile village expected our arrival and knew how and whence we came!

Can wireless do much better than this? Of course, it would be invaluable to the explorer as a means of fixing his position, and it has already been used for that purpose by several Saharan expeditions.

The frontier forts south of the Atlas, where the Foreign Legion guard the edge of the great Hamada desert, depend on their wireless rather than on their guns. Every movement on the scarlet sands is recorded for the benefit of Bou Denib, from which reinforcements can be despatched at a moment's notice.

I was talking to a French officer in one of these forts, impaled like a beehive on the top of a cliff. It appeared, by its isolation, its inadequate water supply and its garrison, limited in numbers and ammunition, to invite attack, but the Commandant assured me: "As long as our wireless holds out, we're all right." In fact, before the nomads could pierce the barbed wire which forms an outer defence, mounted Legionaries would be on their way from the next post and aeroplanes hurrying from Bou Denib.

### Preventing Lawlessness

Wireless is the worst enemy of lawlessness, and, in time, it will conquer the last stronghold of African Touareg or Arabian Wahabi. Already Iba Saoud, the Puritan Sultan of Nejd, is experimenting with an aerial on the mighty expanse of mud root which dominates his capital of Ryadh. His subjects, who impose their conservatism at the sword's point, imagine it a symbol of Western magic and disapprove as vigorously as they dare.

When the Sultan was at Ryadh it used to take six weeks for his officials at Mecca to get an answer to their often despairing letters, and the peace of Western Arabia hung on the pace of a camel! Wireless will consolidate the power of Arabia's strong man, as surely as, in conjunction with the aeroplanes of Basra and Baghdad, it has limited the activities of border raiders.

When I first crossed the Sahara in 1919, there were forts wherein the solitary white officer was cut off from every echo of civilisation, from even the sound of his own language, for six months at a time. If anything happened to him his native corporal carried on, and, if he remembered it, sent a messenger on a dromedary to report the tragedy over several hundred miles of sand.

In Zululand, before the war, I stayed in the hut of a missionary who spoke his own English haltingly, because it was so long since he had heard it.

### Invisible Companionships

Wireless has put an end to such solitary confinement, and the vanguard of French advance in the Sahara is an absurd little mud pillar box with an aerial on top of it. Herein lives quite contentedly a Legionary who has specially applied for the job because it entails slightly higher pay. He rarely sees a fellow creature, but he has the whole world of sound at his disposal. These men live, move and have their being by wireless to such an extent that they become the votaries and the priests of the science they serve.

They are among its greatest experts, for their experiments are their only amusement. A Bedouin once assured me: "You will find a Franzi over the dune. He is mad and he keeps his god in his house with him!"

In my own case, wireless would have saved many troubles, for, on several occasions, my caravan has lost itself in a sandstorm, in a maze of dunes, or in the flat, uncharted desert wherein there is no landmark and no route but a sense of direction. Once, with a party of seventeen—Egyptians, Bedouins and black slaves—we missed our way going south in the middle of a two hundred mile waterless stretch. We had neither sextant, theodolite, nor chronometer. The guide completely lost his head, which, in the desert, is as much a disease as any other fever, and if we had not discovered, by chance, an unknown spring, we should all have died of thirst.

Another Saharan traveller wandered, out of his route for ten days, and lost most of his camels in consequence because a compass is not a sufficient weapon when mirage and sandstorm do their worst!

The modern expeditions, whether by motor or caravan, will be armed with wireless, and the legendary desert drums played by dead victims welcoming an addition to their ranks will be silent.

In fact, there will be no more mystery in the desert!



The desert has a wireless system of its own, apart from the electro-magnetic waves with which we are familiar. And every African or Arabian traveller can tell of mysterious means by which information leaps from one isolated village to another.

# A "Moving Plate" Loudspeaker

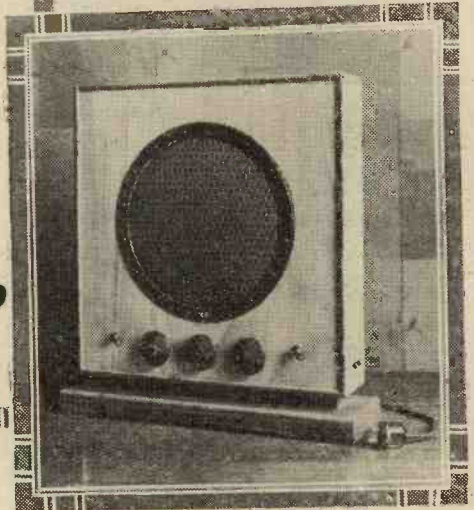

*Another bid has been made for the title of "the Perfect Loud Speaker," with a peculiarly built instrument of German origin.*

*From a Special Correspondent.*

**W**HENEVER enthusiastic radio amateurs meet, one topic is bound to cause, sooner or later, a most animated discussion: "The Perfect Loud Speaker!"

Fortunately for our manufacturers, tastes differ a great deal, and so do the contents of pocket-books and purses; what you may consider the perfect speaker is not necessarily someone else's ideal.

The progress made with the loud-speaker design during the past two years is really amazing. My own speaker has often startled me by rendering a song, for instance, in such a perfectly natural way that one expects to find the singer at one's elbow.

More recently, moving-coil speakers have entered the arena; and if you are fortunate enough to own one, a full orchestra will suddenly invade your room and treat you to perhaps the greatest perfection of loud-speaker reproduction possible to-day — and maybe for some years to come!

## Electro-Static Speaker

All these speakers work on the electro-magnetic principle; in a horn or cone-speaker unit the alternating impulses from the plate of the last valve strengthen or weaken the steady magnetic field set up by a permanent magnet, causing the diaphragm to move with each variation.

In a moving-coil speaker the alternating impulses from the power valve travel through a tiny coil floating in an intense magnetic field. According to the nature of the impulse delivered by the amplifier, this coil moves in or out, taking the small cone with it.

But there is another type of loud speaker which has up to the present been somewhat neglected, mainly on account of constructional difficulties — the electrostatic speaker. It contains no magnets or windings, and has only one moving part—the diaphragm. (See photo.)

Fig. 1 shows a section through the latest model of electrostatic speaker which has been developed by a German inventor, Herr Hans Vogt. Two plates form the working parts of the speaker; one is stiff and perforated with a number of holes ("A"), the other is the very thin diaphragm made from a specially prepared aluminium alloy ("B"). The weight of

the diaphragm is negligible, and it can follow even weak impulses without lag.

The two plates "A" and "B" are mounted in a metal frame and carefully insulated from each other; perforated metal covers protect the working parts and give the speaker a neat appearance.

## Simple Connections

The two plates are very close to each other; they are connected into the circuit as indicated in the diagram, Fig. 2. The maximum high-tension is applied to the stiff plate "A," the impulses from the anode of the power valve reach this plate via the 2 mfd. fixed condenser. The diaphragm "B" is connected to earth or L.T. minus.

Let us see what happens when this

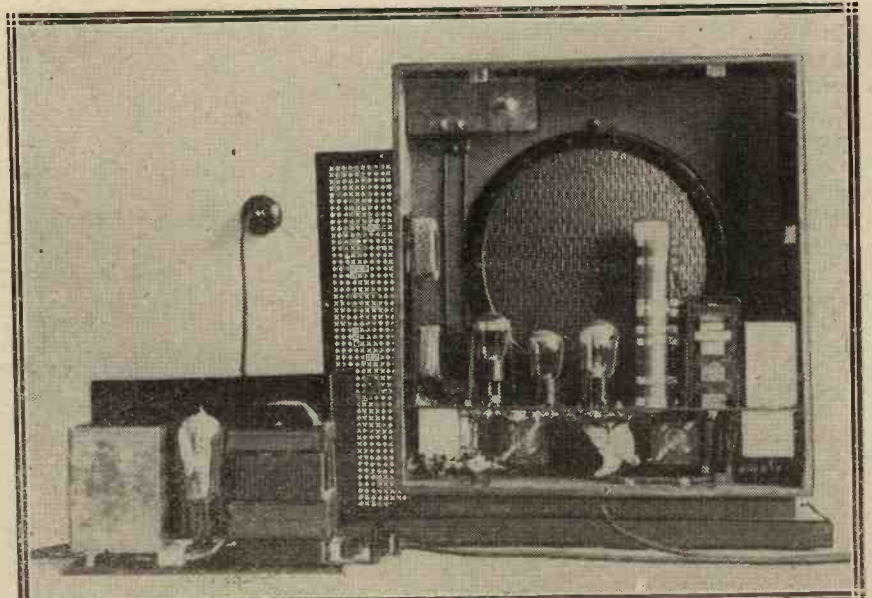

The back of the speaker, showing the built-in three-valve set, and also the inside of the A.C. unit to the left of the photo.

speaker is connected to a receiver. The stiff plate "A" is charged positive, as it is connected to H.T. plus;

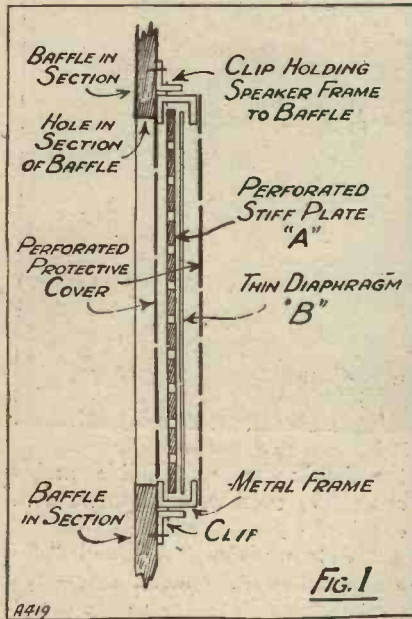

the diaphragm is charged minus. Opposite charges attract each other, consequently the diaphragm will be drawn towards the stiff plate, since the latter cannot yield.

When the set is working, this steady attraction will be disturbed by the alternating impulses, incoming positive impulses will increase the attraction, negative impulses will weaken it. In this way, the diaphragm will swing one way or another, in tune with the ever-changing impulses generated by the power valve.

**Rivals the Moving Coil**

The movement of the diaphragm displaces the surrounding air, and thus reproduces the music or speech sent out from the transmitting station. The reason why the stiff plate "A" is perforated will now be obvious: an air cushion between the two plates would produce a cushioning effect and damp the movement of the diaphragm. With a perforated stiff plate, air can escape through the openings when the diaphragm moves.

This brief description of the working principle will suffice to show that the inventor has struck out in a new direction; many constructional problems had to be overcome before the electrostatic speaker was ready for commercial production.

Tests made with the latest model convinced the writer that this type of speaker is capable of really excellent reproduction, provided your amplifier is above reproach. Like a really well-made moving-coil speaker, it will bring

out—and apparently magnify—defects in the set to a surprising degree.

Every care must be taken to avoid distortion if this type of speaker is to be heard at its best. A baffle of moderate size improves the intensity of the lower notes, and also increases the volume. For this reason, the unit is usually supplied in a wooden cabinet, which also houses a complete three-valve set placed behind the unit. How the speaker deals with the various frequencies can be gauged from the curve, Fig. 3.

**Complete Set Inside**

One of the photographs shows the back of the cabinet with the cover removed, at the left are the two honeycomb coils for the broadcast and long-wave ranges. Then follow, towards the right, the detector, first L.F., and power valve. The potential divider lies just at the right of the power valve.

The three variable condensers are placed under the sub-panel, which carries the valves.

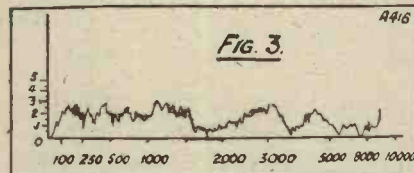

In its standard form, the complete unit operates from D.C. mains, no batteries at all are used in this set. For A.C. operation an additional unit comprising transformer and filter circuit is added, as shown in the illustration.

The method shown in Fig. 2 is not the only way in which the speaker can be connected into the circuit. Alternative methods are easily evolved

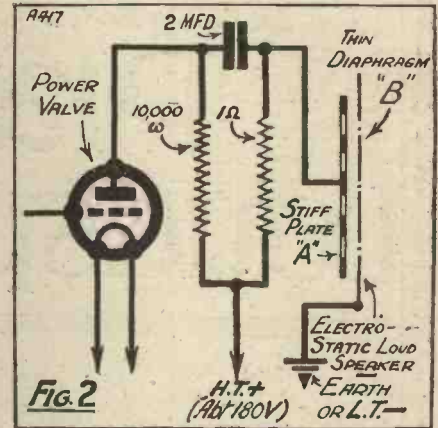

and a choke can take the place of the 10,000-ohm. resistor in the anode circuit of the valve.

**PROGRAMME RELAYED TWICE**

A STUTTGART radio paper recently published a photograph of a postcard from a London listener who stated that he picked up direct from Stuttgart a relay from the American station 2 X A F. The 2 X A F programme in question was a relay of Daventry, and at the time 5 X X was broadcasting a London programme which thus travelled about six thousand miles before it was received again in London!

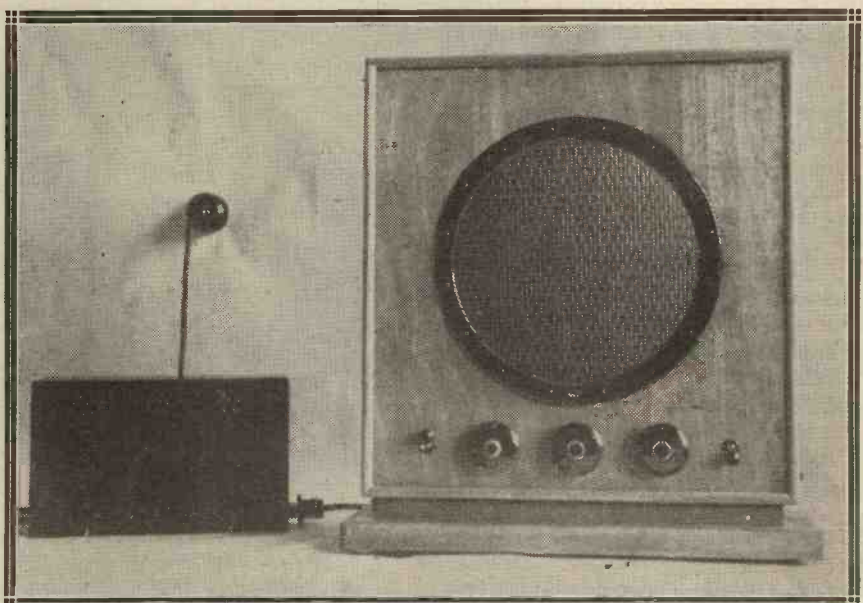

For A.C. operation a special adaptor unit, shown on the left, is required. Note the set controls on the speaker baffle.



## FURTHER ADVENTURES IN LABRADOR

*Have you ever thought what Radio means to the Frozen North? Here is a quietly told but thrilling story which has for a background Labrador—a stark, white background of snow and ice; a land where dog-team is the only means of travel; where tuberculosis rages in the badly-ventilated huts of ill-fed fishermen; and where death by exposure is always ready to punish the daring pioneers who face the frozen solitudes.*

*In these implacable conditions, radio is of incalculable service. Below is the authentic and exclusive story of the chief wireless operator appointed by Sir Wilfred Grenfell to link up the Labrador outposts by means of short-wave wireless.*

By F. DEARLOVE.

IT was with a very pleasant feeling of something accomplished that I went aboard the "Meigle" one terribly cold morning in the early days of November last. Ice was forming on "the Bay," as the natives of Labrador call Lake Melville, that vast inland sea (much wider in parts than the English Channel), and I was only just in time to get clear before the final freeze-up. But it was a fine thing to reflect that North-West River would not have to wait until March for news of friends at home, but would be in touch with all the world by short-wave radio, as well as with the Grenfell base at St. Anthony, Northern Newfoundland, at which station I was scheduled to pass the winter.

### Stormy Seas that Freeze Solid

The voyage was an eye-opener. Before seeing it for myself, I failed to understand how a turbulent stretch of water, lashed to fury by the wind, could possibly freeze solid, even with a temperature far below zero. But as we left North-West River it was freezing very rapidly, and each cloud of spray and spindrift would, on its passage through the air, freeze instantly and strike one like hail. Falling back into the water, it would soon cover the same with a thick layer of "slob," which became thicker every hour until in one short night it would be solid enough to walk over, and very soon the dog-teams were driving over it, covered as it was with deep snow, just as if it had always been dry land.

The "Meigle," though not scheduled to call anywhere on her return to St. John's, finally landed me on the rocks at Fishing Head, and I made my way into St. Anthony once more, and was very soon exchanging ideas with Ted McNeill, who had been operating our station NE8AE during my absence. He had been getting a great deal of practice during this time, and, indeed, was quite qualified to keep the schedules we had nightly with NU2HV, and NU2UO (the "New York Times") for the purpose of handling traffic.

### A Deeply Disappointing Start

During the following week it became obvious that direct communication with North-West River was not as satisfactory as we had thought it would be, but we communicated via NU2HV, with whom we both had schedules. We then began a series of tests to determine the best time of day for direct communication, for, having failed in maintaining contact at night, we decided to give daylight a chance, and asked 2HV to advise NE8WG to this effect. Two days passed, and he informed me there was no sign of North-West River on the air.

Day followed day, and it was borne in on my mind that NE8WG was definitely off the air. There are disappointments in all kinds of pioneering life, but when this happened I felt that I had reached the nadir of them all. Whatever other people thought, in my own mind I had failed; a bitter pill indeed to swallow.

Month followed month and the winter set in in earnest, a thick blanket of snow covered the ground whilst ice covered the sea for miles. The sun shone gloriously for days, making the wearing of dark glasses imperative, for snow blindness is a thing to be dreaded, as I found to my cost when I left them behind on a dog-team trip one day. I found, to my surprise, that during the day, when there was little wind even though the temperature was far below zero, it was not half so cold or unpleasant as our own damp climate at home.



"All the way up to the Hamilton Inlet and past those Dry Islands of sinister memory, the portable set XNE 8FD worked perfectly, schedules being maintained without a hitch, until we landed once again at North-West River."

We were wearing very little extra in the way of warm underwear, though our outside garments consisted of a windproof hooded "dickie" or "parker," as they are called in Alaska, sealskin hat and boots, warm woollen mitts with a large outer sealskin mitten called locally "cuffs." The boots were of quite soft skin, untanned, and were not covered with fur as might at first be imagined. They would be distinctly unpleasant to wear in our country, for the wet would seep through in a very few minutes, as they are not waterproof; but in that cold climate, with a pair of thick woollen duffle vamps over one's socks, the boots are loose on the feet, and, in stimulating the circulation, keep one beautifully warm and comfortable.

### How the Aurora Affects Radio

There is no doubt whatever that on the fine days, which are quite numerous, Labrador and Northern Newfoundland are wonderful countries to live in during the winter. To climb to the top of Fishing Head, and watch the flickering rays of the aurora borealis cover the sky and be reflected on the endless field of ice, hundreds of feet below, glinting on the majestic pinnacles of ice on the mountain behind, and to hear the plaintive wolf-like howl of a husky dog, is an experience never to be forgotten.

We would travel sixty and seventy miles in a day by dog-team, and then there was ski-ing and snow-shoeing, as good, and even better, than one could get in Switzerland. Marvellous though the aurora was to look at, I was never very pleased to see it, for whenever that flickering arc of greenish light appeared in the northern sky, radio

In Labrador—the scene of this thrilling radio romance of real life—Sir Wilfred T. Grenfell has brought untold relief to the inhabitants by organising medical assistance and building hospitals for them. To assist him in this work a generous American wireless enthusiast provided funds for a radio chain of small short-wave stations. The author of this exclusive and absorbing article was chosen as chief wireless operator, and how he "carried on" his titanic task is graphically told in this article.

conditions were not to be depended upon. Communication was then very erratic, and many a night I would just start my traffic when the aurora would appear, and signals would fade out almost immediately.

As the weeks went by and there was still no sign of North-West River, I arranged to send out nightly advice which, presuming their receiver was in order, might have enabled N E 8 W G to get "on the air" once more. But all of no avail. There was nothing for it but to arrange to make a second expedition to North-West River to rectify the trouble, whatever it might be.

My residence, "The Inn," as we facetiously called it, was about half a mile from the radio station, but on the bad nights, with a temperature of twenty-five degrees below zero and a high wind, this distance seemed ten times as great, so that in order to maintain schedules in such periods, when it was decidedly dangerous to venture out at all, I decided to build a portable station, that I might either keep the schedules myself or send any traffic to Ted, who lived at the site of the main station.

### Results with a Self-Contained Portable

In about three weeks the portable outfit was complete, and I found that, with no outside wires connected to it whatever, my signals were reported R9 (with a Mullard P.M.1 L.F. and 90 volts high-tension) in my transmitter at N E 8 A E. The receiver was a special circuit, using three valves (all Mullard P.M.1's), which had been developed at St. Anthony after considerable research to eliminate threshold howl.

Here is the portable transmitter circuit of XNE 8FD. The two coils  $L_1$  and  $L_2$  are two inches apart, whilst the aerial coil is very loose coupled.  $C_3$  (.002 mfd.) is of mica construction to withstand 2,000 volts, as also is  $C_1$ . The  $C_2$ 's are both small receiving condensers of good make.

As installed in XNE 8FD, circuit was so efficient as to oscillate strongly when valve was lit and key pressed, no H.T. being applied. (Grid leak and power supply at points of little or no difference of R.F. potential. Resonance indicator, either H.W. ammeter, or preferably 15 m.a. meter in series with grid leak. Using P.M.1 L.F. valve, use very high-resistance G.L., as shown; for power valves, lower resistance will serve.  $C_3$  prevents short-circuit of power supply in event of flash-over by R.F. energy across condenser  $C_2$ .)

The manner in which this is accomplished is interesting. Apparently the howl is caused by instability of the oscillator, in this case also the detector, the valve commencing and ceasing to oscillate at an audio-frequency when the reaction control was set at that critical value which normally would cause the valve to be just on the edge of oscillation. The howl is, of course, quite distinct from that caused by too much reaction, which blocks the valve, but true "threshold howl" is easily recognised by any short-wave enthusiast.



By inserting a series resistance of about 4-10,000 ohms in series with the detector plate supply, utilising the same instead of an R.F. choke, it was found that the howl was much less apparent, though the valve went into oscillation with a slight click. By inserting a resistance of 50 to 100,000 ohms across the first L.F. transformer primary, this click was reduced, and it was found that threshold howl was non-existent, the valve going into oscillation quite smoothly.

**The 56-lb. Crying Babies**

About this time the men used to go off for miles on the ice after seals, which were around in great numbers. The photograph shows a "whitecoat," or baby seal, weighing fifty-six pounds. These "babies" were quite helpless, being unable to walk or swim, and when the men approached to kill them, by a blow on the head, they would look up with their enormous brown eyes, tears welling up suddenly, and they would cry for all the world like a human baby. It seemed a crime to kill them at all, and yet in Labrador every year they are killed by the thousand. The dead seals would be left in piles, with a pole erected near them for easy location towards the end of the day.



" . . . Sixty and seventy miles in one day by dog-team . . . ! "

Night-time usually found me at the radio station handling traffic, and although I would light a stove on commencing work the temperature hardly seemed to rise at all. One Saturday I was working the British station G 2 X Y, whilst the thermometer was down to 8 below zero in the room. I got very engrossed in the conversation, (for Mr. Littlewood of G 2 X Y lives but a few miles from my own home), when out went the stove.

I was wearing gloves whilst sending, and my dickie hood was well over my head. I glanced now and then at the thermometer, and was astounded to see it drop to 20 degrees below zero. I began to be afraid for the battery, for though it takes 60 degrees below zero to freeze cells which are fully charged, I had been working these cells all day.

**News of the "Bremen's" Landing**

I told 2 X Y what I feared, rose painfully, for my feet were almost frozen, and went below on a tour of inspection. I was only just in time, for the temperature in the battery-room was 28 below zero, and ice was forming in the cells as I watched them. Luckily I had no difficulty in starting the "Delco," so they were immediately put on charge, and so saved. On returning next day I found my H.T. cells quite ruined, and dry cells were substituted, but even they had to be protected from the frost.

The next evening, after my schedule with W N P (the Macmillan Expedition which was at Nain for the

winter, and for whom we used to handle traffic for Newfoundland), I changed over from 80 metres to 45 in order to connect with N U 2 U O, the "New York Times" station, who handled all our traffic for the U.S.A. This station was very full of the fact that an airplane, the "Bremen," and her German-Irish complement had left Ireland that day en route for New York, and as we were on the great circle track it would take we were

The short-wave radio chain referred to in this article was installed by the author, and described by him in MODERN WIRELESS last June. It then consisted of a Labrador base at North-West River, and the main hospital base at St. Anthony, Northern Newfoundland, which were kept in touch with each other and with Sir Wilfred T. Grenfell's office in New York.

asked to keep a good radio watch for any news, although the 'plane herself was not radio equipped. The next night came the news of the 'plane's forced landing on Greenly Island, some seventy miles to the westward of us.

We were very fortunate in being able to give the "Times" news of the 'plane and her crew, which appeared in that paper as fast as we could obtain it. The "New York Times," in return for this service, handles all our New York traffic destined for the Grenfell office, free of charge.

**The Portable Talks to England**

Day by day passed, and I began to make preparations for my second expedition to North-West River. I could not go whilst the ice held, for this was an impassable barrier in the Belle Isle Straits, where the huge "pans" were moving at the rate of six miles an hour. More than one life had been lost through being adrift in zero weather on one of these ice-pans.

I determined to take with me "X N E 8 F D," as the portable station was known on the air, for very good results had been obtained with this set, notably communication with England and the U.S.A., using the P.M.1 L.F. valve. Once I actually communicated with a station in Pittsburg, using no aerial or counterpoise, but simply plugged by means of a "Ducon" adaptor to the lighting circuit!

The discovery of the possibility of this arose from the fact that I noticed a very persistent harmonic around



"A 'baby' seal quite helpless, being unable to walk or swim. When the men approached to kill them they would look up with their enormous brown eyes, tears welling up suddenly, and they would cry for all the world like human babies!"

21 metres on the receiver which caused a dead-spot whenever I used the Ducon (for reception purposes) attached to the lighting circuit. I attached the Evershed hand generator, replaced the P.M.1 by an R.C.A. U.X. 201A. valve, and called C Q on 21 metres, with the result stated. I could hardly believe my ears when the American answered!

The lighting circuit was voltage fed, for one end of the inductance was disconnected, but it would surely puzzle an expert to work out on what harmonic the thing was working. Ted suddenly called me after the contact from NE 8 A E, and I slowly revived to receive his congratulations!

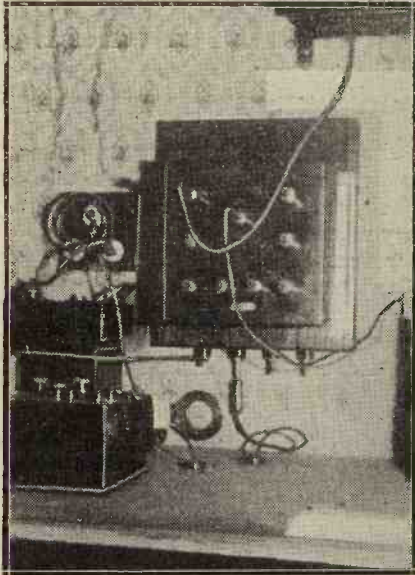

Here is part of the 600-metre transmitter at NE 8 A E (500 - watt Marconi, spark), together with the long-wave receiver, which tunes overall wave-lengths between 200 and 25,000 metres.

By this time I was quite an expert dog-team driver, though before I "qualified" I had some exciting experiences, notably when I lost the trail and got into soft, deep snow over which no team had passed that year. The "komotik," as the sled is called, sank deep, and I dropped over the end to ease the strain on the dogs, which were half buried.

I immediately sank to my arms, whilst the dogs started forward suddenly, and if I had not caught hold of the back of the sled I should have lost the dogs, and have been in a hapless predicament indeed. As it was, I was bound to retain my hold on the back of the komotik and go forward on my knees, using them as snowshoes to bear my weight. This went on for about five miles, and though the temperature was 15 below zero, I was perspiring freely, and I must admit it was about the hardest work I had ever done in my life.

### Off the Trail, with Frozen Feet

I eventually got back on the trail and rested, almost exhausted, on the komotik, incapable of movement for a long time, till I suddenly thought to empty my sealskin boots of snow, when I found to my horror I could not move my legs at all, for the snow which had filled them had melted and then frozen hard. I was in a dilemma indeed, for I suddenly realised all feeling had gone from my feet also. As luck would have it, however, I managed to turn the five dogs and we sped homewards at a speed far in excess of that we had made on our outward trip, and fortunately this time we missed the soft snow, and after about half-an-hour's going reached the hospital, where I was assisted from the komotik, and had the frozen boots cut from my feet.

What agonies one endures when "thawing out."! I certainly do not wish to freeze any more than I did on this occasion. I think I shivered for hours, though happily no ill-effects ensued beyond a partial skinning of both feet, not even a cold!

### Disentangling the Dogs

There were, of course, many amusing episodes, as well as otherwise, and I well remember the first time I started driving the dogs we met another team, mine refused to obey my order to "Keep off," or "Go to the right," and the other huskies went straight through my team, whilst the other driver and myself found ourselves extracting our aching limbs from a mass of snarling and snapping canines. It took us about an hour to disentangle the dogs and traces, to the accompaniment of much sulphurous language. The dogs are quite ferocious, for they are only fed twice or thrice per week.

May gave place to June and we began to look forward to the first mail boat with great excitement, for though we had had mails by dog-team during the past few months, the bulk of our mail would be on the first boat. Moreover, on the first Labrador boat I intended to go north and get NE 8 W G in commission again.

Time passed very quickly, and eventually one miserable foggy day in July I stepped aboard the "Kyle," and stowed X N E 8 F D in the wireless-room. I arranged with Ted for schedules at 2 p.m. E.S.T. and also at 10 p.m. (after he worked C A, who takes our traffic for relay to the "N.Y. Times.")

### When H.T. Alters Wave-length

I will now describe this portable in detail. The transmitter frame was built of well-dried red pine, whilst the circuit was a split Colpitts, identical with that at NE 8 W G, except that either a Mullard P.M.1 L.F. valve or an R.C.A. U.X.201A could be used in the socket. The source of supply was my old standby, the Evershed megger generator, driven by hand, and behind the transmitter panel was an artificial load, automatically placed in circuit when the key was up. It's resistance was such as to allow the same current to be drawn from the hand generator as the transmitter took.

This then ensured that an even load was on the machine at all times, which made it possible to turn the generator with the left hand whilst keying with the right, though for obvious reasons I did not do this when I could get anyone else to turn the same. The circuits and constants are given, and I can certainly recommend it to anyone wishing to build a set tuning from 10 to 60 metres without having to change a coil.

On this page the author tells how on one occasion he lost the trail, dropped from his sled to ease the dogs, and sank to his arms in snow—almost losing his hold upon the sled. Such an accident is likely to be fatal in Labrador, but he managed to escape with frozen feet and the agonies of "thawing out."

The grid leak is a specially high-resistance one to prevent "blooping," due to the very high voltage supply, and both it and the power supply are connected through chokes at points of little or no difference of radio-frequency potential. It will be noticed also that the valve elements are shunted by relatively high capacities, minimising the effect of the change in capacity of the valve elements due to heating and their consequent

expansion, an unsteady high voltage supply, and altogether making for an extremely steady wave, which I am sure every one who heard X N E 8 F D will agree it did have.

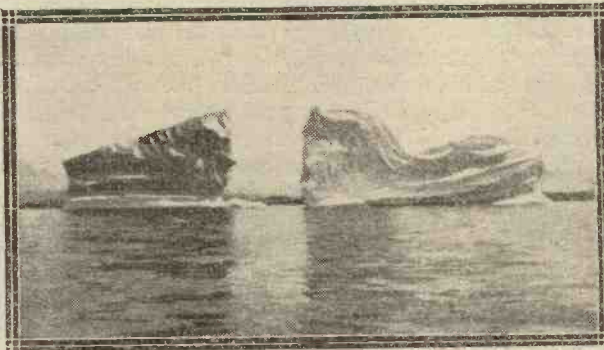

"... Numerous escapes from collisions with huge icebergs ..."

Ordinary receiving condensers were used, whilst the series large-capacity mica condenser prevented a short-circuit of the power supply in the event of a flash-over. A very efficient high-tension type accumulator occupied the remaining space behind the transmitter. Two volts for the receiver valve filaments, and six for the transmitter. Strangely enough it was found that an aerial of almost any length, quite untuned, served as well as one carefully tuned to the fundamental of the set.

### Testing Aerial Radiation

It is obvious, of course, that no radiation would be observed on the hot-wire ammeter using the former type of antenna, so that a very sensitive milliammeter was fitted and connected in series with the grid leak. This instrument would dip whenever the aerial was tuned to a harmonic of the set, and is a method to be recommended to low-power enthusiasts for ascertaining resonance. The set was never worked at resonance, of course, but always at one side or the other. Upon the setting of the aerial tuning condenser the quality of the note and steadiness of the wave depended to a very great extent.

The receiver has already been described, so it will be sufficient to remark that after sixteen months of hard knocking about in this portable set, all the valves are still intact. They were not mounted on springs, either.

A change-over switch, extracted from an army trench set, turned off the valves in the receiver and lit that in the transmitter, changing over the antenna and counterpoise at the same time, and when using the Mullard S.W.50 valve in the transmitter ashore on "high power" it was arranged to start the M.L. converter supplying the same with high-tension. All wiring was hidden behind moulding, and with the exception of the hand generator everything was contained in a mahogany case, 30 in. by 21 in. by 14 in., and covered with "Ducksback," the material from which the dickies are made.

The mahogany was salvaged from the wreck of the S.S. "Bay Rupert," which vessel was taking supplies to the Hudson's Bay Posts last year when she struck a submerged rock and became a total loss on the Labrador coast.

### Communication Regular and Reliable

Another point of interest was the transmitting key. This was a three-contact affair particularly suited to the artificial load arrangement, and was salvaged from the wreck of the H.M.S. "Raleigh," wrecked in the Belle Isle Straits some years ago.

Day after day passed on the voyage north, and never did the 2 p.m. schedule fail. Ted was on the job all right, and we had some interesting chats. We passed Cartwright, where the first Hudson's Bay Post is situated, and there learned of the burning down of the Greatfell School and Orphanage at Gordon, some three miles away, when dozens of children were hurried from the burning building to the care of fishermen nearby. Happily no lives were lost, but quite a number lost all they had in the world. If only N E 8 W G had remained on the air we might have sent relief much sooner than it did arrive.

### We Go Ashore Again

We arrived at Rigolet, at the entrance to the Hamilton Inlet, and by a stroke of good luck Dr. Paddon's yacht, the "Yale," came in shortly afterwards and X N E 8 F D was tenderly transferred and placed below. We got under way, and I had a long talk to Jack Watts, who was operating N E 8 W G, but now that it was out of commission he was Captain of this hardy little craft.

All the way up the Hamilton Inlet and across that vast inland sea, Lake Melville, past those "Dry Islands" of sinister memory, X N E 8 F D worked perfectly, schedules being maintained without a hitch, until we landed after a pleasant passage this time once again at North-West River.

Upon examining the apparatus it was apparent that a few days would have to be spent in repairs, as the armature winding on the M.L. converter had been abraded, so X N E 8 F D came into use again and was transferred to the shore again.

It enabled us to keep St. Anthony advised of progress, and to let anxious friends and loved ones at home know that all was well, for North-West River had been completely shut off since the previous autumn.

I was interested to hear that an airplane which could have been none other than the Bremen passed over North-West River on April 12th, but did not see the place, and continued her way south and, as we know, landed at Greeney next day. After a couple of days work on the M.L. converter, the commutator segments were connected up once more, and the machine was none the worse.

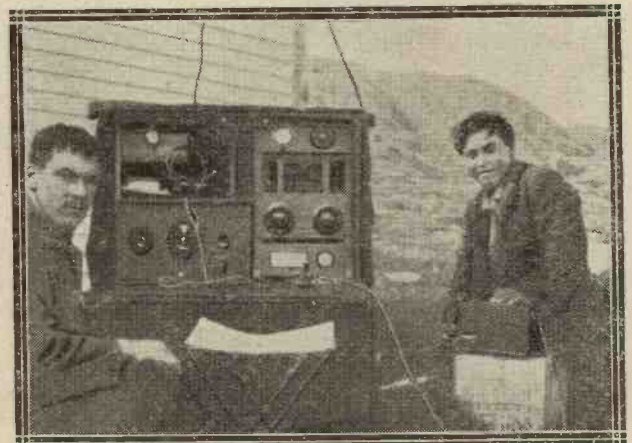

No "mains" in Labrador! So here we see (right) the "man-power" working the Evershed hand generator, which enables X N E 8 F D to go "on the air."

N E 8 W G was on the air again, and I decided to go to the coast to Indian Harbour, where Dr. Paddon had a summer hospital, and there operate whilst the station was open to provide communication with St. Anthony and North-West River.

I reached Indian Harbour after quite an interesting voyage, having kept hourly schedules with NE 8 W G and daily ones with NE 8 A E and NE 8 A Z W, at Brigus, near St. John's, N.F., the only other active station in Newfoundland besides the Grenfell stations. It was clearly shown that the time between 2 and 5 p.m., E.S.T., was the very best for inter-communication with Newfoundland and Labrador, so that this problem was solved once and for all.

### The Epileptic Eskimo

On landing from the "Yale" I had just fifteen minutes before my schedule with St. Anthony, so the set was installed quickly, the aerial run up the flag pole.

The Evershed hand generator was turned on this occasion by an Eskimo boy who, having been cured of epilepsy by Dr. Paddon, gave his services to the hospital. He is quite satisfied to stay there, and wants nothing more than his daily food, clothes, and an adequate supply of tobacco.

For six weeks during the very short Labrador summer I handled hundreds of messages from Indian Harbour to North-West River and St. Anthony, and the radio was

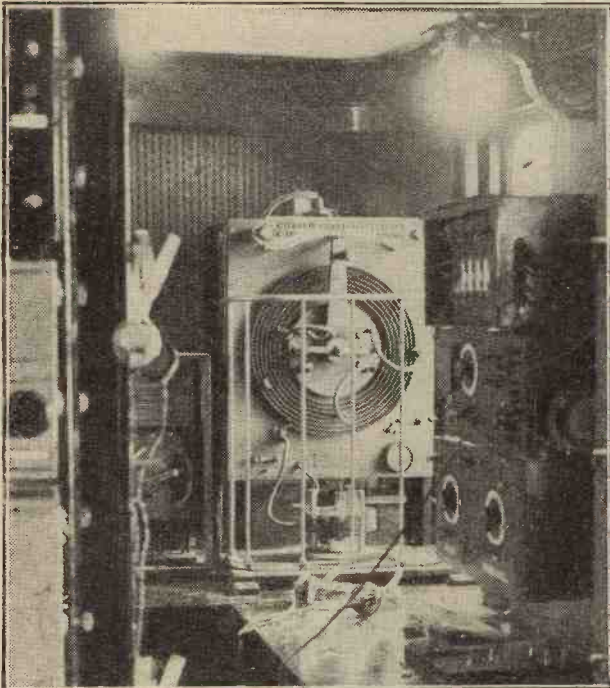

Part of the installation on the "Elettra," Senatore Marconi's famous yacht.

the means of ensuring that patients reached the hospital in time for treatment or operation by specialists who gave their services to Sir Wilfred Grenfell. On Saturdays I invariably connected with G 2 X Y, owned by Mr. Littlewood, of Leeds, who gave me the latest news of home, and I have to thank this station for the splendid way schedules were maintained throughout my sixteen months of exile in Labrador.

On one occasion, Mr. Littlewood conversed with every one of our stations as well as with NE 8 A Z W, which latter has now volunteered his stations as a further link in the Grenfell chain. 2 X Y was always the loudest station heard from Britain, though other stations which came in well were 2 A O, 6 Q B, 6 Y W, 6 W G, 5 B Z, 5 B Y, 5 U F, 6 C I, 2 Z W, and 5 M L. Quite a number of stations were worked, but the list is too long to mention all of them.

Dr. Paddon will have, next year, a larger yacht, the "Maravel," which will be equipped as a medical unit for travelling between his several stations in the continual fight against tuberculosis, so prevalent in Labrador, and it will be fitted with a 50-watt transmitter, which has been donated by Mr. George Williams (the well-known shaving stick manufacturer). Mr. Williams was at Indian Harbour in his yacht, the "Karluk," whilst I was there, and I was fortunate in being able to get his transmitter on the air again after it had been damaged by stormy seas.

It is hoped also to be able to raise enough money to build two more portable stations similar to X N E 8 F D for other Grenfell stations on the Labrador coast. People at home can hardly realise what the existing stations have meant to those isolated so far from home and family.

### All Continents Except Asia

Towards the end of August the approaching winter was making itself felt, and I left Indian Harbour on the "Kyle" for St. Anthony once more. Commander Macmillan, on the "Bowdoin," left Nain at the same time, and we kept daily schedules with them for some time.

We also kept a schedule once per day with the University of Michigan expedition in Greenland, N X I X L, for the purpose of furnishing weather reports for the use of the Rockford 'plane, en route at that time for Greenland. All schedules with St. Anthony and North-West River were kept also, so that we were quite busy, and eventually after quite an interesting return voyage we rounded Fishing Head and arrived in St. Anthony once more.

Some minor improvements were effected—such as Q S Y to 20 metres at the touch of a switch, at St. Anthony—making it possible to work on any of the following waves : 19, 21, 23, 36, 42, 45, 47, 52, 54, and 86 metres, utilising various harmonics of the two antennas and the counterpoise to the very best advantage. Ted was by this time quite a telegraphist, and I was pleased to see that NE 8 A E had worked all continents, with the single exception of Asia, before I left. How I wished that F E E G E Z had been on the other side of the Nile a few miles.

I left St. Anthony, again on the "Kyle," on board which vessel I was getting quite well known, taking with me X N E 8 F D, which had served me so faithfully, and still maintaining schedules with NE 8 A E and NE 8 W G, and embarked for England once again. On the way across schedules worked without a single hitch, and the first day out the G's came in well. On the passage the following stations were worked : E O 1 4 B, three times; E B 4 S S M, E D 7 B S, G 2 Z W, G 2 Z W, G 5 B Z, G 6 C I, G 6 Y W, and G 1 6 W G.

### Handing It Out To Them

The source of supply was, of course, the Evershed megger generator, and I had to turn it myself the whole time; to facilitate this I used it for a seat, turning with my left hand, and keying with the right. Is it any wonder that some of the stations worked thought I was not very chatty? In the transmitter I used the R.C.A. U.X.201A alternately with the Mullard P.M.1 L.F. valve, and found very little difference in the functioning of either, and I really believe for a portable set X N E 8 F D would be hard to beat!

And now here I am at home, writing for the second time for MODERN WIRELESS, in strange contrast to the conditions under which I last wrote, tossing and heaving at anchor on the coast of Labrador, in a ten-ton yacht at the height of an arctic blizzard. And I am wondering now "What next?"

# The "THREE BAND" TWO



*A wonderfully adaptable receiver of an easy-to-build, inexpensive nature.  
Designed and described by A. S. CLARK.*

**A**LL constructors are no doubt aware that the coming winter will see definite advance in short-wave broadcasting, but the progress will not be sufficient to affect transmission on the normal and high-wave broadcast bands.

Those who desire to keep *au fait* with developments will therefore require apparatus capable of receiving on all three bands. Some will have two separate receivers, one for the really short waves and another for the other bands. Everyone, however, cannot afford two sets, nor has everybody the inclination to run two receivers and change batteries and other leads each time a change to short waves is desired.

A set which will receive on all three bands, and which incorporates wave-change switching for the normal and long-wave stations, will, consequently, have great appeal. Such a set is the one described in this article.

## Most Efficient Method

Although schemes which provided switching for all three bands were considered, they were passed by, as efficiency, particularly on the shortest band, could not be obtained with the necessary complicated switching. The arrangement finally decided upon gave wave-change switching for the normal and long-wave broadcast bands, and enabled the set to be used on the short waves by simply changing over three plug-in coils.

An ingenious device with three plugs enables the wave-change switching to be achieved in an extremely simple and also efficient manner. Means are provided for varying the

coupling of the aerial to the tuned coil over a very wide range, so that no difficulty will be experienced in making the set oscillate on the short waves on any aerial.

The circuit diagram is shown in Fig. 1. There are two aerial terminals, one of which is connected to the aerial coil via a neutralising condenser. This condenser is for use on the short waves, to provide very loose coupling to the aerial, if necessary, so that difficulty in obtaining oscillation or trouble from dead spots in the tuning range can easily be overcome.

A potentiometer is also provided to enable the reaction control to be made smooth. Incidentally this component will prove very useful if trouble from threshold howl is experienced.

## Wave-Length Changes

It will be observed that the change of wave-length is obtained by shorting out the loading coil in two sections, and shorting the extra reaction winding. There are thus three points which have to be joined to earth, an easily accomplished matter. For various reasons, including the



Here the set is shown removed from its cabinet, and with short-wave coils in position. In view of its versatility and efficiency its compactness and simplicity are somewhat staggering.

question of easy tuning, it is not desirable to have a variable condenser of .0005 capacity on the short waves.

Provision is therefore made for inserting a .0005 fixed condenser in series with the variable one for the short waves. The effect of this is the

choke. Details of this auxiliary choke are given later.

Since there is only one stage of L.F. amplification, it is desirable to obtain the utmost increase in strength from same. For this reason, transformer coupling is employed. No output

On the top left-hand end are the sockets for the wave-change device, and below them is the potentiometer. To the right of these controls is the tuning condenser dial. This is of the slow-motion type, such being an absolute necessity where short waves

**LIST OF COMPONENTS**

- Panel, 14 × 7 ins. (Radion, Becol, "Kay Ray," Ebonart, Red Seal, etc.)
- Cabinet for same with baseboard 14 × 9 ins. or 14 × 10 ins. (Raymond, Cameo, Caxton, Aircraft, Bond, Makerimport, Peto-Scott, etc.)
- 2 Ebonite terminal strips, one 7 × 2 ins. with 7 terminals, and one 3 × 2 ins. with 3 terminals. (For markings on terminals see wiring diagram.) (Igranic, Belling-Lee, Eelex, etc., for terminals.)
- 1 H.F. choke (R.I.-Varley, Cosmos, Lissen, Marconiphone, Wearite, Bowyer-Lowe, Burne-Jones, Dubilier, Climax, Colvern, etc.)
- .0005 Variable condenser with slow-motion dial (Igranic in set. Any good make, Lissen, Cyldon, Raymond, Formo, Ormond, J.B., Bowyer-Lowe, Dubilier, etc.)
- .0001 or .00015 Variable reaction condenser (Cyldon, Dubilier, Peto-Scott, Bowyer-Lowe, Igranic, J.B., etc.)
- 1 L.T. switch (Lotus, Lissen, Igranic, Benjamin, etc.)
- 3 Sockets and 3 plugs for same (Clix, or similar type)
- 1 Potentiometer, panel mounting (Lissen, Igranic, etc.)
- 2 Anti-vibration valve holders (Benjamin, Lotus, B.T.H., Marconiphone, Burndept, Bowyer-Lowe, Pye, Burne-Jones, Wearite, Formo, W.B., etc.)
- 1 Standard loading coil (Burne-Jones, Wearite, etc.)
- 1 Neutralising condenser (Any standard make).
- 3 Single coil mounts (Lotus, Peto-Scott, Burne-Jones, etc.)
- 1 .0005 Fixed condenser with grid-leak clips (Dubilier, T.C.C., Lissen, Mullard, Igranic, Gecophone, Clarke, Marconiphone, Burne-Jones, etc.)
- 1 .0003 Fixed condenser with grid-leak clips (Dubilier, T.C.C., Lissen, Mullard, Igranic, Gecophone, Clarke, Marconiphone, Burne-Jones, etc.)
- 1 .002 Fixed condenser (Lissen in set. Any good make, see full list above).
- 1 L.F. transformer (Lissen in set. Any good make, Mullard, Igranic, R.I.-Varley, Marconiphone, Ferranti, Philips, etc.)
- 3-megohm grid leak (Ediswan, Lissen, Dubilier, Mullard, Igranic, Pye, etc.)
- Grid-bias plugs, wire, screws, etc.

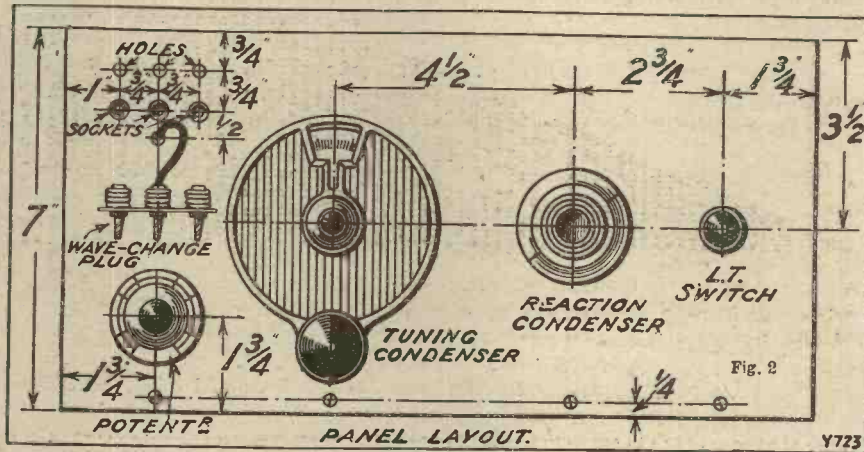

filter is incorporated, as the set is not for loud-speaker work entirely, and it is a simple matter to connect one externally when the set is used for this purpose.

All the terminals, including the aerial, earth and output terminals, are arranged at the back of the set,

are concerned. Next to the slow-motion dial is the reaction condenser, followed by the L.T. on-and-off switch.

**Compact Receiver**

Reference to the back-of-panel photographs will show that no space

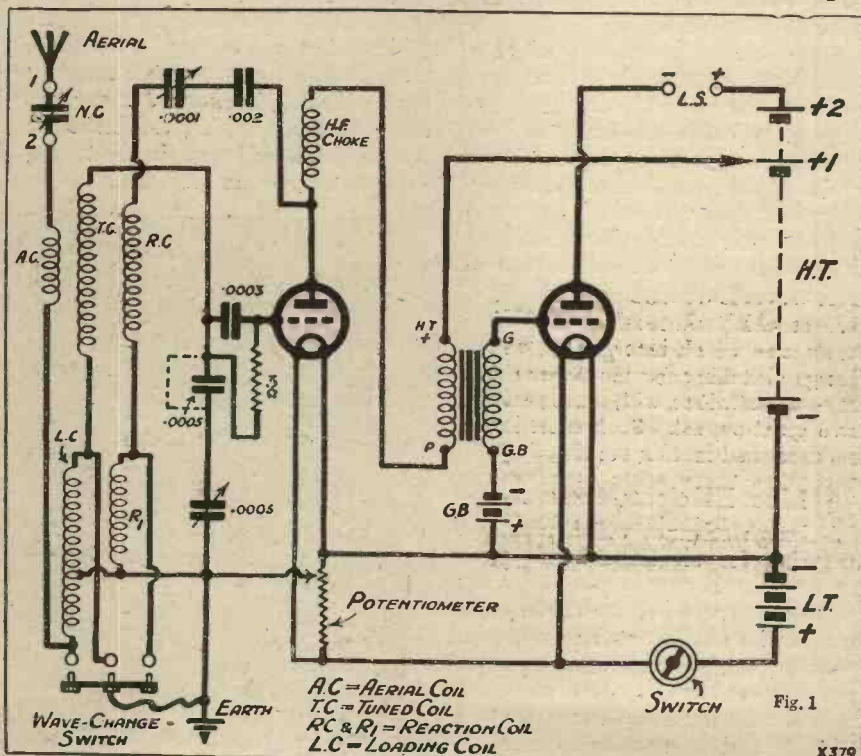

same as using a .00025 variable condenser for tuning purposes.

Capacity-controlled reaction on the Reinartz principle is, of course, provided. If the H.F. choke employed does not work efficiently on the short waves, a small extra choke is inserted in series with the broadcast

only the minimum possible number of components being carried on the ebonite panel. The panel layout has quite an interesting appearance, and the black dials on a mahogany panel give the set quite a handsome appearance.

has been wasted. As a matter of fact, the whole set is quite small considering its triple capacity. It will, therefore, be obvious that thought is necessary when choosing the makes of components to ensure that there is ample room for them.

A list of all the necessary components is given in another part of the article, and suitable makes are in-

tinned. This will greatly simplify the wiring operations when all components are in place. The com-

The angles of the variable condensers, etc., should be so arranged that the soldering tags are as near as possible to the baseboard. This will help to keep the wires short, and accounts for the way the condensers in the original set are placed. When the components are mounted, screw the panel and terminal strips to the baseboard. This is best done with them in the cabinet so that a proper fit is obtained.

Now screw the remaining components, except the loading coil, in place on the baseboard, following the layout shown on the wiring diagram as far as possible. The aerial coil mount is secured by one screw only, this being to enable it to be swung at an angle to the other coils to reduce aerial damping when working on short waves.

Before the loading coil is mounted, the extra reaction winding has to be put on. For this use gauge 28 D.C.C. wire, or any gauge fairly near to this may be used, as the size of the wire is not at all critical. Fifty-six turns in all have to be put on, which means that seven should be placed

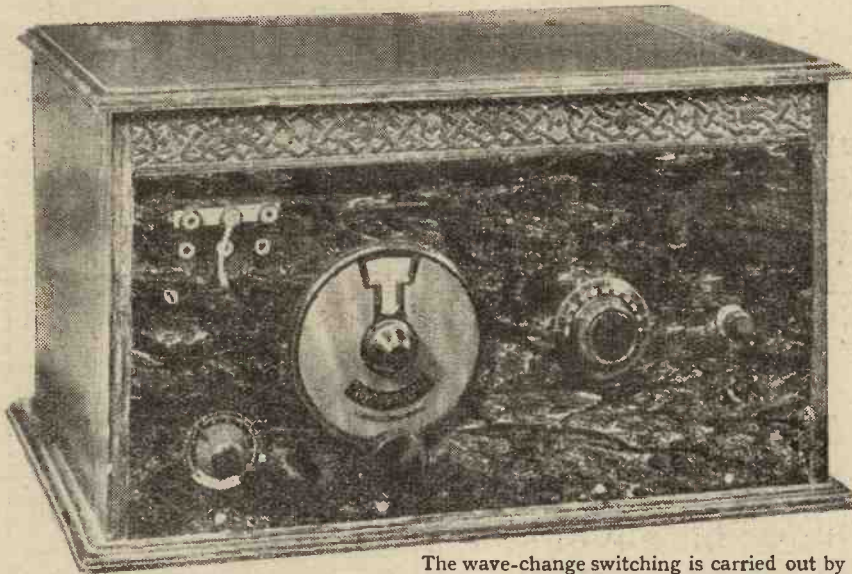

The wave-change switching is carried out by a simple plug-and-socket scheme which is easy to fix up and operate and cheaper than switches.

indicated at the side of each. There is no reason why makes other than those mentioned should not be employed, providing they are of good quality, and the caution given in the preceding paragraph is observed.

The constructional work is quite simple, and is very similar to that of most other small sets. However, for the sake of those who will be building their first, or almost first, set a few details are given. The panel is marked out in accordance with the dimensions given in Fig. 2, the drilling diagram. Do this with a scribe on the back of the panel, not forgetting that everything has to be reversed, since you are not working on the front of the ebonite.

Ease of operation, simplicity of design, and extreme usefulness are the three main characteristics of the "Three-Band" Two.

The panel should be laid on some sheets of soft tissue-paper to preserve its polish. Next, centre-punch all points where holes are to be drilled, and make the required holes of suitable sizes for the particular components to be employed.

The dimensions for the terminal strips can be gathered from the back-panel diagram, and they can now be made.

### Keep Leads Short

Before going any farther, the shanks of all terminals, all soldering lugs, and any other points on components to which soldered connections are to be made should be heavily

ponents which go on the panel may now be mounted.

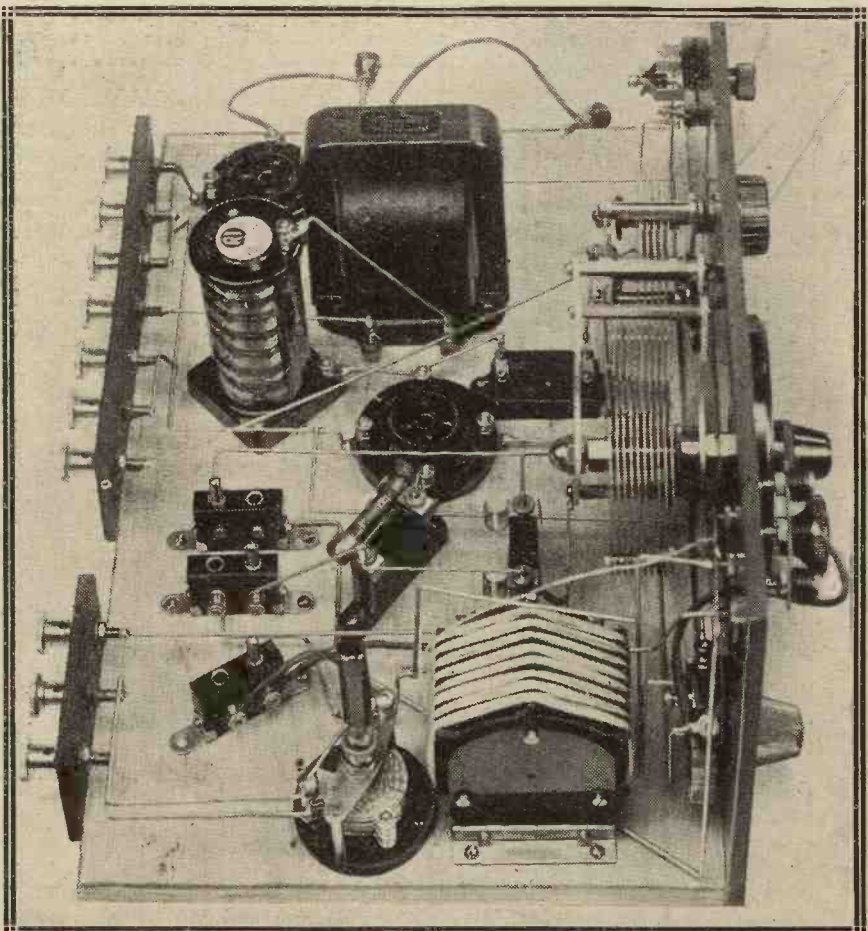

A variable aerial coupling, which is particularly necessary for when the set is working on short waves, is arranged without having to use a variable coil holder. One of the single coil holders is made to swivel on its single mounting screw.

in each slot. Leave a piece of wire about six inches at each end of the winding for connecting purposes. When the loading coil has been screwed into position, attention may be turned to wiring the receiver.

The wiring is carried out with stiff tinned copper wire, either covered or bare as preferred by the constructor. The wiring diagram must be followed exactly, as far as the

connections are concerned. A good idea of the spacing of the wires may be obtained from the photographs which show the back of the set. There is no point in the wiring which calls for special comment, for it is quite straightforward.

**Check Your Wiring**

The wiring to the least accessible components should be carried out

first, and when everything is connected the wiring should be checked.

Before describing the testing and operation of the set, a few notes on the accessories required will not be out of place. A valve of the H.F. or ordinary Det. and L.F. type should be employed in the first position. The second valve should be of the L.F. type if only telephone reception is required.

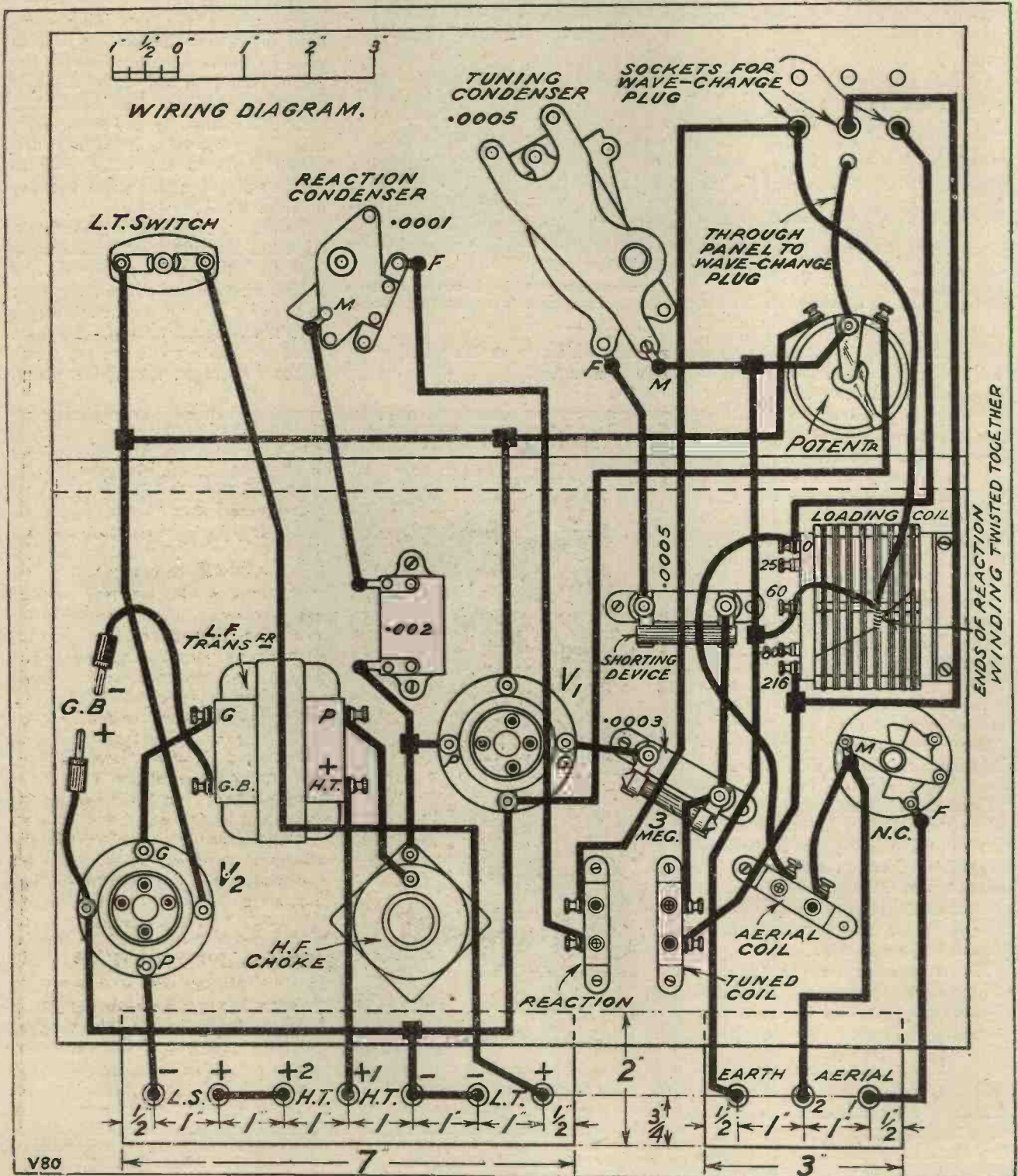



When a loud-speaker is used, a power valve must be employed if good quality is to be expected.

Ordinary plug-in coils will be required for the normal broadcast wave-band as well as a set of short-wave plug-in coils.

The wave-band covered by the short-wave coils will probably be marked on the boxes containing them or on the coils themselves. The reaction coil should be the same size or a turn or two larger than the tuned coil, and the aerial coil should have 2 or 3 turns.

### Preliminary Tests

The set should be first tested on the lower broadcast band. The aerial in this case should go on to the A<sub>2</sub> terminal, and the wave-change plug must be inserted in its socket. This plug will be found at the top left-hand side of the panel. It consists of three Clix or similar plugs mounted on a strip of brass which has three holes drilled in it.

On the panel are three corresponding sockets, and when the triple plug is inserted in these they are earthed, thus shorting out the long-wave coils. Above the sockets will be seen three holes in the panel into which the triple plug is placed when long-waves are to be received.

The potentiometer should be placed right over to its positive side and the receiver then tuned as a normal two-valve set. Should reaction control prove rather sudden, the potentiometer can be moved a little way towards the negative end when the reaction control will become perfect. The aerial coil should be close up to the secondary unless extra great selectivity is required, when it may be swivelled away a little. The aerial coil may be a No. 30, 35, or 50, and should be coupled to a No. 60. The reaction coil may be a No. 40 or 50, the best size being found by trial.

### Wave Changing

All that is now necessary to use the set on long waves is to remove the wave-change plug. If no reaction effect is now obtained, the connections to the reaction winding round the loading coil should be reversed.

When using the set on short waves, the plug on the panel should be inserted. It is also necessary to connect the aerial to the A<sub>1</sub> terminal.

No doubt the reader has wondered why grid-leak clips are provided for the fixed condenser which is in series with the variable tuning condenser. When this is shorted, namely, for the broadcast bands, a piece of copper

tube the diameter of a grid leak is inserted in these clips.

If you cannot obtain such a piece of tubing, an old grid leak with the end cups shorted by means of a piece of wire soldered across same may be employed. This shorting device has, of course, to be removed to use the set on short waves.

The size coils to use have already been indicated. The aerial coil should be placed at an angle of about 40 degrees or 50 degrees to the tuned coil, and the neutralising condenser should be at its maximum capacity.

The next step is to get the set to oscillate over the whole of the tuning condenser dial. If certain parts of the dial appear "dead," then the set is not oscillating there, and the series aerial condenser must have its capacity reduced a little, and the aerial coil can be turned away from the tuned coil a little more. Increas-

ing the H.T. a little will also help, but this should not be carried too far, as it may cause "ploppy" reaction. You can also try an H.F. choke consisting of about 50 turns of fine gauge wire on a cotton reel inserted in series with the ordinary H.F. choke at the point already mentioned.

### Short-Wave Stations

In order to help the reader to find stations at first, a list of the tuning dial readings for a number of stations which should be heard are given.

These were obtained on the original set with a 4-turn Igranic coil. The readings will not be exactly the same on every set, but will serve as an indication of where to search.

2 X A D . . . . .	12.75 degrees.
5 S W . . . . .	21.00 "
8 K . . . . .	29.00 "
P C J J and 2 X A F . . . . .	46.50 "
3 L O . . . . .	48.50 "
A German station . . . . .	84.00 "

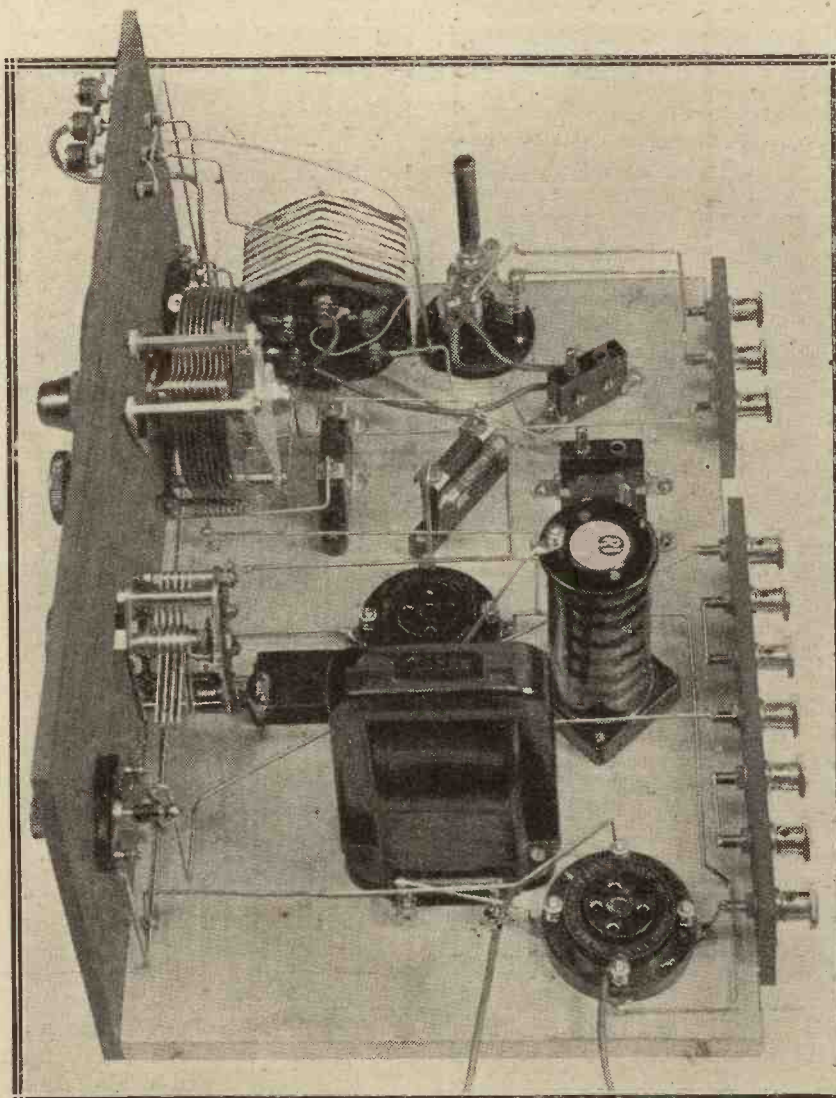

When the coils and valves are removed from the set it is seen that the components are comparatively widely spaced. Certainly no room is wasted, but by careful design, even on short waves, the set is remarkably effective.

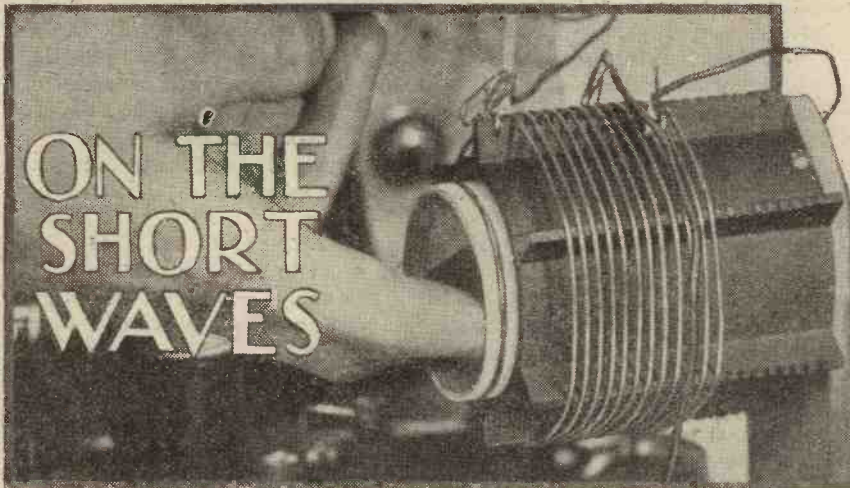

*Notes of Interest on Short-Wave Receivers and Reception Conditions.*

*By W. L. S.*

I HAVE just built myself what I consider to be the ideal short-wave receiver. It is not often that I am satisfied with a set, but I must admit that on this occasion I have made a set for myself with which I can find no fault! And the annoying part of it is that both in circuit arrangement and general design it is almost exactly like the other dozen or so with which I have been playing for some months!

**Component Details**

Here, however, are a few details for the benefit of readers who are interested. Circuit, straight-detector and one-stage L.F., series feed, with throttle-controlled reaction. Coils, home-made single-layer, with very small reaction coils placed right inside the grid coils. Plug-in, with four pins and a suitable base.

Variable condensers, .00013 for tuning and .0002 for reaction; both placed a few inches behind the panel, connections being made with the slow-motion dials on the front panel by means of ebonite rod. Grid condenser, .0001, and grid leak, 6 megohms. Other peculiarities, nil!

**No Threshold Howl**

I have tried the set out with at least eight different types of valve as detector and have never yet managed to produce that crowning catastrophe, threshold howl. Background is extremely quiet, and this has been found to be due to the high value of the grid-leak and also to the use of a low-ratio L.F. transformer.

The layout is such that the minimum of wiring in the grid and plate

circuits of the detector is necessary, and both batteries are shunted by a 2-mfd. condenser on the baseboard immediately in front of the terminal strip.

I am afraid there is nothing more I can say about the set. Probably

**DOES YOUR CHOKE CHOKE?**

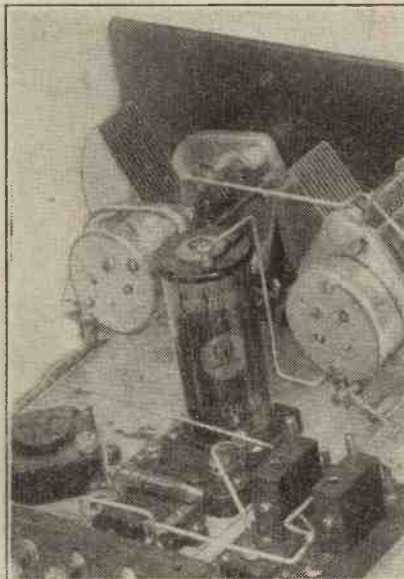

In short-wave work the H.F. choke is of paramount importance, and only a good quality component should be used.

by next month I shall have found all sorts of faults with it and scrapped the thing entirely in favour of another.

Ten-metre work has been going strong since I wrote last month's notes, and at last some British stations have been in touch with the States on this wave-length. The honour of being

"first across" falls to G 6 L L, owned and operated by Mr. J. W. Mathews, of Clapton. G 2 O D was across very soon after, and was in communication with two or three Americans straight away.

**16-Metre Broadcasting**

This is all the more remarkable since it was practically his first "try-out" of the 10-metre set, which he promptly christened by achieving what others had been struggling for months to do! G 2 K F and others in London have worked across, and G 6 D H, of Clacton-on-Sea, has been heard by W 2 J N when only using an input of three watts or so! So 10 metres is undoubtedly going to be one of the big noises when the other bands are crowded right out.

What is the wave-length of the lowest broadcasting station that any readers have yet heard? I have heard two Americans giving musical programmes on about 16 metres, but the only telephony I have heard below this is the transatlantic 'phone. I have no doubt that a wholesale shift round, such as is bound to occur early in the New Year, will result in the springing up of several regular broadcasting stations below 16 metres.

I suppose one of the chief reasons why nothing of this sort has been seriously attempted hitherto is that the various companies responsible for the broadcast stations are afraid that they will have no "listening public" if they go too low, on account of the difficulty of getting a receiver down there. There are no great technical difficulties on the transmission side. Their listeners should read "M. W."

**S.G. H.F. Success**

I venture to suggest that the "screened-gridder" for short-wave work is going to enjoy great popularity next year. I was never greatly impressed by the results given by the average "straight H.F." set below 100 metres or so, but two or three sets of the screened-grid variety have set me thinking, with the result that I have built a handy little unit for putting in front of my present set when I particularly want to get a distant broadcast on the loud speaker for any length of time.

In my opinion there is no advantage in switching the unit in if one simply wants to have a "nose round," but if you are after something definite, and mean to stick to it when you have found it, it is most distinctly worth the trouble. The expense is not more than a few shillings above the price of the screened-grid valve.



**T**HERE is one thing only that makes wireless worth while, and that is the programme. I speak for the majority and for always. Wireless therefore becomes more and more worth while as the technical side of the art obtrudes less and less. The technical side obtrudes less and less as reliability, simplicity, ease of maintenance and first-class quality of reproduction becomes more and more the main features of the receiver.

This article is to deal with the question of quality of reproduction considered from some possibly new aspects.

### Question of "Transients"

I want to deal with the question of transients. A transient is the momentary state of affairs when the impinging sound or electrical copy of the sound changes from zero frequency to a frequency, or from one frequency to another. The conductor raises his baton, a hush and crash, the orchestra plays the opening bars. How during this transient period does the system respond? How does the wave-front of sound from the loud speaker resemble the wave-front of the sound impinging upon the microphone? This is quite a different problem from the study of electro-mechanical reproducing systems at their steady state condition.

Consider the upper part of Diagram 1, which shows the curve of an alternating current suddenly started—the closing of the switch before the

*The phenomenal success of the B.B.C., just six years old, has been due in no small measure to the untiring energy and perseverance of its chief engineer. The technique of broadcasting in this country is second to none, and this chat upon quality will help all listeners to get the best from the broadcast fare at their disposal.*

tuning note, the opening of the relay which releases the six-dot seconds.

This is an "ideal" diagram, it shows the current starting abruptly. Consider, now, the amplifier, which inevitably follows any form of coupling, with the sounds in the air. Will this allow such a sudden starting without protest?—equivalently, will it faithfully follow such an abrupt stoppage as shown in the true transient diagram? And, if it does not, if it makes a "slurring" of the picture as shown in the bottom part of the diagram, how can we expect "perfect" reproduction, or, conversely, does it make any difference?

### A "Slurring" Effect

Measurements and photographs show that, in fact, the amplifier is responsible for some distortion of transients, and slurs the abrupt precipices of start and stop. In a capacitive (as against a transformer) type of amplifier this is likely to be due to the charge left in a condenser. During the steady state, of course, the charge is being changed to the

beat of the alternating forces, but suddenly leave a charge alone and it will relatively slowly discharge, slurring the result.

This has nothing to do with steady states nor so-called "time constants" of capacity-resistance circuits; what upholders of the transformer type of amplifier argue is a distortion due to a time constant in resistance-capacity amplifiers does not exist in the steady state, while the transient distortion of which I am writing exists in a transformer amplifier just as much. Consider the sudden stoppage in an inductive circuit, and you will see that there will equally be a hang-on due to the slow collapse of lines of force.

### Loud-speaker Resonance

A fully-loaded transformer would, of course, not suffer from the defect, being to all intents and purposes, looked at from the primary circuit, a resistance load. But show me a fully-loaded transformer equally responsive from 30–10,000 cycles a second; the excellent "steady state" performance of transformers is unquestionably due to the fact of their being unloaded but still partly inductive.

The D.C. amplifier would appear alone to give—theoretically, at any rate—the immediate response to transients. If you wish to magnify Morse-code impulses, which may be one a second (or one a minute, if you like, on a long dash) up to thousands a second when working

high speed, a D.C. amplifier is essential. It would be interesting to see, if ever we get a loud speaker suitable, if the ear can detect any difference between a D.C. and a conventional type of amplifier. I repeat, if we ever get a loud speaker suitable itself to respond to transients.

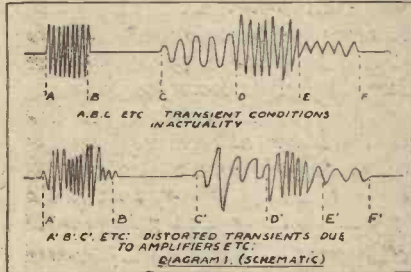

Any resonance in a loud speaker must surely result in a hanging-on at that resonance when a steady state of alternating force is withdrawn. The hanging-on will depend upon the damping. Perhaps one of the greatest criticisms of typical moving-coil loud speakers is the rather woolly type of reproduction, and one wonders if they lose that "attack," which musicians especially consider essential to good reproduction, because of certain pronounced and inherent resonances.

**New B.B.C. Experiments**

It is true that the comparison of two loud speakers by a musician may favour that which has a worse frequency characteristic, but, nevertheless, has a greater aperiodicity. May it be that resonance should at all costs be eliminated from loud-speaker movements? May it be that resonance is tolerable, but not over certain limits of the spectrum? May it be that the whole thing doesn't matter, and the ear neglects slurred transients just as it does not worry as to phase-change in the disturbance? (This is well known from a theorem of Helmholtz, and has since been experimentally verified—so he tells me—by Dr. Van der Pol, of Holland.)

These points require investigation, and it may interest readers to know that with the above somewhat vague ideas as a basis the B.B.C. is starting experiments to photograph the transient state stage by stage from microphone to loud speaker. The ear is the final judge, and we may hope, therefore, by eliminating transient distortion, to see whether it makes the faintest difference or whether, just as likely, it makes all the difference.

There is another aspect of dis-

tortion in receivers which I fear often escapes designers. I refer to differential reaction in the high-frequency circuits, that is to say, their tendency to react differently at different frequencies. It is only natural that in all reactive circuits there is an inherent tendency to react at the frequency of the carrier-wave rather than that of the outer side-bands, but few people realise that a set apparently in a non-oscillating condition before and even during modulation may actually, on strong bars modulation; burst into momentary oscillation.

**Unwanted Reaction**

I once had a set which had no actual reaction adjustment, and yet the quality could be good, bad or indifferent or frightful, according as the H.F. circuits were adjusted—according, in fact, to the degree of spurious reactions. It is a point well worth noting, and designers should try more and more to attain that cast-iron stability which in all our work is essential to a proper result.



The Chief Engineer—Capt. P. P. Eckersley.

**H.T. ELIMINATORS**

It is very seldom that H.T. eliminators deliver their rated outputs. As a matter of fact, the majority of reputable manufacturers of units do not claim definite voltages. The reason for this is that the voltages of supply mains are apt to vary. We believe that the Board of Trade regulation allows an error not exceeding 4 per cent, although we have had cases brought to our personal knowledge where this has been exceeded.

But even 4 per cent means a variation of ten volts with 250 supply, and comparatively small though this may be, it is a possibility well worth bearing in mind.

Mains supplies are generally so reliable that one is apt to regard them as being almost inhumanly stable. Nevertheless, slight hitches are apt to occur at the most perfect of power stations, with consequential discrepancies in the voltages supplied. Sometimes these evince themselves in flickering of the lamps, but this means a pretty considerable variation. Lesser departures can, in the case of a multi-valver, expertly adjusted, and using a mains unit, cause distortion. Possibly we are indicating a very infrequent cause of trouble, but, nevertheless, it is a point well worth bearing in mind.

**ODD ITEMS**

The world's ... liner, S.S. Olympic, works on a wave-length of 20 metres, under the call-sign G L S Q.

Failure to charge a battery regularly and efficiently is the cause of a large proportion of L.T. battery troubles.

On no account should the liquid from a cell be poured into any kind of metal container, as the acid immediately attacks the metal, and both will be ruined.

If when charging a battery violent gassing starts, do not let this continue, but reduce the charging rate until the recharging is finished.

**Filling Accumulators**

When mixing distilled water with acid for making the electrolyte for an accumulator, the acid must be poured into the water very, very slowly. (On no account should the water be poured into the acid.)

If the level of the electrolyte in an accumulator falls owing to evaporation, do not replace this with tap water. Only distilled water should be used for the purpose.

When adding distilled water to an accumulator to replace losses by evaporation, remember that the battery should be charged immediately after the water is added, so as to "mix" the new electrolyte.



*"This struggle has gradually gone outside the realm of television, and has taken the form of a large-scale attempt to the British system of broadcasting . . . ."*

*By a Special Correspondent.*

**SOME FUNDAMENTAL FALLACIES.**

**T**HE 10,000,000 listeners in the British Isles—the majority of whom are dissatisfied with the wireless provender offered them by the British Broadcasting Corporation—will be immensely interested to learn that for the first time in its career the B.B.C. is faced with the prospect of real and effective competition."

(SUNDAY DISPATCH, 4th November,—main news story).

" . . . In the United States, where better organisation, individual effort, and keener imagination has governed the field, broadcasting has become part and parcel of the daily life of the people. Here, where the B.B.C. has been allowed to become a calculated experiment in State Socialism, it has been a dismal and depressing disappointment . . . ."

(SUNDAY DISPATCH, 4th November,—first leading article).

"We turned down the offer on the grounds of public policy. If it is now really the case that a privately-run station is to be erected in France for the purpose of competing with the British Broadcasting Corporation, we suggest that the Government's attitude toward any such development should also be governed by considerations of public policy. The Government should at once inform the French authorities that the scheme is unwelcome to all of us on this side of the Channel . . . ."

"We have in the British Broadcasting Corporation a system which has proved itself under men of high ability. It is a well-organised corporation with a range of enterprise, efficiency, and interests that is rapidly widening. To allow a private concern in a foreign land to set up an opposing service would be wholly bad from every point of view."

(DAILY EXPRESS, 5th November,—first leading article).

*"Are We to Have Broadcast Anarchy?"*  
*"There may be much to complain of in the B.B.C.'s efforts to reconcile amuse-*

ment with instruction. Nevertheless, there is a good deal of prudence in the view that one authority should control our broadcasting, since the alternative policy of unlimited competition may lead to an irritation of minds as well as to a disturbance of 'waves.'"

(DAILY MIRROR, 6th November,—first leading article).

These quotations are fairly symptomatic of the trend of a recent phase in the great television offensive which began with the announcement by the B.B.C. in October that it would have nothing further to do with television in its present stage of development. The bitterness of the struggle is unparalleled in the history of wireless, but the B.B.C. has wisely

refrained from being drawn into an open exchange of invective.

**What Will Happen?**

It is known that the considerable political and financial resources of both sides have been strained to the utmost in move and counter-move. This struggle has gradually gone outside the realm of television and has taken the form of a large-scale attempt to rival the British system of broadcasting and replace it by an alternative. Fortunately, however, the lay press are alive to the danger of this tendency, and most newspapers are pointing the right moral.

It is an interesting speculation,

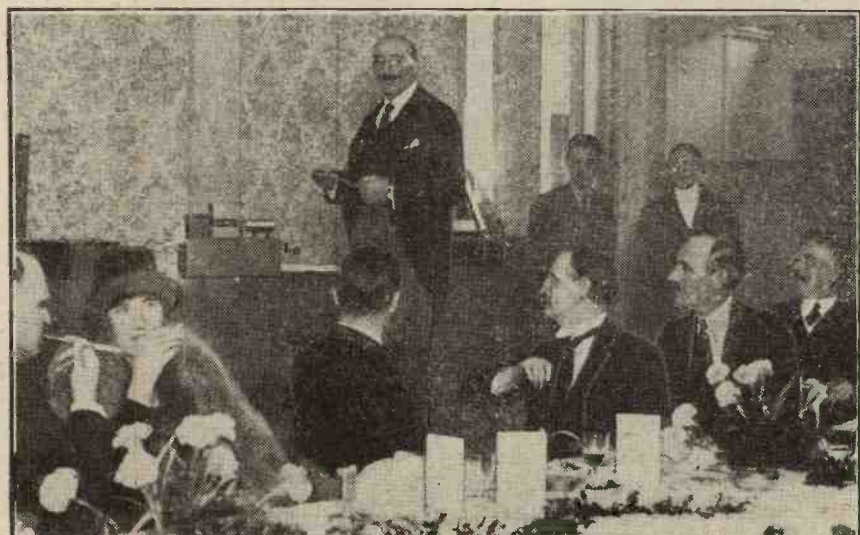

Capt. Fulton demonstrating his Fultograph at the Savoy Hotel. Radio pictures are being transmitted successfully from 5 X X, Daventry, but these must not be confused with television.

however, to consider what would happen in the unlikely contingency that the projected chain of "English hours" for Continental stations materialised. First of all, suppose that it were true that the 10,000,000 British listeners were heartily dissatisfied with B.B.C. programmes and would gladly welcome better fare from abroad. What is promised them under the new arrangement? "A complete chain of programmes full of varied and exciting interest, organised and arranged by English enterprise with English artists and English music" transferred to the Continent for broadcasting back to England.

### Box-Office Effect

Assuming that this chain of programmes were organised and were successful, and that it were preferred to B.B.C. programmes by British listeners, what would be the "box-

office basis, it is absurd to speak of a "challenge to the B.B.C." through the encouragement of distant listening in this country.

It stands to reason that as long as oscillation does not reach vexatious proportions it is definitely to the advantage of the B.B.C. that listeners should enjoy the maximum variety of programmes from foreign as well as home stations.

But this is not the whole story. Anyone who has a working knowledge of the practical problems of programme building, as well as an appreciation of the standard of attainment of the best European stations, knows full well that those listeners in Great Britain who are fortunate enough to possess the requisite apparatus already enjoy the best programmes which the Continent can produce. There is no nationality in music or in other forms of art. For

ability to carry on without the unsatisfactory artificial aids which make American programmes possible. If any tinge of advertising is introduced into the "English hours" from the Continent they will labour under a very considerable, probably a fatal, initial disadvantage. Obviously they will have no appreciable audience on the Continent, and still less in this country.

### Extremely Expensive

A further point concerns the economics of the organisation of these hours. Much is being made of their purely English character, and it is stated that, of course, the artists and organisers will have to travel from England to the Continental centres, whence their efforts will be broadcast.

All this adds to the expense of an already expensive business. It means incidentally that the best artists will not be available, because they will probably be averse from accepting a moderate fee, and the inconvenience of going abroad for a single or, at least, only two or three engagements, with the added risk of being permanently black-listed by the B.B.C. On economics alone, competition with the B.B.C. is out of the question.

Turn to another aspect of the problem. It has been presumed so far that a very large proportion of the British listening public is both equipped and willing to listen to foreign programmes in the ordinary way. The justification for this is extremely slender.

### Quality First

Now that the era of "wireless wonder" is definitely a matter of history, the vast majority of listeners seek quality rather than doubtful novelty. There is still, of course, the enthusiastic experimenter and the intrepid "reacher-out." But this genus is an infinitesimal proportion of the great army of 10,000,000 listeners which is claimed by the B.B.C. With the average listener, the desire to report abnormal feats of reception is replaced by the desire to enjoy good programmes with consistent and uninterrupted signal strength. In this respect the doctrine of the B.B.C. on the technical side has been justified up to the hilt. Moreover, not a large proportion of the listening public is sufficiently well-off to be able to afford the distant listening apparatus of reception.

Now what about the B.B.C. programmes? It would be indeed a bad day both for the B.B.C. and its listeners if the mention of programmes

(Continued on page 634.)

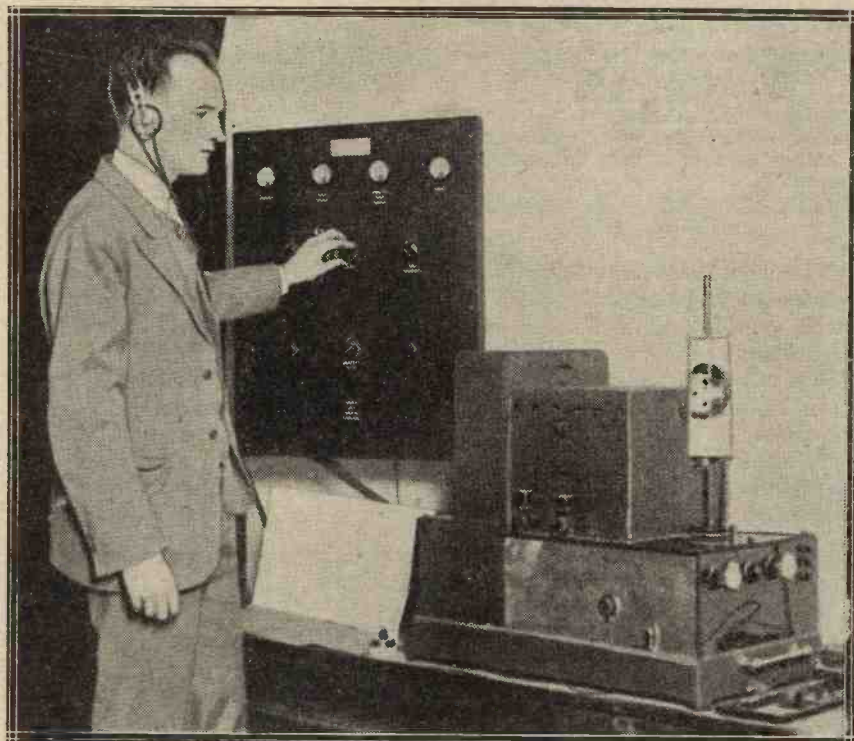

The transmitting apparatus used in connection with an American system of radio-pictures.

office" effect in the first instance? It is a requirement of the law of the land that everyone who maintains wireless receiving apparatus in this country must pay a licence fee of 10s. per annum. For the purpose of this licence it does not matter whether the signals received come from London or Singapore. But—and this is the acid test—about 7s. of every 10s. licence fee paid reaches the B.B.C.

Fundamentally, therefore, on the

those who are able to receive programmes from the Continent, the prospective "English hours" will have an attraction definitely inferior to that of the established programme features indigenous to the Continent.

### A Fatal Step

It is stated that advertisements are to be used to help finance these sponsored programmes. The British listening public is rightly jealous of the distinction enjoyed by the B.B.C. in its

# Beam Beacons



*How radio is helping navigators of the sea and air.*

By  
**J. C. JEVONS**

**T**HERE are several ways in which the directional properties of wireless waves can be used to enable an errant navigator to discover his whereabouts, either at sea or in the air. Such methods are, of course, most valuable at night, and in foggy weather, when lack of visibility rules out the lighthouse and other recognised aids to navigation.

For instance, when using a rotating frame aerial for reception, the strongest signals are heard at the moment when the plane of the loop windings points directly towards the transmitting station.

On the other hand, the signals fall to zero, or a minimum value, when the frame is turned until its plane lies broadside on to an imaginary line connecting the transmitter and receiver.

In this way a mariner or aviator is at once able to "place" himself, to the extent of knowing that he must be somewhere along the line connecting his vessel to the wireless transmitting station, which has a known geographical position.

By taking an independent observation on a second transmitter, he gets what is known as a "cross bearing." The intersection of the two "line" bearings when plotted against the other gives the navigator his exact

point or position on the map.

Although such a method of direction-finding appears simple in theory, several difficulties arise on the practical side. In the first place, if the rotating loop aerial is located on board a ship, the accuracy of the "line" bearing must of necessity depend to some extent upon the steadiness of the ship's course, and also to some extent upon the accuracy with which the direction of the ship's head is ascertained from the compass reading at the precise moment of observation.

## Getting Reliable Readings

Again, the bearing given by the point of zero reception on a frame aerial is admittedly more accurate than that obtained when using the position of maximum signal strength.

In practice, however, there is always a certain amount of extraneous "noise" on a ship, and still more on an aeroplane, and this reduces the chance of taking a reliable "zero" point observation.

Accordingly, what is done in practice is to shift the work of analysing the direction of the incoming signal

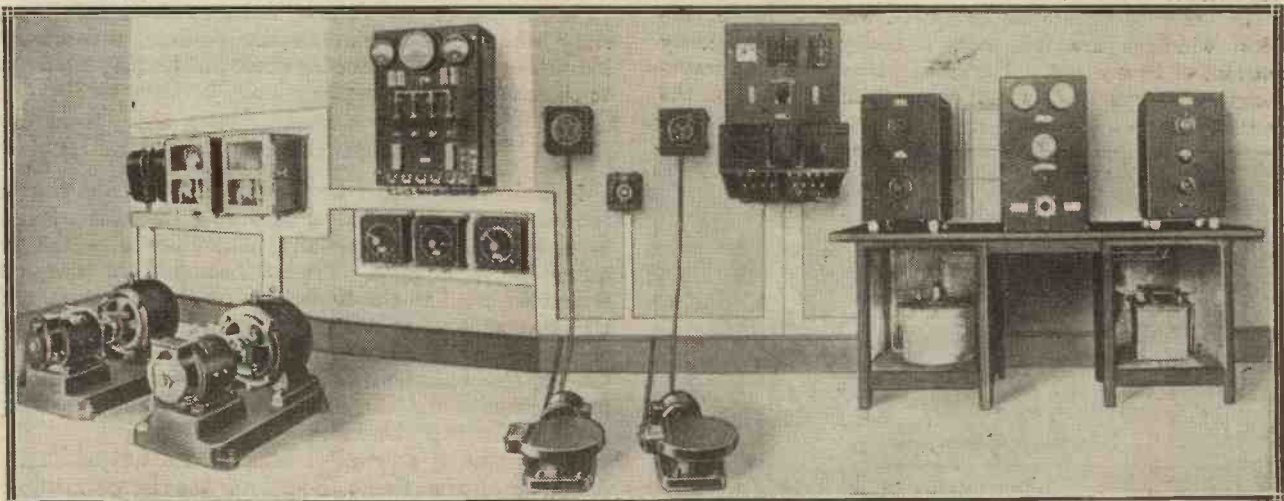

The Marconi 500-watt beacon transmitter at Round Island. No skilled men are required to operate it as it is almost automatic. The photo shows, left to right, the main switch with the two automatic starters underneath, the revolution indicators and the duplicate character motors (on floor) which form the automatic signalling keys. To the right can be seen the two master control clocks. The outfit sends out signals at regular intervals.

wave from the ship's operator to the operator in charge of a definite land station specially equipped for D.F. working.

The procedure is then as follows: The ship's operator calls up the land station and asks the operator there to take bearings. The land operator rotates his D.F. search coil until he gets an accurate zero reading on the ship's signal, and then morses back the required information. The ship's operator next calls up a second land station and repeats this procedure, and from the cross bearings so obtained he plots out his precise position at sea.

For many reasons it is desirable that the navigating officer should be able to obtain his bearings directly, i.e. on board the ship, without having to wait for a land station to do this for him, and then transmit the readings as previously explained.

In the ordinary way this would obviously necessitate the fitting of a rotating-coil receiving system on board ship. But, quite apart from the objections set out above, other complications occur due to the presence of the ship's funnels, stays, and other metallic masses, which deflect the true direction of the incoming signals and give rise to what is known as quadrantal error.

### Improving the System

Attention has accordingly been turned to the use of D.F. signals which are made strongly directional at the transmitting end, and which do not require the use of frame aerials to determine their direction in reception.

A later stage of development is represented by the directional transmitters erected at Inchkeith and at South Foreland by the Marconi Company. These are constructed along the lines of the original Marconi beam system.

The main drawback to the Inchkeith and South Foreland type of "beacon" lies in the fact that in order to keep the size of the rotary reflecting system within manageable dimensions, the transmitted wave-length must be kept very short, i.e. from six to ten metres, and this involves the use of special receiving apparatus on board the ship.

In the case of the rotating radio beacon erected at Fort Monckton, near Gosport, in connection with which the Radio Research Board have just issued their official report, the transmitting aerial consists of a simple six-turn frame coil, 5 ft. square.

In order to ensure an adequate working range, the loop windings are fed with a heavy high-frequency current of 40 amperes. The station transmits on a wave-length of 525 metres, so that signals can be heard on the standard type of receiver.

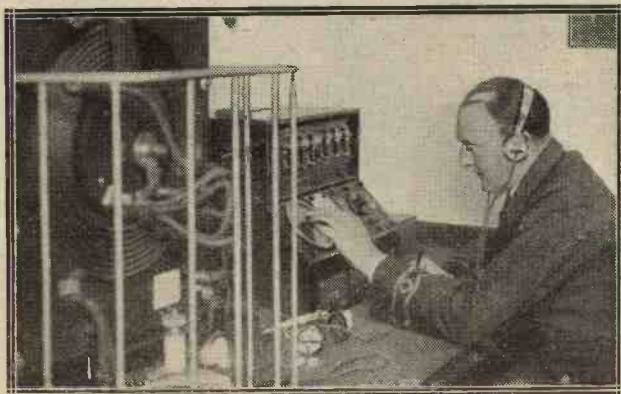

An operator adjusting the Marconi direction-finder on the "Alcantara," which is stated to be the largest motor liner in the world.

The frame aerial is mounted to rotate bodily, and very special measures are taken to ensure that an absolutely constant speed of one revolution per minute is maintained.

As the frame aerial rotates, a characteristic signal is sent out at the precise moment when the beam is pointing northwards. This is superposed on the constant carrier-wave, and is heard by the navigator at sea over and above the continual C.W. or heterodyne note.

In the first place, as the rotating beam of signal energy sweeps across the ship, the C.W. note in the receiving 'phones will rise and fall in strength periodically. Shortly before or after the moment at which the signals fall to

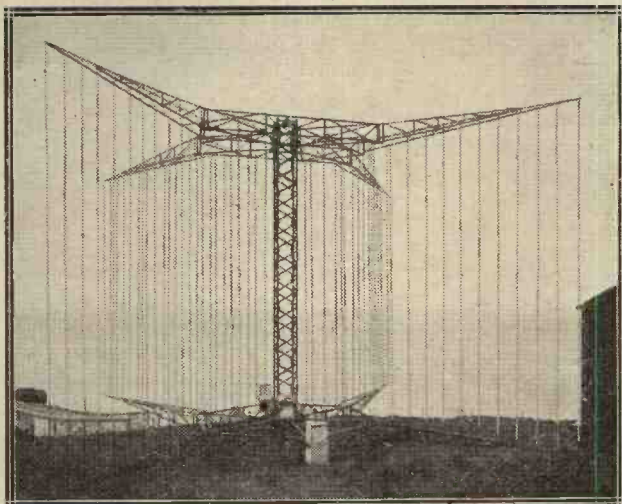

The revolving network which acts as the beacon at a radio Beam station.

zero the observer will hear the characteristic N point signal.

The point of minimum signal strength indicates one line in space, i.e. that directly connecting the ship to the known geographical position of the rotating beam station. The characteristic N signal, on the other hand, indicates a second line in space, i.e. that pointing due North and South.

The time interval between the two events, as recorded on a chronometer, indicates the exact angle between these two lines, because as previously explained a complete rotation of the wireless beam occurs once in every sixty seconds. The chronometer reading, accordingly, indicates to the navigator his exact line bearing relatively to the land beacon.

### Direct-Bearing Readings

In order still further to simplify matters, the face of the chronometer, instead of recording the time interval in seconds, may be specially marked to give the required bearing at sight. The index hand of the timepiece is first adjusted to the N position on the dial-piece, and the chronometer is set going immediately this signal is heard in the 'phones. The watch is then stopped directly the continuous C.W. note sinks to zero, when the index hand shows the exact bearing of the ship relatively to the radio beacon.

As a result of a series of tests carried out under the direction of the Radio Board of the Department of Scientific Research it was found that for clear open-sea ranges up to 50 or 60 miles, bearings taken on the Fort Monckton radio beacon were correct within an extreme margin of error of only 5 degrees.



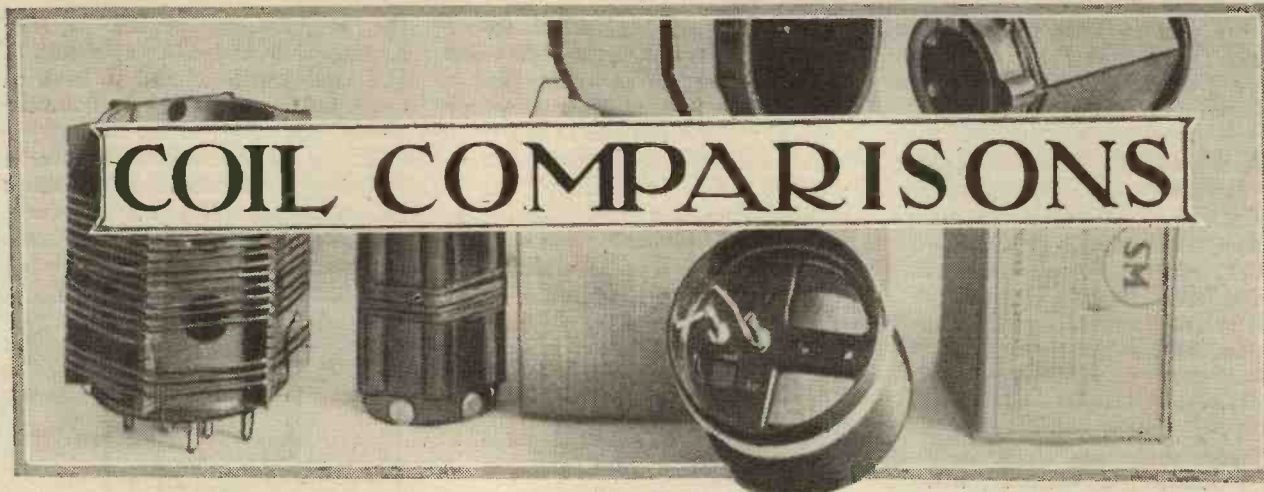

*Are your coils efficient? The question of the H.F. resistance of a tuning-coil is an important one, as is shown in this article.*

*By C. P. ALLINSON, A.M.I.R.E., F.Inst.P.Inc.*

"I AM using Litz coils," complained a friend to me the other day, "but the performance of the receiver is probably worse rather than better when compared against my old-fashioned coils. I wish you could give me an idea of where the trouble lies?"

Not only was I able to give him an idea as to where the trouble lay, but I was able to show him exactly where it was located. That I was able to do so was due to the fact that I am in possession of instruments by means of which I can measure the H.F. resistances of coils.

Incidentally, this H.F. resistance bridge also enabled me to demonstrate to him the fact that the tuning condensers he was using (which were cheap ones) were causing a very definite loss of signal strength in his receiver, and he was so impressed by the actual reading which I showed him that he immediately scrapped his old condensers and put in a pair of really efficient and up-to-date ones.

### H.F. Losses

I do not think that many amateurs realise to what extent a poor performance from a receiver may be located in the H.F. circuits. Though the faults may not be sufficiently serious appreciably to impair the functioning of the receiver, they may nevertheless cause a certain loss of signal strength resulting in the set giving a poor overall performance.

Litz coils are now coming into their own and their popularity is certainly well deserved from the point of view of the efficiency obtainable with them. For the home constructor, however,

they certainly present certain problems, one of which will be indicated through the solution of the difficulty that my friend experienced.

When he told me what was happening, I suspected what, of course, you will probably have already guessed, that some of the strands in the Litz wire were not making connection at one end, with the result

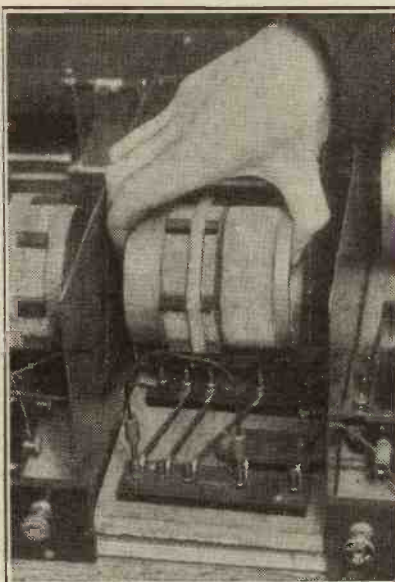

A specially wound low-loss Litz coil designed for use with the 1928 "Solodyne."

that the H.F. resistance of the coil was increased.

Judging from the number of turns and the appearance of the coil which I tested for him, I was of the opinion that its H.F. resistance should not have been more than 3.5 to 4 ohms. When placed on test on the H.F. resistance bridge, however (which is

built on the lines of the bridge described by P. C. Baker recently), it was found that its actual H.F. resistance was in the neighbourhood of 5 ohms.

I was thus able clearly to demonstrate to him that he had dropped several strands in the process of finishing off the ends of this wire, a fact which he had been disinclined to believe until he saw the actual figures for himself.

### A Fallacy

I should like here to kill a fallacy that has been in existence for some time with regard to the use of Litzendraht wire in coils. It has for some time been taken for granted by experimenters that if a single strand is dropped when making connections to a Litzendraht coil, the H.F. resistance of the inductance will be very greatly increased. I understand, however, that as a result of a number of readings taken by the Bureau of Standards, which, incidentally, I have myself confirmed, the variation in H.F. resistance of an inductance wound with Litzendraht wire in which one or more strands is not connected is almost directly proportional to the variation in D.C. resistance. This means that if 27/42 Litz is used, and one strand is dropped, then the H.F. resistance of the coil will go up approximately by 1/27th; if two turns are dropped, by 2/27ths, and so on.

The actual results I obtained, of course, did not exactly follow these proportions owing to the conditions under which I was working introducing an error of plus or minus

2½ per cent at least. They were, however, near enough, and the figures which I obtained may be of interest, and are as follow :

H.F. resistance of 160-microhenry coil, wound with 27/42 Litz wire, 3.9 ohms.

H.F. resistance with one strand broken, 4.1 ohms.

H.F. resistance with two strands broken, 4.35 ohms.

H.F. resistance with three strands broken, 4.6 ohms.

"Litz coils are now coming into their own, and their popularity is certainly well deserved."

It will be seen, therefore, that although dropping a strand in a Litz coil will certainly increase the H.F. resistance, it does not do so to any appreciable or serious extent. I hope that these tidings will gladden the hearts of those amateurs who up to now have not been keen on using this wire for fear of spoiling a whole coil by dropping one strand.

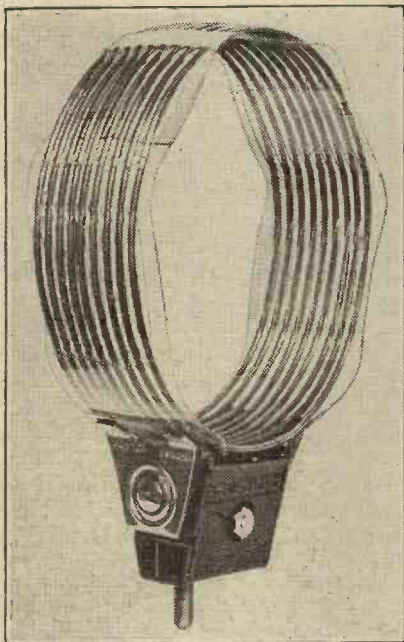

A commercial short-wave plug-in coil that is efficient in its operation.

My friend was so interested in the method of obtaining these H.F. resistances that he asked me to test out various makes of coils in front of him, not only so that he would thoroughly be able to grasp the principle of the H.F. resistance bridge I was using, but also to get an idea of the efficiency of different types of inductances.

Naturally, all the inductances I measured did not have the same value of inductance, so in order that a comparative idea of their efficiency might be gained it was necessary to reduce them all to a common denominator, and this is usually done by dividing the Resistance by the Inductance, the resulting figure being known as the R/L value of the coil.

### Wonderful Apparatus

It will at once be seen what a wonderful piece of apparatus an instrument of this description is, and it is indeed an essential piece of apparatus for anyone engaged in design work in wireless.

It is a fairly simple matter to design a circuit on paper; coils and valves of a certain type are to be used and certain results are to be obtained. When, however, it comes to carrying theory into practice we find that we are up against a number of snags which have to be overcome.

We may determine in the course of the design work that certain coils should have an H.F. resistance not exceeding a certain figure. The coils are then designed to have an H.F. resistance somewhere about the value predetermined. When, however, the coil is made according to design you will probably find that its H.F. resistance is considerably higher than was intended, but, of course, we can only find this out if we actually measure its H.F. resistance.

When you are the possessor of an H.F. resistance bridge it is a fairly simple matter to get out the coil required for use in a particular circuit, and thereby we can ensure that a theoretical design when carried out into practice shall be a success.

### Important Practical Points

The above notes show some practical applications of the H.F. resistance bridge which was recently described in MODERN WIRELESS, and before going on to describe other applications of this extremely useful piece of apparatus I think it as well to give some hints here on points to watch when using the bridge.

One of the most important things to determine is that you are working on the straight-line portion of the characteristic of the valve, and this is most easily done by taking a large number of readings for one particular coil at a fixed coupling and see whether these all fall on a straight line. If there is any serious departure from a straight line it is extremely probable that you are not working on

the straight-line portion of the characteristic and different values of H.T. and grid leak need to be tried out in order that we may work on the correct operating point.

Having made suitable adjustments for taking five or six readings for one coil, all of which lie on a straight line, we have settled one of the most important points.

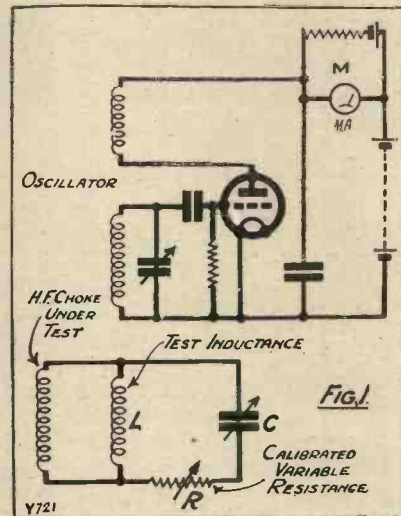

Next we have to make sure that we are not using too tight a coupling between the oscillator coil and the coil under test. In order to determine this we take three readings, say, for the coil at three different couplings. If we find that the H.F. resistance given for the three positions of coupling is within experimental limits, we can then assume that the looser of the two or three couplings we used is perfectly safe for taking all readings at. We can note the deflection obtained at this value of coupling when no resistance was connected in series with the test coil and arrange that all future tests be made so as to give a deflection not greater than that.

The effect of breaking one or two strands of Litz in a coil is not so serious as is often imagined.

The next point which needs to be borne in mind is that the test coil must not be placed within three or four inches of the screen into which the H.F. resistance bridge is built. If the coil is placed too close to the screen then, of course, the damping will undoubtedly be increased and its H.F. resistance will appear to be greater than it really is. This warning applies in particular to coils having a large diameter and a short length, since

the field of a coil of this description is somewhat inclined to spread.

It is desirable when using this bridge that the condenser which tunes the coil under test be calibrated. By this means we can obtain the inductance of the coil, since the H.F. resistance of the coil only does not necessarily give us a true idea of its efficiency. It is obvious that a coil having a low value of inductance will give a small resistance, likewise a large coil will give a higher resistance, so that it is important to know the inductance of a coil as well as its H.F. resistance.

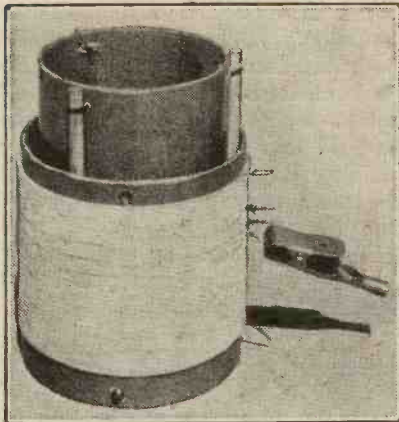

A tapped transformer with sliding primary coil, so that the coupling can be varied between wide limits.

A true measure of a coil's efficiency is obtained by dividing the inductance by the resistance, or, rather, as is usually done, divide the resistance by the inductance, the result being expressed as a ratio as previously described.

Thus a highly efficient coil will have an  $\frac{R}{L}$  ratio lying between .0125 to .025. A coil of average efficiency will lie between .025 and .04, and when the  $\frac{R}{L}$  value increases beyond this we are getting into a region of somewhat inefficient inductances.

**Further Uses**

This applies in particular, of course, to the smaller inductances, such as are used on the lower broadcast band, where the small value of inductance required makes it a fairly easy matter to design a highly efficient coil.

Let us now consider to what other uses we can put this H.F. resistance bridge. It was shown by the method we use for obtaining the H.F. resistance of the coil (see previous article) that by plotting the reciprocal of the change of current in the plate circuit of the oscillator valve against the

added resistance we get a straight line. It is, therefore, clear that the reciprocal of the change of plate current is proportional to the change of current in the tuned circuit, and is, therefore, proportional to the voltage across it.

**Testing Components**

From this we can, therefore, determine the percentage change in voltage caused by connecting such components as valve holders, coil holders, and other apparatus of this description in parallel with the tuned circuit.

Further, since the connection of the component under test has the effect of introducing an added resistance in series with the tuned circuit, this value can easily be determined by measuring the H.F. resistance of the coil with the component connected in parallel with it.

It will be found that the readings obtained of the H.F. resistance appear to have risen, and the difference between the H.F. resistance of the coil itself and its resistance when the component is connected across it gives the equivalent series resistance of this component.

**A Better Method**

Actually, a sounder way of looking at the question is to determine the equivalent *shunt* resistance of the component, and this can be obtained from quite a simple formula, which I give here for the benefit of the more advanced experimenters who may wish to work out the figures.

The expression is

$$r = \frac{W^2 L^2}{R}$$

Where  $r$  = equivalent shunt resistance we wish to find.

$R$  is increase in series resistance due to presence of component under test.

Thus if  $R_0$  = H.F. resistance of coil and  $R_1$  = H.F. resistance of coil with component under test connected in parallel, then  $R = R_1 - R_0$ .

$L$  is the inductance in henries and  $W = 2\pi F$ .

I will not describe the experiments I made with various coils, condensers, and valve holders, and so on, since these have all been done at various times, although they are certainly useful as a guide to the comparative efficiency of the various components.

There is one aspect of the question, however, in which I was very much interested, and the results of the experiments I carried out may also prove of interest to readers, as I do

not think they have been dealt with at all extensively.

In view of the number of circuits in which some form of shunt feed is used on the H.F. side, it occurred to me that it would certainly be of value if some comparative tests were made with different types of H.F. choke, and for this purpose I got

**Tuning condensers in many cases cause a definite loss of signal strength.**

together nine or ten different chokes of commercial make, together with various types of plug-in coil which could be used efficiently as chokes, and carried out a number of comparative tests, using the H.F. resistance bridge for the purpose.

**Measuring Choke Resistances**

The H.F. choke to be measured was connected in parallel with the tuned circuit of the H.F. resistance bridge. First of all, the resistance of the coil itself was carefully checked up, after which the inductance to be used as a choke was connected in parallel with the coil, being carefully shielded both from the coil and from the oscillator itself, so as to avoid any interaction from taking place.

I was chiefly interested in the figures obtained round about London's wave-length, and the oscillator was therefore set at a frequency in the neighbourhood of this frequency. The readings obtained were checked over at a later date with a view to reducing the experimental error as far as possible and the figures I am

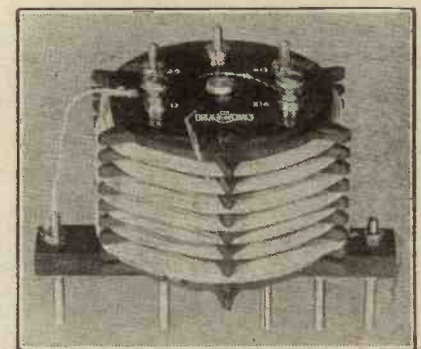

One of the "Modern Wireless" standard loading coils—a useful and well-designed piece of apparatus.

going to give are a mean of the various figures obtained.

Since I think it will be clearer to the general reader, I am giving these figures as being the apparent increase

(Continued on page 626.)



*The grid leak is an important piece of apparatus and its value greatly controls both the quality and sensitivity of radio reception.*

By CHARLES GOLENPAUL.  
(American Mechanical Laboratories.)

**B**ECAUSE a .00025-mfd. condenser and a 2-megohm grid leak are generally specified in connection with valves used as detectors, it has become a religious belief that these values are correct and beyond reproach.

Anyone who has done a bit of experimentation soon arrives at the conclusion that the grid leak may run anywhere from  $\frac{1}{2}$  to 8 megohms, depending on the valve, the circuit and the signal strength, while the grid condenser may give better results when of .001 mfd. capacity than the dogmatic .0003 mfd.

**Grid-Leak Rectification**

However, the condenser is not as critical in its contribution towards better radio results as the grid leak, hence we shall confine ourselves to the latter.

With the usual three-electrode valve there are two methods of obtaining rectification, namely: (1) by means of a bias battery, and (2) by means of a grid leak, which is the more popular method. The grid-leak method is more sensitive than grid-bias detection.

However, marked distortion may take place with this method on powerful signals unless the resistance value of the grid leak is materially reduced. Thus for distant reception, or the detection of weak signals, grid-leak values as high as 5 megohms may be employed, with surprising increase in loud-speaker response, while on local and powerful signals the grid-leak value may be reduced to 2, 1, or even  $\frac{1}{2}$  megohm, with ample loud-speaker volume accompanied by far less distortion. With the introduction of the grid-leak clarostat, representing a resistance range of from .1 to 10 megohms, with precise adjustment and permanent resistance of any value, it becomes possible to place the grid-leak function on the same precision basis as capacity or inductance in the radio circuit. Noise, heretofore the main fault of variable grid leaks, has been entirely eliminated.

The indirectly-heated valves require a critical grid leak for best detection. The value is not known without trial, as valves and other conditions vary widely. Certain A-C valve manufacturers recommend trying several values between  $\frac{1}{4}$  megohm and 9 megohms.

With a variable grid leak, however, it becomes possible to determine the correct value. The variable grid leak also acts as a satisfactory volume control and eliminates the need for a separate device for this purpose.

In short-wave reception the grid leak is quite critical in value. Experimenters sometimes try as many as fifty grid leaks before the satisfactory value has been found. The best value is usually between 4 and 8 megohms.

**On the L.F. Side**

Aside from the detector, the grid leak has an important function to serve in resistance and impedance coupling. While the plate coupling resistance usually is not critical, the grid resistor is of considerable importance. By means of precise resistance of grid leak it becomes possible to employ larger coupling condensers, therefore passing lower frequencies for the desired bass notes, while effectively preventing blocking or choking by lowering the grid-leak resistance.

It is well to note in passing that resistance coupling is capable of responding to very low frequencies, with the result that there is sometimes set up a low-frequency oscillation, due to coupling between circuits, known as "motor-boating."

The simplest way to offset motor-boating when it does occur is to use a lower resistance of grid leak for one or more stages, together with smaller blocking or coupling condensers.

Often the lowering of the grid-leak resistance in the first or second stage will serve the purpose. In this respect a variable grid leak, substituted for the first or second fixed grid leaks, will serve as a simple cure.

\*\*\*\*\*  
**COIL COMPARISONS**  
—continued from page 625  
\*\*\*\*\*

in the series resistance in the tuned circuit, which is obtained by connecting the choke in parallel with the coil.

Some of the chokes which I tried were very good; for instance, the one gave an apparent increase in series resistance of only 1.8 ohm, others, however, went up to 12 ohms, or even over. Another good choke was the Lissen, giving an apparent increase of only 0.9 to 1 ohm. This figure is extremely good, and compares very favourably with the results given by using high-efficiency inductances as chokes.

Here are ten chokes which were tested. The inductance used in the tuned circuit had a resistance of 3.9 ohms. The following equivalent series of resistances were obtained (these figures include the coil resistance): Choke No. 1, 23 ohms; No. 2, 7.2 ohms; No. 3, 8.2 ohms; No. 4, 9.2 ohms; No. 5, 9 ohms; No. 6, 7.3 ohms; No. 7, 16 ohms; No. 8, 5.5 ohms; No. 9, 4.7 ohms; No. 10, 5.37 ohms.

**Peculiar Phenomenon**

Choke No. 1, it will be seen, gives an extremely bad reading. It is interesting to note, however, that this choke was specially designed for use in reaction circuits, and has been used with success down to 12 metres

and up to 3,000 metres or more, giving smooth and progressive control at all frequencies. Incidentally, it is one of the cheapest chokes on the market, and when used in practice in a shunt-feed circuit it certainly did not give the reduction in signal strength that one would expect.

Choke No. 5 is not an H.F. choke at all. Actually, it is the primary winding of an Igranic G type L.F. transformer. This merely serves to confirm what I have found myself in actual practice, that this transformer primary serves the purpose of an H.F. choke and enables this component to be dispensed with. It is not always desirable to do so, since H.F. currents are liable to get over into the L.F. side and may cause trouble.



# BROADCASTING AND THE NEXT ELECTION

BY COMMANDER THE HON. J. M. KENWORTHY R.N., M.P.

*In this trenchant and timely article the author says: "The Ether belongs to no man. The B.B.C. is the property of the people. I therefore demand its unrestricted use, equally and fairly distributed, for all of the political parties."*

**H**ow should wireless be used at the next General Election?

That the election will be of vital importance everyone is agreed. For one thing, there will be another 5,000,000 voters on the registers, many of whom have taken no interest in politics before. That wireless could be made of very great service in elections admits of no doubt whatever. It has just played a tremendous role in the Presidential election in America. Indeed, it has been used in the United States as never before. Every important speech of the political leaders has been broadcast throughout the Union.

At the last General Election in this country, in 1924, the wireless facilities, used for the first time, it is true, were altogether inadequate. Each of the

leaders of the three political parties, Conservative, Labour, and Liberal, was allowed the use of the ether once only during the whole of the campaign. No one else out of some 1,500 candidates had even this privilege.

## O.B. Failure

Mr. Baldwin was the most wily. He was advised of the great importance and effect of a good wireless "talk," so he wrote a special speech for the occasion and delivered it from the B.B.C. studio at Savoy Hill. Mr. Macdonald and Mr. Lloyd George, on the other hand, did not give a special wireless talk, but each had one of their speeches at a great mass meeting relayed. The result was what might have been expected. The transmission was not good—Mr. Macdonald

in particular was moving about the platform a little as he spoke, as is his custom, and the interruptions, friendly and otherwise, the applause and the shouting of slogans, were relayed, too.

This should be rectified next time. If only the three party leaders are to be allowed to use the ether, they should each have equal facilities and should give their talk from the studio; and I should suggest that they do it early in the campaign before they lose their voices!

But there ought to be far more broadcasting at this coming election. During the fortnight's campaign the great issues before the public have a way of altering, and some that appear important at the beginning of the campaign sink into insignificance



Radio was a great factor in the recent American Presidential election, and this photograph shows one of the orators (using loud-speaker equipment) who helped Hoover to win his sweeping victory.

before the end; while new problems which interest the public—who, after all, have the responsibility of voting—crop up.

**Broadcasts For All**

But why should the ether be reserved exclusively for these three eminent gentlemen? The electors are only voting for them in their own constituencies. They are voting for their own local candidates, at any rate by constitutional theory, everywhere else. They have a perfect right to hear the candidates they have to vote for or against.

With the huge modern-day electorate it is impossible to reach more than one-third of them, *at the outside*,

It is only a matter of organisation. Perhaps the candidates in the more remote districts like the Orkneys and Shetlands, the Outer Hebrides and the more distant provincial towns, would not be able to do this. But so long as it is fairly applied all round, wherever possible the difficulties should not be insuperable.

Many infirm, elderly or invalid voters, in any case, cannot get to public meetings; and they would appreciate the opportunity of being able to hear the candidates, what they have to say, and their views on local problems at their own firesides. For these local questions play a large part in our politics, and rightly so.

Mr. Baldwin and Mr. Macdonald

It may be said that some candidates have better broadcasting voices than others. That, I am afraid, can no more be helped than the fact that some candidates are better-looking than others. All men are equal in the sight of God, but we all differ in our personalities.

**Permission Refused**

Since the General Election no use of the wireless at bye-elections has been permitted. I fought a bye-election a couple of years ago in my own constituency, and in response to a number of requests from elderly people and others who could not get to meetings, I approached the Postmaster-General to know if he would allow me and each of the other two candidates who opposed me to have a turn at our local broadcasting station which is in the constituency we were contesting.

The Postmaster-General refused all facilities point-blank and I heard that his reasons were that he thought I would have an advantage over the other two; but as I had already represented the constituency for over eight years, the advantage would have been for my opponents, who were comparatively unknown. And, broadly speaking, the use of the ether will advantage the lesser-known candidates more than the men well known locally. But I say again that, if it is done fairly all round, that cannot be helped.

Again, some politicians are first-rate addressing crowded public meetings, where the audience acts as an inspiration and the occasional heckler and the "voice" as a stimulus. Mr. Lloyd George and Mr. Winston Churchill are examples of this type. Perhaps they wouldn't be so good in the quiet atmosphere of the broadcasting studios. But they cannot have it all ways. Wireless is so important nowadays that any public man ought to be able to speak well to the microphone. Presently it will be nearly as important to the politician as reading and writing, and only of secondary importance to speaking itself in the ordinary way.

**Present Policy**

As for the nervous politician who is terrorised at speaking in public and is put completely "off his stroke" by unsympathetic interruptions, I am always sorry for him or her; and to this type of candidate broadcasting will be a boon. In any case, the present policy of allowing as little use as the British Broadcasting Corporation

(Continued on page 694.)

**POLITICAL CARTOON POSSIBILITIES**

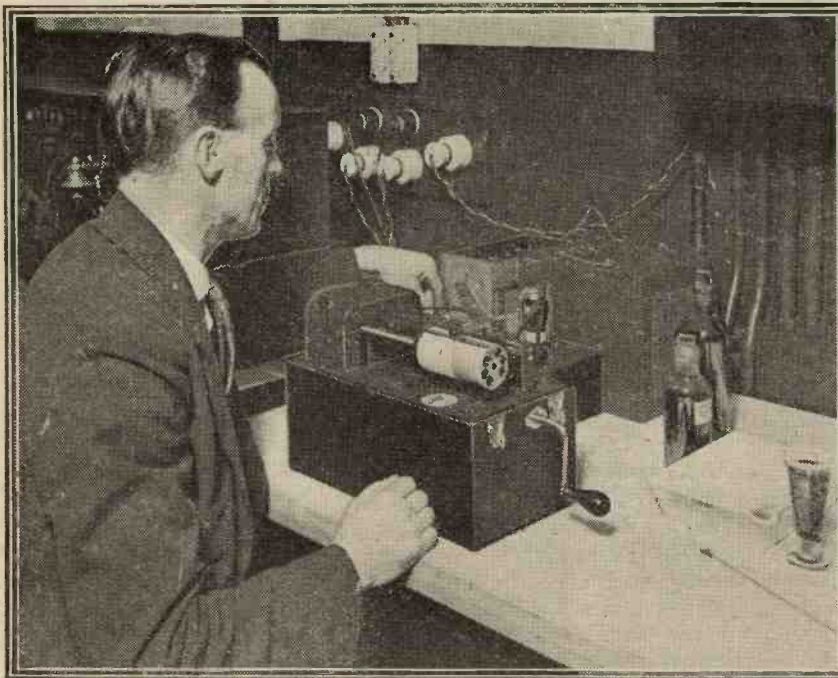

Here is shown the "Fultograph" apparatus, installed by the B.B.C. for broadcasting "still" pictures. Obviously there are great possibilities in such an instrument for political propaganda in cartoon form.

by means of public meetings. The capacity of the halls and assembly rooms, the opportunities of the public to attend the meetings and the physical endurance of the candidates will not permit of more than this percentage actually hearing and seeing them.

Television will help in the future; but that is a matter of the future, and its development does not yet bring this possibility within our reach. In the meantime, why not organise the broadcasting arrangements in such a way that as many as possible of the candidates in the constituencies shall have an opportunity of broadcasting one set speech at least in the studios of their local stations.

making one national speech on national subjects, cannot possibly touch specially on the agricultural questions which affect the farming districts, often differing in different parts of the country, the fishing questions and shipping matters which affect the ports, the problems particularly affecting the textile, engineering and coal districts, to take only a few examples. I daresay it is not practical to universalise such facilities, because we have not enough wireless stations to broadcast the election addresses of the candidates in each constituency and to fit them all in, but we should most certainly use the wireless whenever we possibly can.



# WHY NOT A VALVE?

*The gift of a valve, or a set of valves, is one of the most acceptable of Xmas presents and is sure to delight any of your friends who owns a valve receiver.*

*By KEITH D. ROGERS.*

ONCE more that time of the year is upon us when we all begin to search round the radio stores for suitable presents for our "listener" friends—and what a job it is! We are faced with a galaxy of possibilities which can almost be described as nerve-shattering to the average person.

## What Shall We Give?

Shall we give Uncle George a battery, a loud speaker, a transformer, and Arthur a mains unit? Or would the latter be more acceptable to Percy? While perhaps Geoffrey would prefer the transformer. In our endeavours to find a suitable present we come up against all sorts of snags, and many reasons why we should not give this or that.

Probably if we consider a mains unit we suddenly remember that we do not know anything about the mains upon which it is to be used, or the set with which it is to be worked. If we think of giving an L.F. transformer we have no idea whether it will be of any use, and, as for batteries, we are still in the dark as to what type and what capacity our friend wants.

## Always Acceptable

Now why not do away with the majority of that worry and decide to give all your friends valves? To the enthusiastic radio listener nothing is more acceptable than a good valve, and it is not a difficult matter to find out what voltage L.T. supply he uses, and what the type of set.

Even if the valve is not required at the moment it will come in very nicely

as a spare, or will replace one of his old valves which has gone a bit off colour. I know that, personally, if I were in the position of the ordinary radio listener I would much rather have a valve than anything else, unless perhaps it be a particularly good loud-speaker.

After all, a valve is always acceptable. It is easy to post, is not expensive to buy, and the modern valve is thoroughly reliable. In most receivers the average valve, having an impedance of somewhere between 10,000 and 20,000 ohms is as acceptable as is the ordinary power output valve. Super-power valves, of course, require a little more care in choosing, and you have to know more about the sets on which they are to be used, while the same applies perhaps to the R.C. valves.

But I know of nobody who would not be grateful for an H.F. valve, for this can be used as H.F., or detector, or 1st L.F. in many cases, while an output valve of the ordinary

power variety is another extremely welcome gift.

Screened-grid valves and pentodes, of course, should not be considered unless full details of the circuits to be used with them are known, while the same applies to mains-operated valves which naturally are not suitable for use in every circuit.

So your motto this Christmas can be: "Give him a valve." As a rule, unless the recipient of a present has a particularly distinct liking for any make of valve, you can choose your valve from any of the well-known makes and be certain to give full satisfaction with your gift.

## Some Good Examples

And while talking about valves as Christmas gifts, I may as well tell you that I have had one of the most acceptable "Christmas gifts" in the form of a set of B.T.H. valves which have just been sent in for test. These constitute the range of Mazda nickel-filament valves which are so well

### AN XMAS OPPORTUNITY.

A corner of a multi-valve receiver where the gift of one or more valves would greatly relieve the cost of building and prove very acceptable. If you know of anyone building a new receiver, a set of valves will always be appreciated.

Find out as much about the set as you can, what L.T. and H.T. are to be used, for such information will help you considerably in your choice.

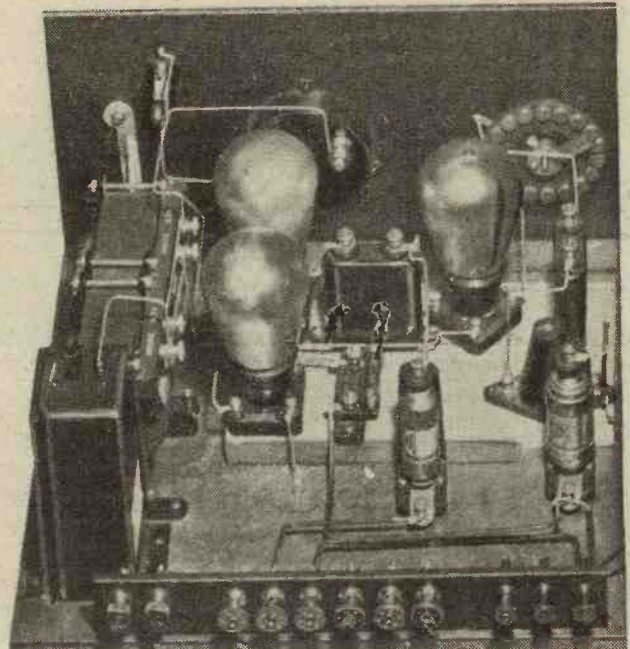

known in the B.T.H. advertisements, and introduced by the well-known figure of Sergeant Nickel. I remarked upon a few of these last month, but since then have been carrying out a more thorough test.

### All Good

How I am to differentiate between the different valves as regards efficiency of operation I do not know; they all appear to be equally efficient. No matter whether it is the H.F.210, G.P.210, L.F.215, P.227, L.F.407, P.615, etc., etc., they all work well—an ideal range from which to choose a Christmas present.



The Cossor version of the new five-electrode valve now popularly known as the Pentode. Don't forget the Pentode requires a special output transformer if it is to be wholly satisfactory.

Especially efficient do I find the G.P., L.F., and power valves, which are provided in very useful characteristics. For instance, in the 2-volt range we have the usual H.F. valve of 28,000 ohms, and then we have a G.P.210 of 14,000 ohms, with a magnification factor of 13.

### On the L.F. Side

This is followed by the 7,000 ohms L.F.215, with a magnification factor of 7, and then a P.227 of 2,000 ohms and a magnification factor of 4. A very useful method of arranging the valves, enabling one to pick a valve for every stage in any set out of the 2-volt range.

The same applies, with figures very little different, except in the case of the L.F.407, amongst the 4-volt valves. The L.F.407 has a magnification factor of 8 with an impedance of only 5,700 ohms. This means there is rather a jump between the G.P.407 with 14,000 and the L.F., but in the majority of circuits you will find that this fits in quite well.

### Six-volt Valves

As regards the 6-volt Mazda valves, perhaps the best criticism, or rather recommendation, that I can give is to say that as I am writing this the loud

speaker is giving forth the strains of Jack Payne's dance band from 5 G B via two of the B.T.H. valves.

These are being used in the L.F. portion of the set as 1st and 2nd stages, and are the G.P.607 and the P.615, preceding the special output stage.

It is impossible in the space at my disposal to give full details of all these valves, though I must certainly recommend the P.X.650 to those who want a big output super-power valve operating on 200 volts or under. But don't over-run this valve—it is designed for 200 volts and over-running will quickly ruin it. It has a really good grid swing at somewhere about 35 volts grid bias, and takes a plate current of only 23 to 24 milliamps. Unfortunately, it takes half an amp. on the filament, but those who want a really good loud-speaker reproduction will not mind this extra filament current.

### The "S.G.P." Three

With regard to the sets described in this issue, the only one which really requires any discussion on the subject of valves is the "S.G.P." Three.

This receiver, as you will see from the article, is in two parts; the screened-grid H.F. and the detector forming one section, and the pentode amplifier the other. Each part can be used independently of the other, and the former can be used either separately or with any other L.F. amplifier.

Now, herein lies the only snag, for you want to choose your detector valve according to the way you are going to use the set. The screened-grid valve can be a two-volter of any good make; B.T.H., Ediswan, Cossor, Mullard, Osram, Marconi, Six-Sixty,

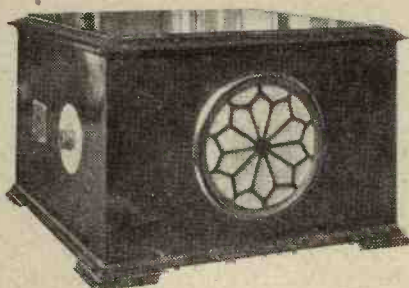

Some moving-coil speakers have their amplifiers with them as does this B.T.H. outfit, but others require special output valves to do them justice. It is just as well to find out what speaker your friend uses before you give him an output valve.

all make excellent screened-grid two-volters.

The detector valve must also be of the two-volt type, but its other characteristics will have to suit the

particular use to which it is to be placed. For instance, if the "S.G.P." Three is to be used as a whole, the detector being followed by the pentode amplifier, then the detector can well be of the 10,000-20,000-ohm type, preferably an H.F. valve of the latter impedance, or some near figure.

### Choosing a Detector

If the H.F. and detector section is to be used alone it should have a detector of the H.F. variety, while if the H.F.-Det. section is to be used



The Ediswan 2-volt screened-grid valve, which has an impedance of 140,000 ohms, and a magnification factor of 140. This makes a useful present if you want to give an S.G. valve.

with an ordinary amplifier the detector will have to be varied in accordance with the coupling device used between it and the following amplifier.

Where this is a transformer, the H.F. type of detector or moderate impedance L.F. valve will be most suitable, say, between 10,000 and 20,000 ohms. Where resistance coupling is used, the impedance of the detector can be anything from 20,000 to 60,000, according to the resistance value employed.

### For Resistance Coupling

Preferably, I should use one of about 20,000 to 30,000 ohms, and a coupling resistance of not more than 250,000 ohms. The resistance capacity type of valve is likely to be overloaded by the input from the screened-grid valve on average working, though it might be advantageous to use one if you are going in for D.X. work.

Don't forget that if you use resistance-capacity coupling you will benefit by employing a higher voltage of H.T. than you would normally use when transformer coupling is provided.



# BRIGHTER BROADCASTING



*Beverley Nichols is a young man with a past—obviously. He wrote his autobiography when he was twenty-five and has been President of the Union at Oxford. Many people would consider that a life's work, but B.N., at twenty-eight or so, has demonstrated many times that he has a future as well. His ideas on brightening up the B.B.C. are given here for the first time. And they are jolly good ideas, too.—THE EDITOR.*

**I**F Mrs. Smith, of 49, Blank Street, Kensington, will proceed at once to the Hula Lula Restaurant in Soho, she will discover Mr. Smith dining with a blonde and brazen person of her own sex, of whose existence she was previously unaware."

Now, that sort of thing, in my opinion, would enormously enhance the brightness of broadcasting. It would also act as a clean and healthy influence on the morality of the metropolis. All that is needed is a small addition to the staff of the B.B.C.—a competent detective service that would keep a paternal eye on the doings of its subscribers. And just think of the excitement that would occur in the households of those to whom Mr. Smith was personally known!

"I always thought that man looked double-faced!"

"Who wouldn't—with a wife like that?"

"What do you think she'll do?"

"Why not go and see?"

### Willie's Woolly Bear

Whereupon—such is the depravity of mankind—the entire family would probably leap into a taxi—arriving at the Hula Lula Restaurant just in time to see an outraged Mrs. Smith telling the blonde lady exactly what she thought of her.

Or, again:

"If Mr. Robinson, of 900, Waverley Mansions, Greenwich, will look in the top drawer of Mrs. Robinson's bureau, he will find something of considerable interest to him."

"Something of considerable interest to him! Whatever can that mean?"

"Probably a letter from some man."

"Or a photograph!"

"Or it might be a will!"

Anyway, whether it be a letter, or a photograph, or a will, it would be exciting. And that is more than can be said for the children's hour as it is now arranged. If you obtain a thrill from the knowledge that little Willie Jones will find a woolly bear if he looks under granny's bed, I wish you would tell me why. Personally, when I hear those gruesome catalogues beginning, I switch off the radio and play a little Bach.

However, you may tell me that the idea is not practical, and that it could only have been conceived by a

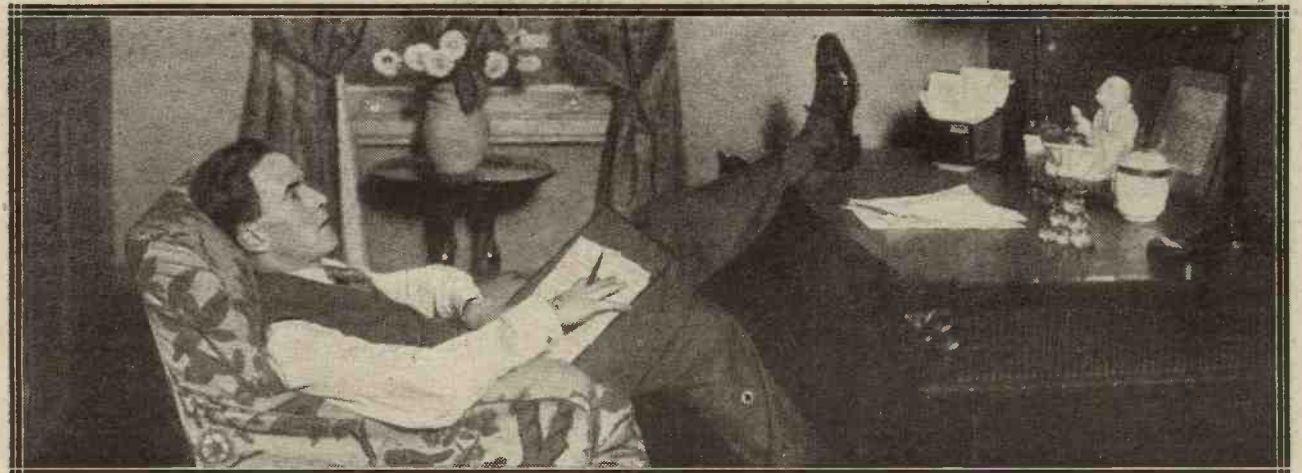

Mr. Beverley Nichols, the well-known writer, whose rise to fame has been rapid and spectacular.

depraved person like myself, who has no respect for other people's feelings. If that is so, here is another idea, which is practicable.

It is a form of lottery, and it is based upon the old parlour game of "musical bumps." Do you remember that game? One wandered round in a circle while an earnest lady played the piano. And then, when the music stopped, one sat down heavily on—the floor, the person to sit down the last being "out." It was most thrilling, especially towards the end. I remember a riotous occasion when I put tin-tacks in another boy's—but perhaps we had better not go on with that.

**"The Melody Lingers On"**

Why not extend the principle and have a little gamble on it? The B.B.C. could announce that a violin solo would begin at precisely eight o'clock, and after a few minutes would abruptly stop. The competition could be announced some days before in order that listeners-in might send to the office their forecast, to the fraction of a second, as to the precise time which the violin would play.

In a few seconds I shall announce eight o'clock. Ready? Ten seconds more—five seconds more—crash!"

**Chambah Music's Champion**

The watches are switched to eight, and in thousands of homes eager eyes are glued to those watches. Mr. Jones, in Ealing, had forecast 2 minutes and 27 $\frac{3}{4}$  seconds. The time arrives, but still the violin plays on. He switches off the radio with a disgusted grunt, saying: "I never did like violins, anyhow." Mrs. Peterson, of Mayfair, has forecast 4 minutes precisely. When the four minutes has passed, she switches off with an acid smile, and says: "Of course, the only thing I really like to hear is chambah music."

And then, somewhere in some tiny room, at precisely 7 minutes and 28 seconds, there is silence. The violin stops, and Miss Wilkins, stenographer, gives a little scream. Seven minutes and 28 seconds! That was the time she had sent in. Seven minutes and 28 seconds! The music which is ringing in her head is very much sweeter than the music which has just stopped, for it means a new frock, and a holiday, and all the

whenever I have listened to the broadcasting of a play I have been filled with a longing to hear not only the play itself, but the audience's comments upon it. Is it quite impossible that this should be done?

How infinitely diverting it would be, for example, if a small transmitting set were concealed under the seat allotted to Mr. Hanner Swaffer at a first night, so that throughout the British Isles one might hear the sonorous snore which, on the following morning, he transfers to print! Even more enthralling would it be were it possible to broadcast the conversation from the bar between the acts, in order that one might compare the verbal criticisms of some of our kindest critics with their mellifluous prose.

**Television Too True**

Some people have suggested to me that the only thing which is necessary for brighter broadcasting is an extension of the television system, whereby one can see the broadcaster as well as hear him. I entirely disagree with that theory. If you have stood, as I have stood, in that little curtained room on Savoy Hill, and listened to exquisite sounds emerging from the most repellent mouths, you would be of the same opinion. Let us keep some of our illusions.

For myself, speaking honestly, for a change, the brightest form of broadcasting would consist entirely of Bach violin sonatas, and the earlier work of Mozart. But then, I am one of those tedious people who were born highbrow, however much they may attempt to conceal it.

**BRIGHTER BROADCASTING?**

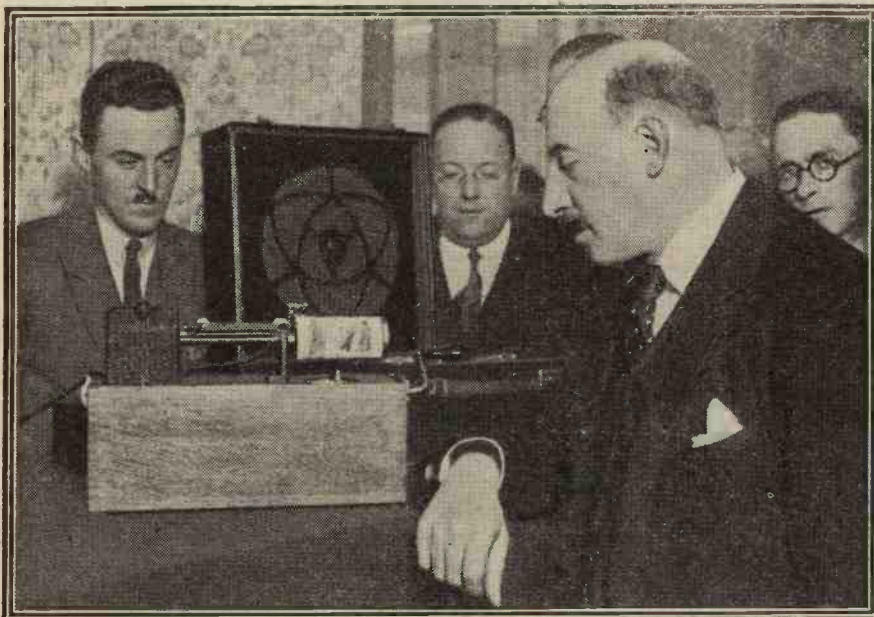

Will the use of the Fultograph photograph wireless receiver do anything towards brightening up our radio programmes?

And the competitor who most nearly forecast the actual time would receive a cash prize.

If that would not provide a thrill, I don't know what would. Supposing that the prize were £100, and that the actual evening had arrived. Through the loud speaker booms the voice: "Get your stop-watches ready.

other happy things that most of this unfortunate race associates with an extra hundred pounds.

Quite seriously, I offer this idea to the B.B.C. for consideration. I fail to see any practical argument against it.

Some of my other ideas mayn't be quite so practical. For instance,

**RADIO WRINKLES**

Variations in the *volume* of sound do not affect the ear so much as might be expected, and most people would be unable to detect a difference of even 25 per cent on certain notes.

When trying to drive a screw into a place where it cannot be held with the fingers, get a slip of paper or stiff cardboard, pass the screw through the end of it and hold it in position with one hand while you drive the screw with the other.

When overhauling your aerial remember that a large shell type insulator may be employed instead of a pulley at the mast head. Provided it is of ample proportions, there is then little danger of the wire supporting the aerial fouling, or breaking.

# The "M.C." DRIVER

Full constructional details of a rectifying and smoothing unit designed for supplying current for the field coils of moving-coil loud speakers.

By G. V. COLLE.

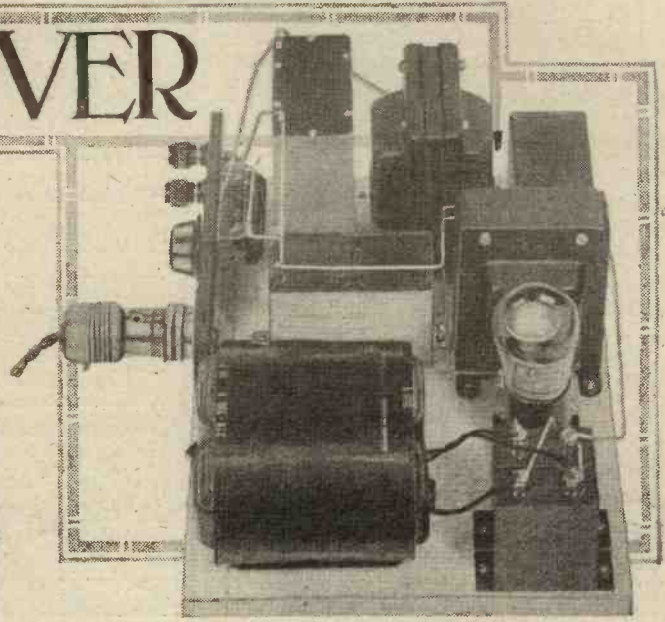

**M**OST manufacturers of moving-coil loud speakers produce four types, namely, those to operate from an L.T. accumulator, those to work from D.C. mains, a third type to operate from rectified A.C. from A.C. mains, and a fourth type which derives its magnetic field from permanent magnets.

All these types of loud speakers were not made to compete with each other, but rather to suit the widely varying conditions under which they might be operated.

Briefly, the D.C. and A.C. models were designed to operate in homes where mains are installed. The L.T. and permanent-magnet types are for

Although the loud speakers are given in the above order, it does not, of course, rule out the possibility of utilising, say, an L.T. field winding in a house where A.C. or D.C. mains are installed. In such a case, however, it means that the full advantage of obtaining an economical and convenient current supply is wasted, unless some method of trickle charging or running from an L.T. rectifier is installed.

It would be as well to commence a comparison by stating that moving-

attaching directly to the output of the receiver. Both the D.C. and L.T. models can be connected direct to their sources of current without the need for rectifiers. Sometimes it is necessary to place an ordinary 40- or 60-watt metal filament lamp in series with the mains on the D.C. model, so as to regulate the current and prevent overheating of the windings. With field coils of higher resistance (greater number of turns) where the current does not exceed, say, 60 milliamperes; the coil can be connected directly across the D.C. mains without harm.

### Easiest, But Not Best

The moving-coil loud speaker which is most troublesome to instal is, without doubt, the model designed to operate from A.C. mains, because one is very much tempted to avoid the bother of a special A.C. rectifier and go in for an L.T. field winding.

Unfortunately, the easiest way is not always the best way, and the "snag" here is the cost of upkeep. We have to balance the initial cost of an A.C. rectifier, about £7, or a

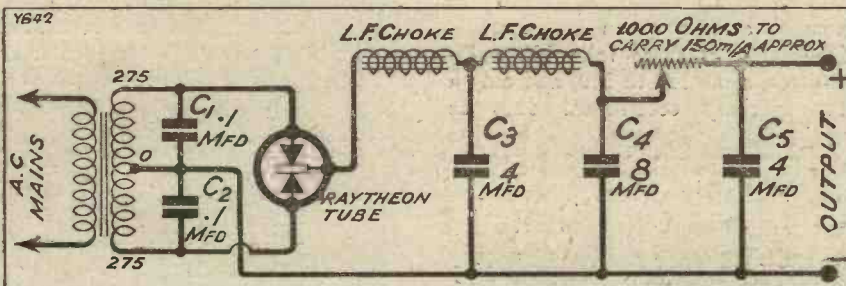

residences where no mains are laid on, the final choice between the two resting with the permanent-magnet type if the question of current consumption is an acute one.

coil loud speakers with field windings for D.C. mains or L.T. accumulator supplies are the easiest to instal, with the exception of the permanent-magnet type, which only requires

### LIST OF PARTS REQUIRED

- 1 A.C. transformer No. 783, giving 275 + 275 volts output, 100 milliamperes (Heayberd. Any good make giving similar output).
- 1 Raytheon rectifying valve giving 135 milliamperes (Rothermel).
- 1 UX socket for rectifying valve (Rothermel).
- 2 14-henry L.F. smoothing chokes (R.I.-Varley heavy-duty type).
- 2 4-mfd. 1,000-v. test condensers (Any good make, Lissen, Mullard, Ferranti, T.C.C., Hydra, Dubilier, etc.).
- 1 8-mfd. 1,000-v. test condenser (Hydra in unit. Any good make).
- 2 1-mfd. 1,500-v. test condensers (1,000-v. test would also be suitable). (T.C.C. in unit. Any good make.)
- 1 1,000-ohm "Truvalt" variable resistance (Rothermel).
- 2 Insulated terminals, marked Output +, Output - (Belling & Lee).
- 1 Batten lamp socket, standard size.
- 1 Adaptor ping to fit socket.
- Quantity of flex wire.
- 1 Piece of ebonite 7 in. x 2 in. x 1/4 in.
- 1 Baseboard 9 in. x 12 in. x 1/4 in. or 1/2 in. thick.
- 1 Strip of wood 7 in. x 1/2 in. x 3/8 in. for ebonite board support.
- Quantity of Systoflex and No. 16 or 18 S.W.G. tinned copper wire.

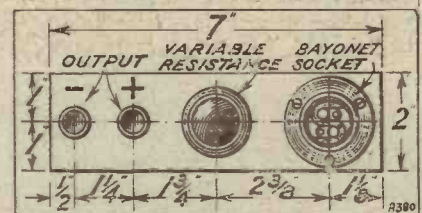

little less, against the cost of, say, charging an accumulator over a period of three to four years, at regular intervals, and include the cost of the accumulator itself. The

current drawn from the mains with the A.C. rectifier is less than half that required to illuminate an ordinary house lamp for any given period of time. Even if these two sources of current are equally costly, then we must remember an A.C. rectifier, such as described hereunder, once installed, will not require attention for at least six months (the minimum life of the lamp), if that, and, of course, it is only necessary to switch on and off as required.

**Heavy Current Output**

In the case of the L.T. field winding the current consumption will not be less than .5 ampere (and more likely .75 or 1 ampere), and if a separate accumulator is employed then it will be necessary to "top" this with distilled water at regular intervals, and this represents an unavoidable extra job, even if a trickle charger is used. In addition, it will require charging, say, once every two weeks.

Balancing one method against the other, most readers will agree that while the L.T. field winding has its advantages in certain cases, the A.C. model is to be preferred, provided it is used with mains of the standard frequency of 50 to 60 cycles.

The field coil supply unit to be described is suitable for most standard A.C. supplies, and the A.C. transformer is available in various windings all of which give a standardised

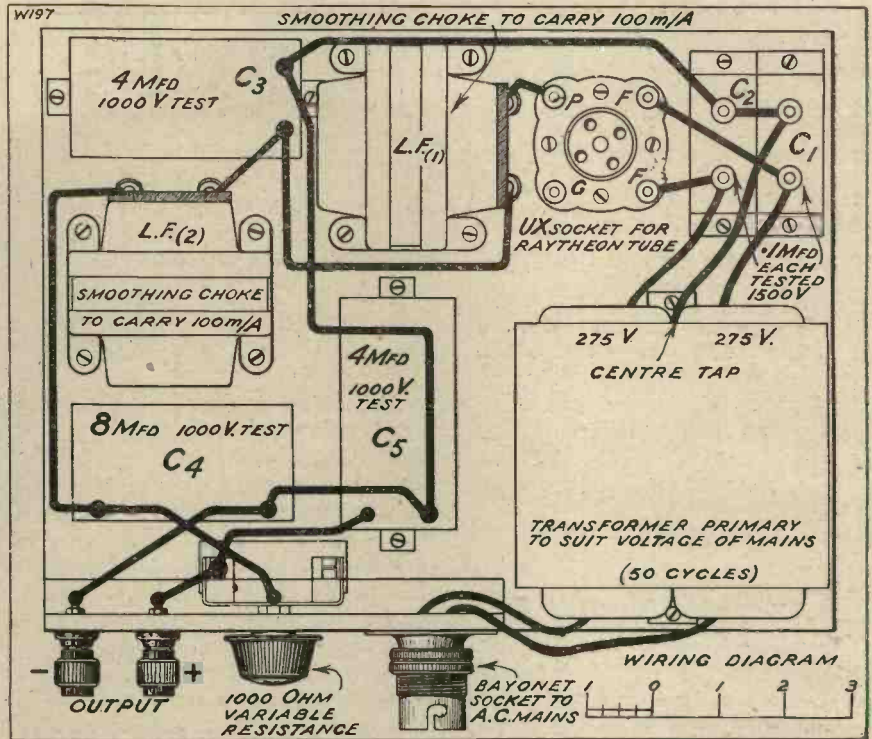

output of 275 volts + 275 volts, allowing for full-wave rectification.

In designing the unit, it was realised that a heavy current output would be necessary to meet the requirements of most of the makes of field coils now on the market, since most of these take 100 milliamperes, some 120 to 130, and only a few specially economical ones as

little as 60 milliamperes. The rectifying valve chosen was a Raytheon, which, giving an output of up to 135 milliamperes, covers all the field consumptions mentioned above. The voltage available is about 180, after allowing for a drop in the valve and small voltage losses in the chokes, but when passing 50 milliamperes the voltage rises to about 200 volts and at this figure gives a very good field on a coil which is normally rated 60 milliamperes at 240 volts.

**Silent in Action**

A milliammeter reading 0-100, or an ammeter reading 0-1 or 0-2 ampere, is a very useful instrument, and can be utilised for measuring the current from the output of the rectifier, being connected in series with one of the leads going to the field coil on the loud speaker.

To enable a correct adjustment of current to be made in the field coil, a 1,000-ohm variable wire-wound resistance is provided on the output of the rectifier, and as the current-carrying capacity of the wire is rated at 158 milliamperes, it will be seen the wire is capable of withstanding the current passed by even a fairly low-resistance field coil.

This rectifier is very silent in action, and can be relied upon to give a silent background when a transmission temporarily stops, a great asset if one is at all critical concerning "background" noises.

There is little to say regarding the construction of the unit beyond

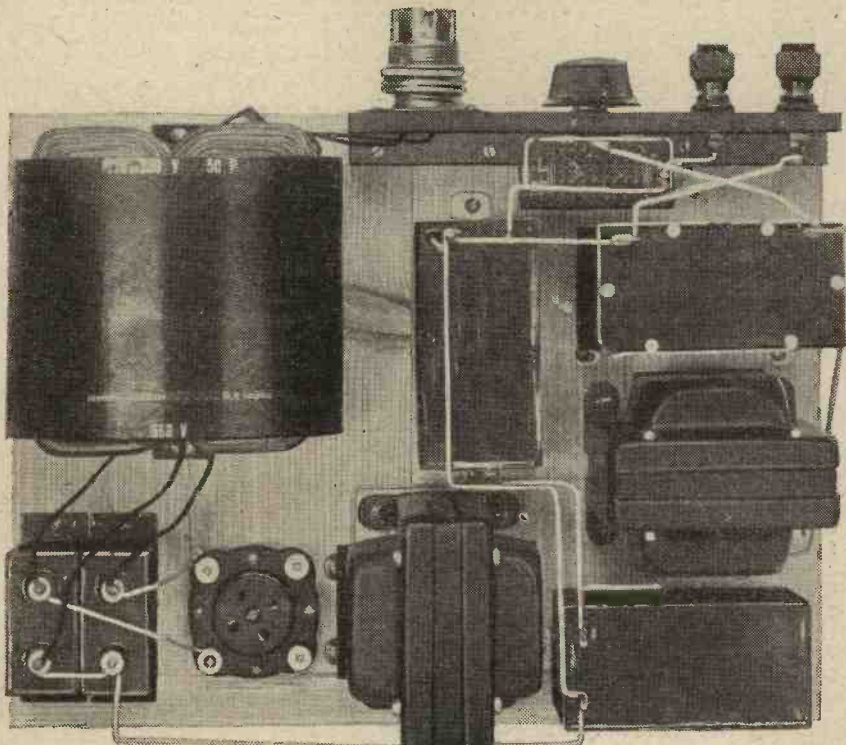

The components are few in number and of normal types. A power socket is fitted which makes it easy to bring the unit into action.

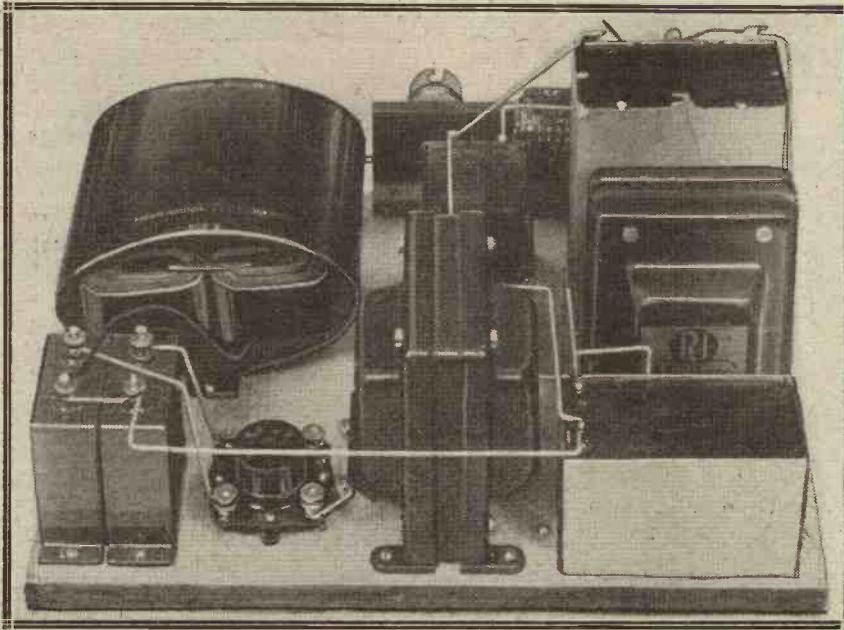

You will be able to trace every lead in this and the other photographs.

warning prospective constructors to arrange the leads on the L.F. choke (situated between the two condensers) before screwing it in position on the baseboard, as the terminals are rather awkward to turn once screwed down.

Reference to the wiring diagram and photographs will give all essential information. The diagram shows clearly how the various terminals are joined, and a list of the point-to-point connections is given below which will serve to check this before connecting up.

It should be remembered that *all* wiring and external leads of an instrument of this kind should be treated cautiously, and with every possible regard to the prevention of accidental shock, etc.

### Protective Covering

The components need be screwed down in only approximate positions, according to the photographs. A point worthy of attention is the valve holder, which is not of usual design, but must be obtained with the Raytheon valve.

It is not intended that the completed unit should be left uncovered, as shown in the photographs, because the valve might easily get broken if something were to drop on it. The arrangement was adopted to suit the cabinet-type moving-coil loud-speaker "baffle," where the rectifier could be placed on a piece of sponge rubber under the loud-speaker unit inside the cabinet.

Should an ordinary "baffle" board be employed, it will be necessary to enclose the rectifier in a suitable container, such as a perforated copper box. The "box" could be in effect

a deep lid, to drop over the whole unit and to screw to the edges of the baseboard, with the exception of the section where the controls project from the ebonite board, which would have to be cut out. The box would measure 9 in. by 12 in. by 5 in. deep internally, and could be cut from a sheet of perforated copper or zinc about  $\frac{1}{32}$  in. thick.

With reference to general points

of design, it will be observed a standard batten holder was employed for the input leads from the A.C. mains, and two completely-insulated Belling & Lee terminals for the output (marked H.T.+ and H.T.-). Actually, there is no definite polarity for the field-coil winding of the loud speaker, so that it is immaterial how the two leads from the field coil winding are connected to the terminals on the unit as long as the leads are rearranged in the same order if the rectifier is disconnected at any future date.

### POINT-TO-POINT CONNECTIONS.

Centre tap on secondary of A.C. transformer to one tag of each of the .1-mfd. condensers  $C_1$  and  $C_2$ , to one tag of the 4-mfd.  $C_3$ , to one tag of the 4-mfd.  $C_5$ , to one tag of the 8-mfd.  $C_4$ , and to the output terminal.

One end of the A.C. secondary winding (marked 275 volts) to the remaining end of  $C_1$  and to one filament ("F") socket on the U.X. valve holder.

Remaining end of the A.C. secondary transformer winding to the remaining tag of  $C_2$  and to the other "F" socket on the U.X. valve holder.

"P" terminal on U.X. valve holder to one side of the L.F. choke (1). Other side of the same L.F. choke to the remaining tag on the 4-mfd.  $C_3$  and to one side of the L.F. choke (2).

Remaining side of the L.F. choke (2) to the remaining tag of the 8-mfd.  $C_4$  and to the centre contact on the 1,000-ohm variable resistance.

Left-hand end contact of resistance to the output + terminal and to the remaining tag of the 4-mfd.  $C_5$ .

Input (primary) leads on the A.C. transformer to the two brass plungers in the bayonet socket, for the A.C. mains.

This completes the wiring.

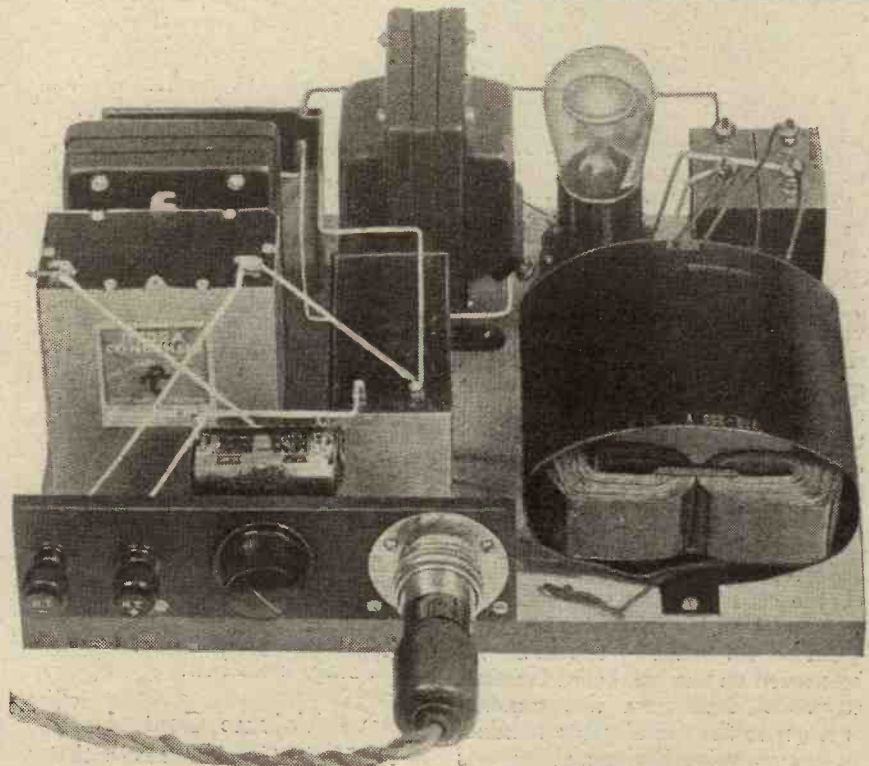

Connections are made to the speaker by the two terminals shown above. A current control is mounted on the same panel. The whole unit can be fitted behind the speaker's baffle, or in its cabinet if such is used.



# Questions Answered

## The "Viking" IV

R. K. (Cardiff) asks whether it is possible to use a screened-grid valve in the "Viking" IV (described in the December, 1927, issue of "M.W."). In the event of this modification being feasible he wishes to know if the existing wiring requires much alteration.

Since this query is applicable to many sets of this particular type we have decided to give a detailed answer.

Now, the H.F. stage in the "Viking" IV is completely shielded, together with the H.F. valve itself.

This fact makes the use of a screened-grid valve possible.

The circuit, however, is of the split-primary type and requires slight alteration because of the impedance of the screened-grid valve. The ordinary small untuned primary winding is not ideal if the full benefits of the amplifying properties of this valve are to be made use of.

The neutralising condenser should be removed altogether. Terminal 4 on the S.P. transformer should be disconnected from C<sup>5</sup>, and terminal 5 from the plate of the H.F. valve holder. Instead, H.T. +1 should be joined to one side of a good-quality H.F. choke, the other side of which should be taken to the terminal on the top of the bulb of the S.G. valve. A lead from this same terminal should also be joined to one side of a .001 fixed condenser, which can be placed in the screening box. The other terminal of the .001 condenser is taken to terminal 1 on the six-pin coil.

An extra H.T. + terminal will be needed on the baseboard terminal strip. A lead from this terminal is taken to the "old" plate terminal on the V<sub>1</sub> valve holder and supplies the inner-grid potential.

While this modification can be

applied to a number of similar circuits, it will not be satisfactory if interaction can take place between the coils.

This means that the screening must be fairly complete or alternatively "fieldless" coils should be employed.

We are frequently asked whether S.G. valves can be adapted to circuits which utilise large inductances of less recent type. The reply is, in practically every case, no.

## THE TECHNICAL QUERIES DEPARTMENT

Are you in trouble with your set?

Have you any knotty little Radio problems requiring solution?

The MODERN WIRELESS Technical Queries Department has been thoroughly reorganised and is now in a position to give an unrivalled service. The aim of the department is to furnish really helpful advice in connection with any radio problem, theoretical or practical.

Full details, including the revised and, in cases, considerably reduced scale of charges, can be obtained direct from the Technical Queries Department, MODERN WIRELESS, Fleetway House, Farringdon Street, London, E.C.4.

A postcard will do: on receipt of this all the necessary literature will be sent to you free and post free, immediately. This application will place you under no obligation whatever. Every reader of MODERN WIRELESS should have these details by him. An application form is included which will enable you to ask your questions, so that we can deal with them expeditiously and with the minimum of delay. Having this form you will know exactly what information we require to have before us in order to solve your problems.

The reason is that the extensive field of such large coils would make it practically impossible to avoid instability, and even if screening were tried, the losses in the screen due to the proximity of the large-sized windings would render the H.F. stage inefficient.

## Volume Control

D. H. C. (London) states that he is situated within six miles of the London station and the last valve

in his set—a detector and two R.C. stages—becomes overloaded.

He seeks for some efficient method of cutting down the volume, but says that he does not remember seeing one in "M.W." applicable to his set.

D. H. C. will find it quite easy to obtain any volume he wishes if he cares to include a 1- or 2-megohm potentiometer in his receiver.

The grid resistance and wire from the coupling condenser to the grid of the first L.F. valve should be removed. The two ends of the potentiometer resistance strip should be connected in place of the grid resistance, i.e. one to grid bias negative and the other to the grid side of the coupling condenser.

The moving arm of the potentiometer should be joined to the grid of the valve.

## Output Filters

H. D., (Gravesend).—"I am modifying my receiver in order to use an output filter and the choke I have purchased has a D.C. resistance of 300 ohms.

I am told that by employing a choke circuit I am virtually increasing the H.T. voltage on the anode of the valve. Is this so?"

A certain drop in voltage occurs across any winding when current is flowing. Hence, if you apply a certain H.T. voltage to a valve and the current has to pass through a loud speaker or choke winding, the actual voltage at the plate of the valve will be the H.T. voltage less the volts dropped across the winding. A choke can be wound with comparatively thick wire, and because of this its D.C. resistance is generally much lower than that of a loud speaker. In the majority of cases the drop in volts is reduced by more than 50 per cent when a good choke is used in place of the speaker windings.

## Suitable Milliammeter

V. C. S. (Chatham) is purchasing a milliammeter for his four-valve set, and is in some doubt as to the most suitable scale reading for his particular purpose. He asks our opinion.

It depends, V. C. S., upon the current taken by your valves.

If the set is one of conventional type it is probable that it will include a super-power valve in the last socket. In this case, assuming that you are using an H.T. voltage of, say, 120, and wish to use the milliammeter for detecting distortion, we suggest a 0-25 scale.



# THE "R.G." CRYSTAL SET

*A receiver incorporating novel and useful ideas. Among other things it enables an instantaneous change-over from the one station to another to be made by means of a simple switch.*

By G. V. DOWDING, Grad.I.E.E.

There would not appear to be much scope for originality in the design of crystal sets, and this is perhaps all for the good. It enables one to concentrate on the few factors of vital practical importance. And, consequently, the novelty in this particular crystal set is its unique combination of simplicity, usefulness and effectiveness. It was designed specifically for a certain class of listener—those living within the 80- to 100-mile range of 5 G B Daventry, and 30 or so from 2 L O, or other such main stations, and no compromises are made in order to cater for people in other areas.

### Simple Station Settings

On the panel of the instrument there are only the terminals for aerial and

#### COMPONENTS REQUIRED.

- 1 Panel, 5½ in. × 8½ in. (Any good branded material).
- 1 Case as per text (Special size, but can probably be obtained from any of the larger cabinet makers, Camco, Raymond, Bond, Pickett, Artercraft, Caxton, Makerimport, etc.).
- 2 Compression-type variable condensers, .00025 mfd. or .0003 mfd. (Formo, Igranie, etc.).
- 1 Crystal detector (Any good semi-permanent type, R.I.-Varley, Brownie, etc.).
- 1 Push-pull on-off type switch (Lotus, Lissen, Benjamin, etc.).
- 1 Coil former, 3 in. diameter, 3½ in. length (Pirtoid, Paxolin, Radion, Beool, etc.).
- Wire, terminals, etc., as per text.

earth and telephone connections, the crystal detector adjustment and a switch. You push the switch in when you want the one station, and pull it out when you want the other. There is no reason why the set should be provided with an ordinary variable condenser dial, for there are only the

two stations that it can receive. And when the set is first connected up to the aerial, adjustments are made for the reception of these stations, after which the tuning need never be

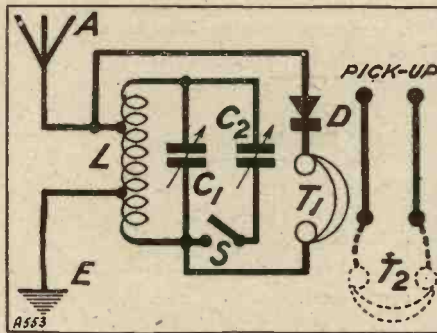

referred to again. The initial adjustments are effected by two compression-type variable condensers.

The price of these and a switch will hardly be as much as that of an ordinary variable condenser with dial, so that there is probably an

\*

Tuning adjustments are made with two small compression-type variable condensers. After this no further reference need be made to this part of the set. The stations are brought in as desired by operating a simple switch. You can use a gramophone pick-up with this crystal set!

\*

actual saving of money. The coil is a home-made one and the cabinet of an inexpensive variety. Therefore, taking everything into consideration, I hope the set will prove a most attractive proposition.

A modern departure is made by making it suitable for gramophone pick-up work. A statement like that no doubt sounds completely absurd when used in connection with a crystal set, but if readers will carefully consider the idea I think that they will eventually agree that the only absurd part about it is its simplicity! I fully explained the scheme in a short article I contributed to the Gramophone Section recently and, briefly again, it is this:—

### 'Phone Pick-up Reception

First of all there is a great deal to be said for the direct telephone reception of energy developed by a pick-up. If you connect the leads from a pick-up to a pair of telephone receivers you obtain a volume slightly greater than that given by an ordinary crystal set, and the reproduction is of a distinctly superior nature.

Moreover, anyone can listen to the

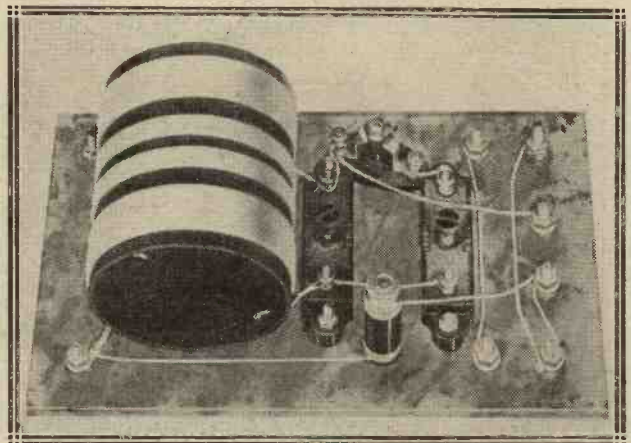

gramophone playing without this interfering with the enjoyment of any others who may be sharing the room. The crystal set is so arranged that the pick-up can be connected to it besides two pairs of telephone receivers. On

one pair of telephone receivers you can hear either 5 G B or 2 L O, as you wish, and on the other pair another listener can at the same time enjoy gramophone records, and neither programme will affect the other.

**A Sensitive Circuit**

This means that in the same room one person can be running over the latest gramophone records while the other listens to broadcasting, and a change-over can be made when desired; and you can, of course, connect two or more pairs of telephone receivers to either source of entertainment. The scheme is made possible merely by the addition of four terminals and two leads to the set. Actually these form connecting links between the pick-up and telephone receivers.

Regarding the crystal set itself, this has given excellent results—results in point of sensitivity rather above the average. A scheme of auto-coupling and crystal tap are introduced. The aerial and detector circuit are connected to one tap on the coil and the earth to another. Across the coil is connected a compression type variable condenser. This provides the tuning for the lower wave-length station.

There is another variable condenser which can be brought into circuit by closing a switch. This additional

standards, although it will be appreciated that exceptional sharpness of tuning can only be obtained in the majority of cases at the expense of strength of signals. In these circumstances this set will prove of the greatest possible value to the man who is above about four and within

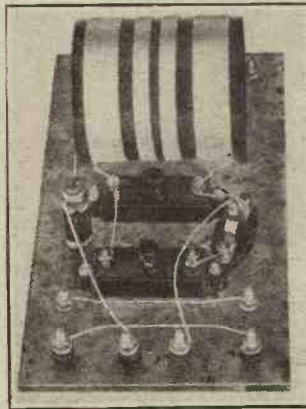

There are no connections between the gramophone pick-up terminals with their accompanying telephone terminals and the rest of the circuit.

about twenty miles of his local station. If he is within the shadow of the broadcaster's aerial, as it were, his only real chance to get the alternative programme will be to use a valve set. I want to make this point clear in order that no one constructor of this receiver shall be disappointed.

You will judge by the photographs

knows nothing at all about radio. Amateurs should remember that Xmas is coming!

The parts needed are very few in number, although don't forget to gather them all together before you actually start work. Remember, too, that you will require nuts and bolts for fixing the components to the panel. You need not fix the terminals for the pick-up if you do not so desire, but if you have a gramophone I would certainly advise you to make this provision.

**An Excellent Beginning**

If this set happens to form your first radio outfit there is a strong probability that you will eventually graduate to valves, and that the electrical reproduction of gramophone records will follow as a natural course of development is almost inevitable. Remember, that the only additional accessory required for this is a pick-up, and that such a device can be purchased for a sum as low as 13s. 6d. You can acquire a pick-up and actually use it before the time comes when you feel that you are able to instal valve apparatus.

The drilling of a panel is a straightforward operation, but do not be content to mount the compression variables by means of one screw each. This does not provide sufficient security.

If you do not purchase the actual components used in the original set, it may happen that the panel dimensions given are not suitable. In this case you will need to make slight readjustments.

**The Panel Arrangement**

Moderate variations of the component positions will not matter and a symmetrical appearance on the top of the panel is the main requirement. But you can easily throw this out if you are not careful, and it is surprising what a diversion of even an eighth of an inch in the centring, for instance, of a terminal will make. For this reason I find it better to drill small holes to start with, as these are easier to make, and these holes can easily be bored out to greater dimensions with larger drills, or reamed out with a reamer or the tang of a file.

You will notice that I have wound the coil in sections. It is not vital that this should be done, although it makes a neater job and assists you in connecting it up accurately.

A gap is allowed in the centre of the coil so that the mounting screw can pass through. At a quarter of an inch or so from one end of the former two

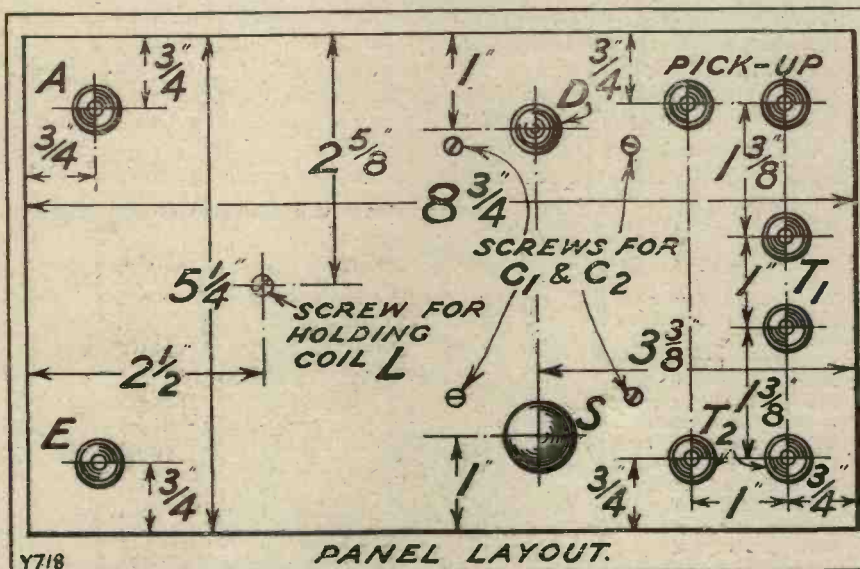

condenser provides extra capacity for the tuning in of the higher wave-length station. Once the setting for both stations has been determined, you change from one to the other merely by opening or closing that switch.

The set is well up in regard to selectivity to the highest crystal

accompanying this article that the set is a remarkably easy one to construct. It is, indeed, a one evening's job for the most laborious builder.

**Ideal Gift Set**

I need hardly point out that it makes an ideal gift set, for it is an excellent receiver for the relative who



small holes should be bored and the wire threaded through. About four inches should be left for connecting purposes. (24 gauge cotton-covered wire is suitable for this coil.)

Then 22 turns should be wound on, closely and tightly. At this point make a loop, about three inches in length, and thread this through two further holes, leaving a space of about a quarter of an inch, and wind eleven more turns.

Following this a space of a quarter of an inch or so and then eleven turns again. This is the point for a further tapping, which is followed by another section of 22 turns of wire.

The coil is finished off in a similar way to which it was begun, an end length being allowed for joining the coil in circuit.

### Two Tapping Loops

One hole in the centre of the former through which a small nut and bolt should pass will give you sufficient fixing, as this will be supplemented by the four leads from the coil acting as miniature "guy supports"!

When the coil is wound, this can be mounted on the panel together with all the terminals and other parts. The two tapping loops should be joined to the aerial and earth terminals. Don't break the wire. Remember that the coil essentially consists of one continuous winding.

Remove the insulation from the wire in the loop and twist the bare wire into one solid lead. Then place the lead underneath the washer and screw down the nut on the terminal. If you omit the washer the nut will cut into the wire and sever it. This is also liable to happen if you screw the washer down too tightly.

If you are an adept at soldering, soldering will be advisable. You can join the lead from the one end of the coil to a terminal of each of the two small variable condensers. Similarly, the other end of the coil is joined to the terminal of one condenser and one telephone terminal, and one terminal of the switch.

### Very Simple Wiring

The remaining contact of the switch is taken to the empty condenser terminal. The remaining telephone terminal is connected to one side of the crystal detector, the other side of this being joined to the aerial terminal.

You can, of course, use the same sort of wire for these connections that you employ for winding the coil provided you carefully bare the ends of the leads so made. But a stouter and more secure job is made if you use tinned copper wire of 18-gauge, or

special connecting material such as Glazite.

The leads are few in number and the wiring is very simple, but as there are two of the small variable condensers you can easily trip up over it if you are not careful.

### The Pick-up Terminals

The set can be fitted into a single case (as per photo), which must be at least 3½ ins. deep.

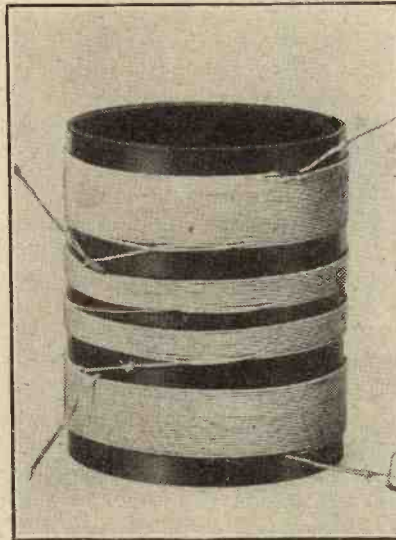

This is the coil used in the R.G. set. The four points of connection are shown by the projecting leads.

You have now completed the crystal set and there remains only the gramophone pick-up terminals to join up. These are entirely separate from the remainder of the circuit.

panel marking will improve the appearance of the set.

I am afraid you will find that the sets of transfers supplied by most wireless dealers will not contain all the wording you want. You will get the "aerial," "earth," "phones," and, perhaps, "switch" lettering, but will have to make up the other marks by clipping out individual letters—a tricky and rather lengthy job, but one that is worth while.

In order to adjust the receiver the panel should be placed on its side so that you can get at both the crystal control and the small variable condensers. First of all, place the switch in its "off" position; this will be, in most cases, when it is pushed in.

### Adjusting the Set

Now adjust the variable condenser nearest the coil until you hear your local station, which should come in loudly provided the detector is moderately sensitive. Then close the switch and adjust the other variable condenser, which is then brought into circuit, until 5 G B is heard.

You can then go from the one station to the other merely by opening or closing the switch, and there is no reason why the panel should not now be screwed to the case. Providing the aerial is not altered, or the stations change their wave-lengths, you will not again have to refer to the interior of the receiver.

Obviously you should make careful condenser adjustments. Do not do this with your hand too near the coil, but use instead a long piece of wood

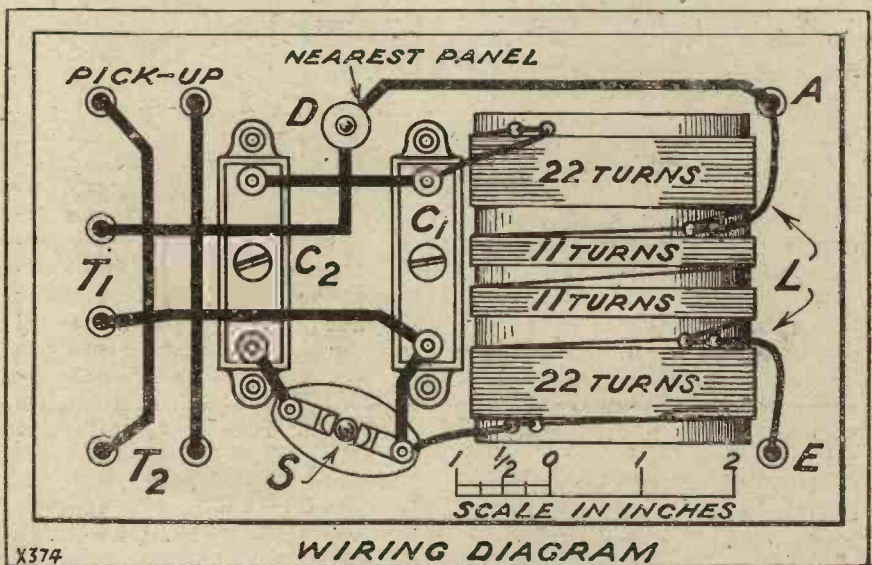

X374

WIRING DIAGRAM

As the adjustment knob of the crystal detector and the switch are somewhat similar in appearance, some sort of indicating panel marking is to be recommended, and in any case

such as a skewer, cut at the one end to fit into the condenser adjustment screws. Turn these screws slowly. You can afford to spend a few minutes on this operation!

# RUMOURS—AND SOME FACTS

## THE LEGAL POSITION.

ONE of our special correspondents deals in another part of this issue with the question of the possibility of challenges to the B.B.C. monopoly, with special reference to the rumoured broadcasting and television service which is to be started on the Continent in the New Year.

### Turned Down by Fleet Street

In the past there have often been rumours of a service independent of the B.B.C. (the idea being based, of course, on the early experiments of the "Daily Mail," when English concerts were broadcast from the Hague before the formation of the B.B.C.). As a matter of fact, we have been well aware of this proposal for some time past. In a sense, it has been hawked round Fleet Street, and there is one big London daily newspaper which was asked, some time ago, to take up the scheme. That newspaper, quite rightly, turned the offer down on grounds of public policy.

The idea of a privately run station being erected in Holland, or France, as rumour has it, for the purpose of competing with the B.B.C. is bound to be open to criticism, and in practice it is bound to fail.

There are many reasons why it will, should its solicitors be foolhardy enough to go ahead with their proposed scheme, and some of those reasons are set forth in the special article we publish in this issue.

### Some Fundamental Limitations

In any case, infringement of the B.B.C. wave-lengths or of other Continental broadcasting station's wave-lengths would be resented at once, and the International Radiophone Bureau would undoubtedly take up the matter with the Governments concerned. If, as has been suggested, a wave-length not used by a broadcasting concern is chosen, then the limitation of the scheme is obvious as regards British listeners. Quite obviously the majority of listeners in this country who are not interested in the technicalities of radio possess receivers capable of tuning-in only broadcasting wave-lengths, and consequently any service put out for them, from abroad on wave-lengths outside the broadcasting band could not be received.

Furthermore, the tremendous expense which would be incurred makes it pretty obvious that the quality and type of programme to be broadcast cannot possibly compare with the B.B.C.'s.

It has also been suggested that this new venture, should it bear fruit, may include television broadcasts. A good deal has been said lately by the supporters of a certain television system to the effect that it is amazing that the B.B.C. should turn down this television system when it has met with the approval of the Post Office engineers.

We happened, however, to be in the House of Commons a week or two ago when Lieut.-Commander Kenworthy asked the Postmaster-General whether any system designed for the transmission of moving photographs and actual events—these moving pictures to be received with

Recently the Postmaster-General was asked in the House of Commons if he would state his present policy with regard to Television.

So many conflicting statements on the subject have appeared that this survey of the legal position will be of special interest to readers.

suitable apparatus by listeners possessing wireless receivers—had been tested, and with what result.

And, further, why the Postmaster-General refused permission for the B.B.C. stations to be lent for television purposes by the Baird transmission system. And, again, whether the monopoly of the B.B.C. is held to cover the transmission of pictures by television by a private company from a private experimental station.

To be precise, this was Question No. 71 on the Question List for Thursday, November 8th, 1928. It is well to have this date correctly because the Postmaster-General's reply was very illuminating in view of the fact that it has been repeatedly stated that the Post Office authorities considered television to have progressed sufficiently to warrant it having a trial through a B.B.C.

station. This was the Postmaster-General's reply:

"I know of no system which is at present capable of transmitting moving pictures of actual events for satisfactory reception by wireless listeners."

The Postmaster-General went on to say, in his reply:

"I have not refused permission for the use of the B.B.C. stations for television tests. The Governors of the Corporation decided, in the exercise of the discretion vested in them, after a demonstration by the Baird Company, who hold an experimental licence, that the system did not at present fulfil the conditions which would justify a public trial through one of their stations. I have recently received an application from the Baird Company for further facilities. This application is at present under consideration, and I am not yet in a position to say anything further."

### The Legal Aspect

It must be borne in mind that the B.B.C.'s monopoly is a legal affair, and it does not expire until 1936. Legally, it is quite likely the Postmaster-General has power to permit a television service on a limited scale, and providing, of course, it would not cause interference with other stations, or spoil the service for British broadcasting listeners.

But when it comes to considering an application for a television service, with an accompaniment of speech and music, a direct infringement of the B.B.C.'s monopolistic charter is at once apparent, and on legal grounds it is most improbable that any rival service will be allowed in this country to compete with the B.B.C., whether by speech or music and television, unless the B.B.C. agrees. If the B.B.C. does not agree, then there is very little chance for any other rival concern in this country until the expiration of the monopolistic licence in 1936.

### Rumours and Statements

However, we need not stress this subject any further, because it is quite inevitable that by the time this issue is on sale further rumours and further statements concerning the above subject are bound to have made their appearance.

Let it suffice that we should be thankful that, unlike America, mushroom growth concerns cannot start rival broadcasting services in this country and thus render the ether even more chaotic than it is at present.

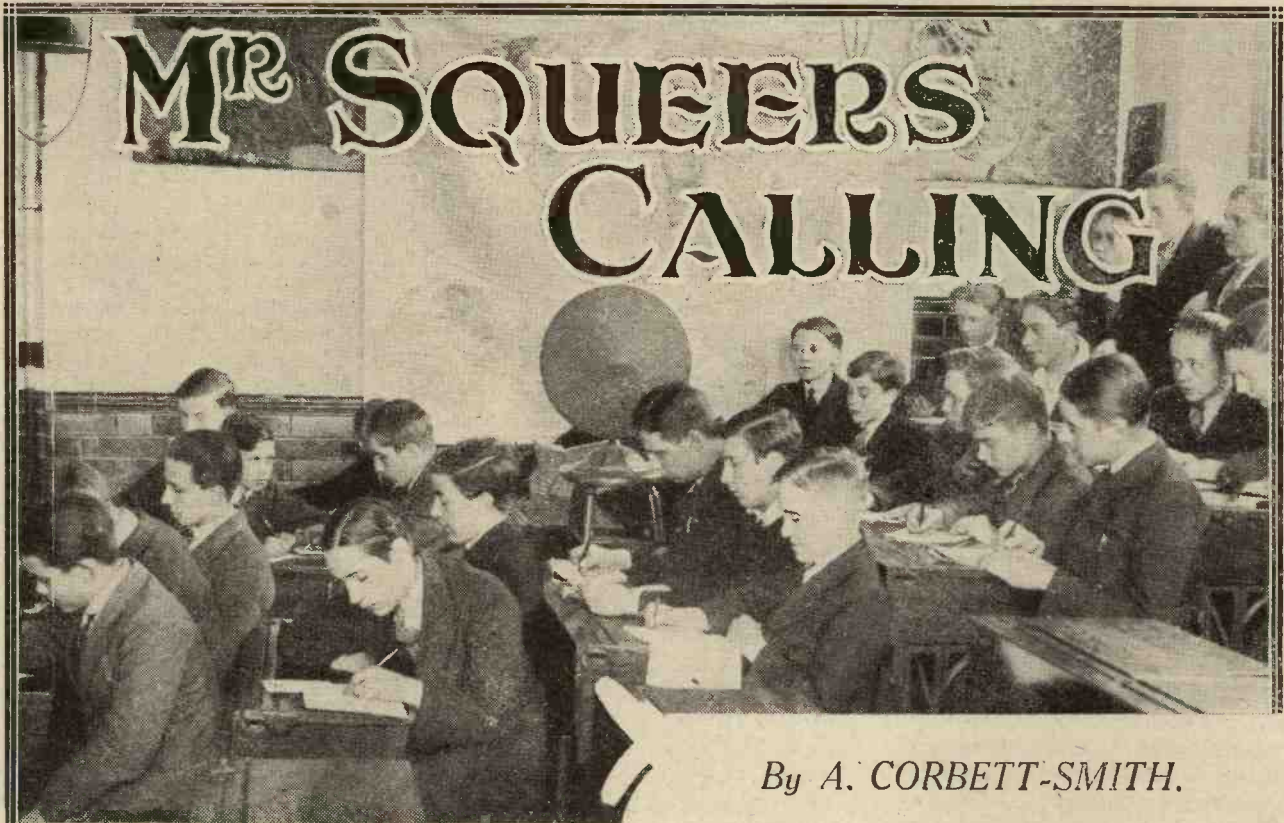

By A. CORBETT-SMITH.

*Lovers of Dickens will know all about Mr. Squeers—the headmaster who gave young Nicholas Nickleby such a bad time. Many listeners to-day feel a fellow sympathy for poor Nick—and a greater dislike for Mr. Squeers.*

**M**IND you, I cannot help feeling that it is all rather a pity. But then, you see, I am one of those, hopelessly old-fashioned persons who delight in colour and laughter, and dancing, and little children, and the lovely English countryside, the sea in all its moods and all the thousand-and-one simple, homely and radiant things that go to make genuine human happiness. Those are what I like to share with folk.

Not that I object to education, as such. You must not think that. Education is a very wonderful thing, and I often envy those who have had the book-learning. I had only the training in games which Winchester and Oxford give. Such education as I have since acquired I have had to pick up for myself in doing things about the world. So I quite realise what I have missed.

Still, as I say, I do think that it is rather a pity that the B.B.C. should now be giving up its entertainment side to devote itself exclusively to education in its sternest form.

**Take It or Leave It!**

But at least it has the honesty to come out into the open. We do know exactly where we are. Criticism is disarmed. We can take it or leave it. There only remains for the B.B.C. to regularise its position; to abolish the absurd anomaly of running the nation's adult education through the Post Office, as though it were a vast correspondence class, and to set itself frankly under the Board of Education.

Of course, we have all seen it coming. It was inevitable. The line of least resistance. They had no alternative. Mr. Rudyard Kipling has remarked that it was with the

Union of 1707 that the English were "finally and fatally subjugated by the Scot." But Mr. Kipling spoke too soon. He should have waited until 1928 and made the acquaintance of the Director-General of the B.B.C.

Now at last we know just what Sir James Barrie meant when he wrote of the "appalling" effect of a Scotsman



These Liverpool scholars not only listen to broadcast lessons, but they actually made their own receiver with which to do it.

with a £300 education being "let loose upon the world." "Appalling to think of, especially if he went amongst the English." But even Barrie's imaginative genius must boggle at the lurid reality.

Well, there it is. *Vae victis!* We must make the best of it. We English have had to endure the yoke of a long line of conquerors in our 4,000 years of history, but I am not sure that this, the latest, may not prove to be the heaviest.

**"Incapable of Sustained Effort"**

Yet, after all, I think that the B.B.C. is quite right. It has shown conclusively that it is quite incapable of any sustained effort in popular entertainment, given as it should be given—in the spirit and with the broad humanity of Charles Dickens. Much better, then, to concentrate upon the side of pure education which (within the limits of the radio medium as the B.B.C. use it) is perfectly easy and simple and no more than a matter of organisation. This they can do and are doing admirably, and they are meeting a definite need which will go on expanding.

It is odd, though, why and how they still go on floundering with their "entertainment." Making their pitiful little attempts to create a kind of bastard "art" out of radio. As if such a thing were possible.

Take, for example, the latest effort, as I write. Allured by the glowing advertisements of "Kaleidoscope" as being an entirely new experiment and advance in radio drama, something which no one who wished to keep abreast of modern thought and creative art could afford to miss, I made a special point of hearing the performance. And, in order to hear it under the best possible conditions, I went down to Savoy Hill, where I was given a big arm-chair beside the finest type of loud speaker in existence.

I went down most anxious to give to that "experiment" the fullest possible encouragement in a special newspaper article. In fact, I thus stood to make money out of it, apart from the pleasure of dealing with a new work of distinction. I listened with such care that I noted on paper every single detail as the performance ran. And there were no fewer than 124 separate fragments of speech, music and sound effect.

"What did you think of it?" asked a senior official. "Experiment?" I cried. "You are precisely where I left you in 1924, if so far." And I went out in utter dejection of spirit. For I had lost my Press fee into the bargain. There was nothing to write about.

Technically, and upon the engineering side, the production was a marvel. They had worked it in seven different studios. A wonder of ingenuity and dovetailing. Not the ghost of a hitch throughout the eighty-five minutes. But, as a piece of living, creative, human art it did not hold a candle to fifteen minutes from Miss Mabel Constanduros. Given a fairly sound knowledge of music and literature and any competent journalist in Fleet Street could have carpentered the scenario.

**Education's Stranglehold**

The B.B.C. complains that the Press does not support its efforts by regular and constructive criticism. There is the answer: What is there to criticise—if this were a specimen of a "high light"? I may be a stern critic of inefficiency, but in thirty years of journalism no one has ever accused me of injustice or bias. And here I was particularly anxious and sympathetic. What that performance must have sounded like in a Wimbledon villa or in a shepherd's hut on the Westmorland fells I dare not imagine!

*(Continued on page 690.)*

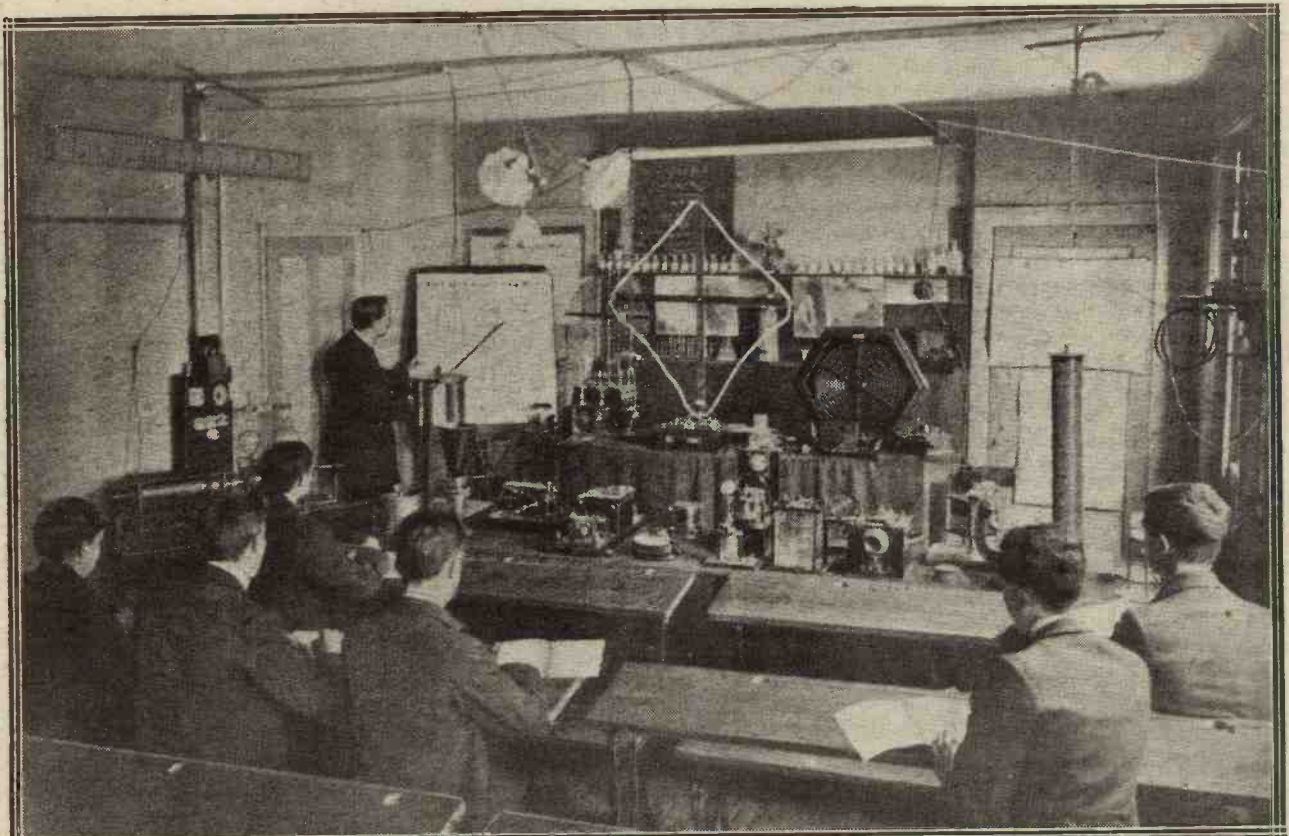

In addition to the lectures broadcast to children there is a demand for wireless instruction for adults and for those who have left school. This is particularly true of America, where some radio colleges grant degrees to students.



ONCE more, comrades, I drop the mashie and take up my pen to indite unto thee a goodly matter. (*That's as may be.*—Ed. "M.W.") Ignoring that unfriendly interpolation, I pass on to remark that by a special intervention of Providence in the interests of a (working) journalist—or columnist, as an American paper was recently good enough to baptise me—Christmas comes but once a year. Writing, as I am, in the sweltering summer sun (*Don't give the game away.*—Ed. "M.W."), I am somewhat at a loss to work up a proper Yuletide atmosphere. Where are the snows of yesteryear? Search me!

**Christmas Numbers**

The nearest thing to Christmas is the lump of hokey-pokey which that horrid little boy on the breakwater is lapping his tongue round, unless you count the frozen mitt handed to me by the girl in the tobacconist's when I asked her what time Fred usually called for her and if he ever had to work late.



"... They picked out a lovely seven-and-sixpenny crystal set ..."

These Christmas numbers! I knew a Fleet Street chap who spent the whole of one Boxing Day writing his next year's Christmas stuff, so that when it was called for in July there it was all nice and seasonable. Unfortunately, however, he was shifted to an Australian paper the following

March, so his "copy" didn't fit the climate and he had to cut out the snowballs and chilblains and insert kangaroos, wallabies, dingoes, and laughing jackasses.

**Artificial "Atmosphere"**

Even then it seemed to read queerish, so he cut out Santa Claus, the "waits" and Christmas-boxes, and substituted larrikins, blue gums, boomerangs, and a nice bit about Sydney Harbour. Then the editor dropped him a cautious line asking how he felt and whether he would care to see the staff doctor. So now he writes his Australian Christmas articles, all about ice and electric fans, in a local cold storage warehouse.

Coming to radio topics, I shall never forget poor old S—. When the broadcasting boom began way back in '22 he got a spurt on and cleaned up about two dozen Christmas stories, all written around crystal sets and L.F. amplifiers.

The first year was a walk-over; the yarns went with a whizz and he got into some real toney magazines. In 1923 he scraped through, on the strength of the L.F. amplifiers. In 1924 he had to descend from first-class radio publications to Sunday newspapers and boys' magazines.

**Mass Production Fails**

The year 1925 saw the Sunday papers sour on him; they wanted multi-valve dope and touches of television, whilst the more expensive boys' magazines demanded radio-controlled airship stories and reflex valve circuits. I know he popped his dress clothes that Christmas—to avoid being dry.

In 1926 he sold his remaining yarns to the "Hicklebarn and Cowfold Messenger," which had just got wise to radio, and began to be a radio prophet. He had had enough of mass production.

That just naturally recalls to my mind the case of Carter Bolls. Bolls and Plunk, you know; manufacturers of high-class horse pills. Every cavalry regiment in the Empire has blown a Bolls down the gullet of a stallion. Well, this Bolls owned to a Mrs. Bolls and a Bollette, said Bollette being masculine; and come Christmas last year as ever was, Bolls determined to get his heir a radio set.

**Choosing Presents**

Horse pills being slow-moving stock, owing to the mechanisation of the Army, Bolls was wonky on the bank balance and began to repair his fortunes by economy in Christmas presents. Young Bolls naturally had to help the old man bear the burden, so old Bolls, late one night, indicated to Mrs. Bolls that the Treasury would stretch as far as "a nice toy wireless" for Bolls, junr. And in due course they went to the C.S.S.A. to inspect such trifles.



"... But Bolls spotted a placard ..."

They picked out a lovely seven-and-sixpenny crystal set, guaranteed to receive 2 LO if you lived in the Bargain Basement at Selfishes. But on emerging from the emporium Bolls spotted a newspaper placard which read, "Cavalry to retain horses." Realising that "every knacker needs a Boll," he rushed back, cancelled the order and selected a one-valver.

Several days later Boll read in his newspaper that the king of Cadonia had treated a sick cassowary with a Boll, with such astounding results that he proposed to erect a monument to Boll and to make his Court take Bolls instead of "that little daily dose of Crushem." The result was that the one-valver was replaced by a thing with three valves and a patent frequency meter.

Christmas drew on apace, and the Bollette, all unconscious of his fate, continued to be as exemplary as possible. He actually cleaned his teeth on two occasions, without definite orders. And he refrained, on one occasion, from leaving his footer boots in the drawing-room. If ever

a boy made superhuman efforts to deserve the gratitude of his parents—Bollette was him.

On December 4th a drunken soldier in the Argentine shot a "Bolls" into a spavined mustang out of a blunderbuss, with the result that the old screw won the Corned Beef Stakes and galloped half-way back to the starting-post before the rest had realised what had detained them.

**Surprising Success**

Then the President, who had dropped big money on the race, heard of the matter and promptly ordered the army to shoot some Bollses into a herd of condemned cattle. This done, the beast grew curly horns and a foot of extra fat. This sort o' thing was absolutely *jam* for the cattle kings, and they ordered Bollses by the carload.

So the Bolls' three-valver was given to a poor relation, and Bolls stepped out of his gem-studded Rolls-Royce, threw away half a seven-shilling cigar, and ordered a real radio set.

The thing was as big as a telephone booth, and was cased in ebony picked out with platinum. It had ten valves and a cellarette; a roulette and a manicure set were incorporated at the back of the loud speaker. The valves were blown from Venetian glass and the electrons in their filaments were specially grown under



"... Pa, wrestling in the kitchen with a cork ..."

glass by Edison. It could navigate under its own petrol power, and could be used as a lawn-roller. It was far too costly to give to a mere kid, and so the Bollette got a gold watch, which he tarnished with the extra-special bitter tears of the "poor little rich boy."

But there, I did not start out to harrow your feelings, but to inspire you with Christmas jollity and mirth. So gather round and listen to Uncle. 'Cos what I reely and trooly meant to do was to relate the story of "Christmas Eve, or Little Percy's Pet Newt." Poke up the fire and don't interrupt.

Once upon a time it was Christmas Eve. The cottage nestled in a fold of a blasted heath, though as the Home Secretary was sensitive they had altered the name to Rosebud Park; No. 10 it was, *alias* "Kilmarnock Towers."

Let us enter. Passing through the bead curtain of the hall (or passage) we see on our right the parlour. It is full of Presents from Ramsgate, crocheted doylies, mouldering stuffed canaries, and pictures of the Guards leaving Waterloo (Platform 6) for the Boer War. A low moan is heard. That is Pa, wrestling in the kitchen with a cork that has slipped into the bottle, I guess. Let us intrude upon the tragedy.

**The Lonely Vigil**

The Kitchen. Seated in a low chair by a handful of fire is Mother. She darns a sock—or to judge by her language, the sock is a *darned* sock. An old man crouches over the fire, moaning at a cross-word puzzle. Mother speaks:

"Eleven o'clock! Eh, dearie me! Will he never come?"

(Pa). "Never! Them furrin parts gets a man, I reckon."

(Ma). "There is his supper! Just as I have laid it this many a weary night—hoping agin hope. But he never comes. Yet—it's gone when I come down of a morning—just as though the angels had come in the night."

(Pa). "He always liked his food, too. Specially onions." (*Bursts into tears and opens a bottle of Bass.*)

(Ma). "I *did* think that he might come to-night, seeing it's Christmas Eve. It isn't asking much. Take your boots off my fender!"

(Pa). "My boy-oy-oy is far away, roamin' in Chiny, Afriky, Australy and Hinjia. Far, far away-ee." (*Consults his Bass.*)

**For His Sake**

(Ma): "Bildad—er—don't you think we might, on this night of all nights, for *his* sake—mightn't we be a little extra kind to Perp—Percy's newt? A little sauce on his ants'-eggs, or perhaps tickle his tail a bit, eh? Remember, Bildad, that Percy once lay in your arms, an innocent little child. Oh, let us be kind to his newt."

(Pa): "Yup." (*Sobs.*)

(Ma): "Do you know, Bildad, when I look into his newt's eyes I sometimes think I see a look that says: 'I accept these ants'-eggs for Percy's sake.' Come, husband, let us change Percy's newt's water."

(*They hover lovingly over the beastie.*)

(Pa): "It's mor'n I can bear, mother. Why don't he come? Must my grey hairs go down in so-horror to the gerrave? Chiny, Afriky, Ameriky! Give him another ants'-egg, mother, in case he should wake in the night. Oh, that his young master were here—so that I need not bother with the plaguey thing."

(Ma): "Hush, Bildad! These harsh words ill become you. This newt binds us to our darling son, for he loved it."



"... He always liked his food, too, specially onions. ..."

(Pa): "Ay—and left it and us. We and the newt are equals in that respect. Chiny, Afriky and Ameriky!"

(Ma): "Peace, Bildad! Be strong. Suffer in silence. Our son will come in his own good time. Love and hunger will bring the wanderer home. Is that a hole in your sock?"

**Return of the Prodigal**

(Pa): "I know, Badalia! Your brave spirit flames like a candle within my soul. Hot stuff, what? Your ineffable courage bears me up—hup—up, like a neagle bears up—hup—up her youngsters. Chiny, Afriky, Australy! Pray Heaven he comes soon. The gas alone—"

"Look, the newt wants his good-night tickle. You go first. I shall break down if we go together."

(Ma): "Ickle, ickle, newty, nighty night. Percy's near his newt."

(Pa): *Blub, blub.*

(Ma): "Hark! His clumping step! MY BOY!"

(*Enter Percival Hogsbottle.*)

"Hello! Got any grub?—Shocking cold up there. You ought to have heard 3 L O on the loud speaker. Tophole! Don't you wait up, ma!"

(Ma): "!!!"

(Pa): "Afriky, Ameriky, Chiny!"  
He was only a radio lad and they were proud of him. Good-night, friends—go-ooo-d-night, and a Happy Old Christmas to you all.

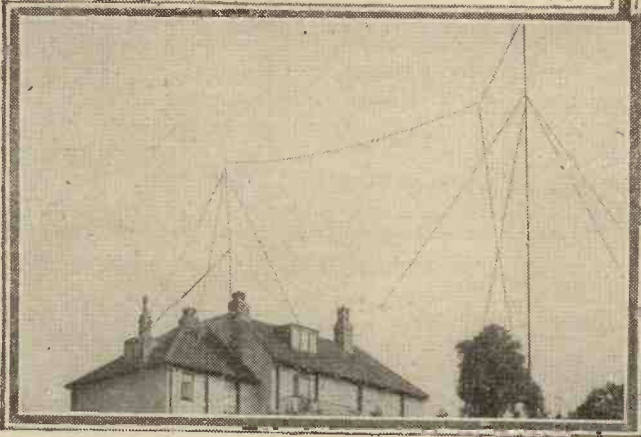

# LESSENING LEAKAGE

*We all want to get the maximum results from our sets, yet all the time they are in use losses are occurring. This practical and helpful article tells how leakage may be avoided and results improved by attention to the little points that matter.*

**By P. R. BIRD.**

**A**LL the time that a wireless set is in action it is hampered by losses. Some of these losses are inevitable, and so will not be considered in this article, but a great many others are preventable. In order to illustrate how they arise and how they may be cured, we will take the case of an ordinary valve set employing a detector and capacity-controlled reaction.

This is the most common form of circuit in use to-day, and a brief consideration of its working will throw a good deal of light upon leaks and losses, not only in a valve set of this particular kind, but in any other kind of wireless set.

## Resistance and Range

Stated simply, we can say that not only are there a great number of losses, but there are several different kinds of loss.

First and most important of these

is resistance, which occurs at all joints. A certain amount of resistance is invariably to be found at all screw-down terminals, plug-in joints, and pressure joints; and, using a crystal set upon a ship's aerial, with no nearby transmitters or receivers to complicate effects and no aerial screening, I have known the range of reception to be increased hundreds of miles merely by cleaning and tightening the lead-in contacts!

## Screw-Down Contacts

Getting down to every-day instances, we will look for likely losses in the set shown in our diagram (Fig. 1). In the aerial wire itself any joint is sure to provide resistance. Theoretically, too, the connection between the aerial and the lead-in, and from this to the set, will give rise to further small losses, but these can be reduced as far as possible by cleaning the two surfaces which are

in contact, and making the screw-down pressure as strong and as firm as possible.

## Aerial and Earth

If there is a fixed condenser in the aerial lead, as is often the case, and as is shown in the diagram (A.S.C.), there will be slight contact losses at each terminal. The coil holder, too, will give rise to the possibility of loss at the spring contacts where the plug and socket meet, and the points where it is joined to the set are another source of potential loss.

Unless the earth wire is cleaned and well screwed down to the earth terminal there will be loss here, and finally there is often unnecessary resistance at the buried earth or water-pipe. In the former case damp earth should be packed tightly around the earth plate, and in the latter case the clip which fastens to the pipe should be really clean and firmly fixed.

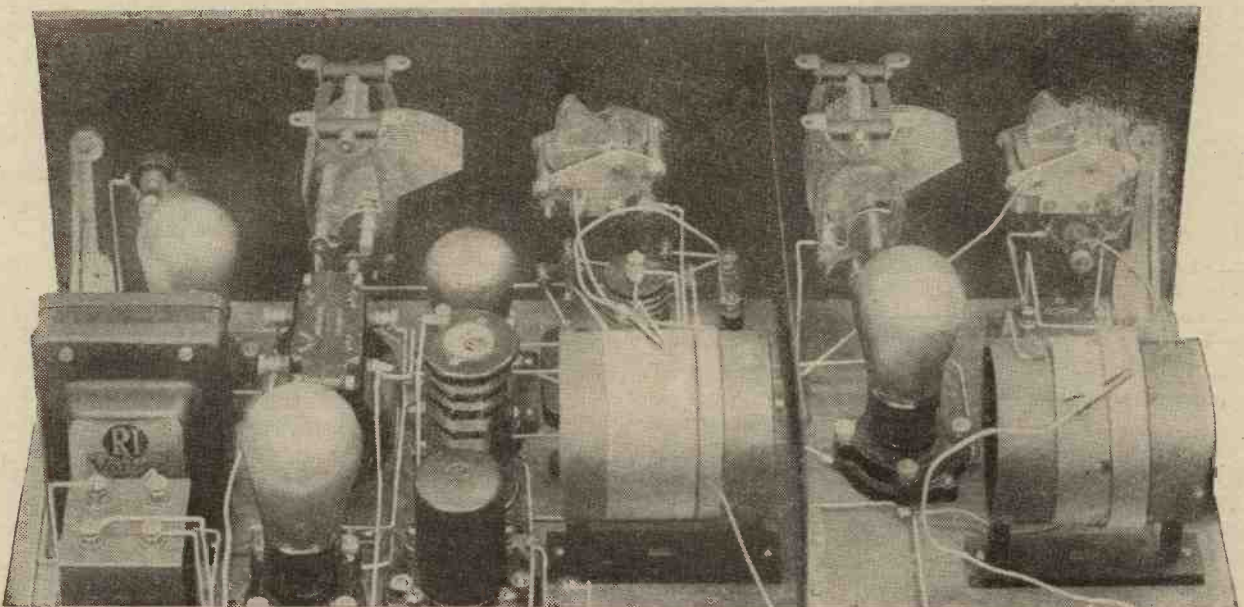

It is in the high-frequency end of the set that the more serious set-losses occur. For this reason the H.F. end (right) of the receiver shown is spaced more widely than the rest of the set, where close proximity is comparatively unimportant.

When the energy has been transferred from the aerial coil to the grid coil things are no better theoretically, for here again there are many possible leakage points. Each end of the coil winding fixes into a coil holder, and unless the contact here is tight and clean, losses will occur. Equally important is the tuning condenser  $C_1$  into which the current flows, so that all the leads to this, and the contacts joining this to the coil, may give rise to resistance losses.

### Capacity Leakage

Furthermore, there is a possibility of loss at the grid condenser  $C_2$ , and as the grid leg of the valve itself fits the valve holder with a pressure contact, we see that it is only after passing a dozen points of potential leakage that the energy picked up by the aerial arrives on the grid of the valve.

As a matter of fact, after this point there are scores of other possible leakage points, but from here onwards the energy is amplified, and consequently, although the resistances are still present, their effect is less noticeable; and it is in the aerial and H.F. circuits that resistance losses are particularly important.

of the losses are of a far less conspicuous kind.

Prominent amongst these are the losses due to capacity leakage. To understand these we shall have for a moment to consider the diagram and what happens in a set of the kind illustrated. The high-frequency currents induced into the aerial by the distant broadcasting station flow across the aerial series condenser (A.S.C.), and through the aerial coil A, down to the earth. The currents are oscillating, that is to say, they race up and down across this pathway a million times per second, or thereabouts.

As they pass through the aerial coil A, they start up a corresponding magnetic commotion in the space surrounding the coil, where the grid coil  $L_1$  is arranged to cut across this magnetic field. This results in similar currents being induced in the grid coil  $L_1$  when tuned suitably by the condenser  $C_1$ , the aerial currents in effect being reproduced across the grid circuit  $L_1-C_1$ . One end of  $L_1-C_1$  is joined to the filament of the valve direct. The other end of  $L_1-C_1$  is joined to the grid of the valve through the condenser  $C_2$ , and across this the high-frequency voltages will thus be applied to the grid of the valve.

### Shunted to Earth

It will be noticed that the high-frequency currents have no difficulty whatever in "flowing through" condensers. Even in the ordinary set we have been considering they have passed across the condenser A.S.C. and across the grid condenser, and we now have to remind ourselves that a condenser is simply two metal areas separated by air, or by some other insulator.

Remembering this, consider what the effect of an insulated aerial wire lying across a drain-pipe or across a gutter-pipe will be.

Those two surfaces, the aerial wire on the one hand and the metal on the other, are in effect a small condenser, rather like the condenser which is sometimes to be included in the aerial lead. We can call this extra condenser X (see diagram). We have seen that the high-frequency currents will easily traverse either A.S.C. or  $C_2$ , consequently they will also easily traverse the condenser X. But if they do this, notice that the whole input to the set is reduced by all the energy which is shunted across this condenser to earth!

Instead of the distant broadcasting station's impulses coming down the

aerial and affecting the aerial coil A, the coil  $L_1$ , etc., on their journey to earth, a certain proportion of the energy will choose to pass through the condenser X and run via the gutter-pipe which constitutes the other side of X, direct to the earth, passing by the set altogether.

It is for this reason that all the aerial wire right up to the aerial coil itself should be kept well away from

In a crystal set resistance losses can be very serious, so all joints should be kept in good condition, with particular attention to the metal surfaces and to the pressure which is holding them together. The cleaner they are, and the tighter they are pressed together, the better reception will be.

walls, gutter-pipes, and other earthed metal objects of this kind.

There is yet another common source of loss to which a reference must be made. It has already been stated that the aerial current flowing through the aerial coil A sets up a magnetic field in the space around that coil; and we find that when the coil  $L_1$  is placed close to the aerial coil A, it there has induced in it a corresponding energy which has been drawn from the aerial coil. It stands to reason that if the aerial coil  $L_1$  can draw energy away from the coil A, any other coil similarly placed will probably do the same, and here we see the possibility of a third class of loss.

Suppose, for argument sake, that the coil A was placed very closely to a copper shield. There is no doubt that a certain proportion will try and set up currents in the copper shield, thus leaving less energy available for supplying the coil  $L_1$ .

### The Importance of Spacing

This is why set designers are so careful about the spacing of their coils and of the various components around them. The loss, or "damping," as it is called, introduced by metal adjacent to an aerial coil may be very considerable, although there is nothing to show for it in the set itself, except to an experienced eye. Any or all of the losses referred to above may have occurred simultaneously and in greater or smaller degree, so that the chances are if you review your set carefully in the light of the preceding facts you will certainly find some method of improving your reception and lessening leakage.

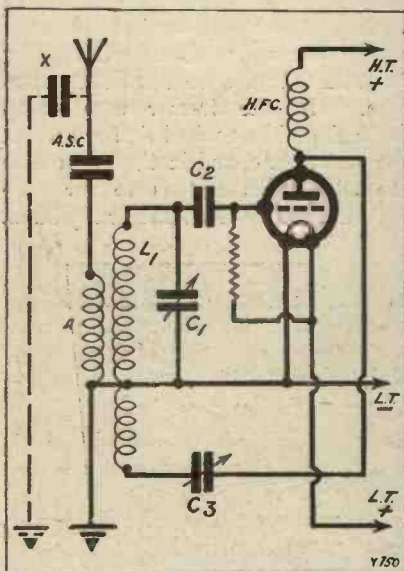
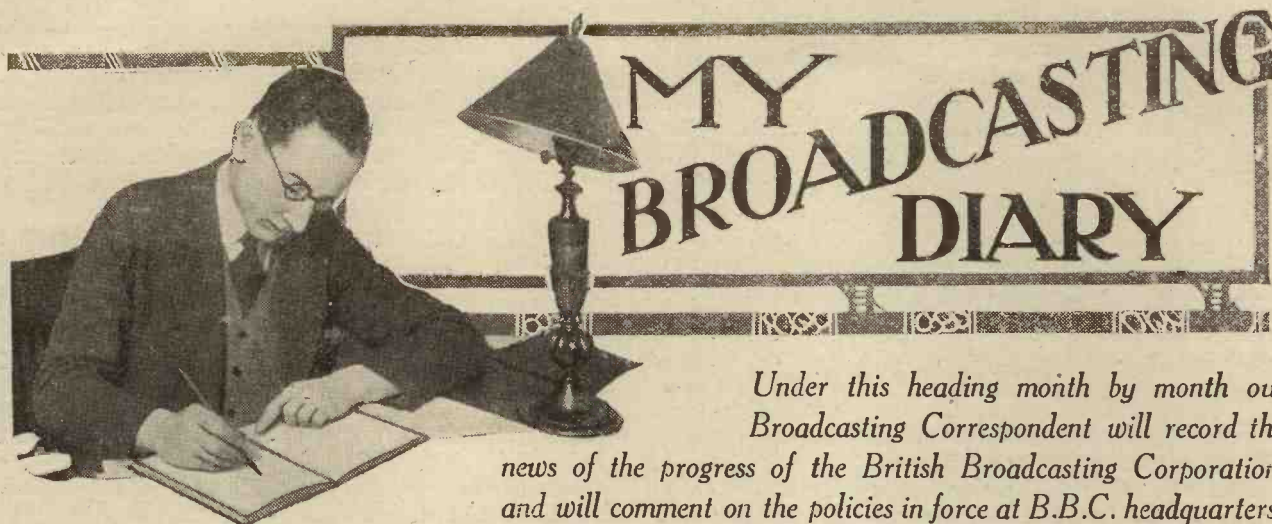

Fig. 1. This diagram shows how aerial energy may be lost by an accidental condenser-effect (X) between the aerial and gutter-pipes, damp walls, etc.

So far we have dealt only with resistance losses. The probability is that if you improve all the joints named along the lines mentioned above, you will notice a distinct improvement in your reception. Good pressure and clean contact alone, however, are not sufficient, for many





*Under this heading month by month our Broadcasting Correspondent will record the news of the progress of the British Broadcasting Corporation, and will comment on the policies in force at B.B.C. headquarters.*

### Real Vaudeville At Last

**M**Y listening friends all agree with me that the best thing the B.B.C. has done since the opening of 5 G B is to introduce real variety and vaudeville from the Palladium. These regular turns, which started with Van and Schenk, have proved easily the most agreeable of the varied fare provided by Savoy Hill. Their success confirms, *inter alia*, my suspicion that it was really a waste of time for the B.B.C. to try to originate and elaborate light entertainment on its own.

There was justification for this only so long as the music-hall managements maintained their boycott of the microphone. Now that the hostile front has been heavily and permanently breached, the B.B.C. would be well advised to demobilise, or divert that large section of their programme organisation hitherto engaged in making an inferior imitation of the real thing. Savoy Hill should make up its mind to take all its light entertainment straight from Music Halls. If broadcasting artists are really worth while they will be taken on by enlightened Music Halls.

### Lord Clarendon Listens

Gossip has it that Lord Clarendon, Chairman of the B.B.C., has begun to listen to the programmes in his beautiful Hampstead home, Pitt House. It is said that he is no fonder of talks than the ordinary listener. Incidentally, Lord Clarendon is a much more active Chairman than he was expected to be.

### Another Beecham Hitch?

Sir Thomas Beecham has been unusually silent about broadcasting since his famous "hoggery" speech at Leeds in October, but I am told that terrific struggles are going on behind the scenes. Either a new permanent National Symphony Orchestra will emerge from all this smoke of battle, or there will be a terrific explosion. I back the chances of a Permanent Orchestra because I believe that Sir Thomas is much more interested in advancing the cause of music than in playing havoc with the stupidity he encounters in some parts of Savoy Hill. But if Sir Thomas ever gets within striking distance of the Music Advisory Committee of the B.B.C. fireworks are inevitable.

### More O.B.'s From Churches

I understand the B.B.C. is contemplating a change in its policy about religious services. In the past there

has been a preponderance of studio services. It has become apparent, however, that the services taken from churches and chapels are much more popular with listeners. Accordingly, the microphone is to make its appearance in a great many places of worship throughout the country. In this connection, there will be an endeavour to specialise in churches of historic interest and in places of worship where the singing is of a high order.

### Programme Criticism

It is customary for the B.B.C. to complain of the absence of competent, well-informed, and sustained criticism of programmes. By a generous distribution of free sets, and by providing in some cases free maintenance, the B.B.C. endeavoured to induce the professional

### RADIO RESCUERS OF NOBILE



The radio room of the "Citta di Milano," which played a large part in the rescue of General Nobile, the Arctic explorer, when his airship was wrecked on drifting ice near the North Pole.

critics to deal with broadcasting in the same systematic way in which they deal with theatre and concert performances.

Except for Queen's Hall Concerts and for a very few isolated efforts, such as "Kitesh," and the "Pretenders," the broadcasting programmes in this country have not attracted criticism in the serious sense. One reason for this, of course, is that broadcasting is still "news"

and it pays the newspapers better to deal with prospective rather than retrospective programmes.

Another reason is that the B.B.C. has so far failed to realise the importance of the provision of a comfortable and efficient "listening post" in the West End. Now that the move to Langham Place is definite, the B.B.C. will probably let this stand over; but I do hope that in connection with the plan for the new building, due account will be taken of the desirability of appropriate accommodation for critics. It will be only in this way that broadcasting will gradually be considered worthy of the same criticism devoted to other arts.

### Regional Scheme Progress

I understand that there has been such difficulty in securing agreement about the site of the new North of England twin-wave transmitter that it will be some weeks yet before the first sod is turned. It is hoped, however, so to expedite the construction that the original programme will still be observed.

In other words, the B.B.C. has not lost hope of being able to begin transmission in the Pennines by the end of 1929. Meanwhile, satisfactory progress is recorded at Brookman's Park, north of London. It is practically certain that the new London station will be doing public experiments before the end of August.

### RADIO-POWER TESTS

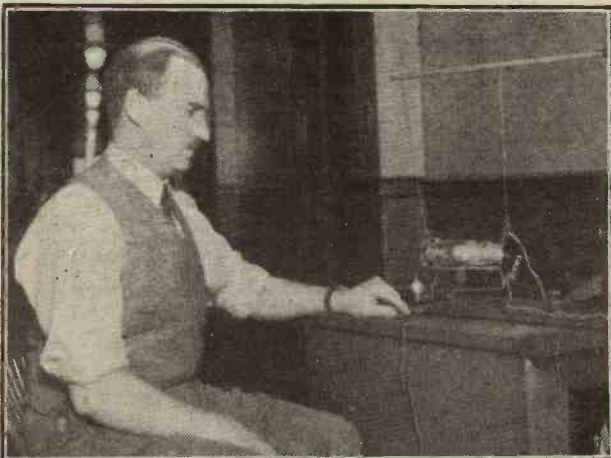

Dr. Phillips Thomas seated before the apparatus with which he recently demonstrated his theory of Radio-Power.

### Collapse of Listeners' Committee

It looks as if the famous Listeners' Committee has either been assassinated or has committed *hara-kiri*. Anyway, Captain Fraser's Committee has not met for some months and there seems no prospect of its re-assembling. For one thing, the whole basis of its representation has collapsed.

The Wireless Association is no more; the Wireless League maintains a shadow existence; the Radio Association is not more substantial; the Radio Society of Great Britain seems pretty well bored with the whole proceeding. Exit the Wireless Organisations Advisory Committee which, while it functioned, did some very useful work, and left its impress on programmes.

### THE REGIONAL SCHEME.

"It is practically certain that the new London station will be doing public experiments before the end of August. . . . The B.B.C. has not lost hope of being able to begin transmission in the Pennines by the end of 1929."

It would be a pity if this Committee were to pass away without leaving any continuing link. The obvious sequel, of course, is that Captain Ian Fraser, M.P., should be appointed by the Postmaster-General to one of the two vacant seats on the board of the B.B.C. Such an appointment would give universal satisfaction and would be a long step towards the proper representation at Savoy Hill of the views of the man-in-the-street.

### B.B.C. Wields the Big Stick

After years of more or less abortive negotiation for the parcelling out of the ether, the B.B.C. lately fell back on the time-honoured method of using force. With the tacit agreement of the Germans, the B.B.C. has been clearing its wave-band of unauthorised interference by the simple expedient of drowning the offenders. This has produced a much more wholesome atmosphere in Europe. But it is hardly a tribute to League of Nations' methods in effective international intercourse!

### Dick Sheppard's Successor

I wonder how many listeners know that the voice which has become so popular in the weekday morning services is that of the Rev. Hugh Johnson, Curate at St. Martin-in-the-Fields. Mr. Johnson bids fare to rival the great Dick Sheppard in the affection of listeners and in his good works.

### International Signals

An International Committee under the chairmanship of Mr. H. G. Williams, M.P., Parliamentary Secretary to the Board of Trade, is proceeding to compile a Revised International Code of Signals in seven languages—English, French, German, Italian, Japanese, Norwegian and Spanish. This committee and the work which it is undertaking are the outcome of a suggestion which was made at the International Radio Conference last year at Washington.

## "M.W.'s" Exclusive Broadcasting News.

- ☞ Now that Broadcasting is a powerful force in the life of the nation, a well-informed survey of its developments and possibilities is becoming increasingly necessary.
- ☞ In "My Broadcasting Diary," MODERN WIRELESS presents to its readers month by month a thoughtful, exclusive and authentic review of British Broadcasting. Compare this with any similar feature in any other periodical and you will realise at once the superiority of

"Modern Wireless."

## OPERATING THE "RHAPSODY" FOUR

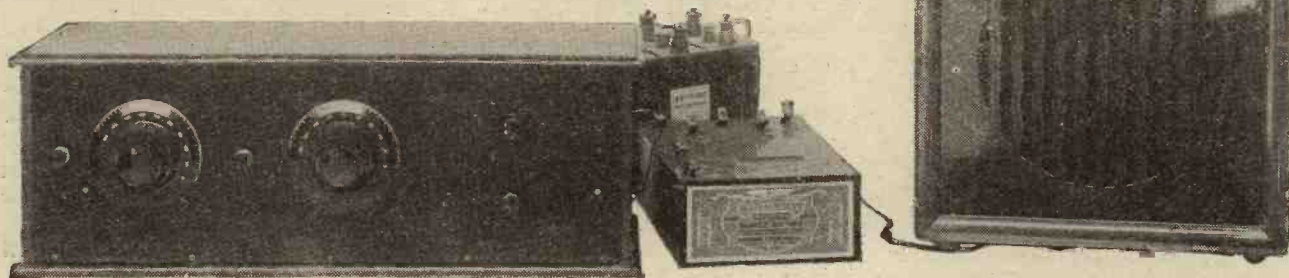

*In this article are details of the valves to use and method of neutralising the long-range loud-speaker set described last month.*

*By A. JOHNSON-RANDALL.*

**L**AST month I gave full details of how to build that excellent general-purpose receiver, the "Rhapsody" Four.

I have had an opportunity of testing this set very thoroughly, and as a sensitive long-range receiver it gave very good results indeed.

To commence with, I tried it on the normal broadcast wave-band of 250 to 500 metres. In the aerial socket, I placed a No. 35 coil, and in the secondary a No. 60. These two sizes are correct for the 250- to 500-metre band, but there are cases where a little more selectivity is beneficial.

In such cases a No. 25 coil would be better than a No. 35, but, of course, the signal strength might fall off a little, especially on 5 G B.

It depends upon your distance from the local station whether you will need the smaller coil or not. The valves you will require are three of the so-called "H.F." type in the first three sockets, and a power type in the last stage.

### Suitable Valves

There are so many of these valves available now that it is impossible to name them all. Generally speaking, an H.F. valve is one having an amplification factor of round about 20. To name some of those in the leading makes, we have, in the 2-volt class: Marconi or Osram, H.L.210; Ediswan, H.F.210; Mullard, P.M.1 H.F., or P.M.2DX; Mazda, H.F.210; Met-Vick, S.P.16/G; Cossor, 210H.F.

The H.T. voltages I suggest are: H.T. +2, 120 volts, and H.T. +1, 100 to 120 volts. Do not use low voltages if you want to get the best results. Remember to use the grid

bias specified by the makers for the particular valves and H.T. voltages you are using. You will find this stated on the pamphlet supplied with the valve.

For most "H.F." valves  $1\frac{1}{2}$  to 3 volts is usually O.K., and for an ordinary power type,  $7\frac{1}{2}$  to 9. If you use one of the super-power class you will need more than this, probably 15 volts or so.

Now pull both the wave-change switches out and switch on the valves. If the neutralising condenser is at its minimum, that is, with the moving vanes all out, it is almost certain that the H.F. valve will oscillate directly you adjust the two tuning dials in order to tune in your local station.

I am, of course, assuming that you are not using any reaction. To stabilise the H.F. valve, rotate the neutralising condenser until the vanes are about a quarter in mesh. Then readjust the tuning controls, noting whether the set now shows any tendency to oscillate.

### Neutralising

If so, again adjust the neutralising condenser until the receiver becomes quite stable over the whole wave-band. The setting is not critical with this particular set, because the layout has been carefully worked out, and there is not a very great tendency for the H.F. stage to become unstable.

*(Continued on page 692.)*

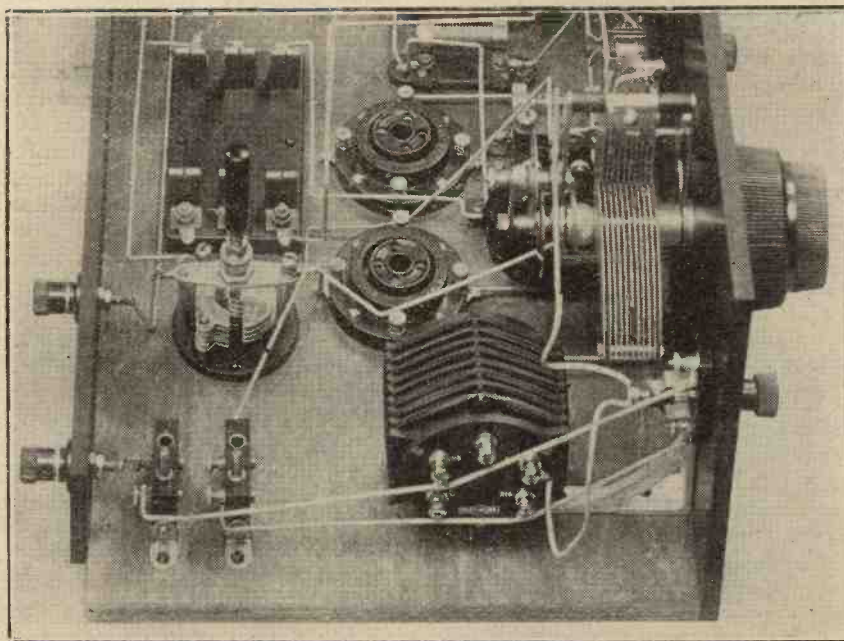

This is the H.F. end of the "Rhapsody" Four, showing the neutralising condenser set "all out."



# WHAT READERS THINK

The "Constant" Three—"M.W." Short-Wave Sets—The 1928 "Solodyne"—Reducing Charging Costs—5 SW Programmes.

## The "Constant" Three

SIR,—With reference to the "Constant" Three, as published in the September issue of MODERN WIRELESS, you will no doubt be interested to know that I have had exceedingly good results with one of these sets. I have also added to the set a further stage of screened-grid amplification, and changed the audio side to include one stage R.C. and one stage transformer, using a Mullard 252 in the last stage. I am using 15 and 24 volts respectively grid bias for the two audio stages, and have retained the reaction arrangements as given by your contributor. The only alteration necessary was to strip off some 20-odd turns from the reaction winding, and to use a flatly tuned aerial circuit as a volume control, substituting an H.F. transformer wound to a specification given by your contributor for the aerial coil used in the original set. This has not complicated the tuning arrangements in any way. The extra H.F. stage is, of course, screened in a similar manner to the original one. After trying various types of loud speakers, I am now using a Ferranti Exponential horn, and shall shortly change to a linen diaphragm. Stations are received from all parts of Europe at full strength and selectivity is razor sharp.

Yours faithfully,  
W. F. ELLIOTT.

Birmingham.

## "M.W." Short-Wave Sets

SIR,—Let me congratulate you on the excellence of your monthly and the designs for sets which you are bringing forth with such striking regularity. I have tried many of the sets, and I find that they are more than good. The short-wave sets which I have built are the "Universal" short-wave set, the short-wave set using Colvern coils, the "Wide-Range" Two, and the "Austral" Three. I use the "Wide-Range" mostly for my short-wave work as

it is easy to control; and there are no dead spots in it. I have added a third valve to same. Of course, the L.F. unit for all these sets is the same, the wiring of each stopping at the detector unit. This does not mean that the other sets are in any way bad, but the "Wide-Range" is my latest. All the sets have given equal satisfaction and pleasure. I have to date logged more than twenty telephony stations with these sets.

The stations which come on the loud speaker are ANH, ANE, PCLL, 5SW, and PCJJ. At good headphone strength I get 2XAD, 2XAF, 3LO, 6AG, and one or two other unidentified stations probably in Japan. At readable headphone strength I get 2NM, 2FC, and several other amateurs.

I am reading a lot of contending opinions from short-wave enthusiasts re reception of 5SW here. I am listening regularly to that station from March 1st, 1928, and I may safely say that it is the best and most reliable station. PCJJ, which is put forward as an ideal, hardly ever comes up to the mark of 5SW, either in intelligibility or in volume. I am keeping a regular log of both these stations. From May to June PCJJ was only a whisper, whereas 5SW was coming in at good headphone strength.

With best wishes for the success of your paper.

Yours faithfully,  
A. H. V. RAO.

Secunderabad, Deccan.

## The 1928 "Solodyne"

SIR,—I have been testing the 1928 "Solodyne," which I have made up as given in January number of MODERN WIRELESS.

When I call my set a "Solodyne" I call it by the wrong name, as I have three condensers separately controlled instead of gang condensers. This is the only difference between my set and the set given. I made

my own long- and short-wave coils. I have logged 73 stations on the loud speaker as yet, but during the winter I shall probably get a number more.

I am using 2-volt valves in all stages, which work perfectly.

I am looking forward for improvements by the MODERN WIRELESS staff of this set. When I say improvements, I mean the fitting of the new Pentode L.F. valves, etc.

With these fitted this set should be one of the finest sets ever given for home constructors.

Wishing MODERN WIRELESS all the best of luck.

I am,  
Yours faithfully,

CHARLES A. BAXTER.

P.S.—I would like to tell you I have still got the nine-valve super-heterodyne given in MODERN WIRELESS, May, 1925, which is still unbeaten for long-distance work and selectivity. This set has been in use every day for three and a half years and still going strong and holding its own. This, I think, proves that MODERN WIRELESS was in advance to any other paper on wireless in those days, as well as now. I have every edition from the first on the bookshelf. Thanking you once again for all good things that have come from your paper.—

C. A. B.

Camb.

## Reducing Charging Costs

SIR,—In connection with the article on accumulators and charging in a recent MODERN WIRELESS, I would like to bring to your notice a method of reducing charging costs when direct current is being used at a cost of 5d. or 6d. a unit. It is not always possible to work in charging with reading, and

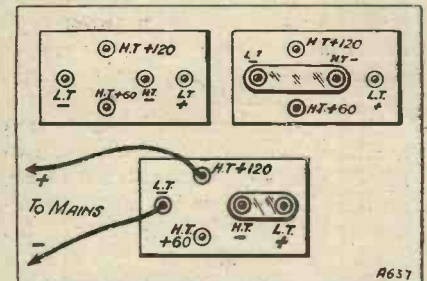

How Mr. Little solved the charging problem.

consequently the light has to be used specially for charging, and as the writer says, it may cost 7s. 6d. to charge a 2-volt cell of 50 or 60 amps. This was my problem, and I solved it by buying four D.T.G. Exide cells, which I discharged in parallel and charged in series. The initial cost was

# Build this Receiver in 6 Simple Steps

*and Span the Eastern Hemisphere*

When you build the Lissen S.G.3 Receiver, at once you enter into a new realm of radio. With this screened-grid circuit you have all the continental broadcast stations available at any time of the day and night; and this development of radio Lissen has put within the reach of all by publishing a STEP-BY-STEP Chart and Wiring Diagrams which for sheer simplicity have never been approached. You will *not* make this Lissen S.G.3 Receiver in five minutes—but you *will* make it without possibility of failure, and when you have made it you will have a receiver that will give you

## DANCE MUSIC ON SUNDAY IF YOU WANT IT!

You can range the continental stations in search of the kind of entertainment to suit your mood. Because until you build this new Lissen Receiver you have never known what selectivity means. Stations come in clear, distortionless, loud at almost every degree of the dials; yet there is no interference of one station with another, no critical or difficult tuning. Lissen show you how to make this set—Lissen supply you with *all* the components—yet Lissen do not tie you down to buying any complete "kit of parts." If you follow the directions, you will have a radio set of which you will be proud to say "I made it myself."

## A HANDSOME CABINET OF WOOD!

Lissen do not tie you to a cabinet of tin, because iron (i.e., tin) in a tuning circuit damps the tuning and reduces selectivity. So Lissen suggest you should choose a cabinet of polished wood, and make the receiver a handsome piece of furniture.

## EVERY RADIO DEALER CAN SUPPLY THE LISSEN PARTS

10,000 radio dealers sell Lissen components. From any one of them you can get the parts you need for this receiver. Your nearest Lissen dealer will help you with it and advise you. You can buy the parts by instalments or all at once, just as you like.

**LISSEN LIMITED,**  
20-24 Friars Lane, Richmond, Surrey  
(Managing Director: THOS. N. COLE.)

## MADE IN SIX SIMPLE STEPS WITH STANDARD LISSEN PARTS THROUGHOUT

You can obtain from any radio dealer or direct from factory a FREE STEP-BY-STEP chart and Wiring Diagram for the Lissen S.G.3. Lissen have simplified the building of it, firstly by using standard Lissen parts throughout; secondly by supplying a ready-drilled panel, a baseboard with component layout marked, aluminium screens all ready to erect.

You have not got to buy any particular make of valve; you choose whatever make you like. You have not got to buy a particular cabinet—you can choose one for yourself. And you have not got to buy a complete kit of parts, because Lissen know you probably have many Lissen parts already in use in an old receiver.

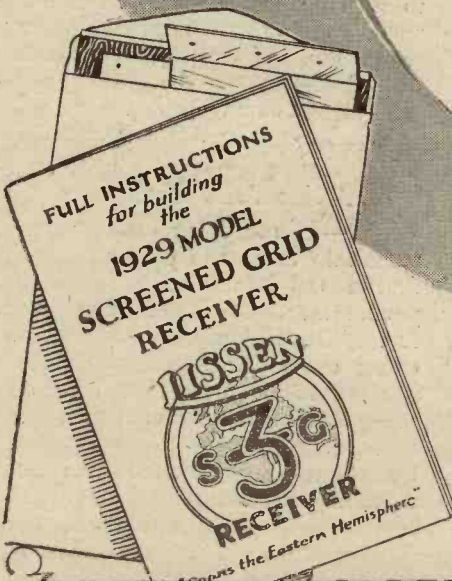

no greater than a single 60-amp. cell, and I cut out three-quarters of my charging costs. These little cells are eminently satisfactory when used at a low rate of discharge.

The article on breaking all connections from batteries to set should have included instructions for making a third set of connectors for charging. I made these up for a friend whose knowledge of electricity is slight, and he has found them most convenient. They are as follow :

Panel containing five valve pins connected to batteries.

Panel containing five valve sockets connected to set ; L.T. — and H.T. — are joined by a copper strip under the nuts, and one lead taken to one terminal on set.

Panel containing five valve sockets ; H.T.— and L.T.+ are joined and leads taken from H.T.+ 120 and L.T.—, thus placing batteries in series for charging purposes.

To connect the batteries for charging is as simple as plugging in a valve or coil, and is done just as quickly,

I have taken MODERN WIRELESS for four years now, but have not seen such a set. I hope we may soon have one. I trust these suggestions may be useful.

Yours faithfully,  
H. S. LITTLE.

Knock, Belfast.

\*\*\*\*\*  
**PERTINENT  
PRACTICALITIES**  
\*\*\*\*\*

Irregular and noisy reception can sometimes be caused by impurities inside the accumulator, and if this is suspected it is a good plan to connect a pair of telephones across the terminals. (Very little current will flow because of the high resistance of the 'phones, but if there is an irregularity in the supply this will be indicated by clicking noises.)

\* \* \*

In grid-bias batteries in which the 1½-volt tapping is very close to the negative tap, the battery will be shorted if the plug is carelessly adjusted so that it will bridge the gap between these two. So care should be taken to avoid this.

**A JAPANESE GIANT**

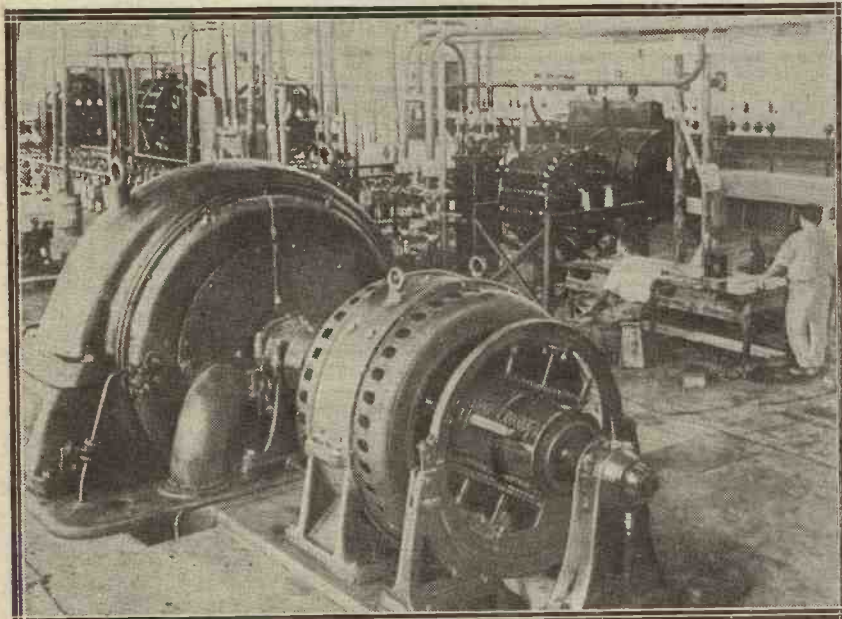

One of the most powerful stations in the Far East is the Isami station in Japan. The generators, which develop 850 kilowatts, are shown here.

the flex leads being permanently attached to a small charging board. It is principally useful, of course, for the H.T. accumulator, it being found cheaper to send the L.T. to the local charging station.

I want to build up a 1-V-2 set, screened-grid tetrode for H.F., and some simple system for switching from broadcast band to Daventry band, with proper solenoid coils and transformers (not commercial plug-in coils).

If the lid of a grid-bias battery is turned upside down and screwed direct to the baseboard this will make a convenient stand in which the battery may be held in position on the baseboard.

\* \* \*

When connecting up a low-frequency amplifier to a valve set *do not join up the H.T. — terminal*. It is unnecessary to do so, and will certainly lead to serious trouble if the connections in the amplifier are different from those in the set, in regard to the H.T. — and filament.

**5 S W Programmes**

SIR,—As an overseas short-wave enthusiast I should like to put forward views on the transmissions from 5 S W.

The quality of transmission is excellent, better even than P C J J of Holland. On a two-valve Bowyer-Lowe S-W. set I get very clear reception on headphones.

As far as this part of the globe (India) is concerned, the time of transmission is open to criticism. I am stationed in Western India, with 5½ hours' difference from English winter time, and 4½ hours from summer time. 5 S W switches on at 7 p.m. English time. This means during the summer months 11.30 p.m. in India, and during the winter 12.30 a.m. It also means that one misses the English 6.30 p.m. news transmission by half an hour. The next news transmission is 9 p.m. English time, which means 1.30 a.m. in summer, and 2.30 a.m. in winter in India. Could not 5 S W switch on half an hour earlier to give the news to the Indian Empire ?

Then as regards the material transmitted. Much of 2 L O's 7 p.m. programme consists of addresses; one night we had Infant Welfare, and Aeroplane Engines. Then we have the British Spas, etc. I think that what most of us want is alternate nights of classical music and dance music.

5 S W must be faced with a multitude of conflicting claims. The above is, however, one point of view, from a community which is in close touch with England, inasmuch as it is not, for the most part, permanently resident in India, but returns to England on leave and on retirement, and is therefore always eager to get into, and keep in, close touch with England.

Yours truly,  
ANGLO-INDIAN.

**A Reader's Tribute**

SIR,—I so enjoy the "non-technical" articles in your magazine that I feel I must write to thank you for them. The one on "Sir Oliver Lodge," for instance, and that interesting one a few months ago about Grenfell in Labrador—the sort of thing that no other magazine seems to have. We can't all be experts, but we can enjoy the life-like radio touch in our reading.

Yours faithfully,  
J. W. N.

Ilford.

# RADIO AND THE GRAMOPHONE

In this section of *MODERN WIRELESS* each month will be discussed both technical and other data, of value to the set owner who is also interested in gramophones.

Besides articles of a practical nature, a brief survey and critique of the latest gramophone records is included, making the section of vital interest to all music lovers.

Conducted By **KEITH D. ROGERS.**

## CONTENTS

	Page		Page
<b>Round the Turntable</b> .....	2	<b>Choosing Records</b> .....	9
A collection of "odds and ends" of interest to radio and gramophone enthusiasts.		This article gives some useful advice on the choice of records for pick-up work.	
<b>This Month's Pick-up Programmes</b> ..	2	<b>Your Xmas Programme</b> .....	10
A representative collection of items specially chosen for their suitability for pick-up reproduction.		Make your gramophone records augment your radio set this Christmas.	
<b>The "Sologram"</b> .....	3	<b>Pick-up Chatter</b> .....	11
Details of an up-to-date radio-gram outfit based on the 1928 "Solodyne."		Some interesting points on the subject of the chatter usually associated with electrical "sound boxes."	
<b>On the Track</b> .....	6	<b>Recent Record Releases</b> .....	12
A valuable article discussing in a simple manner the vital question of needle alignment.		Our regular review of some of the records published during the month, written from the point of view of their suitability or otherwise for electrical reproduction.	

## A RADIO-GRAM XMAS

**T**HIS Christmas will be a Radio-Gram Christmas. With the advances made in the design of radio receivers, increase in efficiency of loud speakers, and the improvements in pick-ups, the combined programme of radio and gramophone items has come into its own.

The electrically-reproduced gramophone record is well in advance of the best mechanical reproduction, while the advantages of the combined radio and gramophone receiver place it in a sphere of usefulness all its own.

### Good Results Easily Obtained

The best of it all is that if you have a reasonably good radio receiver and loud speaker, you can use this for electrical gramophone reproduction without in any way impairing its normal operation.

Furthermore, the "extras" merely consist of a "pick-up" (and these can be had for 15s. upwards) and some means of rotating the gramophone record and applying the pick-up. An old gramophone can be used with perfect results, or you can rig up a motor and turntable and pick-up arm very cheaply, for it need not be elaborate, though it must be reliable.

The needs of the radio-gram enthusiast are now

well catered for, and it is becoming easier to obtain first-class results with a minimum of cost and trouble. So this Christmas make *your* set do double duty—provide gramophone as well as radio programmes.

In this month's "Radio and the Gramophone" section we have a number of articles of vital interest to all radio and gramophone enthusiasts. A description of a really first-class radio-gram set, the "Sologram," is given, the radio portion being based on the well-known and unsurpassed 1928 "Solodyne," while the L.F. end is specially designed for pick-up reproduction.

### An Essential Point

Another especially interesting article concerning the correct tracking of pick-ups and sound-boxes is written by G. V. Dowding, Grad.I.E.E., Technical Editor of *MODERN WIRELESS*, and will be of great value to all owners of gramophones and radio-gram sets.

And, finally, let us remind our readers of one or two essentials to a really Merry Radio-Gram Christmas—fully-charged batteries, some good records, plenty of needles, and, close at hand, *MODERN WIRELESS*.

# ROUND THE TURNTABLE

by  
"TONE ARM"

A page of odds and  
to all radio and

ends of interest and value  
gramophone enthusiasts.

WHEN a pick-up is properly aligned, five or six times of use should improve a record, the needle burnishing the sides of the grooves and smoothing off any little irregularities which may have appeared during the process of manufacture. It is essential, however, to keep the record spotlessly clean, and the writer invariably dusts his records with a small brush, or with one of the special pads, before use.

## Avoid Worn Needles

Whatever you do don't go back and play the same record, or even part of the same record, again, just turning the needle a little, as many people do. If you do go back to the beginning again, you will find that the needle is so ground that it is more or less chisel shaped, and this chisel shape may go across the groove of the record and do it no end of damage. Especially will this be so if the needle is turned slightly. Unfortunately, turning the needle emphasises this, chisel effect, and the damage to the record is greatly increased.

Needles are not expensive items, and it is far cheaper to change after every side than to halve or even quarter the life of your record.

\* \* \*

It is often useful to earth the pick-up arm and the motor of your gramophone, especially if this latter is of the electric type. Even with a clockwork motor earthing sometimes has a beneficial effect if the outfit is inclined to be unstable and L.F. howl tends to make itself heard.

\* \* \*

Overloading when a pick-up is being used is often to be found in the first stage (the erstwhile detector valve of the radio set). A potentiometer volume control across the pick-up will help, but if a cure is required without any reduction in volume then a valve able to carry a bigger grid swing will have to be used.

## Curing Overloading

Sometimes an increase of H.T. will rectify matters if the overloading is very slight, and assuming the grid bias is properly adjusted, but a better

way is to change the valve for something a little "bigger."

Don't trail your pick-up leads along the wall or floor, parallel and close to the loud-speaker leads or you may get a howl due to the "singing round the ring" effect.

## So it Goes On

In other words, the loud-speaker currents will induce similar impulses into the pick-up leads, and these will be amplified through the valves and once more appear in the loud-speaker leads. And so it goes on, round and round.

\* \* \*

A magnetised screwdriver of the long, thin variety is useful for picking up refractory needles that have wandered into awkward places. The magnetised screwdriver is also useful for dealing with small steel screws when they have to be inserted in out-of-the-way spots.

\* \* \*

A short needle often gives better results than a long one owing to its less tendency to whip. If the long type is used it should be fixed well home in the chuck.

## This Month's Pick-up Programme

### ORCHESTRAL.

- Valse de Concert— .. H.M.V. D1492  
Glazounov  
San Francisco Symphony Orchestra.
- Overture—Flying Dutchman Parlo. E10761  
—Wagner  
State Opera House Orchestra, Berlin.

### INSTRUMENTAL.

- Melody in F— .. .. Bruns. 15137  
Rubinstein  
Leopold Godowsky.
- Toccatas—Roellmann and .. Col. 9497  
Gigont  
Edouard Commette and Lyons Cathedral  
Organ.

### OPERATIC.

- Ocean, Thou Mighty H.M.V. D1504  
Monster—Oberon—Weber  
Florence Austral.
- L'heure exquise—Hahn Parlo. R.O.20068  
Nino Vallin.

### VOCAL.

- Hear, de Lam's a-crying— H.M.V. B2838  
L. Brown  
Paul Robeson and Laurence Brown.
- A Sergeant of the Line— Zono. 5189  
Squire  
Foster Richardson.

### CHORAL.

- Couldn't Hear Nobody Pray.. Zono. 5159  
Utica Jubilee Singers.
- Hail! Queen of Heaven .. Col. 4967  
London Catholic Choir.

### BAND.

- Cadets March—Sousa .. .. Parlo. E6067  
Massed Military Bands.
- New Sullivan Selection .. .. Col. 9495  
H.M. Grenadier Guards.

### CINEMA ORGAN.

- Just Like a Melody out of H.M.V. B2828  
the Sky  
Jesse Crawford.
- American Patrol .. .. Col. 5038  
Pattman.

### SYNCOPATED AND LIGHT ORCHESTRAL

- Pot-pourri of Waltzes .. H.M.V. C1544  
Marek Weber.
- That's a Good Girl .. .. Zono. 5186  
(Selection)  
The London Orchestra.

### SYNCOPATED VOCAL.

- Stay out of the South .. .. Col. 5031  
Trix Sisters.
- Was it a Dream .. .. H.M.V. B2834  
The Revellers.
- Parisette .. .. Parlo. R207  
Mistinguett.

### DANCE.

- Queja Indiana .. .. Parlo R210  
Canaro's Band.
- The Rag Doll .. .. H.M.V. B5528  
Chinese Syncopators.
- Hawaiian Bluebird .. .. Bruns. 3845  
Hanapi Trio.

### MISCELLANEOUS.

- The Man in the Ditch .. .. Col. 5026  
Edgar Wallace.



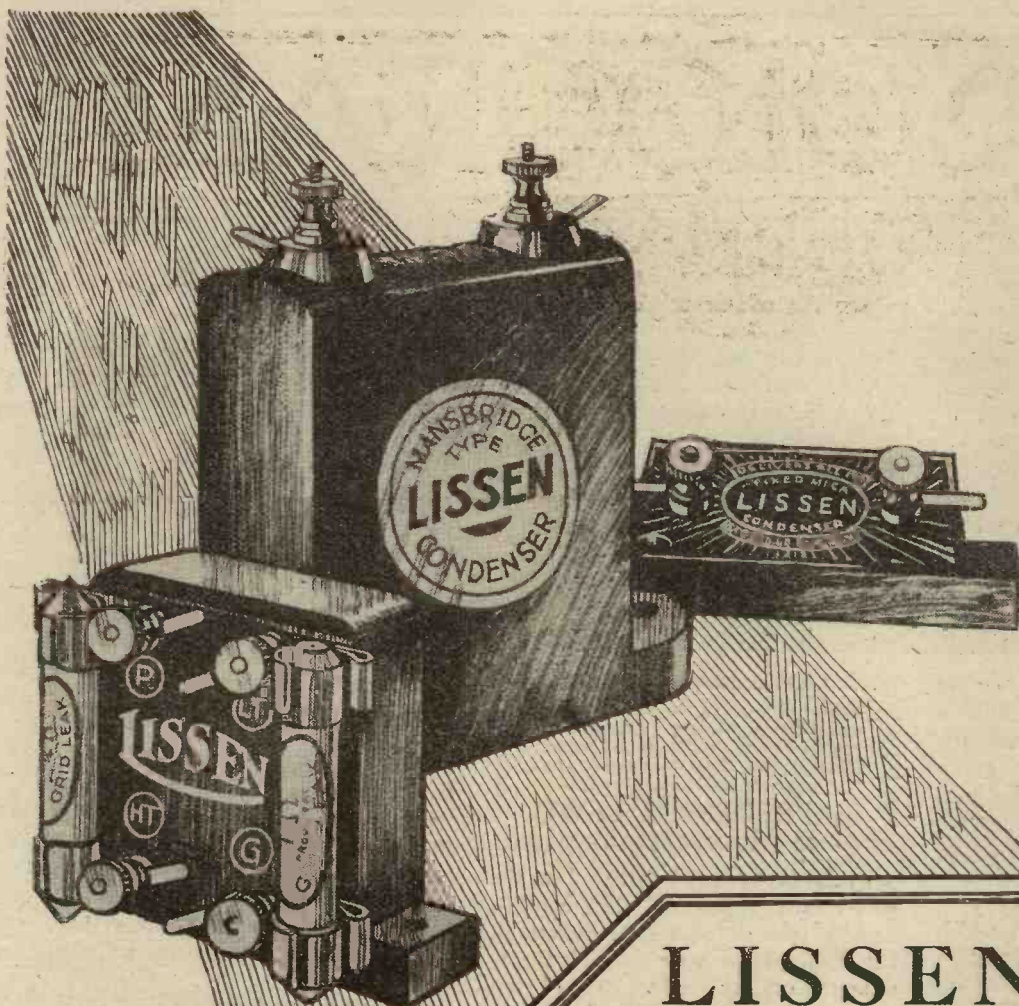

# LISSEN CONDENSERS

deliver all their stored-up energy

Because you are using bigger H.T. voltage—because you are seeking always more power and more purity from your set—because you are going out for ever more distant stations—your need for condensers that will stand up to all demands without leakage and without breakdown is more urgent now than ever.

And Lissen condensers *will* stand up to the new conditions as they have stood the test of the past six years. In tens of thousands of sets, in every conceivable circuit, they have proved the claims that Lissen make for them—utter reliability, complete freedom from leakage, and the unflinching delivery of *all* their stored-up energy.

## LISSEN FIXED CONDENSERS

have become the standard fixed condensers in almost every published circuit. Accurate to within 5 per cent of stated capacity.

·0001 to ·001 mfd. 1/- each  
 ·02 to ·006 mfd. 1/6 each.

## LISSEN R.C.C. UNIT.

It is of utmost importance in an R.C.C. unit that the condenser should be absolutely leak-proof. If your condenser leaks in an R.C.C. unit you will lose volume. The Lissen Condenser fitted to the Lissen R.C.C. unit will never leak, never vary. It delivers all its stored-up energy all the time. The resistances too are unchanging. 4/- each.

## LISSEN (Mansbridge) Type CONDENSERS.

Hermetically sealed in non-conducting case; cannot be short-circuited on the case. Deliver all their stored-up energy and have the biggest margin of safety of any condenser made.

·01 to ·05	1/8
·1	1/8
·25	2/-
·5	2/8
1	2/8
2	3/6

**INSIST UPON LISSEN PARTS EVERY TIME**

**LISSEN LIMITED**  
 20-24

**Friars Lane, Richmond, Surrey**  
 (Managing Director: THOS. N. COLE)

# The "SOLOGRAM"

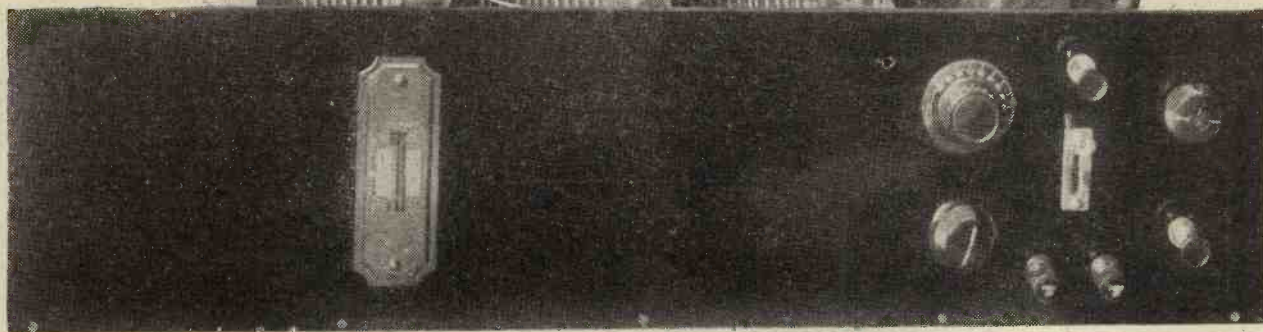

**I**N this and a succeeding article I hope to give some idea of a complete radio-gramophone outfit that should appeal to many wireless enthusiasts who want a good long-range radio receiver together with an adequate gramophone reproducing amplifier.

The whole outfit, as I shall show it, is housed in one large cabinet which contains the whole affair—set, gramophone, loud speaker, mains unit, and gramophone record cabinet.

This month I am giving a brief outline of the set with sufficient details to enable the more expert readers to make up the set if they so desire. I do not advise the less tutored to attempt the task.

*Some details of the receiver and amplifier portion of an up-to-date Radio-Gram outfit based on the 1928 "Solodyne" which has proved most successful.*

**By FREDERICK LEWIS.**

In the first place, it is based on the well-known "Solodyne" (1928 model), having two screened-grid valves of the S.625 type with special transformer coupling. The rest of the design includes an anode-bend detector valve and reaction which can be cut out at will by means of a switch.

### Three L.F. Stages

The detector is followed by three resistance-coupled stages, having low

anode resistances, to enable valves with fairly reasonable grid swings to be used.

Naturally, a pick-up switch is fitted, this switch automatically turning out the filaments of the H.F. valves and placing the pick-up in the grid circuit of the detector valve, which now becomes the first L.F. valve, thereby providing four L.F. stages when the pick-up is being used.

The panel measures 28 in. by 7 in. by 1/4 in., while the baseboard is 28 in. by 12 in. The full length of the baseboard is covered with sheet copper, the components being mounted on separate little baseboards. All filaments, screens, H.T.—, and by-pass

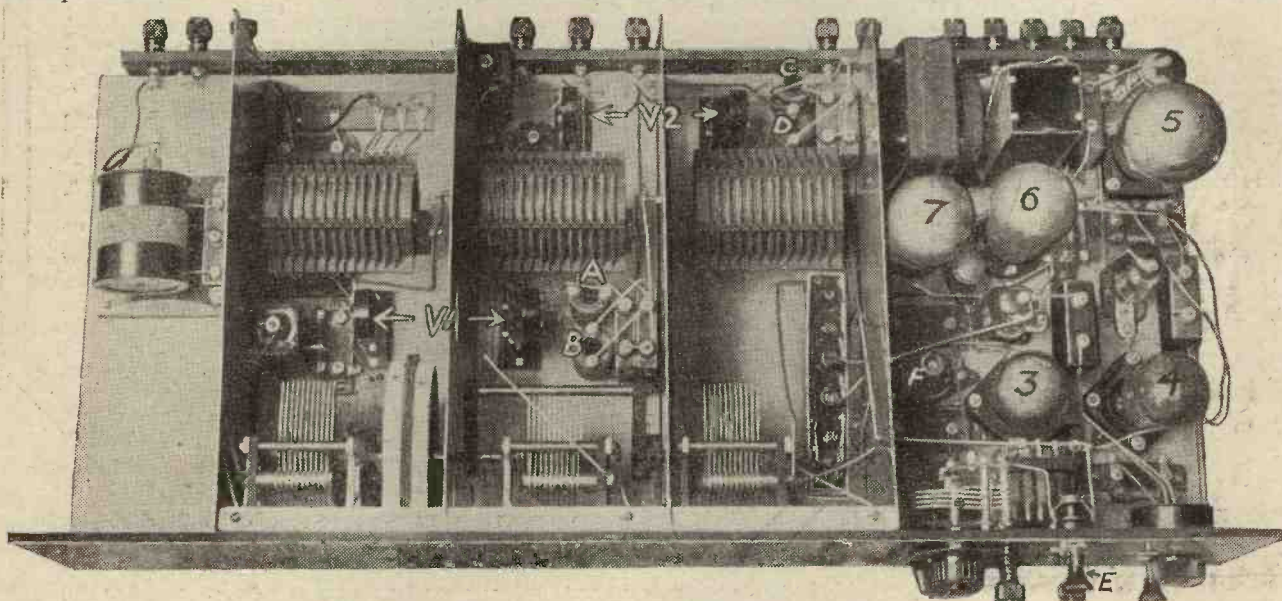

The "Sologram" with long-wave coils in position. The grid-bias battery in the fourth "compartment" is for the detector and the pick-up.  $V_1$  and  $V_2$  are S.625 valves;  $V_3$ , 30,000 ohms;  $V_4$ , 7,000-13,000 ohms;  $V_5$ , 5,000 ohms;  $V_6$  and  $V_7$  are 1,700-2,400 ohms.

condensers are earthed via the large sheet of copper.

The volume is controlled by either of two means when radio is being received: (1) the filaments of the H.F. valves, and (2) the potentiometer-grid leak method of controlling the input to the first L.F. valve. When the pick-up is employed the latter volume control is used, though in the completed outfit a extra volume control across the pick-up itself is employed. But this is external to the set and does not concern us here.

As regards the values of resistances, condensers, etc., these are given in the theoretical diagram, and it will be found no very difficult job to make the set if you study it in conjunction with the directions given with the original 1928 "Solodyne" published in the January number of MODERN WIRELESS.

**The Output Stage**

The resistances in series with the last valves are provided in case L.S.5A or D.F.A.7 type valves are used, which take 4.5-5 volts, and thus can be used with a 6-volt accumulator. When 6-volt output valves are employed the resistances are shorted.

It is essential, of course, to have a good output filter choke, for it may have to carry up to 60 milliamps if really large valves are employed.

The drum-control arrangement is different from that shown in the original "Solodyne," being of the two-

and these would probably need somewhat different H.F. transformers. The S.625 valves are very efficient and give quite enough magnification—too much on most of the Continental stations; the volume controls having

**CHIEF COMPONENTS.**

- 1 Triple-gang condenser, with screens.
- 1 Set short-wave coils and basas.
- 1 Set high-wave coils.
- 1 Panel 28 in. x 7 in. x 1/4 in.
- 1 Baseboard 28 in. x 12 in. (5-ply.)
- 1 Sheet copper 28 in. x 12 in. x 3/8 in.
- 5 Small baseboards to fit between screens, etc.
- 1 28/14-henry choke.
- 2 Parex valve holders for S.625 valves.
- 1 Wave-trap (standard).
- Terminal strips.
- Terminals.
- 5 Valve holders.
- 1 4-mfd. condenser.
- 2 L.T. switches.
- 1 Switch (D.P.D.T.) for panel mounting.
- 1 .0001-mfd. Bébé condenser.
- 1 6-ohm rheostat.
- 1 Volume-control potentiometer.
- 5 H.F. chokes (small).
- 3 1-mfd. mica condensers.
- 4 2-mfd. Mansbridge condensers.
- Fixed condenser, anode resistances, grid leaks, G.B. cells for H.F. valves (Type T), fuse, etc.

to be brought into play and even the reaction at zero on a large number of them.

The A.C. mains battery eliminator used for the H.T. supply will be described in the next article, but it might be remarked that two valve holders are employed so that either

the last valve, a potential divider providing lower H.T. voltages for the other stages. Not the slightest hum is present.

It is essential in the construction of the set to use inter-valve coupling condensers of the mica variety, and preferably suitable for at least a working voltage of 250 volts. If 500-volt (working) condensers can be obtained, these should be used in the last two stages, in case the eliminator is switched on before the filaments, or left on after they have been turned off.

**Changing Over**

And while talking about switching I must stress the advisability of turning off the H.T. while switching over from "radio" to "gramophone," and vice-versa. This switching process momentarily frees the grid of the detector valve and may result in quite a violent surge through the L.F. portion of the set, besides being bad for that particular valve which is devoid of grid bias for a moment while the switch is being thrown over.

As regards valves the following impedances have been found suitable for the detector and L.F. stages: 17,000-30,000 ohms for detector, first L.F. 7,000-13,000, second L.F. 3,000-6,000, and for last stage 1,700-3,000 ohms.

For most purposes one valve in the last paralleled sockets is quite sufficient, and I have used such valves as the P.625 (the 625A has too low a

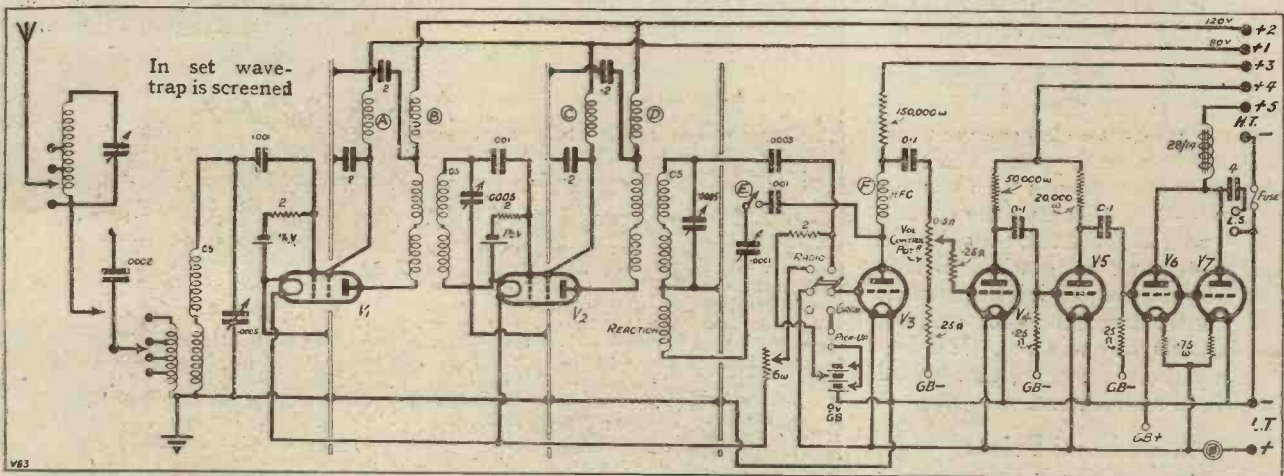

The theoretical circuit of the "Sologram." The letters refer to the letters on the photograph on the previous page. A, B, C, and D, are small H.F. chokes, F is the reaction H.F. choke, E is the break-reaction switch, and can be placed anywhere in the reaction lead. Separate 1 1/2-volt batteries are used to bias the S.G. valves, V1 and V2. The .0005-mfd. condensers are ganged and drum-driven.

drum type, allowing separate aerial tuning if desired. This is a great help to selectivity, as is the system of aerial tappings and the standard wave-trap included in the set.

The receiver is not designed for the upright type of screened-grid valves,

250 or 400 volts H.T. can be obtained, no changes being necessary to the transformer, which is of the tapped variety.

For many purposes the 250 volts is quite sufficient, though for "extra heavy" work I use 300-400 volts on

maximum H.T. voltage), P.V.625, L.S.5A, D.F.A.7, P.X.650 (B.T.H.), etc. It will depend upon the grid swing required and the output needed what valve the reader will employ. The actual valves generally used are H.L.610 (det.), G.P.607,

P.615 (B.T.-H.), and, finally, a P.625, or Ediswan 625, B.T.H. P.X.650, etc. When using the P.625 (Osram or Marconi) here, I find it a great advantage to use two in parallel, otherwise it is not usually necessary.

Results on radio with this set are comparable with those obtained by the original "Solodyne" described in the January MODERN WIRELESS.

For some reason or other the paralleling of the output valves makes far more difference when the P.625 is used than when other types of valves are employed. This is probably due to the fact that the M/I ratio becomes even more apparent, while the H.T. current taken is not so great as to cause a really serious drop of voltage in the choke, as is the case where the lower impedance valves are used. I certainly recommend the P.625 as an exceedingly valuable output valve.

### The Output Condenser

The output condenser has to stand the highest voltage, and should be of first-class construction. That used in the set photograph is tested to 1,000 volts, so can safely be worked at 500 volts without fear of breakdown.

It is essential that this condenser be of the high voltage type, because it has to stand practically the full H.T. across it. A breakdown of this condenser means a short of H.T. which, while not being serious owing to the fuse placed in the H.T. negative lead, would nevertheless be annoying, while a partial leak might cause noisy reception or weakened results.

It will be noted in the photograph on this page that the pick-up switch is of the three-pole change-over type. This is not necessary, and was used because the double-pole type was not at hand—it is, of course, the double-pole type that is wanted, the switch in the photograph being wired so that two sets of poles are joined together. This assists in making good contact, but is not really required. If I had had a D.P.D.T. switch, that would have been used instead.

### Some Final Points

The output choke is an important feature, and *must* be of good quality, and capable of carrying a heavy plate current. Naturally, it should also be of as low a D.C. resistance as possible.

In some cases it may also be found advantageous to connect a .0001 or .0002 mfd. fixed condenser between the top of the resistance in the plate circuit of the detector valve

and some convenient earthed point.

This acts as a useful H.F. by-pass for those impulses which get past the H.F. choke, and I find it helps to clean up the reception on some of the long-wave stations, without appreciably cutting off the higher musical frequencies that are being passed through the L.F. portion of the set.

In the original set photographed and diagrammed here, this condenser was omitted, but it is well worth trying.

It might be thought that the H.F. chokes shown in the plate and screened-grid leads of the S.G. valves

are too close together, and that interaction might take place, but I have tried screening these chokes and placing them farther apart without in any way affecting results.

### Stopping Motor-Boating

As placed in the set they are easy to wire up, and do not upset the layout of the rest of the circuit, while they do stop motor-boating in the H.F. end, should that bugbear have any tendency to commence.

Next month I will discuss the housing of the set, the eliminator, and the rest of the outfit.

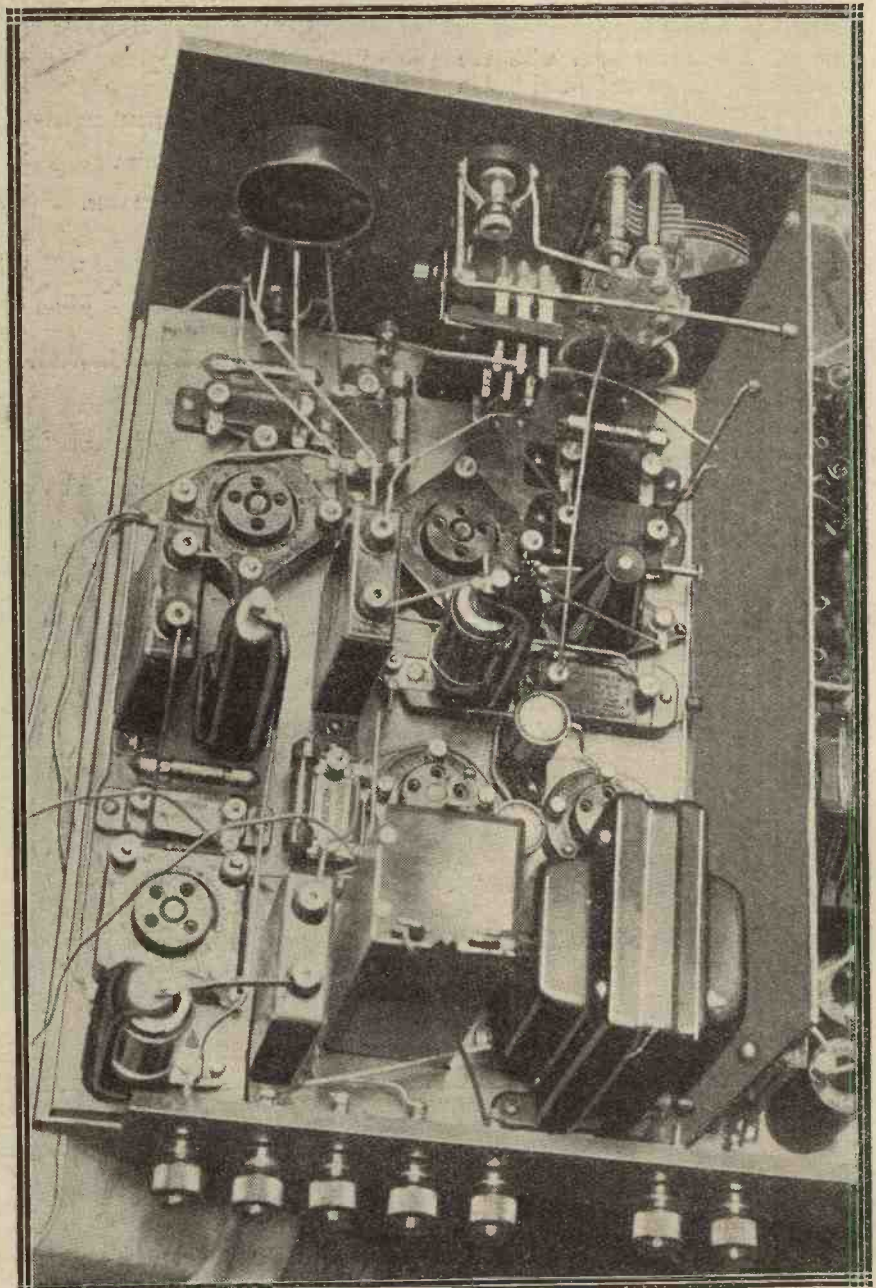

This shows the L.F. end of the "Sologram." The 4-mfd. output condenser is in the foreground next to the choke, while the copper sheet beneath the top baseboard can be seen projecting on the left, for it lies on the main under-baseboard.

# PHILIPS RECEIVERS

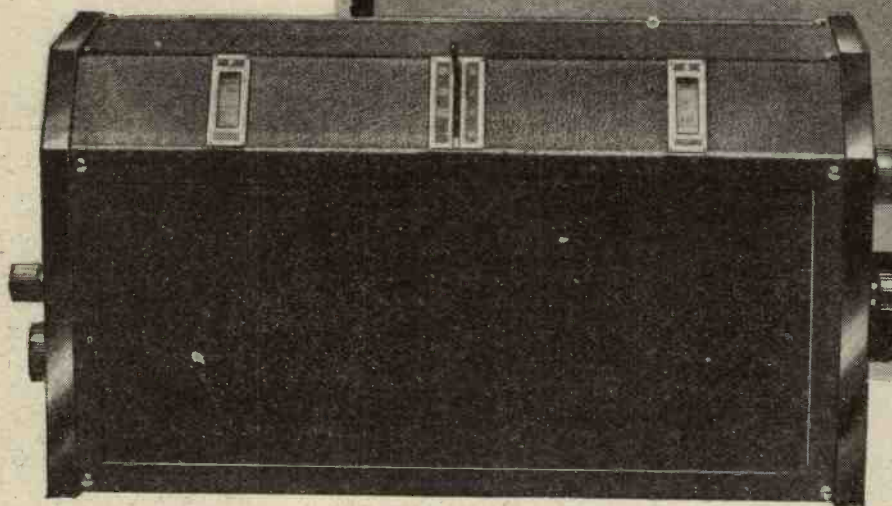

Philips Receivers employ the very latest valves, give brilliant performance and have advantages of simplicity, small cost, low maintenance and attractive appearance.

**Type 2514. Philips 3-valve ALL-ELECTRIC RECEIVER.**

A.C. screened grid, steep-slope detector and Pentode valves. H.T., L.T. and G.B. entirely from A.C. mains. Receives all main British and Continental stations. Volume to operate any moving coil speaker. 200 to 2,000 metres. Gramophone pick-up facilities. Average current bill 5/- per annum.

Complete with all valves, leads, etc., for A.C. mains - **£23**

**Type 2501. 3-valve RECEIVER.**

Similar to 2514. Takes L.T. supply from A.C. mains. Only requires H.T. unit, either Philips unit 372 or 3902.

Complete with valves and leads - **£16 - 10**

**Type 2502. 3-valve RECEIVER.**

For those who have no A.C. electric supply, or who prefer to use batteries.

Complete with valves and leads - **£15**

**Type 2515. Philips 2-valve ALL-ELECTRIC RECEIVER.**

A.C. steep-slope detector and Pentode valves. Abundant volume from local and high-power stations. Operates moving coil speaker. Wavelength range 200-2,000. Single dial tuning. Volume control. Gramophone pick-up facilities.

Complete with valves and leads - **£12 - 10**

# PHILIPS *for Radio*

Write for complete Leaflets of all Philips Radio Products.



*It is impossible to exaggerate, both from the wear and tear point of view and from that of quality of reproduction, the importance of the correct tracking of a gramophone needle. It is not easy to carry out, but if you follow the directions in this special article you will find no difficulty in getting the best out of your radio-gram outfit.*

**BY A SPECIAL CORRESPONDENT.**

**I**N order that a pick-up should operate at its best and impose the least wear on the records it should offer a certain definite needle pressure (depending upon its own individual design), and the needle should have a correct vertical angle and run tangentially with the record grooves. The

subject without resorting to advanced geometry. If you and I were brilliant mathematicians the whole business could quickly be disposed of, but I take it that most of you have got rather rusty in respect of your chords and tangents, so I will stick to simple "right angles," and other such simple terms.

then the tracking may become extremely bad.

But what is this "tracking," you may well ask. Well, it is seeing that the line-of-needle runs completely with the groove of the record in which the needle is running. Fig. 1 shows a

"Tracking" is a very important thing. If your pick-up needle is badly out of track your results are bound to be poor, while records may be ruined after playing them only a few times.

**What is Tracking?**

In the early days of the gramophone boom many firms rushed into production with instruments which were very badly designed. But, eventually, conditions were ironed out and now one rarely finds a gramophone having a badly tracked needle—when it uses an ordinary sound-box. But even so, it does not follow that similar perfection results when you fix on a pick-up. Needle alignment might then be thrown out completely.

Especially may this be the case if an adaptor has to be used, and, further, should the pick-up fix on towards the left of the tone-arm, looking at the front of the instrument,

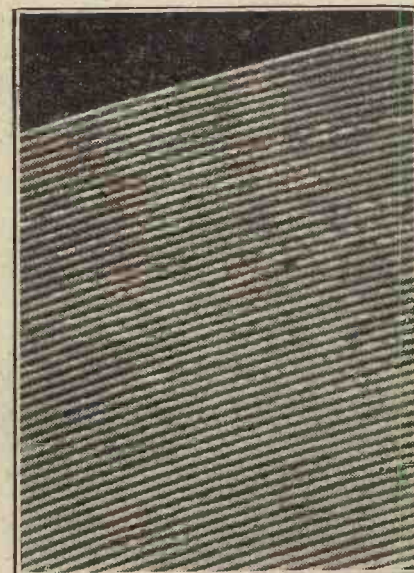

The grooves of a new record appear like this. How long they remain in good condition depends largely upon the tracking of the needle.

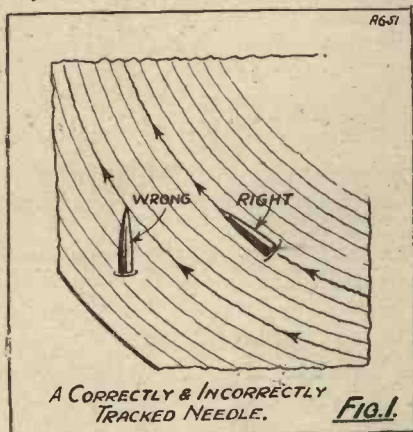

A CORRECTLY & INCORRECTLY TRACKED NEEDLE. **Fig. 1.**

question of weight has recently been dealt with and vertical angle is likewise frequently covered in various articles. But needle-track alignment has so far been explained in this supplement only very briefly, and then rather technically.

I am going to endeavour to discuss

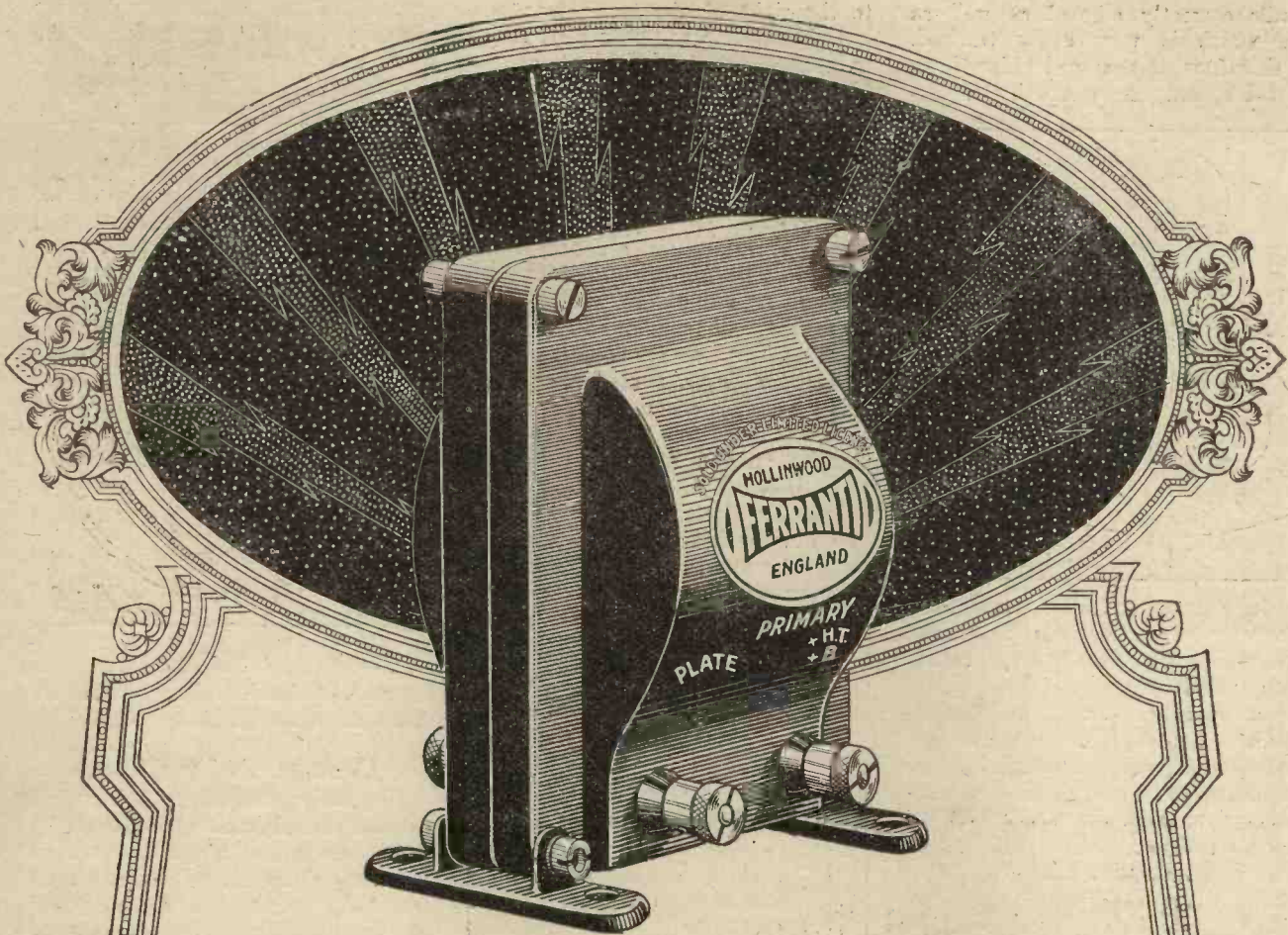

1. Ferranti Audio Frequency Transformers are definitely the most suitable for any set.
2. Valve Experts who publish instructions and diagrams for your assistance do so primarily to sell Valves, and their advice in respect of Valves is sound.
3. As Transformer Experts, we are prepared to demonstrate beyond dispute that any of the advertised sets are better with Ferranti Transformers.

*You must have a good Transformer—  
and the best is*

# FERRANTI

FERRANTI LTD.

HOLLINWOOD

LANCASHIRE

FERRANTI

needle correctly aligned as well as one which is very badly tracked. In this drawing you are looking down on the record, the wavy lines repre-

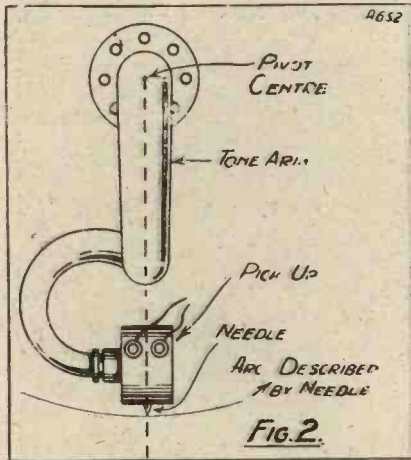

sented grooves. The arrows indicate the way the record is revolving. Everything is, of course, rather exaggerated.

I must explain the phrase "line-of-needle" before I go any further. Line-of-needle indicates an imaginary line drawn along the needle and continuing through the sound-box or pick-up and tone-arm. The needle itself obviously lies directly in this line.

**The Line-of-Needle**

In some tone-arm and pick-up combinations the line-of-needle will be found to run directly to the tone-arm pivot centre, as in Fig. 2, although in many others it will pass far to the left or right of this point. The shape of the tone-arm does not affect this line-of-needle, or, at least, I should say you should not take this into account when thinking the problem over.

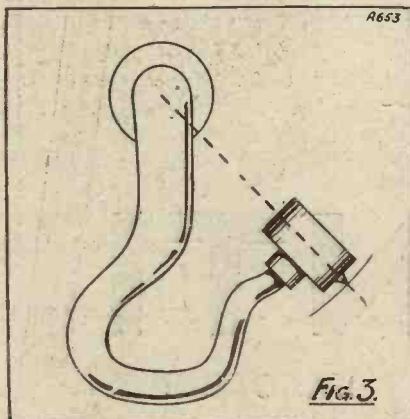

Fig. 3 shows a fantastically shaped tone-arm to which a pick-up is attached. In the ordinary course of events the line-of-needle would pass

to the right of the tone-arm pivot, but the pick-up has been bent round to make it hit the pivot centre. Not that this is necessary, I am only showing it thus for explanatory purposes.

**Path Across Record**

Now as a tone-arm swings, so the needle describes an arc across the record. The line-of-needle also (and obviously) swings as well. The needle's arc of travel need not worry us at all, what we are concerned with is the changing line-of-needle; does this necessarily mean that the needle is adapting itself to the various grooves on the record? Unfortunately, it does not.

If you refer to Fig. 4 I will show you how to judge when a needle is tracked, and we will then be able to pass on to the performances of an average tone-arm.

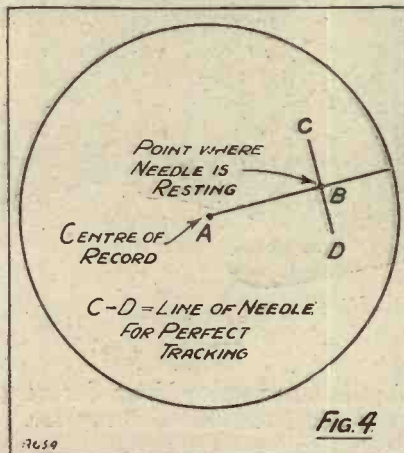

In order to discover the correct line-of-needle for any point on the record proceed as follows: Cut a piece of paper exactly the size of a record, and place this on the turntable. Make a dot at the point where the needle is resting. Draw a line from the centre of the record through this dot and another at right angles to the first line, cutting this exactly at the dot. The second line gives the correct line-of-needle.

You can proceed in the same way at any point of the needle's travel.

**Varying Angles**

Now let us get down to practical cases. Many gramophones have their tone-arms fitted at the top centre of the cabinet platform, as indicated in Fig. 5. If the line-of-needle runs back to the pivot centre and the needle point can rest on the exact centre of the record (according to common practice) then the needle alignment is about ten degrees out at the innermost

groove, fifteen degrees at a point midway in the playing portion of the record and twenty degrees out of alignment at the edge of the record. This is

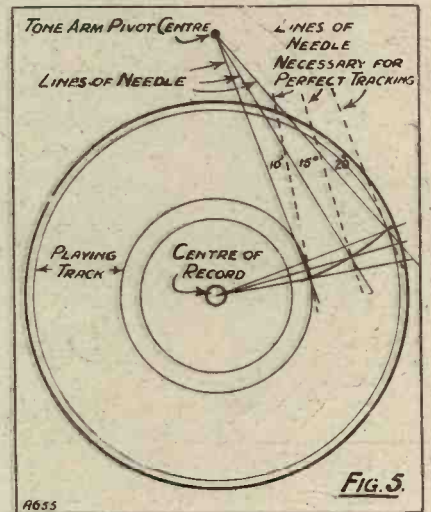

pre-supposing the use of a 7½-in. tone-arm and a certain 12-in. record. In cases the error might be worse.

**Damage Easily Caused**

Obviously, serious record damage can be caused with a needle so far out of track and reproduction must suffer. At 20 deg. a chiselling effect must inevitably result and the walls of the grooves be shaved down. From previous articles you must have learnt that a groove in the record is really a wavy line (see Fig. 1) which causes the needle to swing to and fro—were the needle at right angles to the track it could only act as a cutting point.

With the tone-arm fixed centrally as in Fig. 5, it will be seen that the

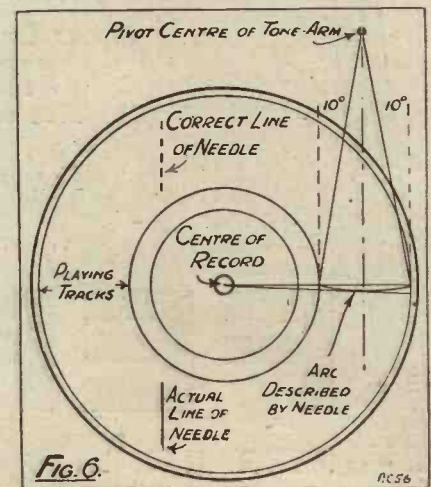

needle-alignment is definitely bad at first and gets worse towards the edge of the record. By shifting the tone-arm over to the right, as in Fig. 6, so





HIGH TENSION		
WINNER	60 volts,	7/-
WINNER	66 volts,	7/6
WINNER	99 volts,	11/6
WINNER	120 volts,	14/-
GRID BIAS		
WINNER	9 volts,	1/3

EVER READY CO.  
(G.B.) LTD.  
Holloway, N.7



*Don't forget the Battery  
for the Wireless —*

*Remember—we said  
NO MORE experiments  
WE'LL STICK TO*

**EVER READY**

*Regd*

that there is perfect needle-alignment when the needle is in the middle of the playing area of an average record, one ensures that the maximum error will not exceed some 10 deg. This error

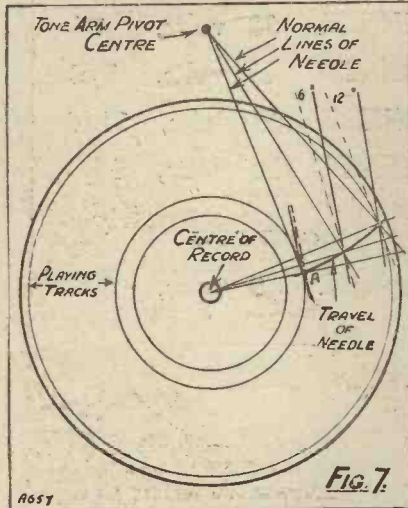

will be reached at each side and will be increasingly smaller as the needle gets nearer that central point.

But 10 deg. is too much for the inner grooves when the record is travelling much slower and the waves in the surface are closer together. Towards the outer grooves it might not matter so much, although even here tracking is vitally important, and it is also here where record wear is most noticeable.

**Decreasing the Error**

You could decrease the error by lengthening the tone-arm, but this is not always a practicable proposition. You may find this shifting of the tone-

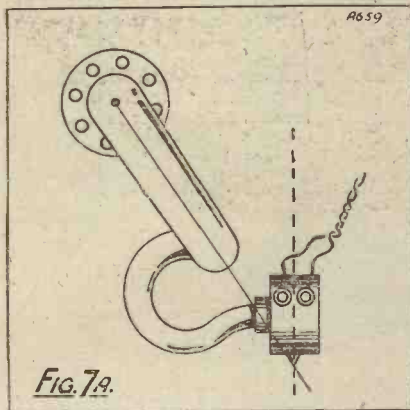

arm gives you the best results, but there are other things which can be done.

Let us go back to a central tone-arm mounting (Fig. 7). Supposing we arrange things so that the tracking is perfect at the innermost groove. Then it gets gradually worse towards the outermost grooves, and as the needle normally travels it is rather

bad to start with and gets better as it travels towards the centre. This is working the right way, and if we must have an error, then let us have it as small as possible, and towards the edge of the record.

With a 7½-in. tone-arm a maximum error of about 12 deg. results, and this is not too bad. It would be less were the tone-arm longer.

Now, how can we alter the line of needle so that it corresponds with perfect alignment at the point "A"? Well, we could bend the pick-up round, as at Fig. 7A. But, in the majority of cases, this would mean bending the tone-arm.

**A Better Method**

Another plan, and a better one, is to shift the pick-up over by using an adaptor, as at Fig. 8. If it can be brought over so that needle point is 1½ in. to 2 in. out of line with the tone-arm to the right.

It may be that you have your pick-up as nicely tracked as possible already, in which case the foregoing remarks will operate as confirmation.

Many tone-arms have out-of-centre goose-necks or out-of-line over-to-the-right sockets, but many operate correctly only when certain specified sound-boxes are used. Your pick-up may, as I have said before, throw things right out. But you can easily detect the degree of error by applying the simple geometry indicated.

be able to gauge this by watching the paper label and fixing on some point on it nearest to the point of greatest swing. If necessary you can

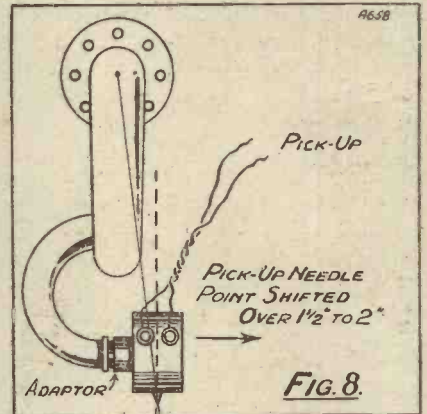

slow down the gramophone in order to do this.

Then draw a thick line in pencil or with a pen on the paper label from the centre hole outwards exactly in line with this movement. Then with a moderately small round file the central hole should be enlarged in the direction of that line so that it takes an oval character. The enlargement should correspond with the degree of swing. If the tone-arm is swinging out by as much as an eighth of an inch, as closely as you can judge it, then the hole should be enlarged in that one direction by half that degree.

**CURING SWINGING**

A SWINGER is a record whose central hole is not accurately placed. This fault can always be spotted if you carefully watch the sound-box of a gramophone as the record is being played. This will sway backwards and forwards to each revolution of the turntable. The movement may be as much as an eighth of an inch or more in bad cases. The effect on the reproduction is that the pitch of the sound rises and falls. The misplacement of the hole is caused by wearing of the die during the production of the record.

It may be that you have been loaded with some swingers in the past and have put them aside in disgust. But you can cure the swinging trouble in quite a simple manner. A note should be carefully made at which point on the record the sound-box swings out farthest. You will easily

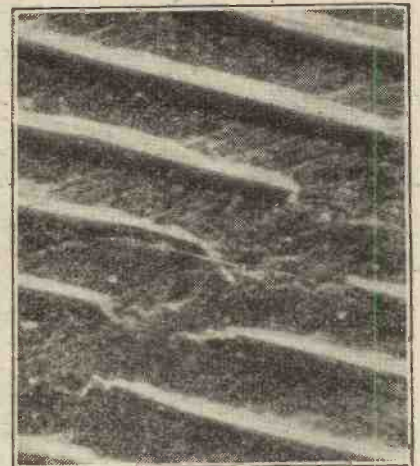

The result of bad tracking. The walls of the record (magnified some 300 times) have been broken down.

A very slight enlargement of the hole may be all that is necessary. When you want to play the record place it in position and then press it over as far as you can in the direction opposite to that of the mark on the label. Owing to its weight and the friction of the material on which it rests it will maintain this position and then play correctly.

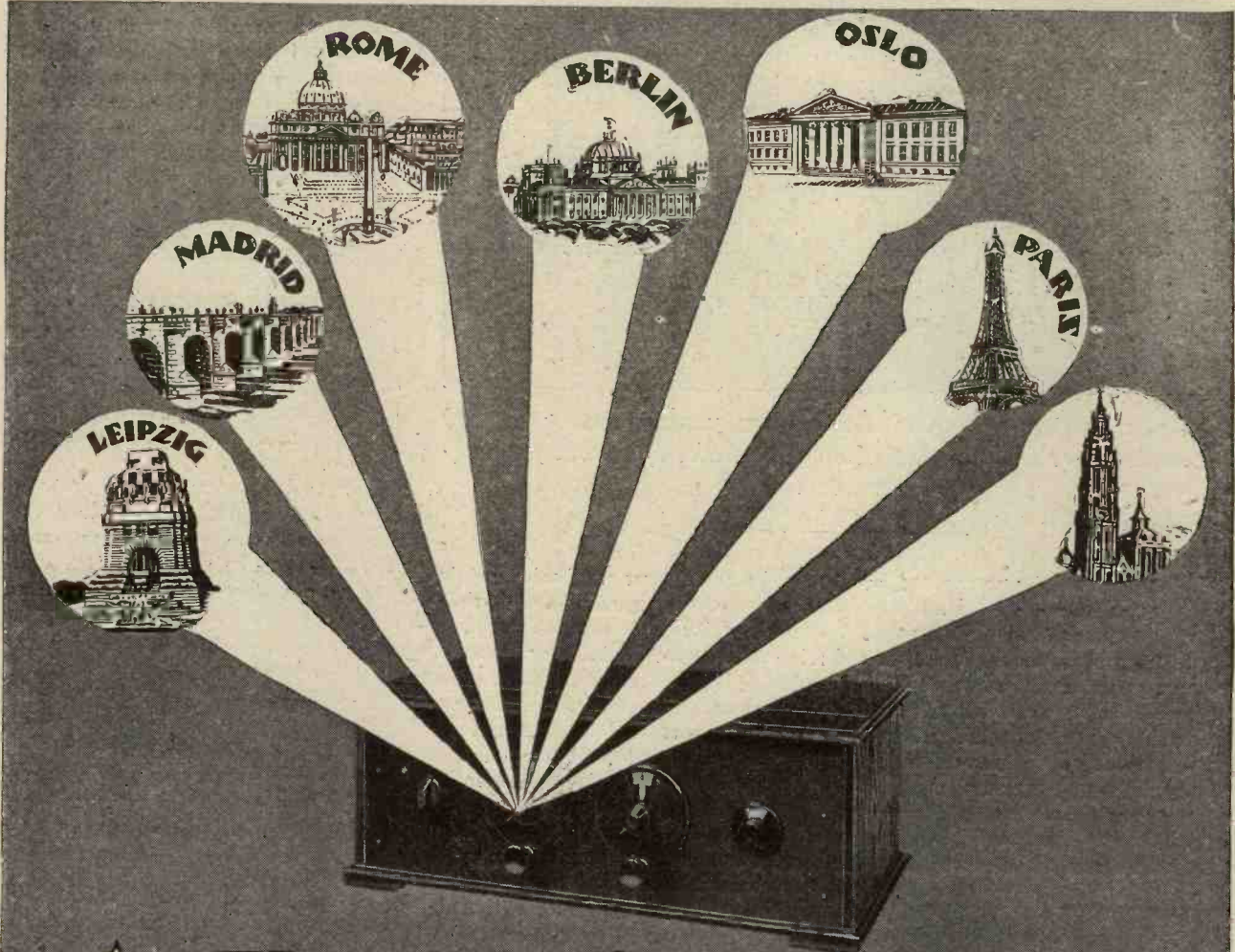

Throw the Searchlight  
 on Foreign Stations with  
**SIX-SIXTY'S**  
**GREAT MYSTERY RECEIVER**



No longer a mystery, Six-Sixty's great new Receiver has proved itself the very finest of the popular home-built sets. Dozens of European programmes searched out and brought in every night—no interference between them—the tone noticeably pure—the volume ample for any room. The Six-Sixty valves are carefully matched to promote supreme efficiency—and remember, **the extra valve makes all the difference.**

*Fill up this coupon and learn how to build and use this marvellous set. So simple you can't go wrong.*

**SIX-SIXTY RADIO COMPANY,**  
**122, CHARING CROSS ROAD, LONDON, W.C.2.**

To **SIX-SIXTY RADIO COMPANY,**  
 122, Charing Cross Road, London, W.C.2.  
 I am interested in this Set. Send me all constructional details, please.  
 Name .....  
 Address .....

M.W.1.



*When you want a new record how do you go about your purchase? This article gives some useful advice on the choice of records for pick-up work.*

*By G. W. EVANS.*

**W**HEN you want a new record for your pick-up reproducer how do you go about getting that record from the many that are available at the dealer's shop? Do you just decide upon an item and go along and say: "I want so-and-so," hear the record and bring it home, do you keep to one particular make of record, or go through all the makes that contain that particular item before you make your choice?

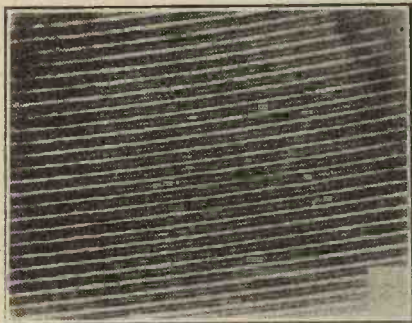

This record is in good condition—compare it with the photo in column 3.

I always do the latter. When I want a new record, whether it be vocal, orchestral, organ, whatever the item, I go along to my local dealer and say: "I want such-and-such an item. Who has recorded it?" He will probably say: "H.M.V., Columbia, Parlophone, and Brunswick; two of them organ and the other two instrumental." I then say: "Let me hear them all, if I may," and we proceed with the test.

**Be Careful**

Now this is where you have to be very careful. In the first place you will probably find that the record is played upon one of the latest H.M.V. or Columbia gramophones. These, it

must be noted, over-emphasise certain portions of the musical scale, while they may give quite a false idea of the force and punch behind any record.

I have heard records played on some of the best gramophones which have been very loud and almost blatant which, when tried at home on the pick-up, have been quite moderate in strength and without any suspicion of brassiness or harshness anywhere in the record. Others I have heard which have been apparently quite satisfactory on the gramophone but have been practically hopeless when put upon the ordinary set with the pick-up.

**Four Features**

So when I go to the shop and ask for a record and listen to the test, I listen particularly for four main features. First, whether there are any real bass notes trying to come out through the gramophone—which you must remember will not reproduce bass notes of any really great depth in anything like their true tone; next, whether there are any high notes being smothered by the general tone of the instrument; then whether there are any portions on the record inclined to chatter; and, finally, whether there is any background hiss and, if so, to what extent it is noticeable.

I have heard good music, especially organ music, absolutely ruined by the background hiss which went on the whole time.

So when you go along to your dealer's for a new record, hear all the records that have been made of any particular item you like and note the various points of each. Avoid those records which come out with sudden

blares which cause the gramophone needle and sound-box to chatter, and also avoid those which have any serious background of hiss. If the hiss is noticeable to any great extent on an ordinary gramophone you may rest assured that unless you have a particularly efficient scratch filter it will be more noticeable on the pick-up, especially on the soft passages. And such records should be avoided.

**Listen for Bass Notes**

Above all, listen to those bass notes. If you listen attentively you will find out when the gramophone is giving bass and when it is merely manufacturing a sort of imitation bass on its own.

The real bass will come through occasionally behind all the mellowness and general tone of the gramophone, and if you can hear it coming through you may rest assured it will come through even more when you try it at home on your pick-up.

If there is no sign of bass, but just ordinary medium tone in the record, provided, of course, that the piece being played should include some deep bass notes, then you should try another make of record to see if that will give you a better reproduction of the lower frequencies.

You must not be taken in by the wonderful reproduction given by any of the proprietary gramophones. They are specially designed to give the best on the record, but you must bear in mind the fact that that record you are buying is for use on a pick-up, and those points which you know your pick-up emphasises and brings out best must be looked out for on the record, otherwise when you get it home you may be very disappointed and surprised that the reproduction you get is nothing like that you heard at the shop.

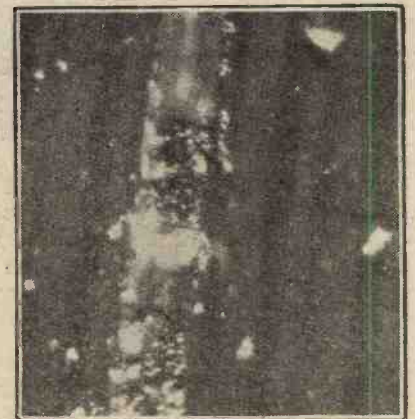

Highly magnified view of part of a record track which has completely broken down. This causes bad "blasting."

# MAZDA

THE NICKEL FILAMENT

# VALVES

Made in  
England.  
All  
British  
Labour



Made at the same  
factory as the  
Mazda Lamp.....  
the Mazda Valve  
has the same  
wonderful organ-  
isation behind it.  
Mazda Valves  
are the world's  
latest and best.

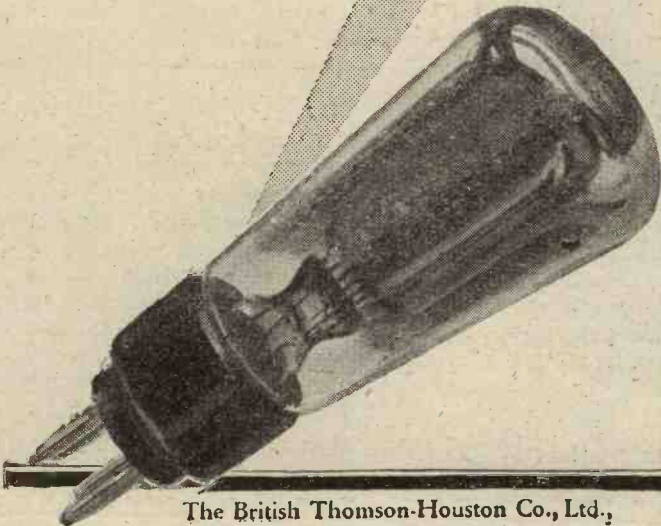

The British Thomson-Houston Co., Ltd.,

3106

# YOUR XMAS PROGRAMME

Make your gramophone records—electrically reproduced—augment your radio set to form the ideal programme this Xmas.

By A CORRESPONDENT.

I WONDER how many of my readers realise that if their receiver is capable of giving good gramophone reproduction as well as radio reception they have an almost unlimited possibility of providing the ideal Christmas programme?

Naturally enough the B.B.C. will do its best to provide a suitable programme for Christmas, but it is impossible for one concern to satisfy everybody, and if you have a set which will reproduce your gramophone records with anything like realism you can adapt that programme to your own needs.

## The Ideal Programme

Suitable as a programme of Christmas carols or dance music may be during the festive season, it is not always acceptable by everyone or by every group of people. You may be having a little party of your own, and may want to dance when the B.B.C. is sending out carols, or you may prefer some ordinary light variety when the B.B.C. is sending out dance music. You cannot blame the makers of the wireless programmes. They do their best to satisfy the majority, but if you want to get the best possible musical programme during the Christmas season you must turn to your Radio-Gram receiver.

Just switching on the radio, then going to the gramophone, back to the radio, and then back to the gramophone again, and so on, in a haphazard sort of way, however, is not good enough. This will more than likely bore your audience and be far worse than leaving the radio set switched on and taking whatever the ether likes to give you.

## Carefully Thought Out

If you want to turn out a really good programme this must be carefully thought out beforehand, and then adapted according to the likes and dislikes of the assembled company. But it must be put through smoothly and without long waits, or grunts from the speaker, as it is switched on and off.

Nothing is more irritating to an audience than to hear a gramophone record, and then be switched suddenly on to radio which is in the middle of a song, or just sending over the last few blasts from a band.

If you switch over from the gramophone to radio you should listen yourself to the radio before you put it through to your audience, and make sure that you are at the beginning of an item, and that that item is of interest.

Watch your times very carefully, and see that if a particular item starts at a quarter past nine you do not suddenly switch it on at seventeen minutes past nine and arrive near the middle of it, having to take it off hurriedly and go back to the gramophone once again.

A great deal can be done with a suitable choice of records if the programme is mapped out carefully beforehand, and that programme should be adhered to as far as possible. Having the records you choose, get

them in order in a pile and work steadily through that pile as required, punctuating the various record numbers with suitable bits of radio music or entertainment according to the published programme.

If the set is in a different room from the speaker, it is also a great improvement to have a small microphone on these occasions, so that after any item, whether it be radio or gramophone, especially if the former is not announced at all, you may make your own announcements to your guests.

## Announcing Items

It is very annoying to have a gramophone record put through and not to know what the number is called, and still more annoying to have to search through your pile to let your listeners know what it was when someone asks you later on.

Somebody is sure to say: "That was a nice thing you played just now—not the last record, but two or three further back." Then you find you cannot remember and have to go and hunt it up, hoping you get the right one. Someone probably tries to hum the tune, and this attempt may not always be recognisable, and so you get a little hitch in the programme.

It is much better to have a little microphone or a substitute which will act as a microphone, placed in parallel via a switch with the pick-up circuit, so that you can switch over from the pick-up to the microphone and then switch back to the pick-up and get along with the record.

And, finally, do not forget to have all your batteries well up, a good stock of records, a reliable radio programme guide, and one or two spare valves. If you do all this I feel quite sure you will have a really merry Christmas!



NOT THIS XMAS.

An idea of how far gramophone reproduction has advanced can be obtained from this photo of an old "original"—the Edison Bell phonograph of thirty years ago.



# PICK-UP CHATTER

*The noise direct from the needle and pick-up mechanism is often difficult to eliminate. The following ideas and details will be of interest to radio-gram listeners.*

By KEITH D. ROGERS.

**N**UMBERS of readers have written in to MODERN WIRELESS to ask if there are any means by which the chatter of the pick-up itself can be rendered less obtrusive. Apparently great numbers have been using pick-ups on portable gramophones which have no lids, or upon ordinary machines which have badly fitting lids, and have also been using the pick-ups on ordinary tone-arms.

What happens is that the chatter from a pick-up itself is audible either through the lid, or straight off the pick-up if no lid is fitted to the gramophone, and also a certain amount of chatter is magnified through the tone-arm and sound conduits and comes out in the usual way.

## Reducing Noise

One method of reducing this is to plug the tone-arm with cotton wool, keep the horn part of the gramophone shut, and to keep the lid shut and to line it with felt. Even so, with the majority of pick-ups the chatter is so great that on loud passages it will be



A sound-proof cabinet specially designed for pick-up work. Note the terminals for pick-up and "earth."  
(Made by Beagley and Musto.)

audible several feet away, even when the lid is shut and when felt is used.

Unfortunately, in very many cases the better the pick-up the more will it chatter, although one must admit there are exceptions to this rule as there are to any other. So the best

way to tackle the problem is to do so away from the pick-up itself and to mount the pick-up in a really sound-proof chamber.

Although gramophone reproduction via valve amplifiers and radio sets has been generally used for many months now, I have only come across one firm which fully caters for the man who wants to use a pick-up outfit in preference to his ordinary gramophone. This firm has been very carefully watching the progress of gramophone reproduction, and has incorporated many of the ideas which seem to be essential for providing really silent pick-up running and satisfactory operation generally.

In the first place, the firm markets a gramophone of the table type at a reasonable range of prices, and including either a single-spring or double-spring motor and a sound-proof lid. This lid is "rabbited" all the way round, and while the whole gramophone is made of half-inch wood, which can be reckoned as pretty soundproof, the lid dips down into the well of the machine all the way round, even at the back where hinges are, and forms an absolutely soundproof chamber.

## Quite Inaudible

Even with the noisiest pick-up you can only just hear it working on a noisy record if you put your ear right up against the lid of the gramophone. As far as the chatter problem is concerned, this method seems to have solved it.

Now, as far as the weight problem of pick-ups is concerned, this firm supply with the machine a special adjustable tone-arm of very simple construction, and fitted with a removable spring which can be altered not only in tensile strength, but its leverage can be adjusted to suit any pick-up.

The tone-arm, or rather pick-up arm, is a handsome piece of work, is very well balanced, has no end-play whatever, although the movement

"across" the record is perfectly smooth and easy.

It is hollow and takes the wire from the pick-up right down through the platform to two terminals fixed at the back of the gramophone. So there is no trouble about leads coming out through holes anywhere, and in addition an extra terminal marked "earth" is provided, which is connected internally to both the tone-arm and the motor, so that the whole of the metal mechanism of the instrument can be earthed—a very useful point where many sets are concerned. I have come across several cases of howling due to the fact that neither tone-arm or motor has been earthed.

## A Useful Feature

A further feature is a ring of wood underneath the turntable close to the edge, and this prevents needles and the like from getting underneath, a trick they are always fond of doing.

Any pick-up can be fitted to it, a little adjustable pick-up holder being provided on the arm, so that the instrument is practically universal.

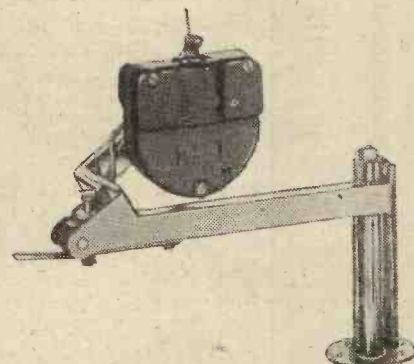

The "Beamu" pick-up carrier—an ingenious and efficient piece of mechanism—sells for 10s. 6d.

The cabinet can be either of oak or mahogany, or of a cheaper wood covered with black leatherette, and is of first-class workmanship.

It is rather refreshing to find a firm that has gone into the problem really seriously, and has not been satisfied with letting the amateur get on with the business as best he can on his ordinary gramophone.

But I must not forget to mention the name of the makers of this machine, known as the "Beamu" Drive, who have a factory on the outskirts of London and showrooms at 47, Cranbourn Street, London, W. The name of the firm is Messrs. Beagley & Musto, and the price of the "Beamu" is extremely reasonable, according to model, and is complete with pick-up arm.



EVERYTHING *The* **G.E.C.** ELECTRICAL  
*Your Guarantee*

## For Xmas Gifts

Two suggestions from the wide range of GECOPHONE Receivers & Loud Speakers

# GECOPHONE

Registered Trade Mark

## VICTOR 3

MADE IN ENGLAND



**PRICE**  
including  
**ROYALTY**  
and  
**OSRAM**  
**VALVES**  
**£6.17.6**

What better Gift could you choose than the "VICTOR 3"—the wonderful set which in so short a time has sold in thousands and has become the talk of the world of wireless!

It is an attractive, strong, compact set and is sold at the truly amazing price, for a three-valve set, of £6 17 6, including ROYALTY and OSRAM VALVES.

—or this popular  
**GECOPHONE**  
**Cabinet Cone**  
**LOUD**  
**SPEAKER**

The Loud Speaker that sets a standard—a beautiful instrument whose handsome appearance is befitting to its purity and refinement of reproduction.

Cat. Nos.: B.C. 1690 (Solid Mahogany), B.C. 1692 (Solid Oak).

**PRICE**  
**£5 10 0**



MADE IN ENGLAND.

Sold by all Wireless Dealers.

# Specified for the new Master 3



*Recognition of efficiency*



Here we show the Colvern Combined Wave Coil in the new Mullard Master Three\* as well as a view of the ingenious switch concealed in the base.

## The Colvern Combined Wave Coil gives selectivity and volume

THE fact that coil-changing is dispensed with in The New Mullard Master Three is the outcome of the specially designed Colvern Combined Wave Coil specified. Its high efficiency is entirely due to skilful manufacture on the one hand and efficient design on the other.

Each coil is tested before despatch in a duplicate New Master Three Receiver in order to ensure that it functions exactly in conformity with that used in the original receiver. This is your safeguard and you are advised to adhere to the author's specification.

17/6

# COLVERN

## ACCURATE SPACE WOUND COILS

Advertisement of Colvern Ltd., Romford, Essex



## RECENT RECORD RELEASES

### Broadcast

THE Vocalion people have kept a good eye on Christmas this year, and have brought out a number of light and "Christmassy" items. A couple of carol records, including *O Come All Ye Faithful* and *While Shepherds Watched*, on X1, by the Festal Choir, need mention.

The Rev. Pat McCormick, the popular successor of Dick Sheppard at St. Martin's-in-the-Fields, has made a couple of records entitled, *A Message of Happiness*, on X4; while the inimitable Mabel Constanduros has come to the fore with official Christmas fare in two Buggins items: *Mrs. Buggins Makes the Christmas Pudding*, and *The Bugginses Prepare for a Party* (X6). She is assisted in these by Michael Hogan, another radio favourite, who takes the part of Father Buggins.

Among the dance numbers there are many delightful little items, notably *My Inspiration is You* and *My Angel*, by Ramon Newton, with Dance Band accompaniment (310). *The Rag Doll* (F.T.) and *Roll Away Clouds* (F.T.), by Harry Bidgood and his Broadcasters. *Lucky in Love* (F.T.) and *I'm Sorry* (W.) (306), by the same band, are also good. Ciro's Club Band have recorded, among others, *I Can't Do Without You* (W.), on the other side of which is *He's Tall and Dark and Handsome* (F.T.), by Harry Bidgood and Co. (309).

The Broadcast Twelve are, it seems to us, mainly of a religious order. Two outstanding discs this month are *The Bridal March* (Lohengrin) and *The Wedding March* (Mendelssohn), played by Allan Brown, F.R.C.O., on the City Temple Organ (5028), and two West-

minster Choral Society items: *Lift Up Your Heads* and *Worthy Is The Lamb* ("Messiah") on 5026.

### H.M.V.

Most interesting among the recent H.M.V. records must be mentioned a new Chaliapine recording of Schubert's *Death and the Maiden* and *The Wraith*. Both are perfect recordings and we can recommend music lovers to get these items. They are on the 8s. 6d. red-label series and are listed as D.B.1184.

Of the lighter music the *Valse de Concert* (Op. 47), by Glazounow, played by the San Francisco Symphony Orchestra, can be well recommended. It affords a good test of a pick-up outfit, being rich in bass notes and yet prominent at times in the "fiddles." Recorded on D1492.

*Ocean Thou Mighty Monster* (Oberon), D1504, forms a two-part record by Florence Austral and the Royal Opera House Orchestra at Covent Garden, while *I Can't Do Without You* and *The Dance of the Blue Danube* (Cinema Organ), Jesse Crawford, is an excellent light piece of recording. (B2833.)

### Parlophone

The records which strike us most this time in the Parlophone list are two tangos, which are excellently done and give us the real thing. The whole recording was done in Buenos Aires, the home of the tango. Among the dance items, therefore, must be mentioned the following: *Caido del Cielo* and *Queja Indiana*, with *Araca* and *Barrio Reo* (Tangos), by Orquesta Tipica Francisco Cararo at Buenos Aires (R210 and R209.)

Another delightful item is *Just Like a Melody* and *Because My*

*Baby*, by Joe Venuti and his Orchestra (R201)—a clear-cut really good recording.

Also the well-known Goofus Five give us another disc that is sure to be popular—*Borneo* (F.T.) and *Mamma's Grown Young* (F.T.) R203.

### Pathé

The record that most appeals to us of all the excellent Pathé Actuelles and Pathé Perfects that we have heard this month is the *Golliwog's Cake Walk*, by Debussy. This is recorded and rendered in excellent fashion and with a brightness and clearness that it would be almost impossible to improve upon. The side-drums come out with that crispness that one hears in real life and not with the indistinct woolliness that is so typical of many recordings. An excellent piece of work and one that should be heard by all.

We did not like Mistinguett, on the smaller Actuelle—she was harsh and not at all clear.

The dance records by Pathé Perfect are all good—these 1s. 6d. records keeping up their standard in a remarkable manner.

### Zonophone

A large number of good records can be counted upon every time the Zonophone people issue a list, and this latest is no exception. Outstanding numbers are a further "Vocal Gems" recording of Gilbert and Sullivan operas, a National Symphony Orchestra double disc, and a number of light items, such as selections by the London Orchestra, Clarkson Rose, Maurice Elwin, etc.

The Vocal Gem this month is from the Mikado (Pts. 3 and 4) (A344), while the National Symphony Orchestra gives us *Orpheus in Hades* (2 Pts.), by Offenbach. (A346, double-sided.)

Of the London Orchestra selections we prefer *That's a Good Girl*, which is an excellent recording, the part taken by the organ coming out extremely well. (5186. 10 in.)

Clarkson Rose sings: *The Pink Plant Pot* and *More Than Anybody* (5197), while Maurice Elwin gives us *My Inspiration is You* and *A Kiss Before the Dawn* (5196). Both these 10-inchers are excellent.

We hope to discuss the British Brunswick release next month, as they did not arrive in time for us to comment upon them in this issue.

★ ALL-ELECTRIC ★

For working entirely off the Electric Light Supply

3 valve set complete \* for less than £21

4 valve set complete \* for less than £26

(\* Everything necessary except Loud Speaker)

Low in cost because of their simplified design these two Met-Vick Receivers give a high quality performance comparable with the well known Met-Vick de luxe Five Valve Mains Sets.

They embody Met-Vick A.C. Valves, A.N.P. Coils, and moulded resistances, and employ resistance-capacity couplings.



**MET-VICK  
3 VALVE A.N.P. SET**

A delightful little set suitable for Loud Speaker reception from the local station and the two Daventry stations, and also, under favourable conditions from several Continental Stations. An excellent set for the alternative programmes.

**PRICES**

with short and long wave coils (including Royalties)

£20 17 0  
List MS 4735

£20 10 6  
List MS 4742

£13 17 0  
List MS 4736

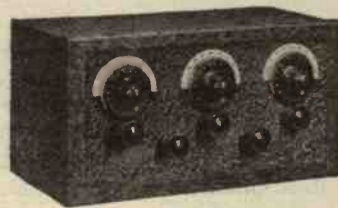

**MET-VICK  
4 VALVE A.N.P. SET**

An "All Necessary Performance" Set capable of giving ample volume and good quality, from the local stations and the two Daventry Stations, and Continental Stations at good volume free from interference. A remarkably selective set.

**PRICES**

with short and long wave coils (including Royalties)

£25 14 6  
List MS 4738

£25 10 0  
List MS 4742

£18 9 6  
List MS 4739

The following specifications include everything necessary except Loud Speaker.

With Met-Vick A.C. Valves (2 or 3 A.C./G and one A.C./R) complete in Fabric Cabinet and with a 'Met-Vick' model 'B' L.T.-H.T. & G.B. Eliminator for A.C. mains operation.

Similar but for D.C. mains operation with "Met-Vick" Model "B" H.T. & G.B. Eliminator and separate L.T. Eliminator.

Similar but with S.P. 2 volt Valves for Battery operation, complete with 2 V. 30 amp. Accumulator, 120 V. H.T. Battery and 9 V. Grid Battery.

For A.C. Mains or Battery operation Kits of component parts are also supplied for home constructors. List 7117/2.3.4.5.

**MET-VICK**

Mains Operated Sets for Satisfaction

Ask your dealer for particulars of the Set which interests you, and, if desired, for details of convenient hire purchase terms, or write:—

**METRO-VICK SUPPLIES LIMITED**  
155 Charing Cross Road, London, W.C.2.

For the Met-Vick Five Valve Sets for D.C. & A.C. Mains operation ask or send for List M.S. 4740.

For the Met-Vick Five Valve Sets for Battery operation ask or send for List MS 4741

# RADIO ABROAD



## Station Power

**T**HE power of radio broadcast stations is often referred to very loosely by the public, and this has called forth comment from Mr. O. H. Caldwell, of the United States Federal Radio Commission, who considers that all stations ought to be rated in terms of horse-power.

One of his reasons for this suggestion is that he thinks uninitiated people are apt to get a very wrong impression of the actual power used by a comparatively powerful transmitting station, and consequently they are apt to think that power stations may interfere with atmospheric or other conditions. A large station like W E A F or K D K A, which are both 50-kw. transmitters, is not really formidable he says, as compared with a fairly large 7-seater motor-car, which consumes somewhere about the same power.

When the thing is translated into terms of horse-power and we realise that a station is using only 60 to 70 horse-power, it gives a very different idea.

## Indian Broadcasting

The Indian Broadcasting Company seems to be full of troubles. It is not so very long ago that Mr. Eric Dunstan, a popular member of the B.B.C. staff, went over to take charge of the Indian broadcasting organisation and carried with him the cordial good wishes of his many friends in this country. He has, however, had a constant struggle against difficulties, not the least of which has been the lack of adequate finance.

## Programme Troubles

Early in the present year Mr. Dunstan returned to England for a short period in order to see if he could raise the further funds required for the proper operation of the Indian Broadcasting Company. Finally, owing to the fact that the funds are still inadequate and that the programmes are suffering in consequence, with a resulting decline in popular interest, Mr. Dunstan and other European members of the staff of the Indian Broadcasting Company have resigned.

This is a great pity, and it is to be hoped that the necessary money and other facilities will soon be forthcoming for the establishment of Indian broadcasting on the basis which it obviously deserves.

## Eindhoven

The new short-wave station at Eindhoven which is working on a wave-length of 41.3 metres, is specially adapted for communicating with amateur stations throughout the world.

The station has been operating for some little time and reports have been received from short-wave experimenters in various parts of Europe. According to these reports, excellent reception has been obtained and the station is proving of great value and interest from the experimenter's point of view.

## Sunday Concerts

In this connection, listeners will now be able to hear a special Sunday evening programme broadcast fortnightly from Hilversum. These concerts are intended to bridge the gap—which has been much complained of—in the B.B.C. programmes on Sunday evenings between 5.30 and 8 p.m., and are being provided by arrangement with Messrs. Brandes, Limited, the well-known radio manufacturers.

The programmes consist of orchestral selections directed by De Groot. The transmissions are made on a wave-length of 1,071 metres, and any views, criticisms or suggestions in connection with the same will be welcomed by Messrs. Brandes, Limited, at Cray Works, Sidcup, Kent.

## Power Line Dangers

You will remember that not so very long ago a fatal accident took place in this country in which a radio listener was electrocuted. Although, happily, such fatalities are exceedingly rare—there have not been more than two or three since broadcasting began—one has occurred recently at Lakeside, Ontario, Canada, a Mrs.

## THE LAUSANNE BROADCASTING STATION

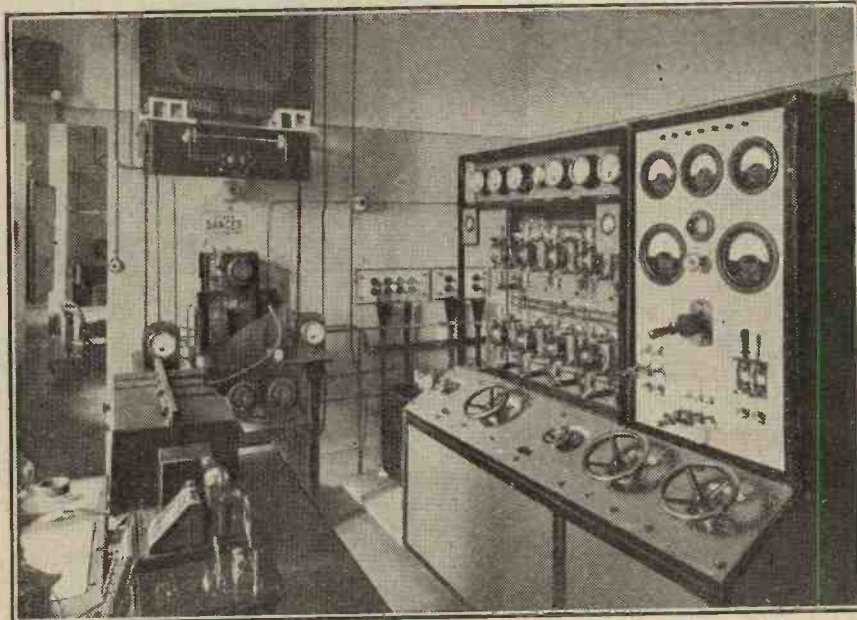

A photo sent by a reader who visited the station a few weeks ago. The control room is shown. In the left foreground is the 5-valve microphone amplifier, on the right being the six modulating control valves, the three oscillating valves and the sub-control valve. In the background is the H.F. tuning apparatus.

Messrs. Philips Lamps, Limited, of 145, Charing Cross Road, London, W.C.2, who are interested in this matter, request that any experimenters who hear the above-mentioned station should communicate with them, giving a concise report of the reception obtained.

Legault having been electrocuted in switching off the electric light whilst she was wearing the radio headphones. It turned out that the aerial had come into contact with a municipal 2,000-volt power-line, and at the inquest a jury in Montreal returned a

(Continued on page 706.)

**UNCANNILY  
REAL!**

**THE LATEST  
& GREATEST!**

**M.P.A. DUAL INDUCTANCE  
IS MOVING COIL  
REPRODUCTION  
WITHOUT ITS DISADVANTAGES**

Entirely self-energising! Requires neither accumulators, mains, special valves, nor transformers. Built on a new principle exclusive to M.P.A! Hear it at your Dealers! You cannot fail to appreciate the extraordinary superiority of the M.P.A. Dual Inductance Speaker. "IT GETS THE BEST FROM YOUR SET"—any set, even a two valve receiver. Its volume, clarity and mellow beauty of tone make it the most remarkable "loudspeaker" value obtainable.

Price . . . . . 7 guineas

Other M.P.A. Models include the Popular Plaque, 29/6; De Luxe Plaque, 47/6; Table Grand Speaker, 5 guineas; Table Cabinet Speaker, 54 17s 6d; Moving Coil Speakers from 10 guineas; and the "Octroda" 8-Electrode Self-Contained Stationary Set, 12 and 17 guineas. For Irish Free State prices write Brown Bros. (Ireland), Lower Abbey Street, Dublin, C.8. All Wireless Dealers Stock M.P.A. Products.

*The M.P.A. WAY—Products to the value of £5 and over can be obtained on Hire Purchase Terms for £1 down*

**M.P.A.**

*Hearing that is  
Almost Seeing*

Dept. 10, M.P.A. WIRELESS LTD.

62, Conduit St., London, W.1. Tel.: Gerr. 6844-8

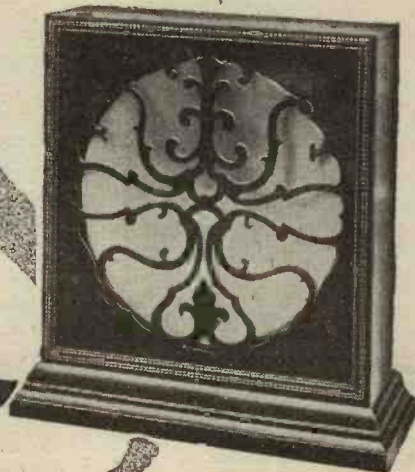

Streets

# In Our Test Room



*New R.I. and Varley Components—New Ediswan "R.C. Threesome"—New Met-Vick Device—Catalogues recently reviewed, etc., etc.*

## New R.I. and Varley Components

WE have been waiting a long time for such a component as the new R.I.-Varley Bi-Duplex transformer. This remarkable L.F. transformer is capable of handling up to 20 milliamperes before saturation troubles start occurring. How valuable this component is will be seen from the fact that many ordinary L.F. transformers saturate at something around 3 milliamperes.

This new Bi-Duplex transformer has a ratio of 3 to 1 and a low D.C. primary resistance. It can be used in an ultimate stage when a power valve is employed preceding it, for even when it is carrying 15 milliamps the frequency response curve is practically a straight line between 50 and 3,000 cycles, rising only a little between 3,000 to 6,000 cycles.

It is, of course, a large component, although not ungainly. It is square in shape and its plainly marked terminals are widely separated. It is



The R.I. and Varley Bi-Duplex L.F. transformer, which can handle up to 20 milliamps.

completely enclosed in a frosted black metal covering. The price is 27s. 6d. and, in the circumstances, this is very reasonable. Its arrival will certainly give a further fillip to transformer coupling. Carefully tested in a powerful set using power and super-power valves, the results were above criticism. High amplification could be achieved and the valves fed to their capacity without ill-effects.

Manufacturers and traders are invited to submit for test purposes radio sets, components and accessories to the "Modern Wireless" Test Room at Tallis House, Tallis Street, London, E.C.4. Under the personal supervision of the Technical Editor all tests and examinations are carried out with the strictest of impartiality.

Readers can accept the Test Room reports published monthly under the above heading as reliable guides as to the merits and demerits of the various modern productions of the radio industry.

## Universal Power Transformer

Another interesting R.I.-Varley transformer we have recently had on test is the Universal power type. Suitable for inputs of 200 to 250 volts at 40 to 100 cycles, an H.T. output of 250—0—250 is obtainable together with an L.T. of 5 volts 2 amps., 4 volts 6 amps., or 8 volt at 5 amps. This again is a most substantially built article, and can be thoroughly recommended to mains units enthusiasts.

The new R.I.-Varley aperiodic tuner covers wave-lengths between 265 and 600 metres, and between 1,200 and 2,000 metres, when tuned with a .0005-mfd. variable condenser on a standard aerial. Easily mounted on the panel of a set the reaction has a slow-motion control, readings being

discernible through an aperture revealing a hair-line and a scale in black and red showing respectively negative and positive positions of the reaction coil.

## An Easy Wave-Change

A substantial switch at the bottom of the dial enables the wave-change to be carried out. The tuner in effect is a solenoid coil of most efficient design. Ample selectivity is provided through auto-coupling in the aerial. Reaction control is completely successful over both wave-length bands. For such a well-made and useful device, 25s. appears to us to be a wonderfully attractive price.

## New Ediswan "R.C. Threesome"

Messrs. Ediswan recently introduced two entirely new "R.C. Threesome" designs. It will be remembered that the original "Threesome" consisted of a Det.-2 L.F. resistance-coupled throughout and employed plug-in



This Universal power transformer has both H.T. and L.T. windings.

# ANOTHER LEWCOS ACHIEVEMENT!

## **SUPER** SIX-PIN COILS with interchangeable **PRIMARIES** FOR ORDINARY VALVES OR **SCREENED GRID VALVES**

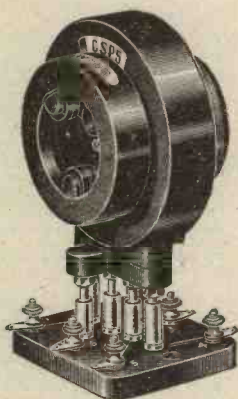

PAT. NO.  
271,384

### AERIAL COIL

250-550 metres (Ref. C.A.C.5) Price 10/6  
1,000-2,000 metres (Ref. C.A.C.20) „ 12/6  
Interchangeable reaction coil (if required) 3/- extra.

### H.F. TRANSFORMER

250-550 metres (Ref. C.S.P.5) .. Price 10/6  
Interchangeable Primary Coil 3/-  
1,000-2,000 metres (Ref. C.S.P.20) Price 12/6  
Interchangeable Primary Coil 4/-

# LEWCOS (REGD.) SUPER COIL

*Obtainable from all dealers and*

**THE LONDON ELECTRIC WIRE  
COMPANY AND SMITHS LIMITED,**  
Church Road, Leyton, London, E.10

*Trade Counter and Cable Sales :*

**7, Playhouse Yard, Golden Lane, London, E.C.1**

*Full descriptive leaflet "R.34" free on application.*



coils with magnetic reaction. A remarkable simplicity of assembly was achieved by means of using inter-plug-in units.

The new "Threesomes" have far more efficient circuits, though they still possess the simplicity of assembly and the compactness of the original. The two circuits are known as Nos. R/3 and R/3T. The first is Det.-2 L.F. resistance-coupled throughout, the second has a transformer-coupled stage. The first two stages of both models are identical, and effective wave-change arrangements are introduced, all the necessary coils being

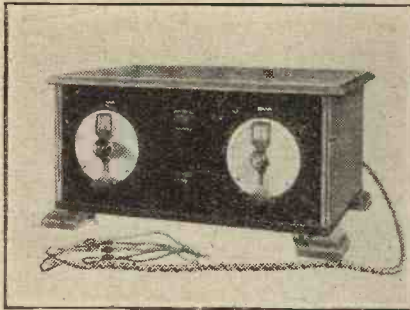

The New Ediswan "R.C. Threesome."

built into an inductance unit, which also carries the detector valve. Tuning and capacity reaction are controlled by two slow-motion dials mounted on the front of panel.

Paper models are supplied with the book of instructions, enabling the whole construction of the set to be seen at a glance. The inductance unit and two resistance-coupling units, complete with valve holders, or one resistance-coupling unit and a trans-

former and valve holder, all plug together and mount *en bloc* on the baseboard.

Into the end of this chain is plugged the multi-flex cable for the L.T. and H.T. battery connections. This saves much wiring, and all that remains are a few leads connecting the condensers and switches. The complete assembly of either "Threesome" can only mean a matter of something less than an hour, even in the case of the most inexperienced of constructors.

The Ediswan people sent us all the essential components for the assembly of an "R.C. Threesome." These we have tested, and find them perfectly satisfactory. The "Threesome," and we refer to both types collectively, is a first-class, modern three-valve set, and on both the ordinary and high wave-lengths it gives results well up to standard. That little or nothing has been lost by the simplified form of assembly is a tribute to the designers. We predict even greater popularity for the new "Threesome" than was achieved by the original.

### New Met-Vick Device

We recently received a Met-Vick Elastic Aerial Unit from Messrs. Metro-Vick Supplies, Ltd. The unit is a fairly small though remarkably substantially built device for connection externally to a receiver in order to enable a balance to be obtained between sensitivity and selectivity, suitable for varying conditions. We do not think we can better the

maker's own description of the article, which is as follows:

"The use of a small aerial for selective reception is too well-known to need further comment. To erect a particular size of aerial for any specialised single station reception

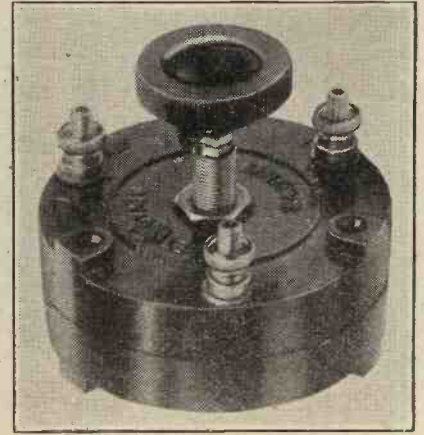

The Met-Vick Elastic Aerial Unit.

is a matter of experiment, but when many stations are to be received from various ranges, under varying conditions of interference and with various degrees of signal strength, aerials of different sizes would be required to obtain the best results under the different conditions.

"There are many methods of selective reception in use at the present time, some depending upon loose aerial coupling, others on the introduction of fixed series condensers and still others on loose inter-valve couplings, all of which have the equivalent effect of reducing the pick-up from the aerial for anything but a narrow band to which the receiver is tuned.

"The Elastic Aerial Unit was primarily designed for use when the regional broadcasting scheme was first discussed. Under this system two powerful stations would operate in one district with only a comparatively small difference of wave-length, with the result that on an average aerial with a normal reacted detector circuit, considerable overlapping or interference would bound to be experienced. If the receiver were made more selective by means of reaction, the strong incoming signals from both stations would tend to swamp the detector and prevent closer reaction.

"The only cure for reception under such a proposed regional scheme was to consider the question of reducing the aerial to a very small size and increasing the sensitivity, and hence the selectivity, by reaction.

(Continued on page 634.)

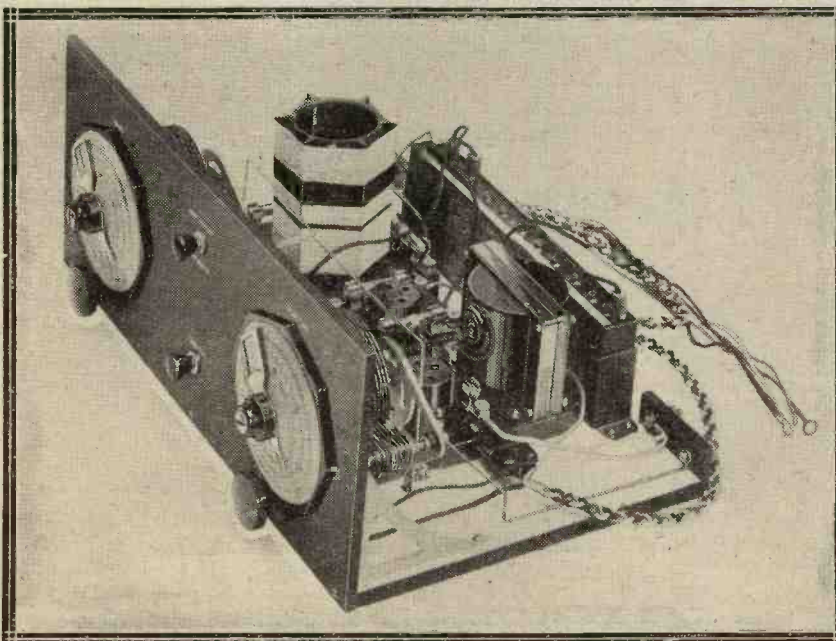

The type R/3T has one stage of R.C.C. L.F. and one transformer-coupled L.F. The detector valve is accommodated in the coil unit.



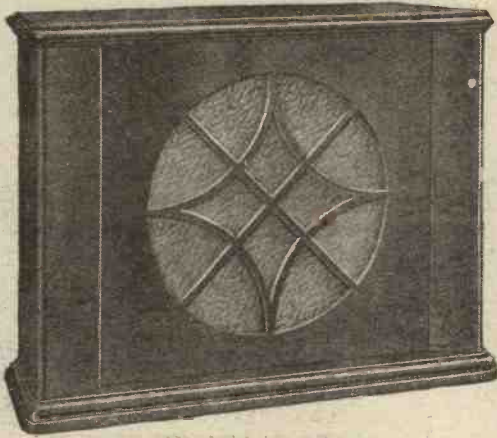

## The supremacy of **BLUE SPOT** Speakers!

'Blue Spot' speakers 49 and 59 reproduce music with absolute accuracy on upper, lower and middle registers alike. Every note receives its proper emphasis—the whole composition flowing with all the beauty and grandeur of the orchestra itself.

*Reality* is the explanation of 'Blue Spot' success. Whether it is the matter-of-fact voice of the announcer or the swing of dance music the same sense of realism is present.

Quality of workmanship and science of design make rendering faithful to a high degree. There are no mechanical noises to trouble you.

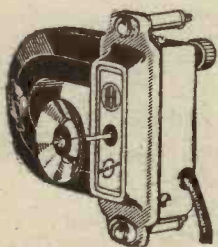

The speaker illustrated above is 'Blue Spot' 59. The Cone is of special paper mounted on balza wood, which in turn is floated on a baffle plate by means of soft leather segments. In handsome mahogany cabinet  
Price £4 4 0

The driving unit is the wonderful 66K shown here (4 pole balanced armature with adjusting screw), which can also be obtained separately . . . . . Price 25/-

'Blue Spot' cabinet cone speaker 49 is enclosed in a good-looking Trolite case giving great volume without distortion and yet at the same time gives pleasing results with low H.T. valves.  
Price £2 2 0

**F. A. HUGHES & Co. Limited**  
204-6, Great Portland Street,  
London, W.1.

Distributors for Northern England, Scotland, and North Wales: H. C. Rawson (Sheffield and London), Ltd., 100, London Road, Sheffield, and 185, Princess Street, Manchester.

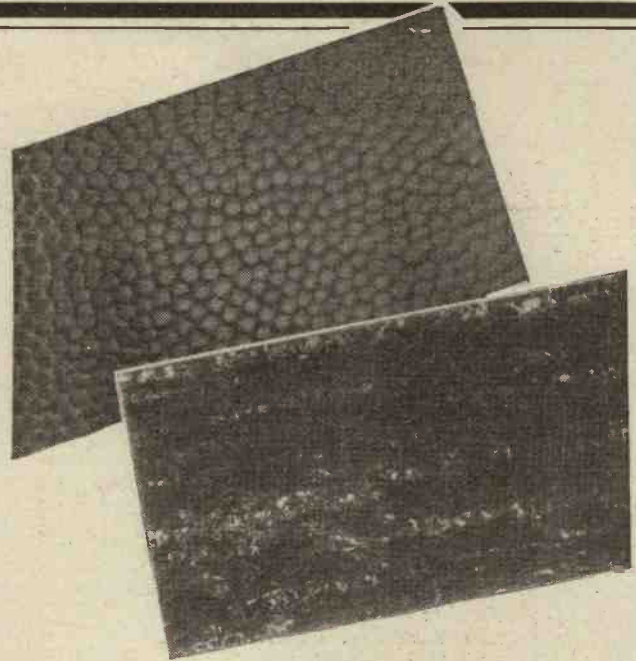

## Build it with a *Trolite Panel*

This is the busy season for constructors. Whether for home use or for presentation you can be sure that Trolite—in any one of its six distinctive finishes—will provide a panel worthy of the new set.

Trolite apart from its distinctive appearance has these important advantages—it is easy to handle and safe to machine; it does not collect moisture and reduces surface leaks to a minimum; it keeps its good finish and does not oxidise or fingermark.

Trolite is supplied by wireless dealers in panels of any size, in two thicknesses and in black mahogany or walnut patterns. Trolite strips, readily affixed by acetone without screws, are also supplied to any length and put the neatest possible finish to the panel.

*The panels illustrated are the new "Trolite Morocco" and the "Walnut Grained." Trolite panels are also available in black or mahogany grained, and in wavy or cut etched patterns, and are sold at competitive prices. Beadings are made in three colours and two patterns at ninepence a foot.*

# TROLITE

## RADIO PANELS

**F. A. HUGHES & CO., LTD.** (Dept. W.3.)  
204-6, GREAT PORTLAND ST., LONDON, W.1.  
MANCHESTER: 185, PRINCESS STREET.

# A Wonderful Christmas Number of "POPULAR WIRELESS"

On Sale December 6th.

Price 3d. as usual.

## THE "POPULAR WIRELESS" "WHITE PRINTS."

A new service for amateurs!

Commencing in the special Christmas Number of "Popular Wireless," on sale Thursday, December 6th, readers will find a new innovation in radio journalism which should make a very strong appeal.

The "Popular Wireless" White Print Service will begin with a one-valve set specially designed for amateurs who wish to change from short to long waves.

This White Print may easily be torn out and kept as a reference sheet and, in due course, the amateur will be able to have by him a thoroughly comprehensive and invaluable collection of all the important and practical circuits used in radio reception.

The last page of "Popular Wireless" has been specially reserved for the reproduction of the new White Print theoretical diagram and layout of all the best known circuits.

On no account miss this new service which "Popular Wireless" is providing for its readers, commencing with the special Christmas Number.

AMONG the many features which will be included in the special Christmas Number of "Popular Wireless," the amateur will be interested in the magnificent receiver: "The Empire Two"—a specially designed set for short and long waves which can be easily and cheaply built, and which will embody all the latest developments in radio reception.

Special contributions to the Christmas Number include: A fine article by Captain Eckersley on "Service and Invention"; a fascinating article on Christmas Radio Experiments, and a valuable guide to Choosing Your Christmas Presents.

Commander Kenworthy also contributes a provocative and deeply interesting article entitled, "If I Were P.M.G."; and Sir Oliver Lodge, Senatore Marconi, Dr. J. A. Fleming, and many other famous men contribute messages to this special issue.

ORDER YOUR COPY NOW

and be sure of not missing this greatly enlarged Christmas number of "P.W." The new "White Print" Service alone is worth the modest 3d. charged for

# "POPULAR WIRELESS"

*The Leading Radio Journal with the Highest Circulation.*



# RUN YOUR SET ENTIRELY FROM THE SWITCH

**T**HIS free T.C.C. Book shows you how — shows you in simple straightforward language, aided by diagrams and photographs, how to build **H.T.** and **L.T. Eliminators**. The L.T. Eliminator incorporates the wonderful new T.C.C. Electrolytic Condensers which have a capacity of 1500 mfd in a case only 5 inches high.

Write for a copy of the free T.C.C. Book and build your own H.T. and L.T. Eliminators. You will save money by running your Set entirely from the switch. And in using T.C.C. Condensers in your H.T. and L.T. Eliminators you will build instruments that are utterly safe and reliable.

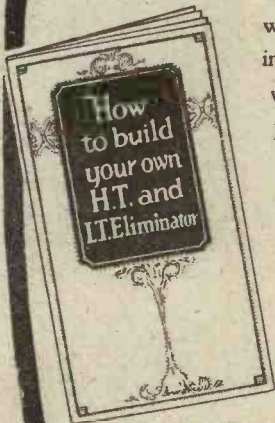

BE SURE TO USE

# T.C.C. CONDENSERS

To Telegraph Condenser Co., Ltd., Wales Farm Road, N. Acton, London, W.3.

I enclose 1d. stamp. Please send me your book showing how to build Eliminators—H.T. or L.T.

Name .....

Address .....

M.W. DEC.

6401.

# THE RIGHT PRICE THE RIGHT DESIGN THE RIGHT VALVE HOLDER VIBROOLDER

One and sixpence—that's all the Vibrolder costs you—and for that small outlay you are obtaining all that is most efficient in valve holder design and construction.

One piece anti-microphonic springs, jointless from contact point to terminal. Valve sockets formed by the coils of the springs themselves, self-aligning because they are free to give laterally as well as vertically. Unique transparent dust-proof cover to the base—all these advantages combine to make the Vibrolder an asset in any receiver.

PRICE

# 1'6



Due to its great popularity—1,500,000 having already been sold—the Original Benjamin anti-phonic valve holder, is still retained. Price 2/-

# BENJAMIN

Electric Ltd., Brantwood Works, Tottenham, London, N.17.

# The Jolliest Books for Boys and Girls

*Pages of Pictures—Coloured Plates*

THERE is nothing that will please children better than one of these splendid Gift Books. They are packed with the jolliest stories, pictures, jokes, puzzles, riddles, and games. All these Annuals are superbly illustrated and most of them contain beautiful coloured plates and many pages are printed in colours. They are strongly bound in brightly-coloured covers and are cheaper than the average toy and more durable. Each will give pleasure for many months to come.

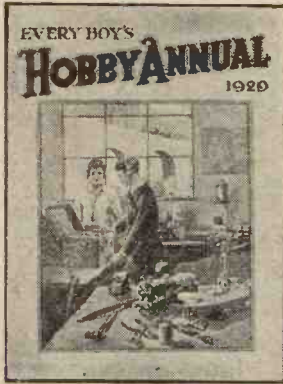

A splendid book for boys. "How-to-Make" articles, lavishly illustrated. **6/- net.**



Pages of Pictures of Tiger Tim and the Bruin Boys, also adventure stories and fairy tales. **6/- net.**

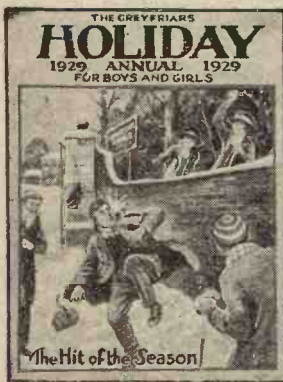

Delightful stories of the famous schoolboy characters from St. Jim's, Greyfriars, and Rockwood Schools. **6/- net.**

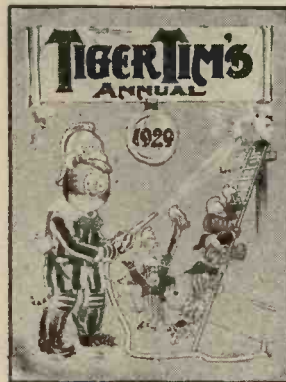

Tiger Tim's own book. Stories and pictures of the famous Bruin Boys, for children up to 12 years of age. **6/- net.**



Full of amusing pictures and stories. All the happy characters from the weekly coloured paper, PLAYTIME. **6/- net.**

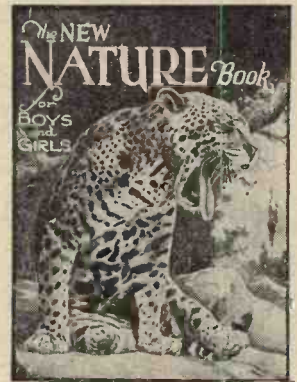

Deals with bird and animal life. Hundreds of photographs direct from life. **6/- net.**

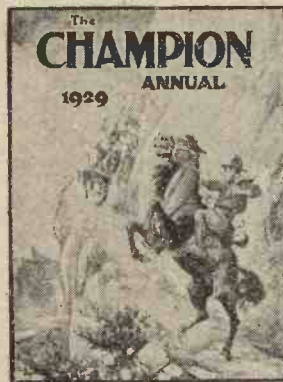

Adventure! Athletics! School! Splendid stories and articles for schoolboys. **6/- net.**

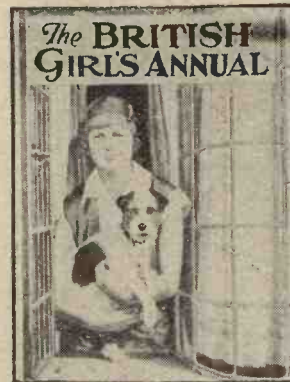

Stories of school life, sport, and adventure, and entertaining and useful articles. **5/- net.**

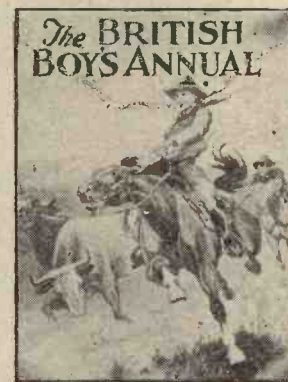

An ideal book for boys. Thrilling stories of school, sport, mystery and adventure and entertaining articles. **5/- net.**

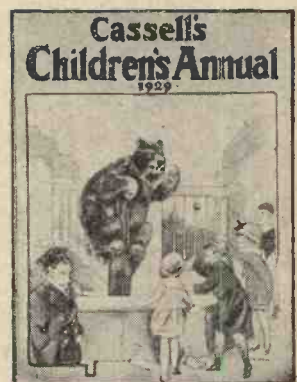

Charming adventure, fairy, animal and humorous stories and dainty verse. For boys and girls up to 10 years of age. **5/- net.**

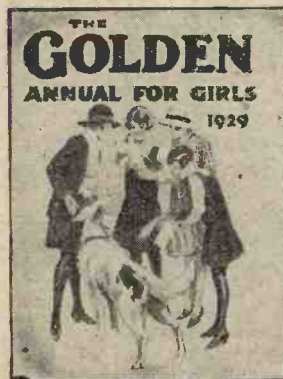

Entrhralling stories of school-life, adventure, mystery—for schoolgirls of all ages. **4/6 net.**

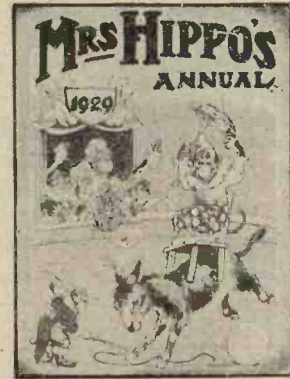

For younger boys and girls. Adventures of the Hippo Girls and all the favourite PLAYBOX characters. **3/6 net.**

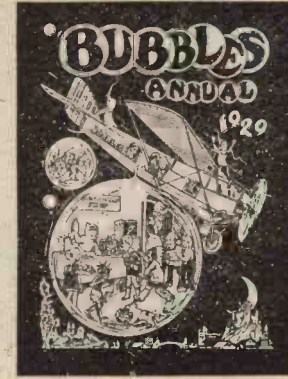

Features the amusing pranks of the Bunty Boys from the well-known weekly paper, BUBBLES. **3/6 net.**

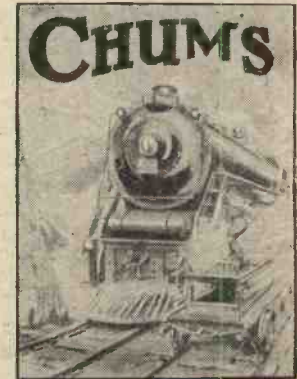

832 pages of reading. Twelve magnificent colour plates, school and adventure stories, and interesting articles. **12/6 net.**

Invaluable to  
**EVERY Amateur  
and Constructor.**

The "POPULAR WIRELESS"

**BLUE PRINTS**  
of TESTED CIRCUITS

P.W. BLUE PRINT  
Number

1. DETECTOR VALVE WITH REACTION.
2. OUT OF PRINT.
3. 1-VALVE L.F. AMPLIFIER.
4. CRYSTAL DETECTOR WITH L.F. AMPLIFIER.
5. H.F. (Tuned Anode) AND CRYSTAL WITH REACTION.
6. H.F. AND CRYSTAL (Transformer Coupled, without Reaction).
7. 1-VALVE REFLEX WITH CRYSTAL DETECTOR (Tuned Anode).
8. 1-VALVE REFLEX AND CRYSTAL DETECTOR (Employing H.F. Transformer, without Reaction).
9. H.F. AND DETECTOR (Tuned Anode Coupling, with Reaction on Anode).
10. H.F. AND DETECTOR (Transformer Coupled, with Reaction).
11. DETECTOR AND L.F. (With Switch to Cut Out L.F. Valve).
12. OUT OF PRINT.
13. 2-VALVE REFLEX (Employing Valve Detector);
14. OUT OF PRINT. 15. OUT OF PRINT.
16. H.F. (Tuned Anode), CRYSTAL DETECTOR AND L.F. (With Switch for Last Valve).
17. CRYSTAL DETECTOR WITH TWO L.F. AMPLIFIERS (With Switching).
18. 1-VALVE REFLEX AND CRYSTAL DETECTOR, with 1-VALVE L.F. AMPLIFIER, Controlled by Switch.
19. OUT OF PRINT. 20. OUT OF PRINT.
21. THE 2-VALVE LODGE "N."
22. "THE GUARANTEED REFLEX."
23. THE 1-VALVE "CHITOS."
24. THE "SPANSACE THREE," Three-Valve Receiver employing 1 Neutralised H.F. Valve, Detector with Non-Radiating Reaction Control, and 1 L.F. Valve.
25. OUT OF PRINT.
26. A "STRAIGHT" 4-VALVER (H.F., Det. and 2 L.F.
27. OUT OF PRINT. [with Switching].
28. A "MODERN WIRELESS" 5-VALVER (H.F., Det. and 3 L.F.).
29. AN H.T. UNIT FOR DIRECT-CURRENT MAINS.
30. A REINARTZ ONE-VALVER.
31. A STANDARD TWO-VALVER (Detector and L.F.).
32. THE "CUBE SCREEN" THREE (H.F., Det. and L.F.).
33. A "KNIFE EDGE" CRYSTAL SET.
34. AN H.F. AND DETECTOR TWO-VALVER.
35. THE "UNIVERSAL THREE" (Det. and 2 L.F. stages resistance-coupled).
36. THE "SPANSACE FOUR" (H.F., Det. and 2 L.F.).
37. THE "LONG SHORT" CRYSTAL SET
38. A TWO-VALVE L.F. AMPLIFIER.
39. THE "SYDNEY" TWO.
40. THE "SUPER SCREEN" THREE.
41. THIS YEAR'S "CHITOS" ONE-VALVER.
42. THE "Q AND A" THREE. A simple set (Det. and 2 L.F.).
43. THE "INEXPENSIVE FOUR."
44. THE "ECONOMY FIVE." For long range loudspeaker work.

ALL "POPULAR WIRELESS"  
BLUE PRINTS—6d. EACH

All orders for these Blue Prints should be sent direct to the "Popular Wireless" Queries Department, Fleetway House, Farringdon Street, London, E.C.4, enclosing a stamped addressed envelope and a postal order for 6d. for each Blue Print ordered

**"BUY**  
**DUBILIER**  
COMPONENTS

—and  
you can  
count the  
cost as a  
**NON-**  
recurring  
one!"

**DUBILIER**  
PRODUCTS

If unobtainable from your dealer  
write to us giving his name and  
address.



**DUBILIER**  
Regd. Trade Mark.

*Dubilier  
for Durability*

Advt. of Dubilier Condenser Co.  
(1925), Ltd., Ducon Works, Victoria  
Road, N. Acton, W.3.

**A CHALLENGE TO THE B.B.C.**  
 —continued from page 620

no longer aroused acute argument in almost every household throughout the country. The intensity of criticism of programmes is due to a general public interest in the subject far more than to inherent defects in the programmes. Needless to say there is vast room for improvement. The B.B.C. has done much good work, but has left undone much good work. The saving grace of the situation is that its programmes attract an ever wider audience and stimulate an ever growing interest.

**Characteristically British**

In point of fact, the British public is both proud and fond of the B.B.C. It is at once one of the most cherished and most characteristic of British products. If there are still people who really think that they command any substantial support for measures designed to cripple or stultify the B.B.C. they are in an entirely false heaven.

mission of speech and music. It is at least doubtful whether it would not be illegal to tamper with the monopoly conferred on the B.B.C. by Parliament in 1925.

Suppose that television is stymied both by failure on the continent and by failure to secure a satisfactory licence to transmit in this country. There remains the possibility that the Postmaster-General may order the B.B.C. against its wishes to lend one of its stations for the same kind of testing as has been going on in connection with "Fultograph." If the Postmaster-General were to take this step he would probably be in a stronger position legally than if he endeavoured to licence the Baird Company to transmit speech and music as well as vision.

On the other hand, the imposing of an order of this kind running directly counter to fundamental B.B.C. policy would produce a situation in which it would be difficult for the Governors of the B.B.C. to avoid resignation. In this direction, therefore, there is the possibility of a first-class political crisis.

Meanwhile, insufficient attention has been paid to that part of the

**IN OUR TEST ROOM**  
 —continued from page 678

"The simple mechanical reduction of the aerial size would immediately limit the reception of the two local stations, and preclude reception of distant stations when the local stations were not in operation; while under some conditions, especially within a few miles of the local stations, the total removal of the aerial might not be sufficient to reduce the signal strength on the coils of the set itself, or the signals picked up on the earth wire itself, to allow that degree of selectivity required.

**A Balancing Principle**

"To allow a large aerial to be retained for distant reception and when required, when local interference is not present, and to allow for the strong signals picked up on the coils of the set itself for earth wire to be balanced out, the Elastic Aerial Unit has been designed on the neutrodyne or balancing principle by inserting in the aerial circuit an auto-transformer coil earthed in the centre, from the extreme ends of which on the reception of signals voltages 180 degrees out of phase will be developed.

"To these two extremes are connected two fixed plates of a condenser, while moving from one plate to another is a movable plate to which is connected the aerial terminal of the wireless receiving set.

"If the movable plate is close to either fixed plate, the signal strength is equal to that normally obtained with the aerial connected to the set itself, as the capacity is about .00025, but as the movable plate approaches the centre position between the two fixed plates, not only does the series capacity reduce to a very small value but a reverse impulse is obtained from the other end of the coil.

**A Reverse Impulse**

"If the coils of the set or the earth wire are picking up signals, then the balance is not central but slightly displaced towards that end of the coil which will give a reverse impulse to compensate for the signals obtained on the coils of the set or the earth wire.

"It will be seen that under these conditions an aerial can be varied  
 (Continued on page 686.)

**"POPULAR WIRELESS" SPECIAL XMAS NUMBER**

On Sale December 6th. Price 3d. as Usual.

**BUILD THE "EMPIRE" TWO**  
 AND ENJOY A REAL RADIO CHRISTMAS.

**EASY TO MAKE. INEXPENSIVE. RELIABLE.**

After or during the certain failure of the continental proposals, I believe an effort will be made to secure a special licence enabling the Television Company to broadcast both speech and vision simultaneously on a wavelength of 200 metres or of about 50 metres, with a power of 3 or 3½ kw.

**Future Possibilities**

The B.B.C. will naturally oppose that part of the licence which would authorise the transmission of speech and music. If, even in the face of this protest, the Postmaster-General were to grant facilities for speech and music as well as for vision, a very interesting legal position would arise. The B.B.C. would be justified in seeking an overriding legal decision on the interpretation of its Charter and Licence with respect to the trans-

B.B.C. statement (when it reported adversely on the last demonstration of television) that "the Corporation would be ready to review its decision if and when development justified it."

The logical and right line for the television people is to follow this up with patience. There can be no denying that the preponderant voice of competent unbiased opinion is that, until a radical development in principle has taken place, television should not be represented as capable of incorporation in a broadcasting service.

The B.B.C. has a definite duty to their service and to their listeners in protecting them against premature exploitation, whatever its motive. As for pretentious schemes of competition or "challenges," these are as ridiculous as they are futile.

**GIVE YOUR SET  
A CHRISTMAS BOX**

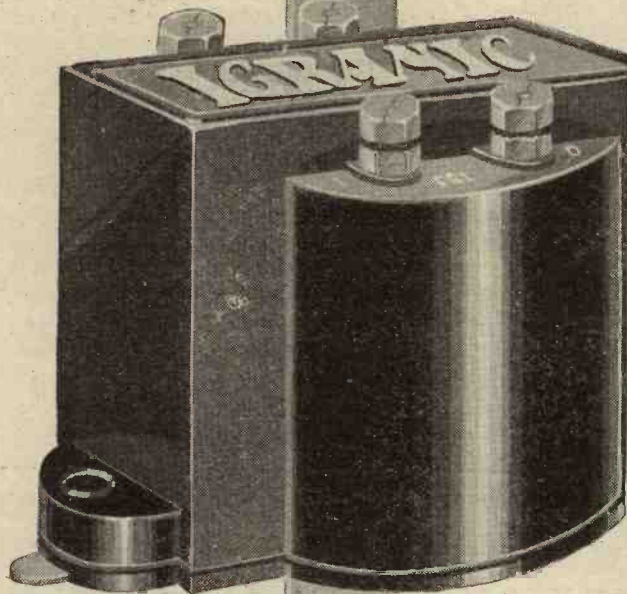

**SPECIAL** programmes from all stations! Can your set receive them—without distortion?  
Do not let an inefficient transformer spoil your pleasure.  
Give your set—and yourself—a Christmas box—an **Igranitic "J" type transformer**, the most efficient of its kind in the world.  
Hear the difference it makes!

Ratio 3 : 1 for valves with impedances of 10,000 to 20,000 ohms.  
Ratio 6 : 1 for valves with impedances of 5,000 to 10,000 ohms.

Price **17/6**

*There is an Igranitic Transformer for every purpose. Send to-day for illustrated list.*

**IGRANIC ELECTRIC CO., LTD.,**  
149, Queen Victoria Street, LONDON, E.C.4

Have you read "Radio, How It Works and How To Get The Best From It"? Price 6d. Send this coupon with your name and address and get YOUR copy FREE!

Name .....

Address .....

J 718

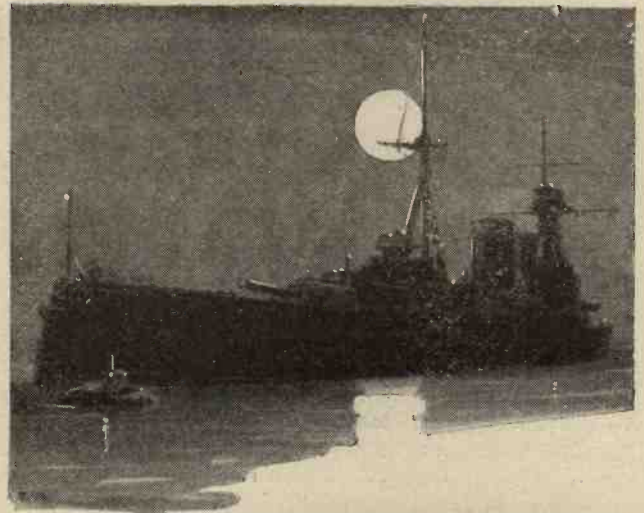

**ENGINEERING  
PRECISION**

Accuracy is the beginning and the end of engineering. In constructing wireless instruments, no less than in constructing giant battle cruisers, not a slip must be made—either in design or execution. Absolute precision is a feature of J.B. instruments, their workmanship is exact in every detail and consequently they do exactly what they are designed to do, no more, no less.

The Drumm Dial illustrated here is startlingly novel in design. It enables the Control Knob to be placed immediately below the scale, thus the scale may be brought flush with the panel and may be read with ease. A powerful and positive friction drive prevents backlash and slip. Vernier ratio, 16-1.

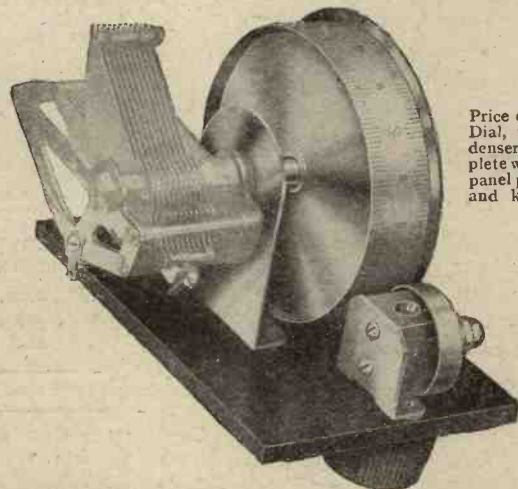
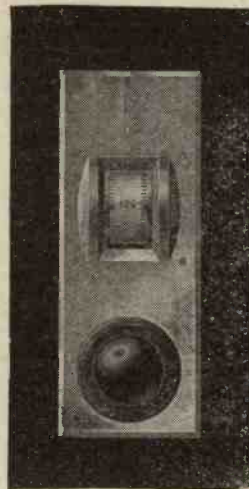

Price of J.B. Drumm Dial, without condensers, but complete with attractive panel plate and knob. **10/6**

**PRECISION INSTRUMENTS**



Advt. of Jackson Brothers, 72, St. Thomas' St., London, S.E.

**IN OUR TEST ROOM**  
—continued from page 684

from its maximum down to absolutely nothing, and so perfect is the balance that, with two H.F. valves in a five-valve set, the local station fully tuned-in can be cut out to zero by a fraction of a turn.

“Since no signals can be obtained, then an aerial from a few inches to hundreds of feet can be obtained continuously variable to meet any requirements. For selective reception the adjusting knob should be turned towards the middle or balance point, so as to work with the smallest possible aerial consistent with signal strength and one’s ability to tune critically.

**An Ideal Volume Control**

“A twist of the knob brings back the full-size aerial again for distant reception. The use of this unit with a small aerial for portable sets in conjunction with a frame aerial will allow that little extra signal strength without completely destroying selectivity.

“The unit itself forms an ideal volume-control device. The unit is

applicable to simple two- and three-valve reacted detector circuits as well as to multi-valve sensitive receivers, where, in the latter case, the reduction of the size of aerial makes so much difference to the performance of the set, both in freedom from interference and sharp selectivity.

**For the Long Waves**

“Many multi-valve sets at present

**WIRELESS CONSTRUCTOR**

**Special Xmas Number**

On Sale December 14th. Price 6d.

*One of Mr. Percy W. Harris's best efforts—and that means something to those who know a good radio set.*

are swamped by being used on too large aerials.

“A unit is also made for long-wave work, although selectivity is primarily required on the B.B.C. wave-length band.”

We have carefully tested the unit on various normal kinds of receivers,

and find it completely substantiates the manufacturers’ claims.

**Trade Publications**

The 1928-29 catalogue of The Ever-Ready Company covers all kinds of batteries as used for radio purposes, as well as many other lines of interest. There are pocket lamps, torches, hand-lamps, electro-medical apparatus, and so on. The catalogue is a de luxe production and has many clear illustrations.

The Rothermel Corporation, Ltd., have three new publications: the 1929 radio catalogue, the second edition of “The Great Voice” booklet, and the Centralab Circuit Booklet. The last is being distributed free of charge, but for the first and second, 6d. and 3d. respectively are charged.

**The “Weilo” Transformer**

In our November issue there was a test report concerning the “Weilo” L.F. transformer, in which a conditional compliment was paid, stating: “If it is to be retailed at 15s. or under . . .” Actually, the “Weilo” transformer sells much below that figure, the prices being: power type 11s. 6d., heavy type 8s. 6d. In these circumstances the component is *unconditionally* good value for money.

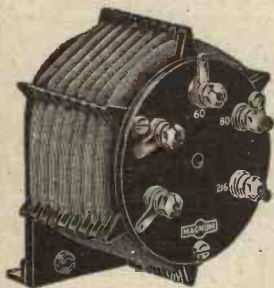

**MAGNUM LOADING COIL,**  
7/6



**MAGNUM H.T. AUTO FUSE,**  
1/6

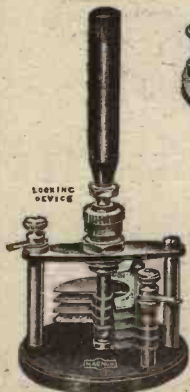

**MAGNUM NEUTRALISING CONDENSER,**  
5/-

**MAGNUM “UNIVERSAL” THREE**



Astounding results on the ultra-short waves from 15 metres up to 2,000 metres. Price, including coils, valves and royalty,

**£18**

Free demonstrations within 50 miles of London.

The most perfect set yet designed for the overseas listener.

**MAGNUM WAVETRAP,**  
15/-



**MAGNASCREEN**



10 in. x 6 in. with three terminals, 2/6  
7 in. x 6 in. with two terminals, 1/9

**MAGNUM 6-PIN BASE,**  
2/-

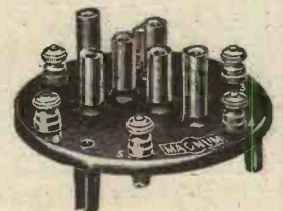

MAGNUM Components are specified for the “S.G.P.” Three and other sets described herein. Also Master Three Star, Six-Sixty Mystery Receiver, etc., etc. New Season’s Catalogue, and comprehensive lists on application.

**BURNE-JONES & CO. LTD.,**  
**MAGNUM HOUSE**  
TELEPHONE: HOP 6257-8  
**296, BOROUGH HIGH ST. LONDON. S. E. I**



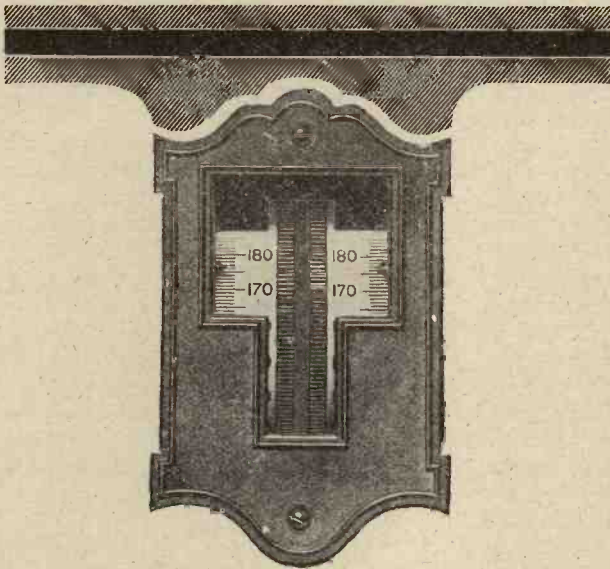

# "SYNCHRATUNE" Cyldon's great Achievement for better gang control

THE Synchronatune system provides gang control with the added advantage of individual adjustment of the aerial and H.F. stages from the front of the panel. The condensers are mounted on a strong aluminium chassis, which requires two holes only for panel mounting. The Bakelite drums protrude through a beautifully finished bakelite escutcheon plate with recessed window, through which is shown scales reading 0 to 180 degrees.

Suitable for all receivers using 2 or more tuning condensers.

**PRICES:**

Synchronatune Twin '0005 . . .	£2. 7. 0.
Synchronatune Twin '0003 . . .	£2. 5. 0.
Synchronatune Triple '0005 . . .	£3. 12. 6.
Synchronatune Triple '0003 . . .	£3. 9. 6.

Escutcheon Plate and Drums are of Standard Black Finish, but Walnut, Oak, Mahogany or Rosewood Finish can be supplied at 5/- extra.

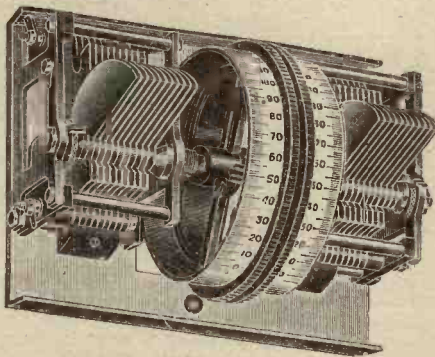

# CYLDON

The ARISTOCRAT of CONDENSERS

SYDNEY S. BIRD & SONS, LTD.,  
Cyldon Works, Sarnesfield Road, Enfield Town.

Phone: Enfield 2071-2.

Grams - "Capacity, Enfield."

Goodall Ad.

## A NON-INSULATED TERMINAL IS DANGEROUS

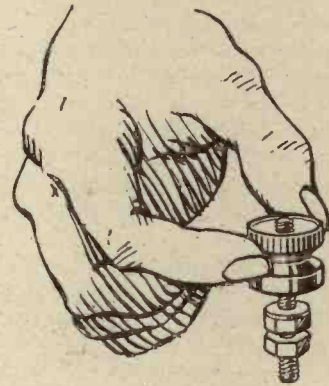

The gravest dangers are incurred with the use of non-insulated terminals, especially in the case of Receivers working off Mains. The most prevalent of these dangers is severe shock, but even fire can be caused by disregarding the precaution of perfect insulation.

Fit Belling-Lee terminals to your Receiver at once. Belling-Lee are famous throughout the world as the most perfect of all terminals. Equipped with every refinement, they are, in addition, completely insulated with polished black bakelite. It's so very little trouble to do this, and think of the worry it saves you.

fit  
Belling-Lee  
and be  
Safe!



New  
Reduced  
Prices:—

Type 'B'—Standard large and completely insulated model, with non-rotating name. 6d. each.

Type 'R'—Low priced model with rotating name, head only insulated. 3d. each.

# BELLING-LEE TERMINALS

BELLING & LEE, LTD., Queensway Works, Ponders End, Middlesex.

**CHOOSING YOUR RADIO CHRISTMAS PRESENTS**  
—continued from page 568

hard to find out what sort of stuff would be welcomed by an owner of a radio set. For instance, you might hear a man complaining bitterly that he cannot cut the local station out, and that this swamps other stations to which he desires to listen. This sort of remark would give you a clue immediately as to the kind of present he would find acceptable.

A simple wave-trap, costing about fifteen shillings or perhaps less, would enable him to cut out that interfering station. Another radio friend might be heard to complain that because of the valves he is using, his H.T. battery runs down quickly. Here is a case where a nice fat H.T. battery of the correct voltage, of course, would make an ideal Christmas present.

**Why Not a Meter?**

There cannot be many radio amateurs or listeners who do not want something or other. How many listeners, for instance, have voltmeters or hydrometers with which they can test the conditions of their

batteries? A hydrometer costs only a shilling or two, a suitable voltmeter with two ranges for testing both L.T. and H.T. batteries can be purchased for round about the half-sovereign mark.

The real radio amateur—the man who is always experimenting with sets—is an easy case for present giving. There are, for instance, a large number of loud-speaker units. If a man of the nature mentioned whom you know has not yet had a moving-coil loud speaker, he would find most welcome a unit of this sort. If he has only an old horn type loud speaker, give him a cone unit.

You have cone units ranging in price from 13s. 6d. to 30s.

In other pages in this issue there are many photographs of representative radio sets, components and accessories. These, together with the advertising section, should very greatly assist you in making your selection of presents. In giving advice on the subject, one can at the best only generalise.

Radio is a vast thing, and its possibilities from a present-giving point of view are great. And not only has one to consider how much one can spend on a present, but also exactly what will appeal most to the

recipient. If you want to give a friend who smokes a present of tobacco or cigarettes, the only problem you have to solve is how much you can spend on the gift of tobacco. But when you have made up your mind, as you undoubtedly will do if you give the matter any serious consideration whatever, that you are going to give radio presents, by arriving at this conclusion you have not reached the end of the task.

**A Lasting Gift.**

In actual fact, you are not much nearer than that of merely having made up your mind to give a present, but you do know this at least about a radio present: Providing it is carefully chosen, it is not just going to give a few moments of pleasure and then be forgotten, it will help to provide entertainment and pleasure (and education if wanted!) for years.

Chocolates and cakes are eaten; cigarettes and tobacco burnt; items of apparel are worn out and thrown away. By New Year's Day there will have been a mighty clearance of Christmas presents. Some will have been gone for ever, and others tucked away in cupboards and attics, but a radio Christmas present—well, it speaks for itself!

**The Peto-Scott**

**"RADIOGRAM SENIOR"**

A combined Receiver and Gramophone housed in a luxurious cabinet. The Receiver uses Pentode valve and brings you programmes from a wide range of British and Continental Stations. Gramophone is of the highest quality double-spring type and plays two twelve-inch records with one winding.

Send **55/9** Balance in Easy Instalments

**ULTRA DOUBLE-ACTION AIR COLUMN LOUD SPEAKER**

Perfect reproduction over the whole range of frequencies due to automatic segregation of high and low notes.

Send **8/3** Balance in 11 monthly instalments of 8/3

**MOVING COIL LOUDSPEAKERS**  
Leading makes supplied

Magnavox Moving Coil Loud Speaker .. **14/8**

Balance in 11 monthly instalments of 14/8.

R.K. Loud Speaker Unit **15/2**

Balance in 11 monthly instalments of 15/2.

Marconiphone Moving Coil Loud Speaker .. **11/7**

Balance in 11 monthly payments of 11/7.

**COSSOR "MELODY MAKER"**

Complete kit including valves in sealed carton. This wonderful Set can be built in 90 minutes.

Send **10/-** Balance in 11 monthly instalments of 14/7

*The Easy Way*  
**TO PERFECT RADIO**

**"BIG BEN"**

Complete kit of components, including Drilled Panel and Cabinet for building this Receiver.

Send **21/-**

Balance in 11 monthly payments of 21/-

**The "INVINCIBLE" FIVE**

A complete kit of components for building this wonderful Receiver. Write for detailed price list.

Send **26/6**

Balance in 11 similar monthly payments.

**ORDER YOUR SUPPLIES**

**NOW**

and

**AVOID THE CHRISTMAS RUSH**

**PETO-SCOTT CO., LTD.,**

77, City Road, E.C.1. 62, High Holborn, W.C.1

Phone: Clerkenwell 9405. Phone: Chancery 8266.

4, Manchester Street, Liverpool. Phone: Liverpool, Central 2134.

Write, call or 'phone for everything in Radio.

**The Peto-Scott**

**"MAJESTIC SCREENED GRID THREE"**

A set of remarkable range and selectivity. Uses Detector, Triode and Pentode valves. Brings programmes from all Europe. Supplied complete with valves, batteries and Loud Speaker of leading makes. Royalty paid.

Send **27/6** Balance in Easy Instalments

**REGENTONE ELIMINATOR**

Model W.1a. 1 variable tapping 0 to 100 volts, 1 fixed 90 volts and 1 power. Maximum Current 30 m/a at 180 volts.

Send **13/1** Balance in 11 monthly instalments of 13/1

**MULLARD "MASTER THREE STAR"**

Complete kit of components, including panel and cabinet.

Send **10/-** down and 11 payments of 15/3

**POST THIS COUPON**

for our Big List

Full details of everything Radio on Easy Terms, please.

NAME .....

STREET .....

M.W.12.

TOWN .....

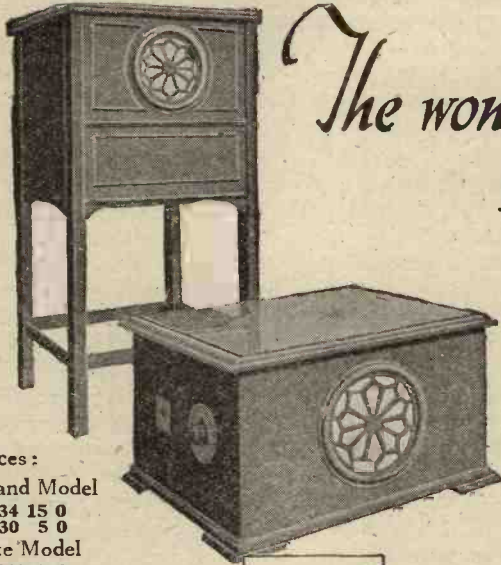

Prices:  
**Table Grand Model**  
 A.C. £34 15 0  
 D.C. £30 5 0  
**De Luxe Model**  
 A.C. £40 0 0  
 D.C. £36 0 0

Here is the R.K. Unit—the actual sound reproducing portion of the R.K. Speaker. Supplied complete with special output transformer & cone diaphragm  
**Price £8 5 0**  
 Filter Unit £1 5 0 extra



# The wonderful R.K. moving coil Reproducer in new models at reduced prices

It is universally admitted that an R.K. Reproducer is essential for perfect sound reproduction. It will be welcome news to many to learn that this wonderful instrument can now be obtained in new and cheaper forms.

The illustrations show the new models—the “Table Grand” and “De Luxe.” The equipment consists in each case of the complete mains-driven amplifier and moving-coil unit contained in a well-finished cabinet.

The wonderful atmosphere of reality which characterises the performance of the original R.K. Reproducer is present in these new instruments. Arranged for reproduction from either a radio set or from a gramophone record using an electrical pick-up.

Ask your dealer to demonstrate the capabilities of these instruments.



MADE IN ENGLAND.

ALL BRITISH LABOUR.



The British Thomson-Houston Co. Ltd.

## “CLIX” — The Pioneers of Perfect Contact

WHICH SET ARE YOU BUILDING?

Cossor's New Melody Maker  
 Mullard Master Three \*  
 Ediswan 1929 R.C. Threesome

For easier assembly and certainty of contact, be sure and ask your Dealer for “Clix.”

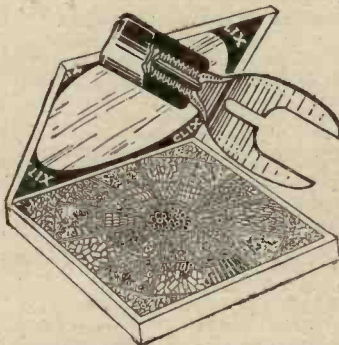

World-Wide Patents. Look for this Show-case on your Dealer's counter.

### CLIX

#### SPADE TERMINALS

“Clix” Spade Terminals are far ahead of all other makes because the patented Bridge Wiring Channels and Shank slot present the most effective and convenient means of wire attachment ever devised. Made of best brass and highly plated. Also supplied lead-plated. We recommend this type for use with accumulators.

Price 2d. Each.

Red or Black Insulators. Obtainable in two sizes suited to all types of Screw terminals.

#### CLIX

#### PANEL TERMINALS

For quick and efficient contact and also for fine appearance, you will find these terminals are better for Spade, Pin or Wire connections.

Price 4d. Each.  
 Indicating Discs 1d. Each.

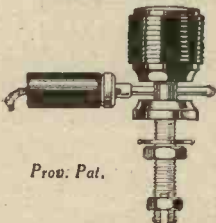

Prov. Pat.

**LECTRO LINX, LTD.,**  
 254, VAUXHALL BRIDGE RD., LONDON, S.W.1

## BUILD THE PEERLESS “RESONIC 2”



Regd. No. 456002.

### A Christmas Pastime.

Anyone can build this set in 60 minutes. No drilling. No soldering. All wires cut and bent. JUST ASSEMBLE and then immediately enjoy the radio entertainment which is of splendid tone and comes in at good loud-speaker volume. Circuit allows use of standard valves (1 H.F. and 1 Power).

Blueprint and easily followed Diagram of Connections included with every set. Cabinet and full Kit supplied in carton.

**COST ONLY £3. 15. 0**

Obtainable from all dealers, or

**THE BEDFORD ELECTRICAL & RADIO CO., LTD.,**  
 22 Campbell Road, Bedford.

Scottish Office: 113 St. Vincent Street, Glasgow, C.2.

**MR. SQUEERS CALLING**  
 —continued from page 642

It is true that, from the outset, the Press has steadily ignored radio entertainment. The reason is beyond my understanding. At least the "baby" might have been encouraged a little. The B.B.C., whilst scoring a complete and devastating revenge, will be the first to admit that it has suffered severely by that silence.

**An Undisciplined Child**

It has grown up like an undisciplined child. And a child's character is formed within the first four or five years of life. It has never known the guidance of an instructed public opinion. Now it is too late. One need only compare the mass of detailed Press comment given to the cinema, and its beneficent result, to picture what regular criticism could have done for radio. At least, we should certainly have been spared so mixed a board of directors in command of a mighty artistic enterprise.

And now the professional educationist and school-teacher has at last

got his strangle-hold. Study the speeches made at the recent British Association Meeting and any lingering doubt must vanish. Note the mass of educational pamphlets being poured out. Read the 1928 Official Handbook, "New Ventures in Broadcasting." To put it bluntly, we are for it.

**CAPTAIN ECKERSLEY**  
 writes in  
**THE "P.W." SPECIAL**  
**XMAS NUMBER**  
 On Sale *DECEMBER 6th.*  
 Don't miss the B.B.C. Chief Engineer's fine article on  
**"Service and Invention"**  
 and, incidentally, on "Television."  
 "P.W.'s" Xmas Number this year will be unsurpassed in quality and quantity.

The Director of Education lately confessed with pride that, through the education of radio, he had been able to recognise an air from Rimski-Korsakoff when sung by a Scots railway shunter! I confess that I

should have felt happier had he been able, instead, to recognise it for "A Little of What You Fancy Does You Good!" It would have argued a common humanity and a touch of the Old England which is so swiftly vanishing. But then, as I have said, I am hopelessly old-fashioned.

It is a queer kink in the national character, this passion for "reforming" and "educating" other folk. In commerce it is making us lose markets right and left. We are always interfering in other folks' business. And always we set about it with the blunt directness of a St. George interfering with someone else's dragon.

**No Imagination**

A touch of imagination, a graceful gesture, a delicacy of tact and perception, the human approach, a happy laugh would make all the difference. Alas, there is no hint that any of these will be in evidence in the new B.B.C. school! Instead—"out slates and copybooks!" "W-i-n-d-o-r, a winder or casement. Now go and clean it!" Mr. Squeers has arrived. And it's brimstone and treacle morning!

A. CORBETT-SMITH.

(Copyright in the U.S.A.)

**A NEW**

**DIAL**

WE have every confidence in placing before the Radio public a new and improved BurTon Micro-Log Dial, our latest product, illustrated herewith, is the result of several years' experience of the great weakness of Dial construction, together with our vast knowledge of what is required for superfine tuning. One point alone which will make this product an outstanding feature of the 1928-1929 Season is the special logging position, which is situated on the front of the Dial, enabling all stations to be logged clearly by means of the pointer upon the centre knob. This celluloid strip is situated free from any interference, can easily be replaced, and, further, any logging marks can be removed from this surface by being erased with india rubber in the usual manner, which is quite impossible with other logging devices.

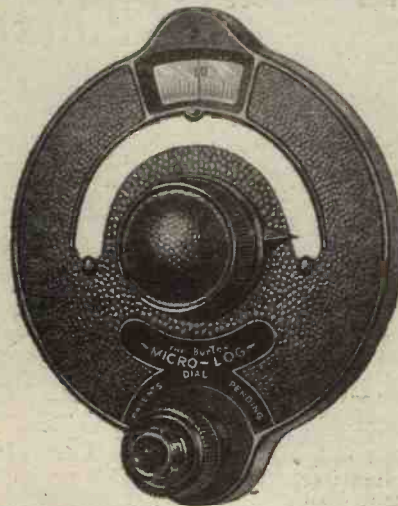

The BurTon Micro-Log Dial, De Luxe Model

Registered Design. Patents pending.  
 Slow Motion only 5/6 each  
 With Fast and Slow Motion 6/- each

THERE are two models of this dial, one which gives slow motion only, and the other, which by the simple means of revolving one knob for the fraction of a turn frees the slow-motion device, enabling the centre knob to be moved quickly to any of the stations which have previously been logged on the celluloid logging strip.

We feel sure this new BurTon Micro-Log Dial will please you because of its graceful design, its ease of mounting to any condenser, its velvety smoothness, its freedom from back-lash, and finally, because it is the only Dial which gives you a practical solution to the logging problem.

Truly the product of master craftsmen who specialise in the production of Radio Dials.



(REGD. TRADE MARK.)



REGD. TRADE MARK.

**C. F. & H. BurTon, PROGRESS WORKS, WALSALL, ENG.**

# The right combination

# for PERFECT RADIO

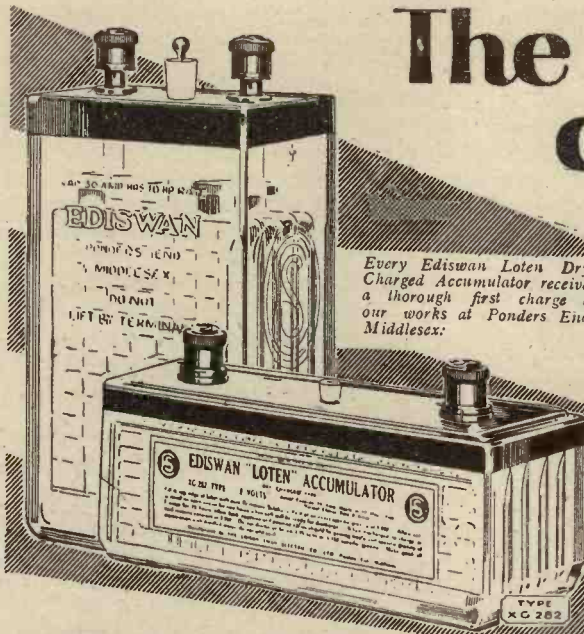

Every Ediswan Loten Dry-Charged Accumulator receives a thorough first charge at our works at Ponders End, Middlesex.

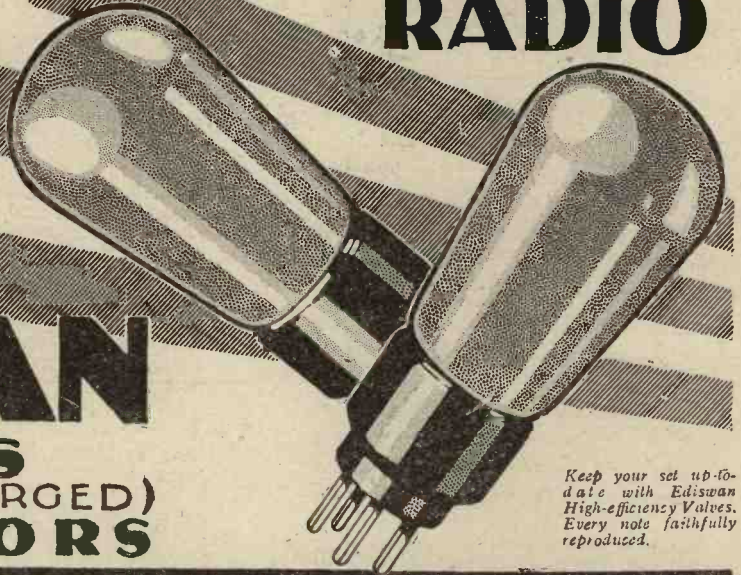

Keep your set up-to-date with Ediswan High-efficiency Valves. Every note faithfully reproduced.

## EDISWAN VALVES AND LOTEN (DRY CHARGED) ACCUMULATORS

<b>PAREX</b> <b>PRODUCTS</b>  <b>A</b> <b>R</b> <b>E</b> <b>XCELLENCE</b>		<b>THE "THREE-BAND" TWO</b> Standard Loading Coil - 7/6 H.F. Binocular Choke - 7/6 <b>AUDIO-FREQUENCY OSCILLATOR</b> Described in page 587. Standard Screening Boxes of highly polished and mottled copper (untarnishable), 12/6	<b>THE "S.G.P." THREE</b> Standard Screen 7 ins. x 6 ins. - 3/6 H.F. Binocular Choke - - - 7/6 <b>"SOLOGRAM"</b> Set of 4 copper Screens - - - 17 6 each Baseboard Screen - - - 7 6 " Short-Wave Coils - - - 15/- " Long-Wave Coils - - - 15/- " Wave-Trap - - - 15/- " Small H.F. Choke - - - 4 6 " Parex Valve Holders, highly polished, 4, 6 per set.
	<b>E. PAROUSSI</b> <sup>10</sup> , FEATHERSTONE BUILDINGS, HIGH HOLBORN, W.C.1. Phone: Chancery 7010.		

High-grade  
**QUEEN ANNE STYLE FIGURED OAK CABINET**  
 Height 3 ft. 3 ins. Depth 1 ft. 3 ins.  
 For Panels up to 21 ins. x 7 ins.  
 Baseboards up to 11 ins.  
**£5.5.0**  
 Packing Free. Carriage Paid.  
 Prices of other sizes in proportion. Manufacturer of all types of wireless cabinets and furniture of every description. Illustrated lists free.  
**GILBERT, CABINET MAKER, SWINDON.**  
 Estimates Free. Estd. 1866.



**LANG & SQUIRE**  
 THE ALL BRITISH  
**MOVING COIL**  
 LOUD SPEAKER  
**£3:15:0 £4**  
 Set of Parts less Stand. With Stand.  
 Pot Magnet wound for D.C. Mains. 12/6 Extra.  
 The Steel Pot Magnet, wound for 2, 4 or 6 volts, requires only 3 to 4 watts. At 6 volts the current is between '5 and '75 amps.  
 The Moving Coil has a large tapered flange at one end which makes certain of the coil keeping its shape. Our cone is made up with three-ply paper. This has entirely got over the objectionable hissiness to be heard from some moving coil speakers. All over-tones are reproduced. Nothing is lost.  
**LANG & SQUIRE, LTD., WALES FARM ROAD, ACTON, W.3.**



**OPERATING THE  
"RHAPSODY" FOUR**  
—continued from page 649

In fact, it is only the valve capacity which requires "balancing out."

**Tuning-In**

The set is now ready for use on the normal broadcast band, and all that you have to do is to rotate the two tuning dials until you hear a station, and then adjust the reaction control for maximum signal strength. With a little practice you will be able to keep the reaction condenser adjusted to its most sensitive position just short of the oscillation point, so that as you rotate the tuning controls you are all the while maintaining the set in its most sensitive condition.

Incidentally I have tried R.C. valves in the H.F. socket, but I do not find them so good as those of the H.F. type. This applies to both the long waves and the normal broadcast band.

Now to go over to the long waves to receive 5 X X, push in the two wave-change switches. This gives you a resistance-coupled H.F. stage, and

all the tuning is carried out on the first (aerial) tuning control. The other tuning condenser is not required.

You will not be able to obtain reaction on 5 X X, but actually I find that with the original set there is a distinct increase in volume when the reaction condenser moving vanes are all in.

This simple wave-change scheme is very effective for ordinary domestic purposes, and there are no snags. I

Remember December 14th  
**WIRELESS CONSTRUCTOR**  
Special Xmas and  
New Year Number  
On Sale  
Price 6d. as usual

find that the 80 tapping on the loading coil gives the best results with my particular aerial.

**Long-Wave Reception**  
If you require stations other than

5 X X on the long waves you can easily adapt the receiver for this work by changing the broadcast A.N.P. coil for one with a winding suitable for 1,000 to 2,000 metres (5 X X wave-band). This coil should be inserted in the place of the existing coil and the second wave-change switch pulled out as for the normal broadcast wave-band.

In this way you will have the small wave-change switch set for 5 X X, i.e. pushed in, and the other in the position that you use it when you are listening to your local station or 5 G B.

**Re-Neutralising**

The neutralising condenser may require a little readjustment, but this is rather difficult to say definitely. The "Rhapsody" Four was tested on an aerial having a length of 100 ft. and an average height of 15 ft. 2 L O, 5 G B and 5 X X came in at full loud-speaker strength on a cone at a distance of 15 miles from the London station.

A large number of Continental transmissions was also received at excellent strength on the loud speaker, and there is no doubt that this set will bring in practically every station worth listening to.

# FERRANTI

## Circuits for simple 2-Valve and 3-Valve Receivers

Full-sized charts are now available and may be obtained from your dealer or from us on request.

*No Radio knowledge required  
No soldering necessary*

Performance: These receivers are capable of giving good reproduction from the local station and Daventry 5 X X. Other stations may be received at various strengths, according to the situation of the listener.

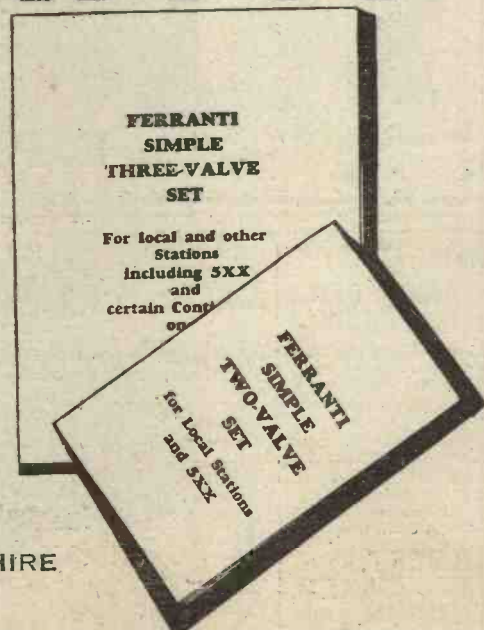

FERRANTI LTD. HOLLINWOOD LANCASHIRE.

# Is your H.T. down?

DOES this question ever worry you? It need not if you have alternating current mains in your home. The new B.T.H. H.T. Eliminators provide a constant H.T. current. They are free from all "hum" and are definitely guaranteed to deliver the milliamperes specified.

The 5 m.a. type is intended for use with the average 1 or 2 valve set working at present from a small capacity dry battery. For larger receivers, the 10 m.a. type should be used. Install a B.T.H. Eliminator today, and have a constant, unflinching, trouble-free and inexpensive supply of H.T. from now on. Ask your dealer to tell you all about these eliminators.



**5 Milliamp Type**  
200/250 volts, 40/100 cycles.  
**Price £4 10 0, including valve**

**10 Milliamp Type**  
200/250 volts, 40/100 cycles.  
**Price £6 15 0, including valve**

*The above prices are applicable in Great Britain and Northern Ire and only*

# B.T.H. ELIMINATORS

The British Thomson-Houston Co. Ltd.

5043



## The Heart of the Set

Regular transmission of current, steady, smooth response to the extra demand, no "murmurs," these are the qualities which make these batteries with the sturdy, extra-thick plates the Premier Batteries for wireless sets. Ask your dealer; or write for detailed list to

# PREMIER

Accumulator Co. (1921) Ltd.  
Northampton  
Estd. 1898

Z-Type High-Tension Premier. In handsome teak case, as illustrated.

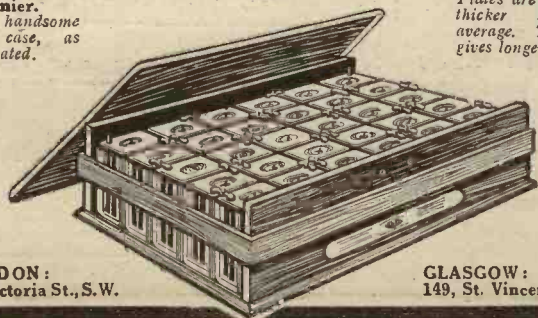

The Low-Ten Premier. Plates are 50% thicker than average. This gives longer life.

LONDON: 53, Victoria St., S.W.

GLASGOW: 149, St. Vincent St.

## WEILO CIRCUIT No. 3

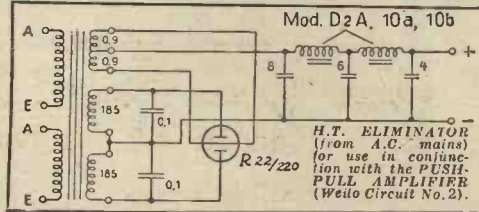

We strongly recommend the use of a mains set (Eliminator) as the source of anode current supply, as in this instance batteries would be too expensive. The Eliminator Anode Voltage is in the region of 220 volts. To obtain maximum efficiency specify Weilo Transformers and Chokes; they are built by experts, with a precision and skill that makes higher-priced instruments a totally unnecessary expense.

Stocked by Harrods and good-class dealers. Send now for all particulars of this circuit, and catalogue describing the famous N.S.F. and Weilo range of quality components to Dept. M.W.

### GUARANTEED TWO YEARS. PRICES OF WEILO MODELS FOR USE WITH CIRCUIT NO. 3.

- Weilo Anode Transformer, Model 14a ... 19/6
- Weilo Choke, Model 10c, 100 m.a. ... 22/6
- Weilo Choke, Model 10b, 50 m.a. ... 18/6
- Weilo Choke, Model 10a, 30 m.a. ... 10/6
- Weilo Choke, Model D.2a, 20 m.a. ... 8/6

S. W. LEWIS & CO., LTD., 39, Victoria Street, London, S.W.1.  
Indian Agents, Bombay Radio Co., Bombay & Calcutta.

Illustrated, Model 10a Choke.



Illustrated, Model 14a Weilo Anode Transformer.

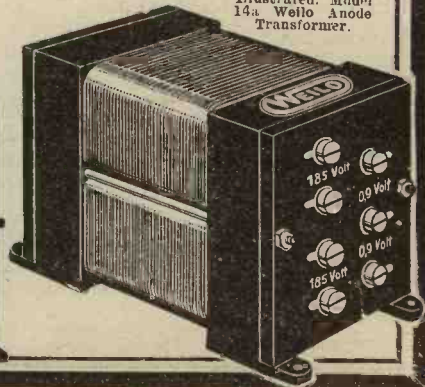

**BROADCASTING AND  
THE NEXT ELECTION**  
 —continued from page 628—

decently can of wireless for political purposes had better be put aside.

Wireless is an extremely important means of communicating information and forming ideas; and it is becoming more important every day. It can no more be kept out of the political field than the newspapers can. The B.B.C. has dropped most of the inhibitions that were placed on controversial debates, and some of the talks that we get in the ordinary programmes are frankly political. Therefore we may just as well go the whole hog and make the utmost use of the wireless that we can in order to take the fullest advantage of this incomparable means of spreading the truth.

**Unrestricted Use**

And now I confess to being a little controversial myself in what I am going to write. From my political point of view I want the truth and the facts to get out. I am prepared for a hostile Press, and that cannot be helped. But the ether belongs to

no man. The B.B.C. is a public corporation and the property of the people. I therefore demand its unrestricted use, equally and fairly distributed, for all of the political parties.

One criticism I have heard made of the use of wireless for political purposes is that it will discourage people from going to political meetings. I do not believe it. Our difficulty in my constituency has always been to get halls big enough to hold them.

**KEEP UP TO DATE**

**Read "Popular Wireless"**

Every Thursday. Price 3d.

And, on the contrary, I believe the fullest use of broadcasting for political purposes will cause the apathetic voter to sit up and take notice. In order that our democratic institutions should function efficiently we want to do all we can to reduce the political apathy that still exists in many parts of the country.

The only restriction should be one against personal attacks on the opposing candidates; partly because

the B.B.C., like all respectable institutions, would wish to discourage verbal dog-fights and encourage serious arguments; and partly in order to safeguard the B.B.C. itself from penalties under the law of libel. Indeed, the use of wireless in politics might raise the controversial level of some of the gentry who insist on standing for Parliament, and whose sole arguments consist in personal abuse and vituperation.

**Appeal to the Masses**

The hide-bound party politicians, whom no argument will move from their mental stand-pat attitudes, can always switch off when the "other man" is broadcasting. It is not much use appealing to them in any case. It is the vast mass of the people who really only take an active interest in politics at election times that we should be after. I believe broadcast speeches and addresses would be a convenience and a boon to the majority.

And for this and other reasons I have mentioned above it should be used to its utmost capacity. And if it led to more people taking out wireless licences and buying wireless sets, that would be all to the good also.

# "THE TEXT BOOK IDEAL"

475 HOURS LIFE AT A CONTINUOUS AVERAGE DISCHARGE OF 10mA.

**A Splendid Record**

Ripaults Self Regenerative H.T. Batteries successfully passed through severe independent tests conducted by all the following well-known public and trade journals:—

- WIRELESS WORLD
- MODERN WIRELESS
- AMATEUR WIRELESS
- THE BROADCASTER
- POPULAR WIRELESS
- THE WIRELESS TRADER

ACCEPT ONLY FULLY SUBSTANTIATED claims on Life and Performance of H.T. Batteries. Write for Free copies of "test" reports on Ripaults Self Regenerative Batteries.

## Ripaults



**SELF REGENERATIVE  
H.T. BATTERIES**

Give 50% Longer Life.

STANDARD CAPACITY. DOUBLE CAPACITY.	
(Chocolate Label.)	(Blue Label.)
60 Volts... ..10/6	60 Volts... ..15/6
99 Volts... ..16/6	90 Volts... ..22/6

**TREBLE CAPACITY.**

(Orange Label.)  
60 Volts ... .. 19/6  
90 Volts ... .. 29/6

9 Volt Grid Bias 1/9    18 Volt Grid Bias 3/6

*Ripaults chosen for the New Cossor  
Melody Maker.*

Obtainable through all Dealers. If any difficulty locally, write us.

The "Wireless World" says:

"... THE RIPAULT BATTERY CONFORMS TO THE TEXT BOOK IDEAL OF DRY CELL BATTERY PERFORMANCE."— See "The Wireless World," Nov. 7th issue, page 640.

**The "WIRELESS WORLD"  
TEST**

was carried out on one of our 60 Volt Double Capacity Batteries, Type C.H.M. (Blue Label).

**LIGHT ON THE H.T. BATTERY.**

Read this 24-page Booklet. It gives the secret of good reception. Post Free for 2d. stamp. Please mention "Modern Wireless."



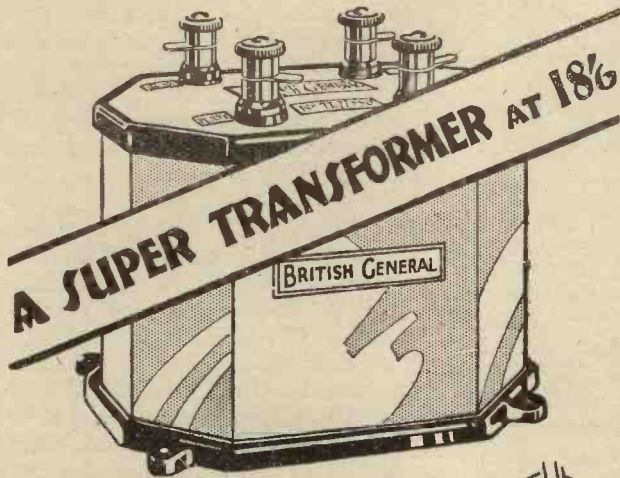

A real winner! Made and guaranteed by a firm of wide experience in Radio Manufacture; tested and recommended by the leading designers; approved by experts and public alike. Guaranteed pure distortionless reception. For the sake of better reception fit a British General Super Shrouded Transformer.

18/6

Two ratios, 5:1 and 3:1

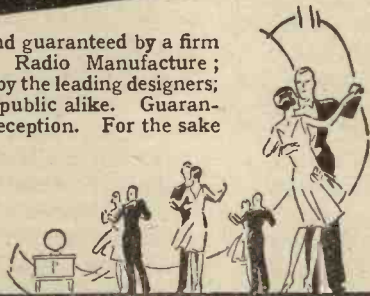

**BRITISH GENERAL**

Manufacturing Co., Ltd., Brockley Works, London, S.E.4

DESIGNED TO  
NEW STANDARDS

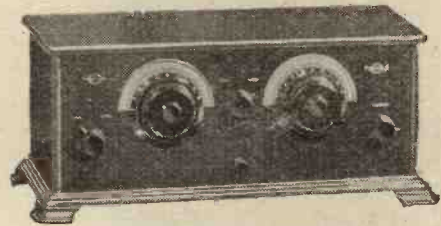

THE "PENTOVOX THREE"

A BIGGER brother to the valve preserves fine quality of the marvellous Pentovox Two, reproduction in ample loud- the extra screened grid H.F. speaker volume. Wave-length Valve extending considerably ranges are 250 to 500 metres, the range of stations and satisfying within and 1,200 to 2,300. There are no coils to change. Log scales are provided to chart the various stations.

List No. 344. Set with three special valves tested and matched to set, including Royalty £11.0.0

Write for full literature of Bowyer-Lowe Sets and Components.

**BOWYER-LOWE**  
TESTED RADIO APPARATUS  
**Pentovox 3**

OTHER NEW BOWYER-LOWE SETS:  
The Pentovox Two.  
The Vox Populi Screened Three.  
The Vox Populi Screened Four.  
The Gramo-Radiophone.  
The Senior Cone Reproducer.

Bowyer-Lowe Co., Ltd., Radio Works, Letchworth, Herts.

Build a COMPLETELY SCREENED Set.

**FORMO**  
ARTHUR FREEMAN & CO.  
**"Screened 3 Grid"**  
NO COIL CHANGING

An amazingly simple Set to construct and operate.

Obtain a Broadsheet from your dealer and read why you should:—  
COMPLETELY SCREEN THE GRID.

NO COIL CHANGING  
From HIGH WAVE to LOW WAVE on a push-pull switch.

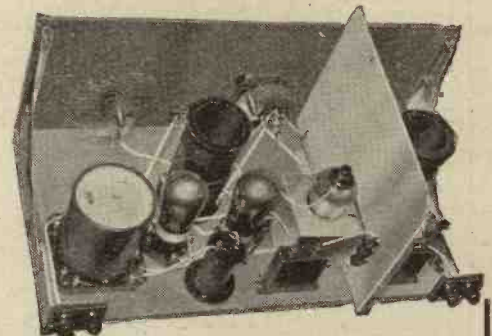

Send Post Card for FREE FULL SIZE LAY-OUT PLAN & WIRING INSTRUCTIONS.  
**THE FORMO CO.,** Crown Works, Cricklewood Lane, London, N.W.2

For Discerning Men & Women

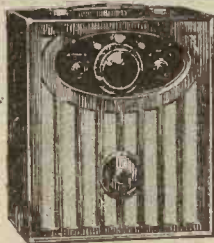

The MELOSET for TONE

The DISTASET for RANGE

TWO NEW TRUPHONIC MODELS

NO AERIAL  
NO EARTH  
NO RISK  
NO EXTRAS

The "Meloset" (illustrated) is an upright mahogany model (5 valve straight circuit) giving a beautiful tone on the local and all high power stations. The "Distaset" is a suitcase model (screened grid H.F.) for extreme range. The set for the South Coast, West Country, and all difficult situations.

TRUPHONIC LTD.,  
121-123, Rosebery Avenue, E.C.1.  
Showrooms, 324, Regent Street, W.1.  
Ask your dealer to demonstrate your choice.

ONE PRICE  
£24:15:0

COMPLETE, INCLUDING ROYALTIES, TECHNICAL DETAILS WITH PLEASURE.

WHEN ORDERING CABINETS

FOR THE SIX-SIXTY MYSTERY RECEIVER  
30/- Oak, 33/- Mahogany  
THE MULLARD PORTABLE V  
50/- Oak, 58/- Mahogany  
MASTER THREE STAR  
24/- Oak, 27/- Mahogany  
BE SURE AND SPECIFY

PROMPT



DELIVERY

Send for our Latest Lists to—  
CARRINGTON Mfg. CO. LTD., CAMCO WORKS, SANDERSTEAD RD., SOUTH CROYDON  
Phone: Croydon 0623.

# READY RADIO

SUPPLY COMPANY,  
159 BOROUGH HIGH ST.,  
LONDON BRIDGE, S.E.1.

3 Minutes from London Bridge Southern Rly. and Tube Stations.

Telephone: HOP 5555 (Private Exchange).  
Telegrams: READY HOP 5555, LONDON.

## DEMONSTRATIONS

DURING BROADCAST HOURS.

HEAR BEFORE YOU BUY!

### "S.G.P." THREE

AND

### MULLARD "MASTER THREE"

Also Demonstrations of other successful Radio Press receivers.

### IMMEDIATE DESPATCH

of ALL the CORRECT parts for these Receivers.

Write, Wire or Phone Your Orders

### "S.G.P." THREE

H.F. and Det. Unit.

1 Ebonite Panel, 14" x 7"	£ 8. 4
1 Cabinet in solid Oak or Mahogany (Ready Radio)	6 0
1 Synchronising Twin Disc Condenser (Cydon)	1 0 0
1 .0001 Reaction Condenser (Bouyer-Lowe)	2 7 0
1 On-Off Switch	5 9
2 Valve Holders (Lotus)	1 0
2 Six-pin Coil Bases (Burne-Jones)	3 6
2 H.T. Fuses and Holders (Burne-Jones)	4 0
21 mfd. Condenser (Dubilier)	3 0
12 mfd. Condenser (Dubilier)	5 0
100,000-ohm Resistance (Lissen)	3 6
1 H.F. Choke (R.I.-Varley)	12 6
1 .0003 mfd. Condenser (Dubilier)	2 6
1 .001 mfd. Condenser (Dubilier)	2 6
1 2-megohm Grid Leak & Holder (Mullard)	3 9
1 Terminal Strip	1 9
9 Terminals (Belling-Lee)	3 4
1 Screen, 7" x 6" (Burne-Jones)	1 3
10 ft. Glazite	10
Flex. Screws, etc.	1 0
1 Set Short Wave Coils (Lewcos)	1 6 0
1 Set Long Wave Coils (Lewcos)	1 7 0
2 Valves, S.G. and Det.	113 0
<b>TOTAL (including Valves)</b>	<b>£11 4 8</b>

### L.F. Unit.

1 Ebonite Panel, 7" x 6"	£ 2. 6
1 Cabinet (Ready Radio)	10 0
1 L.F. Transformer (Brown Type A)	110 0
1 Single Fil. Control Jack (Lotus)	2 6
1 Volume Control Potentiometer (Gambrell)	6 9
1 Output Transformer (Marcomphone Universal)	1 0 0
12 mfd. Condenser (Lissen)	3 6
1 Fuse and Holder (Burne-Jones)	1 6
1 Valve Holder (Lotus)	1 9
6 Terminals (Belling-Lee)	2 3
1 Terminal Strip, 6" x 2"	9
10 ft. Glazite	10
Flex. Screws, Wander Plugs, etc.	1 0
1 Pentode Valve	1 5 0
<b>TOTAL (including Valve)</b>	<b>£5 8 4</b>

### MULLARD "MASTER THREE"

ALL PARTS IN STOCK.

Kit of Parts - - - -	£6 11 7
Cabinet - - - - -	£1 5 0
Valves - - - - -	£1 13 6

### READY BUILT SETS COMPLETE WITH VALVES

Price, including Royalties,

"S.G.P." Three (Complete)	£19 12 6
"Big Ben" - - - - -	£14 15 0
"Touchstone" - - - -	£17 5 6

### RING HOP DOUBLE FIVE DOUBLE FIVE

INLAND: All orders post free. OVERSEAS: Consignments carefully packed and insured.

## STRIKING THE RIGHT NOTE

—continued from page 592

and for the output a super-power valve with adequate bias. One hundred and twenty volts high-tension is used, the general condition of the batteries being checked from time to time, without opening the case, by means of the triple voltmeter.

The method of adjusting the instrument is as follows: The loud speaker is connected to the output terminals and, before switching on, the adjustable condenser in the first oscillator box is set somewhere near its maximum. Next, with the variable condenser of the second oscillator set at minimum, and the neutralising condenser at about half capacity, the adjustable condenser in the second oscillator is turned by means of an insulated screwdriver or a piece of wood to about the same setting as the first.

The set is now switched on and a musical note will be heard in the loud speaker. Now turn the adjustable condenser in the second oscillator until you reach a zero beat-note. Next place the lids on both boxes, and you will probably find the musical note will appear again owing to the slight variation of inductance due to the placing of the lids on the boxes.

### Illuminating Tests

A touch of the neutralising condenser in parallel with the main tuning condenser will bring you back to zero again. And now, if you turn the variable condenser from zero up to maximum you will get a pure musical note in the loud speaker which will run right up above audibility as you turn.

This audio-frequency oscillator will very likely teach you more about loud speakers in half an hour than you would otherwise learn in a couple of years! Before doing any serious experimental work, however, you will need one or two additional pieces of apparatus. The first is a small terminal board with six terminals provided with a double-pole double-throw change-over switch (generally called a "battery type").

Two of the terminals (which you should mark "oscillator") should be joined to the two blades of the switch and each other pair of terminals to the particular pair of switch contacts. If you can, build or buy a

good moving coil loud speaker and use this temporarily as your standard by connecting it to one pair of terminals, using the other pair for the loud speaker to be compared.

Now run over the musical scale with your variable, and you will find that the response of the moving coil is quite good, although it may fall off somewhat in the upper register. It will, however, be particularly good for the low notes. Now connect one of the ordinary cone types, and without making any comparisons run over the musical scale with this. The response will seem to you to be good, but on the lower notes the cone will probably sound a little rattley or "papery."

### False Low Notes

Now make a rapid change-over on the switch while you are running down the low notes. In nine cases out of ten, on the really low notes of the scale, you will find the reproduction given by the cone type an octave higher than that given by the moving coil for the same setting of the oscillator! This is due to the fact that the cone type generally reproduces not the genuine low note, but the first harmonic of it.

Now pick out a pair of loud speakers, one of which is generally reputed to be good for music and not so good for speech, and the other as being good for speech but poorer on music. You will find that the speaker which is good on music and poor on speech has a fairly good low-tone reproduction with perhaps some amount of boominess, but is deficient in the upper register, whereas the speaker which is good on speech will be good on the upper register, but rather deficient on the lower.

### Cone versus Horn

You will also be able to see how much different makes vary in sensitivity, and if you take the older horn type (some of the new horn types are much better) you will find why we all welcomed the cone in preference to the horn when the former first arrived!

The reader who wants to do accurate work will, of course, measure the output of his oscillator and draw a curve by means of a valve voltmeter to make himself acquainted with the response curve of his actual output. Occasional readjustment of the zero beat will be needed by means of the neutralising condenser, but otherwise the oscillator will run for very long periods with no more attention than switching on and off.

**KEEP YOUR EYE ON THE NEEDLE OF A**

**SIFAM**

**RADIO METER AND LET IT TELL YOU WHERE DISTORTION ENDS AND PURITY BEGINS**



*Ask your dealer to show you the popular price range and write to Dept. M.W. for free leaflet "What simple meters can show you."*

SIFAM ELECTRICAL INSTRUMENT CO., LTD. M.B.  
BUSH HOUSE, ALDWYCH, W.C.2.

\*\*\*\*\*

**THE OSLO ECHO**  
**A STRANGE RADIO EXPERIMENT.**

From a Special Correspondent

\*\*\*\*\*

THE wireless experiments of two Norwegians have recently caused a good deal of comment because of certain sensational theories put forward. Professor Stormer, of Oslo, has declared that he has proved by experiments that wireless signals can be echoed back from outer space to the earth from distances up to something like 1,584,000 miles.

This is rather a staggering claim, and yet the Director of the Polytechnic Academy of Copenhagen, Professor Pedersen, has given it as his considered opinion that there is no reason to doubt the deductions and the explanation given by Professor Stormer.

It was at first suggested that these echo effects were probably due to the moon, but reflection will show that the echo could not have been from the moon because that heavenly body is only 239,000 miles away from the earth. And the echo certainly could not have been from any of the planets, for the nearest is 25,000,000 miles away.

**Round the World**

It appears that a few weeks ago an engineer at Oslo, a Mr. Hall, observed that an echo from the transmissions of the Dutch wireless station at Eindhoven acted on his receiving set up to three seconds after the actual signal itself had been received. In other words, he noticed, as German engineers did once in a recent experiment, three recurring echoes, each fainter and each a seventh of a second later as the wave from the station came back from its round-the-world journey three times.

Now, as radio waves have a speed of 186,000 miles a second, it is clear that the echo observed by Mr. Hall and Professor Stormer must have been thrown back from a point in space 279,000 miles from the earth. Professor Stormer and Mr. Hall have repeated their experiments and have used the Eindhoven station as the transmitter.

On October 11th, an agreed signal was transmitted, picked up on the receiver and then afterwards the echo was received, somewhat weaker but so distinct (according to a report in the "Daily Mail") that the Professor and those with him could

(Continued on page 701.)



**Equal to 3 Ordinary Batteries**

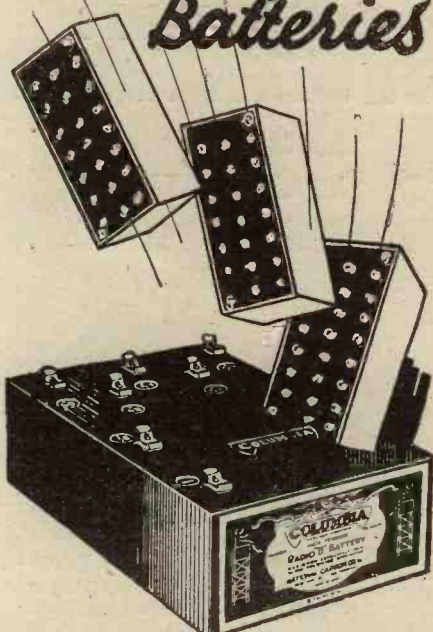

**Columbia**

Not a battery but a SUPER BATTERY—that is the correct description of the Columbia No. 4780 Triple Capacity H.T. Battery. It possesses the emission of three ordinary batteries, the lasting power of three ordinary batteries and the quality of three ordinary batteries.

For the man with the good Receiver, this Columbia battery is indispensable. It's as essential as the good valves he uses.

You are proud of the results yielded by your Receiver—you'll be prouder still when you use this Columbia battery.

60 volts. New Reduced Price £1 : 0 : 0.  
This battery is specified for "Six-Sixty" Great Mystery Receiver."

**Columbia RADIO BATTERIES**

J. R. MORRIS, Imperial House, Kingsway, London, W.C.2.

SCOTLAND—

J. T. Cartwright, 3, Cadogan Street, Glasgow.

**NO RADIO WITHOUT DARIO**

(See page 707.)

Make or Buy a Gramophone or Cabinets only for Wireless at a quarter shop prices. Size 32 x 30 x 16, with double spring motor, 12 in. Velvet table, swan tone-arm, soundbox, horn, cups. £5, carriage paid. All the above fittings less Cabinet, £1 18s. 6d. Motors 9s. Accessories. List Free. 64-pp. Drawing and How to make Gramophone. 3d.



REGENT FITTINGS Co., M.W., 120, Old Street, London, E.C.1.

ALL APPLICATIONS for ADVERTISING SPACE in "MODERN WIRELESS" must be made to the Sole Advertising Agents, JOHN H. LILE, LTD., : : 4, LUDGATE CIRCUS, LONDON, E.C.4. : :

# ALL-METAL WAY UNITS



## METAL RECTIFIERS FOR ELIMINATORS AND BATTERY CHARGERS

- NO VALVES
- NO ELECTROLYTE
- NO MOVING PARTS
- NO WEAR

Type H.T.1



Output  
200 volts, 100 m.a.

For H.T. Eliminators or Chargers  
Price: 84/-

Type G.B.1



For Grid  
Bias Battery  
Eliminator.  
Output 40 volts.  
Price: 17/6

Type A.3

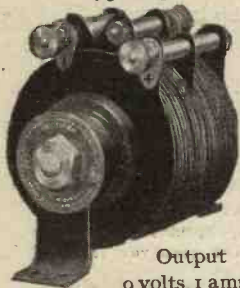

Output  
9 volts, 1 amp.  
for L.T. Eliminators, L.T.  
Chargers, Pot-magnet supply  
for Moving-coil Loud-  
speakers.

Price: 23/6

Type A.4. Similar to above,  
but output 4 volts, 2 amps.  
39/6

The Westinghouse Brake  
and Saxby Signal Co. Ltd.  
82, York Road, London, N.1

Send id.  
stamp  
for our book  
"The All-  
Metal Way,"  
How to build  
H.T. and  
L.T.  
Eliminators  
and  
Chargers.

### BROADCASTING IN 1928

—continued from page 582

the Grand National were all well done over the microphone. There was a workmanlike series of eye-witness accounts of such affairs as the Open Golf Championships, and the Motor-Cycle Races in Ireland and the Isle of Man.

In the realm of stunts, the relay of the Tunney-Heeney fight from New York attracted most general interest. This was a feather in the cap of Keston. But not such a big one as the subsequent surprise relay of the running commentary of the landing of the "Graf Zeppelin" near New York. The latter was correctly described as the first "quality" transatlantic relay by wireless link. It was the first test with the spaced aerials completed at Keston. If this can be repeated at will, then we are in for some remarkable new features from the States next year.

#### Most Impressive Event

The most impressive event of the broadcasting year was the relaying on Armistice Day of the Cenotaph service from London to all British stations. Then in the evening of Armistice Day the great Albert Hall Rally of the British Legion, promoted by *The Daily Express*, carried wartime songs and stirring memories throughout the length and breadth of the British Empire.

The short-wave station 5 S W, at Chelmsford, was successful in reaching the Antipodes, India, and Canada, as well as South Africa, and the intervening Colonies and Protectorates. The Menin Gate relay on August 8th was certainly another "peak" of 1928.

#### Better Talks

Talks have been better, but there is still vast room for improvement. The free discussions, and debates on things that matter between bright talkers, have given real entertainment value to a growing proportion of the programme of the spoken word. Mr. Maxton v. Sir Ernest Benn on Socialism; Mr. J. H. Thomas v. Lieut.-Col. Moore Brabazon on Transport; but, above all, Mr. J. H. Thomas v. Mr. R. D. Blumenfeld on a little of everything—this is the stuff to give 'em.

But I would sound a note of warning on the year's tendencies on the professedly educational side. There

has been a tremendous lot of hot-air about new Councils and Committees galore, to uplift the poor, miserable public through broadcasting. A good deal of this has been rightly described as an attempt at "Minority Rule."

But I do not take the situation quite as seriously as some other students of broadcasting. For I feel that the B.B.C. does not really mean to do much about it; probably Savoy Hill are up to a bit of shrewd exploitation.

#### Indefinite Hold-up?

They will "get away" with the *kudos*, and then say that the plans must wait the Regional Scheme, which, of course, will not be completed for years and years (for this purpose)! If this is the case, then I have no quarrel with Savoy Hill. If, however, they are misguided enough to be in earnest about the pet schemes of educational faddists, then they are in for a rough time.

Taking a broad view, 1928 in broadcasting was not at all a bad year. Despite the contrary assurances of my friend at Savoy Hill, there has been a fair crop of "peaks," and some really fine achievements.

The programmes have improved steadily. Those of 5 G B, still free of talks, are undoubtedly the best and most popular. It is 5 G B that keeps up licence revenue and makes its steady, if slow, increase possible. The chief danger to B.B.C. programmes now is the rut of routine arrangement.

#### Arrangements Too Rigid

Thus there is real danger of a talk on the martial habits of the mosquito getting in the way of a speech by Sir James Barrie, merely because the mosquito talk had been arranged months ahead as part of some blessed "syllabus."

My advice to the B.B.C. for 1929 is to shake the programmes free of their rigidity of arrangement, and to encourage genius rather than safety-first tactics in programme building.

But the chief thing is to regain something of the spirit of adventurousness which so happily characterised that little zealous band of enthusiasts who started British broadcasting six years ago. I want to see some big "bloomers"—some really shocking blunders; better far than a steady level of imperturbable, undeviating efficiency tending towards mediocrity through staleness.

And a final tip. Do make the best of the Fultograph. You have a great chance to enliven the news bulletin, and brighten other dull spots by intelligently chosen and placed pictures.

*For those who appreciate  
good Music*

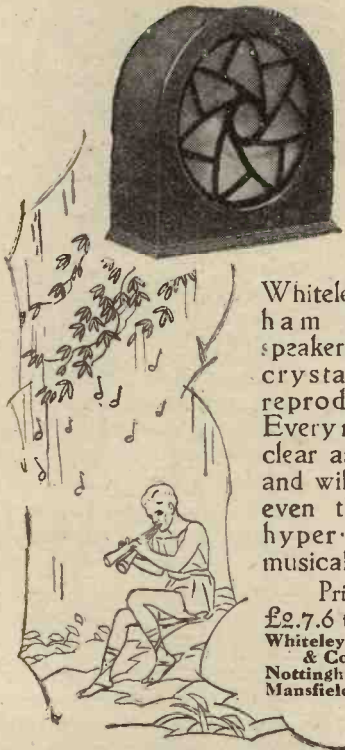

Whiteley-Boneham Loud-speakers render crystal clear reproduction. Every note is as clear as a bell, and will satisfy even the most hyper-critical musical listener.

Prices:  
£2.7.6 to £4.4.0  
Whiteley-Boneham  
& Co. Ltd.,  
Nottingham Road,  
Mansfield, Notts.

**AN XMAS HINT:**  
Every "Receiver"  
says "DARIO"

(See page 707.)

Have you bought  
your **DIX-ONEMETER**  
yet?

The HOME for your  
WIRELESS SET

AN IDEAL  
CHRISTMAS  
PRESENT

at most moderate price. The Model illustrated, solid oak throughout, is made in various sizes for small or large Receivers. Accommodation for batteries and loud speaker. Many other models for choice. Sent on 7 days approval, so you take no risk. Delivery from stock.

Write for full particulars FREE:—  
MAKERIMPORT CO. (Dept. 2),  
9, YORK STREET (off Duke Street), LIVERPOOL



With Drop Front.

From £4 : 15 : 0

WHEN REPLYING TO ADVERTISEMENTS  
PLEASE MENTION "MODERN WIRELESS"

**THE PATENT QUESTION**  
PROPOSED REFORMS  
By a Special Correspondent

IN view of the present importance of patents in the wireless industry, and of their effect upon prices and manufacture generally, it is interesting to record the findings of a committee recently appointed by the British Science Guild, under the chairmanship of Dr. Eccles, F.R.S., to consider what changes could advantageously be made in the present system of granting patents.

The committee quite candidly agree that it may be argued in the first place that a patent system is not actually necessary for the well-being of industry. They dispose of this contention, however, by pointing out that, quite apart from its being a measure of natural justice to the inventor, it brings many indirect advantages to the community in general.

**A Valuable Record**

For instance, the present operation of our patent system encourages inventors to embody their ideas in written specifications, which are afterwards published and thus circulate new ideas to form the basis of still further progress. Again, invention is the natural bridge between scientific discovery and the requirements of practical industry, so that the collected patents of any country form a valuable, and indeed unique, record of the growth of applied science in that country.

Finally, an organised patent system is now in operation in practically every civilised nation in the world.

Our own patent system dates back for more than three hundred years, and is the oldest in existence. It has been amended from time to time by various Acts of Parliament, but still lags some way behind the modern requirements of an essentially scientific age.

**Important Recommendations**

In order to remove outstanding anomalies, the committee make the following recommendations:—

(a) A patent should not be rendered invalid by any paper "anticipation" which dates back more than fifty years. If since that time no one has made practical use of the idea, then the re-discovery is meritorious.

(Continued on page 700.)



**BUY YOUR RECORDS  
WITH YOUR WIRELESS**

WITH the opening of our new gramophone saloon, another extension to our rapidly-growing business, it is now possible for all lovers of music to purchase gramophone records at the same time as their wireless parts and accessories.

We have already been appointed official agents for

**COLUMBIA  
ZONOPHONE  
HIS MASTER'S VOICE  
PARLOPHONE  
ETC.**

and other leading makes, and hold large stocks for immediate delivery.

Pay a visit to our gramophone saloon, hear and choose your records in comfort.

**XMAS  
PRESENTS**

Solve your Xmas present problem by visiting our showrooms. What could be more acceptable as a present than a portable gramophone, a small table grand, or a few good records? Or, if they are wireless enthusiasts, a low-priced portable set, or some useful adjustments, such as—

- Wet High-Tension Battery,
- G.E.C. Music Magnet Kit,
- Cosser Melody Maker Kit,
- New Master 3 Star Kit,
- Mullard Portable Five Kit,
- Soldometa Soldering Outfit,
- Voltmeters,
- Ampmeters,
- Red Spot Loud-Speaker Unit,
- New Lion Amplion Speakers.

If you cannot call, write for our new gramophone booklet, "Sound Waves from Days," or Wireless booklet, "Rays from Days," or our Comprehensive Catalogue, post free, 6d. (free to callers).

**WILL DAY LTD.**

(The Best in the West)

18-19, Lisle St., Leicester Sq., W.C.2.

Telephone - Regent 0921-0922.

Telegrams - "Titles, Westrand, London."

**CONTINUOUS DEMONSTRATIONS  
FROM 9 A.M. - 7 P.M.**

# Radio's finest tuner



Range 250-2,000 metres, a change-over switch.

## The PANEL PLATE UNIT

Consists of Double Wave-band Tuner, Slow Motion Tuning Condenser, Change-Over Switch, assembled on an embossed antique brass escutcheon plate, the whole being mounted on an oak, walnut or mahogany Panel fitted with angle brackets. Price... **35/-**

A Collapsible Cabinet is another accessory which will be welcomed by Set Builders; this is made to fit the above Panel Plate and in the same finish; it is assembled in a few minutes. Price... **28/-**

## The BASE-BOARD UNIT



By linking five connecting wires from this Unit to the Panel Plate or any other Tuner a complete Two or Three Valve Loudspeaker Receiver of amazing performance is built.

- II Valve Transformer **37/6**
- III " " **50/-**
- III " R.C.C. " **23/-**

ALL LAMPLUGH RADIO PRODUCTS



are guaranteed for 12 months

# LAMPLUGH THE QUALITY TUNER

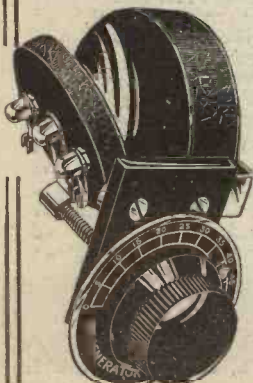

An ideal Aerial Tuner for Professional and Amateur Radio Set Builders, covers the entire broadcast band from 250-2,000 metres, only requires Push Pull Switch to effect the change. Circuit diagram is supplied with each. Price **12/6**

Send for lists and wiring diagrams from

**S. A. LAMPLUGH, Ltd.,**  
King's Rd., Tyseley, Birmingham

## THE PATENT QUESTION

—continued from page 699

(b) The official "search" should be extended so as to cover all available text books and technical periodicals for the previous fifty years. At present the search is confined to prior patent specifications, so that if a patent is issued as officially clear of anticipation, it may still be open to attack in the Courts as having been previously described in some publication other than a previous patent.

### Cheaper Legal Aid

(c) The Comptroller of the Patent Office should be empowered to try infringement actions by mutual consent of both parties. This would afford a far cheaper avenue for testing the validity of a patent than the present expensive procedure in the High Courts.

(d) A special "short term" patent should be introduced to protect inventions of a minor or "design" character (such as a detail improvement in an existing circuit or wireless component). Short-term patents should be granted cheaply, quickly, and for a period not exceeding seven years.

It very often happens that such inventions, although not of a complicated nature, would prove very lucrative in a quick market. At present, owing to delay in securing effective protection, the inventor has to face unfair competition before he is in a position to sue for infringement.

### More Encouragement to Inventors

Amongst other suggestions is one recommending that more help should be given by the Patent Office in assisting inventors, before they actually file an application, to discover how far in fact they are on new ground, and to what extent their work may have already been anticipated by previous workers in the same field. This could be done on payment of a small fee and in many cases would save the full cost of the complete specification.

Finally, it is pointed out that the Patent Office makes an annual profit of over £80,000 which, at present, is paid over to the Treasury. This it is contended, should be expended on giving increased assistance to inventors.



YOUR need is selectivity—You want to cut out completely interfering stations, either Local or Distant, and to receive any station desired. You can do this in a minute by fitting the Harlie Wave-Selector between your Aerial and Set. It increases volume too!

Whatever Set or Aerial you may have, the Harlie Wave-Selector will increase its selectivity, range and volume. You must at least try-out this wonderful Wave-Selector. Obtain it from your dealer, or request us to forward by post C.O.D. under the conditions of our £100 guarantee.

**NO ALTERATION TO SET—JUST PLUG AERIAL INTO SOCKET PROVIDED—FULL PARTICULARS ARE GIVEN.**

4 3/4" high, 3 1/2" diameter. In finest grade black crystalline finish throughout.

2 MODELS SUPPLIED:

- (a) Normal Waveband, 200-700 metres.
  - (b) High Waveband, 700-2000 metres.
- Please state model required when ordering.

## £100 GUARANTEE

Money returned in full if the "Harlie" Wave-Selector proves unsatisfactory, and is returned to us within 7 days of purchase.

(Dept. F.),

**HARLIE BROS.,**

Balham Road, Lower Edmonton, N.9

# fit HYDRA CONDENSERS

**and forget them**

You know how troublesome cheap condensers can be—when your set is out of use, or breaking down in your eliminator and causing trouble all around.

**Fit HYDRA Condensers in your set or eliminator and you need never give them another thought**

Because HYDRA condensers are made to a scientific standard of precision which is constant throughout their life; they are constructed with the one dominating idea that the name of HYDRA must always stand for utter reliability.

Tested 500 volts, 240 volts D.C. or 160 A.C. working voltage.

**PRICES:**

2 mfd. .. 3/6      1 mfd. .. 2/6

Do not accept a silver condenser without the Hydra label. Others are imitations, and we are not responsible in case of breakdown.

Obtainable from all radio dealers. If any difficulty write—

**LOUIS  
HOLZMAN**  
34, Kingsway  
London, W.C.2.



## MOVING COILS!

Send for our FREE 36-page booklet TO-DAY. It tells all about Moving Coil Loudspeakers, and how to get perfect reception.

**BAKER'S SELHURST RADIO**  
89, Selhurst Rd., Sth. Norwood, S.E.25

**CLAROSTAT**  
VARIABLE RESISTANCES FOR VOLUME, TONE, DISTANT CONTROL, ELIMINATORS ETC.,

As frequently specified by 'The Experts':  
• HIGH QUALITY • LOW PRICE •  
New 20-Page Brochure free on request.  
Many unique circuits.

**CLAUDE LYONS LTD.**  
76, OLDHALL ST., LIVERPOOL.

Make  
**The DAILY SKETCH**  
YOUR Picture Paper

PLEASE be sure to mention  
"MODERN WIRELESS"  
when communicating with  
Advertisers.      THANKS!

## THE OSLO ECHO

—continued from page 697

not possibly mistake the signals to be other than those sent out from Eindhoven.

The curious thing is that Professor Stormer gave certain time periods, which he put down as having elapsed between the sending out of the signals and the reception of the echo. The times were: 3, 4½, 5, 8, 13, 15 and 17 seconds.

### Reflecting Layers

According to these times, then, the signals must have been thrown back from points distant from the earth as follows:

279,000, 317,000, 434,000, 745,000, 1,211,000, 1,398,000, 1,584,000 miles.

Professor Pedersen, although stating that he considered it possible now to penetrate space with radio signals from the earth, thinks that such an experiment cannot be made by the use of long wave-lengths. By means of ultra-short waves he believes it possible to penetrate the Heaviside Layer, and Professor Stormer's experiment seems to have proved this up to the hilt.

Professor Pedersen's explanation for the variation in time is that the waves on their journey through space met with electrically-charged layers of rays, or ionised particles, which threw the waves back. They may have crossed the paths of the waves at different distances from the earth, which, he suggests, accounts for the variations in the times recorded by Professor Stormer.

### Peculiar Time Intervals

An engineer said he could not offer any explanation of the reception of an echo so late as seventeen seconds; for, as he pointed out, it takes a wireless wave a seventh of a second to travel round the world, and, as in the recent German experiment, three recurring echoes have been recorded, each fainter and each one-seventh of a second later as the wave passed back from its round-the-world journey three times.

He further pointed out that it is usually considered that only a very short wave of one or two metres would pass through the Heaviside Layer—the layer of electrons which are thought to lie in the high levels of the atmosphere at a distance of 100 or 200 miles above the surface of the earth.

The unquestioned merit of Celestion lies not only in the refined beauty of its appearance but more



Model C12

Models from £5/10/4      Made under License

in its almost unbelievable realism

**CELESTION**  
The Very Soul of Music

British throughout  
Insist on your Dealer demonstrating, or call at our

SHOWROOMS:  
**106 VICTORIA ST SW1**  
(One Minute from Victoria Station)

First on Merit on Demonstration.

**XMAS  
1928**

Make sure of a good  
reception with—



**TREBLE-DUTY TERMINALS**

**40 DIFFERENT  
INDICATING TOPS**



Eelex Treble-Duty Terminals are unique. For ease of wiring and neatness of effect they are unexcelled. Whilst the choice of forty different indicating tops makes accidental connection a practical impossibility. Make them the centre of industry in your set. You will then be assured of a fine reception.

**Send for our Free  
Comprehensive Booklet  
S.D.**

—which every Wireless Constructor and Experimenter should have. This interesting booklet gives you full particulars of other Eelex accessories designed to save you money and to ensure the finest reception. A postcard will bring it post free.

**J. J. EASTICK & SONS**  
Eelex House, Bunhill Row,  
Chiswell St., London, E.C.1.  
Phone Clerkenwell 9282

**THE PARIS WIRELESS  
EXHIBITION**

From Our Own Correspondent.

THIS exhibition, bigger and better than ever before, was a credit to its organisers, The Syndicat Professionnel des Industries Radio-Électriques. There were 268 exhibitors. A few British firms had stands, but the trade body only permits members who manufacture their products in France to exhibit.

**Only One Moving Coil**

Even the wireless expert intent on examining the latest moving-coil loud speakers—of which, incidentally, I could see only one, price 4,500 Frs., on the Radio L L Stand—or pentode valves, found himself carried away in admiration of the beauty of the exhibits. Fine inlaid wood, stains and lacquers were combined to produce sets of the greatest beauty, and of such variety that no difficulty would be found in procuring one to fit in with any scheme of house decoration.

Antique pieces of furniture, such as fall-front bureaux, log-boxes and chests of drawers, have already been converted for wireless purposes, but the most ingenious adaptation that I saw was an antique grandfather clock with a dummy gauze face and imitation hands, behind which was the loud speaker; the frame aerial was fitted where the pendulum and weights originally hung, and the accumulators were placed in the base of the clock case. Messrs. Cholin, Ferry & Paul, of Nancy, made this adaptation, and their representative told me that they were arranging to fit a "movement" which would work the hands on the painted gauze face, so making the antique case a complete timepiece in spite of its wireless interior.

**Better Quality**

Good reproduction is undoubtedly of greater importance than fine presentation in wireless, and as usual in such an exhibition demonstrations had to be given elsewhere, some firms arranging transport facilities for potential customers. That the French manufacturer is concentrating on better reproduction is shown from the fact that the 80-volt high-tension

supply is being less and less used and the 120- and 140-volt plate batteries are replacing it. Although, as I said before, there is only one example of the moving-coil loud speaker, the reason presumably is that here the cone is considered sufficiently good; perhaps it is—it is certainly more economical.

I noticed very little simplification of control, and the knobs on the panels of receiving sets seemed as numerous as ever, but I was certainly impressed by the "Système synoptique," by which any station can be obtained in half a second; there is a chart of all stations and a horizontal and a vertical rod, each rod operated by a screw, all that is necessary is to move the rods until they cross each other immediately over the station on the chart which is required. This is made by the Société États Péricaud. There were various other devices for obtaining foreign stations, but this one seemed to be the best.

**Radio-gram Sets**

This exhibition showed a marked development in the production of gramophone and wireless combinations, and, moreover, within the reach of most purses. The Ampliphonaubert No. 1, price 3,725 Frs., requires no batteries at all, but is operated from any electric light supply. The Panorganum is a portable wireless and gramophone combination the size of a "tennis" suitcase.

Space does not allow of an adequate description of so comprehensive an exhibition, but the exhibitors here have catered for everyone,—the cottager, the millionaire, the ignorant and the expert. The Radiola show a multi-valve receiver made on the mass-production principle, which they sell at 700 Frs. This exhibit attracted much attention. There was an instructive studio exhibit, and Radio-Toulouse demonstrated their picture-receiving apparatus.

The Exhibition was held in the Gallery of the Grand Palais, on the Champs-Élysées. Underneath, in the body of this huge building, was the Motorcycle and Bicycle Show.



**PERFECT CONTROL of H.F. & L.F.**



**THE NEUTROVERNIA**  
In these days of Screened Grid Valves the sensitivity of the modern circuits cannot always be used to the full owing to the local station or the nearest high power station causing interference.

By connecting the Neurovernia in series with your aerial the selectivity of your receiver can be adjusted exactly to suit the prevailing conditions.

The Neurovernia can be used with perfect efficiency as either a Balancing or Neutralising Condenser or Capacity Reaction Control.

Price 5/6

**THE VOLUVERNIA**

Here is a true volume control, one which does not create distortion. It gives you just the volume you desire and keeps your reproduction pure at all times.

The "Voluvernia" gives perfectly smooth control from maximum to minimum for Gramophone Amplifier or Radio Receiver.

Price 6/9

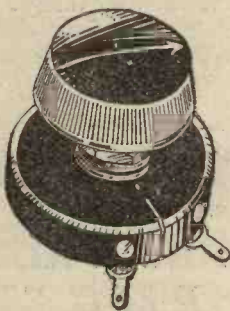

From all Dealers. Write for "Components Booklet M."

**GAMBRELL RADIO, LTD.**  
6, Buckingham St., Strand, London, W.C.2.

**DARIO**  
KEEPS EVERY SET "In Training"

(See page 707).

**Cabinets of Quality for every Set.**  
Full illustrated particulars from the Actual Manufacturers. V. C. Bond & Sons, 61, Hackney Grove, Mare St., London, E.4.

**WET H.T. BATTERIES**  
Solve all H.T. troubles  
SELF-CHARGING, SILENT, ECONOMICAL  
JARS (waxed) 2 1/2" X 1 1/2" sq., 1/3 doz.  
Zincs, New type, 11d. doz. 8AOS 1/2 doz.  
Sample doz. (18 volts), complete with bands and electrolyte, 4/3, post 9d.  
Sample unit, 6d. Illus. booklet free.  
Bargain list free.

**AMPLIFIERS, 30/- 2-VALVE SET, £1**  
M. TAYLOR, 57, Studley Rd., Stockwell, London.

**IGRANIC'S**  
NEW BOOKLET  
"RADIO HOW IT WORKS- AND HOW TO GET THE BEST FROM IT" **PRICE 6 D**  
**free**  
DURING **NOVEMBER & DECEMBER**  
PLEASE MENTION "MODERN WIRELESS" WHEN REPLYING TO ADVERTISEMENTS

**RADIO NOTES AND NEWS OF THE MONTH**  
By "G. E."

**The Region for the Regional**  
It seems highly likely that the next B.B.C. high-power Regional scheme station will be somewhere near Blackstone Edge, a famous moor lying between Rochdale and Halifax, at an altitude of 1,553 ft. above sea-level. B.B.C. engineers have been exploring parts of the moor in the neighbourhood of Cotton Stones, which lies in the Soyland Urban Council area, and enquiries have been addressed to the Council relative to the erection of the station, and asking if a daily supply of 10,000 gallons of water could be guaranteed. (Water, of course, is absolutely necessary for the maintenance and efficient running of a high-power station, cooling of valves, etc., etc.)

**PCJJ's Brother**

Philips Radio Company have built a new short-wave station at Eindhoven, similar to PCJJ; the new station will use the call-sign PBF 5, and will work 41.3 metres. A continuous-wave system is employed, and only Morse code will be transmitted. The station is maintained for communication with amateur stations throughout the world, and already very satisfactory reports have been received.

**Want to Buy It?**

A complete wireless station is for sale. This station is built on one of the Seychelle Islands, in the heart of the Indian Ocean. It was built during the war for the Navy, but as the Admiralty no longer requires it the Governor of Seychelle has invited tenders from anybody who wants to buy it en bloc.

**Broadcasting's Birthday**

On November 14th, the B.B.C. celebrated its sixth birthday. It seems long ago now since we first visited the B.B.C.'s old studio on the top floor of Marconi House, when the microphones were suspended by pieces of string from the ceiling, and everything was very rough and ready.

Despite, however, the drawbacks which the old B.B.C. suffered from in the early days of broadcasting, there was a spirit of adventure and dash about the whole business which, alas, to-day is rather lacking at Savoy Hill,

(Continued on page 704.)

**"UTILITY" MITE CONDENSER**

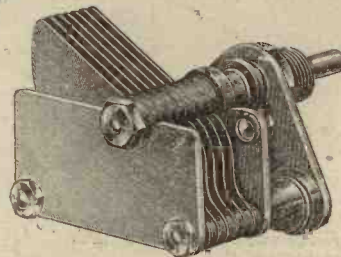

**Demand effects a Price Reduction**

The constructor of small sets has welcomed the "Utility" space-economising "Mite" Condenser. So much so that the large demand has enabled us to effect an all-round reduction of prices—the new figures are below. It should be noted that this small article is guaranteed efficient—its principle is that of our standard Condensers and it will give every satisfaction in use.

Cap.	With Dial	Less Dial	Vernier
-0005	7/6	6/6	10/-
-0003	7/-	6/-	9/6
-0002	6/3	5/6	9/-

**"UTILITY" POPULAR CONDENSERS WITH THUMB-CONTROL TUNING**

Experimenters who desire the advantage of thumb-control tuning may now obtain the popular "Utility" Square Law and Logarithmic pattern Condensers equipped with a fully guaranteed device of this kind. The action is delightfully smooth, and free from backlash, and the ratio wide enough to give really fine adjustment.

**PRICES:**

Cat. No.	Cap.	With T.C. Adjustment	Condenser only
191	-0005	13/-	8/6
192	-0003	12/-	7/6
193	-0002	11/-	6/6

"Utility" Components may be seen at your local Wireless Dealers. They offer you the highest possible quality at a reasonable price, and every article carries a fully protected guarantee.

**Utility GUARANTEED COMPONENTS**

Made and Guaranteed by

**WILKINS & WRIGHT, LTD.,**  
"Utility" Works, Holyhead Road, Birmingham.

Your Local Wireless Dealer Stocks "Utility" Components

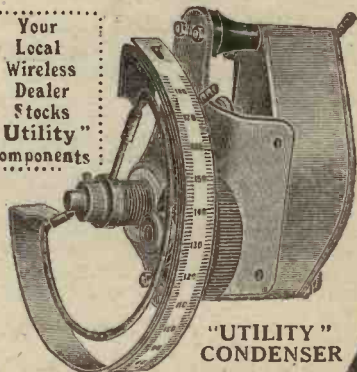

**"UTILITY" CONDENSER WITH THUMB-CONTROL TUNING**



**THE  
"M.C. DRIVER"**

In connection with the article appearing in this issue by Mr. G. V. Colle, the following components are being supplied from stock.

- SUPRECISION Transformer, No. 783, 275+275 v., 100 m/a. 26-
- SUPRECISION CHOKE, No. 757, double wound, taking the place of two 14-henry L.F. . . . 20-
- Condensers C1 & C2, 0.1 mfd. 5-
- "      C3      4 mfd. 11-
- "      C4      8 mfd. 19 6
- "      C5      4 mfd. 11-
- Raytheon Valve, Type B.H. 32 6

Full details of all Eliminator components with diagrams are contained in the interesting list No. 935.

Write, 'phone or call,

**F. C. HEAYBERD & CO.**  
8/9, Talbot Court, Eastcheap, E.C.3.  
(One Minute from Monument Underground Station.)

**RADIO NOTES AND  
NEWS OF THE MONTH**  
—continued from page 703

where organisation has been so perfected that the tinge of Robotism is very apparent.

**Murder Trial Broadcast**

In Mexico City arrangements were made to broadcast the proceedings of the trial of Jose Leon Toral, who has been accused of the assassination of General Obregon. This is probably the first time in which a murder trial has been broadcast by the State, and the step has been taken in view of the tremendous interest shown in the trial.

**"M.W." Sets Demonstrated**

London readers who doubt their own constructional powers, but who would like a "Three-Band" Two, or the "S.G.P." Three, will be glad to know that the Ready Radio Supply people are supplying these sets fully made up. These two, and other popular "M.W." sets, can now be heard in action at the firm's new showrooms at 159, Borough High Street, London, S.E.1.

**Berlin Begins**

The Koenigswusterhausen wireless station in Germany commenced the trial of broadcasting pictures by the Fulton system on Tuesday, November 20th, at 9.45 G.M.T. If any of our readers picked up these transmissions we should be very glad to hear from them.

**COMMANDER KENWORTHY, M.P.**

WRITES IN

**The "P.W." Xmas Number  
"If I Were P.M.G."**

*A provocative article which you will enjoy reading.*

Don't forget the date—December 6th—"P.W." on Sale.  
Price 3d. as usual.

**ACCLAIMED—THE BEST!**

"The HALL MARK by which your Set is judged and admired."

FOR  
FINEST  
DRAWING  
ROOM  
SETS.



AT  
MAKERS'  
PRICES,  
£100!

For  
Every Set.

"RADIOLA" de luxe

THE CABINET USED FOR "BIG BEN"  
BY PERCY W. HARRIS.

From £5-5-0 up to £25.

**SNUG. TROUBLE-FREE. STYLISH.**  
THE LUXURY OF £50 to £100 RECEIVERS.

Over 3,000 delighted clients have bought Pickett's Cabinets THROUGH THE POST. Every Cabinet is sent ON APPROVAL. Guaranteed complete satisfaction.

A Useful Present for Xmas

LET US HELP YOU. Send for lists to actual makers.—



ALBION ROAD, BEXLEYHEATH.  
Near London.

**Misleading Motorists**

Motorists and cyclists noticed a curious error in broadcasts by the B.B.C. not so very long ago. Part of the ordinary news bulletin included a notification of lighting-up time, and on recent Saturdays this time has been incorrectly stated by half an hour. Complaints have been received at Savoy Hill, and the B.B.C. has admitted that the times which were handed to it by the News Agencies were inaccurate. The matter, however, has now been corrected.

**Relay Wave-lengths**

This month all relay stations will broadcast on one exclusive wave-length, viz., 288.5 metres. This alteration, which we recorded in a recent issue of MODERN WIRELESS, is being made because of considerable interference with the B.B.C. relay transmissions. In congested areas it has been found that reception during transmitting hours is seriously interfered with by foreign stations broadcasting on the same common wave-length.

It is hoped that by broadcasting from relay stations on an exclusive wave-length this heterodyne interference will be eliminated.

**The "Vestris" Tragedy**

The tragedy of the "Vestris" would undoubtedly have been worse had it not been for the saving value of wireless at sea. The Marconi Company point out that over eight thousand lives have been saved directly by wireless in connection with major disasters at sea during times of peace.

**Standing on the "Wall"!**

A message from New York reports that the wireless on board the "Vestris" was handled with the greatest skill from the time the first S.O.S. signal was sent out at 2.57 G.M.T. on November 12th, until the ship was abandoned at 6.20 p.m.

According to reports, the operator, Mr. O'Loughlin, was reduced to transmitting his messages while standing on the "wall" of the wireless room, which had become the floor, owing to the terrible list of the ship.

**The Emergency Equipment**

The "Vestris" was equipped with a Marconi 1½-kilowatt installation, with emergency apparatus; a continuous long-wave transmitter for special service; and a valve receiver.

(Continued on page 705.)

**RADIO NOTES AND NEWS OF THE MONTH**  
—continued from page 704

The set of the "Vestris" was strong enough to enable the ship to carry out communication to distances up to 1,500 miles with its C.W. apparatus, and up to 500 miles on its main spark transmitter. The latter set would be used for the S.O.S. signal.

**When the Dynamos Fail**

Further reports from New York say that the wireless operator of the "Vestris" was able to carry out communication for three hours on his main installation, and then to continue communication with his emergency set until the ship had to be abandoned. The main set would have been fit to operate as long as the ship's dynamos were working, and the operator would then have to change over to his emergency set, which is operated by battery power, owing either to the abandoning of the engine room, or because water had put out the fires and cut off the steam power.

**Then and Now**

It is interesting to remember that wireless was introduced into the British Merchant Service in 1901, when the Marconi Company fitted the Beaver Line Steamship, "Lake Champlain," with apparatus. To-day there are very few ships of importance not fitted with wireless gear. From 1901 until the present day no fewer than 6,000 British merchant ships have been fitted with Marconi apparatus. At the present moment there are over 15,000 ships throughout the world which are equipped with the Marconi gear.

**The "Titanic" Tragedy**

The life-saving possibilities of wireless were first brought home to the public in 1899, when the East Goodwin Lightship, which had just been fitted with transmitting gear, called for assistance when it was struck in a fog by a steamship.

Perhaps the most dramatic example of the use of wireless was when the "Titanic" sank in 1912. Undoubtedly, had it not been for wireless the loss of life, terrible as it was, would have been far greater, and possibly the fate of the "Titanic" might never have been really ascertained definitely.

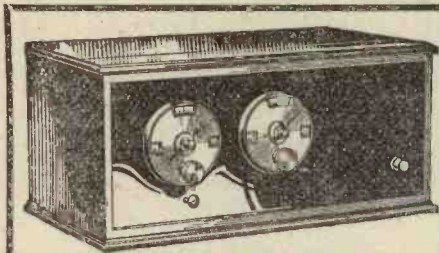

**MULLARD MASTER 3\***

This new and wonderful set must appeal to young and old, amateur or experimenter—in fact, EVERYBODY!

**These Components are those ACTUALLY AS SPECIFIED BY MULLARD**

**BEWARE SUBSTITUTES**

	£ s. d.
3 Lotus valve holders .. . . .	3 9
Colvern combined wave coil .. . . .	17 6
Mullard Permacore, L.F. .. . . .	1 5 0
Climax "L.F.A.," L.F. .. . . .	1 5 0
Climax L.F. choke .. . . .	7 6
Benjamin battery switch .. . . .	1 3
J.B. 0005 log variable .. . . .	11 6
J.B. 00035 log variable .. . . .	10 6
Mullard 0003 and 2 meg. .. . . .	5 0
Mullard 0001 .. . . .	2 6
Magnum Brackets .. . . .	2 6

**£5 : 12 : 6 Carr. Pd.**

**PLEASE ADD 3/6 AND I WILL SEND WITH KIT OF PARTS**

Actual value of above Accessories is 21/-

**MULLARD VALVES.**  
2-v. 4-v. 6-v.  
P.M.1 H.F. P.M.3 P.M.5X  
10/6 each.  
P.M.1 L.F. P.M.3 P.M.5X  
10/6 each.  
P.M.2 P.M.4 P.M.6  
12/6 each.

**H.T. BATTERIES**  
Siemen's 100 v.  
L.T. Exide or  
Oldham 2v. 45 amp.

**COSSOR/NEW MELODY KIT OF PARTS FOR ABOVE**

	s. d.
Metal cabinet, complete with terminals and strips, baseboard, wire, flex, etc., screen assembly, grid bias 9 volts, and clips. The lot .. . . .	17 6
Ormond push-pull switch .. . . .	1 3
2 Ormond log 0005 .. . . .	12 0
2 Cossor pat. S.M. dials .. . . .	9 0
Peto-Scott 0001 .. . . .	4 6
Peerless 6 ohm .. . . .	2 0
5 W.B. valve holder .. . . .	5 0
Wearite H.F. choke .. . . .	6 6
3 T.C.C. condensers .. . . .	8 0
Dubilier 3 meg. .. . . .	2 6
3 1/2-1 ratio L.F. .. . . .	15 0
2 v. screened grid .. . . .	22 6
2 v. Power valve .. . . .	12 6
2 v. R.C. valve .. . . .	10 6

**Total £6 : 8 : 9 CARR. FWD.**

**WITH ABOVE KIT (only) YOU CAN BUY (Actual List 25/-)**  
2 B.B.C. Wound Coils .. . . . for 2/6  
2 5 X X ditto .. . . . for 2/6  
For Cossor New Melody.

**K. RAYMOND**

27 & 28a, LISLE ST., LONDON, W.C.2

Coms to L'FICESTER SQUARE TUBE.  
This address is at the back of Dalv's Theatre. Phones: Gerrard 4637 and 2821

**HOURS OF BUSINESS** EVERY DAY 9 to 8  
SATURDAY 9 to 9  
SUNDAY MORN 11 to 10

**SPEAKER CABINETS**

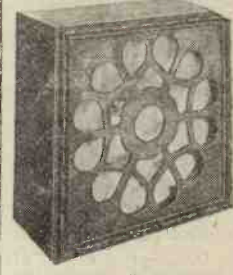

Takes 10-in. Cone, 9/11; 12-in. Cone, 12/11; 15-in., 16/11. Handsomely Polished Oak Finish. Will take Blue Spot. By post 1/3 extra.

**BLUE SPOT UNIT** 25/-  
68K. 101. Balanced Armature

Quotations for Sets of Parts over 20/- in value. Customers are requested to make out List (if for a particular circuit please give title, date, and name of paper). Lowest possible estimate given. Please write plainly.

**Copper Screens Aluminium Screens**

12x6, 10x6, 9 1/2 x 6 in stock.  
M.W. Screening Boxes, 12/6

**If its Wireless You Want Try Here First**

**Loud Speakers**

- Ediswan One-Der 50/-
- M.P.A. Plaque .. 29/6
- Philips' Seven' Corner .. 50/-
- Amplion Cabinet 60/-
- Do., Mahogany .. 63/-
- Ferranti .. 63/-
- Amplion .. 35/-
- Amplion .. 60/-
- Wonder .. 19/11

Ebonite cut while you wait at 1/4 square inch, also 1 inch at 1/4. Only the best supplied. Drilled Panels for all Circuits.

**AMERICAN TYPE CABINETS, from 10x7 to 21x7, IN STOCK.**

**LISSEN**  
Valve-holders, 1/-; Fixed Con., 1/-, 1/6; Leaks, 1/-; Switches, 1/6, 2/6; Latest 2-way Cam Vernier, 4/6; Rheostats, 2/6; B.B., 1/6; Lissenola, 13/6; L.F. Transformers, 8/6; Coils, 60X, 6/4; 250X, 9/9; 60-v. H.T., 7/11; 100-v., 12/11; Super 60-v., 13/6; Grid Bias, 1/6; 4-5, 5/4; Super L.F., 19/-; Variable 0003, 6/-; 0005, 6/6.

**OUR NEW CATALOGUE 1/- LATEST UP-TO-DATE SETS & COMPONENTS.**

**MULLARD SCREENED GRID & PENTODE VALVES.** 2 and 4 volt.

**BRANDES**  
Wonderful Slow Motion Variable Condensers, with Dial 0005, 12/6; 0003, 12/-; Matched Headphones, 8/- pair, 4,000 ohms. L.F. 3-1, 12/-; 5-1, 12/6.

**MULLARD VALVES LEADING STOCKIST**

Brands Table Talker, 30/-  
Brandola Horn Type, 50/-  
The Ellipticon Cone Speaker, 77/-

We stock Igranite, Climax, Ever-Ready, Hellesen, Siemens, Formo, Ferranti, Wearite, Ormond, J.B., Benjamin, Lotus, Mullard, Dubilier, Lissen, Lewcos, Utility, Magnum, Peto-Scott, Peerless, Burdett, Eye, Marconi, McMichael, Cosmos, Carborundum, R.I. & Varley, Gambrell, Brown's, Sterling, Amplions—in fact, everything it is possible to stock in Radio-Paris.

**C.O.D.** Orders accepted U.K. over 5/- in value. All orders sent in strict rotation.

**COUPON "Modern Wireless" (Dec., '28)**  
Only one coupon on any one order.

If you spend 25/- or more you can buy for 3d. extra any one (only) of the following:

- S.M. Dial, 100 ft. 7/22 Indoor Aerial, 12 vds.
- Lead-in, Fuse and Holder, 12 Nickel Terminals,
- 60X Coil, H.F. Choke, Permanent Detector,
- Battery Switch, 0003 and 2-meg. Leak, 9-volt
- Grid Bias, Panel Brackets, 6-pin Coil Base,
- 100 ft. Insulated Aerial, Loud Speaker Silk Cord,
- 30 ft. Covered Connecting Wire, Ebonite Panel,
- 9 x 6.

**ONLY AVAILABLE AT K. RAYMONDS**

# how to make sure of your panel.....



Drilling "Resiston" is simple. The long, unbroken "chips" curl away from the drill point, leaving a clean hole free from ragged edges or cracks.

A cheap panel may be very costly in the end. But how, you ask, is it possible for an ordinary person to tell whether the quality of an ebonite panel is good or bad? To make sure of obtaining an ebonite panel guaranteed to be of the highest grade it is only necessary to specify "Resiston."

"Resiston" panels contain a higher percentage of pure rubber than any panel on the market.

Guesswork has been eliminated. The old idea of a panel cut from the sheet has gone. To-day you purchase a "Resiston" panel cut squarely to size, with its edges accurately ground, its surface beautifully polished, packed carefully in a stout manilla envelope. No waste—either in time or material—you buy exactly the size you need. There are sixteen sizes from which to make your choice.

**Send for new booklet.**

Please send me, free, a copy of your new booklet, "The Panel Makes all the Difference."

M.W. Dec.

NAME .....

ADDRESS .....



6437

## RADIO ABROAD

—continued from page 674

verdict holding the Municipality of Lakeside criminally responsible for the woman's death.

### Hungarian Comforts

The Hungarian State railways are making a new departure, in connection with the comfort of passengers in trains, by introducing radio headphones for each seat in all classes of carriage. The first train so provided will run at the end of the present month, and a fee of 3d. will be charged for the service. The broadcast receiver, which supplies the headphones throughout the train, is fitted into a special compartment and is under the care of a qualified operator.

### Radio Trams

The transmission of power by radio has been a dream of engineers for many years past, and, on a small scale, it is correct to say that radio power transmission has been accomplished. But experiments on a much larger

## BUY THE BEST.

All the articles in "Popular Wireless" are written

## BY THE BEST

radio contributors and set designers. Why not get authoritative information from

**POPULAR WIRELESS?**

Every Thursday. Price 3d.

scale are now taking place in a large works on the Continent, with a view to transmitting power to tramcars and like vehicles without the need for an overhead trolley wire or any live rail or other conductor.

### Poulsen Arc

The power is, of course, transmitted by means of high-frequency waves, a 20,000-cycle Poulsen arc being used, and the received power being converted by means of a mercury-arc rectifier. If this system proves practicable it will mean that great simplification will be made in the running of municipal vehicles and an enormous reduction in cost. Such vehicles will, in fact, have the freedom and mobility of motor-buses, whilst being as clean and easily handled as electric mcars.

## Canadian Affairs

The control of broadcasting in Canada is likely to be in the melting-pot in the near future, since a Federal Radio Investigation Committee has been appointed in Ottawa to go into the whole question as to whether broadcasting should continue under private ownership or whether the Dominion should follow the more or less government monopoly system as in this country.

## Finland

A new 35,000-watt broadcasting station, operating on 1,525 metres, has now commenced operations in Lahtis, Finland.

## Edison on the Radio

Mr. Thomas Edison, the famous inventor, is to place on the market, through one of his companies and in co-operation with the Splitdorf Company, a combined electric gramophone and radio receiver.

An American contemporary waggishly remarks that these sets must be intended for listening entirely to the sporting events, since, according to Edison's statement some few months ago, this is about the only useful service which can be rendered by so unmusical a device as a radio receiver!

## Circuit Diagrams in Braille

The construction and wiring of radio receivers is now a standard form of work in blind institutions, and the American Braille Press, in co-operation with a French radio concern, has published constructional details and wiring diagrams printed in the Braille system, the wiring diagram being in relief dots. The framework is provided with tuning dials marked with raised characters.

## Europe to Canada

Radio telephone service from England to Canada has been extended so that subscribers in Belgium, Germany, Holland, Sweden, and France may also be served.

Ordinary cables connect these countries to the English transmitter at Rugby and telephone connections are made in the usual manner. From Rugby the voice currents go by radio to Canada.

## A New Zealand Broadcast

During a recent flight from Australia to New Zealand, a distance of about 1,200 miles, the pilot, Captain Kingsford-Smith, sent frequent radio reports of his progress and these were relayed by New Zealand broadcasting stations.

(Continued on page 707.)

**RADIO ABROAD**  
—continued from page 706

**Wireless Wedding**

The first "official" radio wedding took place in New York recently during the Radio World's Fair, when the minister officiated at one place, the music was played at another place and transmitted by radio, and the bridal couple were in a third place, the three "parties to the contract," so to speak, being in communication by radio. The whole ceremony was broadcast through station W G B S.

**Radio World's Fair**

This Radio World's Fair appears to have been a most extraordinary event. One of the other interesting items was the Coronation of the Radio Queen of America for 1928-29, the honour falling upon a Miss Lita Korbe. Madison Square Gardens, to the tune of 60,000 sq. ft. of floor space, was converted for the purposes of the Fair, and it is computed that over a million dollars' worth of radio apparatus was on show.

**Encouraging the Constructor**

An interesting item for the experimenter and set-builder was the award of a special gold medal by the promoters of the Exhibition for the set which, in their opinion, represented the highest achievement in amateur set-building.

**South Africa's Complaint**

Listeners in South Africa are, of course, more dependent upon D.X. transmissions than we are in England, and consequently they are more concerned about the nature of the programmes and announcements in America and various parts of Europe than British listeners are.

In the "Christian Science Monitor," Boston, U.S.A., recently was a letter from a radio listener in Bloemfontein who said that ordinary radio enthusiasts found it very difficult to follow the American announcers, owing to the fact that they spoke so rapidly. K D K A apparently is not so bad as W G Y and certain other stations. Chelmsford, England, and P C J J, Hilversum, Holland, are singled out for special praise, in that the announcements are distinct in every word.

**Submarine Telephony**

The British Post Office and the American Telephone and Telegraph  
(Continued on page 708.)

**N  
O  
R  
A  
D  
I  
O  
W  
I  
T  
H  
O  
U  
T  
D  
A  
R  
I  
O**



**DARIO**

**VALVES**

**—AND THE CHEAPEST WAY, TOO,**

guaranteeing utmost satisfaction. Just look at the prices below—made possible by reason of the biggest valve output in the world. Radio without Dario can never be radio at its best. SUPERLATIVE FINISH—LOWEST CONSUMPTION.

2	V 0 L T	General Purpose.	5/6
		.05 amp.	
		R.C.C., .06 amp.	
		Super-Power, 18 amp.	

4	V 0 L T	General Purpose.	7/6
		.05 amp.	
		R.C.C., .07 amp.	
		Super-Power, 1 amp.	

From your dealer or direct:

**IMPEX ELECTRICAL, LTD.**

(Dept. L.)

538, High Road, Leytonstone, E.8.

**5'6**

Irish Free State  
Agent:  
**BURWOODS,**  
of Cork.

**7'6**

**RADIO ABROAD**

—continued from page 707

Company have decided jointly to build additional transmitters for the Atlantic telephone service. At present two channels are available, and it is expected that a third transmitter will be in operation by next July, whilst the construction of a fourth transmitter is under consideration.

**Competition**

In the meantime, it was announced by the Bell Telephone Company, of New York, that a special submarine cable had been perfected which is capable of carrying telephony with the same facility as an ordinary short-distance land-line; furthermore, that the construction of a transatlantic telephone cable was now under consideration.

If this is correct it seems that a serious rival to the radio transatlantic transmitter is likely to enter the field, particularly as the submarine telephone cable service would not be liable to interference from the various causes well known in connection with radio transmission.

**Radio in Mining**

According to information from Paris, an ingenious system has now been perfected for discovering the whereabouts of metals and metallic ores by means of radio. This latest discovery, which follows upon announcements of somewhat similar efforts during the past two or three years, has been made by a Roman Catholic priest, and he has carried

out considerable experiments in the Pyrenees. The apparatus used locates the position of the metallic deposits by means of their effect upon an oscillatory circuit, somewhat after the fashion of the old Hughes' balance. It is expected that gold, platinum, and silver will be located in the mountain range.

Two important dates to remember.

"P.W." SPECIAL CHRISTMAS NUMBER

**On Sale December 6th.**

"WIRELESS CONSTRUCTOR" CHRISTMAS and NEW YEAR NUMBER

**On Sale December 14th.**

Prices as Usual.

**Shielded Plugs**

The United States Bureau of Aeronautics has been carrying out experiments designed to suppress interference which arises in aeroplane sets from the ignition system of the aeroplane engine.

In collaboration with a well-known firm of radio manufacturers, they have now discovered how to make specially shielded sparking-plugs, and, according to reports, the interference from the ignition to the aeroplane receiving set is reduced to such a small amount that the range of the aircraft receiver is more than doubled.

**Trouble in India**

The merger between Imperial Wireless and Cables has caused a good

deal of dissension in India, and at the meeting of the Indian Assembly at Simla recently a special motion was carried with the intention of having an investigation into the merger from the Indian financial standpoint. Part of the complaint seems to be that India has not been sufficiently represented at the Imperial Wireless and Cables Conference.

**Radio Below Zero**

When Commander Byrd, the well-known American explorer, sets out on his forthcoming expedition to the Antarctic, he will take with him five portable transmitters with batteries encased in special boxes lined with wool. He has arranged a special and very ingenious system whereby the various exploring parties, whether travelling by sledge or by aeroplane, shall remain in constant communication with the base and with the supply ship by means of radio.

The portable transmitters, which will be called upon to operate under weather conditions of exceptional severity—in some cases the temperature being 60 to 70 degrees below zero—have been designed by the Burgess Laboratories of Madison, Wisconsin.

After a good deal of experiment with various types of batteries, it has been found advisable to carry special dry batteries for this work.

**"Lost and Found"**

An American station (W B G S, New York) has lately started a useful little item in its daily broadcast which consists of announcements of "Articles lost and found." This is well appreciated by the public.

**INDEX TO ADVERTISERS**

American Hard Rubber Co., Ltd.	PAGE 706
Amalgamated Press Annuals	682
Baker's Selhurst Radio	701
Bedford Electrical & Radio Co., Ltd.	689
Belling & Lee, Ltd.	687
Benjamin Electric, Ltd.	681
Bird, Sydney S. & Sons, Ltd.	687
Bond, V. C., & Sons, Ltd.	703
Bowyer-Lowe Co., Ltd.	695
British General Mfg. Co., Ltd.	695
British Thomson-Houston Co., Ltd.	667, 689, 693
Brown, S. G., Ltd.	582
Burne-Jones & Co., Ltd.	686
Burton, C. F. & H.	690
Carrington Mfg. Co., Ltd.	695
Celestion Radio Co.	701
Clarke, H., & Co. (M/cr.), Ltd.	669
Cossor, A. C., Ltd.	584
Colvern, Ltd.	671
Day, Will, Ltd.	699
Dublier Condenser Co. (1925), Ltd.	683

Edison Swan Electric Co., Ltd.	PAGE 691
Eastick, J. J., & Sons	702
Ever Ready Batteries	663
Electradix Radios	699
Ferranti, Ltd.	661 and 692
Forno Company	695
Gambrell Radio, Ltd.	703
Garnett, Whiteley & Co., Ltd.	Cover iii
General Electric Co., Ltd.	671
Gilbert, J. C. (Cabinets)	691
Graham Ampion, Ltd.	561
Hayberd, F. C., & Co.	704
Holzman, Louis	701
Hughes, F. A., & Co., Ltd.	679
Harlie Bros.	700
Igranite Electric Co., Ltd.	685 and 703
Impex Electrical, Ltd.	707, 697, 699, 703
Jackson Bros.	685
Lampugh, S. A., Ltd.	700
Lewis, S. W., & Co., Ltd.	693
Lissen, Ltd.	651 and 655
London Elec. Wire Co. & Smiths, Ltd.	677
Lectro Linx, Ltd.	689
Lyons, Claude, Ltd.	701
Makerimport Co.	699
Metro-Vick Supplies, Ltd.	673
Morris, J. R.	697
M.P.A. Wireless, Ltd.	675
Mullard Wireless Service Co., Ltd.	Cover iv

Philips Lamps, Ltd.	PAGE 659
Faroussi, E.	691
Peto-Scott Co., Ltd.	685
Pickett's Cabinet Works	704
Premier Accumulator Co. (1921), Ltd.	693
"Popular Wireless"	680 and 683
Raymond, K.	705
Ready Radio Supply Co.	696
R. I. & Varley, Ltd.	Cover ii
Ripaults, Ltd.	694
Rothermel Corporation, Ltd.	563
Regent Fittings Co.	697
Six-Sixty Radio Company	685
Sifam Electrical Inst. Co., Ltd.	697
Taylor, M.	703
Telegraph Condenser Co., Ltd.	681
Truphonic, Ltd.	695
Westinghouse Brake & Saxby Signal Co., Ltd.	698
Wilkins & Wright, Ltd.	703
Whiteley, Boneham & Co., Ltd.	609

All communications concerning advertising in "Modern Wireless" must be made to John H. Lile, Ltd., 4, Ludgate Circus, London, E.C.4. Telephone: City 7261

# Best for Any Set

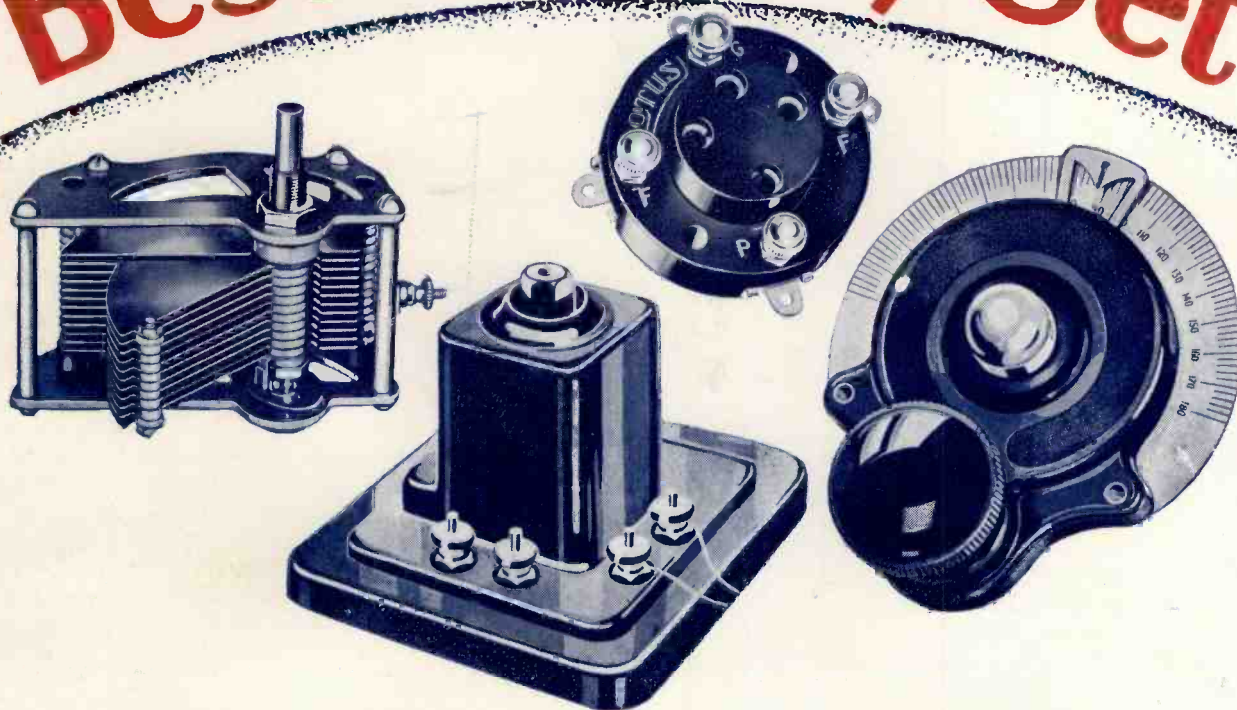

What better present for your wireless friend than a set of Lotus components for his new set? Anyone who is making a Mullard Master Three Star, Cossor Melody Maker, or any other popular circuit will welcome a present of these accurate, reliable components.

For the household there is an ideal present for which everyone will thank you—a Lotus Remote Control, providing simultaneous reception and independent control in every room!

*From all wireless dealers.*

## LOTUS COMPONENTS

*Made by the makers of the new Lotus Sets.*

Garnett, Whiteley & Co., Ltd., Lotus Works,  
Broadgreen Road, Liverpool.

*Have you had the new Lotus Booklet? This little Booklet comes free on receipt of a postcard to Garnett, Whiteley & Co., Ltd. It tells you all about the new Lotus Screened and Pentode Valve sets. If you do not possess a copy, send for it to-day!*

*The Experts*



The Valve with  
the wonderful  
Mullard P.M. filament.

**Mullard**

**THE · MASTER · VALVE**

MULLARD WIRELESS SERVICE CO., LTD., MULLARD HOUSE, DENMARK STREET, LONDON, W.C.2

ARKS