

MODERN WIRELESS



November.

1/-

Vol. 2. No. 2.

Edited by JOHN SCOTT-TAGGART, F.Inst.P., Member I.R.E.

November, 1923.

Special Autumn Home Construction number

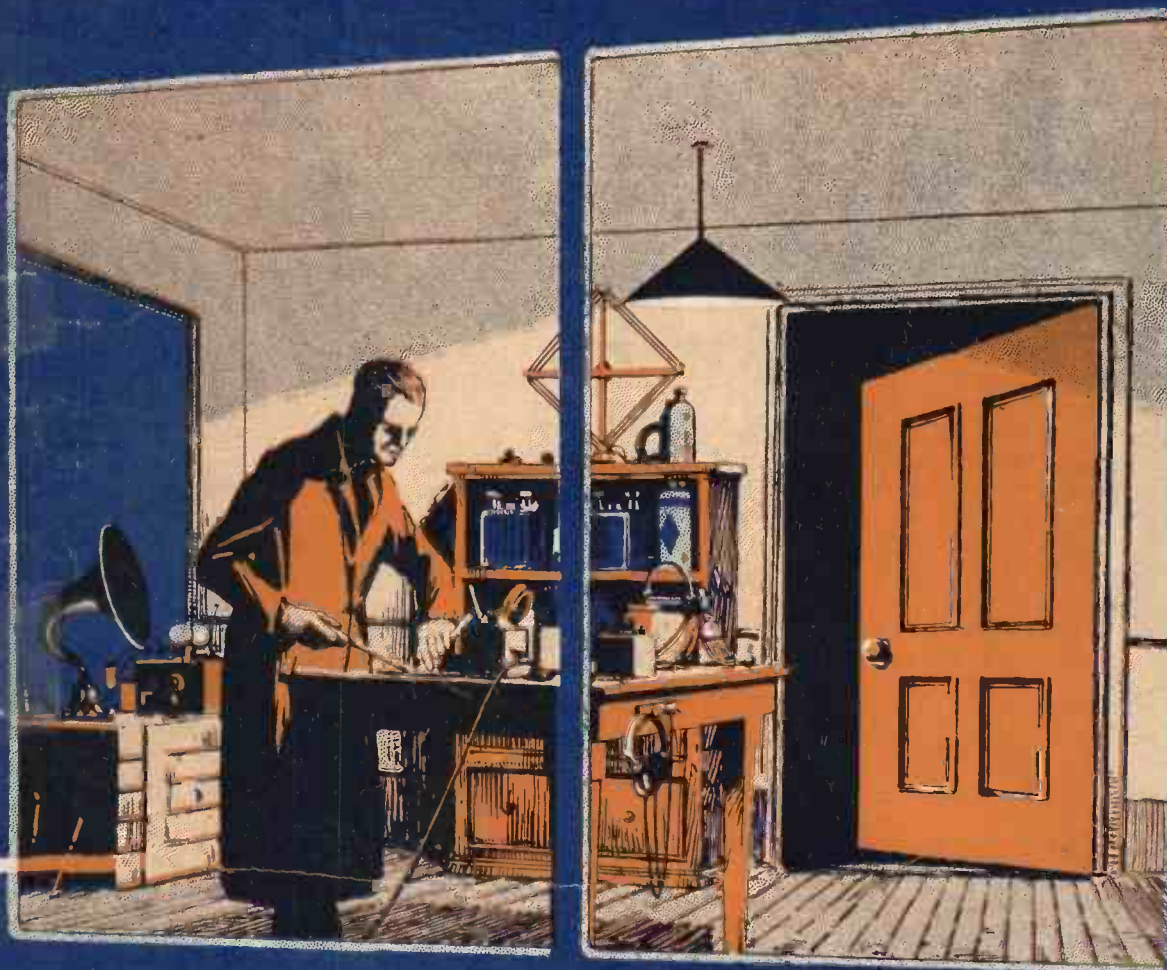

eps

Vol. II.

No. 2

SPECIAL ARTICLES ON HOW TO MAKE:

- A HIGHLY SENSITIVE THREE-VALVE SET. *By Percy W. Harris.*
- A CRYSTAL RECEIVER WITH WAVE-TRAP. *By G. P. Kendall, B.Sc.*
- A PORTABLE ST 100 RECEIVER. *By John Scott-Taggart, F.Inst.P.*
- A HETERODYNE WAVEMETER. *By Alan L. M. Douglas.*
- A SINGLE VALVE-NOTE MAGNIFIER.
- ACCESSORIES FOR PEANUT VALVES.

FRAME AERIALS.

LOUD SPEAKERS.

CRYSTAL HOLDERS.

FREE WITH THIS ISSUE—"JUNIOR WIRELESS." A 16-PAGE MAGAZINE FOR BOYS.

WECOVALVES

(PEA-NUT TYPE).



No. 44215—A.

PATENT Nos. 17580 (1915) 180090 (6641-1921).

Dimensions : 2½ in. × ⅝ in.

Price - - - £1 10 0

THE WECOVALVE.

THE new wireless valve which is to revolutionise wireless reception. Only 2½ inches high and ⅝ inches in diameter, this small size valve can be used equally well either as a detector or amplifier and operates off a single dry cell, no accumulators being necessary. The **WECOVALVE** is the most economical valve existent, requiring only 0.25 of an ampere at 0.8 to 1.1 volts, and its life is more than twice that of tungsten and other dull-emitter valves. The **WECOVALVE** has a special Bayonet Cap which prevents the possibility of destruction through careless insertion in the valve socket.

Operating Characteristics:—

Filament Current 0.25 amps.

Detector Plate Voltage 17 - 22 volts.

Filament Voltage 0.8 - 1.1 volts.

Amplifier Plate Voltage 22 - 45 volts.

THE SOCKET.

This **WECOVALVE** socket is arranged for four soldered connections and has contact points faced with a gold and silver alloy which ensure perfect contact with the base of the valve.

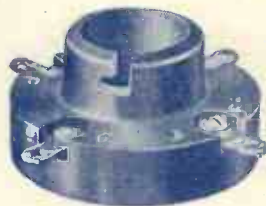

No. 44090.

Dimensions : 1½ in. × ⅜ in.

Price 1s. 6d.

THE ADAPTOR.

The **WECOVALVE** adaptor makes it possible to use the Weco Valve in your existing sets. Designed to fit into valve sockets which carry the ordinary four pin type valves, this adaptor enables everyone to take advantage of the great economy in current consumption which the use of the Weco Valve effects.



No. 44092.

Dimensions: 1½ in. x 1¼ in.

Price 3s. 6d.

WRITE FOR BOOKLETS—

W.E. Co./32/W. 528 & W.E. Co./32/W. 529.

Western Electric Company Limited.

(Wholesale Only)

Connaught House, Aldwych, London, W.C.2. Telephone: Central 7345 (9 lines).

Branches: Glasgow, Leeds, Birmingham, Manchester, Newcastle, Cardiff, Southampton, Dublin.

The LISSENIUM AGE—

LISSEN parts anticipate to-morrow—

To aid users in obtaining the highest possible efficiency we have seen to it that there is a LISSEN part for every purpose. LISSEN made throughout, every part places at the user's command a service and efficiency which will sustain the fine tradition of the LISSEN Factory. Up to the present more than thirty times as many LISSEN parts have been bought in 1923 as in 1922. Why? Because it has been found worth while to fit LISSEN parts. If you build your set you have got to use it—if you fit one LISSEN part you can depend upon it—if you fit all LISSEN parts you can depend upon the set. WE EXPECT TO HEAR FROM YOU IF YOU ARE NOT SATISFIED.

AMERICAN TELEPHONY ON THREE VALVES ONLY —but ALL LISSEN PARTS

Several reports have come to hand recently of American Telephony being received on 3 Valves only—but using ALL LISSEN PARTS, 1 LISSEN REGENERATIVE REACTANCE for 1 stage H.F., 1 DETECTOR and 1 H.F. A standard circuit was used.

Build—with ALL LISSEN PARTS!

1. SUCCESSFULLY USED in the reception of AMERICAN TELEPHONY—LISSEN REGENERATIVE REACTANCE replaces aerial reaction—non-radiating—introduced into the anode circuit, it forms an unequalled first stage radio frequency! Cheaper, easier to handle than plug-in coils **5/6**
2. Rapid tuning is possible with the LISSEN REACTANCE—adds range, power and steps up signals like a good audio-frequency transformer **32/6**
3. USERS SAY LISSENSTAT CONTROL is the "most beautiful control imaginable," and it is! The interposition of the elastically deformable metal discs—there lies the secret of that perfectly free movement of the whole resistor column of the LISSENSTAT. This feature CANNOT BE DUPLICATED, FOR IT IS PROTECTED BY DEFINITE PATENT CLAIMS ... **7/6**
4. LISSEN VARIABLE GRID LEAK—for correct grid potential—continuously variable $\frac{1}{2}$ to 6 megohms. Positive stops both ways ... **2/6**
5. LISSEN VARIABLE ANODE RESISTANCE—continuously variable 20,000 to 250,000 ohms—for dual, super-regenerative circuits, etc. Positive stops both ways. Same size and appearance as LISSEN Variable Grid Leak **2/6**
6. LISSEN T₁ TRANSFORMER, an incomparable Transformer. Use it always immediately behind the Detector Valve and for pure power amplification ... **30/-**
7. LISSEN TUNER—sharp tuning on all wavelengths—convenient and compact—150 to 4,000 metres ... **22/6**
8. LISSENAGON COILS—there are three extra numbers in the series, Nos. 30, 40 and 60. This makes all the difference in tuning over the lower wavelengths, and obviates the use of excessive capacity. These coils are intermediate between 25 and 35, 35 and 50, and 50 and 75 ... Price, 30 coil, 4/10, 40, 4/10, 60, 5/4
9. LISSEN MICA VARIABLE CONDENSER—low resistance, no losses, signal strength always great, .001, .00025, and .0005... **17/6**
10. LISSEN VERNIER ADJUSTER—adds vernier adjustment to any existing condenser—drill one hole close enough to bevelled edge of condenser dial so that depression of adjuster engages its rubber friction washer on dial **2/-**

Other LISSEN PARTS include LISSEN T₃ TRANSFORMER. An excellent light Transformer. One of the best made ... **16/6**

LISSEN T₂ TRANSFORMER ... **25/-**

LISSEN FIXED CONDENSERS, .0001 to .0009 2/-, .001 to .003 2/6, .001 to .006 3/-

There are other Lissen Parts as well.



LISSEN PARTS INCLUDE EVERYTHING you need to go behind your panel

LISSEN PARTS have done away with all the bother of fitting—they go together easily—THEY ARE THE LARGEST SELLING PARTS

LISSEN PARTS ARE SOLD EVERYWHERE—should any attempt be made to sell a substitute, send direct to factory. No postage charged DEALERS—claim your liberal stocking discount—all Radio, Motor, Electrical and Hardware Factors sell Lissen Parts—or send direct

LISSEN LIMITED

20-24, WOODGER RD., GOLDHAWK RD., SHEPHERD'S BUSH, LONDON, W.12

N.B.—Close to Goldhawk Road (Met.) Station, Shepherd's Bush (Central London) or Hammersmith Tube. Buses 11 and 32. Phone: 1072 Hammersmith.

BUILD—WITH ALL LISSEN PARTS!

H.T.C. TRANSFORMERS

reduce distortion to the absolute minimum.

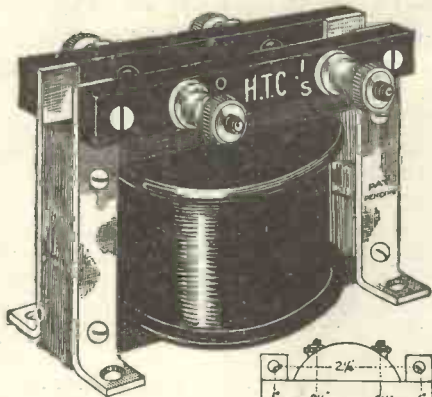

LENGTH = 2 5/8"
HEIGHT = 2 1/4"

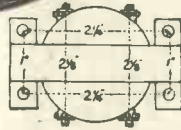

The principal factor to the success of the H.T.C. Transformer is the feature (prov. pat.) which gives a greater mass of iron at a lower magnetisation than any transformer yet produced of its size. High magnetisation of the iron core is the direct cause of distortion. The H.T.C. Transformer operates on telephony equal to other makes costing twice its price. That this is said is conclusive to the efficiency of the maker's design that the H.T.C. Transformer should give the maximum amplification with distortion reduced to the absolute minimum. Therefore no interaction. H.T.C. Transformers may be mounted side by side. They have been proved exceptionally efficient on the S.T.100. This, without doubt, is one of the most rigorous tests to which a transformer may be subject.

WHAT ANOTHER SAYS: *London,*
In retailing your transformer at 15/-, I consider you make a free present of a 10/- note with each one.

Yours very truly,
T. F. M.

Let your next Transformer be an H.T.C. You'll want another, because they are free from distortion.

Price 15/-

H.T.C. VALVE HOLDERS

High resistance and low capacity are determined by the spacing of the valve legs themselves. In the manufacture of the H.T.C. valve holder, allowance is made for the varying spacing of legs of the different types of valves.

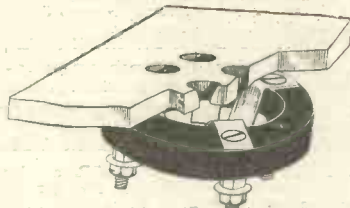

Type C for below panel mounting.
Price 1/6.

No metallic parts used in construction are exposed, making it impossible to short the H.T. across the filament.

Illustrations show two methods of mounting the H.T.C. valve holder. There are at present in production five types of the H.T.C. valve-holder, providing a special pattern for all practical purposes.

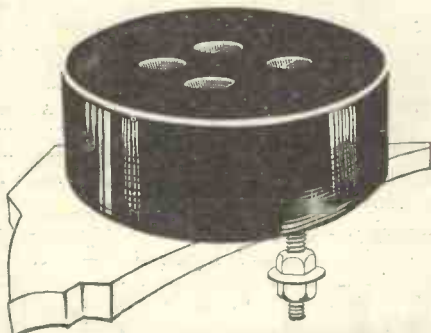

Type A for above panel mounting.
Price 2/-

Trade enquiries are solicited.

H.T.C. ELECTRICAL CO.
2 & 2a, BOUNDARIES ROAD, BALHAM, S.W.12
TELEPHONE: Battersea 374.

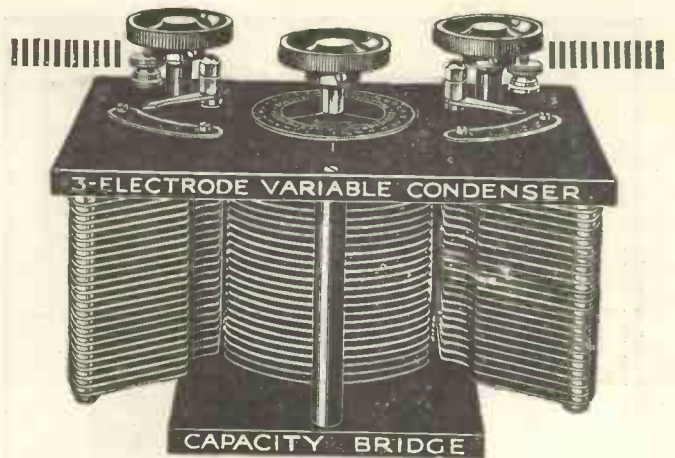

A Striking Testimonial to the VARIABLE BRIDGE CONDENSER 3-E.V.C.

(3-Electrode Variable Condenser)

THE GENERAL ELECTRIC COMPANY

(The largest electrical organisation in the United Kingdom, whose Technical Research Laboratories and staff are second to none) have, after careful test and examination, undertaken the manufacture of the 3-E.V.C. (under licence from Autoveyors, Limited).

Variable Bridge Condensers are now obtainable from all **GENERAL ELECTRIC CO.'S Branches, Agencies and Gecophone Service Depots** throughout the world.

Beyond the wide use of the 3-E.V.C. as a rejector of all unwanted sounds, its enormous popularity as a CAPACITY BRIDGE has encouraged the manufacturers to improve it, both as regards workmanship and material used, to the very highest degree of efficiency. This involves a slight increase in retail prices, which, on and after October 1st, will be .001 Panel Mounting, 47/6. Cabinet mounted, 55/-.

The 3-E.V.C. is obtainable from all high-class wireless dealers, or direct from

AUTOVEYORS LTD

Radio Engineers and Contractors,

84, VICTORIA ST., WESTMINSTER, S.W.1.

Telegrams: "Autoveyor," Sowest, London.



EVERYTHING for the RAD. O CONSTRUCTOR

—even to Explanatory
Wiring Diagrams. Showing
all the components required,
and their relative positions
for wiring up, these diagrams
are in booklet form and are
obtainable from your dealer
at 1/- each.

Woodhall Paxolin Variometer.
Constructed of Paxolin tubing (not cardboard) the $\frac{3}{4}$ walls allow close coupling. The bearings are accurate and robust. Wound to 300-450 metres and attached to panel by drilling one hole only. Complete with Terminals (less knob and dial).
List No. 15341. 6/9 each



Valve Adapter.
Provided with suitable clips for carrying the "Q," "QX," "V24," and other special valves which are not suitable for the ordinary type of holder. Permits the quick interchange of valves.
List No. 17312. Price 5/6

Brown Brothers
with which is amalgamated
**THOMSON & BROWN BROTHERS
LIMITED.** Wholesale only.
Head offices and warehouses:—
Great Eastern Street, London, E.C. 2.
118, George Street, Edinburgh, and
Branches.

TRADE ONLY SUPPLIED. Kindly order from your
usual dealer.

SIEMENS

LOUD SPEAKER.

An instrument of the highest class.

CLEAR
RECEPTION.

NO
DISTORTION.

HANDSOME
APPEARANCE.



PRICE, each

120 ohms, £2 10 0

2,000 ohms, £2 12 6

4,000 ohms, £2 15 0

Also manufacturers of
WIRELESS ACCESSORIES OF ALL KINDS.
*Descriptive pamphlet obtainable from your local wireless dealer
or stores.*

SIEMENS BROTHERS & CO., LIMITED,
Woolwich, London, S.E. 18.

**WHOLLY BRITISH
MANUFACTURE**

STERLING

WE ARE EXHIBITING AT THE ALL-
BRITISH WIRELESS EXHIBITION,
WHITE CITY, SHEPHERD'S BUSH,
NOV. 8th to 21st, Stand No. 108/9.

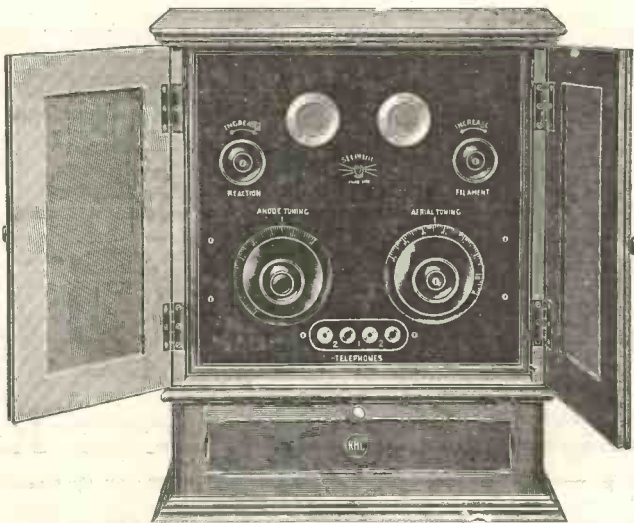

TWO-VALVE LONG RANGE RECEIVING SET

With Anode Tuning and Reaction

This instrument will meet all the requirements of those desiring perfect reception of Broadcast music and speech, either from local or distant stations, when operated on a standard P.M.G. aerial.

The first valve is a high-frequency amplifier, and the second a detector; the anode circuits being coupled with a "Sterling" Anode Reaction Unit. Aerial tuning is accomplished with the "Sterling" Variometer provided; and anode tuning with the "Sterling" variable air condenser.

In highly finished Walnut Cabinet, complete with two "R" Valves, one pair of "Sterling" No. R 1238 Super Quality Head Telephones (2,000 ohms) with cord and plug, high-tension dry battery, low-tension accumulator and connecting cords.

PRICE £20:0:0

B.B.C. Tariff, 17/6 extra net.

Obtainable from all Electrical Dealers and Stores.

STERLING TELEPHONE & ELECTRIC Co., Ltd.,

Manufacturers of Telephones and Radio Apparatus, etc.
(WHOLESALE ONLY)

Telephone House, 210-212, TOTTENHAM COURT ROAD, LONDON, W.1.

Telegrams: "Cuculla, Wesda, London."

BIRMINGHAM:
150, Edmund Street

CARDIFF:
10, Park Place.

MANCHESTER:
14, St. Peter's Square.

NEWCASTLE-ON-TYNE:
21, Moseley Street.

WORKS:
Dagenham, Essex.

V

HULLO

CALLERS' PRICES ONLY. VALVES.

Having purchased 500 Valves
COSSOR, EDISWAN and MULLARD ORA
from a firm giving up business
I offer same while they last at
12/6 each

No Post Orders.

RAYMOND'S VARIABLE CONDENSERS

Assembled complete with Aluminium
ends, ebonite bushes, knob, pointer and
flat bush (including screws).

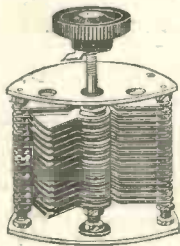

.001	7/-
.00075	6/-
.0005	5/-
.0003	4/6
.0002	3/9
.0001	3/3
Vernier	3/-

D.C.C. WIRE (including Reels).

S.W.G.	1 lb.	1/2 lb.	1/4 lb.
18	2/9	1/6	1/-
20	3/-	1/8	7/11
22	3/3	1/10	1/-
24	3/8	2/-	1/2
26	4/6	2/6	1/4
28	4/9	2/8	1/6

Also 30, 32, 34, 36 stocked.

L.F. INTERVAL TRANSFORMERS.

5-1 Radio Instruments, Ltd.	(1)	25/-
5-1 Igranic	(2)	21/-
5-1 Formo	(3)	15/-
5-1 Raymond		12/6

Goods to the value of 1d in the 1/- given on items 1, 2, 3.

HEADPHONES.

Raymond Lightweight 'Phones, 4,000 ohms	11/11
N. and K., medium size, 4,000 ohms	12/6
Spide, very fine value, 4,000 ohms	14/9
Spide, grand for Crystal Sets, 8,000 ohms	16/11
Brunet, best type, 4,000 ohms	16/6
Loud Speaker Receiver, 50 laminations each pole, fine value	18/11

CALLERS' PRICES ONLY.

Buy Best Goods at Low Prices.

Terminals (complete with Nuts).		
Large W.O.	doz.	1/3
Telephone, W.O. Pillar	doz.	1/-
Small Pillar	doz.	-/8
Switch Arm, 12 Studs and Nuts	the lot	-/10
Small Variometers 250/650		2/4
Larger Variometers, 250/650		2/11
Igranic Variometer, Ebonite, 250/650		15/-
2-Way Coil Holders, for Duolateral Coils		5/6, 4/6
3-Way Coil Holders, for Duolateral Coils		6/11, 5/11
French R Valves		10/-
Phillips R Type		7/-
Stop Pins with shoulder	2 a 1d, doz.	-/5
Fixed Condensers to .001		-/10
Fixed Condensers to .005		1/3
Fixed Condensers to .006		1/6
Valve Pins	doz.	-/6
Valve Sockets	doz.	-/9
2 4, 5 B.A. Nuts	3 doz.	-/6
Basket Coils	Set of 6	2/-
Spade Terminals	doz.	-/4
Vario Couplers, with Knob		4/11
Glass Enclosed Whisker Detector		1/6
High-class Whisker Detector (large), enclosed		2/6
Fine Perikon, 2 Crystals, enclosed		3/-
Small Perikon, 2 Crystals		1/6
Bell Wire, D.C.C., I.G.	10 yds.	-/6
Twin Flex	12 yds. 1/7, 4 yds.	7d.
Plug Coils, Ebonite		1/-, -/9
Extra Quality, cfitto on bzte		1/-, 1/3
Pillar Terminals, Nut and Washer, 2 B.A., Large	2 for	-/6
Switch Arms	-/8, -/9, -/10	1/-
Filament Resistances	1/8, 1/10, 2/-	2/3
Igranic Resistances		4/6
Igranic Vernier		7/-
4 Cats Whiskers, one gold		-/4
Single Basket Coil Holders		1/4, 1/3
Variable Grid Leaks		1/5
Bretwood Variable Grid Leaks, guaranteed 3 years		3/-
Pin Terminals, screw pattern	1/3 doz.	2 for -/3
Spade Terminals, screw pattern		-/9, 1/-
Shaw's Genuine Horizite		3/-, 2/3, 2/-
Grid Leaks and Condensers, .0003		doz. 1/-
Valve Sockets, with shoulder		5 for 2/-
Basket Coils, Duplex Waxless		100,000 ohm Resistance
Variometer on Ebonite, ball rotar, wound, D.C.C.		8/11
Accumulator, 6 v. 50 zmp. in handsome wood case, strap handle		27/6
Accumulators, 6 v. 60 amp., best make		33/-
D.C.C. Wound Tapped Coils		2/-, 1/6
Double Phone Cords	pair	-/9, 1/6
Wound Coils, 12 x 4, best quality		2/6
Wound Coils, 6 x 3, best quality		1/9
Aerial Wire, 7/22, hard drawn (subject to stock)	100 ft.	2/1
D.P.S.T. Switches, special		1/3
S.P.D.T. Nickel on Ebonite		2/3
D.P.D.T. Nickel on Ebonite		2/9
2 B.A. Rod, 12 in.	2 for	-/5
Basket Coil Holders, for 3 Coils		5/6
Plug and Socket, brass	pair	-/11
Fixed Condensers .01		1/6
Pocket Lamp Batteries (best)	6 for	2/3
Special Filament Resistance very fine value		2/-
Igranic Coils, 25 upwards in stock.		
D.P.D.T. Nickel Switches for panel mounting.		3/-
Special!		
4 v. 40 a. Accumulator, callers only		16/6
H. T. Batteries	60 v. 9/6. 26 v. 4/9	

All previous lists cancelled.

Hours of Business:

Every Day,
9 a.m. to 7.45 p.m.,
Sundays,
10.30 a.m. to 1 p.m.



Variometer on Ebonite
Complete 12/-, 15/-.



Transformer L.F., 12/6
and 15/-



Enclosed Detector
Perikon, 2 crystals, 3/-
whiskers 2/6 2 Crystals
Whisker, 2/6.



3-Way Coil Holder,
5/6, 6/6, 7/6.



Fixed Condensers from
-10d.



Knob and Dial (Ebonite)
1/6, 2/-

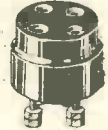

Ebonite Valve Holder
Hand Turned 1/-, 1/3.

RIGHT OPPOSITE
DALY'S
GALLERY DOOR

M. RAYMOND
27, LISLE STREET, W.C.2

RIGHT OPPOSITE
DALY'S
GALLERY DOOR

OPEN EVERY DAY 9 a.m. to 7.45 p.m. SUNDAYS 10.30 a.m. to 1 p.m.

EVERYBODY

TESTIMONIALS.

POST ORDER PAGE.

ONLY GOODS ON THIS PAGE, AND AT PRICES MENTIONED, ARE SENT BY POST IN STRICT ROTATION AND AT EARLIEST POSSIBLE MOMENT. OWING TO THE TREMENDOUS DEMANDS ON OUR MAIL ORDER DEPT., IT IS QUITE IMPOSSIBLE TO GUARANTEE RETURN DELIVERY.

Bampton Grange, Penrith, Cumberland.
August 24, 1923.
"I am writing to tell you of the marvellous results from one of your '0003 condensers purchased some time ago. The signals were wonderfully increased in volume, clarity and tone since I coupled the condenser to my set. Please forward me your new catalogue."
Sincerely yours, N. Eastley.

"Fairleigh," Church Street, Highbridge.
August 24, 1923.
Sir,—On Monday last I purchased at your establishment a 3-way coil holder for 6s. 6d. I am delighted with the quality and finish of the holder and should like to take the opportunity of stating that although I have studied your adverts, week by week I have hitherto refrained from sending orders as I thought the prices must entail "cheap and nasty" stuff, which is dear at any price. Now, however, I have a very different opinion.
—Yours, W. Chant.

Grove Mills, Heckmondwike.
Kindly forward me your new list of best goods in stock. I previously had one of your valuable condensers and found same most satisfactory.—W. Sykes.

81, Walsgrave Road, Coventry.
August 28, 1923.
Sir,—My parts duly to hand this morning for which I thank you. With regard to the condenser and filament resistance, I consider these excellently finished and splendid value for money. You will in due course have further orders from me and will certainly recommend you to my wireless friends.
Yours faithfully, F. R. Smith.

Parkview, Cumbernauld, By Glasgow.
September 6, 1923.
Dear Sirs,—I received your goods, in fulfilment of my last order a few days ago, and must express myself as being thoroughly satisfied with them. Your condensers in particular are shillings cheaper than anything obtainable here, considering the quality, which, to say the least, is surprising.—Yours, J. Henderson.

Youngwoods, Alverthorpe, Wakefield.
October 4, 1923.
Dear Sir,—I beg to acknowledge safe receipt of 3 variable condensers, etc., and to say I consider them remarkably good value. When wanting further accessories I shall certainly write you again and recommend your goods to wireless friends.—Yours truly, H. R. Haigh.

140, Coventry Road, Birmingham.
September 29, 1923.
Dear Sir,—I received your goods this morning. Thanks exceedingly for your prompt attention. I am delighted with the condenser, it far exceeded my expectations and in my estimation is much better than many of the condensers now on the market at 17s. 6d. You may be sure that I shall recommend you to all my friends and I hope to place further orders with you in the course of a post or so.—I am, yours faithfully, I. MacQueen.

RAYMOND'S Variable Condensers

POST FREE
U.K. only.

Completely Assembled with aluminium end plates, 2 fixing screws, knob, pointer, flat bush, and ebonite bushes

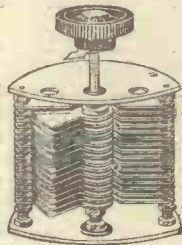

- .001 7/6
- .00075 6/9
- .0005 6/6
- .0003 5/4
- .0002 4/6
- .0001 4/-
- Vernier 3/9

HEADPHONES.

- Sipde, 4,000 ohms ... 14/11
- Sipde, 8,000 ohms ... 17/11
- Brunet, 4,000 ohms ... 17/11

B.B.C. Premier, very fine value, light in weight, no spacing rings, 4,000 ohms, full of music, complete with headband and cords
17/11 pair.

LOUD SPEAKER RECEIVER.
50 Laminations in each pole, with cord complete ... 18/11

LOUD SPEAKER (Amplion Junr.), 54/-
(Subject to manufacturers' delivery).

N AND K, Light in weight, 4,000 ohms, pair ... 13/9

ALL PREVIOUS LISTS CANCELLED.

POST FREE U.K. only.

- Accumulators, high-class make, 4 v. 40a. ... 22/6
- Very Large Terminals, 2 B.A. Nut and Washer ... 6 for 2/6
- Valve Holders, Turned Ebonite, and nuts, each 1/8 3 for 4/-
- Valve Sockets and Nuts, Plain ... doz. 1/3
- Valve Sockets, with Shoulder and Nuts ... doz. 1/6
- Variable Grid Leak ... 2/-, 2/3
- Variable Grid Leak, "Bretwood" guaranteed 3 years ... 3/6
- Valves, Cosor, Ediswan, Multard ... each 15/6
- Duplex Waxless Basket Coils ... Set of 5 2/8
- Basket Coils, 6 in set, up to 3,500 ohms ... set 2/6
- Ebonite Coil Plugs, very best. Each 1/3 ... 6 for 6/6
- Ebonite Coil Plugs on Stand. Each 1/6 ... 6 for 7/6
- Ebonite 2-Way Coil Holders on Stand ... 6/-, 6/6, 7/-
- Ebonite 3-Way Coil Holders on Stand ... 7/-, 7/6, 8/6
- Ebonite Basket Coil Holders and Plug ... 2/2
- Screw Spade Terminals, 6 for 1/- ... doz. 1/6
- Screw Pin Terminals, 6 for 1/- ... doz. 1/6
- Variometers and Knob, Wound D.C.C., small ... each 3/8
- Variometers and Knob, Wound D.C.C., large ... each 4/6
- Ebonite Variometers and Knob, Wound D.C.C., Ball Rotor ... each 10/-
- Edison Bell or Igranite ... each 15/-
- Bell Wire I.C. D.C.C., 20 g., 110 yds. ... 5/6
- Bell Wire, I.C. D.C.C., 20 g., 55 yds. ... 3/6
- Twin Flex for Leads, 12 yds. ... 2/3
- Grid Leaks, 2 mg. ... 1/3
- Double Phone Cords ... pair 1/4
- Dubilier Fixed Condensers, up to .0005 ... 3/-
- Dubilier Fixed Condensers, .001 to .006 ... 3/6
- Dubilier Grid Leaks ... each 3/-
- Dubilier Anode Resistances, 100,000 ohms ... 5/6
- 100,000 ohms, Resistance, good ... 2/6
- D.P.D.T. Switches, Nickel, on Ebonite, small ... 3/6
- S.P.D.T. Switches, Nickel, on Ebonite, small ... 2/9
- Switch Arms, Best, 12 Studs and Nuts ... lot 2/-
- Grid Leak and Condensers ... 3/-
- Vernier Resistance "Igranite" ... 7/6
- Filament Resistances, "Raymond" ... 3/-
- Filament Resistances, 5 ohms ... 2/3, 2/6, 2/9
- Filament Resistances, 7 ohms ... 3/-, 4/6, 5/-
- Potentiometers Igranite, 7 ohms ... 7/6
- L.F. Interval Transformers, "Radio Instruments" ... 25/-
- L.F. Interval Transformers, "Igranite" ... 21/-
- L.F. Interval Transformers, "Edison Bell" (square) ... 25/9
- L.F. Interval Transformers, "Formo" ... 15/9
- L.F. Interval Transformers, "Raymond" ... 13/6

Terminals—Phone, W.O., Pillar, Fancy ... doz. 1/9
All complete with nut and washer.

The Simplex Broadcast Crystal Set.

THE MOST EFFICIENT, SIMPLE AND INEXPENSIVE CRYSTAL SET MADE. RANGE, 200-600 METRES. WILL RECEIVE ALL BROADCASTING STATIONS WITHIN A RADIUS OF 40 MILES, USING TELEPHONES OF AVERAGE SENSITIVITY, WITH A STANDARD P.M.G. AERIAL. VERY FINE TUNING OBTAINABLE USING BASKET COILS OF VERY LOW SELF CAPACITY. EVERY SET SOLD HAS BEEN TESTED AND IS GUARANTEED. SIMPLE, CHEAP AND EFFICIENT.

12/6 per set.

Right is reserved to return cash.

RIGHT OPPOSITE
DALY'S
GALLERY DOOR

M. RAYMOND
27, LISLE STREET, W.C.2

RIGHT OPPOSITE
DALY'S
GALLERY DOOR



Contents

	Page
Editorial	59
Regular Programmes	60
The Coast Dweller's Crystal Set	61
By G. P. KENDALL, B.Sc.	
In Passing	64
The Transatlantic Receiver... ..	66
By PERCY W. HARRIS, Assistant Editor.	
What to Do with Two Valves	72
By JOHN SCOTT-TAGGART, F.Inst.P.	
The All-British Wireless Exhibition	75
A Note Magnifier for the All-Concert Receiver... ..	80
By PERCY W. HARRIS, Assistant Editor.	
Rhythmic Beat Time Signals	83
By A. HUGHES BARLOW.	
The Licence Question—A Settlement at Last	85
The Official Statement Issued by the Postmaster-General	86
How to Make a Portable ST100 Receiver	88
By JOHN SCOTT-TAGGART, F.Inst.P.	
The Construction of a Heterodyne Wave-meter	91
By ALAN L. M. DOUGLAS.	
Single Layer Inductance Coils	99
A Reunion	100
New Books	102
From a Reader	103
Some Causes of Weak Reception	105
By R. W. HALLOWS, M.A.	
Practical Notes	109
Tested by Ourselves	113
Above and Below the Broadcast Wave-lengths	114
Radio Society of Ireland	117
For Crystal Users	118
JUNIOR WIRELESS.	

Editor :
JOHN SCOTT-TAGGART,
F.Inst.P.

Joint Assistant Editors :
PERCY W. HARRIS.
E. REDPATH.

Staff Editors :
E. H. CHAPMAN,
M.A., D.Sc.
A. D. COWPER, M.Sc.
G. P. KENDALL, B.Sc.
R. W. HALLOWS, M.A.
S. G. RATTER.

Scientific Adviser :
Prof. G. W. O. HOWE,
D.Sc., M.I.E.E.

Advisory Editors :
Prof. R. WHIDDINGTON,
M.A., D.Sc.
Prof. C. L. FORTESCUE
M.A., M.I.E.E.

Advertisement Managers:
SCHEFF PUBLICITY
ORGANISATION, LTD.,
1-5, Pall Mall, London,
S.W.1.
Tel.—Rever 2440.

MODERN WIRELESS

All correspondence relating to contributions is to be addressed to the Editor of "Modern Wireless."

Radio Press Ltd

PUBLISHERS OF WIRELESS WEEKLY

DEVEREUX COURT.

• STRAND.W.C.2 •

1 ch.—Central 370.

Nothing contained herein is to be regarded as permission or encouragement to infringe any patent rights.



AT long last the air has cleared and the home constructor knows exactly where he is with regard to the law and his duties to his fellow-countrymen. Whilst the Postmaster-General's compromise—for it is truly a compromise—has by no means satisfied everyone, at least it places broadcasting on a far more sensible basis than heretofore. It is only fitting that our first number under the new system should be a special constructor's number, and we feel sure that readers will be more than satisfied with the fare we have to place before them. For the benefit of those new listeners who are situated in the Bournemouth and Aberdeen areas and within crystal receiving range of Newcastle, we are describing a special crystal set with which has been incorporated a wave-trap to give the necessary selectivity in these parts. Listeners too frequently complain that they are unable satisfactorily to hear the broadcast concerts owing to "jamming" from ships, and the set in question should go far to remove the troubles of the seaboard listener. For the more experienced experimenter we have the remarkable and highly sensitive three-valve receiver to which the name "Transatlantic" has been given; for the man who wishes to get further strength with his set so as to operate a loud-speaker we have the Single-Valve Magnifier described on another page. The experimenter with leanings towards accurate measurement in his work is catered for by the provision of an article describing how to make a heterodyne wavemeter; the man who wishes to carry his set about with him is given the portable

ST roo, containing all the batteries in a case with the receiver itself; while distributed throughout the book are numerous constructional notes, hints and tips which will help to simplify the work of the true home constructor.

We would like once more to draw attention to the fact that the circuits and apparatus described in this magazine are essentially practical. The descriptions of sets are written and the drawings and photographs made from apparatus which has been carefully constructed from materials and with tools readily available to every experimenter, and where special problems have been met with in the construction of the sets these are elucidated. Only in this way can the home constructor be truly served.

Now that the constructor's licence has been definitely settled, may we enter a plea for the better standardisation of radio parts? At the present time much difficulty is experienced from the fact that so many parts are different in ways which prevent the constructor substituting one for another. Take, for example, the plug-in type of intervalve transformer. What is more natural than that an experimenter should desire to compare the relative merits of various makes of transformer; yet, although all these transformers are mounted on standard valve bases, there is no standardisation whatever in the manner of connecting the primary and secondary windings to the pins. For this reason only certain makes can be used unless the wiring is changed each time the change of transformer is made—quite an impracticable proceeding in most cases.

hear a great deal of the activities of the National Association of Radio Manufacturers, popularly known as the N.A.R.M. Surely they can do something towards proper standardisation of parts without the necessity of manufacturers losing their individuality in the process.

One more point: it is high time that ebonite was properly graded for sale. At present one buys a sheet of a black substance the insulating qualities of which must be taken on trust. In comparatively few cases do we know who is the actual manufacturer, and not one experimenter in a thousand is in a position properly to test the insulating and other properties of his ebonite panel. Particularly

when trying out new circuits it is essential that we should be able to rely upon insulation. The sale of inferior ebonite, while it may bring quick profit to the dealer, does an immense amount of harm to the trade, for the inexperienced constructor will often blame a first-quality component for faults which, did he but know it, arise from ebonite used to carry this part. A suggestion was made some weeks ago in *Wireless Weekly* that ebonite should be sold plainly marked on one side with the maker's name and an indication of its quality. We believe that at least one firm is taking steps to issue such ebonite, and other firms will doubtless follow suit.

THE EDITOR.

REGULAR PROGRAMMES FROM BRITISH AND FRENCH BROADCASTING STATIONS
(Times in Greenwich Mean Time.)

GREAT BRITAIN.

Station.	Call Sign.	Wave-length.	Times.
Cardiff ...	5 WA	353	3.30 to 4.30 p.m. (except London) and 5.0 p.m. to 10.30 p.m. London (day transmission) 11.30 a.m. to 12.30 p.m. <i>Sundays.</i>
London ...	2 LO	363	
Manchester ...	2 ZY	370	8.30 to 10.30 p.m. London also 3.0 p.m. to 5.0 p.m.
Bournemouth	6 BM	385	
Newcastle ...	5 NO	400	
Glasgow ...	5 SC	415	
Birmingham	5 IT	420	
Aberdeen ...	6 BD	495	

Note.—These wave-lengths may be altered shortly.

FRANCE.

PARIS, EIFFEL TOWER. (FL, 2,600 metres.)
Weekdays (daily).

- 6.4 a.m. Meteorological forecast.
- 11.15 a.m. Meteor. forecast and time giving.
- 2.0 p.m. Financial bulletin.
- 5.10 p.m. Concert.
- 6.20 p.m. Meteor. forecast.
- 1.15 p.m. Meteor. forecast.

Sundays.

- 5.10 p.m. Concert.
- 6.20 p.m. Meteor. forecast.

Other concerts specially announced from time to time.

PARIS, RADIOLA. (1780 metres.)

Weekdays (daily).

- 11.30 a.m. Information (Cotton Exchange, Havre, Liverpool, Alexandria).
- 11.40 a.m. Concert.
- 4.0 p.m. Commercial information.
- 4.10 p.m. Financial information.
- 4.20 p.m. Concert.
- 7.45 p.m. News.
- 8.0 p.m. till 9.0 p.m. Concert.
- Thursday, 8.45 p.m. till 9.30 p.m. Dancing concert.

Sundays.

- 1.0 p.m. till 2.0 p.m. Concert.
- 7.45 p.m. News.
- 8.0 p.m. till 8.45 p.m. Concert.
- 8.45 p.m. till 9.30 p.m. Dancing concert.

PARIS. SCHOOL OF POST AND TELEGRAPHS. (450 metres.)

Tuesday and Thursday.

- 7.30 p.m. Concert.
- And very frequent radiophone transmissions of plays (comic operas).

LYONS. YN, 3,100 metres.

- 9.45 a.m. Concert (gramophone).
- 2.35 p.m. Financial news.

THE COAST-DWELLER'S CRYSTAL SET

By G. P. KENDALL, B.Sc., Staff Editor.

Residents in the Bournemouth, Aberdeen, Newcastle and Cardiff areas are frequently troubled with ship jamming. This set will enable them to eliminate such interference.

THE conditions of reception in and around the new broadcasting areas of Aberdeen and Bournemouth seem to be such as call for the adoption of some special method of interference reduction. In both districts difficulty occurs in broadcast reception at times as a result of the inevitable interference by "spark" stations working on 300, 450 or 600 metres, since the stations in question may often be very close to the receiving station and use a good deal of power. The elimination of such interference may be attempted by two chief methods, namely, by using an ultra-selective circuit, such as a loose-coupled tuner, or by incorporating some form of rejector or filter circuit in the receiver as a more or less separate unit.

An inductively coupled tuner is, of course, capable of reducing interference to a great extent, but it complicates the operation of the receiver, and does not seem to appeal to the average constructor. The devices now known as "wave-traps," on the other hand, are capable of producing a more complete elimination of the interference, enable the controls of the receiver to remain of a fairly simple nature, and possess the

merit of novelty and interest. Moreover, there remains much to be learned of their possibilities, and a great deal of most interesting experimental work can be done upon them with the aid of very simple apparatus.

The receiver which is about to be described represents a fairly

Percy W. Harris in MODERN WIRELESS. A trap unit is incorporated which can be used as either a series absorber or a parallel shunt, and a switching arrangement is provided for cutting out the trap circuit when it is not required, this last being desirable in view of the fact that the inclusion of the trap in

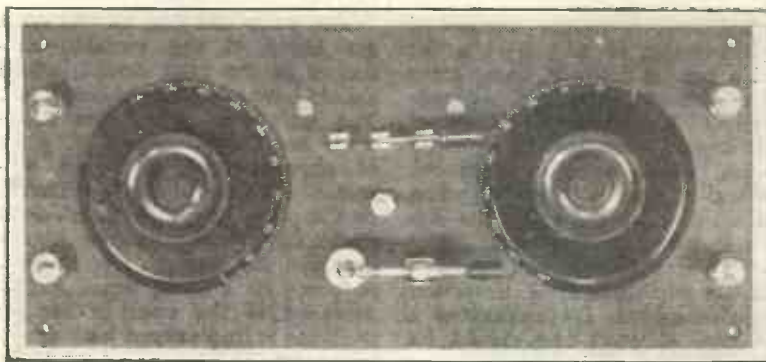

Fig. 1.—A plan view of the finished set.

successful attempt to apply the wave-trap principle to a simple crystal set of the single-circuit type. No claims are made that it is new in principle, but it seems to be the first practical set to be designed and built for the express purpose of using the eliminating circuits recently described by Mr.

circuit usually produces a reduction of signal strength—only a slight one if the wave-trap is properly arranged, but nevertheless to be considered.

The trap circuit consists of a coil and condenser capable of covering the broadcast wave-band and extending upwards to 600 metres. Wound directly upon this coil are six turns of wire, which serve to couple it to the aerial circuit by connecting them either in series or parallel with the main tuning unit. In series we have the form of trap known as "type B," "type C" being the parallel connection. In type B the trap circuit is tuned to the wave-length of the interfering signals, and acts as an absorber, allowing the signals of the desired station (to which it is *not* tuned) to pass it by unabsorbed. This type seems to require a fairly considerable difference between the desired and undesired wave-lengths to function efficiently, but, given that, it gives very satisfactory elimination with little loss of signal strength,

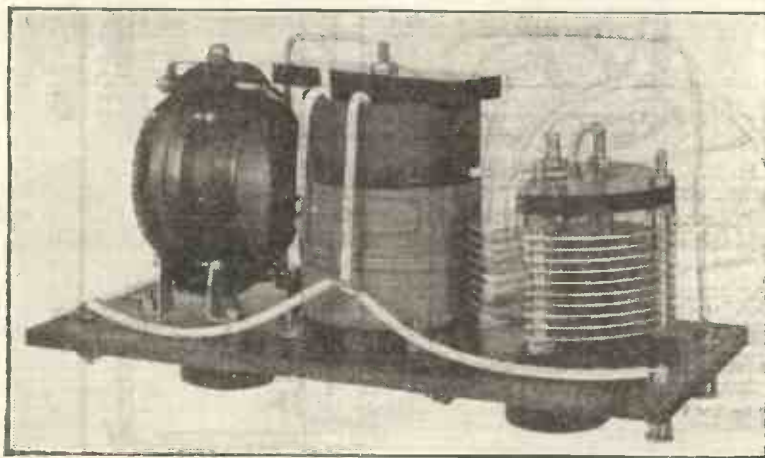

Fig. 2.—A view showing the internal arrangement of the receiver.

Type C, on the other hand, will separate signals whose wave-lengths are very close to each other, but is prone to produce a more noticeable reduction in the strength of the desired signal. It is consequently a matter for experiment to determine which of these two types is more suitable in a given set of conditions, and accordingly the wiring diagrams show how either type can be connected up in the receiver illustrated. Both types should certainly be tried. The circuit of the set when using type B and type C is shown in Figs. 3 and 5.

The construction of the receiver is a fairly simple matter, all the parts being mounted upon an ebonite panel measuring $4\frac{1}{2}$ in. by 10 in. and $\frac{1}{4}$ in. thick. The crystal receiver proper consists of a variometer of any good make and a crystal detector, these parts being clearly shown in the photographs. Immediately in front of the crystal detector is a small switch, whose function is to cut the wave-trap out of circuit when not wanted, as shown in the circuit and wiring diagrams. Any suitable small switch can be used, but the miniature type illustrated is recommended. Its connections in the type C wave-trap should be carefully noted and copied.

At the left of the panel are the aerial and earth terminals, and on the right are those for the telephones. These latter are, not shunted by a telephone condenser, since I have failed to observe any improvement in results when using one in this or any other crystal set. This probably depends upon

the telephones used, and it is possible that some makes require a condenser for the best results.

The knob and dial on the right are those of the variable condenser in the trap circuit, which should have a capacity of $0.0003 \mu\text{F}$. The coils constituting the wave-trap are wound upon a piece of ebonite tube $2\frac{1}{2}$ in. in diameter and 4 in. long, attached to the panel in a manner which is made fairly clear by the photograph of the underside of the set. A piece of 2 B.A. brass rod is attached to the panel either by inserting it in a tapped hole or by using two nuts, one above and one below the panel. This passes up the axis of the ebonite tube, and an ebonite cross-piece measuring $3\frac{1}{2}$ by 1 by $\frac{3}{8}$ in. is slipped on to the projecting end, and a nut is screwed down after it, thus causing it to clamp the tube firmly against the panel.

It might be expected that the

presence of this metallic object right inside the field of the coil would have harmful effects, but careful experiments with and without the rod failed to show that it had the slightest effect upon either the strength of signals or the efficiency of the wave-trap as such, and therefore this very simple method of attachment was adopted.

The wave-trap winding consists of No. 28 double-cotton covered wire, 75 turns being the number adopted. The actual number of turns adopted appears to have a considerable effect upon the behaviour of the trap, and it is here that much further experimenting is needed. The number quoted is one found to be successful in practice, but it is probable that other ratios of inductance to capacity would be found by a patient experimenter which would give even better results. Determinations of this sort, however, are somewhat laborious to make,

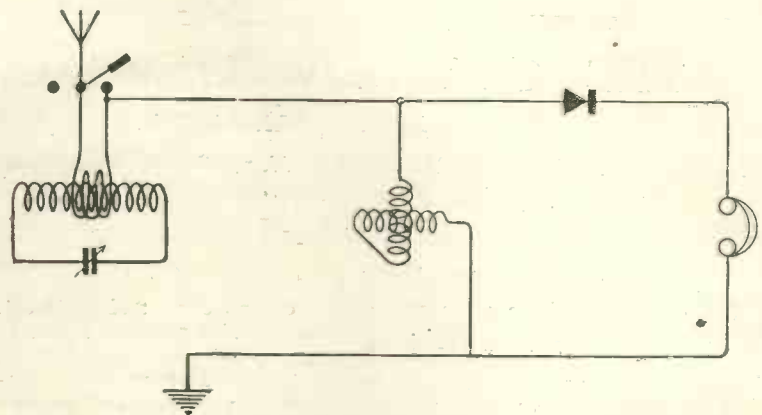

Fig. 3.—The circuit when type B wave-trap is used.

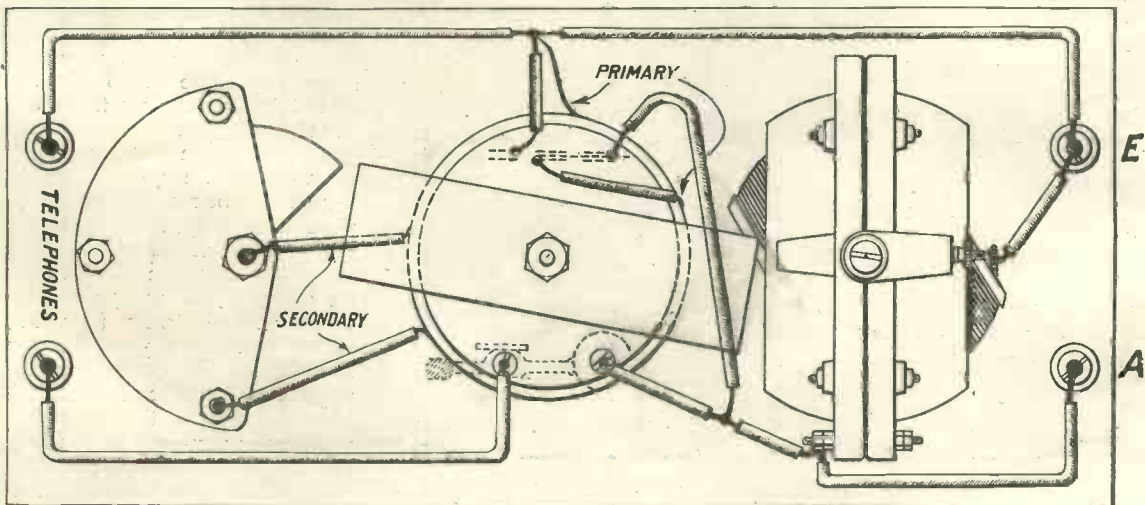

Fig. 4.—The wiring for type B wave-trap.

since each experiment involves winding a new coil, tappings being out of the question on account of the peculiar dead-end effects which they introduce into circuits of this sort.

The coil coupling this to the aerial circuit consists of six turns of No. 20 gauge double cotton-covered wire, wound directly on top of the first coil, in the centre. This winding can be seen in the photographs, and its connections will be made clear by the wiring diagrams, in which it is marked "primary." (The coil of 75 turns is marked "secondary" in these diagrams.) The ends of the 75-turn coil were secured by passing them through holes in the ebonite tube, and those of the 6-turn winding by means of tape loops, whose ends are passed under the turns and pulled tight in the usual way.

The choice of the above-mentioned sizes for the wire was the result of a certain amount of experiment, and seems to provide something like the correct amount of damping in the wave-trap coil. This choice had to be somewhat of a compromise, however, since the coil had to be designed as to function with reasonable efficiency as either type B or type C trap. Actually, a fair amount of damping is desirable in type B, whereas type C works best with low damping. The reason for this will be understood when it is remembered that type B is tuned to the wave-length of the undesired signal and works by absorbing it, whereas type C acts upon a different principle; this last is tuned to the

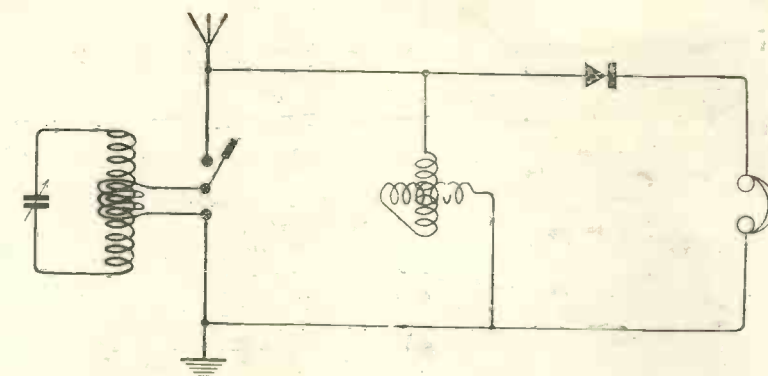

Fig. 5.—The circuit for type C trap.

desired signals and acts (apparently) as a rejector to them, causing them to pass through the receiver. Undesired signals, however, pass through it fairly freely, since they are of a different wave-length and are thereby shunted past the receiver proper without affecting it. For this reason, of course, the setting of the condenser to eliminate a given signal will be different with the type B and type C circuits. With type B, it must be set to tune the trap circuit to the wave-length of the undesired signal, and will require slight alteration for eliminating different 600-metre stations, while with type C it is required to tune the trap to the wave-length of the desired signals, so that all others will be by-passed. With type C, then, the condenser once set will not require readjustment, whatever the wave-length of the interfering signals.

The wiring of the set can be followed out quite easily with the

aid of whichever of the wiring diagrams is chosen, and should be done with tinned-copper wire of No. 18 or No. 20 gauge, all joints being carefully soldered. Since the wiring is extremely simple and all connections are well separated from each other, it is quite unnecessary to sleeve them in systoflex. It was done in the case of the receiver illustrated simply and solely to make the wiring plainly visible in the photograph, which end can always be achieved by the use of white systoflex.

The actual dimensional lay-out of the panel is not given in connection with this set, because the exact positions of the holes must be dependent upon the make of the components, and it was not desired to specify that the latter should be of any particular brand. So long as the general arrangement indicated in the illustrations is preserved, satisfactory results are assured.

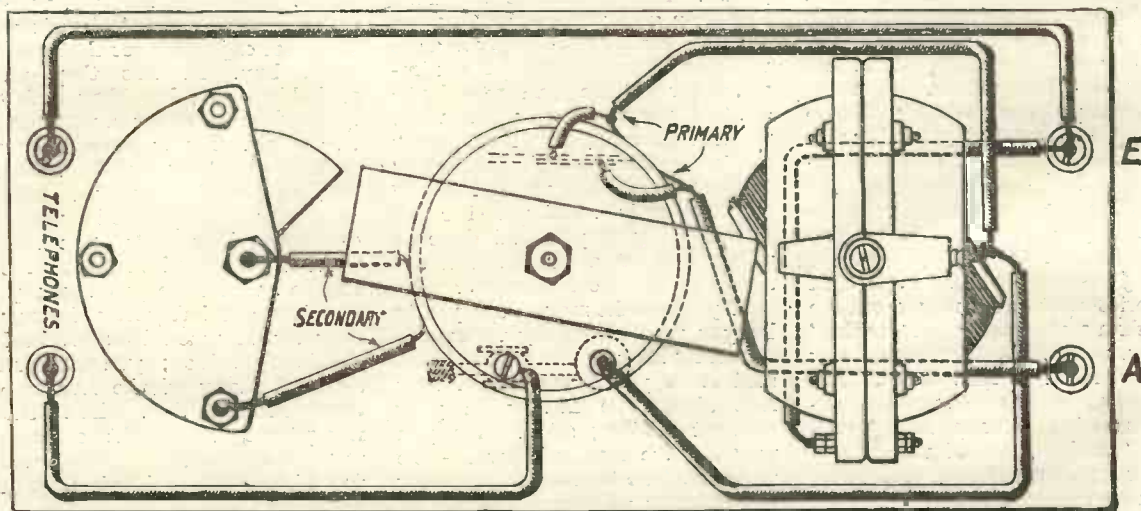
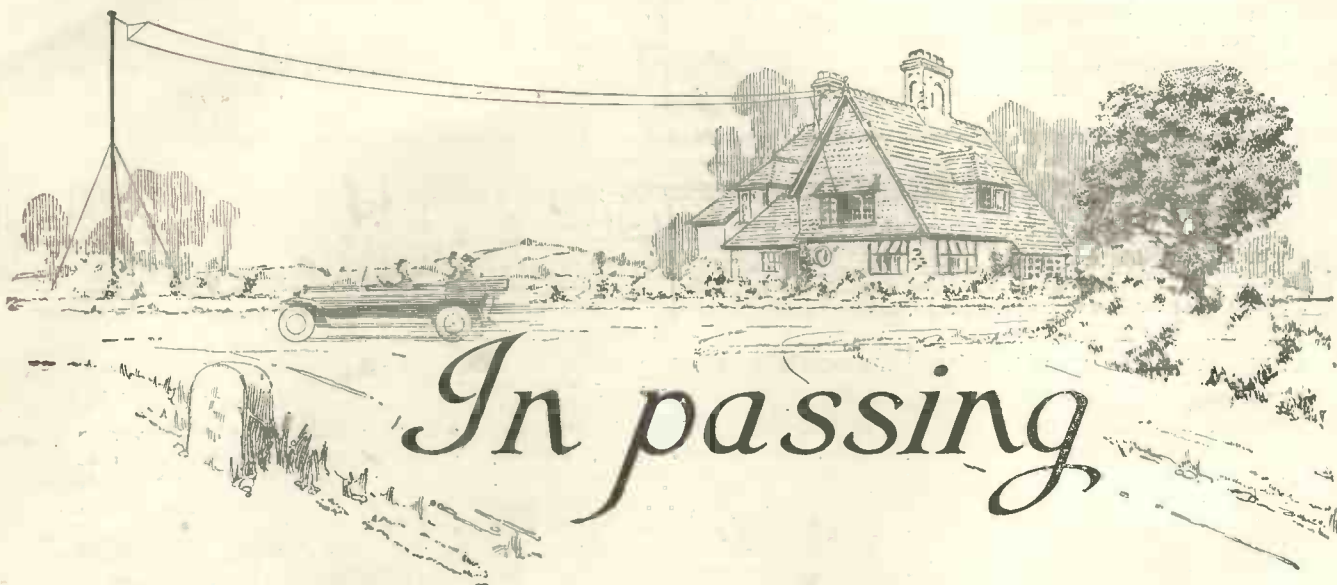

Fig. 6.—The wiring of the set for type C trap.



In passing

W The New Bootlegging WIRELESS men across the Herring Pond are suffering sorely, I see, from bootlegging. By this I do not mean that they are being deprived of the sustenance that is needed during the long nightly vigils when they listen in eagerly for signals from distant quarters of the globe. No, the trouble is not here. It is something far more serious. The bootlegging of spots of comfort having become so profitable that it now stands at the head of American national industries it is not surprising that the fertile brains of Uncle Sam's children should have led them to branch out in other directions in their pursuit of the nimble dollar. The latest field for the bootlegger's, that is to say the law-dodger's, activity is in the manufacture and sale of spurious valves.

"Beware the Bootleg Radio Tube" screams a big headline in one of their papers, and the ensuing article goes on to show how extensive are the activities of the newest type of criminal. It appears that in the City of Newark, New Jersey, alone there exist illicit factories that are turning out no less than 3,500 counterfeit "toobs" a day, whilst another 2,000 a day are produced in New York. The bootlegged articles are perfect imitations of U.V. 201 A's, "peanuts" and a host of well-known valves; perfect, that is, to the eye, but when they are installed upon the set to perform the proper

duties of valves, a horrid awakening awaits the purchaser. Being made of inferior stuff their filaments eat current at prodigious rates, only to snuff out after a few hours of work. Then Habakkuk P. Blinks, or Zerubbabel K. Hertzheimer, or whatever the luckless buyer's name may be, shoots glances of fire through his horn-rimmed specs., tears tufts from the luxuriant growth upon his head, and screams aloud in a terrible voice: "Bootlegged again, b'gosh!"

This Freedom

America may be the land of the free, but if this be freedom then thank all the powers that we know it not. Fancy what it would be like if on going to buy an Ora you had to "moisten the finger and see whether the white trade mark impressed upon the glass would rub off." Picture your anguish if, without warning, shops of the baser sort were flooded with dud valves looking for all the world like the genuine article. Would life be worth living if you had done in thirty bob on a peanut that ate about an ampere of current?

If you are the man I take you to be you would straightway convey the thing back to the criminal who sold it to you; you would beat him about the head with your stoutest walking stick, then you would make him swallow it—the valve not the stick—whilst telling him exactly what you thought of h.m. The valve bootlegger's

career would, I think, be a short one in this country, for we wireless folk are a hasty lot, having much to try our tempers.

All that Glitters

It happened not long ago that the Bliggstreets, our local *nouveaux riches*, installed in their palatial home the most wondrous of wireless sets. It lived in a gorgeous marquetry cabinet "embellished" with all kinds of amazing twiddly bits in wood, brass, ivory, and, if one is to believe Mrs. Bliggstreet, solid gold. The cabinet was in fact a kind of cross on a small scale between a Gothic cathedral, a Japanese temple and a Turkish mosque. Within was a marvellous array of valves.

Its owners averred that it was the most expensive set that money could buy. In this they were probably right, but they omitted to mention also that it was one of the worst. Never have I heard such excruciating sounds as those belched forth by the loud speaker cunningly incorporated into its economy. You may have heard what thoroughly bad transformers can do on an ill-designed set; you may know probably how vile music may sound when brought in by oscillating valves; you may have sampled many of the horrors of distorted reception. But these things are as nought compared with the ghastly noises poured forth by the three hundred guinea Dulcivox when Mr. Bliggstreet has cleared its decks for action.

How the Party Went Off

"I like plenty of noise, m'lad," he says, cheerily, and he gets it. Speakers all seem to have swallowed potatoes of the largest size, singers crack on every other note, orchestras appear to consist of players who have omitted to tune their instruments, the piano resembles a hamstrung banjo, the violin an amorous Thomas Pussy's serenade to his lady love.

It was unfortunate, perhaps, that the Bliggstreets should have chosen to turn on this atrocity on the night when they had a large party in order to lionise Signor Strombonelli (né John Gupp), the violinist, whose playing was the rage of the musical world. The maestro listened with horror in his eyes and sagging jaw to its first raucous notes; then he turned a mute gaze upon his hostess, as who should say: "What the blank, blank, blank is *that* instrument of torture?" "Oh, don't you think this wireless is just splendid," gushes Mrs. Bliggstreet; "there's nothing like it for making a party go off!" "It's making this party go off, anyhow," screamed the soul-stricken man of music, who fled incontinently from the room, seized the first hat he saw in the hall and strode out into the night weeping the salt tears of a broken man.

Abominations

Quite seriously, why are so many people content with sets that are anything but a pleasure to listen to? A good set is a joy for ever, bringing in speech and music without a sign of roughness or distortion; but a bad set that is being forced, made to produce the largest possible volume of sound without any regard to purity or smoothness, is the kind of thing that I would like to see yoked like the Ancient Mariner's albatross to the neck of my worst foe, with its phones locked about his ears, its filaments glowing their brightest and crackliest, and its high tension voltage gingered up almost to bursting point. No viler thing exists.

Yet you may see it and hear it at its worst in many a saleroom

where languid young demonstrators who ought to know better spend their time in making the sets under their charge produce enormous volumes of dreadful noise, instead of in adjusting them so that they are really worth listening to.

On the Best Authority

Years ago the charming inhabitants of Southern France had a terrible reputation for drawing the long bow as no other men could draw it. This, however, was entirely unjust, as the author of a famous work has abundantly proved; he has shown that it is merely the result of the cheery effect of the bright sunshine of those parts which makes them view everything through slightly amplifying spectacles. Here is a story that comes from Tarascon and may, therefore, be accepted as absolutely true.

An ancient farmer went to the village telephone one morning to give an order to the stores in the big town. On his return he gat him to his pigstyes whilst Madame his wife was busy in the garden. High above their heads, so high that it was a mere unnoticed speck, sailed an aeroplane. Filled with the cheerfulness that the southern sun inspires, and unmindful of the fact that he carried cargo, the pilot proceeded to loop the loop from sheer high spirits. Out fell a parcel which landed with a resounding thud just at the old lady's feet. "Say, then, Jean," she shrilled, "the boots that thou didst order are arrived already by wireless!"

The Radioswankist

I always rather love the man who professes to have a soul above the "tripe served out by the local broadcasting station," and seeks his amusements from others farther afield, at home, or even on the Continent. You know the kind of man I mean. Whenever you ask him how things are going he is at great pains to explain that having a musical soul he cannot stand the _____ programmes, but always makes use of those of _____, the latter being the most remote of

all broadcasting stations. His proud words do not take you in; you know that you are listening to one of the most amusing forms of wireless swank. He probably could not distinguish with certainty between *God Save the King* and *Yes, We Have No Bananas* if his musical ear were put to the test. It is not fine programmes that his soul craves for; he wants you to say to yourself, "Now here is a man with a set that is really worth calling a set."

In your wireless youth you probably took him at his face value, but as you grow more seasoned and gain experience of the little ways of radiomaniacs you read him like an open book. And the funny thing is that he knows all the time that you don't believe a single word of what he is saying. The "Oh, I *never* think of using *that* station" attitude is, however, an excellent one to impress beginners who are getting a little uppish. Have you not found it so? I have. Be sure, though, that they are beginners.

Insults

The quarrel that I have with many wireless books is that they are written by supermen to whom even the most abstruse things are as plain as the proverbial paint. Having conducted you through the first stages of an argument by means of a bewildering mass of figures interspersed with cryptic signs they finish you off by saying: "It will thus be obvious (note the insult of that obvious) that this resolves itself into the simple (another insult) formula

$$\sqrt{\cos \phi} = 2^3 \sqrt{\frac{9 \tan 4 \alpha}{\text{moon's age}}}$$

in seconds; or something of that kind.

Then you fling the book into the fire and resolve that spillkins is a far more elevating pastime than wireless. Yes, ours is a thorny path and we are indeed noble fellows to follow it as we do.

THE LISTENER-IN.

VISIT THE "RADIO PRESS" STAND AT
THE ALL-BRITISH WIRELESS EXHIBITION

THE "TRANSATLANTIC" RECEIVER

Two Stages of Tuned High-Frequency

By PERCY W. HARRIS, Assistant Editor.

With this remarkable receiver no outdoor aerial, earth, indoor aerial or frame is required to receive broadcasting up to eight or ten miles from a broadcasting station. With an outdoor aerial it brings in all the broadcasting stations without resort to critical reaction. It is admirably suited to listening for Transatlantic telephony, and on a Ducon or indoor aerial it will often bring in all British stations with ease.

THE value of high-frequency amplification in a wireless receiver cannot be too strongly emphasised.

For long distance reception, we need some arrangement of valve or valves which will magnify the incoming currents to a point when they will pass the detector valve.

be added to existing sets. Unfortunately, it is exceedingly difficult to design good high-frequency amplifiers, for there are so many problems connected with the efficient working of these devices that few multi-stage high-frequency amplifiers are ever brought to a state of perfection.

cabinet containing two further valves as note magnifiers. The set will then be a five-valve set with two H. F. detector and two note magnifiers. I am calling it the "Transatlantic receiver" because it will suit those readers who are anxious to listen during the coming winter to the concerts broadcast from the United States. The handling of this set, as will be explained later, is a little different from the ordinary receivers, but the degree of amplification obtainable on weak signals is surprising. It is, of course, possible to receive all the broadcasting stations in this country quite easily, and, indeed, they have all been received with this set on a "Ducon." On an outdoor aerial the reception of British broadcasting is decidedly improved—good quality speech and music coming through from all the stations without that recourse to the last ounce of reaction to bring them in. For this reason distant music and speech is far purer and less distorted than is possible with any receiver containing only one stage of high-frequency amplification.

Let us describe the set in detail. It contains a socket for a plug-in aerial coil, three terminals arranged with a strap between two of them, so that the tuning condenser can be placed either in series or in parallel with the inductance, a .0005 variable condenser for tuning the receiver, two plug-in transformers accurately tuned with a .00025 μ F variable condenser and three valves of the low capacity type. The whole of the apparatus is carried on an ebonite panel 12 inches by 8 inches, which can be supported in any kind of cabinet desired. I have placed mine in a sloping front cabinet which I happened to have on hand and which suits this very well. There is, of course, no reason why the panel

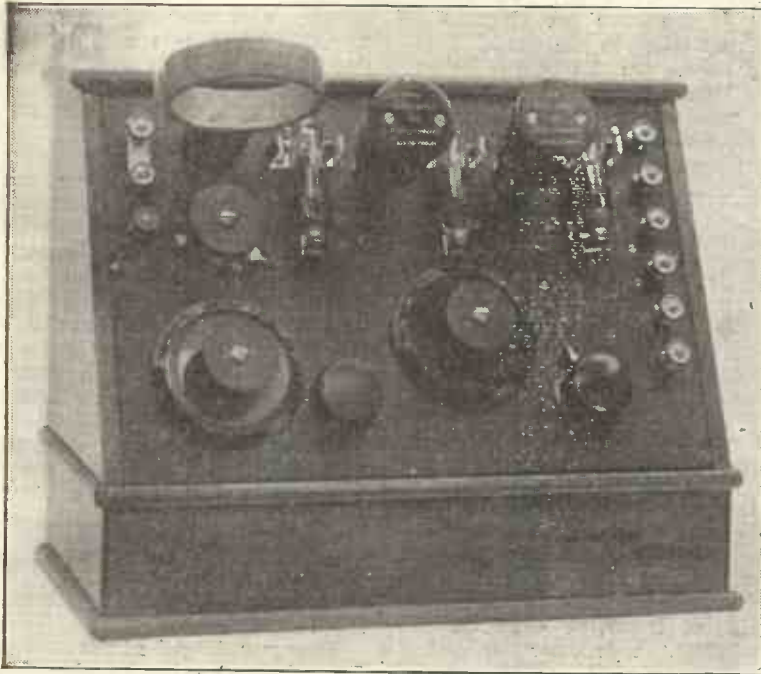

The complete instrument with valves and transformers in place.

Once they are sufficiently magnified, we can add low-frequency stages or note magnifying valves, and obtain any degree of strength we can reasonably require. That many amateurs realise the necessity of high-frequency stages for long distance reception is shown by the number of requests we receive to describe how further stages of high-frequency magnification can

The present receiver is an attempt to obtain efficiency in high-frequency amplification without the usual complication of adjustment. It consists, as the photograph shows, of a cabinet containing the tuner and three valves; the first two acting as high-frequency amplifiers and the last as a detector. In next month's MODERN WIRELESS I propose to describe a companion



The set with valves, coil transformers removed to show construction.

should not form the top of a box in the manner used in so many commercial sets.

In designing the set with two stages of high-frequency, I knew I should be "up against" the old problem of self-oscillation, and I naturally took steps to reduce the tendency to this self-oscillation to the lowest possible point. The layout of the parts is such that the wiring is the shortest possible, and the coupling between grid and plate circuits arising from the closeness of the valve pins and leads, in the usual four-pin valves and sockets, is avoided by using the type of valve shown. In these instead of the leads from the filament, grid and plate being brought through the base of the valve, they are taken through the ends and sides well apart from one another, and the clips between which these valves are mounted also well spaced. The two first valves used for high-frequency amplification are V 24's, while the detecting valve is a QX, this latter being specially designed for detection, although when used with a higher

plate voltage than in the present set, it also makes an exceedingly good high-frequency amplifier. These valves, unfortunately, are much more expensive than the ordinary four-pin type. Mullard's, however, make a low-capacity valve with a similar mounting, but slightly larger, known as the "Ora B" which costs only 15s. 6d. The spacing of the clips for these however, requires to be slightly greater. Thus by careful wiring and the use of low capacity valves and sockets, the coupling between stages is reduced to the lowest possible figure. In passing it may be stated that the "neutrodyne" receiver is designed with neutralising devices to stop this tendency to self-oscillation, but it is not a very easy instrument for the beginner to make, and will not be dealt with here.

The tuning difficulty I have overcome by using a special form of condenser for tuning the two high-frequency stages. This consists of two variable condensers on the same shaft, the two condensers being very accurately matched so as to have the same capacity and all adjustments from zero to maximum. The one used was made by the Marconi Scientific Instrument Co., and the two condensers have a capacity of .00025 μ F each—quite a nice valve for tuning in high-frequency stages. The

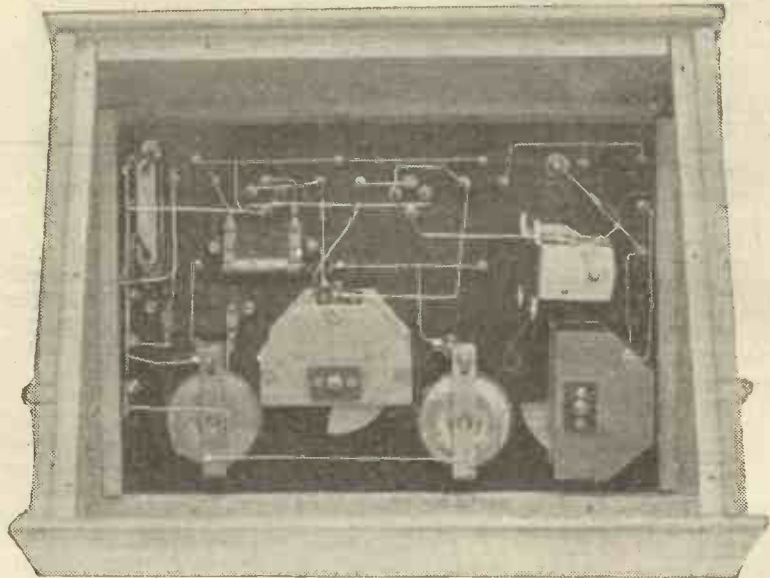

The wiring is very simple and short, so as to avoid unwanted interaction. The two Igranic resistances are joined by a soldered wire on the frames, and not on the usual terminals. This keeps the wire clear of the condenser vanes.

Fallon people have also just placed a similar condenser on the market, which will suit this receiver quite well. This condenser would of course do to tune two tuned anode coils, but when we use tuned anode amplification it is necessary to have grid leaks and intervalve condensers, which add slightly to the complication of the wiring. The transformer coupling makes the wiring extremely short and simple—naturally one of the points I was aiming to achieve. The observant reader will have noticed by this time that there are no terminals or seeming pro-

valves, and in fact when designing a receiver with reaction, I frequently connect the grid of the high-frequency valve to the positive leads and make up for the losses so introduced by reaction. In the present case I decided to use a potentiometer for the accurate adjustment of just the positive voltage required.

The principle upon which a potentiometer operates in such a set does not seem to be clearly understood by all readers. If we connect the grid of a valve to the positive lead of the battery, there will be a positive bias on the grid

is shown immediately below the plug-in coil. As I estimated in designing the set, only a very slight positive bias is requisite to check the self-oscillation, and as the slider of the potentiometer is connected to the grids of the two h.f. valves, we can adjust matters very nicely. Reaction, then, is adjusted on the potentiometer and, as we shall explain later, on the filament resistances.

A word now regarding the arrangement of terminals on the left-hand side of the instrument. I was anxious to avoid all switches in this set, for wherever we intro-

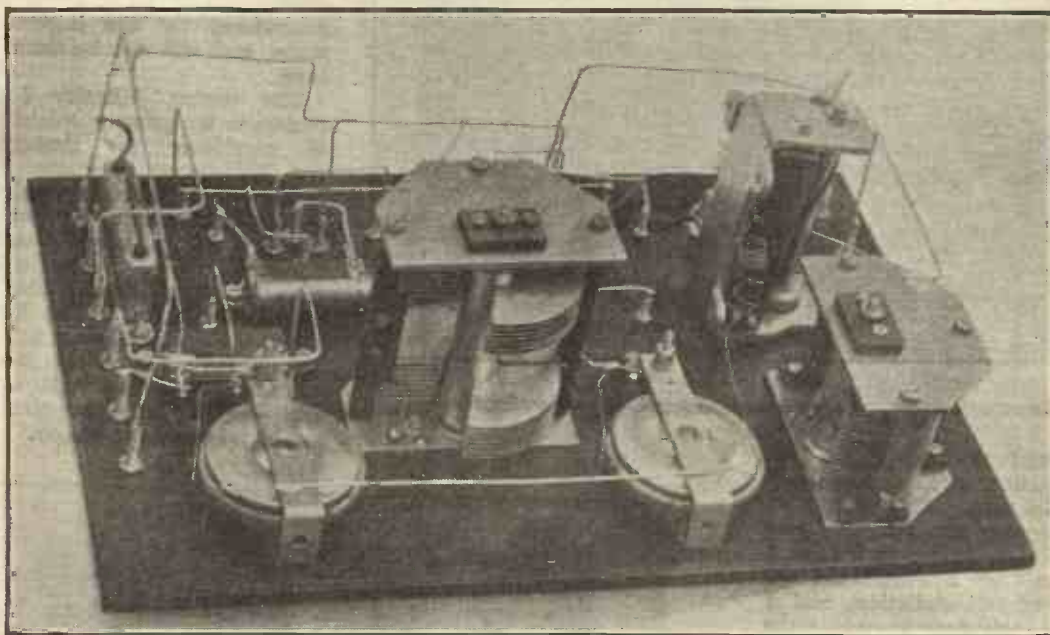

A "close-up" of the back of the panel, showing the double condenser.

vision for reaction in this set. In designing this receiver I aimed that in short wave work there should be no necessity for them. I hoped in the design so to arrange the parts that the receiver could be kept just off the point of self-oscillation so that the maximum reaction should be usable at will, and expected that if I took all the precautions enumerated and connected the grids of the first two valves to the negative lead of the battery, the set would just oscillate when the two stages were tuned to one another. This proved to be the case, the oscillation not being very violent. Now we can check self-oscillation by putting a small positive bias upon the grids of the

depending upon the voltage of the low-tension battery. If we connect it to the negative lead, there will be zero voltage on the grid. If now we connect across the positive and negative leads from the accumulator a high resistance of several hundred ohms, arranged so that a slider can run along the turns, when the slider is pushed over to the negative side, we shall have as before zero voltage, and when to the positive side, the positive voltage mentioned. Between these two points we can set the slider so as to give a very accurate adjustment of grid voltage anywhere between zero and the maximum. Such a potentiometer is connected in this set, and its knob

duce switches we must have complication of wiring. For this reason I hope readers will not write to me, and ask for a new diagram with switches to cut in or out the stages of amplification used. If we were to introduce such switches into the present set, we could not possibly have the simplicity of wiring and consequent reduction of the tendency to self-oscillation. The wiring, too, would "unbalance" the two high-frequency stages, and it would probably not be so easy to tune two stages on the one condenser.

I believe I was the first to introduce the three terminal method for obtaining series, and parallel connection of the aerial tuning

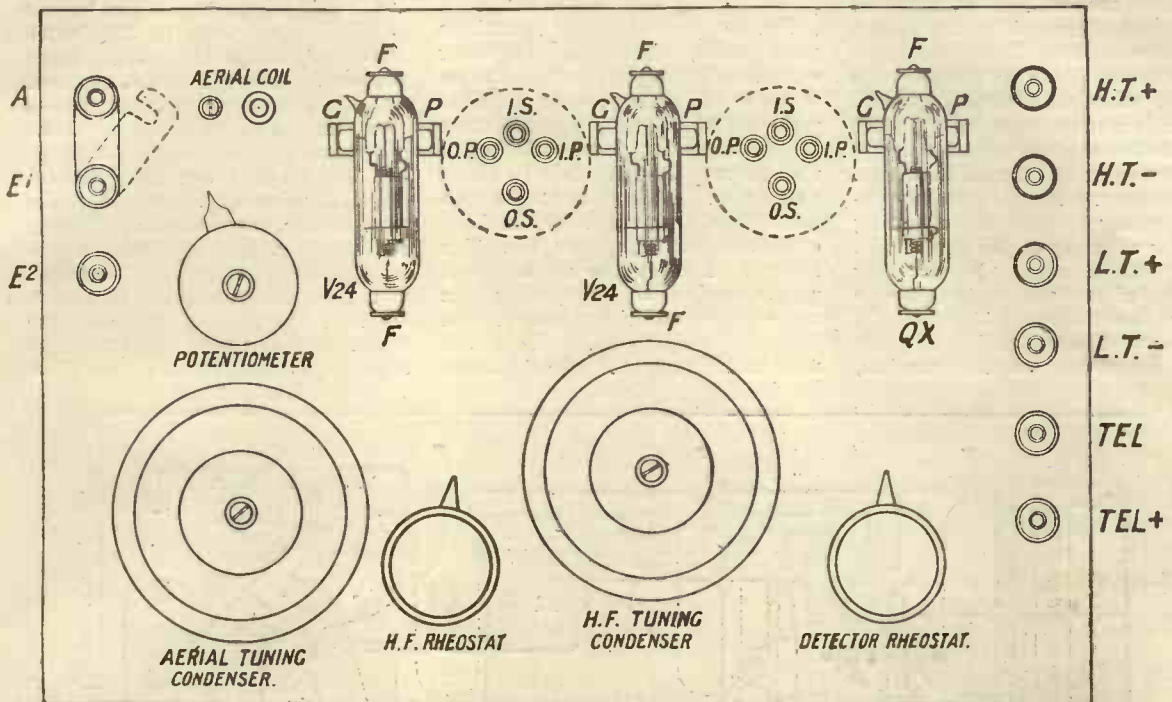

Arrangement of terminals, etc.

condenser. It is a very simple arrangement, the wiring for which is scarcely longer than for the ordinary fixed parallel or series arrangement. The two upper terminals are connected by a strap; the aerial being always connected to the top terminal. If now we keep the strap closed and connect the earth to the bottom terminal, the condenser will be in parallel with the aerial tuning inductance. If we open the strap and connect the earth to the middle terminal, then the condenser will be in series.

How to Build the Set

To build the set we shall need the following components:—

- 1 ebonite panel, 12 inches by 8 by 1/4 inch thick.
- 9 terminals.
- 1 socket for plug-in coils.
- 1 variable condenser, 0.0005 μ F capacity.
- 1 double condenser, the two parts being each of .002 or .00025 μ F capacity.
- 1 potentiometer.
- 2 filament resistances (it is not necessary to have three, as the two high-frequency valves can be controlled from a common resistance).
- 3 sets of clips for tubular valves.
- 1 potentiometer.

- 2 sets of valve sockets for plugging in the transformers (I strongly advise you to use the separate legs here and not the ebonite-cased sockets usually supplied, as we want to get the minimum capacity between the legs, and we shall get this by drilling the panel to take four separate sockets in each case. There is then a minimum of ebonite between the legs).
- 1 fixed condenser, 0.0003 μ F, and grid leak 2 megohms (the Dubilier type with clips in which the leak is

held is quite suitable here, the leak being left in the clips).

- 1 fixed condenser .002 μ F.
- 1 fixed condenser .01 μ F or larger (in the particular receiver described I used the Dubilier type 577 which is very convenient for panel mounting, but a Mansbridge up to 1 μ F would be just as suitable if you can find room for it).
- 1 quantity of No. 18 bare-tinned copper wire for wiring up.
- 1 pair of plug-in transformers.

Note.—The plug-in transformers must be matched. It is useless un-

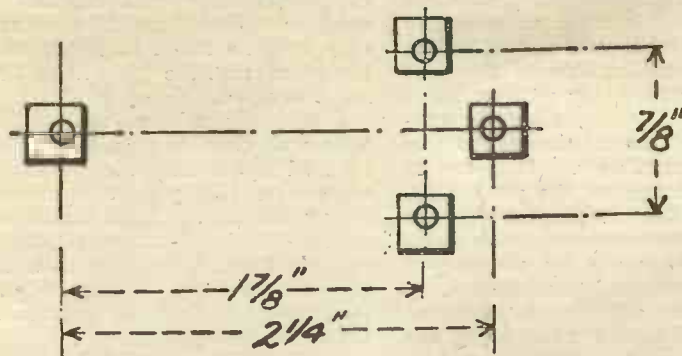

Full-size drilling diagram for the valve clips for V 24 and QX valves. Ora B valves will require slightly different spacing.

less they are both of exactly the same dimensions. For this reason they should both be of the same manufacture. Those shown were made by Messrs. McMichael, Ltd., and have a range stated to be from 300 to 600 metres, when a .0003 μ F condenser is connected across the primary. Actually in my receiver owing to shortness of wiring and low capacity of the valves, the range with a .00025 μ F condenser is from about 250 metres up to nearly 600 metres. There are a number of different makes of plug-in transformers on the market,

Laying Out the Panel

Before you actually purchase your panel, obtain all the other components and lay them out on a sheet of paper to see whether you will be able to arrange them all in the space given. Potentiometers vary considerably in shape and size. That used in the present set was made by the Marconi Scientific Instrument Co. The Igranic people make an excellent potentiometer of practically the same size as their well-known filament resistances, which are used in this set. Any good make

cardboard of the exact size of the panel you will require, and mark out the holes for the various components. You will probably want to make several changes before you are quite satisfied. When you have your dummy, the panel can be marked out and drilled. It is, of course, possible to make up this receiver on a wooden panel, as in my other instruments described in MODERN WIRELESS, but owing to the fact that the low capacity valves used require some space on the panel, not much is saved by using wood. Owing to

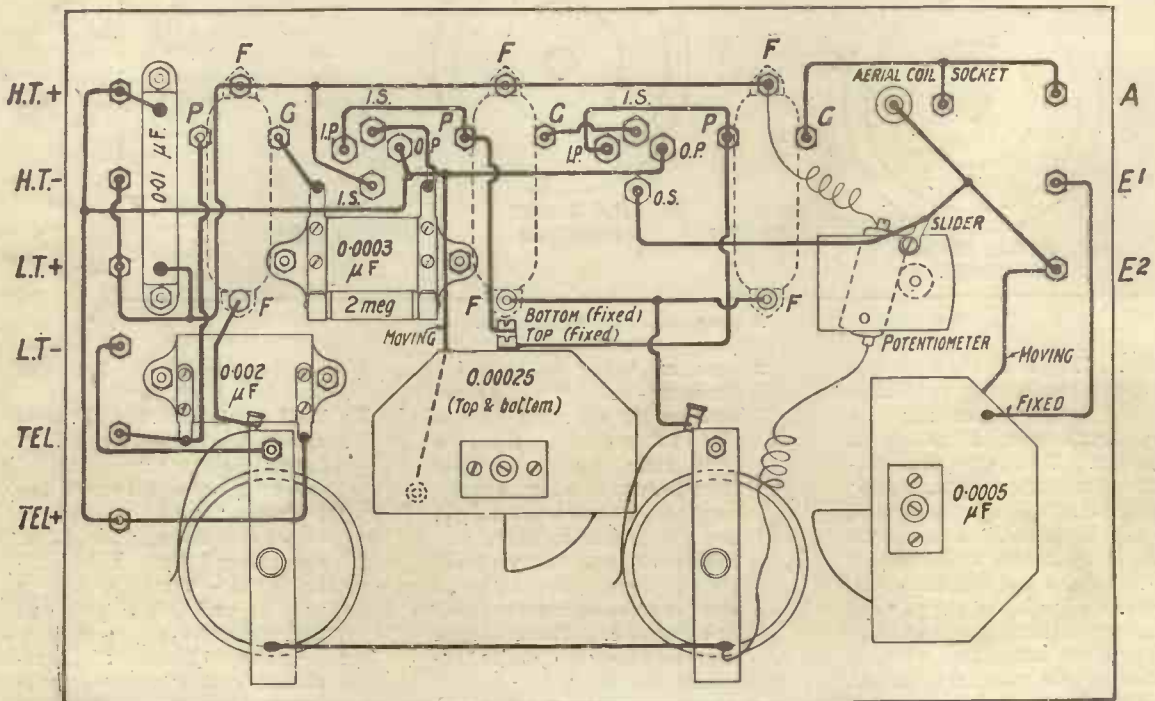

Practical wiring diagram. Note particularly the leads which go to bottom and top fixed plates of the double condenser.

many of them being very excellent devices. It is, however, necessary to make sure when purchasing, that the connections of the pins are either as in my receiver, or if they are different, then the connections of the instrument must be altered accordingly. It is one of the advantages of the present instrument that as plug-in coils are used we can cover any wavelength range we require by plugging-in different coils and transformers.

Note re valves.—Although as mentioned two V 24 and QX are used, the set will work quite well with three V 24's. This point is mentioned as the V 24 is a slightly cheaper valve than the QX.

of potentiometer will do, and I simply mention the matter so that care may be taken in laying out the panel that the parts fit in the space allotted.

I strongly advise readers to adhere as close as possible to the detailed layout shown in the illustration on this page and to the wiring diagram. Some makes of variable condenser have very large end plates, and in some cases it may be necessary slightly to extend the panel in order to include the aerial tuning condenser.

Wiring Up

Before drilling your panel I advise you to make a dummy on

the fact that the panel is comparatively small and therefore not particularly dear, I would advise you to use an ebonite panel in this instrument.

Although I so frequently emphasise the necessity of removing the surface skin from ebonite before mounting parts, I still find a number of readers ignore this precaution.

When all the parts are in place, take a smooth file and rub the tips of all screws, etc., which have to be soldered. Having done this take a fine brush and remove every particle of brass filing from the set. Then place the minutest touch of flux on the points of all

screws to be soldered, avoiding like the plague the use of an excess of this material. In this set more than any other I have described, it is essential to preserve the insulation at the highest possible pitch of perfection, and if you use much soldering flux, the hot iron will tend to make it sputter all over the place, and give conducting film which is the last thing you want. Use a hot clean soldering iron, wiping it frequently with an old piece of cloth to remove the scum. Carefully tin the head of every screw, and if the soldering iron is hot enough, the solder on the head of the screw will run together as a little bead. If you have not yet made up a set using stiff wiring for connections, you may imagine the work is very difficult. You will find it, however, quite easy if you follow the instructions given below. The stiff wiring adds greatly to the appearance of the set, and incidentally is economical as you avoid the expense of buying insulating tubing. A further advantage is that it enables you to space the leads to the best possible advantage to prevent the unwanted interaction to which I have referred.

With the wiring diagram in front of you (as usual a full size wiring diagram as a blue print is obtainable from Radio Press, Ltd., price 1s. 6d., post free), take a straight piece of wire and cut it and bend it to join the first two connections (it does not matter which connection you make first so long as they are all properly done in the end). Now take the hot soldering iron, dip it in the solder and hold it successively to the two ends of the piece of wire you have cut. See that the ends are nicely tinned with a thin film. Having tinned the two ends, hold one end of the wire in place on its particular screw, and place the soldering iron at the point of contact, when if the temperature is right you will find that the solder bead on the end of the terminal and the solder film on the end of your wire will run together neatly in a well-finished joint; the other end can now be done in the same way.

If you find difficulty in bending to all the shapes, you can cut shorter leads and solder other lengths on afterwards. This sometimes makes it easier in joining up. Successful wiring up with this wire is dependent on three things:

(1) have your points well tinned beforehand with a small bead of solder on the end; (2) make sure that the ends of your wires are quite clean and also nicely tinned; (3) be sure that your soldering iron is very hot and perfectly clean at the end. You will soon succumb to the fascination of wiring up in this way, and the results obtained are electrically more efficient than by any other method. For this reason stiff wire connections are being more and more introduced into commercial sets.

Operating the Set

When the set is fully wired up, turn the rheostats in the "off" position, place the valves in position, plug-in the transformer and connect up the batteries. You will need a six-volt accumulator

which give you the best results. When accurately tuned to the nearest station turn your potentiometer knob from one end position to the other. At one end the signals will be much stronger than at the other. The end at which they are weakest is the positive end, and you will aim to work as near as possible to the opposite end.

We now come to the peculiar procedure with such a receiver which may confuse you at first. Dim the filament slightly until the signal strength starts to go off; it is possible now that the speech and music will be distorted due to self-oscillation. Turn the potentiometer slowly from its negative position towards the positive until the distortion ceases. If you are acquainted with self-oscillation you will recognise the symptoms. When

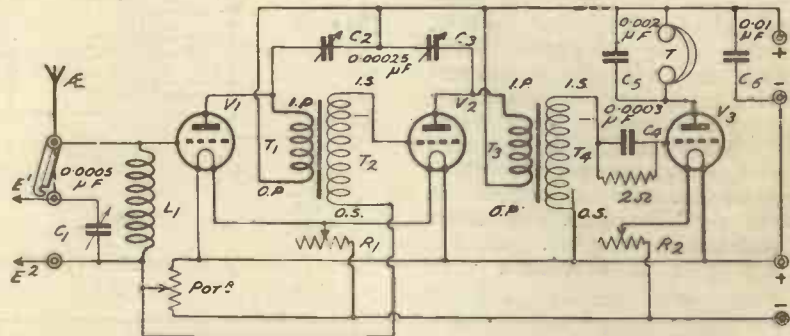

The theoretical diagram.

for these valves as they work at something over 5 volts on the filament. Fifty volts high tension will be quite enough as these valves are not designed for very high tension. High resistance phones will, of course, be needed. For the reception of British broadcasting, plug-in a 25 or 35 Igranic, Atlas, Gambrell A, a No. 2 or a No. 3 Burndept concert coil or any other make of coil suitable for the particular wavelength band. I also find the "Magnum" tapped coil quite good in this instrument.

First of all connect your condenser in parallel. Now turn your valve to almost the brightest position of the filament resistances; put your potentiometer to one end of its run, and set your variable condensers at about half way. Turn the two variable condensers until you pick up the nearest station (this will be an easy matter), and then note the position on the two condensers

you are used to these controls try for a different station. By this time you will know which way to turn the condenser towards the station you want, for you will know the wavelength of that to which you have been listening. If, for example, you have been listening to London and wish to turn to Birmingham, you will need to advance the condensers towards the maximum to hear it. You will not need to make a very great advance with the high-frequency tuning condensers, and first of all you may gather the impression that the set is not at all selective. Gradually turn the condensers and adjust the filament resistance controlling the high-frequency valve (you will find this very critical); and a point will be reached when you will suddenly pick up the station for which you are searching in great volume in the telephones. Final adjustment will be on the

(Continued on p. 87.)

WHAT TO DO WITH TWO VALVES

By John Scott-Taggart, F.Inst.P., Editor.

Some advice to those who wish to receive signals with two valves.

I AM not infrequently asked what circuit I would recommend for two-valve reception. My answer would vary according to the requirements of the individual questioner. Does he wish to carry out long-distance reception using headphones, or is he desirous of working a loud-speaker? What kind of apparatus is available? Has he a good quality intervalve transformer? Is his experience and adjusting ability sufficient to justify the recommending of some circuit which requires a little more than ordinary ability to make it function to the best advantage?

All these questions require answering before a really satisfactory reply can be given. I propose in the following article to deal with several two-valve circuits which may be thoroughly recommended, and to give some details of values of different components.

I propose to deal both with

circuits using crystal detectors and those in which a three-electrode valve is used as a detector. The crystal, if of a good type, will be found a very useful detector, and it operates very well in conjunction with valves.

Probably the best circuit for

those who have already used a crystal detector is the simple one shown in Fig. 1. In this circuit L_1 represents the variable inductance which may, say, be of the slider type and consist of a $3\frac{1}{2}$ in. diameter tube wound for 5 in. with No. 24 enamelled copper

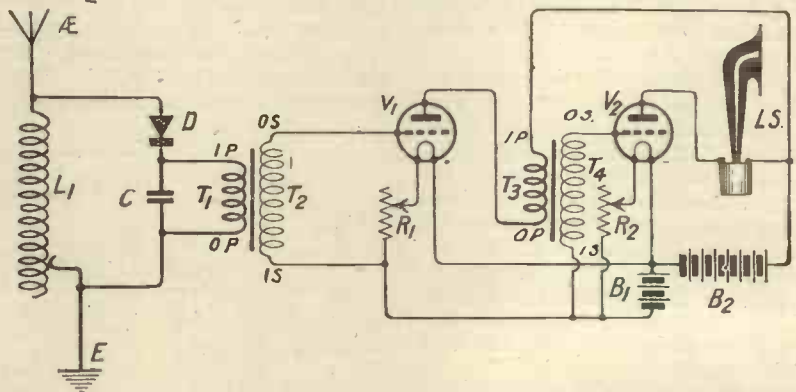

Fig. 1.—Probably the best circuit for those who have already used a crystal detector.

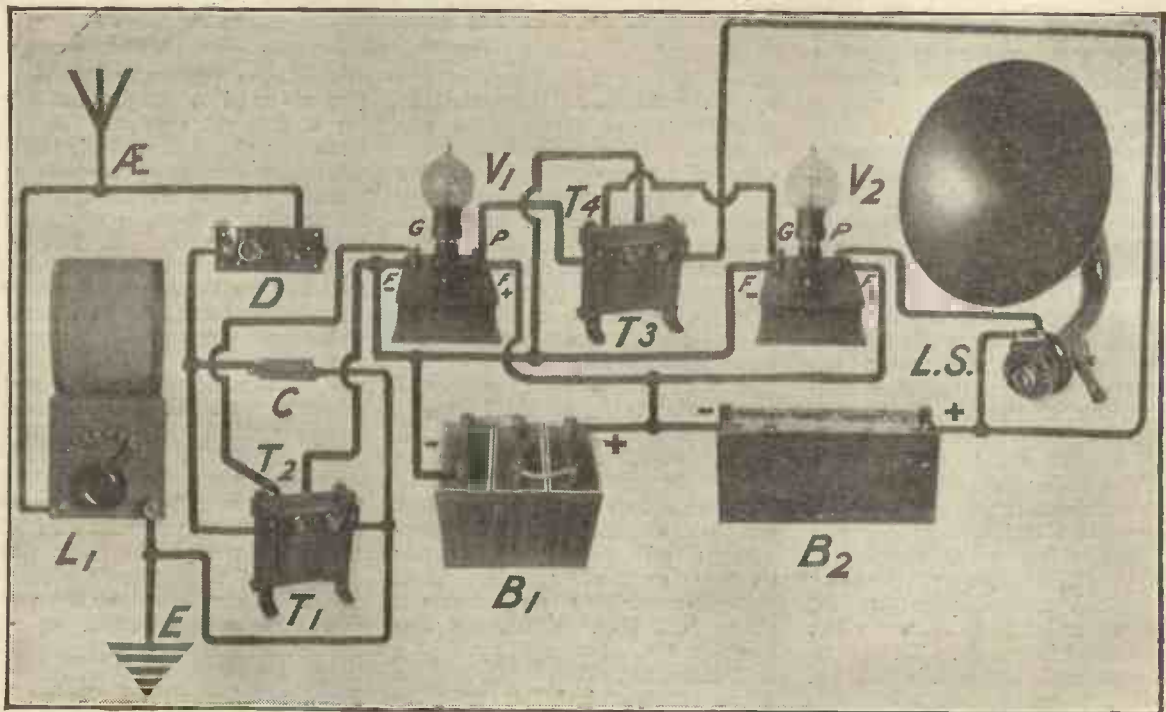

Fig. 2.—Figure 1 shown pictorially.

wire. Instead of the inductance L_1 , an inductance shunted by a variable condenser may be employed. If it is not desired to use the plug-in type of coil, the inductance L_1 might consist of 60 turns of No. 26 gauge double cotton covered wire wound on a cardboard tube $3\frac{1}{2}$ in. in diam. er. Tappings may be taken at every ten turns and the used portion of the inductance shunted by a variable condenser of $0.0005 \mu\text{F}$ capacity. Preferably, a $0.001 \mu\text{F}$ condenser, in series with a fixed condenser of $0.001 \mu\text{F}$, should be connected across L_1 as explained in last month's article entitled "From Crystal to Valve." The object of the two condensers is so that the fixed one may be cut out with the result that the variable condenser has now a capacity of $0.001 \mu\text{F}$, whereas the combination has an effective maximum capacity of $0.0005 \mu\text{F}$.

Across L_1 we have the crystal detector D , preferably of the cat-whisker type, and the primary T_1 of the intervalve transformer $T_1 T_2$. A fixed condenser C of $0.002 \mu\text{F}$ capacity is preferably connected across T_1 . This condenser, in

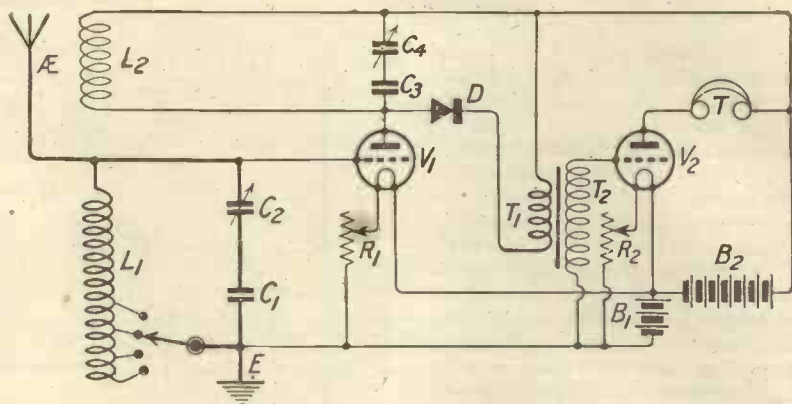

Fig. 3.—A circuit with high frequency amplification.

many cases, may be omitted without any disadvantage. The secondary T_2 is connected across the grid and negative terminal of the filament accumulator B_1 . In the anode circuit of the first valve we have the primary T_3 of the step-up intervalve transformer $T_3 T_4$. In the anode circuit of the second valve we have the loud-speaker LS. The high-tension battery B_2 may have a value of from 60 volts up to 120 volts, louder results being

obtained with the higher voltage if the incoming signals are comparatively strong. This circuit is only suitable when good, clear signals are obtained with the crystal detector alone.

Fig. 2 shows the Fig. 1 circuit arranged, using components.

It will not be long before the beginner will want to try a circuit using high-frequency amplification, and in this he is wise. The first circuit which I would recommend

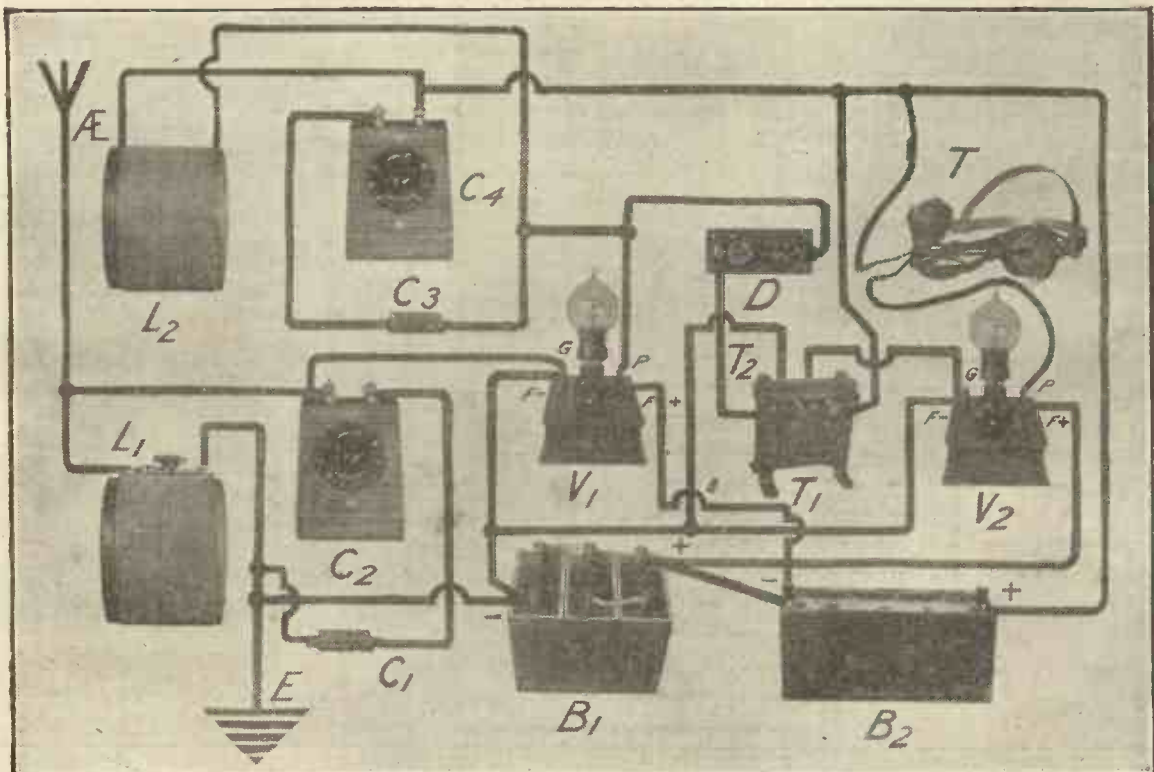

Fig. 4.—How to connect up the components in Fig. 3.

the beginner to try is shown in Fig. 3. It will be seen that the variable inductance L_1 , shunted by the condensers C_1 and C_2 , is in the grid circuit of the first valve which acts as a high-frequency amplifier. In the anode circuit of this valve we have the variable inductance L_2 , shunted by the condensers C_3 and C_4 . Across the tuned anode circuit, as it is called, we have the crystal detector D and the primary T_1 of the step-up intervalve transformer $T_1 T_2$. The secondary T_2 is connected across the grid of the second valve and the negemal terminal of the filament accumulator B_1 . The telephones, or loud-speaker, are included in the anode circuit of the second valve.

The beginner will be well advised to keep the inductance L_2 well away from the inductance L_1 when first experimenting with this circuit. It is important to tune both the grid circuit and the anode circuit accurately by means of the variable inductances and the variable condenser. Correct tuning is more or less a knack, but there should be no difficulty in tuning a simple circuit of this nature.

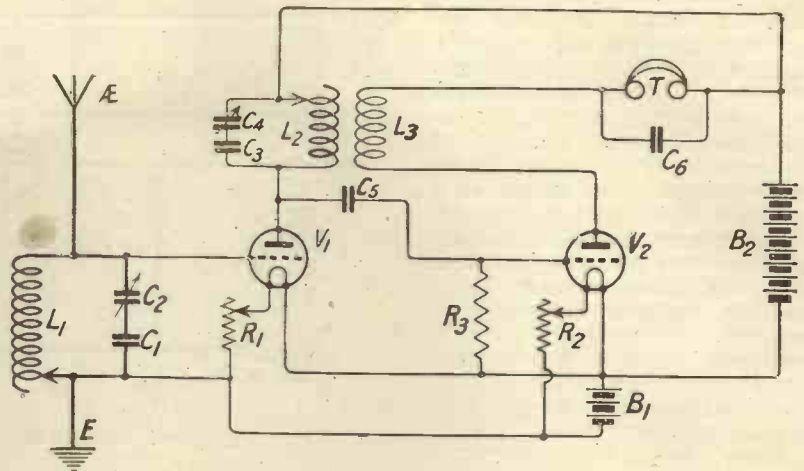

Fig. 5.—The well-known ST34 circuit.

The inductance L_1 may consist of a 3½ in. tube wound with No. 26 gauge double cotton covered wire. Tappings may be taken at the 10th, 20th, 30th, 40th and 50th turns. The inductance L_2 may consist of a similar coil omitting the 10th turn tapping and providing a total of 70 turns, tapped at the 20th, 30th, 40th, 50th, 60th.

and 70th turns. The coil is wound on a 3 in. tube which may slide in and out of L_1 .

The next circuit which I would advise the beginner to construct is shown in Fig. 5 and is commonly known as the ST 34.

The first valve acts as a high-frequency amplifier, the amplified
(Continued on page 104.)

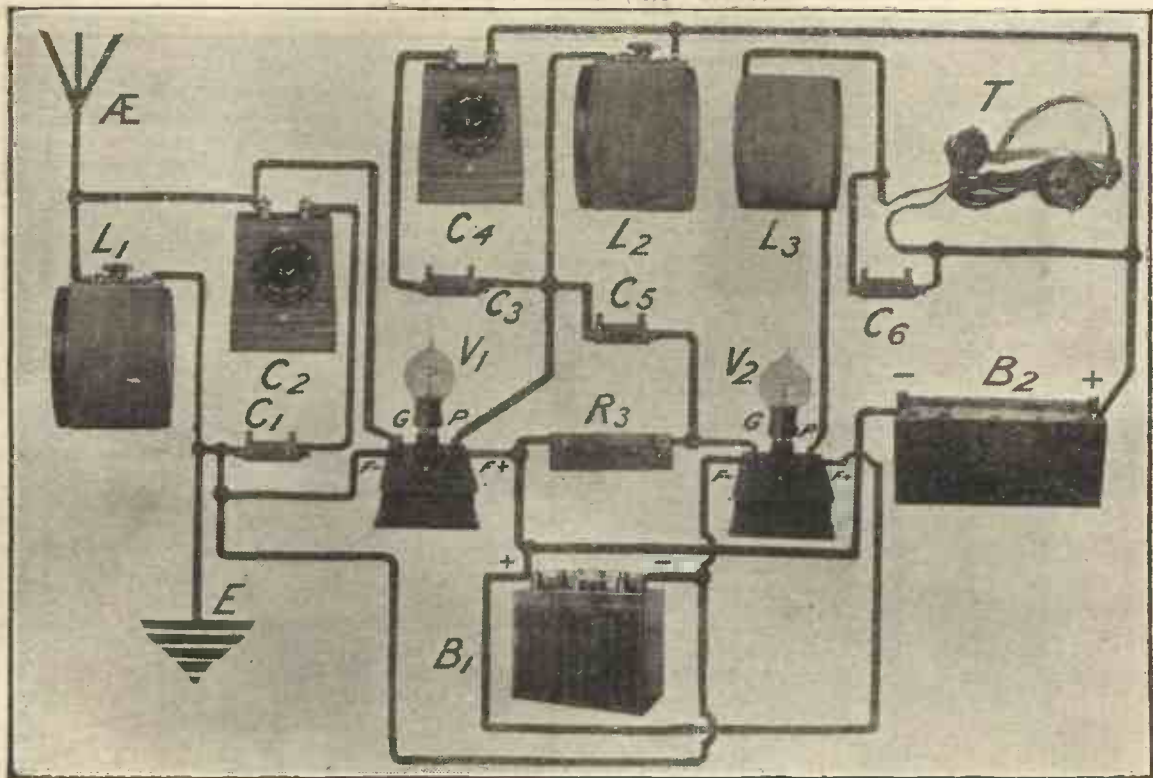

Fig. 6.—ST34 circuit shown pictorially.

THE ALL-BRITISH WIRELESS EXHIBITION

Interesting Exhibits at the "White City"

A FORTHCOMING attraction, appealing particularly to wireless enthusiasts, and of more than ordinary interest to the public generally, is the All-British Wireless Exhibition and Convention, to be held at the White City, Shepherd's Bush, W., from November 8 to November 21. This Wireless Exhibition is being organised in conjunction with the National Association of Radio Manufacturers. The active participation of this powerful association will ensure presentation on an adequate scale of all that is most up-to-date in wireless progress.

Amateurs and experimenters will find all their requirements fully catered for, while the needs of those who have yet to make their first acquaintance with wireless are by no means being neglected. Apart from the actual exhibits, comprising almost every conceivable form of wireless apparatus, there will be a series of lectures and demonstrations, the latter by special arrangement with the British Broadcasting Co., Ltd. Full advantage is being taken of the ideal facilities of the White City to provide for the comfort and convenience of visitors on an elaborate scale. The Exhibition organisers are Bertram Day & Co., Ltd., 9 and 10, Charing Cross, London, S.W. 1.

At the time of writing, the following firms have arranged to exhibit, but many others have probably come in at a late hour:—

Ashley Wireless Telegraph Co.
Auckland's Wireless, Ltd.
Abbey Industries, Ltd.
Autoveyors, Ltd.
Auto Sundries, Ltd.
Amalgamated Press, Ltd.
British Thomson-Houston Co., Ltd.
British L. M. Ericsson Mfg. Co., Ltd.
Burndept, Ltd.
Brown, S. G., Ltd.
Burns, J., Ltd.
Bowyer-Lowe Co., Ltd.
Beldam Tyre Co., Ltd.
British Ebonite Co., Ltd.
Brown Bros., Ltd.

Ball, T. C.
Coomes, J. A., Ltd.
Canadian Brandes, Ltd.
Chloride Electric Storage Co., Ltd.
Cossor Valve Co., Ltd.
Chambers, L. J., & Co.
Clmax Patents, Ltd.
Cassell & Co., Ltd.
Dubilier Condenser Co., Ltd.
Davenport Wireless, Ltd.
Day, Bertram, & Co., Ltd.
Diamond Wireless, Ltd.
Edison Swan Electric Co., Ltd.

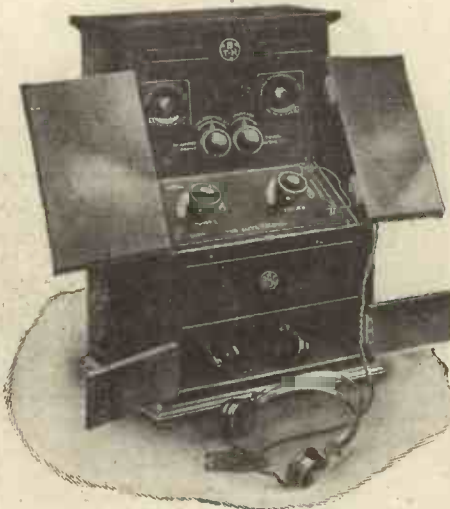

An interesting two-valve receiver exhibited by Messrs. British Thomson-Houston Co., Ltd.

Ever-Ready Co., Ltd.
Eagle Engineering Co., Ltd.
Economic Car Light, Ltd.
Fuller's United Electric Works, Ltd.
Falk, Stadelmann & Co., Ltd.
Fallon Condenser Co., Ltd.
General Electric Co., Ltd.
General Radio Co., Ltd.
Graham, A., & Co.
Gamage, A. W., Ltd.
Great Motor Ballot.
Hart Accumulator Co., Ltd.
Henderson, W. J., & Co.
Hestavox, Ltd.
Hough, J. E., Ltd.
Hart Collins, Ltd.
Harwell, Ltd.

Igranic Electric Co., Ltd.
Jones, Sydney, & Co.
Marconi's Wireless Telegraph Co., Ltd.
McMichael, Ltd.
Metropolitan-Vickers Co., Ltd.
Mullard Radio Valve Co., Ltd.
Marconi Scientific Instrument Co., Ltd.
McClelland, J., & Co., Ltd.
MacDonald, J., & Co.
Marshall, Percival & Co.
National Wireless and Elec. Co., Ltd.
Odhams Press Ltd.
Pye, W. G., & Co.
Peto Scott Co., Ltd.
Preen, A., & Co.
Peronet, Ltd.
Radio Communication Co.
Radio Instruments, Ltd.
Rogers, Foster & Howell, Ltd.
Rawlplug Co., Ltd.
Radio Press, Ltd.
Radio Supplies, Ltd.
Radiax, Ltd.
Sterling Telephone Co., Ltd.
Siemens Bros. & Co., Ltd.
Solidite Mfg. Co., Ltd.
Telephone Mfg. Co., Ltd.
Trader Publishing Co., Ltd.
Vanstone, W., Ltd.
Western Electric Co., Ltd.
Wireless Press, Ltd.
Wilton Wireless, Ltd.

SOME OF THE EXHIBITS.

MESSRS. AUCLAND'S WIRELESS, LTD., are showing a complete range of every component part required by the amateur for transmitting and receiving. Complete sets of parts ready for assembling, suitable for amateurs who hold a constructor's licence. Complete broadcast receiving apparatus ranging from crystal and crystal-valve combinations. Sets of single-valve, 2-valve and 3-valve receivers.

MESSRS. AUTOVEYORS, LTD., have arranged to exhibit, amongst other items, the following:—

CLIX

The Electro-link with 159 uses.

It consists of a combined plug and socket which provides an instantaneous contact suitable for any point of electrical connection.

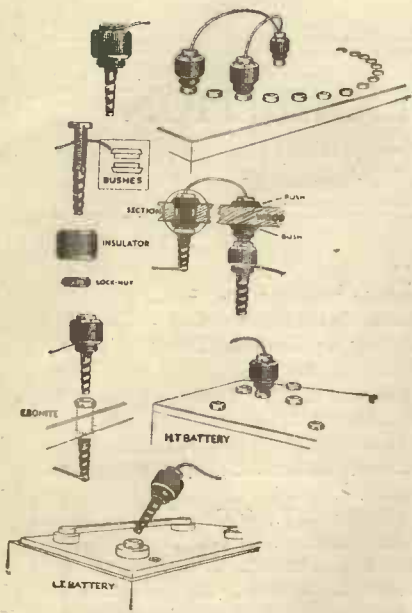

The Clix link shown by Messrs. Autoveyors, Ltd.

Variable Bridge Condenser (3-E.V.C.)

For panel-mounting or cabinet-mounted.

This comprises three sections, each consisting of a tier of rotary or semi-rotary parallel plates of one-third disc area. Whilst providing all the essentials of the ordinary 2-electrode condenser, it has the all-important addition of the coupling of the third electrode, which may be employed with marked advantage in special applications.

Filtron

Variable Grid Leak and Potentiometer.

This device has proved very useful in radio circuits which necessitate a variable high ohmic resistance of precision.

Filtron Combination

A combined variable grid leak and variable grid condenser.

The main features of MESSRS. ASHLEY WIRELESS TELEPHONE CO., LTD., exhibit this year will be their "Claritone" Loud-speaker and new "Claritone" Headgear.

Not only has the design been carefully executed so that it will be extremely comfortable to wear, having for its main feature as regards design the new hygienic headband, but also the ear-pieces are moulded ebonite, the pole-pieces being moulded solidly into the ear-pieces themselves, each ear-piece

also having the advantage of being quickly removable from the stirrup. A special feature which is worthy of note is a lever adjustment which prevents the ear-cap from swivelling too far round.

Another line will be their new component parts. Each small component part is specially packed in a small carton, together with a small pamphlet of instructions on the working of the component, and each component will also carry the Company's guarantee.

in a box composed of four panels of B.T.H. insulating compound standing on a polished walnut base and capped with a cover of the same material. Its dimensions are approximately 10 in. x 7½ in. x 7 in.

Type B₄ valves are used, and when in use the filaments are visible through inspection windows provided in the cover. These valves have been specially designed for power amplification, and reproduction is free from all valve noises. The valve has unique characteristics in that the current consumption is very low, only 0.25 amp. at 6 volts being required. This represents about one-sixth of the current consumption of other makes of power-amplifying valves.

Two switches are provided: one a pull-out switch for switching the amplifier "on" or "off," the other being a rotary switch controlling the intensity of reproduction. By means of this switch the volume of sound can be so regulated as to be suitable for all conditions.

A variety of loud-speakers will also be exhibited by this firm, of which we may mention the following:—

FORM C₁.—This loud-speaker is encased in polished aluminium and is provided with an enamelled horn. The air-



An Ever-Ready battery for dull emitters.

THE BOWYER LOWE CO., LTD., will exhibit their crystal and valve receivers, component parts, wave-meter, wave-trap, audibility meter, and many other interesting devices for the experimenter. In particular their new line of components for wood panel mounting will attract attention.

THE BRITISH THOMSON-HOUSTON COMPANY, LTD., are arranging to show a complete line of receivers, of which one is illustrated on the previous page. They are also showing a large amplifier for loud-speaker work.

This amplifier is designed for use with loud-speakers when a comparatively large volume of sound is required.

The working parts are enclosed



An attractive "Cosmos" set.

gap adjusting screw is mounted on the top of the receiver case.

FORM C₂.—This instrument is provided with a "swan neck" horn, which can be fitted either with a wooden or a metal flare. The air-gap screw is out of sight, but is very readily accessible.

FORM C₃.—This is designed for use with the tone arm of a gramophone, using an adapter. The sound-box can readily be replaced by this model, and excellent results obtained.

FORM D.—This instrument is of the electro-dynamic type, which is provided with a permanent magnetic field generated by a battery of cobalt steel magnets. Thus the necessity for a field-exciting accumulator is avoided. To operate this loud-speaker the large two-valve amplifier is necessary.

The output terminals of the amplifier are connected to the primary winding of a telephone transformer housed within a circular base of moulded insulating compound. Upon this base is mounted the magnetic structure. The secondary winding of the transformer is connected to a moving coil which floats freely in the permanent magnetic field. By this means any variation of current in the coil causes a corresponding movement which is transmitted to a specially selected diaphragm rigidly attached to the coil.

THE BRITISH L. M. ERICSSON MANUFACTURING CO., LTD., are showing a line of receiving apparatus, their well-known headphones and their loud-speaker.

MESSRS. S. G. BROWN, LTD., are exhibiting their loud-speaker and telephone headpieces in several patterns.

THE COSSOR VALVE COMPANY'S stand will undoubtedly attract much attention, as they are showing for the first time the new Cossor dull emitter valve, for which many advantages are claimed.

G. DAVENPORT (WIRELESS), LTD. —The exhibit of this Company will comprise a complete range of components and sets.

Special attention will be centred on a new headphone, BBC stamped; of exceptionally light construction, with adjustable headband.

It is claimed that reception is both true and undistorted with this headphone, which will be marketed through the trade at 17s. 6d. per pair.

The range of sets includes a crystal set at £1 is. od., crystal and valve set, Note Magnifiers and the new "DW₃" Regenerative Reaction Set. This consists of H.F. valve, detector, with tuned anode coupling and reaction, together with one L.F. valve.

Three anode coils replace the ordinary tapped anode, controlled by one special anti-capacity switch. The reaction coil operates on the particular anode coil in circuit. Aerial tuning is carried out by means of a Lissen tuner with variable air condenser, whilst the anode circuits are tuned by a .001 variable air condenser with vernier plate with separate control.

and the casing, which measures 13 in. x 7½ in. x 7 in., is covered in "Levant" leatherette. The fittings are well finished and heavily nickel-plated, and a neat carrying handle is provided.

Within the cabinet a sound conduit of entirely new design is arranged. In form and construction the conduit is the result of series of experiments conducted with the single purpose of obtaining maximum amplification and added tonal quality within the smallest possible limits of space. From the receiver unit to the trumpet mouth the development is gradual and in the course of the length of the conduit a special grade of rubber,

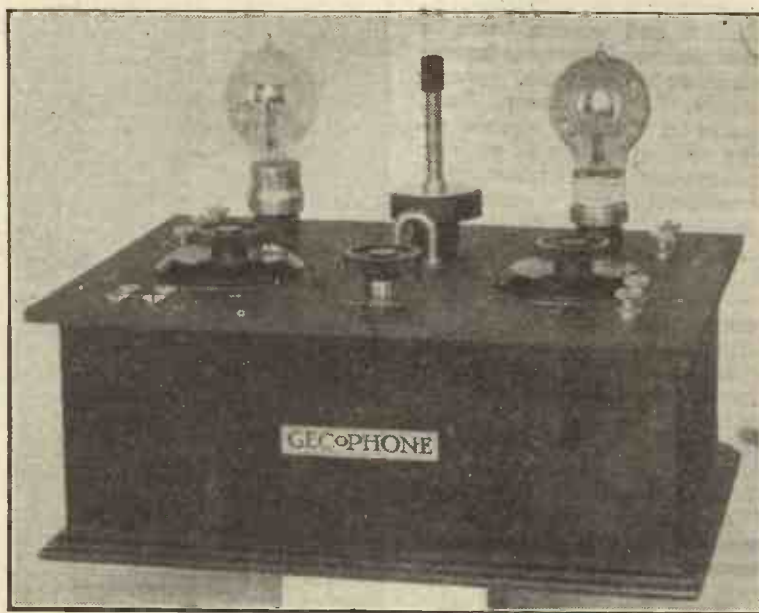

A new Gecophone set.

The panel is handsomely mounted in an enclosed cabinet of Jacobean design, whilst all terminals are at the rear of the panel.

THE EVER-READY COMPANY (GREAT BRITAIN), LTD., will exhibit all kinds and sizes of dry cells and accumulators, particularly their "Hercules" types of dry batteries for dull emitters. They will exhibit the convenience and efficiency of these on their stand.

One of the most interesting exhibits on the stand of MESSRS. ALFRED GRAHAM & Co. will be the portable Amplion loud-speaker.

In appearance the instrument resembles a high-class box-camera

a metal alloy, and, finally, wood are employed.

The receiver unit is the latest Amplion construction wherein diaphragmic resonance is avoided by the method in which the diaphragm is retained in position. Adjustment is effected in the usual Amplion manner by turning a knurled nut at the rear of the receiver casing.

Telescoping to only 11½ in. for stowage, each limb of the metal tripod extends to 3 ft. 4 in., but it is not necessary to open to the full length unless desired. Alternatively, the portable Amplion may be placed on a table or other available support, and the tripod remains where it is.

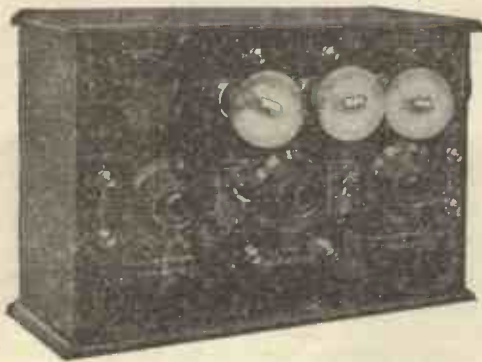

The McMichael M.H.B.R. 3 exhibited at the White City.

series of receivers have been put up as broadcast components for the home constructor to assemble. These cover the same range as the experimental sets. They provide the same series of combinations as other sets, viz., M.H.1, M.H.2, etc. Supplied with each of these sets is a diagram and descriptive matter showing how they are to be assembled.

M.H. Accessories and Components.

The complete range of the accessories and com-

with single-valve and 2-valve "Crystal-Set Amplifiers," specially designed to fit into the Crystal Set. They will also show a comprehensive assortment of Radio accessories, components and parts.

The special circuit now employed in the improved "Cosmos" Radiophone valve sets gives remarkable results, the performance obtained with two valves being fully equal to that hitherto obtained with three.

The "Cosmos" valve sets are designed on a "unit" principle. The "Cosmos" Radiophone 2-valve set consists of a 2-valve tuner unit, with the necessary batteries and telephones; the addition of a

Messrs. Graham are also showing their latest models of "Amplion," which are now fitted with improved mechanism and wooden horns in place of the metal trumpets heretofore used on most models.

Messrs. L. McMichael, Ltd., specialise in "M.H." wireless receiving sets, which are all entirely British-made and of a high standard of manufacture and performance. Their stand (No. 83) at the All-British Wireless Exhibition will contain a selection of some of the more important of their M.H. products, and can roughly be divided into experimental receiving sets and units for the experimenter; broadcast sets for the broadcast listener-in; home assembly sets for the home constructor; M.H. components for the home constructor; components and accessories for the experimenter and constructor, and general accessories for all purposes.

Home Assembly Sets.

In order to provide for the home constructor the whole of the M.H.



The Radio Instruments wave-trap.

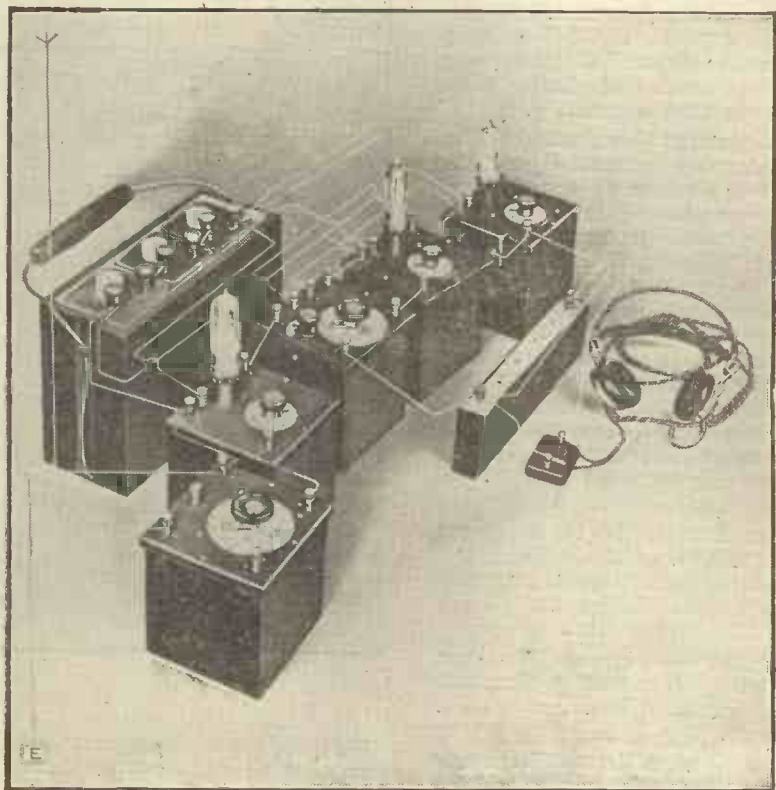

"Cosmos" Radiobrix for the experimenter.

ponents will be displayed, giving some idea of the finish and design which characterise M.H. products.

The chief features of the exhibit of METROPOLITAN-VICKERS ELECTRICAL CO., LTD., will be their latest improved types of 2-valve and 4-valve sets with dual amplification circuits, and the "Cosmos" Radiobrix. They will also be exhibiting a new 6-valve set with frame aerial, and in addition the "Cosmos" Radiophone Crystal

2-valve note-amplifier unit converts this into a 4-valve set. Each unit is connected up to the next by a single plug, which cannot be inserted wrongly, so that connecting up is simplicity itself. The units are arranged to fit into handsome cabinets of various designs, or they may be used by themselves. Thus one may start with a comparatively inexpensive form of valve set, to which one may afterwards add if desired, and

so build up by degrees an elaborate set.

The "Cosmos" Radiobrix comprises a comprehensive range of units, by various combinations of which the Radio experimenter or amateur can build up any type of receiving set, and by connecting up the standard Radiobrix in various ways an immense variety of circuits can be tested and used.

The 6-valve set comprises three high-frequency amplifying valves, a carborundum crystal detector, and three low-frequency amplifying valves. The high-frequency vario-transformers are coupled together, so that simultaneous tuning of all three intervalve circuits is effected by the movement of a single knob. Non-radiating adjustable reaction coupling is also fitted. Very fine tuning is thus obtained, and maximum efficiency over the whole range of wave-lengths, with the simplest possible adjustment. The crystal detector is screwed up tight, and there is no need to search for a sensitive spot; it is adjusted by means of a potentiometer, and once this is set it will remain for weeks without needing further adjustment. This type of detector gives extremely perfect rectification without distortion. The low-frequency amplifying circuits are specially designed to give the clearest and purest possible reproduction.

THE NATIONAL WIRELESS AND ELECTRIC Co. are showing their "Gnat" crystal receiver and various valve receivers, as well as numerous component parts and accessories.

MESSRS. D. G. PYE AND Co., of Cambridge, are showing:—

Patent tuning coils of the plug-in type of extremely low self-capacity and of very robust character.

Tuning coil holders for 2 and 3 coils fitted with vernier adjustments giving very fine adjustment of reaction.

Variable plate condensers of the best quality, with fine adjusting plate.

Patent anti-capacity switches for panel mounting suitable for high or low frequency and which incorporate a good rubbing contact.

A system of unit valve panels from which an efficient multi-valve set can be built up.

Complete receiving sets of 2, 3 and 4 valves covering ranges from 300 to 3,400 metres. These sets are mounted in various designs, including the Simple Sloping Cabinet, a table type with a hinged lid covering valves, etc., and a very well designed pedestal type with self-contained loud speaker.

A 2-valve power amplifier of moderate cost and of very high efficiency.

Two low-frequency transformers which have been designed to give a uniform amplification over the whole range of music frequencies. One is particularly efficient on weak signals; this should be used after the detector valve. The other is for subsequent stages and

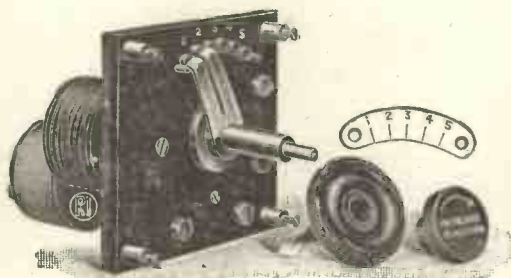

Radio instruments combined variable reaction and anode reactance.

power amplification and is suitable for the loudest loud-speaker work.

MESSRS. PERO SCOTT Co., LTD., are showing their well-known receivers, and a new set of components for wood mounting, which enable the experimenters to dispense with expensive ebonite sheets.

RADIO COMMUNICATION Co., LTD. are showing:—

The 1924 Model "Polar" 7-valve cabinet set fitted with remote control. This is the very latest form of their well-known 7-valve set, but in this case it has been fitted into a cabinet, which can be had in either of the period styles — Chippendale mahogany, Adam mahogany, Jacobean oak. The remote control enables one to control the set from an armchair without approaching it.

Other set exhibits are the 4 and 7 valve sloping panel and bookcase sets, with which the public are already familiar.

The next item in importance is the "Polar" Bloc system. This is a cleverly designed and absolutely unique system of set construction (somewhat on the lines of Meccano), by which a complete

receiving set may be constructed in a short space of time, embodying any type or make of apparatus without undue mechanical process.

A further exhibit is the "Polar" Economy Peanut Valve and Equipment. This has already been placed on the market. Its outstanding feature is extreme economy in space and also extreme economy in maintenance costs.

The "Polar" specialised accessories form another feature of the exhibits and comprise:—

The "Polar" Condenser; the "Polar" Cam Vernier Coil-holder; the "Polar" Fuse and Fuse-holder; the "Polar" Dynaphone; the Holderstat; the "Polar" Battery Tester and many others.

RADIO INSTRUMENTS, LTD., have arranged to exhibit the following:—

The Lyrian Series

These comprise cabinet receivers having 4 valves with self-contained loud-speaker and high-tension battery. The loud-speaker can be supplied separately if desired.

The models are shown in satin-wood, silver birch, mahogany, antique oak and various other styles to suit customer's taste.

Standard Valve Sets

These are made in various types, namely, 1, 2, 3, 4, 5 and 7 valves.

All models are now fitted with a sloping hinged lid arranged so that the instrument can be closed with the valves and battery leads, etc., in position. This renders the instrument dustproof and will be a great boon to users.

The outstanding feature of all R.I. receivers is their wide range of wave-length, all sets from two valves upwards being suitable for a range of wave-lengths of from 300 to 4,000 metres, bringing in all the British and Continental telephony. No plug-in coils are used, the change from one wave-length to another being effected by a well-made tapping switch. These are claimed to be the only broadcasting instruments on the market with this wide range of wave-length.

All instruments from two to five valves are fitted with variable intervalve reaction and one H.F. tuned anode, L.F. stages following according to the number of valves. The 7-valve sets are fitted with three

(Continued on page 103.)

A NOTE MAGNIFIER FOR THE ALL-CONCERT RECEIVER

By PERCY W. HARRIS, Assistant Editor.

Many requests have been received for a design of a note-magnifying panel to add to the "All-Concert" Receiver described in the September issue. The set described here has been specially made for the purpose and will convert the "All-Concert" Receiver into an efficient four-valve set.

SO many letters have been received from readers who have successfully constructed the "All-Concert" Receiver, asking for a suitable note magnifier to add to it, that I have now produced one to match the set. It is designed to stand alongside the "All-Concert" Receiver, the connection being as shown in Fig. 6. It will be noticed that separate terminals are provided for the high-tension supply to the note magnifier, so that if very high magnification is required (using a power valve), a high tension voltage of the requisite figure can be applied without upsetting the working of the preceding valves. The same low-tension battery is used in both sets, the terminals being bridged as shown. Additional terminals are also provided for grid cells, so that we can, if necessary, place a negative bias upon the grid of the note magnifier valve when using a high voltage on the plate. This is sometimes necessary to avoid distortion. However, in the majority of cases it will not be necessary to use these terminals and they are then bridged by a wire or a strip of metal. If the same voltage is used on the note magnifier as on the previous valves, we can use the same high-tension battery for both sets, leads being taken from the battery to the two sets of terminals.

The construction of the magnifier does not call for any special skill and will

be clear from an examination of the photographs and diagrams. The following are the components required:

- I valve socket,
 - 10 terminals,
 - I filament resistance,
 - I intervalve transformer of good reliable make,
 - I Mansbridge condenser of .3 μ F up to 1 μ F.
- A suitable panel either of ebonite or wood.

If you use a wooden panel, it will be necessary to provide yourself with ebonite flanges and bushes for the terminals and with the flange type of valve socket or else four separate valve sockets mounted on a piece of ebonite which can be placed over a hole in the panel. The filament resistance can be mounted straight on to the wood of the panel. In the particular instrument described I used the bushes and special wooden panel-mounting valve sockets supplied by the Bowyer-Lowe Co. These have a very neat appearance and are a part of a new line of components which enable one to dispense entirely with the usual ebonite panel.

The various parts can be fastened to the panel quite simply, but there may be a little difficulty with the Mansbridge condenser if it is not fitted with flanges for mounting. If there are no special means of mounting it may be necessary to cut two small pieces of brass to form right-angle brackets and to solder them to the sides of the condenser after the black paint has been removed. These right-angle brackets should have holes drilled in them so that



Fig. 1.—The complete unit.

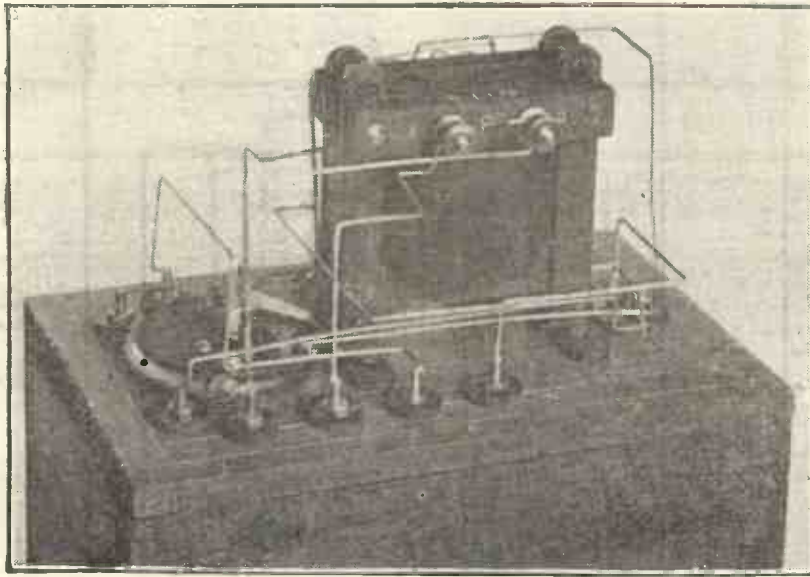

Fig. 2.—One view of the underside of panels showing stiff wiring.

wood screws can be used for securing the condenser to the panel. A Dubilier type 577 condenser of $.01 \mu F$ is suitable for use in this particular set and has provision made for panel mounting, but it is much more expensive than the Mansbridge type.

Wiring up is carried out with No. 18 bare tinned copper, either round or square section. Full details of how to carry out this wiring with thick wire are given in my article in this issue dealing with the construction of the "Transatlantic" receiver, so I need not go into further details here.

Operating the Set

This panel, when connected up to the All-Concert Receiver, converts it into an excellent all-round four-valve set. I cannot recommend the addition of a further note magnifying stage, as three note magnifiers together are never satisfactory, introducing, even with the best transformers, a certain amount of distortion which is unpleasant. Furthermore, three note magnifiers magnify every slight disturbance and atmospheric noise into a most distressing crash. Also, if signals are so weak that they require three stages of note magnification to make them audible then they will be unsuitable for the operation of a loud-speaker. If further amplification is required it should be by means of high-frequency and not of low-frequency.

The operation of this set is simplicity itself, as all one needs to do is to connect it up to the All-Concert Receiver and switch on the filament. Any good make of valve will do, and if very high magnification is required I would suggest the use of one of these valves designed for use in power amplifiers. When these are used a much higher plate voltage will be required, necessitating a good robust intervalve transformer. Unless the maker recommends his transformer for use in a power amplifier I cannot advise you to use a power valve, for these latter are useless without high plate voltage and a high plate voltage will burn out many of the transformers on the market. Make sure then, if you intend using power valves, that your transformer is suitable. Power valves will require

a special grid battery for which I recommend the ordinary type of high-tension battery tapped for at each 3 volts. This should be connected across the terminals marked "grid cells" and variations of grid potential should be tried until you get the best results.

Of course, this amplifying unit can be connected to any other receiver. The only point to bear in mind when using it is that it is essential for both magnifier and

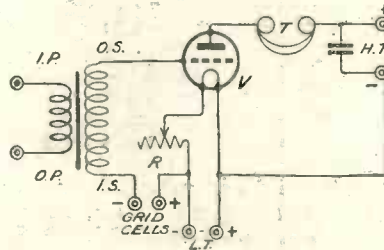

Fig. 3.—The circuit diagram.

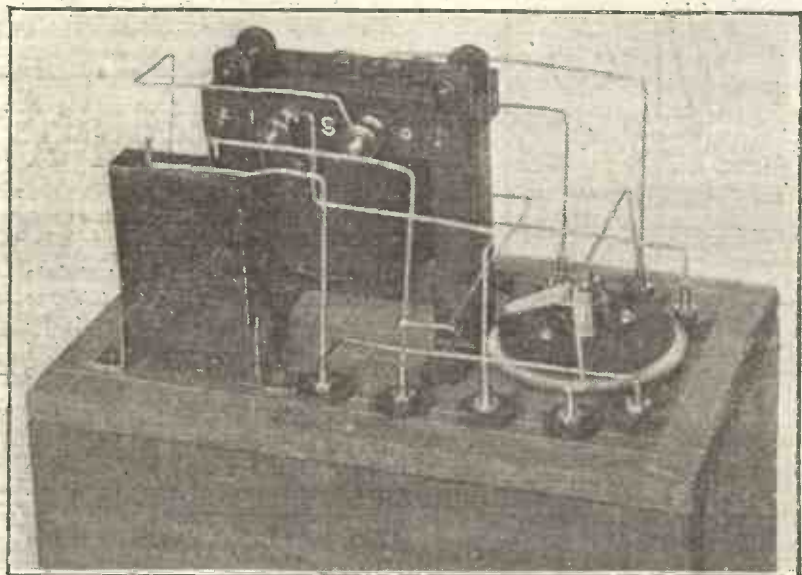

Fig. 4.—Another view of the underside, showing the Mansbridge condenser across the H.T. terminals.

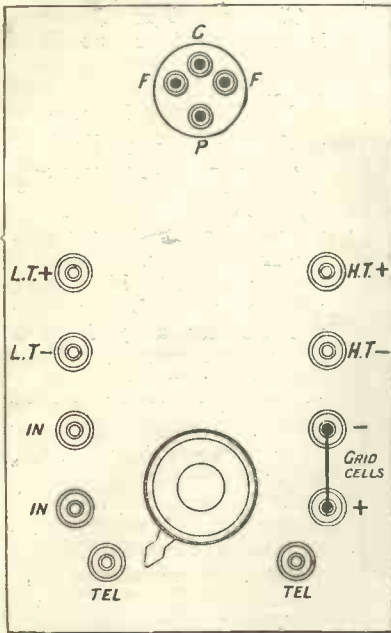

Fig. 5.—Arrangement of terminals.

receiver to have their high-tension batteries connected the same way, *i.e.*, the high-tension negative must be connected to the low-tension positive. Furthermore, it is essential that the all-filament resistances shall be placed in the negative leads of the valves and not in the positives. These two points are standard in all modern wireless receivers.

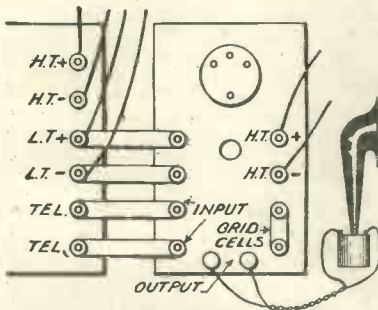
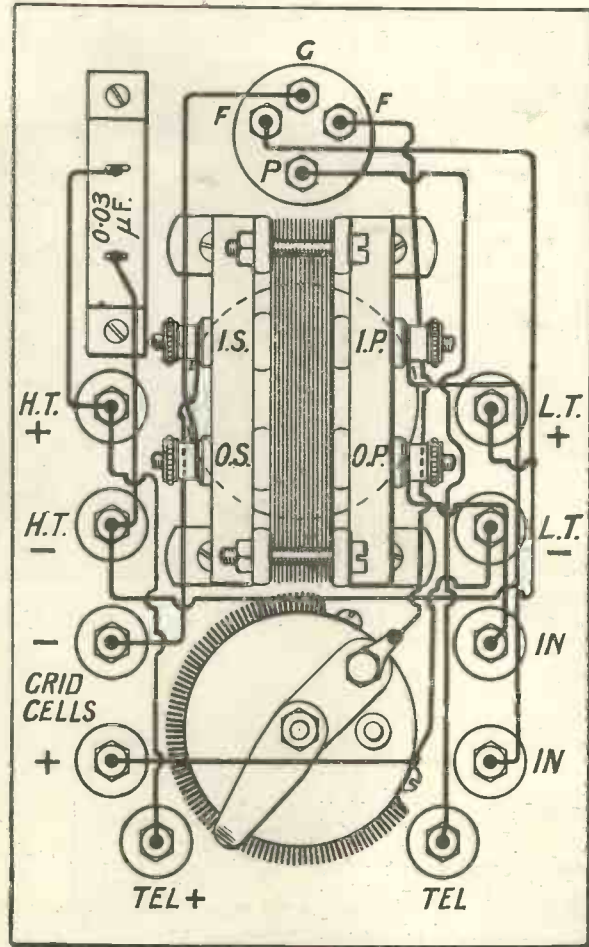

Fig. 6.—How to join the set to the "All-Concert" receiver. The same accumulator is used for both sets and, if desired, the same H.T. battery. Grid cells are only inserted when very high voltages are applied to the plates.

NOTICE. Blue Prints of the all-concert receiver are still obtainable. Price 1/6 post free.



The wiring diagram. Note carefully the I.P., O.P., I.S. and O.S. connections. Their positions may differ with different transformers, but the wires must always be connected as shown.

FROM A READER.

To the Editor,
MODERN WIRELESS.

SIR,—Allow me to congratulate you on the design of the "Three Valve All-Concert Receiver" described in this month's MODERN WIRELESS (September). I have been using this circuit for some considerable time, and still find it the best all-round broadcast receiver. I use a .001 μF. variable condenser instead of .0005, in series-parallel arrangement with the A.T.I. All B.B.C. stations come in with good strength. Eiffel Tower, Radiola, Paris and Dutch concerts with fair strength. When only using 2 valves (H.F. and detector)

with one stage of low frequency, I receive Eiffel Tower on a loud-speaker (Brown Junior High Resistance) sufficiently loud to be comfortably audible.

On the 21st September, between 1.45 to 2.30 a.m. I picked up WGY—General Electric Co., Schenectady, New York. The music was perfect and the speech quite clear. The other artistes could be heard clapping in the studio. They were announcing a 500 dollar competition for a Radio drama play. (Aerial twin 45 ft. long on 40 ft. mast.)

I am, etc.,
STANLEY F. BRIGHTY.

London, N.W.

RHYTHMIC BEAT TIME-SIGNALS

By A. HUGHES BARLOW, of Fleet Road Central School, Hampstead.

Many readers have asked for a popular explanation of the strange "dot time" signals from the Eiffel Tower. This article makes the method quite clear.

DO you remember the first time you received the Eiffel Tower time signals? What a gloriously exciting experience it was! And even now that the glamour has worn off by familiarity, there is a fascination about those dots and dashes that quite outshines that of 2LO's "56-57-58-59-DONG."

Your next thrill was probably the reception of Nauen's time signals on 3,100 metres. If you have a good crystal, and a good ear, you can get Nauen without valves; but a valve with reaction will give them more comfortably. At five minutes before Greenwich noon you listen-in, and hear first a succession of V's, then "POZ, MGZ" followed by the well-known International Time Signals.

All this is quite simple, and has been described many times; but what about those mysterious tick-tick-ticks that we hear at about ten o'clock in the morning? Do you receive them with a complete understanding of their import? Or is their use still confined to the deceiving of our guileless friends into the belief that they are actually hearing the tick of the clock at Paris Observatory?

Now, as the writer combines a passion for wireless experimenting with a love for astronomy—having probed the starry depths for many years with "home-constructed" telescopes—perhaps you will forgive him if he airs a bit of his knowledge about other sorts of time than the ordinary, "mean," everyday variety.

Greenwich Mean Time is, as its name suggests, an average time, so arranged that a good, steady-going clock or watch need not be disturbed in the regular carrying out of its duties.

True Solar Time is sometimes faster, sometimes slower than the average or Mean Time, and depends on the actual time taken by the sun to travel (apparently, of course) from the meridian of Greenwich, round the world, and

back to its starting-point. The True Solar Day varies in length as the year proceeds, its greatest value being about 30 seconds more than the Mean day, and its least value being some 21 secs. less than the normal 24 hours. The Mean Solar Day is merely the average of 365 of these slightly varying solar days.

The astronomer, however, needs an invariable time measure, corresponding to some invariable astronomical fact, and this he finds in the Sidereal Day, which is the time taken by the earth in making a complete rotation on its axis. The Sidereal Day is 3 min. 56.55 secs. less than the Mean Solar Day that ordinary mortals keep; and, being itself divided into 24 equal parts called sidereal hours, which again are divided into sidereal minutes and seconds, it is obvious that all these divisions are slightly shorter than the corresponding divisions of the ordinary day. Also, it will be easily understood that the discrepancy between Sidereal Time and Mean Time gets greater day by day until a whole period of 24 hours separates them—and then, of course, they are together again. This occurs once a year, near the commencement of spring.

Now, it is the astronomer's sidereal clock that is corrected by the so-called "Scientific Time Signals" sent out by the Eiffel Tower twice a day, viz., at 10 a.m. and 10 p.m. G.M.T., and so their practical value to the ordinary listener-in is nil. Still, he can get real pleasure in "taking" the signals and in qualifying himself to give a satisfactory demonstration and explanation of them to his friends.

Let us take an actual example:—On Sunday, October 7, the writer tuned-in to 2,600 metres a few minutes before ten a.m. by the dining-room clock. At about two minutes to ten, F.L. began by giving a preliminary course of signals consisting of 59 dots, followed by the sign — . — . — six times repeated, "F.L." twice, and — . . . — twice. By this time all the observatory,

listeners-in were, no doubt, ready for the test, which began at a few seconds after the hour. Dot, dot, dot went the F.L. transmitting clock, beating neither solar seconds nor sidereal seconds, but a slightly shorter one — .98 of a sidereal second, to be exact—so that the series of 300 dots (and spaces) took about 4 minutes 53 seconds in transmission. To make the counting of the dots rather easier there were pauses in place of the 60th, 120th, 180th and 240th dots. All this was duly noted.

Now if the astronomer knew the exact time of the transmission of these dots, he could proceed at once to correct his clock by them by noting which dots synchronised with the ticks of his own clock's pendulum. But, as a matter of fact, not even the F.L. operator himself knows the exact times until he makes a calculation based on the observed synchronising of certain of the dots with the swinging of the pendulum of the Paris Observatory clock, which has itself been corrected by observations of the meridian transits of the stars. So we must needs wait about thirty-five minutes for the announcement of the times of sending the first and last of the 300 dots.

At 11.35 the writer took up his receivers again and noticed that F.L. was engaged on his daily "U.R.S.I." announcement; and at 11.36 the long two-minute dash was given, (this is the "cue" for the astronomer, as the Sidereal Time announcement immediately follows it). The writer then read: "Observatoire de Paris," — . . . — "Temps Sideral" — . . . —

11 00 09 74 11 05 02 97 — . . . — . . . —

This meant that the first dot was transmitted at 11 hrs. 00 mins. 09.74 secs., and the last at 11 hrs. 05 mins. 02.97 secs., both in Sidereal Time.

I may say here that the Sidereal Time at 10 a.m. G.M.T. on this date (Oct. 7), as calculated from the almanac, was 11 hrs. 00 mins. 06 secs., so that the first dot was sent about 3 secs. after the hour, and the last 4 mins. 53.23 secs. later.

Now, the method adopted by the astronomer to check his Sidereal clock is this: He watches the pendulum of the clock as it ticks out the sidereal seconds, and at the same time he counts the dots from F.L. until one of them exactly synchronises with the tick of the pendulum. Suppose at this moment that his clock says 11 hr. 02 min. 49 secs., and that the FL dot was number 163. He knows that

the absolutely correct time is 11 00 09 74 (the time of the first dot) plus $\frac{1}{2} \frac{6}{9} \frac{2}{9}$ of the whole time of the sending of the dots (which—by simple subtraction—he knows to be 4 min. 53.23 secs.), $\frac{1}{2} \frac{6}{9} \frac{2}{9}$ of this being 2 min. 38.87 secs., the true sidereal time of the 163rd dot must have been 11 02 48 61, and so the astronomer's clock is shown to be .39 of a second slow. As, by this method, the clock can be corrected to the nearest hundredth of a second, the greatest possible error still remaining is .005 or $\frac{1}{200}$ of a second, and this is near enough for all ordinary astronomical purposes.

If you have patiently followed me so far, you may now be wondering how you can tell whether your reception is correct, as you have no means—so you think—of knowing approximately the Sidereal Time at 10 a.m. G.M.T. This need not trouble you long. For a shilling you can get Zadkiel's Almanack from any newsagent, and in it you will find the Sidereal Time at Mean Noon for every day in the year. Subtract 2 hrs. 0 min. 20 secs. from this, and you get the Sidereal Time at 10 a.m. G.M.T. In order, however, that no one need omit this observation for want of data, I append the ten o'clock Sidereal Times for every day in November:

	hrs.	mins.	secs.	hrs.	mins.	secs.
Nov. 1	12	38	40	16	13	37 48
2	12	42	36	17	13	41 45
3	12	46	33	18	13	45 41
4	12	50	29	19	13	49 38
5	12	54	26	20	13	53 34
6	12	58	23	21	13	57 31
7	13	02	19	22	14	01 27
8	13	06	16	23	14	05 24
9	13	10	12	24	14	09 21
10	13	14	09	25	14	13 17
11	13	18	05	26	14	17 14
12	13	22	02	27	14	21 10
13	13	25	58	28	14	25 07
14	13	29	55	29	14	29 03
15	13	33	52	30	14	33 00

SPECIAL NOTE.

On listening-in at 10.40 on Oct. 14, the writer was interested to receive the following transmission from F.L.: "Notez.—Partir du 15 Octobre inclus les silences seront remplacés par des traits dans les émissions de signaux rythmés." (Note that on and after Oct. 15, the "silences" will be replaced by dashes in the emission of the rhythmic signals.)

This has been verified by subsequent observations. The dashes are more striking than the "silences" they replace; and they occupy the time of two beats.

THE LICENCE QUESTION: A SETTLEMENT AT LAST.

EVERY wireless enthusiast will be delighted that a settlement has been arrived at with regard to the broadcasting problem and the position of the home constructor. We give below the official statements issued by the G.P.O., which make most of the points quite clear. However, on perusing the report it is apparent that several matters of considerable importance were left undecided and in particular the position of the experimenter in relation to broadcasting seemed very peculiar. It was strange to us that holders of experimental receiving licences issued after October 4 would be prohibited from listening to the broadcast transmissions for the purpose of entertainment, and our companion journal, *Wireless Weekly*, accordingly wrote to the Post Office authorities pointing out that the new regulations operated unfairly against the holder of a new experimental licence inasmuch as he is prohibited from enjoying even a Sunday afternoon concert, unless a constructor's licence (15s.) is obtained in addition to his experimental licence (10s.).

Wireless Weekly suggested that future applicants for experimental licences should, upon payment of an additional sum of 5s., be exempt from signing the declaration regarding listening-in to broadcasting.

They also mentioned that they had communicated with the British Broadcasting Co. in this matter, and understood that such an arrangement as suggested above would be perfectly satisfactory from their point of view.

By return, *Wireless Weekly* received the following reply:—

General Post Office,
London, E.C. 1.

October 5, 1923.

SIR,—I am directed by the Postmaster-General to acknowledge receipt of your letter of the 4th inst., and to thank you for the suggestion contained therein.

The Postmaster-General has communicated with the British Broadcasting Co. concerning the point

you raise and the best means of meeting it, and a further communication will be sent to you as soon as a decision is reached.—I am, Sir, your obedient servant,
(Signed) S. W. PHILLIP.
For the Secretary.

POINTS TO NOTE.

Existing experimental receiving licences are not to be interfered with in any way.

Existing experimental transmitting licences also will not be interfered with in any way, and new licences of this type will be issued upon compliance with the usual conditions and upon payment of the existing fee of 20s. per annum.

Owners of unlicensed receiving apparatus of any type will be required to take out before October 31 a special interim licence at a fee of 15s.

Those who desire to construct their own receiving apparatus, but are not qualified for an experimental licence, can obtain a constructor's licence (fee 15s.) upon application at any head or branch Post Office in the Kingdom. Both the interim and constructor's licences will remain in force until the end of 1924. Under the terms of these licences, foreign-made components may not knowingly be used in the construction of apparatus.

Experimental receiving licences (fee 10s.) will continue to be issued, but, in addition to the present condition, applicants will be required to sign a declaration to the effect that they will not use the broadcast programmes except for experimental purposes.

This declaration can be dispensed with by a further payment of 5s. Provision for this is made on the application form.

And on October 16 the following further letter:—

SIR,—With further reference to your letter of the 4th inst., I am directed to inform you that the Postmaster-General has decided to adopt your suggestion concerning the conditions attached to new Experimental Receiving Licences.

As recently announced, any

person who applies in future for an Experimental Receiving Licence will be asked to sign a declaration that he will not use his set for the reception of broadcast programmes except for experimental purposes. In accordance with the present decision, however, provision will be made on the new application forms for this declaration to be dispensed with, if the applicant prefers instead to pay a fee of 15s. a year in place of the normal fee of 10s. He will then be entitled to receive broadcast programmes for entertainment purposes.

Experimental Receiving Licences will, of course, only be issued to *bona-fide* experimenters.—I am, Sir, your obedient servant,

(Signed) J. F. BROWN,

We have come to the conclusion that, in general, a satisfactory settlement of the broadcasting problem has been arrived at, and consider that the Postmaster-General and the British Broadcasting Co. are to be congratulated. Naturally, there remain a few minor points to be disposed of, but these are chiefly in reference to matters which affect the B.B.C. and its individual members rather than users of wireless apparatus.

The response to the appeal to experimenters and users of wireless apparatus to put themselves right in regard to the law has been very gratifying, and although in some quarters the idea that the so-called "pirates" would act honourably was scouted, the most optimistic person could not have wished for a better response. This shows, as we have always believed, that the home constructor and new experimenter was as anxious to contribute his quota to the expenses of broadcasting as the most conscientious purchaser of a B.B.C. licence. Up to the time of writing this note some half a million wireless licences have been issued, of which quite a half have been the special interim licences to people who had not previously taken out a licence but were using a set at the time the report was published.

THE OFFICIAL STATEMENT ISSUED BY
THE POSTMASTER-GENERAL

IN giving instructions for the issue of the Report of the Broadcasting Committee, the Postmaster-General desires to express publicly—as he has already done privately—his warmest thanks to the Committee for the great care which they have given to the consideration of the novel and difficult questions referred to them by his predecessor.

The Report makes the following main recommendations:

That a Broadcasting Board should be established by Statute.

That the broadcasting service should not be operated by a Government Department, and that the existing service of the British Broadcasting Co. should be continued and extended for two years upon modified terms.

That one form of licence at a fee of 10s. a year (of which the Broadcasting Co. should receive 7s. 6d. and the Government 2s. 6d.) should be issued and placed on sale at Post Offices.

That no protection should be given to the British manufacturers by the licence.

Sir Laming Worthington-Evans finds that it is not possible for the scheme recommended by the Committee to be brought fully into operation immediately. As the Committee themselves point out, it has been necessary to have regard to the existing agreement with the British Broadcasting Co., which does not expire until December 31, 1924. Under this agreement, and in accordance with the statements made in the House of Commons at the time, the manufacturers are entitled to protection, and no licences were intended to be granted to any persons not using sets marked "B.B.C." and manufactured by members of the company.

The immediate cause of the appointment of the Committee was the deadlock which had arisen between the Post Office and the company in regard to the proposed introduction of another form of licence, viz., a "constructor's

licence," to persons who make their own sets or assemble them from ready-made parts, but who do not desire to carry on experiments. These receiving sets were being used contrary to the terms of the agreement. Large numbers of such persons had applied to the Post Office for licences, and probably many others, realising that no licence was in existence appropriate to their case, have been using their apparatus without making application.

The continuance of the present situation would be bad for all parties, the Broadcasting Co. because it is losing a revenue upon which it has counted, and the Post Office because, as the Department entrusted with the administration of the law regarding the licensing of wireless apparatus, it is unable to enforce the contemplated restriction.

In these circumstances a compromise has had to be sought. In order to recognise the company's rights under its agreement and at the same time to meet the views of the Committee as far as immediately practicable, the Postmaster-General has agreed with the Broadcasting Co. that a constructor's licence should be issued for a limited period at an annual fee of 15s. (as compared with the fee of 10s. charged for the B.B.C. licence). The additional 5s. for the constructor's licence is justified because otherwise the constructors would be obtaining the benefit of the Broadcasting Co.'s programme without making a proportionate contribution to the expense.

The company have agreed to this arrangement on condition that the licensee gives an undertaking that, in constructing his apparatus, he will not knowingly use parts manufactured elsewhere than in Great Britain or Northern Ireland. In all the circumstances, and especially having regard to the unemployment which at present exists and which would be accentuated by the importation of any considerable scale of wireless receiving

apparatus from abroad, the Postmaster-General has accepted this condition.

There are, however, probably 200,000 persons already in possession of unlicensed receiving apparatus, and, as the Committee point out, these persons are paying nothing towards the cost of the programme, because in the past there has been no licence applicable to them. A special interim licence will be issued at a fee of 15s., covering their present apparatus, whether made or purchased and wherever made or purchased, which will be granted to them provided that they apply for licences before October 15.* No charge will be made for past user, and no proceedings will be taken in respect of past user if the licence is taken out before October 15.*

Constructors' and interim licences as above will be placed on sale at all head and branch post offices and certain sub-offices on and from October 4. Applicants for such licences, as well as for the existing B.B.C. licence, will be required to fill up and sign a simple form. Copies of these application forms may be obtained not only at head and branch offices, but at all sub-offices at which money orders are issued.

This system of licensing will be continued for an interim period expiring on December 31, 1924, after which it will be possible for the single form of licence recommended by the Committee to be introduced, without any condition as to the marking or origin of the licensed apparatus, if it should be then thought desirable.

Out of the fees of 15s. for the constructor's licence and 10s. for the B.B.C. licences, the company will, if the House of Commons agrees, receive 12s. 6d. and 7s. 6d. respectively, instead of 5s. per licence which they receive under the existing scheme.

The Postmaster-General is not satisfied that, even with the in-

*EDITORIAL NOTE.—This date was later extended to October 31.

creased contribution from licence fees, the revenue of the Company will, for some time to come, be sufficient to provide adequate programmes without a substantial contribution in the form of royalties on the sale of sets by the manufacturers who form the Company. Hence he has stipulated for the continued payment of such a contribution, but on a reduced scale. The reduction will be approximately 50 per cent., except in the case of crystal receiving sets, where it will be considerably more. This reduction should enable a cut to be made in the cost of receiving sets. The proportion of the licence fees receivable by the Company will, after December 31, 1924, be placed on a sliding scale based on the number of licences on the one hand and the cost of maintaining an adequate broadcasting service on the other hand. Any surplus profit accruing to the company over and above 7½ per cent. on its capital and a necessary reserve for depreciation, etc., of plant and machinery will be surrendered to the Post Office; in other words, the profits of the company are limited to 7½ per cent.

The existing experimental licence, at an annual fee of 10s., will continue to be issued from the General Post Office to persons who are able to satisfy the Postmaster-General that they desire the licence for *bona fide* experimental purposes, and are qualified to conduct experiments, and who sign a declaration to the effect that they will not use the broadcast programmes except for experimental purpose.

Each new licence (as distinct from renewed licences) will cover a period of twelve months from the first day of the month of issue. Renewed licences will cover twelve months from the date of expiration of the old licence.

The basis of membership of the Broadcasting Company will be extended so as to include dealers, with suitable representation on the board of directors for the new membership if it becomes at all substantial; and the deposit of £50 now required from members will be abolished. The licence held by the company will be prolonged, on suitable conditions, to the end of 1926, as recommended by the Committee.

If the company supply a satis-

factory service and are willing to erect additional stations where the Postmaster-General may consider them necessary, he will not license any other broadcasting service during the interim period up to December 31, 1924.

After that date, if the Postmaster-General should consider it desirable that additional stations should be established in any town or district where the company's service is not adequate, and if the company are not prepared to provide such stations, the Postmaster-General reserves the right not only to license other organisations to do so, but also to give them an appropriate share of the revenue arising from new receiving licences in the district in question. He also reserves the right to license other services (without regard to geographical area) without withdrawing from the company any part of the licence fees to which they may be entitled. In either case, he reserves the right to allot suitable wave-lengths to the new organisation, while taking all reasonable steps to avoid creating interference with the company's services.

The Postmaster-General proposes at an early date to appoint an Advisory Board, as recommended by the Committee, to assist him in all important questions relating to broadcasting. He has noted with pleasure the Committee's commendation of the present broadcasting service; and he trusts that the service will give increasing satisfaction under the new conditions, and that a great impetus will be given to the sale of British-made receiving apparatus.

In the enforcement of the new scheme of licensing, much will depend upon the willing co-operation of the public. So long as there has been no licence to fit the case of the many thousands of "listeners" who are using home-made apparatus, it would have been unreasonable for the Post Office to attempt to enforce the law with any strictness; but now that such a licence is available, there will no longer be any excuse for the use of receiving apparatus without licence. The Postmaster-General believes, however, that the "listening" public will require no pressure in this respect. He is confident that they will be not only willing, but anxious, to put them-

selves right as regards the law, and at the same time to contribute their quota towards the cost of a service which is affording them so much enjoyment.

Copies of the Broadcasting Committee's Report may be purchased through any bookseller or directly from H.M. Stationery Office at the following addresses: Imperial House, Kingsway, London, W.C.2, and 28, Abingdon Street, London, S.W.1; York Street, Manchester; 1, St. Andrew's Crescent, Cardiff; and 120, George Street, Edinburgh. Its price is 9d., or, if ordered by post, 1d. extra for postage.

G.P.O., October, 1923.

(Continued from page 71.)

tuning condenser, filament resistance and potentiometer. You will not find the detector filament resistance at all critical, and once the best position has been found for this, it can be left there. If you have difficulty in making the set oscillate, try the condenser in series.

The first night I tested this set on British broadcasting I succeeded in listening to Glasgow and Newcastle without the slightest interference from London, although this latter station is only six miles from me. Manchester came in far better than I had ever heard before with only slight interference from London. Cardiff could only be heard properly when London was not working, although, of course, a trap circuit connected with this receiver completely eliminates this jamming.

With the set on the table and the high and low-tension batteries connected and a 50-coil plugged into its socket, it is quite good enough for telephonic reception up to 10 miles from a broadcasting station without any aerial or earth whatever. I have read an amateur at 13 miles in this way. However, even on an outdoor aerial the volume is never great enough to work a loud-speaker satisfactorily, even from a local station, as there is no note magnification to give volume. In next month's issue I shall describe a companion cabinet with two note-magnifying valves so as to work a loud-speaker, also a few modifications for obtaining reaction on long waves.

HOW TO MAKE A PORTABLE ST. 100 RECEIVER

By JOHN SCOTT-TAGGART, F.Inst.P.

This article deals with a portable two-valve receiver which may be used with either a frame aerial or an outdoor aerial, and which will give loud-speaker results on even small aerials up to 20 miles from a broadcasting station.

IN response to many requests, I am giving below the description of an ST. 100 receiver which has given excellent results and which presents a neat appearance. The set is illustrated in Fig. 1.

It will be seen that the panel, under which are mounted the various components, is fixed into a box provided with a deep lid, on the top of which is secured a leather strap. Two hooks are provided to close the lid which on the other side is hinged.

The circuit used is the ST. 100, which is contained, with various modifications and alternatives, in my second book of valve circuits entitled "More Practical Valve Circuits."* The circuit has been modified somewhat in order to provide for the alternative use of the aerial condenser C_1 in series or parallel with the aerial inductance L_1 . Also, terminals are provided for the use of a loop instead of an aerial. These various terminals are shown as A_1 , A_2 , B, C and E in Fig. 2. In Fig. 2, two terminals T_2 and T_1 are provided in the two grid circuits. A battery of from 3 volts to sometimes 9 volts may be connected across the terminals T_2 and T_1 , T_2 being next to the negative terminal and T_1 to the positive terminal of the battery. To start with, however, the terminals T_1 and T_2 should be short-circuited; likewise, the author recommends that the aerial should be connected on to the terminal A_1 so as to use the variable condenser C_1 in series with the aerial inductance L_1 , the terminal A_2 should have nothing connected to it, while B and C should be short-circuited; the earth lead is taken to the terminal E. The loud-speaker LS is con-

nected across the terminals T_8 and T_7 , the high-tension battery across the terminals T_5 and T_6 , and the six-volt accumulator across the terminals T_3 and T_4 .

In Fig. 2, T_{12} , T_{10} , T_9 , T_{11} is a step-up intervalve transformer, T_{12} and T_{10} being the primary and T_9 and T_{11} being the secondary.

etc. These connections were found to be suitable with the transformer employed in the set, but if the completed instrument tends to buzz at low frequencies, the constructor is advised to try reversing the leads to one of the primary windings.

In Fig. 2, various points in the circuit are numbered; for example,

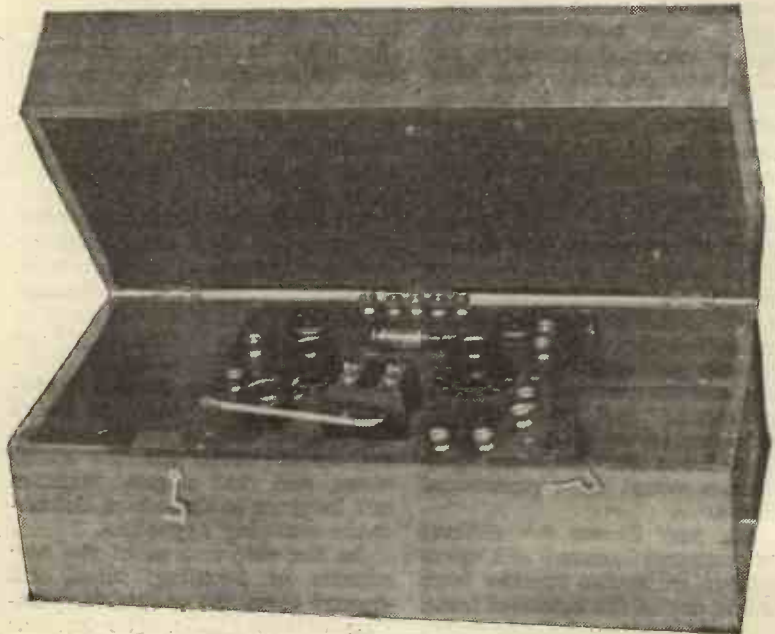

Fig. 1.—The complete instrument in case.

Likewise, T_{14} , T_{18} , T_{13} , T_{15} is a similar intervalve transformer. The condenser C_2 is a fixed condenser of $0.001 \mu F$ capacity. The fixed condenser C_3 , which is connected across the terminals T_7 , T_8 , has a value of $0.002 \mu F$; the resistance R_2 is a 100,000 ohms fixed resistance; the transformers, it will be noted, are marked on Fig. 2 in such a way as to indicate which is the "in" secondary and "out" secondary (IS and OS),

T_{24} , T_{23} . These different points correspond to the wiring diagram, Fig. 6, so that anybody studying this latter figure will be able to see at a glance where the various points come on the circuit diagram, Fig. 2.

Fig. 3 shows a closer view of the panel itself. It will be seen that at the back of the panel we have four terminals which correspond to A_1 , A_2 , B, C and E in Fig. 2 and Fig. 6. At the right of the

* Published on November 7 by Radio Press, Limited, Price 3s. 6d., cloth bound.

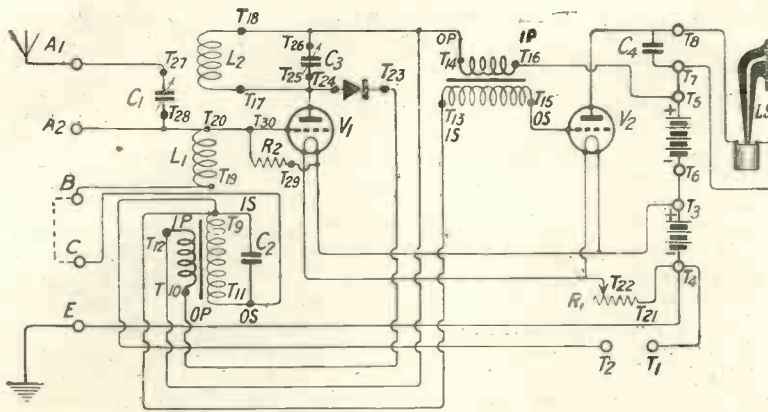

Fig. 2.—The circuit diagram numbered to correspond with the wiring diagram.

panel we have four terminals, the top two go to the high-tension battery, while the lower two go to the filament accumulator. The two terminals in front correspond to the terminals T_1 and T_2 in Fig. 2 and 6; these terminals are usually shorted, but a grid battery may be connected across them if desired. The two terminals on the left of the panel have connected to them the leads from the loud-speaker. The crystal detector will be seen in the middle background. It is of the cat-whisker type enclosed in a glass tube. Two Polar condensers are shown on the panel; each of these condensers has a maximum capacity of $0.0005 \mu\text{F}$. Other types of condensers could, of course, be equally well employed. In the front of the panel is a two-coil holder; the left-hand holder is fixed, while the right-hand one may be moved through an angle of about 90 degrees by means of the long extension handle consisting of a piece of brass rod with an ebonite knob at the end.

Fig. 4 is a plan of the panel, showing how the different components are arranged. It will be noted that in the left-hand corner we have the filament rheostat which controls the filament current to both valves.

Fig. 5 is a back view of the panel showing how the transformers and condensers, etc., are mounted. It will be seen that a special ledge is provided for mounting the two intervalve transformers. This ledge is preferably a piece of ebonite supported by two other pieces of ebonite screwed to the panel. It will be noted that

the wiring is done with thick bare copper wire, preferably tinned. No. 16 gauge wire will do, or No. 14. All the connections are soldered. If this method of wiring is found too difficult, there is no reason why properly insulated copper wire should not be employed. It is to be noted that two fixed condensers are used; a condenser of $0.001 \mu\text{F}$ capacity is connected across the terminals of the secondary of the right-hand transformer, and that a fixed condenser of $0.002 \mu\text{F}$ capacity is connected across the two terminals on the right to which the loud-speaker is connected.

Fig. 6 is the actual wiring diagram. The Figure will require close, attention to see what

the various terminals belong to. The terminals T_{13} and T_{15} are the I S and O S terminals of one of the transformers. The terminals T_{14} and T_{16} , which, of course, are on the other side of the transformer, are the O P and I P terminals respectively. Similarly, the terminals T_9 and T_{11} are the I S and O S terminals of the other transformer, while T_{10} and T_{12} are the O P and I P terminals on the other side of that transformer. R_2 , of course, is the 100,000 ohm resistance mounted between two clips. T_{23} and T_{24} have nothing to do with the two Polar condensers, but are the screws which go to the terminals of the crystal detector. The two little vertical rectangles, T_{25} and T_{26} , are the terminal lugs of the Polar condenser. The similar connections, T_{27} and T_{28} are the terminal lugs of the other Polar condenser. The holes, T_{19} and T_{20} pass the wire connections going to the moving coil holder which contains the coil in the anode circuit of the first valve (L_2). The holes, T_{17} and T_{18} similarly communicate with the fixed coil holder which contains the aerial coil L_1 .

It is to be noted, with regard to these connections, that when operating the set, the two coils should at first be kept well apart; that is to say, at right angles to each other. As the moving coil is brought closer to the fixed coil, reaction should be introduced, and an in-

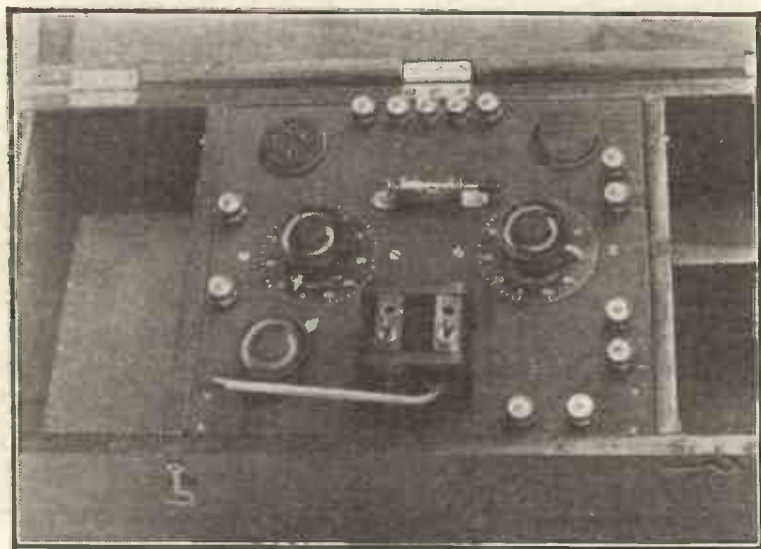

Fig. 3.—A "Close-up" of the panel.

crease of signal strength noted as the two variable condensers are readjusted. If the signal strength does not increase, it is a clear indication that reverse reaction is being obtained. Owing to the large number of plug-in coils which are now being employed, it may be found necessary to reverse the connections to one of the coils to get the reaction effect. This reversal of connections is best done on the moving coil. In the case of most coils, it is a very simple matter to undo one or two screws, and without undoing the connection reverse the coil itself on its holder; screw up again and use the coil as before, preferably marking it with the letter R to indicate that its coil has been reversed from the normal. The alternative is to reverse the leads going to T_{17} and T_{18} .

As in Fig. 6 it is not possible to show the condenser C_4 very clearly, a special remark will be noted above the terminal T_7 . This is to the effect that there is a condenser C_4 of $0.002 \mu F$ connected across the terminals T_7 and T_8 .

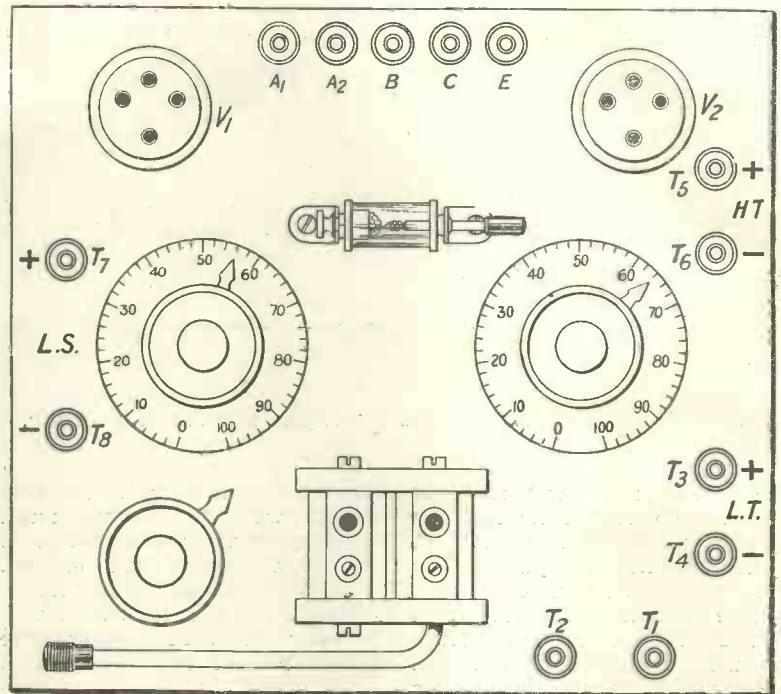

Fig. 4.—Panel plan.

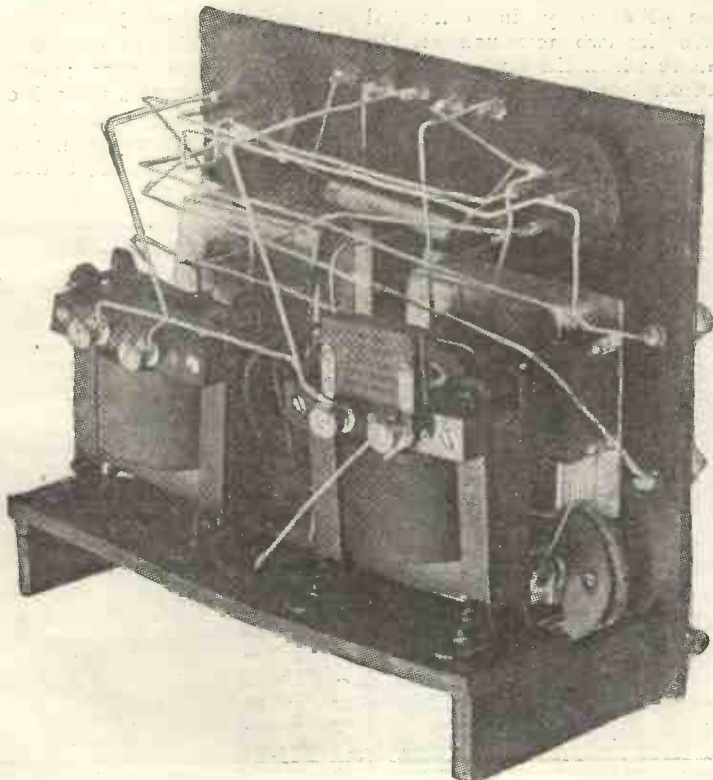

Fig. 5.—A photograph of the rear of the panel.

The box, into which the panel is mounted, is dimensioned as shown in Fig. 7. The ebonite panel measures 9 ins. by 8 ins., and is secured by four terminals let into the wooden vertical partition shown in Fig. 7. The other dimensions of the box are clearly indicated in Fig. 7. The compartment on the left contains a 100 volts high-tension battery, as the set is intended to operate with 100 volts. A special high-tension battery of 100 volts and of suitable size has been specially designed by Messrs. A. H. Hunt, Limited, Tunstall Road, Croydon. The two compartments on the right side of the box are intended to hold the coils, etc., and to provide a compartment for the filament accumulator. The size of the accumulator will depend upon whether dull emitter valves or ordinary valves are employed. An ordinary dry battery, suitable for dull emitter valves, might be placed in one of the compartments, or, if preferred, a dry battery could be connected in each of the compartments.

Those readers who prefer to mount the panel in an ordinary box without any compartments may, of course, do so.

Continued on page 98.

THE CONSTRUCTION OF A HETERODYNE WAVE-METER

Covering a Wave-length Range of from 300—4,500 Metres

The following article describes how a simple and reliable generator of local oscillations for use in heterodyne reception of continuous waves and for other purposes may readily be made.

By ALAN L. M. DOUGLAS.

A LOCAL oscillation generator employing a three-electrode valve is of the greatest value to the experimenter when receiving continuous waves, especially in the longer wave-lengths where the loss in efficiency due to the employment of self-heterodyning receivers is very considerable. In addition, the intensity of the oscillations is readily controlled, and any desired degree of coupling with the receiving amplifier may be obtained. Again, if suitably connected and accurately made, the device may be calibrated against standard waves and subsequently employed as a wave-meter. Finally there are many experimental purposes for which the oscillator may be used in conjunction with an ordinary reaction circuit in order to produce great selectivity, or under certain circumstances an increase in signal strength.

The instrument detailed in this article is remarkably simple in adjustment and operation, and, owing to the nature of the inductances, may be relied upon to remain constant in operation at all times—provided the battery heating the filament does not discharge itself too far.

Before examining the constructional data let us observe the general design and arrangement of the instrument. From the photographs, Figs. 1 and 2 (which show front and rear views of the

device), it will be apparent that there are only two adjustments to be made for the production of continuous waves of any frequency between the range limits of the instrument. This feature greatly increases the usefulness of the heterodyne, and is due to the introduction of separate reaction coils into the various oscillatory circuits instead of adjusting the coupling of the grid coil. This function is carried out by means of the rotary switch seen in the centre of the panel in Fig. 3, and the scheme of con-

nections will be observed from Fig. 4. It will be seen that a valve of the V 24 pattern is used in the oscillator, and the low capacity existing between the fitting and also in the valve itself makes this pattern particularly suitable for use in the shorter wave-lengths where the frequency is abnormally high. The reader is therefore advised to adopt this make of valve, as it is also a very consistent oscillation generator and most reliable. The filament circuit, it will

be observed, is arranged to incorporate a small rheostat (referred to later on) with the intention of allowing the valve to work at about 5.4 volts from a 6-volt battery, at which point it appears to work best. A variable rheostat might be used, but this entirely upsets the working of the instrument, and it would not be suitable for calibration.

Let us now see what materials are required for the actual construction of the oscillator before we proceed any further. In the first place an ebonite panel 8 in. by 6½ in. by ¼ in. thick will be required, which might be finished to suit. In the author's case this panel was obtained with the edges already cut and rounded off, which saved a certain amount of initial and more or less unpleasant work. Such panels may be obtained from several supply houses, and in this particular size are of great use for any component parts of receiving amplifiers, etc.

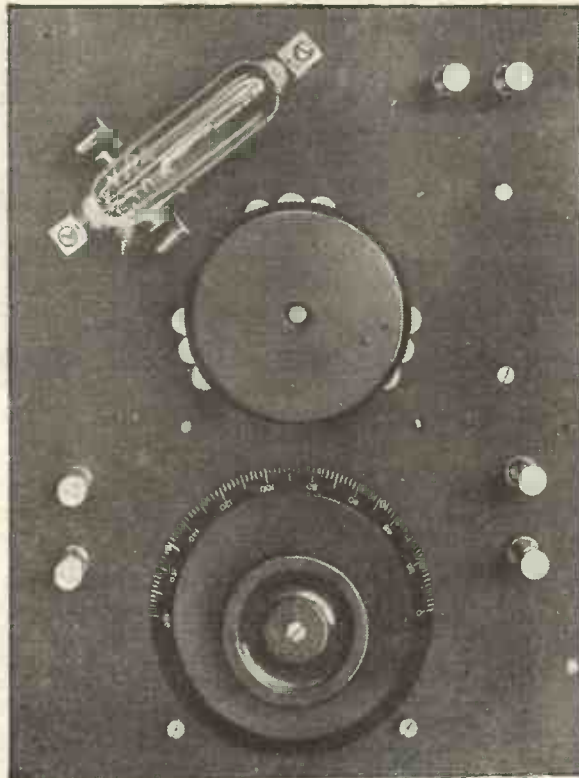

Fig. 1.—Front view of oscillator.

Having obtained the panel to the dimensions already given, there will also be required:—

4 oz. No. 40 swg. d.s.c. copper wire.

$\frac{1}{4}$ lb. 18 swg. bare tinned-copper wire and 3 yards systoflex tubing for connecting up.

1 variable condenser having a capacity of 0.0012 μ F, which should preferably have an air dielectric in order that the minimum capacity may be small.

1 small fixed condenser of 0.0005 μ F capacity.

2 yards of No. 23 swg. d.s.c. Eureka wire.

9 contact studs and nuts, etc.

A 2-inch ebonite knob and spindle, knob, etc.

About 6 in. of $\frac{1}{4}$ in. by $\frac{1}{16}$ in. springy phosphor-bronze strip.

2 feet of No. 4 B.A. screwed brass rod and nuts.

4 in. by 4 in. by .002 in. copper foil. V.24 valve clips and nuts, etc.

3 ebonite coil formers, which will be detailed, and for which about 3 $\frac{1}{2}$ in. by 12 in. by $\frac{1}{2}$ in. ebonite sheet will be required.

About 12 square inches of $\frac{1}{8}$ in. ebonite sheet.

6 B.A. by $\frac{1}{2}$ in. screws and nuts, 6 terminals.

1 in. of $\frac{1}{2}$ in. ebonite rod.

1 V.24 Valve.

This completes the list of component parts, from which it will be seen that nothing very formidable is required, with the possible exception of the variable air condenser. This should be purchased ready made, as it is vital that the capacity should remain constant. It is, however, possible to construct quite a satisfactory device oneself, if due care is taken, but attention might be drawn to the necessity for having really rigid end plates. These should be at least $\frac{3}{8}$ in. thick. 2 B.A. brass rod should also be used for the side supports, as greater rigidity is thereby assured. Several excellent condensers having metal end plates are now on the market, and can be recommended; they may be obtained from advertisers in this journal.

Turning now to Fig. 5, which shows the construction of the ebonite blocks carrying the necessary coils, it will be seen that circles have to be turned out of the slabs to accommodate the coils. In order to ensure these latter fitting well, and as the depth of winding may vary somewhat in individual cases, it will be best to make the coils first and turn the holes in the ebonite later. The various coils are all wound with the No. 40 swg. d.s.c. wire in the form of basket coils on a 1 in. ebonite former, which should be

therefore be turned out to about 1 $\frac{1}{8}$ in., and a separator, to ensure correct coupling between the grid and anode coils, consisting of a disc of $\frac{1}{8}$ -in. ebonite sheet 1 $\frac{1}{8}$ in. dia. (with a 1-in. centre hole, through which, of course, the former passes), should be made. While the coils, etc., for the first range are therefore newly made, we can assemble the complete oscillatory circuit for this range in the following manner. The slab, having the hole turned in its centre, is laid on the bench on a sheet of glass and one 75-turn basket coil placed in it, the leads being brought out. The separator is then inserted and pressed down in the first coil. The former is placed through the separator and the first coil and the second coil put into position on the former until it is also lying within the slab of ebonite. The leads from these are brought out and a little paraffin-wax is poured into each coil so as to hold the entire assembly firmly in position. The first range slab is now complete.

The coils for the second oscillating system can now be prepared if desired, and the anode coil for this group may consist of 150 turns of the same wire as previously used on the same size former: this will occupy just under a 2-in. hole in the slab, so that the recess may be turned out to this diameter. Fig. 6 will

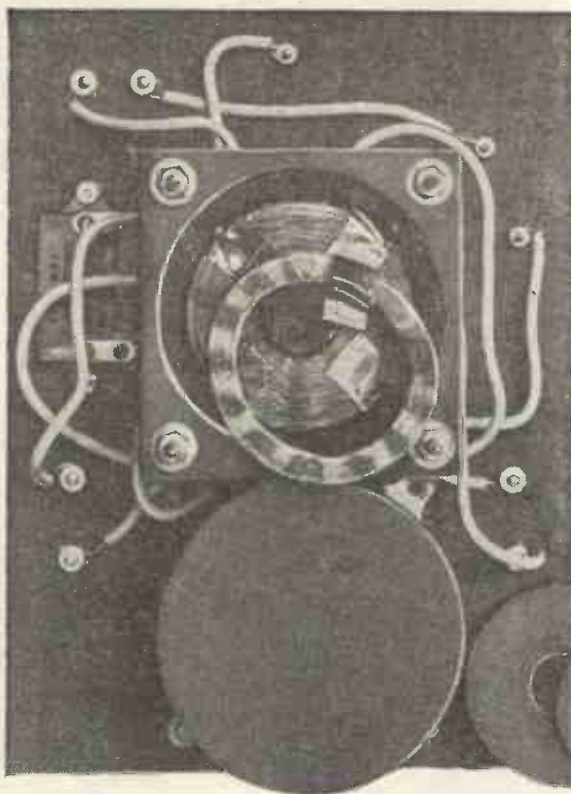

Fig. 2.—View of instrument, showing grid and anode coils separated, and ebonite spacing washers.

cut up into 3 $\frac{1}{2}$ -in. sections. The first coil should have 75 turns of the 40 d.s.c. wire, which will determine the diameter of the hole to be turned in the first block for this coil. At the same time another coil of 75 turns may be made, as these constitute the anode and grid coils for the first or lowest range of the oscillator. The wavelength range of this set of coils is from 300 to 760 metres.

The overall diameter of this coil will probably be approximately 1 $\frac{3}{8}$ in. The hole in the slab should

make clear the appearance of the slabs and the method of turning the cover disc for the last coil, whilst the photograph, Fig. 4, shows at the bottom right-hand corner two of the separator discs.

Another of these latter discs may now conveniently be turned up, so as to space the second grid coil from the anode coil, and the grid coil itself, consisting of 60 turns of the No. 40 d.s.c. wire, placed in position. The leads from these coils should be brought out at the top and bottom of the slabs

respectively, and are to be well separated.

Wax can be used to fill up the interstices of the coil and make the whole second range slab complete as before.

At this point it will be convenient to note that the screen which is fitted over the first range coils may be made. This consists of a plate of thin copper sheet of the same area as the slab and having four holes punched through its corners, so as to anchor it firmly in the guide supports for the coils, and is necessary to prevent the proximity of the large coils minimising the production of oscillations in the lower range. It is cut from sheet copper and electrically connected to the junction between the H.T. — and the L.T. +, as shown in the circuit diagram. Care must be taken to see that none of the fine wire leads from the coils are in danger of short-circuiting on this plate, and grooves should be fitted along the surface of the ebonite where these wires pass out.

Connections to the range slabs are made by means of small 8 B.A. cheese-headed brass screws attached

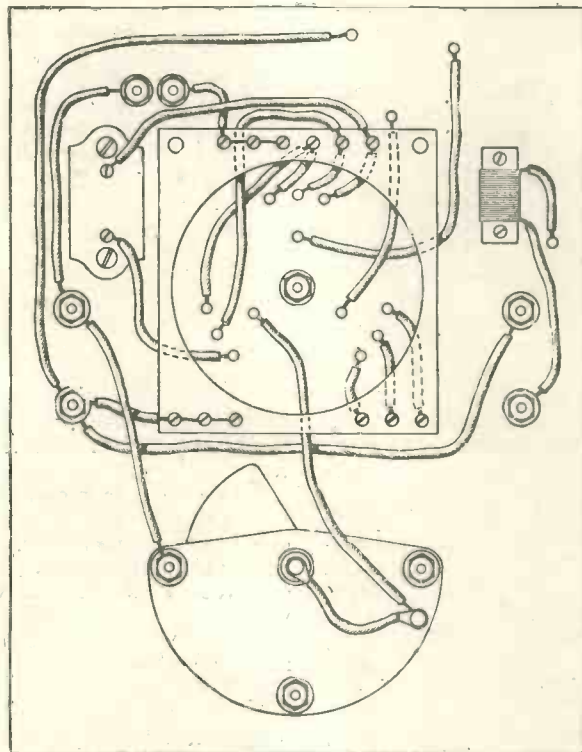

Fig. 4.—Layout of underside of panel and wiring scheme

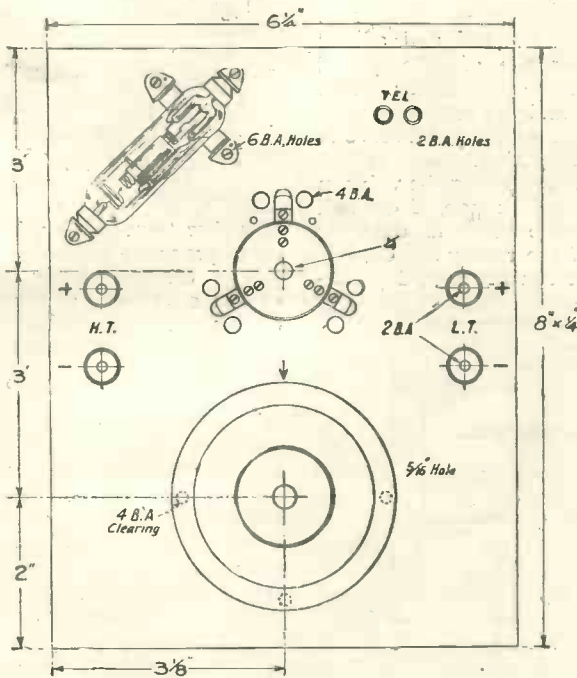

Fig. 3.—Layout of top of panel.

to the underside of the small range disc, and which can be clearly seen in the figures. A row of screws along the top connects the anode coils in circuit, and a similar row at the foot connects the grid coils; the common wire being that attached to the linked screws in each case. The construction of the highest range coils may now be undertaken, and the hole for this will require to be 2 7/8 in. diameter in its slab. The anode coil consists of 300 turns of the No. 40 d.s.c. wire in the 1-in. former, with the separator as before, and the grid coil 140 turns of the same wire on the same size of former. The cover-plate shown in Fig. 5, which protects this last slab, may be made and attached if desired, the leads from the coils having been brought out and the slab filled with wax as in the previous cases. This completes the construction of the coils, and it only remains to examine their method of mounting.

This is carried out, as will be seen from the figures, by means of B.A. screwed brass rod attached to the rear of the panel and passing through four holes in the corner of the slabs. No special instructions

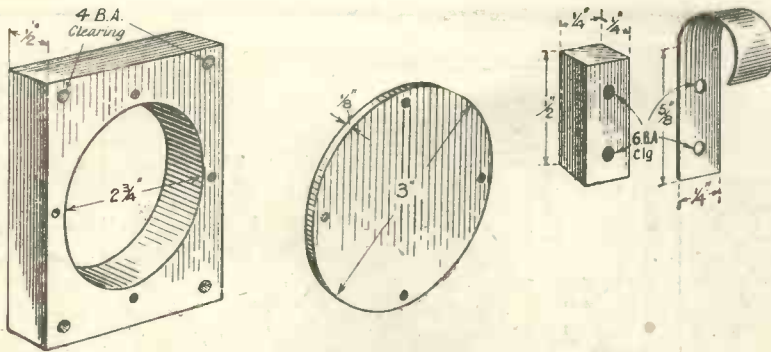

Fig. 5.—Ebonite coil holders and details of switch arms.

are necessary here, as the rods are screwed into tapped holes in the panel and the slabs held in place by means of nuts and washers suitably disposed on the rods.

The next item to which attention should be directed is the construction of the range switch which can be seen in the photograph, Fig. 1, and also in detail in Fig. 6. This has, as will be seen, three arms which make contact simultaneously with three different sets of contact studs. One of these arms controls the anode coils, one the grid coils, and the third the capacity introduced by rotation of the condenser knob. This is less relatively on the shorter range than on the other two. The constructional details are clear from the figures, it being merely necessary to say that care must be taken, should the knob selected for this switch have a metal bush, that only one of the three arms be in contact with this. Connection to the other two is made by means of flexible rubber-covered wire soldered to the contact arms and brought through appropriate holes in the front of the panel. In con-

necting up it is so far immaterial which arm is which, as long as the proper sequence of studs is adhered to.

This switch is mounted in the centre of the panel in any manner convenient to the reader, as it is a purely mechanical job and may be constructed in various ways at will.

The next item will be the filament rheostat, which is a very simple job. It is of such a nature that the valve burns at a fixed temperature all the time, provided that a six-volt accumulator reasonably charged is used. The resistance is 1.4 ohm, and this made from 2 yd. of No. 23 swg. d.s.c. Eureka or other resistance wire wound on a short length of 1 in. diameter ebonite rod and affixed to the underside of the panel, beneath the range slabs. Two 6 B.A. by 1/2-in. brass screws inserted from the front of the panel serve to hold this in position.

The clips for holding the valve in position may be made, if desired, from the same material used for the arms of the rotary switch, but at least one contact should prefer-

ably be rigid. The method of attachment can be seen from the photograph, and it is of importance that the valve should be so fitted in order that the anode-grid connections on the various circuits may be short.

The variable air condenser already referred to may be affixed to the panel as shown, and in this case again the terminal or other connections should be placed so that they are near to the switch. A condenser having rigid plates and a perfect contact with the rotating spindle should be used in order that inaccuracies may not arise.

The L.T. and H.T. terminals can, of course, be of any desired type, and the telephone contacts (which are normally short-circuited) might

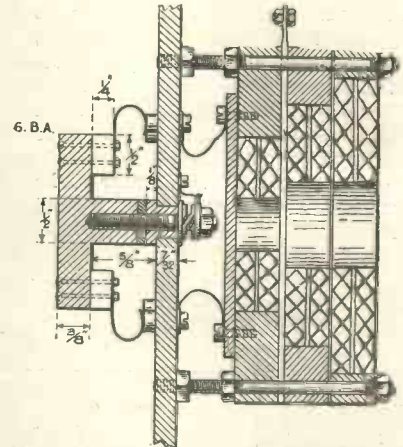

Fig. 6.—Assembly of coils and switch.

be either terminals or, better still, an appropriate plug connection.

This completes the description of the oscillator, a final word in connection with the wiring being necessary. Should oscillations not be produced on one of the ranges, the connections to the grid coil of the range in question should be reversed; this may be effected by means of the screws connections already referred to. It may save trouble if it is remembered that when wiring up the coils, if the direction of winding of each pair is the same, then if the connection to the grid is taken from the inner end of the first coil, the connection to the anode will come from the outer end of the second coil.

Fig. 7 shows the theoretical wiring scheme.

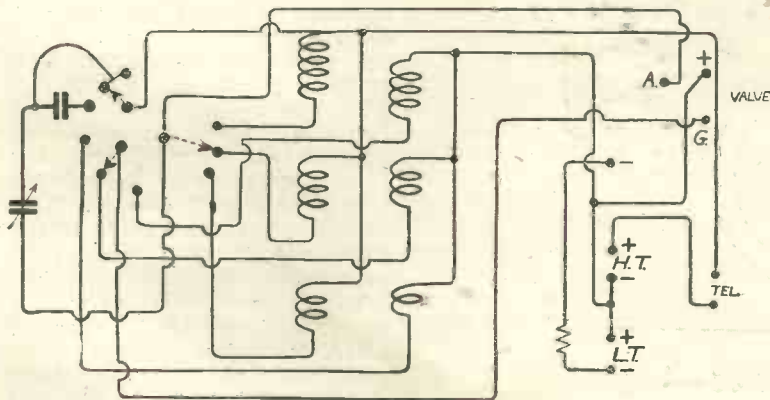

Fig. 7.—Theoretical circuit diagram.



Ultra Long Waves

IT is likely that we shall hear a good deal in the near future of the use of ultra-long waves for wireless transmissions, particularly those over great distances. Very short waves, of which we spoke some time ago in these notes, have the great advantage that they can be focused by means of suitable parabolic reflectors into a beam or pencil and so directed in a straight line. As we saw, very successful tests have been made with waves ranging from $1\frac{1}{2}$ to 15 metres, the directing properties of the transmitter being such that signals could not be picked up by stations half a mile off a straight line joining transmitter and receiver. Against this, however, must be set the fact that, speaking generally, a very short wave-length means a very short range; the writer believes that 100 miles is the greatest distance over which such transmissions have been attempted up to date. Even waves of far greater length, that is to say those which lie between 180 and 1,500 metres, are very much affected by a whole host of varying factors. Their range is enormously increased at night time, they are much affected by the dampness or dryness of the soil over which they travel and they are very liable to be deflected by ranges of hills, especially in the daytime. Thus a receiving station situated in a valley

may become a "blind spot" to short waves during the hours of daylight, but be able to pick up long ones. By night these effects will not be quite so marked, though, other conditions being equal, the long waves will still give rather more powerful signals.

How Short Waves Dissipate Energy

This is due chiefly to the condition of the upper atmosphere. Through a medium which is a perfect dielectric wireless of all kinds pass without loss of energy,

so approaches more nearly the surface of the earth. Even the middle layer may at times become ionised.

The longer the wave the more sharply will it be reflected back to earth by the ionised layers, and, conversely, the shorter it is the more will it tend to dissipate its energy in the conducting or semi-conducting portions of the atmosphere. The advantage of using great wave-lengths for stations that must be able to rely upon covering huge distances at any time during the twenty-four hours is now apparent.

Wave-lengths near Audible Frequencies

The highest wave-length now in commercial use is that of Bordeaux, which transmits on 23,450 metres; but it is likely that before long we shall see stations using 100,000 or even 300,000 metres. At 23,450 the frequency is 12,793, which approaches the upper limit of audibility. At 100,000 metres it would be 3,000 and at 300,000 only 1,000. Either of these last is well within the compass of the human ear. In fact, a frequency of 1,000 is only a little above the average for broadcast transmissions; low frequency transformers intended for receiving telephony are usually designed for an average frequency of 750 cycles a second.

The use of ultra-long wave-lengths, then, opens up the way to entirely new fields in wireless. Experiments already made in this

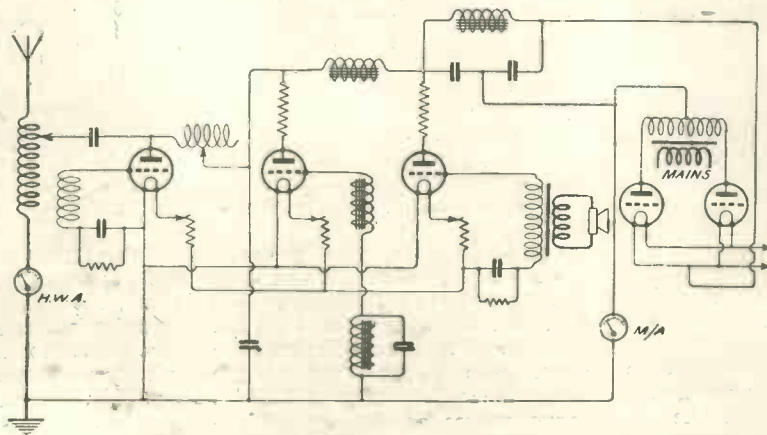

Fig. 1.—A typical aerodrome transmitting station.

but if the medium loses its dielectric qualities and becomes more and more of a conductor there will be considerable losses by absorption as waves travel through it. Further, in such conditions short waves will dissipate a much greater proportion of their energy than will long ones. By night only the outer portion of the atmosphere is ionised, but during the hours of daylight the ionised conducting layer rapidly increases in depth and

country and in France have shown that extremely good results are obtainable. It may well be that the adoption of wave-lengths from four to twelve times the length of any now in use will go far to solve the pressing problem of the overcrowding of the ether.

Atmospherics and Long Waves

There can be no doubt that it will result in longer ranges for given power and that it will render long distance wireless transmissions much more reliable than they are at present. One difficulty, however, will probably arise, and that is the question of preventing interference from atmospherics. Anyone who has experimented with a very large tuning inductance, one with a value of the order of 2,500 microhenries, when atmospherics were at all bad will have found that certain of them come in not as scraping or tearing noises, but as loud musical notes. This would seem to show that as we approach 100,000 metres we are coming near the wave-length of at any rate some atmospherics. As their strength is infinitely greater than that of any transmission, very serious interference might be expected if their tuning approximated to that of received signals.

Aerodrome Stations.

Most wireless men can remember the time when broadcasting did not exist and when the experimenter who was working in the daytime on telephonic reception was almost entirely dependent upon the air stations. The Eiffel Tower could usually be relied upon for something during the afternoon, and at night there were the amateurs. F.L., however, had then, as now, a wave-length of 2,600 metres and was, therefore, outside the scope of short wave work, whilst the amateurs, then working on 1,000 metres, were rare birds before nightfall. It was on Croydon, Lympne and Pulham that we relied chiefly, and to-day they are as useful as ever, for they are always to be found at work during flying hours.

The chief home stations, in addition to these three, are now Manchester, Guernsey and Renfrew, so that wherever one's station may be there is always a wide choice of home transmissions at different ranges. Beyond these there are the stations at Le Bourget, St. Inglevert and at Rotterdam, all of which are to be heard at frequent intervals transmitting weather reports or ascertaining from pilots the position of their 'planes.

"Ground" Transmitters

Croydon, perhaps the best known of all aerodrome stations, has an imposing aerial of the twin four-wire cage type 250 feet in length, suspended between lattice girder masts 130 feet high. The transmitter is Marconi built, and follows the lines of Fig. 1, which shows a typical aerodrome transmitting installation: At Croydon the oscilla-

delivers 140 milliampères at 1,700 to 2,000 volts.

Aeroplane Sets

The original R.A.F. aeroplane transmitting set is seen in Fig. 2, and the Marconi commercial 'plane set in Fig. 3. The latter is now in universal use on British passenger 'planes. It is known as the A.D.2 and consists of a modulator and an oscillator, with choke control. The valves are of a special aircraft pattern, rated at 60 watts. A wind-driven generator supplies 600 volts to the anodes. The ranges of this transmitter are: Continuous Wave 200 miles, Tonic Train 130, and Telephony 100.

In favourable circumstances the telephonic range given above is considerably exceeded; recently a 'plane was in direct verbal communication with Croydon from the time of leaving the aerodrome until it was over Le Bourget. Croydon, however, uses a very powerful receiver with four stages of high-frequency amplification.

'Plane Ranges

The amateur using two H.F. stages may feel quite satisfied with his set if it will bring in aeroplane telephony at from 25 to 30 miles. With this combination the writer has on several occasions heard

pilots stating that they were just leaving or arriving at the French coast, the point given being about 80 miles from his aerial. But these receptions took place on particularly favourable days when the signal strength of all distant stations was above the normal.

To pick up 'plane transmissions demands quick and accurate tuning; quick because the pilot's replies or queries are usually very short, and accurate since these comparatively feeble transmissions allow little or no margin of error. If your set is tuned carefully to Croydon's wave-length it will not usually be necessary to touch either A.T.C. or C.C.C. in order to catch a message from a 'plane to which he is speaking. It is best to work with the coupling between A.T.I. and C.C.L. or the reaction coupling. Tiny variations in these, the latter

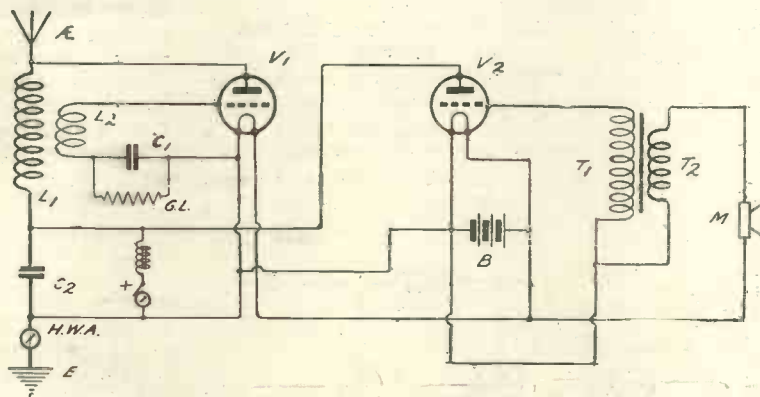

Fig. 2.—The original R.A.F. aeroplane transmitting set.

tor is duplicated, two 500-watt valves being used in parallel. The input is 1½ kilowatts. The high tension supply is obtained by means of a transformer from the mains, the stepped up voltage being 7,000. This is rectified by a pair of valves, as seen in the drawing. This rotary transformer is one of the blots on Croydon's otherwise fair escutcheon, for every experimenter knows its loud hum, which can be heard the moment the switch is thrown over. Croydon's ground to air telephonic range is 200 miles.

The other stations are fitted with the Service (R.A.F.) Transmitter type 56, though in some cases modifications have been made. This transmitter uses the E 9B 250-watt valve, and is rated at ¼ kilowatt. The anode supply is obtained from a generator which

especially, generally suffice to enable one to obtain the necessary sharpness of tuning.

Reaching the Short Wave-lengths

Many people find it very difficult indeed to get down to 180 or even 200 metres with sets that are not built specially for short wave work; in fact, quite a number of experimenters complain that they cannot tune in the amateurs at all successfully now that they are working on the very short wave-lengths. The cause of the trouble may lie at several points in the set. When, for instance, high frequency transformers are fitted, these are seldom so wound that they will tune down efficiently to below 250 metres or thereabouts. It will be found better to substitute the tuned plate method of coupling, using as anode inductance coils of the smallest possible self capacity.

Again, four-pin valves seated in moulded ebonite holders make matters difficult owing to the fairly large capacities existing not only within the valve but also between the sockets, which are separated by an excellent dielectric. The combined capacities in a four-pin valve mounted in this way may amount to as much as .00006 μ F, which is quite sufficient to make it very hard to reach the short waves.

The Series Condenser

A point frequently overlooked is that the aerial tuning inductance may be much too large, making it necessary to turn the pointer of the series mounted variable condenser almost to zero. One occasionally comes across a friend who complains bitterly about the feebleness of a particular station's transmissions. He has done everything that he ought to have done, he explains, placed the condenser in series and obeyed all other rules. Examination generally shows that the condenser to bring in this station must be set at something under 10 degrees. This means that the aerial is practically cut out, for even at high frequencies the reactance of a tiny

capacity such as that used is very great. The result is that reception is very poor, and that the set falls in oscillation at the slightest provocation.

A moment's thought will show that when the condenser is in series the old rule about using the biggest inductance and the smallest capacity does not apply. It holds good only when the condenser is in parallel. When it is in series it is a sound rule not to let its capacity be reduced below .00025 μ F. Hence, if its maximum capacity is .001 μ F the pointer should not be turned below 45 degrees; if .0005 μ F, then 90 degrees should be the lowest limit.

Unsuitable Wiring

The wiring of the set, again, may be so carried out as to make

The Aerial at Fault

Sometimes it is not the set but the aerial that is at fault. Amateurs are occasionally fired with the idea of erecting a very large aerial whose roof consists of many parallel wires. Though excellent for long wave reception, such a contrivance will not give good service on the shorter wave-lengths. The capacity of a standard amateur aerial consisting of twin wires 60 feet long, separated by six foot spreaders and suspended 30 feet above the ground is about .0003 μ F. Every added wire increases the capacity and therefore the natural wave-length of the aerial. You can load an aerial up to many times its natural wave-length, but any attempt to receive short waves with an aerial of large capacity will result either in no signals being heard at all, or in their coming in with very poor strength.

Aerial insulation is another particularly important point to notice in connection with short wave reception. Most of the losses that take place in the receiving aerial are due to currents passing by capacity through the insulators. The higher the frequency the more easily will currents escape; hence on short waves it is naturally essential to reduce insulator capacity to its smallest possible limit.

LAMBDA.

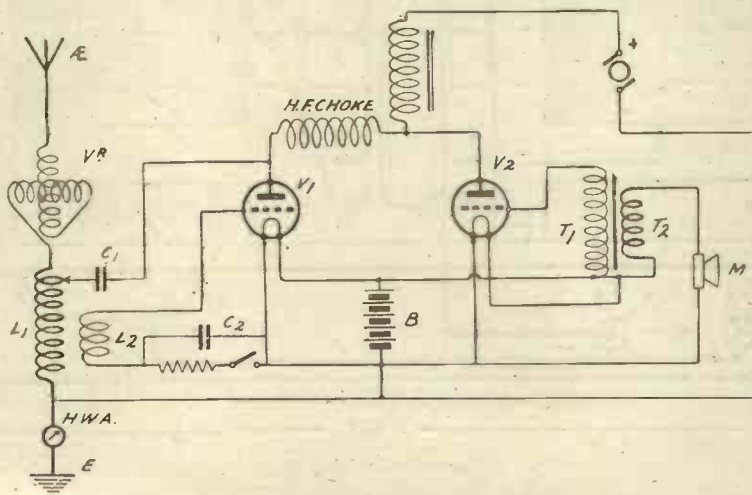
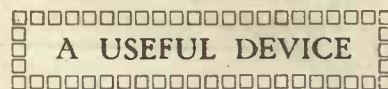

Fig. 3.—The Marconi Commercial' Plane set.

it quite unsuited to work at very high frequencies. On the longer waves a certain amount of capacity between plate and grid leads may not give rise to appreciable ill effects; but once we descend to the short waves the presence of any such capacity is felt at once. It puts up the natural wave-length of the circuits, making it sometimes impossible to tune below certain fairly high limits satisfactorily, and it increases very markedly the tendency to self oscillation.

To make the set efficient on short waves re-wire it, eschewing insulated leads and using stiff bare wire. Keep all wires as short as you possibly can, separate them well and see that no two run parallel and close together.



The Bay-Brooke Co., Ltd., of Harborne, Birmingham, send us a specimen of their valve templates. This consists of a square of glazed cloth having printed on it the correct spacing of the valve pins and the pencil screw, together with two circles. The outer circle is the average diameter of an R valve and the inner circle is the average diameter of an Ora, Ediswan A.R., Dutch, Cossor or Xaudion valve. The back of the template is covered with a special adhesive composition which readily adheres to ebonite.

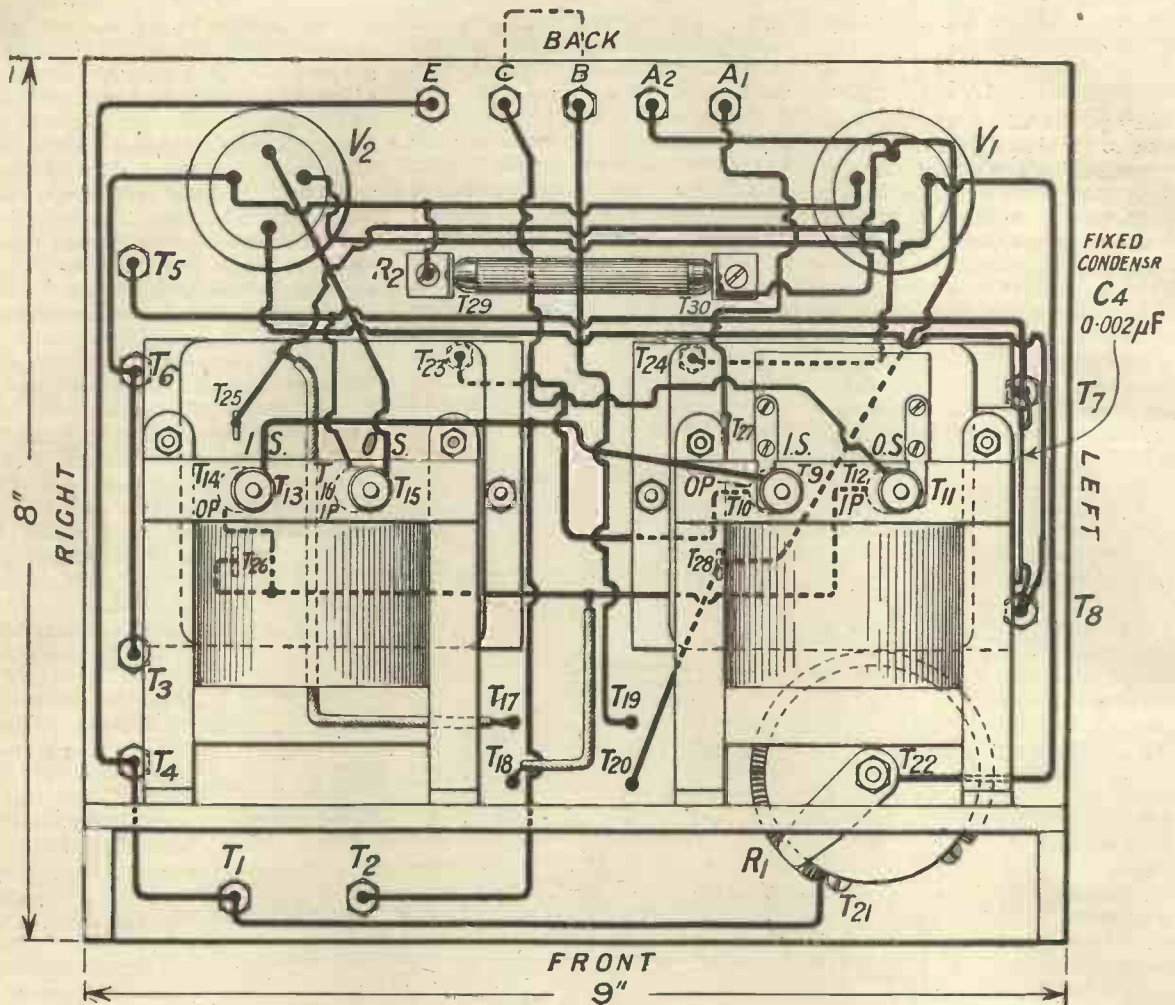

Fig. 6.—The actual wiring diagram.

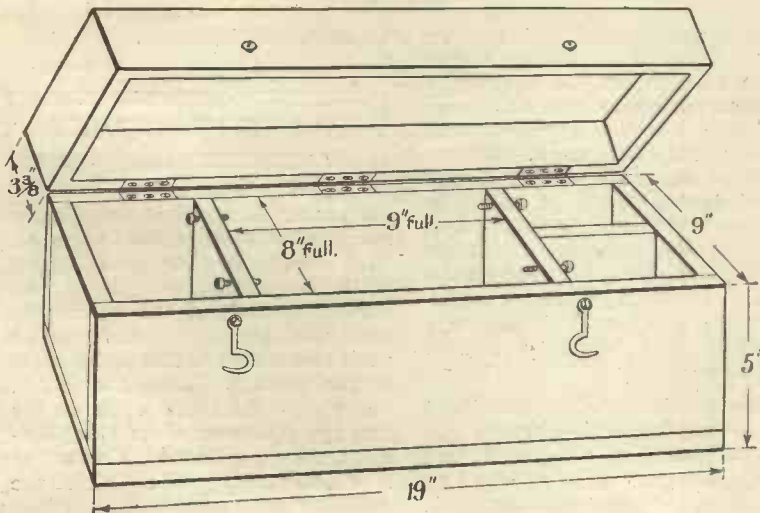

Fig. 7.—The box dimensions.

Continued from page 90.

A complete blue print, containing both a full sized wiring diagram, similar to Fig. 6, and also a full sized panel layout, as in Fig. 4, only larger, is obtainable from Radio Press, Limited, D'Vereux Court, Strand, W.C.2, for the sum of 1s. 6d., each. These blue prints are produced purely for the convenience of those of our readers who desire them.

READ
Wireless Weekly
for
Latest Wireless
News.

SINGLE-LAYER INDUCTANCE COILS SUITABLE FOR RADIO FREQUENCY STANDARDS*

EDITORIAL NOTE.—The following article, which is a reprint of a publication issued by the Bureau of Standards of Washington, will be found to be exceedingly useful to all who desire to obtain accuracy in their radio frequency measurements. If the coils described are wound exactly as indicated and used with variable condensers, the value of which is accurately known, the experimenter will be able to construct a calibrated wavemeter with great ease.

OWING to the increased interest in radio-frequency measurements, this paper has been prepared, giving rather detailed instructions for the construction of a series of single-layer inductance coils suitable for radio-frequency standards. Coils of this type have many uses in the laboratory where a fixed inductor of a known inductance and having a small radio-frequency resistance is desired. This type of coil in conjunction with a high-grade variable air condenser such as the Bureau of Standards type forms a very dependable and accurate wavemeter.

This series of inductors, seventeen in number, have been designed to cover the approximate inductance range of 8 to 5,000 microhenries. Beginning with the smaller coil, each successive coil has approximately 1.5 times the inductance of the previous coil. The following table gives the approximate values of inductance of each of the coils in the several groups :

Coil designation number.	Group.	Inductance L microhenries.
1 ...	I. ...	8.0
2 ...	II. ...	12.0
3 ...	II. ...	17.9
4 ...	II. ...	26.7
5 ...	II. ...	40.
6 ...	III. ...	59.8
7 ...	III. ...	89.4
8 ...	III. ...	134.
9 ...	III. ...	200.
10 ...	IV. ...	299.
11 ...	IV. ...	447.
12 ...	IV. ...	669.
13 ...	IV. ...	1000.
14 ...	V. ...	1495.
15 ...	V. ...	2235.
16 ...	V. ...	3342.
17 ...	V. ...	5000.

The several coils have been designed and grouped so that the coil rings for the coils in groups II, III and IV are cut from the waste from the rings in group V. The coil in group I. (one coil only) is small and is therefore grouped by itself to avoid design difficulties.

No definite specifications for size and kind of wire can be given. It is probable that after the complete series of coils have been made, either in sheet or moulded materials, sufficient measurements can be made to determine these factors. It is possible to use various kinds of solid conductor such as bare copper, tinned or nickelled bare copper, enamelled copper, single or double cotton-covered copper, single or double silk-covered copper. All other factors being the same, when solid copper wire is used, the bare wire would be preferable. This is because (1) such wire does not add another dielectric in the field of the coil, and (2) cotton, silk or other such fibres may contain a percentage of moisture which will further add to the distributed capacity of the coil. When bare wire is used it would seem preferable, from the standpoint of appearance and also because of certain electrical and mechanical advantages, to use either tinned or nickelled wire. The uncoated wire will become discoloured and form an oxide coat which is not a good dielectric. Furthermore, the tinned or nickelled wire is more easily soldered. If silk or cotton-covered wire is used, it is probable that the silk would be preferable, but for general use it cannot be definitely stated that the advantage gained would be sufficient to demand its use. The use of solid enamelled wire may add to the appearance of the finished coil, and for the coils having sufficiently large winding pitch the electrical characteristics may for practical purposes be comparable to those of cotton or silk-covered wire.

* Prepared by J. I. Preston, Physicist, and M. S. Strock, Assistant Physicist.

High-frequency ("litzendraht") cable can also be used. It is understood that high-

frequency cable employs two types of dielectrics (insulation) in itself. The individual strands are of small diameter wire, enamel-covered, and the assembled cable is given a single or double serving of silk. This outer covering is essential to protect the fine wire and the enamel insulation underneath. If high-frequency cable is used, it is very important that it pass certain requirements. Two important requirements are, that each individual strand should be continuous throughout the entire length of the cable and each strand should be insulated from every other strand throughout the entire length. As to the size of the wire, it would seem that, for mechanical reasons, the wire should not be much larger than No. 18* (B. & S.). This limitation permits of the use of high-frequency cable as large as 48 strands of No. 38† wire.

* Approx. No. 19 S.W.G.
 † Approx. No. 40 S.W.G.

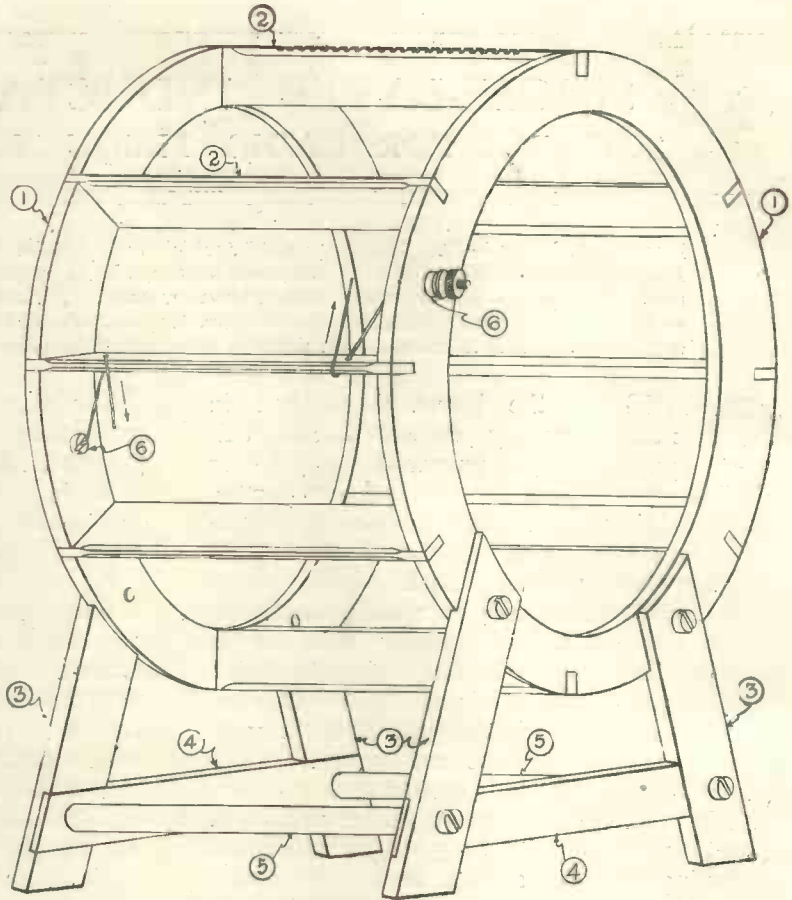

Fig. 1. Details of the coil formers. Dimensions are given in the table on the next page.

Practical Hints on Using the Tables

It will be noticed that the inductance of the coils is given in microhenries. To calculate the wave-length with these coils it is only necessary to use the simple formula (wave-length in metres)

$$\lambda = 1.885 \sqrt{L \times C}$$

(L in microhenries and C in microfarads)

Every wireless club should have an accurately calibrated variable condenser of good make, against which the members should be able to calibrate their own variable condensers. If the reader is able to calibrate a variable condenser, then with the aid of these coils and the data there given, he will be able to determine wave-lengths accurately.

These coils cover a wave-length

range of from the shortest waves now in use up to just over 4,000 metres with a .001 μ F variable condenser. In Figs. 1 and 2 all dimensions are given and constructional details furnished to enable the experimenter to build up his coils to the best advantage. The small tables in Fig. 2 may need a little explaining. The column marked SYM means symbol and refers to the symbols used in the figures. Column 2 marked REQ means the number required. Thus in the first table where under REQ 8 is given this indicates that in making the coil you will require eight ribs. Similarly two brace rods are required. The columns marked with the letters A to K refer, of course, to the various letters in the diagram. To give one further example, also taken from the first table, the radius of the coil marked B in the diagram and in the table is 5.12 centimetres. When the purpose of these tables is grasped the reader will find it very easy to use them.

P. W. H.

A REUNION

Arrangements have been made for the Annual Reunion Dinner for past and present officers of the W/T School and Squadron, Royal Air Force, to take place in London, on December 5. It is to be regretted that it will not be possible to issue direct invitations this year to all ex-officers interested, owing to the fact that certain records, containing lists of addresses, have been mislaid. The Secretary will therefore be glad if those concerned will regard this announcement as a personal invitation. Applications for tickets (which will be ten shillings, inclusive) should be made to the Secretary, Reunion Dinner, Wireless School, R.A.F., Winchester.

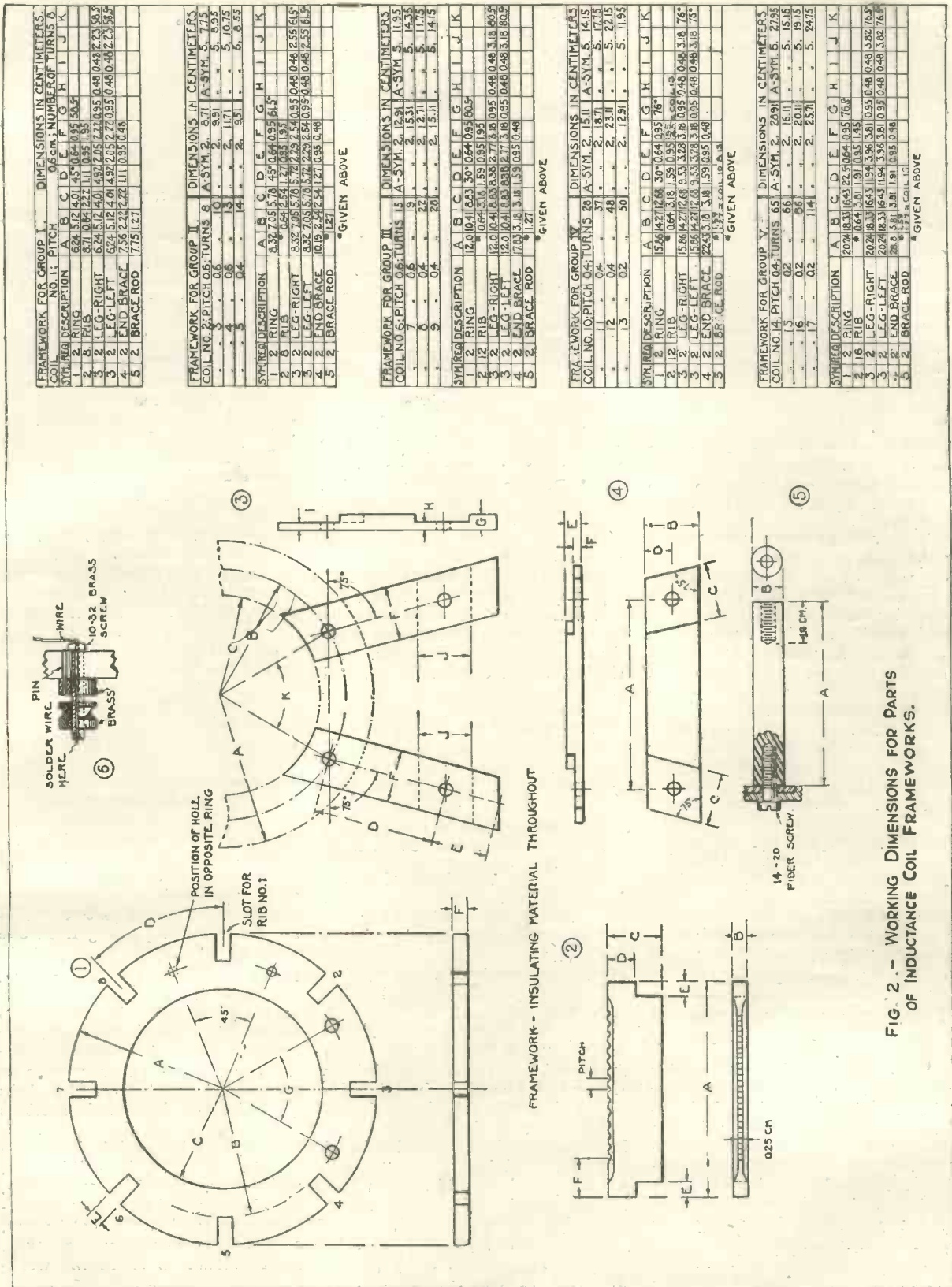

NEW BOOKS.

Valuable Additions to the Wireless Library.

THE autumn publishing season of Radio Press opens this month with the appearance of a group of new books of great interest to all types of wireless enthusiasts. Detailed announcements regarding their date of publication appear elsewhere in this magazine, and it will be seen that they appeal to all classes. Readers will be interested to learn something of their principal contents, and we give on this page a general outline of the scope of each book.

Radio Valves and How to Use Them. By John Scott-Taggart, F.Inst.P.

This volume constitutes a complete course in the theory and operation of the thermionic valve, commencing with such elementary considerations of its working as will enable the absolute beginner to tackle the subject easily and leading right on to the theory of such recent developments as the Flewelling circuit. The text of the book takes the form of question and answer, the questions having been carefully framed to bring up the difficulties which perplex beginner and advanced experimenter alike in such a way as to settle the problem once and for all in the mind of the reader. A special feature of the book is the plentiful use of pictorial diagrams, which have been specially drawn to show the relation between a theoretical circuit diagram and the actual wiring of the corresponding receiving set.

Twelve Tested Wireless Sets and How to Build Them. By Percy W. Harris.

Probably one of the most popular writers of constructional articles, Mr. Harris has described in *MODERN WIRELESS* and *Wireless Weekly* a large number of extremely practical and useful receiving sets, and certain of these designs are brought together for the first time in this book, together with information and description not previously published. A new set of special interest is a three-

valve Reinartz receiver of original design, incorporating a stage of high-frequency amplification in such a way that the original virtues of the Reinartz circuit are preserved.

Every set has been constructed by the author himself and exhaustively tested, and therefore the reader may feel confident that each one is a thoroughly practical design. The earlier designs have been amplified and several additions suggested by the experience of readers have been made.

More Practical Wireless Circuits. By John Scott-Taggart, F.Inst.P.

Another book on the general lines of the perennially-useful "Practical wireless valve circuits." Besides a great variety of standard circuits of all sorts, the volume contains all the latest developments in super-regenerative, super-heterodyne and reflex circuits, including ST75, ST 76, ST100, and a number of original and hitherto unpublished circuits. Each circuit is accompanied by a short description and some useful notes on its working. Correct values of all the components in each circuit are given.

500 Wireless Questions Answered. By E. Redpath and G. P. Kendall, B.Sc.

One of the first things that the beginner in wireless discovers is that there is an amazing difference between understanding the general principles as expounded in an elementary text-book and possessing the really practical and detailed knowledge required to construct and operate wireless sets successfully. "500 Wireless Questions Answered" has been compiled for the express purpose of bridging the gap and solving all the problems which confront the beginner when he turns to the practical side of wireless, explaining the "why" of many things which even the more experienced experimenter often does not understand.

The volume is broken up into sections covering all the principal branches of the science and is

provided with a very full index, so that any required piece of information may be readily found.

Pictorial Wireless Circuits. By Oswald J. Rankin.

The ideal book for the beginner who finds it difficult to wire up a set from a circuit diagram. Each component is represented pictorially and the actual wiring is shown, so that no technical knowledge is required to assemble a set. A variety of good standard valve and crystal circuits are given, each accompanied by useful notes and the values of the components, besides a miscellaneous section of switching arrangements, etc., and a useful data section.

Wireless Sets for Home Constructors. By E. Redpath.

Mr. Redpath is well known to the wireless public as a writer of sound and practical constructional articles, and as this book contains a collection of his most successful sets, together with previously unpublished descriptions of several new sets of original type, it should meet with a ready welcome. The original constructional articles have been enlarged to include explanations of the theory and operation of the sets, and much useful and interesting matter has been added.

Full instructions are given for making a variety of sets, both crystal and valve, the latter including examples employing from one to four valves.

Home-built Wireless Components.

This book constitutes a veritable encyclopedia for the man who makes his own components. It contains detailed instructions for the construction of every type of component part by the best methods, and has whole sections dealing with such things as valve panels, variable grid leaks, frame aerials, coils and coil-holders, resistances, variable condensers, switches, crystal detectors, potentiometers, and fixed condensers, and is unusually fully illustrated. An invaluable book in the workshop.

(Continued from page 79.) stages of H.F., the standard H.F. transformers being used for intervalve coupling, followed by 3 L.F. intervalve transformers.

Components

The components comprise high- and low-frequency transformers, anode reactances, condensers (both fixed and variable), series parallel switches, the famous L.F. transformers, rheostats, coil-holders, crystal detectors, the new patent R.I. eliminater for cutting out interference, and various switches, etc., used by experimenters.

The most interesting of all the components are the new improved H.F. and variable intervalve reaction units specially designed for panel mounting; these are self-contained, with switches, and can be fitted to any experimenter's panel in a few minutes by using the scale of the component as a drilling template. In the case of the variable intervalve reaction unit

a special drilling template is provided.

RADIO SUPPLIES, LTD., are showing a special line of broadcast apparatus: apparatus for the use of experimenters, and components to suit constructors' licences which have just been issued. They have also a special line in low-frequency transformers, telephones, and their well-known Electronite crystal. They are also showing high-tension batteries of superior quality.

THE STERLING TELEPHONE AND ELECTRIC Co., LTD., are showing their well-known line of receivers, including the combined Valve-and-Crystal Receiving Set, two-valve long-range receiver and four-valve long-range instrument. They are also exhibiting their Radio unit system, Baby, Standard and Magnavox loud-speakers, and a variety of component parts for the experimenter, including their new variable air condensers (square and low).

FROM A READER.

DEAR SIRS,—I have recently put up the "All Concert" set described in the September number of MODERN WIRELESS, but instead of a box I used a panel, 0.5 microfarad between H.T., and 3 megohms gridleak.

The results are excellent. Last night I got Radiola on the loud-speaker and Eiffel Tower also on previous night. Using headphones, I have had most Continental stations. I have not had many English stations, as I am too near 2LO, and have not as yet had a chance of working it between 3.30 and 4.30. My aerial is about 50 feet high and a twin of about 35 feet long lead-in about 20 feet. Valves, 2 Ediswan (A.R.), 1 Mullard Ora as detector.

One day, when I can find the energy, I intend to have a shot at America.

Many thanks for the excellent circuit. Yours faithfully, M.R.C.S.
Upper Norwood, S.E.

IN A FRENCH HIGH-POWER STATION.



The giant aerial tuning inductances at the St. Assise station, near Paris. This station communicates direct with America.

(Continued from page 74.)

oscillations appearing in the tuned anode circuit consisting of the inductance L_2 shunted by the two condensers C_3 and C_4 , C_3 being the variable condenser. The bottom of the circuit L_2 , C_3 , C_4 is connected through the grid condenser C_5 to the grid of the second valve, a gridleak R_3 of about two megohms resistance being connected in the position shown. In the anode circuit of the second valve is the reaction coil L_3 which is variably coupled to the inductance L_2 , and in this anode circuit we also have the telephone; T shunted by a fixed condenser C_6 of 0.002 μ F capacity.

It is important to see that the coil L_3 introduces reaction into the circuit L_2 , C_3 , C_4 , and not reverse reaction. It is therefore important to try reversing the leads to L_3 to see which way round gives the best results. The inductance L_1 may consist of the same number of turns, etc., as the inductance L_1 in Fig. 3, while L_2 may consist of the same number of turns, etc., as

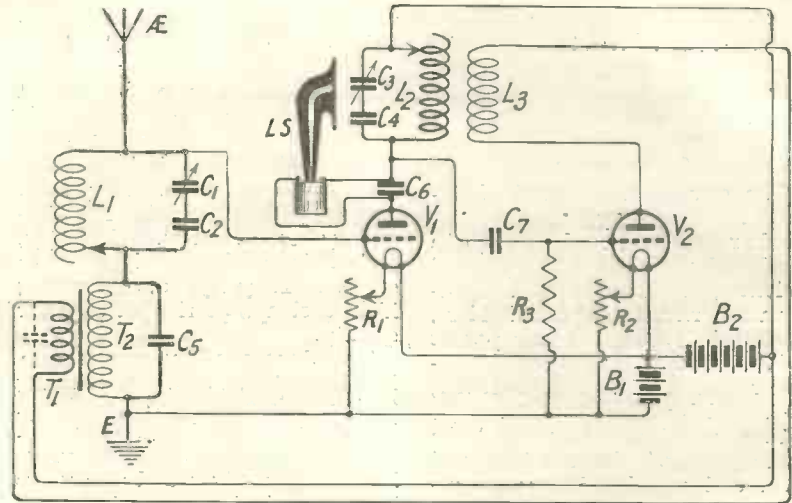

Fig. 7.—The ST 75 circuit.

L_2 in Fig. 3. The reaction coil L_3 in Fig. 5 may consist of 50 turns of No. 26 gauge double cotton covered wire wound on a 3½ in. tube, slipping over the inductance L_2 .

Fig. 6 shows how the different components are wired up. This method of illustrating them should

prove of assistance to those who are not yet familiar with the use of circuits.

We now come to the ST 75 circuit which appears to enjoy considerable popularity. This circuit is a development of the ST 34 shown

(Continued on page 117.)

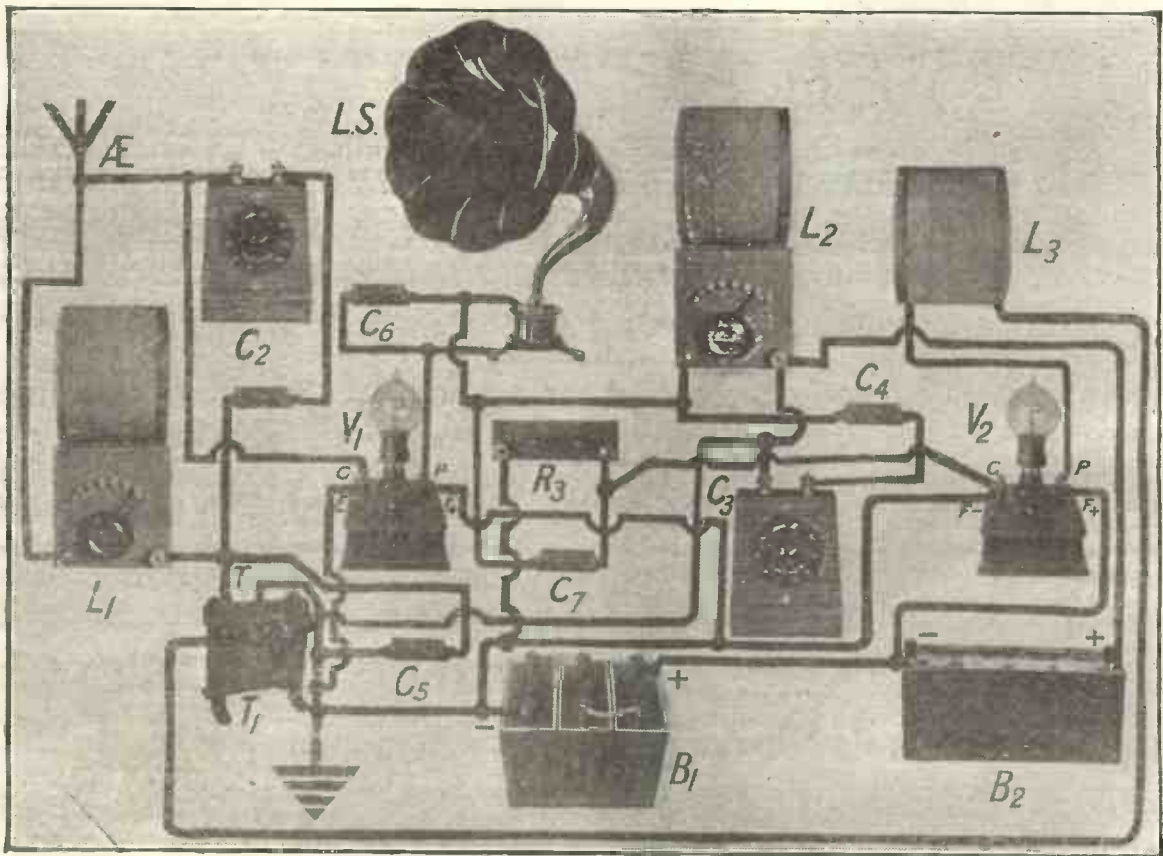

Fig. 8.—The above circuit shown in photographic form.

SOME CAUSES OF POOR RECEPTION

By R. W. HALLOWS, M.A., Staff Editor.

Are your signals mysteriously weak? This article may help to solve your reception problems very rapidly.

THERE is probably no wireless enthusiast who has not had experience at one time or another of weakness in reception, whose cause was most difficult to trace, if, indeed, it did not baffle all attempts at finding a solution. The most curious cases are those in which the lack of strength is permanent. A set known to work perfectly under normal conditions is installed in a certain locality, and straightway it refuses to produce more than a fraction of the volume of sound that should be heard in its telephones or loud-speaker.

If no fault is to be found with aerial, earth or batteries, the only conclusion that one can come to is that this particular locality is a blind or partly blind spot. Such places are quite numerous. Poorness of reception in them is caused sometimes by the presence of large masses of semi-metallic substance such as the slag heaps that are to be found round Sheffield—a notorious blind spot—and other towns where iron and steel are worked. Or it may be that the soil is of such a porous character that it becomes rapidly dry and parched for some distance below the surface. Over dry soil wireless waves travel extremely badly. It has been calculated (Fig. 1) that a transmitting station whose range over a perfectly conducting surface would be 1,000 miles, may not be able to cover more than one-twentieth of that distance over arid areas, and these figures accord well with observed facts.

A blind spot can always be identified by comparing the performances of other receiving sets in the same neighbourhood. If all of those in one particular area are affected, the cause must lie in local conditions. Sometimes, however, it will occur that, though neighbour-

ing sets are giving good results, nothing can be done with that in use in a certain house. In this case there is something in the building itself—an iron frame, an iron staircase, or even a complicated system of water or heating pipes that is providing a screen sufficient to deflect impulses. I came across an instance of this some months ago when I was on a visit to the West Country.

The set was a Burndept four-valver in perfect condition, but even when a Brown's microphone amplifier relay was added it could not be made to work a loud speaker. The only broadcasting station that was audible at all was Birmingham, whose transmissions came in very

weakly. All kinds of expedients were tried, but results did not improve. Eventually someone had the inspiration of rigging up a frame aerial, and a considerable increase in

signal strength was at once obtained. The set is now used with an indoor aerial suspended round the cornice of the room. Its signal strength and range are both excellent, but whenever the outside aerial is tried, the same poor results are obtained. I cannot explain why this should be, but anyone who is similarly circumstanced may find that his difficulties are solved by the adoption of an indoor aerial, for I have known several other cases of the same kind in which it has given much better results than the normal outdoor aerial.

If signal strength varies considerably from time to time the cause for a falling off is frequently to be found in neighbouring aerials whose owners allow them to oscillate. The oscillations may not be sufficiently powerful to give rise to audible squeals or howls, but if the sets from which they emanate are rather flatly tuned, they may cause either a slight increase

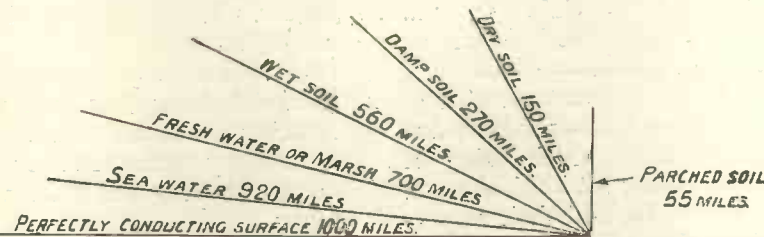

Fig. 1.—Zenneck's calculation of the effect of surface losses upon the range of a given transmitting station.

or a slight decrease in the signal strength of other receivers according to the phase difference between the locally radiated waves and those of the transmitting station. It is for this reason, I believe, that we sometimes hear of amazing feats of reception with crystal sets ;

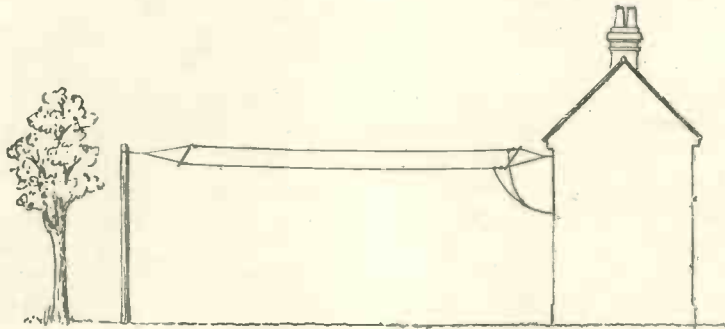

Fig. 2. An aerial screened at both ends.

in certain conditions they are aided by the radiation from other aerials. It also accounts for the prevalence of one kind of fading in districts which have a large wireless population.

The causes of trouble mentioned so far are such as are beyond the control of the victim. We now come to those with which he can deal. It may not always be easy to find them, but once they have been tracked down, something can be done to improve matters. These divide themselves into two classes: those due to faults in the appliances which bring in oscillations for the receiving set to deal with, that is, the aerial, the earth, and their respective leads; and those due to defects in some part of the set itself.

One of the commonest causes of poor reception is to be found in the aerial so slung that it is screened at both ends. Fig. 2 gives a typical example of this. The free end of this aerial is blanketed by the tree, its other end by the building itself. With an aerial of this kind, reception may be fairly good in winter-time, but in summer it will fall off markedly. The reason is that in winter the tree is dry and leafless, whilst in summer it is not only full of sap, but is also covered with a mass of juicy leaves. If the tree happens to lie in line between the free end of the aerial and a broad casting station which is some distance away, the chances are that that station's transmissions will not come in at all during the summer months.

The aerial shown is rather too low. The cure here is to suspend the house end from a chimney-stack and to raise the other until it is on the same level or a little higher. The tree should be trimmed if possible.

But even if height is obtained, and screening done away with, the aerial may still prove unsatisfactory. Fig. 3 shows a thoroughly bad arrangement, which contains a surprising number of faults. In the first place the free end is the lower of the two. This is undesirable. Now look at the down lead. Its branches, instead of coming from the very ends of the suspended wires, are fixed to points at some distance from the insulators. This turns what was intended to be an inverted L aerial into one of the

T type, with arms of unequal length. When reception is in progress, the portion ABD will be tuned to one wavelength and the portion CBD to another, for each has its own natural wavelength which is varied by the tuning inductance and the condenser. With a down-lead affixed in this way tuning cannot be sharp and signal strength will suffer. Yet it is one of the most usual of faults in aerial design, as you may easily see by noticing next time you are travelling through a town by train, tram or 'bus, how often it occurs in those that are visible as you pass along.

Notice, too, that the down-lead shown in the drawing is long and slack. If any wind is blowing it will sway now against the building, now away from it, producing changes in signal strength due to the varying capacity to earth. The earth lead is too long, and it rests upon the surface of the ground for some distance before it goes down to make contact with the plate.

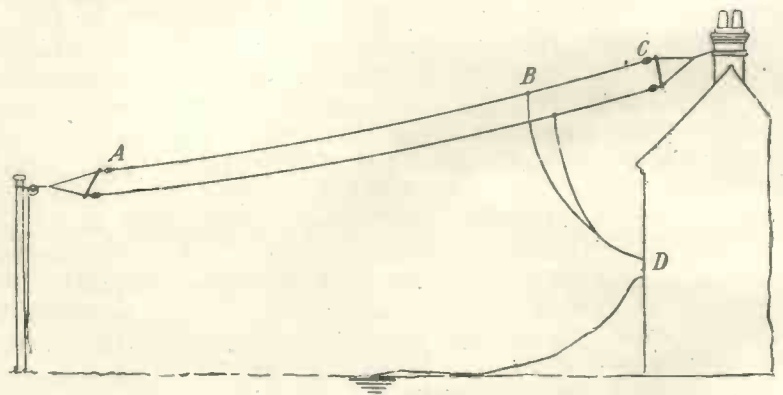

Fig. 3. How many faults can you find in this aerial ?

This lead should be as short as possible, and it should be insulated from the ground, being supported, if necessary, on a short pole until it is actually over the plate, otherwise a considerable resistance may be set up which will materially affect reception and may give rise to self-oscillation of the most puzzling kind.

Our "fearful example" among aerials is provided with only one insulator at either end of each wire, which is not enough. If insulators are of good quality, leakage in the receiving aerial does not occur as a rule across their surfaces unless these become covered with a conducting coat of soot and dust. But considerable leakage may take place by capacity.

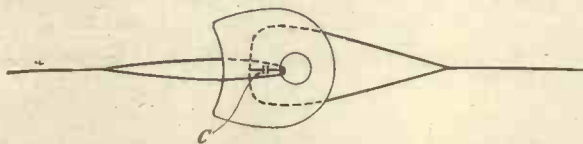

Fig. 4.—How leakage occurs by capacity C in an insulator.

Fig. 4 shows an insulator of the shell type in which the aerial wire is separated from the supporting wire or rope by a thickness of porcelain. There is capacity between the two, which we may represent by the little condenser shown at C , through the porcelain dielectric. Now, if we place condensers in series, their total capacity is reduced, for it is calculated

by the formula: $\frac{I}{C_1} + \frac{I}{C_2} + \frac{I}{C_3}$. A single insu-

lator may by its capacity offer a fairly free path to earth for oscillating currents; but when we add others in series the capacity is so greatly reduced that even they cannot pass to any appreciable extent. To be on the safe side it is best to have two insulators at each end of both wires and one at the junction between supporting wire and bridle. An aerial with a smaller number of insulators may work quite well, but results will be improved if attention is paid to this point.

Both lead-in and earth lead should be of stout cabled wire so as to offer the smallest resistance. The tubes through which they are brought into the house must be stout and made of material with good insulating qualities such as ebonite, porcelain or glass. If these tubes are not good, leakages will occur through the woodwork of the window frame, especially in wet or damp weather.

Turning now to the set itself, we are faced with a whole host of possible causes of poor signal strength. Let us take the batteries first of all. Be careful of long leads if you are using

valves that require the full voltage output of your accumulator. This applies especially to ORA valves and others of this type worked from a 4-volt accumulator.

The high-tension battery may suffer badly at the hands of its bridging condenser. The paper dielectric condensers generally used for the purpose are usually good enough, but sometimes they develop a small leak, and if the battery is left with its plugs in place when the set is out of use, it will run down rapidly. No one would think of suspecting a new or nearly new H.T. battery; yet it, or rather its condenser, may be the source of the trouble. These condensers should be tested from time to time in the following simple way. Switch on both batteries, then switch off first the L.T. and then the H.T. Wait a few moments and switch on the L.T. battery again. There should be a loud click in the 'phones due to the discharge of the condenser. With a really good condenser the click should be heard even if the set has been switched off for a considerable time. If it is not there on switching on after, say, 30 seconds, the condenser should be discarded.

Are the wiring connections beneath your panels all that they should be? Are they soldered, or merely made with nuts? If they are of the latter kind a falling off in signal strength that cannot be otherwise explained is probably due to one of them that has worked or jarred loose. To make quite sure of your connections, solder them all; but take care when you do so, for there is a pitfall here that may give trouble. If too much resinous flux is used it will "spit" when the soldering iron touches it, and a good deal will be deposited on the ebonite. Examine a panel when soldering operations are finished and you will probably find a thin film of the flux lying between terminals or valve legs. Some experiments made the other day with a megger were enlightening. Clean ebonite showed a resistance of hundreds of megohms, but when two points were taken between which there lay a thin coating of the flux, the resistance was found to have fallen to less than one megohm. Between one pair of valve legs it was actually as low as 600 ohms. When, therefore, you do soldering jobs, be careful to clean the panels well afterwards with petrol.

For the same reason panels should never be marked out with a lead pencil, for the lines that it makes provide high resistance leaks

and may result in very poor performances when the set is finished.

Many of us are very fond of switches. It is so convenient to be able to throw a valve in or out of action by the mere touch of a knob, or to change from one circuit to another without the bother of undoing a single connection. But switches, especially on the H.F. side of the set, are a delusion and a snare, for they may lead to endless trouble. There must always be a certain amount of capacity between the parts of even the best designed of them, and additional capacity among the H.F. components is exactly what we do not want. But their worst fault is that their contacts are often not sufficiently good, and what an effect a poor contact can have in a grid or plate circuit will be fully realised by any who have had experience of leads that looked all right, but were the tiniest bit loose. Be sparing, then, of your switches, and keep the blades and the contacts of those that you must use bright and clean.

Valves themselves can provide perplexing problems. The prongs of the ordinary type should be opened out with a penknife, as everyone knows, to make them fit tightly into their sockets; but even this will not suffice if the pins are greasy or dirty. It is a good thing to give them a shine up at intervals with a piece of worn emery cloth; the resulting increase of sound in the receivers will sometimes be an agreeable surprise. It is particularly important that the plate and grid contact caps of "test tube" valves, like the V 24 or the Mullard S 5, should be kept bright. The spring clips do not make a very powerful contact with them in any case, and if they are dull or dirty there may be a big falling off in signal strength. The clips that hold the gridleak, and the caps of the leak itself, should receive the same attention.

These are some of the chief causes of poor signals in the valve set. All that has been said about connections and about fixed condensers applies equally to the crystal receiver, and there are one or two special points about it that must be noticed.

The first concerns the single or double slide

type of tuning inductance, which may be responsible at times for poor performances. If the inductance is badly made, or if it has been in use for a long time, the slider may fit rather loosely on the square or triangular rod upon which it travels. If this is so it can be twisted slightly from side to side. On examining the inductance carefully you will probably find that it is possible for the spring point to make either good or bad contact with the turns of wire according as the slider is turned a little upon the rod. One's natural tendency in moving the slider along is to twist it a little, hence when the set is in use, contact with the point may be very bad. The best way of tightening up the slider is to drill and tap a 3 B.A. hole through it and to fit a screw as

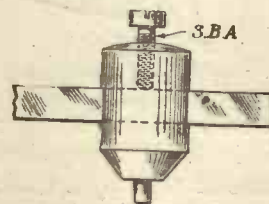

Fig. 5.—How to remedy a loose slider.

shown in Fig. 6. The screw can be used to take up any play, and to fix the slider in position with a firm contact once the correct tuning adjustment has been found.

The crystal itself must be kept perfectly free from grease or dust. An occasional rub over with a small tooth brush dipped in spirits of wine—not methylated spirits, which contains impurities that will form a coating when the alcohol evaporates, or petrol, which is unsatisfactory for the same reason—will keep it in condition. The contact point of the "cat whisker" should be kept smooth and rounded by being touched every now and then with a fine file.

There are countless other possible causes of poor signal strength, but to mention all would need more space than that allotted to one short article. The whole secret of having an efficient wireless set is to pay constant attention to little points of detail, for it is causes that might seem trifling that often rob us of the volume of sound which should be ours to hear.



A RHEOSTAT FOR "PEANUT" AND OTHER DULL EMITTERS.

THE special rheostat about to be described will be of particular interest to those who wish to work the latest type of "Peanut" low-temperature valves off a 6-volt accumulator. It can be used either in addition to, or as a substitute for the existing rheostat, and as it enables minute adjustments of current and potential to be made, it will be found extremely handy also for use with soft valves of the "high temperature" type, whose filament potential is extremely critical.

pillars so that they are perfectly in line.

The former is a 2-in. length of ebonite rod $\frac{1}{2}$ in. in diameter. If a screw-cutting lathe is available it is best to put a very shallow thread upon it to take the wire windings. This, however, is not absolutely necessary. Through the long axis of the former a 2 B.A. hole is drilled and tapped, every precaution being taken to see that this is true. A $6\frac{1}{2}$ -in. length of 2 B.A. screwed rod is then inserted as shown in Fig. 1 so that $2\frac{1}{2}$ in.

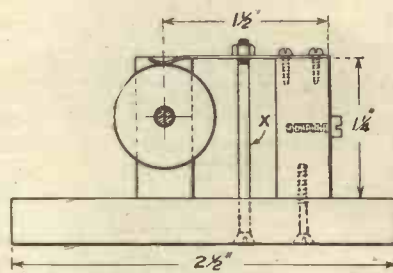

Fig. 2.—Showing the pillars.

to prevent the screwed rod from shifting in the former when the rheostat is in use.

The former may now be mounted as seen in the drawing and a knob fixed to the longer end of the rod. Fig. 2 shows the details of the contact pillar and the arm which it supports. The pillar is of ebonite or brass and has the same dimensions as those used for supporting the brass rod. The arm is a springy piece of phosphor bronze $1\frac{1}{2}$ in. long and $\frac{1}{8}$ in. wide at the end fixed to the pillar. At the other end it is tapered off to about $\frac{1}{2}$ in. in width and is curved as shown in the drawing in order that its action may be smooth. The adjusting screw (X, Fig. 2) allows the pressure of the arm upon the windings to be regulated so that a good contact is always obtained. Screws to take the leads from the low-tension battery are provided in the pillar B and in the contact pillar.

The rheostat described has a resistance of a little over 30 ohms. The carrying capacity of the wire used is .59 ampere. The rheostat can therefore be employed to regulate a pair of any of the following valves: Weco valve, A.R.D.E., D.E.V., D.E.Q. and L.F. Ora A. It must not be used with more than one D.E.R. or L.F. Ora B or C; otherwise it may be burnt out.

R. W. H.

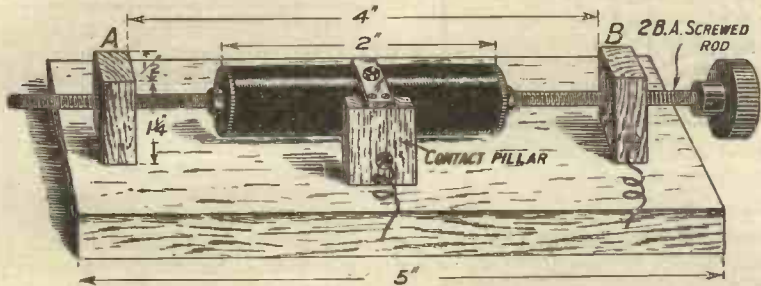

Fig. 1.—The finished resistance.

The base consists of a piece of ebonite $\frac{1}{4}$ in. thick, measuring 5 in. by $2\frac{1}{2}$ in. On this are mounted the two brass pillars A and B (Fig. 1), by means of 4 B.A. screws driven upwards from below. The pillars are $1\frac{1}{2}$ in. in height, $\frac{1}{2}$ in. wide and $\frac{1}{4}$ in. thick. In these 2 B.A. holes are drilled and tapped, their centres being $\frac{1}{2}$ in. from the bottoms of the pillars. The threads should be an easy fit for 2 B.A. studding. Care must be taken to make the holes absolutely true and to mount the

protrude at one end and $2\frac{1}{2}$ in. at the other in order to provide a hold for the knob.

Upon the former are wound 70 turns of No. 30 Eureka resistance wire spaced with thread, which is afterwards removed. The windings must be as tight and as even as possible. One end is anchored by being passed through a fine hole drilled in the ebonite; the other is clamped between the end of the former and the nut D. This nut, together with C, serves

A HOLDER FOR "PEANUT" VALVES

THE little "Peanut" valves now on the market demand a special type of holder since they are made with caps of the American type. There are no pins but simply four small contact points, and the valve fits into its holder in much the same

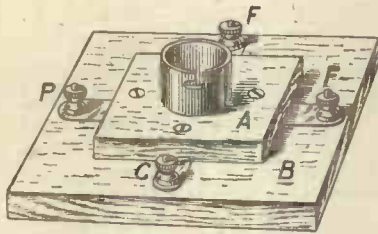

Fig. 1.—A peanut holder.

way as an ordinary electric bulb, except that the bayonet grip is secured by a single pin. The usual American holders are of no use, for this little valve is barely $\frac{5}{8}$ inch in diameter at the cap. Both holder and adapters have been placed on the market in this country and very good they are.

The holder has, however, two drawbacks from the point of view of the experimenter who makes bench "hook-ups": in the first place it is too small to stand quite safely by itself, being only $1\frac{1}{2}$ inches in diameter; secondly, it is not adapted for the rapid making of connections, which is essential with experimental work. The contacts

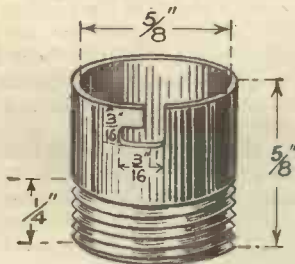

Fig. 2.—The ebonite socket.

of the holder are small metal lugs to which leads must be soldered.

The design described below has the advantage of being considerably larger and therefore much steadier; it is also provided with 4 terminals

so that connections may be made or unmade in a moment.

Fig. 1 shows the appearance of the finished holder, which consists of a short length of ebonite tube fixed into an upper plate A. Then it is mounted on the lower plate B by means of 4 B.A. screws. On the lower plate are four terminals from which run metal strips that serve to form the contacts.

The tube (Fig. 2) has an inside diameter of $\frac{3}{8}$ in. and outside diameter of $\frac{5}{8}$ in. It is $\frac{5}{8}$ in. long. An L-shaped slot for the retaining pin is cut as shown in the figure. This slot should, however, not be cut until the tube has been mounted on Plate A, for the end of the "foot" of the inverted L must

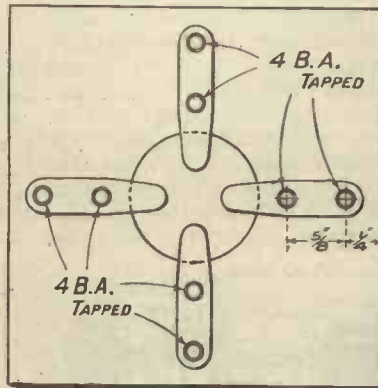

Fig. 3.—Underside of "A" in Fig. 1.

come exactly over the nearest edge of the strip connected to the grid terminal.

The tube should preferably be threaded for $\frac{1}{4}$ in. and screwed into plate A. If, however, the resources of the workshop do not permit the doing of this, plate A can be made circular in shape and the tube fixed in place by means of a couple of 4 B.A. screws driven in from the edge. These screws must be arranged so as not to foul those which fix this plate to plate B and also secure the contact strips. Fig. 3 shows the lay-out of plate A, that of plate B being given in Fig. 4. The $\frac{7}{8}$ in. diameter hole shown in Fig. 4 need not be made right through the ebonite; it must,

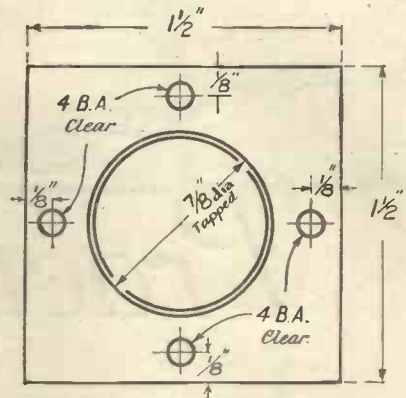

Fig. 4.—Underside of "B" in Fig. 1.

however, be deep enough to allow room for the contact points to move.

The contact strips are made of phosphor bronze or brass. They are $\frac{1}{4}$ in. wide, tapering to rather less than $\frac{1}{8}$ in. at their free ends. The points of the contacts rest on the circumference of a circle slightly less than $\frac{1}{4}$ in. in diameter. These should be bent a little upwards so that they may press firmly against the leading-out lugs of the valve.

R. W. H.

VALVE-LEG SWITCHES

VALVE pins and sockets are being used more and more in wireless apparatus for switching purposes, especially by experimenters who like to be able quickly to try out new circuits without making alterations under the panels of their sets. If the connections to the various components are terminated in valve sockets, and a number of short flexible connections made with a valve pin attached to each end, it is surprising how quickly a new circuit can be set up. The contacts are very reliable, as they are kept clean by the rubbing action of inserting

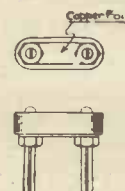

Fig. 1.—The connecting link.

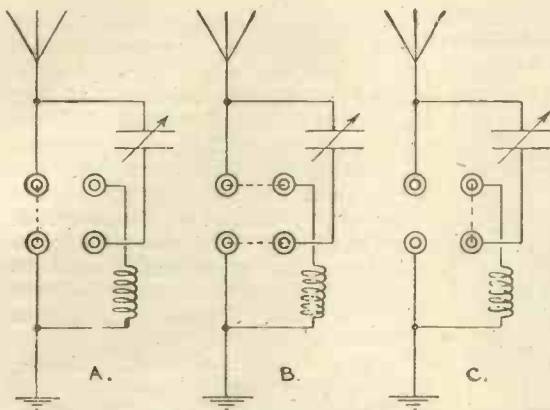

Fig. 2.—Aerial switching.

the pins. Switches constructed in this way take up very little space on the panel, and they have the advantage over the usual stud form of switch that the sockets can be spaced well apart, while brass dust is not likely to collect on the surface of the ebonite and reduce the insulation. In many cases it is possible so to arrange the circuits that fixed links can be used to make the connections, thus doing away with flexible wires, which are better avoided. A few examples of valve pin switches of this kind may be of interest.

The first is a useful series-parallel switch which only occupies about one square inch of the panel. The sockets should be arranged in the form of a square and spaced about $\frac{1}{8}$ in. apart, the drilling being done accurately, so that the links about to be described may be interchangeable. These links (see Fig. 1) consist of a small piece of $\frac{1}{4}$ in. ebonite shaped as shown, and drilled and tapped to take two valve pins which are screwed into it, the connection between the pins being a strip of copper foil clamped under two nuts on the pins. The method of wiring is given in Fig. 2, which also illustrates, by means of dotted lines, where links may be plugged in to obtain the various connections. In "A" the aerial is connected direct to earth and the tuning coil and condenser disconnected, protecting the set from static discharges when not in use, while "B" and "C" show the tuning condenser in parallel and series respectively with the inductance. It will be noticed that two links are needed when the condenser is in parallel, but only one when it is in series.

Another purpose to which this form of switch may be put is to connect a fixed condenser in series or parallel with a variable one. The fixed condenser will reduce the minimum capacity when connected in series, and increase the maximum when in parallel. Thus a smaller con-

denser can be used which will not require so deep a case as would be necessary if a single adjustable capacity were employed to cover the same range of wavelength, and finer tuning will be

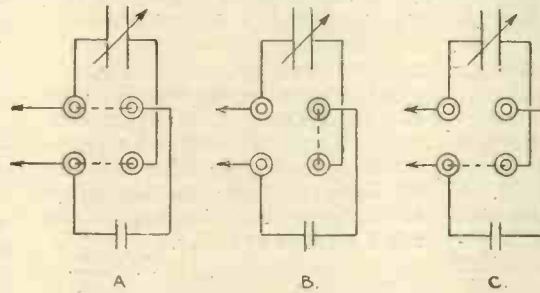

Fig. 3.—Capacity switching.

obtained when the two condensers are in series. Fig. 3 illustrates this arrangement, "A" showing the condensers in parallel and "B" in series, while in "C" the variable condenser alone is connected. Three ranges are in this way available.

Fig. 4.—Another aerial arrangement.

The two arrangements described above may be combined by using eight sockets joined up as in Fig. 4. The method of plugging in the links will be the same as already explained; Fig. 4 gives as an example the two condensers in series with each other but in parallel with the tuning coil.

A third use for this type of switch is in connection with variometers. The two coils of these instruments, stator and rotor, are usually connected in series, but if they are joined in parallel, the wave-length is reduced. The variation covered by a given instrument can thus be very much increased by means of a series-parallel switch.

Care must be exercised in connecting up the switch that it is as

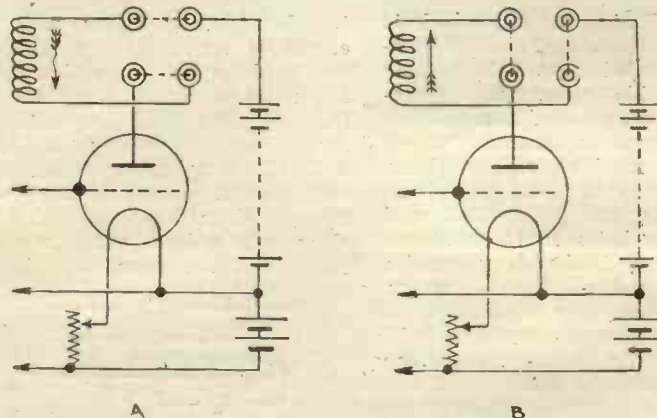

Fig. 5.—Reversing the sense of the reaction coil.

In Fig. 5 so that the same direction of movement of the dial or pointer will give increase or decrease of to be able to reverse the direction of current through the coil, and this can be done by inserting the

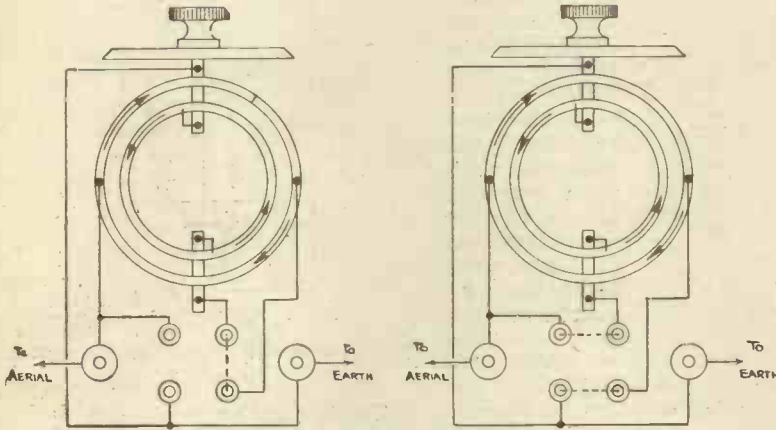

Fig. 6.—Variometer switching.

wave-length whichever way the coils are connected. Diagram "A" Fig. 5 shows the windings in series, while "B" indicates the links plugged in to join them in parallel.

The same arrangement of valve-legs arranged in the form of a square can also be made to serve as a reversing switch. Fig. 6 explains one use in connection with wireless apparatus. When a reaction coil is used, it is convenient

reversing switch between the anode of the valve and the reaction coil. The arrows show how the current may be reversed by plugging the links vertically or horizontally.

Many more examples of the use of this system of changing connections rapidly might be given, but these examples will be sufficient to show that it has important advantages over the use of the usual form of switches.

G. H. L.

terminal. If preferred the hole in the brass strip may be elongated so that the top crystal may be moved to make contact with any part of the lower crystal. The top crystal cup is held by a terminal and spring washer so that its position may be slightly altered without slackening the terminal which holds the brass strip in its place. The upper nut is used to apply the contact pressure between the crystals. Suitable combinations are:

Top Crystal:—Galena, zincite, metal points.

Lower Crystals: — Tellurium, graphite; bornite, calcapryrite, tellurium; iron pyrites and silicon.

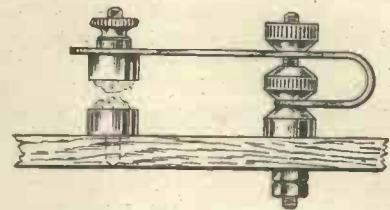

Fig. 2.—The finished detector.

Metal points will be found to be more stable in the form of short needle than wire spirals. A pair of these detectors with a switch would be admirably suitable for a dual circuit with crystal detection.

S. C. H.

AN EASILY MADE CRYSTAL DETECTOR

A CRYSTAL detector which is rigid, neat and easily adjustable, being especially suitable for the double crystal type of detector, can be constructed from a double terminal such as those advertised in this journal at various times. Take a strip of brass 3 in. long, $\frac{5}{16}$ in. wide, and $\frac{3}{32}$ in. thick, and drill three holes in it as shown in Fig. 1. It is then bent round a piece of rod of $\frac{3}{8}$ in. diameter, so that the right-hand hole is directly above the central hole. Now take the ebonite upon which the detector is to be mounted and mark the hole for the centre of the double terminal. Then taking

length $1\frac{1}{4}$ in. as radius and the centre of the hole just marked as centre, draw an arc, and upon it mark the centres of the three (or other number decided upon) holes for the lower crystal cups, and then drill the four holes to suit the components. Insert the three cups, connect them together, and from them take a lead, whilst another lead is taken from the double

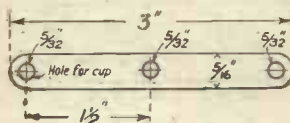

Fig. 1.—The strip.

A PANEL HINT

It may interest readers to know how I get over the high cost of ebonite, using a material which is much cheaper and works quite well. The necessary materials are, one baking tin (size depends on size of panel required), enough paraffin wax (miner's lamp wax or candles) to cover about $\frac{3}{8}$ in. in the tin, and enough $\frac{1}{4}$ in. plywood (five-ply, preferably) to make the panels. To proceed, cut and sandpaper the panel to size. Next, melt the wax in the tin until it just begins to smoke, immerse the wood and let it cook, keeping it immersed; turn it occasionally. Cook it for about twenty minutes altogether. Drain on one corner, and scrape if necessary. Ordinary wood is very liable to warp unless frequently turned.

L. S. WILSON.



SPECIAL NOTE.—All apparatus described in this section has been tested by our expert, and readers can therefore rely fully on the opinions given.

T. C. B. Filament Resistance.

We have received from T. C. Ball a later and improved pattern of the type of filament resistance previously submitted for test, and which had already produced a favourable impression by its compactness and smoothness of action.

This resistance occupies less than a square inch on the panel, and a depth of about two inches. The stout brass frame requires but two small holes for fixing below the panel. A neat knob actuates a spindle with a quick-thread screw, which moves a spring sliding contact the length of a solenoid-form of resistance in three complete turns, giving a very fine and smooth adjustment. Positive stops are provided at each end of travel, of course; and there is a definite off position. Convenient terminal screws are fitted in this improved form. The insulation was good on test; the resistance of the coil tested about 5 ohms, and it carried the current for an R valve without heating up noticeably.

On extended trial in actual reception of broadcasting, and also in laborious and critical experimental work, the velvety smoothness of action and complete silence in operation were noticeable: critical adjustment of detector valve and critical control of oscillation became easy with this long screw action and the absence of back-lash.

The workmanship and finish of

this later pattern are all that one could desire; it can confidently be recommended to those who are tired of the trashy type of components now flooding the market, and who will appreciate a thoroughly sound and reliable fitting which will outlast half a dozen of the ordinary cheap type.

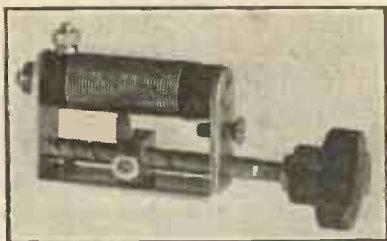

The T.C.B. Resistance.

An Anode Resistance

We have received from Messrs. Dubilier Condenser Co. (1921), Ltd., a sample of the type of anode resistances which they make with from 20,000 to 100,000 ohms resistance. These are substantial units, in appearance suggesting enlarged editions of the well-known grid-leak resistances made by this firm; with brass caps, and mounted between clips on an ebonite strip about 4 in. by 1 in., with two handy terminals, the whole being substantially constructed and well finished.

On practical trial of the 100,000 ohm resistance submitted, the value

was found to be correct; in resistance-capacity high-frequency coupling, with 120 volts H.T. and R valves, it was free from the unpleasant wheezing and crackling noises often associated with anode resistances; and on the longer waves gave excellent amplification, the Paris Radiola concert on 1,780 metres being readily picked up with two valves and this intervalve coupling, as well as a world of long-wave Morse.

As stabilising resistance in the S.T. 100 circuit, the value appeared to be a little high, as whistling threatened, especially when a small series condenser was used in the aerial circuit. For this purpose, the resistances of this series of rather lower value would be preferable.

Dynaphones.

Messrs. Radio Communication Co., Ltd., have provided an opportunity of testing their "Dynaphones," a telephone set in which it is claimed both the usual direct magnetic action on the diaphragm is obtained, and also an electro-dynamic effect, by the induction of currents directly in the diaphragm, and the reaction of these in a permanent magnetic fill. Great clearness of reproduction is claimed, as a result, and the possibility of using a much larger, and more robust, winding. The resistance of the windings is 4,000 ohms; a very large

audio-frequency impedance is quoted by the makers.

The phones are unusually light and small; and comfortable on the head. They are neatly finished, and a good length of cord is provided. In crystal and valve reception the tone was clear, and there was no noticeable distortion

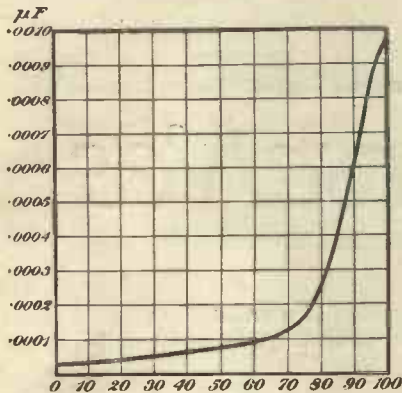

Calibration curve of the Connecticut condenser.

even if signals were not very loud in comparison with the ordinary type. They represent an interesting experiment in one line of attack on that appalling inefficiency factor of the present type of telephone, where less than one per cent. of the electrical energy is usefully employed.

A Variable Condenser.

An interesting type of variable condenser is that submitted for test by Messrs. R. A. Rothermel, Ltd.: the "Connecticut" condenser. This is a very compact form, with only two plates, and a mixed dielectric of air and mica, the adjustment of its capacity being effected by altering the relative distance of the metal plate by a screw and nut action.

The effect of this, with the high dielectric constant of the thin mica plate coming into play principally when the plates are brought extremely close, is to give a peculiar type of calibration-curve. The latter shows an extremely small minimum capacity, and slow increase with angular rotation of the screw spindle, at first: then, as the air-gap is reduced, and the mica begins to fill a larger fraction of it, and finally predominate, an extremely rapid rise in capacity to a high maximum (relative to the bulk of the instrument). Actually,

in many cases this non-linear characteristic can be extremely valuable: e.g., by simply slipping the scale back (provision for which operation is made in the instrument) the same condenser can be used as a "vernier" or fine-tuning condenser of low maximum and extremely low minimum capacity. A low ohmic loss is also claimed for the condenser, the conductors being massive and the path of flow short.

On test, the insulator was found excellent; on most careful comparative trial with a standard air-dielectric condenser, no sensible difference in signal-strength on the broadcast wave could be detected when used alternately with the same inductance, etc. The calibration was checked, and showed the extremely low minimum of .00004 μF, and maximum close to the nominal value of .001 μF. The condenser was silent in use, and easy to adjust. The workmanship and general appearance were good, the condenser being mounted in a composition case about 3 in. diam. and 2 in. high; with a knob, and engraved scale reading to 100; substantial stops; and terminals mounted on an extension of the base in the "portable" type submitted.

Condensite Celoron Panel.

A sample of the "Condensite Celoron" panel material, an alternative to the customary ebonite (which it closely resembles in superficial appearance), has been sent for inspection and practical test by the Diamond Fibre Co. In an interesting booklet accompanying the sample there was a great deal of information as to the various grades of this material manufactured for most varying purposes, and useful information as to machining operations and finishing. The Grade 10, for radio equipment, it is claimed, can be sawn, drilled, tapped, turned or milled; but cannot be moulded when once cured. It is described as being essentially vulcanised fibre impregnated with a phenol-formaldehyde condensation product and hardened by heating. It is made in sheets and rods up to 3 in. thick; and tubes up to 6 in. diam. Certain methods of machining give best results, and are given in detail, as mentioned. Very sharp tools, frequently changed, appear to be the main requisite.

On practical test of the sample, it was found to work with the usual radio-constructor's small tools quite well, being in fact similar to very hard fibre. As with fibre, care had to be taken to keep the tools sharp; and drilling had to be done with a light cut; if force was used, the drill tended to jam. It could be tapped, filed, etc.; and a pleasing mat finish could be got with fine emery-paper, if preferred to the polished surface (free from the treacherous properties of new ebonite surfaces) on the material as supplied. A 3/16ths in. panel seemed to be mechanically strong enough to replace thicker ebonite, and gave no trouble from splitting out at the back when drilled. The edges could be finished attractively. Electrically, the insulation was unexceptionable. The material stood up to the severe test of soldering close up to the panel without unpleasant results.

An Interesting Voltmeter.

We have been afforded recently an opportunity of inspecting examples of the Moullin low-reading A.C. voltmeter, and of viewing the processes of assembling and bench tests of the instruments, by Messrs. The Cambridge and Paul Instrument Co., Ltd.

This voltmeter depends for its action on the rectifying properties of a triode valve, and therefore has minimal electrical capacity and power-absorption, and is independent of frequency. It is made in two forms: type A employs the curvature of the anode current grid potential characteristic; no separate H.T. battery is needed, and the scale reads directly (on a unipivot microammeter) from 0 to 1.5 volts; type B uses a grid-condenser and leak, with separate H.T. battery of about 70 volts; the scale reads from 0 to 10 volts (on a unipivot milliammeter).

In both instrument zero-adjustments on the pointers compensate for slight variations in the batteries; as only 3.6 volts are used on the valve-filaments, and the valves are aged before calibration, their effective life will be long; and the makers will, we understand, undertake the replacement and recalibration at a moderate charge.

The particular advantage of the

B type is that an A.C. superimposed on a D.C. can readily be measured. Many other applications are suggested: e.g., as high-frequency ammeter, by measuring the P.D. across a known capacity or inductance; conversely, measuring small inductances by passing a known H.F. current through them and measuring the P.D. across the terminals; measurement of signal E.M.F.s in radio receivers and at different stages in amplifiers, etc. An actual measurement was witnessed at the works: the P.D. across the secondary of two very loosely coupled inductances being measured directly with the A type, at a frequency of about 16 cycles, and the variation with degree of coupling readily followed. Other examples of measurements of this type are some made recently by Mr. M. H. Lawes on the P.D. across tuning inductances on a P.M.G. aerial in London, of a type invaluable as a guide to progress in real experimental work: e.g., on 2 LO's carrier-wave a P.D. of 1.9 volts was found across a basket-coil corresponding to a little over No. 40 of plug-in types, with parallel condenser; 4.2 volts across one corresponding to about 80 turns with series condenser, undamped; but sinking to 1.3 volts and only .95 volts respectively when perikon crystal was placed across them—thus giving real data on the long-debated "series versus parallel condenser" controversy. Similarly with loose-coupled primary and secondary coils, the voltmeter gave 1.6 volts optimum (when coupled at 1 to 3 inch centres) with primary tuned by parallel condenser; 1.5 volts optimum at 3-inch centres with equal-sized coils, the first tuned by series condenser. With these instruments a great deal of light can be thrown on such very practical problems.

In finish and workmanship the instruments are beyond criticism; they are beautiful examples of the British instrument-maker's art.

A.D.C.

A Large Primary Cell, the "A.D."

Messrs. Le Carbone have submitted for test an interesting type of giant wet cell, Type B.I.C., for making up primary batteries for supplying filament current under circumstances where the (always troublesome) accumulator is not available. This is of the Leclanché

type, with agglomerate blocks around carbon positive plates; and a very large box-shaped zinc negative plate comes very close to the positive, giving an exceedingly low internal resistance. The makers claim that manganese is not used for depolariser. The electrolyte appears to be a familiar and innocuous powdered substance, readily made up and safe to carry in stock. The zincs can be renewed at a cost that compares favourably with that of a couple of trips to the garage with an ordinary accumulator for recharging.

The cell is in a neat black composition container, about 6½ in. by 8 in. by 10 in.; and is quite light when uncharged. Terminals and



The A.D. Primary Cell.

connecting straps are provided. If preferred the electrolyte is supplied ready made up in a can; but it was a very easy matter to dissolve the powder and set up the cell, which gave over 20 amperes on actual test in short-circuit shortly after filling; and about 1.4 volts on practical test over a considerable period with a dull-emitter valve. There was absolutely no sign either of polarisation or of noise. We can see no reason why this cell should give any more trouble in use than an ordinary wet bell-battery; and the renewal of spent zincs and electrolyte would be the simplest possible job, and not at all costly. While, of course, the E.M.F. of a single cell

is low, too low in fact for any but the pea-nut type of dull-emitter valve, two will run a two-valve set with English dull emitters for a very long period. We have no hesitation in strongly recommending these giant cells for use in remote country districts and the like where the charging of accumulators is an even more harassing problem than it is to the suburbanite.

The Darimont Cell.

Messrs. Darimont Electric Batteries, Ltd., have submitted for test a couple of their Type T15 primary cells, of nominal 73-75 ampere-hours available capacity, which are suitable, it is suggested, for use to replace accumulators for supplying the L.T. current to valves. These are of the two-fluid type, with zinc and carbon poles; the electrolytes being, respectively a viscous emulsion with sodium chloride as main constituent, as excitant; whilst a solution mainly of ferric chloride is used as depolariser. A porous pot is used; and it is claimed that a semi-permeable membrane is formed by precipitation in the pores of the pot, thus preventing diffusion and mixing of the electrolytes.

The cells are in glass containers, about 6 in. square by 9 in. high; and a terminal and connecting strap are provided. When spent, the old electrolyte is to be poured out, and fresh material together with new zincs substituted.

On a practical test-run, taking the current equivalent approximately to that required by a greedy R valve, about 3-4 ampere; the two cells gave 1.7 volts available E.M.F. at the start; after 24 hours' continuous run—a fairly severe test compared with ordinary intermittent use—the E.M.F. had fallen to 1.4; and after 48 hours (corresponding to about 36 ampere-hours, or, say, a month's casual listening for an hour or so every evening on one valve) to 1.2 volts nearly. On open circuit the E.M.F. at the end of the run was 2.5 volts approximately, or 1.8 volts when giving the current corresponding to one dull-emitter valve. On short circuit the two cells gave 1½ amperes at the end. Considerable frothing was noticeable, as well as marked electric endosmosis into the porous pot, at the conclusion of the test run; some mixing of electrolytes had evidently occurred as well.

These results confirm the elaborate tests made with similar cells, mainly at lower and intermittent discharge-rates, by the National Physical Laboratory; the internal resistance of the cells, which is quite appreciable, also coming out about the same. Evidently, whilst quite suitable for operating one or two dull-emitter valves for considerable periods (one cell, for example, being adequate for a peanut type of dull emitter), the limited available voltage (on account of the sensible internal resistance) would make the L.T. equipment for a multi-valve receiver using ordinary valves rather



The Darimont Cell.

cumbersome. For use with one or two English dull emitters there are decided possibilities for this interesting type of primary cell.

Anode Reactance with Variable Reaction.

Messrs. Radio Instruments, Ltd., have submitted for test a unit, suitable for panel mounting by the amateur constructor, comprising a tapped reactance coil covering a range from 200 to 4,000 metres wave-length with 5 tapplings when used with a .0002 μ F variable con-

denser; and a swinging reaction-coil controlled by a small knob coaxial with the wave-length control. This is arranged for mounting behind the panel in an elegant and exceedingly convenient way by the provision of a small false panel, on which the instrument is assembled; and of four small brass columns by which the whole is fixed in the rear of the receiver panel by four small screws.

On practical test on a two-valve receiver in London, with R valves and about 70 volts H.T. representing approximately standard practice, on a fairly good suburban aerial, comfortable loud-speaking was obtained on local broadcasting; Birmingham, the Ecole Supérieure (Paris), Newcastle and Glasgow came in well on the phones, and easily readable, Glasgow in particular being very good, loud and steady, whilst 2 LO was going; Bournemouth at surprising strength and intelligible even whilst London was on, with critical reaction—not a common feat with commercial types of apparatus. The ships came in in a loud chorus; Aberdeen's good-night was clear, though faint; and amongst the longer waves Eiffel shouted finely on two valves, with innumerable other Morse stations.

Tapped Anode Reactance.

From Messrs. Radio Instruments, Ltd., comes also a semi-aperiodic tapped reactance unit, with the same type of panel-mounting by means of a small false panel, and three small brass columns, a white engraved scale appearing on the front of the receiver panel and also providing a drilling template. This covers from 150 to no less than 20,000 metres wave-length with 12 tapplings; having a total resistance of over 600 ohms it comes under the semi-aperiodic class, and no tuning condenser is needed to bridge between the tapplings, the tuning being flat enough to dispense with it. This, of course, greatly simplifies the tuning of a circuit, as if capacity reaction is used from the second valve anode to the first grid, as in the tests carried out with this instrument, there are only the two controls necessary, A.T.C. and reaction. In the tests it was found to cover amply the range claimed: London came in strongly on the two valves towards the lower limit; and a regular boiler-makers' chorus of

noisy C.W. Morse all along the higher ranges, some stations being audible over the house with 'phones alone. There was no doubt as to the effectiveness of the anode reactance coupling, though careful use of reaction was necessary to tune out 2 LO and some noisy English stations of medium wave-length, even in the top range.

For those experimenters who find interest in long-wave Morse this unit, which has the same high finish as the unit already mentioned, will provide a compact and convenient interval coupling unit.

The other unit of this series was also tested and found satisfactory.

A Moderate Priced 2-Valve B.B.C. Receiver.

Messrs. Bowyer-Lowe have recently tackled the problem of designing and marketing a two-valve broadcast receiver which will meet the wants, and suit the purse of the man of moderate means. The result is an interesting little set which has been submitted to us for practical trial.

This "utility" instrument is neatly cased in a polished hardwood box, with ebonite panel forming the lid; is well-finished, and the components are of reliable make. An on-and-off switch is fitted, but no filament resistance; and accommodation is provided for leading coils of the plug-in variety.

An extremely simple resistance-capacity-coupled circuit is used, rectification being performed by a crystal, which is in a movable fitting plugging into the panel. The well-known Bowyer-Lowe variometer incorporated in the set tunes from about 340 to 660 meters on a P.M.G. aerial, and is the sole control.

On practical trial on local transmissions, clear signals were obtained, at pleasant strength for two or more pairs of phones, in an outer suburb. A little trouble was experienced with the particular crystal supplied with the set, but when replaced by another of the same make (which has already been noticed in the columns of the Radio Press) a good spot was easily found.

In all, the receiver is a neat, ingenious, and good-looking little instrument, in which pains have been taken to give good value for money.

(Continued from page 104.)

in Fig. 5, and it is possible, by the correct use of an intervalve transformer, $T_1 T_2$, to increase the signal strength some four or five times. It will be seen from Fig. 7 that the loud-speaker, shunted by a condenser C_6 of 0.002 μ F capacity, or more, is connected in the anode circuit of the first valve next to the anode. The second valve acts as the detector, and the low-frequency currents, which pass in the anode circuit of the second valve, flow through the primary T_1 of the step-up intervalve trans-

former $T_1 T_2$, the secondary P_2 is included in the aerial circuit and impresses low-frequency potentials on the grid of the first valve. This valve proceeds to amplify the low-frequency currents, the magnified currents then flowing through the loud-speaker LS.

The values of the different inductance coils are similar to those given in connection with Fig. 5.

Fig. 8 shows, pictorially, how the different component parts, indicated by letters in Fig. 7, may be wired up.

THE RADIO SOCIETY OF IRELAND

A GENERAL meeting of the Radio Association of Ireland was held in the Municipal Technical Institute, Kevin Street, Dublin, on October 16, 1923, Professor W. J. Lyons presiding. There was a large attendance, including representatives of the old Dublin Wireless Club, of business interests, of the Universities, and the communications branch of the National Army and the Post Office engineering staff.

The chairman spoke of the large number trained in wireless at the Municipal Technical Institute, but the slump in shipping had given no outlet and others qualified for certificates were unable to get an examination. With these men originated the idea of an Association, but not as an Association of Professional Wireless telegraphists and not as catering for enthusiastic amateurs. They had to consider all interests, especially in view of the development of broadcasting. The Government had also to determine whether a man who got the Postmaster-General's certificate here would have the same rank as the man who got the British Postmaster-General's certificate. The Government would also need advice on the question of broadcasting. Mr. E. Hancock, president, Institute of Electrical Engineers, spoke of home manufacture and protection for apparatus made in Ireland. Mr. Bridle, secretary of the Dublin Wireless Club, agreed that there was room for only one association in Ireland;

Professor J. J. Dowling, National University, dealt in detail with the development of wireless for broadcasting weather forecasts, and mentioned the efficient system in operation in the eastern states of America, due to wireless.

Professor Lyons, in summing up, said he was satisfied with the meeting, and hoped the Dublin Wireless Club would discuss the matter, bearing in mind that they all had common interests.

It was announced that the Association's secretary had received a letter from the secretary to the G.P.O. approving the Association, and that its co-operation in securing the observance of the regulations by holders of licences would be welcomed, and would be glad to seek the view of the Radio Association on any questions that might arise. The Executive Report gave the following as having agreed to become vice-presidents:—W. D. Morgan, Esq., B.A.; J. J. Dowling, Esq., M.A., National University; G. Marshall Harris, Esq., M.I.E.E., General Manager, Dublin United Tramway Co.; Professor W. Thrift, T.C.D., Trinity College, Dublin; T. Hempenstall, Esq.; Professor Hackett, M.A., Ph.D., College of Science, Dublin; Professor T. Dillon, M.A., D.Sc., University College, Galway. The formation of a programme was left to the Executive Committee.

H. HODGENS, Hon. Sec.
Radio Dept.,
Municipal Technical Institute,
Kevin Street, Dublin.

RADIO PRESS INFORMATION DEPARTMENT

Owing to a tremendous increase in the number of queries, and the policy of the Radio Press to give expert advice and not merely "paper circuits," it has been found necessary to enlarge our staff dealing with such matters. The slight delay in answering letters will shortly cease. In view of the expense incurred we are reluctantly compelled to increase our charge for replies to 2s. 6d., according to the rules below.

If readers will comply with the conditions laid down they may be assured of more prompt attention.

All queries are replied to by post, and therefore the following regulations must be complied with:—

- (1) A postal order to the value of 2s. 6d. for each question must be enclosed, together with the coupon from the current issue and a stamped addressed envelope.
- (2) Not more than three questions will be answered at once.
- (3) Complete designs for sets and complicated wiring diagrams are outside the scope of the department and cannot be supplied.
- (4) Queries should be addressed to Information Department, Radio Press, Ltd., Devereux Court, Strand, London, W.C.2, marking the envelope "Query."

APPRECIATION

DEAR SIRS,—I am pleased to inform you of the results I have obtained using the ST.100 circuit described in MODERN WIRELESS, No. 6. Using 1 Mullard Ora and 1 "R" Valve, Hertzite detector, Igranic L.F. transformers, aerial condenser in series, Nos. 75 and 100 Igranic honeycomb coils, 117 volts, H.T. shunted by 1 mfd. condenser. The following are some of the stations I have received:—

2LO, 5IT, 5WA, 5NO, 5SC, 2BD (Aberdeen Testing), School of Posts and Telegraphs, Paris, Croydon (GED), 2BO (Writtle), and dozens of amateurs including 2WX (Brierly Hill, Staffordshire, which is 98 miles from here). The following stations are heard on the loud speaker:—2LO, 5IT, and 5SC. Glasgow can be heard in a 15-ft. square room loud and clear, almost as loud as London.

Yours faithfully,
W. E. Goss.

Gt. Berkhamsted.

FOR CRYSTAL USERS.

Hints and Suggestions on Mounting and Using.

WE are glad to see that manufacturers in increasing numbers are placing crystals on the market ready mounted in suitable cups. Seeing that the majority of crystals are used by beginners, who cannot be expected always to realise the importance of such matters as not overheating the Wood's metal when mounting, avoiding touching the surface of the crystal with warm fingers, and other important points, ready mounted crystals should go far towards making good reception more general.

* * *

Facility of interchange will bring about in turn greater curiosity on the part of the user as to the relative merits of the various crystals. We must remember that the requirements of all listeners are not the same, for the man who lives in the shadow of a broadcasting station can well sacrifice a little sensitiveness in his crystal in return for added reliability. On the other hand, the man living, say, 25 to 30 miles from the station will need to get a very fine adjustment on his crystal if the set is to give any results worth speaking of, and for this reason he would be bound to seek everywhere for sensitivity even at the sacrifice of constancy of adjustment. For the "close-up" man carborundum with a suitably applied potential is almost ideal, the contact between the carborundum and the metal plate being so firm that even considerable vibration of a table will not put it off adjustment. It is sometimes argued that the necessity of applying a separate potential to the carborundum crystal is a good reason for avoiding it, but now that excellent potentiometers are obtainable in every dealer's shop at a reasonable figure, and as flashlight dry cells are so cheap, there is no real reason for avoiding its use in situations where it will serve such a good purpose. Any wireless book dealing with crystal receivers will explain the use of a potentiometer and how to connect it up.

It is surprising that with such a good demand for crystal receivers there should be such a lack of originality in design, especially in regard to the detector itself. More than 90 per cent. of the crystal receivers placed on the market are fitted with a very crude form of adjustment for the cat-whisker point, and in nine cases out of ten the cat-whisker itself is much too thick. We have frequently advised the use of a gold cat-whisker, and at present a large number of such wires are on the market, but unfortunately in the majority of cases we find that the percentage of gold is extremely low and that the wire consists mainly of copper. Such alloys, while slightly better than ordinary copper, are by no means free from tendency to oxidise. Silver cat-whiskers are often sold, and are probably superior to those in which there is a tiny percentage of gold. Silver whiskers have the advantage of greater springiness than the gold. When the latter is of a good quality, it is frequently extremely soft and easily pushed out of place or bent into an awkward shape, which makes the setting of the crystal difficult.

* * *

A point of interest in the design of a crystal receiver which is frequently overlooked is the necessity of connecting the slider and its rod to the earth and not to the aerial. If the slider is connected to the aerial, every time we adjust it and bring our hand against the rod signals will be shunted to earth through our body. If, on the other hand, the slider is earthed, we shall not alter the tuning by touching the rod. As long as the wire itself and the aerial terminals are well insulated from the framework, there is no need whatever to insulate the rod from the base, as in any case it is connected to earth. The crystal itself should always be connected between the aerial terminal and the telephones, not, as we sometimes see in beginner's sets, between the telephones and the earth terminals.

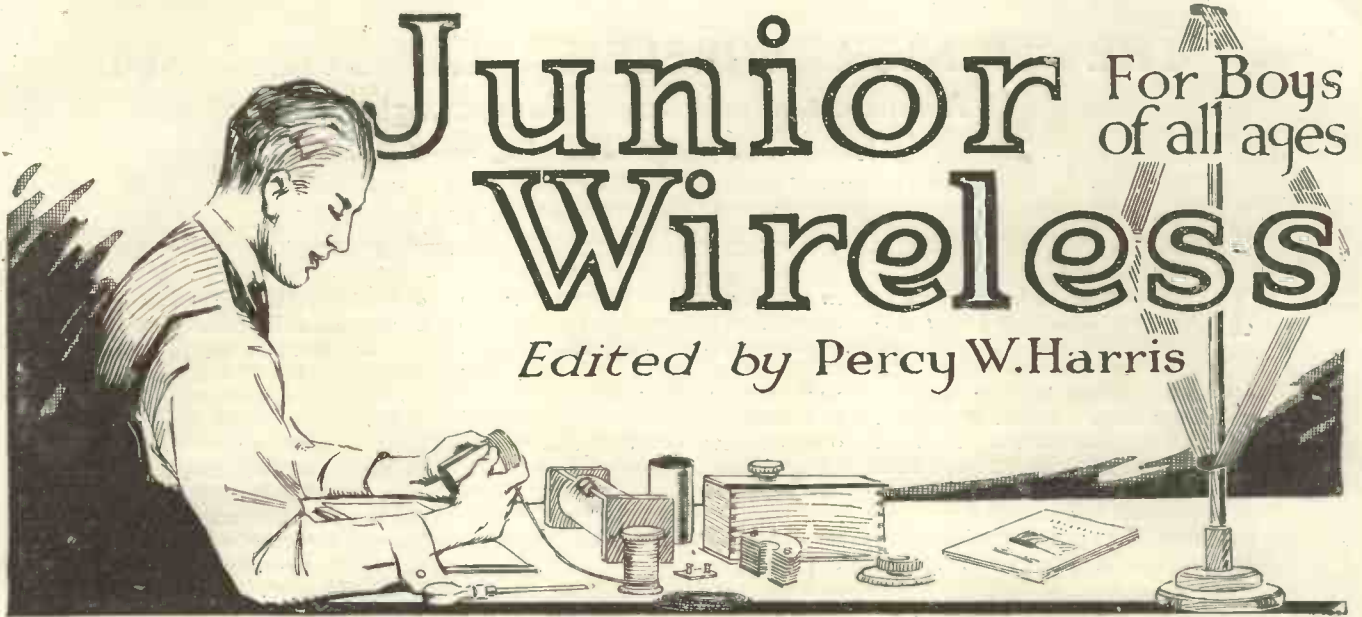

Vol. 1. No. 3.

NOVEMBER.

Published Monthly.

THE EDITOR'S CHAIR

WHEN the members of the British Broadcasting Co. met together recently to consider the new regulations regarding licences, a suggestion was made that a special schoolboys' licence might be issued to be granted by the schoolmaster to suitable applicants. I do not know whether there would be any particular advantage in this, as it is very easy for any boy to go to the nearest post-office and obtain a constructor's licence, and I have no doubt that thousands of my readers have done so since the publication of our last issue.

Now is the time to start a school radio club, if you haven't one already. On another page Dr. Chapman, who has had much experience with such clubs, tells you just how to proceed. There are many advantages in a school radio club, not the least of which is the great benefit which comes to every member by the interchange of ideas and experiments. We cannot go far in amateur wireless without experimenting, and it must not be forgotten that it is by no means always the highly trained experts who make great inventions; many have been produced by those who only recently started to study the subject. Major Armstrong,

who has contributed much to wireless and who is known to every reader as the inventor of the famous "Armstrong super," was scarcely more than a schoolboy when his first great discovery of regeneration

in America and C. S. Franklin in England. We hear a great deal in these days about the use and abuse of reaction, so I have arranged to publish this month an article describing in simple language just what reaction is. To show you the practical application of reaction in a way which cannot cause interference to your neighbours, we also publish a complete and detailed description of how to make a two-valve receiver utilising reaction in the best way. With this I am sure you will get wonderful results; it is a set which is just about as efficient as is possible to get it, and on a good aerial, when conditions are normal, you should be able to hear several, if not all, of the broadcasting stations. The two-valve note magnifier, described in the first issue of JUNIOR WIRELESS, when added to this receiver will make a splendid set with loud-speaking strength.

A good wireless set is always worth a good cabinet. Bought cabinets are generally expensive items, and most boys will want to make their own. In this number we publish an article by Mr. R. W. Hallows, M.A., which will tell you how to make your wireless wood-work to the best advantage.

THE EDITOR.

Contents.

	Page
Editor's Chair - - - - -	33
Junior Wireless Reaction Set By G. P. KENDALL, B.Sc.	34
Boring Large Holes - - - - -	37
The School Radio Club - - - - -	38
A Set in a Matchbox - - - - -	39
A Folding Frame Aerial - - - - -	41
Reaction: a simple explanation	43
Wireless Cabinet Work - - - - - By R. W. HALLOWS, M.A.	46

was published. Marconi himself had not come of age when he invented wireless telegraphy; so age does not count for everything, does it?

The principle of regeneration—or as we call it on this side of the water, "reaction"—was described about the same time by Armstrong

THE "JUNIOR WIRELESS" REACTION SET

A simple non-radiating set for the beginner.

By G. P. KENDALL, B.Sc., Staff Editor.

We can recommend this set as highly efficient in spite of its simplicity. It should receive all British broadcasting on a good aerial.

IF reaction is to be used so as not to annoy one's neighbours, and yet to get the full benefit of it oneself, it must be confined to one of the circuits which are not connected or coupled to the aerial, and one of the most practical ways of doing so is that shown in the circuit. This is known as circuit S.T.34 and was originated by the Editor of MODERN WIRELESS. It consists of one valve acting

in the circuit diagram, which automatically consists of two basket coils, one of which is fastened to the base board and the other to a wooden arm which is pivoted at the end so that it can be moved over the lower coil. Variations of tuning can therefore be done by moving the arm. These two coils with their wooden strip can be seen on the left of the photograph of the set.

coils, because your aerial may be of unusual dimensions.

The plate circuit is tuned by another basket coil, L_3 , and a variable condenser C_1 . The coil has eighty turns of No. 22 double cotton-covered wire and it is fastened to the base-board with string as before.

The variable condenser should have a capacity of .0003 μ F, and the method of mounting it will be described later. The reaction coil is a basket having fifty turns of No. 28 double cotton-covered wire, fastened to the right-hand wooden arm in the way already explained.

Materials Required

The set is a very cheap one to construct, besides being very easily made, as the following list will show. The total cost should not exceed 30s., the one shown in the photographs having cost rather less.

- 1 base-board, 9 by 15 in.
- 2 wooden arms, 8 by $1\frac{1}{2}$ by $\frac{1}{4}$ in.
- 2 filament resistances.
- 2 flange-type valve sockets.
- 7 terminals.
- 1 variable condenser of .0003 μ F. This should be of the type having more or less square ebonite top and bottom plates, for reasons which will become apparent later.
- 1 grid condenser of good make, capacity .0003 μ F.
- 1 grid leak, also of good make, 2 megohms.
- $\frac{1}{2}$ lb. No. 22 d.c.c. wire.
- 1 oz. No. 28 d.c.c. wire.
- 1 telephone condenser of .002 μ F. capacity.
- Systoflex and tinned copper wire for connections.

Base-board

The base-board I used was bought ready-made for 4s., and is made of well dried and varnished mahogany which has proved to be a very good insulator, no ebonite being used anywhere. If you make it for yourself remember to

as a high-frequency amplifier with a tuned plate circuit, across which is connected the detector valve (V_2 in the diagram) through the usual grid condenser (C_2). Reaction is obtained by providing a "reaction coil" L_4 in the plate circuit of the detector valve which is arranged to couple with the tuned anode coil L_3 , the coupling being varied to produce the required effects.

Tuning Arrangements

The aerial circuit is tuned by means of a very simple form of variometer represented by L_1, L_2 ,

The coils are fastened to the base and to the arm respectively by drilling holes in the wood and tying each coil tightly in place with string. Each coil consists of 40 turns of No. 22 S.W.G. double cotton covered wire, and they are joined in series, that is, the end of one is joined to the beginning of the other, as shown in the diagram of variometer connections. They should be joined so that the current flows the same way round in each for most sizes of aerials, but if you find a difficulty in tuning in with the set when finished try reversing the two connections to one of these

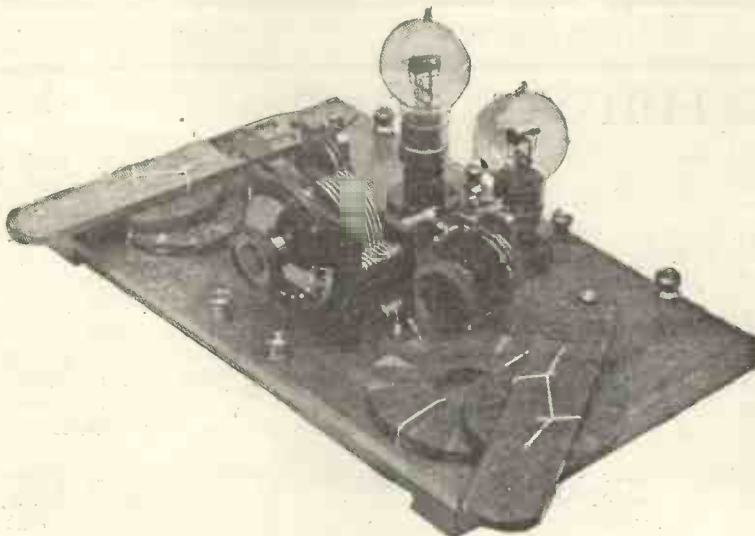

Notice the simple variometer on the left. It is made from basket coils. The condenser tunes the anode coil, and reaction is obtained by moving the right-hand strip.

put two crosswise pieces at the ends to lift it off the table to leave room for the wiring, etc., underneath. Suitable dimensions for these pieces are 1 in. square by 9 in. long, and they can be fastened to the board with glue or a few screws.

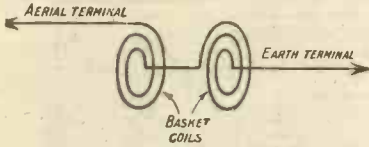

How the variometer coils are joined.

I should strongly advise you not to take any risks with the insulation of your base-board, but to separately insulate each terminal by proceeding as follows: Drill the holes for the terminal shanks a little large, insert the terminal and pour very hot melted paraffin wax round each before screwing down the nuts. The wax will soak into the wood and render it damp-proof and prevent leakage in damp weather. A still better method would be to fit the terminals with the ebonite bushes now sold by various firms.

Since the terminals have to be attached directly to the base the latter should not be thicker than $\frac{3}{8}$ in., and would be better if only $\frac{5}{16}$ in.

Filament Resistances

It must be noted that the filament resistances are to be of the pattern which can be mounted on the top of the board, such as those illustrated in the photograph. These are of Igranite make and seem very convenient for sets laid out on boards, although cheaper ones would serve quite well.

Mounting the Variable Condenser

The reason for specifying a variable condenser having square top and bottom plates will now be seen. The condenser is mounted upon the board by placing it upon edge and passing two wires over the ebonite top plate and down through two holes in the board. If these wires are twisted up tight the condenser will be held firmly in position.

Winding the Coils

The coils are all wound upon the double basket principle, and seem efficient in use, since the results given by the set are certainly very good. The method of winding is similar to that of the ordinary

basket type, with the exception that where in basket winding the wire is looped alternately over and under the spokes of the spider, in double basket winding it is taken under two and over two spokes. The result is a stronger and more compact coil.

After winding the coils should be soaked in diluted shellac varnish (thin it down with about half its volume of methylated spirit), dried and well baked in front of the fire (allow them to dry for half an hour before baking). They can then be bound with insulating tape and mounted in the way I have explained.

The two wooden arms carrying the moving coils are mounted so as to turn upon a point near their ends by means of two pieces of 2 B.A. screwed brass rod. These are passed through holes in the base-boards and the arms, the

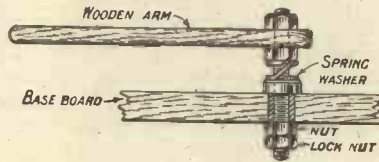

How to secure the arms.

latter being held at the right height by means of nuts and a pair of spring washers, as shown in the diagram.

Arrangement of Terminals

Of the terminals arranged at the back of the board, that on the left (in the photograph) is the aerial

terminal, that on the right is the earth, and the one in the centre is a common terminal for the negatives of both high and low tension batteries. Immediately to the right of this is the H.T. positive, and on the left is the L.T. positive.

Notice that the connection shown dotted in the circuit diagram is not made inside the set at all, but is to be done with a piece of wire between the earth terminal and one of the battery terminals. This is to enable the user to connect the earth to either the positive or negative of the accumulator, since it is interesting to try which gives the best results with various adjustments of the reaction. In general it is best to connect this wire to the positive, partly because that seems the most efficient for long distance work, but chiefly because it reduces the risk of any oscillations in the plate circuit getting back into the aerial circuit and being radiated to the annoyance of everyone around. I should be interested to hear from those who make up this set which connection they find the best, either for producing loud signals from a near-by station or for picking up a far distant one.

The two terminals at the front are for the phones, and the telephone condenser is screwed to the underside of the board beneath them, as is shown in the wiring diagram.

Mounting the Grid Leak

The method of mounting the grid leak is fairly plain in the

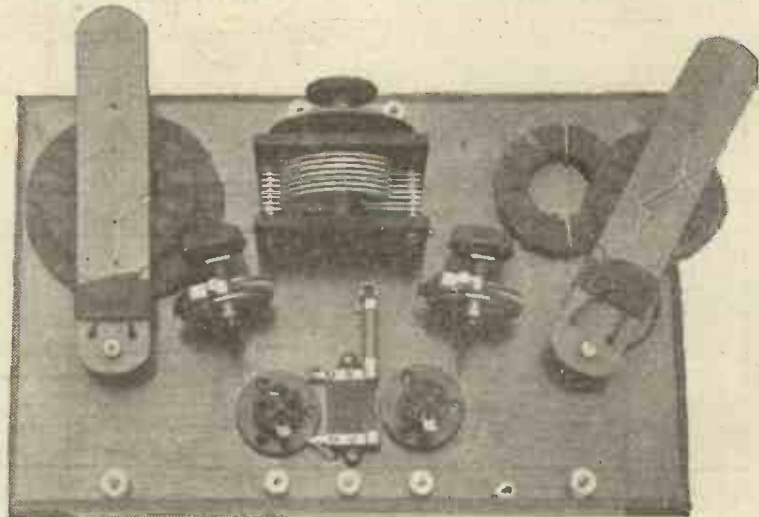

A view of the set from the rear.

photograph. One end of it is held by one of the clips of the Dubilier grid condenser, while the other is held by a grid leak clip (sold by most dealers in accessories) screwed to the base-board without any special insulation, since this end is at the potential of the filament and does not require isolation. The position of the grid condenser (between the valve sockets) is worth noting, and should be followed carefully, since it enables the grid connection wires to be kept very short.

Wiring

The wiring will be quite easily followed out from the diagram showing the underside of the board, and pains should be taken to copy it exactly. It should be done with No. 20 tinned copper wire, with the exception of the connections to the moving coils, which require short pieces of flex. All the wires should be sleeved in Systoflex, with the possible exception of those of the filament circuit, which only require to be covered where they cross and might touch others. A few pence can be saved in this way.

All joints should be soldered, of course, and care should be taken to see that every connection is really good and sound. A point to be noted is that the wires shown dotted in the diagram run on the surface of the board.

the arrangement of the terminals. Also make sure that the batteries are properly connected *before* placing the valves in their holders.

All this being done, put the phones on, turn the valves up until they are fairly bright, and proceed

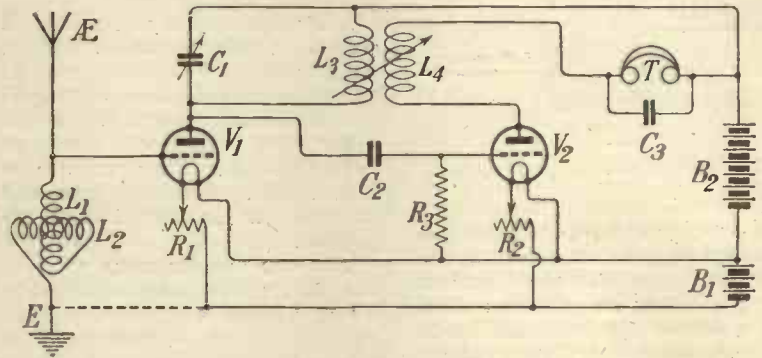

The theoretical diagram.

Operating the Set

When the set is finished and ready to be tested, connect up aerial, earth, batteries and phones, and remember to add the connection shown dotted in the circuit diagram and mentioned in connection with

to tune in as follows: First bring the reaction coil over the tuned anode coil gradually, at the same time varying the tuning condenser, until the set begins to oscillate. Test for oscillation by touching the set of plates of the

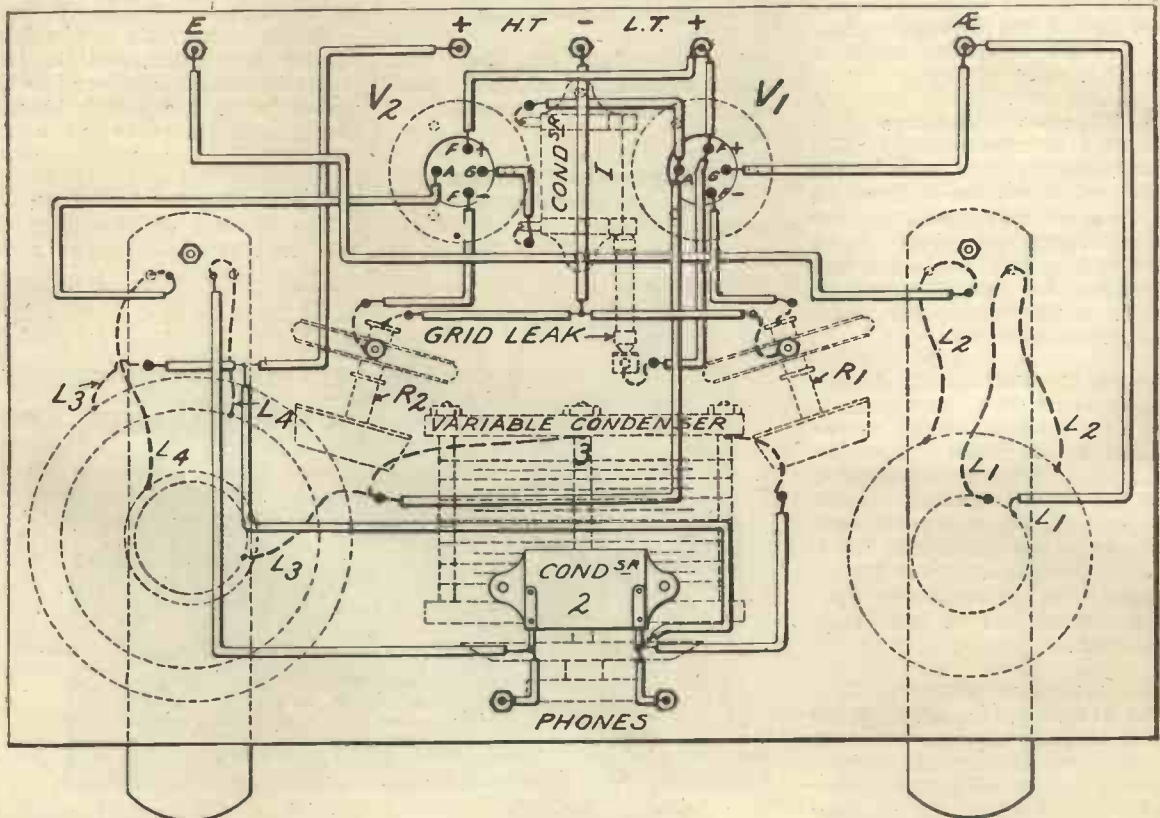

Practical wiring diagram.

variable condenser which are connected to the plate of the first valve; when the set is oscillating a strong click will be heard each time these plates are touched. If the set will not oscillate, reverse the connections of the reaction coil.

Next, keep the set oscillating and search for carrier waves by turning the condenser slowly and moving the left-hand upper coil quickly backwards and forwards across the lower (fixed) one. When a carrier wave has been picked up tune to the "silent point" (that means the place midway between the squeals) and gradually weaken the reaction until self-oscillation stops, re-adjusting the condenser as you do so. The speech and music will then be heard clearly. It may assist you to know that the broadcasting stations will come in at points between zero and 50 on the condenser scale.

Should you experience any difficulty in getting the signals properly tuned in on the aerial circuit, remember about reversing the connections of one of the aerial coils. It may interest you later to try the effect of connecting a small fixed condenser of about .0003 μ F between the aerial and the aerial terminal of the set, since this sometimes improves results considerably.

Almost any valves may be used in this set, such as Mullard Ora, Ediswan A.R., any type of R valve, or A.R.D.E. if dull emitters are preferred. About 60 volts H.T. will give good results with any of the foregoing valves.

Results Obtained

Remarkably good results have been given by the set shown in the photograph, apparently as a result of a happy choice of coil values and the shortness of the important wires. At my address in North London I can hear both Glasgow and Birmingham faintly but clearly on a Ducon aerial (i.e., when using the lighting mains as an aerial) with very careful and critical adjustment of tuning and reaction, so that with an outside aerial most of the B.B.C. stations should be heard in almost any situation. As a result of the thick wire used for the coils tuning is sharp and Glasgow can be heard with only very slight interference from London at a distance of five miles from Z.L.O.

With the addition of the note magnifier described in the first number of JUNIOR WIRELESS very good loud-speaker signals should be obtained up to distances of about fifty miles.

through a right angle. As the drill is intended for ebonite there is no need to harden the cutter, so it should be left to cool slowly. When cold the cutter may be cut to size and formed. The cutting edge should be left about $\frac{1}{8}$ in. long. (It will then be possible to cut ebonite up to about $\frac{1}{4}$ in. thick.) The shank should not be left longer than about 2 in. long. The formation of the cutting edge will best be understood by reference to the diagram, care being taken to see that the actual cutting edge occurs on a diameter. The set screw should be of steel or iron (not

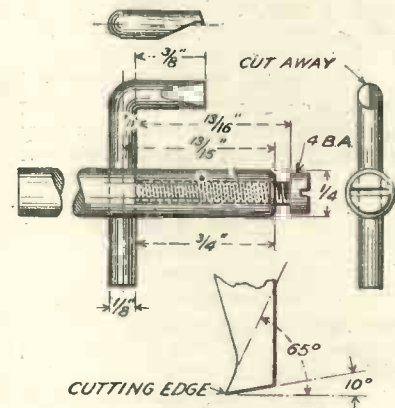

Fig. 1.—How to make the drill.

AN ADJUSTABLE DRILL FOR LARGE HOLES

MOST amateur constructors at some time or other have wanted to drill a large hole in ebonite and have been at a loss to find a suitable drill. Twist drills of over $\frac{1}{2}$ in. are rather costly, and, as is well known, do not leave a truly circular hole. For holes up to, say, 1 $\frac{1}{2}$ in. diameter which do not need to be an exact size, an ordinary wood-worker's centre-bit may often be made to serve the purpose. There are times, however, when it becomes necessary to drill a large hole, for which the cost of a twist drill would be out of the question and of such a size that a centre-bit could not be obtained. In such cases the drill to be described will be found to "fill the bill."

This drill, or more correctly boring-bar, will bore holes of any

size from $\frac{1}{2}$ in. to about 3 in. diameter, cleanly and accurately. It is quite simple to construct and, unlike a twist-drill, does not need accurate grinding to make a true hole.

The main body of the drill consists of a piece of silver steel about 6 in. or 8 in. long and $\frac{1}{4}$ in. diameter. Be sure that it is $\frac{1}{4}$ in. (0.250 in.) diameter, and not a few thousandths of an inch one way or the other. Drill a $\frac{1}{8}$ in. hole $\frac{1}{2}$ in. from one end for the cutter. At the same end drill a 4 B.A. clearance hole up the centre of the rod until it meets the cross hole. This hole, which is for the set screw, must now be tapped 4 B.A. To make the cutter, take a piece of $\frac{1}{8}$ in. diameter silver steel, heat one end to a bright cherry red in the fire, and bend one end

brass, as it is too brittle) and the head should be less than $\frac{1}{4}$ in. diameter.

The drill may be used in either a large hand drill or a carpenter's brace, or for preference a drilling machine. The pressure should be just sufficient to produce a thin shaving but no more.

To use the drill, first drill a $\frac{1}{4}$ in. hole with a standard size twist-drill, then insert the drill or boring-bar (having previously set the cutter to the required radius) and drill half-way through. Reverse the panel and cut through from the reverse side. If the brace has been kept vertical the hole produced will be found to be quite clean without any ragged edges or mark where the first cut finished.

It cannot be emphasised how useful a stock of various sizes of silver steel can be. It is not expensive, about a shilling a pound, and is most useful for making odd sized taps and drills. It is quite easy to forge and harden and with a little skill quite a number of useful tools may be made from a few lengths of silver steel.

THE SCHOOL RADIO CLUB

By E. H. CHAPMAN, M.A. (Camb.), D.Sc. (Lond.).

Every school should have its Wireless Club. This article will tell you how to start it.

THERE is always a fascination about forming and running a school radio club. For one thing, there will crop up a number of those delightful surprises which make school life so enjoyable. You find, for example, that Jones of the lower fourth, whose record for school work is such a poor one, can use his fingers with all the skill of an experienced mechanic when it comes to building the school wireless set. You may also find that Smith, who has never once opened his mouth when the school debating society has been debating on the usual subjects, can speak most intelligently on a matter of scientific interest.

For the formation of a school radio club two things are necessary: enthusiasm and capital. Of the former essential, enthusiasm, there cannot be too much. With regard to the second essential, however, although it is impossible to lay down any hard and fast rules, one thing is certain, the usefulness of a school radio club may be just as easily spoiled by too much capital at the beginning as by too little. It is far and away better to start a club in a small way than to begin in a big and ambitious manner. Clubs which at the commencement have few members and very little apparatus, generally succeed, but clubs which start with many members and much apparatus have a curious knack of fizzling out suddenly. The great thing to remember is that it is comparatively easy to arouse enthusiasm over a new thing, while it is a difficult matter to retain interest and enthusiasm when the newness has worn off.

At the outset a school radio club will depend for its being on two or three, not more, stalwart wireless enthusiasts. There will be many more boys who are interested, but the initial work always depends on the two or three stalwarts. First of all the radio club requires a leader. In most cases it is pretty obvious who that leader should be. One or other of

the prime movers in starting the club will, by force of personality, stand above the others. He is the one to be made leader. As to the title of this wireless club leader, there is no better plan than to call him captain. All the other school clubs have a captain, and by using the same title for the chief officer of the radio club you will be giving that club some, at least, of the dignity and standing of the other school clubs.

Let us suppose that our three stalwart wireless enthusiasts are named Brown, White and Green. Let us also suppose that White, by reason of his personality, is the obvious choice for captain. Then one of the other two, Brown say, should clearly be made vice-captain and Green should be made honorary secretary.

A most important point is to enlist the sympathies of the headmaster and to ask him to become the president of the club. Interviews with a headmaster are often strikingly painful, but White, Brown and Green have nothing to fear when they approach the headmaster on behalf of the school radio club. A headmaster likes to see his boys busy and, above all, he likes to see them take the initiative. Next there is the matter of vice-presidents. If there should happen to be any other master who is interested in wireless he should be persuaded to act as a vice-president also.

Having now a complete list of officers of the radio club, a notice should be put up calling a meeting of all those interested in wireless. This notice should be signed by the honorary secretary *pro tem*.

Let us suppose that those interested have met together and that one of the vice-presidents from the chair has explained that a radio club is to be formed. The first formal business will be the election of the proposed officers. There should be no opposition. The school wag may propose a red-haired fellow for captain on the grounds that a plentiful supply

of copper wire is required, but take no notice of him. Let him wag.

Other matters to discuss and decide on at this meeting are (i.) rules of the club, (ii.) subscription, and (iii.) programme for the term. With regard to the rules of the club, the best advice to follow is to keep the rules as few and as simple as possible. Circumstances vary so much from one school to another that one cannot say much about the subscription except to suggest that it be as small as possible, since there are so many calls on a schoolboy's purse these days. The drawing up of a programme for the term is an engaging and interesting task for the captain, vice-captain and the honorary secretary. Here are suggestions for the programme of a school radio club which meets weekly:

1. Lecture on capacity. Experimental illustrations. Questions and answers.
2. The construction of a simple crystal set. Open discussion.
3. Experiments with a simple transmitter and receiver.
4. Lecture on inductance. Experimental illustrations. Questions and answers.
5. The construction of a one-valve set. Open discussion.
6. Experiments on aerials, outdoor, indoor and frame.
7. Lecture on primary and secondary batteries. Experimental illustrations. Questions and answers.
8. The construction of a low frequency amplifier. Open discussion.
9. Experiments with portable aerials and portable sets with a view to the construction of a set for the next school camp.

There is scope for a great deal of careful thought in the drawing up of a programme for a school radio club. It must not be forgotten that the school scientific apparatus is a great asset. Far more experimental work can be done by a school radio club than by other radio clubs.

A RECEIVING SET ON A MATCHBOX

By W. ERIC BARNES.

Matchbox sets are not new, but this instrument is efficient as well as small.

THE small crystal set described hereunder was constructed of quite elementary pieces of material, and the reproduction by the reader will be found a moderately simple matter.

The windings, on the variometer principle, were designed to approximate a wave-length of 350 to 380 metres, in order to receive the broadcast concerts from the London station 2 LO.

The various aerials to which this set has been connected have been fifteen to twenty miles distant from 2 LO, and the reception has proved very satisfactory, being very clear and distinct, and the set readily accommodates three or four pairs of 'phones without uncomfortable diminution in signal strength.

The special interest of the construction lies in the former carrying the two windings, which consists of an ordinary matchbox with its sliding tray. The outer winding comprises 55 turns of No. 24 D.C.C. wire, and is wound on the outside of the box, and the inner winding of

forty turns of the same size wire is wound on a block of wood, the size of which when wound should fit snugly inside the tray.

To anchor the ends of the windings, "baby ribbon" $\frac{1}{4}$ in. wide will prove effective, and is employed by folding, say, 3 in. back on itself, thus forming a loop $1\frac{1}{2}$ in. long. During the process of winding the coil, and before the last eight to ten turns are put on, place the loop in position to approximate the finish of the last turn, wind the rest of the turns over the ribbon,

thread the last turn through the loop, and make fast by gently pulling one or both of the ends of the ribbon, which project through the winding, until the final turn is firmly held. Four inches or so of free end of wire should be left for connecting up later. The windings should be given a coat of shellac varnish and allowed to set firmly before further handling.

The base for mounting the terminals and crystal, etc., can be cut from $\frac{1}{8}$ in. sheet ebonite (a good quality worn-out gramophone record will make a fairly serviceable substitute), size 2 in. by $1\frac{1}{4}$ in., drilled and counter-sunk as shown

the sliding contact is a piece of $\frac{1}{4}$ in. diameter brass rod, turned or filed at one end (Fig. 5), to drive into the ebonite base, and drilled and slotted at the other to receive the sliding contact rod. A piece of $1/16$ in. diameter brass wire with a glass bead firmly fastened to one end will serve as a contact rod, to which a spiral consisting of three or four turns of fine brass or copper wire (to act as a cat-whisker contact) will be later fitted and soldered to the opposite end when mounted in the post. A connecting strip from the post to the condenser is cut from strip brass $1\frac{1}{4}$ in. by $\frac{1}{4}$ in. by .020 in., drilled and bent as in

Fig. 6.

The 'phone condenser, Fig. 3, consists of eight pieces of copper foil $1\frac{1}{4}$ in. by $\frac{3}{8}$ in., and nine pieces of .003 in. thick mica 1 in. by $\frac{3}{4}$ in., assembled alternately in the usual manner, allowing $\frac{1}{4}$ in. to fold over on the top to form connections. A little shellac varnish is smeared over the plates during assembly, taking care that the varnish does not spread to the outer edges,

which form the connections, the condenser being ultimately clamped between two stout metal plates and slightly warmed in an oven for about one hour and afterwards allowed to cool before removal from the clamp.

With four 6 B.A. by $\frac{1}{2}$ -in. counter-sunk brass screws, four hexagon nuts to suit, and two 4 B.A. brass washers, the assembly can be proceeded with. Mount the condenser between the two terminal holes drilled in base, fit a screw to each hole, and a washer over the

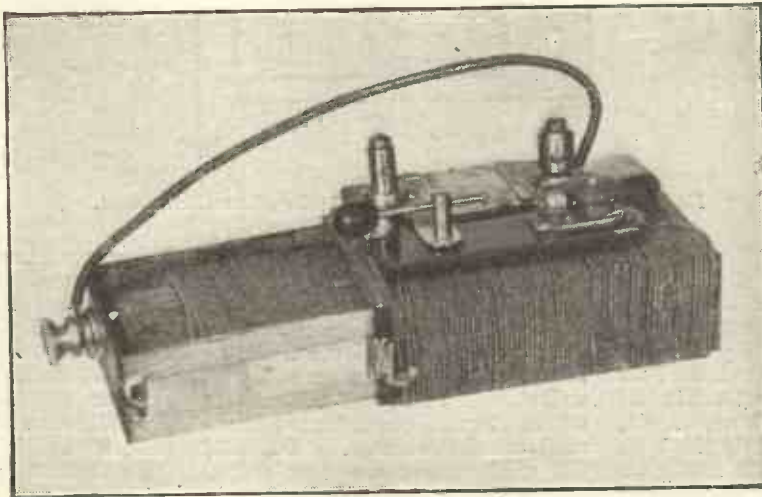

This matchbox receiver is tuned by pulling the interior in and out.

in Fig. 1. To fasten the base to the wound box a pair of brass clips will be required. These can be cut from medium hard strip brass $\frac{7}{8}$ in. by $\frac{3}{8}$ in., about .02 in. thick, bent as shown in Fig. 2.

The crystal holder is a small spacing washer, as used in variable condensers, and is sawn through with a fret-saw or filed with a fine slotting file as shown in Fig. 3, and soldered to a strip of .020 in. brass $\frac{3}{8}$ in. by $\frac{1}{4}$ in., and drilled for the terminal screw, the assembly showing as in Fig. 4. The post carrying

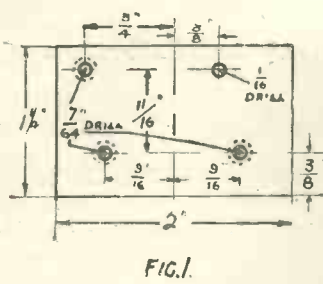

FIG. 1.

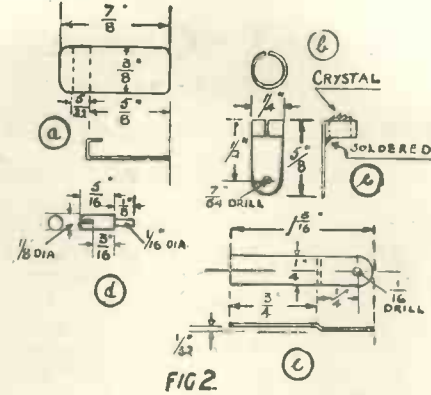

FIG. 2.

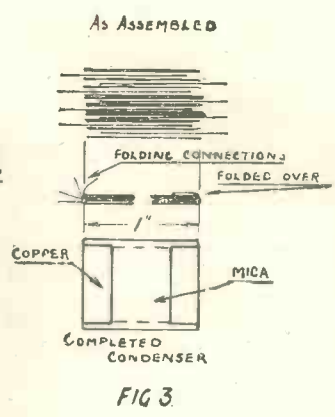

FIG. 3.

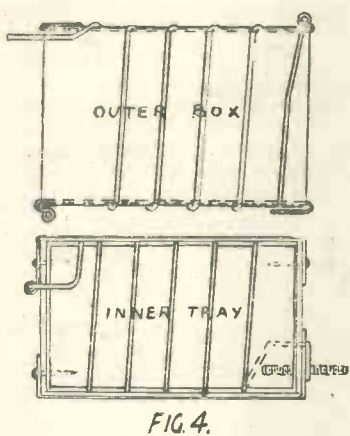

FIG. 4.

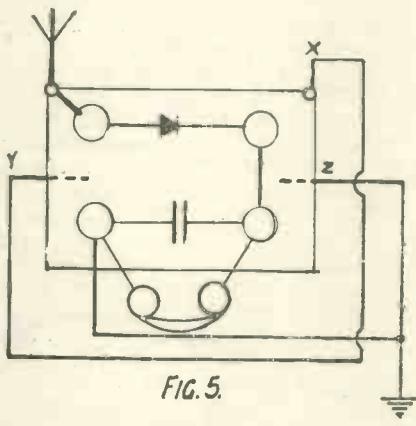

FIG. 5.

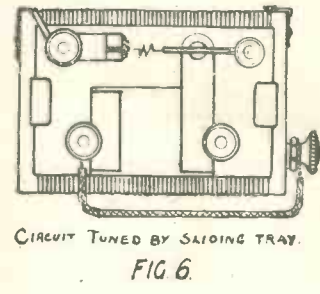

FIG. 6.

Full constructional details are given in the above illustrations.

screw so that it clips the contacts of the condenser, and thread on a nut. The post and connecting strip, Figs. 5 and 6, can now be fitted. The shouldered portion of the post is passed through the hole in the strip, and just entered in the hole provided in the base. Next, gently drive the post into the base until the shoulder rests firmly on the strip. Push in the contact rod and solder the "cat-whisker" in position.

The crystal holder is fitted to the base with a screw and nut through the top left-hand corner hole (viewing base with 'phone condenser nearest you), the beginning of the outer coil being subsequently joined to this screw.

The coil connections can be made quite simply by connecting two short lengths of flex between the outer fixed winding and the inner sliding coil, or a neater job can be made by mounting strips of .010 in. by 1/4 in. brass (acting as wiping contacts), Fig. 7, and fastened to the two longer sides of the outside

of the tray, and to the corresponding inner faces of the outer case, so that each pair of strips forms contact at every position that the sliding tray can assume. Needless to add, these strips must be well cleaned or a poor contact will result. Further, in order to accommodate the extra .040 in., i.e., the thickness of the four strips, choose a box in which the tray is a loose fit sideways. The writer found that a Bryant and May box was the most suitable and the strongest of the many varieties available. To complete the assembly, the base is given a coat of shellac on its underside, also the face of the coil upon which it will rest, together with the plain ends of the clips, Fig. 2, and while the shellac is still wet push in the longer ends of the clips between the coil and box, and with the base in position, set the clips so that the bent, or hook, end firmly clamps the base. Leave to set.

Join up the windings and the rest of the circuit as in Fig. 8.

Before permanently joining up and fixing, make a rough test in order to determine that the correct working relationship or sense of the two coils has been made. Two remedial tests will suffice to put matters right.

(a) Reverse tray and re-test, and/or

(b) Reverse junction X-Y to X-Z. The aerial terminal is the screw carrying the crystal holder and the beginning of the outer coil. A further hexagon nut, or better, a small milled-edge nut, will permit connection to the aerial. The earth terminal is mounted to the tray, and formed by a piece of 6 B.A. screwed brass rod 1/4 in. long, screwed into the wooden block inside the tray, and made firm by shellac smeared on the threads before screwing in. If the outer end of the screw is held in a small flame for a few moments the shellac will set hard. Connect the outer or free end of the inner coil to this point by a nut,

(Continued bottom of next page.)

THE CONSTRUCTION OF A NOVEL FOLDING FRAME AERIAL

THE use of a frame aerial for receiving circuits has not progressed as rapidly as might have been expected, considering the many advantages this form of aerial has over the outdoor type. It is probably due to the fact that the energy received in the average frame aerial is so small that it requires a circuit employing a sensitive valve detector and various stages of amplification for satisfactory long-distance reception.

However, it is not generally appreciated that excellent results can be obtained with a frame aerial using a simple circuit such as the S.T.100 for the reception of

frame aerial which was designed with the object of obtaining a compact and portable frame which could be brought into use at a moment's notice, and when not required could be packed away in a very small space. The construction is simple and the cost negligible.

It is not important to follow the dimensions given, as no doubt the experimenter will have his own ideas as to the most suitable size for his particular requirements, but it is generally agreed that within certain limits a large frame with few turns is the best combination for short-wave reception, and more turns on a smaller frame for long-wave reception.

On reference to Figs. 1 and 2 it will be seen that the principle of the frame is based on a trellis formation, and indeed there is very little description necessary to explain the construction.

The wood used for a three-foot square frame is $1\frac{1}{4}$ in. wide by $\frac{3}{8}$ in. thick.

Four pieces are cut measuring 3 ft. $1\frac{1}{4}$ in. long, and four pieces 6 ft. $\frac{5}{8}$ in. long.

In the four shorter lengths $\frac{3}{16}$ in. clearance holes are drilled exactly $\frac{5}{8}$ in. from each end, that is to say 3 ft. apart.

In each of the longer lengths one $\frac{3}{16}$ in. clearance hole is drilled $\frac{5}{8}$ in. from the end and another $\frac{3}{16}$ in. clearance hole is drilled exactly 3 ft. from this.

The assembly is simple.

Two frames are actually formed, each having two of the 6 ft. $\frac{5}{8}$ in. lengths of wood and two of the 3 ft. $1\frac{1}{4}$ in. lengths. A glance at Fig. 1 will make it clear how these are connected together. Four 2 B.A. screwed brass rods are used on which are placed small porcelain or ebonite bobbin insulators. The length of these

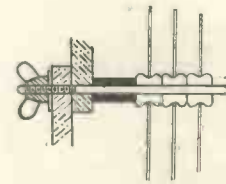

Fig. 3.—Details of spacing tube.

brass rods is governed by the number of turns used on the aerial.

For example, to receive the British Broadcasting with this 3 ft. frame, ten turns are necessary using a .0005 μ F max. condenser. Therefore, ten insulating bobbins will be required on each brass rod, if standard porcelain bobbin insulators as supplied by the General Electric Co. are used, the turns will be $\frac{1}{2}$ inch apart, and with two 2-inch end distance piece, which can be made up with eight extra porcelain bobbins or two 2-in. lengths of ebonite tube (Fig. 3) the length of each brass rod will then be 12 in., which allows for lock nuts to fasten the frame together. It is important to use a wing nut at one of the joints for locking the frame when in position.

It will also be seen from Fig. 1 that, for the sake of rigidity, two cross pieces of wood are fixed to the legs of the frame.

In conclusion, it should be borne in mind that when considering the design of a frame aerial the wire used should have a low resistance. A suitable gauge is 22 to 16 S.W.G., and the tuning condenser should have a maximum capacity of about .001 μ F at most. P. J. B.

(Continued from previous page.)

also a flexible connection long enough to allow full movement to the slide and joined at the other end to the left-hand 'phone terminal. If strips as in Fig. 7 are used, make one connection under this nut, the flex not being required.

The crystal used was hertzite, and is retained in the holder by springing the slot with a screwdriver whilst inserting the crystal, and upon release the crystal becomes firmly gripped in the holder.

Improvements will naturally suggest themselves to the reader and may be readily incorporated, the foregoing merely illustrating a rough-and-ready arrangement which, however, has proved exceedingly efficient. Used in conjunction with two valves and a loud speaker, full-toned reception was obtained.

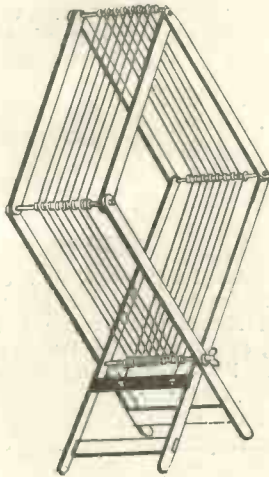

Fig. 1.—The frame open.

local broadcasting stations if the distance is not too great. From the experimenter's point of view there are many possibilities in the development of frame aerial reception, and it must be agreed that a great advancement will be made in the progress of wireless from a popular point of view when a substitute can be found for the unsightly outdoor aerial which will give results reasonably approaching those obtained with the standard Post Office aerial.

It is the writer's object to describe a novel form of folding



Fig. 2.—Closed for packing away.

A TRIPLE MOVEMENT COIL HOLDER.

AN excellent basket coil holder, having a triple adjusting movement for tuning in purposes, may be made as shown in Fig. 1. It is particularly easy to manipulate, is in no way a cumbersome article, and is a great improvement on the existing types which only have the one or two movements.

The base is made up of $\frac{3}{8}$ in. mahogany, 9 in. by 3 in., and is drilled in the manner shown in the details in Fig. 2. A rectangular portion is cut out each end of the base to make a rigid fit for the two supports. The six holes are drilled in the positions shown to receive six terminals. Two side supports are next required which are made

is drilled through the centre to make a tight fit on the $\frac{3}{16}$ in. rod. On the bottom edge a hole is drilled and tapped to receive a short length of 2 B.A., to which a bushed knob is fixed. A hole is then drilled on each side edge and tapped to receive two terminals which take the connections from the coil. A groove is made to receive the coil support which is made of $\frac{1}{8}$ in. ebonite $\frac{3}{8}$ in. by $2\frac{5}{8}$ in. The support is placed in the groove and fixed with one screw. The hole in the support is drilled to clear a 6 B.A. screw which holds the coils by means of a nut. The moving coil holders are made in a similar manner with a few exceptions. The ebonite square blocks, the

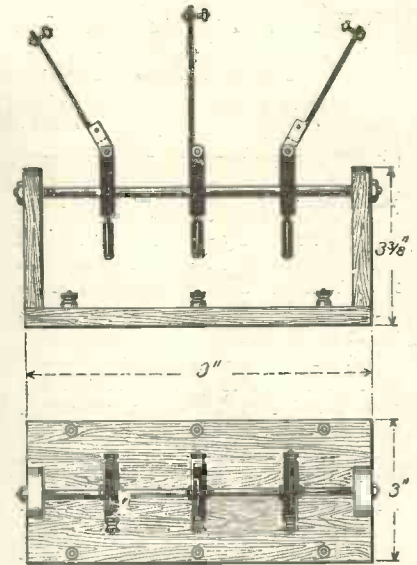

Fig. 1.—A new basket coil-holder.

to receive the coil support, which is the same as that used for the fixed coil with the exception of the length, which is $2\frac{3}{8}$ in. When a pair of these are assembled they are attached to the ebonite block by means of the two terminals, a spring washer being placed between the terminals and the side pieces. The three holders are then placed on the $\frac{3}{16}$ in. rod, which is fixed into base supports and tightened up each end by means of two nuts. It will be seen that the coil holders may be adjusted by means of a sliding movement along the rod, or by a radial movement to the left and right, or by a further radial movement backwards and forwards. Connections are made from the terminals on the coil-holders to the corresponding terminals on the base.

H. B.

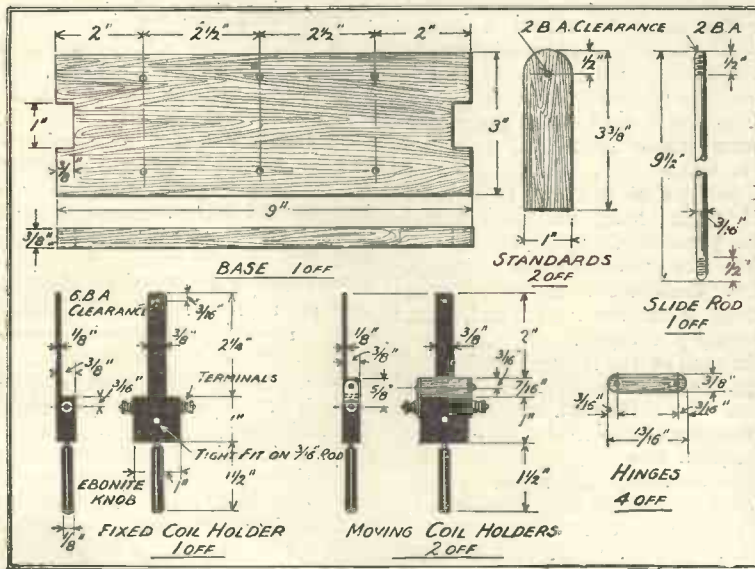

Fig. 2.—How to make the parts of the holder.

from $\frac{3}{8}$ in. wood 1 in. by $3\frac{3}{8}$ in. The hole is drilled to clear a 2 B.A. rod. These supports are forced into the slots in the base and fixed with one screw each. The slide rod is made from some $\frac{3}{16}$ in. round brass, $9\frac{1}{2}$ in. long, tapped for $\frac{1}{2}$ in. each end to a 2 B.A. thread. Next the coil-holders are made. To make the fixed one, a block of ebonite is cut 1 in. square. A hole

terminals, and the knobs are made as before, but the support is slightly different. Four side-pieces are made of ebonite $\frac{1}{8}$ in. by $\frac{3}{8}$ in. by $\frac{1}{4}$ in., and two holes are drilled in each. One hole is to receive a small fixing screw and the other is to clear the terminal screw. Between each pair of these side pieces is fixed a wooden block $\frac{3}{8}$ in. square by 1 in., which is grooved as before

Do not miss
Radio Press Stand
at the
All British Wireless
Exhibition.

REACTION: A Simple Explanation

By G. P. KENDALL, B.Sc., Staff Editor.

Misuse of reaction is the cause of the howls you sometimes hear when listening to broadcasting.

IN many ways the wireless valve (or "toob" as our American friends call it) is a good and faithful servant, but a shockingly bad master, and in no respect is it more so than in the matter of reaction. If we understand it and know how to use it properly, reaction is one of the most useful properties of the valve, and will enable us to do wonderful things with simple sets, but if we let it become uncontrollable, and if we do not understand its ways, it will not merely spoil our own reception, but it will convert our set into a miniature transmitter and radiate enough energy to interfere with everyone in the neighbourhood.

It is most important that every boy who means to play the wireless game decently and according to the rules should clearly understand about this part of the possibilities of reaction. Only by gaining a good knowledge of it will he be able to feel sure that he is not causing annoyance to his neighbours, and, moreover, such knowledge will remove all temptation to run the risk of causing annoyance, because it will show him how to use reaction in safe ways.

Before we try to see what reaction is and what it does we must first remind ourselves of the working principle of the valve, and here I am going to advise all new hands at wireless to get some simple book, such as "Wireless Valves Simply Explained," by the Editor of MODERN WIRELESS (which can be obtained from the Radio Press at Devereux Court, Strand, W.C. 2).

The reason for my recommending you to do so, of course, is simply that although I will give here just the elementary idea of how a valve works, so that you may understand reaction, everyone ought to know more about valves than that if they are to be used properly.

Inside a valve, as you may see for yourself, are three principal parts (hence the name "three-electrode valve"), these being the filament, which is usually a fine straight wire capable of being

heated by a current from an accumulator; the grid, consisting of a wire spiral or gauze surrounding the filament; and then outside this again is the plate (also called the anode), which is generally a metal tube or hood enclosing the other parts. When the filament is heated, a stream of electrons passes through the grid to the plate, and the action of the grid is to enable us to control the stream in such a way that we can amplify any given signals.

If small fluctuations of voltage, such as incoming signals produce, are applied to the grid, relatively large variations result in the volume of the stream of electrons passing through it, and, hence, the same signals are reproduced on a larger scale in the plate circuit. A fuller explanation of the action of the valve was given in the first issue of *Junior Wireless*.

The fundamental principle of reaction is really very simple, when once we have grasped the idea of there being more energy flowing in the plate circuit of the valve than in its grid circuit. This being so, we can see that, if we can feed a little of the energy in the plate circuit back again to the grid in such a way as to increase that which is already present, this increase will be amplified and will appear as a still greater increase in the currents flowing in the plate circuit.

The total result is greatly to augment the energy available in the plate circuit, as we shall see if we take a numerical example. Suppose that signals containing one unit of energy are flowing in the grid circuit, and assume that the valve magnifies them ten times; there will therefore be ten units of energy in the currents flowing in the plate circuit. Now suppose that one unit is fed back into the grid circuit and is added to the one unit already there, what will happen? Since the valve is supposed to magnify ten times whatever signal energy is present in the grid circuit, we shall now have twenty units of energy in the plate circuit, from which must be sub-

That New Set

Why waste panel space?

THE T. C. B. Resistances

(Regd. No. 199657.)

occupy less than one square in. of the panel. Silent, compact, with full on stop and off switch—the perfect resistance at last.

6 ohm Filament R'stance	Price	4/-
Dull Emitter Resistance	"	4/-
300 ohm Resistance	"	5/-

Of all Agents or from

T. C. BALL,

39, Windsor Road, Ealing, W.5.
See them at stand 23a at the White City.

MAKE YOUR OWN HIGH EFFICIENCY TUNING COILS.

See page 50 October "Modern Wireless."
DOUBLE SPIDER FORMER, STAGGERED
Makes self-supporting coils up to 3,000 metres.
Accurately spaced. Brass body. Toledo Steel, screwed, removable prongs.
Complete, Carriage Paid, 7s. 6d.
LIVINGSTON, 497, Hessele Rd., HULL.
Coil holders complete with strip, plugs, etc., 1s. 9d.

1/6 D-X-ITE 1/6

Finest Crystal Manufactured.
Speaks for itself.

Obtained only from

J. E. JONES & Co.,
33, Stormont Rd., Lavender Hill,
LONDON, S.W. 11.

"CATSEYE" CRYSTAL DETECTOR

Ever-set and ready. Smallest,
Loudest, Latest. Complete with
holder 1/6 post free.
A.P.A.I.L., 37, Red Lion Street,
LONDON, W.C. 2.



Agents Wanted

LOOK!

How attractive
these little
"ads." are on
the Pages of

JUNIOR WIRELESS

BOOK!

yours for the
December Number

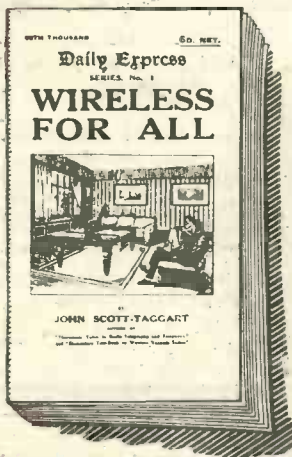

Every beginner needs this Book.

THIS is the most famous little book ever written on Wireless—thousands upon thousands have been sold since it was first published a little over twelve months ago.

It is safe to say that no other book has been the means of explaining the mysteries of Wireless to so many people. Old or young, all need this little book when taking up Wireless, because it treats the subject so fully. The author—John Scott-Taggart, F.Inst.P., is a recognised Wireless authority, and he has certainly succeeded in presenting a somewhat difficult technical subject in a most readable and bright manner.

Contents

How to Tell what Station is Working—How Wireless Signals are actually sent—Light and Wireless Waves Compared—Meaning of Wavelength—How Wireless Waves are Set up and Detected—How Wireless Stations work at the same time without interfering with each other—Does Weather affect Wireless?—Waves from a Wireless Telephone Station—General Notes on Different Kinds of Waves Received—How a Wireless Receiver Detects Waves—The Aerial—The Earth Connection—How a Wireless Set is Tuned to a Certain Wavelength—The Variable Condenser—The Crystal Detector—The Complete Wireless Receiving Circuit—Special Tuning Arrangements—How a Valve Works.

6^d

From all Booksellers, or 7d. post free direct:

RADIO PRESS, LTD.,
DEVEREUX COURT,
STRAND, W.C. 2

Radio Press Wireless Library No. 1.

tracted the one unit which is being continuously fed back to boost up the currents on the grid side. Thus, we now have nineteen units of energy in the plate circuit where previously we only had ten, showing that we have nearly doubled our signal strength.

These figures, of course, are quite imaginary, and must not be taken as representing exactly what happens, but they do illustrate the principle of reaction as being based upon the idea of feeding energy back into the grid circuit to be re-amplified.

Now let us try to get a somewhat clearer and more exact idea of the way reaction helps to boost up the signals in the grid circuit. It will be remembered that when we speak of signal currents in the grid circuit we mean oscillating currents of high frequency which are produced by the passing wireless waves. Now, ordinary circuits possess what is called "damping," which means that when the passing waves cease to energise them the oscillations gradually die down and cease, or are "damped out." This is because there are various causes of loss in every circuit, chiefly among which is the resistance of the tuning coil.

This damping out of the oscillations may be very well illustrated by the analogy of a pendulum set swinging and gradually coming to

rest; if there were no friction in its bearings and the air offered no resistance to its passage it would continue to swing indefinitely and would never come to rest. Similarly, in a wireless circuit if there were no energy losses there would be no damping, and oscillations once started would never die out. Now, if we kept giving the pendulum a gentle tap at the end of each swing we could make it keep on swinging for a much longer period before coming to rest, and if the taps were strong enough it would be possible to keep it swinging indefinitely. This, of course, would happen when the amount of energy supplied to the pendulum by the series of taps equalled the energy expended in overcoming the friction in its bearings and the air resistance.

We shall see that very similar things take place in a wireless circuit, since the damping of such a circuit is very much like the friction and air-resistance losses in the pendulum case, and acts similarly in causing the oscillations to die out gradually. Just as in the case of the swinging pendulum we can prolong the dying-down process by supplying energy to compensate for that which is lost, so in an oscillatory circuit we can feed in energy and wipe out the effects of damping.

If we use reaction to feed energy back into the grid circuit of a valve

UNCLES AND AUNTS.



Here are the Uncles and Aunts from the London station. Reading from the left:—Uncles Arthur, Rex, Jeff; Aunts Vivian, Sophie, Phyllis, and (standing behind) Uncle Caractacus.

we can so adjust matters that the oscillations produced by passing waves are prolonged and die away gradually, or we can feed back a larger amount, so that once oscillations are started they are maintained indefinitely. This latter condition is called "self-oscillation," and occurs when the energy fed back balances that lost in overcoming resistance, and so on.

To all intents and purposes this process is equivalent to reducing the damping of the circuit, and it is most beneficial in increasing the sharpness of the tuning of the circuit, since it is well known that the lower the damping the sharper the tuning, and this holds good up to the point at which self-oscillation commences, when the damping is said to be reduced to zero.

The actual method of producing reaction is quite simple; it is usually done by including in the plate circuit of the valve a coil which is arranged to act inductively upon the tuning coil in the grid circuit, either by placing the two coils in a two-coil holder or by arranging one to slide within the other. Coils so placed are said to be inductively coupled, since currents flowing in one coil cause similar currents to flow in the other by the familiar process of electro-magnetic induction. Hence, this arrangement is often called reaction coupling. A set using this kind of reaction is described elsewhere in *Junior Wireless*.

So far we have only considered the beneficial properties of reaction, which are undoubtedly great; many people regard it as being at least as good as an extra high-frequency valve. We must not forget, however, that reaction wrongly used may be a curse instead of a blessing, not only to the user but to all his neighbours as well. It is quite easy to see how this may be if we remember that reaction is capable of producing continuous oscillations in the grid-circuit of a valve. If that grid circuit is connected to an aerial, it is obvious that oscillations will flow in the aerial, and the whole becomes a miniature transmitter radiating rather weak continuous waves.

This radiation, of course, takes place upon whatever wave-length the user of the set is receiving, and, hence, if he is trying to receive broadcasting, the radiation will be right on top of the waves from the broadcasting station and will

produce howls and whistles in the receivers of everyone within many miles who may happen to be listening to the same station. Moreover, the speech heard in the oscillating receiver will be more or less distorted and spoiled, although a little louder than when the reaction is properly adjusted.

To make proper use of reaction when receiving telephony it should be adjusted so that the circuit is almost oscillating, but not quite. Bring the coils gradually together, noticing how the "signals" get louder as you do so, until the point is reached at which the set begins to oscillate, and then separate the coils a little so that it stops and the speech or music is heard loudly and clearly. To be able to do this accurately and easily you must know how to find out when the set is oscillating, which is a little difficult if you happen to be very close to a broadcasting station. The surest way to find out is to keep touching the aerial terminal with your finger, which will cause clicks in the phones when the set is oscillating; but usually it is quite obvious when the set begins to oscillate, because the speech becomes distorted and varying and the tuning makes loud whistling and howling noises. These latter disappear when the set is tuned exactly to the wave-length of the broadcasting station, and are not heard at all when the receiver is only a few miles from the transmitter, and, therefore, you must not conclude that your set is not oscillating if you do not hear any howls or whistles.

It is quite clear that when such a receiver is being adjusted there are bound to be moments when it oscillates and becomes a public nuisance. It is permitted, however, to use reaction upon any circuit which is not coupled in any way to the aerial, and consequently we can obtain all the benefits of reaction in a legal manner if we use a "tuned anode" circuit with reaction coupled to the anode coil. This arrangement is a fairly safe one to use, since if oscillations are generated they are more or less confined to the tuned anode circuit and do not get into the aerial circuit to be radiated. The reaction set illustrated elsewhere in *Junior Wireless* should be studied in this connection, since it employs the permitted form of reaction coupling.

Max-amp

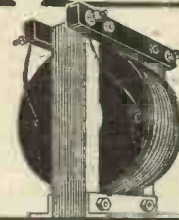

The highest grade Intervalve Transformer. Laminated core, well insulated windings, tested to 500 volts. Very silent in action and free from all distortion. Fully guaranteed. 1s/6
PETO-SCOTT CO., LTD.,
 Head Office:
 64, High Holborn, W.C.1.
 Branches:
 99, High Holborn, W.C.1.
 3, Wellington Street, W.C.2
 4, Manchester St. Liverpool

L.F. Transformer

No. 2A, 12B and 75 'Buses pass the Door.

YES WE HAVE NO HALF MILLION SATISFIED CUSTOMERS. BUT WE HAVE NO DISSATISFIED ONES.

WE STOCK EVERY CONCEIVABLE PART, NUT OR SCREW FOR WIRELESS.

ALL
LISSEN, WILTONIA, EDISON-BELL, and FORMO
 PRODUCTS, AND ALSO

Give You Extra Good Postal Service.

WRITE OR CALL FOR LIST.

4 DOZ. ASSORTED NUTS, SCREWS,

CLIPS, ETC.,

Given Free

WITH EVERY ORDER £1 OR OVER.

BELL WIRELESS CO.

BELL GREEN, LOWER SYDENHAM, S.E.

A Marvellous Wireless Patent WILLESFORD'S MULTI- POINTED CAT'S-WHISKER

Makes Crystal Set as loud and better toned than valve set. No trouble finding points. At all retailers 1/- or by post P.O. 12/-

Buying Agents asked
WILLESFORD'S, 20/1, Buckinham Street, Strand, London, W.C.2.

LONDON RADIO COLLEGE, LTD.

Stafford House,
 82/83, HIGH STREET, BRENTFORD.

Students trained for the
 Marine Wireless Service
 & Appointments obtained.

Apply for full particulars Dept. M.

2 in. x 2 in.

£3

per insertion.

What is Reaction?

THE whistling sound of an oscillating set is familiar to you—perhaps you have even suffered from your neighbour's set. But do you really understand what Reaction is? There has been plenty of articles about Reaction in all the Wireless Magazines, but practically none of them ever go so far as to explain its true meaning and how it is caused.

In "Wireless Valves Simply Explained," however, the author takes great pains to clear up this and all other technical difficulties which are so often glossed over. Buy a copy to-day—you'll enjoy reading it.

"Wireless Valves Simply Explained"

By JOHN SCOTT-TAGGART,
F.Inst.P.

(Editor of Modern Wireless and Wireless Weekly.)

Contents

- The Theory of the Thermionic Valve.
- The 3-Electrode Valve and its Applications.
- Cascade Valve Amplifiers.
- Principles of Reaction Amplification and Self-oscillation.
- Reaction Reception of Wireless Signals.
- Continuous Wave Receiving Circuits.
- Valve Transmitters.
- Wireless Telephone Transmitters Using Valves.
- Broadcast Receivers.

2/6

From all Booksellers, or 2/8 post free direct:
RADIO PRESS, LTD.,
DEVEREUX COURT, STRAND, W.C.2.
Radio Press Wireless Library, No. 10.

MAKING YOUR OWN WIRELESS CABINETS

By R. W. HALLOWS, M.A.

In this article instructions are given for building neat and efficient cabinets for any wireless set.

NEITHER great skill nor an extensive outfit of tools are necessary for carrying out the various woodworking jobs that crop up when wireless apparatus is under construction. The main thing, as we shall see, is to be accurate in the preliminary marking out; then

added pleasure of knowing that for its good appearance your set owes nothing to other people's efforts.

The first thing to decide is the wood that you are going to use. Bought cabinets and other wooden components are usually made of mahogany, an expensive wood very difficult to work in on account

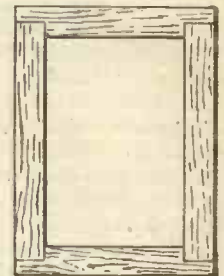
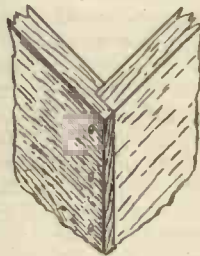
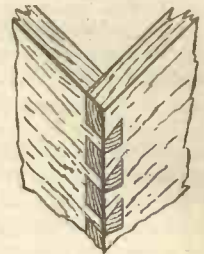
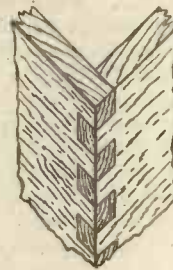

How to make joints in wireless cabinets. The bottom picture shows how to fit ebonite strips for terminals.

use the tools carefully and not in a hasty slapdash fashion. By making your own cabinets, baseboards, coil mountings and so on you can save a good deal of money, for all of these things are expensive to buy ready made. "Shop finish" is certainly very beautiful, but by making use of the simple methods to be described you can turn out really good-looking articles that do the set credit, and you have the

of its hardness. But mahogany is by no means the only wood suitable for the purpose. Walnut is cheaper, easier to work and capable of taking a beautiful finish. Even well-seasoned deal has much to recommend it, for it is very cheap and it looks quite well when its surface has been carefully smoothed and varnished.

The best wood of all for the amateur is probably oak, which

fulfils all requirements and looks quite as well as mahogany when it has been finished up. For cabinets the wood should be from $\frac{1}{4}$ to $\frac{3}{8}$ inch thick when planed down according to their size; for single layer inductance mountings $\frac{1}{2}$ inch thick, and for baseboards from $\frac{1}{2}$ inch to $\frac{3}{4}$ inch.

There is only one case where oak is not quite a suitable wood, and that is when you are making a crate to hold your accumulator. For this teak should be employed, well treated with the beeswax compound that is used for polishing floors. Dilute sulphuric acid has a very rapid and destructive action upon softer woods, but beeswaxed teak is practically immune from its attacks. Hence if any of the acid from the batteries should happen to splash on to the crate, you need have no fear of the consequences so long as this wood is used.

Here is an easy way of finishing up oak which gives it medium brown colour with a pleasant semi-polished surface:—Rub the wood down with fine glass paper until you have made it as smooth as you can, then apply linseed oil—a good deal of it—and allow it to soak in. A cabinet so treated has quite a good appearance and it can be used as soon as it is dry; but the process is not complete. After some days you will find that the grain of the wood has risen, making inequalities in the surface. Rub it down again and repeat the dressing of oil. A third smoothing off and oiling may be needed after two or three weeks. Once the wood has settled down and dried thoroughly it may be polished with a little beeswax and turpentine.

Now let us suppose we are going to tackle the making of an oak cabinet 6 inches by 10 and 4 inches deep for housing a crystal set or a valve panel. We must first of all settle what kind of joints we are going to make at the corners. The first four figures show some of the various joints that may be used. In the first illustration is seen the mitred joint, which is the same as that used at the corners of picture frames. In order to be able to make it you must have a mitre board, that is a saw guide to enable the ends to be cut at an angle of exactly 45 degrees, and a shooting board by means of which they are planed up true.

The mitred joint is excellent for very shallow cabinets such as those used for containing small fixed condensers, grid-leaks and so on, but it is not easy to make up a cabinet four inches deep in this way.

The plain dovetail (as shown in the second picture) is better. The dovetail proper is strong and looks well; it is first rate for boxes such as the accumulator crate that have to carry heavy weights. It is, however, not very easy to make neatly without some experience of wood working. The simplest of all joints is that made by "halving" which is shown in the fourth illustration. It is neat, easy to make and strong. We will therefore select it for the cabinet in hand.

We will use $\frac{3}{8}$ inch wood throughout. We shall, therefore, require two pieces 6 by 4 inches for the ends and two 9 $\frac{1}{2}$ by 4 for the sides. If we were dovetailing, the sides would be the full 10 inches in length, but halving in lops $\frac{3}{16}$ inch off either end. The fifth and sixth illustrations will make this plain. For the bottom we need a piece 6 $\frac{1}{2}$ by 10 $\frac{1}{2}$ in order to allow for a bevelled edge projecting $\frac{1}{4}$ inch all round.

The first step is to plane down the long edges of the plank from which ends and sides are cut until they are absolutely straight and parallel. We then mark it out with the help of the set square and cut it with a stiff-backed saw. Next we rule a line $\frac{3}{8}$ inch from each end of the short pieces and a second right across the end $\frac{3}{16}$ inch from what is going to be the inner surface. The piece of wood lying between these lines is removed with the saw, and any roughness is smoothed down with a small chisel.

We can now put the ends and sides of the box together roughly by means of one fine brass screw at each corner. When driving small brass screws into oak or other hard wood always make the holes big enough, otherwise the screws are liable to break as they are forced in. The heads of the screws should be countersunk either with a countersinker or by making a few careful turns with a $\frac{1}{4}$ inch twist drill at the top of each hole.

Now for the bottom. Bevel off the edges with a plane, then using the set square mark a pencil line $\frac{1}{4}$ inch inside each edge. Three-



Save Money this way—

It is not difficult to make the majority of the components for your Wireless Set if you can only get the right information.

The book "*The Construction of Wireless Receiving Apparatus*," should be particularly useful to any enthusiast who possesses a few simple tools and who can follow out elementary instructions. With a little care, your home-made apparatus should work almost as well as bought components, and will leave you money to spend in other directions.

You can make all these Components at home—

Anode and Grid Resistances.
Filament Rheostats.
Potentiometers.
Crystal Detectors.
L.F. Transformers.
H.F. Transformers.
Basket Coils.
Slab Coils.
Solenoid Coils.
Duolateral Coils.
H.T. Batteries.
Condensers.

1/6

From all Booksellers, or 1/8 post free direct

RADIO PRESS, LTD.,
DEVEREUX COURT, STRAND, W.C.2

Radio Press Wireless Library No. 8.



Splendid Broadcast Sets made without special skill.

IT is not often easy to condense into a single constructional Article all the details necessary for a complete beginner to build up a Broadcast Receiver.

Naturally the space in a Magazine like MODERN WIRELESS is rather limited. Therefore, if you are looking for a first-class book on how to build good Crystal Sets, you cannot do better than get this one. "How to make your own Broadcast Receiver" is written by John Scott-Taggart, F.Inst.P. (Editor of MODERN WIRELESS and *Wireless Weekly*). It deals with the whole subject from A to Z, and if you are at all handy with your fingers, you can easily build up an excellent Receiver at small cost.

Remember you do not need to know a single thing about Radio—it's all in the book, and you can learn it in a few hours.

1/6 Get a copy TO-DAY.

From all Booksellers, or 1/8 post free.
RADIO PRESS, LTD.,
DEVEREUX COURT, STRAND, W.C. 2.

Radio Press Wireless Library, No. 3.

sixteenths of an inch inside these lines drill four holes in each of the long sides and three in the short. These holes should allow the screws that you are using to pass through them easily, and they should be countersunk on the lower side.

Place the frame of the cabinet on the bottom so that its edges rest on the pencilled lines. Then pierce holes in one side by passing a bradawl through those already drilled in the bottom. Drive screws upwards from below. The other side and the two ends are fixed in the same way, the set square being used as well as the pencilled lines to see that the corners form exact right angles. The halved joints may be securely fixed by driving two additional screws into each.

The ebonite panel may be mounted directly on to the top of the cabinet, but a neater job is made if it is let in to lie flush. If this is done the cabinet's *inside* measurements must be the same as the dimensions of the panel. Thus

for a piece of ebonite measuring 10 by 6 inches a cabinet made of $\frac{3}{8}$ inch wood would have to be $10\frac{1}{2}$ by $6\frac{1}{2}$ outside. If the panel is to lie flush, cut out two battens measuring 10 inches in length by $\frac{1}{2}$ inch thick by $\frac{3}{8}$ inch wide and fix them by screws to the inside of each long side the thickness of the ebonite below the top. The panel can then be screwed down to them.

The panel, may however, be made of oak, which is a great saving in expense. If this is done, valve holders or detectors must be mounted on small blocks of ebonite and terminals on long strips of the same insulating material. A way of making an oak panel with ebonite insets is shown in the seventh picture. The position to be occupied by the ebonite having been carefully marked out with pencil and set square, the wood is removed with a fretsaw. Small battens are then screwed on to the underside at each end of the slot and the ebonite is secured to these.

CATALOGUES RECEIVED NEW SETS AND COMPONENTS

Messrs. Peto-Scott Co., Ltd., send us their new catalogue of wireless components—a well produced list containing prices and illustrations of all kinds of wireless apparatus from completely finished sets down to the smallest accessories in the way of screws. In this catalogue will be found many items which the experimenter needs and which he does not quite know where to buy. Cabinets for wireless sets and accumulator boxes are two examples of what we mean.

From the Bowyer-Lowe Co., of Letchworth, we have received several leaflets describing their crystal receiver, Mark 1, the Bowyer-Lowe "Ne Plus Ultra" (a two-valve and crystal receiver), and the Bowyer-Lowe wave trap, type C, the circuit which was described by Mr. Percy W. Harris in *Wireless Weekly* and MODERN WIRELESS. They also send an interesting little booklet entitled "The Charm of Wireless," containing popular descriptions of their various receivers and component parts.

From the Sterling Telephone and Electric Co., Ltd., we have received leaflets describing their crystal receiving set with low-frequency amplification, a simple crystal receiving set with a semi-automatic crystal detector, and their variable air condensers (square law) with and without vernier. These latter instruments are of particular interest to those who are making wave-meters, for the wave-length curve with these condensers is a straight line.

We have received from the Metropolitan Vickers Electrical Co., Ltd., a highly artistic showcard of their Cosmos radiophones. It contains a large picture in colours entitled "Ethereal Dance and Song," depicting nymphs dancing round a tree with Pan playing his pipes in the branches. Below, on a dark background, are shown two Cosmos radiophones, one an elaborate cabinet instrument and the other a small crystal set.

It's the valve that counts!



"R" Type Valve.

Length, including cap, 110 m/m.
A general purposes valve which will perform all the diverse functions of the Thermionic Valve.

PRICE 15/- EACH.

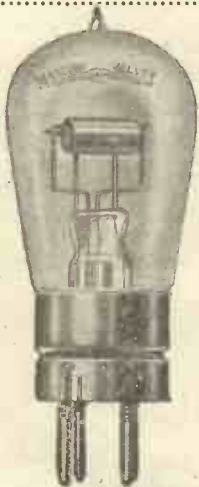

"D.E.R." Type Valve.

Length, including cap, 115 m/m.

The special feature of this valve is that the filament current and voltage, i.e., the working filament wattage, is very small, being in some cases less than ONE QUARTER of that required by ordinary valves having similar operating characteristics. The filament runs at a dull red temperature, thus ensuring a very long life, as well as freedom from crackling, etc.

PRICE 27/6 EACH.

If you use a Valve Receiving Set you will do well to realise that the efficiency of your outfit is largely dependent upon your choice of Valves. **It's the Valve that counts.**

You will positively ensure the best reception of vocal and musical items by using **MARCONI VALVES** which are made—and made to last—with the same scrupulous care that has always characterised the manufacturing operations of the famous OSRAM Factory.

You use OSRAM Lamps at home—use the Valves with the "OSRAM MADE" reputation!

BUY BRITISH GOODS ONLY.

We are exhibiting at the N.A.R.M. Exhibition, White City, November 8—21.

MARCONI VALVES

MADE AT THE OSRAM LAMP WORKS

(Wholesale only) Sold by leading Electrical Contractors, Wireless Dealers and Stores.
The General Electric Co., Ltd., Magnet House, Kingsway, London, W.C.2.

Published November 8th.

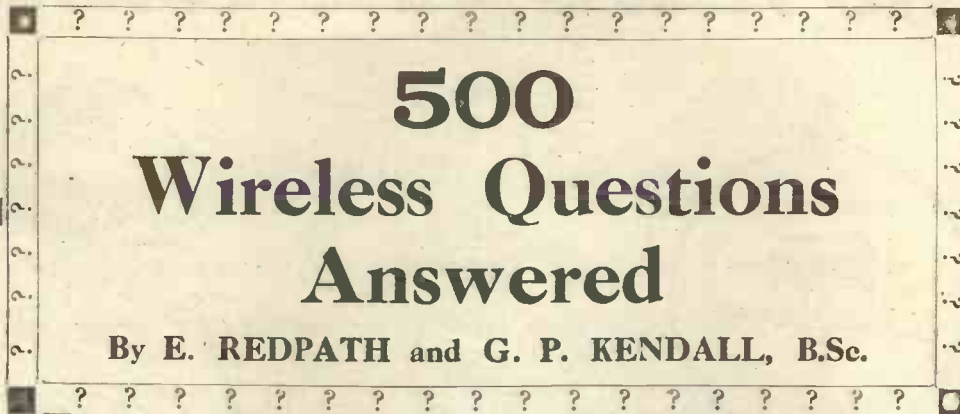

**Questions
about :**

- Aerials.
- Frame Aerials.
- Earths.
- Waves.
- Wave-Lengths.
- Tuning Coils.
- Tuning Condensers.
- Valves.
- Reaction.
- Primary Batteries.
- Secondary Batteries.
- Crystal Sets.
- Amplifiers.
- Grid Leaks and Condensers.
- Loud-speakers.
- Wire.
- Range (transmitting and receiving.)
- Interference.
- Morse Signals.
- Sounds and Signals heard
- Telephone Receivers.

An expert at your elbow !

THIS Book is going to be one of the most useful and popular Radio Books ever published. No matter how much or how little you know, there will often arise little difficulties and queries which need explanation.

Instead of having to wade through pages of text-book matter to obtain the information you need, all that you have to do is to refer to *500 Wireless Questions Answered* and in a moment you have the information accurately and concisely.

If you are in difficulties with the Set you are building—if the Set you are using is not working to your complete satisfaction, it is probably due to your lack of knowledge of some fundamental Wireless principle. Get the facts from this real "Wireless Encyclopædia"; it will save its cost to you time and again.

Published by

RADIO PRESS LTD.,
Devereux Court, STRAND,
W.C.2.

*From all Booksellers
and Newsagents or
2/8 post free.*

2/6

Radio Press Series No. 13.

The New Arrival

THE "MULLARD WECOVALVE."

Mr. "ORA" welcomes the baby "Mullard Wecovalve" to the family. Like most fathers he looks to his son to uphold the traditions of the house and, indeed, to go one better.

The baby "Mullard Wecovalve" shows every evidence of living up to these expectations. It consumes very little current, lasts twice as long as other valves, and needs no accumulators.

If you are buying or making a new set, Wecovalves will save you money as they cut out accumulators.

If you have a valve set, Wecovalves will pay for themselves in a few weeks.

In any case write to the manufacturers or ask your dealer for List M.W.I. It tells you all about this wonderful new valve.



MULLARD WECOVALVE	30/-
SOCKETS	1/6
4-PIN ADAPTORS	3/6
FILAMENT RESISTANCE FOR WECOVALVES	3/9

*We are exhibiting at the
N.A.R.M. Exhibition,
White City, Nov. 8-21.
Stand 90.*

Full Manufacturing Licence under British Patents, Nos. 17580, 123126, 180090.

Mullard

Advt. of The Mullard Radio Valve Co., Ltd., Balham, S.W.12.

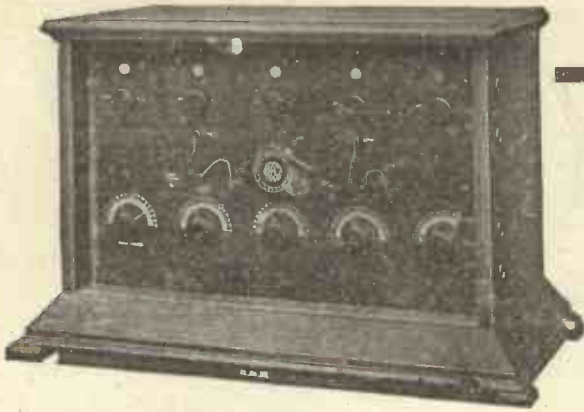

TINGEY SUPERFIVE CABINET RECEIVER

The last word in Perfect Reproduction, Selectivity, and Strength of Signals.

Enclosed in Lock-up Oak Cabinets, complete with High Tension Battery of 120 Volts.

Composed of Two High Frequency, one H.F. Rect., and two L.F. Power Valves. By means of two simple Wander plugs any combination or number of valves may be employed.

Each set is supplied with a set of Coils covering the wavelengths of British Broadcasting Stations. Other sets of Coils may be supplied at extra charge.

Price, as illustrated, including Special Valves and High Tension Battery **£56 . 5 . 0**

ASK FOR SUPERFIVE PAMPHLET.

We manufacture Valve Sets 1, 2, 3, 4 and 5 Valves, also an excellent Crystal Set.

Send for our new Components LIST—free on request.

Few Agencies still open.

Offices and Showrooms:—

Open 8 to 7, Saturdays 8 to 1.

92, Queen St., Hammersmith, London, W.6.

'Phone:

Hammersmith 1916.

'Grams:

"Tingoidar, London."

Chiswick Agents: The Askew Motor Works, Ltd., 72, High Road, W.4.



SAVE MONEY!

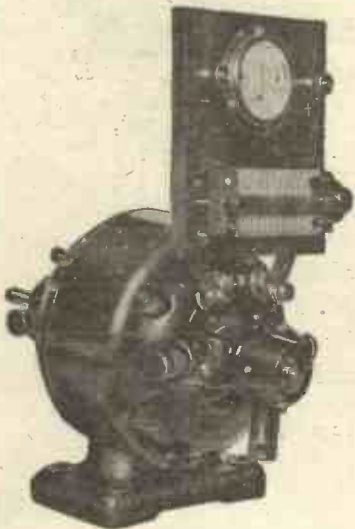

For D.C. Circuits ONLY.
Output 5 amps., 9 volts.

CHARGE

your
Filament Batteries
at HOME with
ELLA Converters.

These little machines are noiseless in running, require no attention, and SAVE their cost in a few months.

Price £5-12-6

If required can be fitted with regulating resistance and pole indicator-ammeter.

PRICE: As illustration, £6 15 0

Resistance and Ammeter mounted ready to fit L.T. terminals of existing Converters.

PRICE £1 2 6.
Send for "ELLA" Wireless Accessories List.

VALVES from stock. Marconi-Osram, Mullard, Ediswan, Cossor, etc. Also New PEANUT.

TRADE SUPPLIED.

LIONEL ROBINSON & CO.,
(Dept. M.W.), 3, Staple Inn, London, W.C.1.

See Adv. page xxix.



RADIO PRESS
Wireless Library
No. 3

A Crystal Set is
always useful

1/6

From all Booksellers,
or 1s. 7½d. post free.

Radio Press Ltd.,
Devereux Court,
Strand, W.C.2

When your accumulator runs down, your H.T. Battery develops noises right in the middle of a Concert, you would give anything for means of carrying on.

Why not prepare for such a contingency now by getting this book and building one of the three Crystal receivers described in it?

You will be surprised how efficient they are—yet how simply they can be constructed, without the necessity for special tools, and from the most elementary materials.

Written by John Scott-Taggart, F. Inst. P.
Editor of this Magazine.

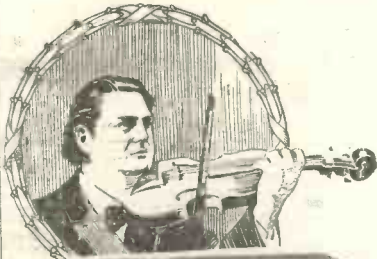

FELLOWS

Lovers of Music.

Wherever you live, stay at home in comfort and enjoy all the best concerts brought to your music room by the Fellows Super Two Set.

A 2-Valve Set of superior quality mounted in a highly finished case, that will receive any British or Continental telephony even though the nearest Broadcasting Station is working.

PRICE: COMPLETE WITH H.T. BATTERY ACCUMULATOR, 100 ft. 7/32 STRANDED COPPER WIRE, 2 INSULATORS, 1 pr. 4,000 ohms HEAD PHONES.

£9

plus B.B.C. Tax, 17/6, Marconi Tax, £1 5s., and 2 valves.

A new 2-valve amplifier mounted in cabinet uniform with super 2 set £5 10s., plus B.B.C. tax, 10/- and Marconi Tax £1 5s., plus 2 valves.

FELLOWS MAGNETO Co., Ltd., LONDON, N.W.10

Telephone: Willesden 1560-1. Telegrams: "Quixmag," Phone, London.

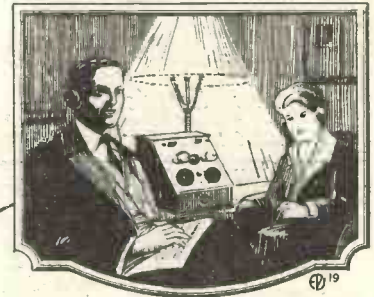

Where there's Electric Light there's Wireless

Use your electric light wires as an aerial in perfect safety.

Plug a "Ducon" into any lampholder or wall socket, connect it to your wireless receiver and you will receive the broadcasting perfectly. USE A "DUCON" and you don't need an aerial.

"Ducons" are perfectly safe—each one is tested to 2,500 volts; they consume no current and do not affect the electric light in any way. They constitute an ideal filament in cases where an outside aerial is not possible.

The **DUCON** 10/-

POSTAGE, 6d.

is obtainable from leading wireless dealers, electrical contractors and stores, or direct from the makers. Dealers not yet stocking are invited to write for Trade Terms.

OVER 50,000 IN USE.

The Dubilier Condenser Co. (1921) Ltd. (Dept. D)
 Ducon Works, Goldhawk Road, Shepherd's Bush, W.12

'Phone—Hammersmith 1084.

'Grams—Hivoltcon, Phone, London.



GREAT RADIO SENSATION

NO OUTSIDE AERIAL.
NO EARTH.
PORTABLE AS A
GRAMOPHONE.
COSTS LITTLE.
GETS ALL STATIONS
ON ITS
FOLDING FRAME AERIAL.

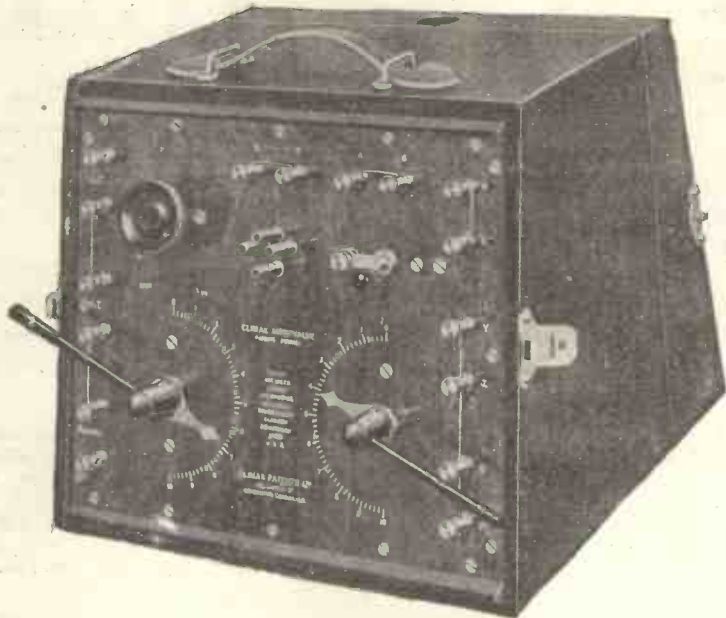

*The Set for the
Broadcaster,
Constructor
and
Experimenter.*

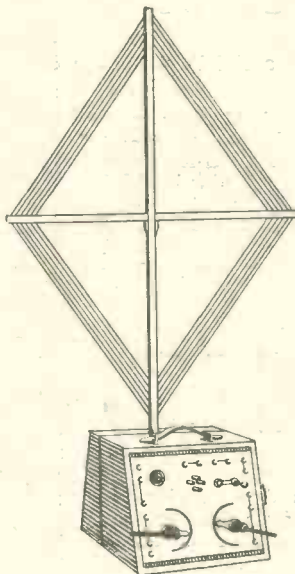
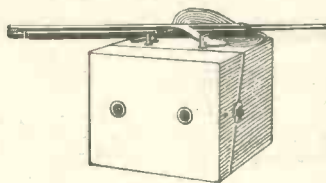

A WIRELESS SET that *doesn't* want a water-pipe and doesn't want you to go on to the roof to put up an aerial in the garden you may not have.

A wireless set that is self-contained and as portable as a small gramophone. A wireless set that cuts all the nuisance out of wireless and gives you all the pleasures.

Its efficiency gives you all the broadcasting stations.

Its selectivity cuts out those you don't want.

Its simplicity gives you ease of operation.

Its one valve gives you economy.

Its design enables you to construct and experiment.

It's British made of British materials by skilled British workmen.

Its workmanship makes it a pleasure to have in the home.

It is called the

CLIMAX MONOVALVE

And now look at the Price!

THE CLIMAX MONOVALVE, WITH CLIMAX
COLLAPSIBLE FRAME AERIAL,
If used with BBC licence, BBC Tax 11/- extra.

£10

Accessories required:—Head Telephones, Valve and Batteries. Approx. cost, £4, according to choice.

This advertisement will be seen by thousands.

If you want early delivery, place your order now, either direct or with your usual dealer.

CLIMAX PATENTS Ltd., 182, CHURCH ST., KENSINGTON, LONDON, W.8.

Telephone: Park 2023.

Wireless Exhibition, White City, Stand 25, November 8—21.

(E.P.S.1.)

" IGRANIC " RADIO DEVICES GIVE ENTIRE SATISFACTION

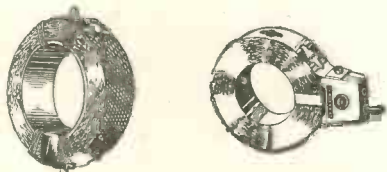

IGRANIC HONEYCOMB COILS

(De Forest Patent 141344.)

These world famous coils are renowned for their high efficiency, low self-capacity, small absorption factor and minimum high-frequency resistance. No dead-end losses. Each turn surrounded by air pocket. Made in two types, plug and gimbal mounted. Wavelengths approximately 100 to 25,000 metres. The only coils that uphold their claims for negligible losses. Prices vary with sizes.

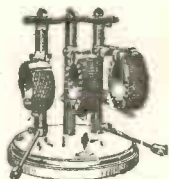

GIMBOLDER TUNING STAND

(Patent applied for.)

This coil holder has been designed and produced for accommodating gimbal mounted honeycomb coils, which enable extremely fine settings to be obtained. In addition to the angular relation of the coils being varied, they can also be rotated about their own axis, thus giving extremely fine and critical adjustment when used on selective and regenerative circuits.



FILAMENT RHEOSTAT

(Patent No. 195903.)

A splendid instrument for filament control under all conditions. Novel method of construction ensures smooth and silent operation. Designed for individual valve control. Adjustable contact fingers. Permits of resistance values from zero to four ohms by fine variation. Supplied in two types, plain and vernier.

Prices : Plain, 4/6 Vernier, 7/-.

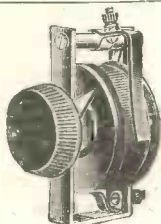

BATTERY POTENTIOMETERS

(Patent applied for.)

An Igranic Potentiometer is a necessity where one or more stages of high frequency amplification is used. Stabilises grid and eliminates noises and self oscillation. Resistance 300 ohms. Current consumption negligible. Nickelled finish, complete with fixing screws, knob and pointer. Price 7/-.

Inspect Our Devices at our
STAND No. 43
All British Wireless
Exhibition
White City, November 8 to 21



INTERVALVE TRANSFORMERS

(Patent No. 235013.)

Designed for the distortionless reproduction of speech and music. The steel shroud effectively shields from external interference. Recent improvements in design render it the finest amplifying transformer obtainable.

Prices : Shrouded, 21/- Open, 20/-.



TYPE S R VARIOMETER

Designed for secondary and tuned anode circuits. Wavelengths 150 to 600 metres approximately. Similar to Type "H", but with larger winding. Moulded insulation and windings impregnated solid. Price 18/-.

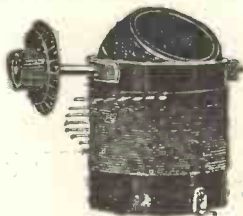

TYPE H R VARIOCOUPLER

Stator and rotor of hard moulded insulation, and windings impregnated solid. Tappings on primary enable fine tuning to be obtained, thus eliminating condenser. Coupling continuously variable over wide range. Price, with knob, dial and fixing brackets, 19/-.



TYPE H VARIOMETER

Recommended for use in the aerial circuit of crystal and valve sets. Wavelength range approximately 150-600 metres, with P.M.G. standard aerial. Stator and rotor best quality mouldings, windings self-supporting and impregnated solid. Price, with knob, dial and fixing bracket, 15/-.

ALL HIGH-CLASS DEALERS STOCK THEM

WRITE FOR LISTS Z109.

Manchester—30, Cross Street
Birmingham—73/4, Exchange Buildings
Glasgow—50, Wellington Street

149, Queen Victoria Street,
LONDON.



Cardiff—Western Mail Chambers
Bradford—18, Woodview Terrace, Manningham
Newcastle—90, Pilgrim Street

Works :
Elstow Road, BEDFORD.

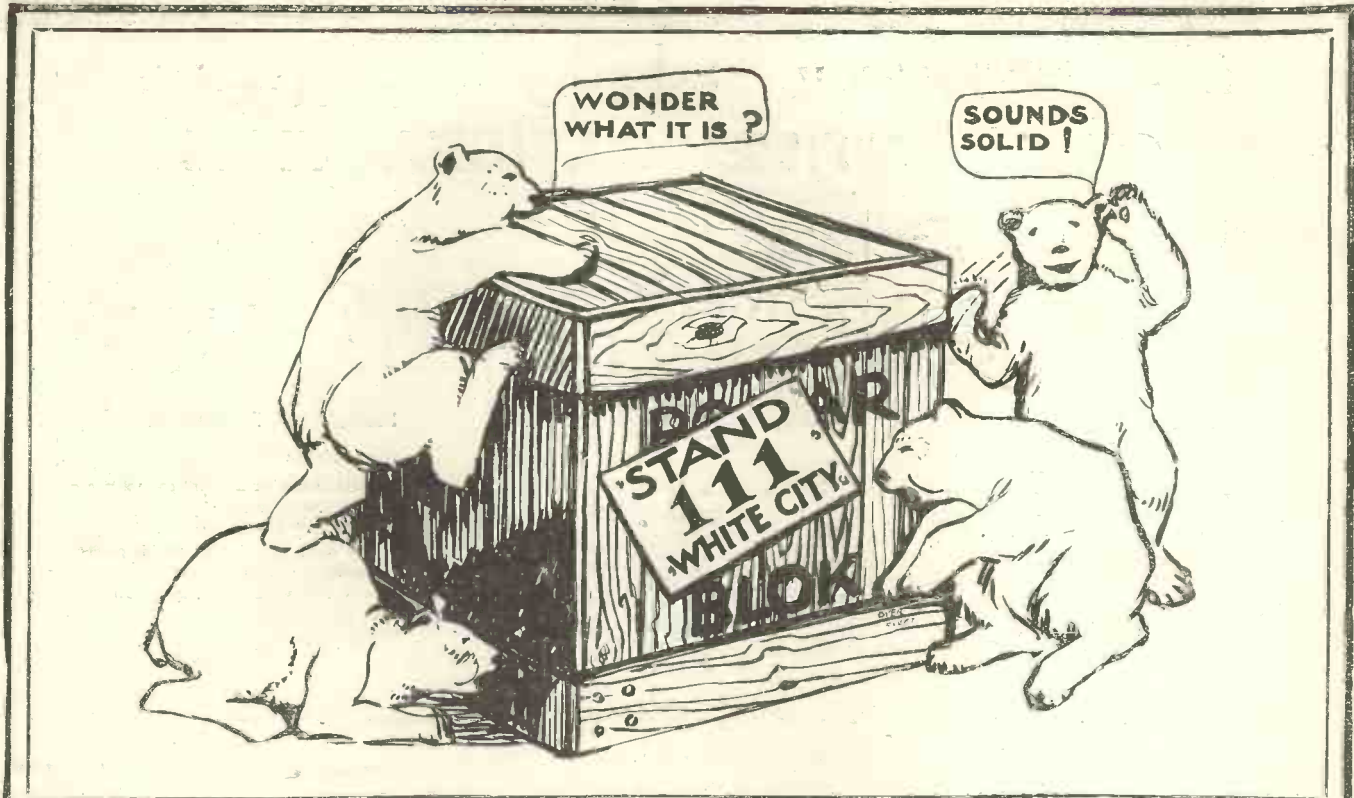

At present a Mystery —will later be History!

☞ Something more permanent than a LUXOR interest here: No mouldering in musty museums for the contents of this box—to be shown to the Wireless world on November 8, at the N.A.R.M. Exhibition, White City.

☞ “Polar Blok” is going to place perfect wireless sets within the hands of everybody who can hold a screwdriver, and is going to give those amateurs with an experimental turn of mind their ideal conception of elastic set-building.

☞ Don't forget the Stand Number, 111, and don't miss seeing the most practical, simple, neat and economical scheme ever presented to the Wireless Public.

‘POLAR BLOK’

STAND No. 111 N.A.R.M. EXHIBITION,
WHITE CITY, NOV. 8 to 21.

RADIO COMMUNICATION Co., Ltd.,

Telephone:
CENTRAL 8480
(3 lines).

34/35, NORFOLK STREET,
LONDON, W.C.2.

Telegrams:
RADIOCOMCO-ESTRAND,
LONDON.

Fleet Ad. Co.

EQUIPMENT FOR EXPERIMENTERS

PRELIMINARY SAFETY

NO matter what type of circuit you intend using in your receiving set, your results are wholly dependent upon the quality of your preliminary component purchases. Modern Radio experience and research is embodied in all WEBBER PRODUCTIONS. They ensure preliminary safety in outlay, and are supremely neat, compact and economical.



W53

The WEBBER COMPLETE SAFETY VALVE PANEL W53 is illustrated. This panel is fitted with a POLAR FUSE to protect the valve and an Igranite Rheostat to give smooth control. The Rheostat terminal is clearly marked to enable positive and negative lead changes during experiment.

Size complete 4 in. by 4 in.

With ordinary rheostat Price 16/6
 With vernier " " 19/6

Approved by the Radio Communication Co., Ltd., and on view at 35, Norfolk Street, W.C. 2.

Write for descriptive list, post free.

N. V. WEBBER & Co., Radio Engineers,
 Walton House, Walton-on-Thames, Surrey.

ARKS2

WELCOME NEWS

—For the Experimenter

TOTALLY NEW EQUIPMENT FOR SET-BUILDERS.

FOR some time past much of our time has been concentrated on the production of a complete series of component parts with the help of which the assembly of the latest receivers, embodying the ideas set forth in "Wireless Weekly" and "Modern Wireless," can be made with the minimum of time, and with the certainty of first-class results.

The designs of these components are entirely new, and constitute further examples of the efficiency and robustness of Bowyer-Lowe productions.

Equipped with a selection of these components, the experimenter will be able to assemble a receiver of pleasing appearance in an extremely short time, while the expense incurred in changing from one circuit to another is trifling.

An illustrated descriptive pamphlet is now ready and a copy will be sent on application. Send a postcard now.

Supplies of the components can be obtained from any wireless dealer, or, in case of difficulty, we shall be pleased to supply direct.

Visit
 Stand
 6
 Wireless
 Exhibition
 White City,
 Nov. 8-21



The BOWYER-LOWE Co., Ltd.,
 Manufacturers of Wireless Instruments,
 Radio Wks., Commerce Avenue, Letchworth, Herts.

Wholesale Distributors:
 MILLIGANS WIRELESS, Ltd., 23-25, Renfrew St. GLASGOW
 H. WADSWORTH SELLERS & Co., Standard Buildings, Leeds

WINTER NIGHTS AND FIRESIDE COMFORT reach perfection if you possess the "DESKOPHONE"

Its purity of tone is a constant delight. **INSTAL ONE NOW**

"THE DESKOPHONE"

TWO-VALVE SET
 (P.O. No. 2020)

Tuner, High Frequency Amplifier and Detector, complete, with Headphones. H.T. Battery, Aerial, Lead-in Wire, and Insulators.

LOW FREQUENCY AMPLIFIER, built to the same design, can be added to greatly increase the volume of sound.
 PRICE, £4 : 12 : 6. Royalty Paid. Valve only extra.

Send for particulars of our new 4 Valve Model

PRICE £28 COMPLETE

Royalties and all accessories included.



PRICE £12 : 17 : 6 COMPLETE

PRICE WITHOUT ACCESSORIES, £9 : 17 : 6.

Royalties £2 : 2 : 6 Extra. Valves Extra.



'Phone: HOLBORN 2368

The HOLBORN RADIO Co., Ltd., 267, HIGH HOLBORN, LONDON, W.C.1.

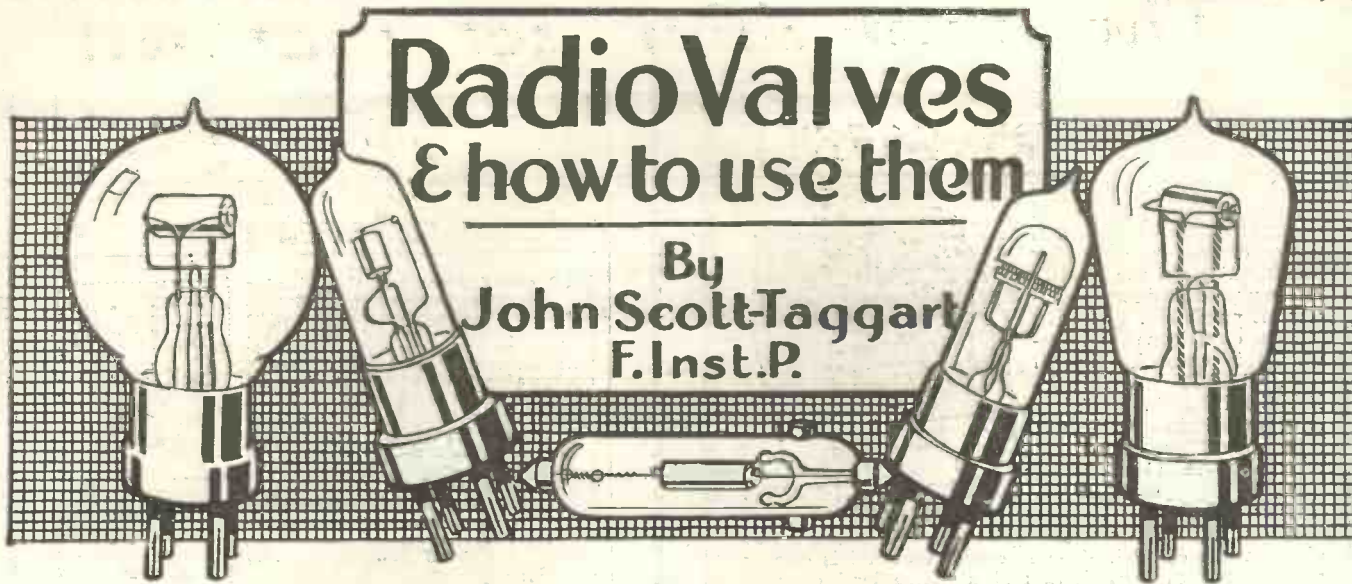

JUST
PUBLISHED!

— a complete course of
instruction on the Valve

Can you answer
these questions fully ?

What is meant by Reactance-capacity coupling ?

Which is more selective—"Tuned Anode" or "Reactance capacity" for H.F. use ?

What is Reaction ?

What is meant by "Dual Amplification" ?

How is self-oscillation caused ?

What is an aperiodic transformer and its advantages ?

2/6

from all Booksellers, or
2/8 post free direct from
publishers.

RADIO PRESS, LTD.,
Devereux Court, Strand, ...
W.C. 2.

TO make real progress in Wireless you must be able to understand the principles of the Radio Valve. The importance of this cannot be emphasised too strongly.

While there are several Books on the Valve by the same author, none of them covers quite the same field as "*Radio Valves and how to use them.*"

This Book is rather more elementary in its appeal and should be extremely useful to those who are beginning to take a more serious interest in Wireless.

Its explanations are most lucid and graphically illustrated by a very large number of diagrams. It is a Book which, although dealing with a difficult subject, is most fascinating and intriguing in its appeal. A Book which ought, in fact, to be on every wireless enthusiast's book-shelf.

It is written from the point of view of the man who is going to use valves.

Radio Press Series No. 12.

The Two-valve set that will give YOU satisfaction—



The Aeolian Co., Ltd.,
Aeolian Hall, 131-137, New Bond Street.
LONDON, W. 1.
3/10/23.

Gentlemen,

We really must express our appreciation of the remarkable 2-valve wireless set you are supplying to us, and which we understand is your standard model, approved by the Postmaster-General.

Exhaustive tests have been made, and in whatever part of the country they have been carried out, every station, including Paris (450 metres), has come in with equal volume.

Thus, Glasgow at 400 miles comes in with the same volume as London (26 miles). The set is sufficiently critical to make tuning-in a pleasure, and the only difficult piece of tuning we found was when our chief engineer, Mr. M. R. Howard, tuned in the Buffalo (N.Y., U.S.A.) transmission on Sunday morning last on the same 2-valve instrument. This transmission was received clearly at Chesham, Bucks, and almost every item was heard, not imaginatively, but as a concrete fact, and no higher tribute could be paid to your remarkable circuits.

Yours faithfully,
THE AEOLIAN CO., LTD.
(Signed) MAURICE R. HOWARD.

THE Mark



of Efficiency.

THE NEW V.S.1 TWO - VALVE COSMOS RADIOPHONES

are giving highly satisfactory Broadcast and Telegraphy reception in all parts of the British Isles, as is shown by the few extracts given from the numerous testimonials we are receiving.

These sets are now fitted with :—

- (1) A dual amplification circuit whereby results are obtained with two valves fully equal to those hitherto obtained with three.
- (2) A highly efficient non-radiating reaction circuit.

The results are :—

UNEQUALLED RANGE,
ENORMOUS AMPLIFICATION,
PERFECT REPRODUCTION,

and the sets are designed for simple operation, so that these results can be obtained by the beginner who has no wireless knowledge or skill.

"Cosmos" Radiophones are sold through the trade, but we extend a hearty invitation to all who contemplate the purchase of a set to pay a visit of inspection to our Showroom in your district. You will not be pressed to buy, but you will have the opportunity of hearing "Cosmos" reception and of seeing the whole range of "Cosmos" components and the very latest development, "RADIOBRIX."



LONDON :
232-233, High Holborn, W.C. 1.

BIRMINGHAM :
Daimler House, 33-34, Paradise St.

BRISTOL :
43, Park Street.

CARDIFF :
Metrovick House, Custom House St.

METROPOLITAN Vickers

ELECTRICAL

CO. LTD

Head Office & Works: TRAFFORD PARK, MANCHESTER ^R/_{Z35}

EDINBURGH :
127, George Street.

MANCHESTER :
14, Long Millgate.

NEWCASTLE-ON-TYNE
Cosmos House, 7, Saville Row.

SHEFFIELD :
Howard Gallery, Chapel Walk,
Fargate.

T. O. BUSS, Scientific Instrument Maker,

77, CLERKENWELL ROAD, LONDON, E.C.1.

Established 1850.

Exhibition Awards—London 1862. Sydney 1879. Melbourne 1880.

HEADPHONES 14/11

Genuine French Telephones, most sensitive obtainable, 4,000 ohms with cords (Double Receivers) ... post free

French "Brunet" Headphones 4,000 ohms 17/6 POSTAGE 9d.

VALVES.

Dull, Emitter	27/6
Cossor, Pink Top	15/-
Marconi "R" a.v., 45/60	15/-
Ediswan	15/-
Cossor, P.2	15/-
Mullard Ora	15/-
French "R," best type	10/6

CONDENSERS. Complete Sets of Parts.			Assembled Complete for Cabinet Mounting.		
Approx. Capacity Microf'ds.	No. of Plates.	Price.	Approx. Capacity Microf'ds.	Price.	
.001	57	7/6	.001	8/-	
.00075	43	6/9	.0005	5/11	
.0005	29	5/6	.0003	5/2	
.0003	19	4/6	.0002	4/6	
.0002	13	3/6	.0001	4/-	
.0001	7	3/-			

FIXED CONDENSERS, .0003, .0005, .002, .003, 10d. and 1/- each. .004, 1/6 each. Post, 3d.
VARIABLE GRID LEAK, 6/- each.
GRID LEAK AND CONDENSER, .0003, 2/6 each. 100,000 ohms Resistance, 2/3 each. Postage on above, 3d. each.

WIRELESS PARTS AND ACCESSORIES.

Aerial Wire, 7/22 bare copper, stranded. Price per 100 ft., 2/6 and 2/4. By Post, 3/6.
Aluminium Vanes, 1 doz., 5d. By Post, 8d.
Basket Coils, 7 in. set, 3/- set. By Post, 3/4.
Brass Washers, 2, 3, 4 or 5 B.A. ... dozen 2d.
Nuts, 2 B.A. ... dozen 2½d.
Nuts, 3, 4 or 5 B.A. ... dozen 2d.
Rod (screwed)—
 2 B.A., in 12-in. lengths .. each 3d.
 3 B.A., in 12-in. lengths .. each 3d.
 4 B.A., in 12-in. lengths .. each 2½d.
Contact Studs, ½ in. by ¼ in., complete with nut and washer, 5d. doz.
Copper Foil Sheets, uniform thickness, 12 in. by 3 in. 3d. each.
Crystal Detectors on Ebonite, 1/6 each.
Crystal Detector, cup enclosed with glass cover, dust proof, 3/6. By Post, 4/-.
Ebonite Dials, with engraved scale 0-180, 1/- each. By post, 1/6.
Engraved Ivorine Scales, 0-180 round ends, 4d. ea.
Filament Resistance, 1/6, 2/6 each. By Post, 1/10 and 2/10.
Inductance Coils Wound Enamel Wire, 12 by 4, 3/- By post, 5/-.
½ Insulating Sleeve, 4d. yd. By post 4/- doz. yds.
Insulators, Egg, 4 for 11d., 2/6 per doz. By post, 3/6 doz.
Insulators, Reel, 1½d. each. By post, 6d. doz. extra.
Intervalve Transformers (low frequency), tested and guaranteed 5-x, 14/- each. By post, 15/-.
Knobs, with brass nut (2 B.A.), 3d. each. By post, 3½d.
Large Spacer Washers, 3 doz., 9d. By post, 1/-.
Lead-in Tubes, ebonite with brass terminals, 9 in., 1/- By post, 1/4. 12 in., 1/4. By post, 1/8.
Slider and Plunger, 4d. By post, 6d.
Slider Knob, Plunger and 13 in. rod, 8d. the set. Cannot be sent by post.
Small Spacer Washers 6 doz. 1/- By post, 1/4.
Switch Arms, with polished knob, bushed 2 B.A. nut, laminated blade, spring coil washer, nuts and bush, 1/- and 1/6 each. By post, 1/3 and 1/9.
Tin Foil, free from lead. Sheets, 17 in. by 11 in., 4d. each.
Valve Legs, with nuts and washers, 1d. each, 9d. doz.
Valve Holders ebonite, complete with nuts, 1/-.
Valve Pins, split, 7d. doz.

Terminals.

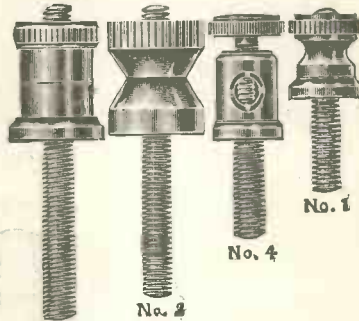

No. 3 Terminals, 2 B.A., with nut and washer, 2/- doz. By post, 2/6.
No. 2 Terminals, War Office Pattern, with nut and washer, 1/3 doz. Post, 1/9.
No. 4 Terminals, Telephone, with nut and washer, 1/3 doz. By post, 1/9.
No. 1 Terminals, with nut and washer, 1/- doz. By post, 1/6.
Terminals (large), aerial and earth, complete with 2 nuts and 2 washers (2 B.A.), 2 for 8d. By post, 1/-.

"EBONITE"

Postage free. Any size cut.

	s.	d.		£	s.	d.
8x1x½	..	7	12x10x½	..	7	6
4x4x½	..	1	17x8x½	..	8	9
7x6x½	..	2	18x18x½	..	15	9
10x6x½	..	3	36x18x½	..	1	7
17x5x½	..	5				

Post free.

Instrument Wires

British Made Copper Wires. Prices per lb.

Other sizes in stock. A charge of 3d. extra is made for reeling off in small quantities. Postage extra.

S.W.G.	per lb.	ohms. per 1,000 yds.	S.C.C.	D.C.C.	S.S.C.	D.S.C.	Examld.
22	140	39	2/9	3/-	4/-	5/-	2/8
24	230	63	3/-	3/6	4/6	6/-	2/8
26	340	95	3/7	4/1	5/-	8/-	3/2
28	530	140	4/4	4/8	6/-	9/-	3/3
30	716	200	6/-	5/6	7/-	10/-	3/10
32	950	262	6/-	7/3	8/-	12/6	4/2
34	1,300	362	7/-	8/3	9/-	13/6	4/4
36	2,000	530	8/8	10/-	12/-	15/6	4/8

Wireless Crystals

"Hertzite"	1/-	Carborundum	6d.
Zincite	9d.	Molybdenite	6d.
Silicon	6d.	Iron Pyrites	6d.
Bornite	6d.	Galena	6d.
Copper Pyrites	6d.	Graphite	6d.
Wood's Metal	6d.	Tellurium	1/-

Post free.

Intervalve Transformers

Size 3x3x1½. Ebonite Top and Bottom. Ratio 5 to 1. Post free. **15/-**
H.F. Variable Transformer, 5 Tappings, 14/6. Post 6d. extra.
H.F. Transformers, Plug-in Type, from 4/6. Post 4d. extra.

Celluloid Accumulators

BEST BRITISH MAKE.

	Amp. hrs.	Amp. hrs.	Price.	Post.
Oldham	6	20	40	28/- 2/-
"	6	30	80	35/- 3/-
"	6	40	60	45/- 3/-
Rotax	4	20	40	17/- 1/-
M.A.L.	4	20	40	18/- 1/-
"	2	20	40	10/- 1/-
H.T. Batteries,	30 volt,	5/6	(by post,	1/3 extra).
H.T. Batteries,	60 volt,	9/6	(by post,	1/3 extra).

Inductance Tubes

Cardboard.
 12x2½, 4d. Post 2½d. 12x3½, 6d. Post 4d.
 12x3, 5d. Post 3½d. 12x4, 8d. Post, 5½d.

Mahogany Boxes

	Polished.	Post.
4½x4½x3½ in.	...	2/9 3d.
4½x4½x5 in.	...	3/3 6d.
6½x6½x4 in.	...	4/6 1/-
13x6½x4 in.	...	7/- 1/-

Any size to order.

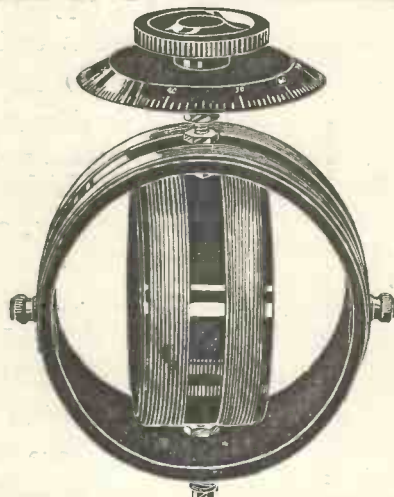

VARIOMETERS.

Bushed Bearings, Ebonite Dial 0-100, and Knobs. Metal Parts Plated. Wave-length 340 to 560 metres.
 Possessing high insulating properties, and the finish of the instrument throughout is excellent.
 Adequate provision is made for mounting on a panel, and the dial is neatly and clearly engraved.
 A variable condenser of .0005 microfarad capacity in series of parallel for the short and longer wavelengths respectively.

Marvellous Price **4s. 6d.**

Post 6d. extra.

TRADE SUPPLIED. Terms on Application.

Burndept

*Instruments bearing the above name
are Renowned the whole world over*



The New Ultra IV.
Mark II. All
Purpose Receiver.

THE Burndept Ultra IV. Mark II. is the last word in Wireless Receivers. It is a 4-valve set with one valve amplifying at Radio Frequency, and a detector, followed by two stages of note magnification. No Radio Frequency transformers are used, but the design allows for steady and regular High Frequency amplification on all wave-lengths from 150 to 25,000 metres.

A new feature of importance has been incorporated with the original design, the last stage of Audio Frequency is now a power stage, using a power valve, and gives a much greater volume of sound, morse or speech, music and song, without in any way impairing the hitherto unequalled quality of reproduction so closely associated with the earlier models. On the other hand, there is a decided improvement, and critics will be surprised at the full faithful mellow reproduction, and the complete absence of the feeling that the strength was being forced.

Each valve is separately switched and is controlled by a separate Rheostat, two important points in experimental receiver design.

The price remains the same.

No. 104 S in sloping cabinet, £35, to which must be added Broadcast Tariff, £1 5s. 0d.

The best all-round tuner for use with the Ultra IV. Mark II. is the Burndept Mark III. designed for selective double-circuit tuning, and provided with a Tune-standby switch and a long handle Vernier Condenser for fine adjustment.

No. 123 S.—Price £9 10s. (In sloping cabinet).

Performance.

With the Ultra IV. Mark II. a reasonably good aerial, usual locality and intelligent handling, all British Broadcast Programmes and the French and other continental concerts should be heard—most of them on a Loud Speaker. Reports of American Broadcast reception on loud speakers are not uncommon, but this we cannot guarantee. London Broadcasting is heard with this instrument in places as far apart as Christiania, Rome and Madrid. It is well worth your consideration.

All-British Wireless Exhibition. To be held at the White City from November 8th-21st, under the auspices of the National Association of Radio Manufacturers. Our Stands No. are 75 and 112.

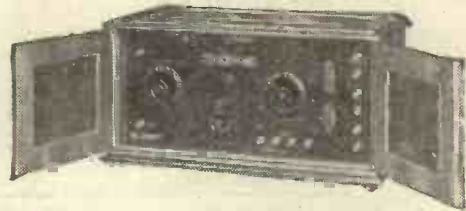

The New Ethophone V. Broadcast Receiver.

ALL Ethophones are primarily designed for Broadcast reception, and the design calls for the highest efficiency combined with simplicity of control, and can be used successfully by any member of the family. The tuner and receiver is incorporated, the valves and high-voltage batteries are enclosed out of harm's way, but are instantly accessible, the whole thing forming a complete unit.

The new Ethophone V. Mark II. is a tuner, receiver and power amplifier combined, while the price is only that of a receiver of premier quality. The last valve is a power stage, which allows an enormous volume absolutely undistorted, whether it be speech, music or song, the tone produced is sweet and mellow over the whole range of the musical scale.

There are many people who are dubious about the purity of tone obtainable from a Loud Speaker. We would like them to call at any of our showrooms, and to demonstrate to them, when we feel confident that what they hear would be in the nature of a revelation to them. The most conservative musical critic could find no cause for complaint. To obtain these results, we would use the Ethovox Loud Speaker.

The Ethophone V. Mark II., when used on a moderately good aerial, and with a little practice in handling will bring the programme of all the British broadcast stations to your home, most of them on a Loud Speaker. Further, there are very few places where French and other continental concerts cannot also be heard on a Loud Speaker.

Regularly we hear from customers that they have received American broadcast on this instrument, but this we cannot guarantee.

The Ethophone V. was taken into the Arctic by the Merton College Arctic Expedition and the members were able at times to listen to British broadcast concerts.

No. 508.—Ethophone V. Mark II. complete with valves and High Voltage Battery
Price £37 10 0
To which must be added Broadcast
Tariff 1 5 0

Our new catalogue, consisting of 88 fully illustrated pages, will be received from the printers on November 1st. We are confident that this will be the finest descriptive wireless catalogue yet produced in this country. Everybody interested in wireless should have it on his bookshelf for reference. Write to us for a copy.

A Written Guarantee is sent out with all Burndept Apparatus.

BURNDEPT LTD., Head Office : Aldine House, Bedford Street, Strand, W.C.2.

Branches : LEEDS, NEWCASTLE, CARDIFF, NORTHAMPTON.

'Phone: Gerrard 7794

'Grams : " Burndept, Westrand, London."

BURNDEPT

WIRELESS APPARATUS

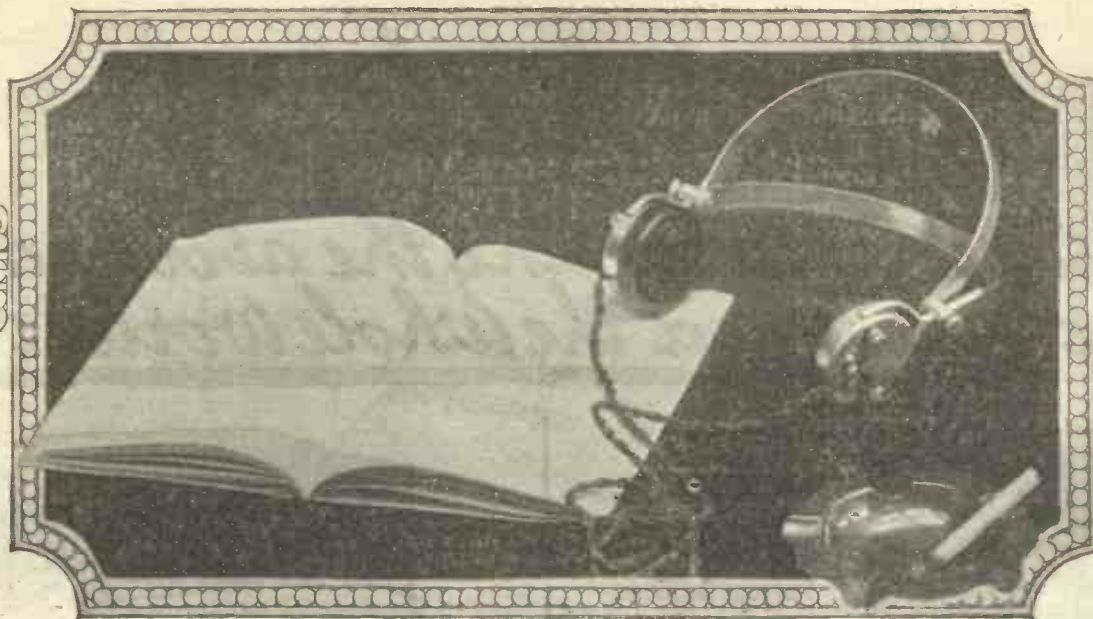

Dependable Books —your greatest aid

Choose your Books
from this List:

	Price.
1. Wireless for All By JOHN SCOTT-TAGGART, F.Inst.P.	6d.
2. Simplified Wireless By JOHN SCOTT-TAGGART, F.Inst.P.	1/-
3. How to Make Your Broadcast Receiver By JOHN SCOTT-TAGGART, F.Inst.P.	1/6
4. How to Erect Your Wireless Aerial By MITTELL, A.M.I.E.E.	1/-
5. The Construction of Wireless Receiving Apparatus By P. D. TYERS.	1/6
6. The Construction of Crystal Receivers By ALAN L. M. DOUGLAS.	1/6
7. How to Make a "Unit" Wireless Receiver By E. REDPATH.	2/6
8. Pictorial Wireless Circuits By OSWALD J. RANKIN.	1/6
9. Wireless Valves Simply Explained By JOHN SCOTT-TAGGART, F.Inst.P.	2/6
10. Practical Wireless Valve Circuits By JOHN SCOTT-TAGGART, F.Inst.P.	2/6
11. Wireless Licences and How to Obtain Them By E. REDPATH.	1/-
12. Radio Valves and How to Use them By JOHN SCOTT-TAGGART, F.Inst.P.	2/6
13. 500 Wireless Questions Answered By G. P. KENDALL and E. REDPATH.	2/6
14. 12 Tested Wireless Sets By P. W. HARRIS.	2/6
15. More Practical Wireless Circuits By JOHN SCOTT-TAGGART, F.Inst.P.	3/6
16. Home Built Wireless Components By E. REDPATH.	2/6
17. Wireless Sets for Home Construction By E. REDPATH.	2/6
Elementary Text-book on Wireless Vacuum Tubes By JOHN SCOTT-TAGGART, F.Inst.P.	10/-
	(post free)

TO attempt to understand Wireless without the aid of good books, is both foolish and shortsighted. True, you can make a certain amount of progress by your own endeavours—just as you can learn to swim without the assistance of an instructor—but in each case progress is much more rapid and pleasant if you have a helping hand to guide you.

The list of books given here comprises a complete library, dealing with every phase of Wireless. Each book is written in a masterly fashion by an authority. The fact that Radio Press, Ltd., are publishers exclusively of Wireless Books is a guarantee of their accuracy and dependability.

These books can be obtained from all booksellers or direct from publishers (postage 2d. per volume extra).

RADIO PRESS, LTD.
Devereux Court, Strand, W.C.2.

Radio Press Series.

Silvertown

WIRELESS ACCESSORIES.

FOR more than 50 years we have been manufacturing Electric Apparatus, a period of experience that guarantees consistently high quality in our Wireless Accessories. There can be no better assurance of reliability than the name "Silvertown."

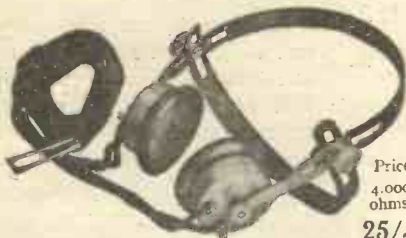

Price
4,000
ohms
25/-

SILVERTOWN TELEPHONE HEADPIECES.
The "Stalloy" diaphragms are matched so as to secure a balance of tone and quality. Light and comfortable, highly sensitive, easily adjusted, first class workmanship and finish. Resistance 120, 2,000, 4,000, 8,000 and 12,000 ohms.



CRYSTAL HOLDERS.

Mounted on ebonite base 3 in. by 2 in. with glass to protect crystals from dust. A feature of this crystal holder is that it can be easily taken to pieces and set up again.
Price 4/6 each.

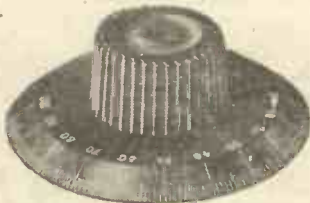

EBONITE CONDENSER DIALS AND KNOBS.
In one piece, graduated in white 0-100 or 0-180, highly finished. Complete with fixing screw. Dial approximately 3 in. diameter.
Price complete, 1/3 each. Dials only 10d. each.

**SILVERTOWN
"FEATHERWEIGHT"
INSULATOR.**

Weight 3/4 oz.
Length 5 in.
Price 2/- each.

Small in diameter, small area for service leakage.
Cup in centre keeps a portion of the insulator dry in wet weather.
Ends are made of Duralumin, to reduce weight. Electrical efficiency is superior to that of a number of porcelain insulators in series. The "capacity" effect of Silvertown Insulators is very small.
These are the best and most effective insulators ever devised.

**SILVERTOWN "EVER-
DRY" INSULATOR.**

Weight 2 1/2 oz.
Length 7 in.
Price 3/- each.



SILVERTOWN INTERVAL TRANSFORMERS.

Tested 1,000 volts between winding; and 2,000 volts between winding and frame. 2 1/2 in. high by 3 1/2 in. wide by 2 1/2 in. deep overall. Weighs 1 lb. 3 1/2 oz. Price 21/- each.

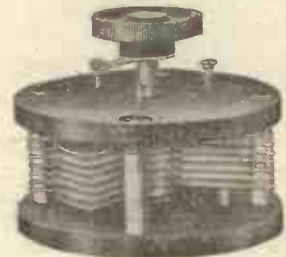

SILVERTOWN VARIABLE CONDENSERS
(for panel mounting).

Capacities 0.0001, 0.0002, 0.0005, and 0.001 mfd. Moving vanes are shaped to give low minimum capacity. These condensers are fitted with a stop to allow of a movement of 180 degrees only. Prices 7/6, 8/-, 11/6 & 15/- each.



SILVERTOWN POTENTIOMETERS
(for panel mounting).

On rectangular ebonite former, complete with knob and pointer. Former mounted on cast brass frame. Resistance approximately 400 ohms. Price 7/6 each.

Silvertown Accessories are obtainable of all dealers. When buying Wireless Accessories specify Silvertown and be sure of having the best.

MAKERS—The Silvertown Company, 106, Cannon Street, London, E.C.4.

TRADE **Grelco** MARK



REMEMBER TO REMEMBER
to send for
OUR 100-PAGE CATALOGUE

IT IS STILL THE LARGEST YET PUBLISHED AND CONTAINS THOUSANDS OF USEFUL ACCESSORIES REQUIRED BY THE AMATEUR. PRICES ARE REDUCED TO THE VERY LOWEST, CONSISTENT WITH BEST WORKMANSHIP. SPECIAL DEPARTMENT TO DEAL WITH MAIL ORDERS.

Post 3d. Free.

Telephone: MUSGRAVE 202 Works: ELUGH

ELECTRIC (GRAFTON) COMPANY

64, GRAFTON STREET, TOTTENHAM COURT ROAD,
W.C.

On Sale Shortly.

A message to
the man who
has never built
a Receiving Set.

FOR the man who has read Books and Articles on how to build Receiving Sets and who still feels that he does not possess the requisite amount of skill to build a really good one, we have a new idea.

We are shortly publishing a series of Portfolios, each one dealing with one Receiving Set in a very comprehensive manner. The Portfolio will contain a Booklet describing the Set, how it is made and operated and illustrated with actual photographs to show every stage of construction together with full size working drawings.

No effort has been spared to make these instructions clear and lucid and any man can commence building his Set with every confidence that he will achieve complete success.

Envelope No. 1.

Ready Nov. 7th.

Containing instruction Booklet, full-size working drawings, complete list of all components, etc., for building up a 2-Valve Reflex Receiver employing the well-known S.T. 100 Circuit. Designed by John Scott-Taggart, F.Inst.P.

2/6

Envelope No. 2.

Ready Nov. 21st.

Containing instruction Booklet full size working drawings, complete list of all components, for building up a 4-Valve Receiver embodying a large number of entirely new features. Designed by Percy W. Harris (assistant editor Modern Wireless).

2/6

RADIO PRESS LTD.

Devereux Court - STRAND, W.C.2.

Phones: REGENT 609. EAST HAM 172. WIMBLEDON 2398.

THE I.R.M. 3 VALVE SET.



A highly efficient receiver with one stage of H.F. (tuned anode) amplification, and one stage note magnification. This set will receive all British and Continental broadcasting. Loud-speaker results have actually been obtained at over 350 miles range.

Panel 10 inches square only. **PRICE**, completely assembled, with B.B.C. and Marconi Licences paid, £9 9s.

Best quality components for this set or any circuit supplied to constructors and experimenters at lowest possible prices. Technical advice free.

THE I.R.M. WAVE TRAP. With this trap attached to any set, a station half a mile away can be completely cut out. Price 15s. 6d.

SEND FOR ILLUSTRATED PAMPHLETS.

The Wonderful "N.S." Accumulator may be charged in one hour. Will not sulphate under any circumstances. Can be charged and discharged at any rate without damage. May be left idle and uncharged for an indefinite period without deteriorating. Better and cheaper than any other accumulator on the market.

PRICES:—

4 volt, 30 A.H. actual, £1 2s. Carriage, 2s. 3d.
6 volt, 30 A.H. actual, £1 10s. Carriage, 2s. 9d.

WE SUPPLY EVERYTHING WIRELESS. SEND US YOUR INQUIRIES.



INTERNATIONAL RADIO MANUFACTURERS, Ltd.,
16, Palace House,
128, Shaftesbury Avenue, W.1
and at 39, Station Rd., Manor Park, E. 12.

AMATEUR CONSTRUCTORS!

We Supply Everything. ALL BRITISH.

Tapped inductances are far in advance of any other tuning, providing the tappings are correctly arranged. Our tuning inductances are wound on specially impregnated 3/16 in. tubes with 26 s.w.g. double cotton-covered 2 Dyer wire in the following ratio: 10 sections of 10 turns each, and 10 sections of 1 turn each. This winding will tune from 200 to 1,000 metres. Price 3/-.

Ebonite panels for the tapped inductances, 7 in. by 5 in. by 3/16 in., drilled for 2 sets of 11 each contact studs and terminals, complete with 22 studs, 2 switch arms, 2 ph. me. earth and aerial terminals, assembled as shown, and blue print of connections. Price 7/-.

Polished Mahogany sloping front Cabinet for above panel, Price 6/-.

The C-11 and Panel make a most efficient tuner for Crystal or Valve.

Cut out your Local Station with our new REJECTOR. The REJECTOR is fitted into a polished mahogany cabinet. We guarantee you can cut out your local station and receive others, providing your set has the necessary range. Price 19/6.

P. H. BOYS & CO., Electrical and Wireless Engineers,
187, GOSWELL RD., LONDON, E.C. 1

Phone: Clerkenwell 4454.



Exide

THE LONG LIFE BATTERY.

*Huge
price
reductions*

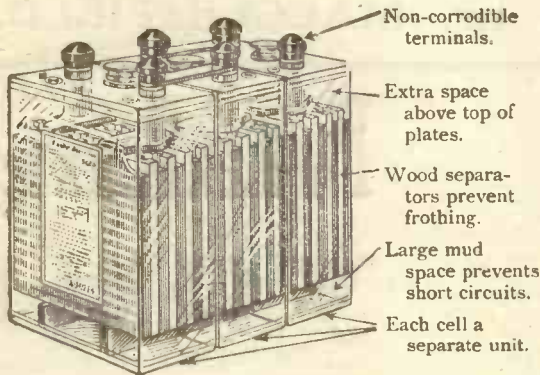

	4 Volt		6 Volt	
	old price	new price	old price	new price
C23	34/-	27/-	51/-	40/6
C24	40/-	32/-	60/-	48/-
C25	46/-	37/-	69/-	55/6
C26	52/-	42/-	78/-	63/-

Exide Batteries Do Not Froth on Charge.

Ask for New Price List giving Reductions In All Types.

Stand No. 7.
WIRELESS
EXHIBITION
WHITE CITY.

Obtainable from all
Dealers and Garages,
and
350 Service Agents

THE Chloride ELECTRICAL STORAGE
COMPANY LIMITED.



HEAD OFFICE & WORKS: CLIFTON JUNCTION, NR. MANCHESTER.

LONDON: 219-229, Shaftesbury Avenue, W.C. 2.

BIRMINGHAM: 57-58, Dale End.

MANCHESTER: 1, Bridge Street.



Use Chloride
Batteries for
House Lighting.

RADIONS Ltd.,

Beg to announce that in consequence of their ever-increasing business in

Repairing Wireless Valves

they have now taken extensive works, and equipped them with the most modern plant. This plant is operated by a highly-skilled staff, and they are now in a position to give the utmost satisfaction, combined with **PROMPT DELIVERY.** Write for Prices and Particulars.

RADIONS Ltd.,

LORD STREET,

Telegrams :
"Radions, Bollington."

BOLLINGTON, nr. MACCLESFIELD.



Efficiency Inductances
Double Plug or Plug
and Socket.

Making your own set?

If so you should use only components of proved efficiency and reliability.

Our components are not built to a price, but to a definite quality standard. The coils illustrated here are an example of the scientific design of our apparatus. All the turns in the coil are spaced and all the coils for any wavelength are the same size. Those with the fewest turns for the lowest wavelengths consequently have the greatest spacing—an important feature.

A list of coils, coil-holders, condensers, transformers, rheostats, etc., will be sent on request, and all our apparatus may be inspected at our London Office.

Gambrell Bros., Ltd.

76, Victoria Street, S.W.1. Phone : Victoria 9938.

Works : Merton Road, Southfields, S.W.18.

Phone : Putney 2100.

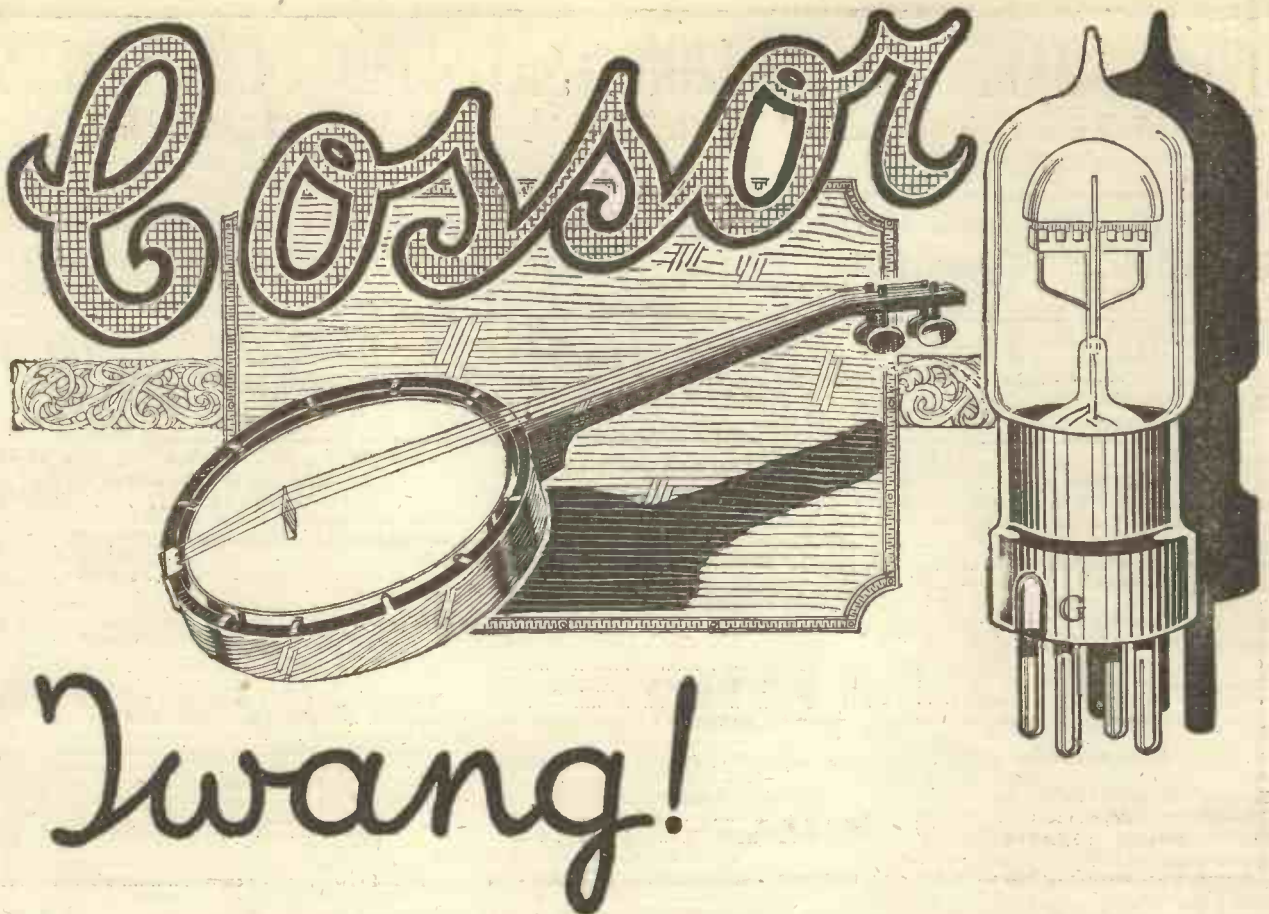

—use Cossor Valves and cut out the Banjo accompaniment!

YOU may have heard noises like the twanging of banjo strings when you have been using a Loud Speaker. Perhaps you have been unable to account for these sounds, and have imagined them to be faults in transmission. It is probably nothing of the kind! These noises are termed microphonic noises and may be actually produced by the valves in your set.

Now, owing to its unique construction, the Cossor Valve is singularly free from microphonic noises. Let us explain why.

The Grid of the Cossor is hood-shaped and wound on a stout Grid Band. The wiring is securely laced and anchored in no less than three distinct positions to every turn. The result is a grid which is particularly robust and rigid.

TYPES :
 P1. For Detector and Low Frequency use 15/-
 P2 (with red top). For High Frequency use each
 From all Dealers.

The most exacting tests have failed to show any signs of movement of the Cossor Grid, no matter what the working conditions are. That is the secret of its remarkable freedom from microphonic noises.

A spiral Grid, on the other hand, is much more delicate and prone to transmit the slightest vibration of the set. Such movements are so imperceptible as to be almost unnoticeable in the ordinary way, but Radio picks them up and, magnifying them, spoils the purity of your reception.

When next you buy valves, make up your mind to cut out the banjo accompaniment and choose Cossor Valves—their greater amplification factor, freedom from distortion, and higher efficiency for long-distance work will make you regret that you had not bought them sooner.

COSSOR VALVE Co., Ltd.—HIGHBURY GROVE, LONDON, N 5.

OVER HALF A MILLION SATISFIED CUSTOMERS

WIRELESS! WIRELESS! WIRELESS! and EVERYTHING for it.
DON'T PAY MORE! PIONEERS OF CHEAP PRICES. Great Britain's Largest exclusive Wireless Stores

NOTE.—We are exclusively WIRELESS — NOT DABLERS!
Quality, Quantity and Consistency our Motto.
 See our six-window display of popular bargains.

We offer for the first time the new "FELLOWS"
 Lightweight Headphones, 4,000 ohms. A masterpiece of workmanship. A guarantee with every pair. Honestly worth 30/- Per pair **18/6**
 Special Offer—STERLING New
 Lightweight Headphones, Stamped B.B.C., 4,000 ohms. ... Our Price **19/3**

ELKAY LIGHTWEIGHT Headphones. 4,000 ohms **12/9** **BRUNET 'Phones.** The genuine article ... **13/11** **N. & K. 'Phones.** The genuine article. Our Price **12/9**

EDISWAN Valves .. **12/3**
COSSOR Valves .. **12/3**
MARCONI "R" Valves **12/3** } **Bankrupt Stock and of Limited Quantity. Guaranteed all New.** { **MULLARD "ORA" Valves 12/3**
EDISWAN DULL EMITTER.
 Our Price **25/9**

DUTCH VALVES	6/11	BELL WIRE , tinned copper, 12 yards	6d.	VARIABLE CONDENSERS of high quality. With Aluminium Top and Bottom plates. Complete with knob and dial, guaranteed accurate:—	
PHILLIPS DUTCH VALVES	7/11	VALVE LEGS , nut and washer each 1d., per doz. 10d.		Vernier	3/-
L.F. TRANSFORMERS , Ratio 5 to 1. All guaranteed (postage, 1/-)	11/3	VALVE PINS , nut and washer each 1d., per doz. 9d.		.0002	4/6
CRYSTAL DETECTORS	1/9, 1/3 and 10jd.	PLUNGER SPRINGS , complete	1d.	.0003	5/6
CRYSTAL DETECTORS , enclosed in glass case	2/6, 2/3, 1/6	SLIDER ROD , brass, 13 in. long, 1/2 in. square, drilled	3jd.	.0005	6/-
AERIAL WIRE , 7/22, guaranteed hard-drawn copper, 100 ft. (postage, 1/-)	1/10jd.	SLIDER KNOB	2d.	.00075	7/-
CONDENSER VANES , fixed or moving, per doz.	3jd.	SWITCHES ON EBONITE , S.P.S.T. (quality the best)	1/6	.001	8/-
REAL GOLD CAT'S WHISKERS , each 2d., per doz.	1/5	SWITCHES ON EBONITE , S.P.D.T. (quality the best)	1/11	SUPER QUALITY 2-WAY COIL HOLDER ...	5/3
SILVER CAT'S WHISKERS , each 1d., per doz.	7d.	SWITCHES ON EBONITE , D.P.D.T. (quality the best)	2/9	REAL EBONITE 3-WAY COIL HOLDER	7/9
CONDENSER SCALES , 0 to 180	3jd.	CONDENSER SPINDLES , all sizes in stock, from	1jd.	O.B.A. NUTS	per doz. 4d.
IVORINE LABEL SET , 12 different titles, the set	6jd.	SCREWED ROD , 2 B.A., 12 in. long	3d.	DETECTOR ARMS , Ball Joints, Ebonite Handle and Whisker Holder	3jd.
BASKET COILS , set of 6, up to 3,000 metres ...	2/4	" " 4 B.A., 12 in. long	2jd.	WOOD SCREW TERMINALS	each 1jd.
SLEEVING , 3 yds. assorted colours, for	11jd.	RUBBER - INSULATED LEADING - IN WIRE	per yd. 1jd.	SHELLAC	per bot. 10jd. and 6d.
NUTS , 2 B.A.	per doz. 2jd.	INSULATORS , white reel, 2-in., each 1d., per doz. 11d.		AERIAL PULLEYS	each 10jd., 8jd., 6d. and 4jd.
NUTS , 4, 5, 6 and 8 B.A.	per doz. 2d.	INSULATORS , white egg	each 2d., per doz. 1/8	TINFOIL	large sheet 4d.
WASHERS , 4 B.A.	per doz. 1d.	WOUND INDUCTION COILS (postage, 9d.):—		COPPER FOIL , 6 in. wide	per ft. 5d.
CONTACT STUDS , with nuts and washers, per doz.	4d.	12 x 4 9 x 4 8 x 2 1/2 6 x 3 6 x 2 2/5 2/3 1/11 1/8 1/5		GRID LEAKS , 2 1/2 and 2 meg.	each 10jd.
TERMINALS , with nut and washers, each 1d., and 2d.	1jd. and 2d.	TAPPED INDUCTANCE COILS , 20 tappings, wound to 1,500 metres	each 2/6	FLEX (Twin) , various colours,	per yard 2d.
EBONITE KNOBS , 2 B.A.	each 2d. and 3d.	VARIOMETERS (Tube type), complete with knob	3/11 and 2/11	CONNECTING WIRE , tinned copper, 20 gauge 3 yards	2d.
SPACING WASHERS , large	per doz. 2jd.	DOUBLE 'PHONE CORDS , full length	11jd.	ENAMEL WIRE , in 1/2, 3/4 and 1 lb. reels:—	
CRYSTAL CUPS , 2 screw, each 1d. 4 screw, each 2d.	per doz. 1jd.	HERTZITE , Genuine Large Piece	9jd.	22 24 26 28	
FIXED CONDENSERS , all capacities	each 10jd.	TALITE , Genuine Large Piece	9jd.	per lb. 2/4 2/8 3/2 3/6	
EBONITE , cut to any size by machinery while you wait	per lb. 3/6	PERMANITE , Genuine Large Piece	9jd.	Note.—Bobbins, 2d. each extra.	
TELEPHONE TERMINALS , nuts and washer, each 1jd., per doz. 1/3		ZINCITE , Genuine Large Piece	9d.	POTENTIOMETERS , guaranteed up to 500 ohms, superior make, compact size	7/3
W.O. TERMINALS , nuts and washers, each 2d., per doz. 1/7		BORNITE , Genuine Large Piece	6d.	CRYSTAL DETECTOR , glass enclosed, fitted on 4 x 2 ebonite panel with terminals for aerial, earth and 'phones, already wired and beautifully finished	4/9
PANEL BUSHES , drilled	each 1jd., per doz. 1/3	MIXED CRYSTALS (6 kinds)	9d.	VALVE HOLDERS	each 10jd. and 1/3
TOP CONDENSER bushes	each 1d., per doz. 9d.	CARBORUNDUM	5jd.	BATTERIES , H.T., dry:—	
BOTTOM CONDENSER bushes each 1d., per doz. 7d.		ZINCITE and BORNITE , both in box	7/-	30 volts, including Wander Plugs	5/9
SWITCH ARMS , 4 laminations, ebonite knob, complete with panel, bush, nuts and spring washer	8jd.	COIL PLUGS , real ebonite	1/3, 10jd. and 9jd.	60 volts, including Wander Plugs	9/6
STOPS , with nuts	per doz. 6d.	H.F. PLUG TYPE TRANSFORMER :—		AMALGO-PLASTIC METAL , for fixing crystals. No Wood's metal necessary	6d.
FILAMENT RESISTANCES , smooth action, marvellous value	1/9	1. 150 to 450 metres	3/9	GOLD SEAL PLASTIC METAL , for fixing crystals	6d.
FILAMENT COMPLETE CIRCLE RESISTANCE SCALES , 0 to 300	2/6	2. 250 to 700 "	4/-	IVORINE NAME-PLATES , all readings, each 1d., per doz. 9d.	6jd.
		3. 450 to 1200 "	4/3	EARTH CLIPS , Copper, adjustable	each 5jd.
		4. 900 to 2000 "	5/6	RADIONETTE CRYSTAL SET , complete stamped B.B.C. and including one pair 4,000 ohms 'phones, 100 ft. 7/22 aerial wire, 4 insulators, lead-in tube, 6 yards lead-in insulated wire and adjustable earth clip. Ready to listen-in. Honestly worth 3 gns. ...	36/6
		5. 1600 to 3200 "	4/9	RADIONETTE ONE-VALVE 'L.F. AMPLIFIER for above	34/6
		6. 2200 to 5600 "	5/-	CABINETS , all shapes and sizes in stock.	

IMPORTANT NOTICE. In view of the enormous increase in our Mail Order business, we wish to inform our customers that all post orders are dealt with in strict rotation and at the earliest possible moment. Follow the Crowd to Elkay Corner.

"ELKAY" WIRELESS CO.,
 225 & 227, BISHOPSGATE, LONDON, E.C.2.
 Open Saturday all day. To the Trade—New Trade Counter now open.

Please remit ample postage. We open Sundays, 11-2.30 Note our Telephone Nos.— Wholesale, Bishopsgate 2313. Retail, Central 8544.

SPECIAL TERMS TO RADIO CLUBS.

SAVE MONEY BY STUDYING OUR ADVERTISEMENTS.
 For alterations of prices see our weekly Advertisements in "Wireless Weekly,"
 "Popular Wireless," and "Amateur Wireless."

TRADE MARK

EVER-READY

BRITISH MADE

WIRELESS DRY BATTERIES & ACCUMULATORS

OVER 20 years' experience and research, the finest materials, expert supervision, and careful testing at all stages of manufacture are the reasons for the superiority of "Ever-Ready" Wireless Batteries.

The consistent high standard of quality has established for "Ever-Ready" products a reputation for absolute reliability which is jealously maintained.

The "Ever-Ready" Series embrace all types of Batteries for every wireless purpose. A new and complete list of standard sizes will be sent on request to:—

Service D.X. Dept.

The EVER-READY Coy. Great Britain, Ltd.
Hercules Place, Holloway, London, N.7.



BRITISH MADE

*Insist on
"Ever-Ready" Batteries for Wireless
& obtain satisfaction & 100% efficiency.*

"ELLA"

BATTERY CHARGERS.

They work from a Lamp-holder.



CHARGE

your
Filament Battery
AT HOME.

Illustration shows the "ELLA" Battery Charger for use on alternating current circuits. It is supplied complete with Pole-Indicating Ammeter, Adaptor and Flexible for Lampholder connection and spring clips with wires for coupling to Battery.

Price :
£6 6s., carr. paid U.K.
High or Low voltage. State Frequency when ordering.
Your Electricity Meter shows both voltage and frequency.
Delivery early November.

Also "ELLA" Battery Charger for D.C. Circuits. Complete with Switch-board, etc.
See MODERN WIRELESS, October.

Price, £6 15s., carr. paid.
In returnable box, 4s. extra.
Delivery from Stock.

FOR A. C. CIRCUITS ONLY.
Output 3/10 amps, 6/8 volts.

Send for ELLA Wireless List. TRADE SUPPLIED

LIONEL ROBINSON & CO.

(Dept. M.W.), 3, Staple Inn, London, W.C.1.

See also Advt. Page xii.

TO THE WIRELESS PUBLIC

REPUTATION—You must have seen, heard, or tried the famous French S.I.D.P.E. Head Phone—100,000 net sale and still going strong. The Premier Telephone and Wireless Co., Ltd., were the pioneers of this master production.

EXPERIENCE—Now—as a result of 20 years' telephone experience—we wish to introduce another masterpiece, **The Premier Phone.** Each Phone is stamped Premier (PTC).

GUARANTEE—Ask your Wireless Dealer for the **PREMIER PHONE.** Don't accept imitations. Write direct for a sample, 17/6 post free. **Every Phone guaranteed perfect.**

SPECIFICATION—Light in weight. Highly efficient. 4,000 ohms resistance. Beautifully finished aluminium, with insulated connections. Stalloy Diaphragms, no Spacing Rings, easy fitting, comfortable riding Ear-pieces, and Cords of the best finish.

ALL PHONES GUARANTEED

"They're full of music!"
All British.
Stamped B.E.C.



17/6
post free.

And the S.I.D.P.E. Phone at 15/- subject. S.I.D.P.E. loud-speaking Receivers, 50 laminations each Pole Piece, 21/- subject.

Trade Quotations on application.
PREMIER TELEPHONE and WIRELESS Co., Ltd.,
62, OXFORD STREET, W.1.
Tel. No. : Museum 67.

No more Wireless Masts

UTILITY ENDORSED BY THE EDITOR OF "WIRELESS WEEKLY."



OUR HIGH GRADE RUBBER COVERED TELEPHONE CABLE GIVES WONDERFUL RESULTS AS AN AERIAL INDOORS AND OUT.

Wireless Masts and Insulators Abolished.

The simplicity in erection is beyond the dreams of all wireless enthusiasts, as the troublesome insulators are absolutely unnecessary. Suspend this wire where you will, lead in, and your result is there.

It is a simple matter to make a portable aerial from this wire or to run a lead-in from the house to the garden, whether it is a few yards or half a mile.

Ideal for telephone work all over the world.



READ THIS CONVINCING UNSOLICITED TESTIMONIAL.

32, Alverstone Rd., Waddiscombe, and Sept., 1923.

The Manager, New London Electron Works.
Dear Sir,—I am pleased to inform you that the wire arrived safely yesterday, for which many thanks.

I should like to mention that I have taken my ordinary aerial down, and erected one with your thin wire, and with 80 feet I obtain results much better in every way than I had before.

Yours faithfully—(Signed) GEO. FURMINGER.

Supplied in 3 Thicknesses on original drums.

Special terms to the Trade.

Class 0	$\frac{1}{2}$ mile drums (Thin for light work).	15/-	Per drum,
Class 1	$\frac{1}{1}$ mile drums (Medium for most jobs).	35/-	Carriage forward.
Class 2	$\frac{2}{2}$ mile drums (Thickest for heavier work).	70/-	

Orders for 6 miles assorted (if required), carriage paid. Smaller Quantities of Class 1 (medium) sent carriage paid.

100 feet, 1/8 500 feet, 6/3 1,000 feet, 10/3

(Sufficient for the finest AERIAL.)

Carriage Paid.

Ideal for all Training Purposes in the Garden, Fruit Trees, Peas, Beans, etc.

NEW LONDON ELECTRON WORKS, LTD.,

99, Regent's Dock, Limehouse, E.14.

Telephone: East 1821.

Telegrams: "Stannum, Step, London."



The Sequel to "Wireless for All"

AFTER your Wireless friend has read "Wireless for All," get him a copy of this Book. He will be deeply interested in the practical explanation as to how a Wireless Set receives and will appreciate the elementary instructions for building an efficient Crystal Set from the simplest of materials.

Simplified Wireless

By JOHN SCOTT-TAGGART
F.Inst.P.
(Editor of *Wireless Weekly*)

Contents.....

Some General Remarks regarding Wireless—The Telephone Receiver—Transformers—Air-core and Iron-core Transformers—Step-up and Step-down Transformers—Inductances—Condensers—Frequency and Wavelength—The Aerial Circuit of a Wireless Receiver—The Use of a Variable Condenser when Tuning—The Crystal Detector—A Receiver Using a Variable Condenser—Loose-coupled Circuits—Notes on the Erection of Aerials—Frame Aerials—Loud Speakers—How to Make a Simple Broadcast Receiver—Operation of the Receiver—The Variable Inductances—Some simple forms of Crystal Detector—The Telephone Condenser—The Complete Arrangement of the Apparatus—Operation of the Circuit.

Post Free direct 1/1

Sold by all Booksellers and published by

RADIO PRESS LTD.,
Devereux Court,
Strand, W.C.2



Hello! Hello! Hello! C.O.—“ATLAS” COILS calling

“ATLAS” Patent Plug-in Coils

Tune in Telephony Trium-
phantly on
Long or Short Waves.
Adjustment Simplicity itself.
Superiority unsurpassed.

Capacity reduced to a mini-
mum.
Optimum Wavelength
Range.
Induction—Maximum ob-
tainable.
Leave nothing to be desired.
Signal Strength increased.

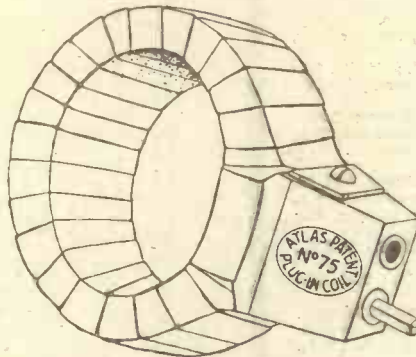

SPECIAL FEATURES :

Wound in true concentric circles, thus obvi-
ating sharp bends. Result : fine tuning.
Air-spaced between layers and turns.

Users say :
“ Absolutely the best.”

Coil No.	Wavelength in metres with .001 Variable Condenser in shunt.		Price s. d.
	Min.	Max.	
25	120	375	5 0
35	175	515	5 0
40	180	650	5 2
50	230	780	5 2
65	280	1000	5 6
75	325	1120	5 6
100	410	1520	7 0
150	660	2300	7 10
200	850	3100	8 8
250	1280	4150	9 0
300	1550	4940	9 5
400	2045	6380	10 3
500	2980	8900	10 6
600	4000	12100	11 0
750	4970	15000	11 10
1000	6100	20000	12 8
1250	7000	22000	14 0
1500	8200	26000	15 0

Enquiries solicited for all Radio Components.

CATALOGUE ON REQUEST.

Discounts for Quantities.

Trade Terms on Application.

Our Works are replete with Modern Machinery and our Staff is expert in all matters Radio.

ONLY HIGH-CLASS GOODS SUPPLIED, AND ALL INSTRUMENTS TESTED AND PASSED PRIOR TO LEAVING OUR WORKS.

H. CLARKE & CO. (Manchester) Ltd.,

Radio Engineers,

ATLAS WORKS, OLD TRAFFORD,

MANCHESTER.

TELEPHONE Nos: 683 and 793 Trafford Parks
grams: "PIRTOID, Manchester."

WITHIN 24 HOURS!

**GUARANTEED GOODS, DELIVERY BY RETURN—
IF UNSATISFACTORY MONEY RETURNED IN FULL.**

Aluminium Vanes, 5d. doz. Aerial Pulleys, 6d. Anti-Capacity Handles, 6d.
Cats Whiskers—Gold, 2d.; Silver, 1d.; Spearpoint, 1d. Packet of 4, 6d.
Coils, Basket, Set of 6, 2/-. Waxless, 2/4. 4½vt. Batteries (British) 6d. each.
Coil Holders, solid ebonite, 2-way, 3/6; 3-way, 4/6. Sockets, 7d. each.
Condenser and Grid-leaks, 2/6. Grid-leaks, all mcgs., 1/- and 1/6.
Condensers, Fixed.—To .001, 9d.; To .005, 1/-; To .01, 2/-; To .1, 3/6;
Ditto., Variable—.001, 8/-; .0005, 5/11; .0003, 5/2; .0002, 4/6;
.0001, 4/-. With ebonite or aluminium end plates, .088 spacers.
Condenser Dials, 0.180, 11d.; with knob, 1/4 and 1/9. Bushes—Top, 1d.;
Bottom, 1d.
Ditto End Plates, 1/6 pair, drilled and tapped. Solid ebonite.
Contact Studs, 4d. doz. Stops, 2 a 1d. Connecting Wire, tinned copper,
3 yds. 2d.
Crystals. Every make stocked. Zincite, 9d.; Bornite, 6d.; Talite, 1/-;
Hertzite, 1/-; Galena, Silicon, Carborun dum, 3d.; Copper Pyrites, 6d.
Gold Seal Elastic Meta for fixing Crystals, 6d. box.
Crystal Cups, 4-screw, 1½d. Detector Glasses, 4½d. each. Buzzers, 2/6.
Crystal Detectors. Plain brass, 1/3; Nickel, 1/6; Dustproof, 1/9, 2/6;
Plug-in Type, 3/6; Perikon, 2/6, 3/6 (with Zincite and Bornite).
Crystal Detector Parts, in envelope, 10½d. Nickel, 1/-.
Earth Clips, adjustable, 6d. Ebonite, 3/6 lb., any size. Fil. Resist. Dial, 9d.
Filament Resistances, 1/6, 2/-, 3/-; with dial, 2/6; porcelain base, 4/6.
Foil. Copper, 3d. foot. Tin, 4d. Formers, 12 by 2, 3d.; 12 by 4, 4d.;
12 by 5, 5d.
Headphones. Continental, 12/9; British, 18/6; Very Best, 22/6. N. & K.,
12/9.
Insulated Hooks, 1½d. Tape, 6d. roll. Insulators—Egg, 1½d.; Reel, 1d.;
Shell, 2d. Frame Aerials, detachable, 19/6.
Jack and Plug, 1/6. Lightning Arresters, 2/6 each. Spade Terminals, 1d. each.
Knobs, finest, 4d. and 2d. Lead-in Tubes, 12 in., 11d.; 9 in., 10d.; 6 in., 9d.
Loud-Speaker Aluminium Trumpets, 6/9 each. Screwed Rod, 12 in. 2 B.A.,
3d.; 4 B.A., 2½d.
Mica, .002, 2d. sheet. Nuts, 2 B.A., 2½d.; 4/5/6/8 B.A., 2d. doz.; O.B.A.,
4d. doz.
Scales, Ivorine, 0.180, 3d. Set Name Tabs, 6d. Bell Wire, 12 yds. 6d.
Slider Rods, 3½d. Plunger, 2d. B-st Ebonite, 6d. Wound Vario-couplers, 6/6.
Spacers, large, 2½d. doz.; small, 1½d. doz. Spring Washers, 3d. doz.
Sleeving, all colours, 3 yds., 2 mm., 11d. Shellac, 8d. bottle.
Switches, lacquered brass on ebonite, S.P.S.T., 1/-; S.P.D.T., 1/6;
D.P.D.T., 2/-.
Switch Arms, 1st quality, 8d. Screws, all B.A.'s—To ¼ in., 5d.; To 1 in.,
9d. doz.
Transformers, H.F. Plug, 1, 250/600, 3/9; 2, 350/700, 4/-; 3, 500/900,
4/3; 4, 800/1,350, 5/6; 5, 1,600/3,200, 4/9; 6, 2,200/5,600, 5/-.
Transformers, approx. 5 to 1, L.F., 11/9 and 15/-; all guaranteed.
"Powquip," 13/6; best nickel, 14/6. Bobbins, 1/6. H.F. Formers, 2/-.
Terminals, W.O., 2d.; telephone, 1½d.; pillar, 2d.; wood screw, 1½d.
Telephone Cords, 10½d. Tablets (Earth, Aerial, etc.), 1d. each. Flex (twin)
2d. yd.
Variometers, double wound, 2/11; Ebonite mounted, 6/6.—Formers, 6d.
pair. Wound Coils, 12 by 4, 2/5; 6 by 3, 1/8; 9 by 3, 2/3.
Valve Holders, finest ebonite, 1/3; moulded, 9d. (all with nut and washer).
Valve Legs, 1d. each. Valve Pins, 1d. each. Voltmeters, 6/8, 7/6.
Wander Plugs, 3d. each. Washers, all B.A.'s, 1d. doz. Wood's Metal, 3d.
EVERY ACCESSORY ON THE MARKET STOCKED.

Largest Stocks in British Isles.

Imperative.—Kindly send ample postage; balance always refunded.
SEND FOR FREE LIST. Trade supplied at separate trade counter.

RADIO STOCKS, Ltd.

Museum 4213. (Mail Order, "Radio House.")

87/89, NEWMAN ST., OXFORD ST., LONDON, W.
Between Oxford Circus and Tottenham Court Road,
And at 44a, Cranbourn St., Leicester Square, W.

You'll need a
Diary anyway,
so why not have
a Wireless one?

FOR your appointments—to
chronicle your doings—for the
thousand and one things
intimately connected with your life,
you need a Diary.

This year, purchase a Wireless
Diary and get some useful information
without extra cost.

These two Radio Press Diaries are
both extremely neat and well-produced
little Books. They do everything
that a Diary should do—they are
convenient in size and shape—do not
bulge the pocket—strongly bound
to give a whole year's service, and
more besides, if needed. Just the
Diary, in fact, to suit the most
critical.

The Handbook and Diary contains
data of a more technical nature than
that in the Popular Diary.

Radio Press Handbook
and Diary for 1924.

READY
NOV. 15th.

Size 5½ in. by 3½ in., solidly bound
in grained leather cloth, fitted with
pencil. Diary portion shows a whole
week at an opening. Large number
of pages of technical data, including
several pages of electrical formula
which will prove invaluable to the
serious worker.

On sale at all Booksellers,
Post free 2/8. **2/6**

Radio Press Popular
Wireless Diary for 1924.

JUST OUT!

Size 2¾ in. by 4¼ in. Strongly bound
in pluviusin with rounded corners.
One complete week shown at each
opening. Wireless pages include in-
formation on call signs, circuit
diagrams, Morse Code, electrical data,
full instructions for building a com-
plete Receiving Set, etc., etc.

On sale at all Booksellers
Post free 1/1½. **1/-**
In leather, with pencil
Post free 1/8' **1/6**

Published in conjunction with
CHAS. LETTS & Co.

The GRAMAPHIX LOUD SPEAKER

This is a most efficient device, to
which the ordinary headphones
are clipped and the Gramaphix
mounted on the tone-arm of a
gramophone.

**Straight or Curved Horns
supplied to fit Gramaphix**

Straight	6/6	Wireless List 'I' sent post free.
Curved	12/6	
Gramaphix... ..	10/6	

[Postage 9d. extra.]

RICHARD MELHUIS, Ltd.,

Electrical Engineers and Wire'less Experts,

50, 51 & 84, FETTER LANE, LONDON, E.C.4. Est'd. 1828.



THE J. B. PRECISION VARIABLE CONDENSERS

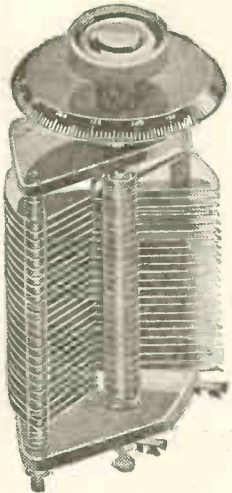

BRITISH MANUFACTURE.
SCIENTIFICALLY DESIGNED
BY EXPERTS.

ONE HOLE ONLY FOR FIXING
TO PANEL.

LARGE METAL-TO-METAL
BEARINGS.

Owing to the ACCURATE
CLOSE SPACING, these Instru-
ments take up much less room
in Panel.

COMPLETELY ASSEMBLED
WITH **KNOB & DIAL**

.001	8/6	PACKING
.00075	7/-	and
.0005	5/9	POSTAGE
.0003	5/5	Extra.
.0002	5/-	One only 9d.
VERNIER	4/-	Two 1/-
		Three 1/3

These Condensers are being used by leading makers of sets, who after severe test for best results have given their preference to the **J. B.** which is **YOUR GUIDE TO REAL SATISFACTION.** They are unconditionally guaranteed to be scientifically correct, mechanically perfect, and built for unusual durability.

Obtainable through your Dealer or direct from the Manufacturers:

JACKSON BROS.,
8, POLAND ST., OXFORD ST.,
LONDON, W.1.

FIRST FLOOR

'Phone: Gerrard 6187.

LONDON, W.1.

Works: LEWISHAM, S.E. 'Phone: Lee Green 1225. Trade Inquiries Invited

A lot depends upon your Battery

Make sure it's a Fuller "Block"—the battery that is built for wireless and which has proved by comparative test to be the best for any set. Here are a few of the reasons why: *Double the output* compared with an ordinary plate type battery of the same rating, it holds its charge even when inactive for months and there is never any risk of accidental shorting or fire. Get one to-day, a twelve months' guarantee goes with it.

6-VOLT L.T.

Ebonite containers, leather handles:

	£	s.	d.
B. W. X. 6/24	1	9	3
B. W. X. 6/45	2	0	0
B. W. X. 6/60	2	8	6
B. W. X. 6/90	3	8	9
B. W. X. 6/120	4	7	6

30-VOLT H.T.

Impregnated wood case, outside terminals, sliding lid.

	£	s.	d.
H. T.	1	10	0

Stocked by all our Service Agents. Additional Agents required in towns not yet covered. Over 100 fully equipped Wireless Battery Service Agents throughout the country ready to give you advice and charge batteries.

Demand FORMO Products

OBTAINABLE FROM ALL RELIABLE TRADERS.
A NEW "FORMO" LINE.

Plug-in
Detector with
the
FORMO
JOINT.
Price
4/-.

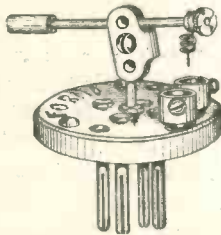

Ideal for S.T.100 and other Circuits and General Experimental Work. Will work on all Standard Circuits except Transformer Coupled and Freak Circuits.

Illustrated List B.22 on application.

YOU ARE CORDIALLY INVITED TO VISIT OUR STAND AT THE ALL-BRITISH WIRELESS EXHIBITION, NOV. 28th to 21st.

DO NOT BUY SWISS OR GERMAN NUTS, TERMINALS, SCREWS, ETC. WE MAKE AND SUPPLY BETTER GOODS AT LOWER PRICES.

THE FAMOUS FORMO TRANSFORMER

is, through sheer merit, the most widely used. It is not sold by frantic advertising. Owing to stringent test, breakdown under all ordinary working conditions is impossible.

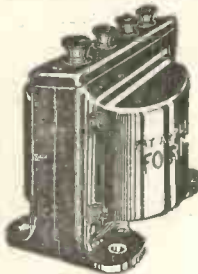

To meet all requirements it is now supplied in the following windings.

- A. Ratio ... 1-2
- B. Ratio ... 1-3
- C. Ratio ... 1-4
- D. Ratio ... 1-5

D. is supplied as standard winding.

We advise D. for 1st Stage, B. for 2nd Stage.

One Price, 18/-

Shrouded Type.

THE FORMO OPEN TYPE TRANSFORMER IS THE FINEST GENERAL PURPOSE INSTRUMENT OBTAINABLE AT 15/-. THE FORMO RHEOSTAT IS NOT EQUALLED AT 2/6. Make Use of the Formo Service.

The FORMO COMPANY,

Office and Works : 32, CRICKLEWOOD LANE, N.W. 2. 'Phone : Hamp.1787.

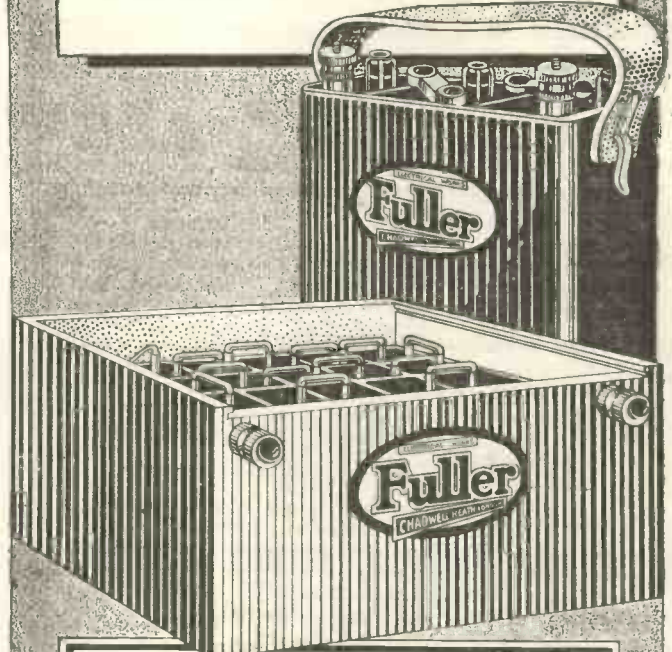

Fuller's United Electric Works Ltd.

WOODLAND WORKS, CHADWELL HEATH, E.

Telephone : LONDON 1200 (6 lines).
London Depot : 58, HIGH ST., W.C.2. (Adjacent to Tottenham Ct. Rd. Stn.). GERRARD 5070.
Telegrams : "FULLER, CHADWELL HEATH."



The "MAXONE"

Superlative All-British Headphone. Sold with a guarantee of satisfaction. All parts replaceable. **22/6** each.

If you want the *very best* out of your set—that extra finer tuning, and purer reproduction insist on "Maxone" guaranteed components.

See how they sell! A smile of satisfaction on every customer's face.

Keenest prices to factors and the Trade.

Don't miss our stand—No. 28—at the Wireless Exhibition. Special demonstrations of the famous *Claraviv* 3-valve receiver. Gives the best results in your drawing-room or picnicking or on 'the river.' Special portable types. Send for folder and Press reports on its wonderful performances.

J. MACDONALD & CO., Wireless Manufacturers,
2, High Street, Camden Town, London, N.W.1.

*Phone: North 4386.

*Grams: "Fraochan, Norwest, London."

B.B.C.

**WIRELESS
 DRY
 BATTERIES**

For
B.B.C.
 Sets

No. 1 W.

Standard Pocket Lamp Size—4½ volt with patent spiral wire terminals and plug sockets to take Wander Plugs.

Note:—1 doz. = 54 volts.

Used units replaced easily.

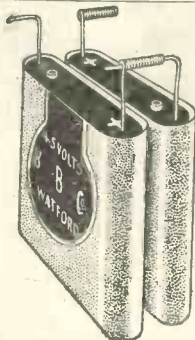

To connect in Series insert straight Terminal in Spiral of next battery. Bend spiral and thus ensure permanent electrical connection without soldering.

BRITISH MADE.

Patent applied for.

PRICE CARRIAGE PAID, 7/- PER DOZEN, WITH PLUG.

Standard Sizes:

No. 2 W. Slab, 16½ volts, 3-volt tappings. Size approx. 9 x 1 x 3 ins. ...	Price 3/- each
No. 4 W. Slab, 36 volts, 3-volt tappings. Size approx. 10 x 1½ x 3 ins. ...	" 6/6 "
No. 5 W. Block, 60 volts, 3-volt tappings. Size approx. 9½ x 3½ x 3½ ins. ...	" 12/- "

Prices include Wander Plug. Carriage Paid.

Manufactured by

Telephone: Watford 617

The BRITISH BATTERY CO. LTD.
CLARENDON RD., WATFORD, HERTS.

By the Author of:

Elementary Text-book on Wireless Vacuum Tubes.

Wireless Valves simply explained.

Practical Wireless Valve Circuits.

Wireless for All.

Simplified Wireless.

How to make your own Broadcast Receiver, etc., etc.

More Practical Wireless Circuits

By **JOHN SCOTT-TAGGART, F.Inst.P.**

Editor of "Modern Wireless" and "Wireless Weekly"

ONE of the first—and still the standard—Books on Valve Circuits "Practical Wireless Valve Circuits" has been so appreciated by many thousands of keen Wireless experimenters throughout the country, that the author has been encouraged to bring out a second Book of Circuits.

This is an entirely new work and contains the fullest details of the well-known S.T. 100, also the S.T. 75, 1-, 2-, and 3-Valve dual amplifications circuits, the Armstrong Super, the improved Flewelling, etc., etc.

In addition there are a number of original Circuits by the Author which have not yet been made public, and which are likely to arouse quite as much interest among enthusiasts as did the S.T. 100.

This is not a book for casual reading, but one which every experimenter should have in his reference library. Its utility is very much increased by the fact that all working valves are given.

This Book contains all valves of components up to S.T. 150 together with all the valves for the circuits in "Practical Wireless Valve Circuits."

Sold by all Booksellers, or sent post free, 3/6.

Published by
RADIO PRESS, LTD.
 Devereux Court,
 Strand, W.C.2

3/6

Radio Press Series No. 15.

The 3 Stages comprise sufficient equipment for most experiments with 3 Valve Circuits, both "Straight" and "Dual."

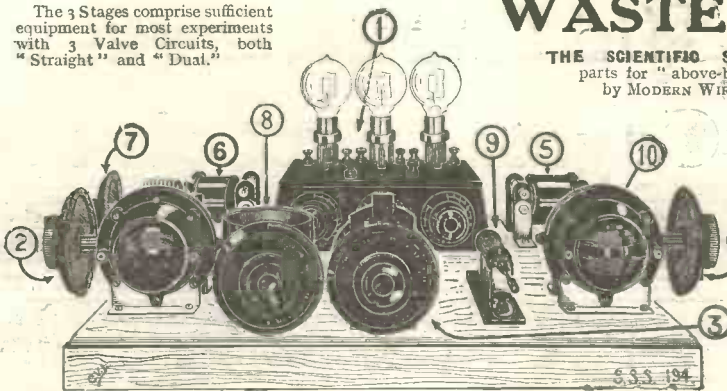

WASTE NOT—WANT NOT

THE SCIENTIFIC SUPPLY STORES' component parts for "above-board" assembly, as advocated by MODERN WIRELESS and WIRELESS WEEKLY. Eminently suitable for experimenting with the modern reflex circuits. Assembly is progressive and no part is wasted, all being useable in successive stages.

Stage 2, 2 Valve Reflex (E.G., St. 100).
Additional to Stage 1
1 valve Panel £0 8 6
(3) 1 L.F. Transformer ... 0 13 6
£1 2 0

Stage 1.
Single Valve Reflex
1. Single Valve, Expn. Panel £0 8 6
3 & 4. 2 Variometers at 15/- 1 10 0
6. L.F. Transformer... 0 13 6
9. Crystal Detector ... 0 2 6
10. Stabilising Resistance, Variable ... 0 3 6
3 Fixed Condensers, .002, .0003, at 1/- ... 0 3 0
Baseboard, 12 in. by 18 in. 0 4 9
£3 5 9

Stage 3.
3 Valve, E. G., St. 100 and H.F.
All components for Stage III, as illustrated, £6 9 0

SCIENTIFIC SUPPLY STORES,
126, Newington Causeway, S.E.1. Telephone: Hob 4177.

Turnock's Specialities

K7/4000 ohms. Headphones, retail at 14/6.
(A line of special value.)

XPI8 Grasshopper Crystal Set, retail at 21/-



A proprietary article of attractive appearance. Crystal is operated by a special non-oxidizing Magnet, giving perfect adjustment non-microphonic. It has parallel tuning arrangement. Its popularity has assured it success. A Crystal Set of finality.

Turnock's Telephone Works,
41, High Street, Aston, BIRMINGHAM.

Your Aerial!

TAKE a little trouble with your Aerial and you will be amply repaid by the vastly superior results you will get. Besides, a poorly erected Aerial is often a menace—it might collapse and cause serious damage. Better put up a good one while you are on the job. Get a copy of this Book and read how easily a good one may be erected.

Radio Press, Ltd.,
Devereux Ct., Strand, W.C.2.

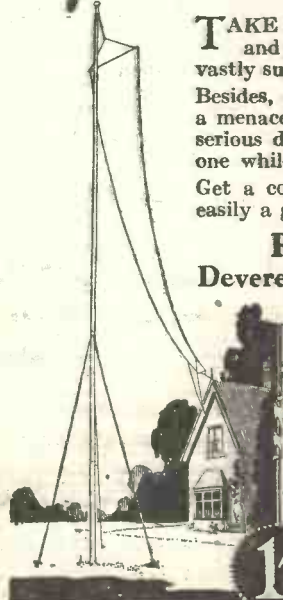

From all Booksellers and Newsagents, or 1/11 Post Free.

Radio Press Wireless Library No. 4.

1/-

How to erect your Wireless Aerial

By B. Mittell, A.M.I.E.E.

ADVERTISEMENT RATES

" WIRELESS WEEKLY."

ORDINARY POSITIONS.

13 insertions consecutive - £15 per page and pro rata.
6 " " - £15 plus 5% per page and pro rata.
1 to 5 " " - £15 plus 10% per page and pro rata.

NEXT MATTER (In columns only).

13 insertions consecutive - £20 per page and pro rata.
6 " " - £20 plus 5% per page and pro rata.
1 to 5 " " - £20 plus 10% per page and pro rata.

SCHEFF PUBLICITY ORGANISATION, LTD.

(Advertisement Managers, Wireless Weekly and Modern Wireless),

125, PALL MALL, LONDON, S.W.1.

Phone—Regent 2440 (2 lines).

JUST PUBLISHED

The Construction of Crystal Receivers

By Alan L. M. Douglas

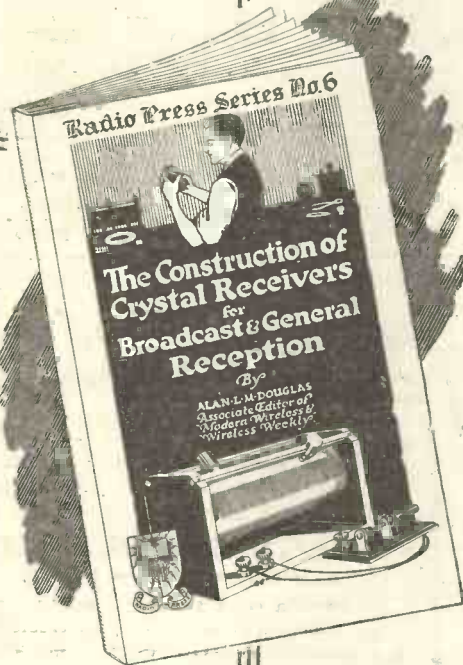

—and the Crystal Receiver still gives the purest speech

IN spite of the very marked advance in the design and construction of Valves, there is no shadow of a doubt that the Crystal still gives the purest speech.

Many remarkable long-distance reception tests have been recently carried out, and would show that the Crystal Receiver is far from being superseded.

Even if you already possess a Valve Receiver, it will be to your advantage to get this new Book and build one of the super-crystal Sets described in it. Besides enabling you to make interesting comparative tests, you will have a very useful receiver as a stand-by in case your Valve Set should fail you at a critical moment.

Published by
RADIO PRESS, LTD.,
Devereux Court,
STRAND, W.C.2.

1/6

Sold by all Booksellers and Newsagents, or 1/8 post free direct.

CONTENTS.

The Crystal Detector—its Development and Design.

Crystal Reception Circuits.

Inductances for Crystal Work. (Single layer solenoid, honeycomb, basket, slab, inductively coupled, etc.).

Condensers fixed and Variable. Full constructional details.

Telephone Headgear—incl. transformers and loud-speakers.

How to make a Crystal Receiver for British Broadcasting. (Wave-length range, 250-600 metres.)

How to make a long Range Receiver. (Wave-length, 300-3,000 metres).

The "Mark III." Short-wave Government Tuner, and useful conversions and modifications.

Aerial and Earth Circuits—their faults and remedies.

Appendix containing instructions for making three extremely simple and practical sets.

Radio Press Series No. 6.



EFESCAPHONE

WIRELESS RECEIVING SETS

IT'S AS SIMPLE AS ABC

to install and operate "EFESCAPHONE" Wireless Receiving Sets. Printed instructions are enclosed with all sets, valve or crystal.

The "Nelson" model de luxe illustrated is a superb valve set. The wavelength range is exceptionally wide—from 150 to 4,000 metres—enabling the user to pick up not only British Broadcasting Stations, but Paris, The Hague, and ships' signals. The two-valve set has a telephony range of approximately 125 miles with headphones, and the three-valve set a range of 250 miles with headphones or 75 miles with a loud speaker.

Finally, the appearance of "Efescaphone" Sets is all that could be desired. The layout is neat and compact; the cabinet work distinctive. In the set illustrated the instrument panel is enclosed, when not in use, by a neat roll shutter, and the headphones accommodated in a cupboard in the base. All connecting wires are out of the way at the back of the cabinet.

Ask your wireless dealer for particulars or write for Illustrated Catalogue of this and less expensive sets and name of local agent.

Wholesale Only—**FALK, STADELMANN & CO., LTD.**

EFESCA ELECTRICAL WORKS,

83, 85, 87, Farringdon Road, London, E.C.1

And at Glasgow, Manchester and Birmingham.

Listen-in with an Efescaphone

THE "NELSON"

(Model de Luxe)

Reduced prices complete with everything except valves.

No. R. 90002. Two-valve set ... £22
 No. R. 90003. Three-valve set ... £26

Plus BBC tariff extra.

*Just switch on and
 Charge your Accumulator
 at home*

The Tungar (for use on Alternating Current only) will enable you to charge your wireless battery at home, without trouble and at negligible cost. It has no moving or vibrating parts, and *requires no attention*. Install a Tungar and avoid the risk of your battery running down when you are entertaining guests.

Full particulars from your nearest dealer or from—

The British Thomson Houston Co., Ltd.

77, Upper Thames St., E.C. Branches in all large towns.

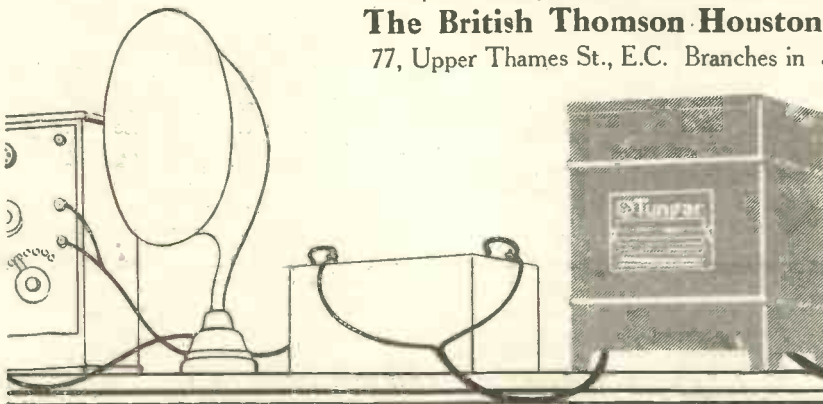

Tungar

**FOR CHARGING BATTERIES ON
 ALTERNATING CURRENT SUPPLY**

—GRIFFIN'S—

80, NEWINGTON CAUSEWAY
 Hop 1806. (Corner of Lancaster St.)
Elephant & Castle, London, S.E.1.

AGENTS for all the LEADING Manufacturers.
 "Polar" STOCKISTS. Genuine Radio Experts.
SPECIALISTS IN PARTS FOR ALL CIRCUITS
 Including "S.T.200" and "P.W." Combination.
SPECIALS.

"GRIFFIN" Hedgehog L.F. Transformers, Ratio 47 to 1, ... 22/6
We claim they have no equal. Acknowledged to be the finest on the market.

No. 2 "GRIFPHONES," 4,000 ohms. Adj. Pole Pieces ... 13/6
 Sent "on appro." Beautiful Finish
 Small D.P.D.T. Switches for panel mounting, nickel plated ... 3/-

CALL AT OUR SHOWROOMS AND INSPECT THE LARGEST RANGE OF COMPONENTS IN SOUTH LONDON.
Advice free. New Catalogue free on application. Also trade list.

JUST OUT!

—but I don't understand Circuit diagrams

WHEN a wireless enthusiast decides to build his own Set, his first job is to study the necessary wiring diagram. And that is where quite a number meet their Waterloo.

Those of us who can read circuit diagrams as easily as we can our morning paper are apt to show but little sympathy for the extreme novice making his first flounders into Wireless.

Radio Press, however, appreciate that the correct reading of circuit diagrams is the first essential to the successful building of a Set, and are publishing an entirely new Book which completely cuts out this difficulty.

Every circuit diagram in "Pictorial Wireless Circuits" is shown pictorially—that is to say, the actual components used are drawn instead of conventional signs for them. Thus there will be no excuse, for example, for any enthusiast not knowing the correct position for his filament rheostat.

Altogether over 70 circuits are shown, ranging from simple Crystal Receivers to more elaborate Multi-valve Sets.

If difficulty in reading Circuit diagrams has hitherto prevented you from building or improving your Set—get a copy of this Book to-day. It will be eighteenpence well spent!

Pictorial Wireless Circuits

by
OSWALD J. RANKIN

From all Book-sellers **1/6** 1/7½ post free

Published by
RADIO PRESS, LTD.
 Devereux Court, Strand, W.C.2

Radio Press Series No. 8.



A Sign of Service

To the EXPERIMENTER.
 To the CONSTRUCTOR.
 To those purchasing COMPLETE SETS.

We are Radio Engineers of long and wide experience, able to advise you with confidence and without prejudice.

Why not call at our lounge showroom, where we have reputable apparatus and parts from terminals to a 1½ K.W. ship set.

You will find that we can help you—call to-day for a demonstration or write to us.

GENERAL WIRELESS, LTD.,
 Gen. 8460.
21a, GARRICK STREET, W.C.2.
 Near Leicester Square Tube.

JUST ONE

EL-BE UTILITY
 For others see "MODERN WIRELESS" October, 1923.
 "EL-BE MODERN" TUNER

Beautifully finished on Polished Stand.

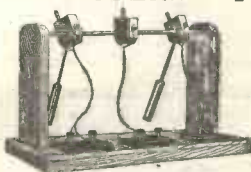

12 months' guarantee.

Gives you finest possible tuning.
 ASK YOUR DEALER FOR IT.

LEIGH BR DS. 37, Silmou h St., Kings Cross, London, W.C.1.
 Tel. Museum 4547.

NO MORE H-T BATTERY TROUBLE

CLICKS and crackles in your phones or loud-speaker generally indicate that one or more of the small cells of your H.T. Battery has become run down or polarised.

The "M-L" Anode Converter obviates the use of H.T. Batteries. It will give you smooth, noiseless reception, and can be relied upon to function always. Worked from the ordinary 6-volt accumulator of your set, its consumption is only 1.15 amperes. The low-tension battery input is regulated by a rheostat, giving complete control of the anode potential.

For power amplifier work where the life of the ordinary H.T. Battery is very limited it is ideal.

THE "M-L" TWIN COIL TRANSFORMER.



will give you clearer, stronger signals and greater range from your set. High Primary Inductance. Very Low Self Capacity. Entire absence of distortion. Primary to Secondary Ratio 1-4.

A User writes:

"It is the best transformer I have tried so far, and I have had considerable experience since 1917. I am delighted with the results I am now getting, thanks to you."

PRICE
30/-

CARR. PAID.
Ready for Mounting.

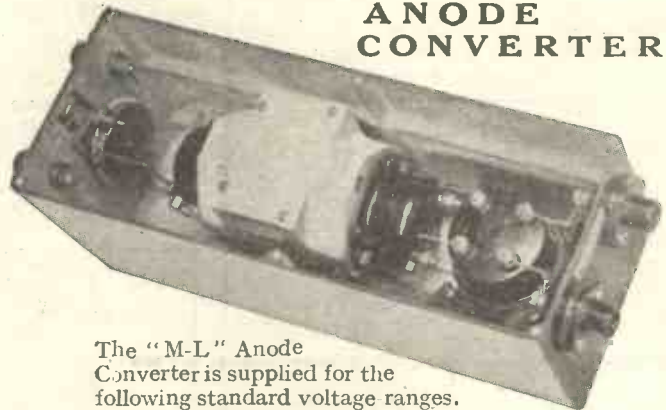

THE "M-L" ANODE CONVERTER

The "M-L" Anode Converter is supplied for the following standard voltage ranges. Special machines can be made to order.

Type "A," 6-70 volts .. For general reception.
Type "B," 6-120 volts } For two-stage power
Type "C," 12-300 volts } amplification.

All types can give up to 15 milliamps. continuously without overheating. Write for prices and full particulars.

We invite Traders to write us for terms.

THE M-L MAGNETO SYND., LTD.,
WIRELESS DEPT., COVENTRY.



The Mark of

High Efficiency.

ROWLEY & LOUIS,

12, The Broadway, Muswell Hill, N.10.

Telephone: Hornsey 668.

COIL HOLDERS

Aluminium and Ebonite. Anti-capacity handles. Highly finished and of excellent value.

3-way.....6/6. 2-way.....5/6

Headphones:
Genuine Brunets, 4,000 ohms... 16/6
N. & K., best finish, very loud 14/11
French D.L., 4,000 ohms..... 11/6

Aerial Wire, 7/22 copper, 100 ft. 2/2
Lead-in Wire.....per yd. 2d. and 3d.
Silk-covered Twin Flex...per yd. 0/3
Switch Arms, complete, best only 0/9
Filament resistances, best only... 2/-
Fixed Condensers..... 1/-
Best Condenser Dials 2/-
Basket Coils, 250-5,000 metres, set of 7 3/-

Ebonite Valve Holders, best quality..... 0/9
Valve Sockets..... per doz. 0/9
Valve Pins..... per doz. 0/6
Brunet L.F. Transformers..... 14/-
High-class Guaranteed L.F. Transformer..... 9/6
H.F. Transformers, any wave length 3/6

Crystal Detectors, in glass 1/6
Shaw's Genuine Hertzite, large... 0/8
Herbo Cat's Whisker improves results on any crystal set..... 0/6
Phone Cords, best.....per set 1/3
Condenser Plates.....per pair 11d.
Contact Studs..... per doz. 0/4
Small Spacers..... per doz. 21d.
Large Spacers..... per doz. 0/3
Brass Bushes.....each 11d.
2 and 4 B.A. Threaded Rod, per ft. 0/3
Shell Insulators, large ... each 0/6
Shell Insulators, small..... each 0/3

Reel and Egg Insulators ... each 0/2
Insulated Hooks each 0/2
Spade Terminals, threaded, each 11d.
Bushed Ebonite Knobs; best, each 0/3
Lead-in Tubes, any length, per in. 0/1
Best Ebonite, only in sheets, 1/8 in., 3/16 in., 1/4 in.,...per lb. 4/6
Systoflex, bestper yd. 0/5
Systoflex, cheapper yd. 0/3
Best quality Coil Holders, 2-way 5/6
Best quality Coil Holders, 3-way 6/8
Knife Switches for panel mounting 0/8
Engraved Rheostat Dials...each 0/4
Crystal Cups, with 4 screws, each 6/2
C.A.V. Accumulator, 6 volt, 60 amp., in case with switch, fuses etc.....£1 19 0
Special R type Dutch Valve, guaranteed best quality 8/6
All types of valves at cut prices.

Instrument Wires.

No.	Prices	per lb.	Enam.
	D.C.C.	D.S.C.	elled
18	2/6	3/9	2/3
20	2/6	3/0	2/3
22	2/8	3/11	2/8
24	3/4	4/4	2/6
26	4/-	4/11	3/-
28	4/6	5/10	3/4
30	5/4	6/10	3/9
32	7/2	7/10	3/11
34	8/-	8/10	4/4
36	8/0	11/6	4/8

All sizes in stock.
rd. extra for reeling under 1 lb.

All goods sent off same day as ordered.
Enclose sufficient for postage, extra postage will be returned.

AN ANNOUNCEMENT OF IMPORTANCE TO WIRELESS ENTHUSIASTS

'ASTRA' COMPONENTS

A veritable revolution in components for Receiving Sets of every description is portended by the introduction of "ASTRA" COMPONENTS.

In every case a sound engineering production; in every instance a unique component of unique properties, and in every detail a reliable but inexpensive job.

For instance:—

The 'ASTRA' Vernier Condenser

can be added to any existing condenser, giving micrometer adjustment. Can also be used for panel mounting as a separate instrument. Ebonite, with anti-capacity handle; only one connection necessary. 7/6, Post Free.

The 'ASTRA' Dual Switch

a super-tuning device which can be used to tune in any circuit, on crystal or valve, without condenser, and enables user to handle high-frequency circuits over a range of 200 to 3,000 metres, without condenser. Fine tuning, no dead-end effects, micrometer adjustment, anti-capacity handles, ebonite and brass. 10/6, Post Free.

WATCH for further announcements of other "ASTRA" components, but in the meantime WRITE US about your wants, and we will add your name to our mailing list for advice of everything we market.

George Manufacturing Co.
Nelson Chambers, High Street, Birmingham.
Tele.: Central 5778. Tele.: ACTINA, Birmingham.



The French Thomson-Houston Phone.

FRENCH THOMSON-HOUSTON PHONES

The Headphone with the Two Years' Guarantee

All GENUINE French Thomson-Houston Headphones are now Guaranteed against Defective Workmanship for 2 years. A guarantee is given with each Headphone sold. What more do you want?—This speaks for itself. If your local Dealer cannot supply you send direct to us.

DELIVERY AT ONCE FROM LONDON STOCK. Revised List post free.

LIST No.	SPECIFICATION.	TOTAL RESISTANCE	PRICE	POSTAGE.
250	Polished aluminium detachable receivers. Double horn headbands, fully adjustable. Long flexible cords. Beautifully finished and perfect workmanship throughout. Undoubtedly the very best value for money obtainable.	4,000	19/-	6d.
210	As above, but fitted with double imitation tortoiseshell headbands. Particularly suitable for ladies.	4,000	22/-	6d.
212	As No. 250 but wound to a total resistance of 8,000 ohms.	8,000	24/-	6d.

READ THIS.—Have you a Crystal Set? If so you cannot afford to be without one of our "Eccentro" Detectors. A real novelty in Detectors (vide "Amateur Wireless"). It is Semi-automatic Dust-proof, Shock-proof and a temper saver. IT NEVER FAILS.

NOTE.—This is not the "Hit and Miss" Type, it is a real piece of Mechanism and something to give entire satisfaction.

Our price 8/- Post free.

TRADE SUPPLIED AT RIGHT PRICES.

W. JOANES FOR PHONES

42, Jenner Rd., Stoke Newington, London, N.16

(Phone : Dalston 4741.

Telegrams : "Creneva, Stoke, London."

To get the Best Results from your S.T. 100 and "All-Concert," you must use MAGNUM TAPPED COILS, designed especially for use with all experimental circuits.

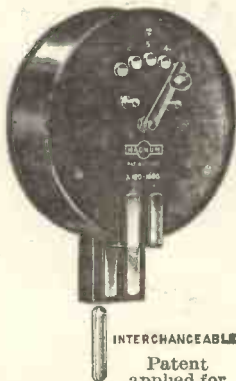

No. 1 Coil, 180-1,000 metres 15/6
 No. 2 Coil, 600-2,600 metres 17/6
 Post free Cash with Order.

The Pleasure and Romance of Wireless is unbounded when "Listening" on a Set of your own construction, but—

MAGNUM COMPONENTS ARE ESSENTIAL.

MAGNUM COMPONENTS for the TRANSATLANTIC RECEIVER as described in this issue. £ s. d.
 Rotary Filament Resistance 0 4 6
 Dubilier H.T. Condenser ... 0 7 6
 Dubilier Grid Leak and Condenser ... 0 5 0
 Dubilier Fixed Condenser .002 0 3 0
 Variable Condenser .0005, with scale and knob ... 0 8 0
 Dual Condenser .00025 ... 1 17 6
 Potentiometer ... 0 9 6
 Patent H.F. Transformer ... each 0 4 6
 Interchangeable applied for Terminals (lacquered) " 0 0 2

Valve Clipsper set 0 1 0
 Valve Legseach 0 0 1
 V 24 Valves... .." 1 4 0
 Q.X. Valves" 1 4 0
 Magnum No. 1 Aerial Coilper lb. 0 15 6
 Ebonite, 1/4 in. thick" 0 4 0

MAGNUM COMPONENTS for "ALL-CONCERT" NOTE MAGNIFIER.

Magnum Transformer 0 15 0
 Filament Resistance, with scale 0 2 6
 Terminals (lacquered) each 0 0 2
 Valve Legs, mounted on Ebonite 0 1 2
 Ebonite Bushes and Discs each 0 0 2

Cash with order. Carriage Paid on Orders for £2 or over.

BURNE-JONES & Co., Ltd., Manufacturing Radio Engineers,
 MONTFORD PLACE, KENNINGTON ROAD, LONDON, S.E. 11.
 'Phone : Hop 6257.

R.E.C.

(BRITISH)

Wireless Apparatus

Greatly Reduced Prices

R.E.C. Telephones
 R.E.C. Crystal Sets
 R.E.C. Amplifiers
 R.E.C. Valve Sets

SPECIAL EXHIBITION.

Call at our Showrooms and see for yourself the remarkable value we are offering.

THE RADIO EQUIPMENT CO. LTD.,

Offices and Showrooms :

Bank Chambers, 329, HIGH HOLBORN, LONDON W.C.1

Telephone : Holborn 1229.

Telegrams : "Exportation, Holb, London."

Build this Splendid 1-Valve Reflex Set

—British throughout, conforms to all the P.M.G.'s Regulations.

THE new Constructor's Licence will now enable you to build any Set, provided—
 1. That you use British components.
 2. That the Set does not cause interference.

You cannot do better than build this splendid one-Valve Reflex Set, which will enable you to pick up every B.B.C. station at any time. You can add a Peto-Scott Amplifier when you wish to use a Loud Speaker. Remember this Set gives you the equivalent of practically three Valves at the cost of only one. Send for a set of parts to-day and start building it up.

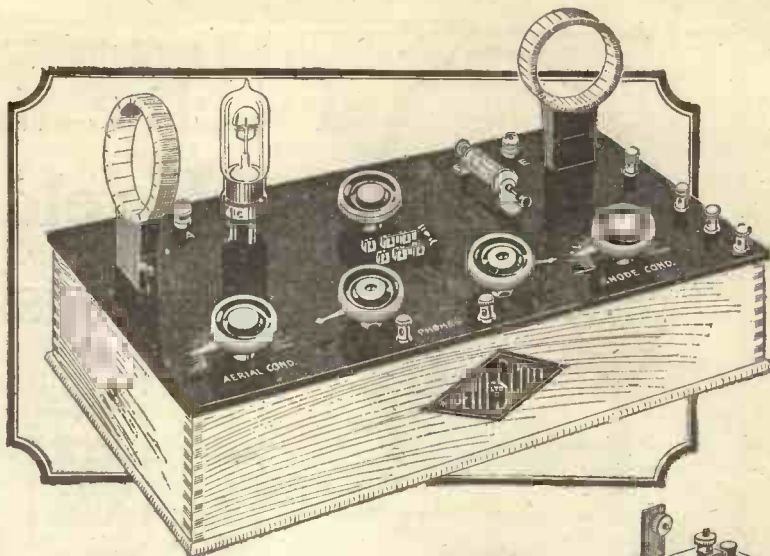

Complete Set of Parts

Ebonite Panel, 1 in. thick, engraved, drilled, and tapped. Polished Cabinet to fit. Variable Condenser .001 assembled; ditto .0002 (in parts for assembling); one MAX-AMP Transformer; Rheostat, two Utility switches, Series-parallel Switch, Crystal Detector, two Coil Holders, Valve Sockets, all terminals, screws, insulating sleeve, &c., and full instructions, inclusive of all royalties

£4 12 6

Something New!

Self-recuperative Batteries

Our latest introduction—interesting tests in our own workshops have proved that these new Batteries will outlast at least three of the large Dry Batteries usually recommended for use with Dull-Emitter Valves. Each battery gives 1.5 volts per cell and continuous output of .5 amps for a period of 4 1/2 hours. Last for months without any attention—a boon to country dwellers, as four in series can be used with the ordinary type of Valve.

10/6
each.

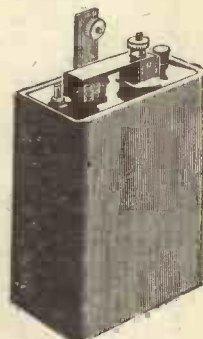

Catalogue 3d.

Peto-Scott Co., Ltd.,

Head Office: 64, HIGH HOLBORN, W.C.1

Branches: 99, High Holborn, W.C. 1. 3, Wellington St., Strand, W.C. 2; Cardiff: 94, Queen St. Liverpool: 4, Manchester St.

BUY and BUILD

your sets from

BROWN'S of Manchester

A few good lines to be going on with.

Single Earpieces (complete with Cord)	2,000 ohms	6/-
" " " "	4,000 ohms	7/-
DOUBLE "Headphones" (French make)	4,000 ohms	16/-
" " (French Thomson-Houston imitation Tortoiseshell Bands)		
" " " "	4,000 ohms	22/-
" " (Sterling Type, R 1260)	4,000 ohms	25/-
" " " (" " R 1238)	4,000 ohms	42/-
" " (Brown's Featherweight)	4,000 ohms	25/-
" " " " "D" Type)	4,000 ohms	52/-
Crystal Detectors (on Ebonite Base)		2/-
" " (Enclosed)		2/6
" " (Perikon)		4/9
Variometers, Panel Mounting		6/- & 7/6 each
" " "Sterling Type"		21/-

All IGRANIC Components Stocked.

ACCUMULATORS. All sizes in stock. We also charge and repair same. Everything for the wireless enthusiast.

Call and see us to discuss your wireless problems. Send P.C. for list. Postage free on orders of 30/- and over in U.K.

BROWN & CO.,

Electrical and Radio Engineers,

17, Newton St., Piccadilly; & 4a, Withy Grove, Manchester.

'Phone: City 6912 and Cent. 5443.

SCHEFF PUBLICITY ORGANISATION

125, PALL MALL, LONDON, S.W. 1

are Advertisement Managers for

MODERN WIRELESS AND WIRELESS WEEKLY

Particulars on application of RATES for both publications.

'Phone: Regent 2440 (Two Lines).

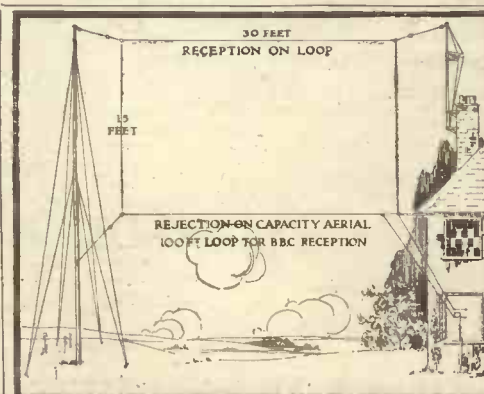

'TURRET'

Columbian Pine Masts

How to fix an efficient 100-ft. Aerial in a 30-ft. garden.

100-ft. Aerial with Insulators, Slings, etc., 7/9

28-ft. complete, 59/6 and 37/6

36-ft. - 79/6

42-ft. Telescopic 89/6

56-ft. do. 26 18 6

13-ft. Roof Masts, 28/6

13-ft. Poles, 5/9

SIMPSON & BLYTHE, 8-9, Sherwood St., Piccadilly, W.1.

'Phone: 2650 Geraud

Published
Nov. 8th.

Twelve tested Wireless Sets



Mr. Harris's latest and
best constructional Book.

By P. W. Harris

Assistant Editor of
"Modern Wireless."

Shows you how
to build all these
Receiving Sets :

1. A 2/6 Crystal Set
2. A Crystal Set on a New Principle.
3. A single Valve Magnifier.
4. A 2-Valve Magnifier.
5. A Simple 2-Valve Receiver.
6. A 2-Valve Cabinet Set.
7. An "Old Folks" Receiver.
8. A 3-Valve "All Concert" Receiver.
9. A "Transatlantic" Receiver.
10. A 3-Valve Reinartz Set.
11. An S.T. 100 Set for the beginner.
12. Wave traps in various forms.

A new Book by the master designer of home-built Sets

PROBABLY no writer of Books and Articles dealing with the constructional side of Wireless is more popular than Percy W. Harris.

The reasons for this may be two-fold. Firstly that he takes extraordinary pains to make every detail clear and intelligible to even the veriest novice, and secondly, that the Instruments he describes, although refreshingly original in design, give extraordinarily good results.

No purchaser of this Book need be afraid that he does not possess sufficient skill to build a Wireless Receiving Set or that elaborate tools are necessary. If he has sufficient patience to follow clear diagrams and explanations, and if he can use a small saw, a file and a drill, then success is assured.

Published by

RADIO PRESS LTD.,
Devereux Court, STRAND, W.C.2.

2/6

From all Book-
sellers and News-
agents or 2s. 8d.
post free.

Radio Press Series No. 14.

Manufacture of Broadcasting Apparatus.

Use of Patents.

THE pioneer work of the Marconi Company in connection with wireless telegraphy and telephony is well-known, and as the result of many years of research work and considerable expenditure, the Company controls numerous patents relating to the manufacture or use of wireless telegraph and telephone apparatus.

The Company is prepared to grant a licence for the use of its patents in connection with the manufacture of broadcasting apparatus to any member of the British Broadcasting Company, Limited.

A large number of firms (including the principal manufacturers) are already so licensed and pay royalty for the use of these patents, and all apparatus manufactured under licence is so marked.

Any person or firms manufacturing or offering for sale valve apparatus embodying patents controlled by Marconi's Wireless Telegraph Company, Ltd., without its permission render themselves liable to legal proceedings for infringement.

Whilst hoping that it will not be forced to take legal proceedings the Marconi Company wishes to give notice of its intention to protect its own interests and those of its licensees, and in case of infringement the Company will be reluctantly compelled to take such steps as may be necessary to defend its patent rights.

Marconi's Wireless Telegraphic Co., Ltd.,
Marconi House, Strand, London, W.C.2.

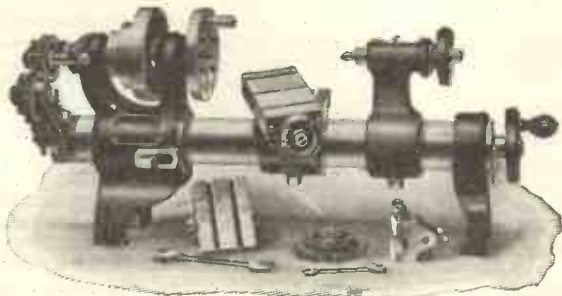

To all Experimenters

the ideal tool for all-round utility, wide scope and genuine worth is the

DRUMMOND 4-in. Universal Lathe

Besides all turning and screw-cutting, this lathe, with its circular bed, sliding saddle with slotted face, and the slotted and swivelling top slide, enables thousands of milling, drilling, boring and facing jobs to be performed speedily and accurately. Our lists give full details. Price only **£9**

DRUMMOND BROS. LTD. REID HILL GUILDFORD

Post this Coupon

Please send me list of 4-in. lathes, with details of deferred payment system. Name.....
Address

(Send in unsealed envelope for 1d.)

Regd.

Claristal

SET.

WIRELESS
Constructional Receiving Set.

British Made.

PHENOMENAL RESULTS!
Will receive Signals and Broadcasting Entertainments as loudly and clearly as most expensive Crystal Sets. Can easily be constructed in a few minutes.

No Tools or Technical Knowledge required.
Complete Set of Parts, including "Sonyts" Crystal, packed in attractive box, with illustrated diagram of Instructions.

5/6. Post 3d.

We also supply the Set ready constructed. Price, including B.B.C. Fee, 7/6. Post 3d. The "Claristal" Aerial Set, comprising: 100 ft. Aerial Wire, 6 Insulators, Leading-in Tube, and 3 yds. Insulated Wire, 3/6. Post 6d.

Double Head Receivers, British Made, 4,000 ohms, 17/6, post free.
Single Head Receivers, 2,000 ohms, 9/6, post free. Complete with Cords and stamped B.B.C.

The UNIVERSAL ELECTRIC SUPPLY Co., Ltd.
4 BROWN STREET, MANCHESTER.
ESTABLISHED 1892. Box No. G.P.O. 519.

Fully illustrated Radio Catalogue post free on request.

"DUANODE" CONDENSER

"As good as the best"

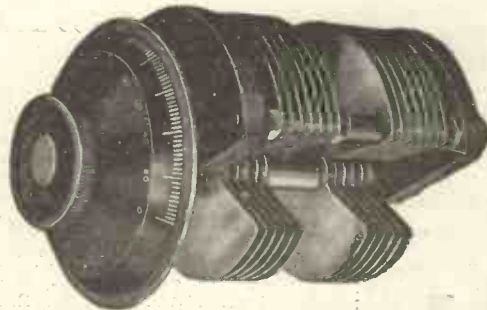

Realising the difficulty of tuning a circuit in which two stages of tuned anode H.F. Amplification is used, we have designed the "DUANODE" Condenser, as illustrated. This Condenser consists of TWO matched Condensers operated by one knob. Thus by using matched COILS it is possible to tune BOTH circuits perfectly with one operation only. The two sets of fixed Vanes are carefully

insulated one from the other, and the moving Vanes connected electrically; the spindle can thus be connected to H.T. Positive. This condenser can also be used for other purposes. The two halves (each of .0002 mfd.) can be used in series or parallel, giving capacities of .0001, .0002 and .0004. Price 25/-

For "FALLON" COMPONENTS see our advertisements in "Wireless World," "Amateur Wireless" and "Popular Wireless" every week.

We are Exhibiting at the All-British Wireless Exhibition (Stand No. 11), White City, Nov. 8th-21st.

REPUTATION.—Your component is not a "FALLON" unless the name "FALLON" appears on same.

Our motto is **QUALITY FIRST**, and every article carries our money back guarantee.

All BRITISH Manufacture. Prompt Delivery.

Cash with order. Please include postage on each article.

FALLON THE CONDENSER PEOPLE,
230a, Hermitage Road, London, N. 4.

Phone: Tottenham 1932.

London Agents:—Vanstones, Ltd., 61, Chandos Street, London, W.C.2
Sole Trade Distributors:—Messrs. G. W. I., Ltd., Shanklin Road, Crouch End, London, N.8, to whom all Trade Enquiries should be sent.

FALLON CONDENSER MANUFACTURING CO., Ltd.

Wireless



A cheerful fire—
a cosy chair—and—

“the finest weekly
Radio Magazine
ever produced.”

WITH a very wide range of Wireless publications now being issued, you may be interested to ask, “What sort of a Magazine is *Wireless Weekly*, and who buys it?”

Radio Press, Ltd.—its publishers—are actuated by much the same motives as the builders of a superfine car, who persistently, and often in the face of great difficulties, refuse to produce anything but the best.

Their aim is to publish a Weekly Magazine worthy of the best type of Wireless experimenter. They realise that although Radio may not be an intellectual pursuit, it has always attracted, and is still attracting, some of the keenest brains in the country.

To-day the fascination of wireless is complete. From the big business man to the butcher's boy—all are imbued with the keenest desire to know more of its mysteries.

Quite frankly, *Wireless Weekly* is intended to appeal to those able to appreciate a really first-class weekly publication—to those with a sense of discrimination and proportion—and as such it carries a great amount of prestige and importance.

If you desire to be kept up-to-date and to obtain a worth-while opinion on the Radio problems of the day, then see to it that you are a regular reader.

Published every
Wednesday, and
sold by all
Newsagents.

6d.

“and more than
worth it!”

EDITORIAL STAFF.

Editor.

JOHN SCOTT-TAGGART, F.Inst.P.

Assistant Editors.

E. REDPATH. P. W. HARRIS.

Scientific Adviser.

PROF. G. W. O. HOWE, D.Sc., M.I.E.E.

Advisory Editors.

PROF. R. WHIDDINGTON, M.A., D.Sc.

PROF. C. L. FORTESCUE, M.A., M.I.E.E.

Staff Editors.

E. H. CHAPMAN, M.A., D.Sc. G. P. KENDALL, B.Sc.

A. D. COWPER, M.Sc. R. W. HALLOWS, M.A.

S. G. RATTEE.

RADIO PRESS, LTD.,
DEVEREUX COURT, STRAND, W.C.

“As good as Modern”

Weekly

Constructional Articles really up-to-the-minute!

The development of the reflex Circuit as far as its popularity among amateurs is concerned dates from the announcement of the very successful S.T. 100 Circuit.

The fullest details of this Circuit, together with constructional Articles on how to build up different types of Sets incorporating its principles, have been given in *Wireless Weekly*.

Obviously a weekly Radio paper—if its editorial staff is live—always has the advantage over a monthly magazine in the matter of speedy information on new ideas. The aim and purpose of *Wireless Weekly* has always been to present to its readers the fullest details of every development in Wireless as quickly as possible.

The new Flewelling Circuit is a typical example. Here is a super-sensitive one-valve Receiver—almost absurd in its extreme simplicity—yet hundreds of readers have built it up and are getting extraordinary results from it.

Mr. Flewelling wrote his article expressly for the benefit of readers of *Wireless Weekly*.

Remember this point, too: the Editorial Staff of *Wireless Weekly* are Wireless Experimenters to a man, and with such experts as John Scott-Taggart, F.Inst.P., E. Redpath, and Percy Harris writing exclusively for Radio Press publications, you cannot afford to miss the results of their contributions to the science of Radio.

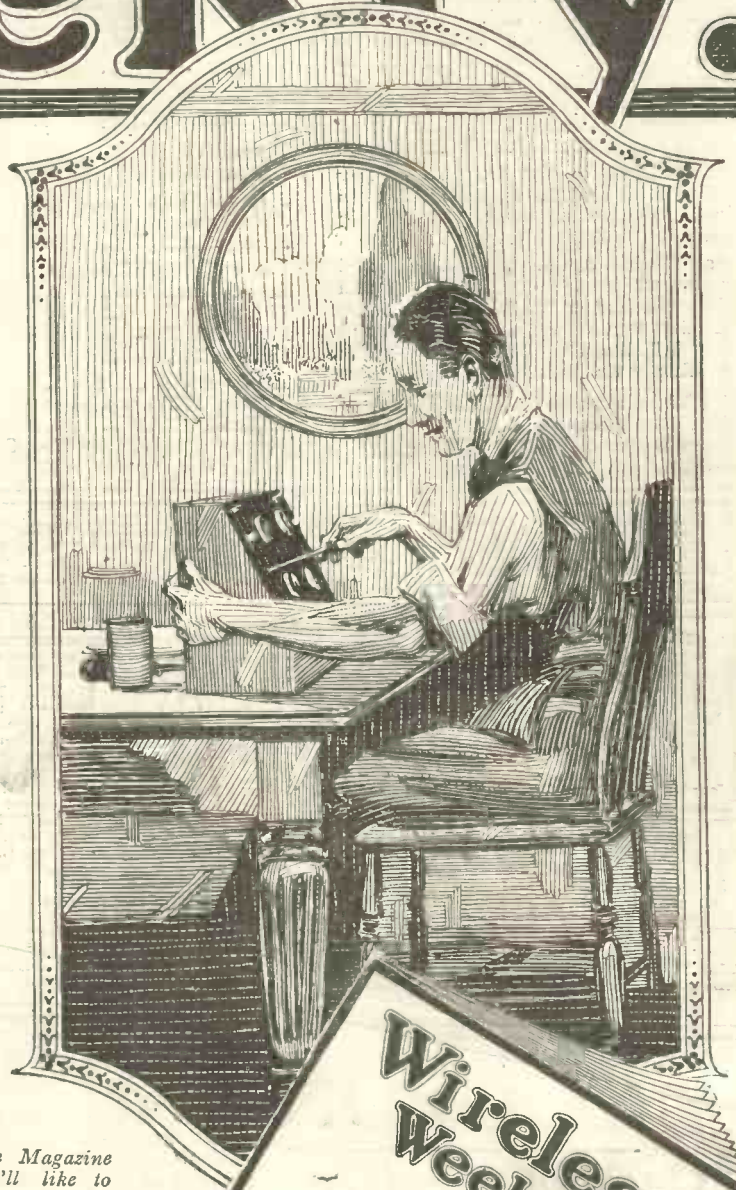

The Magazine you'll like to tell your friends you read.

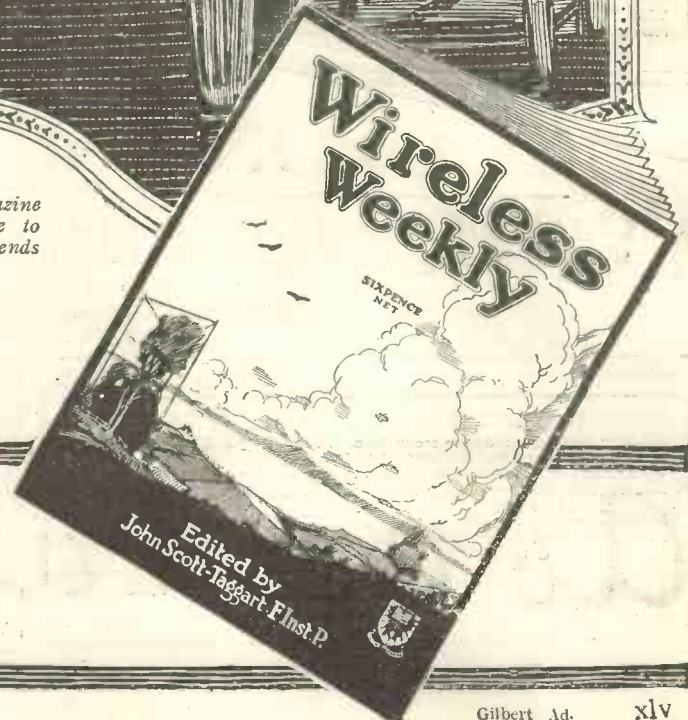

Wireless

Index to Advertisers

	PAGE		PAGE		PAGE	
A.P.A.I.L. ..	Junior Wireless	43	Formo Co. ..	xxxiii	Mullard Radi Valve Co. Ltd.	
Autoveyors Ltd. ..	iv	Fuller's United Elec. Works, Ltd.	xxxiii	(Facing matter) ..	xi	
Ball (T.C.) ..	Junior Wireless	43	Gambrell Bros., Ltd. ..	xxvi	New London Electron Works ..	xxxix
Bell Wireless Co., Junior Wireless	45	General Electric Co., Ltd. (Facing matter)	ix	Peto-Scott Co., Ltd. (The)	xli and Junior Wireless 45	
Bowyer-Lowe Co. ..	xvii	General Wireless Ltd. ..	xxxviii	Premier Telephone Co. ..	xxxix	
Boys (P.H.) & Co., Ltd. ..	xxiv	George Mfg. Co. ..	xxxix	Radio Communication Co., Ltd.	xvi	
British Battery Co., Ltd. (The)	xxxiv	Grafton Electric Co. ..	xxiv	Radio Equipment Co. ..	xl	
British Thomson-Houston Co., Ltd.	xxxvii	Griffin's ..	xxxviii	Radio Instruments, Ltd.	Cover iv	
Brown Bros. ..	v	Holborn Radio Co. ..	xvii	Radiations, Ltd. ..	xxvi	
Brown & Co. ..	xli	H.T.C. Electrical Co. ..	iv	Radio Stocks, Ltd. ..	xxxii	
Burndept, Ltd. ..	xxi	Igranic Electric Co., Ltd. ..	xv	Raymond (M.) ..	vi, vii	
Burne-Jones, Ltd. ..	xi	International Radio Mfrs. ..	xxiv	Robinson, Lionel & Co. ..	xii, xxix	
Buss (T.O.) ..	xx	Jackson Bros. ..	xxxiii	Rowley & Louis ..	xxxix	
Chloride Elec. Storage Co. ..	xxv	Joanes, W. ..	xl	Scientific Supply Stores ..	xxxv	
Clarke (H.) & Co. (Manchester), Ltd.	xxxi	Jones, J. E. ..	Junior Wireless 43	Siemens Bros. & Co., Ltd. ..	v	
Climax Patents Ltd. (Facing matter)	xiv	Laker (John & James) Co. ..	xlvi	Silvertown Co. ..	xxiii	
Cossor Valve Co. ..	xxvii	Leigh Bros. ..	xxxviii	Simpson & Blythe ..	xli	
Dixon (Leslie) & Co. ..	xlvi	Lissen Co. ..	iii	Slider (G. W.) ..	xlvi	
Drummond Bros. ..	xliv	Livingston J. O. ..	Junior Wireless 43	Sterling Telephone and Electric Co., Ltd.	v	
Dubilier Condenser Co. (1921), Ltd. (Facing matter) ..	xiii	London Radio College, Junior Wireless	45	Tingey Wireless, Ltd. (Facing matter)	xii	
Elkay Wireless Co. ..	xxviii	MacDonald, J., & Co. ..	xxxiv	Turnock's Telephone Works ..	xxxv	
Ever Ready Co. (Gt. Brit.), Ltd.	xxix	Marconi Wireless Telegraph Co., Ltd.	xliv	Universal Electric Co., Ltd. ..	xliv	
Falk, Stadelmann & Co., Ltd. ..	xxvii	Melhuish (Rd.) ..	xxxii	Webber, N. V. ..	xvii	
Fallon Condenser Co. ..	xliv	Metropolitan-Vickers Elec. Co. Ltd.	xix	Western Electric Co., Ltd. ..	Cover ii	
Fellows Magneto Co., Ltd. (Facing matter) ..	xiii	M. L. Magneto Syndicate ..	xxxix	Willesford ..	Junior Wireless 45	

EDINBURGH.
Spensers (Scotland), Ltd., 119, George St.,
Edinburgh. Agents for Burndept. Ltd.

WALKERS' WIRELESS
Hold the largest variety of wireless apparatus in the North. Send for particulars.
31, Westgate Road, Newcastle-on-Tyne.

Geo. Wilkinson, Wireless Specialist, 152,
Church Street, Preston (opposite Miller
Arcade). Supplies and Service.



**For perfect tuning use the
G. W. SLIDER.**
You cannot tune a coil inductance correctly without it. Made in nickel plated brass. All first-class dealers stock it, or a sample will be sent to your dealer for your inspection. Ask to see it.
Price 1/- or post free 1/3. From
John & James Laker, 457, Romford Rd., London, E.7



"LAKER" STEEL MASTS. These well-made sectional steel masts are built for Service. The steel tubing is of large diameter (2 inches) having a big margin of reserve strength. "Laker" Masts are easily assembled and erected; they present a handsome appearance when set up. Prices, with accessories painted green, ready for erection.
25ft. 25/- 30ft. 42/- 35ft. 52/- 40ft. 63/- 45ft. 75/-
JOHN & JAMES LAKER, Engineers.
457, Romford Road, London, E.

"EIFFEL TOWER" MASTS.
(Trade Mark) Reg. Des. 694837.
WILKINSON. Lonsdale Road,
Write for Lists. Kibburn, N.W.6.

WIRELESS INVENTORS.
Advice Handbook on Patents and Trade Marks. Consultations free.—B.T. King, Regd. Patent Agent, 146a, Queen Victoria St., E.C.4. Phone: Central 682. 36 yrs. refs.

POST PAID WIRELESS MATERIALS.
Brown's Type A New Ex-Govt. 120 ohm. Headphones, 25s. 60 volt H.T. Battery 6s. Complete Price List Free.—J. H. TAYLOR & Co., Macaulay Street, Huddersfield.

EDINBURGH.
Wm. Sinclair, 60-64, Thistle St., Edinburgh,
All component parts in stock at lowest prices.

SOMERSET.
A. A. TURNEY, Middle Ivythorn, Streets,
Somerset. Wireless Engineer, 1912-1923.
—Experience counts! Portable Set visits anywhere on request.

COUPON

Questions and Answers

In future this coupon must be accompanied with 2/6 P.O.
"MODERN WIRELESS" November, 1923.

USE THIS COUPON

in writing to advertisers in "Modern Wireless."

CUT HERE

In connection with your announcement in MODERN WIRELESS, please supply me with:

Enclosed please find remittance of.....
(Leave blank if not an order)

If an open envelope is used in applying for catalogues a half-penny stamp will cover postage.

Name.....

Address.....

Date.....

ELCTRADIX RADIOMETERS.

Wavemeters from 100 to 10,000 metres. From £2 10 0. New Ex. W.D. Milliameters for Fine Tuning 17/6 to 35/-.
Voltmeters, Panel and Portable. 2 volts to 2,500 volts, 5/- to £5.
Recorders. Wireless Morse linkers make long wave reception interesting. £6 10 0.
Motor Alternators. Wonderful £30 machines for £3. Ex. Aircraft.
Potentiometers. Army 350 ohm 3/6. For details see "Wireless World" or our 3d. Catalogue.
We have many thousand pounds' worth of the pick of Government Wireless gear displayed at our London Showrooms at 9, Colonial Avenue, Minorities (near Aldgate Station).
LESLIE DIXON & CO. Ave. 41