

THE MARCONI REVIEW

No. 35.

March-April, 1932

Editor: H. M. DOWSETT, M.I.E.E., F.Inst.P., M.Inst.R.E.

THE NEW HIGH POWER BROADCAST STATION AT BEROMUNSTER, CANTON LUCERNE

The new transmitter for the Swiss Telegraph and Telephone Administration installed by the Marconi's Wireless Telegraph Company possesses the following characteristics :—

It is capable of introducing into the aerial system unmodulated energy of 60 kw. and of transmitting on any wavelength between the limits of 300 and 600 metres (1,000/500 kcs.).

The frequency constancy of the carrier wave is maintained by the employment of a Marconi valve master oscillator.

The modulation is deep and free from distortion over a range of frequencies between 30 and 10,000 cycles.

The transmitter is of the latest type and possesses many new and novel features, which are briefly described in the following article.

General Description of Equipment.

A GENERAL view of the broadcast station is shown in Fig. 1 and its geographical position in Fig. 2.

The system of modulation employed is that generally termed low power modulation, that is, modulation is introduced into one of the low power stages and the modulated high frequency energy obtainable from this stage is amplified by subsequent stages.

This system of amplification of modulated high frequency possesses certain advantages amongst which are the possibility of increasing at some future time the power radiated by the addition of further stages of amplification or alternatively by the employment of still larger power valves in the final amplification stage.

The transmitter comprises the following principal parts :—

Constant Frequency Valve Drive.

Modulated Amplifier.

Intermediate Amplifier.

The New High Power Broadcast Station at Beromunster, Canton Lucerne.

Power Amplifier.
Main Closed Oscillatory Circuit.
Coupling and Aerial Tuning Units.
Control Desk.

In Fig. 3 is shown the arrangement of the various units each of which is enclosed within a highly polished aluminium and glass case.

The novel method of mounting the units on a raised platform has a pleasing effect and safeguards visitors from coming into contact with parts of the equipment which are of necessity at a high electrical potential during the periods of transmission and moreover has the advantages of providing space under the panels for the accommodation of water pipes, cables and conductors.

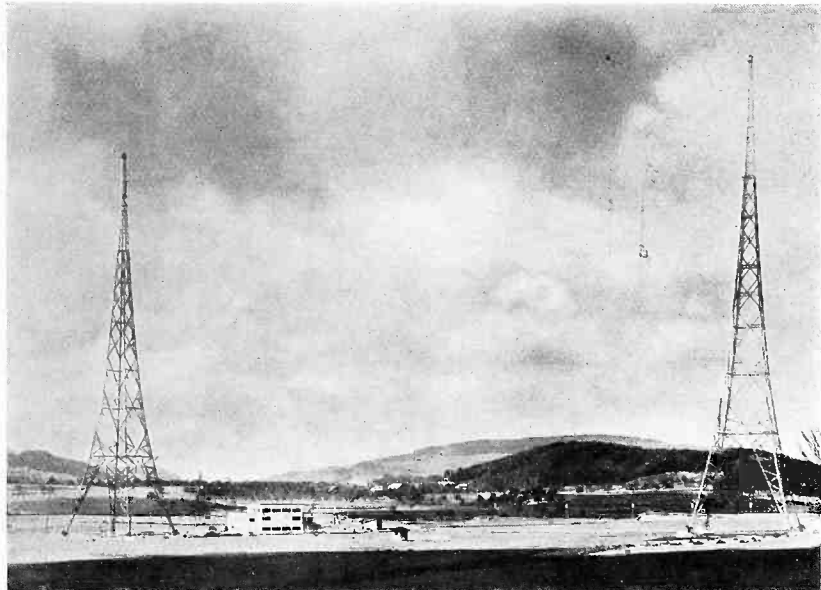

FIG. 1.

Mercury Power Rectifier.

This represents one of the most recent developments in rectifier design, although mercury arc rectifiers have been in use for many years for electric railway and tramway systems.

It has only been rendered possible to employ this system of rectification for extra high voltage by the enterprise of the Marconi Company working in conjunction with the Swiss Brown Boveri Company.

The first high voltage mercury arc rectifier of this type was installed in the high power radio station at Warsaw, Poland. The splendid results there obtained and since improved upon have fully justified the Swiss Telegraph Administration

The New High Power Broadcast Station at Beromunster, Canton Lucerne.

in adopting this system of rectification for their principal broadcast station. To an engineer the robust all-metal construction makes a peculiar appeal and to the electrical engineer the high efficiency obtainable (about 95 per cent.) a truly remarkable achievement.

In Fig. 4 it will be seen that the claim for robustness is justified.

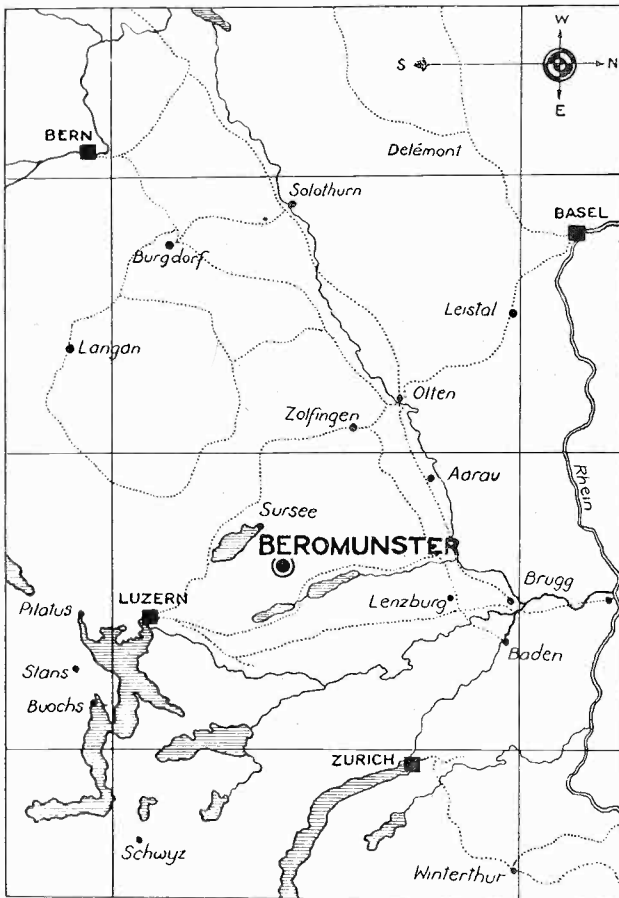

FIG. 2.

metallic arc in a vacuum. The rectifying action is due to the fact that between two metallic electrodes, insulated from each other and in a highly evacuated space, current can only pass if the negative electrode (the cathode) is excited, that is, made hot as a result of electronic emission.

Suitable electrodes are used, one of which is excited. The vapourised electrode material is automatically returned. Thus an apparatus is produced which, on being connected to an alternating current supply, allows current to pass in one

The principle of operation is as follows. The three phase current as obtained from the supply terminals is passed through a voltage regulating transformer, then through the main power transformer to the six phase mercury arc rectifier.

The rectified current thus obtained is then passed through a smoothing or filter circuit to reduce the ripple voltage to a value within .05 per cent.

The electrical characteristics of the rectifier are:—

Input supply :
11,500 volts, 3 phase
50 cycles.

Output voltage
regulation at any
voltage between 5,000
and 12,000 volts.

The full load 270
kw. at 12,000 volts
22.5 amps.

Fig. 5 shows the mercury arc rectifier circuits in schematic form.

The operation of the mercury arc rectifiers depends on the valve action of a

The New High Power Broadcast Station at Beromünster, Canton Lucerne.

direction only. The vapourised electrode material is in fluid form, the metal mercury being made use of.

The arc is struck between an auxiliary striker and the mercury cathode, and subsequently maintained between special pairs of anodes called main anodes. These anodes are supplied from their own transformer which has the neutral point connected to the cathode through an ohmic and inductive resistance.

The cathode spot now maintained at a white heat due to the resistance offered, remains, so long as a current flows from cathode to anode.

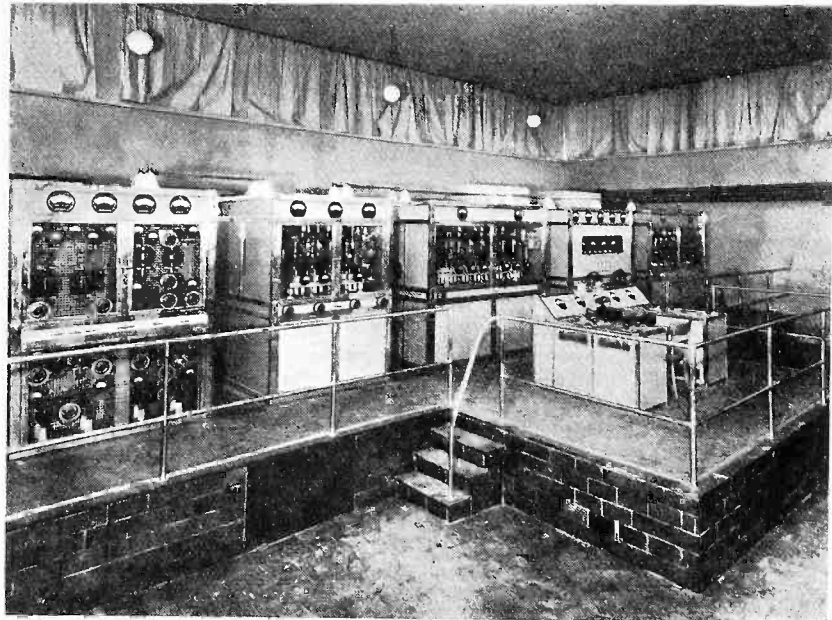

FIG. 3.

The arc is contained in a metal chamber. The insulated mercury cathode is located in the centre of the bottom of the arc chamber or cylinder.

The anode supporting plate forms the top of the arc chamber. The main anodes are spaced in a circle round this plate each having its insulated bushing. Besides these main anodes, there are two smaller excitation anodes (already referred to as maintaining the cathode hot), fed through a single phase alternating current circuit, independently of the main current.

The upper portion of the rectifier, comprising the anode plate, can be raised from the arc cylinder to enable the interior of the cylinder to be inspected. The cylinder is surrounded by a water jacket.

A pump with necessary pipes and accessories is supplied for the circulation of the cooling water, the rate of flow of which will depend on the output of the arc.

The New High Power Broadcast Station at Beromunster, Canton Lucerne.

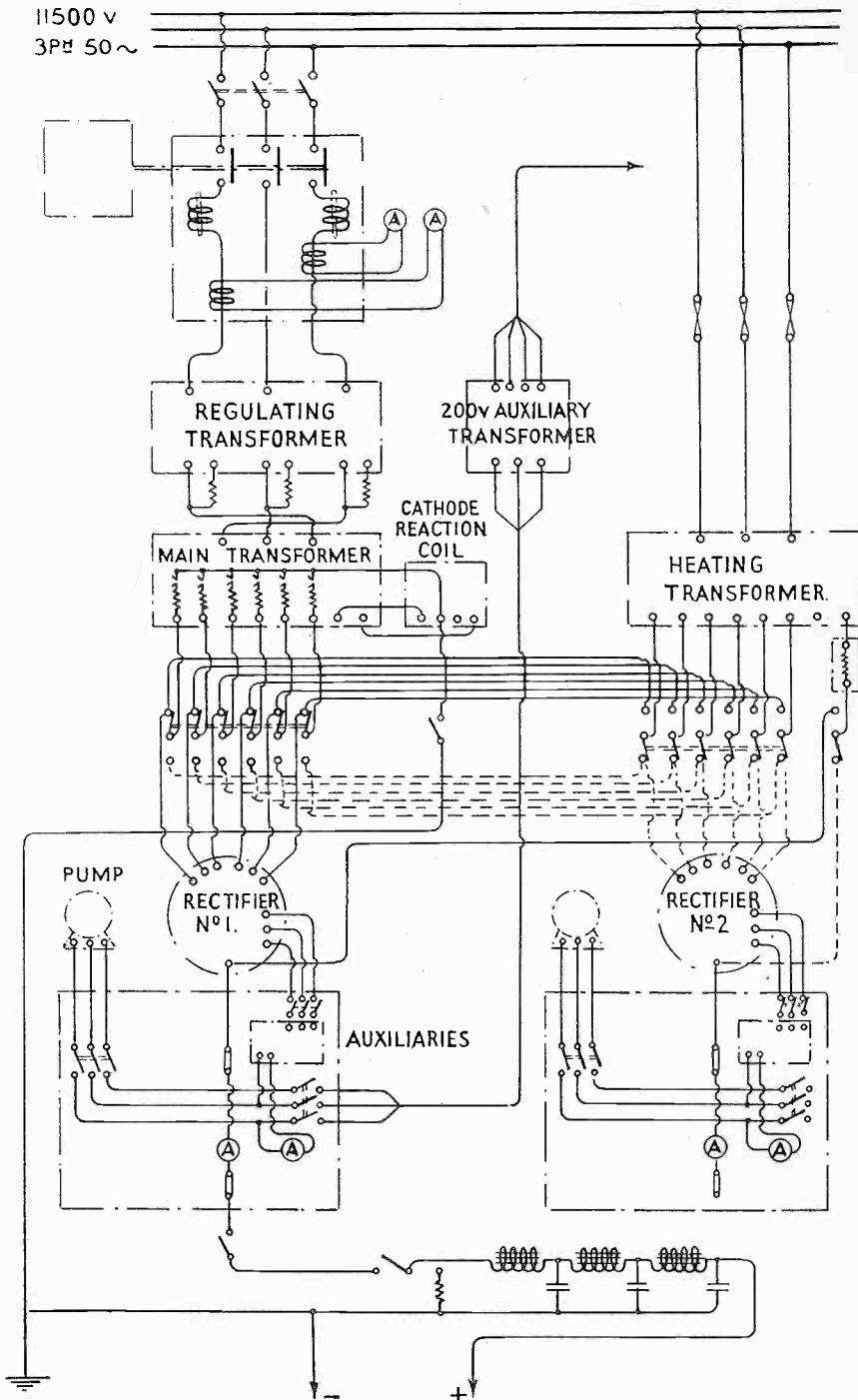

FIG. 5.

In order to indicate the temperature of the anode plate a thermometer is placed in an aperture in the anode plate, and is visible from outside, so that the temperature can be controlled.

To maintain the vacuum inside the chamber, a mercury vapour vacuum pump is mounted directly on the anode plate, and a motor-driven auxiliary oil vacuum pump is mounted on an insulated bedplate. These pumps are automatically controlled, and the degree of vacuum is indicated by means of an electrical device.

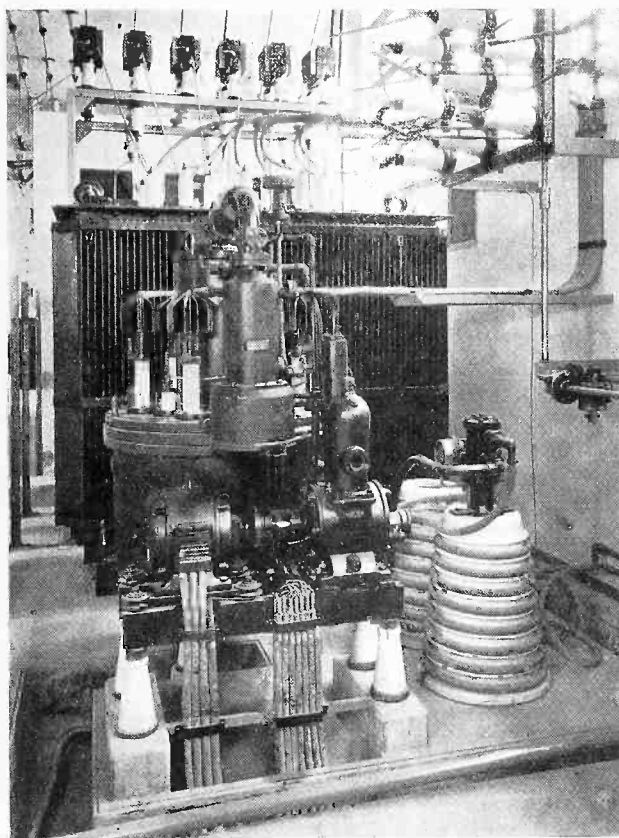

FIG. 4.

temperature within the chamber is kept constant to within narrow limits by means of an automatic thermostat and relay working in conjunction with heater lamps.

The master oscillator operates at one half the desired frequency and is used to drive the frequency doubling circuit, consisting of a screened grid valve and the necessary H.F. circuits for harmonic selection of the required stabilised frequency.

The starting up and shutting down of the rectifier is simple, and is effected by a remote control panel which closes the circuits of the starting and exciting rectifiers, thus starting up the ignition and excitation of the rectifier, at the same time starting up the water cooling system.

Control of the D.C. output volts of the rectifier is brought about by the use of a remote controlled oil immersed switch connected to numerous taps of a transformer on the primary alternating current supply to the arc. In this manner the D.C. output volts can be regulated in steps from half to full value.

Constant Frequency Master Oscillator.

The constant frequency master oscillator unit consists of an aluminium case containing the master oscillator valve with its massive tuning coils and condensers which is placed within a heat insulated chamber. The tem-

The 1st and 2nd bridge isolator circuits comprise two cascaded stages of accurately balanced bridge amplifier circuits, so arranged that there is no back reaction to the drive.

The 2nd bridge mounts 4 Type L.S.5 valves and has sufficient output to drive the next magnifier stage.

The master oscillator circuits are energised from storage batteries.

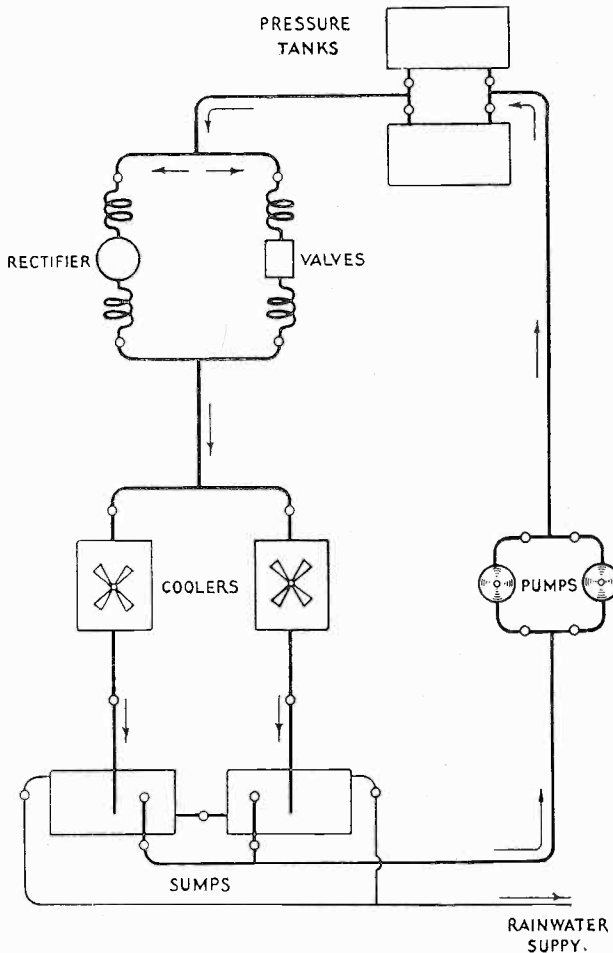

FIG. 6.

so that no grid current flows. This is in order that the load on the drive shall remain constant and completely free from any inter-actions from the subsequent modulated stages.

The isolator is directly coupled to the succeeding stage (modulated amplifier) by means of a variable connection on the anode tuning inductance.

H.F. Magnifier.

The high frequency magnifier circuit consists of a Type D.E.T.2 valve completely isolated in a screening box, and complete with all necessary apparatus for high frequency magnification of the output from the master oscillator.

The filament current for the valve is taken from the D.C. 25-volt supply, the anode being fed from an H.T.-D.C. motor generator which also supplies the anode voltage for the next stage. The H.F. magnifier stage is inductively coupled to the succeeding isolator stage by means of a variable coupling.

Isolator Stage.

The isolator consists of one Type D.E.M.2 valve mounted in a screened case, complete with H.F. inductances, condensers and necessary indicating instruments. The filament current is supplied from the main filament lighting machine.

The circuit is neutralised and the valve is provided with a negative grid bias adjusted

Modulated Amplifier.

The modulated amplifier consists of one Type D.E.T.3 valve mounted in a screened case, complete with H.F. inductances, condensers and necessary indicating instruments. The anode voltage is taken from the 3,000 D.C. supply, and the filament current is supplied from the main filament lighting machine. The circuit is neutralised and the anode supply is connected through an iron core choke coil for purposes of modulation.

The modulated amplifier is inductively coupled to the succeeding stage (intermediate amplifier) by variable coupling coils tuned by a variable condenser.

Modulator and Sub Modulator.

The modulator and sub-modulator consists of one Type M.T.9l valve and one Type D.E.T.2 valve mounted in a screened case, complete with coupling resistances, condensers and necessary indicating instruments. Both valves are fed from the H.T.-D.C. machine. The current for the filaments of the modulator (M.T.9l) and the sub-modulator (D.E.T.2) is supplied from the main filament lighting machine.

The modulator is resistance-capacity coupled to the sub-modulator, and the latter is arranged for transformer coupling to the final stage speech amplifier. The design of this stage is such that full modulation of the modulated amplifier is obtainable before grid current is reached in the modulator.

Spare Valve Holders.

Spare valve holders are provided so that in the event of a failure a reserve valve can be switched into circuit.

Intermediate Amplifier Unit.

The intermediate amplifier consists of two water-cooled valves mounted in a screened aluminium framework, complete with H.F. inductances, condensers, water-cooling apparatus and necessary indicating instruments. The valve filaments are heated from the main filament lighting machine, and the anode voltage is taken from the main power rectifier supply at approximately 10,000/12,000 volts. The circuit is neutralised, and a high negative grid bias is provided so that comparatively small power is required for the modulated amplifier to drive this stage.

Two spare valve holders are included so that a reserve valve can be switched into circuit on either side of the bridge balance, in case of failure of the working valve.

The intermediate amplifier is coupled to the succeeding stage (main amplifier) by variable coupling condensers and tuned by a variable inductance.

Power Amplifier Unit.

The main amplifier consists of two screened frameworks each mounting eight Type C.A.T.6 water-cooled anode valves, complete with water-cooling apparatus and necessary indicating instruments. A spare valve holder with H.T. switch is provided in each panel so that a reserve valve may be switched in circuit. The

The New High Power Broadcast Station at Beromunster, Canton Lucerne.

filament current is supplied from the main filament lighting machine and the anode voltage is taken from the main rectifier supply at approximately 11,500 volts, a motor generator being used to provide the grid bias potential. Modulation indicators are fitted to the grid and anode circuits of this amplifier.

The peak voltmeter consists of a two electrode rectifying valve connected in series with a blocking condenser across the terminals of which it is desired to measure the peak voltage. In parallel with the anode filament circuit of the rectifying valve is connected a moving coil milliammeter in series with a high resistance. The resistance is of such a value that the milliammeter can be calibrated to give an indication of the voltage across the rectifying valve and hence the peak volts across the terminals to which the apparatus is connected.

The ratio of the indications on the power amplifier anode peak voltmeter when the transmitter is unmodulated and again when being modulated thus gives an indication of the modulation of the transmitter.

High Frequency Circuits.

The main power amplifier closed oscillatory circuit comprises a copper tube inductance, two air dielectric high tension condensers and two oil dielectric tuning condensers. The whole of this portion of the equipment is completely enclosed in an aluminium case in order to secure freedom from reaction with any one of the prior circuits.

From the coupling winding is taken a pair of feeder lines which convey the modulated carrier wave energy to the aerial coupling circuits placed in the feeder house under the aerial.

The feeder lines, where they pass through the transmitting room, are shielded by encasing copper tubes.

In the feeder house are the aerial tuning inductance, condensers and coupling coil as required for tuning the aerial system to the working wavelength and coupling the feeder system to the aerial.

Control Unit.

The system of automatic central control of the broadcast transmitter has been highly developed. It has been rendered possible for the station attendant when seated at the control desk to operate, control and supervise the proper operation of the complete transmitter.

A complete range of measuring instruments is mounted on the front of the unit. These serve to provide means for correctly adjusting the principal circuits.

The lamps and audible signals indicate when the control circuits are or are not properly completed. Press buttons are fitted controlling the various automatic circuit breakers.

This unit is built of polished aluminium and takes the form of a writing desk.

Aerial System.

The aerial system which is of the T type, is suspended from a pair of 125 metre lattice steel insulated towers placed 200 metres apart. Directly underneath the aerial down lead is placed the feeder house containing the aerial tuning and coupling units.

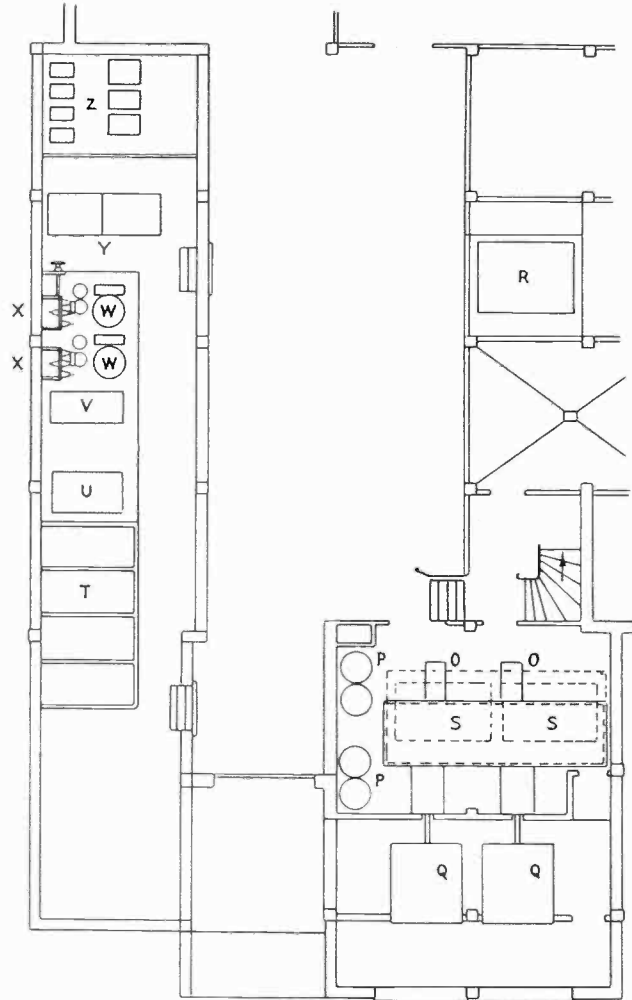

FIG. 7.

In order to secure minimum losses, the towers are insulated from ground and the high frequency and modulated energy is brought from the transmitting station at a distance from the aerial system by means of an aperiodic feeder circuit of low loss and negligible radiation.

Owing to the large number of thunderstorms which occur in this mountainous district, special lightning protection is provided for at the base of the towers, and at the point where the aerial is led into the feeder house.

Earth System.

This consists of a number of metal plates buried vertically in the ground in the form of two concentric circles of earth plates. These rings of plates are connected by insulated wires to the main earth terminal in the feeder house.

The earth system is further extended in a radial fashion under the aerial by a large number of copper wires buried in the ground and extending practically over the whole of the site.

The principal electrical characteristics of the aerial system are :—

Capacity, .0007 m.f.

Natural period, 720 metres.

Effective resistance for the working wavelength of 459 metres, 50.4 ohms.

Electric Power Supplies, Motor Generator and Switchgear.

The electric power required for operating the broadcast installation is obtained from the 3 phase 50 cycle supply at approximately 11,500 volts and transformed down to a low voltage supply at 380 volts as required for the motor generators and auxiliary circuits. The power supply is 11,500 volts for the main power mercury arc rectifiers.

The high voltage direct current required for feeding the power amplifiers is provided by a Brown Boveri mercury arc rectifier, already described.

The mercury arc rectifier chambers are duplicated and means are provided for switching either one into circuit.

Duplicated motor generators are installed for the purpose of providing the low voltage direct current required for heating the filaments of the power valves, grid negative supplies and for the H.T.-D.C. supply required for the modulated amplifier stage.

An all-metal built-in main power switchboard is provided for the purpose of controlling the various machines and auxiliary circuits, excepting the accumulator battery circuits, which are separately controlled from another switchboard installed in the transmitter room.

The total electric power required for operating the transmitter at full power (60 kw. 75 per cent. modulation), is approximately 260 kw.

Electrical characteristics of plant :—

Arc Rectifier, D.C. Output	270 kw. 12,000 volts.
Filament Lighting Motor Generators	1,200 amps. 10/25 volts. Exciter 110 volts.
Grid Negative Motor Generators5 amps. 1,500/2,500 volts. .5 amps. 350/500 volts. .4 amps. 200/300 volts.
Modulated Amplifier H.T. Generators5 amps. 2,500/3,000 volts. Exciter 110 volts.
Water-cooling Radiators, each	Heat dissipating capacity 92,000 g.c. per hour.

Valve Water Cooling Equipment.

The system employed for cooling the water after it has been passed through the valve water jackets is shown in Fig. 6.

The essential features are :—

- (A) Closed circulating system. By this method the same water is continuously circulated through the valve jackets. The heated

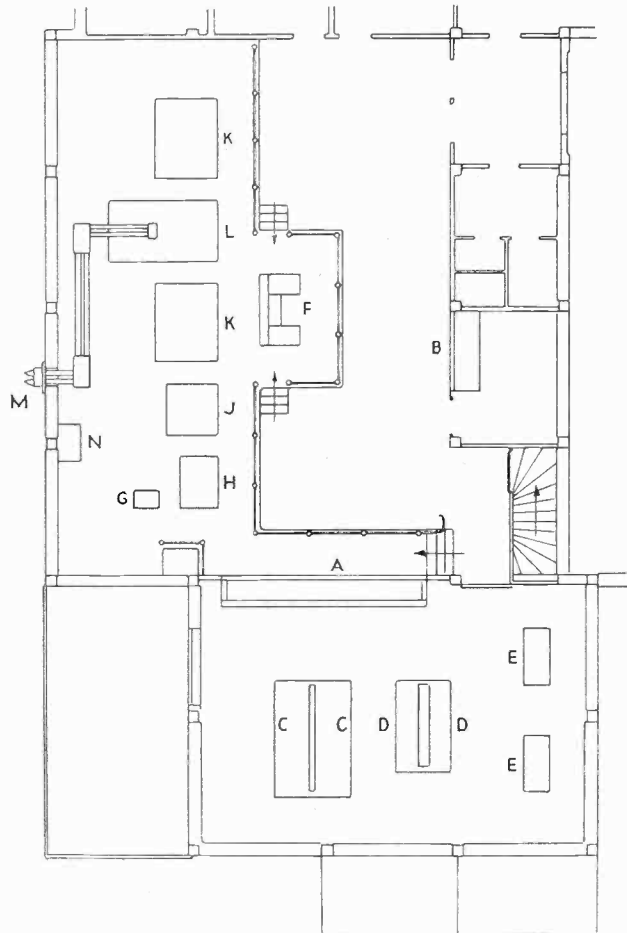

FIG. 8.

water as it comes from the valves is cooled by passing it through a tubular radiator through which is forced a blast of air by means of a motor driven fan. By the use of a closed circulating system it is rendered possible to use pure water of high electrical resistance for cooling the valves.

- (B) Air pressure water feed tanks. This method provides a supply of cooling water at the correct pressure for cooling the valves.

and the need for mounting overhead tanks is obviated. Further, the whole of the water cooling plant can be placed in the basement of the building. This simplifies the problem of preventing freezing during the winter months. Also the water pressure to the valve can be conveniently regulated to meet requirements. A complete set of automatic and semi-automatic controls is provided in order to secure a reliable and continuous supply of cooling water to the valve jackets at the required temperature, pressure, and volume. The water cooling system is in duplicate and the capacity is such that only one half is in service under normal conditions.

General Arrangement of Installation.

In Fig. 7 is shown the position of the plant in the ground floor of the transmitting building.

The air cooled radiators (Q) are contained within an enclosure. The fresh air is taken in at the right, blown through the radiators and exhausted into the air in front of the coolers. The two pairs of pressure water tanks each of 900 litres capacity, are shown on the left.

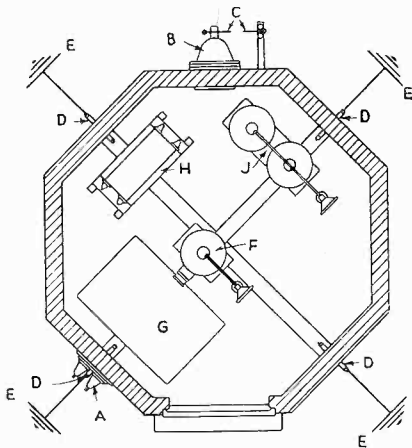

FIG. 9.

The duplicated pumps (O) are mounted over the covers of the inter-connected twin sump tanks.

On the left there is the H.T. enclosure and the power supply cubicles (T). Rectifier power regulating transformer (U), Power transformer (V), and alongside are the duplicated mercury arc rectifier chambers (W), with their auxiliary apparatus, insulating coils, oil and mercury vacuum pumps and heating transformer.

At the far end of the enclosure is the H.T.-D.C. switch panels (Y), and behind these are the H.T. condensers and chokes comprising the smoothing circuit (N) for the rectified alternating current. On the left is shown the rain water storage tank (R).

In Fig. 8 is shown the layout of the plant and equipment on first floor.

The main power control switchboard (A) is built into the wall dividing the transmitting and machinery rooms. The battery charging switchboard (B) is also of all-metal construction and built in, and provides for the charging of the accumulator batteries required for supplying current H.T. and L.T. for the drive and speech input units. This latter unit is placed in the engineer's office. Items (C), (D) and (E) are the valve filament heating, grid negative and modulated amplifier H.T. motor generator sets.

The New High Power Broadcast Station at Beromunster, Canton Lucerne.

The desk type control unit (F) is placed in front of the main transmitter panels ; valve drive unit (G) is next to the combined modulator and modulated amplifier unit (H).

(J) is the intermediate modulated amplifier. (K) and (K) are the main power amplifiers unit, (L) contains the main closed high frequency circuits within a screened enclosure from which a pair of feeder lines lead to the feeder terminal unit (M), placed in the wall of the building, (N) is the mercury arc rectifier remote control unit.

The feeder house is placed underneath the centre of the aerial system and within this building are placed the following units, as shown in Fig 9 :—

- (A) Feeder Lead-in Insulators.
- (B) Aerial Lead-in Insulator.
- (C) Aerial Lightning Arrestor.
- (D) Earth Lead-in.
- (E) Earth Connections.
- (F) Feeder Condenser.
- (G) H.T. Air Condensers.
- (H) Aerial Inductance.
- (J) Aerial Tuning Series Condenser.

H. A. EWEN.

ECHO SIGNALS IN TRANSATLANTIC PICTURE TELEGRAPHY.*

By H. M. DOWSETT.

PART I.

The Paper describes the various types of multiple signals and their causes, the influence of the Heaviside layer, and then gives a history of investigations carried out by the Marconi Company into short wave propagation phenomena covering the period from 1925 to 1931.

The facsimile echo signals discussed were all received at the Somerton Station of Imperial & International Communications, Ltd. They were transmitted on the dates given from the New York station of R.C.A. Communications, Inc., the Montreal station of the Canadian Marconi Company, and the Capetown station of Overseas Communications of South Africa, Ltd. The research was in charge of Mr. T. L. Eckersley, and Mr. K. W. Tremellen was responsible for the signal strength measurements quoted.

General.

THE subject of echo signals, which I have been invited to discuss in the present paper, concerns the now well-known phenomenon that a single dot signal transmitted by short wave radio to a distance, when received on a tape or photographic recorder running at a sufficiently high speed, may be found to have become split up during its passage through the atmosphere into a series of dots instead of one dot, thus producing the effect of a repetition of the signal or what is called "multiple" or "echo" signals.

The importance of the study of this subject is becoming widely recognised, as it bristles with problems that are vital to the art of radio communication, and the efforts of the physicist, the mathematician, the engineer, and the inventor are therefore being applied in an increasing degree to their solution.

The existence of echo may impose a serious limitation on the speed at which we can transmit telegraph signals without serious distortion of wave form and readability; it may render telephony unintelligible, and restrict the speed of facsimile to that at which the echo images overlap the main image. How best to eliminate echo has therefore become one of the major problems of radio.

The presence of echo is not always, however, a bad feature. In slow speed transmission the energy of the echo signal is added to that of the main signal so that the field strength at the receiver is increased; and as echo exists as a result of the electrical characteristics of the medium through which the signals are propagated, a systematic study of echo periods has enabled the mathematical physicist to fill in many gaps in our knowledge of the state of the upper atmosphere where the wave propagation takes place.

* A Paper read on December 9th, 1931, before the Television Society at University College, London.

Antipodal Effects.

It had been anticipated by Marconi and others that signal broadcast from any given station would travel in all direction round the world and converge at the Antipodes, so that a greater field strength would be found in the antipodal region than just outside it.

This was actually proved by field strength measurements made on board the sloop *Aldebaran* during her voyage to the Pacific in 1920 to study radio propagation phenomena for the French Government. As reported by M. Guierre, it was found for instance that signals from Lyons on 15,100 m. increased at the Antipodes so that they were stronger than those from other European stations, and when the ship reached the Antipodes of Nantes, wavelength 11,000 m., a similar strengthening of the Nantes signals was noticed.

Long Wave Interference Effects.

The first recorded case of interference effects being observed between signals, which were proved to be arriving by different paths from the same transmitting station was in March, 1922, when N. M. Rust, an engineer of the Marconi Co., who had been sent to South America with apparatus for the measurement of signal strength, and the direction of signals, to obtain information required for the design of the long wave stations projected for the Imperial Chain, made the following report from Cabo Frio, Brazil:—

“With this adjustment we determined that NPO (Cavite, Philippine Islands) came in entirely from the East. . . . Later we found NPO coming in weakly from the West and decreased in the East. At a certain point the two intensities were equal. . . . With a bi-directional receiver very peculiar effects were noted. The two waves coming around the earth in opposite directions over different paths, were constantly changing in their phase relations, and consequently interfered, sometimes adding, sometimes cancelling. . . . Under these conditions NPO was unreadable on a bi-directional receiver because of the interference, but was readable with a uni-directional receiver with maximum either East or West.”

The wavelength of NPO was 14,300 m.

Almost at the same time, a similar effect was recorded by another Marconi engineer, K. W. Tremellen, engaged on the same work on the S.S. *Dorset*. In a report from Auckland, New Zealand, dated March 29th, 1922, he wrote:—

“About the 18th March, 1922, a peculiar effect was noticed on Rocky Point. His signals were blurred. . . at first we thought his key was sticking or he was being interfered with by another C.W. station on the same wave. . . and we got an idea that signals were coming both ways round and interfering with themselves. . . this effect has been noticed right up to Auckland and has been chiefly noticed on WQK (Rocky Point), WGG (Tuckerton), and to rather less extent on WII (New Brunswick) and WSO (Marion), with a suspicion on OUI (Hanover) and POZ (Berlin). . . it seemed rather incredible that signals should come round the wrong way from NY (New York) even though it is the dark way.”

These observations of Tremellen's were actually checked by him with a direction finder and confirmed. The wavelengths concerned were of the order of 16,000 metres.

It may be remarked that interference effects between long waves have a greater likelihood of being observed when the receiving station is several thousand miles away from the transmitting station.

The proof that a long wave signal is able under certain conditions to completely encircle the earth is not easy to obtain, but that this effect does occur was verified by N. M. Rust in the winter of 1923, when using a Bellini-Tosi aerial giving a heart-shaped diagram at Chelmsford, so arranged that its minimum was in the direction of Carnarvon. This aerial normally received clearly defined weak signals from Carnarvon, wavelength 14,000 metres, obviously arriving by the direct route. Occasionally, however, at certain periods in the morning, when conditions were favourable for round the earth reception, a beat effect was noticeable similar to that observed in Brazil, which was explained by the interference between the direct ray and the round the earth ray travelling in the opposite direction.

Short Wave Round-the-Earth Echo Signals.

Echo signals were reported by A. W. Langridge in July, 1925, when listening at Brentwood to signals from Poldhu on 25 metres. They occurred at a time after sunset which we now know to be a suitable one for the propagation of round the earth echoes on this wavelength.

During the month of June, 1926, echoes of the order of one-seventh second corresponding to the complete circuit of the earth were regularly observed at Broomfield by K. W. Tremellen, following the signals from the short wave transmitter AGB (Berlin) on 26 metres. These echoes occurred about the sunset period, the echo signals following the shadow band at this time.

Short Wave Echoes due to Scattering.

From the commencement of short wave working, a type of echo signal which produced a blurring effect had been noted, having an interval of one-twentieth or one-thirtieth second after the receipt of the main signal. These echoes were investigated at Chelmsford on the cardioid direction finder in 1926.* They were specially marked at times during the dark hours on signals from AGB (Berlin) 26 metres, and whereas the direct signals from Berlin were received from the East, these echo signals were shown by the cardioid receiver to be coming at this time from a westerly direction. The distance could be calculated, and it was found that they came from a reflecting or scattering region within the skip distance.

A region of this type is never very clearly defined.

These echoes are troublesome because the main signal in the skip is received by the direct ray, and is frequently weak. Echoes of this nature were first photographically recorded by Quack, and by Taylor and Young.

* T. L. Eckersley, "Short Wave Wireless Telegraphy." Journal I.E.E. Vol. 65, 1927.

Short Wave Echoes due to Multiple Reflections.

The attempts made by the Marconi Co. to introduce high speed facsimile between Somerton and New York in July, 1928, brought to light the existence of a type of very quick echo having a lag on the main signal which may be anything from 0.0007 to 0.006 second.†

These so-called echoes have a strength comparable with that of the main signal, and cannot be separated from it. In fact it seems clear that they really form part of it, being due to rays which reach the reflecting and refracting layer at a slightly different angle to those which constitute the main signal.

Very Long Period Echoes.

There are in addition echoes which are very rarely observed, having a period from one to two seconds up to several minutes, the cause of which is still unknown.

They are of scientific interest only at the moment and need not be discussed here, as they affect commercial working no more than does an occasional atmospheric.

Of these various types of echo, the echoes due to scattering and the echoes due to multiple reflections are the most serious in their distortion effects on the shape of high speed signals, whether the transmission considered is telegraphy, facsimile or television.

The Propagation of Short Waves through the Atmosphere.

If we are to understand the conditions that produce these types of echo, we must study the manner in which the electro-magnetic waves are propagated through the medium and the general characteristics of the medium.

We know for instance that if an aerial is radiating about 1 kw. on a wavelength of about 20 metres during daylight, the field strength falls off quickly with distance, so that at about 100 k.m. away telegraph signals may be too weak to read, but if we continue to increase the distance from the transmitting aerial we find that the signals come on again at about 800 km., and increase in strength for another 100 km. or so before commencing to gradually fall off once more.

By using a frame aerial receiver, it can be shown that the signals up to 40 or 50 km. are carried by rays which travel almost parallel to the earth, and therefore they remain in the lower atmosphere, whereas those which are received at 800 km. and over are conveyed by rays which reach the earth from the upper atmosphere at an angle of 20 to 30 degrees with the ground.

In this case, propagation is said to take place by "direct ray" for the first 40 or 50 km., and by "indirect ray" beyond 800 km., and the range between 40 or 50 km. and 800 km., where signals are either weak and unreliable or vanish altogether is called the "skip distance."

† T. L. Eckersley, "Multiple Signals in Short Wave Transmission." Proceedings Inst. Radio Engineers. Vol. 18, No. 1, January, 1930.

The Heaviside Layer.

As the indirect ray reaches the earth at an angle, it must have passed through a region in the atmosphere which is capable of bending it down, or refracting it, and this region is called the Heaviside layer.

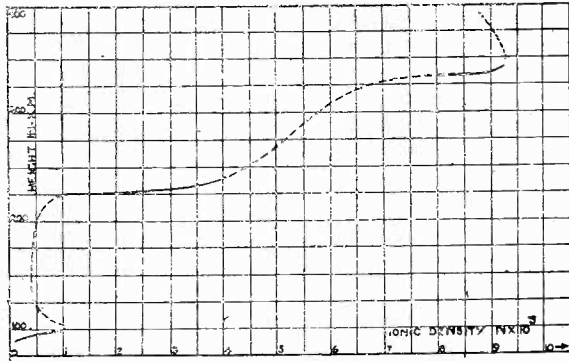

FIG. 1. *Ionic density in the Heaviside Layer.*

The present day explanation of why these short wave rays are bent down again to the earth is as follows:—

We know that the upper atmosphere is ionised, and twenty years ago it was shown by Eccles that if the ionic density is great enough, and the air pressure is so low that the free path of the electrons between the gaseous ions is sufficient for them to respond to the ray impulses without such motion involving collisions with these ions, or with the neutral molecules, then the motion

of the electrons should impart a phase shift to the wavefront of any electro-magnetic pulse in the medium, causing the wavefront to bend forward and the rays in consequence to bend downward.

Experimental research of late years has done much to confirm this theory, but it will be realised that in order to calculate the strength of signals at a distance this theory must be strongly reinforced with data, and there are several factors which we require to know.

We have to determine

- (A) The height of the Heaviside layer.
- (B) The ionic density in it.
- (C) The density of the air in this region.
- (D) The mean free path of the ions at this height.

The range obtainable on any of the short wavelengths is also found to depend on the height of the sun relative to the great circle through the transmitting station in the direction considered.

The sun in fact is responsible for the ionisation in the daytime of that part of the upper atmosphere which is immediately below the main Heaviside layer, and this introduces another factor we require to know:—

- (E) The re-combination factor which takes into account the change in the ionic density from daylight to night conditions.

The experimental and mathematical research work of many investigators in this country, in the United States and in Germany, particularly of Eckersley, Appleton, Breit, Tuve, Dahl, Kenrick and Jen, has enabled us to form a physical picture of the Heaviside layer and its general characteristics, which is as follows:—

Ionic Density, Refraction and Absorption in the Layer.

At a level of about 80 km. above the earth, the ionic density in winter is becoming appreciable, and the mean free path between atoms is increasing, but it is not until a region of about 100 km. above the earth is reached, where the ionic density N has a value of 10^5 per c. cm., and the mean free time between collisions lies between the limits $0.5 + 10^{-6}$ and $0.5 + 10^{-7}$ § that conditions exist which can cause the incident indirect rays of certain frequencies to be refracted down to earth again.

The lower limit of free time would allow ray frequencies corresponding to wavelengths of 150 metres and less to be refracted, while the upper limit would reduce the value of maximum wavelength to be refracted to 15 metres.

Above these limits of wavelength, and certainly above 150 metres, refraction must be accompanied by absorption as ionic collisions take place within the periodic time of one oscillation. For all wavelengths above 1,000 metres, no ray passes through the 100 km. layer, they are all absorbed in it. While there is some bending at all these wavelengths, the lower angle rays travel greater distances than the rays of high angle, as there is less absorption in the lower atmosphere than in the layer.

Wavelengths from 1,000 metres down to 100 metres are also all confined below the 100 k.m. layer, but they experience in the lower atmosphere an increasing absorption and a decreasing absorption in the 100 km. layer as the wavelength is made shorter. Reflections from the layer therefore increase as the wavelength falls.

From 100 metres down to about 70 metres it would appear that in general the 100 km. layer reflects all rays up to vertical incidence, but occasionally the ionic density is not sufficient to completely confine all the higher angle rays of the shorter wavelengths, and these escape through to a still higher layer at an elevation of about 212 km., where the ionic density is approximately 2.4×10^5 per c. cm., or about $2\frac{1}{2}$ times the density of the 100 km. layer. This second layer refracts down to earth all the high angle rays of the 100 to 70 metre wavelengths that escape through the lower layer. It is on these wavelengths that multiple signals are very pronounced. From 70 metres down to about 9 metres there is every indication, confirmed in particular by T. L. Eckersley's analysis of echo signals obtained on a Transatlantic facsimile channel, that the lower angle rays are refracted by the 100 km. layer, rays of a greater angle are refracted down at the 226 km. layer, and there is also strong evidence of refraction at a height of about 340 km., where the ionic density is about 9×10^5 per c. cm., or nearly 10 times the maximum value of N at the 100 km. level, and is sufficient to bend down all the high angle rays of the longer wavelengths of this group which escape through to it, and most of the high angle rays of the shorter wavelengths of the group.

Thus from some facsimile echoes obtained on 22 metres between New York and Somerton, it was calculated by Eckersley that the maximum ray angle was 9° for the 100 km. layer, higher angles were refracted from the 340 km. layer, and some rays up to vertical incidence escaped completely through the 340 km. layer.

§ T. L. Eckersley, "An Investigation of Short Waves." *Journal I.E.E.* Vol. 67, p. 992, 1929.

Echo Signals in Transatlantic Picture Telegraphy.

While it appears to be established that there is a distinct fall in ionic density between the 100 km. and 212 km. levels, as indicated in Fig. 1, there is some likelihood that there is a gradual increase in ionic density from the 212 km. level to the 340 km. level, above which our probing methods have not succeeded in penetrating.

At 15 metres, the 340 km. layer does nearly all the refraction that occurs, and high angle radiation escapes through it to an increasing degree. At wavelengths less than 9 metres signals are conveyed by direct ray only, as all rays that reach the Heaviside layers pass through them.

Such in brief is the picture which is presented to us of the refracting region of the upper atmosphere during daylight, and in winter, to which we have to look for an explanation of the very quick echo which has been found to be so prevalent in Transatlantic facsimile.

In summer daylight the ionisation is greater, and the lower parts of the layers are therefore nearer to the earth. As the ionic density is greater, more high angle rays are bent down to the earth, so that multiple echoes should increase, and as the shorter wavelengths will not escape through the layers so easily, they will become more available for long distance communication.

It can be shown that if the gradient of the ionic density remains the same, then the signal strength at all points will be the same if $\lambda^2 N$ remains constant.

Thus let the normal density N fall in winter to half what it is at the same hour in summer, then the same strength signals will be given in winter by a wavelength 1.4 times the summer wavelength. The normal density, however, does not vary as much as this.

As soon as the sun has passed the zenith, the ions commence to re-combine. They are in no great hurry about it, as it appears that the ions at the 340 km. level are free for about four hours. At nightfall the density throughout the layer has become considerably less, but the minimum point is reached just about sunrise. The lower fringes of the layer are now higher than before, although they are still within 20 miles of the normal. There is less absorption at the 100 km. level and more at the 340 km. level. More high angle rays escape through than during the daytime, so that signals on a given wavelength should be weaker and there should be less echo, and a longer wavelength should give stronger signals than the original daylight wavelength.

(To be continued.)

CAN

DIRECTION FINDERS

TYPES D.F.G.9A & D.F.G.9B

The Direction Finder Type D.F.G.9a has been designed principally for use with the small type of shielded frame aerial, and this combination has proved particularly suited to naval conditions where rapid manipulation, both as regards waverange change and directional observation, are of prime importance. In order to extend the usefulness of this instrument into the general purpose category, subsequent modification has resulted in the model styled D.F.G.9b, and these two instruments represent the Marconi Company's most recent development in this class of work.

The Type D.F.G.9a receiver is described in this article and will be followed by a description of the D.F.G.9b at an early date.

WITH regard to the design of Direction Finding apparatus for naval work, modern demands impose four important conditions in addition to the usual requirements of range and accuracy.

- (1) The reception diagram must be capable of denoting the direction of a distant transmitter by a sharply defined "zero" signal.
- (2) Simple tuning and rapid waverange change.
- (3) All vital component parts of the apparatus must be easily accessible for inspection and maintenance.
- (4) The mechanics of the complete assembly must be sound in every detail.

In the Direction Finder D.F.G.9a, the well-established advantages of the aperiodic Bellini-Tosi system have been retained, but the entire design is based on the above specified conditions.

The first important feature is the inclusion of a supplementary circuit (coupled to the amplifier) for the purpose of sharpening scale definition at the point of "zero" signal.

The tuning condensers and also the H.F. transformers of the main amplifier are ganged and a separate heterodyne is employed for the reception of C.W.

The complete amplifier may be withdrawn or removed entirely from the instrument assembly without disconnecting a single wire, and the action of withdrawing the amplifier automatically breaks both H.T. and L.T. supplies.

Carefully machined castings ensure reliable mechanisms and sturdy construction.

This instrument is intended to be combined with Frame Aerial Type 354N/32, which is illustrated in Fig. 1.

The complete instrument, which is shown in Fig. 2, comprises two main units :—

- (1) The radio-goniometer.
- (2) The amplifier and associated circuits, which include zero sharpening device and a local oscillator.



FIG. 1.

The goniometer is of recent pattern with large open scale and double ended pointer. Field coils have spaced windings of low inductance, and the search coil, which is loosely coupled, is tuned over the entire waverange of 300-4,000 metres. For the purpose of quadrantal correction, each field coil may be shunted by a variable inductive choke, and these components are contained in the goniometer unit. The search coil is connected by flexible screened cable to its tuning components in the top left hand compartment of the amplifier unit. This circuit includes a screen grid valve whose output is transformer coupled to the main amplifier. The amplifier, which occupies the whole of the lower section of the instrument, comprises two H.F. screen grid stages (transformer coupled), leaky grid detector, and two note magnifiers, the first of which is coupled by resistance capacity, and the second by an iron core transformer. An output transformer provides for low resistance telephones and isolates the headgear from high tension voltages.

The system of ganging for the main amplifier permits of easy readjustment or checking when desired. For the purpose of adjustment, the condenser stators may be advanced or retarded with respect to the moving vanes by slackening the appropriate pinch bolts and engaging push rods provided for the purpose. These rods are inserted through bushed holes in the front panel of the amplifier, and register with tapped collars on extensions of stator spindles. When a final setting for all circuits is obtained, the condenser stators are locked and the push rods removed. These rods, together with a locking spanner, are stored in a small rack inside the amplifier. The ganged condensers are bevel driven and are controlled from the front panel by a vernier dial suitably calibrated in metres. A simple adjustment allows all trace of backlash to be removed in the event of wear (Fig. 3).

Waverange change is effected on the commutator principle, that is, the required number of H.F. transformers per stage are contained on the same cylindrical former which is capable of rotation within a frame carrying brush contacts to which the

Direction Finders.

circuit components are connected. All three transformers are mechanically coupled so that they operate together and are controlled by a 4-position lever from the front of the main amplifier panel. In this way multi-waverange reception is

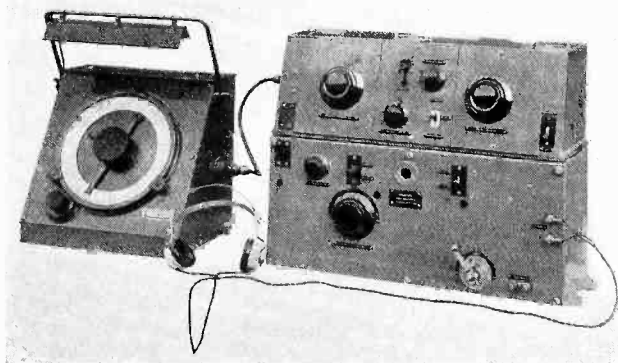

FIG. 2.

accomplished without increasing the stage and interstage wiring over and above that required for a single waverange. Provision is made for short circuiting the grid coils adjacent to those in use during manipulation. This is to prevent absorption resulting from undesirable resonances. Figs. 3 and 4 show the transformer

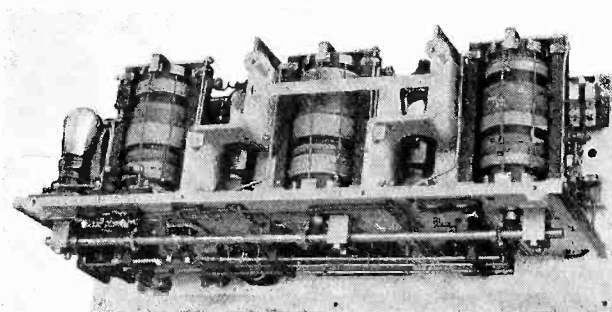

FIG. 3.

mechanism, and also emphasise the small amount of amplifier wiring. Each transformer may be removed from the amplifier, complete with its frame, contacts and bevel by removing six screws, which also release the compartment wiring.

Direction Finders.

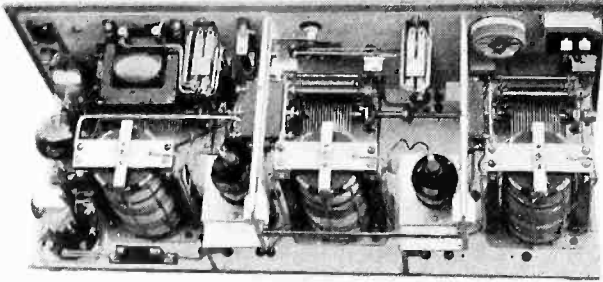

FIG. 4.

The amplifier provides for four waveranges, as follows:—

Range 1	300-600 metres.
„ 2	600-1,400 „
„ 3	400-2,800 „
„ 4	2,800-4,000 „

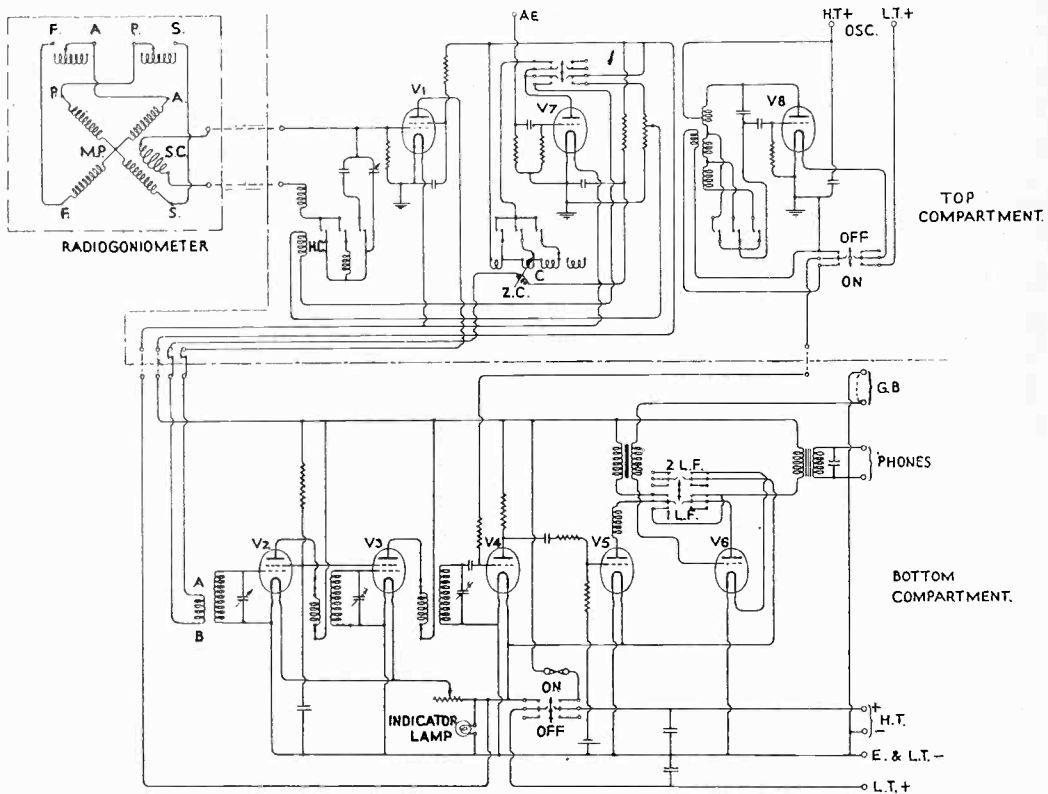
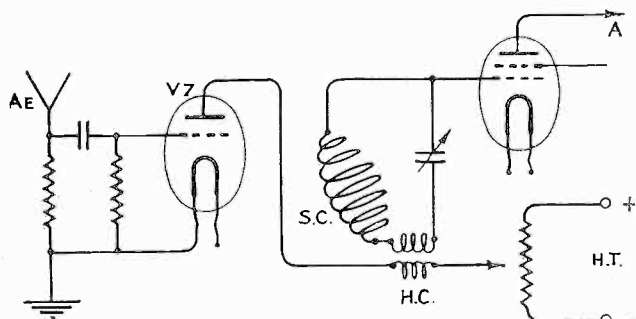
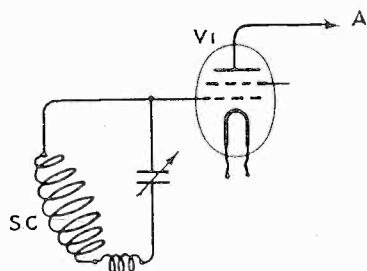
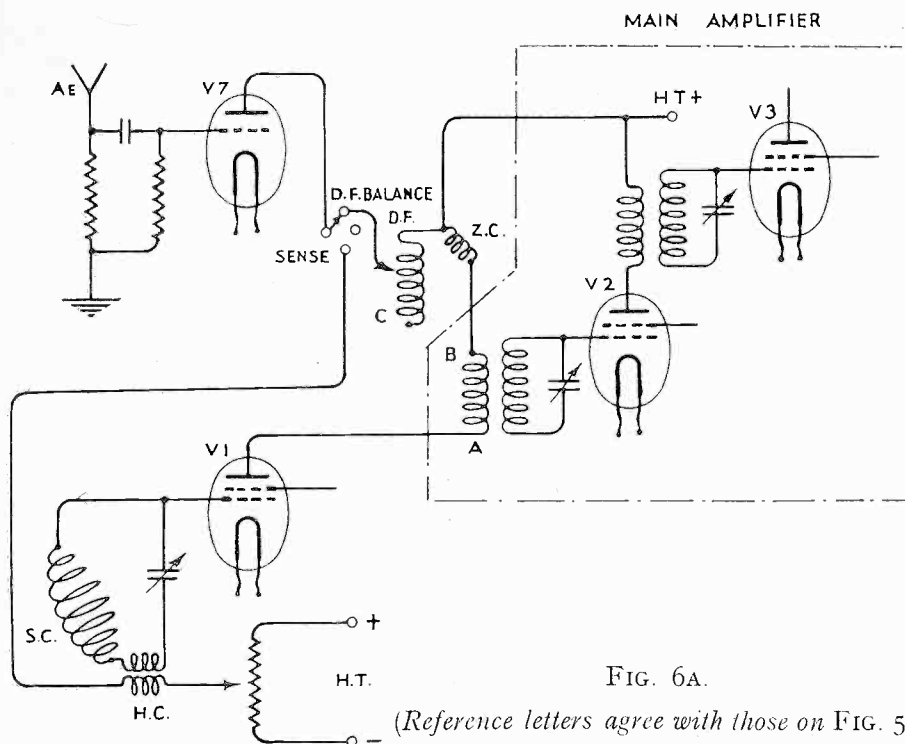

FIG. 5.

With regard to the three compartments in the upper portion of the set, that on the left contains the search coil tuning components; in the centre are the zero-sharpening and "sense" circuits, and in the right is the local oscillator. These three sections are controlled by a ganged switch which covers the waverange in three steps, as follows:—



Direction Finders.

Range 1	300- 900 metres.
„ 2	900-2,800 „
„ 3	2,800-4,000 „

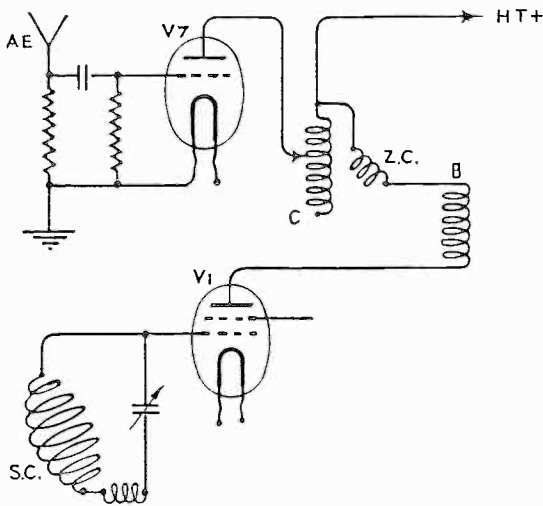

D.F. balance position.

Vertical aerial coupled to amplifier to balance for sharp zeros.

FIG. 6D.

A selector switch for spark or C.W. is positioned at the lower right hand side of the oscillator compartment. Search coil and oscillator circuits are calibrated in metres.

L.T. and H.T. supplies for the amplifier are normally 2 volts and 120 volts respectively, but 4 or 6 volt valves may be used if desired. Screen grids are fed through a drop resistance from the H.T. busbar within the instrument.

In the event of a power valve being desired in the last stage, provision is made for connecting additional grid bias external to the set. The electrical arrangement of the complete instrument is shown in Fig. 5.

A small vertical aerial is used for the dual purpose of "zero-sharpening" and sense. The pickup from this aerial is amplified by a separate high frequency valve, the output from which is controlled by the D.F. "sense" switch in such a manner that the anode circuit may be coupled either to the main amplifier for zero-sharpening or to the search coil for "sense." In the "sense" position the anode supply to this extra valve is fed by a potentiometer, and on this control the reception diagram may be varied from "all round" to "cardioid."

The zero-sharpening and "sense" circuits are shown schematically by Fig. 6.

MARCONI NEWS AND NOTES

MORE NEW MARCONI BROADCASTING STATIONS

BROADCASTING has become a regular feature in the lives of civilised peoples throughout the world, and growing licence figures from every country indicate that its popularity is still rapidly increasing after more than a decade of remarkable progress. Marconi broadcasting installations have played a considerable part in the advance of this new art and science, and recent orders include a new Marconi station for the completion of the "regional" broadcasting scheme in Switzerland, and another to be erected in Buenos Aires.

The new station for Switzerland is a Marconi Type P.A.19a installation and it is to be erected on Monte Ceneri, near Tessin, in Italian Switzerland, where it is expected to be in operation by the end of this year. It will have an energy of 15 kilowatts unmodulated power in the aerial.

The new Marconi station at Buenos Aires will operate on a power of 20 kilowatts and will serve a large area around the Argentine capital. Regular transmissions, under the control of Radio Excelsior of Buenos Aires, are expected to commence early next year.

Before either of these stations are heard, however, the new Marconi high power broadcasting station in the Irish Free State will be opened. A special effort is being made to prepare the station in time for the Eucharistic Congress in June, as it is desired that the powerful new voice of the Free State shall be inaugurated by a special series of broadcasts of this event. The station will have an unmodulated aerial energy of 60 kilowatts, and arrangements have been made whereby its power can be doubled at a later date.

Novel Marconi Apparatus.

A NOVEL type of apparatus (illustrated on page 29) has been constructed by the Marconi Company for use in Northern Rhodesia, to link up the many isolated administrative posts in the territory with each other and with Government headquarters by means of short-wave wireless communication.

The wireless equipment consists of a Marconi Type A.D.19 transmitter, this being an aircraft transmitter of 150 watts power, embodying an independent drive and having a wave range of 40-60 metres, and a Marconi Type R.G.28 receiver with a wave range of 10-200 metres. Power is derived entirely from a tandem pedal-

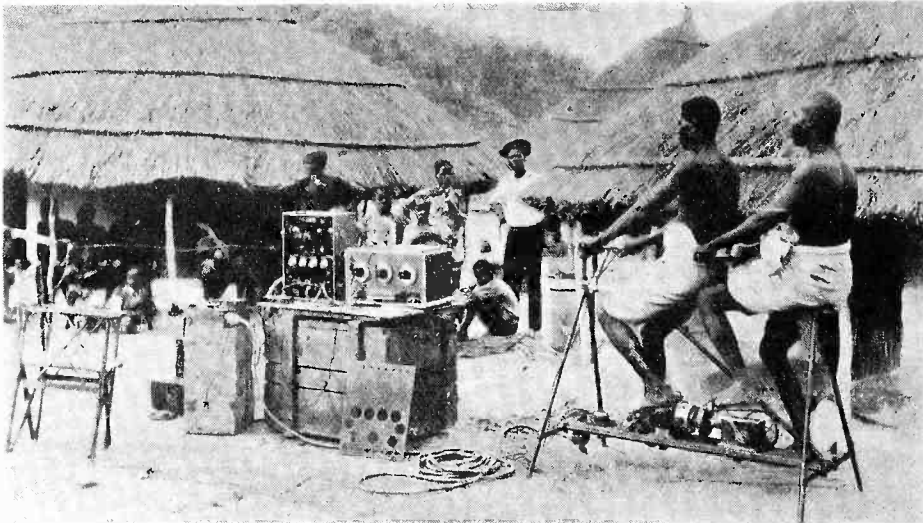

Marconi equipment with pedal-operated generator in use in Northern Rhodesia.

driven generator which supplies both high and low tension circuits, the high tension supply being 1,000 volts at 130 milliamps., and the low tension supply, 9-10 volts, at 6 amperes. To indicate the correct pedalling speed, voltmeters, marked at only

one point, are fitted on each handle bar, so that when native workers are employed in pedalling they can be instructed to maintain a speed that will keep the voltmeter needle on that mark. The pedals are connected by a chain, and drive the generator through suitable gearing, a flywheel being fitted to ensure a sufficiently steady output. This simple but effective power plant can be driven continuously without undue exertion, and the native pedallers are said to enjoy thoroughly this new form of physical exercise.

During tests of the equipment, satisfactory communication was maintained over distances up to 500 miles, despite difficult atmospheric conditions.

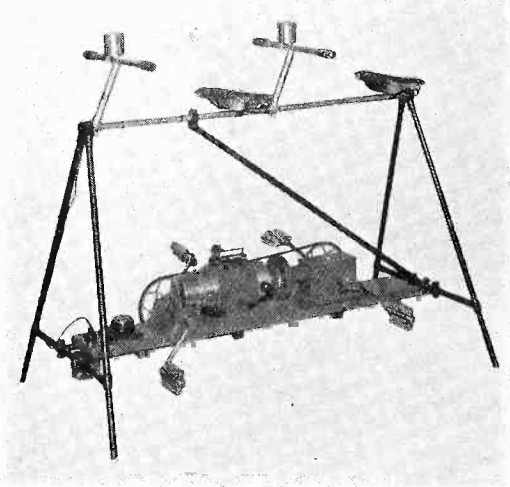

The pedal-operated generator.

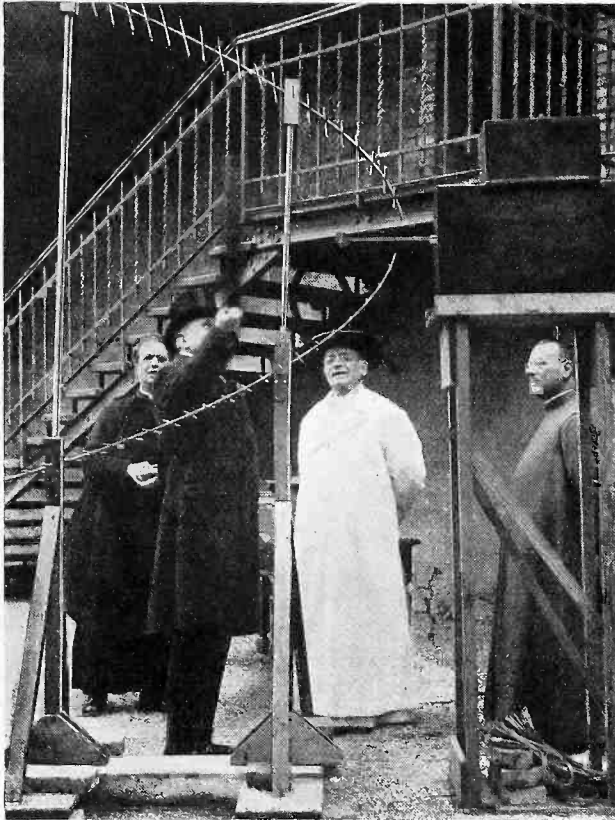

Marchese Marconi (with arm uplifted) explaining his new ultra-short-wave radio telephone apparatus to His Holiness the Pope (central figure in white) during recent tests of the apparatus in the Vatican grounds. On the conclusion of these tests Marchese Marconi was warmly congratulated by the Pope, who authorised the establishment of a wireless telephone service between the Vatican and his summer villa in the Alban Hills, for which the new ultra-short-wave system will be utilised.

Air-Taxi's Wireless Telephone.

AN air-taxi fitted with Marconi telephone equipment which enables the pilot to keep in touch with the ground wherever he may be flying over Great Britain, or practically throughout Europe, is the latest addition to London's transport facilities.

This is the Puss Moth machine flown by Captain Laurence Hope, of Air Taxis, Limited, which is being equipped with Marconi light aeroplane apparatus, Type A.D.22. Incorporating a special telephone transmitter as well as a receiver the apparatus enables the pilot not only to receive weather reports and other communications regularly broadcast from ground stations, but also at any time to speak to the aerodromes himself and ask for any information he may require for his guidance or assistance in the air.

Should he, for instance, encounter during flight a bank of fog or thick cloud he can call up the nearest suitable ground station, confirm his position by wireless

direction finder, learn whether the conditions of bad visibility are local or general and judge with confidence whether it is possible to continue to his destination. Such services are regularly performed for the pilots of passenger-carrying aircraft on the regular air routes by such wireless stations as those at Croydon, Lympne, and Pulham aerodromes, and they are equally available to the owners of private machines fitted with wireless transmitters and receivers.

Captain Hope uses his Puss Moth air-taxi very largely for newspaper work, where speed is of the first importance, and he realises that on many occasions such information would be very valuable to him, enabling him to decide, while still in the air, the quickest and safest means of delivering his photographs or other Press matter. At the same time, he can inform his waiting colleagues of his movements so that unexpected delays are reduced to the minimum.

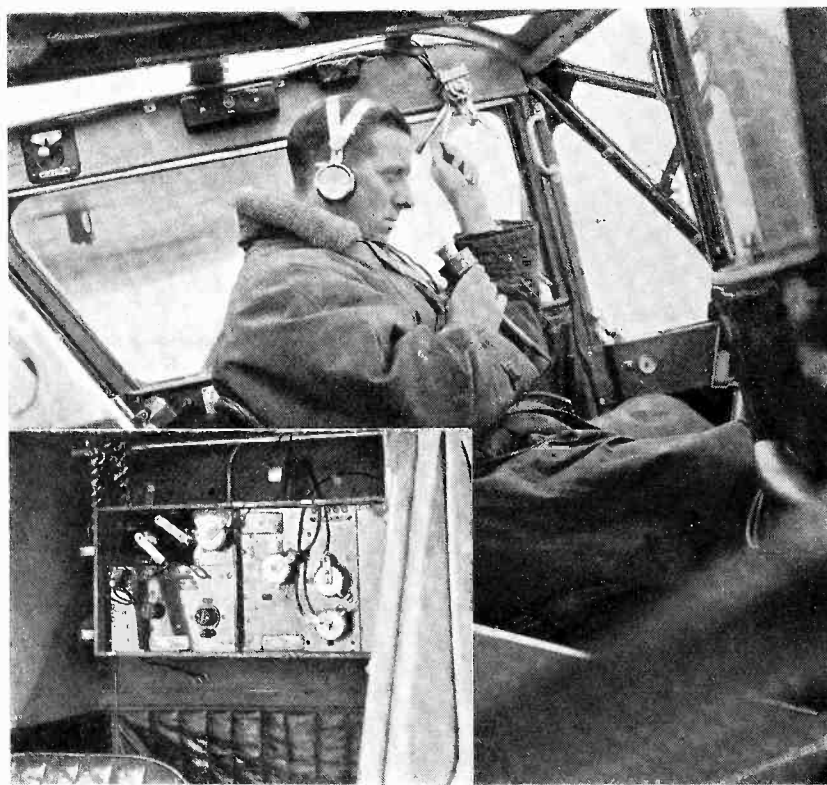

Captain L. Hope operating the Marconi telephone in his air-taxi. Inset: The equipment installed at the rear of the passenger compartment.

Marconi Beam System.

CONGRATULATORY telegrams were exchanged between Mr. E. T. Fisk, Managing Director, Amalgamated Wireless (Australasia) Ltd., and the Marchese Marconi, on Friday, April 8th, marking the fifth anniversary of the opening of the Beam wireless service between England and Australia.

Mr. Fisk telegraphed :—

“To-day is the fifth anniversary of opening Beam wireless service between England and Australia which has operated faultlessly from its inception. Please accept my personal congratulations upon this demonstration of the wonderful success and efficiency of your Beam wireless system. Greetings and kind regards.”

Marchese Marconi's reply was as follows :—

“Highly appreciate your remembrance and greetings on occasion fifth anniversary inauguration Beam wireless service between England and Australia which has so successfully confirmed my expectations. Wish you and your collaborators continued success.”

Wireless for International Flight.

MARCONI wireless equipment has been chosen by Prince Bibescu of Roumania, President of the International Federation of Aviation, for a flight over Central Africa which he is to undertake in March under the auspices of the Federation. The flight is intended to be an international venture, with a Roumanian pilot, German aeroplane, French motors, and British wireless.

The selection of Marconi wireless equipment is a tribute to this Company's supremacy in this highly specialised phase of communications, for on many sections of his long flight Prince Bibescu will be traversing wild country and will be entirely dependent upon his wireless equipment for keeping in touch with his bases, obtaining weather and landing reports, and securing aid in case of emergency. During a considerable portion of the flight he will be able to communicate with the chain of wireless stations from Cairo to Capetown, most of which were erected last year by the Marconi Company for the Imperial Airways trans-African route.

Prince Bibescu's wireless apparatus will be the Marconi Type A.D.18a telegraph-telephone set, with emergency equipment which will enable him to transmit and receive messages on the ground in the event of a forced landing. In this special equipment a light collapsible mast enables a temporary aerial to be rigged in place of the trailing aerial used in flight, while the power generator, which is normally mounted in the slip stream and wind-driven, is operated by a small petrol engine.