

# MAPLIN PROJECTS BOOK TEN

SPECTRUM EASYLOAD  
DRAGON 32 EXTENDIPORT  
80m RECEIVER  
ORIC I MODEM INTERFACE  
32 LINE DIGI-TEL EXPANSION  
AUTO-WAA EFFECTS UNIT  
2.1kW POWER CONTROLLER  
FLUORESCENT TUBE DRIVER

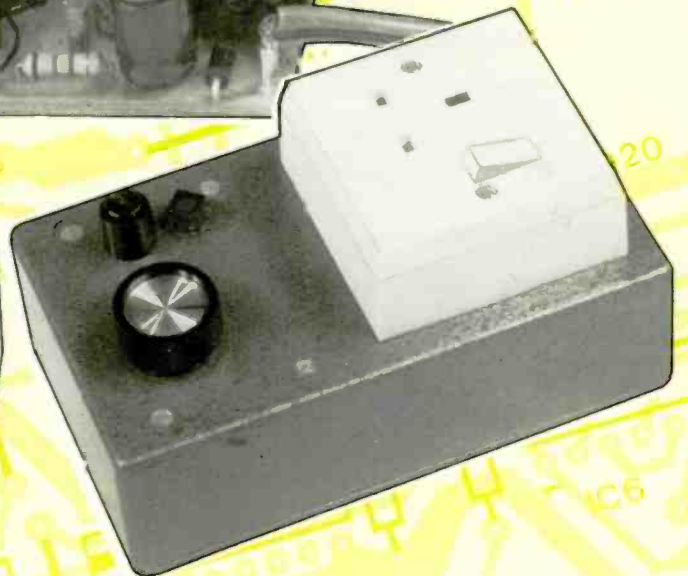

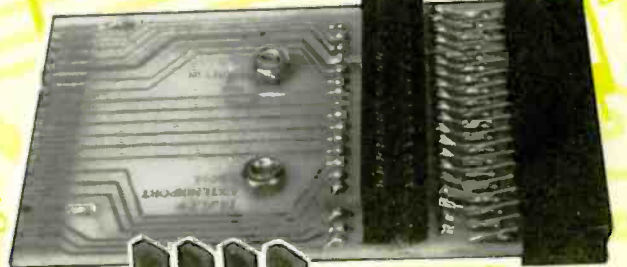
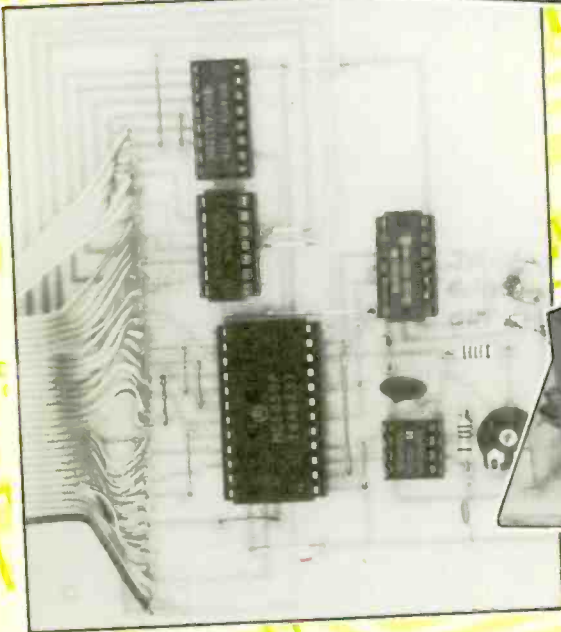
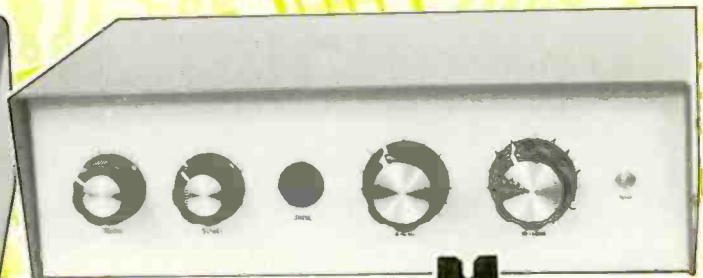

# DID YOU MISS THESE ISSUES?



**Project Book 1 Universal Timer.** Programmable mains controller. **Combo-Amplifier.** 120W MOSFET power amp. **Temperature Gauge.** 10°C - 100°C, LED readout. **Pass The Bomb!** Pass-The-Parcel with a difference. **Six easy-to-build Projects on Veroboard.** Car batt. monitor; Colour snap game; CMOS Logic Probe; Peak Level meter; Games timer; Multi-colour pendant. **Order As XA01B (Maplin Project Book No. 1) Price 70p NV.**

**Project Book 2 Digital Multi-Train Controller.** Controls up to 14 model trains. **Home Security System.** Six independent channels. **Digital MPG Meter.** With large LED display, a must for more economical motoring. **Order As XA02C (Maplin Project Book No. 2) Price 70p NV.**

**Project Book 3 ZX81 Keyboard.** 43 keys, plugs directly into ZX81 with no soldering. **Stereo 25W MOSFET Amp.** 25W r.m.s per channel; Disc, Tape, Tuner & Aux. **Radar Intruder detector.** 20 metres range, may be used with our security system. **Remote Control for Train Controller.** Remote control by infra-red, radio or wire. **Order As XA03D (Maplin Project Book No. 3) Price 70p NV.**

**Project Book 4 Telephone Exchange.** Up to 32 extensions on 2-wire lines. **Remote Control for Amplifier.** Volume, balance and tone controlled via infra-red link. **Frequency Counter.** 8 digit DFM, 10Hz - 600MHz range. **Ultrasonic Intruder Detector.** Areas up to 400 square feet can be covered. **Order As XA04E (Maplin Project Book No. 4) Price 70p NV.**

**Project Book 5 Modem.** 300 baud transmission speed over normal telephone lines. **Inverter.** 240V AC 60W from 12V car battery. **ZX81 Sound Generator.** 3 tone generators fully controlled from BASIC. **Central Heating Controller.** Optimised performance with this advanced system. **External Horn Timer.** Exterior intruder alarm. **Panic Button.** Add on to our Home Security System. **Model Train Projects.** Add on to our Multi-Train Controller. **Interfacing Micro processors.** How to use parallel I/O ports, with circuits. **Order As XA05F (Maplin Project Book No. 5) Price 70p NV.**

**Project Book 6 VIC20 & ZX81 Talkbacks.** Speech synthesis projects. **Scratch Filter.**

Tunable active circuit 'reclaims' scratched records. **Bridging Module.** Converts two 75W MOSFET amps to one 400W full bridge amplifier. **Moisture Meter.** Finds damp in walls and floors. **ZX81 TV Sound and Normal/Inverse Video.** TV sound and inverse video direct. **Four Simple Veroboard Projects.** Portable Stereo Amp; Sine Generator; Headphone Enhancer and Stylus Organ. **Order As XA06G (Maplin Project Book No. 6) Price 70p NV.**

**Project Book 7 CMOS Crystal Calibrator.** For amateur radio receiver calibration. **DX'er's Audio Processor.** Improved sound from Communications Receivers. **Enlarger Timer.** An accurate timer for the darkroom. **Sweep Oscillator.** Displays AF frequency response on an oscilloscope screen. **VIC20 and ZX81 Interfaces.** RS232 compatible. **Order As XA07H (Maplin Project Book No. 7) Price 70p NV.**

**Project Book 8 Spectrum Modem/RS232 Interface.** 2400 baud self contained operating system. **Synchime.** Simulates bells, gongs and other chiming sounds. **Dragon 32 RS232/Modem Interface.** Plugs into ROM expansion port. **Codelock.** Programmable electronic lock. **CMOS Logic Probe.** Digital display shows logic states. **Minilab Power Supply.** Versatile unit for the test bench. **Dragon 32 I/O Ports.** Two 8-bit ports. **Doorbell for The Deaf.** Flashing lamp attracts attention. **Order As XA08J (Maplin Project Book No. 8) Price 70p NV.**

**Electronics Issue 9 Spectrum Keyboard.** 47 full travel keys. **VIC Extendi-board.** Three expansion ports, one switchable. **Oric Talkback.** Speech synthesiser for the Oric 1. **Infra-Red Movement Detector.** 30 metres range outdoors. **TDA7000 FM Radio.** Complete FM receiver on a chip. **ZX81 High Resolution Graphics.** 256 x 192 fine pixel display. **Ten Projects!** Personal Stereo Dynamic Noise Limiter; Logic Pulser; ZX81 1K Extendi-RAM; TTL/RS232 Converter; Pseudo Stereo AM Radio; and more. **Order As XA09K (Maplin Magazine Volume 3 Issue 9) Price 70p NV.**

**Project Book 10 Spectrum Easyload.** Helps cassette loading with the Spectrum. 80m

**Receiver.** Simple SSB direct conversion receiver. **Fluorescent Tube Driver.** 8W 12V for camping and caravanning. **Auto-Waa.** Automatic waa-waa effects unit. **Digi-Tel Expansion.** Expands Maplin Telephone Exchange to 32 extensions. **Oric 1 Modem Interface.** Adapts the Oric 1 to the Maplin Modem. **Dragon 32 Extendiport.** Makes the Dragon's cartridge socket more accessible. **Order As XA10L (Maplin Project Book No. 10) Price 70p NV.**

**Electronics Issue 11 Mapmix.** Six channel audio mixer. **Xenon Tube Driver.** Xenon flash tube module with strobe. **Enlarger Exposure Meter.** Simple inexpensive tool for the darkroom. **8 Channel Fluid Detector.** Check/control fluid level in up to 8 containers. **Servo & Driver Module.** Servo mechanism with driver module kit. **Mk II Noise Reduction Unit.** Improves signal/noise ratio of tape recordings. **Cautious Ni-Cad Charger.** Controlled charging of ni-cad cells. **Motherboard for The BBC Micro.** Gives easy access to ports. **Order As XA11M (Maplin Magazine Volume 3 Issue 11) Price 70p NV.**

**Electronics Issue 12 RTTY Unit.** The TU1000 receives/transmits Radio Teletype; connects to computer via RS232. **Computadrum.** Use your computer as a drum synthesiser. **Light Pen.** Draw onto the TV screen or select menu options. **PWM Motor Drive.** Reversible model motor driver for 6V and 12V. **Order As XA12N (Maplin Magazine Volume 3 Issue 12) Price 70p NV.**

**Electronics Issue 13 Explosive Gas Alarm.** Flammable gas detector. **Flash Meter.** Get your exposure right when using your flash gun. **Musical Announcer.** A doorbell with a difference. **Mains Controller.** An add-on for the 8-Channel Fluid detector. **Order As XA13P (Maplin Magazine Volume 4 Issue 13) Price 75p NV.**

**Electronics Issue 14 Live Wire Detector.** Invaluable aid for the handyman. **Trundle.** The line follower robot as featured on Channel 4. **Zero 2.** High quality 'turtle' robot. **4-Channel PWM Controller.** Digital control of motors and servos. **Display Driver Module.** How to use our LED bargraph display ICs. **Control-A-Train.** Full inertia control of model trains. **Order As XA14Q (Maplin Magazine Volume 4 Issue 14) Price 75p NV.**

# Electronics

THE MAPLIN MAGAZINE

## PROJECT BOOK TEN

This Project Book replaces issue 10 of 'Electronics' which is now out of print. Other issues of 'Electronics' will also be replaced by Project

Books once they are out of print. For current prices of kits, please consult the latest Maplin price list, order as XF08J, available free of charge.

### CONTENTS

	Page
<b>Hero Goes to School</b> ..... <i>Even a robot has to learn.</i>	2
<b>Spectrum Easyload</b> ..... <i>Enhance cassette loading of programs into your Sinclair Spectrum.</i>	4
<b>Dragon 32 Extendiport</b> ..... <i>Extend the Dragon 32 cartridge slot.</i>	9
<b>80m Amateur Receiver</b> ..... <i>Direct conversion receiver for the 80m band.</i>	10
<b>Oric 1 Maplin Modem Interface</b> ..... <i>Open up a whole new world with your Oric 1.</i>	15
<b>32 Line Digi-Tel Expansion</b> ..... <i>Expansion details for the Maplin Digi-Tel Telephone Exchange.</i>	18
<b>Auto-Waa Effects Unit</b> ..... <i>Create waa-waa effects with this easy to build unit.</i>	22
<b>2.8kW Power Controller</b> ..... <i>Ideal for controlling electric drills, soldering irons, etc.</i>	25
<b>Fluorescent Tube Driver</b> ..... <i>8 watt/12 volt circuit, ideal for camping, etc.</i>	28

**Editor** Doug Simmons  
**Production Manager** Hugh Moir  
**Technical Editors** Robert Kirsch,  
Dave Goodman

**Art Director**  
**Technical Artists**

Peter Blackmore  
Roy Smith  
John Dudley

**Published by** Maplin Electronic Supplies Ltd.  
P.O. Box 3, Rayleigh, Essex  
**Typeset by** Essex Process & Engraving Co.  
**Printed by** Mayhew McCrimmon Ltd.

*For Personal Service*  
**CALL IN AT ONE OF  
OUR SHOPS**

*We have shops in London, Manchester,  
Birmingham, Southampton and Southend*

#### LONDON

159-161 King Street, Hammersmith, W6.  
Telephone: **01-748-0926.**

#### MANCHESTER

8 Oxford Road, Manchester.  
Telephone: **061-236-0281.**

#### BIRMINGHAM

Lynton Square, Perry Barr, Birmingham.  
Telephone: **021-356-7292.**

#### SOUTHAMPTON

46-48 Bevois Valley Road, Southampton.  
Telephone: **0703-225831.**

#### SOUTHEND

282-284 London Road, Westcliff-on-sea.  
Telephone: **0702-554000.**

*Excellent parking at all locations.*

*All shops open 9am to 5.30pm*

*Tuesday to Saturday (closed Monday).*

MAPLIN ELECTRONIC SUPPLIES LTD. Mail Order: P.O. Box 3, Rayleigh, Essex SS6 8LR. Tel: Southend (0702) 552911.





# HERO GOES TO SCHOOL

There was a hushed air of expectation in the school as David Snoad, Maplin's National Sales Manager called for Hero the Robot to bring himself onto the stage. David had just finished explaining to the 400 pupils at Earls Hall Junior School in Southend, how famous Hero is as a result of his personal appearances on BBC TV's "60 Minutes" and "Pebble Mill At One" programmes and on chat shows on Central, Anglia and Tyne Tees television.

"We want Hero!" the children shouted when the robot did not appear and a voice from off-stage said, "Please be quiet, I'm trying to sleep. And anyway, I'm feeling shy."

David became exasperated, "If you don't come out, I'll pull your plug out!"

The children strained forward; the naughty schoolboy image those few words had conjured, had already endeared Hero to them. And when Hero at last propelled himself onto the stage, his diminutive appearance — less than 1 metre high — further reinforced their identification with him.

Hero made a wide tour around the stage until David said, "Come here!" and the robot at once turned, went up to David and stopped. The children were totally convinced that Hero was moving and speaking entirely from decisions made within his own 'brain'. After all there were no wires attached to him and there was no visible aerial for remote control.

It may come as quite a surprise to you to learn that the children were absolutely correct. From the moment Hero came onto the stage, everything he did was as a result of instructions pre-programmed into his microprocessor 'brain' and silicon chip memory. There was no remote control by radio, infra-red or anything else. Throughout the entire 2 hour demonstration Hero did it all, all by himself!

However, Hero did have his own microphone which David placed beside him. The robot then demonstrated the movements he can make, describing each one: "I can move my arm"; "I can turn my head" and so on.

David invited six children onto the



stage to make up a panel to ask the robot questions. The children sat on chairs, three on each side and the first question was, "What can you say?"

"Everything that has ever been said, or ever will be said," replied the robot. Hero demonstrated his ability to speak other languages as well then, by saying some French and Spanish phrases.

## Spelling Tests

The next questioner asked, "How do you spell coat?"

"K O T E," said Hero.

"That's not right!" said David.

"You asked me how I spell coat, not how the dictionary spells it," said Hero. Not a very original joke, but the children enjoyed it. "Anyway, robots don't need coats." And David then explained to the children how vital robots are for working in areas where it would be dangerous or impossible for humans to work due to excessive heat for example.

"Hero will now show you how he can spell his name," said David, and placed in

front of the robot, but in the wrong order, the four letters of his name on large pieces of card. Without further intervention, Hero moved the letters around. At one point it looked as though he was going to spell it incorrectly, but when he moved the last letter it was right and the children applauded loudly.

The children on stage began to get fidgety and David asked Hero to tell him if any child moved when his back was turned. When David spoke to one of the two groups on the stage, a boy on the other side slowly raised his leg.

"Something moved!" said Hero to the delight of the audience. This pantomime sequence had all the children rocking with laughter.

When Hero demonstrated his ability to sing, his rendition of Jingle Bells, with which the whole school joined in, earned him a school choir badge which he is still very proud of.

Finally, Hero was asked what he would like for Christmas. "A cuddly toy," he replied.

"You're just an old softy at heart," said David.



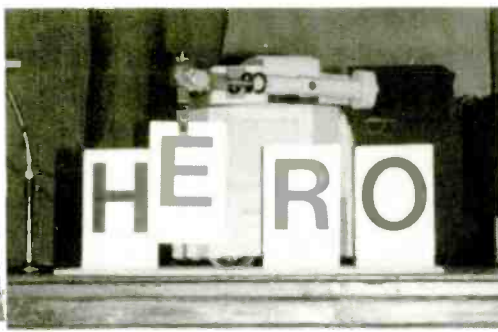

And Hero replied, "Robots need love and cuddles too, just like humans."

"What's the time?" asked one of the children. Hero gave the correct time from his internal real-time clock which runs continuously.

The realisation that the presentation had lasted nearly two hours and that it was nearly time for lunch, led to the robot going into his grand finale, a rendition of Old MacDonald Had A Robot — "...with a ready here and a ready there. Here a ready, there a ready, everywhere a ready, ready..."

## Letters to Hero

The children clapped loud and long. They had thoroughly enjoyed themselves and learned a lot as well. As they were leaving the hall, one little girl asked David in a very serious tone if Hero had a girlfriend. "He didn't have a girlfriend before today," said David, "but he's made friends with lots of nice little girls this morning."

In the afternoon, the children watched a film about industrial robots which had been kindly loaned to us by the Ford Motor Company. Afterwards, each class, unbeknown to David, wrote him a letter and here are some of the best ones.

Nicola Squibb wrote, "I enjoyed every moment of the show; it was fantastic the way Hero was controlled. I thought the way his arm worked was very unusual. I liked his singing a lot and I thought he was a very clever robot, but the next time he spells coat, he should look it up in a dictionary first."



Mario Lawton of Class 1E wrote, "I liked it when Hero refused to come on and when he spelt his name. His singing is very nice, but mine is better. I hope he likes his choir badge. I hoped that we could touch him. Love Mario."

Rebecca Hindle of Class 2K wrote, "I liked Hero very much because he made me laugh. I liked Hero when he put the letters in the right place. He's very clever. I also liked it when the boy told a joke and he laughed, but Hero wouldn't stop laughing. I think Hero is cute."

The mysterious Andrew W. wrote, "I like the things that Hero can do. I would like to have a robot like Hero. I hope he is being a good boy."

Graham Newell of Class 3J wrote, "Hero was a bit rude at first, but he was just joking. My favourite bit was when he was joking and telling fibs to you when he was asked a question."

But our favourite letter of all came from Sarah Staplton of Class 2B who wrote, "We enjoyed Hero being here and we enjoyed his singing. I think he's very clever to do all he did for us. Do you keep him at home or is he just your friend?"

*Continued on page 8.*







# SPECTRUM EASYLOAD

- ★ Connects between Micro and Recorder.
- ★ Battery Powered — No Bus Connections.
- ★ Save and Load Indication.
- ★ Mic Output for Second Recorder.
- ★ Charging From Spectrum P.S.U.

by Dave Goodman

Much has been written about cassette loading and saving problems associated with Sinclair Micro's, which tend to show that difficulties of one sort or another are being experienced. Many low cost recorders suffer from poor high frequency response which can sometimes be improved by careful re-alignment of the record/playback head. Systems with record level AGC can fluctuate if the signal level is too high producing large low-frequency transients and attenuated harmonics, none of which leads to reliable operation!

The rule, therefore is always to use good quality recorders and data cassettes whenever possible if problems are to be minimised, but even so one particular nuisance still exists. When making a cassette recording, input signals can be 'monitored' from the ear socket. On most recorders, either a small percentage of signal is taken from the mic input directly or via signal processing circuitry, allowing the user to listen in with an ear-piece when recording and is fine for normal use. However, the Spectrum 'ear' and

'mic' ports are effectively coupled together, through internal circuitry, and with both sockets connected to a recorder, a closed loop is generated. The result of this is signal feedback similar to the howl heard when microphones are placed too close to amplifier loud speakers, and data is corrupted or lost altogether. One recommended method to prevent this from happening is to remove the ear lead when saving, or mic lead when loading programs and trust that the appropriate connections are made each time this is done. After a while wear and tear takes its toll; plug leads can pull out and sockets become loose, returning the original reliability problem. An improvement would be to place a change-over switch between recorder and micro which selects either ear or mic leads separately.

## Simple Save, Easy Load

Figure 3, block diagram, shows the basic switching method employed in the module with both mic and ear signal paths disconnected via SWA and SWB.

When a signal is output from the Spectrum mic socket, SWB operates (Figure 3B) completing a path to the recorder mic socket and preventing SWA from operating. The ear connection is thus isolated between recorder and micro. Similarly signals present at the recorder ear socket (Figure 3C) are detected and SWA operates completing a path to the Spectrum ear socket and preventing SWB from operating. Save or Load monitors detect signal directions and operate switches appropriate to the required route automatically.

## Circuit Description

Data output from the Spectrum is high-pass filtered by C1, R1 and R3 to reduce the amplitude of low frequency signals. IC1B imposes AGC on the signal keeping the level constant for good recording quality. At the start of a Spectrum save routine, a short header tone is sent allowing the recorder AGC to stabilise. This tone is of higher frequency than the serial data train and being high impedance, from source, can suffer

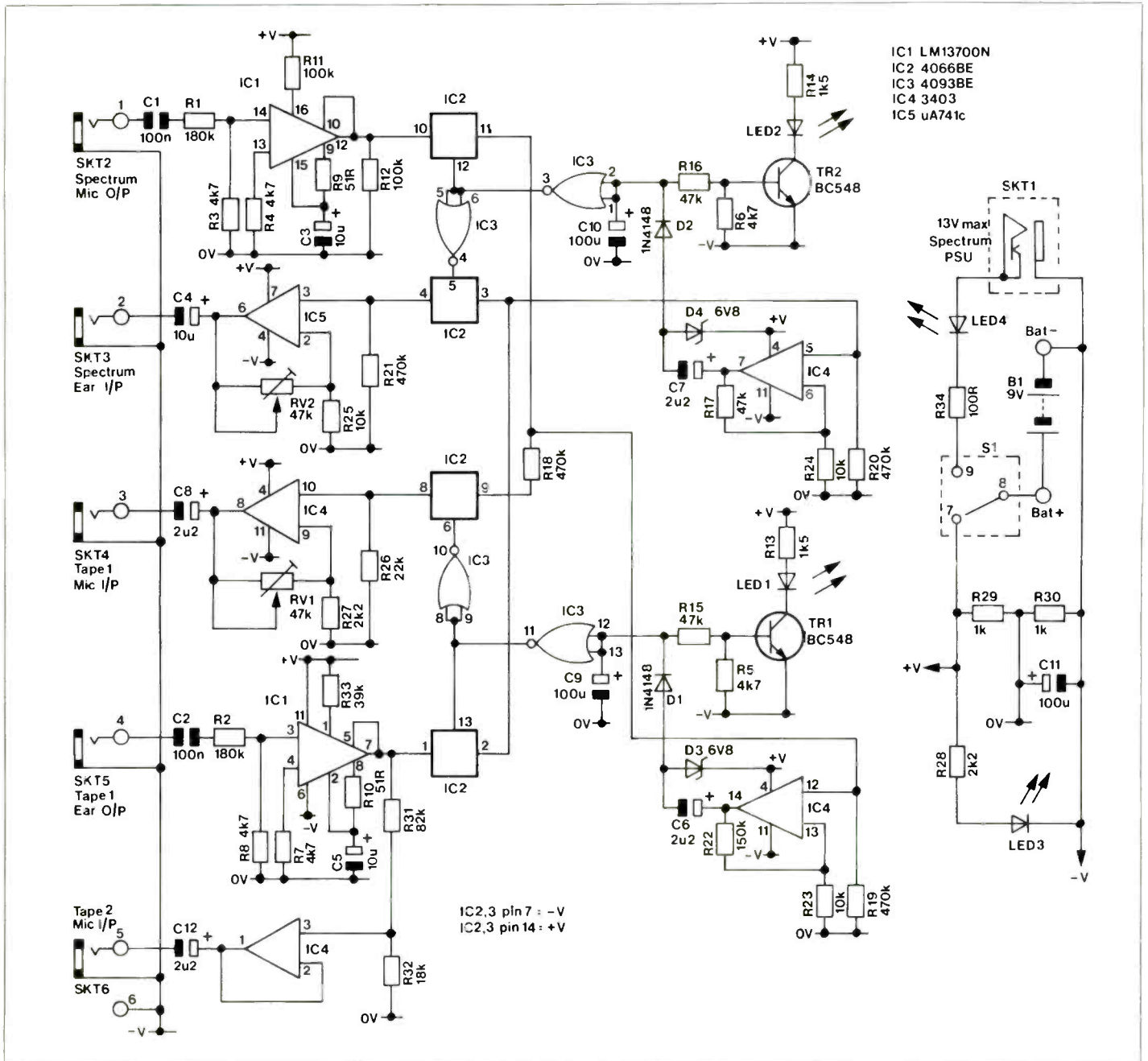
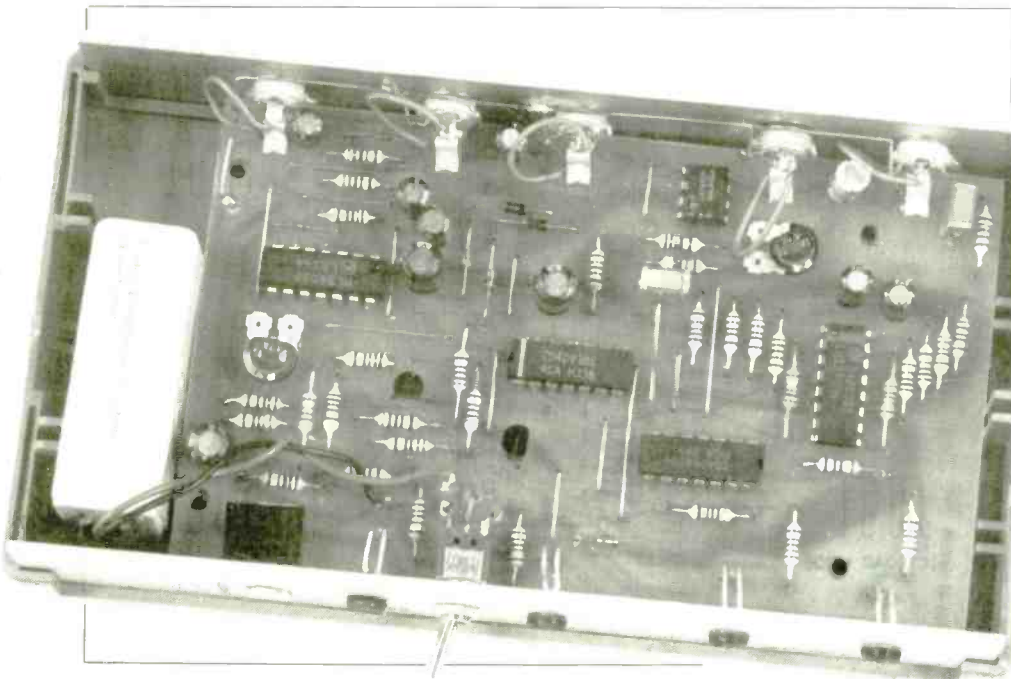

Figure 1. Circuit diagram



attenuation, causing incorrect AGC settings. IC1B therefore maintains a constant amplitude on all composite data signals. IC2D is normally closed (Bilateral switch) and IC4 amplifies the incoming signal for charging C9. TR1 conducts, operating LED1 (indicating that 'save' mode is selected) and IC3D output goes low. IC3C operates switch IC2C and the processed signal is further amplified by IC4 to pass at a low impedance to the recorder mic (input) socket. To prevent the monitor signal from activating IC2B, IC2A is held open while IC2C is closed and the return path is thus disconnected. Providing that the recorder is set to record, data signals are stored on tape until the save routine has completed and no further signals are present; whereby LED1 is extinguished, switch IC2C is opened and IC2A is closed.

When loading from tape, IC1A AGC amplifier determines a suitable signal level for driving the Spectrum ear input. A minimum input level of 0.4V is required from the recorder, which corresponds to



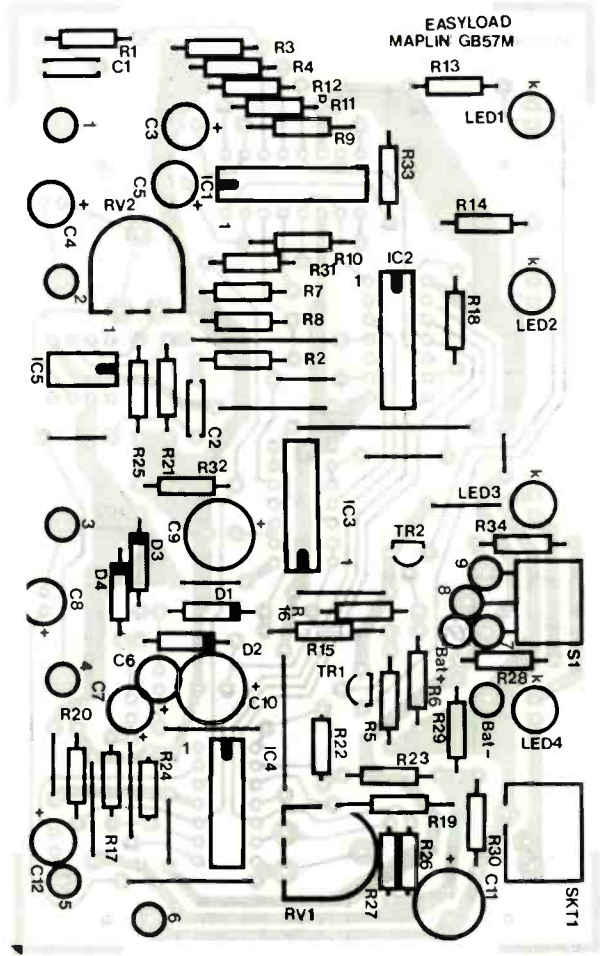
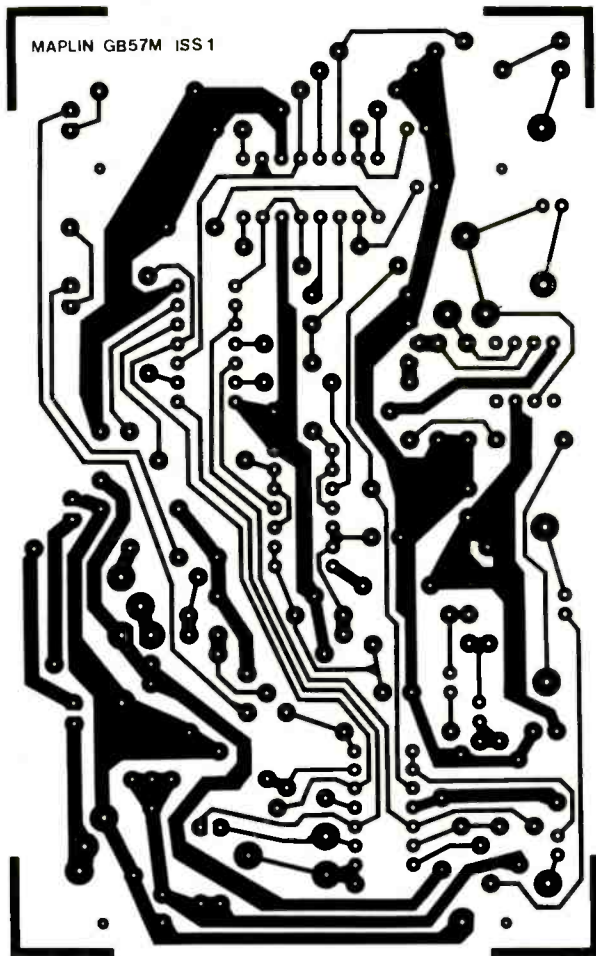

Figure 2. PCB Layout and overlay

a low volume setting, although higher levels up to 3V will make little difference. IC4B amplifies the signal and produces a voltage across C10, TR2 conducts operating LED2 (LOAD mode selected) and IC3A output goes low. IC3B closes switch IC2B whereby the data signal is further amplified to approx. 4V by IC5. RV2 can be used for trimming the amplitude to suit individual Spectrum input requirements. IC2D is held open, while IC2B is closed, thus breaking the loop as before. With loading completed, LED2 extinguishes, IC2B opens and switch IC2D closes. In both save and load modes, capacitors C9 and C10 discharge slowly with the absence of data signals ensuring a small delay before releasing the bilateral switches. Occasionally short gaps appear between data streams, which would cause IC4B or IC4D to break the signal path, resulting in lost data, so a delay is necessary for preventing this action.

### P.S.U.

Power is supplied to the module from a PP3 battery which delivers 9V at 10mA. S1 in the 'ON' position connects 9V to LED3 and potential divider R29, R30. Three voltage rails of +4.5V, -4.5V and 0V are generated for supplying the IC's, but only in the 'ON' mode. If a rechargeable type nicad (HW31J) is used, then periodic recharging is available using the Spectrum power supply connected to

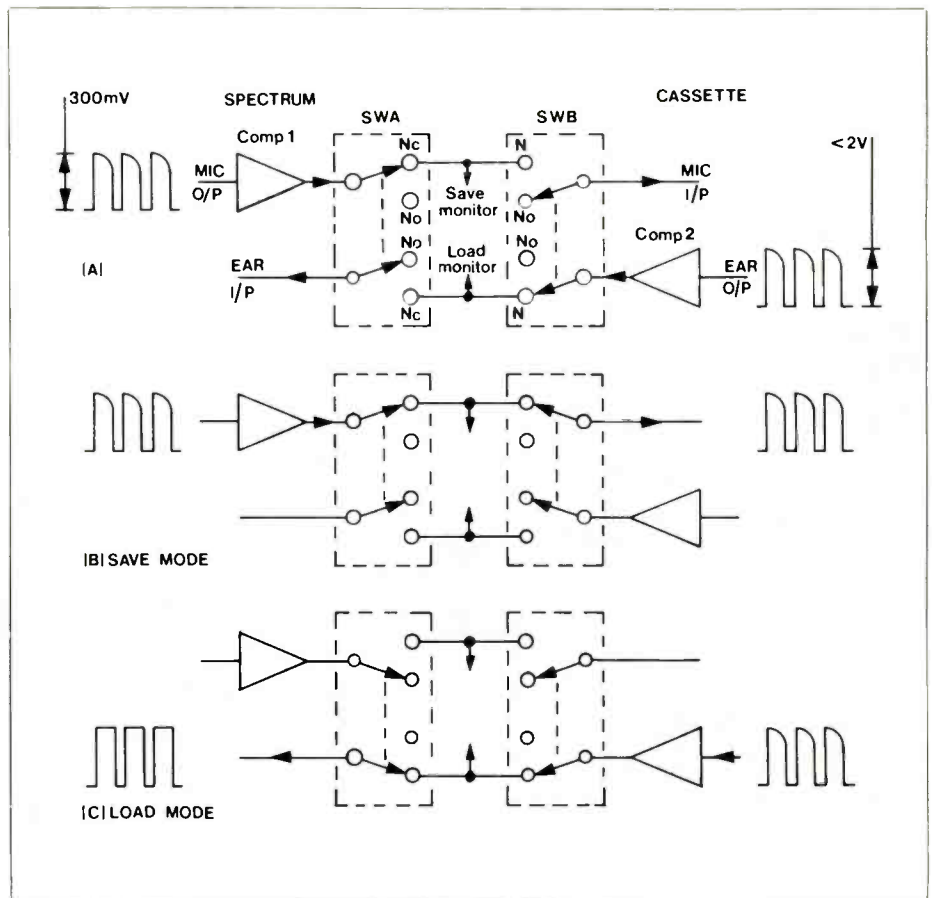

Figure 3. Switching modes



SKT1, LED4, R34 and S1 in the 'charge' position set a 10mA charge rate for the battery and *only* Spectrum power packs should be used for this purpose.

## Construction

Use 24 gauge BTC to fabricate 17 links required for insertion into the PCB (see Figure 4). Place each link over a line printed on the legend and push flat down into the PCB. Carefully bend and insert diodes D1 and D2 then Zener diodes D3 and D4. In all cases, position the bar-end printed around one end of the component body, to line up with the bar on the legend, as these components must be fitted correctly. Resistors R1 to R34 can next be bent to shape and fitted into the PCB. Solder all components to the track pads and cut off excess wire ends. Fit IC's 1 to 5, RV1, RV2, and TR1, TR2 (referring to Figure 4). When inserting capacitors C1 and 2 (Polycarb's) treat each connection lead carefully as they are easily broken. If breakage does occur, it is possible to re-solder these leads to the body edge, but is not advisable. Mount PC electrolytics C3 to 12; the longest lead is +V and the shortest lead (minus sign on body) is -V. Note that these components stand vertical with the base flat onto the PCB. Again, solder the remaining components in place, remove excess wires and fit 9 Veropins, pin 1 to 9, from the track side. Press them home with the soldering iron and solder in place. Insert SKT1 and press down onto the board. Solder in position. Finally wire the battery clip with +ve (red lead) to 'BAT+' and -ve (black lead) to 'BAT-'. Terminal pins are not required for these connections so solder direct into the PCB.

Clean the tracks and joints with solvent or thinners and a brush to facilitate inspection. Ensure all joints are sound with no shorts apparent between pads etc, then recheck assembly and components.

## Case & Final Assembly

If mounting the project into a box (Verobox LL08J) then Figure 5 shows recommended drilling and mounting arrangements. LEDs 1 to 4 are mounted directly onto the PCB and bent at right angles so they may protrude through the metal side plate. When using holders, push them into each hole from the outside before inserting the LED. Switch S1 also mounts onto this panel and the three terminals are wired directly to each pin immediately behind on the PCB. 3.5mm sockets SKT2 to 6 are mounted on the opposite panel. Snip off the bottom contact (Figure 4) before fitting and wire to each pin as shown. The -ve return connection is commoned to each socket and terminated on pin 6. Pins 1 to 5 are wired to the centre terminals on each socket only. Place S1 in the 'Charge' position which is left when viewed from the front and connect the battery. Just enough room between PCB and box has been allowed to accommodate the PP3 battery or a rechargeable version.

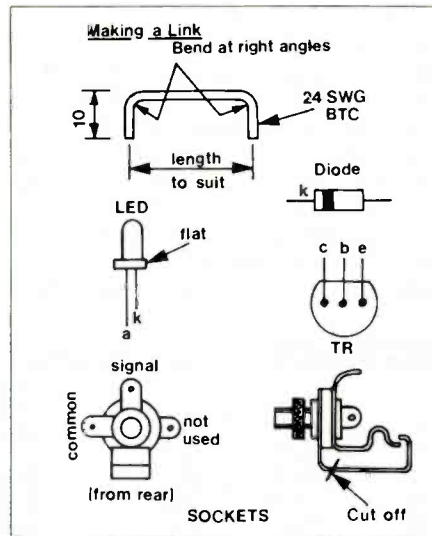

Figure 4. Pinouts

## Testing

A multimeter is required for voltage/current checks. The first check requires the meter being connected between battery +V terminal and +ve clip terminal. Set the meter to current range and switch S1 to the ON (right) position. LED 3 illuminates and the supply current should be 10 to 12mA. Now insert a Spectrum PSU into SKT 1 and turn switch

S1 from 'ON' to 'Charge'. LED 3 goes out and LED 4 illuminates with a charge current reading between 7 and 10mA. Remove the PSU plug and LED 4 extinguishes with zero current reading. Switch to 'ON' position again, remove meter and reconnect the battery clip.

Set the meter to Volts range and connect the -ve lead to battery -ve. Switch to ON and check quiescent state of Bilateral switches IC2 as follows: - IC2 pin 5 and pin 6 = 0V (low), IC2 pin 12 and pin 13 = 9V (high).

Next check the op-amp supply rails are correct by removing the meter negative lead and reconnecting to 0V. The most convenient place to find the 0V connection is on the link between resistors R17 and R20. Place the meter positive lead on IC5 pin 7 and check for +4.5V. Also check for -4.5V on IC5 pin 4. Note that the exact readings are dependant on the battery voltage and could be between 4.3 and 4.8V.

These general checks give a good indication that all is well so far. If any, or all readings do not correspond to the values given, assume a fault exists and go no further until the problem is cleared. IC's and PC electrolytic capacitors are often inserted wrongly and are worth re-checking. Set both RV1 and RV2 with

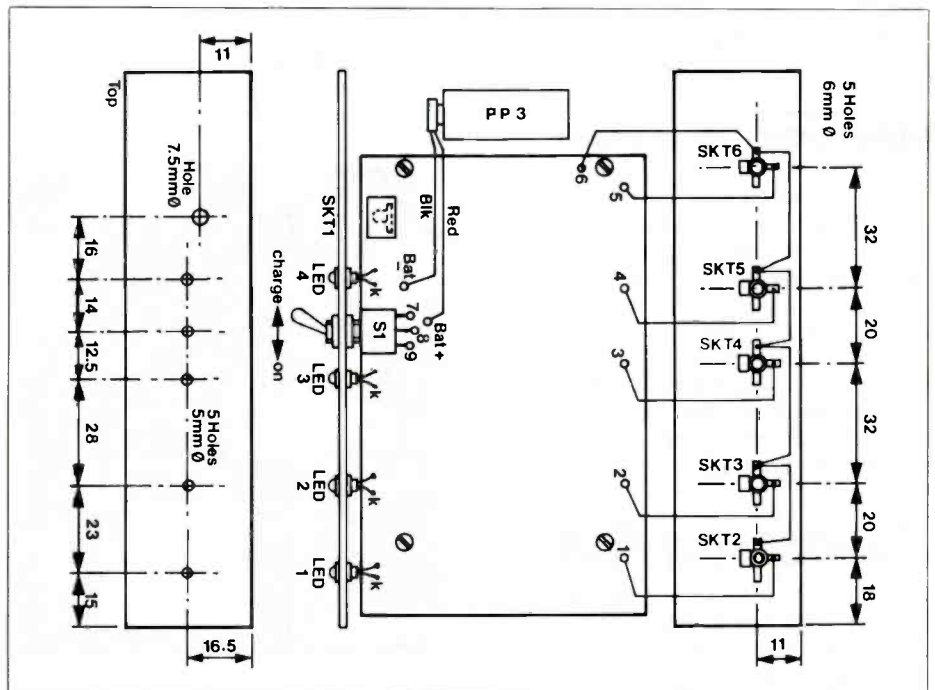
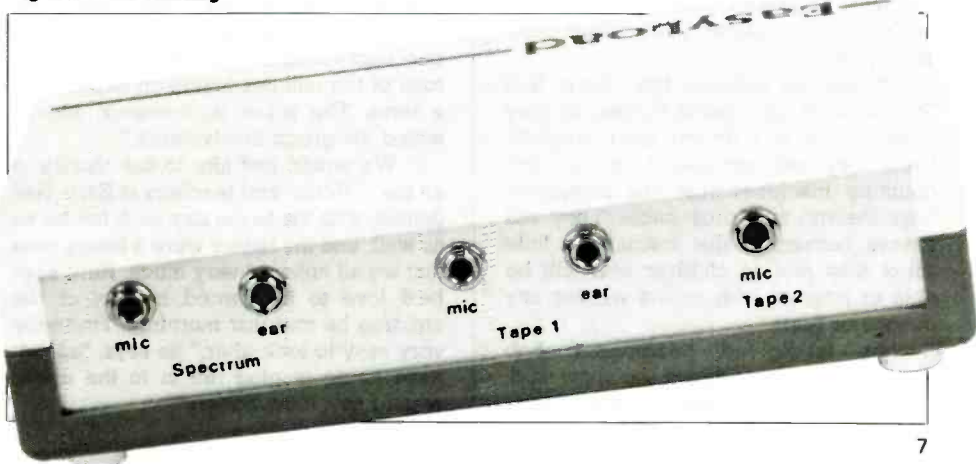

Figure 5. Box drilling



their wipers to halfway position. Connect the cassette recorder ear socket to SKT5, Tape 1 Ear O/P, and switch on the module. Play back a pre-recorded program and adjust the volume control to about 1/3rd travel. LED2 will illuminate until either data disappears or the recorder is turned off. Repeat the test with recorder ear connected to module SKT2, Spectrum mic, and check LED1 only illuminates.

In case of confusion the Spectrum connections are EAR = SKT3 and MIC = SKT2. Recorder connections are EAR = SKT5 and MIC = SKT4. SKT6 presents a processed output from SKT5 for connection to a mic input on a second recorder and may be used for making back up copies of your own programs.

Final testing involves the addition of two connecting cables, terminated both ends with 3.5mm plugs. Connect both

mic and ear Spectrum ports to SKT2 and SKT3 on the module. Connect the two new cables (see parts list) from the recorder mic and ear sockets to SKT4 and SKT5 on the module, switch on and try loading a program. Adjust either recorder volume or RV2 as necessary if problems are encountered. When saving programs, RV1 can be adjusted if playback levels are too low or noisy, but the half travel setting should be adequate.

## SPECTRUM EASYLOAD PARTS LIST

### RESISTORS:— All 0.4W 1% Metal Film

R1,2	180k	2	(M180K)
R3-8 inc.	4k7	6	(M4K7)
R9,10	51R	2	(M51R)
R11,12	100k	2	(M100K)
R13,14	1k5	2	(M1K5)
R15,16,17	47k	3	(M47K)
R18-21 inc.	470k	4	(M470K)
R22	150k		(M150K)
R23,24,25	10k	3	(M10K)
R26	22k		(M22K)
R27,28	2k2	2	(M2K2)
R29,30	1k	2	(M1K)
R31	82k		(M82K)
R32	18k		(M18K)
R33	39k		(M39K)
R34	100R		(M100R)
RV1,2	47k Hor Sub—min Preset	2	(WR60Q)

### CAPACITORS

C1,2	100nF Polycarbonate	2	(WW41U)
C3,4,5	10uF 35V PC Electrolytic	3	(FF04E)
C6,7,8,12	2u2F 63V PC Electrolytic	4	(FF02C)
C9,10,11	100uF 10V PC Electrolytic	3	(FF10L)

### SEMICONDUCTORS

D1,2	1N4148	2	(QL80B)
D3,4	BZY88C6V8	2	(QH10L)
TR1,2	BC548	2	(QB73Q)
IC1	LM13700N		(YH64U)
IC2	4066BE		(QX23A)
IC3	4093BE		(QW53H)
IC4	3403		(QH51F)
IC5	uA741C(8 pin)		(QL22Y)

### MISCELLANEOUS

LED1-4 inc.	Mini ed Red	4	(WL32K)
S1	SPDT Ultra Min Toggle		(FH98G)
SKT1	PC Mtg Power Skt		(RK37S)
SKT2-6 inc.	3.5 Jack Skt	5	(HF82D)
	Mini ed Clips	4	(YY39N)
	PP3 clip		(HF28F)
	Verccpin 2141	1pkt	(FL21X)
	Spectrum Easyload PCB		(GB57M)

### OPTIONAL

Case			(LL08J)
Plugpack Q		2	(RW28F)

A Complete Kit of parts (excluding Case and Plugpack Q) is available.  
Order As LK39N (Spectrum Easyload Kit)

## HERO GOES TO SCHOOL *Continued from page 3.*

So how was it all done. Well the fact is that Shakin' Stevens has got nothing on David Snoad! The trigger needed to make Hero say the next line of his pre-programmed speech was in fact David surreptitiously moving his leg into the detection range of Hero's ultrasonic range-finder. Everything was, of course, carefully rehearsed and the children on the stage only asked the questions they had been told to ask.

## Robots Are Fun

Hero's entrance routine and the part where he spelt his name was achieved by having controlled him directly to make each move before the show. When controlled in this way from his 'teaching pendant', he remembers everything and can repeat it absolutely precisely as often as required.

When the children from Earls Hall School come up against robots, as they undoubtedly will during their working lives, they will not see them as giant daunting machines that are incomprehensible and unapproachable. They will always remember that enchanting little robot they met as children and will be able to interact with robots without any qualms or fears.

As far-sighted headmaster Bob Shaw, who had organised the show said, "Few such demonstrations have comm-



anded such a high level of interest. As a means of demystifying the robot, the event was a great success. The school's one microcomputer allows each pupil a total of ten minutes hands-on experience a term. The robot is, however, ideally suited for group involvement."

We would just like to say thanks to all the children and teachers at Earls Hall School, who made the day such fun for us as well, and the letters were a lovely idea that we all enjoyed very much. Hero says he'd love to be owned by any of the children he met that morning. "I'm really very easy to look after," he says, "all you have to do is plug me in to the mains when I say, 'Low battery!'"

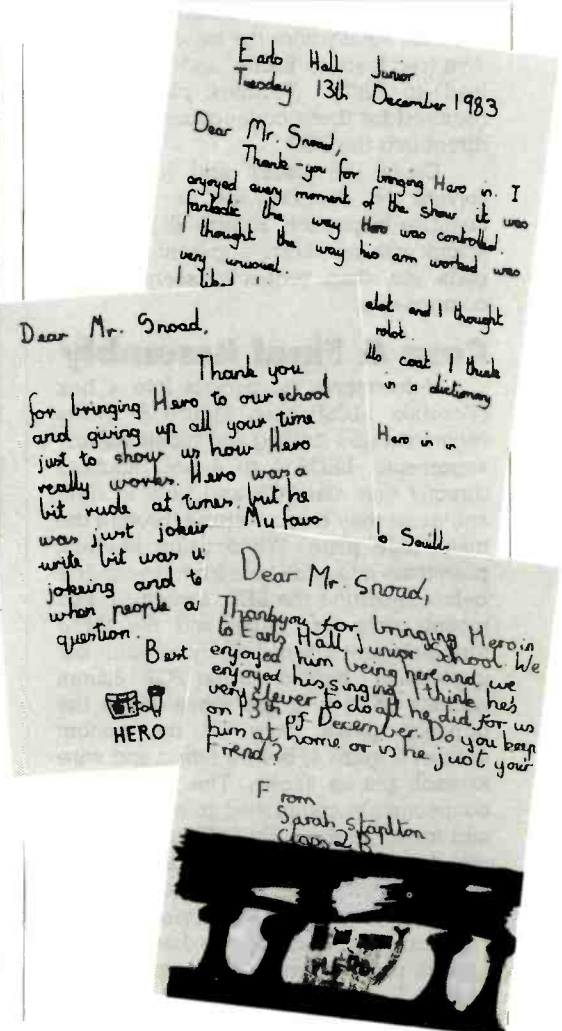









# 80 Metre Amateur Receiver

- ★ Direct conversion design
- ★ Excellent introduction to amateur radio
- ★ Single-sideband and CW operation
- ★ Straightforward construction
- ★ Alignment without test gear

The cost of amateur radio equipment is generally quite high these days, and this tends to give newcomers to the hobby the impression that amateur band transmissions can only be received using a vast array of the latest in ready-made gear. In fact quite good results can be achieved on the short wave amateur bands using relatively simple home-constructed equipment. Conditions on the short wave bands are, to say the least, rather difficult these days, principally due to the overcrowding and high output power of many commercial transmitters. Even using sophisticated receiving equipment a reasonable amount of skill is required in order to obtain good results, and when using a simple receiver the amount of patience and skill needed is that much greater. However, provided it is used carefully and sensibly, a simple receiver of the type described here can provide creditable results and a lot of fun.

In order to make the finished set as easy as possible to set up ready for use a single band direct conversion design has been adopted. The band chosen is 80

metres, which in the U.K. extends from 3.5 to 3.8MHz (the upper limit is 4MHz in the U.S.A. and some other countries). This is admittedly not the best band for long distance reception, and one of the high frequency bands would be better in this respect. On the other hand, it will provide reception of European stations after dark, with stations from further afield being received when conditions are favourable (North American stations have been received using the prototype). During the daytime there will often be transmissions from British amateurs, and there is unlikely to be a total lack of stations for long. The high frequency bands, especially now the current sunspot cycle is nearing its minimum, tend to be 'dead' for much of the time, and are not currently an attractive proposition for a single band receiver.

## Single Sideband

Tuning an amateur band transmission properly tends to be rather more difficult than tuning in an ordinary AM broadcast station. The reason for this is

the widespread use of SSB (single sideband) as the transmission mode. This is a form of AM transmission, but it is very different from the reception point of view. With an ordinary AM signal a small tuning error will probably give no more than a slight loss of audio quality, and might be totally unnoticeable. With an SSB transmission even a very small tuning error is usually sufficient to render the audio output completely unintelligible. It is not essential to understand the basics of SSB and the way it is resolved by this receiver, but it should certainly help to make the set easier to use, making the tuning of a station a less 'hit and miss' affair.

Probably the most convenient way of looking at an SSB transmission is to think of it as an audio frequency signal where the frequencies have all been raised by a certain amount to bring them into the radio frequency range. For example, if frequencies at 1kHz, 2kHz and 3.5kHz were to be fed into an SSB transmitter operating at 3.7MHz, the RF output frequencies would be at 3.701MHz (3.7MHz



+ 1kHz), 3.702MHz (3.7MHz + 2kHz), and 3.7035MHz (3.7MHz + 3.5kHz), bearing in mind that 1kHz is equal to 0.001MHz. The strengths of the RF output signals are proportional to the strengths of the corresponding audio input signals. Of course, with a voice input to the transmitter the audio signal would be comprised of a multitude of audio frequencies, and it would be changing from one instant to the next. However, the principle of operation remains unchanged, and with a complex audio input a correspondingly complex RF output is generated.

In practice there are actually two types of SSB, lower sideband (LSB) and upper sideband (USB). With the system described above the RF output signals are higher in frequency than the basic 3.7MHz transmission frequency, and this is upper sideband. With lower sideband the output frequencies are below the basic transmission frequency, or in the example given above this would give outputs at 3.699MHz (3.7MHz - 1kHz), 3.698MHz (3.7MHz - 2kHz), & 3.6965MHz (3.7MHz - 3.5kHz). Figure 1 shows these examples in diagrammatic form, and should help to clarify things.

In addition to SSB, the other main transmission mode used by amateurs on the short wave bands is CW (continuous wave), which is a form of Morse Code transmission. It consists just of keying a radio frequency signal on and off, and this type of transmission can be resolved by any SSB receiver.

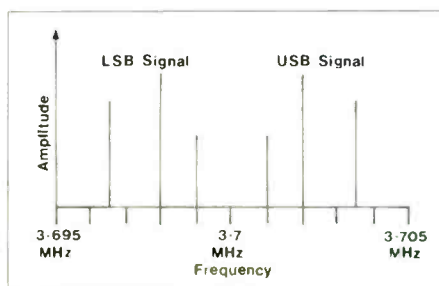

Figure 1. An SSB signal can be transmitted as upper or lower sideband.

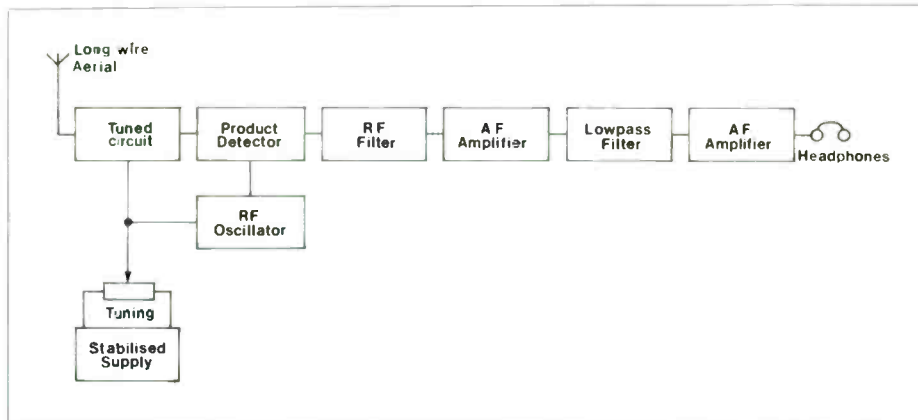

Figure 2. Block diagram of the Direct Conversion Receiver.

## Direct Conversion

The most simple type of receiver which is suitable for single sideband reception is the direct conversion type, and it is a receiver of this kind which is featured here. Direct conversion receivers use the heterodyne effect to reverse the transmission process, and shift the received radio frequency signals back down to the original audio frequencies. Figure 2 shows the receiver in block diagram form, and this helps to explain the way in which incoming signals are processed.

Signals from the aerial are coupled to a tuned circuit which acts as a passive bandpass filter. This eliminates most signals that are well outside the frequency range that is of interest, but there are still a great many signals present at the output of the filter, and it does not significantly aid the selectivity of the set. Its purpose is to cut down the number of signals fed to the rest of the receiver to manageable proportions.

The product detector and RF oscillator stages are responsible for demodulating received signals. The output of the product detector contains all the input frequencies, plus the sum and difference frequencies. In this application it is the difference frequency that is of importance, as it is this that constitutes the demodulated

audio output. For example, if a 3.7MHz SSB transmission is to be received, the RF oscillator must be set to operate at 3.7MHz. An audio input to the transmitter at (say) 1kHz would give an RF output at either 3.701MHz or 3.699MHz, depending on whether the signal is an upper sideband type or a lower sideband one. In either case the difference between the 3.7MHz operating frequency of the RF oscillator and the signal frequency will be 1kHz (3.701MHz - 3.7MHz = 1kHz and 3.7MHz - 3.699MHz = 1kHz).

Provided the oscillator is tuned to the correct frequency, any audio input frequency at the transmitter will be converted back to the same audio frequency by this heterodyne process at the receiver. However, if the oscillator is not at quite the right frequency, all the audio output frequencies will be wrong. If the oscillator is placed slightly too far away from the SSB signal the difference frequencies are increased, as are the audio output frequencies. Due to the increase in the pitch of the audio output this is popularly known as the 'Donald Duck' effect. If the oscillator frequency is taken too close to the SSB transmission, the opposite occurs, with a lowering in the pitch of the audio signal. The oscillator frequency has to be placed just below an upper sideband signal, or just above a lower sideband signal. If it is placed on the wrong side, the high audio frequencies become low frequencies, and the low audio frequencies become high ones. This inversion of the signal 'scrambles' it completely so that the overall pitch is about right, but probably not a single word would be understandable. This is easily corrected by simply tuning through the transmission, and then with the oscillator positioned on the right side, the tuning is adjusted for an output of the correct pitch. In practice there is always going to be a small error in the pitch of the output signal, and there is no way of determining what is precisely the correct pitch anyway. It is therefore a matter of adjusting the tuning to produce the audio pitch that sounds best.

The reception of CW transmission is far less critical, and it is just a matter of tuning the oscillator close to the transmission frequency so that the difference frequency provides an audio output. The pitch is relatively unimportant, and you can adjust the tuning control for any audio

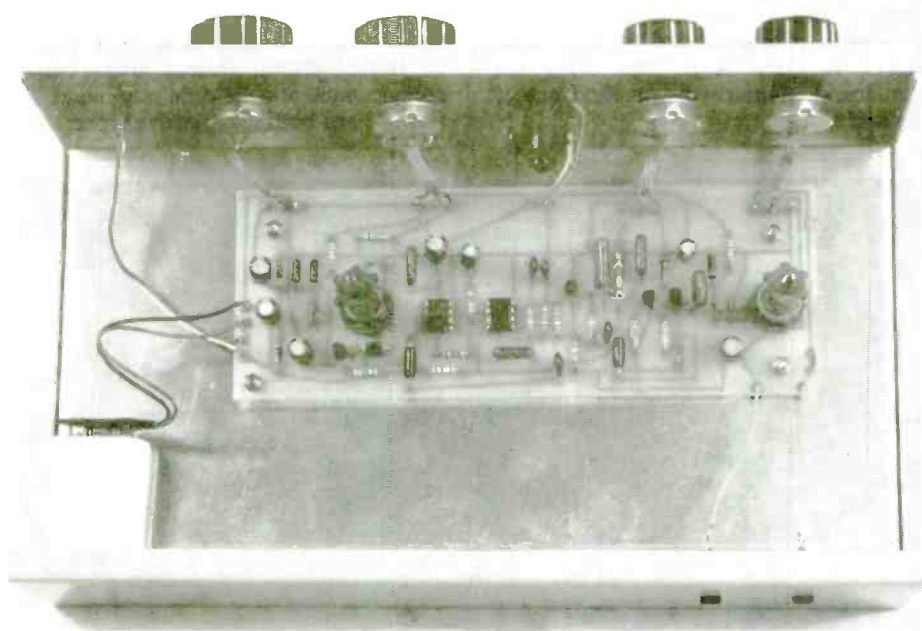

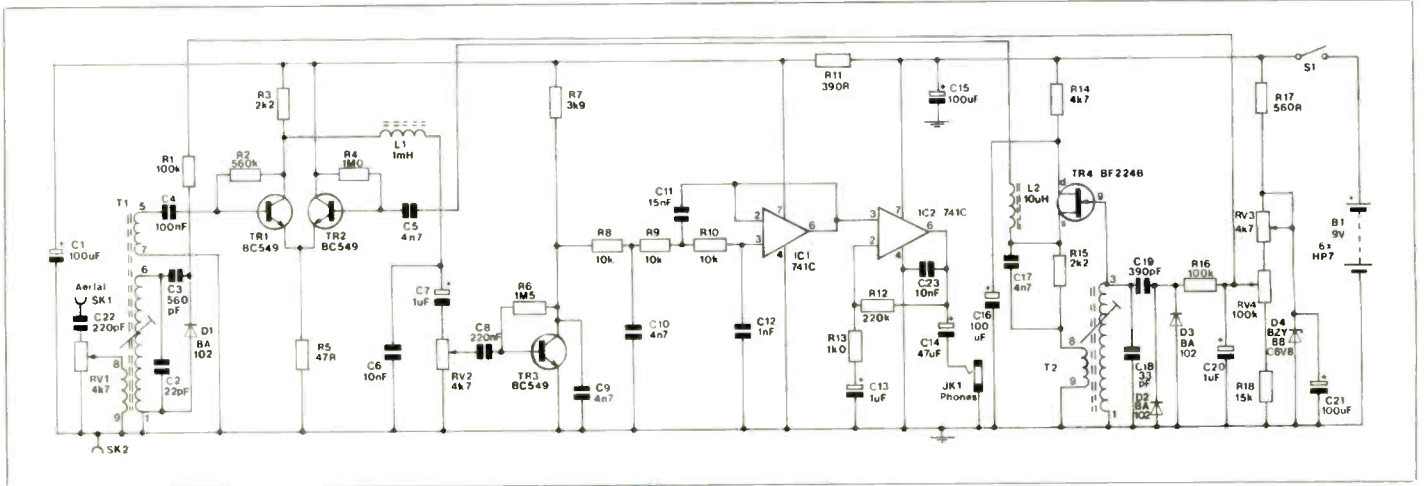

Figure 3. The Direct Conversion Receiver circuit diagram.

frequency you like. With a simple receiver of the type featured here it does not normally matter which side of the CW signal the oscillator signal is placed, although it may sometimes be found that one side suffers less from adjacent channel interference than the other.

Apart from the audio signal, the sum signal and the input frequencies are present at the output of the product detector. These are easily removed though, as they are all radio frequency signals, and a simple passive filter is all that is needed to do this. An amateur band receiver requires a high level of overall gain, and with a direct conversion receiver the bulk of the gain is generally provided by the audio stages. Two high gain audio amplifiers are therefore included in the unit. A lowpass filter is fitted between these stages, and it is an active 18dB per octave type. The purpose of the filter is to cut down adjacent channel interference, and it is this filter which provides most of the receiver's selectivity.

Most low frequency band receivers have the tuning provided by ordinary variable capacitors, but in this case variable capacitance (varicap) diodes are used. In order to obtain good stability the tuning voltage is obtained from a regulated supply. In this application there is no technical advantage in using varicap tuning, and this method is used merely because it is less expensive than using variable capacitors of suitably high quality.

## The Circuit

Figure 3 shows the full circuit diagram of the receiver. The main winding of T1, together with the capacitance provided by C2 and tuning diode D1, forms the input tuned circuit. The aerial signal is fed to the low impedance coupling winding on T1 via C22 and RF attenuator RV1. The latter can be used to reduce the aerial signal if the receiver is overloaded. C22 helps to prevent audio signals from being picked up at the input of the circuit.

TR1 and TR2 are used in a simple product detector configuration. Some more sophisticated circuits were tried, but although the least expensive and most simple, this one gave the best results. The

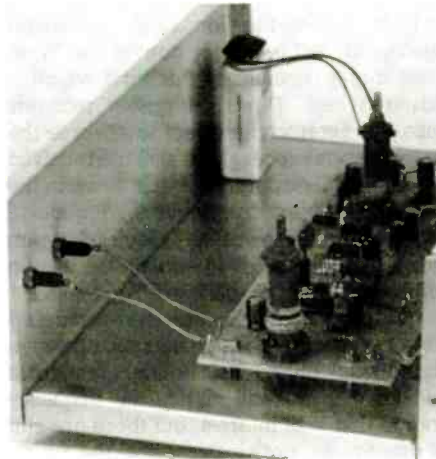

oscillator uses TR4 as a source follower stage with frequency selective positive feedback provided by T2. In order to obtain a large enough capacitance swing using BA102 varicap diodes. It is necessary to use two of these wired in parallel (D2 and D3). This permits coverage of the full 3.5 to 4.0MHz band.

R17 plus D4 provide a stabilised supply of 6.8 volts for the tuning circuit. RV4 is the main tuning control, and RV3, which provides only a limited tuning range, is used for fine tuning. Tracking between the RF and oscillator is not perfect, but as the frequency range covered is quite small, and the bandwidth of T1 is quite large, this does not significantly degrade the performance of the set.

L1 and C6 provide RF filtering at the output of the product detector, and the remaining audio signal is coupled to the volume control, RV2. TR3 is used as the basis of the first audio amplifier which is a straightforward high gain common emitter stage. The output of TR3 is taken to the lowpass filter which is a conventional third order design having a cutoff frequency of about 3.5kHz. IC1 is used as the unity gain buffer stage for the filter.

The second audio amplifier stage uses operational amplifier IC2 as a non-inverting amplifier having a voltage gain of about 220 times. C23 aids the stability of the circuit. The output of the set is intended for use with medium or high impedance headphones, although it also seems to work quite well with inexpensive low impedance types, or even with a crystal earphone.

Power is obtained from six HP7 batteries connected in series, or any other 9 volt battery of fairly high capacity. As the current consumption of the receiver is about 8 to 9 milliamps the use of a small 9V battery is not recommended.

## Construction

Most of the components are mounted on the printed circuit board. Details of the circuit board and wiring are given in Figure 4.

Start by fitting resistors, capacitors, and the two inductors (L1 and L2). Then fit the semiconductor devices, taking care to connect each one the right way round. IC1 and IC2 are both inexpensive types and it

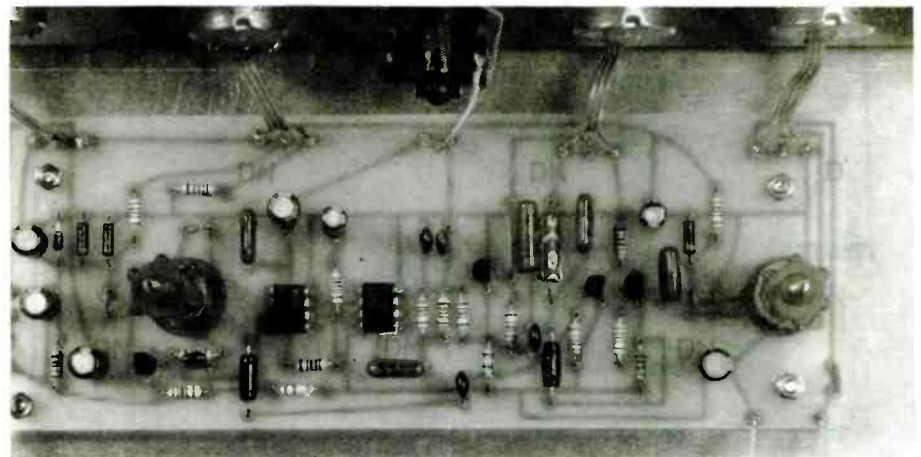



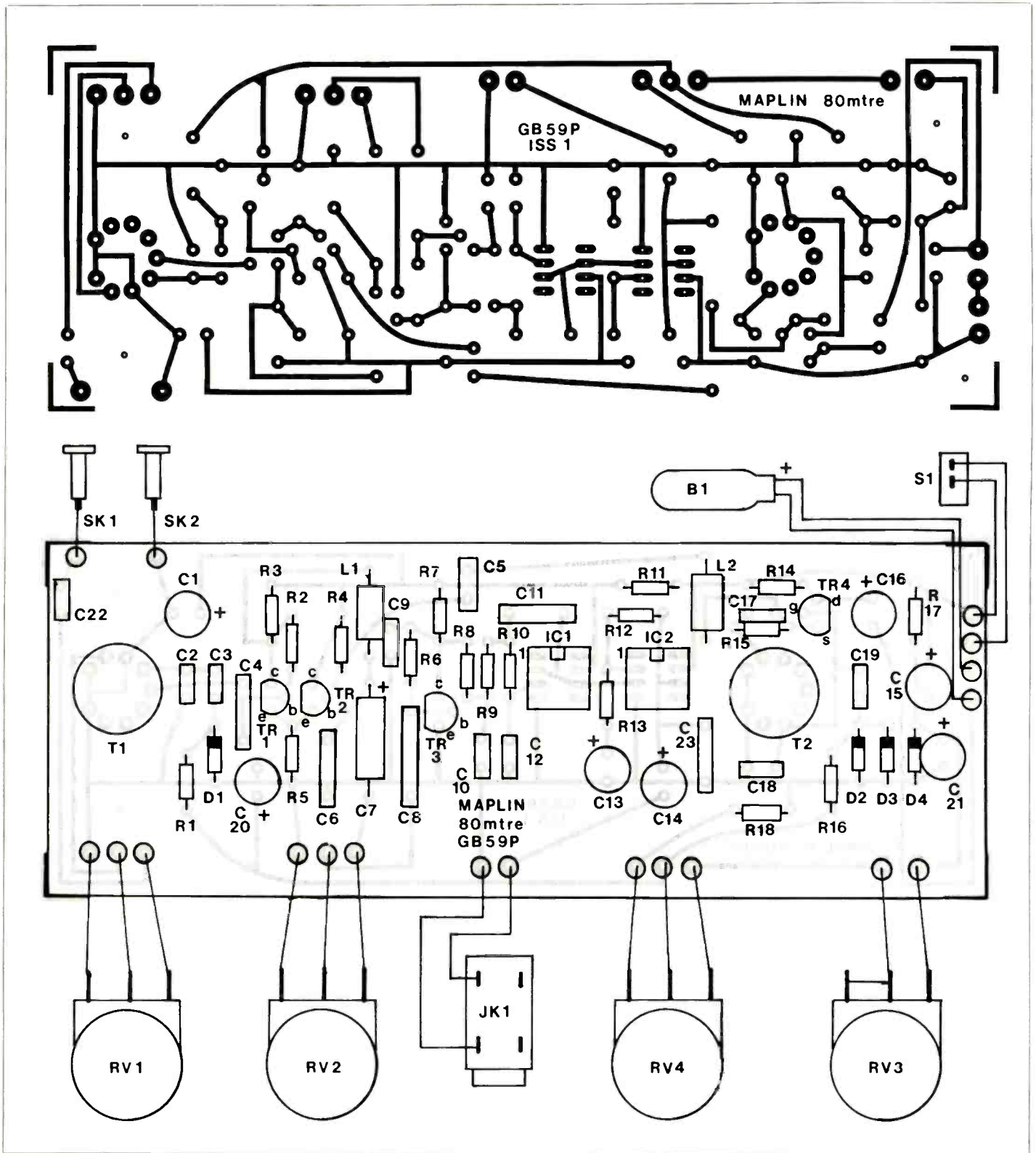

Figure 4. PCB track, legend and wiring diagram.

is probably not worthwhile using sockets for these. T1 and T2 are designed as plug-in coils (which fit a B9A valveholder) rather than for printed circuit mounting. Despite this they can be mounted direct on the board without too much difficulty. The only problem that might arise is getting solder to flow over the pins properly, and to avoid difficulty it is advisable to clean the pins prior to fitting and connecting the coils. This is easily done using fine sandpaper or by scraping the pins with the blade of a penknife. For packing purposes the coils are supplied with their cores fully screwed down, but in normal use the cores will need to be

unscrewed somewhat. They should therefore be set so that about 10 millimetres of metal screwthread protrudes from the top of each one.

It will be easier to make the connections to the off-board components if Veropins are fitted to the board at the appropriate places.

A metal instrument case which measures about 250 by 150 by 75mm makes an ideal housing for this project, although it could be fitted into a somewhat smaller case if desired. The five controls and the headphone socket are mounted on the front panel, and the general layout can be seen from the photographs. It is

advisable to adhere to this layout as the final wiring up of the unit will then be easier. The aerial and earth sockets are mounted on the rear panel of the case.

The printed circuit board is mounted on the base panel, or if the specified case is used, it is mounted on the aluminium chassis supplied with the case. It should be positioned so that the components mounted on the front panel are roughly aligned with the part of the board to which they will be connected. Spacers are used over the mounting bolts to keep the connections on the underside of the board clear of the metal case or chassis. Finally, the battery clip is wired to the board and

the remaining wiring is added using ordinary multistrand connecting wire.

If the unit is powered from six HP7 cells these must be fitted into a plastic battery holder. Connections to the holder are made via an ordinary PP3 style battery clip. Alternatively, the receiver can be powered by a large 9 volt battery such as a PP7 or PP9, but note that these use the larger type of battery connector.

## Aerial and Earth

It is not essential to use a very long aerial, and quite good results should be obtained using 10 or 20 metres of wire positioned as high as possible. It is also not essential to use proper aerial wire, and fairly heavy duty PVC covered connecting wire or about 18 swg enamelled copper wire should be perfectly satisfactory. In the long term it would be advisable to install the aerial properly, but initially a make-shift arrangement is perfectly satisfactory and it gives you the opportunity to determine what gives the best results. A short indoor aerial is far less than ideal, especially for a low frequency short wave band such as 80 metres. Apart from giving relatively weak reception, an aerial of this type is more prone to pick up interference from television sets etc.

An earth connection can provide a substantial improvement in results on the 80 metre band, but, nevertheless, good

results can be obtained without one provided a reasonably efficient aerial is used. If you do wish to use an earth, this can consist of a length of metal rod or pipe pushed into the ground and connected to SK2 of the receiver via a piece of wire which should be as short as possible. Do not use the mains earth. Apart from the safety aspect, this would almost certainly introduce mains "hum" into the receiver.

## Adjustment and Use

With the set installed and switched on, and with both RV1 and RV2 well advanced, by adjusting tuning control RV4 it will probably be possible to tune in a few stations of some kind. It should then be possible to adjust the core of T1 to peak the sensitivity of the receiver. Assuming that a suitable RF signal generator is not available, the only way to set the core of T2 for the correct frequency coverage is to use trial and error. This is a matter of searching for 80 metre amateur transmissions by adjusting RV4 and the core of T2, and then giving T2's core any setting which brings all these stations within the coverage of RV4. It is probably best to make the final adjustment after dark, and preferably at the weekend, as this is when the band is likely to be most heavily used. In general, the lower half of the band is used for CW transmissions, and the upper half is used for SSB. Remember to adjust the core of

T1 for peak performance once the core of T2 has been given its final setting. The bandwidth of T1 is quite wide, and the setting of its core is not too critical.

As explained earlier, tuning in an SSB signal properly is quite tricky, but with a little practice it is something that is easily mastered. Very careful tuning is required in order to bring the audio output to the correct pitch, and the final tuning is much easier using fine tuning control RV3. With RV1 fully advanced the product detector may become overloaded, leading to the breakthrough of broadcast stations or other transmissions. It is obvious when this happens since the tuning controls will have no effect on a signal of this type. The breakthrough can be eliminated by backing off RV1 somewhat. With a receiver of this type it is generally better to have the volume control well advanced and the RF attenuator control advanced no further than necessary.

Amateur stations use callsigns, and the first one or two letters of the callsign denote the country in which the station is operating. All British callsigns start with the letter "G", and plenty of these should be heard on 80 metres. There should also be no shortage of other European stations, such as West Germany (DM/DL) and the USSR (U). Stations in the USA (W) may be heard in the early hours of the morning.

## PARTS LIST FOR 80M RECEIVER

### RESISTORS All 0.4W 1% Metal Film unless specified.

R1,16	100k	2	(M100K)
R2	560k		(M560K)
R3,15	2k2	2	(M2K2)
R4	1M0		(M1M)
R5	47R		(M47R)
R6	1M5 ½W 5% Carbon film		(B1M5)
R7	3k9		(M3K9)
R8-10	10k	3	(M10K)
R11	390R		(M390R)
R12	220k		(M220K)
R13	1k0		(M1K)
R14	4k7		(M4K7)
R17	560R		(M560R)
R18	15k		(M15K)
RV1,3	Pot lin 4k7	2	(FW01B)
RV2	Pot log 4k7		(FW21X)
RV4	Pot lin 100k		(FW05F)

### CAPACITORS

C1,15,16,21	100uF 10V PC Electrolytic	4	(FF10L)
C2	22pF Ceramic		(WX48C)
C3	560pF Ceramic		(WX65V)
C4	100nF Polyester		(BX76H)
C5,9,10,17	4n7 Mylar	4	(WW17T)
C6,23	10nF Polyester	2	(BX70M)
C7	1uF 63V Axial Electrolytic		(FB12N)
C8	220nF Polyester		(BX78K)
C11	15nF Polyester		(BX71N)
C12	1nF Mylar		(WW15R)
C13,20	1uF 100V PC Electrolytic	2	(FF01B)
C14	47uF 25V PC Electrolytic		(FF08J)
C18	33pF Ceramic		(WX50E)
C19	390pF Ceramic		(WX63T)
C22	220pF Ceramic		(WX60Q)

### SEMICONDUCTORS

IC1,2	uA741C (8 pin DIL)	2	(QL22Y)
TR1,2,3	BC549	3	(QQ15R)
TR4	BF244		(OF16S)
D1,2,3	MV2108	3	(QY81C)
D4	BZY38C6V8		(QH10L)

### MISCELLANEOUS

L1	1mH Choke		(WH47B)
L2	10uH Choke		(WH35Q)
T1	Tras Coil 3T Blue		(HX77J)
T2	Tras Coil 3T Red		(HX78K)
S1	SPST Ultra Min Toggle		(FH97F)
SK1	2mm Socket Red		(HF47B)
SK2	2mm Socket Black		(HF44X)
JK1	¼" Jack Socket Brk		(HF90X)
	Printed Circuit Board		(GB59P)
	Veropin 2145	1pkt	(FL24B)
	Knob K7B	2	(YX02C)
	Knob K7C	2	(YX03D)
	9V Battery Holder		(HQ01B)
	PP3 Clip		(HF28F)
B1	(HP7 Batteries 6 reqd)		
	Wire	1m	(BL00A)

### OPTIONAL

	Case Blue Type 233		(XY48C)
	Bolt 6BA x ½"	1 Pkt	(BF06G)
	Nut 6BA	1 Pkt	(BF18U)
	Spacer 6BA x ¼"	1 Pkt	(FW34M)

A kit of parts (excluding case, fittings & batteries) is available.  
Order As LK41U.



# ORIC 1 MAPLIN MODEM INTERFACE

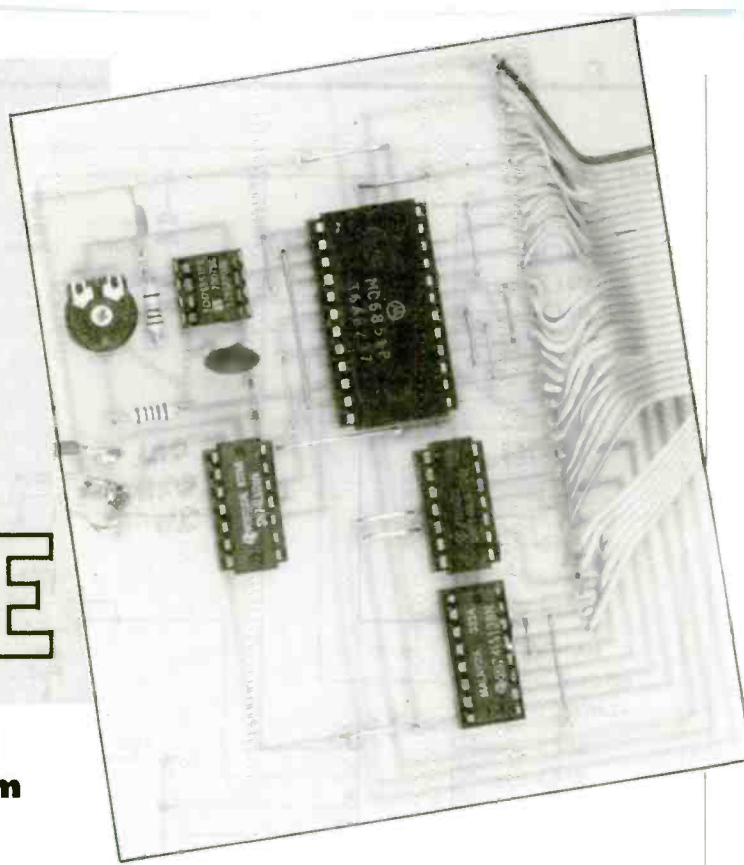

★ **Build this inexpensive project and use your Oric with the Maplin Modem**

by Robert Penfold

For a home-computer in its price range, the Oric 1 has a respectable range of interfaces, but unfortunately it does not have an RS232C or RS423 serial interface, and it cannot be directly linked to the very popular Maplin Modem project. However, the Oric 1 does have an expansion port which provides the full control, data, and address buses, and a relatively simple circuit is all that is needed to interface this to the Maplin Modem.

It is an interface of this type which forms the subject of this article, and the unit is a sort of "stripped down" RS232C interface. The Maplin Modem does not use any of the RS232C handshake lines (clear to send, data terminal ready, etc.), and so none of these are implemented in this interface. Also, the RS232C system uses signal levels of -12 and +12 volts rather than the more usual 0 and 5 volts. The Oric 1 provides only one voltage of +5 volts, and the maximum current available is only about 100 milliamps. In order to provide full RS232C output levels it would therefore be necessary to have a separate mains power supply unit for the interface. Fortunately the Maplin Modem has both standard RS232C and TTL inputs/outputs. Thus there is no difficulty

in driving it from this interface which is powered from the Oric 1, and which sends/receives standard TTL logic levels. This simplifies the circuit and avoids the need for a separate power supply, but it should be realised by users of the interface that it is unlikely to operate properly if used with RS232C equipment unless suitable level shifting circuitry is added (such as the Maplin TTL/RS232C Converter project).

## The Circuit

Figure 1 shows the full circuit diagram of the Oric 1 Modem Interface. The Oric 1 48K machine has a vacant area of memory between #BFE0 and #BFFF, but it is not unused in the normal sense. The Oric 1 48K machine uses 64K RAM chips, and the full 64K address range of its 6502 microprocessor is therefore occupied. The ROM containing the operating system and the BASIC interpreter is used to program part of the RAM, and the remaining 48K (approximately) is available for program storage. The address range from #BFE0 to #BFFF is unused in the sense that it is not in the section of the RAM normally used for program storage, and it is not used by the

BASIC interpreter or operating system either. There is RAM at this address range though, and it can only be used for input/output devices if the RAM is disabled. This address range is totally unused in the 16K Oric 1 incidentally.

The address decoding is provided by IC1 and IC2. As only a single input/output device is used in the interface, only partial address decoding is required. IC1 is a 3 to 8 line decoder which is used to decode A12 to A15. A12 is connected to the positive chip enable input of IC1, while the other 3 lines are fed to the normal inputs of IC1. IC2 is an eight input NAND gate, and this is used to decode address lines A4 to A11. The output at pin 8 goes low when all the inputs are high. Pin 8 of IC1 is used to drive one of the negative chip enable inputs of IC1. Output 5 of IC1 (pin 10) goes low when A14 is low, but the other 11 decoded address lines are high, and this corresponds to the required address







alternative for an application such as this where only a single, fairly low baud rate is needed, is to use an ordinary C-R oscillator. In this case a straight-forward 7555 astable circuit is utilised, and RV1 is adjusted to give the correct operating frequency. Under software control the 6850 can have a clock frequency at 1, 16, or 64 times the baud rate. In practice it is best to have the clock frequency at 16 or 64 times the baud rate as the clock is then automatically synchronised with incoming data. In this circuit the clock oscillator operates at 4.8kHz and the 6850 is set to the divide by 16 mode to give 300 baud operation.

Although the 6850 has four registers, it has only one register select input (pin 11). This is driven from address line A0, and the port therefore occupies addresses #BFF0 (49136 decimal) and #BFF1 (49137 decimal). In fact accessing any address from #BFF0 to #BFFF will operate one or other of these registers, but the base addresses given are the obvious ones to use. Only two addresses are needed for the four registers as two are read only registers, and the other two are write only types. The table below shows the four registers available and how they are accessed:—

ADDRESS	READ	WRITE
49136	Status Register	Control Register
49137	Receive Register	Transmit Register

Of course, the 6850 is fed from the read/write line of the computer so that the appropriate register at each address is connected through to the data bus. The 6850 needs a timing signal at its 'Enable' input, and this is provided by the Oric's clock signal. Although the Oric 1 uses a high speed version of the 6502 micro-processor, the system clock operates at 1MHz, and a standard 6850 is perfectly adequate for use with this machine.

## Construction

Details of the printed circuit board are provided in Figure 2. Start by fitting the resistors, capacitors, and the link wires. The latter are made from about 24 swg tinned copper wire, or pieces of wire trimmed from resistor and capacitor leadouts will do if no suitable wire is to hand. Provided these wires are kept quite taut it is not necessary to add insulation to any of them.

Next the integrated circuits are fitted to the board. Although IC4 is a CMOS

device it does not require any special anti-static handling precautions. IC3 is a MOS device, and is a relatively expensive component. It is therefore worthwhile using a (24 pin DIL) IC socket for this device, even if the others are connected directly to the board. Also, do not fit IC3 into its socket until the unit is in other respects complete, and leave it in the anti-static packaging until that time. Note that IC3 has the opposite orientation to the other four integrated circuits.

The board is connected to the Oric's expansion port via a length of 34-way ribbon cable and a 34-way IDC socket. It is advisable to obtain the socket and cable ready connected (they are supplied thus in the kit). The IDC socket fits the expansion port of the Oric 1 and the free end of the cable connects to the board. Be careful to connect the cable to the board the right way round (consult the expansion port connection diagram on page 151 of the Oric 1 manual). Before connecting the cable, strip a small amount of insulation from the end of each lead and tin it with solder. It should then be quite easy to connect the leads to the board, one by one, being careful not to get any leads crossed over. An alternative to direct connection is to use two 17-way Minicon connectors.

## In Use

Connect the interface to the Oric's expansion port before switching on the Oric. Once switched on the computer should function normally — switch off at once and recheck the interface if it does not.

The accompanying program (figure 3) enables the interface to be used with the Maplin modem and CASHTEL. When initially testing the unit try running this program with the input & output of the interface connected together. Characters typed on the keyboard should appear on the screen, but this should not happen if the link from the output to the input of the

```

10 POKE 49136,3
20 POKE 49136,21
30 CLS
40 IF (PEEK(49136)AND1)=1
   THEN PRINT CHR$(PEEK(49137));
50 IN$ = KEY$
60 IF IN$="" THEN POKE 49137,ASC(IN$)
70 GOTO 40

```

Figure 3. Program listing

interface is cut.

The 6850 does not have a reset input, but is instead reset under software control by writing a value of 3 to the control register (i.e. POKE 49136,3). The control register is also used to select the required word format, after a master reset has been performed. There are eight word formats available, as detailed in the table provided below.

### VALUE WORD FORMAT POKED

1	7 bits, 2 stop bits, even parity
5	7 bits, 2 stop bits, odd parity
9	7 bits, 1 stop bit, even parity
13	7 bits, 1 stop bit, odd parity
17	8 bits, 2 stop bits
21	8 bits, 1 stop bit
25	8 bits, 1 stop bit, even parity
29	8 bits, 1 stop bit, odd parity

Deducting one from these values sets the 6850 to the divide by 64 mode, and reduces the baud rate to 75. The CASHTEL system requires 8 data bits and one stop bit, and 21 is the value to be POKED to the control register. However, when accessing other systems it might be necessary to use a different word format and the corresponding control number.

The ASCII codes of characters to be transmitted are written on the transmit register at address 49137. Bit 1 of the status register can be read to determine if the transmit register is empty, and ready to receive the next character, but this is normally unnecessary if the keyboard is the source of the transmitted characters, due to the relatively slow rate at which characters will be supplied to the interface. The receive data register full flag is at bit 0 of the status register, and it is normally necessary to check this and only read the receive register when a new character has been received. Otherwise multiple readings of each character will occur. The receive register full flag is automatically reset when the receive register is read.

Those who require full information on the 6850 should consult the relevant data sheet (which is available from Maplin price 40p).

Initially RV1 should be set at about half resistance, but it will probably be necessary to trim this component slightly before precisely the right baud rate is obtained and the interface operates properly with the CASHTEL system, etc.

## ORIC MAPLIN MODEM INTERFACE PARTS LIST

<b>RESISTORS:- All 0.4W 1% Metal Film</b>		IC3	MC6850F	(WQ48C)	
R1	100k	(M100K)	IC4	ICM7555	(YH63T)
R2	1M	(M1M)	IC5	74LS08	(YF06G)
RV1	Hor S-Min Preset 1M	(WR64U)	<b>MISCELLANEOUS</b>		
<b>CAPACITORS</b>		SK1	34-way IDC Socket & Cable	(BK96E)	
C1	100nF Disc Ceramic	(BX03D)	Veropins 2145	1 pkt (FL24B)	
C2	100pF Ceramic	(WX56L)	Printed Circuit Board	(GB55K)	
<b>SEMICONDUCTORS</b>			24-way DIL Socket	(BL20W)	
IC1	74LS138	(YF53H)	A kit of all the above parts is available. Order As LK40T (Oric Modem I/F Kit)		
IC2	74LS30	(YF20W)			

# 32-LINE EXPANSION

**for the Maplin Digi-Tel Telephone Exchange**

- ★ Expansion board for up to 32 extensions
- ★ No call can be interrupted or overheard by another caller
- ★ Standard 2-wire connection to all telephones
- ★ All phones powered by the 2-wire line
- ★ Mains connection required only at the exchange
- ★ May be used with standard British Telecom phones
- ★ Up to 16 telephones may be in use at any one time

by Robert Kirsch

## Introduction

This article describes the additions to the 16 line Digi-Tel Telephone Exchange (described in the September/November 1982 edition of 'Electronics' and Maplin Project Book Four) to enable a further 16 lines to be added thus increasing the total capacity to 32 lines. The expansion board is the same size as the 16 line mother board and may be mounted above or below it; most of the interconnecting wires coming from the left hand side of both boards. There are six additional connections between the two boards, details of which are shown in Figure 3b.

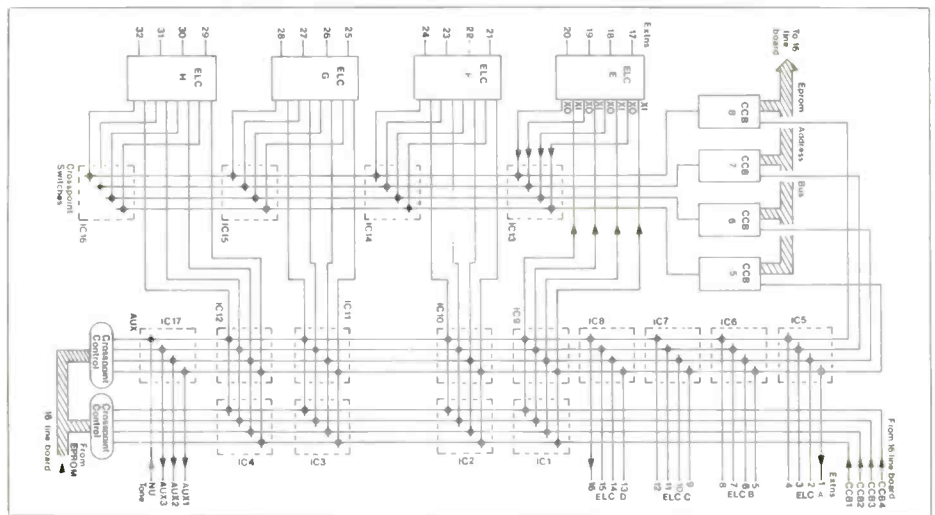
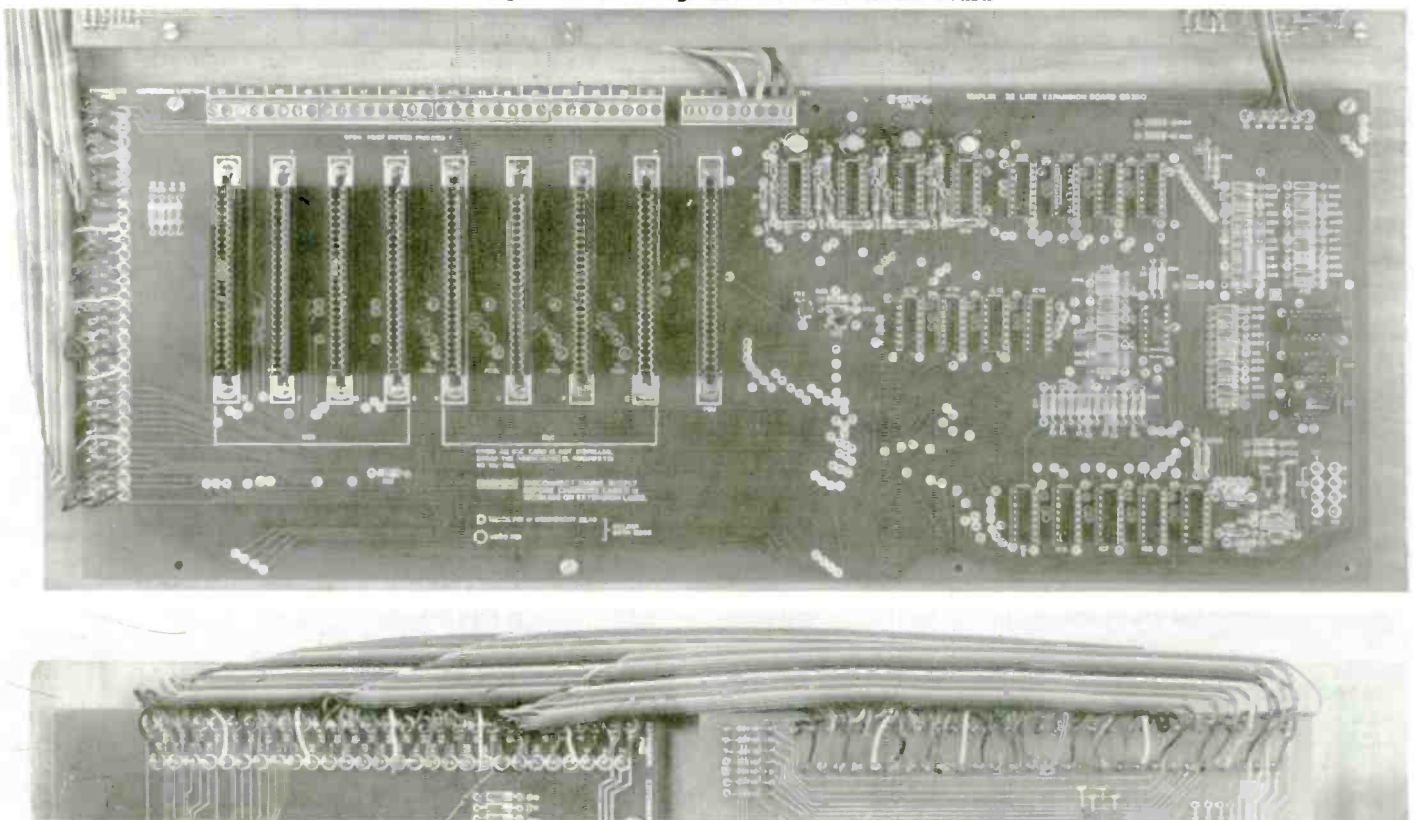

Figure 1. Block diagram of 32 line extension board







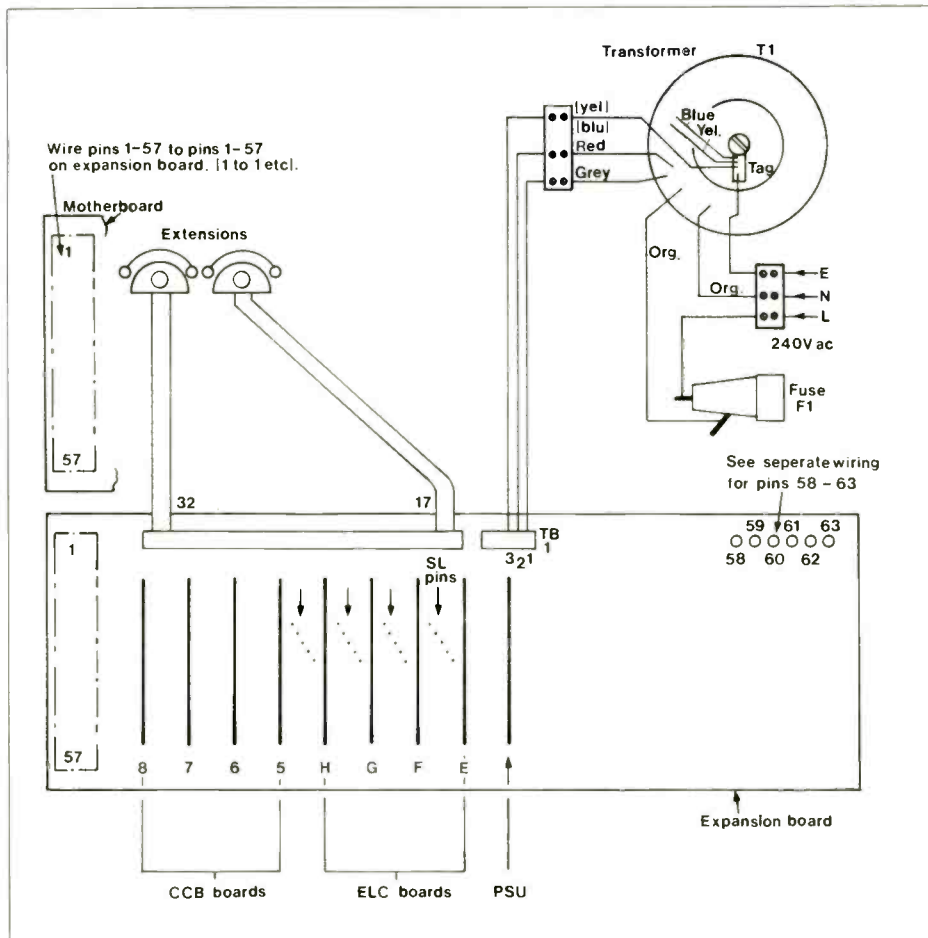

Figure 3a. Wiring diagram

The expansion board can be equipped with up to 4 E.L.C. cards and up to 4 C.C.B. cards, in the same manner as the 16 line exchange, depending on the number of additional extensions required. A modified P.S.U. card is used that does not include the components for the 100V ringing as this is fed, along with all timing pulses etc. from the 16 line board.

## Numbering Scheme

The relationship between the extension system number, and the number dialled to obtain that extension is reprinted in figure 3c.

## Circuit

See Figures 1,2 & 4. The principle of operation is the same as that described in Part 1 but, as in this case the 4 C.C.B. cards on the 16 line board must have access to the new 16 extensions, 4 additional CP switches (IC's 1-4) are provided. The 4 C.C.B. cards on the expansion board, switch to any of the 32 lines using the 8 CP switches (IC's 5-12). A calling extension is switched to a free C.C.B. card by one of the 4 CP switches (IC's 13-16). All control of output CP switches is accomplished by the EPROM logic on the 16 line board and for this reason both EPROM address and data lines are extended between the two boards.

When extensions 17-32 are dialled on the 16 line Digi-Tel, the EPROM (M4 YELLOW) connects the call to NU tone, therefore a new EPROM (M5 BROWN) is provided in the expansion kit, which has the correct codes for routing to the new

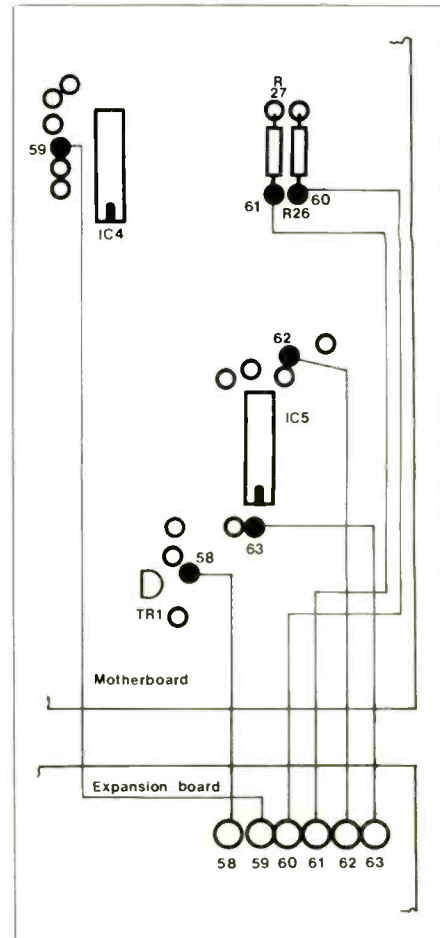

Figure 3b. Additional inter-board wiring

extensions. Both boards have 3 auxiliary outputs. These may be used independently or both sets may be connected in parallel, the busy tone being returned if a second board tries to switch to a circuit already in use.

## Construction

Refer to P.C.B. legends, parts lists and Figures 3a & 3b. The board is constructed in the same way as the 16 line one, not forgetting to solder on both sides of the board components marked with a ring on the legend. D.I.L. sockets should be used for all CP switch IC's (IC1-17) and these components should not be inserted until the construction has been completed and all P.S.U. voltages have been checked.

System Extension Number	Number Dialed	System Extension Number	Number Dialed
1	21	19	39
2	22	20	30
3	23	21	41
4	24	22	42
5	25	23	43
6	26	24	44
7	27	25	45
8	28	26	46
9	29	27	47
10	20	28	48
11	31	29	49
12	32	30	40
13	33	31	51
14	34	32	52
15	35	Aux 1	8
16	36	Aux 2	9
17	37	Aux 3	0
18	38		

Figure 3c. Number conversion table

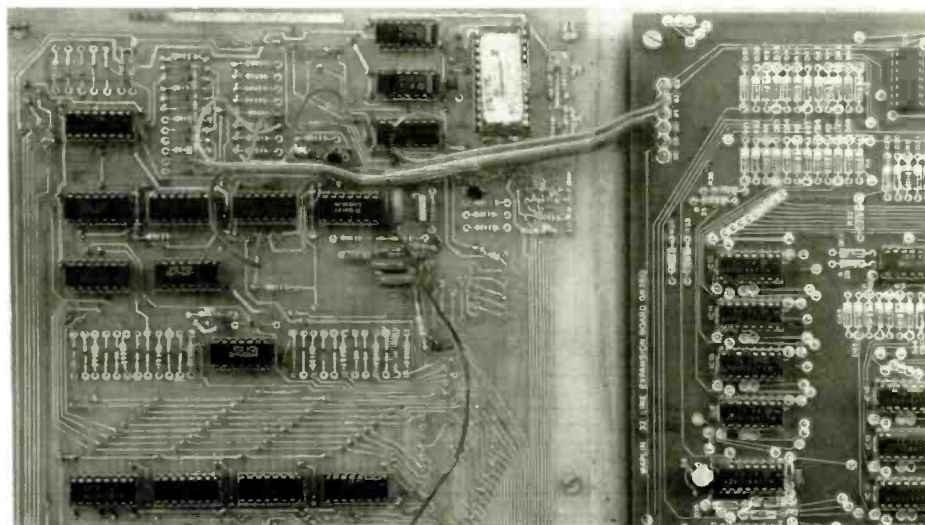



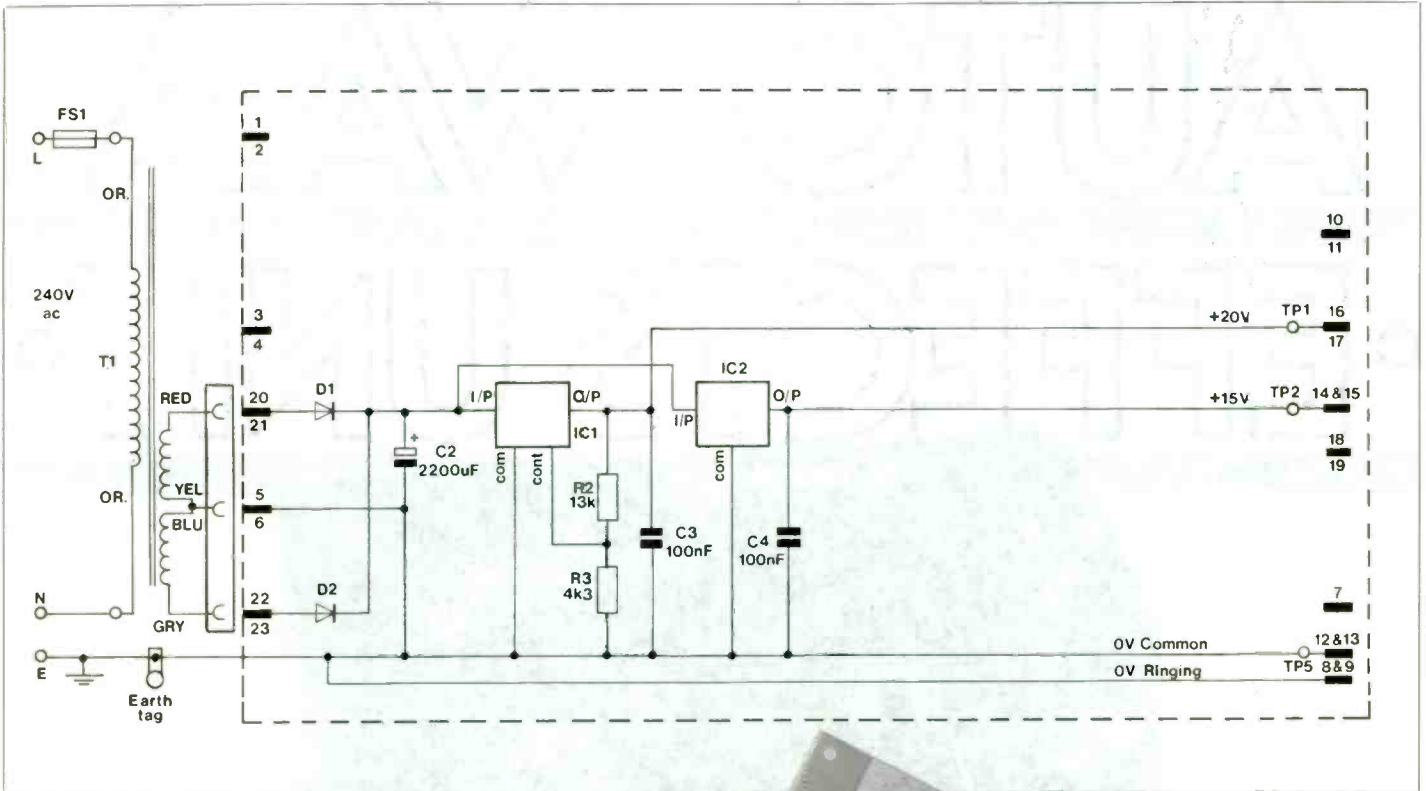

Figure 4. Modified PSU circuit

## EXPANSION BOARD PARTS LIST

RESISTORS: All 0.4W 1% Metal Film

R1-20,25,27,29-31,37,10k	26	(M10K)
R21-23,26,28,32-36 100k	10	(M100K)
R24 2M2	1	(M2M2)

CAPACITORS

C1-4 100uF 25V PC Electrolytic	4	(F11M)
--------------------------------	---	--------

SEMICONDUCTORS

D1-65 1N4148	65	(QL80B)
D66 BZY88C12V		(QH16S)
IC1-17 45100BE	17	(QO51F)
IC18 4081BE		(CW48C)
IC19-21 40106BE	3	(CW64U)
TR1-3 BC548	3	(QB73Q)

MISCELLANEOUS

P.C. Board		(GB35Q)
8 way P.C. Terminal	5	(RK38R)
Edge Connector 124	9	(FL85C)
Edge Connector Foot G	9	(FL91Y)
Edge Connector Foot H	9	(FL92A)
DIL Socket 16 pin	17	(BL19V)
Track Pin	6 pkts	(FL82D)
Veropin 2145	1 pkt	(FL24B)
Bolt 6BA x 1/2"	2 pkts	(3F06G)
Nut 6BA	2 pkts	(BF18U)
Washer 6BA	2 pkts	(BF22Y)

## ADDITIONAL PARTS

T1 Toroidal Transformer 24V/24V		(TK86T)
Safuseholder 20		(X96E)
F1 Fuse A/S 2A		(WR20W)
Terminal Block 5A		(HF01B)
Tag 2BA	1 pkt	(BF27E)
C6A Mains White	2m	(XR04E)
Wire 3202 White	2m	(XR37S)
Ribbon Cable 30 way	2m	(XR67X)
EPROM 2716/M5		(QY60Q)

OPTIONAL

P.B. Telephone	Set of 4	(XG19V)
P.B. Telephone	As req	(XG18U)
4-wire Phone Cable	As req	(XR66W)

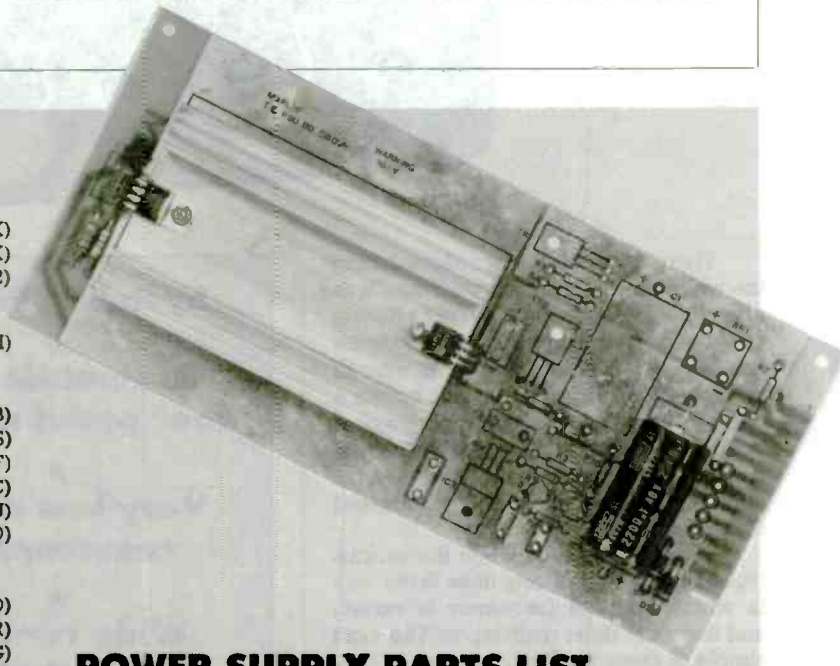

## POWER SUPPLY PARTS LIST

RESISTORS:— All 0.4W 1% Metal Film

R2 13k	(M13K)
R3 4k3	(M4K3)

CAPACITORS

C2 2200uF 40V Axial Electrolytic	(FB91Y)
C3,4 100nF Polyester	2 (BX76H)

SEMICONDUCTORS

D1,2 1N5401	2	(QL82D)
IC1 uA78GU1C		(WQ79L)
IC2 uA7815UC		(QL33L)

MISCELLANEOUS

P.C. Board	(GB07H)
Heatsink 4Y	(FL41U)
Bolt 3BA x 1/2"	1 pkt (BF06G)
Nut 6BA	1 pkt (BF18U)
Washer 6BA	1 pkt (BF22Y)
Track Pins	1 pkt (FL82D)
Veropin 2145	1 pkt (FL24B)

A kit is available containing all the parts in the above 3 lists, excluding optional parts.

Order As LK37S (Digi-Tel 32-Line Expansion Kit)

# AUTO~WAA

## EFFECTS UNIT



There are several ways of producing the well known and much used waa-waa effect, but in each case the basic effect is generated using some form of bandpass filter which is swept up and down over all or part of the audio band. This boosts a fairly narrow and continuously changing band of frequencies, and it is mainly the consequent variations in the relative strengths of harmonics in the processed signal that give the effect.

The difference between the various types of waa-waa effects units is the way in which the filter frequency is varied, and there are three main types. The most simple of these is where the filter is controlled manually using a foot-pedal. The other two types operate the filter automatically, one using an oscillator to sweep the filter in a cyclic manner, and the other using a sort of envelope generator to move the filter frequency in sympathy with the strength of the processed signal.

This auto-waa unit is of the third type, and this form of waa unit has the advantage of being very easy to use while giving an excellent range of effects. With this design it is possible to adjust the minimum filter frequency to practically any audio frequency, and a sweep depth control is also included. Another useful feature of the unit is a resonance control which enables the bandwidth of the filter to be adjusted. The filter is actually a 12dB per octave lowpass type, but positive feedback is used to give a peak in the response just above the cutoff frequency, and this type of filter probably gives the best waa effect. With the resonance control fully backed-off the filter

by Robert Penfold

★  
**Automatic – no  
foot pedal needed**

★  
**Very low power  
consumption**

★  
**Wide range of  
musical effects**

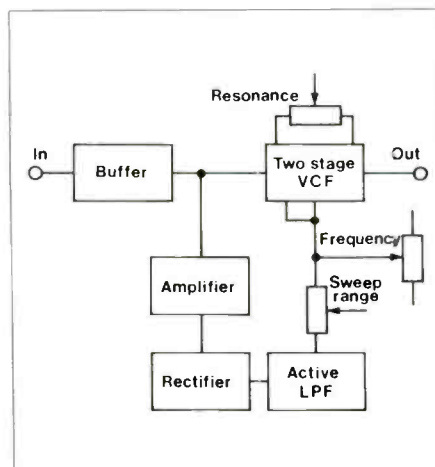

Figure 1. Block diagram

operates as a straight forward 12dB per octave lowpass filter, and the unit then gives a more subtle but useful effect.

### Block Diagram

The block diagram of Figure 1, helps to explain the general way in which the circuit functions.

A buffer stage at the input gives the circuit a reasonably high input impedance and provides a suitably low drive impedance for the subsequent stage. Some of the output from the buffer stage is fed through a two stage voltage controlled filter (VCF) and then to the output. The rest of the output from the buffer stage is fed to an amplifier, and the amplified signal is then rectified to produce a DC control voltage for the filter. The operating frequency of the filter is roughly proportional to the control voltage, and the DC output from the rectifier is roughly proportional to the amplitude of the input signal. As the amplitude of the input signal rises and falls the operating frequency of the filter is therefore moved up and down in the required manner. The sweep range control is included between the rectifier and the VCF, and the base frequency control is also included in this part of the unit.

For this system to work properly it is essential for the control voltage to be an accurate reflection of the input level, and it must have fast attack and decay times so that it accurately tracks the input signal. On the other hand, the output from the rectifier must be well smoothed to prevent audio signals being fed to the control input of the filter and producing distortion products. In this design the use of a three stage active filter instead of a single smoothing capacitor gives fast attack and decay times with no significant breakthrough at audio frequencies.



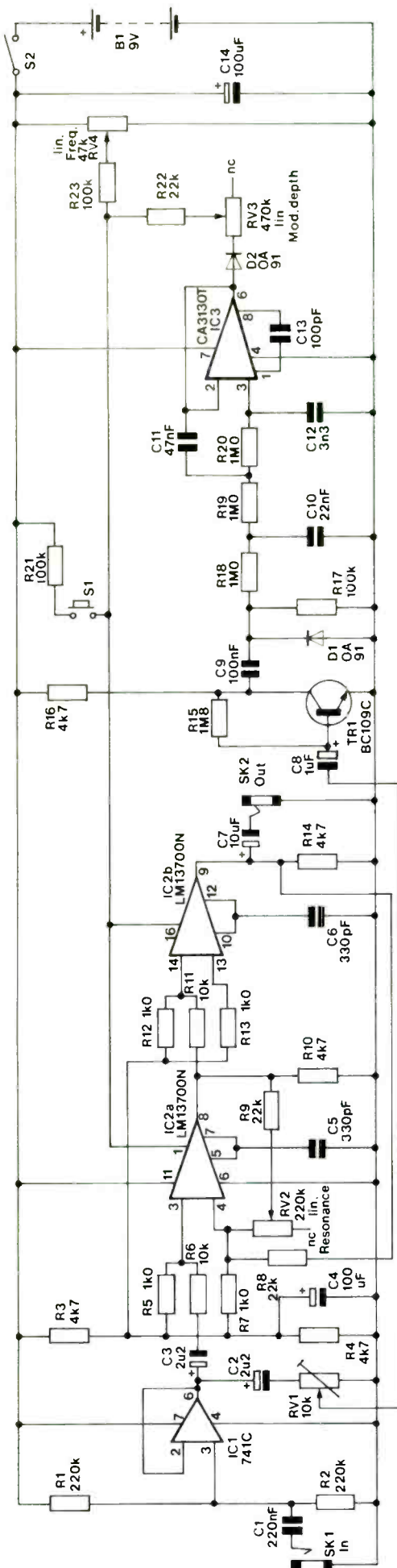
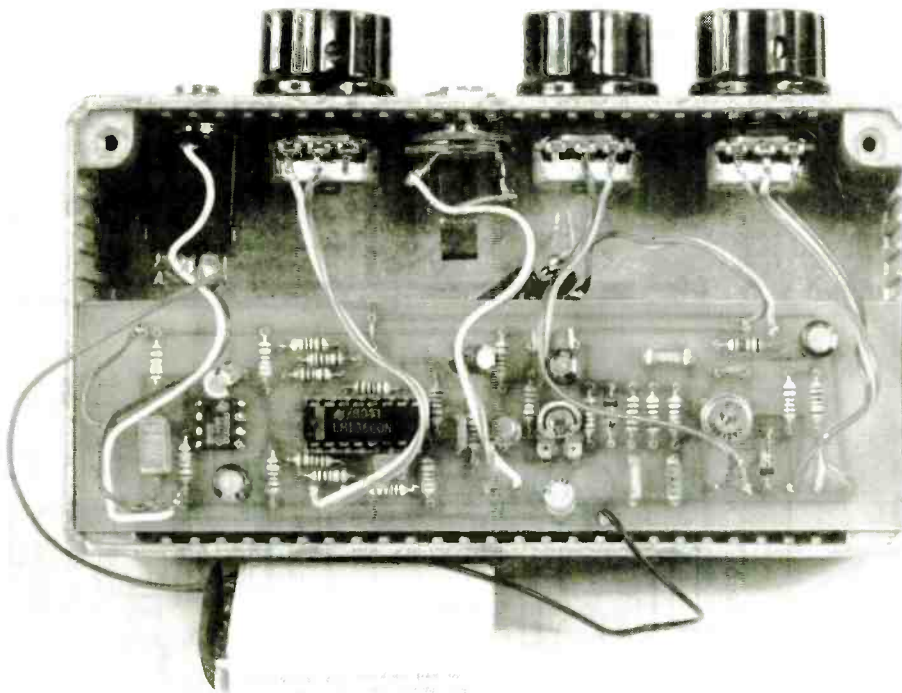

Figure 2. Circuit diagram



## The Circuit

The circuit is based on an LM13700N dual transconductance amplifier, as can be seen by referring to the circuit diagram of Figure 2.

IC1 is used as the buffer amplifier at the input of the unit, and this provides the circuit with an input impedance of over 100 kilohms. C3 couples some of IC1's output to the VCF which uses both transconductance amplifiers and buffer amplifiers of the LM13700N, IC2.

With RV2 set at minimum resistance the circuit operates as a straight forward 12dB per octave lowpass filter with R8 and R9 setting the nominal voltage gain of the circuit at unity at pass frequencies. The frequency at which the roll-off commences is determined by the values of filter capacitors C5 and C6, and the gain of the amplifiers (which is in turn dependent on the bias current fed to pins 1 and 16). The cutoff frequency can therefore be varied by means of a control current, or a control voltage if a resistor is added in series with the control inputs so that the current flow is roughly proportional to the input voltage. The filter's cutoff frequency can be varied manually using RV4 which supplies a variable control voltage — R23 is the series resistor. The cutoff frequency can be set anywhere within the audio range. If S1 is closed, a strong bias current is fed to the filter regardless of the setting of RV4 so that the cutoff frequency is set above the upper limit of the audio band and the filtering is effectively removed. In practice S1 is a foot operated switch and it enables the waa effect to be easily switched in and out.

The filter is actually a state-variable type with bandpass filtering available at the output of IC2a, but this output is

unused in this application. Instead, a form of bandpass filtering is obtained at the output of IC2b by adjusting RV2 for increased resistance so that the feedback over IC2a is decreased. This gives a boost in gain, but only over a narrow band of frequencies immediately below the cutoff frequency. This form of filtering gives the required boost over a narrow band of frequencies, but it gives normal (unity) voltage gain at frequencies below this band. As a result of this there is no attenuation of the fundamental frequencies in the processed signal, and it is for this reason that this type of filtering gives what is generally accepted as a better waa effect than conventional bandpass filtering.

A certain amount of the output from IC1 is taken via preset attenuator RV1, and then amplified by TR1 which is used as a straight forward high gain common emitter amplifier. The amplified signal is rectified by D1 and then applied to the input of the active filter which is based on IC3. This is a conventional three stage circuit apart from the fact that R17 biases the input of the filter to earth and the filter only handles positive half cycles. A CA3130T is used in the IC3 position because this has a CMOS output stage which enables its output to go within a few millivolts of the negative supply rail. Most operational amplifiers, such as the standard 741C device, have a minimum output voltage of about 2 or 3 volts which is far too high to give acceptable results in this circuit. Another advantage of the CA3130T is that it has an extremely high input impedance, and due to the high value of filter resistors R18 to R20 this is essential. The filter resistors have been given such a high value in order to enable the low cutoff frequency of about 10 Hertz to be achieved using reasonably low filter

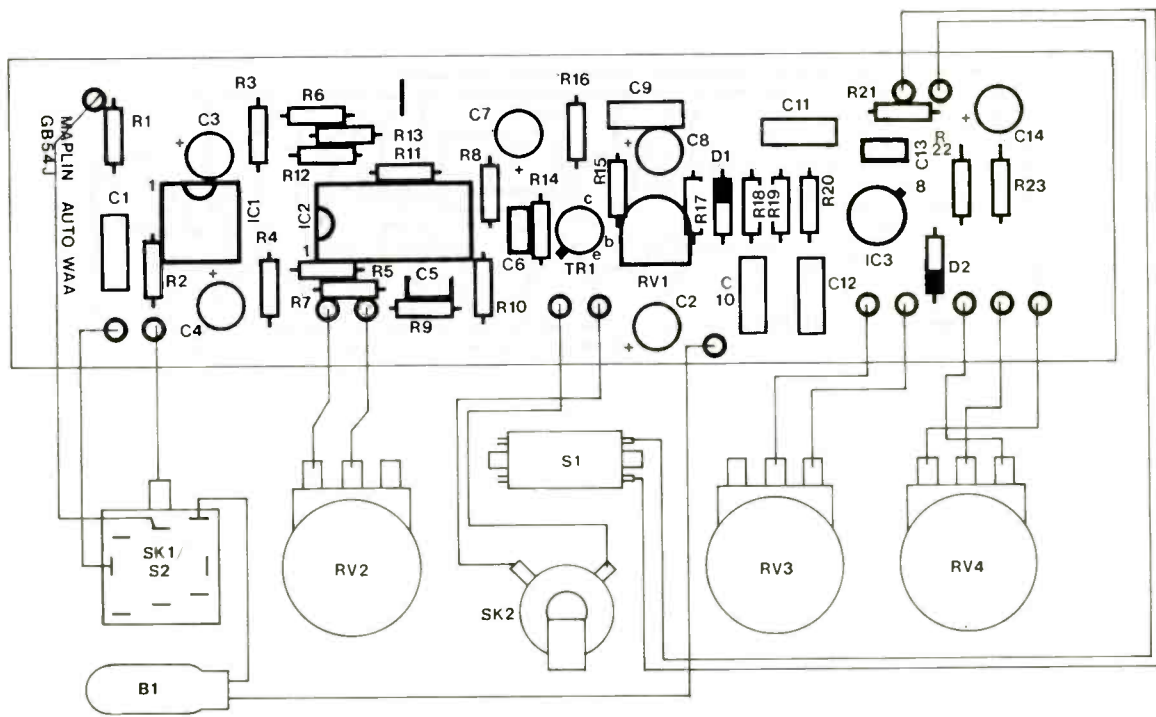
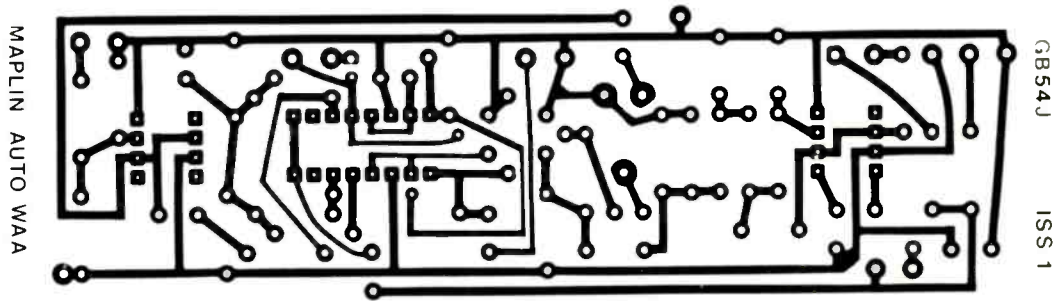

Figure 3. Legend, artwork and wiring diagram

capacitor values. This cutoff frequency gives more than adequate attack and decay times but ensures that there is no significant ripple on the DC output signal.

The output of IC3 is coupled to the control input of the VCF by way of D2, R22, and RV3. The latter acts as the modulation depth control. D2 is needed to prevent any interaction between the depth and frequency controls.

As the circuit has a current consumption of only about 4.5 milliamps a small (PP3 size) 9 volt battery can be used as the power source and will give many hours of operation.

## Construction

Full details of the printed circuit board are provided in Figure 3. The resistors, capacitors, and single link wire are soldered in place first, followed by the semiconductor devices. IC3 has a MOS input stage and should therefore be fitted in place last of all, while taking the usual MOS handling precautions. D1 and D2 are germanium diodes which are more susceptible to damage by heat than silicon devices. Appropriate care not to overheat these components should be taken when they are being soldered to the board. It is helpful to fit Veropins at

places where connections to off-board components will eventually be made.

For this type of project a very tough case is required, and one which screens the circuit from electrical noise is also an asset. A diecast aluminium box is ideal, and the printed circuit board has been designed to fit a 150 by 80 by 50mm case of this type. The two sockets and three potentiometers are mounted on the front panel (which is one of the 150 by 50mm sides of the case), and S1 is mounted centrally on the top panel. S2 is a pair of make contacts on SK1 and the unit is therefore automatically switched on and off when a jack plug is plugged into and removed from SK1. An ordinary on/off switch could be used if preferred, but it would be difficult to accommodate this on the rather crowded front panel, and the suggested method is probably the most practical solution. Incidentally, this method of on/off switching is often used for musical effects units.

Next the hard-wiring is added, as shown in the wiring diagram of Figure 3. This is all quite straight forward and should not give any problems. Finally, the printed circuit board is fitted into the set of guide rails nearest the rear of the unit with the component side facing forwards.

There is plenty of space for the battery to the rear of SK1, and a piece of foam material can be used to keep the battery in place.

## Adjustment

The only preset control is RV1 which must be adjusted to suit the input signal level. If it is set too far in a clockwise direction the filter frequency will tend to go to its highest level even when the input signal has fallen well below its peak level. If it is set too far in the opposite direction the filter frequency will be virtually static at the level set using RV4. A suitable setting for RV1 is found by empirical means, and is any setting that produces a good waa effect with the filter frequency sweeping up and down in sympathy with volume of the processed signal. The unit can handle a low level signal from (say) a low output guitar pick-up, or a high level signal from a high output pick-up, keyboard instrument, or any similar signal source. However a very low level signal, such as the output from a microphone, would require a certain amount of preamplification.

Results are likely to be best with RV2 well backed off, RV4 set for a base frequency around the middle of the audio

*Continued on page 27.*



# 2.8kW POWER CONTROLLER

- ★ Controls up to 12 Amps at 240VAC
- ★ 99% Power Transfer
- ★ R.F.I. Suppression
- ★ Simple Construction

by Dave Goodman

By utilising the PC12 thick film IC this Power Controller can handle loads up to 2.8kW — much greater than most, reasonably priced, commercially available units. Voltage levels are continuously variable from 240V down to between 2 and 20V, this final level being dependent on the load applied, up to a maximum of 12 amps. The unit is therefore suitable for controlling lamps, electric drills, soldering irons, bar type electric fires and many other electrical items. The module may be incorporated into a complete project, to provide a self-contained power controller, as described later in this article. Alternatively it may be used to suit a particular application.

## Circuit Description

IC1 is a thick film hybrid device with an integral heat sink mounting plate, requiring RV1 for varying the conduction phase angle between 160 and 0 degrees. The Triac is turned on after an applied ac waveform has passed through zero volts and it remains on until, after passing through its peak, the waveform again reaches zero thus turning the triac off again. This process is repeated during the next half-cycle as shown in Figure 1. Triacs differ from thyristors in that they are able to conduct during positive and negative half cycles (effectively a switched diode). This means that full cycle control and hence 99% power transfer is available at maximum current.

Full power is available with RV1 set fully clockwise i.e. minimum resistance (see circuit diagram, Figure 2). Increasing resistance between output pin 2 and control input pin 1 determines the phase angle or position along the waveform where IC1 will turn on. At maximum resistance the phase angle is in direct opposition and no power is delivered, but this action must not be compared with that of a mechanical switch, as full mains potential is available with no load connected.

Due to the fast switching action of IC1, harmonics are generated especially

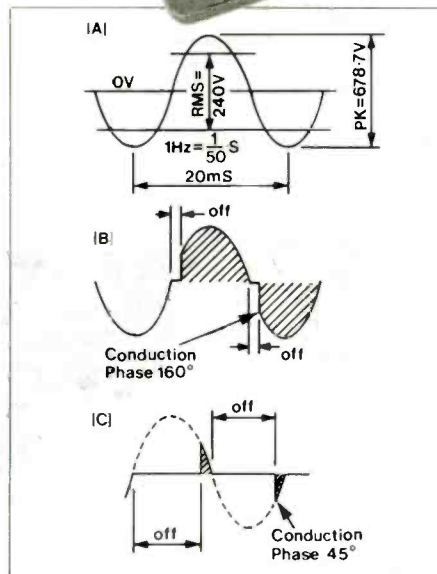
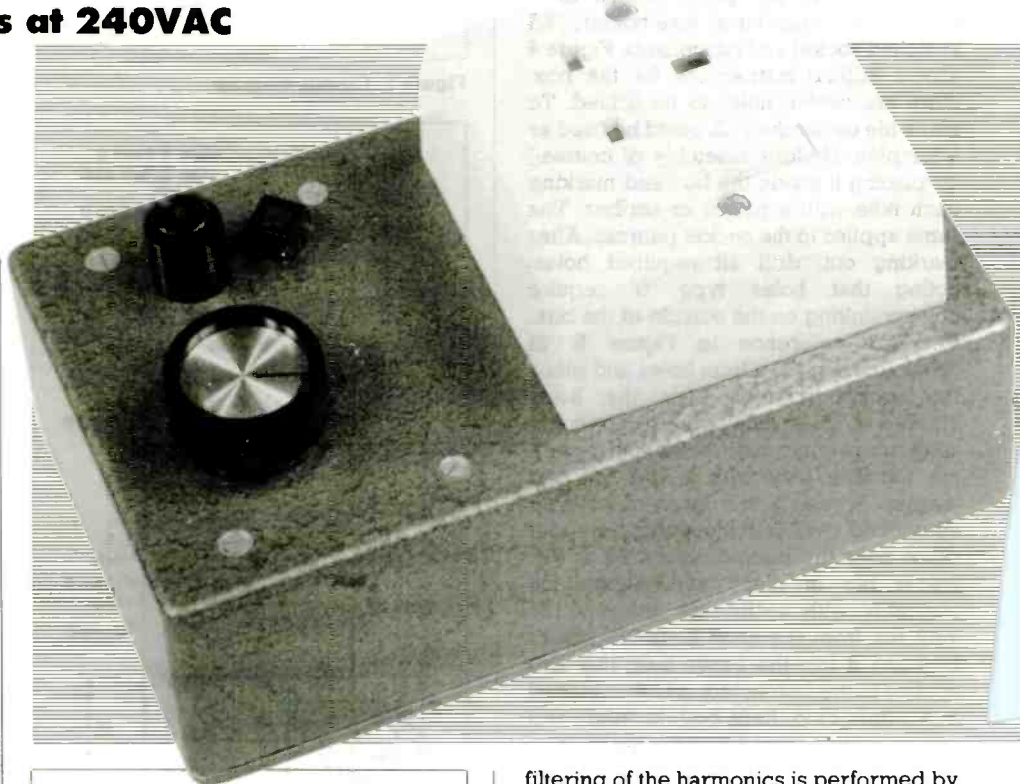

Figure 1. Triac conduction waveforms

at 50% power setting. These harmonics are extended up into the R.F. range and are radiated along the connecting cables and into the air producing R.F. interference and a loud buzz in audio equipment! Not only is R.F.I. an annoyance, it must meet Department of Trade and Industry requirements, so L.C.

filtering of the harmonics is performed by C1, C2 and RFC1 to 4. Four 3 amp chokes handle the 12A maximum current availability, offering a low impedance at 50Hz and a high impedance to high frequency signals. A neon lamp N1 indicates permanently when mains is applied without a load, but will not be on if fuse FS1 blows. With a load connected, N1 indicates fully at maximum power and dims progressively as power levels are reduced by RV1 down to a minimum.

## PCB Construction

Insert all five Veropins (P1-5) into the holes marked with a circle, (see Figure 3, pcb artwork and legend) push the pin heads firmly down to the board and solder in place. Mount the four chokes (RFC1-4) and the suppressor caps C1 and C2, solder these components in place and remove excess wire ends. It is important to push all components down on to the board so that they cannot be moved about and cannot break away from their positions. Remove the nut and washer from RV1 and insert into the board from the component side. As shown in Figure 5, two terminals are soldered to pins 4 and 5 and the third is not used and may be cut off or bent away.

Replace both washer and nut on RV1 and tighten up to the PCB.

IC1 pins 1, 2 and 3 are inserted and soldered from the track side of the PCB and IC1 is set approximately 12mm away from the board (see Figure 5). The heatsink bracket is completely isolated and can be connected to mains earth without problem. Note that IC1 must be bolted onto a suitable heatsink and for use with high load currents, the heatsink will need to be rated at between 3° and 4°C per Watt.

## Box Drilling and Assembly

The parts list gives details of a suitable box, neon lamp, fuse holder, 13A switched socket and miscellanea. Figure 4 shows drilling instructions for the box; there are twelve holes to be drilled. To make life easier the PCB could be used as a template (before assembly of course!) by placing it inside the box and marking each hole with a pencil or scriber. The same applies to the socket pattress. After marking out, drill all required holes, noting that holes type 'b' require countersinking on the outside of the box.

With reference to Figure 5, fit grommets into the 13mm holes and place the socket pattress over the holes marked 'a', insert half-inch x 4BA countersunk screws into both holes and secure the top one only with a 4BA nut and washer. Spread a thin layer of heatsink compound over IC1 mounting plate and place over the bottom screw. Fit a 4BA solder tag in place and secure the assembly with a 4BA nut. Remove the lock nut from the neon lamp N1 before inserting it into the 11mm hole; this also applies to the fuse holder which is placed in a 14mm hole. Refit both locknuts and tighten down. Insert 1 inch x 6BA countersunk screws into the four holes marked 'b', and slide a spacing collar over each one. The assembled PCB is positioned over these screws with the spindle of RV1 protruding through the 7mm hole. Secure the PCB with 4 x 6BA nuts and washers.

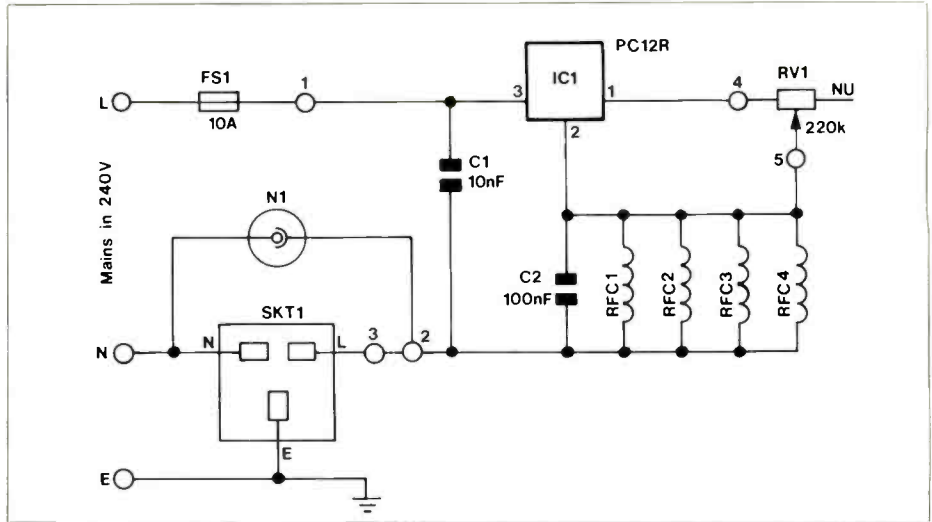

Figure 2. Circuit diagram

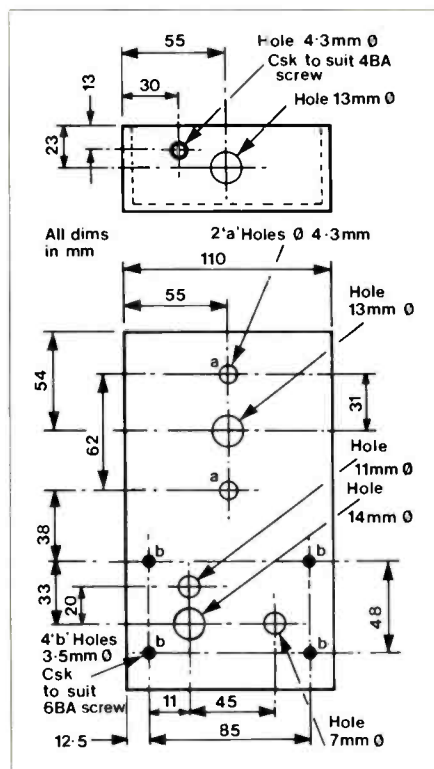

Figure 4. Case drilling details

## Wiring Details

Refer to Figure 5. Strip away approx. 18 inches of insulating sheath from one end of the 13A connecting cable. Pass this end through the top grommet into the box and clamp in place with a 5/16 inch 'P' clip and 1/2 inch x 4BA countersunk screw, nut and washer. Measure and cut the live (brown) wire and solder it to a terminal on FS1. Use three inches of brown wire and join the other FS1 terminal to PCB pin 1. Connect another wire length between one terminal of N1 and pin 2. Solder the remaining 5 to 6 inches to PCB pin 3 and feed through the grommet for connection to SKT1. Both the blue and green/yellow wires from the cable should now be cut to approx. 8 inches long and placed through the grommet.

Solder one end of neutral (blue) wire to the unused terminal of N1 and solder one end of the earth (green/yellow) wire to the 4BA tag on IC1. Thread both wires through the grommet to SKT1. There should now be five wires protruding through the box: 1 brown, 2 blue and 2 green/yellow. Terminate both blue wires to terminal N (neutral), both green/yellow wires to terminal E (earth) and the Brown wire to terminal L (live) on the switched

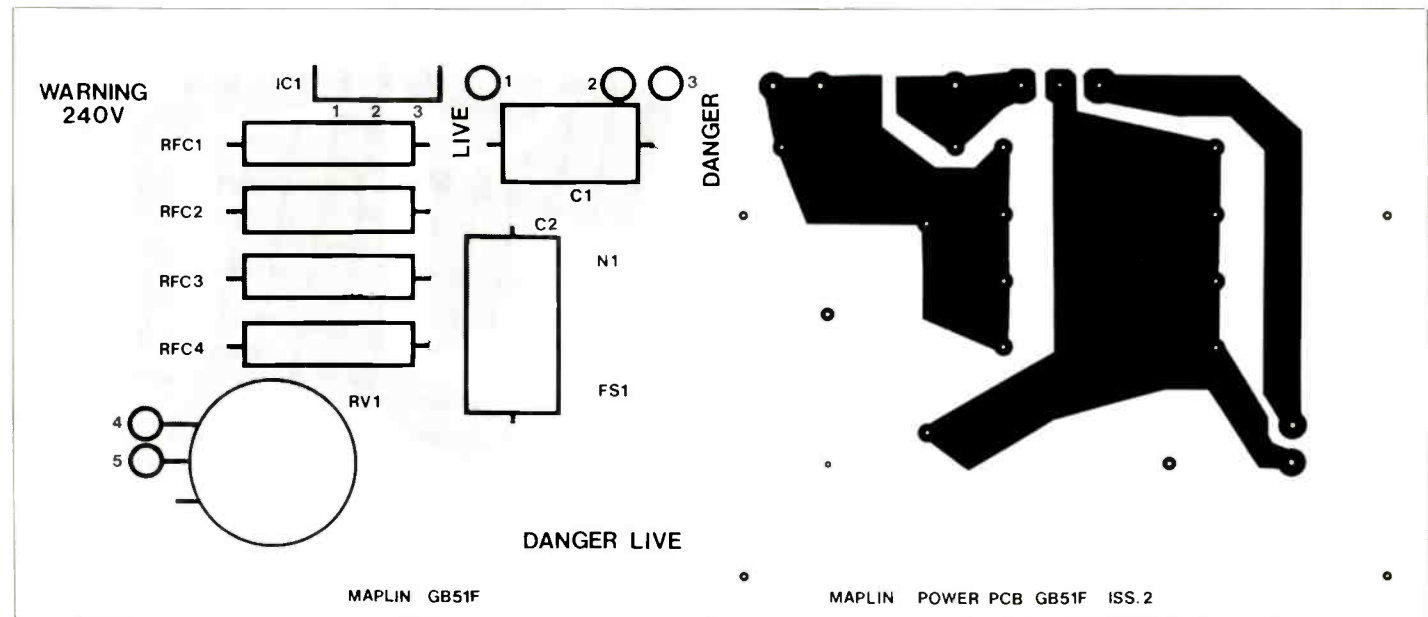

Figure 3. Artwork and legend



socket SKT1, then secure to the patrix with both screws provided. Finally cut off RV1 spindle half an inch above the box and fit a control knob. Insert a 10A 1 1/4" fuse into FS1 holder and bolt on the bottom box cover.

## Testing and Use

Connect the 13A cable to the mains supply and switch on. N1 should light up, but note that varying RV1 will slightly alter the light output of N1. Unscrew the terminal post in FS1 and let it pop up — do not remove it — and N1 will go out. Retighten the terminal post. If you have a bedside or table lamp available plug it into SKT1, ensuring that its own switch is on! Turn SKT1 switch off and RV1 fully anti-clockwise. N1 should be illuminated until SKT1 is switched on, whereupon it will go out. Slowly turn RV1 clockwise. Neon N1 will gradually brighten, as will the test lamp. Do not worry if a quiet buzz is heard with RV1 at maximum — this is quite normal.

Problems can be encountered when controlling inductive loads such as pump motors. Changing the power factor causes the triac to fire intermittently and heavy currents will be passed, which may blow FS1, even for a small load. Finally, remember that the switch on SKT1 only disconnects output power to the load and does not remove mains supply from the unit. Therefore keep loose wires, fingers etc. away from the PCB as full mains is present and potentially dangerous!

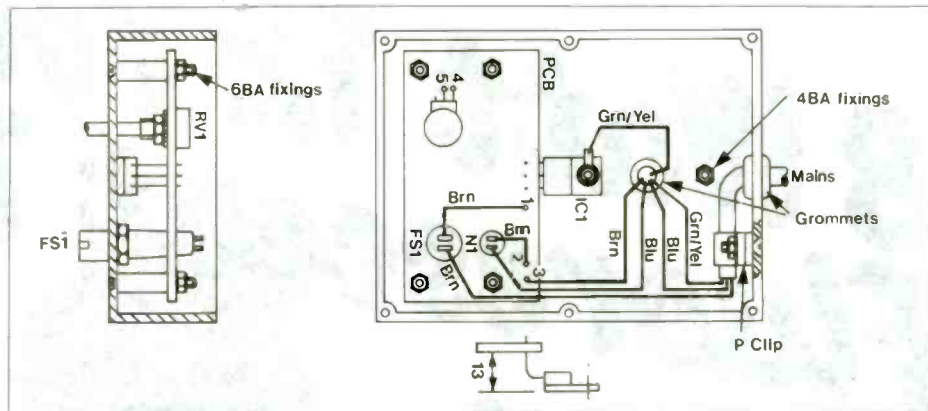
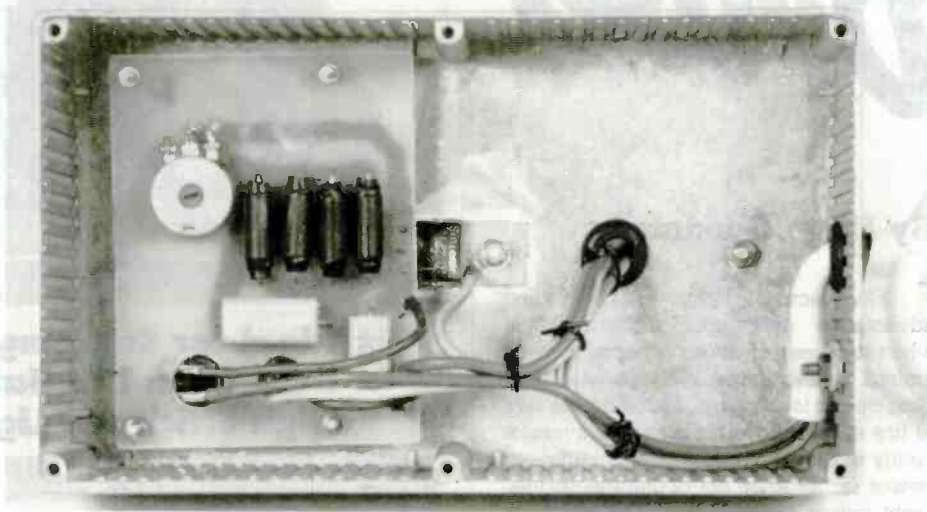

Figure 5. Assembly and wiring



Continued on inside back cover.

## AUTO-WAA Continued from page 24.

band, and RV3 set for a medium to high modulation depth. However, a little experimentation will soon show what settings give the best effects with a particular instrument. Bear in mind that setting RV4 for a low base frequency could result in fundamental frequencies in the processed signal being substant-



ially boosted as the filter sweeps through them, and with a high level input overloading with attendant distortion could result. There is also a danger of overloading the equipment fed from the output of the unit, and the best effect tends to be obtained with the filter sweeping over medium and high frequencies anyway.

## PARTS LIST FOR AUTO-WAA

RESISTORS:- All 0.4W 1% Metal Film unless otherwise stated.

R1,2	220k	2	(M220K)
R3,4,10,14,16	4k7	5	(M4K7)
R5,7,12,13	1k0	4	(M1K)
R6,11	10k	2	(M10K)
R8,9,22	22k	3	(M22K)
R15	1M8 Carbon film 1/2W 5%		(B1M8)
R17,21,23	100k	3	(M100K)
R18,19,20	1M0	3	(M1M)
RV1	10k Hor Sub-min Preset		(WR58N)
RV2	220k Pot Lin		(FW06G)
RV3	470k Pot Lin		(FW07H)
RV4	47k Pot Lin		(FW04E)

### CAPACITORS

C1	220nF Polycarbonate		(WW45Y)
C2,3	2u2 63V PC Electrolytic	2	(FF02C)
C4,14	100uF 10V PC Electrolytic	2	(FF10L)
C5,6	330pF Ceramic	2	(WX62S)
C7	10uF 35V PC Electrolytic		(FF04E)
C8	1uF 100V PC Electrolytic		(FF01B)
C9	100nF Polycarbonate		(WW41U)
C10	22nF Polycarbonate		(WW33L)
C11	47nF Polycarbonate		(WW37S)
C12	3n3 Polycarbonate		(WW25C)
C13	100pF Ceramic		(WX56L)

### SEMICONDUCTORS

D1,2	OA91	2	(QH72P)
TR1	BC109C		(QB33L)
IC1	uA 741C (8-pin DIL)		(QL22Y)
IC2	LM13700N		(YH64U)
IC3	CA3130T		(QH28F)

### MISCELLANEOUS

SK1	DPDT Jack Socket		(BW80B)
SK2	Jack Socket Open		(HF91Y)
S1	Press Toe Sw 1		(FH92A)
S2	(Part of SK1)		
	Printed Circuit Board		(GB54J)
	Knob K7B	3	(YX02C)
	Wire	1 pkt	(BL00A)
	Battery Clip (PP3 Clip)		(HF28F)
	Veropins 2145	1 pkt	(FL24B)

### OPTIONAL

	Battery 9V PP3 Nicad		(HW31J)
	Case		(LH73Q)
	Cabinet Feet	1 pkt	(FW19V)
	16 Pin DIL Socket		(BL19V)
	8 Pin DIL Socket		(BL17T)
	Bolt 4BA 1/4"	1 pkt	(BF02C)
	Nut 4BA	1 pkt	(BF17T)

A kit of parts (excluding optional items) is available.  
Order As LK36P (Auto Waa Kit)



# 8 Watt 12 Volts Fluorescent Tube Driver

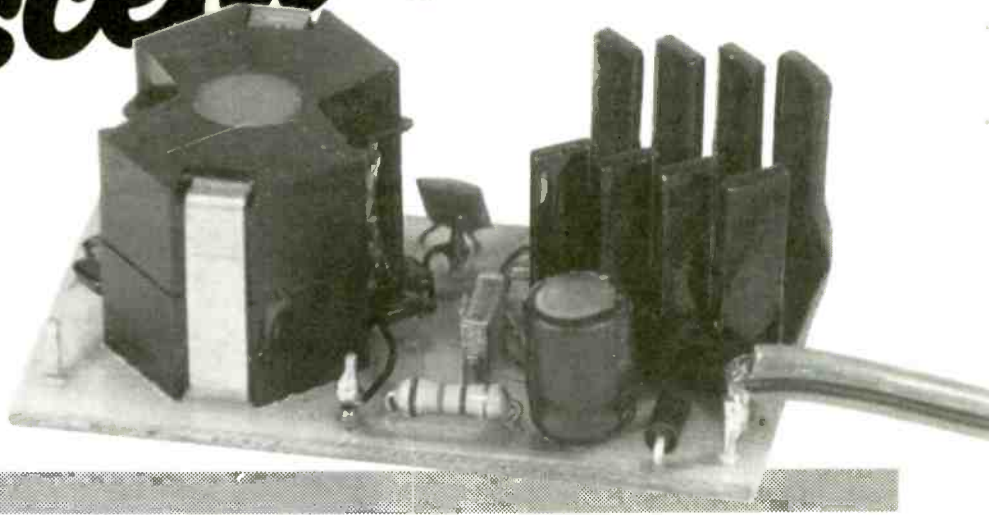

By Dave Goodman

Fluorescent lights have many advantages over incandescent lamps when used out of doors especially when limited power resources are available. Heat output is very low, reducing the risk of fire especially in tents and an average family car battery could supply sufficient power for up to 15 hours continuous use. Light output radiates from the length of the tube, not from one focussed point making diffusers and reflectors unnecessary, and being much kinder on the eyes. Unfortunately there is one problem with fluorescent tubes: high voltages are required to 'Strike' and run them, so a method of driving many hundreds of volts from a 12 volt source must be employed. Our fluorescent tube driver meets the requirements and provides a system at much lower cost than commercially available units.

## Circuit Description

When power is applied, TR1 is turned on hard via R1 and L2. L1 is energised and passes a high current which induces a pulse in L2 and turns TR1 off for the duration of the pulse. No current flows through L1 at this time and L2 offers a low impedance path from R1 to TR1 base thus turning it on again. Due to this alternating field a large voltage is developed across L1 — around 100 volts — and step-up winding L3 generates several hundred volts, enough to strike the fluorescent tube. The load now remains constant across L3 and the oscillation frequency is maintained by time constant R1 and C2.

Under normal load running conditions a 50kHz square wave at 250 volts should be present across pins 5 and 6. In case of reversed battery connections, D1 prevents damage to both TR1 and battery from occurring, and it will not pass current under these conditions. C1 decouples the supply rails and prevents RF transmission from long battery-lead cables (see circuit diagram, Figure 1).

## Transformer Construction

Three separate windings are required, see Figure 2, these being:

Secondary L3: 200 turns of 34swg (0.3mm) E/C wire

Secondary L2: 15 turns of 34swg (0.3mm) E/C wire

Primary L1: 30 turns of 24swg (0.6mm) E/C wire

Wind L3 first on the bobbin (Figure 2a) by tinning the E/C wire and soldering it to

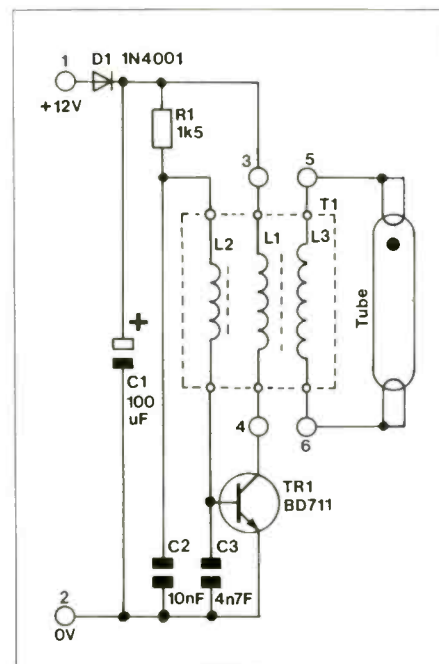

Figure 1. Circuit diagram

- ★ Ideal for Camping, Caravans and Boats
- ★ Runs from 12V Battery Supply
- ★ High Efficiency Light Output

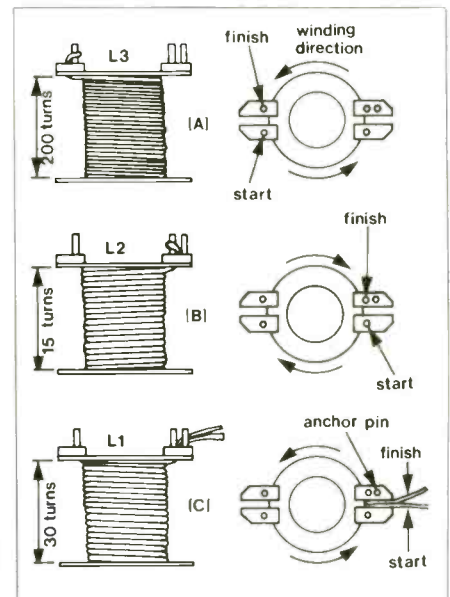

Figure 2. Construction of T1

the terminal L3 start. Wrap each turn close to the previous one and build up in layers. Approximately 30 to 32 turns can be made across the former, so six layers should be built up as neatly as possible. Terminate L3 finish as before and insulate the windings with a single layer of PVC insulating tape wrapped tightly around the coil. Next wind L2 (Figure 2b) starting and terminating on the opposite two bobbin pins (3rd one not used). Again, spread all 15 turns tightly across the previous coil L3 — eight turns across and 7 turns back. Finally, wind L1 straight on top of L2 (Figure 2c). Leaving two inches of spare wire, wind two layers, 15 across and 15 back again leaving two



inches of spare wire. Wrap three turns of PVC tape tightly around L1 to prevent it from unwinding and drop into one section of T1. Fit the remaining section over the bobbin and secure both halves with metal clips clamped over each end. Before fitting onto the pcb make sure the windings of L2 and L3 have been soldered correctly to their bobbin pins and remove any excess solder which may prevent insertion into the board.

## PCB Construction

Refer to the parts list and Figure 3. Mount the capacitors C2,3 and resistor R1. Insert diode D1 correctly to the legend on the PCB to ensure correct polarity. Next insert Veropins 1 to 6. Position the vaned heatsink and mount TR1 (Figure 4) making sure that the leads of TR1 go through the board and tighten the nut and bolt. Insert C1, which is polarised, and finally fit T1. L1 is soldered to pins 3 and 4 and the two wire ends should be scraped to remove the enamel before tinning. Solder components and cut-off all excess leads.

## Using the Module

Connect an ammeter in series with pin number 1 and +12 volt supply; supply common or -ve goes to pin 2. Set the ammeter scale to allow a reading of 1 amp or more and apply power. A high pitch whistling may be heard, with a current reading of 0.4 to 0.5A. If the reading is 1A or more, switch off and reverse L1 connections to pins 3 and 4

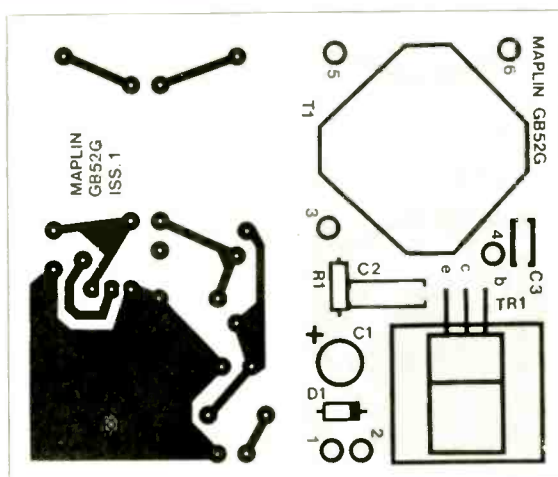

Figure 3. PCB legend

and check again. Remove power and connect an 8W 12 inch fluorescent tube across pins 5 and 6. The tube will probably have two starter terminals at each end (four altogether). Join each pair together before connection to the pcb. Keep all connections short and insulate bare terminals to prevent the risk of shock. Remember high voltages are present here and could be dangerous, even with limited current availability!

Apply power again and the tube should glow dimly, then after a second or two light up completely. Check current reading is approximately 0.5A. No whistling should be audible and the tube should not flicker, but if this is not so, try reversing L1 connections to pins 3 & 4 or reverse tube connections to pins 5 and 6.

The inverter can drive two tubes in

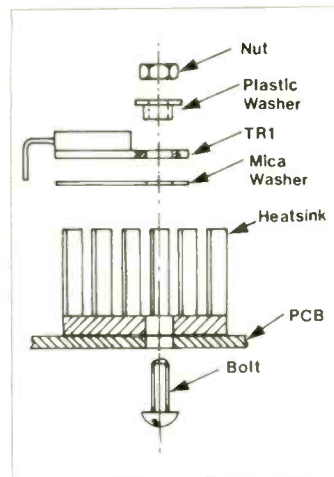

Figure 4. Mounting the transformer and heatsink

series (not parallel), at slightly reduced light output levels and the supply current will rise by 100mA or so when doing this. Resistor R1 can be increased up to 2k to reduce light output (and supply current) or taken down to 470R for increased light output, with supply current up to 1A. With the specified value for R1, tube life expectancy should be high and the prototype has been running for a great many hours without problem.

For housing the tube, clear plastic piping as used on water tank overflows etc. can be utilised and fitted to a small plastic box containing the inverter. The module could then be potted for safety and a cork fitted into the open end of the pipe.

## TUBE DRIVER PARTS LIST

RESISTORS:- 1/2W 5% Carbon Film			
R1	1k5 (See text)	(S1K5)	
CAPACITORS			
C1	100uF 25V PC Electrolytic	(FF11M)	
C2	10nF Carbonate	(WW29G)	
C3	4n7F Ceramic	(WX76H)	
SEMICONDUCTORS			
D1	1N4001	(QL73Q)	
TR1	BD711	(WH15R)	
MISCELLANEOUS			
L1	30 Turns x 24swg E.C.W.	(HX09K)	
L2	15 Turns x 34swg E.C.W.	(HX10L)	
L3	200 Turns x 34swg E.C.W.	(HX11M)	
T1	Ferrite Pot Core Type 3	(BL28F)	
	Bobbin Type 3	(BL42V)	
	Clip Type 3	(WR23A)	2
	24swg Enamelled Copper Wire	(FL58N)	1 reel
	34swg Enamelled Copper Wire	(FL24B)	1 reel
	Mounting Kit	(GB52G)	
	Heatsink	(BF06G)	
	Veropin 2145	(BF18U)	1 pkt
	Tube Driver P.C.B.	(LQ11M)	1 pkt
	6BA x 1/2in Bolt		1 pkt
	6BA Nut		1 pkt
	12V 8W Fluorescent Tube		

A complete kit of parts is available.  
Order As LK35Q (Tube Driver Kit)

Continued from page 27.

## POWER CONTROLLER PARTS LIST

RESISTORS			
RV1	220k Lin Pot	(FW06G)	
CAPACITORS			
C1	10nF 1/5 Cap 250V AC	(FF53H)	
C2	100nF 1/5 Cap 250V AC	(FF56L)	
SEMICONDUCTORS			
IC1	PC12R	(QY38R)	
MISCELLANEOUS			
RFC1-4 Inc	RF Supp Choke 3A	4	(HW06G)
	Power P.C.B.		(GB51F)
	Veropin 2141	1 pkt	(FL21X)
N1	Pan Neon Red		(RX83E)
FS1	1/4" Fuse 10A		(WR16S)
	Safuseholder 1/4"		(RX97F)
SKT1	Single Switched Socket		(HL71N)
	Surface Pattach 29mm Single		(YB15R)
	Grommet Large	2	(FW60Q)
	6BA x 1" Countersunk Screw	1 pkt	(BF13P)
	4BA x 1/2" Countersunk Screw	1 pkt	(BF10L)
	6BA x 1/2" Spacer	1 pkt	(FW35Q)
	4BA Tag	1 pkt	(BF28F)
	6BA Washer	1 pkt	(BF22Y)
	4BA Washer	1 pkt	(BF21X)
	6BA Nut	1 pkt	(BF18U)
	4BA Nut	1 pkt	(BF17T)
	Knob K2		(HB24B)
	13A HD Mains Cable	As req	(XR10L)
OPTIONAL			
	Case DCM5006		(LH74R)

A complete kit of parts (excluding case) is available.  
Order As LK34M (Power Controller Kit)

