

SATELLITE • INTERNET • TV • COMPUTERS • VIDEO

No. 97

FULL  
SOR

JANUARY 1996 • £2.25

Printed in the United Kingdom



# ELECTRONICS

*The Maplin Magazine*  
Britain's Best Selling Electronics Magazine

## Z80 Development System – serial interface/monitor for the Z80 CPU Module

GPS Development System – decodes GPS Satellite signals for your PC

Build a high quality, manual/autoranging digital multimeter

Hipparcos star mapping – how it was achieved

Informative new series investigating EMC – ElectroMagnetic Compatibility

Digital VHS explained – the latest video recording 'wizardry'

Plus much much more!



# Christmas Crackers for you to build!

Finish off the pud, pick up your soldering iron and make a Merry Christmas with these festive projects from Maplin!



**1**  
PROJECT RATING

## Spruce up your Christmas Tree!

This fine example of arboreal high technology is decorated with 21 LEDs in three seasonal colours, which can be made to flash or twinkle at three different rates. The kit also contains a full-size template to help you make your tree.

Order Code 51082: LED Xmas Tree.

**£12.99**

Details in *Electronics* No. 48 (XA48C)

Available from your local branch!

All items subject to availability. Prices include VAT. E&OE

**3**  
PROJECT RATING

## Christmas Tree Light Sequencer

Give your Christmas tree an extra sparkle this year! When coupled to one or more sets of lights, this unit can produce various attractive lighting sequences and fade patterns. The unit has three output channels each with a maximum output power of 400W, making it ideal for disco light sequencing, attention-grabbing shop window displays or an extremely bright Christmas tree!

Order Code 51085: Christmas Light Sequencer.

**£49.99**

Details in *Electronics* No. 84 (XA84F)



**1**  
PROJECT RATING

## Christmas Superstar

Give the fairy a rest this year and see your neighbours pine with jealousy because 'yule' have the smartest tree in the street! Lift your tree decorations onto an astral plane with our 19-LED, four colour, twinkling Christmas Star. The kit includes all the items needed, except the star itself which you can use your own creative flair to design.

Order Code 51080: LED Xmas Star.

**£7.99**

Details in *Electronics* No.41 (XA41U)



**1**  
PROJECT RATING

## Twinkling Christmas Candle

This simple to build, high-tech electronic candle has a realistic pseudo-random flicker, but won't burn a hole in your pocket – or anything else for that matter. Ideal for decorations, nativity plays, and carol singing. The kit includes constructional details of a suitable cardboard lantern for the festive season.

Order Code 51083: Twinkling Xmas Candle.

**£7.99**

Details in *Electronics* No. 72 (XA72D)

Please note case not included in kit





## PROJECTS FOR YOU TO BUILD!

### Z80 DEVELOPMENT SYSTEM 4

This project, consisting of an RS232-linked serial interface board and associated Windows-based software, enables the evergreen Z80 CPU Module to be programmed from an IBM-compatible PC, rather than having to resort to a fiddly hexadecimal keypad. Allows the quick and easy creation and downloading of binary or Intel hex format files, perfect for experiments using the Z80 microprocessor.

### GPS DEVELOPMENT SYSTEM 24

Use this educational and highly entertaining project in conjunction with your PC via an RS-232 interface, to receive and decode signals from NAVSTAR GPS satellites, allowing you to pinpoint your precise location on Earth and to hugely enhance your navigation facilities. Provides a useful building block for use in other fixed and mobile projects requiring an accurate and reliable GPS decoding stage.

### RS-232 TO 8-BIT CONVERTER MODULE 40

An inexpensive, simple to build and very useful multipurpose PIC microcontroller-based I/O module, that allows your PC to communicate with and control a wide variety of external peripherals, ranging from input sensors and A/D converters to output indicators, relays and motors. Control software is easily implemented in BASIC.

### DIGITAL MULTIMETER 64

A superb, easy to build, high quality, manual and auto-ranging digital multimeter project kit, with all the features you would expect of a modern design. Experience the satisfaction of owning and using test gear that you constructed and calibrated yourself, rather than having to rely on an off-the-shelf, ready built instrument.

## FEATURES ESSENTIAL READING!

### WHEN LIGHTNING STRIKES 16

Why does lightning exist, how is it formed and what can be done to safeguard valuable and sensitive electronic equipment against its striking effects? Find out the electrifying facts on this mysterious phenomenon, in this thunderous article by Ian Poole.

### ACCESS CONTROL 22

This article by Frank Booty describes the latest methods of electronically recognising our unique bodily features such as fingerprints, eye patterns and voices, instead of using forgeable keys and swipe-cards in order to gain access to protected areas.

### HIPPARCOS 32

Douglas Clarkson describes the theory behind obtaining a far more accurate portrayal of the layout of known stars within the universe than we currently have, and details the technology that went into the HIPPARCOS mission.

### EMC 46

John Woodgate investigates the machinations behind the recent, controversial directives from the EC, to ensure that all new electrical and electronic appliances comply with the strict electromagnetic compatibility (EMC) requirements.

### DIGITAL VHS EXPLAINED 50

This article from Reg Miles, (a new name to *Electronics*) comprehensively describes the latest technology to appear in the world of video recording, that of Digital VHS, or D-VHS, covering the features it will offer, how it works, and whether or not you will be able to view your existing collection of prized video tapes on the new machines!

### GUIDE TO MODERN DIGITAL ICs 58

In the fifth part of this series, Ray Marston takes a close look at the versatile 4007UB CMOS IC, and demonstrates how its two pairs of complementary MOSFETs and inverter stages may be configured to operate as logic gates, single-stage and ring-of-three astables, transmission gates, crystal oscillator stages, and micropower circuits, practical examples of which are shown.

### THE INTERNET 72

In the second part of this useful series from Stephen Waddington, the focus is turned to the Internet Providers, the services and features they offer, and at what cost. Essential reading for anyone considering signing up to the information superhighway, but who requires guidance on which services they will be needing, and who is best able provide them.

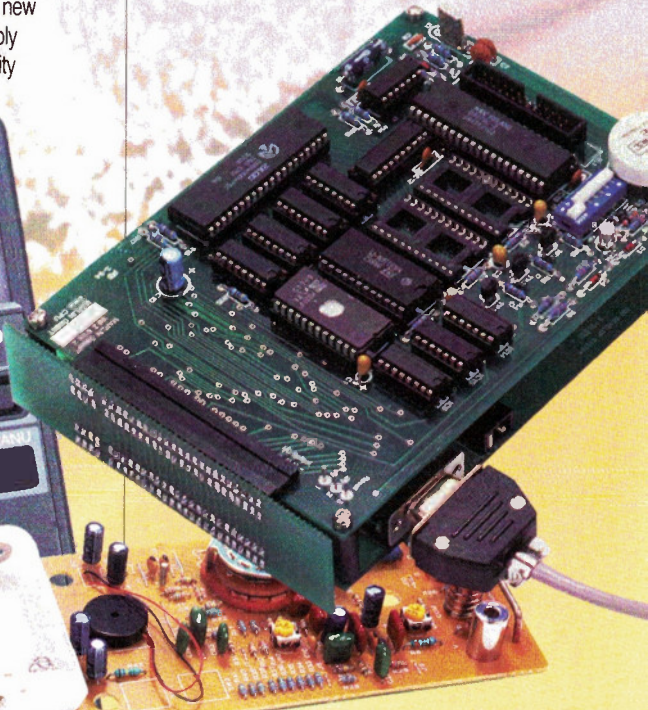
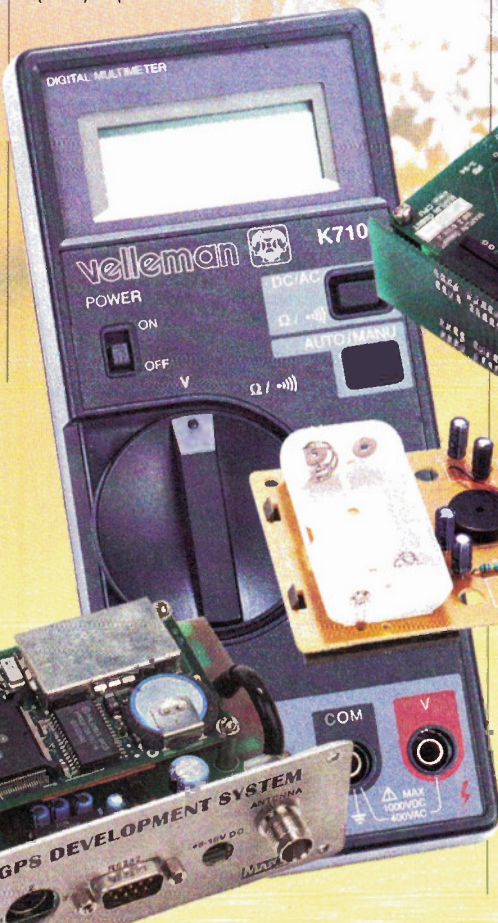

## REGULARS NOT TO BE MISSED!

FROM THE EDITOR ...	2	WHAT'S ON & DIARY DATES	21	NEXT ISSUE	69
TECHNOLOGY WATCH	3	CLASSIFIED ADVERTS	54	AIR YOUR VIEWS	70
ORDER COUPON	13	STRAY SIGNALS	55	@INTERNET	76
HOW TO SUBSCRIBE	14	NEWS REPORT	56		

# FROM THE EDITOR...

Hello and welcome to this month's issue of *Electronics*! As usual we have, a fine collection of projects and features for you to read and build.

## Leading Edge of Technology

With the recent introduction of Intel Corporation's Pentium® Pro and the 82450



Brian Bath,  
Head of Design  
and Interpretation,  
English Heritage.

family of PCI chip sets – the 82450GX for servers, and the 82450KX for workstations and high performance desktops, computing has taken another leap forward. Already a large number of OEMs are shipping computers which have the 150/60MHz, 180/60MHz or 200/60MHz versions with internal 256k cache. Due to the architecture of the Pentium® Pro it is possible to have up to four Pentium® Pro microprocessors per motherboard.

This now opens the way for performance normally associated with main frame computers to be realised but at greatly reduced cost. One ambitious plan between Intel and English Heritage is to create a virtual reality model of Stonehenge, whereby personal computer users will be offered a 'virtual tour' of Stonehenge at any time of day, on any calendar date, in years past, present and future.

## Cable Tied

The new cable network has now been installed in my area. Looking at the cost so far of all the available options such as movie, sports and entertainment channels, it does seem to work out more expensive than satellite per month, although there are major discounts available on buy-back schemes regarding trading in the satellite receiver. On the cable telephone front, the

costs are down, but the Internet service access through cable does not seem to be available until later this year.

## Eurostar Competition

The winners of the eurostar competition will be announced in next month's issue.

## Apologies

We would like to apologise to those of you waiting for the Light Sequencer Sound-to-Light Adaptor project; due to unforeseen circumstances, this has been postponed until a later date.

So until next month, from the rest of the *Electronics* team, enjoy this issue.



ABC  
CONSUMER PRESS

Front Cover Picture:  
©Copyright 1995  
Maplin Electronics plc,  
All rights reserved.

## EDITORIAL

Editor Robin Hill FBIS, G4DVJ

Technical Authors Maurice Hunt BSc (Hons),  
Mike Holmes.

Print Co-ordinators John Craddock,  
Len Carpenter

News Editor Stephen Waddington BEng (Hons)

Drawing Office Ross Nisbet

Technical Illustrators Paul Evans, Nicola Hull,  
Kevin Kirwan Dip.Comp.

Project Development Chris Barlow,  
Dennis Butcher, Alan Williamson, Nigel Skeels

## PRODUCTION

Art Director Peter Blackmore

Production Controller Jason Hyatt

Designers Jim Bowler, Matt Buhler

Layout Artists Tracey Walker, Adrian Dulwich,  
David Holt, Daniel Drake.

Photography Co-ordinator Tracy Swann

Published by Maplin Electronics plc.,

P.O. Box 3, Rayleigh, Essex, SS6 8LR.

Tel: (01702) 554155. Fax: (01702) 553935.

Lithographic Reproduction by

Planographic Studios, 18 Sirdar Road, Brook

Road Ind. Estate, Rayleigh, Essex SS6 7UY.

Printed by St Ives (Caerphilly) Ltd.,

Caerphilly, Mid-Glamorgan, CF8 3SU.

## MANAGEMENT

Senior Manager Design

and Publications Steve Drake

Publications Manager Roy Smith

Development Manager Tony Bricknell

## ADVERTISING

Jackson-Rudd & Associates Ltd.,

2 Luke Street, London, EC21 4NT.

Tel: (0171) 613 0717. Fax: (0171) 613 1108.

Advertisement Manager Eric Richardson.

## UK NEWSTRADE DISTRIBUTION

United Magazine Distribution Ltd.,

16-28 Tabernacle Street, London EC2A 4BN.

Tel: (0171) 638 4666. Fax: (0171) 638 4665

©Copyright 1995 Maplin Electronics plc.

Copyright: All material is subject to worldwide copyright protection, and reproduction or imitation in whole or part is expressly forbidden. Permission to reproduce printed circuit board layouts commercially or marketing of kits must be sought from the publisher.

Advertisements: Whilst every reasonable precaution is undertaken to protect the interests of readers by ensuring, as far as possible, that advertisements appearing in the current issue of *Electronics* are bona fide, the publisher and staff of the magazine cannot give any undertakings in respect of statements or claims made by advertisers, whether on printed page or on loose insert. Readers who have reasonable grounds to believe that they have been misled are advised to contact their local Trading Standards Office.

Editorial: The views of individual contributors/authors are not necessarily those of either the publisher or the editor. Where errors occur corrections will be published as soon as possible afterwards.

Publisher's Statement: Maplin Electronics plc., take all reasonable care to prevent injury, loss or damage of any kind being caused by any matter published in *Electronics*. Save insofar as prohibited by English law, liability of every kind including negligence is disclaimed as regards any person in respect thereof.

## Project Ratings

Projects presented in this issue are rated on a 1 to 5 for ease or difficulty of construction to help you decide whether it is within your construction capabilities before you undertake the project. The ratings are as follows:

- 1 Simple to build and understand and suitable for absolute beginners. Basic of tools required (e.g., soldering iron, side cutters, pliers, wire strippers and screwdriver). Test gear not required and no setting-up needed.
- 2 Easy to build, but not suitable for absolute beginners. Some test gear (e.g., multimeter) may be required, and may also need setting-up or testing.
- 3 Average. Some skill in construction or more extensive setting-up required.
- 4 Advanced. Fairly high level of skill in construction, specialised test gear or setting-up may be required.
- 5 Complex. High level of skill in construction, specialised test gear may be required. Construction may involve complex wiring. Recommended for skilled constructors only.

## Ordering Information

Kits, components and products stocked by Maplin can be easily obtained in a number of ways:

Visit your local Maplin store, where you will find a wide range of electronic products.

If you do not know where your nearest store is, Tel: (01702) 552911. To avoid disappointment when intending to purchase products from a Maplin store, customers are advised to check availability before travelling any distance.

Write your order on the form printed in this issue and send it to Maplin Electronics, P.O. Box 3, Rayleigh, Essex, SS6 8LR. Payment can be made using Cheque, Postal Order, or Credit Card.

Telephone your order, call the Maplin Electronics Credit Card Hotline on (01702) 554161.

If you have a personal computer equipped with a MODEM, dial up Maplin's 24-hour on-line database and ordering service, CashTel. CashTel supports 300-, 1200- and 2400-baud MODEMs using CITT tones. The format is 8 data bits, 1 stop bit, no parity, full duplex with Xon/Xoff handshaking. All existing customers with a Maplin customer number can access the system by simply dialling (01702) 552941. If you do not have a customer number Tel: (01702) 552911 and we will happily issue you with one. Payment can be made by credit card.

If you have a tone dial (DTMF) telephone or a pocket tone dialler, you can access our computer system and place orders directly onto the Maplin computer 24 hours a day by simply dialling (01702) 556751. You will need a

Maplin customer number and a personal identification number (PIN) to access the system. If you do not have a customer number or a PIN Tel: (01702) 552911 and we will happily issue you with one.

Overseas customers can place orders through Maplin Export, P.O. Box 3, Rayleigh, Essex, SS6 8LR, England, Tel: +44 1702 554000 Ext. 326, 327 or 351; Fax: +44 1702 553935.

Full details of all of the methods of ordering from Maplin can be found in the current Maplin Catalogue.

## Subscriptions

Full details of how to subscribe may be found on the Subscription Coupon in this issue. UK Subscription Rate: £23.76/12 months, £11.88/6 months.

## Prices

Prices of products and services available from Maplin, shown in this issue, include VAT at 17.5% (except items marked NV which are rated at 0%) and are valid between 27th October 1995 and 29th February 1996 errors and omissions excluded. Prices shown do not include mail order postage and handling charges, which are levied at the current rates indicated on the Order Coupon in this issue.

## Technical Enquiries

If you have a technical enquiry relating to Maplin projects, components and products featured in *Electronics*, the Customer Technical Services Department may be able to help. You can obtain help in several ways: over the phone, Tel: (01702) 556001 between 9.00am and 5.30pm Monday to Friday, except public holidays; by sending a facsimile, Fax: (01702) 553935; or by writing to: Customer Technical Services, Maplin Electronics plc., P.O. Box 3, Rayleigh, Essex, SS6 8LR. Don't forget to include a stamped self-addressed envelope if you want a written reply! Customer Technical Services are unable to answer enquiries relating to third-party products or components which are not stocked by Maplin.

## 'Get You Working' Service

If you get completely stuck with your project and you are unable to get it working, take advantage of the Maplin 'Get You Working' Service. This service is available for all Maplin kits and projects with the exception of: 'Data Files' projects not built on Maplin ready etched PCBs; projects built with the majority of components not supplied by Maplin; Circuit Maker ideas; Mini Circuits or other similar 'building block' and 'application' circuits. To take advantage of the service, return the complete kit to: Returns Department, Maplin Electronics plc., P.O. Box 3, Rayleigh, Essex, SS6 8LR. Enclose a cheque or Postal Order based on the price of the kit as shown in the table below (minimum £17). If the fault is due to any error on our part, the project will be repaired free of charge. If the fault is due to any error on your part, you will be charged the standard servicing cost plus parts.

Kit Retail Price	Standard Servicing Cost
up to £24.99	£17.00
£25.00 to £39.99	£24.00
£40.00 to £59.99	£30.00
£60.00 to £79.99	£40.00
£80.00 to £99.99	£50.00
£100.00 to £149.99	£60.00
Over £150.00	£60.00 minimum

## Readers Letters

We very much regret that the editorial team are unable to answer technical queries of any kind, however, we are very pleased to receive your comments about *Electronics* and suggestions for projects, features, series, etc. Due to the sheer volume of letters received, we are unfortunately unable to reply to every letter, however, every letter is read – your time and opinion is greatly appreciated. Letters of particular interest and significance may be published at the Editors' discretion. Any correspondence not intended for publication must be clearly marked as such.

Write to: The Editor, *Electronics* – The Maplin Magazine, P.O. Box 3, Rayleigh, Essex, SS6 8LR, or send an e-mail to AYV@maplin.demon.co.uk

# TECHNOLOGY WATCH!

with Keith Brindley

Readers will be aware of the Labour Party's deal with British Telecom, in which (if the Labour Party comes to power at the next general election) the new Labour Government will release the ban on British Telecom providing entertainment to its telephone customers in the form of videos, television channels, home shopping and so on. To date, since the promise of digital television, British Telecom has not been allowed to provide such services, simply because it was always thought that the advantage British Telecom has as an existing network provider (most houses in the country are networked to a telephone, after all) would be unfair. To a large extent, of course, this is true. Cable television companies have to install a network, while British Telecom already has one. In its single twisted-pair state, it's pretty limited, on the other hand, and a total ban on providing entertainment services could probably be viewed as overkill. To provide a full-featured network requires significant recabling in the local loop between users' premises and exchanges, and even more significant cabling along the national backbone of the telephone network. When you consider what's happening in other media fields (see later comment on News International), you would be forgiven for thinking that British Telecom has got its hands quite severely tied by the current ban by comparison.

By the by, the Labour Party's share of the deal with British Telecom is far more important, and comprises two main advantages. First, British Telecom has agreed to connect, for free, all colleges, hospitals, libraries and schools to any network British Telecom might build in the process of having its hands untied. This is a tremendous scoop. We're not talking dial-up 'phone connections to an already slow and cumbersome Internet here, which is what some schools have at present. No, what's on offer is a direct connection to a superior network, with all the advantages of high-bandwidth and speed.

Second, and in effect, the direct result of the first advantage, what the Labour Party promises if it gets to power, is the existence of a complete fibre network (an information superhighway if you want to use the much-hyped vernacular) where there is simply not going to be one otherwise. Using British Telecom to do it is pretty logical when you think about it; an organised industry which knows how to do it and has the technology to do it with. The only thing which has prevented the UK having an information superhighway so far is the current legislation. The benefits of having the network far override the monopoly which British Telecom will enjoy under the deal. What this country will gain from the network is complex and inestimable. What we lose if no such network is built (which will be the case under current Government control) is simple – our future.

## What Goes Up, Must Come Down

There's no stopping some people. Rupert Murdoch's News International has bought NTL's Advanced Products Division. The new News International wing will be called Digi-Media Vision – a name we'll probably all get to know very well over the next year or so. It is a new move for the media group, which so far, has had no interest in hardware, instead preferring to maintain its position as a large media supplier. However, with the advent of digital television technology, News International is becoming increasingly involved in an area which, to date, has had little or no supervision. Governments are loathe to interfere, all favouring to let market forces take control, and to a large extent, this is justified. But governments really should get more involved at least in a supervisory role, because although they have no real idea of technology and its capabilities, they can guide the effects that the technologies will have on consumers. And what are governments there for, but to look after consumers? Granted, we only ever see such a caring Government in an election year, but (whatever Ministers say) that's

surely a government's proper job in the other years of an elected term too. News International's satellite broadcasting arm (BSkyB) is already seriously committed to digital television by satellite (here, in the States, and in Asia), and this purchase gives News International an unparalleled advantage in being instrumental in guiding digital terrestrial television too. Of course, it's just in the UK at present, but the experience News International will gain with this venture could easily be applied to the worldwide market shortly. Digi-Media Vision, under its old cloak of the Advanced Products Division of NTL, was a strong player in the MPEG series of picture compression and transmission systems. News International's experience as a satellite television programme provider of both analogue and digital television channels, and the new direction into the hardware behind it, combined with the experience it has developing a conditional access satellite television system (for itself and for Hughes' system in the States) means that (more than likely) any future conditional access system on digital terrestrial television will be the News International system.

I'm not arguing that News International shouldn't be allowed to get into digital terrestrial television hardware – far from that. Neither am I arguing that digital terrestrial television (or any other form of television, or technology in general for that matter) should be state-controlled. No, the state has enough say in our lives without all that. It is just that too much power in any one organisation's hands might lead to excesses which aren't the best for the consumer. I don't believe for a split second that News International will take advantage of its situation to isolate other contenders, or guide technology in a direction which would force others out of the business altogether. It is something to be concerned about, though.

*The opinions expressed by the author are not necessarily those of the publisher or the editor.*

## LIFE WITH MICRO CHIP...

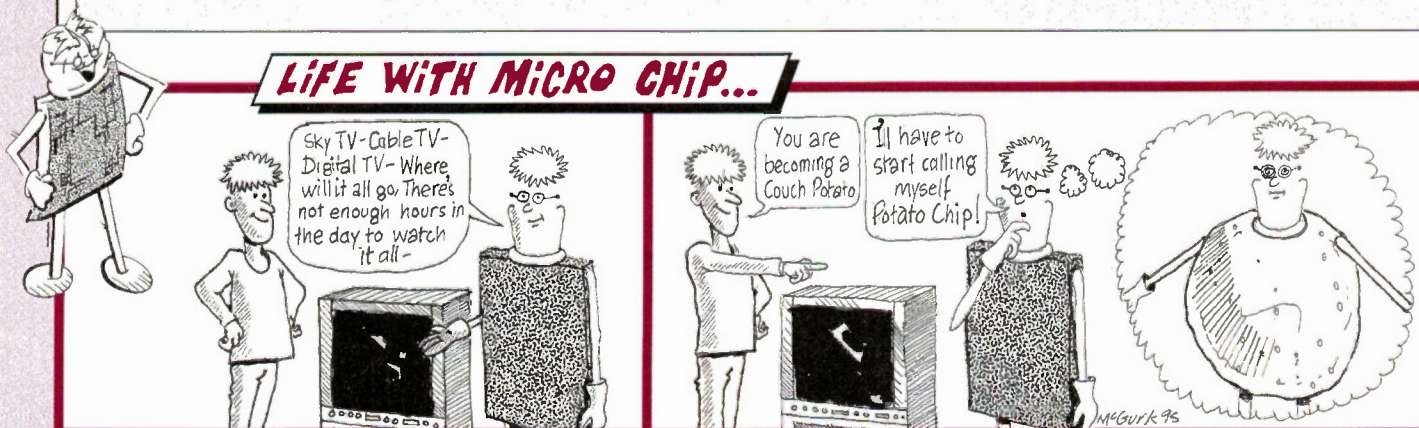

**KIT AVAILABLE  
(90053)  
PRICE £34.99 A1**

*Design by Robin Abbott,  
Chris Barlow and Nigel Skeels  
Text by Robin Abbott and Maurice Hunt*

# Z80 DEVELOPMENT SYSTEM

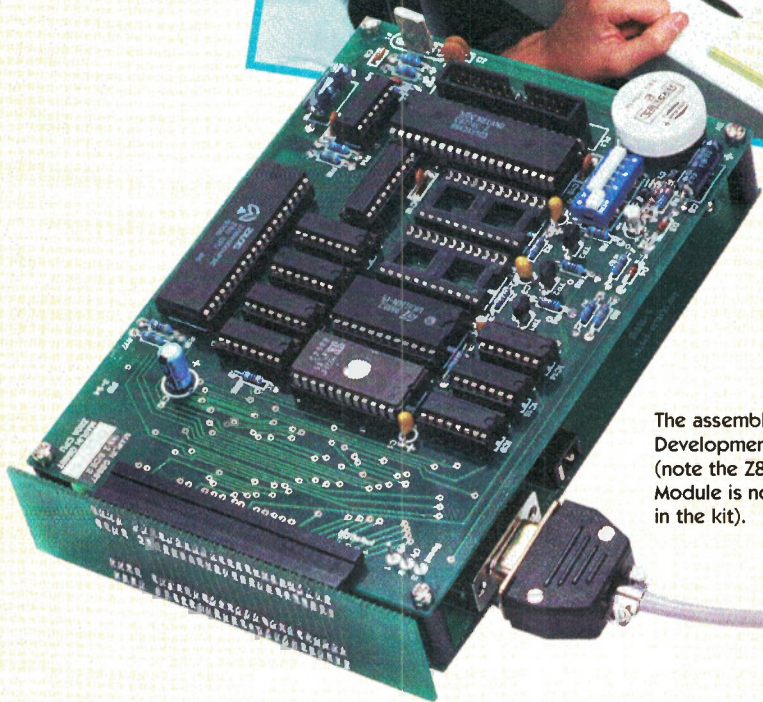
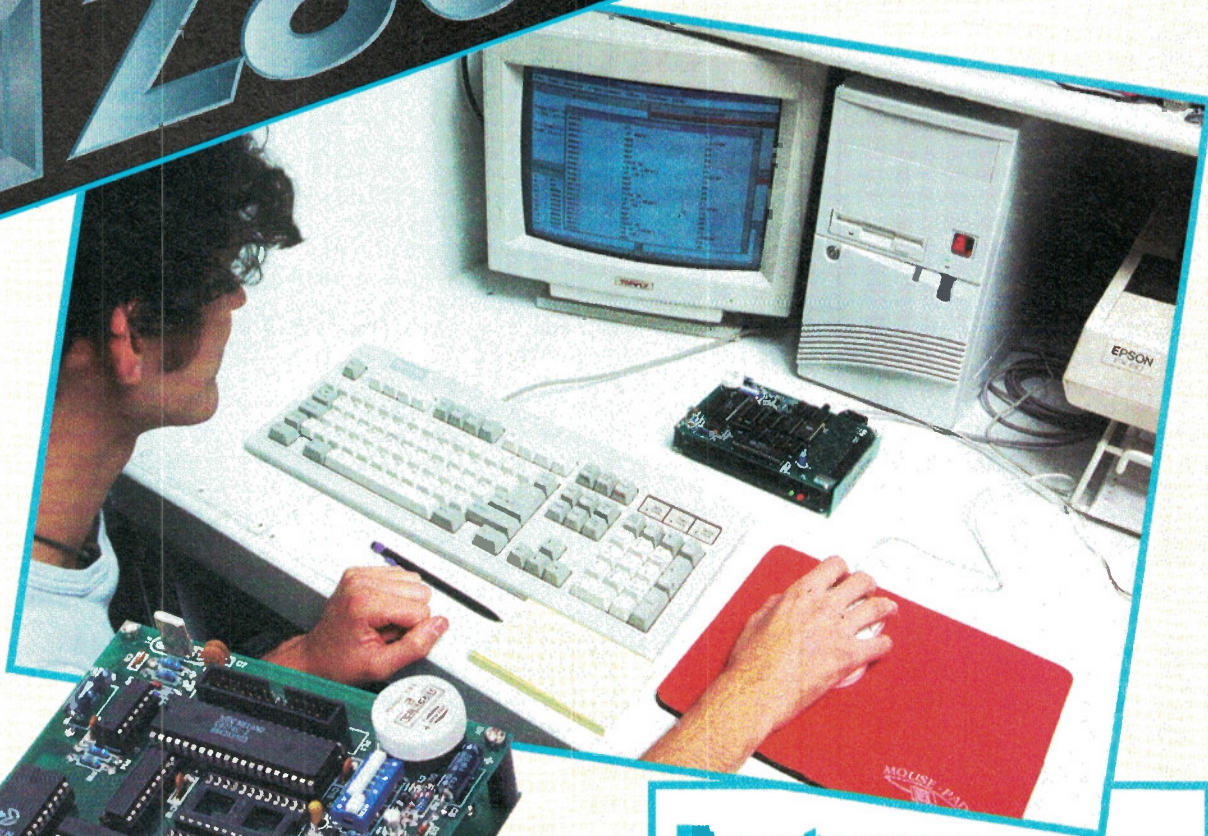
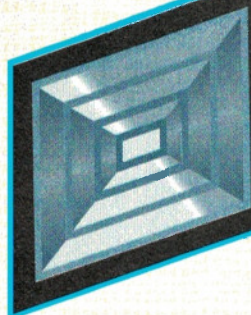

The assembled Z80 Development System (note the Z80 CPU Module is not included in the kit).

## Features

- \* IBM-compatible PC-based
- \* Single RS-232 data link
- \* Built-in power supply regulation
- \* Neat and strong two-tier board construction

## Applications

- \* Software development
- \* Educational purposes
- \* Control systems
- \* Programmer for Z80 projects



Many electronics engineers and home constructors will have discovered the advantages that microcontrollers hold in modern design. The single-chip construction and on board ROM, RAM and peripherals make them ideal for embedded control applications. However, these devices still lack in applications which require a large amount of storage, where high-level languages are to be used, or which have a heavy or specialist I/O requirement. In this type of application, the constructor is forced to return to the more traditional microprocessor.

Photo 1. Z80 Development System assembled PCB and the assembled snap-off connector PCB.

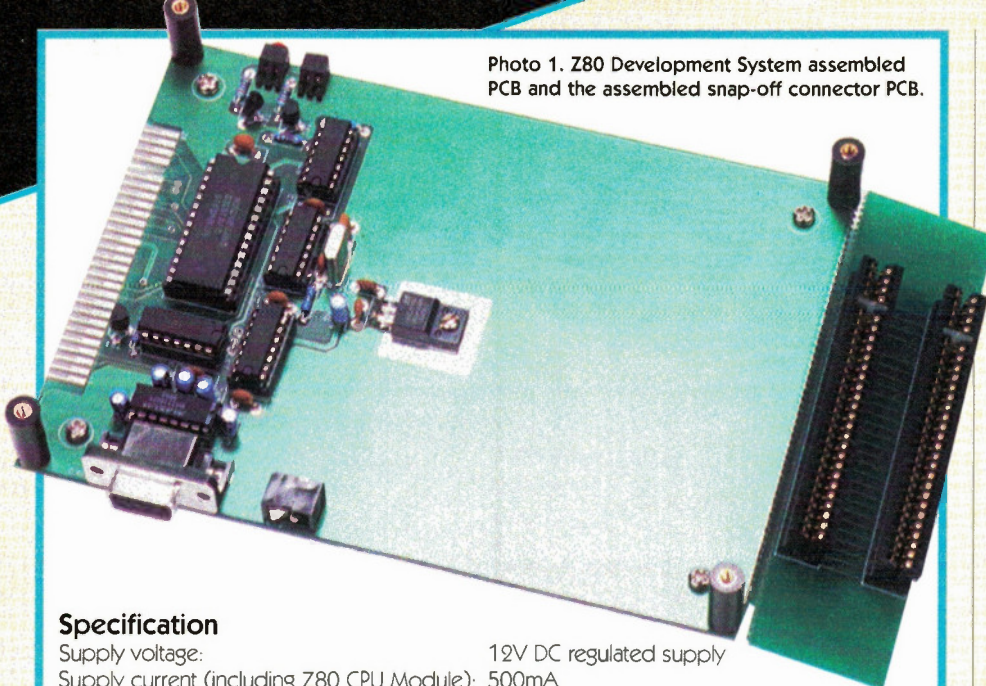

and edge connectors to link the two boards (see Photo 1), an RS-232 data cable, and a power supply, working in conjunction with the existing Z80 CPU Module (not supplied in the kit). The serial interface card plugs into the Z80 expansion connector, and provides a three-wire, RS-232 compatible interface, operating at 9,600 or 19,200bps. The serial interface card also includes 5V power supply regulation, which is also used to power the main Z80 card, and there are two software-controlled LEDs connected to output port 12, which indicate the status of the software, and may be used by application programs. The serial interface uses interrupts, which allows the card to send and receive information transparently to application software.

The monitor on the Z80 card runs in a 2K-byte EPROM. The monitor contains the code necessary to interface to the serial card. Application routines which need to send or receive serial data, may do so by loading one register with a definition byte, and then issuing a restart instruction (RST 10). The monitor serial interface routines automatically implement an Xon/Xoff serial protocol for flow control and 128-byte buffers for received and transmitted data. The monitor includes a series of routines to communicate with the host PC, to implement the remote debugging functions. The monitor and serial buffers take up 633 bytes of RAM, leaving the rest for application software.

The host PC software consists of a Z80 development environment, which allows projects to be edited, assembled and linked. Projects consist of a list of assembler files and object files. Assembler files are standard Z80 text files. Object files are assembler files which are already linked, and which can contain library modules where only the code used is linked. The environment allows assembler files to be edited and then assembled and linked. Any errors found during the assembly will automatically be highlighted in the source files, allowing very rapid tracing and correction of syntax errors.

### Specification

Supply voltage: 12V DC regulated supply  
 Supply current (including Z80 CPU Module): 500mA  
 PCB dimensions (including snap-off section): 199 x 119mm  
 Height of completed assembly: 45mm (maximum)  
 Visual indicators: Red and green LEDs indicating status of output port 12.

For low-cost applications, and with a 64K-byte addressing space, I/O space, and a wide-ranging instruction set, the Z80 processor is still a first choice, and the Maplin Z80 card provides an excellent basis for Z80-based control projects. This article describes a serial interface and monitor for the Maplin card, which allows programs to be developed on a Windows-based PC, downloaded to the module and debugged on the real system, and can even be set to run from battery-backed RAM to test real systems before blowing code into PROM.

This project, which comprises of a serial interface board, RS-232 data link and associated Windows™-based software used in conjunction with the Z80 CPU Module,

enables the programming of the ever-popular Z80 microprocessor by means of an IBM-compatible PC. The project is based around the existing Z80 CPU Module (LK67X), which previously, had to be programmed using the Z80 Keypad (LT15R), in hexadecimal. Therefore, this project facilitates far speedier and more convenient programming of the Z80 in assembly language, in addition to simple debugging and compiling of the Z80 programs.

### Project Description

Refer to Figure 1, showing the block diagram of the Z80 Development System. The project hardware consists of the serial interface card

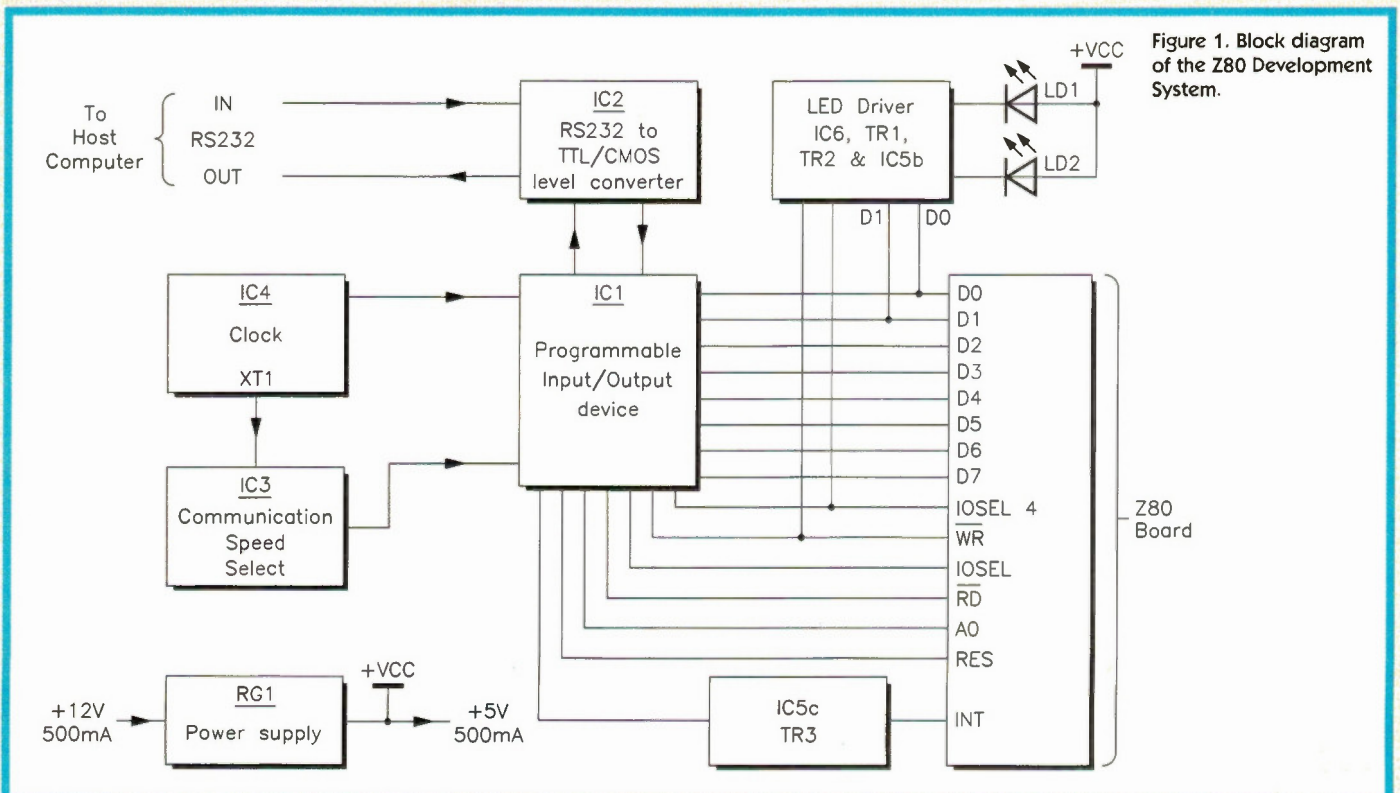

Figure 1. Block diagram of the Z80 Development System.

The host PC software also includes a separate program, which is the remote monitor. The remote monitor communicates with the Z80 monitor through the Z80 serial card and provides a wide range of functions to aid debugging. In addition, the host software contains a terminal which can be used to communicate with application programs while they run. Full instructions on the use of the PC host and remote monitor are included with the software. This article describes the operation and construction of

the serial card, and provides an introductory tutorial to the use of the assembler and monitor.

## Operation of Xon/Xoff Protocol

The Xon/Xoff protocol used by the card is probably the most useful method of low-level flow control used on RS-232 interfaces. It only requires a 3-wire serial link, but uses two special characters, the Xon character

(ASCII code 17) and the Xoff character (ASCII code 19). When Xon/Xoff signalling is in use, then these characters cannot be sent normally across the interface (the monitor uses an escape code whenever it has to send these characters).

The monitor has an area of RAM, which it uses to store characters which have been received from the serial interface, and for characters which are waiting to be transmitted, these areas of RAM are called the receive buffer and the transmit buffer,

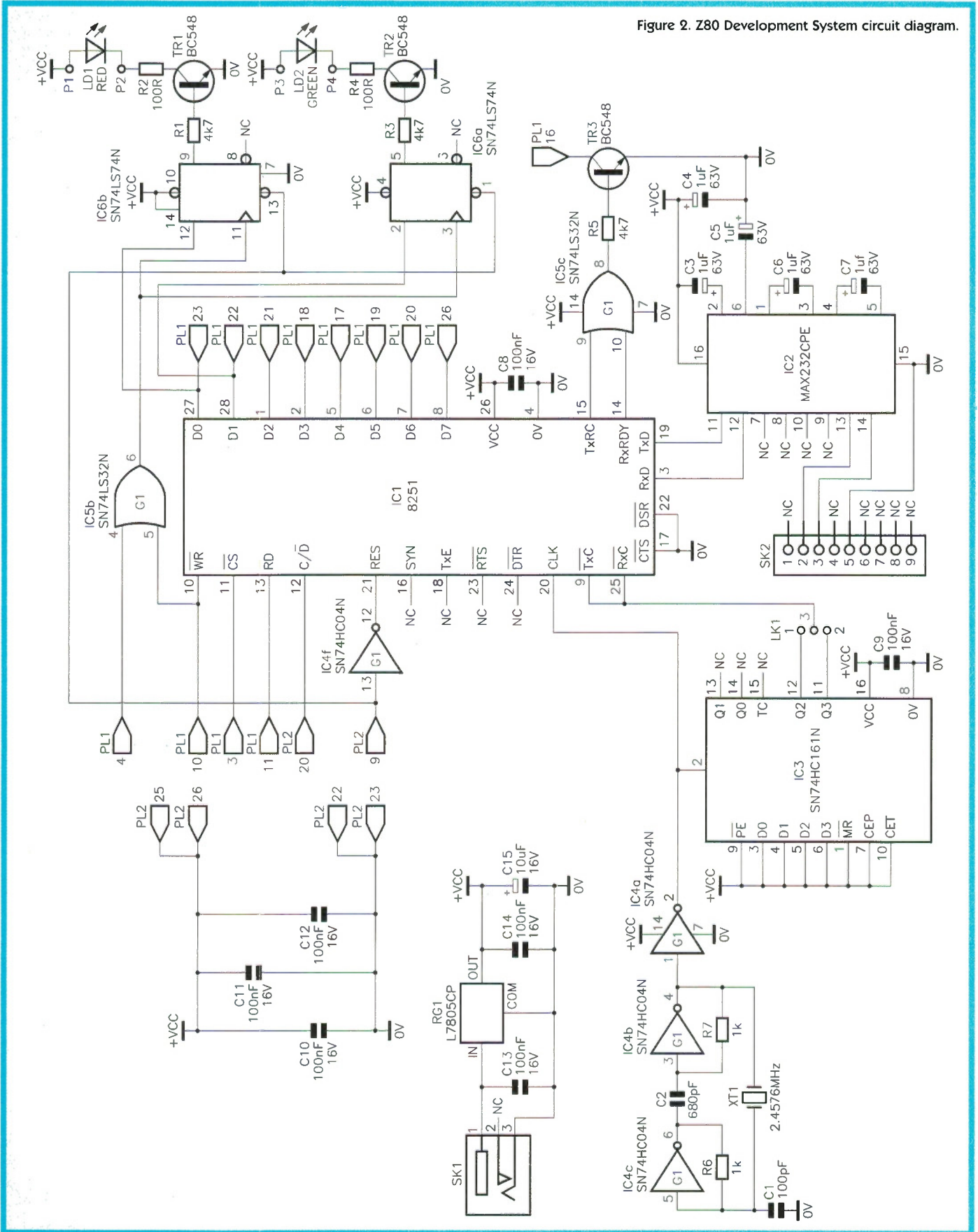
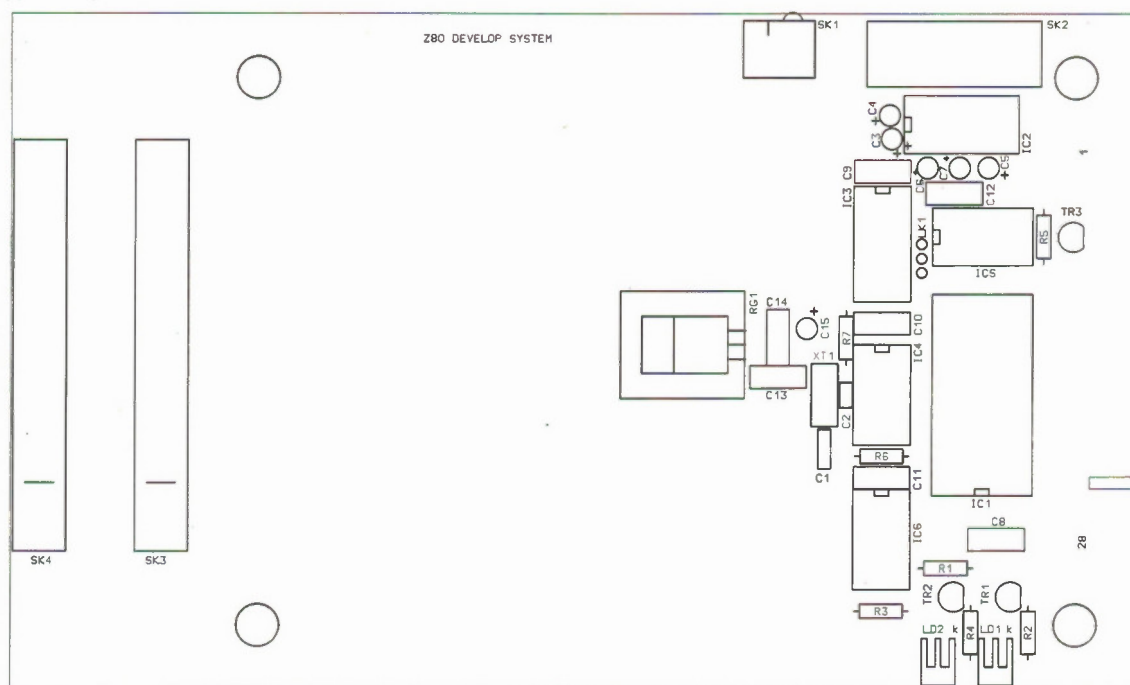

Figure 2. Z80 Development System circuit diagram.



Figure 3. PCB legend and track (scale 75%).



respectively; each holds up to 128 characters. Whenever the serial chip has sent, or received a character, it sends an interrupt to the processor. If a character has been received, the monitor program reads the character and stores it in the receive buffer. If the receive buffer now holds more than 96 characters, the monitor sends an Xoff character immediately. The Xoff character causes the host PC to stop sending any further characters, and the limit of 96 characters is used to allow a little space for the time that the host PC will take to stop sending information. Now it is up to the application program to read characters from the receive buffer, and when it has read sufficient characters to reduce the size of the receive buffer below 32 characters, the monitor sends an Xon character which allows the host PC to start sending information again. The transmit buffer operates in a similar fashion, if an Xoff character is received, then it stops sending information, and the buffer is allowed to fill up. When it is full, the application software is not allowed to send further information until the buffer starts emptying again. The monitor includes all the routines for dealing with Xon/Xoff signalling, which are documented with the remote monitor software.

## The Z80 CPU Module (Not in Kit)

For a circuit description and other details of the Z80 CPU Module, see *Electronics* Issue 15 (pages 2 to 7) or Issue 58 (pages 56 to 68). The only alteration made to the board when used in conjunction with this project, is a replacement, preprogrammed 2716 EPROM, which is plugged into the board's IC10 expansion socket.

The Z80 CPU Module will accept up to 8K-bytes of memory, which is decoded in 2K-byte (2,048 byte) blocks. The first block contains the operating system in either ROM or EPROM, and the remaining blocks can be either RAM, ROM, or EPROM. Additionally, static CMOS 2K-byte RAMs may be fitted

(totalling 6K-bytes), and switched battery back-up is available to provide retention of CMOS data, if required.

## Serial Interface Circuit Description

The block and circuit diagrams of the serial interface are given in Figures 1 and 2, respectively. Power from a 12V regulated supply is applied to the board via the DC power socket, SK1. Voltage regulator RG1 reduces this to 5V, and this is used to supply both the interfacing circuitry as well as the Z80 CPU Module. Heatsinking for the regulator is achieved by the very large area of unetched copper cladding adjacent to the regulator, and this also forms a ground plane to minimise interference problems. The snap-off section of the PCB is used to link the two boards via two edge connectors, the CPU Module sitting 20mm above the interface board on PVC spacers. The edge connector cannot be used to carry power to the main card, because it needs a low-impedance drive with as little noise as possible. The serial card is reset at the same time as the Z80 CPU Module.

Wherever possible, CMOS ICs are used, TTL is only used where level matching to CMOS is not possible. The heart of the serial interface is provided by IC1, an Intel 8251A serial interface chip. This IC provides a complete duplex serial transmitter and receiver, and interrupt control. The IC provides synchronous and asynchronous interface modes, of which only the asynchronous mode is used here. The clock is provided by IC4b and IC4c, which implement a 2.4576MHz crystal oscillator. This value is divided by 16 in IC3. The transmit and receive clocks to IC1 must be 16 times the rate of the serial interface, so LK1 is used to select between the divide by 8, or divide by 16 outputs of IC3, which result in a 19,200 or 9,600bps serial rate from IC1. It is recommended that 9,600bps is used for most applications, as 19,200bps leaves very little time for the processor to do

any real work between interrupts! The decoded I/O outputs of the Z80 are used to select IC1.

The interface between IC1 and the RS-232 line is provided by IC2, a MAX232 device, which provides RS-232 line levels from a 5V DC supply. The interrupt signal is an open-collector drive, which allows a variety of different interfacing devices to be controlled. IC5c combines the transmit empty and receiver full signals from IC1 and TR3 drives the interrupt line.

IC6a and IC6b are the output port buffers for driving the LEDs. The LEDs are mapped to I/O port 4, and are addressed on output port 12 (0C hexadecimal), LD1 being the red LED, which is driven by bit 0 of the output port, while LD2 is the green LED and is driven by bit 1 of the port. If an application needs to use output port 12, then it may do so with no interference from the serial card, which will not respond to read requests. However, the LEDs will flash in time with any data written to the port.

## Construction and Testing

Construction of the serial card is very straightforward. Refer to the PCB legend and track diagrams, shown in Figure 3. Insert the wire links first, however, note that only one link is made for LK1. Link the centre pin to the connection closest to the edge connector SK1 for 9,600bps, or to the other connection for 19,200bps. For most purposes, the 19,200bps setting is recommended, which makes for faster downloading of the data. Insert and solder the resistors next, then (in order) the IC sockets (ensuring the notches are aligned correctly), transistors, capacitors, voltage regulator (see Figure 4 for mounting details) and then the edge connector, power plug and the quartz crystal. Do not place the ICs into their sockets just yet.

Fit the 10mm PVC spacers (not supplied) using screws and washers to the serial interface board – these act as plinths to lift the board off the surface. Fix the serial

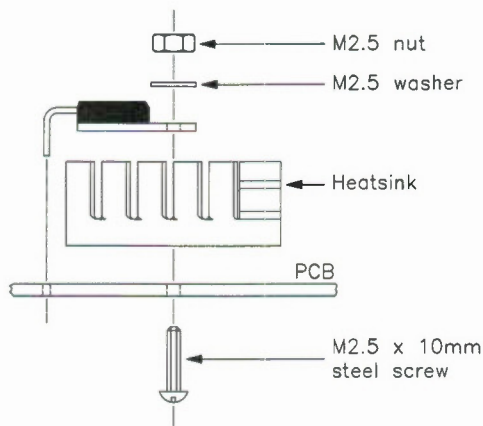
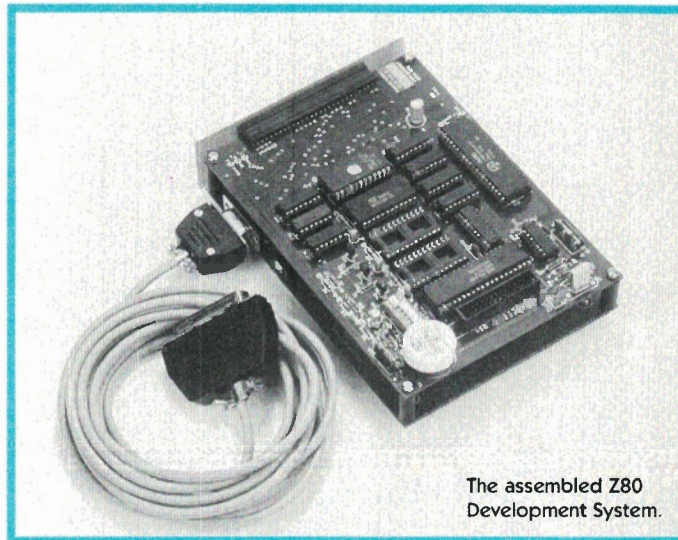

Figure 4. Voltage regulator mounting.



The assembled Z80 Development System.

interface board to the Z80 CPU Module board, as shown in Figures 5 and 6. The boards are separated by 20mm PVC spacers held in place with screws and washers, and the snap-off section of the PCB is used to link the two boards via the edge connectors, making for a rigid assembly. The serial cable must be made up next. Figure 7 shows the connections of the 9-way D-type socket on the serial interface board. Make up a cable using connectors appropriate to your PC, or you may prefer to purchase a ready-made cable. If your PC has a D9 (9-way) serial port, a straightforward DB-9 male to DB-9 female cable (Order Code DD28F) can be used. However, if your PC has a D25 (25-way) serial port, the above cable will need to be used in conjunction with the appropriate 9-way to 25-way adaptor, such as JM50E (female-to-female). It is advisable to check the connectors on your PC before buying.

Check that there are no misplaced components, short circuits, solder bridges, whiskers or dry joints, and remove excess flux from the PCBs using a suitable solvent. Connect a regulated power supply of between 7 and 35V (absolute maximum!) DC to SK3, ensuring correct polarity – centre tip positive. Also ensure that the power supply is capable of providing at least 500mA – a supply of lesser capacity will result in spurious operation of the system. Check that there is a 5V supply to the appropriate points on each of the IC sockets. Disconnect the supply, and insert all the ICs, taking the usual precautions when handling CMOS devices. Insert the monitor EPROM in the Z80 card position IC10, and ensure that the Z80 card has a RAM device in position IC11. Plug the Z80 card into the serial card. Now connect the power supply. If all is well, then after about 1 second, LEDs LD1 and LD2 will illuminate, indicating that the monitor has completed the memory tests and is ready for use.

Connect the serial card to the host PC using a serial cable, as per the wiring diagram shown in Figure 8. Use a terminal emulator on the PC, such as **TERMINAL.EXE** (which is supplied free with Windows). Set the emulator communications parameters to the correct port. Set the port to 9,600bps, Xon/Xoff signalling, 8 bits, no parity, and 1 (or more) stop bits. Using **TERMINAL.EXE**, this can be selected by using the **Settings | Communications** menu option (Communications option within the Settings menu). Now reboot the Z80 card, either by

Figure 5. Exploded assembly diagram.

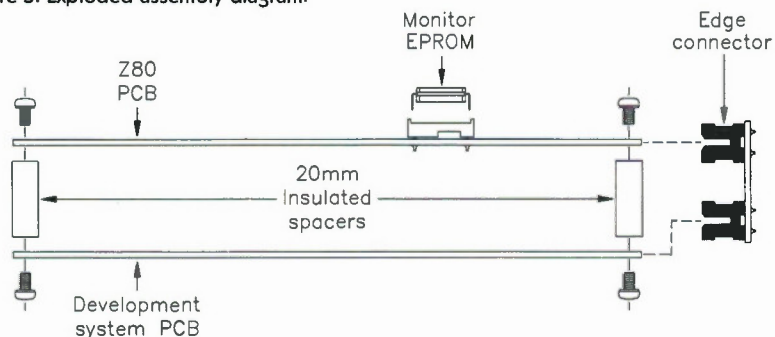

Figure 6. Final assembly.

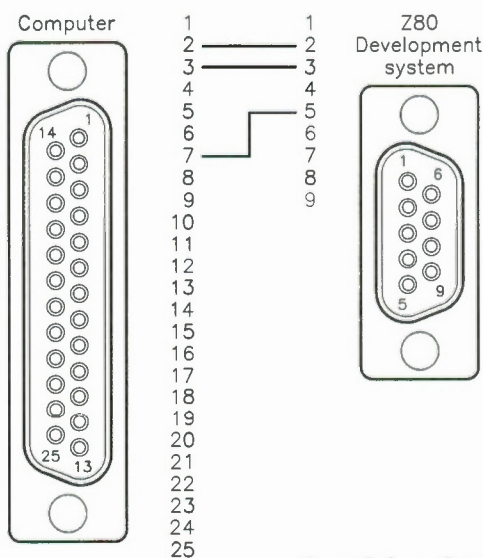
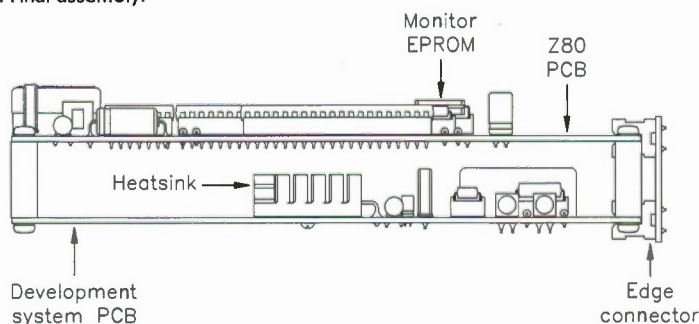

Figure 7. 9-way D-type connector pinout.

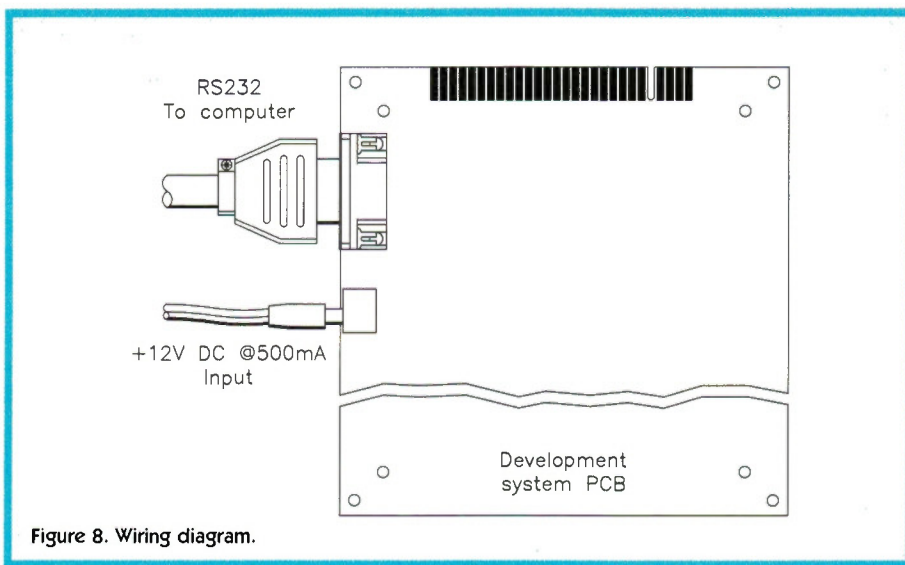

Figure 8. Wiring diagram.

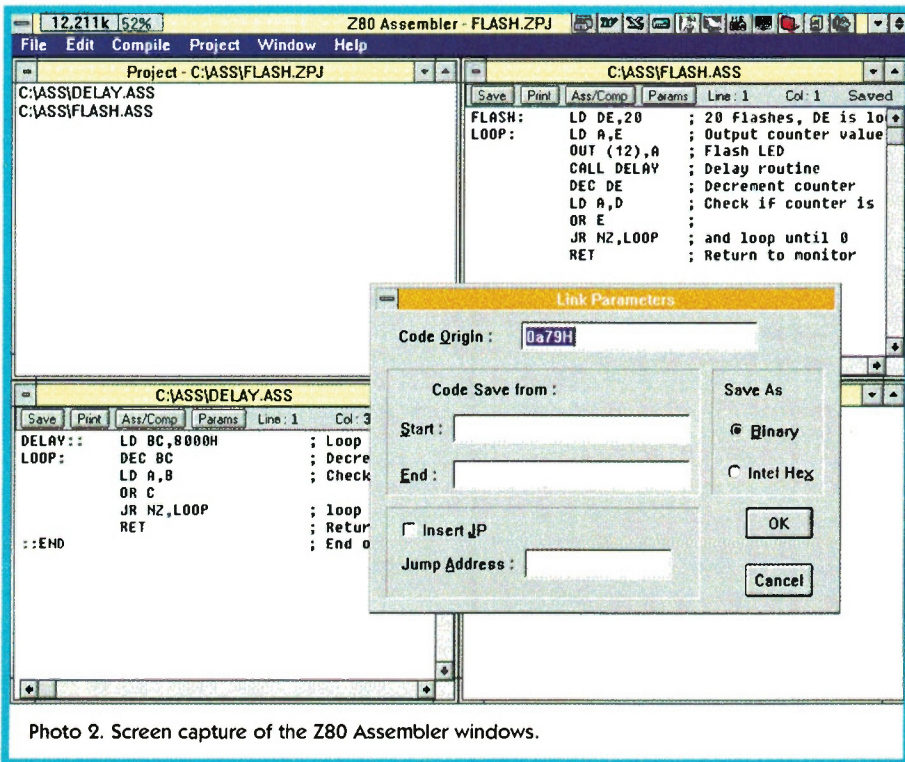

Photo 2. Screen capture of the Z80 Assembler windows.

resetting it or by disconnecting and then reconnecting the power supply. The card should respond with a copyright message to the terminal. This message will be in the following form:

**'@A0FFF, Z80 Monitor Maplin Z80 card, (C) Robin Abbott 1989, V1.1'**

The @A is a standard response used by the remote monitor. The 0FFF may differ for each system, and is the hexadecimal address of the last byte of RAM found by the monitor when it is initialised.

Finally, clear the terminal window (use **Edit | Clear buffer** in **TERMINAL.EXE**), and type the @ character followed by A (must be a capital A). The monitor will respond with copyright message again.

If all these tests have passed, then the monitor and serial card are ready for use.

## Using the Development Environment and Monitor

Install the development software by inserting the disk and running the install program. This can be achieved from the program manager, using the **File | Run** menu option, then

entering **A:\INSTALL.EXE**. This will install the software and a new program manager window for the assembler. To look at how the environment and debugger can be used, we will look at a simple example. The example is a short program, which will flash the two LEDs 20 times and then return control to the monitor.

## Assembler Environment

Run the Z80 assembler environment by double-clicking the assembler icon in the Z80 assembler window.

To start with, we shall open a new project which will contain two files, one consists of the routine which will flash the LEDs, and the other of a simple routine which will execute a short delay. In practice, the delay routine might be part of a library of assembler routines. Click on the **Project | Open Project** menu and enter the filename **FLASH**. This will be the name of our project. The screen will now display two windows, one titled **Message** and the other titled **Project**. Click on the **Project | Add Item** menu, and enter the filename **FLASH.ASS**, whereupon

an editing window will appear entitled **FLASH.ASS**. Enter the following code into the window:

```
FLASH: LD DE,20 ; 20 flashes, DE is loop
        count
LOOP: LD A,E ; Output counter value
      OUT (12),A ; Flash LED
      CALL DELAY ; Delay routine
      DEC DE ; Decrement counter
      LD A,D ; Check if counter is
              0 yet
      OR E ;
      JR NZ,LOOP ; and loop until 0
      RET ; Return to monitor
```

Position the cursor on the word **CALL**, and press **Ctrl and F1** together to bring up the help file entry on the **CALL** instruction, and return to the assembler. There is a menu option at the top of the edit window entitled **Save** – clicking on this will save this file. Now repeat the procedure to add another file to the project, call this file **DELAY.ASS** and enter the following code:

```
DELAY::LD BC,8000H ; Loop counter
LOOP: DEC BC ; Decrement counter
      LD A,B ; Check end of loop
      OR C ;
      JR NZ,LOOP ; Loop
      RET ; Return
::END ; End of module
```

In this file, we are using modules. A module is a segment of code which will only be linked if it is called, this makes the code much more efficient. A library consists of a number of modules, but in this case, there is only one module. The label **DELAY::** introduces a module, which finishes at the line which reads **::END**. Whenever the linker detects that label **DELAY** has been used, then all the code between **DELAY::** and **::END** is linked into the output file. Within a module, labels cannot be accessed from outside the module, so labels in a module can be the same as labels outside it. Note in this case, that the label **LOOP:** is used both in the main program and in the module **DELAY**. Save this file. Select the **Window | Tile** menu option.

To assemble and link the code, click on the **Compile | Make** project menu item. A dialogue box will appear, which has a number of options. Enter "0A79H" in the **Code Origin** box. The main screen should now look like Photo 2. Now click on 'OK'. The assembler will now assemble each of the files in the project, and then link them to run at address 0A79 hex (This is the address of the first free byte in the monitor). Next, select the **DELAY.ASS** window and change the line **LD BC,8000H** to **LD BC,BC**. Compile the project again and this time, an error will occur, as **LD BC,BC** is an illegal opcode. The error will appear on the message window. Double-click on the error, and the **DELAY.ASS** window will come up with the cursor on the line with the error, which can now be corrected.

To produce a listing file, click on the **DELAY.ASS** window and click the **Params** button at the top of the window. A dialogue box will appear; click on the **Produce list file** check box and then make the project again – this time you must use the **Compile | Assemble/Link All** menu selection to make the project, because the file has not changed, and the **Compile | Make Project**

menu only assembles files when they have changed.

Now open the file **DELAY.LST** (use the **File | Open** menu option), and a listing of the assembly will appear, as shown below:

```
0001: DELAY:: LD BC,8000H; Loop counter
0002: DELAY: 01 00 80
0003: LOOP: DEC BC ;Decrement counter
0004: LOOP: 0B
0005: LD A,B ;Check end of loop
0006: :78
0007: OR C
0008: :B1
0009: JR NZ,LOOP ; loop
0010: :20 FB
0011: RET ; Return
0012: :C9
0013: :END ;End of module
0014: :
```

Lines appear in pairs, the first line is the source code line number, followed by the source code line. Below it is the machine code address (in hex), followed by the label (if any), followed by the bytes in hex, which are assembled from the source line. Note in the example, that the code was assembled into object files which were then linked, so the address is the offset of the code from the beginning of the file. Double-click on the close box at the top left of the **DELAY.LST** window to close this window.

Now we have a binary file called **FLASH.BIN**, which can be downloaded to the target system and tested. There are also a number of other files used by the remote monitor, which include symbol and addressing information.

## Remote Monitor

The remote monitor can be run by double-clicking the icon in the program manager, or by using the **Compile | Run Debugger** menu option in the assembler. The remote monitor must be powered up and connected to the host PC. If the monitor fails to establish communication with the Z80 card, then use the **File | Serial Port** menu on the monitor to select the correct serial port and bit rate. When all is well, a copyright message will be displayed showing the last memory location found by the monitor. As standard, the monitor holds five sub-windows. One important note before starting, is that all numbers in the remote monitor are in hex as a default. To enter a decimal number, use the @ character before the number.

Use the **Windows | Tile** menu option to arrange all windows so that they are visible. As an example, we will download the example program shown above, which flashes the LEDs on the serial card. Use the **File | Upload Object** menu option to select the file **FLASH.BIN**. The code will be downloaded to the Z80 card, and the symbol table will be loaded into the monitor. To check that the code has been downloaded, it is possible to produce a disassembly. Use the **Memory | Open Disassembly** menu option. A dialogue box will appear, with a prompt for a start address. Enter the label **FLASH**, and a disassembly window will appear with the code that was written as the example.

We will set a pause breakpoint at the label **LOOP**. This type of breakpoint will pause the program briefly, and then continue

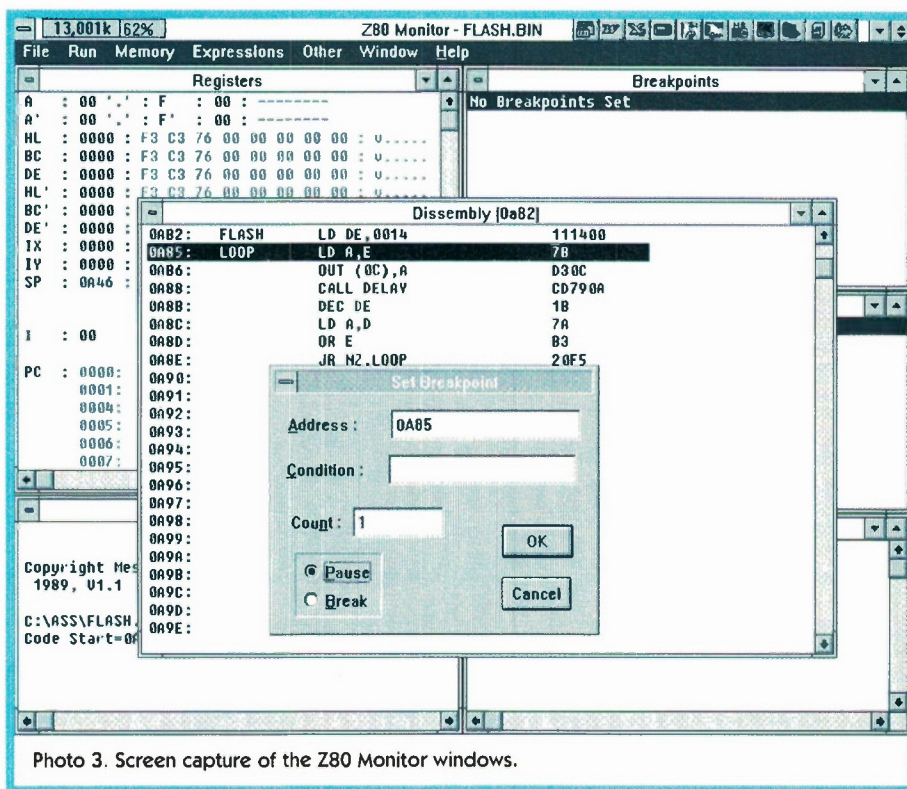

Photo 3. Screen capture of the Z80 Monitor windows.

operation, having updated all the register displays. Double-click the line in the disassembly window which starts with label **LOOP**. The set breakpoint dialogue will appear, containing the address which was clicked. The condition box is available for entering any valid expression. Every time that the breakpoint is hit, the expression is checked, and when the expression is true, the breakpoint will be honoured and the program stops. For the moment, leave the condition box blank, and click the Pause box. The monitor window should now look like Photo 3. Press enter, and the breakpoint will be set and displayed in the monitor's breakpoint window. Close the disassembly window by double-clicking the close box in its top left-hand corner.

Run the program by using the **Run | Go Address** menu option. A dialogue box will appear to allow the start address to be set. Enter the label **FLASH** and the program will run, flashing the LEDs. As it does so, the register window will be updated displaying the registers every time that the label **LOOP** is hit. Watch the DE register counting down from 14 (Hex) to 0, when the program will terminate and control will return to the monitor. Double-click the breakpoint in the breakpoint window, which will bring up the Set Breakpoint dialogue box again. Change the breakpoint to a normal one by clearing the pause box, and enter the following expression into the condition box:

```
[A<7] AND [A>0]
```

Run the program again, and this time, the program will stop when the A register takes the value 6. As the program runs, the information window will show a '.' character each time that breakpoint is hit and the condition is not met. Now use the **Run | Next** menu option to execute the program one instruction at a time; the F8 key can be used instead of the menu option. Watch the register window, which will show the registers changing as each instruction is executed. Instead of the **Run | Next** option, we could use the **Run | Step** option, which

has the disadvantage that the delay routine will be single-stepped, which will take a very long time.

Finally, use the **Run | Clear All Breakpoints** menu option to return the code to normal. Now we will set the monitor to autoboot into the flash routine. Use the **Other | Set Autoboot** menu option, and enter the label **FLASH**. Reset the Z80 card. After a short pause, the card will automatically run the program, flashing the LEDs, and will then return control to the monitor; when it does so, the monitor will display the copyright message on the terminal window. If the Z80 card has RAM battery back-up, then the power can be disconnected and the host PC removed, and power reconnected, and the program will still run. To disable the autoboot, use the **Other | Set Autoboot** option and enter the address 0.

This simple program is adequate for exploring all the functions of the monitor – try setting watch expressions, displaying memory contents and experimenting with different breakpoint types.

Note that once a program is successfully downloaded and running, the RS-232 link may be detached from the Z80 system, and it will remain running. Additionally, the power to the system can be turned off, and when it is re-established, the program will again remain running, due to the battery back-up facility. To switch this off, in order for example, to quickly reset the Z80 module's memory, switch the DIL switches marked 1 to 3 on the CPU module to the 'edge' position, then return them to their previous position.

If you wish to operate outputs other than simply flashing the two LEDs on the serial board, you will need to either wire up an extra extension edge connector via ribbon cable soldered to the existing edge connector terminals, or once a program is downloaded into the Z80 CPU Module's memory, remove the lower interface board altogether, and use the CPU Module as a stand-alone unit, or install it into a piece of equipment that it is being used to control.

## Z80 DEVELOPMENT SYSTEM PARTS LIST

RESISTORS: All 0.6W 1% Metal Film

R1,3,5	4k7	3	(M4K7)
R2,4	100Ω	2	(M100R)
R6,7	1k	1	(M1K)

CAPACITORS

C1	100pF Ceramic Disc	1	(WX56L)
C2	680pF Ceramic Disc	1	(WX66W)
C3-7	GenElect 1μF 63V	5	(AT74R)
C8-14	100nF 16V Ceramic Disc	7	(YR75S)
C15	GenElect 10μF 63V	1	(AT77J)

SEMICONDUCTORS

IC1	8251	1	(YH49D)
IC2	MAX232CPE	1	(FD92A)
IC3	SN74HC161N	1	(UB41U)
IC4	SN74HC04N	1	(UB03D)
IC5	SN74LS32N	1	(YF21X)
IC6	SN74LS74N	1	(YF31J)
TR1-3	BC548	3	(QB73Q)
RG1	L7805CP	1	(CR14Q)
LD1	PCB Mounting Red LED	1	(QY86T)
LD2	PCB Mounting Green LED	1	(QY87U)

MISCELLANEOUS

SK1	PCB Mounting Power Socket	1	(RK37S)
SK2	Right-angled 9-way D-type Socket	1	(FG25C)
SK3,4	2 × 28-way PCB Edge Connector	2	(FG23A)
XT1	2.4576MHz Crystal	1	(FY81C)
	Z80 EPROM MS12	1	(95037)
	Z80 Development Disk	1	(95038)
	14-pin DIL Socket	3	(BL18U)
	16-pin DIL Socket	2	(BL19V)
	28-pin DIL Socket	1	(BL21X)

TO220 Vertical Vaned Heatsink	1	(JW29G)
M2.5 × 10mm Steel Screw	1 Pkt	(JY30H)
M2.5 Shakeproof Washer	1 Pkt	(BF45Y)
M2.5 Steel Nut	1 Pkt	(JD62S)
M3 × 20mm Insulated Spacer	1 Pkt	(FS38R)
PCB	1	(GJ25C)
Instruction Leaflet	1	(XV69A)
Constructors' Guide	1	(XH79L)

OPTIONAL (Not in Kit)

M3 × 10mm Insulated Spacers	1 Pkt	(FS36P)
12V Regulated Power Supply	1	(YZ21X)
9-way D-type Plug	1	(RK60Q)
25-way D-type Socket	1	(YQ49D)
Twin Core Lapped Screen Cable	1m	(XR20W)
Z80 CPU Module	1	(95036)

The Maplin 'Get-You-Working' Service is available for this project, see Constructors' Guide or current Maplin Catalogue for details.

**The above items (excluding Optional) are available as a kit, which offers a saving over buying the parts separately.**

**Order As 90053 (Z80 Development System) Price £34.99 A1**

Please Note: Where 'package' quantities are stated in the Parts List (e.g., packet, strip, reel, etc.), the exact quantity required to build the project will be supplied in the kit.

The following new items (which are included in the kit) are also available separately, but are not shown in the 1996 Maplin Catalogue.

Z80 Development System PCB **Order As 90054 Price £17.99**

Z80 EPROM MS12 **Order As 95037 Price £12.99**

Z80 Development Disk **Order As 95038 Price £2.99**

The following item is not included in the kit, but is available separately.

Z80 CPU Module **Order As 95036 Price £38.99**

# SEETRAX CAE RANGER PCB DESIGN

WITH COOPER & CHYAN AUTOROUTER

**RANGER2 + SPECCTRA £400.00**

**RANGER & SPECCTRA AUTOROUTER**

Together giving the most cost effective PCB design system on the market TODAY!

SEETRAX'S ease of use combined with COOPER & CHYAN'S renowned gridless autorouter, at an outstanding price.

R2 Outputs: 8/9 & 24 pin printers, HP Desk & Laser Jet, Cannon Bubble Jet, HP-GL, Gerber, NC Drill, AutoCAD DXF  
Demo Disk available at £5.00 +VAT

**RANGER2 £150**

Upto 8 pages of schematic linked to artwork  
Gate & pin swapping - automatic back annotation  
Copper flood fill, Power planes, Track necking,  
Curved tracks, Clearance checking,  
Simultaneous multi-layer auto-router

**RANGER2 UTILITIES £250**

COOPER & CHYAN SPECCTRA auto-router (SPI)  
Gerber-in viewer, AutoCAD DXF in & out

**UPGRADE YOUR PCB PACKAGE  
TO RANGER2 £60**

**TRADE IN YOUR EXISTING PACKAGE TODAY**

Seetrax CAE, Hinton Daubnay House, Broadway Lane, Lovedean, Hants, PO8 OSG

Call 01705 591037 or Fax 01705 599036 + VAT & P.P

All Trademarks Acknowledged

# ELECTRONICS SOFTWARE

If you are looking for a means of improving your knowledge of the basics of electronics then this software is for you.

## ELECTRONICS PRINCIPLES 2.1

- ★ Insulators, Conductors, Resistance ★ D.C. Circuits
- ★ Capacitance and Inductance ★ A.C. Series Circuits
- ★ A.C. Parallel Circuits ★ Reactance and Impedance
- ★ A.C. and D.C. Power ★ Frequency and Tuned Circuits
- ★ Using Numbers ★ Complex Numbers, Phase Angles
- ★ P.N. Junction Diode ★ Bi-polar and MOSFET Transistors
- ★ Operational Amplifiers ★ Logic Gates ★ Digital Number Systems
- ★ Combinational Logic ★ Flip Flops ★ Counters and Shift Registers
- ★ Memory ★ Microcomputer operation

Now an extended range of electronics topics with an improved graphics presentation, available to electronics hobbyists, students, schools, colleges, and used for training within industry throughout the UK and overseas. A fully interactive electronics program where the user selects from over 250 analogue and digital topics. Circuit diagrams, wave forms, phase angles, voltages and currents or logic states are shown, drawn to scale, in full colour. Formulae are given demonstrating all the calculation steps, exactly as in a textbook, using your input values.

An 'on screen' electronics package including circuit theory to enable a learning through doing approach to encourage experimentation. For the young student, mature hobbyist or the engineer that just needs to keep up-to-date in an easy and enjoyable way.

*Having reviewed a dozen, or more, educational software packages designed to "teach" electronics, I was more than a little sceptical when I first heard about Electronics Principles: there seemed to be little that could be done that has not been done elsewhere. When I started to use the package my views changed. Indeed, I was so impressed with it that I quickly came to the conclusion that readers should have an opportunity to try the package out for themselves! - MIKE TOOLEY B.A. Dean of Faculty of Technology, Brooklands Technical College.*

Complete package **Still only £49.95**

## ELECTRONICS PC TOOLBOX VERSION 2.0

An extended and improved version of the popular Toolbox software. Presents commonly used formulae in a way that makes calculations easier thus encouraging experimentation in circuit design.

Covers D.C. Calculations from Ohm's Law to Loading a Potential Divider; Further D.C. Calculations from Power Ratio Decibels to Kirchhoff's Laws; A.C. Calculations from Average Peak Current to Filters and Admittance; Capacitance Calculations from Values to RC Time Constants; Inductance Calculations from Values to Selectivity; Binary Calculations from Addition to 2's Complement; Numbers and Phase Angles from Addition to Polar to Rectangular; Operational Amplifiers from Inverting Op.Amp to Op.Amp Differentiator. **Only £19.95**

These programs require a PC (or fully compatible system) running DOS or Windows with an 80286 or better processor and VGA (ideally colour) graphics. In addition you must have 4Mb of hard disk space, a high density (1.44Mb) floppy drive and at least 640K of RAM. We also recommend the use of a mouse. Site licences are available - please enquire.

Available from

EPT Educational Software, Pump House, Lockram Lane, Witham, Essex. UK. CM8 2BJ. Tel/Fax: 01376 514008.

Add £2 per order for UK post and packing. Make cheques payable to EPT Educational Software.

Visa and Mastercard orders accepted - please give card number, expiry date and cardholders address if different from the delivery address.

OVERSEAS ORDERS: Add £2.50 postage for countries in the E.E.C. Overseas readers, outside the E.E.C. countries add £3.50 for airmail postage.

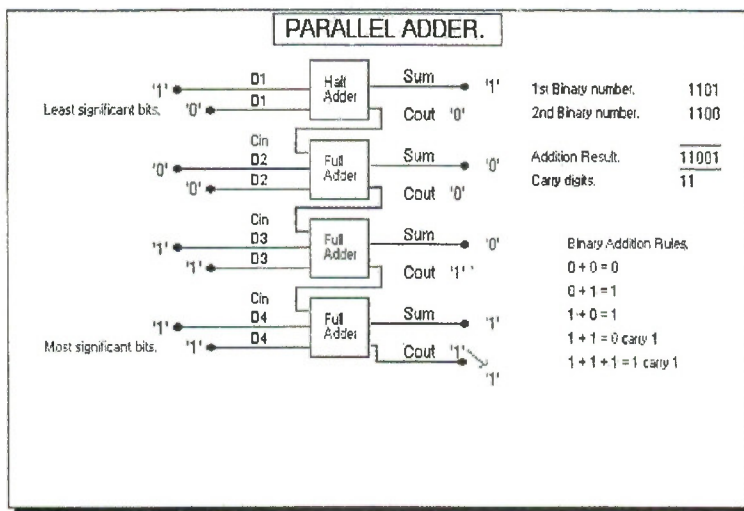

## GCSE ELECTRONICS VERSION 2.0

Designed to complement the *EPE Teach-In No. 7* publication, which contains a complete electronics course aimed at GCSE and A Level students, this software can also be used as a stand alone learning package for everyone interested in electronics. From simple d.c. current flow and Ohm's Law it covers the whole GCSE syllabus including a.c., semiconductors, op.amps, digital electronics, radio and fibre optic communications, digital numbering systems and goes on to look at microprocessor c.p.u.s, 6502 addressing modes and instruction sets. It even produces a program listing, which can be saved or retrieved from hard disk, when any of the instructions from the listed instruction set are input, thus allowing the user to monitor the registers for each of the addressing modes.

The original version is now widely used in schools and colleges throughout the UK.

An interactive, user friendly medium which assists learning in an enjoyable and interesting way.

**Only £39.95**

For more information or software upgrades call us on 01376 514008

## GCSE MATHS now version 2.0

A series of programs covering all the major topics required by the school syllabus. Designed to be user friendly enabling you to study or revise in what we believe is an interesting and enjoyable way. There are nearly one hundred and fifty menu driven screens with interactive graphics, enabling a "learning through doing" approach to encourage experimentation. Now being used in many schools throughout the UK.

**Only £49.95**

## JUST FOR FUN!

EPT Lottery Selector. Windows version. **£5.00 + £1 p&P**



# SUBSCRIBE TO

**\* BRITAIN'S BEST SELLING \*  
ELECTRONICS MAGAZINE!**

# ELECTRONICS

*The Maplin Magazine*



**\* 2 FREE ISSUES** if you agree to subscribe by Direct Debit or Continuous Credit Card, saving you £6.12!

**\* FREE DELIVERY TO YOUR DOOR,** and there are no additional carriage charges.

**\* PLUS – News, reviews, readers letters, competitions and lots, lots more besides!**

To subscribe just send a cheque/postal order for £11.88 made payable to Maplin Electronics, P.O. Box 3, Rayleigh, Essex SS6 8LR. **OR** you can take advantage of our offer of two free issues by completing the coupon below and agreeing to pay by Credit Card or Direct Debit. The two free issues offer only applies if you use one of these two methods of payment. Simply fill in the 'Payment by Credit' or 'Payment by Direct Debiting Mandate' and return it to Maplin. Every time, about 1 month before your subscription is due, we will send you a letter giving details of the subscription rate and telling you the date on which we will charge your Credit Card or debit your bank account. If you do not wish to continue your subscription, you have until that date to let us know, and we will then cancel your authority to bill your Credit Card or cancel your mandate. Otherwise, if you do nothing, your subscription will continue. The authority or mandate you give us does not allow us to charge anything other than the Maplin Magazine subscription. The benefit to you is that you no longer need to remember to renew your subscription or send off any more cheques or postal orders. Payment is made automatically.

**\* YES, SAVE MONEY** by taking a subscription, it's cheaper than buying each individual copy.

**\* REGULAR SUBSCRIBERS' SPECIAL OFFERS**

Super savings on selected products!

**OVERSEAS READERS – SUBSCRIBE NOW!** – Phone Maplin Export: +44 1702 554155 Ext. 326, 327 or 351. Full details on request.

Subscription rates for 6 issues are: £16.20 (or 40 IRCs) in Eire, Europe and surface mail outside Europe; £24.24 (or 60 IRCs) Air Mail outside Europe.

Subscription rates for 12 issues are: £32.40 (or 80 IRCs) in Eire, Europe and surface mail outside Europe; £48.48 (or 119 IRCs) Air Mail outside Europe.

**AFRICAN READERS – SUBSCRIBE NOW!** – Phone Maplin South Africa: +27 24 51 5124.

Subscription rate for 6 issues is: R114,00; Subscription rate for 12 issues is: R215,00.

## TAKE THE NEXT 2 ISSUES OF THIS MAGAZINE FREE!!

Because we're so certain that now you've seen the Maplin Magazine you'll want to receive it regularly, we're offering to send you the next two issues free of charge with absolutely no obligation to continue. Just fill in the details below and if after receiving two issues you do not wish to continue, just let us know at least one month before the next issue is due and we will cancel your subscription. The two free issues will be yours to keep whatever you decide. If you already have a subscription, fill in the details below and we'll add two issues free of charge to your current subscription. **SEND NO MONEY NOW.** About 2 weeks before the third issue is due, we will charge you £11.88 for the next six issues, unless you have cancelled. This offer is not available to those already paying by Direct Debit or Continuous Credit Card or those who have stopped payment by either method within the last year. **THIS OFFER IS OPEN TO RESIDENTS WITH U.K. ADDRESSES ONLY.**

**PLEASE START MY SUBSCRIPTION WITH ISSUE**  (If left blank subscription will start from next issue.)

EITHER

★ PLEASE ADD YOUR ADDRESS, SEE BOTTOM RIGHT ★

**PAYMENT BY CREDIT CARD.** Please charge my Credit Card Account

I authorise you until further notice in writing to debit my CREDIT CARD account by £11.88 and in future, with any amounts which, after notification, MAPLIN ELECTRONICS plc may debit thereto in respect of my subscription to the Maplin Magazine.

Overseas subscribers see above.

Customer Number (if known) .....

Access  Visa  American Express  Expiry Date  /

Account No.

Signature

Date

OR

**PAYMENT BY DIRECT DEBITING MANDATE** in favour of Maplin Electronics plc, P.O. Box 3, Rayleigh, Essex SS6 8LR.

Direct Debit payment option is only open to customers with bank accounts in the U.K. including Channel Isles, Isle of Man and N. Ireland.

Please note: Instructions cannot be accepted to charge Direct Debits to a Deposit or Savings Account.



Bank Sort Code

Bank Account Number

Name of account to be debited

Bank Address

I authorise you until further notice in writing to charge my account, with you, any amounts which MAPLIN ELECTRONICS plc may debit thereto by Direct Debit in respect of my subscription to the Maplin Magazine.

I will inform the bank in writing if I wish to cancel this instruction.

I understand that if any direct debit is paid which breaks the terms of this instruction, the bank will make a refund.

Signature

Date

Enter your address and Maplin customer number, if known.

Postcode

Put this form in an envelope and address it to: Maplin Electronics, Freeport, P.O. Box 3, Rayleigh, Essex, SS6 2BR.



# Don't despair . . . Repair!

The all new Electronics Service Manual shows you how to troubleshoot and repair electronic equipment successfully. It is suitable for the beginner and more experienced enthusiast, trainee or repairman.

## You can become a repair expert

- Understand electricity and electronics.
- Confidently use test equipment to pinpoint problems.
- Become skilled at understanding flow charts, circuit diagrams and manufacturers data.
- Successfully identify components and understand their function.
- Learn how to skillfully remove and replace components.

## One source for all your repair needs

The Electronics Service Manual will get you started, or help develop your skills, in repairing and servicing electronic equipment. Over 850 pages, loose leaf A4 format in a durable, sturdy ring binder all for just £39.95 plus £5.50 post and packing.

## Continue to broaden your repair expertise

You'll receive regular Supplements (about five a year) with new technical notes and information to enable you to service and repair an increasingly wide range of equipment. Each Supplement contains around 160 pages all for only £23.50 plus £2.50 p&p. You can of course return any Supplement (within ten days) or cancel the Supplements at any time.

**GUARANTEE**

Our 30 day money back guarantee gives you **complete peace of mind**. If you are not entirely happy with the Manual, for whatever reason, simply return it to us in good condition within 30 days and we will make a **full refund of your payment** – no small print and no questions asked.

(Overseas buyers do have to pay the postage charge)

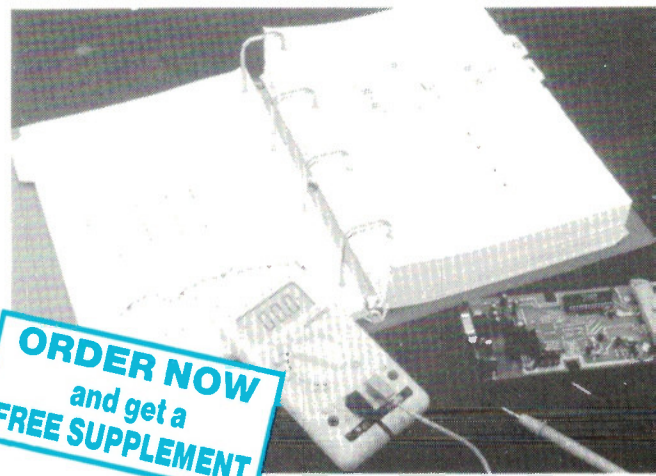

## THE ELECTRONICS SERVICE MANUAL

### Covers:

- Safety
- Underpinning Knowledge
- Practical Skills
- Test Equipment
- Servicing Techniques
- Reference Data
- Full Index

**Easy to use format, professionally edited by Mike Tooley BA to be easily understandable by the beginner yet valuable to the more experienced enthusiast, trainee or repairman.**

Wimborne Publishing Ltd., Dept. A1  
Allen House, East Borough, Wimborne,  
Dorset BH21 1PF.  
Tel: 01202 881749. Fax: 01202 841692.

**PLEASE** send me the **ELECTRONICS SERVICE MANUAL** plus a **FREE SUPPLEMENT**

I enclose payment of **£45.45**. I shall also receive the appropriate Supplements several times a year. These are billed separately and can be returned (within 10 days) or discontinued at any time. Should I decide not to keep the Manual I will return it to you within 30 days for a full refund.

FULL NAME .....  
(PLEASE PRINT)

ADDRESS.....  
.....

..... POSTCODE .....

SIGNATURE.....

I enclose cheque/PO payable to Wimborne Publishing Ltd.

Please charge my Visa/Mastercard (Access)

Card No. .... Card Exp. Date .....

### ORDER FORM

Simply complete and return the order form with your payment to the following address:

**Wimborne Publishing Ltd, Dept. A1  
Allen House, East Borough, Wimborne,  
Dorset BH21 1PF.**

**OVERSEAS ORDERS:** All overseas orders must be prepaid and are supplied under a money-back guarantee of satisfaction. If you are not entirely happy with the Manual return it within a month for a refund of the purchase price (you do have to pay the overseas postage). **SEND £39.95 PLUS THE POSTAGE SHOWN BELOW:**

EIRE	AIR MAIL ONLY £11
EUROPE (E.E.C. Countries)	AIR MAIL ONLY £20
EUROPE (non E.E.C.)	SURFACE MAIL £20, AIR MAIL £26
U.S.A. & CANADA	SURFACE MAIL £25, AIR MAIL £32
FAR EAST & AUSTRALIA	SURFACE MAIL £31, AIR MAIL £33
REST OF WORLD	SURFACE MAIL £25, AIR MAIL £44

Note surface mail can take over 10 weeks to some parts of the world. Each manual weighs around 4kg when packed.

All payments must be made in £'s Sterling payable to Wimborne Publishing Ltd. We accept Mastercard (Access) and Visa credit cards.



A thunder-storm can produce a magnificent display of light and noise. It can be an exhilarating experience to watch a storm in progress, especially out in the country, where it is sometimes possible to see the hill tops being struck by lightning. In the cities, buildings are sometimes struck, particularly if they are tall.

by Ian Poole

# WHEN LIGHTNING STRIKES!

**T**HE Empire State Building in New York is struck over a thousand times a year, and tall buildings in the UK also suffer. The British Telecom Tower in London also receives many direct strikes. Fortunately, tall buildings like these are designed to withstand direct strikes and they suffer little or no damage.

In some areas of the world, thunderstorms are far more frequent than they are here in Britain. In fact, over the whole of the globe, there are several thousand storms taking place at any one time, and about a hundred lightning-strikes every second. Some figures seem to suggest that the greenhouse effect may be causing storms to occur more often.

When storms occur, enormous amounts of energy are unleashed. Houses, trees, and any other structures which are hit can be severely damaged if they are not properly protected. Despite the fact that storms occur on about ten days in each year in Britain and there are many discharges in each storm, comparatively few houses are struck. However, even without a direct strike, these electric storms can still cause considerable amounts of damage and inconvenience, especially to sensitive electronic equipment.

Possibly the most obvious possibility for damage is seen by television and radio equipment. Even without a direct strike, considerable voltages can be induced in aerials. For

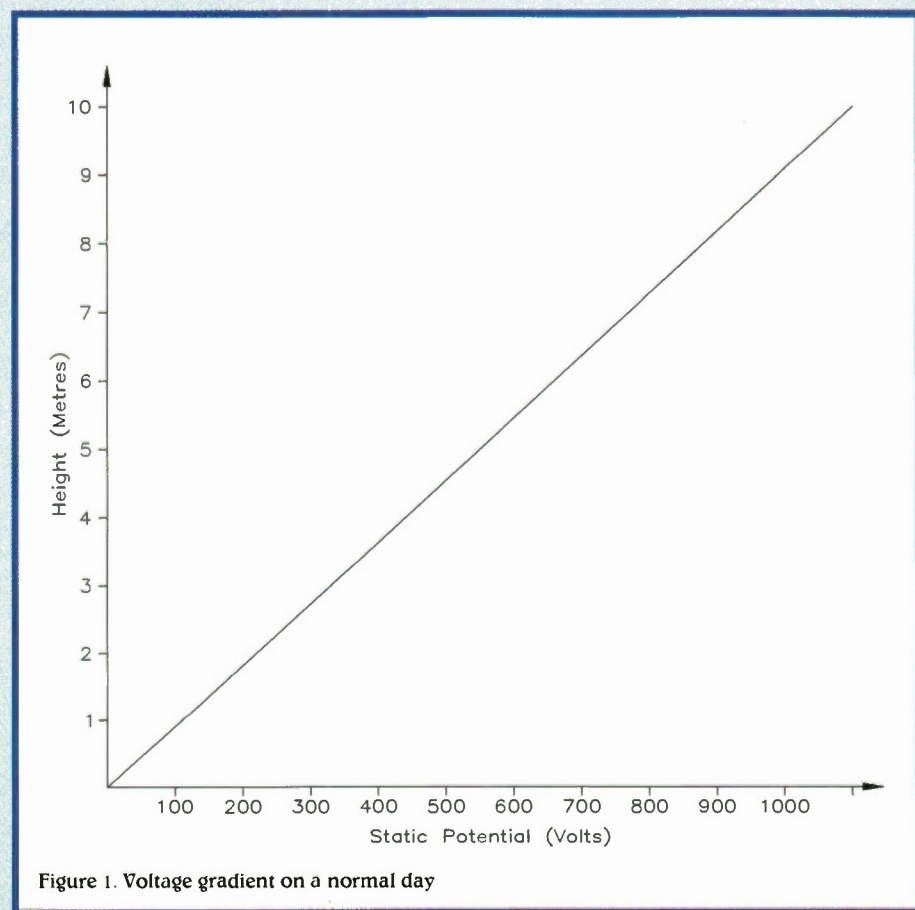

Figure 1. Voltage gradient on a normal day

short wave aerials, the voltages induced can reach several hundred volts, even when the discharge is a mile or more away.

Another way in which lightning can cause problems, is when power lines are struck. This energy can travel along the supply system, resulting in large voltage spikes appearing at the input to sensitive equipment. Near strikes can also induce large voltages into wiring, which can be equally damaging. These aspects are becoming increasingly important where computers are concerned. Spikes and surges of this nature can cause damage to equipment or possibly more importantly, it can cause data to become lost or corrupted, losing many hours of valuable work.

However, before looking at ways of protecting against the effects of lightning, it is interesting to look at how the storms arise, and how a lightning strike occurs.

## A Normal Day

During an electric storm, some enormous voltages are generated. However, even on a normal day, there is a large electrostatic voltage gradient. It is normally around 100V/m, as shown in Figure 1. It is caused by the charged particles entering the atmosphere from the sun, and it means that the ionosphere is held at a colossal voltage above the earth.

## The Storm

Thunder-storms can occur in a number of ways. Generally, they are associated with hot summer days, but they can also appear at other times of the year and even in winter, when it is colder. There are two main types of storm. The most familiar occurs on a hot summer's day, and it gives plenty of warning of its arrival. It needs hot, still air, which rises in small or local thermals, carrying with it huge quantities of water. Because the air is still, these thermals remain well-defined, and rise to considerable heights. As the air rises, it cools and the water condenses, forming a type of cloud known as cumulo nimbus. These clouds can be seen in the distance as great dark storm clouds, rising very high into the air. In fact, the top of these clouds can be many miles high. Inside them, it can be very violent, as some small aircraft have found to their peril. As the air is still, these storms move very slowly, and can last for a number of hours.

The second type of storm can occur at any time of the year, and it is associated with a frontal system of air. The approach of the cool air causes the warmer air to be pushed out of the way rapidly. In turn, this causes much of the warmer air to rise very quickly, and the turbulence this causes can result in thunder-storms. As these fronts have to be fast-moving to cause thunder, the storms that they generate do not stay in any place for long and appear to be short-lived. Even so, they still produce quite a lot of electrical activity.

## Storm Voltages

Thunder-storms drastically alter the normal voltage gradient which exists in the atmosphere on a normal day. The steadily increasing positive voltage is totally disrupted. The bottom of a thunder-cloud is negatively charged with respect to the earth, but the top of the cloud is positively charged. The cloud grows as the thermals bring in all

the new water vapour. As a result of the condensation of these colossal amounts of water, heat is released high up in the cloud, which increases the thermals and further water is carried up even higher. Eventually, the top of the cloud freezes. This point may be several miles high and the potential many millions

of volts above the Earth, see Figure 2. The matter is complicated still further by the fact that positively charged hailstones from the top of the cloud start to fall and meet the warm rising air. This results in a cold, positively charged centre to the storm, surrounded by a negatively charged area.

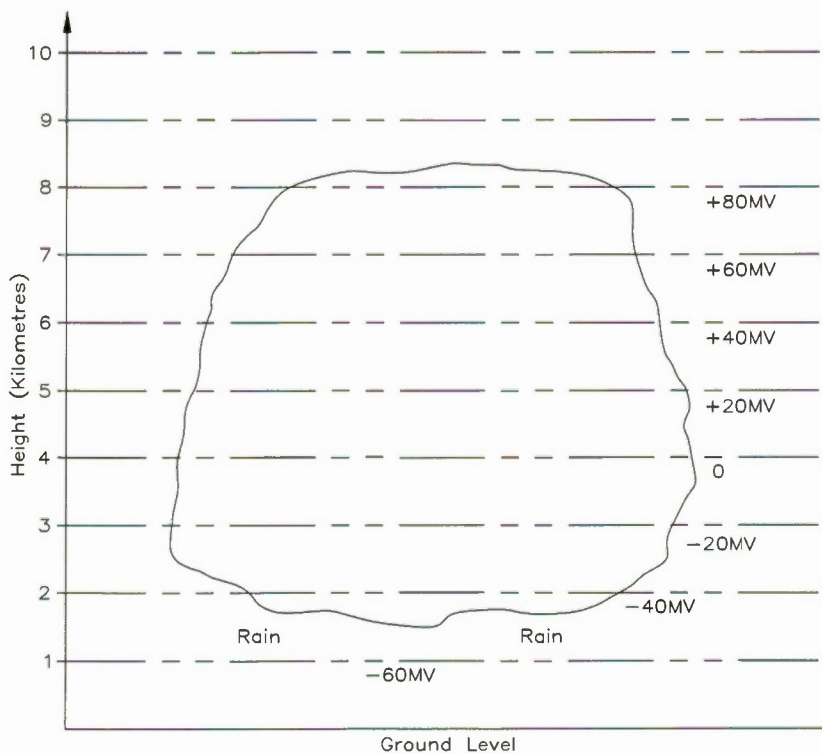

Figure 2. Charge associated with a thunder-cloud

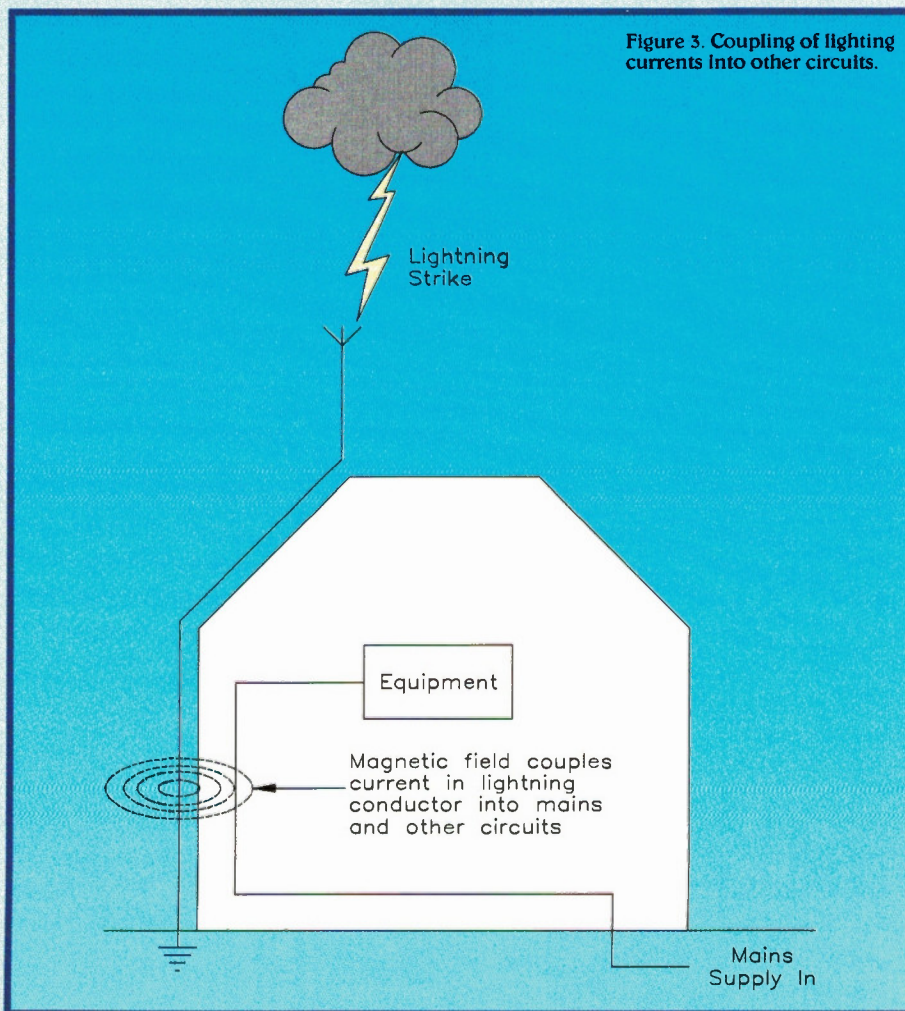

Figure 3. Coupling of lightning currents into other circuits.

These potential changes can be detected quite easily by an electrometer, which can be used to monitor the onset of a storm. Whilst the storm is still some distance away, the normal voltage gradient will exist and the electrometer will register a positive reading. Then, as the storm clouds are still some way off, the reading will start to fall. In fact, these variations can be detected up to 15 miles away on the most sensitive instruments.

As the storm-clouds approach, the readings will fall still further, and actually change from positive to negative. With the onset of rain, there is a very sharp transition from neg-

ative back to positive. This can happen in a matter of seconds, and the actual potential reached can be quite large, often reaching several thousand volts per metre.

### Lightning Formation

Lightning is formed because the voltage gradient becomes so high that the air actually breaks down, and current flows. However, the way in which this happens is not as straightforward as might be expected. The lightning consists of two main parts. The first is known as a leader. Under the cloud, there

is a lot of turbulence, and this causes areas of high charge to occur. This results in the areas where the voltage gradient becomes so steep that the air actually breaks down, and a path of about 50m becomes ionized. This in turn, brings the electrical bottom of the cloud down by this amount. The process is repeated many times and each time, the stroke progresses towards the ground. Not all leaders continue to the ground, and many split into several tracks. This is why photographs of lightning usually show one main track of ionization, with several leaders which end without reaching the earth.

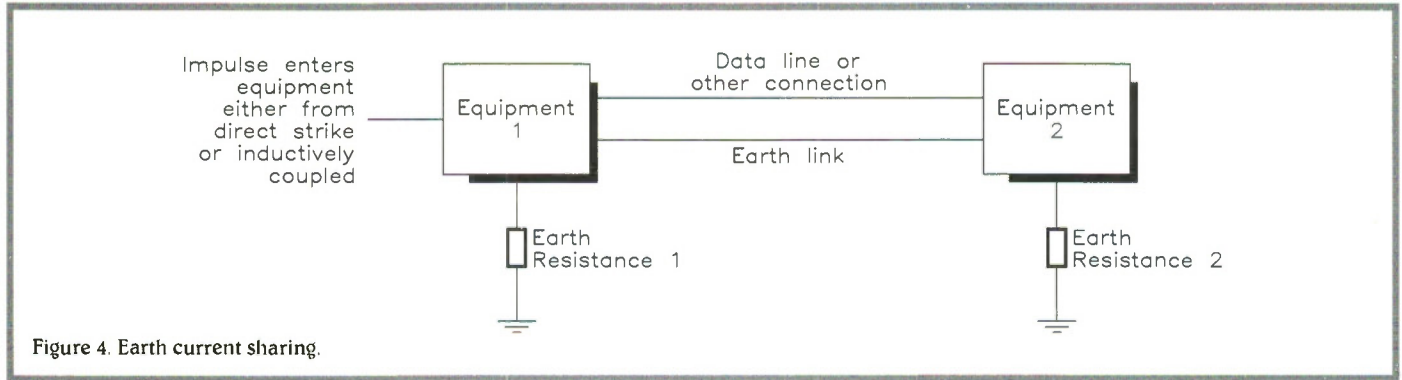

Figure 4. Earth current sharing.

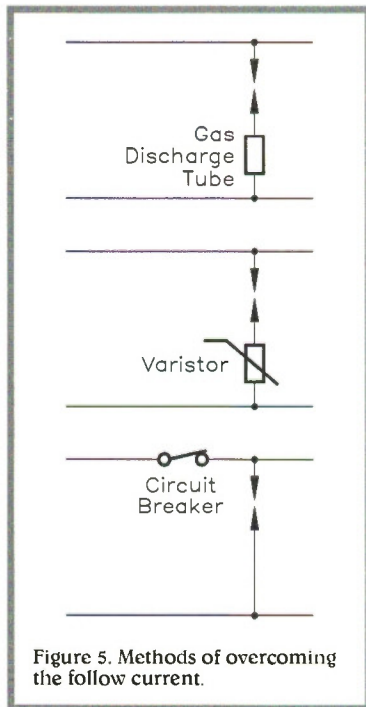

Figure 5. Methods of overcoming the follow current.

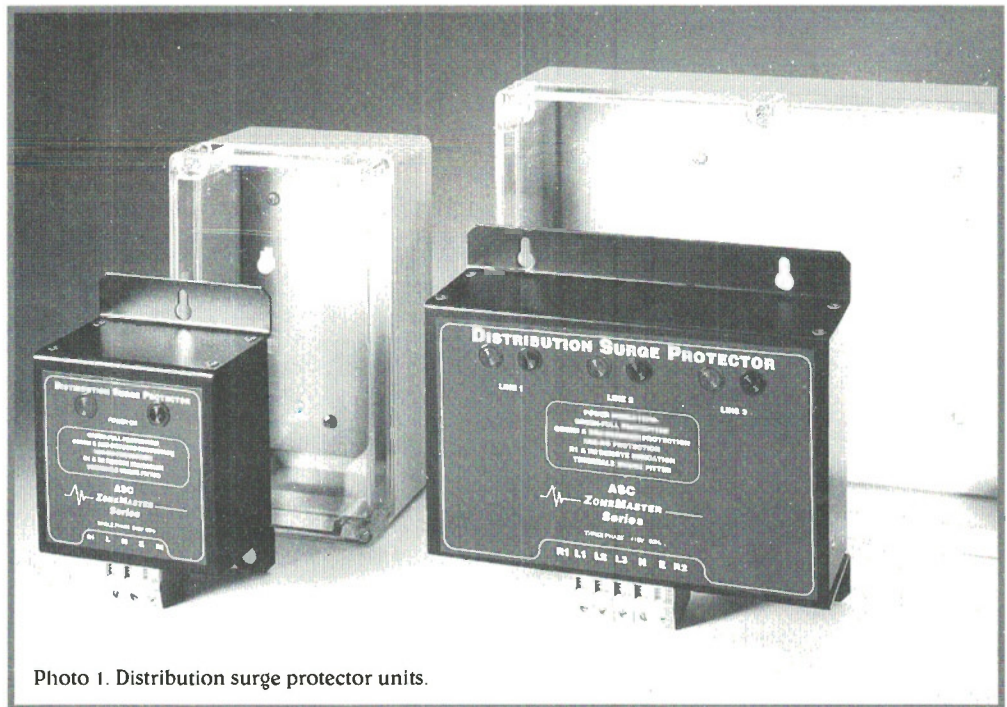

Photo 1. Distribution surge protector units.

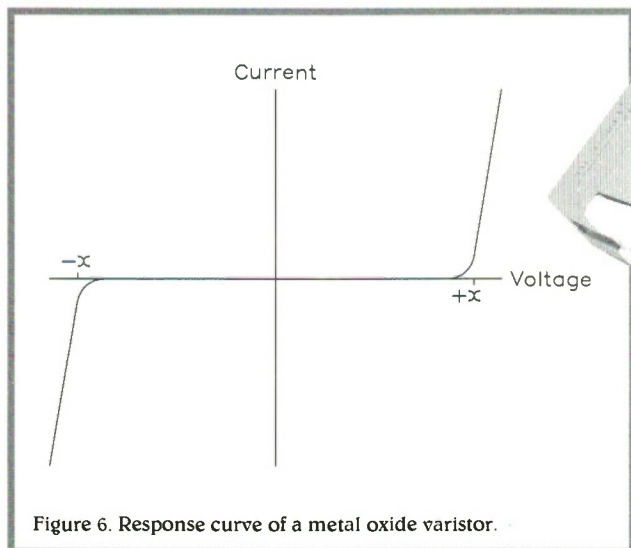

Figure 6. Response curve of a metal oxide varistor.

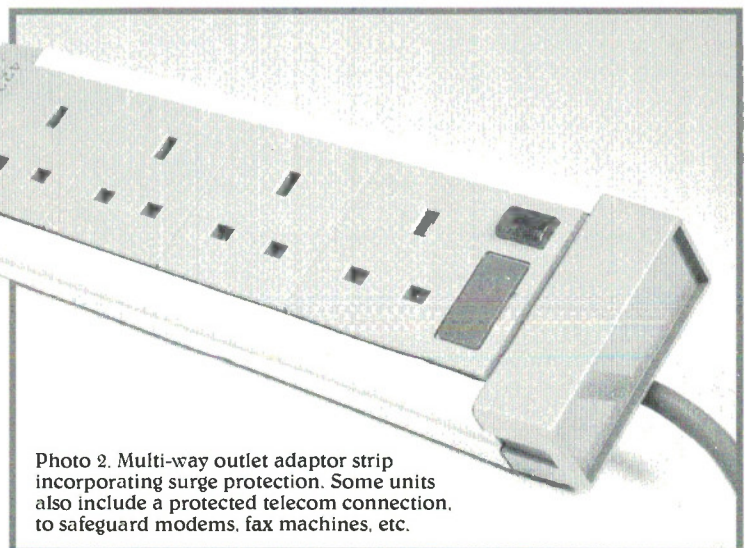

Photo 2. Multi-way outlet adaptor strip incorporating surge protection. Some units also include a protected telecom connection, to safeguard modems, fax machines, etc.

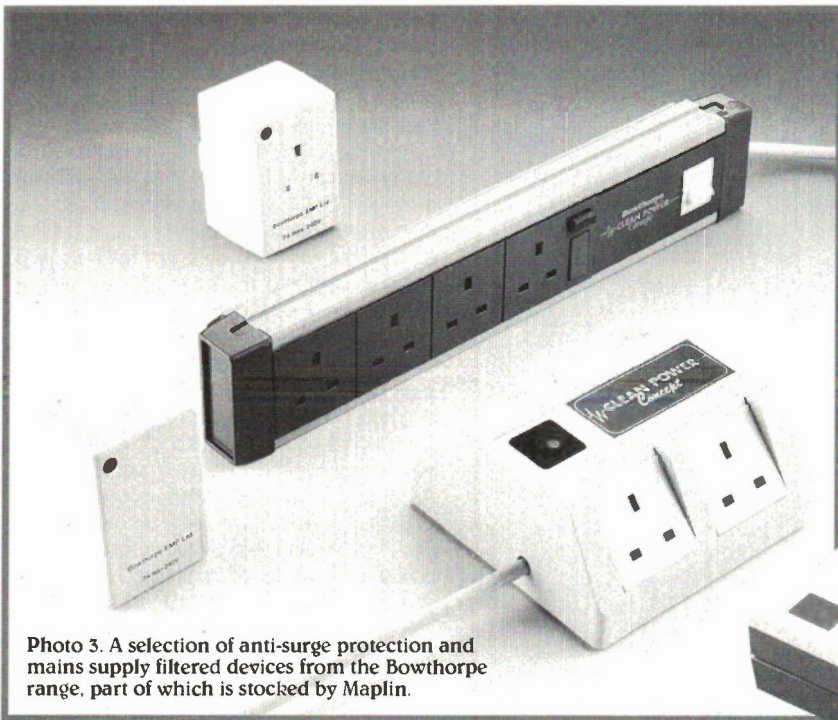
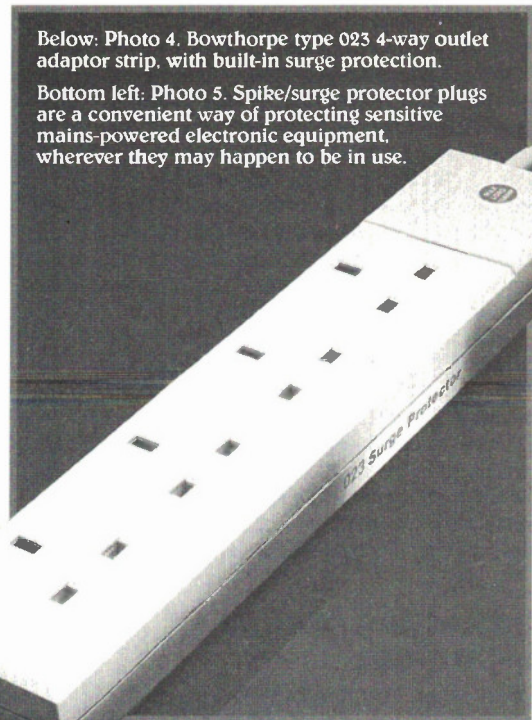

Photo 3. A selection of anti-surge protection and mains supply filtered devices from the Bowthorpe range, part of which is stocked by Maplin.



Below: Photo 4. Bowthorpe type 023 4-way outlet adaptor strip, with built-in surge protection.

Bottom left: Photo 5. Spike/surge protector plugs are a convenient way of protecting sensitive mains-powered electronic equipment, wherever they may happen to be in use.

When the leader nears the ground, it induces an opposite charge generating upward-moving leaders from the ground. These travel upwards from the tallest points in the vicinity, to meet the leader from the cloud. The two strokes meet at a point which is usually about 50-60m above the ground, often the one from the tallest object reaching the downward leader first. When this occurs, there is a short-circuit path between the cloud and the ground. It is at this point that the main discharge occurs, with a current flowing upwards from the ground to the cloud. Potential differences in excess of several hundred million volts are involved, and peak currents between about 10,000 to 100,000 can flow.

The colossal current flowing gives rise to the dissipation of massive amounts of heat. This causes the air in the immediate vicinity of the conduction channel to rise to temper-

atures in excess of 20,000°C. This enormous rise in temperature causes the air to expand along the whole length of the stroke. This occurs very rapidly and sets up a shock wave, which moves outwards to give the characteristic sounds of thunder.

The lightning stroke is completed very quickly. The leader is the slowest, travelling at a speed of around three hundred miles a second. The main discharge is much faster. This travels at a speed of about 37,500 miles a second. The stroke is also over very quickly. It only takes about 10µs for the current to rise to its peak value, with current densities of over 1,000A/cm².

After the main stroke has been completed, there is a possibility that a large amount of charge still remains. In this case, a second discharge may take place. This can occur a few milliseconds after the first discharge is completed. A leader propagates down the

original path, completing the circuit to ground, whereupon the second stroke occurs.

## Effects of Lightning

Electronic equipment can easily suffer damage in an electric storm. This can happen in a number of ways. The most obvious occurs when the equipment of a cable leading to it suffers a direct strike. Fortunately, this occurs comparatively infrequently, as the effects are disastrous.

The secondary effects of a lightning-strike are far more common. For example, lightning may strike a high voltage power line. When this occurs, a large surge will be sent down the power line. Although there are lightning arresters installed in the power system, some of the surge can still get through to the normal 230V distributed mains supply. Spikes of several kV appearing at the mains outlet can arise on occasions. Fortunately, much of the distribution wiring in the UK is below ground (apart from the grid distribution system itself), and the effects of strikes are often dissipated by the time they reach the consumer.

Surges can also be created in other ways. Near strikes, or those which hit lightning-arresters, can generate surge voltages in power cables and data lines either capacitively or inductively. Also, imperfect earthing can cause currents to flow along data lines connecting two pieces of equipment.

If there is any coupling between different circuits, this can also cause surges to be induced. If a lightning strike is safely conducted to earth as shown in Figure 3, then large magnetic fields will be created in the vicinity of the conductor. By Faraday's laws of induction, changes in the magnetic field will cause a voltage to be induced in any nearby conductors. As the currents from a lightning-strike are very large and rise very rapidly, very large voltages can be induced in nearby wiring. This wiring can be any cabling, including mains wiring or data cables. When this happens, it is not uncommon to see voltages in excess of several thousand volts generated.

The other way in which voltages can be

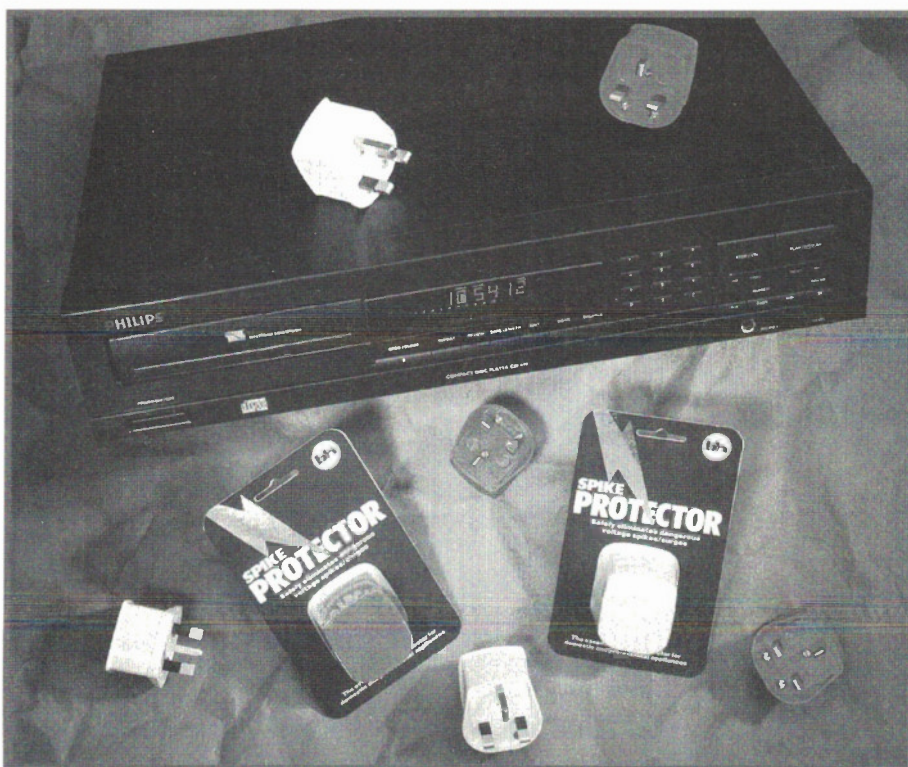

generated occurs when two pieces of equipment are connected together, as shown in Figure 4. Here, a large voltage is generated and passes to earth near the first piece of equipment. However, as the earth is not perfect and a small resistance exists, some current will flow through the wire connecting the two pieces of equipment and then to earth of the second piece of equipment. This can result in voltages appearing on data lines for computers, which are very much higher than would normally be expected.

It is interesting to note that it is not just lightning that causes surge voltages to be induced in wiring. Often, pieces of electrical machinery being turned on and off can send a large back emf along the mains wiring. This can be seen by the power input to other pieces of equipment. The spikes can also be inductively coupled into other cabling as well, making any cables liable to pick-up.

## Protecting Against Lightning

Often, when lightning causes damage, the true cause is not known. When a piece of equipment fails, it is usually attributed to a random failure and little investigation into its cause is undertaken. As a result, many of the failures caused by lightning go unnoticed, and no steps are taken to prevent any further occurrences.

Fortunately, this is beginning to change. Failures in computer systems can be very costly. Even though hardware can be insured against lightning damage, the software and lost data cannot be recovered. Sometimes, when a company relies on its computer for the day-to-day running, lost data and downtime can cost much more than the hardware repairs. It is for this reason that many companies are beginning to take the risk far more seriously, and seek ways of reducing the possibility of damage and data corruption.

## Protective Devices

There are three main devices which are used in protection against surges and spikes. The largest of these is a gas-filled discharge tube. This has the highest surge current handling capacity, many being able to discharge transient currents of up to 10kA. This makes this type of device ideal for arresting any surges on the incoming mains line.

These tubes are based on a spark gap, which is one of the oldest types of arresting device. In its most basic form, it simply consists of two electrodes often made from carbon and spaced between 60 and 150µm apart. The spark then occurs in the air gap between these two electrodes. The disadvantage of this type of device is that electrodes erode after a large or sustained discharge.

To overcome this problem, the electrodes can be made of metal and the whole device enclosed in a tube filled with an inert gas such as argon. This sealed tube is the gas discharge tube used today. Under normal operation, it has little effect on the line. However, when a surge appears, the breakdown voltage of the tube is exceeded and it starts to conduct. This provides a low resistance path for the surge current, which can be safely dissipated to ground.

One of the problems with a discharge tube is that when the arc is struck between the two electrodes, it can easily be maintained,

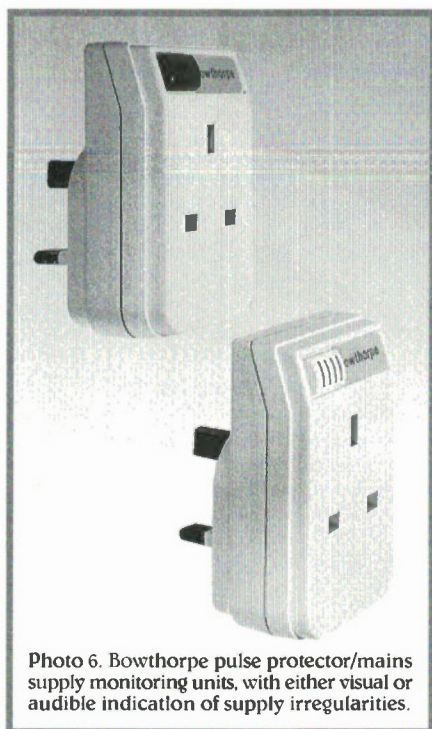

Photo 6. Bowthorpe pulse protector/mains supply monitoring units, with either visual or audible indication of supply irregularities.

even after the transient is completed. The current which flows is known as the 'follow current', and it can be maintained almost indefinitely. There are a number of ways of overcoming this problem. One is to add a resistor in series with the tube as shown in Figure 5, but this reduces the efficiency of the tube. Alternatively, a varistor can be used instead. Finally, a circuit breaker can be employed, which will be triggered when the discharge tube conducts. However, by the time the breaker has acted, the transient will have passed and been dissipated by the tube.

A second type of device is called a metal oxide varistor. The term varistor can be applied to almost any resistor whose resistance is voltage dependent. However, the term is normally used in conjunction with devices which actually dissipate energy. Varistors can be made from a variety of materials. Most modern ones are manufactured from mixtures of metal oxides of which, zinc oxide is generally the main ingredient. Older types of varistors were made from silicon carbide. These were initially intro-

duced in 1930, and although they do not have a very non-linear curve, they are more robust than many of the modern metal oxide versions. This factor alone has meant that they are still used in some areas today.

A varistor generally has a smaller surge current handling capacity than the discharge tube, but it is much faster acting. The reaction time can often be less than 50ns. However, they can have a relatively high capacitance, and this makes them unsuitable for any data transmission or high-frequency applications. Under normal operating conditions, a varistor has a relatively high resistance, but as the voltage rises, its resistance falls, so that the surge can be safely conducted away to earth. The varistor is bipolar as shown in Figure 6, and it acts the same way for surges of either polarity.

Whilst varistors are very useful, they do have the disadvantage that their efficiency falls after a number of discharges have passed through them. Despite this, they are very effective and are often used in conjunction with discharge tubes for primary protection. Zener diodes are often used for protection. Whilst their surge current handling capability is smaller than discharge tubes or varistors, their operation is very fast, often reacting within pico-seconds. Each type of protection device has its own advantages and disadvantages. To exploit the advantages of the individual components, many protection units will include two or more types of device.

## Where to Protect

To obtain the optimum protection, different types of safeguard equipment should be installed in different places. In this way, any harmful spikes can be dissipated as early as possible. Normally, the primary protection will be fitted across the incoming supply at the first point where access can be gained. If the supply is a three-phase one, then individual diverters are generally connected from each supply to earth. The neutral line should also have its own diverter as well, otherwise this could carry a harmful spike. At this point, it is worth limiting the voltage to about 600V. However, it is found that ringing within the installation can bring the voltage back up to levels as high as 2kV. Further pro-

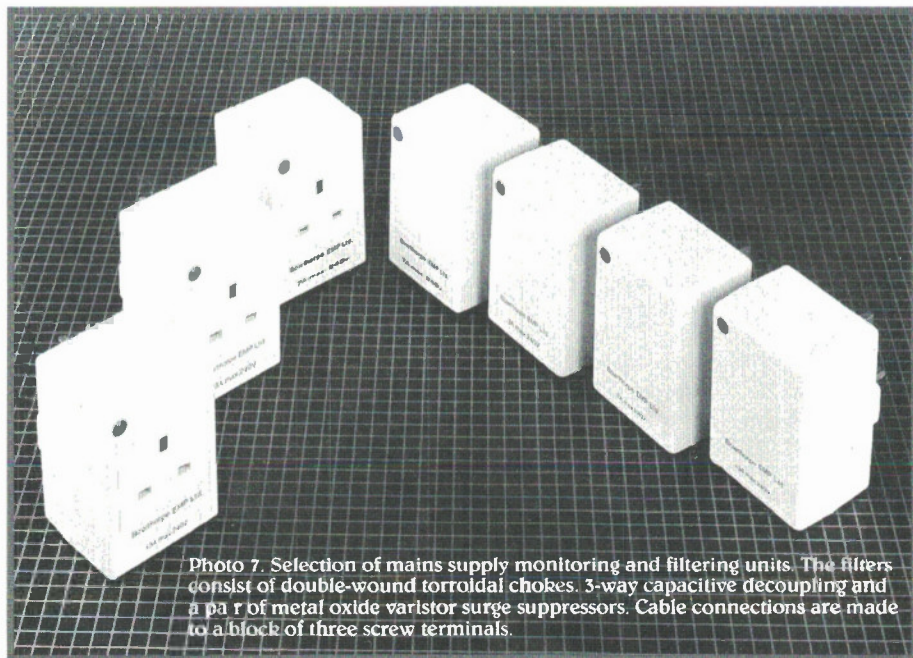

Photo 7. Selection of mains supply monitoring and filtering units. The filters consist of double-wound toroidal chokes, 3-way capacitive decoupling and a pair of metal oxide varistor surge suppressors. Cable connections are made to a block of three screw terminals.

tection is needed to overcome these effects, as well as those caused by electrical equipment within the building. In a large building, this protection may well be provided for individual floors or other defined areas, by means of distribution surge protectors, as shown in Photo 1. This method of protection may often be similar to that provided at the supply point.

The final protection should be provided where equipment is connected to the supply. Here, multi-way outlet adaptor strips (see Photos 2 to 4) or surge protection plugs and sockets like those illustrated in Photos 5 to 7 may be used. These have a lower current dissipation capability and a higher breakdown voltage than the primary protection devices. In this way, the primary protection devices take the full force of the surge, and leave the secondary devices to take care of local surges and the effects of ringing. If they had a lower breakdown voltage than the primary devices, they would tend to take the full force of the surge and draw the surges towards the equipment being protected.

Whilst it is very important to protect the

mains input to equipment, computer systems are also likely to have a large number of interconnecting cables to enable the data to be transferred. In a computer network, it is likely that the network cables may be many tens or hundreds of metres long. These cables are naturally very susceptible to the pick up of transients. To protect them, special protection units are available, which are specially manufactured, often with connectors on either end, so that they can be conveniently inserted into the line with the minimum of disruption.

## Summary

Whilst lightning is the most drastic form of voltage surge likely to be seen by most equipment, there are many other sources of electrical surges. Motors and many other forms of electrical equipment, including fluorescent lights, can generate large spikes when they are switched. These spikes travel down the power lines, or may sometimes be induced into data cables, causing problems with sensitive systems.

With an ever-increasing dependence on computers and other electronic equipment, it is important that the correct surge and spike protection is incorporated. Whilst it may seem an unwanted outlay during the installation phases of a project, it could save its cost many times over when the system is in operation.

## Acknowledgment

Thanks are due to Bowthorpe EMP Ltd., for their help in the preparation of this article. For further information, contact: Bowthorpe EMP Ltd., Stevenson Road, Brighton, East Sussex BN2 2DF. Tel: (01273) 692591. Fax: (01273) 601741.

## Surge Protection Devices

Surge protection devices stocked by Maplin: Surge Protecting Mains Plug, Order Code KU20W.

Surge Clock (Counts the number of damaging spikes on the mains supply), Order Code KR42V.

13A Pulse Protector, Order Codes CX64U and CX65V.

# What's On?

## Science Museum says "You're Just as Well Off With Mystic Meg!"

There are people who think that given enough information and a cleverly programmed computer, we will one day be able to correctly predict the winning numbers of the lottery. These people will be disappointed when they visit a new exhibition on the revolutionary theory of chaos at the Science Museum in London, which shows that the National Lottery result could never be predicted.

'Chaos: Making Sense of Disorder' is the latest in the Science Box series of exhibitions, focusing on contemporary science, technology and medicine. The science of chaos has thrown new light on the scientist's classical idea that everything can be predicted if the starting conditions and the right equations are applied. Chaos theory shows that the outcome of complicated systems such as the National Lottery machine can never be predicted, because the slightest change in starting conditions leads to a completely different behaviour.

Chaos theory is currently being used to study the functions of the heart and the brain. This research could have enormous impact in monitoring potential heart attack victims and anticipating, and possibly controlling, epileptic fits.

'Chaos: Making Sense of Disorder' will focus on these and other applications, demonstrating why things are not often as they seem, and highlighting everyday examples of where chaos can be found, such as capsizing boats, dripping taps, and rabbit breeding. The exhibition is open from now until 14 April 1996. Entrance is included within the Science Museum's general admission price of £5.00 for adults, and £2.60 for children.

Contact: Science Museum, Tel: (0171) 938 8192.

## New Courses for Design Engineers

The Smallpiece Trust Design and Management Training Centre in Leamington Spa has just published its 1996 Training Calendar, which features over 40 short courses specifically developed for engineers and managers in industry. Smallpiece has a proven reputation and over 30 years experience in delivering a unique range of short courses in engineering design topics - ranging from a one-day programme in Failure Modes and Effect Analysis, through to specialist courses in Concurrent Engineering and Design for Assembly. The centre also provides authorised AutoCAD training and offers a wide range of cost-effective

courses from Foundation level AutoCAD through to advanced programming and 3D applications.

Contact: Smallpiece Trust Design and Management Training Centre, Tel: (01926) 336423.

## Vintage Communications Fair

The fifth National Vintage Communications Fair will take place at the Pavilion Hall of the NEC in Birmingham on Sunday 3 December. The event will feature thousands of rare and collectable vintage technology items, with a special emphasis on early radios, television receivers, gramophones, telephones, and classic 1950's Hi-Fi equipment.

The National Vintage Communications Fair typically attracts up to 300 dealers from the UK, USA and continental Europe. For the hardened collector, it is the event of the year, while for the newcomer thinking about starting a collection, it's an opportunity to meet leading collectors, clubs, societies and specialist magazines.

Contact: The National Vintage Communications Fair, Tel: (01398) 331532.

## Can we Cope with the Workplace Revolution?

We are in the process of a second industrial revolution - which will change the world of work in ways which will have a profound effect on Britain as a cohesive community. This was the view presented by Baroness Brenda Dean, Labour spokesperson on employment in the House of Lords, speaking last month at an IBM sponsored seminar.

Baroness Dean was one of three speakers at the seminar, entitled 'The Changing World of Work', which explored issues surrounding the impact of technology on working patterns. Also speaking at the conference were Mr Eberhard Kohler, Research Manager at the European Foundation for the Improvement of Living and Working Conditions, and Mrs Steve Shirley OBE, Founder Director of the FI Group.

Among the issues addressed by Baroness Dean was high unemployment and the question of whether business has a social responsibility or simply a responsibility to ensure economic success. She also voiced concerns over the ability of present structures in Britain to meet the challenges and threats of profound changes in the working environment, which will be brought about at an increasing rate by advances in technology.

Mr Eberhard Kohler looked at ways to tackle these issues in a presentation entitled 'Working in the information society - practical experiences and future options'. Mr Kohler currently leads a four year research programme aimed at 'Restructuring the World of Work', and was able to give an informed insight into the problems and opportunities associated with the technological revolution.

One of the first people to bring the issues of technology and business together, during the 1960s, was Mrs Steve Shirley. She spoke of what she called 'FI's journey to empowerment' and her quest to transfer control of the FI Group into the hands of 'those who make the business work'. A wide range of subjects was discussed in relation to empowerment of the employee, including the roles of education, working committees, staff audits and employee trusts. Contact: IBM, Tel: (0171) 830 8488.

## DIARY DATES

Every possible effort has been made to ensure that the information presented here is correct prior to publication. To avoid disappointment due to late changes or amendments, please contact event organisations to confirm details.

**27 November.** Balun and Matching, David Yates, G3PDQ, Stratford-upon-Avon and District Radio Society, Stratford-upon-Avon. Tel: (01789) 295257.

**28 to 30 November.** Computer Graphics Expo, Wembley Centre, London. Tel: (0181) 995 3632.

**7 to 11 December.** Computer Shopper Show, Wembley Centre, London. Tel: (0181) 742 2828.

**11 December.** Open Evening, Stratford-upon-Avon and District Radio Society, Stratford-upon-Avon. Tel: (01789) 295257.

**19 December.** Christmas Social, Bury St. Edmunds Amateur Radio Society, Suffolk. Tel: (01284) 764804.

**25 December.** Christmas Greeting on Air, 11.00am 145.275MHz, Stratford-upon-Avon and District Radio Society, Stratford-upon-Avon. Tel: (01789) 295257.

### 1996

**8 January.** Winter Social, Stratford-upon-Avon and District Radio Society, Stratford-upon-Avon. Tel: (01789) 295257.

**16 January.** Annual General Meeting,

Bury St. Edmunds Amateur Radio Society, Suffolk. Tel: (01284) 764804.

**20 January to 25 March.** Science Museum Superhighway UK Tour National Museum of Wales, Cardiff. Tel: (0171) 938 8192.

**21 January.** Oldham Amateur Radio Club Mobile Rally, Queen Elizabeth Hall, Civic Centre, West Street, Oldham, Lancs. Doors open 11am, 10.30 for disabled visitors. Event features the usual traders and a Bring and Buy Stall. Morse Tests available on demand. Talk-in on S22 via GB4ORC, commencing 7.30am. Mobile Contact prize, up to 2pm. Refreshments and free Parking will be available. Tel: (01706) 846143 or (0161) 652 4164.

**22 January.** Projects, Grouses, Problems and Solutions, Stratford-upon-Avon and District Radio Society, Stratford-upon-Avon. Tel: (01789) 295257.

**12 February.** DX Cluster, John Clayton G4PDQ, Stratford-upon-Avon and District Radio Society, Stratford-upon-Avon. Tel: (01789) 295257.

**26 February.** Test Equipment Evening, Stratford-upon-Avon and District Radio Society, Stratford-upon-Avon. Tel: (01789) 295257.

Please send details of events for inclusion in 'Diary Dates' to: News Editor, *Electronics - The Maplin Magazine*, P.O. Box 3, Rayleigh, Essex SS6 8LR.

# ACCESS CONTROL

by Frank Booty

**B**IOMETRICS, the most foolproof method of automated personal identification in demand in an increasingly automated world, can offer much in the way of security. Here is an analysis of the different methods of identification, starting with fingerprint recognition, into which most of the work in biometric identification has been expended.

Anyone in business today may use more than 10 computer passwords – Personal Identification Numbers (PINs) for automated teller machines, and telephone calling, membership and credit cards. Finding satisfactory methods of identifying employees or customers can be difficult. Some techniques are easy to get round, some are too expensive, and others are seen as too intrusive.

One area where technology is enhancing the ability to identify people, is biometrics. Biometric systems are automated methods of verifying or recognising the identity of a living person on the basis of some physiological characteristic, such as a fingerprint or iris pattern, or an aspect of behaviour like handwriting or keystroke patterns.

While biometrics is being applied to both identity verification and identity recognition, the problems each involves are somewhat different. Verification requires the person being identified to lay claim to an identity, so the system has a binary choice of accepting or rejecting the person's claim. Recognition requires the system to look through many stored sets of characteristics and pick the one that matches the characteristics of the unknown individual being presented (a more difficult task).

There is a range of biometric systems in development or on the market, because no one system meets all needs. In developing these systems, there are trade-offs covering component cost, reliability, discomfort in using a device, the amount of data needed, and other factors. Fingerprints, for example, have a solid history of reliability (as Police forces worldwide will testify) but the electronic imaging components required for capturing a fingerprint cost hundreds of pounds, and the data describing a fingerprint (the template) is large. By contrast, the tools required to capture a signature (a pen or stylus and tablet) are low in cost and the template is very small. But signatures are not as stable as fingerprints, varying with people's emotional state. Voice is also cheap to capture, relying on low-cost microphones or existing telephones, but varies with emotions and states of health change, and has a large template size.

## Psychological Factors

With eye recognition, both retina scanning (close contact with the recognition device) and iris scanning (done from a more comfortable distance), people can be disconcerted because of the basic protectiveness people

exhibit over their eyes. With hand recognition, in which a hand is placed on a plate, it is different: people do not appear to be bothered, probably because shaking hands is so common. However, in some applications, eye recognition's psychological effect is a benefit, as it is a serious recognition method whose seriousness tends to discourage intruders.

## Underlying Concepts

It is still early days for biometric technology. Biometrics actually dates back to the ancient Egyptians, who measured people to identify them. The first commercial device, however, was only introduced in the 1960s. Potential users of biometrics in such areas as banking, government, finance, healthcare and business see benefits in the technology, but need reliable devices at affordable prices. What is wanted are systems that rarely reject authorised individuals, catch most if not all imposters, and cost under £500. Currently underway, is a steady technology evolution, not a revolution. For the foreseeable future, biometrics will not eliminate the need for cards, passwords and PINs.

Biometric devices have three primary components: an automated mechanism that scans and captures a digital or analogue image of a living personal characteristic; a unit handling compression, processing, storage and comparison of the image with the stored data; and an interface with application systems. These pieces are configured to suit different situations. One common issue is where the stored images (reference templates) reside: on a card, presented by the person being verified, or at a host computer.

Recognition occurs when an individual's image is matched with one of a group of stored images, which can prove time-consuming and costly for computers. For most applications today, recognition systems that

rely on exhaustive computer-held database searches are just too expensive. Instead, the greatest share of these systems depends on a verification system, which calls for the user to lay claim to an identity by presenting a code or a card. A formula or algorithm for matching two items then compares the live and enrolled images of the user's characteristic.

All systems have to recognise a living person. But fraud is of course possible (here, all sorts of things are possible from latex fingers, plaster hands and prosthetic organs, to digital audio tapes). Many simple solutions abound, plus a lot of work is now being carried out on foolproof schemes, for example, ultrasound fingerprint readers that will examine subcutaneous structures.

Biometrics encompasses both physiological and behavioural characteristics (see Figure 1). A physiological characteristic is a relatively stable physical feature, such as a fingerprint, iris pattern, facial feature, etc., which is basically unalterable without trauma to the individual. A behavioural trait, however, has some physiological basis and also reflects a person's psychological make-up. The most common trait used in identification is a person's signature.

The differences between physiological and behavioural methods are important. Barring injury or acid attack, a person's fingerprint is the same day in, day out, whereas a signature is influenced by both controllable actions and unintentional emotional factors. It is after all, easier to build a machine that guides the finger to the same position every time than it is to write algorithms to take into account emotional states or the effects of Beijing flu.

So, no one biometric will serve all needs. Managers responsible for a company's security might decide to use different techniques in different parts of an operation, e.g., voice verification in the executive area and fingerprints in the computer and telecommunications rooms.

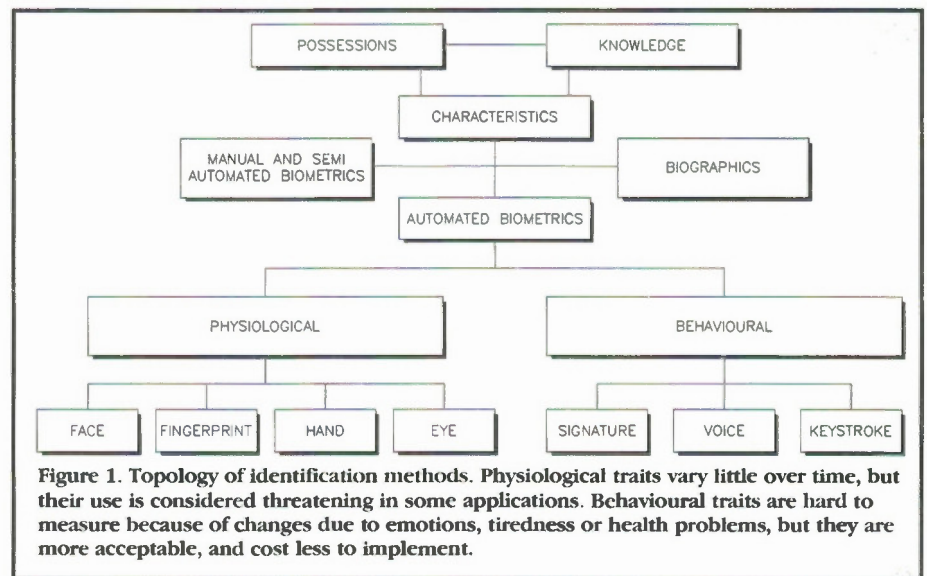



## Fingerprints

For general security and computer access, control applications fingerprints are gaining popularity. Estimates are that the chance of two people having the same prints (including twins) is less than one in a billion. In verifying a print, many devices analyse the position of details called minutiae, such as the endpoints and junctions of print ridges. These devices assign locations to the minutiae, using x, y and directional variables. Some devices also count the number of ridges between the minutiae, to form the reference template. Several companies claim to be developing templates of under 100 bytes. Other machines approach the finger as an image processing problem, and apply custom very large scale integrated (VLSI) chips, neural networks, fuzzy logic and other technologies to the matching problem. More than 12 companies are thought to be working on new fingerprint identification systems (and most claim their systems will offer better false rejection rate performance, lower cost and smaller templates).

Algorithms for the automated identification of criminals' fingerprints were developed in the 1950s in the US by the FBI, with the National Bureau of Standards, Cornell Aeronautical Laboratory and Rockwell. In the 1960s, NEC in Japan, Printrak of California and Morpho Systems of Paris joined the fray. Today, some are looking into the suitability of neural network techniques: ICL and Cambridge Neurodynamics, and Orincon of San Diego. Then there are systems from Identix of the US and Digicom Europe of Brussels.

Digicom's system, built to ISO 9000 standards, has a 1% first attempt false rejection rate (FRR) and a false acceptance rate (FAR) of 1/100,000. The most commonly discussed measure of a biometric's performance is its identifying power, which is defined by the two statistics of FAR and FRR. To set the desired balance of FAR and FRR, many machines have variable thresholds. If the tolerance setting is tightened to make it harder for imposters, some authorised people may find it harder to gain access. Conversely, if it is easy for rightful people to gain access, then the rightful could slip through. Most early adopters of biometrics have found that training people in using the machines effectively is the best way to reduce false rejections.

Digicom's system uses optoelectronics and image recognition technology to scan a fingerprint and compare it with a known reference template. Up to 250 fingerprint templates can be stored by the terminal, which are further identified through a four digit code. Interestingly, acquisition and comparisons are not carried out on the fingerprint image, but on the most important morphological elements. Readout and comparison are effected in less than one second, furthermore, the Digicom units can be connected to local area networks (Ethernet NetWare or TCP/IP for the technically minded).

The last point also means that the system can increase the level of security, not only for access control (physical security), but also for increasing the security level of the data network (data access control). Thus, an operative could administrate data on a network only if he/she had been authorised by a security system manager in advance.

Fingerprints have overcome the stigma of their use in law enforcement and military applications. While some applications shy away from the technology for this reason, there are those which actually build on the mystique of seriousness. Fingerprint recognition is appropriate for many applications, and is a familiar idea to most people, even if only from watching the many police dramas on TV. It is unintrusive, user friendly and relatively inexpensive, and bears a pedigree of uniqueness and stability.

## You Need Hands

The 3-D shape of someone's hand has advantages as an identification device. It is fast (scanning a hand and getting a result takes about 1-2 seconds), and it only needs about 9 bytes for data storage, enabling storage on magnetic stripe credit cards. Not much effort is called for from the user, and the authorised user is not often rejected. Research has also shown that people apparently like the technology. There is a hand geometry identification unit which has been developed in the US (by a company called Recognition Systems of California), and is commercially available.

A user punches in an identification code, and places a hand on a plate between a set of guidance pins. Above the hand is a charge coupled device (CCD) digital camera, which captures the side and top views of the hand simultaneously with the help of a mirror. The black and white digital image is analysed by software running on a built-in microprocessor to extract identifying characteristics from the hand picture. The software compares those features to features captured when the user was enrolled in the system, and signals the result.

Analysis is based on measuring and comparing geometries. These and a set of matrices derived from interrelationships of the dimensions of the hand, are used to produce the 9 byte identity feature vector stored in the system during enrolment. With data compression, the current US system can store 20,000 identities. Enrolment involves taking three hand readings, and averaging the resulting vectors.

The system's limitation is its size. As it has to accommodate most hands, it cannot be built into a keypad or doorknob. There's also the theory that one could trick the machine by capturing someone's hand geometry, finding out the ID number, and creating a fake hand. But in practice, it turns out to be more resistant than conventional security tools such as pass cards, codes and keys.

## The Eyes Have It

Retinal pattern recognition is uncomfortable, because the individual must touch or remain close to a retinal scanner. However, it's the iris that is the focus of attention as a biometric means of identification. Standard monochrome video or photographic technology in combination with software and standard video imaging techniques, can accept or reject an iris at distances of 30 to 45cm.

Every iris has a detailed and unique texture, which remains stable over decades. This part of the eye is one of the most striking features of the face. It is easily visible as a coloured disk behind the clear protective window of the cornea, surrounded by the white tissue of the

eye. Its structure is unique, as is the fingerprint, but it boasts more than six times as many distinctly different characteristics as the fingerprint. It cannot be modified surgically without damage to vision, and it responds to light (a natural test that cannot be falsified).

At the time of writing, no system is on the market, although one is expected to become available soon. The system will comprise a standard video camcorder as the video image source, a video frame grabber, and a workstation for computational analysis.

As a result of highly complex calculations, a 256-byte iriscode is computed and stored as the code for future comparison. Then, the signature of a given iris as belonging to a specific person (the file template) has to be drawn up within the framework of statistical decision theory. More complex decisions and calculations are then made before an accept or reject decision is made. Laboratory prototyping has so far produced error rates of 1 in 131,000.

## Here's Looking at You

Because a person's appearance is constantly changing, using the face for automatic identification is complex. Changing facial expressions, hair style and beards or moustaches, plus lighting conditions, create images that differ from earlier captured images on film or videotape. However, the application of image processing techniques and the use of neural networks to classify images has made the task possible.

A US firm, Neurometric Vision Systems, developed a face recognition system based on an IBM PC, with a frame grabber and custom digital signal processing card. The facial image is captured by a video camera and digitised. Software running on the card locates the face, scales and rotates it, and converts it to a set of vectors. These are input to a neural network for comparison against stored data. The existing system can keep up to 5,000 faces in its database, and with multiple digital signal processing cards and video camera multiplexing, can identify up to 20 people per second. Future systems will be able to work with databases of up to 50,000 images, and ultimately, a million faces. When a face is sought in databases of this size, it will take from 20 to 120 seconds to find a face.

Faces that might fool a human observer, like those of identical twins, might also fool the Neurometric system. But it is claimed to be more objective than most in picking up on minor differences between twins, and in distinguishing persons with similar mannerisms but differing facial features. For access control applications, the system would work in conjunction with a security camera and badge or personal identification system to confirm an identity.

## Speak to Me

Speech matching is the least invasive and the most natural to use of the biometric recognition technologies. In a speech-based identification system developed by AT&T, the user speaks a phrase, about a second long, into a handset. The phrase is digitised by a digital signal processor and shrunk by voice compression software. The pattern is then stored on a PC and verified against test samples. Once approved by the voice template gener-

*Continued on page 45.*

**KIT AVAILABLE**  
(See note below)  
**(90079)**  
**PRICE**  
**£32.99**

# GPS DEVELOPMENT SYSTEM

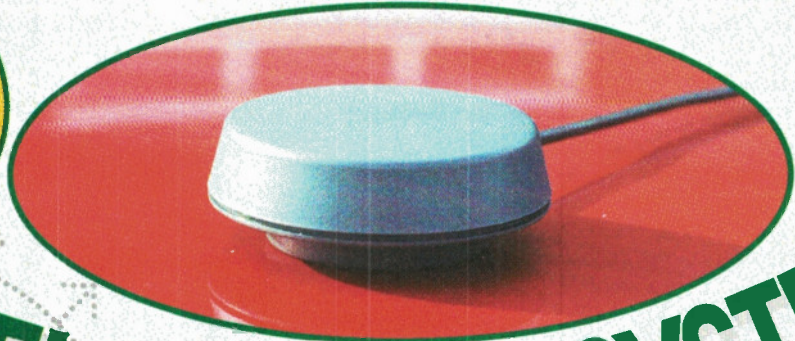

Top: Optional magnetic mounting vehicle antenna.  
Centre: Typical vehicle installation.  
Bottom: Assembled GPS Development System.



Ever since man could walk, he has relied on two-dimensional navigation to find his way around the World. He found that by taking visual bearings on familiar landmarks (such as hills), he could 'fix' his position, relative to the position of those landmarks. In these modern times, while the basic principle remains the same, the method is considerably more advanced.

## AN INTRODUCTION TO TWO DIMENSIONAL NAVIGATION

Text by Dennis Butcher and Mike Holmes  
Design by Dennis Butcher



Please Note: Oncore Receiver Module, Antenna and sundry items are *not* included in the kit and must be purchased separately.

### FEATURES

- Simple construction
- Inexpensive GPS system
- Direct connection to personal computers/portables
- Simple 12V power requirement for cars and boats
- Direct command and control from BASIC programs

### APPLICATIONS

- Development platform for all mobile GPS
- Car, boat and hand-held applications
- 'One-off' development

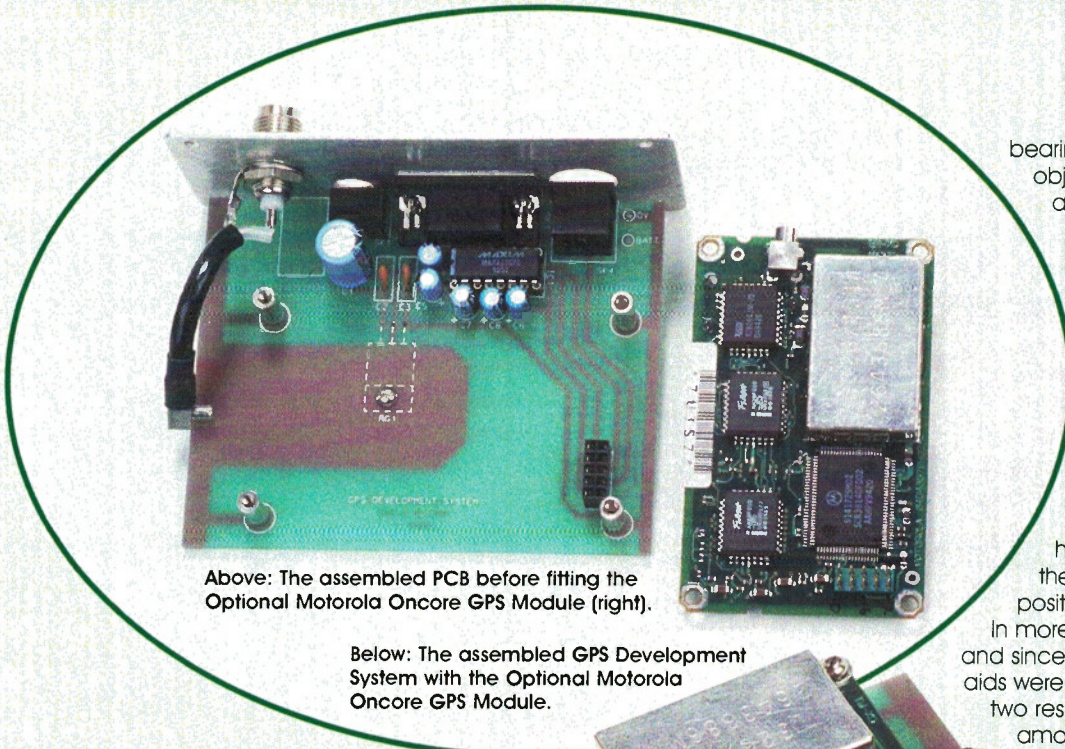

Above: The assembled PCB before fitting the Optional Motorola Oncore GPS Module (right).

Below: The assembled GPS Development System with the Optional Motorola Oncore GPS Module.

bearing on each of three outstanding objects (hills, church steeples or anything that will be easy to identify on a map or nautical chart). Next, plot the lines of bearing on your map (or chart). The result is almost invariably a triangle around the intersection of the lines, known to sailors as a 'cocked hat' (after the tricorne hat worn by officers of the Navy since before Nelson's time). Your actual position will (hopefully) be somewhere in this cocked hat area, and the size of it is the possible error in your plotted position.

In more recent times, notably during and since World War II, radio navigational aids were introduced. These helped in two respects – they removed a certain amount of the human error, and they made it possible to obtain a position in adverse conditions such as fog and when the stars were obscured by cloud, or for vessels and aircraft out of sight of land. Two systems still in common use today, and which you may

OVER the centuries he refined this technique of navigation, simultaneously pushing forward the frontiers of technology to improve the accuracy. Lodestones, astrolabes, the magnetic compass, the sextant and, of course, timepieces have all played their part, but the basic methods have remained the same.

The method of visual position fixing is shown in Figure 1. First take a note of the time, and then take a

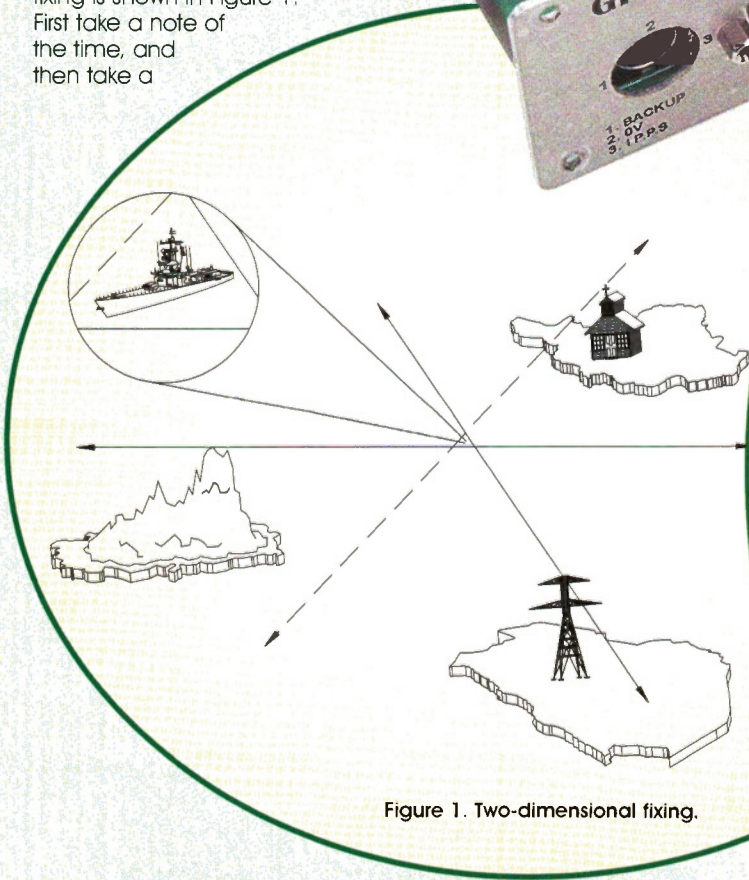
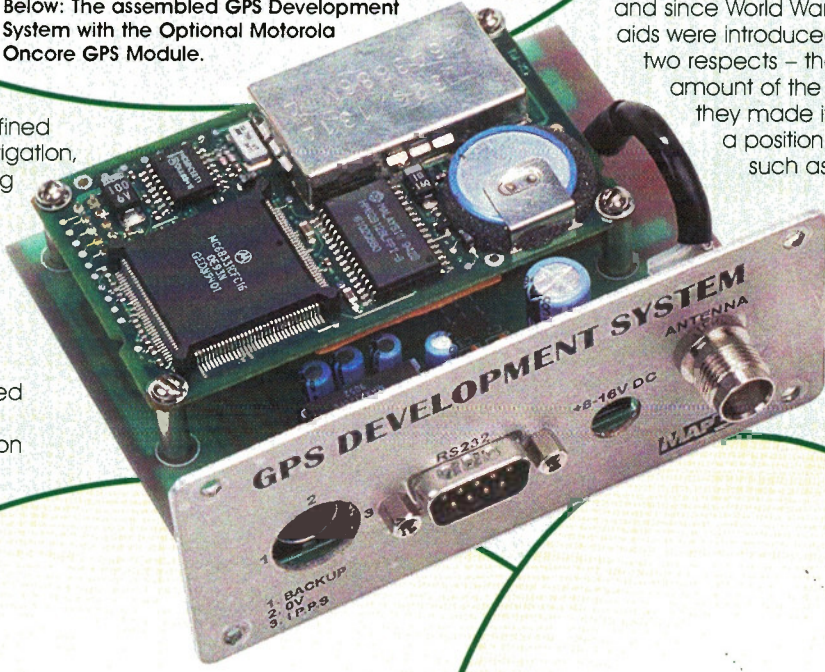

Figure 1. Two-dimensional fixing.

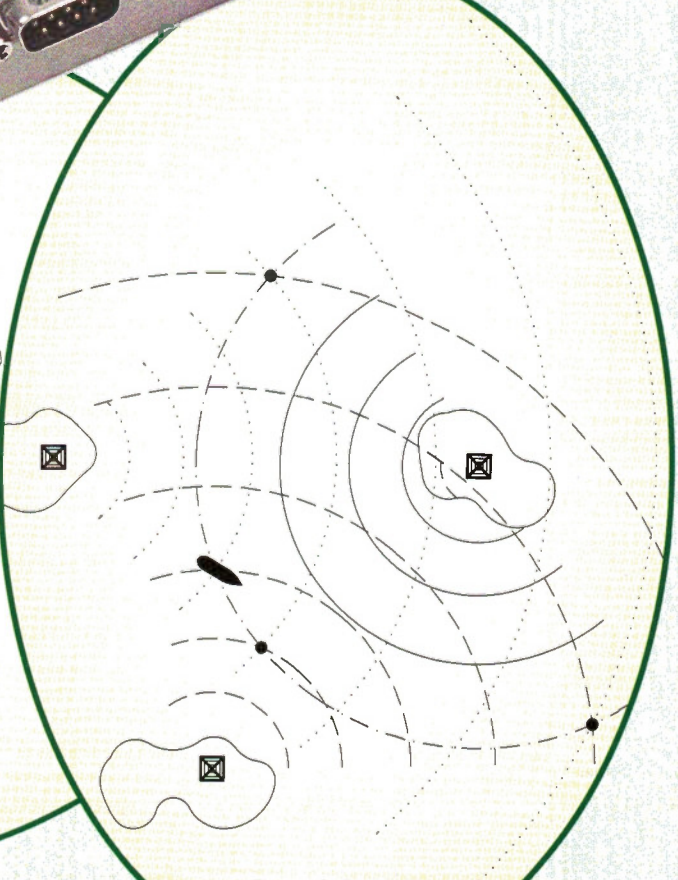

Figure 2. Parabolic Fixing Systems.

have heard of, are Decca Navigator and LORAN (Long Range Aid to Navigation). They are sometimes called parabolic fixing systems because of the invisible parabolic 'lanes' created by the way they work. Figure 2 shows an idealised Decca chain. Each transmitter sends a CW (Carrier Wave) signal out at a different but related frequency, and the receiver works out the phase relationship between the different signals received. Where the phase is the same for all of the received stations, an 'intersection' occurs as shown in Figure 2 by the three black dots. Special charts showing the 'lanes' have to be used with this system, but there are several disadvantages. You have to know which 'lane' you are in before you can use the fix (each lane is 4 miles wide, although changes made to the system in recent years can give lanes in tenths of a mile). Also, as it is a short range system, there is only good coverage over coastal areas, but aircraft move too fast to make use of this system.

LORAN works in a slightly different way, although the basic principle is the same. Instead of using the phase difference, LORAN uses the time delay from

transmission to reception to work out position. When the master transmitter sends, the signal is received by each slave station in the chain (usually three for each master) and, after a predetermined time delay, each slave then transmits its own signal. At the receiver, the time delays between

receiving the Master signal and each slave signal is used to calculate the position. LORAN has the advantage over DECCA of having a much wider coverage (pan oceanic), and can be used by aircraft. However, both systems are prone to operator error and also suffer adverse radio wave propagation

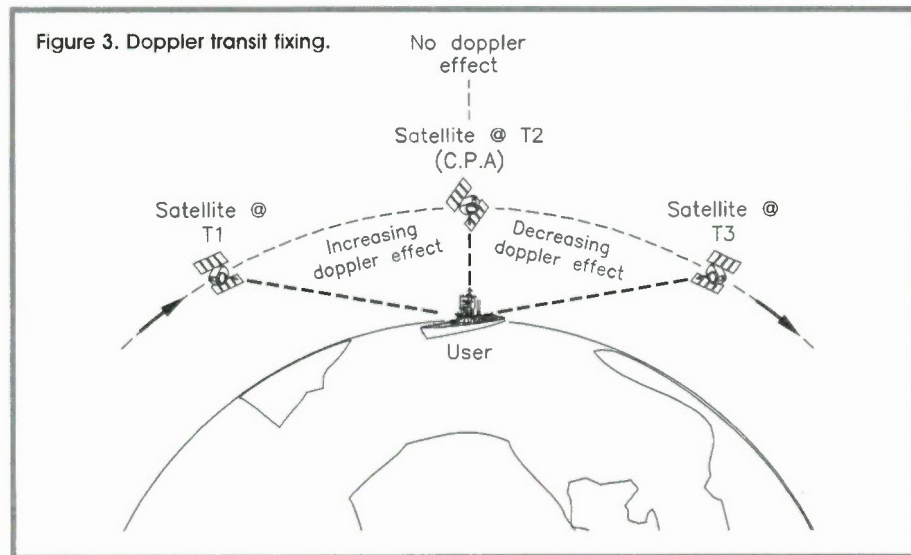

## Specification

### Electrical Characteristics (Receiver (Rx.) only)

Power Supply:	5V ±0.25V DC @ 50mV ripple (Max.)
Power Consumption:	1.1W @ 5V
NVR Backup power – 3V onboard battery:	15µA typ., 60µA max.
External:	2.5V to 5.25V DC, 15µA typ., 60µA max.

### Physical Characteristics

Dimensions, Rx. Module:	50.8 × 82.6 × 16.3mm
Active Antenna Module:	102(dia.) × 22.6mm
Weight, Rx Module:	51g
Active Antenna Module:	136.2g

### Connectors

Data/Power:	10-pin unshrouded header (on 0.1in. centres)
RF:	Right Angle OSX (sub-miniature snap-on)
Rx to Antenna Connection:	Single coax (for active antenna: 6dB max. loss at L1; 1575.42MHz)

### Environmental Characteristics

Operating Temperature:	-30C to +85C
Humidity:	95% non-condensing (+30C to +60C)
Altitude:	60,000ft. (18km) max. or >60,000 ft. (18km) for velocities < 1000 knots

### General Characteristics

Rx. Architecture:	8-channel
L1:	1575.42MHz
C/A Code:	1.023MHz (Chip Rate), Carrier Aided Tracking (Code plus Carrier Tracking)
Tracking Capability:	8 simultaneous satellite vehicles

### Performance Characteristics

#### Dynamics -

Velocity:	1000kts (515m/s) (> 1000 kts @ < 60,000ft)
Acceleration:	4g
Jerk:	5 m/s <sup>3</sup>

Acquisition Time (TTF):	20 seconds typical (with current almanac, position, time and ephemeris) 45 seconds typical (with current almanac, position and time) 2.5 seconds typical reacquire
Positioning accuracy:	< 25 metres (without SA*) < 100 metres (SA on*)
DGPS Accuracy:	1 to 5 metres typical
Timing Accuracy:	130ns observed (1 sigma) with SA on. In Position Hold Mode; < 50ns observed (1 sigma) with SA on.
Antenna:	Active Microstrip Patch Antenna Module, powered via coax cable from Rx. (5V @ 25mA)
Passive antenna options:	49 Standard; 2 user defined.
Datums, default:	WGS-84

### Serial Communication

#### Input control and Output Messages:

Latitude, Longitude, Height, Velocity, heading, time, satellite tracking status (Motorola Binary Protocol).

Selected NMEA-0183 Version 2.00 format outputs available.

S/W selectable output rates (continuous or polled).

Extensive command and control messages.

TTL Interface.

### GPS Development Kit

(with Rx. and Active Antenna Module fitted)

Power Supply Voltage:	8 to 16V DC
Power Supply Current:	240mA (max.) with active antenna 220mA (max.) without active antenna
Power Connector:	2.1mm Power Socket
Serial Interface:	RS 232 9,600 baud (max.)
Serial Connector:	9-way D-Type (DCE) (Baud rate depends on operating mode selected, but power up default using Motorola Binary Format is 9600bd)
1PPS timing signal:	+VE DC pulse; measured at leading edge
Timing Connector:	3-pin Mini-DIN

effects (sky wave reflections, gravitational distortion, etc.) either of which introduce errors.

## Space Age Navigation

In the early 1960's the first operational **NAVSAT (NAVigational SATellite)** network, called Transit, was put into operation by the USA. A number of satellites were placed in a low orbit around the earth, and position was determined by tracking a satellite as it passed overhead, as shown in Figure 3 positions T1 to T3. The satellite transmitted the time and its own position continuously, and from this information, and the doppler shift observed in the signal, it was possible to derive a fairly accurate position fix on the ground. The major drawbacks of this system were that it took a relatively long time (up to 15 minutes) to obtain a fix. There were only a few satellites in orbit at any one time, so it could be several hours between fixes if a suitable satellite was not 'in view'. Two consecutive fixes may be

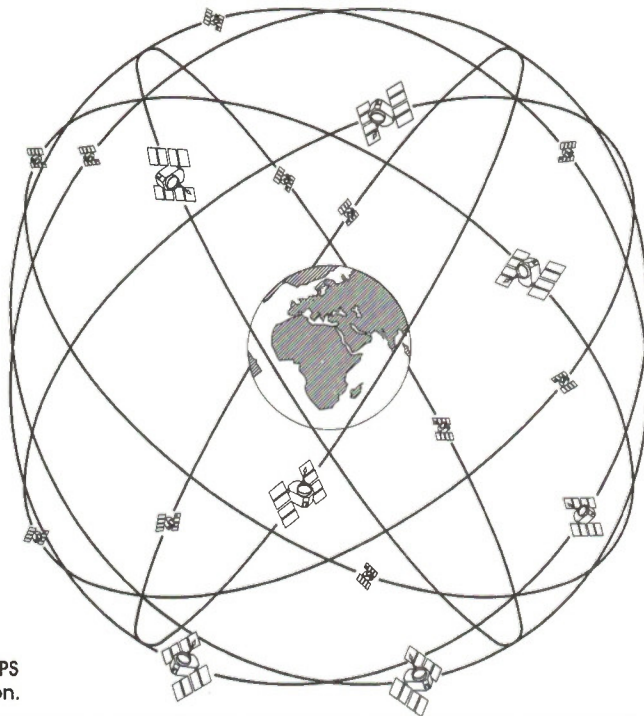

Figure 4. GPS constellation.

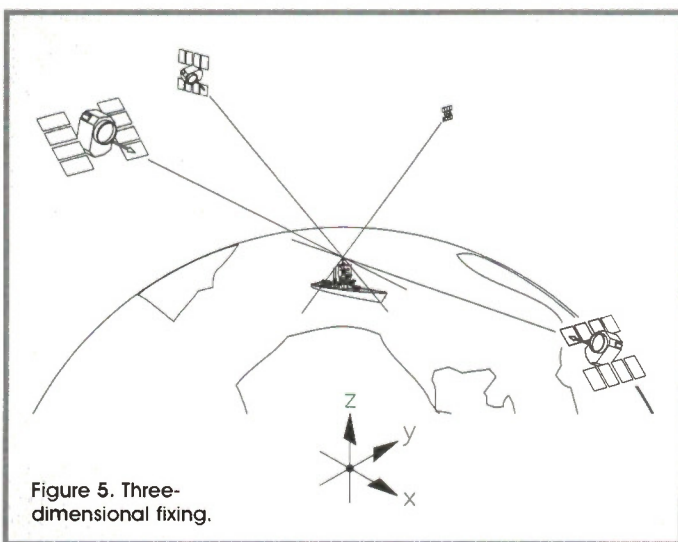
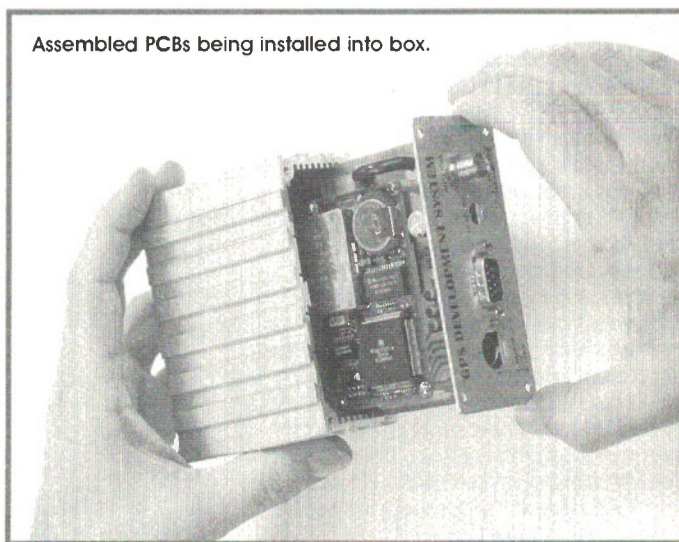

Figure 5. Three-dimensional fixing.



Assembled PCBs being installed into box.

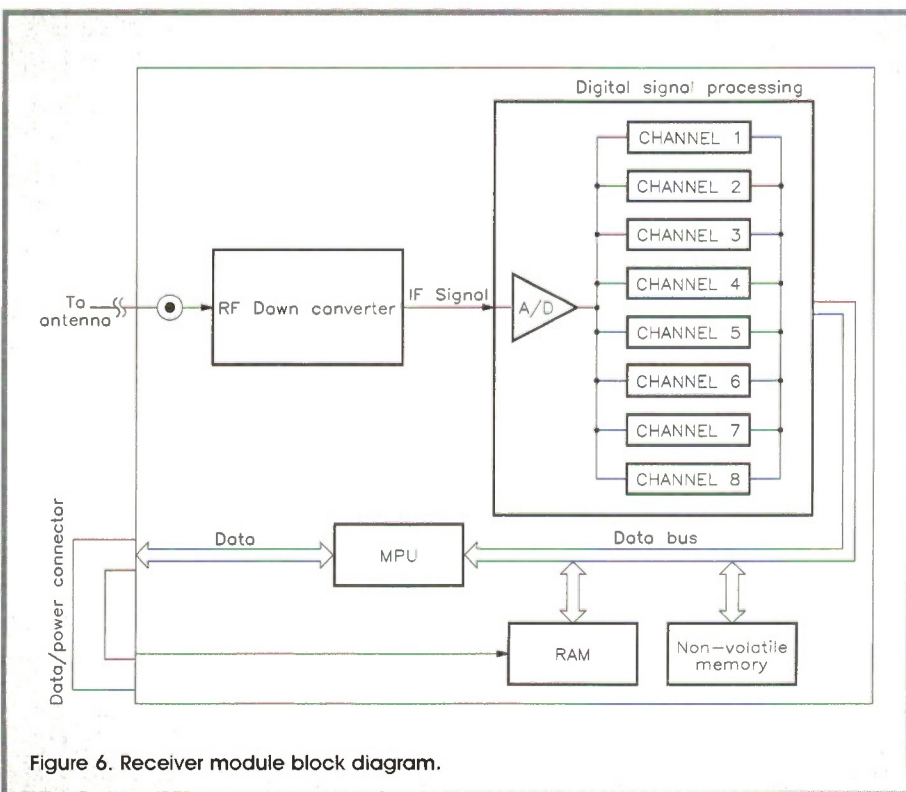

Figure 6. Receiver module block diagram.

required to obtain an accurate position, and it was not practicable with the technology of the time to launch enough satellites to cover all areas of the globe. Added to these problems, NAVSAT was a military system, which could not easily be used by mere mortals – the receiving and decoding equipment was classified, bulky and very expensive!

Although this system brought a space-age solution to the problem of obtaining an accurate position fix, it could only be practically used alongside 'traditional' methods (star fixes and radio 'navaids' such as LORAN and DECCA) and to correct errors in dead-reckoning inertial navigation systems.

All of these systems had one additional, common limitation – none of them could provide a height datum for the user.

## Introduction to GPS

NAVSAT successfully paved the way for its successor, the Navstar Global Positioning System, and in the 1970s the first GPS satellites were launched. This is a truly global network of satellites, placed

in orbits so that most of the Earth's surface is adequately covered by the 'web' (Figure 4). The system is now fully in place in the 1990s and allows anyone with the right hardware to receive several of the GPS satellites simultaneously. GPS uses both the hyperbolic time-delay system of ranging, similar to LORAN, combined with the doppler shift system of Transit to give an accurate position based on the range from the satellites to the user.

Tracking three satellites gives an accurate two-dimensional position, but when four satellites are in view, an accurate user height can be determined and the fix can be refined to give a few centimetres! (See Figure 5.)

## The Motorola GPS Receiver

A number of GPS receivers exist today, but most were originally developed for the high-end (or expensive!) marine or surveying markets, and are often out of reach of the hobbyist. DIY hasn't been a very easy option; GPS signals are transmitted at 1,575.42MHz (not the easiest of frequencies for a home-build system), and use a complicated modulation scheme that would probably tax Einstein on a good day!

An ideal system for either a hobbyist or a professional developer who wants to use GPS in their own system (hand-held, mobile, etc.) would be a complete receiver and decoder in a small and relatively inexpensive package. Well, Motorola have done all of the hard work and produced a complete GPS receiver on a single-board! Not only that, they have also produced a range of antennas to complement the system, with mountings for vehicle, boat or fixed use. (No, that's not a mistake – there is a use for a fixed GPS receiver, but we'll come to that later.)

## VP Oncore

The latest offering from the Motorola GPS range is the VP Oncore receiver. It is small (50 x 82 x 12mm), lightweight (51g) and has excellent performance characteristics.

In addition to its superior tracking capability (eight simultaneous satellites) it has superb acquisition and re-acquisition capabilities that make it ideal for use in typical mobile and hand-held environments.

The architecture of the receiver is not really important in the context of this project, because the module is ready-built and fully tested, so it is probably enough to follow the receiver block diagram, Figure 6.

The sensitive RF Down Converter section (the GPS specification calls for a minimum usable signal strength of -130dBm to be available to the civilian user; this some 17dB or more below the theoretical noise floor of the receiver!) converts the 'L1' signal (centred at 1575.42MHz) to the IF for the A/D input of the DSP, which then separates each satellite signal and assigns it to a channel number.

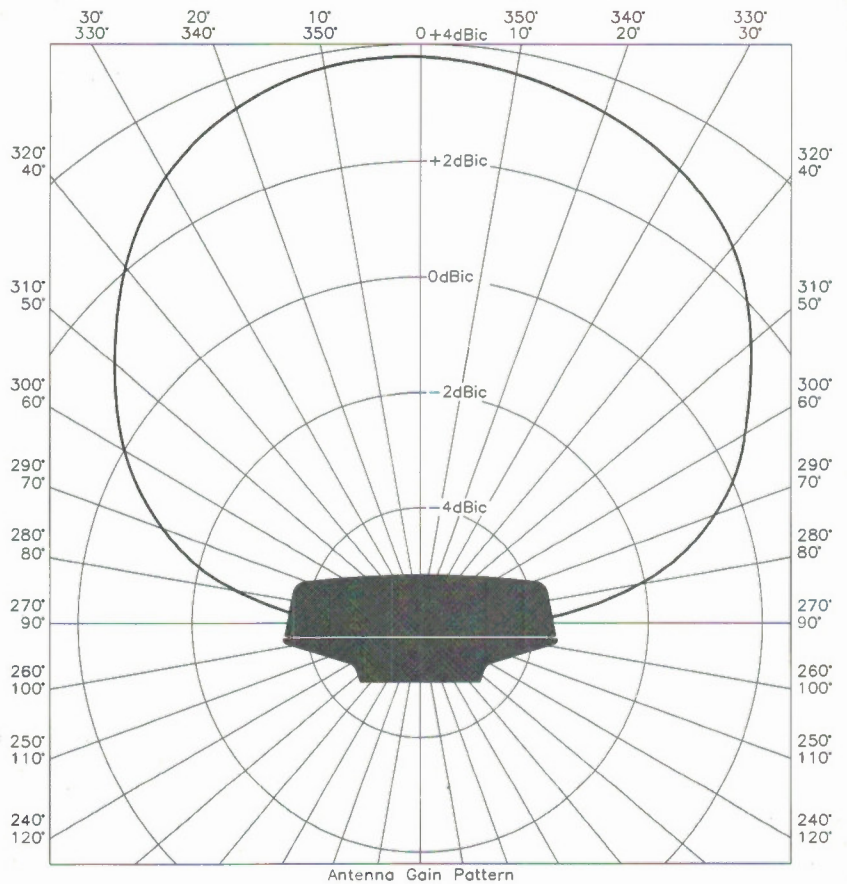

Figure 7. Active Antenna block diagram.

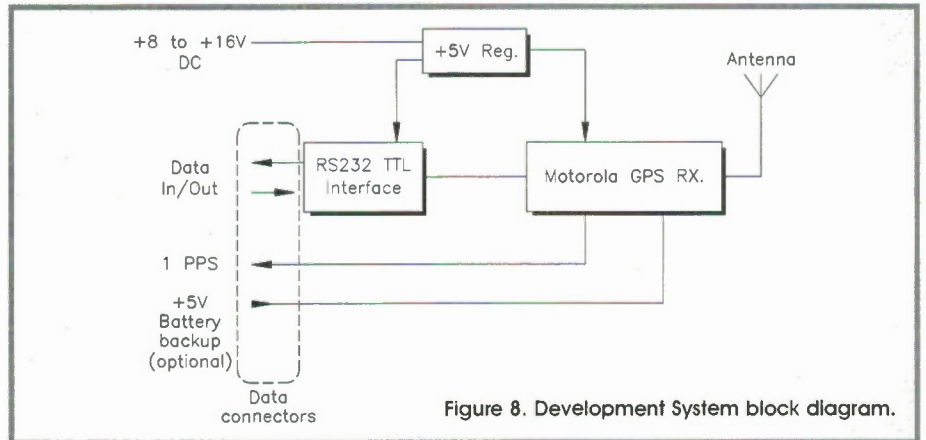

Figure 8. Development System block diagram.

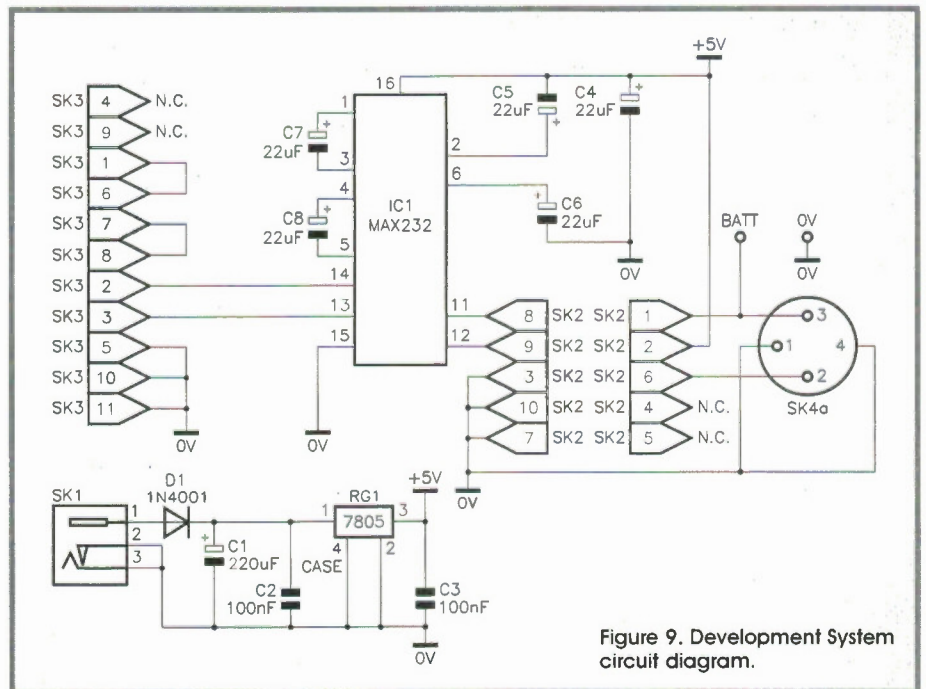

Figure 9. Development System circuit diagram.

All the GPS satellites transmit on just two frequencies, called L1 and L2, using spread spectrum techniques. The L2 frequency is 1227.60MHz and carries the P Code, which is only available to military users so it doesn't concern us here. On the L1 frequency the individual satellite signals are identified by a phase-inverted, pseudo-random code running at a rate of 1.023MHz, called the Clear/Acquisition or C/A code. In Addition, Binary Phase Shift Keyed (BPSK) data is added to the system at a rate

of 50 baud, giving the satellite's own position and transmission times.

The MPU extracts all of the relevant data from each channel and calculates latitude, longitude, height, velocity, heading, time, satellite tracking status and current almanacs and ephemeris. The ephemeris data is stored into the battery-backed onboard RAM and there is an onboard EEPROM for storing custom operating parameters and almanacs. The (optional) battery backup also enables retention of

the Real Time Clock value. The MPU also carries out command and control instructions received via the data/power connector, and transmits positional, status and time signals through the same connector.

## Antenna

The Active Antenna Module supplied by Motorola is a microstrip patch design and its hemispherical coverage (Figure 7) ensures excellent full sky coverage

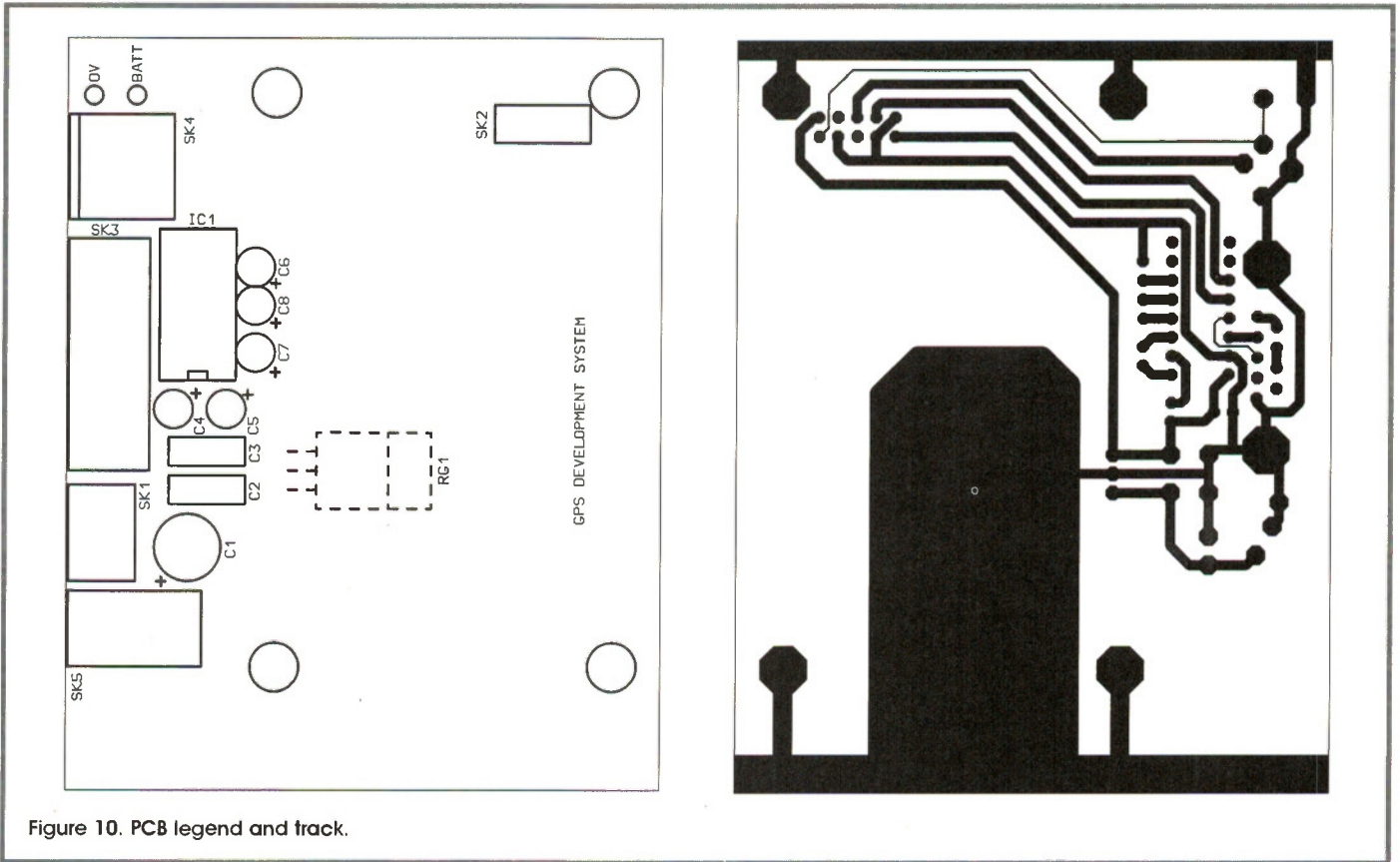

Figure 10. PCB legend and track.

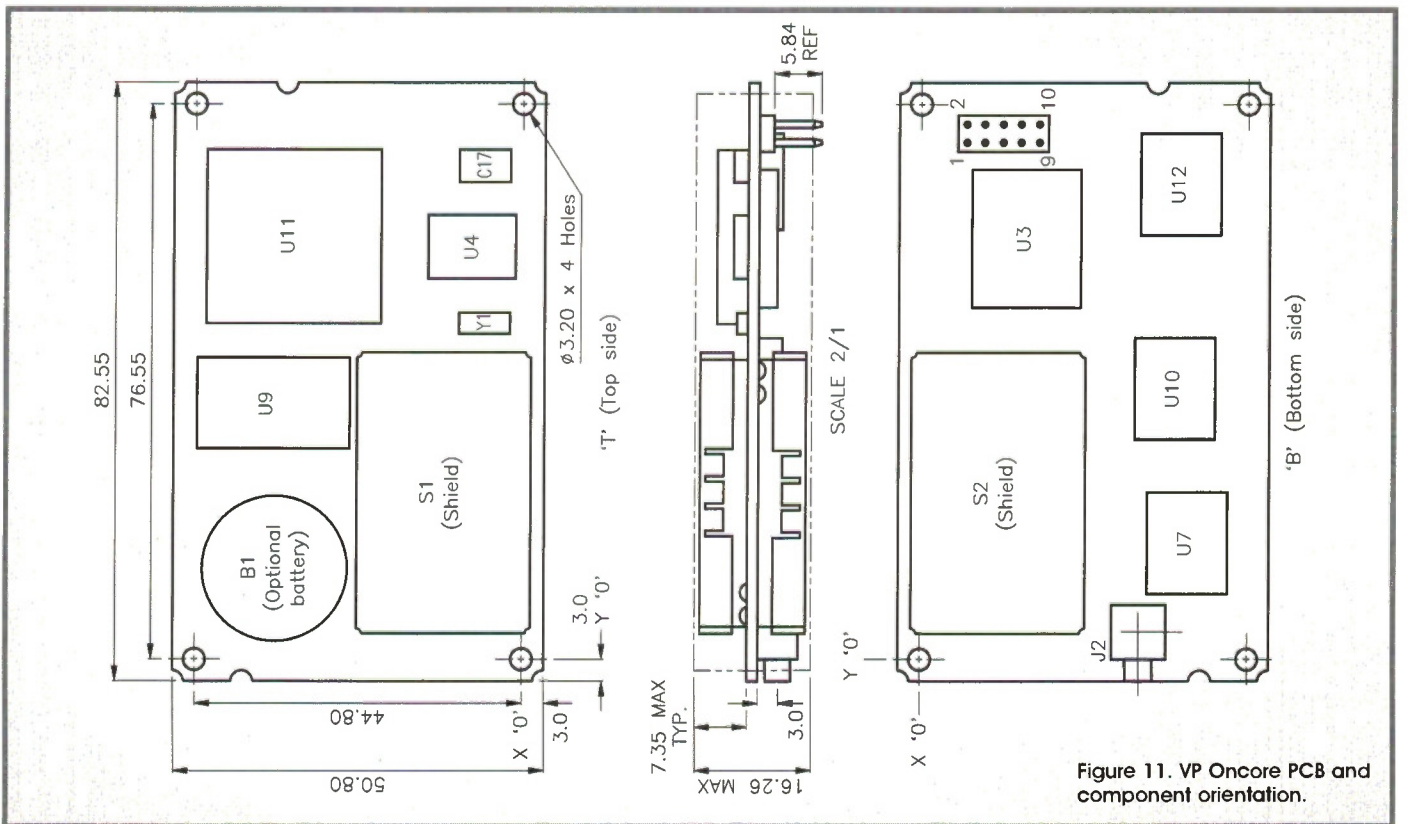
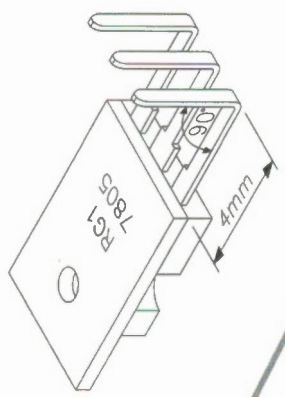

Figure 11. VP Oncore PCB and component orientation.

Figure 12. Preparation and fitting of RG1.



NOTE  
Internal central  
dovetail to top

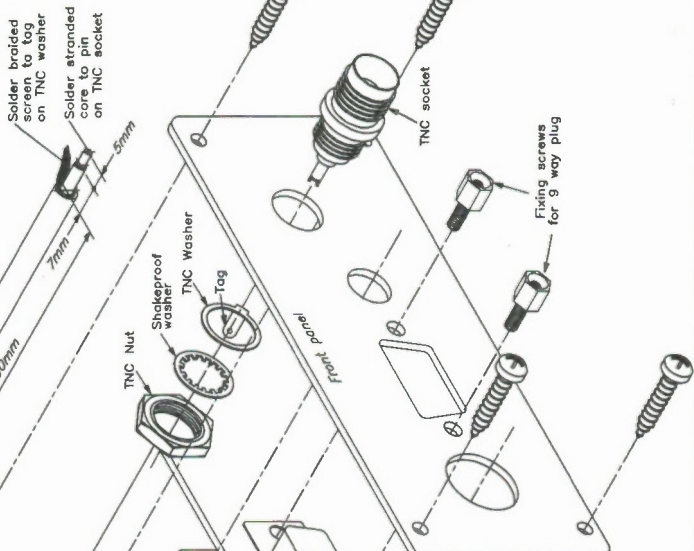
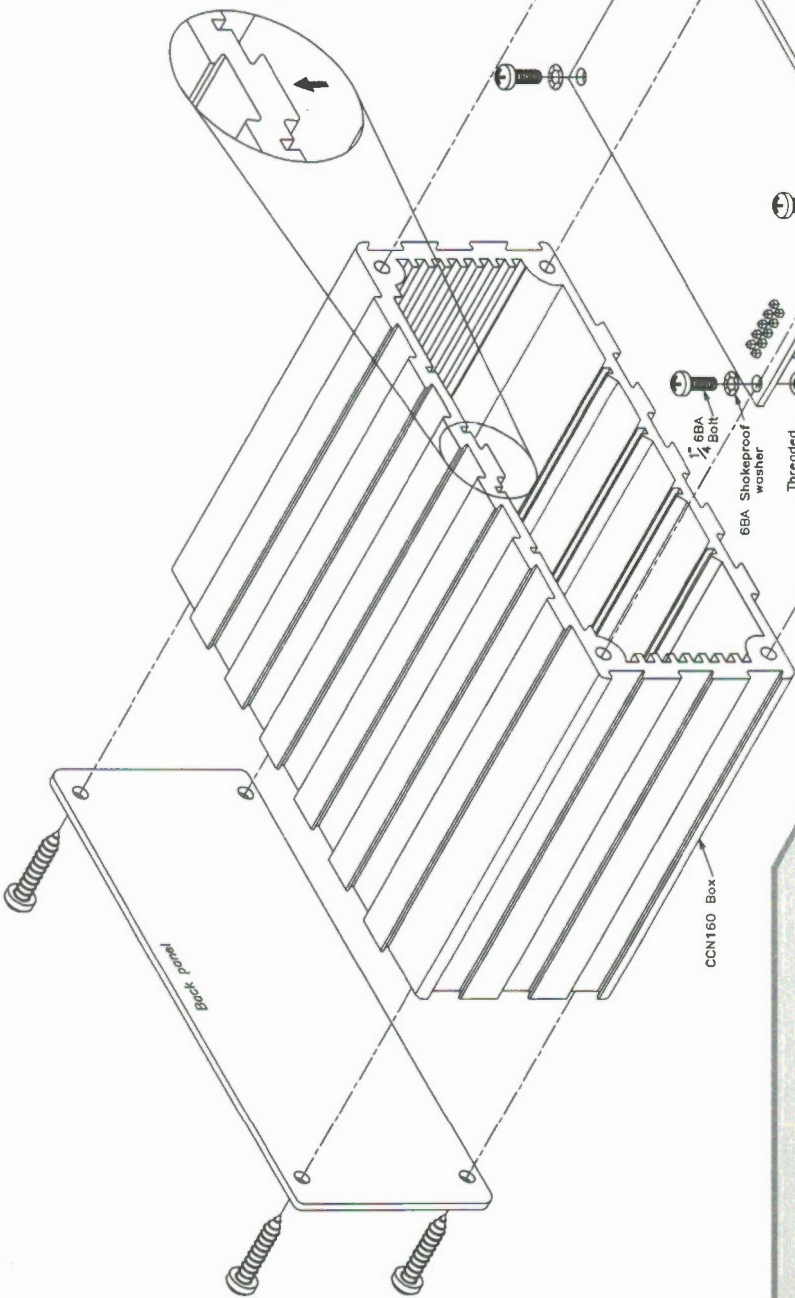

Figure 13. Exploded assembly and typical wiring.



The completed GPS Development System and Optional accessories.



above the horizon whilst alleviating ground-reflected multipath effects.

The onboard low power preamplifier helps to overcome cable losses and gives an improved signal/noise ratio at the receiver. (If required, a receiver option is available for a passive

antenna, with the preamp mounted on the receiver board.)

## GPS Development Kit

The aim of the Development kit is to provide a protective housing for the VP

Oncore receiver board, and to provide a standard power and RS232 serial interface, so that anyone can link a personal computer to the receiver and develop their own applications - or even just use it as a stand-alone navigational aid with a laptop computer.

```

DECLARE SUB interpret (modem$)
DECLARE SUB setup ( )
DECLARE FUNCTION todeg$ (inp.posn!)
DECLARE FUNCTION ttv4$ (textstr$)
DECLARE FUNCTION ttv2! (textstr$)
DECLARE FUNCTION addchecksum$ (com$)

quit$ = CHR$(0) + CHR$(16) ' Value returned by
INKEY$ when ALT+q is pressed.
SCREEN 12
WINDOW (0, 0)-(400, 400)
CLS
LOCATE 25, 60
PRINT "Press ALT+q to quit";

OPEN "COM1:9600,N,8,1,cd0,cs0,ds0,bin" FOR RANDOM AS
#1 LEN = 256 'Open communications; Change to
"COM2:..." if using serial port 2

setup 'Send the basic startup parameters for
GPS Rx.

ON ERROR GOTO errorhandler

DO ' Main loop.
keyinput$ = INKEY$
IF LOC(1) < 30 GOTO endloop ' Check the Serial
Port; if characters are waiting EOF(1) is true
modem$ = INPUT$(LOC(1), #1)
interpret (modem$)
modem$ = ""
LOCATE 1, 1
endloop:
LOOP UNTIL keyinput$ = quit$
CLOSE

END
errorhandler:
RESUME NEXT
END

FUNCTION addchecksum$ (com$)
x = 0
FOR n = 1 TO LEN(com$)
y = ASC(MID$(com$, n, 1))
x = x XOR y
NEXT n

END$ = CHR$(13) + CHR$(10)
addchecksum = com$ + CHR$(x) + END$
END FUNCTION

SUB interpret (modemchars$) STATIC
modembuffer$ = modembuffer$ + modemchars$
posmes = INSTR(1, modembuffer$, "@@Ba")
messagelen = LEN(modembuffer$)
IF posmes = 0 THEN EXIT SUB
IF messagelen - posmes < 68 THEN EXIT SUB
modeminput$ = MID$(modembuffer$, posmes)
modembuffer$ = MID$(modeminput$, 68)
aa$ = LEFT$(modeminput$, 4)
IF aa$ <> "@@Ba" THEN EXIT SUB

month = (ASC(MID$(modeminput$, 5, 1)))
day = (ASC(MID$(modeminput$, 6, 1)))
year = (ttv2(MID$(modeminput$, 7, 2)))
hour = (ASC(MID$(modeminput$, 9, 1)))
MIN = (ASC(MID$(modeminput$, 10, 1)))
SEC = (ASC(MID$(modeminput$, 11, 1)))
msec = (ttv4(MID$(modeminput$, 12, 4))
latit = (ttv4(MID$(modeminput$, 16, 4))
longit = (ttv4(MID$(modeminput$, 20, 4))
mslheight = (ttv4(MID$(modeminput$, 28, 4))

DIM lat AS DOUBLE, lon AS DOUBLE

lat = (latit / 3600000) * (3.141592654# /
180)
lon = (longit / 3600000) * (3.141592654# /
180)

velocity = (ttv2(MID$(modeminput$, 32, 2)))
heading = (ttv2(MID$(modeminput$, 34, 2)))
dop = (ttv2(MID$(modeminput$, 36, 2)))
doctype = (ASC(MID$(modeminput$, 38, 1)))
vissats = (ASC(MID$(modeminput$, 39, 1)))
tracsats = (ASC(MID$(modeminput$, 40, 1))

PRINT ; "[Date "; day; "/"; month; "/"; year;
"]
[Time "; hour; MIN; SEC; "]"
PRINT
PRINT "Lat: "; todeg$(latit)
PRINT "Lon: "; todeg$(longit)
PRINT
PRINT "Height (MSL): "; : PRINT USING
"#####.##"; mslheight / 100
PRINT
PRINT "Velocity: "; : PRINT USING
"#####.##"; velocity / 100
PRINT "Heading: "; : PRINT USING
"#####.##"; heading / 10
PRINT
PRINT "DOP"; : PRINT USING "###.##"; dop / 10;
IF doctype = 1 THEN PRINT ": DOP type is
HDOP";
IF doctype = 0 THEN PRINT ": DOP type is
PDOP";
PRINT
PRINT
PRINT "Visible Sats:"; vissats; " Tracked
Sats:"; tracsats
END SUB

SUB setup
com$ = "@@Cg" + CHR$(1)
com$ = addchecksum(com$)
PUT #1, 1, com$
com$ = "@@Ba" + CHR$(1)
com$ = addchecksum(com$)
PUT #1, 1, com$
com$ = "@@Bh" + CHR$(0)
com$ = addchecksum(com$)
PUT #1, 1, com$
END SUB

FUNCTION todeg$ (inp.posn)
posn = inp.posn
msec = 1
pdeg = FIX(posn / 3600000!)
posn = posn MOD 3600000!
pmin = FIX(posn / 60000!)
posn = posn MOD 600000!
psec = FIX(posn / 1000!)
msec = posn MOD 1000!
todeg = STR$(pdeg) + STR$(pmin) + STR$(psec) +
STR$(msec)
END FUNCTION

FUNCTION ttv2 (textstr$)
a = ASC(LEFT$(textstr$, 1))
b = ASC(RIGHT$(textstr$, 1))
ttv2 = (256 * a) + b
END FUNCTION

DEFINING A-Z
FUNCTION ttv4 (textstr$)
al = 16777216: b1 = 65536: c1 = 256: t = 0
a = ASC(MID$(textstr$, 1, 1))
IF a AND 128 THEN t = 1
IF t = 1 THEN a = a XOR 255
b = ASC(MID$(textstr$, 2, 1))
IF t = 1 THEN b = b XOR 255
c = ASC(MID$(textstr$, 3, 1))
IF t = 1 THEN c = c XOR 255
d = ASC(MID$(textstr$, 4, 1))
IF t = 1 THEN d = d XOR 255
tempttv4 = ((a * al) + (b * b1) + (c * c1) + d)
IF t = 1 THEN ttv4 = tempttv4 * -1 ELSE ttv4 =
tempttv4
END FUNCTION

```

Listing 1. GPS Test Routine.

Continued on page 38.

# Hipparcos - The Road Map in the Sky

Gazing up at the night sky, it would seem simple to study and compile a 'road map of the sky' using good terrestrial telescopes. While such surveys have already been undertaken, the problem with Earth-based observation is that it places a limitation on the accuracy of measuring position, relative brightness and relative distance based on parallax measurements. This is due to atmospheric distortion and refraction, thermal variation of telescope systems and also the gravitational stresses acting on large Earth-based telescope systems.

**T**HE Hipparcos (Hipparcos = High Precision PARallax COLlecting Satellite) mission is an ambitious European Space Agency initiative to provide astronomers with an improved set of star references on which to base subsequent astronomical studies. A 'star mapping' project was proposed in Europe as early as 1966. After a long process of scientific discussion and developments in technology, Hipparcos was finally approved in March 1980. While the mission encountered more than a few problems, a large set of data was, in fact, captured during the mission's data capture period. This is still being processed extensively by computer to produce as the end product, a 'definitive' map of the sky as seen from space. The value of the Hipparcos mission is perhaps best appreciated by briefly reviewing the fundamental aspects of star observation - the determination of parallax, magnitude and position.

Right: Photo 1. Hipparcos undergoing tests at ESTEC.

Above left: Photo 2. Artist's impression of the operational satellite.

Below Right: Photo 3. Details of the image and signal data of the main high resolution detection system and star mapper grid (top left).

## Parallax

In conventional survey work, such as that outlined in Figure 1, distances can be estimated by measuring the relative angles to a point P from two points of observation, A and B, a known distance apart. Thus, as an example, for a separation of 500m between points A and B and a subtended angle of 5°, it can be simply calculated that point P is 5.7km from point B or A. This principle can also be applied to objects in the solar system.

Thus, if the moon is observed from the Earth by observers A and B at opposite sides as outlined in Figure 2, then the angle subtended is 0° 57' 2.6" with reference to the Earth's diameter. For more distant objects, the parallax angle decreases. For the sun, the corresponding angle is 0° 0' 8.79414" of arc. When such measurements are attempted with more distant objects, such as the nearest stars in the Milky Way, the parallax angles are considerably smaller. Even the

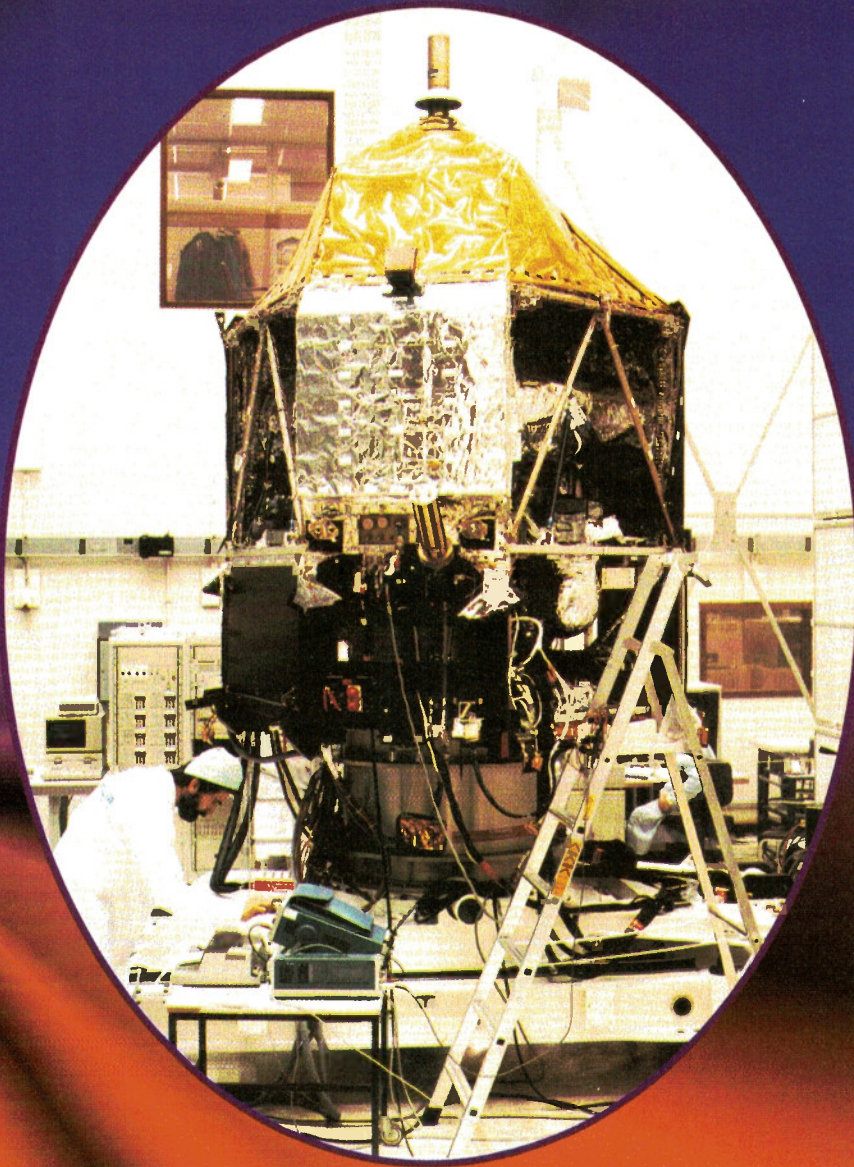

Below: Figure 1. Estimating the distance of point P from points A and B, by measurement of relative angles and the separation of A from B.

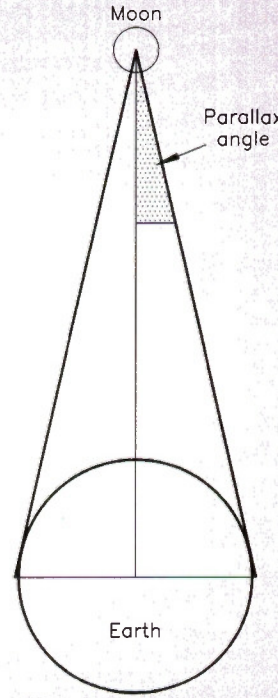
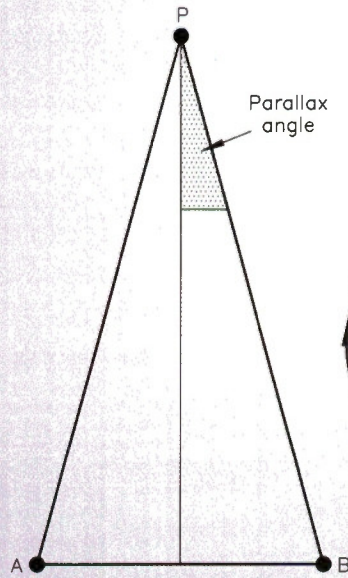

Above: Figure 2. Terrestrial Referenced Parallax example of moon observation.

closest star, Alpha Centuri, with the greatest value of parallax, has a value of 0.76" of arc. Figure 3 shows the geometry of stellar parallax.

Astronomers use the unit of the parsec, equal to 3.26 light years, as a distance measure. It corresponds to the distance at which the parallax angle subtended by a star is 1" of arc. Alpha Centuri is thus at a distance of 4.29 light years from the Earth – equivalent

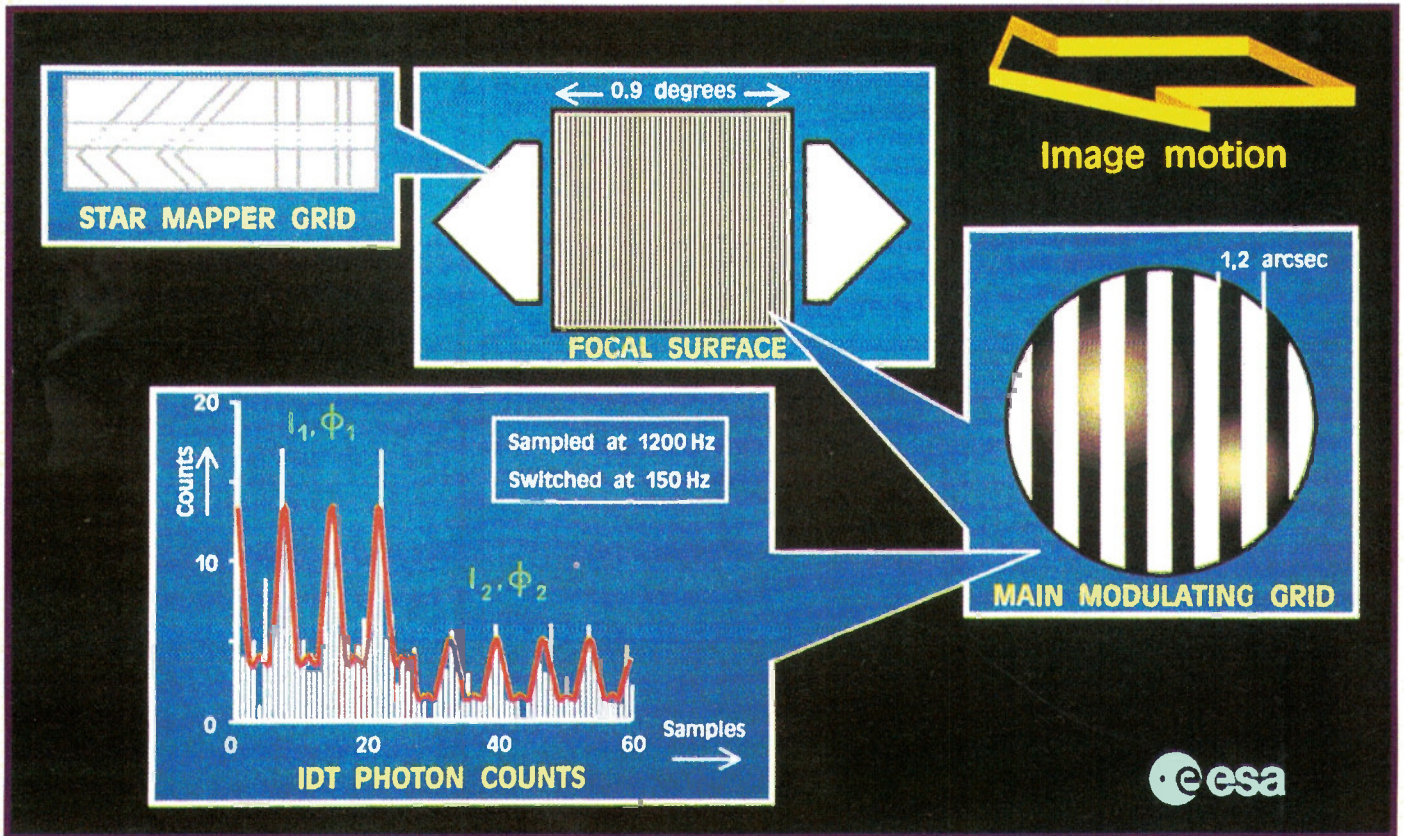

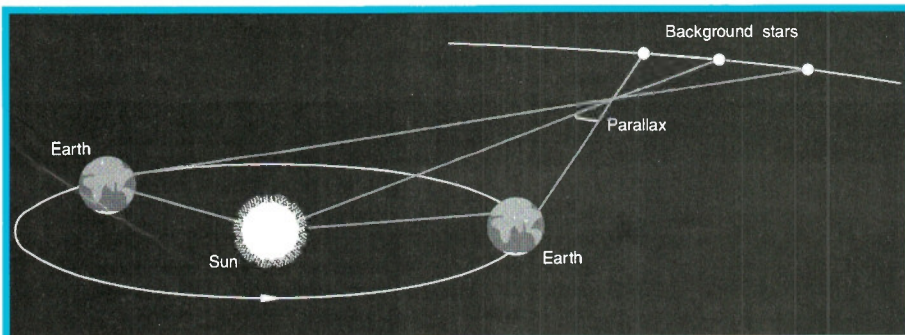

Figure 3. Stellar parallax: The parallax angle can be observed with reference to opposite points of the Earth's orbit round the sun.

to 0.76 parsec. The Hipparcos mission was designed to determine, among other parameters, the parallax of stars with an accuracy of 0.002 arc second. At this level of resolution, a star with 0.002 arc second corresponds to a distance of around 1,650 light years. Only about 40 stars lie sufficiently close to the sun to have parallax larger than 0.2 arc seconds.

By being able to measure more accurately the parallax values of the set of stars investigated, this would allow their relative distances to the Earth to be calculated in greater detail. This data is of considerable importance in studying the behaviour of stars in general. The relation of star brightness to distance is a key feature of many forms of stellar observation – such as the study of Cepheid variable stars.

## Magnitude

While values such as star parallax could not be determined by the ancient world, at around 130 BC, the Greeks had a means of classifying the brightness of stars. The brightest stars were of first magnitude and the faintest, sixth magnitude. The development of the telescope and later methods of photographic and electronic means of measuring star brightness, led to an evolution of the scale of measurement of star brightness. The scale currently adopted, based on the proposition of the English Astronomer N. R. Pogson in 1856, gives:

$$\text{Difference of magnitude} = 2.5 \times \text{LOG}_{10} \left( \frac{L1}{L2} \right)$$

Where L1 and L2 are the absolute brightness of the stars. Thus, stars which have a ratio of 10 in absolute brightness, have a difference of magnitude of 2.5. From Earth, the faintest stars observed are of the 23rd magnitude.

## The Input Catalogue

A key initial phase of the Hipparcos mission was the classification of an 'Input Catalogue' of stars for subsequent observational work. This task represented a considerable task for the world's astronomers, and not least, for the Hipparcos mission team. Over 500,000 proposals were received in 214 separate scientific submissions. A final set of 118,000 objects was selected. This phase, however, was one which forced astronomers to tidy up their own observational data. In the words of a key team member, Hipparcos was 'the biggest vacuum cleaner astronomers have ever seen'. Part of the difficulty was defining a common reference system for the various catalogues, and ensuring that the objects were defined in an unambiguous way.

As part of a deliberate strategy in mission planning, data was processed by a series of independent European scientific consortia – INCVA, FAST, NDAC and TDAC. The major task of producing an absolute star reference from the observational data is being undertaken by the INCA and FAST consortia.

## The Launch and Revised Mission

Photo 1 shows Hipparcos undergoing tests at ESTEC, and Photo 2 shows an impression of the operational satellite. The craft was launched from Kourou in French Guyana on 9th August 1989. At launch, the satellite mass was 1,140kg. The power requirements of the satellite, of 285W, was provided by an array of three solar panels. Data from the satellite was relayed to the Earth station at a rate of 24K-bit/s. While Hipparcos could be described as a 'small' satellite, its state-of-the-art optical detection systems and the complex data-processing facilities required to control it, made it one of ESA's most ambitious projects.

Repeated but unsuccessful attempts were made to fire the apogee boost motor, which would convert the craft's initial orbit into a geostationary one. During a period of intense review, it was determined that the mission could be salvaged by using reserves of fuel on the craft to modify its orbit into an eccentric ellipse type, as indicated in Figure 4.

One problem with this orbit, however, was that Hipparcos would have to pass through radiation belts which would interfere with the optical detection systems (Cerenkov radiation), and also degrade the

performance of the array of solar panels. Also, in the revised orbit, periods of solar eclipse would last as long as 100 minutes – this would pose serious problems for the power requirements of the satellite. There was a danger that the craft's Ni-Cd batteries would be drained, and the on-board computer (based on Texas Instruments' 9989 microprocessor) malfunction.

The passage of Hipparcos through the radiation belts degraded the craft's own data for its attitude control system. There was also atmospheric drag at the perigee (closest approach) position. Initial data relayed by Hipparcos after each perigee pass had to be analysed by ground control to reset Hipparcos's attitude control system.

Initially, it was planned that a single ground station would be sufficient to monitor and control the spacecraft. The satellite was eventually tracked by three ground stations, Odenwald (Germany), Perth (Australia) and NASA (Goldstone, USA). The major problem for the controllers was that the complex ground control system at Odenwald for both monitoring and commanding, had to be replicated at both Perth and Goldstone in a matter of months.

During its operational period, ground station contact with the craft was achieved for approximately 60% of the time. The data at the perigee position was, however, usually of a degraded value, and could not be used in scientific survey work. It was realised, however, that with a reduced life expectancy of the satellite, all delays in observation were, in effect, shortening the total period of observation of the mission. The first period of observation of the craft began in November 1989. The project was eventually terminated in August 1993, following loss of communication with the on-board computer.

From an awkward beginning, the Hipparcos mission has managed to attain most of its observational goals. The complexity of the project, however, would have been considerably reduced had the craft been successfully placed in the planned geostationary orbit. The observational mode of the mission was, however, able to proceed satisfactorily without the perturbation of an intervening atmosphere and the gravitational stresses and strains which can reduce the positional accuracy of ground-based telescopes.

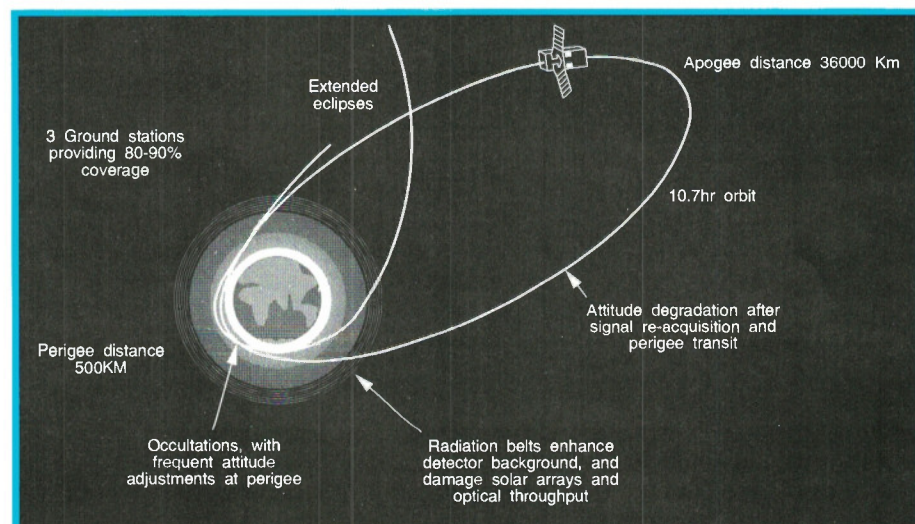

Figure 4. Revised orbit structured for the Hipparcos mission. The radiation belts both interfere with the detection systems and damage the efficiency of the solar arrays.

## Star Detection System

The satellite was designed to spin slowly, completing an orbit in just over two hours. The optical detection system detected light from a 'preceding' direction and a 'following' direction, which were separated by about 58°. This was undertaken by means of two surfaces of a beam combining flat mirror assembly, as indicated in Figure 5. The rays from each input were then processed by a Schmidt reflective telescope with a focal length of 1,400mm, and a primary mirror of 290mm. The star images from the two fields of view are modulated by a highly regular grid of 2,688 transparent parallel slits located at the focal surface and covering an area of 2.5 × 2.5cm. The period of the grating is around 9µm – equivalent to 1.2 arc seconds of 'sky'.

This focal area corresponded approximately to an area of 0.9 × 0.9° of sky. The dissector tube detector consisted of a photomultiplier detector with a sensitive aperture of 58 arc seconds. This sensitive 'spot' (290µm diameter) could be scanned rapidly under computer control within the 0.9 × 0.9° observational window. This spot was approximately 1% of each dimension of the focal sensitive area. Usually, the ground control system would be able to use the input star catalogue to position the centre of the sensitive 'spot' to within 1 arc second of the selected star. Only one star could be followed at a time by the dissection tube system.

Figure 6(a) indicates a typical star field that would be observed. Since Hipparcos observes two fields of stars in the same focal plane, the pattern of stars is repeated approximately every 20 minutes – corresponding to the time it takes the satellite to spin through 58°. In the drawing, the solid circles are seen twice, the squares move out for the last time of observation, and the crosses move in for the first time. Measurements can be undertaken, for example, on the first set of solid circle stars and the square stars, with an offset of 58° and relative differences within the 0.9 × 0.9° focal display area. In Figure 6(b), references can be made between the solid circle stars appearing for the second time and the crosses appearing for the first time. This method of observation ensures that relative position measurements can be accurately

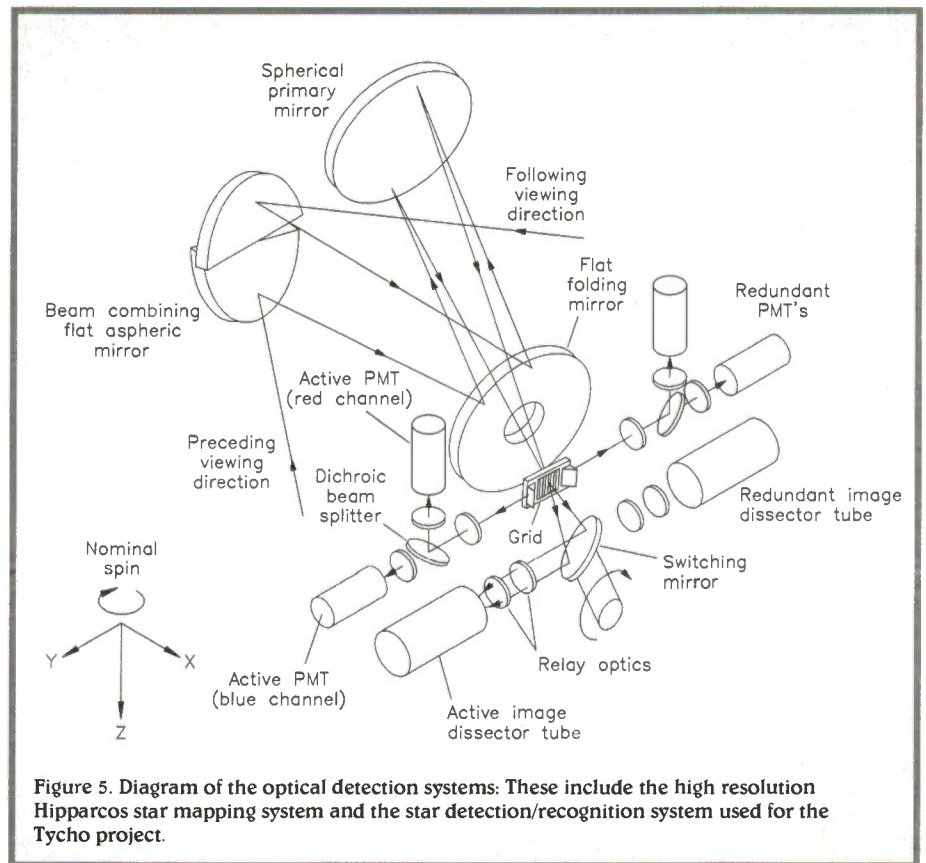

Figure 5. Diagram of the optical detection systems: These include the high resolution Hipparcos star mapping system and the star detection/recognition system used for the Tycho project.

made on stars a significant distance apart. If observation was to be made within the 0.9 × 0.9° window, then this would increase the chance of observational errors of a cumulative type. With the slow change of the craft's spin axis, the picture sweeps 'sideways' across the sky. The separation of fields of view by 58° was selected primarily to ensure optical stability of the imaging system.

Photo 3 shows details of how data was obtained by the dissection tube/grating system. As the telescope scanned the sky, the starlight was modulated by the slit system and the modulated light was sampled by the image-dissector-tube detector, at a frequency of 1,200Hz. At a given time, typically four or five of the reference stars were present in the combined fields of view. As one set of measurements were made with the preceding field of view, this was repeated a short time later by the following scan. The Hipparcos

data thus consisted of sets of data which, when processed, would produce a star map with positional accuracies of high accuracy. The mission has been able to achieve a positional accuracy of at least 50 times greater than had been possible with Earth observation telescopes.

The counts/sample data indicates the typical variation in signal as the object in the field of the dissection tube crosses the grating system. Although there are only about 10 samples per period of grating in the time domain, analysis of a large number of sampled periods of a star signal gives a highly accurate value of the relative phase of the signal – of the order of milli arc seconds. In this system, there is also the problem of signal-to-noise. If the grating had been made smaller, then the photon counts would have been reduced and the signal-to-noise ratio degraded.

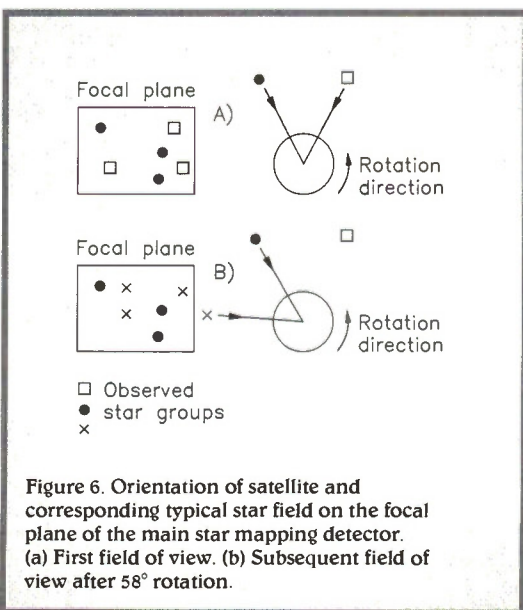

Figure 6. Orientation of satellite and corresponding typical star field on the focal plane of the main star mapping detector. (a) First field of view. (b) Subsequent field of view after 58° rotation.

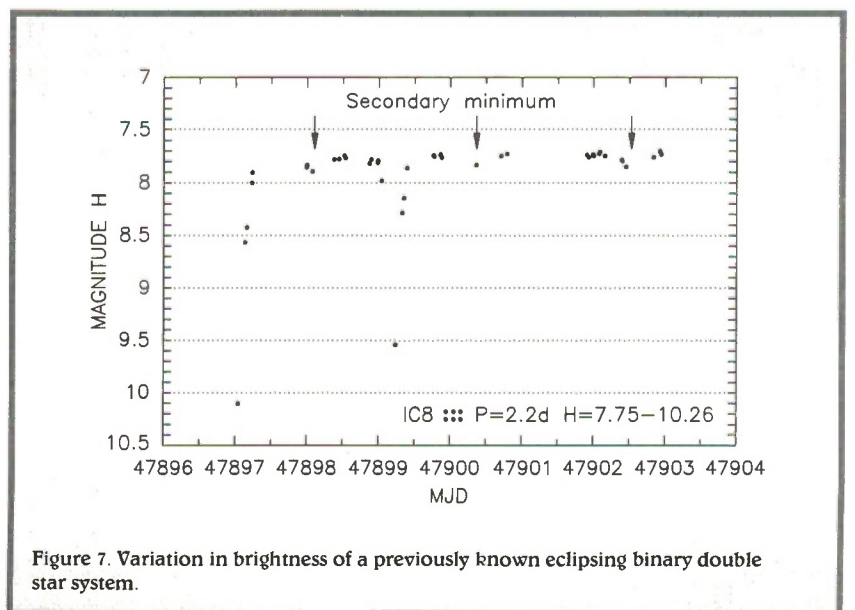

Figure 7. Variation in brightness of a previously known eclipsing binary double star system.

As Hipparcos swept out the circles of observation every 2 hours, each circle would typically contain data relating to 2,000 one-dimensional star positions. The axis of the satellite was controlled so that the series of circles scanned would, in time, cover the entire sky several times during the mission.

The short-term thermal stability of the payload was designed to be 0.05°C, to ensure good thermal stability of the optical systems. The optical enclosure had been constructed from carbon-fibre reinforced plastic skin panels, using 12-ply multilayers, and loss of moisture from this material led to slight shrinkage in the telescope axis. However, this eventuality, had been anticipated and ground control would typically optimise the focal length on a weekly basis.

The attitude of the satellite could be altered by ground control using the series of on-board attitude control motors. Such changes were minimised, in order to maximise mission duration. Accurate values of attitude, however, were a vital part of the observational programme.

The star mapping detectors used for the Tycho project could detect star images on either side of the main focal plane grating. Only one detector system was active at a time. As star images crossed the non-uniform modulating grid used by the star mapping system (see top left of Photo 3), the absolute

position of a star could be detected with an accuracy of around 1 arc second. This was sufficient to establish the satellite attitude and direct the main dissector tube sensitive aperture to a star on the focal detection plane. The light from the observed star was split by a beam splitter, in order to measure star brightness in two wavelength extents. Data was typically sampled at 600Hz.

## The Tycho Project

The Tycho experiment undertaken by Hipparcos measured parameters on around 1 million stars, but with reduced resolution. This study was able to provide a reference map of star brightness of considerably higher accuracy, for use as a baseline for astronomical observations. Astronomers would be able, for example, to use the new updated set of references for measurement of relative magnitude of new objects. The photometric data obtained from this study was able to identify features such as new binary star systems, where periodic brightness variations were caused by the periodic occlusion of stars around a centre of mass.

## Data Analysis

The process of amalgamating these great circles into an integrated and validated mapping of accurate star positions, represents

perhaps one of the most challenging data-processing ventures from space exploration. Such a task could not be contemplated without the use of powerful computing facilities. The main difference between Hipparcos and other missions such as Hubble, has been the ability to scan the entire sky at a consistently higher resolution. Systems such as Hubble were not designed as a general-purpose star catalogue system, even though the resolution of Hubble is many times greater than that of Hipparcos.

It was possible to make repeated observations on specific stars. The high levels of observational accuracy in star brightness has led to the detection of numerous double stars – systems where stars rotate around each other and consequently, produce a regular change in brightness. Also, the change in brightness of Cepheid stars has been able to be observed with high levels of precision.

## Preliminary Observational Findings

Figure 7 indicates the light curve for a previously-known eclipsing binary double star system. Such systems show minima in their light output, due to the obscuration of one star by another as two very close stars orbit around their common centre of mass.

Figure 8 indicates the appearance of a Cepheid variable star. Such stars are extensively used by astronomers to estimate inter-stellar distances. The maximum luminosity of a Cepheid star is a function of its period of variability. By accurately determining such a period, and measuring the relative brightness, the relative distance of the star can be estimated. The calibration of such stars is a cornerstone of astronomy, both in the Milky Way and beyond.

Figure 9 indicates the luminosity of a newly-discovered variable system. The system appears to have a period of variability of around 8.4 hours. Since the Hipparcos mission enabled the measurement of specific stars on numerous occasions during the three year observational period, the relative motion of stars was able to be measured with previously unobtainable levels of accuracy.

## Proper Motions of Stars

In the Milky Way, while all the stars appear 'fixed', they do possess relative motions – termed proper motions, due to the motion of stars about the galactic centre. In Figure 10, the straight-line positions indicate the limits of positional accuracy of a star during the first 19 months of the mission. When a curve fit solution is computed, the motion of the star is the solid curved trace. The relative motion of the Earth around the sun produces the 'e' artifact. In this example, the star in question is estimated to be at a distance of 27.5 parsecs, with an angular motion of 8 arc seconds per century. This corresponds to a star velocity of 300 million km per year, or over 10km/s. At this distance, it would take 20,000 years for the star to move through an angle subtended by the diameter of the full moon. These findings are a reminder that the sky as observed on Earth has slowly, but continually, been changing. Would the sky of 250,000 years ago be recognised today?

In the Tycho project, specific reference stars which have previously been adopted

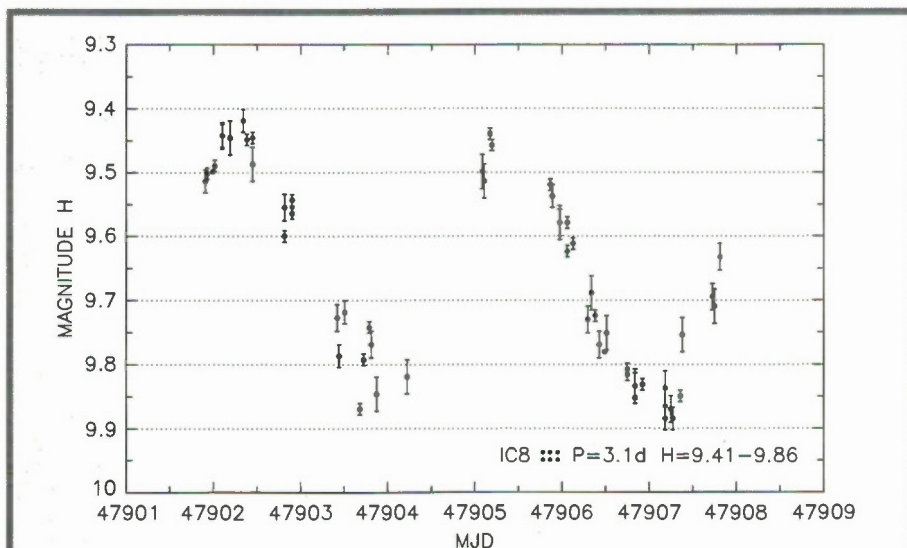

Figure 8. Variation in brightness of a Cepheid variable star. The object's maximum luminosity is a function of its period of variability

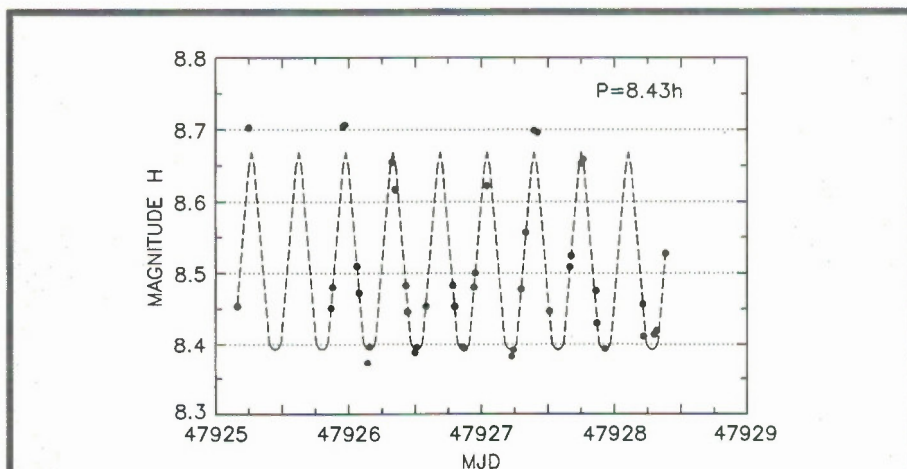

Figure 9. Variation in brightness of a previously unknown eclipsing binary double star system. A variability period of around 8.4 hours is indicated.

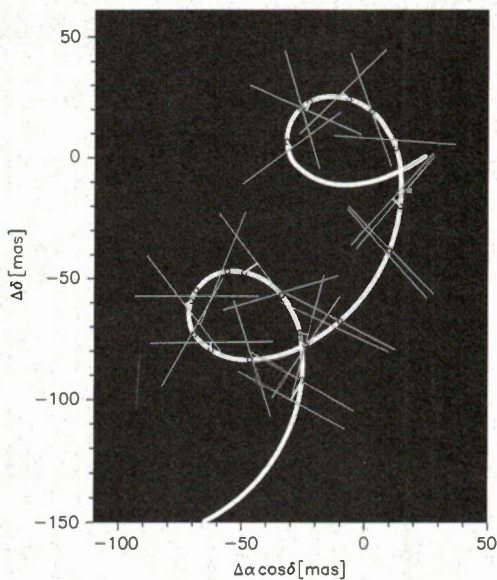

Figure 10. Data on the 'proper' motion of star as observed by Hipparcos. Curved profile is computed motion of star relative to Earth.

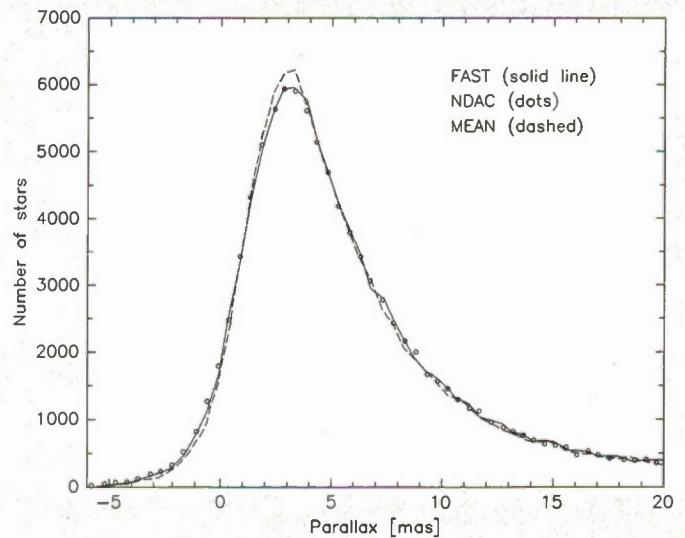

Figure 11. Data on the distribution of stars as a function of observed parallax, based on a preliminary set of data from Hipparcos. A residual tail of negative parallax is introduced due to observational errors.

as ground-based photometric standards, provided reference stars with which to compare the extended set of stars catalogued as part of the Tycho mission. It is possible to indicate the considerable expansion of positional and photometric data which the Hipparcos (main mission) and the Tycho project have achieved. In a  $5 \times 5^\circ$  area of Ursula Major, ground-based astronomy positional and photometric standards has previously catalogued 28 and 15 reference stars, respectively. This was increased by the Hipparcos data set and Tycho project, to 71 and 389, respectively.

Figure 11 indicates a rather intriguing result of the Hipparcos data. On the vertical axis, is shown the number of stars observed, and on the horizontal axis, the corresponding calculated parallax. There are a small number of observations of stars with negative parallax, corresponding to measurement errors of very distant stars. The most frequently observed parallax is around 5 milli arc seconds, which corresponds to an astronomical distance of 6,520 light years. The tail of obser-

vations beyond 20 milli arc seconds corresponds to those stars within 50 parsec of the Sun (160 light years). This figure gives information about our 'near' neighbours in the galaxy.

In Figure 11, the FAST data (solid line) and NDAC (dots) correspond to data processed by different consortia. While some data has been released by the various consortia, it is estimated that the fully resolved and verified Hipparcos and Tycho catalogues will be released to the general scientific community at the beginning of 1997.

## Summary

There is no doubt that the Hipparcos Star data will be of immense value to subsequent astronomy work. The Hipparcos Star catalogues will form the definitive star reference for objects in our sector of the galaxy. It remains to be seen what developments will allow cataloguing with improved accuracy for more remote objects – such as those corresponding to parallaxes of

micro arc seconds and distances of tens of thousands of light years. The success of the optical systems used in Hipparcos, however, will prove a good foundation for new star mapping probes of the 21st Century. 

## Further Reading

*The Hipparcos Mission: Pre-Launch Status*  
ESA SP-1111

Volume 1: *The Hipparcos Satellite*

Volume 2: *The Input Catalogue*

Volume 3: *The Data Reductions*

*ESA's Report to the 30th COSPAR meeting*,  
Hamburg, Germany, 1994. ESA SP-1169.

*ESA Bulletin*, Number 69, February 1992.  
Hipparcos Mission Feature.

## Points of Contact

(Publications) ESA Publications Division,  
Estec, Postbus 299, 2200 AG, Noordwijk,  
The Netherlands.

(Media) ESA, 8-10 rue Mario-Nikis,  
75738 Paris Cedex 15, France.

# SAMSUNG'S ROYAL OPENING

**T**HE Queen opened the £450 million Samsung Complex at Wynyard Park in Billingham Teesside, in October. With a turnover of US\$64 billion last year, Samsung the Korean-based multinational is one of the world's largest corporations.

The opening ceremony was attended by nearly 300 local dignitaries, including representatives from national and local government, business and industry, the media (including *Electronics* Editor Robin Hall) and suppliers to Samsung Wynyard Park. After the official opening, guests were entertained to lunch at Wynyard Hall, the home of Sir John and Lady Hall.

The industrial complex, currently on a 200 acre site, has already created 300 new jobs in the area. A second stage of development is due to start in 1997 to manufacture other products, such as facsimile machines, and provide a research and development centre. On completion of the second stage of development, around 3,000 new jobs will have been created at Samsung Wynyard Park.

Samsung have also purchased the 8-83 acre former Trico site on the Great West Road, Brentford, for the construction of its new European headquarters. The new complex will eventually accommodate all London-based staff, which is expected to create 500 jobs by the year 2000.

For further information, Tel: (0171) 734 6030.

# TECHNICAL INFORMATION SERVICES

76 Church Street, Larkhall, Lanarks, ML9 1HE  
Tel: (01698) 883334 Fax: (01698) 884825  
Technical Help Line (01698) 884585

We have the World's Largest Selection of:

## SERVICE MANUALS CIRCUIT DIAGRAMS

We also have 100s of Titles on TVs, VCRs, Satellites, Midi Systems, Computers, Test Equipment, etc...

Please Phone or Send an SAE for FREE QUOTE & CATALOGUE of Publications

## Circuit Description

Referring to the block diagram (Figure 8) and schematic circuit diagram (Figure 9) there are only four major blocks to this kit. The power supply, which converts the incoming 8 to 16V DC to +5V ( $\pm 0.25V$ ), consists of RG1 and C1 to C3. This supplies power to the receiver board and to IC1 (the MAX232), which, together with its charge-pump capacitors C4 to C8, forms the TTL to RS232 converter.

SK2 is the 10-way header socket which mates with the header plug on the receiver board, and provides the connections for all power and data to and from this board, with the exception of the RF signal and Antenna Power, which is fed via a miniature OSX connector mounted on the receiver.

## Construction

The Development Kit PCB legend is shown in Figure 10, while the layout of the VP Oncore receiver module, showing component orientation, is in Figure 11.

The Development Kit can be assembled by anyone with a knowledge of soldering techniques but without any more than a very basic understanding of electronics. The main point to note is that the receiver board is static sensitive, and that the usual antistatic precautions must be taken whenever handling this board. Keep it in the antistatic bag in which it is supplied until you are ready to install it, but once the kit is assembled and cased, it should be reasonably immune to damage from electrostatic discharges.

The same precautions apply to handling the Active Antenna module. In addition, remember that this is mounted on a brittle ceramic substrate and should not be subjected to severe shock, so do not drop it! (When mounted in any of the recommended antenna housings, it is considerably more robust and able to stand up to the normal stresses of its working environment.)

Solder in position all resistors, socket SK6, all capacitors, and sockets SK1, SK2, SK3 and SK4, in that order. Insert and solder the 16-pin DIL socket, aligning the notch at one end to the white marker block on the legend. DO NOT insert IC1 yet.

Referring to Figure 12, bend the legs of the regulator as shown. Insert the legs into the three mounting holes from the track side of the PCB, and fix the device using 1 6BA x 6.3mm ( $\frac{1}{4}$ in.) screw, shakeproof washer and nut as shown in Figure 12. Finally, solder the three legs into position and trim off the excess leads from the component side of the board. Remove the MAX232CPE IC from its protective packaging and carefully insert it into the IC socket at IC1 position, making sure to orientate the pin 1 marker to the end of the socket having the notch. Referring to Figure 13 (exploded assembly diagram), fix the four threaded 6BA spacers into position on the PCB using 1 6BA screw and shakeproof washer for each; DO NOT fit the receiver board yet.

Take the supplied prepunched and printed front panel, and fit the TNC socket to the hole marked 'ANTENNA'. Here the solder tag should be bent back at about 90° to allow soldering of the coax braid later. Remove the two fixing screws from the 9-way D-type plug and fit the front panel assembly into position using these two screws.

Carefully check the PCB and assembly for any stray pieces of wire or solder 'bridges', also recheck the polarity of all the electrolytic capacitors. (If a multimeter is available, apply power to the assembly and check that it draws <50mA, also check that pin 2 of SK2 is at a potential of +5V relative to 0V.)

At this point a 3V backup battery, of a type such as is used with computer motherboards, can be wired to the backup PCB connections if desired. This will preserve the Real Time Clock value while the unit is switched off.

If you are satisfied that all is well, then, while following all antistatic precautions, remove the receiver board from its protective packaging. Carefully align the male 10-pin header connector on the receiver board with SK2 on the Development Kit PCB, and push it gently but firmly home. Immediately secure it to the four 6BA threaded spacers using four 6BA screws and shakeproof washers.

Again referring to Figure 13, take the coax lead supplied with the Active Antenna Module and cut off one connector (both ends are identical), together with approximately 60mm of cable (take care not to damage the connector!). Taking the short length of cable, prepare the cut end and solder the inner conductor and braid to SK5. Plug the miniature OSX connector into the RF socket on the receiver board.

Take one end plate (these are supplied with box CCN160), and fix it to one end of the box with four of the supplied self-tapping screws. (These can be quite tight as the screws have to cut their own thread.) Discard the other end plate.

If required, cut the optional rubber strips to length and slide them into the appropriate slots on the outside of the box. Carefully slide the assembled PCB and attached front panel into the box, using the two lowest slots; note that the internal central dovetail on the inside box must be uppermost, otherwise it will snag on the regulator. Ensure also that any excess coax cable is not snagged on the sharp edges of the box.

When you are sure that the assembly is aligned correctly, fix it in place using the remaining four self-tapping screws supplied with the box. Any excessive 'skew' between the front panel and the PCB can be corrected by slackening the two securing screws on the front of the 9-way D-type connector, moving the panel and re-securing.

Fit the supplied TNC plug to the bare end of the remaining length of coax cable and connector. Assemble the Antenna Module into the housing of your choice (refer to Optional Parts List), following the instructions in the Motorola GPS Product Guide, supplied with the Receiver Board.

## Using the Development Kit

The development kit and receiver are now ready to be tested. Any computer with a serial interface capable of operating at 9600 baud will be suitable, but for simplicity I shall only refer to an IBM compatible PC using COM 2, and the use of QBASIC routines (QBASIC replaced GWBASIC in MS DOS version 3, and is provided with MS DOS 4.00 onward). These should be easy enough to translate into any other flavours of basic, or the routines could be rewritten for Pascal, C or any other development language.

Connect the 9-way D-type connector to COM 2 on the computer using a suitable DTE to DCE connection cable. Place the antenna on a flat surface (or on a suitable mount if you are using anything other than the magnetic base) with a clear view of the sky and connect the TNC plug to SK5 on the main unit. Connect a suitable power source and switch on.

The communication protocol used by the Receiver is fully described in the User's Guide, but a brief description follows here, along with a short routine to enable the receiver for the first time. The factory default configuration as contained in the EEPROM, is as follows:

```
Receiver not in Binary Mode
Position idle mode selected (i.e.
does not output any message)
Almanac in EEPROM (Probably > 1
month old)
Latitude and Longitude = 0
No 'Satellite Visible' until first fix
GMT Offset = 0:00
```

Listing 1 (also provided as a 'QBasic' listing on a disk with the development kit) is a routine which sets the receiver in position fix mode, outputs position data once a second and displays the following information:

```
Current
Geometry: DOP and DOP type Satellite
Visibility and Tracking Status
Date: Day/Month/Year
Time: UTC in Hours:Minutes:Seconds
Position: Latitude and Longitude in
degrees, minutes and seconds
Velocity: In metres/second
Heading: 0 to 359.9° relative to true
North
Height: In metres, MSL (relative to
Mean Sea Level)
```

If all is well when the routine is run for the first time, absolutely nothing will happen! Now is the time to go for a cup of coffee and wait for your first fix, because this usually takes about twenty minutes. If the battery backup option is fitted, then subsequent fixes following power-up will take considerably less time (e.g., one board I powered up after two months in a drawer, and with the time and date out by several days, acquired a first-fix in about four minutes).

When the first fix is acquired and data suddenly appears on your computer



screen there are one or two things to be aware of. Firstly, the heading will show sudden (and often very large) variations. This is because the antenna is stationary

and the MPU on the receiver board has no way of working out which way it is pointing!

Secondly, the position and height will

probably be constantly changing; this is mainly due to SA being turned on (unless the US Government decide to turn it off again before this article is published!). The Latitude and Longitude will show a gradually moving offset which will always be around the actual position. Although the rate of change looks quite horrendous, it is actually shown in thousandths of a degree, so in real terms it isn't very fast at all. The total errors in position are <100 metres with SA on, and <25 metres with SA off. The displayed height will vary quite dramatically, again due to SA.

## And Finally

This article should give you enough information to build and set up a basic GPS station, and the development kits will also include a more comprehensive GPSTRAK program (again written in QBASIC so that you can use the code in your own applications). At the time of writing, the boards were in the process of being upgraded from 6 to 8 channels and this has meant that the full demo program has to be slightly reworked to incorporate the extra data.

This software will be covered in more detail in Part 2 in next month's issue of *Electronics*, together with additional information about, and features of, the VP Oncore receiver module. These include differential GPS applications and technical reports showing the versatility and durability of the Motorola hardware, with algorithms and short listings to convert the Latitude and Longitude output from the GPS receiver to Ordnance Survey National Grid References.

## Glossary of Terms

**DGPS:** *Differential GPS*, a method of improving positioning accuracy by calculating SA errors.

**DOP:** *Dilution of Precision*. A description for the uncertainty of a position due to geometric factors, (for example a poor geometric configuration of the satellites being tracked). Used with a prefix letter to indicate which element is affected:

**RDOP:** Relative (normalized to 60 seconds).

**GDOP:** Geometric (three co-ordinates plus the clock offset in the solution).

**PDOP:** Position (three coordinates).

**HDOP:** Horizontal (two horizontal co-ordinates).

**VDOP:** Vertical (Height only).

**TDOP:** Time (clock offset only).

**Doppler effect:** When a source of sound moves towards or away from a listener, the pitch, or frequency of the sound is higher or lower than when the source is at rest. The classic example of this effect is the rise and fall of the pitch of the whistle of a locomotive as it approaches and recedes from the listener. Similar results are obtained when the listener approaches or recedes from a stationary source of sound. This phenomenon, the *Doppler effect*, applies to all types of waves, including electromagnetic (light and radio), and is named after Christian Johann Doppler, an Austrian scientist.

**Ephemeris:** An astronomical almanac or table of predicted positions of celestial bodies.

**GMT:** *Greenwich Mean Time*. In the UK, BST is 1 hour ahead of GMT. See UTC.

**GPS:** *Global Positioning System*.

**NMEA-0183:** *National Marine Electronics Association* communications format; developed as a standard format for transmitting and receiving GPS and other navigational data.

**P Code:** *Protected or Precise Code*. A very long (about  $10^{14}$  bits) code transmitted at a rate of 10.23MHz that only repeats itself about every 38 weeks. Only made available to authorized (mainly military) users.

**PPS:** *Pulses-Per-Second*.

**SA:** *Selective Availability*. Pseudo-random noise introduced to the GPS signals to deliberately degrade positional accuracy. Controlled by the US Department of Defense; see DGPS for a method of correcting this artificial error.

**TTF:** *Time To First Fix*.

**TTL:** *Transistor-Transistor Logic*. A logic system commonly used for microprocessor communication.

**UTC:** *Universal Time Co-ordinated*. Approximately equal to GMT, but maintained by the US Naval Observatory. GPS time is directly related to UTC. (UTC - GPS = seconds; 5 seconds in 1988.)

## GPS DEVELOPMENT SYSTEM PARTS LIST

### CAPACITORS

C1	220µF 16V PC Electrolytic	1	(FF13P)
C2,3	100nF 16V Miniature Ceramic Disc	2	(YR75S)
C4-8	22µF 25V PC Electrolytic	5	(FF06G)

### SEMICONDUCTORS

D1	1N4001	1	(QL73Q)
IC1	MAX232CPE	1	(FD92A)
RG1	L7805CV	1	(QL31J)

### MISCELLANEOUS

SK1	PC Mounting Power Socket	1	(RK37S)
SK2	10-Way Header Socket	1	(95050)
SK3	9-Way Right-Angled D-Range Plug	1	(FG66W)
SK4	Miniature 3-Way DIN PCB Socket	1	(JX13P)
SK5	50Ω TNC Socket	1	(FE81C)
PL1	50Ω TNC Plug	1	(AJ26D)
	GPSTRAK Software Disk	1	(95051)
	16-Pin DIL Socket	1	(BL19V)
	Threaded Spacer 6BA	1 Pkt	(LR72P)
	6BA x 6.3mm (1/4in.) Bolt	1 Pkt	(BF05F)
	6BA Shakeproof Washers	1 Pkt	(BF26D)
	Alloy Box with Covers CCN160	1	(YN51F)
	PCB	1	(90080)
	Drilled and Printed Front Panel	1	(95012)
	Instruction Leaflet	1	(XV71N)
	Constructors' Guide	1	(XH79L)

### OPTIONAL (Not in Kit)

	Motorola Oncore GPS Module (Real Time Clock and Back-up Battery)	1	(95040)
	GPS Antenna Module	1	(95041)
	Antenna Vehicle Magnetic Mount Kit	1	(95042)
or	Antenna Vehicle Fixed Mount Kit	1	(95043)
or	Antenna Non-Mobile Post Mount Kit	1	(95044)
or	Antenna Marine Mast Mount Kit	1	(95045)

Rubber Feet	1 Pkt	(XR93B)
Serial Cable	1	(DD48C)
12V DC Mains Adaptor PSU	1	(YB23A)
GPS Oncore User's Guide	1	(95046)
GPS Oncore Software Command Manual	1	(95047)
GPS Antenna Cable	1	(95048)

The Maplin 'Get-You-Working' Service is available for this project, see Constructors' Guide or current Maplin Catalogue for details.

**The above items (excluding Optional) are available as a kit, which offers a saving over buying the parts separately.**

**Order As 90079 (GPS Development System Kit) Price £32.99**

Please Note: Where 'package' quantities are stated in the Parts List (e.g., packet, strip, reel, etc.), the exact quantity required to build the project will be supplied in the kit.

The following new items (which are included in the kit) are also available separately, but are not shown in the 1996 Maplin Catalogue.

GPS Development System PCB **Order As 90080 Price £3.49**  
 Drilled and Printed Front Panel **Order As 95012 Price £3.99**

The following new items are *not* included in the kit, but are available separately, and are not shown in the 1996 Maplin Catalogue.

Motorola Oncore GPS Module **Order As 95040 Price £234.99**  
 GPS Antenna Module **Order As 95041 Price £72.99**  
 Antenna Vehicle Magnetic Mount Kit **Order As 95042 Price £8.99**  
 Antenna Vehicle Fixed Mount Kit **Order As 95043 Price £8.99**  
 Antenna Non-Mobile Post Mount Kit **Order As 95044 Price £8.99**  
 Antenna Marine Mast Mount Kit **Order As 95045 Price £8.99**  
 GPS Antenna Cable **Order As 95048 Price £26.99**

**1**  
PROJECT  
RATING

# RS232 to 8-bit

# DIGITAL

KIT  
AVAILABLE  
(95018)  
PRICE  
£14.99

# I/O Converter Module

Text by Tony Bricknell and Maurice Hunt

READY  
ASSEMBLED  
(95049)  
PRICE  
£19.99

This single board, PIC microcontroller-based RS232 to 8-bit Input/Output Converter Module is useful for applications where a parallel to serial conversion (and vice versa) of digital data is required, making it ideal for use in computer-controlled systems and peripherals, or for experimental and educational purposes.

## FEATURES

- \* Each I/O line individually configurable as input or output
- \* Byte or bit read and write
- \* Configuration can be altered on-line through the RS232 interface
- \* Single 5V DC supply voltage
- \* I/O lines are TTL and CMOS compatible
- \* Auto baud rate selection
- \* Auto format/parity selection
- \* On-board CMOS microcontroller

## APPLICATIONS

- \* Digital I/O expansion of any computer with an RS232 interface
- \* Computer-based process control and automation
- \* Capture of digital signals, switches, detectors, etc.
- \* Computer control of relays, indicators, motors, pumps, etc.

### Specification

Operating voltage:	5V DC
Maximum current consumption:	100mA
Maximum load per output:	10mA
Operating speed:	600/1,200 Baud
Visual indicator:	Red LED confirming serial data received
PCB dimensions:	80 x 44mm

Figure 1. Circuit diagram.

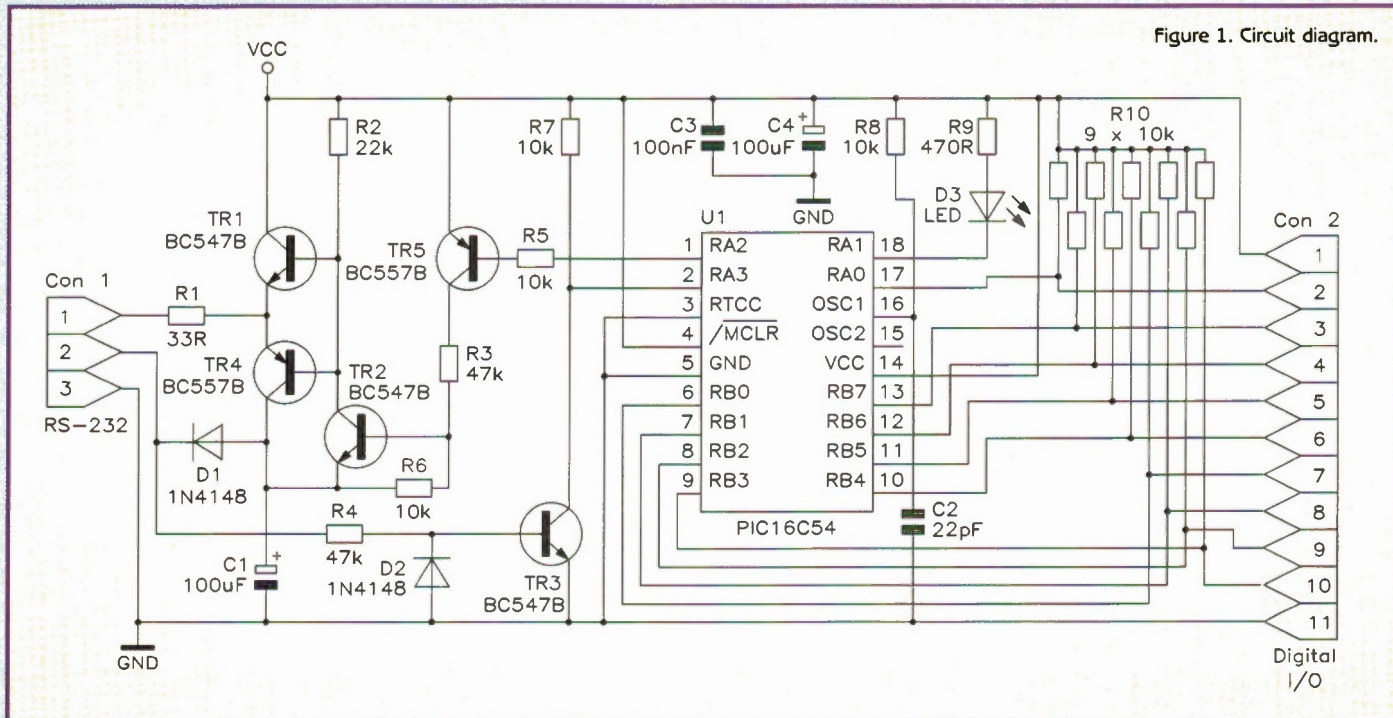

One useful application for the module is in a computer-controlled security system. Several passive infra-red sensors (PIRs), positioned about the premises can be connected, through the Converter Module, to a host computer, allowing intruders' movements to be mapped throughout the building. However, there are many more possibilities where this module will be ideal, and this article explains how to build the unit and put it to use.

### Circuit Description

Figure 1 shows the circuit diagram of the module, which is based around the

preprogrammed PIC microcontroller, U1. The module requires a single supply of +5V at an absolute maximum of 100mA, which is supplied by the computer to which the module is connected. The supply voltage required by the module to transmit an RS232 logic 1 (-3 to -25V) is derived, ingeniously, from the host computer via D1 and C1. An 8-bit CMOS microcontroller is used to interface between the serial and parallel formats.

Con 1 is the RS-232 input socket on the module, with RX being the input to the module, and TX being the output. GND must also be connected to the computer's ground. The baud rate may be 600 or

1,200 Baud, and the format may be 7 or 8-bit, odd or even parity. No handshaking signals are used. The module automatically switches to the received format, and sends the output back in the same format, hence, no adjustments are required to the module.

Con 2 is the parallel I/O port. A single 5V DC supply voltage (from the computer) is connected between the +5V and GND. D0 to D7 are the digital I/O terminals, while CLK outputs a strobe signal each time new information from the computer is put on the outputs. This can, for instance, be used as an Interrupt or as a trigger for a flip-flop or monostable multivibrator.

All I/O lines are provided with 'pull-up'

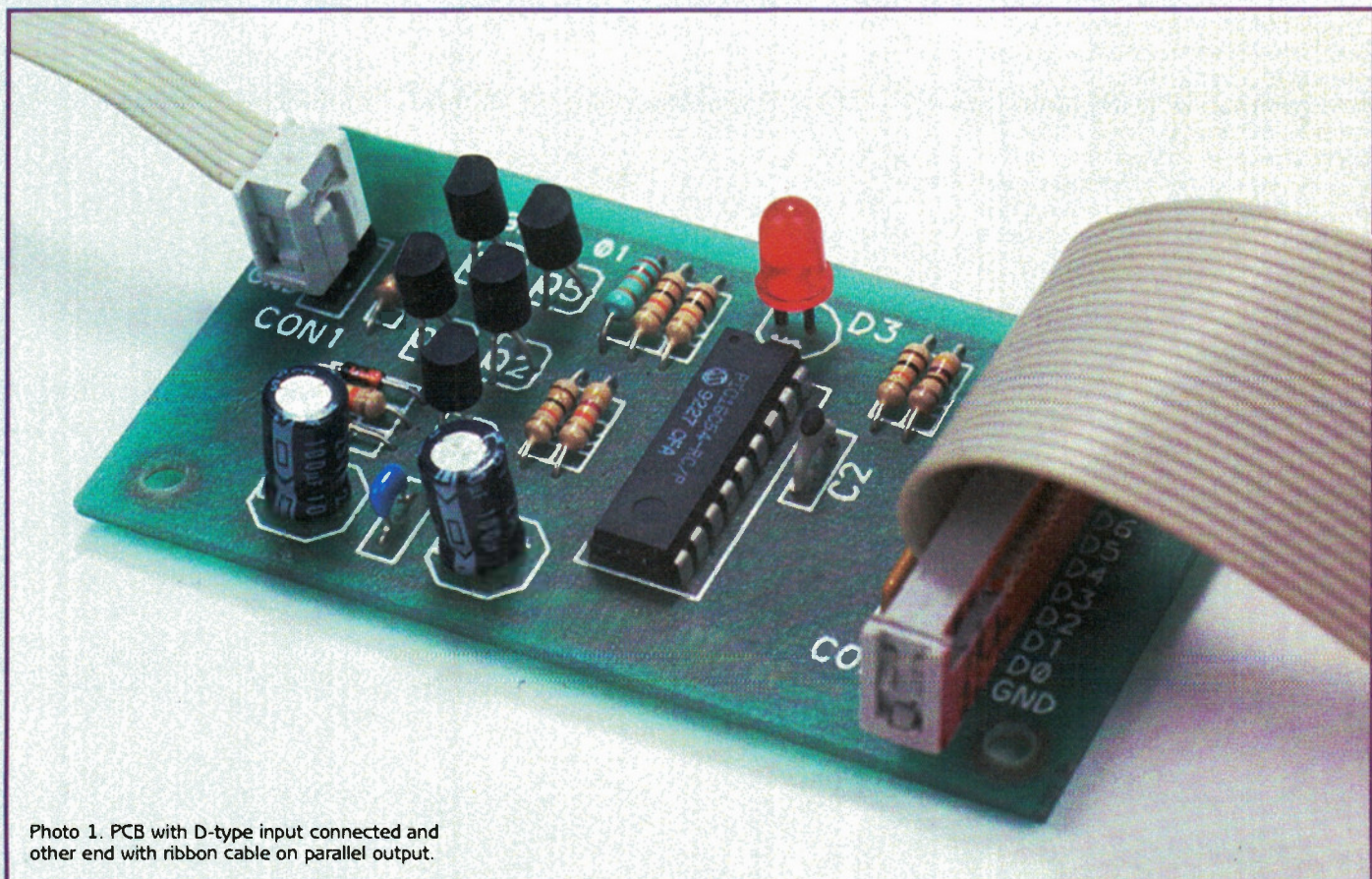

Photo 1. PCB with D-type input connected and other end with ribbon cable on parallel output.

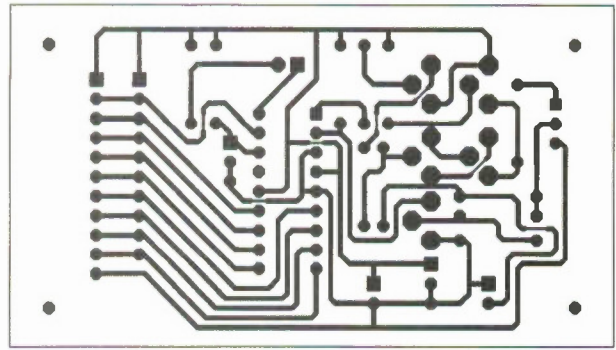
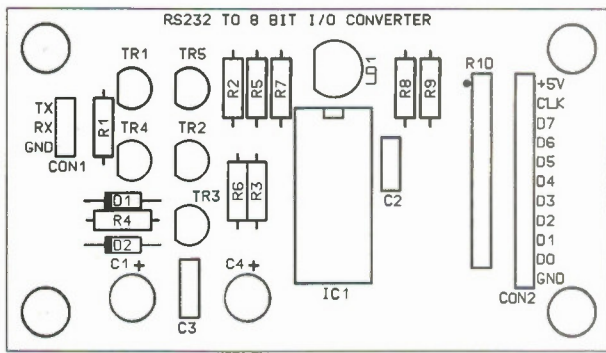

Figure 2. PCB legend and track.

resistors (courtesy of R10, a 9-way 51L array), so that a minimum of external components is necessary. LED D3 flashes briefly each time a valid command is received from the computer, and it also turns on following powering-up of the module, and remains on until the first command has been received.

## Construction

Refer to the PCB legend and track drawings, shown in Figure 2. Assembling the PCB is straightforward, commensurate with the low project rating. Install the components in order of ascending component size, commencing with the diodes and resistors, including the 51L resistor array, ensuring that it is fitted the correct way round. Next, fit the DIL IC holder with the notch aligning with the PCB legend, since it will be easier to fit flatly onto the board without the taller components having already been fitted. Progress through to the capacitors, transistors and LED, and then the connector pins, which will first have to be cut into strips of 3 and 11 pins (they are supplied in strips of 36 pins).

Ensure that the correct polarity of the semiconductors and electrolytic capacitors is observed, and take care to avoid solder bridges, whiskers and dry joints. Clean excess flux off the board using a suitable solvent, and finally, plug the IC into its socket, taking antistatic precautions when doing so. Make a final check for misplaced components before powering-up the unit for the first time.

```

10 OPEN "COM1:1200,N,8,1" AS #1 'Open file 1 as Com1, 1200 baud, 8 bits, no parity
20 PRINT #1,"!C0" 'Configure all lines as output
30 LINE INPUT #1,A$ 'Module answers
40 IF A$ < > "!ACK" THEN 190 'If answer not !ACK then error
50 PRINT #1,"!W255" 'Set all lines high
60 PRINT "Logic 1"
70 LINE INPUT #1A$ 'Module answers
80 IF A$ < > "!ACK" THEN 190 'If answer not !ACK then error
90 GOSUB 160 'Pause...
100 PRINT #1,"!W0" 'Set all lines low
110 PRINT "Logic 0"
120 LINE INPUT #1,A$ 'Module answers
130 IF A$ < > "!ACK" THEN 190 'If answer not !ACK then error
140 GOSUB 160 'Pause...
150 GOTO 50
160 FOR F=1 TO 1000 'Delay subroutine
170 NEXT F
180 RETURN
190 PRINT "Error !"
200 END

```

Listing 1. Test software.

```

10 'REED SWITCH CONNECTED BETWEEN D0 AND GROUND
20 '-----
30 OPEN "com1:1200,o,7,1" AS #1 ' 1200 baud, 7 databits, odd parity
40 PRINT #1,"!CB01" ' Configure D0 as input
50 LINE INPUT #1,A$ ' Module answers 'ACK'
60 PRINT #1,"!RB0" ' Read level on D0
70 LINE INPUT #1,A$ ' Answer = "!IO" if switch closed
80 PRINT A$ ' Answer = "!I1" if switch opened
90 GOTO 60

```

Listing 2. Program to register the state of a reed switch connected between D0 and ground.

Figure 3. RS232 connections to the module.

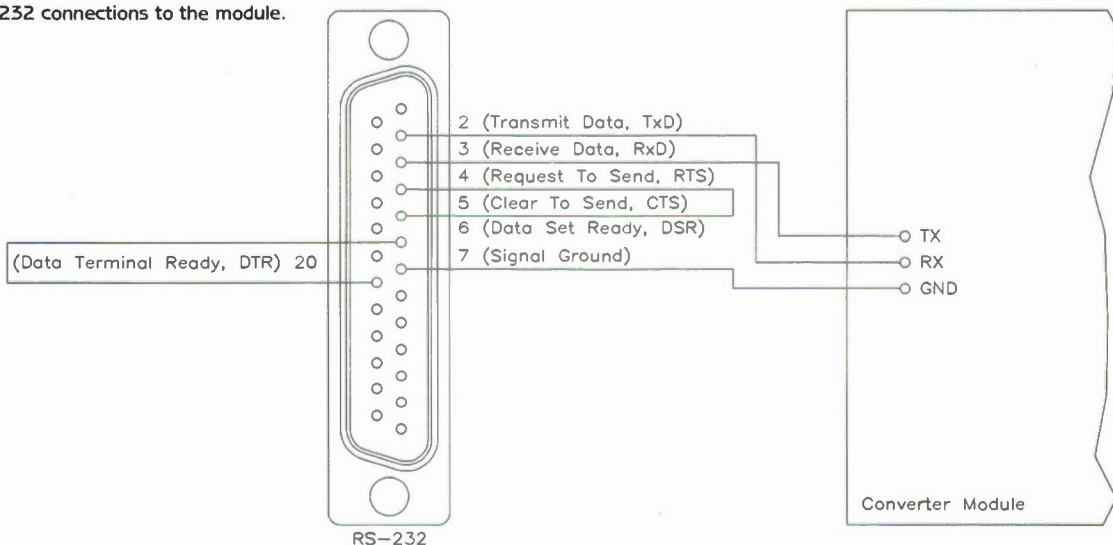

# Setting Up

Figure 3 shows how to connect the module to any computer fitted with a standard 25-way, D-type RS232C port. No handshake signals are required, and the module sets its baud rate, bit format and parity on the first transmission from the host computer. Once this connection has been made, a simple program written in BASIC can be used for testing the system. Listing 1 shows such a program for PC-compatible machines. It should be fairly easy to modify this program to run on other computers. The program sets all bits as outputs and toggles them between logic 1 and logic 0 at short intervals. This allows each output to be checked with a logic probe, oscilloscope, multimeter or the test circuit, originally shown for the IBM PIO card project (*Electronics*, Issue 43), which is reproduced in Figure 4. The suggested strip-board layout for the test circuit is shown in Figure 5.

```

10 'BLINKING LED CONNECTED AT D1
20 '-----
30 OPEN "com1:1200,o,7,1" AS #1 ' 1200 baud, 7 databits, odd parity
40 PRINT #1,"!CB10" ' Configure D1 as output
50 LINE INPUT #1,A$ ' Module answers 'ACK'
60 PRINT #1,"!WB10" ' Switch LED on
70 LINE INPUT #1,A$ ' Module answers 'ACK'
80 FOR TIME=0 TO 100 : NEXT TIME ' Small delay loop
90 PRINT #1,"!WB11" ' Switch LED off
100 LINE INPUT #1,A$ ' Module answers 'ACK'
110 FOR TIME=0 TO 100 : NEXT TIME ' Small delay loop
120 GOTO 60
    
```

Listing 3. Program to flash an LED connected to D1.

and Photo 1 shows the test circuit fully assembled.

The period of the square-wave output may be adjusted by altering the number in line 160, presently set at 1000. A lower

number will increase the frequency of the square-wave, and a higher number will have the opposite effect. When a logic probe is used to test D0 to D7 in turn, each will show logic 1 and logic 0 alternately, whilst

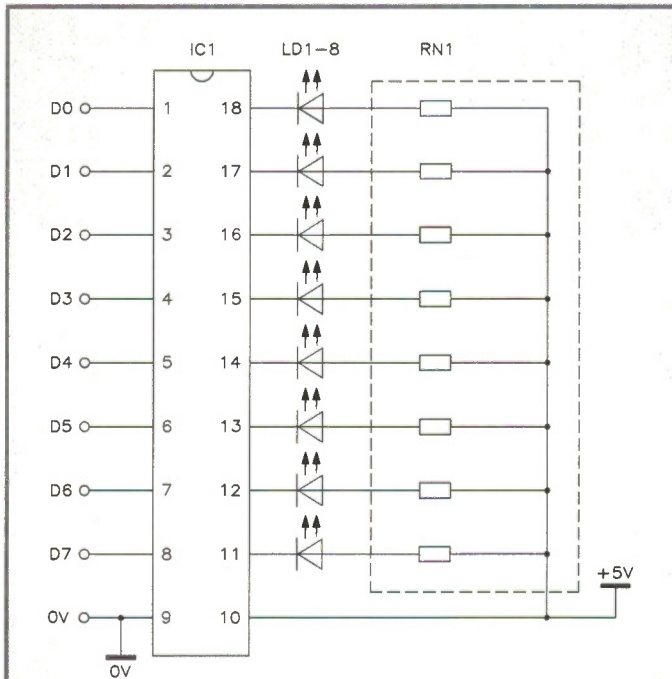

- |                             |         |       |
|-----------------------------|---------|-------|
| IC1 ULN2803A                | [QY79L] | 1 off |
| LD1-8 Rectangular red LED   | [YY45Y] | 8 off |
| RN1 220R SIL resistor array | [RA24B] | 1 off |

Note: If separate +5V supply is used both RS232 Converter 0V and supply 0V must be connected to CON2, pin 11.

Figure 4. Circuit diagram of a suitable test circuit.

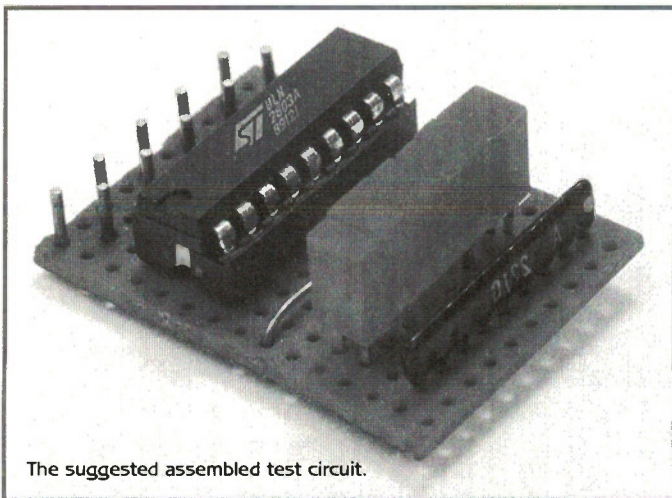

The suggested assembled test circuit.

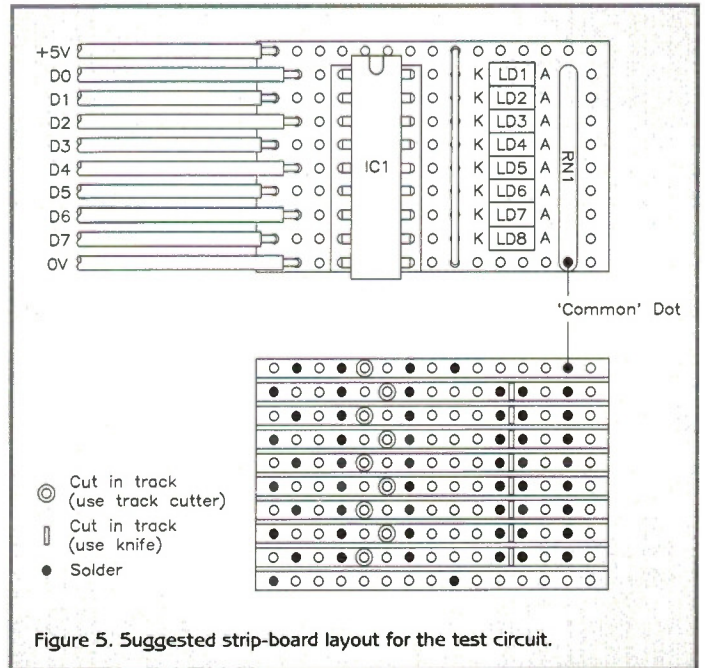

Figure 5. Suggested strip-board layout for the test circuit.

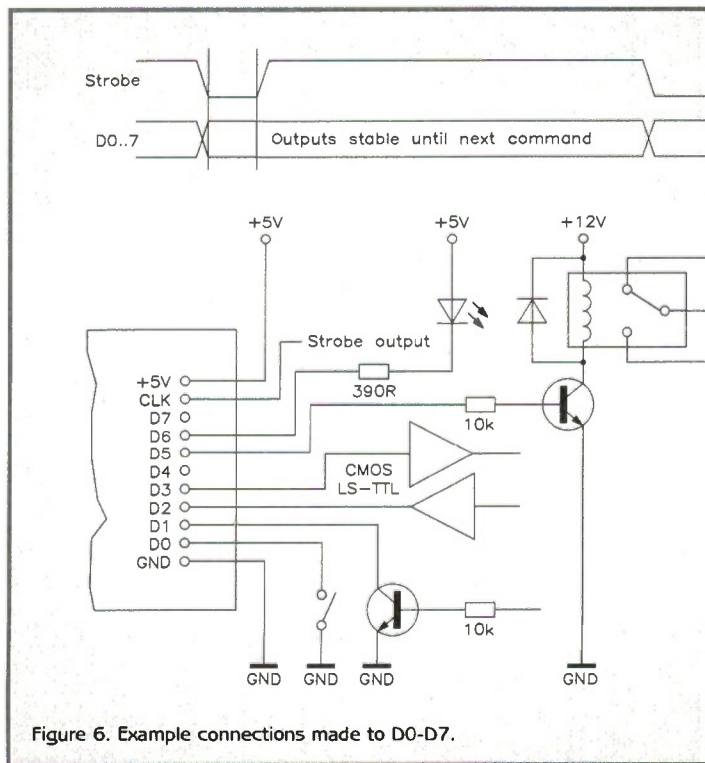

Figure 6. Example connections made to D0-D7.

an oscilloscope will show a slow square-wave. With a multimeter (set to its 5V DC (or higher) range, the display will show alternately 5V and 0V. Using the test circuit shown, the LEDs will flash on and off together.

However, note that as the module derives the negative voltage required for the RS232 communication from pin 2 on Con 1 (Rx), this pin MUST be connected to the host computer. Figure 6 shows some possible

connections using the parallel I/O port. Alternatively, one of the programs supplied with the module can be used for testing.

## Control Commands

The Converter Module is controlled with standard ASCII characters sent from the host computer through the RS232 line. All commands start with an exclamation mark (!), and end with a carriage return (CR). The answers from the module have the same format. The six different commands accepted by the module are:

- !R (CR)** Read byte  
Read the inputs as a decimal value  
Answer:  
!Ixxx (CR), in which xxx = 3 characters from 000 to 255. If this command is executed on a line that is configured as an output, it will read as low.
- !Wxxx(CR)** Write byte  
Write the decimal byte value to the outputs, in which xxx is a 1 to 3 digit number ranging from 0 to 255  
Answer:  
!ACK (CR) if command accepted.  
!NACK (CR) if command invalid
- !Cxxx(CR)** Configure byte  
Configure lines as input or output, in which xxx is a 1 to 3 digit number ranging from 0 to 255  
Bit = 0 = Output  
Bit = 1 = Input  
Answer:  
!ACK (CR) if command accepted  
!NACK (CR) if command invalid
- !RBx(CR)** Read bit  
Read input line x (0 to 7)  
Answer:  
!I0 (CR) if line low  
!I1 (CR) if line high  
If this command is executed on a line that is configured as output, it will be read as low
- !WBxy(CR)** Write bit  
Write y to output x, in which x is the output line (0 to 7) and y is the logic level (0=low, 1=high)  
Answer:  
!ACK (CR) if command accepted  
!NACK (CR) if command invalid
- !CBxy(CR)** Configure bit  
Configure line number x (0 to 7) as output (y=0) or input (y=1)  
Answer:  
!ACK (CR) if command accepted  
!NACK (CR) if command invalid

The LED on the module (D3) briefly flashes each time a valid command is received from the computer. E

```

10 ' Clear screen and open serial communication
20 ' =====
30 KEY OFF : CLS
40 OPEN "COM1:1200,n,8,1" AS #1
50 LOCATE 5,23 : PRINT "RS-232 TO DIGITAL I/O SAMPLE PROGRAM"
60 LOCATE 6,23: PRINT "=====
70 LOCATE 11,25: PRINT "1) Read level on input line" ' Display menu
80 LOCATE 12,25: PRINT "2) Set output line high or low"
90 LOCATE 13,25: PRINT "3) Configure line as input/output"
100 LOCATE 14,25: PRINT "4) Exit to operating system"
110 LOCATE 9, 1: PRINT STRING$(80,"-"); ' Draw menu border
120 LOCATE 18, 1: PRINT STRING$(80,"-");
130 LOCATE 16,44: PRINT " "
140 LOCATE 16,30: INPUT "Your choice ";CHOICE ' Get selection
150 GOSUB 650
160 ON CHOICE GOTO 200,300,450,600 ' Execute request
170 GOSUB 650: LOCATE 20,10: PRINT "Invalid selection" ' Unknown request
180 GOTO 130 ' Restart
190 '
200 ' Selection 1 : Read input line
210 ' =====
220 LOCATE 20,10: INPUT "Input line to read (0..7) ";NUM ' Get line number
230 IF NUM < 0 OR NUM > 7 THEN GOTO 170 ' Valid D0 to D7
240 NUM$ = RIGHT$(STR$(NUM),1) ' Make character
250 PRINT #1,"!RB"+RIGHT$(STR$(NUM),1) ' Send to module
260 LINE INPUT #1,ANS$ ' Check answer
270 LOCATE 20,10: PRINT "Level on line number";NUM;"is "; ' 0 = low level
280 IF MID$(ANS$,3,1)="0" THEN PRINT "Low" ELSE PRINT "High" ' 1 = high level
290 GOTO 130 ' Restart
300 '
310 ' Selection 2 : Set output line high or low
320 ' =====
330 LOCATE 20,10: INPUT "Output line to write to (0..7) ";NUM ' Get line number
340 IF NUM < 0 OR NUM > 7 THEN GOTO 170 ' Valid D0 to D7
350 LOCATE 21,10 ' Get requested
360 INPUT "Enter '0' to set level low, '1' to set high";LEV ' output level
370 IF LEV = 0 THEN LEV$ = "0" ELSE LEV$ = "1" ' "0" or "1"
380 PRINT #1,"!WB"+RIGHT$(STR$(NUM),1)+LEV$ ' Send request
390 LINE INPUT #1,ANS$ ' Check answer
400 GOSUB 650
410 IF ANS$ << " !ACK" THEN PRINT "Command refused": GOTO 130 ' !NACK = refused
420 LOCATE 20,10: PRINT "Output line";NUM;"set "; ' Else display
430 IF LEV$ = "0" THEN PRINT "low" ELSE PRINT "high" ' output level
440 GOTO 130
450 '
460 ' Selection 3 : Configure line as input or output
470 ' =====
480 LOCATE 20,10: INPUT "Line to configure (0..7) ";NUM ' Get line number
490 IF NUM < 0 OR NUM > 7 THEN GOTO 170 ' Valid D0 to D7
500 LOCATE 21,10 ' Get request
510 INPUT "Enter '0' for output '1' for input";INOUT ' "0" = output
520 IF INOUT = 0 THEN INOUT$ = "0" ELSE INOUT$ = "1" ' "1" = input
530 PRINT #1,"!CB"+RIGHT$(STR$(NUM),1)+INOUT$ ' Send request
540 LINE INPUT #1,ANS$ ' Check answer
550 GOSUB 650
560 IF ANS$ <> " !ACK" THEN PRINT "Command refused": GOTO 130 ' !NACK = refused
570 LOCATE 20,10: PRINT "Line ";NUM;"configured as "; ' else report
580 IF INOUT$ = "0" THEN PRINT "output" ELSE PRINT "input" ' configuration
590 GOTO 130 ' Restart
600 ' Exit to system
610 ' =====
620 CLS ' Return to
630 SYSTEM ' operating system
640 '
650 ' Subroutine : Clear area on screen
660 ' =====
670 LOCATE 20,10: PRINT STRING$(70," ") ' Clear line 20
680 LOCATE 21,10: PRINT STRING$(70," ") ' Clear line 21
690 RETURN ' Return to
700 END ' Main program

```

Listing 4. RS-232 to digital I/O sample program.

## RS232 TO 8-BIT DIGITAL I/O CONVERTER MODULE PARTS LIST

RESISTORS: All 0-6W 1% Metal Film (Unless Specified)

R1	33Ω	1	(M33R)
R2	22k	1	(M22K)
R3,4	47k	2	(M47K)
R5-8	10k	4	(M10K)
R9	470Ω	1	(M47OR)
R10	10k 9-resistor SIL Array	1	(DL78K)

CAPACITORS

C1,4	100μF 10V Radial Electrolytic	2	(FF10L)
C2	22pF Monolithic Ceramic Plate	1	(RA34M)
C3	100nF 50V Ceramic Disc	1	(DK05F)

SEMICONDUCTORS

D1,2	1N4148	2	(QL80B)
LD1	5mm Red LED	1	(WL27E)
TR1-3	BC547	3	(QQ14Q)
TR4,5	BC557	2	(QQ16S)
IC1	PIC16C54RC/P M511	1	(DT02C)

MISCELLANEOUS

Con 1,2	1x36 Straight Pin Strip	1 Strip	(JW59P)
	18-pin DIL Socket	1	(HQ76H)
	PCB	1	(GJ39M)
	Instruction Leaflet	1	(XV85G)
	Constructors' Guide	1	(XH79L)

OPTIONAL (Not in Kit)

IC1	ULN2803A	1	(QY79L)
-----	----------	---	---------

LD1-8	Rectangular Red LED	8	(Y45Y)
RM1	220Ω SIL Resistor Array	1	(RA24B)
	Stripboard (2.54mm)	1	(JP46A)
	PCB Pins 1mm	1 Pkt	(FL24B)
	Ribbon Cable 10-way	1 Length	(XR06G)
	3-way PCB Latch Housing (2.54mm)	1	(BX97F)
	10-way PCB Latch Housing (2.54mm)	1	(FY94C)
	PCB Latch Housing Terminal	2 Pkts	(W25C)

The Maplin 'Get-You-Working' Service is available for this project, see Constructors' Guide or current Maplin Catalogue for details.

**The above items are available as a kit, which offers a saving over buying the parts separately.**

**Order As 95018 (RS232 to 8-bit I/O Converter Module) Price £14.99**

Please Note: Where 'package' quantities are stated in the Parts List (e.g., packet, strip, reel, etc.), the exact quantity required to build the project will be supplied in the kit.

The following new items (which are included in the kit) are also available separately, but are not shown in the 1996 Maplin Catalogue

RS232 to 8-bit I/O Converter Module PCB

**Order As 95019 Price £2.99**

Preprogrammed PIC16C54RC/P M511 Microcontroller

**Order As 95039 Price £10.99**

Ready assembled RS232 to 8-bit I/O Converter Module

**Order As 95049 Price £19.99**

## ACCESS CONTROL – Continued from page 23.

ator software, it is transmitted to a smart card reader and stored on a smart card.

A common criticism of voice recognition has to do with impersonations. This is not regarded as serious, however, as the devices purposely focus on characteristics of speech other than those that people listen for and imitate. Speech patterns are formed through a combination of physiological and behavioural factors that are impossible to duplicate. There are many companies working in this area, including ITT, British Telecom, NCR/AT&T, Digital Equipment and Texas Instruments.

## Sign Here

Verifying signatures in the financial world has caused signature dynamics to be a key development area for biometrics. The answer to signature recognition, is to distinguish between habitual parts and those that vary with every signing. Static signature capture is

becoming a popular replacement for pen and paper in bank card, PC and delivery service applications.

Verification devices rely on wired pens, sensitive tablets, or both. Yet the financial community has been slow to adopt automated signature verification methods for credit cards and checking account applications, because bankers demand very low false reject rates. So, developers have concentrated on computer access and physical security instead.

## Tap those Keys

Keystroke dynamics, or typing rhythms, is a developing area of biometrics. The method is to analyse the way a user types at a terminal, by monitoring the keyboard inputs 1,000 times a second. The user does not realise he is being identified unless told. The better the user is at typing, the easier it is to make the identification.

The advantages in the computer environ-

ment are obvious – neither enrolment nor verification disturbs the regular work flow, as the user would be tapping the keys anyway. Since the input device is the existing keyboard, the technology costs less. Keystroke dynamics may also come in the form of a plug-in board, built-in hardware and firmware or software.

However, there are some difficulties to be overcome. Differences in the physical characteristics of keyboards and communications protocol structures are issues which developers have to surmount, but it is one of the most eagerly awaited biometric technologies.

## Conclusion

Biometrics is emerging as the most foolproof method of automated personal identification in demand in an increasingly automated world. The years ahead will produce some exciting systems in the personal recognition, access, security and control systems areas. 

# IMPORTANT NEWS FOR OVERSEAS READERS!

Obtaining components and kits for the projects featured in **Electronics** is now easier than ever in the following countries and regions:

**Channel Islands**  
C.I. Components Ltd.,  
Crossways Centre,  
Bray Road,  
Vale, Guernsey.  
Tel: 01481 44177  
Fax: 01481 42291

**Middle Eastern Region**  
**Saudi Arabia**  
(Alkhubar Region)  
Fadan Establishment,  
P.O. Box 848  
Alkhubar 31952  
Kingdom of Saudi Arabia  
Tel: 3 898 2737  
Fax: 3 898 2737

**United Arab Emirates (U.A.E.), Bahrain, Kuwait, Oman, Qatar**  
Maplin Middle East Company,  
P.O. Box 47019,  
Hamdan Street,  
Abu Dhabi, U.A.E.  
Tel: (971) 02 760332  
Fax: (971) 02 760317

**Lebanon**  
N and Y Controls,  
P.O. Box 175414,  
Beirut, Lebanon.  
Tel: (01) 443091/397467  
UK Office:  
Tel: (44) 1702 347614  
Fax: (44) 1702 77161

**African Continent**  
**South Africa, Namibia, Botswana, Lesotho, Swaziland, Mozambique, Angola, Zimbabwe**  
Maplin South Africa (Pty) Ltd.,  
P.O. Box 1846,  
Somerset West, 7129  
Republic of South Africa.  
Tel: (024) 51 51 24  
Fax: (024) 51 51 27

**Mediterranean**  
**Malta**  
Cam Services, Cam Centre,  
Off Canon Road, Qormi,  
QRM 09, Malta.  
Tel: 484650  
Fax: 447174

**Gibraltar**  
Mail Order International,  
c/o Medsun,  
P.O. Box 225,  
93-99 Irish Tawn,  
Gibraltar.  
Tel: 79797  
Fax: 74664

**Far Eastern Region**  
**Pakistan**  
Link Pakistan, Suite Number 2,  
2nd Floor,  
I-R Plaza, Markaz F-10,  
Islamabad, Pakistan.  
Tel: 51 291406  
Fax: 51 282319

**Countries and Regions Not Listed**  
Export Department,  
Maplin Electronics plc.,  
P.O. Box 3, Rayleigh,  
Essex, S56 8LR, England.  
Tel: +44 1702 554155  
xtn 326, 327 or 351  
Fax: +44 1702 553935

Export catalogue and pricing details are available from the listed distributors.

**MAPLIN**  
ELECTRONICS AND BEYOND

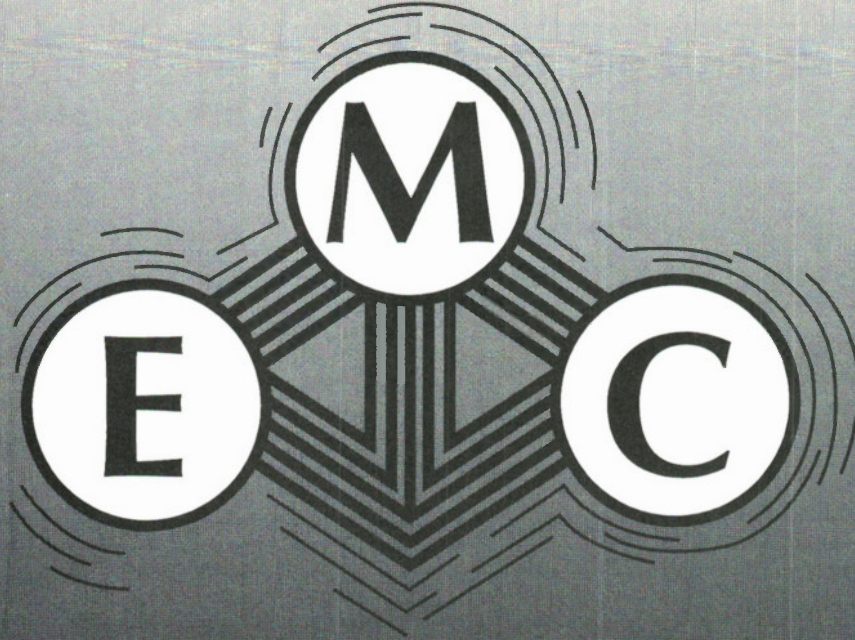

# – an Extra Major Calamity?

by J. M. Woodgate B.Sc.(Eng.), C.Eng.,  
M.I.E.E., M.A.E.S., F.Inst.S.C.E.

## Part 1—Where We Are and How We Arrived There

EMC stands for 'electromagnetic compatibility', a mouthful which has a correspondingly complex official definition. What it boils down to, is that any piece of electrical or electronic equipment can potentially interfere with the operation of any other, but if they don't, then the two pieces are 'compatible'.

**W**HILE the interference problems are usually more evident if two pieces of equipment are close together, they could even be on opposite sides of the world. Consider, for example, trying to receive in Australia a short wave transmission from Britain on a frequency very close to that of a much higher-powered transmitter in France. To eliminate interference from the unwanted transmitter, you would need a receiver with good selectivity and good cross-modulation performance, because even a directional antenna would not be much help.

### The Stone (or at least Crystal) Age

Interference problems between transmitters appeared even in the very early days of radio, because the simple receivers had poor selectivity and some types of transmitter, notably spark transmitters, produced signals of quite wide, and fairly uncontrolled, bandwidth. The situation became better and worse practically simultaneously, when triode valves were introduced in receivers. The valve provided the opportunity to obtain better selectivity through the use of more tuned circuits, less heavily damped by both signal source and load. However, the intentional or unintentional occurrence of RF positive feedback ('reaction' if it was intentional) both increased selectivity and made every receiver a potential, and all too often an actual, oscillator and transmitter.

### Electrical Interference

Around 1930, the increasing use of radio for other purposes than broadcasting, and the increased use of electrical machines in industry and the home, led to the realisation that these machines could also cause serious interference with radio reception. Most of the trouble was due to sparking, and some of the early household equipment, such as food mixers and electric shavers, used motors or speed-control devices which generated very energetic sparks. This energy was barely constrained by tuned circuits, so it was radiated from the wiring over a very large bandwidth indeed (for those days), such as 10Hz to at least 30MHz, as measured on a vintage electric shaver before I threw it away. There was some attempt to reduce the spark energy, but this was designed simply to reduce the vaporization of the contacts, not to minimise interference.

### First British Legislation

The intervention of the Second World War, bureaucratic inertia and very different political attitudes from today's, even in the post-war Labour government, delayed legal controls on electrical interference in this country until the 1949 Wireless Telegraphy Act. The preservation of this early 20th century name for radio communication is sufficient evidence of the bureaucratic inertia aspect. This Act, which was quite controversial at the time, sought

only to protect AM broadcasting on long and medium waves, and it was only after several more years, and increasing public agitation, that a legal requirement was introduced to require cars to be fitted with suppressors to reduce interference with Band 1 television transmissions (41.5 to 68MHz).

### Voluntary Restraint and the German Dimension

During the 1960s and 70s, there was a gradual increase in both legal and voluntary control of potentially interfering emissions. One example of voluntary control was the agreement on limiting oscillator radiation from television and FM radio receivers, adopted by most major manufacturers in Europe to prevent interference between one receiver and another when the oscillator frequency fell within the reception band. However, during this time, the German government, prompted by the German Post Office, introduced very stringent controls on emissions from all kinds of electrical and electronic equipment, partly justified by the post-war restrictions on the number and power of their broadcast transmitters. These controls, incidentally, had the effect of defending the German electronics industry against foreign competition, but of course, that was regarded by the authorities as a regrettable necessity.

### First Steps by the EEC

By the early 1970s, the politicians of the EEC (as it then was) realised that the different laws on radio interference in the members states represented a considerable technical barrier to trade, something the Treaty of Rome was supposed to get rid of. They therefore introduced two Directives, one on radio interference from household appliances, and one specifically on interference from fluorescent lamps. These Directives were based on CISPR 14 and CISPR 15, two international performance standards for emissions, produced by CISPR (Comité International Spéciale des Perturbations Radioélectriques, a subsidiary body of the International Electrotechnical Commission, or IEC). Directives of this kind are not themselves laws, but the member states are required to bring them into force in terms of their own laws, so that, in theory, the laws are the same over the whole Community (take no bets on this!). The technical requirements of the standards were, with some changes, included in the Directives themselves, and this proved to be a BIG mistake, because all standards are frequently revised. This is not (contrary to legend) because the standards bodies want to keep selling new versions, but because electrical and electronic science and engineering are still evolving rapidly. It takes long enough to revise a standard, but when it comes to revising legislation, we are talking decades.

### A 'New Approach'

Faced with this problem (which industry had been telling them about for some years), the EEC launched the concept of 'New Approach Directives', which would set requirements only in very general terms, and allow equipment manufacturers to rely on standards to prove that their equipment satisfied the detailed technical requirements. This cleared the way for a new and far more comprehensive



sive Directive on radio interference, which has become known as 'the EMC Directive', even though it is not the only, and certainly not the first, Directive concerned with this subject. It was published in 1989, and was due to come into force on 1st January 1992. But, it was found essential to introduce a four year delay so that equipment manufacturers could redesign, or make new products, meeting the requirements of the Directive. So now it comes into force on 1st January 1996, although the industry in general (but not, of course, Maplin Electronics plc) is still far from ready. Computer manufacturers are pleading for another five years of development before they can cope with some of the requirements.

## The CB Radio Problem

The rash of interference complaints which arose when CB radio equipment began to flood into Europe, led to another aspect of EMC being brought to wide notice. There had been problems of this nature before, right back to the restarting of television broadcasting after the Second World War, and some spectacular accidents, involving many fatalities, in the military field. The problem is that a piece of equipment may be overly-sensitive to a perfectly legitimate radio signal or electric, or magnetic field. This is known as susceptibility or 'lack of immunity'. In the early days of post-war television, many receivers were 'wide open' to legal amateur radio transmissions, which often fell in the IF band of the receiver. Although the Post Office (which was then in charge of such matters) would help if the problem was technically soluble, if it was not, the amateur was simply shut down, and told not to transmit on that band or bands.

The problem came up again with CB radio, especially the illegal AM variety, because many television receivers were overly sensitive around 27MHz, and they now have to meet requirements in this respect (standard BS905-2/EN55020). The result of these problems was that the 1989 Directive not only seeks to control emission of potentially interfering signals, but also requires attention to the achievement of an adequate degree of immunity.

## European Standards

The standards which are intended to support the Directive are standards prepared or adopted by the European standards bodies CENELEC, ETSI and CEN. We need not be concerned with the latter two, because they deal with telecommunications and non-electrical matters (except automobile electronics), respectively. When CENELEC looked at the standards available to support the EMC Directive, it was concluded that none of them were satisfactory and all would have to be revised. This took (and is still taking!) an enormous amount of time, because it is easy to agree a standard if conforming to it is voluntary, but if you might go to jail if your product does not conform, you are likely to be much less willing to agree.

## The Export-market Question

The situation is complicated, because some EU countries see the EU as almost their sole export market, and will, therefore, settle for purely European standards, while others, including Britain, want to trade worldwide and

do not want to have to make different versions of products for different countries. They thus want European EMC standards to be as close as possible to the international standards produced by IEC and CISPR, preferably identical. There is a further dimension introduced by some countries for what can only be politely described as philosophical reasons. This involves thinking of all the possible (and sometimes, it seems, extremely quasi-possible) EMC effects that could occur, and then insisting that all equipment meets requirements for these effects (usually called 'phenomena', which indicates the type of approach), whether there has ever been an actual reported case of such interference or not. For example, the mains supply voltage waveform is not usually precisely sinusoidal – it contains harmonic distortion. These harmonics can, it appears, cause problems to very large electric motors. OK – there is provision in the standards system so that motors can be tested for this effect, but some countries want *everything* potentially subject to similar testing, even though the result is virtually certain to be 'no effect'.

## Scope of the Directive

The Directive applies to ALL manufactured electrical and electronic equipment offered for sale or used for the first time in the EU after 31st December 1995. Some equipment, of course, is not 'manufactured' – anything you make at home for your own use. Kits, however, are regarded as 'manufactured', and Maplin has to ensure that a sample made-up kit of each type meets the relevant requirements of the Directive. Again, some equipment is incapable of producing significant emissions or of being unduly lacking in immunity, such as a torch. A digital watch is sometimes quoted as another example, and emissions are indeed almost undetectable, but a badly-designed watch could well misbehave under the influence of an RF field.

## Home-constructed Equipment

This does not mean that anything you make at home can freely interfere with anything else. There are two aspects to this. The Directive refers to the definition of 'radio amateur' in the ITU Radio Regulations. Home-constructed equipment for amateur radio use is definitely outside the Directive, presumably because the licence legislation can be used to control any cases of interference. However, much home-constructed equipment is not for 'amateur radio'; it may be a computer peripheral, a security system, or any one of the hundreds of applied electronics projects brought to you by this magazine. It was suggested to

the British Department of Trade and Industry (DTI, which is the government department responsible for implementing the Directive in this country), that all home-constructed equipment should be treated in the same way, but this was not accepted. It *appears* (and it is virtually impossible to obtain clear rulings on such matters) that home-constructed equipment which causes interference, and is not for 'amateur radio' use, would be dealt with under the old Wireless Telegraphy Act legislation, part of which is not being repealed. However, the DTI does assure everyone that there are no plans to recruit 'EMC Police' to go around looking for minor violations of the rules, and, apart from pirate radio stations, whose owners and operators are considered to have had fair warning already, any violations that do come to notice will first be dealt with by 'advice', and only if the advice is ignored and the offence is repeated, will serious action (prosecution of offenders) be undertaken.

## Trading Standards and the CE Mark

Products made in large numbers and sold in shops will be investigated by Trading Standards officers. In order to show that a product is claimed by the manufacturer to meet all the EU Directives that apply to it, a special 'mark' has been devised, and it even has its own Directive, the 'CE Marking Directive'. The mark is shown in Figure 1, and in many cases, it will appear on the product itself, *but this is not compulsory*. It could be on the carton or in the instruction book, for example. The CE mark is NOT a product quality mark, unlike the BSI Kitemark, it is simply supposed to show that the product can legally be sold, and be transported across national borders, in the EU.

You may already have seen the CE mark on toys, because it is required by the Toys Directive to be shown. What has actually happened is that the mark has simply been added by some manufacturers in the Far East 'across the board' to everything they make. Indeed, the fact that a toy is produced by an unscrupulous manufacturer and is actually dangerous, makes it more likely that the manufacturer just adds the CE mark without doing anything to improve the toy. Much of industry warned that the CE mark scheme would not work, but the EU bureaucrats have to find out the hard way, thereby wasting millions of our taxes.

## EMC and Unfair Competition

The concept of the wide-ranging EMC Directive was 'sold' to some politicians with the aid of scare-stories about industrial robots running wild, driverless trains failing to stop and aircraft falling out of the sky. Now, it is certainly true that any or all of these things *could* happen, but it is hardly a justification for all that the Directive can imply. It bears down particularly hard on the smaller manufacturers, whose sales volume is not large. For them, the cost of testing sample products to make sure that they conform to the requirements of the relevant standards has to be spread over fewer unit sales, so that their products tend to become priced out of the market. Again, the manufacturer who skimps on testing, trusting that he will not be caught, can offer lower prices, at least for a while.

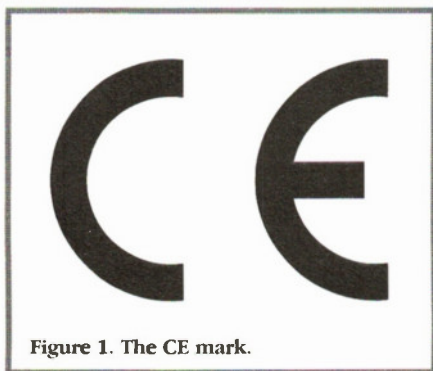

Figure 1. The CE mark.

## Double Whammy

In fact, the EU has dealt manufacturers a 'double-whammy', by extending the CE marking scheme to the Low Voltage Directive, which seeks to ensure that all electrical and electronic products are adequately safe in respect of electric shock, explosion due to discharge of stored electrical energy, fire and excessive temperature, ionising radiation (X-rays from cathode-ray tubes), laser radiation, chemical hazards from batteries and other components (such as RF transistors that contain toxic beryllium oxide) and mechanical hazards (tipping over, or injury from moving parts). The Low Voltage Directive (LVD) has been in force for several years, but from 1st January 1997, the attachment of the CE mark is a specific claim by the manufacturer, not simply that the product conforms to the EMC Directive requirements and is 'safe' in terms of the LVD, but that it *conforms to the requirements of the relevant European safety standard*, which could be a very different matter. Some Maplin products come within the scope of EN60950, which is basically aimed at computer equipment, but most should conform to EN60065, basically aimed at radio and television equipment. In the case of security systems, there is an as yet unresolved dispute: the European manufacturers have chosen to follow EN60950, but there is a body of opinion that says that EN60065 is more appropriate, especially for DIY systems.

## EMC Phenomena

Out of the endless list of theoretical possibilities, we can select some emissions which are most likely to cause interference, and some disturbances which are likely to show up inadequate immunity. A large number of the emissions and disturbances are effects which come with the mains supply. There are two reasons for this: first, there is a Directive, and an associated standard, EN50160, controlling the quality of the mains supply, and the electricity supply industry is naturally keen to ensure that anything that this standard allows to be delivered with the 50Hz will not result in equipment misbehaving. The second reason is that (apart from in the military world) EMC problems other than radio interference were first made subject to a formal standards-based attack by the industrial electrical and electronic controls industry, which was in the process of producing the multi-part international standard IEC801, when it was 'hijacked' to be converted into part of the even more

massive main IEC standard on EMC, IEC1000. This industry sector found that spurious signals on the mains supply were a major source of immunity problems, and another was electrostatic discharge, so these are very prominent in the list of phenomena.

## Emission Phenomena

Figure 2 shows a diagram of emissions from equipment. Descriptions of the various types of electromagnetic emissions follow:

**Radiated RF energy:** according to the basis of the Directive, this should be subject to limits over the whole frequency range from 9kHz to 400GHz, but in practice, only the range 30MHz to 1GHz is controlled for most types of equipment. This is partly due to the difficulty of making repeatable measurements outside this frequency range.

**Conducted RF energy:** the problems with measuring radiated energy at lower frequencies are dealt with by measuring conducted emissions on the cables connected to the equipment, since these are the main source of lower-frequency emissions in the range 150kHz to 30MHz. The most important cable is the mains lead, because once the RF energy gets into the wiring in the building, it can and does go anywhere, notably next door, so that nice Dr. Jekyll at No. 6 very soon becomes nasty Mr. Hyde! For most equipment, too, the mains lead is the longest lead connected to it.

There are two sorts of radiated and conducted RF: *continuous* and *discontinuous*. Continuous disturbances are generated by devices such as clocked logic, phase-controlled dimmers, and anything that continually produces fast-edged waveforms. Discontinuous interference is produced in more-or-less isolated bursts, by switches, thermostats and programmable timers, for example. Different methods have to be used to measure the two kinds of disturbance.

**Magnetic field:** mains transformers, for example, emit magnetic fields with the main component at 50Hz, often with strong harmonics at 150 and 250Hz. This can be a serious problem with rack-mounted equipment and stacked Hi-Fi, particularly since cassette-deck heads are specifically designed to pick up magnetic fields. Electricity (kilowatt-hour) meters are particularly 'good' emitters.

**Electric field:** there are not many sources of significant electric fields, apart from high-voltage power lines and electric fencing.

**Mains harmonic currents:** it may seem strange at first to refer to currents at har-

monics of the mains frequency as emissions, but they are. While motors and other devices can produce such harmonic currents, the most significant for *Electronics* readers is the DC power supply. Irrespective of whether it is a 'linear' supply, with a mains transformer, or a switch-mode supply with a rectifier connected directly to the mains, if it includes a reservoir capacitor, it draws current from the mains supply in the form of a narrow pulse nearly centred on the peak of the voltage waveform (see Figure 3). There was a full analysis of this in my series on power supply design (*Electronics* Issues 48 to 50), but for now, we just note that any short current pulse can be broken down into a current at the fundamental frequency plus a series of currents at harmonic frequencies – integral multiples of the fundamental frequency. For most purposes, it is not the harmonic currents themselves that matter, but the flattening of the peaks of the mains voltage waveform. In fact, one power supply which causes peak flattening makes life difficult for other power supplies, because their output voltages (or the input voltage to the regulator circuit if the power supply is regulated) depend on the peak voltage of the mains supply, and this is exactly what is being squashed down.

An extreme case of mains harmonic current disturbance concerns half-wave rectification directly from the mains supply, which was very common in radio and television receivers between 30 and 40 years ago. This technique results in strong zero-order harmonic currents, or plain old DC, which is very effective in saturating the core of the sub-station transformer. Apart from getting very hot, the transformers used to produce very loud buzzing noises, and more than one actually exploded. Direct half-wave rectification is, therefore, now banned except in a few special cases.

**Mains voltage dips and fluctuations:** while the source impedance of the mains supply is very low, as you find out if you short-circuit it, the value is not zero. This is why the current pulses drawn by rectifiers flatten the peaks of the voltage waveform. So, if the current drawn by a piece of equipment varies a good deal, over periods from about 30ms to 1s, the resulting variations in the supply voltage make the lights flicker, and this can be very annoying. Such problems mostly occur with domestic appliances such as washing machines, that have powerful heaters and motors that switch on and off automatically. Photocopiers can also produce this effect, and it is suggested that disco lights, too, are not innocent.

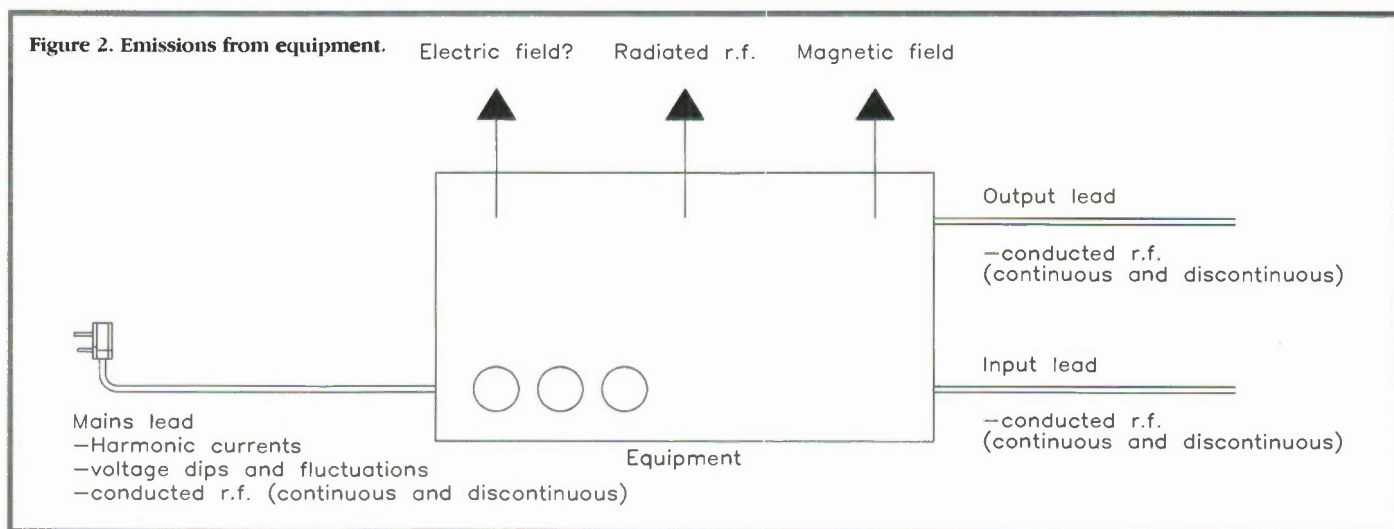

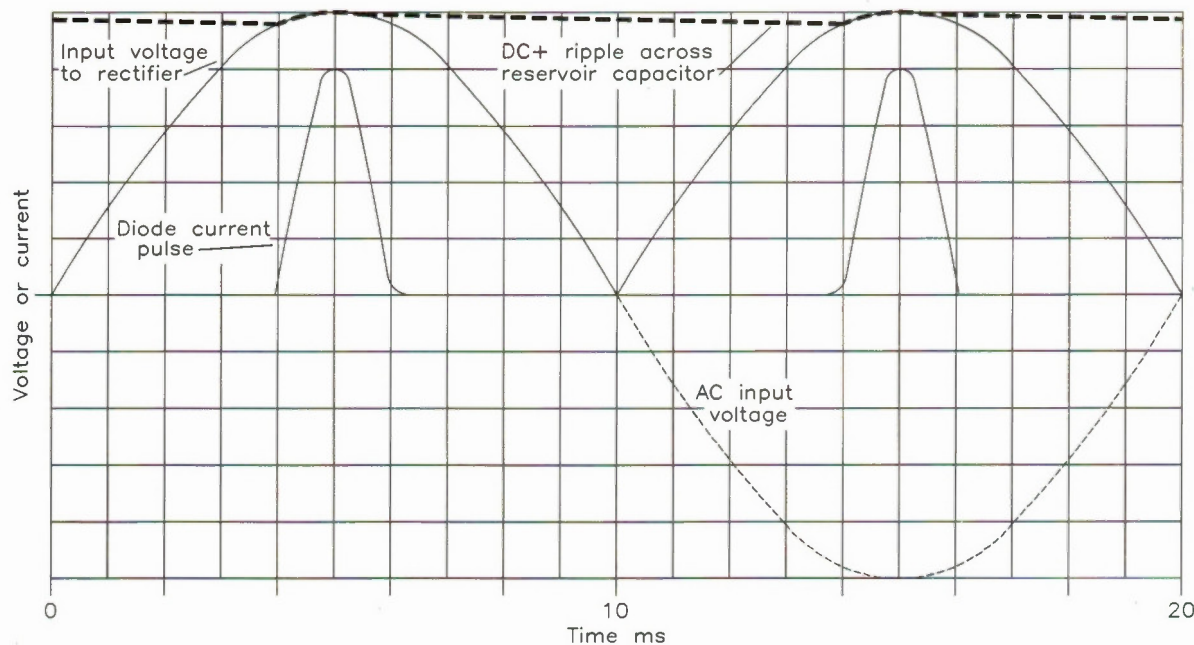

Figure 3. Voltage and diode current waveforms in a full-wave rectifier circuit.

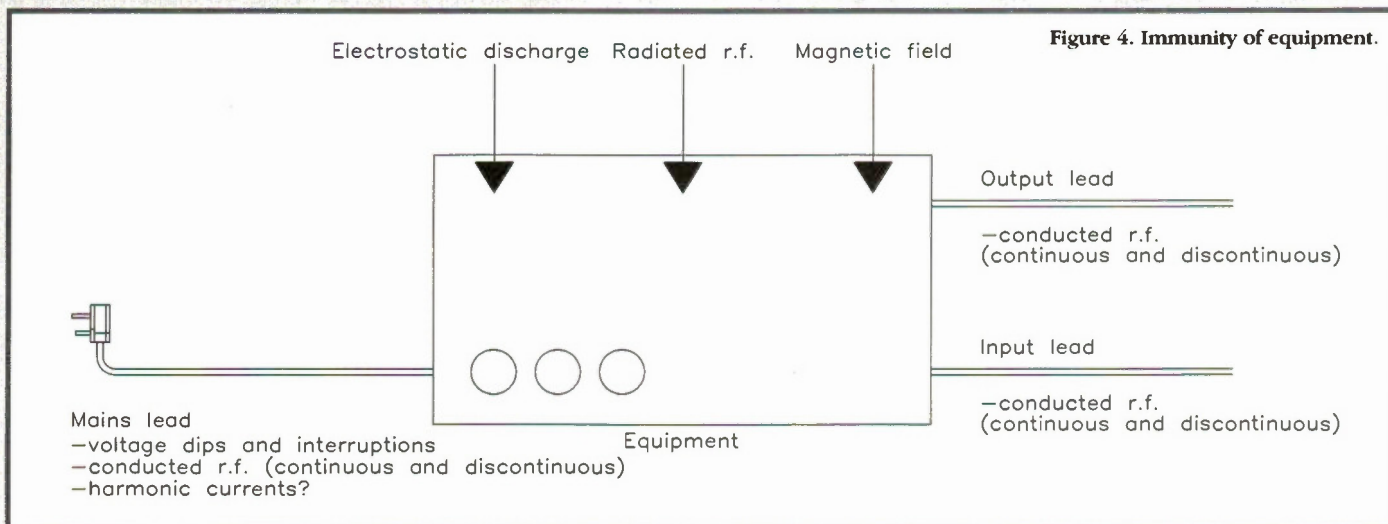

Figure 4. Immunity of equipment.

A problem here, is that the relevant standard, EN61000-3-3, is ambiguously written, and it has proved necessary to try to obtain clarifications on some points. This has happened because it is difficult to find people willing, or whose employers are willing for them, to edit the standards thoroughly before publication.

## Immunity Phenomena

There are obvious parallels between what is emitted and what is received, but there are also differences (see Figure 4).

**Radiated RF energy:** effects could be simply annoying, such as television interference, or very dangerous, such as failure of an electronically-controlled braking system. A major factor is that there may be nothing visible to suggest that a problem may occur, unlike the case of conducted RF considered next, where it may be obvious that a cable is too close to a source of RF.

**Conducted RF energy:** this is particularly a problem with audio and video equipment, especially if the incoming RF is amplitude-modulated, because the transistors in the affected equipment rectify the AM signal and the modulation appears within the audio or

video band, as noise or another intelligible signal. CW or FM signals are usually much less troublesome. Since the carrier amplitude is substantially constant, the effect of rectification is to produce a DC bias shift, which may have no significant effect unless it is quite large.

Poser-phones are a particular nuisance in this respect, because they can be used very close to cables or other equipment, and some types use a carrier system that is 100% square-wave modulated at 200Hz. Apart from conventional RF sources, there are wide-band disturbances on the mains supply, some of which result from switching operations on the high- and medium-voltage grid networks. As indicated above, the electricity supply industry is very keen to ensure that such disturbances do not cause equipment to malfunction.

**Magnetic field:** all sorts of equipment contains parts, even just loops of wire, in which external magnetic fields can induce disturbance voltages. Obviously, equipment that uses magnetic effects, such as cassette recorders and disc drives, can be particularly vulnerable.

**Electric field and electrostatic discharge:** external electric fields can induce currents in

conductors, but as mentioned above, strong electric fields are rare, except where electrostatic discharge is a real threat. There are two types: *air discharge*, which probably acts mainly through its accompanying electric field, and *contact discharge*, which can not only produce very high voltage across points which should only experience very low voltages, but can also produce quite enormous currents – 30A or more. In addition, the transient voltages and currents contain spectral components up to at least 1GHz.

**Mains harmonics:** As mentioned above, these are a problem only in certain special cases.

**Mains voltage dips and interruptions:** dips may occur due to load switching, as well as effects in the supply authority's equipment, while interruptions usually occur through damage to cable or overhead wiring. These effects are usually most troublesome for data processing equipment and automatic machinery, which may lose data or operating sequence.

## The Story Continues . . .

Next time, we will look at some sources of emissions and some circuits which may have poor immunity.

# D VHS

## DIGITAL VHS

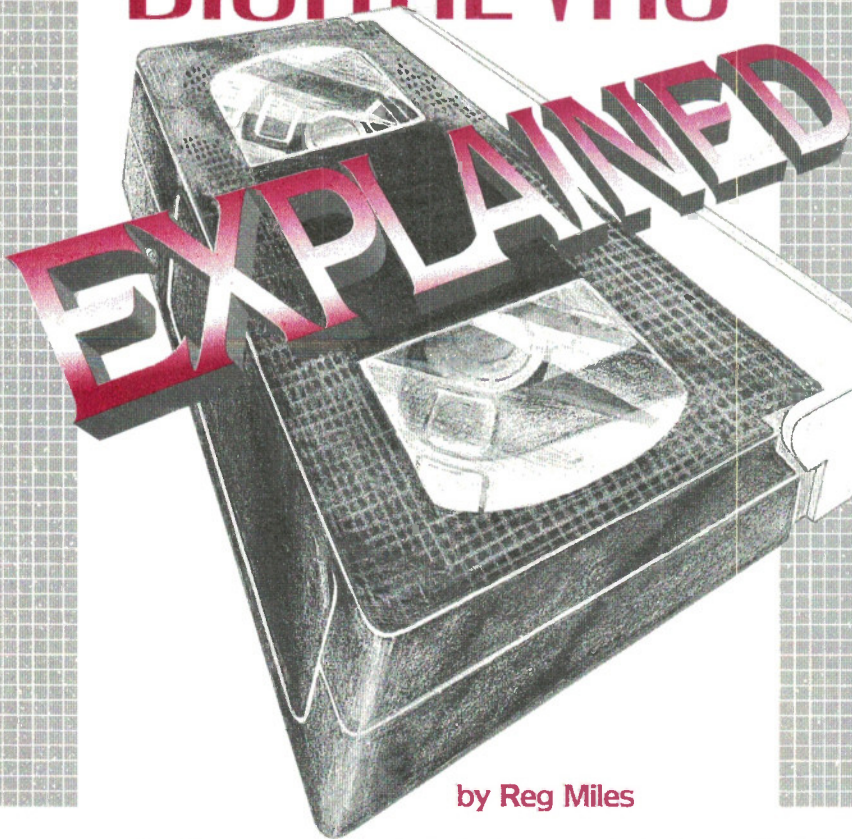

by Reg Miles

One reason for the success and comparative longevity of the JVC invented VHS format has been its adaptability; it has been able to embrace a number of developments for which it was never designed and yet, has not sacrificed compatibility in the process. A tape recorded on an early machine will still play on the latest models, an advantage that will continue with the latest development of Data/Digital VHS (to be called D-VHS). D-VHS is a development that will keep this format abreast of the coming use of digital broadcasts, while at the same time broadening its scope to encompass areas beyond video recording in this ever more digital world.

**T**HE success of VHS was far from certain at the beginning, however. When launched in 1976 (1978 in the UK), its picture quality was inferior to that of Sony's Beta format which had just beaten it onto the market, and both were criticised for their poor audio performance. The inferior picture was due mainly to its slower writing speed (head-to-tape velocity) of 4.85m/s against 5.83m/s, which has a direct effect on resolution. The fact that the wider VHS track gave a better signal-to-noise (S/N) ratio did not do much to help matters, for it soon became apparent

that it was easier to improve the S/N ratio than the resolution. The criticism of audio performance was rather unfair on both: with most of the 12.7mm tape width used for video tracks, there was room for only 1mm of audio track at the edge (see Figure 1), and the tape speed of just 23.39mm/s (18.73mm/s Beta) had been chosen to maximise recording time.

However, when stereo was introduced by dividing the audio track and adding a guard-band between left and right, reducing each to just 0.35mm, its inadequacy became very obvious – a point exacerbated by the

introduction of half-speed Long Play. In 1983, Sony found the solution in Audio FM, whereby two frequency modulated carriers were squeezed into the NTSC Beta video signal, enabling audio to be recorded through the video heads with a bandwidth of almost 20kHz. When JVC attempted to follow suit, it discovered that the VHS bandwidth was insufficient. Thwarted, the engineers developed an ingenious alternative, known as Depth Multiplex Recording. Here, dedicated audio heads on the drum record the two FM audio signals to the full depth of the tape's oxide coating, and then the following video heads record their higher frequency signals at the surface (shown by Figure 2), crosstalk being largely avoided by azimuth differences. Again, a bandwidth of almost 20kHz was achieved. Ironically, when Sony tried AFM on PAL machines, with their broader bandwidth there was not sufficient room, and Depth Multiplex Recording also had to be adopted. JVC has subsequently added PCM audio, sandwiched between the FM audio and video layers – but only on a few NTSC models.

### High Quality (HQ)

Improvements to the VHS picture followed in 1985, in the form of the High Quality (HQ) circuitry enabled by advances in electronics and tape technologies. HQ consists of two basic elements applicable to PAL machines: a raised white clip level and a detail enhancer; a third, optional, element is luminance noise reduction. The function of the white clip circuit is to clip the top of the pre-emphasised luminance signal to prevent over-modulation; with HQ, this is raised by 20%, resulting in clearer rendition of details. The detail enhancer sharpens the picture when the frequency is high and amplitude low, and luminance noise reduction is self-explanatory. That same year, Sony launched Super Beta, which was distinctly better. But by then, VHS was winning the battle for the public's hearts and wallets, making further Beta developments increasingly irrelevant outside Japan.

### Super VHS (S-VHS)

It wasn't until the development of Super-VHS in 1987 (1988 in Europe) that picture quality came of age. One of its more significant achievements was to increase the luminance bandwidth from about 3MHz to more than 5MHz (see Figure 3), boosting the horizontal resolution from around 250 lines to 400. S-VHS also introduced separate pro-

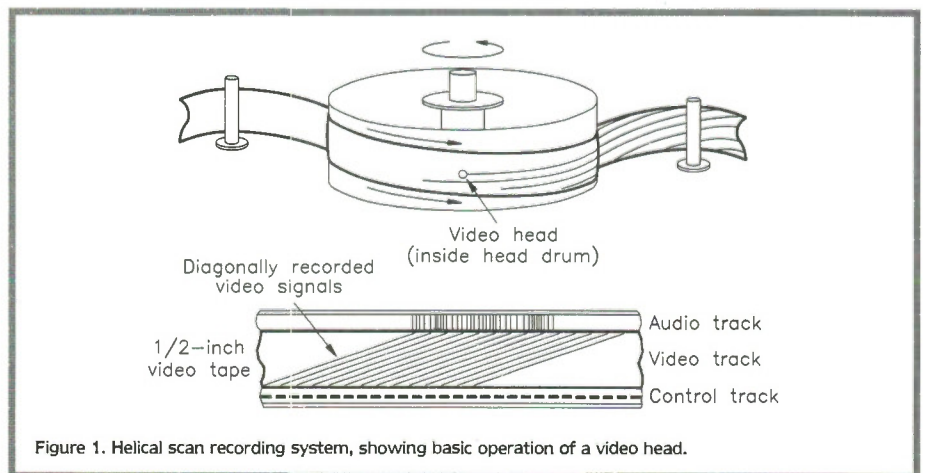

Figure 1. Helical scan recording system, showing basic operation of a video head.

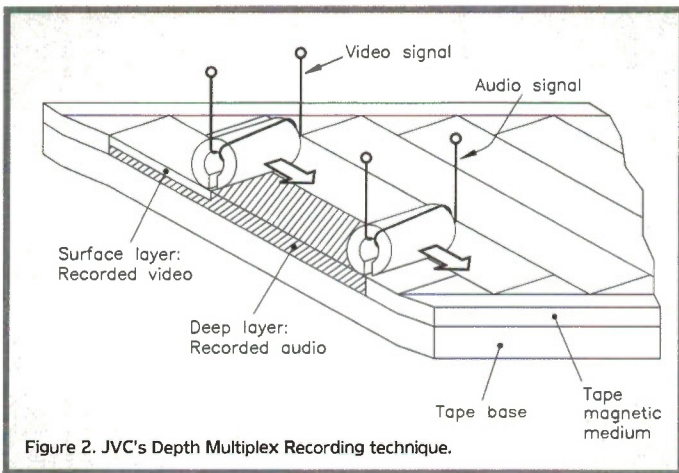
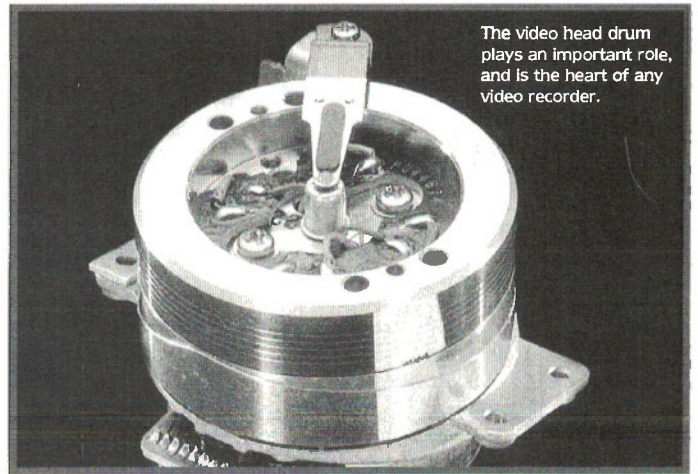

Figure 2. JVC's Depth Multiplex Recording technique.



The video head drum plays an important role, and is the heart of any video recorder.

cessing of the luminance (Y) and chrominance (C) signals (refer to Figure 4), reducing such effects as spurious colour on finely patterned areas, and allowing European S-VHS VCRs to handle both PAL and SECAM TV systems, while an increase in frequency deviation from 1 to 1.6MHz improved both dynamic range and S/N ratio (shown in Figure 3). The standard VHS cassette was retained, but with an additional identification hole. The tape, however, required finer magnetic particles to cope with the sub-micrometre wavelengths resulting from the increased luminance bandwidth. Because of these changes, VHS and S-VHS recordings are not directly compatible: all S-VHS VCRs do have the facility to record and play VHS tapes (with no quality improvements); but VHS machines cannot play S-VHS recordings unless quasi S-VHS playback circuitry is incorporated, but the result will be VHS quality.

### Widescreen VHS (W-VHS)

Before parting company with analogue VHS, there is one more development that should be mentioned because it pushes the format to what may well prove to be its limit – Widescreen, or W-VHS. At present, it is limited to Japan's 1,125-line High Definition TV system (known as Hi-Vision) and standard 525-line NTSC, although it could easily be adapted to record a European 1,250-line HDTV system and 625-line PAL/SECAM system (however, it seems unlikely that Europe will adopt an analogue HDTV system). W-VHS adds two extra pairs of video heads, which record half of the odd and half of the even fields on one track, and the other halves on an adjacent track, the signal having been divided up by digital signal processing (as Figure 5 demonstrates). It will also record NTSC at higher quality than both S-VHS and normal VHS. However, W-VHS itself is incompatible with both, and requires metal particle tape to cope with the higher frequencies. Potential uses include recording two normal definition TV programmes at once, or two camera signals – possibly for 3D programming or ultra-wide panoramic material. JVC Professional is promoting it in Europe as the least expensive means of high definition origination for presentations and displays.

D-VHS, conversely, is not intended for origination, but to record digital signals exactly as they are and to output them in the same state. This is bitstream recording: a method of recording compressed or processed signals directly as digital data. Thus, it will

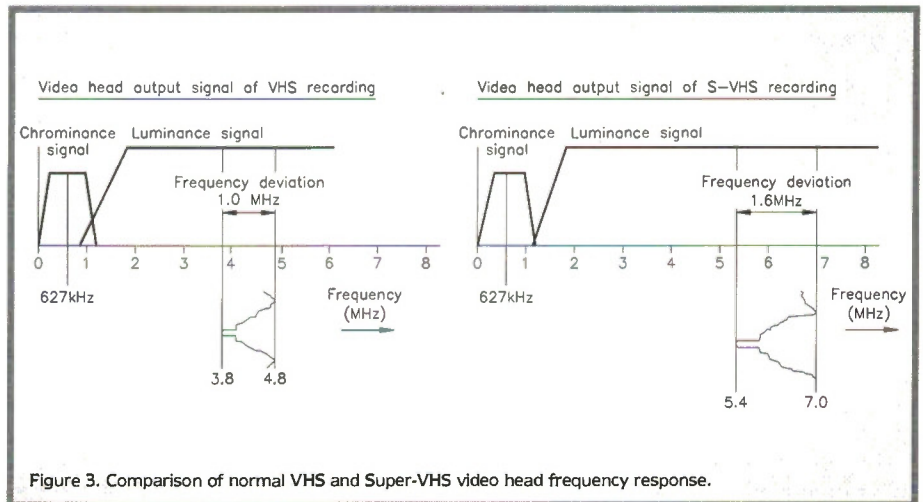

Figure 3. Comparison of normal VHS and Super-VHS video head frequency response.

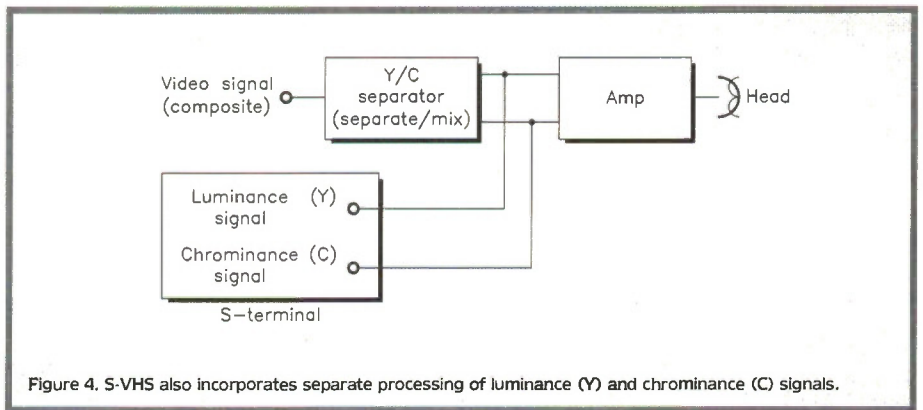

Figure 4. S-VHS also incorporates separate processing of luminance (Y) and chrominance (C) signals.

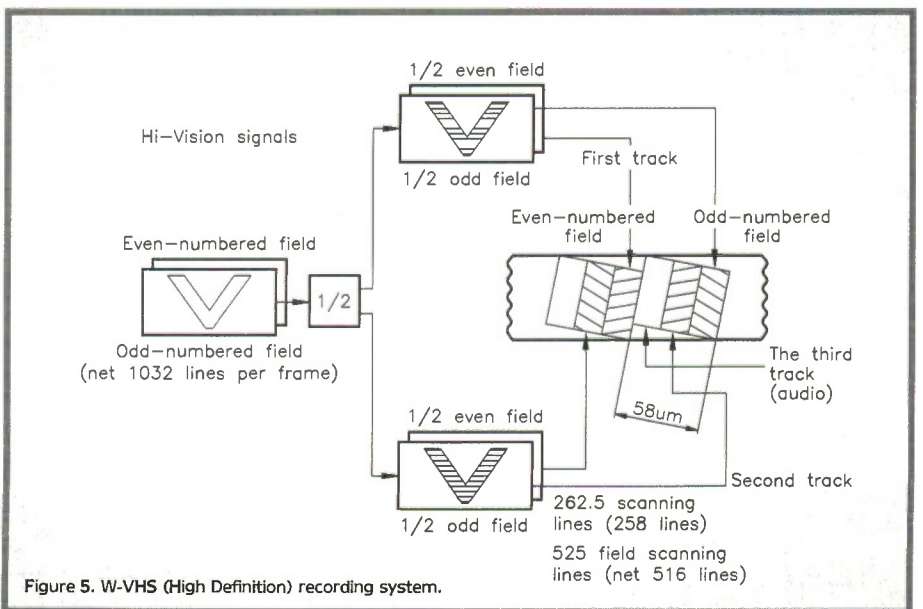

Figure 5. W-VHS (High Definition) recording system.

record equally as well from a satellite receiver, a computer, or any other digital source; the only real limitation being the data rate of the signal. The reason for adopting bitstream recording rather than a formatted approach, is the cost consideration: obviously a system that will begin its life in the domestic domain has to be affordable, and those who buy one will be assumed to have digital expansion and D-A conversion built into an existing set-top box.

Figure 6 shows the use of D-VHS for recording digital broadcasts, taking the data stream from the tuner and returning it on playback. This unfortunately means that an encrypted programme will be recorded as such, and will still need to be paid for. Programmes that are multiplexed together will also be recorded as such; the multiprogramme mode allowing the VCR to simultaneously record up to six multiplexed data streams, relying on the set-top box to select the desired programmes on playback.

### Future Developments

Future set-top boxes will, therefore, require bitstream outputs and inputs to interface with D-VHS, together with the facility for the VCR to control the box when in timer recording mode. JVC co-operated with Hitachi and Thomson to develop an interface for the Digital Satellite System launched in the USA in 1994, while for the upcoming Echostar digital broadcasts in the USA, JVC will co-operate with Philips; whether the company will have to co-operate with others to develop interfaces for the European Digital Video Broadcast system and others planned for the future, remains to be seen. Other companies have already been involved in the initial development of D-VHS itself, with Hitachi, Matsushita and Philips/Grundig providing technical contributions. Other electronics companies have also expressed their support for the format, including: GoldStar, Mitsubishi, Samsung, Sanyo, Sharp, Sony,



JVC Digital-S video recorder.

Thomson, Toshiba, and most of the major tape manufacturers. The announcement of D-VHS by JVC, is a punctuation between the initial research and more specific developments, and is intended to alert the video industry to the future direction of VHS.

Because D-VHS cannot handle analogue recordings, it will be added to analogue VCRs – either VHS or S-VHS, thus maintaining compatibility with the vast number of VHS and far fewer S-VHS recordings, as well as allowing the recording of analogue material. The price premium of D-VHS in the UK is expected to add around £250 to the price of an analogue machine, thus, a basic NICAM VHS model will retail for about: £650, and the S-VHS version for about £300 more. JVC predicts that analogue and digital video will co-exist for the next 15–20 years, and that prerecorded video software will continue to be produced in analogue form – unless the market dictates otherwise.

### D-VHS Operation

D-VHS is based on the conventional VHS mechanism, and employs the same tape path with the same pair of heads for digital

and analogue. In the case of digital, the heads record the tracks in single swipes with a provisional width of 29µm. The drum rotates at the normal PAL/SECAM speed of 1,500rpm (1,800rpm for NTSC), thus obviating the complication of having to change the speed for analogue recording. Metal tape has also been avoided, S-VHS tape is used in a conventional cassette, but with an additional identification hole.

Three recording modes are proposed: Standard, High Definition and Long Play. The first has a maximum input data rate of 14.1M-bps and a recording rate of 19.1M-bps, the difference is necessary to be able to incorporate error correction, which takes the form of the much-used Reed-Solomon code. The modulation system employs the Serial Interface-Non Return to Zero Information used in a number of digital systems, such as CD, which cuts interference by not giving a signal when it reads a zero. The recording time is 5 hours with a capacity of 31.7G-bytes, or 7 hours and 44.7G-bytes with thin tape. The detailed specifications for HD and LP modes have yet to be decided, but the input data rate for the former has been set at a maximum of

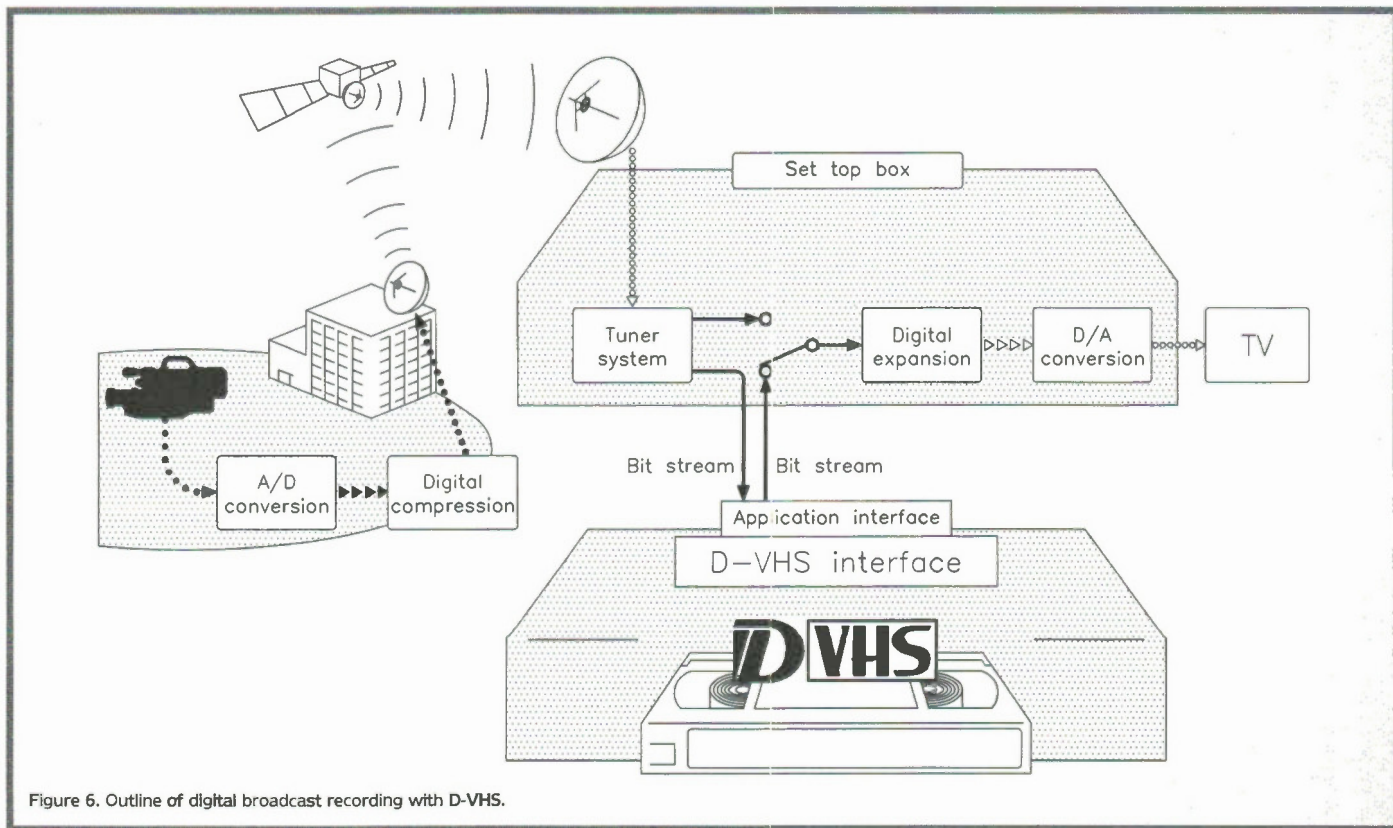

Figure 6. Outline of digital broadcast recording with D-VHS.

28.2M-bps with recording times of 2.5 and 3.5 hours, while the latter will record for 49 hours at 2M-bps.

JVC will probably launch D-VHS first in the USA in 1996, and in other countries as digital broadcasting becomes available. Once it has become established in this initial role, it is intended to take advantage of the bit-stream recording to make it also work as a multimedia system. It will not be able to compete with the rapid access of disc-based systems, but it does possess the advantages of high storage capacity at low cost. Other future applications, include video games, computer tape streamers, the transmission of video pictures over phone lines, and security systems. The last role would advantageously exploit the 49-hour LP mode and the facility to record up to six multiplexed signals simultaneously. As yet, there is no interface available that can change the output signals of the cameras to a multiplexed bitstream, but JVC reports that interest has already been expressed by a number of security companies, and it seems inevitable that such a system will not be long in materialising.

### Dynamic Drum (DD) System

Another innovation announced by JVC at the same satellite-linked press conference, is the 'world's first Dynamic Drum system'. The DD is a solution to the mistracking that occurs when a VCR plays at any speed other than that at which the tape was recorded,

until now been necessary to maintain compatibility between recordings made on one VCR and played on another. In the case of the DD system, both the lead rail and the drum are able to move independently. The drum assembly is supported by four bearings on the base and four on the lead ring (two front and two back in each case), with strong spring loading to maintain the assembly in a neutral position for normal recording and playback (depicted in Figure 7a). Inclination of the drum and lead ring is accomplished by a motor acting on screws which push the lead ring and drum up one side or the other (see Figure 7b), stability being maintained by the spring pressure. The range of motion is shown in exaggerated form in Figure 8, the actual movements being in  $\mu\text{m}$ . The precise inclination of the DD is determined by the System Control in response to the strength of the FM signals from the video heads – the stronger the signal the more accurate the tracking (as Figure 9 shows). Fore and aft inclination is also possible to provide for future applications. The DD system is not essential for D-VHS but it will help, just as it will for VHS and S-VHS. It should appear on an S-VHS model to be launched in November 1995 – with a price premium of £30–£40.

### Additional Functions of the DD System

While the basic function of the DD is to enable noise-free pictures from still to fast

picture search, it also has the potential for more advanced functions. It can overcome the problem of mechanical deviations in the tape transport mechanism caused by various factors which result in deformed video tracks, it will provide smoother slow motion, while for specialised uses, it can be used to record a single track or series of tracks when in the pause mode. Recording is also possible in reverse, thus allowing endless recording by changing direction at each end of the tape, with the only problem being the need to cool the motors to prevent them from overheating. Finally, it will enable the recording density to be increased, by exploiting the tracking accuracy to reduce track width.

### Digital S Professional Formatted System

The professional side of JVC has also been experimenting with digital recording, and has developed Digital S. This differs from D-VHS in being a formatted system, recording a compressed component digital signal. It is intended for production and post-production uses in the sub-broadcast market, taking signals from cameras and other VCRs. JVC's consumer arm is relying on the new Digital Video Cassette format to cope with the needs of camcorder users in the future (for it seems unlikely that there will be a D-VHS camcorder). DVC was jointly developed by a number of companies, including JVC, and employs a cassette of metal tape approximately the size of that used for DAT.

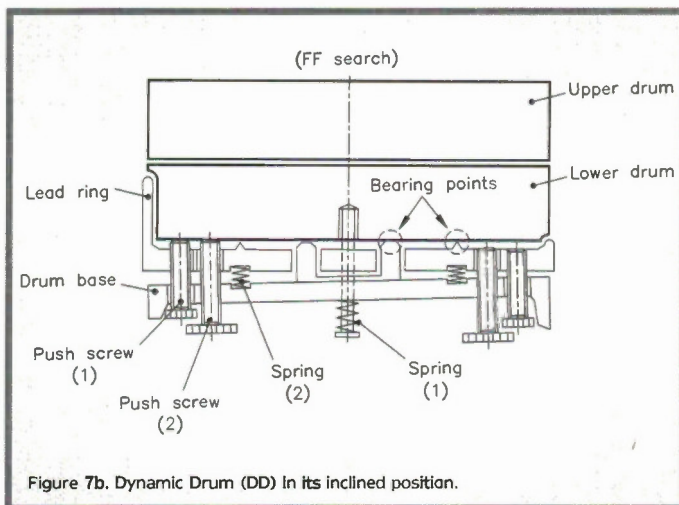
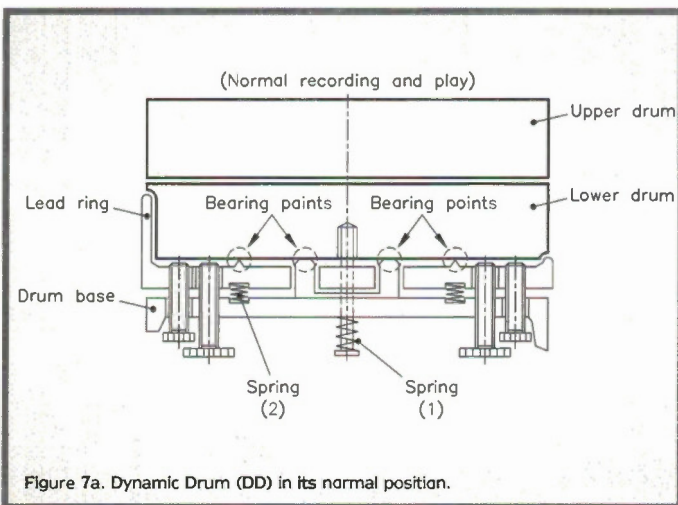

creating noise bars as the heads cross other tracks. The idea of automatic track following is not a new one: the now obsolete Philips/Grundig developed V2000 consumer format had its video heads mounted on piezo-ceramic plates that moved in response to control voltages, and many professional machines utilise some form of track following heads. But, there is always the problem with heads that can move relative to the drum, that wear on the actuating mechanisms or temperature changes can actually introduce mistracking. With DD, the heads are fixed relative to the drum, and it is the drum itself that moves.

A normal VHS drum assembly is composed of a fixed lower drum mounted on a lead rail to keep the tape from slipping off, which is firmly mounted on a diecast base, with a rotary upper drum incorporating the video (and audio) heads mounted on the lower drum. This fixed drum assembly has

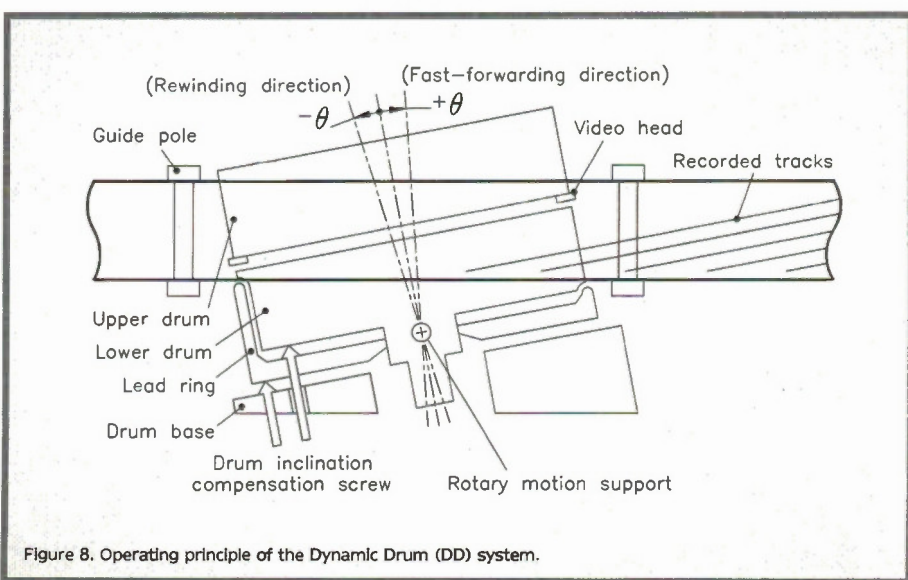

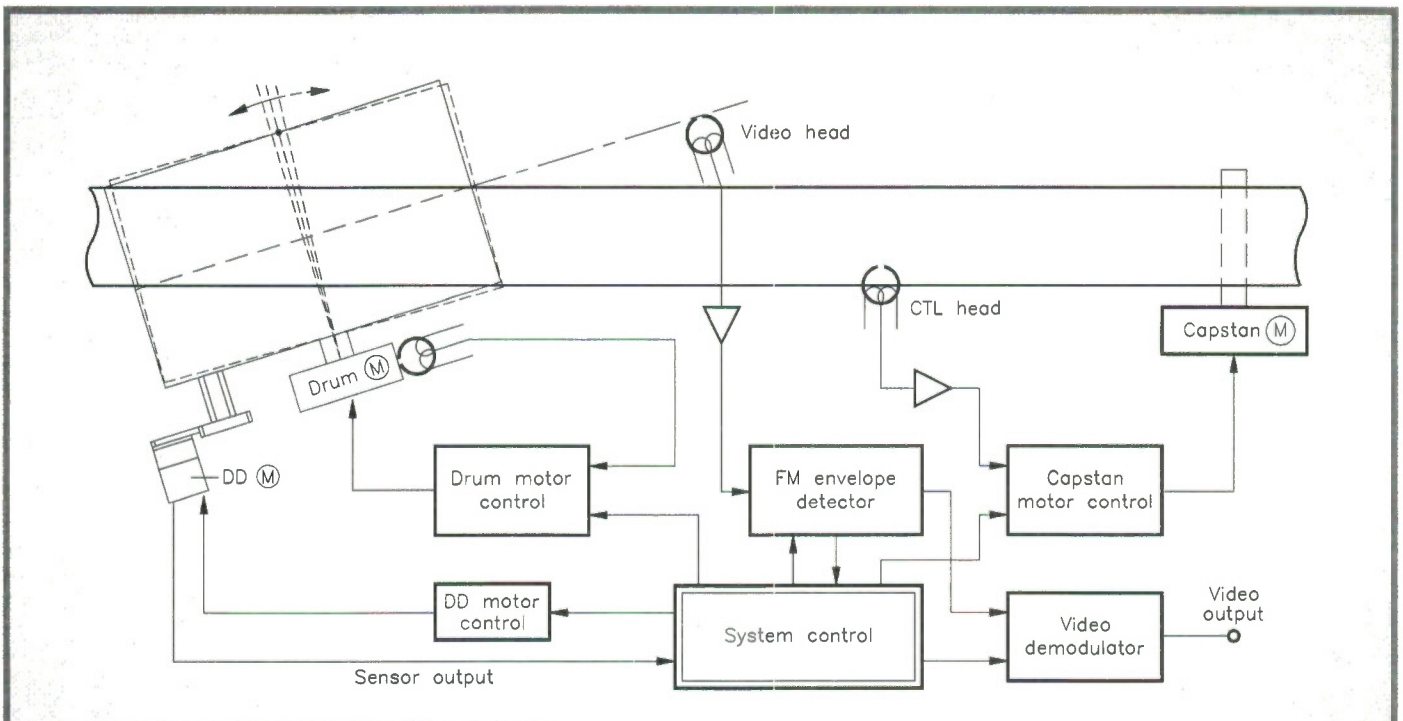

Figure 9. Block diagram of the Dynamic Drum (DD) control system.

Digital S is a rather radical redesign of the format, although S-VHS playback is retained. As a component machine, it treats the luminance and chrominance signals (R-Y, B-Y) separately, using the standard 4:2:2 sampling ratio of  $Y=13.5\text{MHz}$  and  $R-Y/B-Y=6.75\text{MHz}$ , which halves the horizontal resolution of the chrominance but with little noticeable effect, because it is the luminance that provides the important image detail. The 8-bit quantisation gives 256 grey scale levels, and the signal is compressed by a factor of 3:3:1 for recording, using a system based on the Discrete Cosine Transfer technique, which transforms picture blocks into discrete frequency spectra for processing, producing a data rate of 50M-bps. Audio is two channel PCM, sampled at 48kHz, in 16-bit quantisation. Both channels are capable of being individually edited, because

although recorded on the same tracks as the video, the audio is in different sections. In addition to the tracks being segmented, there are twelve per frame instead of two, to cope with the high data rate, each 20µm wide. They are recorded by four heads on the drum, which rotates at 4,500rpm – three times normal PAL speed. The drum has the same 62mm VHS diameter, but employs a triple layer structure with top and bottom sections fixed, and a rotating centre section carrying the heads. This layout is used to improve track linearity, by providing more precise tape positioning, and it has low inertia for precise control when switching to S-VHS rotation. The cassette is the same size as the S-VHS one but has a dustproof housing, and uses metal particle tape, giving 105 minutes at 57.8mm/s.

A wide range of facilities are provided.

Playback speeds can be varied over a considerable range, with picture search at 32x normal. Another useful facility is pre-read, or read before write, also found on other professional digital VCRs, in which the heads read the video and audio and following heads write it back in the same place after the signals have passed through a mixer, caption generator, or whatever. This can be used to enable one machine to imitate a two machine edit suite, or two machines to imitate a three machine set-up, with obvious savings in cost. Digital S prototypes have been shown, but production models are not expected before 1996. The combination of new and existing technologies should ensure that VHS in all its various forms, both consumer and professional, will continue to be successful well into the 21st Century.

#### AUDIO

**MILLENNIUM 4-20 METALWORK**, loaded PCBs at moderate prices. One only, complete stereo chassis, uprated choke/capacitor PSU, 7581A output valves with current balance circuit, ceramic valveholders, £350. Tel: (0181) 427 1378 (Harrow).

#### COMPUTERS

**AMSTRAD PC1640 COMPUTER**, with manual and original software, EGA monochrome, 20M-byte disk, as new. Ideal as a word processor. £75. Tel: (01923) 776159.

#### VARIOUS

**AVO 8 Mk. 5**, £130, **AVO 7**, £50. Well maintained with leads clips and prods, or £160 for both collected, or carriage at cost. Tel: (0121) 5562171 (Nr. Walsall).

#### HAMEG 60MHz DUAL-TRACE

**OSCILLOSCOPE**, excellent condition, little used with one × 10 probe. Offers around £350. Racks full of various chips and bits. For offers and details, Tel: (0151) 632 6557 (Wirral).

**LARGE DRAWING BOARD (A0)** for sale. Screws to table top. Cutting mat surface, parallel motion, with dust cover. £45 o.n.o. Buyer collects. Tel: (01268) 755543 (evenings).

#### BBS CORNER

**APPLE CRACKERS**. FirstClass Client BBS, mainly for AppleMac and PC users. Baud rate 2.4K-bit/s to 14.4K-bit/s, 8 data bits, no parity, 1 stop bit. Tel: (01268) 781318/780724.

**MACTEL METRO/ICONEX**. FirstClass Client BBS, AppleMac and PC users. E-mail address on Internet for registered users. Baud rate 2.4K-bit/s to 14.4K-bit/s, 8 data bits, no parity, 1 stop bit. Tel: (0181) 543 8017 (Metro) or (0115) 9455417 (Iconex).

**SPIDER! AMIGA BBS**. The lighter alternative. Mainly Amiga and some PC files. Fidonet, MercuryNet and Mufonet. Online games. Speeds up to 19200. Tel: (01568) 613520.

## CLASSIFIED

Placing an advertisement in this section of *Electronics* is your chance to tell the readers of Britain's Best Selling Electronics Magazine what you want to buy or sell, or tell them about your club's activities – Absolutely Free of Charge! We will publish as many advertisements as we have space for. To give a fair share of the limited space, we will print 30 words free, and thereafter the charge is 10p per word. Placing an advertisement is easy! Simply write your advertisement clearly in capital letters, on a postcard or sealed-

down envelope. Then send it, with any necessary payment, to: Classifieds *Electronics-The Maplin Magazine*, P.O. Box 3, Rayleigh, Essex S56 8LR. Advertisements will be published as soon as possible, space allowing. No responsibility is accepted for delayed publication or non-inclusion of advertisements.

Readers who have reasonable grounds to believe they have been misled as to the nature of an advertisement are advised to contact the Publisher and their local Trading Standards Office.

#### CLUB CORNER

**AARS (Aberdeen Amateur Radio Society)** meets on Friday evenings in the RC Hall, 70 Cairngorm Crescent, Kincorth. For details contact: Martin, (CM0JCN), Tel: (01569) 731177.

**THE BRITISH AMATEUR ELECTRONICS CLUB** (founded in 1966), for all interested in electronics. Four newsletters a year, help for members and more! UK subscription £8 a year (Junior members £4, overseas members £13.50). For further details send S.A.E. to: The Secretary, Mr. J. F. Davies, 70 Ash Road, Cuddington, Northwich, Cheshire CW8 2PB.

**DERBY AND DISTRICT AMATEUR RADIO SOCIETY** meets every Wednesday at 7.30pm, at 119 Green Lane, Derby. Details from: Richard Buckley, (G3VGV), 20 Eden Bank, Ambergate DE56 2GG. Tel: (01773) 852475.

**E.U.G. User group** for all 8-bit Acorn Micros, since 1991. Still going strong. Programming, news, information, sales. Contact: E.U.G., 25 Bertie Road, Southsea, Hants. PO4 8JX. Tel: (01705) 781168.

**BURY ST. EDMUNDS AMATEUR RADIO SOCIETY**. Meetings held at Culford School, 7.30pm for 8.00pm on the third Tuesday of each month, unless otherwise stated. Further details from: Kevin Waterson, G1GVI, 20 Cadogan Road, Bury St. Edmunds, Suffolk IP33 3QJ. Tel: (01284) 764804.

**THANET ELECTRONICS CLUB**. For school age Ham Radio and Electronics enthusiasts, enters its 18th Year. Meetings held every Monday evening from 7.30pm at The Quarterdeck, Zion Place, Margate, Kent. For further details contact: Dr. Ken L. Smith, (G3JJK), Tel: (01304) 812723.

**CRYSTAL PALACE & DISTRICT RADIO CLUB**. Meets on the third Saturday of each month at All Saints Church Parish Rooms, Beulah Hill, London SE19. Details from: Wilf Taylor, (G3DSC), Tel: (0181) 699 5732 or Bob Burns, (G3COU), Tel: (01737) 552170.

**WINCHESTER AMATEUR RADIO CLUB** meets on the third Friday of each month. For full programme contact: G4AXO, Tel: (01982) 860807.

#### SCIENCE AT YOUR FINGERTIPS,

for 'hands-on' science experiences and experiments, *Science at Your Fingertips Science Review*, Membership £2.50. For further details, please contact Daniel and Caroline Gee, The S.A.Y.F., 37 South Road, Watchet, Somerset TA23 0HG.

**THE LINCOLN SHORT WAVE CLUB** meets every Wednesday night at the City Engineers' Club, Waterside South, Lincoln at 8pm. All welcome. For further details contact Pam, (G4STO) (Secretary). Tel: (01427) 788356.

**TESUG (The European Satellite User Group)** for all satellite TV enthusiasts! Totally independent. TESUG provides the most up-to-date news available (through its monthly 'Footprint' newsletter, and a teletext service on the pan-European 'Super Channel').

It also provides a wide variety of help and information. Contact: Eric N. Wiltsher, TESUG, P.O. Box 576 Orpington, Kent BR6 9WY.

**MODEL RAILWAY ENTHUSIAST?** How about joining 'MERC', the Model Electronic Railway Group. For more details contact: Paul King (Honorary Secretary), 25 Fir Tree Way, Hassocks, West Sussex BN6 8BU. Tel: 812723.

**SEEMUG (South East Essex Mac User Group)**, meet in Southend, every second Monday of each month. For details Tel: Michael Foy (01702) 468062, or e-mail to mac@mukeyfoy.demon.co.uk.

**SOUTHEND AND DISTRICT RADIO SOCIETY** meets at the Druid Venture Scout Centre, Southend, Essex every Thursday at 8pm. For further details, contact: P.O. Box 88, Rayleigh, Essex S56 8NZ.

**SUDBURY AND DISTRICT RADIO AMATEURS (SaDRAP)** meet in Gt. Comard, Sudbury, Suffolk at 8.00pm. Visitors and new members are very welcome. Refreshments are available. For details please contact Tony, (G8LTY), Tel: (01787) 313212 before 10.00pm.



# Stray Signals

by Point Contact

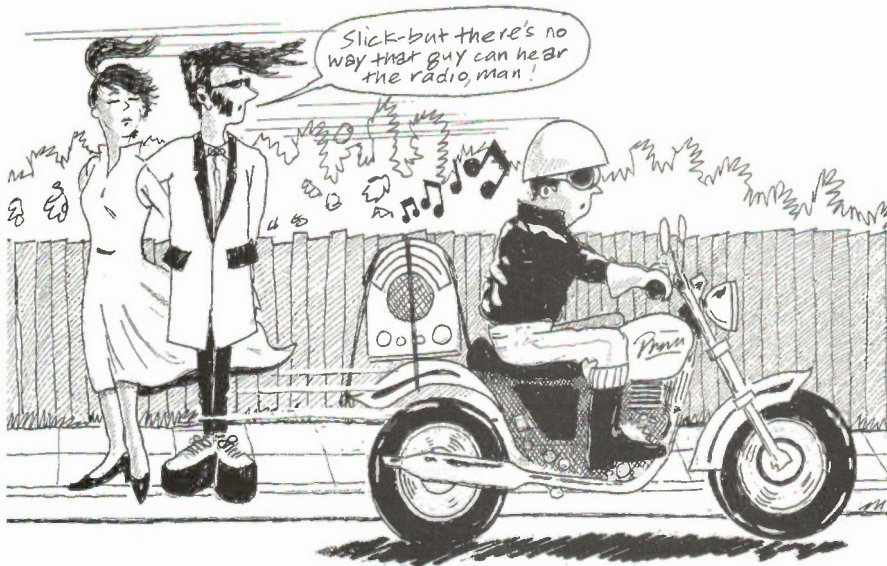

## Reliability

Semiconductors are, by and large, exceedingly reliable devices. Nevertheless, from time to time, one is faced with the task of troubleshooting some piece of equipment of other. The easiest faults to find are the really basic ones, such as an open circuit track in the power supply, leaving the equipment completely dead.

The most difficult are the intermittent faults – after all, you cannot find a fault which is annoyingly no longer there once you have at last got around to taking the covers off, even though you know it will reappear a day later once the item is back in use. Some faults are built-in and almost incurable, like the 'memory plague' which bugged users of a certain home computer popular in the early eighties. There, the problem was cross-talk between board tracks in the memory area, leading to occasional faulty reads or writes to RAM when an unfortunate collection of pulses on the address and data buses occurred.

One of the most annoying faults that PC ever faced was with a table radio, which, he had bought (in the 1950s) as a staff purchase for some friends living a couple of miles away. Occasionally, the radio would simply refuse to function when switched on, and PC felt morally obliged to sort it, the radio being, of course, just out of guarantee. So, I went round to my friends on my motorbike, had a quick peep in the rear through the ventilation holes in the back to check that the heaters were alight, and back to my home for more detailed investigation. It worked perfectly over the period I had it, only playing up again after being returned.

Naturally, my friends soon decided that PC was totally incompetent as a service engineer, and only on the umpteenth occasion did I finally crack it. The set was of the AC/DC variety, with a series heater string in series with the dial lights and a mains dropper. At last it played up for me, and after initially thinking that at least the heaters were all OK, I noticed that the IF valve (which unusually was at the earthy end of the chain) was not in fact alight – not easy to spot, due to the miniature all-glass valve's screening can fitting over the valveholder's deep skirt. Removing the valve and peering through the glass at the base end, it was just possible to notice an unusually long tail of heater wire projecting past the spot-weld to the heater pin. The tail was, in fact, resting lightly on a pin connected to some internal screening, this pin being earthed at the valveholder. The long heater tail was at the end of the heater which was not earthed, so when it happened to make contact, the IF valve stopped working, but the motorbike journey had vibrated it free again!

## Steam Radios

Mr and Mrs PC like to go out at the weekends. This may be a ramble of anything up to ten miles or so, on one of the guided walks organised by the Leisure Department of Hampshire County Council, and listed in a leaflet obtainable from any library – many other county councils organise similar arrangements. Or it may be, as members, to one of the properties of the National Trust. Last year, whilst away for a few days on a mini holiday in Somerset,

we visited Montacute House. Afterwards, we took a walk around the nearby village of the same name. There, we chanced across a cafe with, strangely, a Radio Museum in the back garden. The Montacute Radio Museum turned out to be very nicely arranged, with a display not only of old televisions, radios, wireless sets and wind-up gramophones, but also long-forgotten objects from yesteryear, such as lead blacking for grates, packets of Oxydol and Rinso, and other whiffs of nostalgia from the days between the wars. The visit to the village, the museum and the House, together with nearby Tintinhull House Garden made a very pleasant day out, fortunately enhanced by good weather.

## Mr Who?

As well as enjoying himself scribbling these notes every month, PC also writes articles and books under a variety of pen names. However, he recently found himself endowed with yet another name, unwanted and unloved. Having many years ago paid his money and registered with FEANI (the European Federation of National Engineering Associations), PC is entitled to recognition of his qualifications anywhere in Europe, should he ever feel inclined to work abroad. In return for the money, he is entitled to use the title Eur Eng or Eur Ing (European Engineer) and FEANI ordains that it should be used before any other title, prefix or honour. (They actually give a fictitious example to show the principle; I cannot remember it exactly, but it is something like Eur. Ing. Doctor The Right Honourable Viscount Muck OM, OBE, VC, DSO, JP, BSc. Hons., C. Eng., MIEE, MR)

As his college tie was rather worn and dilapidated, PC recently sent off for a new one, prefixing his name with Eur. Ing. The tie duly arrived, in an envelope addressed to Mr Eur. Ing! One can excuse the man in the street for never having heard of FEANI or Eur. Ing., but one might have expected the Imperial College of Science and Technology (where PC spent a less than brilliant year before failing the BSc. Eng. Part I exam) to have heard of it.

Yours sincerely,

*Point Contact*

*The opinions expressed by the author are not necessarily those of the publisher or the editor.*

# NEWS

## Report

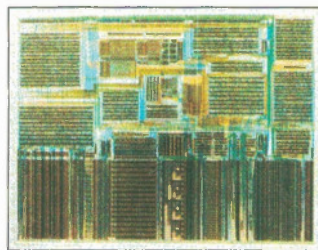

### IDT Memory Shipments up by 500%

Integrated Device Technology (IDT) is dramatically increasing shipments of the IDT71V256SA 32Kx8 15ns SRAM, third generation 3-3V design, to support Pentium PC demand. The company is increasing shipments of this product by 500% through to March 1996.

According to industry sources, 35 million Pentium systems are expected to be shipped this year, virtually all of which will use secondary cache memory. Ideally, 256K-bytes of high-speed cache is appropriate for maximum performance, and by using IDT's 71V256SA 32Kx8, users will see a 30% increase in Pentium system performance versus systems with no cache.

### TI Samples First ARM Thumb Core

Texas Instruments (TI) is the first Advanced RISC Machines (ARM) partner to fabricate a Thumb variation of the 32-bit ARM RISC microprocessor. Evaluation ARM7TDMI devices are being made available to TI customers developing high-volume consumer, communications and computing applications requiring 32-bit RISC performance with low power consumption at low cost. TMS470 evaluation devices integrate the ARM7TDMI core and a 100,000-gate gate array. The core contains only 74,203 transistors and on a 0.6µm, 3-level metal process, it takes up a mere 4.8mm<sup>2</sup>, about 7% of the chip's area. The fully static core delivers 36mips (Dhrystone 2.1) with a 40MHz clock.

Thumb aware processor cores combine the capability to execute both the 32-bit ARM and the 16-bit Thumb instruction sets. Careful design of the Thumb instructions allow them to be decompressed into full ARM instructions transparently during normal instruction decoding, without any performance penalty. ARM's approach differs from other 32-bit processors implementing a 16-bit data bus, which require two 16-bit memory accesses to execute every 32-bit instruction ('SX' style) and so, halve performance.

Contact: Advanced RISC Machines, Tel: (01223) 400400.

### Lexmark Production Facility in Scotland

Lexmark International is to open a £26 million inkjet cartridge production facility in Rosyth, Fife. Manufacturing of colour and monochrome cartridges is expected to begin in the second quarter of 1996, creating up to 500 new jobs during the next three years. The new 90,000ft.<sup>2</sup> building will house cartridge production lines in a virtually dust-free environment.

### Compact Scanner, Copier and Fax Device

Fax, photocopier, scanner – they are all the same thing, according to Plustek Electronics. The company has just announced PageReader, a multi-function 256 greyscale sheetfed scanner, photocopier and fax machine. Priced at £199, PageReader is supplied with Recognita Plus Optical Character Recognition (OCR) software, allowing users to convert scanned documents

to text files, and an imaging application, iPhoto Plus, for the management, manipulation and conversion of graphical files. Documents and images are scanned at resolutions of up to 800dpi. In addition, the PageReader's own utilities convert the scanner to a photocopier and plain-paper fax machine, when used in conjunction with a printer or fax modem.



### Speech Recognition Speeds Hospital Diagnosis

IBM has today launched a new speech recognition solution, called VoiceType Dictation for Pathology. The system is already in use in the Histopathology Department of London's Royal Free Hospital to assist consultants in analysing biopsy tissue samples and presenting diagnoses. IBM VoiceType Dictation is a generic speech recognition system with many potential applications. VoiceType was tailored specifically for pathologists by a team of UK doctors and IBM's own experts at Hursley Park, Hampshire.

IBM VoiceType Dictation is an accurate system which analyses the spoken word and immediately turns it to text on a computer screen, at a rate of 70 to 100 words a minute. Customised to recognise each user, and to input standard phrases from key words, VoiceType enables consultants to dictate, check and authorise reports at once, without the need to double-check clerical errors, which are commonplace when working with medical vocabularies. The time saved is critical, both for the patient, whose doctor receives the consultants' opinion quickly and can then collate diagnoses and form a treatment plan, and for the department, which can improve productivity and quality.

VoiceType Vocabulary for Pathology contains over 19,000 words derived by analysing reports from UK hospitals. The standard UK English version of 32,000 words, contains a general business vocabulary. As well as recognising word-by-word input in context, VoiceType can be prompted by single word commands to bring in user-defined phrases, significantly reducing the amount of time spent typing, correcting and proof-reading reports.

Contact: IBM Software, (01705) 492249.

### HP Gets Organised

Another PDA hits the market. The new OmniGo 100 hand-held organiser features a fully rotatable screen for either horizontal or vertical display, which allows users to switch between pen and keyboard interfaces. In addition, the unit comes with 1M-byte of RAM, one standard PCMCIA Type II card slot for additional data storage, and a serial port for PC and printer connectivity. Priced at £290, the OmniGo 100 includes diary and financial analysis software. And if you can tell us how it differs from the mass of other PDA-type products on the market, we would be delighted to hear from you!

Contact: Hewlett-Packard, Tel: (01344) 369222.



### ISDN Teleworking Misses the Mark

If you binned your 14.4 modem months ago, and are finding that a 28.8 version is not much better, then perhaps it's time to upgrade to ISDN. At least, this is what KNX want you to do. The company had launched a PC ISDN kit aimed at teleworkers. The device features data management handling, which ensures that your ISDN connection is only active when data is being sent or retrieved, a high level of security encryption, and Call Line Identification (CLI).

However, with UK ISDN charges remaining sky-high, the KNX ISDN kit will probably remain out of the price-range of the lone teleworker. If there is an application for the device, it is more likely to be in remote office environments, where a small group of people need connection to the Internet or other company offices.

Contact: KNX, Tel: (01756) 702500.



### Troubleshooting Toolbox for Windows

Still haven't got the hang of Windows '95? Well, Bill Gates didn't promise it would be right first time. An industry has grown on the back of Windows '95 to correct installation errors, optimise performance, and resolve hardware conflicts. One company riding high on the bandwagon is Quarterdeck. This month, the company has launched WINProbe 4, a cross-platform troubleshooting toolbox to help users get the most out of their Windows '95 and Windows 3.1 systems.

Priced at £49.95, WINProbe 4 diagnoses the source of hardware and configuration problems through over 200 individual tests, so that users can find the reason for hardware problems. A real-time Status Panel provides monitoring of critical Windows functions. Additionally, WINProbe 4 features on-the-fly optimisation of Windows 3.1 and Windows '95 memory and system resources. A Tune-Up option provides hundreds of general tips on optimally configuring the system to obtain peak performance.

Contact: Quarterdeck, Tel: (01245) 496699.

### PC Card for the Desktop

The SwapBox Plug 'n Play adds PC Card functionality to the desktop PC. The device has a dual slot for use of two Type I/II cards, or one Type I/II and one Type III PC Cards. From SCM Micro-systems, the Swapbox fits into a 3.5-in. drive bay, and connects via a ribbon cable to an internal controller card. The Swapbox costs £179.

Contact: SCM Microsystems, Tel: (01793) 619242.

### Personal Numbering

A variety of hypothetical schemes have been suggested for personal numbering. Under such a system, individuals would have a single telephone number for work, mobile, home, faxes, and voicemail. In October, Digital Mail offered its own strategy for personal numbering, and went one step further by offering a commercial service.

For £5 per month, Digital Mail will issue you with a Personal Digital Number (PDN), which is a normal direct-dial UK telephone number, and a 4 digit PIN (Personal Identification Number) for private access. While this does not provide direct access to an individual, it means that voicemail, or faxes can be left at your PDN, and by extending the service, you can use your PDN as your username for e-mail.

Contact: Digital Mail, Tel: (0171) 231 2929.

### New Radio for New Spectrum

In readiness for the release of the new Band 1 spectrum by the Radio-communications Agency, Diplomat Communications Systems have produced a 25W Band 1 radio. In addition to standard PMR features such as five tone signalling, CTCSS and DCS, the radio also incorporates remote stun and revival control, and a beacon facility. In addition to Band 1 coverage, the radio covers 30 to 250MHz.

Contact: Diplomat Communications Systems, Tel: (01256) 381656.

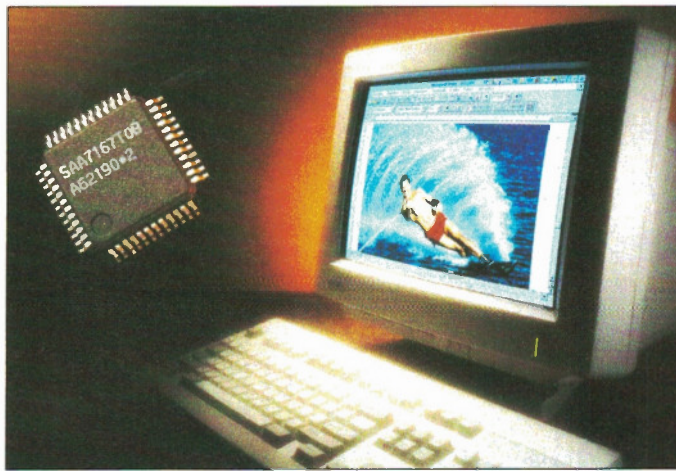

### Casualty Data Reaches Hospital Before Ambulance

In the first trial of its kind in the UK, a mobile data network operated by RAM Mobile Data is being used by Kent Ambulance to transmit patients' vital signs to Accident and Emergency departments before the ambulance reaches the hospital. Vital information including ECG waveform, pulse oximetry, heart rate and blood pressure is captured at the scene of an incident or on the way to the hospital. It is then transmitted to the receiving hospital in a matter of seconds over RAM's wireless data network.

The information is monitored at the receiving end by a consultant, who can make an immediate diagnosis and transmit information and instructions back to the ambulance crew. RAM Mobile Data has been granted a 25 year licence by the DTI, and operates an advanced public wireless data network.

Contact: RAM Mobile Data, Tel: (0181) 990 9090.

### DAC Merges with Digital Video

Philips Semiconductors has introduced a new member of its Desktop Video chipset, called the SAA7167 YUV-to-RGB Video DAC. The device not only converts digital video into RGB signals, it also mixes these signals with an external RGB channel – providing a low-cost solution to the problem of merging digital video sources with standard VGA graphics.

Contact: Philips Semiconductors, Tel: (+31) 40 72 20 91.

### Memory for Low Power Applications

Intel has announced 8- and 4M-bit SmartVoltage boot block flash memory devices, characterised at 2.7V. The 28F800CE and 28F400CE devices, available in 8- or 16-bit architectures, are designed to support the non-volatile memory requirements of wireless handheld devices such as mobile phones and PDAs.

Contact: Intel, Tel: (01793) 403000.



### Multistandard CLI Recognition and Decoding

Call Line Identification (CLI) provides the recipient of a telephone call with information about the caller's telephone number before the receiver is picked up. Consumer Electronics' FX602 chip meets the requirements of most current analogue Calling Line Identification system specifications – including the current ETSI draft specification.

The compact single-chip decoder/demodulator performs complete recognition and collection of CLI information from a telephone line, and working with a controller, will recognise and process all CLI information and deliver the data for display.

Contact: Consumer Electronics Limited (CML), Tel: (01376) 513833.

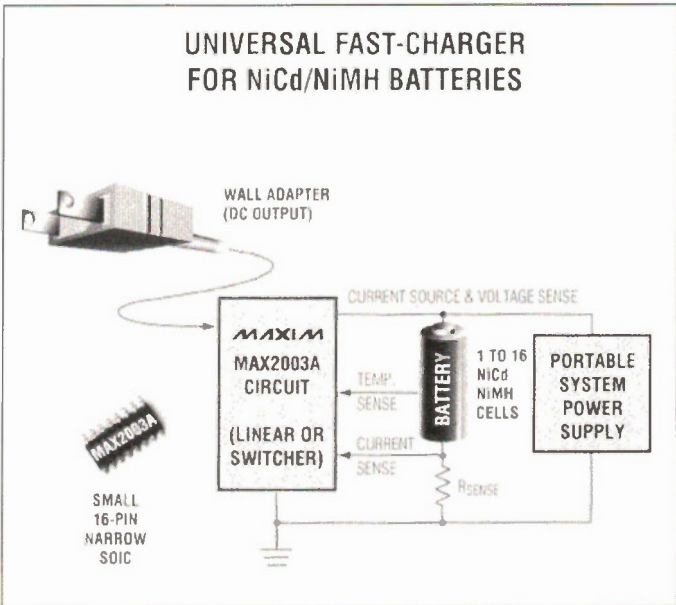

### Chip Enables Rapid Charging

To obtain optimum performance from Ni-Cd and Ni-MH batteries, a controlled charging regime is essential. Here lies a major conflict. Consumers typically demand fast charging times – who wants to wait 12 hours for a battery to charge to full capacity? Until recently, charging circuits have been complex, constructed from discrete components entirely to the designer's specification.

After working with battery manufacturers to develop an optimum rapid charge regime, Maxim have launched the MAX2003A, which allows Ni-Cd and

Mi-MH batteries to be charged rapidly by monitoring key battery parameters during charging, and optimising its charge current output.

Fast charge termination is accomplished by five methods: temperature slope; negative delta slope; maximum temperature; maximum time; and voltage. To promote battery conditioning and optimum capacity measurement, the MAX2003A allows a switch activated discharge before charge option. Other features include optional top off charging and direct drive for LED status lights.

Contact: Maxim, Tel: (01734) 303388.

# A Practical Guide to Modern Digital

# ICs

by Ray Marston

Part 5

The best way to learn about modern CMOS is by experimenting with the inexpensive 4007UB IC. The 4007UB houses little more than two pairs of complementary MOSFETs and one simple CMOS inverter stage; all of these elements are independently accessible, and can be configured in a variety of ways. The 4007UB is thus a very versatile IC, and is ideal for demonstrating CMOS principles to students, technicians, and engineers. It can be readily configured to act as a multiple digital inverter, a NAND or NOR gate, a transmission gate, or a uniquely versatile 'micropower' linear amplifier or oscillator, etc. This part presents a selection of practical circuits of these types.

## 4007UB Basics

Figure 1(a) shows the functional diagram and pin numbering of the 14-pin 4007UB, which houses two complementary pairs of independently-accessible MOSFETs, plus a third complementary pair that is connected in the form of a basic CMOS inverter stage. Each of the three independent input terminals of the IC is internally connected to the standard CMOS protection network shown in Figure 1(b). All MOSFETs in the 4007UB are enhancement-mode devices; Q1, Q3 and Q5 are p-channel types, and Q2, Q4 and Q6 are n-channel types. Figure 1(c) shows the terminal notations of the two MOSFET types; note that the 'B' terminal represents the bulk substrate. All modern '4000B-series' and fast '74-series' CMOS ICs are designed around the basic elements shown in Figure 1, and thus it is useful to get a good basic understanding of both the digital and the linear characteristics of these elements, starting off with those of the basic MOSFETs.

## Digital Operation

The input (gate) terminal of a MOSFET presents a near-infinite impedance to DC voltages, and the magnitude of an external voltage applied to the gate controls the magnitude of the MOSFET's source-to-drain current flow. The basic characteristics of the enhancement-mode n-channel MOSFET are such that the source-to-drain path is open circuit when the gate is at the same potential as the source, but becomes a near short-circuit (a low-value resistance) when the gate is heavily biased positive to the source. Thus, the n-channel

MOSFET can be used as a digital inverter by wiring it as shown in Figure 2; with a logic-0 (zero volts) input, the MOSFET is cut off and the output is at logic-1 (the positive rail voltage), but with a logic-1 input, the MOSFET is driven on and the output is at logic-0.

The basic characteristics of the enhancement-mode p-channel MOSFET are such that the source-to-drain path is open when the gate is at the same potential as the source, but becomes a near-short when the gate is heavily biased negative to the source. The p-channel MOSFET can thus be used as a digital inverter, by wiring it as shown in Figure 3. Note that in the Figure 2 and 3 inverter circuits, that the ON currents of the MOSFETs are determined by the R1 value, and these circuits thus draw a significant quiescent current when their MOSFETs are driven ON. This snag can be overcome by connecting the complementary pair of MOSFETs in the classic CMOS inverter configuration shown in Figure 4(a).

In Figure 4(a), with a logic-0 input applied, Q1 is driven fully on and the output is thus firmly tied to the logic-1 (positive rail) state, but Q2 is cut off and the inverter thus passes zero quiescent current via this MOSFET. With a logic-1 input applied, Q2 is driven on and the output is firmly tied to the logic-0 (zero volt) state, but Q1 is cut off and the circuit again passes zero quiescent current. This 'zero quiescent current' characteristic of the complementary MOSFET inverter is one of the most important features of the CMOS digital inverter, and the Figure 4(a) circuit forms the basis of the entire CMOS family of digital ICs. Q5 and Q6 of the 4007UB are fixed-wired in this CMOS inverter configuration.

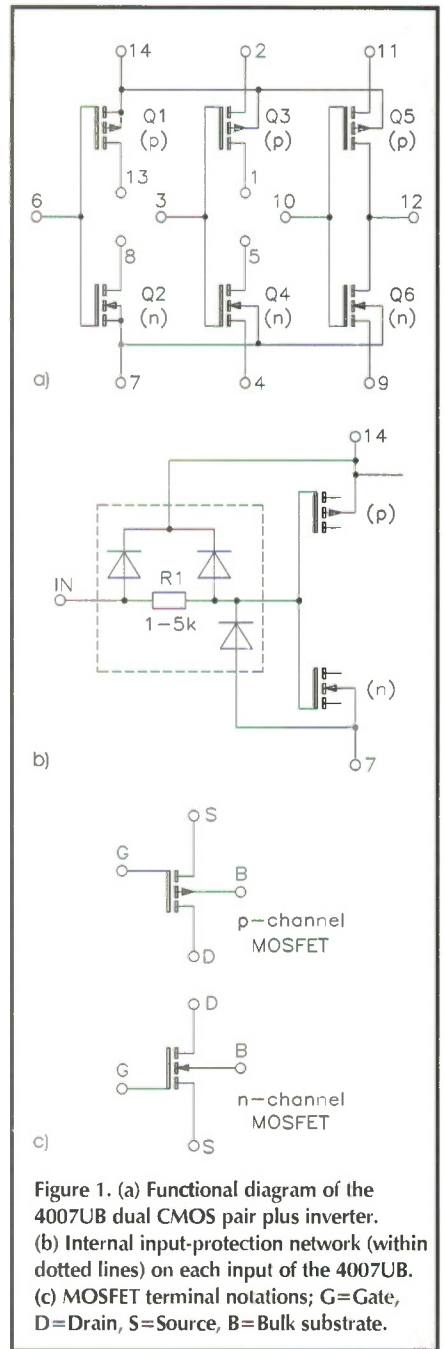

Figure 1. (a) Functional diagram of the 4007UB dual CMOS pair plus inverter. (b) Internal input-protection network (within dotted lines) on each input of the 4007UB. (c) MOSFET terminal notations; G=Gate, D=Drain, S=Source, B=Bulk substrate.

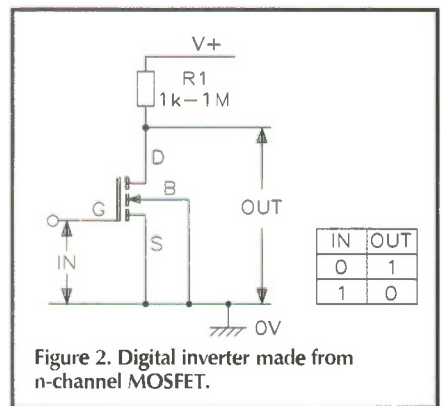

Figure 2. Digital inverter made from n-channel MOSFET.

## Linear Operation

To fully understand the operation and vagaries of CMOS circuitry, it is necessary to understand the linear characteristics of basic MOSFETs. Figure 5 shows the typical gate-voltage/drain-current graph of an n-channel enhancement mode MOSFET. Note that negligible drain current flows until the gate voltage rises to a 'threshold' value of about 1.5 to 2.5V, but that the drain current then increases almost linearly with further increases in gate voltage.

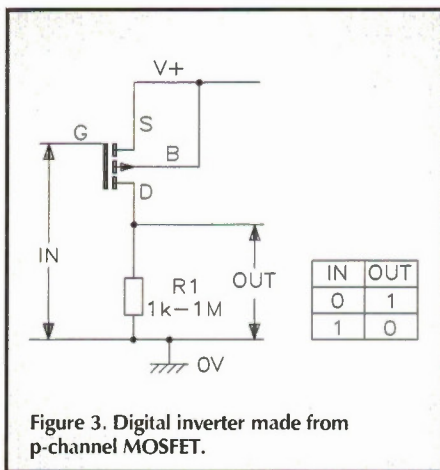

Figure 3. Digital inverter made from p-channel MOSFET.

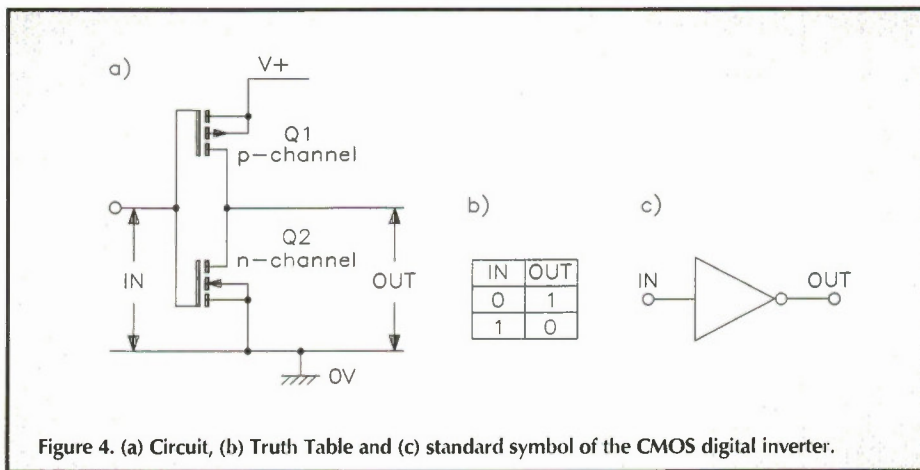

Figure 4. (a) Circuit, (b) Truth Table and (c) standard symbol of the CMOS digital inverter.

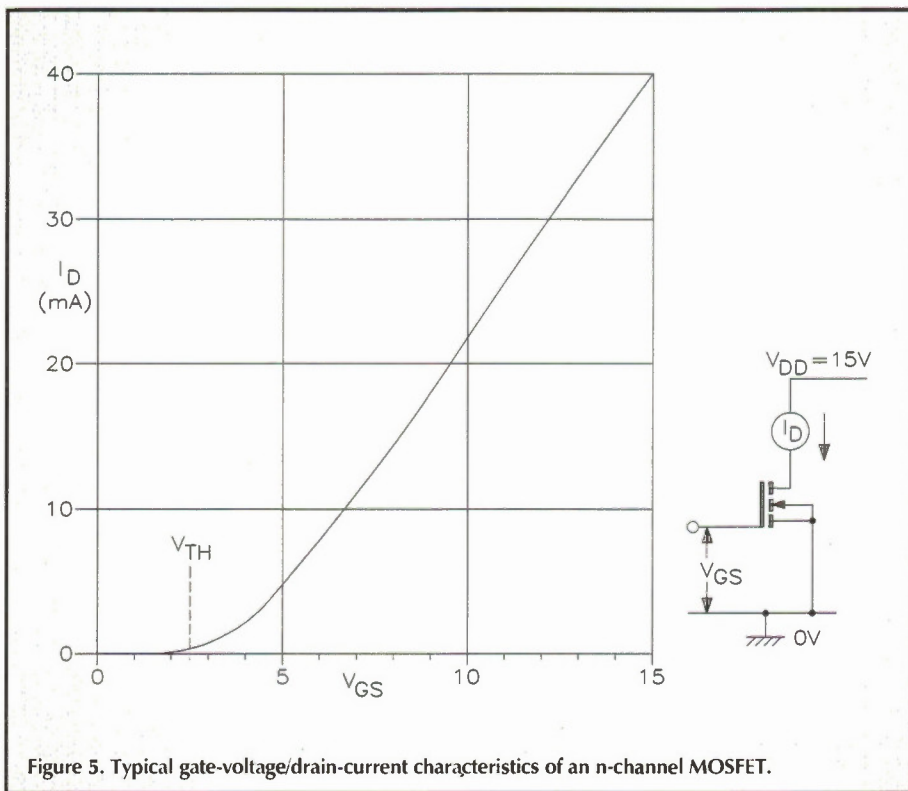

Figure 5. Typical gate-voltage/drain-current characteristics of an n-channel MOSFET.

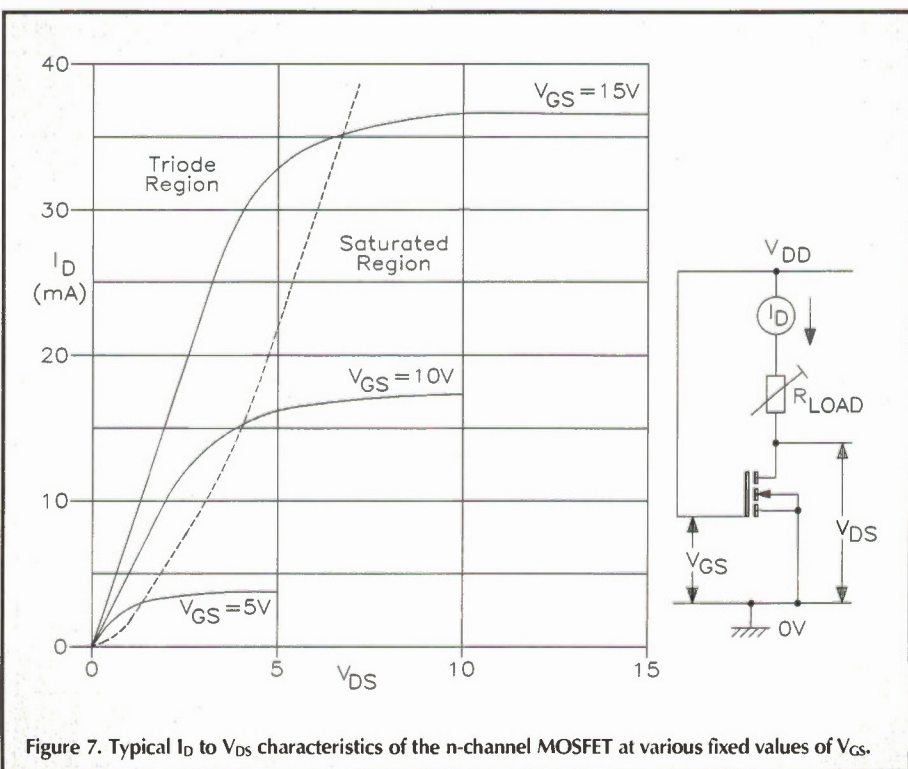

Figure 7. Typical  $I_D$  to  $V_{DS}$  characteristics of the n-channel MOSFET at various fixed values of  $V_{GS}$ .

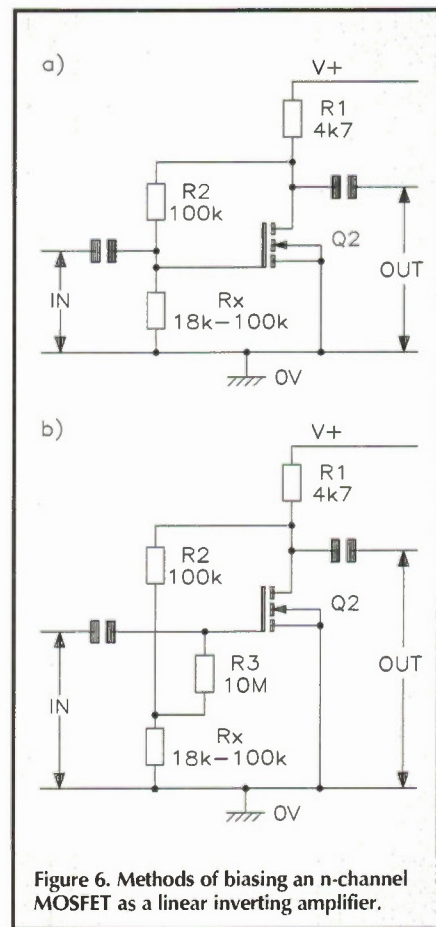

Figure 6. Methods of biasing an n-channel MOSFET as a linear inverting amplifier.

Figure 6 shows how to connect an n-channel 4007UB MOSFET as a linear inverting amplifier. R1 serves as the drain load of Q2, and R2-Rx bias the gate so that the device operates in the linear mode. The Rx value must be selected to give the desired quiescent drain voltage, but is normally in the range 18 to 100kΩ. The amplifier can be made to give a very high input impedance, by wiring a 10MΩ isolating resistor between the R2-Rx junction and the gate of Q2, as shown in Figure 6.

Figure 7 shows the typical  $I_D/V_{DS}$  characteristics of an n-channel MOSFET at various fixed values of gate-to-source voltage. Imagine here that, for each set of curves,  $V_{GS}$  is fixed at the  $V_{DD}$  voltage, but that the  $V_{DS}$  output voltage can be varied by altering the value of drain load,  $R_L$ . The graph can be divided into two characteristic regions, as indicated by the dotted line, these being the *triode* region and the *saturated* region.

When the MOSFET is in the saturated region (with  $V_{DS}$  at some value in the nominal range 50 to 100% of  $V_{GS}$ ), the drain acts like

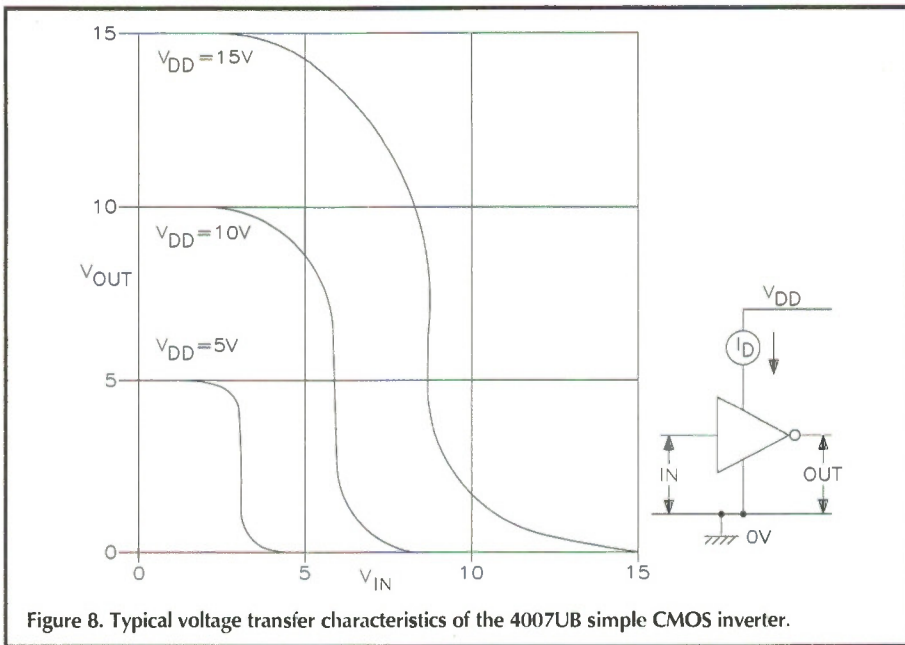

Figure 8. Typical voltage transfer characteristics of the 4007UB simple CMOS inverter.

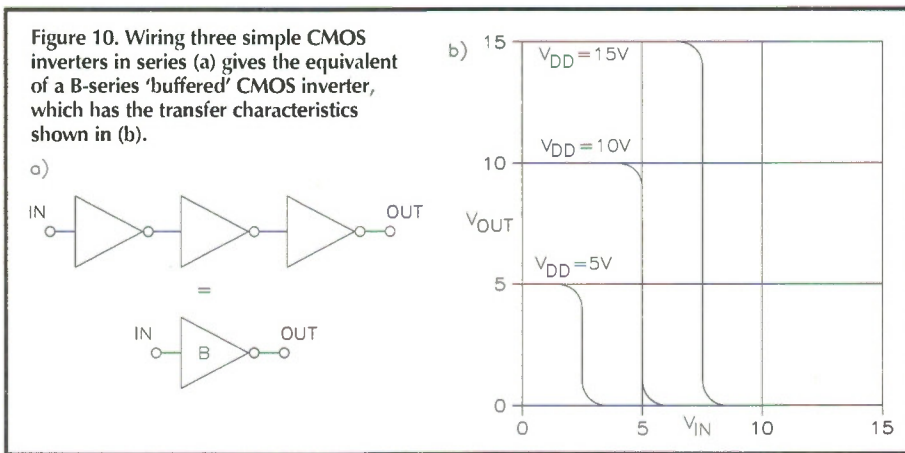

Figure 10. Wiring three simple CMOS inverters in series (a) gives the equivalent of a B-series 'buffered' CMOS inverter, which has the transfer characteristics shown in (b).

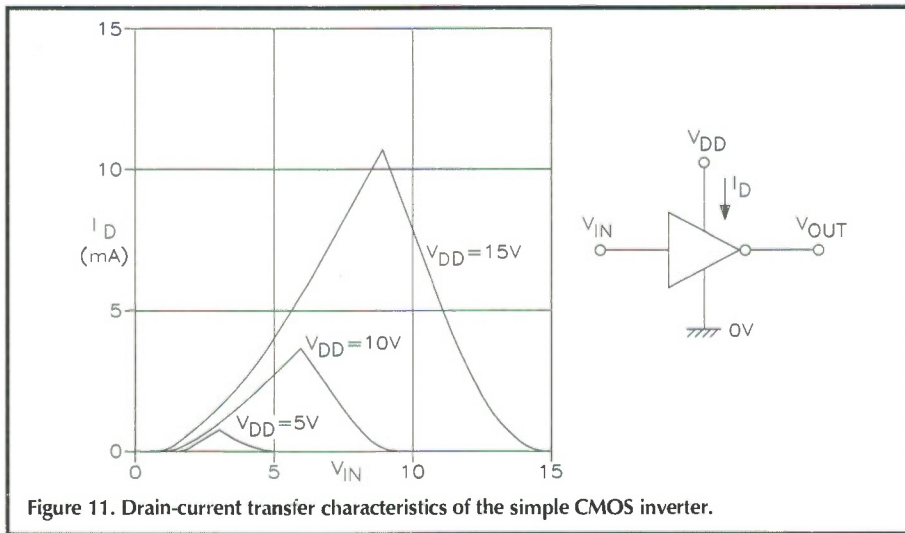

Figure 11. Drain-current transfer characteristics of the simple CMOS inverter.

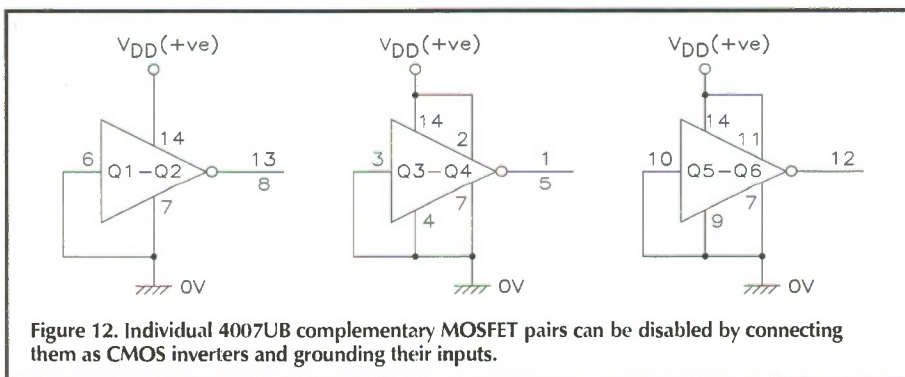

Figure 12. Individual 4007UB complementary MOSFET pairs can be disabled by connecting them as CMOS inverters and grounding their inputs.

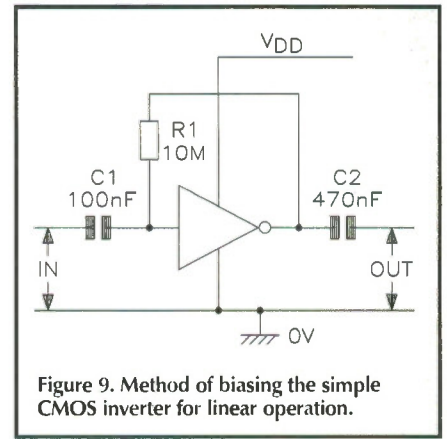

Figure 9. Method of biasing the simple CMOS inverter for linear operation.

a constant current source, with its current value controlled by  $V_{GS}$ : a low  $V_{GS}$  value gives a low constant-current value, and a high  $V_{GS}$  value gives a high constant-current value. These saturated constant-current characteristics provide CMOS with an output 'short-circuit proof' feature, and also determine its operating speed limits at different supply voltage values.

When the MOSFET is in the triode region (with  $V_{DS}$  at some value in the nominal range 1 to 50% of  $V_{GS}$ ), the drain acts like a voltage-controlled resistance, with the resistance value increasing approximately as the square of the  $V_{GS}$  value.

The p-channel MOSFET has an  $I_D/V_{DS}$  characteristics graph that is complementary to that of Figure 7. Consequently, the action of the standard CMOS inverter of Figure 4 (which uses a complementary pair of MOSFETs) is such that its current-drive capability into an external load, and its operating speed limits also increase in proportion to the supply rail voltage.

Figure 8 shows the typical voltage-transfer characteristics of the 4007UB's standard CMOS inverter at different supply voltage values. Note (on the 15V  $V_{DD}$  line, for example) that the output voltage changes by only a small amount when the input voltage is shifted around the  $V_{DD}$  and 0V levels, but that when  $V_{in}$  is biased at roughly half-supply volts, a small change of input voltage causes a large change of output voltage: typically, the inverter gives a voltage gain of about 30dB when used with a 15V supply, or 40dB at 5V. Figure 9 shows how to connect the CMOS inverter as a linear amplifier; the circuit has a typical bandwidth of 710kHz at 5V, or 2.5MHz at 15V.

Wiring three simple CMOS inverter stages in series as in Figure 10(a) gives the direct equivalent of a modern '4000B-series' 'buffered' CMOS inverter stage, which has the overall voltage transfer graph of Figure 10(b). The B-series inverter typically gives about 70dB of linear voltage gain, but tends to be grossly unstable when used in the linear mode.

Finally, Figure 11 shows the drain-current transfer characteristics of the simple CMOS inverter. Note that the drain current is zero when the input is at either zero or full supply volts, but rises to a maximum value (typically 0.5mA at 5V supply, or 10.5mA at 15V) when the input is at roughly half-supply volts, under which condition, both MOSFETs of the inverter are biased on. In the 4007UB, these ON currents can be reduced by wiring extra resistance in series with the source of each MOSFET of the CMOS inverter; this technique is used in the 'micropower' circuits shown later in this article.

# Using the 4007UB

The 'usage' rules of the 4007UB are quite simple. In any specific application, all unused elements of the device must be disabled; complementary pairs of MOSFETs can be disabled by connecting them as standard CMOS inverters and tying their inputs to ground, as

shown in Figure 12; individual MOSFETs can be disabled by tying their source to their substrate (B), and leaving the drain open circuit.

In use, the input terminals must not be allowed to rise above  $V_{DD}$  (the supply voltage) or below  $V_{SS}$  (0V). To use an n-channel MOSFET, the source must be tied to  $V_{SS}$ , either directly or via a current-limiting resistor.

To use a p-channel MOSFET, the source must be tied to  $V_{DD}$ , either directly or via a current-limiting resistor.

## Practical Circuits

### Digital

The 4007UB elements can be configured to act as any of a variety of standard digital circuits. Figure 13 shows how to wire the IC as a triple inverter, using all three sets of complementary MOSFET pairs. Figure 14 shows the connections for making an inverter plus non-inverting buffer; here, the Q1-Q2 and Q3-Q4 inverter stages are simply wired directly in series, to give an overall non-inverting action.

The maximum source (load-driving) and sink (load-absorbing) output current of a simple CMOS inverter stage self-limits at about 10 to 20mA as one or other of the output MOSFETs turns fully on. Higher sink currents can be obtained by simply wiring n-channel MOSFETs in parallel in the output stage. Figure 15 shows how to wire the 4007UB so that it acts as a high-sink-current inverter that will absorb triple the current of a normal inverter. Similarly, Figure 16 shows how to wire the 4007UB to act as a high-source-current inverter, and Figure 17 shows the connections for making a single inverter that will sink or source three times more current than a standard inverter stage.

The 4007UB is a perfect device for demonstrating the basic principles of CMOS logic gates. Figure 18 shows the basic connections for making a 2-input NOR gate. Note that the two n-channel MOSFETs are wired in parallel so that either can pull the output to ground from a logic-1 input, and the two p-channel

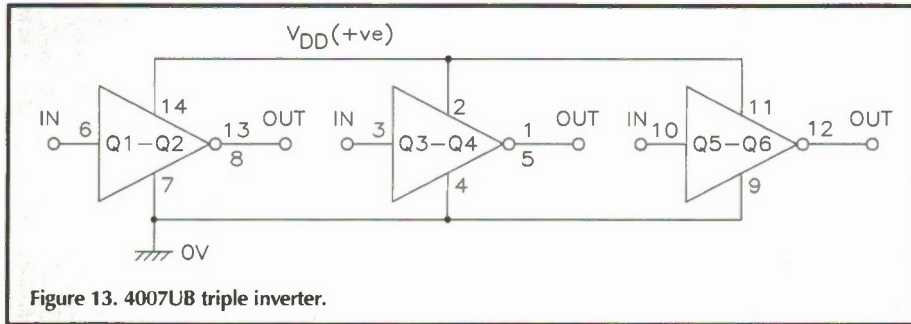

Figure 13. 4007UB triple inverter.

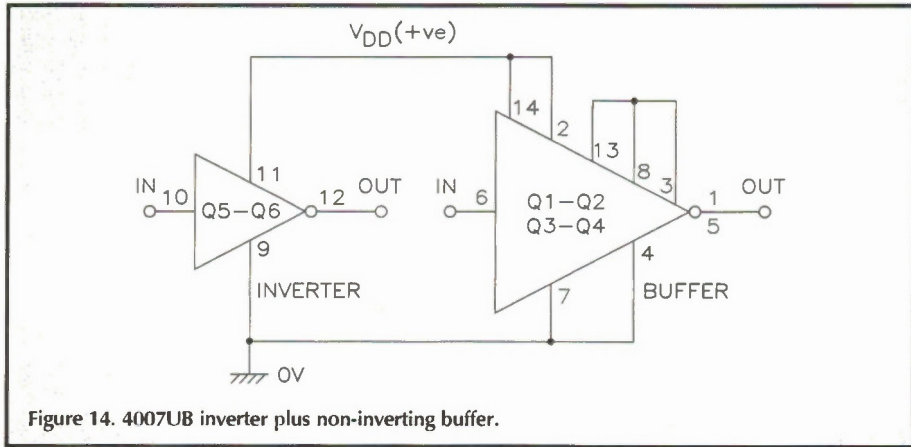

Figure 14. 4007UB inverter plus non-inverting buffer.

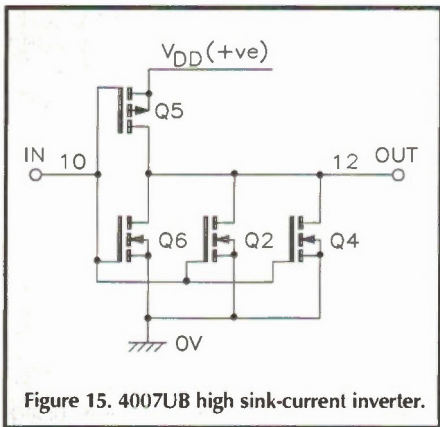

Figure 15. 4007UB high sink-current inverter.

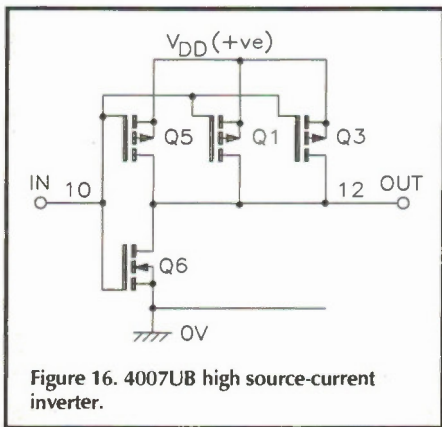

Figure 16. 4007UB high source-current inverter.

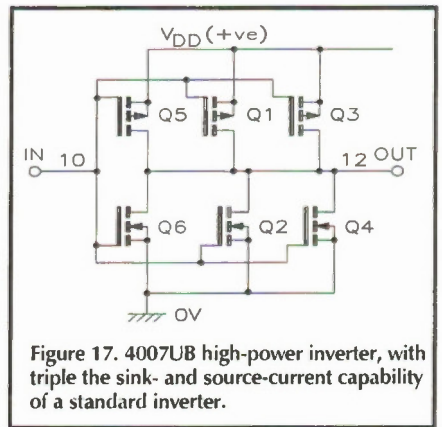

Figure 17. 4007UB high-power inverter, with triple the sink- and source-current capability of a standard inverter.

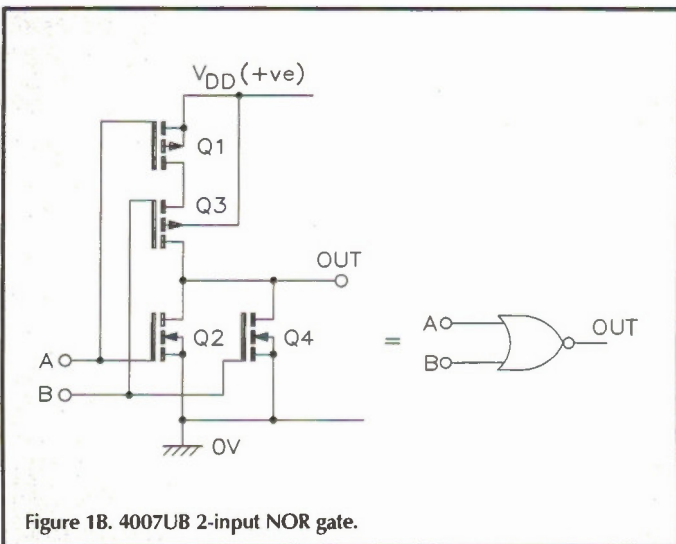

Figure 18. 4007UB 2-input NOR gate.

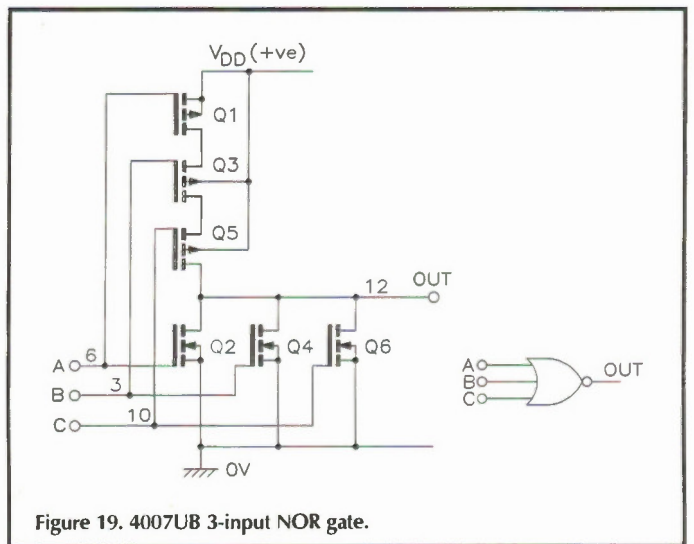

Figure 19. 4007UB 3-input NOR gate.

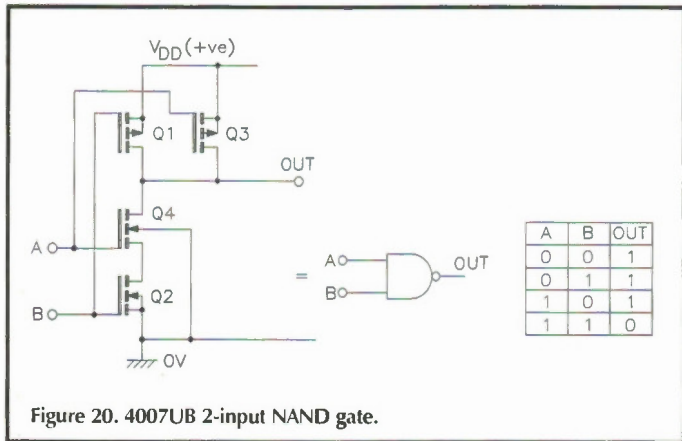

Figure 20. 4007UB 2-input NAND gate.

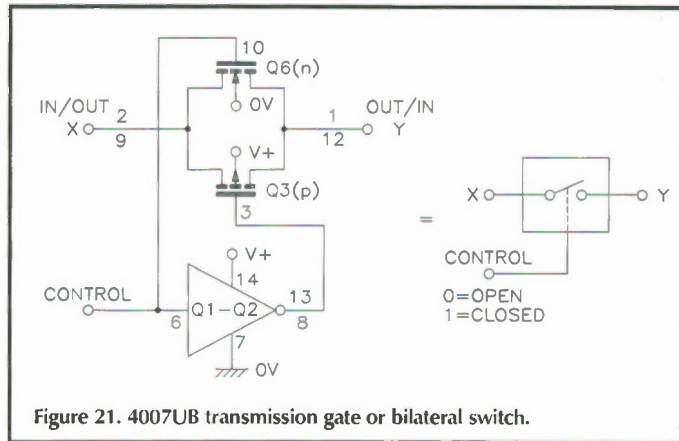

Figure 21. 4007UB transmission gate or bilateral switch.

MOSFETs are wired in series so that both must turn on to pull the output high from a logic-0 input. The truth table shows the logic of the circuit. A 3-input NOR gate can be made by simply wiring three p-channel MOSFETs in series and three n-channel MOSFETs in parallel, as shown in Figure 19.

Figure 20 shows how to wire the 4007UB as a 2-input NAND gate. In this case, the two p-channel MOSFETs are wired in parallel and the two n-channel MOSFETs are wired in series. A 3-input NAND gate can be made by similarly wiring three p-channel MOSFETs in parallel and three n-channel MOSFETs in series.

Figure 21 shows the basic way of using the 4007UB to make another important CMOS element, the transmission gate or bilateral switch, which acts like a near-perfect switch that can conduct signals in either direction and can be turned on (closed) by applying a logic-1 to its control terminal or turned off (open) via a logic-0 control signal. In Figure 21, an n-channel and a p-channel MOSFET are wired in parallel (source-to-source and drain-to-drain), but their gate signals are applied in antiphase via the Q1-Q2 inverter. To turn the Q3-Q6 transmission gate on (closed), Q6 gate is taken to logic-1 and Q3 gate to logic-0 via the inverter; to turn the switch off, the gate polarities are simply reversed. The 4007UB transmission gate has a near-infinite OFF

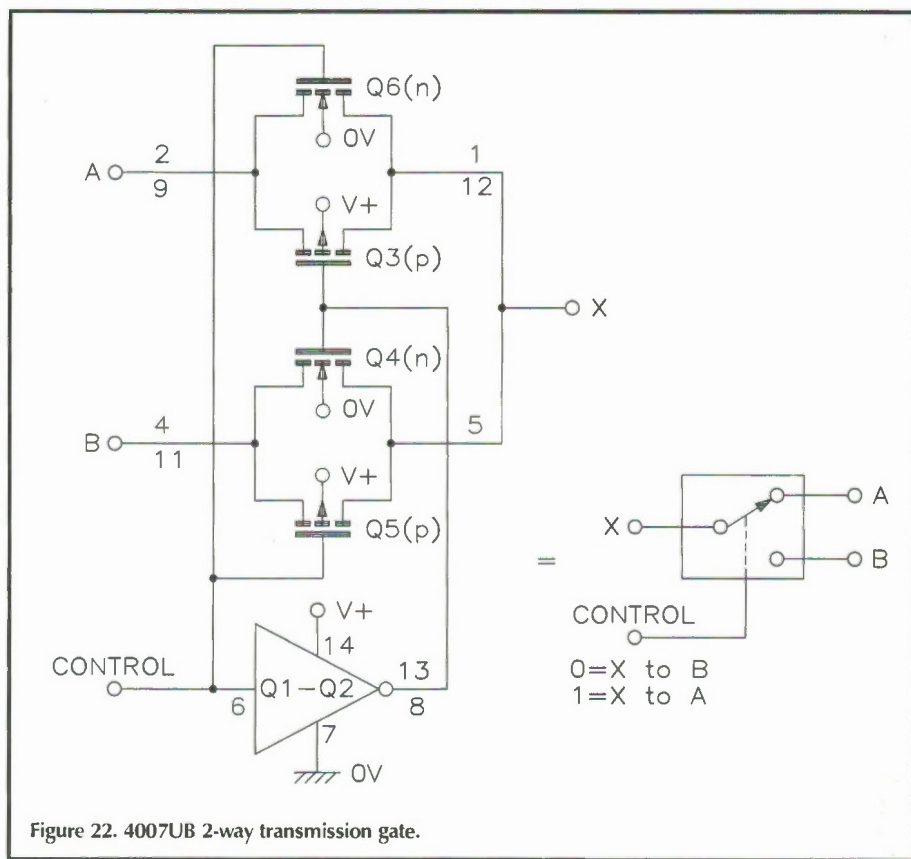

Figure 22. 4007UB 2-way transmission gate.

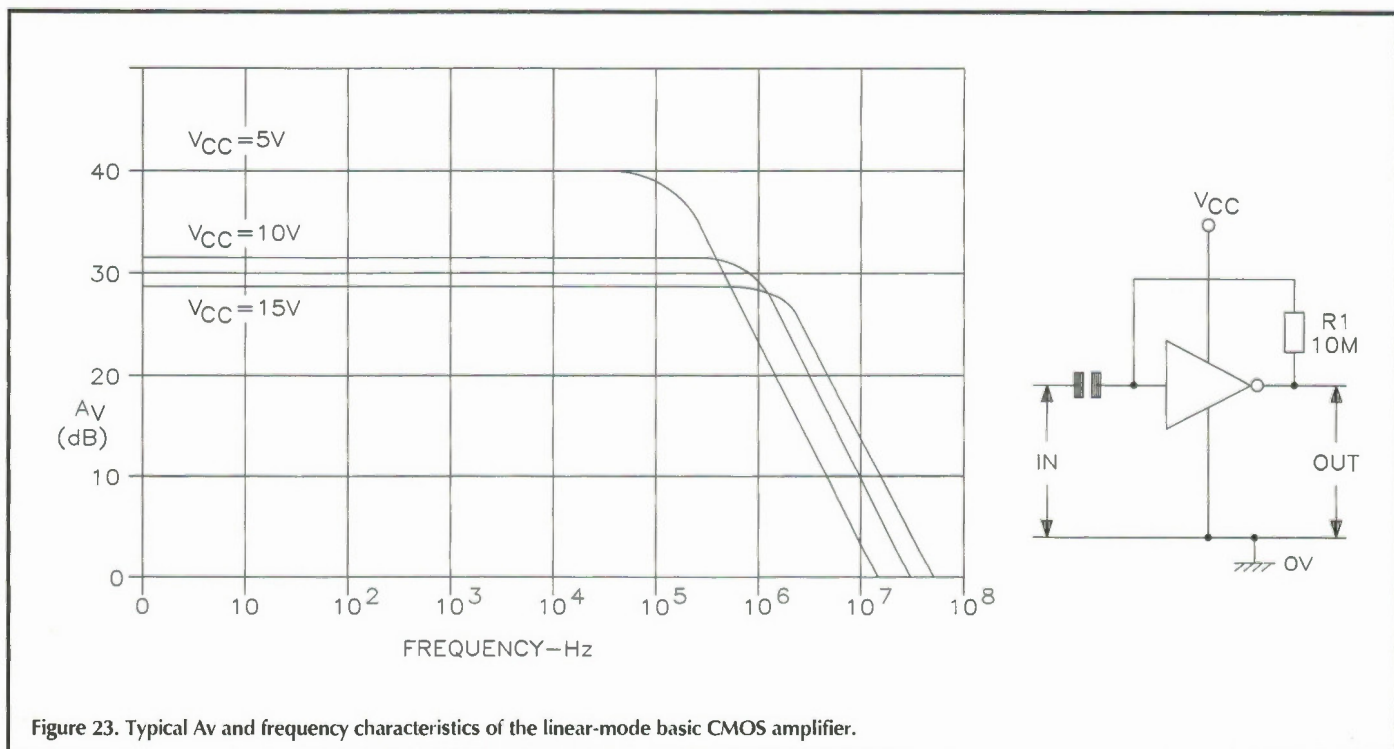

Figure 23. Typical Av and frequency characteristics of the linear-mode basic CMOS amplifier.



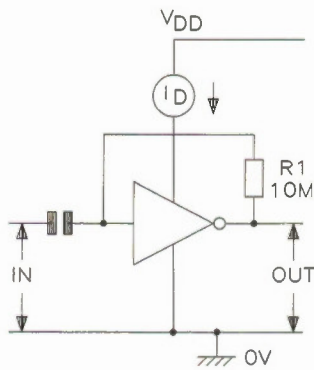
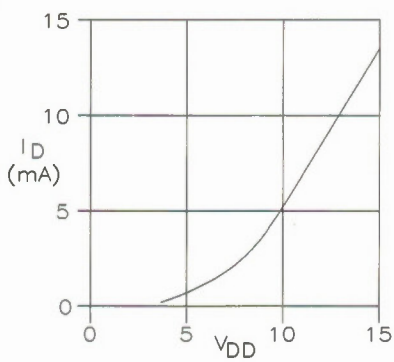

Figure 24. Typical  $I_D/V_{DD}$  characteristics of the linear-mode CMOS amplifier.

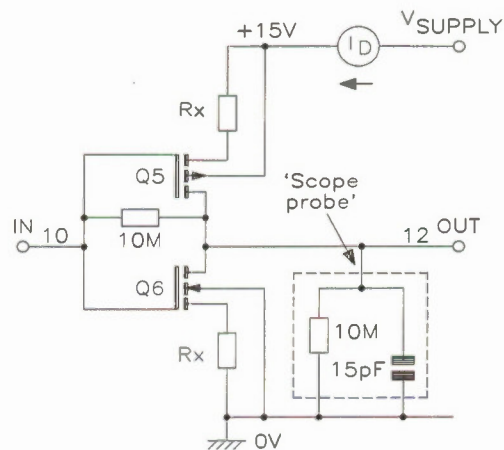

Figure 25. 'Micropower' 4007UB CMOS linear amplifier, showing method of reducing  $I_D$ , with measured performance details.

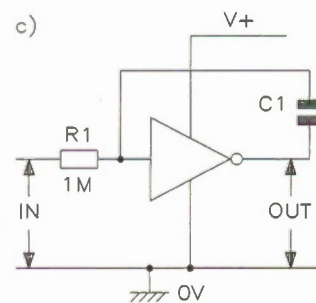
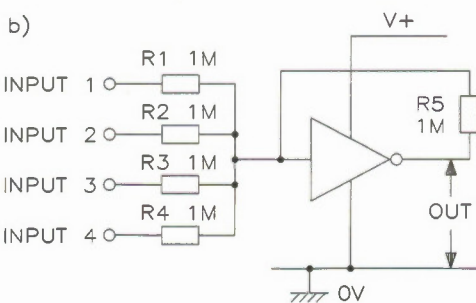
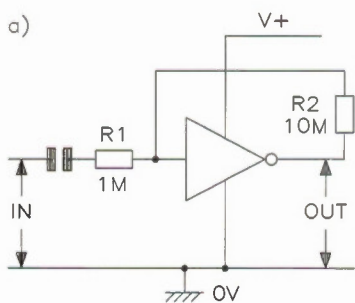

Figure 26. The CMOS amplifier can be used in a variety of linear inverting amplifier applications. Three typical examples are shown here.

resistance and an ON resistance of about  $600\Omega$ . It can handle all signals between 0V and the positive supply rail value. Note that, since the gate is bilateral, either of its main terminals can function as an input or output.

Finally, Figure 22 shows how the 4007UB can be wired as a dual transmission gate that functions like a single-pole double-throw (SPDT) switch. In this case, the circuit uses two transmission elements, but their control voltages are applied in anti-phase, so that one switch opens when the other closes, and vice versa. The 'X' sides of the two gates are shorted together to give the desired SPDT action.

## Practical Circuits

### Linear

Figures 6 to 9 have already shown that the basic 4007UB MOSFETs and the CMOS inverter can be used as linear amplifiers.

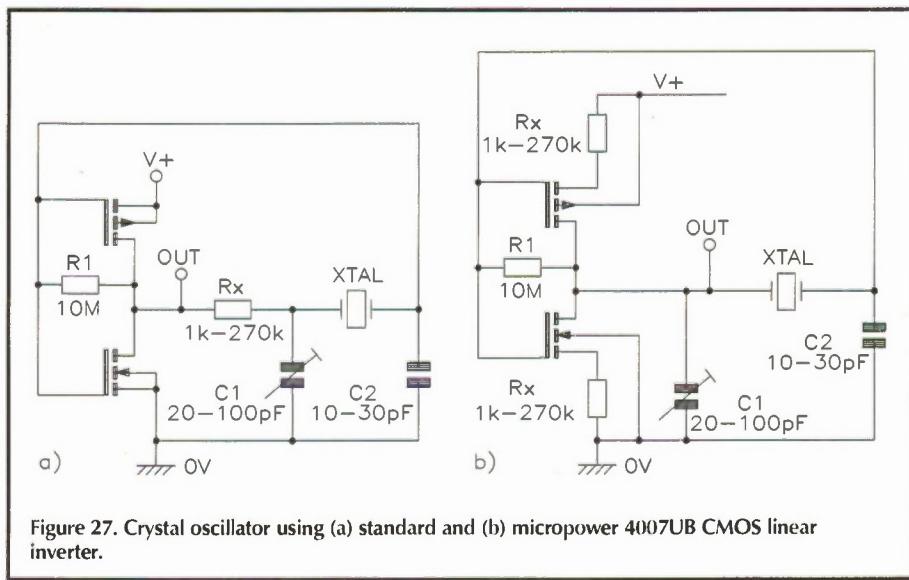

Figure 27. Crystal oscillator using (a) standard and (b) micropower 4007UB CMOS linear inverter.

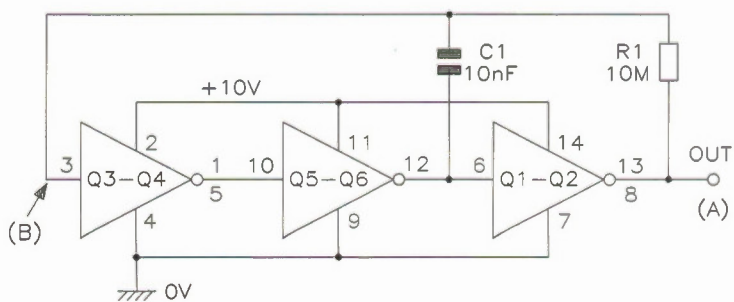
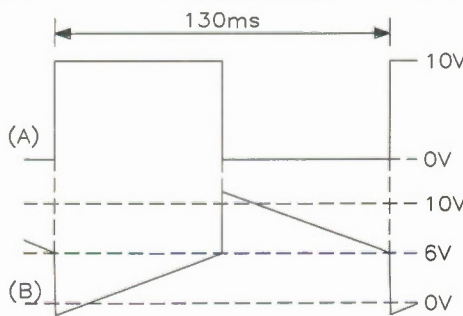

Figure 28. This 4007UB ring-of-three astable consumes  $280\mu A$  at 6V, and  $1.6mA$  at 10V.



# K7100 Digital Multimeter Kit

by Maurice Hunt

## Review

The K7100 Digital Multimeter is supplied in the form of a high quality, partly assembled kit, that is simple to build and straightforward to calibrate. Correct assembly in accordance with the instructions supplied will produce a reliable and accurate piece of invaluable test-gear, essential for anyone who has to deal regularly with the testing and fault-finding of electrical and electronic equipment. The instrument has selectable manual or automatic range selection, and has all the features of a modern multimeter.



**KIT AVAILABLE (95011)**  
**PRICE £60.99**  
**AI**

### IMPORTANT! SAFETY WARNING

This Digital Multimeter is designed for use in a domestic environment and is not suitable for industrial applications. The unit is suitable for use in INSTALLATION CATEGORY (OVERVOLTAGE CATEGORY) I ONLY, as defined by IEC 664. This category covers signal level, telecommunication, electronic equipment, etc. The maximum safe measuring voltage is 250V AC (rms) or DC. The unit is not suitable for use on three-phase mains supplies or distribution systems. ALWAYS REMOVE THE TEST LEADS FROM THE MULTIMETER BEFORE OPENING THE CASE FOR BATTERY OR FUSE REPLACEMENT OR FOR ANY OTHER PURPOSE. The unit is not suitable for use in a damp environment. This product is double-insulated.

## FEATURES

- \* Switchable autoranging or manual range selection
- \* Automatic zero setting
- \* Automatic polarity selection
- \* Simple construction and calibration
- \* Overvoltage indication
- \* Low battery indicator
- \* Range indicators
- \* Very low power consumption
- \* Compact, modern design
- \* Includes test leads

### General Specification

Display:	3½-digit LCD
Sampling rate:	2 per second
Input impedance:	10 <sup>10</sup> MΩ
Operating temperature:	0 to 40°C
Battery type:	2 × AA 1.5V cells
Power consumption:	<5mW
Overcurrent protection:	200mA 250V fuse
Dimensions:	170 × 75 × 28mm
Weight:	200g (including batteries)

EVERYTHING you need to build the K7100 Digital multimeter is included in the kit, including solder and wire for the jumper links. However, to construct it, you will need a soldering iron with a maximum recommended power of 40W, plus a pair of wire-cutters and a cross-head screwdriver. Additionally, two fresh AA batteries will be needed for powering the meter upon its completion. The build-up time will vary (depending on the experience of the constructor), the one shown in the photographs taking 2.5 hours to build and calibrate.

Construction is straightforward, since the PCB is printed with the locations of the components, and the majority of the components (with exception of the larger items) are supplied on sheets of paper with the component part number and value printed adjacent to the part – these can be depended on as being correct, which is just as well, since most of the resistors are very small and having up to five bands, they are difficult to read. The instructions supplied with the kit show the order in which the kit is best assembled, generally following our usual guidelines and procedure of working from the smallest components up to the largest.

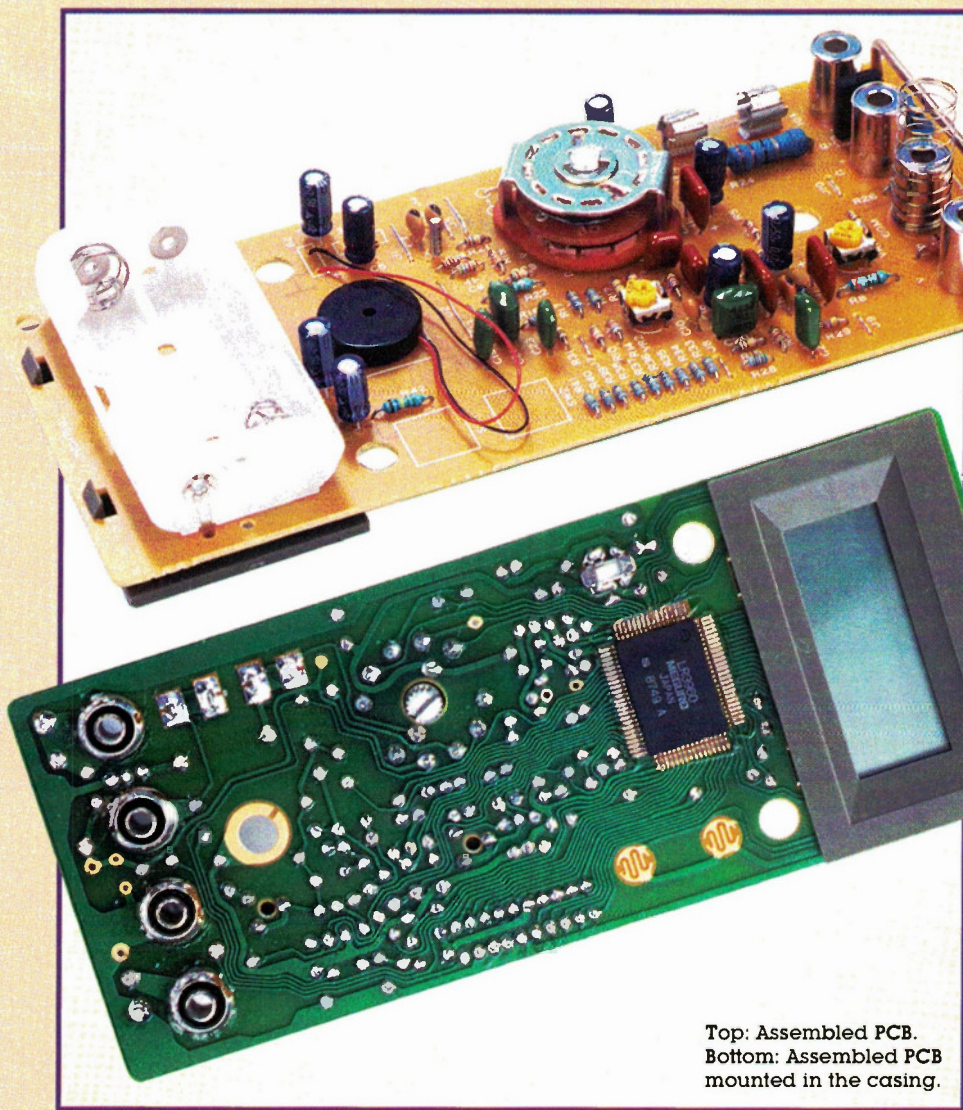

Top: Assembled PCB.  
Bottom: Assembled PCB mounted in the casing.

in the kit; there is no need for it, although the instructions made no mention of these points, and this particular project builder had to stop, think and recheck for a few minutes to make sure that mistakes had not been made! Additionally, wire for the links and solder is supplied in the kit, along with the manganin wire, but no identification was given to distinguish the wire types, and no mention was made that solder was supplied in the kit! However, it is easy to work this out by process of elimination, and the fact that the solder is soft, easy to bend and the soldering iron melts it, whilst the wire for the links is stiffer and thinner, and the soldering iron doesn't melt it. The manganin wire is a prebent length, to fit the holes drilled in the PCB for it. The completed article has a few spare, unused component placings in the PCB, these being for C8, R43 and R44 - these parts are not required.

The prebent manganin wire shunt must be mounted at a height of exactly 10mm above the PCB, since this determines the accuracy of the 10A current range. However, this is easy enough to accomplish, since the shunt is a good fit in the PCB, and holds itself in place while you measure its height off the board and solder it in. Adjustments to its height can easily be done after soldering it in, if necessary, and a diagram is provided in the instructions to clarify the mounting details.

The rotary switch cannot be fitted in the wrong position according to the instructions, although I admit, I did

The PCB as supplied, comes in part-assembled form, with the LCD display and surface-mount integrated circuit premounted, which eliminates a good deal of the tricky assembly usually associated with building your own digital multimeter. The on/off slide switch, battery holder, piezo sounder and test lead terminals are also premounted on the board. This leaves you to fit the wire links, resistors, capacitors, diodes, potentiometers, quartz crystal, power transistor, fuseholder clips and fuse, rotary switch, switch knob and cap, conductive rubber push switches, front panel label, coiled earthing spring, and what is described in the instructions as a 'heavy prefolded resistance wire' - which is a shunt for the 10A current range, made of manganin wire, of about the same gauge as coat-hanger wire, but a different colour! Take care to observe correct polarity with the electrolytic capacitors, diodes, and power transistor.

Building the kit in accordance with the instructions is quite simple, the only slight stumbling blocks being that the wire links are numbered from J1 to J10 on the PCB, but there is no J6 printed on it, and similarly, the capacitors are numbered C1 to C23 on the board, but C8 is not supplied

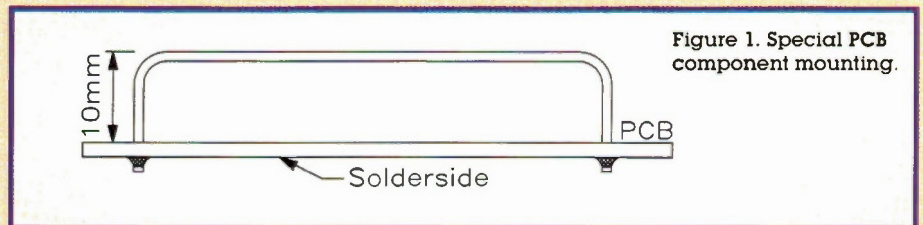
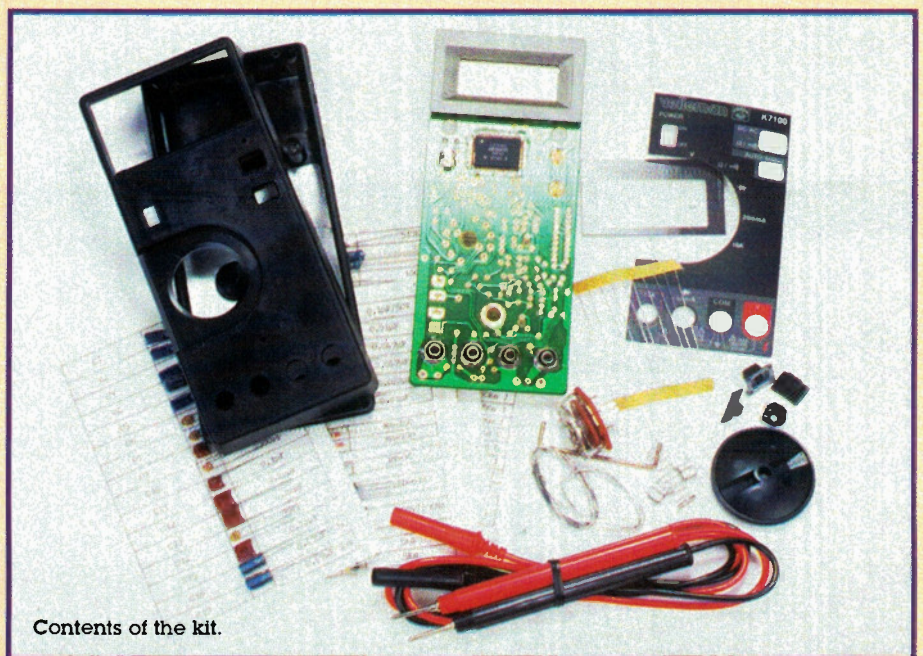

Figure 1. Special PCB component mounting.



Contents of the kit.

not try too hard to disprove this claim – what they mean is that you can install it either way around, so long as the pins line up with the holes in the PCB, and that you mount the switch on the component side of the board.

Having built up the board with all components, you will find that you have one potentiometer left over (of a larger size than the two fitted to the PCB); this is supplied for calibration purposes, described later.

Having checked your work for misplaced components, solder bridges, whiskers, tracks, etc., clean off excess flux on the board using a suitable solvent. Peel off the backing, and affix the self-adhesive front panel label to the upper lid of the casing, taking care to position it accurately, and smoothing it down with a cloth.

With the board completed, fit the two conductive rubber pushbuttons (for AUTO/MAN and DC/AC) into their corresponding positions in the upper lid, ensuring that the four pins in the lid fit into the notches in the rubbers. Turn the rotary switch fully anti-clockwise, then place the board into the upper lid. Press the board against the lid (by holding the rotary switch), and turn the assembly over, prior to fitting the knob onto the switch shaft, with the pointer lining up with the 'V' position printed on the front panel label.

Next, fit two fresh AA batteries into the holder (the correct way round!), and ensure that the fuse is installed into its holder. Switch on the meter,

Technical Specification			
Function	Range	Number of Steps	Accuracy
DC voltage	200mV to 250V	4	0.8%
AC voltage	2 to 250Vrms	4	1.0%
DC current	200mA to 10A	2	1.2%
AC current	200mA to 10A	2	1.2%
Resistance	200Ω to 20MΩ	6	2% maximum
<b>Continuity:</b> 0 to 200Ω, continuous buzzer, display indicator.			
<b>Diode Test:</b> 0 to 1V, Test current 0.6mA, display indicator.			

and the display should spring into life (after a short delay period), giving a reading on the autoranging DC mV range (the voltage range default state). If this works okay, there is no reason why you should not now reward yourself, and have a play around with the switches to familiarise yourself with their functions, before getting down to the serious business of calibrating the instrument.

## Calibration

For accurate calibration of the instrument, a good, known-to-be-accurate digital multimeter is required as a reference. Calibration is achieved by adjustment of the two trimmer potentiometers, RV1 and RV2, which set the reference settings for the AC and DC voltage measuring ranges, respectively. The resistance and low current ranges are precalibrated by means of the fixed value on-board resistors, while the high current (10A) range is calibrated

by means of the prebent manganin shunt's height off the board, as described earlier.

## DC Adjustment

For this, first turn the range selector switch to the 'V' position. The instructions state that you should use the (supplied) spare 5kΩ potentiometer connected as a potential divider, with a battery of between 1.5 and 9V connected to the potentiometer end (track) terminals. Then, with the test leads connected to the COM and V terminals on the multimeter and connected in parallel with the leads of the meter you are using to calibrate with, use the test leads to measure the output of the potential divider (a diagram is provided in the instructions). Adjust potentiometer RV2 until both multimeters are giving the same voltage reading, and then vary the potential divider output to ensure the readings still concur.

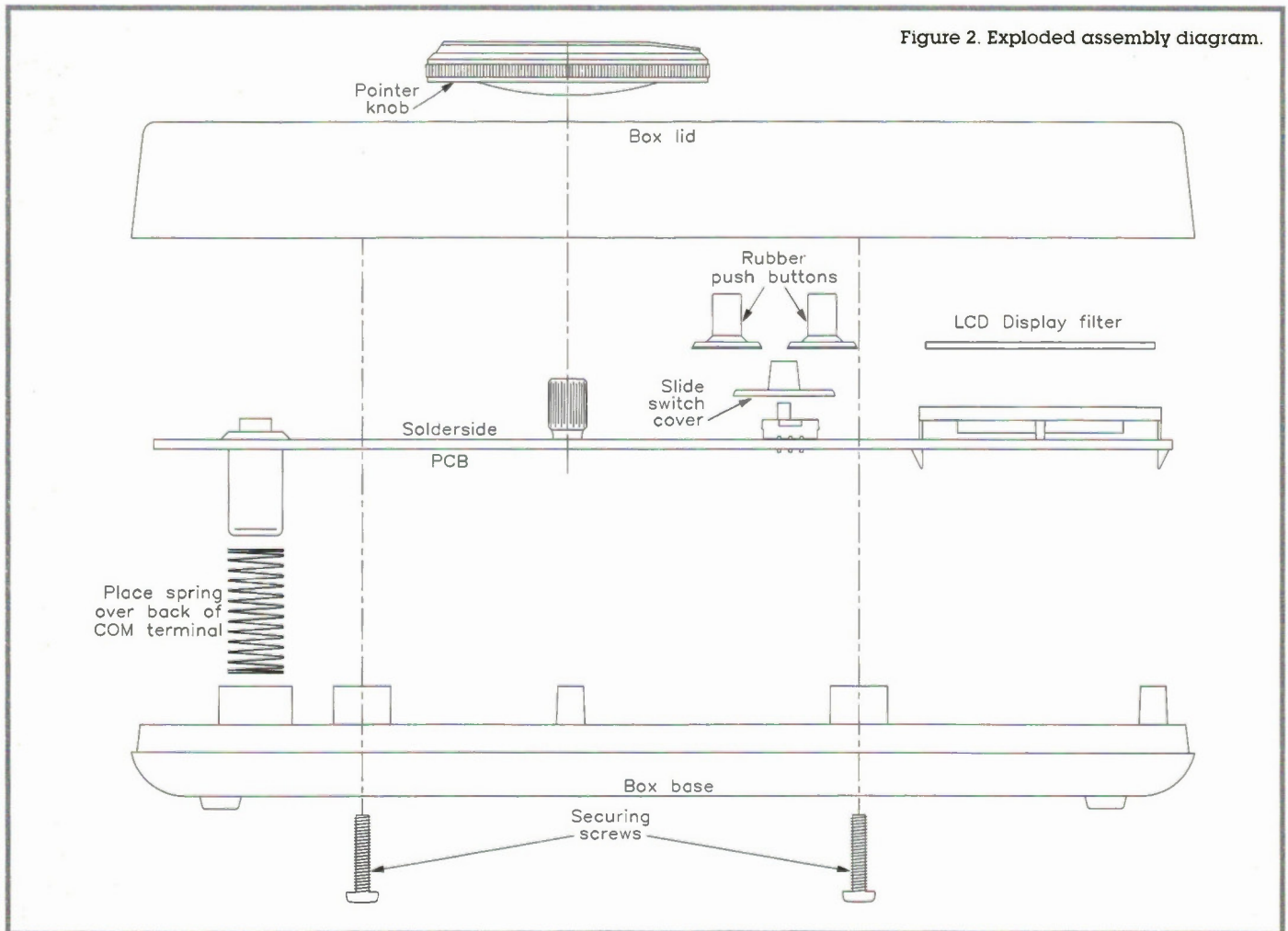

Figure 2. Exploded assembly diagram.

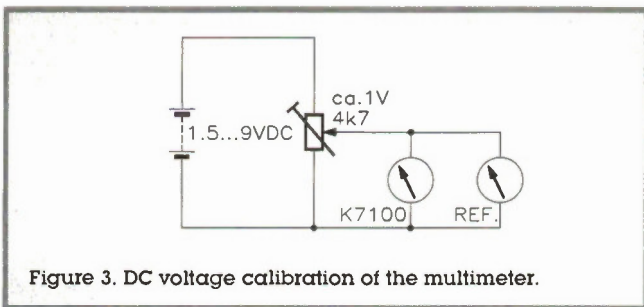

Figure 3. DC voltage calibration of the multimeter.

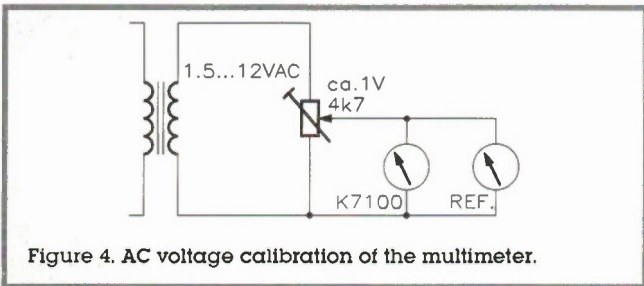

Figure 4. AC voltage calibration of the multimeter.



The completed Digital Multimeter.

Alternatively, you could use a variable, stabilised DC power supply to provide the test voltage, instead of connecting up the potential divider network. Then, you would have an unused 5k $\Omega$  potentiometer for use in another project!

## AC Adjustment

Again, the range switch should be in the 'V' position. Replace the battery in the potential divider network with a low-voltage transformer, supplying between 1.5 and 12V AC. Connect up the test meter in parallel with the multimeter, and repeat the procedure for DC adjustment, only this time, vary RV1 until the readings match. Alternatively, use a low voltage, variable AC power supply in place of the potential divider network.

This completes the calibration of the multimeter.

## Other Tests

### Current Measuring

With the DC/AC ranges calibrated you will want to try out the current and resistance measuring ranges. For current measuring, switch the range selector to (initially) the 10A position, the meter to DC measuring, and apply DC current via the COM and 10A terminals – you can use a resistor in series with a voltage source, or a variable current source for this. If the reading is within 0.2A (200mA), then move the test lead to the mA terminal, and the range selector switch to the '200mA' position for a reading with better resolution. Repeat the tests with AC currents, remembering to switch the meter over to AC measuring mode beforehand.

### Resistance Measuring

For testing of the resistance ranges, arm yourself with a number of fixed value resistors covering the range 1 $\Omega$  to 20M $\Omega$ , and compare the readings obtained with this multimeter and the

test meter – they should be consistent. Or use a single 20M $\Omega$  potentiometer, or a number of potentiometers covering the entire resistance range catered for by the meter.

### Diode Testing

Select the diode symbol position on the range selector. Use the test leads in the COM and  $\Omega$ /mA terminals, and connect the diode under test across them. A reading should be given in one direction only with conventional diodes, with the possibility of either one reading only, or two different readings for Zener diodes, depending on which way round it is connected and on the breakdown voltage of the Zener under test.

### Continuity Testing

Select the  $\Omega$ /sounder symbol position on the range selector, and press the DC/AC/ $\Omega$ /sounder button until the sounder symbol appears on the display. Place the test leads in the COM and V terminals, and hold them together, the buzzer should emit a continuous tone, indicating continuity (i.e., a low resistance circuit). The continuity tester will work with resistances of up to 200 $\Omega$ , but will not sound for resistances of above this figure – which would indicate a lack of continuity.

### Final Construction and Use

With the calibration procedures completed to satisfaction, the multimeter can be completed, as follows. Mount the coiled spring over the COM (-) terminal (it is a tight fit, but will slide on without much force). The spring connects up with the earthing/screening foil that is prestuck onto the inside of the casing. Place the lower half of the casing onto the lid assembly, and use the three cross-head screws to hold the unit together. Following a final test to ensure correct calibration on all ranges in comparison with a known-to-be-accurate meter, the digital

multimeter is now ready for use. The only maintenance required will be to periodically replace the two AA batteries, when the 'B' (low battery) sign shows in the display, and to replace the 200mA fuse should it blow due to excess current being applied while using the 0-200mA ranges (a spare fuse is provided in the kit).

Care should be taken, however, to avoid exceeding the upper limits on the voltage and current ranges stated in the specification table, since this could compromise safety, and lead to irreparable damage to the instrument. As is advised with most multimeters, select a range higher than that required for measuring a voltage or current, then change down if it is safe to do so, to minimise the risk of overloading the meter. Note that if the ranges are exceeded with this meter (up to a point) the overrange indicator (a '1' in the most significant, leftmost digit of the display) will be shown. This acts as a warning to either reduce or remove the excess input, or to select a higher range, as quickly as possible. Alternatively, select the autoranging feature (MANU symbol not showing on the display), and let the multimeter work out for itself the best range for it to be on!

## K7100 DIGITAL MULTIMETER

The Maplin 'Get-You-Working' Service is available for this project, see Constructors' Guide or current Maplin Catalogue for details.

The K7100 Digital Multimeter is available in kit form only.

**Order As 95011**  
**(K7100 Digital Multimeter)**  
**Price £60.99<sup>1</sup>**

Please Note: Some parts, which are specific to this project (e.g., PCB), are not available separately.

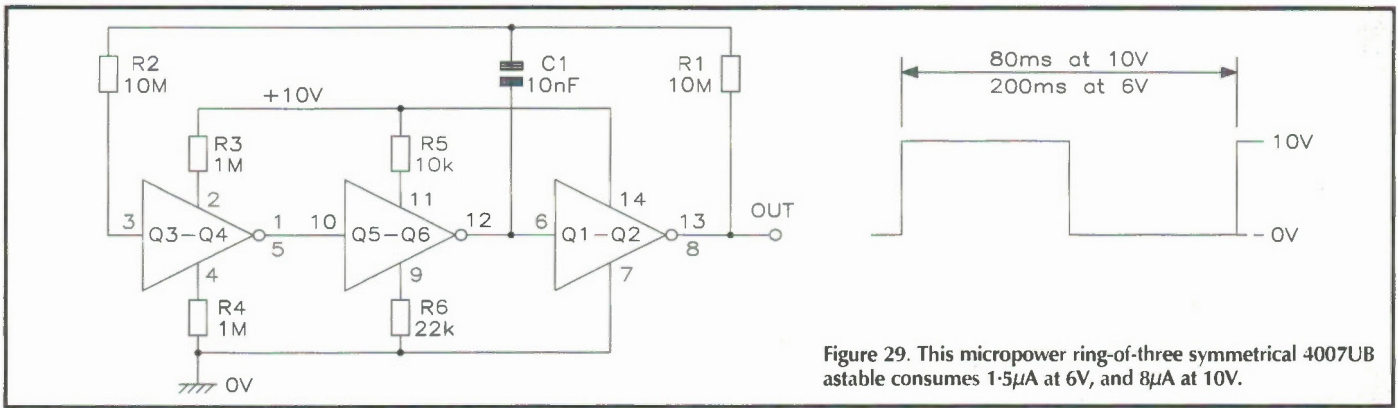

Figure 29. This micropower ring-of-three symmetrical 4007UB astable consumes 1.5µA at 6V, and 8µA at 10V.

Figure 23 shows the typical voltage gain and frequency characteristics of the linear CMOS inverter when operated from three alternative supply rail values (this graph assumes that the amplifier output is feeding into the high impedance of a 10MΩ/15pF oscilloscope probe). The output impedance of the open-loop amplifier typically varies from 3kΩ at 15V supply, to 5kΩ at 10V, or 22kΩ at 5V, and it is the product of the output impedance and output load capacitance that determines the bandwidth of the circuit; increasing the output impedance or load capacitance reduces the bandwidth.

As you would expect from the voltage transfer graph of Figure 8, the distortion characteristics of the CMOS linear amplifier are not very good. Linearity is fairly good for small-amplitude signals (output amplitudes up to 3V Pk-to-Pk with a 15V supply), but the distortion then increases progressively as the output approaches the upper and lower supply limits. Unlike a bipolar transistor circuit, the

CMOS amplifier does not 'clip' excessive sine wave signals, but progressively rounds off their peaks. Figure 24 shows the typical drain-current/supply-voltage characteristics of the basic CMOS linear amplifier. Note that the supply current typically varies from 0.5mA at 5V to 12.5mA at 15V.

### 'Micropower' Circuits

In many applications, the quiescent supply current of the 4007UB CMOS linear amplifier can be usefully reduced, at the expense of reduced amplifier bandwidth, by wiring external resistors in series with the source terminals of the two MOSFETs of the CMOS stage, as shown in the 'micropower' circuit of Figure 25. Table 1 shows the effect that different resistor values have on the drain current, voltage gain and bandwidth of the amplifier when it is operated from a 15V supply and has its output feeding to a 10MΩ/15pF oscilloscope probe.

R1	I <sub>D</sub>	AV (V <sub>OUT</sub> /V <sub>IN</sub> )	Upper 3dB Bandwidth
0	12.5mA	20	2.7MHz
100Ω	8.2mA	20	1.5MHz
560Ω	3.9mA	25	300kHz
1kΩ	2.5mA	30	150kHz
5k6Ω	600µA	40	25kHz
10kΩ	370µA	40	15kHz
100kΩ	40µA	30	2kHz
1MΩ	4µA	10	1kHz

Table 1. Measured performance details of the 'micropower' 4007UB linear amplifier shown in Figure 25.

It is important to appreciate in the Figure 25 circuit, that these additional resistors add to the output impedance of the amplifier (the output impedance roughly equals the R1-A<sub>v</sub> product), and this impedance and the external load resistance/capacitance has a great effect on the overall gain and bandwidth of the circuit. When using 10kΩ values for R1, for example, if the load capacitance is increased to 50pF, the bandwidth falls to about 4kHz, but if the capacitance is reduced to a mere 5pF, the bandwidth increases to 45kHz. Similarly, if the resistive load is reduced from 10MΩ to 10kΩ, the voltage gain falls to unity. Thus, for significant gain, the load resistance must be large relative to the output impedance of the amplifier.

The basic (unbiased) CMOS inverter stage has an input capacitance of about 5pF and an input resistance of near-infinity. Thus, if the output of the Figure 25 circuit is fed directly to such a load, it will show a voltage gain of about ×30 and a bandwidth of 3kHz when R1 has a value of 1MΩ; it will even give useful gain and bandwidth when R1 has a value of 10MΩ, but will consume a quiescent current of only 0.4µA! The CMOS linear amplifier can be used, in either its standard or micropower forms, to make a variety of fixed-gain amplifiers, mixers, integrators, active filters and oscillators, etc. Three typical basic applications are shown in Figure 26.

One attractive 4007UB linear application is as a crystal oscillator, as shown in Figure 27(a). Here, the CMOS amplifier is linearly biased via R1 and provides 180° phase shift, and the Rx-C1-XTAL-C2 pi-type crystal network gives an additional 180° of phase shift at the crystal resonant frequency, thereby causing the circuit to oscillate. If this circuit is needed to provide a frequency accuracy within only 0.1% or so, Rx can be replaced by a short and C1-C2 can be omitted; for ultra-high accuracy, the correct values of Rx-C1-C2 must be individually determined (Figure 27 shows the typical range of values). In micropower applications, Rx can be incorporated in the CMOS amplifier, as shown in Figure 27b. If desired, the output of the crystal oscillator can be fed directly to the input of an additional CMOS inverter stage, for improved waveform shape/amplitude.

### Practical Circuits Astable

One of the most useful applications of the 4007UB, is as a ring-of-three astable multi-vibrator; Figure 28 shows the basic configuration of the circuit. Waveform timing is controlled by the values of R1 and C1, and

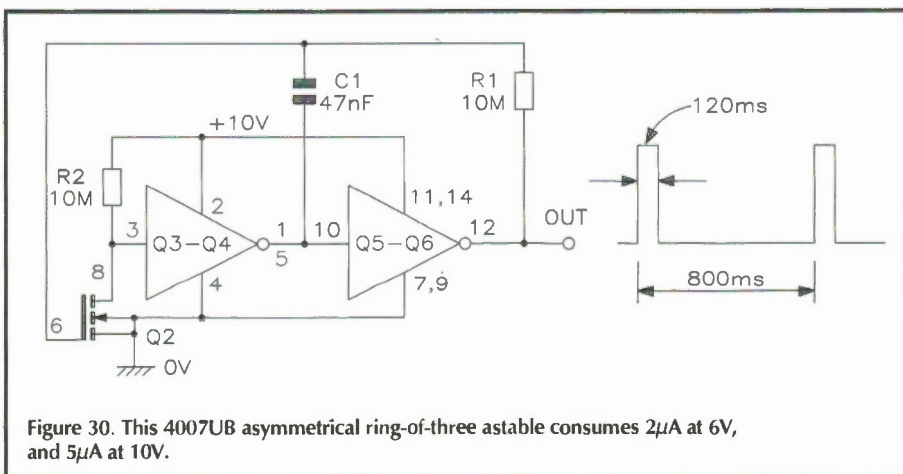

Figure 30. This 4007UB asymmetrical ring-of-three astable consumes 2µA at 6V, and 5µA at 10V.

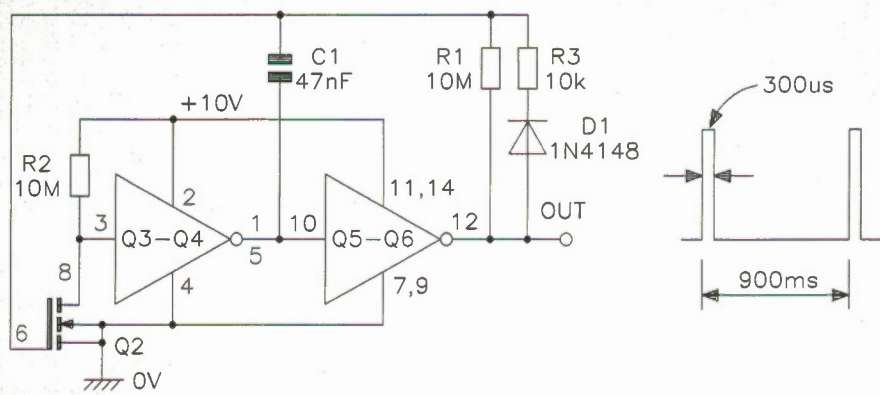

Figure 31. This dual time-constant version of the 4007UB astable generates a very narrow output pulse.

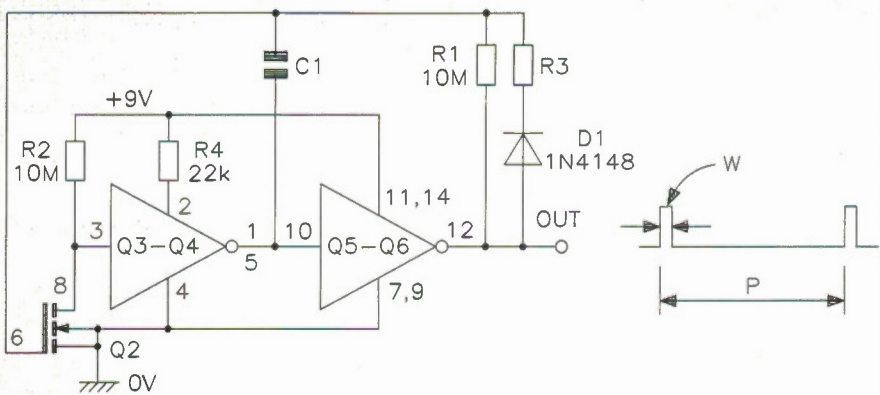

Figure 32. This micropower version of the 4007UB dual time-constant astable consumes absolutely minimal currents.

C1/R3 Values	$I_{\text{mean}} @ 9V (\mu A)$	W ( $\mu s$ )	P (ms)
47nF/10k $\Omega$	1.5	300	900
10nF/33k $\Omega$	3.5	160	180

Table 2. Effects of C1 and R3 values on the astable circuit of Figure 32.

the output waveform (A) is approximately symmetrical. Note that for most of the waveform period, the front-end (waveform B) part of the circuit operates in the linear mode, so the circuit consumes a significant running current.

In practice, the running current of the Figure 28 4007UB astable circuit is higher than that of an identically configured B-series 'buffered' CMOS IC such as the 4001B, the comparative figures being 280 $\mu A$  at 6V or 1.6mA at 10V for the 4007UB, against 12 $\mu A$  at 6V or 75 $\mu A$  at 10V for the 4001B. The 4007UB circuit, however, has far lower propagation delays than the 4001B and typically, has a maximum astable operating speed that is three times higher than that of the 4001B.

The running current of the 4007UB astable can be greatly reduced by operating its first two stages in the 'micropower' mode, as shown in Figure 29. This technique is of particular value in low-frequency operation, and the Figure 29 circuit in fact, consumes a mere 1.5 $\mu A$  at 6V or 8 $\mu A$  at 10V, these figures being far lower than those obtainable from any other IC in the CMOS range. The frequency stability of the Figure 29 circuit is not, however, very good, the period varying from 200ms at 6V to 80ms at 10V.

Figure 30 shows the 4007UB configured as an asymmetrical ring-of-three astable, with the 'input' of the circuit applied to n-channel MOSFET, Q2. The circuit consumes a mere 2 $\mu A$  at 6V or 5 $\mu A$  at 10V. Figure 31 shows how the symmetry of the above circuit can be varied by shunting R1 with the D1-R3 network, so that the charge and discharge times of C1 are independently controlled. With the component values shown, the circuit produces a 300 $\mu s$  pulse once every 900ms, and consumes a mere 2 $\mu A$  at 6V or 4.5 $\mu A$  at 10V.

Finally, to complete this look at the 4007UB IC, Figure 32 shows how the current consumption of the above circuit can be even further reduced by operating the Q3-Q4 CMOS inverter in the micropower mode. Table 2 gives details of circuit performance with alternative C1 and R3 values. This circuit can give years of continuous operation from one 9V battery.



There are more terrific projects and features heading your way in next month's super issue of *Electronics - The Maplin Magazine*, including:

### PROJECTS

#### 12/24V TO 220V INVERTER

This clever unit converts 12 or 24V DC from a car battery or similar power source into a mains level 220V AC supply, capable of powering most

mains appliances. Perfect for camping and caravanning, mobile maintenance and repair work, or as emergency reserve back-up in the event of mains power cuts.

#### ELECTRONIC VOLUME PEDAL

Fed up with that crackly potentiometer-based volume pedal messing up your soulful guitar session? Then build this electronic version, which operates by breaking the light beam by means of an opto sensor and beam breaker, to give predictable, crackle-free electric guitar volume control.

#### GPS DEVELOPMENT SYSTEM PART 2

Continuation of the Global Positioning System (GPS) Development System project, which allows your desktop or portable PC to download and decode signals from NAVSTAR GPS satellites via an RS-232 interface and BASIC software.

#### CCD CAMERA TV MODULATOR UPDATE

This project enables the conversion of the composite video signal from our range of monochrome or colour charge-coupled device (CCD) cameras into UHF, allowing the images to be displayed on a TV screen or recorded by a VCR. The modulator is compact enough to fit into the standard camera housings along with the camera itself.

#### SLAVE FLASH TRIGGER

This project has the potential to make a large improvement in your standards of photography. It sets off a remote slave flash-gun on 'seeing' the flash of light given out by the main flash, to enable a more effective and even lighting of the scene being photographed.

#### FEATURES

The February 1996 issue of *Electronics* contains a heart-warming variety of fascinating features to help keep those win-

ter blues at bay, including: New Microscopy, in which Douglas Clarkson investigates new forms of atomic microscope technology to sense atoms; Social Computing by Frank Booty, describing a paradigm that will use computers as a basis for improved communications between people and organisations; while What Are Phase Locked Loops by Ian Poole, clarifies how PLLs operate, how to use them, and applications for these useful circuit stages. Additionally, we will bring you the continuing instalments of EMC by John Woodgate, Practical Guide to Modern Digital ICs by Ray Marston, and The Internet by Stephen Waddington.

*All this, plus all your favourite regulars as well!*

### ELECTRONICS - THE MAPLIN MAGAZINE

BRITAIN'S BEST SELLING ELECTRONICS MAGAZINE

**A readers' forum for your views and comments.  
If you would like to contribute, please  
address your replies to:**

**The Editor, Electronics – The Maplin Magazine  
P.O. Box 3, Rayleigh, Essex SS6 8LR, or send  
an e-mail to: AYV@maplin.demon.co.uk**



Dear Sir,  
Returning to computing after a number of years at university, I discovered that the entire electronics and computer market had radically changed. Most of the hobby electronics magazines had gone, as had the old microcomputers. Whilst it may seem to many that technology had simply progressed onto new things, the difference compared to the 1980s is a stark one in several areas. The old 8-bit micros (e.g., ZX81) allowed youngsters to learn about programming, and plugging all sorts into the back of the machine, as well as playing games, and it was possible to have a state-of-the-art machine for a relatively low cost. Today, this is not the case, with games only consoles with expensive plug-in ROM cartridges available for under £500. To buy a new PC or Mac means an outlay of £500 minimum. Many PCs are owned by the family, and being expensive items, very few youngsters would be allowed to plug home-made projects into the back of them! Programming them is not easy either, and is certainly far removed from the first tentative steps made by many putting Spectrums into infinite loops on a Saturday morning. At a time when we need to open up paths for youngsters to get into the sciences, all the avenues that were afforded by the old 8-bit micros have disappeared. Microcontrollers aren't elegant. Dig out a ZX81 – it is smaller than you remember (they always are) and they're drop-dead gorgeous! I feel the Spectrum should be resurrected as the low-cost, most easily available second-hand machine. There are plenty around for £20 or so, and many of the games for it are as playable as some of the current 'interactive animations'. I'm suggesting rerunning some of the older projects that plugged into the back of the Spectrum, perhaps with a new rack-mounting motherboard



## STAR LETTER

*In this issue, David Harrison (prospero@pncl) wins the Star Letter Award of a Maplin £5 Gift Token, for his letter concerning 8-bit micros.*



system, or a high-rise modular approach to peripheral cards. Alternatively, new interfacing could be used to link it up with a 3.5in. FDD, hard drive, masses of RAM, VRAM, RGB/SVGA interface, sound cards, A/D, etc. Plugging an 8-bit micro into a hard drive isn't going to be easy – it may require the new motherboard to be as much of a

computer in itself as an expansion chassis, but what a project! I don't think that microcontrollers and PIC projects will carry most hobbyists along with them, or introduce younger people to electronics. As an aside, I run a web-site, called MiSnet, at <http://www.pncl.co.uk/~prospero/misnet.html> which is an educational and special



needs site for teachers, parents, researchers and carers. We can place support groups' information on one of our pages without charge (subject to acceptability, etc.) Odd perhaps for Electronics, but teachers are notoriously hard to access through normal means for IT, whereas science and electronics teachers will read your magazine. David Harrison, prospero@pncl.

*Agreed, the old 8-bit home computers were arguably more attractive to hobbyists and experimenters, even though there was a limit to what could be achieved with them without first having to add on a lot of extras. As you say, the Spectrums and their ilk are now very affordable, and hence, expendable in the event of a project causing damage. Complete and working, boxed ZX81s can now be found in car boot sales up and down the country for around the £5 mark (I once bought a ZX81 for 50p, from an autojumble of all places, and soon had it working after replacing its blown Z80 CPU at the cost of a couple more pounds!). Best buy now, before they rise in price as 'collector's items'! These micros are undoubtedly ideal for beginner projects. However, if we were to do reruns of old projects for these computers (which were after all, given a very comprehensive airing in their time, to the point that folk started complaining!), there would probably be complaints to the effect that we weren't coming up with enough new technology projects; most people seem to prefer seeing something new rather than decade-old technology. However, and quite coincidentally, as a compromise to satisfy those interested in using a modern PC in conjunction with the old 8-bit microprocessor technology, we have the Z80 Development System project elsewhere in this issue!*



### Doctor in Trouble?

As the author of 'CD Versus Vinyl', I'm writing in response to the letter entitled 'RIAA Correction' (Air Your Views, Issue 94), and have several comments to make to Dr. David Pickett about remarks made about my article. Whilst Dr. Pickett doesn't mention what his PhD is in, I'm gratified that a high-ranking academic from an establishment as distinguished as the Indiana University School of Music found only one aspect of an 18,000 word series fit to criticise. I'm sure that the good doctor must have at hand some hard-to-come-by material, and that this would make the basis of a very interesting future article. . . . The criticism made about the "table purporting to compare the performance of LPs and CDs" I'll accept with some humility. It would have been fairer (and in hindsight, much less misleading) to have labelled it (or certain aspects of it) differently, with the comparison made, where appropriate, only between the CD system and that part of the vinyl reproduction system where the audio designer has control over the system specifications (preamp noise and distortion performance, for example). Additionally, a typographic error (on my part) in the table in question, left the Wow and Flutter columns of my submitted table diagram with a question mark, and whilst, as Dr. Pickett says, wow is not only a function of the turntable, but of the record itself, it's also very much a function of the quality of the original recording. Any wow, flutter, noise, distortion, etc. which is perpetrated at the mixing and mastering stage (perhaps caused by the poor mic. amps, EQ, etc.) will be heard on replay,

regardless of the quality of the record pressing, the mechanical integrity of the deck itself, or indeed (and most contentiously, with the early digital recordings) whether the recording is reproduced using a digital (CD) system. In fact, the better the reproduction system, the more deficiencies in the original recording will tend to stand out. Amplifier, loudspeaker quality and listening environment also all play a not insignificant part in the coloration and quality of the perceived sound, whether that sound is sourced from a vinyl disc or a CD. Furthermore, the high level of ambient noise (45 to 50dBA) in a typical living room, and the complete inability of the untrained person to differentiate between changes in level of less than 3dB when listening to unfamiliar programme material, would, on the face of it, conspire to make a mockery of any necessity either for a 90dB dynamic range, or for frequency response deviation of  $\pm 0.5$ dB, from any reproduction system. Listening to music is, first and foremost, a subjective experience, which should be done for pleasure, and whilst my own acuity is perhaps questionable, I can readily accept that although I cannot always hear the difference between the formats, if other people can, and are prepared to pay the money, then for them, it's a worthwhile investment. To my mind, good audio engineering comes about as a result of pragmatic acceptance not only of the objective argument, but the subjective one too. Perhaps a fitting epitaph for the subject comes ironically, from the mouth of Ken Ishiwata, one of the top men at Marantz, who was quoted a few years ago as saying

"Digital is business, (but) vinyl is pleasure" . . .  
Mike Meechan, Berks.

*Thank you for writing in to 'set the record straight!' (groan!) regarding these aspects of sound recording and playback technology.*

### Mind the Gap!

Dear Sir,  
I would like to know the following:  
1. What is the formula for working out the VA rating on transformers?  
2. How can I check a transformer for current?  
3. What has happened to Bob's Mini Circuits? It is time he was back! Would you please ask Bob if he will draw me a circuit for a two-tone train horn, a simple device and small, so that it will fit into my diesel loco.  
Mr. K. Hall, Potters Green, Coventry.

*The VA rating of a transformer is the maximum obtainable figure of the product of the voltage and current that the transformer is capable of supplying from the secondary winding. If, for example, you require 11V at 4A (44VA) from a transformer, you would use a transformer that is capable of supplying at least that rating, and preferably, a bit more, e.g., a 50VA 12V one. To check a transformer's primary winding current, an ammeter would be placed in series between the winding and the supply, with the secondary connected to the load that it is expected to supply. To measure the secondary winding current, the ammeter is connected in series with the load, whilst the primary winding is connected to the AC voltage source.*

*Attempting to measure the maximum current that the transformer secondary winding is capable of giving, by connecting the ammeter directly across the output terminals is not recommended, as damage to the transformer may result, i.e. meltdown! It is better to calculate the maximum output current from the VA rating, assuming this is known, of course. Bob's Mini Circuits will be making another appearance soon in Electronics. However, since he came up with a two-tone diesel loco horn in the April 1995 issue (No. 88), I should think it will be a while yet before another is heard down the line!*

### Pins and Needles

Dear Sir,  
In response to Point Contact's comments on microminiaturisation, Mr. G. C. of Staffordshire wrote in with two useful tips, which are well worth passing on to readers.  
1. He recently discovered in the window of a needlework shop, some slip-on magnifying lenses which clip onto any pair of spectacles, and hinge up out of the way when not in use. Sold under the brand Hobby Lupe, Ref. RX-48, they are available in magnifications of  $\times 1.5$  and  $\times 2.5$ , and in case your local needlework shop cannot help, contact: Daylight Studios, 223A Portobello Road, London W11 1LU.  
2. In the same shop, he saw a very fine crochet needle, labelled 'INOX 1', inoxidisable being French for stainless, and 1 being, presumably, the size. He finds this an invaluable aid in removing small outline devices. The tip can be hooked under each leg in turn, whilst a



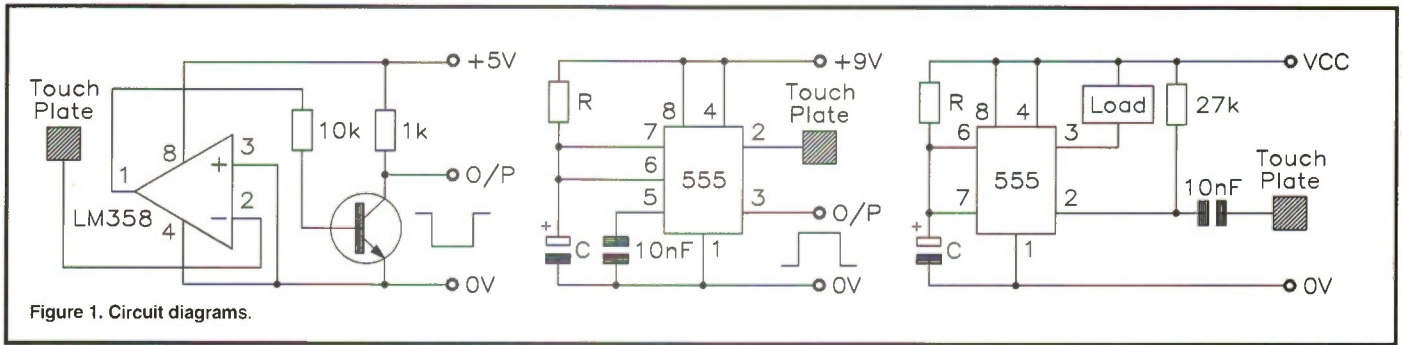

Figure 1. Circuit diagrams.

fine tip soldering iron is applied to the joint; the leg can then be lifted, leaving the board track undamaged. An alternative (to 1 above) is a powerful pair of ready-made readers, available at many opticians. I have some where the two lenses, the bridge and the lugs to which the arms attach, are all a one-piece moulding in glass-clear plastic. They cost no more than a few pounds, and I bought the strongest, with a power of +4 dioptres, and another pair at +2.5 dioptres. For a person with perfect vision, +4 dioptres will bring the far-point in to just 10in. If you are a little short-sighted to start with, it will be even closer, for instance, I need lenses of -1 dioptre for a point at infinity, so wearing the +4 readers instead of my normal specs, things are in focus at just 8in!

Ian Hickman, Waterlooville, Hants.

Thank you for writing in with these tips, which will be very useful, particularly to those embarking on projects using surface mount devices. However, ensure that the glasses are only used for their intended purpose, since prolonged use of inappropriate lenses could lead to eye strain or damage to vision. Consult an optician if in doubt.

### A Touchy Subject

Dear Sir,  
We have many projects which involve door chimes, the one vital part in such a system being the bellpush. What we normally get for the job is a cheap bit of corrodible metal and plastic, which in my experience, quickly needs replacing by a similar short-lived item. Is there not some sort of proximity detector system or capacitive switch that could be housed in a weather-proof box? Or am I out of date, and such a device is available? If so, I'm in the market for a couple!

David Collins, Virkie, Shetland.

In their defence, most good quality bell-pushes will last many years, if not a lifetime, if correctly installed and given some protection from the elements. Perhaps your experiences are down to the relatively harsh climate in Shetland! The idea of using a touch switch to operate a door chime is novel, but could give rise to the problem of callers to your door repeatedly pressing it or applying excessive pressure to it, perhaps thinking that the switch was broken due to the lack of any mechanical 'feedback' movement. There would also be the possibility of a touch switch not working properly in conditions of high humidity or fog, etc., because of the input being effectively shorted to ground. However, a touch switch circuit is relatively easily made, either based around the good old NE555 timer IC, a high gain op-amp circuit (see circuit diagrams shown in Figure 1 at the top of the page), or by using a dedicated touch switch chip, used in conjunction with a suitable touch pad, such as our triangular version, HY01B. Note, however, that the circuits shown are only suitable for battery-

operated units, since an earthed mains transformer-powered circuit will be likely to prevent the detection of the minute trigger input signal. An alternative, and possibly more reliable method of switching, is to use a small temperature sensing IC, to detect the heat of a caller's finger pressing on it, relative to the ambient temperature.

### Source with Your Chips?

Dear Editor,  
I feel I must register my disappointment that the source code for microcontrollers, etc., is not included with the articles that use them. As these devices form a major part of the functionality of the projects that include them (the Video Kaleidoscope is a good example), not including the source code reduces the educational content of such projects by a substantial degree. In the December issue, your reply to A. Bianchi stated that the disclosure of the source code is up to the designer. In what way is the copyright of software different from that of the hardware in which it resides? If the designers are willing to reveal every detail of the hardware design, why are they so shy about revealing the software? Does it have anything to do with the designer being the sole supplier of the programmed device, I wonder? How does the price, to the project builder, of the programmed PIC in the Video Kaleidoscope differ from that of a blank PIC? As someone who has some experience of using and programming these useful devices, I feel that not including the source code (or at least, a flow or structure chart) leaves the documentation of the project incomplete.

Andy Baxman, University of Portsmouth.

The source code is not listed in instances where Maplin acquires rights to it (such as is the case with the Video Digitiser, Serial Line Tester and Micron III projects), because we have to protect our not inconsiderable investment in the acquisition of software rights, development resources and stock for this type of project. Development costs for these kits are high, and we also have to program the devices and hold stock of programmed units; therefore, these costs need to be recuperated by the sale of kits or preprogrammed devices for the kits in order to make the project commercially viable. Also, from feedback we have received, it seems that the majority of readers would prefer not to see lengthy reams of source code in the magazine, to the detriment of space for articles or other projects. Where possible, and space allowing, we do publish a flow chart for microcontroller-based projects, recent examples being the Micron III and MIDI Test Box. Since most project builders will only be making the one example, or at most, a few examples of a kit (as opposed to the large numbers that a commercial venture would churn out), generally there are no objections to purchasing a preprogrammed device -

certainly a cheaper option than having to purchase a complete PC-based development system.

### Tune in to Radio Africa

Dear Editor,  
From the southern tip of Africa, I have to congratulate you on a very interesting magazine. Seven months ago, I saw the magazine in a book shop and since then, I cannot wait for the next issue to hit the stands in order for me to read it from front to back. After reading the first magazine, I immediately ordered the back issues to the beginning of the year. I think the advantage that *Electronics* has over other electronics magazines, is the fact that Maplin has a branch in Cape Town. This makes it easier to get the advertised kits and components. Another factor is the diversity of the articles, whereas all the other magazines concentrate on electronic projects and topics. *Electronics* covers all electronic-related topics. I am a qualified electronic technician, but over the last five years, I devoted my career to software development. However, I still nurture a very keen interest in electronics. Seeing that we sit on the border of the 'global village', your magazine makes it just that little easier for hobbyists to keep in touch with the developments in the European electronics field. I am busy building the 4-20 Valve Amplifier, which will form part of a complete Hi-Fi system. I could go out and buy a Hi-Fi of any description over the counter, but where's the fun in that? It is a lot more fun to do my homework and develop a system to my own specifications. I will also be designing the speaker system, and the remote control. However, documentation/circuitry has been hard to find for a suitable stereo synthesized AM/FM tuner - any ideas? I do, however, have one criticism. In the

January 1995 edition, you had an article on receiving signals from a weather satellite. I was a bit disappointed to read that the receiver is only available in ready-built form. Why not publish it as a project, and then everybody can build it to suit their finances, as you have done with the valve amplifier? In the September 1995 issue, you announced a competition with prizes all consisting of visits to Eurotunnel. Seeing that *Electronics* is available internationally, why not offer a competition with a prize that is worthwhile to everyone, including us here in South Africa? Come to think of it, why don't you offer more electronics-related competitions? Keep up the good work, and once again, thanks for an excellent magazine.

Robbie Zielemans, Sasolburg, S. Africa.

Thank you for your comments, and good luck with your ambitious sounding Hi-Fi project. Issue 67 (July 1993) contains an article (including circuit diagrams) on the Velleman Synthesized Digital VHF/FM Tuner kit, Order Code VF20W, which has provision for a remote control facility when used in conjunction with the Infra-red Transmitter (VE47B). This design of tuner (which may be operated in mono or stereo) also incorporates a VHF FM cable connection, but alas, does not cover the AM band. Regrettably, the MapSat 2 Receiver is not available in kit form. The majority of competitions are run in conjunction with other companies, recent examples being BT and Eurotunnel. We would certainly consider similar future competitions with companies in nations other than Britain, but since *Electronics* is published here, and has the majority of its readers in Britain, inevitably, there is a degree of bias involved as regards the 'catchment

## £10 DISCOUNT VOUCHER

£10 off the purchase price of  
The **ELECTRONICS SERVICE MANUAL**  
Cut out and send in this voucher, or photocopy,  
with your order. (See the advertisement  
elsewhere in this magazine.)

Voucher cannot be used with any other discount offer.  
Voucher only valid for use before March 30, 1996.

# The Internet

## PART:2

# 01

### Review of Internet Providers

There are numerous Internet providers able to connect you online. In Part 2 of this series, Stephen Waddington takes a look at a selection, and the services they offer.

#### Provider

CityScope Internet Services  
59 Wycliffe Road, Cambridge CB1 3JE.  
e-mail: sales@cityscope.co.uk  
Tel: (01223) 566950/(01223) 566951.

#### Outline

Founded almost two years ago, CityScope was established to provide Internet connectivity to small companies, individuals, clubs and societies. The company's primary focus is to provide a high quality service to the non-technical user.

#### Services

Flagship service is CityScope IP-GOLD. This includes single user access to:

- A World Wide Web browser giving simple, graphical access to most Internet services
- Access to CityScope's Global Online services
- E-mail package (Unipalm's Mail-it)
- CityScope Connection
- Windows/Macintosh Usenet software

#### Getting Online

Global Online Disk provided as part of the IP-GOLD package gives Windows and Macintosh users Internet access in a simple to use, quick to install package.

**Dial-in Locations:** CityScope has six POPs (Points of Presence), which enable access to the Internet across a total of 210 lines: London, Edinburgh, Manchester, Bristol, Birmingham and Cambridge.

**Support:** 24-hour e-mail support. Telephone helpline during office hours.

**Sign-up Cost:** £50.

**Online Subscription Costs:** £180.

#### Summary

Services are not necessarily the cheapest available, but are high quality. Emphasis here is primarily ease of use. Guaranteed modem-to-user ratio will never drop below one modem per 30 users, so you will rarely hear the engaged tone when you try to get through.

#### Provider

Compulink Information eXchange (CIX)  
The Sanctuary, Oakhill Grove, Surbiton,  
Surrey KT6 6DU.  
e-mail: cixadmin@cix.compulink.co.uk  
Tel: (0181) 390 8446/(0181) 390 6561.

#### Outline

CIX (Compulink Information eXchange) is the UK's largest provider of dial-up e-mail facilities, Usenet access, Online conferencing, full Internet privileges and a large database of Files. An example list of files available from the Internet Conference is shown in Photo 1.

#### Services

CIX users have access, via the CIX Internet Gateway, to the full spectrum of Internet tools – FTP, Usenet, GOPHER, Telnet (a method of logging into host computers), WWW, and Internet Relay Chat (a method of conducting conversations via the keyboard online in real time with other users). The CIX Internet Gateway also allows CIX users with accounts on other systems on the Internet to telnet into CIX to access it, thus saving their telecom charge. Best of all, because CIX is a conferencing system, users are able to ask questions, share pointers, discuss interesting sights, and get advice and technical support.

#### Getting Online

CIX is supported by a wide range of off-line readers on various machine types, which means that your on-line time is minimised. Contact CIX direct for details.

**Dial-in Locations:** London.

**Support:** E-mail and telephone support during office hours.

**Sign-up Cost:** To join CIX initially will cost you a one-time £25 registration fee. Included in this charge, is the cost of your first CIX manual.

**Online Subscription Costs:** Four pence per minute off-peak, six pence per minute peak. Peak time is Monday to Friday 8.00am to 5.00pm. This charge covers all connection speeds, all modem types, and use

Photo 1. Typical File List, which accompanies each of the conferences on CIX.

Photo 2. CIX do not charge a premium for high-speed modern connections

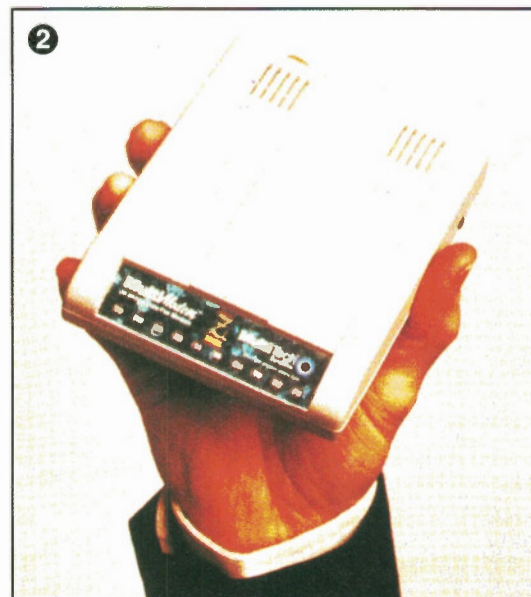
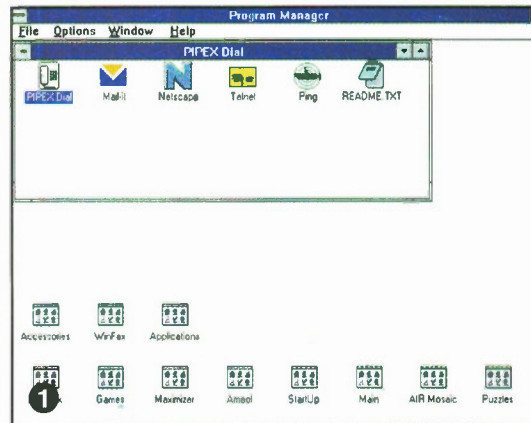

of nearly all of the CIX facilities. CIX does not charge extra for the use of the CIX Internet gateway, for mail storage, or for high-speed modem connections – see Photo 2. E-mail to all sites is also covered in this charge.

There is a monthly minimum of £6.25, which is effected if a user's total usage charge bill comes to less than £6.25. Users are billed monthly in arrears. CIX users can opt to pay by Visa, Access, Mastercard, Diners Club Card, or Direct Debit with the £6.25 monthly minimum.

## Summary

CIX are slightly behind providers such as Pipex and CompuServe, who provide WWW browsers combined with e-mail software. Consequently, getting started is complicated if you wish to gain WWW access. Users are predominantly technical, a fact confirmed by the number of hardware and software discussion conferences.

## Provider

CompuServe Information Service  
1 Redcliff Street, PO Box 676, Bristol BS99 1YN.  
e-mail: 70006,101@compuserve.com  
Tel: (01734) 391064/(01734) 394711.

## Outline

Established in 1979, the CompuServe Information Service provides its worldwide membership of over 2.8 million with online access to more than 2,000 online services, to meet both business and personal interests.

## Services

CompuServe offers access to the Internet for e-mail, newsgroups, telnet FTP and the WWW. All of these services utilise CompuServe's point-and-click interface, and require no prior knowledge of the Internet. WWW access is achieved using CompuServe's NetLauncher package, consisting of an Internet Dialer – see Photo 3 and WWW Browser such as Spry Mosaic (Photo 4), available free to all members.

## Getting Online

CompuServe can be accessed by any modem-equipped personal computer utilising the CompuServe Information Manager graphical interface, as shown in Photo 5, or any general communications software.

**Dial-in Locations:** CompuServe operates a worldwide dial-in data network, and has eight nodes in the UK. Additionally, members can access CompuServe using the BT GNS Dialplus service and Mercury's 5000 network. While these offer a total of 170 nodes across the UK, there are additional charges – see online subscription costs.

**Support:** In addition to freephone UK support (Monday to Friday, 9.00am to 6.00pm, 10.00am to 5.00pm Saturday), CompuServe has local support offices in Germany and France, providing freephone support for Germany and Switzerland and a local call help line in France. All other European countries are supported by offices in either the UK, Germany or France.

**Sign-up Cost:** None.

**Online Subscription Costs:** All costs are billed in US dollars, typically to a credit card. Free for the first month, thereafter, US\$9.95 per month. Three hours of Internet access included. Thereafter, free for basic services; Internet products: All speeds up to 28,800 baud = US\$2.50/hour; Extended services: All speeds up to 28,800 baud = US\$4.80/hour. Beware! CompuServe charge for e-mail from other service providers. Costs start at US\$0.15. Additional access charge for dial-in to non-CompuServe node; GNS Dialplus: US\$4.20/hour; Mercury 5000: US\$2.50/hour.

## Summary

The Rolls-Royce of Internet Providers. Has a reputation for high cost, but has a number of very useful services. Favoured for ease of use by individuals who are primarily non-technical. Points of Presence (POP) across the UK and worldwide are useful if you travel widely.

## Provider

Delphi Internet  
The Elephant House, Hawley Crescent,  
London NW1 8NP  
e-mail: ukservice@delphi.com  
Tel: (0171) 757 7080/(0171) 757 7160.

## Outline

Delphi Internet, one of America's fastest-growing consumer online services, is now available to UK users. Delphi Member services are not 24-hour, but instead open for business seven days a week, from 10.00am to 10.00pm weekdays, and from 12.00am to 8.00pm at weekends.

## Services

The Delphi service offers news headlines and specialised content from *The Times* and *The Sunday Times*, as well as full access to the Internet and the vast online resources of the US Delphi service.



Photo 3. CompuServe's Internet Dialer.

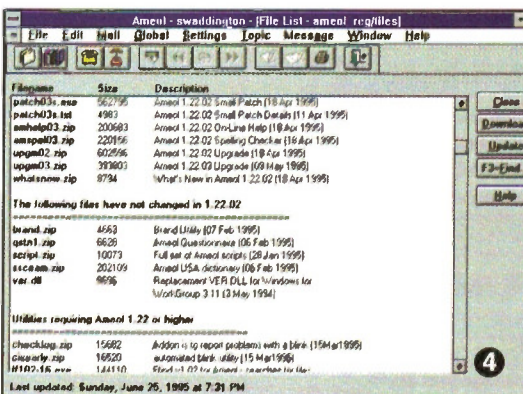

Photo 4. Spry Mosaic is used to access the WWW via CompuServe.

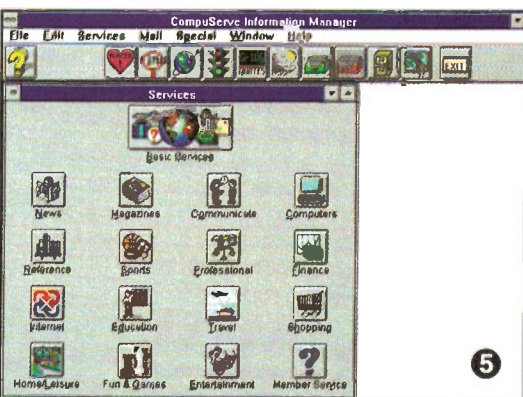

Photo 5. The CompuServe Information Manager graphical interface

Using Delphi, customers are able to:

- Read news headlines from *The Times*, and then comment on the news in an online *Times* forum.
- Access forums run by a number of other media companies and unique, specialist information providers.
- Gain access to all of the Internet's capabilities, including e-mail.
- Connect to more than 6,000 specialised Internet Usenet groups, using FTP, Telnet and GOPHER.
- Full text based access to the World Wide Web (WWW).
- Join in one of hundreds of channels of worldwide real time conversations, using Internet Relay Chat.

## Getting Online

To become a member of Delphi UK:

- Set communications software to 8 data bits, no parity and one stop bit. Emulation should be set to VT100 and handshaking to Xon/Xoff.
- Dial (0171) 284 2424.
- Once connected, access the Delphi host computer by typing @D <return>.
- At the username prompt type **godelphi**.
- At the password prompt type **inet1194**.

**Dial-in Locations:** The Delphi service can be accessed via a local telephone call from more than 100 UK nodes, including all major cities. Access through BT's GNS network is surcharged at the a rate of £1.50 per hour, with a sluggish maximum speed of 2,400 baud.

**Support:** Telephone support during office hours.

**Sign-up Cost:** None.

**Online Subscription Costs:** Delphi costs from £10 a month. New subscribers are given five free hours of connection time, to acquaint themselves with the service. Delphi access is available to UK customers under two service plans:

- The 10/4 plan, at £10 per month, includes the first four hours of use each month; additional use is £4.00 per hour.
- The 20/20 plan, at £20 per month, includes 20 hours of use, with additional use at £1.80 per hour. This plan will be the most economical for users who expect to be online more than 6.5 hours each month.

## Summary

Delphi is good if you want to explore the *Sunday Times* online. Its value added services are similar to CompuServe, and certainly match the quality, but it is extremely poor on Internet services. Delphi has a long way to go to match its bigger brother, CompuServe.

## Provider

Demon Internet  
Gateway House, 332 Regents Park Road, Finchley,  
London N3 2QQ.  
e-mail: sales@demon.net  
Tel: (0181) 349 0063/(0181) 349 0309.

## Outline

Demon is currently one of the fastest-growing Internet providers. The big difference between Demon and other providers, is that after the monthly subscription, there are no other online costs.

## Services

Facilities offered include:

- Direct PPP Dial-up access to the Internet
- No online charges or charges for mail
- Full read/write Usenet news

- FTP directly to the desk top computer
- Multiple mail addresses
- Local Inter Relay Chat server

## Getting Online

To get started, you will need to mail the following details to: **Internet@demon.net**, or phone details through to the Demon sales department, stating the following information:

- Credit Card Number and expiry date
- Address
- Telephone Number
- Three preferred machine names for Internet address (@machinename.demon.co.uk)

Free/shareware software for most computers is available for download using standard communications programs.

**Dial-in Locations:** An amazing 900 access lines across many nodes, including London, Birmingham, Bradford, Bristol, Cambridge, Cardiff, Coventry, Edinburgh, Gloucester, Hull, Isle of Wight, Leeds, Leicester, Liverpool, Luton, Manchester, Newcastle, Nottingham, Preston, Reading, Sheffield, Wolverhampton.

**Support:** London-based helpline open during office hours. Tel: (0181) 371 1010.

**Sign-up Cost:** £12.50 + VAT.

**Online Subscription Costs:** £10.00 per month + VAT, billed by credit card monthly in advance.

## Summary

Demon is a good all-round service. It is particularly favoured amongst individuals outside London, because of its large number and geographic spread of dial sites. The fixed monthly cost is also a bonus for individuals likely to spend large amounts of time online. Emerging services include World Wide Web space, design and build services.

## Provider

The BBC Networking Club  
BBC Networking Club, Sulgrave House,  
Woodger Road, Shepherds Bush W12 8QT.  
e-mail: info@bbnc.org.uk  
Tel: (0181) 576 7799/(0181) 576 1130.

## Outline

The BBCNC exists to promote the Internet (a worldwide communications system using computers and phone lines), to schools, colleges and anyone who has not used the Internet before.

## Services

On joining the club, you will receive two passwords, one of which will let you gain access to the BBCNC bulletin board called Auntie, and the other to gain access to the Internet. From Auntie, you can download further software to your computer, which will enable you to explore the Internet as a whole. This software will include the communications software necessary to access the Internet. This software will enable members to run applications such as browsers for reading the World Wide Web, which include: Mosaic, Netscape, MacWeb for Macintoshes and WinWeb for PCs, FTP, Telnet, Usenet news, and client e-mail software. These applications will be freely available, either in the starter kit, or from the BBC.

## Getting Online

To use the service to connect to the Internet within the UK, you will first need to buy a starter kit containing the

Internet connection software and a start-up guide, before subscribing to the service.

**Sign-up Cost:** The starter kit software is currently available for the PC or Apple Mac, at £25 + VAT.

**Dial-in Locations:** Points of Presence exist in Cambridge, London, Bristol, Birmingham, Manchester and Edinburgh. Initially, only about 35% of the population will be within a local call charge, but as more people join the Club, the BBC hope to increase the number and range of PoPs accordingly.

**Support:** E-mail and telephone support during office hours.

**Online Subscription Costs:** The subscription fee is £12.00 + VAT per month, currently payable quarterly by direct debit, cheque or credit card. Internet users, who will be classified as 'Associate Members', will be asked to pay £5.00 + VAT per month.

## Summary

If you are a BBC fan, then this is for you. Like Delphi, the benefit in using this service is that it includes numerous value-added services. Not recommended if you wish to explore the wider world of the Internet.

## Provider

PIPEX (Public IP Exchange)  
216 Cambridge Science Park, Cambridge CB4 4WA.  
e-mail: sales@pipex.net  
Tel: (01223) 250120/(01223) 250121.

## Outline

PIPEX offers commercial access to the Internet via a range of dial-up and leased-line services. The network is designed to have no single point of failure, and significant international bandwidth allows it to offer excellent performance and 99.5% network availability. PIPEX, at the beginning of 1995, has over 400 leased line customers in the UK and over 600 directly connected customers in all, representing 80% of the UK commercial leased-line market. A number of UK Internet Providers (including BBCNC, IBMPCUG, Cityscape, Pavilion, RedNet, ExNet, Easynet, Almac, and Direct Connection) based their services on the PIPEX network, and sell low-cost dial-up access.

## Services

The majority of the PIPEX customers are large businesses, who require leased-line connectivity directly to the Internet. PIPEX does, however, cater for individual users, and supports the full Internet access simpler to many of the other heavyweight providers, such as CityScape and CompuServe.

**Getting Online:** PIPEX offer an integrated communications package called PIPEX Dial, as shown in Photo 6. This includes a Telnet package, WWW browser and mail suite. Contact PIPEX for details.

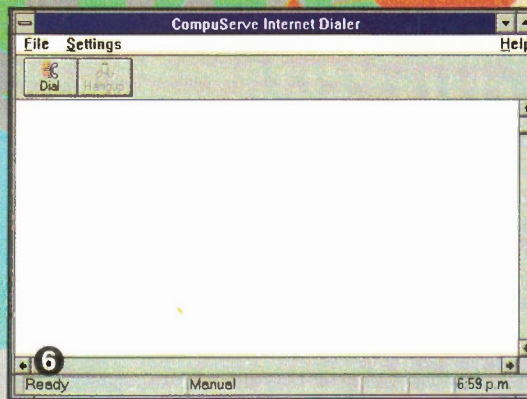

Photo 6. PIPEX Dial, the integrated software suite from PIPEX.

**Dial-in Locations:** All major cities across UK, together with over 100 additional POPs.

**Support:** 24-hour e-mail support. Telephone helpline during office hours.

**Sign-up Cost:** £50.

**Online Subscription Costs:** £180 per year, payable in quarterly advanced installments.

## Summary

High quality Internet service, which does not include any value-added services like its counterpart, CompuServe.

## Ten Tips to Getting Online

Before going online, consider the points below and rate them in order of importance, before seeking answers from a variety of Service Providers.

- Is there a sign-on cost?
- What are the online subscription costs and structure?
- Is telephone/e-mail support available, and during what times?
- Is local call or toll free cable access available in your area?
- What is the scope of the Internet access (e-mail, FTP, GOPHER, Usenet, WWW)?
- What is the ratio of user/modem dial-in points?
- What support structures are available?
- What is the fastest speed of your modem support?
- Is a free trial period available?
- Are software packages available from the Internet Provider?

## About the Author

Stephen Waddington has been an Internet user for the past two years, and can be reached at swaddington@cix.compulink.co.uk. Initially using it solely as a medium for e-mail, he is now a regular net surfer. Stephen uses CompuServe, which he favours for its professionalism and graphical WWW access, and CIX, which he claims is good for regular conferencing and e-mail.

# MAPLIN

## SOUTH AFRICA

Calling all customers in Southern Africa ...

... your new 1996 Maplin Catalogue is now available.

Maplin South Africa (Pty) Ltd.  
P.O. Box 1846, Somerset West, 7129, RSA  
Telephone: (024) 515124 Fax: (024) 515127

**R39,95**

from any branch of CNA  
or by Mail Order from  
Maplin South Africa



# @Internet

While the World Wide Web isn't the only part of the Internet, it is by far the most popular one, and it's growing too, at an incredible rate. This is simply because its so accessible, various graphical interfaces such as Mosaic and Netscape make it easy to use and considerably less daunting than the other sectors on the Internet. It is not just the Web itself, of course, which is simple to use. With just a little knowledge, it's not that hard to design and write Web pages, and many thousands of sites exist featuring pages which have been written by individuals. It is hardly surprising that it's so popular among users.

There is a sort of stampede to do this. Made easier by the way most software publishers have rushed to produce some sort of tools to allow pages to be produced with the products they sell, users have been dragged along with the tide. This is nothing to worry about, mind you, as anything which generates interest in anything to do with the Internet has got to be good. In time, things will settle down, but meanwhile, enjoy it.

Utilities abound to allow ordinary word processors to output pages in hypertext markup language (HTML) format – the language of the Web – and some word processors have now appeared with the tools built in. However, it's the arrival of the big-boys in more conventional publishing, the desktop publishing programs such as Adobe PageMaker and QuarkXPress, which will mean more to potential users than word processors. In the same way that a magazine publisher or a book publisher would merely laugh if they were asked to generate their products using only a word processor, so it will be soon with Web site publishers. Word processors are best at allowing users to write and edit words, DTP packages

are the best when creating pages – in dead-tree or wired forms.

A straightforward Web page isn't just a question of stringing together a few words and some GIF pictures. To create a page which is of real use to anyone, you need a lot more than that. Create a page where users keep coming back, and you've done a good job. If you haven't done a good job, a user will only look at the page once and never return.

The modern idea is to produce a page which includes a Web engine. Now, there are several kinds of Web engines and even more are being developed. However, the main ones of interest here are search engines (where you type in a keyword or keywords and the engine searches through a databank to find the information you want); registration and preference engines (where you enter your details and preferences and the engine produces personalized information for you as it is generated elsewhere on the Web); and remote control (where you control a device via the Internet). Search engines are common enough, but finding a good one isn't all that easy. A couple of the best are listed in Site Survey. The other two types of Web engines are only in their infancy, but are developing at a rapid rate of knots. We hope to show some in later issues.

To be honest, a lot of pages around the World Wide Web really shouldn't be there at all. The fact that they are is merely a credit to the principle behind the Internet, of free enterprise and development, but that doesn't make them any better. A badly designed Web page is the difference between a scrappy letter for a job application (coffee-stained, dog-eared and scruffy) and a typed curriculum vitae. Basically, these pages should only be there to serve as a reminder as to how not to do it.

## Health Education Authority

The Health Education Authority has launched a Safe Sex/AIDS information site on the World Wide Web. The site is now open at <http://www.wad.hea.org.uk>. In addition to its information content, the site allows you to download a

Red Ribbon screen saver, with ribbon designs by the likes of Joanna Lumley and Chris Evans. There are also links to various other AIDS information sources. The site has been established as part of the build-up to World AIDS day on 1 December, but the site will remain open for the indefinite future.

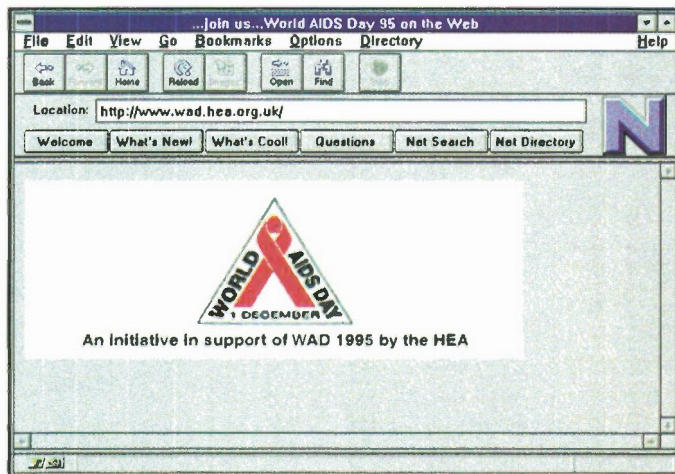

## New Browser from Netscape

Netscape has released a new version of its World Wide Web browser Netscape Navigator 2.0. The new Internet navigator brings Web exploring, e-mail, news-groups, chat, and FTP capabilities together in a seamlessly integrated

package. It provides a superior platform for live online applications, supporting Live Objects and other interactive multimedia content, such as Java Applets, frames, and Netscape inline plug-ins. Netscape Navigator can be downloaded from the Netscape WWW site at <http://www.netscape.com>

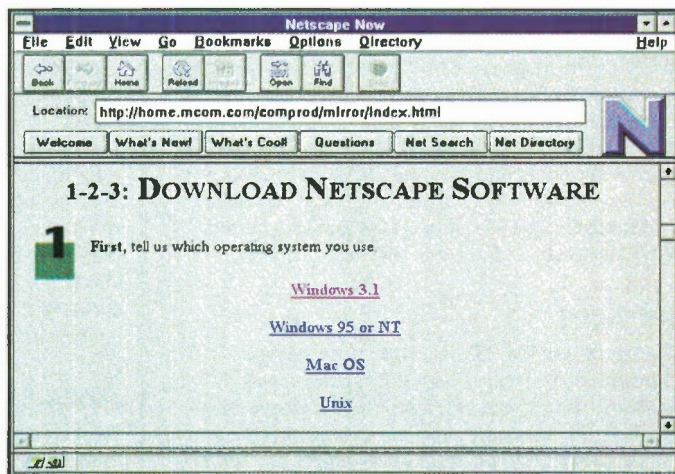

## Snap! Crackle! Pop! Web Page

Kellogg has beaten its rivals in the cereal market with the launch of a World Wide Web site. The Kellogg site is hosted by the company's popular Rice Krispies cereal brand characters, Snap! Crackle! and Pop! Users who log onto the Kellogg site at <http://www.kelloggs.com>, begin their adventure at the Kellogg Clubhouse. From the foyer, Snap! Crackle! and Pop! direct users to the recreation room, lounge and kitchen, where each character hosts a different room. Bold colours and graphics invite users to visit the recreation room for downloadable commercials and audio clips, and a Snap! Crackle! Pop! screensaver; the lounge for games, and images of promotional items from the past 30 years; and the kitchen for recipes, nutritional information and a look at Kellogg's cereal boxes from around the world.

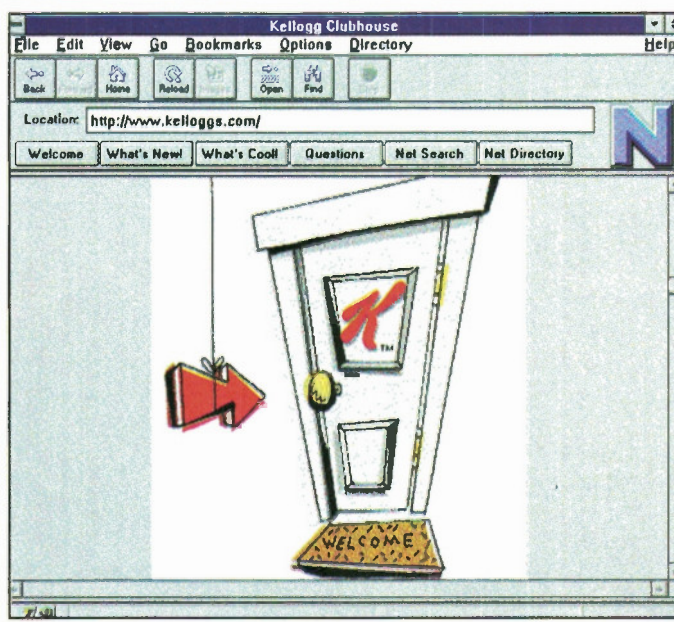

## Survey Reveals Parental Anxiety

Independent research published this month by online services provider, UK Online, reveals that parents are anxious about what their children may find on the Internet. The survey reveals that around 70% of parents worry about their children having access to adult material on the Internet. The overwhelming majority (93%) claimed they would prefer to have some parental control over what their children may find in cyberspace. Nearly half were worried that children 'going online' may interfere with their homework. The survey goes on to show that over half of British families feel that boys and girls are equally likely to benefit from online computer services. However, 21% still felt that boys were more likely to benefit than the 3% who thought girls would benefit the most.

Contact: UK Online, Tel: (01749) 333313.

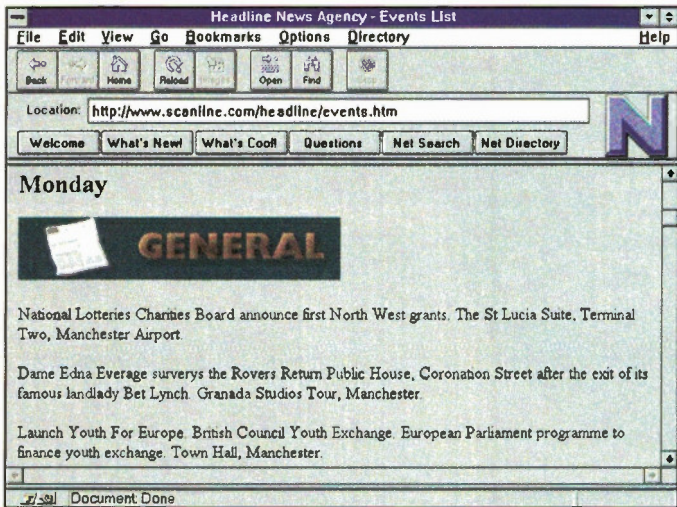

### Manchester News Agency on the Web

Headline News Agency has become the first news agency in the North West to join the information superhighway with its own site on the World Wide Web at <http://www.scanline.com/headline/>. The agency, which was established more than a decade ago, has kept pace with high-speed news technology since the early 80s as

one of the first in the city to offer electronic copy filing via modem. Now, Headline has gone on-line, with web pages which give a brief history of the company, information about the area in which we work and how we operate. Visitors to Headline's web page can also access details about copyright regulations and a weekly diary of media events taking place across the Greater Manchester area.

### Bug Strikes Conservative Home Page

After announcing the arrival of the Conservative party home page last month at <http://www.conservative-party.org.uk>, we can reveal that its impact has been undermined by a programming error. The site includes a selection of policy letters from John Major, accessed from icons on the home page. The first is a picture of a family, labelled 'Values' - when it is selected, the screen is filled by a blank page!

### Internet-ready Voice/Data Modem

The Sportster Vi is an entry level v.32bis 14.4 fax and data modem, which US Robotics are bundling with Internet access, in addition to voice/data-handling software that will enable a PC to cope with telephone answering, voicemail and fax. The price tag of £99 includes all cables and phone connectors, as well as up to three months free access to the Internet via Unipalm Pipex. Contact: US Robotics, Tel: (01734) 288200.

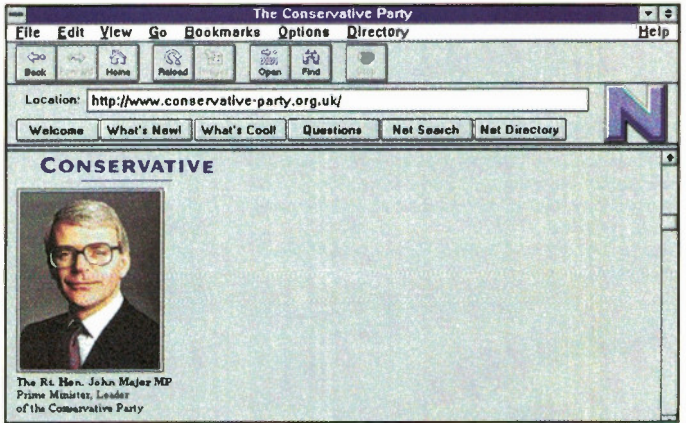

# Site Survey

## The month's destinations

The Yahoo search engine is worth a look, if only because it is good to see how a search engine should be. It is at: <http://www.yahoo.com/search.html>

Many archives now feature a search engine at their front end. It is an obvious way to ensure that users of archives don't slow down the whole system by logging on for long periods while wandering around the archive looking for items of interest. A quick search on the front-end engine locates interesting things far more rapidly. Some enterprising individuals have created pages which link cleverly with other sites. Gary Hopkins' Hidden Rivers of the World Wide Web, at: <http://www.netaxs.com/~hopkins/rivers/rivers.html> is one such implementation. This is how Web pages should be generated. A similar, though currently not so well-implemented page is the Internet Computer Index, at: <http://ici.proper.com/>

If you are looking for the Internet tools which everyone needs for connection, look at Stroud's Consummate Winsock Apps List (CWSA), at: <http://cwsapps.texas.net/> for IBM-compatibles, or for Macs, at Andrew's MacTCP Drive-Thru, at: <http://www.echonyc.com/~andrewj/drive-thru.html>

These are both very useful and imaginative tool pages. Finally, for those who wonder whether it is worthwhile generating a Web site

at all for fear it is going to be ridiculed on these very magazine pages, look at the World War II archive at: [http://192.253.114.31/D-Day/Table\\_of\\_contents.html](http://192.253.114.31/D-Day/Table_of_contents.html)

This complete site is generated and maintained by a High School in the USA. When schools get in on the act in such a professional looking way, then it is easy to see where the next generation of Internet providers are coming from. If you know of any good Web sites generated by schools in the UK, let us know, at [site\\_sur@maplin.demon.co.uk](mailto:site_sur@maplin.demon.co.uk)

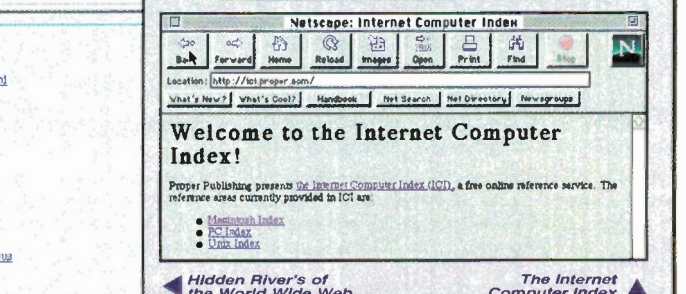
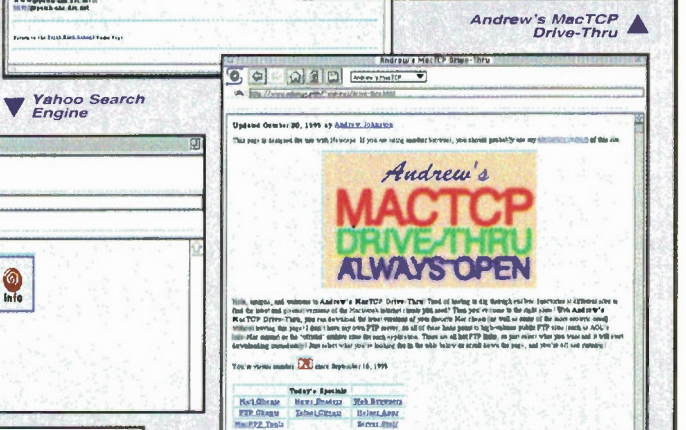
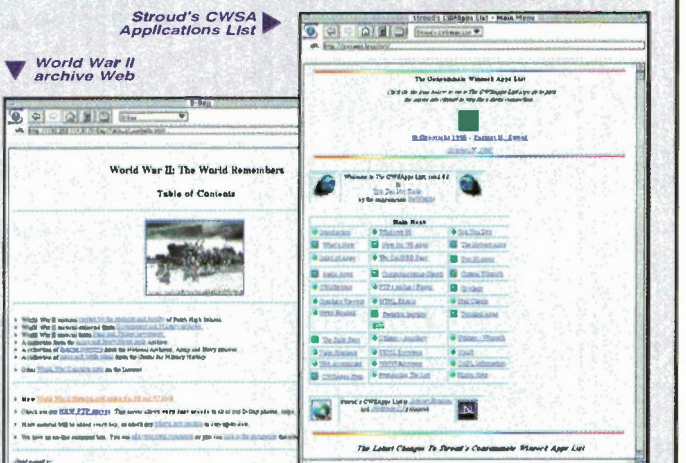
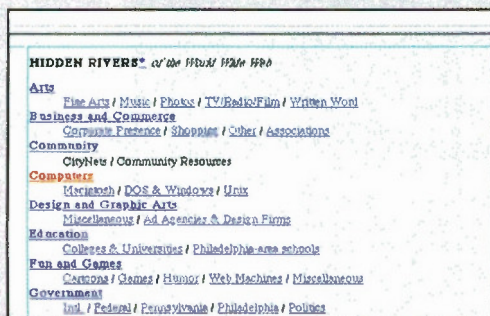
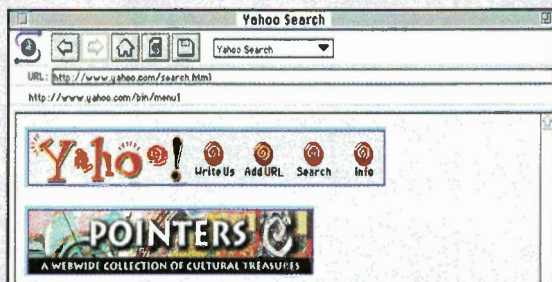

These descriptions are necessarily short. Please ensure that you know exactly what the kit is and what it comprises before ordering, by checking the appropriate issue of *Electronics* referred to in the list.

The referenced back-numbers of *Electronics* can be obtained, subject to availability, at £2.10 per copy.  
Carriage Codes - Add; A: £1.60, B: £2.30, C: £2.90, D: £3.40, E: £4.00, F: £4.70, G: £5.50, H: £6.00.

# DID YOU MISS THESE PROJECTS?

The Maplin 'Get-You-Working' Service is available on all of these projects unless otherwise indicated.

To order Project Kits or back-numbers of *Electronics*, phone Credit Card Sales on (01702) 554161. Alternatively, send off the Order Coupon in this issue or visit your local Maplin store.

**Maplin: The Positive Force In Electronics**

All items subject to availability. Prices include VAT. E.&OE



**ELECTRONIC MEMOPAD**

Record messages up to 16 seconds long for playback - up to 10 years later! Ideal for memos and messages in the office or home, and a boon to the blind, partially-sighted, and anyone with reading or writing difficulties.

Order as: LT79L, £29.99. Details in *Electronics* No. 87, March 1995 (XA87U).

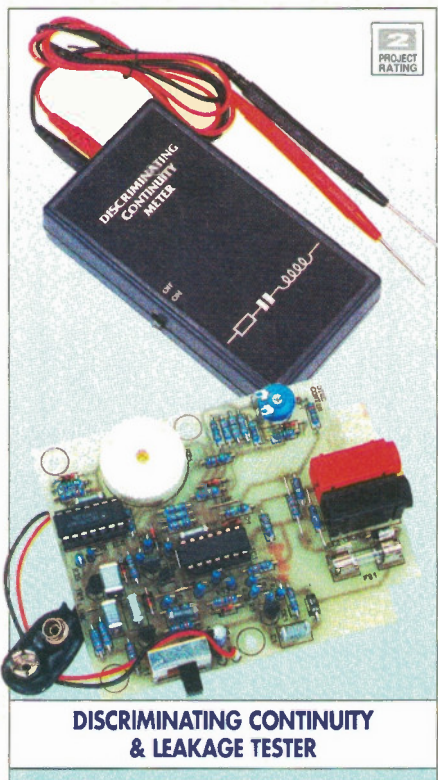

**DISCRIMINATING CONTINUITY & LEAKAGE TESTER**

Test for more than just 'Go' or 'No go' conditions with this ingenious tester. A variety of sound outputs of varying pitch and duration allow you to differentiate amazingly accurately between a good connection and a high resistance one, test for leakage, and check both passive components and semiconductors.

Order as: LT78K, £19.99. Details in *Electronics* No. 87, March 1995 (XA87U).

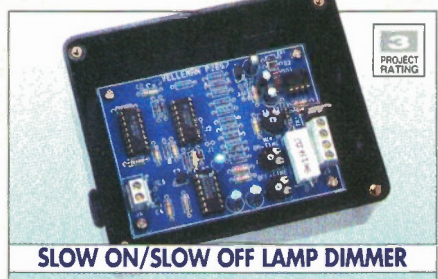

**SLOW ON/SLOW OFF LAMP DIMMER**

Look - no hands! Instead of the normal manual control, this dimmer uses two variable timers to slowly increase or decrease the level of light. Both the 'on' and 'off' timers are variable from 1 second to 30 minutes. Ideal lighting control for slide/film shows, and as a gently reducing 'slumber' switch.

Order as: VE51F, £15.99. Details in *Electronics* No. 87, March 1995 (XA87U).



**SOUND ACTIVATED FLASH TRIGGER**

Produce exciting pictures of darts bursting balloons, bullets passing through light bulbs, etc., with this inexpensive flash trigger. The sound of mum's best bone china hitting the floor triggers the unit which operates your flash-gun in time to photograph the bits whilst still in mid-air.

Order as: LT86T, £14.99. Details in *Electronics* No. 89, May 1995 (XA89W).

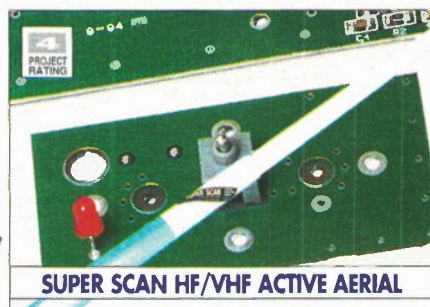

**SUPER SCAN HF/VHF ACTIVE AERIAL**

Improve your scanner's reception with this active, broadband aerial. The aerial supplied with most scanners is perfectly adequate for local reception, but a significant improvement can be made in the reception of long distance (DX) and weaker stations by using a fixed, active aerial like the Super Scan. (Plastic aerial housing and PSU box not included in kit.)

Order as: LT27E, £29.99. Details in *Electronics* No. 89, May 1995 (XA89W).



**VOICE VANDAL**

Create your own distortion effects and 'alien' voices with this entertaining audio project. Both music and voices can be 'vandalised' by pitch changing, clipping and echo effects. Ideal for plays, amateur dramatics or just for fun. Dad's Max Bygraves collection will never sound the same again! (Case not included in kit.)

Order as: LT82D, £29.99. Details in *Electronics* No. 89, May 1995 (XA89W).

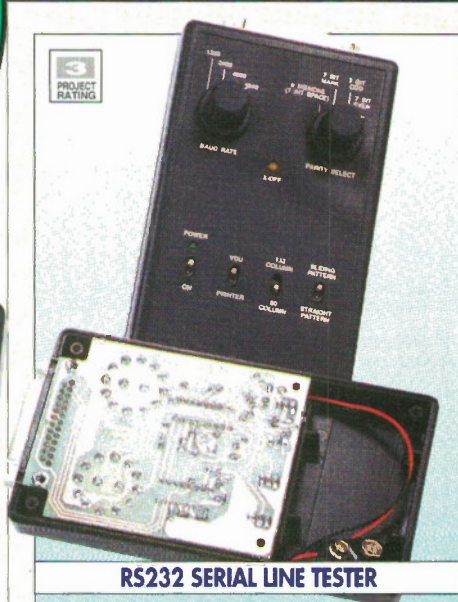

**RS232 SERIAL LINE TESTER**

Troubleshoot RS232 equipment quickly and conveniently with this battery powered, hand-held tester. The tester produces a short RS232 message and is ideal for checking terminals, printers, and other serial equipment, as well as their interconnecting data cables.

Order as: LT83E, £32.99 A1. Details in *Electronics* No. 89, May 1995 (XA89W).

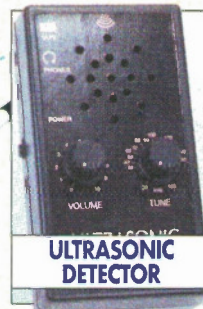

**ULTRASONIC DETECTOR**

Bats in the belfry? Noisy mechanical bearings? Not sure if your dog-whistle works? This novel project converts ultrasonic sounds into audible sounds enabling them to be heard by the human ear. Other applications include testing of ultrasonic remote control units and ultrasonic alarm detectors.

Order as: 90008, £39.99 A1. Details in *Electronics* No. 90, June 1995 (XA90X).

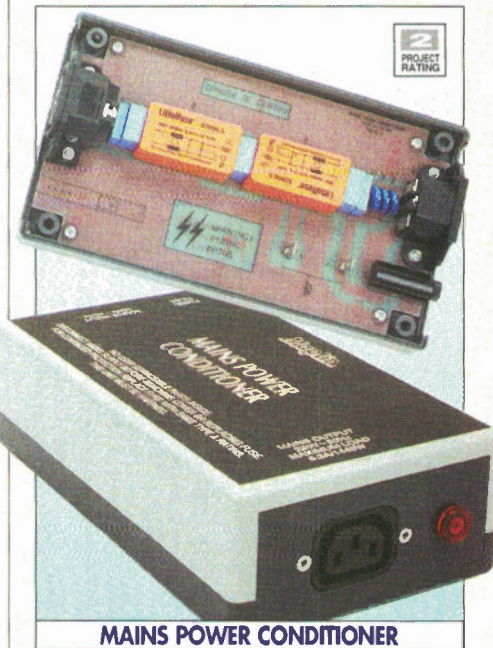

**MAINS POWER CONDITIONER**

No, it won't make piles of towels all soft and fluffy, but it will help to remove spikes, transients and noise from the mains supply, which could otherwise upset sensitive equipment like computers, TVs, Hi-Fis, test gear and communications equipment.

Order as: 90019, £32.99 A1. Details in *Electronics* No. 91, July 1995 (XA91Y).



These descriptions are necessarily short. Please ensure that you know exactly what the kit is and what it comprises before ordering, by checking the appropriate issue of *Electronics* referred to in the list.

The referenced back-numbers of *Electronics* can be obtained, subject to availability, at £2.10 per copy.

Carriage Codes - Add; A: £1.60, B: £2.30, C: £2.90, D: £3.40, E: £4.00, F: £4.70, G: £5.50, H: £6.00.

# DID YOU MISS THESE PROJECTS?

The Maplin 'Get-You-Working' Service is available on all of these projects unless otherwise indicated.

To order Project Kits or back-numbers of *Electronics*, phone Credit Card Sales on (01702) 554161. Alternatively, send off the Order Coupon in this issue or visit your local Maplin store.

**Maplin: The Positive Force In Electronics**

All items subject to availability. Prices include VAT. E&OE

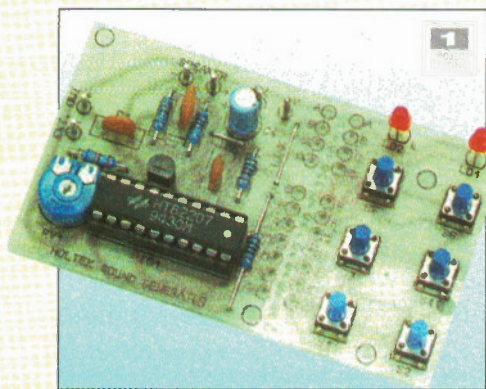

**WESTERN SOUND GENERATOR**

Mosey on down to the workshop and build this super 'audio six-shooter'. The easy-to-build unit produces 6 'Wild West' sounds like horses, guns, etc., for plays, toys, novelty doorbells, or simply just for fun.

Order as: 90030, **£7.99**. Details in *Electronics* No. 92, August 1995 (XA92A).

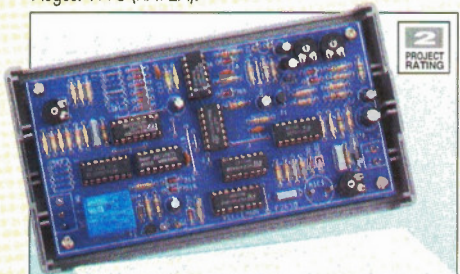

**CALL CODE SWITCH**

Don't just 'phone home', 'phone the microwave and start your dinner cooking! This telephone activated switch and timer can be used for a host of remote control functions like turning lights on and off while you're on holiday. What is more, there are no huge 'phone bills or direct connections, as the unit is controlled by the sound of the 'phone ringing.

Order as: 90029, **£22.99**. Details in *Electronics* No. 92, August 1995 (XA92A).

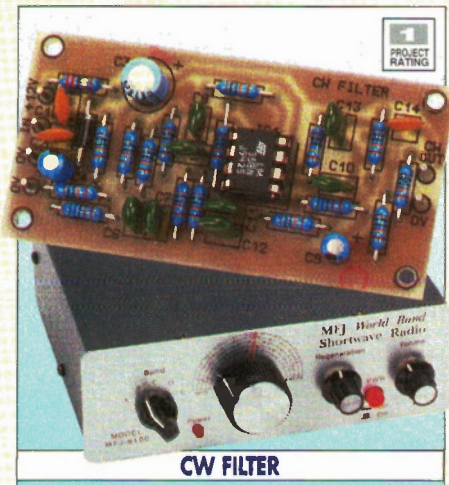

**CW FILTER**

A very useful add-on continuous wave (CW) peak filter circuit for basic shortwave receivers, which helps to separate closely bunched Morse CW signals and cut out the 'unwanted' ones. The unit operates from 11 to 15V DC and is small enough to fit inside many existing receivers.

Order as: 90045, **£4.99**. Details in *Electronics* No. 93, September 1995 (XA95D).

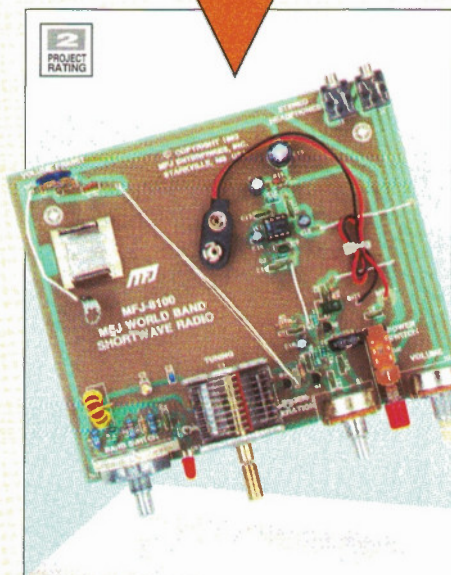

**SHORTWAVE REGENERATIVE RECEIVER**

Listen to the world and recapture some of the look and feel of the early days of short wave radio reception. The receiver covers frequencies from 3-5 to 22MHz in 5 bands, using a regenerative technique, and is therefore easy to build and set up.

Order as: 90032, **£69.95** C. Details in *Electronics* No. 92, August 1995 (XA92A).

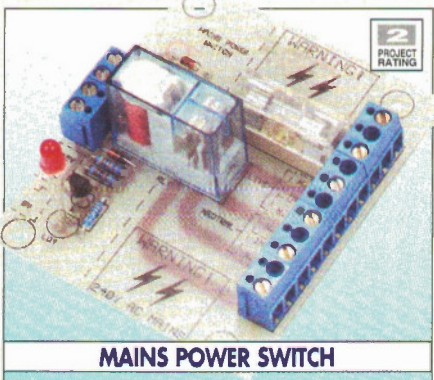

**MAINS POWER SWITCH**

Give power to the elbow of your low-voltage projects, etc., by enabling them to control mains-operated equipment. This versatile, low-cost project can safely switch 230V AC mains equipment up to a maximum current of 5A (resistive). The versatile inputs give the option of either low-voltage (9 to 15V DC) or an open or closed contact. Order as: 90043, **£6.99**. Details in *Electronics* No. 93, September 1995 (XA95D).



**MULTI-STROBE**

The flashiest strobe in town! This stand-alone strobe unit can also be 'daisy-chained' with more units to produce stunning multiple strobe effects, controlled via the built-in RS232 input. Features include built-in variable speed controller and optional remote-control oscillator.

Order as: 90015, **£34.99** A1. Details in *Electronics* No. 92, August 1995 (XA92A).

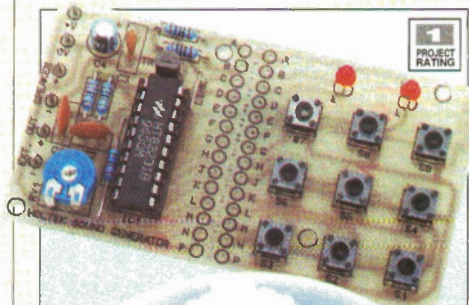

**ANIMAL SOUND GENERATOR**

An electronic farmyard of 12 animal sounds at the push of a button, without the usual accompanying smells, or mess to clear up! Ideal for toys, games, doorbells, plays, etc. Nine push-buttons select pig, cow, cockerel, hen, frog, sheep, cat, horse and a 'medley' of elephant, dog, bird, duck, plus all the other sounds in sequence.

Order as: 90033, **£6.99**. Details in *Electronics* No. 93, September 1995 (XA95D).



# BIG SAVINGS for SUBSCRIBERS!

That's right, if you subscribe to *Electronics-The Maplin Magazine*, or take out a subscription NOW, you will qualify for these amazing savings!

Hurry! Offers end 6th January '96

**SAVE  
£5**



## Mini FM Radio

Catalogue Price £14.99

**SUBSCRIBERS' PRICE £9.99**

**SAVE  
£7.50**



## Remote Car Alarm

Catalogue Price £29.99

**SUBSCRIBERS' PRICE £22.49 A1**

A Add UK Carriage £1.60

**STOP  
PRESS**

**25%  
SAVINGS  
ON ALL  
SUBSCRIBERS'  
SPECIALS**

**SAVE  
£5**

## Circuit Breaker

Catalogue Price £19.99

**SUBSCRIBERS' PRICE £14.99**



## Mains Connector

Catalogue Price £11.99

**SUBSCRIBERS' PRICE £8.99**

Code 51098



## Wireless Clock Module

Catalogue Price £22.99

**SUBSCRIBERS' PRICE £16.99**

**SAVE  
£6**

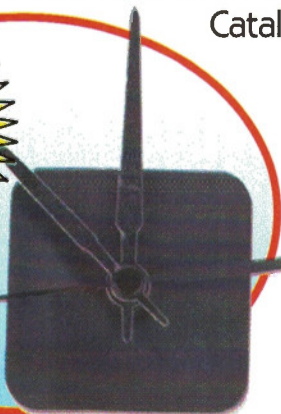

**Subscribe  
NOW!**  
see page 14 for  
details

When ordering, please quote your Subscribers' Membership number (telephone Enquiries on 01702 552911 if not sure) and the special order code number. All items are subject to availability. Prices include VAT. Catalogue prices refer to the 1996 Catalogue. Overseas subscribers telephone +44 1702 554155 Ext. 326 for carriage charges. Normal UK mail order carriage charges apply. E&OE.

As a fully paid-up subscriber  
you can use the special  
Subscriber-only order  
codes and save  
**25%**

# With over 14,000 products the new Maplin Catalogue is now bigger than ever



## THE EIFFEL TOWER

Built in 1889 by Alexandre Gustave Eiffel, the Eiffel Tower is 984 feet high and gives an unrivalled view of the whole of Paris.



## THE NEW MAPLIN CATALOGUE

Built for 1996 by Maplin, the new catalogue is almost 1,200 pages long and gives an unrivalled view of the whole world of electronics.

**Now Only £2.95**

**8-Way 100A Switched Consumer Unit** £30.99

**VAST RANGE OF ELECTRICAL FITTINGS AND CABLES**

**RANGE OF SATELLITE RECEIVERS AND ACCESSORIES FROM 64p TO £660**

**Satwalker Satellite Dish Rotator** £179.99

**Sport 500 Helicopter Kit** £129.99

**RADIO CONTROL MODELS, CONTROL GEAR AND SPARES FROM 99p TO £400**

**OVER 400 PAGES OF ELECTRONIC COMPONENTS FROM PRESETS TO PIC CHIPS**

## JUST LOOK AT THESE SUPERB EXAMPLES!

**Advantage Wired Burglar Alarm Kit** £99.95

**HOME, CAR AND PERSONAL SECURITY FROM £7 TO £200**

**OVER 300 KITS FOR YOU TO BUILD FROM £5 TO £599**

**Electronic Siren Sound Generator Kit**

**Magellan GPS2000 Personal Navigator** £234.99

**RANGE OF NAVIGATION AIDS FROM £13 TO £560**

**OVER 100 PAGES OF COMPUTER AND NETWORK PRODUCTS**

**Safertap Non-Disruptive LAN Access Port** £23.99



Get your copy now from **WHSMITH, John Menzies and Maplin stores nationwide**  
Or order direct NOW on 01702 554161

Catalogue Mail order Price £3.45 (inc p&p). Prices refer to the 1996 Maplin Catalogue and are inclusive of VAT. All items are subject to availability. E&OE. Maplin Electronics, P.O. Box 3, Rayleigh, Essex, England SS6 8LR.

Catalogue available in Southern Africa from CNA or direct from Maplin SA (024) 515124. R39,95 (inc p&p).