

# A

# ELECTRONICS

*The Maplin Magazine*  
Britain's Best Selling Electronics Magazine

APRIL 1995 • £2.10

**How to Build the  
MICRON Mk III - Rugby  
Clock Decoder**

**CD versus Vinyl -  
Is the Status Quo  
about to Change?**

**They're back -  
Robert Penfold's  
Mini Circuits**

**A Versatile  
Interface Board  
for your PC**

**Make it Funtime  
with the Sound  
Activated Trigger  
Project!**



**Read all  
about the  
History of  
Electronics**



ISSN 0957-5456  
04  
9 770957 545077

# NEWTON STEREO VALVE PREAMPLIFIER

Following in the footsteps of the highly-acclaimed Millennium valve power amplifier, is this versatile modular preamplifier. It includes RIAA equalised preamp and optional tone control modules, and a specially designed PSU. Records have never sounded so good!



**IT IS  
THE PERFECT  
COMPANION FOR  
MILLENNIUM  
4-20**

Full details of how to build this superb valve amplifier can be found in the January and February 1995 issues of *Electronics – The Maplin Magazine*.

*Electronics – The Maplin Magazine*  
(January 1995 Issue)  
*Electronics – The Maplin Magazine*  
(February 1995 Issue)

(XA85G) **£2.10 NV**

(XA86T) **£2.10 NV**

RIAA Phono Module Kit  
Tone Control Module Kit  
Power Supply Kit

(LT76H) **£34.99 A1**

(LT77J) **£39.99 A1**

(LT75S) **£44.99 B4**

Carriage: kits marked [A1] add £1.55, kit marked [B4] add £2.20. If ordering several kits, the maximum total carriage is £6.00. Handling: add £1.50 to each order.

Please note: carriage and handling charges apply to Mail Order only – you do not pay carriage or handling if you purchase these kits from Maplin Regional Stores.

Photograph shows fully assembled Newton preamplifier with tone controls and optional switches. The Newton preamplifier is not available ready built. The kits listed are rated 4 (Advanced) on the 1 to 5 Maplin Construction Rating Scale.

Prices include VAT at 17.5% except items marked NV which are rated at 0%. All items subject to availability. Prices are correct at time of going to press (errors and omissions excluded), but may be subject to change.

**MAPLIN ELECTRONICS plc.**, P.O. Box 3, Rayleigh, Essex SS6 8LR. Tel: (01702) 554161  
Fax: (01702) 553935. For details of your nearest Maplin Regional Store Tel: (01702) 552911

## PROJECTS FOR YOU TO BUILD!

### MICRON III

Build this Rugby MSF radio-controlled clock and forget about ever having to correct the time or switch between GMT and BST, for this super-precise timepiece does it all automatically!

8

### BOB'S MINI CIRCUITS

A variety of five engaging projects, comprising a 2-Tone Train Horn and Model Train Signal Lights for the model railway enthusiasts, Digital Capacitance Meter, Simple Graphic Equaliser to improve sound shaping of audio equipment, and an Audio/Visual Metronome to assist the musicians amongst you!

24

### SOUND ACTIVATED TRIGGER

Add an extra dimension to your photography! This unit triggers an electronic flash-gun in response to a sharp sound, e.g., balloons bursting, guns being fired, fireworks exploding, and other striking images you wish to film.

32

### COMPUTER INTERFACE BOARD

Expand on your IBM-compatible PC's versatility and usefulness, by constructing this fully optoisolated interface board, to allow computer control of up to 16 input and 16 output channels, both analogue and digital.

40

## FEATURES ESSENTIAL READING!

### HISTORY OF ELECTRONICS

In this fascinating résumé charting the development of electronics, and its pioneers, Ian Poole investigates the Thermionic Age, covering progressions in valve technology, and the subsequent invention of the cathode ray tube (CRT).

3

### RIAA - CD VERSUS VINYL

This new series by Mike Meechan details the development of Compact Disc (CD) technology, comparing this format to its predecessor, the vinyl record, and to its current rival formats, including Digital Audio Tape (DAT), the Digital Compact Cassette (DCC), and MiniDisc.

16

## FILTERS

The concluding part of this highly informative series by J. M. Woodgate describes how modern filter circuit designs are increasingly achieved with computer analysis models and response simulations, these filter design tools allow very complex filters to be produced efficiently, saving hours poring over design tables, and performing hundreds of calculations.

58



## REGULARS NOT TO BE MISSED!

ABOUT THIS ISSUE...	2	@INTERNET	37	CLASSIFIED ADS NEXT MONTH	55
TECHNOLOGY WATCH	7	READERS' LETTERS	39	NEWS REPORT	56
HOW TO SUBSCRIBE	22	STRAY SIGNALS	51	NEW BOOKS	64
ORDER COUPON	23	DIARY DATES	53		

# ABOUT THIS ISSUE...

Hello and welcome to this month's issue of *Electronics*! To anyone remotely involved in the use of computers, either at work or in the home, it will be apparent that, in conjunction with press coverage (hype?) concerning the multimedia information superhighway, there has been much talk lately of Internet, the computer network that links millions of computers around the world, via telephone links. Indeed, there was a documentary on TV recently, painting a picture (in Virtual Reality, of course!) of how 'networking' in this manner will shape our lives in the next millennium.

The Internet service providers are reacting to this increasing demand, by introducing new on-line systems, with UNIX transparent systems for use with MS-WINDOWS™ and AppleMac™. What is surprising, is that the Internet has been around now for many years, having originally been devised for military use, and then utilised for Universities worldwide, but has only recently taken off for general use by businesses and private individuals. People are rapidly realising the advantages of the e-mail facility over conventional ('snail') mail, and its cost-effectiveness, particularly for overseas communication.

There are newsgroups (of which there are thousands, covering every subject under the sun!), for people to read, free of charge. Some newspapers are now putting pages of daily news onto World Wide Web, i.e. *Electronic Telegraph*. The *Guardian* newspaper operates a news database, allowing particular news event topics to be entered, whereby the corresponding article(s) date and page number will be given. It will become feasible for many more of the populace to work from home, and a scenario is emerging of a world entirely

dependent on computers for its very survival – will it become a nightmare situation? An additional concern is the ever-growing use of security cameras everywhere one looks, except that with progress in their miniaturisation extending to development of cameras on a chip, soon you will not even be able to spot them! The ultimate spy. Still, with everyone working from home, and dependent on computers for everything, no-one will need to go out and risk having their every action caught on film. It might also provide a solution to road transport problems, with greatly reduced numbers of commuters to congest the roads. In the meantime, help ease any feelings of paranoia that the dawning technological age might bring, by constructing the wide variety of super projects in this issue, and reading the informative features!

This month, you can choose from no less than eight projects, including an interesting selection of Bob's Mini Circuits, a very useful Multi-Channel, fully Opto-Isolated Interface Board for IBM-compatible PCs, a Sound-Activated Flash Trigger for capturing explosive images on film, and to ensure precision timing in your life, why not build the Micron III, a Rugby MSF Radio-Controlled Clock, which is always utterly accurate – one day, all clocks will be made this way!

So until next month, from everyone here at *Electronics*, enjoy this issue!



## Exclusive Subscribers' Club Special Offer



On offer this month, to subscribers only, is a 23-piece Screwdriver and Socket Set – it is available for just £5.79 (plus £1.55 carriage), normal price £6.99 (plus £1.55 carriage), a saving of over 17%! If you are a subscriber, full details of how to order the 23-piece Screwdriver and Socket Set are included on the special offer leaflet in this issue – if the leaflet is missing, contact Customer Services on (01702) 552911. If you are not a subscriber and would like to take advantage of future special offers and other benefits of subscribing, turn to page 22 of this issue to find out more. Note: if ordering by Mail Order, normal handling charges apply, but if you purchase from one of our retail outlets, you won't have to pay the carriage charges.



**ABC**  
AUST BUREAU OF CIRCULATIONS  
CONSUMER PRESS

Front Cover Pictures:  
Fleming's Thermionic Valve,  
© Copyright Science Museum  
Photo Library 1995  
Bulb Passing Through Glasses,  
© Copyright Pictor International Ltd.  
Other Pictures:  
© Copyright 1995 Maplin Electronics  
plc., All Rights Reserved.

## EDITORIAL

Editor Robert Ball AMIPRE

Assistant Editor Robin Hall FBIS, G4DVJ

Technical Authors Mike Holmes, Brian Clark, Maurice Hunt BSc (Hons)

Print Co-ordinators John Craddock, Len Carpenter

News Editor Stephen Waddington BEng (Hons)

Technical Illustrators Ross Nisbet, Paul Evans, Nicola Hull, Kevin Kirwan

Project Development Chris Barlow, Dennis Butcher, Alan Williamson, Nigel Skeels

## PRODUCTION

Art Director Peter Blackmore

Production Controller Steve Drake

Designers Jim Bowler, Matt Buhler

Layout Artists Tracey Walker, Adrian Dulwich, David Holt, Jason Hyatt, Daniel Drake

Published by Maplin Electronics plc.,

P.O. Box 3, Rayleigh, Essex, SS6 8LR.

Tel: (01702) 554155. Fax: (01702) 553935.

Lithographic Reproduction by

Planagraphic Studios, 18 Sirdar Road, Brook Road Ind. Estate, Rayleigh, Essex SS6 7UY.

Printed in the United Kingdom by

St Ives (Caerphilly) Ltd., Caerphilly, Mid-Glamorgan, CF8 3SU.

## MANAGEMENT

Publications Manager Roy Smith

Development Manager Tony Bricknell

Drawing Office Manager John Dudley

Marketing Manager Vic Sutton

## ADVERTISING

Jackson-Rudd & Associates Ltd.,

2 Luke Street, London, EC21 4NT.

Tel: (0171) 613 0717. Fax: (0171) 613 1108.

Advertisement Manager Eric Richardson.

## UK NEWSTRADE DISTRIBUTION

United Magazine Distribution Ltd.,

16-28 Tabernacle Street, London EC2A 4BN.

Tel: (0171) 638 4666. Fax: (0171) 638 4665

©Copyright 1995 Maplin Electronics plc.

Copyright: All material is subject to worldwide copyright protection, and reproduction or imitation in whole or part is expressly forbidden. Permission to reproduce printed circuit board layouts commercially or marketing of kits must be sought from the publisher.





Advertisements: Whilst every reasonable precaution is undertaken to protect the interests of readers by ensuring, as far as possible, that advertisements appearing in the current issue of *Electronics* are bona fide, the publisher and staff of the magazine cannot give any undertakings in respect of statements or claims made by advertisers, whether on printed page or on loose insert. Readers who have reasonable grounds to believe that they have been misled are advised to contact their local Trading Standards Office.

Editorial: The views of individual contributors/authors are not necessarily those of either the publisher or the editor. Where errors occur corrections will be published as soon as possible afterwards.

Publisher's Statement: Maplin Electronics plc. take all reasonable care to prevent injury, loss or damage of any kind being caused by any matter published in *Electronics*. Save insofar as prohibited by English law, liability of every kind including negligence is disclaimed as regards any person in respect thereof.

## Project Ratings

Projects presented in this issue are rated on a 1 to 5 for ease or difficulty of construction to help you decide whether it is within your construction capabilities before you undertake the project. The ratings are as follows:

-  Simple to build and understand and suitable for absolute beginners. Basic tools required (e.g., soldering iron, side cutters, pliers, wire strippers and screwdriver). Test gear not required and no setting-up needed.
-  Easy to build, but not suitable for absolute beginners. Some test gear (e.g., multimeter) may be required, and may also need setting-up or testing.
-  Average. Some skill in construction or more extensive setting-up required.
-  Advanced. Fairly high level of skill in construction, specialised test gear or setting-up may be required.
-  Complex. High level of skill in construction, specialised test gear may be required. Construction may involve complex wiring. Recommended for skilled constructors only.

## Ordering Information

Kits, components and products stocked by Maplin can be easily obtained in a number of ways:

Visit your local Maplin store, where you will find a wide range of electronic products.

If you do not know where your nearest store is, Tel: (01702) 552911. To avoid disappointment when intending to purchase products from a Maplin store, customers are advised to check availability before travelling any distance.

Write your order on the form printed in this issue and send it to Maplin Electronics, P.O. Box 3, Rayleigh, Essex, SS6 8LR. Payment can be made using Cheque, Postal Order, or Credit Card.

Telephone your order, call the Maplin Electronics Credit Card Hotline on (01702) 554161.

If you have a personal computer equipped with a MODEM, dial up Maplin's 24-hour on-line database and ordering service, CashTel. CashTel supports 300-, 1200- and 2400-baud MODEMs using CCITT tones. The format is 8 data bits, 1 stop bit, no parity, full duplex with Xon/Xoff handshaking. All existing customers with a Maplin customer number can access the system by simply dialling (01702) 552941. If you do not have a customer number Tel: (01702) 552911 and we will happily issue you with one. Payment can be made by credit card.

If you have a tone dial (DTMF) telephone or a pocket tone dialler, you can access our computer system and place orders directly onto the Maplin computer 24 hours a day by simply dialling (01702) 556751. You will need a

Maplin customer number and a personal identification number (PIN) to access the system. If you do not have a customer number or a PIN number Tel: (01702) 552911 and we will happily issue you with one.

Overseas customers can place orders through Maplin Export, P.O. Box 3, Rayleigh, Essex, SS6 8LR, England; Tel: +44 1702 554155 Ext. 326 or 351; Fax: +44 1702 553935.

Full details of all of the methods of ordering from Maplin can be found in the current Maplin Catalogue.

## Subscriptions

Full details of how to subscribe may be found on the Subscription Coupon in this issue. UK Subscription Rate: £21.95/12 months, £10.98/6 months.

## Prices

Prices of products and services available from Maplin, shown in this issue, include VAT at 17.5% (except items marked NV which are rated at 0%) and are valid between 3rd March and 31st August 1995 errors and omissions excluded. Prices shown do not include mail order postage and handling charges, which are levied at the current rates indicated on the Order Coupon in this issue.

## Technical Enquiries

If you have a technical enquiry relating to Maplin projects, components and products featured in *Electronics*, the Customer Technical Services Department may be able to help. You can obtain help in several ways; over the phone, Tel: (01702) 556001 between 9.00am and 5.30pm Monday to Friday, except public holidays; by sending a facsimile, Fax: (01702) 553935; or by writing to: Customer Technical Services, Maplin Electronics plc., P.O. Box 3, Rayleigh, Essex, SS6 8LR. Don't forget to include a stamped self-addressed envelope if you want a written reply! Customer Technical Services are unable to answer enquiries relating to third-party products or components which are not stocked by Maplin.

## 'Get You Working' Service

If you get completely stuck with your project and you are unable to get it working, take advantage of the Maplin 'Get You Working' Service. This service is available for all Maplin kits and projects with the exception of: 'Data Files'; projects not built on Maplin ready etched PCBs; projects built with the majority of components not supplied by Maplin; Circuit Maker ideas; Mini Circuits or other similar 'building block' and 'application' circuits. To take advantage of the service, return the complete kit to: Returns Department, Maplin Electronics plc., P.O. Box 3, Rayleigh, Essex, SS6 8LR. Enclose a cheque or Postal Order based on the price of the kit as shown in the table below (minimum £17). If the fault is due to any error on our part, the project will be repaired free of charge. If the fault is due to any error on your part, you will be charged the standard servicing cost plus parts.

Kit Retail Price	Standard Servicing Cost
up to £24.99	£17.00
£25.00 to £39.99	£24.00
£40.00 to £59.99	£30.00
£60.00 to £79.99	£40.00
£80.00 to £99.99	£50.00
£100.00 to £149.99	£60.00
Over £150.00	£60.00 minimum

## Readers Letters

We very much regret that the editorial team are unable to answer technical queries of any kind, however, we are very pleased to receive your comments about *Electronics* and suggestions for projects, features, series, etc. Due to the sheer volume of letters received, we are unfortunately unable to reply to every letter, however, every letter is read – your time and opinion is greatly appreciated. Letters of particular interest and significance may be published at the Editors' discretion. Any correspondence not intended for publication must be clearly marked as such.

Write to: The Editor, *Electronics – The Maplin Magazine*, P.O. Box 3, Rayleigh, Essex, SS6 8LR, or send an e-mail to [ATV@maplin.demon.co.uk](mailto:ATV@maplin.demon.co.uk)

# A BRIEF HISTORY OF ELECTRONICS

## PART 3: The Thermionic Age Arrives

by Ian Poole

THE middle to late nineteenth century saw the first practical uses for the new science associated with electricity. The telegraph, telephone and a variety of electrical discoveries showed the world the importance of electricity. However, these discoveries were only stepping stones for other developments which were to be crucial in the formation of electronics as we know it today.

Without doubt, the discovery of radio was of immense importance. People investigating better ways of making receiving and transmitting equipment made many discoveries which were at the very core of the birth of electronics. It is probably with the discovery of the thermionic valve that electronics really came into existence. However, to see how the valve was discovered, it is necessary to look back at the discovery of radio, and the first clues to its existence.

### Maxwell's Equations

The story of radio really starts with a brilliant young Scot named James Maxwell. Born in June 1831, Maxwell entered Edinburgh University at the age of sixteen and it was soon realised that he was a student with exceptional gifts. Although Maxwell spent time at a number of universities, it was while he was at King's College in London that he undertook most of his research into electromagnetic theory. In this work he proved the existence of an electromagnetic wave. However, Maxwell's work was chiefly theoretical and he was not able to demonstrate the existence of the phenomenon in practice.

Many people came close to discovering an electromagnetic wave. It is even thought that Galvani might have seen the effects of electromagnetic radiation whilst he was experimenting with electrical currents. Others, including people like Henry, Edison, and Thomson describe experiments which demonstrated its effects. However, it was a German named Heinrich Hertz who was the first to

understand that he was using the waves which Maxwell had discovered theoretically.

Hertz performed many experiments and demonstrations. In one an induction coil was used to develop a large voltage across a spark gap attached to two large spheres. When a spark jumped across the gap it was found that a smaller spark would jump across a gap in a coil placed within a number of metres of the transmitter, see Figure 1.

In addition to his practical demonstrations of the existence of electromagnetic waves, Hertz discovered a number of their properties. For example he showed that they had the same velocity as light, and that they were refracted in the same way.

### Radio Comes Alive

One of the main forces behind the early development of radio was a man named Guglielmo Marconi. If it was not for his drive and intuitive approach it is quite possible that radio would not be where it is today. He gave a tremendous impetus to the development of radio, particularly in its very early days. He was the first person to set up a company to provide radio links between ships and the shore, and for a time he held a worldwide monopoly on certain aspects of radio.

Marconi was born in Bologna in northern Italy in 1874. He received a private education, but despite this personal attention he failed the entrance examinations to the Italian Naval Academy and Bologna University. Fortunately Marconi had become very interested in science and he was helped and encouraged by a family friend named Righi, who was a lecturer at the University. As a result Marconi was able to sit in on many of his lectures, and he also had use of the laboratories.

Righi taught Marconi about the newly discovered Hertzian, or radio, waves which he found fascinating. Soon Marconi was talking about increasing the distances over which communication could be made. Even at this early stage in his career he was able to make significant improvements to much of the equipment of the day.

Initially Hertz had only been able to communicate over distances of a few tens of metres. Marconi was soon able to make contact over distances of up to 2km. Not only did he see the improvements which could be made to the equipment, but he quickly saw



James Maxwell.  
©Institution of Electrical Engineers.

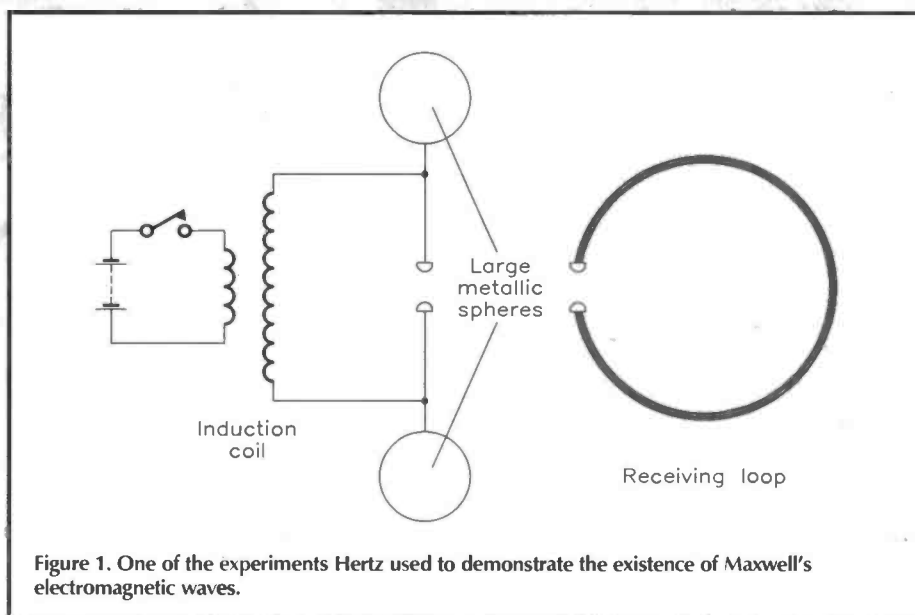

Figure 1. One of the experiments Hertz used to demonstrate the existence of Maxwell's electromagnetic waves.



Heinrich Hertz.  
©Institution of Electrical Engineers.



Guglielmo Marconi.  
©Science Museum Photo Library.



Ambrose Fleming.  
©Science Museum Photo Library.

the commercial possibilities of radio. He approached the Italian Ministry of Posts. To his great surprise he was turned down and there appeared to be little chance of any other openings in Italy.

Being very shrewd, Marconi also saw the possibility of using radio for marine communications. He saw Britain as the most powerful maritime nation of the time, and decided to go there to sell his ideas. However, he first met W. H. Preece the chief engineer of the Post Office, and gave him a number of demonstrations. Preece had been interested in the potential of radio for some time and he was very impressed with what Marconi had been able to show him.

## Business Grows

Even though Preece gave Marconi his backing, the rest of the Post Office was less enthusiastic and delayed giving Marconi an order. Undeterred by all these refusals he turned to the British Navy who visualised its use at sea, and they decided to use Marconi's equipment. Not content with supplying the just British Navy, Marconi also started to sell his equipment to other maritime users. Initially the take-up was slow, but various organisations started to see its advantages. Organisations like Lloyds endorsed its use as a means of sending distress signals. With this the use of radio started to increase even further, and Marconi's companies began to grow.

Not satisfied with only supplying radio for maritime communications he soon started to investigate other possibilities and soon the idea of using radio for long distance communications links arose. Initial experiments like sending a message across the English Channel in 1899 proved valuable for propaganda. The main goal was to be able to send a message across the Atlantic. This was not an easy task in view of the severe limitations of the equipment of the day.

There were many difficulties which needed to be overcome, but Marconi quickly set up stations at Poldhu in Cornwall and Newfoundland. Gales destroyed aerials, and there were many other setbacks. Even so the first message was received in late 1901, and Marconi became a legend in his own time.

This was undoubtedly a major success, and it proved the value of radio as a means of sending long distance messages. However, it

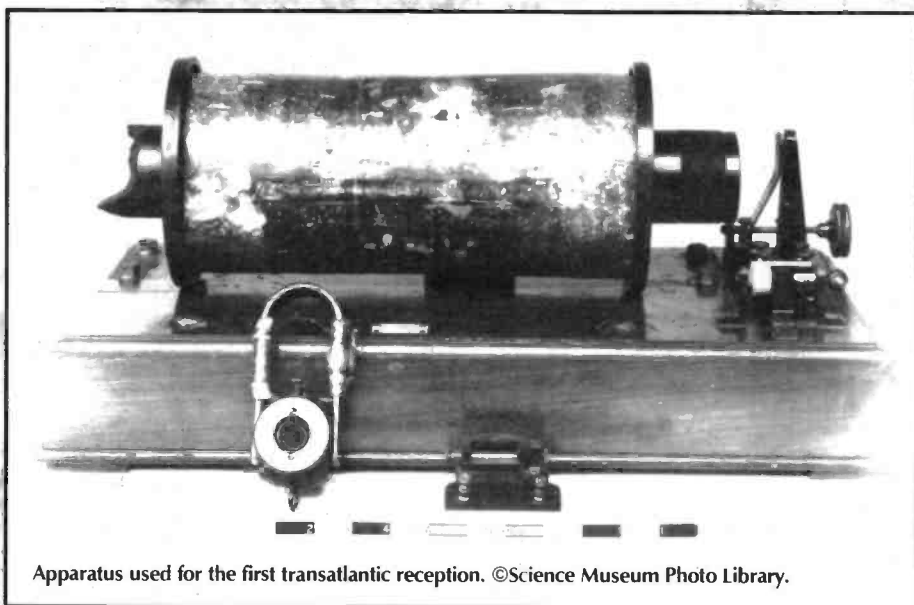

Apparatus used for the first transatlantic reception. ©Science Museum Photo Library.

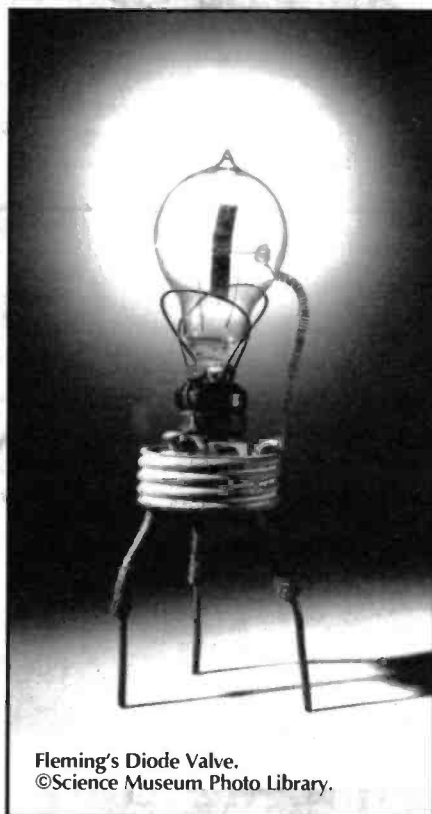

Fleming's Diode Valve.  
©Science Museum Photo Library.

also proved that the equipment of the time had some severe limitations which needed to be solved before any further steps could be taken in improving radio communications.

## Other Developments

Before continuing with the story of radio it is necessary to look at some of the other discoveries that were to play a vital role, such as the development of the thermionic valve. One of the first was made by Professor Guthrie in 1873. He was investigating how charged objects behaved. One of his experiments involved heating up a metal sphere and holding it in a vacuum. He found that if he charged it up with a negative charge it steadily lost its charge. However, the same was not true if the sphere was positively charged.

The next major piece was fitted into the jigsaw by Thomas Edison ten years later. At this time he was experiencing difficulties in increasing the life of electric light bulbs. One of the problems which they encountered was that the inside of the bulb became blackened after only a short time of use. It was thought that it was caused by carbon atoms from the filaments hitting the glass. As it was known that the particles were negatively charged, Edison decided to introduce a second element into the envelope so that a negative potential could

be placed on it to repel the atoms from the filament. In doing this Edison noticed that a current could pass in one direction between the two elements but not in the other.

Edison was fascinated by this effect, even naming it the Edison effect. However, in a very uncharacteristic move, he could not find a use for it and left the idea for someone else to use.

## Flemings Happy Thought

The person who eventually put the effect to good use was a man named Ambrose Fleming. He was professor of electrical engineering at University College in London.

Fleming had seen a demonstration of the effect made by Edison, and took to repeating the experiment himself in 1889 with some bulbs made for him by the Ediswan Company. Like Edison, Fleming found the effect fascinating, but was not able to apply it to a practical use.

However, a few years later Fleming returned to the experiments and he noticed that if an alternating current with a frequency of around 100Hz was passed through the bulb then it was rectified. Fleming later demonstrated the effect to the Physical Society, but again did not develop his findings any further.

Apart from being professor of electrical engineering, Fleming was also a consultant to Marconi. In fact, it was Fleming who designed the transmitter which sent the first trans-Atlantic message. As a result Fleming was very well aware of the limitations of the equipment of the time. He knew that the weakest link was the detector in the receiver. Coherers and magnetic detectors were the normal means of detecting signals, both were very insensitive.

With this in mind Fleming came across the idea of using the Edison effect as a means of detecting radio signals. He described that he was walking down Gower Street in London one sunny day in spring and he had 'a sudden very happy thought'.

Fleming quickly instructed his assistant to set up an experiment to see if the idea worked. To their delight it proved to be very successful. Fleming patented his new invention in 1904, calling the device his 'oscillation valve' because it worked in a similar way to a valve used to restrict water flow to one direction. The idea was a major step forward in radio technology,

De Forests Audion.  
©Science Museum  
Photo Library.

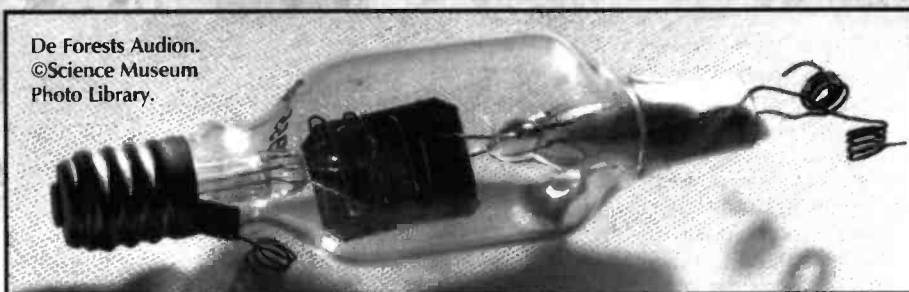

and even though the new device was still in its infancy it was a great improvement over the other detectors of the day, see Figure 2. It was also a major milestone in the history of electronics, because the diode was probably the first component of the electronics era.

## Three Electrodes

The next major development was made by an American named Lee de Forest. He investigated many aspects of Fleming's oscillation valve, making a number of copies of the device. He also experimented with different configurations of electrodes in his attempts to make a better rectifier. Many of his researches used a third element inserted between the cathode and anode, he took out a number of patents for variations on this basic theme in 1905 and 1906. However, it was not until 1907 that he developed a usable device. In this he placed a fine mesh or grid between the cathode and anode to give a device he called an Audion. Whilst three-element valve or triodes are normally used for amplification, in these early days the basic principles associated with thermionic technology were not well understood. As a result the Audion was only used as a leaky grid detector.

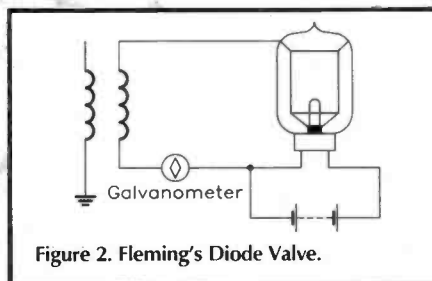

Figure 2. Fleming's Diode Valve.

## Slow Take-Up

Valves were not widely used at first. Their applications were quite limited because they were only used as detectors, and they were very expensive to produce. Also much cheaper crystal detectors like the famous cat's whisker were starting to be used. Although the cat's whisker was notoriously unreliable, the cost of valves meant that their use was kept very much at bay for a number of years.

It was not for several years that valves started to 'come into their own'. In fact, it was around 1911 when the idea of using valves to amplify signals was discovered. De Forest himself was quick to exploit this potential, and he made an amplifier using three Audions for the large electrical company AT&T. The performance of the amplifier was very poor, but those who evaluated it saw a great potential. Soon the company was making Audion amplifiers for use as telephone repeaters. This made usable long distance telephone links.

## Theoretical Understanding

Much of the early development work with valves had been very practical in nature and little theory had been used. In fact, people had very little understanding of their operation and several misconceptions had built up.

One of these misconceptions was that certain gases were needed in the glass envelope if they were to work properly. An American researcher named Irvin Langmuir proved that this was not the case. He showed that valves with a complete vacuum would operate much better.

Soon new high vacuum or 'hard' valves started to appear. However, a number of other improvements came about as a result of the use of a high vacuum. It was now possible to put special coatings on the heaters to improve their emission. This had been tried previously, but the gasses in the envelope had only contaminated the coatings and ruined the whole valve. With the emissions from the heaters improved, their temperatures could be reduced, greatly improving reliability.

## More Electrodes

Valves were almost exclusively used in radio and associated applications. Some were used as audio amplifiers, but a large number were used for amplifying signals at radio frequencies. This gave a number of problems because it was very difficult to prevent them from oscillating at these frequencies. One of the major problems was caused by the capacitance between the anode and the cathode which lead to feedback between the output to the input.

Several attempts were made to overcome this problem. An English radio engineer, named H. J. Round produced a design for a low-capacitance valve. To achieve this he took the anode lead out through the top of the glass



envelope, thereby keeping as far away from the grid leads in the base. This did give an improvement, but it was not the final solution to the problem.

The problem was finally overcome by the introduction of a further grid. Round had been involved with radio development for a number of years and he hit upon the idea of introducing a second grid between the original or control grid and the anode. Initial developments were encouraging, giving a reasonable improvement. However, it was not until 1926 that he had optimised the idea sufficiently to give a repeatable solution. With this new tetrode valve, Round achieved much higher gains than were previously possible.

Whilst the tetrode was a great success, the introduction of the screen grid had produced an annoying discontinuity in the characteristic of the valve. This was overcome by the introduction of yet another grid, the suppressor grid. By applying a negative voltage potential to this grid, the tendency of the electrons to bounce off the anode as they struck it was reduced, eliminating the discontinuity.

## Indirect Heat

Not only were the early valves expensive to buy, they were also expensive to run. Radio sets of the time had to use individual batteries for the heaters, so that each valve could be biased properly.

One of the most important developments of the valve in terms of enabling it to be used more widely was the introduction of the indirectly heated cathode. Initially the cathode itself was heated by passing a current through the heater, and then using the same element as the cathode. When it was discovered that the heater could be physically separated from the cathode this enabled all the heaters in a set to be run from the same supply which could be derived from a mains transformer. This was a great advantage because it enabled the cost of running a valve radio to be greatly reduced.

## Valve Era

In the following years the production of valves rose and the prices fell. Even so prices were still high by today's standards. In 1925 the price of a simple triode was about one pound five shillings (£1.25). When put in perspective this was about the average weekly wage for the time. Nevertheless production continued to rise and by 1939 ten million valves were being produced in Britain each year. Naturally with the outbreak of war this valve production rose dramatically, falling off after the cessation of hostilities.

After the war, valves were still being widely used as there was no other alternative. Development still continued although much of the impetus was placed on making them smaller. Before the war, many valves were up to six inches tall and up to two inches in diameter. With electronic equipment becoming more complicated, individual circuits had to be made smaller. Accordingly new ranges of smaller valves were introduced, and by the early 1960s very few of the large types were in use.

## Cathode Ray Tubes

Thermionic technology was not just confined to use in amplifying and rectifying applications. It was also developed so that it could be used to display patterns as a cathode ray tube (CRT).

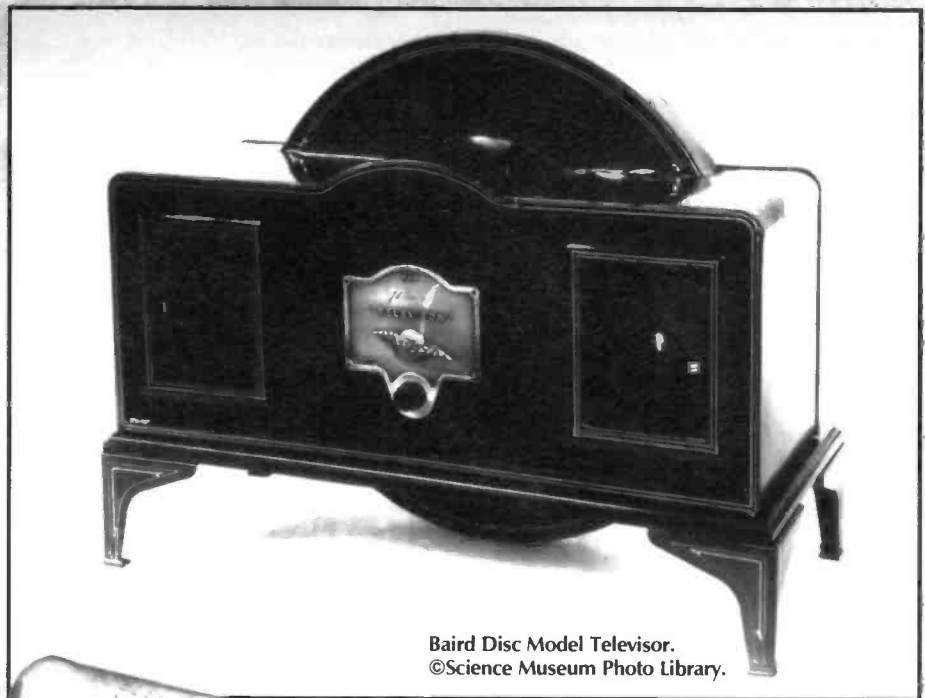

Baird Disc Model Televisor.  
©Science Museum Photo Library.

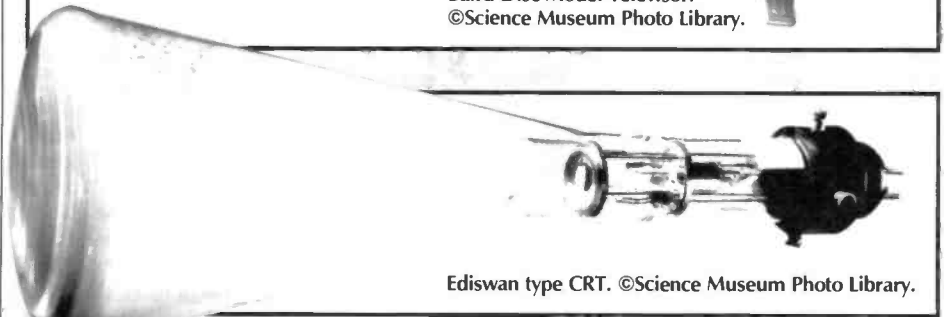

Ediswan type CRT. ©Science Museum Photo Library.

In this application it has played an important contribution to today's electronics scene, where it is still in widespread use.

The initial discoveries leading to the CRT occurred surprisingly early. Many people knew of the Edison Effect, and researchers had discovered many of the properties of the 'rays' which came from the cathode of the bulb. It was known that the rays travelled in a straight line, and it was also discovered that they could be deflected by magnetic and electric fields.

Some people thought that the rays were some form of light radiation, whilst others believe minute particles were leaving the cathode. Finally the debate was resolved by a scientist at the Cavendish Laboratories, Cambridge named J. J. Thomson. Using some complicated reasoning and analysis, in 1897 he managed to deduce that it was not some form of electromagnetic ray, but particles leaving the cathode.

Work was also progressing in Germany where Braun developed a very basic cathode ray tube just before the turn of the century. This development was taken a step further by a Russian named Rosing who managed to display some crude outlines of a number of shapes in 1907. However, the means of generating the signals to feed to the tube was purely mechanical, and was very limited.

A major impetus to the progress of the CRT was given by the development of an early television system. A Scot named John Logie Baird had developed a mechanical system. Despite amazing odds Baird produced a workable system, even transmitting signals across the Atlantic in the late 1920s. Whilst the Baird system was to fall by the wayside, it did give the impetus for the system we now use to receive its development.

This system was developed mainly by EMI, and by 1937 the first experimental broadcasts

were being made from Alexandra Palace in North London. A crucial part of the system was the CRT display which they managed to improve to a sufficient degree for it to be used.

With the outbreak of war, television research became almost dormant for a number of years. This was not so for the CRT. It was an essential part of the radar systems which were just starting to be used. As they gave Britain an important edge in detecting enemy raiders, development of all aspects of radar, including the CRT, was given the highest priority.

After the war television started to rise again; with this the idea of colour television arrived. In 1942 Baird devised a system using two images displayed on a screen and then combining them through filters to give a single image. Whilst this was very ingenious, it did not prove to be practicable. Instead the shadow-mask system used today was devised by RCA in 1950. Initially the tube was very expensive to manufacture and this was one of the many reasons why colour television did not take off for many years.

Finally colour television did become a reality. It was first adopted in the USA, but then in 1967 the BBC launched their inaugural service from the Crystal Palace transmitter.

Since then, the success story of the cathode ray tube has been phenomenal. Not only is it used in televisions, but with the introduction of the personal computer its production has risen when other thermionic devices have been consigned to museums.

Thermionic technology may seem rather outdated in our current highly integrated and miniaturised electronics scene. However, it is hard to see how the science would have developed without it. It is certain that if the diode valve and all its subsequent derivatives had not been invented, then we would not be as far advanced as we are today. [2]



# TECHNOLOGY WATCH!

with Keith Brindley

## This is the Age of the (Pulse) Train ...

British Rail is planning a European-wide optical fibre network, to be laid alongside rail tracks throughout the continent. As a member of Hitrail, the European railways consortium, BR has jointly formed Hermes Europe Railtel to co-ordinate and link-up the member's networks into a continental-wide service. The idea of Hermes is to act as a service provider and clearing-house, selling transmission capacity to public communications operators, thus making it easier for one operator to deal with any other member country to get telecommunications capability there. Effectively, when one service provider requires a point-to-point link with another country's operator, Hermes will be able to provide it. Construction of Hermes starts this month and is expected to be completed within three years, to coincide with telecommunications deregulation throughout Europe.

## CD Video (!)

Philips and Sony are developing a home video system which "will permanently alter the home video market and do for Hollywood and filmed entertainment what the CD did for the music industry". The system is based on CD technology, as you would expect, and uses high-density CD to store films, along with multichannel digital sound and subtitling. Pictures and sound are said to be "stunning, compared with VHS videotape", but there again, Philips and Sony are bound to say that aren't they? Because JVC developed VHS, whilst they developed the ill-fated V2000 and Betamax video formats, respectively. And, I have to say, we have surely heard all this before, have we not? There

have been other disc-based home video players before (by, er... Philips and Sony, weren't they?) which were touted as being the next best thing since sliced bread, too. But what happened to them, eh? Then, there is Philips' Digital Compact Cassette (DCC) and Sony's MiniDisc audio systems, which are currently selling like hot cakes – yes, er um, so hot no-one is touching them! And what about DAT, R-Dat, S-Dat, DASH and a host of other suitably qualified acronyms? ('SOD-DAT', anyone?)

The truth is, Philips and Sony are dying to get in on the act, but nobody is letting them. While CD itself was embraced by the audio industry, which almost fell over itself trying to get rid of the snap, crackle, pop and hum of scratched vinyl records and Dansette turntables, TV watchers are not generally of the same ilk. Almost everyone has a VHS videocassette recorder, and apart from a critical few, most are generally quite happy with it. The lack of take-up of MAC broadcast systems via satellite (*vis-à-vis*: the demise of British Satellite Broadcasting via the Marco Polo satellite, against the overwhelming popularity of Astra's bog-standard PAL broadcasts) must surely give a warning to the big-two electronics manufacturers. Never mind the quality – feel the width!

As an example, let us take the standard TV system PAL. PAL has served its end-users (that is, anyone who watches a TV set just about anywhere in Europe) admirably. True, it is an old system, and it has its technical limitations, but those limitations are not generally noticed by the money-paying person in the street. When its lack of stereo audio was cited as being the reason for its coming fall from grace, NICAM was developed for PAL. When its lack of widescreen facility and quite

severe colour problems was brought up, PALplus has put down on the table. Digital TV has long been regarded as being the ultimate, yet no adequate digital system has been developed to take the place of PAL, which still reigns supreme, and probably will do for the next few years at least. People are quite happy (to date) with PAL. There are two questions which this example begs. First, does the user actually *want* a better picture? Second, will the user pay any more *money* for a better picture?

Bluntly, if the new CD-based video systems are not cheap – and that means no more expensive than existing VHS videocassette recorders – they do not stand an earthly. And if they cannot record, why bother at all? Not many people will.

## And finally ...

While it is far too soon to begin to count the cost of the recent earthquake in Japan, which in terms of human suffering is uncountable anyway, I have already heard people talking about the effects it will have on end-user prices of consumer (particularly computer-based) electronic equipment. There is no doubt that other developments have already conspired to upset integrated circuit and memory prices over the last few years, and a technophobic fear of the same thing happening again might induce a panic epidemic in the industry. The whole thing makes me think about how computers virtually rule the world's stock exchanges and money transactions, on the whim of a computer simulation. Let us not get carried away before we create that scenario.

*The opinions expressed by the author are not necessarily those of the publisher or the editor.*

## LIFE WITH MICRO CHIP...

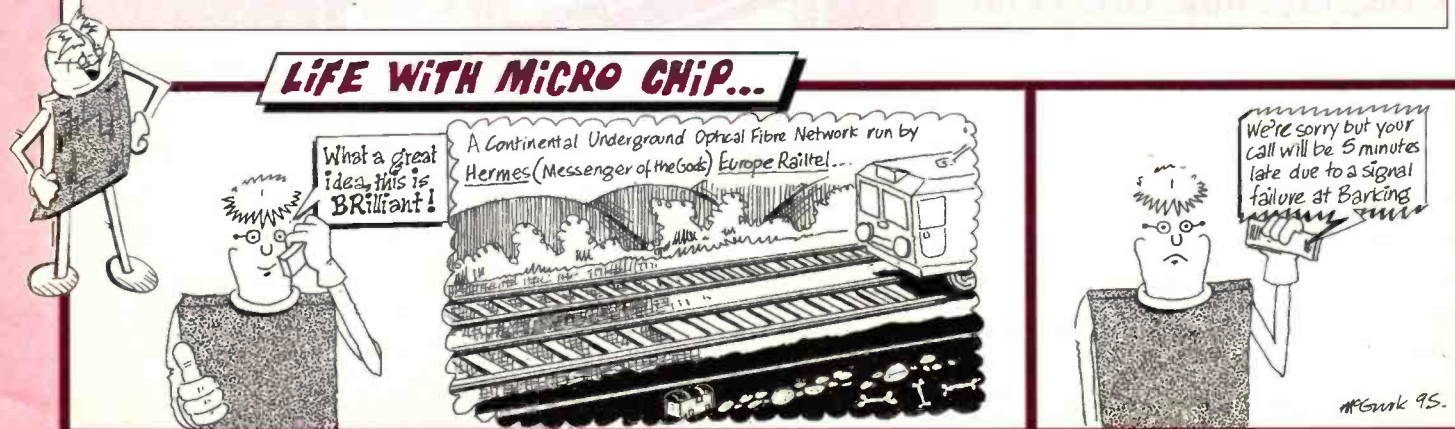

With all the clocks in the modern home, on the Hi-Fi, video recorder, microwave oven, etc., probably all displaying slightly different times, it would be useful to have an accurate time reference, that would automatically set the time itself. Micron III, a Rugby MSF radio controlled clock, will decode the Rugby time signals received by the existing Maplin Rugby time receiver kit (LP70M), and display both time and date simultaneously, making it different from the ordinary 'run-of-the-mill' timepiece.

**3**  
PROJECT  
RATING

**KIT  
AVAILABLE  
(LT03D)  
£47.99**  
B1

# MICRON MK III

## RUGBY MSF RADIO CONTROLLED CLOCK

Design and Text  
by Robert Thomas

### FEATURES

- ★ Displays time and date
- ★ Time set by Rugby MSF transmission
- ★ Time and date can be manually set
- ★ Clock will free run
- ★ Microcontroller controlled
- ★ Software calculates leap years
- ★ Tricolour LED status indicators
- ★ Uses Maplin Rugby Clock Receiver modules

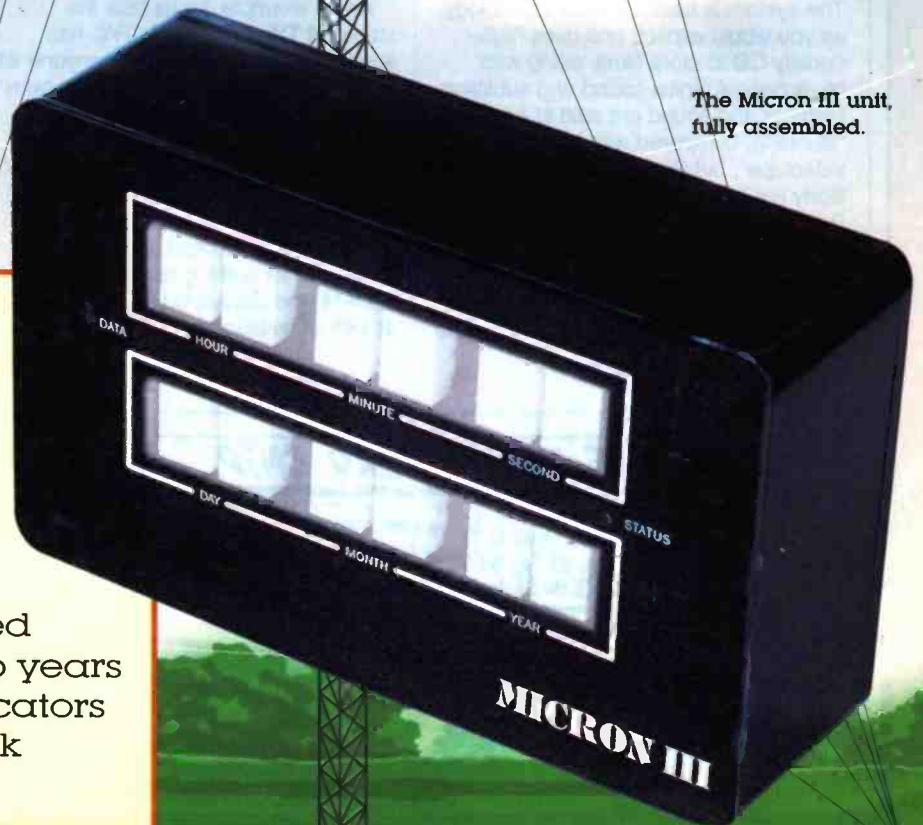

The Micron III unit, fully assembled.

Two tricoloured LEDs are included in the display to indicate the MSF data input and time status, to show if the clock has locked onto the MSF signal. The clock will also 'free run' in the event that the signal is lost due to the transmitter being off the air for maintenance or poor reception conditions, and will calculate all time data including the number of days in the month and leap years.

## The Rugby MSF Time Signal

The MSF signal is a single-frequency transmission of 60kHz, modulated by on/off keying to convey the time information. A description of the code was given in the Rugby Clock Receiver project published in *Electronics*, Issue 47 (November '91), and the following is a recap of that article with information not mentioned before, with emphasis made on the salient points relating to this project.

The location of the 60kHz Rugby clock transmitter is shown in Figure 1. 'MSF' is not an acronym for anything, it is in fact the radio call sign for the Rugby clock. There are several similar facilities throughout the world; 'M' identifies Rugby as belonging to the UK ('M' being one of several United Kingdom 'block' letters). That there are three letters to the call sign indicates that it is also a 'coastal station' - even though it is not actually located anywhere near a coastline!

Two different types of code are transmitted, the 'slow code', which Micron III decodes, and the 'fast code', which is ignored by this design. Both codes are transmitted in serial binary coded decimal form, the 'fast code' is transmitted on the first second of every minute, while the 'slow code' is sent on the remaining seconds.

These items are not included in the kit, but are required for operation of the Rugby Clock Receiver.

The assembled radio frequency PCB (PCB2).

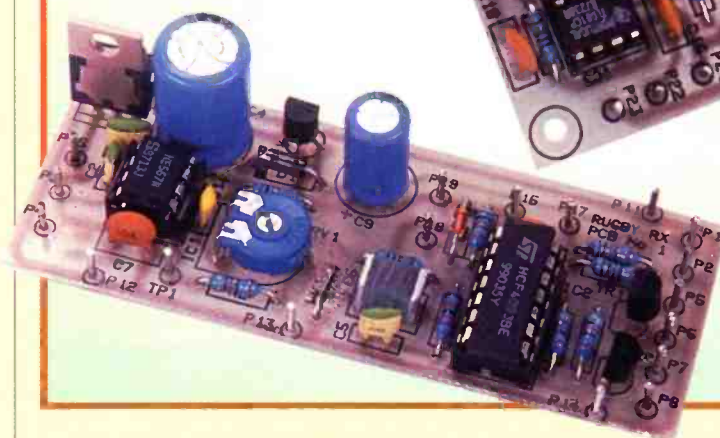

The assembled phase locked loop PCB (PCB1).

The 'slow code' data is normally sent at a rate of one bit per second, but because more than 59 bits of information need to be transmitted, some 'seconds' carry two bits of information, as 1st and 2nd data bits. Every second the transmitter is switched off for 100ms to indicate the start of the period, and in the following 200ms, as determined by the carrier being on or off, 1 or 2 bits of

data are sent. Table 1 summarises the slow code transmission.

A unique set of one's and zero's, that cannot occur elsewhere in the data, is sent once per minute. The decoding equipment finds this 'framing pattern', enabling it to decode the data bits in the correct order. Parity bits are also transmitted to guard against erroneous data, due to noise or poor signal reception, and when added to the number of 'ones'

Figure 1. Location of the Rugby MSF transmitter.

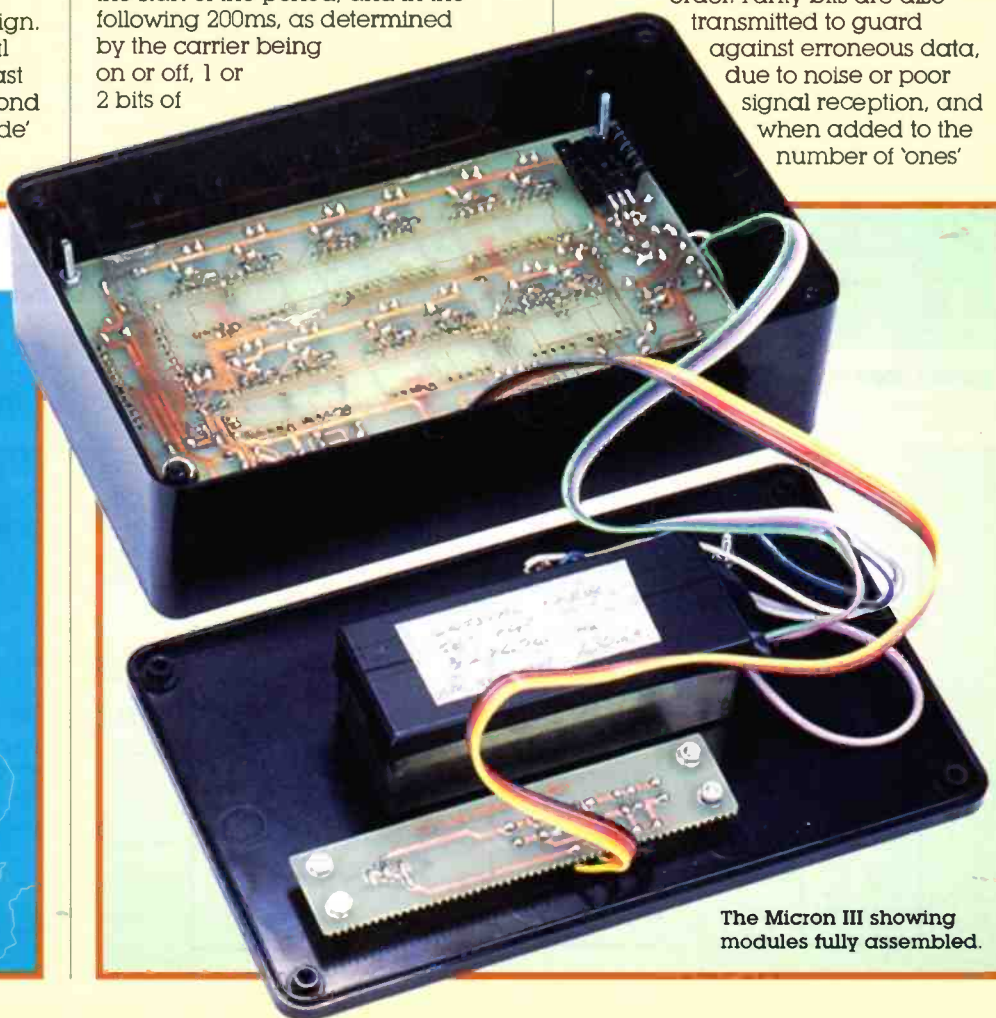

The Micron III showing modules fully assembled.

Second	1st data bit	2nd data bit
0	'Fast code' - not used by this design	
1 to 16	D.U.T. 1 code - not used by this design	
17	8	Year (Tens)
18	4	
19	2	
20	1	
21	8	
22	4	Year (Units)
23	2	
24	1	
25	1	
26	8	Month (Tens)
27	4	
28	2	
29	1	
30	2	Month (Units)
31	1	
32	8	
33	4	
34	2	Day (Tens)
35	1	
36	4	
37	2	
38	1	Day of Week (0 = Sunday)
39	2	Not used by this design
40	1	Hour (Tens)
41	8	
42	4	
43	2	
44	1	Hour (Units)
45	4	
46	2	
47	1	
48	8	Minute (Tens)
49	4	
50	2	
51	1	
52	0	Minute (Units)
53	1	
54	1	
55	1	
56	1	
57	1	
58	1	
59	0	
		Year parity bit
		Day & Month parity bit
		Day of Week parity bit
		Hour & Minute parity bit
		BST (not used)

Table 1. 'Slow Code' data.

received for their corresponding data field, should add up to an odd number (i.e. odd parity).

## Circuit Description

Refer to the block diagram Figure 2, the circuit diagram Figure 3a, and the flow chart Figure 4a. (Figures 3b and 3c are circuit diagrams of the two parts of the existing receiver kit LP70M, the 'front-end' of the decoder.) The decoder design is based around the PIC16C71 microcontroller, which decodes the MSF signal, and holds and computes all the data necessary for the clock. Crystal XT1 controls the timing of the microcontroller and thus the free running accuracy of the clock, and variable capacitor VC1 allows the crystal frequency to be adjusted slightly. The MSF signal is input on I/O port A, pin RA0, with pull up resistor R13 to ensure this pin is not left open circuit when the receiver is not connected to the clock. Manual time set switches SW1 to SW4, and associated pull-up resistors are connected to the remaining port A connections. The common sides of the switches are connected to ground via a 'manual time set enable' switch SW5.

High efficiency, common anode, seven segment displays are used to achieve a good display brilliance, whilst keeping the drive currents low and the circuit design simple. The displays are connected together to form a common anode multiplexed display, by connecting all the common segments together and the common anode for each display to its own drive transistor. Display data is outputted from the microcontroller on I/O port B. Data on pins RB0 to RB3 of the microcontroller, output to the BCD to seven segment decoder IC3, which in turn switches on the appropriate segments of the displays via current limiting resistors R15 to R21. Data on pins RB4 to RB7 switches the appropriate output of the 4- to 16-line decoder, IC2, low, which in turn switches one of display's common anode connections to the 5V supply rail through its associated drive transistor.

Tricolour (multicolour) LEDs LD1

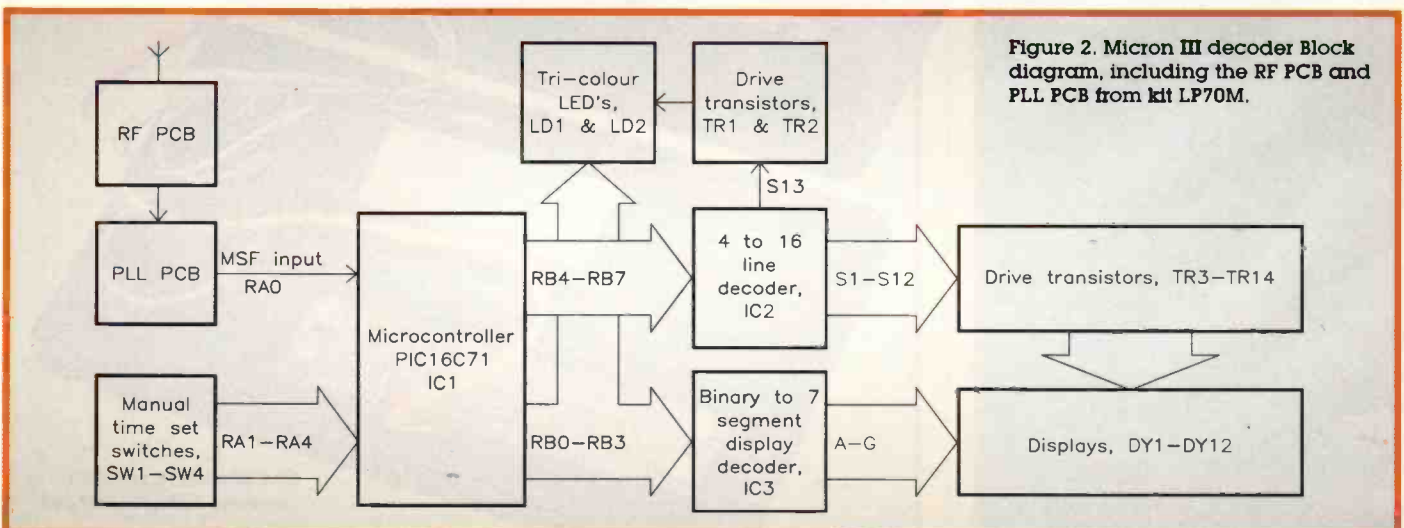
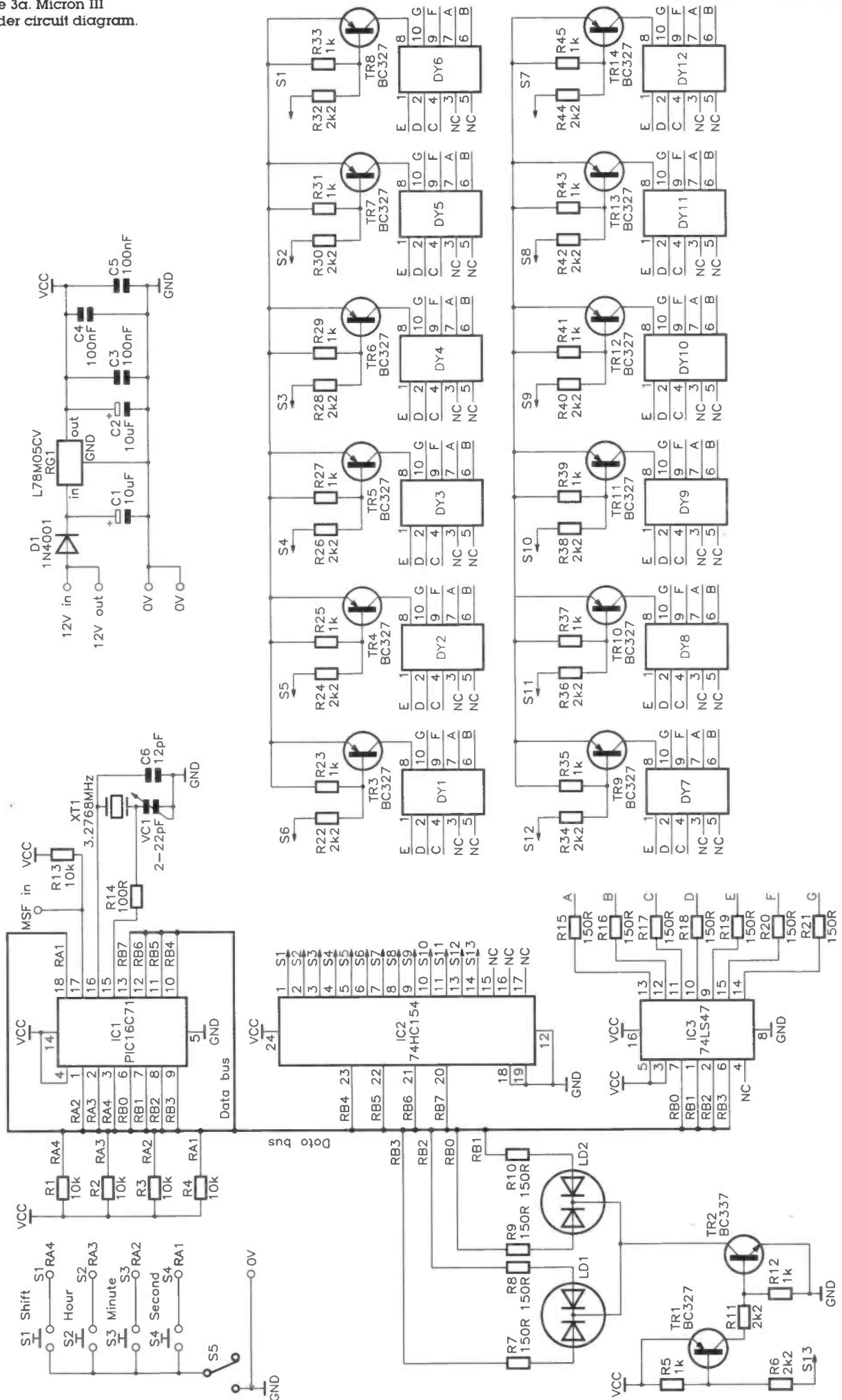

Figure 2. Micron III decoder Block diagram, including the RF PCB and PLL PCB from kit LP70M.

Figure 3a. Micron III decoder circuit diagram.



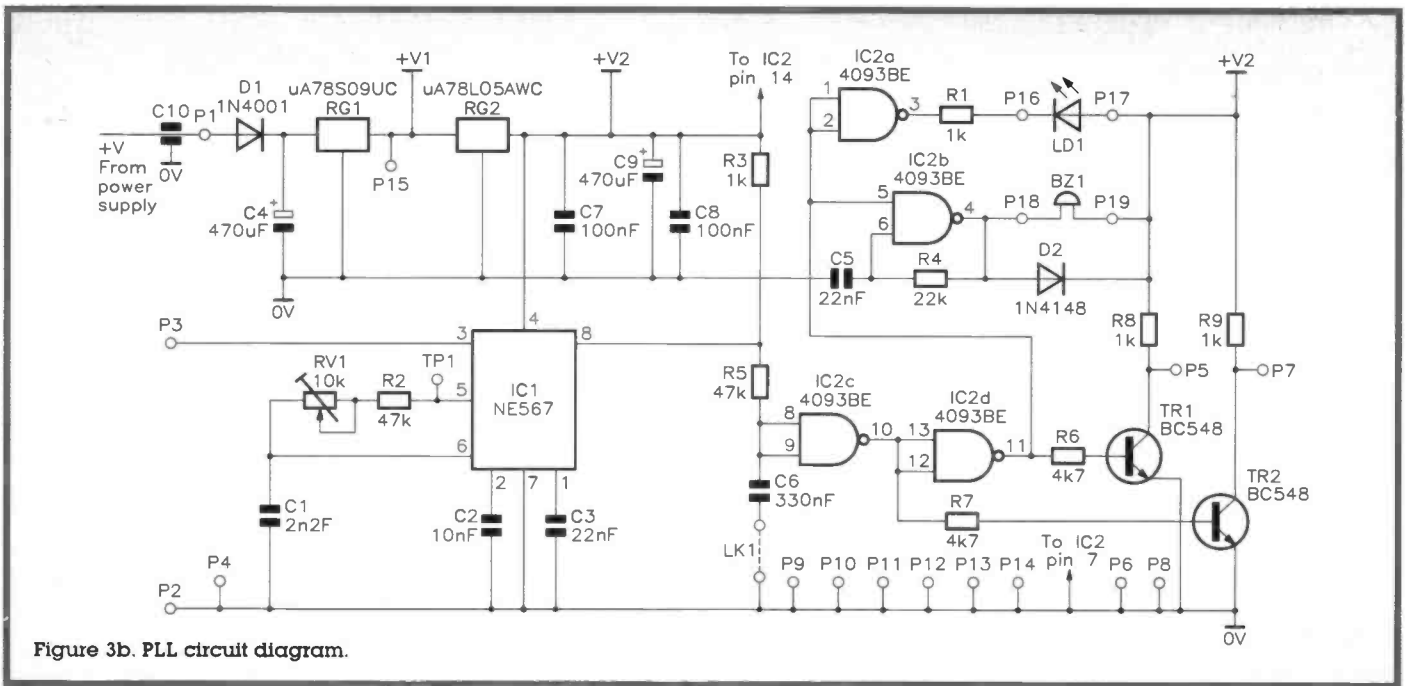

Figure 3b. PLL circuit diagram.

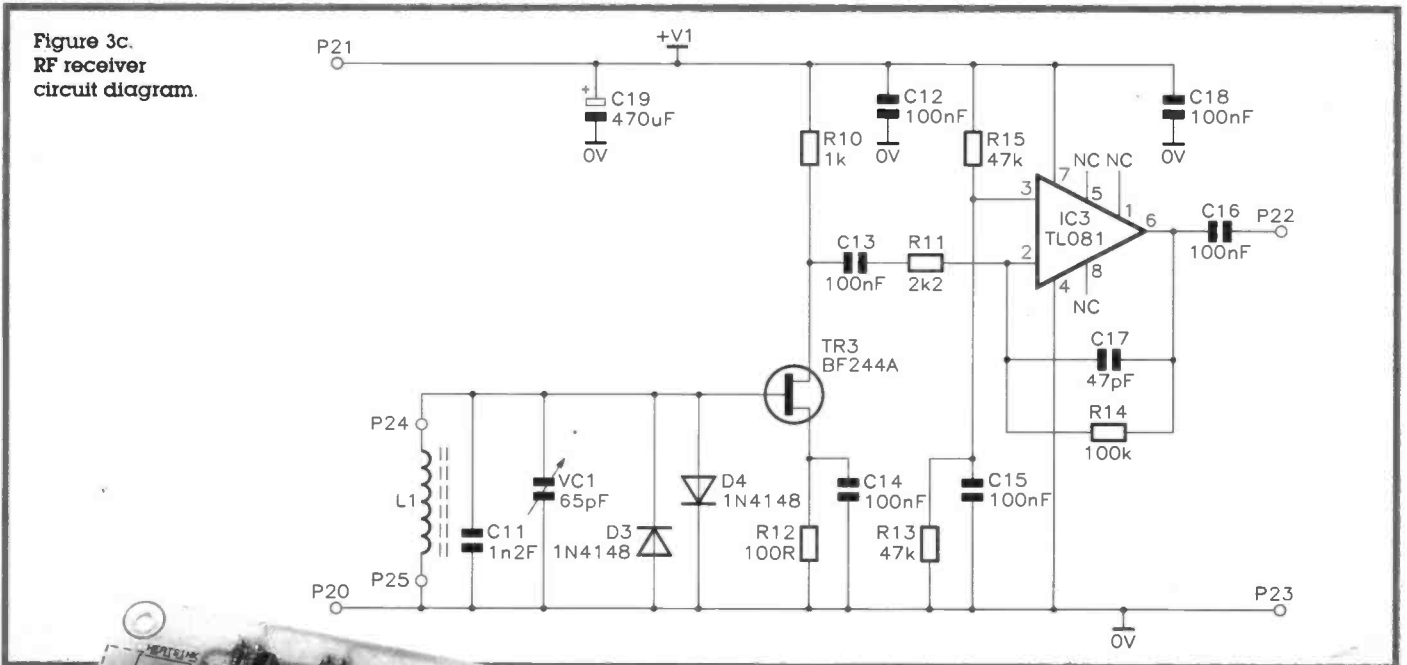
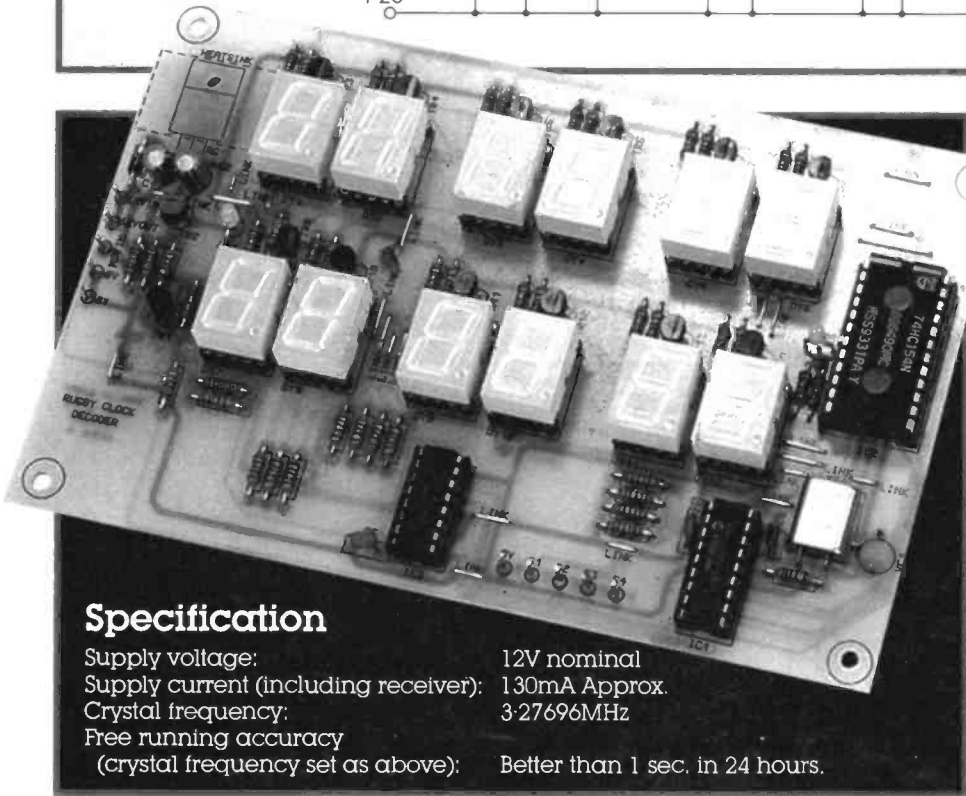

Figure 3c. RF receiver circuit diagram.



**Specification**

Supply voltage:	12V nominal
Supply current (including receiver):	130mA Approx.
Crystal frequency:	3.27696MHz
Free running accuracy (crystal frequency set as above):	Better than 1 sec. in 24 hours.

and LD2 are driven directly from the microcontroller via current limiting resistors R7 to R10, and their common cathode connection is switched to 0V by transistors T1 and T2, controlled by the 4- to 16-line decoder IC.

D1 protects against supply reversal and RG1 converts the incoming 12V supply to a regulated 5V, this is used by all the components of the clock. Smoothing/decoupling is achieved by capacitors C1 to C5. Provision is made by extra PCB terminals for the 12V incoming supply to be sent out again to supply the receiver.

**PIC16C71 and Software**

The PIC16C71 microcontroller is a microprocessor with integrated EPROM (1K) for program storage, and RAM (36 bytes) for data storage. Each EPROM memory location is 14 bits wide and the RAM memory locations are 8 bits wide. Also included is an 8-bit real-time clock counter (RTCC),

watchdog timer to reset the processor should a 'lockup' occur, an 8-bit prescaler, which may be used with either the RTCC or the watchdog timer, and an 8-bit analogue to digital converter (not used in this application). There are 35 single word instructions in the instruction set and each takes a single program cycle (crystal frequency/4) to complete, except for branch instructions, which take two program cycles. For those who wish to learn more about this IC's internal architecture, a data sheet may be obtained, for a small cost, from Maplin. The PIC16C71 was chosen from the PIC range of ICs for this project not only because of its small physical size and relatively large memory, but mainly because it generates an internal interrupt signal on a RTCC overflow, making time measuring software easier to write.

Figure 4a shows the flow diagram for the software that drives the displays, and is a continual loop that is only broken when an interrupt occurs from an RTCC overflow (every 10ms). The program then jumps to the interrupt routine, which contains the software for decoding the MSF signal, updating the clock data registers at the appropriate times and scans the manual time set switches, incrementing the time registers accordingly. Even leap years and the number of days in the current month are calculated, for use when the clock is 'free running'. After the interrupt routine has completed its tasks, control is returned to the display

routine. The flow diagram for the interrupt routine is shown in Figure 4b, with emphasis on decoding the MSF signal, as a full flow diagram would take many pages and is beyond the scope of this article. For those who are interested, the software uses nearly the whole 1K x 14-bits of program memory, the display routine uses 16 memory locations and the interrupt routine uses nearly all the remaining. Also the full 36 bytes of data memory is used.

## Construction

The clock is made from one printed circuit board that can be snapped in two. These become the main electronics and display board, and a separate time setting board (there is only one PCB listed in the Parts List).

When soldering components onto the main board, care should be exercised so that the very narrow and close tracks are not bridged and that the height above the board of any component is *not higher than that of the displays*. Refer to the PCB layout (Figure 5) and Parts List when fitting components.

Begin by fitting the wire links, resistors and diode, then the displays and IC sockets, making certain that they sit firmly down onto the board. The displays fit into socket strips, supplied as 32-ways on a strip. These are broken into 5-way pieces and attached to each 5-way group of display pins. The capacitors should be fitted next, making certain that

the positive terminals of electrolytic capacitors C1 and C2 are adjacent to the (+) indicators on the PCB legend. Note that VC1 is mounted on the *track side* of the board. This is best achieved by making the end of its legs flush with the component side of the board, thus allowing a soldering iron to be carefully inserted, on the *track side*, underneath it, to solder it in place. This position makes it readily accessible for adjustment when the PCB is installed. Crystal XL1 is mounted flat on the board and small long nosed pliers need to be used to hold the wires close to the can when bending them, as undue stress made on the wires where they enter the crystal case can fracture the can seal.

The transistors and two tricolour LEDs can be inserted next. Each LED has three leads and the shortest is the anode of the 'green' section, which should be inserted through the PCB hole opposite the flat part of the circle outline on the PCB legend. The transistors' orientation should be aligned as per the board legend. The LEDs and transistors must all be no higher above the PCB than that of the 7-segment displays.

The voltage regulator RG1 can be mounted next with its heatsink. Note that it is mounted on the track side of the PCB (see also Figure 8). Finally, the PCB pins should be inserted and the ICs fitted into their sockets, observing the normal antistatic precautions.

The only thing to note when constructing the switch board is that the terminal pins must be cut to a height of approximately 3mm above the PCB after soldering, so as not to impede mounting the switch board in the box.

## Final Assembly

The tray of the box will become the front of the clock, and a hole will need to be cut for the display area, see Figure 6. Stick masking tape strips across the bottom, outside the box as this will protect the surface and enable the cutting lines to be marked easily. The power connector, socket for the receiver input and switch PCB can be mounted on the lid (back of the clock) or bottom side of the box depending on the preference of the constructor to have the clock either wall mounted or free standing. The Maplin Rugby clock receiver, PCB 1 (phase locked loop PCB) in its screening can, can be mounted on the inside of the lid, and this should be considered when deciding where to fit the switch PCB. Figures 6 and 7a show the hole cutting details and stick-on front panel design (Figure 7b is the legend for the setting switches).

Two lengths of ribbon cable approximately 200mm long must be fitted to the main board as shown in the wiring diagram (see also Figure 9) before fitting the display board in the box, so that the board may be accurately aligned with room for

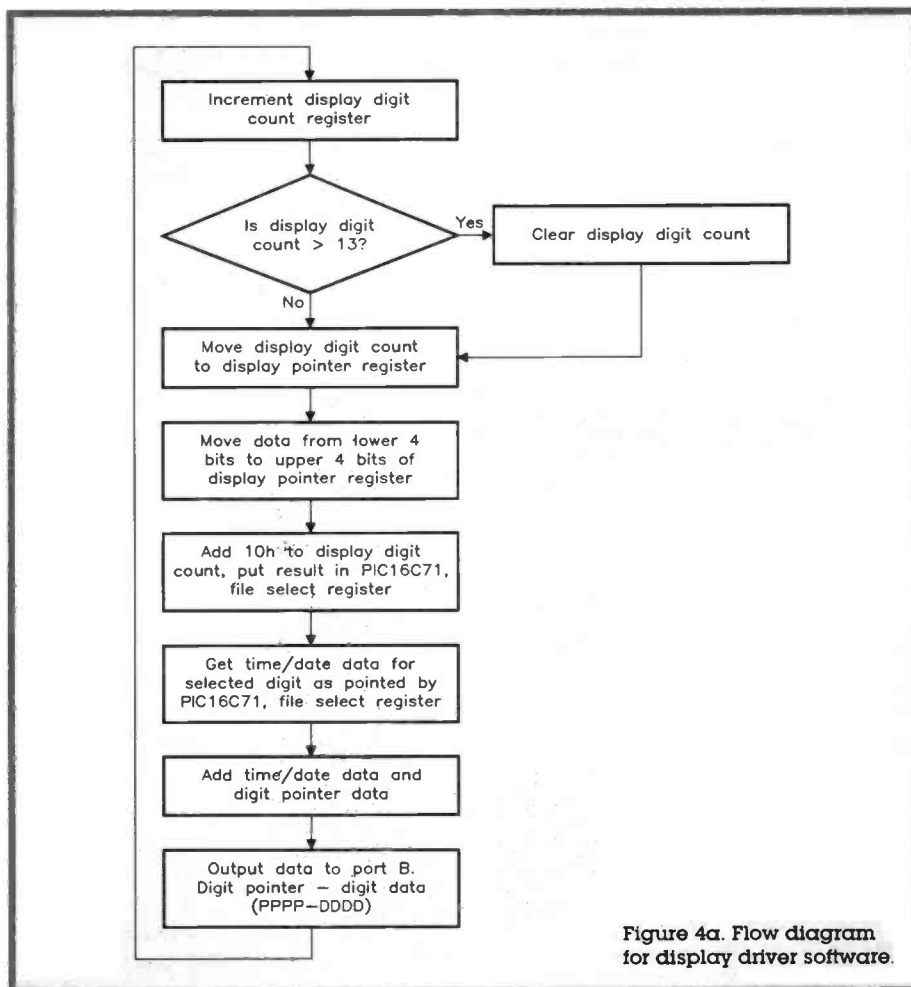

Figure 4a. Flow diagram for display driver software.

the ribbon cable that connects to the switch board to pass between the display board and the side of the box. The display board is held in position in the box by four M3, 20mm long, countersunk screws with 1/4in. and 1/8in. spacers and a nut, to make up the desired height to position the displays properly relative to the front panel, see Figure 8. The heads of the screws, in countersunk holes, will be hidden by the stick-on front panel when the unit is finished. The front panel incorporates windows for the displays.

approximately. Turn the receiver (PCB 2) until it is correctly pointing at Rugby, at which point the left hand (MSF code) tricolour LED on the clock display will start flashing between red and green at one second intervals. Red indicates that the MSF transmitter is off, and green that it is on. After approximately one to two minutes (if the receiving conditions are OK and you have not been unfortunate enough to choose a period when the transmitter is off for maintenance) the clock will set the correct time and date, and the right-hand (status)

tricolour LED will switch from red to green. Red indicates that the clock had not been successful in decoding the time within the last minute, and green indicates that it has. You will also notice that the status LED momentarily flashes red at the time that the seconds count changes from 59 to 00, when the clock is decoding the MSF signal correctly; this is due to the way the software program works.

To set the free running accuracy of the clock, variable capacitor VC1 must be adjusted. If an accurate frequency counter is available,

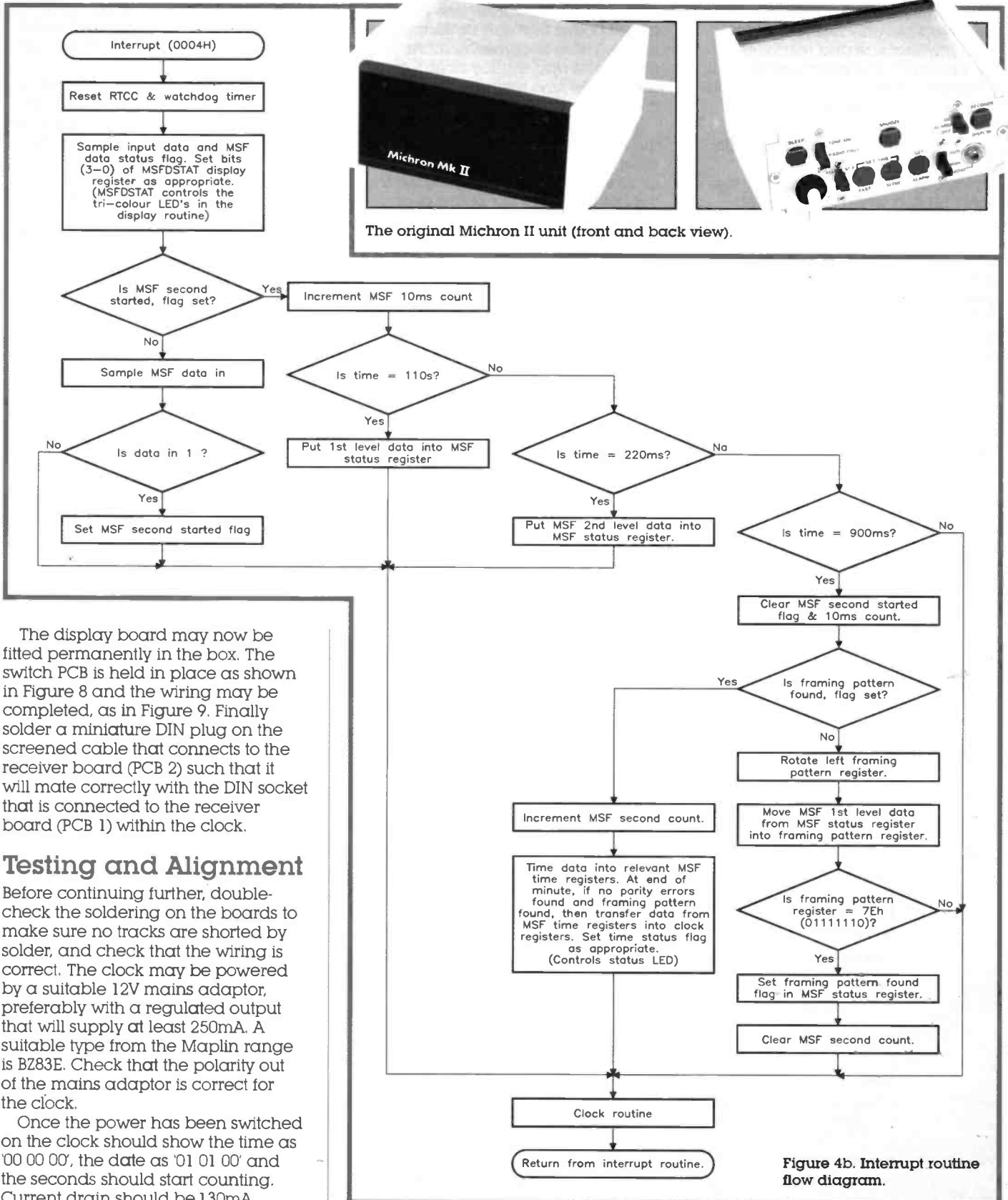

The display board may now be fitted permanently in the box. The switch PCB is held in place as shown in Figure 8 and the wiring may be completed, as in Figure 9. Finally solder a miniature DIN plug on the screened cable that connects to the receiver board (PCB 2) such that it will mate correctly with the DIN socket that is connected to the receiver board (PCB 1) within the clock.

## Testing and Alignment

Before continuing further, double-check the soldering on the boards to make sure no tracks are shorted by solder, and check that the wiring is correct. The clock may be powered by a suitable 12V mains adaptor, preferably with a regulated output that will supply at least 250mA. A suitable type from the Maplin range is BZ83E. Check that the polarity out of the mains adaptor is correct for the clock.

Once the power has been switched on the clock should show the time as '00 00 00', the date as '01 01 00' and the seconds should start counting. Current drain should be 130mA

Figure 4b. Interrupt routine flow diagram.





Consider, if you will, the music/Hi-Fi industry at the present time. As far as the technology is concerned, CD is, to use the vernacular, most definitely the 'happening' format of the moment, with analogue cassette coming a close second. Nevertheless, other, newer digital formats such as DAT, DCC, and the Mini-Disc are all vying for supremacy in the shops, and likely as not, the giants among the consumer electronics manufacturers will have a whole host of other, wonderful, beat-all-other formats waiting in the wings for the right moment and the 'punchiest' marketing campaign. Winners are not necessarily judged on technical merit or superiority, but on the might of advertising campaigns, with sales in direct proportion to the financial muscle of the corporations involved. The present AUDIO industry rerun of the late-seventies/early-eighties' battle of the formats – video, that is (VHS versus Betamax versus Video 2000), and a similar one before IBM gripped, and then lost, the personal computer market – could conceivably get worse before it gets better . . .

by Mike Meechan



versus

## A Battle of the Formats – Irretrievably Lost?



### PART 1

**W**HILE rationally, it cannot be denied that digital audio – CD in particular, but aided and abetted by NICAM-encoded television broadcasts and video movies – has placed much greater emphasis on the importance of audio fidelity and quality, there are many, still, who believe (either cynically or realistically, depending on your point of view) that the strategies employed during the marketing of CD have been very ruthlessly executed. Much to the detriment of many consumers at the end of the chain – in other words, you and me.

Just in what way has this been to the detriment of all concerned, you might well ask? It is a widely held opinion that the compact disc has almost single-handedly revived and revitalised a stagnant and somewhat ailing audio engineering industry, bringing the manufacturers out of the doldrums, creating new jobs, an upwardly spiralling economy, and peace and happiness to the earth, among other things. All of this has been happening while simultaneously educating a much larger section of the general public to the pleasures of high-fidelity audio.

The last statement holds true to such an

extent that many, once denied the pleasure because of cost, now enjoy previously undreamed-of clarity and fidelity in their music, thus heightening awareness, and improving listening acuity and perception. This must be considered a worthwhile achievement.

How, then, can all of this be at odds to the well-being of the consumer? The author is one of a growing number becoming increasingly disgruntled by the attitudes both of the Hi-Fi giants (the consumer electronics corporations), and of the major record manufacturers – a serious misnomer, if ever there was one, as we shall soon see. This widespread disenchantment has been caused by the way that this band of Luddites or 'disbelievers' perceive both the marketing of CDs, and the manipulation of the general public (mass-media brainwashing).

#### Chronology of Compact Disc

Philips first studied the possibility of using optical storage techniques for audio material way back in 1974. The tried and tested method of using analogue modulation (as used in video storage) was deemed to be

unsuitable, but they saw that digital storage offered a much likelier and more satisfactory possibility.

Small disc diameter was reckoned to be an obligatory requirement for the new format. Meetings were arranged between 35 of the major consumer electronics companies (not surprisingly, most were Japanese) and, in the late seventies, tentative proposals were forwarded as a result.

The year 1979 saw Sony Corporation collaborate with Philips in the invention of the CD, producing an error correction system for use with the optical disc technology of Philips. (This somewhat unholy collusion between two rather unlikely allies arose when each discovered that the other was covering the same ground on parallel paths, and co-operation rather than competition would prove more fruitful, since both Sony and Philips were falling over each other's patents so often that litigation and recourse to the courts would have been the only other possible solution.) However, it is the latter who are now globally accepted as being the main instrumental force in its inception. It is Philips, therefore, who can be 'indicted' for the principal and instrumental

part the company played when they fired the first marketing hype, and coined the somewhat unfortunate marketing phrase (as it transpired), of 'Perfect sound forever'. The popularity of CD is because, at the time digital audio was thrust upon the market, the public were particularly susceptible to a new format, especially one that was to be accompanied by such clever, hard-hitting advertising campaigns.

The debate about CD, the cost of discs, and the question of how long the format will persist in the wake of other, newer developments in the pro-audio industry, is very topical – a journalist summed up the debacle quite succinctly in the phrase, 'compact discord!' In many ways, downright corporate greed of some of the larger companies has prevented the expected upsurge in sales of the newer formats, which are all still waiting for the necessary boost before they can be globally accepted as a viable 'format' . . .

The analogue cassette deck is still holding

results in a recording that is in many ways 'cleaner' than the original, as anything unwanted and present in the original can be 'surgically' removed.

However, compact disc recordings are said by many to be devoid of richness, liveliness and realism, since any sound outside the 20kHz ceiling must be generated internally by the electronics. Certain instruments, such as piano and violin, produce frequencies (overtones) well above the accepted audible frequency ceiling. These can create intermodulation and beat frequencies with signals residing inside the audible spectrum, and so add their own individual character to the perceived sound.

In good players – slightly more expensive than the examples quoted above – better filtering, over-sampling, and anti-aliasing techniques have yielded digital transformations lacking the 'clinical' – if we can continue the medical allusion – subjective qualities of some of the earlier first and second-gener-

that are lost to most mere mortals. We readily accept that a very small percentage of the population have natural aptitude for certain sports, train hard, and become Olympic champions. Good amateurs cannot and dare not deny the existence of such individuals.

With hearing, the yardstick of measurement is only slightly different, but clouded in many ways by the fact that we are only just beginning to understand what is involved in the perception of sound. (This includes the physical, physiological and psychological effect that it has upon the individual.) Why then should the skill of listening to sound (particularly that which is reproduced by an artificial means, and heard and discriminated by the ears and brain of a huge number of people of greatly varying aptitudes and acuties), differ markedly from any other physical or mental skill which is either inbred or has to be learned . . .

Listening to music is analogous to that more usual, recognised, tangible kind of tal-

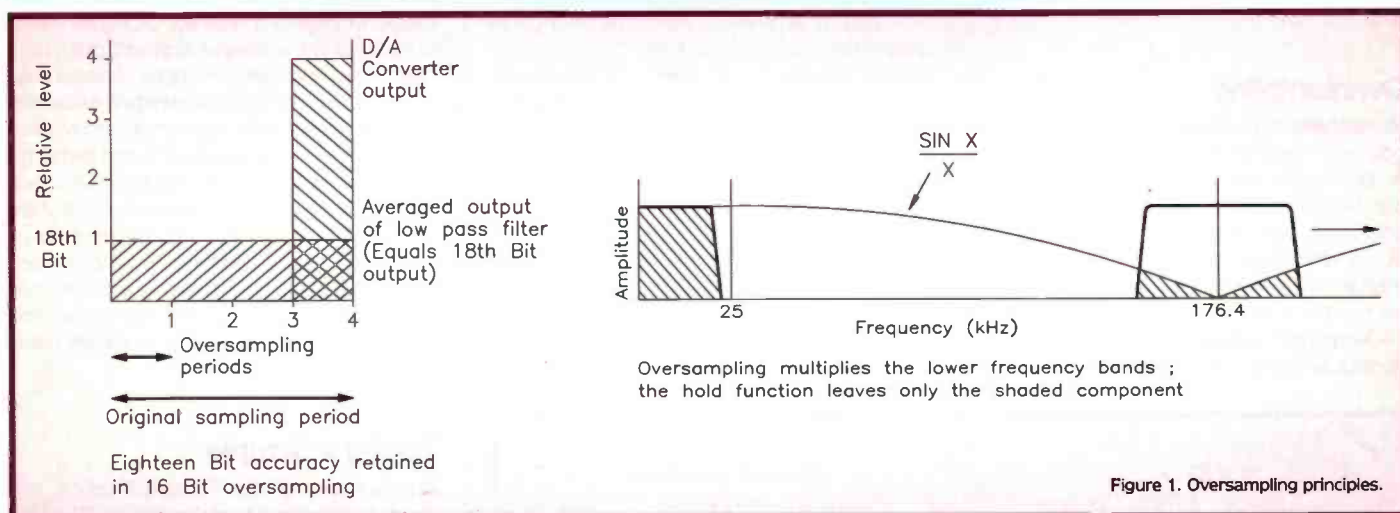

Figure 1. Oversampling principles.

its own despite the initial artificial excitement over DCC and the MiniDisc. The price of the software has dissuaded many people from committing themselves to one or other of the formats, and, for the present, it seems that the manufacturers have cut their own throats.

## CD – The Lowdown

It is generally accepted that most compact disc players (within a strict 20Hz to 20kHz bandwidth), sound better than most record decks (such as those found on budget-to-mid-priced gear, stack-and-rack systems, music centres and the like). CD players – albeit the bare-bones, no-frills type – can now be purchased for around or even under £100. Since it is also an undeniable fact that a good digital recording can, theoretically, sound better, brighter, clearer or cleaner than a good analogue recording, it would seem that the CD must win hands down over vinyl. It has been said that the eclipse of the vinyl disc is not so much a comment on the deficiencies of the LP, but a testimony to the technological excellence of the LP. Or so the pundits, marketing men and manufacturers would have us believe . . .

Some might even be so bold as to say that a digital recording can actually improve on the original, since the signal could be analysed bit-by-bit in the digital domain (using computerised techniques), and noise and imperfections then removed. This

ation players. Recent machines give a sound perceived by many of the subjective fraternity to be more 'natural' in character.

Case proved, end of story, and never mind that some of the jury is still out . . . Well, not quite. It is a somewhat falsely accepted axiom that CD, just because it uses digital storage techniques, must be perfect. Surely, one might say, a binary number is either true or false, with nothing in-between? So what if the laser picks up a wrong number because the disc is warped, scratched or any one of a hundred different things which also affect vinyl (and to which the CD was completely impervious, or so the original marketing campaigns would have had us believe)? Over two thirds of the 15 thousand million or so bits needed to record a full CD are dedicated to error detection and correction.

The right sample will ALWAYS appear, and be converted, right?

Unfortunately, a CD versus vinyl argument cannot be fully resolved in terms of numbers and techniques. As in most audio engineering disciplines, plausible answers founded on scientific fact CAN be given to explain what it is in some players that makes them sound different to others. Such phenomena plagues certain models, and can make them sound rough and edgy, or harsh and clinical. If all of this sounds as though I am a hard-line objectivist, I should perhaps say that I firmly believe that SOME people are born, or can train themselves, to hear parts of sound

ent, wine-tasting. Both musical appreciation and wine-tasting are sensory experiences, and since no sensible person would consider purchasing a bottle of vintage Chateau Lafitte '59 on the basis of a gas chromatograph analysis of its contents, the enjoyment of wine (or likewise, music) cannot be measured. It is very difficult, if not well-nigh impossible, to evaluate directly the emotional experience coefficient in real versus reproduced music. So says T. W. Woodford in a somewhat cutting and aposite piece on the subjectivity of the listening experience.

As in every single area of audio engineering, it is attention to detail, particularly the finer points of the design, which create a recording and reproducing chain which is as transparent as possible.

Aside from fundamentals, such as pro or semi-pro, or the number of features offered, the difference in price of any audio apparatus within a given classification, be it a mixer, DAT machine or a pair of headphones, is basically down to attention to detail. Why should CD players be any different? As a consequence of this lack of attention to detail, early players received deservedly mixed press. 14-bit converters were just about in the vanguard of technology available at that time, so some technical 'jiggery-pokery' was necessary if pseudo 16-bit resolution was to be yielded from the conversion system. What had happened with the early players was that the retrieval of information from the disc placed demands

far in excess of what the technology of the age was capable of. Basically, the CD was foisted upon an eager public just a little too prematurely. In some ways, they have been trying to make up ground lost at that point in the evolution ever since.

## Converted to CD

16-bit converters WERE around at this time, it was just that they were VERY expensive, and subject to long-term reliability and drift problems. Without the use of oversampling, RF noise becomes a noticeable and horribly audible intrusion. Later in the eighties (circa 1985), two new 16-bit converters appeared on the market, one from the Burr-Brown Corporation in America, and the other from Philips. Today, this Philips converter is still very highly regarded. In fact, it is a classic in many people's eyes and has been adopted almost as an industry standard by many Western Hi-Fi manufacturers (and some of the top-of-the-range Japanese machines, too).

## Oversampling

Nevertheless, cunning and devious methods were employed to improve upon the technology of the moment. The sleight-of-hand was known as 'oversampling', and not only did it achieve almost-16-bit resolution, but it shifted an audible nasty known as 'digital noise' further up into the inaudible part of the audio spectrum, see Figure 1.

Oversampling avoids the use of 'brick-wall' analogue filters. Rather, the digitised sound

is processed using an oversampling digital filter before conversion back to the analogue domain. This avoids the phase shifts and other tonal anomalies inherent in analogue filters with very fast roll-off characteristics, since it allows the use of filters with much gentler attenuation rates, once the signal has been converted to analogue again. Some of the emotional subtleties and nuances of the audio signal – reverberant, timbral, ambient or otherwise – which were distinctly missing from the earlier players, and are still missing from many modern-day examples, are captured, to a limited extent, in good machines using this kind of technology.

## Bitstream – Simple Sampling?

'Bitstream' took the new oversampling technique to previously undiscovered limits. This conversion technology makes use of a binary waveform, clocked at rates of up to 100MHz, to represent the audio waveform. Instead of amplitude representation, the Bitstream system uses time division to represent the signal. Advantages include better low level linearity and zero-cross distortion, since the use of 1-bit conversion means that errors are constant and not relative. It is not without its problems, however. The high clock rate causes RF radiation in the VHF region of the spectrum, and can cause intermodulation products to appear with in-band signals. Subjectively, this is fatiguing to the listener. Other problems inherent to the fast clock rates of the Bitstream system include accuracy and long-term stability.

Furthermore, jitter in the timing chain causes rapid pitch fluctuations (akin to flutter in an analogue machine), which makes treble sound 'smeared'.

RF radiation is basically a mechanical problem. Good designs overcome it with suitable shielding between analogue and digital components of the system, adoption of RF style PCB ground planes and board architecture, rigid adherence to the strict separation of logic and analogue grounds, and hefty grounding throughout the system.

However, oversampling, and greater number of bits involved in resolving the analogue signal, do not necessarily guarantee improved sonic fidelity. Proof of this is in the existence of markedly rough-sounding 18 and 20-bit designs that use oversampling techniques. Though, intuitively, it might seem strange, it is often the devices peripheral to the main circuitry, and their mechanical and electrical characteristics, which have even more bearing on the final sound. By mechanical, we mean PCB layout and board support (more of this later). Crosstalk exists not just in the analogue domain, but in the digital one, too. Left and right channel data streams can corrupt one another, especially if multiplexed onto the same converter. Digital, as well as analogue ICs, can be microphonic, which can cause colouration and lack of clarity in the perceived sound. Careful fixing of the boards, with anti-resonant housings and careful damping of all mounting points, help to alleviate mechanically related problems, which are most noticeable and objectionable during loud or complex passages of music.

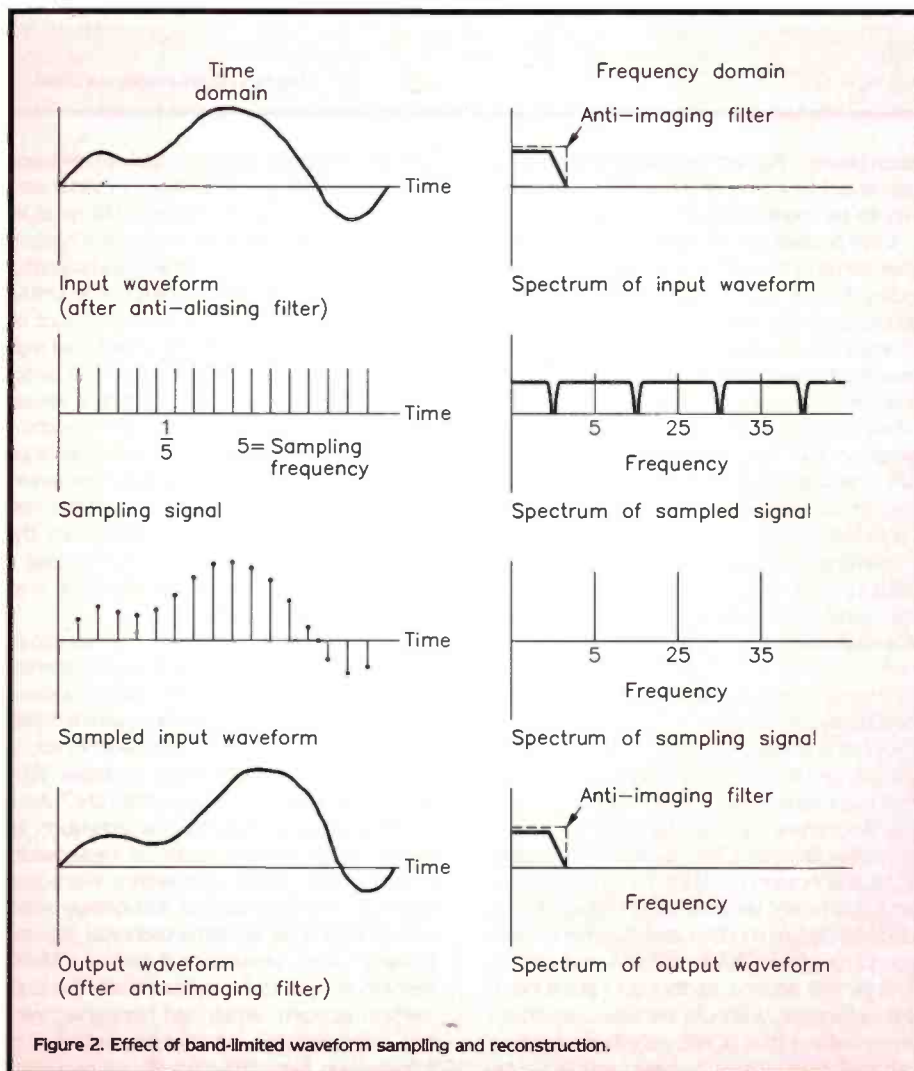

## Taking a Sample

Another part of the CD specification, laid down in stone in a book known as 'The Red Book', which exacerbated the problems of the early machines and is a subject of much debate even now, is that of sampling frequency. The sampling frequency is fixed at 44.1kHz. In order to comply with the Nyquist criterion for sampled waveforms (so that a phenomenon known as 'aliasing' is avoided), the highest frequency which can be recorded and subsequently retrieved is around or below 22kHz, see Figures 2 and 3. Early machines used very fast roll-off filters, operating in the analogue domain, so that no information above a 22kHz ceiling could be stored, and then played back (as an alias waveform, of course). See Figure 4.

It is upon this point that many proponents of analogue seize, since frequencies above this unnatural ceiling can be felt in replayed music. We have already mentioned that the ear is like any other bodily faculty. With the proper training, it can be educated to detect tonal anomalies and distortions which others, perhaps lacking this training or knowledge of the mechanisms involved in hearing (psycho-acoustics), just cannot perceive in sound or music. Theoretically, compact disc is fine, but many feel that the human ear deserves better resolution, i.e. higher sampling speeds for high frequencies. The difference might only be heard by very few people, but in many ways it is these few who form the de facto reference as far as absolute fidelity is concerned. Intuitively, it seems rather bizarre that we can possibly represent a complex waveform shape with just two values...

Why wasn't a higher sampling frequency chosen, you might ask? This would have allowed much higher frequencies to have been recorded. Quite simply, it was a question of economics. A compact disc, in line with specifications laid down in the aforementioned Red Book, holds a certain number of bits of information. A higher sampling frequency, allowing higher audio frequencies to be reproduced, would have resulted in correspondingly less playing time. The final sampling frequency chosen, and now used in practice, was a compromise of playing time (what the average punter would consider to be good value) against the highest frequency able to be reproduced. On this point, it is interesting to note that legend suggests that the playing time of CD was decided after Philips' engineers consulted conductor Herbert von Karajan. He, in turn, advised that the new format should be able to store a complete rendition of his own performance of Beethoven's Ninth without interruption!

More of the population is likely to be swayed by 70 odd minutes of 20Hz to 20kHz bandwidth music for a given cost than, say, 30 minutes of extended bandwidth material for the same money. The marketing departments would quite rightly say that true audiophiles are in a minority when compared to the mass market of the average listener...

Furthermore, the filters themselves can cause problems with the phase of the signal. A signal at LF will be delayed less than one at HF; non-linearities in the phase response of the signal can cause obvious problems with fidelity. Subjectively such steep filters sound unnatural. Advances in technology, and the widespread use of over-sampling techniques means that all the brutal filtering required of the system is done in the digital domain. This allows the use of analogue filters with much gentler attenuation ratios, which in practice means a more natural reproduced sound. Still, there can never be any information stored from signals above 22kHz...

In addition to these problems, there is a definite skimping on other fundamentals on the analogue and construction side of things in many entry-level or mid-priced CD players. Too many analogue final stages, i.e. op amps, still use components that have been around for ten or fifteen years. Op amps with quite extraordinary specifications as regards noise, slew-rate and distortion are not so thin on the ground these days, and some cost only pence more than the previously mentioned examples. Sadly, few of these esoteric audio performers are to be found residing in the bowels of the mass-produced players. In addition, many designs seem to feature PSUs where there is scant regard paid to power supply performance specifications such as ripple rejection. Common power supplies are often used for both analogues and digital sub-systems; both systems must suffer when this approach is employed. Further, commoning of analogue and digital grounds at inappropriate places, lack of RF and other shielding, and insufficient separation of hostile analogue and digital signals causes subtle corruption and crosstalk, and can make a mockery of the resolution and accuracy of a 16 or 18-bit converter. Even the choice of type of logic family employed to do the digital work can

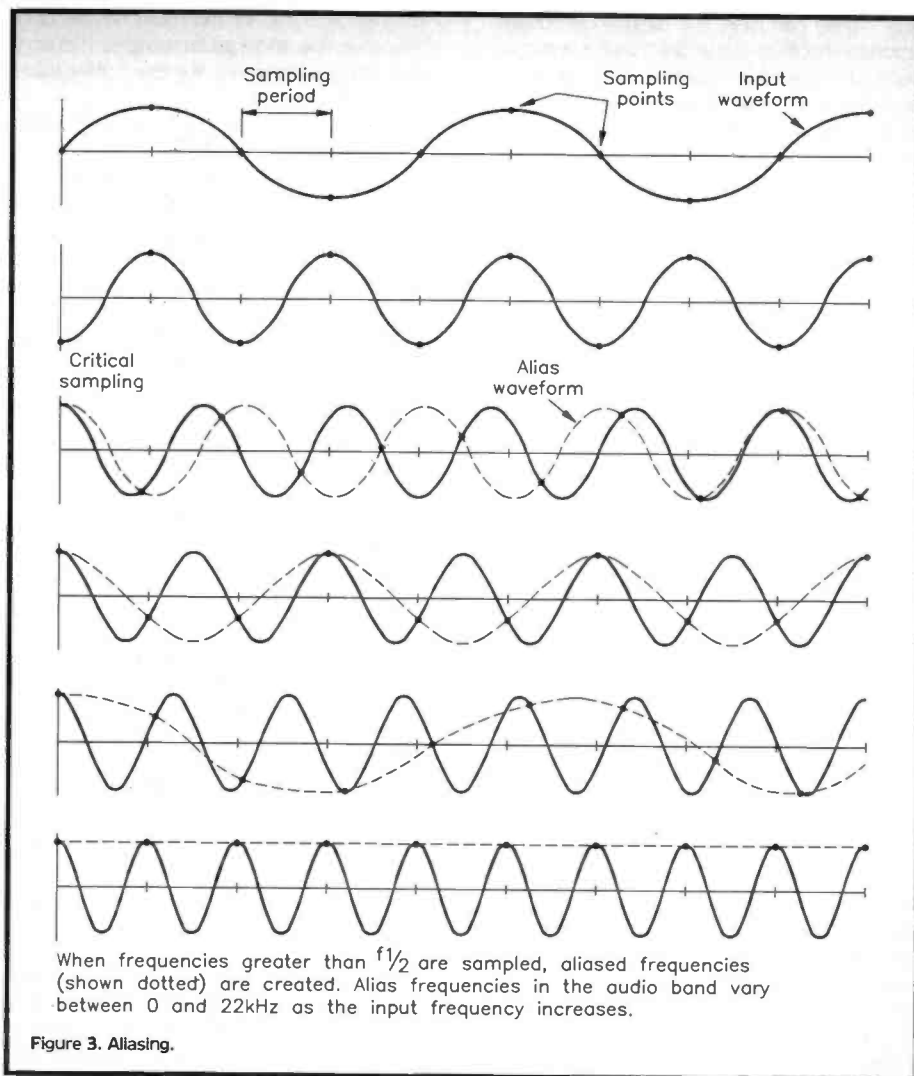

Figure 3. Aliasing.

have a subtle bearing on the sound of the machine.

Such a blatant 'design-down-to-a-price' philosophy mars the performance of the whole piece of equipment and suggests, perhaps, why budget players can, in fact have a sound which is perceived, subjectively, as 'rough' in character. See Table 1 for typical comparisons of vinyl and CD performance characteristics.

If we can now pursue the CD marketing angle, one need only walk into any high street music outlet (even those with the word 'record' in the name) to discover that it is becoming increasingly difficult, if not well nigh impossible, to buy good, or not-so-good, old-fashioned vinyl. Cassettes or CDs, yes, of course, how many? Albums, 'fraid not, Sir/Madam. That is not just with recent releases, where the 'available only on CD or cassette' banner is all too familiar. This scenario holds true for back catalogue stuff, also. 'Record' companies have tempted the consumer over to the CD/cassette formats by extolling the virtues of the former (quality, convenience) and by including extra tracks or mixes (missing from the record edition) on the latter. Okay, to give them their due, the LP format does not lend itself technically to playing lengths much over thirty minutes per side, but the ploy already mentioned has been remarkably successful. Many of the distributors of classical material now no longer include vinyl disc as an available format.

For many of us, it remains a sad fact of life that the Compact Disc has all but displaced vinyl from the record collector's

shelves, and sales of CD and cassette, despite the bizarre pricing anomaly, far outstrip those of the vinyl format. The classical music record labels (Nimbus initially, followed closely by Deutsche Grammophon) were the first to announce that future recordings would be available only on CD or cassette, and as far as back catalogue stuff on vinyl was concerned, this would only be until stocks were exhausted. More recently, this is happening with all new releases, and the only way to track down much sought and treasured old vinyl is through the second-hand shop or the record collectors fayres.

One of the other unassailable attractions of CD must be that it is a great format for the average listener. It is robust, the discs will tolerate some abuse, although not as much as the initial hype would have had us believe, and there are no pops or clicks. Further, cueing up and playing a disc requires absolutely no manual dexterity whatsoever. This means that damaged tone arms and styli become a thing of the past...

Vinyl has its strengths too. The disc shape, as a storage medium, is optimal for fast access and retrieval. Witness the universal acceptance and use of it for storage purposes within the world of personal computers (the floppy disk). Hard disc or Winchester storage systems have been used in mini and mainframe computers for much longer. CDs themselves use many of the elements of disc technology because it has been proven over the hundred year history of analogue recordings, and works. Some audiophiles claim that they prefer vinyl discs to CD for one reason and one reason

only – they can hear the difference. These proponents of analogue claim that it is something of a backward step to stop frequencies above a certain threshold, when it has taken over a hundred years for analogue technology to advance sufficiently to be able to cope with them and reproduce them. As confirmation of this, it has been mentioned already about the low sampling frequency of the format, and why it means that the reproduction of CD can be perceived by some as unnatural. Moreover, the process of manufacturing a vinyl disc is relatively straightforward, and more economical than other media, although it is error and blemish-prone, and for most producers even now, it remains inherently labour-intensive.

We have already mentioned the major technological upheaval that the sound recording industry has undergone in the few years since the birth of digital storage and optical retrieval systems for audio. Despite all of the excellent attributes of CD, and there are indeed many, analogue recording using vinyl discs and mechanical recording/retrieving systems have been around for over one hundred years, and a large amount of the much-loved music of famous composers, orchestras, bands, and the sounds of historical events, has only been captured in the intricate excursions of the analogue record groove. (The omission of the 'vinyl' term was deliberate, since early records were recorded on all sorts of different base materials.) The format persists in the countless millions of discs hoarded in audiophiles' archives, music libraries and radio stations, as well as in the homes of that sad bunch of people, the personal devotees of analogue.

The contents of such discs can never totally be rerecorded using modern-day digital techniques, so it remains of vital importance that the art of preserving, restoring and reproducing such material remains both in the present, and in years to come.

Aficionados of the format must remain optimistic that the apparatus necessary to continue doing so remains for the foreseeable future, and beyond.

Nevertheless, and after due consideration of all the above, it might not be too obvious to some why the engineer should persist in the design and development of electronics and mechanics destined for integration into a music replaying format seen by many as tired, out-of-date or downright obsolete. Then again, despite the somewhat negative press, perhaps it is. To summarise; back in the golden era of vinyl, there might have been justification for the inclusion of a quality phono preamp project in an electronics magazine. Is this still the case in the digit-orientated nineties, or is it purely a nostalgic look at an obsolete technology, superseded in all aspects by CD, DAT and other digital formats?

For the reasons why the author, at any rate, reckons that vinyl is still a force to be reckoned with, we must first cast our minds back to the golden decade between 1970 and 1980. At this time, there were only two formats considered as serious contenders by the audiophile fraternity. These were vinyl disc and open reel-to-reel (tape recorders). Obviously, open reel was OK if one wanted to record material from disc, but the lack of 'software', for want of a better term, or pre-recorded tapes, somewhat limited its acceptance as a common replay medium, and thus the vinyl disc ruled supreme, for domestic use, at least.

The compact cassette format has been ignored deliberately. This was because, until such times as tape formulations superior to the basic  $Fe_2O_3$  were readily available, and machines were equipped with Dolby B, C, or similar, rival noise reduction systems, and signal enhancement systems such as HXPro, this format was not considered capable of high enough quality and fidelity to be considered serious – indeed, for a long

time, it was seen by many as a very crude record/replay medium, popular only because of its convenience. Other faddish, or short-lived formats such as 8-track have also been ignored, for similar reasons.

Now, the scene is set for the serious audiophile to enter, stage left. Apart from massive, initial capital expenditure on the equipment (compatible stylus/turnarm/deck/amplifier/ speakers), what also sets the audiophile apart from the proletariat of listeners, is in the regularity with which the stylus is changed and the fact that any records are kept in pristine condition. It is also likely that he/she updates the collection regularly, since an expensive interest (obsession?) as this suggests a great love of music, listening and allied pleasures, and a voracious appetite for new material must be met by buying new records.

By the time the early eighties came along, and the general public have now been introduced to the compact disc, the record collection represents a sizeable investment in time, space and money. This newfangled format intrigues the audiophile, but initial reports mention a 'clinical' sound, not like the warmth associated with analogue discs, and the new players ARE expensive. Perhaps it is just a passing fad? A few more years elapse, the new format grips the public's imagination, the quality of players increases (as well as the number of features offered), and the cost falls. In some aspects, the sound of a good player is now comparable to, or better than the two grand, stylus/arm/deck combination.

But what finally convinces many audiophiles? In a word, convenience, and not just because CDs are easier to keep in good, playable condition (since they are more robust, smaller, and easier to store and catalogue), although this is a contributing factor. Rather, it is the fact that it is now becoming increasingly difficult to track down

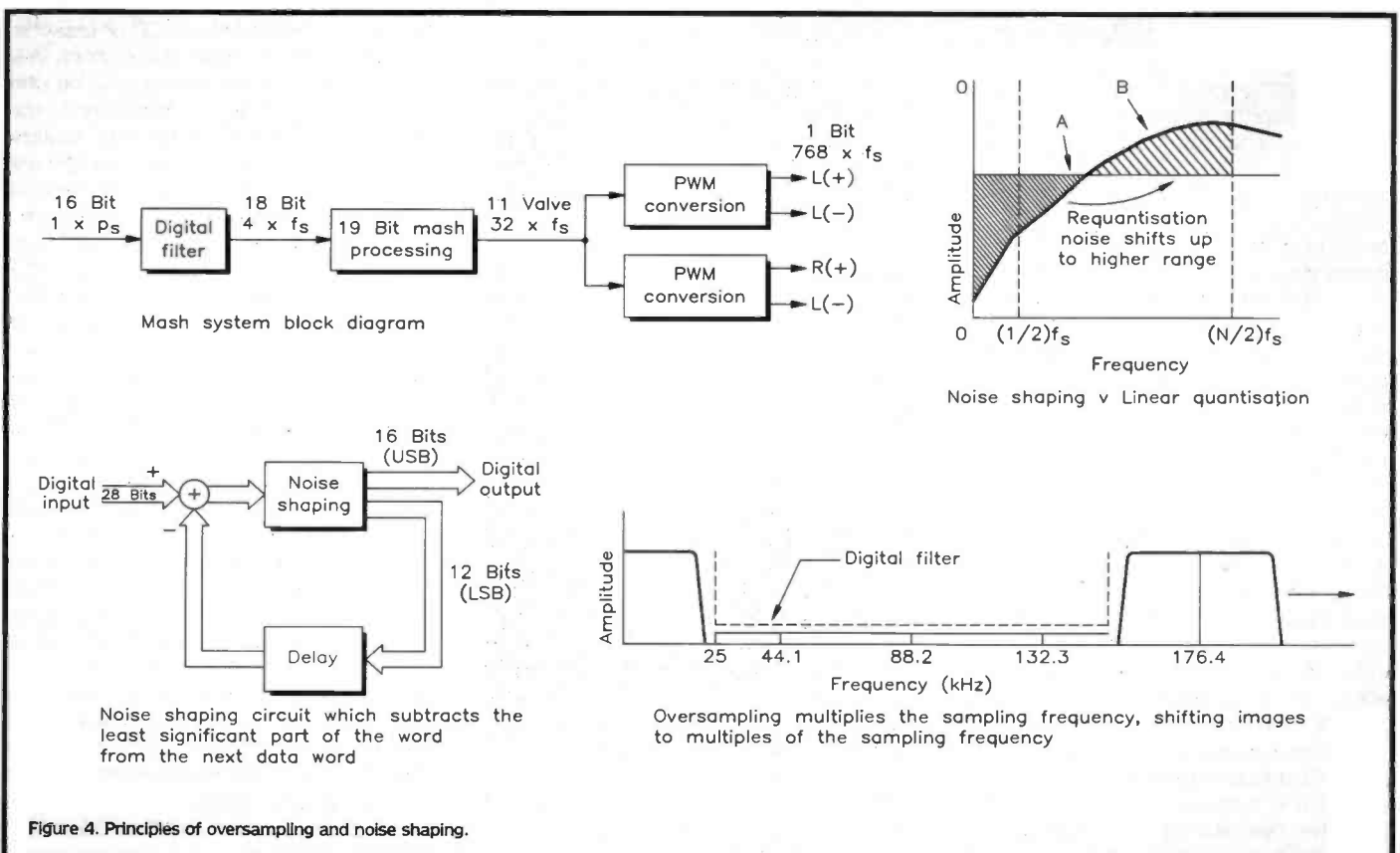

Figure 4. Principles of oversampling and noise shaping.

Parameter	Compact Disc		Vinyl	
	Quoted	Typical budget player	Moving magnet	Moving coil
Frequency range	20Hz to 20kHz $\pm$ (0.2dB)	20Hz to 20kHz $\pm$ (0.5dB)	RIAA $\pm$ 0.2dB	5Hz to 150kHz <sup>2</sup>
Signal to noise ratio	>100dB	90dB	>82dB <sup>1</sup>	$\geq$ 68dB <sup>3</sup>
Channel separation	>100dB >90dB @ 1kHz	95dB @ 1kHz 70dB @ 20kHz	>20-30dB	>30-40dB
THD (+noise)	<0.004% (<0.002% @ 1kHz)	0.1% @ 20Hz <sup>4</sup> 0.03% @ 1kHz 0.12% @ 20kHz	<0.002% all frequencies	<0.003% <sup>5</sup>
Intermodulation distortion	<-90dB	-69dB @ 0dB	$\leq$ -88dB	-
Out of band rejection (f>24kHz)	50dB	51dB	N/A	N/A
Wow and flutter	Unmeasurable	-75dB (0.025%)	?	? <sup>6</sup>

Notes: 1. Depends on cartridge output level and impedance (quoted value assumes 5mV O/P, 500 $\Omega$  resistance).  
2. Depends on particular cartridge.  
3. Assumes 200 $\mu$ V output.  
4. Worsens at reduced levels because of reduced resolution from compact disc.  
5. Quoted for cartridge (final value depends on quality of cartridge and tonearm combination).  
6. Depends on quality of turntable.

**Table 1. Comparison of compact disc and vinyl performance specification.**

(no pun intended) many releases in the vinyl format. This is quite the opposite of the situation just after the advent of CD when the discs themselves were difficult to source.

Nevertheless, short of a massive capital injection to replace all the existing vinyl collections of the past decades with CD, the audiophile is stuck with this outmoded format for all older material. This is a very simplistic argument and suggests that with the right amount of money, any vinyl collection could be replaced by a CD one. In reality, this can never be the case, since many memorable and historic musical performances have been captured only on vinyl (perhaps the masters have been lost or damaged), and in any case rare albums and singles ARE rare because they have, perhaps, been deleted from manufacturers' catalogues.

Despite this somewhat depressing opening gambit, new circuit designs, semiconductors, mechanical techniques and materials have been developed on a regular basis since the dawn of CD. All of these can, perhaps, improve the quality of this jaded medium of sound reproduction. The introduction, by many semiconductor houses, of audio-specific, integrated circuit packages with both superlative performance and reasonable cost has done much to improve matters. We shall conveniently gloss over the fact that much of the capital necessary to finance the development and manufacture of such chips may have come directly off the back of CD-related products, such ICs being, in many cases, a direct offshoot of the need for better analogue front-end components in any CD system.

It is upon just such a basis that this project (which will be the subject of Part 3) was developed. For avid record collectors (especially of old or rare material), there has never been a better time to buy vinyl, since, one by one, music lovers sell off vast record collections to the second-hand shops. Much of the material on offer is in a condition that leaves much to be desired (dirty, scratched, warped or worn), while others have been lovingly looked after and parted with only

after much soul-searching (or nagging from a long-suffering spouse)!

It is the author's own opinion that there is most definitely some life in the old dog yet. A typical number of 'white label' or promotional record releases in the late seventies/early eighties (the supposed 'golden years' of vinyl) might have been in the order of 10 to 20. Presently, it might number 30 to 50. (We'll pretend that many of these 'musical' offerings owe as much to REAL music as painting-by-numbers does to the works of Michelangelo, and so might be referred to in slightly baser terms). Whatever your musical persuasion, the proliferation nowadays of MIDI set-ups and commercial studios equipped with MIDI compatible equipment has encouraged 'bedroom' mixers and aspiring young bands to do most of the recording/production work in home studios. Bands thus spend much less time (and money) in the commercial studio, where all that is necessary might prove to be some final polishing, before the mix is committed to a master tape. The capital saved can be used to finance a small production run of vinyl discs (or, sadly, and probably, DATs) for distribution to local record shops/nightclub DJs, radio stations and record company A & R men.

It is statistically likely that serious vinyl junkies (and DJs) will still be playing their discs in thirty or forty years time. New 'software' might prove difficult or impossible to attain, but vinyl collections built up over this time will still be listened to. It is akin in many ways, I think, to the valve amplifier, which is still used in many guises and whose employment in high quality circuit design can still (usually) be fully justified. (A broadcast-quality compressor/limiter, intended for use in radio stations, and which I recently had the pleasure to audition, used valve technology, but produced one of the smoothest, most transparent performances I have ever heard from such a unit...)

It is heartening to note that some of the smaller, more specialist audio equipment manufacturers (happily, most of who are

British) are still developing new techniques to improve vinyl disc reproduction (including – a few years ago – a turntable with laser pick-up). That this is true suggests they, too, hold a similar, sympathetic belief. In many ways, these manufacturers seem to care more about their customers' wants and desires, and less about overriding commercial whims and profiteering, since smaller production runs mean less financial risk (and more room for the personal touch). The same cannot be said of their counterparts, the consumer electronics giants. One might be so bold as to suggest that it is for this reason that these manufacturers are held, world-wide, and justifiably so, to be in the vanguard of the audio electronics industry. Doesn't it just make you proud.

Next month, we leave the philosophising behind and look at some of the design hurdles which must be overcome in the quest for an ultra low noise, low distortion RIAA preamp, i.e. one which is able to be integrated into a good Hi-Fi system and perhaps give CD a run for its money. The series is directed toward the new generation of engineers, weaned on CD, and who I hope will be as interested as I was in discovering more about a process that is as much an art-form as a science.

## References

- Principles of Digital Audio*, Ken Pohlmann, SAMS.
- The Digital Difference, Home and Studio Recording*, Ben Duncan, September 1992 (published by Music Maker Publications).
- Letters, Electronics World and Wireless World*, T. W. Woodward, January 1989 (published by Reed Publishing).
- Optical Disc Storage*, Richard Lambley, January 1989, *Electronics World and Wireless World*, (published by Reed Publishing).
- Compact Disc*, Barry Fox, (*The Audio Electronics Reference Book*, edited by Ian R. Sinclair), published by BSP Professional Books.







# Bob's Mini Circuits

by Robert Penfold

## Two-Tone Train Horn

This is a simple sound effects unit for model railway enthusiasts. On pressing the push-button switch, a two tone horn sound is produced of the type associated with diesel locomotives. In other words, an initial tone lasting about one second in duration, followed by a tone 50% higher in pitch, and also having a duration of about one second. If preferred, the horn can be triggered automatically at a certain point on the track (just before a level-crossing, for instance). Automatic triggering is possible using a reed switch under the track, and a magnet fitted in a piece of the rolling stock.

The circuit, shown in Figure 1, is based on three 555 timers. Two of these operate as monostables which control the timing of the tones, and the third actually generates the tone. IC3 acts as the tone generator, and it operates in a standard 555 astable mode. The output of IC3 drives a high impedance loudspeaker via a simple low-pass filter (R6 & C5). The filter provides a more realistic sound by removing the higher frequency harmonics in the output signal. Note that IC3 should be a standard 555 and not a low power type. Low power versions of the 555 are not very good at driving low impedance loads, and will not give good results in this circuit. LS1 must be a high impedance (50Ω or greater) loudspeaker, and *not* an 8Ω type.

IC1 is a standard 555 monostable which has its trigger input taken high by R2 under standby conditions. The trigger input is taken low when S1 is operated, and an output pulse is then generated at pin 3 of IC1. R1 and C2 set the pulse duration at about 2 seconds or so. This pulse is used to control the gate input of IC3. Normally the gate input at pin 4 is held low and no oscillation is produced. During the output

a little over a second once the output pulse from IC2 has ceased. With IC2's output low, the tone from IC3 is pulled higher in pitch. VR1 is adjusted to give the correct difference between the pitches of the two tones.

Low power 555s are used for IC1 and IC2 in order to minimise the current consumption of the circuit. Under quiescent conditions the current consumption is about 8mA, but it increases to about 20 to 25mA when the horn is sounding. A fairly high capacity battery is needed, such as six AA (HP7) size cells in a plastic holder. Connections to the holder are made via a standard PP3 battery clip.

Construction of the unit is very straightforward. Although the lower power 555s use CMOS technology, they do not require any special handling precautions. If you require manual and automatic triggering, simply wire the reed switch and the push-button switch in parallel. In fact it is possible to trigger the circuit from several reed switches at strategic points around the track by simply wiring them all in parallel. VR1 is adjusted by trial and error to obtain what is judged to be the most realistic

effect. When triggering the unit manually make sure that you only operate S1 momentarily. If it is held down for a second or more the timing of the circuit will be affected, and the correct effect will not be produced. If desired, the duration of the sound effect can be changed by altering the values of R1 and R3. The total duration of the sound is proportional to the value of R1. R3 should be maintained at about half the value of R1.

## Simple Digital Capacitance Meter

This digital capacitance meter provides an interesting alternative to a simple analogue capacitance meter. The cost is comparable to an analogue equivalent, and the resolution and accuracy of the two digit display is at least as good as that provided by a small panel meter. The unit covers a useful spread of capacitance values in its five measuring ranges. These have full-scale values of 990pF, 9.9nF, 99nF, 990nF, and 9.9μF. An overflow indicator is included.

In order to keep the unit as simple as possible the control logic has been kept to a bare

pulse from IC1 the gate input is taken high, and a tone is generated by the circuit. IC2 is the second monostable, and this is triggered at the same time as IC1. It has a shorter output pulse duration which is set at just over one second by R3 and C3. The output pulse from IC2 is coupled to the modulation input of IC3 via VR1. During the initial second or so after triggering, the output of IC2 will be high, and it will pull the output frequency of IC3 lower. IC3 will remain switched on for

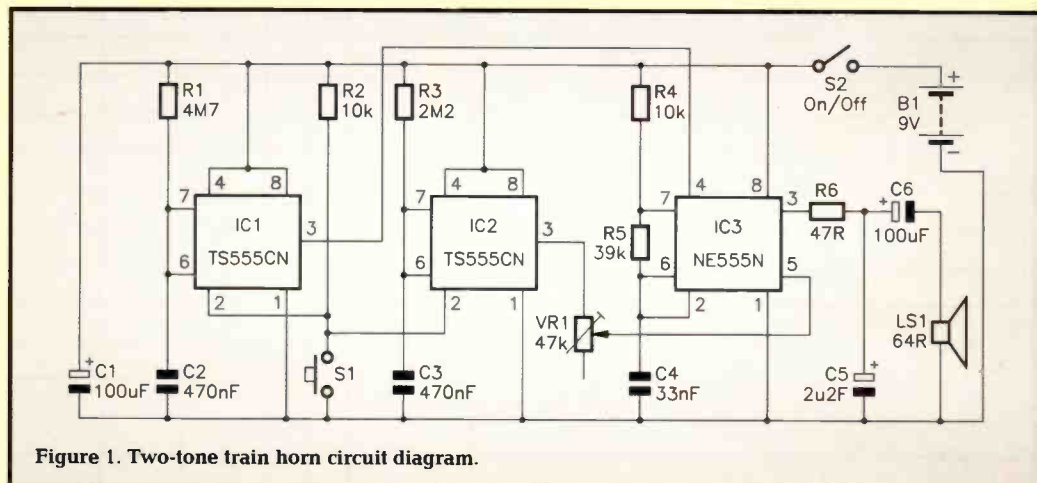
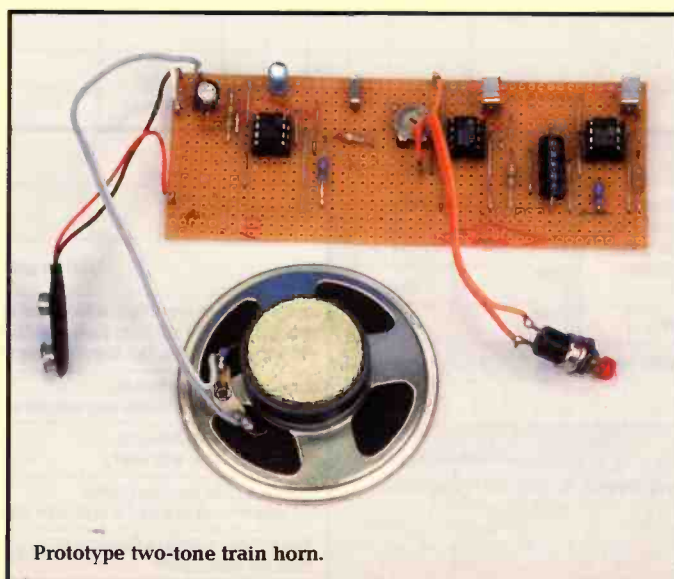

Figure 1. Two-tone train horn circuit diagram.



Prototype two-tone train horn.

minimum. In effect, the user provides some of the control logic by pressing a push-button switch when a reading is required, and operating a second button to reset the display to zero before the next reading is taken. The circuit diagram is shown in Figure 2. Looking at the operation of the circuit in broad terms, IC5 acts as a monostable which has the test capacitance as the capacitive element of the C-R timing circuit. IC4 acts as a clock oscillator which feeds into a two digit counter based on IC2 and IC3. The output pulse from the monostable controls the gate input of the counter circuit, and the count only proceeds during an output pulse from the monostable.

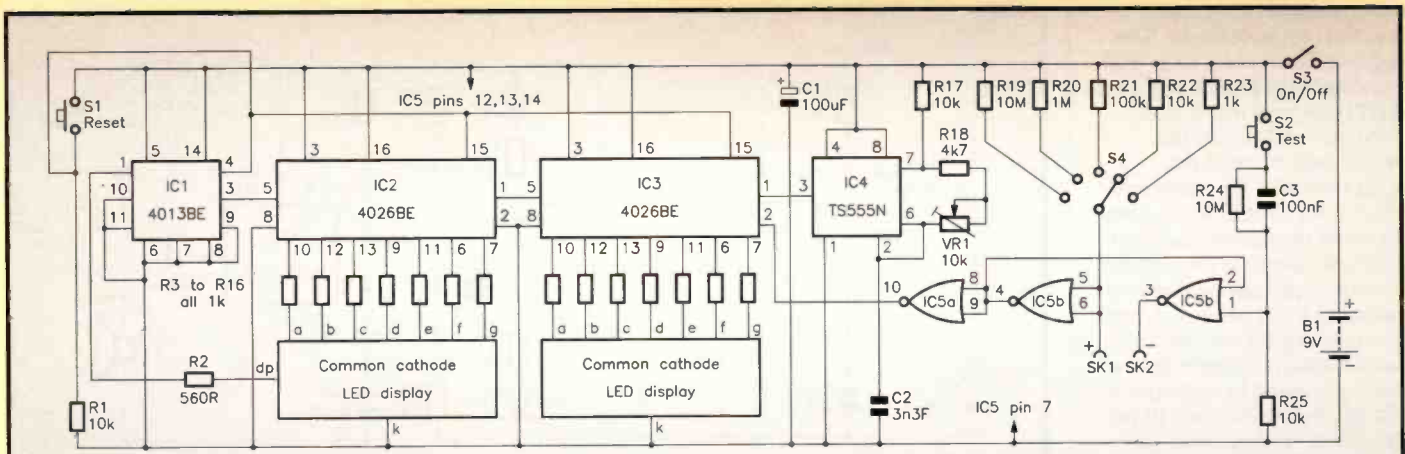

Figure 2. Simple Digital capacitance meter circuit diagram.

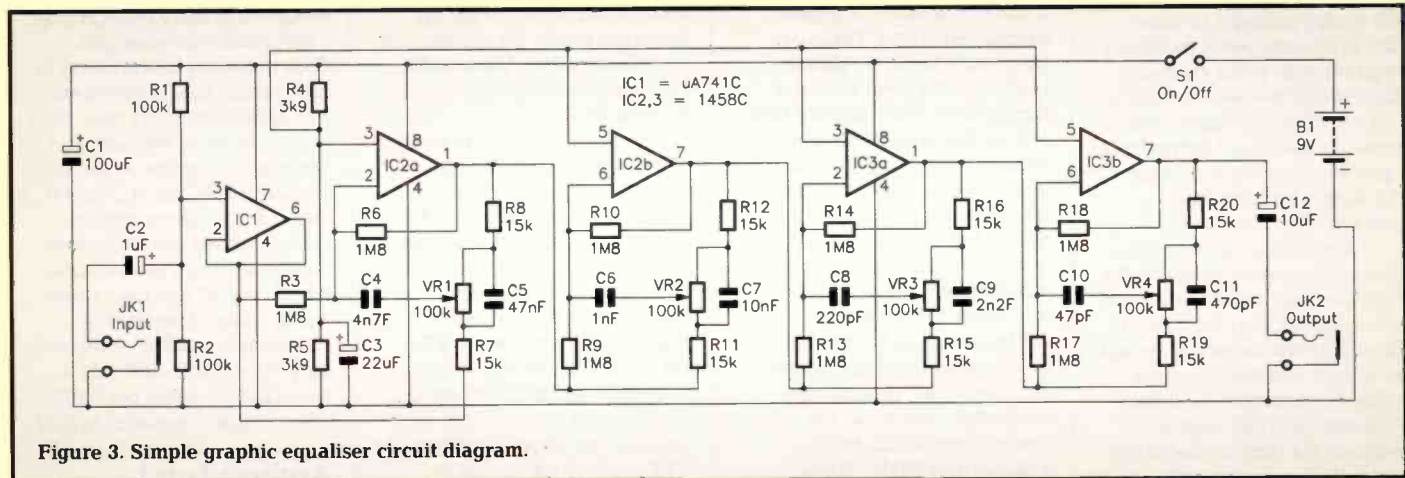

Figure 3. Simple graphic equaliser circuit diagram.

The higher the test capacitance, the longer the monostable pulse duration, and the higher the count. There is a linear relationship between the test capacitance and the number of clock pulses registered by the counter. In practice the clock frequency is chosen so that the counter directly indicates the test capacitance.

Looking at the circuit in a bit more detail, the monostable is based on two CMOS NOR gates (IC5b and IC5c). The low self-capacitance of this configuration ensures good accuracy with small test

capacitances. IC5a acts as an inverter at the output of the monostable. This gives a better output waveform and also provides output pulses of the correct polarity for the gate input of IC3. The fourth gate in IC5 is left unused. S4 provides five switched timing resistances which give the unit its five ranges. R19 provides the 990pF range - R23 provides the 9.9μF range. S2 is used to trigger the monostable and take a reading. R24 and C3 provide 'debouncing' for S2.

The clock oscillator is a standard 555 astable. A low

power 555 is used in order to keep the current drain from the battery as low as possible. VR1 enables the clock frequency to be adjusted, and this is the calibration control. The counter is a straightforward design based on two CMOS 4026BE decade counters and display drivers. The carry out output of IC2 drives the input of a 'D' type flip/flop (IC1). The 4013BE is actually a dual flip/flop, but in this circuit only one section is utilized. This acts as a sort of data latch which switches on the overflow indicator if the count goes beyond '99'. With a

two digit display and right-hand decimal points, it is not really possible to use the decimal point segments for their intended purpose. Therefore, the decimal point of one display is used as the overflow indicator, and the other one is simply left unused. It is still quite easy to convert readings into their corresponding capacitance values. S1 is used to reset both the main display and the overflow indicator. The current consumption of the circuit varies depending on the number of display segments

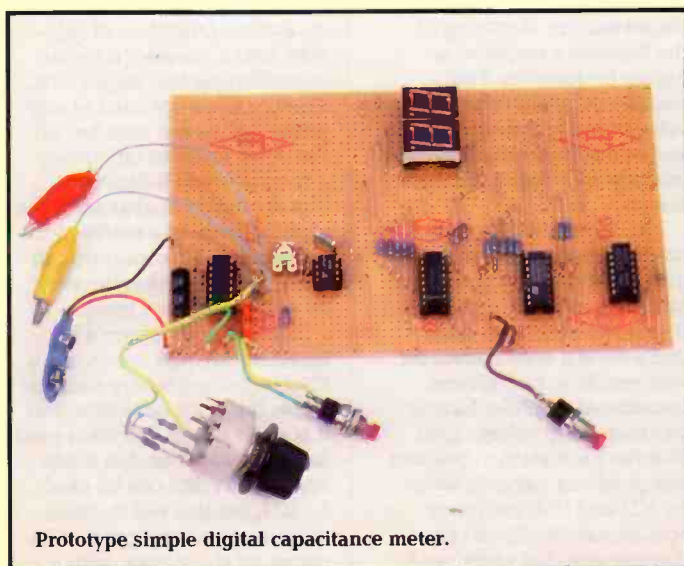

Prototype simple digital capacitance meter.

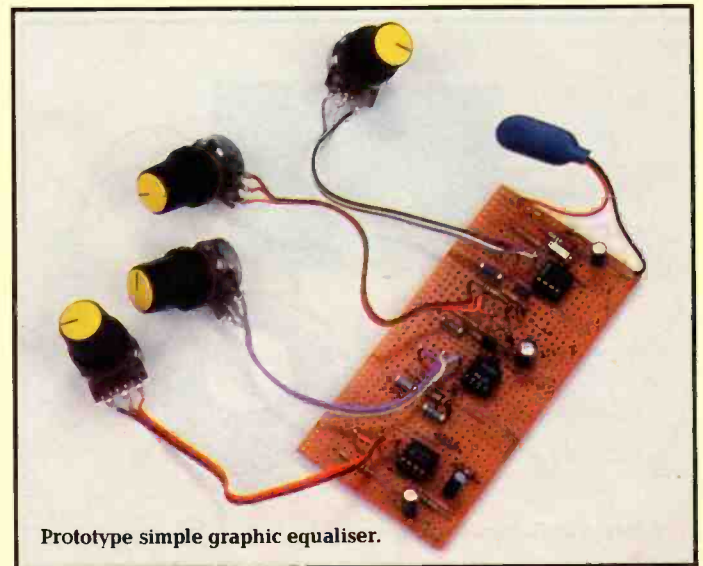

Prototype simple graphic equaliser.

that are switched on, but it is in the region of 50mA. This requires the use of a fairly high capacity battery, such as six AA (HP7) size cells in a holder.

When constructing this project bear in mind that, apart from IC4, the integrated circuits are CMOS types. They therefore require the standard antistatic handling precautions. The displays must be common cathode LED types. IC3 drives the units display (i.e. the right-hand display). A holder for the display is made by cutting a 20-pin DIL holder into two 10-pin SIL types, or 'Soldercon' pins can be used. SK1 and SK2 can be a couple of 1mm sockets mounted on the front panel of the unit, and many capacitors will readily connect to these. However, a couple of test leads terminated in small crocodile clips will be needed in order to make the connections to some types of capacitor. Alternatively, a pair of crocodile clip leads can simply be hard wired direct to the circuit board.

A close tolerance capacitor is needed in order to calibrate the unit. The unit can be calibrated on any range, and the value of the calibration capacitor should be at least half the full-scale value. For example, an 8.2nF capacitor could be used to calibrate the unit on the 9.9nF range (R20 switched into circuit). A series of readings would be taken, and RV1 would be adjusted by trial and error to obtain a consistent readings of '82' on the display. One final point is that capacitors should always be discharged before connecting them to any capacitance meter.

## Simple Graphic Equaliser

A full-blown graphic equaliser covers the entire audio range in about eight to ten bands, with each level control covering roughly one octave. These days many audio devices incorporate

a sort of cut down version of graphic equaliser. These are frequently found in 'ghetto blasters', and even personal stereo units. They usually have four or five level controls with each one covering a couple of octaves or so. This obviously gives far less precise control than a full graphic equaliser, but, on the other hand, it is much better than simple bass and treble tone controls.

The circuit in Figure 3 is for a simple four band graphic equaliser. The approximate centre frequencies of the controls are 80Hz, 400Hz, 1.8kHz, and 8kHz. These respectively control the bass, lower middle, upper middle, and treble frequencies. Each control can provide a maximum of about 12dB of boost and cut at its centre frequency. The frequency response is essentially flat with all four controls centred, and the voltage gain is then approximately unity.

IC1 acts as a buffer stage at the input of the circuit, and it provides an input impedance of about 50kΩ. The buffer stage is followed by a series of four response shaping circuits, one for each band. All four stages utilize the same configuration, and this is based on an

operational amplifier in the inverting mode. R4, R5 and C3 provide a half supply bias for the non-inverting inputs of all four stages.

If we consider the operation of the first stage (which is based on IC3a and covers the lowest frequency band), R3 and R6 are a negative feedback network which sets the voltage gain at unity. However, frequency selective negative feedback is provided by R7, R8, VR1, C4, and C5. If we ignore C5 for the moment, C4 significantly shunts R6 at high frequencies when the wiper of VR1 is at the top end of its track. This gives increased feedback at high frequencies, and high-frequency cut. With the wiper of VR1 at the bottom end of its track, C4 shunts R3 at high frequencies. This gives reduced negative feedback and high-frequency boost. R3 and R8 limit the effect of C4, and keep the maximum amounts of boost and cut within reasonable bounds. C5 is used to effectively short circuit VR1 at high frequencies, which nullifies C4 and leaves the circuit with its basic unity voltage gain. The circuit values are chosen so that C4 can introduce high-frequency boost or cut over the frequency range that is of interest, but C5 eliminates any doctoring of the frequency response at higher frequencies. The steadily reducing capacitance values used in the subsequent stages results in them covering progressively higher frequency ranges.

The component layout is not particularly critical since the circuit can only produce a modest amount of voltage gain. It should be borne in mind that setting a level control for 'cut' results in the relevant operational amplifier having less than unity voltage gain. This does not seem to produce any problems using 1458Cs for IC2 and IC3, but many operational amplifiers can become unstable when used

at less than unity voltage gain. The LF353N for example, does not seem to work well in this circuit, with severe high-frequency instability occurring at some control settings. It is therefore advisable to use the humble 1458C for IC2 and IC3, rather than a more modern device, unless the alternative device is known to be stable when used at less than unity voltage gain. The current consumption of the circuit is only about 5mA, and a PP3 battery is therefore perfectly adequate as the power source.

## Audio/Visual Metronome

The original metronomes were purely mechanical devices having clockwork mechanisms ('Maelzel's' metronomes). These are rapidly becoming collectors items, and modern metronomes are of the electronic variety. Mechanical metronomes have a swinging arm, rather like an inverted pendulum, and they produce a 'clicking' sound each time the arm reaches the limit of its swing. This gives both a visual and an audible indication of the beat rate.

This electronic metronome also produces a series of 'clicking' sounds to give an audible indication of the beat, and it provides a visual indication that is roughly analogous to the swinging arm of a mechanical metronome. The beat rate can be varied from approximately 30 to 300 beats per minute.

The circuit in Figure 4 is based on two 555 timers and a CMOS 7-stage binary counter. IC1 is the clock generator, and it is a low power 555 timer used in the standard astable mode. An ordinary 555 can be used for IC1, but this will increase the current consumption of the circuit by about 8mA, with a

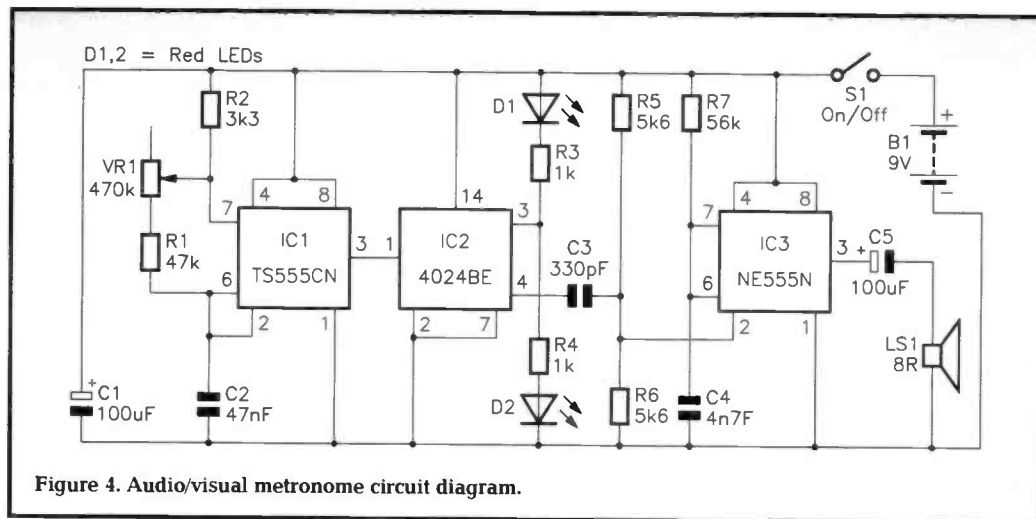
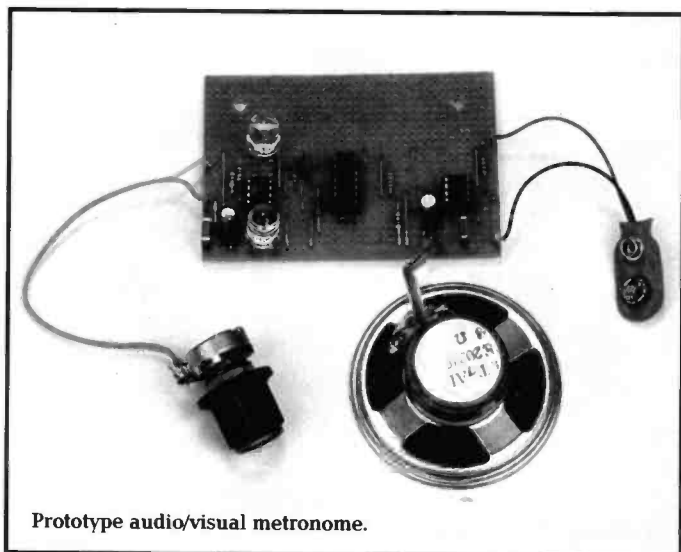

Figure 4. Audio/visual metronome circuit diagram.



Prototype audio/visual metronome.

much shorter battery life. The timing components are R1, R2, VR1, and C2. Although the 'click' rate is in the frequency range 0.5Hz to 5Hz, the clock oscillator has to operate over a much higher range of frequencies as it drives the speaker via 6 stages of the binary divider. It therefore operates at 64 times the output frequency, or in other words at around 32 to 320Hz. An advantage of this system is that it avoids the expense of a good quality, high value timing capacitor.

IC2 is the seven stage binary divider, a CMOS 4024BE. C3 couples the output from the sixth stage of IC2 to the input of a 555 based monostable circuit. The trigger input of IC3 is biased to about half the supply voltage by R5 and R6. Negative output transitions from pin 4 of IC2 briefly take the trigger input of IC3 below one third of the supply potential, and an output pulse is produced at pin 3 of IC3. R7 and C4 set the duration of the output pulse at a fraction of a millisecond, which gives a suitably high pitched 'click' sound. C5 couples the output pulses from IC3 to a moving coil loudspeaker. I would not recommend using a low power version of the 555 timer for IC3 as many of these seem to give erratic operation when driving low impedance loads. Also, the output stages of some low power 555s cannot supply high enough output currents to give good results in this application.

The output of IC2's seventh divider stage is used to drive the two LEDs, which are connected so that they operate out-of-phase. D2 is switched on when pin 3 of IC2 goes high - D1 is switched on when it goes low. As each LED only switches on at every other 'click', the LEDs are operating at half the 'click' frequency. Hence the LEDs are driven from stage seven of IC2 while the 'click'

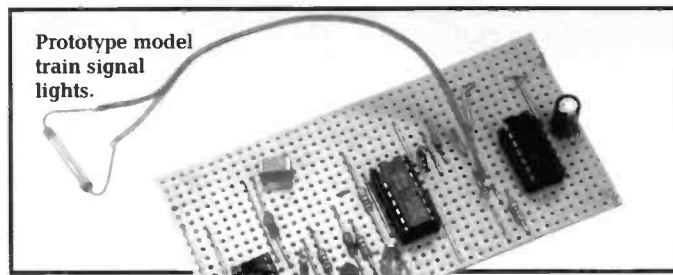

generator is driven from stage six.

The current consumption of the circuit is about 12mA. This necessitates the use of a fairly high capacity battery, such as six HP7 size cells in a plastic holder. Construction of the unit is fairly straightforward, and the component layout is not critical. Bear in mind though, that IC2 is a CMOS device which requires the standard antistatic handling precautions. Virtually any LEDs are suitable for D1 and D2, but large high efficiency LEDs will be much more conspicuous than small low efficiency types. A scale calibrated in beats per minute must be marked around VR1's control knob. The calibration points must be found by trial and error, with the beat rate being determined by counting the number of 'clicks' in a one minute period. At high beat rates adequate accuracy should be obtained by counting the number of 'clicks' in twenty seconds, and then multiplying by three to get the beats per minute.

## Model Train Signal Lights

This is a circuit for a simple three-colour signal for a model railway. It operates automatically, changing from 'green' to 'red' as the train passes the signal. After a preset time the signal changes to 'amber', and after a further period it goes back to 'green' once again. This is a sort of simplified version of the real

thing, where the signals change as the train passes by sensors along the track. In this case there is only one sensor, which is positioned beside the signal. The other changes are provided by a timing circuit, which is slightly less authentic, but makes the signal much easier to install.

The circuit, shown in Figure 5, is built around IC2, which is a CMOS decade counter and one-of-ten decoder. In this case only outputs '0' to '3' of the decoder section are utilized, the other seven outputs are simply ignored.

C3, R7, and D4 supply a reset pulse to IC2 at switch-on, so that it commences with output '0' high. This switches on D1, which is the 'green' signal LED. IC1 is a 555 timer which is used here as a low-frequency clock oscillator which provides a clock pulse to IC2 every three seconds or so. The first clock pulse results in the '0' output going low, and output '1' going high. This switches off D1, and switches on D2 (the 'red' signal LED). On the next clock pulse output '1' goes low and output '2' goes high. This results in D2 switching off, and the 'amber' LED (D3) turning on. On the next clock pulse output '4' goes high, but due to the coupling through R6 this resets IC2 so that output '4' immediately returns to the low state, and output '0' goes high. This takes the circuit back to its initial state, with D1 switched on, and a 'green' signal being produced.

Some control logic is needed, so that the circuit only goes through this sequence of events when it is triggered by the passing train. The circuit must halt once it has cycled back to a 'green' signal. This control logic is provided by IC3, which is a 4013BE dual 'D' type flip/flop. In this circuit only one section of the device is used. The inputs of the unused section of IC3 are connected to the 0V supply in order to protect them against static charges and to avoid spurious operations. The other section operates really as just a simple set/reset flip/flop, with the clock and data inputs simply being wired to earth. Like IC2, IC3 is supplied with a reset pulse at switch-on. This takes the Q output low, which in turn inhibits IC1 so that no clock signal is produced. R8 ties the 'set' input of IC3 to earth, but this input is pulsed high when sensor switch S1 is activated. This takes the Q output of the flip/flop high, and activates IC3. This results in the signal changing to 'red' immediately, and to 'amber' and then 'green' after a few seconds. IC3 is reset when output '4' of IC2 pulses high, so that once the signal returns to 'green', the Q output of IC3 inhibits IC1. This holds the signal at green until S1 is activated again. The sequence is then repeated, and will be repeated each time S1 is activated. The current consumption of the circuit is about 15mA, or about 7mA if a low power 555 is used for IC1.

Construction of the actual railway signal is obviously unusual. D1 to D3 must be mounted in a model signal, and it is not too difficult to improvise something reasonably convincing. Rather than controlling the LEDs directly, IC2 could be used to control them via common emitter switching transistors. This would enable a higher drive current to be used, and would also permit miniature filament bulbs to be used. S1 can be either a micro-switch or a reed type. In the case of a micro-switch, things must be arranged so that the actuator is operated by the passing train. For this application a reed switch mounted under the track is preferred. This is operated by a small bar magnet fitted in a piece of rolling stock. This method requires no direct contact with the train, which eliminates any slight risk of occasional derailments. Note that IC2 and IC3 are CMOS devices which require the usual antistatic handling precautions. The duration of the 'red' and 'amber' signals is easily altered as it is roughly proportional to the value of R2.

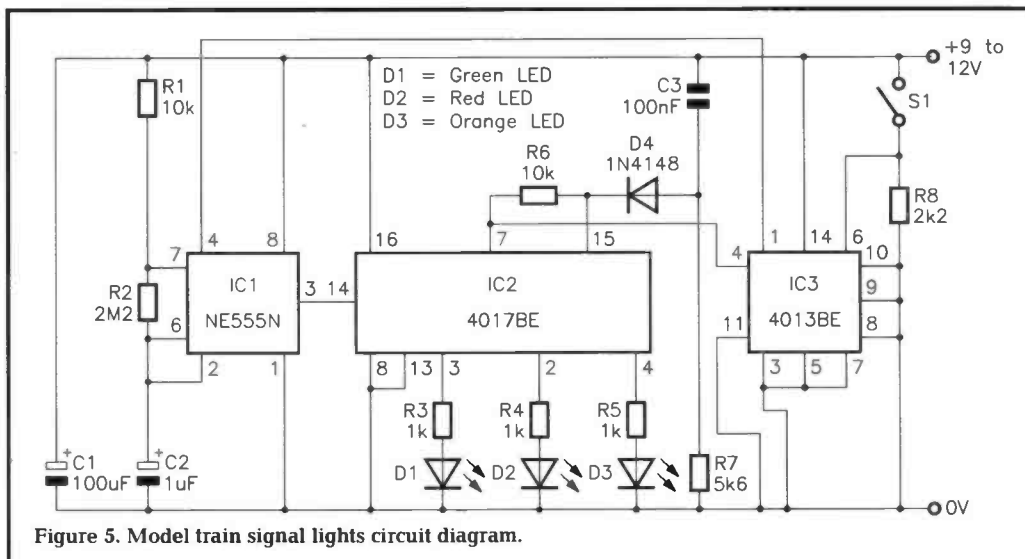

Figure 5. Model train signal lights circuit diagram.

## BOB'S MINI-CIRCUITS PARTS LIST

### TWO-TONE TRAIN HORN

RESISTORS: All 0.6W 1% Metal Film (Unless specified)

R1	4M7	1	(M4M7)
R2,4	10k	2	(M10K)
R3	2M2	1	(M2M2)
R5	39k	1	(M39K)
R6	47Ω	1	(M47R)
RV1	47k Miniature Horizontal Preset	1	(UH05V)

### CAPACITORS

C1	100μF 10V Electrolytic	1	(FB48C)
C2,3	470nF Polyester Layer	2	(WW49D)
C4	33nF Polyester Layer	1	(WW35Q)
C5	2μ2F 100V PC Electrolytic	1	(FB15R)
C6	100μF 10V PC Electrolytic	1	(FF10L)

### SEMICONDUCTORS

IC1,2	TS555CN	2	(RA76H)
IC3	NE555N	1	(QH66W)

### MISCELLANEOUS

LS1	66mm Diameter 64Ω Speaker	1	(WF57M)
S1	Push to Make Switch	1	(FH59P)
S2	SPST Ultra Miniature Toggle	1	(FH97F)
B1	AA Size Cells	6	(FK55K)
	6 × AA Battery Holder	1	(HQ01B)
	Battery Clip	1	(HF28F)
	8-Pin DIL Socket	3	(BL17T)

### DIGITAL CAPACITANCE METER

RESISTORS: All 0.6W 1% Metal Film (Unless specified)

R1,17,22,25	10k	4	(M10K)
R2	560Ω	1	(M560R)
R3 to 16, R23	1k	15	(M1K)
R18	4k7	1	(M4k7)
R19,24	10M	2	(M10M)
R20	1M	1	(M1M)
R21	100k	1	(M100K)
VR1	10k Miniature Horizontal Preset	1	(UH03D)

### CAPACITORS

C1	100μF 10V Electrolytic	1	(FB48C)
C2	3n3F Polyester Layer	1	(WW25C)
C3	100nF Polyester Film	1	(BX76H)

### SEMICONDUCTORS

IC1	4013BE	1	(QX07H)
IC2,3	4026BE	1	(QX15R)
IC4	TS555N	1	(RA76H)
IC5	4001BE	1	(QX01B)
Display 1,2	0.5in. Common Cathode 7-Segment Display	2	(FR41U)

### MISCELLANEOUS

S1,2	Push to Make Switch	2	(FH59P)
S3	SPST Miniature Toggle Switch	1	(FH97F)
S4	6-Way 2-Pole Rotary Switch	1	(FF74R)
SK1	Miniature Red Crocodile Clip	1	(FM37S)
SK2	Miniature Black Crocodile Clip	1	(FK34M)
B1	AA Size Cells	6	(FK55K)
	6 × AA Battery Holder	1	(HQ01B)
	Battery Clip	1	(HF28F)
	8-Pin DIL IC Socket	1	(BL17T)
	14-Pin DIL IC Socket	2	(BL18U)
	16-Pin DIL IC Socket	2	(BL19V)
	20-Pin DIL IC Socket	1	(HQ77J)

### SIMPLE GRAPHIC EQUALISER

RESISTORS: All 0.6W 1% Metal Film (Unless specified)

R1,2	100k	2	(M100K)
R3,6,9,10,13, 14,17,18	1M8	8	(M1M8)
R4,5	3k9	2	(M3K9)
R7,8,11,12,15, 16,19,20	15k	8	(M15K)
RV1,2,3,4	100k Linear Potentiometer	4	(FW05V)

### CAPACITORS

C1	100μF 10V PC Electrolytic	1	(FF10L)
C2	1μF 100V PC Electrolytic	1	(FF01B)
C3	22μF 25V PC Electrolytic	1	(FF06G)
C4	4n7F Polyester	1	(WW26D)

C5	47nF Polyester	1	(WW37S)
C6	1nF Polyester	1	(WW22Y)
C7	10nF Polyester	1	(WW29G)
C8	220pF Polystyrene	1	(BX30H)
C9	2n2F Polyester	1	(WW24B)
C10	47pF Polystyrene	1	(BX26D)
C11	470pF Polystyrene	1	(BX32K)
C12	10μF 50V PC Electrolytic	1	(FF04E)

### SEMICONDUCTORS

IC1	μA741C	1	(QL22Y)
IC2,3	MC1458CN	2	(QH46A)

### MISCELLANEOUS

JK1,2	Standard 1/4in. Jack	2	(HF91Y)
S1	SPST Ultra-Miniature Toggle Switch	1	(FH97F)
B1	PP3 Size Battery	1	(FK58N)
	PP3 Battery Connector	1	(HF28F)
	8-Pin DIL IC Socket	3	(BL17T)

### AUDIO/VISUAL METRONOME

RESISTORS: All 0.6W 1% Metal Film (Unless specified)

R1	47k	1	(M47K)
R2	3k3	1	(M3K3)
R3,4	1k	2	(M1K)
R5,6	5k6	2	(M5K6)
R7	56k	1	(M56K)
RV1	470k Linear Potentiometer	1	(FW07H)

### CAPACITORS

C1,5	100μF 10V PC Electrolytic	2	(FF10L)
C2	47nF Polyester	1	(WW37S)
C3	330pF Ceramic	1	(WX62S)
C4	4n7F Polyester	1	(WW26D)

### SEMICONDUCTORS

IC1	TS555CN	1	(RA76H)
IC2	4024BE	1	(QX13P)
IC3	NE555N	1	(QH66W)
D1,2	10mm Red LED	2	(UK28F)

### MISCELLANEOUS

S1	SPST Miniature Toggle Switch	1	(FH97F)
LS1	77mm Diameter 8Ω Speaker	1	(YW53H)
B1	AA (HP7) Size Cells	6	(FK64U)
	Battery Clip	1	(HF28F)
	6 × AA Battery Holder	1	(HQ01B)
	8-Pin DIL IC Socket	2	(BL17T)
	14-Pin DIL IC Socket	1	(BL18U)

### MODEL TRAIN SIGNAL LIGHTS

RESISTORS: All 0.6W 1% Metal Film

R1,6	10k	2	(M10K)
R2	2M2	1	(M2M2)
R3,4,5	1k	3	(M1K)
R7	5k6	1	(M5K6)
R8	2k2	1	(M2K2)

### CAPACITORS

C1	100μF 25V PC Electrolytic	1	(FF11M)
C2	1μF 100V PC Electrolytic	1	(FF01B)
C3	100nF Polyester	1	(WW41U)

### SEMICONDUCTORS

IC1	NE555N	1	(QH66W)
IC2	4017BE	1	(QX09K)
IC3	4013BE	1	(QX07H)
D1	Green LED	1	(WL28F)
D2	Red LED	1	(WL27E)
D3	Orange LED	1	(WL29G)
D4	1N4148	1	(QL80B)

### MISCELLANEOUS

S1	Miniature Reed Switch	1	(FX70M)
	Magnet	1	(FX72P)
	8-Pin DIL Socket	1	(BL17T)
	14-Pin DIL Socket	1	(BL18U)
	16-Pin DIL Socket	1	(BL19V)

The Maplin 'Get-You-Working' Service is not available for these projects.  
*The above items are not available as kits.*

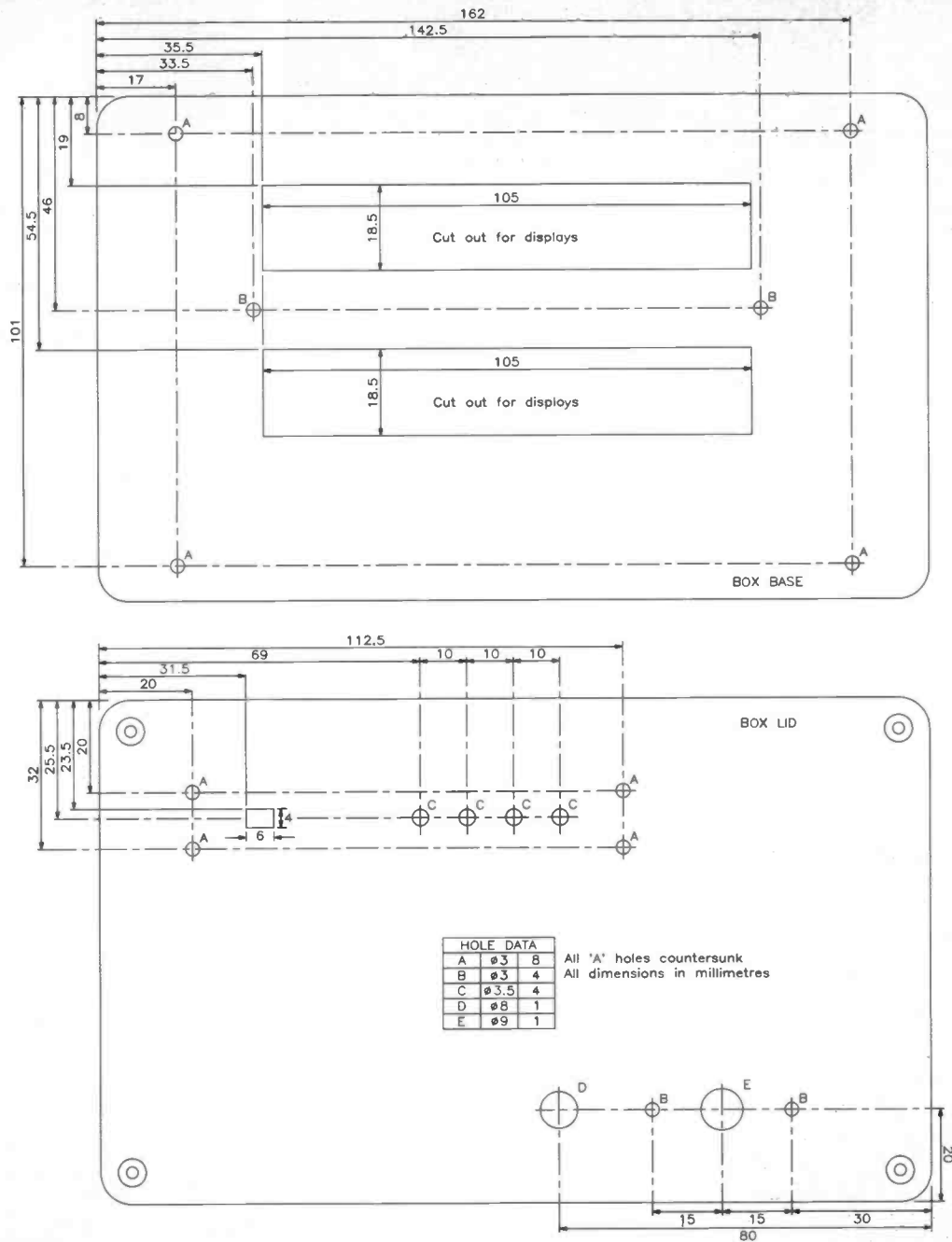

Figure 6. Box drilling details.

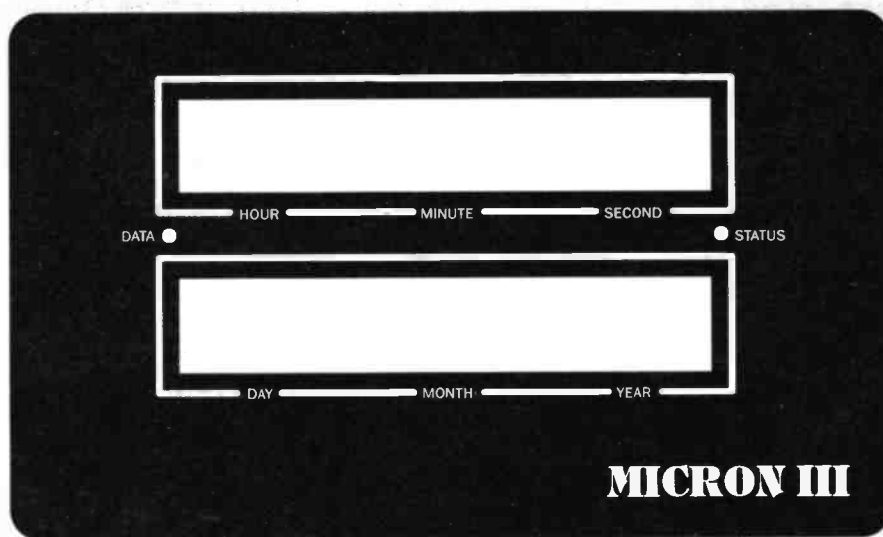

Figure 7a. Stick-on front panel label design (scale 2/3).

**MICRON III**



Figure 7b. Stick-on rear panel guide for switch controls.

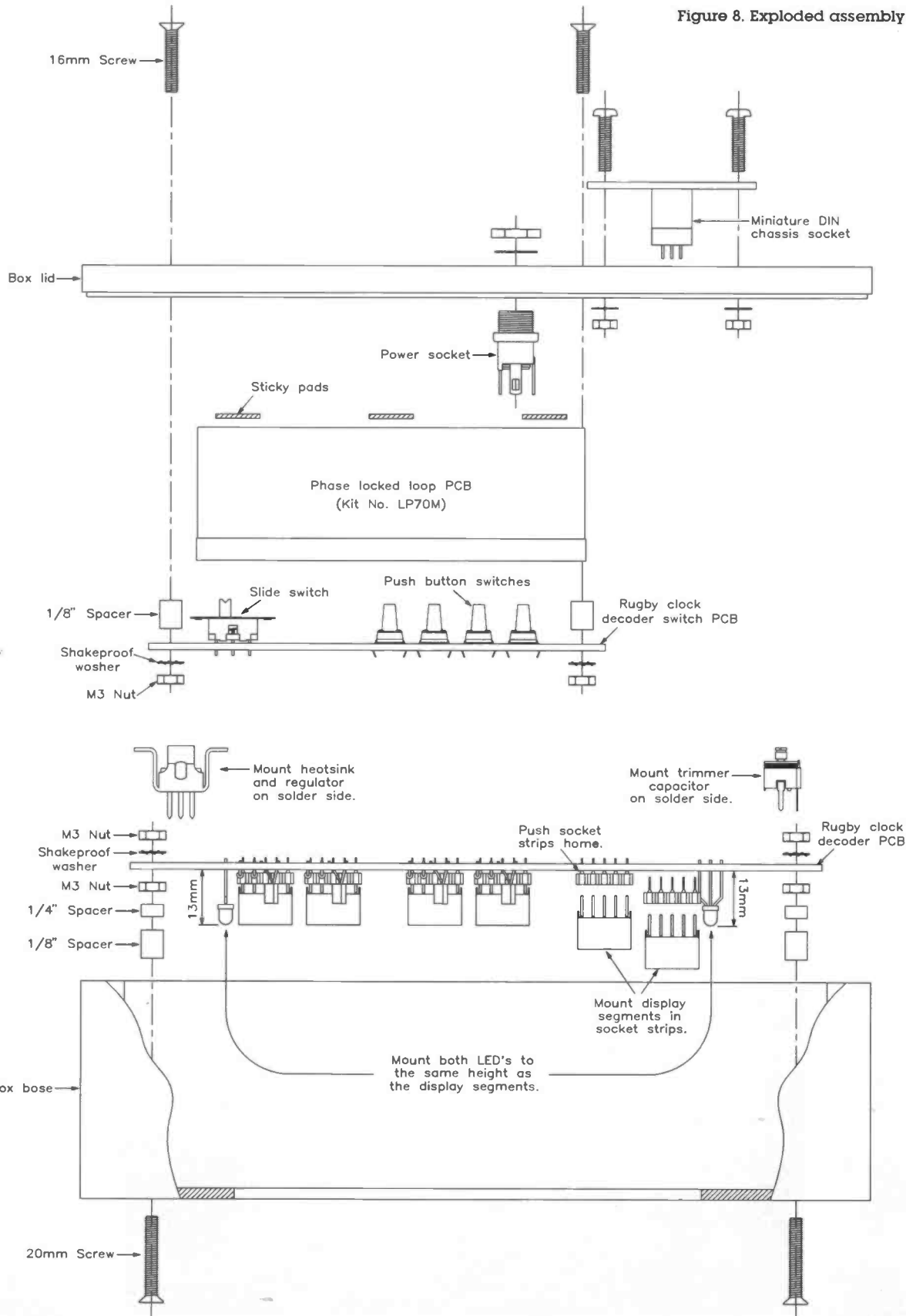

Figure 8. Exploded assembly diagram.



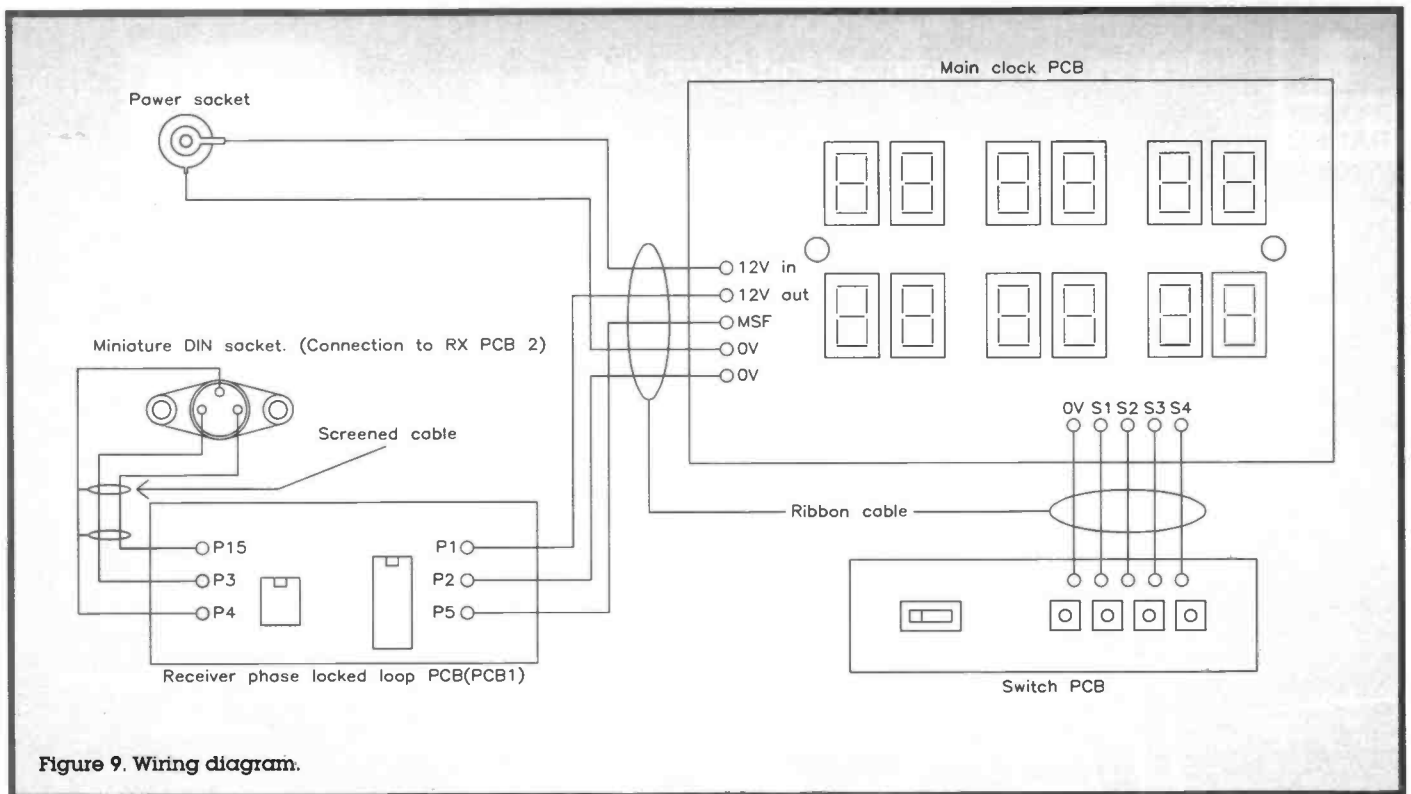

Figure 9. Wiring diagram.

## MICRON III RUGBY CLOCK DECODER PARTS LIST

RESISTORS: All 0.6W 1% Metal Film (Unless specified)

R1,2,3,4,13	10k	5	(M10K)
R5,12,23,25, 27,29,31,33, 35,37,39,41, 43,45	1k	14	(M1K)
R6,11,22,24, 26,28,30,32, 34,36,38,40, 42,44	2k2	14	(M2K2)
R7,8,9,10,15, 16,17,18,19, 20,21	150Ω	11	(M150R)
R14	100Ω	1	(M100R)

### CAPACITORS

C1,2	10μF 35V Minelect	2	(JL05F)
C3,4,5	100nF 16V Minidisc	3	(YR75S)
C6	12pF Ceramic	1	(WX45Y)
VC1	22pF Trimmer	1	(WL70M)
XT1	3-2768MHz Crystal	1	(FY86T)

### SEMICONDUCTORS

D1	1N4001	1	(QL73Q)
RG1	L78M05CV	1	(QL28F)
TR1,3-14	BC327	13	(QB66W)
TR2	BC337	1	(QB68Y)
IC1	PIC16C71 MS06	1	(AS53H)
IC2	PC74HC154P	1	(UB38R)
IC3	SN74LS47N	1	(QQ52G)

### MISCELLANEOUS

LD1,2	Multicolour LED (3mm)	2	(GW62S)
DY1-12	Common Anode (0.56in.) Red 7-Segment Display	12	(CZ56L)
S1-4	High Tactile Switch (9.5mm)	4	(KR90X)
S5	Sub-Miniature SPST Slide Switch	1	(FF77J)
	16-Pin DIL Socket	1	(BL19V)
	24-Pin DIL Socket	1	(BL20W)
	18-pin DIL Socket	1	(HQ76H)
	32-Way DIL Socket Strip	4	(DC17T)
	Plastic Case 180 × 110 × 55mm	1	(LH51F)
	Clip on TO220 Heatsink	1	(KU50E)

PCB Pins (1mm)	1 Pkt	(FL24B)
M3 × 1/4in. Spacer	1 Pkt	(FG33L)
M3 × 1/8in. Spacer	1 Pkt	(FG32K)
M3 × 16mm Pozi Screw	1 Pkt	(JC70M)
M3 × 20mm Pozi Screw	1 Pkt	(JC71N)
M3 Shakeproof Washer	1 Pkt	(BF44X)
M3 Nut	2 Pkts	(JD61R)
Twin Lapped Screened Cable	1m	(XR20W)
10-Way Ribbon Cable	1m	(XR06G)
3-Way Miniature DIN Chassis Socket	1	(JX07H)
2.1mm Panel Mounting Power Socket	1	(JK09K)
Front Panel	1	(KP82D)
Rear Panel	1	(KP84F)
PCB	1	(GJ04E)
Instruction Leaflet	1	(XV27E)
Constructors' Guide	1	(XH79L)

### OPTIONAL (Not in Kit)

3-Way Miniature DIN Line Plug	1	(JX01B)
60kHz Rugby Receiver Kit	1	(LP70M)
12V Regulated Mains Adaptor	1	(BZ83E)
Quickstick Pads	1 Strip	(HB22Y)

The Maplin 'Get-You-Working' Service is available for this project, see Constructors' Guide or current Maplin Catalogue for details.

*The above items (excluding Optional) are available as a kit.*

**Order As LT03D (Micron III Kit) Price £47.99** Net  
Please Note: Where 'package' quantities are stated in the Parts List (e.g., packet, strip, reel, etc.), the exact quantity required to build the project will be supplied in the kit.

The following new items (which are included in the kit) are also available separately but are not shown in the 1995 Magazine Catalogue.

Micron III PCB Order As GJ04E Price £6.49  
Front Panel Label Order As KP82D Price £5.99  
Rear Panel Label Order As KP84F Price £1.99



Design by Alan Williamson  
Text by Alan Williamson and Robin Hall

# SOUND ACTIVATED FLASH TRIGGER

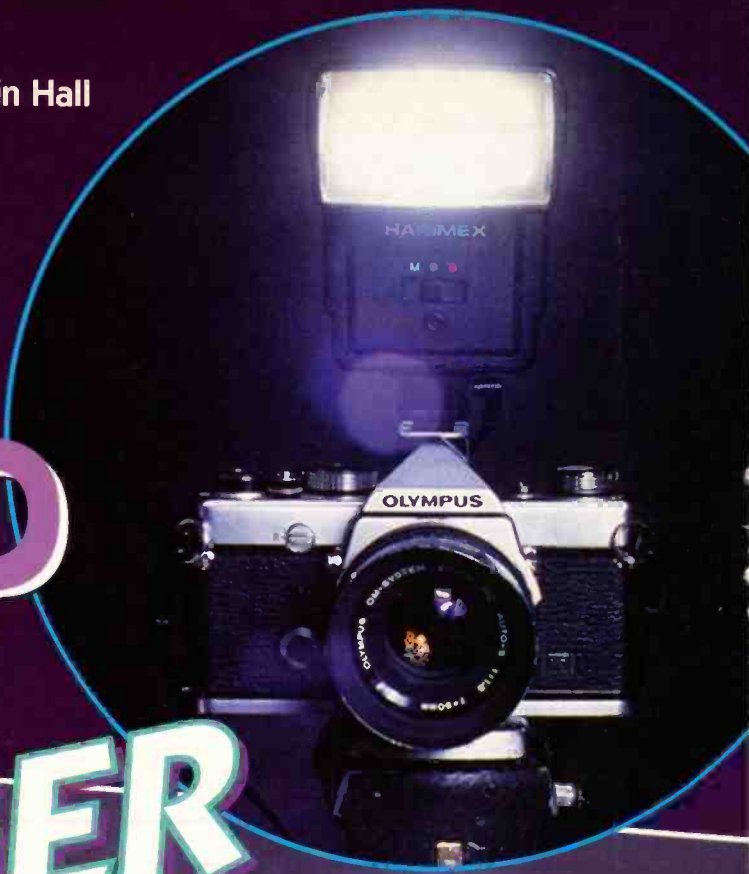

**KIT  
AVAILABLE  
(LT86T)  
PRICE  
£14.99**

Have you ever wondered how it is possible to take photographs of bullets passing through light bulbs, or darts through balloons? One method is to use a high-speed film camera costing many hundreds of pounds; alternatively, a cheaper method is to use a standard single frame camera in conjunction with a sound-activated flash trigger. Presented here is a design for the latter.

## Specification

Supply Voltage Range:	+5 to 18V
Operating current	
Quiescent at 5V:	1.7mA
9V:	2.1mA
18V:	2.1mA
Operating at 5V:	5.3mA
9V:	9.8mA
18V:	23.2mA

The prototype PCB before mounting the potentiometers.

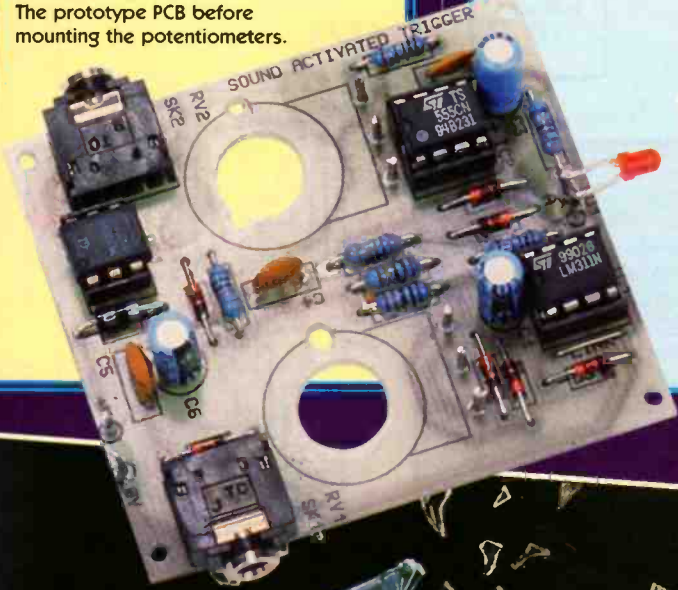

The assembled PCB.

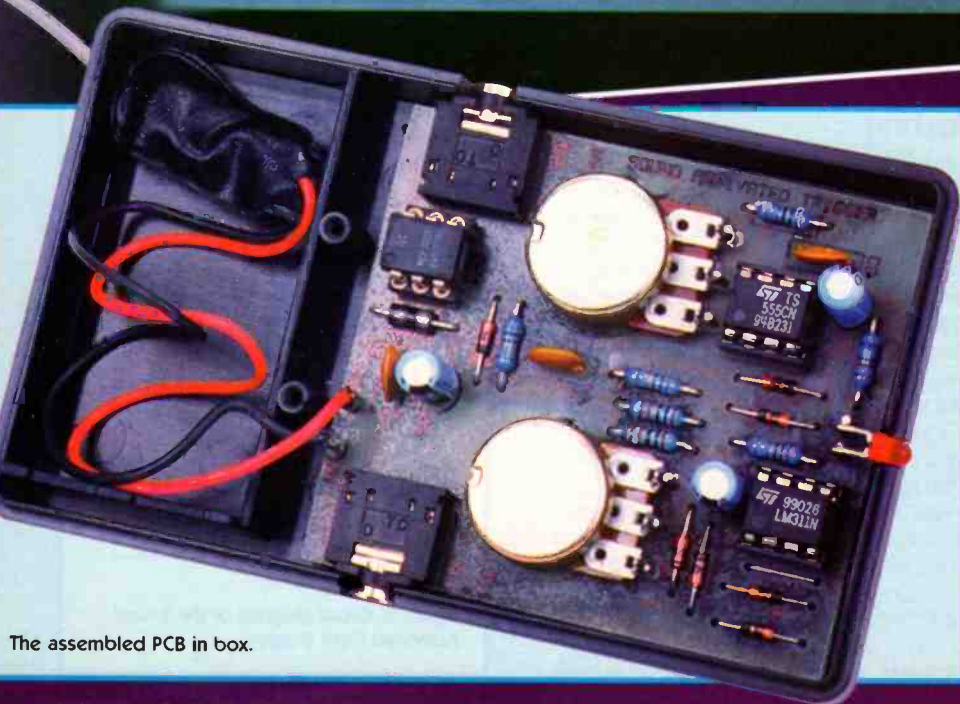
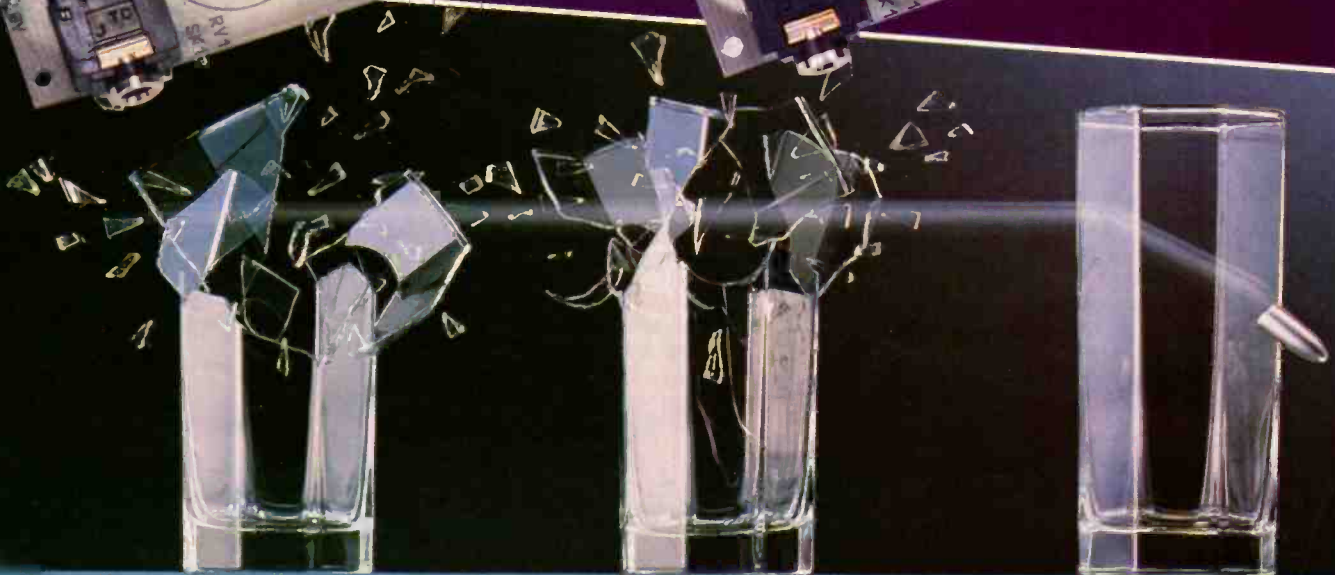
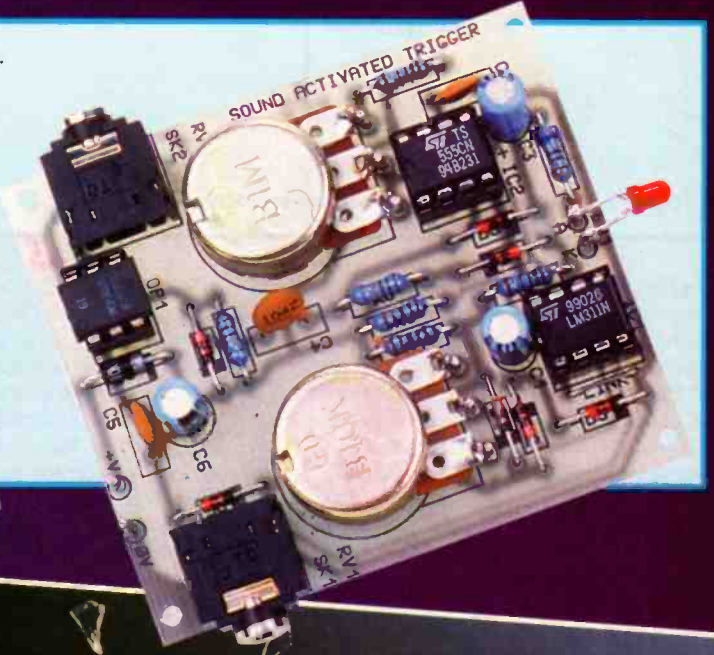

The assembled PCB in box.

**S**OUND activated photography can find many uses, especially for special effects. In this design, the microphone is directly coupled, so that it can be used in the 'pressure mode'. This is where the sensitivity of the microphone is such, that it can be used to register pressure waves not normally heard; for example those caused by a door opening or closing. This project need not be limited to using it with a flash gun. Other uses,

such as in security applications, where a trigger is required to activate the alarm recording equipment spring to mind.

## Circuit Description

The block diagram of the Sound Operated Flash Trigger (see Figure 1), and the circuit diagram (see Figure 2); will assist the reader in understanding how the circuit operates.

Power is applied to the circuit when a 'mono' jack plug is inserted into the microphone socket SK1. The jack plug short circuits the ring and sleeve contacts of SK1, and completes the circuit of the 0V battery line. This is convenient and eliminates the need for a separate switch, and reduces the chance of the unit being inadvertently left switched on.

Power is supplied via R1 which charges up reservoir capacitor C1, this keeps a constant supply for the electret microphone, and prevents any modulation from the microphone from appearing on the

**Warning:** High voltages can be present on the terminals of some flash-guns. Care should therefore be taken at all times when handling or interfacing flash-guns to this project.

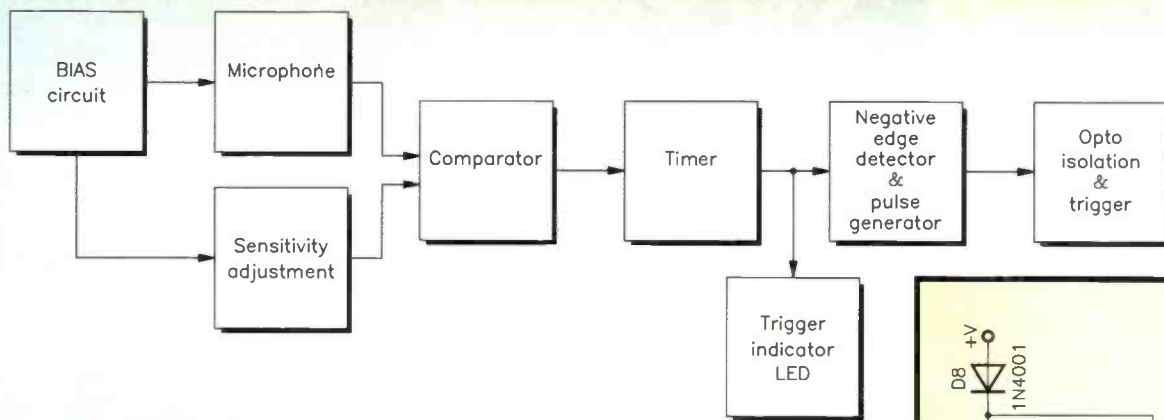

Figure 1. Block diagram of the Sound Activated Flash Trigger.

supply rail. D1 to D3 are used as a voltage reference; with the electret microphone being powered from the reference voltage via R2. The microphone is directly connected to the non-inverting input of the comparator (IC1). The inverting input has an approximate 700mV adjustment range below the reference level (which also acts as the sensitivity control) as potentiometer RV1 is connected across part of the reference (D1).

This arrangement ensures that supply voltage or temperature variations do not unduly affect the circuit operation once set. Diodes D4 and D5 limit input signal excursions to 0.7V above the positive supply rail and 0.7V below the 0V supply rail.

The trigger input of the 555 and the output of the comparator (which is an open collector) requires a pull-up resistor; therefore R3 serves both devices.

To trigger the comparator, in this circuit configuration, the microphone must pull the voltage potential at the non-inverting input below the potential at the inverting input. The normally high output will then become active low and trigger the low-power 555 timer; the output of the 555 will then become high and LED LD1 will illuminate. The output pulse from the 555 is adjustable between 110µs and 110ms; because the pulse is so short capacitor C3 is employed to 'stretch' the pulse to enable it to be seen. This pulse is the trigger delay (duration=delay).

When the 555 resets, a pulse is produced through C4, and this pulse illuminates the LED within the opto-device (OP1) and triggers the triac into conduction, this in turn fires the flash-gun. An opto-triac was chosen because it provides total isolation from the circuit and because a triac is a bidirectional device, so it does not matter which way round the trigger lead is connected.

## Construction

Construction is fairly straightforward, refer to the Parts List, and Figure 3 for the PCB legend and track. Begin with the smallest components first, working up in size to the largest, insert the PCB pins from the track side; be careful to correctly orientate the polarised devices, i.e. electrolytic capacitors, diodes and ICs. The ICs should be inserted into their sockets last of all. Figure 4 illustrates the modification to the potentiometers before fitting to the PCB.

Thoroughly check your work for misplaced components on the PCB, and also solder bridges and dry joints. Finally, clean all the flux off the PCB using a suitable solvent.

In order for the electret microphone to be protected, a sleeve grommet is used, and should be fitted over the cable before soldering the device to the cable. The electret microphone is a polarised device and it is essential that it is wired correctly. Note the solder pad connected to the case; this is the 0V pad; attach the earth braid of the screened cable to this and the inner core to the larger solder pad. To finish off connect a 3.5mm mono jack plug to the other end of the screened cable, with the inner core connected to the tip of the jack plug and the earth braid to the sleeve connection.

## Box Preparation

The case included in the kit, is a moulded high-impact ABS box with an integral PP3 battery compartment (KC95D). Box drilling and cut-out details are shown in Figure 5. Use the label (Figure 6) as a template, mark and drill the holes for the microphone socket and the LED, clean up any plastic swarf, and fit the label in position. Next fit the PCB, press down and screw in position. The two main halves of the case are held together by two self-tapping screws. A pocket clip is provided with the case and is fixed to one half of the case by two self-tapping screws from the within the case.

## Testing

It must be pointed out that pre-electronic [Pre-historic? – Ed.] flash-guns will probably not work with this project (all the ones we tried, did not) as they are intended to be triggered from a mechanical shutter which has very low resistance. The 'ON' impedance of the triac is several tens of ohms, or higher (depending upon the amount of current flowing through the device) and is therefore probably too high to trigger such units.

There are a couple of simple tests to carry out, to see if the proposed flash-gun is suitable.

First of all; set a multimeter to the highest DC voltage range (400V DC) and connect it to the flash-gun trigger contacts; switch 'ON' the flash-gun (be careful, one flash-gun we tried charged up to +225V and discharged to -160V). Wait until the 'ready' light illuminates, then note the voltage; a desirable

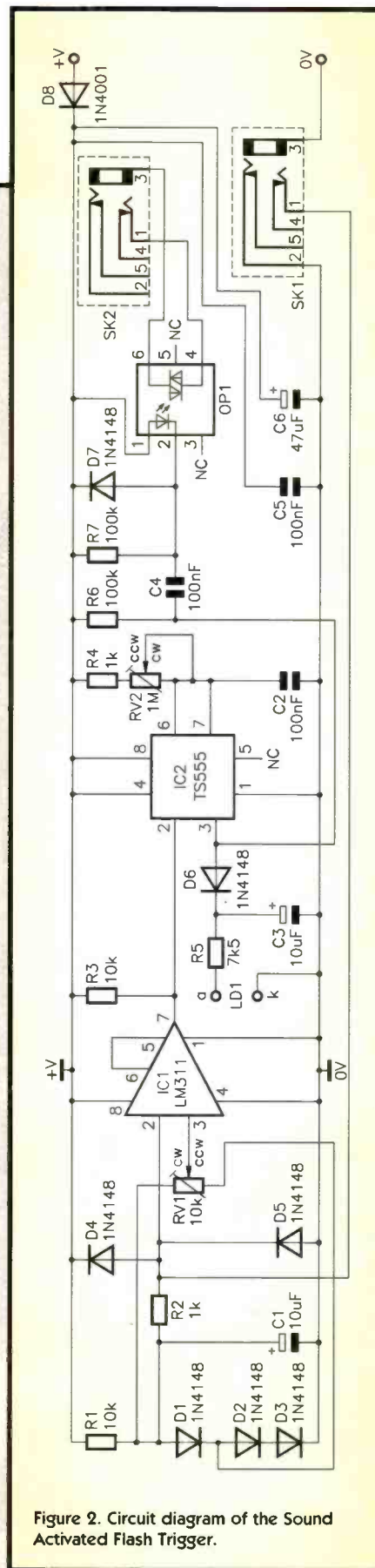
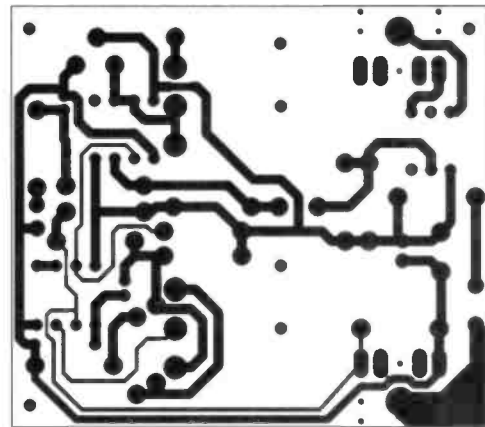
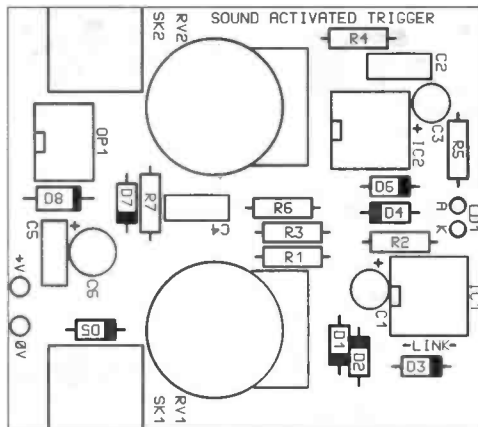

Figure 2. Circuit diagram of the Sound Activated Flash Trigger.

**Figure 3. PCB legend and track.**



reading will be around the total battery supply voltage. The second test is to see if a 47 to 100Ω resistor will trigger the flash-gun.

### Use

A piezo transducer could be used in place of the microphone, but would require AC coupling (i.e. 100nF 50V ceramic, BX03D) to the circuit.

Camera flash-guns are usually fitted with a 'hot shoe', a trigger cable/socket, or both. Flash-gun trigger cables are usually fitted with a miniature coaxial plug. Some large flash guns will be fitted with a miniature coaxial socket. Such connectors are not in common use for anything other than photographic applications, for this reason they are not available from Maplin; the best place to buy them is from a good photographic shop! Such shops will stock camera flash extension cables, fitted with a male coaxial connector at one end, and a female connector at the other. Cut off the *unwanted* connector and fit a mono 3.5mm jack plug in place of the original connector. If the flash-gun does not have a trigger cable or socket, a 'hot shoe adaptor' can be purchased from a photographic shop. The adaptor allows connection to be made to the flash gun terminals that would normally connect to the camera when slid into the camera's 'hot shoe'. Such an adaptor will be fitted with a trigger cable or socket. Once the adaptor is fitted, proceed as if the flash-gun was originally fitted with a trigger cable or socket. It is possible that other connectors will be encountered, in this case it is best to refer to the flash-gun manual or seek advice from a good photographic shop.

### Operation

To fit the 9V battery unclip the cover on the rear of the unit and attach the battery to the battery clip. Once in position, replace the cover, the battery will be held in position by the cover.

Referring to Figure 7, fit the 3.5mm microphone cable plug into the left-hand side of the unit and point in the general direction of the object to be photographed, and fit the 3.5mm trigger cable plug into the right-hand side; attach the other end to the flash-gun. Use a tripod mount for the camera. Set the photograph shot in the light and photograph in complete darkness. Set the correct film speed. Attach the shutter release cable to the camera, set the shutter speed to 'B', focus the lens, note the distance and

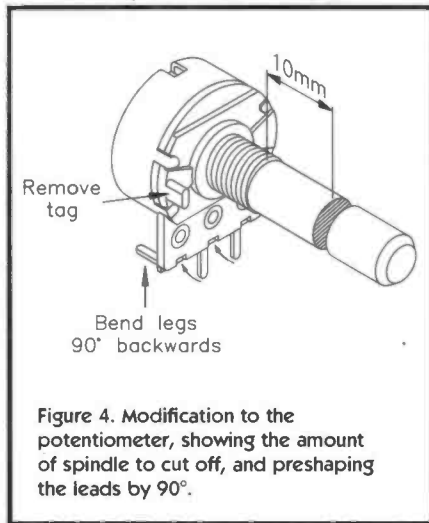

**Figure 4. Modification to the potentiometer, showing the amount of spindle to cut off, and preshaping the leads by 90°.**

set the appropriate aperture for your film speed. Unlock the shutter, switch off the light, press the shutter cable release and lock (note, the camera shutter is OPEN).

Trigger the event (i.e. pop the balloon etc.) the flash will then fire. Unlock the shutter cable release to close the camera shutter to prevent further exposure. Switch on the light,



**Figure 6. Front panel label design.**

**Figure 5. Box drilling and cut-out details.**

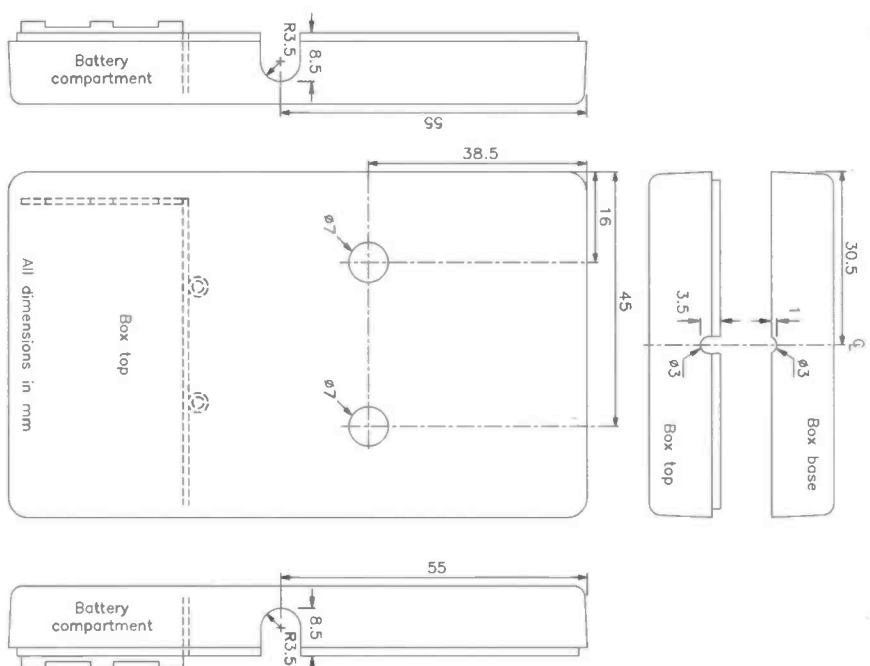

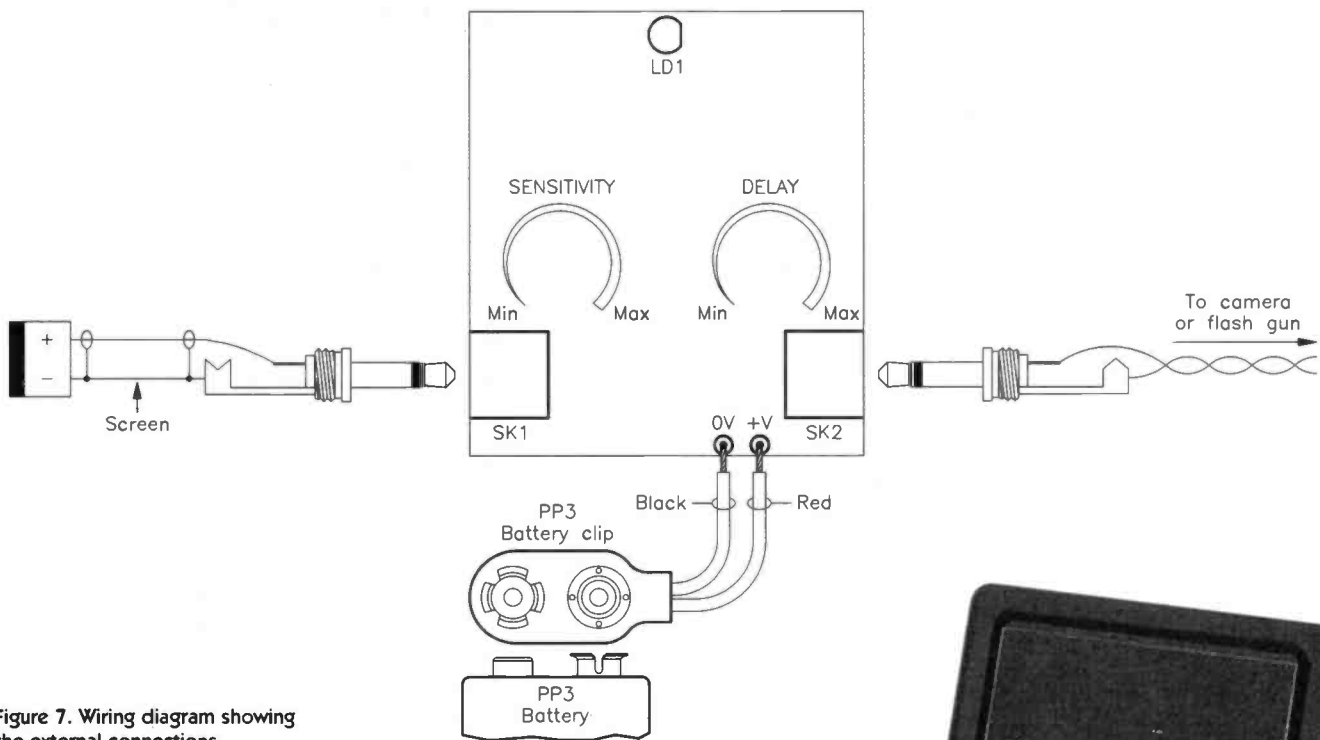

Figure 7. Wiring diagram showing the external connections.

wind the camera on to the next frame and set up the next shot.

On the front of the unit are two controls for sensitivity and delay. Adjust these as necessary to achieve the desired result, much experimentation will be required.

There are fast occurring events that can be photographed using the Sound Activated Flash, some which are shown in this article.

A slightly less dramatic but no less spectacular method is to explode a balloon using a sharp knife or dart. Another interesting effect is to drop a coin into a bowl of water, as the coin hits the water it 'plops'. Some experimentation will be necessary, but a lot of fun can be had. Whatever method is chosen, remember that in all cases, safety comes first.



## SOUND ACTIVATED FLASH TRIGGER PARTS LIST

RESISTORS: All 0.6W 1% Metal Film (Unless specified)

R1,3	10k	2	(M10K)
R2,4	1k	2	(M1K)
R5	7k5	1	(M7K5)
R6,7	100k	2	(M100K)
RV1	10k Linear Potentiometer	1	(JM71N)
RV2	1M Linear Potentiometer	1	(JM76H)

### CAPACITORS

C1,3	10 $\mu$ F 50V Radial Electrolytic	2	(FF04E)
C2,4,5	100nF 50V Disc Ceramic	3	(BX03D)
C6	47 $\mu$ F 25V Radial Electrolytic	1	(FF08J)

### SEMICONDUCTORS

D1-7	1N4148	7	(QL80B)
D8	1N4001	1	(QL73Q)
LD1	HP Miniature Red LED 2mA	1	(CZ28F)
OP1	Triac Isolator	1	(QQ10L)
IC1	LM311N	1	(QY09K)
IC2	TS555CN	1	(RA76H)

### MISCELLANEOUS

	Subminiature Omni Electret Microphone Insert	1	(FS43W)
	8-pin DIL Socket	2	(BL17T)
	Single-ended PCB Pin 1mm	1 Pkt	(FL24B)
	6-pin DIL Socket	1	(CJ79L)
SK1,2	PCB 3.5 Stereo Socket with Contacts	2	(JM20W)
	PP3 Battery Clip	1	(HF28F)
	3.5mm Stereo Plug Plastic	2	(HF98G)
	Knob RN15 Red	1	(FE76H)
	Knob RN15 Blue	1	(FE74R)
	Pocket Clip Case	1	(KC95D)

Cable Single Black	1m	(XR12N)
5.1mm Sleeve Grommet	1 Pkt	(JX71N)
Front Panel Label	1	(KP85G)
PCB	1	(GJ10L)
Instruction Leaflet	1	(XV36P)
Constructors' Guide	1	(XH79L)

### OPTIONAL (Not in Kit)

Alkaline PP3	1	(ZB52G)
Cable Single Black	As Req.	(XR12N)

The Maplin 'Get-You-Working' Service is available for this project, see Constructors' Guide or current Maplin Catalogue for details.

**The above items (excluding Optional) are available as a kit, which offers a saving over buying the parts separately.**

**Order As LT86T (Sound Activated Flash Trigger) Price £14.99**

Please Note: Where 'package' quantities are stated in the Parts List (e.g., packet, strip, reel, etc.), the exact quantity required to build the project will be supplied in the kit.

The following new items (which are included in the kit) are also available separately, but are not shown in the 1995 Maplin Catalogue

Sound Activated Flash Trigger PCB **Order As GJ10L Price £2.49**

Sound Activated Flash Trigger Front Panel

**Order As KP85G Price £1.99**

# @Internet

Among the many acronyms and abbreviations used by Internet personnel is FTP, which stands for *file transfer protocol*. FTP is quite simply a communication method for users to link onto remote computers, then to download any particular files of interest back to their own computer. There are several shareware programs which provide FTP ability to users, and there other protocol systems which do the same sort of thing.

To link to an FTP site you require a user ID and name. If you are paying the site provider a fee, or if you are a proper user belonging to the organisation (e.g., an employee) you will have this. And you will probably have full unlimited access. But if you are not registered you might have a problem getting onto the computer site without a proper password.

Fortunately, many FTP sites realise the need to allow outside users in, and so provide outside access via an *anonymous* user ID. Quite literally, when asked by the computer what your name is, simply enter *anonymous*, after which you enter your e-mail address as your password. Your e-mail address means you can be contacted if there are problems with your session.

Usually, the areas you can reach in the location will be restricted, but there will often be sufficient information available to keep you happy. Anonymous FTP is simply a safe way to make information publicly available.

## Where's the Bill, Bill?

When Windows 95 finally makes its public appearance, it is now known that it will come with most of the software you need to get on to the Internet. However, at the moment Microsoft is not planning to provide a web browser with it, instead shipping a licensed version of Mosaic at a later date. This may change, of course, if Windows 95 release date slips any further than its now proposed August 95 release.

Of particular interest to us here, is the recent news that Microsoft has formed a

partnership with UUNET Technologies to produce the Microsoft Network, a global TCP/IP-based network through which members will have full Internet access. Dial-up connection via modem at speeds up to 28.8K, as well as ISDN connection is planned by the end of the year – most likely to coincide with general release of Windows 95. It will be a little longer before the UK has the service, no doubt.

## CompuServe Joins Internet's CommerceNet

Amongst an array of announcements last month, CompuServe announced that it is to join CommerceNet as a sponsoring member. CommerceNet is a consortium of organisations and businesses gathered to conduct market trials of commerce over the Internet.

CommerceNet, a non-profit company, comprising computer companies, financial institutions, electronic information services, and organisations devoted to business-to-business transactions, is funded by a UK Government grant under the Technology Reinvestment Project and matching contributions from members and other sources.

Contact: CompuServe, Tel: (01272) 670 700.

## CIX Plans For SLIP Internet Access

The CompuLink Information eXchange (CIX) has announced plans to offer full Internet SLIP and World Wide Web access for its subscribers.

According to CIX officials, all 15,000 subscribers to CIX will be able to access the SLIP service on dial-up from next month onwards. The rapid phasing in of full Internet services, which will be routed through CIX's Internet service provider, EUnet, is in direct response to the company's pre-Christmas survey of subscriber's desires for 1995.

CIX is also working towards allowing subscribers to have their own pages on the World Wide Web (WWW). According

to CIX, a package has been written by in-house programmer Paul Gardner, to allow for the creation and editing of WWW pages.

Although only one of several services to announce full SLIP access in the UK, CIX claims it will offer the fastest dial-up access to WWW services in Europe, thanks to the creation of special driver software and the ability of CIX to cache incoming Web data. Dial-up access will be at 28,800bps on modem links.

Contact: CIX, Tel: (0181) 390 8446; e-mail: [mat@cix.compulink.co.uk](mailto:mat@cix.compulink.co.uk)

## Silicon Graphics Nets Music

Southern Studios, the London-based record company and independent music distributor, has teamed up with Silicon Graphics to bring music to the Internet. The agreement creates a new way of delivering music samples to an online audience.

Plans call for the company to act as the European centre for the Internet Underground Music Archive (IUMA). IUMA is run from the University of California at Santa Cruz. The archive provides independent bands with an outlet to distribute samples of their songs to an online audience. Southern Studios claims that its success has led to deals with mainstream labels Warner Brothers and Geffen Records.

Contact: Silicon Graphics, Tel: (01734) 257 500; e-mail: [stevev@reading.sgi.com](mailto:stevev@reading.sgi.com); Southern Studios, Tel: (0181) 888 8949; e-mail: [john@southern.com](mailto:john@southern.com)

## Site Survey – the month's destination

One of the nice things about net surfing is the fact that wherever you go you are sure to find a Geordie. No. That's not what I mean! Ignore it! Still, it's along the same lines. The point I am making is that the hyperlink strategy of web browsers and the like means that you regularly bump into links which bring you home – or at least back to your own locale.

## Mastercard Go Online

Mastercard International, one of the world's leading issuers of credit cards, has signed an agreement with Netscape Communications, producer of the popular Netscape Navigator software for the World Wide Web. The agreement means that from mid-1995, Mastercard will connect its private network to the global Internet via Netscape security software, allowing merchants to achieve authorisation of transactions conducted with any of Mastercard's 360 million cards.

Currently merchants typically use a leased line or conventional dial-up line to connect their credit card terminals to Mastercard. The biggest stumbling block in fully exploiting the massive potential of the Internet by merchants had been the unsecured paths between their computers and the 25 million users. Previously, the only way to conduct trade across the network was to send credit card details as plain text or to encrypt the message with scrambling software.

The plain text transmission opened the transactions up to possible monitoring along the network. The encryption of the data made it secure, but still too clumsy for widespread use. Recognising the problem, Netscape recently released a new version of its World Wide Web browser Navigator which now incorporates a built-in encryption based on the RSA encryption algorithm. This allows users to conduct secure, encrypted transactions with merchants running Netscape's Commerce Server.

This month, I was browsing around NASA's huge repository (to coin an Americanism) at: <http://www.nasa.gov/> in Virginia USA. When I came across a hyperlink to the European Space Agency, at: <http://www.esrin.esa.it/>

Naturally, I jumped a cyberwave or three and linked back to Europe to see what's what. It is a relatively new spot, which at ESA's own admission is not too smooth, but there is a great deal to look at anyway.

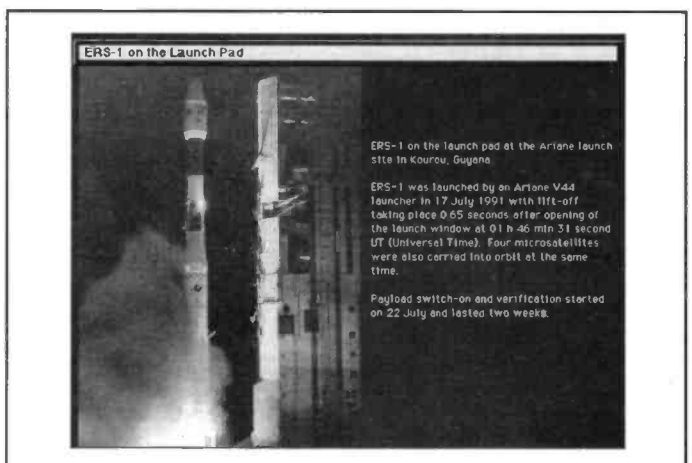

ERS-1 on the Launch Pad

ERS-1 on the launch pad at the Ariane launch site in Kourou, Guyana

ERS-1 was launched by an Ariane V44 launcher in 17 July 1991 with lift-off taking place 0.65 seconds after opening of the launch window at 01 h 46 min 31 second UT (Universal Time). Four microsatellites were also carried into orbit at the same time.

Payload switch-on and verification started on 22 July and lasted two weeks.

# £1.50 OFF!

Use this coupon to claim a £1.50 discount on up to THREE tickets to the National Computer Shopper Show

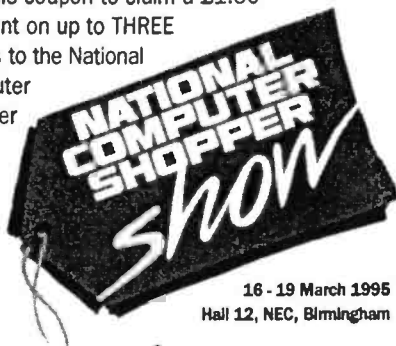

16 - 19 March 1995  
Hall 12, NEC, Birmingham

BLENHHEIM

Sponsored by Computer Shopper Magazine

Show opening times

Thursday 16 - Sunday 19 March 1995 9.30am - 5pm

Photocopies not valid. Valid on entry to show only.

I am claiming £1.50 off  or  or  tickets. PLEASE TICK.

# TECHNICAL INFORMATION SERVICES

76 Church Street, Larkhall, Lanarks, ML9 1HE  
Tel: (0698) 883334 Fax: (0698) 884825  
Technical Help Line (0698) 888343

We have the World's Largest Selection of:  
**SERVICE MANUALS  
CIRCUIT DIAGRAMS**

We also have 100s of Titles on TVs, VCRs, Satellites, Midi Systems, Computers, Test Equipment, etc ...  
Please Phone or Send an SAE for FREE QUOTE & CATALOGUE of Publications

# Maplin SOUTH AFRICA

Calling all readers in Namibia, Botswana, Angola, Zimbabwe, Lesotho, Swaziland, Mozambique and South Africa.

1994/5 CATALOGUE  
**R299,95**  
(inclusive)

For all your component needs there is only one name to remember!

For a fast, friendly and reliable service, call us now!

Maplin South Africa (Pty) Ltd.  
P.O. Box 1846, Somerset West, 7129, RSA  
Telephone: (024) 515124 Fax: (024) 515127

The World's Positive Force in Electronics

## ATTENTION!...ATTENTION!...ATTENTION!...ATTENTION!

### IMPORTANT NEWS FOR OVERSEAS READERS!

Obtaining components and kits for the projects featured in *Electronics* is now easier than ever in the following countries and regions:

**Channel Islands**  
C.I. Components Ltd., Crossways Centre, Braye Road, Vale, Guernsey.  
Tel: 01481 44177  
Fax: 01481 42291

**Middle Eastern Region**  
United Arab Emirates (U.A.E), Bahrain, Kuwait, Oman, Qatar  
Maplin Middle East Company,

P.O. Box 47019, Hamdan Street, Abu Dhabi, U.A.E.  
Tel: (02) 760332  
Fax: (02) 760317

**Bahrain**  
Capital Electrical Equipment, P.O. Box No. 2637, Manama, Bahrain.  
Tel: 273141/273144  
Fax: 275324

**Sultanate of Oman**  
Abdallah Alhashimi and Alsawafi Trading (Associates) P.O. Box 262, Mina Al Fahal, Post Code 116, Sultanate of Oman.  
Tel: 595243  
Fax: 595243

**Lebanon**  
N and Y Controls, P.O. Box 175414, Beirut, Lebanon.  
Tel: (01) 443091/397467  
UK Office:  
Tel: (44) 1702 347614  
Fax: (44) 1702 77161

**African Continent**  
South Africa, Namibia, Botswana, Lesotho, Swaziland, Mozambique, Angola, Zimbabwe  
Maplin South Africa (Pty) Ltd., P.O. Box 1846, Somerset West, Republic of South Africa.  
Tel: 24 51 51 24  
Fax: 24 51 51 27

**Mediterranean**  
Malta  
Cam Services, Cam Centre, Off Canon Road, Coomi, QRM 09, Malta.  
Tel: 484650  
Fax: 447174/484748

**Gibraltar**  
Mail Order International, c/o Medsun, P.O. Box 225, 93-99 Irish Town, Gibraltar.  
Tel: 79797  
Fax: 74664

**Far Eastern Region**  
Pakistan  
Link Pakistan, Suite Number 2, 2nd Floor, I-R Plaza, Markaz F-10, Islamabad, Pakistan.

Tel: 51 291406/7  
Fax: 51 282319

**Singapore & Malaysia**  
Tech-Con Electronics & Trading, Block 1013, Geylang East Avenue 3, #02-144 (Geylang East Industrial Estate, Singapore 1438.  
Tel: 7419918  
Fax: 8411228

**Hong Kong**  
Aries Electronics Company, 13th Floor, Unit D, Prime Mansion, No. 1 Fleming Road, Wanchai, Hong Kong.  
Tel: 2891 4116  
Fax: 2891 4122

**Countries and Regions Not Listed**  
Export Department, Maplin Electronics plc., P.O. Box 3, Rayleigh, Essex, SS6 8LR, England.  
Tel: +44 1702 554155 xtn 326 or 351  
Fax: +44 1702 553935  
Export catalogue and pricing details are available from the listed distributors.

**Maplin ELECTRONICS**  
THE WORLD'S POSITIVE FORCE IN ELECTRONICS!

# ELECTRONICS

The Maplin Magazine

# INDEX

The Maplin Magazine

INDEX - VOLUMES 1 to 13, NUMBERS 1 to 82

CONTENTS

1981-1982

1983-1984

1985-1986

1987-1988

1989-1990

1991-1992

1993-1994

1995-1996

1997-1998

1999-2000

2001-2002

2003-2004

2005-2006

2007-2008

2009-2010

2011-2012

2013-2014

2015-2016

2017-2018

2019-2020

2021-2022

2023-2024

2025-2026

2027-2028

2029-2030

2031-2032

2033-2034

2035-2036

2037-2038

2039-2040

2041-2042

2043-2044

2045-2046

2047-2048

2049-2050

2051-2052

2053-2054

2055-2056

2057-2058

2059-2060

2061-2062

2063-2064

2065-2066

2067-2068

2069-2070

2071-2072

2073-2074

2075-2076

2077-2078

2079-2080

2081-2082

2083-2084

2085-2086

2087-2088

2089-2090

2091-2092

2093-2094

2095-2096

2097-2098

2099-2100

2101-2102

2103-2104

2105-2106

2107-2108

2109-2110

2111-2112

2113-2114

2115-2116

2117-2118

2119-2120

2121-2122

2123-2124

2125-2126

2127-2128

2129-2130

2131-2132

2133-2134

2135-2136

2137-2138

2139-2140

2141-2142

2143-2144

2145-2146

2147-2148

2149-2150

2151-2152

2153-2154

2155-2156

2157-2158

2159-2160

2161-2162

2163-2164

2165-2166

2167-2168

2169-2170

2171-2172

2173-2174

2175-2176

2177-2178

2179-2180

2181-2182

2183-2184

2185-2186

2187-2188

2189-2190

2191-2192

2193-2194

2195-2196

2197-2198

2199-2200

2201-2202

2203-2204

2205-2206

2207-2208

2209-2210

2211-2212

2213-2214

2215-2216

2217-2218

2219-2220

2221-2222

2223-2224

2225-2226

2227-2228

2229-2230

2231-2232

2233-2234

2235-2236

2237-2238

2239-2240

2241-2242

2243-2244

2245-2246

2247-2248

2249-2250

2251-2252

2253-2254

2255-2256

2257-2258

2259-2260

2261-2262

2263-2264

2265-2266

2267-2268

2269-2270

2271-2272

2273-2274

2275-2276

2277-2278

2279-2280

2281-2282

2283-2284

2285-2286

2287-2288

2289-2290

2291-2292

2293-2294

2295-2296

2297-2298

2299-2300

2301-2302

2303-2304

2305-2306

2307-2308

2309-2310

2311-2312

2313-2314

2315-2316

2317-2318

2319-2320

2321-2322

2323-2324

2325-2326

2327-2328

2329-2330

2331-2332

2333-2334

2335-2336

2337-2338

2339-2340

2341-2342

2343-2344

2345-2346

2347-2348

2349-2350

2351-2352

2353-2354

2355-2356

2357-2358

2359-2360

2361-2362

2363-2364

2365-2366

2367-2368

2369-2370

2371-2372

2373-2374

2375-2376

2377-2378

2379-2380

2381-2382

2383-2384

2385-2386

2387-2388

2389-2390

2391-2392

2393-2394

2395-2396

2397-2398

2399-2400

2401-2402

2403-2404

2405-2406

2407-2408

2409-2410

2411-2412

2413-2414

2415-2416

2417-2418

2419-2420

2421-2422

2423-2424

2425-2426

2427-2428

2429-2430

2431-2432

2433-2434

2435-2436

2437-2438

2439-2440

2441-2442

2443-2444

2445-2446

2447-2448

2449-2450

2451-2452

2453-2454

2455-2456

2457-2458

2459-2460

2461-2462

2463-2464

2465-2466

2467-2468

2469-2470

2471-2472

2473-2474

2475-2476

2477-2478

2479-2480

2481-2482

2483-2484

2485-2486

2487-2488

2489-2490

2491-2492

2493-2494

2495-2496

2497-2498

2499-2500

2501-2502

2503-2504

2505-2506

2507-2508

2509-2510

2511-2512

2513-2514

2515-2516

2517-2518

2519-2520

2521-2522

2523-2524

2525-2526

2527-2528

2529-2530

2531-2532

2533-2534

2535-2536

2537-2538

2539-2540

2541-2542

2543-2544

2545-2546

2547-2548

2549-2550

2551-2552

2553-2554

2555-2556

2557-2558

2559-2560

2561-2562

2563-2564

2565-2566

2567-2568

2569-2570

2571-2572

2573-2574

2575-2576

2577-2578

2579-2580

2581-2582

2583-2584

2585-2586

2587-2588

2589-2590

2591-2592

2593-2594

2595-2596

2597-2598

2599-2600

2601-2602

2603-2604

2605-2606

2607-2608

2609-2610

2611-2612

2613-2614

2615-2616

2617-2618

2619-2620

2621-2622

2623-2624

2625-2626

2627-2628

2629-2630

2631-2632

2633-2634

2635-2636

2637-2638

2639-2640

2641-2642

2643-2644

2645-2646

2647-2648

2649-2650

2651-2652

2653-2654

2655-2656

2657-2658

2659-2660

2661-2662

2663-2664

2665-2666

2667-2668

2669-2670

2671-2672

2673-2674

2675-2676

2677-2678

2679-2680

2681-2682

2683-2684

2685-2686

2687-2688

2689-2690

2691-2692

2693-2694

2695-2696

2697-2698

2699-2700

2701-2702

2703-2704

2705-2706

2707-2708

2709-2710

2711-2712

2713-2714

2715-2716

2717-2718

2719-2720

2721-2722

2723-2724

2725-2726

2727-2728

2729-2730

2731-2732

2733-2734

2735-2736

2737-2738

2739-2740

2741-2742

2743-2744

2745-2746

2747-2748

2749-2750

2751-2752

2753-2754

2755-2756

2757-2758

2759-2760

2761-2762

2763-2764

2765-2766

2767-2768

2769-2770

2771-2772

2773-2774

2775-2776

2777-2778

2779-2780

2781-2782

2783-2784

2785-2786

2787-2788

2789-2790

2791-2792

2793-2794

2795-2796

2797-2798

2799-2800

2801-2802

2803-2804

2805-2806

2807-2808

2809-2810

2811-2812

2813-2814

2815-2816

2817-2818

2819-2820

2821-2822

2823-2824

2825-2826

2827-2828

2829-2830

2831-2832

2833-2834

2835-2836

2837-2838

2839-2840

2841-2842

2843-2844

2845-2846

2847-2848

2849-2850

2851-2852

2853-2854

2855-2856

2857-2858

2859-2860

2861-2862

2863-2864

2865-2866

2867-2868

2869-2870

2871-2872

2873-2874

2875-2876

2877-2878

2879-2880

2881-2882

2883-2884

2885-2886

2887-2888

2889-2890

2891-2892

2893-2894

2895-2896

2897-2898

2899-2900

2901-2902

2903-2904

2905-2906

2907-2908

2909-2910

2911-2912

2913-2914

2915-2916

2917-2918

2919-2920

2921-2922

2923-2924

2925-2926

2927-2928

2929-2930

2931-2932

2933-2934

2935-2936

2937-2938

2939-2940

2941-2942

2943-2944

2945-2946

2947-2948

2949-2950

2951-2952

2953-2954

2955-2956

2957-2958

2959-2960

2961-2962

2963-2964

2965-2966

2967-2968

2969-2970

2971-2972

2973-2974

2975-2976

2977-2978

2979-2980

2981-2982

2983-2984

2985-2986

2987-2988

2989-2990

2991-2992

2993-2994

2995-2996

2997-2998

2999-3000

A comprehensive index to *Electronics - The Maplin Magazine* is now available from Maplin. The index covers every issue from December 1981 to October 1994. Included are details of every article, series and project published during that period. Conveniently arranged, sectionally and alphabetically, it'll take minutes instead of hours to find the exact issue number and page you need. You'll be able to rediscover a wealth of information you never knew you had! A list of all the *Corrigenda* published is also included, so you will be able to find details of changes or amendments. You'll find the index an invaluable addition to the issues of *Electronics* that you have. If your collection is incomplete, many issues are still available as back issues. The Magazine index costs just 80p NV and can be obtained (subject to availability) from Maplin Stores countrywide; by Mail Order, using the Order Coupon in this issue, or by calling the Credit Card Hotline, Tel: (01702) 554161, Order As XU87U. You'll wonder how you ever managed without it!

### DID YOU MISS US ?

If you've ever wanted to lay your hands on an elusive issue of *Electronics - The Maplin Magazine*, then we can help! Many editions are still available, as back issues. Where issues are out of print, details of projects that are still current can be found in Maplin Projects Books and Best of Maplin Projects Books. Copies of back issues (subject to availability) can be obtained from Maplin Stores countrywide; by Mail Order, using the Order Coupon in this issue, or by calling the Credit Card Hotline, Tel: (01702) 554161. If you are not sure which issue or Projects Book you require, refer to the Magazine Index (XU87U) or call Customer Services, Tel: (01702) 552911. Photocopies of out of print feature articles are available; a charge will be made, dependent on the length of the article to be copied - call Customer Services for details.

### NO HANDLING CHARGES !

If you are *only* ordering a copy of *Electronics - The Maplin Magazine* Index or back issues of the magazine, the normal £1.50 Mail Order handling charge does not apply!





A readers' forum for your views and comments.  
If you would like to contribute, please  
address your replies to:

The Editor, Electronics – The Maplin Magazine,  
P.O. Box 3, Rayleigh, Essex SS6 8LR, or send  
an e-mail to: AYV@maplin.demon.co.uk

### What a Gas!

Dear Editor,  
A friend and I have identical gas fires with an electric 'log effect' at the bottom. The only difference is that his looks more 'alive' than mine because he has a random flicker on the two tubes, supplied by an electronic circuit. In 25 years as an electronics hobbyist, I have never seen a circuit for mains random flickering. Is there a possibility that the clever people in your design department could conceive such a circuit, using CMOS?  
Eddie Chamont, Colchester, Essex.

If your friend's gas fire is identical, as you say, then surely yours should also have the flicker effect facility? Unfortunately, without details of the particular model of fire you have, it is not possible to provide exact information on modifying it. However, most fires with this effect, both gas/electric or all-electric, achieve the flicker effect either by using special bulbs mounted below the actual heating bars (similar to the 'candle-effect' type), or by a red lamp, above which is a heat convection-operated rotating bar with reflective fins, mounted below a fibreglass coal-effect cover, which allows simple switching on and off of the effect, independent of the bars. I imagine it would require a circuit with high current switching capability to flicker the actual bars themselves on and off, and, as these usually remain glowing for several seconds when turned off, the resultant effect would not be very realistic, not to mention uneconomic in terms of energy consumption. Due to the safety aspect, we would not advise tampering with the fire in an attempt to achieve this effect, besides which, the heat of the fire might fry CMOS chips, although your idea could be successfully implemented using carbon-based chips, of the COAL variety!

### Beginner's Pluck

Dear Editor,  
I wrote concerning the layout of the Maplin Catalogue (AYV, January 1994), and feel that the 1995 Catalogue indexing has improved matters. Please do not restructure again for a few years! Having a very shallow knowledge of electronics (but keen to learn), I find many of your articles are lacking in explanation. To quote p.24 of Issue 84, "Anyone who is a complete electronics novice... It is nothing more than a ripple clocked up/down counter", this already puts me off, because I do not know what ripple clocking is! With your Zero Crossing Opto Switch (LP55K), why is the neutral switched, as I would think it safer to switch the live? Finally, a number of appliances I have come across, e.g., timed bathroom fans and some PIR sensors, seem to derive their low voltage supplies via dropping resistors, avoiding use of a mains transformer.  
John Huddleston, Abingdon, Oxon.

Good to hear that you approve of the new catalogue layout. In the magazine, we try to strike a balance with each article, to appeal to beginners and experienced readers alike, and in fact, we receive a few letters of the opposite argument, i.e., that the descriptions cover an excess of off-repeated 'basics'. The article referred to has a project rating of 2, which is defined as being unsuitable for absolute beginners, hence the project description assumes the reader has moderately advanced knowledge of electronics, which would cover a basic understanding of ripple counters. In simple terms, ripple clocking is where the pulses pass along each stage of the counter in turn, 'rippling' through (as a stream) from input to output, at a rate controlled by the clock

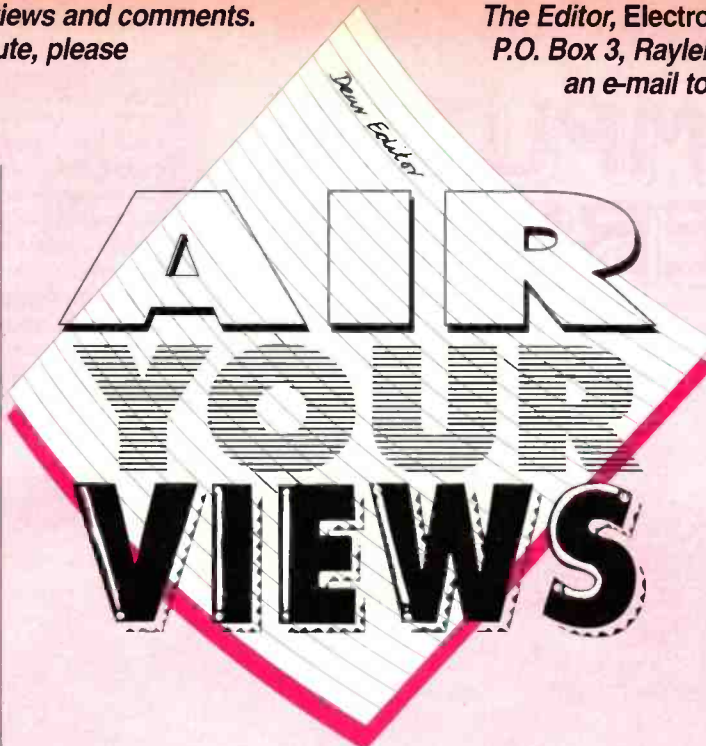

## STAR LETTER

In this issue, Morgan Jones of Southampton, wins the Star Letter Award of a Maplin £5 Gift Token for his analysis of the Newton valve preamp.



### Newton Analysis

Dear Editor,  
I read the 'Newton' valve preamp article with interest, and, since it indirectly related to my letter that *Wireless World* published in 1985, I analysed the RIAA equalisation both theoretically (from IE formulae), and by network analysis computation, taking into account the anode resistance of the ECC83 valve in your configuration (approximately 76kΩ), and its Miller capacitance (approximately 90pF). There appears to be a design error, since the computer plot of frequency response between 10Hz to 40kHz from an RIAA pre-equalised source should have shown a flat midband response with a falling low-frequency response, however, your values give a 0.6dB bump centred on 560Hz (also just visible on your plot). It might be thought that a deviation this small is of little consequence, but broadband effects like this are very significant, particularly if they occur in the midrange. Additionally, although low frequencies initially fall away, the response begins to shelve at 10Hz. I then entered my calculated values for R4 (32k1Ω) and C8/C9 (9n91F), ignoring C5 in my calculations, but including it in the computer analysis. These new values removed the bump, but the wrong LF roll-off remained, so I investigated down to 10mHz (I did not have the benefit of CAD in 1985). C5 introduces a shelf into the LF response,

but an additional 15ms high-pass filter can correct this. To conclude, for correct IEC response, component changes should be as follows: R4 = 33kΩ parallelled with 1M1Ω, R11 = 100kΩ, C5 = 56nF, C8 = 820pF, and C9 = 9n1F. Note that the value of R11 is the total resistance to ground from that point, the ideal implementation being to use a 100kΩ potentiometer parallelled with a 10MΩ resistor, thus providing volume control.

Thank you for sharing the results of your analysis and suggested changes, which I agree with, with the exception of C5, which is not supposed to serve the LF roll-off function, but is intended only to provide DC blocking, and whose value was unfortunately dictated by component availability and cost. Ideally, its value should allow a wide pass band, requiring a component of high quality and working voltage (e.g., 100nF, 500V Polypropylene), however, such a device is too large and expensive, hence a compromise was found in the 22nF, 400V (largest rating in stock) Polyester specified. There was no more to it than that! However, I advise against using a volume control directly across the output of V1b (across R11), and recommend instead linking this output directly to the line driver (V2) input, with the potentiometer across its output. As implied earlier, this retains compatibility with comparatively lower input impedance transistorised equipment.



frequency. Regarding your question on the opto switch, the reason, as explained by its designer, Alan Williamson, in AYV Issue 42, is to ensure maximum safety, since, as the earth and neutral lines are at the same potential at the substation, there is a reduced likelihood of insulation breakdown, than would be the case

if it switched the live line. Appliances operating from the mains supply via a simple voltage drop resistor supply, generally have very low power consumption, and hence do not require the relatively high power handling offered by transformers, or high-wattage resistors that would generate a lot of heat. An example is a neon lamp,

often used as an 'on' indicator, which operates at around 90V and only a few mA, and is wired in series with a 1/4W resistor of around 270kΩ, to allow direct mains operation.

### Bi-directional Valve (it works both ways!)

Dear Sir,  
I have been a reader of *Electronics* for 18 months, and always look forward to the next issue. I was brought up in the valve era, and trained as an audio/radio/public address engineer during the 1950s, and remained in audio and telecommunications until retirement 3 years ago. The re-emergence of interest in valve equipment is intriguing, as are comments made by some of your authors, regarding earlier valve circuit design. In particular, I refer to Issue 85 (Jan '95), and the Newton stereo valve preamp. The last paragraph on page 5, and the comment "... so-called Mullard 'two-valve' and 'three-valve' designs." Why refer to them as "so-called", when in fact they were published by Mullard? Mullard had an Applications Research Laboratory, which prepared specimen design circuits, and, realising the merit of encouraging the hobbyist, the Technical Service Dept. published a series of designs from circa 1954, including the famous 'Five Ten' amplifier.

The preamp circuits published were not derived from a commercial design, as you suspect, but were designed for commerce or hobbyist use, in an age following World War II, and a "tighten your belt" economic situation, hence the simplified design, unreservedly criticised by your statement "consequently it has duff elements to it, such as the tape outlet that is merely tapped off the anode load...". This was a commonly-used form of tape outlet at the time; you have to regard the design in the light of what was then the current technology. Additionally, one must be careful when 'mixing technologies', since valve audio circuits are basically high impedance, whereas solid-state audio circuits are low impedance. This is intended as constructive criticism, and I hope it does not give offence. More power to your elbow; bring back the valve sound! Trouble is, it's so expensive by comparison.  
Keith Wilson, Bedford.

Mike Holmes replies:  
Thank you for raising these points. When I wrote "so-called", I meant that if anybody talked about '2- and 3-valve' preamp circuits, it was on the basis that it was understood by all of the time, that the circuits were of Mullard origin, or at least I interpreted it that way. I was at least half right though, when I stated that the designs were 'commercial', insofar that the 'Circuits for Audio Amplifiers' book you mentioned, says in the preface that the designs are convenient for equipment manufacturers as well as service engineers, and home constructors. Thank you for reminding me that, following WWII, the fifties were still quite frugal times, explaining the 'economy' in component count. Given these restraints, Mullard did rather well. (Personally, I only had a ration book up until the age of 1, so I do not really remember what it was like.) I will admit to completely getting the wrong end of the stick about the tape outlet method. This was also noticed by John Woodgate, who explained the relevant standard that applied at the time, subsequently revised. Nowadays, the requirements are different, and there are many (solid-state) pieces of equipment to plug into, hence the inclusion of low impedance output buffers.

Text by Alan Williamson and Robin Hall

# COMPUTER INTERFACE BOARD

To enable a computer to communicate with the outside world, it is usually fitted with a keyboard, a display and perhaps a mouse. If however, it is to be used in control applications, or certain control functions are to be carried out, then an interface is needed. The Computer Interface Board featured here excels in its simplicity of use and installation.

The assembled Computer Interface Board with cables attached.

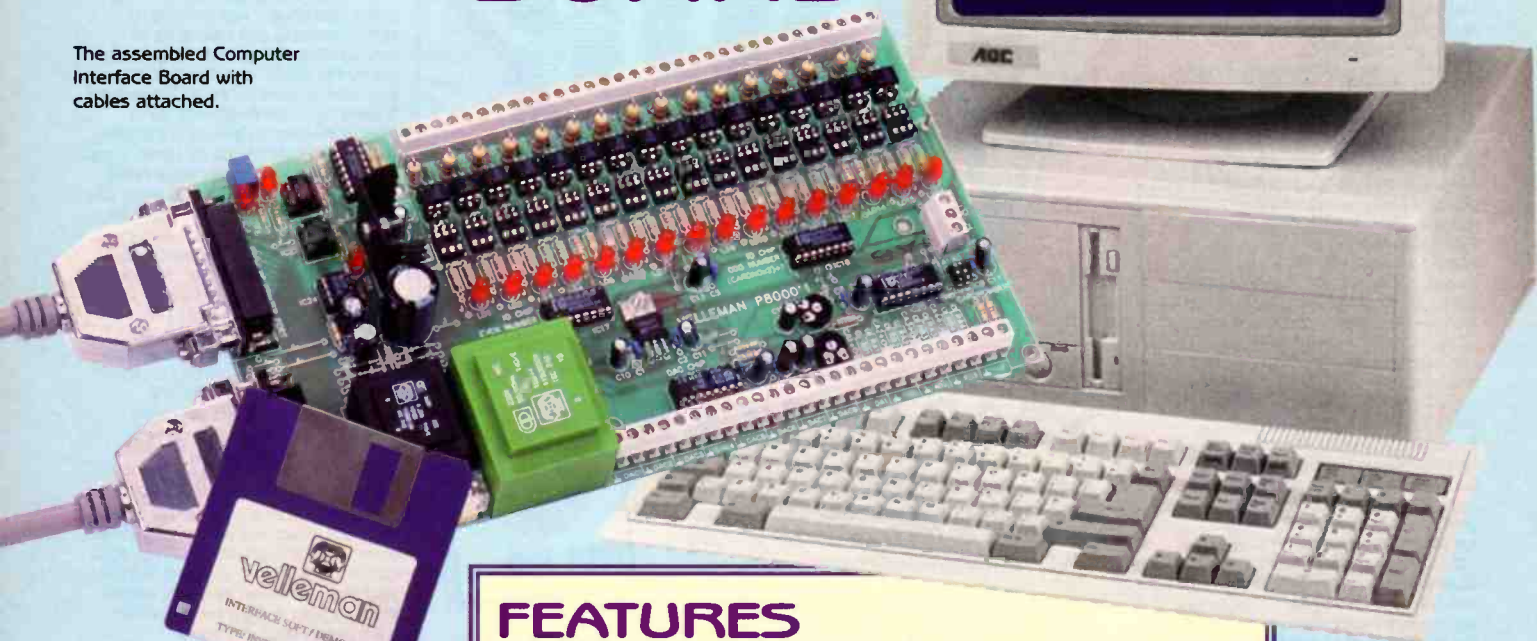

KIT AVAILABLE  
(VF54J)  
PRICE £84.99

## FEATURES

- ◆ Interface board for IBM compatible PCs
- ◆ Simply connects to the printer port
- ◆ Printer by-pass connector on board
- ◆ 16 Optoisolated input or outputs
- ◆ 8 to 6-bit (64 step) analogue outputs
- ◆ 1 to 8-bit (256 step) analogue output
- ◆ 4 to 8-bit (256 step) analogue inputs
- ◆ Full optoisolation to computer

**3**  
PROJECT  
RATING

- 1 Quad Relay Card.
- 2 Codelock Receiver.
- 3 Infra-red Codelock.
- 4 15-channel Infra-red Receiver.

- 5 Computer Interface Board.
- 6 2-wire 8-channel Communication Receiver.
- 7 Quad Triac Switch.

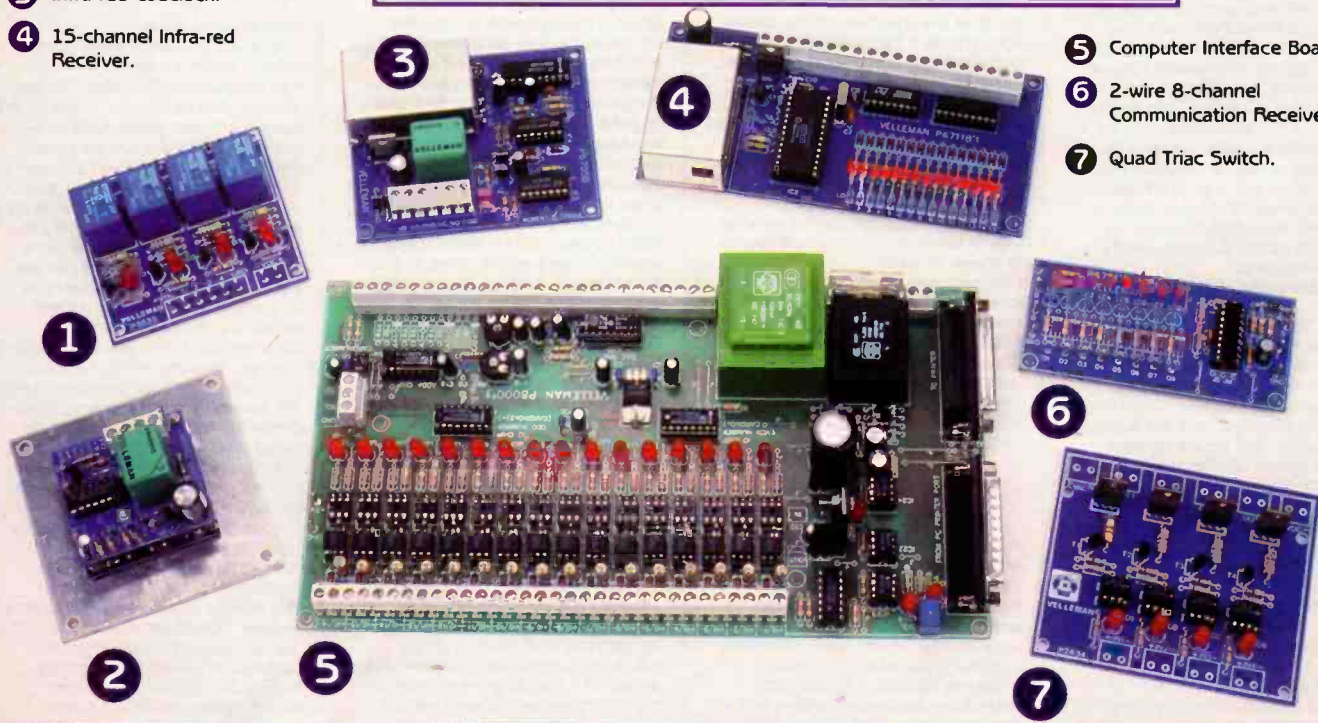

The assembled Computer interface PCB.

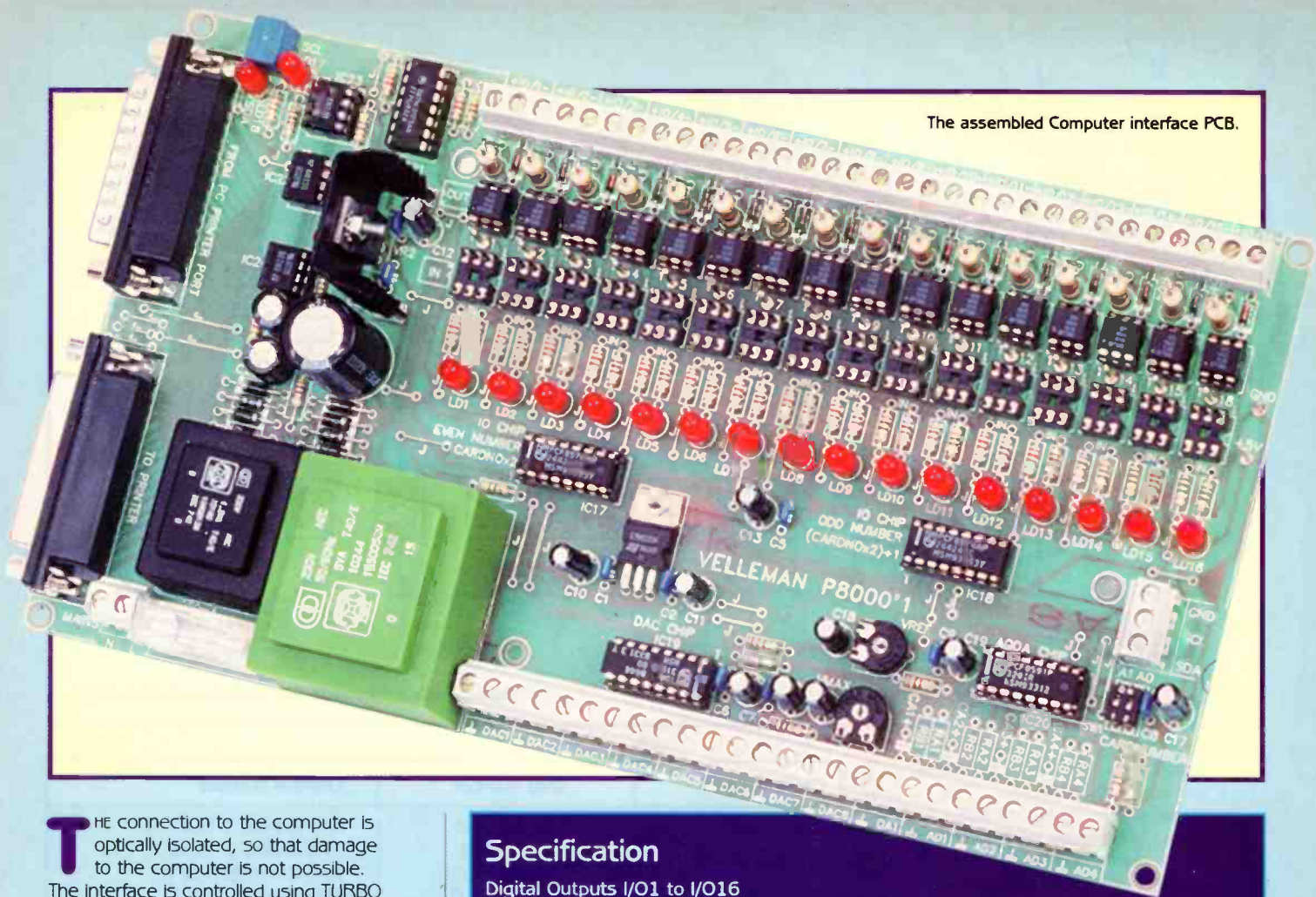

**T**HE connection to the computer is optically isolated, so that damage to the computer is not possible. The interface is controlled using TURBO PASCAL™ procedures. These procedures are preprogrammed and are provided along with a number of tests and example programs on the diskette supplied. (See disk supplied file: MAN\_GB for an overview of I<sup>2</sup>C procedures and functions.)

To connect the Interface board to the computer, the printer port is used (note that there is no need to install an extra printer port as the printer can be connected directly to the interface board). Although it must be noted that the printer has priority over the interface when connected.

Three lines from this port are used, namely, 'Select' (pin 13), 'Autofeed' (pin 14) and 'Select in' (pin 17). Communication between the computer and interface is by means of a serial link. One line (Select In) serves as the clock signal, the second (Autofeed) as the data output, and the third (Select) as the data input. All communication routines are contained in a single, special 'unit' written in TURBO PASCAL™. This unit can be operated from MSDOS™ or MSWINDOWS™. Thus, there is no need to be concerned about the communication protocol.

Only the lines that use the I<sup>2</sup>C need to be fed in to user programs and the

**WARNING!** Mains voltage is potentially lethal, it must therefore be treated with the greatest respect at all times; for your safety, it is important that insulators are fitted to all the exposed mains connections.

## Specification

### Digital Outputs I/O1 to I/O16

Optocoupler, open collector output: 50mA 30VDC Maximum  
Minimum conversion time to set 16 outputs: 800µs

### Digital Inputs I/O1 TO I/O16

Optocoupler input: Min 5V/5mA, Max 20V/40mA  
Minimum conversion time to read 16 inputs: 800µs

### Analogue Outputs

8 outputs, DAC1 to DAC8; resolution: 64 steps  
Minimum conversion time to set one output: 600µs  
Minimum conversion time to set 8 outputs together: 2ms  
Maximum output current: 6mA  
Minimum output voltage (at 2mA): 0.1V  
Maximum output voltage (at 2mA): 11.5V (adjustable)  
Resolution per step (from 0.1V to 11.5V): 160mV ±90mV

1 Precision output, DA1; resolution: 256 steps  
Conversion time to set output: 600µs  
Maximum output current: 2mA  
Minimum output voltage: 0V  
Maximum output voltage (at 500µA): 4.5V (adjustable)  
Resolution per step (from 0V to 4.5V): 17.5mV  
Deviation: 30mV Maximum

### Analogue Inputs

4 analogue inputs, AD1 to AD4; resolution: 256 steps  
Minimum conversion time to read one input: 1ms  
Minimum conversion time to read 4 inputs: 1.6ms  
Minimum input voltage: 0V  
Maximum input voltage: 5V  
Input impedance: 50MΩ nominal  
Resolution: 19.5mV  
Deviation: 30mV Maximum

Communication protocol: I<sup>2</sup>C bus  
Supply voltage: 220 to 240VAC  
PCB dimensions: 237 x 133mm

LED indication on each I/O channel  
25-way 'D-type' male connector to computer  
25-way 'D-type' female connector to printer

NB: conversion speed is dependent on chosen computer

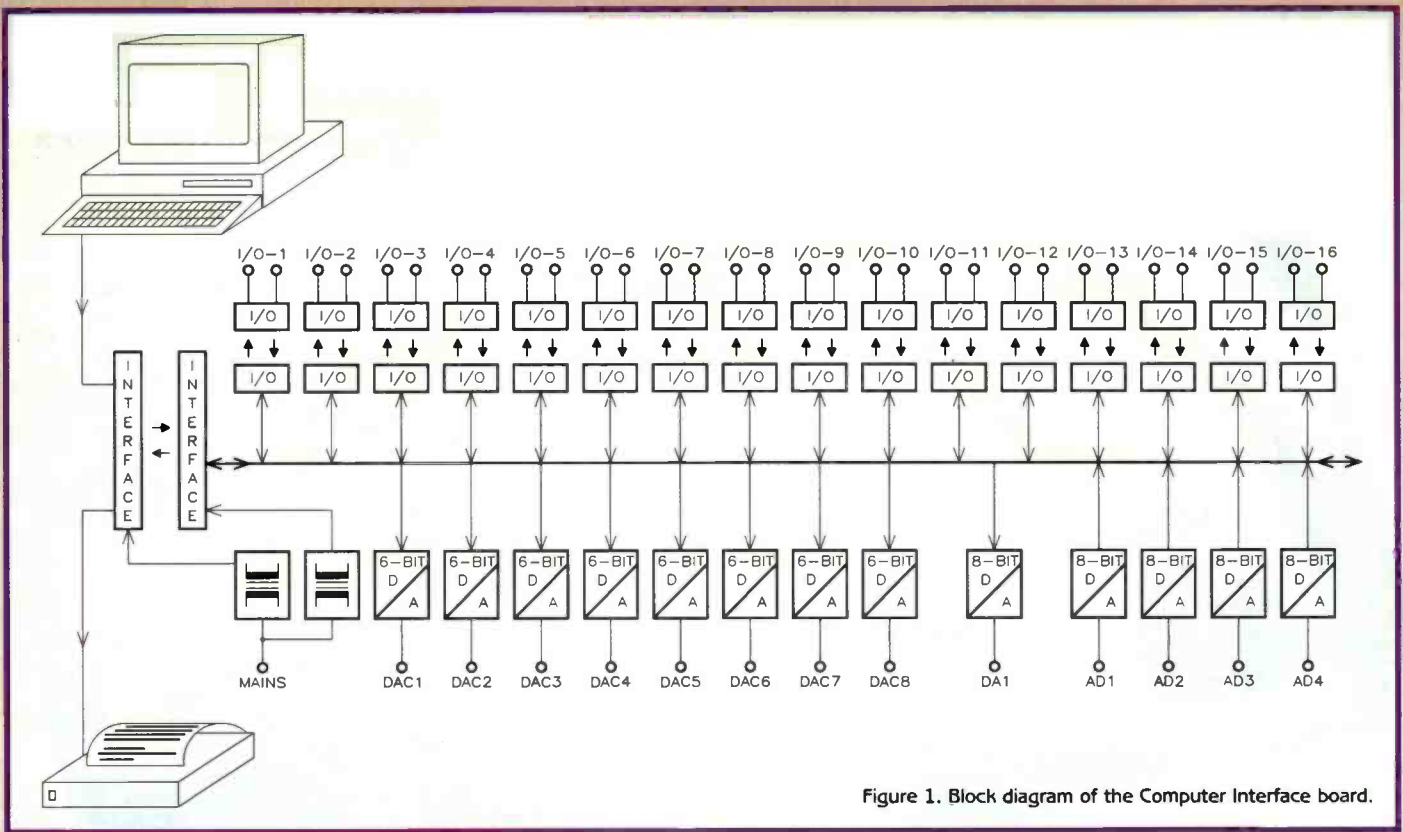

Figure 1. Block diagram of the Computer Interface board.

configuration part of the printer port being used, also needs to be set.

Every user written program must contain this configuration information. This specifies the printer port being used. The communication speed (maximum clock speed = 100kHz) is adjusted according to the computer speed. To a large extent this needs to be found experimentally. Initially the maximum speed can be set, and then reduced until reliable communication is established. Next the input/output channels can be configured. The default settings are for; printer port LPT1 on the motherboard, maximum communication speed, all Input/output channels set as Inputs, all analogue output channels set to minimum, and the status of all Input channels are read in.

After this has been done the main control program can follow. A complete overview of all procedures, functions, constants, and variables that are used by the 'i2C unit' follows.

The example programs can also be carefully studied in order to gain an insight as to how to construct your customised application programs.

Note that all examples are written for TURBO PASCAL for MSWINDOWS™. If the examples are to be run from TURBO PASCAL™ for MSDOS, then the units 'WinCrt' and 'WinDos' must be replaced with 'Crt' and 'Dos' respectively.

The Interface itself has 16 optically isolated digital connections, which can be freely chosen as either inputs or outputs (e.g., 6 inputs and 10 outputs) according to how they are set up by the user. In addition, there are eight analogue outputs with 6-bit resolution, one analogue output with 8-bit resolution, and four analogue inputs of 8-bit resolution. If more digital outputs are required, then the analogue outputs can be used by setting to minimum or maximum output voltage. If there are too few inputs, then the analogue inputs may be used. In this way it is very simple to track the state of a

Card Number	Chip Number	Channel Number
0 (OFF-OFF)	IO-chip no: 0 IO-chip no: 1 DAC-chip no: 0 AD-chip no: 0 DA-channel: 1	IO-channels: 1 to 8 IO-channels: 9 to 16 DAC-channels: 1 to 8 AD-channels: 1 to 4
1 (OFF-ON)	IO-chip no: 2 IO-chip no: 3 DAC-chip no: 1 AD-chip no: 1 DA-channel: 2	IO-channels: 17 to 24 IO-channels: 25 to 32 DAC-channels: 9 to 16 AD-channels: 5 to 8
2 (ON-OFF)	IO-chip no: 4 IO-chip no: 5 DAC-chip no: 2 AD-chip no: 2 DA-channel: 3	IO-channels: 33 to 40 IO-channels: 41 to 48 DAC-channels: 17 to 24 AD-channels: 9 to 12
3 (ON-ON)	IO-chip no: 6 IO-chip no: 7 DAC-chip no: 3 AD-chip no: 3 DA-channel: 4	IO-channels: 49 to 56 IO-channels: 57 to 64 DAC-channels: 25 to 32 AD-channels: 13 to 16

**Table 1. SW1 Settings**

rotating switch by connecting in a different voltage for each switch index position.

Please note that these extra input and output channels are not optically isolated. If this capacity is still not sufficient for a particular application, then up to four interface boards can be connected together (one master and three slaves), such enormous potential exists.

Each Interface board is given its own identification by means of a two-pole DIP-switch SW1 (see Table 1 for channel numbering).

The Interface can be used with many other Velleman kits such as:

- K6714, 16-channel relay card (VF10L).
- K6710 and K6711, 15-channel remote control (VE72P), (VE73Q).

- K2607, thermometer adaptor (VE65V).
- K6700 and 6701, 2-wire communication (Max. 16-channels), (VE70M), (VE71M).
- K2633, 4-channel relay card (VF00A).
- K2634, 4-channel triac card (VE97F).

## Circuit Description

As an aid to understanding the circuit, a block diagram of the Computer Interface board is shown in Figure 1 and the circuit diagram in Figure 2. There are two mains transformers in the circuit; the first transformer supplies power to the circuit via the 7805 and 7812 regulators. The second transformer is required to power the isolated (computer) side of the optocouplers.

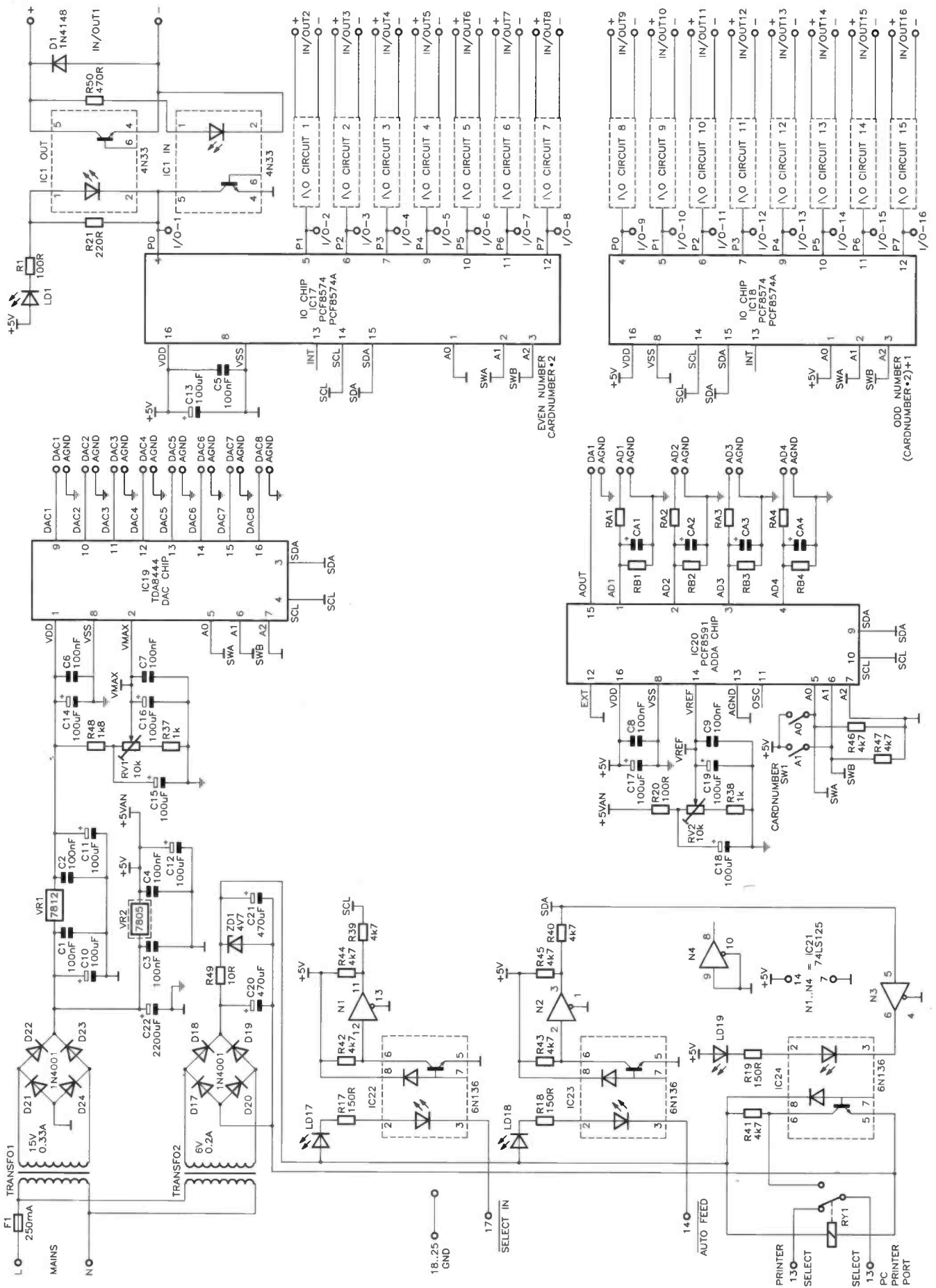

Figure 2. Circuit diagram of the Computer Interface Board.

The optocouplers IC22 and IC23 allow isolated clock and data transfer from the computer printer port 'Select In' and 'Autofeed' data lines. Data is transferred back from the card to the computer via the buffer N3, optocoupler IC24 and relay RY1.

The circuit around the optocoupler IC1 shows both the Input and output configurations, however, only one of which will be used in practice. The circuits 1 to 15 are identical to the circuit of IC1.

IC17 to IC20 are under the control of the I<sup>2</sup>C bus which is the SCL (clock) line and the SDA (data) line; the devices will only respond if the code set with the DIP switches (SW1 A0 and A1) matches the code in the data sent from the computer.

IC17 and IC18 are remote 8-bit I/O expanders which contain a power on reset, an input filter, an I<sup>2</sup>C bus control, interrupt logic, a low-pass filter, an 8-bit shift register and eight I/O port latches. IC19 is an Octuple 6-bit DAC, containing a reference voltage generator, an I<sup>2</sup>C bus slave voltage controller and the 8 discrete DACs. IC20 is a Quadruple 8-bit multiplexed ADC with an 8-bit DAC, the device contains a power on reset, an oscillator, logic control, an analogue multiplexer, an analogue buffer, two sample-and-hold circuits, a DAC, a successive approximation register logic, a comparator, a DAC data register, an ADC data register, a status register and an I<sup>2</sup>C bus interface.

## Construction

Construction is fairly straightforward; begin with the smallest components first, working

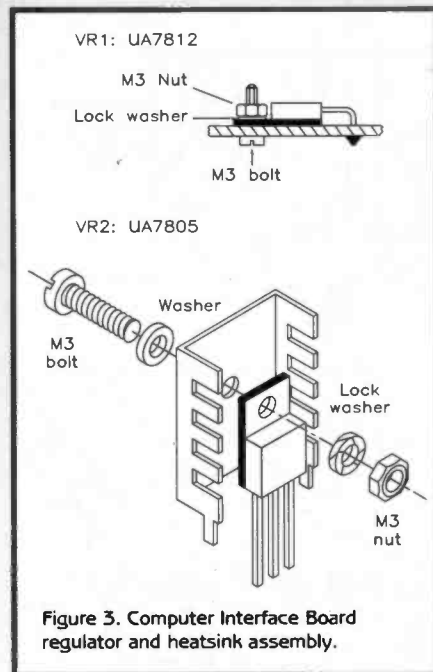

Figure 3. Computer Interface Board regulator and heatsink assembly.

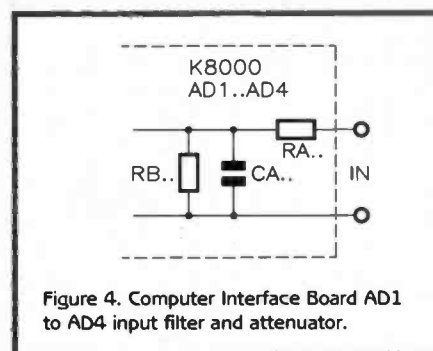

Figure 4. Computer Interface Board AD1 to AD4 input filter and attenuator.

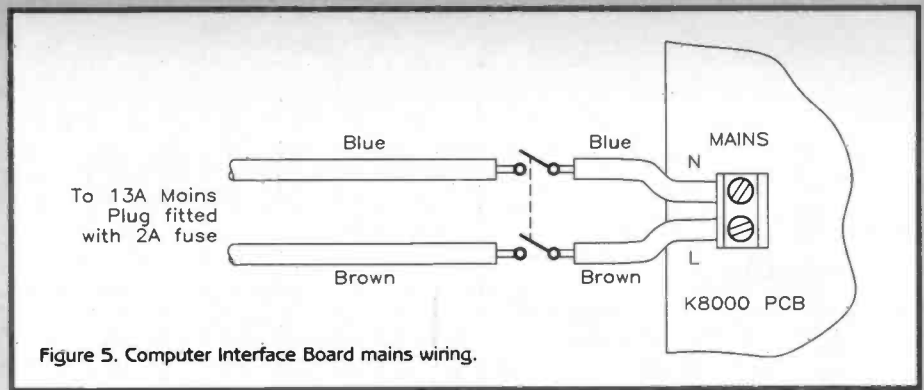

Figure 5. Computer Interface Board mains wiring.

up in size to the largest. Be careful to correctly orientate the polarised devices, i.e. electrolytics, diodes and ICs. The ICs should be inserted into their sockets last of all. If you require any additional information about

soldering and assembly techniques, they can be found in the Constructors' Guide (XH79L).

First fit the wire links, use the banded tinned copper wire for the links. Next fit the

The 'I<sup>2</sup>C-unit' contains the following global variables:

VARIABLE	TYPE	Read/Write	INITIAL VALUE	DESCRIPTION
StatusPort	Integer	R/W	\$0379	Address of the status register of the selected printer port
ControlPort	Integer	R/W	\$037A	Address of the control register of the selected printer port
I <sup>2</sup> CbusDelay	Integer	R/W	1	Speed reduction factor for adjusting maximum communication speed to the computer speed
AD	Array[1..16] of Integer	R		Contains the status (value between 0 and 255) of the sixteen Analogue-to-Digital converter channels
DA	Array[1..4] of Integer	R/W	0	Contains the data (value between 0 and 255) of the four 8-bit Digital-to-Analogue converters
DAC	Array[1..32] of Integer	R/W	0	Contains the data (value between 0 and 63) of the thirty two 6-bit Digital-to-Analogue Converter channels
IOconfig	Array[0..7] of Integer	R	\$0FF	Each bit contains the configuration of the corresponding channels of the eight IO-ports. Bit high (1) = input; bit low (0) = output
IOdata	Array[0..7] of Integer	R		Each bit contains the status of the respective channel of the eight IO-ports. Bit high (1) = channel on; bit low (0) = channel off
IO	Array[1..64] of Boolean	R		Contains the status of the sixty four Input/Output channels. True = channel on; False = channel off

Table 2. Global Card Variables

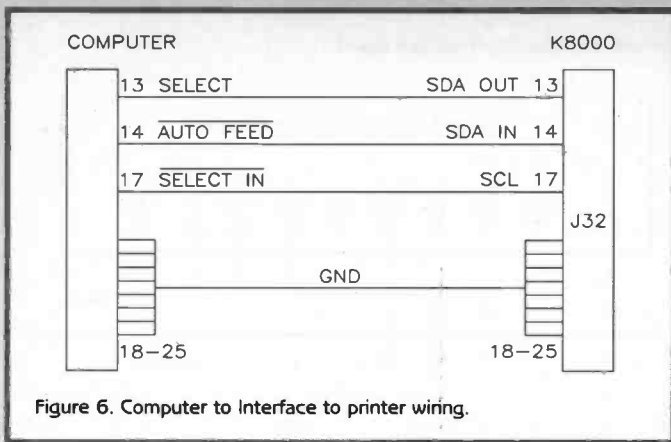

Figure 6. Computer to Interface to printer wiring.

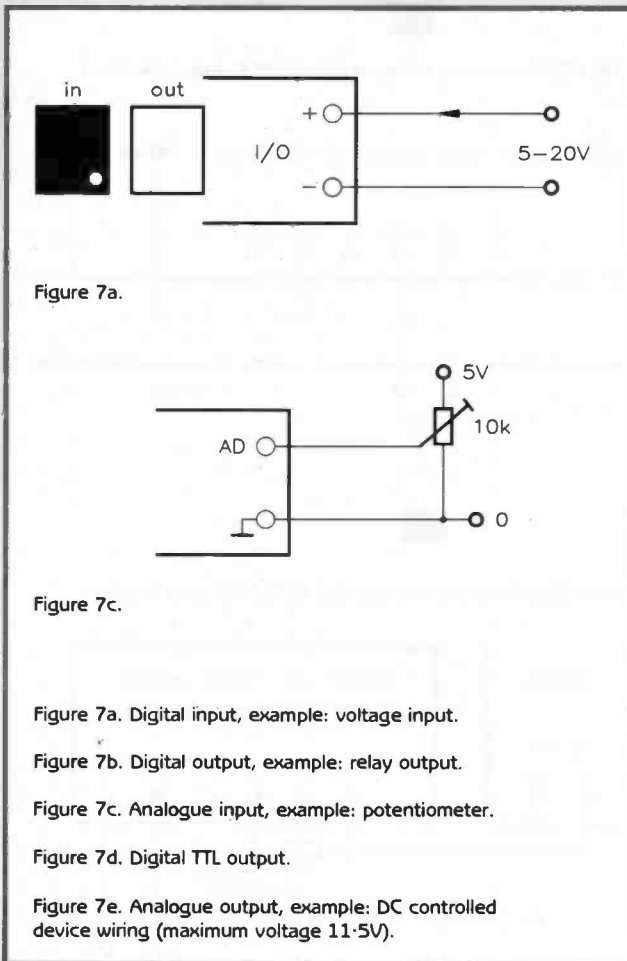

Figure 7a.

Figure 7b.

Figure 7c.

Figure 7d.

Figure 7a. Digital input, example: voltage input.

Figure 7b. Digital output, example: relay output.

Figure 7c. Analogue input, example: potentiometer.

Figure 7d. Digital TTL output.

Figure 7e. Analogue output, example: DC controlled device wiring (maximum voltage 11.5V).

Figure 7e.

$\frac{1}{4}W$  resistors, followed by the  $\frac{1}{2}W$  resistors, these are larger in physical size. The diodes come next, and care must be taken to fit the diodes the right way round; the cathode is indicated by a band on the body of the diode, and this must face the thick white band on the PCB legend. Similarly fit the Zener diodes, observing polarity.

Mount the IC DIL sockets next, making sure that the notch corresponds to the notch on the legend. Insert the PCB pins from the component side and solder on the track side. Fit the ceramic capacitors, and then next fit the polarised capacitors, taking care to insert the devices correctly – the negative lead is identified by a black band and (-) symbols on the capacitor's body.

Then fit the LEDs, making sure that the 'flat' on the LED's body (indicating the cathode lead), corresponds to the straight line on the PCB legend. Next fit the relay, and the presets. Mount the fuseholder and fit the fuse and then refit the plastic cover. Identify and fit the 2-pole DIP switch. Fit the

regulator VR1 on the PCB using the M3 nut, screw and washer; fit the regulator VR2 onto the heatsink, see Figure 3.

Fit the single terminal connector block for the mains input and the three terminal connector on the board. Next fit the terminal blocks together onto the PCB, these will number sixteen on one side and thirteen on the other.

Mount the printer port sockets, J32 is male, and J33 is female. These must be mounted flush on the PCB before soldering. Fit the two transformers, the pins are keyed so that they will only fit one way round. Finally insert the ICs (observe orientation notch).

Note: ICs 1 to 16 (optocouplers) have two positions, input or output, for test purposes it is best to fit the optocouplers in the output positions.

Thoroughly check your work for misplaced components, solder whiskers/bridges and dry joints. Finally, clean all the flux off the PCB using a suitable solvent.

If desired, a voltage divider or filter can be fitted to each analogue input. The voltage divider can be useful if a higher input voltage than normal is to be monitored. Normally a maximum of 5V can be accommodated by the input. The filter can be useful for eliminating (mains) hum from the signal; refer to Figure 4 for an example of an input filter and attenuator.

No attenuation and no filtering. Fit a link wire in place of RA, CA should be left open circuit. Input impedance = 100k $\Omega$ .

50Hz mains filter (low pass). Using the following formula ( $f = 1/2\pi RC$ ) different values for R and CA can be calculated as a function of frequency. If a high value is arrived at for CA, then an electrolytic capacitor can be used, but check the polarity. RB should be left open circuit.

A divide by 10 input attenuator. This enables 50V to be connected to the input; with the given values of R = 18k $\Omega$  (180k $\Omega$ ), RB = 2k $\Omega$  (20k $\Omega$ ), the input impedance will be 20k $\Omega$ , with the values

Figure 8. A selection of projects (more on following pages) to use in conjunction with the Computer Interface Board.

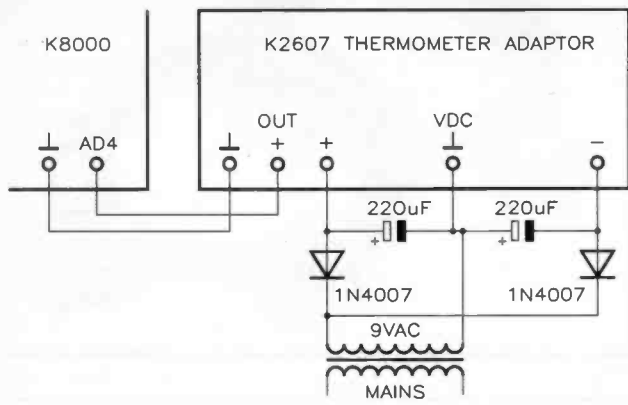

Figure 8a. K8000 interface wiring to the K2607 Thermometer Adaptor

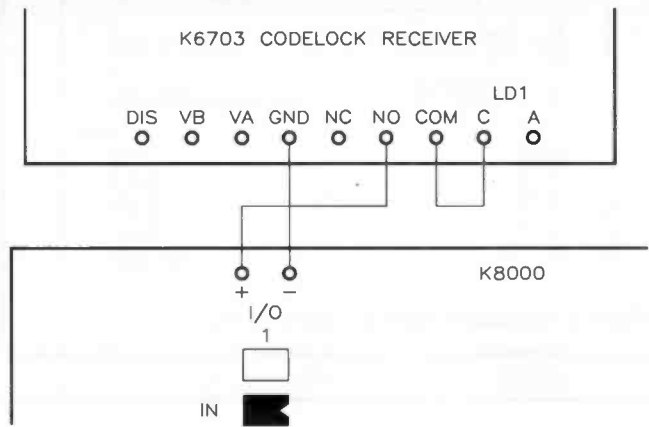

Figure 8b. K8000 interface wiring to the K6703 Codelock Receiver.

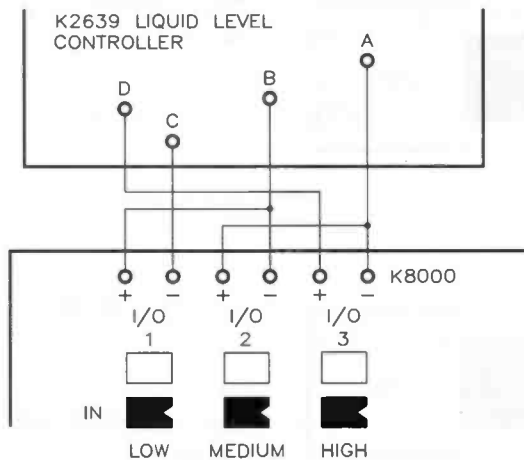

Figure 8c. K8000 interface wiring to the K2639 Liquid Level Controller.

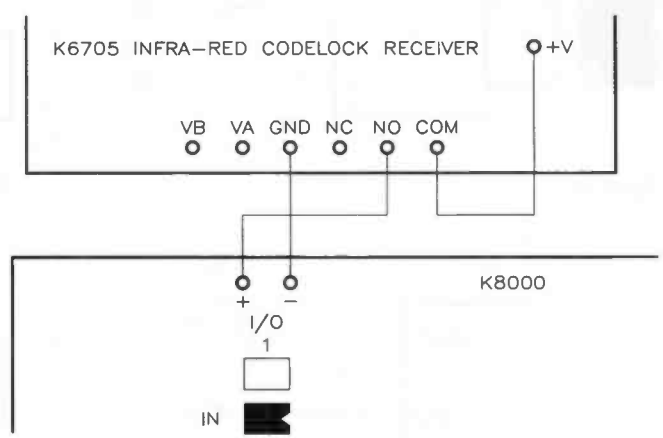

Figure 8d. K8000 interface wiring to the K6705 Infra-red Codelock.

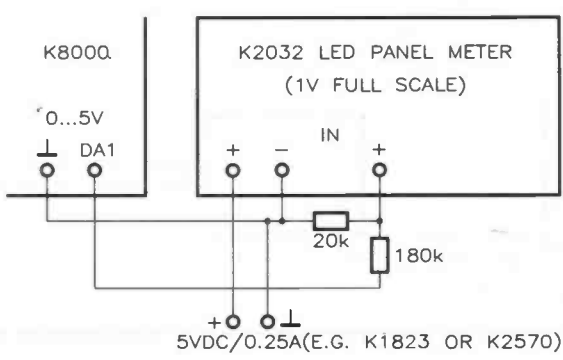

Figure 8e. K8000 interface wiring to the K2032 LED Panel Meter.

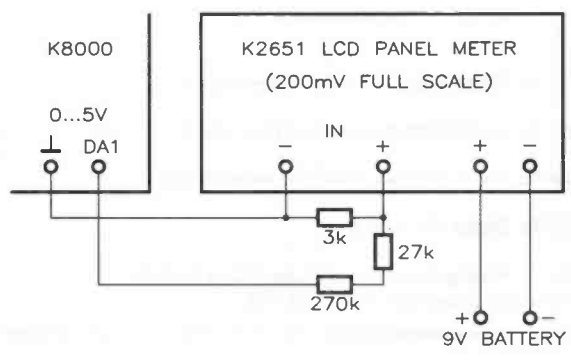

Figure 8f. K8000 interface wiring to the K2651 LCD Panel Meter.

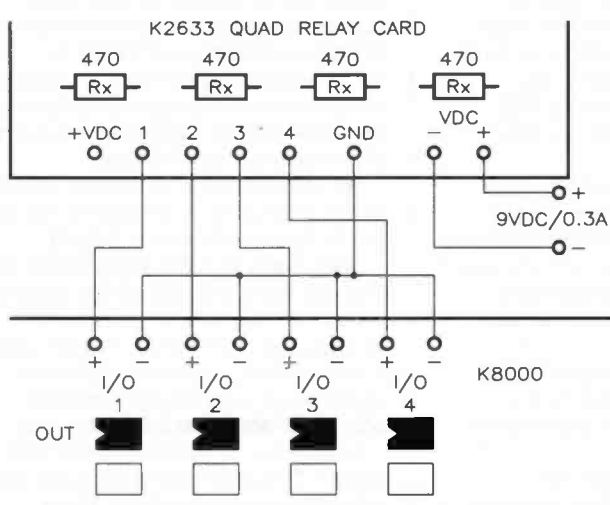

Figure 8g. K8000 interface wiring to the K2633 Quad Relay Card.

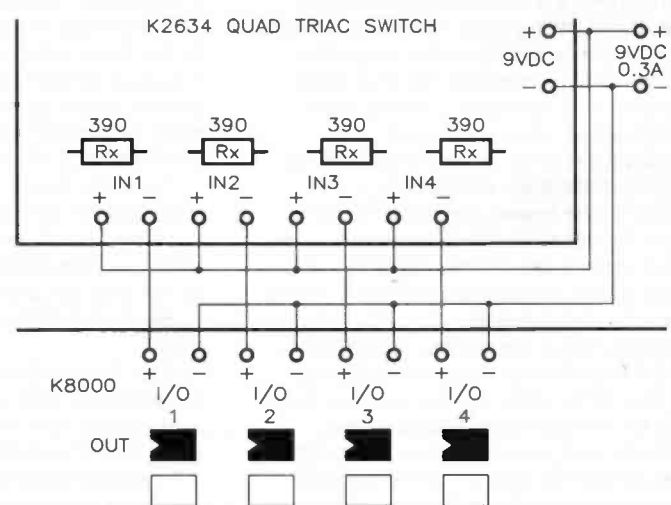

Figure 8h. K8000 interface wiring to the K2634 Quad Triac Switch.



Projects for use in conjunction with the Computer Interface Board. To order, quote Stock Code Number

Project	Stock Code	Project	Stock Code
Thermometer Adaptor	(VE65V)	Quad Triac Switch	(VE97F)
Codelock Receiver	(VE13M)	Universal Relay Card	(VF10L)
Liquid Level Controller	(VF11M)	15-channel Infra-red Receiver	(VE73Q)
Infra-red Codelock	(VE09M)	2-wire 8-channel Communication Receiver	(VE71M)
LED Panel Meter	(VE60Q)	20cm Common Anode Display	(VE51F)
LCD Panel Meter	(VE61R)	Zero Crossing Opto Switch	(LP55K)
Quad Relay Card	(VF00A)	Remote Power Switch	(LP07H)

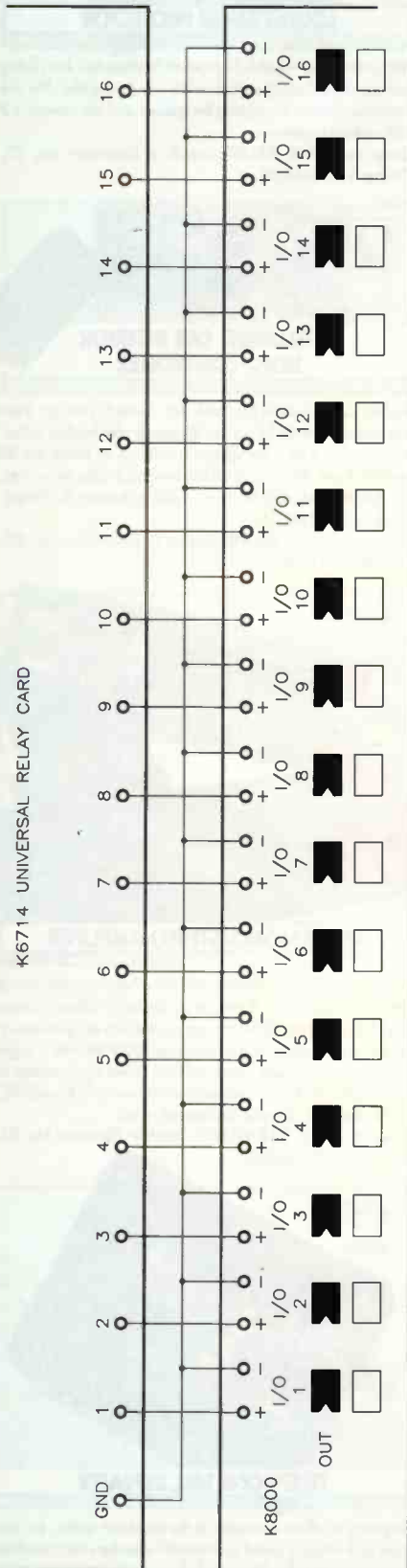

Figure 8i. K8000 interface wiring to the K6714 Universal Relay Card.

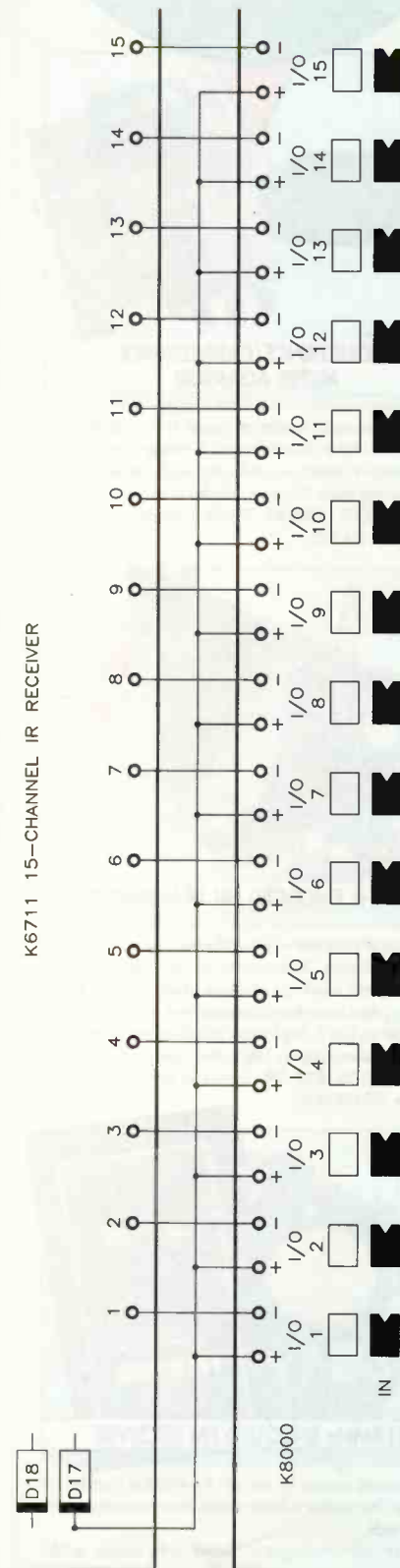

Figure 8j. K8000 interface wiring to the K6711 15-channel Infra-red Receiver.

given in brackets the input impedance will be 200kΩ. With higher input voltages, it is advisable to keep resistor values high, otherwise high power resistors must be used for R. The formula for power dissipation is  $(V^2/R)$  and the formula for attenuation is  $(att = RB/R+RB)$ .

Conversion of current to voltage. In order to avoid interruptions, it is possible for a variable current as the reference input value which is used for current to voltage conversion. A variable current from 4 to 20mA is converted to a voltage of 0.8 to 4V. Fit a link for R,  $RB = 200\Omega$ , CA is left open circuit.

## Connector Numbering

Input/output numbering is important, especially when several interface boards are used together, as the numbers will be used by the control programs. Cut out the desired number from the label provided.

Input/output (I/O): I/O1 to I/O16, or if used as slaves; I/O17 to I/O32; I/O33 to I/O48 or I/O49 to I/O64.

Analogue outputs (DAC): DAC1 to DAC8, or if used as slaves; DAC9 to DAC16; DAC17 to DAC24 or DAC25 to DAC32.

Precision analogue output (DA): DA1, or if used as slaves; DA2, DA3 or DA4.

Analogue inputs (AD): AD1 to AD4, or if used as slaves; AD5 to AD8, AD9 to AD12 or AD13 to AD16.

## Testing

Prior to testing the interface with a computer, a number of 'passive' tests can be done. However, this involves the interface being powered from the mains supply, a suggested mains wiring diagram is shown in Figure 5. The interface should therefore be installed into a suitable enclosure before ANY tests are carried out.

Apply power to the interface; normally no LEDs will illuminate. Using a multimeter set to read 20V DC, check the voltage between the +5V and GND test pins.

Connect one end of a test lead to the GND pin, then in turn connect the free end of the test lead to the test pins numbered 1 to 16; the LED associated with that channel should illuminate.

There are two test programs included on the disk with the kit, the program TSD8000D.EXE can be operated from DOS, and the program DOSTST8000W.EXE from Windows. The programs are self-explanatory.

Global card variables are shown in Table 2.

## Connection and Use

The interface board can be connected to the computer parallel port via a standard D25M to D25F PC cable. If a printer is not required, then the cable can be made as shown in Figure 6; with the cable length up to 10m.

Continued on page 54.

These descriptions are necessarily short. Please ensure that you know exactly what the kit is and what it comprises before ordering, by checking the appropriate issue of *Electronics* referred to in the list.

The referenced back-numbers of *Electronics* can be obtained, subject to availability, at £2.10 per copy.

Carriage Codes - Add; A: £1.55, B: £2.20, C: £2.80, D: £3.30, E: £3.90, F: £4.45, G: £5.35, H: £6.00.

# DID YOU MISS THESE PROJECTS?

The Maplin 'Get-You-Working' Service is available on all of these projects unless otherwise indicated.

To order Project Kits or back-numbers of *Electronics*, phone Credit Card Sales on (01702) 554161. Alternatively, send off the Order Coupon in this issue or visit your local Maplin store.

**Maplin: The Positive Force In Electronics**

All items subject to availability. Prices include VAT.

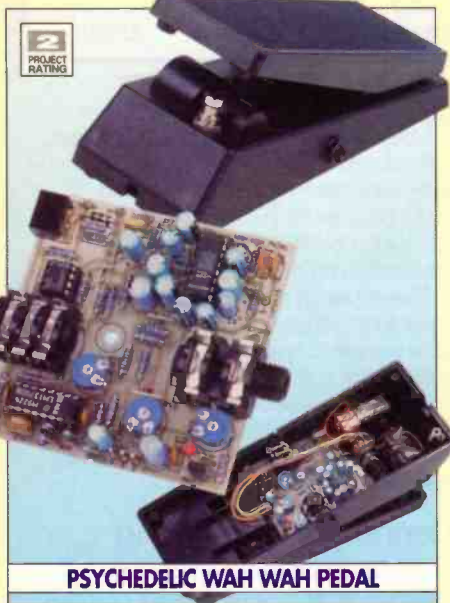

**PSYCHEDELIC WAH WAH PEDAL**

Recapture the classic sound of the '70s with this superb '90s technology Wah Wah Pedal. The kit includes a ready-made foot pedal and is ideal for electric guitars and other musical instruments. Order as: LT43W, £34.99 B3. Details in *Electronics* No. 82, October 1994 (XA82D).



**2 METRE FM RECEIVER**

An inexpensive 2 Metre frequency modulation (FM) receiver. Ideal for the newcomer just starting out, or for the dedicated enthusiast who wants to monitor a local frequency whilst keeping more sophisticated equipment free. (Case not included in kit) Order as: CP21X, £31.95. Details in *Electronics* No. 83, November 1994 (XA83E).

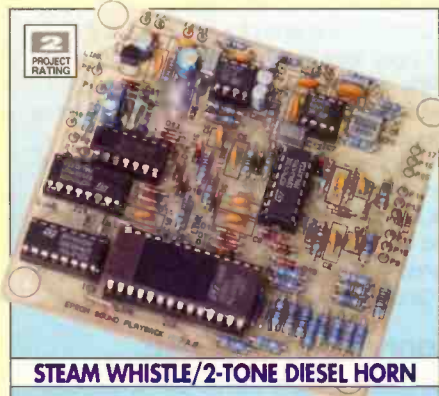

**STEAM WHISTLE/2-TONE DIESEL HORN**

A must for serious model train enthusiasts! Three separate trigger inputs allow either or both sounds to be played. This kit really does include everything - even the whistle and horn sounds are supplied on EPROM!

Order as: LT61R, £14.99. Details in *Electronics* No. 83, November 1994 (XA83E).



**INDUCTANCE/CAPACITANCE METER ADAPTOR**

Add inductance and capacitance ranges to your basic digital multimeter. This clever unit produces a DC voltage proportional to the inductance or capacitance under test, which can be measured by your existing meter. (Case not included in kit.) Order as: RU38R, £39.95. Details in *Electronics* No. 82, October 1994 (XA82D).



**418MHz ENCODED FM TRANSMITTER**

A DTI approved transmitter which can be encoded with one of over 4,000 different codes. The transmitter can be triggered by a closing switch contact, which can be simply a push-button, or a negative going pulsed output from other equipment, e.g., the Telephone Bell Repeater kit, LT67X. Applications include remote control, wireless security systems, paging, help buttons, and much more. Order as: LT87U, £26.99. Details in *Electronics* No. 83, November 1994 (XA83E).



**418MHz ENCODED FM RECEIVER**

A DTI approved receiver for use with the 418MHz Encoded FM Transmitter. The receiver will only respond to a transmitter set with the same code. When a correctly coded signal is detected by the receiver, an LED lights and a piezo sounder operates. Fitting a relay (not supplied) in place of the piezo sounder allows the receiver to operate other electrical equipment for remote control applications. (Case not included in kit.) Order as: LT88V, £39.99. Details in *Electronics* No. 83, November 1994 (XA83E).



**LOUDSPEAKER PROTECTOR**

Help protect your valuable high-power loudspeakers from being damaged by DC voltages produced by a faulty amplifier. This unit constantly monitors the input to the speaker and 'disconnects' it if a DC voltage is detected. Order as: VF44X, £9.49. Details in *Electronics* No. 82, October 1994 (XA82D).



**INTELLIGENT CAR INTERIOR LIGHT CONTROLLER**

Add the convenience of this 'intelligent' device to your car. It not only keeps the interior light on for 30 seconds after the door is shut, but also turns it off if the ignition is switched on before the 30 seconds elapse. Plus, it turns off the interior light after ten minutes if a door is accidentally left open, avoiding draining the battery. (Case not included in kit.) Order as: LF65V, £9.99. Details in *Electronics* No. 82, October 1994 (XA82D).



**400W MONO/STEREO AMPLIFIER**

A compact and robust amplifier with a low harmonic distortion of only 0.003% at 1kHz. It can be configured as either a stereo amplifier producing 100W rms per channel into 4Ω speakers, or as a bridged mono amplifier producing 200W rms into a single 4Ω speaker. Total music output is 400W. Power supply voltage is ±30 to ±35V DC for 4Ω speakers or mono, and ±40 to ±45V DC for 8Ω speakers. (Speaker not included in kit.) Order as: VF40T, £59.99 H10. Details in *Electronics* No. 83, November 1994 (XA83E).



**TELEPHONE BELL REPEATER**

Requiring no direct connection to the telephone system, this unit picks up the ringing sound and repeats it elsewhere via a remotely wired piezo sounder. Alternatively the repeater can be connected to the 418MHz Encoded FM Transmitter and Receiver, LT87U and LT88V, to produce a 'wireless' telephone pager. (Box not included in kit.) Order as: LT67X, £10.99. Details in *Electronics* No. 83, November 1994 (XA83E).

These descriptions are necessarily short. Please ensure that you know exactly what the kit is and what it comprises before ordering, by checking the appropriate issue of *Electronics* referred to in the list.

The referenced back-numbers of *Electronics* can be obtained, subject to availability, at £2.10 per copy.

Carriage Codes - Add: A: £1.55, B: £2.20, C: £2.80, D: £3.30, E: £3.90, F: £4.45, G: £5.35, H: £6.00.

# DID YOU MISS THESE PROJECTS?

The Maplin 'Get-You-Working' Service is available on all of these projects unless otherwise indicated.

To order Project Kits or back-numbers of *Electronics*, phone Credit Card Sales on (01702) 554161. Alternatively, send off the Order Coupon in this issue or visit your local Maplin store.

**Maplin: The Positive Force In Electronics**

All items subject to availability. Prices include VAT.



**CHRISTMAS TREE LIGHT SEQUENCER**

Give your Christmas tree an extra sparkle this year! When coupled to one or more sets of lights, this unit produces various interesting lighting sequences and fade patterns. The unit has three output channels each with a maximum output power of 400W, making it ideal for disco light sequencing, attention-grabbing shop window displays or an extremely bright Christmas tree! (Case not included in kit.)

Order as: LT69A, **£39.99**. Details in *Electronics* No. 84, December 1994 (XA84F).



**VHF CROSSED DIPOLE AERIAL**

This simple to construct VHF aerial has a hemispherical polar pattern, and is suitable for many VHF applications including the MAPSAT weather satellite receiver. (Mast not included in kit.)

Order as: LM00A, **£16.99** B2. Details in *Electronics* No. 85, January 1995 (XA85G).

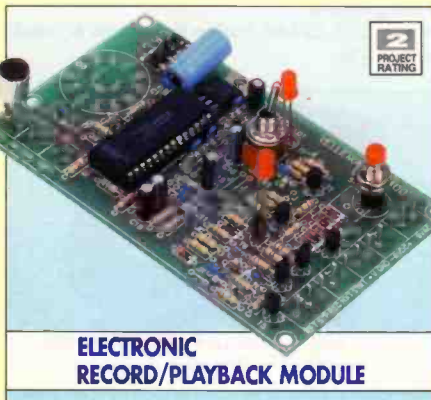

**ELECTRONIC RECORD/PLAYBACK MODULE**

Record and playback messages up to 16 seconds long, with this analogue EEPROM module. The memory is non-volatile, so no battery back-up is required. Ideal for model sound effects, answering machines, etc.

Order as: VF43W, **£29.99**. Details in *Electronics* No. 85, January 1995 (XA85G).



**GAME SCORER**

The ideal companion for games of all kinds that require a score to be kept. Points can be added or subtracted in units, tens or hundreds and cleared to zero at the press of a single button. (Case not included in kit.)

Order as: LT68Y, **£24.99**. Details in *Electronics* No. 84, December 1994 (XA84F).



**2-METRE 30W AMPLIFIER**

An RF power amplifier to boost the output power of low powered 2m equipment. Ideal for extra power when using hand-held transceivers in the car. The amplifier automatically switches from Receive to Transmit when it detects RF from the transceiver.

(Case not included in kit.)

Order as: RU36P, **£39.95** D1. Details in *Electronics* No. 85, January 1995 (XA85G).



**'NEWTON' POWER SUPPLY UNIT**

A low noise, high voltage, power supply, which although designed specifically for the 'Newton' Valve Preamplifier, can also be used as the basis for many other valve audio projects.

Order as: LT75S, **£44.99** B4. Details in *Electronics* No. 85, January 1995 (XA85G).



**IN-CAR AMP PSU**

Especially designed to enable the 400W Mono/Stereo Amplifier (VF40T) featured in November's *Electronics* to be used for in-car audio. Also suitable for other in-car systems requiring a  $\pm 35V$ , 300W, unregulated supply generated from the car's 12V supply. Order as: VF38R, **£66.99** H0. Details in *Electronics* No. 84, December 1994 (XA84F).

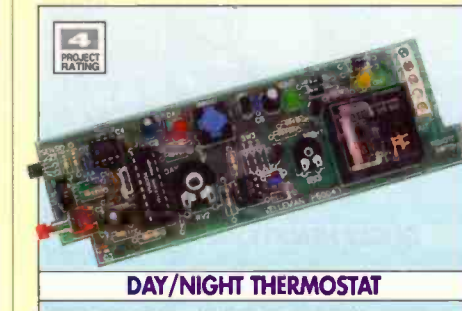

**DAY/NIGHT THERMOSTAT**

Many heating controllers offer only a single fixed temperature setting and On or Off timing. This ingenious, compact thermostat also comprises a timer allowing different temperature settings for day or night, to be automatically selected. Requires only a simple 9 to 12V AC supply.

Order as: VF36P, **£49.99**. Details in *Electronics* No. 84, December 1994 (XA84F).

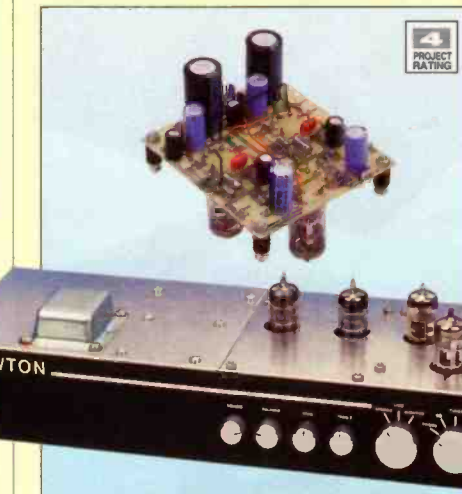

**'NEWTON' RIAA PHONO MODULE**

Part of the 'Newton' Valve Preamplifier project, this phono module comprises an RIAA equalised preamp for magnetic cartridges, and a line driver for auxiliary inputs from CD players, tuners, etc.

Order as: LT76H, **£34.99** A1. Details in *Electronics* No. 85, January 1995 (XA85G).

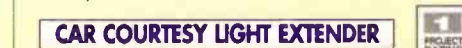

**CAR COURTESY LIGHT EXTENDER**

With the help of a couple of extra diodes, this project, originally featured in *Electronics* No. 44, can double as an automatically setting car anti-theft visual deterrent. (Additional components not included in kit.)

Order as: LP66W, **£3.49**. Details in *Electronics* No. 85, January 1995 (XA85G).

These descriptions are necessarily short. Please ensure that you know exactly what the kit is and what it comprises before ordering, by checking the appropriate issue of *Electronics* referred to in the list.

The referenced back-numbers of *Electronics* can be obtained, subject to availability, at £2.10 per copy.  
 Carriage Codes - Add; A: £1.55, B: £2.20, C: £2.80, D: £3.30, E: £3.90, F: £4.45, G: £5.35, H: £6.00.

# DID YOU MISS THESE PROJECTS?

The Maplin 'Get-You-Working' Service is available on all of these projects unless otherwise indicated.

To order Project Kits or back-numbers of *Electronics*, phone Credit Card Sales on (01702) 554161. Alternatively, send off the Order Coupon in this issue or visit your local Maplin store.

**Maplin: The Positive Force In Electronics**

All items subject to availability. Prices include VAT.



**GUITAR HEADPHONE AMPLIFIER**

Now you can practise in private and without annoying the family or neighbours (where's the fun in that?). Clip this inexpensive project to your belt and throw yourself into your most torturous, ear-wrenching solo and you won't even disturb the cat.  
 Order as: LT80B, **£12.99**. Details in *Electronics* No. 86, February 1995 (XA86T).

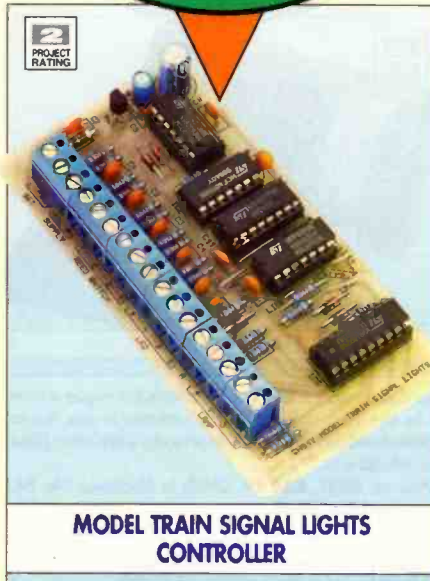

**MODEL TRAIN SIGNAL LIGHTS CONTROLLER**

Build authentic 2, 3 or 4 aspect signalling systems with this superb Signal Lights Controller project. The passage of the train can be detected by magnetic sensors on the track, automatically advancing the signal lights in the correct sequence.  
 Order as: LT66W, **£9.99**. Details in *Electronics* No. 86, February 1995 (XA86T).

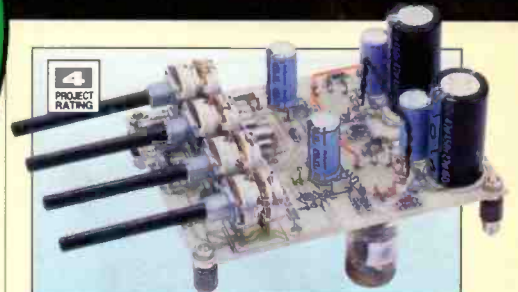

**'NEWTON' VALVE PREAMPLIFIER TONE CONTROL**

Completing the set of modules for the 'Newton' Valve Preamplifier, is this passive stereo valve Tone Control Unit which provides bass boost and cut of +16dB and -12dB @ 20Hz max., and treble boost and cut of +18dB and -19dB @ 20kHz max.  
 Order as: LT77J, **£39.99** A1. Details in *Electronics* No. 86, February 1995 (XA86T).

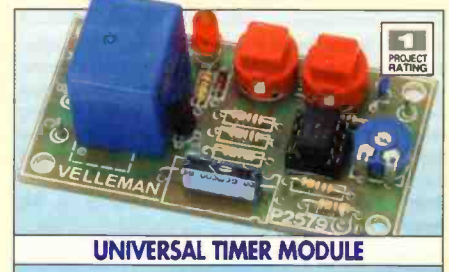

**UNIVERSAL TIMER MODULE**

Employing the classic 555 timer IC, you are sure to find many uses for this Universal Timer project. With a switch-on or switch-off delay variable between 2 seconds and 15 minutes, this timer is ideal for applications like egg-timers, snooze controls and automatic control of equipment like tape recorders etc.  
 Order as: VF06G, **£8.99**. Details in *Electronics* No. 86, February 1995 (XA86T).

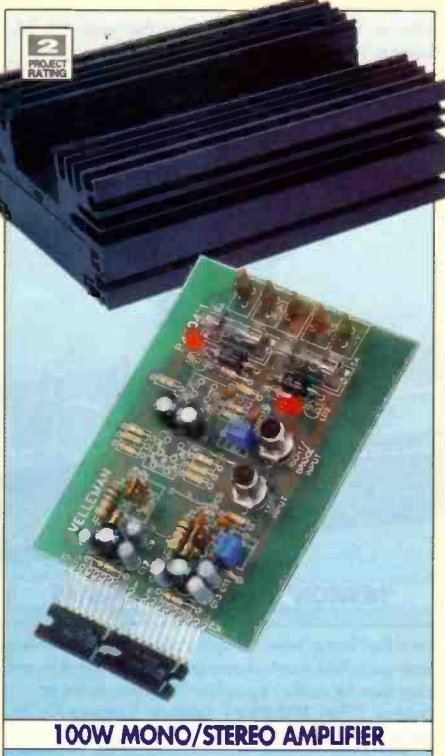

**100W MONO/STEREO AMPLIFIER**

This versatile amplifier module can be configured as either a stereo amplifier producing 50W per channel into 8Ω, 40W per channel into 8Ω, or a bridged mono 100W amplifier. The design features overload and short circuit protection, and speaker 'pop' protection at switch on and switch off. Power supply requirement is ±28V.  
 Order as: VF39N, **£48.49** G8. Details in *Electronics* No. 87, March 1995 (XA87U).



**DISCRIMINATING CONTINUITY & LEAKAGE TESTER**

Test for more than just 'Go' or 'No go' conditions with this ingenious tester. A variety of sound outputs of varying pitch and duration allow you to differentiate amazingly accurately between a good connection and a high resistance one, test for leakage, and check both passive components and semiconductors.  
 Order as: LT78K, **£19.99**. Details in *Electronics* No. 87, March 1995 (XA87U).



**ELECTRONIC MEMOPAD**

Record messages up to 16 seconds long for playback - up to 10 years later! Ideal for memos and messages in the office or home, and a boon to the blind, partially-sighted, and anyone with reading or writing difficulties.  
 Order as: LT79L, **£29.99**. Details in *Electronics* No. 87, March 1995 (XA87U).

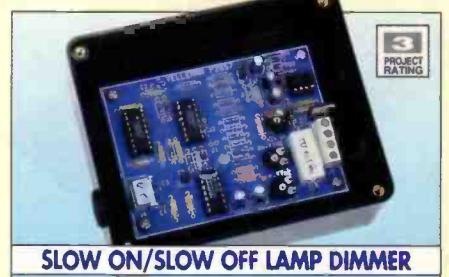

**SLOW ON/SLOW OFF LAMP DIMMER**

Look - no hands! Instead of the normal manual control, this dimmer uses two variable timers to slowly increase or decrease the level of light. Both the 'on' and 'off' timers are variable from 1 second to 30 minutes. Ideal lighting control for slide/film shows, and as a gently reducing 'slumber' switch.  
 Order as: VE51F, **£15.99**. Details in *Electronics* No. 87, March 1995 (XA87U).

# Stray Signals

by Point Contact

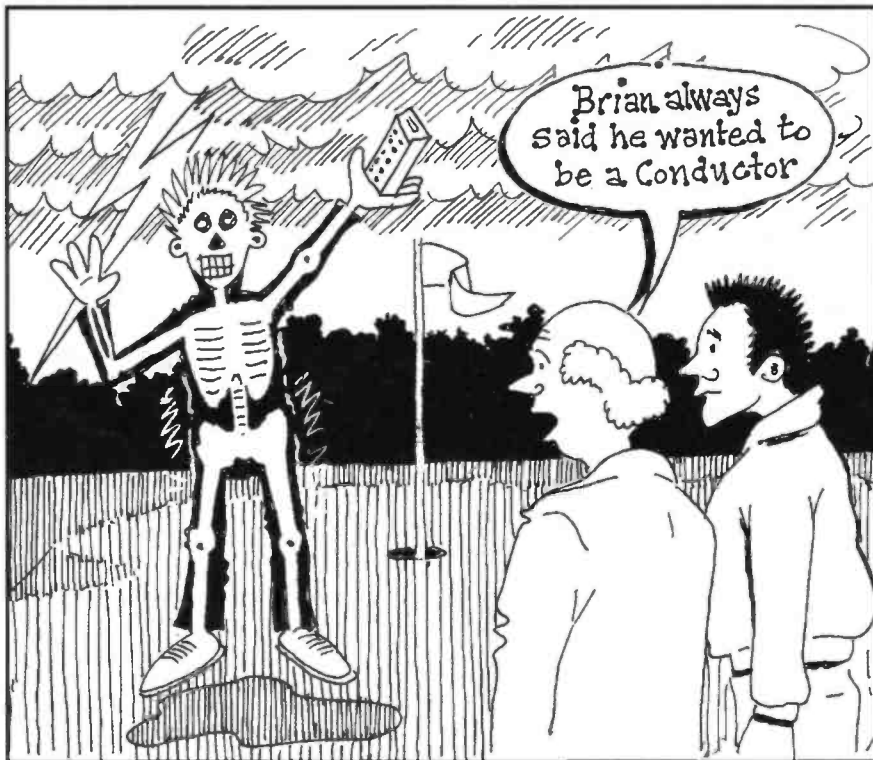

## Technical Advances

PC ceased to be surprised by technological advances, a long time ago – they are always making things bigger and better (or in the case of electronics, smaller and better). For example, last August, NASA announced that a 3m tall eight-legged robot named (appropriately!) Dante II had completed the exploration of the crater floor of Mount Spurr (an active volcano near Anchorage in Alaska). Studded with sensors and armed with eight video cameras, Dante II had spent seven days mapping the surface of the crater, measuring the temperature of the escaping gases and analysing their composition. Unfortunately, whilst climbing out after completing his assignment he toppled over and broke one of his legs, but the press release reassuringly added that helicopter attempts to rescue him were continuing.

Later the same month, in the United States, DEC announced the first commercially-available microprocessor to offer more than 1Gop/s (one billion operations per second). The 9.3 million-transistor Alpha 21164, with its 300MHz clock rate, employs a superscalar architecture. The chip itself measures 16.5mm by 18.1mm, and consumes 40W of power. What the press release did not make clear, is exactly how the chip is prevented from melting!

Only a month later (almost to the day), workers at the French National Centre for Scientific Research announced that they had developed an all-plastic, metal-free transistor. Using modern printing

techniques, thin layers of various materials were built up to construct paper-thin FETs, using plastic-like organic polymers and graphite inks for conductors. The work could eventually result in computer screens which roll up like a window blind for storage, making the bulky display monitor of PC's ancient 8086-based PC even more of an anachronism than it is now. (At the moment, PC is in the throes of getting used to his new Toshiba laptop – a Christmas present from Mrs PC – and converting from his early shareware wordprocessor program to a more modern one for Windows, enabling compatibility with his publisher.)

Among other things where electronics is very useful are little hand-held sensors for various things. Non-contact tachos, and optical pyrometers for measuring furnace temperatures are examples that come to mind. Less popular, with motorists, is the hand-held radar speed meter, whilst another hand-held gadget is now saving lives in the USA.

## Danger to Life and Limb

In the aftermath of the horrendous earthquake in Japan, one is again suddenly aware of the danger to life and limb from the more violent moods of Mother Earth. Fortunately, in these sceptred isles, we are relatively free from such risks. True, various parts are prone to flooding, but this is usually more a threat to property than to life itself, while hurricanes, such as those of 1987 and 1990, are thankfully very rare. The last earthquake to do much damage in Britain was, I believe, in Chelmsford, in

1912 or thereabouts. As in so many other ways, the USA is well to the fore when it comes to natural disasters. Which do you think kills most Americans annually – hurricanes, forest fires, floods, tomados, wild animals, earthquakes? Well, in fact, more people there are killed yearly by lightning than by all the other things put together.

Now, Airborne Research Associates of New England has developed a hand-held lightning sensor which is claimed to give up to 30 minutes advance warning of an impending thunderstorm. For reliability and discrimination, it uses two sensors. One detects the electric field changes associated with lightning discharges, and the other is an optical sensor. This is very sensitive to the minute variations in light level due to cloud-to-cloud flashes, which the eye (having a logarithmic response to light levels) does not see. Thus, golfers, building site workers and others most at risk if caught out in the open, can head for cover before an errant ground strike gets them.

## Tailpiece

The workflow of the Drawing Office at the firm where PC is currently helping out, revolves around an advanced CAD system. Once a PCB is fully drawn and on the database, in addition to being on the network, it will appear in due course under its part number as a microfiche, neatly filed with thousands of others, as well as its circuit diagram, cableforms, etc., in a couple of filing cabinets next to the microfiche viewer. This latter is a splendid piece of equipment, which, at the press of a button, will instantly deliver a print of the drawing onto A3 paper; wonderful! But, if the circuit diagram you are after is not yet on the database, and still only in the CAD system, getting hold of a print is more difficult. First, find a friendly inmate of the D.O., and ask him to help. Then, in due course, by a route of which one is unaware, a drawing is produced, which with luck, finds its way to your desk. Recently, a colleague was heard bemoaning the delay in getting some PRINTS, but later that day, was seen triumphantly showing them off. Apparently, he had resorted to psychological warfare tactics: he explained that he had hit upon the idea of just happening to be passing through the D.O. once an hour, whistling "Some day my PRINCE will come. . . ."

Yours sincerely,

*Point Contact*

The opinions expressed by the author are not necessarily those of the publisher or the editor.

# ELECTRONICS PRINCIPLES 2.0 EDUCATIONAL SOFTWARE

Complete package only  
**£49.95**  
plus £2.00 post and packing.

Visa and Mastercard orders accepted.

Other software available:  
Electronics 'PC' Toolbox 2.0  
£19.95, GCSE Electronics £24.95  
and GCSE Mathematics 2.0 £49.95.

For full details and a demonstration disk send £2.00 per title to:  
EPT Educational Software, Pump House,  
Lockram Lane, Witham, Essex, CM8 2BJ.  
Telephone: 01376 514008

- \* Insulators, Conductors, Resistance
- \* D.C. Circuits
- \* Capacitance and Inductance
- \* A.C. Series Circuits
- \* A.C. Parallel Circuits
- \* Reactance and Impedance
- \* A.C. and D.C. Power
- \* Frequency and Tuned Circuits
- \* Using Numbers
- \* Complex Numbers, Phase Angles
- \* P.N. Junction Diode
- \* Bi-polar and MOSFET transistors
- \* Operational Amplifiers
- \* Logic Gates
- \* Digital Number Systems
- \* Combinational Logic
- \* Flip Flops
- \* Counters and Shift Registers
- \* ROM and RAM Memory
- \* Micro-computer operation

Electronics Principles 2.0 is a major revision of the successful original version reviewed in *Electronics - The Maplin Magazine*, January '94, used by students, hobbyists, schools and colleges, also for training within industry throughout the UK and overseas. Version 2 now includes all the digital and analogue topics (listed left).

"The package is very easy to use and will provide the student, or novice with a more enjoyable alternative to a 'bland' textbook. It certainly makes learning Electronics a lot more interesting! Graphical representation is extremely good with waveforms being produced particularly well..."

J. R. Mosely  
*Electronics*

## SEETRAX CAE - RANGER - PCB DESIGN

**Ranger1 £100**

- \* Schematic capture linked to PCB
- \* Parts and wiring list entry
- \* Outline-(footprint) library editor
- \* Manual board layout
- \* Full design rule checker
- \* Back annotation (linked to schematic)
- \* Power, memory and signal autorouter - £50

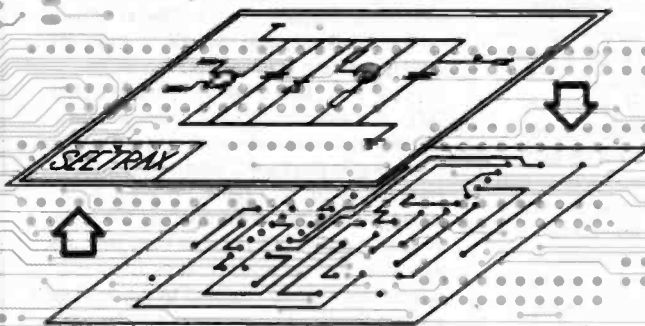

**Ranger2 £599**

All the features of Ranger1 plus

- \* Gate & pin swapping (linked to schematic)
- \* Track highlighting
- \* Auto track necking
- \* Copper flood fill
- \* Power planes (heat-relief & anti-pads)
- \* Rip-up & retry autorouter

**Ranger3 £3500**

All the features of Ranger2 plus

- \* UNIX or DOS versions
- \* 1 Micron resolution and angles to 1/10th degree
- \* Hierarchical or flat schematic
- \* Unlimited design size
- \* Any-Shaped pad
- \* Split power planes
- \* Optional on-line DRC
- \* 100% rip-up & retry, push & shove autorouter

**Outputs to:**

- \* 8/9 and 24 pin dot-matrix printers
- \* HP Desk/Laser Jet, Canon BJet, Postscript (R3 only)
- \* HP-GL, Houston Instruments plotters
- \* Gerber photoplotters
- \* NC Drill Excellon, Sieb & Meyer
- \* AutoCAD DXF

All systems upward compatible. Trade-in deals available.

Call **Seetrax CAE** for further information/demo packs.

Tel 0705 591037

Fax 0705 599036

Seetrax CAE, Hinton Daubnay House, Broadway Lane,  
Lovedean, Hampshire, PO8 0SG

All trademarks acknowledged.

## DIARY DATES

Every possible effort has been made to ensure that the information presented here is correct prior to publication. To avoid disappointment due to late changes or amendments please contact event organisations to confirm details.

**1 to 2 March.** Electronic Books International, Wembley Centre, London. Tel: (0171) 976 0405.

**3, 10, 17, 24 & 31 March.** 'Caught in the Net', Arts Theatre, 6-7 Great Newport Street, London WC2. Tel: (0171) 836 2132.

**7 March.** Junk Sale, Sunbury & District Radio Amateurs, Wells Hall Old School, Great Cornard. Tel: (01787) 313212.

**7 to 9 March.** Computers in Libraries, Wembley Centre, London. Tel: (0171) 976 0405.

**16 to 19 March.** Computer Shopper Show, NEC, Birmingham. Tel: (0181) 742 2828.

**27 March.** Surplus Sale, Stratford-upon-Avon and District Radio Society, Stratford-upon-Avon. Tel: (01789) 740 994.

**4 April.** Antennas, Sunbury & District Radio Amateurs, Wells Hall Old School, Great Cornard. Tel: (01787) 313212.

**7, 14, 21, 28 April.** 'Caught in the Net', Arts Theatre, 6-7 Great Newport Street, London WC2. Tel: (0171) 836 2132.

**9 to 11 April.** European Computer Trade Show, Business Design Centre, London. Tel: (0181) 742 2828.

**10 April.** AGM, Stratford-upon-Avon and District Radio Society, Stratford-upon-Avon. Tel: (01789) 740 994.

**22 April.** Special International Marconi Day, exhibition station at Puckpool Park, Wireless Museum, IOW. Tel: (01983) 567665.

**24 April.** Visit to Sutton Coldfield, Stratford-upon-Avon and District Radio

Society, Stratford-upon-Avon. Tel: (01789) 740 994.

**2 May.** Starting in Contesting, Sunbury & District Radio Amateurs, Wells Hall Old School, Great Cornard. Tel: (01787) 313212.

**5 May.** 'Caught in the Net', Arts Theatre, 6-7 Great Newport Street, London WC2. Tel: (0171) 836 2132.

**8 May.** Working Wartime CW Short-wave Station, to celebrate VE-Day, Puckpool Park Wireless Museum, IOW. Tel: (01983) 567665.

**8 May.** Two Metre Foxhunt, Stratford-upon-Avon and District Radio Society, Stratford-upon-Avon. Tel: (01789) 740 994.

**16 to 18 May.** Internet World, Wembley Centre, London. Tel: (0171) 976 0405.

**6 June.** Using Thermionic Valves, Sunbury & District Radio Amateurs, Wells Hall Old School, Great Cornard. Tel: (01787) 313212.

**12 June.** Open House/Night-on-the-Air, Stratford-upon-Avon and District Radio Society, Stratford-upon-Avon. Tel: (01789) 740 994.

**14 to 15 June.** Government Computing & Information Management, Royal Horticultural Halls, London. Tel: (0171) 587 1551.

**26 June.** Top Band Foxhunt, Stratford-upon-Avon and District Radio Society, Stratford-upon-Avon. Tel: (01789) 740 994.

**27 to 29 June.** Networks Exhibition, NEC, Birmingham. Tel: (0181) 742 2828.

**4 July.** Operating QRP, Sunbury & District Radio Amateurs, Wells Hall Old School, Great Cornard. Tel: (01787) 313212.

Please send details of events for inclusion in 'Diary Dates' to: The News Editor, *Electronics - The Maplin Magazine*, P.O. Box 3, Rayleigh, Essex SS6 8LR.



### Caught in the Net

Caught in the Net captured the imagination of the 1994 Edinburgh Fringe Festival, leaving a twitching trail of reluctant anoraks in its wake. Now the show is moving to the Arts Theatre, London. Rewritten and accompanied by a mind-boggling array of multi-media hardware, including CD-Rom and CD-I technology, video footage, live video feeds and international live link-ups, hi-resolution computer graphics and a few sampled surprises, *Caught in the Net* will be a weekly global event, making history as the first truly interactive West End show. The show will also feature special guests from London's comedy scene and travellers in Cyberspace will be invited to

drop in. Venue: Arts Theatre, 6-7 Great Newport Street, London WC2; Dates: Please refer to listing information; Box Office: (0171) 836 2132; Tickets: £5.00/£7.50.

### National Computer Shopper Show - Birmingham NEC

The National Computer Shopper Show is coming back to Birmingham after its successful launch last year. The show is for everyone from first-time buyers to experienced users; from dedicated home-users to business people buying systems for their homes or offices. Claiming to be the largest forum for anyone looking for personal computers,

peripherals and software, the Computer Shopper Show offers visitors free and independent buying advice plus the opportunity to get hands-on experience before they buy. With two shows a year, and an annual attendance of more than 50,000 visitors, the Computer Shopper Show is the only UK event where vendors can meet a huge audience who come specifically with the intention of making a purchase, consequently visitors can expect huge bargains. Venue: NEC, Birmingham; Dates: 16 to 19 March; Ticket hotline: (0121) 767 4343; Tickets: £8 for adults, £5.50 for under 16s and OAPs.

*Shopper Show money-off coupon on page 37.*

## FOR BARGAINS AND MORE, VISIT YOUR LOCAL STORE!

For personal service, visit our stores at:

- Belfast** 357-359 Lisburn Road.
  - Birmingham** Sutton New Road, Erdington.
  - Bradford** 28 Valley Road, Ham Strasse.
  - Brighton** 65 London Road.
  - Bristol** 302 Gloucester Road, Horfield.
  - Cardiff** 29-31 City Road, Routh.
  - Chatham** 2 Luton Road.
  - Cheetham Hill** 169 Cheetham Hill Road, Cheetham Hill.
  - Coventry** 12 Bishop Street.
  - Dudley** Unit 7, Sterling Park, Pedmore Road, Brierley Hill.
  - Edgware** 146-148 Burnt Oak, Broadway.
  - Edinburgh** 126 Dalry Road, Dalry.
  - Forest Hill** 107-113 Stanstead Road.
  - Glasgow** 264-266 Great Western Road.
  - Hammersmith** 120-122 King Street.
  - Ilford** 302-304 Green Lane.
  - Leeds** Carpet World Building, 3 Regent Street.
  - Leicester** Office World Building, Burton Street.
  - Liverpool** Edge Lane, Fairfield.
  - Manchester** 8 Oxford Road.
  - Middlesbrough** Unit 1, The Forbes Building, 309-321 Linthorpe Road.
  - Milton Keynes** Unit 2, Office World Building, Snowdon Drive, Winterhill.
  - Newcastle-upon-Tyne** Unit 4, Allison Court, (The Metro Centre) Gateshead.
  - Northampton** 139 St. James Road.
  - Nottingham** 86-88 Lower Parliament Street.
  - Portsmouth** 98-100 Kingston Road.
  - Preston** Unit 1, Corporation Street.
  - Reading** 129-131 Oxford Road.
  - Sheffield** 413 Langsett Road, Hillsborough.
  - Slough** 216-218 Farnham Road.
  - Southampton** 46-48 Bevois Valley Road.
  - Stockport** 259-261 Wellington Road South.
  - Stoke-on-Trent** 39-45 London Road.
  - Southend-on-Sea** 282-284 London Road.
- Ring 01702 552911 for further details.

## MAPLIN STORES NATIONWIDE

## PCB and SCHEMATIC C.A.D.

### EASY-PC

**£98**  
+VAT & P+P

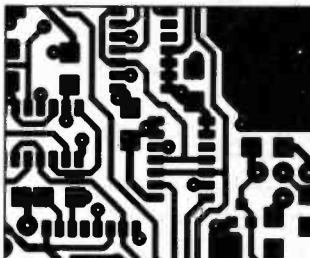
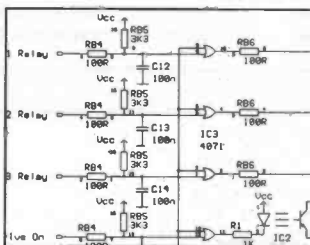

- Runs on PC/XT/AT/286/386 with Hercules CGA, EGA or VGA and many emulations.

- Design Single sided, Double sided and Multilayer boards.

- Use Surface Mount components.

- Standard output includes Dot Matrix / Laser / Inkjet printers, Pen Plotters, Photo-plotters and NC Drill.

- Award winning EASY-PC is in use in over 18,000 installations in 80 Countries World-Wide.

- Superbly Easy to use.

Options - 500 piece Surface Mount library - £48.00  
1000 piece symbol library - £38.00. Gerber Import facility - £98.00

For full info' please phone, fax or write to:

**Number One Systems Ltd.**

Ref: MAP, Harding Way, Somersham Road,  
St. Ives, Huntingdon, CAMBS, England, PE17 4WR  
Telephone:- 0480 461778 (7 lines) Fax: 0480 494042  
International:- +44 480 61778 Credit Cards Welcome



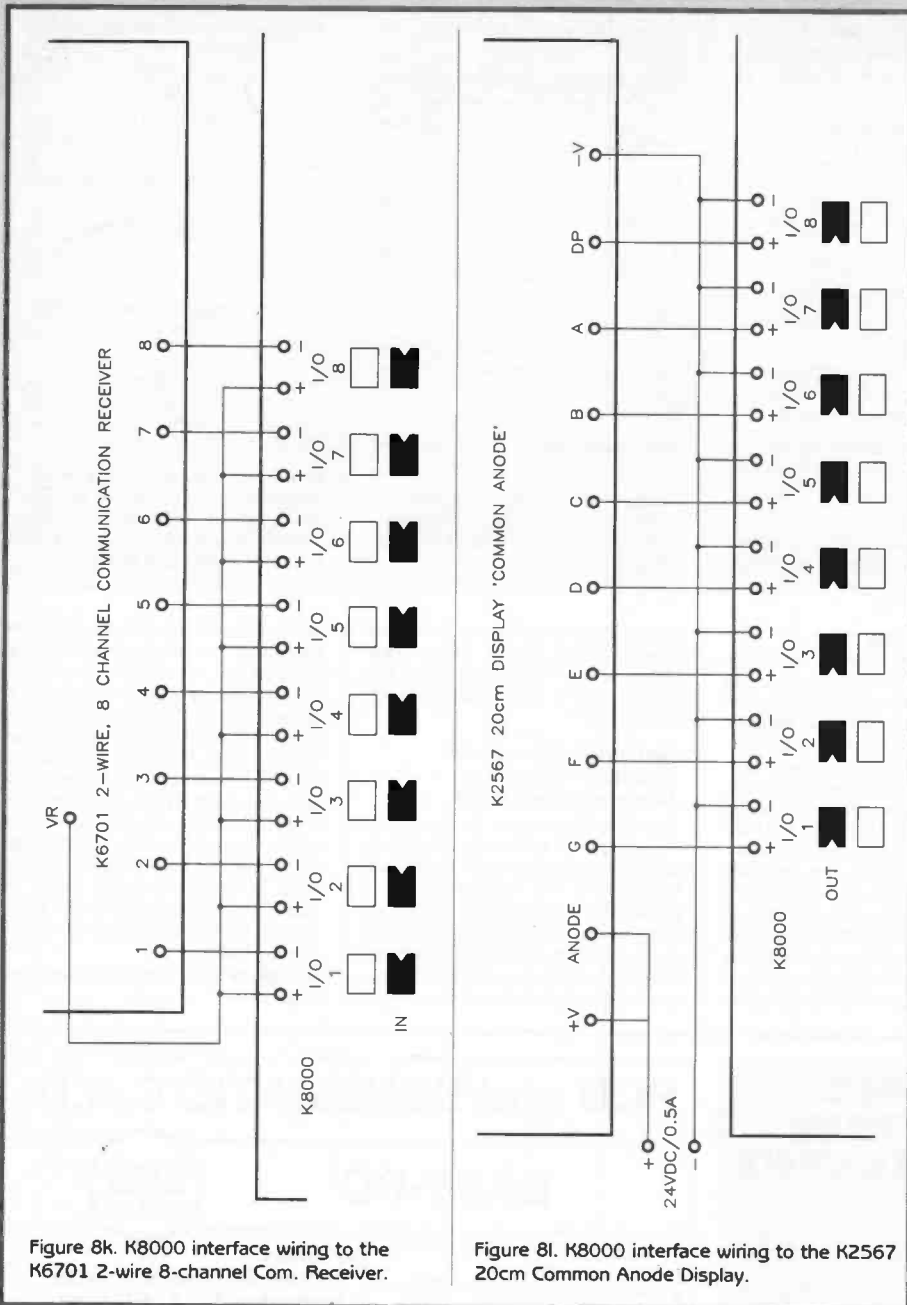

If a printer is required, then the cable length should be kept as short as possible to avoid data corruption; a standard parallel PC Centronics printer cable can then be used to connect the printer to the interface board.

If the interface has been built as a slave unit, then three 'loop through' connections between each of the cards 'SDA', 'SCL' and 'GND' terminals MUST be made via the three pole connector J31.

With the Interface board connected to the computer via a suitable connector, decide on whether to use the MSDOS™ or MSWINDOWS™ based program. Do not connect the printer to the interface at this stage. Power up the board, there should not be any LEDs illuminated. Run the selected program and follow the instructions. First set up the parallel port LPT0, LPT1 or LPT2. Most PC's will have a parallel port normally designated LPT1.

### Overview of Connection Types

The following drawings are an overview of the connection types:

1. Digital input. Figure 7a. Voltage input.
2. Digital output. Figure 7b. Relay output. Figure 7d. TTL output.
3. Analogue input. Figure 7c. Potentiometer.
4. Analogue output. Figure 7e. DC controlled device.

The interface board has many uses, and can be connected to other projects, such as shown in Figures 8a to 8l, and in Figures 9a to 9b.

Please note that the text files on disk are in multiple languages, i.e. English version MAN\_GB.

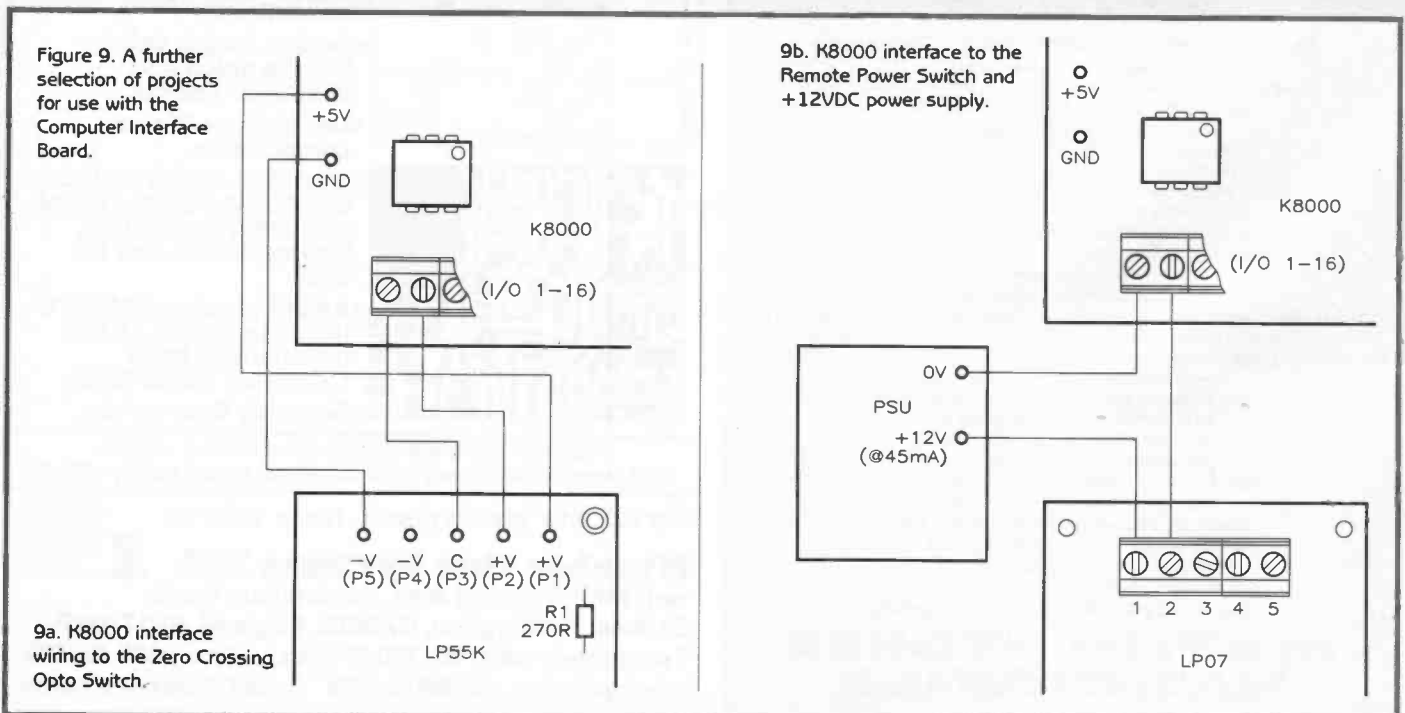



## COMPUTER INTERFACE BOARD PARTS LIST

RESISTORS: All 0.25W 5% Metal Film (Unless specified)

R1-R16	100Ω	16
R17-R19	150Ω	3
R20	150Ω	1
R21-R36	220Ω	16
R37,R38	1k	2
R39-R45	4k7	7
R46,R47	4k7	2
R48	1k8	1
R49	10Ω 0.5W	1
R50-R65	470Ω 1W	16
RV1,RV2	10k	2

### CAPACITORS

C1-C9	100nF Monolithic Ceramic	9
C10-C19	100μF 16V Electrolytic	10
C20-C21	470μF 16V Electrolytic	2
C22	2200μF 25V Electrolytic	1

### SEMICONDUCTORS

LD1-LD19	3mm Red LED	19
VR1	UA7812	1
VR2	UA7805	1
IC1-IC16	4N33	16
IC17,IC18	PCF8574A	2
IC19	TDA8444	1
IC20	PCF8591	1
IC21	74LS125	1
IC22-IC24	6M136	3
D1-D16	1N4148	16

D17-D24	1N4001	8
ZD1	4.7V Zener	1
MISCELLANEOUS		
J1-J30	2-way Terminal Connector	30
J31	3-way Terminal Connector	1
J32	25-way D-type Plug PCB Mount	1
J33	25-way D-connector Socket PCB Mount	1
SW1	DIL DIP Switch	1
	6-pin DIL IC Socket	32
	8-pin DIL IC Socket	3
	16-pin DIL IC Socket	5
	PCB pins	18
	PCB	1
	Heatsink	1
F1	T250mA Fuse	1
	20 x 5mm PCB Fuseholder	1
Transf01	Transformer 15V	1
Transf02	Transformer 6V	1
RY1	Relay	1
	Disk	1

The Maplin 'Get-You-Working' Service is available for this project, see Constructors' Guide or current Maplin Catalogue for details.  
**The above items are available in kit form only.**  
**Order As VF54J (Computer Interface Board) Price £84.99**

Please Note: Some parts, which are specific to this project (e.g., PCB), are not available separately.

### WANTED

**OLD STYLE VALVE AMPLIFIER** for enthusiasts project. Mono or stereo, working or not. Also wanted, old QUAD Electrostatic speakers, any condition. Tel: P. Ward. (0116) 2918504.

### AUDIO

**BOSE 301/3 SPEAKERS**, £270. Bantham 96-way 1U patchway, £150. DENON PRA1500 remote control preamp, £150. ADCOM 100+100W stereo slave amplifier. AKD D190 microphone, £85. All as new, unused. Tel: (01953) 883533 (Norfolk).

**WURLITZER, SIDE MAN**. Drum machine model 5000, collectors item. Made in late '50s, early '60s. Valve and mechanically operated. In full working order. £300 o.n.o. Tel: Ian Marshall (01536) 81900.

### MAPLIN 5600 SYNTHESIZER

Fully assembled and in working order. Hardly used offers?  
 Tel: (01923) 236486 (Watford, Herts).

### VARIOUS

**ICL848 EMULATOR** for Texas 77C82 microcontroller. Unwanted acquisition. Offers. 8-gang EPROM Programmer, programs up to 1MB EPROMS. £100.

Tel: Mr. Pickering (0161) 485 7367.  
**UV EXPOSURE UNIT** (for double-sided PCBs), Transistor Tester, Imac RS232 Multiplexors, Mega insulation tester,

# CLASSIFIED

Placing an advertisement in this section of *Electronics* is your chance to tell the readers of Britain's Best Selling Electronics Magazine what you want to buy or sell, or tell them about your club's activities—Absolutely Free of Charge! We will publish as many advertisements as we have space for. To give a fair share of the limited space, we will print 30 words free, and thereafter the charge is 10p per word. Placing an advertisement is easy! Simply write your advertisement clearly in capital letters, on a post-card or sealed

down envelope. Then send it, with any necessary payment, to: Classifieds *Electronics—The Maplin Magazine*, P.O. Box 3, Rayleigh, Essex SS6 8LR. Advertisements will be published as soon as possible, space allowing. No responsibility is accepted for delayed publication or non-inclusion of advertisements.

Readers who have reasonable grounds to believe they have been misled as to the nature of an advertisement are advised to contact the Publisher and their local Trading Standards Office.

RGB monitor suits BBC Computer, AVO8 multimeter plus resistance and current extension units, Octal based industrial timers and relays, LPL Photographic enlarger, UV PROM Eraser, printer switch 4-way, answering machine, Brother HR40 printer, boxes of fuses, speed controller for mini tools, thermocouples and related measuring equipment. Tel: (01676) 533892 for further details (West Midlands near NEC).  
**FERROGRAPH RTS 2** test set, needs attention hence £75. **ADVANCE J2 AF**

Generator working £25. 2 Gould OS 255 15MHz scopes 1 working 1 needs attention. £50 the pair. Tel: (0181) 556 0770.

### CLUB CORNER

**SEEMUG** (South East Essex Mac User Group), meet in Southend second Monday each month. For details Tel: Michael Foy (01702) 468062, or e-mail to mac@mikefoy.demon.co.uk.

**WIRRAL AND DISTRICT AMATEUR RADIO SOCIETY** meets at the Irby Cricket Club, Irby, Wirral. Organises visits, DF hunts,

demonstrations and junk sales. For further details, please contact: Paul Robinson (G0JZP) on (051) 648 5892.

### SOUTHEND & DISTRICT RADIO

**SOCIETY**. Meets at the Rocheway Centre, Rochford, Essex every Friday at 8pm. Details F. Jensen (G1HQQ) P.O. Box 88, Rayleigh, Essex SS6 8NZ.

### CRYSTAL PALACE & DISTRICT RADIO

**CLUB**. Meets on the third Saturday of each month at All Saints Church Parish Rooms, Beulah Hill, London SE19. Details from Wilf Taylor, G3DSC. Tel: (081) 699 5732.

### WIRRAL AMATEUR RADIO SOCIETY

meets at the Ivy Farm, Arrowe Park Road, Birkenhead every Tuesday evening, and formally on the 1st and 3rd Wednesday of every month. Details: A. Seed (G3FOO), 31 Withert Avenue, Bebington, Wirral L63 5NE.

### BBS CORNER

**APPLE CRACKERS**. FirstClass Client BBS, mainly for AppleMac and PC users. Baud rate 2.4K-bit/s to 14.4K-bit/s, 8 data bits, no parity, 1 stop bit. Tel: (01268) 781318/780724.

**MACTEL METRO/ICONEX**. FirstClass Client BBS, AppleMac and PC users. E-mail address on Internet for registered users. Baud rate 2.4K-bit/s to 14.4K-bit/s, 8 data bits, no parity, 1 stop bit. Tel: (0181) 543 8017 (Metro) or (01602) 455444 (Iconex).



There are more terrific projects and features heading your way in next month's super issue of *Electronics - The Maplin Magazine*, including:

### PROJECTS

#### RS232 SERIAL LINE TESTER

This compact, multifunction tester will pinpoint problems with your RS232

equipment speedily, allowing troubleshooting of VDU terminals, printers, modems, multiplexers and RS232 cabling. Also provides an introduction to the world of PIC microcontroller-based projects.

#### VOICE VANDAL

An audio signal distortion unit, to transform speech input, by means of digital signal processing, and selective feedback, into an altered form, ranging from mild to wild! Also incorporates switchable echo of adjustable depth.

#### STEREO RIAA CORRECTION PREAMP

Dig out your old record collection, and relive a bygone era, by replaying them through your modern RIAA stereo CD amplifier, using this preamp to correctly match the turntable, ensuring optimum enjoyment of those vinyl sounds.

#### SUPERSCAN

Dramatically improve the reception of

your UHF/VHF/HF radio equipment, by building this high gain, wideband surface-mount technology active aerial, aimed primarily at scanner receivers, for enhanced capture of Amateur, CB, Aircraft, Marine, Emergency Services, Television and Taxi frequencies, over the standard scanner whip aerial.

#### BATTERY SAVER

Conserve energy! This circuit can be built into most battery-powered equipment, to provide automatic power-down after a chosen period, avoiding annoying and costly battery drain in the event of equipment being accidentally left on.

#### FEATURES

Special features include: 'Compact Disc Interactive', describing everything you wanted to know concerning the latest developments of CD-i, the interactive audio, visual system that is taking the multimedia market by storm,

with its wide-ranging, revolutionary applications for consumer and industrial electronics, whilst 'Development of the Defibrillator' outlines the development of this, literally shocking, piece of emergency-service equipment, a saver of thousands of lives. New series include 'Sailing Ships to Satellite', chronicling the history of ship communications systems, 'The Art of Electronic Music' begins a four-part investigation into the evolution of synthesizers, and we continue with 'The History of Electronics' and 'RIAA - Design Considerations' series.

**All this, plus all your favourite regulars as well!**

Reserve a copy at your newsagents or take out a subscription NOW to avoid disappointment!

## ELECTRONICS - THE MAPLIN MAGAZINE

BRITAIN'S BEST SELLING ELECTRONICS MAGAZINE.

# NEWS

## Report

### UK - Video Game Advertising to be Regulated

The British Advertising Standards Authority (ASA) has announced it is extending its coverage to include video games advertising, following a number of complaints over violent adverts appearing in children's games for stronger games aimed at a more adult audience. The problems stem, from the recent take-up of adverts for other games being included, either in the printed materials within a games box, or even in the game itself, without notice being made on the cover of the box. As with video cassettes and film trailers, the games industry must now take care to include only that advertising material which is deemed suitable for the age group of the game being bought. According to the ASA, another problem arises from the product placement of ads for sports equipment, such as Nike and Adidas, in the game material. ASA officials claim that children are too impressionable to allow them to look through advertising material without supervision. Sports goods manufacturers, meanwhile, claim that their advertising material in games is passive, and at the same level as general TV and media advertising.

Contact: ASA, Tel: (0171) 580 5555.

### Survey Reveals Frame Relay and ISDN set to Explode

Major UK network users are not planning to revolutionise their networks, they are not planning dramatic increases in bandwidth availability at the desktop, and they are not planning wholesale adoption of ATM. Equally, multimedia applications will not achieve huge sales yet, but Frame Relay and ISDN technology will both experience dramatic growth over the next two years. These are the conclusions of a comprehensive survey of over 620 major UK network users conducted by Alcatel Data Networks at the end of last year.

Contact: Alcatel Data Networks, Tel: (01256) 843254.

### Ethernet Running on Flat Telephone Wire

Tut Systems has announced the UK release of its Silver Streak product range, a full-speed (10M-bit/s) Ethernet solution to run across ordinary flat telephone cable. The Silver Streak range provides network users with the productivity gains of high performance networking in a low-cost system. Users can create an Ethernet network by attaching a Silver Streak Connector to the AUI port of a PC (AAUI on Macintosh). These drop boxes can then be daisy-chained together using ordinary telephone wire to build a network of up to 30 nodes over a distance of 185m. Tut Systems claim that no significant technical expertise is required.

Contact: Tut Systems, Tel: (001) 510 682 6510.

### Triple Clock Generator

The W42C26 available from IC Works is a unique single VCO clock generator with three simultaneous clock outputs, which is designed to supply a 14.318MHz system clock, a 7.2MHz keyboard clock and a selectable CPU clock. Operating from a single 5V or 3.3V supply, it offers smooth glitch-free transitions for 'Green PC' power management systems, which conserve power by matching the system clock speed to the task.

Contact: METL, Tel: (01844) 278781.

### PerfectOffice 3.0 for Windows

Novell UK has announced that PerfectOffice 3.0, its first desktop application suite, is available in the UK by the end of January 1995. PerfectOffice 3.0 combines WordPerfect with applications in six different categories. The new product goes beyond traditional suites by offering superior program integration with PerfectFit technology, task automation with the first cross-application script-

ing language and network benefits for both end-users and IT managers. PerfectOffice 3.0 is also the first suite to include workgroup publishing tools for collaborative computing across networks. Until 30th April 1995, users of any version of Novell's business application or NetWare can upgrade to PerfectOffice Standard 3.0 from £149.

Contact: Novell, Tel: (01344) 724 000.

### Japan Out of Numbers

A Ministry of Posts and Telecommunications (MPT) survey suggests that Japan's cellular telephone system will run out of new subscriber numbers as early as next spring unless action is taken. It has responded by establishing a study group to examine the issue, and expects to announce a new policy next January. At present, all cellular phone numbers are seven-digit codes prefixed by 030 or 040 depending on distance. The proliferation of service providers, and the policy of allocating a separate code to each, means that the system is unable to accommodate its theoretical 10 million subscriber capacity, restricting it in practice to about six million. Options under consideration include adding 080 and 090 prefixes, and allocating an extra digit to the number itself.

### Computers to Russia

In an event which truly signals the end of a major trade barrier between the US and Russia, two Cray supercomputers have been ordered by Rosgidromet, the Russian Federal Service for Hydro-meteorology and Environmental Monitoring in Moscow. According to Frank Parisi of Cray, this is the first supercomputer sale to Russia by any company. The contract includes the supercomputers, third-party equipment and software. Also involved is the construction of a dedicated computer room to house the systems and related equipment. Installation of the Crays is scheduled for mid-1995.

Contact: Cray, Tel: 0101 612 683 7395.

### High-Speed LAN

Two industry leaders, Texas Instruments and Compaq Computer Corporation, have joined together to develop a new networking architecture capable of high speeds and flexible enough to accommodate different protocols. This new technology, known as ThunderLAN, is designed to provide networking customers a clear path to 100 to 200M-bit/s networking for existing local area network (LAN) environments. This new architecture, which supports either of the high-speed Ethernet standards (100 Base-T or 100 VG-AnyLan), increases performance up to ten times over that of existing LAN implementations.

Contact: Texas Instruments, Tel: (01234) 223511.

### UK Phone Trouble

Despite announcing the full extent of the trunk code renumbering scheme two years ago, OfTel, the Government appointed telecoms watchdog, is having to undertake a massive advertising campaign to get the message across that virtually all geographic trunk codes have changed. Although the new codes started operating last summer, the old codes continue to be supported by the network, but this parallel working ceases on April 16 this year. At that point, only the new codes will work. British Telecom has admitted that they are worried that many businesses are still unaware of the code changes, which require the insertion of an extra 1 before the current dialing code, after leading zero for trunk access. International calls, which do not require the '0' trunk access code, will need an extra 1 after the 44 country code. Phone subscribers in Bristol, Leeds, Leicester, Nottingham, and Sheffield have got a new set of trunk codes, as well as a new phone number created by adding a single digit to their existing numbers. The new codes for the five cities are as follows: Leeds 0113; Sheffield 0114; Nottingham 0115; Leicester 0116 and Bristol 0117. Leeds, Sheffield, and Leicester numbers have switched to seven digit working by the insertion of a leading 2. For example, Leeds 123456 will become Leeds 212 3456. Nottingham and Bristol, meanwhile, will use a 9 in place of the 2. BT has set up a 24-hour customer response centre to discuss Phoneday related matters, as well as offering to send out more information if required. The number, which is accessible free of charge from anywhere in the UK, is (0800) 010101.

Contact: British Telecom, Tel: (0171) 356 5369.



### Budget PCs

Siemens Nixdorf Information Systems has launched Scenic, a budget range of PCs, into the UK market. The cost reduction has been achieved by removing many of the enhanced security features required by specialist users, sliding disk covers, and integrated network connections. £942 buys the Scenic 4L, a 25MHz 80486SX-based system with

4Mb of memory and a choice of hard disks. Flagship of the Scenic series is the £2,000 Scenic 5T Pentium-based Tower system.

All machines come with Windows for Workgroups 3.1 and MS-DOS 6.2, pre-installed at the factory.

Contact: Siemens Nixdorf, Tel: (01344) 862 222.



### Portable Cut Price Printing from HP

Hewlett-Packard has slashed the price of its DeskJet 320 and DeskWriter 320 series of portable inkjet printers by 11%. The company claims that the price cuts make its mobile inkjets more accessible to notebook PC and Mac Powerbook users. Both the Deskjet 320 and DeskWriter 320 series with cut-sheet feeder, are priced at £249, effective immediately, while the non-cut-sheet feeder-equipped versions are reduced to

£229. The DeskJet 320 and the DeskWriter 320 can print three pages of black text per minute and a colour page in about four minutes. The printers support a variety of paper media as well as transparency film and labels. The cut-sheet feeder offers automatic feeding of up to 60 sheets of paper or 20 sheets of transparency film. Contact: Hewlett Packard, Tel: (01344) 360 000.

### ABS Microcontrollers

Texas Instruments has signed an agreement with ITT Automotive of Frankfurt, Germany, to supply them with customised microcontrollers, based on TI's proven PRISM methodology. The TI microcontrollers will enable ITT to integrate more integration for lower costs, time to market and higher system speed into its market leading anti-lock braking system (ABS). Under the agreement, TI is expected to ship more than eight million of its 8-bit and 16-bit customised microcontroller systems annually by 1997, and up to ten million systems by the year 2000. They will be used in ABS systems installed in high, medium and low-range vehicle models.

Contact: Texas Instruments, Tel: (01234) 223511.

### Mobile Data

Cellnet, the main rival to Vodafone, which launched its data over GSM (Global System for Mobile Communications) digital mobile phone network, is claiming to have caught up, and even overtaken Vodafone GSM with its new GSM data service. Effective immediately, Cellnet GSM users are able to send and receive data and fax using their mobile. Vodafone users will have to wait until the start of the new year for their outbound fax service, as well as inbound services. According to Cellnet officials, however, the Cellnet Digital Data service is the only mobile data product in the UK capable of transmitting data both to and from a mobile phone.

Contact: Vodafone, Tel: (01635) 33251; Cellnet (01753) 504000.

### EPROM Prices on Downward Spiral

EPROM (Erasable, Programmable Read-Only Memory) prices are continuing to decline, as demand for discounts from users intensifies, and low-priced imports, especially from Taiwan, are increasing rapidly. Excess supplies of flash memory chips is also making it dif-

ficult for EPROM prices to bounce back. Volume-user one megabit (Mb) chip prices are between 200 and 290Yen (£1.30 to £1.90), down 30% from the beginning of the year. Some foreign chips are reportedly priced below 200Yen (£1.30).

### Device Links Phone and TV

AT&T has announced the TV Information Centre, a gadget that connects a television and a telephone to let consumers pay bills, view news and sports updates, check stock prices, and sift through phone messages on their television screens. The AT&T TV Information Centre will take information delivered over ordinary telephone lines and display it on the TV screen. To operate it, people will use hand-held remote control units like those that change channels on TV sets today. In fact, AT&T said its remote control will be able to operate many brands of TV sets and videocassette recorders as well as the AT&T device. Information will be downloaded to the TV Information Centre in packets at times set by the customer, so the phone line will not be tied up all the time the customer is using the device.

Contact: AT&T Consumer Products, Tel: (001) 201 581 4067.

### Subliminal PC Exposure

The average movie goer or television viewer may not give it a thought, but the brand of personal computer that appears, even briefly, in movies like *City Slickers II* or television shows like *NYPD Blues* is big business. Indeed, computer company Compaq is aggressively seeking that exposure as another way to reach consumers. Producers do not pay for the use of the machines. Compaq, and other PC companies loan the machines to the shows in order to get the exposure. According to Gian Carlo Bisone, Compaq Vice President of North American marketing, television and film placement is an important marketing strategy to reach consumers and reinforce the growing role of PCs in homes and businesses. "Product placement in films and television series provides very positive exposure for us, and we plan to increase our activity in this area".

Contact: Compaq, Tel: (001) 713 374 2510.

### Microsoft to Introduce Bob Interface

Microsoft Bob is a new Microsoft user interface designed for the home computing market that is supposed to be easier to use than the Windows graphical user interface (GUI) currently available. However, you still need Windows on your computer in order to use Bob. David Thatcher, Microsoft group product manager, told the British news service Reuter that the company will be promoting the simpler interface across its consumer software line. Some analysts question whether users will feel they are being patronised by the cartoon characters, but children will likely take to the idea. Bob uses animated characters to move through various on-screen rooms where the user can write letters, balance

cheque-books, keep personal calendars, send and receive e-mail, play a game called GeoSafari and keep track of household functions. The animated characters are smart enough to learn the user's preferences and offer help in accomplishing the desired task by engaging the user in a dialogue. Microsoft apparently has great faith that the integrated help provided by the characters is good, since there is no manual for Bob. The user can select a character from a cast of several, choosing the one that best fits his or her personality. Microsoft reckon Bob will be available at the end of March priced US\$99.

Contact: Microsoft, Tel: (01734) 270 001.

### Digital Quality Broadcasting

The prospect of receiving near CD quality audio broadcasts, in the home and car, is to be accelerated by the development of consumer radio equipment to the new Digital Audio Broadcasting (DAB) standard. The DAB Receiver Development Club recently established by Roke Manor Research and Enigma, will enable UK based radio and audio manufacturers to participate in joint activities to turn low-cost DAB receivers into a reality. The DAB Receiver Development Club will address two key issues, namely, the early availability of low-cost DAB receiver chips and of multi-band radio designs, the latter arising from the allocation of different fre-

quencies across Europe. The club also intends to develop a DAB chip and a multi-band receiver OEM radio board obtaining this chip by the end of 1995 with initial production volumes early in 1996. Engineering interfacing information permitting the early design of the OEM module into consumer products will be made available to club members early in 1995. Club members will incorporate the module in their introductory DAB products, obtaining product differentiation from their user interfaces, styling and market positioning.

Contact: Roke Manor Research, Tel: (01794) 833658; Enigma, Tel: (01291) 625422.

### ECOS'95 - European Convention on Security and Detection

On 16th to 18th May 1995, the Institute of Electrical Engineers (IEE) will be hosting a major convention on electronic security at the Metropole Hotel, Brighton. This will be organised with support from many security and professional organisations, and comes at a time when there are significant developments occurring

in most areas of electronic security, including: imaging, biometric recognition, detection of explosives and drugs, communications and network security, perimeter protection and security systems.

Contact: IEE, Tel: (0171) 344 5477/5478; e-mail: conference@iee.org.uk

### MS-DOS Compatibility Cards from Apple

Apple Computer, has launched two new compatibility products which were announced at COMDEX last November, the Power Macintosh 6100 DOS Compatible system and the DOS Compatibility Card for the Power Macintosh 6100 and Macintosh Performa 6100 series. According to

Apple, the compatibility card, which plugs into the Macintosh CPU slot, makes it possible for Power Macintosh users to also have the capabilities of a Windows- and DOS-based PC in the same machine. Prices start at US\$739.

Contact: Apple Computer, Tel: (0181) 569 1199.



### Full Licence Age Limit Reduced

The minimum age requirement of 14 for the Full Amateur Licence has always been frustrating to those who have passed the RAE below this age, and have then had to wait some years before being able to obtain their Licence. The Novice Licence was a big step forward, encouraging young people into amateur radio by making limited facilities available to them, but the anomaly still remained where those under 14 who had passed the exams for a Full Licence still only had access to the limited Novice facilities. The RSGB is pleased to report

that recent discussions with the Radio Authority have resulted in making the Full Licence facilities available to anyone over the age of 10 who has passed the Full Licence exams, provided they have also held a Novice Licence for at least one year. The conditions that will be applied are as follows. The person must be at least 10 years of age and must have held an Amateur Radio (Novice) Licence Class (A) or an Amateur Radio (Novice) Class (B) for at least one year. In addition, they must have passed the required examinations for the full Class (A) or Class (B) licence, including the 12WPM Morse test for Class (A).

Contact: RSGB, Tel: (01707) 659015.



# FILTERS

## Part 7: Computers in Filter Design

**J. M. Woodgate B.Sc.(Eng.), C.Eng., M.I.E.E., M.A.E.S., F.Inst.S.C.E.**

In the last part of this series, we finally get around to reviewing available computer software for filter design.

**T**HERE are two ways in which computers can be used to design analogue filters – either by using general circuit analysis and simulation programs to check the performance of filters designed on paper, or by using dedicated software that takes the filter specification as input, and actually does the design itself. This software may or may not include a check by actual simulation that the filter performs correctly. Such a check is not necessary, in theory, if the design program takes account of enough second-order effects, such as stray capacitances, inductor losses and the detailed characteristics of active devices (if any).

The first procedure has a certain merit, in that the designer has to do the actual design using the computer in his head. This isn't meritorious in itself, but it does mean that the design is being carried out by someone who knows more or less how the thing works, and even, perhaps, if it doesn't, why not. Against this, the inclusion in the calculations of those second-order effects leads to very complicated equations which humans are not so good at.

The complementary danger with the second procedure is that it can be done by anyone trained to use the software, whether or not they know anything about filters, or even electronics. So, if the program falls over, or the specification is entered wrongly (which may well be more likely), the resulting garbage may be accepted at face value.

### Computers

Some readers may know that I used a BBC Micro (not even a Master) for many years, and that I switched to an Acorn A5000, which has an IBM-PC software emulation option. (I say 'IBM-PC', because with the launch of the Acorn RISC-PC and the Power-PC, the simple abbreviation 'PC' is

now all-but meaningless.) This emulation is of an 80188 (a what?) CPU, which is a bit less evolved than an 80286, so it won't cope with much of the latest PC software, and has speed problems with graphics printing.

Many thousands of BBC Micros are still around and PC users would be astonished at what can be done with 32K of memory and eight bits. The 640K of base memory in an early PC would not be the limitation that it is now considered to be if the highly economical code writing that the software writers for the BEEB developed were widely carried over to the PC. It is easy to quote the well-known game *Elite* as an example, but this is written in machine code. A more potent example may be the very large number of submissions to the competition that one magazine ran some years ago, for playable and interesting games that consisted of just one line of BBC Basic, only 255 characters including the line number and the final CHR\$(13)!

For that reason, I don't apologise for mentioning either the BEEB or the A5000 in this article, and when you read on, I hope you will see why. However, several of the programs mentioned are intended for PC-compatibles, so almost everybody should be catered for. (No, nothing for the *Spectrum*, sorry!) I have concentrated on programs which are good value for money, especially shareware and public-domain (PD) programs. For new computer users I would explain that the authors of PD programs waive all their copyright except (usually) they do not allow bits of their programs to be used in others. Such programs can be freely copied and distributed, provided there is no charge except for the disk

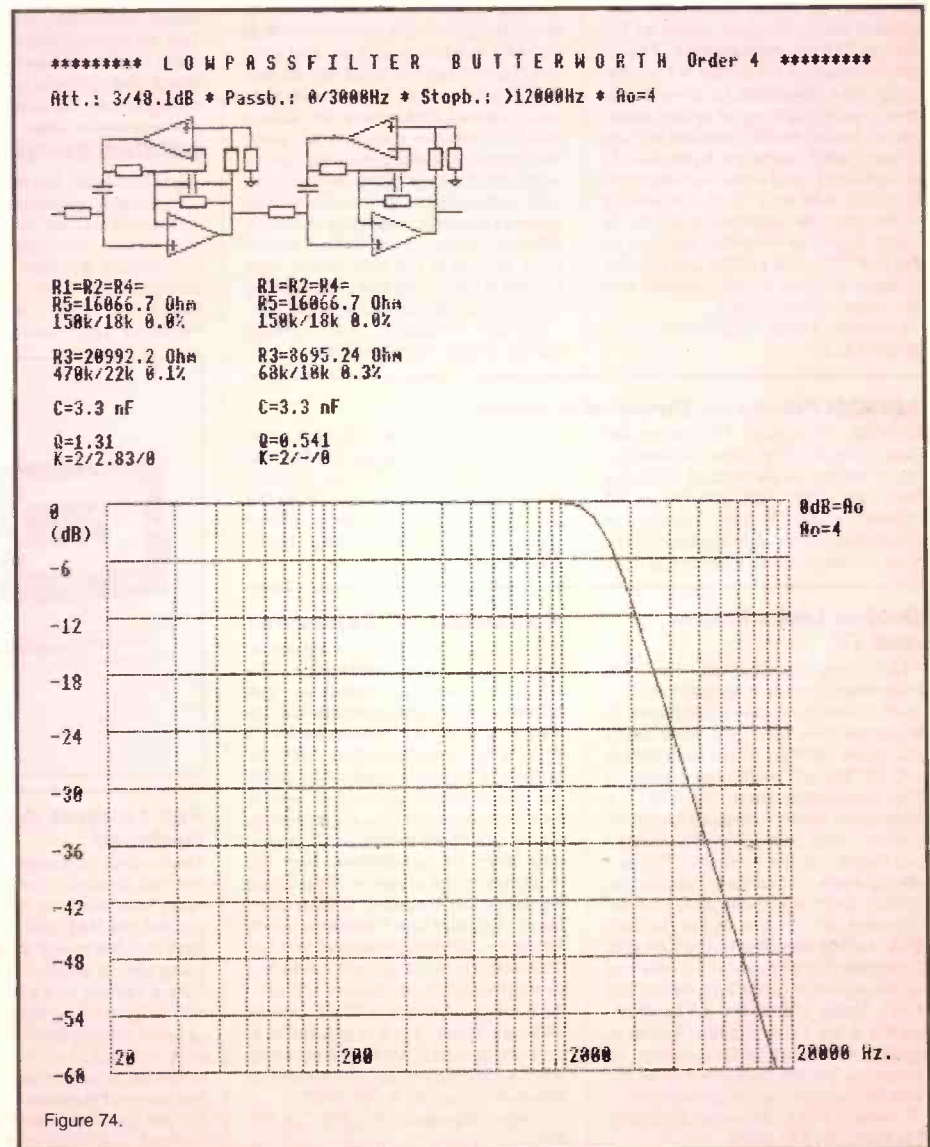

Figure 74. Typical print-out from Eldesign II on a dot-matrix printer.

and the time taken for copying, etc. Shareware is supplied on the same terms for a trial period. If you want to continue to use the program after trying it out, you send the author a registration fee, which often brings a newer and better version of the program and perhaps a printed manual and some more free software. Registration fees can be as low as £10, but some can be as high as £50 or \$100: however, for this you are likely to get a program that would cost several hundred pounds as a commercial product. Another variety of program is 'plugware', which is software supplied free or for a very low price, to advertise and promote the products that it is concerned with.

We need a simple term to describe what sort of program we have, in the above terms, and I have not found one in common use, so I propose to use 'ware status' – maybe it will catch on (and maybe not!). 'Payware' means a normal commercially available program.

## Circuit Analysis and Simulation Programs

These programs take the component values and interconnections of a circuit and determine such things as frequency response, and input and output source impedances. Most will also calculate phase response and group delay. There are usually some limitations on the types of components that can be handled. Tapped inductors are particularly difficult, and most programs require input and output to have a common 'zero potential' terminal, and therefore will not cope with balanced inputs or outputs, unless fictitious perfect transformers are included to convert balanced to unbalanced.

Some programs will either allow the same circuit to be analysed with a range of values for one component, without requir-

ing the operator to run the program several times, or will investigate the effects of component tolerances by what is known as the 'Monte Carlo method'. In its simplest form, the program runs repeatedly with a set of component values chosen at random within the ranges calculated from the component nominal values and tolerances, and lists or plots the results. In many cases, a hundred runs or more can be requested (but don't ask for listed results!), which gives a very good idea of what spreads in performance will occur in practice.

In most cases, these programs are fairly unlikely to fall over and give a wrong result, although they vary quite a bit in how well they model active devices. The most likely source of error is the entry of the initial data, and I have found it essential to draw a complete circuit diagram, and mark on it the input data in the form required by the program, before trying to enter it to the computer.

I am not going into very much detail about individual programs of this type, because this article concentrates on the 'other' sorts of programs – filter design programs.

## Filter Design Software

Although filter design is only one narrow field of electronics, the value and importance of it can be seen from the fact that special software is written for it. In the old days, most big labs had a 'filter king' (not a cigarette!), and if you wanted a filter, he (or she) designed it for you. Such luxuries have generally fallen to the power of the 'little grey figures men', and if you need a filter you have to design (or bodge) it yourself. How much more satisfactory (and less nail-biting) to design it!

All but one of the programs that I have found will only design active filters. This can be something of a disadvantage if you want a crossover network or some other type of filter where a passive design is most suitable.

Some plugware programs will only design filters that can be implemented with the chips that are being plugged, but others offer a more general choice of designs in a first section of the program, the 'fitting' of the design to the chip(s) being dealt with in a second section. Even so, there may be some limitations, such as a restriction to even-order filters only. In fact, this restriction can also be found in design programs that are not plugware.

An allied 'feature' of some programs is that they do not deal with passive first-order filters: if the program will design odd-order filters (all of which include one first-order section) at all, the first-order section is designed around an op amp. There seems to be no good reason for this: perhaps it is because the addition of a first-order section at the input of a Sallen and Key second-order circuit appears not likely to work. The input impedance of the second-order circuit is not constant, or obviously high enough to be neglected. Nevertheless, we have seen in previous Parts of this series that the simple addition process does work.

In the following survey of available programs, I have included all that I have come across. Obviously, there are bound to be others that I have not found, especially on

Figure 75. Results of 50 Monte-Carlo runs on the filter shown in Figure 74.

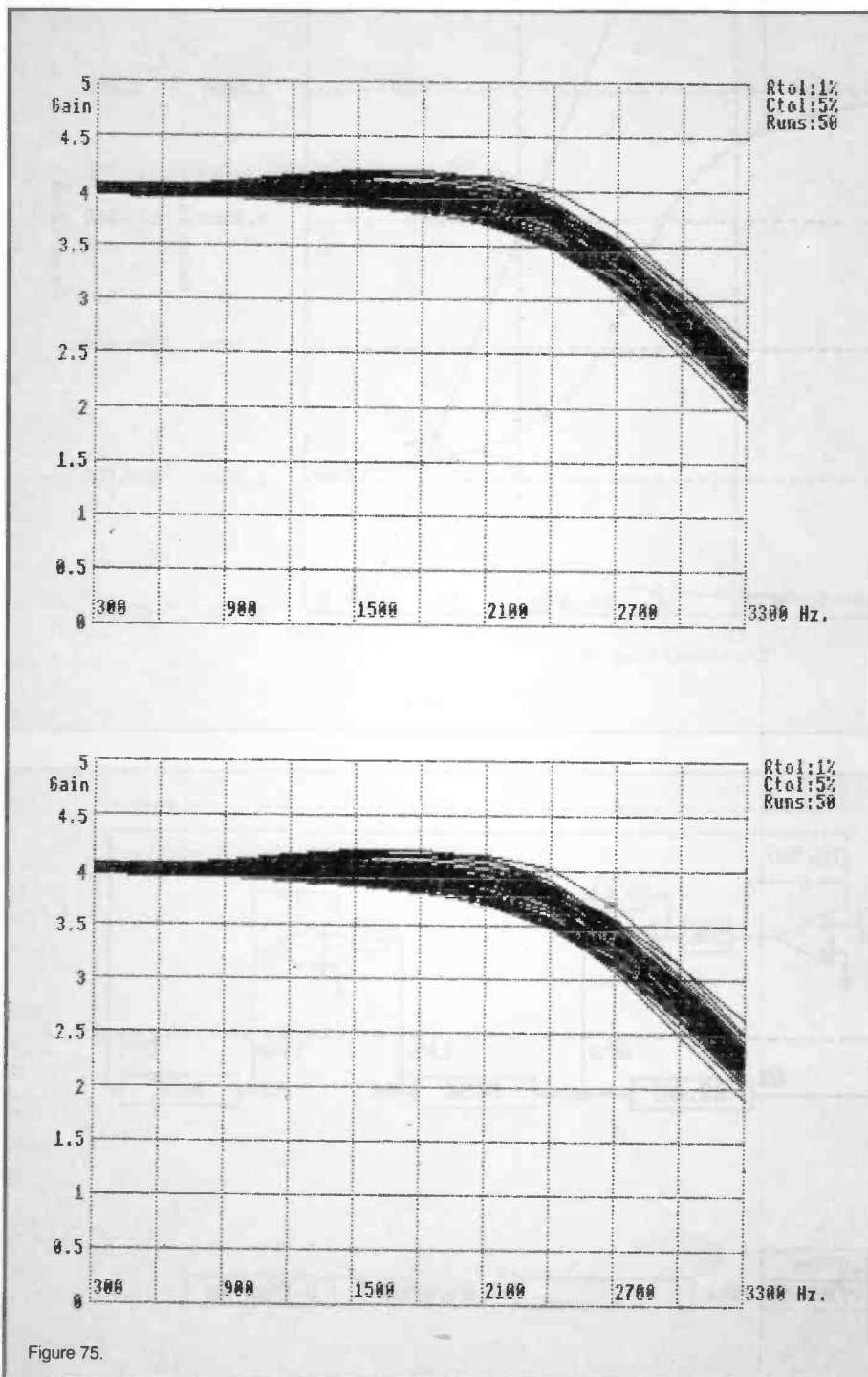

Figure 75.

Internet, etc. If you find a really good one, why not tell the Kindly Editor?

## Programs for the BBC Micro

First, we will deal briefly with general circuit analysis programs.

**Markie Analysis:** This was written in 1985 by David Markie, then of the BBC. It is quite comprehensive, even including tapped inductors, and quite quick, considering the platform (and I don't mean 3 minute

waits!). It will also handle centre-tapped coils and show the effects of component value variations in four selectable steps. Its graphing, however, is somewhat let down by primitive axis labelling. The ware status of this program is uncertain: it has been available in the BEEB world for a while.

**Figure 76.** Example of graphical output from the MAX274/275 design software.

**Figure 77.** Circuit diagrams of the two sections of the filter design of Figure 76, as printed out by the software.

Perhaps if David Markie reads this, he would contact the Editor.

**Analyser II:** This is an extremely well written program, using overlays to overcome memory limitation problems. It includes a very ingenious printer driver that produces graphs from a 9-pin dot-matrix printer in text mode. It handles transformers, but not tapped inductors. The product is no longer listed as available from Number One Systems, but a written enquiry might produce a copy from the store-room. Alternatively, it is occasionally seen as a second-hand item.

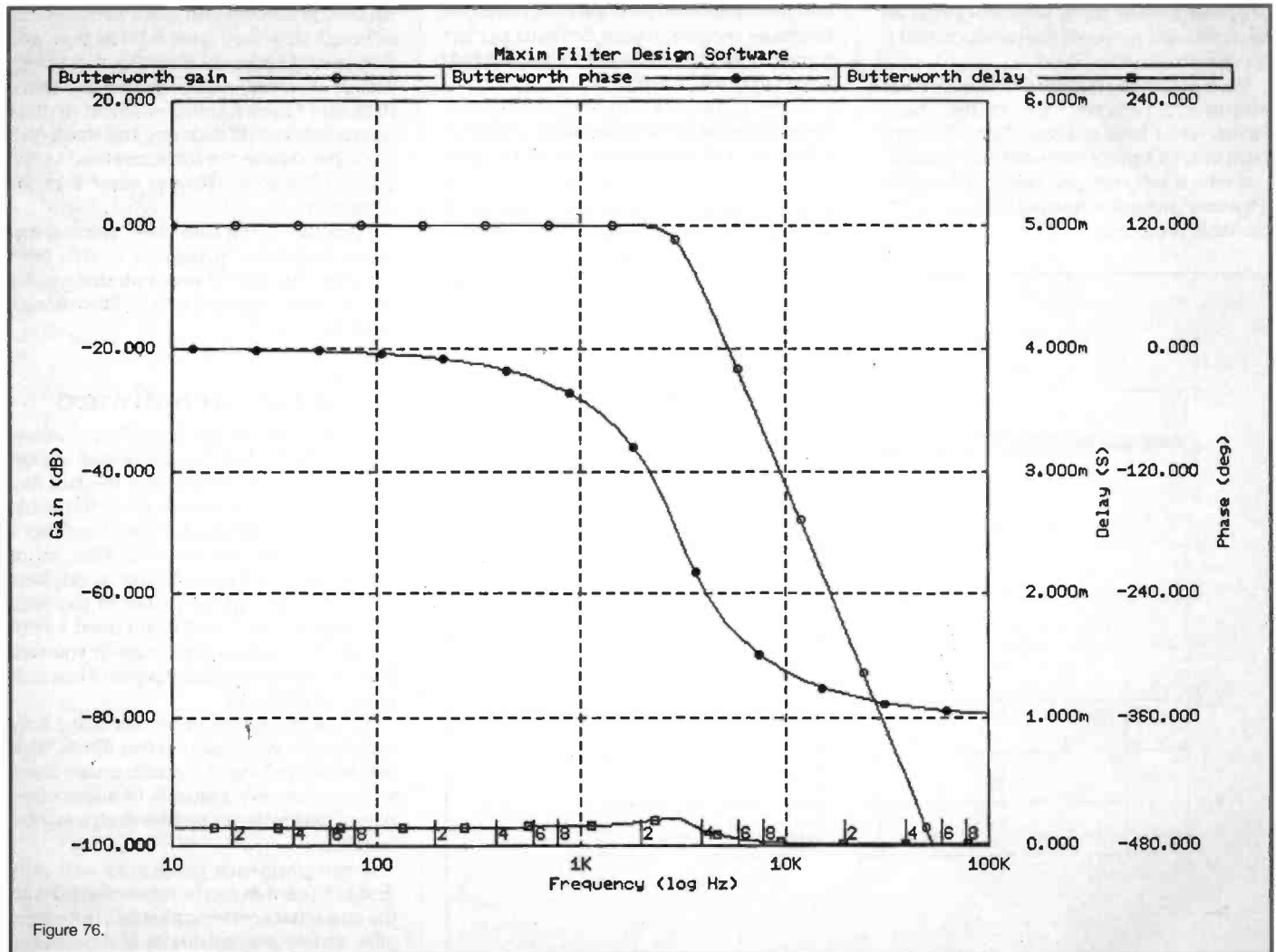

Figure 76.

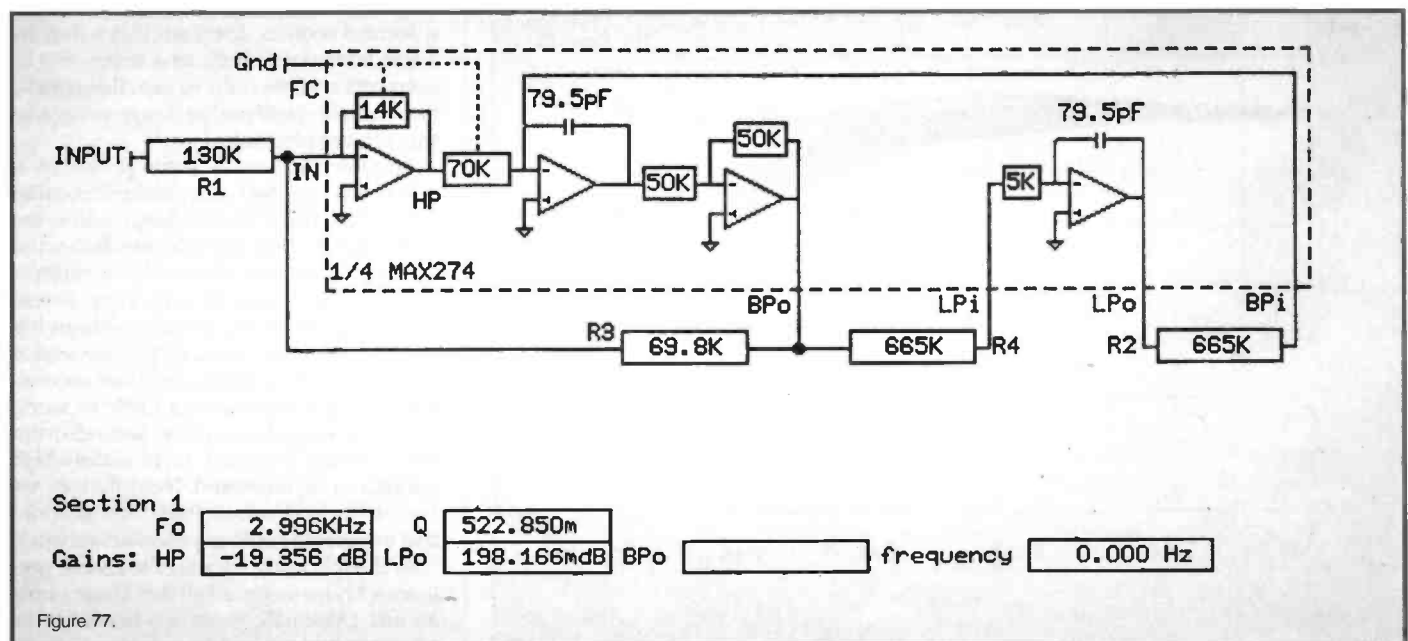

Figure 77.

## Programs for the Acorn A5000 and Similar Machines

I cannot deal with the question of which Acorn machines will run these programs, because I only have an A5000 to try them on. Those machines that will not run the PC Emulator V1.8, or do not have a PC card instead, will obviously not run any of the programs that are intended for PCs.

**Markie Analysis:** The original version will run under the BBC emulator, and there is a version with a RISC-OS WIMP front-end, produced by Paul Skirrow of Octopus Systems. This is not readily available because of the uncertainty of the ware status of the original code. (RISC-OS is the Reduced Instruction-Set Computer Operating System used in current Acorn computers. WIMP means 'Windows, Icons, Mouse and Pointer', according to me, anyway, and Windows is a generic term, not to be confused with Microsoft Windows.)

**Spice for Acorns:** This is in two parts: the basic Spice suite (version 3A6, which is quite old but still very usable) and a RISC-OS graphics front-end called Nutmeg, written by Frank and Erik van de Pol and based on the original Nutmeg from the University of California at Berkeley. Spice is extremely versatile and powerful: you can do all kinds of circuit analysis with it, but it needs learning, and inputting data can be tedious. This program is PD and can be found on bulletin boards. The UK source appears to be HENSA (Higher Education National Software Archive?) at Lancaster University. It is definitely not for beginners!

**Programs to run under the PC Emulator or PC card:** Of the programs listed in the next section, I have tried Analyser III, PC-ECAP and ACIRAN, and they all run quite well and reasonably quickly under the Emulator. If they will run from a PC card, they should run more quickly, in some cases very much more quickly.

## General Circuit Analysis Programs for IBM PC Compatibles

**Analyser III:** This payware is a worthy successor to Analysers II. It runs under DOS and has its own interactive screens for input and results. It will cope with tapped inductors and will interface directly with some other programs supplied by Number One Systems. It will run reasonably quickly on an Acorn with PC Emulator, but the display can become corrupted due to a glitch somewhere in the screen clearing routines and the mouse tends to have a mind of its own. Print-out on a PC is quite quick, but can take more than 10 minutes per page of graphs on an Acorn. Not everyone likes the style, either, and I often post-process the graphs as sprites to 'lighten' the presentation.

**PC-ECAP:** This program is shareware, and is available from PDSL (and very likely elsewhere). It is quite comprehensive, and will handle transformers but not tapped inductors. It also has a model for a transconductance amplifier, which is unusual, and will calculate standing wave ratios and return loss. There is a 34-page manual on the disk as a text file. Both dot-matrix and laser printers can be used, but ink-jet printers which cannot fully emulate

Maxim Integrated Products Filter Design Software  
Version 1.01

### Circuit description:

\* See data sheet or design software for resistor connections \*

#### SECTION 1

##### MAX274 Lowpass Section

Fo = 3.000KHz  
Q = 541.196m  
Output pin = Lpo  
FC pin = Gnd  
R1 = 133.333Kohms  
R2 = 666.667Kohms  
R3 = 72.159Kohms  
R4 = 661.667Kohms  
Holp = gain at DC = 1.000 V/V

#### SECTION 2

##### MAX274 Lowpass Section

Fo = 3.000KHz  
Q = 1.307  
Output pin = Lpo  
FC pin = Gnd  
R1 = 133.333Kohms  
R2 = 666.667Kohms  
R3 = 174.208Kohms  
R4 = 661.667Kohms  
Holp = gain at DC = 1.000 V/V

Figure 78.

Stage 1 of 2

Low Pass 4 Pole Filter

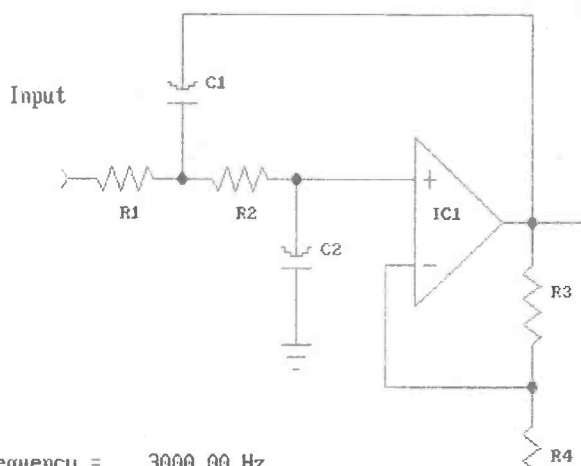

Cutoff Frequency = 3000.00 Hz

R1 = 68000 Ohms Choice 16 of 43 choices

R2 = 68000 Ohms Percentage of error = -4.55

R3 = 5900 Ohms C1 = 0.00082 uF

R4 = 39200 Ohms C2 = 0.00082 uF

Parts are calculated for 5 percent tolerance.

Hit the F1 key to print the screen on the printer, or ENTER to continue

Figure 79.

a laser printer will not print the graphs correctly (the axis labelling goes wrong).

**P-Spice:** This is another shareware program available from PDSL. It is a 'classroom' version of Spice, which means that it is said to be somewhat cut down for use by undergraduates and is clearly much cheaper than any of the payware full versions. It has one or two odd 'features', for example, it will only store its results on Drive C, and requires at least 4Mb of free space on that drive, otherwise it won't even install! Up to now, I have therefore been unable to try it out.

**ACIRAN:** This program originates from Scotland, and is shareware available from PDSL. It is quite easy and intuitive to use – there is a manual on the disk but it is not

**Figure 78. Circuit description print-out for Figure 76.**

**Figure 79. Example print-out from Active Filter Design Software on a dot-matrix printer.**

necessary to keep searching through it to find out why something unexpected has happened. The version that I have (V3.4), which is not the latest, performs Monte-Carlo analysis, but, when run on the A5000 under the PC Emulator, seems to randomise the component values for each simulation *frequency*, instead of for each *frequency sweep*. This means that the resulting 'frequency response curves' are not in fact the responses of any realisable sample of the circuit. This only applies, of

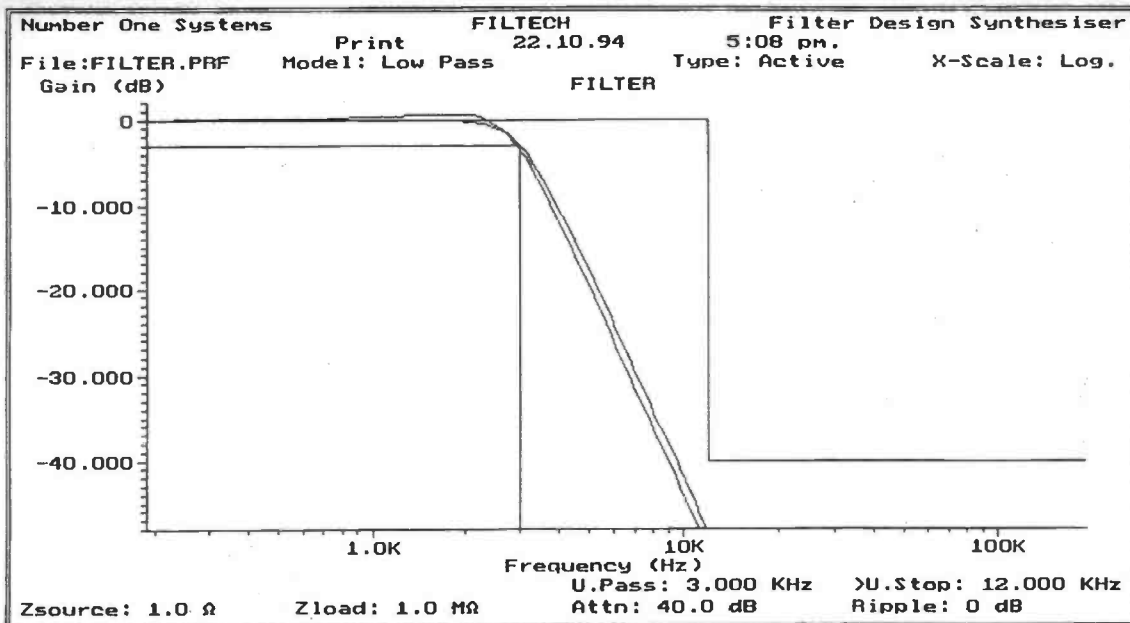

Figure 80.

course, if the Monte-Carlo option is invoked. It is possible that this has been changed in a later version. Transmission lines and voltage-controlled current sources can be included in circuits.

## Dedicated Filter Design Programs

**ELDESIGN II:** This is an astonishing program, written for the BBC Micro in 1985 by Dr. Paul Spronck. It is very little known in this country: Dr. Spronck tells me that only five copies were sold here. It will design low-pass, high-pass, band-pass and band-reject filters with Bessel, Butterworth, Chebyshev, inverse-Chebyshev or Cauer (Thomson or elliptic) response shapes, which is much more than most programs will do. It also draws circuit diagrams of the filters, using Multiple-Feedback, Sallen and Key or Anthoniou sections. The Sallen and Key sections are of a different type from those considered in this series, and I haven't dealt with Anthoniou sections at all. This is simply because there are just too many circuit options available, and I have had to pick only those which seem most likely to be attractive to home constructors. That is not to say that Anthoniou sections are particularly difficult to implement, but they need two op amps and you cannot choose the gain.

The program calculates the component values, and then calculates how best to make up those values from standard E12 or E24 series components. The only criticism that I have is that it is not immediately obvious which components in the diagram correspond to the circuit references in the results. On top of this, Monte-Carlo analysis can be done (properly), with sufficient flexibility in the run-time parameters to allow 50 or more runs to be done in a reasonable time, even on a basic 32K machine. There is an added feature in that runs 1 and 2 use sets of values at the high and low limits of tolerance respectively, which are not necessarily the worst cases, but at least you know that they have been covered. Purely random choices might

Figure 80. Typical graphical print-out from Filtech.

occasionally show a bias. These results can only be graphed on linear axes, but the ideal response can be plotted either on linear or log-frequency, response-dB axes. It would probably be fairly easy to change this if more memory were available. There is a customisable screen-dump routine for 9-pin dot-matrix printers, which even includes a self-test procedure! The 50-page manual is very clearly written (don't forget that Dr. Spronck is writing in a foreign language!) and is almost a text-book on filters in itself. Figure 74 shows a typical print-out on a dot-matrix printer, and Figure 75 shows two graphs from 50 Monte-Carlo runs on the same filter design.

At present, the program is on an Acorn DFS-format 5.25in. protected floppy disk (a floppy can be inserted in the drive either way up, and is in 40-track format on one side and 80-track on the other.) The program is so good that I have suggested to Paul Skirrow of Octopus Systems that he might consider co-operating with Dr. Spronck to make it commercially available again in forms to run on PCs and Acorns at a sensible price. We shall see: if this proves impracticable, the program may appear in the public domain. Almost all of it is written in BBC Basic, so it should translate to Q-Basic with few problems.

**Maxim MAX274/275 filter design software:** These 'continuous time' devices (which I have dealt with in an earlier Part of this series) are not at present available from Maplin, but Maxim is one of the few semiconductor manufacturers which will talk to people who aren't in the market for a million or so devices. The software comes as part of the MAX274 Evaluation Kit, available at a reasonable price from Maxim directly.

The program is in two parts: the first part will design many sorts of filter and provide lists of frequency, phase and delay responses, together with graphs. The graphs part (see Figure 76) needs a bit of learning, but there is good on-line help

available. The second part calculates the resistor values for implementing the filter, and appears to choose half of the four section MAX274 device even if only two sections are necessary, unless the operating frequencies extend into the range which is covered only by the MAX275. Component values can be chosen from the standard E96 (1% tolerance) range or the 0.1% range, as befits a program for use by professionals. The circuits of the sections, with the resistor values, can be printed out (see Figure 77), and can be saved as graphics files, but the version that I have falls over in this procedure. In some places where you can have a print-out, the menu allows you to print to a file instead, and choose the filename, of course. But the only way to print these circuits to file is to choose 'Print to file' from the Printer Configuration option on the main menu, and choose the filename then. This is all OK for the first section, but if you try to do it again, the program tries to set the graphics resolution of the *disk drive*, which naturally does not respond! The resulting error flag stops you changing the filename for the second circuit. If you try to cheat by changing the name of the first file by putting the disk into another machine, you find that 'printer' access is still blocked. The only thing to do is to ensure that the filter has been saved in the first section of the program, quit the program and start again. Luckily, this does not take long. Section data can be printed out as text, as shown in Figure 78.

**Active filter design tools:** This is another PDSL shareware program, with a particularly plaintive copyright notice. It has a number of curious features, but will design a wide range of different sorts of filter. However, it needs more sophisticated input than just the filter specification, such as the number of sections. Of course, you can either use the design equations given in previous Parts of this series to find the required number of sections, or use the program to find out by trial and error. The program will give up to 200 alternative sets of values, and you can choose the component tolerances, but this does not apply to



gain-setting resistors, which are given as raw calculated values. Circuits can be printed out, but only as graphics dumps on dot-matrix (see Figure 79) or on a laser printer. Printing does not work on my ink-jet printer. There may well be an improved version of this program available to registered users.

Filtech: This is another of the most comprehensive payware products produced by Number One Systems, who started writing for the BBC Micro, but have now switched

entirely to the PC. It will run on the Acorn 5000 but a bit slowly: a PC card in the Acorn would no doubt improve matters. This is the only package of those considered here that will design passive (LC) filters (but apparently assumes loss-free components) and which specifically caters for ink-jet printers (see Figure 80) rather than lumping them in with laser printers (with varying degrees of success). It will design Bessel, Butterworth and Chebyshev filters from 2nd up to 6th order, and active filters in bi-quad or Sallen and Key form. Circuit data is printed out in Number One Systems@ standards 'netlist' form (see Figure 81),

which is fully explained in the manual. This is very comprehensive, and includes considerable practical information on filter design as well. The program will detect the presence of other software from the same stable, such as the general circuit analysis program Analyser III, and can transfer data directly. Analyser III itself can link directly to other software, such as Z-Match (a Smith Chart program for transmission line work) and Easy-PC (a PC board designer). Analyser III would allow the effects of component losses in passive filters to be fully investigated. Filtech is a program for professional use, and this is naturally reflected in the price.

Figure 81. Component list for the filter design of Figure 80.

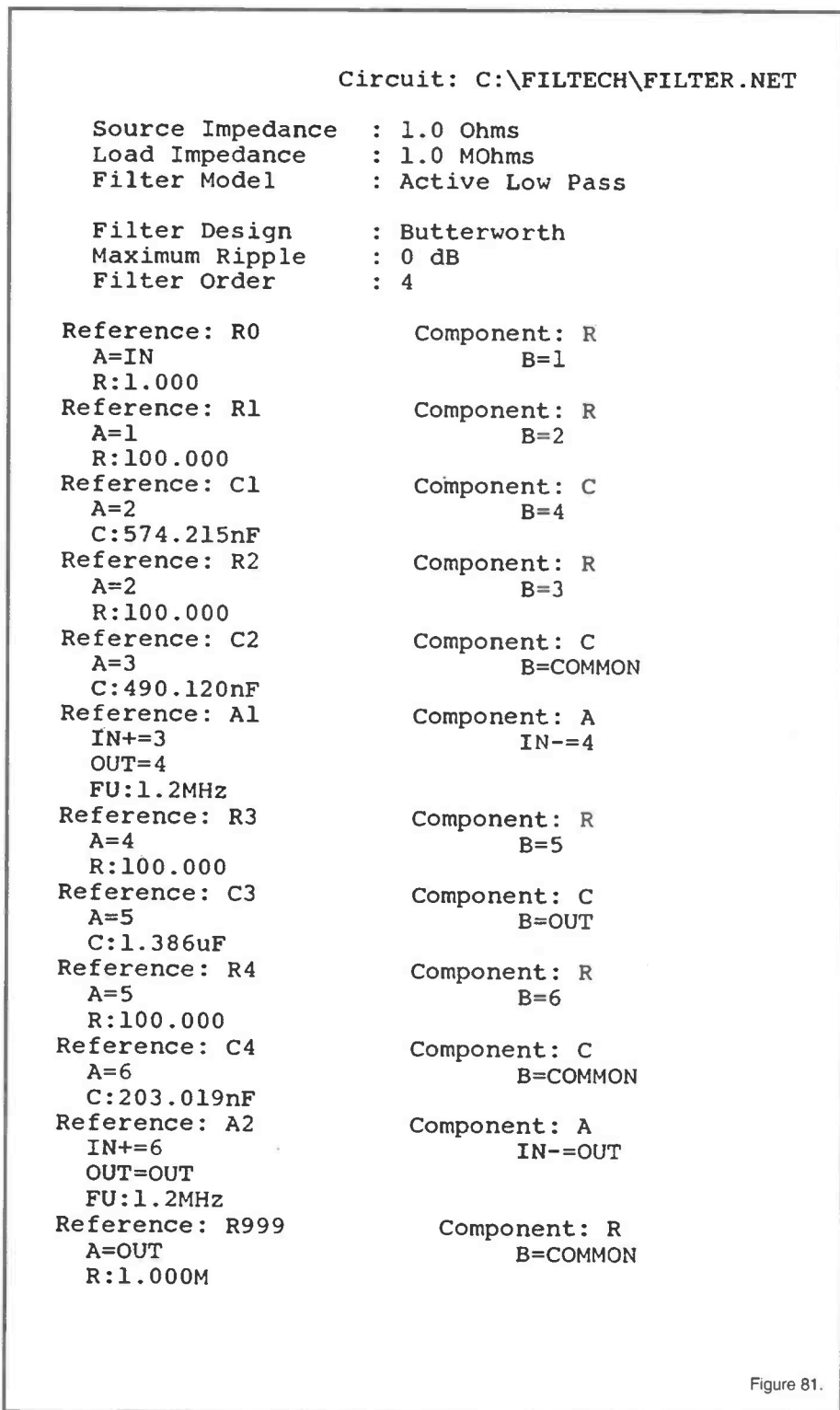

Figure 81.

## Contacts

A number of potential suppliers have been mentioned in this article, so here are the (current) contact details:

Maxim Integrated Products (UK) Ltd.,  
21C Horseshoe Park, Pangbourne, Reading  
RG8 7JW.

Telephone (01734) 845255 (Non-professional enquirers should write, not telephone).

Number One Systems Ltd., Harding Way,  
Somersham Road, St Ives, Huntingdon  
PE17 4WR.

Telephone (01480) 461778, Fax 01480 494042.

Octopus Systems, 9 Randwell Close,  
Ipswich IP4 5ES.

Telephone (01473) 728943, Fax 01473 270643.

Internet: PSkirrow@arcade.demon.co.uk

PDSL (Public Domain Software Library),  
Winscombe House, Beacon Road, Crow-  
borough, Sussex TN6 1UL.

Telephone (01892) 663298, Fax 01892 667473,  
BBS (8n1) (01892) 661149.

## Books

I have mentioned several times that design tables are to be found in books. The following selection should help.

*Electronic Filter Design Handbook* 2nd Edition by A. B. Williams. Published by McGraw-Hill. Extensive design data and tables of values. Very good but not inexpensive. You might find a copy of the first edition available second-hand, in which case, buy it!

*Filter Handbook* (Maplin Stock Code WS75S) by Stephan Niewiadomski. Design data, tables and BASIC programs for the PC. Largely reliable, but has a few 'features'.

*Active Filter Cookbook* by Don Lancaster. Published by Howard W. Sams and Co. Very clearly written, with both descriptive text and mathematics. Includes tables of values. Perhaps the best book for the serious home-constructor.

*Practical Electronic Filters* (Maplin Stock Code WZ22Y) by Owen Bishop. Low-cost practical book, including projects and worked examples.

## Tailpiece

This is the last in the series on filters. There is scope in the subject for at least another seven articles, but the Kindly Editor and I think that this is enough for now! 

All of the books featured on this page are available from Maplin Regional Stores and by Maplin Mail Order. To find your nearest Maplin Regional Store Tel: (01702) 552911 or to order call the Credit Card Hotline on Tel: (01702) 554161

# NEW BOOKS

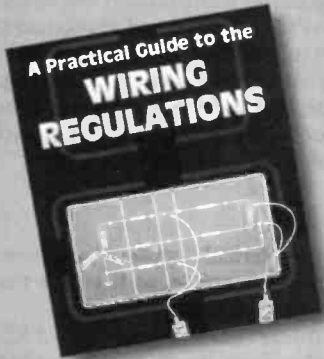

## A Practical Guide to the Wiring Regulations

by Geoffrey Stokes

The 16th Edition of the IEE Wiring Regulations have been the industry standard for a few years now, and despite the numerous books, articles and guidance material already published, the Regulations still cause confusion. Most electrical engineers, contractors and electricians will recognise when a proposed solution does not meet the requirements, but may find it difficult to attribute a precise regulation number to it, or what action to take to solve it. This is not surprising since the subject of electrical installations is vast and complex.

This guide sets out to make life a little easier, and topics are addressed together with the pertinent Regulation's number listed where appropriate. Where necessary some background guidance is given together with worked examples embodied in the text at the appropriate place. Drawing on his experience at the IEE and NICEIC, the author has produced a very detailed and practical guide.



1994. 245 x 172mm. Order As AN24B (Practical Wire Regs) £22.50 NV A3

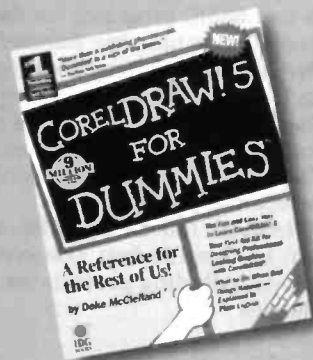

## CorelDRAW! 5 For Dummies

by Deke McClelland

CorelDRAW is the most popular graphics software for the PC, and now includes 12 separate programs, each

### AN APPROACH TO AUDIO FREQUENCY AMPLIFIER DESIGN

An original publication of GEC Ltd.

This book will appeal to all valve enthusiasts, young or old, it contains 17 high quality designs covering 5W to 1100W, that originated from the research laboratories of GEC Ltd. (UK). Many of the designs are based on the KT66 and KT88 tetrodes, which were, and still are, probably the most highly regarded valves ever produced for audio amplification.

The designs include a simple amplifier for home use, to a very large amplifier for public address in auditoriums and stadiums.

Two high quality preamplifiers are included, one being a simple minimal one and the other a more sophisticated design with full bass and treble controls.

Each circuit includes a comprehensive parts list and specifications allowing the reader to construct their own version of the designs.

This book is a treasure chest of authoritative valve information that is written in a straightforward 1950s conservative style. The valve enthusiast will find full explanations of all the important considerations in designing high quality valve amplifiers.

1994. 227 x 150mm. Order As AN28F (Approach AF Amp Dsgn) £13.95 NV

AN APPROACH TO AUDIO FREQUENCY AMPLIFIER DESIGN  
Seventeen Circuits from 5- to 1100-watts

A PUBLICATION OF THE GENERAL ELECTRIC CO. LTD. OF ENGLAND  
REPRINTED AND DISTRIBUTED BY Audio Amateur Press

EDITORS CHOICE

of which can be used independently or in conjunction with one of the other supplied programs. There are several important enhancements to all of the programs which now includes the new CorelVENTURA! (also known as Ventura Publisher, a comprehensive desktop publishing program).

As with all Dummies' books, the reader is taken on an informative and humorous tour of this comprehensive package, providing the information

needed to create professional quality logos, illustrations and special effects very quickly. The reader will be able to integrate the powerful programs: DRAW!, PHOTO-PAINT!, CHART!, MOVE! and VENTURA! and learn professional techniques for designing documents, editing scanned photos, and creating on-screen presentations. Additionally, you are shown how to combine text and graphics to create impressive documents, along with simple time-

saving ideas for creating special effects such as rotating and stretching graphics. A thoroughly recommended book.



1994. 234 x 188mm. Order As AN25C (CorelDRAW! / Dummies) £18.99 NV

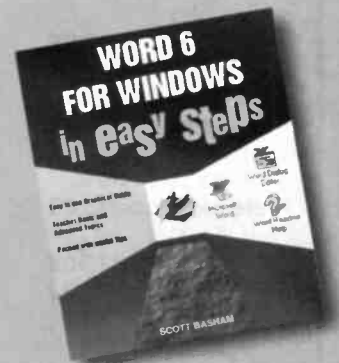

## Word 6 For Windows in Easy Steps

by Scott Basham

Word Processing was one of the first popular applications for the modern personal computer, making the old typewriter a thing of the past. Today the most popular personal computer configuration is the IBM PC compatible and Microsoft's Windows graphical environment. Naturally, Microsoft provides a wide range of applications including spreadsheets, database, graphics and presentation software. Microsoft Word 6 for Windows is widely recognised as one of the best available, and is a very popular package. In fact, Word 6 is a very big package and has retained its position as market leader, by providing a vast range of useful features, taking it from word processing into the realms of graphical and data-orientated documents.

This book is a clear and concise graphical guide using simple instructions to teach the reader all the essential Word 6 techniques in easy steps. The book is not intended to replace the Word 6 manual but should be treated as a cost-effective training guide or as a quick reference guide.



1994. 226 x 186mm. Order As AN27E (Word 6 For Windows) £14.95 NV



British Book



American Book



European Book



Illustrated



Softback



Hardback



Number of Pages

# RETURN TO THE SOUND THAT TIME FORGOT!



**IT'S NOT A  
DINOSAUR!**  
**FOR TIMELESS  
QUALITY VALVE  
SOUND - AT AN  
AFFORDABLE  
PRICE!**

"... handles vocals wonderfully, bringing body and texture to images, making them seem fuller and more real than most solid-state amplifiers... The 4-20 brings you the benefits of valves, with few of the drawbacks... the 4-20 delivered plenty of output with low distortion... it offers a good introduction to the realm of valve amplifiers, outperforming many commercial designs."

Nick Lucas, Hi-Fi World, November 1994.

Full details of how to build this superb valve amplifier yourself may be found in the January and February 1994 issues of *Electronics - The Maplin Magazine*.

**Complete Kit  
Just £199.50<sup>H18</sup>  
SAVE OVER £20!**

*Electronics - The Maplin Magazine* January 1994 Issue

*Electronics - The Maplin Magazine* February 1994 Issue

Power Supply Kit Only

Amplifier Kit Only

Complete Monobloc Amplifier Kit [1 x Power Supply Kit + 1 x Amplifier Kit]

Complete Stereo Amplifier Kit [1 x Power Supply Kit + 2 x Amplifier Kit]

(XA73Q)	Price £1.95 NV
(XA74P)	Price £1.95 NV
(LT44X)	Price £59.99 C6
(LT45Y)	Price £79.99 C6
(LT71N)	Price £129.50 H12 Save over £10!
(LT72P)	Price £199.50 H18 Save over £20!

Carriage: kits marked **C** add £2.80, kits marked **H** add £6.00. If ordering several kits maximum total carriage is £6.00.

Handling: add £1.50 to each order. Please note: carriage and handling charges apply to Mail Order only - you do not pay carriage or handling if you purchase these kits from Maplin Regional Stores. Export customers please call Maplin Export Department or your nearest distributor.

Photograph shows Stereo Millennium 4-20 Amplifier (LT72P). The Millennium 4-20 Amplifier is not available ready built. The kits listed are rated 4 (Advanced) on the 1 to 5 Maplin Construction Rating Scale.

**Maplin Electronics plc.**, P.O. Box 3, Rayleigh, Essex, SS6 8LR. Tel: (01702) 554161. Fax (01702) 553935.

For details of your nearest Maplin Regional Store Tel: (01702) 552911. Maplin Export Department +44 1702 554155 xtn 326 or 351.

Prices include VAT at 17.5% except items marked NV which are rated at 0%.

All items subject to availability. Prices are correct at time of going to press (errors and omissions excluded), but may be subject to change.

**NEW**

**FULL COLOUR GUIDE TO ELECTRONIC PRODUCTS**

Sept 1994–Aug 1995

# Maplin



BS 5750  
Part 2 1987

Level B:  
Quality Assurance  
RS12750

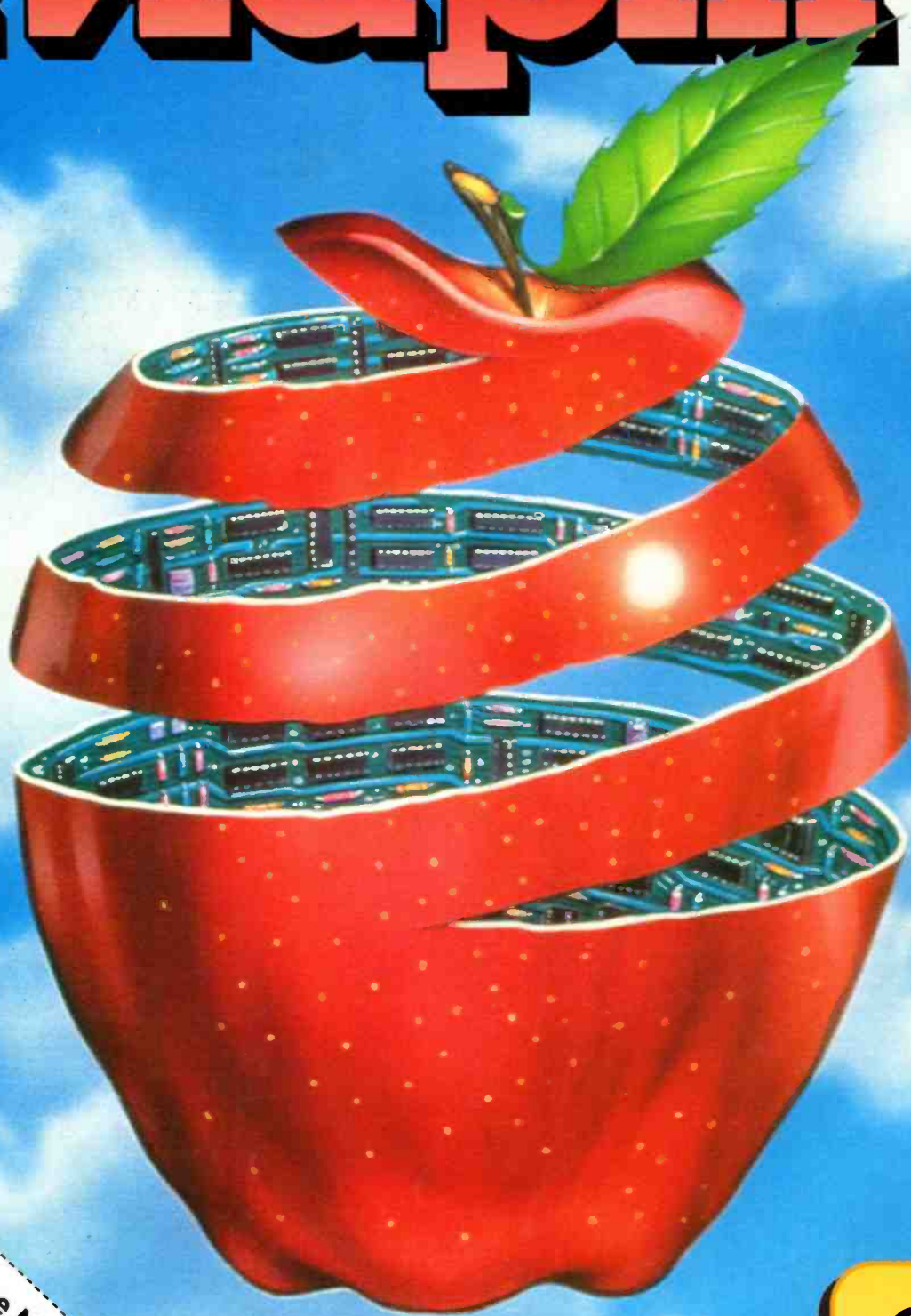

**Order your copy of the New MAPLIN Catalogue on sale NOW!**  
Pick up a copy from any branch of WHSMITH, branches of John Menzies in Scotland ONLY, Eason & Son in N. Ireland ONLY, and Maplin stores nationwide for just £3.45 or post this coupon now to receive your copy for just £3.95 inc. p&g. If you live outside the U.K. send £7.30 or 18 IRCs for Airmail in Europe (including Republic of Ireland); £6.50 or 16 IRCs for surface mail outside Europe; or £12.30 or 30 IRCs for Airmail outside Europe.  
I enclose £3.95/£7.30/£6.50/£12.30 (delete as applicable).

Name .....  
Address .....  
Post Code .....  
Send to Maplin Electronics,  
P.O. Box 3, Rayleigh,  
Essex, England  
SS6 8LR  
MW95

Over 800 colour packed pages  
with hundreds of Brand New  
Products at Super Low Prices.

**ONLY  
£3.45**

Available from all branches of WHSMITH, John Menzies in Scotland ONLY, Eason & Son in N. Ireland ONLY, and Maplin stores nationwide. The Maplin Electronics 1995 Catalogue – **OUT OF THIS WORLD!** Southern Africa customers please contact Maplin (South Africa) Telephone (024) 51-5124