

RADIO · PHYSICS · TEST EQUIPMENT · VIDEO

No. 76

FULL
SOR

APRIL 1994 • £1.95

Printed in the United Kingdom

E

ELECTRONICS

The Maplin Magazine
Britain's Best Selling Electronics Magazine

SAVE £4.50
ON ENTRANCE TO
THE COMPUTER
SHOPPER SHOW!

Discover the Secrets of How Semiconductors are Made



**Build Your Own
20m Transmitter
and Receiver**

Exclusive! Report on Fuzzy Logic Developments
Keep Food Safe with a Fridge Check Project
Versatile Video Preamplifier for You to Build
Test Car Circuits with a Simple Test Probe
New Series: How to Use Digital Panel Meters



Twelve great reasons to get Electronics under cover...



The Maplin magazine binder holds twelve issues of *Electronics - The Maplin Magazine*. If you have not got the world of electronics covered, now's your chance! This great quality binder comes in hard-wearing laminated art board, that not only looks good on your bookshelf or workshop desk, but is also a great way to build up an electronics reference library of your own!

Now you can keep all of your copies of *Electronics - The Maplin Magazine*, together and on hand, for when you need that extra piece of information. To order your binder simply fill in the order coupon provided in this issue, or call the Credit Card Hotline on 0702 554161, or visit your local Maplin Store. Only £5.95. (Mail Order, please add £1.40 Handling charge.) Order code: XH99H.

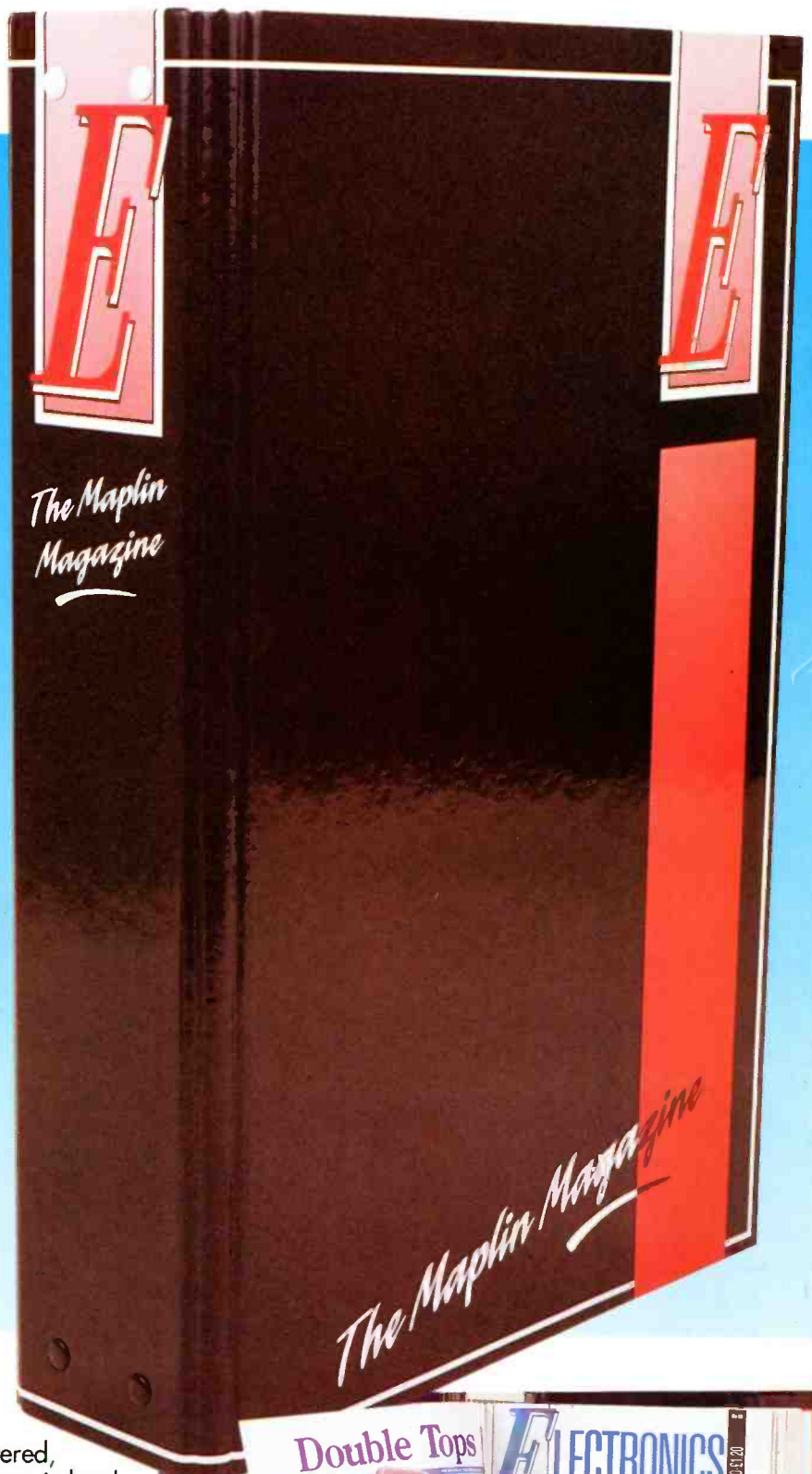

**THE NEW MAPLIN MAGAZINE BINDER...
A GREAT WAY TO GET THE WORLD OF ELECTRONICS COVERED!**



PROJECTS FOR YOU TO BUILD!

FRIDGE CHECK

Guard against food poisoning with this low-cost project. Once built and left in a fridge it will alert you to any excessive rise in temperature – a condition that will, unnoticed, promote bacteria growth in food.

12

LOW NOISE HIGH FREQUENCY PREAMPLIFIER

This Data File project based on the SL561 low noise preamplifier IC is ideal for video applications.

28

20m CW TRANSMITTER & DIRECT CONVERSION RECEIVER

Get into amateur radio cheaply and easily with these two projects. Both can be combined in one case to form a single versatile unit.

44

SIMPLE CAR CIRCUIT TESTER

Find car electrical faults fast with this low-cost, easy to build, project.

59

FEATURES ESSENTIAL READING!

THE SECRETS OF SUPERCONDUCTIVITY EXPLAINED

From floating magnets and particle detectors to levitating trains and medical body scanners, superconductors are the magic ingredient. In this revealing article Douglas Clarkson looks at what superconductors are, how they were discovered, the current state of the art, practical uses and what developments are ahead.

4

LATEST DEVELOPMENTS IN FUZZY LOGIC

Fuzzy logic, a comparatively new technology, is finding many applications in both domestic and industrial equipment. This exclusive feature reveals some exciting news about the latest developments in this field.

19

HOW SEMICONDUCTORS ARE MADE

Ever wondered how a BC108 transistor and a 4011 NAND gate started life, well here's your chance to find out!

20

WHAT ARE SCANNERS?

Ian Poole explains what scanning radio receivers are and what they can be used for. He also reviews a typical modern hand-held scanner.

24

FIBRE DISTRIBUTED DATA INTERFACE EXPLAINED

The future of computer communications or just another standard that nobody wants? Frank Booty answers these questions and more.

33

HOW TO USE DIGITAL PANEL METERS

Ray Marston demonstrates how digital panel meters can be used in practical applications. Tried and tested circuits are included covering a multitude of possible uses.

37

THE INTELLIGENT DATA NETWORK

54

Tomorrow's technology or today's reality? Can sensors and systems be configured to communicate intelligently? Stephen Waddington shows that they can, and reveals what local operating network technology has to offer.

DESIGNING AND BUILDING SUB-WOOFER SYSTEMS

60

John Woodgate describes the processes involved in designing and building high performance sub-woofer systems – particularly with in-car and domestic applications in mind.

POWER ELECTRONICS IN THEORY AND IN PRACTICE

68

Practical circuits, based on the silicon controlled rectifier, are presented in the latest instalment of this informative series.

REGULARS NOT TO BE MISSED!

ABOUT THIS ISSUE...	2	HOW TO SUBSCRIBE	17	CLASSIFIED ADVERTS	53
TECHNOLOGY WATCH	3	ORDER COUPON	18	NEXT MONTH	66
DIARY DATES	9	NEW BOOKS	36	STRAY SIGNALS	67
NEWS REPORT	10	READERS' LETTERS	42	DID YOU MISS?	71

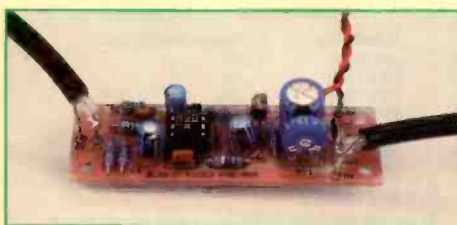
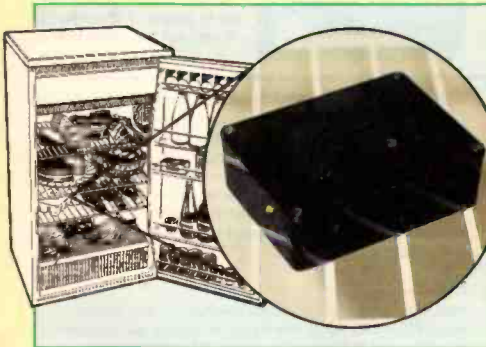

ABOUT THIS ISSUE...

Hello and welcome to this month's issue of *Electronics*! 'A chain is only as strong as the weakest link...' This saying can be applied to great many systems, processes or methods encountered in every day life; it is especially true in the world of electronics and the related field of computing. When designing systems to be fault or error tolerant, it is necessary to consider worst case scenarios, however, it can be a great deal harder to think of all the possible 'what if' cases...

This can be particularly true of software based systems which expect a particular input or a range of input values. Typical simple examples include 'menu' options on a computer program, e.g. 'Press A, B or C', what happens if the user types 'X' or a lower-case letter instead of an upper case letter? Good programmers ensure that such inputs are properly filtered, converted or error trapped. For example, inputs outside the range A to C are completely ignored and the program waits for a valid entry, or alternatively a suitable error message flashes on screen together with a 'beep' to alert the user to the invalid entry. 'User friendly' enhancements to the program are desirable and include the program being written to accept both uppercase and lower case letters as being equally valid. It is also necessary to consider the deliberate wrong entry, by a user trying to outsmart the programmer, with combinations of 'system' keys such 'Ctrl' and 'Alt'. Less easy to foresee scenarios include, the internal office mail being placed on the keyboard and causing the keyboard buffer to overrun. Poor programmers don't consider matters of this nature as being 'their problem'; programs then behave unexpectedly or lock up.

A system I encountered some years ago employed some very complex processor-based servo electronics, for rapidly and accurately positioning a piece of equipment. To move the equipment swiftly, powerful motors were needed; positional information was provided by high resolution shaft encoders. Most of the time it performed its task admirably. However, when it did fail, it really did FAIL! What the system designer had not considered in his theoretical model, on which the physical system was based (perhaps because he had not been taught to consider it at university), was the chance of an input variable disappearing! In this instance, the flexible wire that carried the positional information became open circuit. When this happened, the servo system got a little confused, applied full power to the motors, ignored the limit switches and

powered the equipment through its end stops! An expensive and potentially dangerous design oversight. What should have happened when the servo electronics lost one of its inputs was that the system failed safe - halting the motors in a predetermined way.

Safety critical systems such as those used in power stations, chemical plants, aircraft, train signalling systems usually adopt the principle of *parallel redundancy*, that is the vital parts of a system are duplicated. Critical information is gathered by two sensors and the information carried by two separate cables following different physical routes - so if one sensor or its cable fails, the other can still provide information. Parallel redundant processing systems have a supervisor system that monitors the output from the parallel units (usually three). Under normal circumstances the outputs from all of the processors match. If however, a discrepancy occurs the supervisor takes the majority vote of the two processors that agree as being correct, shuts down the rogue processor, flags the failure (sirens and lights) and maintains correct system operation. The system can then be safely shut down and repaired.

In some modern cars, the accelerator pedal operates a potentiometer or a shaft encoder. The signal produced is interpreted by the engine management system that controls the amounts of air admitted to, and fuel injected into, the engine. The days of a direct cable linkage to a carburettor are fast diminishing - at least if the cable snaps, a return spring is there to back-off the revs! If you have a modern car, what would happen if the sensor or its cable went faulty? In theory it should fail-safe, but will it?

In recent years, aircraft manufacturers have been the subject of criticism over fly-by-wire aircraft, in such an aircraft, the pilot's control column and various other levers and pedals operate switches and positional sensors. The information is read by computer and passed onto the control surfaces (rudder, ailerons, etc.) and engines by data cables. In older aircraft the control surfaces were physically connected by steel cables, linkages, etc., and assisted by hydraulics. Fly-by-wire systems have been blamed, in part, as possibly contributing to plane crashes. Pilots have reported CRT screens, on which graphical representations of traditional instruments are displayed, going blank at critical periods. Bugs in computer software at this level are a little more serious than bugs in a word processing program.

All of these safety critical systems rely on the correct response being preprogrammed; questions arise as to how the system will respond to an event that has not been thought of. To be able cover for an almost infinite range of combinations of possible problems occurring in real-time is very difficult and is helped to some extent by using knowledge based systems programmed with sets of 'rules'. These rules include a means of prioritising events according to urgency. Testing such systems is even harder, simulation systems are used prior to equipment going into final service. But what happens if the computer makes the wrong decision?... Humans, although fallible, generally cope better with unforeseen circumstances. Faced with serious life threatening problems, humans deal with the most pressing matters first, temporarily ignoring the unimportant ones (a rapidly approaching mountain is more important than landing gear that won't retract). Faced with choices, humans act with some degree of reason and rule out the obviously incorrect options, the computer might just metaphorically shrug its shoulders, or flash up 'call service engineer'. I'm not advocating such systems are unsafe - there are official bodies to approve such systems - but it is worth thinking about the issues involved.

Perhaps in the future, when buying a car or boarding a plane, we may adopt a similar maxim to that of computer software purchasers - never trust software that is version X.0, especially if it's version 1.0 - there's bound to be some bugs!

So until next month's issue I hope that you enjoy reading this issue as much as the 'team' and I have enjoyed putting it together for you!



R. Ball

ABC
ASSOCIATION OF BUSINESS OF CIRCULATING
CONSUMER PRESS

Front Cover Pictures:
© Copyright 1994 Pictor International, and Tony Stone Images. Virtually every aspect of our lives has been affected by semiconductor devices one way or another; the technology is new, but the raw material is as old as the earth.

EDITORIAL

Editor Robert Ball AMIPRE
Technical Authors Robin Hall FBIS, G4DVJ, Mike Holmes
Print Co-ordinators John Craddock, Mike Brett
News Editor Stephen Waddington BEng (Hons)
Technical Illustrators Ross Nisbet, Lesley Foster, Paul Evans, Nicola Hull
Project Development Chris Barlow, Dennis Butcher, Alan Williamson, Nigel Skeels

PRODUCTION

Art Director Peter Blackmore
Production Controller Steve Drake
Designer Jim Bowler
Layout Artists Tracey Walker, Adrian Dulwich, Nadine Clark, Paul Andrews
Published by Maplin Electronics plc., P.O. Box 3, Rayleigh, Essex, SS6 8LR. Tel: (0702) 554155. Fax: (0702) 553935.
Lithographic Reproduction by Planographic Studios, 18 Sirdar Road, Brook Road Ind. Estate, Rayleigh, Essex SS6 7UY.
Printed in the United Kingdom by St Ives (Caerphilly) Ltd. Mid-Glamorgan, CF8 3SU.

MANAGEMENT

Publications Manager Roy Smith
Development Manager Tony Bricknell
Drawing Office Manager John Dudley
Marketing Manager Vic Sutton

ADVERTISING

Jackson-Rudd & Associates Ltd., 2 Luke Street, London, EC21 4NT. Tel: (071) 613 0717. Fax: (071) 613 1108.
Advertisement Managers Eric Richardson, Jim Slater

UK NEWSTRADE DISTRIBUTION

United Magazine Distribution Ltd., Castle House, 37-45 Paul Street, London EC2A 4PB. Tel: (071) 490 2020. Fax: (071) 490 1239.

© Copyright 1994 Maplin Electronics plc.

Copyright: All material is subject to worldwide copyright protection, and reproduction or imitation in whole or part is expressly forbidden. Permission to reproduce printed circuit board layouts commercially or marketing of kits must be sought from the publisher.

Advertisements: Whilst every reasonable precaution is undertaken to protect the interests of readers by ensuring, as far as possible, that advertisements appearing in the current issue of *Electronics* are bona fide, the publisher and staff of the magazine cannot give any undertakings in respect of statements or claims made by advertisers, whether on printed page or on loose insert. Readers who have reasonable grounds to believe that they have been misled are advised to contact their local Trading Standards Office.

Editorial: The views of individual contributors/authors are not necessarily those of either the publisher or the editor. Where errors occur corrections will be published as soon as possible afterwards.

Publisher's Statement: Maplin Electronics plc. take all reasonable care to prevent injury, loss or damage of any kind being caused by any matter published in *Electronics*. Save insofar as prohibited by English law, liability of every kind including negligence is disclaimed as regards any person in respect thereof.

Project Ratings

Projects presented in this issue are rated on a 1 to 5 for ease or difficulty of construction to help you decide whether it is within your construction capabilities before you undertake the project. The ratings are as follows:

- Simple to build and understand and suitable for absolute beginners. Basic of tools required (e.g., soldering iron, side cutters, pliers, wire strippers and screwdriver). Test gear not required and no setting-up needed.
- Easy to build, but not suitable for absolute beginners. Some test gear (e.g., multimeter) may be required, and may also need setting-up or testing.
- Average. Some skill in construction or more extensive setting-up required.
- Advanced. Fairly high level of skill in construction, specialised test gear or setting-up may be required.
- Complex. High level of skill in construction, specialised test gear may be required. Construction may involve complex wiring. Recommended for skilled constructors only.

Ordering Information

Kits, components and products stocked by Maplin can be easily obtained in a number of ways:

Visit your local Maplin store, where you will find a wide range of electronic products. If you do not know where your nearest store is, refer to the advert in this issue or Tel: (0702) 552911. To avoid disappointment when intending to purchase products from a Maplin store, customers are advised to check availability before travelling any distance.

Write your order on the form printed in this issue and send it to Maplin Electronics, P.O. Box 3, Rayleigh, Essex, SS6 8LR. Payment can be made using Cheque, Postal Order, or Credit Card.

Telephone your order, call the Maplin Electronics Credit Card Hotline on (0702) 554161.

If you have a personal computer equipped with a MODEM, dial up Maplin's 24-hour on-line database and ordering service, CashTel. CashTel supports 300-, 1200- and 2400-baud MODEMS using CCITT tones. The format is 8 data bits, 1 stop bit, no parity, full duplex with Xon/Xoff handshaking. All existing customers with a Maplin customer number can access the system by simply dialling (0702) 552941. If you do not have a customer number Tel: (0702) 552911 and we will

happy issue you with one. Payment can be made by credit card.

If you have a tone dial (DTMF) telephone or a pocket tone dialler, you can access our computer system and place orders directly onto the Maplin computer 24 hours a day by simply dialling (0702) 556751. You will need a Maplin customer number and a personal identification number (PIN) to access the system. If you do not have a customer number or a PIN number Tel: (0702) 552911 and we will happily issue you with one.

Full details of all the methods of ordering from Maplin can be found in the current Maplin Catalogue.

Prices

Prices of products and services available from Maplin, shown in this issue, include VAT at 17.5% (except items marked NV which are rated at 0%) and are valid between 4th March and 31st August 1994. Prices shown do not include mail order postage and handling charges, which are levied at the current rates indicated on the Order Coupon in this issue.

Technical Enquiries

If you have a technical enquiry relating to Maplin projects, components and products featured in *Electronics*, the Customer Technical Services Department may be able to help. You can obtain help in several ways: over the phone, Tel: (0702) 556001 between 2pm and 4pm Monday to Friday, except public holidays; by sending a facsimile, Fax: (0702) 553935; or by writing to: Customer Technical Services, Maplin Electronics plc., P.O. Box 3, Rayleigh, Essex, SS6 8LR. Don't forget to include a stamped self-addressed envelope if you want a written reply! Customer Technical Services are unable to answer enquiries relating to third-party products or components which are not stocked by Maplin.

'Get You Working' Service

If you get completely stuck with your project and you are unable to get it working, take advantage of the Maplin 'Get You Working' Service. This service is available for all Maplin kits and projects with the exception of: 'Data Files'; projects not built on Maplin ready etched PCBs; projects built with the majority of components not supplied by Maplin; Circuit Maker ideas; Mini Circuits or other similar 'building block' and 'application' circuits. To take advantage of the service, return the complete kit to: Returns Department, Maplin Electronics plc., P.O. Box 3, Rayleigh, Essex, SS6 8LR. Enclose a cheque or Postal Order based on the price of the kit as shown in the table below (minimum £17). If the fault is due to any error on our part, the project will be repaired free of charge. If the fault is due any error on your part, you will be charged the standard servicing cost plus parts.

Kit Retail Price	Standard Servicing Cost
up to £24.99	£17
£25 to £39.99	£24
£40 to £59.99	£30
£60 to £79.99	£40
£80 to £99.99	£50
£100 to £149.99	£60
Over £150	£60 minimum

Readers Letters

We very much regret that the editorial team are unable to answer technical queries of any kind, however, we are very pleased to receive your comments about *Electronics* and suggestions for projects, features, series, etc. Due to the sheer volume of letters received, we are unfortunately unable to reply to every letter, however, every letter is read - your time and opinion is greatly appreciated. Letters of particular interest and significance may be published at the Editors discretion. Any correspondence not intended for publication must be clearly marked as such.

TECHNOLOGY WATCH!

Cold Christmas Turkey

In the pre-Christmas run-up last year, Sega and Nintendo spent some £20 million or so in the UK alone on advertising. Now while that sounds a lot (and indeed, it would pay my wife's Visa card bill for a month or two) you have to take it in context of the products – that is games consoles and games themselves – which the companies were likely to take. They were, in fact, each aiming for the lion's share of something around half a billion pounds-worth of business – and in this respect £20 million is peanuts. Around four percent of total UK revenue. One game alone (Super Mario 3) has made more than £500 million in revenue world-wide, and on its launch last October over 500,000 copies of another game (Mortal Kombat) were sold around the world in a single day.

It's a sign of the times that fortunes of monies like these are being spent and earned from what amounts to little more than toys, and it's a sign of the times that parents and guardians of these youngsters (or the youngsters themselves, for that matter) have the available funds to keep their kids' addictions supplied.

And what are these games? Little more than reaction testing arcade-style cartoon-based teasers, which create goggle-eyed physically underfit motor-morons of our youth? Or do they teach children how to apply themselves methodically to problems and increase concentration levels? Obviously, it's not in my hands to answer *those* questions, and it's not in my hands to criticise a society which allows its youngsters to spend or persuade their parents to spend these fortunes in the first place.

On the other hand, it is my brief to look at the technologies involved and comment on possible future scenarios. Games consoles – and that includes any of the available formats, not just Sega and Nintendo – are based of course on microprocessors. The very same microprocessors you get in computers. Some parents or guardians have even mistaken the act of buying a games console as being the equivalent of buying a home computer (believing that little Johnny is upstairs doing his homework when really he's battling it out with Bubonic the Hedgehog, or Super Harry-O 25) except that most of these games consoles aren't in any way, shape or form, like a

computer. While – yes – they have the same components inside, and – yes – they have a monitor (or at least a TV screen) in all but a couple of notable cases they don't do any standard computer tasks at all.

Like computers themselves, on the other hand, their capabilities all mirror the trends inherent to the microprocessing hardware they are built around. In the beginning were the table tennis-type games. They very soon evolved to 8-bit microprocessor-based games, which in turn have given way to the 16-bit microprocessor-based consoles. In the short-term these will move over to 32-bit systems, and ultimately systems based on the PowerPC and (maybe) Pentium microprocessors will be developed. Well, I say *ultimately*, but that's just a figure of speech, of course. There will be generations of games systems based on every future generation of microprocessor family that's developed as time goes by. In the short-term again, there'll be more and more CD-ROM-based systems, of which a few have got on to the market recently.

While there's been little of it so far, I predict that there'll be a combination of games available to date only on these games consoles and ordinary computer systems. In the past this has been *possible* but economically unviable because of the cost of upgrading personal computers to effectively a multimedia format to be able to take advantage of the games in question. But with lower computer prices, and many systems available now with the technical potential to play games, it's just a question of time before it happens. There always have been computer games, of course (that is, games played on *true* computers – not the games console-type of machine), but what Sega and Nintendo (among others) have to offer is really in a different league. Still, I somehow can't see me stopping off half-way through writing Technology Watch to play Streetfighter 14.

Where will it stop? Indeed, will it stop at all? With mass-produced virtual reality just around the corner, and games consoles now (well, nearly, anyway) able to generate it, what's the future for our youth? What's the future for the rest of us? If we can just slip on our VR headset and be in a different (interactive, sensory, exciting, stimulating, perceptory and so on) world, why come back to the real world

at all? For that matter, what's the *point* of a real world?

Turning around

What do you do when you finish that cool, thirst-quenching (aluminium) can of cola? What do you do when you've emptied a (glass) milk-bottle? How do you get rid of that pile of old (paper) newspapers? When the (CFC-filled) fridge finally gives up its ghost, what do you do with it? The answer to all these questions – or should be; as any responsible citizen of the 90s will know – is that you recycle. By recycling, earth's valuable but dwindling resources can be persuaded to last a little longer, smaller amounts of waste need to be tipped onto our ever-expanding dumps, fewer noxious and harmful by-products are released into our fragile ecosystem, and quite a few people are given a job.

But answer this now. What do you do with your old telly, or radio, or Hi-Fi, or personal stereo, or digital clock, or battery-driven toy, or – while we've just been on the topic – last year's games console? Chances are the answer is simply to dump it. But doesn't that strike you as a waste? Pun intended.

It's a waste because those devices (or at least many of their constituent parts) can be recycled. Just like glass, aluminium, steel, paper and the rest, electronic parts are valuable. In many existing cases some of those parts can even be reused, for the benefit of society in general, and for the benefit of the manufacturers involved.

All it would take is an initiative to encourage manufacturers to design products which are easier to recycle, and a structured method of actually recycling the products in the first place. The Industry Council for Electronic Equipment Recycling, comprising manufacturers, users, recyclers, suppliers and local authorities is attempting to persuade the Government to take steps to set up such an initiative. This makes considerable sense in the light of impending European regulations which are set to cover disposal of electronic appliances. I'll keep readers posted about the situation as things happen.

The opinions expressed by the author are not necessarily those of the publisher or the editor.

LIFE WITH MICRO CHIP...

"It's a crime when kids today are addicted to computer games Byte. Like us, they should be out & about, fresh air, exercise, and more..."



Yes it has to stop! life's too short-lived for living not simply for surviving the next level of Harry O's.



Here, ta, thanks. I reserved Super Mario 4 and Mr Hedgehog 9 for the weekend.



THE SEARCH FOR SUPERCONDUCTIVITY



by Douglas Clarkson

So much of today's civilisation relates to the technology of the use of electricity and the limitations currently encountered in its generation, transmission, storage and utilisation. Sources of power remote from centres of civilisation such as hydroelectric power tend not to be utilised due to problems of power losses in transmission lines. The potential of superconductivity to alter radically this perspective is widely appreciated and numerous groups are making a determined effort to move from a recent era of startling laboratory findings to one which can demonstrate a range of matching applications.

THERE is great diversity within the groups seeking to exploit the technology. The more 'favourable' applications, for example include the development of lower cost Nuclear Magnetic Resonance scanners and the development of low loss power transmission cables.

Everyone, however, will be familiar with the basic concept of superconductivity where the electrical resistance of a material vanishes to zero. Superconductivity was discovered by Kamerlingh Onnes in 1911. Initially working with a solid mercury wire, it was found that resistance vanished at a temperature of around 4 Kelvin (K).

Subsequently, it was found that as many as twenty-seven of the chemical elements demonstrated low temperature

Element	T _c (Kelvin)
Tungsten	0.015
Zinc	0.88
Aluminium	1.20
Indium	3.41
Tin	3.72
Mercury	4.15
Lead	7.19
Niobium	9.20

Table 1. Transition temperatures (T_c) of some superconducting elements.

Above: Computer-generated image of the crystal structure of the high-temperature superconducting material yttrium-barium-copper-oxide. Yttrium atoms are shown as silver, barium as green, copper as blue and oxygen as red. (Photograph reproduced courtesy of, and ©Copyright, IBM Research.)

superconductivity. The temperature at which a substance becomes superconducting is called the Transition temperature (T_c). Table 1 indicates the values of T_c for a range of chemical elements.

The early demonstrations of superconducting materials, however, did not initially produce any practical applications, as the initial superconducting materials could only sustain relatively small currents flowing through them. More and more laboratories around the world became equipped to undertake low temperature research although this did not lead to any remarkable discoveries. By 1933, only eleven superconducting elements and around fifty superconducting alloys and compounds had been discovered.

Small Beginnings

Two researchers in the USA, John Hulm (initially from Cambridge University) and Bernard Matthias, shared a keen interest in searching for new superconducting compounds. Matthias was a renowned expert in the field of ferroelectrics while Hulm had also independently done work in this field. The two workers began a period of research for new superconducting materials. Two years were spent 'baking' a range of compounds such as niobium and carbon in a vacuum oven and then investigating the conductivity of the compounds at low temperatures. Technology, however, was on hand to help, when Hulm came across a reference to an electric arc furnace which could very rapidly achieve the temperatures required to fuse together the compounds he wished to investigate.

At this stage Hulm was joined by George Hardy, an able graduate chemist in the process of investigating compounds for superconductivity. One initial surprise was the discovery that niobium monoxide was a superconductor. Until then, it had been considered that oxides did not exhibit this property. The compounds formed by silicon and vanadium were extensively investigated. The 'winning' formula of three atoms of vanadium for every atom of silicon with a transition temperature of 17K was eventually discovered.

Matthias had by now taken up an appointment at Bell Labs in New Jersey and when eventually told by Hulm of his success with the electric arc furnace, established this facility in his own laboratory. Through links which Matthias had with the other research establishments the electric arc method of fusing compounds became widely adopted and the pace of superconducting research increased significantly.

Using all the technical resources available at Bell Labs, however, a solution was found. What was unknown was the critical field which the wire could withstand. Tests subsequently proved that it could withstand a field of 8.8 Tesla – the value of field produced by the largest copper solenoid at Bell Labs. Thus Matthias had

shown the way forward for practical superconducting magnets using liquid helium temperatures.

The development of superconducting magnets was especially vital for research in fundamental particle physics where very high values of magnetic fields were required to be maintained over exceptionally long distances. Within CERN, for example, experiments require rings some 27km long and with high values of magnetic fields present. The wider commercial advantage, however, of using superconductors did not develop. The significant cost of liquid helium and the difficulty of maintaining its ultra cold temperature of 4.2K were to remain great limitations.

While there was still significant interest in superconductivity around the world, subsequent research in the 60s, 70s and early 80s did not see any significant breakthrough for materials with much higher values of T_c .

The Swiss Connection

Work had been progressing at IBM's impressive Thomas J. Watson Laboratory at Yorktown, some 30 miles north of New York, on the Josephson junction – an ultra fast switch incorporating superconducting material. A visiting physicist, K. Alex Muller from IBM's research facility at Zurich became interested in this field of endeavour. Upon returning to Zurich in the summer of 1983, he interested a young crystallographer Johann Bednorz in helping him investigate the superconducting properties of likely compounds.

Over two years were spent researching compounds containing mainly nickel, but without success. A reference, however, to a new ceramic containing barium, lanthanum copper and oxygen alerted the researchers to a compound which had a high probability of being superconducting. The samples were duly prepared before the Christmas holidays and tested in the new year of 1986. The resistance of the sample fell to zero at 35K. This was the breakthrough that had been so long awaited.

Bednorz and Muller were delighted but at the same time very cautious. Photo 1 shows the two researchers. Measure-

ments were repeated and checked, and it was then decided to publish a paper on what they had discovered. They published their findings in a slightly obscure journal. This would cause them little embarrassment if they were mistaken in their conclusions, but would still secure their precedence in the discovery. Such is the nature of the scientific establishment.

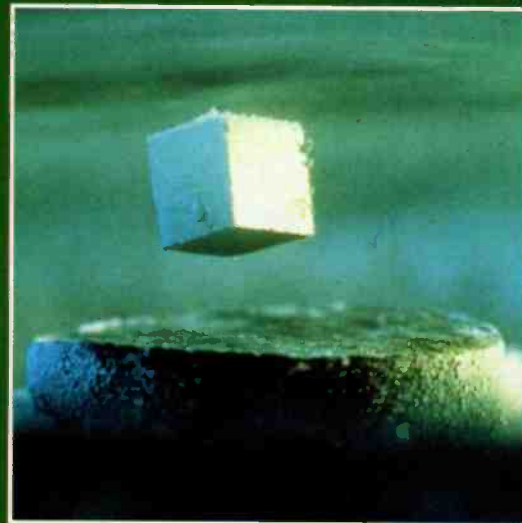

Photo 2. The small magnet floats in air above the superconductor surface because of a physical phenomenon known as the Meissner effect, whereby superconducting material excludes magnetic fields from the material's interior. When chilled in liquid nitrogen, the superconductor acts as a perfect mirror to the magnet, causing it to levitate as it sees its reflection in the superconductor. (Photograph reproduced courtesy of, and ©Copyright, IBM Research.)

The Race Begins

After the Swiss paper was published, major research teams around the world began to crank up their activity. The Swiss researchers were soon after awarded the Nobel Prize for Physics. One group at the University of Houston under the leadership of Professor Paul Chu had been seeking a breakthrough in superconductivity studies since heading his team in Houston in 1979. Chu was almost on the point of giving up when the work of Bednorz and Muller was finally published.

Working in collaboration with a former student at Alabama University, Maw-Kuen Wu, the two teams began to investigate variations on the Swiss recipe. Efforts at both labs began to concentrate on compounds of yttrium, barium, copper and oxygen. It was at Wu's lab in Alabama, however, that the initial breakthrough was made on 29 January 1987, where evidence of high temperature superconductivity was observed. Over the next few days improved samples gave routine T_c values around 90K – well within the cooling range of liquid nitrogen. The era of high temperature superconductivity had arrived.

The discovery was written up as a scientific paper in *Physical Review Letters* and dated 6 February for publication on 2 March. It transpired, however, that numerous groups had been playing around with the same compounds in early



Photo 1. K. Alex Muller (left) and J. George Bednorz of IBM's Zurich Research Laboratory provided the spark that ignited the excitement of the world scientific community by their discovery, in 1986, of high-temperature superconductivity in a class of oxide materials. They received the 1987 Nobel Prize in Physics for their contribution. (Photograph reproduced courtesy of, and ©Copyright, IBM Research.)

1987. At Bellcore, for example, the 'correct' mix had been synthesized on 3 January, but had not been tested for superconductivity until 25 February.

The bake of chemicals was found to consist of a green phase and a black phase. It was soon discovered that the black phase was the superconducting material. The atomic structure of the famous compound is shown in the title photograph on page 4. Following the initial discovery of the Houston compound, researchers at IBM laboratories subsequently discovered that the new superconducting compounds could carry currents up to 100 times higher than previously believed.

The events between 29 January and 18 March – the date of a major meeting on the topic of superconductivity in New York, will long be remembered as one of the most dynamic periods in basic research this century.

At this time superconductivity was headline news with photographs of 'floating' magnets such as shown in Photo 2 being given great prominence.

Techniques were developed at IBM for the plasma spraying of superconducting films onto component surfaces. This was a key element of the production of SQUIDs (Superconducting QUantum Interface Devices) an example of which is shown in Photo 3.

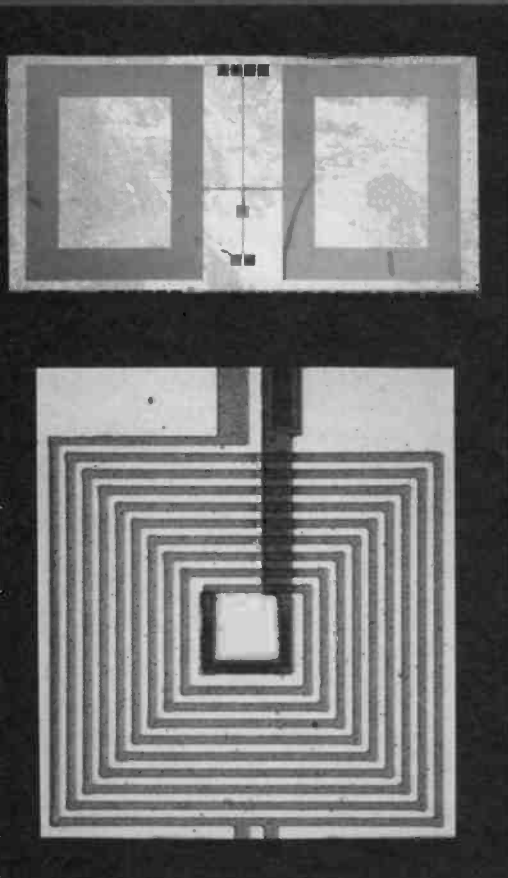

Photo 3. The upper part of the photograph shows two 3 x 4mm counterwound superconducting pickup coils. In the centre, shown enlarged in the lower part of the photograph, is a small 250 x 250µm superconducting square. It is the multilayer spiral input coil that focuses the magnetic field being measured onto the superconducting quantum interference device (SQUID) that is hidden directly underneath. (Photograph reproduced courtesy of, and ©Copyright, IBM Research.)

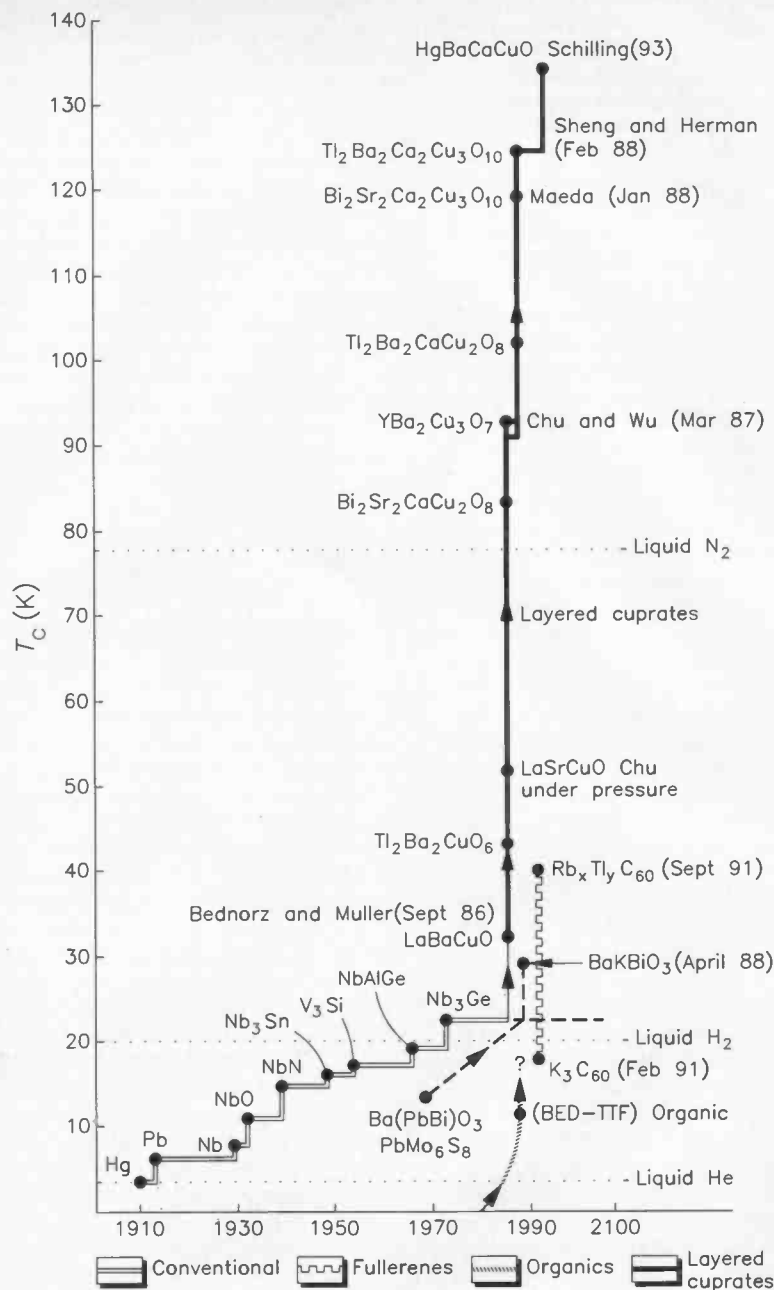

Figure 1. This figure highlights the rapid rise in critical temperature since the initial breakthrough by Muller and Bednorz in 1986. (Figure reproduced courtesy of, and ©Copyright 1991, *Physics World*.)

Subsequent Developments

A group of researchers at the University of Arkansas in October 1987 discovered superconducting material using thallium as a substitute for yttrium, and they achieved superconductivity at about 82K – still above the temperature of liquid nitrogen. On the day of their press conference announcing their result on 22 January 1988, the Japanese, however, announced superconducting materials using bismuth, barium, calcium, copper and oxygen in two phases at 75K and 105K. The 'bismuth breakthrough' had, already been discovered 'in secret' by the German company Hoechst in November and subsequently patented. The group at Arkansas subsequently improved the performance of their thallium superconductor – raising its T_c to 125K. Thallium,

however, is a highly toxic element. In the drive to produce practical wires and films for real applications thallium and bismuth compounds are more promising.

Figure 1 shows how superconducting research has rapidly raised values of critical temperatures of such compounds.

In the spring of 1993, researchers found that mercury incorporated into superconducting compounds increased critical temperatures still further to 133.5K. This new wave of superconducting research using mercury is perhaps a reminder that science sometimes goes round in circles – in 1911 mercury was the first element to demonstrate superconducting properties.

Exploiting Technology

While groups are searching for new HTC (High Critical Temperature) compounds, a considerable amount of effort is being

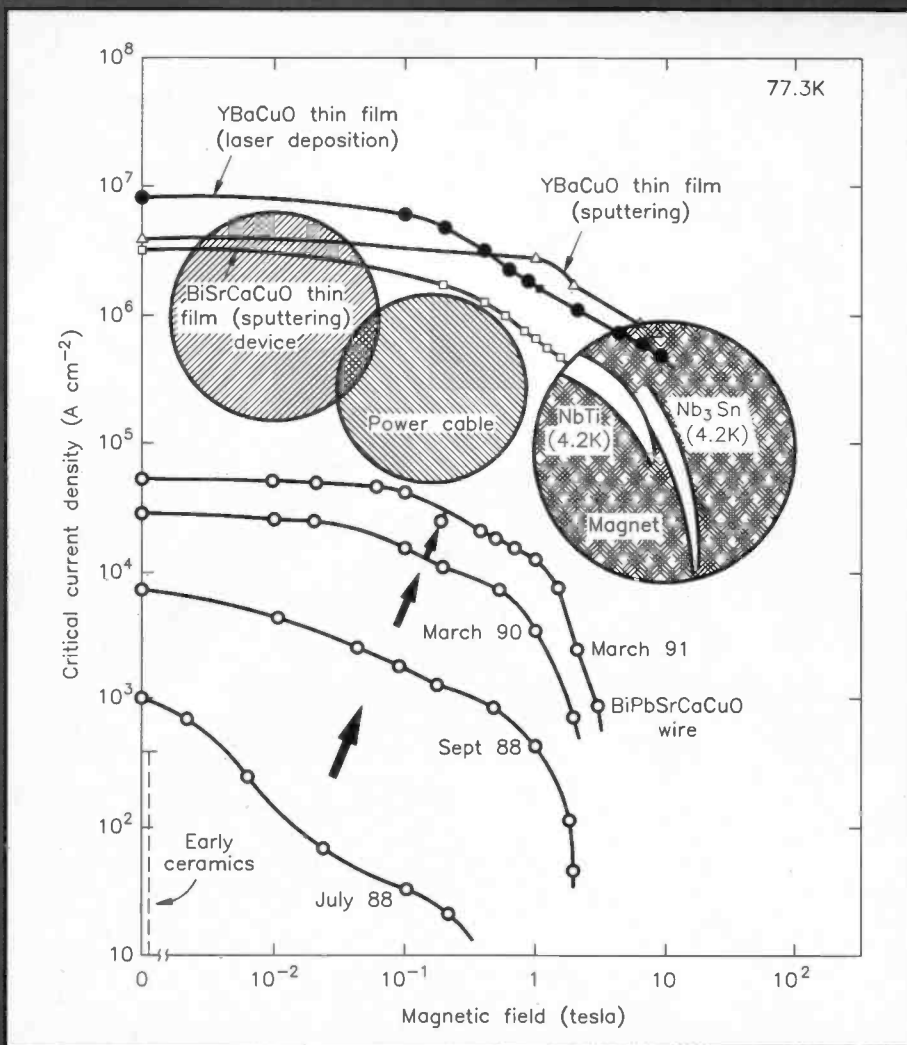

Figure 2. Variation of critical current density as a function of magnetic field for wire and thin film superconductors. The circular areas indicate the bounds within which specific application parameters can be met. (Figure reproduced courtesy of, and ©Copyright 1991, *Physics World/Sumitomo*.)

directed towards harnessing the technology which is already able to be demonstrated.

The key parameters of a superconducting wire or film are the critical current density (the highest current density achieved at superconducting temperatures) and the maximum value of magnetic field which can be tolerated. Figure 2 shows how year by year curves of BiPbSrCaCuO wire at liquid nitrogen temperatures are inching forwards to meet requirements of power cables. The disadvantage of existing high voltage power transmission lines is that they are unsightly and dissipate energy in the conducting wires. The advantages of superconducting power transmission lines are that they can be sited underground and would reduce transmission losses. One potential problem, however, in centres of population is that the likely size of the magnetic fields surrounding such wires is likely to be much higher than for conventional cables. Considerable research requires to be undertaken to both evaluate possible adverse effects of higher field values and determine if magnetic fields can be reduced by active shield techniques.

It has been anticipated that transportation systems will be considerably influenced by superconducting technology. As for land based systems, considerable effort has been expended in

developing so called MAGLEV (Magnetic Levitation) systems where superconducting magnets are used to levitate an entire train which is then free to 'float on air'. Japan's MAGLEV train, the MLU-002 is one of her superconductivity technology showpieces. In Germany a 20.6km test

train was in operation in the early 1980s in Lower Saxony near the Dutch border. The track was extended to 31.5km in 1987 and the prototype train achieved a world record of 435km/hr

The Japanese, however, have been imaginative in developing superconductivity in new areas. The superconducting ship, the Janato-1, which weighs 280 tonnes and attains a speed of 20 knots seeks to harness an entirely new method of propulsion involving superconductivity.

Various groups are investigating the direct storage of energy in the high values of magnetic fields established by superconducting magnets. The energy in a cubic metre of space in which is established a magnetic field of strength 1 Tesla is around 800,000 Joules and is proportional to the square of the field strength! Figure 3 illustrates potential energy storage as a function of field strength.

So far experimental storage units with a diameter of about 4 metres have been constructed with a capacity of 30MJ. It can be appreciated, however, that if the size is increased by a factor of 5 and the field by a factor of 4, then the storage capability would be increased by a factor of 400 to around 12,000MJ. This could deliver 100MW over a period of two minutes at 100% efficiency. There is clearly some way to go before this mode of energy storage is viable.

The level of sensing of extremely low magnetic fields attained with liquid helium cooled SQUIDS has now been achieved with SQUID devices cooled by liquid nitrogen. Signals of amplitude around 10pTesla (10^{-12}) - typical of the amplitude of signals generated by the human heart can now be routinely monitored. If an alternating current of amplitude 1A was flowing along a long wire, then such a SQUID device could detect the magnetic field signal at a distance of 10km. SQUIDS are already finding application in advanced electronics instrumentation, non-destructive testing, geological surveying and biological and potentially neurological monitoring.

Commercial success has been

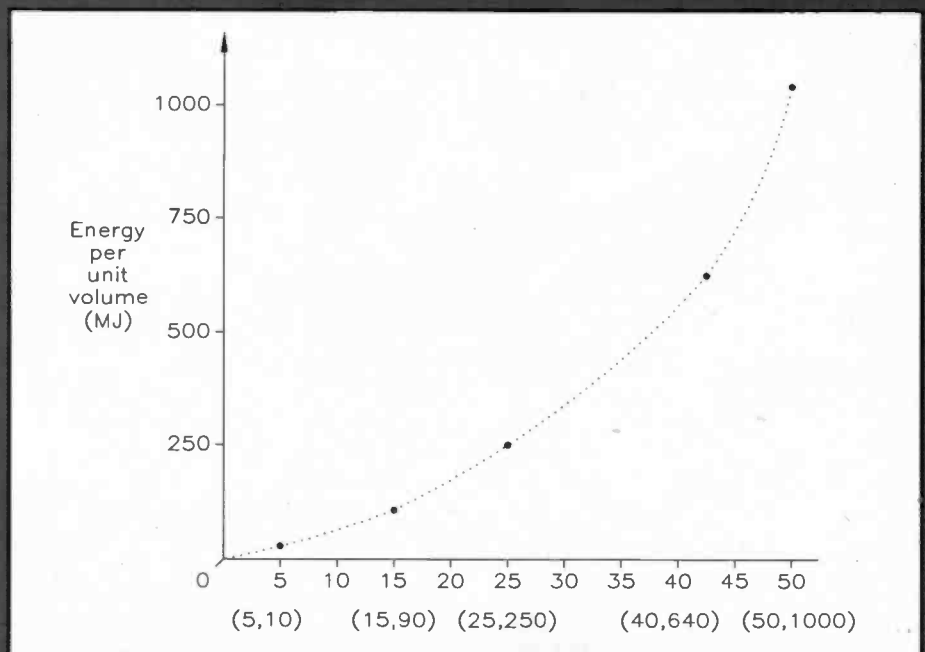

Figure 3. Variation of stored energy per unit volume (m^3) as a function of the value of the magnetic field in Tesla.

achieved using HTC materials in microwave applications. The group at Birmingham in collaboration with industrial partners has developed short dipole antennae and microwave band pass filters which outperform 'copper' equivalents.

As higher and higher magnetic fields are generated using superconducting magnet technology; the energies of particles that can be held within a circular accelerator of a given diameter can be increased. One option with projects such as the Superconducting Super Collider is to wait until higher field magnets are available so that smaller sized (and cheaper) accelerators can be constructed.

One of the early applications of superconductivity was in Magnetic Resonance Imaging where images are obtained from mapping nuclear magnetic resonance of atoms within the body. In order to produce images of highest quality it is essential that the magnetic field is highly uniform within the volume being scanned. High homogeneity fields at the level of variation of 5 parts per million within a 50cm sphere can be readily achieved. Field strengths achieved are typically between 0.5 Tesla and 2 Tesla. While there are advantages to scan patients at higher field strengths, such high fields tend to influence cardiac function and are not used in routine clinical practice.

A conventional superconducting magnet will employ an iron core to help limit the extent of the stray field from the mag-

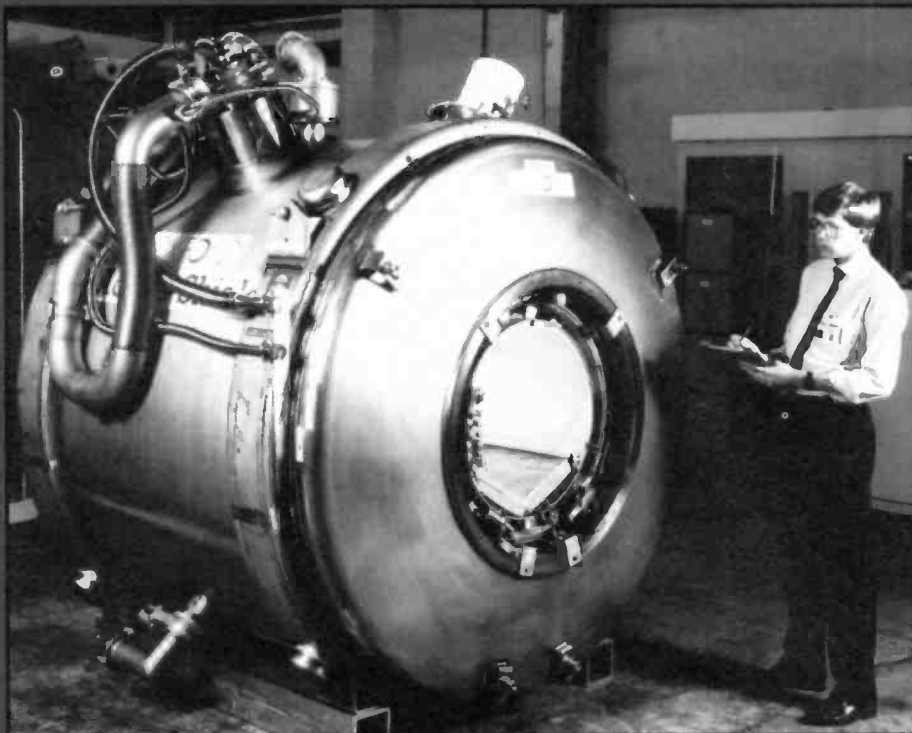

Photo 4. Active shield superconducting magnet. (Photograph reproduced courtesy of, and ©Copyright, Oxford Magnets.)

net. Newer technology so called 'active shield' magnets use ancillary magnetic circuits to cancel the field of the main magnet. Typically at a core field of 2 Tesla, the 5 gauss line in the radial direction will appear at 11 metres from a con-

ventional magnetic and 3 metres from an active shield type.

Photo 5 shows a typical active shield liquid helium superconducting magnet assembly. Helium is still used as the cooling liquid of choice since only liquid helium superconducting wire elements can withstand very large mechanical stresses due to the 'pull' on the current carrying wire in the strong magnetic field.

Photo 6 shows some typical MRI scans made possible with such superconducting magnet technology. With the MRI scan, a 'slice' through an area to be imaged can be scheduled as required. Also, MRI systems do not involve any dose of ionising radiation to the patient. This is making them increasingly popular as a diagnostic tool. Also, MRI is undergoing a rapid phase of technological development while CT systems are relatively static.

Summary

Around the world something like \$1 billion is being spent in the field of superconductivity research. Attention is being directed both to the discovery of new HCT materials and the technological exploitation of materials already discovered. Such technology is likely to have the biggest impact on the management of energy - its generation, utilisation and storage.

The rapid growth of superconductivity research has highlighted the need for 'interdisciplinary co-operation' in science generally. The physicist, the chemist, the materials scientist, the crystallographer all have a role to play in achieving progress.

Further Reading

Physics World, Institute of Physics, July 1993, Mercury sends superconducting critical temperature soaring.

Superconductors: The Breakthrough, Robert M. Hazen, Unwin, 1988.

The Path of No Resistance, Bruce Schechter, Simon and Schuster, 1989.



Photo 5. Typical MRI head scan images. Specific 'slices' through the head can be selected and image details produced based on a range of tissue characteristics. The most basic one is proton density. (Photograph reproduced courtesy of, and ©Copyright, Oxford Magnets.)

SAVE UP TO £4.50 ON ENTRANCE TO THE NATIONAL COMPUTER SHOPPER SHOW!



The National Computer Shopper Show is coming to Birmingham for the first time. The UK's number one PC selling event is being launched in one of the new purpose-built exhibition halls at the NEC, Birmingham.

In the past two years one million PCs have been bought by the home user in the Midlands. The Computer Shopper Show is opening in Birmingham in response to this developing PC market. The Show is for everyone from first-time buyers to experienced business users.

The National Computer Shopper Show runs from the 24th to the 27th March and brings together over 100 leading companies. The venue is the National Exhibition Centre, Birmingham, and everything you might want to buy is going to be there – desktop computers, notebooks and portables, printers, a wide variety of peripherals, thousands of software applications for both DOS and Windows, multimedia, CD ROM upgrades and software.

Annually over £24 million of business is conducted at the two Shopper Shows and with the National Show taking place in late March the figure is expected to rise as education and business buyers take up allowances before the end of the tax year.

Feature areas at the National Show include:

An independent advice centre staffed by independent journalists from Computer Shopper Magazine, this is where to come for free and impartial advice on your next computer purchase. Everyone has felt intimidated by computer jargon at one time or another and a visit to the Advice Centre will help dispel the mysteries for you.

There will be two presentations each day on the essential pointers to buying a computer. This will be followed by a question and answer session where advisers will answer any individual queries you may have.

The days of only having your computer at home are gone. Come and see the latest in the mobile revolution – palmtops, laptops and notebooks.

For small business computer users the best way to make a decision when buying software is to see it

demonstrated – in the Software Presentation Theatre a number of big name suppliers will be showing their latest packages throughout each day. Again you will be given the opportunity to ask any questions you may have.

For the fun side of computing, there will be a dedicated leisure area, packed with PCs running the latest games software. Throughout the show there will be organised games challenges, preview footage of soon-to-be-released blockbusters as well as giving visitors the opportunity of trying out the latest software. There are hundreds of prizes to be won and there will be a team on hand to answer any queries.

The huge diversity of machines on the market can be confusing to potential buyers who are often bewildered as to which machine is best for them. The Shopper Show gives visitors the opportunity to see and try a whole range of products and offers free, expert, independent, buying advice.

Electronics readers wishing to visit the show will get £1.50 off each ticket (£7.00 for adults and £5.00 for under sixteens) up to a maximum of 3 tickets (total saving £4.50) if they use the voucher on this page. Contact: Blenheim Online, Tel: (081) 742 2828.

Tickets

If you book your National Computer Shopper Show tickets in advance (as well as getting as much as a third off standard show prices) you can get two InterCity Saver or SuperSaver tickets for the price of one, if you are travelling from London Euston, Watford Junction or Milton Keynes. Full details of this offer are available from the box office, Tel: (021) 767 4343.

Above: One of many seminars offering independent advice.

SAVE £1.50 again and again and again!

Electronics - The Maplin Magazine

Use this coupon to claim a £1.50 discount on THREE tickets to the National Computer Shopper Show

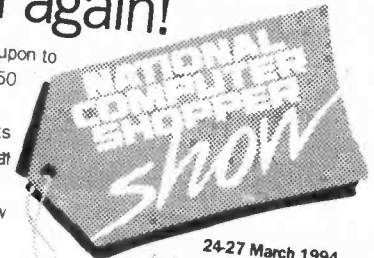

24-27 March 1994
Hall 11, NEC, Birmingham

BLENHAIM

Sponsored by Computer Shopper Magazine

Show opening times

Thursday 24 - Saturday 26 March	10.00am - 6pm
Sunday 27 March	10.00am - 5pm

Photocopies not valid. Valid on entry to show only.
I am claiming £1.50 off 1 or 2 or 3 tickets. PLEASE TICK.

DIARY DATES

Every possible effort has been made to ensure that information presented here is correct prior to publication. To avoid disappointment due to late changes or amendments please contact event organisations to confirm details.

1 March. Hardware, Sudbury and District Radio Amateurs, Wells Hall Old School, Great Comard. Tel: (0787) 313212.

1 to 3 March. Enterprise Computing 1994, Earls Court 2. Tel: (081) 742 2828.

5 March. VHF Convention, Sandown Exhibition Centre, Sandown Park, Esher, Surrey KT10 9AJ. Tel: (0707) 659015.

8 to 10 March. CAD/CAM, National Exhibition Centre, Birmingham. Tel: (071) 404 4884.

9 to 10 March. Instrumentation, Exhibition Centre, Harrogate. Tel: (0822) 614671.

12 to 13 March. The London Amateur Radio & Computer Show 1994. Lee Valley Leisure Centre, (Picketts Lock), Picketts Lock Lane,

Edmonton, London, N9. Tel: (0923) 893929.

18 March. Chris Hamilton looks at the attempts to transfer 78rpm records to cassette, LP and CD in a lecture entitled 'Its not what it purports to be'. 6.45pm, National Sound Archive, 29 Museum Road, London. Free tickets by arrangement. Tel: (071) 323 7760.

22 March. Peter Copeland, Conservation Manager, National Sound Archive discusses the preservation of media by copying in a lecture entitled, 'The Scientific Estimation of Sound Quality and its Relevance to Sound Preservation'. 6.45pm, National Sound Archive, 29 Museum Road, London. Free tickets by arrangement. Tel: (071) 323 7760.

21 to 24 March. Control '94 Conference, Institution of Electrical Engineers, University of Warwick, Warwick. Tel: (071) 240 1871.

22 to 24 March. Nepron Electronics, National Exhibition Centre, Birmingham. Tel: (081) 948 9900.

24 to 27 March. National Computer Shopper Show, National Exhibition Centre, Birmingham. Tel: (081) 742 2828.

5 April. Equipment Sale, Sudbury and District Radio Amateurs, Wells Hall Old School, Great Comard. Tel: (0787) 313212.

5 to 7 April. Storage & Recycling Systems '94, Institution of Electrical Engineers, University of Keele, Keele. Tel: (071) 240 1871.

11 to 13 April. Cable and Satellite '94, Olympia Grand Hall, London. Tel: (081) 948 9900.

12 to 24 April. Computation in Electromagnetics Conference, Institution of Electrical Engineers, University of Nottingham, Nottingham. Tel: (071) 240 1871.

19 to 21 April. Communications Solutions Exhibition, National Exhibition Centre, Birmingham. Tel: (081) 948 9900.

19 to 21 April. Business Telecomms 1994, Olympia 2, London. Tel: (081) 742 2828.

19 to 21 April. Fifth Electrical Safety in Hazardous Areas Conference, Institution of Electrical Engineers, London. Tel: (071) 240 1871.

21 April. Lecture by Norman White of Nimbus Records on the making of the Nimbus 'Prima Voce' series of Opera CDs based on old 78rpm records. 6.45pm, National Sound Archive, 29 Museum Road, London. Free tickets by arrangement. Tel: (071) 323 7760.

22 to 24 April. MIDI & Electronic Music Show, Wembley, London. Tel: (0222) 512128.

23 April. International Marconi Day Exhibition, Wireless Museum, Puckpool Park, Seaview, Near Ryde, Isle of Wight. Tel: (0983) 567665.

26 to 28 April. Seventh Road Traffic Monitoring & Control Conference, Institution of Electrical Engineers, London. Tel: (071) 240 1871.

Please send details of events for inclusion in 'Diary Dates' to: The News Editor, Electronics - The Maplin Magazine, P.O. Box 3, Rayleigh, Essex SS6 8LR.

NEWS

Report

Dual-Scan Projection



Sharp has launched a new colour liquid crystal display (LCD) overhead projection panel. Called the QA-350, the new projection screen incorporates an innovative 9.4-in. dual-scan LCD screen that offers greater definition than previous designs.

Developed by Sharp, dual-scan enables the top and bottom halves of the screen to be scanned simultaneously. Combined with advanced digital processing this produces vivid high contrast images. Contact: Sharp (061) 205 4255.

Environmental Measurement

ITT Instruments has introduced a new modular test kit for checking environmental and electrical parameters during the professional installation and servicing of heating, ventilating and air-conditioning systems in commercial, industrial and other climatically controlled environments.

The new CX51 system will measure temperature, humidity, air speed and light as well as standard electrical measurements.

The test kit is based on the company's MX51 hand-held digital multimeter also contains a measuring sensor interface, four interchangeable sensors, two electrical test probes and a telescopic handle to assist measurement in difficult locations.

The CX51 uses a Pt100 platinum resistance thermocouple to measure temperature from -40°C to $+80^{\circ}\text{C}$ with a resolution of 0.1°C and an accuracy of $\pm 0.5^{\circ}\text{C}$. Humidity measurement range using a capacitive sensor is from 10% to 98% relative humidity (RH), with a resolution of 0.1%RH and an accuracy of $\pm 3\%$ RH.

Air speed is measured using a hot-wire anemometer and covers the range 0 to 10ms^{-1} and an accuracy of $\pm 2\%$. For light-level measurements, a silicon cell with a built-in correction filter is used to give a range from 0 to 100,000lux, with a resolution of 1lux and an accuracy of $\pm 1\%$. Contact: ITT Instruments (0753) 511799.

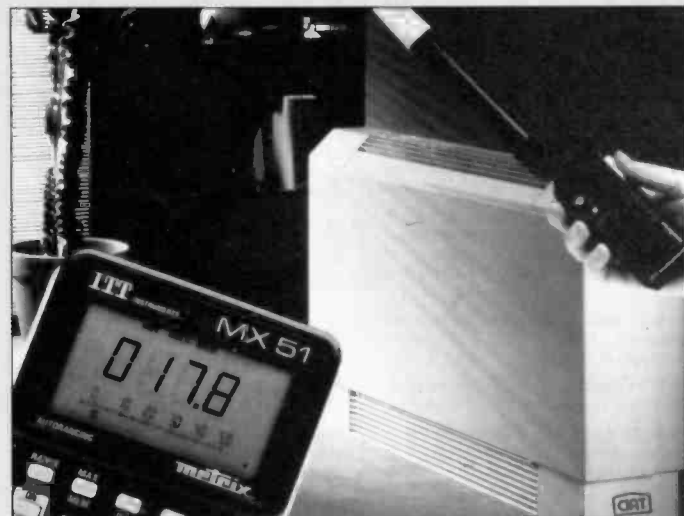

Entries Required for Young Engineer 1994

The Engineering Council has launched its Young Engineer for Britain 1994 competition with prizes totalling £20,000.

The competition is open for entries from young people aged from 11 to 19, in full-time education, or working in industry. The overall winner – The Young Engineer for Britain 1994 – will receive a personal prize of £1,000, a trophy and £1,500 for their school or organization.

The aims of the competition are to encourage young people to undertake project work and strengthen links between education and industry. Regional finals will be held in June and July, with the national final held during September in London.

The judges are looking for innovative project whether simple or complex from individuals or teams of up to four. So get working you budding designers, it would be good to see a few *Electronics* readers amongst this year's regional and perhaps even national finalists.

Entry forms can be obtained from the Engineering Council, 10 Maltravers Street, London WC2R 3ER.

Telephone Renumbering

Telecommunications watchdog, OfTel has announced the timescale for the implementation of the national code change.

On the 16 April 1995 – PhONEday – the geographic UK telephone numbering scheme will change by the addition of the digit '1' after the prefix '0'. For example the dialling code for York will change from '0904' to '01904', while the code for inner London will change for '071' to '0171'.

Prior to PhONEday, during June this year, operators will open up their networks for testing and the new codes will be accepted in some areas. By 1 August 1994, new and old codes will run in parallel in all areas, while the new international code will be implemented, changing from '010' to '00'.

According to OfTel Director Don Cruickshank "Renumbering is an essential element in the development of a competitive market in telephony services in the UK". OfTel is to establish a Numbering Administration Unit which will take over the responsibility of number allocation from BT, thus ensuring that numbers are allocated fairly amongst licensed telephone competitors in the future.

Meanwhile the main operators, BT, Kingston and Mercury as well as OfTel have set up helplines for customer queries. Contact: BT (0800) 01 01 01; Kingston (0482) 602876; Mercury (0500) 041995; OfTel (071) 634 8756.

Lighting Arsenal's Way into Europe

Arsenal Football Club, who last season won both the FA Cup and the Coca Cola Cup, have completed two ambitious lighting projects as part of a £20million upgrading scheme at its Highbury ground.

The first, a refurbishment of the flood-lighting comes in the wake of victories that have put the club into contention for this year's European Cup Winners Cup. Luminaires located along each edge of the side stands have been refurbished to match the best schemes in continental Europe. Metal halide lamps rated at 2kW have raised lighting levels to above the 1200lux required under UEFA rules.

The second lighting project involved fitting out the interior of the club's new North stand, which has been designed to provide an area with improved facilities for fans. Here 130, 60,000-hour Philip's QL lamps have been used to provide a light source that Philip's estimate will outlive the stand itself. Contact: Philips Lighting (081) 665 6655.

A Fistful of Motors



The Bioengineering Centre in Edinburgh has a history of R&D in upper limb prostheses or artificial arms, extending over thirty years.

Its most recent project is a two year research grant funded by the Chief Scientist's Office at the Scottish Office Home and Health Department to build an all electrically powered arm prosthesis – believed to be the first in the world.

The artificial arm has five powered movements: shoulder elevation; rotation across the body; elbow flexion; wrist rotation and a gripping hand.

The shoulder elevation and elbow flexor motors are identical and rated at 23W. Researchers chose DC motors from Electro Mechanical System's because of their high power to weight ratio and compactness.

Both motors drive a linear actuator via an EMC type 30/1 planetary gearhead. The hand and wrist rotor use the 1319 motor and type 15/5 gearhead while the shoulder motor uses a 1331 motor and a differential ratio type 15/5 gearhead. Contact: Electro Mechanical Systems 0734 817391

3V Surface Mount Oscillator

UK crystal manufacturer International Quartz Devices (IQD) has responded to the growing demand for 3V chipsets by launching the IQXO-66 miniature 3V surface mount oscillator.



Measuring only 7.5 x 5 x 2.3mm, the ceramic device is available over a wide frequency range from 1.5MHz to 50MHz. With an input voltage of 3V $\pm 0.3\text{V}$ and a maximum supply current of 8mA from 1.5 to 39.999MHz and 12mA from 34 to 50MHz, the unit is ideally suited to low power applications such as notebook computers, PCMCIA peripherals and data logging equipment.

Sample quantities are available from IQD to enable designers to experiment with the new device. Contact: IQD 0460 77155.

Rubber Electricity



The UK's first waste tyres-to-energy power station was officially opened at the end of last year in Wolverhampton by Professor Stephen Littlechild, Director General of The Electricity +6 Supply.

The £48million plant, which will generate electricity by recycling ten million waste car and lorry tyres, has been developed by US-owned Elm Energy and Recycling(UK).

The tyres will combust in five fired furnaces, pre-heated to 900°C. Steam raised in boilers will be routed to a turbo-generator to produce electricity.

Each year almost 20,000 tonnes of scrap steel wire will also be produced for the Midlands steel industry, 3,000

tonnes of zinc compound for the Midlands zinc smelting industry and 7,000 tonnes of calcium sulphite, which is used in the production of building materials, or by the waste water treatment industry.

Power from the Elm Energy plant, which has created employment for 70 people, is being purchased by Midlands Electricity for input into the National Grid. It will generate 25MW of power – enough to supply 25,000 homes.

The project was built by the Anglo-US consortium TBV power, a joint venture between Wolverhampton-based Tarmac Construction and Black & Veatch Engineering of Kansas City, which specialises in power plant design.

Communications of Yesteryear

The Museum of Communication near Edinburgh shortly commences its programme for 1994. The museum collection comprises over 26 tonnes of material including electrostatics, telegraphy, telephony, gramophone, photography, cinematography, radio, television and computer equipment plus a technical library.

This year's exhibition entitled 'Dots, Dashes and Dials', previews from 7 to 16 April, at King's Building, Edinburgh University, as part of the 1994 Edinburgh International Science Festival. Opened daily from 10.00am until 5.00pm, admission will be £1.00 for wage earners, otherwise 50p.

After the festival, the exhibition returns to its home in Bo'ness for the rest of the season between 7 May and 2 October. As the exhibition is manned solely by volunteers, it opens only at weekends between 1.30pm and 5.30pm. The

Museum can be opened at other times, for groups or individuals by prior arrangement. Entrance here is free, although a donation box is placed prominently.

The Museum of Communication was started in 1975 by its Curator Harry Matthews of the University of Edinburgh, Department of Electrical Engineering. From humble beginnings in the university's Radio Laboratory, it rapidly encroached into the Department of Physics.

In 1987, the Museum became affiliated to the Bo'ness Heritage Area and the collection (which had outgrown all available space), was moved to Bo'ness, where it is now stored.

If you are in the Edinburgh area or planning to visit in the near future, stop off at the Museum of Communication – we strongly recommend a visit. Contact: (0506) 823424 or (0506) 824507.

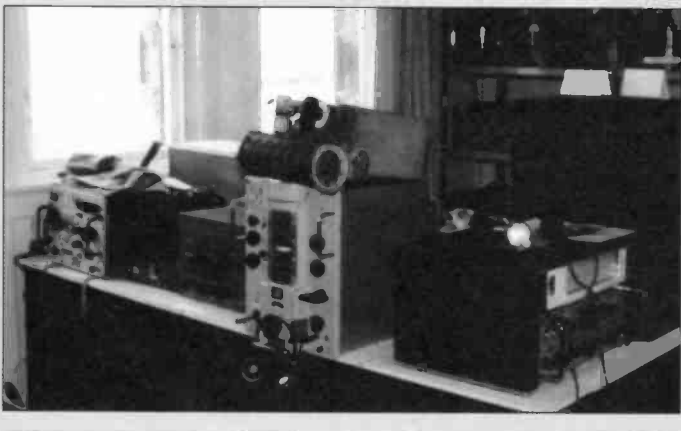

Inland Revenue Admits RSI Does Exist

Repetitive Strain Injury (RSI) does exist. At least according to a recent £79,000 out-of-court settlement between the Inland Revenue and former employee and RSI sufferer Mrs Kathleen Harris.

The result sets an important precedent only three months after High Court Judge John Prosser rejected a claim by a Reuters journalist – a decision which has since been criticised by the Health and Safety Commission.

Mrs Harris is now registered disabled and claims invalidity benefit after retiring through ill-health from her secretarial position after 15 years in a west London tax office. She had to perform up to 16,000 keystrokes an hour, nearly 4.5 per second.

Unions have thousands of RSI claims pending, and safety experts fear that the health problems caused by an estimated four million keyboards in the UK will grow without proper safeguards.

One Electron per Bit

Japanese semiconductor manufacturer Hitachi has developed a prototype single-electron memory device, working at room temperature, paving the way for the production of an 8-gigabyte non-volatile memory integrated circuit.

Eight gigabytes represents four times the amount of information contained on a compact disk and more than 500 times the amount of data in the most advanced flash memory chips available on the market.

Conventional semiconductor memories require more than 10,000 electrons to represent a single bit of information.

High Voltage, Fast Recovery Diodes

International Rectifier has added a range of 1200V devices to its HEXFRED family of ultra-fast, soft-recovery diodes.

HEXFRED diodes are pin-for-pin compatible with conventional diodes, and can therefore be used as direct replacements with no design modifications.

However, the designer can achieve the greatest cost benefits and efficiency improvements by taking full advantage of both the low reverse recovery current which causes power switches to run at much lower temperatures, and the ultra-fast soft recovery which will result in lower radio frequency interference and reductions of snubber components.

The new 1200V components are available in single-die and dual-die configurations, with forward currents specified from 6 to 30A. IRRM values range from 4.4 to 5.8A, with t_{rr} in the range 26 to 30ns. Contact: International Rectifier (0833) 713215.

Multi-international Design

The vision of the global manufacturer serving a world market is fast becoming a reality. While growing nationalism seems increasingly to dominate the geopolitical sphere, the world economy is characterised by large companies which market products across national boundaries.

The product designer, able to interpret cultural differences and thus span national divides, is crucial to this process. A forthcoming exhibition at the Design Museum in London, entitled 'Designed in One, Made in the Other' will highlight the ways in which manufacturers pursue the vision of the global market.

The exhibition will comprise a number of case study exhibits based around manufacturers in the consumer electronics, automotive, medical and capital goods sectors.

Each case study will illustrate the issues raised by the growth of global markets. How, for instance, has the communications revolution accelerated the design process? How do multinationals create the climate within their companies for co-operation when their corporate cultures are so diverse? Can global manufacturing really satisfy national tastes?

Particular emphasis will be placed on the role of the designer in the process of globalisation. The speed at which products must reach the market in order to achieve competitive advantage is now crucial to manufacturers. The part that the designer plays in the product's development therefore becomes of prime importance.

This exhibition will examine the designer's role and the design management processes which underlie global manufacturing. A subtext of the exhibition will be the fascinating manner in which Japanese companies have used designers, educated and sometimes based in the UK, to enhance the work of their domestic product development expertise. Contact: (071) 403 6933.

Pocket Electronic Reader

NEC has launched an electronic device in Japan that proposes a new way of reading information. The pocket-sized, liquid crystal supply (LCD) interactive electronic reading device is called Digital Book Player.

It is the first product of its kind to use floppy disks, making it versatile and easy to use. The selection of titles available, range from novels, quizzes and guide books to learning to play chess.

The Digital Book Player's floppy 3 $\frac{1}{2}$ in. disk is MS DOS compatible, enabling documents created on a PC to be downloaded and read at a later date. In future the device could be connected via telephone lines to newspaper offices and financial institutions enabling statistics or daily newspapers to be downloaded.

The Digital Book Player measures 169 x 130 x 30mm, incorporates a 5.6in. screen, weighs approximately 430g and will retail in Japan at ¥12,000 – approximately £80.

The launch in Japan will be followed by a release into the UK market later this year. Contact: NEC Europe Ltd (071) 353 4383.

Tourist Terminal

Multimedia has come to Paris. Now tourists can get computer aided guides to the city while they are changing their currency or travellers cheques.

Exact Change has installed 35 interactive terminals into 10 of its Parisian exchange bureaux. Tourists can use the terminals to discover hotel availability, car rental costs and the opening times of museums and other attractions.

Each section is illustrated and can be selected by touching the screen. It indicates the nearest metro and bus stations, opening times, styles and prices, which are all offered in English, French, Spanish or German. The information can be viewed by district or by alphabetical listing and can be printed out at any point.



There are also opportunities for advertisers to develop self-contained interactive sequences. For example EuroDisney has its own slot within the sight-seeing section where they can promote forthcoming attractions.

Eurocar has a self-contained car rental sequence that details features of the cars along illustrations and rates. Cars can be booked from the terminals, paid for over the exchange counter and delivered to the bureaux.

The multimedia tourist guides are the creation of the UK design consultancy IN.form. Plans are now a foot to extend the scheme to other European cities. Contact: IN.form (071) 729 1880.



Design and Text
by James Aynsley

**KIT
AVAILABLE
(LT53H)
Price
£8.49**

Most people never bother to measure the temperature inside their fridge – they just rely on bottles of milk not being 'off'. This is not good enough. For safety's sake, everyone should keep a careful check on the temperature at which food is stored. It is generally agreed that the temperature should be maintained at 5°C (41°F) or below to keep harmful bacteria at bay. Any higher, and germs multiply at a surprising rate, possibly resulting in food poisoning.

One way of checking this is to use a traditional thermometer. However, this is not very convenient, and reading it regularly requires some commitment on the part of the user. Also, if it is left inside the fridge it is likely to get broken. Using the 'Fridge Check' requires no conscious effort, yet it provides a simple and effective solution to the problem. Note that this project is designed for use in a household refrigerator – it is not suitable for deep freezers which operate at much lower temperatures (~18°C approximately).

Continuous Monitoring

The Fridge Check is a battery-powered circuit which is simply left inside the fridge and forgotten.

A sounder will then produce a high-pitched tone if the temperature ever exceeds a preset limit. This will normally be 6° to 7°C (43° to 45°F), but may be adjusted anywhere from 0° to 15°C approximately (32° to 59°F). This could possibly make the unit useful for other purposes.

Timely Reminder

One reason for a warning being given is electrical failure – possibly due to a blown fuse, faulty thermostat or the mains plug being pulled out of its socket accidentally. Putting warm food in the fridge will also tend to trigger the unit as will, of course, leaving the door open (acting as a reminder for children and the elderly).

Tests on the prototype show that the specified sounder is loud enough to be heard throughout a medium sized kitchen, providing there is not too much background noise. The tone is high-pitched (3.5kHz approximately) so, although not loud, soon attracts attention. The whole device, including battery, is built in a very small plastic box so it takes up hardly any space. Therefore, as well as being useful for full-size refrigerators, it can be used in the smaller gas-

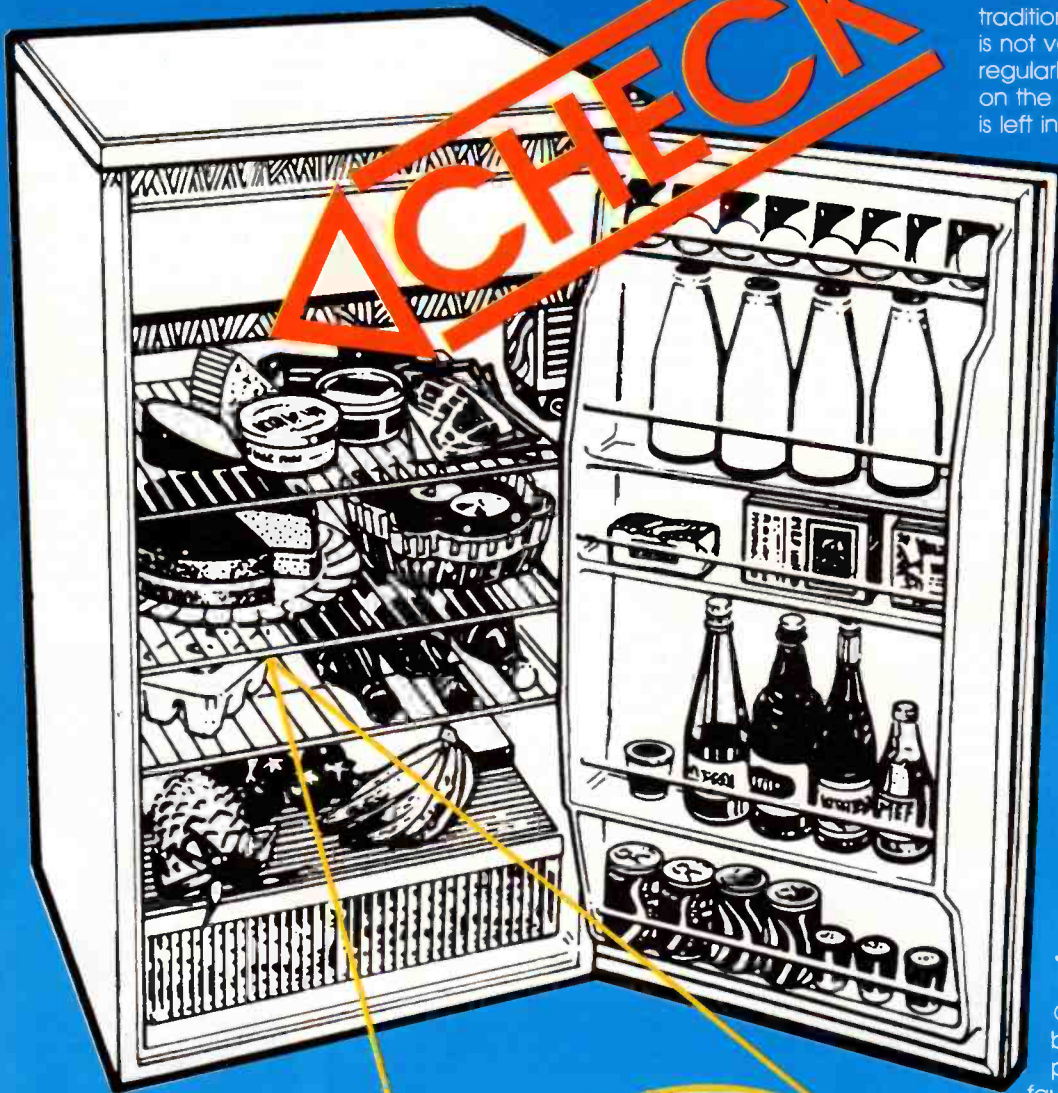

Keep food safe with this simple monitor

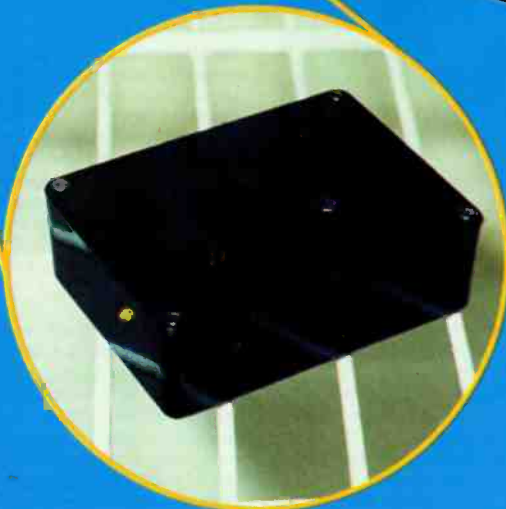

operated variety found in boats and caravans. Failure of the flame in these fridges soon results in a rise of cabinet temperature and the consequent ruination of food.

The standby current of the unit has been kept extremely low (less than 30µA) so a whole year's operation may be obtained from one alkaline PP3 battery. This, of course, assumes that the unit has not sounded very often. While the sounder is operating the unit uses just over 4mA. Building Fridge Check is straightforward with a very small number of components involved, making it an ideal beginners' project. It will, however, be necessary to have a good-quality thermometer, capable of reading around 5°C, available at the end of construction for setting-up purposes. Apart from this, no special equipment or techniques are needed for testing.

It is not essential to understand how

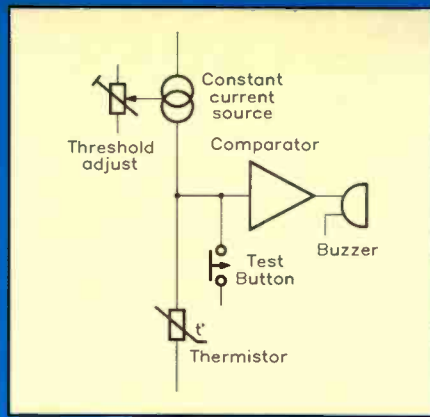

Figure 1. Block diagram.

the circuit works in order to build it. However, for those readers who are interested, an explanation follows. Anyone wishing simply to construct the device may omit this section and go straight to 'construction.'

Circuit Description

The simplified block diagram of the Fridge Check is shown in Figure 1, and the complete circuit diagram in Figure 2. The whole circuit is accommodated on a single small PCB, details of which are shown in Figure 3.

The design centres on two integrated circuits. The first, IC1, is a *constant current source* and the second, IC2, is a *precision voltage detector*. The actual temperature sensor is a negative temperature coefficient bead thermistor, TH1. This responds to changes in ambient temperature by varying its resistance – as the temperature *rises*, the resistance *falls*. Figure 4 shows a graph of resistance against temperature over the range useful to this project, and it will be seen that its value is approximately 350k at a nominal operating temperature of 6°C.



PCB installed in box.

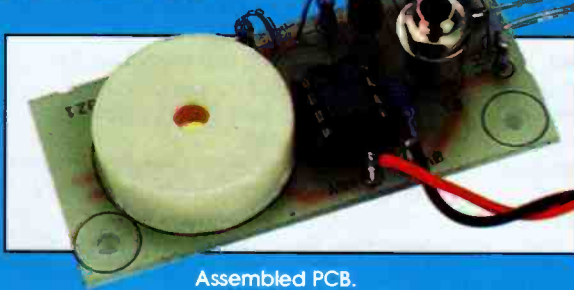

Assembled PCB.

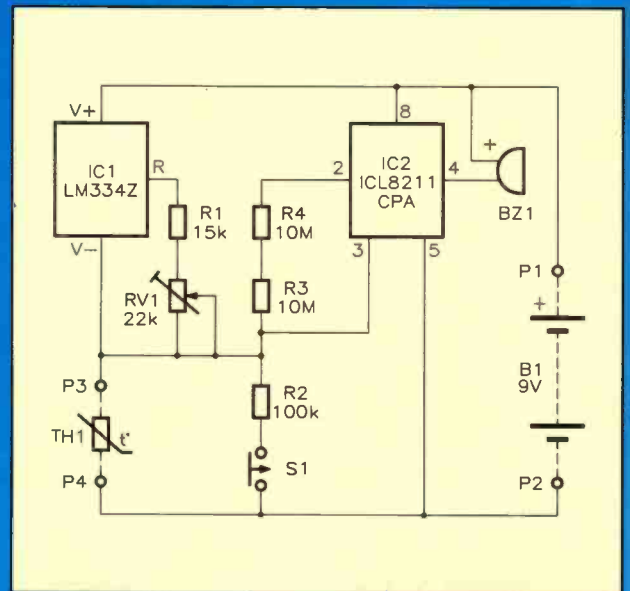

Figure 2. Circuit diagram of the Fridge Alarm.

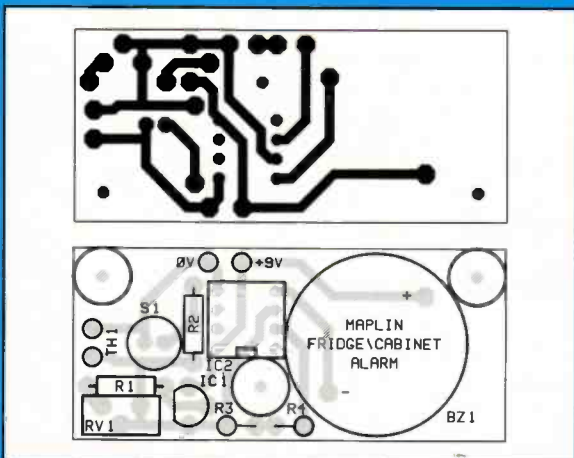

Figure 3. PCB legend and track.

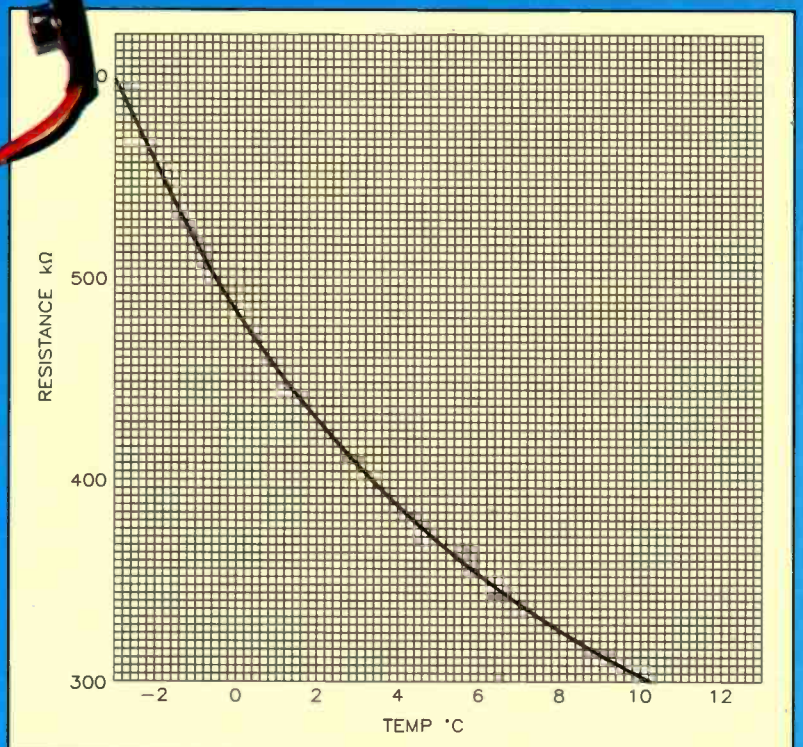

Figure 4. Temperature gradient graph.

IC1 is set up to provide a precisely known current (I_{set}). This is determined by the resistance connected between pins R and V-, and more will be said about its value presently. In operation, I_{set} flows from the supply, through the IC from pin V+ to pin V-, and hence through thermistor TH1.

With a constant current flowing through TH1, a voltage will be developed across it in proportion to its resistance – that is, as predicted by Ohm's Law. Thus, on a rise in temperature, the resistance falls and the voltage falls also. Note that this voltage is virtually independent of that of the supply by virtue of the use of the current source. This means that, as the battery ages, the circuit will continue to respond to the same temperature level that was set.

IC1 exhibits a small temperature dependence of its own – as the temperature rises, I_{set} also rises at the rate of 0.33% per °C. Although this increased current would otherwise cause a rise in voltage across R1, the fall caused by the thermistor action is very much greater, so the temperature effect of IC1 may be ignored.

Down the Sink

The voltage developed across the thermistor is monitored by IC2. This is achieved by applying the voltage to pin 3, the threshold input. Above 1.15V it has no effect. However, when it falls below this level, pin 4, an open collector transistor switch at the output, turns on, providing a current sink. The effect is that, when the thermistor reaches a specific value reflecting a rise in temperature, current will flow from supply positive, through sounder BZ1 (causing it to operate), to 0V via IC2 pin 4.

The threshold of 1.15V is not adjustable, as it is fixed by internal circuitry. It is therefore necessary to arrange for the voltage across the thermistor to be equal to this at the chosen operating temperature. I_{set} therefore needs to be adjustable and, in practice, the range 2µA to 4µA will be found satisfactory. The formula linking the resistance between IC1 pin 'R' and pin 'V-' with I_{set} is:

$$R = \frac{0.0677}{I_{set}}$$

Calculation shows that the resistance will need to lie between about 33kΩ (for $I_{set} = 2\mu\text{A}$) and 17kΩ for $I_{set} = 4\mu\text{A}$). This is extended to include a small margin by a 15kΩ fixed resistor, R1, connected in series with 22kΩ preset potentiometer RV1. During setting up RV1 will be adjusted so that the sounder operates at the required temperature.

Current Limiting

The current allowed to sink into IC2 pin 4 is limited to 7mA by on-chip circuitry. This is sufficient for the

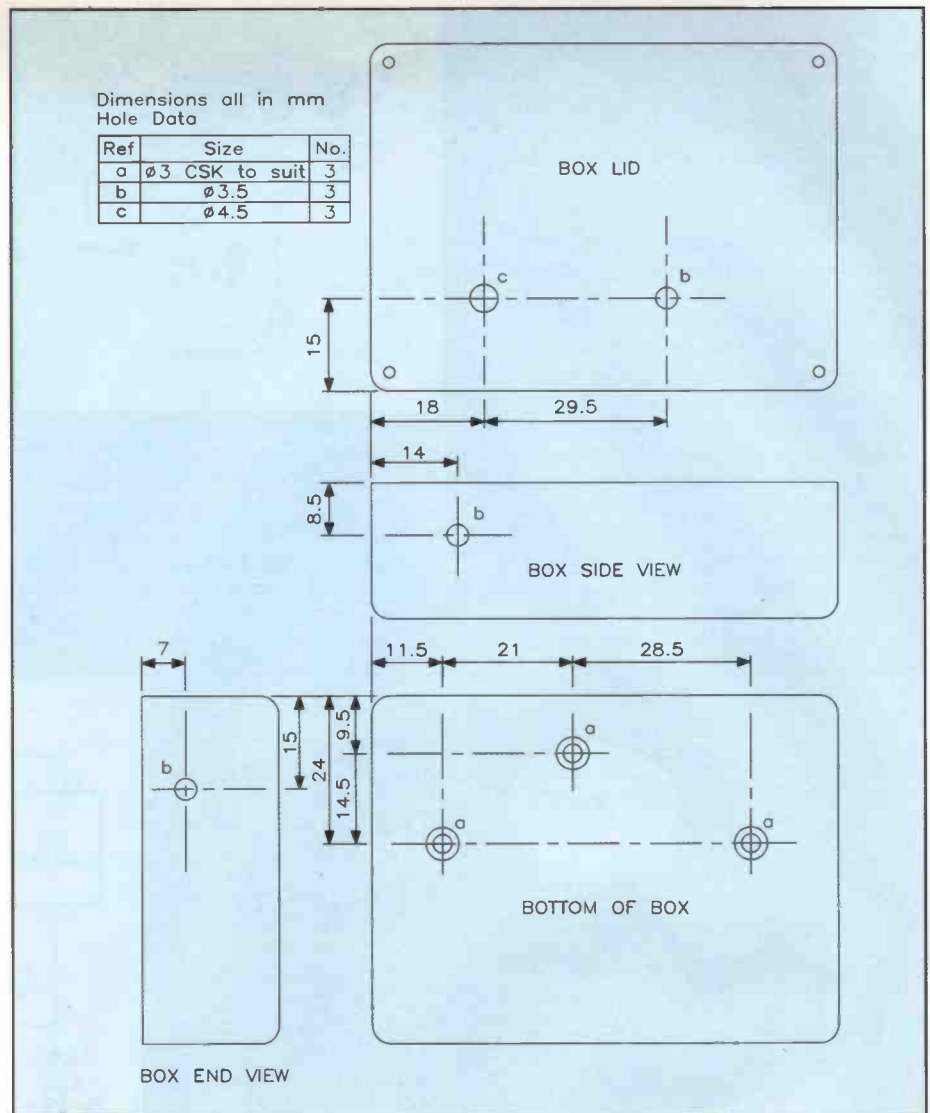

Figure 5. Box drilling details.

specified solid-state sounder, BZ1 which only requires about 5mA. However, if a different sounder device is required, its current requirement will need to be checked to make sure it is suitable.

Resistors R3 and R4, connected in series between IC2 pins 2 and 3, provide a little positive feedback. Pin 2 of the device is the 'hysteresis' output, and is switched low whenever the main output, pin 4, is switched low. Connecting this to the main input at pin 1, via a suitable network, sharpens the switching action at the critical temperature point. Thus, when the buzzer sounds, the temperature

will need to fall by 1°C approximately for it switch off again. This eliminates any tendency for repeated on-off switching at the operating point. It has been found that a value of 20MΩ is quite enough for the feedback resistor, but because the metal film resistor range of values stops at 10MΩ two 10MΩ resistors are used in series.

Despite the operating temperature being virtually independent of supply voltage, a battery-check facility is still desirable. This is because, eventually, the battery would become too weak to operate the sounder successfully. The test takes the form of pressing

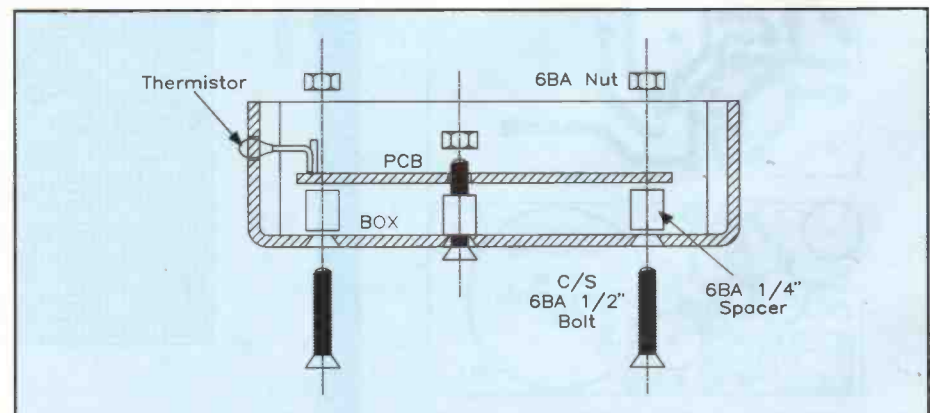

Figure 6. Assembly details.

push-to-make switch, S1. On doing this, IC2 pin 3 is connected to supply 0V via resistor R2, and TH1 which now appears in parallel. The voltage at pin 3 will now be less than the 1.15V threshold, whatever the setting of RV1, so the sounder will operate and confirm that all is well – or not as the case may be.

Construction

Construction of Fridge Check is based on a single-sided PCB. The topside component legend is shown in Figure 3. Figure 5 shows the drilling details for the specified box for which this PCB is designed, while Figure 6 shows how the PCB is mounted, more of which later. For now, refer to the Constructors' Guide for details of how to recognize, handle and solder specific types of components.

All the components for Fridge Alarm, apart from the battery, are mounted on the circuit board. The recommended component assembly order is as follows. Firstly, fit and solder the 8-pin IC socket, followed by preset potentiometer RV1, then R1 which should lie flat with the board, followed by R2, R3 and R4. For sounder BZ1, mount it flush with the board, noting that the polarity is important when fitting or it will not work (the polarity is marked on the plastic body on the underside and must correspond to the (+) and (-) symbols on the PCB legend). Cut off the excess leads on the copper track side after soldering.

Next, fit and solder IC1 into position, pushing it through the PCB to half the length of its connecting leads, and observing correct orientation. This is indicated on the PCB legend; align the shape of the device to that on the legend (IC1 is a 3-leaded device and looks like a transistor). Soldering should be carried out quickly here, since this component can be damaged by excessive heat. It may be prudent to wait several seconds between soldering each lead, just to make sure.

Before fitting the thermistor TH1, sleeve its leads – plastic insulation stripped from connecting wire is suitable – using the full length of the connecting wires (the sleeve should fall short by approximately 5mm). Fit and solder this component into position. Cut the red and black wires for the battery clip to a length of 5cm and, referring to Figure 7, solder them to the appropriate pads on the PCB – red to +9V and black to 0V. Leave the thermistor standing vertically from the PCB for the moment. Solder the switch itself to the other PCB. Adjust RV1 to the mid-track position – this setting will be approximately correct.

After a careful check for errors, such as dry joints, solder bridges, etc., insert IC2 into its socket taking care to orientate it correctly. The notch at one end of the package, which

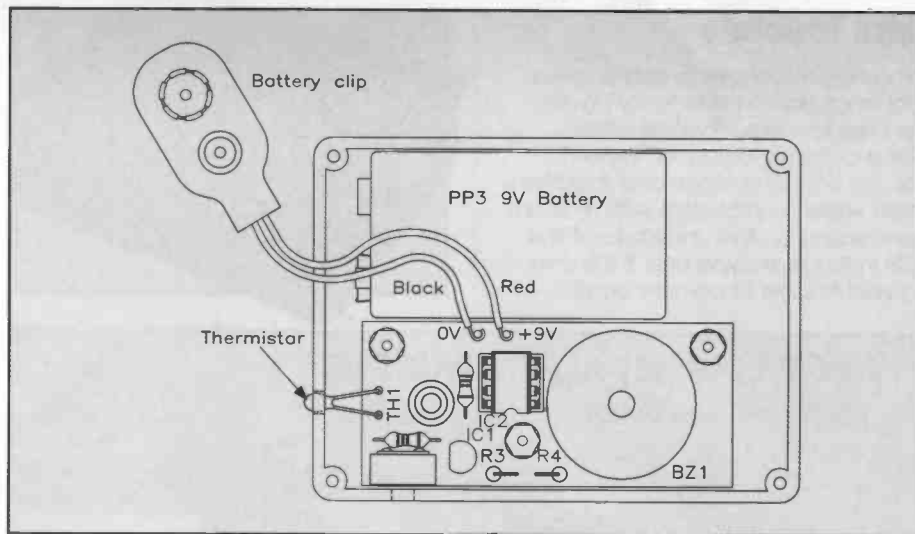

Figure 7. Wiring diagram.

identifies pin 1, must align with the white marker block on the legend. *Note that this component is a CMOS device and may be damaged by any static charge which might be present on the body.* For this reason, try not to touch the pins while inserting it into its socket. Alternatively, touch something that is earthed before doing so.

Preparing the Case

With reference to Figure 5, mark the fixing holes for the PCB in the positions shown. Mark also the position of the thermistor on the side. Using the PCB as a template, check that the battery will fit – make any adjustments as necessary. Remove the PCB and drill the mounting holes in the box. Drill a 3.5mm diameter hole in the side for access to the adjustment trimmer RV1, one close to the thermistor position and two in the lid, one for the battery-test switch S1 (4.5mm), the other directly above the sounder position for the sound to pass through (3.5mm).

Mount the PCB according to Figure 6, using the 6BA x 1/2in. bolts, 6BA x 1/2in. spacers and nuts. The board should take up a position where the sounder almost touches the lid of the box when this is in place. S1 will be accessible through the hole already drilled in the lid.

Testing and Adjustment

A basic check can be made without further adjustment. This will confirm that assembly is correct and that everything is working. To do this, connect and insert the battery – the audible warning device should operate immediately while the thermistor is at room temperature. Cool the thermistor by touching it on something very cold – a bag of frozen food, for example. The sounder should stop working after a short delay. Confirm that the sounder operates when the switch is pressed. If these tests work, it is likely that the Fridge Check will operate correctly in service. Remove the battery to prevent excessive drain. Bend the

thermistor end leads so that the device stands level with or slightly protruding through the hole drilled in the case.

The simplest way to set up the circuit accurately is to use the fridge itself. However, you will first need to check that the temperature is correct by using an accurate thermometer. This should be placed somewhere near the middle of the cabinet and left for several minutes with the door closed to stabilise. It should then be read *quickly*. If necessary, the thermostat should be adjusted and the fridge left as long as necessary for the temperature to reach its new value of 5°C or as required. The top shelf will normally be a little warmer than the bottom one, so exactly where the temperature is monitored will depend to some extent on the way in which food inside will be stored.

Check that RV1 can be adjusted using a small screwdriver. Reconnect the battery and place the unit close to the thermometer inside the fridge. Preset potentiometer, RV1, should now be adjusted in a series of small steps to the position where the warning *just* remains off. Clockwise rotation (as viewed from the left-hand edge of the PCB) reduces the operating temperature. Keep checking the temperature, as opening the door will cause it to rise. For this reason, the fridge should be opened as little as possible and plenty of time allowed between operations for the temperature to fall and stabilise again. Note that it may take several minutes for the unit to respond to the fridge temperature. With the setting correct, it should be found that the sounder will operate when the door is opened for 30 seconds or thereabouts. If the operating temperature is set too finely, the unit will tend to trigger when the fridge door is opened and closed in normal use. Further adjustment to the response time could be made by moving the thermistor behind the hole in the box. The battery will need no additional support if the specified box is used.

Final Touches

It may be necessary to make some final small adjustments to RV1 over the next few days for best effect. Once correctly adjusted, the unit can be left in the fridge and forgotten. There were no problems with moisture condensing on the underside of the PCB in the prototype unit. If this ever caused trouble (shown by erratic

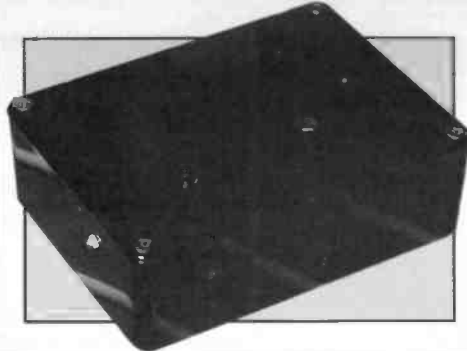

behaviour), a light spray of Acrylic Conformal Coating (DM82D) would prevent problems. If the sounder can be heard louder with the lid removed, increase the diameter of the hole. Remember to check the battery every few weeks and renew it at least once a year. It should also be replaced as a matter of course if ever the sounder has operated continuously for some time.

FRIDGE/CABINET ALARM PARTS LIST

RESISTORS: All 0.6W 1% Metal Film (Unless specified)

R1	15k	1	(M15K)
R2	100k	1	(M100K)
R3,4	10M	2	(M10M)
RV1	22k Vertical Enclosed Preset	1	(UH17D)

SEMICONDUCTORS

TH1	150k Bead Thermistor	1	(FX43W)
IC1	LM334N	1	(WQ32K)
IC2	ICL8211CPA	1	(YH43W)

MISCELLANEOUS

S1	Sub Miniature Push Switch Black	1	(JM01B)
BZ1	PCB Piezo Sounder	1	(KU58N)
	8-Pin DIL IC Socket	1	(BL17T)
	PP3 Battery Clip	1	(HF28F)
	Plastic Box T2	1	(KC91Y)
	6BA x 1/2in. C/S Screw	1 Pkt	(BF12N)
	6BA x 1/4in. Spacer	1 Pkt	(FW34M)
	6BA Nut	1 Pkt	(BF18U)
	1mm PCB Pin 2145	1 Pkt	(FL24B)

PCB	1	(GH70M)
Instruction Leaflet	1	(XU59P)
Constructors' Guide	1	(XH79L)

The Maplin 'Get-You-Working' Service is available for this project, see Constructors' Guide or current Maplin Catalogue for details.

The above items are available as a kit, which offers a saving over buying the parts separately.
Order As LT53H (Fridge/Cabinet Alarm Kit) Price £8.49.
 Please Note: Where 'package' quantities are stated in the Parts List (e.g., packet, strip, reel, etc.), the exact quantity required to build the project will be supplied in the kit.

The following new item (which is included in the kit) is also available separately, but is not shown in the 1994 Maplin Catalogue.

Fridge Alarm PCB **Order As GH70M Price £1.95.**



Chelmer Valve Company for High Grade Audio Valves

Major Brands e.g., Mullard, Brimar, Philips, GE (UK), GE (USA), etc.

A2900 GEC	£12.00	GZ34 Mullard	£10.00
E80F Philips	£10.00	GZ37 Mullard	£7.00
ECC81/CV4024 Mullard	£6.00	6CA7/EL34 GE	£9.50
ECC82/CV4003 Mullard	£6.00	6L6GA Sylvania	£7.00
ECC88 Mullard	£6.00	6SN7GT Brimar	£4.50
E88CC Mullard	£8.50	6V6GT Brimar	£4.00
EF86/CV4085 Mullard	£8.50	12AT7WVC Sylvania	£6.00
EL84 Mullard	£6.00	6146B GE	£15.00
EL84 GE (USA)	£5.00	6550A GE	£15.00
GZ32 Mullard	£8.00	7581A GE	£12.00
GZ33 Mullard	£8.00		

CVC PREMIUM: Our own BRAND from selected worldwide sources, processed in our special facility to provide low noise/hum/microphony Pre-Amp Valves and Power Valves burnt-in for improved stability and reliability.

PRE-AMP VALVES

ECC81/12A17	£5.00
ECC82/12AU7	£4.00
ECC83/12AX7	£5.00
ECC85	£4.00
ECC88	£5.00
EF86	£4.00
E81CC (GOLD PIN)	£6.00
E82CC (GOLD PIN)	£6.00
E83CC (GOLD PIN)	£6.00
E88CC (GOLD PIN)	£7.00
E80F	£9.00
E83F	£5.50
6SL7GT	£4.00
6SN7GT	£4.20

POWER VALVES

2A3 (OCTAL) or (4 PIN)	£14.00
211	£22.00
300B	£50.50
811A	£9.50
845	£29.90
EL34/6CA7	£7.50
EL84/6BQ5	£4.00

POWER VALVES - cont.

E84L/7189A	£5.10
KT66	£9.20
KT88	£12.50
KT88 (GOLD Q)	£18.50
6L6GC	£6.50
6L6WGC/5881	£8.00
6V6GT	£5.00
6146B	£10.20
6336A	£30.00
6550A	£11.00

RECTIFIERS

GZ33	£4.50
GZ34/SAR4	£5.00
5U4G	£5.00
5Y3GT	£3.20
5Z4GT	£3.50

SOCKETS

B9A (PCB)	£1.60
B9A (CHASSIS)	£1.60
OCTAL (CHASSIS)	£1.75
4 PIN (UX4)	£3.00
4 PIN (for 211)	£11.00

Add £1.00 per valve for matching if required.
 Plus Post & Packing £3.00 + VAT at 17.5% for UK/Europe.
 Send/Fax order with cheque or credit card details to:

Chelmer Valve Co., 130 New London Road, Chelmsford, Essex CM2 0RG
 Tel: (0245) 265865 Fax: (0245) 490064

DUE TO OUR EXPANSION PLAN,
WE OFTEN HAVE VACANCIES FOR:

Branch Managers Assistant Managers and Counter Staff

for our new stores opening throughout the UK.

Combine business with pleasure –
**TURN YOUR HOBBY INTO
A WORTHWHILE CAREER
WITH A POSITIVE FUTURE!**

If you are an electronics enthusiast and are looking for an interesting career with one of the UK's leading electronics suppliers – look no further!

Retail experience would be a great asset, and to become part of the team, you will need to be self-motivated and have a cheerful, outgoing personality.

Applicants must be of smart appearance, and have a good working knowledge of electronic components.

In return we offer excellent working conditions, a first-class basic salary plus commission, pension scheme, generous staff discounts, and real prospects for a secure and exciting career.

If you are seeking a fulfilling career in a High Tech Environment, then write to us **NOW!**

Send full career details/CV and an indication of the area that you would prefer, to:

The Personnel Manager,
Maplin Electronics plc,
Valley Road, Wombwell,
Barnsley, S73 0BS.

Maplin
ELECTRONICS

**THE POSITIVE FORCE
IN ELECTRONICS**

SUBSCRIBE TO

*** BRITAIN'S BEST SELLING ELECTRONICS MAGAZINE! ***

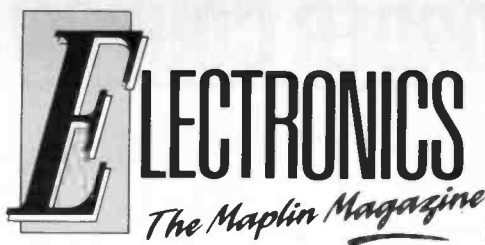

* **2 FREE ISSUES** if you agree to subscribe by Direct Debit or Continuous Credit Card, saving you £5.64!

* **FREE DELIVERY TO YOUR DOOR**, and there are no additional carriage charges.

* **PLUS** – News, reviews, readers letters, competitions and lots, lots more besides!

* **YES, SAVE MONEY** by taking a subscription, it's cheaper than buying each individual copy.

* **5% SUBSCRIBERS' DISCOUNT CLUB CARD** saves you money on further purchases!

To subscribe just send a cheque/postal order for £9.96 made payable to Maplin Electronics, P.O. Box 3, Rayleigh, Essex SS6 8LR. OR you can take advantage of our offer of two free issues by completing the coupon below and agreeing to pay by Credit Card or Direct Debit. The two free issues offer only applies if you use one of these two methods of payment. Simply fill in the 'Payment by Credit Card' or 'Payment by Direct Debiting Mandate' and return it to Maplin. Every time, about 1 month before your subscription is due, we will send you a letter giving details of the subscription rate and telling you the date on which we will charge your Credit Card or debit your bank account. If you do not wish to continue your subscription, you have until that date to let us know, and we will then cancel your authority to bill your Credit Card or cancel your mandate. Otherwise, if you do nothing, your subscription will continue. The authority or mandate you give us does not allow us to charge anything other than the Maplin Magazine subscription. The benefit to you is that you no longer need to remember to re-new your subscription or send off any more cheques or postal orders. Payment is made automatically.

OVERSEAS SUBSCRIBERS – SUBSCRIBE NOW! – Phone +44 702 554155 Ext. 326 or 351.

Subscription rates for 6 issues are: £14.50 (or 37 IRCs) in Eire, Europe and surface mail outside Europe; £20.50 (or 53 IRCs) Air Mail outside Europe.

TAKE THE NEXT 2 ISSUES OF THIS MAGAZINE FREE!!

Because we're so certain that now you've seen the Maplin Magazine you'll want to receive it regularly, we're offering to send you the next two issues free of charge with absolutely no obligation to continue. Just fill in the details below and if after receiving two issues you do not wish to continue, just let us know at least one month before the next issue is due and we will cancel your subscription. The two free issues will be yours to keep whatever you decide. If you already have a subscription, fill in the details below and we'll add two issues free of charge to your current subscription. SEND NO MONEY NOW. About 2 weeks before the third issue is due, we will charge you £9.96 for the next six issues, unless you have cancelled. This offer is not available to those already paying by Direct Debit or Continuous Credit Card or those who have stopped payment by either method within the last year. THIS OFFER IS OPEN TO RESIDENTS WITH U.K. ADDRESSES ONLY. PLEASE START MY SUBSCRIPTION WITH ISSUE 77

EITHER

★ PLEASE ADD YOUR ADDRESS, SEE BOTTOM RIGHT ★

PAYMENT BY CREDIT CARD. Please charge my Credit Card Account

I authorise you until further notice in writing to debit my CREDIT CARD account by £9.96 and in future, with any amounts which, after notification, MAPLIN ELECTRONICS PLC may debit thereto in respect of my subscription to the Maplin Magazine.

Customer Number (if known)

Access Visa American Express

Account No.	
Signature	Date

OR

PAYMENT BY DIRECT DEBITING MANDATE in favour of Maplin Electronics PLC, P.O. Box 3, Rayleigh, Essex SS6 8LR.

Direct Debit payment option is only open to customers with bank accounts in the U.K. including Channel Isles, Isle of Man and N. Ireland. Please note: Instructions cannot be accepted to charge Direct Debits to a Deposit or Savings Account.



Bank Sort Code	Bank Account Number
----------------	---------------------

Name of Account to be debited

The Manager

I authorise you until further notice in writing to charge my account, with you, any amounts which MAPLIN ELECTRONICS PLC may debit thereto by Direct Debit in respect of my subscription to the Maplin Magazine.

I will inform the bank in writing if I wish to cancel this instruction.

I understand that if any direct debit is paid which breaks the terms of this instruction, the bank will make a refund.

Signature	Date
-----------	------

Enter your address and Maplin customer number, if known.

	Post Code

If you wish, you can put this form in an envelope and address it to: Maplin Electronics, Freepost, P.O. Box 3, Rayleigh, Essex SS6 2BR.

INFINITESIMAL FUZZY LOGIC

by Lars Ipolof

You may have already come across the relatively new concept of 'fuzzy logic' in camcorder focus circuits or even washing machines. The underlying idea was first developed about 30 years ago by Dr. Lotfi Zadeh in California. To understand what it is, we need to look first at ordinary logic, where something is either 'true' or 'not true'. This is fine for computers, but is not so good a representation of the real world. For example, is a speed of 25m/s 'fast' or not? Well, if it means running the 100m in 4 seconds, it is, but if it's your air speed in a fixed-wing aircraft, it most definitely is not. Not only for ordinary human communication but for many applications in robotics and other automatic processes, something more refined than 'yes or no' is required.

VARIABLES & DOMAINS

In order, for example, to move a robot arm to a given point, we have to measure how far that point is from some previously fixed reference point. This distance is a variable, and the range of values it can take, say from zero to 500mm, is called the domain of that variable. In fuzzy logic, we divide the domain up into a number of bands, with 'fuzzy' names. We could say that 0 to 100mm is 'close', 100 to 250mm is 'fairly close', and so on, up to 400 to 500mm being 'far away'. If the distance is actually 0, then we are 100% sure that it is 'close'. But at 100mm, it is equally obviously 50% 'close' and 50% 'fairly close'. We can extend this idea, so that a distance of 75mm is rated as 60% 'close' and 30% 'fairly close', and so on. The assignment of the percentage values is not something which can be calculated exactly, and in a practical application it might be based initially on informed guesswork and refined by experimenting.

The first practical application of fuzzy logic was reported by Dr. Abe Mamdani, then of Queen Mary College, London, in the 1970s. As you might expect from a research scientist, he used the electronics to control a steam engine! However, the vast majority of practical applications, from heavy infrastructure projects like water supplies and transport systems to cameras and microwave ovens, have been developed in Japan, South Korea and China.

We can use fuzzy band names in programming our robot arm. For example, we can say in the program (actually in a 'meta-program', written in 'meta-language') statements like: "If distance is far away, make speed maximum" and "If distance is fairly close, cut power to half and apply brake gently." Our robot should perform much better than one which has only two operating states - maximum speed and hard braking. That last point is very important. Our braking system cannot be one which is either 'all on' or 'all off'. It has to accept an input of at least several digital bits. The same applies to the motor speed control - it has to give several speeds, not just zero and maximum. In practice, even to make a robot arm do quite simple jobs, we need several program statements of the type shown above, but because they are simple, and do not require highly precise results, they can be processed quickly by the control computer.

Furthermore, they lend themselves to parallel processing, with a transputer or several conventional processors, which gives a further possible increase in processing speed.

In some control systems, speed of response is very important. A high-speed laser cutter will cut too far and waste raw material if the control system is slow in responding. More dramatically, even quite a simple system may fall into chaotic behaviour if one of its inputs moves outside a restricted range. While the processor is programmed with fuzzy logic, it has to produce a definite single-valued output, and this is achieved by a voting and averaging process. For example, there may be several factors that control the speed of our robot arm. We take the highest per-

centage values for membership of each speed band and calculate a weighted average to give the final speed requirement.

SENSORS & PROCESSORS

Naturally, we use sensors to provide all the inputs for the control processor, and mostly these are analogue sensors which require analogue-to-digital converters (ADCs) to give digital inputs to the processor. Since in principle we do not need high accuracy, we could use perhaps 4-bit converters and processors, for low cost and high-speed. However, as systems become more refined, the number of bits increases, so that we might now be considering 32- or even 64-bit systems, if it were not for the exciting new development which this article announces.

GOING TO THE LIMIT OR BEYOND?

In our first example, we had four classes of distance: close, fairly close, fairly far away and far away. Suppose we increase the number of classes to ten. This will allow us to exercise finer control of the speed. In turn, we need a more precise read-out from the distance sensor, which means more digital bits. However, if we increase the classes to an infinite number, we need an *infinite* number of bits to describe the sensor output. This is the principle of INFINITESIMAL FUZZY LOGIC, newly developed in the laboratories of Lagado University, Laputa.

OPPORTUNITIES FOR SIMPLIFICATION

The scientists at Lagado are having some difficulty with the ADC and processor to handle an infinite number of bits. There may be a way out of this difficulty. The sensor already has an output of its own which is a continuous function of the distance. We can use this directly to control the speed of the motor, just by controlling the applied voltage. We no longer need an ADC, or an infinite-bit processor, or voting and averaging. We could call this simplified arrangement an 'analogue control system'. For further information, write to Lars Ipolof, P.O. Box 940401, Lagado, Laputa, clearly marking the envelope 'Infinitesimal Fuzzy Logic'.

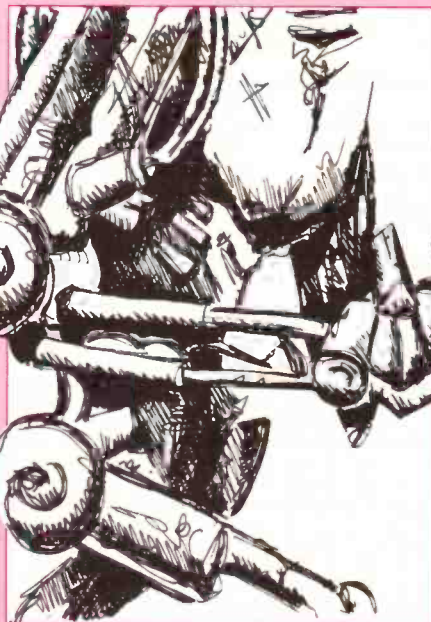

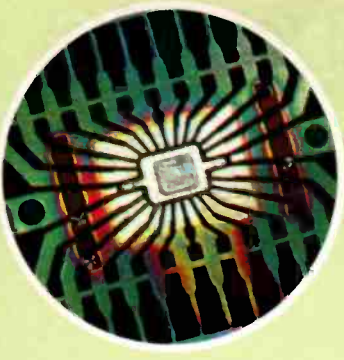

SEMICONDUCTOR PROCESSING

by Stephen Waddington BEng(Hons), M.I.E.E.E, A.I.E.E, A.I.T.S.C.

PART ONE Refining of the Raw Materials

Semiconductor science and technology constitute one of the wonders of the modern world. Nobody who is involved in the science of electronics can fail to be impressed with the progress that has been made over the past four decades. The results are apparent throughout virtually every home in this country and to the uninitiated must appear as nothing less than magic. Most of this progress is due to the increasing sophistication of the manufacturing processes based on semiconductor materials such as silicon and germanium. In this short series we will be considering the refinement of raw semiconductor materials, the design and production of a functional device and then the packaging to produce the familiar transistor or integrated circuit. Having described the tools of fabrication, we will conclude by making a brief excursion into the bounds of customised design and explain how integrated circuit designers have set about creating the familiar NE555 timer; the CMOS 4001 quad 2-input NOR gate or its counterpart TTL device the 7402.

Definition

Semiconductor materials are distinguished by having their specific electrical conductivity somewhere between that of good conductors and good insulators as shown on the scale in Figure 1. By far the most popular of these materials in engineering terms is silicon (Si). Although germanium (Ge) – which like silicon belongs to Group IV of the Periodic Table – offers a higher performance, finding applications in high frequency and fast acting transistors. A further possibility is the use of a cocktail of semiconductor materials from Groups III & V or Groups II & VI of the periodic table. From these, materials such as gallium arsenide (GaAs) for light emitting diodes or cadmium sulphide (CdS) for light detectors have evolved. Even more complex combinations allow materials to be tailored precisely to suit required applications. Copper Indium Diselenide (CuInSe₂) is an excellent example of this type of construction, dipping into Groups I, III and VI of the periodic table. The result is a material which is currently the source of a flurry of research having exhibited excellent characteristics for solar cell applications. Table 1, shows the whole of the periodic table, with useful semiconductor material shown shaded. Initially we shall consider only the most familiar semiconductor material – silicon.

Purity

As we shall see, electronic devices demand the use of absolutely pure semiconductor materials into which discrete amounts of foreign dopant are introduced. The dopant is typically injected in minute quantities in the order of parts per million, to control the electrical properties of the final device. The semiconductor must normally be in the form of a single crystal since desirable electrical properties depend upon the ordered periodic nature of electrons within the substance. Any departure

Figure 1. Typical resistivity of conductors, semiconductors and insulators.

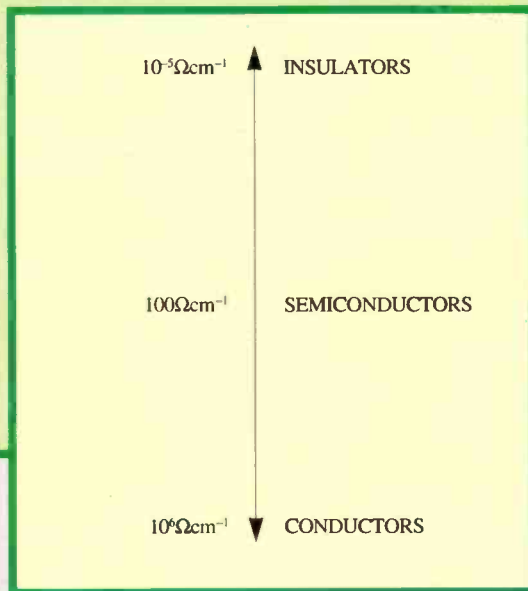

Table 1. Periodic Table with useful semiconductor materials.

IA																0															
1 H	IIA															2 He															
3 Li	4 Be															10 Ne															
11 Na	12 Mg	III A	IVA	VA	VIA	VII A	VIII				IB	IIB	13 Al	14 Si	15 P	16 S	17 Cl	18 Ar													
19 K	20 Ca	21 Sc	22 Ti	23 V	24 Cr	25 Mn	26 Fe	27 Co	28 Ni	29 Cu	30 Zn	31 Ga	32 Ge	33 As	34 Se	35 Br	36 Kr														
37 Rb	38 Sr	39 Y	40 Zr	41 Nb	42 Mo	43 Tc	44 Ru	45 Rh	46 Pd	47 Ag	48 Cd	49 In	50 Sn	51 Sb	52 Te	53 I	54 Xe														
55 Cs	56 Ba	57 La	72 Hf	73 Ta	74 W	75 Re	76 Os	77 Ir	78 Pt	79 Au	80 Hg	81 Tl	82 Pb	83 Bi	84 Po	85 At	86 Rn														
87 Fr	88 Ra	89 Ac																													
<table border="1" style="width:100%; text-align:center;"> <tr> <td>58 Ce</td><td>59 Pr</td><td>60 Nd</td><td>61 Pm</td><td>62 Sm</td><td>63 Eu</td><td>64 Gd</td><td>65 Tb</td><td>66 Dy</td><td>67 Ho</td><td>68 Er</td><td>69 Tm</td><td>70 Yb</td><td>71 Lu</td> </tr> </table>																		58 Ce	59 Pr	60 Nd	61 Pm	62 Sm	63 Eu	64 Gd	65 Tb	66 Dy	67 Ho	68 Er	69 Tm	70 Yb	71 Lu
58 Ce	59 Pr	60 Nd	61 Pm	62 Sm	63 Eu	64 Gd	65 Tb	66 Dy	67 Ho	68 Er	69 Tm	70 Yb	71 Lu																		
<table border="1" style="width:100%; text-align:center;"> <tr> <td>90 Th</td><td>91 Pa</td><td>92 U</td><td>93 Np</td><td>94 Pu</td><td>95 Am</td><td>96 Cm</td><td>97 Bk</td><td>98 Cf</td><td>99 Es</td><td>100 Fm</td><td>101 Md</td><td>102 No</td><td>103 Lr</td> </tr> </table>																		90 Th	91 Pa	92 U	93 Np	94 Pu	95 Am	96 Cm	97 Bk	98 Cf	99 Es	100 Fm	101 Md	102 No	103 Lr
90 Th	91 Pa	92 U	93 Np	94 Pu	95 Am	96 Cm	97 Bk	98 Cf	99 Es	100 Fm	101 Md	102 No	103 Lr																		

or inappropriate fault within the crystal lattice is detrimental and will render the potential characteristics of a fabricated device at best poor.

When grown in a production laboratory, a silicon crystal usually takes the form of an ingot with a mirrored metallic appearance. Current technology allows single crystals of up to 30cm (12in.) diameter and 1.5m length to be routinely grown. This is only the start of the process; the crystal must next be cut up into fine slices, ready to be formed into integrated or transistor circuits. Figure 2, summarises the production of an integrated circuit, and details the areas we will examine in coming months. Inevitably, because of the complicated production processes, it is difficult to produce pure wafers and after fabricating the required circuit pattern on a wafer, engineers must perform tests to establish and discard any defect areas upon the wafer. Photo 1 shows a machine called a Macroscope from Sira Electro-optics capable of testing semiconductor wafers. The examination and testing of whole wafers is relatively new. Previously, the wafer had to be split into individual integrated circuits, and contacts made, before tests could be undertaken. The Macroscope on the other hand requires minimal sample preparation and causes no damage during testing.

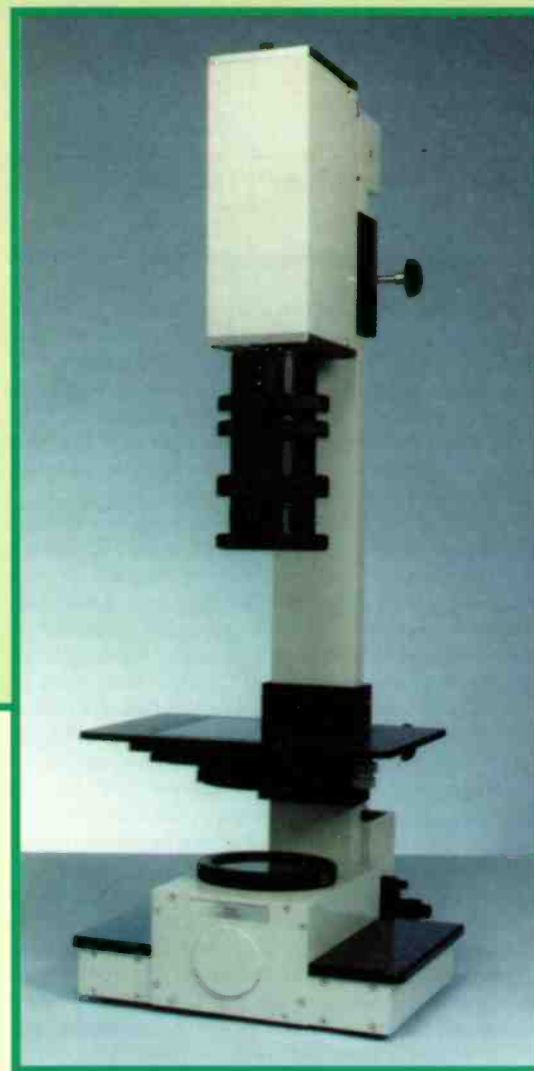

Photo 1. A Macroscope from Sira Electro-optics.

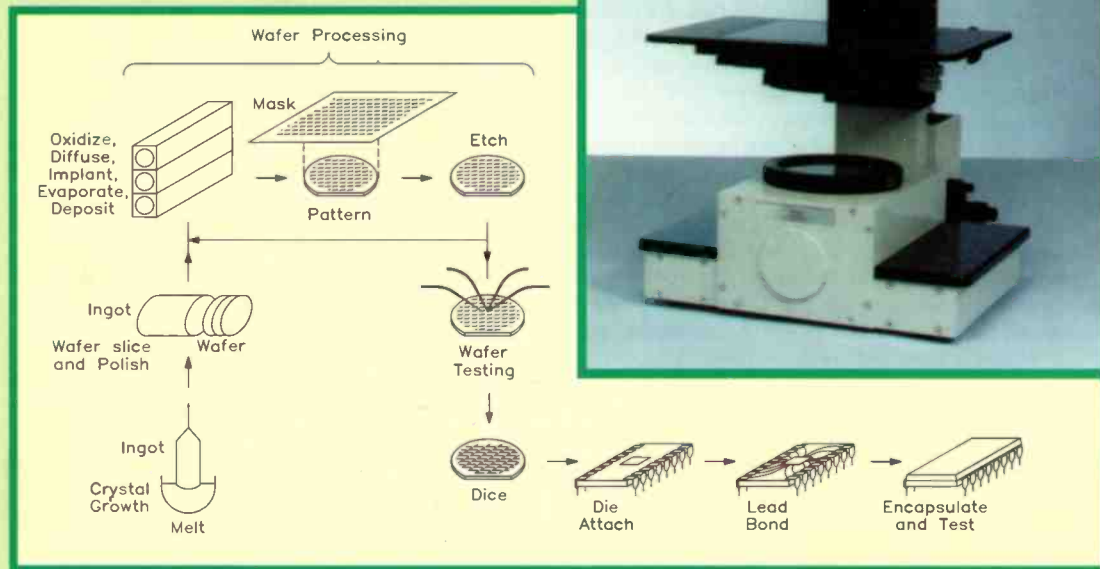

Figure 2. Integrated circuit manufacturing flow chart.

Flaws

Fabrication techniques currently allow integrated circuits with several million active gates to be formed. Indeed, the figure is expected to continue to rise as it has done over the past thirty years. Matters are complicated by the continual reduction in feature dimensions, further necessitated by the requirement of a high packing density of integrated circuits upon each wafer. This means that even the smallest flaw upon a silicon wafer will render the surrounding area worthless and it must ultimately be rejected. The fabrication of devices that ultimately fail is pointless and costly. It is therefore essential that engineers are able to produce pure wafers capable of countering the problems posed by Very Large Scale Integration (VLSI) production techniques. To this end, manufacturing problems and costs cannot be dealt with in isolation from the saleability of the final successful device. The cost to the consumer must be sufficiently low to capture the imagination of the electronics market.

Several models exist, able to predict the likely distribution of flaws on a wafer. From this statisticians are able to predict accurately the number of affected chips and consequently the likely yield from a wafer. All models agree that as chip sizes increase with the complexity of VLSI circuits, even a low defect density causes a significant reduction in yield and consequently increase in cost. Further, as packing density rises and feature size falls, even small size defects can cause catastrophic failure, leading to whole wafers being

scrapped. For high productivity manufacturing, it is critical to keep defect density small.

Growing a Silicon Ingot

Silicon is one of the most abundant elements in the earth. It is always found in a compound form – sand consists of silicon combined with oxygen – SiO_2 . It is initially purified as far as possible by chemical methods; reduction with carbon yields metallurgical grade silicon of up to 99% purity as detailed in the chemical equation below:



By combining it with hydrochloric acid (HCl), it is converted to SiHCl_3 . Further purification is achieved using fractional processes similar to those employed in the petroleum industry. Finally reduction in hydrogen results in pure silicon vapour which is deposited on thin silicon rods in which the concentration of undesirable particles is in the order of one in 10^9 silicon atoms. Such silicon would have a resistivity of about $200\Omega\text{cm}^{-1}$ which is sufficient for many semiconductor applications.

Zone Refining

For special purposes even higher grade semiconductor material is required. This is often obtained using a method called Zone Refining. The essential concept is based on the fact that impurities in an otherwise pure substance tend to migrate to the area of the substance at the most intense

Figure 3. Practical Zone Refining system.

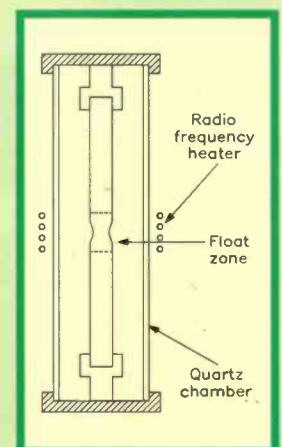

	Silicon	Germanium	Gallium Arsenide
Atomic number	14	32	—
Atomic weight	28.08	72.60	144.6
Density	$2.33 \times 10^{-3} \text{ kgm}^{-3}$	$5.33 \times 10^{-3} \text{ kgm}^{-3}$	$5.32 \times 10^{-3} \text{ kgm}^{-3}$
Melting point	1420°C	937°C	1237°C

Table 2. Characteristics of typical semiconductor material.

temperature. Thus, if silicon is melted and left to solidify, impurities drift to the molten part of the mixture as the material solidifies. Remember at this point that the concepts presented here apply not only to silicon, but also to any semiconductor that is grown in a polycrystalline form. Thus Zone Refining and the additional manufacturing methods as presented apply equally to other materials such as germanium and gallium arsenide.

Zone Refining is achieved by sequentially heating areas of a silicon bar formed by purification. Figure 3 illustrates a practical system in which a silicon rod is mounted vertically inside a quartz chamber. Table 2, details some of the fundamental characteristics of silicon, alongside other popular semiconductor materials. Of particular concern is the melting temperature of 1420°C. This value must be exceeded by the heating equipment to ensure a molten zone is achieved. At such temperatures this is problematic as silicon becomes quite reactive. Consequently Zone Refining is usually undertaken in a hydrogen atmosphere to prevent spurious reactions between the silicon rod and oxygen in the air that would otherwise lead to the formation of silicon oxide.

Located outside the quartz chamber is a radio frequency coil fed with a substantial current supply at a frequency in the order of 500kHz. The coil is moved vertically along the length of the quartz tube inducing eddy currents in the section of the Si bar inside the coil. The coil movement is maintained through a stepper motor and mechanical gear chain, ensuring a constant uniform traverse. Localised melting occurs and providing the coil is moved very slowly the melted section will remain small. The strong surface tension of molten Si combined with its low density is sufficient to support the molten zone in its place as illustrated in Figure 4.

The impurities migrate to the molten area of the bar. Since the molten area literally moves with the radio frequency heater, the impurities are swept through the length of the rod. Several passes of the rod may be undertaken, obtaining a purer length of silicon rod with each pass. The relatively dirty end of the bar is then sawn off and recycled to be incorporated back into a later purification process.

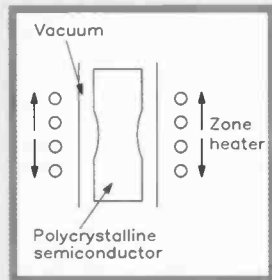
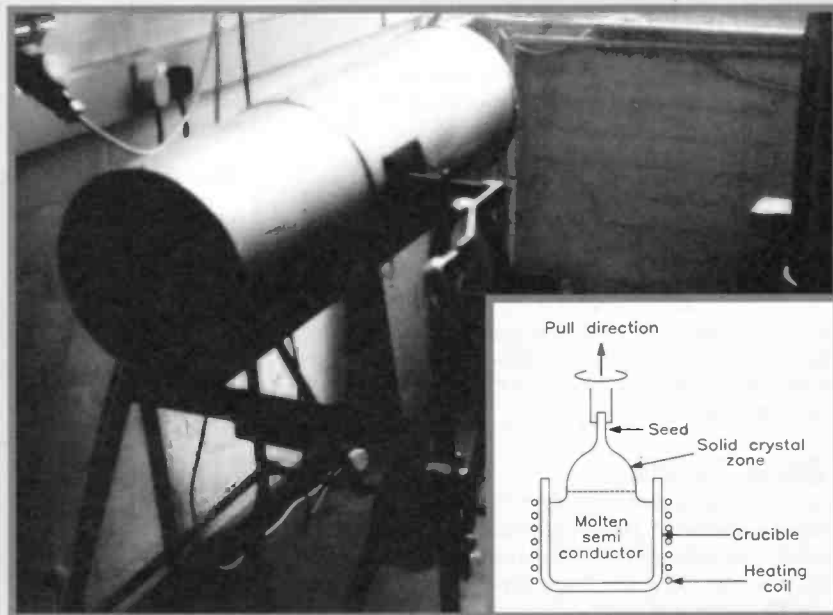

Figure 4. Float-Zone melt.

Photo 2. An enclosed ampoule for a Bridgeman System. Inset: Figure 5. Crystal Puller system.



Single Crystal Semiconductor from Float Zone

Conversion of the polycrystalline rods to single crystal is achieved using a technique very similar to the Float Zone system. Here a piece of poly-silicon rod produced by purification and possibly having been zone refined several times, is mounted over a piece of single crystal. The silicon crystal – or seed – is pre-cut in the crystallographic orientation desired for the single crystal rod.

Radio frequency heating is again used to melt the bottom of the polycrystalline rod and the top of the single crystal. If the heating coil is now moved slowly upwards, the melt zone follows directly, leaving the silicon to solidify in the orientation and structure of the single crystal. A further mechanical system is used to rotate both the crystal and the rod in opposite directions to each other thus ensuring that a uniformity of temperature and composition is maintained. As the radio frequency heater continues to move through the length of the silicon rod, the rod's polycrystalline structure is transformed to that of a single crystal. Crystals of 25mm diameter and 750mm long are routinely grown using this method.

Czochralski or Teal-Little Puller

A second method of producing a larger diameter silicon crystal directly from a metallurgical grade silicon melt is the Puller system. The process begins with undoped silicon and precise amounts of highly doped polycrystalline Si placed in a fused quartz crucible. The doped Si provides the final pulled crystal with the desired resistivity. The crucible is set within a carbon holder and the complete unit – as illustrated in Figure 5 – is placed within an enclosed pressurised atmosphere to prevent oxidation.

The silicon is melted by resistance heating and a small Si seed crystal of desired orientation is dipped into the liquid Si. The seed and crucible are rotated in opposite directions and the seed is slowly withdrawn. As soon as dislocation free growth is achieved, the liquid temperature is slightly reduced to allow the crystal to form into the desired diameter; additional growth is then maintained by precisely monitoring the pull rate. Growth periods can be quite protracted taking up to thirty or more days to effect a complete pull. Timing is further extended by the post growth period. During this time, the temperature of the ingot must be carefully reduced otherwise unwanted impurities and dislocations may form.

Bridgeman Growth

There are many materials that when heated beyond their melting point, release toxic vapour. This is particularly true for compound semiconductors such as containing phosphor, arsenic or selenium. To enable single crystals of materials which contain these elements to be grown, scientists must opt for a sealed crucible. The final technique we shall discuss – The Bridgeman Technique – allows for this necessity.

The solid semiconductor is heated in an enclosed ampoule – as illustrated in Photo 2 – to a temperature beyond its melting point and is then allowed to cool in a controlled manner. As the liquid semiconductor cools, a series of single crystals form. Multiple seeding occurs as the single crystals form, promoting the growth of larger ingots as shown in Figure 6.

The Bridgeman technique can be achieved horizontally or vertically, since the melt is enclosed. By slowly removing the crucible from a hot zone into a cooler zone, the molten material is forced to solidify from the lower end of the crucible. The Bridgeman crucible is usually a tube of circular cross-section with a sharp point formed at a closed end; Photo 3, shows a complete Bridgeman unit.

In one of the three forms discussed, melt growth is the most widely applied method for the production of relatively low melting point crystal. An advantage of having the metal in the liquid state is that considerable control can often be exercised over the solidification process. Additionally, purification can occur simultaneously with crystal growth.

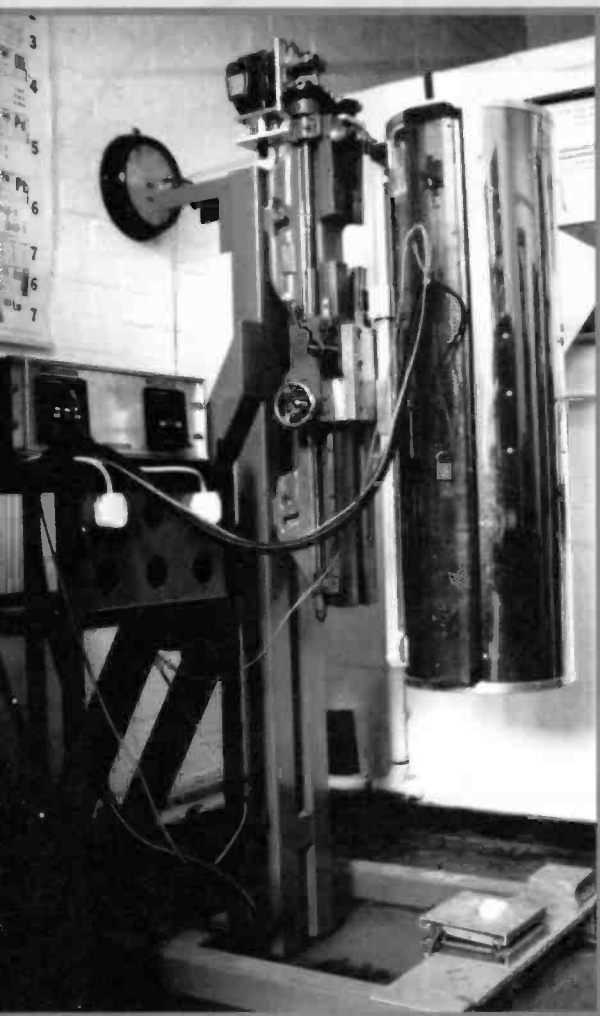
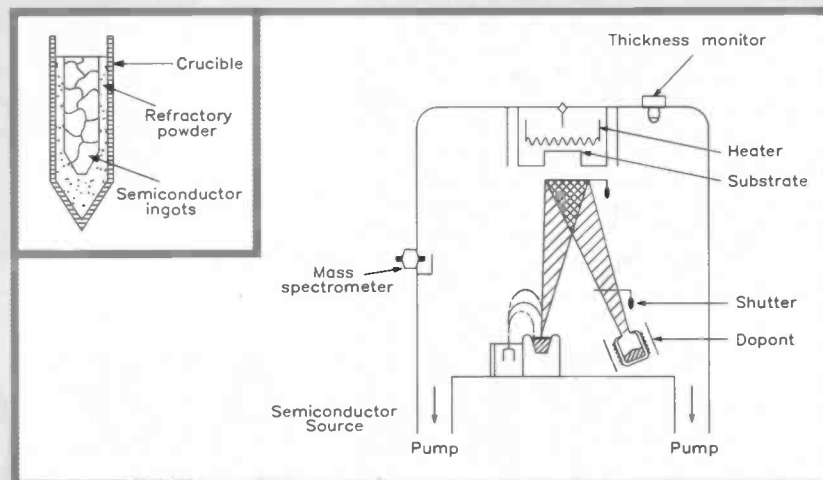

Photo 3. A complete Bridgeman System.

original and consequent material; scientists must be careful to match the crystallographic structure of the two substances. Most integrated circuits are formed using this method, with a silicon wafer slice – grown using a Puller method – acting as a ground plane. The major advantage of the technique is that the resistivity and dimensions of layers can be closely controlled. An accuracy of $\pm 30\%$ is considered good for Puller methods, while the figure reduces considerably to $\pm 10\%$ for epitaxial layers.

Throughout all the fabrication techniques we have discussed, cleanliness is essential. If you consider, that dopants are introduced in 1 to 10 part dopant to 10^6 silicon, then levels of cleanliness must far exceed this. Most work, as explained, is undertaken in a partial vacuum or at least a chemically inert atmosphere, enabling the levels of purity demanded, to be readily obtained. This is particularly important when considering epitaxial layers. The crystal perfection of an epitaxial layer will never exceed that of the substrate, and is usually inferior; crystal perfection depends



Inset: Figure 6. Ingots grown using a Bridgeman unit. Figure 7. Schematic Molecular Beam Epitaxy system.

predominantly on the initial state of the substrate crystal and then the epitaxial process itself.

The most common epitaxial technique, is Molecular Beam Epitaxy (MBE). This is a non-chemical-vapour deposition technique that uses an evaporation method. Figure 7 illustrates a schematic MBE system. The epitaxial layer is grown on a heated substrate in vacuum; the predominant material and required dopant being evaporated from separate sources at different rates, in order to achieve the desired doping density. Typical growth rates are in the region of 0.01 to $0.3\mu\text{m}$ per minute. The process has a low throughput, since a vacuum environment must be established before work can begin. This makes the technique inherently expensive, though advantages over chemical schemes surpass cost and make the method the subject of continued research.

Conclusion

By now I hope you have at least a fleeting appreciation for how raw semiconductor materials are formed, though I realise this article leaves an awful lot to be explained. Material science is a hybrid subject that has evolved rapidly over the past four decades. Text books in the area seem to demand a working knowledge of an array of subjects including, chemistry, mathematics, physics and not least electronics. I do not claim to be an ardent expert in more than one of these fields, but I do hope that this article has gone at least part way to presenting a basic understanding of the essence of the topic. Next month doping techniques and physical connections are examined.

References

- D. W. Jones, University of Birmingham, Refractory Metal Crystal Growth Techniques, Crystal Growth.
- A. Barlev, Semiconductors and Electronic Devices.
- B. Tuck and C. Christopoulos, Physical Electronics.
- G. Farrell, University of Salford, Integrated Circuit Fabrication & Design – An Engineering Perspective.

Wafer Slicing

Ingots grown using either the Bridgeman or Puller methods must next be sliced into individual wafers. Slices of about a millimetre thickness are cut using a diamond impregnated saw. This causes extra problems and is almost guaranteed to damage the crystal lattice near the silicon surface, resulting in poor resistivity and degrading the future performance of the semiconductor. Fortunately, the damaged area – which is about $20\mu\text{m}$ deep – can be removed by etching in a mixture of hydrofluoric and nitric acids. The surface is then polished using a fine diamond powder slurry to give a strain-free, highly flat region.

Semiconductor Production in the UK

The production of integrated circuit grade silicon in this country is minimal. At *Electronics*, we are only aware of a couple of laboratories manufacturing specialised semiconductor materials. The majority of work is undertaken in the United States and Japan, with this country concentrating efforts mainly on the intermediate steps of wafer production. Industry aside, there are a number of British universities working on the production of novel semiconductor materials. Of particular note is the University of Salford, from where we source the majority of the photographs. Here researchers under the leadership of Dr. R. D. Tomlinson are refining methods of producing Copper Indium Diselenide, the solar cell semiconductor mentioned earlier. To this end, the Salford Materials Group exports CIS wafers to photovoltaic research groups around the world.

Epitaxy

Applying a totally different tact, it is not always necessary to grow crystals in an ingot form. Epitaxy is the science of growing a single crystal structure on top of a wafer. The new structure is essentially a molecular extension of the

SCANNERS are a totally new breed of radio, designed specifically for modern listening requirements. Normally covering the VHF and UHF portions of the spectrum, many of these radios can receive signals above 1,000MHz (1GHz), and down into the Medium Wave band, see Figure 1 for reference.

Apart from boasting a phenomenal RF performance, these radios use the latest in processor technology. This enables them to be packed full of facilities which are essential for today's listener. Obviously the main feature which gives them their name is that they are able to scan a band or a number of pre-programmed channels, stopping when a signal is present. Coupled with a host of other features, this makes these scanners very flexible and powerful pieces of radio equipment.

Scanners represent a quantum leap in technology when they are compared to their predecessors. Before scanners were introduced, people wanting to tune the radio bands had to be content using ordinary general coverage communications receivers. Whilst these sets were often excellent for their intended use, they usually only covered frequencies up to 30MHz. The few units which did cover the VHF and UHF bands were intended for professional use. Some of these sets appeared on the second hand market, but even then they were only available at a price.

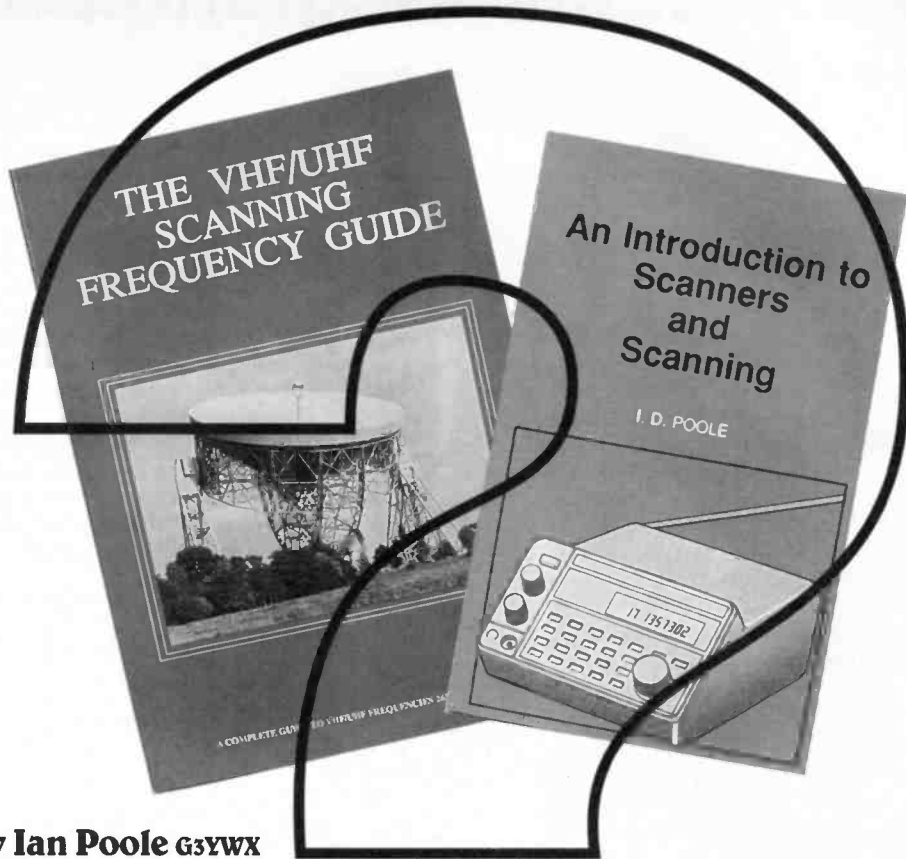

By Ian Poole G3YWX

WHAT ARE SCANNERS

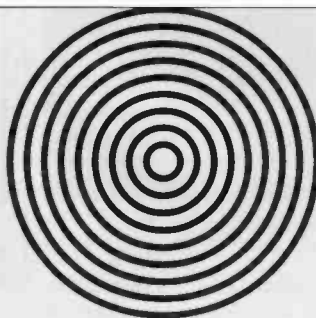

The first scanners that appeared on the market were very simple by today's standards. They were crystal controlled and because they required a different crystal for each frequency they only had a limited number of channels. Soon more sophisticated receivers arrived. They use frequency synthesizers to give crystal controlled stability, but without the need for a different crystal for each channel.

Initially many scanners only had limited frequency ranges, missing large spans at various frequencies. Now the latest scanners can give continuous coverage from the highest frequency to the lowest.

Legality

In recent months many reports have been seen in the press about 'radio hams' picking up conversations made by people using cel-

lular telephones. It now appears that it was not likely to have been a casual listener, but instead it was more probably one of the intelligence wings of Her Majesty's own government. However, it does serve to illustrate the point that these scanners can pick up a very wide variety of transmissions which are not for general listening. It is hardly surprising that there are laws governing this.

In view of this it is worth clarifying the law about owning and using these receivers. In the United Kingdom it is perfectly legal to own and use a scanner. Indeed ordinary HF communications receivers have been available for many years and they can pick up all manner of signals.

However, any receiver, whether it is a scanner, communications receiver or even an ordinary transistor portable radio should only be used for picking up signals intended

for general reception. These include sound broadcasts, transmissions by radio amateurs and citizen's band enthusiasts, and standard frequency transmissions. Then at sea, weather or navigational information can be received. It is also possible to pick up weather satellite transmissions but permission must be sought from the Department of Trade and Industry Radio Regulatory Department.

These laws may seem rather strict and heavy handed, but they have been introduced in an attempt to preserve people's privacy and rights.

Scanner Requirements

There are a very large variety of transmissions which can be heard on a scanner. Multimodes, different spacing between the channels and the use of a range of bands all mean that the scanner has to have a very

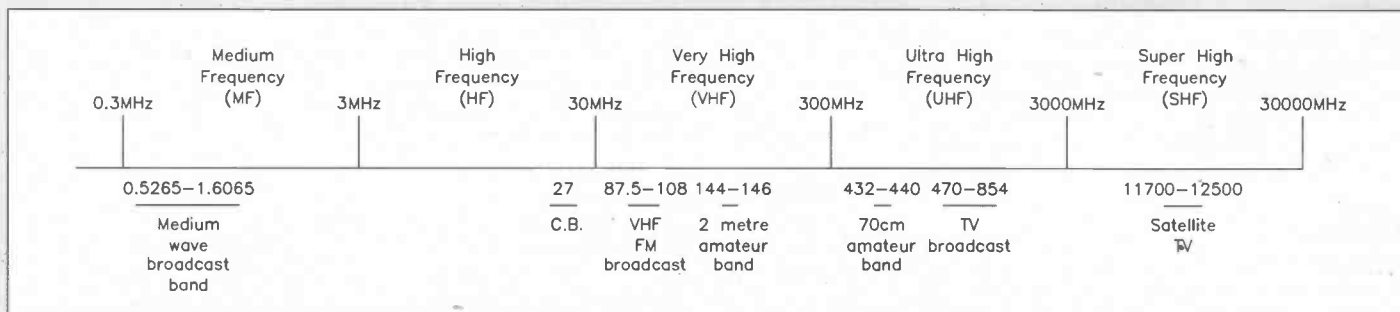

Figure 1. The Radio Spectrum.

comprehensive set of facilities. Especially if it is to be able to cope with all the transmissions it will be able to pick up.

The scanner will have to be able to resolve a number of different transmission modes. Wideband FM, narrowband FM, and AM are the most widely used modes on the frequencies covered by most scanners.

The most common use of wideband FM is for sound broadcasting in the VHF FM band between 87.5 and 108MHz. Anyone scanning this band will find it full of stations, local and national, and both independent and from the BBC. Wideband FM is also used for television sound as well.

Wideband FM uses a deviation of $\pm 75\text{kHz}$. This means that the bandwidth needed for the transmission is 200kHz. However, the transmissions may be found on either odd or even multiples of 100kHz.

Narrowband FM is also widely used. CB, radio amateurs and all forms of mobile radio use it extensively. Because it uses the variations in frequency to carry the audio information instead of any amplitude variations it is ideal for use in mobile applications where the signal level varies widely as the vehicle moves.

Generally the deviation used is $\pm 3\text{kHz}$, very much less than that used for broadcasting. However, the channel spacing varies according to the user. The spacing for CB is 10kHz and for radio amateurs it is 25kHz. For most commercial private mobile radio use, the channel spacing has been reduced from 25kHz to 12.5kHz because of the pressure on spectrum allocations. Even so there are still some bands where 25kHz spacing is used.

Amplitude modulation is still widely used. Its most common use is for broadcasting on the long, medium and short wave bands. In this context it is noteworthy that the spacing for transmissions on the long and medium wave bands is 9kHz whereas on the short wave bands it is just 5kHz where the pressure on spectrum is much greater.

Apart from this use, AM is used for VHF and UHF airborne communications. All airborne communication in this section of the spectrum uses AM unlike the majority of other point to point communications above 30MHz that use FM.

Facilities for other modes like SSB and Morse are found less frequently on scanners. One reason for this, is that SSB and Morse do not lend themselves to scanner operation so well. This is because a carrier is not present all the time and the scanner can easily pass over it. Besides this the pitch of the beat frequency oscillator needs to be adjusted for each signal to enable it to be copied correctly. Finally SSB is not widely used on the frequencies traditionally covered by scanners. Normally it is used for long haul HF voice communications on frequencies below 30MHz. The greatest users of SSB above 30MHz are radio amateurs.

Main Functions

Scanners are certainly no ordinary radios in many terms. However the basic building blocks and the principles they use are exactly the same as those employed in virtually every other radio on the market today. They use the superhet or superheterodyne principle (see *Electronics* October 1992 Issue 50) to convert the incoming signal on whatever frequency it may be to a fixed intermediate frequency. Figure 2 shows a block diagram of

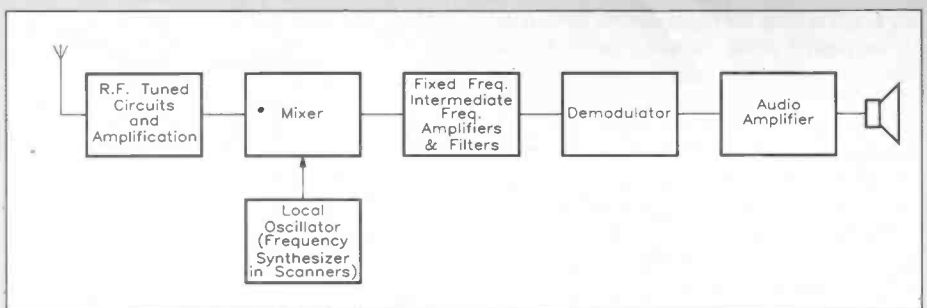

Figure 2. Block Diagram of a Superhet Receiver.

a superhet receiver. By doing this, it is possible to amplify and filter the signal far more effectively. It is far easier to make an effective filter on a fixed frequency of the designer's choice than to make one at the frequency of the incoming signal. In fact, many scanners will have two or more frequency conversions and different intermediate frequency stages. This is done to ensure that the best performance is achieved. The first IF is normally high in frequency to ensure that the image response is not a problem. A lower IF is then used to give the sharp selectivity needed to separate the individual signals.

Beyond the basic radio frequency circuit blocks, microprocessor technology enables the radio frequency circuitry to function in a far more sophisticated manner. As a result the radio can offer a whole new range of facilities which the more traditional sets could not offer.

One of the most important features of radio, is the tuning. It must be possible to set the receiver to the required frequency. In traditional radios a tuning knob is used in conjunction with a band change switch. Today most scanners have a tuning knob and can be tuned in the normal way. However, their frequency can be set in a number of other ways as well. A keypad can be used to enter the frequency directly into the radio. Besides this, the keypad often has up and down keys which can be used to shift the frequency up or down by a certain increment. When the set is tuned in this way it moves from one channel to the next. The step size between these channels can be altered. Scanners have a number of set step sizes which can be used which correspond to the most commonly used channel spacing, 100kHz for wideband FM, 25kHz and 12.5kHz for narrowband FM and 5kHz for broadcast AM. Other step sizes are often provided and can be useful on occasions.

As an alternative, preset frequencies can

be recalled from memory. Most scanners today have upwards of 100 different memories. Using these memories it is possible to store the frequencies where known stations are situated. Often these memories are split into banks of memories which can be scanned separately or consecutively. This has the advantage that it is possible to use different types of memory for different types of station.

The way in which a scanner selects the mode of operation is very important. On some, the mode is automatically selected dependent upon the frequency which is in use. This is often perfectly satisfactory because for the majority of the time only certain modes are used on particular bands. However, for the more discerning scanner user it is much preferable to be able to select the mode in use.

One important feature of any scanner is the squelch control. This circuitry detects whether a signal is present. When one is present the audio output is turned on and the scanner will stop scanning and remain on the frequency whilst the signal is present. When the signal disappears then the audio output will be inhibited and the scanner will restart its scan or search.

By inhibiting the audio, the large levels of background noise which would otherwise be present are removed. This has the additional advantage on portable sets that battery life is extended, because the current-hungry audio stages are not operational during these periods.

Any receiver with a squelch facility will have a control. This is used to adjust the level at which the squelch is activated. In this way it is possible to set it at very low levels so that any signal will activate it. Alternatively, it is possible to set it so that only strong signals can activate it. The control is important because different situations will require different settings of the control. In some

Yupiteru MVT-7000

To demonstrate what could be done with a scanner a Yupiteru MVT-7000 was put through its paces. This receiver is an extremely compact and versatile scanner covering 8 to 1300MHz (down to 100kHz with reduced sensitivity). It contains all the usual facilities expected in a scanner plus a few extra ones. A full multi-function keyboard gives control of all the scan and search modes besides allowing direct control of the tuning. Then each of the ten user selectable programmable search patterns can be called up in either delay or audio frequency search modes and a priority option allows a special frequency to be monitored more closely.

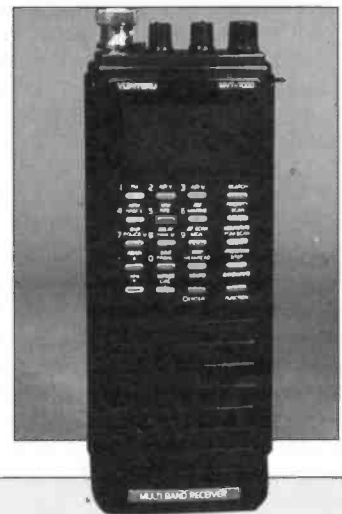

instances it may be necessary to have it set so that even weak signals can be heard. However, noise and signals which may be too weak to copy will activate the squelch. At the other extreme, if it is set so that only strong signals are heard then some interesting medium strength signals may be missed. As a result the control can be set as required.

When looking for signals on the bands, there are two modes which a scanner can use. The first is called the scan mode and gives the scanner its name. It involves taking the frequencies out of memory and then monitoring them one at a time in sequence. The second mode is called search and involves searching a band starting at a particular frequency and tuning up or down until it finds a station.

The rates at which the scanner can perform these operations vary slightly. Searching is easier than scanning because the frequencies are next to one another and the receiver does not have to alter its frequency as much. When scanning, the frequencies can be almost anywhere within the coverage of the receiver. As a result, time has to be allowed for the circuits in the receiver to settle sufficiently, and obviously this takes more time. Typically a scanner might be expected to search 20 channels per second, whilst the scan rate will be a little slower at 15 channels a second.

When scanning it is often useful to be able to miss out one or more of the preprogrammed channels without having to alter the settings on the radio to any major degree. It may be that a particular channel is temporarily occupied with a transmission which is not of any interest. In cases like these it is possible to use the lockout facility. By using this it is easily possible to prevent a channel from being monitored. Then when the channel needs to be monitored again it is very easy to reinstate it.

Although it is often useful to miss out a particular channel, it is sometimes important to be able to monitor a frequency more closely. To accomplish this a Priority facility is often included. During scanning this enables the priority channel to be monitored more frequently than the others. Also, when listening to one frequency, the scanner may return to the priority channel to see if there is a signal there. In this way a frequency of special interest can be closely monitored whilst using the scanner to listen to other frequencies.

Another important facility on a scanner is the delay facility. This determines the time a scanner will remain on a channel once a transmission has ceased. This is very useful because transmissions will often be intermittent. Without the delay the scanner would immediately resume scanning. This would mean any further transmission made, even shortly after the original one ceased would be missed. By adjusting the delay, it is possible to let the scanner remain on the frequency for a set amount of time, allowing intermittent transmissions to be heard.

Types of Scanner

Scanners come in a variety of different forms. Probably the most obvious are the base station types for use at home. These sets are normally mains powered and they are larger than some of the others which are available. Because size is not such a problem they normally have more facilities than other sets, and the controls are a bit larger. In addition,

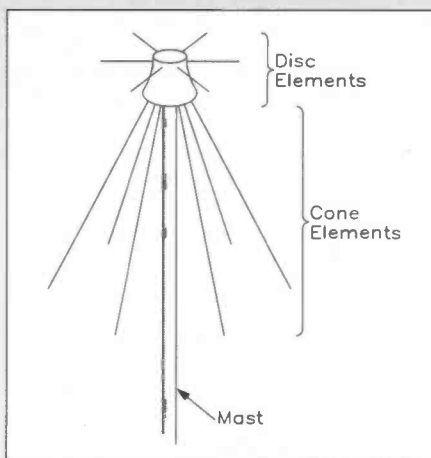

Figure 3. A Discone aerial.

the increased size means that a better speaker can be used to give improved reproduction.

Many people like to be able to operate scanners from cars. Accordingly a variety of mobile sets are available designed specifically for 12V DC operation, although many of the base station ones are dual purpose being able to operate from 12V DC or 240V AC on the mains.

There is a growing interest in portable or handheld sets. These are incredibly compact and it is amazing just how much functionality is squeezed into such a small space.

They run from internal batteries, although there is often provision for 12V, enabling operation from a car battery. In view of the constraints which battery operation brings, the audio power output of these sets is normally less than the base station or mobile ones. Often the output power is about 200mW. This is usually quite adequate for most applications. However, it is not sufficient for noisy environments like the inside of a moving car.

Aerials

Like any radio receiver the performance of the scanner can only be as good as the aerial. A poor aerial will greatly limit the performance of the set, whilst a good one will enable it to bring in stations from far and wide. Unfortunately good aerials take a certain amount of effort and cash. If they are to be installed properly externally. However, this is a very good investment because it will make an enormous difference to the set.

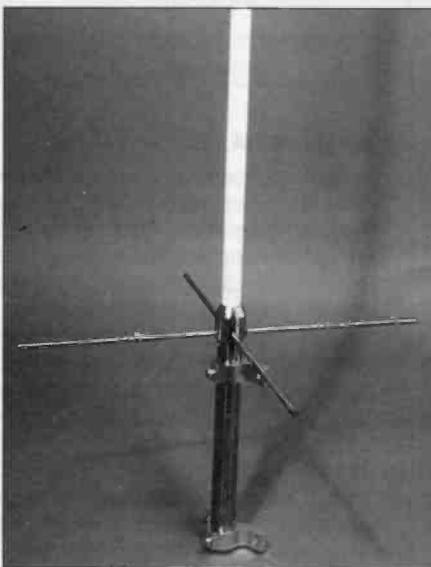

Photo 1. Wideband aerial.

Often sets, especially portable ones come with a small extendable aerial. They are very useful because they are convenient to carry and use whilst out and about. However, they are not at all efficient. It is a matter of balancing their performance against their convenience.

For the real enthusiast a large fixed aerial is a necessity. It will vastly out perform any of the small portable aerials, especially if it is installed in a good position. The most popular type is called a discone aerial: which takes its name from its shape as shown in Figure 3. This type is very popular because it is able to function over a wide bandwidth. Some aerials boast a coverage which extends over a range of as much as 10:1. The more usual types of aerial are similar to those used for television reception, and operate over a comparatively narrow bandwidth. This is the reason different aerials have to be used in different parts of the country where different channels are used.

The discone manages to achieve its enormous frequency coverage because of its unusual shape. With the effect of the disc and the cone together enabling it to resonate over a wide band of frequencies, refer to Figure 3. The Royal DX 1300 (CM09K) is an ideal match for scanning receivers. It is fully weatherproofed and supplied with mounting hardware for a 2in. mast. Photo 1 shows another type of wide band aerial.

A variety of active aerials are also available. These are usually more compact than their non-active counterparts. They also differ in having an amplifier as an integral part. This serves not only to increase the level of the signal, but also to enable the aerial to present the correct impedance match to the feeder. Again these aerials are suitable for wideband operation, but their disadvantage is that they need a power source.

Feeder

To enable any aerial to operate to its best it should be mounted outside and away from any other aerials such as television aerials which might act as a screen. Along with this a good quality low loss cable should be used. As scanners have a 50Ω aerial input impedance, 50Ω coax should be used; not the 75Ω variety which is used for television and Hi-Fi tuners.

Unfortunately low loss cable can be expensive, especially if a long run is needed. However, there is no point in going to all the trouble to install an efficient aerial and then throw away the advantage by using poor feeder cable. In fact, the benefit of using a high grade cable will be noticed more as the frequency is increased. At the low end of the frequency range the loss introduced by the cable may only be small, but as the frequency rises the cable loss becomes very much greater.

Yupiteru MVT-7000

The MVT-7000 is a very convenient size, just right for hand-held operation. In addition, it is very light and perfectly capable of being carried in a pocket, although care should be taken to ensure it does not slip out!

Referring to photo on previous page, on the front of the unit is the liquid crystal display which not only indicates the frequency but also assists in displaying the various functions of the radio. It also serves as a very useful signal strength indicator.

Below the display is the keypad. This

Specification of the MVT-7000

Frequency range:	8 to 1300MHz (down to 100kHz with reduced sensitivity)
Memories:	200
User Defined Search Patterns:	10
Steps:	5/10/12.5/25/50/100kHz
Modes:	AM, NBFM (narrowband FM), WBFM (Wideband FM)
Sensitivity:	NBFM > 0.5µV for 12 dB SINAD WBFM Nominally 0.75µV for 12 dB SINAD AM Nominally 0.5µV for 10 dB S/N
Scanning Rate:	Approximately 15 channels per second
Search Rate:	Approximately 20 steps per second
Delay Time:	Selectable 2 seconds fast, 4 seconds slow
Display:	Variable contrast
Audio Output:	130mW into 8Ω
Power Requirements:	4.8V from 4 x AA Ni-Cds (supplied) 12V external DC
Current Consumption:	Approximately 160mA at full audio output. Approximately 95mA when squelch has muted the audio output.

enables all the functions of the radio to be accessed. Organised in a logical fashion there is a total of twenty keys which the average finger should find little difficulty in operating. To cater for all the functions of the radio many of the keys are dual function. Whilst this may seem to be a disadvantage at first it does reduce the number of keys and the complexity of the front panel. This in itself is a great advantage, and after all, the majority of functions which require two key presses do not normally need changing all the time. In summary it leads to a much more convenient operation of the receiver.

A few controls are also included on the side of the radio. There is a variable control for the LCD contrast. Below this there is a lamp key for illuminating the display. This is a very useful function as anyone who has used any receiver in poor lighting conditions will agree. The third control is a lock key. When this is on, it prevents any key-presses from altering the setting of the radio. This can be useful if the radio is likely to be knocked, or possibly if it is used in a pocket. Finally, there is an access hole for a reset button, and to activate this, a pen tip or similar point is required. This is to reset the micro-

processor and memories. This is a very handy addition as under some circumstances it can be very difficult to return the radio to a known state if the wrong keys are pressed!

On the top of the set are the usual tuning, volume and squelch controls. In addition there is an attenuator switch. This is useful when operating the set in conjunction with a good aerial when strong signals can be picked up which might otherwise overload the set. Normally the set would be operated with the attenuator out, but on a few occasions it may be very useful.

There are two sockets on the top of the set. The most obvious is the aerial BNC socket, but there is also provision for an external speaker or earpiece. Finally, on the other side of the radio is the socket for the external 12V DC supply. This is very important for those who will use the radio for extended periods without being able to recharge the batteries.

On the back of the radio towards the bottom is the compartment for the four AA batteries (4 x Ni-Cds are supplied). Access to them is easy and the polarity markings are very clearly marked.

Operation

Basic operation of the radio was straightforward. Even with its own telescopic aerial it proved to be very lively picking up stations over the whole range of its coverage. Surprisingly with such a short aerial the short wave bands were full of stations. The VHF FM band was also full, as would be expected and plenty of amateur and CB stations could be heard.

When using the various scanning modes, the operation of the receiver was naturally a little more complicated. However, the operating manual was well set out showing step by step instructions for each mode of operation. Copious diagrams were included showing which buttons to press and in which order. This made it particularly easy to follow. Even the occasional lapse into 'Japanese' English did not prove to be a problem.

With a radio having the facilities of the MVT-7000 it would naturally take the newcomer a little while to master all the functions. However, it only takes a few minutes after using the set to pick up a wide variety of signals from the whole of the radio spectrum. For the seasoned enthusiast there should not be any problems in using the set. All the functions are logical and it should be possible to use the set without much recourse to the manual.

Summary

The Yupiteru MVT-7000 (CM00A) is a very neat and handy scanner ideal for either the newcomer or for the more experienced user. To use it was a pleasure. It packs a vast number of functions and facilities into a small space and offers excellent value for money. Priced at £369.95 H1, it comes complete with Ni-Cds, charger, telescopic aerial, car connector, earphone, and of course the manual.

Further Reading

An Introduction to Scanners and Scanning by I. D. Poole.

Order Code WZ62S Price £4.95.

The Complete VHF/UHF Frequency Guide by B. Laver.

Order Code WT70M Price £9.95.

Satellite Components Catalogue

Specifications and Applications for all the components you're ever likely to need from 3 to 13GHz, including all the latest developments, upgrades and, of course, competitive prices.

TRAC Satellite Systems

£1.95

Inc. P&P

(0642) 468145 FAX : (0642) 440927
Commerce Way, Skippers Lane, Middlesbrough TS6 6UR.

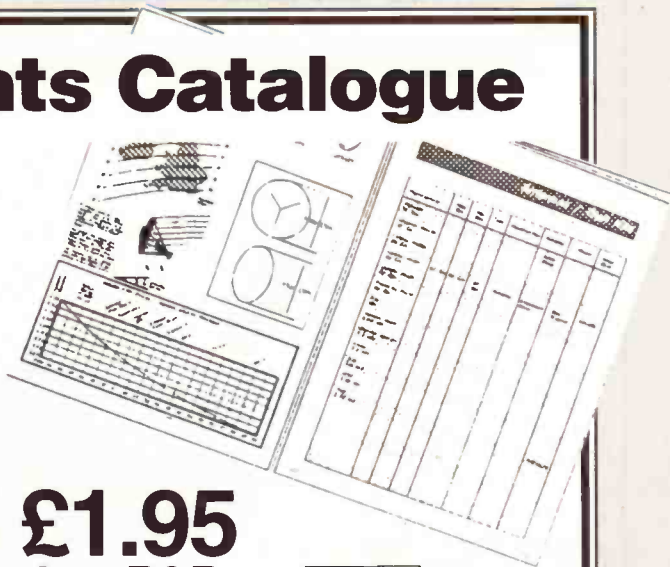

'Data Files' are intended as 'building blocks' for constructors to experiment with, and the components suggested provide a good starting point for further development.



KIT AVAILABLE (LT48C)
Price £6.99

SL561C Low Noise Preamplifier



Design by
Chris Barlow

Text by
Robin Hall and
Chris Barlow

FEATURES

- * Gain up to 60dB
- * Low noise
- * Good bandwidth

APPLICATIONS

- * Video preamplifier
- * Video buffer
- * Video distribution system

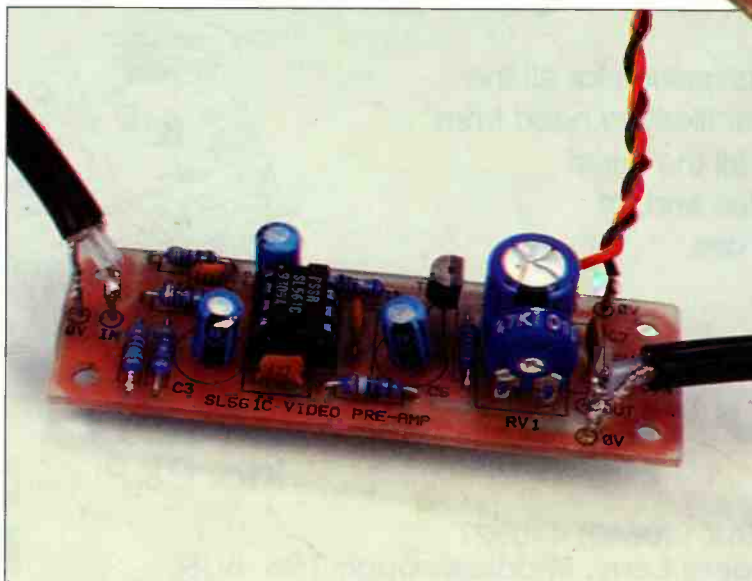
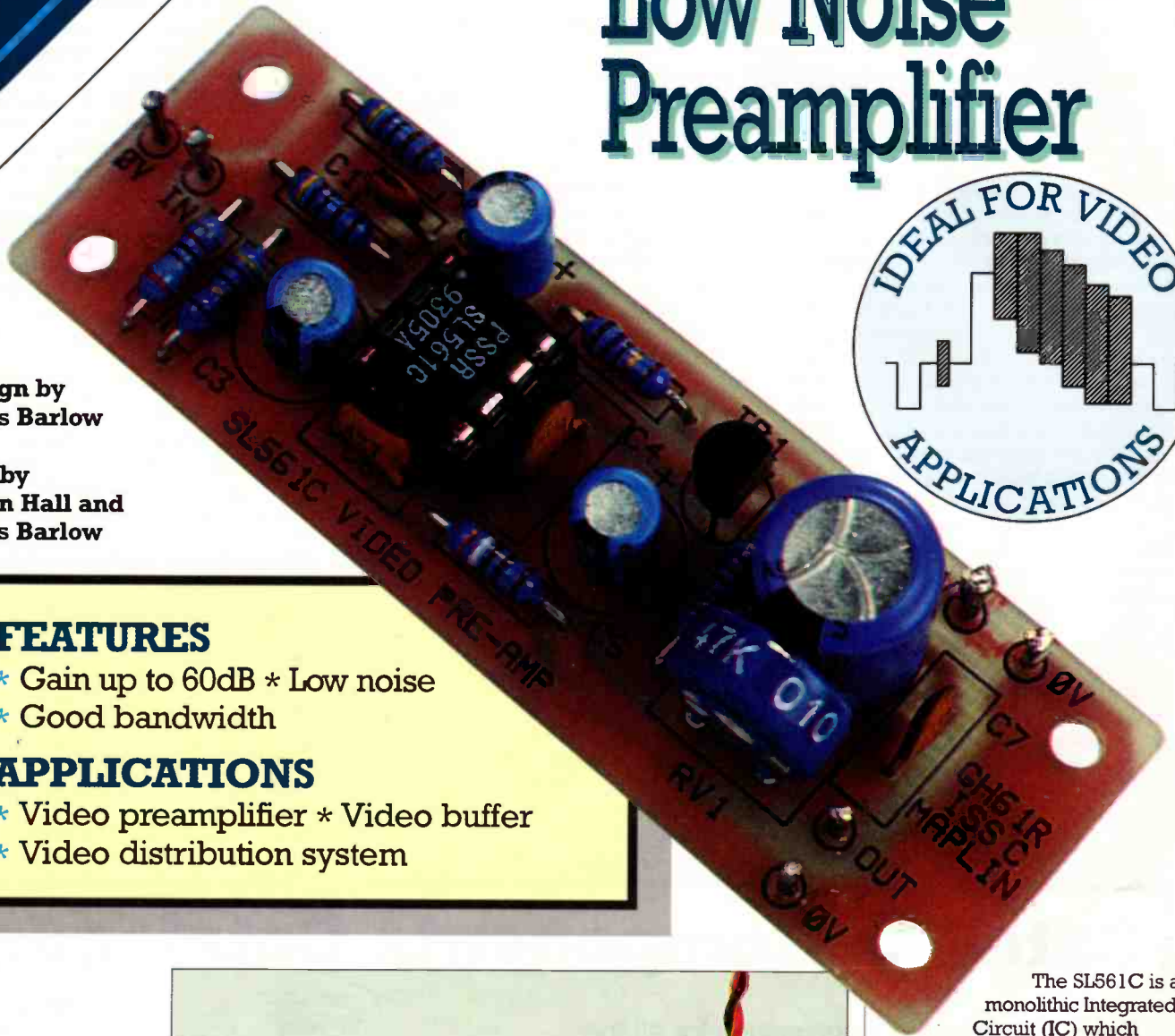

Above right: Close-up of the assembled Video Preamplifier board.
Right: Video Preamplifier board showing typical wiring connections.

The SL561C is a monolithic Integrated Circuit (IC) which can be used in a number of different low noise preamplifier roles. It contains nine very high performance transistors; and associated biasing components, see Figure 1. All this circuitry is held in an 8-pin DIL (Dual-In-Line) package as shown in Figure 2. The absolute maximum ratings and electrical characteristics of the IC are detailed in Table 1. Its high gain, low noise design makes it suitable for use in audio and video systems at frequencies up to 6MHz. Noise performance is optimised for source

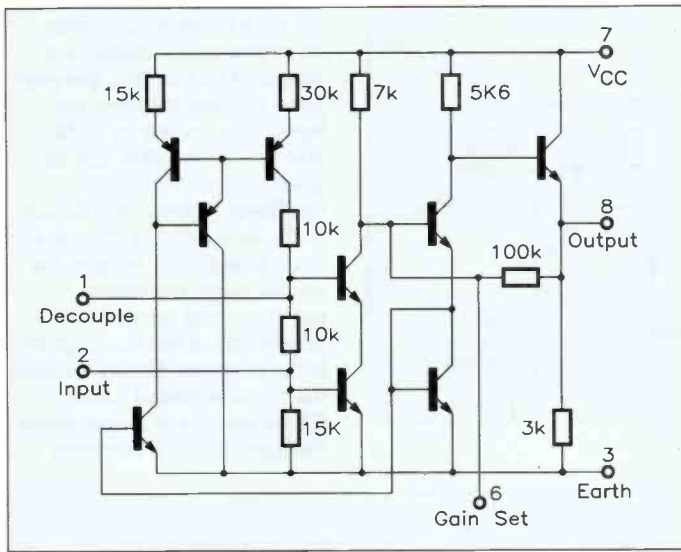

Figure 1. SL561C internal circuit diagram.

impedances between 20 Ω and 1k making the device suitable for use with a number of transducers including photo-conductive infra-red (IR) detectors, magnetic tape heads and dynamic microphones.

The SL561C has an impressive specification, see Table 1, and its possible

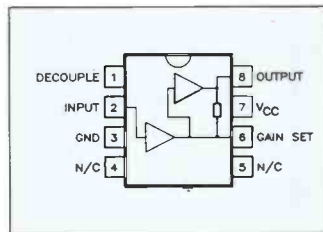

Figure 2. SL561C pin connections.

applications are too numerous for just one article to cover. However, it is hoped that the Video Preamplifier application will provide a good starting point for your further experimentation.

Circuit Description

A circuit diagram for the video preamplifier is shown in Figure 3. The power is applied to the PCB as follows, positive to the +5V pin and negative to one of the 0V ground pins. This supply must be within the range of +4.5 to +7V and have the correct polarity otherwise damage may occur to the components. The positive DC supply is

applied to pin 7 of IC1 (SL561C) and via R7 to the emitter of TR1 (BC328).

Main supply rail decoupling is provided by C5 (100 μ F) with additional high-frequency decoupling provided by a 100nF disc ceramic capacitor C4.

The video input to IC1 (pin 2) is made via an R/C attenuator network, R1 to R4 and C1, C2. Two criteria must be met if the external video device and the SL561C chip are to perform at their optimum level, namely matched input impedance and level. The incoming video signal is applied to the video input pin on the PCB and its ground is connected to its 0V

Specification of Video Preamplifier Prototype

Power supply voltage:	5V DC
Supply current:	40mA
Bandwidth:	24MHz (-3dB)
Input level:	1V (Pk-to-Pk)
Input impedance:	4k7 (no termination) 75 Ω (terminated)
Output level:	2V (Pk-to-Pk)
Output load impedance:	75 Ω

Characteristic	Value			Units	Conditions
	Minimum	Typical	Maximum		
Voltage Gain	57	60	63	dB	Pin 6 O/C
Equivalent input noise voltage		0.8		nV/ $\sqrt{\text{Hz}}$	100Hz to 6MHz
Input resistance		3		k Ω	
Input capacitance		15		pF	
Output impedance		50		Ω	
Output voltage	2	3		V p-p	
Bandwidth		6		MHz	
Supply voltage		5	10*	V	
Supply current		2	3	mA	
Storage temperature	-55*		+125*	$^{\circ}\text{C}$	
Operating temperature range	-55*		+100*	$^{\circ}\text{C}$	

Test conditions: $V_{CC} = 5\text{V}$; Source impedance = 50 Ω ; Load impedance = 10k Ω ; $T_{amb} = 25^{\circ}\text{C}$.
* Absolute Maximum ratings.

Table 1. Absolute maximum ratings and electrical characteristics.

pin. The input impedance of the attenuator is significantly higher than the 75 Ω termination resistance required by most video equipment. To correct this a termination resistor R1 (82 Ω) is placed across the video input. If this is omitted the input impedance will increase to approximately 4k7 which will be useful if the video equipment is already terminated by some other device, i.e. a VCR or monitor. The video signal is then attenuated by resistors R2 & R4 to drive pin 2 of IC1 at the correct level, with capacitor C2 providing the AC coupling. It is of great importance that this signal is at the correct level as it will directly influence the harmonic content of the amplified video signal, see Figure 4. To optimise the noise performance of the SL561C, the source impedance must be between 20 Ω and 1k see Figure 5. This parameter is satisfied by R4 being a 47 Ω resistor. The video attenuator stage is bypassed at high frequencies

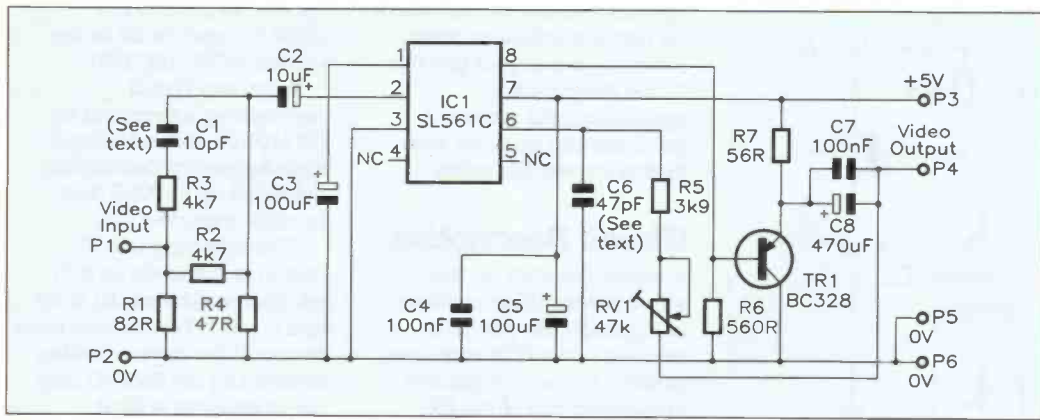

Figure 3. SL561C Video Pre-amplifier circuit diagram.

by a low value (10pF) ceramic capacitor, C1 and a 4k7 resistor, R3. This has the effect of boosting the upper frequencies by a small amount, producing a slightly sharper picture. If this enhanced image is not required, then C1 and R3 may be omitted.

The low-frequency response is determined by the capacitors C2 and C3. C3 decouples an internal feedback loop on pin 1 and if its value is close to that of C2 an increase in gain at low frequencies occurs. For a flat response either make C3 less than 0.05 of C2 or make C3 five times, or more, greater than C2.

The bandwidth or upper cut-off frequency of the pre-amplifier can be reduced to any desired value by the capacitor C6 from pin 6 to ground. No degradation in noise or output swing occurs when this capacitor is used. A frequency response graph is shown in Figure 6 which depicts the differing -3dB response curves produced by capacitors C1 and C6. Table 2 lists the components fitted/not fitted for the corresponding response curves shown in Figure 6.

The quiescent current of the output emitter on pin 8 of the SL561C (see Figure 1) is approximately 0.5mA and only capable of driving

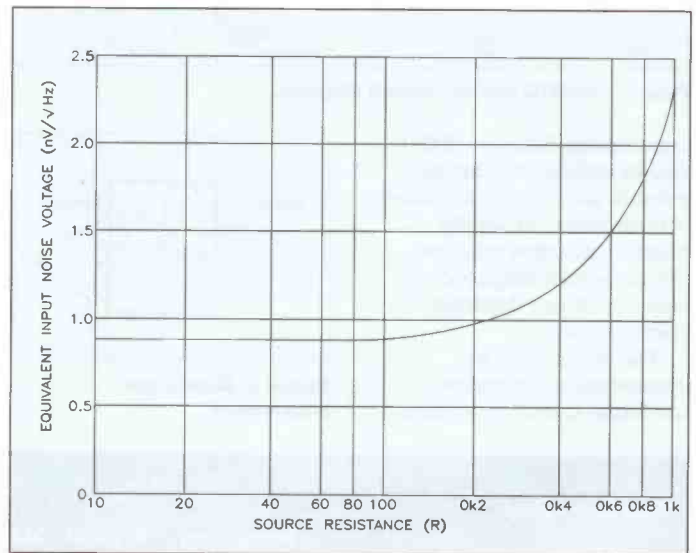

Figure 5. Noise versus source impedance.

moderately low impedance loads. As larger voltage swings are required into low impedance loads this current is increased by a 560Ω resistor, R6, from pin 8 to ground. However, even this is not enough to drive the low impedance loads used by video systems and to accommodate this a PNP transistor TR1 is used as a video output buffer. The video signal is AC coupled via C7 and C8 to the video output pin on the circuit board.

Provision is made to adjust

emitter (without resistor or bypass capacitor), at values of gain less than 40dB this input stage, rather than the output stage, determines the maximum output voltage swing. To keep distortion below 10%, the input signal level on pin 2 should be limited to 5mV or less, see Figure 4.

PCB Assembly

Removing a misplaced component can be difficult so please double-check the type, value and polarity

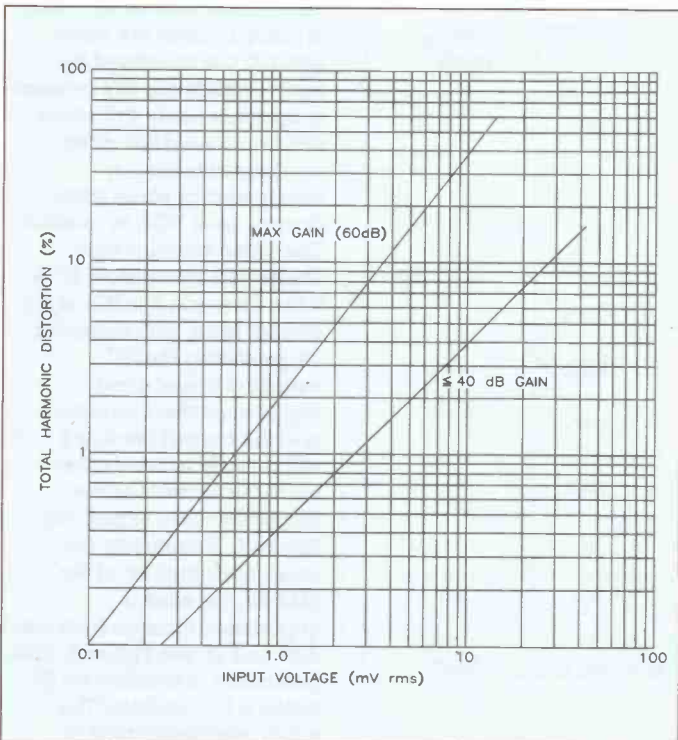

Figure 4. Harmonic distortion at 20kHz

A = 53MHz (+1.5dB peak at 20MHz)	No C1 or C6
B = 50MHz (+5dB peak at 10MHz)	C1 and no C6
C = 12MHz	No C1 and C6 (47pF)
D = 24MHz (+3.5dB peak at 7MHz)	C1 and C6 (47pF)
E = 6MHz	No C1 and C6 (100pF)
F = 10MHz (+1.75dB peak at 4MHz)	C1 and C6 (100pF)
G = 1MHz	No C1 and C6 (470pF)
H = 2MHz	C1 and C6 (470pF)

Table 2. Component options.

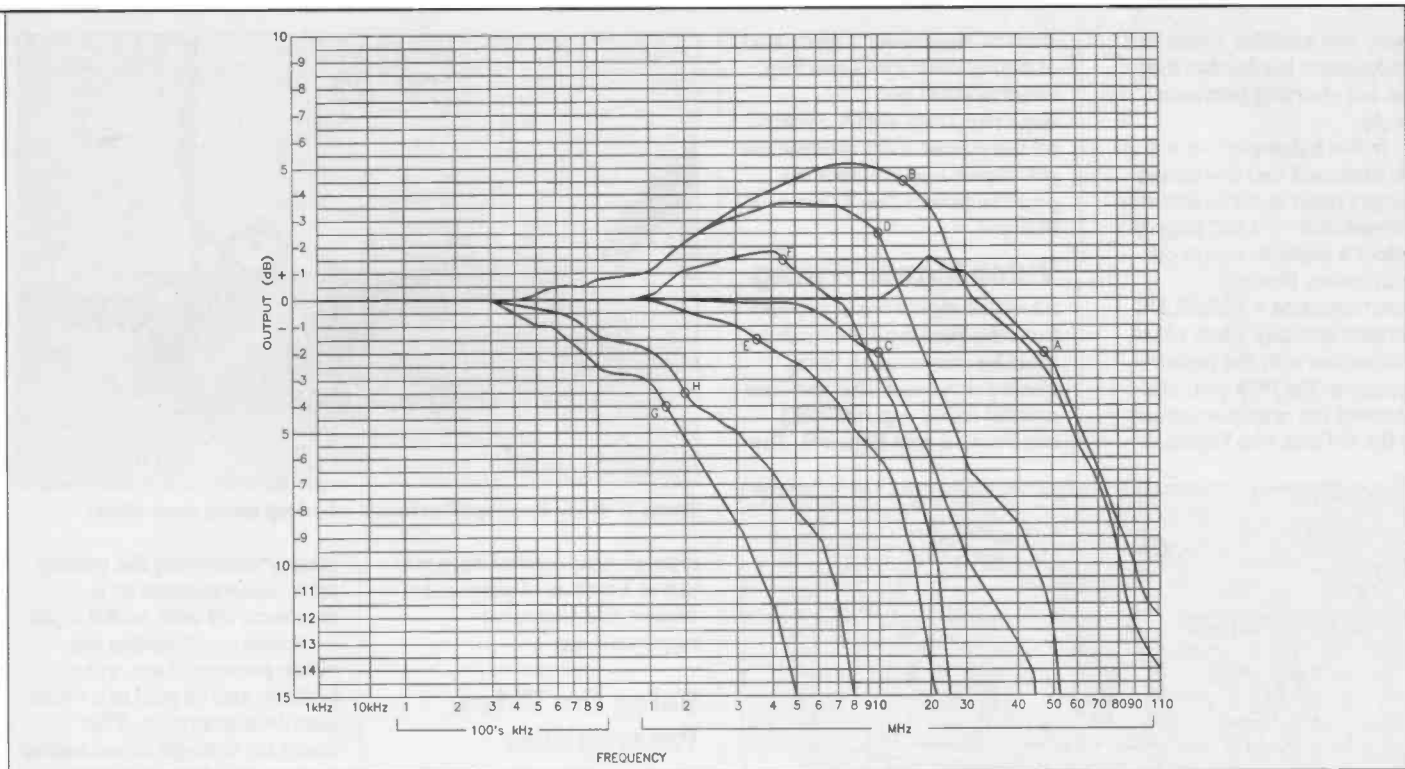

Figure 6. Typical frequency response of preamplifier.

before soldering! The PCB has a printed legend that will assist you when positioning each item, see Figure 8.

The sequence in which the components are placed is not critical. However, the following instruction will be of use in making the task as straightforward as possible. It is easier to start with the smaller components such as resistors (R1 to R7) followed by the ceramic capacitors (C1, C4, C6, C7) and electrolytic capacitors (C2, C3, C5, C8). The polarity for the electrolytic capacitors is shown by a plus sign (+) on the PCB legend. However, the majority of electrolytic capacitors have the polarity designated by a negative symbol (-), in which case the lead nearest this symbol goes away from the positive sign on the legend.

Next install the preset resistor RV1 and set it to the fully anticlockwise position.

When fitting the 8-pin IC socket and the SL561C chip, ensure that you install them in the correct position, matching the notch with the block on the legend.

Finally, mount the BC328 transistor TR1, making sure that its outline aligns with the package outline on

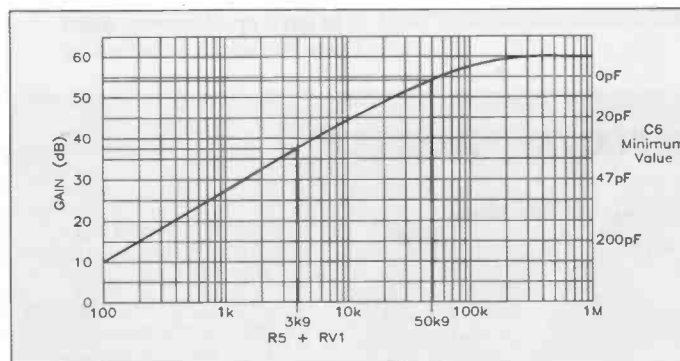

Figure 7. Gain set by R5 & RV1.

the legend. Install the six terminal pins ensuring that you push them fully into the board.

This completes the assembly of the PCB. You

should now check your work very carefully making sure that all the solder joints are sound. It is also very important that the solder side of the circuit board does not

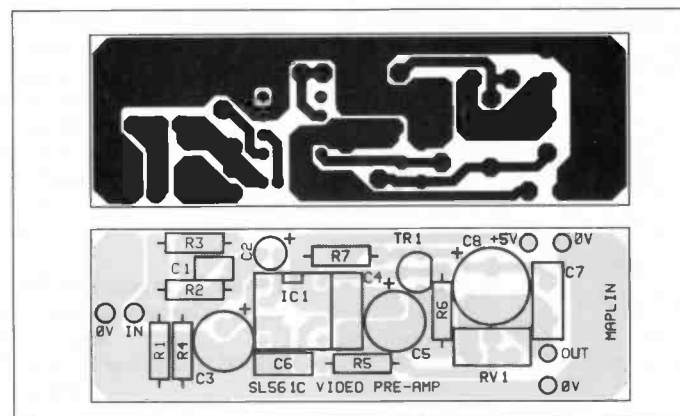

Figure 8. PCB legend and track.

have any trimmed component leads standing proud by more than 3mm, as this may result in a short circuit. Photo 1 shows the completed Video Preamplifier board.

DC Tests

The initial DC testing procedure can be undertaken using the minimum amount of test equipment. You will need a multimeter and a power supply capable of providing +5V DC up to 100mA. All the following readings are taken from the prototype using a digital multimeter; some of the readings you obtain may vary slightly depending upon the type of meter used!

Without any wires connected to the PCB terminal pins, carefully lay the PCB assembly on a non-conductive surface, such as a piece of dry paper or plastic. The first test is to ensure that there are no short circuits before connecting the DC power supply. Set your multimeter to read OHMS on its resistance range and connect its two test probes to the +5V and 0V PCB pins. With the probes either way round, a reading greater than 10kΩ should be obtained. If a significantly lower reading is registered,

then check solder joints and component leads, that they are not shorting between tracks.

In the following test it will be assumed that the power supply used is set to provide a regulated +5V DC supply. Select a suitable range on your meter that will accommodate a 100mA DC current reading. Then place it in series with the positive supply to the PCB pin, and connect the negative supply to the 0V pin, see Figure 9.

Turn on the power supply and observe the current reading, which should be approximately 40mA. Switch off the power, then remove the test meter and connect the positive power line to the +5V PCB pin.

Video Signal Wiring

All video signal wiring to and from the preamplifier module must be made using good quality screened 75Ω low-loss coaxial cable e.g., (XS32K), see Photo 2 and Figure 9. The

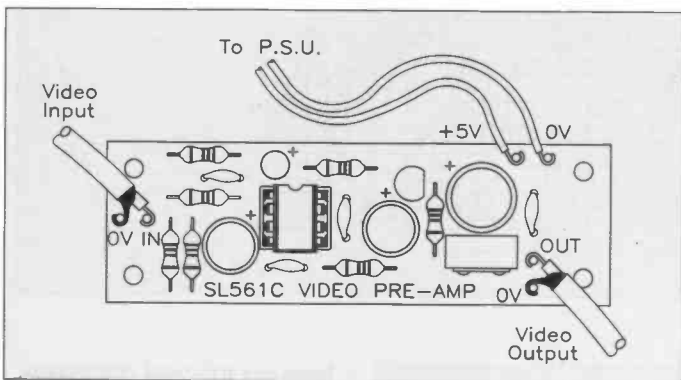

Figure 9. Wiring.

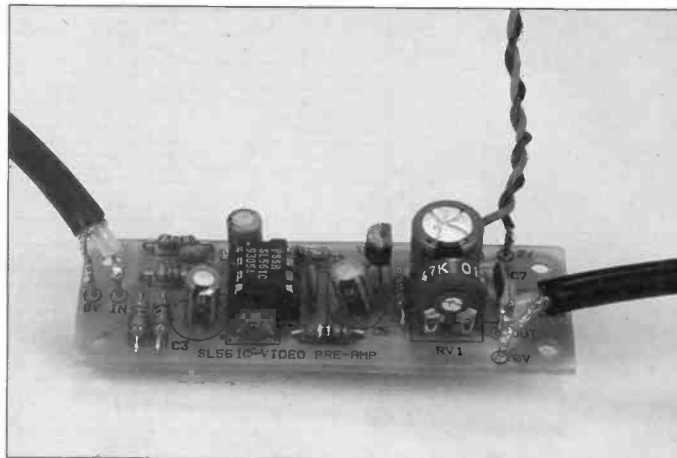

Photo 2. Video Pre-amplifier board wired up using coax cable.

type of video connectors you use is a matter of personal choice and technical requirements.

Using the Video Pre-amplifier

To obtain the best results from the video preamplifier an oscilloscope should be used to set it up. However, good results can be achieved by

simply observing the picture on a video monitor or a domestic TV with an AV input.

Useful applications are video preamplifiers, video buffers, and as part of a video distribution system. This could be a single video signal such as that from a satellite decoder, fed into the inputs of a number of SL561C boards, with the outputs to individual monitors.

SL561C VIDEO PREAMPLIFIER PARTS LIST

RESISTORS: ALL 0.6W 1% Metal Film (Unless Specified)

R1	82Ω	1	(M82R)
R2,3	4k7	2	(M4K7)
R4	47Ω	1	(M47R)
R5	3k9	1	(M3K9)
R6	560Ω	1	(M560R)
R7	56Ω	1	(M56R)
RV1	47k Sub Min Enclosed Vertical Preset	1	(UH18U)

CAPACITORS

C1	10pF Metallised Ceramic	1	(WX44X)
C2	10µF 16V Sub Min Radial Electrolytic	1	(YY34M)
C3,5	100µF 16V Sub Min Radial Electrolytic	2	(RA55K)
C4,7	100nF 16V Mini Disc Ceramic	2	(YR75S)
C6	47pF Metallised Ceramic (See text)	1	(WX52G)
C6	100pF Metallised Ceramic (See text)	1	(WX56L)
C6	470pF Metallised Ceramic (See text)	1	(WX64U)
C8	470µF 16V Radial Electrolytic	1	(FF15R)

SEMICONDUCTORS

TR1	BC328	1	(QB67X)
IC1	SL561CDP	1	(DB47B)

MISCELLANEOUS

8-pin DIL Socket	1	(BL17T)
Single-ended PCB Pin 1mm (0.04in.)	1 Pkt	(FL24B)
PCB	1	(GH61R)
Instruction Leaflet	1	(XU58N)
Constructors' Guide	1	(XH76L)

OPTIONAL (Not in Kit)

Phono Chassis Socket	As Req.	(YW06G)
----------------------	---------	---------

Phono Screen Plug	As Req.	(HH01B)
UHF SO259 Chassis Socket	As Req.	(BW84F)
UHF PL259 Plug	As Req.	(BW81C)
UHF PL259 Reducer Small	As Req.	(BW82D)
UHF PL259 Reducer Large	As Req.	(BW83E)
BNC Chassis Socket 75Ω	As Req.	(FE31J)
BNC Plug 75Ω	As Req.	(FE99H)
Peritel (SCART) PCB Straight Socket	As Req.	(JW34M)
Peritel PCB Right Angle Socket	As Req.	(FV89W)
Peritel Plug	As Req.	(FJ41U)

The Maplin 'Get-You-Working' Service is not available for this project.

The above items (excluding Optional) are available as a kit, which offers a saving over buying the parts separately.

Order As **LT48C (SL561C Low Noise Preamplifier)**
Price £6.99.

Please Note: Where 'package' quantities are stated in the Parts List (e.g., packet, strip, reel, etc.), the exact quantity required to build the project will be supplied in the kit.

The following new item (which is included in the kit) is also available separately, but is not shown in the 1994 Maplin Catalogue.

SL561C Low Noise Preamplifier PCB Order As **GH61R**
Price £1.99.

AN UNCERTAIN FUTURE FOR FDDI-II

by Frank Booty

THE Fibre Distributed Data Interface (FDDI) X3T9.5 is the ANSI standard for high-speed 100M-bit/s (mega bits per second) data traffic over optical fibre based networks. FDDI passes tokens and data frames around a ring of optical fibre much like the Token Ring standard. There are differences but these are only where necessary to support faster speeds and longer transmission distances of FDDI. The system as used by FDDI called 4B/5B, encodes 4 bits of data into 5 bits for transmission, this way, fewer signals are required to send a byte of information. Another difference is the way the token is managed, in FDDI a new token is circulated immediately by the sending workstation after it transmits a frame. FDDI classifies attached workstations as asynchronous and synchronous, and uses a complex algorithm to allocate network access to the two classes of devices.

Enter FDDI-II

The standard FDDI-II is designed to handle not only asynchronous data but also the isochronous communications needs of voice and video.

Although there are no Fibre Distribution Data Interface-II (FDDI-II) products available yet, there are hints that FDDI-II is waiting in the wings in secret development efforts that might produce results. Early in 1991, FDDI-II was heralded as the inevitable direction of campus networking and the natural evolution of FDDI in campus backbone and front end desktop networks.

However, many factors have stunted the expectations for FDDI-II. These factors, which had once caused some to conclude that FDDI-II was dead, include: the FDDI market is only - as of the end of 1992 - beginning to show momentum; FDDI-II is forward compatible, not backward compatible; FDDI-II (like FDDI) is a shared medium, limiting the total use by all stations on a ring to an aggregate of 100M-bit/s; the standards are not yet complete; no visible chip sets have been developed and no products announced; and alternative technologies - including Ethernet switching (private Ethernet), FDDI switching (private FDDI) and Asynchronous Transfer Mode (ATM) - will be able to provide sufficient dedicated bandwidth to the desktop.

The following recent events however, hint that FDDI-II is not dead yet. Instead they indicate that it is simmering in a clandestine effort that may or may not bear fruit. These events are: interest in the FDDI-II standards committee increased

significantly throughout 1992; IBM, Apple and some semiconductor houses are working on FDDI-II technology; and ATM is still in its honeymoon stage. Many basic problems must be overcome before campus ATM networks will be available, reasonably priced, inter-operable and able to connect smoothly with existing networks.

Users' bandwidth needs are rising constantly and will continue to grow year by year. Most of the current bandwidth requirements come not from exciting new applications, but from basic use of the network by more and more people. Therefore each network user is generating more traffic for communicating with co-workers, sending electronic mail, sharing files, filing reports, exchanging spreadsheets and accessing servers (PC and mainframe).

In addition, future office applications will provide still higher levels of employee productivity, but with correspondingly greater bandwidth requirements. These applications include document imaging, video conferencing, multimedia and many other integrated video/voice/image data systems. But how will FDDI-II really differ from FDDI, and how will it fare in the market?

History

The original FDDI standard was developed to meet the rising bandwidth needs of organisations with expanding enterprise networks. So FDDI's 100M-bit/s of bandwidth has chiefly been used to interconnect LANs (Local Area Networks) within site backbones. Use of FDDI to directly integrate high powered technical workstations, and to a lesser degree, PCs, is just beginning in a meaningful way. Like

Ethernet and Token Ring, FDDI is a shared medium. Data bandwidth is shared among all the stations attached to the FDDI ring. This is one area where FDDI-II will add more capability. It will allow a user to share the bandwidth with voice and video applications in addition to data applications. Thus, FDDI-II will add local circuit switching to the packet switching currently available in FDDI.

But another differentiator casts some doubt on FDDI-II. Because it is an upward compatible enhancement to FDDI, all stations on an FDDI-II ring must support FDDI-II or the entire ring will revert to FDDI. This upward compatibility with no backward compatibility is enough to cast some doubt on FDDI-II's market viability.

Network Protocols

LANs work in either of two basic methods, CSMA/CD (Carrier Sense Multiple Access with Collision Detection). A LAN protocol which when a workstation or node, transmits data packets onto the network and raises the carrier, the other nodes detect the carrier, 'Carrier Sense', and listen for the information to detect if it is intended for them. The nodes have network access, 'Multiple Access' and can send if no other transmission is taking place. If two workstations attempt to send simultaneously, a collision takes place, 'Collision Detection'. The other method is Token Passing, this is where data frames move around the network from workstation to workstation. When a workstation wants to send a frame it waits for the token which is a three byte message, indicating that the LAN is idle, it then turns the token into a data frame, which then travels along the network to

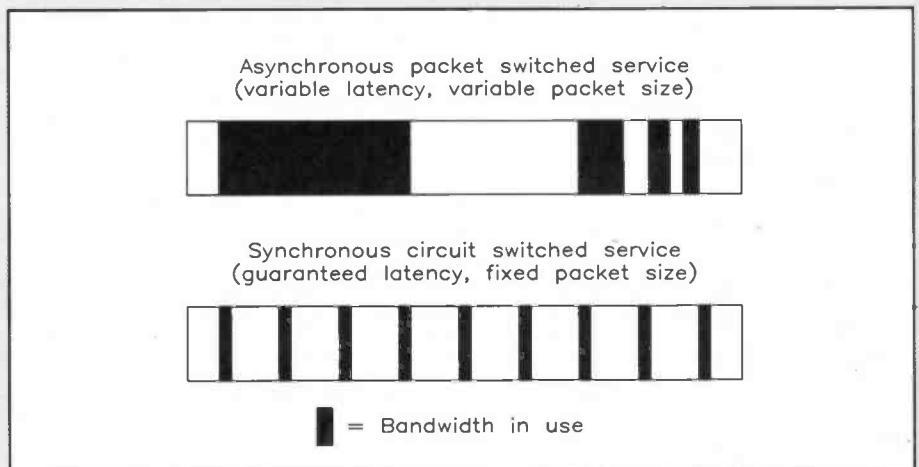

Figure 1. Packet switching versus circuit switching.

its neighbour, which regenerates the signals making up the frame, and passes the result to the next downstream station and so on until it reaches its destination. Here certain bits in the data frame are changed and it is then sent on its journey, until the sender receives its own frame back, if all is correct it relinquishes use of the LAN by putting a new token into circulation.

So most network data transmissions can be sent in large or small portions. If the bandwidth of the network is occupied when a transmission is desired, then the data is sent when the network bandwidth is available, after some delay or latency. The length of the delay depends on the amount of data being transmitted by another station. Thus when a user transmits data on an FDDI network (or other non-isochronous Ethernet or Token Ring), there is often a variable *latency* (or variable delay) before the data is transmitted. So most traffic from data applications moves at random times in random amounts see Figure 1.

Multimedia Applications

However, real time voice and video applications have very different characteristics than data applications. Real time voice and video traffic occurs in fixed time intervals and at fixed packet sizes. Therefore, a real time voice conversation or video transmission across a network must be guaranteed a portion of the network's bandwidth. But an additional capability is required so that there are no interruptions or gaps in the voice or video stream. That capability is called a *guaranteed latency*. This combination of an allocated portion of bandwidth and *guaranteed latency* gives

FDDI-II a circuit switched advantage for such applications.

But FDDI-II is only one potential technology for carrying real time voice and video. Other solutions provide increased bandwidth to the desktop by segmenting existing networks, and include Ethernet or FDDI switches and multiport bridges. Another such technology is ATM switching. ATM will probably be a ten year solution, but only after the technology is developed and inter-operable, which should be by the end of 1994.

FDDI-II Operation

FDDI-II is basically a circuit switched service embedded in FDDI technology. Isochronous bandwidth is allocated for up to sixteen channels of 6.144M-bit/s each, with any unallocated bandwidth available for asynchronous packet traffic. Another way to look at it is that each of the sixteen 6.144M-bit/s channels can be allocated for asynchronous or isochronous use. And each channel can accommodate up to three E1 pipes or other subchannels as small as 64K-bit/s.

The sixteen channels use up 98.3M-bit/s of the 100M-bit/s FDDI-II bandwidth. This leaves room for a 768K-bit/s packet switched channel, which is always available and can never be assigned to isochronous duties. The remaining 928K-bit/s is used for headers and other overhead protocols. FDDI is regulated by a 125µs clock. This means that a second is divided into 8,000 cycles and each cycle has a duration of 125µs.

To create isochronous capabilities, the bandwidth of each of the sixteen FDDI-II

channels is divided into 8 bit chunks (octets) that are evenly spaced within 96 cyclic groups per 125µs cycle. The isochronous bandwidth in each 125µs cycle can be viewed as an array of octets formatted in sixteen channels and 96 cyclic groups. This matrix of small chunks of bandwidth allows the predictable, uninterrupted transmission of many simultaneous voice and video applications.

Future Requirements

User studies indicate the major motivation for those planning to purchase FDDI-II products was multimedia, video, voice and video-conferencing applications with inherent isochronous communications requirements. Video-conferencing is the most frequently named application. There are some who would purchase FDDI-II to keep up with new technology (also there are some misinformed people who believe FDDI-II would bring them more bandwidth). Then, reasons given by users for not purchasing FDDI-II are related to the fact that the technology does not exist yet and is unknown or unfamiliar. Some users declare they would use FDDI or ATM technology rather than FDDI-II. Some users in the USA who have said they will purchase FDDI-II products have said they would do so between 1993 and 1996 - and consider FDDI-II a future requirement.

Although FDDI-II features 100M-bit/s of bandwidth that can be used simultaneously for existing packet traffic and for the new isochronous traffic needs of interactive video and voice, it has several limitations that represent valid drawbacks. For one, FDDI-II is forward but not backward

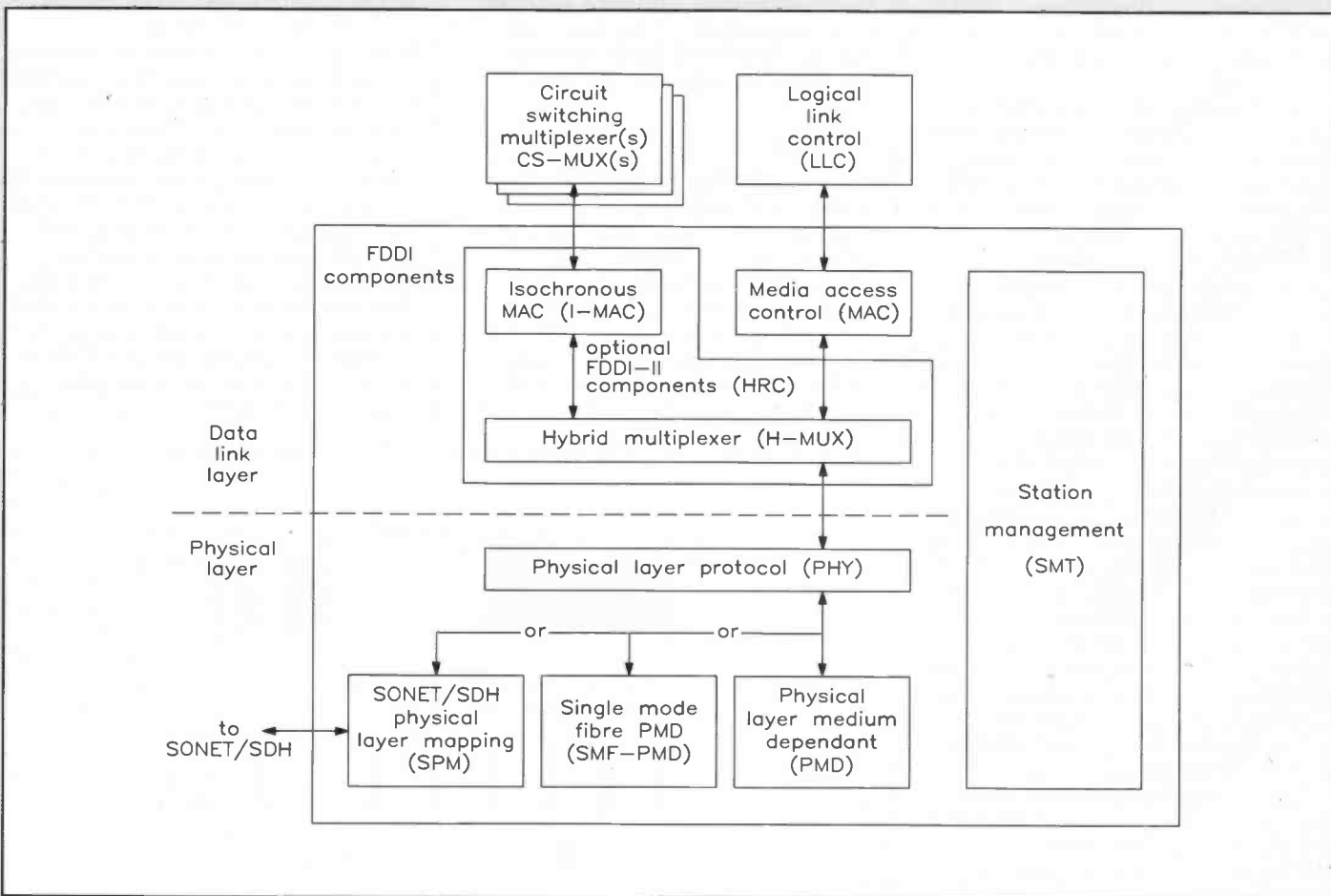

Figure 2. The FDDI-II standard expands upon many of the existing components of the FDDI standard.

compatible, therefore, FDDI-II traffic cannot run simultaneously with FDDI traffic. The pragmatic arrangement is to separate FDDI rings from FDDI-II rings. This can be achieved using intelligent hubs with high-speed non-FDDI backplanes or with FDDI to FDDI-II bridges.

Another solution mentioned in industry circles is the so-called FDDI-II friendly FDDI chipset. This may be the most suitable for installations with no current investment in FDDI. Still, there are as yet no publicly available FDDI-II chipsets and no available FDDI-II products. It is however, a fluid situation. The FDDI market itself has been slow to gather momentum. Most implementations of it thus far have been for site backbones. In addition, the high price of FDDI connections (relative to Ethernet and Token Ring), the slow progress made by the TP-FDDI committee to define ways to run FDDI over copper twisted pair, and the development of Ethernet switching and multiport bridging products all combine to retard any kind of fast growth in the FDDI market.

What the Future Holds

Both FDDI and FDDI-II are also limited in that their 100M-bit/s bandwidth is shared among all attached stations. The more stations, the less bandwidth available for each. Therefore, as networks grow in size

and use, FDDI networks will have to be segmented in the same way Ethernets have been segmented. And when those much heralded multimedia applications - like video-conferencing and other video applications - finally do arrive, users will have to ask whether sharing 100M-bit/s provides enough local horsepower. True, FDDI-II is designed to fill a need for voice and video isochronous communications, but ATM is also coming to fill the same needs, and with switched non-shared full-bandwidth connections. And if future ATM pricing approaches that of FDDI networking, then how will FDDI-II survive? ATM will not arrive from many vendors or fit into existing internets until at least 1994, so there is certainly a market window for FDDI and possibly for FDDI-II.

The bottom line is that no one network technology will ever sweep all others away. Already there are Ethernet, 4/16M-bit/s Token Ring and FDDI. There are also Ethernet switching and multiport bridging. There will be ATM, but not as fast as some are predicting. By 1995 there will be a range of networking technologies with different bandwidths, different price points and different capabilities. Users will be able to choose the right mix of bandwidth, price and capabilities to suit their needs.

Whether FDDI-II will be one of the surviving technologies in 1995 is an

unresolved question. However, FDDI-II is not dead. Its existence will be determined by a few network providers' decisions to invest in FDDI-II technology, products and marketing. Its health will be determined by similar end user buying decisions.

The FDDI Standards - An Understanding

The original ANSI FDDI specification is composed of three parts: MAC, PHY and SMT (as described below and in Figure 2). SMT defines a set of sophisticated LAN management protocols and services, ensuring that users can fully manage multivendor FDDI LANs. FDDI is unique as the only LAN standard with extensive management capabilities in the standard itself.

For FDDI-II, updated versions of MAC and PHY have been almost completed and are known as MAC-2 and PHY-2. A new expanded version of SMT, known as SMT-2, is under development and will include the services necessary to support isochronous circuit switching simultaneously with packet switching. Another related standard - Hybrid Ring Control (HRC) - has been developed to also handle circuit switching and packet switching.

ANSI's Specific FDDI Standard Components

MAC (Media Access Control) - defines access to the FDDI physical layer medium and describes packet formatting, token handling, addressing, cyclic redundancy checking and recovery mechanisms.

MAC-2 - a revision of the original MAC to address oversights and corrections not directly related to FDDI-II.

PHY - Physical Layer Medium Dependent (PMD) defines the transmission medium, including the fibre link, power levels, jitter requirements, bit error rates, optical components and connectors. Several important PMDs describe multimode fibre (MMF-PMD), single mode fibre (SMF-PMD), copper

(TP-PMD), low-cost fibre (LCF-PMD) and FDDI to SONET/SDH physical layer mapping (SPM).

SMT (Station Management) - defines the FDDI station configuration, ring configuration, and ring controls including station insertion and removal, initialisation, fault isolation and recovery, scheduling and statistics collection.

SMT-2 - a revised superset of SMT that supports new network configurations and FDDI-II isochronous channel management services.

HRC (Hybrid Ring Control) - a new FDDI-II standard composed of two major parts: H-MUX (hybrid multiplexer) fits between PHY and MAC and supports the mixture of isochronous and packet data services. H-MUX multiplexes data between the packet MAC and the I-MAC, controlling the flow of the two types of traffic. I-MAC is the data link layer interface from an isochronous stream (such as a video camera feed or voice telephone connection) to FDDI-II's isochronous network services.

Taken together, these standards define 100M-bit/s fibre optic dual counter rotating FDDI and FDDI-II local area networks.

General Terms

ANSI	American National Standards Institute.
ANS X3T9.5	The committee sponsored by ANSI which developed the standard for the Fibre Distributed Data Interface (FDDI).
Asynchronous	Where data is not related to a fixed time frame of reference, but does need individual start and stop bits surrounding each byte.
Backbone Network	High capacity network (FDDI) linking other networks of lower capacity.
Bridge	Equipment that connects different LANs.
Contention	Determines how workstations can access the same cable.
Gateway	Connect LANs with different protocols and translates.
Hub	The centre of a star topology network, file servers often act as the hub of a LAN.
Isochronous	Having identical resonant frequencies or wavelengths.
LAN	Local Area Network, data sharing communication system.
Latency	Time interval between when a network station seeks access to a transmission channel and when access is acquired.
Multiplexer	Device that switches two or more signals to be transmitted on a data channel simultaneously.
Nodes	Points in a network where service is provided.
Packet	A group of bits, including address, data and control elements, which are switched and transmitted together.
Protocols	A set of rules for communicating between computers.
Routers	Connect LANs with same protocols but different hardware.
Server	Computer providing service to LAN users, sharing access to disks, files and printers.
Synchronous	Communications link in which the data and character bits are transmitted and received at a fixed rate without start and stop bits.
Workstation	Personal computer connected to a LAN.

NEW BOOKS

Instrumentation and Test Gear Circuits Manual

by R. M. Marston

Primarily, this book is a manual of modern instrumentation and test gear circuits that will be of immense value to the industrial, commercial, or amateur electronics engineer or designer. This book is filled with nearly 500 varied and extremely useful carefully selected practical circuits, diagrams, graphs and tables. The diverse range of practical circuits cover; attenuator and filter circuits, basic meter and multimeter circuits, electronic analogue meter circuits, digital panel meter circuits, waveform generator circuits, scope trace doubler, timebases, digital frequency meters, power supply circuits and many more.



Editor's Choice

The text covers the subject in a very readable, basic, comprehensive style, with mathematics kept to a minimum. Each chapter starts by explaining the basic principles of the particular topic and is followed by a wide range of practical circuits. All the practical circuits have been designed, built and fully evaluated by the author, who is well-known to the readers of this magazine. The majority of the semiconductors specified in the designs are reasonably priced and readily available.

This well presented and enjoyable book will be of equal interest to all amateurs and students of electronics as well as the practical design engineer, technician and experimenter.

1993. 440 pages. 225 x 138mm, illustrated.

Order As AA37S

(Test Gear Crct Man) £16.95 NV

Computing for the Terrified!

by Steve Greenwood

If you have just started a new business or changed your job, then the chances are you will be confronted with a PC. To many people, computers are second nature, but to others they are a frightening experience.

This handy and inexpensive book is



not designed to teach you how to operate a wordprocessor or spreadsheet, but it is intended to make the reader feel more comfortable using a machine that is running such applications. The book will provide you with an insight into the many and varied uses such a machine can be put to, as well as a detailed explanation of computer jargon.

The clear and concise text starts with a basic introduction to the computer that includes switching-on, and hardware. The technical detail is very light and is really the minimum necessary to understand computers. Equally, this is true of the other topics that are covered, such as DOS, launching programs and data. There is even a reassuring chapter entitled 'What might I break?', which should help the novice to avoid problems. The book also gently introduces the reader to graphical interfaces such as Windows as well as PC networks. At the end of the book is a very handy glossary of terms that provides a brief explanation to many of the less familiar terms used in the book, as well as other standard industry phrases.

A well-written book that should be of great benefit and reassurance to the computer novice.

1993. 160 pages. 217 x 151mm, illustrated.

Order As AA52G

(Comp F/The Terrified) £6.95 NV

Upgrading & Fixing PCs For Dummies

by Andy Rathbone

As with the other books in this series, this book is not really for dummies, but for those people who are short of time and are not really interested in becoming a PC whiz-kid. With the help of this book and suitable screwdrivers, you should be able to repair or upgrade your PC and you will not need to learn anything during the process. This book is more a reference that provides a host of little gems of information. By following the step-by-step instructions and

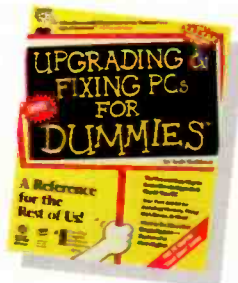

pictures, you can upgrade your computer to run today's most powerful software by adding memory, or a new or bigger hard drive.

The book is divided into five parts, with part one being aptly titled 'Biting Your Fingernails'. This well-written section is a very gentle introduction to your computer and should remove any doubts you have about taking the lid off your machine. Part two deals with the parts you can see such as the keyboard, mice, modems, the monitor and printers. Part three deals with the internal workings and part four explains how to tell your computer what you have done. This last part includes topics such as CONFIG.SYS and AUTOEXEC.BAT files, settings etc. Finally, Part five provides a wide selection of hints and tips covering easy and difficult upgrades, improving your computer's performance, error messages and the meaning of warning beeps.

A highly recommended book for the non-technical and even the technical PC user.

1993. 360 pages. 235 x 188mm, illustrated. American Book.

Order As AA55K

(Upgrade PCs/Dummies) £17.99 NV

Shortwave Listening Guidebook 2nd Edition

by Harry L. Helms

It is a strange fact of life that in this age of satellite television and digital communications, that shortwave listening should still be a very popular hobby. By rights, shortwave radio should have gone the same way as telegraphy over land lines. But, to many people, shortwave radio still remains a fascinating pastime.



So what makes a shortwave listener? Regardless of the particular frequencies or bands they listen to, SWLs are searching for something out of the ordinary – listening for signals that the general public does not normally receive. This book provides all the information that is required to become a successful SWL in a concise and non-technical way, and in a style that is very easy to read.

The opening chapters deal with an introduction to SWLing and an understanding of the shortwave bands. Suggestions for selecting a shortwave receiver are included, as well as a discussion on antennas and

accessories. A very informative chapter is included on radio propagation.

There are several chapters devoted to the major international shortwave broadcasters, as well as domestic types, and utility stations such as maritime and aeronautical. There is even a chapter on unusual, illegal and mysterious stations, such as pirate radio.

The book is entertainingly written and not only provides an introduction and the requirements for SWLing, but includes a very informative history of the subject – well worth a read.

1993. 338 pages. 228 x 152mm, illustrated. American Book.

Order As AA53H

(S/Wave List GuideBk) £17.50 NV

An Introduction to Satellite Communications

by F. A. Wilson

Satellites have become a very important part of our everyday life. Not only are they instrumental in providing us with a plethora of additional television

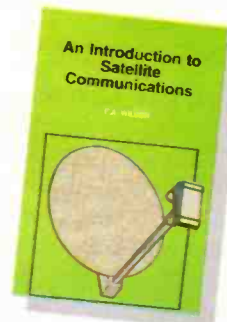

programmes, but they are also vital in the fields of communications and navigation. There are literally hundreds of them circling the earth already, and there are many more planned to join them.

The aim of this book is to provide the reader with an insight into the workings of satellites – the technical level of the book is moderate. It has not been written with the expert in mind but is intended for the general electronics engineer or enthusiast who wishes to obtain a basic understanding of the technology.

However, providing the reader has an elementary understanding of electronics, then they should have little difficulty in following this book. Only basic mathematics is required throughout.

The text starts with a gentle overview of the subject followed by interesting chapters on 'getting them up there', and 'keeping them up there'. The following chapters discuss antennas, transmission, telephony and data systems, television broadcasting and other services. At the back of the book there is comprehensive glossary of satellite communication terms and other important tables and charts.

1993. 240 pages. 198 x 129mm, illustrated.

Order As AA56L

(Intro Sat Comms) £5.95 NV

PART ONE

by Ray Marston

HOW TO USE

LCD

DIGITAL Panel Meters

In this new 4-part mini-series, Ray Marston unravels the mysteries of how to use the modern 3½-digit LCD panel meter modules, and shows a number of practical application circuits.

Modern LCD Digital Panel Meter (DPM) modules are versatile units that can easily be used to measure voltage, current, resistance, capacitance, frequency, temperature and a whole lot more, with accuracy. This new mini-series sets out to explain how they work and how to use them, and to present the reader with a variety of tried-and-tested practical application circuits that can be used with any manufacturer's range of DPMs.

This part explains essential DPM basics and general information for their use. This, when sensibly applied, should enable the reader to use any old or modern DPM in any of the application circuits that will be presented later in the series. Part Two will go one step further, presenting essential application details of the two specific LCD DPM modules listed in the current edition of the Maplin Catalogue. Parts Three and Four will concentrate entirely

on practical DPM application circuits, ranging from simple multirange volt and current meters to complex multimeters, capacitance meters, and digital frequency meters, etc.

DIGITAL PANEL METER BASICS

Modern Digital Panel Meter (DPM) modules are essentially sensitive, high-resolution DC voltmeters that can be used to replace moving coil meters in virtually all precision 'analogue' measuring applications. They combine a special A-to-D converter chip, an LCD readout and few other components in a compact module that consumes less than 1mA from a 9V supply, and costs little more than a good quality moving coil meter. Usually, these modules provide a 3½-digit readout and have a basic full-scale measurement sensitivity of $\pm 199.9\text{mV}$, with $100\mu\text{V}$ (2000-count) resolution, and a typical calibrated precision of $0.1\% \pm 1$ digit. They can, however, be made to read any desired current or voltage range by connecting suitable shunts or dividers to their input terminals. With additional external circuitry the modules can also be made to indicate AC voltage or AC current, resistance, capacitance, frequency, or any other parameter that can be converted into a linear analogue voltage.

Using the DPM modules such devices can be home-built with little difficulty, but cannot compete with commercially manufactured, 3½-digit units for small size, low-cost, attractive appearance, and precision. Most of these modules are designed around a GE/Intersil ICL7106, 7126, or 7136 A-to-D converter and driver chip. Figures 1 and 2 show, as a matter of general interest, the outline and basic application diagram that is common to the 40-pin DIL versions of all three of these low-power CMOS ICs.

Each houses a precision A-to-D converter with LCD drive circuitry, etc. The A-to-D converter uses the dual-slope inte-

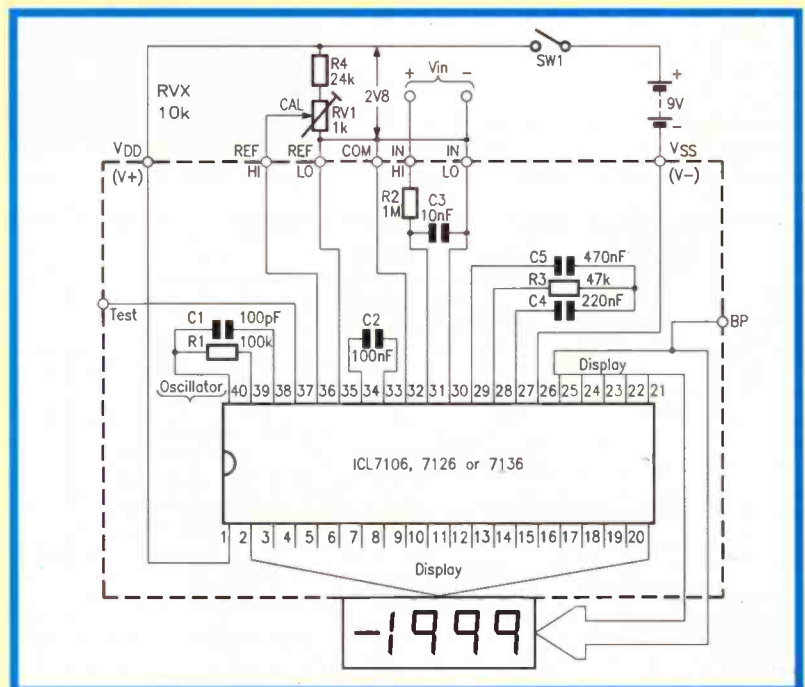
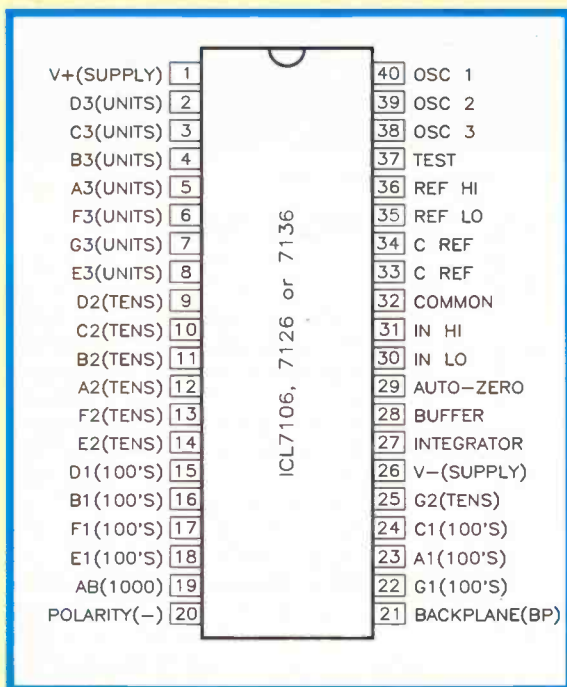

Figure 1. Outline and pin notations of the ICL7106/7126/7136 LCD-driving DPM IC.

Figure 2. Basic application diagram of the ICL7106/7126/7136 as a 0 to 199.9mV DC voltmeter.

gration technique, which provides high noise rejection and near-perfect conversion linearity, but has a non-critical clock frequency. The IC accepts a true differential input voltage and provides digital conversion accurate to within ± 1 count over the entire ± 2000 count readout range. An auto-zero function ensures a zero reading at 0V input, and polarity indication is automatic. The ICL7106 typically consumes 1mA from a 9V supply; it is now rarely used in new DPMs. The ICL7126 and 7136 typically consume only 70 μ A of operating current, and are widely used (in sub-miniature flat-pack form, with different pin numbering) in most modern DPM modules.

All the ICL7106/7126/7136 internal functions are controlled by clock signals derived from a built-in oscillator, which (in Figure 2) is set to operate at about 48kHz by R1 & C1. This frequency is divided by four and then used to control a three-phase conversion cycle (signal integrate, reference de-integrate, and auto-zero) which occupies 16,000 oscillator cycles. This gives the DPM a rate of approximately three update readings per second. R3 & C4 set the integration time constant, and C5 enhances the auto-zero circuitry's noise immunity. R2 & C3 form an input low-pass filter and overload protection network.

In Figure 2, all the aforementioned components are shown within the dotted lines, which enclose the IC's minimal operating circuitry. In action, the IC actually measures and compares the relative values (ratios) of its V_{in} and V_{ref} inputs and produces an LCD display of $1000 \times V_{in}/V_{ref}$. Thus, to make the circuit function as a 0 to 200mV DC voltmeter, the REF LO, IN LO, and COMmon terminals of the module must be shorted together as shown. The input (test) voltage must be applied between the IN LO and IN HI terminals, and a 100mV reference voltage must be applied between the REF HI and REF LO terminals. The IC includes a Zener regulator that generates a stable 2.8V between the COM and V_{DD} terminals. In the diagram this voltage is tapped by R4 & RV1 and used to generate the 100mV REF HI to REF LO reference voltage. The circuit of Figure 2 thus functions as a basic 0 to 200mV DC voltmeter, giving an over-range indication by blanking the three least significant digits of its display.

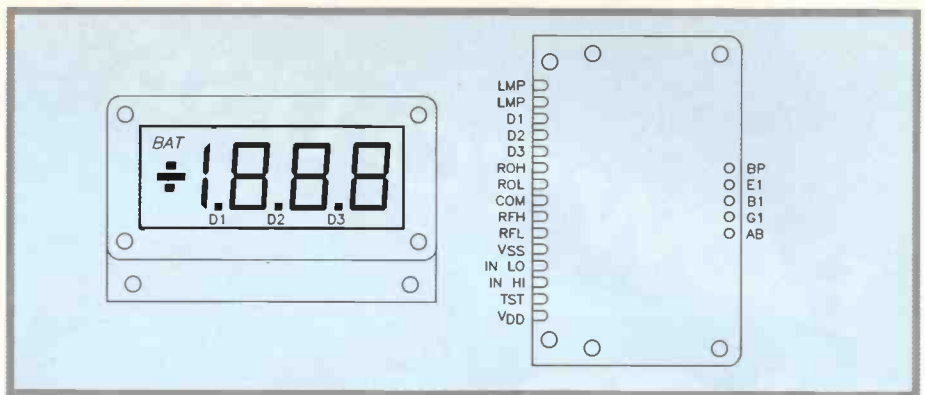

Figure 4. Typical front face and rear panel terminal notations of an old-style or 'simple' DPM.

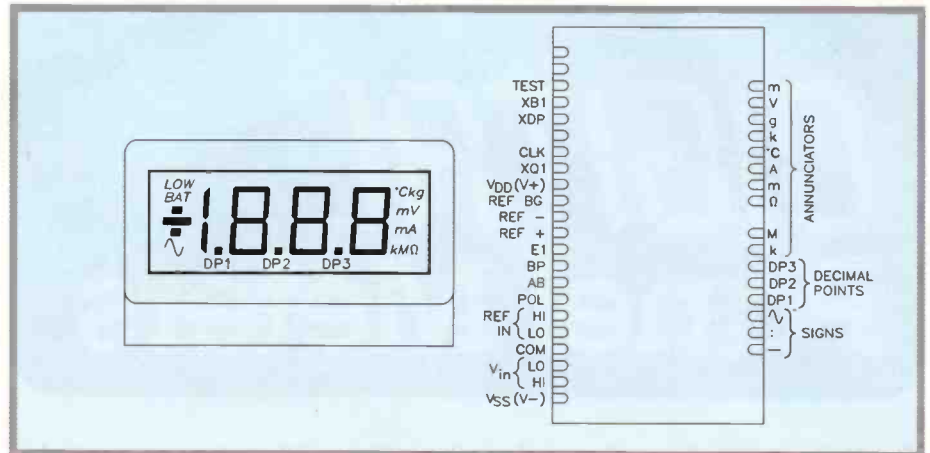

Figure 5. Typical front face and rear panel terminal notations of a modern DPM.

Characteristic	Data (at 25°C)
Display:	3 1/2-digit LCD
Full-scale sensitivity:	± 199.9 mV
Power supply voltage:	7V to 10V DC (9V nominal)
Supply current:	1mA typical for ICL7106 70 μ A typical for 7126/7136
Initial calibration accuracy:	$\pm 0.1\% \pm 1$ count
Zero input reading:	± 000.0 typical
Display resolution:	1 count = 100 μ V
Input leakage current ($V_{in} = 0$):	<10pA
Operating temperature range:	0°C to +50°C
Input impedance (min.):	100M Ω
Clock frequency range:	40kHz to 50kHz
Sample rate:	2.5 to 3 readings/second
'Low battery' threshold level:	7.2V typical

Figure 6. Main parameters and features of a typical modern DPM.

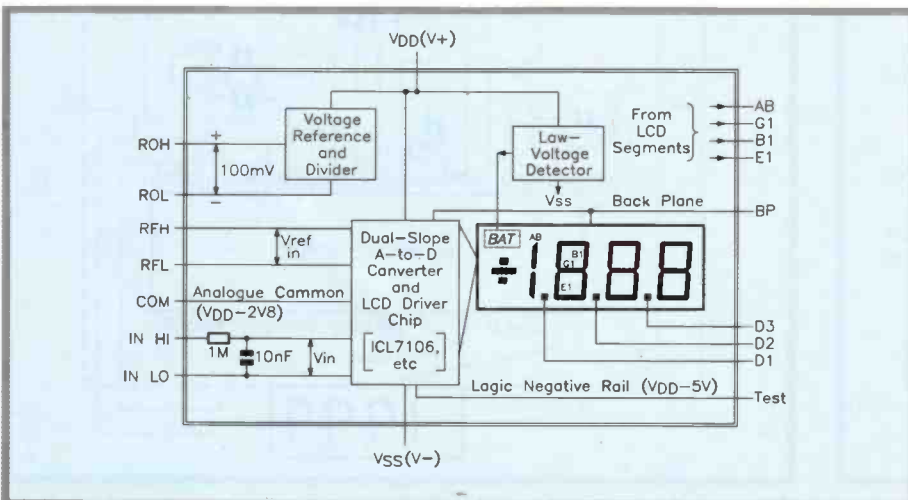

Figure 3. Block diagram and terminals of a typical 3 1/2-digit DPM.

PRACTICAL DPMs

The simple circuit of Figure 2 makes a useful single-range voltmeter, but is too crude to make a really useful DPM. It has, for example, no facility for driving LCD decimal points or legends or annunciators, which must be driven from an inverted backplane signal. In practice, however, this problem can easily be overcome by adding a simple CMOS logic gate IC to the basic circuit.

Another useful gadget fitted as standard to most DPMs is a simple 'LOW BATTERY VOLTS' warning unit, which flashes the display when the battery needs replacement. When these two circuits are added, you end up with a standard and highly versatile commercial-grade DPM that can, in essence, be represented by the diagram of Figure 3. Other gadgetry

that may be built into the module (or easily added externally) are a bandgap voltage reference to give improved calibration stability, a pair of CMOS logic ICs to give automatic over-range and under-range indication, and a supply-voltage inverter, to allow the module to be used with single-rail power supplies.

Standard 3½-digit LCD DPMs of the type shown in Figure 3 are produced by several manufacturers. Normally they differ only in the fairly minor details of the arrangement of their internal circuitry and displays, and in the number and notations of the terminals available to the user. Figures 4 and 5 show examples of the display front face layout and rear panel terminals of old and modern-style DPMs that are very typical of the genre. Figure 6 lists the main parameters and features that are typical of modern DPMs. The salient points to be noted from these are as follows:-

Normally, DPMs are designed to be powered from a 9V battery connected between the V_{DD} (V+) and V_{SS} (V-) terminals. DPMs display the relative ratios of their input and reference-input voltages. Each of these voltages is applied via a pair of terminals (RFH [or REF HI] and RFL [or REF LO] for the reference, IN HI and IN LO for the input). The potentials on these terminals must not deviate from the COM terminal by more than ±2V. The terminals have input impedances of typically 5,000MΩ (100MΩ minimum), with typical leakage currents of only a few pA. The IN HI terminal features an internal DC integrating filter.

Most DPMs have a single built-in reference voltage source. The voltage between the COM and V_{DD} (V+) terminals is Zener-regulated at 2.8V, and has a typical temperature coefficient of 80ppm/°C. Any reference voltage below this value can be obtained by wiring a simple potential divider between these two terminals. Some DPMs also contain a precision 1.2V bandgap reference, and when ROL (REF-) is tied to COM, a stable 100mV is generated between ROH (REF+) and ROL (REF-) and has a typical temperature coefficient of 50ppm/°C.

Access to the display's decimal points is provided externally on terminals notated D1, D2, D3 (or DP1, DP2, DP3). Usually, the left-hand point (or digit) is referred to as '1' and right-hand one as '3' (as shown in Figure 3), but in some modules this practice is reversed. Access to all useful signs and annunciators is also externally available (see Figure 5). Each

of these points or symbols can be turned on by connecting it to an inverted backplane (BP) signal, and the DPM invariably includes circuitry that makes this task easy. In old-style DPMs the points can usually be turned on by connecting

the point terminal to the V_{DD} (V+) terminal. In modern units the points and symbols can be turned on by simply connecting them to the XDP terminal; the manufacturer's leaflet supplied with the DPM explains these options.

The waveforms of the AB (1000 digit), G1, B1, and E1 (hundreds) segments of the LCD display are often externally available, either directly or in inverted (X) form. They can be used (in conjunction with external circuitry) to detect under-range and over-range operating conditions in some applications.

BASIC DPM CONFIGURATIONS

Figures 7 to 10 show four different ways of connecting the DPM's main terminals to provide different measurement ranges. Figure 7 shows the connections for making the DPM act as a ratiometric voltmeter, which (ideally) gives a reading of '1000' when two input voltages have identical values, irrespective of the actual values. Note that diagram (a) shows the notations and point-driving methods used in old-style (as Figure 4) DPMs, while diagram (b) shows the connections applicable to a modern-style (Figure 5) unit. In the latter case the 'mV' sign is activated via the XDP terminal and auto-polarity action is engaged by shorting the (-) and POL terminals. Note that, throughout the remainder of this series, most of the circuit diagrams use the basic notations of Figure 7(a) to avoid unnecessary repeti-

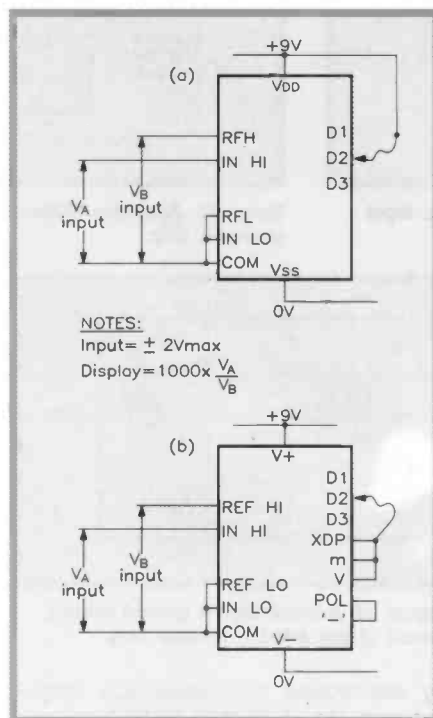

Figure 7. Basic ratiometric voltmeter connections using (a) old-style and (b) modern-style DPMs.

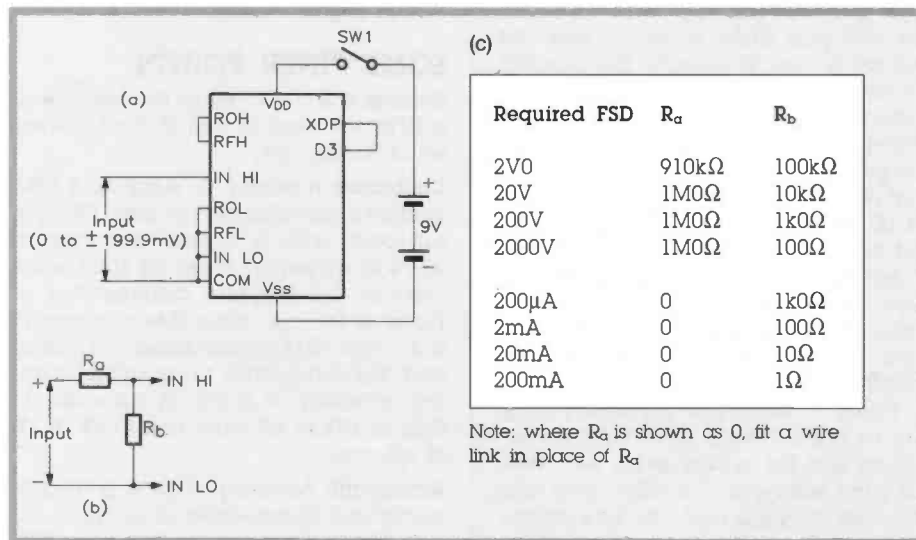

Figure 8. (a) shows the standard '199.9mV full-scale' connections of a DPM. This basic circuit can be made to read alternative full-scale values of voltage or current by connecting the input via the network of (b), using the values shown in (c).

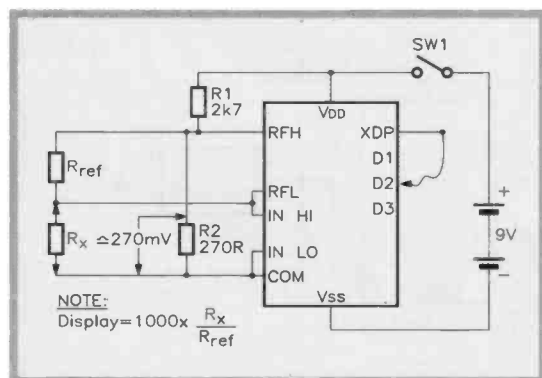

Figure 9. Precision resistance meter, using ratiometric technique.

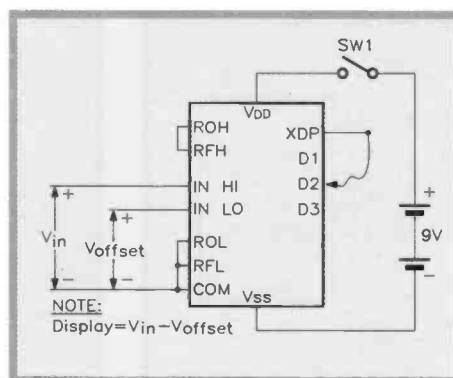

Figure 10. Method of applying zero-offset to the basic '199.9mV DC' meter circuit.

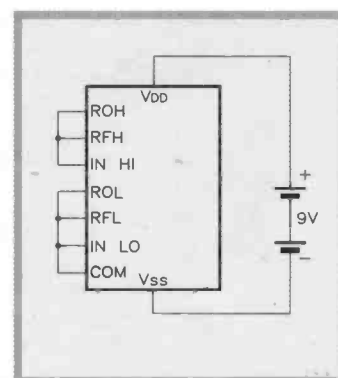

Figure 11. Ratiometric-accuracy test circuit.

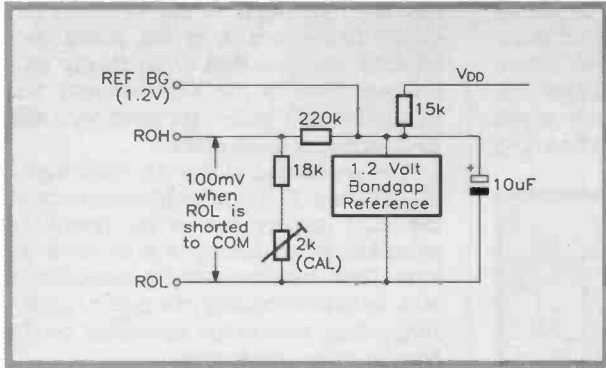

Figure 12. Typical bandgap reference circuit has an input impedance of about 20k.

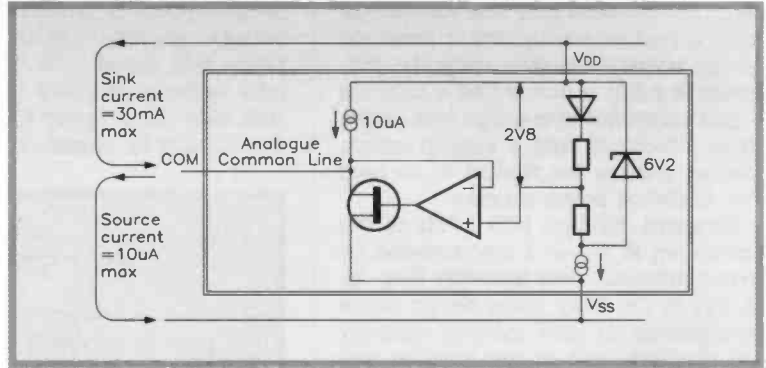

Figure 13. Analogue COMMON line biasing circuit within the A-to-D converter chip.

tion, but show the modern method of driving the decimal points (via XDP). In these diagrams minor details, such as auto-polarity indication and annunciator activation, are left to the common sense of the reader.

Figure 8(a) shows the standard way of using the DPM as a 0 to 199.9mV DC meter, using the built-in 100mV voltage (from ROL and RFL) as a precision reference. Decimal point D3 is activated via XDP so that the unit reads '100.0' when 100.0mV as applied between IN HI and IN LO. Note that this basic circuit can be made to read different full-scale values of voltage or current by connecting the network shown in Figure 8(b) to the DPM's input, using the component values shown in Figure 8(c).

Figure 9 shows the DPM connected as a precision ohmmeter. Here, the divider R1 & R2 generates roughly 270mV between the RFH and COM terminals, and this voltage is used to energise the potential divider R_{ref} & R_x . Identical currents flow through these two resistors, and the generated voltage across R_{ref} is applied across the RFH and RFL reference terminals, and that of R_x is applied across the IN HI and IN LO input terminals. The display reading thus equals $1000 \times R_x/R_{ref}$. If R_x has a decade value (1k Ω , 10k Ω , etc.) the display gives a direct readout of the R_x value (this reading is independent of the actual value of the energising voltage across R2).

Figure 10 shows how an offset voltage can be applied to the basic voltmeter circuit so that the display reads zero when the input voltage is at a value *other* than zero. This facility is useful in, for example, temperature reading applications in which a sensor IC provides an output of 1mV/ $^{\circ}$ K, thus giving an output of 273.2mV at 0 $^{\circ}$ C and 373.2mV at 100 $^{\circ}$ C.

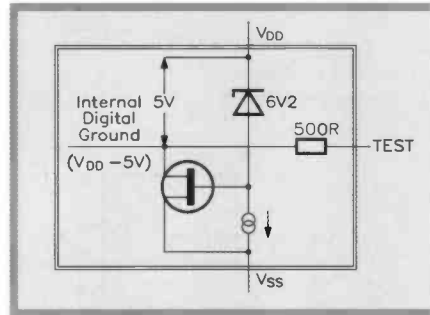

Figure 14. Internal digital ground biasing circuit of the A-to-D converter chip.

By connecting the sensor IC's output between the COM and IN HI terminals, and applying a 273.2mV offset between COM and IN LO, the DPM (which reads the differential value of the input) can be made to give a direct reading of temperature in degrees Celcius.

SOME FINER POINTS

Readers wishing to make the best use of a DPM will need to refer to the following set of 'tuning tips':

Calibration Accuracy. As supplied, a DPM module is pre-calibrated to read 199.9mV full-scale, with a typical accuracy of $\pm 0.1\%$ of reading ± 1 count (at 25 $^{\circ}$ C) when used in the standard configuration of Figure 8. The best attainable accuracy of a 3½-digit (2000-count) meter is ± 1 digit, and this corresponds to an actual reading accuracy of 0.05% at full-scale, to 0.5% at 10% of full-scale, and to 5% at 1% of full-scale.

Ratiometric Accuracy. A DPM is a ratiometric unit. If connected as in Figure 11, with identical voltages applied to the RFH and IN HI terminals, it should ideally read '1000' ± 1 count, but in practice it usually gives a reading about 0.1% below this

figure. This discrepancy is caused by the action of the potential divider of the internal 1M Ω filter resistor, and the input impedance of the IN HI line. When the meter is supplied for use in the voltmeter mode, it is pre-calibrated to allow for ratiometric errors.

Reference Accuracy. The built-in '100mV' reference (between ROH and ROL) of the DPM is factory-calibrated so that the meter reads '100.0mV' (1000) with 100.0mV input applied. This is achieved by adjusting V_{ref} to compensate for the meter's ratiometric error. If the ratiometric error is 0.1% low (reading 999), V_{ref} is also set 0.1% low (at 99.9mV) to give the correct 'voltmeter' accuracy. The ' V_{ref} ' reference voltage is only precisely accurate when ROL is tied directly to COM (which is normally 2.8V below V_{DD}), and when ROH is loaded by an impedance greater than 50M Ω or so. Figure 12 shows the typical circuit of the internal bandgap reference that is fitted to some modules. The circuit's output impedance is about 20k Ω , so an external loading of 2M Ω introduces an error of 1% and 20M Ω an error of 0.1%. The high input impedance of the RFH input causes zero loading error.

Input Connections. All the internal analogue action of the DPM's A-to-D converter IC is referenced to the COM (common) line. In use, the INPUT and REFERENCE inputs should not vary from the COM line by more than $\pm 2V$. If the terminals rise beyond these levels, the input leakage currents may rise to hundreds of picoamps, invalidating the auto-zero action of the chip. The IC may be damaged if the terminals rise above $V_{DD} - 0.5V$ or fall below $V_{SS} + 1V$.

The 'COM' Terminal. The module's COM terminal is derived from the circuit shown

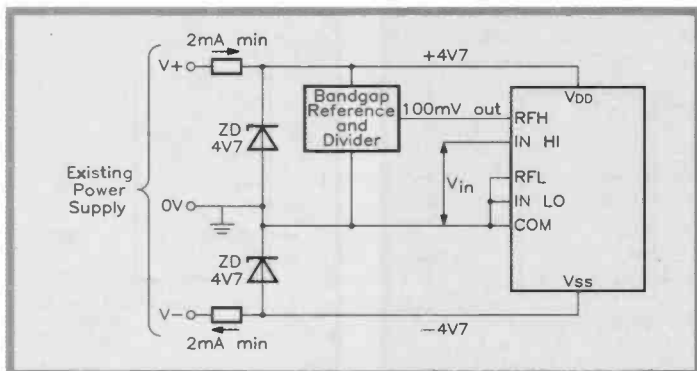

Figure 15. Method of building a DPM module into existing equipment that is powered from split supply rails.

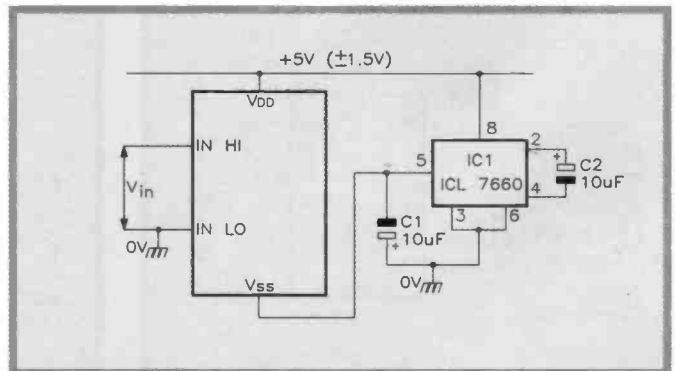

Figure 16. Method of powering a DPM from a single-ended, input-referenced supply.

in Figure 13, which is within the A-to-D chip, and enables the COM terminal to be used as either a precision voltage reference or as an externally biased analogue reference point. When used as a precision voltage reference, only low (that is below 100µA) external sink currents can be allowed to flow between V_{DD} and COM. Under this condition the module's basic calibration is valid. The COM terminal is about 2.8V below V_{DD} and has a typical temperature coefficient of about 80ppm/°C. Note that external load currents of up to 30mA may be allowed to flow between V_{DD} and the COM terminal (which has an impedance of about 15Ω in this mode). However, in this case the module's basic calibration may be invalid, and the RFH and RFL terminals may need to be driven from an external reference.

The COM terminal can, at most, only source a maximum current of 10µA. Thus it can be tied to a value that is more than 2.8V below V_{DD} by simply connecting it to an external bias voltage of the required value (as shown in the example of Figure 15), but must not be biased more than 4.7V below V_{DD}. Note that in this mode the module's basic calibration may be invalid, and the RFH and RFL ter-

minals may have to be driven from an external reference.

Test & BP. The negative or ground rail of the A-to-D converter chip's digital circuitry is internally biased at about 5V below V_{DD} by the internal circuit shown in Figure 14, and is coupled to the TEST terminal via a 500Ω resistor. This terminal can be used as the negative rail of external digital circuitry that is powered from V_{DD}, provided that the TEST currents do not exceed 1mA. If TEST is shorted directly to V_{DD} the LCD should read '-1888' (in some models the B and G segments of the left-hand '8' are blanked in this TEST mode). Under this condition 10mA flows into the TEST pin and a DC voltage is applied to the LCD; this voltage may damage the display if sustained for several minutes.

The backplane (BP) drive signal to the display switches fully between TEST and V_{DD} at a rate of about 50 to 60Hz. The actual frequency is not critical, but equals the oscillator frequency divided by 800.

Power Supplies. In most applications, DPMs are simply powered by a 9V battery or a fully floating, 9V single-ended supply connected between the V_{DD} and V_{SS} terminals. A DPM can, however, be

built into a piece of equipment and powered from existing 'split' supply rails by using the circuit of Figure 15. COM is tied to the existing 'common' rail, V_{DD} is fed from +4.7V, V_{SS} from +4.7V, and the two sets of input terminals are referenced to the COM terminal. RFH must be driven from an external reference, as shown.

Alternatively, the DPM can be powered from a single-ended 5V (nominal) supply, in which IN LO is referenced to the 0V 'chassis' line, by using the basic circuitry of Figure 16. Here, IC1 is a special ultra-efficient voltage converter IC (available from Maplin) that generates an equal-value negative supply from a positive source, and in this case provides a -5V output from pin 5. Thus the DPM has a total of 10V applied between V_{DD} and V_{SS}.

Part Two will present essential application details of the two LCD DPM modules stocked by Maplin, together with practical application circuits.

The reader is asked to note that this mini-series is based on Chapter 7 of the author's *Instrumentation and Test Gear Circuits Manual* (published by Butterworth-Heinemann Ltd.), with extra material added. This book is available from Maplin, see *New Books* on page 36 of this issue.

STOP PRESS . . . STOP PRESS . . . STOP PRESS . . . STOP PRESS

IMPORTANT NEWS FOR OVERSEAS READERS!

Obtaining components and kits for the projects featured in *Electronics* is now easier than ever in the following countries and regions:

Middle Eastern Region
United Arab Emirates
Maplin (Middle East),
P.O. Box 47019,
Hamdan Street,

Abu Dhabi,
United Arab Emirates.
Tel: +971 2 760 332
Fax: +971 2 760 317

Lebanon
N&Y Controls,
P.O. Box 175414,
Beirut, Lebanon.
Tel: +961 1 443 091

African Continent
South Africa
Maplin (South Africa),

P.O. Box 1846,
Somerset West 7129,
South Africa.
Tel: +27 24 515 124
Fax: +27 24 512 507

Mediterranean
Malta
CAM Services,
CAM Centre,
Off Cannon Road,
Qormi, QRM 09, Malta.
Tel: +356 484 650
Fax: +356 447 174

Far Eastern Region
Pakistan
Link Pakistan,
Suite Number 2,
2nd Floor,
I-R Plaza,
Markaz F-10,
Islamabad,
Pakistan.
Tel: +92 51 281 130
Fax: +92 51 282 319

Countries and Regions Not Listed
Export Department,
Maplin Electronics plc.,
P.O. Box 3,
Rayleigh,
Essex,
SS6 8LR,
England.
Tel: +44 702 554155
xtn. 326 or 351
Fax: +44 702 553935

Export catalogue and pricing details are available from the listed representatives.

Maplin
ELECTRONICS

THE WORLD'S
POSITIVE FORCE
IN ELECTRONICS!

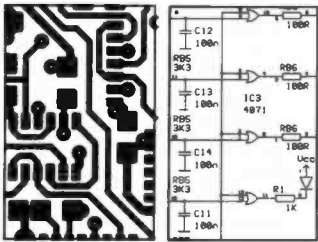
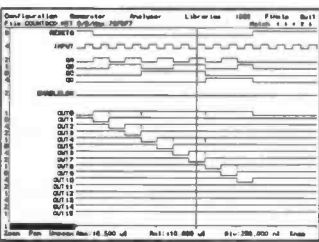
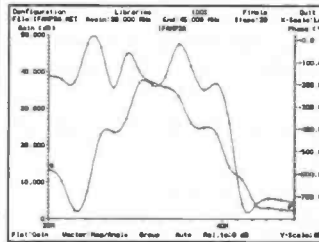
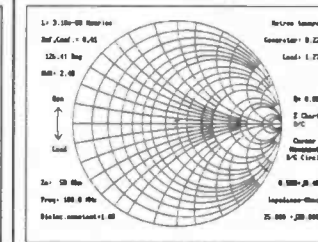
PCB & SCHEMATIC CAD	DIGITAL SIMULATION	ANALOGUE SIMULATION	SMITH CHART CAD
EASY-PC £98	PULSAR £195	ANALYSER III £195	Z-MATCH II £195
			

- Design Single sided, Double sided and Multilayer boards.
- One software package for Schematics and PCB's.
- Standard output includes Dot Matrix / Laser / Inkjet printers, Pen Plotters, Photo-plotters and NC Drill.
- Award Winning EASY-PC is in use in over 18,000 installations in 70 Countries World-Wide.
- Runs on PC/XT/AT/286/386 with Herc, CGA, EGA, VGA.
- Optional libraries S.M. Components etc. From £38.00

- At last! A full featured Digital Circuit Simulator for less than £1000!
- Pulsar allows you to test your logic designs without the need for expensive test equipment.
- Catch glitches down to a pico-second per week!
- Includes 4000 Series CMOS and 74LS Libraries.
- Runs on PC/XT/AT/286/386/486 with EGA or VGA. Hard disk recommended.
- 74HC / HCT Libraries optional at £48.00 each.

- NEW powerful ANALYSER III has full graphical output.
- Handles R's, L's, C's, Bipolar Transistors, FET's, Op-Amp's, Tapped and Untapped Transformers, and Microstrip and Co-axial Transmission Lines.
- Plots Input and Output Impedances, Gain, Phase and Group Delay.
- Covers 0.001 Hz to >10GHz
- Runs on PC/XT/AT/286/386/486 with EGA or VGA displays.
- Very fast computation.

- Z-MATCH II takes the drudgery out of RF matching problems and includes many more features than the standard Smith Chart.
- Provides quick accurate solutions to many matching problems using transmission line transformers, stubs, discrete components etc..
- Supplied with comprehensive user instructions including many worked examples.
- Runs on PC/XT/AT/386/486, CGA, EGA, VGA.
- Ideal for both education and industry.

For full info' Phone, Fax or Write to:

Number One Systems Ltd.
The Electronics CAD Specialists



Technical support free for life!
Programs not copy protected.
Special prices for Education.

REF: MAP, HARDING WAY, ST.IVES, HUNTINGDON, CAMBS, PE17 4WR, ENGLAND.

Telephone: 0480 461778 (7 lines) Fax: 0480 494042 International: +44-480-461778 Fax: +44-480-494042

Prices Exclude P&P and VAT

ACCESS, AMEX, MASTERCARD, VISA Welcome.

Something Overlooked . . . ?

Dear Sir,
I am pleased that you have resurrected the valve amplifier with your 'Millennium 4-20' project, as I have wanted to build one of these for some years, but found it impossible to obtain O/P transformers.

My only concern, however, with your circuit is the PSU where, on switching on, the HT peaks at 500V or more until the valves warm up. This could lead to 'flashover' in the valves and breakdown of electrolytics C2 & C7. We were always taught not to put HT directly onto cold valves.

C. W. Meakin, Manchester.

. . . Then Again, Perhaps Not.

Dear Sir,
Regarding the 'Millennium' PSU circuit, I have always found that rectifier valves were the cause of most troubles and I think that you have produced an excellent power supply which should give a long life. I think that you have been wise to design the PSU as a separate unit, as there is nothing as frustrating as having to replace or substitute parts of a built-in PSU.

Geoffrey Healey, Warwickshire.

Nowadays, while valves are comparatively easily available, transformers tend to be very difficult to find and are often prohibitively priced. Fortunately, the 'Millennium' transformers are made by a very capable manufacturer (who hasn't lost the art of winding a quality product). And because Maplin is able to place sizeable orders, the cost to the constructor is really quite low, considering that it is not a mass-market product. Transformers make or break a valve amp, because of this I'm sure that the 'Millennium' transformers will be the basis of many different readers' designs. Whilst at first glance the HT may appear to 'crash in' as soon as the PSU is switched on, C2 & C7 are preceded by resistors, forming an integrator. Modern electrolytics are far superior in many ways to their ancestors, high leakage currents won't be a problem. The EL34 output valves will not flashover as they are designed not to! It would be possible to switch the HT 'on-line' after a delay, but 'quality' 500V DC rated switches or relays are not easy to find and is probably not worth the effort. The use of a valve rectifier only brings about significant changes to the overall sound of a valve amplifier when it is driven into clipping. This is only desirable of a guitar amplifier when the classic overdriven (soft clipping) valve sound is sought

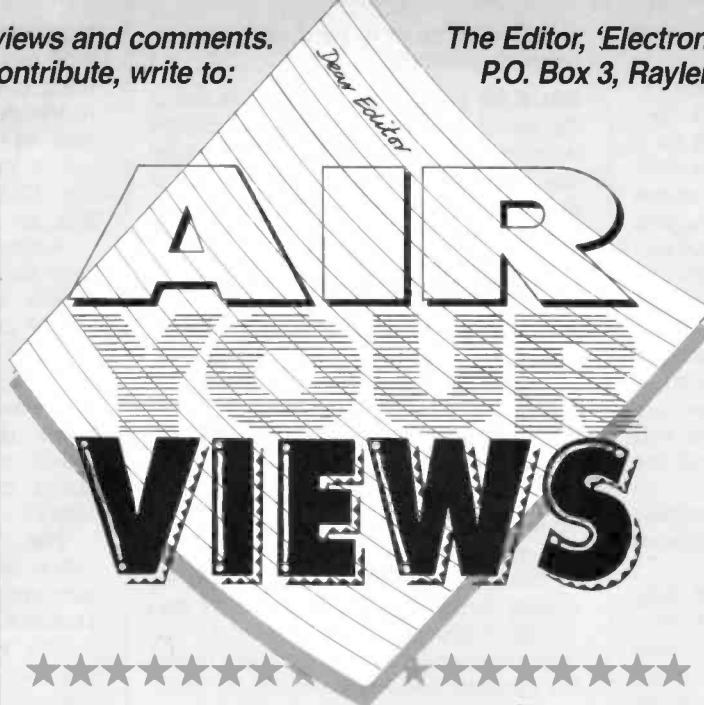

S·T·A·R L·E·T·T·E·R

This issue Mr Malcolm Perry, of Kidderminster, Worcestershire, wins the Star Letter Award of a Maplin £5 Gift Token for his helpful tip for reusable floppy disk and video cassette labels.



Erasable Labels

Dear Editor,
Computer disks, video tapes, etc. that are used frequently for only temporary storage soon develop disfigured labels which become unusable if written over each time they are used. I solved the problem for my computer disks by covering the new clean label with clear self-adhesive film, as sold in High Street stationers for covering and protecting books. This film can then be written on with a felt-tip pen for overhead

projectors, in different colours. The ink is moisture proof and resistant to erasure by sweaty fingers. When no longer needed, the information can be wiped off by the eraser attached to the pen, or a cloth damped with methylated spirit. The film can also be used to protect permanent labels.

Thank you for your very sensible suggestion, I must try it sometime!

after. For a domestic Hi-Fi amplifier, which the Millennium is, such operation is not appropriate. The inclusion of a valve rectifier would be more for nostalgia, as opposed to performance.

Not Only, but Also . . .

Dear Sir,
Congratulations on the 'Millennium 4-20' feature; the articles also provide unusually comprehensive background design details which are most welcome. I have wanted to build a 10W valve amp, generally similar to the Mullard 510, for some time, but preferred to use a PCB. The article has done most of the work for me and provided a ready-made PCB! Not only is it logical to install the O/P valves on the chassis rather than the PCB, but

it also allows modified designs to use the same board. The PSU module can also be used for other valve designs. Can we expect to see a matching preamplifier? In conclusion, can we have more articles of the quality and comprehensiveness of the Millennium please?
J. R. Tilsley, Surrey.

"Allows modified designs to use the same board" - of course it does! "PSU can be used for other purposes" - it sure can. Well spotted, that man! A valve preamp has been designed in theory, and a prototype is currently under construction, we'll keep you informed. . .

These above letters are just some of many that have been received about valves, and they're not all from 'golden oldies' either!

Ni-Cd Mysteries Unravalled

Dear Editor,
With reference to Mr. H. Foster's letter on Ni-Cd batteries ('Air Your Views' Issue 74), I have taken a keen interest in this subject due to flying radio controlled model aircraft, and I tender the following information.

Firstly, the difficulty of determining the state of charge is because Ni-Cds have a very flat charge/discharge curve. The most common method is to discharge fully prior to the charge. This is OK when dealing with a single cell, but can cause damage to a cell that is part of a pack. Most discharge arrangements limit it to 1V per cell per battery, because the danger is that a weak cell in a pack may be reversed. If the nickel side is exhausted first, then hydrogen gas is formed, causing permanent loss of electrolyte and storage capacity. If recharging at the original I₁₀ rate then takes place, further damage can occur after full charge. This 'avalanche' effect will soon destroy the cell. The safest method is to limit discharge to 1V per cell per battery.

The second point is that Ni-Cds are designed to absorb over-charging at a limited rate, i.e. I₁₀. If charging continues beyond the point needed to restore the nickel side, oxygen ions are produced but, having no material to oxidise, they eventually return to the negative side, the cadmium. Current thus passes through the cell harmlessly. The voltage will rise to 1.3V when this occurs. Further, Ni-Cds seem to prefer a 'healthy active life'. Cells left dormant for long periods lose activity, hence 'loss of charge' or 'memory effect'. It would seem that the cadmium crystalline structure 'grows', developing fine 'hairs', which can eventually cause a short circuit. I have managed to rescue such cells by giving them a high flash current to remove the short. It then has a fast 1/2 charge followed by a similar discharge. This may need repeating several times but, once normality returns, a lengthy charge of I₁₀ for 20 hours can be applied. The gentle over-charging seems to finalise the recovery process.

F. T. Jeffrey, Berkshire.

Thanks for your comments! Readers may be interested to know that an easy to build 'Intelligent Ni-Cd Charger' project will be published in the very near future. A dedicated chip is employed in the design to handle the complete discharge/charge cycle.

Sans Bass Pedals

Dear Sir,
With regard to the MIDI Keyboard Scanner (*Electronics* Issue 69), the article mentions that further MIDI projects may be considered if there was enough interest. Well I would like to express an interest in a MIDI bass pedals project. I have a MIDI keyboard, but find designing anything using the E510 data sheet beyond me. Are there any such projects in the offing?

Mark Rollinson, Birmingham.

Dear Sir,
I have for some time considered building a set of bass pedals (originally from the XH20W leaflet), but the lack of funds and expertise prevented me. Now, having acquired a set of pedals and convinced myself I can do the rest, I find these parts are no longer available, e.g., the master divider IC. I am really keen to have a set of bass pedals. Can you help?

Brian Bromley, Birmingham.

The leaflet referred to has been discontinued for some years, as have the most essential parts, the pedal-board and the IC – not by us, but by the manufacturers. However, all is not lost! If you've already got the pedal-board, it is a simple matter to connect the E510 MIDI Scanning Module (LT35Q) to it – full details are given in the September 1993 issue of Electronics (XA69A). This will generate MIDI data, not sound, so you will need a MIDI sound module or keyboard to produce the actual notes. Even the cheapest and most basic of keyboards have MIDI these days, so you won't have to dig too deep in your pocket. It is also a good idea to look in the 2nd hand columns of newspapers since keyboards can often be acquired very cheaply by this route.

The suggestions have been passed to the development team. Other MIDI projects are waiting in the wings; including a Simple MIDI Merge and a MIDI Data Analyser – a few other ideas are being considered.

In Search of Suitable Matrix Board

Dear Sir,
I have recently carried out some circuit construction on 'tripad' board, but find that DIL ICs are slightly too wide, leaving only one hole for each pin connection. Do you know if pads with five holes exist? These would allow more components to be joined together. Nevertheless I would recommend this method of circuit

building to anyone for prototypes and one-offs, as it is much easier than designing and making an etched PCB.

Edward Goltstein, London.

DIP board (FL19V) is generally better suited to building IC-based circuits; it can accommodate large numbers of ICs and has a power bus already provided – it is, however, more expensive. As a low-cost alternative you could make your own 'pentapad' board from ordinary stripboard, by cutting tracks in the required groups. Some people find plain matrix board (no copper strips) the easiest to use, since components are simply linked together underneath with wire – there's no need to worry about keeping to copper strips. However, care is needed to keep the circuit wiring neat. Where multiple logic ICs are involved, a wiring pen (HY16S) and combs (FY33L) would be a better choice and a good investment.





The Wrong Impression

Dear Editor,
One of our technicians mentioned to me that your magazine has been running a series on valve technology. I was pleased about this revival of interest in valve electronics for audio, and there is a definite need for design information. To cut a long story short, a colleague built the circuits in Part 3, which didn't work satisfactorily because, in my opinion, the whole design approach is fundamentally flawed. I was able to help him redesign the circuits, and the HT needed to be raised to 250V (150V is too low). My concern is that the series sets out to be a practical guide, yet the design methods lead to circuits which at best are unsatisfactory.
Dr Richard McMahon, University of Cambridge.

Graham Dixey replies: I find these criticisms unnecessarily harsh; the basic principles are perfectly standard and can be found in any text book on the subject. However, I agree that the circuits were hamstrung by a supply limited to 150V. Without the regulation Zeners (or by increasing the number of Zeners), up to 340V DC can be got from the reservoir capacitor. This will automatically lead to the choice of more realistic component values, but still following the design principles described.

[Our very popular 'Valve Data Booklet' (order code XL52G, price £1.25) contains concise but valuable info. for valves stocked by Maplin, including application circuits and load line graphs – Ed.]

MAPLIN'S TOP TWENTY KITS

POSITION		DESCRIPTION OF KIT	ORDER AS	PRICE	DETAILS IN	
1.	(2)	◆ L200 Data File	LP69A	£4.75	Magazine	46 (XA46A)
2.	(1)	◆ Live Wire Detector	LK63T	£4.75	Magazine	48 (XA48C)
3.	(4)	◆ 1/300 Timer	LP30H	£4.95	Magazine	38 (XA38R)
4.	(6)	◆ Car Battery Monitor	LK42V	£9.25	Magazine	37 (XA37S)
5.	(5)	◆ Lights On Reminder	LP77J	£4.75	Magazine	50 (XA50E)
6.	(8)	◆ Courtesy Light Extender	LP66W	£2.95	Magazine	44 (XA44X)
7.	(7)	◆ LED Xmas Tree	LP83E	£9.95	Magazine	48 (XA48C)
8.	(11)	◆ LED Xmas Star	LP54J	£7.75	Magazine	41 (XA41U)
9.	(10)	◆ Stroboscope Kit	VE52G	£14.95	Catalogue '94	(CA11M)
10.	(14)	◆ Simple Melody Generator 1	LM43W	£2.75	Magazine	26 (XA26D)
11.	(13)	◆ Mini Metal Detector	LM35Q	£7.25	Magazine	48 (XA48C)
12.	(-)	◆  Beginners AM Radio	LP28F	£8.95	Magazine	42 (XA42V)
13.	(12)	◆ Electronic Ignition	VE00A	£12.95	Catalogue '94	(CA11M)
14.	(-)	◆  Partytite	LW93B	£12.45	Catalogue '94	(CA11M)
15.	(17)	◆ IBM Expansion System	LP12N	£21.95	Magazine	43 (XA43W)
16.	(-)	◆  UA3730 Code Lock	LP92A	£11.45	Magazine	56 (XA56L)
17.	(20)	◆ 8-bit I/O + RS232	LP85G	£19.95	Magazine	49 (XA49D)
18.	(16)	◆ Universal Mono Preamp	VE21X	£5.95	Catalogue '94	(CA11M)
19.	(18)	◆ 1A Power Supply	VE58N	£8.95	Catalogue '94	(CA11M)
20.	(-)	◆  555 Timer Card	LT34M	£4.95	Magazine	69 (XA69A)

Over 150 other kits also available. All kits supplied with instructions.

The descriptions are necessarily short. Please ensure you know exactly what the kit is and what it comprises before ordering, by checking the appropriate project book, magazine or catalogue mentioned in the list above.

FOR BARGAINS AND MORE, VISIT YOUR LOCAL STORE!

For personal service, visit our stores at:

- Birmingham** Sutton New Road, Erdington.
- Brighton** 65 London Road.
- Bristol** 302 Gloucester Road.
- Cardiff** 29-31 City Road.
- Chatham** 2 Luton Road.
- Coventry** 12 Bishop Street.
- Edinburgh** 126 Dairy Road.
- Glasgow** 264-266 Great Western Road.
- Ilford** 302-304 Green Lane.
- Leeds** Carpet World Building, 3 Regent Street.
- Leicester** Office World Building, Burton Street.
- London** 146-148 Burnt Oak Broadway, Edgware; 107-113 Stanstead Road, Forest Hill; 120-122 King Street, Hammersmith.
- Manchester** 8 Oxford Road; 169 Cheetham Hill Road, Cheetham Hill.
- Middlesbrough** Unit 1, The Forbes Building, Linthorpe Road.
- Milton Keynes** Unit 1, Grampian Gate, Winterhill.
- Newcastle-upon-Tyne** Unit 4, Allison Court, The Metro Centre, Gateshead.
- Northampton** 139 St James Road.
- Nottingham** 86-88 Lower Parliament Street.
- Portsmouth** 98-100 Kingston Road.
- Reading** 129-131 Oxford Road.
- Sheffield** 413 Langsett Road, Hillsborough.
- Slough** 216 Farnham Road.
- Southampton** 46-48 Bevois Valley Road.
- Southend-on-Sea** 282-284 London Road, Westcliff.
- Stockport** 259-261 Wellington Road.
- Stoke-on-Trent** 39-45 London Road.

Plus A NEW store opening soon in **DUDLEY**.
Ring 0702 552911 for further details.

MAPLIN STORES NATIONWIDE

Kits available
CPO9K (Tx)
Price £31.95
CP13P (Rx)
Price £31.95



The assembled transmitter in its optional case.



The assembled receiver in its optional case.

The transmitter and receiver can be integrated to form one complete unit.

20 METRE

CW TRANSMITTER
ALL MODE RECEIVER



Text by Robin Hall G4DVJ



MANY Radio Amateurs will have sophisticated transceivers or transmitter/receivers capable of covering the 20 Metre band (14.00MHz to 14.350MHz), with full power and multimode capability. With a reasonable aerial there is a lot to be said for low power operation (QRP) using crystal control (VXO), Morse code on transmit and multimode direct conversion on receive. The two projects described, can be built as separate units and housed in their own cases, as intended by their designers at Ramsey, or with care, they can be incorporated into one box. It must be noted though that to use the QRP transmitter, either a full Class A Amateur Radio Licence

must be obtained or a restricted Novice licence on the recommended frequencies.

There are two other bands which are available in the QRP series of kits, covering 80 Metres and 40 Metres. Essentially these use the same PCB as they are of similar design, but in some cases use different values of components.

20 Metre CW Transmitter

The QRP-20 is a crystal controlled CW transmitter operating on the 20 Metre band. The crystal frequency can be shifted by up to 5kHz by the VXO control. There are two crystal positions, one crystal 14.060MHz being supplied in the kit. The

transmitter operates from a +12 to +15V DC supply, with a 1W RF output, and there is a built in antenna T-R (transmit/receive) switch.

20 Metre All Mode Receiver

The HR-20 is what is known as a 'direct conversion' 'DC' type of receiver. With this type of receiver there is no need for an 'intermediate frequency' (IF) such as is generally used in the majority of receivers using the 'superhet' principle. The advantages of 'DC' receivers are that they are simple to build, easy to use, and have multimode capability. Disadvantages are that they are limited to one

Specification of 20 Metre Transmitter

DC power supply voltage:	+11 to +15V DC
Supply current:	200 to 400mA
RF output power:	500mW to 1W
Crystal frequency:	14.060MHz
Mode:	CW
Rated antenna load impedance:	50Ω
PCB size:	120 x 102mm

Specification of 20 Metre Receiver

DC power supply voltage:	+9V DC
Supply current min to max:	20 to 135mA
Frequency range:	13.85 to 14.50MHz
Reception modes:	SSB, CW & AM (zero beat)
Rated loudspeaker load impedance:	8Ω
Audio output power:	200mW into 8Ω
PCB size:	120 x 102mm

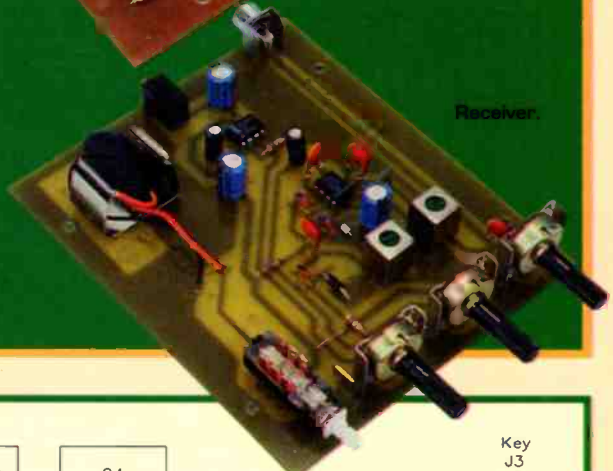

band, restricted tuning range and can be overloaded by strong stations. The use of ICs, varicap tuning and other techniques have minimised some of these disadvantages.

Circuit Description Transmitter

Figure 1 shows the block diagram of the GRP-20.

Referring to the circuit diagram in Figure 2, the external power supply nominally +12V DC, is fed into the power socket J4. The control and generation of the RF oscillator is as follows: the tuning control R1 varies a DC voltage onto D3 and D4, this changes the capacitance of the varicap diodes which in turn series-

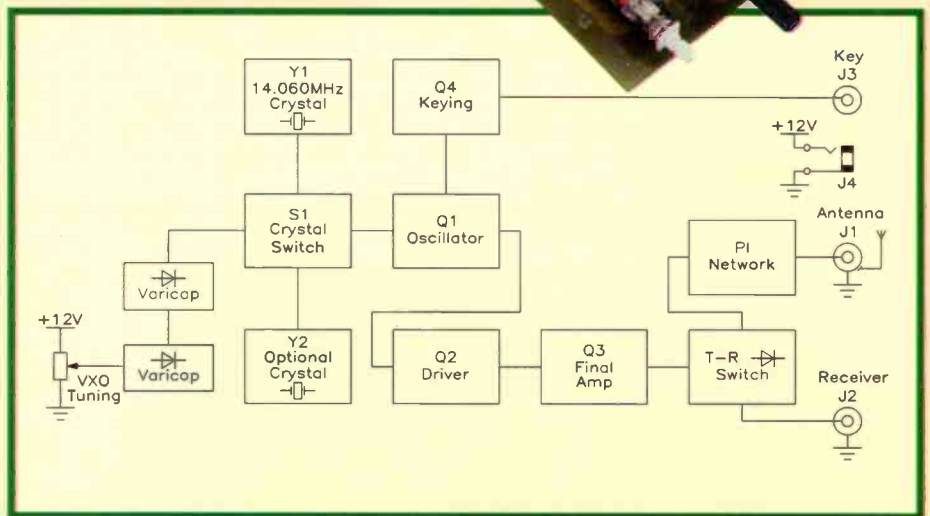

Figure 1. Transmitter block diagram.

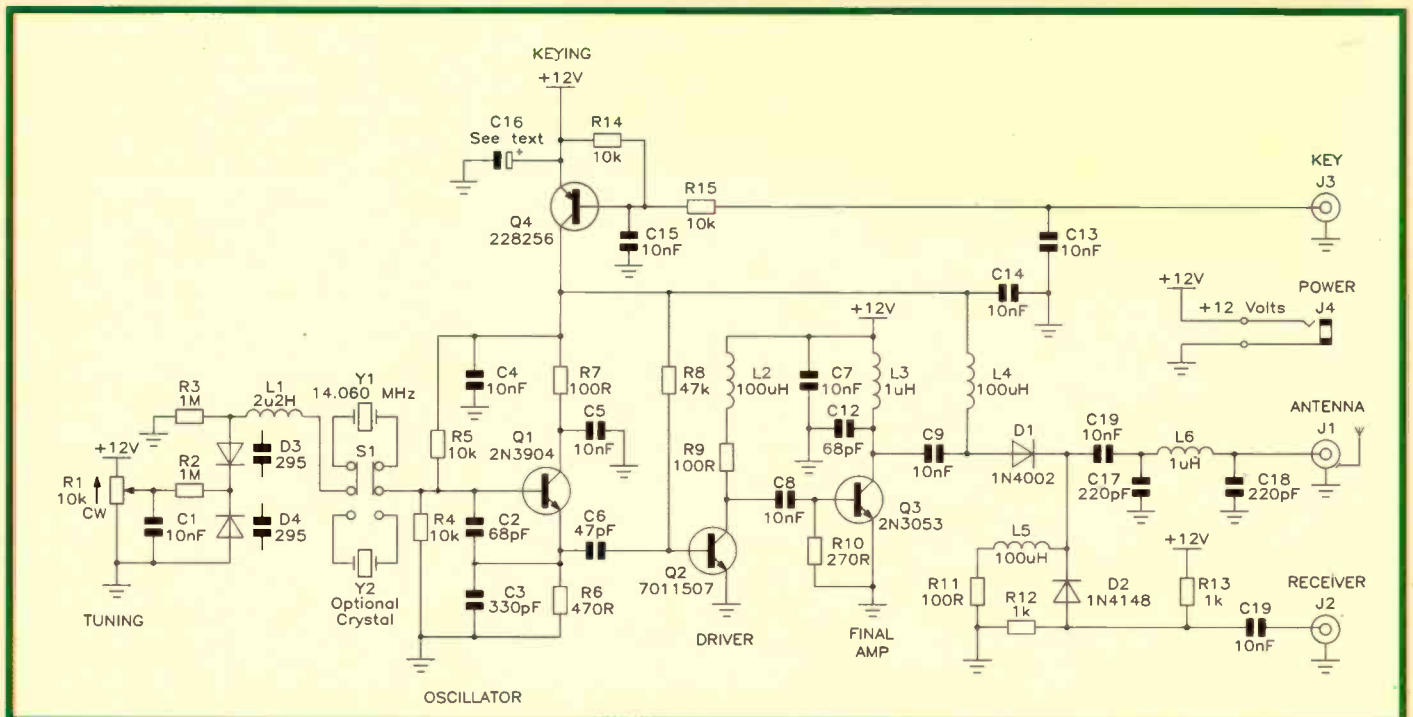

Figure 2. Transmitter circuit diagram.

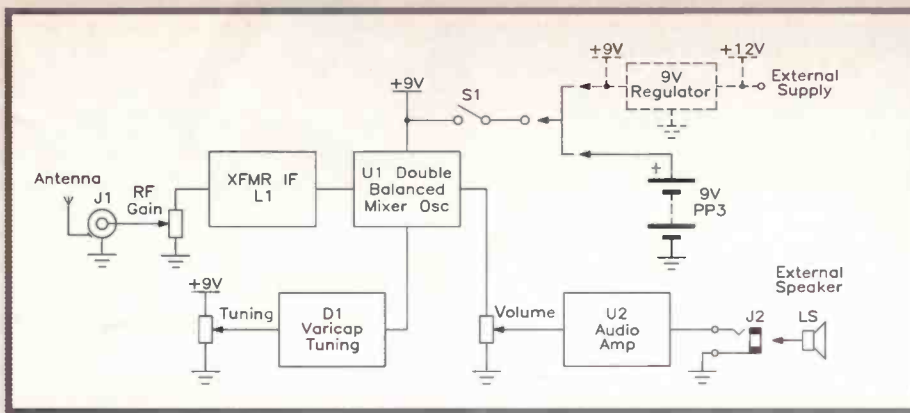

Figure 3. Receiver block diagram.

tunes the inductor L1. Switch S1 selects either crystal position Y1 or Y2; the fundamental frequency of the selected crystal can be shifted by a small amount using the VXO control. The selected crystal is then connected into the oscillator section which comprises Q1, a 2N3904 NPN transistor, R4 to R7 and C2 to C6 – and these provide a low level RF signal at the desired frequency for the next stage. Q2, a 7011 NPN transistor, acts as a buffer driver. This is to stop the next stage loading the oscillator and to provide a higher level of signal for the next stage. L2 is a radio

frequency choke (RFC); this is to stop the RF signal from appearing on the supply line. The signal is then passed by way of C8 to Q3, which is the final amplifier, also known as the power amplifier (PA).

Receiver

Figure 3 shows the block diagram of the HR-20.

Referring to the HR-20 circuit diagram in Figure 4, the receiver is supplied from a +9V DC power source and switched on and off by S1. A suitable aerial is connected to the phono connector J1. The RF signals are then fed into R1 which

is labelled the RF gain control, but in fact acts as an RF attenuator, then onto matching transformer L1. The signals are then passed to U1, an NE602 which performs as a double balanced active mixer and oscillator, which is the heart of this receiver. The nature of the direct conversion means that the tuning of the radio and the local oscillator are very much tied up. The tuning control, R2, varies a DC voltage onto D1, which although it is an ordinary silicon diode, it does exhibit varicap capabilities. The change in capacitance is used, in conjunction with L2 oscillator coil, and C1, C2 & C3 to control the resonant frequency of U1 internal oscillator. A regulated supply for U1 is obtained from the +9V DC power source and regulated by Zener diode D2 to +6.2V. The audio signal is obtained from U1 on pins 4 and 5 and passed via R3, the volume control, to U2, an LM386 audio amplifier IC. The audio is then taken from U2 by C12 to the 2.5mm speaker jack socket J2.

Hints and Tips

There are a number of suggestions that could enhance the use of each kit, preferably these should be included before completion of construction. Using IC sockets is generally a good practice but not essential. They are not provided in the receiver kit, and if they were to be used, would require two 8-pin DIL IC sockets (BL17T).

The separate transmitter version is straightforward, and one tip is to use only enough heat that is necessary to solder the pins of the crystal to the PCB otherwise it may be damaged. Other types of power transistor can be used, and the BFY51 (QF28F) is a good replacement if required.

In the separate receiver version the audio output is via a mono 2.5mm jack socket, and an external 8Ω loudspeaker or 8Ω earpiece with a 2.5mm jack plug is required.

Photo 3. Internal shot of integrated unit.

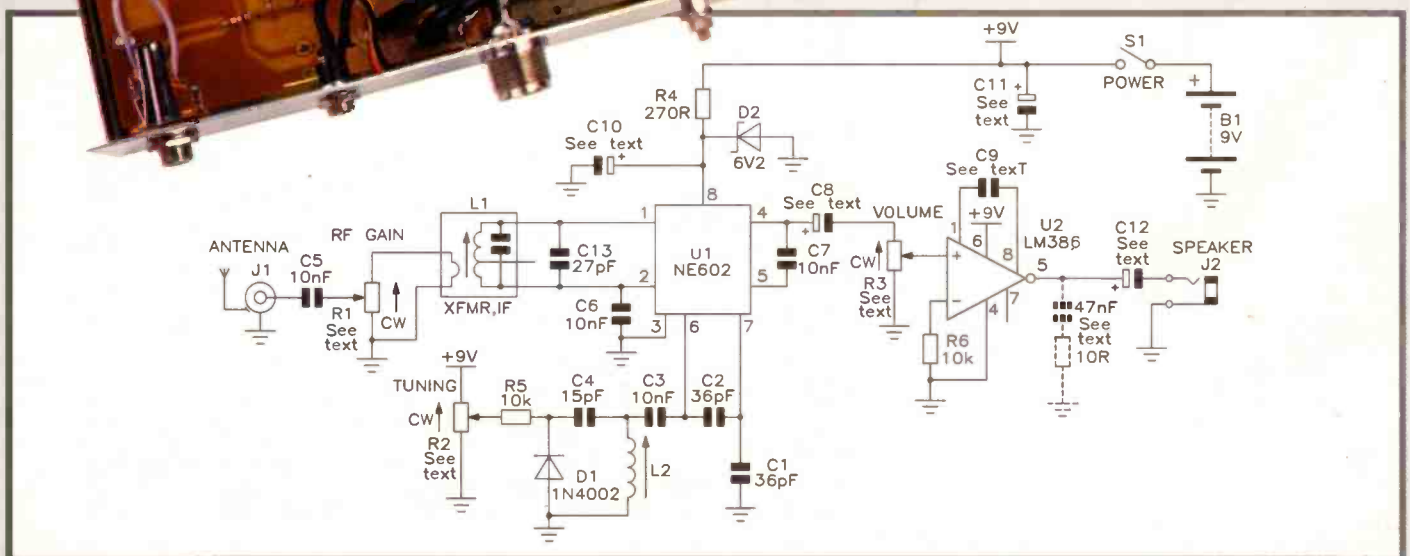
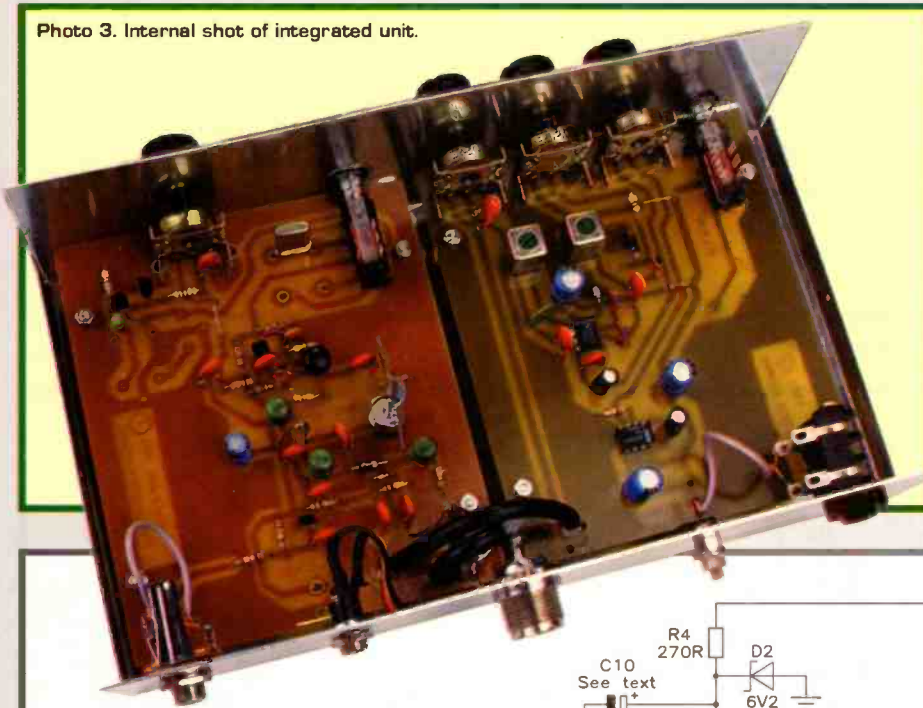

Figure 4. Receiver circuit diagram.

Again if one wanted to make a modification then an internal 8Ω loudspeaker could be mounted in the box, but holes would have to be made in the lid for the sound to escape.

To obtain maximum volume levels of 200mW with an 8Ω loudspeaker with minimum distortion a Zobel network comprising of a 100nF metallised ceramic capacitor in series with a 10Ω resistor across the loudspeaker output may be found necessary.

Another modification is to locate the input to L1 on the underside of the PCB, and solder the isolated pad to ground. The other side goes to the RF gain potentiometer R1. Please note though that the corresponding connections on L2 are not required, as it is only being used as an inductor.

Construction

The kits include PCBs as shown in Figure 5 (transmitter) and Figure 6 (receiver), and all the components required to build them. Choose which kit to build first, and consider whether to integrate the two kits into one box. Sort out and identify the components, this way one gets to know the values and also check to see if any are missing before soldering them in position. There are some very good instructions supplied with the kits, and they show a logical path to follow. If you are new to project building, refer to the Constructors' Guide (order separately as XH79L) for helpful practical advice on how to solder, component identification and the like.

It is best to solder the larger components first, such as switches, jack sockets and potentiometers, and it is important to orientate the semiconductors correctly on the PCB. It is up to the constructor if IC sockets are to be used; they are not included in the kit. Next fit the resistors, shaping the wire leads to suit the holes in the PCB. There are some links to be made up and soldered in position; these can be made up from offcuts from the resistors. When fitting electrolytic capacitors onto the PCB, make sure that the correct polarity is observed. The negative lead of the capacitor is usually marked with a stripe and a negative (-) symbol. Coils, transformers and chokes should be fitted next. One crystal is included in the transmitter kit and this should be soldered in position, either A or B, depending on preference.

The receiver operates from a PP3 9V battery and the battery clip needs to be soldered in making sure the red lead is in the correct position. The completed boards should be checked to see if the

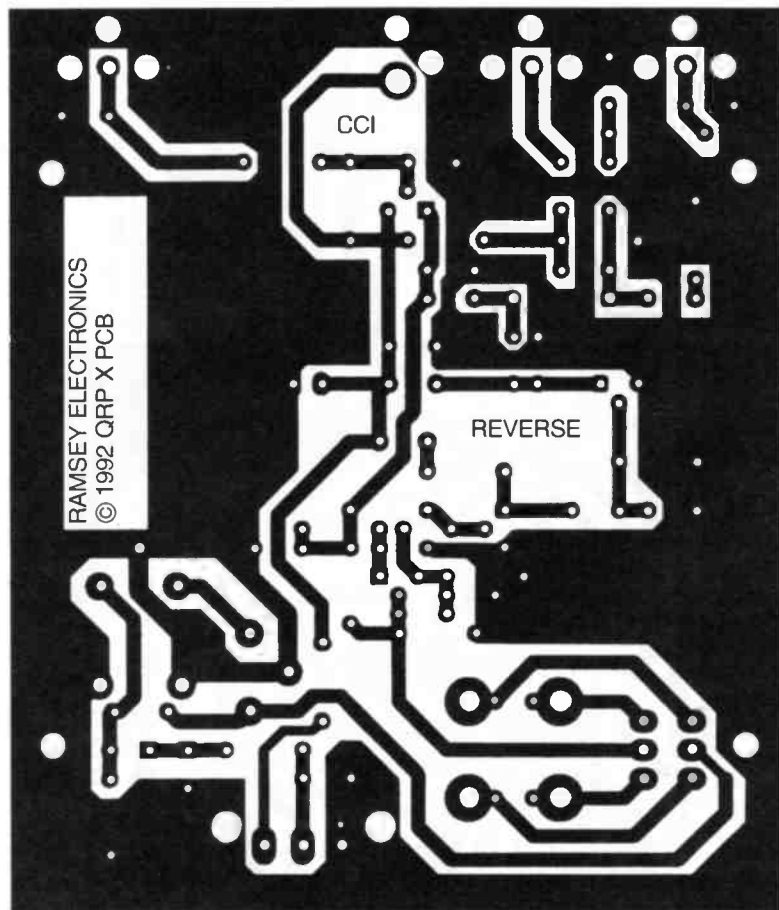
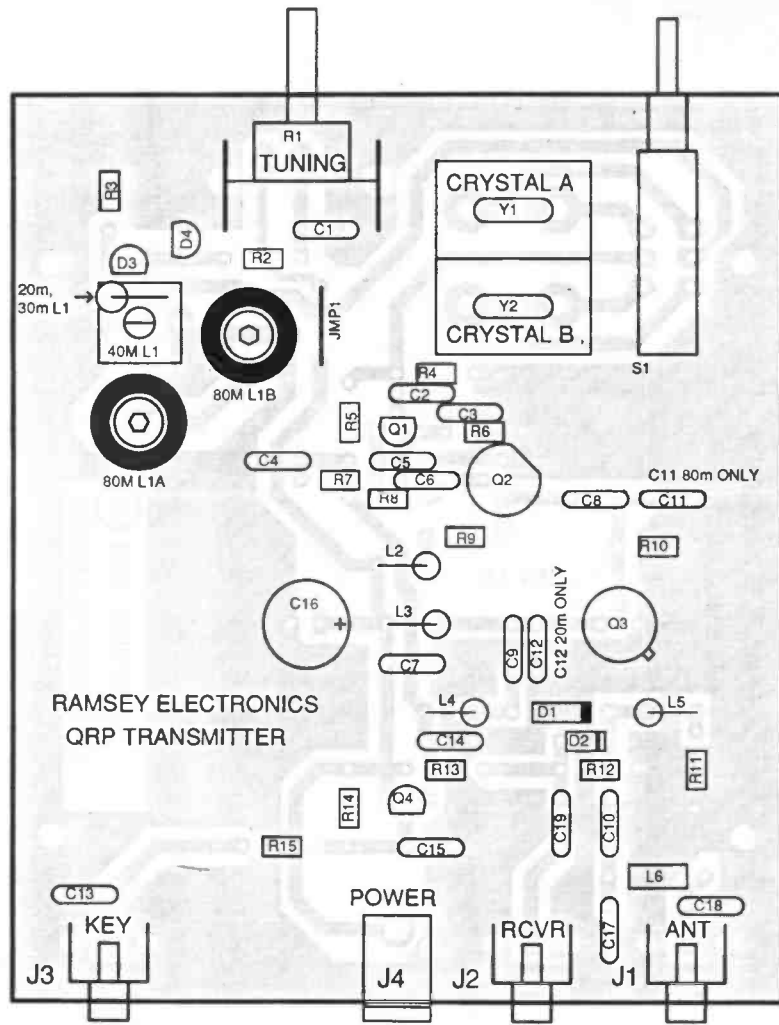

Figure 5. Transmitter PCB legend and track.

© Copyright 1994, Ramsey Electronics, Inc., All Rights Reserved, Used by Permission.

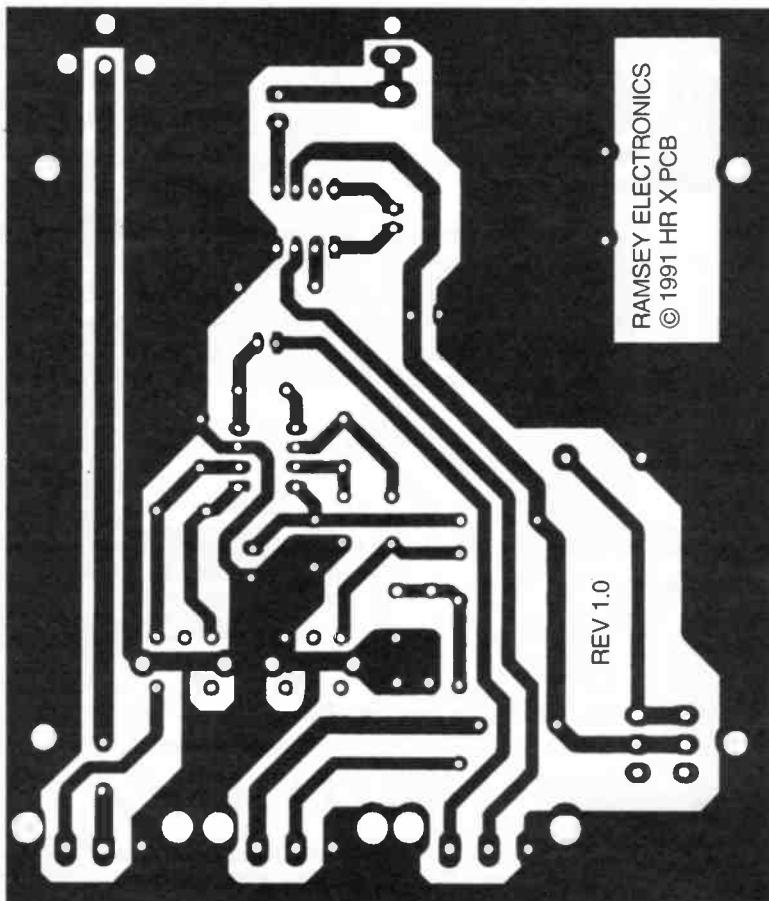
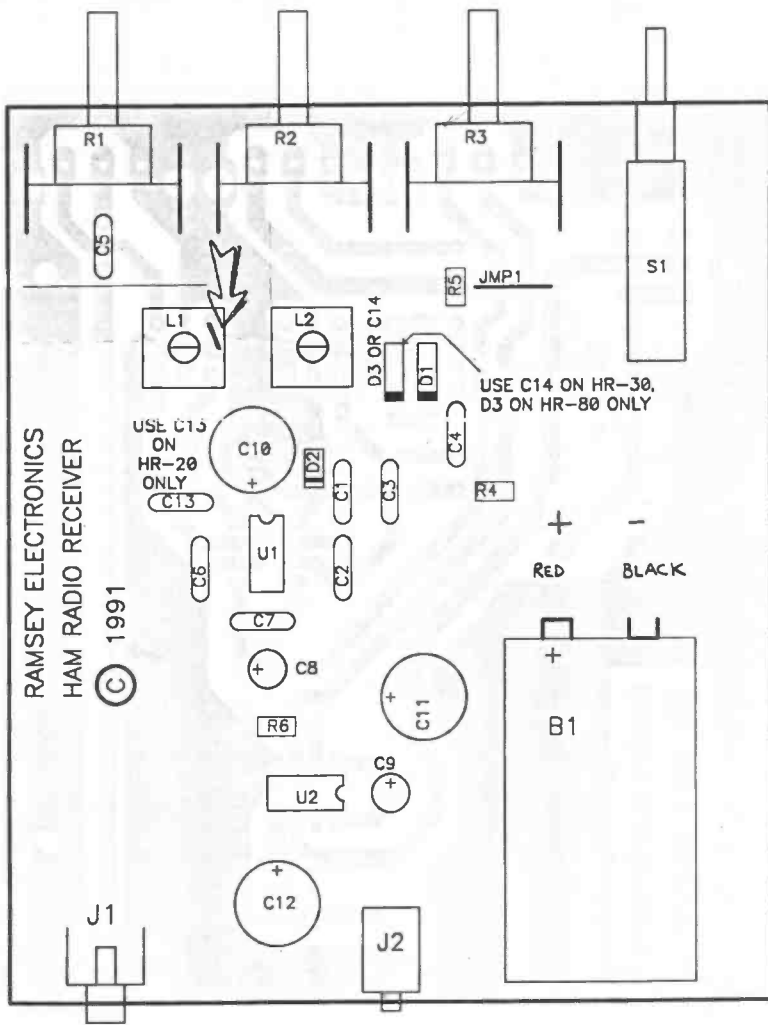

Figure 6. Receiver PCB legend and track.

components have been fitted correctly, and that there are no solder bridges or wire whiskers. Most important is that the power connections are the right way round. Photo 1 shows the assembled transmitter PCB and Photo 2 the assembled receiver PCB.

Separate Cases

There are two cases for the QRP Transmitter (CP12N) and the All Mode Receiver (GK90X). Please note that the receiver case is not shown in the current catalogue! If these are to be used then the individual kits can be screwed into position with the front and back panels in place. To complete each kit the knobs can be pushed home onto the spindles of the potentiometers. Remember to put a 9V PP3 battery into the receiver, before screwing the two halves of the case together! An external 8Ω loudspeaker or 8Ω headphones will also be required for the receiver. For the QRP transmitter an external regulated +12V DC Nominal (e.g., +13.8V DC) power supply is required, such as that used for 27MHz or 2m transceivers. A Morse key or some other keying device will be needed to key the transmitter and a coaxial lead with suitable plugs to go from the transmitter to the receiver. An aerial and aerial tuning unit (ATU) will also be required.

Alternative Construction

If the two kits are to be built into one case then most of the instructions will stand as before except that the aerial, power, key, loudspeaker, aerial connectors, the loudspeaker and battery clip will not be required. In this case the connectors as recommended in the Optional Parts List should be used along with the red and black wires, the 50Ω and audio coaxial cable. Cut two lengths of audio cable about 50mm long and cut back the insulation on one side by about 6mm, and the other by 15mm. Bare the wires and tin before soldering the shorter side onto the positions where the audio and Morse sockets would have been located. Cut a length of about 80mm of 50Ω coax and bare and tin both ends. These go, as shown in Figure 10, into the original locations for the aerial interconnection between the receiver and the transmitter. A shorter length should be prepared from the transmitter output.

For the integrated version a modification to the power supply is required and Figure 7 shows the regulator modification. This is to enable the receiver's OFF/ON switch to control the +12V DC incoming

© Copyright 1994, Ramsey Electronics, Inc., All Rights Reserved, Used by Permission.

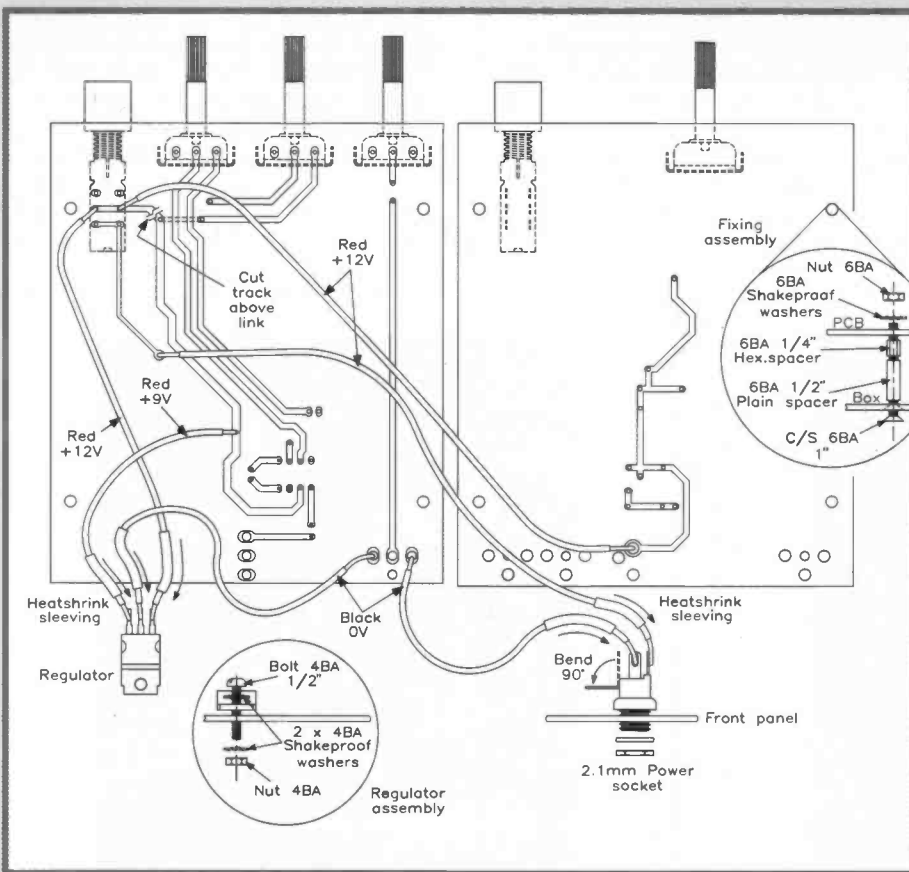

Figure 7. Regulator modification diagram.

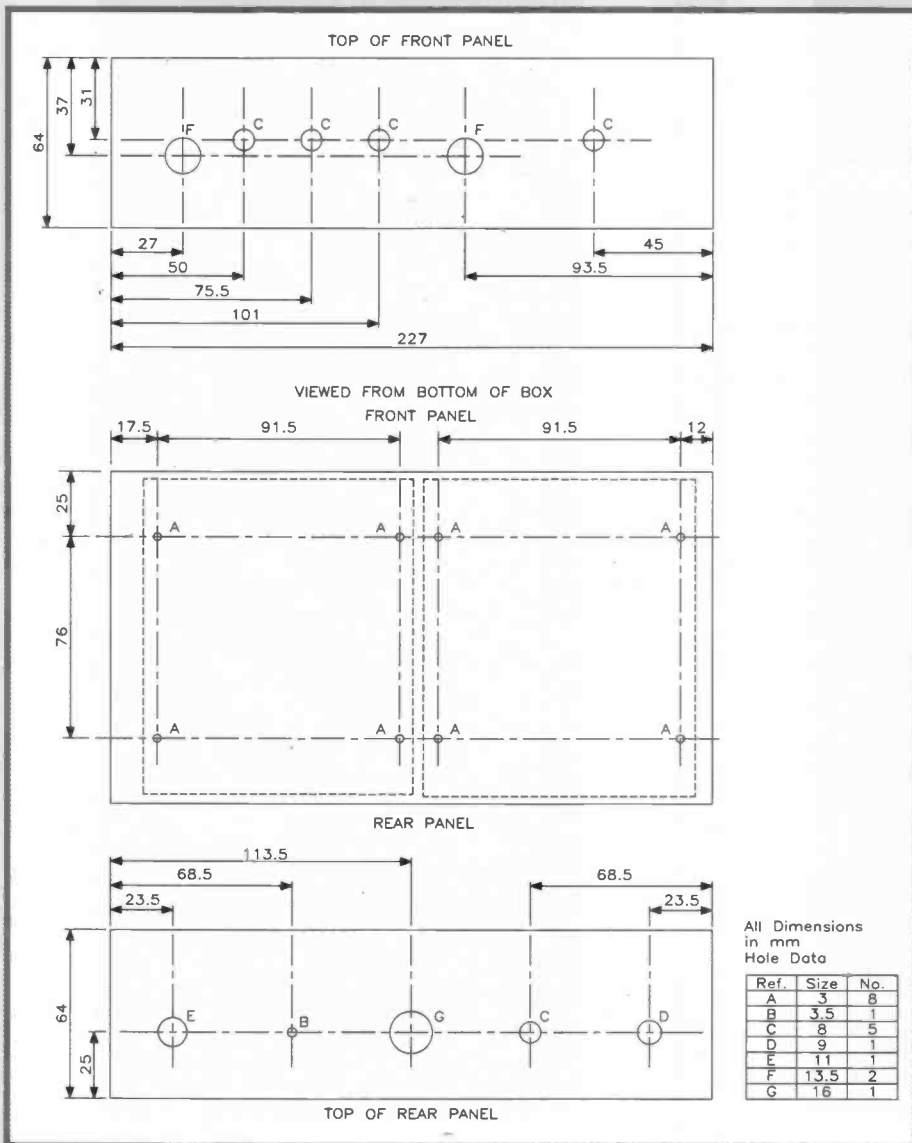

Figure 8. Suggested box drilling for integrated version.

supply for the transmitter, and a 9V DC regulator to reduce the supply for the receiver.

Integrated Case

A suitable box for the combined kits is a smart black vinyl covered box (LM39N), and this can be made into an ideal case. The suggested box drilling details for the integrated version are shown in Figure 8. Drilling holes into the aluminium is fairly easy as the gauge of metal is not great. Care must be taken, when using a file, not to make the holes too big. Suggested front and rear panels are shown in Figure 9a & 9b. The 6BA 1in. screws can be fitted along with 1/2in. plain spacers and fixed in position by hex threaded spacers. Once these are in position, the PCBs can be fitted and held in position by 6BA nuts. The sockets can be then fitted and the connections made according to the wiring diagram in Figure 10. Making sure that the polarity of the power connections are correct, and that the conductor of the coaxial cable is in the right place. To fix the voltage regulator in position a 4BA bolt, washer, nut and solder tag are recommended, but as these are sold in packets of ten, and only one is required of each then maybe an alternative from the constructor's 'bits box' may be found and used. Photo 3 shows an internal shot of the integrated module. Suitable knobs such as (FK39N) can now be fitted onto the spindles, and small round button types such as (KU75S) for the two latch switches.

Setting Up Transmitter

After checking that there are no obvious faults, connect a suitable tuned aerial or dummy load and apply power. There should not be any RF output at this stage, if any is found, switch the power off immediately and check the keying circuit and associated components. If there are no problems, select the desired crystal position and key-up the transmitter. Depending on what test equipment you have available will determine how you confirm that you have an RF output. There should be approximately 1W of RF power, but this depends on a number of factors, not least how the kit was built, the gain of the output transistor and the load impedance. If there is a receiver available with a beat frequency oscillator (BFO) or CW position, then this should be tuned to the crystal frequency, and a pure note should be heard. There is a VXD control on the transmitter and this can alter the frequency by about 5kHz. If no note is heard then rotate the VXD control, further tuning of the circuit can be made by rotating the ferrite core in L1 with

an insulated non-magnetic tool. Unless there is a fault on the circuit then at some point, oscillation should occur.

Receiver

Setting up the receiver should again be fairly straightforward and can be done with the minimum of test

equipment. Connect a suitable aerial, earth and 8Ω loudspeaker, or headphones to the receiver, apply power and switch on S1. If all is well then signals should be heard on the output. The desired tuning range is determined by L1 and adjustment must be made using a non-magnetic tool. If a transmitter is available

which covers the desired frequency band, connect to a dummy load and key-up. Tuning the receiver, one should come across the signal, and this can be used to set it up. If test equipment is available then a signal generator can replace the transmitter, and a typical frequency selected mid-band. On the combined

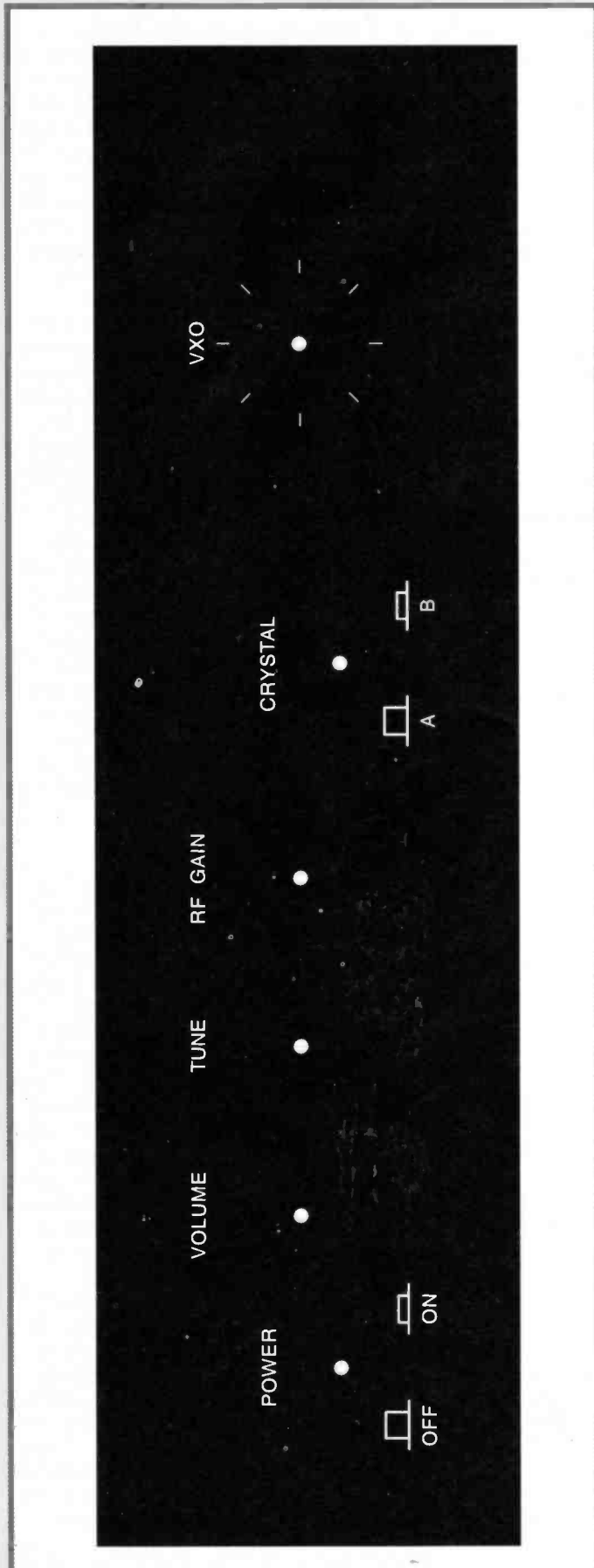

Figure 9a. Front panel label (shown actual size).

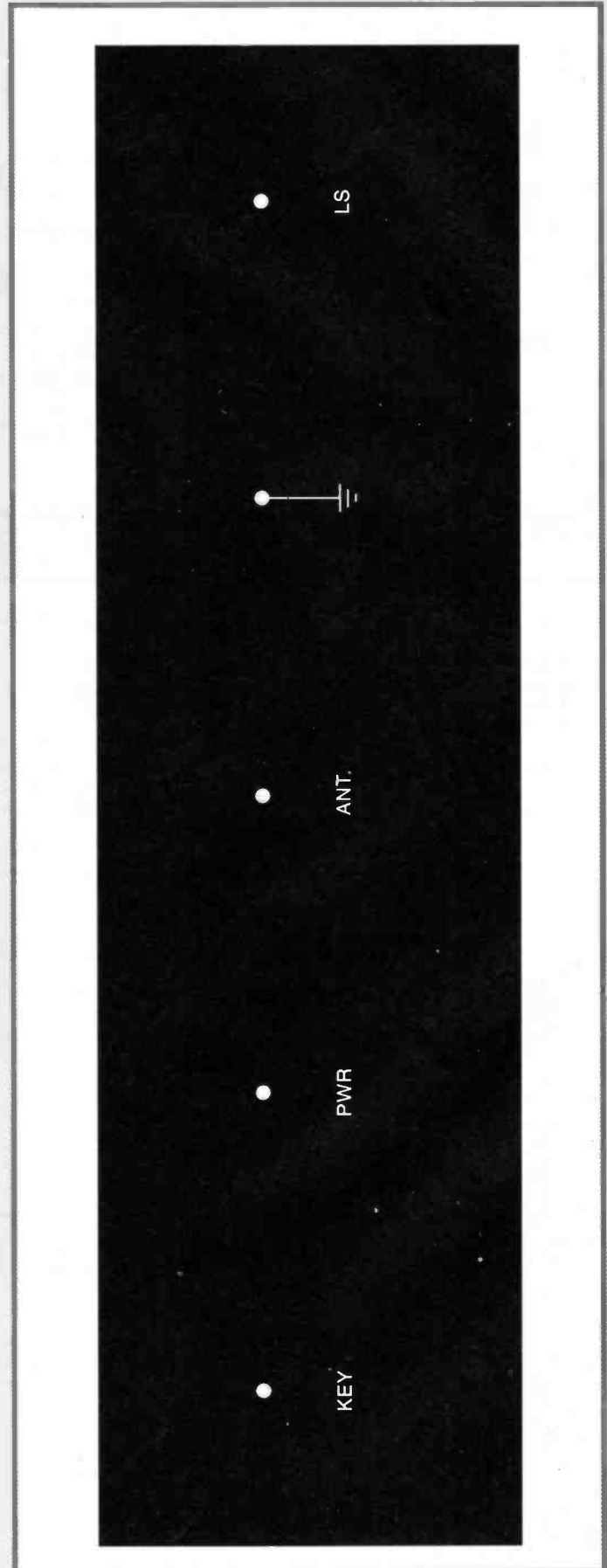

Figure 9b. Rear panel label (shown actual size).

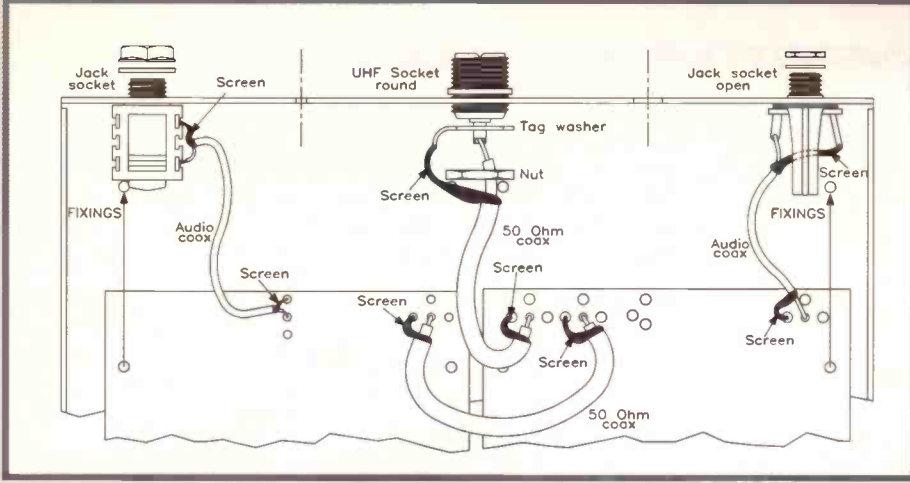

Figure 10. Wiring diagram for integrated version.

receiver/transmitter be aware that if headphones are to be used that there is a fairly hefty thump when keying up the transmitter.

Further Suggestions

Because these kits are of basic designs, there are further modifications that can be made to make them more user friendly. Such as suitable buffering, so that the frequency generated from the direct conversion receiver can be used for the transmitter as well. This would save on crystals and make it operate more like a transceiver. The SL560C Low Noise RF Amplifier could be used as a buffer stage. The diode switching arrangement for the aerial changeover could be improved with relay switching. There is no muting on the modules, because this would have meant a rebuild of the boards. Operation of mute at this stage would inhibit use, but if the frequency was generated from the receiver and used on the transmitter then muting could be used. The 2N3053 can be replaced by a higher power device such as

the 2N3866, and the driver stage replaced also with a higher power device. If extra power is required for QRO operation, then there is a range of 20W HF Amplifiers, with the QAMP-20 (RU32K) available for 20 metres.

Additional Information

QRP operation is a complete hobby in itself and there are clubs for the enthusiast such as the G-QRP Club which produces a monthly magazine *Sprats*. For the general radio amateur or short wave listener, there is the Radio Society of Great Britain (RSGB), which publishes *RadCom*. There are also local radio clubs to go to, and they welcome newcomers to the hobby. Most have talks on amateur radio as well as other subjects, and will also have building competitions, with trophies and prizes. There are lots of radio rallies up and down the country, and some are dedicated to the QRP enthusiast.

Further Reading

There are many books on the subject, covering all aspects of the hobby, from QRP kits, professionally produced equipment, aerials and tuner units. As a start some books



that could be useful are *How to Get Started in QRP* by Dave Ingram, K4TWJ, *Amateur Radio for Beginners* – *How to Discover the Hobby* by Victor Brand, G3JNB, (WT69A). Also *An Introduction to Amateur Radio* by Ian Poole (WS50E), and *Setting Up An Amateur Radio Station* by Ian Poole (WT74R).

An article on The Amateur Radio Novice Licence by Ian Poole appeared previously in *Electronics* June 1993 Issue 66, and *Amateur Radio on the HF Bands* by Ian Poole in *Electronics* March 1994 Issue 74. The SL560C Low Noise RF Amplifier appeared as a Data File in *Electronics* February 1994 Issue 74.

Acknowledgment

Thanks to Waters and Stanton Electronics of Hockley for supplying the initial kits and cases.

20 METRE CW TRANSMITTER PARTS LIST

RESISTORS: All 5% Metal Film (Unless specified)				Q2	7011507	1
R1	10k Potentiometer	1	Q3	2N3053	1	
R7,9,11	100Ω	3	Q4	228256 (2N3906)	1	
R10	270Ω	1	D1	1N4002	1	
R6	470Ω	1	D2	1N4148	1	
R12,13	1k	1	D3,4	295 (Varicap)	2	
R4,5,14,15	10k	4	INDUCTORS			
R8	47k	1	L1	2μ2H	1	
R2,3	1M	2	L3,6	1μH	2	
CAPACITORS				L2,4,5	100μH	3
C6	47pF	1	MISCELLANEOUS			
C2,12	68pF	2	J1,2,3	PCB Mounting Phono Socket	3	
C17,18	220pF	2	S1	PCB Mounting Latch Switch	1	
C3	330pF	1	Y1	14.060MHz Crystal	1	
C1,4,5,7,8,9,10, 13,14,15,19	10nF	11		Transistor Heatsink	1	
C16	100μF 16V Electrolytic	1*		GRP-20 PCB	1	
SEMICONDUCTORS					Leaflet	1
Q1	2N3904	1	* This value may be changed, i.e. 100μF to 200μF with no effect on performance.			

20 METRE ALL MODE RECEIVER PARTS LIST

RESISTORS: All 5% Metal Film (Unless specified)				U1	NE602	1
R1,2,3	10k Potentiometer	3	U2	LM386	1	
R4	270Ω	1	INDUCTORS			
R5,6	10k	2	L1,2	Shielded Coil (42IF123)	2	
CAPACITORS				MISCELLANEOUS		
C4	15pF	1	S1	PCB Mounting Latch Switch	1	
C13	27pF	1	J1	PCB Mounting Phono Socket	1	
C1,2	36pF	2	J2	PCB Mounting Mono 2.5mm	1	
C3,5,6,7	10nF	4		Jack Socket	1	
C8,9	4.7F 35V Electrolytic	2*		HR-20 PCB	1	
C10,11,12	100μF 16V Electrolytic	3*		PP3 Battery Clip Connector	1	
SEMICONDUCTORS					PP3 Battery Mount	1
D1	1N4002	1		Leaflet	1	
D2	6V2 Zener	1	* These values may be changed, i.e. 4μ7F to 10μF and 100μF to 200μF with no effect on performance.			

OPTIONAL ITEMS FOR ABOVE (Not in Kit)

CQRP Plastic Case (Includes Knobs, Feet & Screws)	1	(CP12N)	6BA x 1in. Countersunk-head Bolts	1 Pkt (BF13P)
CHR Plastic Case (Includes Knobs, Feet & Screws)	1	(GK90X)	6BA Full Nuts	1 Pkt (BF18U)
Vinyl Covered Metal Case	1	(LH39N)	6BA Shakeproof Washers	1 Pkt (BF26D)
2.1mm Power Socket	1	(JK09K)	Stick-on feet (square)	1 Pkt (FD75S)
Regulator L78S09CV	1	(UJ55K)	Constructors' Guide	1 (XH79L)
Standard 1/4in. Mono Jack Open Chassis	1	(HF91Y)	<div style="border: 1px solid black; padding: 5px;"> <p>The Maplin 'Get-You-Working' Service is available for these projects, see Constructors' Guide or current Maplin Catalogue for details.</p> <p>The above items (excluding Optional) are available in kit form only.</p> <p>Order As CPO9K (20 Metre CW Transmitter) Price £31.95.</p> <p>Order As CP13P (20 Metre All Mode Receiver) Price £31.95.</p> <p>Please Note: Some parts, which are specific to this project (e.g., PCB), are not available separately.</p> <p>The following new item (which is not included in the kit) is not shown in the 1994 Maplin Catalogue.</p> <p>Matching Case and Knob set for HR Receiver</p> <p>Order As GK90X Price £14.95.</p> </div>	
Standard 1/4in. Mono Jack Plastic Bezel	1	(HF90X)		
UHF Socket Round	1	(BW84F)		
10Ω Metal Resistor 6%	1	(M10R)		
47nF Polyester Capacitor	1	(BX74R)		
8-pin DIL Socket	2	(BL17T)		
Matt Finish Knobs	4	(FK39N)		
Small Latch Round Button	2	(KU75S)		
50Ω Coaxial Cable	1m	(XS51F)		
Hook-up Wire Red	1m	(FA33L)		
Hook-up Wire Black	1m	(FA26D)		
Screened Audio Cable	1m	(XR15R)		
Heat Shrinkable Sleeving	1m	(BF87U)		
4BA x 1in. Round-head Bolt	1 Pkt	(BF04E)		
4BA Solder Tag	1 Pkt	(BF28F)		
4BA Full Nuts	1 Pkt	(BF17T)		
6BA x 1/2in. Plain Spacer	1 Pkt	(FW35Q)		
6BA x 1/4in. Threaded Spacer	1 Pkt	(FD10L)		

RSGB Publications

Invaluable for Experimenters and Constructors

Radio Amateur's Examination Manual (RSGB)

This is the standard textbook that almost every radio amateur needs to study in order to pass the Radio Amateur's Examination.

AVAILABLE FROM MAPLIN **only £6.99**

Amateur Radio Techniques (RSGB)

A very large selection of circuit ideas and devices, information on antennas and related topics plus many constructional hints. 368 pages.

only £7.99

Technical Topics Scrapbook (RSGB)

A reprint of all the Technical Topics pages from Radio Communication magazine 1985-89 inclusive, with an index.

only £9.00

HF Antenna Collection (RSGB)

A wealth of information on antennas, feeders, tuners, baluns, testing, modelling and the mechanics of mounting an antenna safely.

only £9.99

VHF/UHF Manual (RSGB)

The standard guide to theory, techniques and equipment for amateur radio transmission and reception at VHF and UHF. 511 pages.

AVAILABLE FROM MAPLIN **only £10.50**

MANY MORE PUBLICATIONS ARE AVAILABLE

TELEPHONE FOR A COPY OF OUR COMPREHENSIVE BOOK LIST

We are here to help and are only a phone call away

TO ORDER: Either telephone us with your credit card details or send your cheque or postal order to the address below. POST AND PACKAGING: Please add £1 (£1.75 overseas) for one book and £2.00 (overseas £3.50) for two or more books. p&p free on orders over £40. Membership of the Society offers many benefits. Including discounted books and *Radio Communication* magazine every month. For membership details, or a copy of our comprehensive book list, please call 0707 659015.



**Radio Society of Great Britain (Dept. MM4)
Lambda House, Cranborne Road, Potters Bar, Herts EN6 3JE**

DID YOU MISS US?

If you ever want to lay your hands on an elusive issue of *Electronics - The Maplin Magazine*, then we can help! Many editions are still available, as back issues. Where issues are out of print, details of projects that are still current can be found in Maplin Projects Books and Best of Maplin Projects Books. Copies of back issues (subject to availability) can be obtained from Maplin Stores countrywide; by Mail Order, using the Order Coupon in this issue, or by calling the Credit Card Hotline on 0702 554161. If you are not sure which issue or projects book you require, call Customer Services on 0702 552911. Photocopies of out of print feature articles are available; a charge will be made, dependent on the length of the article to be copied - call Customer Services for details.



VARIOUS

COLLECTORS ITEM. Marconi sensitive valve voltmeter and manual. Perfect condition. Serious offers only. Wavetek Model 95 programmable waveform generator, IEEE card, good condition. £500 for quick sale. Two Fluke hand-held multimeters. One new £70. Other well used £40 (new display). Tel: (0443) 685228. (evenings).
TEST GEAR FOR SALE AV08. £60 o.n.o.; Farnell dual stabilised bench power supply, 0 - 30V 0 - 2A, £140 o.n.o.; Gould Advance OS3500 60MHz dual-trace scope, £500 o.n.o. Tel: Pauline Goddard (0702) 204858.

WANTED

COMPREHENSIVE DATA/CIRCUITRY etc., for A.S.T. six PAC plus expansion board as fitted in my IBM-XT computer. Also IBM-XT service data manuals. Contact: M. Knights, 255 Addington Road, Irthlingborough, Northants NN9 5VS. Tel: (0933) 652111.

CIRCUIT DIAGRAM AND COMPONENT DETAILS for an Armstrong tuner/amplifier 626. Tel: (0252) 793711 (Farnham Surrey).
MAINTENANCE INFORMATION and/or circuit diagram for 3M photocopier type 516. Tel: John Lawson (081) 368 5438.
MAIN CHASSIS BOARD and front panel for an Hitachi CT4 14in colour TV. Tel: (021) 426 4471.

OLD ETI MAGAZINES 1972 to 1979. Reasonable amount paid for good condition copies. Willing to collect (London and South East). Tel: (081) 842 3862.

PARTS for Maplin Synthesiser Model 3800/56005. Tel: (0734) 420316.

INFORMATION AND/OR CIRCUIT DIAGRAM for Aiwa Music Centre model AF 5080. Contact: Colin Coates, Y.M.C.A., London Road, Derby DE24 8UT.

COMPUTERS

ZK80, SPECTRUM, ORIC ATMOS, I/O

CLASSIFIED

Placing an advertisement in this section of *Electronics* is your chance to tell the readers of Britain's Best Selling Electronics Magazine what you want to buy or sell, or tell them about your club's activities - Absolutely Free of Charge! We will publish as many advertisements as we have space for. To give a fair share of the limited space, we will print 30 words free, and thereafter the charge is 10p per word.

Placing an advertisement is easy! Simply write your advertisement clearly in capital letters, on a post-card or sealed-down envelope. Then send it, with any necessary payment, to: Classifieds *Electronics - The Maplin Magazine*.

circuits or interface (ZX1, ZX2, speech synth, microdriver, etc.). Contact: Mr. Lamy, 8 rue racary 91530 ST-CHERON.

SPECTRUM 'Plus' or 128K membrane £12.50, parallel (centronics) auto switch (9V PC) £24. Parallel buffer 64K (9V AC/DC) £24 all inc. P&P. Contact: Mr. Perry, 216 Marlpool Lane, Kidderminster DY11 5DC.

SEIKOSHA CP-100A MK2 Dot Matrix printer, boxed, with 2 cables (including parallel connector) £35. Tel: Robert (0235) 765127, Wantage, Oxon.

AUDIO

LEAKE TL/12 plus power amplifier stereo. Also faulty stereo preamp. £50. Tel: (0493) 751 850. (Norfolk).

MUSICAL

FOR SALE. Pair of EMI loudspeakers,

P.O. Box 3, Rayleigh, Essex SS6 8LR. Advertisements will be published as soon as possible, space allowing. No responsibility is accepted for delayed publication or non-inclusion of advertisements.

Private individuals only are permitted to advertise in this section; commercial or trade advertising of any kind is strictly prohibited by law. Advertisements are only accepted by the Publisher on this proviso. Readers who have reasonable grounds to believe they have been misled as to the nature of an advertisement are advised to contact the Publisher and their local Trading Standards Office.

enclosures Type LE4 (4-way) with stands. Impedance 82 25W r.m.s. Price £25. Buyer collects. Tel: (0460) 61955 (Chard).

ELECTRONIC ORGAN COMPONENTS. Final clearance! Keyboards, pedals, drawbars, ICs, technical manuals, Leslie parts, cabinets, valves, etc., S.A.E. for lists. Fred Wright, 23 Merrion Close, Moorside, Sunderland SR3 2QP. Tel: (091) 5288664.

CLUB CORNER

WIRRAL AND DISTRICT AMATEUR RADIO SOCIETY meets at the Irby Cricket Club, Irby, Wirral. Organises visits, DF hunts, demonstrations and junk sales. For further details, please contact: Paul Robinson (G0JZP) on (051) 648 5992.

ELECTRONIC ORGAN CONSTRUCTORS SOCIETY. For details of meetings. Tel: (081)

902 3390 or write 87 Oakington Manor Drive, Wembley, Middlesex HA9 6LX.

CRYSTAL PALACE & DISTRICT RADIO CLUB. Meets on the third Saturday of each month at All Saints Church Parish Rooms, Beulah Hill, London SE19. Details from Wilf Taylor, G3DSC. Tel: (081) 699 5732.

WIRRAL AMATEUR RADIO SOCIETY meets at the Ivy Farm, Arrowe Park Road, Birkenhead every Tuesday evening, and formally on the 1st and 3rd Wednesday of every month. Details: A. Seed (G3FOO), 31 Withern Avenue, Bebington, Wirral L63 5NE.

TESUG (The European Satellite User Group) for all satellite TV enthusiasts! Totally independent. TESUG provides the most up-to-date news available (through its monthly 'Footprint' newsletter, and a teletext service on the pan-European 'Super Channel'). It also provides a wide variety of help and information. Contact: Eric W. Wiltsher, TESUG, Rio House, Stafford Close, Ashford, Kent TN23 2TT. England.

THE BRITISH AMATEUR ELECTRONICS CLUB (founded in 1966), for all interested in electronics. Four newsletters a year, help for members and more! UK subscription £8 a year (junior members £4, overseas members £13.50). For further details send S.A.E. to:

The Secretary, Mr. J. F. Davies, 70 Ash Road, Cuddington, Northwich, Cheshire CW8 2PB.

MODEL RAILWAY ENTHUSIAST? How about joining 'MERG', the Model Electronic Railway Group. For more details contact: Mr. Eric Turner, Treasurer MERG, 38 North Drive, Orpington, Kent BR6 9PQ.

CLUBS. Want to make your PC or Z80 based machine do things, move things? Control lighting/heating, play music! Endless things to do. Join INTERFACE-UG, the interface group for you! Contact: Mel Saunders, 7 Drumcliff Road, Thurnby Lodge, Leicester LE5 2LH.



Text by Stephen Waddington
BEng(Hons), M.I.E.E.E., A.I.E.E., A.I.T.S.C.

CONVENTIONS in electronics are established in one of two ways, either through American, British or European standards committees or by a manufacturer introducing a scheme that industry later accepts as common protocol. Examples of the latter are becoming increasingly common in computing; the IBM Personal Computer (PC) model is well established, while software counterpart Microsoft continues to gain ground with their Windows platform.

COMMON STANDARD

Like these two larger organisations, a smaller 100-man company from California has bulldozed standards committees to produce a general-purpose control protocol that can be used to monitor sensors, control outputs and display system status in a wide variety of applications. Developed by Echelon, LONWorks is a Local Operating Network (LON) with applications ranging from the control circuitry in an automobile or washing machine, to security access schemes for office buildings or prisons.

How does this differ from a Local Area Network (LAN)? What distinguishes a LON from a LAN is its purpose.

LANs are designed to share data such as software programs, documents, images and databases between computers, and share disks and printers. A LAN's performance is measured by throughput, usually in megabits per second.

Conversely, a LON is designed to

NETWORKING INTELLIGENCE

A PROTOCOL FOR CONTROL APPLICATIONS

Technologists talked of the appearance of the 'intelligent building' long before computers became widely available. Yet, while PCs and programmable logic controllers have enabled dedicated control applications to be constructed, we are still waiting for wide area intelligent control systems. Here Stephen Waddington examines an innovative network technology that looks set to revolutionise control applications.

move sensor and control messages that are typically very short and which contain commands and status information that trigger actions. LON performance is measured by the number of transactions completed per second and response time.

THE NEURON CHIP

LONWorks technology enables the creation of intelligent control systems that can automatically supervise sensors and trigger output devices either alone or under the control of a supervisory computer. At the heart of the system is the Neuron chip, an integrated circuit that combines three central processing units, a sophisticated communication protocol, a

FEATURES OF THE NEURON INTEGRATED CIRCUIT

Three 8-bit pipeline CPUs.
On-chip memory.
11 programmable I/O pins.
Two 16-bit timer/counters for frequency and timer I/O.
Sleep mode for reduced battery consumption.
Network Communication Port.
Transmission rates:
0.6k-bits/sec to 1.25M-bits/sec.

700 packets/sec peak data transmission.
280 packets/sec average data transmission.
Collision detection.
Service pin for remote identification and diagnostics.
Unique 48-bit internal identification number.

multitasking operating system, a programmable event driven logic program and a series of I/O lines as illustrated in the block diagram in Figure 1. Two types of Neuron integrated circuits are available, the 3120 Neuron EEPROM and RAM version, or the 3150 Neuron ROM version. Both devices are based on CMOS VLSI tech-

ware to enable data to be transmitted between network elements. This requirement has been eliminated by the technology from Echelon, saving manufacturers both time and cost in the evolution of new products.

Cost and time advantages do not end here either. Conventional control systems have a rigid structure called

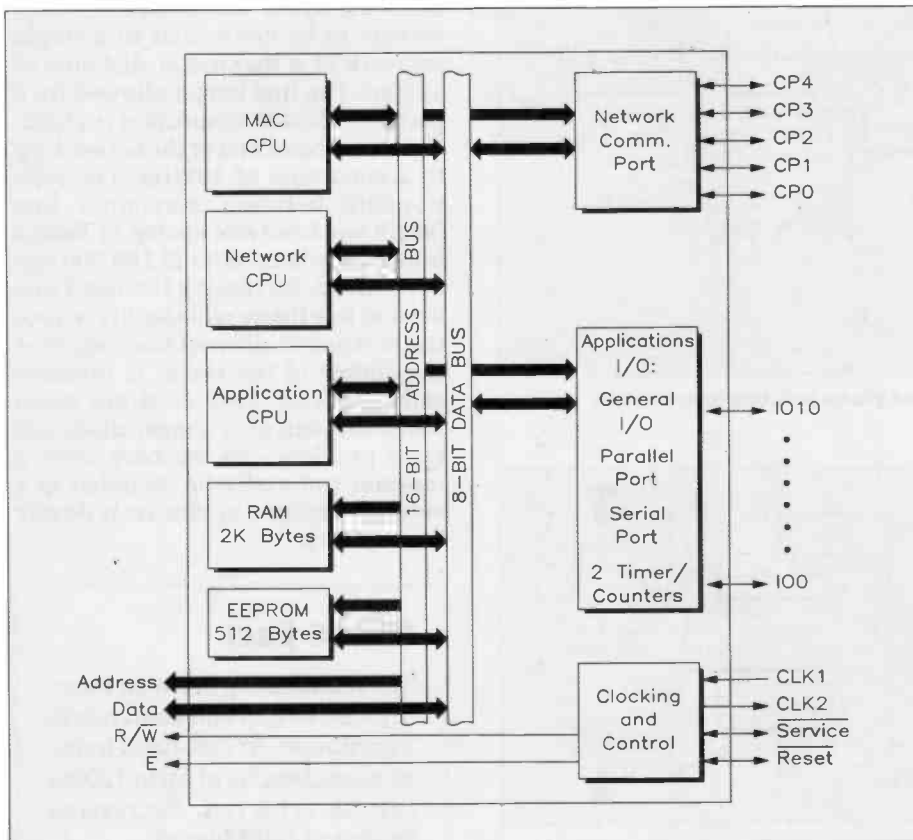

Figure 1. Neuron 3150 Chip block diagram.

nology and are highly integrated, requiring a minimal number of external components. The three 8-bit central processing units are pipelined together, each having a specific role, namely protocol encoding and decoding, application driving, and communications. The chips can send and receive information on either the 5-pin communication port – used for networking – or via the 11-pin applications I/O port.

DEVELOPMENT SAVINGS

Before the introduction of LONWorks and the Neuron integrated circuit, anyone wanting to construct a LON for a control application had to develop both a protocol and the necessary hard-

a bus topology. Local controllers monitor sensors and trigger outputs based on predefined software. The design structure is very rigid, often tied to a core bus as illustrated in Figure 2. This prevents electrical reflections between nodes or network components, limiting data corruption and ensuring efficient transmission rates.

The implementation of this form of bus topology requires careful planning, as all nodes must be routed off the central bus using short branches. Each device requires its own power supply, with perhaps an AC mains connection together with associated filters, junction boxes and maintenance access. If a new sensor or actuator needs to be added to the system, it must fall within a reasonable distance of the control bus, and both power and signal cable stubs must be installed. Alternatively bridging amplifiers may be used to extend terminations, implying additional cost and reduced transmission rates.

SCRAPPING THE RIGID BUS

The LONWorks system abandons the need for an organised bus topology and separate cabling for data signals and power. The layout of the network is no longer important, and both data signals and power lines are combined as shown in Figure 3. By modulating power and data on a common twisted pair, sensors and control devices can be interconnected with little regard for topology.

Instead of being sourced from each network device, power is supplied via an isolating interface to a common point as illustrated in Figure 4. Typically the network voltage is 48V DC. An isolation unit is included within the power supply to protect it from network wiring faults. In applications where high reliability is required, two or more power supplies may be used, sourced from separate AC mains feeds.

Electrical devices that may be connected onto the network include

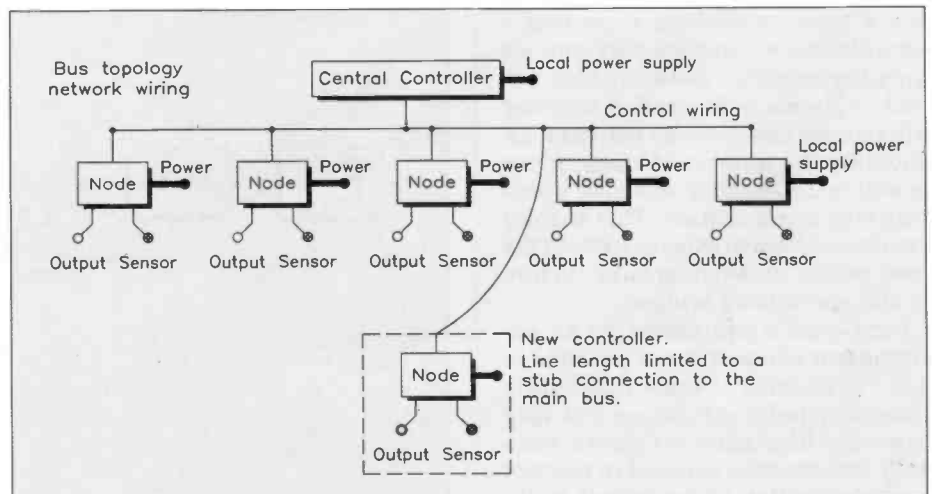

Figure 2. Conventional control systems are very rigid and expansion is limited.

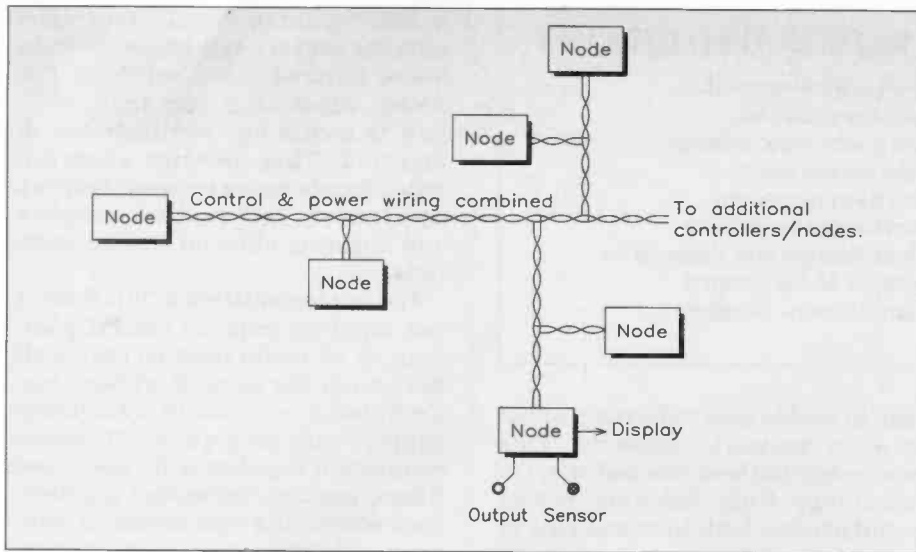

Figure 3. Free Topology Network.

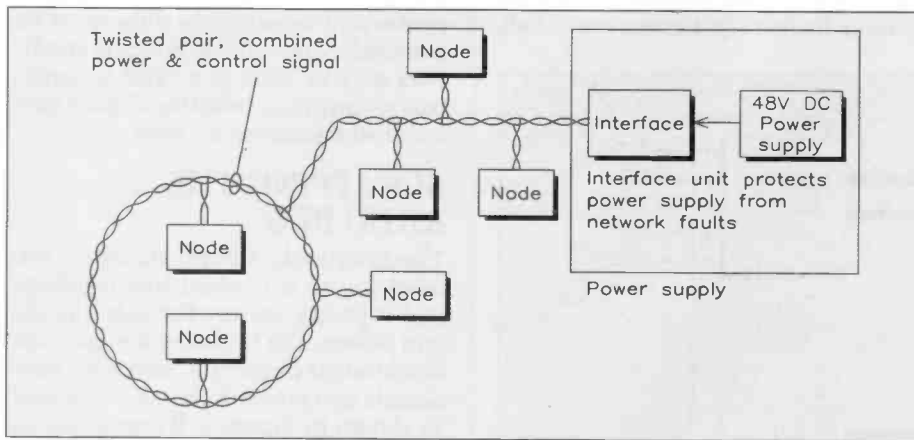

Figure 4. Power to a LONWorks network is supplied via an isolating interface to a common point.

integral switched mode power supplies enabling the network voltage to be regulated to 5V DC at currents up to 100mA for the Neuron chip and various sensors, controllers, actuators and displays. If higher output voltages or currents are required, such as 240V mains or 12V DC, the Neuron integrated circuit can be used to trigger a triac, relay or contactor.

If a LONWorks bus needs to be expanded, new nodes can be added as required. Should a network grow beyond the maximum number of transceivers or the maximum wire distance, further expansion can be facilitated using interconnecting repeaters – essentially two transceivers and an isolating amplifier connected back to back as shown in Figure 5. A repeater will transfer data between two systems, doubling the number of transceivers as well as the length of wire over which they may communicate. This enables a control system to expand without the need to alter the existing bus structure or add specialised bridges.

For portable equipment, or an environment where it is not possible to make a physical connection into a network, a radio or infra-red link may be used as illustrated in Figure 6. Here radio transceivers are used in place of each controller to broadcast radio signals at specific frequencies. Infra-red

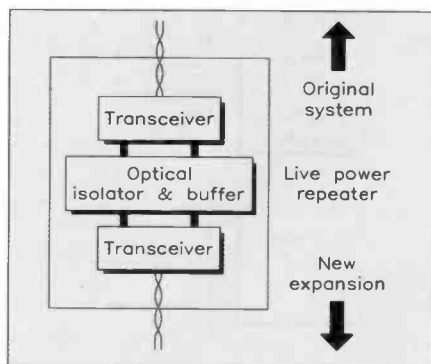

Figure 5. Link power repeater for the expansion of a LONWorks network.

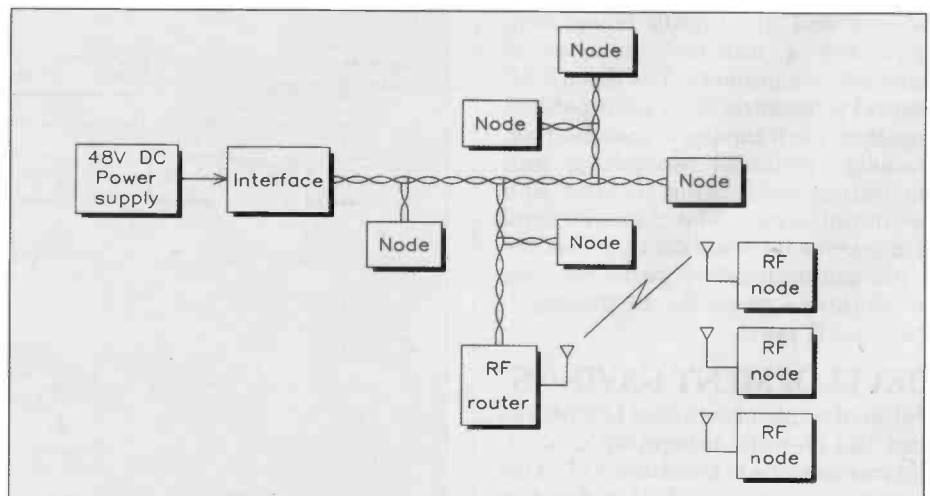

Figure 6. Combined link power and radio frequency control network.

transceivers perform the same function, but employ bursts of infra-red light instead of radio waves. In either case the LONWorks technology remains the same. What changes is the way the data is presented for transmission. Interfacing the Neuron IC to the network medium is a transceiver as shown in Figure 7. This ensures data is presented to the network cable at the correct voltage, or in the case of radio and infrared signals, modulated at the correct frequency.

COMMUNICATION STANDARD

The communication standard adopted by Echelon for data presentation is the Electrical Industries Association RS485. Others could be used although, compared with the older RS232, RS423 and RS422 formats, the standard incorporates a high level of data security, allowing up to 127 nodes or transceivers to be connected to a single network at a maximum distance of 1200m. The line length allowed for a particular RS485 connection is a function of the baud rate of the network up to a maximum of 10MHz. The relationship between maximum line length and baud rate quoted in Table 1 holds up to baud rates of 100,000 bits per second. Increasing the baud rate beyond this figure will sharply reduce the maximum allowed line length as the energy of the signal is dramatically reduced. This does not mean transmissions over longer distances are a problem – as we have seen, a repeater can easily be included in a network structure to effectively double the capacity.

RS485 Fact

The relationship between transmission length and baud rate is logarithmic. At 78K-baud transmission, lengths of up to 1200m can be achieved, decreasing to 18m at 1.25M-baud.

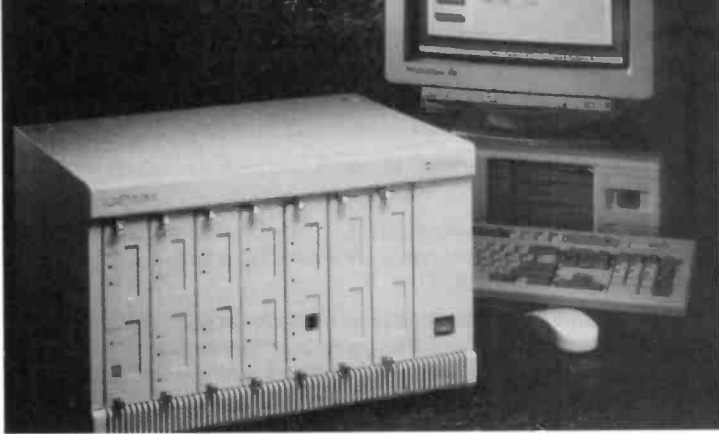

LON builder module.

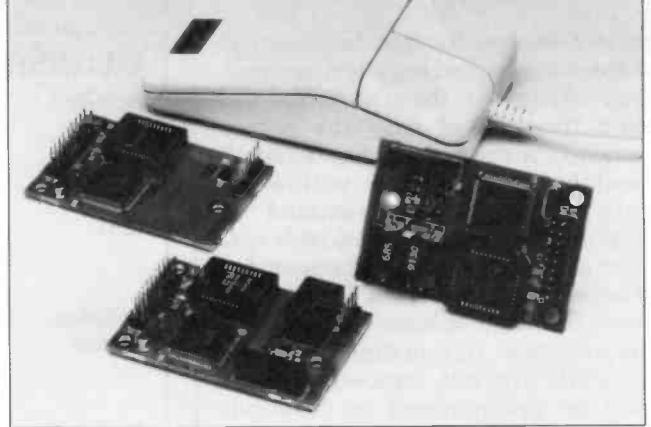

Examples of twisted pair control modules.

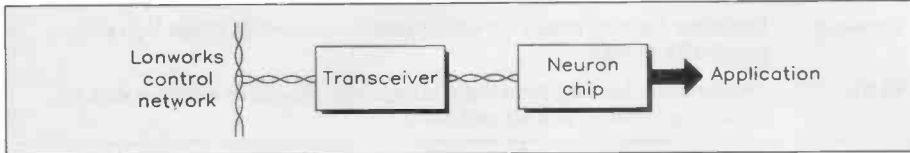
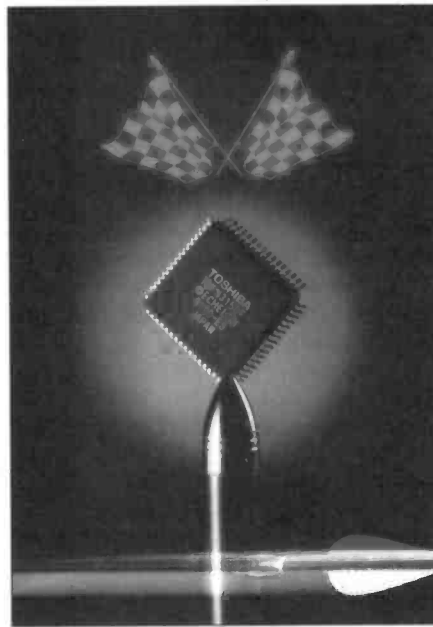

Figure 7. A transceiver interfaces between the Neuron chip and the network.

Bit Rate [k-bits per second]	Average Baud Transmission Rates [k-baud]	Line Length [Metres]
78	177	1200
156	234	450
312	468	150
625	936	45
1250	1875	18

Example of a Neuron chip by Toshiba.



Example of a Neuron chip by Toshiba.

PRACTICAL LONs

So theory aside, how is LONWorks network implemented in practice? According to Echelon it's quite simple. A statement supported by numerous UK-based companies currently working on products incorporating the Neuron integrated circuit include Merlin Gerin, Square D, Schlumberger, IBM, MK Electric and Philips.

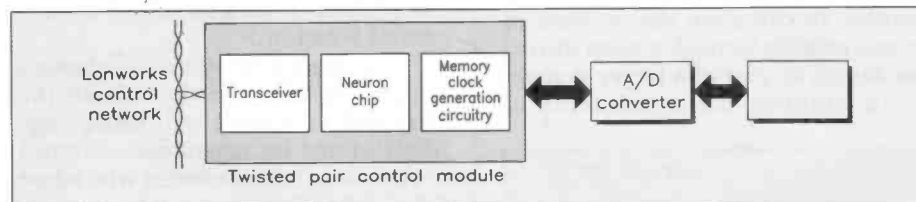

Figure 8. Adapting a thermistor for operation in a LONWorks network.

Licence to manufacture and distribute the Neuron integrated circuit has been granted to Toshiba and Motorola, both of which began volume production at the end of 1991. At present, the chips cost \$10 (£15) each, but the aim is to reduce this cost to \$2.50 (£3.75) by the middle of the decade. A reduction in cost will be essential if the Neuron chip is to be applied to simple electrical devices such as switches and light bulbs.

In fact a Neuron chip can be installed in almost any electrical or electronic device to form a node within a LON. Possibilities vary from a basic device such as a switch to a digital tachog-

raph, from a light bulb to a variable speed motor driver, and might include Programmable Logic Controllers (PLCs) or dedicated computers. The only common feature is that each is capable of transmitting or receiving data to and from other nodes or devices within the network. Figure 8 shows

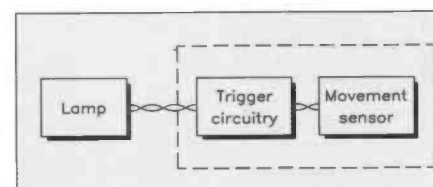

Figure 9. Conventional security lamp system.

Potential LONWorks Applications

- Automotive Electronics
- Intelligent Buildings
- Diagnostic Equipment
- Discrete Control
- Environmental Monitoring and Control
- Home Automation
- Heating and Ventilation
- Instrumentation
- Lighting Control
- Machine Automation
- Power Distribution and Control
- Process Control
- Robotics
- Security Systems

how a temperature sensor might be adapted to become LON compatible.

In the LONWorks system, each device acts alone, functioning independently as part of a network. Each node can transmit and receive signals on the network, enabling numerous devices to communicate with each other, rather than with a single device as in our security light example.

When conventional electrical apparatus is installed in a small control situation, the wiring between devices fulfils a dual purpose. It physically connects the devices and propagates signals – either data or power – between the two. Take for example a security light. Here a movement sensor is linked to an electric lamp as illustrated schematically in Figure 9. When a warm object, such as a person or animal, activates the sensor, the control circuitry switches power to the light bulb, thus illuminating the area of intrusion. Power is maintained for a preset period and then, assuming the sensor has cleared, switched off.

Although this type of control scheme forms the basis of many security systems, it is at best limited. Each device is dependent on the other and if either the sensor or the light bulb is removed, the system has little purpose.

DRIVING DATA

As a LON is data driven rather than command or address driven, a set of network variables such as tempera-

tures, pressures and light levels can be defined in standard engineering terms. Any changes to these variables are then transmitted over the whole network, making them immediately available to every node within the network. Nodes programmed to respond to a transmitted variable will react accordingly with no concern for where the information was generated. Likewise sensors transmitting measurement information on to the network are not concerned with devices programmed to respond. Virtual interconnections between nodes are defined purely by the software. This frees the application writer from tasks such as addressing, buffer management, collision control, message initialisation, message parsing and error management.

If signals require prioritising then this can be handled using separate channels or modulation frequencies on the LON network. For example, data from a fire or gas sensor would be more important than that from a light switch. The former could have life-threatening implications and thus it is crucial that it receives immediate precedence on the network, enabling emergency sounders and alarms to respond as appropriate. To ensure this, priority frequencies are allocated. If these channels become active, the LONWorks protocol demands that other data backs-off allowing the critical data to be immediately rebroadcast.

NEURON DEVELOPMENT

Defining the function of each Neuron IC is a straight forward programming task similar to programming an EEPROM, PAL or PROM. Application code is written in a C-type programming language using a development system consisting of a compiler and a debugger from Echelon. The Neuron C Debugger accelerates software development by providing everything required of a source level debugger; it can stop at any line in a program, execute code one statement at a time

GLOSSARY

Actuator	A transducer that is used to convert electrical energy into mechanical energy. Examples include solenoids, motors and sounders.
Bus	A conductor having low impedance to which two or more circuits can be separately connected.
CPU	Abbreviation for Central Processing Unit. A CPU is the central component of a computer system that co-ordinates arithmetic functions, logical operations, memory access and I/O.
Collision control	If two devices within a network attempt to transmit data, the signals will conflict. A set of control rules specifies subsequent network access. This will give priority to one of the devices while the other must wait for a preset period before making a network access.
Modulation	In general terms, the modification of one signal by another. In particular a process in which the characteristics of one signal – the modulation signal – are superimposed upon another higher frequency – the carrier signal.
Topology	Describes the way nodes are configured on a network, either logically, physically or both.
VLSI	Abbreviation for very large scale integration. Describes a device with a capability between 16k-bit and 1M-bit.

and view variable values. But its real advantage is that it is able to simulate a segment of a network, allowing developers to examine and write network variables so that they can easily monitor and debug connections between nodes. As the network grows, so will the debugger. It will allow anything from 1 to 24 nodes to be monitored at any one time. What is more, it can follow an event from an I/O input at one node, through a network variable update to an output on several other nodes.

To continue our security alarm system example, if the movement sensor was incorporated as part of a LONWorks system, it could serve numerous functions. Inside a building it could maintain its status as a security system, informing a lighting node if activated during the evening. It may additionally provide a link to a security office, or via a RF transceiver to a local police station. During the day, it might send a trigger signal to a modular counter, to calculate the number of people passing through a room during the day or, as part of a larger system, could monitor the movements of

people throughout a building. Finally it could be used as part of a lighting system, adjusting lighting levels within a room throughout the day. The scenario described is summarised in Figure 10.

FUTURE NETWORKING

Separating the functions of each device in this way allows a greater degree of flexibility and inter-operability, and because each node device operates independently of the network, new nodes can be added and connections between devices changed through software modification. Once installed, a LONWorks-based network can become a component in a larger network for the cost of a wire link and possibly a router. For example, the motion detector scenario might be linked to a wider security system covering a building throughout, such as a hospital, university or shopping complex for example. This would enable all sensors within the system to be monitored from a central location.

The continued adoption of Echelon's LONWorks standard throughout the electronics industry will bring huge implications for consumers. Control devices from manufacturers who adopt Echelon's technology will be compatible with each other in the same way that equipment from different manufacturers who have adopted the IBM PC standard is compatible. The cost benefits will be large as manufacturers compete – as they have done in the computing industry – to produce the most efficient and cost effective products. Like a 'do-it-yourself' PC that is made up of parts from different sources, control networks will, in future, consist of products from a number of manufacturers. A central heating system could for example, include intelligent thermostats, pumps, valves and boilers all from separate manufacturers, allowing the consumer to adopt the most effective products available.

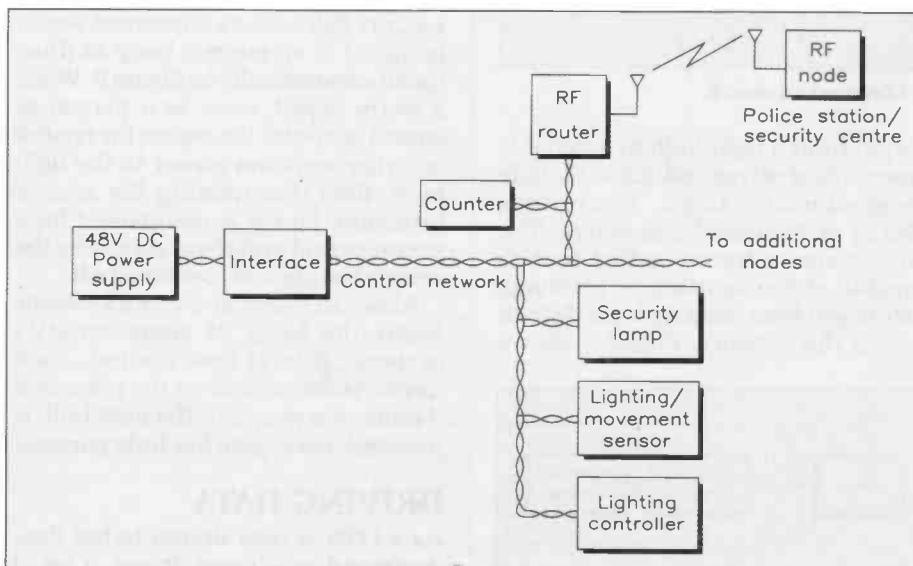

Figure 10. A small practical LONWorks local operating network.

Simple Car Test Probe



This project was designed for basic testing and fault-finding on 12V car electrical circuits, it is probably the simplest and most useful design possible. In many cases, constructors will already have all of the necessary items in their 'spare components box'.

A multimeter can be used to test car circuits, but such an instrument is not always necessary, can be cumbersome to use and in the case of an analogue moving coil meter it will not take to rough treatment very well. Multimeters can sometimes give too much information when all that is required is an indication of whether the supply is connected to a wire or not. Since the Car Test Probe does not cost very much to build, it could be kept in the car's glove compartment or tool roll - it will then be close to hand whenever it is needed to trace a wiring fault (i.e. broken

down in a dark country lane late on a rainy winter's night). If the unit becomes damaged or lost, it's less of a hardship when compared to an expensive multimeter.

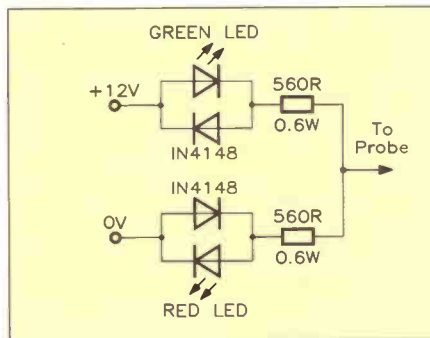

Figure 1. Circuit Diagram of Car Test Probe.

The Car Test Probe is not limited to fault-finding, it will equally be of use when adding car accessories such as a trailer connector, car alarm etc. The unit indicates by means of the LEDs the following conditions: a floating connection, connection to positive supply, connection to negative supply.

The circuit shown in Figure 1 uses just two resistors, two diodes and two LEDs and requires little explanation. The 560Ω resistors serve to limit the current flow through the LEDs and the 1N4148 diodes afford protection against incorrect supply polarity. The Car Test Probe can be built into a probe case or any other suitable enclosure. The LEDs can be of any size from 3 to 10mm to suit the enclosure; 'standard' or 'high-brightness' LEDs can be used - high brightness types have better visibility with high levels of ambient light.

To use the probe simply connect the two crocodile leads to any convenient fused positive and negative supply points; correct supply connection is indicated by *both* the red and green LEDs illuminating. The probe is then touched onto the wire or terminal to be tested, the LEDs will give an indication as summarised in Table 1.

LED State	Indication
Both LEDs lit	Supply connected/probe floating
Red LED lit	Probe connected to positive supply
Green LED lit	Probe connected to negative supply
No LEDs lit	Supply not connected or wrong polarity

Table 1. Car Test Probe LED states and indications.

Happy Motoring!

CAR TEST PROBE PARTS LIST

RESISTORS: ALL 0.6W 1% Metal Film
560Ω 2 M560R

SEMICONDUCTORS

1N4148 2 QL80B
Red LED 1
3mm Red LED WL32K
or 5mm Red LED WL27E
or 5mm High Brightness Red LED WL84F
or 8mm Red LED UK21X
or 10mm Red LED UK25C
Green LED
3mm Green LED WL33L

or 5mm Green LED WL28F
or 5mm High Brightness Green LED CK40T
or 8mm Red LED UK22Y
or 10mm Red LED UK26D
LED Clip 2
3mm LED Clip YY39N
or 5mm LED Clip UK14Q
or 8mm LED Clip UK16S
or 10mm LED Clip UK17T

MISCELLANEOUS

Black Extra Flexible Wire As Req. XR40T
Red Extra Flexible Wire As Req. XR44X

Black Crocodile Clip	1	FS49D
Red Crocodile Clip	1	FS48C
Grommet	1	JX65V
Cable Tie	1	BF91Y
4mm Plug	1	HF62S
4mm Socket	1	HF69A
4mm Probe Set	1	HF33L

The Maplin 'Get-You-Working' Service is not available for this project.

The above items are not available as a kit.

SUB-WOOFER

FOR HOME OR CAR

Part 3: Adding a Tweeter

by J.M.Woodgate

B.Sc.(Eng.), C.Eng., M.I.E.E.,
M.A.E.S., FInst.S.C.E.

When I began this series, I had no intention of dealing with anything more than the basic (sub-) woofer, but since then the attraction of adding a tweeter to make a full-range system has increased. This is intended for home use: for a car system the sub-woofer application is the most appropriate, although another possibility would be a three-way system.

TWO-WAY SYSTEMS

We want, ideally, a loudspeaker system to cover the whole audio-frequency range, 20Hz to 20kHz, but no-one has yet produced a satisfactory single driver to cover that whole range. This is a matter of basic physics: to produce a sufficient sound pressure level at low frequencies requires the movement of quite a lot of air volume, either by pushing a small cone area a long way or a large cone area a short way. But, at the other end of the frequency range, the driver must inevitably be excessively directional *unless* it is fairly small compared with the wavelength of the sound. At 20kHz this is only 17mm, and we could take this as the maximum permissible radius of the diaphragm. Since the air volume we require to move at low frequencies is of the order of 100,000mm³, a diaphragm movement of 110mm to and fro would be necessary! It would be wrong to say that no way of doing this is known, but I doubt whether that

includes any way of doing it with a mechanical system that will also vibrate without resonances and without requiring excessive power input right up to 20kHz. We can see why two-way and three-way (even four and five-way) systems are widely used.

DIVIDING THE FREQUENCY RANGE

We have a range from 20Hz to 20kHz, so where should we divide it? Obviously halfway, but that cannot be halfway arithmetically, because that would mean dividing at 10,010Hz, which is not much more practicable than no division at all. We could try to divide the range 'geometrically' at frequency f_d , which means:

Unfortunately this frequency is still too low

$$f_d = \sqrt{20 \times 20000} = 632\text{Hz}$$

for a practicable tweeter, covering up to 20kHz, to be designed. It is interesting to note

that a three-way system would, following this rule, have dividing frequencies of 74Hz and 5.4kHz, which represents a sub-woofer/bass-midrange/tweeter 3-way system fairly well (but not the conventional 3-way home system, which would have dividing frequencies more like 250Hz and 2.5kHz). The present sub-woofer design could fit into such a 3-way system quite well, and this arrangement would be suitable for a car system.

Since we cannot use the dividing frequency arrived at by simple logic, we must consider the frequency ranges covered by practicable drivers. Our woofer will cover up to 2kHz quite well, and even its piston radius (ignoring the reduction in effective radius due to cone break-up) is only half a wavelength at this frequency, so we may expect it not to be excessively directional. If a driver is excessively directional in a particular frequency range, the sound tends to localise on the loudspeaker in that range, instead of 'filling the room' by exciting the room reverberation (see below), and the reproduction usually sounds 'thin' and the stereo effect is poor.

To reach down to 2kHz with adequate quality, a good dome tweeter is required, and luckily Maplin have an ideal candidate in YN43W, with which I strongly recommend the FD93B grille, to protect the dome from fingers. When fitting the grille, do NOT lift the driver by its mounting flange after you have taken out the four screws, which have to be replaced by the longer ones supplied with the grille. It is possible to get the mounting plate back on to the magnet in the right place, but the process is bad for the nerves! The YN43W is an 8Ω unit (nominally), so if we are going to use a passive dividing (crossover) network, we have no real choice but to use the 8Ω woofer XP25C, otherwise the sensitivities of the two units would not match. However, the type of dividing network that I recommend most strongly is too complex to produce economically in passive form, but easy as a low-level circuit to use with two final amplifiers per stereo channel (this technique is called bi-amping). In this case, the rated impedances can be different, because the consequent sensitivity differences can easily be eliminated by the use of preset gain controls. (The sensitivities are related to the rated, as opposed to the actual, impedances: the latter can be, and often are, different, as we shall see.)

WHAT SHOULD A DIVIDING NETWORK DO?

Ideally, like the bread advertisement, it should neither add anything to the signal or take anything out, but we are not starting with best wholemeal flour in the first place. We have to use two (or more) drivers, and they can't be in the same physical place. The nearest to this ideal is the relatively new concentric arrangement using a very small tweeter, with a samarium-cobalt magnet, mounted in the centre of the bass driver. Unfortunately, neither this, nor the next-best arrangement used by Tannoy, with the tweeter firing through the hollow pole-piece of the bass driver magnet system, is available to the home constructor at an attractive price.

We can reduce the separation of the drivers

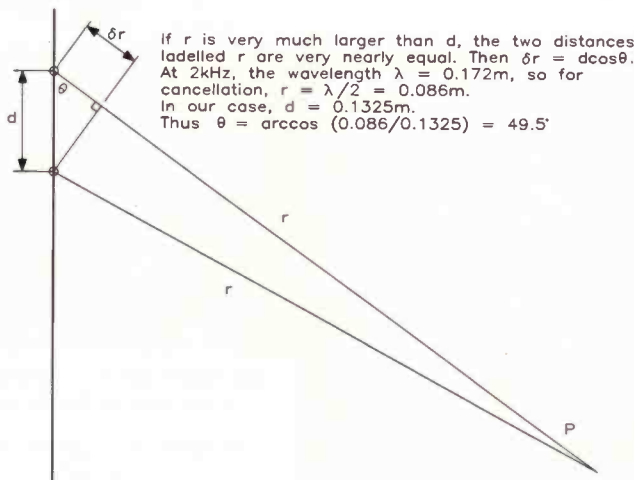

Figure 21. Path length difference for separated drivers

simply by mounting them as close together as possible, which in our case gives a distance between centres of 132.5mm, aided by the small size of the bass driver. However, in common with most other designs, the Maplin tweeter is unnecessarily large: ideally the diameters of the mounting plate and magnet system should be as near to that of the dome diameter as possible. I hope that new designs of tweeter will incorporate this principle. To reduce the frequency-dependent time-delay which normally occurs between the arrival of the sound from the tweeter and the sound from the bass driver (due to the depth of the bass driver cone), we should mount the tweeter behind the plane of the front of the bass driver, but it happens that for our units this is unnecessary, because the difference in the source positions is so small if the bass driver is front-mounted.

The effect of the inevitable separation of the sources, which should normally be in the vertical direction, is that in the frequency range round the crossover frequency, where both units are radiating comparable sound powers, reinforcement and cancellation effects occur at off-axis positions. For example, the path length difference between our two drivers and a listener 2 metres away is equal to half a wavelength of 2kHz, giving cancellation, at 49.5° off axis (see Figure 21). However, this assumes that the two drivers are radiating in phase. Since, by using a dividing network, we are connecting filters in their feed paths, and filters are bound to introduce phase shift (analogue filters, anyway), we must pay attention to the effects of these phase shifts, which may be quite dramatic. For instance, if the phase difference between the driving signals in the above example were 180°, cancellation at 2kHz would not occur at nearly 50° off axis, but precisely on the axis! Ideally, then, we would like zero phase difference between the driving signals in the crossover frequency range.

The next requirement is for a flat frequency response: the overall response of the two drivers together must not be either greater or less than in the frequency ranges where only one driver is effectively operating. Here comes a big question: what do we mean by a 'flat response'? Conventionally, we put a microphone in front of the box and take the frequency response of the sound pressure more or less on the axis. But, we have seen above that the directional response of the bass driver varies with frequency, and in the frequency range where both drivers are operating there are more potential variations. Variation of the directional response is another way of saying that the total sound power output varies, if the on-axis frequency response remains completely flat.

Do we, then, want a flat sound power response? This is a highly controversial question, and has been for some years. The answer seems to be no, but the response should fall with frequency only very slowly, something like 0.5dB/octave. We stand a chance of achieving this with our small bass driver, whereas using a 30cm or even 25cm driver up to 2kHz would make it impossible. It can be shown theoretically that it is, in fact, impossible to get both a flat sound pressure

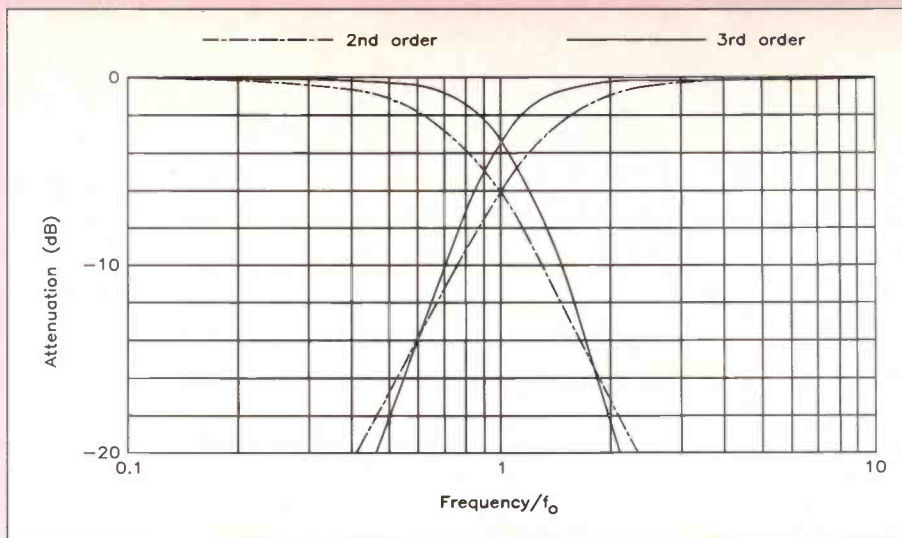

Figure 22. Showing that a pair of second-order filters crossing over at -6dB have greater attenuations between 0.6 and 1.6 times the crossover frequency f_0 than a pair of third-order filters crossing over at -3dB.

response and a flat sound power response with separated drivers, unless we would be prepared to accept a directional response which varies considerably in the crossover frequency range. Good evidence, particularly that published by Dr. Floyd Toole in the AES Journal in 1986, points to the need for a flat on-axis sound pressure response, and - practically as important - a smooth increase in directionality at high frequencies. Or, as an equivalent, that the off-axis responses fall smoothly, and not too much, at high frequencies. Toole's results show that the average response between 30° and 45° off axis should be about 4dB down, while at 60° to 75° off axis, it should be about 9dB down. This is largely controlled by the tweeter design and mounting, but it is important that the dividing network does not cause severe anomalies in the mid-frequency range.

There is another way of looking at this question. When we are listening in a room, we hear direct sound from the loudspeaker(s), reflections from the walls, floor and ceiling, and reverberant or diffuse sound caused by multiple reflections. As we move away from the loudspeaker, the level of direct sound decreases, while that of the reverberant sound does not (unless the room has a strange acoustic behaviour anyway). The sound pressure level of reverberant sound depends on the sound power level radiated by the loudspeaker, while the level of direct sound actually is the sound pressure level produced by the loudspeaker. So, if we are listening relatively close to the loudspeaker, we need a flat sound pressure response, and a directional response that does not change too much with frequency. If, on the other hand, we are listening mainly to the reverberant field, then we may need a flat sound power response, and the precise directional response may be less important.

From all this it could well be that the source of the controversy over the relevance of sound power response lies in differently sized, and differently damped, listening rooms. An acoustically lively room obviously has a stronger reverberant field, which may dominate the direct sound quite close to the loudspeaker, even allowing for the 'Haas effect', whereby the apparent direction of a sound source is determined by the direction of the first sound to arrive, normally the direct sound, even if this is followed by a somewhat

louder sound from another direction, or, in the case of reverberation, no particular direction.

The final requirement (except of course the ever-present one of low cost) is that the attenuations of the filters should reach high values at frequencies quite close to the crossover frequency. This ensures that irregularities in the response of the driver which is not supposed to be operating do not impair the overall response. For example, our bass driver has some peaks in the 4kHz region, which we do not want to hear. To make less than 1dB difference to the overall response, the unwanted one should be at least 12dB down, and preferably more, because a 1dB irregularity may be audible.

This implies a steep rate of cut-off for the filters, but is actually a more directly relevant requirement. If we have zero phase difference between the drivers at the crossover frequency then, for a flat frequency response, the response of each driver, as fed through its filter, must be 6dB down at the crossover frequency. If, however, we have a 90° phase difference, each response must be only 3dB down, which implies a greater overlap between the filter responses, perhaps enough to cancel out a steeper rate of cut-off (see Figure 22).

PASSIVE NETWORKS

Passive crossover networks typically consist of capacitors, inductors and resistors, while some lavish designs also use transformers. Many commercial loudspeaker 'designs' employ just one small capacitor in series with the tweeter: these often sound just the same, or better, with the tweeter disconnected entirely! I assume that anyone who has read this far in a three-part series wants something more satisfying than that.

The first step is to forget any simplistic design formulae that you may have seen. Eventually, we will see some even simpler, yet more versatile, formulae, but we have to begin by dealing with the less than ideal impedances of the drivers themselves. We looked at the bass driver impedance extensively in Part 1, but only up to 200Hz or so. Above this frequency, the impedance rises continuously, due to the inductance of the voice coil. Any dividing network designed on the basis of the impedance being 8Ω and purely resistive simply won't work properly. Unfortunately, designing a filter with an arbitrary and partially reactive load

is not easy, and the best course of action is to eliminate the effect of the inductance. For the tweeter, we have to do more, as we shall see later.

ZOBEL NETWORKS

The books don't throw a great deal of light on who Dr. Zobel was, except that he worked on the early theory of filters at Bell Telephone in the 1920s, but his networks are very useful. We can approximate the impedance of the bass driver above 200Hz by a resistor R and inductor L in series. If we connect in parallel with this combination, another, equal resistor R and a capacitor C in series, the input impedance of the whole circuit can be made purely resistive, and equal to the value of one of the resistors. It isn't magic, and the mathematics is not difficult, but there is an equation about a foot long in the middle of the working, so please excuse me not reproducing it here. The result we need is that, for the impedance to be resistive, the component values are related by:

$$R^2 = \frac{L}{C}$$

For the bass driver, that is all we need to do, and the required Zobel network is 7.9Ω in series with $20.2\mu\text{F}$. The resistor can be made up from 8.2Ω in parallel with 220Ω , and the 8.2Ω should be of at least 5W rating (not higher than 10W unless you are going to do high power sine wave testing, which I do not recommend). The capacitor should preferably be made up from polypropylene components, two of $3.3\mu\text{F}$ and two of $6.8\mu\text{F}$, all in parallel. The circuit is shown in Figure 23a, and the 'before and after' impedance/frequency curves are shown in Figure 23b. I have not plotted the resonance peak very precisely, because it isn't relevant.

For the tweeter, things are not so simple; the main resonance occurs at just below 1kHz and the resulting impedance peak is bound to upset the attenuation characteristic of the high-pass section of the dividing network completely, just in the most critical frequency range. But we can begin by dealing with the voice-coil inductance, which we can measure approximately, as follows. We measure the DC resistance of the voice coil and then find the frequency (well above the resonant peak) where the voice coil impedance is $\sqrt{2}$ times the resistance. At this frequency, the reactance of the voice coil inductance is equal to the resistance. On my sample, the DC resistance was 5.7Ω , and the impedance was $\sqrt{2} \times 5.7 = 8.08\Omega$ at 17350Hz. This gives a voice coil inductance value of:

$$\frac{5.7}{2\pi \times 17350} = 52.4\mu\text{H}$$

and the Zobel network capacitor value is thus:

$$\frac{52.4}{5.7^2} = 1.61\mu\text{F}$$

Note that this value can be calculated directly as:

$$\frac{1}{2\pi \times 5.7^2 \times 17350}$$

This is no more than good approximation, because the effective inductance is not constant, due to eddy current losses in the pole-pieces of the magnet system. It is possible to

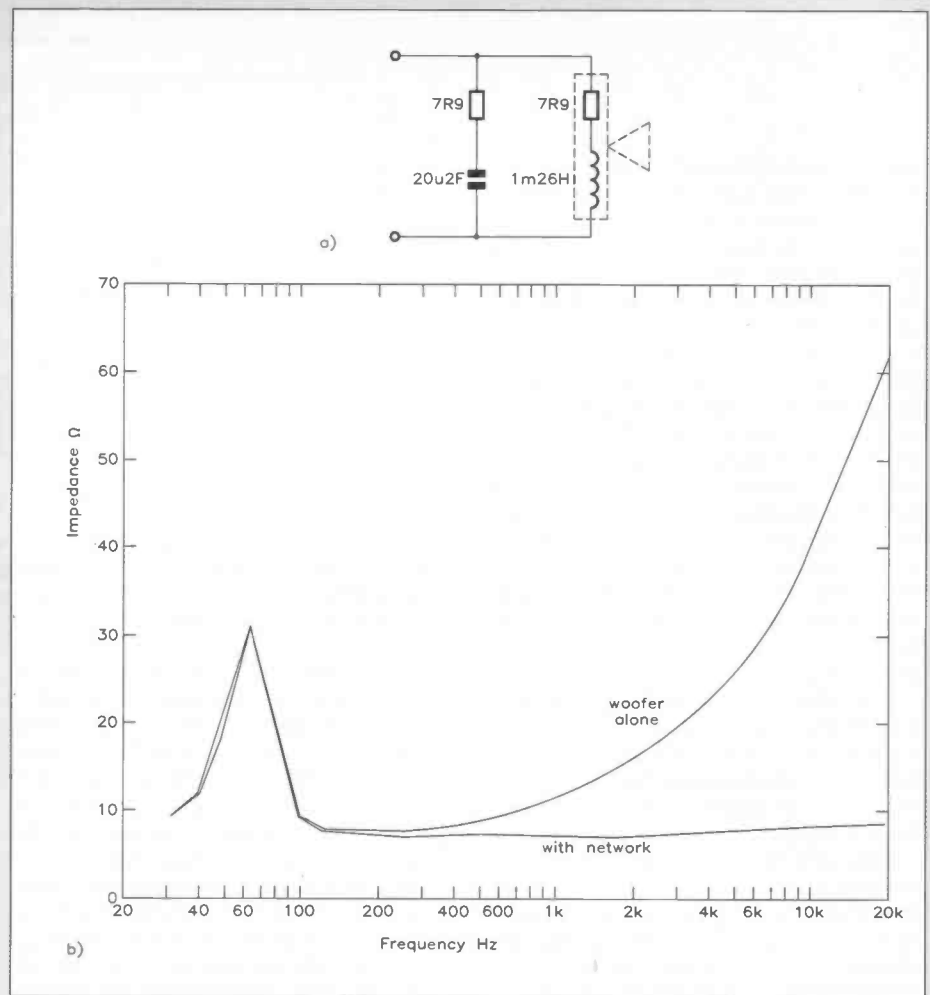

Figure 23 The Zobel network for the woofer; (a) Zobel network circuit; (b) effect of the Zobel network on the impedance/frequency curve.

compensate for this with extra components, but it is usually not necessary, more particularly because all the Zobel network values are related to the DC resistance of the voice coil, and this varies with its temperature, i.e. with signal level! Again the required values can be made up from standard components quite easily. A 5W resistor should be ample for this service.

The cancellation of the resonant impedance peak, by means of a more generalised form of Zobel network, requires a series tuned circuit of the same resonant frequency and Q to be connected across the Zobel capacitor, in series with the Zobel resistor, the whole combination being in parallel with the tweeter. We can find the values from the electrical equivalent circuit of the tweeter, and we saw how to do the necessary measurements in Part 1. The situation is somewhat complicated by the effect of the voice-coil inductance, and Neville Thiele has shown how to deal with this accurately (but the paper was published in Australia). In our case, the voice-coil inductance is only about a quarter of the value used by Thiele in his rather complicated analysis, so we can use the simpler approach which is valid for bass drivers.

MEASURING THE THIELE SMALL PARAMETERS OF A TWEETER

When Thiele did this work, he was dealing with cone tweeters, which have rather different characteristics from those of the dome tweeter we are using. Our dome behaves much more like a bass driver! We went through the procedure in detail in Part 1, so

here we will just have a step-by-step account, with my results in square brackets at each stage:

1. Measure the DC resistance R_e [5.7Ω]
2. Measure the frequency of maximum impedance f_0 [958Hz] and the value of the impedance at this point, Z_0 [25Ω]. If we find that the phase angle of the impedance is near zero at this frequency, we can tell that the voice-coil inductance is not affecting the result. [It was about 4° , so the inductance was not affecting the result.]
3. Calculate $r_0 = Z_0/R_e$ [4.38], and find the two frequencies above and below f_0 where the impedance is $R_e\sqrt{r_0}$ [$f_1 = 714\text{Hz}$, $f_2 = 1255\text{Hz}$]. As a second check for errors or untoward effects, $\sqrt{714 \times 1255} = 947\text{Hz}$, which is adequately close to 958Hz.
4. Calculate $Q_{es} = f_0\sqrt{r_0}/(f_2 - f_1)$ [3.68], and then calculate $Q_{ms} = Q_{es}/(r_0 - 1)$ [1.09].
5. Calculate the component values in the damped parallel-tuned equivalent circuit: $R_{es} = R_e Q_{ms}/Q_{es}$ [19.3 Ω], $L_{ces} = R_{es}/(2\pi f_0 Q_{ms})$ [872 μH] and $C_{mes} = Q_{ms}/(2\pi f_0 R_{es})$ [31.64 μF].
6. Calculate the Zobel network values: $L_1 = C_{mes} R_e^2$ [1.03mH], $C_1 = L_{ces}/R_e^2$ [26.75 μF] and $R_1 = R_e^2/R_{es}$ [1.69 Ω].

The complete circuit, comprising the Zobel network and the equivalent circuit of the tweeter, are shown in Figure 24a, while Figure 24b shows the uncorrected and corrected impedance curves. Again, I have not plotted the resonant peak precisely, because in this case it is very relevant but we want to get rid of it. Note that the elimination of the effect of the voice-coil inductance makes the tweeter

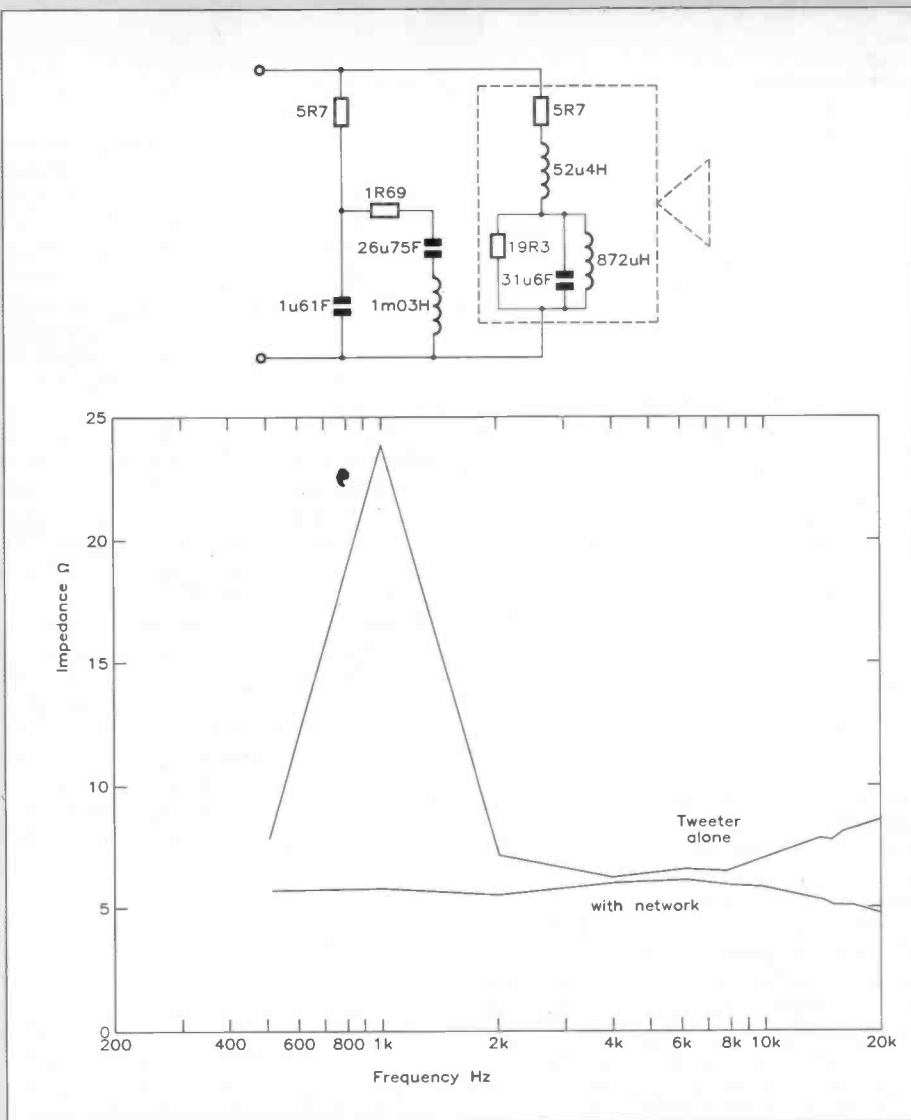

Figure 24. Effect of the Zobel network on the impedance/frequency curve; (a) Zobel network circuit for the tweeter; (b) effect of the network on the impedance/frequency curve.

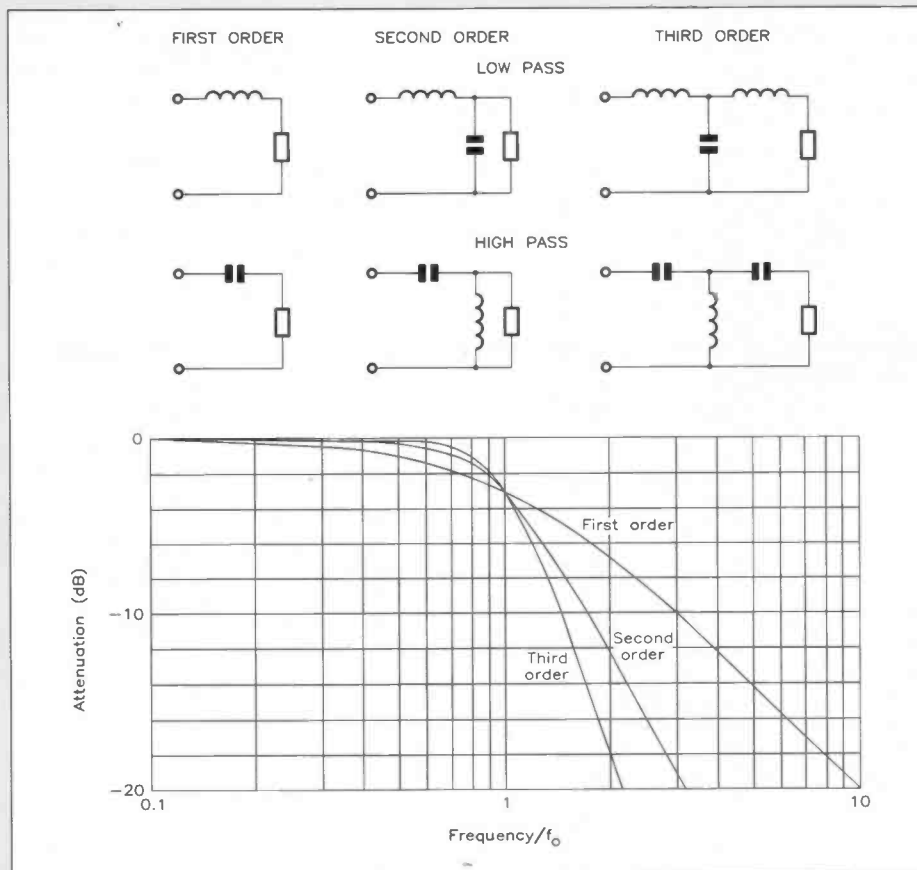

Figure 25. First, second and third order filters and their rates of cut-off.

impedance closer to the DC resistance, of 5.7Ω , than to the rated value of 8Ω , and we will have to allow for this in designing passive crossover networks.

WHICH TYPE OF PASSIVE CROSSOVER NETWORK?

Figure 25 shows basic circuits of filters of different orders. The order is the highest power of the variable which represents the frequency in the equation describing the attenuation characteristic of the filter. (I hope to be dealing with this in greater detail in a later article.)

How do these filters fit in with the requirements we set out earlier? Well, first-order filters have a rate of cut-off of only 6dB per octave (20dB per decade), which is too slow for all but 'cooking' designs. Both drivers would have to work well for some two octaves beyond the crossover frequency, in fact up to 8kHz for the woofer, and down to 500Hz for the tweeter. This is just not practicable.

Second-order filters have cut-off rates of 12dB per octave, which is better, and may be sufficient. In general, an Nth order filter of the type we are considering here ('all-pole') has a cut-off rate of $6N$ dB per octave or $20N$ dB per decade (see Figure 25). However, there are other problems. The low-pass and high-pass filters that make up the crossover network each shift the phase of the signal, and the phase difference between the woofer and tweeter turns out to be 180° at all frequencies. This means that at the crossover frequency, where by definition the outputs of the two drivers are equal, there is a null in the response *exactly on the axis of the system*. We could overcome this by reversing the connections to one of the drivers, so that they would be in phase at the crossover frequency. But if we do this, we get a 3dB peak in the response, which is better than a null, but not good. The peak comes about because each drive signal is 3dB down at the crossover frequency, but the two drivers are now in phase, so their outputs add arithmetically, i.e. the sum is twice (+6dB) that of one driver alone. One way of getting a truly flat response is to keep the crossover at the -3 dB frequency, and add a shallow band-stop filter to remove the 3dB hump. This is not often done; it is possible, but it does not give a flat power response. Another approach is to shift the filter cut-off frequencies apart by dividing the low-pass cut-off frequency by a factor of $\sqrt[4]{3}$, and multiplying the high-pass cut-off frequency by the same factor, so that the drives are 6dB down, instead of 3dB down, at the frequency at which they are equal. We get a pressure response that wriggles, rather than being flat, but the wriggles are only +0.42dB and -0.65dB, and occur only in a narrow frequency range, as shown in Figure 26 (where the crossover frequency is 1.6kHz instead of 2kHz). The inter-driver phase difference is only 45° at the crossover frequency if one driver is connected in reverse polarity. I haven't been able to find any reference to this configuration in the literature, but I am sure it is not original. It seems to have some attractions.

Another practicable crossover network is

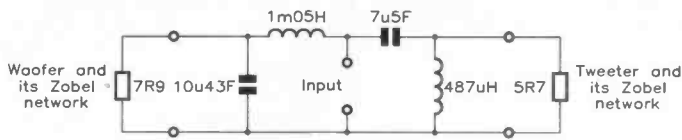

'Separated' 2nd-order passive crossover: each drive is -6dB at 2kHz

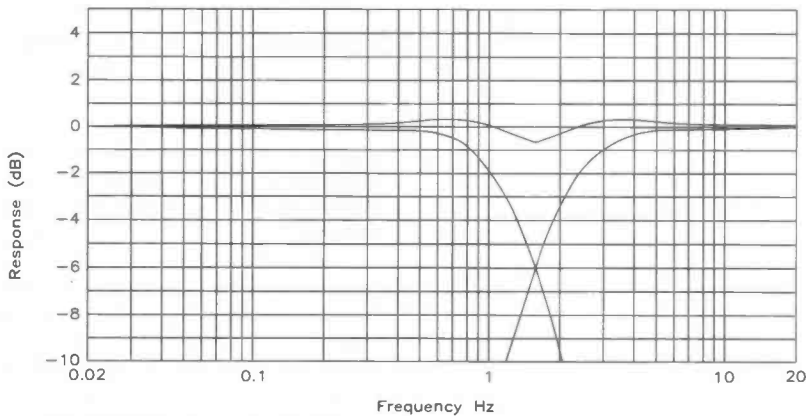

Individual and combined responses of 'separated' second-order passive crossover: here the crossover frequency is 1.6kHz

Figure 26. Characteristics of the 'separated' second-order crossover network; (a) 'separated' 2nd-order passive crossover, each drive is -6dB at 2kHz; (b) individual and combined responses of 'separated' second-order passive crossover, here the frequency is 1.6kHz.

based on third-order filters. In this case, both the power response *and* the pressure response are constant in the crossover range, without manipulating the filter cut-off frequencies. Each driver is 3dB down at the crossover frequency, and the inter-driver phase difference is 90°. This means that whichever way round the tweeter (say) is connected, the pressure response remains flat, but it can be shown that the group delay is three times less if it is connected in reverse polarity. (I can't begin a discussion on group delay here, but perhaps some other time.) The power response is also flat, which, as we saw earlier, means that the directional response varies in the crossover frequency range. This variation is less damaging if the drivers are mounted vertically one above the other, and for some listening conditions, it may be better to have the tweeter *below* the bass driver rather than above. Again using all we have discussed so far, the circuit diagram of the third-order crossover for 2kHz is shown in Figure 27.

COMPONENT VALUES FOR PASSIVE CROSSOVER NETWORKS

The filters used in passive crossovers are NOT the same as the classical text-book filters that work between a 600Ω source and a 600Ω load, nor even 8Ω source and load. The amplifier output source impedance is (or should be) nearly zero, but recall from Part 1 that there is no need to go to the extremes of worrying about 'damping factors': anything less than a tenth of the load impedance is acceptable. Note also that the use of Zobel networks not only makes the crossover work properly, but also makes the impedance of the system as a whole independent of frequency (except at the lowest frequencies), so that the *source impedance does not affect the frequency response*.

The way that the determination of component values is dealt with in modern filter the-

ory (restricting the general case to our special conditions) is to find the values for a reference filter which works between a zero impedance source and a 1Ω load, and has a cut-off frequency (-3dB response level) of 1/2πHz, so that ω = 1 rad.s⁻¹ (radians per second). We then simply scale the values for the load impedance and cut-off frequency that we want. The *only* things we have to get from tables (because they are tedious to calculate, especially for high-order filters) are the component values for the reference filter, and once we have those, we can design filters for any load impedance and any cut-off frequency.

We begin with the second-order low-pass filter (Figure 28a). From tables, the reference filter has an inductor value √2H and a capacitor value (√2/2)F (yes, farads!). Firstly we have to increase the impedances by the ratio of our load impedance (which is a pure resistance, thanks to Dr. Zobel) to 1Ω, so we multiply the inductor value by 7.1, and *divide* the capacitor value by 7.1. We can call 7.1 the 'Z-factor', because it is about scaling for the actual impedance.

Now we have to scale for frequency, but we must remember that the reference filter works at ω=1, not f=1. We could call the scale factor the 'Ω-factor' but I think that would be confusing, so I use the term 'W-factor'. The value of ω for the low-pass filter cut-off is 2π × 2000⁴√3 = 9548, and this is the W-factor. We have to divide both inductor and capacitor values by this, and the end results of the arithmetic are L=1.05mH and C=10.4μF.

The filter tables usually give only the values for low-pass filters, so we have to use the 'lp-hp transform' to get the values for the reference high-pass filter. That sounds very grand, but it is only a matter of changing inductors to capacitors and capacitors to inductors, with the values related by:

$$C_{hp} = \frac{1}{L_{lp}} \text{ and } L_{hp} = \frac{1}{C_{lp}}$$

This transform must be applied to the reference filter values, *not* to the scaled values (Figure 28b). Our high-pass filter has a cut-off frequency of 2000 × 4√3 = 2632Hz, so the W-factor is 2π times this, or 16538. The Z-factor is 5.7: you can see that this scaling method copes with neither driver really being 8Ω and neither cut-off frequency really being 2kHz. Tabulated values would have been useless. The scaling calculations are exactly the same as before, and give C = 7.5μF and L = 487μH.

We can design the third order network in

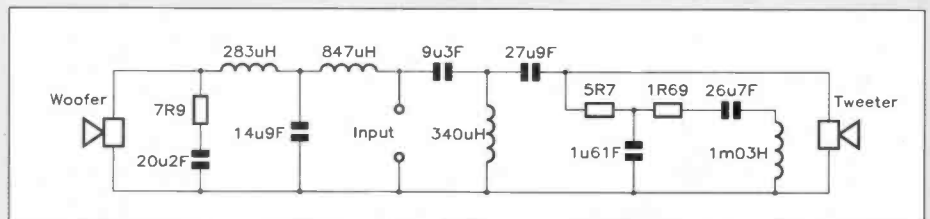
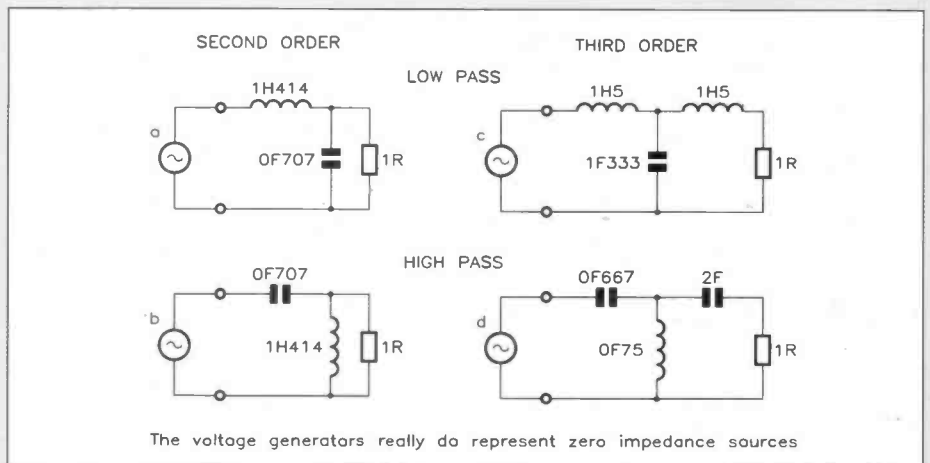

Figure 27. Complete circuit diagram of the third-order passive crossover network and the Zobel networks.



The voltage generators really do represent zero impedance sources

Figure 28. Second and third-order Butterworth reference filters.

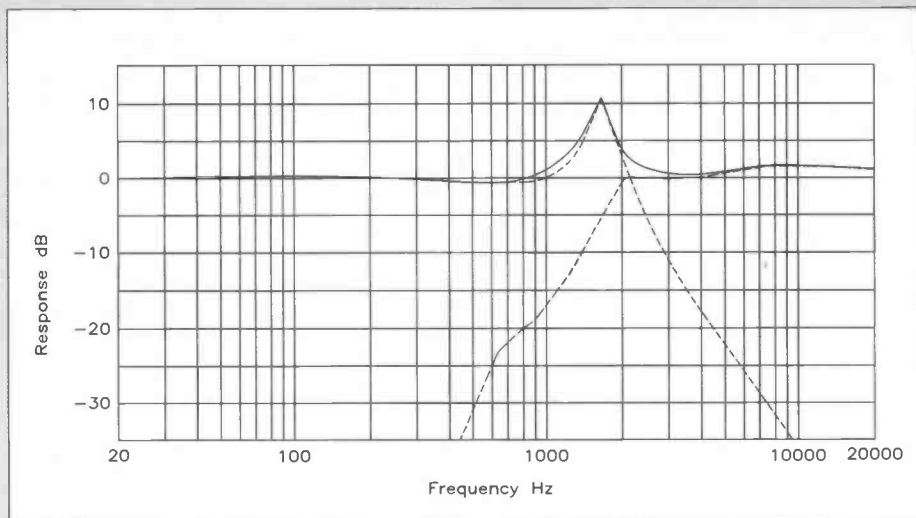

Figure 29. The effects of not using Zobel networks with the third-order passive crossover!

exactly the same way, but here the W-factor is the same for both filters. The reference circuit values are given in Figures 28b and 28c, and the results for the actual circuit values are:

Low pass: $L_1 = 847\mu\text{H}$, $L_2 = 283\mu\text{H}$, $C = 14.9\mu\text{F}$
 High pass: $C_1 = 9.3\mu\text{F}$, $C_2 = 27.9\mu\text{F}$, $L = 340\mu\text{H}$

TO ZOBEL OR NOT TO ZOBEL?

You may think that these crossover networks are complicated enough, without bothering with Zobel networks. You may notice that there are many loudspeakers on the market which don't use them. Well, have a look at Figure 29, which shows what happens with the third-order filters if you don't terminate them properly. Remember, the curves should look like the steeper ones in Figure 22, crossing at -3dB at 2kHz . What do you think the 10dB peak at 1.6kHz is going to sound like? With the less steep second order filters, the effect of the tweeter impedance would be more prominent, but don't forget that the response here should be -3dB at 2kHz , not level. I think the point is well made: *Zobel networks are essential.*

COMPONENTS FOR PASSIVE CROSSOVERS

The two requirements of accurate, stable value and the need to pass quite high current when used with a powerful amplifier make the use of non-polarised (reversible) electrolytic capacitors highly inadvisable.

Polyester or polypropylene capacitors are ideal, and I would like to see Maplin offering $10\mu\text{F}$, $15\mu\text{F}$ and perhaps $22\mu\text{F}$ capacitors of this type. At present, the higher values have to be made up from several units in parallel.

For the inductors, the 'bobbin type inductors' AH21X to AH24B are ideal. I would like to see a 1mH added to the range and perhaps other values up to 2.2mH as well. Alternatively if the empty bobbin cores were available one could wind one's own coils of any value. Where the higher DC resistance can be accepted, the axial lead types UM12N to UM15R and BU45Y to BU47B can also be used. The 'high current toroids' and 'high current toroidal inductors' are completely unsuitable for this application, because the cores saturate at quite low voltages at audio frequencies. If empty bobbin cores could be obtained, one could wind one's own air cored coils of any value up to about 5mH . (*Reels of enamelled copper wire could be used as a starting point. A short while ago one of our readers (Mr. N. P. E. Wheeler) wrote in with the inductances of some 250g reels of e.c. wire as stocked by Maplin. These are: YN81C = 1mH; YN92D = 2.3mH; YN83E = 5.96mH; YN84F = 14.67mH. These can be 'trimmed' to achieve the desired value, although suitable test gear, as explained below, is needed. In addition the 50g reels can be used to make smaller values - Ed.*)

You can check the results of this process with one of the Maplin bridges (the LCR bridge YB82D works quite well), or you can connect the coil in series with, say, a 100Ω

resistor (a value much higher than the reactance of the inductor) to an amplifier delivering 10V at 1kHz , thus passing 10mA through the inductor, across which you measure the voltage. For example, an $847\mu\text{H}$ inductor has a reactance at 1kHz of 5.32Ω at 1kHz , so with 10mA flowing we would get 53.2mV across it.

It is essential to take care that significant magnetic coupling does not occur between inductors. This warning is often followed by an instruction to 'mount the coils with their cores at right-angles.' This certainly won't work if the coils are too close together. They need to be well separated, and you can check for coupling by feeding one inductor with, say, 1V at 1kHz (via a power amplifier with some resistance in series with the inductor), and measuring the voltage produced by the other inductor, which should not be connected to any other components for this test. A value of less than 50mV should be acceptable, and my tests suggest a minimum separation of 50mm if the coil axes are parallel and 25mm if they are at right angles. It is possible to get zero coupling if the axis of one coil passes through the geometrical centre of the other coil, whose axis is at right angles to that of the first coil.

Also, beware of mounting metal-cased capacitors too close to the coils: the metal acts as a short-circuited turn and affects the coil losses. Another point to watch for is the magnetic field from the driver magnets. Don't bring the coils close to the magnets, because this may permanently change the inductance, but a separation of 50mm or so should be acceptable.

In the analyses, I have assumed the capacitors and inductors are ideal, i.e. that they have no losses. For the film capacitors (but not necessarily for electrolytics), that is a fair assumption, and the inductors are good, but not perfect. Where a coil is in series with a resistor, the resistor value can be reduced to allow for the DC resistance of the coil. Where there is a resistor in parallel with the coil, its value can be increased to allow for the losses in the core. To do this precisely, you need a good bridge to measure the Q , but if you take the equivalent parallel loss resistance to be about 20 times the reactance (i.e. $Q = 20$), that will not be far out.

ACTIVE NETWORKS

We looked at active filters in Part 2, and saw that they are made up of capacitors, resistors and op amps. We need no inductors, and no large (and costly) capacitors. On the other hand, we need one power amplifier per driver, but because the power of audio signals tends to be concentrated in the low frequency range, we could use, say a 15W amplifier for

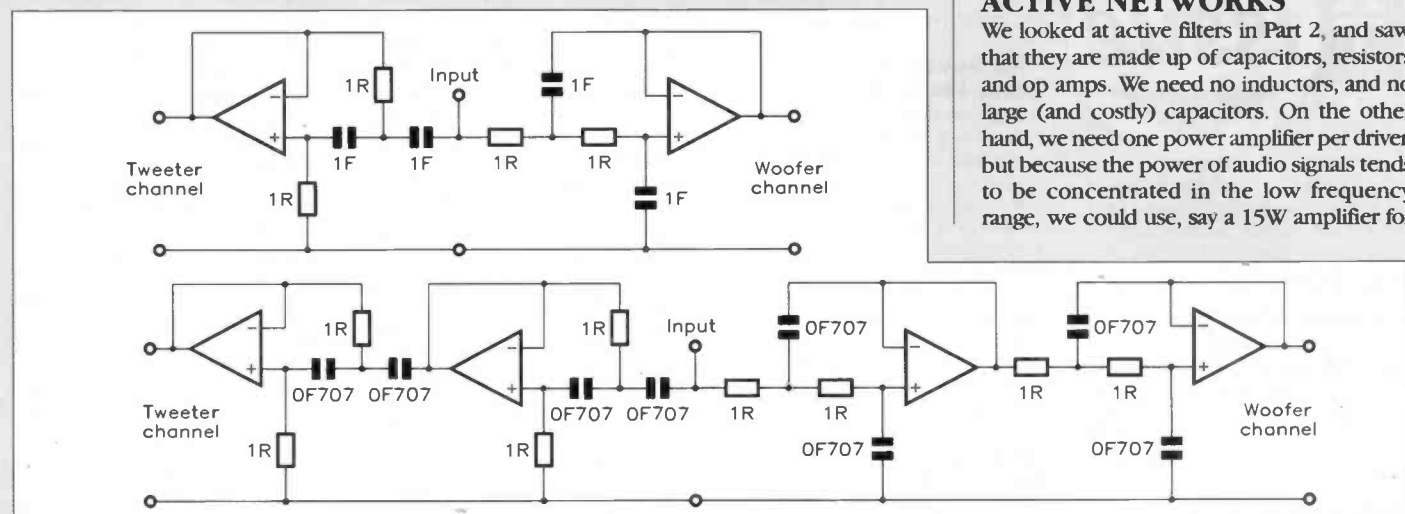

Figure 30. Reference Linkwitz-Riley second and fourth order filters.

the woofer and a 5W amplifier for the tweeter. Other advantages of 'bi-amping' are that low-frequency amplifier overload cannot damage the tweeter by applying large harmonic signals, and intermodulation between high and low frequency signals cannot occur. Furthermore, we can make active filters that would be too complicated to make in passive form.

LINKWITZ-RILEY NETWORK

In 1976, Siegfried H. Linkwitz published a paper in the AES Journal which introduced a new type of filter. He listed the requirements for a crossover network in the following terms:

- Zero inter-driver phase difference at the crossover frequency, to prevent tilting of the directional response.
- Each of the filter responses must (consequently) be 6dB down at the crossover frequency, so that no peaking of the pressure response occurs.
- The zero inter-driver phase difference is preserved over the whole frequency range in which both drivers radiate significantly (i.e. the crossover frequency range or crossover region), so that the directional response varies very little in this range.

He attributes to 'R. Riley' that two identical Butterworth filters in cascade satisfy all of these requirements, but no reference is cited and I have found no other references to papers by R. Riley, whose name is, however, recorded for posterity in the name of this type of filter. My own conjecture is that R. Riley was the janitor at Linkwitz's lab at Hewlett-Packard and, like our own David Bellamy and Fred Housego, proved to have unsuspected intellectual attainments! As we have seen before, satisfying these desirable requirements automatically prevents us from satisfying what may be another desire, which is for constant power response.

We have met Butterworth filters before:

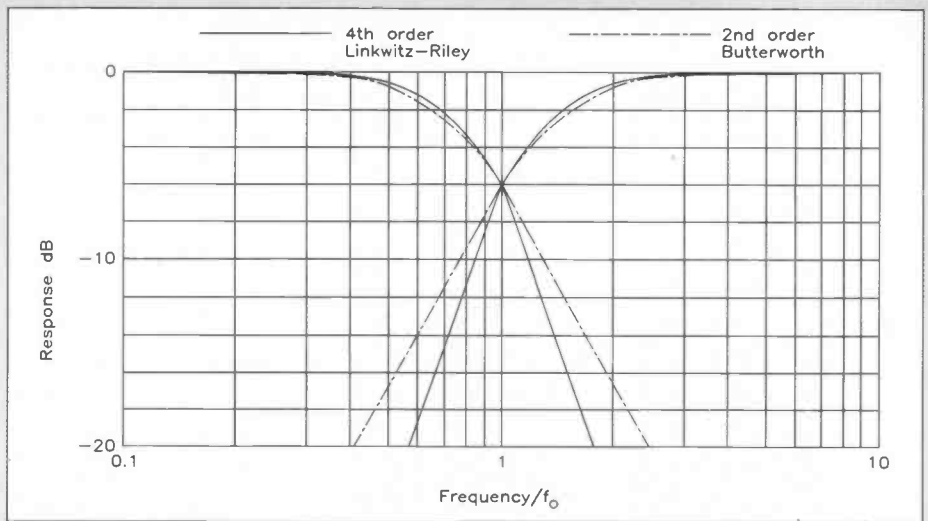

Figure 31. Comparison of the responses of Linkwitz-Riley and Butterworth filters.

these have a frequency response which is 'maximally flat', i.e. no humps in the pass-band and a uniform plunge in the stop-band. The passive filters we looked at above are all Butterworth filters. Because we always have two filters in cascade, Linkwitz-Riley filters are always of even order, and, as for other even-order filters, this means that the two drivers have to be connected with opposite polarities in order to get zero inter-driver phase difference.

The circuits of the reference second and fourth order filters are shown in Figure 30, designed for a cut-off frequency of $1/2\pi$ Hz, and we can use exactly the same scaling technique as for the passive filters to arrive at the circuit values for 2kHz. In this case, we can choose the Z-factor to give resistors that suit the op amps and/or convenient capacitor values. The values that I have chosen are:

SECOND ORDER FILTERS

$R = 10k\Omega$, $C = 8nF = 4.7nF$ and $3.3nF$ in parallel

FOURTH ORDER FILTERS

$R = 6.8k\Omega$, $C = 8.2nF$, $2R = 13.6k\Omega = 27k\Omega$ and $27k\Omega$ in parallel, $2C = 16.4nF =$ (guess!) $8.2nF$ and $8.2nF$ in parallel.

Any audio op amps are suitable: I would tend to choose NE5532 or even NE5534, because compressing all the components round a quad or dual op amp can lead to layout problems. Figure 31 shows the comparison between the responses of fourth-order Linkwitz-Riley filters and second-order Butterworth filters having the same crossover frequency. Remember that the Butterworth pair would give a 3dB peak if used in this way.

WHAT WE HAVEN'T DONE

We have assumed that both drivers have flat frequency responses in their working ranges. We can't do anything about sharp peaks and dips, except choose another driver, but we could use filter circuits to flatten broader humps or hollows. In order to do this, we have to be able to measure the acoustic frequency responses of the drivers, and of the system, quite accurately. I haven't been able to do this because I have written this series in the winter months, when my open-air site is not usable, and most readers don't have any way of doing it at all. For the same reason, no system response curves are included with this article. It may be that the kindly Editor, and less pressure of other work, will allow me to attend to this subject at a later date.



In next month's super issue of *Electronics - The Maplin Magazine*, there are yet more terrific projects and features for you to enjoy. These include:

PROJECTS

2-Wire 8-Channel Communication Transmitter & Receiver

Offers 8 communication channels, expandable to 16 channels, with power supply through the data line. 2-wire communication between transmitter and receiver includes LED status indication of each output. These two kits open up a wide range of possibilities, as part of a security system, for model rail-

ways, remote signalling, and other applications where a number of switching connections are required. Up to eight individual switching devices can be operated from a distance of 50m or more. Further expansion using more modules is also possible, and there are only two connecting wires between the transmitter and receiver.

'Till Saver' Forged Bank-Note Detector

A slight variation on the standard type of bank-note checker, where an ultraviolet light is used to illuminate the bank-notes. Fake or counterfeit notes reflect the UV light whereas real ones do not. Here an extra circuit is incorporated which sounds a buzzer and illuminates an LED if the note is OK, but if fake then the LED will not light and the buzzer will not sound. The unit will operate from a +12V DC supply and hence is ideal for use at Car Boot Sales, where counterfeit notes are often tendered.

IBM PC Centronics Input Port

Allows an IBM PC or compatible to be presented with 8-bit parallel data with a protocol identical to the conventional

Centronics printer format, allowing ASCII data to be quickly downloaded from another machine. Most older 8-bit home computers, for example, can transfer data by a serial communication link via the serial port, but some cannot, so an alternative is to output the data to the printer port. With the PC emulating a centronics printer, not only can data be transferred from old formats to the PC, but a PC can be set up as a printer buffer for another machine, as the Maplin IBM PC I/O Card is used as the input, leaving the conventional printer port free.

Simple MIDI Merge Unit

A sophisticated MIDI Merge Unit can function with simultaneous input signals. In most instances, however, all that is required is a unit that simply mixes two inputs direct into one output, and such a unit remains small and cheap. However, simultaneous inputs must be avoided, or else the output signal will be scrambled and meaningless. Hence the Simple MIDI Merge Unit is more useful, but no less effective, as an automatic MIDI switch.

TV Colour Bar Generator

A test generator that produces pictures which have a colour content, and this

type of test signal is widely used by Broadcasters for checking and setting up all manner of equipment which is required to operate with colour pictures. Colour Bars are also the test signal used when timing colour pictures together for use in any situation where sources need to be switched or mixed, a studio vision mixer for example.

FEATURES

Special features include an 'Out and About' to an unusual Aircraft Museum specialising in aircraft instrumentation; 'Lost Material Recovery' which shows how the professionals transfer audio and video archive material from obsolete formats to modern recordings; and a review of the 'Safeboot' software, designed to prevent unauthorised persons using your PC! Continuing series include How to Use Digital Panel Meters, Power Electronics, IC Manufacturing and a new one about understanding transmission lines. And, of course, all your usual regular favourites!

ELECTRONICS - THE MAPLIN MAGAZINE, BRITAIN'S BEST SELLING ELECTRONICS MAGAZINE.

Stray Signals

by Point Contact

Most of the readers of this magazine, one imagines, are interested in electronics quite apart from (though in many cases no doubt, as well as) any professional involvement – i.e. it is their hobby, or at least one of them. PC has always had a plethora of hobbies, which puts a great demand on available spare time. Some have come and gone, such as 8mm double run cine. Time was when PC would take a black and white movie during the day, develop it using the reversal process after tea, and project it for the amusement of the family later the same evening. Presumably the filmstock would be difficult to get hold of nowadays, camcorders having taken over. Other hobbies have never quite arrived, although threatening to do so imminently—one of these days PC *really will* get around to making an electronic organ. (When he finally retires, no doubt: at present he is in-between, being 'self-employed' writing articles and books under various pen names and doing a little consultancy, etc.) The greatest admiration is due to those brave souls busy building an electronic organ whilst still in full-time employment, not to mention sympathy and condolences for their neglected wives! Another minor hobby of PC's, rather more recently arrived (about ten years ago), is mycology. Not that he goes out on dedicated mushroom hunting forays, as the true devotee of the subject does. But when out and about he always keeps an eye open for fungi of various species, though only recognising a few of them for certain. Last autumn Mrs PC and spouse happened to be in Fordingbridge, and before leaving we took a walk beside the river in a large public open space. There we found *Coprinus Comatus*, not just a single stand of them, but a large area profusely scattered with them. They were just at the right stage for picking, the flesh completely white throughout (later it turns through pink then brown to a squidgy black as the cap autodigests, hence the common name Shaggy Ink-cap). So PC gathered a modest pocketful for his supper, leaving hundreds of others there to spore for another year. There are many other species in the *Coprinus* family, some of dubious edibility and some certainly not edible, and obviously the greatest care is needed whenever gathering any wild mushroom to eat – without a positive identification, *don't*. Fortunately, with its very distinctive appearance, *C. Comatus* – the 'Lawyer's Wig' – is unlikely to be confused with any other species at all, let alone a poisonous one. With their delicate taste they are excellent lightly poached in milk, but for speed PC simply sautéed them briefly in a little butter and served them up on toast – delicious.



During World War II when PC was a young lad, people were from time to time billeted in his parents' house, and on one occasion our guest had the tip of a little finger missing. Boys of that age being curious and forward, PC enquired how it had come about, and learned that it was the result of an accident in the workplace. As PC grew up he continued to encounter, from time to time, the victims of unfortunate accidents, now such misfortunes are a thing of the past. *Accidents* just don't happen any more; any loss or injury sustained at the workplace, in any public place, or under almost any circumstances whatsoever is not an *accident*, it is someone's fault and either he or his employer will be liable. Whilst a comforting thought for the victim, it is a bit scary to realise that almost any one of one's actions, should a totally unforeseen *accident* result, could leave one liable in a court of law. Fortunately no such contretemps has ever disturbed the tranquillity of PC's life, but a misunderstanding nearly landed him in court a few years ago. At the time, he was still employed, and had to travel up to London before dawn on a winter's morning to attend a progress meeting concerning an electronic development project under an MOD contract. PC parked his car near the station, in a public car park which had always been free, behind the new Town Hall. On returning that evening after dark

there was a piece of paper tucked under the windscreen wiper informing him that he had parked in a yellow parking bay before 08:00 hours, which was forbidden, and displayed no parking ticket to boot. "Should he do so again", the message said "a prosecution would follow". A closer inspection of the deserted parking lot revealed a Pay and Display machine in the distance, not easily spotted as there was no lamp standard near it. Adjacent to it was a board detailing just when you could and couldn't park in white bays on the one hand and yellow ones on the other. This left PC completely baffled, since ALL the parking bays were marked out in YELLOW. Only under the whitish light of the headlights as he drove away did the penny drop, the car park was illuminated solely by the usual monochromatic low pressure sodium lights, under which the white lines looked as yellow as the yellow ones! Hardly an accident, but an example of how easily unforeseen circumstances can arise, and clearly the responsibility of the Borough Engineer in charge of the works when the car parking charges were introduced.

Yours sincerely

Point Contact

The opinions expressed by the author are not necessarily those of the publisher or the editor.



THE Silicon Controlled Rectifier, conveniently abbreviated to SCR, is often, though not strictly correctly, referred to as *the thyristor*, when in reality it is just a member of the thyristor family. Nonetheless, it is a very important member and a very versatile one, as we shall see in this article. We shall now review – in this and the next part of this series – a number of circuits, mostly quite different in their application, which will exhibit and exploit this versatility. This voyage of exploration will take the form of a technical introduction on how the circuit works, accompanied by a circuit diagram of course, followed by any relevant and useful comments. For example, this will be especially useful if the circuit needs some modification to allow it to use alternative components. Some of these circuits may be seen to have an obviously useful role to the reader; some may merely serve to provide a better understanding of how a particular configuration operates. In both cases, it is hoped that the reader will find the articles both interesting and useful.

A REGULATED BATTERY CHARGER

Figure 1 shows a circuit that has been designed to provide a regulated charging current for a 12V battery, up to the point where the battery reaches its full terminal voltage. At this point, the circuit switches over to a trickle charging mode. With the component values given, the battery can be charged at up to 6A. By modifying certain

component values, it is possible to increase the charging current up to 300A, as well as being able to deal with a very wide range of battery voltages. For very much higher charging currents the physical construction of the unit has to be scaled up considerably to accommodate larger components and dissipate the extra heat, although the basic principles remain the same.

The operation of the circuit is as follows. Transformer T1 and diodes D1 & D2 constitute a full-wave rectifier, the unsmoothed

output of which is used to power the circuit. One has to bear in mind, therefore, that the anode voltages of both SCR1 and SCR2 consist of a series of half sinewaves and not pure DC. Obviously this comment also applies to the path D3, R1 & RV1 (the trickle charging path in parallel with SCR1), which also includes the battery to be charged. Note also that at any instant the voltage between anode and cathode of SCR1 is the *difference* between the instantaneous half sinewave out of the rectifier and the steady voltage across the battery terminals. From this it is evident that when the battery voltage is low, the anode-cathode voltage will be that much higher; as the battery voltage increases (during the charging period), the anode-cathode voltage reduces. This is a vital point in the operation of the circuit.

When the battery voltage is low, a conducting path exists to the gate of SCR1 via resistor R4 and diode D4. Thus, SCR1 will switch on at some point during each half-cycle of rectified supply voltage and a large charging current will be supplied through SCR1 to charge the battery.

A potentiometer RV2, in series with the fixed resistor R2, picks off a proportion of the voltage across the battery and applies it to the cathode of a Zener diode having a 'breakdown' voltage of 11V. When the

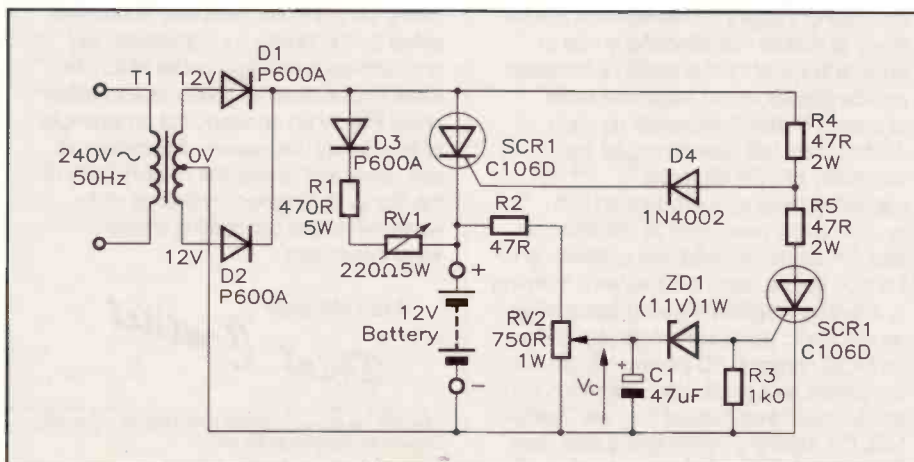

Figure 1. Circuit for a regulated battery charger.

battery terminal voltage is less than its fully charged value, the voltage V_C , which is tapped off by potentiometer RV2, will be less than the voltage required to break down the Zener diode. As a result, SCR2 will be off.

The rest follows easily enough from the above. When the battery voltage is high enough (the fully charged state), the voltage tapped off by the wiper of RV2 causes Zener diode ZD1 to 'break down'. This provides a path for gate current that will cause SCR2 to switch on for a portion of each supply half-cycle. Initially, the point in the supply half-cycle at which SCR2 conducts is 90° after the start of each half-cycle – in other words, at the peaks of the supply half-cycles; this also coincides with peak charging current and maximum battery voltage. However, as charging continues, the battery voltage rises even further and, as a result, SCR2 progressively switches on at an earlier point in each half-cycle. Eventually it will be switching on before SCR1 is able to do so. As soon as this state is achieved, SCR1 will be unable to switch into conduction at all because the low voltage at the junction of the potential divider R4 & R5 will reverse-bias diode D4. The main charging path to the battery is thus open-circuit, and only the trickle charging path, D3, R1 & RV1 now exists. The value of the trickle charging current can be varied by the control RV1.

Comments: Substitute semiconductors have been selected from the Maplin Catalogue, with minor variations as noted. For the 6A limit stated for the circuit, the use of 6A diodes (type P600A) instead of the GE 20A types originally specified should be satisfactory. A C116D 8A SCR has been substituted for SCR1, which was specified as a type C122, of the same current rating. A suitable Zener diode type is the BZX61C11 (Order Code QF54J), which has a power rating of 1.3W. This circuit is offered to those experimenters with sufficient experience to construct, test and develop it themselves, with the usual warning regarding due caution that should be observed when experimenting with mains-operated equipment.

A ONE-SHOT SCR TRIGGER CIRCUIT

It is sometimes useful to be able to trigger an SCR into the conducting state for just one complete half-cycle of the mains supply. This may be required where a single, short pulse of high current is needed, as in solenoid operated stapling guns, impulse hammers and similar devices. The circuit of Figure 2 has been designed to fill this need.

Operation is initiated by closing the push-button switch S1 which has a changeover action. Before being operated, the upper switch contacts are closed, placing a short-circuit across the RC path comprising R2 & C2 in series. Capacitor C2 is thus discharged whenever the switch is in this position. The circuit is designed so that SCR1

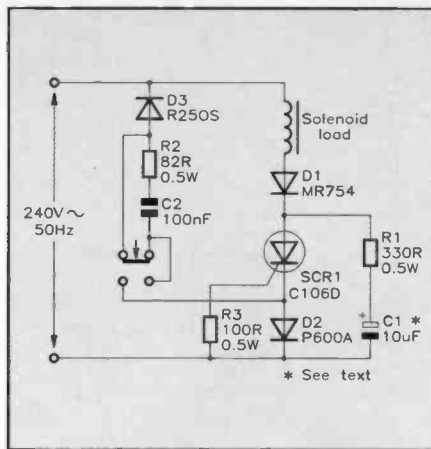

Figure 2. A one-shot SCR trigger circuit.

switches on during a negative half-cycle of the supply, and works as follows.

Consider first the role of the series components R1 & C1. C1 will be charged to nearly the peak value of the mains voltage, on positive half-cycles only of the supply, because of the presence of diode D1. It will, therefore, have a charge relating to its capacitance value. As will be seen, this has to be chosen fairly carefully, and the value quoted in Figure 2 is for guidance only and depends upon the actual SCR in use.

Now consider what happens when switch S1 is pressed. When the incoming mains half-cycle is negative a charging path for C2 will exist through diode D3, resistor R2, the cathode-to-gate path of the SCR and resistor R3. Note that because the mains supply is on its *negative* half-cycle, the polarity is correct for the charging current of C2 to turn the SCR on. The question is, is this compatible with the polarity of the voltage on the SCR's anode, which we know has to be positive for conduction to take place? The answer is yes, because, although there is no conducting path to the mains supply (which is negative at this moment anyway), there is a positive voltage on the anode because of the charge stored in C1, as explained earlier. Conduction does take place and, provided that the charge stored in C1 is large enough, the current supplied to the SCR by C1 will be greater than its holding current. The SCR will still be conducting when the mains supply reverses its polarity. Once this happens, the SCR gets a positive anode voltage directly from the mains supply via diode D1 and the solenoid. Current will, therefore, flow through the solenoid for the whole of this positive half-cycle. At the end of this half-cycle, the SCR commutates (provided that C1 has now discharged itself) and conduction ceases. It does not matter if the switch S1 is still held down, because once C2 is fully charged, no further current flows, and hence there is no gate current to switch the SCR back on again.

The above shows why the choice of the correct value for C1 is so important. If it is too small, its stored charge will be insufficient to supply the holding current for the whole of the negative half-cycle, and the solenoid will never operate. If it is too large, it may still be able to supply sufficient

holding current for several successive half-cycles, with the result that the SCR stays on longer than it should. The final value of C1 will almost certainly be made by 'select at test' procedures.

Releasing the switch S1 shorts out and discharges C2 so that a subsequent operation of this switch would allow another cycle of events to begin. In addition capacitor C1 would have received a new charge from one of the positive half-cycles of the AC mains supply voltage.

Comments: These mostly concern the choice of diodes for the circuit and, to some extent the choice of SCR. The latter depends upon the load current to be switched. Often this will be quite high, even if it is only of short duration. In the original circuit, the load current was assumed to be less than 20A. I have made the assumption that the load current will not, in fact, exceed 6A, simply so that suitable components can be chosen from the Maplin range, a restriction that not everybody will want to accept, naturally. On this basis, both diodes D1 & D2 need to have a 6A current rating, but the peak inverse voltage rating can be quite different, for example 400V for D1 and 50V for D2. Diode D3 handles a relatively small current when charging C2 but must have a peak inverse voltage rating adequate for 240V mains operation. Under certain circumstances – when the mains voltage is positive and C2 is fully charged – the peak inverse voltage across D3 can equal twice the peak value of the mains voltage, that is 680V, and a diode of at least this rating must be used.

On this basis, a suitable diode type for D1 is an MR754 (Order Code YH97F); for D2 a diode type P600A (Order Code UK59P), while for D3 a diode type R250S (Order Code AY26D) will be suitable. The latter is an 800V 6A device.

As far as the SCR is concerned, a C106D should be suitable. This is rated at 400V 5A, but the current rating is rms so that a peak current requirement of 6A should be within its capabilities.

A LOW VOLTAGE DC FLASHER

A flasher circuit can be made up using only a few components and operating from a low voltage DC supply. The circuit is shown in Figure 3(a) and uses a conventional C106 SCR and a complementary SCR. The latter differs from the former in the following way.

If an SCR is triggered by the *injection* of electrons into its *cathode* base, it is said to be *conventional*. If, on the other hand, it is triggered by the *withdrawal* of electrons from its *anode* gate, then it is *complementary*. The original circuit specified a C13 type as the complementary component. However, this has proved elusive to track down and a substitution has been made. We are back to our old friend, the BRY39 PUT (which, I omitted to tell you in the last issue, is the equivalent of the

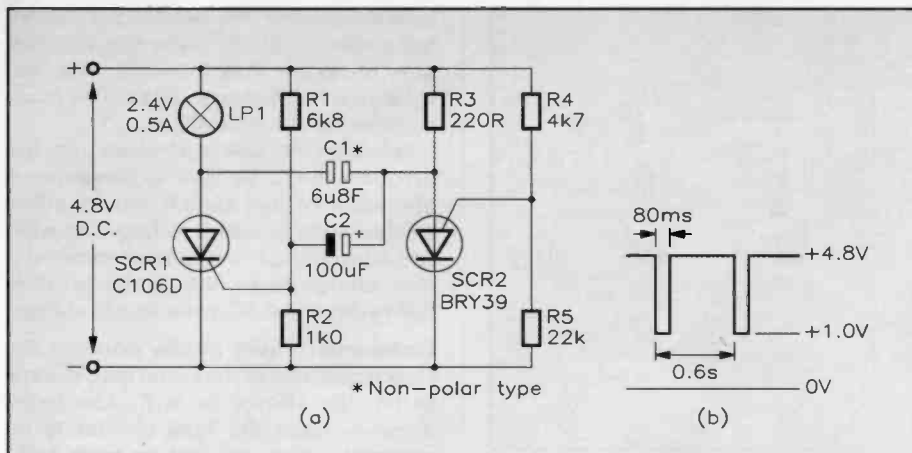

Figure 3: (a) A low voltage DC flasher circuit; (b) waveform at SCR1 anode.

2N6027 PUT, mention of which had been made before). The BRY39 can be used in several modes, one of which is as a Silicon Controlled Switch (SCS), with both gates accessible. By ignoring the cathode gate and using the anode gate, we can employ this device as a complementary SCR.

The circuit works as follows. When power is applied to the circuit, the DC conditions which maintain at that instant cause SCR1 to switch into the conducting state immediately. Because C1 couples the anodes of the two SCRs together, when the anode potential of SCR1 falls, so does that of SCR2. However, there is now a charging path for C1 through R3 and SCR1 to ground. The anode potential of SCR2 thus rises exponentially until eventually SCR2 switches into the conducting state. When it does so, it commutates SCR1 via C1, forcing its anode voltage to go negative, so cutting off the anode current. This negative-going DC change at SCR2 anode is also coupled via C2 to the gate of SCR1. This ensures that the latter device cannot switch back into the conducting state until its gate voltage has risen to about +0.5V as C2 charges through R3 & R2. Once SCR1 has returned to the conducting state, SCR2 will be forced off and a new cycle can repeat.

Comments: Substitution of a BRY39 used as described above has caused no problems. Departures from the original circuit involve reducing the values of R4 & R5 by a factor of 10:1 and using a smaller value for the non-polarised capacitor C1. A 25µF type was not available so a 6.8µF, which was the largest in stock, was used instead. Initially a 10Ω resistor was employed for the 1A load, just to check the circuit out, and since a CRO, connected to SCR1 anode, indicated that all was well, a hunt for a suitable lamp was made. This turned up, and a spare 2.4V, 0.5A torch bulb was used. When connected into the circuit and the power switched on, the result was impressive – short, sharp flashes, rather like an aircraft beacon in frequency and apparent intensity. As the waveform of Figure 3(b) shows, pulses occur every 0.6s and last for 80ms, corresponding to a frequency of 1.67Hz. Each negative-going pulse at the SCR1 anode has a peak amplitude of 3.8V

DC FLASHER CIRCUIT WITH VARIABLE ON AND OFF TIMES

Figure 4 shows a circuit in which two SCRs are triggered alternately by a PUT pulse generator in such a way that each SCR can be on for a different period of time. The circuit works as follows.

Assume that, at this instant, it is SCR1 that is conducting. It offers a low resistance path to ground so that variable resistor RV1 is unable to contribute to the charging current into the timing capacitor C1 and this charging current flows through the other variable resistor RV2 instead. Thus, timing is determined by C1 & RV2 on this particular cycle. Furthermore, because the anode voltage of SCR1 is very low, the gate capacitor C4 of SCR2 is unable to charge up. As the voltage across the timing capacitor rises, there will come a point at which it will exceed the gate voltage of the PUT by about 0.5V. At this point, the PUT will fire and trigger SCR2 into the conducting state. Between the anodes of the two SCRs is connected the commutating capacitor C3, a 10µF non-polarised component. The stored energy in this capacitor forces

SCR1 into the off state, by the usual commutating action.

We now have a simple reversal of conditions, in that SCR2 is now conducting, which means that the only charging path for the timing capacitor C1 is through variable resistor RV1 instead of RV2. Thus timing for the new cycle is determined by C1 and RV1. When the PUT fires this time, its output pulse will trigger SCR1 into conduction and SCR2 will be turned off by the commutating action of C3. By making the two timing resistors variable, the on and off times of the lamp LP1 can be set independently. Of course, it is perfectly possible to replace the 1kΩ resistor R6, in the anode of SCR1, with a second lamp, should there be a requirement for this.

Comments: It is worth mentioning at this stage that Maplin now holds a good range of reversible electrolytic capacitors, such as are required for use as commutating capacitors in SCR circuits. The range of values lie between 1.5µF and 100µF, with a working voltage of 100V, which is adequate for these applications. No changes were felt necessary to this circuit except for the substitution of more readily available diodes instead of the original GE types specified. The lamp can be chosen according to the specific use, but should be restricted to low power varieties only, because of the difficulty of commutating SCRs that are passing high currents. The C106D SCR should be more than adequate for such applications.

A SEQUENTIAL FLASHER CIRCUIT

In the sequential flasher circuit of Figure 5, three lamps are energised sequentially and, if arranged in a line, will represent the strobed lighting arrangement used frequently as turn indicators on American automobiles. While the idea has never really caught on, there is no doubt that it commands attention when used.

In the circuit of Figure 5, the switches S1

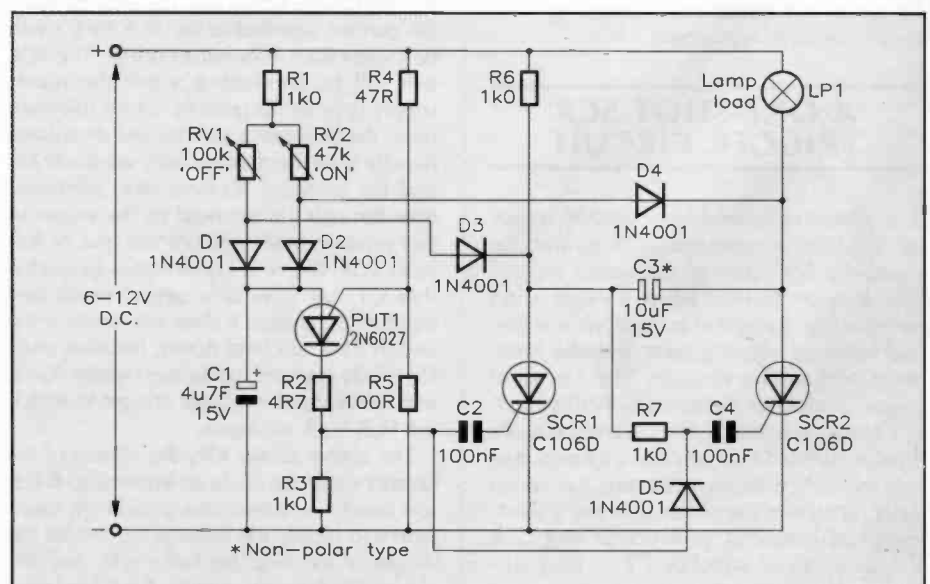

Figure 4. A DC flasher circuit with variable on and off times.

& S2 represent the turn indicator switch and the thermal flasher unit which dictates the rate of the turn signals. This is assuming an automobile application, but the circuit can obviously be adapted to other uses if desired.

When switch S1 is closed, thermal flasher unit S2 will already be closed and the first lamp LP1 will be energised immediately. At the same time, capacitor C1 will start to charge up through resistor R3 and will continue to do so until the firing point of PUT1 is reached. When this is realised, the output trigger pulse of PUT1 will switch SCR1 into the conducting state, thus energising lamp LP2. However, not only is LP2 supplied with power at this instant, but the second PUT/SCR circuit receives its power from the same source. As a result, capacitor C2 starts to charge up through resistor R7 until PUT2 fires, triggering SCR2 into conduction and energising the third lamp LP3. All three lamps are now lit and will remain so until the thermal switch opens, removing power from the circuit and automatically commutating the SCRs. Next time the thermal switch closes, the sequence will repeat.

Comments: It would seem theoretically possible to extend this circuit to the right, merely by cascading further identical

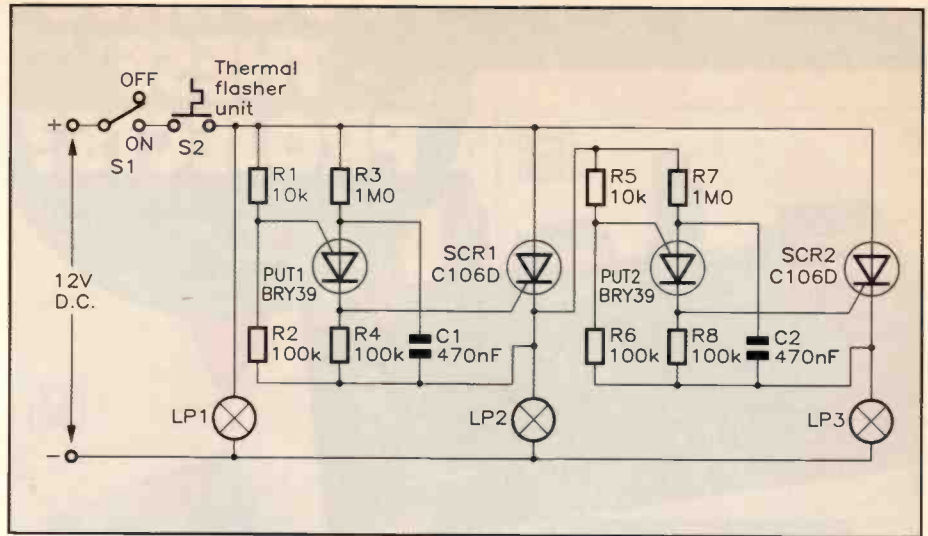

Figure 5. A sequential flasher circuit.

sections, each comprising a PUT and SCR driving a lamp. However, there is a limit, but it is dictated solely by time factors – these are the time taken for an individual unit (PUT/SCR/Lamp) to operate and the total time for which the thermal switch remains closed. All units in the cascaded circuit must complete their cycles within the sequence during the closure time of the

thermal switch contacts. The only control that the circuit designer has over this situation is by varying the values of the timing capacitors to squeeze more timing periods into the available time slot.

Next month we complete our survey of SCR application circuits.

These descriptions are necessarily short. Ensure that you know exactly what the kit is and what it comprises before ordering, by checking the issue of *Electronics* referred to in the list.

The referenced back-numbers of *Electronics* can be obtained, subject to availability, at £1.95 per copy. Carriage Codes – Add; A: £1.45, B: £2.10, C: £2.65, D: £3.15, E: £3.70, F: £4.25, G: £5.10, H: £5.70.

DID YOU MISS THESE PROJECTS?

The Maplin 'Get-You-Working' Service is available on ALL of these projects.

To order Project Kits or Back-numbers of *Electronics*, phone Credit Card Sales on (0702) 554161. Alternatively, send off the Order Form in this issue, or visit your local Maplin Store.

See advertisement elsewhere in this issue for locations of Maplin Stores.

Maplin: The Positive Force In Electronics
All items subject to availability. Prices include VAT.

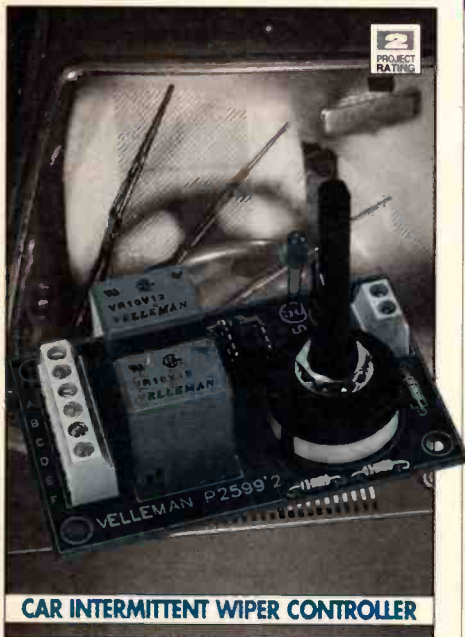

CAR INTERMITTENT WIPER CONTROLLER

An essential device for those of us with older cars and classics, that weren't built with anything more sophisticated than an on/off switch on the wipers! This simple to build project produces three delay periods, and has an LED indicator which lights during the delay period, reminding you that the unit is operating. Order as: VE03D, £12.99. Details in *Electronics* No. 75 (XA75S).

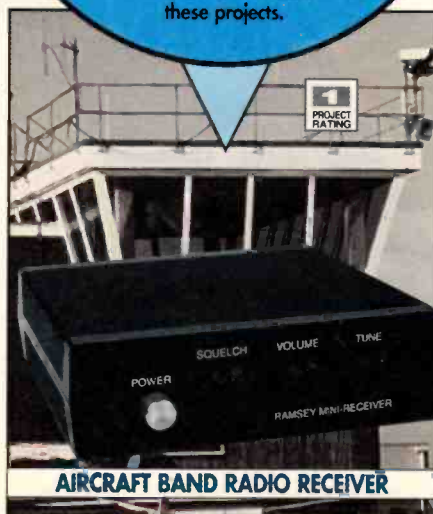

AIRCRAFT BAND RADIO RECEIVER

Listen in on pilot and control tower communications with this super AM airband receiver. The kit is simple to build and requires little alignment. Frequency range is 118 to 135 MHz and the receiver operating voltage is 9V. (Optional case not included.) Order as: CP17T, £29.95. Details in *Electronics* No. 75 (XA75S).

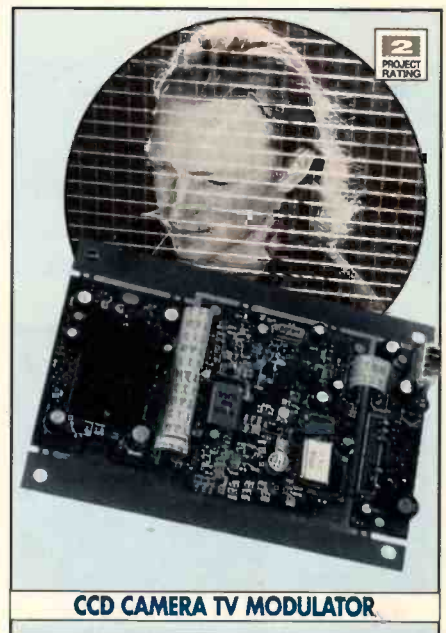

CCD CAMERA TV MODULATOR

A low-cost unit which allows the Maplin colour and black & white CCD Camera Modules to be linked to any normal domestic TV with UHF aerial input. Applications include closed-circuit security systems, and interfacing equipment that only has video outputs to a normal TV receiver. Order as: LT37S, £9.99. Details in *Electronics* No. 75 (XA75S).

These descriptions are necessarily short. Ensure that you know exactly what the kit is and what it comprises before ordering, by checking the issue of *Electronics* referred to in the list.

The referenced back-numbers of *Electronics* can be obtained, subject to availability, at £1.95 per copy.

Carriage Codes - Add; A: £1.45, B: £2.10, C: £2.65, D: £3.15, E: £3.70, F: £4.25, G: £5.10, H: £5.70.

DID YOU MISS THESE PROJECTS?

The Maplin 'Get-You-Working' Service is available on ALL of these projects.

To order Project Kits or Back-numbers of *Electronics*, phone Credit Card Sales on (0702) 554161. Alternatively, send off the Order Form in this issue, or visit your local Maplin Store.

See advertisement elsewhere in this issue for locations of Maplin Stores.

Maplin: The Positive Force In Electronics
All items subject to availability. Prices include VAT.



4
PROJECT
RATING



MILLENNIUM 4-20 VALVE POWER AMPLIFIER

A superb 4-valve, non-hybrid, class AB1 push-pull amplifier with an output of 20W r.m.s. and low output distortion, producing that characteristic valve sound. Construction is simplified by the use of printed circuit boards and no setting up is required.

Order as: LT45Y, **Price £74.95** C6. Details in *Electronics* No. 74 (XA74R).

SAVE MONEY by buying these combined Millennium Amplifier kits:

Save £10! Complete Millennium Monobloc Amplifier Kit (1 x PSU & 1 x Amplifier kit)
Order as: LT71N, **Price £114.90** H12.

SAVE £20! Complete Millennium Stereo Amplifier Kit (1 x PSU & 2 x Amplifier kits)
Order as: LT72P, **Price £179.85** H18.



4
PROJECT
RATING

MILLENNIUM VALVE AMPLIFIER PSU

A Power Supply kit for the Millennium 20W Valve Power Amplifier. The supply is capable of powering up to two amplifier modules for a stereo system, or alternatively you could use two PSU kits and two amplifier modules to produce a pair of 'monobloc' amplifiers.
Order as: LT44X, **Price £49.95** C6. Details in *Electronics* No. 73 (XA73Q).

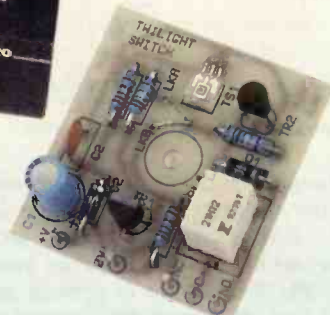

1
PROJECT
RATING

TWILIGHT SWITCH

Using the ULN3390T opto-electronic switch, this versatile project senses the ambient light level and operates the built-in relay at dawn and dusk. Typical applications are automatic control of lighting, night-time security or anywhere that daylight related switching is required.
Order as: LT47B, **Price £5.95**. Details in *Electronics* No. 73 (XA73Q).



2
PROJECT
RATING

EXTRA LARGE LED DISPLAY

A choice of two 20cm (7 1/2in.) 7-segment LED displays, catering for open-collector and open-anode circuits. Ideal for educational equipment, public displays, exhibitions, demonstrations, clocks etc. Connects to existing 7-segment display drivers. Operating voltage: 22 to 26V DC, maximum supply current: 400mA.
Order as: VF01B, Common Cathode Version, **Price £32.95**, or: VE63T, Common Anode Version, **Price £32.95**. Details in *Electronics* No. 74 (XA74R).



3
PROJECT
RATING

MODULAR GRAPHIC EQUALISER FRONT PANEL

A pre-drilled front panel and pre-printed foil to give a professional look to your completed equaliser project. The panel is suitable for a standard 19in. housing having a height of 2 units (2U).
Order as: VE41U, **Price £32.95** A1. Details in *Electronics* No. 74 (XA74R).

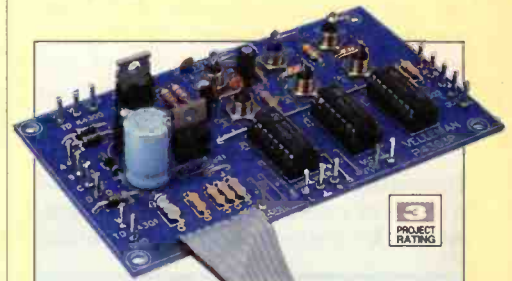

3
PROJECT
RATING

GRAPHIC EQUALISER PSU & SWITCHING UNIT

Part of the Modular Graphic Equaliser System. This project provides a regulated power supply for various of the other units in the system, a front panel mounted line input sensitivity control and also provides all of the necessary switching functions.
Order as: VE45Y, **Price £32.95**. Details in *Electronics* No. 73 (XA73Q).



3
PROJECT
RATING

AUTOMATIC REAR WIPER CONTROL UNIT

At last! Comprehensive control for rear window wipers, tied into the operation of the front windscreen wipers and gearbox. Facilities include: Single shot (when front wipers turned on), Intermittent operation (when front wipers on), and Auto wipe (Reverse gear selected and front wipers on).
Order as: LT46A, **Price £9.95**. Details in *Electronics* No. 74 (XA74R).

These descriptions are necessarily short. Ensure that you know exactly what the kit is and what it comprises before ordering, by checking the issue of *Electronics* referred to in the list.

The referenced back-numbers of *Electronics* can be obtained, subject to availability, at £1.95 per copy.

Carriage Codes - Add: A: £1.45, B: £2.10, C: £2.65, D: £3.15, E: £3.70, F: £4.25, G: £5.10, H: £5.70.

DID YOU MISS THESE PROJECTS?

The Maplin "Get-You-Working" Service is available on ALL of these projects.

To order Project Kits or Back-numbers of *Electronics*, phone Credit Card Sales on (0702) 554161. Alternatively, send off the Order Form in this issue, or visit your local Maplin Store. See base of this page for locations of Maplin Stores.

Maplin: The Positive Force In Electronics

All items subject to availability. Prices include VAT.

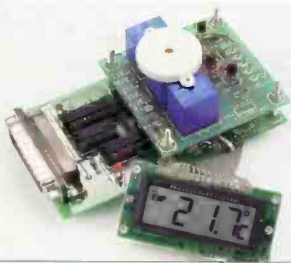

3 PROJECT RATING

LM36P LM37S

1 PROJECT RATING

LP12N

USING TEMPERATURE MODULES

This very practical *Electronics* article details the use of the following projects which, when used in conjunction with the range of temperature modules available from Maplin, can provide some extremely versatile environmental control functions.

Order as: LM37S (Relay Interface Card Kit), **Price £12.45**; LM36P (Serial/Parallel Converter Kit), **Price £14.95**; LP12N (24-line PC I/O Card), **Price £21.95**. Details in *Electronics* No. 71 (XA71N).



2 PROJECT RATING

10-BAND GRAPHIC EQUALISER MODULE

This easy to build equaliser project has ten frequency bands that allow you to adjust audio response to your particular preference. Order as: VE44X, **Price £34.95**. Details in *Electronics* No. 71 (XA71N).

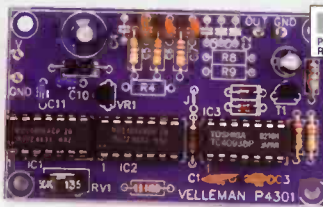

2 PROJECT RATING

PINK NOISE GENERATOR

This easy to build pink noise generator employs a pseudo-random digital noise source and can be easily adapted to produce white noise if required.

Order as: VE43W, **Price £11.95**. Details in *Electronics* No. 72 (XA72P).

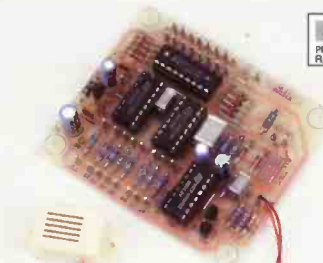

2 PROJECT RATING

PRIORITY QUIZ BUZZER

No more arguments about who got the answer first! This versatile system allows up to eight contestants to battle it out without altercation, and can be expanded in blocks of eight by simply adding more units. Order as: LT41U, **Price £9.95**. Details in *Electronics* No. 72 (XA72P).



2 PROJECT RATING

INFRA-RED SWITCH

Look, no hands! This versatile remote control switch can operate a multitude of electrical or electronic equipment without you even touching it.

Order as: LT38R, **Price £9.95**. Details in *Electronics* No. 71 (XA71N).



4 PROJECT RATING

DIGITAL MODEL TRAIN CONTROLLER

This versatile project allows you to control up to fourteen locomotives on a single layout, with up to four locomotives being active at any one time. The basis of the system is a Common/PSU board, to which one controller is added for each active locomotive. All locomotives require a receiver. To complete the project, a smart, pre-drilled case is available.

Order as: LW61R (Common/PSU), **Price £39.95**; C4; LW62S (Controller), **Price £9.95**; LT29G (Receiver), **Price £12.95**; XG09K (Case), **Price £24.95**. Details in *Electronics* No. 71 (XA71N).



1 PROJECT RATING

STEREO MOSFET AMPLIFIER

A superb high power stereo amplifier that sounds as good as it looks. Bridged configuration transforms the unit into a 600W (music power) mono amplifier.

Order as: VF17T, **Price £299.95** H29. Details in *Electronics* No. 71 (XA71N).

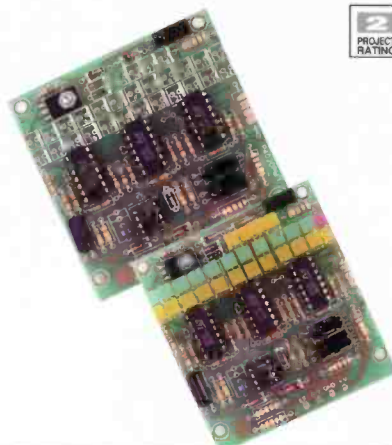

2 PROJECT RATING

LED POWER METER

A pair of LED power meters for the Velleman Stereo MOSFET Amplifier, VF17T. The meters can be used in either stereo or mono configuration. Order as: VF18U, **Price £34.95**. Details in *Electronics* No. 72 (XA72P).



1 PROJECT RATING

TWINKLING CHRISTMAS CANDLE

This simple to build, high tech electronic candle has a realistic pseudo-random flicker, but won't burn a hole in your pocket—or anything else for that matter. Ideal for decorations or plays, as there is no danger of fire, or of the flame being blown out. The kit includes constructional details of a suitable cardboard lantern for the festive season. Order as: LT40T, **Price £6.95**. Details in *Electronics* No. 72 (XA72P).

Visit our stores in: Birmingham, Brighton, Bristol, Cardiff, Chatham, Coventry, **Edinburgh, Glasgow**, Ilford, Leeds, Leicester, London (Edgware, Forest Hill and Hammersmith), Manchester (Oxford Road and Cheetham Hill), Middlesbrough, Milton Keynes, Newcastle-upon-Tyne (The Metro Centre, Gateshead), Northampton, Nottingham, Portsmouth, Reading, Sheffield, Slough, Southampton, Southend-on-Sea, Stockport, plus NEW stores opening soon in Stoke and Dudley. Ring 0702 552911 for further details.

RETURN TO THE SOUND THAT TIME FORGOT!

IT'S NOT A
DINOSAUR!

FOR TIMELESS
QUALITY VALVE
SOUND - AT AN
AFFORDABLE
PRICE!

THE
NEW
MILLENNIUM 4-20
AMPLIFIER

Full details of how to build this superb valve amplifier yourself may be found in the January and February 1994 issues of *Electronics - The Maplin Magazine*.

Complete Kit
Just £179.85[Ⓜ]
SAVE £20!

Electronics - The Maplin Magazine January 1994 Issue
Electronics - The Maplin Magazine February 1994 Issue
Power Supply Kit Only
Amplifier Kit Only
Complete Monobloc Amplifier Kit [1 x Power Supply Kit + 1 x Amplifier Kit]
Complete Stereo Amplifier Kit [1 x Power Supply Kit + 2 x Amplifier Kit]

(XA73Q)	Price £1.95 NV
(XA74P)	Price £1.95 NV
(LT44X)	Price £49.95 ☐
(LT45Y)	Price £74.95 ☐
(LT71N)	Price £114.90 ☐ Save £10!
(LT72P)	Price £179.85 ☐ Save £20!

Carriage: kits marked ☐ add £2.65, kits marked ☐ add £5.70. If ordering several kits maximum total carriage is £5.70.
Handling: add £1.40 to each order. Please note: carriage and handling charges apply to Mail Order only - you do not pay carriage or handling if you purchase these kits from Maplin Regional Stores.

Photograph shows Stereo Millennium 4-20 Amplifier (LT72P). The Millennium 4-20 Amplifier is not available ready built. The kits listed are rated 4 (Advanced) on the 1 to 5 Maplin Construction Rating Scale.

Maplin Electronics plc., PO Box 3, Rayleigh, Essex, SS6 8LR. Tel: (0702) 554161. Fax (0702) 553935.
For details of your nearest Maplin Regional Store Tel: (0702) 552911.

Prices include VAT at 17.5% except items marked NV which are rated at 0%.

All items subject to availability. Prices are correct at time of going to press (errors and omissions excluded), but may be subject to change.