



COMPUTERS • VIDEO • COMMUNICATIONS

No. 57

# ELECTRONICS

*The Maplin Magazine*

Britain's Best Selling Electronics Magazine

SEPTEMBER 1992 • £1.60

**E**XCLUSIVE OFFER!

SAVE £££'s when you buy from Maplin! See inside...

**V**isit the RAF Museum at Hendon FREE!

**E**asy guide to installing a home telephone exchange!

**D**esign your own waveform generator circuits!

**U**se your computer to take control with a versatile interface!

**P**lus!... How to... build a Sound FX Unit, Rescue BBC Computer Files and much, much more!

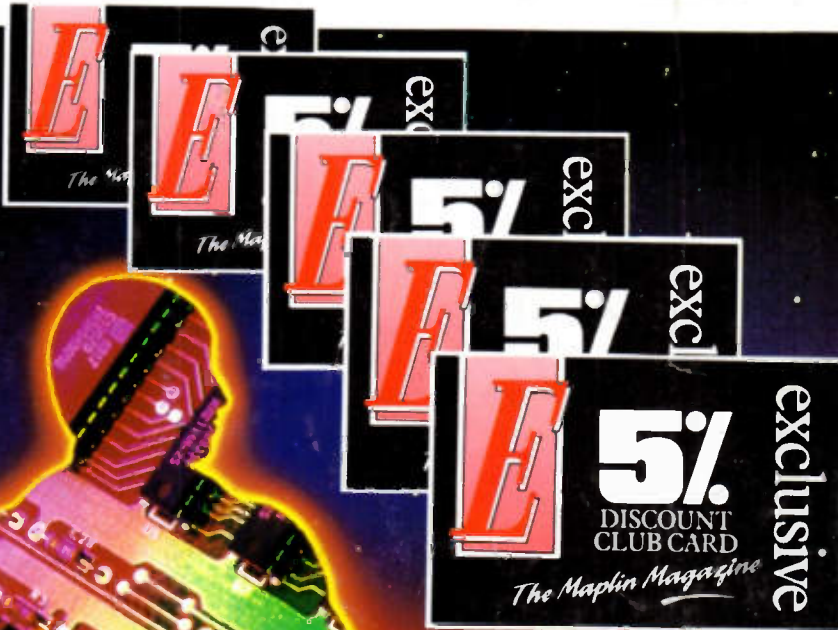

**SPECIAL!**  
More Mini Circuits  
from Robert Penfold

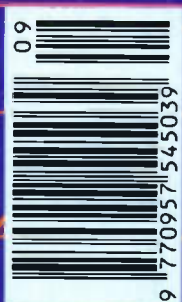

**CENTRONICS RELAY UNIT**



**FLUKE®**



**PHILIPS**

# We Only Skimped On The Price.

## Introducing The Fluke Series 10.

**Fluke quality:** Made in the USA by Fluke, with the same rugged reliability that's made us the world leader in digital multimeters. Count on hard-working high performance - and a three-year warranty to back it up.

**Large, easy-to-read display:** 4000 count digital readout.

**New! Min/Max record with relative time stamp and Continuity Capture™:** Makes intermittent problems easier to find. Records highs and lows - and "time stamps" when they occurred. In continuity mode, opens or shorts as brief as 250  $\mu$ s are captured and displayed.

**Actual size:** Easy to carry, easy to use.

**New! V Chk™:** For fast accurate checks on power sources and supplies, set your meter on V Chk - and let it do the rest. V Chk will determine continuity/ohms; if voltage is present, it will automatically change modes to measure AC or DC volts, whichever is detected. For most initial troubleshooting checks, here's the only setting you need to make.

**Capacitance:** Autoranging from .001  $\mu$ F to 9999  $\mu$ F. No need to carry a dedicated capacitance meter.

**Autoranging with manual option:** Your choice, depending on your situation.

**Sleep Mode:** Shuts itself off if you forget, extending long battery life even further.

**New! Slide switch and a few pushbuttons control all functions:** Designed for true one-hand operation.

**Fast, accurate tests and measurements:** AC and DC voltage measurements to 600 volts, ohms to 40 $\Omega$ ; audible continuity test; and diode test.

**For high performance at Fluke's lowest price, get your hands on the new Series 10.** Stop by your local Fluke distributor and feel what a powerful difference the right multimeter makes - at the right price. For a free product brochure, contact your local Fluke distributor today.



Fluke 10	Fluke 11	Fluke 12
4000 count digital display	V Chk™	V Chk™
1.5% basic dc volts accuracy	Capacitance, .001 to 9999 $\mu$ F	Min/Max recording with relative time stamp
2.9% basic ac volts accuracy	4000 count digital display	Continuity Capture™
1.5% basic ohms accuracy	0.9% basic dc volts accuracy	Capacitance, .001 to 9999 $\mu$ F
Fast continuity beeper	1.9% basic ac volts accuracy	4000 count digital display
Diode Test	0.9% basic ohms accuracy	0.9% basic dc volts accuracy
Sleep Mode	Fast continuity beeper	1.9% basic ac volts accuracy
Three-year warranty	Diode Test	0.9% basic ohms accuracy
	Sleep Mode	Fast continuity beeper
	Three-year warranty	Diode Test
		Sleep Mode
		Three-year warranty

Optional holster with tilt-stand available.



**Safety - a Fluke standard:** Designed to meet UL 1244, IEC 1010, CSA and VDE safety requirements; extensive overload protection built in.

**Audible Continuity:** To perform fast continuity checks, just listen for the beep; no need to watch the display.

**New! TL 75 Hard Point™ Test Leads:** Comfort grip with extra strong tips for extended service life.

Available from

**Maplin**  
ELECTRONICS

For further information phone 0702 552911. Or visit your local Maplin store at Birmingham, Brighton, Bristol, Cardiff, Chatham, Glasgow, Leeds, Leicester, London, Manchester, Newcastle-upon-Tyne, Nottingham, Reading, Sheffield, Southampton, Southend-on-Sea. PLUS - New Stores opening soon in Coventry and South London. Trade enquiries please phone 0702 552961.

The New Series 10.

**PHILIPS**

# CONTENTS

SEPTEMBER 1992 VOL. 11 No. 57

## EDITORIAL

■ Hello and welcome to this month's issue of Britain's best selling electronics magazine! I have some really exciting news for you, but there simply isn't enough room in this 'Editorial Column' for me to tell you about it (perhaps I should allow myself more space in future!), however, all is revealed on page 39! I am sure that most of you will know, or have heard, about the importance of Electromagnetic Compatibility (EMC); indeed Britain, along with all of the other countries in the European Community (EC) have until 1st January 1996 to comply with the EC EMC Directive. This directive applies to most items of electrical and electronic hardware that are imported, manufactured or sold in the EC; and relates to the emission of, and susceptibility to, electromagnetic interference. Obviously the range of such items is very broad; both in terms of design, construction and application. For this reason, in an attempt to simplify matters, items are categorised as *products*, *systems* or *installations*. A TV would be a *product*, a computer would be a *system*, which is made up of separate *products* (monitor, keyboard, processing unit, etc.); and a telephone exchange comprising a number of incorporated *systems* would form an *installation*. However, the directive does not apply to individual components. The question arises, where do kits and projects fall into the equation? The answer at the moment is not clear, and it is not hard to see why! – is the kit when bought 'just a collection of components'? – is the kit when built a *product*? – is the constructor a 'manufacturer'? – would the constructor be breaking the law if his latest project does not comply with the EMC directive? However, 'Electronics' is dealing with the Department of Trade and Industry (DTI) – the body responsible for the administration of the directive in Britain – to find out the answer to these and more questions. We will keep you informed of any future developments! So until next month, all that remains for me to say is I hope that you enjoy reading this issue as much as the 'team' and I have enjoyed putting it together for you!

*R. Ball*

**ABC** 31,125  
A B C Publications, 100, Broad Street  
**CONSUMER PRESS** Jan-Dec '91

- **Editor** Robert Ball
- **Project Development** Chris Barlow, Gavin Cheeseman, Tony Bricknell, Alan Williamson, Nigel Skeels
- **Technical Authors** Mike Holmes, Martin Pipe
- **News Compilation** Alan Simpson, Steve Waddington
- **Technical Illustrators** Paul Evans, Lesley Foster
- Ross Nisbet, Nicola Hull
- **Production Co-ordinator** Alan Wright
- **Print Co-ordinator** John Craddock
- **Advertising Co-ordinator** Kathy Peters
- **Publications Manager** Roy Smith
- **Development Manager** Dave Goodman
- **Advertising Manager** Vic Sutton
- **Drawing Office Manager** John Dudley
- **Art Designers** Peter Blackmore, Jim Bowler
- **Published by** Maplin Electronics Plc
- **Colour Separations** Stirling Graphics Ltd, 16-22 West Street, Southend, Essex SS2 6HU
- **Printed by** Severn Valley Press, Caerphilly, Mid Glam, CF8 3SU
- **Distributed by** United Magazine Distribution Ltd, 1-11 Bernwell Rd, London N7 7AX
- **Mail Order** P.O. Box 3, Rayleigh, Essex SS6 8LR
- **Retail Sales:** (0702) 554161, **Retail Enquiries:** (0702) 552911, **Trade Sales:** (0702) 554171
- **Cashier: (MODEM)** (0702) 552941
- **General:** (0702) 554155
- **Fax:** (0702) 553935, **Telex:** 995695.

## PROJECTS

### 8 DATA FILE: VOLTAGE/FREQUENCY CONVERTER

■ How to use the versatile LM331 voltage/frequency converter IC!

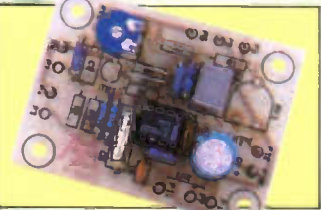

### 21 VIDEO BOX MODIFICATION

■ A simple modification to improve operation of the Maplin Video Box project.

### 24 SOUND EFFECTS GENERATOR

■ Generate a wide variety of sound effects with this novel project.

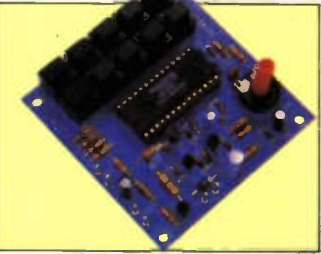

### 40 FUNTRONICS MUSIC MAKER

■ Build this project and have fun learning about electronics and music!

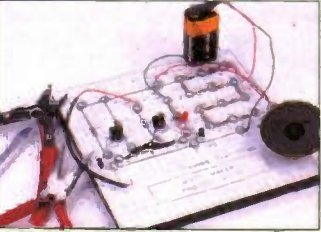

### 46 CENTRONICS RELAY UNIT

■ An ingenious interface unit – for use with any computer that has a centronics parallel printer port.

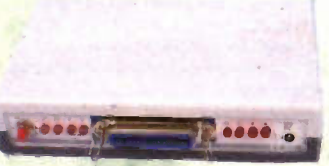

### 62 BOB'S MINI CIRCUITS

■ Robert Penfold returns by popular demand!

## FEATURES

### 4 BBC TO PC FILE CONVERSION

■ Alan Pickard explains how to rescue BBC computer files and transfer them onto an IBM PC or compatible computer.

### 13 CD ROMS

■ Discover the latest developments in compact disc data storage technology.



### 16 TELEPHONE EXCHANGE INSTALLATION

■ How to install a telephone exchange at home!

### 27 ISDN

■ Frank Booty discusses the merits of the Integrated Services Digital Network.

### 32 DESIGNING WAVEFORM GENERATORS

■ Ray Marston reveals the secrets of designing waveform generator circuits!

### 54 VIDEO PROCESSING SYSTEMS

■ Take a look at how video signals are manipulated in digital timebase correctors and frame stores.

### 68 OUT & ABOUT: RAF HENDON

■ A tour of the top museum of aviation.



## REGULARS

- 2 NEWS REPORT
- 22 AIR YOUR VIEWS
- 23 STRAY SIGNALS
- 37 ORDER COUPON
- 38 SUBSCRIPTIONS
- 44 TOP 20 KITS & CLASSIFIED
- 45 NEW BOOKS
- 53 TOP 20 BOOKS

Copyright. All material is subject to worldwide copyright protection, and reproduction or imitation in whole or part is expressly forbidden. All reasonable care is taken to ensure accuracy in preparation of the magazine, but Maplin Electronics plc cannot be held legally responsible for its contents. Where errors occur corrections will be published as soon as possible afterwards. Permission to reproduce printed circuit board layouts commercially or marketing of kits must be sought from the publisher.  
 © Copyright 1992 Maplin Electronics plc.  
 Advertisements. Whilst every reasonable precaution is undertaken to protect the interests of readers by ensuring, as far as possible, that advertisements appearing in the current issue of 'Electronics' – The Maplin Magazine' are bona fide, the publishers and the staff of the magazine cannot give any undertakings in respect of statements or claims made by advertisers, whether on printed page or insert. Editorial. The views of individual contributors/authors are not necessarily those of either the publisher or the editor. Cover Picture. © Copyright 1992 The Image Bank, Joseph Drivas.

Prices shown in this issue include VAT at 17.5% (except items marked NV which are rated at 0%) and are valid between 7th August 1992 and 31st August 1992.

# NEWS

## Report

### The Rolling Tower of Pisa

A British company has been assisting in evaluating the requirements which need to be made to stabilise one of Europe's most famous landmarks. Electronic technology has proved that the Leaning Tower of Pisa is not only leaning, but that it is also rocking and revolving. The Building Research Establishment (BRE) based in Garston, employed by the Italian Authorities to monitor the Tower's movements, installed electrolevels at three levels of the building. This enabled all the Tower's movements to be established – an exercise which has not been undertaken before.

The electrolevels, originally developed for aircraft in-flight navigation have been adapted by BRE for use in projects ranging from tunnels, deep foundations, bridges and dams. Basically an elaborate tilt switch, an electrolevel consists of a glass phial containing an electrolytic fluid and three electrodes spaced at equal distances along its length; as the phial tilts, the quantity of fluid varies, and so does the electrical resistance between them varies.

The most recent attempt to stabilise the Leaning Tower was made in the thirties when Mussolini had 1800 tonnes of cement pumped into the foundations. When further efforts start later this decade, the data from the BRE instruments will be continuously used to check the effects of the remedial work and to give early warning of any changes in the Tower's tilt.

### Matchbox Disk Drive

As work continues worldwide to reduce the size of electronic storage mediums, Hewlett Packard (HP) already recognised for excellence in quality and design of computational products have furthered their claim with the launch of a 1.3in. disk drive. The size of a small matchbox, the device is capable of storing 21.4 Mbytes of information – equivalent in more realistic terms to almost 14,500 typed pages.

The new HP Kittyhawk Personal Storage Module (PSM) apart from adding a further acronym to the computing dictionary, combines the miniaturisation, durability and removability of solid state technology with the cost benefits of conventional disk drive technology. The number of integrated circuits employed in the design is just seven, compared with the 20 to 30 devices typically used in most of today's 1.8 and 2.5in. disk drives; this reduction saves space, weight and power whilst also providing a significant cost advantage.

Hewlett Packard expect the 1.3in. storage device to set the standard for the next generation of small disk drives and storage modules. Likely customers

include manufacturers of palm-top, pen-based and sub-notebook computers. Other possible areas of appeal include printers, facsimile machines, medical equipment and communications equipment.

The module which is the work of a collaboration between several companies including the Citizen Watch Company Ltd of Japan, stores data in a similar manner to a standard Winchester drive. Connection is via a standard AT attachment or specially developed interface card.

### IEE Medal for PCB Inventor

The Institute of Electrical and Electronic Engineers (IEE) has awarded its 1992 Nuffield Silver Medal to Dr Paul Eisler, inventor of the printed circuit, in recognition of his outstanding contribution to the manufacturing industry.

Eighty-five year old IEE Fellow, Dr Eisler patented the printed circuit in 1936. He first demonstrated his new technique in a small two-valve radio and went on to develop twenty-nine British patents relating to the manufacture and design of printed and foil pattern circuit boards between the period 1935 to 1955.

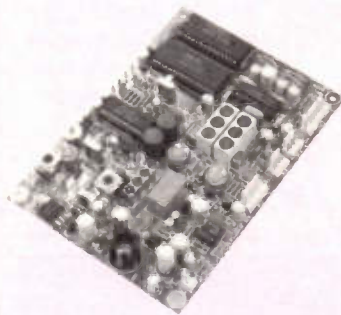

Still an active pioneer in the areas to which he has devoted his life, Dr Eisler has told the story of his work in his book 'My Life with the Printed Circuit' – published by the Associated University Presses in 1989.

Just imagine what the Maplin NICAM Decoder would be like if PCBs hadn't been invented!

### Step by Step

A recent advertisement for US telecomms operator Sprint, explains how to use its 'Discover' cards: Simply dial (800) 347-3000 to access Sprint's nation-wide digital fibre-optic network. At the tone, enter 0 plus the area code and phone number you are calling, then your 16-digit 'Discover' Card number and finally your personal access code. Lets hope Sprint are not advising OfTel on the forthcoming UK re-numbering scheme.

### Explosion-Proof PA

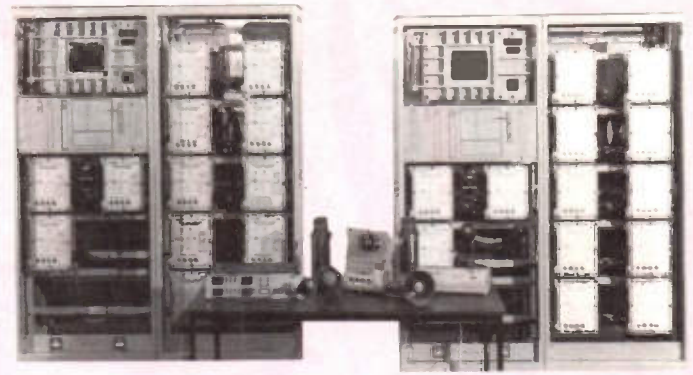

A certified Public Address System with combined Alarm equipment has been designed and built by Spector/Lumenex to meet and exceed the standards recommended by Lord Cullen following his enquiry into the Piper Alpha disaster.

Shortly to be installed on the new Chevron Alba platform, the system christened E.X.P.A.G.A. is designed to carry on working even in the most extreme emergency conditions. The first explosion-proof system of its kind to be installed anywhere in the world, every component is duplicated to ensure that even under the catastrophic failure of one of the two central sub-systems, the one remaining will continue to provide a secure service to all areas of the oil platform.

The Certifying Authority, Lloyds are impressed with the design which

incorporates explosion-proof speakers and beacons distributed such that no one area of the platform is covered by a single device. Associated field cabling is arranged to remove the possibility of common mode failures.

The integrated package is capable of functioning within a gas-filled explosive atmosphere, and will ensure that the loudspeakers and flashing beacons continue to keep personnel informed of an emergency even when all other electrical systems have shut down or failed. In such instances power is maintained by independent explosion-proof batteries.

Leaders in their field, Spector/Lumenex were responsible for the design and eventual construction of a £750,000 Public Address and Alarm scheme at the Sizewell B Nuclear Generation Plant.

### Clear Liquid

There is now no excuse for cloudy beer as Belstock Controls launch a low-cost instrument for measuring haze and suspended solids in a liquid. The in-line turbidimeter and suspended solids monitor measures haze in liquid and suspended concentrations of up to 20% impurity.

Typically useful in water, brewing, chemical and food industries, possible chores for the new transducer include filtration monitoring, contamination monitoring for sewage control, water effluence monitoring and polymer thickness control.

Available in several models the monitor consists of an insertion sensor with an electronic signal converter. The turbidimeter generates a beam of light using a focused incandescent lamp. After being scattered, by particles within the liquid, the strength of the beam is measured with a semiconductor sensor. The silicon detector generates a current signal proportional to the amount of light scattered and after amplification and scaling provides a current signal suitable for operating a control unit, computer or remote alarm. An indicator and 4 to 20mA signal is provided as standard.

The sensor probe can be installed directly in a tank or pipe mounted, with a fully submersible probe available.

### Telephone on a Chip

New from the development laboratories of Austrian firm Asic Mega Systems is the AS2512, a CMOS integrated circuit that incorporates all the features of a telephone. Combining, loudspeaker, microphone and tone ringing functions it contains a high performance amplifier with an anti-Larsen and enhanced tone ringing circuit.

The loudspeaker amplifier includes an anti-clipping circuit to provide low distortion when the required output level exceeds the capabilities of the available supply current. The anti-

Larsen circuit prevents acoustic feedback between loudspeaker and microphone, whilst a switching converter is used to extract available power from the ring signal.

### Electromagnetic Coupling

In what promises to be a major breakthrough, a UK development from start-up company Paraphone has produced the Watsonline, a cable coupling transformer which enables the electromagnetic coupling of signals into and out of a twin cored cable. "This enables you to communicate with what is going on inside a twin cable without actually plugging into it," says Mike. "As a result, you could place the coupling transformer close to your telephone cable and hear precisely what is going on inside". London Underground apart, no doubt M15 are already dialling directory enquiries.

### Switching On

In case you haven't heard it: "How many computer programmers does it take to change a light bulb? None – it's a hardware problem."

### A Burning BT Matter

With BT phonecards being almost standard-issue in wallets – you can now use a Phonecard in rather more than a fifth of BT's 100,000 payphones, the corporation has eliminated one weak link. From this summer, BT Phonecards will be launching new cards which indicate how many units are left. The breakthrough comes about thanks to a new technique which allows a thermographic strip to be printed on the front of the cards, which burns through each time a unit is used. At least it will confirm we have fewer units left on the cards than we thought.

BT has also been giving some

Maplin Magazine September 1992

thought to the design of our bills. Apparently confusion about the content of a bill is the single most common reason that customers get in touch with BT with all too often, the problem being caused by a simple misunderstanding of the information provided. BT sends out about 100 million bills a year, and the redesign has been a massive operation. Customers in London and the South East can expect the new format bills in early September with the national roll-out beginning in October. However, BT point out that Braille or large-print versions of the bill will continue to be available as at present.

### Memory in a Flash

New on the market, at least for computer manufacturers, is an 8-megabit memory component from Intel. The FlashMemory stores one megabyte of code or data in a single chip. Its extremely small form factor makes it the ideal component for today's handheld, pen-based and sub-notebook mobile computers.

At the same time, Hitachi has developed the world's smallest memory cell to open the way for 256M-bit dynamic memory chips: the cell is 0.6 micron wide and 1.2 micron long, about half the size of a memory cell developed earlier to make 64M-bit prototypes.

IBM meanwhile are also chipping in with the news that they have made the world's smallest transistors. The experimental devices are so small that the active area of a single one is just  $\frac{1}{75,000}$ th of the cross-section of a human hair. That is a size that in the future will permit memory-chip fabrication in the realm of 4-gigabits and beyond. Previously, the smallest transistor in existence was 20 times larger in area, and, according to the researchers, these new transistors can readily be further reduced in size by another factor of two. Presumably they come boxed with a microscope.

### Mobile Phones Provide Peace of Mind

Roy Hattersley may have described mobile phones as being addictive, and the Chancellor is less than enthusiastic, but according to Cellnet, they also reduce levels of stress at work. Mobile phones, by making it easier to keep in contact with their customers, help to make users work more efficiently. The most frequent example cited, was when your car breaks down, you can call for help without having to leave the vehicle to look for help.

A further major benefit, guaranteed to reduce stress levels when paying your hotel bills, is to shun the room phone and use your mobile instead. With some hotels adding a loading of four times the basic rate, even a cellular phone call will look cheap.

### Darling - Your Dinner is in the Microwave

According to a team of US scientists, families will be having a microwave oven in virtually every room and they will even be installed on buses and trains. Domestic models will be small enough to sit on the bedside table and will be divided into compartments to produce separate meals at programmed intervals.

Apparently by the year 2000, rather than eating the standard three meals a day format, we will be eating six or more snacks a day. The magazine 'Supermarket' predicts that this will lead to the virtual disappearance of supermarkets stacked high with fresh produce and basic ingredients, in place

of fat-free ready-to-eat meals. Presumably arrangements will be made for us to shop by computer, and for an automated meals-on-wheels delivery service.

It could be we might even get our computer to speak direct to Safeway's. The Talking Computer Company is marketing the Talking Computer 1000, which is basically an IBM compatible PC running under MS-DOS but without a keyboard. It allows full vocabulary dictation for a dictionary of 30,000 words, 5,000 of which are user-defined words. It has the ability to handle all the functions commonly associated with desk-top computers without the need for keyboard literacy including word processing, spreadsheets and databases. It even has the capability to send and receive fax, E-Mail and can communicate over a local area network.

The TC1000 operates at about 30 to 40 words a minute and uses discrete speech recognition technology which adapts continually to a user's voice and therefore improve its performance. Major markets are seen as being disabled users, banking and finance, legal and accountancy services. The price which includes one day's training is £12,500 for the basic model. Or you can try asking it for a better deal. Further details, Tel: 0784- 473737.

### Par for the Course

This month sees the arrival of Microsoft Golf for Windows. This is a new golf game that features photo-realistic and topographically accurate simulations of a real golf course. In addition, the game benefits from its compatibility with the Access Line of PGA Championship Courses and the developments currently underway for the simulation of several UK golf courses.

The game runs on a PC with the MS-DOS operating system version 3.1 or later and requires a VGA. Also of course, the Microsoft Windows graphical environment together with a Microsoft Mouse.

### Or You Could Try a Sip of Water

A US university consortium headed by Steven W. Gilbert believes that the wave of the future is HIPPCUDs. These are Highly Intelligent, Portable, Powerful, Cheap, Unobtrusive Devices that you can stick in your pocket for communications and information management.

### It's a Gas

British Gas reports the introduction of a new meter that could provide links to a range of IT services. The 'Gill' meter features a compact size, an absence of moving parts, and intelligent links to other electronic services. The key, award-winning features are the meter's great accuracy of timing and low power consumption. A standard battery will power a meter for 10 years.

### Have I Got Light for You

A US company has developed a new generation of light bulbs which will last for more than 18 years. The E-Lamp combines the intensity of incandescent bulbs with the energy efficient fluorescent lamps. The same size as traditional light bulbs, and fitting ordinary sockets, the new bulbs are designed to last 14 times longer than incandescent bulbs and twice as long as fluorescent lights. Having no filament to burn out, the lifespan is estimated on being switched on for an average of three hours a day.

### Wide Screen TV Hopes Narrow

A European Commission proposal to provide subsidies for the development of wide screen television has been opposed by the UK Government at a recent meeting in Luxembourg. Britain's Technology Minister, Edward Leigh said that while Britain supported development of wide screen TV, it was not going to spend any money on it. "Wouldn't something as attractive to consumers as wide screen TV happen anyway in a viable time period without a public subsidy", he asks. Lets hope that politicians in the rest of Europe, the USA and probably Japan, don't see it the same way. Certainly Sony of Japan are pressing ahead with developing new TV technologies. The company has just cut the cost of high definition TV by around 70% bringing the price down to a still impressive £5,000. Japan began broadcasting HDTV eight hours a day earlier this year.

### Heave-Ho Me Hearties!

Using conventional telephone lines, a new port navigation system will provide harbours with the facilities of conventional radar systems. As a result, marine pilots will now be able to view raw images transmitted from shore-based radar stations independent of the ship's own systems. Called Pilot-watch, the system will provide a full harbour radar picture of the area upstream and downstream of the new road bridge which crosses the Severn Estuary. The system from DB Electronics comprises eight portable displays and two radar stations, one on the English shore and one on the Welsh shore, remote controlled via telephone lines from a central operations room.

### Diary Dates

Until 31st October. 'Friendly Invasion', RAF Museum, Hendon. Tel: 081-205 9191.

Until January '93. The Iron-Bru Pop Video Exhibition. MOMI, South Bank, London. Tel: 071-815 1339.

6/8 September. European Computer Trade Show, Business Design Centre, London. Tel: 081-868 4466.

13 September. Farnborough Air Show, Society of British Aerospace Companies. Tel: 071-839 3231.

22/24 September. Image Processing Exhibition, Birmingham. Tel: 081-868 4466.

22/24 September. COMEX '92, Wembley, Middlesex. Tel: 081-778 3343.

23 September. Interactive Multi-Media, Loughborough University. IEE. Tel: 071-240 1871.

29 September/1 October. Euro Teleconference '92 Wembley, Middlesex. Tel: 0234 212988.

5/9 October. SICOB (business equipment) Paris. Tel: 071-221 3660.

6/8 October. VOICE '92 (computer telephony and voice automation). Olympia, London. Tel: 081-877 9007.

6/8 October. Exclusively Tools, Wembley, London. Tel: 081-868 4466.

20 October/1 November. British International Motor Show, NEC, Birmingham. Tel (0483) 222888.

Please send details of events for inclusion in 'Diary Dates' to: The Editor, 'Electronics' - The Maplin Magazine, P.O. Box 3, Rayleigh, Essex, SS6 8LR.

**NEW**  
BRITISH MADE



ChipMaster Compact

# HAND HELD 40 PIN DIGITAL IC TESTER

Spot the fault instantly and save pounds with the latest in the range of professional IC diagnostic hardware from ABI.

- TTL / CMOS / memory / LSI interface capability
- Search facility
- Identifies unknown / unmarked devices
- Detection of intermittent faults



**0226 350145**

ABI Electronics Ltd.  
Mason Way,  
Platts Common  
Industrial Park  
Barnsley S74 9TG  
Tel: 0226 350145  
Fax: 0226 350483

**INTRODUCTORY PRICE**

## £245

plus VAT & pp  
(List Price £295 Plus VAT & pp)

---

To ABI Electronics Ltd., FREEPOST, Mason Way, Platts Common Industrial Park, Barnsley, South Yorkshire S74 9BR

Please rush me ..... ChipMaster Compact(s) @ £293.75 inc pp & VAT.  
(tick box)

I enclose cheque for £ ..... payable to ABI Electronics Ltd. 

Please debit my Access/Visa card.  
Expiry date .....

Please send me more information.

Name ..... Signature .....

Address ..... Postcode .....

10 day money back guarantee (if not completely satisfied). Allow 28 days for delivery. Please note that this product is not available from Maplin Electronics. EMM

# Transferring BBC Text Files to PC MS-DOS

by Alan Pickard

Out there, there are many people who have used the BBC Micro extensively as a wordprocessor and still have such a machine in their possession. Such people may find it useful to know that it is possible to transfer files from this machine to an IBM-compatible PC.

This article describes how it is possible to transfer files from the BBC Micro using a serial cable link and suitable software. The files are transferred one by one and are finally reformatted on the PC (see Figure 1).

Some people might think that transferring files in this way is more trouble than it is worth, but it is almost certainly less tedious than retyping articles, book chapters, essays and other individually large files.

## Equipment and Software Requirements

The equipment that I used to transfer files from BBC Micro format to the PC is as follows:

BBC Micro Model B  
100K single sided floppy disk drive  
Wordwise Plus  
\*RS423 serial port

IBM-compatible PC (with 80286 CPU running at 12MHz)  
40Mb hard disk  
1-2Mb 5¼in. floppy disk drive  
1-44Mb 3½in. floppy disk drive  
\*MS-DOS version 3.30  
\*PROCOMM-PLUS  
WordPerfect 5.0

The 'essential' items here are indicated by a '\*'. PROCOMM+ is a communications software package that runs under MS-DOS. Although I will give details of Wordwise Plus (and for that matter, WordPerfect) commands, it should be apparent how to transfer text in, for example, VIEW (BBC) format to that of WordPerfect, WordStar, Locoscript or any other MS-DOS wordprocessor; the principles are the same. Once the BBC Micro is set up to transmit text output as it would to a printer, and the PC is ready to receive it, it is quite easy to 'grab' chunks of text. Although initially DOS files, these can be converted into the appropriate word-processor files, as detailed later.

## Hardware

Figure 2 shows the connection of the two

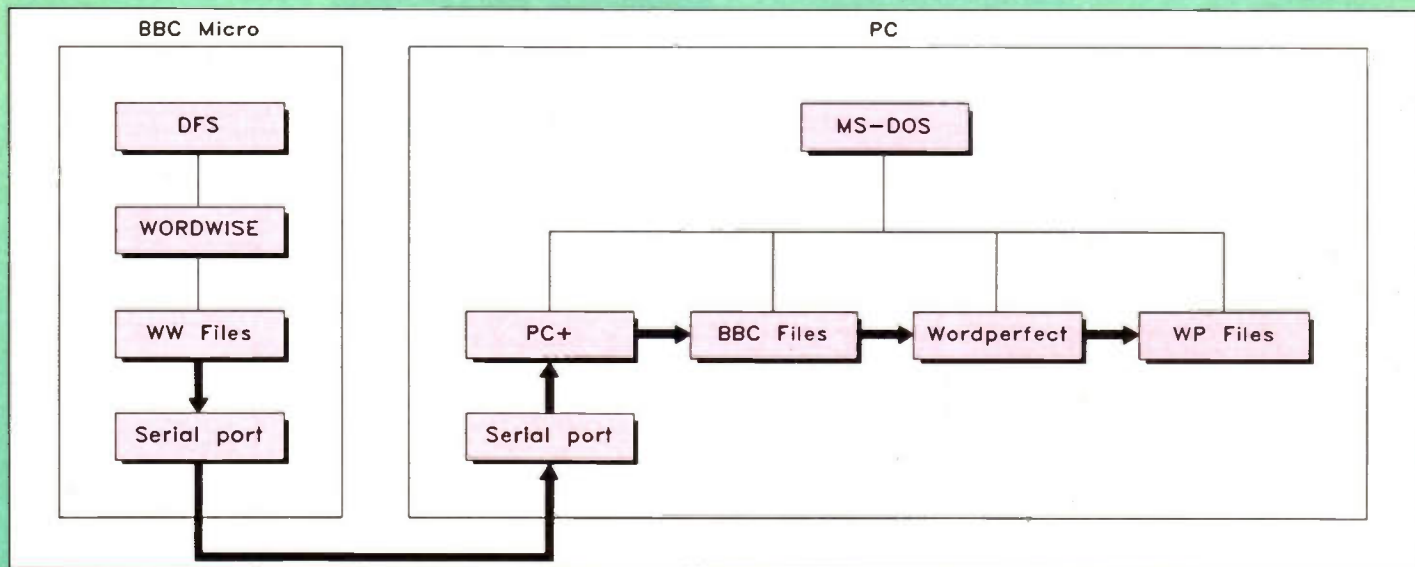

Figure 1. File transfer method

microcomputer systems in terms of hardware, interconnecting leads and also software. Figure 3 gives wiring details for BBC and PC serial ports, while Figure 4 shows serial lead requirements.

## Software

As already mentioned, my text files consisted of Wordwise Plus files which were loaded into the BBC Micro's RAM from disk in the usual way. Unless it is necessary to edit these files before transmission to the PC, they can be transferred by suitable wordprocessor system commands which output text to a printer. Thus, the appropriate commands for any wordprocessor program being run on the BBC micro can be used to provide the same effect.

As it is assumed that readers of this article will be running MS-DOS on their PC, the terminal emulator software PROCOMM+ is a suitable and readily available (shareware) program that runs under most MS-DOS versions, including 3.30. The version of PROCOMM+ that I used was 1.1.1UK. PROCOMM+, supplied by Intuitive Communications(tm), is distributed in Great Britain by Shareware Marketing. This menu-driven software is self-explanatory in use, but specific settings used are detailed later.

## Wordwise and Wordwise Plus

As far as file transfers are concerned, the difference between Wordwise and Wordwise Plus on the BBC Micro are irrelevant as the additional features of Wordwise Plus are related to the creation and editing of files. Some of the embedded commands used by Wordwise are of interest where files transferred must not have their lines of text broken up into alternate long and short lines. This effect, caused by hidden 'hard' CR (carriage return) characters is shown below:

This is a piece of text transferred from the BBC Micro on to the IBM PC. Because the line length is different this ragged effect is produced.

Although the text is successfully transferred, the CR characters need to be removed manually with the delete key, which is very tedious with several long text files. It is therefore very worthwhile to attempt, by trial and error, to reformat Wordwise files via an embedded command. For example, LL66 sets the number of characters per line to 66, so that all text arrives in 'unragged' form. Unfortunately, if you wish to edit the transferred file at a later date using an MS-DOS wordprocessor program, this will affect the right-hand justification. However, as most files are unlikely to be edited, this is something that can be lived with.

## Loading and Downloading

A text file is loaded from disk, examined,

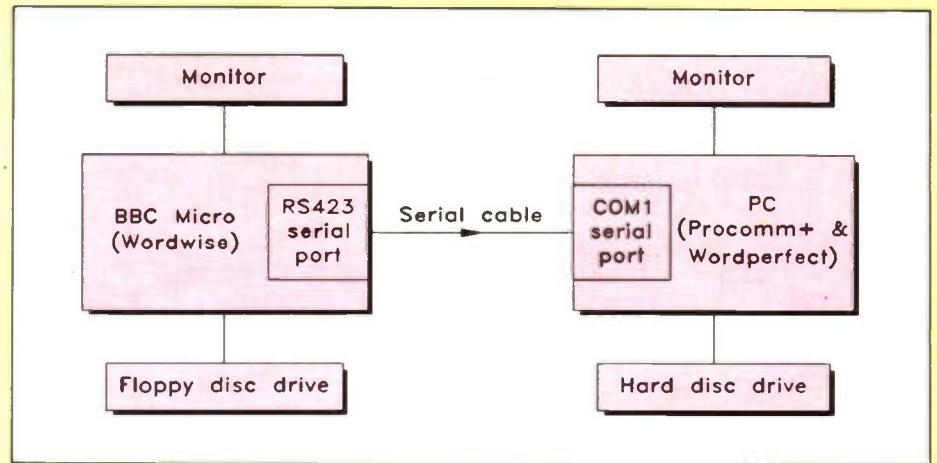

Figure 2. BBC Micro serial connection to PC.

edited if necessary (e.g. re-formatted via embedded commands) and then downloaded by using the printer output command (item 6 'Print text') from the Wordwise Plus menu.

## Setting Up the PC

Having connected the serial cable between the BBC RS423 connector and the PC COM-1 port, it is now necessary to set up the PC. This is achieved by booting up the system from MS-DOS and then running PROCOMM+.

e.g. C:\>CD PCPLUS  
C:\PCPLUS>PCPLUS

This results in the message 'PRESS ANY KEY TO ENTER TERMINAL MODE', followed by a working screen/window

with the message 'PROCOMM PLUS Ready!'.

Pressing ALT-S provides a 'PROCOMM PLUS SEND UTILITY' menu. 'TERMINAL OPTIONS' can then be selected.

ALT-P shows current settings (baud rate, etc.) which should be:

9600,E,7,1,COM1

where 9600 is the baud rate, E denotes 'even' parity, 7 is the number of bits, 1 is the number of stop bits and COM1 is the name of the serial port.

ALT-Z takes you to the main command menu.

ALT-Z gives help information.

ALT-X exits to DOS.

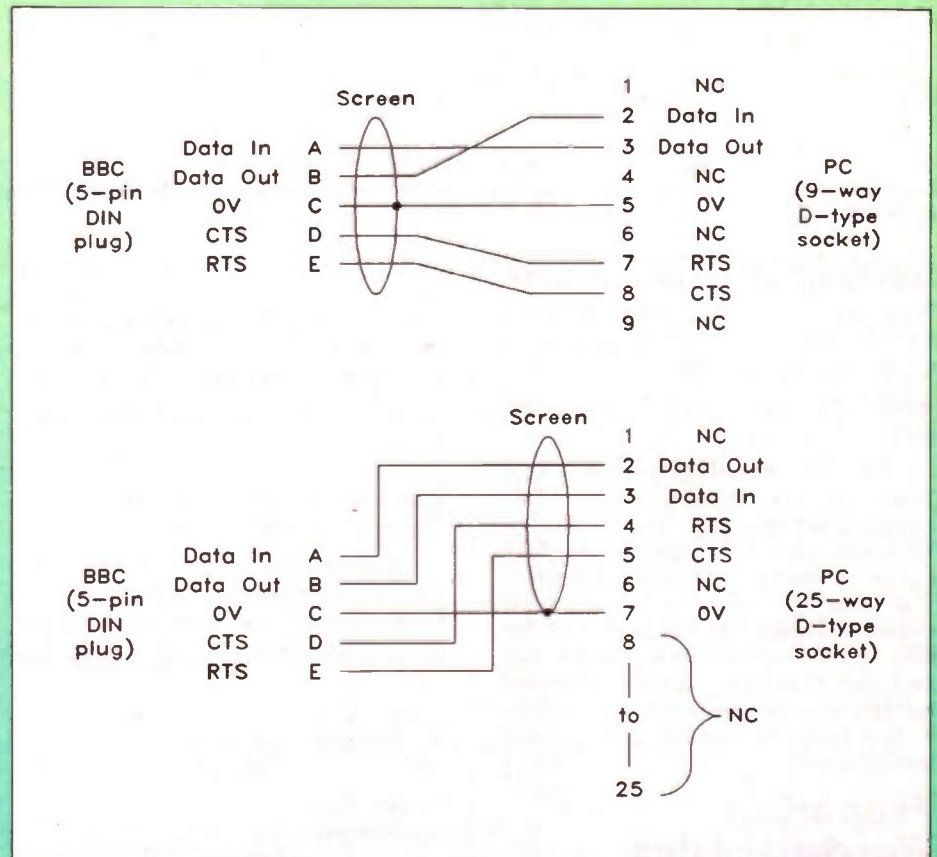

Figure 3. Interconnection details of serial ports; (a) 9-way D-type connector, (b) 25-way D-type connector.

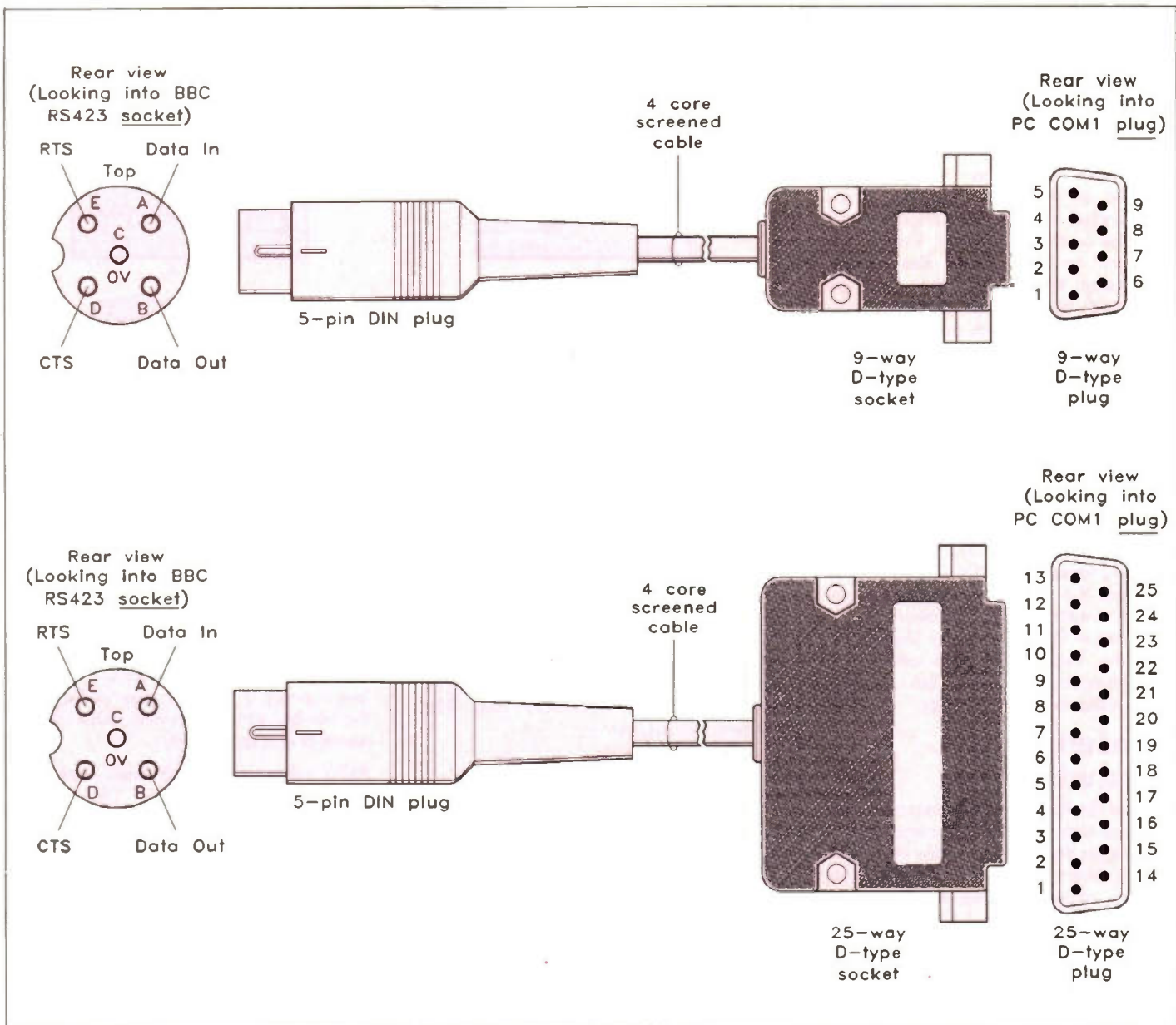

Figure 4. BBC Micro socket and PC plug connections for serial lead; (a) 9-way D-type connector, (b) 25-way D-type connector.

## Setting Up BBC Micro

This process must be enabled using one of the BBC Micro 'FX' commands. This is easily achieved by typing:

\*FX3,5 (to output to screen and serial port)

Following a push of the return key, 'Press any key' appears on the BBC screen. Responding to this causes the Wordwise menu to reappear on the PC's screen, as well as the BBC micro's monitor. The PC is now effectively acting as a duplicate display terminal to that of the BBC Micro. Serial outputting of text can be tested by selecting option 7 ('Preview text') from the Wordwise menu. This results in text being scrolled up both screens simultaneously.

## Preparing Wordwise Files

Re-formatting (no connection with disk 'formatting') of Wordwise files depends

on the format of your PC wordprocessor files in terms of line width/number of characters per line. I will use my Wordwise files (BBC) and WordPerfect file (PC) formats as an example.

Relevant Wordwise embedded commands:

LL66 - line length (LL70 is default)  
PL70 - page length (PL66 is default)

Page length is irrelevant as page breaks will be included as in Wordwise - these will need to be removed manually.

Relevant WordPerfect format parameters:

Format: Line  
7 - Margins - Left 0.5in.  
- Right 0.8in.

Format: Page  
5 - Margins - Top 0.5in.  
- Bottom 0.5in.

8 - Paper Size: 8.27in. x 11.69in.  
Type: Standard

## Creating a PC Header File

Another way of saving time is to produce a 'header' file suitable for your PC wordprocessor. In the case of WordPerfect, loading incoming files into a dummy header file means that you do not have to set up or format the file each time it is 'created'.

Parameters (temporary content) for the dummy header are:

HEADER FILE: LM = 0.5in. and RM = 0.8in. (or any dummy message)

Unfortunately, this process must be done in two stages. I transferred all of my files into appropriately-named DOS files which I then loaded into WordPerfect via the pre-loaded header. This was unavoidable as it is not possible, using PROCOMM+, to do a wordprocessor-to-wordprocessor transfer across two machine operating systems! The requirements are as shown in Figure 5.



Another essential preparation is to set up, on your hard disk, appropriate directories and/or sub-directories for your files. This means that your files will arrive on your hard disk in an organised manner. If you do not do this, they will end up at the directory root level requiring much time-consuming re-organisation.

## Downloading

### BBC:

Ensure that directory or sub-directory exists on PC  
Load file from disk  
Check it  
Re-format it if necessary  
(Ready to) 'Output to printer' (i.e. to PC)

### PC:

PROCOMM+ running (set up as described earlier)  
'PROCOMM PLUS Ready!' on screen  
ALT-F1  
Bleep sounds (acknowledgment)  
'Enter log filename, or CR for default:--'  
(Enter filename, e.g.  
C:\MAPLIN\ARTICLE ret)  
Log window disappears

### BBC:

Press '6' from menu, file is sent to PC Text scrolls on both screens but pauses as chunks of text are written on to PC hard disk

### PC:

Press ALT-F1 again to terminate (no acknowledgment occurs) Check that information has been successfully transferred to a DOS file by exiting from PROCOMM+ to DOS (ALT-X)

## Creating PC Directories/ Filenames

You might find it tempting to dump all of your BBC files into one directory and then sort them out later. This will almost certainly result in the copying of lots of files, and unless the total number of files is very small it is advisable to set up suitable sub-directories under DOS. When asked for a filename ('enter log filename'), you can state this in the form:

C:\SUBDIR\FILENAME.

If you try to create sub-directories at the point of downloading, an error message will be produced. It is also worth pointing out that it is not a good idea to dump large numbers of files into the root directory!

## Terminating File Transfer

After downloading the file from the BBC machine it is then, as has already been stated, necessary to press ALT-F1 to close the file and then proceed to the next download process. Failing to do this will result in two (or more) files being combined at the PC end!

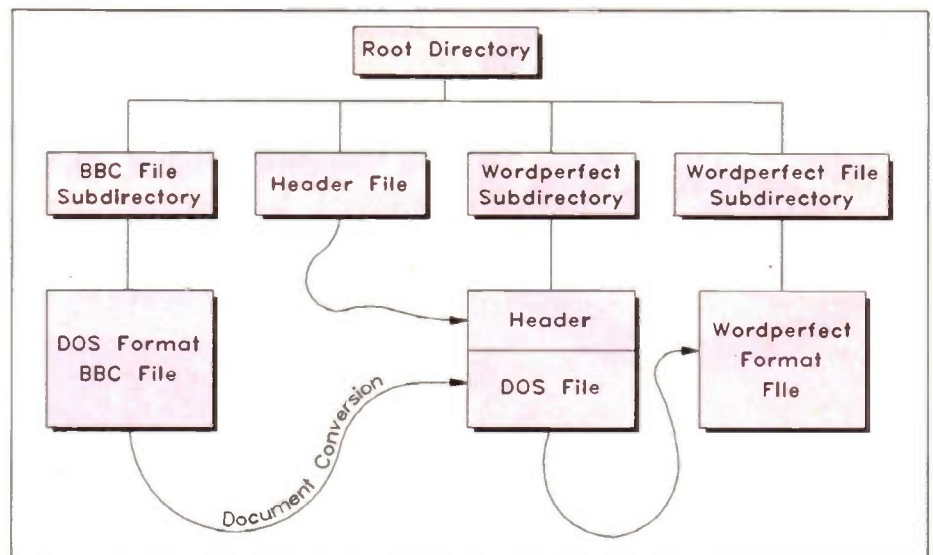

Figure 5. Completion of transferred BBC file into re-formatted WordPerfect file.

## Intermediate Backing Up of Files

It is always good practice, when dealing with text (and other) files, to make copies in case of accidental losses. During a file transfer session it makes sense to copy newly transferred files onto a spare floppy disk, even though the transferred files may not be 'cleaned up'. It is easier to access backed-up files than to go through the transfer procedure again. Files may be backed-up, individually or in complete sub-directories.

## Loading Files into WordPerfect

Once files have been transferred from the BBC Micro, they are simply DOS text files which need then to be loaded into a wordprocessor such as WordPerfect. The best way of doing this is to load your header file into WordPerfect (for convenience this file can be placed in the root directory). Once this suitably formatted file is loaded you can then load, or 'retrieve', your transferred file into this one. Refer again to Figure 5.

The message 'Document conversion in progress' appears at the bottom of the screen while this is in progress. The converted file can then be examined, modified if necessary and then re-saved using the same sub-directory/filename. At this point the file transfer is complete.

## Final Edit of File (and Back-up)

After any final editing, the file can be saved and, of course, easily backed up. The latter is particularly important if you are 'burning your boats', dispensing with your BBC Micro disk files — and even BBC Micro!

## Reading of Transferred Files

Before discarding your BBC Micro and/or disks it is a good idea to read, or examine, all files transferred. This is a wise move,

just in case one or more files did not get copied over successfully, or were not converted into WordPerfect form.

## Deletion of BBC Files

The tidy-minded, or even ruthlessly efficient decision making, individual may wish to delete or recycle all BBC Micro disks and derive great psychological benefit from this cleansing process! A clean break from wasting time with old system files may be beneficial. If, however, you prefer to hang on to them for security then that is your decision.

## Conclusion

Transferring individual files in the way described is somewhat tedious, but is unavoidable unless you have invented some magical technique for directly reading BBC disks. The individual must decide how worthwhile it is by considering the number and size of files to be transferred. The decision is really quite simple — you either decide to transfer, or you don't bother and face the prospect of retyping a file, or a group of files, from scratch!

Whilst I found the process of transferring my collection of book chapters, articles and files (upon which I was in the middle of working prior to obtaining my PC) rather tedious and time consuming, I felt that it was worthwhile. It was also unavoidable, in the absence of a means of reading BBC disks directly. Hopefully in the future, moving from one machine and/or operating system to another will be much more straightforward — and the problem discussed in this article will not exist. Another worthwhile aspect of this exercise has been the removal of the need to run two machines. Having said this, one area that I have not yet explored is the transfer of BBC BASIC programs to a PC. Conversion to GWBASIC, for example, may not be worthwhile but as it is possible to run BBC BASIC on a PC (BASIC86), it should be possible to move programs across using PROCOMM+. Amending them for running purposes may be another story!

**DATA  
FILE**

# LM331

## VOLTAGE-TO-FREQUENCY/ FREQUENCY-TO-VOLTAGE CONVERTER

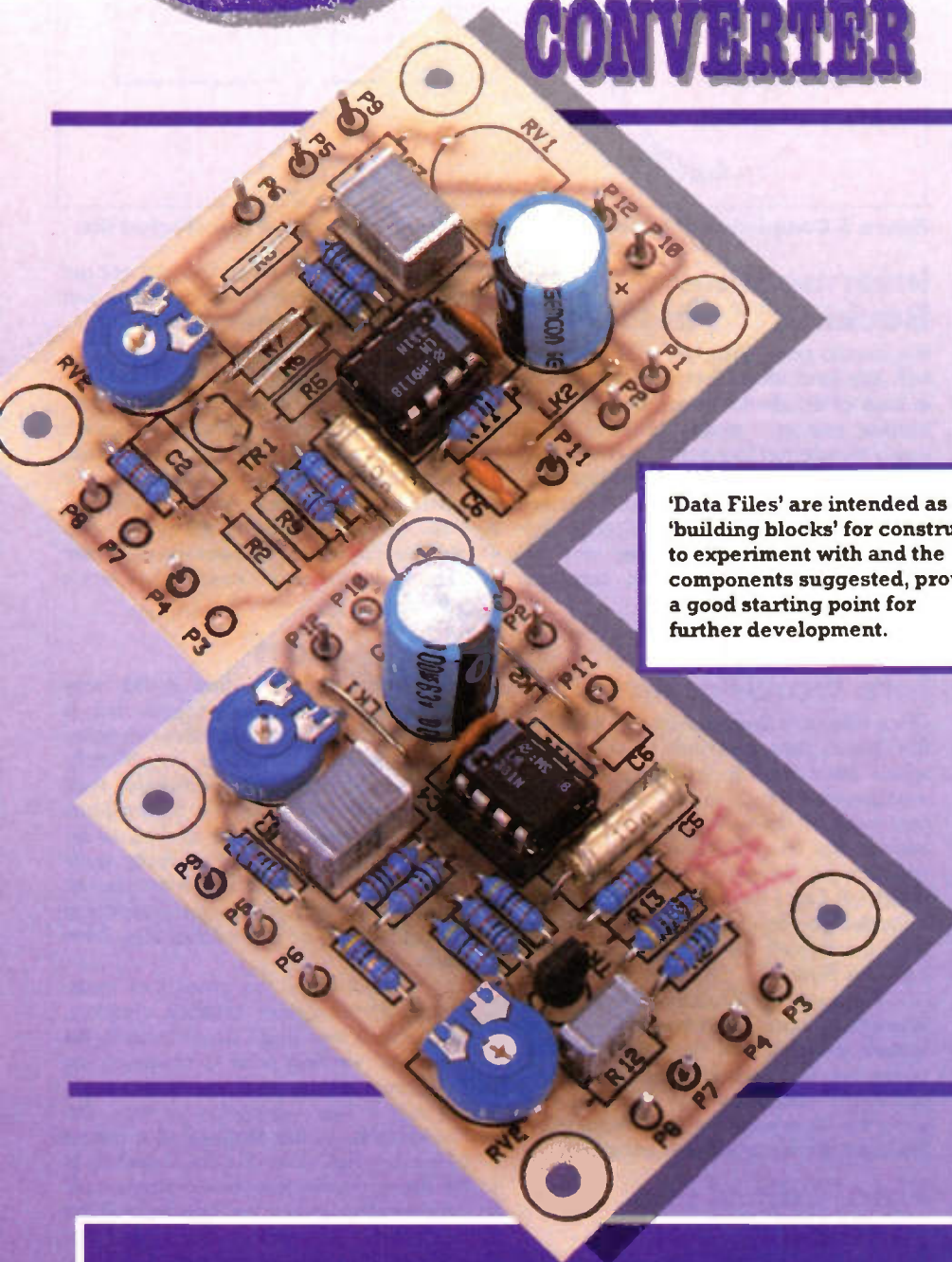

'Data Files' are intended as 'building blocks' for constructors to experiment with and the components suggested, provide a good starting point for further development.

The LM331 is a simple voltage-to-frequency converter suitable for use in analogue-to-digital conversion, precision voltage-to-frequency conversion and many other applications. Figure 1 shows the IC pinout, and Table 1 shows typical characteristics for the device. When the IC is used as a voltage-to-frequency converter, it produces a pulse train which is linearly proportional to the applied input voltage. The device uses a temperature-compensated band-gap reference circuit to provide very good accuracy over the entire operating temperature range. Although the precision timer circuit has low bias currents, the response is sufficiently fast for 100kHz voltage-to-frequency conversion (low bias currents often result in reduced switching speeds and restricted operating frequencies). The output of the device is capable of driving loads of between 5V (i.e. TTL level) and 40V, depending on the supply voltage, and is fully protected against short circuits to  $V_{CC}$ .

### FEATURES

- ★ LOW POWER CONSUMPTION
- ★ GOOD LINEARITY
- ★ EXCELLENT TEMPERATURE STABILITY
- ★ KIT AVAILABLE

**APPLICATIONS** ★ Remote Control ★ Remote Sensing

Parameter	Conditions	Min.	Typ.	Max.
Supply Voltage:	Absolute Maximum			40V
Supply Current:	5V Supply	1.5mA	3mA	6mA
	40V Supply	2mA	4mA	8mA
Operating Ambient Temperature Range:	Absolute Maximum Limits	0°C		70°C
Reference Voltage:		1.7V	1.89V	2.08V
Change of Gain with Supply Voltage:	Supply Voltage = 4.5V to 10V		0.01% V	0.1% V
	Supply Voltage = 10V to 40V		0.006% V	0.06% V
Rated Full Scale Frequency:	Input Voltage = 10V	10kHz		
Output Current (Pin 1):	Resistance Pin 2 ( $R_s$ ) = 14k $\Omega$ ; Pin 1 Voltage = 0V	116 $\mu$ A	136 $\mu$ A	156 $\mu$ A
Operating Range of Current:		10 $\mu$ A	to	500 $\mu$ A

Table 1. Typical characteristics of LM331 voltage-to-frequency converter.

### Voltage-to-Frequency Conversion

Figure 2 shows the block diagram of a simple stand-alone voltage-to-frequency converter. Figure 3 shows a practical implementation of this. Resistor  $R_{in}$  has been included so that the bias current at pin 7 (80nA typical) will cancel the effect of the bias current at pin 6, helping to provide minimum frequency offset.

The resistance at pin 2 ( $R_s$ ) is made up of a 12k fixed resistor and a 5k preset resistor, which is used to trim the gain tolerance of the IC and associated components; it is advantageous to use close tolerance resistors in this application. The capacitors used should feature a low dielectric absorption, depending on the desired temperature characteristics; polystyrene and polypropylene types are suitable. Capacitor  $C_{in}$  is connected between pin 7 and ground to act as a simple input

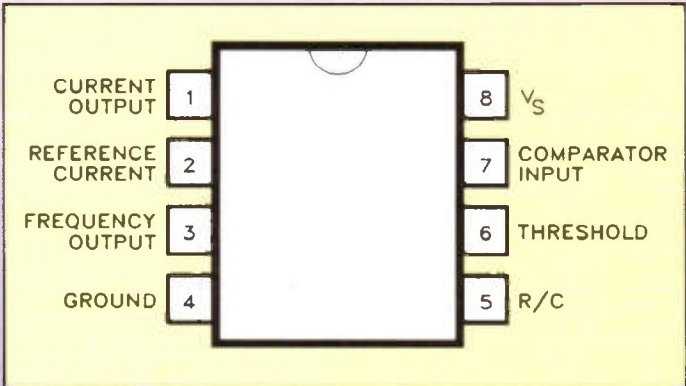

Figure 1. IC pinout.

filter; a value of between 10nF and 1 $\mu$ F can be used for this purpose. When the time constants of the RC networks on pins 6 and 7 are matched, a given voltage step at  $V_{in}$  will result in a corresponding step in output frequency. If  $C_{in}$  is much less than  $C_L$ , a change in voltage at  $V_{in}$  may cause the output ( $F_{out}$ ) to stop momentarily. A 47 $\Omega$  resistor is connected in series with  $C_L$  to produce a hysteresis effect; this helps to improve the overall linearity.

### Frequency-to-Voltage Conversion

The LM331 may also be used to provide a simple frequency-to-voltage converter, and a typical example of this application is shown in Figure 4. In this application, a pulse at the input ( $F_{in}$ ) is differentiated by an RC network and the negative-going edge at pin 6 causes the input comparator to trigger the timing circuit. As with the voltage-to-frequency converter, the average current

flowing from pin 1 is:  
 $I \times (1.1 R_C) \times f$   
 where  $I$  is the current flowing from pin 2 and  $f$  is the input frequency.  $I$  can be calculated by the following formula:  
 $I = V_{ref} / R_s$   
 where  $V_{ref}$  is the reference voltage at pin 2 (typically 1.89V) and  $R_s$  is the resistance between pin 2 and 0V. The current is filtered by a simple RC network. The ripple is typically less than 10mV peak, but the response of the circuit is inherently slow with a 0.1 second time constant and a settling time of 0.7 seconds (to 0.1% accuracy).

### Kit Available

A kit of parts is available, which covers the two basic applications of the LM331 mentioned in this article.

### Voltage-to-Frequency Converter

The kit contains the components necessary to build a simple voltage-to-

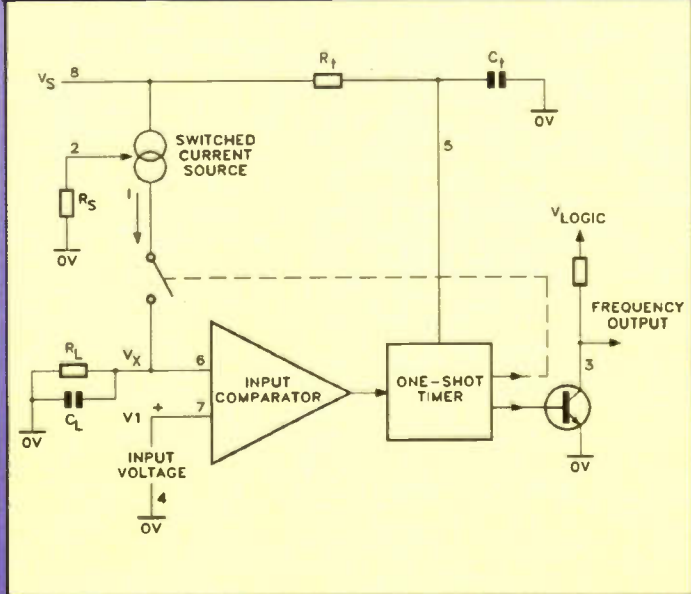

Figure 2. Block diagram of a simple voltage-to-frequency converter.

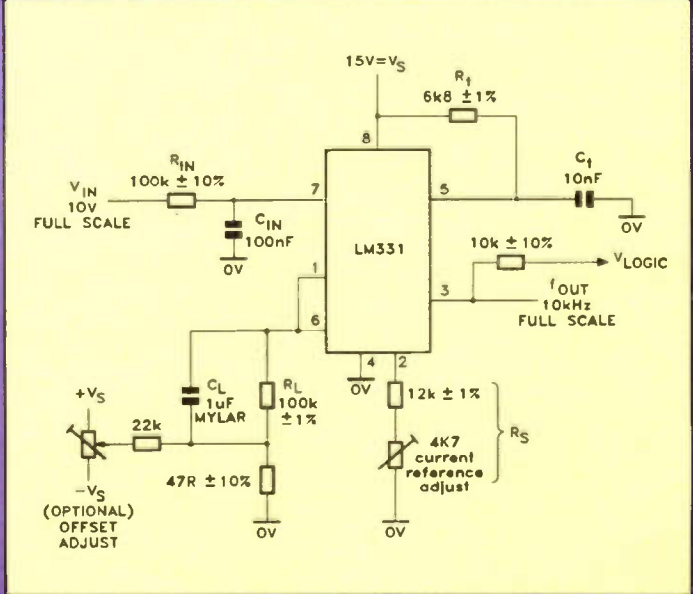

Figure 3. Example of a practical voltage-to-frequency converter.

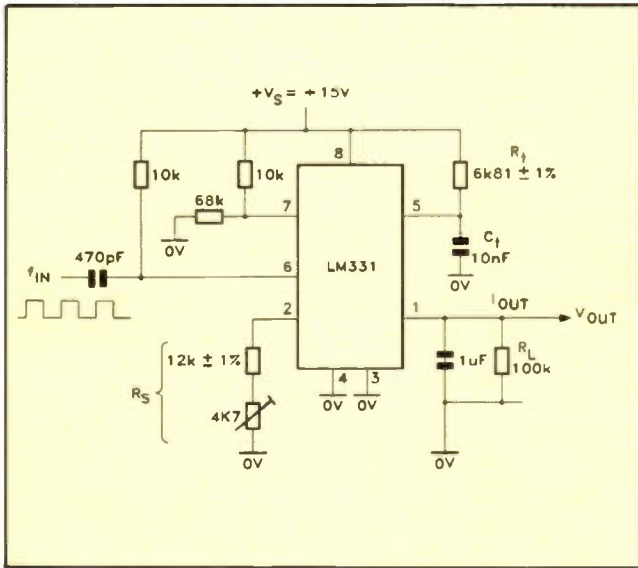

Figure 4. Example of a simple frequency-to-voltage converter.

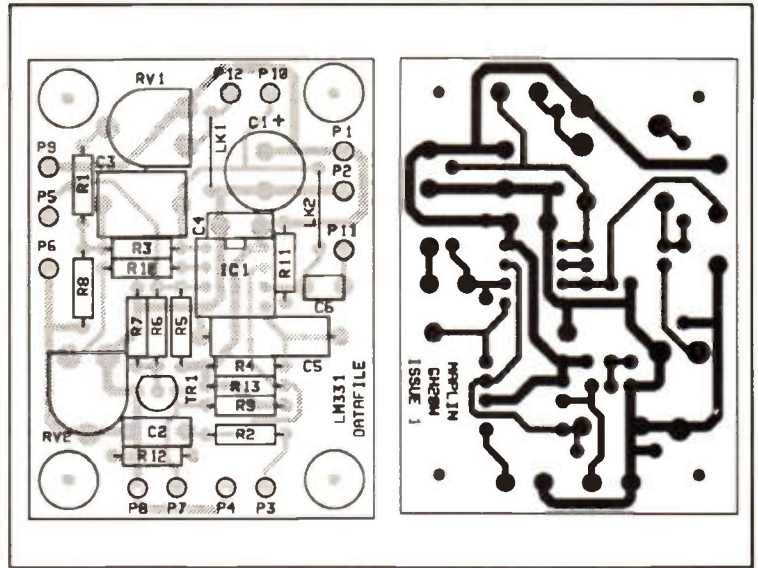

Figure 7. PCB legend and track.

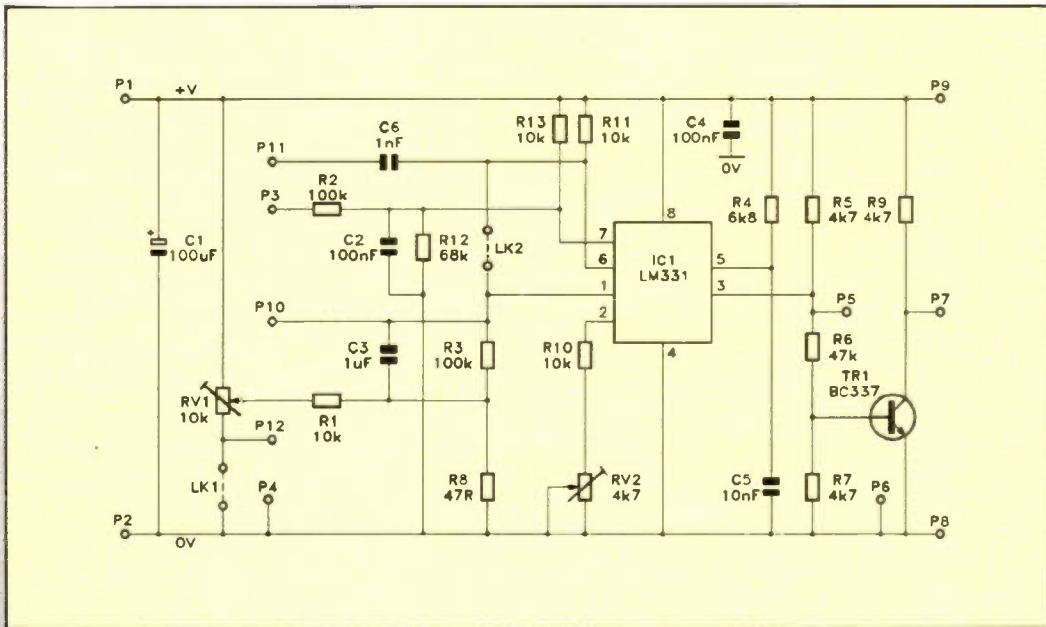

Figure 5. Circuit diagram of module.

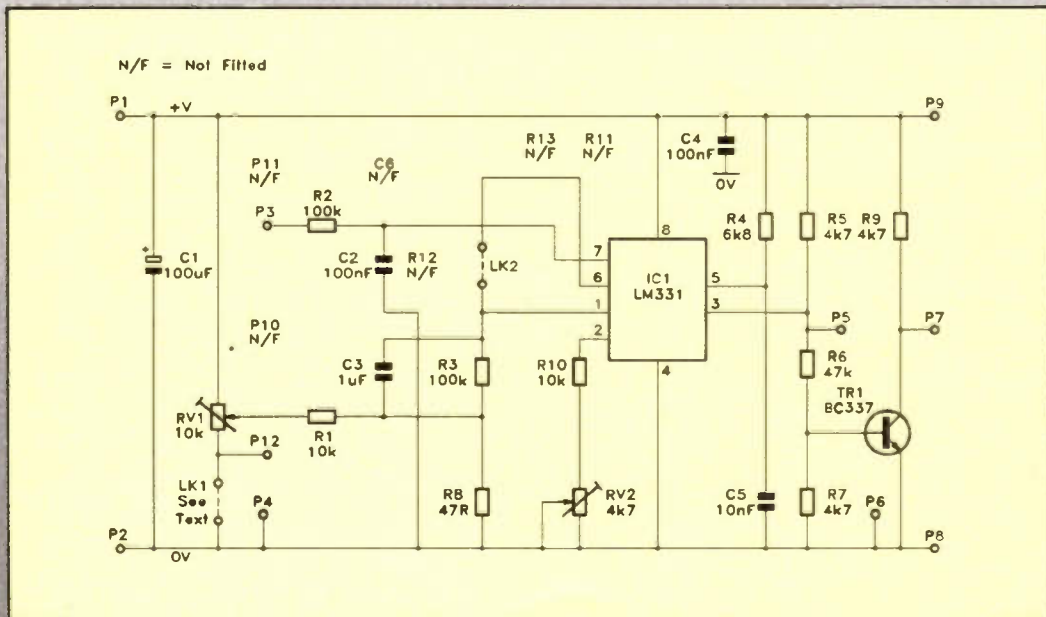
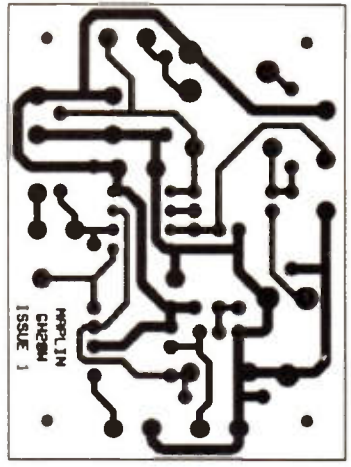

Figure 6. Circuit diagram of a voltage-to-frequency converter module.



frequency converter; see 'Voltage-to-Frequency Converter Parts List'. Figure 5 shows the circuit diagram of the module, while Figure 7 shows the legend. Additional parts are included in the kit to allow the module to be configured as a frequency-to-voltage converter, and in this case it is necessary to fit a different selection of components.

Figure 6 shows the circuit diagram of the module configured as a voltage-to-frequency converter. An input voltage is applied between P3 (input) and P4 (0V); the corresponding output frequency may be taken between P5 (normal output) and P6 (0V), or P7 (inverted output) and P8 (0V). Please note: the normal output at P5 does not swing all the way to +V in this circuit configuration. There are additional +V and 0V pins on the PCB for increased versatility. Wiring information for the voltage-to-frequency converter application is shown in Figure 8.

Link 1 is normally fitted; however, it can be omitted if RV1, the conversion-offset fine-adjustment preset, is to be referenced to an external negative voltage (-10V max.), for increased adjustment range. This external voltage is applied to pin P12. RV2 sets the reference current.

### Frequency-to-Voltage Converter

Figure 9 shows the circuit diagram of the module configured as a frequency-

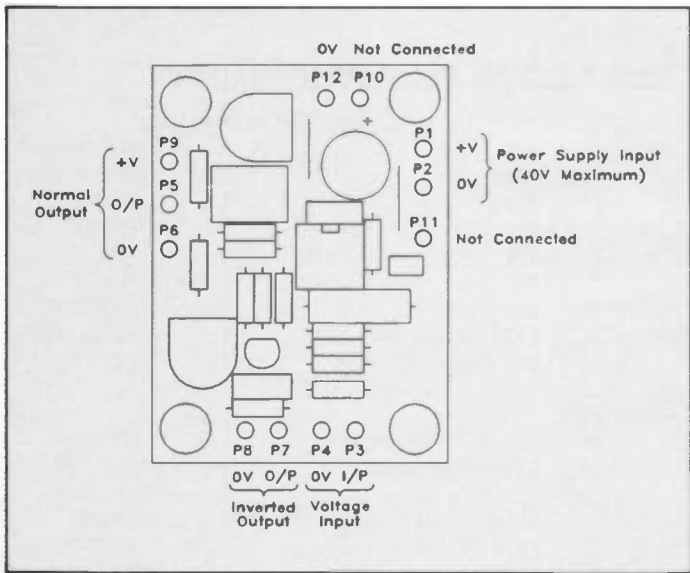

Figure 8. Wiring diagram for voltage-to-frequency converter module.

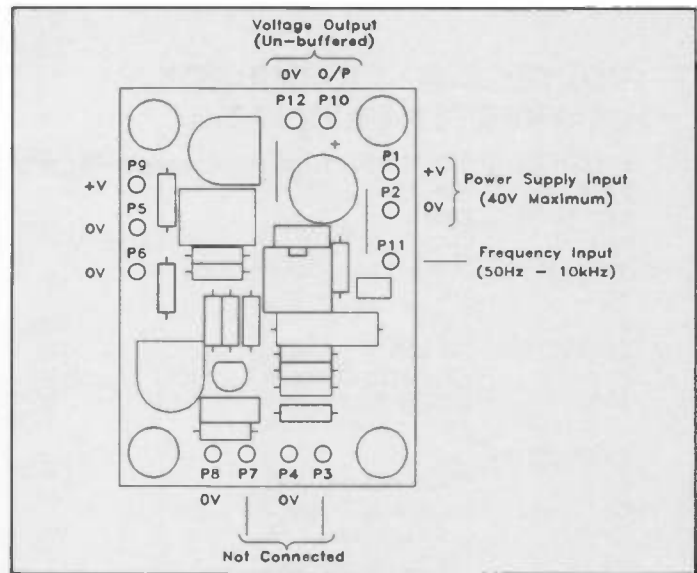

Figure 10. Wiring diagram for frequency-to-voltage converter module.

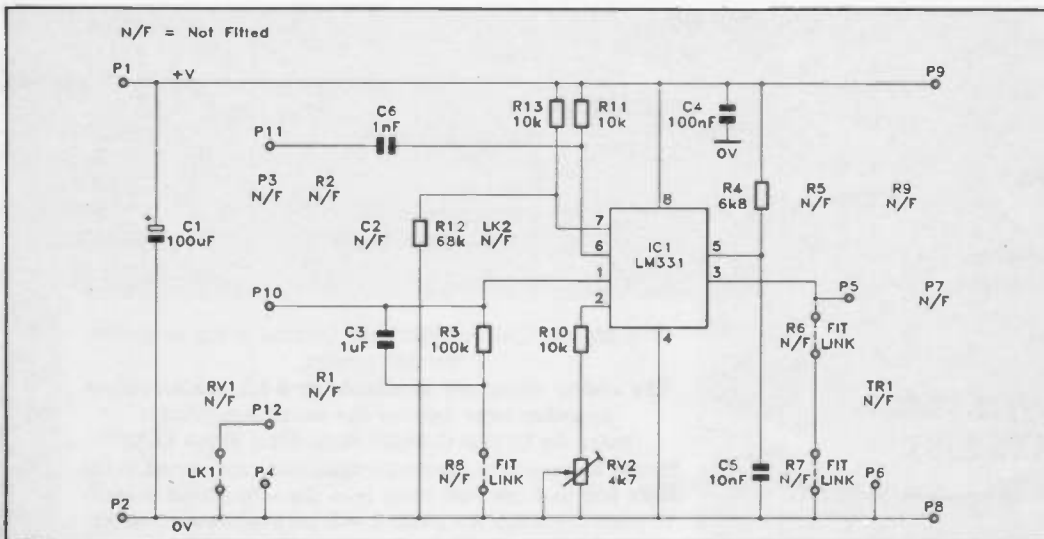
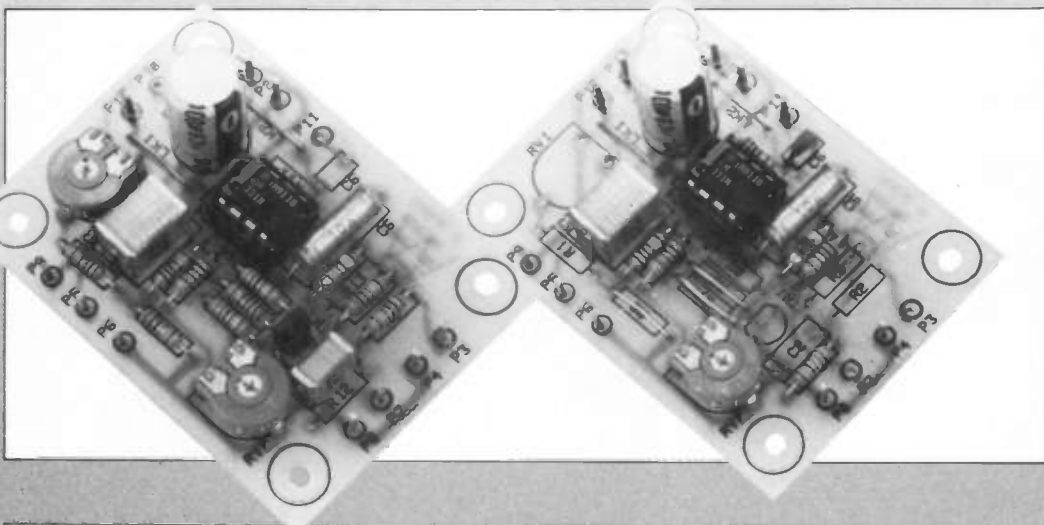

Figure 9. Circuit diagram of a frequency-to-voltage converter module.

to-voltage converter. The 'Frequency-to-Voltage Converter Parts List' identifies the components required for assembly. In this application, an input frequency (1Hz to 10kHz) is applied between P11 (input) and 0V, and an output voltage is taken between P10 and 0V. The output voltage is directly related to the current flowing through R3, the value of which could be changed, if necessary, to provide different output level swings. Because of the high impedance nature of the output, it will normally be necessary to provide additional buffering - unless the circuit is driving a load with a considerably higher impedance than R3. If the circuit is used to drive lower impedances, the output level will be considerably reduced. Figure 10 shows wiring information for the frequency-to-voltage converter application.

Tables 2 and 3 show the specification of each of the prototype circuits.

Please Note: Only the parts itemised in the parts list of the specific application that you are building should be fitted, i.e. if you are building the frequency-to-voltage converter, only fit the parts shown in the frequency-to-voltage converter parts list and so on.



Power Supply Voltage:	5V to 40V
Power Supply Current (at 12V):	8mA
Output Frequency Range (at 12V):	50Hz to 10kHz
Input Voltage Range (at 12V):	0.05V to 10V

Table 2. Specification of prototype voltage-to-frequency converter.

Power Supply Voltage:	5V to 40V
Power Supply Current (at 12V):	6mA
Output Voltage Range (at 12V):	0.05 to 10V
Input Frequency Range (at 12V):	50Hz to 10kHz
Input Level:	As supply voltage

Table 3. Specification of prototype frequency-to-voltage converter.

## VOLTAGE-TO-FREQUENCY CONVERTER PARTS LIST

RESISTORS: All 0.6W 1% Metal film (Unless specified).

R1,10	10k	2
R2,3	100k	2
R4	6k8	1
R5,7,9	4k7	3
R6	47k	1
R8	47Ω	1
R11,12,13	Not Fitted	
RV1	10k Hor Encl Preset	1
RV2	4k7 Hor Encl Preset	1

### CAPACITORS

C1	100μF PC Elect 63V	1
C2	100nF Poly Layer	1
C3	1μF Poly Layer	1
C4	100nF Disc Ceramic	1
C5	10nF 1% Polystyrene	1
C6	Not Fitted	

### SEMICONDUCTORS

TR1	BC337	1
IC1	LM331	1

### MISCELLANEOUS

8-pin DIL Socket	1
Pin 2145	1 Pkt
PCB	1
Instruction Leaflet	1
Constructors' Guide	1

LK1 Fitted (See Text) LK2 Fitted

## FREQUENCY-TO-VOLTAGE CONVERTER PARTS LIST

RESISTORS: All 0.6W 1% Metal film (Unless specified).

R1,2,5,9	Not Fitted	
R3	100k	1
R4	6k8	1
R6,7,8	Fit Link	
R10,11,13	10k	3
R12	68k	1
RV1	Not Fitted	
RV2	4k7 Hor Encl Preset	1

### CAPACITORS

C1	100μF PC Elect 63V	1
C2	Not Fitted	
C3	1μF Poly Layer	1
C4	100nF Disc Ceramic	1
C5	10nF 1% Polystyrene	1
C6	1nF Ceramic	1

### SEMICONDUCTORS

TR1	Not Fitted	
IC1	LM331	1

### MISCELLANEOUS

8-pin DIL Socket	1
Pin 2145	1 Pkt
PCB	1
Instruction Leaflet	1
Constructors' Guide	1

LK1 Fitted LK2 Not Fitted

## LM331 DATA FILE PARTS LIST

RESISTORS: All 0.6W 1% Metal film (Unless specified).

R1,10,11,13	10k	4	(M10K)
R2,3	100k	2	(M100K)
R4	6k8	1	(M6K8)
R5,7,9	4k7	3	(M4K7)
R6	47k	1	(M47K)
R8	47Ω	1	(M47R)
R12	68k	1	(M68K)
RV1	10k Hor Encl Preset	1	(UH03D)
RV2	4k7 Hor Encl Preset	1	(UH02C)

### CAPACITORS

C1	100μF PC Elect 63V	1	(FF12N)
C2	100nF Poly Layer	1	(WW41U)
C3	1μF Poly Layer	1	(WW53H)
C4	100nF Disc Ceramic	1	(BX03D)
C5	10nF 1% Polystyrene	1	(BX86T)
C6	1nF Ceramic	1	(WX68Y)

### SEMICONDUCTORS

TR1	BC337	1	(QB68Y)
IC1	LM331	1	(UL47B)

### MISCELLANEOUS

8-pin DIL Socket	1	(BL17T)
Pin 2145	1 Pkt	(FL24B)
PCB	1	(GH20W)
Instruction Leaflet	1	(XT84F)
Constructors' Guide	1	(XH79L)

The Maplin 'Get-You-Working' Service is not available for this project.

*The above items are available as a kit, which offers a saving over buying the parts separately.*

**Order As LT12N (LM331 Data File) Price £9.95.**

Please Note: where 'package' quantities are stated in the Parts List (e.g. packet, strip, reel, etc.) the exact quantity required to build the project will be supplied in the kit.

The following new item (which is included in the kit) is also available separately, but is not shown in the 1992 Maplin Catalogue.

**LM331 Data File PCB Order As GH20W Price £2.25.**

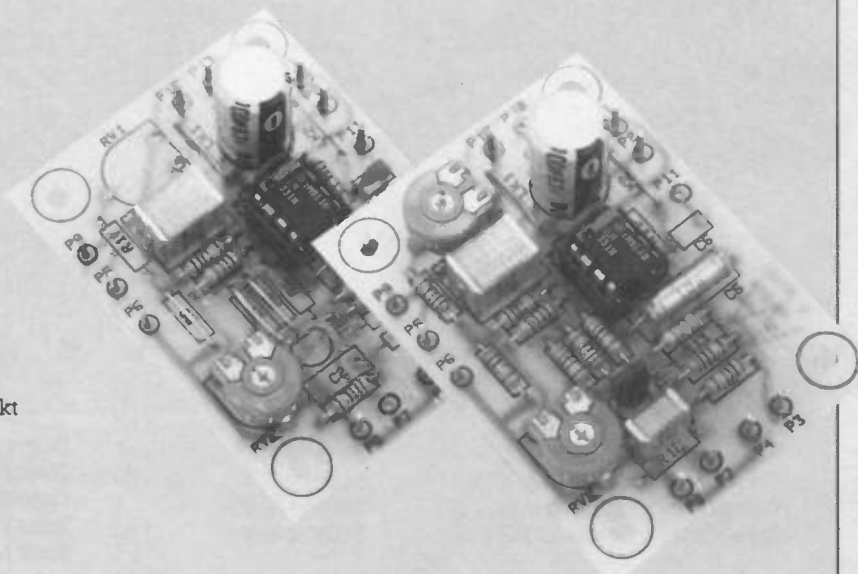

# CD-ROM

## - A Match Made in (Silicon) Heaven

by Stephen Waddington

The engagement was announced years ago, yet it is only recently that the marriage between two modern technologies has taken place. The union of computer and Compact Disc (in the form of CD-ROM - Compact Disc Read Only Memory) allows for full motion video and simultaneous audio sound. This represents a versatile partnership providing the foundation for multi-media applications in the future. The long-term importance of this development is affecting industries as varied as publishing, engineering and insurance.

### Audio CD

Introduced in March 1983, the audio Compact Disc (CD) has had a wide impact on the entertainment industry - Hi-Fi magazines reviewed the new media impressively and predicted the demise of the vinyl record before the turn of the century. Even Mozart's music emerged from the speakers with astounding clarity, causing seasoned proponents of classical works to doubt the value of expensive concert tickets to the Albert Hall, whilst Madonna transformed the living room into Wembley Stadium.

Being a digital medium, the CD audio system is fundamentally different from all its predecessors - information is stored on disc as a vast collection of digits, which are interpreted by a digital-to-analogue-converter, amplified and so transcribed to reach your ears by loudspeakers or headphones.

The discs are plastic and data is pressed into a thin wafer of aluminium during manufacture. Information is retrieved from only one side of the disc - the back (or non-labelled) side - and the track spirals outwards from the centre rather than inwards as with conventional systems. Further fundamental differences relate to the transposition of data from the disc; CD differs from other sound reproduction systems in that there is no physical contact between the disc and the pick-up transducer. Information is buried below the surface of the disc, minimising errors in reproduction due to dust or other marks on the surface (such as the annoying crackles and pops that mar your listening enjoyment of an LP - particularly the grotty 'recycled vinyl' records

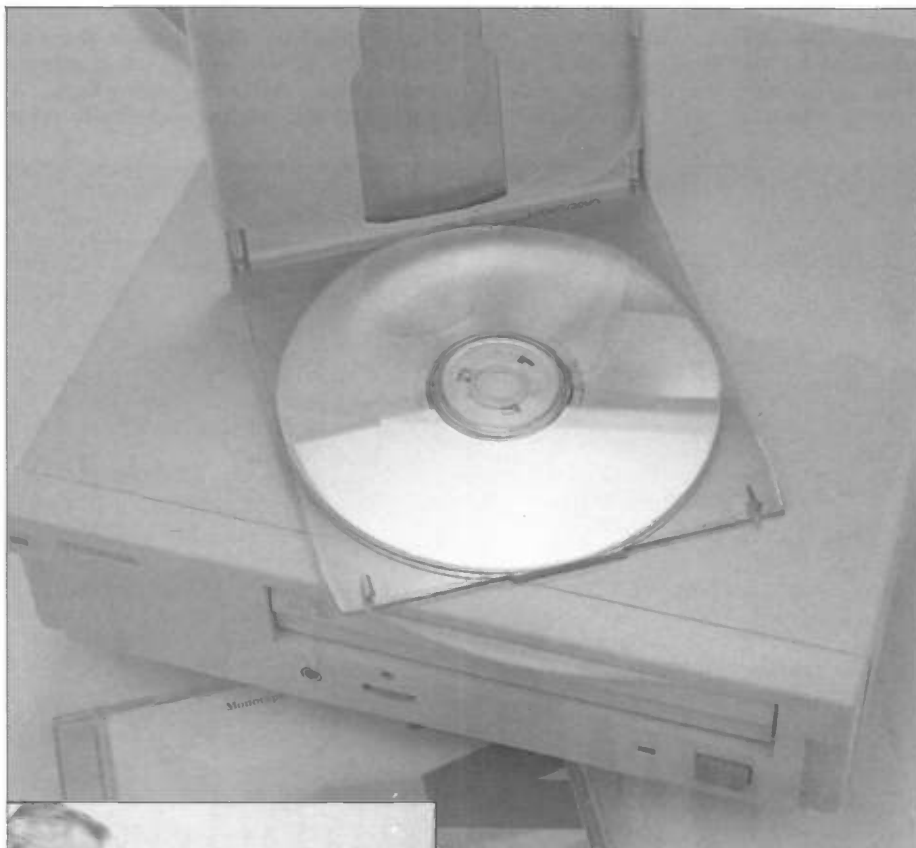

being produced at a time when the record companies are, ahem, trying to convince us of the 'superior sound of CD'!)

### Keeping on the Right Track

Laser technology replaces the stylus of old: a small low-power injection laser continuously emits coherent light, which is focused onto the reflecting surface of the disc - as illustrated in Figure 1. Small bumps, which each have the height of a quarter-wavelength of the laser light, result in destructive interference between

A CD-ROM drive designed to augment an existing computer installation. This Toshiba model is used in Maplin's Desktop Publishing system, and can access over 600Mb from a single disc.

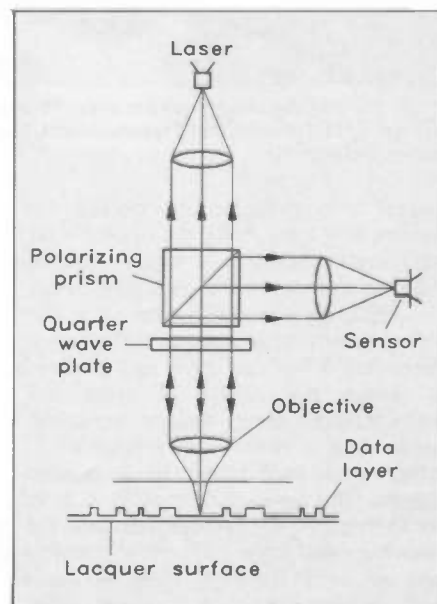

Figure 1. The CD optical pick-up system.

light reflected from the normal surface, and that from the indentations. The reflected light is monitored at a frequency of 41.1kHz by a photo-transistor to produce an electronic signal corresponding to the recorded information on the disc surface.

To maintain high quality conversion, complex control systems are required. The positioning ("tracking") of the laser is continuously scrutinised to overcome any problems that might arise from cross-talk between adjacent tracks or irregularities in the disc surface. An error signal generated by the photo-transistor provides information to the focus servo system, which is used to accurately

to 'repair' corrupted bits. In situations where the damage is so bad that error correction cannot cope, muting circuits are used to cut out the audio completely.

### Completely Data-friendly

Design engineers soon realised that other forms of digital information could be stored on plastic disc, and so CD-ROM was born. The implications of the media for the computer industry are vast. Sheer data capacity and guaranteed retrieval reliability beyond the scope of conventional magnetic discs render the CD invaluable in the storage of drawings, maps or even full colour photographs. A CD-ROM disc has the capacity to store

About Cows', containing everything you could wish to know about the bovine family.

A year's edition of the Times newspaper now appears on CD, followed closely in the bestsellers list by the complete works of Shakespeare and the 12-volume version of the Oxford English Dictionary. New titles are added daily and the library of subjects currently extends to several thousand publications. Akin to book publishing, there are no real limits and because of very low bulk production costs, the manufacturing price of each CD is less than a pound after a master has been pressed. In reality, the marketed cost of each disc is somewhat higher – clearly it is rather ludicrous to be able to produce a twenty volume encyclopedia for a fraction of the cost of the printed version; book publishers would soon be forced to cut prices and would eventually be forced out of business, unable to compete with the cost of CD.

As part of a computer system, CD-ROM allows data to be accessed and printed within seconds. The use of a laser printer results in a printed typeface of a standard that one would expect if browsing through a book. Although not as fast as magnetic-type hard discs, many argue that access time is far quicker than that of the physical process involved in reaching to a shelf, selecting a book and then locating the required page. Librarians regard CD-ROM as a valuable cost-saving tool, allowing literature searches to be performed with considerable ease, and biographical checks improved beyond imagination. Indeed, several universities and polytechnics throughout the country have adopted CD-based reference departments – with others following suit.

Industry is recognising the benefits too; engineering consultants Mott MacDonald are hoping, in the near future, to clear metres of shelving space by committing their library of health/fire regulations, survey maps and British/European standards to plastic. User-friendly computer software allows searches to be performed on key words, or specific records to be summoned up and perused, before committing copy to a printer. Such facilities, provided on a network, will allow staff direct access to hard copies of records that would otherwise have to be ordered from the company library.

### Sony's Data Discman

Mention has already been made of how CD-ROM can perform an integral role as part of a large computer system. However, Japanese technology now allows for a more personal approach. Manufactured by Sony, the 'Data Discman' was Japan's surprise consumer electronics hit of 1991.

1988 saw the release of the 8cm single compact disc player. Sony – inventor of the Walkman cassette player, the superior (but now sadly obsolete) Betamax home video system, and the Video 8 camcorder, hoped again to



The Sony Data Discman, referred to as an 'Electronic Book'. As you can tell from the characters on the screen, this is the original Japanese model. Note that the 3in. minidisc used by this machine is held in a protective case.

control the positioner responsible for moving the lens along its optical axis. Additional feedback control systems maintain the rotational speed of the disc.

Although the audio data on a disc surface is laid out in a sequential manner, the coding is both complex and involved to reduce the effects of noise and contamination from surface scratches. Audio data is coded into frames of 33 bytes, each conforming to a defined pattern. The audio sample utilises 24 of the 33 bytes – a further eight provide the basis for error correction while the first byte of each block is used in audio applications to produce a running time display. Correction algorithms are used

680 megabytes of data – about 250,000 A4 sheets – and is therefore ideal in any situation where data need only be referenced or retrieved. CD-ROM is a WORM media (Write Once, Read Many times) i.e. it can be written to only once and requires special equipment for the purpose. Consequently, fixed databases, like United Kingdom post codes or telephone numbers, are ideal material for such a storage medium. Such information is perhaps trivial compared with some of the recent database titles that grace the market. A veterinary friend, who practices in the Lake District, told me recently that he had been offered the opportunity to purchase a CD, called 'All





The British version of the Sony Data Discman, the DD-1EX, being used in a real-life situation by a civil engineer. Note also Sony's first foray into the cellular telephone market – the CM-H1.

conquer rivals by providing a new concept in consumer electronics. Marketed as the CD equivalent of the 7in. vinyl single, lack of appeal in the American market rendered the product a failure. Sony returned with renewed vigour to the drawing board, and decided instead to adapt the media and so enter the lucrative field of CD-ROM.

Sony's Data Discman is a personal information machine with a large LCD screen (for the visual display of information) and CD-quality audio (for listening to speech and sound through headphones). Primarily a tool for education and information retrieval, the postcard-sized device is supplied with a CD that contains eleven large dictionaries. Its Japanese launch in July 1990 was

supported by the simultaneous launch, by eighteen of Japan's principal publishing houses, of a range of CD-ROM media.

Priced in Japan at ¥48,000 (approximately £200), only cost and imagination are now obstacles. Technology allows for the addition of both colour and moving pictures. Yet to reach the American and European market, price will be a key factor upon which success will depend. After an initial production run of only 500 units however, Sony sold 100,000 in the first year in Japan providing an optimistic foundation for the recent UK launch.

Further devices on the theme of the Data Discman include interactive training devices. Introduced as an aid to field servicing, technicians interrogate the

device to discover which parts of an electronic system have failed and require replacement. Gradually being introduced as a piece of toolbox equipment for domestic service engineers, the CD-ROM replaces the bulky service manuals of old. Tomorrow's engineer will carry a laptop computer complete with CD-ROM drive; a range of CD-ROM discs will exist for each manufacturer's products. Upon attending to a washing machine or dishwasher in need of repair, out will come the laptop computer. Symptoms will be related to the computer, the machine then making a diagnosis of the problem.

One other new area is the possibility of creating your own CDs. With new technology from Sony, it is now possible to write to your own discs. Until recently, the cost of mastering your own discs was prohibitively expensive; however, Sony will now guide you through the process from design to packaging. It is hoped that the service will be exploited by small and medium sized companies wishing to distribute large amounts of information amongst staff.

### Justifying those Claims

CD-ROM is also invading the insurance industry. Numerous insurance groups are hoping to supply their claims assessors with CD-ROM equipment. Already in use is a system employed by the London & Edinburgh Insurance Group, where conventional laptop computers are used to aid vehicle insurance claim assessment. Currently, the laptop computer provides an exploded diagram of a vehicle. Damage and vehicle particulars are noted, and the data is passed back to a mainframe via a communications link. The mainframe calculates the cost of parts for repair, even down to such items as paintwork. The problem now is that of storage capability – with so many cars (and different versions of the same car!) in use, the assessor requires details of each. Diagrams require vast amounts of storage space and the capacity of even the largest floppy disc is reaching saturation. The solution is to employ CD-ROM; an accident assessor could upon visiting, say, a Ford garage, insert the Ford disc – and then replace it with a Toyota disc when visiting the Toyota repair centre afterwards.

The application of Compact Disc wildly exceeds first expectations. Having revolutionised the music industry, we are beginning to see its effect on the rest of business and commerce. The implications of this logical marriage between computer and compact disc are only just being felt – it is evidently going to be a fertile union.

### Acknowledgments

I would like to thank Mr R. E. Wiggins of the Cura Consortium for providing access to archive information, and to Ms F. G. Salter for supplying technical assistance.

# OMNICO M FS-1515 TELEPHONE EXCHANGE

Text by Joe Fuller

APPROVED for connection to telecommunications systems specified in the instructions for use subject to the conditions set out in them.



## Features

- ★ 5 Extensions from 1 Exchange Line
- ★ 30 Number Memory
- ★ Automatic Least Cost Call Routing
- ★ Selective Call Barring
- ★ Automatic Redial and Call-back
- ★ Talk Between Internal Extensions
- ★ Programmable Auto Answer
- ★ Speech Assisted Programming
- ★ Door Phone/Unlatch Facility
- ★ Speaking Clock
- ★ Alarm Call
- ★ Fax Switch
- ★ Baby Monitor
- ★ Easy to Install

Ideal for Home and  
Small Business Use

The Omnicom FS1515 telephone exchange is a feature packed unit, ideal for homes and small businesses; however, I hear you ask, "Why do I need a telephone exchange? at work, yes – but at home?" Well, if you can answer yes to any of the following questions, then you ought to seriously consider the FS1515 as your next home purchase:

- Do you work from home?
- Do you have a fax machine or a MODEM?
- Do you like low phone bills?
- Do you have teenage children?
- Do you like impressing the neighbours?
- Do you like saving time?

The FS1515 enables you to use up to five extensions from one exchange line. Each extension may have one or two telephones. Any approved telephone equipment may be used as an extension telephone to the FS1515, including; pulse/tone dial telephones (including rotary dial types), cordless telephones, answering machines, fax machines and computer MODEMs. FS1515 will enhance the features of your existing telephone system, adding many time and money saving features. Figure 1 shows some possible combinations of telephone equipment, however, these examples are by no means exhaustive.

## Features

Each of the FS1515's features are accessible by dialling a group of digits, the groups are arranged in a simple logical sequence to ensure ease of use. There are however, two separate groups of numbers, those associated with

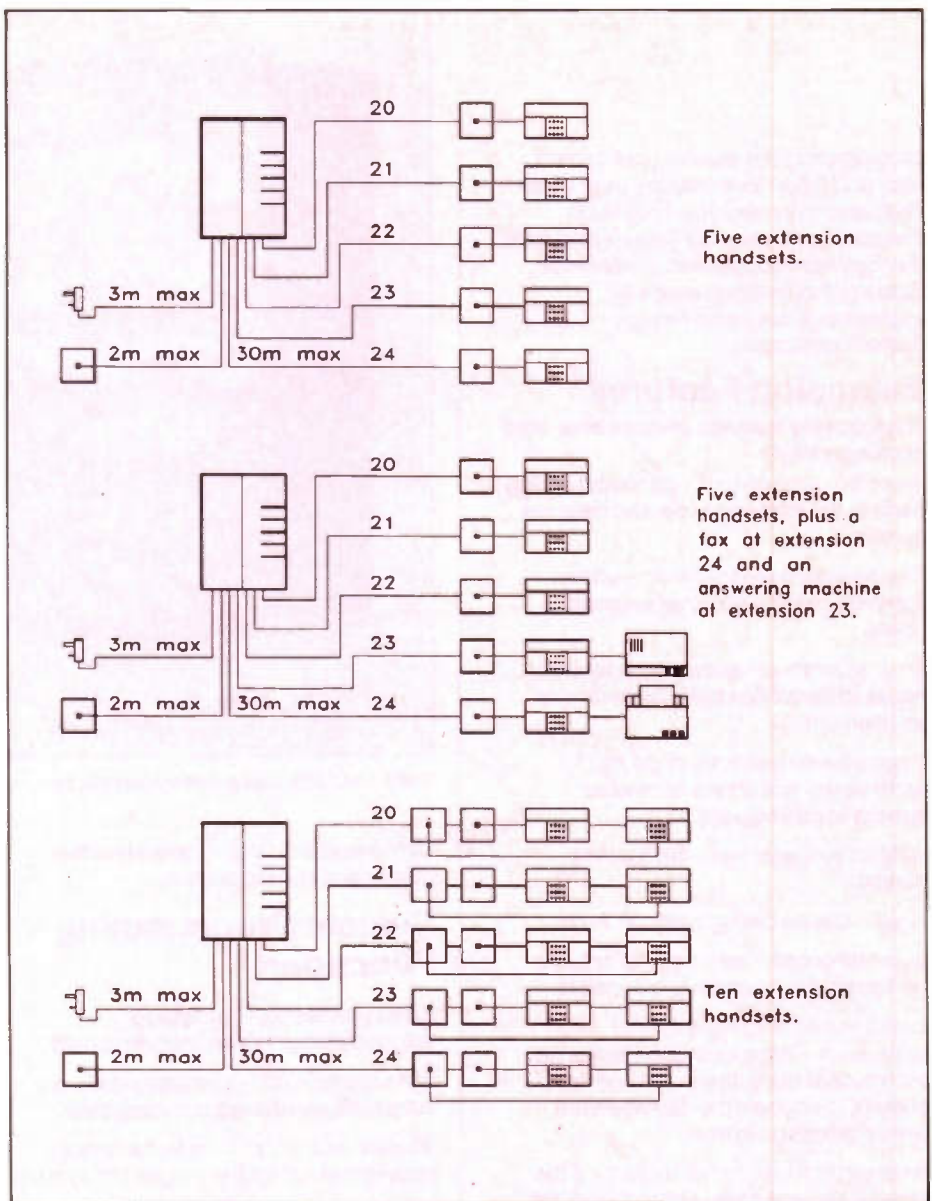

Figure 1. Examples of possible combinations of telephone equipment.

Dialled Number	Function
9 + telephone number	Make an outside call
20, 21, 22, 23, 24	Call an extension
28	Door intercom
29	Page all extensions
30 to 59	Dial stored number
R	Hold
R + extension number	Transfer a call
R70	Call-back an engaged line or extension
R75	Redial reminder in 5 minutes
R75 + time	Redial at set time
78	Last number redial
R71	Intrude on a busy extension
72	Internal ring on/off
73	Internal speaking clock
74 + time	Set alarm call time
76 + extension number	Divert to another extension
77	Enable baby monitor
79	External ring on/off
8	Answer external call (when external ring off)
0	Release door catch

Note:  
time = time in 24hr HH:MM format.  
R = Recall button on telephone (on pulse dial telephones dial 1 instead).

Table 1. Extension feature numbers.

Dialled Number	Function
# + PIN	Enable system programming
*0 + PIN	Reprogram PIN
0	Auto answer on
10	Auto answer off
11 + time	'Please call after...'
12 + telephone number	'Please call...'
13	Fax switch
14	'Sorry, no one is available'
30 to 59	
+ telephone number	Store telephone number
73 + time	Set current time
90 + STD code	Set local STD code
91	Set tone dialling
92	Set pulse dialling
93 + code	PBX access code
94 + pause	PBX pause
95 + PIN	Mercury PIN
96 + telephone number	Mercury access number
97 + pause	Mercury access pause
98 + pause	Seize line pause
99 + telephone number	Answer number
extension number + 0	Allow all calls
extension number + 1	Bar international calls
extension number + 2	Bar as '1' plus premium rate service calls
extension number + 3	Bar as '2' plus trunk calls
extension number + 4	Bar all external calls

Table 2. System programming numbers.

programming the system (call barring, etc.) and those for everyday use. Table 1 illustrates the everyday 'Extension Feature' numbers, and Table 2 illustrates the 'System Programming' numbers. Some of the features are self-explanatory, but some require further clarification.

## Extension Features

The following features are available from each extension:

**Make an outside call** – connects calling party to the exchange line and dials the number.

**Call an internal extension** – allows communication with other extension users.

**Door intercom** – allows occupants to speak to the calling party by means of an intercom.

**Page all extensions** – rings all extensions, first phone answered speaks to calling party.

**Dial stored number** – dials stored number.

**Hold** – places calling party on 'hold'.

**Transfer a call** – an incoming call can be transferred to another extension.

**Call-back an engaged line or extension** – if the exchange line or an extension is busy, the exchange will attempt to connect the call when the line or extension is free.

**Redial reminder in 5 minutes** – if the number you are calling is engaged, the exchange will redial the number after waiting five minutes.

**Redial at set time** – redials an engaged number at a set time.

**Last number redial** – redials last number dialled on that extension.

**Intrude on a busy extension** – if the extension being called is engaged, the calling party can attempt to intrude on the call. The engaged extension will be informed that another caller is attempting to intrude; the engaged extension can then accept the intruding caller if wished.

**Internal ring on/off** – prevents internal calls from ringing an extension.

**Internal speaking clock** – exchange speaks the time.

**Set alarm call time** – sets alarm clock time, exchange rings back at the programmed alarm time.

**Divert to another extension** – diverts calls to another extension.

**Enable baby monitor** – allows an extension to be used as a baby monitor.

**External ring on/off** – prevents external calls from ringing an extension.

**Answer external call (when external ring off)** – allows an external call to be answered when external ring is set to off.

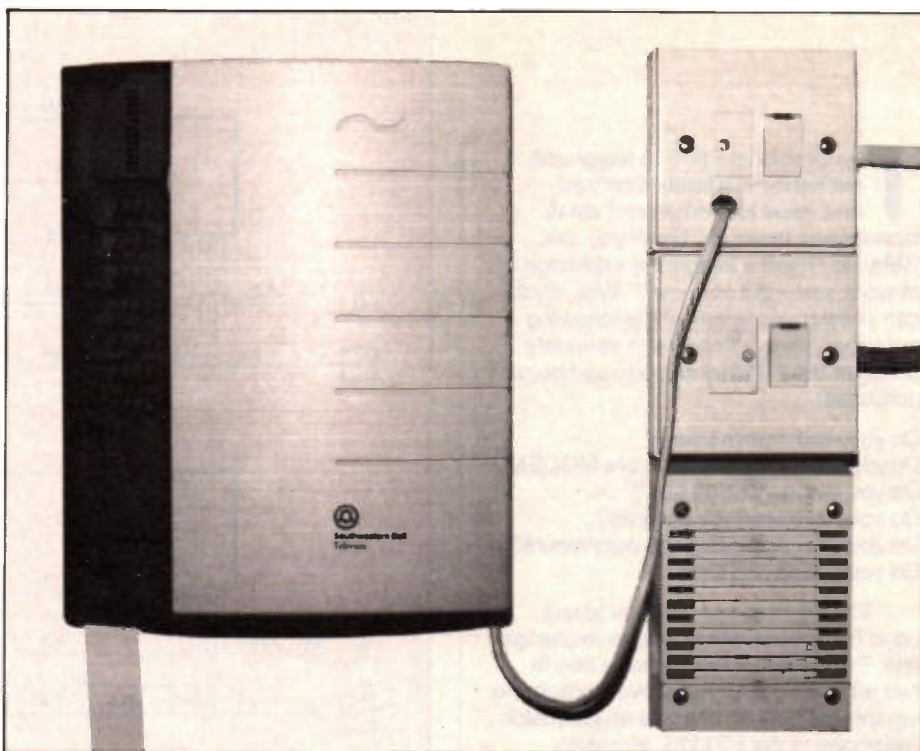

The FS1515 Exchange after installation.

**Release door catch** – operates door catch release mechanism.

## System Programming Functions

**Auto answer on** – exchange automatically answers incoming calls.

**Auto answer off** – exchange does not automatically answer incoming calls.

**'Please call after...'** – informs calling party to call back after programmed time.

**'Please call...'** – informs calling party to call programmed telephone number.

**Fax switch** – informs calling party to dial 'STAR' to connect to the fax machine.

**'Sorry, no one is available'** – informs calling party that no one is available.

**Store telephone number** – stores frequently used telephone number for stored dialling.

**Set current time** – sets internal clock to current time.

**Set local STD code** – stores local dialling code to facilitate call barring.

**Set tone dialling** – selects tone (DTMF) dialling if the public exchange supports tone dialling.

**Set pulse dialling** – selects pulse dialling if the public exchange does not support tone dialling.

**PBX access code** – allows automatic access to private branch exchange when the FS1515 is itself an extension.

**PBX pause** – sets pause to programmed duration to ensure correct operation.

**Mercury PIN** – stores personal identification number to allow use of Mercury exchange lines.

**Mercury access number** – stores number to be dialled to gain access to Mercury exchange lines.

**Mercury access pause** – sets pause to programmed duration to ensure correct operation.

**Seize line pause** – sets exchange line

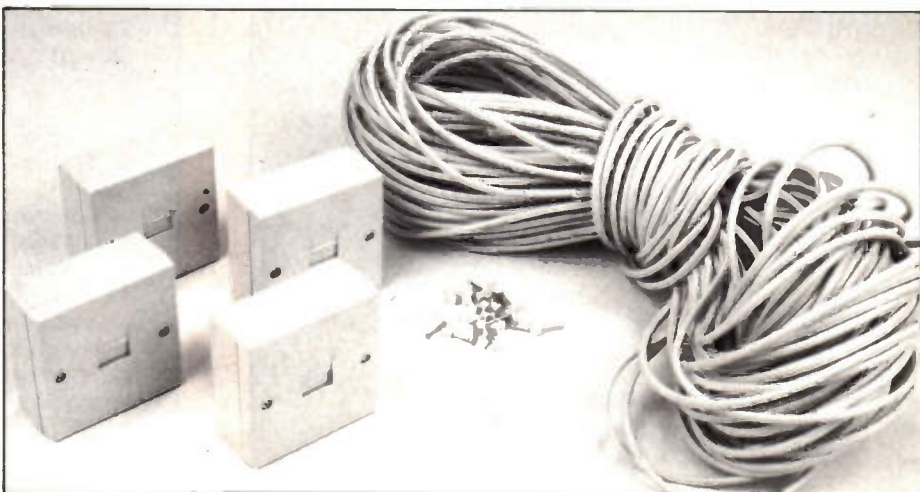

Telephone sockets, cable and clips.

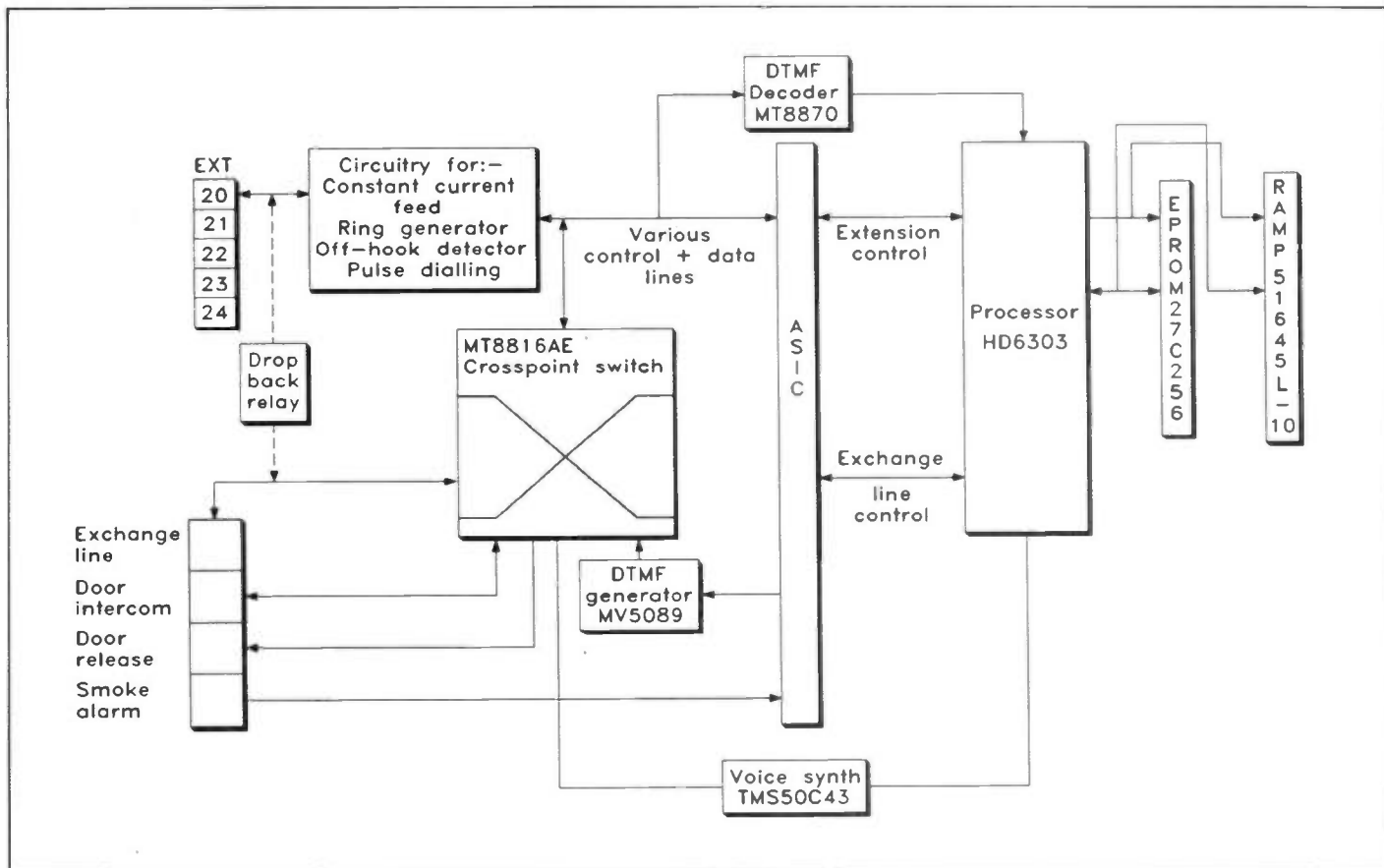

Figure 2. Block diagram of the FS1515 Exchange.

pause to programmed duration to ensure correct operation.

**Answer number** – stores incoming line telephone number to be spoken by exchange to called party.

**Allow all calls** – allows all external calls to be dialled from an extension.

**Bar international calls** – prevents international calls from being dialled from an extension.

**Bar as '1' plus premium rate service calls** – prevents international and premium rate service (192, 0898, etc.) calls from being dialled from an extension.

**Bar as '2' plus trunk calls** – prevents international, premium rate service and trunk calls from being dialled from an extension.

**Bar all external calls** – prevents all external calls from being dialled, except 999.

## Hardware Description

Figure 2 shows a block diagram of the FS1515, the function of each of the blocks is as follows:

### Switch Matrix

The switch matrix is based on the MY8816AE solid state crosspoint switch. This device offers greater reliability, lower noise and less electrical interference compared to its electromechanical equivalent.

### The Processor

The central processing unit of the FS1515 is based on the Hitachi HD6303 processor. This controls the data bus,

which connects to a 32K × 8-bit EPROM (27C256) and an 8K × 8-bit static RAM (P5164SL-10). The processor was chosen because of its numerous I/O lines. This allowed the control logic to be compressed inside an ASIC (Application Specific Integrated Circuit). The ASIC passes information to and from the extension ports, under control of the processor.

### Key System

The FS1515 uses the Texas Instruments TMS50C43 N25 voice IC to confirm system information to the 'system programmer', extension user or calling party when the 'auto answer' feature is in use.

### Extensions

Each extension is provided with at least 25mA of constant current feed to drive the line. Every extension has its own ring circuitry that operates from the power supply. In the addition any extension can be connected to one of two DTMF (Dual Tone Multi Frequency) decoders (MV8870). This ensures that a DTMF decoder is always available if the exchange line is in use and the extension user decides to send DTMF codes to the line.

A DTMF generator (MV5089) is connected to the exchange line, allowing for DTMF dialling or signalling to the exchange.

### PSU

The PSU is internally housed within the FS1515, it is of standard design employing a conventional transformer and linear regulators.

## Software

The FS1515 software allows any DTMF phone to access the system programming features and allows both DTMF and loop-disconnect (pulse) phones to access extension user features.

The FS1515 is fully Mercury compatible and offers least cost routing once the user's Mercury PIN (Personal Identification Number) is programmed in. The unit also features 30 direct access memories for stored telephone numbers, call barring and a whole host of other features and facilities usually only found on much larger PBX systems.

## Accessories

The FS1515 has provision to connect a smoke alarm, door entry system and call logging-printer.

Any smoke alarm that provides 9V across its output terminals, when triggered, can be used. The input circuitry is opto-isolated and will operate regardless of input polarity.

The door entry system allows any extension to talk to the caller at the door and automatically release the door catch if required.

The door release contacts are momentary action (2 seconds make) and are rated at 2A. The intercom should be designed to operate from a 20V 40mA constant current supply. The intercom button signals the FS1515 by directly shorting the intercom supply lines.

The call-logging printer connects to the FS1515 by means of an I<sup>2</sup>C (Inter Integrated Circuit) bus. The printer is due to be released by Southwestern Bell in the near future.

## Installation

The FS1515 Exchange is supplied with a wall mounting kit, plus installation, programming and user's manuals. However a number of sundry items will also be required for installation:

1. 4-wire telephone cable XR66W/PA76H
2. Telephone sockets (secondary) \*
  - FJ43M
  - FT47B
  - FT50E
  - FG28F
3. IDC tool for connection to omnicom FT51F
4. Cable cleats BH19V/YM01B
5. 13A mains plug RW67X
6. 3A plug fuse HQ32K
7. Telephones \* \*\*
8. Tools (electric drill, 5.5mm masonry bit, side cutters, screwdrivers, small hammer, etc.)

### Notes:

- \* see 'Communications' section of the current Maplin catalogue for full details of types and styles.
- \*\* at least one telephone must be of the tone dial type to allow system programming.

If you purchase your FS1515 from Maplin, you will receive an FM850 'feature phone', 50 metres of cable, 4 telephone sockets, an IDC tool and 80 cable cleats with the FS1515 Exchange.

## Exchange Installation

Before attempting to install any part of the FS1515 system, it is important to carefully plan your requirements.

The FS1515 Exchange must be wall mounted and located within 3 metres of a 13A power socket and within 2 metres of the master telephone socket. If you do not have a master telephone socket, you must arrange to have one installed by your telephone service provider (usually BT). It is illegal to fit your own master telephone socket. The FS1515 Exchange should be sited where it will not be subject to excessive levels of heat, dust, humidity, damp, or near sources of electromagnetic interference such as motors, compressors or switchgear.

It may be found that the ideal place for the exchange is not within distance of a mains power socket, telephone master socket, or both! In such cases, install a secondary telephone socket adjacent to the exchange as an extension from the master telephone socket. Mains power can be provided by adding a spur to an existing 30/32A ring main. In keeping with IEE wiring regulations, it is preferable to connect the exchange by means of a switched fused cable outlet, instead of a 13A plug and socket. If in any doubt as to your ability to safely tackle modifications to mains wiring, consult a qualified electrician.

The exchange is secured to the wall by two screws; these, two wall plugs and

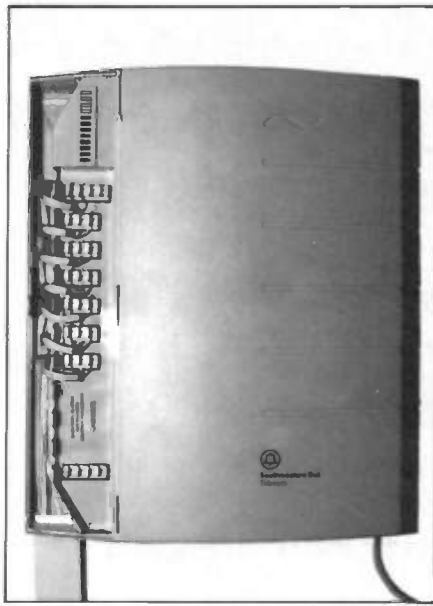

Extension socket wiring.

a drilling template are supplied with the FS1515. If the exchange is to be secured to a stud wall, it is likely that alternative fixing hardware will be required.

## Connecting Extensions

Extension telephones and their respective secondary sockets should be conveniently placed, and may be located up to 30 metres from the FS1515 Exchange. For safety reasons, and to prevent electrical interference, the cabling between the FS1515 Exchange and extensions should be routed separately from other electrical and telecommunications wiring. For neatness, cabling in the vicinity of the exchange may be run in standard 16 x 25mm cable trunking, the FS1515 has cable knockouts to facilitate this.

Standard 4-core telephone cable is used to connect extension sockets to the exchange, however, only 3 out of the 4 cores are used – the spare wire may be cut off.

The connections to the exchange are shown in Figure 3. An IDC (insulation displacement connector) tool should be used to insert the wires into the IDC

connectors – use of any other implement may cause damage to the connector contacts. Place the tool in position, parallel to and above the wire and at right angles to the IDC connector. Push down firmly on the wire, which will force the wire into the connector.

The secondary socket connections are as follows:

- Terminal 2 – Blue with White stripe
- Terminal 3 – Orange with White stripe
- Terminal 5 – White with Blue stripe

Secondary sockets may have either IDC or terminal block type connectors. If terminal block connectors are employed the wires will require stripping before the connections can be made. If IDC connectors are employed, the procedure for connecting the wires to the IDC connectors is as described above.

## Smoke Alarm Connection

It is possible to connect the exchange to certain types of smoke alarm. In the event of the smoke alarm being triggered, the exchange will cause each extension to ring with a characteristic 'urgent' ringing signal; upon answer the exchange will warn "Alarm! Alarm!" A list of suitable smoke alarms is given in the Appendix.

Figure 4 shows the smoke alarm connections on the exchange, note that the polarity of the signal is unimportant.

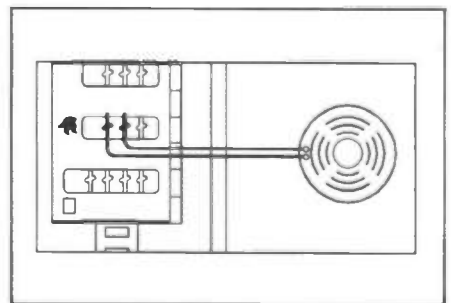

Figure 4. Fire alarm connections.

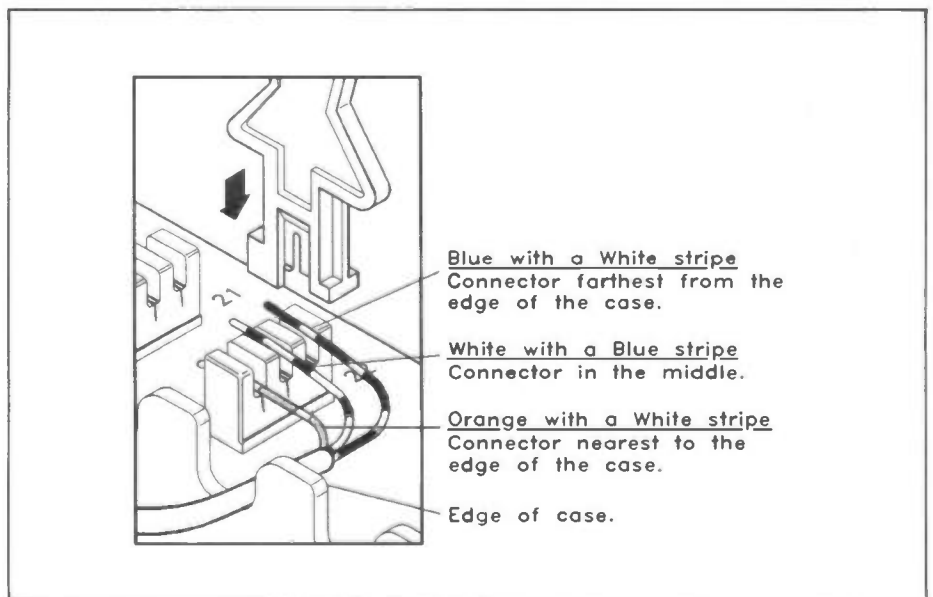

Figure 3. Connecting extension cabling to the FS1515 using an IDC tool.

## Door Intercom and Door Catch Release Mechanism Connection

A door intercom and door catch release mechanism can also be connected to the exchange. When the intercom button is pressed by the calling party, all extensions will ring; the calling party can be spoken to by lifting the handset and dialling 28. If it is wished to allow entry, to the calling party, the door catch release mechanism can be operated by dialling 0. Details of a suitable door intercom and door catch release mechanism are given in the Appendix.

Figure 5 shows how to connect a door intercom and door catch release to the exchange.

## Mains Connection

The exchange is fitted with a two core mains lead and therefore does not require an earth connection. The exchange should be protected by a 3A mains fuse fitted in the 13A plug (or in the fuse carrier of the fused switched cable outlet).

## Appendix

Please note that Maplin cannot, at time of writing, supply smoke alarms or door entry systems for use with the FS1515. However, Southwestern Bell Telecom have recommended the following systems for use with the FS1515.

## Smoke Alarms

Interlinkable photo-optical detector, BRK Model 2011, available from BRK Firelink Distribution, Tel: (0678) 520022.

Interlinkable ionisation smoke detector, First Alert Models, 10 SA 83 R1

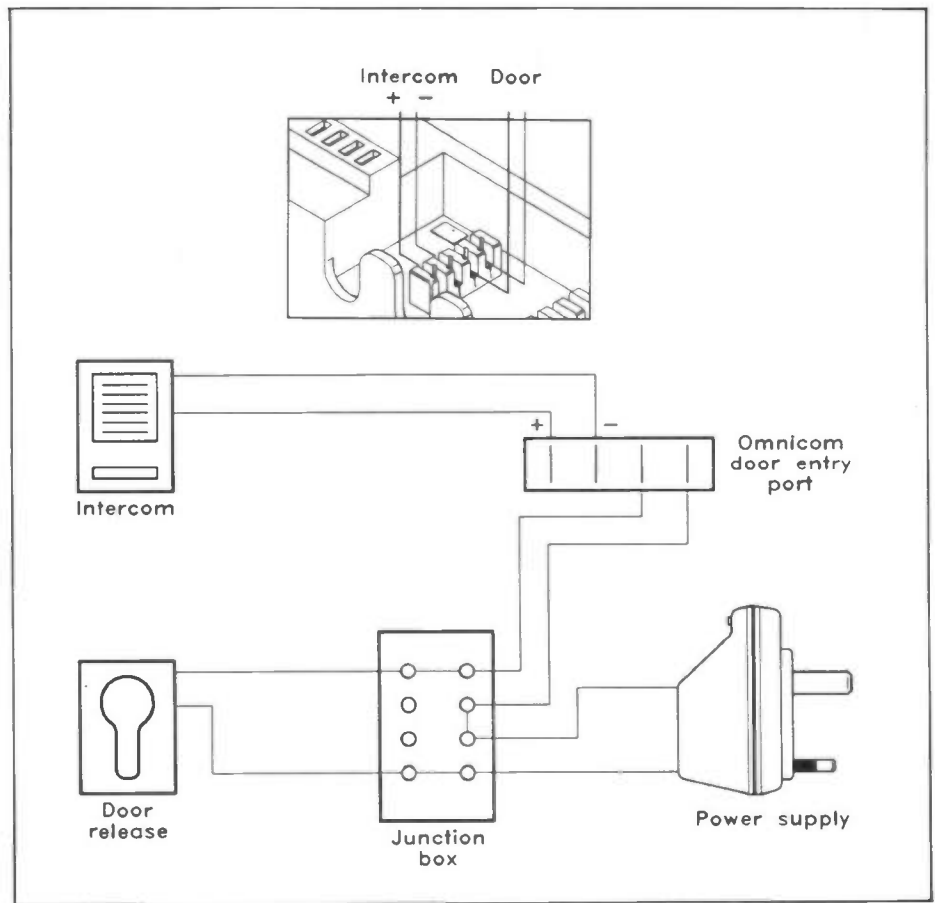

Figure 5. Connecting an intercom and door catch release.

and 12 SA 83 R1/2, are available from all DIY stores, such as B&Q, Texas, Do It All, etc.

## Door Entry Systems

A door entry system comprising an intercom unit and lock release mechanism is available from Compact Products, as Intercom Pack Version Number 2, Tel: (081) 472 1111. A power supply to operate the lock release mechanism is not supplied. Suitable

power supplies are available from Thame Power Ltd. Tel: (0844) 261300.

It must be stressed that this information has been included for the benefit of users and potential users of the FS1515 and Maplin cannot handle any queries arising from, or give any undertakings with regard to, 3rd party suppliers.

The FS1515 Exchange is available from regional Maplin stores and by mail order, **Order Code GK68Y Price £269.95.**

# Modification to Video Box

## Modification to Video Box

Published in 'Electronics', March 1992, Issue 51.

It has recently been reported that when using the Video Box with certain VHS video recorders, a colour shift or distortion to the picture may be noticeable. To correct this, the following modification should be implemented when first building, or to update, your kit.

Add a 47µH Choke (Order Code WH39N) in series with resistor R21; see Figure 1. As there is no physical position on the PCB for this additional component, it must be fitted as shown in Figure 2. De-solder, and lift out of the board the lead of R21 nearest to the edge of the PCB. Next, insert the choke and solder it in place. Finally, solder the free end of R21 to the free end of the choke.

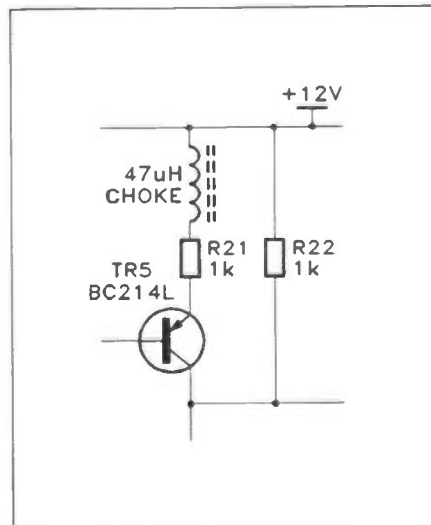

Figure 1. Modified circuit.

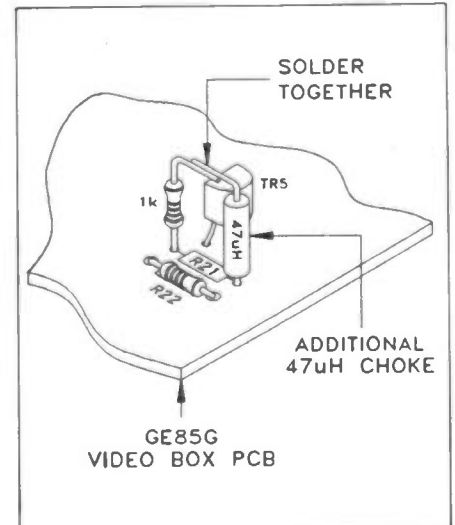

Figure 2. Positioning the choke.

**A readers forum for your views and comments.  
If you want to contribute, write to:**

**The Editor, 'Electronics - The Maplin Magazine'  
P.O. Box 3, Rayleigh, Essex, SS6 8LR.**

### **A Golden Rule**

Dear Sir,  
In reference to your article 'Finishing Off' by David Smith in the May and June issues. Why don't manufacturers produce a single-sided metal rule having the following two scales and divisions?

1) In tenths of an inch and inches.  
2) Metric in millimetres and centimetres.  
However, it seems that the only steel rules available seem to be graduated in sixteenths of an inch etc., and if you are lucky to find one with a tenths scale, it occupies only about a quarter of the rules length. Even then this part may include graduations of twentieths or even hundredths, for which a magnifying glass is required to read the markings. The only rules available with the above two scales are plastic and therefore unsuitable for use in a workshop environment.

The metric scale simplifies layout and marking out operations on cabinets and panels, as it eliminates the mental arithmetic operations required when using an inch and sixteenths scale, for the initial component layout stage. Unfortunately, IC manufacturers seem to be unaware that metric exists, as they scale everything in tenths of an inch. I feel certain that a steel rule of the type above would be warmly welcomed not only in the electronic hobbyists workshop, but also on the workshop floor.

**E. W. Fair, Stoke-on-Trent.**

*Any enterprising ruler manufacturers out there - take note!*

### **Down to Earth Satellite**

Dear Sirs,  
I have only been 'into' electronics for about 2 years and have found your magazine and catalogue instrumental in most of my learning. However, my main field of interest is satellite TV and video. Whilst I appreciate the legality concerning decoders etc. I would like to see more projects relating to satellite TV for example.

1. A satellite dish alignment meter capable of identifying individual satellites with an audio channel (similar perhaps to the one in T11v's\*\*n Sept 1991 which might have been OK had they catered for us novices!).
2. A SECAM to PAL transcoder.
3. An infra-red remote that will both 'learn' codes and be programmable so as to be able to change channel for recording satellite programmes whilst away (I never knew there were that many worth recording! - Ed.). Most of the receivers on the market today are without any timer facilities. I have built an I.R. control (from v'ryd'y 'l'ctr'nics) and coupled it through a very crude timer and switch circuit with a tiny degree of success. I feel that such a control would need the ability to learn both single shot and multiple pulse commands. It could also be used to carry out timing of, say, 4 events. Each event would be a series of pre-programmed steps e.g., switch on, position dish, and select channel. I have, in fact, read an article covering such remotes but no one seems to stock them, and one manufacturer even denies that it makes them!
4. A signal strength meter. Two types to cover most peoples requirements.

# AIR YOUR VIEWS



## **S·T·A·R· L·E·T·T·E·R**

*This issue, R. Pryde from Dunoon, receives the Star Letter Award of a £5 Maplin Gift Token for his letter.*



### **In the Beginning**

Dear Sir,  
Thank you for yet another good read - 'Electronics' issue 55. An excellent mix of interesting subjects!  
One item which caught my eye was the report, on page 53, of the Capital Radio Competition, and in particular the mention of the father of the prizewinner described as '...also an early Maplin customer...' with a 4-digit customer number.  
My customer number is also queried on the rare occasions when I phone in, and usually causes some hilarity when it is

checked and found to be correct, because it only consists of two digits! I wonder how many other 'First Day' customers are still around?  
Since your excellent Glasgow branch opened, I have little need of your phone and mail order services, but in the past I have been very pleased with the very fast response, particularly the phone order service - even to this fairly remote corner of the country!

*If any other readers think that they may hold the earliest 'surviving' Maplin customer number, please write in!*



Designed to be permanent fixings, one would have good deflection of a needle using the AGC voltage which some receivers have available as sockets at the back.  
The other would have to pick up its signal from within the receiver. These would then cover all receivers, enabling the signals to be 'tweaked' to their best using the positioner and focus etc.  
I hope that I have not rambled on too much, and that I have provided some food for thought. I feel sure that the above projects would have a wide appeal.  
Keep up the excellent work!  
**J. F. Blowes, Bexleyheath.**

*Martin Pipe replies:*  
Thank you for your suggestions - they have been passed on to the lab. Some of your suggested projects, interestingly, are already being looked at - the SECAM-to-PAL transcoder, for example. Others, however, cannot be considered on cost or practicality grounds - a signal strength meter that requires an internal connection to an existing receiver, for example. There are many different makes of satellite tuner out there, and it would be impractical to cater for more than a

couple of the most popular units - which would infuriate those who own some of the others! Signal strength meters, however, are available at low cost - one will, I can reveal, be featured in the 1993 Maplin Catalogue, due out soon. As for the 'universal remote control', where have you been hiding? These items have been widely available for some time - many specialist magazines are full of adverts for them! As is often the case, a Maplin kit could never compete on cost grounds with a commercially-available remote control unit of this type. Also many of the units of this type are covered by one or more patents - sorry! Finally, a new series on satellite television is scheduled to begin in Issue 59 (November cover date) of 'Electronics' - something to look forward to!

### **A Fuse in Time... Saves a Life**

Dear Sir,  
The legislation that is to be introduced regarding ready fitted plugs incorporating the correct rated fuse is obviously good news, especially for those members of the community who may encounter either physical

difficulties or other problems in fitting a plug by themselves e.g., the blind. Apart from such people, however, I feel that most people are capable of fitting a plug and in my opinion the real issue is being sidestepped.

The new legislation only concerns new equipment - what about existing gear? Even if the plug is ready-fitted, this does not prevent the fuse from being replaced for some reason, and with an incorrect rating. The plug itself can be damaged by misuse or neglect and will require replacing at some time. The pre-fitting of plugs to new equipment will only reduce or delay the problems in most cases.

The main points for consideration are as follows:

The correct fitting of a plug should be achieved by teaching everyone to fit a plug correctly. This is obviously not an easy task but schools and colleges can show students the correct method. It has been my experience, in the past, that the general public are oblivious to the different fuses available. As well as knowing how to correctly fit a plug, the people should be made aware of the different ratings available for the standard 13A plug.

Situations of misuse cannot be fully avoided; there will always be someone that abuses safety regulations or ignores common sense. Professional people that work with electricity are governed by stringent regulations and codes of practice such as the Electricity at Work Act, which is enforced by the Health and Safety Executive and ensures that the safe use of electricity is not compromised. Certain groups, such as retailers of domestic appliances, may come under the scrutiny of the Environmental Health or local Trading Standards Office, but these requirements do not apply to the average domestic user. There should be some means to make the DIY enthusiast as responsible as the professionals.

Note 16 of the Electricity at Work regulations, which requires a person to be competent to work on electrical equipment, should be more widespread in its scope than just at work. No doubt this regulation will prevent some domestic electrical retailers from fitting plugs - but if they are not 'competent' to fit a 13A plug, can they then be deemed 'competent' or knowledgeable enough to advise and sell electrical goods? I am happy to say that at least some retailers are competent and exhibit a responsible approach to such a situation, but what dangers are the others causing?

**C. L. Rayner, Warrington.**

*Thanks for an interesting, far-reaching, and provocative letter. The idea of 'universal education' as part of the National Curriculum with regards to basic electricity practice is an excellent idea. Perhaps if the dangers associated with incorrectly wired/fused plugs and so on, were made much clearer at the outset, then people wouldn't have adopted this 'couldn't care less' attitude. The protection of life should surely transcend everything else. Perhaps our privatised, electricity industry, with all its profits, should be called upon to sponsor such an activity. But, alas, its public service obligation is now strongly diminished...*



# Stray Signals

by Point Contact



Sometimes PC sits and wonders (he never just sits) what it is that predisposes someone to take up electronics, or indeed engineering in general. Undoubtedly an ingenious streak is an essential ingredient for the successful electronics designer, especially (dare I say it?) if he or she concentrates on analog(ue) circuitry. PC doesn't remember his paternal grandparents, but certainly on the maternal side they exhibited the ingenuity inherited by Uncle M and your humble scribe. For example, Granny H never had trouble buttering a slice of bread, even if the butter was a bit cold and stiff – with most people a recipe for disaster, as the slice just fell to bits. Granny H just buttered the end of the loaf before cutting the slice: this of course was long before the days of sliced bread.

Grandad H's interests were many and varied, including gardening. His specialty was growing delicious tomatoes, the variety that turns golden yellow when ripe, and he always saved his own seed from year to year.

Nothing particularly ingenious about that, but his patent peashooter was quite neat and as far as

I know, all his own idea. It consisted of a length of bamboo cane about a foot long (30cm we would say nowadays), the bore cleared with a red hot poker. The next stage of manufacture required a slot about two inches long in the side, near one end. A length of old clock spring was roughly straightened out (I think he must have known a bit about annealing and tempering) and bent into a fairly open hairpin shape, about four inches long but with one leg an inch longer than the other. The extra inch was then bent back at almost a right angle and inserted into the bore via the slot, nearest the end of the tube. The short end of the 'hairpin' pressed hard against the other end of the slot, so that if pulled back to a closed hairspring shape it stayed jammed put. A dried pea was then popped into the slot and the side of the hairspring nearest the end of the tube eased back. This released the free end which sprang smartly back to its former position, propelling the pea ferociously across the conservatory or garden – not surprisingly Granny H wouldn't let him play with it indoors.

We tend to think of such whimsical activities in an adult as a peculiarly English trait, like taking part in Morris dancing or *Jeu sans Frontiere*. But not a bit of it, as anyone who has seen Tutti Frutti on German television will know, whilst the Japanese get up to the most incredible tomfoolery on television. It was with an appropriate touch of whimsy that NHK, Japan's national broadcaster, inaugurated their HDTV (high definition television) service on the twenty-fifth of November, a date matching the 1125 lines of their HDTV screen, since like the Americans they write dates in month, day order. Still, with the price tag of a set the equivalent of thirty thousand dollars (that's an awful lot of Yen), so far the sets are only found in hotel lobbies and big public buildings.

Talking of television, the PC household was wired for cable TV recently, in fact yesterday, as I write this. The arrangement is quite ingenious, still enabling the TV set to receive BBC 1 and 2, ITV and Channel 4 on channels 1 to 4 via its existing aerial, or any of the cable channels (including BBC 1 and 2, ITV and Channel 4) by selecting channel 6 on the TV and the required cable channel via the set-top adapter. We will thus be able to receive the four terrestrial broadcast channels without the patterning due to interference from other stations, which can make Channel 4 in our area almost unusable in times of very high atmospheric pressure. One can also tape an off-air programme on the video recorder whilst watching a cable channel on the TV or vice versa. The cable also carries VHF FM channels, both those normally receivable at the PC THQ and several others as well, and the appropriate outlet has been wired into the Hi-Fi. Among the latter are VHF FM stereo sound versions of the NICAM stereo sound on some of the cable TV channels – an ingenious arrangement indeed. PC doesn't see himself spending a greatly increased amount of time watching the goggle-box, but only time will tell. The main reason for subscribing is Mrs. PC. Being a linguist, she welcomes the access to foreign language channels; four German and one each of French, Italian, Spanish, Dutch, Russian and Japanese. Of these, the only one she doesn't speak at all (yet) is Japanese, though her Dutch is a bit rusty. PC looks forward to the day, promised soon by the operator, when a full 'phone service will be offered. Bye bye BT!

Yours sincerely,

Point Contact

# Pre-Programmed Sound Generator

Text by Gary Heineken

This pre-programmed sound generator is ideal for use in sound effects production, disco jingles, games and toys. The range of sounds that the completed unit makes is shown in Table 2. Note that the tempo of each effect is adjustable, increasing the unit's versatility. The sounds are created through the use of a Peripheral Interface Controller (PIC), a microprocessor-based Integrated Circuit (IC). The PIC chip contains both non-volatile Read Only Memory (ROM) and volatile Random Access Memory (RAM). It is the ROM that holds the programming instructions used to generate the sound effects, with the RAM storing temporary data processed during the running of the program. The finished unit has provision for the direct connection of an 8Ω loudspeaker, and a line level output for use with a mixer or amplification system.

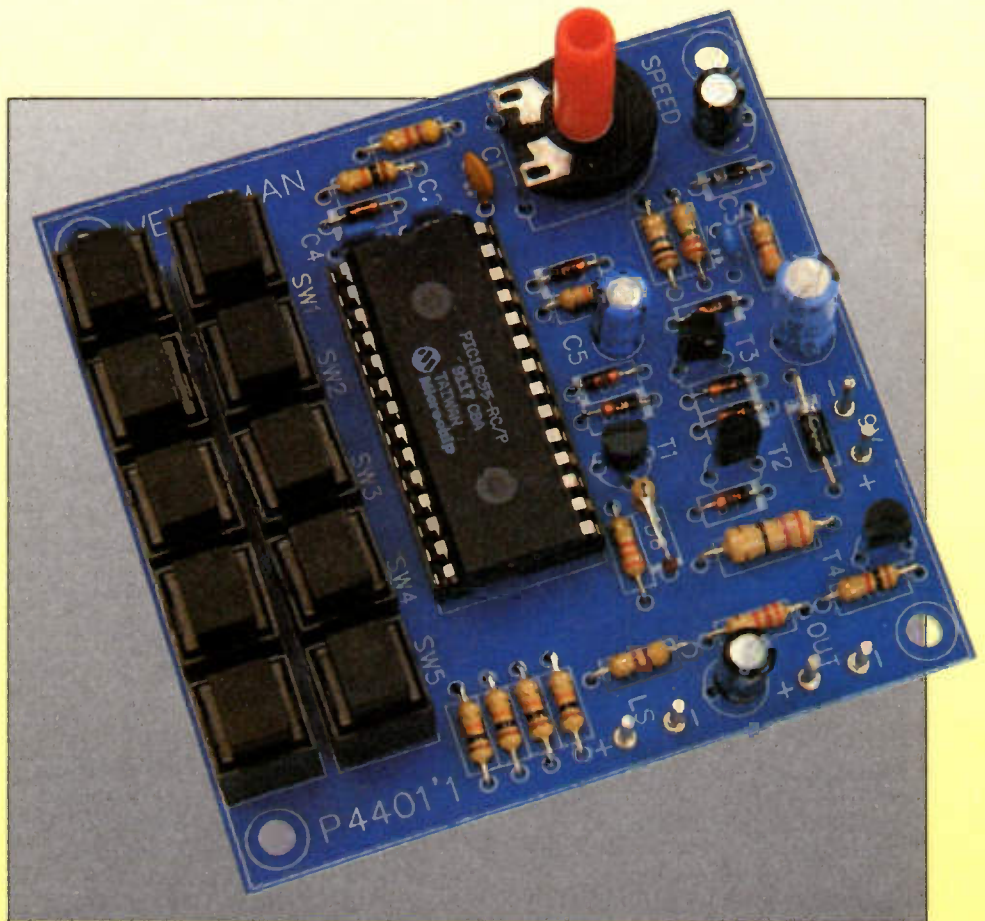

Photo 1. Completed PCB.

Power input:	8 to 10VDC (9V battery)
Standby current:	11mA
Max. current:	100mA
Loudspeaker output:	8Ω/1W
Line output:	1V rms

Table 1. Specifications.

## Circuit Description

To assist you during construction, or fault-finding in the completed unit, a circuit diagram is included in the kit's leaflet. It is also shown in Figure 1 of this article.

As can be seen from Figure 1, most of the circuitry is contained within the PIC chip, IC1. This contains the control system and the sounds, held in digital form in the ROM.

The keyboard matrix, consisting of SW1 to SW10 and pull-up resistors R10 to R13, is continuously scanned by IC1's tiny microprocessor. When a key is pressed, the microprocessor determines which one it was and sends, to pins 18, 19 and 20, a 6-bit digital code that represents the sound.

A simple digital to analogue converter, made up of T1, T2, T3 and associated components, converts the stored code into recognisable sound. There are three sections to this converter,

## Features

- ★ 10 different sounds
- ★ Drives 8Ω loudspeakers
- ★ Adjustable pitch/speed
- ★ Reverse polarity protection

## Applications

- ★ Sound effects
- ★ Disco jingles
- ★ Games and toys
- ★ Alarms

each formed around one of the transistors. The outputs (which are weighted according to their significance in the 6-bit code) from these transistors are summed together via D6, D7 and D8, before being amplified by the Darlington output transistor T4. This device, chosen for its high current gain will, depending upon the power supply used, sink up to 1W into an 8Ω loudspeaker. A line output is also available through a potential divider and DC blocking capacitor C6.

To produce the desired tonal range

1. Tune: 'Wild charge tune'.
2. Mortar shot and explosion.
3. Explosion.
4. Car tyre screech.
5. Tune: 'Snake charmers tune'.
6. Car engine (up/down rpm).
7. Phasor gun.
8. European siren
9. Machine-gun and bullet impact.
10. USA siren.

Table 2. Sound effects available.

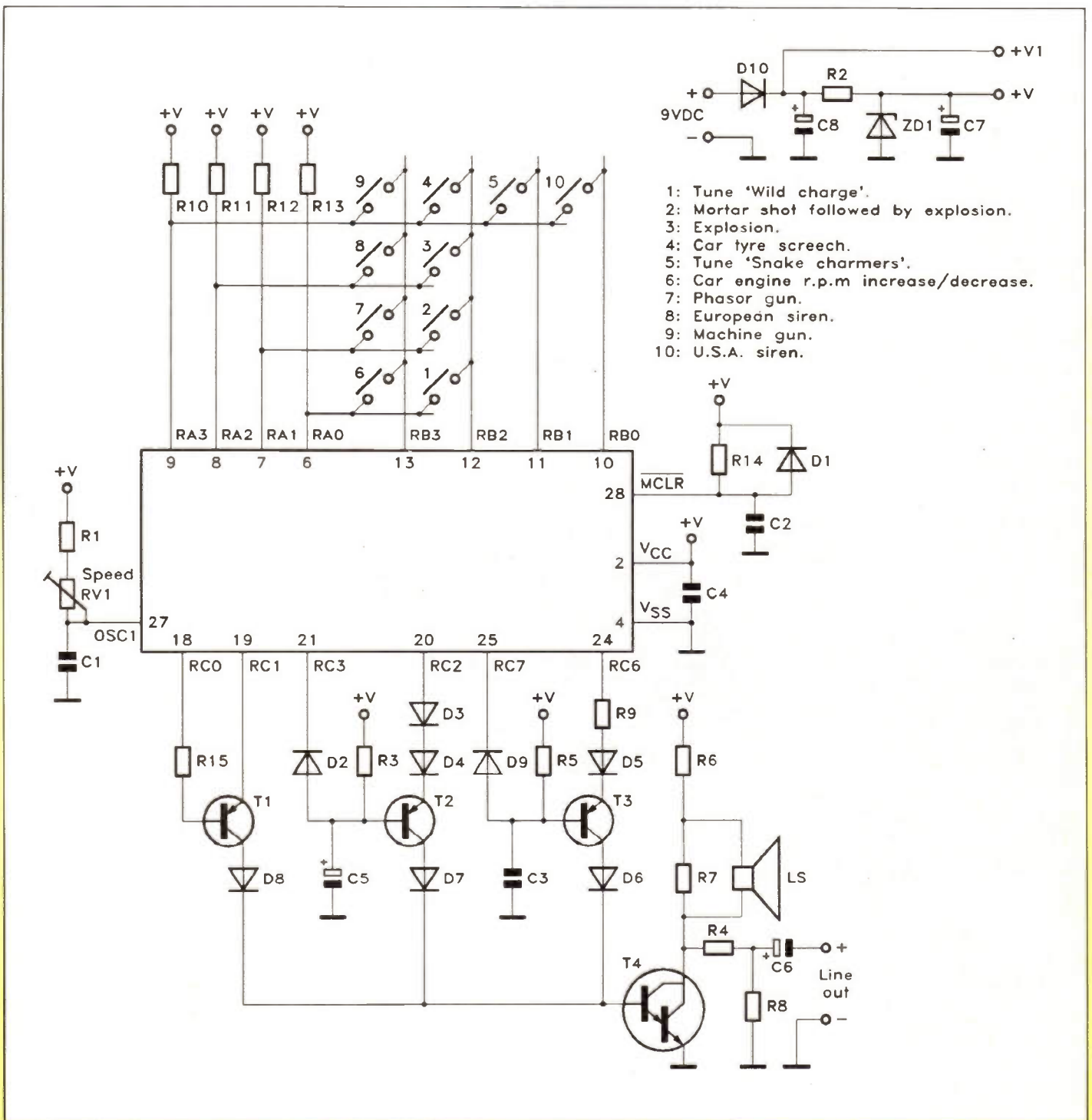

Figure 1. Circuit diagram.

and speed, the frequency of IC1's internal clock oscillator is set by the value of capacitor C1 and the combined values of resistors R1 and RV1.

D10 is used as a protection diode, while C8, R2, ZD1 and C7 form a simple supply regulator. C4 is used to decouple the supply to IC1. The components associated with pin 28 of IC1 reset the device when power is applied.

### PCB Assembly

The information required to help you with the assembly can be found in the instruction booklet, which is included in the kit. This should be read before attempting to build the unit. Additional information on soldering and general assembly techniques, should you need it,

can be found in the Maplin Constructors' Guide (Order Code XH79L).

The printed circuit board (PCB) is a single-sided type, and has a legend to assist you in correctly positioning each item. Removal of an incorrectly-fitted component can be fairly difficult without damaging it, or the PCB, in some way, so please double-check each component type, value, and polarity (where appropriate), before soldering!

The order of construction is not particularly important, but note that IC1 is socketed, instead of being soldered directly to the PCB. This IC should be plugged into its socket last of all, just before testing. When fitting the six PCB pins, insert them from the legend side of the board, pushing them in place with

the aid of a hot soldering iron. In the kit, you will find a spindle that slots into the adjuster of RV1, acting as a control knob.

When completed, your PCB should look like that shown in Photo 1. At this stage you should check your work very carefully, making sure that all the solder joints are sound. It is also very important to make sure that the solder side of the circuit board does not have any trimmed component leads protruding by more than 2mm, as a short-circuit could otherwise result.

### Wiring and Power Supply Considerations

A wiring diagram, which shows all of the interconnections on the PCB, is given in Figure 2. For best results a speaker with

an impedance of  $8\Omega$  should be used. In addition, screened cable should be used to connect line level output of the Sound Generator to your external amplifier (use this if you want a bit more 'beef'!) or your mixer. Note that the line level output is fixed at around 1V rms. The on/off switch is a single pole/single throw type; a wide selection is shown in the 'Switches and Relays' section of the current Maplin Catalogue. Although a 9V battery is recommended, a mains-powered DC supply can be used. This item must be capable of providing 9V at around 100mA.

## Testing and Using the Sound Generator

Testing the Sound Generator is very straightforward. Connect up the unit as shown in Figure 2 and set RV1 to its centre position. Pressing one of the ten push buttons will produce the corresponding effect (see Table 2). Note that some of the effects (such as the sirens and the car engine) require the relevant button to be held down continuously. Adjusting RV1 allows the speed of the effects to be optimised to a particular application.

The Sound Generator has a myriad of different uses. It could be employed during radio or stage plays as a source of sound effects. Likewise, the unit could be used to enhance discos and 'up-front' radio programmes. Coupled with a weatherproof siren-type speaker, the unit could be used as an alarm. Similarly,

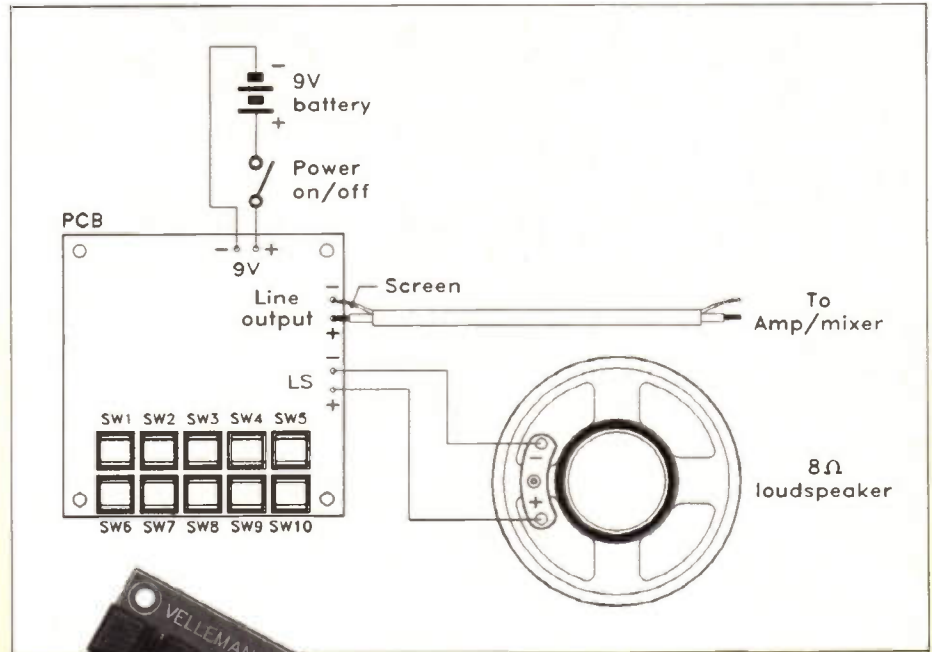
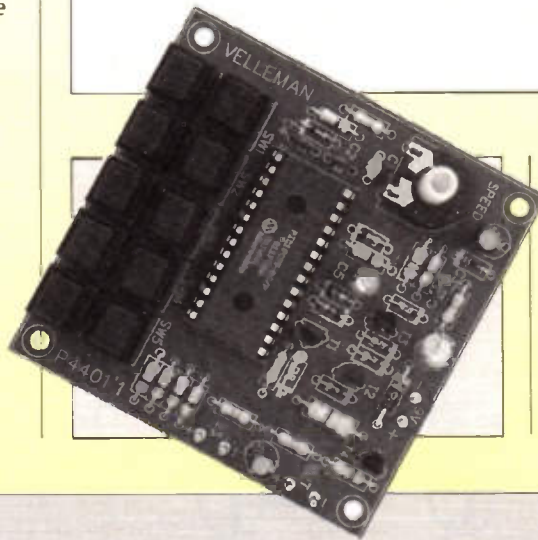

Figure 2. Wiring.

it could be built into a small case with an efficient mylar speaker (such as YN00A) and used as an attention-grabbing personal attack alarm. The clear plastic presentation box could be used, at a pinch, to house the circuit; holes could be drilled in the lid to 'let the sound out', the case being painted, if required, to your design. The Sound Generator could also be used to liven up games, and could be incorporated into childrens toys.



## SOUND GENERATOR PARTS LIST

### RESISTORS

R1	4k7	1
R2	330Ω	1
R3	2M2	1
R4	2k2	1
R5	10M	1
R6	27Ω 1/2W	1
R7	470	1
R8	1k	1
R9-14	10k	6
R15	3k3	1
RV1	47k preset	1

### CAPACITORS

C1	22pF ceramic	1
C2-4	100nF resin dipped ceramic	3
C5	1μF	1
C6,7	47μF	2
C8	100μF	1

### SEMICONDUCTORS

IC1	PIC16C55	1
T1-3	BC557 (or equiv.)	3
T4	BC517 (or equiv.)	1
D1-9	1N4148	9
D10	1N4007 (or equiv.)	1
ZD1	5-6V zener diode	1

### MISCELLANEOUS

SW1-10	Push-to-make switches	10
	IC socket (for IC1)	1
	Clip-on spindle for RV1	1
	PCB Pins	6
	Glass fibre PCB	1
	Instruction Booklet	1
	Presentation Box	1
	(could be used to house project)	

### OPTIONAL (Not in Kit)

	Sub-Min Toggle Switch (Type A)	(FH00A)
	Hook-up Wire	(BL00A)
	Single-core Screened Cable	(XR12N)

### Speaker suggestions

	Loudspeaker Low Cost	(YW53H)
or	3 inch Mylar Speaker	(YN00A)

### Power supply suggestions

	300mA Unregulated DC Power Supply	(XX09K)
or	Alkaline PP3 Battery	(FK67X)

The Maplin 'Get-You-Working' Service is available for this project.

**The above items (excluding Optional) are available in kit form only.**

**Order As VE11M (Sound Generator) Price £24.95.**

Please Note: Some parts, which are specific to this project (i.e. IC1, PCB) are not available separately.

# BROADBAND ISDN

by Frank Booty

The European Commission wants European network operators to have the infrastructure to allow value added suppliers to link into networks within the European framework. It wants telecommunications networks to provide the backbone of economic growth and social well being; it wants networks to be standardised for interlinking, and for them to be open with other services to be provided by value added re-sellers.

The ideal is to build a network from scratch with unlimited funds. But today's equipment and practices are a mix of ancient and modern. The transition is from one network dominated by voice (the '60s network) to one providing a spectrum of services including data, voice and vision. This requires technology and development to be integrated into an existing base in such a way that it doesn't cause it to fall over. And it has to be agreed with other developers.

Most countries' operators are moving from existing telecommunications networks to the sophisticated networks of the future. But there has to be someone to make sure there is no disruption, to provide administrative services and to make sure there is a link to other countries. Signalling and protocols must be harmonised at standards meetings too.

What we do in Europe has to be agreed in Europe. But note that for example STC is now part of Northern

Telecom. Multinationals are exerting their influence on a global basis; take the case of a Bell operating company which has applied to become a member of a European technical standards institute. There are other US concerns which are acting likewise.

Also take the case of services which are available through networks, and map the bandwidth to support these services against the circuit occupancy or utilisation (Figure 1). Networks, whether ISDN, ATM (Asynchronous Transfer Mode) or SDH (Synchronous Digital Hierarchy), can take a variety of services (voice, video, image, etc.).

We need networks that can take a variety of signals, i.e. multi-services networks. There is a debate in the telecommunications and computer world about what is most suited to their needs. What is the right type of network to have? In data networks there are protocols and checking of re-transmission. Where there is a mixture with a real time element in it (not a DP requirement) there is high integrity of information and a lower requirement for real time.

Wideband service, carried over the broadband (defined as a point to point service, not including distributive services such as TV) network and accessed via the ISDN narrowband network, provides a high-class service at affordable cost for domestic users and an adequate service

for small and most medium business sites, at least throughout the 1990s.

With voice, you can't wait but expect fluency. With video, you expect the pictures to be linked together. The issue is to bring both requirements together under one protocol - i.e., ATM which is now widely recognised as the technology for the implementation of broadband networks. This will accommodate a variety of services some of which are predominantly packet based and some vision and image based.

There are two compatible switching technologies for ATM and these are MANs and ATM star switches. A low risk start to the broadband network is achieved with the introduction of MANs linked by simple bridges, providing a service from nodes on dedicated optical customer access connections to large business sites. By offering only a connection-less datagram service at this stage, much of the complexity of network integration is avoided. This is the approach already adopted by AT&T, Bellcore and some organisations with the Switched Multi-megabit Data Service (SMDS).

As the popularity of the service grows, both in geographic and traffic terms, the number of MANs which must be interconnected increases. Where there are more than four fully interconnected MANs, the bridges should be replaced by routers and the switch in the router would be a small ATM star switch. Here, connection

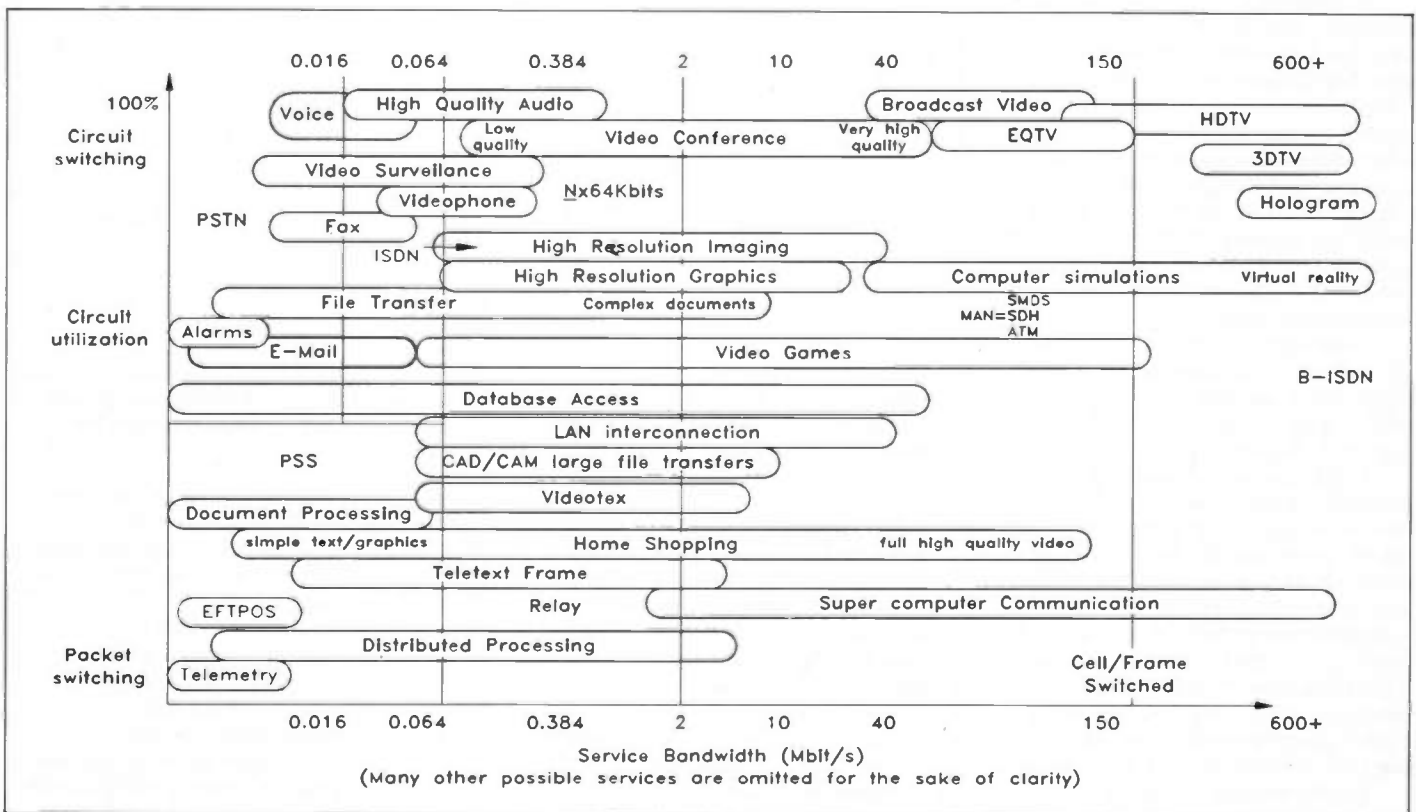

Figure 1. Utilisation of service bandwidth (M-bit/s).

mode services should be added to the datagram service. With further growth, the direct interconnection of routers improves efficiency and represents a major step towards the ultimate target broadband network using large ATM star switches and (possibly) MANs as local concentrators.

A circuit switched network with 64K-bit/s granularity will, however, continue to provide the core services for the majority of users for the foreseeable future. The growth of the broadband network is shown in Panels A to E.

Some large business sites will gain access to the broadband network on direct optical lines using SDH STM-1 links. Initial studies suggest that there is no cost advantage in providing a physical path at less than the 155/150M-bit/s rate (assuming mono mode fibre in all public network applications). Other possibilities, serving a group of customers, include SDH add/drop multiplexers providing a contracted portion of the STM-1 bandwidth for narrowband and broadband services to each customer, or a MAN providing ATM mode and isochronous mode service over a single fault tolerant medium.

Operating companies in Europe and the US are now investing heavily in an ISDN infrastructure. ISDN primary rate access can provide a 1,920K-bit/s bearer channel in Europe or a 1,472K-bit/s channel in the US. This is 200 or 150 times better than a 9.6K-bit/s modem. To achieve superior performance for a packet mode service, the ratio between the upstream bearer rate and the peak user bandwidth should be greater than 8:1 to give good statistical smoothing.

With a 2M-bit/s source, the implied upstream bearer rate should be greater than 16M-bit/s which the broadband network with 150M-bit/s bearers is well able to provide.

New network requirements such as intelligent networks, PCNs and distributed control will put severe demands on the signalling network such that the present 64K-bit/s network will be inadequate. All signalling is therefore expected to migrate to broadband in time, thus D channel signalling will be adapted to ATM near to the local access. The packet switched public data network (PSPDN) is expected to be replaced eventually by ATM mode wideband packet services enabled by the broadband network.

While Figure 2 gives an indication of the growth of the broadband network, a typical local network architecture providing for access to wideband services is shown in Figure 3.

A datagram service may well be considered to be useful by users. The datagram service is provided for by servers usually located on each MAN or at each star switch. The calling subscriber and successive servers in the path are linked by reserved virtual paths. Each server will receive the complete datagram, examine the destination address held in the information field of the first ATM cell, and route to the next server in the relevant direction or to the destination subscriber.

For the network configuration of Figure 2 A, with a single MAN and providing only datagram service,

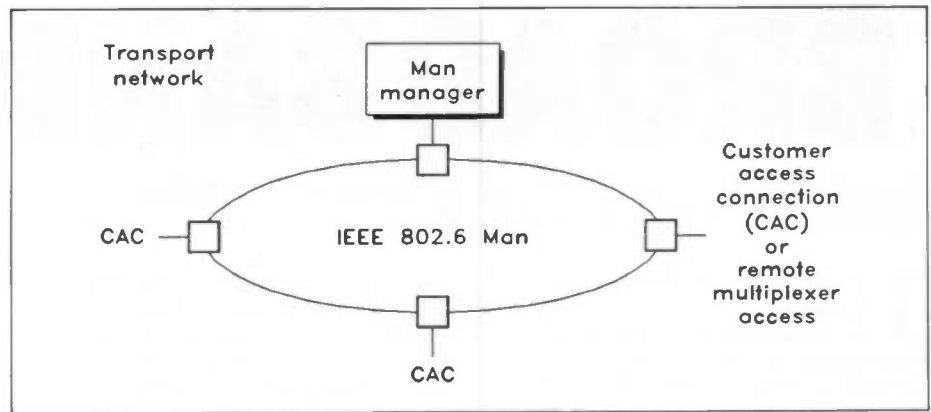

Figure 2. Stages of growth of the broadband network: A, Stage 1. A single MAN is embedded in the transport network. A datagram service is provided to a few large business sites on dedicated optical customer access circuits. Ports are directly addressed. Port address memories are maintained by a manager.

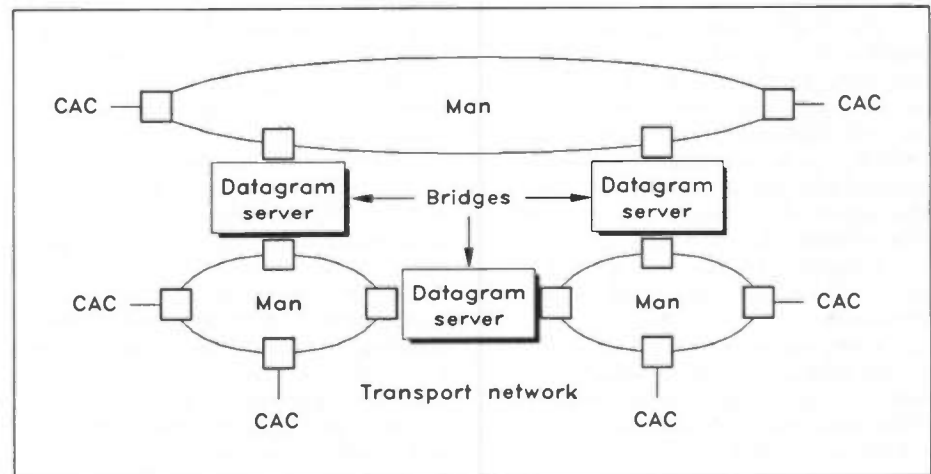

Figure 2b, Stage 2. Further MANs are added to the network, linked by point to point bridges incorporating datagram servers. The limit is about four MANs before the structure becomes unwieldy.

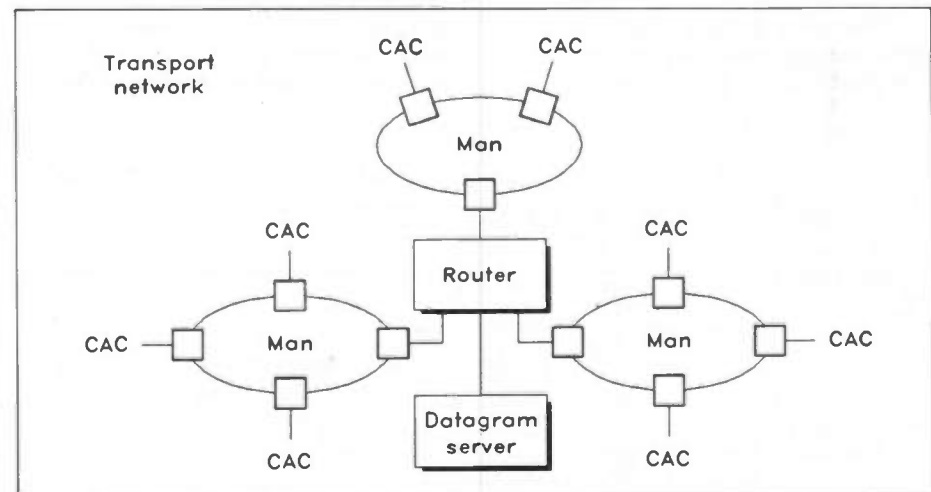

Figure 2c, Stage 3. Groups of bridges are replaced by routers which use small ATM switches, typically with 16 or 32 ports, providing full rate connectivity between MANs and to a datagram server. The majority of the traffic will be on virtual circuits.

each MAN node may provide address translation, kept up to date by a MAN manager. For Figure 2 B, the servers are provided in the bridges while for C, connection mode service is assumed for the majority of the traffic and a limited number of servers connected on router ports provide adequate capacity; similarly for configurations in D and E.

In a typical local access arrangement, the rate adaption unit would have a permanently assigned VP to the nearest datagram server in the broadband network. Access to the service could also

be via the D-channel and an HDLC/ATM adaption unit. This value added service could be particularly attractive to domestic customers where a datagram may replace a letter in many cases.

The provision of an ATM based broadband overlay network may be economically justified by enabling enhanced services access over the narrowband ISDN network. Simultaneously, direct access broadband services may be provided to the relatively few large business users for which the higher access costs are viable.

Transmission networks based on the Synchronous Digital Hierarchy (SDH) offer a number of significant advantages over existing networks, particularly in terms of the ability to manage the capacity. This manageability is crucial as it will enable a faster provision and rearrangement of services, and a much more rapid restoration in the event of facility failure.

It has been noted that there is a wide acceptance of the layered nature of transport networks, with a client/server relationship between layers. Consider a 2M-bit/s based Plesiochronous ('nearly synchronous') Digital Hierarchy (PDH): the 34M-bit/s server network supports the 8M-bit/s client network, and the 8M-bit/s server network supports the 2M-bit/s client network. The signal structure of the server network generally comprises a payload (into which one or more signals from the client network are multiplexed), and a server network 'overhead'. This overhead ensures the integrity of the server network.

So it's possible to distinguish between the bit rates of the server network and those of the client network, e.g., the plesiochronously multiplexed hierarchical bit rate 34,368K-bit/s – the server network bit rate is 34,368K-bit/s but the client bit rate is  $16 \times 2,048\text{K-bit/s}$  (i.e. 32,768K-bit/s).

Likewise, SDH based networks exhibit a server/client relationship between their layers, e.g. higher order Virtual Container (VC) networks serve to support lower order VC client networks. Further, these VC networks can serve to support client signals from the existing PDH.

Agreements in the CCITT have resulted in a significant simplification of the SDH multiplexing structure which offers the potential of widespread networks based on a common set of VCs. So any SDH deployment strategy should recognise the emergence of VC networks in the longer term and the eventual demise of existing PDH bit rates.

Although the multiplexing structure recommended by the CCITT provides for the support of most PDH bit rates, including simultaneous mixes of different bit rates, there are likely to be advantages by limiting the range of PDH bit rates to be supported.

So the strategy should be optimised for the support of the most important client networks of the PDH, whilst taking into account the likely requirements of future client networks such as ATM or digitally encoded TV. This means it is necessary to identify the most important client networks. Figure 4 indicates the broad service categories which either exist or are expected to emerge in the future, and the corresponding network requirements in terms of bit rates.

What emerges is that, currently, 2M-bit/s is a key bit rate and will undoubtedly remain so. 140M-bit/s is also an important rate with rather modest quantity requirements now, but with the likelihood of significant increase especially with the advent of ATM. It is also the PDH server network layer at which protection switching is commonly provided.

Commercially important services are

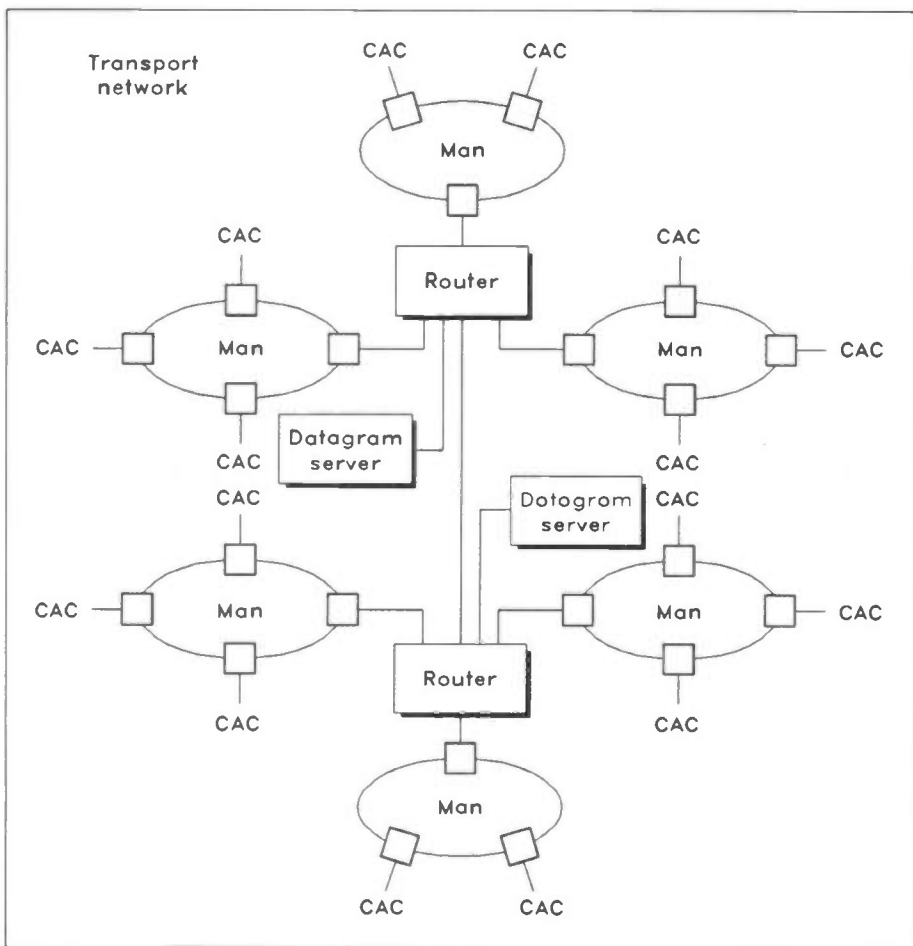

Figure 2d, Stage 4. Isolated routers are now inter-connected by direct links, removing the need to route transit traffic through intermediate MANs, simplifying the structure of the network and setting up the target network architecture.

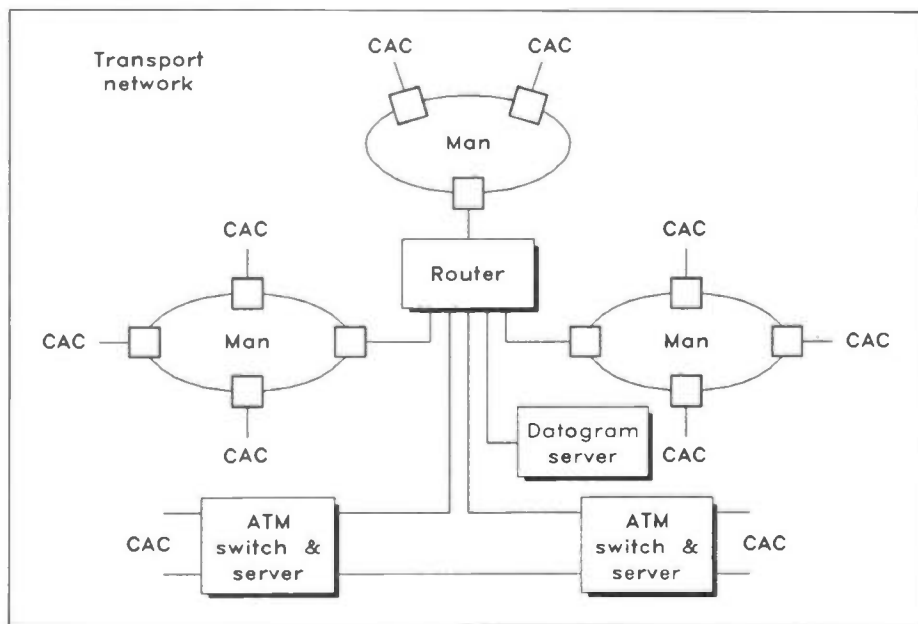

Figure 2e, Stage 5. Routers are now linked to large ATM star switches with directly connected subscribers. The ATM network will continue to grow and the MANs will be relegated to the status of local concentrators.

expected to emerge between 2 and 140M-bit/s, with requirements which will not necessarily be related to existing PDH bit rates. For example, the LAN interconnect and MAN requirements with bit rates of perhaps 10 to 100M-bit/s.

Introductory deployment strategies should be optimised around the rates of 2 and 140M-bit/s for the most important client networks. Such strategies should

not however, jeopardise the emergence of other client networks.

The support of signals at around 140M-bit/s can be provided by SDH based networks, since the signals can be mapped directly into the VC and all SDH based networks will offer VC networking. It is the support of lower bit rate signals which requires more detailed consideration – thus, consider two approaches:

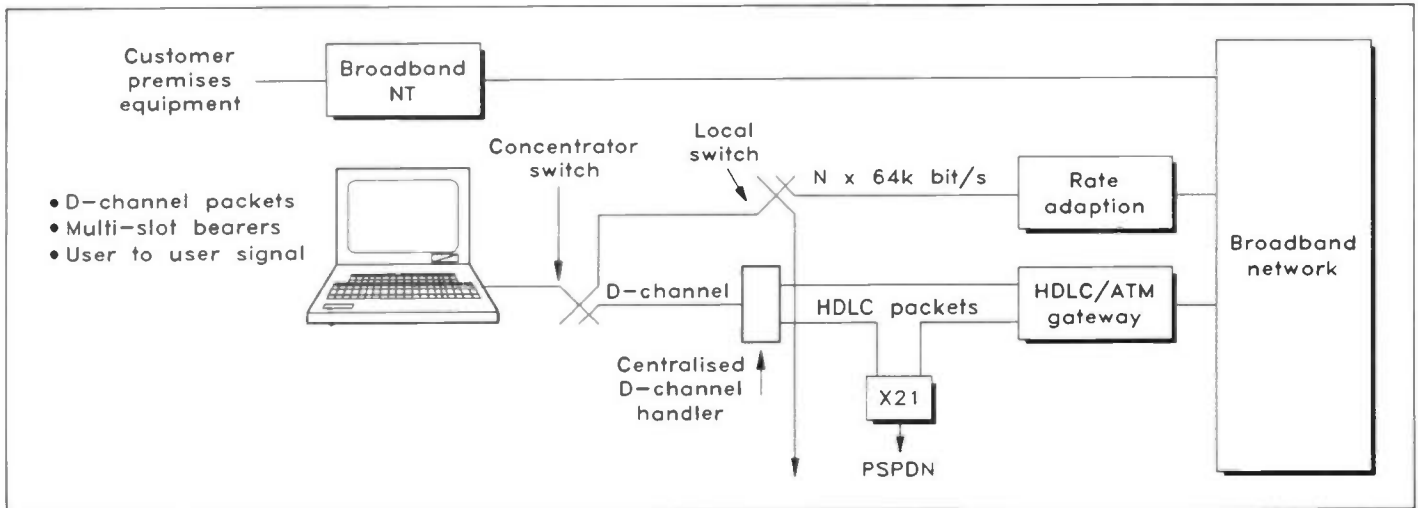

Figure 3. Typical local network architecture showing direct access and wideband access to the broadband network.

Service Categories	Network Requirements
Voice	2M bit/s paths
Low-speed Data	2M bit/s paths
High-speed Data	n x 2M bit/s paths (e.g. 4,6,8,10 up to 30/40M bit/s)
Multi-service (very high-speed Data or Video)	≈ 140M bit/s paths (probably using ATM)
Broadcast TV	Currently 140M bit/s, but moving to lower bit rates (e.g. ≈ 34 or 45M bit/s)
High Definition Television (HDTV)	Currently ≈ 600M bit/s, but moving to lower rates (maybe ≈ 140M bit/s)

Figure 4. Service categories and network requirements.

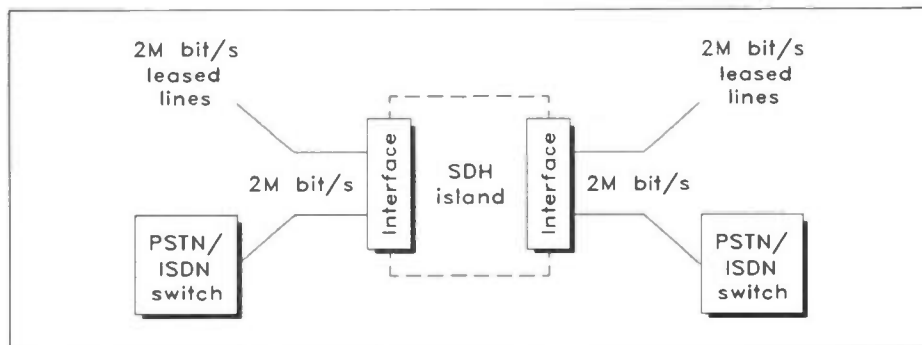

Figure 5. Early introduction stage optimised on key rate.

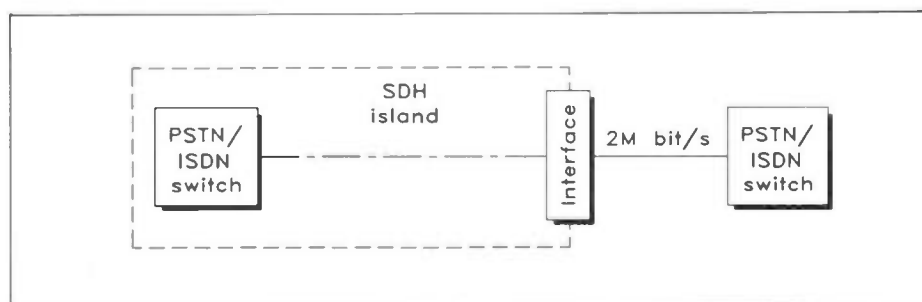

Figure 6. Early introduction with a transmultiplexer function.

**Approach 1:** this recognises the importance of the 2M-bit/s client network. The SDH network is thus mainly organised to offer management of the paths of the 2M-bit/s network and the interfaces to the SDH island are at 2M-bit/s. The early introduction of SDH based facilities can thus be shown in Figure 5, in which the 2M-bit/s signals are mapped onto VCs and

routed across the SDH island. A variant of this approach (Figure 6) is where the interface to the SDH island combines plesiochronous multiplexing and SDH tributary mapping functions in a back-to-back arrangement, sometimes referred to as transmultiplexing. As in the case of Figure 5, the 2M-bit/s signals are supported in VCs in the SDH island.

This approach could prove a cost-effective solution, noting that plesiochronous skip multiplexing can be realised with a fairly modest chip set, and that physical interfaces at 2M-bit/s are not required. It should be noted that in this latter case the SDH island could be just a cross connect equipment at a single site, where the desired initial benefit is the automated management of the site rather than the management of the network as a whole.

Approach 1 has a high degree of future proofing; as plesiochronous islands diminish and the SDH islands increase in size, the same routing principles in the SDH island can be used thus offering a smooth evolution to all VC based SDH transport networks. With time, more and more network elements will have SDH based transmission interfaces (such as the PSTN/ISDN switches shown in Figure 7). However geographically small or widespread the SDH island, it is important from the outset to regard the SDH island as providing VC networking rather than networking of PDH bit rates.

**Approach 2:** this is an alternative for the SDH island to support plesiochronously multiplexed server network layers (i.e., 8, 34 and 140M-bit/s) as well as 2M-bit/s in the case of the 2M-bit/s hierarchy as shown in Figure 8. Elements of existing transmission networks with this approach are replaced or added to by SDH based facilities on a functionally like-for-like basis but with the potential for management.

Plesiochronous multiplexing/demultiplexing, by definition, cannot occur in the SDH island. This approach has the advantage that the planning and routing arrangements developed for the existing network can be used in the SDH based arrangements. But there are some drawbacks: since the 8, 34 and 140M-bit/s signals are server network layers containing plesiochronously multiplexed 2M-bit/s tributaries, plesiochronous multiplexers (outside the SDH island) will continue to be required (Figure 8); and migration to an all SDH based network will require new routing arrangements to be implemented.

It is important to distinguish between cases where a PDH network layer is a



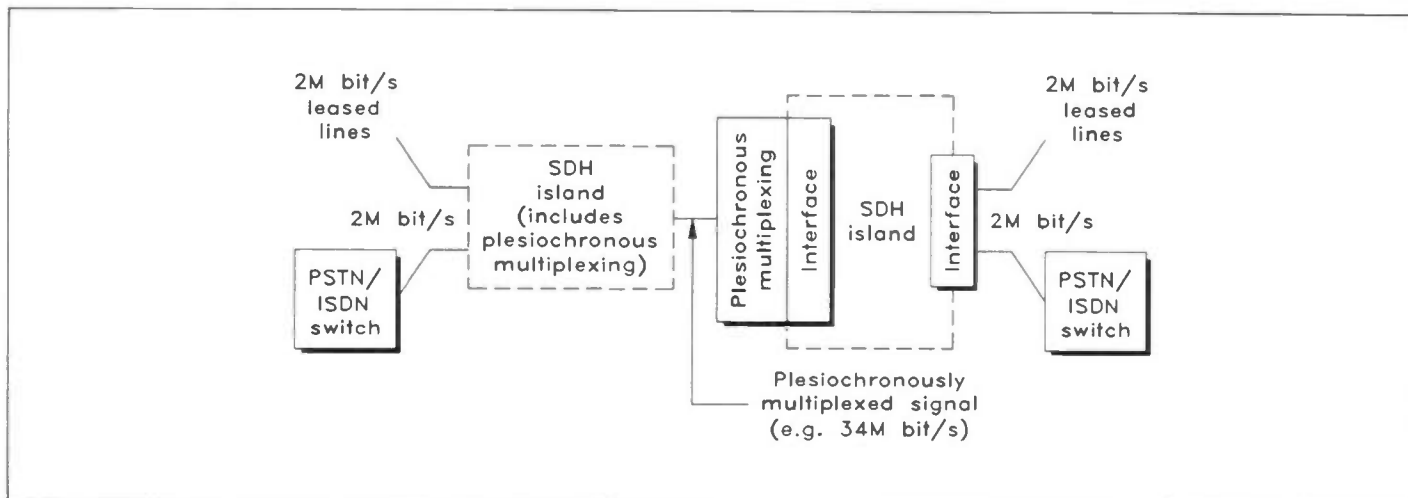

Figure 7. Emergence of SDH-based switch ports.

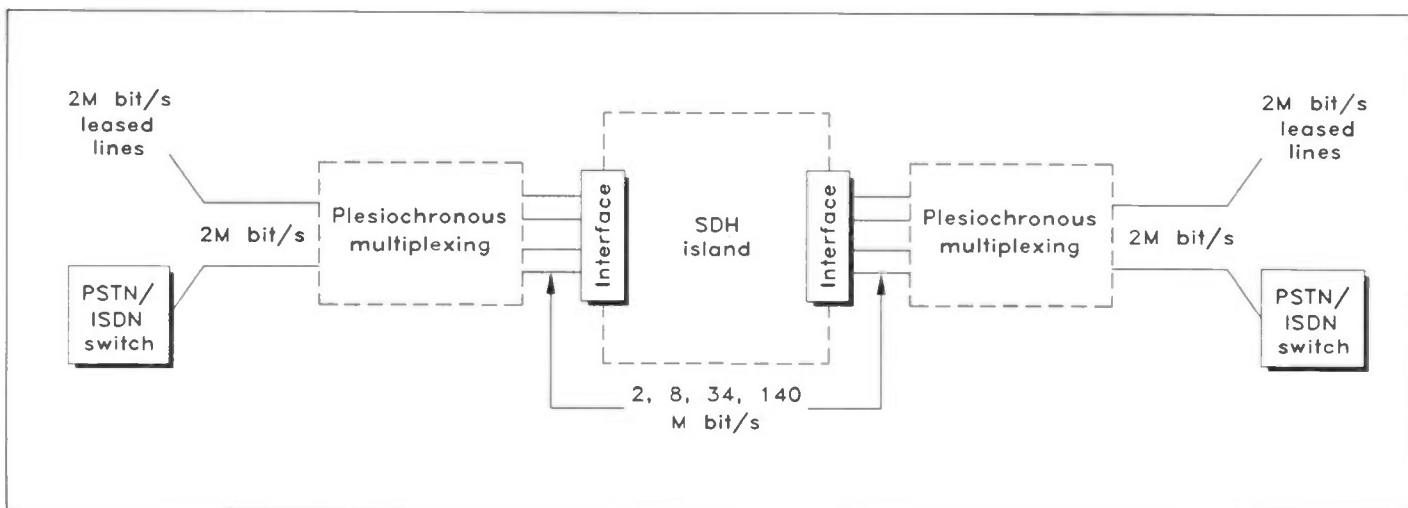

Figure 8. Early introduction supporting all plesiochronously multiplexed rates.

server network, as discussed under approach 2 above, and those where it is a client network only. There are occasions when PDH network layers such as 8 and 34M-bit/s are client networks only (such is the case when these rates are offered as service rates) and they will therefore be required to be supported transparently in the SDH island. In such cases the client PDH rate will be mapped into an appropriately sized server VC.

Although Approach 1 demands a more rigorous examination of client network requirements prior to deployment, it is considered that it has a greater degree of future proofing than Approach 2. For this reason, network operators in Europe envisage adopting the principles of Approach 1. Moreover these principles are reflected in an emerging CCITT draft recommendation on SDH network aspects.

BT considers that in the long term ATM should enable the decoupling of service bit rates from transport rates, and thereby offer the flexibility to meet the uncertain service needs of the future. Within transmission networks, ATM signals will be mapped into the various transport rates that are available. For example, with SDH, ATM signals will generally be mapped into the VC for transmission between ATM switches and terminals.

However, in the pre-ATM environment it will be possible for SDH based networks

to support a range of intermediate rates, e.g. television encoded into 34 or 45M-bit/s. With agreement in the CCITT on the standards of the ATM cell and the broadband ISDN user/network interface (CCITT Recommendations I.361 and I.432), there is the possibility of an early introduction of a LAN interconnect service, using the user/network interface as the customer interface, with full cells mapped into concatenated lower-order VCs.

This concept offers a smooth migration to broadband ISDN for business users, initially with a point-to-point LAN interconnect service, and subsequently, as ATM switches emerge in the network, with full broadband ISDN services. It is considered within BT that this concept could prove an attractive national and, importantly, international service.

This demonstrates that an introductory deployment strategy optimised for the most important existing client networks (i.e., 2 and 140M-bit/s) not only safeguards existing service categories but it also provides a high degree of future proofing for the uncertain demands of future service categories and offers a migratory route to broadband ISDN capability.

In Europe our networks are well advanced. The US however needs high quality data communications facilities. The US wants a high-speed data network in a metropolitan environment. The Europeans

see that sort of need as not so relevant at the moment. They do not want a data only service – they want an ATM solution that allows a variety of services. In summary, the US wants separate networks. In Europe we want one pipe for the lot.

As regards standards, commercial realism has crept in within the last year or two. Standards are important to a company's bottom line. There is no lock-in to a single supplier, and there's no lock-in to a dominant supplier. Companies want purchasing power to get the best deal. It is a customer driven requirement. Therefore standards are important to the bottom line. Chief executives must realise the importance of standards.

We are building things to an architectural framework. Networks have got to be built like this. We link in what is present and what is suitable for the future. Things that have to be borne in mind include such as how do we structure network management, network support, etc., to run commercial services. To support chosen architectures there has to be a range of standards that are mature or are maturing.

Network management problems increase as the network complexity increases, in proportion to the multiplication of added networks, links, applications and resources. But the enterprise network without management is a ticking time-bomb.

# WAVEFORM GENERATOR CIRCUITS

Part 1 by Ray Marston

Ray Marston takes an in-depth look at modern waveform generator circuits.

A wide variety of waveform types are used in modern electronics, and the most basic of these is the sine wave. Sine waves can be produced directly from suitable C-R or L-C oscillators, or can be synthesised with special waveform generator ICs and such. The opening part of this series, concentrates on the two most popular low frequency sine wave generators, the Wien bridge and Twin-T oscillator types.

## Oscillator Basics

Two basic requirements must be satisfied to make a simple sine wave oscillator, as shown in Figure 1. first, the output of an amplifier (A1) must be fed back to its input via a frequency selective network (A2) in such a way that the sum of the amplifier and feedback network phase shifts equals zero degrees at the desired oscillation frequency, i.e., so that  $x^\circ + y^\circ = 0^\circ$ . The second requirement is that the gain of the amplifier must exactly counter the feedback network at the desired oscillation frequency, to give an overall system gain of exactly unity, e.g.  $A_1 \times A_2 = 1$ . If the system gain is less than unity the circuit will not oscillate, and if greater than unity the system will be over-driven and will produce distorted (non-sinusoidal) waveforms.

The frequency selective feedback network used in a sine wave oscillator usually consists of either a C-R (Capacitance-Resistor) or an L-C (Inductor-Capacitor) filter network. C-R networks are generally used at frequencies ranging from a few Hz to about 150kHz; L-C networks are generally used at frequencies ranging from 50kHz upwards; naturally, there is some overlap between these general frequency limits. Regarding C-R based sine wave oscillators, the two most widely used types of frequency selective C-R networks used in modern circuits are the Wien bridge and the Twin-T types;

the once popular 'phase shift' type of oscillator is now obsolescent and rarely used.

## Wien Bridge Oscillator Basics

The best and easiest way of making an R-C based sine wave oscillator is to combine an amplifier and a frequency selective Wien network in the basic configuration shown in Figure 2, in which the Wien network (formed by R1-C1 and

R2-C2) is symmetrical, so that  $C_1 = C_2 = C$ , and  $R_1 = R_2 = R$ . The main feature of this Wien network is that the phase relationship of its output and input signals varies from  $-90^\circ$  to  $+90^\circ$ , and is precisely  $0^\circ$  at a centre frequency of  $1/2\pi CR$ ; at this frequency the network has a voltage 'gain' of  $\times 0.33$ . Thus, in Figure 2 the Wien network is connected between the output and input of a non-inverting amplifier with a voltage gain of  $\times 3$ , so that the circuit gives zero overall phase shift and unity loop gain at ( $f_0$ ), and thus satisfies the basic requirements for sine wave oscillation.

The above is, inevitably, a somewhat simplified explanation of the circuit operation. In reality the Wien network is, because of working component tolerances, rarely precisely symmetrical, and its 'gain' may thus deviate considerably from the ideal  $\times 0.33$  value. To compensate for this and enable the oscillator's loop gain to be set at unity, the amplifier's gain must be variable (either manually or automatically) between  $\times 3$  and (say)  $\times 5$ . Also, the loop gain must initially be slightly greater than unity to start off the oscillation process, but must then be reduced either manually or automatically) to the unity value necessary for low distortion sine wave generation.

Another complication arises from the nature of the amplifier's output stage. If this is a simple emitter follower it may not be capable of providing a low distortion drive to the Wien network. This point can be understood with the aid of Figure 3a, which shows a sine wave driven, NPN transistor emitter follower stage, TR1, itself driving the input of a Wien network, which is represented by C1 and ZL. On positive going half-cycles the forward

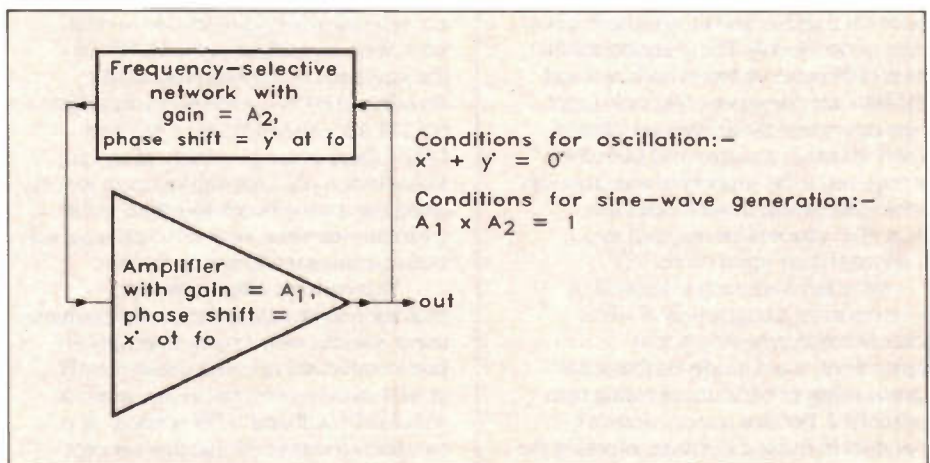

Figure 1. Basic circuit and conditions needed for sine wave generation.

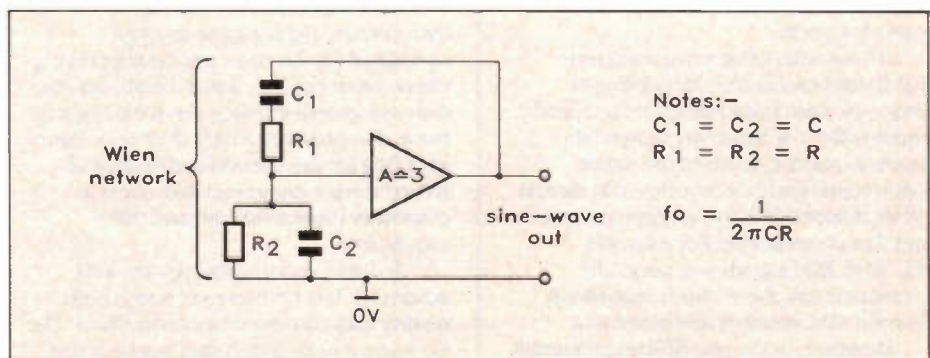

Figure 2. Basic Wien bridge sine wave oscillator.

currents of  $C_1$  and  $Z_L$  are sourced (supplied) by TR1, but on the negative going ones their reverse currents are sunk (absorbed) by  $R_L$ . If  $R_L$  is large relative to  $Z_L$ , the reverse currents of  $C_1$  and  $Z_L$  may be too limited to enable the  $Z_L$  voltage to correctly 'follow' the negative going half-cycles, with the consequent distortion shown in the diagram.

A similar kind of distortion may occur if the amplifier's output stage takes the form of a common emitter amplifier, as shown in Figure 3b, but in this case the distortion that occurs if  $R_L$  is large relative to  $Z_L$  appears on the rising parts of the output waveform, since the  $C_1$ - $Z_L$  source currents flow via  $R_L$ , and the sink ones flow via TR1. Note that these 'distortion' problems do not occur if the amplifier's output takes the form of a complementary emitter follower, since such a circuit can source or sink high output currents with equal ease.

## Transistor Oscillator Circuits

Figure 4 shows the practical circuit of a simple transistor based, 1kHz Wien oscillator that consumes 1.8mA from a 9V supply and has an output amplitude that is fully variable up to 6V Pk-to-Pk via RV2. The circuit operates as follows:

TR1 and TR2 are a direct coupled, complementary feedback pair of common emitter amplifiers, giving a very high input impedance to TR1 base, a low output impedance from TR2 collector, and a non-inverted DC voltage gain of  $\times 5.5 (= \{RV1 + R5\}R5)$  and an AC voltage gain that is variable from unity to  $\times 5.5$  via RV1. TR2's collector load impedance (formed by RV1, RV2, and R5) is about 5k. The red LED is driven via R3, and is used to generate a stable, low impedance, 1.5V bias source that is fed to TR1 base via R2, and thence biases TR2's output to a quiescent value of +5V. The Wien network (formed by R1-C1 and R2-C2 and connected between TR2's output and TR1's input) has an active impedance of approximately 15k and is easily driven by TR2's output. The oscillator's output amplitude is fully variable via RV2.

To set up the circuit in Figure 4, simply connect its output to a scope and adjust RV1 so that a stable and visually 'clean' waveform is generated. Under this condition the oscillation amplitude is limited only by the onset of positive peak clipping as the amplifier starts to run into saturation; this occurs at a Pk-to-Pk amplitude of about 6V, and is really a form of distortion generated, automatic gain control (AGC), and reduces the oscillator's loop gain below the critical 'unity' level as the waveform's amplitude reaches a specific peak value. If RV1 is carefully adjusted this clipping can be reduced to an almost imperceptible level, enabling good quality sinewaves, with less than 0.05% THD, to be generated.

The circuit of Figure 4 is outstandingly useful and economic in both fixed and switched frequency applications, only needing the addition of a single ended supply, provided that

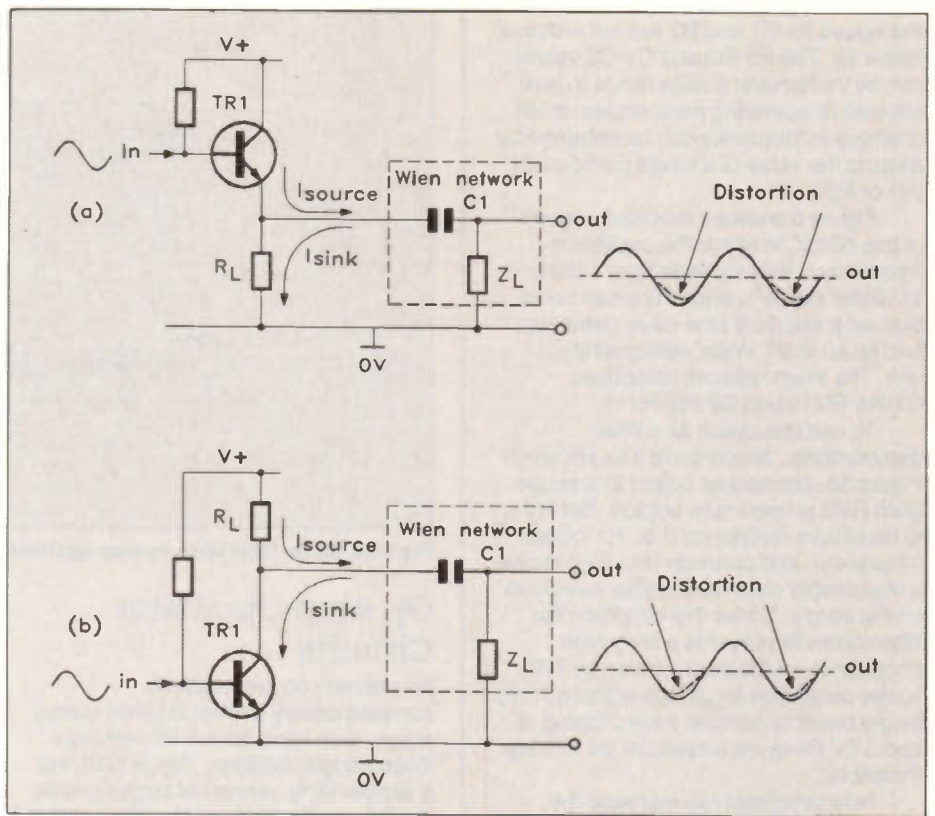

Figure 3. A simple emitter follower (a) or common emitter amplifier (b) generates a distorted output if  $R_L$  is greater than  $Z_L$ .

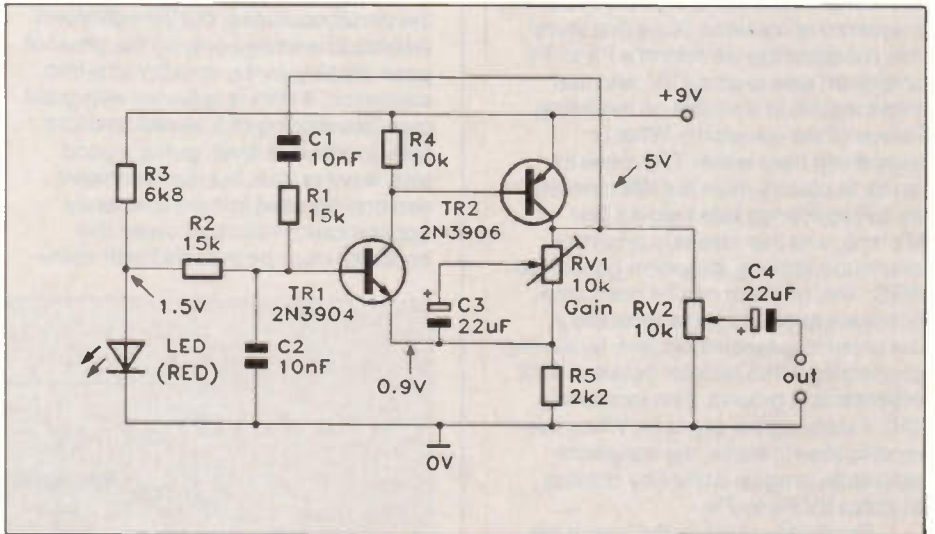

Figure 4. 1kHz Wien bridge sine wave generator with variable amplitude output.

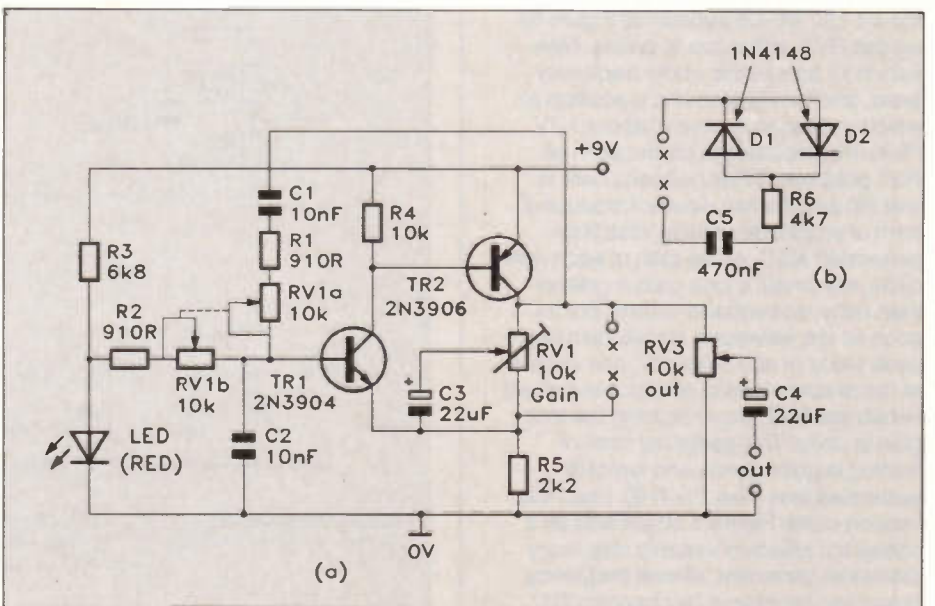

Figure 5. Variable frequency (1.5kHz to 15kHz) Wien demonstration unit.

the values for R1 and R2 are not reduced below 5k. The R1-R2 and C1-C2 values can be varied over a wide range to give alternative operating frequencies; small changes in frequency can be obtained by altering the value of a single component (R1 or R2).

Figure 5 shows a modified version of this circuit, in which the oscillation frequency is fully variable from 1.5kHz to 15kHz via RV1, and which can serve both as a practical sine wave generator and as an ideal 'Wien' demonstration unit. The Wien network comprises C1-R1-RV1a and C2-R2-RV1b.

To use this circuit as a Wien demonstrator, simply build it as shown in Figure 5a, connect its output to a scope (with RV3 at maximum output). Set RV1 to maximum resistance (i.e., for lowest frequency), and carefully trim RV2 to give a reasonably clean and stable waveform on the scope. Under this condition the Wien network presents a fairly high impedance and is easily driven by TR2, so the oscillation amplitude is limited only by the onset of positive peak clipping at about 6V Pk-to-Pk amplitude, as already described.

Now progressively increase the operating frequency by reducing RV1's resistance, retrimming RV2 as necessary to maintain oscillation, until the maximum frequency is obtained. Note that under this condition the waveform's Pk-to-Pk amplitude falls to about 3V, and that slight distortion is visible on the falling halves of the waveform. What is happening here is that TR2 loses its ability to cleanly drive the Wien network as its impedance falls below a few kilohms, and this results in a form of amplitude-limiting, distortion-generated AGC. This problem can be overcome, at the expense of a large increase in the circuit's quiescent current, by simply connecting a 1k5 resistor between TR2 collector and ground, thus increasing TR2's output drive capacity. When this modification is made, the waveform amplitude is again limited by clipping at about 6V Pk-to-Pk.

Finally, to complete the use of the demonstration unit, remove the 1k5 resistor from TR2's collector and connect the D1-D2, R6-C6 network of Figure 5b across RV2, at the two 'x' points. Now vary RV1 across the whole frequency band, and trim RV2 to find a position at which a clean sinewave of about 1.2V Pk-to-Pk amplitude is produced in all RV1 positions. What happens here is that R6 and the two diodes introduce a form of amplitude-limiting, distortion-generated AGC. At the start of each half-cycle, the circuit's loop gain is greater than unity, so oscillation starts, but as soon as the waveform amplitude nears a peak value of about 600mV, one or other of the diodes starts to conduct and shunt R6 across RV2, thus reducing the loop gain to unity. This particular form of limiting is quite gentle and typically generates less than 1% THD. Thus this version of the Figure 5 circuit acts as a cheap but effective variable frequency sinewave generator, whose frequency range can be altered by changing C1 and C2.

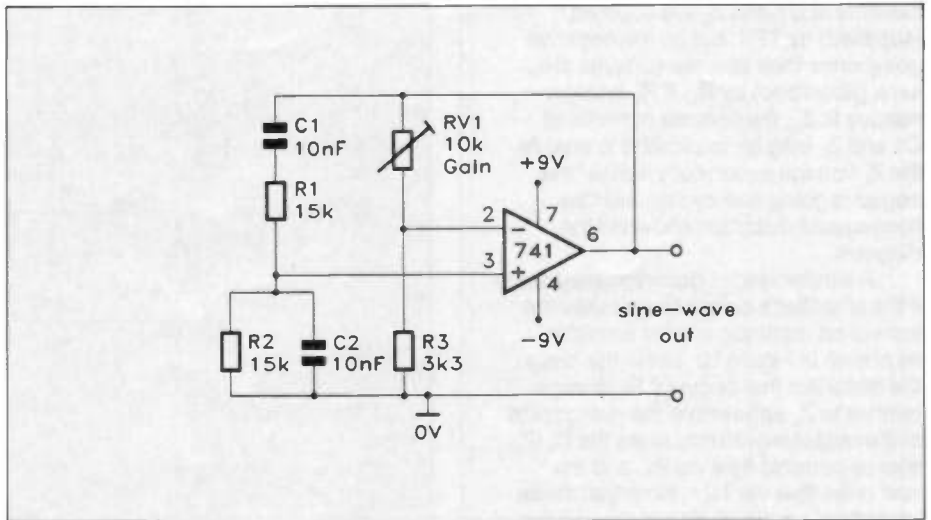

Figure 6. Basic 1kHz Wien op amp oscillator.

## Op Amp Oscillator Circuits

An ordinary op amp, with its complementary emitter follower output stage, is an ideal device for making a Wien bridge oscillator. Figure 6 shows a simple 1kHz version of such a circuit. C1-R1 and C2-R2 form the Wien network, and RV1-R3 control the op amp's closed loop gain. When RV1 is suitably adjusted the circuit oscillates, but the waveform amplitude is limited only by the onset of peak clipping as the op amp runs into saturation. If RV1 is adjusted with great care this clipping can be reduced to a fairly innocuous level, giving a good sine wave output, but this technique can only be used in fixed frequency applications; in all other cases the oscillator must be provided with some

form of AGC, to give amplitude limiting with minimal distortion. Figures 7 to 11 show practical examples of various types of AGC system.

Figure 7 shows three basic ways of regulating the waveform amplitude by using diodes to provide distortion generated AGC, as described earlier. The simple 1N4148 diode regulator is the cheapest system, but (at low distortion levels) gives a Pk-to-Pk output of only 1V. The LED and Zener regulators both give excellent results, and deliver Pk-to-Pk outputs of about 4 and 6V respectively. When using these circuits, simply adjust RV2 to the minimum setting that gives sustained oscillation across the whole frequency band. If the Wien components are well matched, THD may be less than 0.5% under this condition.

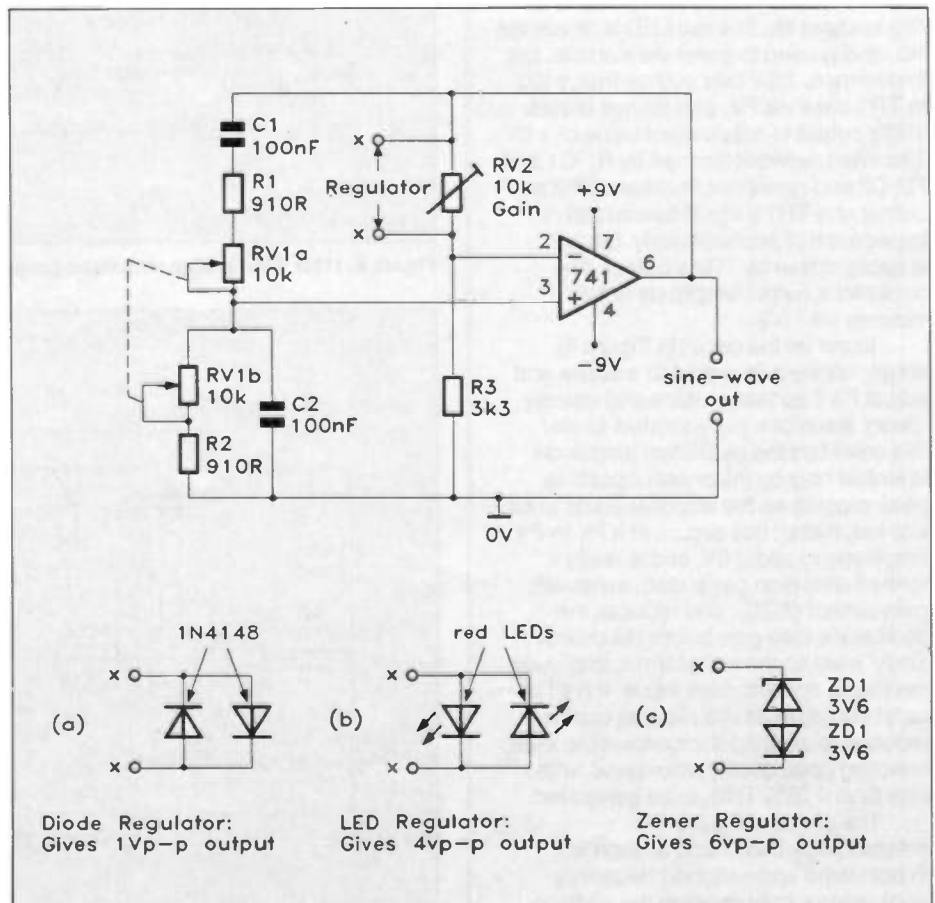

Figure 7. 150Hz to 1.5kHz Wien oscillator, with three alternative types of regulator.

Figure 8 shows a 'diode' regulator variation that gives excellent results in fixed frequency applications. Here, the Wien-plus-regulator feedback loop is taken from the junction of R4 and R5, rather than directly from the op amp output, and this simple modification effectively amplifies the diode regulation voltage by a factor of  $(R4+R5)/R5$ , to give an output of about 6V Pk-to-Pk in this case. If RV1 is adjusted with care, THD levels of 0.1% can be achieved.

## Linear AGC Circuits

The oscillators of Figures 6 to 8 rely on the use of distortion generated AGC to control waveform amplitude, and such circuits have the great advantage of maintaining a constant and judder free amplitude as the frequency is swept up and down the available band. There is an alternative control technique that uses automatic 'linear' gain control. Such oscillators usually generate negligible distortion, but suffer from amplitude 'bounce' when the frequency is swept up and down the available band, as the AGC system 'hunts' for the correct gain value. Figure 9 to 11 show three practical circuits of the latter type.

In the 1kHz oscillator circuit of Figure 9, the output amplitude is stabilised by an RA53 (or similar) Negative-Temperature-Coefficient (NTC) thermistor with a fairly long thermal time constant. TH1 and RV1 form a gain-determining feedback network where TH1 is heated by the output signal's mean power output level, and at the desired amplitude has a resistance value double that of RV1, thus giving the circuit an overall gain of unity. If the output amplitude starts to rise, the temperature of TH1 rises and its resistance falls and thus reduces the gain and restores the original output level; the reverse action occurs if the output starts to fall, and the original output level is again restored. This circuit generates negligible distortion, but the RA53 thermistor is rather expensive.

Figure 10 shows an alternative method of stabilisation, in which a low current lamp is used as a Positive-Temperature-Coefficient (PTC) thermistor, and is placed in the lower part of the gain-determining feedback network. Thus, if the output amplitude increases, the lamp heats up and increases its resistance, thereby reducing the circuit gain and providing automatic amplitude stabilisation. This type of circuit is very popular in the USA.

The above two circuits rely on the heating effect of the oscillator signal, and thus draw fairly high operating currents. Figure 11 shows an alternative system that consumes only a few milliamperes; this circuit uses JFET TR1 as a variable resistance that is voltage controlled via the oscillator's negative peak amplitude (detected via R5, D1, C3 and R4). The JFET's drain-to-source path acts as a low resistance when its gate is biased to zero volts, and as a near infinite resistance when the gate is biased to a negative 'pinch off' value of a few volts. When RV2 is suitably adjusted, the circuit oscillates and generates a low

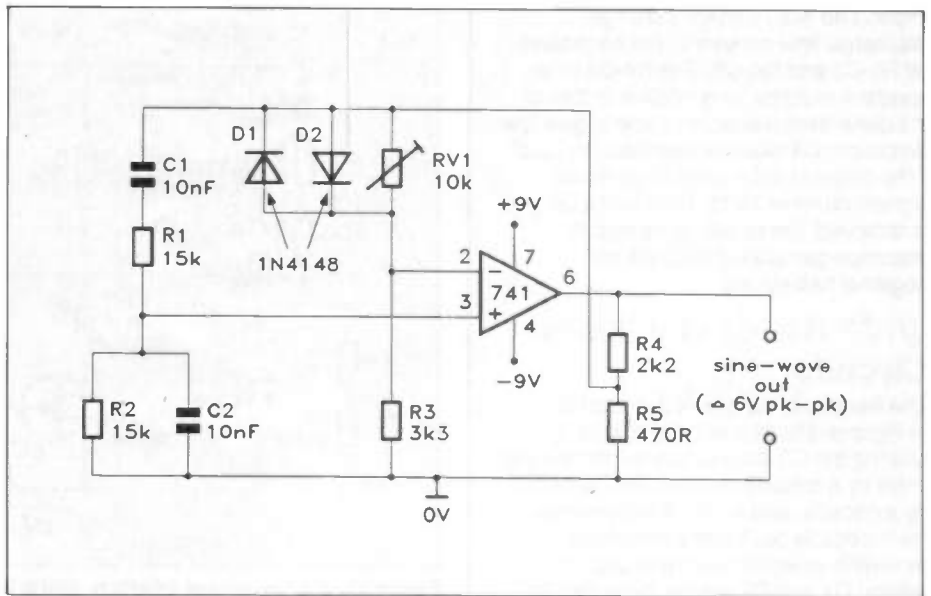

Figure 8. 1kHz Wien oscillator with amplified diode regulator.

distortion output with a Pk-to-Pk value of 'x' volts. If the output tries to rise above this 'x' value, the detected change automatically increases TR1's resistance value and thus reduces the op amp's gain, so countering the attempted rise in output. If the output tries to fall below the 'x' value the reverse action takes place, and the gain increases to maintain a constant output level.

To use the circuit of Figure 11, simply connect its output to a scope and

adjust RV2 to the lowest setting that gives stable oscillation without visible distortion over the whole frequency band. If the Wien components are well matched, THD may be well below 0.1% at 1kHz. The output signal amplitude depends on the 'pinch off' characteristics of the individual 2N3819 JFET, but is typically in the range 2.5V to 7V Pk-to-Pk. If desired, the level can be preset to 8V Pk-to-Pk by wiring a 10k pot across the op amp output and feeding R5 from its

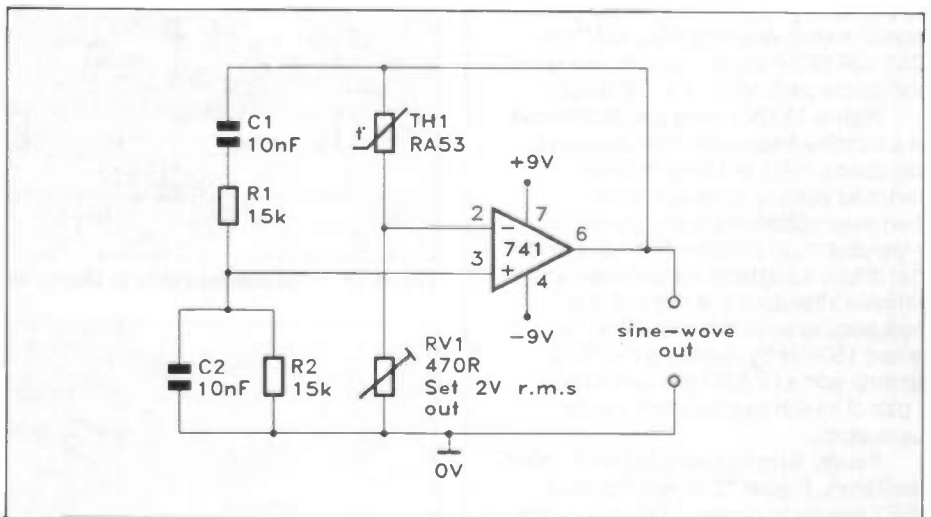

Figure 9. Low-distortion thermistor regulated 1kHz oscillator.

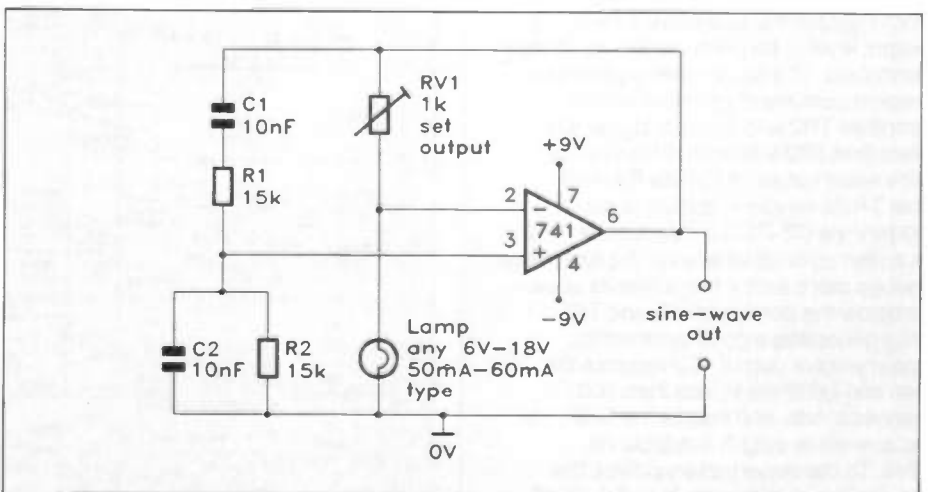

Figure 10. Low-distortion lamp regulated 1kHz oscillator.

slider. The AGC system's charge/discharge time constants are controlled by R5-C3 and R4-C3. The R4-C3 time constant must be long relative to that of the generated waveform cycle to give low distortion; C3 must be increased to  $2\mu\text{F}$  if the circuit is to be used to generate signals down to 15Hz. Note that if C3 is removed, the circuit gives simple distortion-generated AGC via the negative half-cycles.

## Wide-Range Oscillator Circuits

The frequency ranges of the circuits of Figures 6 to 11 can be changed by altering the C1 and C2 values. Increasing them by a decade reduces the frequency by a decade, and so on. A wide-range, multi-decade oscillator can be built by switch selecting alternate decade related C1 and C2 values. Note that the maximum useful operating frequency of this type of circuit is restricted by the slew rate limitations of the op amp; the useful limit is about 20kHz with a 741 op amp, 80kHz with a 741S, 120kHz with an LF355, and 250kHz with a LF356.

When building variable frequency Wien oscillators, note that the two tracks of the frequency control pot RV1 must be well matched if a good, low distortion and stable amplitude performance is to be obtained. In multi-decade oscillators the 'C1' and 'C2' values should ideally all be closely matched on all ranges; if these components are not well matched it may be necessary to provide each range with its own switch selected AGC 'GAIN' or 'DISTORTION' control, to ensure a good and stable performance on all ranges.

Figure 12 shows the practical circuit of a variable frequency Wien oscillator that spans 15Hz to 15kHz in three switched decade ranges. It uses thermistor stabilisation and generates a low-distortion output with an amplitude that is fully adjustable via switched and variable attenuators. If desired, the frequency span of this circuit can be raised 150kHz by replacing the 741S op amp with a LF356 type and adding a pair of switch selected 1nF 'range' capacitors.

Finally, to complete this look at Wien oscillators, Figure 13 shows the basic JFET regulated circuit of Figure 11, now modified to make a low-cost sine/square generator that spans 15Hz to 150kHz. RV3 enables the sine wave's Pk-to-Pk output level to be preset to 8V, as already described. The square-wave generator section consists of common emitter amplifier TR2 and Schmitt trigger IC2. Note that TR2's base is driven by the sine wave output of IC1 via R9, and that TR2's emitter is biased to about -600mV via D2-R11; consequently, TR2 is driven on or off whenever the sine wave swings more than a few millivolts above or below the zero volts rail, and TR2 thus generates a good symmetrical square-wave output. IC2 reduces the rise and fall times to less than 100 nanoseconds, and makes the final square-wave output available via RV5. To conserve battery power, the square-wave generator is switched off (via SW3c and SW3d) when not in use.

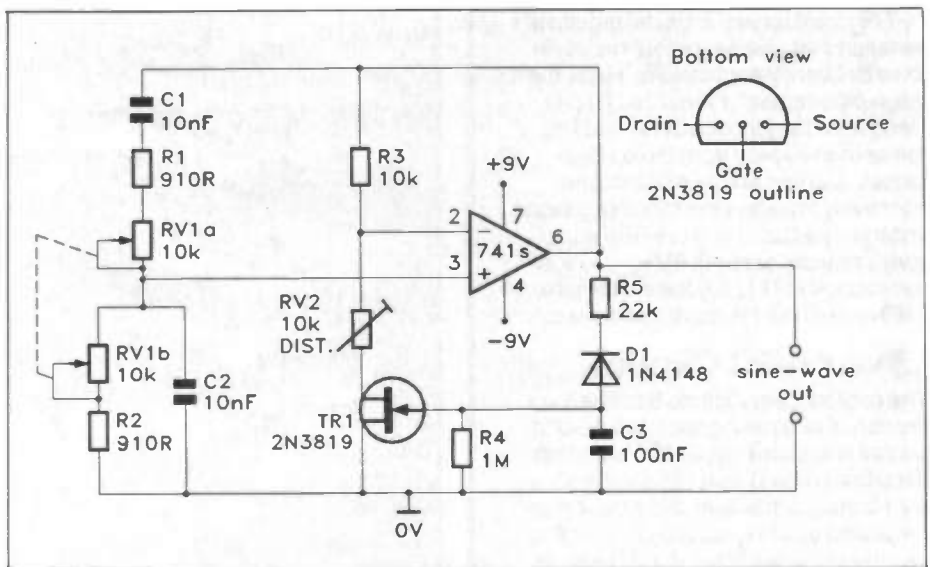

Figure 11. JFET regulated 1-5kHz to 15kHz Wien oscillator.

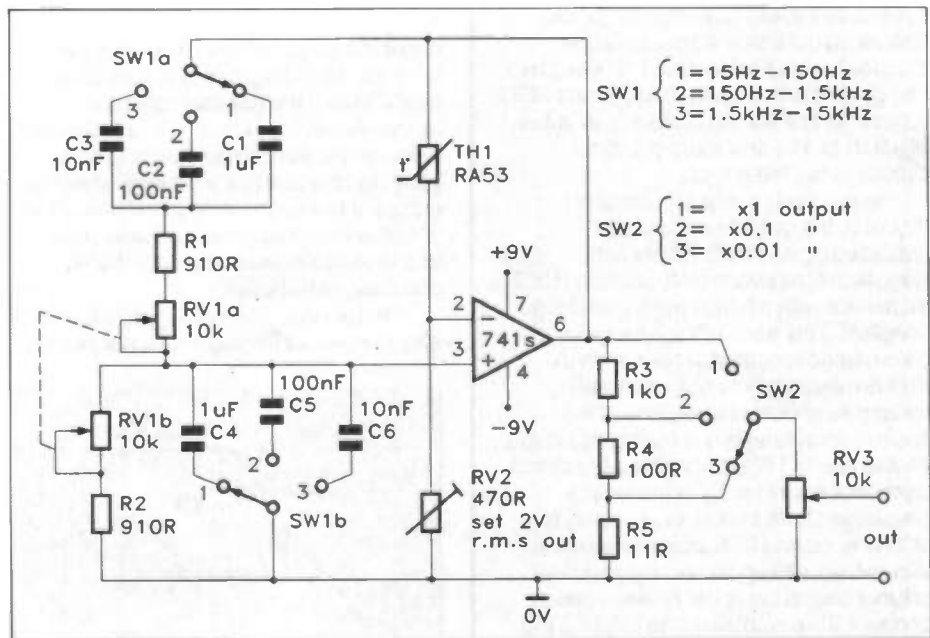

Figure 12. Three decade (15Hz to 15kHz) Wien oscillator.

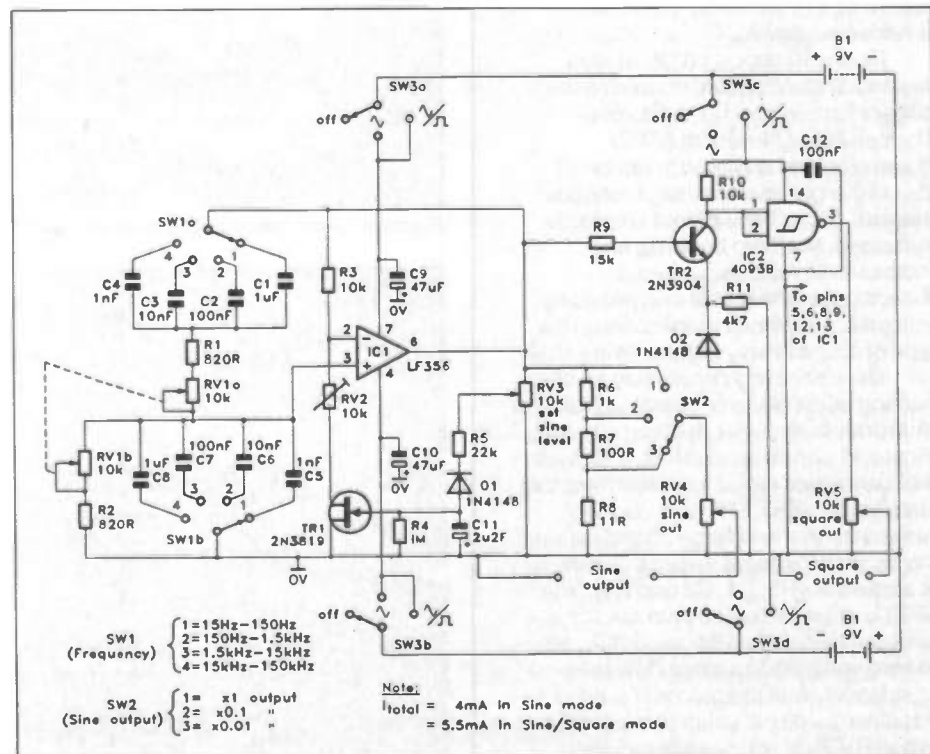

Figure 13. This excellent low-cost sine/square generator spans 15Hz to 150kHz.







# **Maplin** ELECTRONICS

Subscriptions: Maplin Electronics, Freepost, P.O. Box 3, Rayleigh, Essex SS6 2BR.  
Telephone: Sales (0702) 554161 · Enquiries (0702) 552911 · Fax: (0702) 553935 · Telex: 995695.

## **IMPORTANT ANNOUNCEMENT FROM THE EDITOR**

Dear 'Electronics' Reader,

Would you like to have the opportunity to SAVE £££'s whenever you purchase kits, components or other goods from Maplin? If so, then read on!

### **The Club!**

Next month sees the launch of the 'Electronics - The Maplin Magazine Subscribers' Club'. The main benefit of being a member is that you will receive an EXCLUSIVE 5% DISCOUNT CLUB CARD for your personal use. This is the key to obtaining discount from Maplin. You will also be eligible for Subscribers' Club special offers and promotions. Plus of course, you will also benefit from having Britain's Best Selling Electronics Magazine delivered straight to your door FREE OF CHARGE - before it's available in the shops! It still costs less to subscribe than to buy each issue separately!

### **The Good News!**

The good news is, if you are already a subscriber to 'Electronics', you will automatically become a member of the club! If you are not a subscriber, then simply complete the form opposite to receive your copies of 'Electronics' and join The Club - don't delay join today!

### **The Card**

As an ELECTRONICS SUBSCRIBERS' CLUB MEMBER, you will receive your own personal EXCLUSIVE 5% DISCOUNT CARD with next month's issue of 'Electronics'. Whenever you place an order for £20 or more at a Maplin Store, by post, telephone or Cashtel, you will be able to BENEFIT from an EXCLUSIVE 5% DISCOUNT. Naturally there are a few exclusions to the 5% discount; such as postal/handling charges and any products that are already discounted, but I'm sure you will find plenty of other items that you will want to save money on! Full details on how to make the most of your discount card are supplied with the card.

Yours faithfully,



**Robert Ball**  
Editor

**What magazine offers you these benefits?  
'Electronics - The Maplin Magazine' of course!**

Ideal for  
beginners —  
No soldering  
required.

All  
You Need  
to Build Your Own

**FUN**

**TRONICS**  
**PROJECT**  
**No10**

**B**earing in mind that this is the last 'Funtronics' feature in 'Electronics', at least for the time being, we thought that we would save possibly the most enjoyable project till the end! We will not claim that this simple electronic instrument will sound as good as the latest synthesiser or electronic organ, but it does not cost hundreds of pounds either. It uses a stylus type 'keyboard'; in other words, you hold a stylus (prod) and play notes by touching it onto the 'keys', which are actually just screw terminals. Although the instrument has a seemingly limited range of ten notes (from A to the C in the next octave up, with no sharps or flats), it is enough to let you play a range of simple tunes. The unit is 'monophonic'; this means that it can only play one note at a time (which is all that stylus operation permits anyway!).

### How it Works

The full circuit diagram for the Music Maker appears in Figure 1. Essentially, it is just an astable multivibrator, much like the ones used in the Code Communicator (Project No.9) and several of the other 'Funtronics' projects. In this case, the unit must oscillate at several different frequencies, so as to provide a reasonable range

# MUSIC MAKER

Text by Robert Penfold

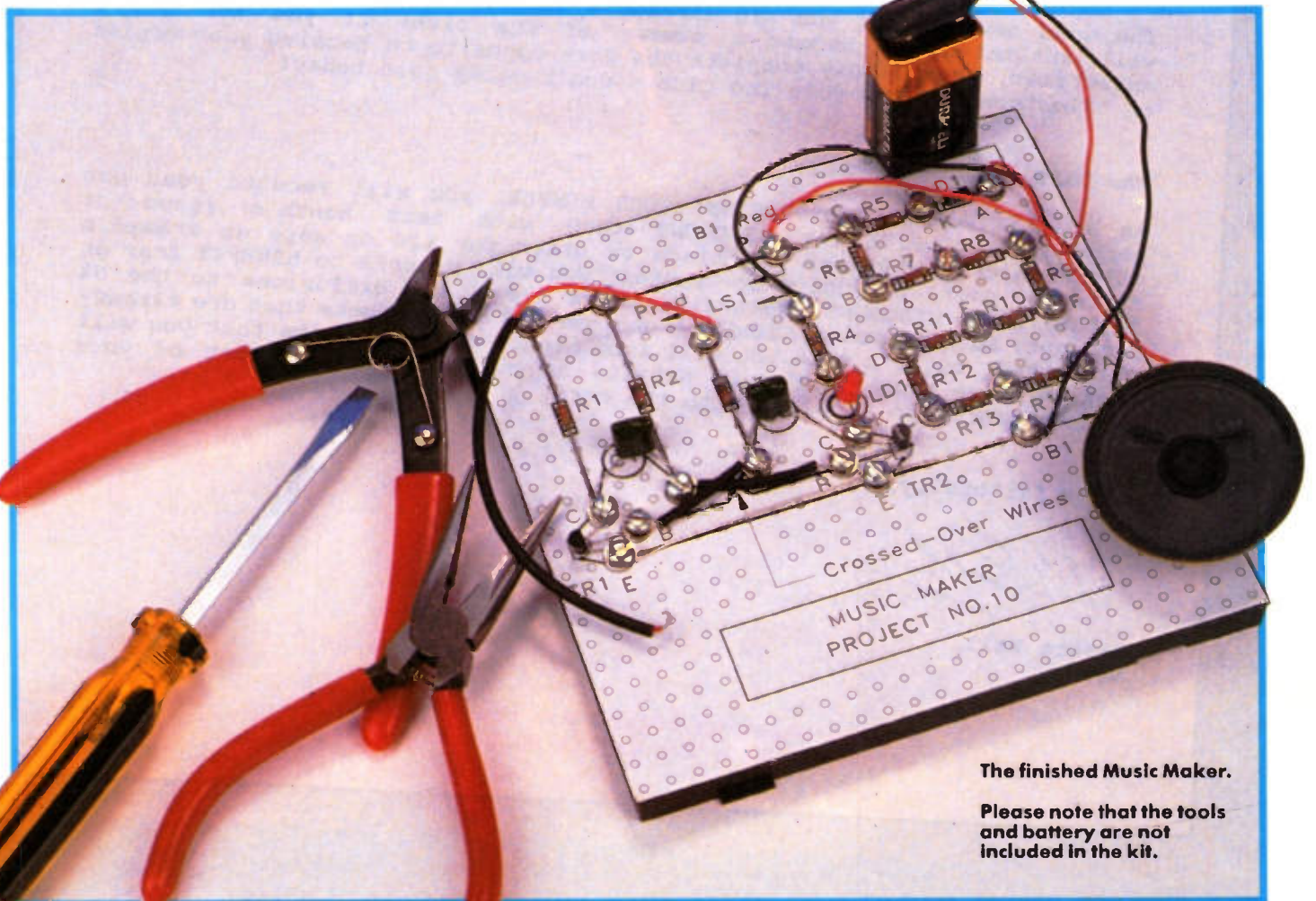

The finished Music Maker.

Please note that the tools and battery are not included in the kit.

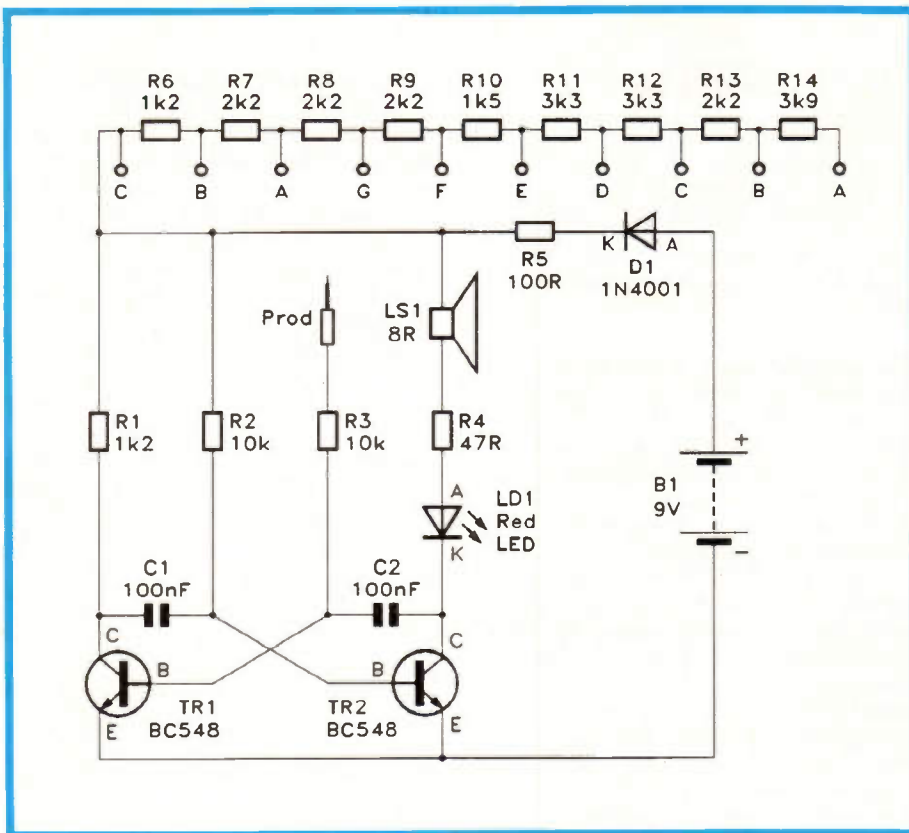

Figure 1. The Music Maker circuit diagram.

of notes. As we saw with earlier projects, the output frequency can be altered by varying the values of certain resistors and capacitors. A number of these components, each of different value, can therefore be used to provide the unit with a range of notes.

In this case, it is the value of one of the resistors that is varied in order to produce the different notes. Resistors normally cost less than capacitors, so this is generally the cheapest approach. One way of doing things would be to have a different timing resistor to produce each note. The alternative method used here is to have a chain of resistors (R6 to R14). The further

along the chain that the stylus is connected, the greater the number of resistors that are connected into the circuit. More resistors connected in this way produces a greater resistance. In terms of pitch, the further along the chain the stylus is connected, the lower the pitch of the note.

This method is better than using a different resistor for each note, in that it enables the pitch to be set a little more accurately. However, the notes will still not be absolutely 'spot on'. Resistors are not perfect, and their actual values are seldom exactly equal to their marked values, often deviating by a few percent. This will result in small

errors in the pitches of the notes. However, the accuracy of tuning should be adequate for a simple instrument of this type.

An essential feature of the circuit is that when the stylus is not connected to a 'key', one resistor of the oscillator is missing from the circuit. This ensures that the circuit does not oscillate and produce unwanted sounds when the stylus is 'between notes'.

## Getting it Together

Firstly, read through this section and then *carefully* follow its instructions, one step at a time. Refer to the photographs of the finished project if this helps.

1. Cut out the component guide-sheet provided with the kit (which is a full-size copy of Figure 2), and glue it to the top of the plastic board. Paper glue or gum should be okay. Do not soak the paper with glue, a few small 'dabs' will do.

2. Fit the link-wires to the board using the self-tapping screws and washers provided. The link-wires are made from bare wire. Loop the wire, in a *clockwise* direction around each screw to which it must connect, taking the wire under the washers. Do not fully tighten a screw until all the leads that are under it are in place, and do not over-tighten the screws, otherwise the plastic board may be damaged. Be careful not to trap the bodies of any components under washers when tightening the screws.

Just below TR1, one wire crosses over another, and it is very important that these wires do not touch together. For this reason, some of the sleeving supplied in the kit should be used to cover the bare wires.

3. Recognise and fit the components, in the order given below, using the same method as for the link wires. Cut the components' wires so that they are just long enough to loop around the screws; otherwise long leads left flapping around may touch each other (this is known as a 'short-circuit') and stop your circuit from working. This is particularly important in the sections of the board around TR1 and TR2.

## Components

a) The first components to be fitted are Resistors R1 to R14. These are small sausage-like components having a leadout wire at each end, and several coloured bands around their bodies. These coloured bands represent the value of the resistor; the resistor colour code is featured in the Constructors' Guide. For each resistor, the colours (and value) are as follows:

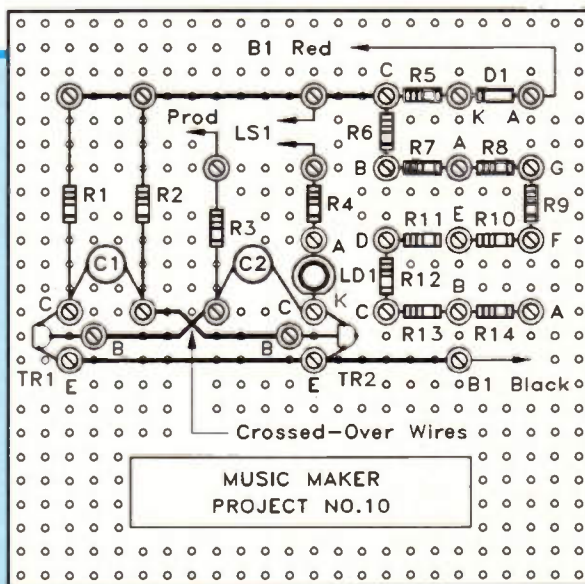

Figure 2. The component guide-sheet for the Music Maker.

Resistor	Band Colours	Value
R1,6	brown, red, red	1200Ω*
R2,3	brown, black, orange	10k
R4	violet, yellow, black	47Ω
R5	brown, black, brown	100Ω
R7,8,9,13	red, red, red	2k2
R10	brown, green, red	1k5
R11,12	orange, orange, red	3k3
R14	orange, white, red	3k9

\* (also written as 1k2)

For each resistor, there is a fourth band, coloured gold, which tells us how near to the given value the resistor is likely to be (in this case, there may be a difference of 5% or less) This fourth band is known as the 'tolerance' band, while the first three bands, shown in the above table, tell us the value of the resistor. Unlike diodes or transistors, it does not matter which way round resistors are connected.

b) Next fit the LED, LD1, which is a 'blob' of clear red plastic with two wires coming out of one end. It is fitted in the position shown on the guide-sheet, and *must* be connected the right way round – or it will not light up. One side of the LED is flattened (the lead on this side of the LED is known as the cathode (K), while the lead on the other, rounded, side is called the anode (A)). The LED, circuit symbol and connections are shown in Figure 3.

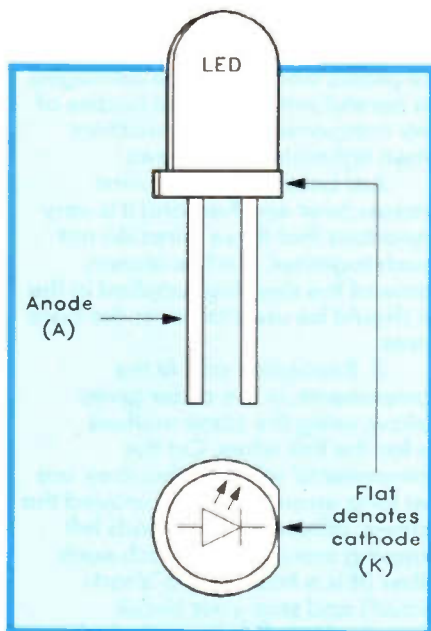

Figure 3. LED symbol and connections (LD1).

Make sure that the LED is fitted so that the 'flattened' side lines up with the drawing of the component printed on the guide-sheet.

c) The next component to be fitted is D1, which is a small tube-like component having a lead at each end of its black body. Like LD1, it must be connected the right way round (In other words, D1 is a 'polarised' component). Its 'polarity', which tells us the way in which it

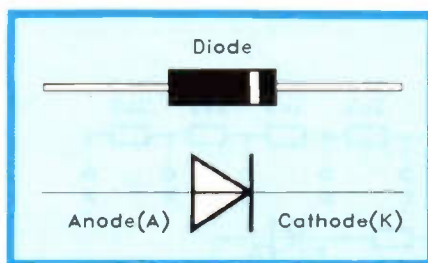

Figure 4. Diode symbol and connections (D1).

must be positioned, is indicated by a white (or silver) band close to one end of the body. D1, its circuit symbol and connections, are shown in Figure 4. The diode should be fitted so that the band lines up with the band on the drawing of the diode on the guide-sheet.

d) C1 and C2, the capacitors, look like little green blobs with two wires coming from the base. As with most capacitors (with the exception of electrolytic and tantalum bead types) it does not matter which way round they are connected. Each should have its value of 0.1 μF included amongst its markings. In most cases this will be shown as 104 (10 with 4 '0's at the end, meaning 100,000 picofarads, which represents the same value.)

e) TR1 and TR2 should be fitted to the board next; these have a small black plastic body and three leadout wires. They are marked with their type number, which in each case is 'BC548'. Other markings may also be present; you will have to get used to picking out the important markings on chips and transistors (and ignoring the others!). You must ensure that TR1 and TR2 are fitted to the board correctly. Figure 5 shows which lead is which, making this task easy.

f) The loudspeaker (LS1) is the largest (and heaviest) component supplied in the kit (except for the board, of course), and can be identified by its black paper cone, which is about 50mm (or so) across. The cone is the part of the loudspeaker that literally pumps out the sound-waves as it moves backwards and forwards. Be careful not to damage the cone, which is made from a delicate paper-like material; sticking a finger through it might not stop the speaker from working, but will not improve its performance either!

LS1 may be connected either way round; use two pieces of insulated wire to connect it to the board. Use wire strippers to remove about ten millimetres of insulation from both ends of each lead. Connect the wires to the tags on the loudspeaker first. The wire is multi-stranded, which means that the metal core consists of several very fine wires. The bare ends of the leads should be twisted together to prevent the wires from splaying apart and breaking off – in addition to making them easier to deal

with. Thread each multi-strand wire through the hole in the corresponding tag, loop it back on itself, and then twist it tightly to make a reliable connection. It is a good idea to use some glue, or a lump of 'Blu-Tack', to fix the rear of the loudspeaker to a vacant area of the board; it is *not* a good idea to leave a delicate component such as this simply hanging loose from the board!

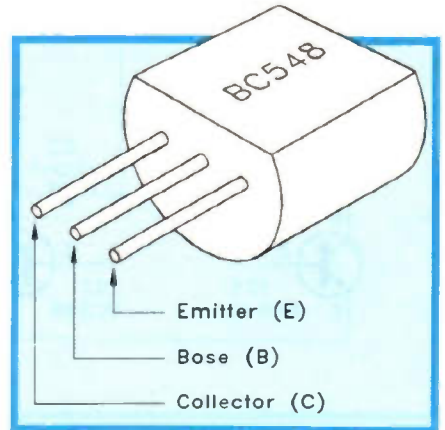

Figure 5. BC548 transistor circuit symbols and lead identification (TR1,2).

g) The probe is made up from a piece of insulated multi-strand wire (coloured red) and a piece of hollow insulated sleeving (also coloured red). The probe should be made up as shown in Figure 6, use wire strippers to remove the insulation where shown. Again, the bare ends of the lead should be twisted together to prevent the wires from splaying apart. Slide the red sleeving over the red wire, and then connect it to the screw on the board marked 'Probe' – this screw can be found at the free end of R3. The free end of the wire is pressed against one of the relevant screws

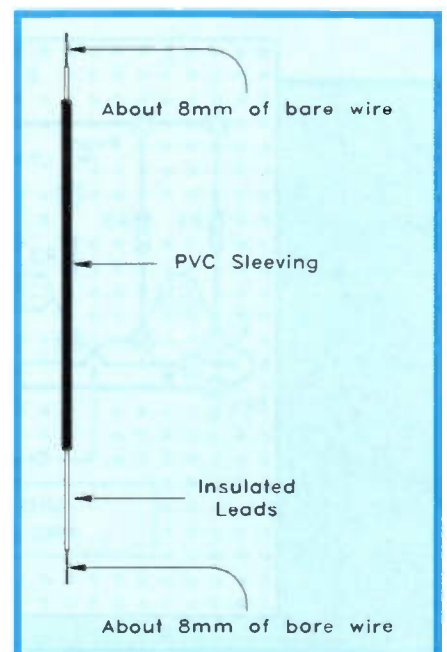

Figure 6. Preparing the probes.

to produce the corresponding musical note; the sleeving acts as the 'body' of the probe.

h) Lastly, fit the battery connector and battery, B1; the connector must be attached to the board with its coloured leads the correct way round. The battery connector has two press-stud clips on a piece of plastic and two wires coming from it, coloured red and black. The red and black leads should be connected as shown on the guide sheet. The 9V PP3 type battery should be connected to the battery connector, it will only fit properly one way round.

## Testing and Use

When the battery is connected there should be no sound from the loudspeaker, and D1 should not light up. Touching the stylus onto one of the 'keys' should produce a note, and D1 should light up quite brightly. Touching the end of the stylus onto different 'keys' should

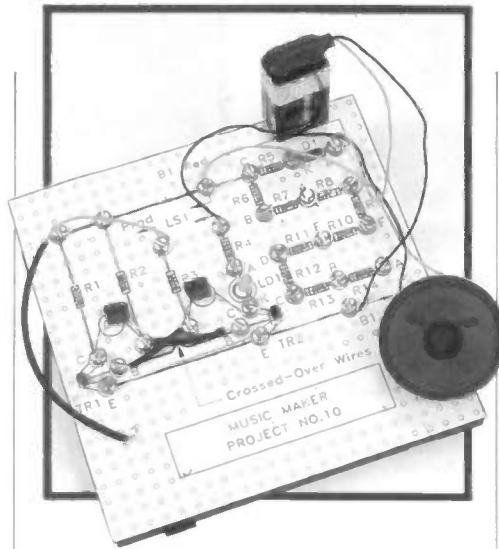

produce a noticeable (unless you are tone deaf!) change in the pitch. The name of the note produced by touching an individual 'key' is shown next to it. If the unit does not function properly, disconnect the battery at once. Recheck the wiring, paying particular attention

to TR1, TR2, D1, and D2. If the high notes work but some of the lower ones do not, there is a bad connection in the chain of resistors (R6 to R14).

If you are reasonably musical, you should soon manage to pick out a few simple tunes playing 'by ear'. Try to work out this simple tune:

CCGGAAG FFEEDDC GGFFEEED  
GGFFEEED CCGGAAG FFEEDDC

The relative pitch of the instrument should be quite good, but the pitch might not be so good in absolute terms. In other words, if you use it to play along with other instruments, it might not be accurately in tune with them.

## Availability

The Funtronics Music Maker is available from Maplin Electronics, through our chain of regional stores, or by mail order, **Order Code LT09K Price £3.95.**

Waveform Generator Circuits continued from page 36.

## Twin-T Oscillators

It was mentioned earlier that another popular design of C-R based sine wave oscillator is the Twin-T type. This circuit is useful in fixed frequency applications, and can be made by wiring a Twin-T network between the output and input of an inverting op amp, as shown in Figure 14. The Twin-T network comprises R1-R2-C3 and C1-C2-RV1. In a perfectly balanced network these components are in the ratios  $R1=R2=2(R3+RV1)$ , and  $C1=C2=C3/2$ , giving zero output at a centre frequency,  $f_0$ , of  $1/2\pi R1C1$  and a finite output at all other frequencies. If the Twin-T is imperfectly balanced it gives a slight output at  $f_0$ , and the output phase errs in the direction of the imbalance; if the imbalance is caused by  $(R3+RV1)$  being low in value, the output phase is inverted relative to the input.

In Figure 14 the Twin-T network is critically adjusted via RV1 so that it gives a small, phase-inverted output at an  $f_0$  of 1kHz. Zero overall phase inversion thus occurs around the feedback loop, and the circuit oscillates at 1kHz. In practice, RV1 is adjusted so that oscillation is barely sustained, and under this condition the sine wave amplitude is limited at about 5V rms by the onset of op amp clipping, and the output waveform has less than 1% THD, and the output amplitude is fully variable via RV2.

Figure 15 shows a simple Twin-T variant that gives slightly less distortion and uses diode D1 to provide distortion generated AGC. To set up this circuit, first set RV2 slider to the op amp output and adjust RV1 so that oscillation is just sustained, giving an output sine wave of about 500mV Pk-to-Pk. RV2 then enables the output signal to be varied between 170mV and 3V rms.

Next month, Part 2 looks at more sine wave generators, including sine wave synthesisers and L-C oscillators.

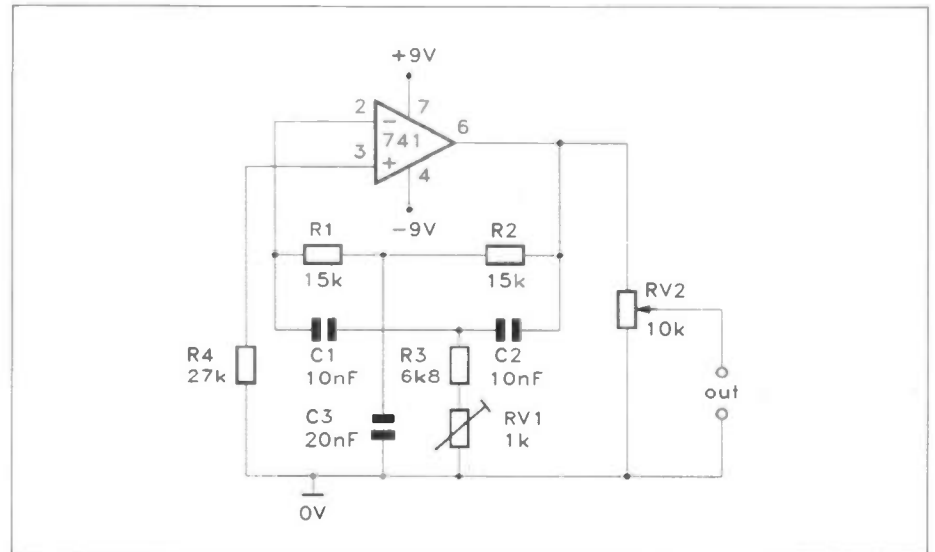

Figure 14. 1kHz Twin-T oscillator.

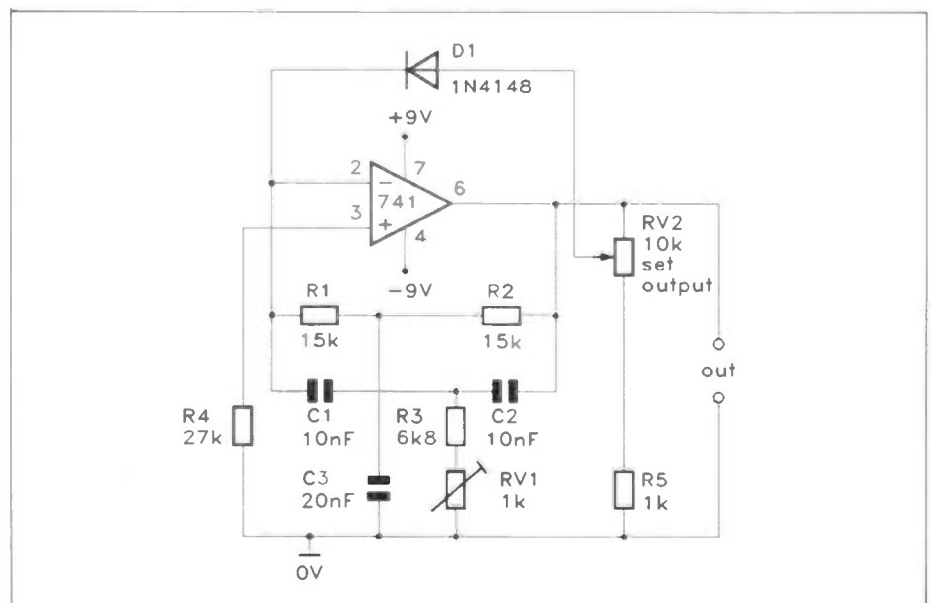

Figure 15. Diode regulated 1kHz Twin-T oscillator.

# MAPLIN'S TOP TWENTY KITS

POSITION	DESCRIPTION OF KIT	ORDER AS	PRICE	DETAILS IN	
1. (1)	MOSFET Amplifier	LP56L	£19.95	Magazine	41 (XA41U)
2. (2)	Live Wire Detector	LK63T	£ 4.25	Magazine	48 (XA48C)
3. (4)	TDA7052 Kit	LP16S	£ 4.45	Magazine	37 (XA37S)
4. (3)	L200 Data File	LP69A	£ 3.95	Magazine	46 (XA46A)
5. (5)	1300 Timer	LP30H	£ 4.95	Magazine	38 (XA38R)
6. (8)	Car Battery Monitor	LK42V	£ 7.95	Magazine	37 (XA37S)
7. (7)	Courtesy Light Extender	LP66W	£ 2.75	Magazine	44 (XA44X)
8. (10)	IBM Expansion Sys	LP12N	£18.25	Magazine	43 (XA43C)
9. (6)	Vehicle Intruder Alarm	LP65V	£ 9.95	Magazine	46 (XA46A)
10. (9)	Mini Metal Detector	LM35Q	£ 6.45	Magazine	48 (XA48C)
11. (11)	Stroboscope Kit	VE52G	£11.95	Catalogue	'92 (CA09K)
12. (15)	LM386 Power Amplifier	LM76H	£ 3.75	Magazine	29 (XA29G)
13. (12)	Low Cost Alarm	LP72P	£12.95	Magazine	45 (XA45Y)
14. (14)	TDA1514A Power Amplifier	LP43W	£16.45	Magazine	40 (XA40T)
15. (17)	MSM6322 Data File	LP58N	£11.45	Magazine	44 (XA44X)
16. (-)	TDA2822 Amplifier	LP03D	£ 6.95	Magazine	34 (XA34M)
17. (20)	SMS2016 Amplifier	LP44X	£12.75	Magazine	41 (XA41U)
18. (-)	15W Amplifier	YQ43W	£ 7.45	Catalogue	'92 (CA09K)
19. (-)	HQ Amp PSU	LP15R	£75.95	Magazine	42 (XA42V)
20. (-)	Siren Sound Generator	LM42V	£ 4.25	Magazine	26 (XA26D)

Over 150 other kits also available. All kits supplied with instructions. The descriptions are necessarily short. Please ensure you know exactly what the kit is and what it comprises before ordering, by checking the appropriate project book, magazine or catalogue mentioned in the list above.

## Maplin

Do you Enjoy your work?  
Or would you prefer to  
Work at what you enjoy?

If you are an electronics enthusiast and looking for an interesting career with a future, Maplin has the answer.

We often have vacancies for

### Branch Managers Assistant Managers and Counter Staff

New Stores opening all over the UK

These vacancies are being created as a result of the Maplin expansion programme and offer real prospects for a secure and exciting career.

Retail experience would be a great asset, and to become part of the team, you do need to be self-motivated and have a cheerful personality.

Applicants must also be smartly dressed and have a good working knowledge of electronic components.

We offer excellent working conditions and job security, a first class basic salary plus commission, pension scheme and generous staff discounts.

If you are seeking an interesting career in a High Tech Environment, then write to us

**NOW!**

Send full career details and an indication of the area you prefer to:  
The Personnel Manager,  
Maplin Electronics plc, Valley Road, Wombwell, Barnsley S73 0BS.

## COMPUTERS

**COMPLETE COMPUTER PACKAGE.** 1MB A500 External Drive, 1084 Monitor, Mouse, 1/2 Stk, Manuals, Disks including: Dpaint, Lemmings, Weltris, etc. £375 the lot. No offers. Tel: (0480) 52329 (Huntingdon).

**FERRANTI 8086 COMPUTER 20MB** hard drive, 54in floppy, CGA monitor. Needs slight attention. £90 plus p&p. Tel: (0254) 760003.

**ACNET IBM PC PROGRAM.** Analyses circuits containing components, transistors, transformers. Gives gain, phase, input, output Impedances, graphplots. £10. S.A.E. for details. Montgomery, 2 Bunby Road, Stoke Poges, Slough, SL2 4BP.

**BROTHER M2518 18-PIN PRINTER.** Wide carriage, over 300cps, colour capability. £180 Tel: Olbe (0705) 814448 (Portsmouth) after 5pm.

**DRAGON 32** Multipac Interface Cartridges Dasm/Demon, Edit+, Tapes, Sprite Magic, Rainbow Writer, MST Business, BASIC Tutorial, machine language utilities. Books: Dragon trainer, Programming Reference Guide. Offers, all or part, contact: T. R. Dowding, Tel: (0733) 840594.

**ATTENTION ALL 6502 PROGRAMMERS** Write fast, efficient and compact M/C programs easily using my Assembly Generator Compiler. Its own expandable language Implements loop structures, conditional tests, string handling, I/O, integer math etc. In 65XX machine code. Complete package runs on C64; source listings can be made available for conversion to another machine. S.A.E. for more details to Level 3, Aurora, Church Road, Laindon, Essex, SS15 5SL.

**BBC B OR 128 ACCESSORIES** all as new and complete with software and handbooks; all half original Watford prices; Wapping Editor with font and art disks. £50; Beeb Hand Scanners, £70; Quest Paint with mouse, £33; apply to Maplin Mag., P.O. Box 3, (Ref: Z003), Rayleigh, Essex, SS6 8LR.

## VARIOUS

**REALISTIC PRO 2022 SCANNER.** 200 Channels, Brand new condition, boxed, hear aircraft, police, marine, radio ham and lots more communications. If postage required, please add £15. Bargain £150 o.n.o. Tel: (0772) 39895.

# CLASSIFIED

Placing an advertisement in this section of 'Electronics' is your chance to tell the readers of Britain's Best Selling Electronics Magazine what you want to buy or sell, or tell them about your club's activities - Absolutely Free of Charge! We will publish as many advertisements as we have space for. To give a fair share of the limited space, we will print 30 words free, and thereafter the charge is 10p per word.

Placing an advertisement is easy! Simply write your advertisement clearly, in capital letters, on a post-card or sealed-down envelope. Then send it, with any necessary payment, to: Classifieds, 'Electronics - The Maplin Magazine'.

**GIANT CLEAROUT!** Long list of unused components including ICs, capacitors, resistors, some in large quantities. All at bargain prices. Send S.A.E. for list: M. J. Dean, Blenheim, Walton Lane, Bosham, Chichester, West Sussex, PO18 8QP.

**COSSOR CDU110 OSCILLOSCOPE.** 20MHz bandwidth, dual trace, delayed sweep, additional differential plug-in amp, service manual. Recently serviced and calibrated. Old but good! £100. Tel: (0753) 885403 (South Bucks.)

**MAPLIN ETI 20 CHANNEL GRAPHIC EQUALISER.** Practical Electronics 'Orion' 30-30W Hi-Fi Amplifiers. Sony ST70 AM/FM Stereo Tuner. £25 each or offers for the lot. Maplin 50W Hi-Fi Amplifier (LW35Q) & PSU with 12in. 80W Loudspeaker, £45.00. All parts for MESS3 Organ available including 49 note keyboards, 13 note pedalboard, all PCBs, Springline reverb rhythm generator etc. If they don't go soon they will be binned, therefore any reasonable offer considered!!! All items are in first class & undamaged condition. Tel: Dave Faulkner, home: (0245) 450050 or work: (0245) 353507 (Chelmsford).

P.O. Box 3, Rayleigh, Essex SS6 8LR. Advertisements will be published as soon as possible, space allowing. No responsibility is accepted for delayed publication or non-inclusion of advertisements.

Private individuals only are permitted to advertise in this section; commercial or trade advertising of any kind is strictly prohibited by law. Advertisements are only accepted by the Publisher on this proviso. Readers who have reasonable grounds to believe that they have been misled as to the nature of an advertisement are advised to contact the Publisher and their local Trading Standards Office.

**PAIR IMF PROFESSIONAL Monitor** Transmission-Line Loudspeakers, magnificent bass, large and heavy, on castors and enclosed in woodgrain formica. Delivery possible. Excellent condition. £250. Contact: John Evans Tel: (0981) 240616.

**TELEMAX 10KVA INSULATION TESTER;** Line voltage simulator; Earth circuit tester, 3M 50-Way cable terminator; 50-Way plugs Male/Female; ICs, Telephone/Dialling/Melody; Quantity components. Reasonable offer: Tel: (071) 722 3065.

## WANTED

**CIRCUIT DIAGRAM** and if possible parts list of Tandy 'Micronta variable power supply' 10 to 24V up to 1A. Tandy catalogue no. 22-9123. Not made any more. Cliff, 119 Cadie Crescent, Portmead, Swansea, Wales SA5 5HU.

**DRAGON 32 COMPUTER BOOKS,** magazine articles on upgrading, modifications, etc. Plus cartridge games, disk drives spares anything. Send full list of whatever, to Denis Ford, 169 Model Village, Creswell, Nr. Worksoop, Notts., S80 4BT.

**HELP!** Model Engineering Club member urgently requires a servicing manual for the club's Ronetronic 400 Stencil Cutter which has expired on us. Tel: (0325) 720937 (Parish). **SPARKRITE 'VOYAGER' CAR COMPUTER** instruction manual, original or photocopy. Please write to: A. Huskisson, 3 Woodhall Road, Penn, Wolverhampton, W. Mids, WV4 4DL.

**INSTRUCTION MANUAL** for Casio FX-730P personal computer (copy or loan) also any info. on peripherals. Tel: Paul, (0744) 37879.

**A3 PLOTTER,** must be HP compatible, in excellent condition, and cheap! e.g. Roland DXY 800A. Tel: Andy, (0299) 827275.

## CLUB CORNER

**ELECTRONIC ORGAN CONSTRUCTORS SOCIETY** 2.30pm, May 16, St Pancras Church Hall, Lancing St, near Euston station, all welcome. Regional meetings. Tel: (081) 902 3390. 87 Oakington Manor Drive, Wembley, Middlesex.

**TESUG** (The European Satellite User Group) for all satellite TV enthusiasts! Totally independent, TESUG provides the most up-to-date news available (through its monthly 'Footprint' newsletter, and a teletext service on the pan-European 'Super Channel'). It also provides a wide variety of help and information for its members. For further information, contact: Eric W. Wütscher, TESUG, Rio House, Stafford Close, Ashford, Kent, TN23 2TT, England.

**THE BRITISH AMATEUR ELECTRONICS CLUB** (founded in 1966), for all interested in electronics. Four newsletters a year, help for members and more! UK subscription £8 a year (junior members £4, overseas members £13.50). For further details send S.A.E. to: The Secretary, Mr. J. S. Hind, 7 Carlyle Road, West Brdglford, Nottingham NG2 7NS.

**ELECTRONIC UK** - the electronics club for the enthusiast, now welcoming new members!! News, views, competitions, projects and loads more. For more information, send S.A.E. to: Electronics UK, 48 Lancing Park, Sussex, BN15 8RF. **MODEL RAILWAY ENTHUSIAST?** How about joining 'MERG', the Model Electronic Railway Group. For more details contact Mr. Eric Turner, Treasurer MERG, 38 North Drive, Orpington, Kent, BR6 9PC.

# NEW BOOKS

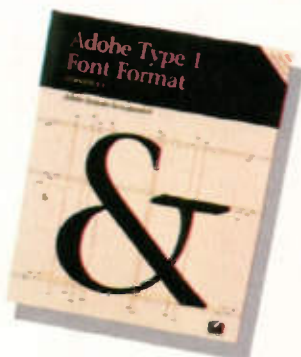

## Adobe Type 1 Font Format

Version 1.1

### Adobe Systems Incorporated

The PostScript® language has become the industry standard for imaging high quality graphics and text for all kinds of professional publications. This powerful language has the ability to efficiently describe the appearance of text, sampled images and graphics on a printed page or display. Since letters are used so frequently in the description of a page, the PostScript language has special facilities to handle collections of letter shapes conveniently and efficiently. These collections are called fonts.

Written by Adobe Systems, the inventors of the PostScript language, this is the official specification for the Type 1 font format. This new, updated version describes the syntax of the Adobe Type 1 format, including complete information regarding font and character level hints, character outline encoding, new flex procedure (V1.1), 'eexec' encryption, charstring encryption, and New Expansion Factor hint (V1.1).

Companion volumes by Adobe Systems are also available through Maplin, including the 'PostScript Language Reference Manual', a definitive guide to the language; the 'PostScript Language Tutorial and Cookbook', a practical and accessible introduction to the language and its capabilities with examples, while 'PostScript Language Program Design' is the proven guide to designing efficient PostScript programs.

American book.  
1990. 108 pages. 231 x 187mm, illustrated.

**Order As WZ15R (PostScript Font Fmt) £13.50 NV**

## CMOS Pocket Guide

Volume 2 - AD7501 - 45434

The CMOS Pocket Guide Volume 2 (special components) covers all the commonly used *Special* devices currently on the market. Being an independent publication, it is able to provide a uniquely comprehensive listing of these CMOS products from all the major manufacturers.

Data which applies to the CMOS series as a whole is not repeated for every device, but is presented in an introductory section, thereby saving a great deal of space for other vital information. Each page describes one component only and is divided into eight sections.

The first section illustrates the device schematic using a clean and simple logic diagram of the internal structure of the component within its pin-out diagram. The next section contains a brief description of the device, followed by full details on operating it, describing input signals and levels at individual pins. This indicates how the device is controlled and its resulting output signals.

The fourth section lists major applications, while the next two sections contain essential data for that particular device in abbreviated form, and a list of relevant manufacturers.



The last two sections contain the device name and number, highlighted for easy reference.

As with its forerunners, the guide extracts all the essential data from the manufacturers' own data books and presents it in a clear and concise format. Translated from the German original.

1991. 314 pages. 184 x 105mm, illustrated.

**Order As WZ41U (CMOS Guide 2) £9.95 NV**

## An Introduction to Microwaves

by F. A. Wilson

Although microwaves had been around for some time, it was not until 1947 that their use for cooking was introduced. Since then, slowly but surely, the term has become a household word, but how many users know what a microwave really is? As electronics enthusiasts, we know all about them – or do we? This book ensures that microwaves are no longer shrouded in mystery, for we can no longer afford to be indifferent to their accomplishments,



since many facets of modern society would collapse without them. Multitudes of telephone calls travel by microwave, as does television over land and by satellite; aircraft are landed safely and even wars are won with the help of microwaves.

This book is not for the expert, but neither is it for the completely uninitiated. It is assumed that the reader has some basic knowledge of electronics and semiconductors. There is some additional help in the appendices for readers who have not involved themselves in the field of communications.

Although electronics is often explained with the aid of mathematical equations, since these are a concise and accurate way of expressing ideas (about anything in fact), they are all very well if you are into this sort of stuff, but otherwise they often only serve to put off would-be enthusiasts. Hence detailed mathematical analyses have been deliberately avoided.

If you are already used to wired components then a study of microwaves will expand your thinking into wave theory and the concept of electromagnetic waves propagating through space instead. The use of microwaves grows inexorably, creating an ever increasing need for a basic understanding of their nature to some degree.

1992. 144 pages. 178 x 111mm, illustrated.

**Order As WZ42V (Intro Microwaves) £3.95 NV**

## Microprocessor System Design

A Practical Introduction

by Michael Spinks

This book introduces the essential concepts and techniques that underline the design of useful electronic circuits, especially microprocessor boards and their peripherals.

No previous knowledge of electronics is assumed: new terms and ideas are explained as they arise, and maths and jargon are kept to a minimum, the book concentrates on helping the reader acquire and understand the few relatively simple elements and techniques from which complex circuits are built up.

The book is not just about microprocessor systems. There is also plenty of information about other electronic circuits and devices, including op amps. After an introduction to these electronic circuits, both analogue and digital components, op amps and PALs, the reader goes on to discover how microprocessors work and how they are used in bus-based systems.

Much of modern electronics is based on the flexibility of microprocessors, and anyone involved in electronics today must have a sound grasp of these devices. In this case the 6809 is used to illustrate how a microprocessor works and the relationships between the hardware and software. The use of microprocessors is developed by considering how to expand a microprocessor system and the use of bus-based systems, which is the way to get a small control system working quickly. Some specialised circuits are then investigated; A/Ds, D/A's and phase-locked-loops. To conclude, some practical aspects of electronics design are examined.

1992. 247 pages. 247 x 188mm, illustrated.

**Order As WZ47B (Micro Sys Design) £19.95 NV**



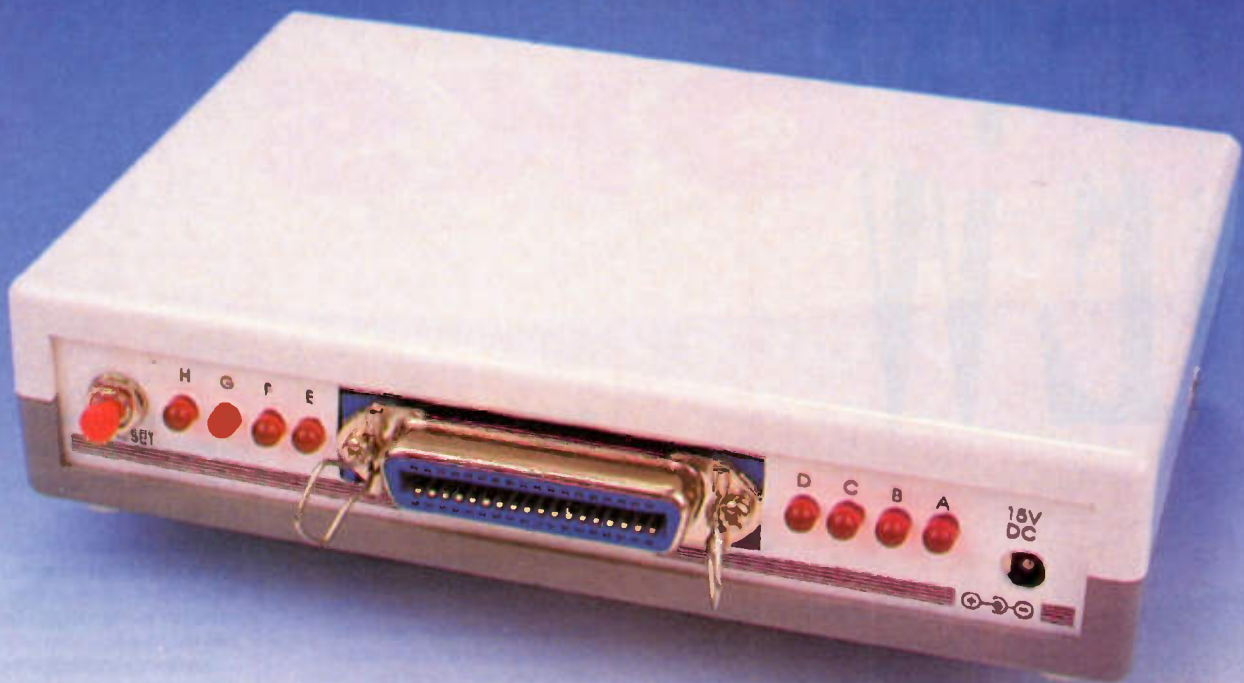

# Parallel Interface Relay Card

by Norman Ford

**T**his simple unit will allow up to eight independent relays to be controlled from any computer having a 'Centronics' parallel printer port. The device behaves as a printer, thus avoiding the necessity for special interfacing electronics or low-level software drivers. The relays are controlled simply by 'printing' an ASCII character, chosen to represent the required relay to be switched. The eight relays are identified with the letters 'a' to 'h', so that, for example, the BASIC statement LPRINT "b" will switch relay 'B' (number two) on, and LPRINT "B" will switch it off.

This method has two distinct advantages over the more usual approach, which is to use each individual bit in an 8-bit byte to represent the required state of each relay. Firstly, it avoids the problem of wanting to be able to PRINT all byte values from 0 to FF hex (0 to 255). The difficulty here is that, in high level languages such as BASIC, certain byte values (notably the control characters, with values less than 32) are translated into quite different values, or even a sequence of values, by the printer driver,

## Applications

- ★ Programmable Low Voltage Switching
- ★ Slide/Tape Recorder Control
- ★ Robotics
- ★ High Power Relay Control

## Specification

Power Supply:	15V DC regulated or 12V DC 800mA unregulated
Maximum Current:	500mA (all relays 'on')
Relay Contact Ratings:	3A DC/AC resistive, 1.5A inductive, 24V DC
Computer Interface:	Parallel printer port ('Centronics')

thus setting the relays differently to that expected or required. For example, 'TAB' (hex 09) is often output as a number of spaces (hex 20), and 'RETURN' (hex 0D) may have a 'LINEFEED' automatically appended to it (hex 0A).

Secondly, using an individual character to represent each relay makes the interface much easier to work with interactively in BASIC, since the state of the relays which are not to be changed need not concern the programmer. This avoids the ANDing and ORing of a number, required where individual bits are used to represent the relay states, all packed into a single byte. Multiple relay changes can be achieved by simply printing a string of characters; the fact that the relays cannot all be switched at exactly the same moment is not a severe limitation, since their inherent switching time is of the order of several milliseconds anyway.

## Printer Handshaking

The typical sequence for outputting data via a computer parallel printer port is shown in Figure 1. First the computer



ensures that the printer is ready to accept data by checking that **BUSY** is low. It then indicates that it has valid data on its output data lines by taking **STROBE** low. The printer then responds, and when it has successfully received the data takes **BUSY** high, and then when the data has been processed (printed or stored in its buffer), it resets **BUSY** low and sends a short **ACKNOWLEDGE** pulse. (In fact most computers only use the **STROBE** and **BUSY** lines for handshaking, merely checking that the printer is not busy before strobing out the next character.)

### Circuit Description

The block diagram of the relay card is shown in Figure 2, and the circuit diagram in Figure 3. When the computer indicates that it has valid data to send by taking **STROBE** low, the NAND gates of IC4 ensure that the state of the D5 line is only latched onto the output line of IC2, addressed by D0 to D2, if D7 is low and D6 is high. This means that the relay card only responds to the printable characters in the range hex 40 to hex 7F, thus excluding both the control characters (with the exception of **DELeTe**), and the special (usually graphics) characters which have bit 7 set to 1. The **STROBE** also triggers the two chained monostables in IC1, which in turn simulate the **BUSY** and **ACKNOWLEDGE** signals normally sent by the printer to indicate that it has successfully received and finished processing the data.

The latched outputs of IC2 drive the relays via the darlington driver array IC3: the relay outputs are taken to connectors along the edge of the board.

The circuit interconnections are arranged so that the characters 'A' to 'H' and 'a' to 'h' control the relays RL1 to RL5. Lowercase turns them on (bit 5 set) and uppercase turns them off (bit 5 clear).

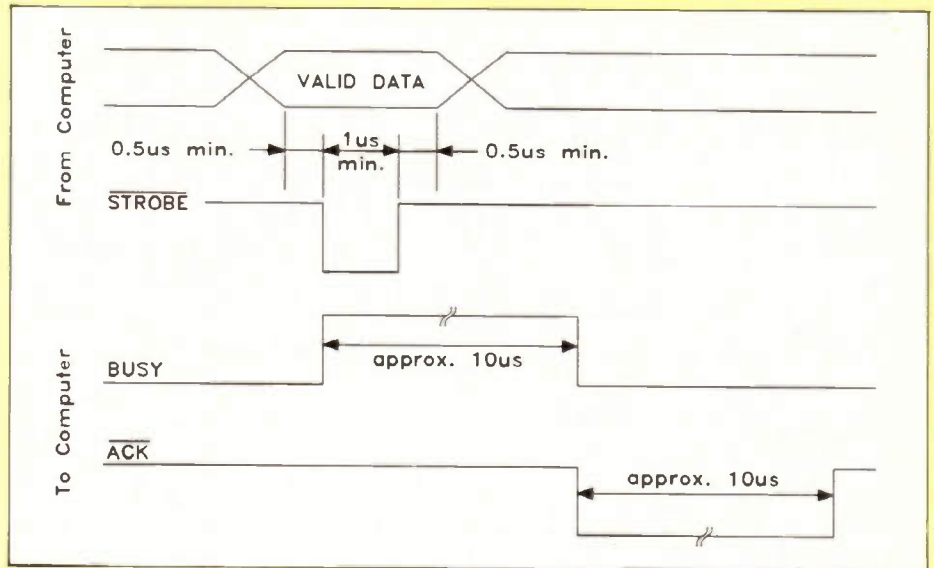

Figure 1. Printer interface handshake timing diagram.

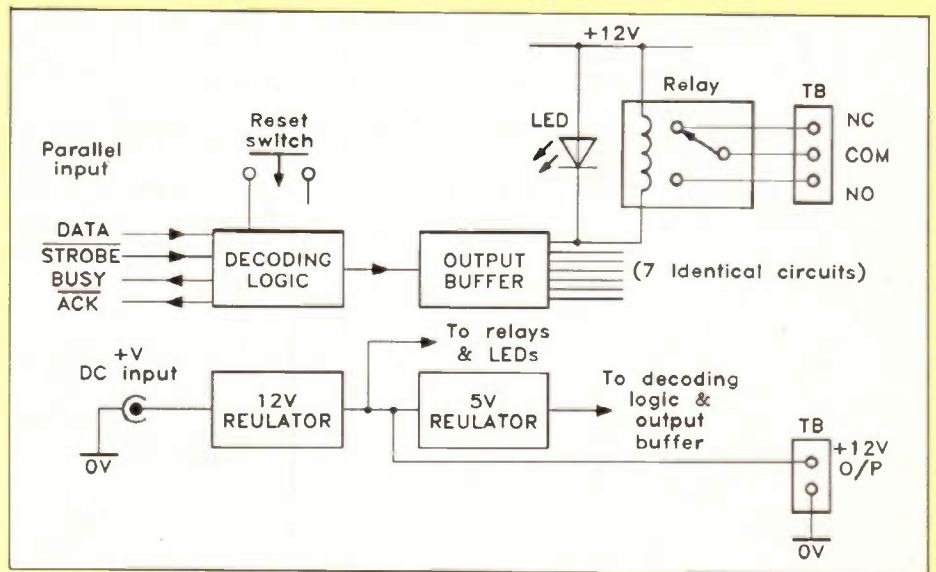

Figure 2. Block diagram.

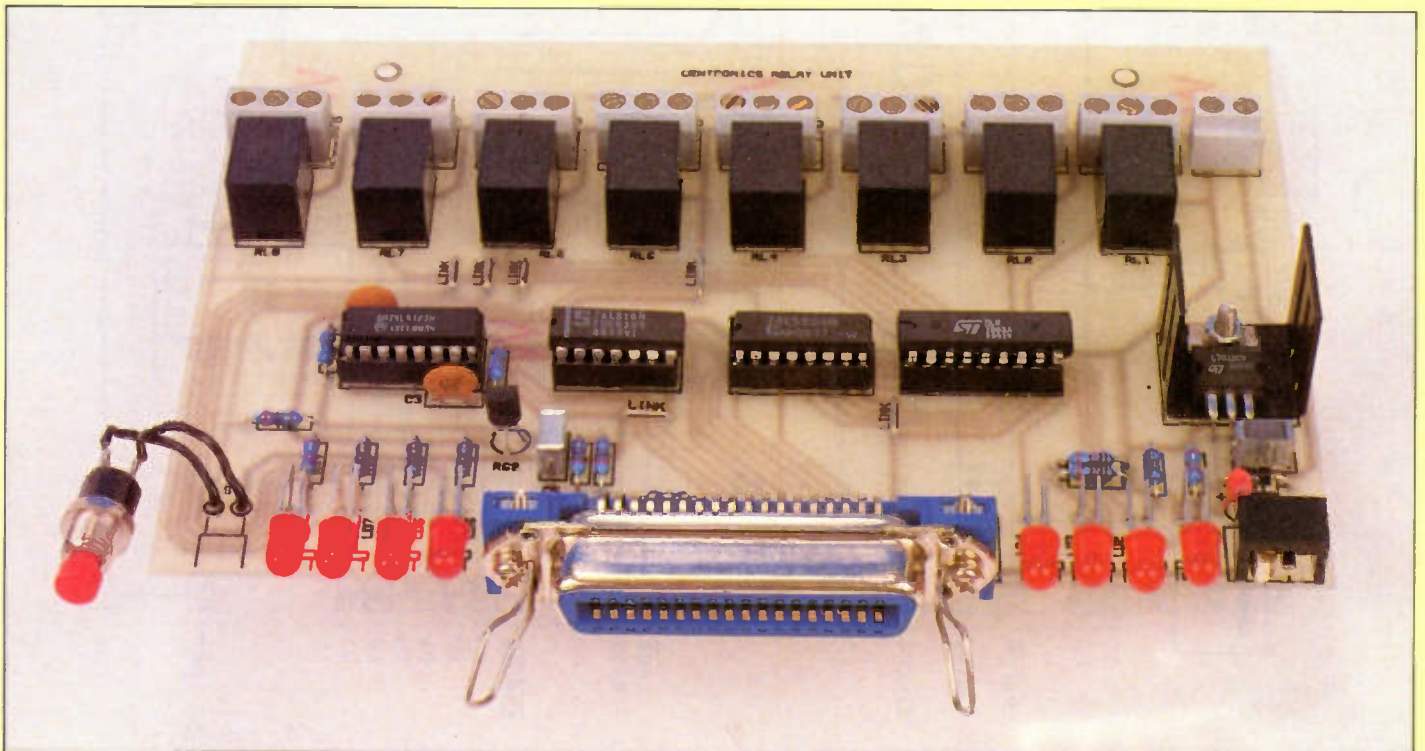
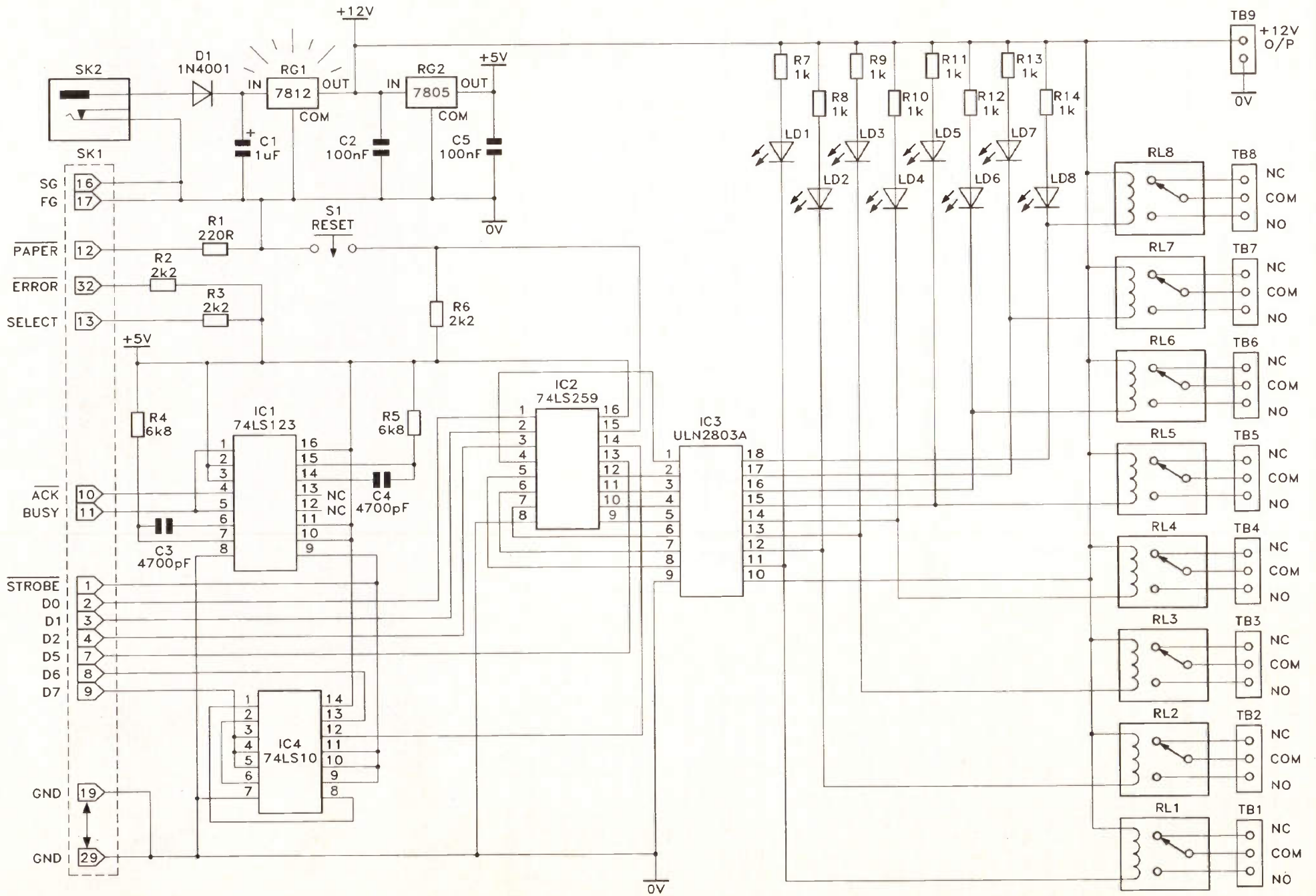

Figure 3. Circuit diagram.



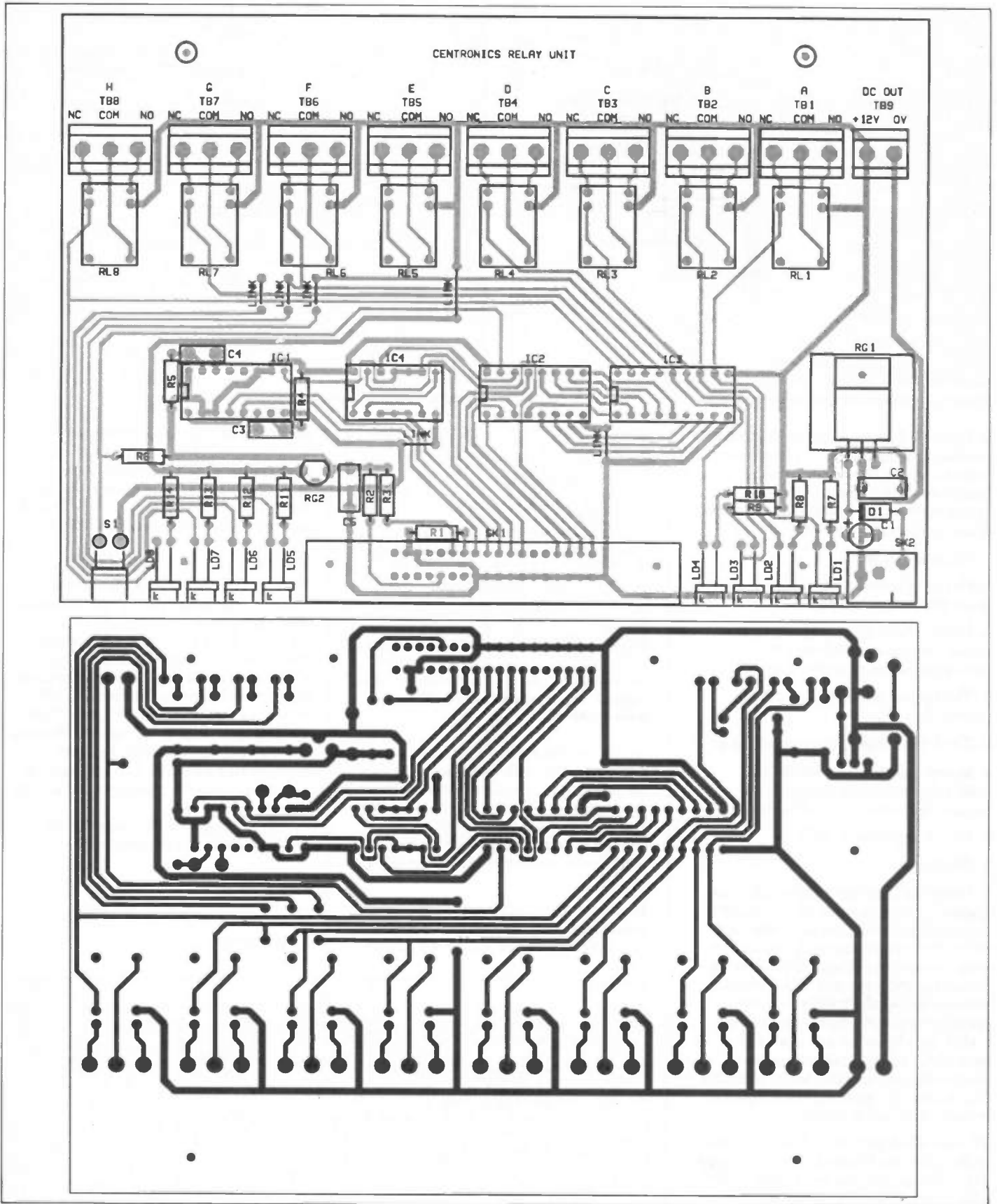

Figure 4. Printed circuit board layout and legend.

Note that for simplicity full decoding of the characters is not implemented, so that in fact the relays will react to other characters in the range 40 hex to 7F hex as well.

### How it Works

IC2 is an 8-bit, serial-in/parallel-out, addressable latch, which means to say that any bit for input can be selected by placing

the appropriate address on pins 1 to 3, and this pattern comes from the character received, 'a to h' or 'A to H'. The state of this bit is altered to reflect that of the input pin 13 (from D5), but, because none of the other bits are addressed, they are not changed. All eight bits are transferred via pin groups 4 to 7 and 9 to 12 to the 8-bit driver, IC3. IC3 has open collector outputs, all with protection diodes against

relay coil spikes built into the chip.

In order to ensure that the computer does not think there is a printer fault (e.g. out of paper, print error etc.) the status lines which would normally come from the printer are tied to the appropriate logic levels.

### Construction

The PCB layout and legend is shown

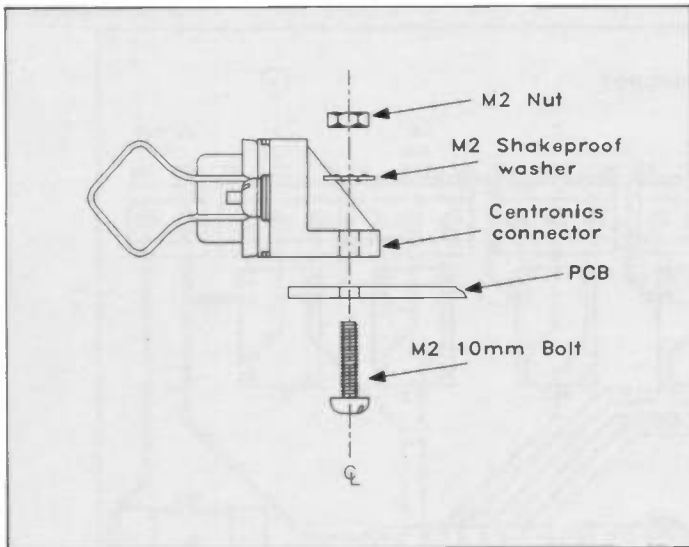

Figure 5. Centronics connector assembly.

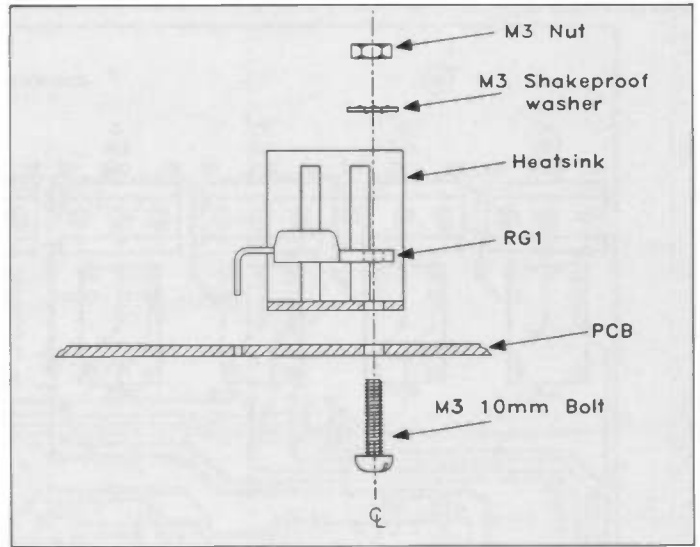

Figure 6. Assembling regulator RG1.

in Figure 4. Obviously not all the relays and their associated LEDs, resistors and output connectors need be installed. During construction it will probably be easiest to mount the components in order of size, in the following steps:

1. Fit the 6 wire links.
2. Fit the 14 resistors and the protection diode D1 (note polarity).
3. Fit the 4 IC holders, aligning each socket's polarising notch with the corresponding mark on the legend.
4. The 5 capacitors (ensuring correct polarity for C1!).
5. The 2.5mm input power socket SK2.
6. Mount the 9 terminal blocks TB1 – TB8, ensuring that the outputs face towards the outside edge of the board!
7. The 5V regulator IC RG2.
8. The 8 relays.
9. Install the Centronics socket SK1 (see Figure 5). Take care that all 36 pins pass successfully through the corresponding holes. Due to their relatively small pitch, great care must be taken when soldering the pins in order to avoid solder bridges between them, which will prove very obstinate to remove once formed. The socket must be bolted into place first, after which it may be advantageous to shorten the pins slightly, before soldering. Use the two M2 × 10mm bolts, nuts and washers provided in the kit.
10. The 12V regulator IC RG1, along with its heatsink (see Figure 6), using the single M3 × 10mm bolt, nut and washer. Only solder the leads to the board after it is correctly positioned and secure.
11. The 8 LEDs, noting polarity and lead dimensions. The polarity is indicated by a 'k' marking the cathode position on the PCB legend; the cathode is the shorter of the two leads. See Figure 7 for details of how to mount each LED in the correct position.
12. Before inserting ICs 1 to 4 into their sockets, examine the board for dry joints, solder bridges and other problems and

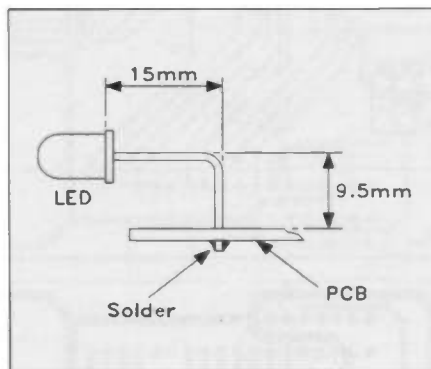

Figure 7. When assembling the LEDs bend leads as shown.

rectify any that exist. You can carry out a resistance test with a multimeter across the supply rails to ensure that there are no short circuits. When fitting the ICs, make sure to align the marker dot or notch at one end of each package with its associated notch in the socket and marker on the legend.

13. Fit the reset switch, allowing connecting leads of about 3cm in length.
- Panel drilling details for the module

are shown in Figure 8. Fit the reset switch to the front panel left hand end and position the LEDs through the appropriate holes. Slide the front panel into the Verobox and secure the PCB with the four self-tapping screws provided.

### Testing

Connect the unit to the computer via a standard Centronics parallel printer cable and apply power via socket SK2 (see Figure 9). Each relay, together with its associated LED, will take about 50mA so that if all 8 relays are to be used around 500mA will be drawn. The Maplin 12V 800mA unregulated supply (Order Code YM85G) is an ideal power source. Pushing the reset button will set all the relays inactive (all LEDs off). Test each relay in turn by printing the characters 'a' through 'h' to the printer port.

For example, to turn relay 'A' on in GW-BASIC, use the statement:

```
LPRINT "a";
```

and to turn it off:

```
LPRINT "A";
```

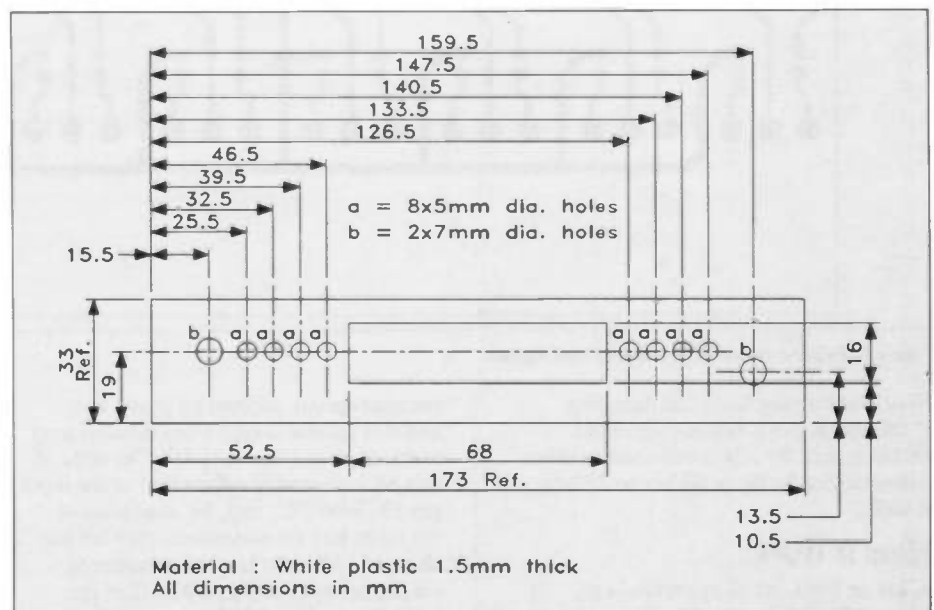

Figure 8. Front panel drilling details.

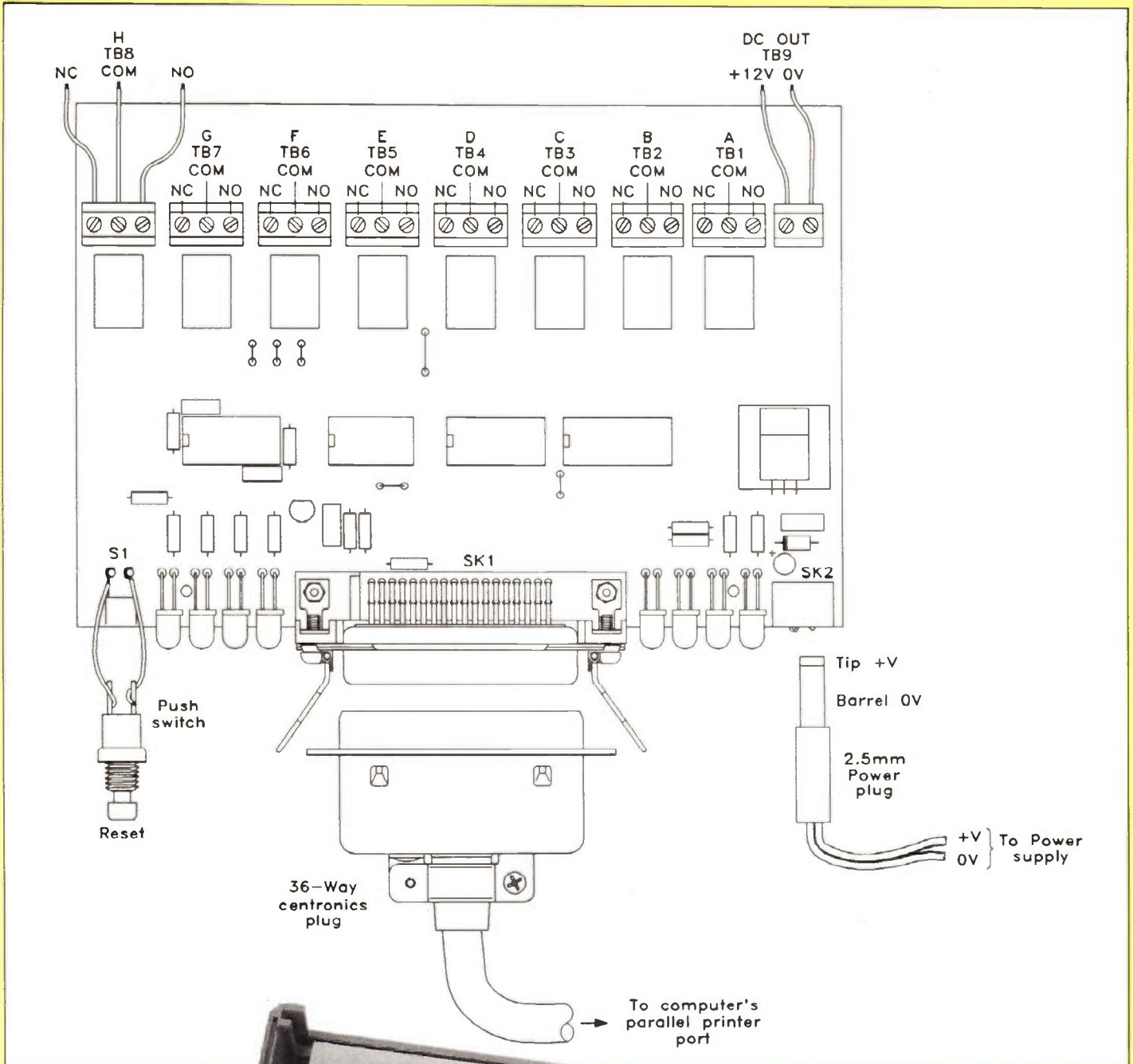
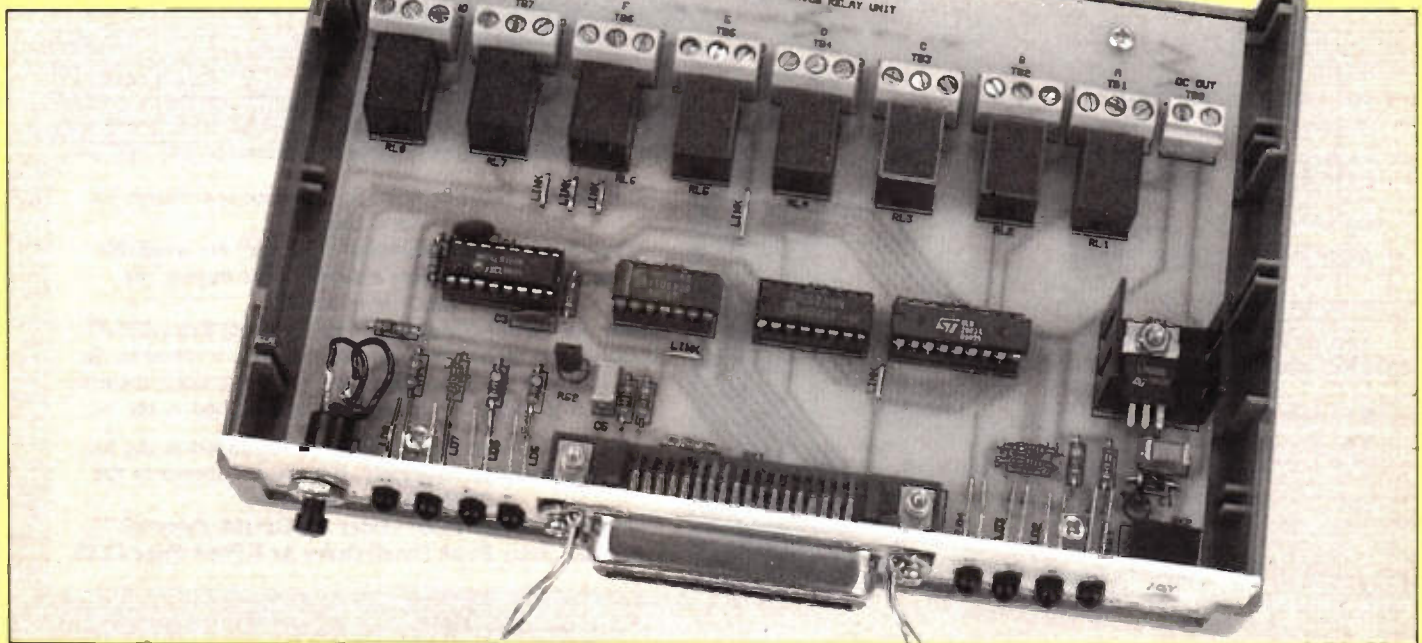
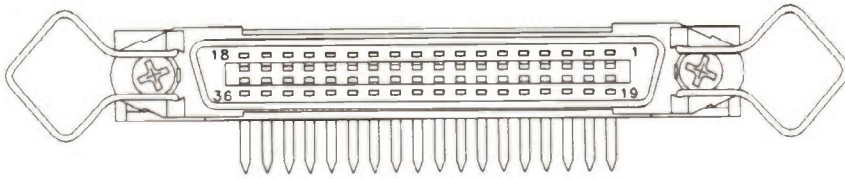

Figure 9. Connection diagram.





Terminal Number	Signal	Terminal Number	Signal
1	STROBE	19	GND
2	Data 0	20	GND
3	Data 1	21	GND
4	Data 2	22	GND
5	N/C	23	GND
6	N/C	24	GND
7	Data 5	25	GND
8	Data 6	26	GND
9	Data 7	27	GND
10	ACKNOWLEDGE	28	GND
11	BUSY	29	GND
12	PAPER*	30	N/C
13	SELECT**	31	N/C
14	N/C	32	ERROR**
15	N/C	33	N/C
16	Signal GND	34	N/C
17	Frame GND	35	N/C
18	N/C	36	N/C

Note:

\* Internally pulled to 0V via 220Ω.

\*\* Internally pulled to +5V via 2k2.

N/C No connection.

Although the semicolon is not essential since the interface will not react to the RETURN/LINEFEED sequence added by the BASIC, its inclusion will speed up execution by avoiding the outputting of unnecessary characters (return and linefeed are control characters and so are ignored by the relay card). A number of relays can be controlled by simply outputting a string. To turn all relays off use:

```
LPRINT "ABCDEFGH";
```

The following simple GW-BASIC program can be used to test the circuit by activating each relay in turn for 1 second. Pressing a key will reset all the relays and terminate the program.

```
10 RS="HABCDEFGH"
20 SS="abcdefgh"
30 I=1: T$=TIMES
40 LPRINT RS;
50 WHILE INKEY$=""

60 WHILE T$=TIMES : WEND
70 T$=TIMES$
80 LPRINT MID$(RS,I,1); MID$( SS,I,1);
90 I=I+1: IF I>8 THEN I=1

100 WEND
110 LPRINT RS;
```

Finally Figure 10 with its associated table shows the various centronics pin connections that are used by the relay driver card.

Figure 10. Centronics connector pin identification.

## CENTRONICS RELAY UNIT PARTS LIST

RESISTORS: All 0.6W 1% Metal Film

R1	220Ω	1	(M220R)
R2,3,6	2k2	3	(M2K2)
R4,5	6k8	2	(M6K8)
R7-14	1k	8	(M1K)

CAPACITORS

C1	1μF 35V Tant	1	(WW60Q)
C2,5	100nF Polylayer	2	(WW41U)
C3,4	4n7F Ceramic	2	(WX76H)

SEMICONDUCTORS

IC1	74LS123	1	(YF48C)
IC2	74LS259	1	(YF97F)
IC3	ULN2803A	1	(QY79L)
IC4	74LS10	1	(YF08J)
LD1-8	LED Red	8	(WL27E)
D1	1N4001	1	(QL73Q)
RG1	μA7812UC	1	(QL32K)
RG2	μA78L05AWC	1	(QL26D)

MISCELLANEOUS

SK1	RA Centronix 36-way Skt	1	(FV88V)
SK2	PCB 2.5mm DC Pwr Skt	1	(FK06G)
S1	Push Switch	1	(FH59P)
RL1-8	Ult-Mn Rly 12V SPDT	8	(YX94C)
TB1-8	3-way PC Terminal 5mm	8	(JY94C)
TB9	2-way PC Terminal 5mm	1	(JY92A)
	DIL Socket 14-pin	1	(BL18U)
	DIL Socket 16-pin	2	(BL19V)
	DIL Socket 18-pin	1	(HQ76H)
	Steel Screw M2 × 10mm	1 Pkt	(JY34M)

Steel Nut M2	1 Pkt	(JD63T)
Steel Screw M3 × 10mm	1 Pkt	(JY22Y)
Steel Nut M3	1 Pkt	(JD61R)
Shakeproof Washer M2	1 Pkt	(LR61S)
Shakeproof Washer M3	1 Pkt	(BF44X)
TC Wire 0.71mm 22swg	1 Reel	(BL14Q)
Slotted Heatsink	1	(FL58N)
PCB	1	(GH16S)
Front Panel	1	(KP46A)
Verobox 214	1	(LQ07H)
Instruction Leaflet	1	(XT82D)
Constructors' Guide	1	(XH79L)

OPTIONAL (Not in Kit)

AC Adaptor Unreg 800mA	1	(YM85G)
IBM PC Printer Cable	If Req	(JC11M)
Male-to-Male Printer Cable	If Req	(JC14Q)
Male-to-Female Printer Cable	If Req	(JC15R)

The Maplin 'Get-You-Working' Service is available for this project.

*The above items (excluding Optional) are available as a kit, which offers a saving over buying the parts separately.*

**Order As LT08J (Centronics Relay Unit) Price £34.75.** Please Note: where 'package' quantities are stated in the Parts List (e.g. packet, strip, reel, etc.), the exact quantity required to build the project will be supplied in the kit.

The following new items (which are included in the kit) are also available separately, but are not shown in the 1992 Maplin Catalogue.

(Centronics Relay PCB) **Order As GH16S Price £4.75.**  
(Centronics Relay Front Panel) **Order As KP46A Price £2.95.**

These are our top twenty best selling books based on mail order and shop sales during June '92.

Our own magazines and publications are not included in the 'chart' below.

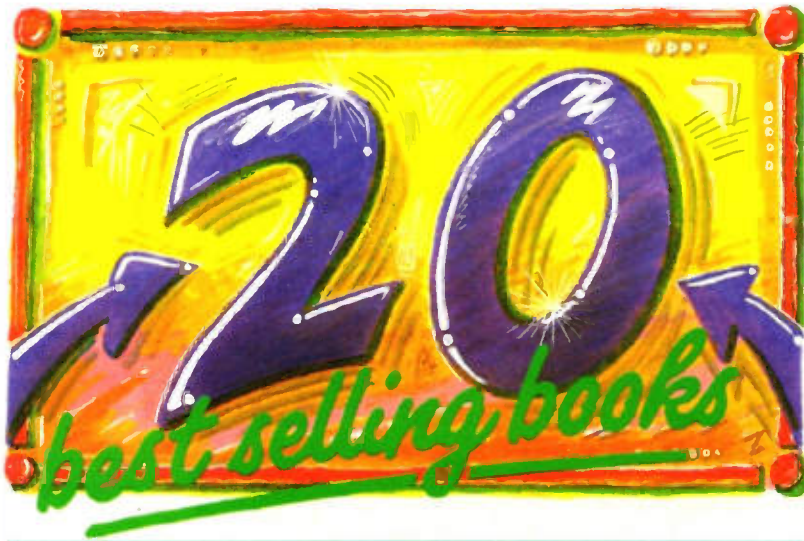

The Maplin order code of each book is shown together with page numbers for our 1992 catalogue. We stock over 250 different titles, covering a wide range of electronics and computing topics.

**2**

IC 555 Projects, by E.A. Parr (LY04E) Cat. P85 Previous Position: 3. Price £2.95.

**3**

A Concise Introduction to MS-DOS, by N. Kantaris (WS94C) Cat. P101. Previous Position: 2. Price £2.95.

**4**

Power Supply Projects, by R.A. Penfold (XW52C) Cat. P83. Previous Position: 4. Price £2.50.

**5**

How to Expand, Modify and Repair PCs and Compatibles, by R.A. Penfold (WS95D) Cat. P104. Previous Position: 5. Price £4.95.

**6**

International Transistor Equivalents Guide, by Adrian Michaels (WG30H) Cat. P76. Previous Position: 7. Price £3.95.

**Number ONE**

**Getting The Most From Your Multimeter**  
by R. A. Penfold

A unique, and very useful book, showing you how to best use your multimeter.  
(WP94C) Cat. P80. Previous Position: 1  
**Price £2.95**

**7**

An Introduction to Loudspeakers and Enclosure Design, by V. Capel (WS31J) Cat. P87. Previous Position: 6. Price £2.95.

**8**

Electronic Security Devices, by R. A. Penfold (RL43W) Cat. P84. Previous Position: 10. Price £2.50.

**9**

Loudspeaker Enclosure Design and Construction (WM82D) Cat. P88. Previous Position: 9. Price £9.95.

**10**

How to Use Oscilloscopes and Other Test Equipment, by R. A. Penfold (WS65V) Cat. P80. Previous Position: 8. Price £3.50.

**11**

The Complete VHF/UHF Frequency Guide, by B. Laver (WT70M) Cat. P93. Previous Position: 12. Price £5.95.

**12**

Electronic Music Projects, by R. A. Penfold (XW40T) Cat. P89. Previous Position: 14. Price £2.50.

**13**

How to Use Op Amps, by E.A. Parr (WA29C) Cat. P79. Previous Position: 15. Price £2.95.

**14**

Remote Control Handbook, by Owen Bishop (WS23A) Cat. P83. Previous Position: 11. Price £3.95.

**15**

Mastering Electronics, by John Watson (WM60Q) Cat. P74. Previous Position: 18. Price £5.99.

**16**

Servicing TV and Video Equipment, by Eugene Trundle (WS76H) Cat. P96. Previous Position: 17. Price £25.00.

**17**

More Advanced Power Supply Projects, by R.A. Penfold (WP92A) Cat. P77. Previous Position: 16. Price £2.95.

**18**

Audio Amplifier Construction, by R. A. Penfold (WM31J) Cat. P87. Previous Position: Re-Entry. Price £2.95.

**19**

Towers' International Transistor Selector, by T.D. Towers (RR39N) Cat. P76. Previous Position: Re-Entry. Price £19.95.

**20**

The Maplin Electronic Circuits Handbook, by Michael Tooley (WT02C) Cat. P82. Previous Position: 19. Price £12.95.

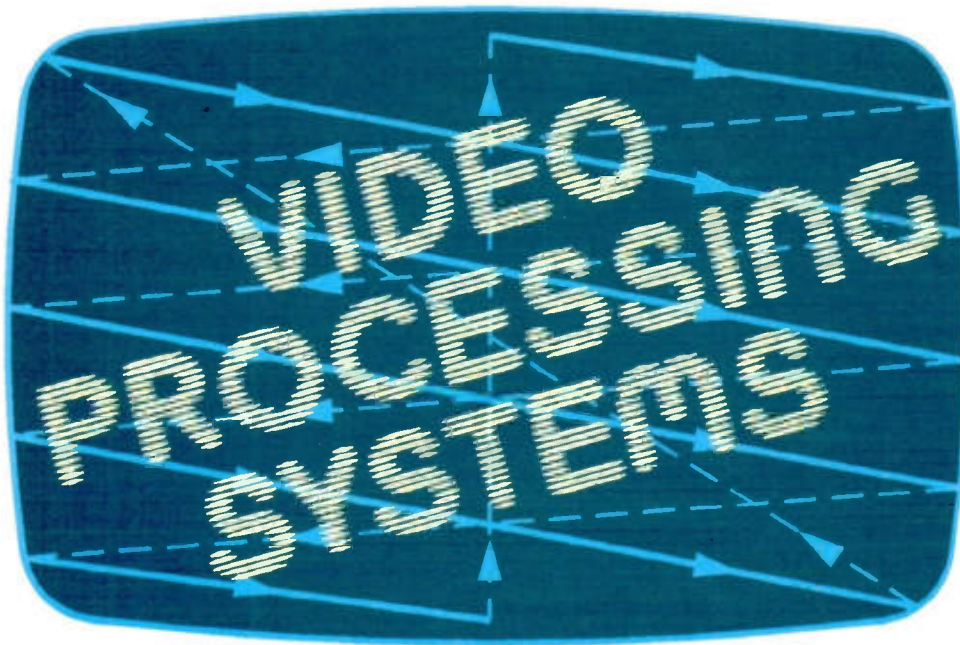

**Part Six by J. A. Rowan**

Digital video processing equipment can come in one of two major forms of architecture, handling either composite or component (YUV) video. Both types of machine must digitise input video, store it, process it and convert it back to analogue form. Both must be able to lock the output video to a local reference, but there the similarities end, as Figure 1a and 1b shows. A component unit which accepts a PAL input must first decode it, then digitise Y, U and V separately, store and process each separately, then recombine the analogue components in a PAL encoder to produce a composite video output. But a unit digitising composite video has only one digital channel, and no encoder or decoder is necessary. On the face of it, it is a much simpler machine and it is difficult to see why the component architecture is ever used for composite video.

**Composite Encoding and Decoding**

Part of the answer lies in the matter of sample frequency. As explained in the separate piece about sampling, composite video must be digitised using a sample clock of three or, preferably, four times the subcarrier frequency. Horizontal picture position must be determined by sync pulse timing, and the question arises as to where to begin sampling. In itself, the start time of sampling is not important, but unless there is some agreement on the subject in both read and write clock generators, some or all of the picture will be shifted horizontally by one or more sample periods. In NTSC there is little difficulty. Four times the NTSC subcarrier is an exact multiple of the line

frequency, and sampling can begin at a fixed time after the sync reference. For PAL however, neither three nor four times the subcarrier is a multiple of line frequency, and sampling must begin at a different time on each line. The complexity of the resulting clock generator is the main reason why composite digitising is only used in PAL where it is essential. Synchronisers normally use composite coding to avoid PAL coding/decoding artifacts, and direct colour VTRs must have composite TBCs (TimeBase Correctors, see Part 5), as high quality PAL decoding cannot be carried out on unstable video. Only a few companies in the world have the expertise to build composite PAL TBCs, and not that many more can build good PAL synchronisers.

*“ Four times the NTSC subcarrier is an exact multiple of the line frequency, and sampling can begin at a fixed time after the sync reference. For PAL however, neither three nor four times the subcarrier is a multiple of line frequency, and sampling must begin at a different time on each line. ”*

The other disadvantages of composite encoding arise from the rigid sample structure. Almost no processing can be carried out on the digitised signal. Standards conversion and digital effects are not very practical, and even maintaining the eight-field sequence causes problems. Subcarrier phase and PAL ID are literally built into each sample, and one field cannot be transformed into another with impunity. For instance, a synchroniser with one frame of storage may have to shift the picture by a half-cycle of subcarrier horizontally and/or a line vertically to output an eight-field-correct signal, and this makes finding any information carried on a specific vertical interval line difficult. Some processing of video is necessary in almost all machines under some circumstances, and most composite coded units do in fact have decoders and encoders for use under non-standard conditions. Normally these cannot be of very high quality, and it is not unusual to see decoding artifacts, along with a distinct loss of resolution, when a direct colour VTR freezes or goes over to slow motion, or a synchroniser freezes on loss of video.

The sample frequency for a component machine has few constraints other than Nyquist, and values from 8MHz to 14.3MHz are found in luminance digitisers, half or a quarter of the luminance frequency normally being used for the chroma channels. The international standard sample frequen-

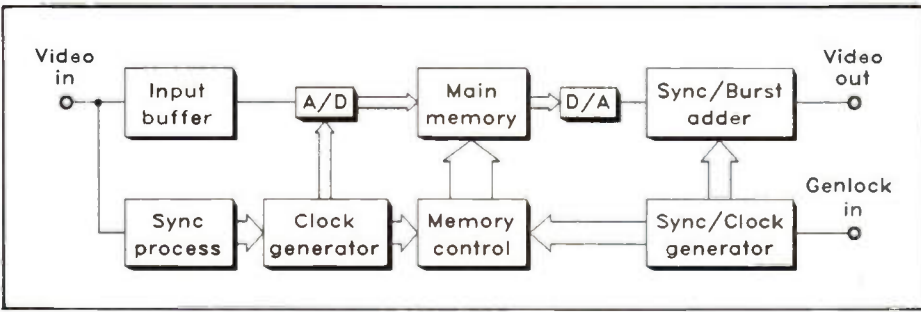

Figure 1a. Overall block diagram, composite coding.

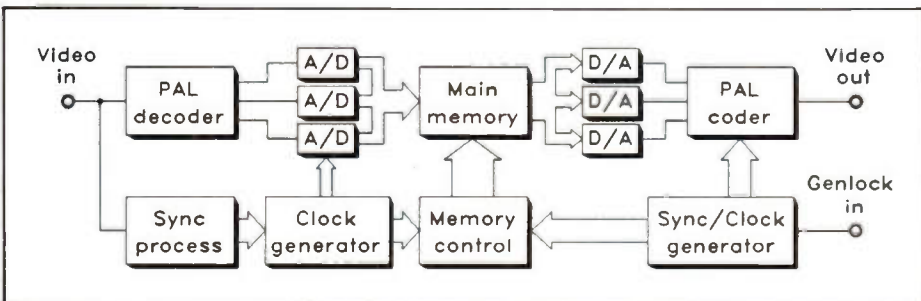

Figure 1b. Overall block diagram, component coding.



cies of 13.5MHz and 6.75MHz are used in most units built in the last few years, but some low-cost machines use lower sample rates.

Where a composite video input is necessary, the PAL decoder can vary considerably in complexity. The separation of luminance from chrominance can be easily carried out with a low-pass filter, but luminance bandwidth is then limited to about 3.1MHz at best. Some VTRs, such as U-Matics and domestic VCRs, cannot record a higher bandwidth anyway so nothing is lost. VTRs that can handle higher luminance bandwidths, such as S-VHS and Hi-8, must provide the playback luminance to the TBC separately to the chroma. Where a full luminance bandwidth is required after extraction from PAL, for example in a broadcast-quality DVE, a comb filter decoder is necessary. In analogue form, this requires two high-quality, one-line delays, and is itself a complex and expensive unit. If four times subcarrier sampling is used with a composite video digitiser, then decoding can be carried out digitally using comb filter techniques. Many DVEs and standards converters do this.

## Single Chip Component Coding

The A/D converters in use today are fairly unremarkable, usually containing a 255-comparator converter, sample-and-hold gate and voltage reference on a single chip. The widespread use of fast A/D converters in oscilloscopes has made suitable chips very small and cheap. It is only ten years or so since a huge A/D chip would have cost over a thousand pounds, which led to techniques such as multiplexing U and V, and sometimes Y as well, into a single A/D converter. Today there is none of that nonsense, and a component machine will have three converters.

*“It is only ten years or so since a huge A/D chip would have cost over a thousand pounds, which led to techniques such as multiplexing U and V, and sometimes Y as well, into a single A/D converter. Today there is none of that nonsense . . .”*

Usually U and V will still be multiplexed, but in the digital domain, as a matter of convenience as much as economy. Since U and V each usually run at half the Y sample rate, it makes sense to use two near-identical digital channels to carry the three signals. In fact, most DVEs have a third wide-bandwidth channel to carry a key

signal. If you wish to manipulate a chroma-keyed object before inserting it into the final background, then you must manipulate the key signal in exactly the same way as the picture. Doing this by hand for each frame of film was what made the special effects in the Star Wars films so expensive. Now, a programme made on videotape can use that kind of effect in real time.

## Memory Addressing Techniques

Memory has changed even more dramatically. Today's frame of storage is likely to consist of a handful of chips, rather than the several PCBs of a decade ago. Memory organisation differs a little from that of computers: machines with asynchronous input and output video must also have a two-port memory with asynchronous access. The access arbitration is usually solved partly by FIFO and partly by time-slots. The genuinely asynchronous read and write clocks are applied to a FIFO which re-times input video to read clock speed and timing, removing the short-term errors at the same time. The FIFO will usually be reset during horizontal blanking, and will be large enough to accommodate the worst possible variation in input video timing that can occur in 64µs. It cannot be large enough to compensate for all variations in input/output timing, since the average input and output video frequencies are not guaranteed to be the same, and so there is no limit to the amount of error which can build up. In order to accommodate such long-term error, the main memory usually has three, or sometimes more, time-slots per read cycle. Read timing is stable by definition, and the other time-slots will normally contain one memory write between them. Where the input video frequency is higher than that of the output, then two time-slots will sometimes be used for writing. When the input video frequency is lower, there will be the occasional read cycle without a write. Other additional time-slots may be used to randomly read or write information for processing purposes asynchronously to the main output read.

If all this seems like a lot of activity to be happening within the average RAM access time, it is. Read and write addresses are not related, and although a double write will normally occur into successive addresses, it is not usually possible to make use of any special page-mode or RAS or CAS-only access the RAM chips might have. Each time-slot must occupy the full random address-in-to-data-out access time. The total length of the three or more time-slots will be many times the luminance sample clock period, which means that a number of samples must be queued and dumped in and out of memory as a block. This memory demultiplex-multiplex technique is what actually decides how many mem-

ory chips are required, as the total number of memory bits needed is the product of the demultiplex width and the actual number of data bits. ICs used in video memory need to contain as many data bits as possible, and even using byte-wide chips, it is not unusual to end up with much more storage than is actually needed, simply to get enough data bits. At least video RAM does not need any provision for refresh of dynamic memory, as judicious allocation of address lines will ensure that the read system will refresh the chips automatically.

There is usually some additional RAM used in a TBC, other than that of the main store. One-line delays are used for a variety of purposes such as field interpolation for freeze, line-based dropout compensation and chroma noise reduction. Shorter periods are used for minor re-timing jobs, such as adjusting luminance-to-chrominance timing. Fast, byte-wide static RAMs are available which can accommodate a read-modify-write cycle within one luminance sample period, and store a complete line of video. Using a read-before-write technique and a presettable counter to supply the addresses, then the delay through the RAM is determined by the counter preset value.

*“Memory has changed even more dramatically. Today's frame of storage is likely to consist of a handful of chips, rather than the several PCBs of a decade ago.”*

A TBC output processor consists mainly of a sync and clock generator which can be 'genlocked'. This produces composite sync, a subcarrier and the other pulses necessary to assemble composite video from components, and also the memory read clock and vertical and horizontal references for the memory read address generator. Video processing is minimal: the possible range of digital values used automatically performs black and white clipping, preventing 'illegal' values of luminance. The D/A converters are not normally stopped and restarted during blanking, but run continuously and fed with digital zero (not necessarily numerical zero) during the blanking period. This avoids any undefined behaviour in the D/A converter, and removes the need for analogue blanking to be applied afterwards. Black level and video gain have already been adjusted manually on the input processor, and only need preset adjustments here. U and V are sent to the subcarrier modulators, usually after having burst pulses added, and then luminance, chroma and sync are combined and sent to the output buffers.

## Video Input and Output Facilities

Most TBCs today will offer an array of outputs: composite video, YUV and S-VHS are common, and some TBCs will generate high-band or low-band U-Matic dub signals. Occasionally, RGB outputs are available, usually as an option. In most units, all output signals are available simultaneously, which sounds easy enough but isn't. YUV and RGB are by definition wide-bandwidth signals with no time delay between their components. PAL coding introduces a large (about 300ns) delay into the chroma path by filtering and modulation, and stand-alone encoders use an expensive analogue delay line to match the luminance timing to it. Y/C timing in digital machines is much cheaper if done in the digital domain, and almost all TBCs do it this way. But this is incompatible with YUV timing, and it is then necessary to delay U and V on the way to the component output buffers. Each of the signal paths must also have individual preset level adjustments to ensure that all types of video output have simultaneously correct levels. Nothing is ever simple. And today most TBCs offer a similar range of input signals.

Actually, the input problem is not so bad. Outputs must be simultaneously available, but obviously only one input at a time is used. Equally obviously, we now need an array of switches to select which input is actually used. We also need to ensure that standard levels of the various types of input video all produce the same digitised values. This has, in the past, led to large numbers of preset gain adjustments in the various signal paths, but today this is more likely to be a group of stored numbers, applied by microcomputer to a single gain-control stage in each of the Y, U and V analogue paths. Switching to a particular input causes the appropriate values to be used to adjust the gains. Usually, another set of numbers exists to adjust the luminance/chrominance timing by varying a delay in the luminance digital path. There is provision for manual adjustment of luminance and chroma gain, Y/C timing and black level in order to correct poor recordings.

Most VTRs have a video input automatic level control available, and usually colour-under machines also have auto chroma level. On cheaper machines such as VHS, these functions are permanently enabled, but professional machines normally have a manual override. Few TBCs have these features, though machines intended for use with domestic and semi-professional formats are acquiring them. In most cases low-level tapes and VTR outputs must be compensated manually, with reference to the output picture and, if possible, a waveform monitor and vectorscope. Auto level control works by adjusting the input gain to maintain a sync pulse level of

300mV, on the assumption that picture and sync levels will have kept the same proportions during any previous level changes. Auto chroma works in a similar manner, using the burst level as a reference. These features can sometimes cause odd effects. If a colour-under VTR directly records the playback output of another, then any loss of video or chroma levels in the play machine or on the playback tape will be largely corrected by the record VTR's auto functions. If a TBC without auto level controls is now interposed, then it will output low-level video or chroma, but attached to full-level sync and burst. The record VTR will not now compensate for the faulty playback video, and the TBC will appear to actually degrade the picture quality. The TBC must now be adjusted manually to provide correct output levels.

## Bypassing

Most TBCs have a 'bypass' facility. If the power fails or is turned off, then, and usually by means of a front panel switch, the video input can be connected straight through to the output. This was important in the days when TBCs were less reliable, and meant that, in the case of a breakdown, the VTR could still be used without re-cabling. Of course, there was no longer the possibility of mixing it with other sources, but at least some kind of work could usually be done. Bypass also has some uses in fault-finding, though a little thought is required to interpret the results. For example, colour may appear less saturated when passed through the TBC than when taken directly from the VTR. This certainly may mean a fault or mal-adjustment in the TBC, but it can mean that the genlock cabling has been rearranged without readjusting subcarrier phase, or simply that the colour output from the VTR or that particular tape is low, and the TBC does not have an auto chroma level control.

Almost all TBCs, whatever their intended use, have at least one PAL output. Most have two identical outputs, except that input video can only be bypassed to one of them. The 75Ω

---

*“ Other diagnostic features have all but vanished, basically for the same reasons that most instruments have disappeared from car dashboards . . . not only are TBCs more reliable, but they are now used by a wider variety of people – few of them able to interpret the results produced by such test facilities. ”*

---

termination of the destination of this output signal becomes the input video termination when the TBC is bypassed, and obviously only one such load may be connected at a time. Often, if bypass is selected with the TBC still powered, the other output will still be available, but if the bypass-capable output has not been connected to anything, then the input video will no longer be terminated and the level will double. So if the TBC, when switched to bypass, gives a distorted, white, clipped picture and loses the signal altogether when turned off, check which of the two (or more) video outputs you are using. Normally output '1' or 'A' will be the bypass-capable one.

Bypass is less useful today, with such a variety of video formats available. It is now also quite likely that no picture monitor will be available, or easily selected, that will display both the normal TBC output and the input format in use. Logically, all inputs should be bypassed to all their respective outputs, but the advantages to be gained appear to be outweighed by the costs. Only PAL inputs are usually bypassed, and then probably only out of a sense of 'tradition'. Other assorted diagnostic features of TBCs have all but vanished, basically for the same reasons that most instruments have disappeared from car dashboards. Meaning that not only are TBCs very much more reliable today than they were ten years ago, but they are now used by a wider variety of people – few of them able to interpret the results produced by such test facilities.

## Video Sampling Techniques

The problem of aliasing was touched on in last month's article, where an attempt to reproduce signals of a frequency close to the sample frequency was shown to produce ludicrous results. More formally, Nyquist's Sampling Theorem says (more or less) that digitising a signal of a frequency higher than half the sample frequency used will result in a distorted version of the original signal, which will appear to have a frequency equal to the difference between the original and the sample frequencies. This new 'alias' frequency is of course unwanted, and every digitiser must therefore contain an anti-aliasing filter to remove possible signal frequency components higher than half the sample frequency. Even if the intended input signal does not contain such components, the filter is still necessary to suppress any noise or other unwanted signals which may be aliased and cause interference to the desired signal.

Introductory texts on digital signal handling begin with Nyquist's Theorem, occasionally mention the term  $x/\sin(x)$ , and then totally ignore any further aspects of sampling or analogue signals. As long as the sample frequency is twice that of the highest signal component, all is assumed to be

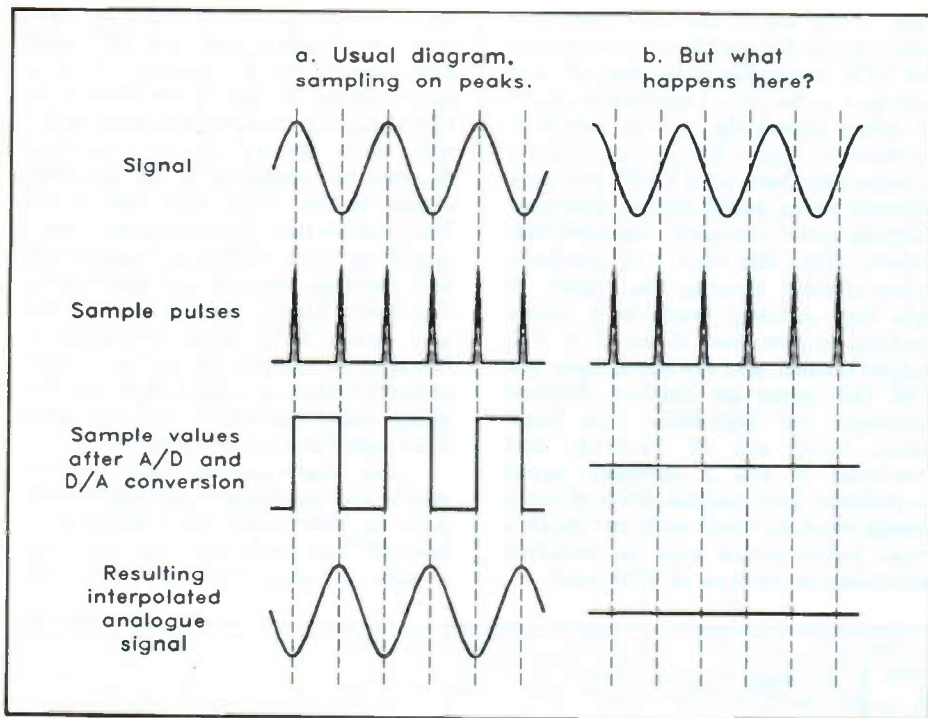

Figure 2. Sampling at Nyquist limit.

well. A diagram like Figure 2a is usually shown to demonstrate that such a sample frequency can then fully represent the signal. Odd how the sample points are always shown at the peaks of the signal. What happens if the sample phase drifts along to the position shown in Figure 2b? Zero is

not a particularly good representation of the original signal. If the signal and sample frequencies are not related, then such a drift will vary the sampled values between zero and the peak level. The sampled signal will be amplitude modulated by the difference frequency between signal and half-sample fre-

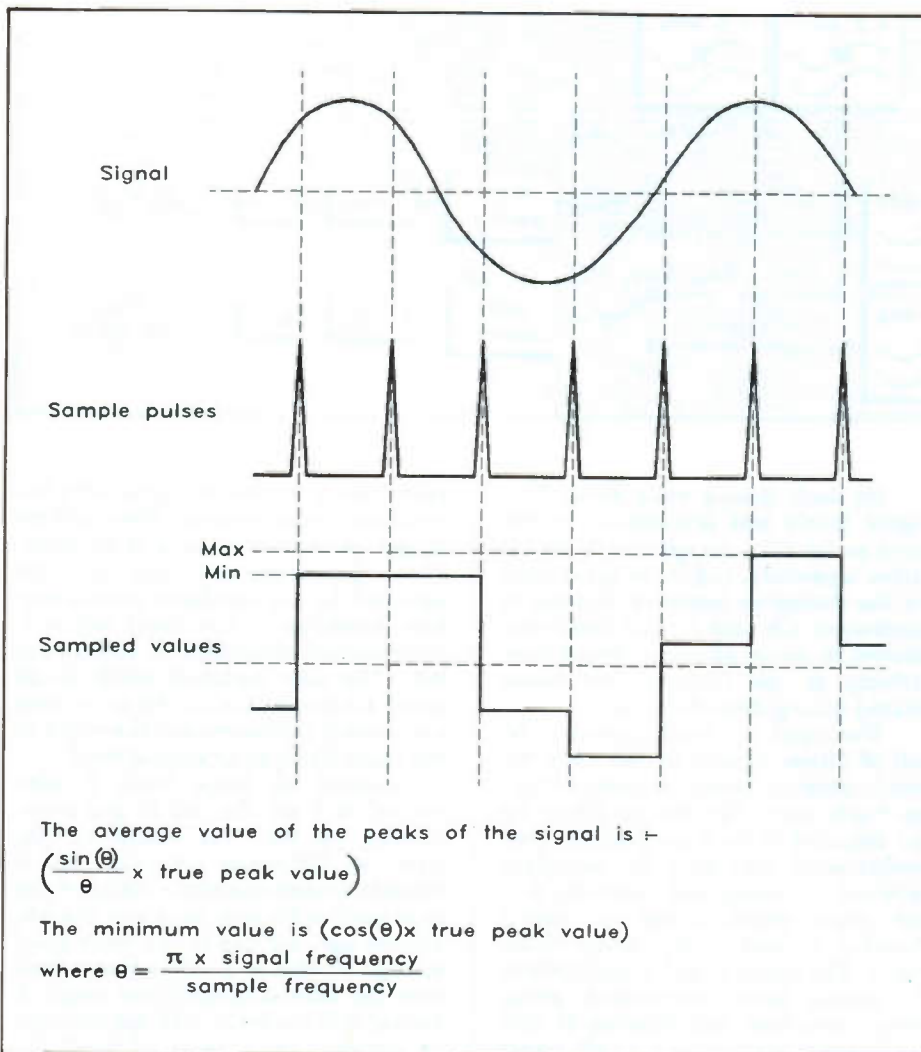

Figure 3. Variation in sampled values.

quencies. To take a more general case, Figure 3 shows a lower signal frequency and the possible range of peak sampled values obtainable. If we assume that each relative phase occurs equally often then the average value can be found by integrating over the sample period and dividing by the latter. This average value turns out to be  $\frac{\sin(x)}{x}$  times the peak value, where  $x$  is  $\pi \times (\text{signal frequency}) / (\text{sample frequency})$ . This is why, when constituting the sampled values into a continuous analogue signal, it is necessary to equalise the frequency response using an  $x/\sin(x)$  characteristic.

This brings us to the other aspect of sampling often skated over, the filter used after digital-to-analogue conversion. This is often dismissed as 'necessary to remove the sample frequency components.' Of course that is an important function, but that job could be done more effectively by a comb filter operating on the sample frequency and its harmonics. The D/A filter is also known as the 'interpolation filter,' which gives a clue to its more important function. The sampled values leaving the D/A converter are those of single zero-length time points on the original signal, and it is the main task of the interpolation filter to restore these to a continuously varying signal, as similar as possible to the original analogue input signal. It could be noted in passing that a theoretically ideal interpolation filter would automatically make the  $x/\sin(x)$  correction and indeed would restore all possible sampled versions of a given frequency to the same, correct, amplitude. An analogue signal absolutely identical to the original could be rebuilt by such a filter, if it could exist. In fact, the closest approach to the ideal filter is an exact copy of the anti-aliasing filter used before digitising. Very good interpolation filters can be made which will restore signals fairly accurately up to about 40% of sample frequency.

The question of sampling frequency lies at the heart of a major problem with composite coded digital equipment. Nyquist's Theorem gives a good guide to the sampling of most natural signals, since the higher frequency components subject to modulation by a sub-multiple of sample frequency are generally present at low levels. This is true of video luminance, which could be effectively sampled at about 13MHz, but not of PAL nor NTSC which contain high levels of subcarrier. Sampling of composite video at less than about 120MHz would result in unacceptable levels of modulation of subcarrier, giving rise to moire patterning on colours. The alternative is to sample at a multiple of subcarrier frequency, so that sample points occur in stable positions relative to the subcarrier signal and no modulation occurs. This is the solution adopted by all commercial equipment which digitises composite video, either three or four times subcarrier being chosen, which brings with it the disadvantages mentioned in the main article.

## TimeBase Corrector Input Processing

Figure 4 shows the outline block diagram of a typical TBC input processor. Only the main signal paths are shown, as marking in all the control commands and processing pulses would almost totally cover the diagram. Similarly, no buffers are shown though of course all signal inputs must be buffered, filters must be correctly terminated and A/D chips usually need a very low-impedance drive for accurate sampling. There may be digital buffers if the data signals travel between PCBs, and some of the older units actually convert TTL logic levels to ECL values to minimise the radiated interference from wiring.

type. On the whole, the easiest and best idea is to use the 4.43MHz chroma from the VTR composite video output, and decode it as for PAL. Luminance would be taken separately, not so much to preserve its higher bandwidth (it must at some time have been 3MHz low-pass filtered) as to avoid further low-pass filtering and consequent transient distortion. Often the extra VTR playback noise allowed through the system in this way actually leads to a worse looking picture than if the VTR PAL output is used, and the advantages of a TBC Dub input are dubious. Neither low-band nor high-band Dub luminance levels are 1V Pk-to-Pk, and low-band Y has a different input impedance from normal. Both of these points must be dealt with by the Dub input buffer, which must be switched according to the type of VTR used.

the other hand, the 5.5MHz Y filter must be complex, and in a TBC with any pretensions to quality or in a synchroniser, it may have twenty or thirty reactive components. Half of the filter will be an all-pass network devoted to correcting the group delay errors of the other half, the actual low-pass section. Designing, and even adjusting, such a filter is a major task and requires unusual test equipment. The 3MHz filter is usually simpler, but still needs fairly high performance. Usually, a couple of active phase-corrector stages is sufficient to provide group delay correction, and the main filter may have no adjustments.

The stages marked 'gain control' will be electronically-controlled amplifiers. In older units there might have been FETs or photo-resistors in passive voltage dividers, but now there are

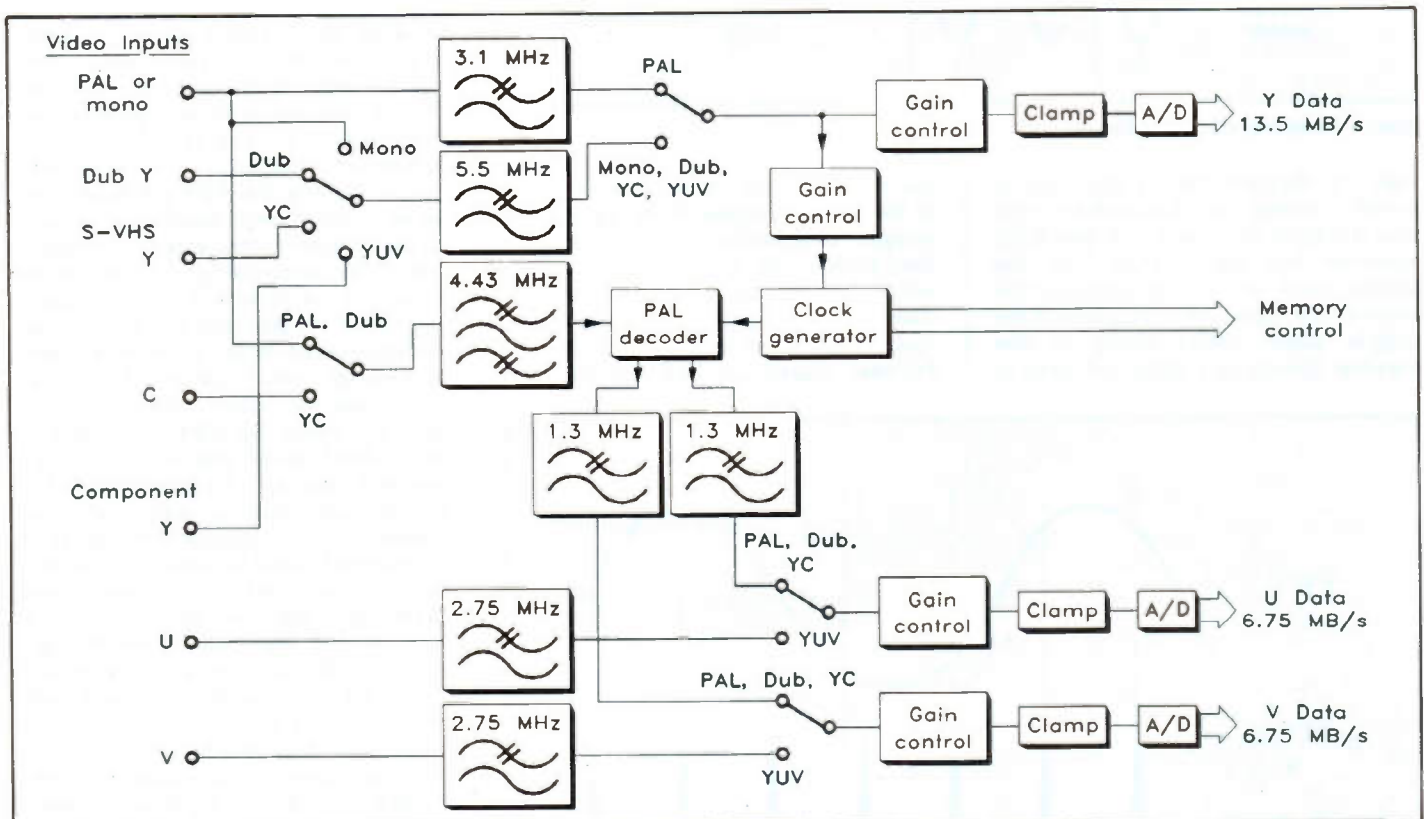

Figure 4. Block diagram, input processor.

The variety of input signals requires considerable switching, all electronic of course. This is basically signal routing, and the same type of components are used here as in vision mixers. The machine shown can accept PAL, Y/C, YUV and colour-under Dub signals. In addition, it can handle monochrome video at full bandwidth, via the PAL composite video input. Monochrome switching is usually automatic, when sync pulses are detected but not bursts, though there is often a manual override.

There is no Dub chroma input shown, as it is not usually worth trying to process it. Dub chroma is not crystal-stable, but has the same instabilities as luminance, preventing good quality decoding. Digitising it directly is a possibility, but the resulting TBC output would only be suitable for recording on another VTR of the same

No such doubts exist about Y/C. Signal levels and processing are the same as for PAL, except that Y and C arrive separately, and there is no need for the damaging low-pass filtering of luminance. Chroma is still band-pass filtered to avoid spurious frequencies arriving at the decoder and being aliased during demodulation.

The input processor appears to be full of filters, though in fact only the two luminance filters are likely to take up much room. The chroma filters are not required to have particularly high performance, and after the mangling received in coding and decoding, it is not really worth trying to correct decoded U and V for group delay errors. The direct U and V input filters do usually have rudimentary group delay correction, but filtering is normally fairly gentle and a single phase correction stage is usually adequate. On

more likely to be voltage-controlled amplifiers or multipliers. They will no longer be driven directly from front-panel potentiometers, but will be operated by the machine control system according to the input selected, with manual adjustment in addition to this. The gain variation needs to be about 4:1 to one to allow for worst-case component tolerances and the worst of the tapes likely to be encountered.

Control of black level is also carried out on the input processor, usually by the A/D clamp circuit. Low-cost TBCs may get away with a brute-force-and-ignorance clamp of the type used in the sync separator of a few articles ago, but this is not really good enough to ensure a stable black level over the normal temperature range. A typical A/D converter will operate over an analogue input range of about 1V, and a few tens of millivolts of clamp

voltage drift is not acceptable. Usually a feedback clamp is used instead, and this also makes control of clamp voltage quite easy. The basic principle is that a sample gate measures the video level during the back porch period (sync period for U and V channels) just before the A/D converter and compares the value to a voltage derived from the user black level control. The difference is amplified and added into a suitable earlier video circuit point. During the time that the sample switch is open, the hold capacitor maintains the same feedback drive. The point of measurement is normally the A/D converter input pin, to minimise errors.

There is usually a number of adjustments necessary in input processors. In the types that do not use microcomputer control of Y, U and V gain, there is normally a gain adjustment to be made for each analogue channel for each possible type of video input, as well as the front-panel user adjustment. A PAL encoder needs control of U and V output levels, decoding phase and quadrature. There may also be a one-line delay, which then needs at least two further adjustments. As with all electronic equipment, there is a move among TBC manufacturers away from manual adjustments and critical analogue techniques, towards automatic and digital circuits to do the same job more reliably and with less maintenance. This, of course, can only go as far as technology and economics allows. Gain and black level control, PAL ID detection and many other functions of an input processor can be implemented digitally, but not always with sufficient resolution. Another two bits of data precision is necessary before most of these processes can be performed digitally with the same performance as the present analogue circuits.

For instance, to maintain luminance black level constant, the digital value must be compared to a reference number at an appropriate time. Correction of an error cannot be made until the error is detected i.e. is large enough to change the digital value by at least one bit. If the error is over-corrected, then further action will not be taken until the digital value becomes wrong in the other direction, a change of two least significant bits (LSBs). The system will hunt between incorrect values either side of the correct one, at an unpredictable rate. This hunting is an unavoidable part of feedback error correction, but with analogue circuits it can be made arbitrarily small (at least until the noise level is reached). The smallest digital value is one LSB, and this is by definition large enough to be perceptible. The solution is to digitise and compare with an extra bit or two, to allow hunting to occur without disturbing the circuit's output values. Unfortunately, the ten-bit A/D converter is not yet cheap enough to allow this.

Similarly, gain control performed digitally requires that sometimes an input step of one LSB does not cause a corresponding output step, or perhaps

causes a step of two LSBs. This destroys the linearity of the A/D conversion, and is not acceptable. Again, the conversion and processing must occur at a greater digital resolution, with a look-up table to return to eight bits later. PAL ID is simpler to deal with digitally, but still not trivial. A negative burst value can easily arrange for the V samples for the next line to be inverted, but in fact what is needed is the two's-complement, not the ones-complement. The hexadecimal value 80 is the zero V value, and must remain 80 when PAL-inverted, not become 7F.

The input sync processor of a TBC, as suggested previously, is fairly complex. At its heart is the luminance sample clock generator, probably of 13.5MHz or 27MHz. This cannot be a crystal oscillator, as its frequency must follow the changes in input video frequency, and is usually an L-C type. The normal frequency variation is about 2% of nominal, which can be handled with varactor diode tuning fairly easily. The total frequency variation necessary depends on the VTR shuttle speed at which a stable picture (not necessarily in colour) is required, these days about 40 times normal. Head-to-tape speed is of the order of a hundred times the linear tape speed, and this range of shuttle speeds requires oscillator frequencies of about 60% to 140% nominal. A varactor-tuned L-C oscillator cannot really achieve this without losing a lot of stability, so it is normal to detect the shuttle mode of the VTR and to switch over to a second, wide-range R-C oscillator, usually a single-chip VCO.

Outputs from the input processor obviously include the Y, U and V data signals, each normally eight bits wide though some low-cost TBCs have used seven and even six bits per channel. A variety of control signals and pulses are supplied to the memory control system. These must include the luminance and chroma sampling clocks, horizontal and vertical references and an odd/even field ident. PAL ID and eight field information is irrelevant to a component TBC memory system, but a synchroniser memory would need these signals. Other horizontal and vertical rate signals may be used to initialise counters and latches and are more easily obtained from the input processor pulse generating system than derived individually from the H and V references.

Sync detection and subcarrier regeneration are likely to use all the noise-immunity techniques mentioned in the earlier article on the subject and many more besides, the object being to make the maximum amount of sense of the wide variety of video signals supplied to the TBC. The TBC is expected to cope with tapes recorded over wide ranges of temperature and humidity, on portable VTRs which may be moving around rapidly and may not have been serviced for several thousand hours. It is expected to deal with poor adjustment of the VTR and/or

the camera and to compensate for low lighting levels. Most of the ability to achieve these objectives comes from a well-designed input processor.

## TimeBase Corrector Output Processing

A typical component TBC output processor is shown in Figure 5, again without the details of control signals, pulses and buffers. Several areas are the same as, or similar to, parts of the input processor. The interpolation filters after D/A conversion are the same as the corresponding anti-aliasing filters, for reasons mentioned elsewhere. At a pinch, the 3.1MHz luminance filter can be omitted to reduce costs, but the picture quality will then be a little poorer with a PAL input. The sync processing is similar with regard to the pulses generated, as the memory read and write address generators will usually need the same sets of reference pulses. Sync, subcarrier and PAL ID recovery circuits can be much simpler, as the genlock reference video feed will be clean and crystal-stable, though it may be looped through many pieces of equipment and so the input buffer may be a hum eliminating type. There is an additional composite sync output to lock a VTR, which is usually about 750µs earlier than the sync on the video output. Older TBCs often had a variety of pulse outputs, such as H and V drives and composite blanking, but today so little other equipment actually uses them that few units provide them.

The delay lines in the component U and V output paths will normally be tapped, and the delay will be adjusted after a digital Y/C delay is set correctly for the PAL output. This can be a factory adjustment, as the circuit delays will not change significantly over the life of the equipment. A way of avoiding the relatively expensive analogue delay lines would be to use a second pair of D/A converters and a short digital delay. With chip prices still falling, it could be a cost-effective alternative.

Both Y and C Dub outputs are shown, since, unlike the input processing situation, it is worthwhile to produce high-band or low-band Dub chroma outputs. On the whole, it is only necessary to heterodyne 4.43MHz chroma with the appropriate crystal-generated frequency to produce Dub chroma, though for high band an additional chroma reference pulse must be inserted during the horizontal sync period. Again, luminance needs additional adjustment for output level and impedance and will also need to be delayed slightly to match the delay in the chroma heterodyne circuit. Dub Y will no longer be synchronous with other Y outputs, but that isn't important.

In general, all signal paths will have to be adjusted for level, and many modern TBCs can supply digitally-generated test signals for this purpose.

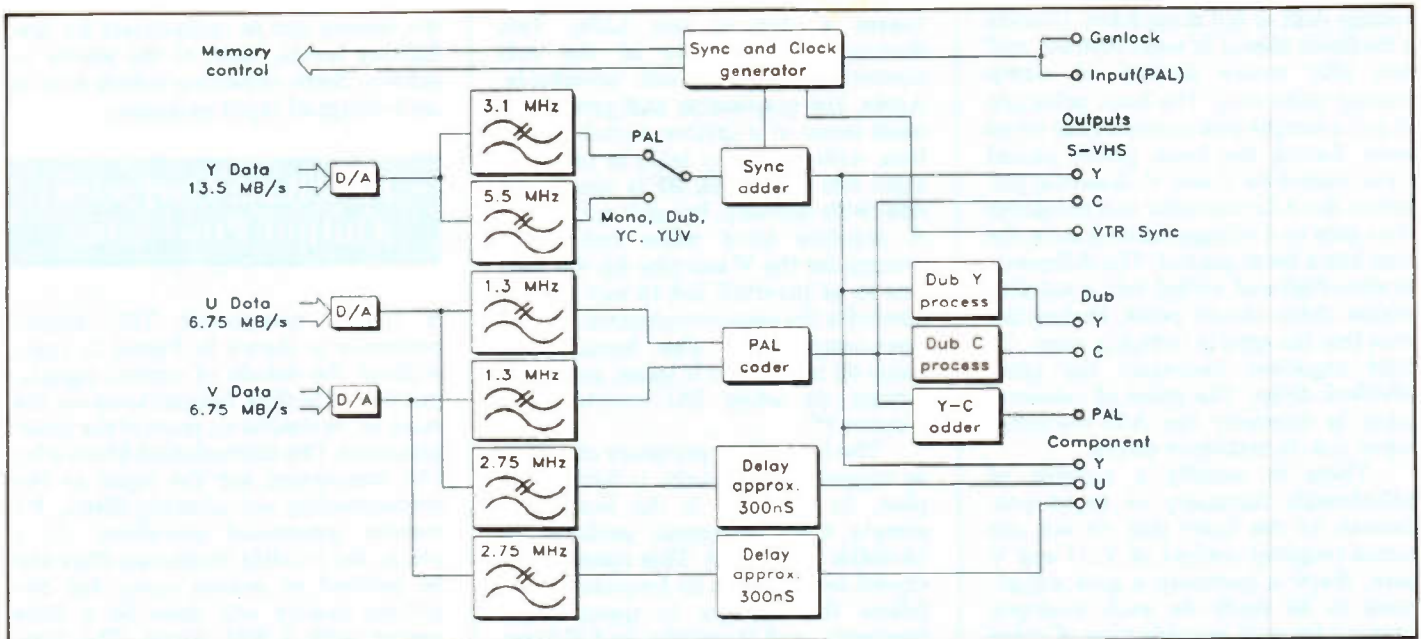

Figure 5. Block diagram, output processor.

Standard digital values are supplied to the D/A converters, usually to produce colour bars, though of course most test signals may be generated in this way. Once the outputs are correct, they can be connected back to the corresponding inputs to align the input processor if no test generator is available.

As is mentioned in the main article, little is done to video in the modern output processor. U and V entering the encoder may well be clamped, or alternatively the balance of the subcarrier modulators may be linked in some other way to the D/A output voltage. Luminance will probably not be clamped, but will rely on good design to avoid too much DC drift of the outputs. Older designs, that stopped D/A conversion during the blanking period, often generated glitches during that time and required analogue blanking later to clean up the output. Blanking is now usually carried out digitally, with video values filtered to prevent rise or fall times of less than 300ns. Logic-level composite sync must also be filtered to achieve the 260ns rise and fall times required in PAL, before being added to output video. Burst is normally generated by adding burst gate pulses (again filtered to produce 300ns edges) to U and V before coding. This avoids the need to adjust burst phase relative to coding phase, as both are by definition the same. As with the input processor, the genlock burst-locked oscillator usually runs at four times subcarrier frequency, making it easy to produce the two modulation carriers in accurate quadrature.

## TimeBase Corrector Memory Architecture

There is not really much that can be said about a typical TBC memory system, as there is no such thing. Even the basic architecture is totally dependent on the facilities provided by the TBC, particularly any digital effects,

along with the characteristics of the memory ICs used.

Some features are fairly fundamental: the use of FIFO (First In, First Out) memories to avoid asynchronous clock conflicts is universal. Before such ICs were available, memory had to be accessed in independent blocks, usually of one TV line in length. Only a few lines of storage were economic in those days, so the problems were not too serious, but it meant that the address and control lines for each block of ICs had to be kept separate, and connected to either the read or write address generator and clocks as appropriate. It also meant that no line could be read and written at the same time, which limited the correction range even more. Today's use of FIFOs with independent read and write time slots allows the read and write address generators to run freely and asynchronously, and even for one to overtake the other if necessary.

This deals with most of the problems of asynchronous video feeds almost automatically. Obviously, infinite storage is neither economic nor desirable, and if video is arriving faster than it is being used, then some must be discarded now and then. Similarly, if less video arrives than is needed then some more must be manufactured, by repeating the occasional field or frame. Read and write addresses are normally generated in sequence, being reset to the start of memory when the end is reached. If the write addresses overtake the read ones, then the read system will suddenly start using data that has just arrived, rather than data which was written the last time that the write addresses passed this point. A complete frame or field will have been dropped, depending on the size of the memory. Similarly, if the write address falls behind the read address, then data will be read that is one memory capacity older, and the previous frame or field will thus be repeated.

Actually, there is a little more to it than that. If, say, a frame is dropped and

then the video timing error slips back a little way, then the addresses may pass again and a frame must now be repeated. If the video source is a free-running VTR then the addresses may cross back and forth several times in the course of a second or so, before one finally draws firmly ahead of the other. Nobody will notice the occasional dropped or repeated frame, but if it happens several times like this, the effect will be very obvious. The solution is to use slightly more than a complete frame of memory, so that if a frame is dropped, the memory still contains a few lines of stored video, and has the capacity to absorb any VTR errors without the addresses re-crossing. You never get something for nothing, however, and the fact that successive frames are no longer written to the same memory addresses means that a frame-based dropout compensator must now be very much more complex, and a line-based one is usually used instead. One TBC of a few years ago actually offered a choice on a front-panel switch, that of disabling the frame-based dropout compensator and adding a little more memory if the VTR was free-running and the 'memory hysteresis' function was required.

Now address switching probably takes up more board space than the memory itself. Dynamic memory is universally used for the megabyte or so required to store a frame of component video. So row and column addresses for both read and write must be routed to the IC address lines, along with a third set if asynchronous processing of stored video is to be carried out. Demultiplexing and multiplexing of video data to the memory ICs is typically by a factor of six or eight, and is usually carried out by serial-parallel shift registers. FIFOs are often also demultiplexed, as they are expensive when required to run at the full luminance sample rate, and it can be cost-effective to use two much cheaper chips with a little control logic than one fast IC.

# On the make with Maplin!

## Three exciting new projects for you to build

The Maplin 'Get-You-Working' Service is available for all three of the projects featured on this page, for full details see the Constructors' Guide or current Maplin Catalogue.

### What a dog!

World renowned producer of quality projects, Velleman, haven't gone to the dogs, they have produced an electronic barking alarm that will send potential burglars barking mad! For many it is impossible to keep a real dog in the home and whilst an electronic siren will deter most burglars, some still persist with the break-in. However, the sound of a furiously barking dog, should be enough to deter even the most hardened burglar, and since only the bark of a dog is required, you can save on shoe leather (walkies), and dog food with this 'electronic watchdog'!

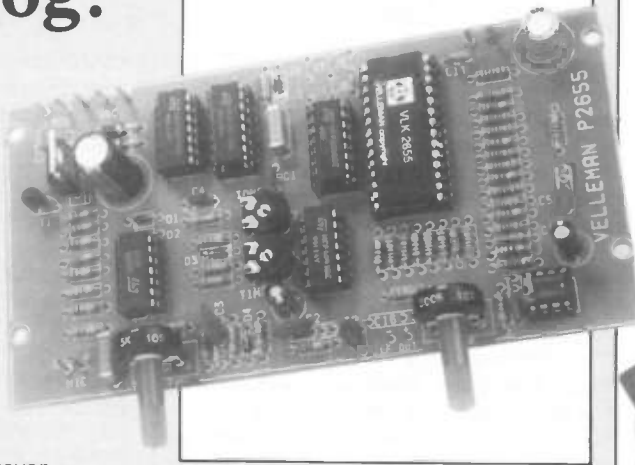

#### VE85G (Velleman Kit K2655) £29.95

Optional items available from Maplin; Horn Speaker (XQ73Q), DC PSU (XX09K).

### A 'Mega' Continuity Tester!



A unique resistance and continuity tester that indicates, on one of three ranges, the resistance value of the item under test. A multi-coloured LED is used as the visual indicator together with a continuity bleep. Ideal for tracking faults, testing components and continuity testing; the tester also provides indication of high leakage resistance, this range being ideal for testing low voltage insulation, capacitor dielectrics, etc. This continuity tester project is perfect for beginner and expert alike!

#### LP51F (Continuity Tester Kit) £8.95

## Inspect our Morse...

A morse decoder from Velleman that enables morse to be converted into readily understandable alphanumeric form. The decoded message is displayed clearly on a large LCD panel. An on-board electret microphone picks up the morse from the loudspeaker of a radio receiver; the decoder operates over a wide range of audio frequencies. This project is ideal for those wishing to learn morse code as the finished project makes a useful practice aid, and may be used to check that transmitted morse is being sent correctly – with adequate spacing – and also to double-check that the correct characters are being interpreted on reception. The decoder features adjustable centre frequency, adjustable sensitivity and lock range, and low voltage operation.

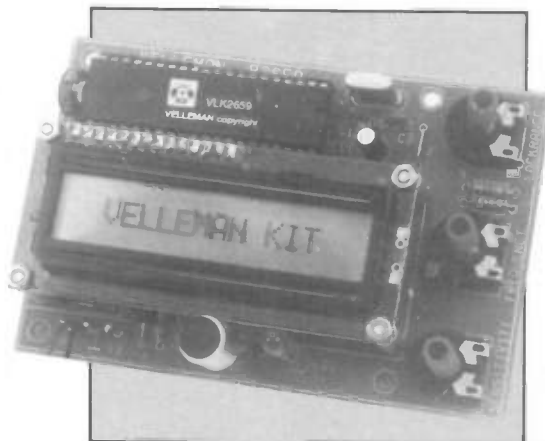

#### VE89W (Velleman Kit K2659) £59.95

### Where can you get them?

Maplin stores nationwide: Birmingham, Brighton, Bristol, Cardiff, Chatham, Coventry, Glasgow, Leeds, Leicester, London (Edgware and Hammersmith), Manchester, Newcastle-Upon-Tyne, Nottingham, Reading, Sheffield, Southampton, Southend-on-Sea. Ring 0702 552911 for further details. For all Mail Order purchases add £1.00 p&p. All items are subject to availability, all prices include VAT.

# Maplin The positive force in electronics

CREDIT CARD HOTLINE 0702 554161. Mail Order to; P.O. Box 3, Rayleigh, Essex, SS6 8LR.

# Bob's MINI-CIRCUITS

From Robert Penfold

## Dual Tracking Effects Unit

In the past Mullard's TDA1022 and TDA1097 'bucket brigade' delay-line chips have been popular for use in effects units and other circuits that require audio signals to be delayed by around 1 to 100 milliseconds. Unfortunately, these two chips were taken out of production a few years ago, and are no longer in the Maplin catalogue. In fact they are probably unobtainable from anywhere now. However, the MN3XXX series of delay line chips are still available, and would seem able to handle virtually anything that was in the repertoire of the two Mullard delay-line chips. The delay-line device used in this project is an MN3207, which is a 1024 stage type.

This unit provides a dual tracking effect, or with a few extra parts, a chorus effect. In essence it is a very simple effect that takes the input from a single instrument and provides an output that sounds like two instruments playing in unison. It is an effect that can be used to enrich virtually any signal, but it gives the

most obvious improvement on fairly simple sounds. For example, it works well with single VCO synthesiser sounds, electric guitars, or even a human voice (via a suitable microphone and preamplifier). In fact it is probably most used with solo voice signals to produce an instant duet. The effect is produced by mixing the input signal with a delayed version of itself.

IC3 is the delay-line chip, and IC6 is the matching clock and bias generator chip. The clock frequency determines the delay time and the maximum bandwidth that can be used. In this case a frequency of around 25kHz has been selected. The delay time is equal to the number of delay-line stages divided by double the clock frequency. This gives a delay time of around 20 milliseconds, which is suitable for the dual tracking effect. A delay of at least 10 milliseconds is required in order to produce the doubling-up effect, but the effect must be no longer than 60 milliseconds as this would give a short echo effect.

The clock frequency must be at least

double the maximum input frequency, but should preferably be three or more times the maximum input frequency. Input signals at excessive input frequencies cause a severe form of distortion known as 'aliasing' distortion. A 25kHz clock rate means that the audio bandwidth of the circuit must be limited to around 8kHz for good results. This is substantially less than the full audio bandwidth, but is wide enough to give good results. It should be borne in mind here that it is only the delayed signal that has this restricted bandwidth. The straight-through signal has the full audio bandwidth, which results in the unit as a whole having no obvious lack of high-frequency response.

The delay-line must be preceded by a low-pass filter which prevents high frequency signals from causing problems. This filter is a standard three stage (18dB per octave) type based on IC2. A buffer stage using IC1 is included ahead of the filter. This provides the unit with an input impedance of about 50k $\Omega$ , and ensures that the filter is fed from a suitably low source impedance. VR1

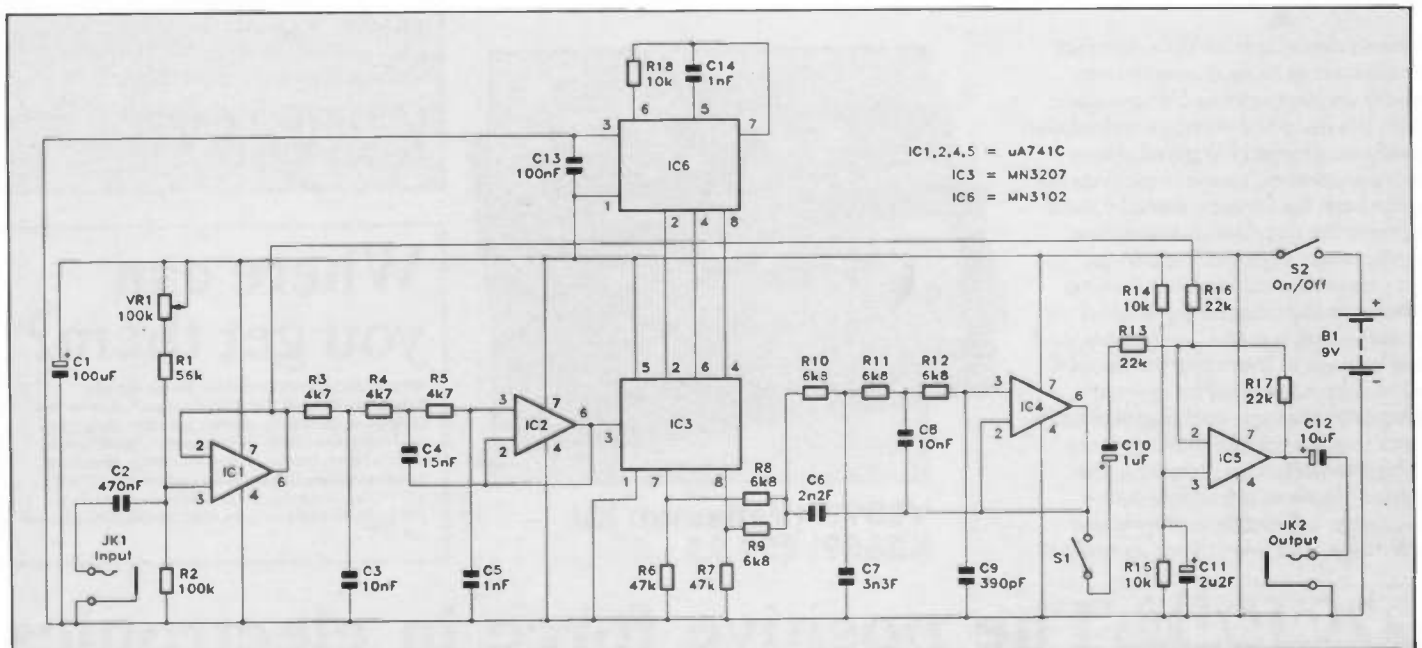

The Dual Tracking Effects Unit circuit diagram.



controls the biasing of IC1, and most of the rest of the circuit for that matter, as it is largely DC coupled. VR1 is adjusted to give optimum large signal handling, and with a 9 volt supply voltage swings of about 3 to 4 volts peak-to-peak can be accommodated.

A low-pass filter is also needed at the output of the unit. R8 and R9 mix the output signals from the last two stages of IC3, and this helps to minimise the clock breakthrough at the output. However, it is an inevitable consequence of the sampling delay-line technique that the output signal is stepped. The low-pass filtering smooths out this stepping to provide an ordinary audio output signal. The filter is a four stage (24dB per octave) active type based on IC4. IC5 operates as a conventional summing mode mixer which combines the delayed and non-delayed signals. S1 can be used to switch out the effect by blocking the delayed signal from the mixer. The current consumption of the circuit is approximately 9 milliamps. A PP3 size battery is just about adequate as the power source, but a higher capacity type such as six HP7 size cells in a plastic battery holder would be a better option if the unit is likely to receive a lot of use.

When constructing the unit do remember that IC3 and IC6 are both MOS devices, which therefore require the normal anti-static handling precautions. If the unit is built as a pedal unit, S1 should be a heavy-duty push-button switch mounted on the top panel of the case, so that it can be operated by foot. The case should be a tough type, such as a diecast aluminium box. If suitable test equipment is available, VR1 should be set for symmetrical clipping using the normal techniques. In the absence of suitable test gear, simply give VR1 any setting that gives low distortion on high level signals. Note that the unit should be fed with high level signals of around one volt rms if it is to achieve a good signal to noise ratio (preamplified signals). With signal sources such as microphones and low output guitar pick-ups the unit must be preceded by an appropriate preamplifier.

## Chorus Unit

This project is basically the same as the dual tracking unit described elsewhere in this article. The only difference between these two effects is that the delay time of a dual tracking unit is fixed, whereas the delay time used in a chorus unit is varied at a low frequency. The difference between the two effects can be subtle, or very obvious. This depends on both the modulation frequency used, and the signal source. By varying the delay time, the effect obtained is an output that sounds like numerous voices or instruments playing in unison, rather than just the two of the dual tracking effect.

Something that should not be overlooked is that the variations in the delay time produces a certain amount of vibrato. In other words, there is some frequency modulation on the output signal. The practical importance of this is that with a polyphonic input signal the musical intervals between the input

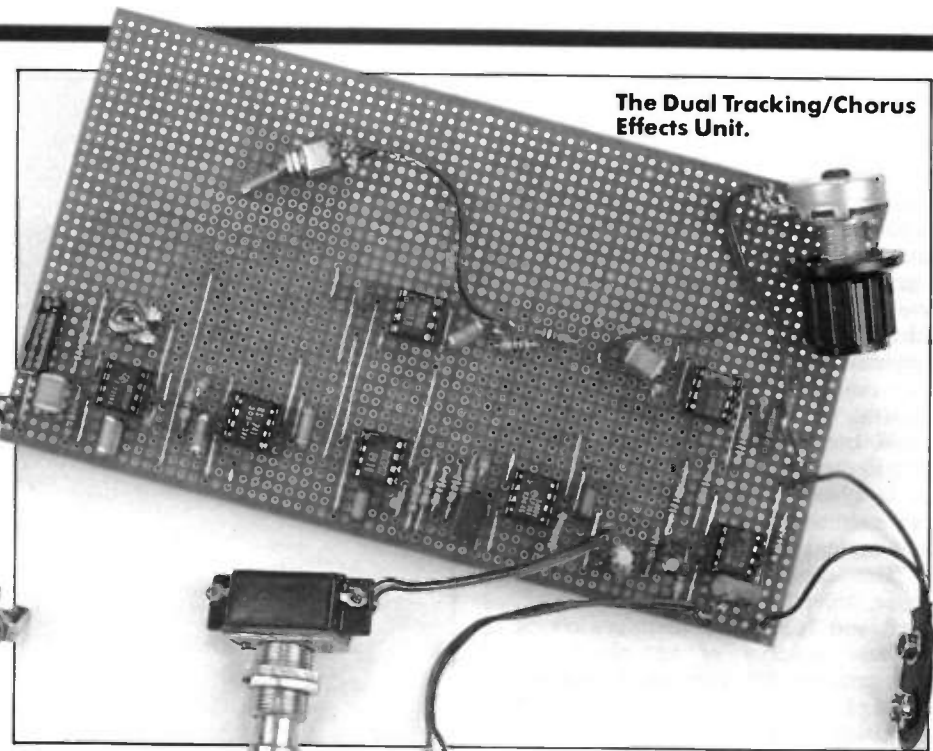

The Dual Tracking/Chorus Effects Unit.

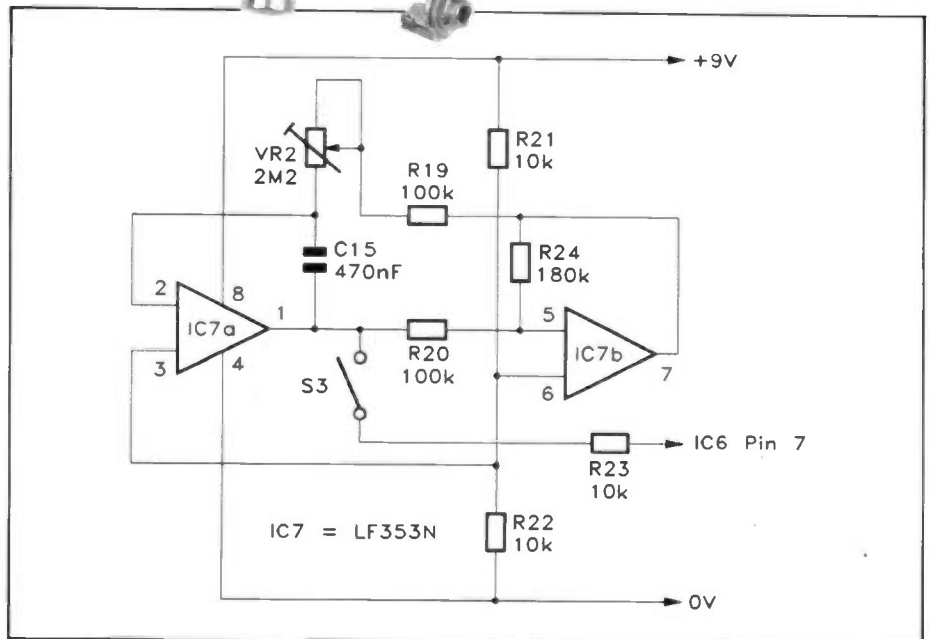

The additional circuitry required to make the Dual Tracking Effects Unit produce a Chorus effect.

frequencies are altered slightly. This can give some slightly discordant results. Unless you like that type of thing, it is best to either switch out the modulation when processing polyphonic signals, or to use fairly low modulation frequencies.

The circuit of the chorus unit is the same as that of the dual tracking unit, but the low frequency oscillator shown here must be added. This oscillator uses a standard configuration that is based on a Miller integrator (IC7a) and a trigger circuit (IC7b). There is a square-wave output from IC7b, and a triangular output from IC7a. In this application the triangular signal is the more suitable signal. It is coupled to the clock oscillator via S3 and R23.

S3 enables the modulation to be switched in and out, while R23 controls the modulation depth. The value of R23 has been made quite low so that reasonably strong modulation is produced. A higher value will give reduced modulation, but would probably give too

little modulation to be worthwhile. A lower value might give stronger modulation, but there is a risk that it would cause the clock oscillator to cut off for a portion of each half cycle. Although the clock oscillator chip does not actually have provision for voltage control, loosely coupling a modulation signal to its C - R timing network gives the desired effect. Connecting the modulation signal to pin 7 of the clock chip seems to give the best modulation range.

VR2 enables the operating frequency of the modulation oscillator to be adjusted from about 0.5Hz at maximum resistance, to about 10Hz at minimum resistance. The effect tends to be much stronger at the high frequency end of the range than at low modulation frequencies. When initially testing the unit it is therefore a good idea to set VR2 at minimum resistance, so that the strongest (and most obvious) effect is obtained. Again a PP3 battery is suitable for the power supply.

## Simple Capacitance Meter

One of the most useful pieces of test equipment for the electronics hobbyist is the capacitor checker. It is also one of the rarest amongst amateur electronics enthusiasts. In the past, few multimeters have included any capacitance ranges. Although the situation has improved somewhat in recent years, the capacitance ranges available remain far from universal, even on digital multimeters. A simple but accurate analogue capacitance meter can be built at quite low cost, and is a very worthwhile investment if your multimeter cannot handle capacitance measurement.

This capacitance meter has four ranges, with full scale values of 1nF, 10nF, 100nF, and 1 $\mu$ F. It can therefore check the vast majority of non-electrolytic capacitors, which have values from a few tens of pF to 1 $\mu$ F. The unit is *not* suitable for testing most electrolytic capacitors however, but it is usually possible to give these a rough (but useful) check using a multimeter.

The circuit relies on the fact that the reactance of a capacitor is inversely proportional to its value. Double the capacitance, and the reactance halves. Halve the capacitance, and the reactance doubles. The test capacitor is connected at the input of an inverting amplifier based on IC2. This has four switched feedback resistors (R6 to R9), and these provide the unit with its four measuring ranges. The voltage gain of the amplifier is equal to the feedback resistance divided by the reactance of the test capacitor. The higher the test capacitor, the higher the gain of the amplifier. The voltage gain of the amplifier is proportional to the value of the test component.

IC1 acts as an oscillator operating at a low audio frequency. This provides a triangular clock signal to the input of the amplifier. The strength of the output signal from the amplifier depends on the

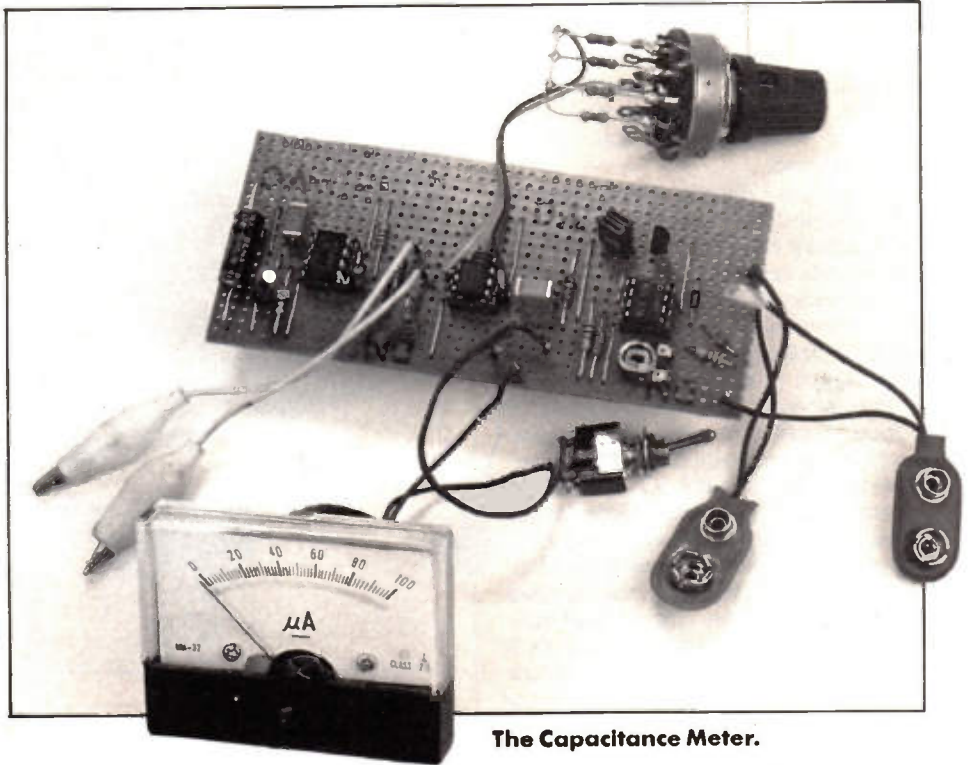

The Capacitance Meter.

gain of the circuit, which is in turn dependent on (and proportional to) the test capacitance. If the output of the circuit is fed to an AC voltmeter circuit, the latter can therefore be calibrated directly in capacitance values, and will have a normal forward reading, linear scale.

The AC voltmeter circuit uses IC3 in a conventional half-wave precision rectifier circuit. This ensures that the unit has good linearity, despite the inherent non-linearity of the diodes. VR1 permits the sensitivity of the voltmeter circuit to be adjusted, and in practice this is used for calibration purposes.

The accuracy of the circuit is dependent on the amplitude of the signal from the clock oscillator remaining constant. A stable output level will only be obtained if the supply voltage is well

regulated. The circuit is therefore powered from two PP3 batteries connected in series to give an 18 volt supply. Monolithic voltage regulator IC4 is used to derive a stable 12 volt supply from this. S2 can be used to connect the meter across the unregulated supply via R13. This effectively converts ME1 into a voltmeter having a full scale value of 20 volts, and enables the battery voltage to be checked. New batteries should be fitted when the loaded supply potential drops to about 15 volts (which corresponds to a reading of 75 $\mu$ A on ME1). The current consumption of the circuit, incidentally, is about 8 milliamps.

Construction of the unit is quite straightforward, but bear in mind that the CA3140E device used for IC1 is a PMOS input device and it therefore requires the usual antistatic handling precautions. Try

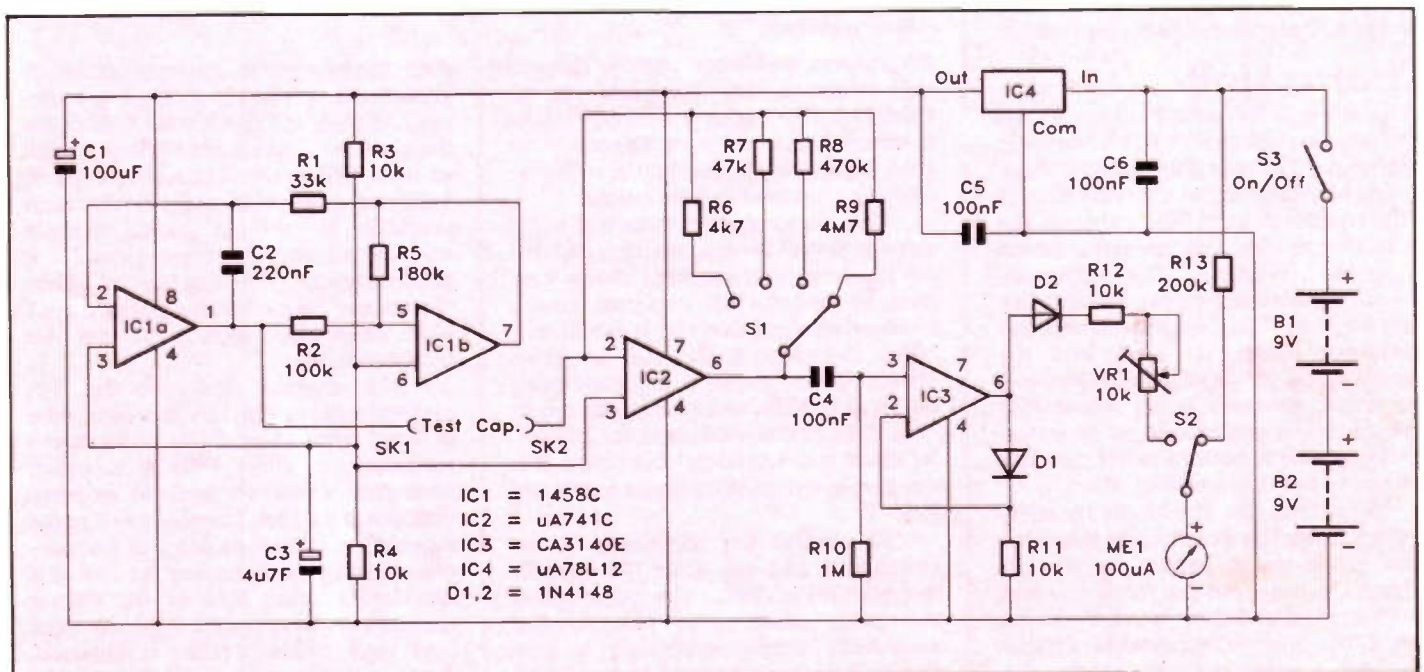

The Capacitance Meter circuit diagram.

to use a layout that keeps the stray capacitance across SK1 and SK2 as low as possible. Unlike some other types of capacitance meter, this configuration has no innate self-capacitance. This means that accurate results should be obtained from low value capacitors *provided* you avoided excessive stray capacitance.

For calibration purposes a close tolerance capacitor having a value equal to one of the full scale values is required. This could be a 10n 1% polystyrene capacitor (BX86T), used to calibrate the unit on the 0 to 10n range. Switch the unit to the appropriate range, connect the capacitor across SK1 and SK2, and then adjust VR1 for precisely full scale deflection on ME1. Provided R6 to R9 are the specified 1% tolerance components, the unit should then give good accuracy on all ranges. Using lower tolerance range resistors and (or) a lower tolerance calibration capacitor will compromise the accuracy of the unit. Also attempting to test large value capacitors on lower ranges will overload the meter and may damage it in extreme cases, so be sure to set the tester up properly before carrying out tests.

## Guitar Compressor

A guitar compressor is an effects unit which merely compresses the dynamic range of the input signal, giving a virtually constant volume for the duration of each note. This gives a less 'twangy' sound with a much longer sustain period. In fact units of this type are sometimes called 'sustain' units, due to this elongated sustain period.

The circuit is based on a VCA (voltage controlled attenuator). The VCA uses transconductance operational amplifier IC2 in a standard configuration. Strictly speaking this is a current controlled attenuator, as the gain is proportional to the control current fed to pin 1 of IC2. R11 biases the linearising diodes of IC2,

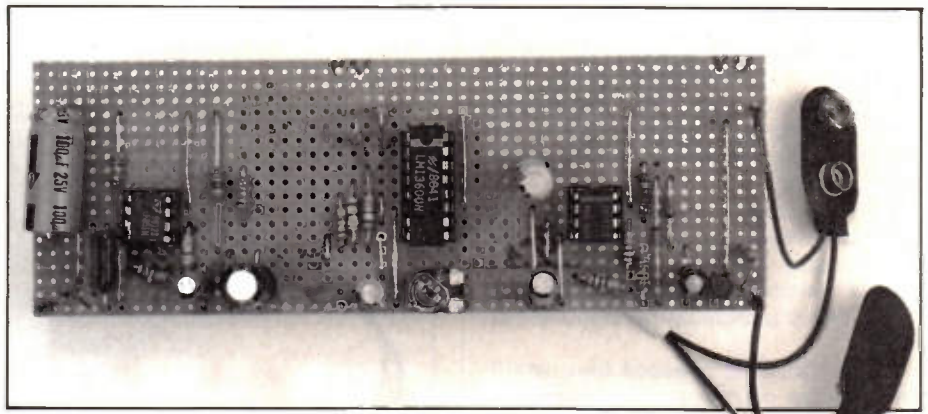

The Guitar Compressor.

and R12 supplies a bias current to the control input. The bias via R12 means that under standby conditions the VCA provides about unity voltage gain.

The VCA is preceded by a pre-amplifier stage which uses IC1 in the non-inverting mode. With the specified value for R4 the circuit has a voltage gain of about 48 times, and this gives good results with my electric guitar. However, this is fitted with low output pick-ups, and with many guitars much lower voltage gain will be needed in order to avoid overloading and severe distortion at the output of VR1. For high output pickups a value of around 22k to 47k would be more appropriate. With most pickups, the output level from IC2 will be somewhat higher than the input level. VR1 can attenuate the output signal, and it is adjusted to give an output level that is roughly comparable to the input level. There is no need for any precise measurements here – it is just a matter of adjusting VR1 to give what is subjectively assessed to be the same volume with and without the unit connected in the signal path.

Some of the output from IC2 is fed to a non-inverting amplifier based on IC3. This is mainly required to act as a buffer

amplifier, but it also provides a small amount of voltage gain (6dB). The output from IC3 is coupled to a rectifier and smoothing network based on D1 and D2. This produces a positive DC signal that is roughly proportional to the amplitude of the input signal. If this signal is strong enough, it biases TR1 into conduction, which results in some of the control bias current being tapped off. This reduces the bias current fed to IC2, which in turn results in increased attenuation through IC2. This gives a simple feedback action, where an increased output level causes more current to be tapped off through TR1, and the gain to be reduced. Once the input signal is high enough to bring TR1 into conduction, this feedback action tends to hold the output signal at an almost constant level.

The value of R15 controls the attack time of the circuit, and this has a strong influence on the effect obtained. A lower value tends to give over-shoot which totally suppresses the initial transient on each note. With the specified value the initial transients are allowed to pass, but at reduced volume, giving a conventional compression effect. A higher value of around 680 or 820 ohms permits the transients to pass largely unaffected. This

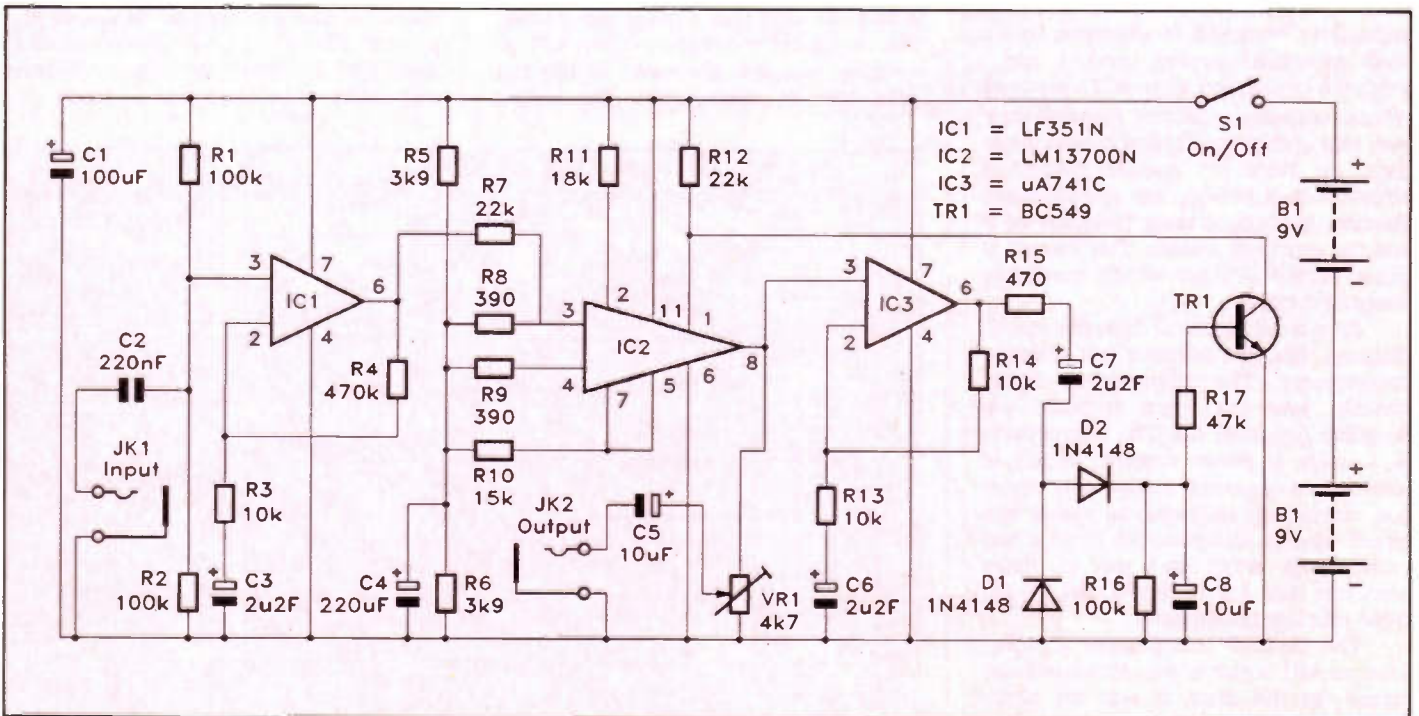

The Guitar Compressor circuit diagram.

retains the 'twangy' guitar sound to a large extent, but still gives the elongated sustain period. I personally prefer this effect, and it might be worthwhile experimenting with different values for R15 to find the one which gives the effect you like best.

No method of switching out the effect is shown in the circuit diagram, but this is easily achieved. A conventional bypass switching arrangement using a DPDT switch is probably the best method to use.

The circuit is powered from two 9 volt batteries connected in series to give an 18 volt supply. The unit will operate from a single 9 volt battery, but this gives less 'headroom' at the output of IC1, and might result in severe distortion with some guitars. The current consumption using an 18 volt supply is about 8 milliamps.

In use, bear in mind that a unit such as this inevitably increases the overall gain in the system. This increases the risk of excessive 'hum' pick-up and problems with feedback. Extra care therefore needs to be taken with the positioning of the speakers, guitars, mains leads, etc.

## Whistle Activated Indicator

In recent years a number of whistle activated gadgets have appeared, such as key-rings and torches. The basic idea is that if an item is mislaid, you simply whistle and a beeper is activated so that you can quickly home-in on the lost item. In the case of a torch, the idea is extended to that where if the lights go out, you whistle and the torch is activated, or an indicator light on the torch is turned on. You can then quickly and easily find the torch.

In order to make use of this type of facility it is not essential to have separate units each with built-in whistle activated indicators. You could, for example, have a shelf on which matches, candles, and a torch are stored, together with a separate whistle activated indicator. Building your own unit of this type is very simple these days, as there are special integrated circuits which provide the amplification, filtering, and other main functions of a whistle activated switch. This circuit is based on the UM3763 whistle controller integrated circuit.

As will be apparent from the circuit diagram, this unit requires few discrete components. The microphone feeds directly into the input terminal via coupling capacitor C1. The microphone is actually a piezo sounder, which is intended to operate the other way round (i.e. converting an electrical signal into sound waves). However, the Piezo effect works both ways, and one of these sounders can act as a low quality but quite efficient microphone.

The UM3763 incorporates a digital filter, and R1 is part of the clock oscillator circuit for this filter. It sets the clock frequency at around 18kHz, which gives a passband of about 1.2kHz to 1.8kHz. This

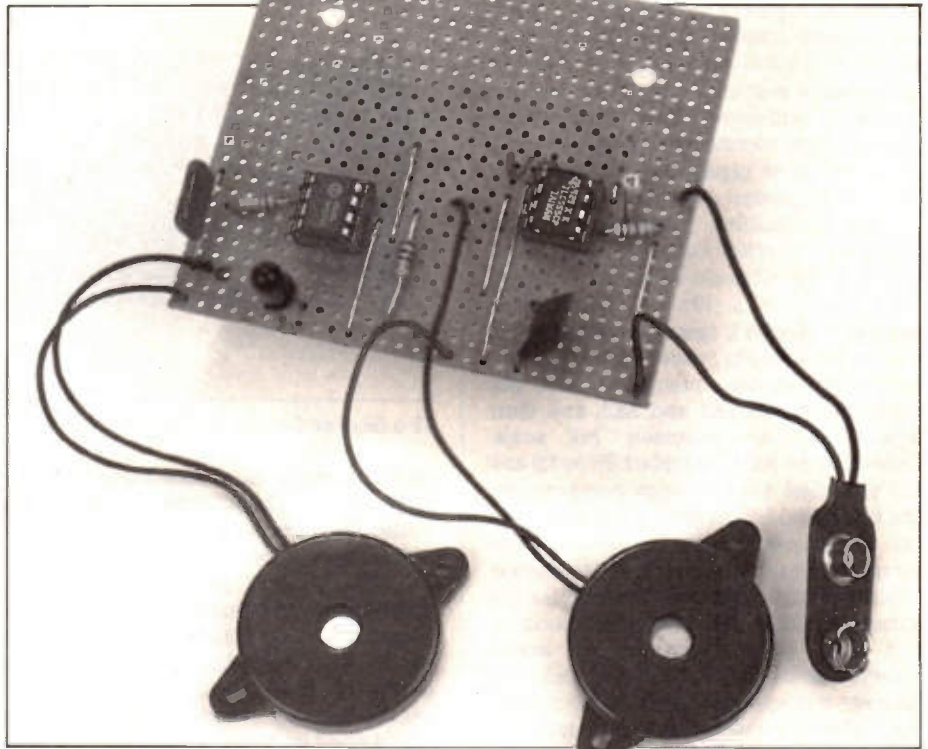

The Whistle Indicator.

is narrow enough to avoid spurious operation of the unit, which would result in greatly reduced battery life. On the other hand, it is wide enough to avoid the problem where only those who have perfect pitch are able to activate the unit! Any reasonably loud and fairly high-pitched whistle seems to activate the unit.

When activated, the output at pin 8 of IC1 goes high. This is used to activate LED indicator D1. The light output is quite low to conserve battery power, but should be sufficient to help find the thing in the dark. This stage also switches on a simple audio oscillator based around IC2. This is basically just a standard 555 astable oscillator which is gated via the reset input. A low power version of the 555 must be used as the standard device would run down the battery too quickly. The output of the oscillator drives a Piezo sounder, which is the same as the one used for the microphone. The output

signal is at a middle audio frequency, below the passband of the UM3763. The unit can be deactivated by whistling a second time. Having the audio output at a relatively low frequency avoids potential problems with acoustic feedback and unstable operation. Even so, it would be a good idea to mount Mic1 and LS1 as far apart as possible so that acoustic feedback is minimised.

With a current consumption of only 100 microamps or so under standby conditions, the two HP7 size batteries which provide the 3 volt supply should have a life of over one year. The batteries are fitted into a plastic battery holder, and this connects to the circuit board via a standard PP3 style battery clip. The on/off switch is not strictly necessary, but it could be useful to be able to deactivate the unit. Also, this provides an alternative means of resetting the circuit. Simply switch the unit off and then on again.

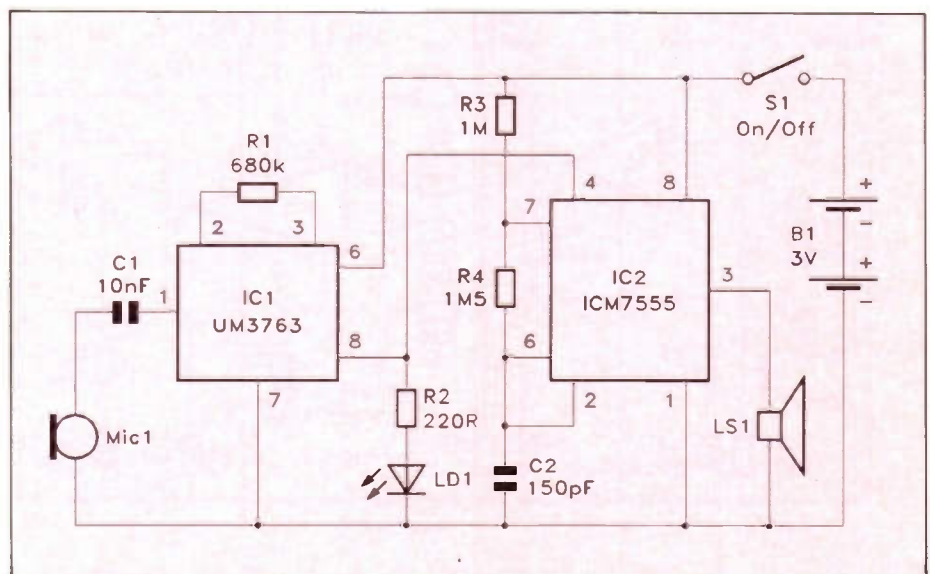

The Whistle Indicator circuit diagram.

## DUAL TRACKING UNIT PARTS LIST

RESISTORS: All 0.6W 1% Metal Film (Unless Specified)

R1	56k	1	(M56K)
R2	100k	1	(M100K)
R3,4,5	4k7	3	(M4K7)
R6,7	47k	2	(M47K)
R8,9,10,11,12	6k8	5	(M6K8)
R13,16,17	22k	3	(M22K)
R14,15,18	10k	3	(M100K)
VR1	100k Min. Hor. Preset	1	(UH06G)

### CAPACITORS

C1	100µF 10V Axial Elect	1	(FB48C)
C2	470nF Polyester	1	(WW49D)
C3,8	10nF Polyester	2	(WW29G)
C4	15nF Polyester	1	(WW31J)
C5,14	1nF Polyester	2	(WW22Y)
C6	2n2F Polyester	1	(WW24B)
C7	3n3F Polyester	1	(WW25C)
C9	390pF Polystyrene	1	(BX52G)
C10	1µF 100V PC Elect	1	(FF01B)
C11	2µ2F 100V PC Elect	1	(FF02C)
C12	10µF 50V PC Elect	1	(FF04E)
C13	100nF Ceramic	1	(YR75S)

### SEMICONDUCTORS

IC1,2,4,5	µA741C	4	(QL22Y)
IC3	MN3207	1	(UR67X)
IC6	MN3102	1	(UR68Y)

### MISCELLANEOUS

JK1,2	Standard Jack Socket	2	(HF91Y)
S1	SPST Min Toggle	1	(FH97F)
S2	SPDT Foot Switch	1	(FH92A)
B1	9 Volt PP3 Size	1	(FK58N)
	Battery Clip	1	(HF28F)
	DIL IC Socket 8-Pin	6	(BL17T)

## CHORUS UNIT PARTS LIST

RESISTORS: All 0.6W 1% Metal Film (Unless Specified)

R19,20	100k	2	(M100K)
R21,22,23	10k	3	(M10K)
R24	180k	1	(M180K)
VR2	2M2 Lin Pot	1	(FW09K)

### CAPACITORS

C15	470nF Polyester	1	(WW49D)
-----	-----------------	---	---------

### SEMICONDUCTORS

IC7	LF353N	1	(WQ31J)
-----	--------	---	---------

### MISCELLANEOUS

S3	SPST Min Toggle	1	(FH97F)
----	-----------------	---	---------

In addition to the above, a full set of the dual tracking unit components listed previously are required.

## CAPACITANCE METER PARTS LIST

RESISTORS: All 0.6W 1% Metal Film (Unless Specified)

R1	33k	1	(M33K)
R2	100k	1	(M100K)
R3,4,11,12	10k	4	(M10K)
R5	180k	1	(M180K)
R6	4k7	1	(M4K7)
R7	47k	1	(M47K)
R8	470k	1	(M470K)
R9	4M7	1	(M4M7)
R10	1M	1	(M1M)
R13	200k	1	(M200K)
VR1	10k Min. Hor. Preset	1	(UH03D)

### CAPACITORS

C1	100µF 10V Axial Elect	1	(FB48C)
C2	220nF Polyester	1	(WW45Y)
C3	4µ7F 63V PC Elect	1	(FF03D)
C4	100nF Polyester	1	(WW41U)
C5,6	100nF Ceramic	2	(BX03D)

### SEMICONDUCTORS

IC1	1458C	1	(QL87U)
IC2	µA741C	1	(QL22Y)
IC3	CA3140E	1	(QH29G)
IC4	µA78L12	1	(WQ77J)
D1,2	1N4148	2	(QL80B)

### MISCELLANEOUS

S1	4-way rotary	1	(FF75S)
S2	SPDT Min Toggle	1	(FH98G)
S3	SPST Min Toggle	1	(FH97F)
B1,2	9 Volt PP3 Size	2	(FK58N)
SK1,2	2mm Socket	2	(HF44X)
ME1	100µA Panel Meter	1	(RW92A)
	Battery Clip	2	(HF28F)
	DIL IC Socket 8-Pin	3	(BL17T)

## GUITAR COMPRESSOR PARTS LIST

RESISTORS: All 0.6W 1% Metal Film (Unless Specified)

R1,2,16	100k	3	(M100K)
R3,13,14	10k	3	(M10K)
R4	470k (see text)	1	(M470K)
R5,6	3k9	2	(M3K9)
R7,12	22k	2	(M22K)
R8,9	390Ω	2	(M390)
R10	15k	1	(M15K)
R11	18k	1	(M18K)
R15	470Ω (see text)	1	(M470)
R17	47k	1	(M15K)
VR1	4k7 Min. Hor. Preset	1	(UH02C)

### CAPACITORS

C1	100µF 35V Axial Elect	1	(FB49D)
C2	220nF Polyester	1	(WW45Y)
C3,6,7	2µ2F 100V PC Elect	3	(FF02C)
C4	220µF 35V PC Elect	1	(JL22Y)
C5,8	10µF 50V PC Elect	2	(FF04E)

### SEMICONDUCTORS

IC1	LF351N	1	(WQ30H)
IC2	LM13700N	1	(YH64U)
IC3	µA741C	1	(QL22Y)
TR1	BC549	1	(QQ15R)
D1,2	1N4148	2	(QL80B)

### MISCELLANEOUS

S1	SPST Min Toggle	1	(FH97F)
JK1,2	Standard Jack Sockets	2	(HF91Y)
B1,2	9 Volt PP3 Size	2	(FK58N)
	DIL IC Socket 8-Pin	2	(BL17T)
	14-Pin DIL IC Holder	1	(BL18U)

## WHISTLE INDICATOR PARTS LIST

RESISTORS: All 0.6W 1% Metal Film

R1	680k	1	(M680K)
R2	220Ω	1	(M220R)
R3	1M	1	(M1M)
R4	1M5	1	(M1M5)

### CAPACITORS

C1	10nF Polyester	1	(WW29G)
C2	150pF Ceramic	1	(WX58N)

### SEMICONDUCTORS

IC1	UM3763	1	(UJ47B)
IC2	ICM7555	1	(YH63T)
D1	Red Panel LED	1	(QY48C)

### MISCELLANEOUS

B1	HP7 Size Cell	2	(FK55K)
LS1	Piezo Sounder	1	(FM59P)
Mic1	Piezo Sounder	1	(FM59P)
S1	SPST Min Toggle	1	(FH97F)
	DIL IC Socket 8-Pin	2	(BL17T)
	Battery Clip	1	(HF28F)
	Battery Box	1	(YR60Q)

The Maplin 'Get-You-Working Service is not available for these circuits.

An aerial view of the Hendon museum buildings.



# TAKE-OFF AT THE RAF MUSEUM

by Alan Simpson

Your Out and About compiler has certainly visited some unusual venues on your behalf these past twenty four months. But never before has he had to park his car between an Air Sea Rescue Launch and an air-to-air missile. But he is not the only one. Every year, a quarter of a million people come to look, to wonder and to enjoy a visit to The Royal Air Force Museum in Hendon, North London. The RAF museum is, as the brochure puts it, many things: a beautifully presented history of aviation; a vast and unique collection of flying machines; a tribute to the men and women (and aircraft) of the RAF and the US Army Air Force; a kaleidoscope of galleries and gallantry, of medals and memorabilia, of uniforms and unsung heroes.

Certainly a visit to Hendon is memorable. The RAF Museum is an essential part of Britain's heritage, an aviation buff's heaven, and a great day out for all the family. While some members of the family may never have heard of Alcock and Brown, let alone the exploits of the 'Red Baron', they will have certainly heard of the Spitfire and Hurricane, (and probably their German equivalent, the Messerschmitt) and the Tornado which had a major role in the somewhat more recent Gulf War.

As the museum's director, Dr. Michael Fopp, puts it, "Our objective is to cover the history and traditions of the RAF and aviation in general. Technical development in military aviation is soon reflected in civil aviation. Radar and transponders, for example, are now standard fittings in your charter flight aircraft, but were

originally developed to help identify friendly from unfriendly planes."

Unusually, for a museum, the location is as relevant as the exhibits. The area was the cradle – if not quite the birthplace – of British aviation. Ballooning around the Welsh Harp at West Hendon became a popular and fashionable pastime in the early

WWII early warning radar equipment and operator. Unlike modern radar, there were no revolving dishes at this time. The antennas were carried on enormous masts like electricity pylons, strung all along the South coast of England.





◀ An American Boeing B17 Flying Fortress. Thousands of these were involved in bombing sorties on Germany, and became a familiar sight to Londoners, literally filling the sky, as wave after wave set out to cross the channel from airfields in the Midlands and Home counties.

The enormous Short Sunderland flying boat is normally completely aquatic, the wheels shown are strictly "bolt-on" extras. This type of aircraft takes its origins from the 'Empire flying boats' of the 20s and 30s, which linked Britain with her colonies in the Middle East and Africa, and which would take-off and land on sea harbours, inland lakes and various places on the river Nile.



# OUT AND ABOUT

1900s. Then, with America's Wright brothers and France's Louis Bleriot pioneering powered flight, a certain Claude Grahame-White decided it was time to get in on the act, and acquired not just a plane from the Bleriot flying school, but a site at Hendon. This rapidly became the central focus of British aviation, attracting many of the leading aviators and aircraft constructors of the day to set up schools at Hendon alongside the Grahame-White aircraft factory. At the outbreak of the First World War in 1914, Hendon was commandeered for military aviation and has subsequently been inextricably linked with civil and military aviation throughout most of the following decades of powered flight. The museum reflects the world of aviation, charting its history and current developments, presenting these to the visitor chronologically, theatrically and even aesthetically. The galleries and displays may have been scripted by aviation historians, but they were assembled by professional designers.

The days of the RAF Hendon fly-past may be long gone – much of the old aerodrome is now a council estate – but you'll still find much to interest



and excite you at the RAF Museum. Britain's national museum of aviation houses one of the world's finest collections of historic aircraft, illustrating the story of flight, from those early Wright brothers up to the present day. The museum complex covers 15 acres, with the main Aircraft Hall occupying two hangers dating from World War I. The complex also includes the Bomber Command Hall and Battle of Britain Experience as well as extensive display galleries.

With over a quarter of a million

◀ The museum's flight simulator enables visitors to experience the thrill of flying without leaving the ground. The 14 seat capsule pitches and rolls in synchronisation with a film and sound track projected inside. Flight experiences include a low-level sortie through Welsh mountains in a Tornado, and a WWI dogfight.

visitors a year, the Museum is the largest and best-attended aviation museum in Europe. Meanwhile the Aerospace Museum at RAF Cosford, in the West Midlands, is Hendon's 'outpost' and attracts over 150,000 visitors a year. This, incidentally, is a large museum in its own right, storing not only some two million objects, but displaying 75 planes (including the British Airway's collection of civil airliners) and acting as a general back-up to Hendon. In addition there is a restoration centre at RAF Cardington where the Museum's reserve collection is also stored and where, at any one time, eight historic planes could be undergoing restoration.

## Don't Fly Past

Between darting through the massed ranks of aircraft, vintage and modern,

A Spitfire of the Battle of Britain Memorial Flight. Actually Spitfires were outnumbered by Hurricanes, which were quicker and easier to build and repair, being constructed from doped canvas over a tubular steel airframe, compared to the Spitfire's complex, stressed skin aluminium structure. The Rolls-Royce Merlin engine (a 24-litre V12) which these two shared was used in many other machines including the Lancaster, Mosquito and the American Mustang. The rectangular 'box' under the starboard wing is the radiator, the long bulge under the other, an oil cooler. These relied on forced air cooling in flight, and if the plane was not airborne within two minutes of starting, the engine would seize up.

the visitor should pause for a moment, and look upwards. The main hall is formed from two Belfast-truss hangers dating back to 1915. This is an interstitial arrangement of wood, cross-membered to give a structural rigidity great enough to allow the use of this material instead of iron and steel, which were in short supply during WWI. A modern roof links the two hangers, allowing some 40,000 square feet of aircraft display and enabling magnificent panoramic views from the ground and from strategic vantage points in the display galleries above. However, despite the sophisticated walkways, captioning and lighting, the aircraft hall still provides much of the typical hanger feel and atmosphere.

As far as possible, the aircraft have been positioned in chronological order. A 'conspectus' (the brochure's term, not mine!) of flying machines is given, from a Bleriot similar to the cross-channel type to a Mach 2 Lightning prototype. The role of the RAF in the somewhat recent Gulf War is highlighted with a Harrier on display. Less aggressive, but worthy, exhibits are the displays by British Airways, ranging from the first link to Paris back in 1916 to the Concorde.

There is a special section in an extension devoted to Bomber Command. On show are the massive bulks of the WWII Lancaster, Wellington and Halifax, and the later Vulcan, bombers. Also present is the Boeing Flying Fortress, the aptly named symbol of American daylight bombing in Europe. But without doubt the most impressive aircraft on show, in terms of its sheer bulk, must be the Short Sunderland V flying boat, having a wing span of 112ft. 10in. and being 85ft. 4in. in length! Long-range Sunderlands began service with Coastal Command as early as August 1939, and later played an essential role in patrolling home water sea lanes against U-boats and surface raiders.

## The Battle of Britain – Fifty Years On

What was originally staged in 1990 as a limited exhibition to mark the 50th anniversary of the greatest air battle in history – 'The Battle of Britain Experi-



Copies of this poster, produced by fighter ace Group Captain A. G. 'Sailor' Malan, were pinned to many air station walls. The request for eight machine guns for the Spitfire was regarded as 'a bit over the top', but the powers that be, were persuaded that the calculation of eight (1,000 rounds per minute) guns were required to destroy a bomber in two seconds. There was only enough ammunition for seven or so such bursts (see rule 1), and fuel for fifteen minutes flying time, spent reaching the combat zone and then (hopefully) returning to the air field (see rule 10).

British fighter pilots spent most of their time waiting for a scramble. Fortunately, the summer of 1940 had excellent weather.

### TEN of MY RULES

#### AIR FIGHTING

- 1 Wait until you see the whites of his eyes. Fire short bursts of 1 to 2 seconds and only when your sights are definitely ON.
- 2 Whilst shooting think of nothing else; brace the whole of the body, have both hands on the sticks, concentrate on your ring's sight.
- 3 Always keep a sharp lookout. "Keep your finger out!"
- 4 Height gives you the initiative.
- 5 Always turn and face the attack.
- 6 Make your decisions promptly. It is better to act quickly even though your tactics are not the best.
- 7 Never fly straight and level for more than 30 seconds in the combat area.
- 8 When diving to attack always leave a proportion of your formation above to act as top guard.
- 9 INITIATIVE, AGGRESSION, AIR DISCIPLINE, and TEAM WORK are words that MEAN something in Air Fighting.
- 10 Go in quickly – Punch hard – Get out!

*Quoted by Malan*





ence', housed in a separate building – has become one of the major attractions of the Museum. Here you can see the legendary Spitfire and Hurricane doing battle with their adversaries, the equally legendary Messerschmitts. As the exhibition makes clear, in the summer of 1940 a Spitfire pilot had total control of a 350mph fighter plane, but which had no radar, no autopilot and no electronics! (Even the crude valve radios didn't appear till later.) His aircraft was armed with eight, 1,000 rounds per minute, Browning .303 machine guns (the same calibre as a soldiers' rifle), and his aircraft was unarmoured, yet over 90 gallons of petrol was situated in

sundry operations rooms become animated as does Winston Churchill. Rather than having each exhibit operating under local control, cable has been installed around the Hall, linking all controls back to a central control room. The sound system is synchronised by visitors passing an 'electronic eye', as far as possible, solid state technology is used, which helps by minimising maintenance costs.

To complete the tour, there are a dozen galleries, covering such aviation activities as paratroopers, maintenance and components, and the development of the first jet engine. You can even join the RAF, visit the cinema, spend some time (and

capsule is mounted on a multi-axis, high speed hydraulic base. Using advanced computer technology, the simulator pitches and rolls in movements that are dramatically synchronised with film and sound track projected inside the capsule. This is not like your typical take-off, or come to that the well respected train journey from London to Brighton film. A variety of flight experiences are offered, including a low-level sortie through the Welsh mountains in an RAF Tornado strike aircraft, and a World War I dogfight with the Red Baron in a Bristol fighter.

Overall, says Chris Elliott, this is not a static exhibition. "Unlike many

The Vickers Wellington was designed by Barnes Wallace, using his geodetic construction for the airframe, which made the aeroplane extremely strong and able to survive extensive damage and still return home. More Wellingtons were built than any other British bomber, yet of the 11,461 that were built, only one complete example survives at Hendon.



front of his lap! He had no crash helmet or protective clothing (England cricketers take note) save a silk parachute. Visitors can also inspect at close hand the German 'revenger' weapons, the V1 Flying Bomb, many thousands of which were launched against London, which is not to be confused with the V2 Rocket, the world's first ballistic missile, also shown.

The Battle of Britain hall gave Chris Elliott, charmingly given the title 'Keeper of Design, Display and Exhibitions', the opportunity to incorporate highly impressive (apparently it impresses the many American visitors) 'talking head' and new lighting technology. Radar screens glow, and

money) in the well stocked shop (except for Biggles hats) or relax at the licensed restaurant. There is also a fully equipped boardroom, lecture theatre and exhibition space which can be hired. If you are really keen, you can even have an evening event amongst the aircraft themselves.

### Beam Me Up Scotty

'Electronics' readers in particular might be expected to make a bee-line for the Flight Simulator Experience. Here, for the price of £1.25 per person, the Cathay Pacific Airways sponsored simulator (bet their pilots don't take off near vertically) enables visitors to experience the thrill of flying without leaving the ground. The fourteen seat

of the exhibits, which are more 'drawing pin' than CAD/CAM technology, we are moving more and more towards interactive display techniques. Unfortunately we can't always let visitors feel and touch many of the exhibits, especially if they are priceless relics, but we are incorporating computer-driven audio/visual cockpits which the visitor can clamber into, plus lots of push-buttons." Chris maintains close links with many audio visual technology companies and is constantly on the look-out for new ideas – providing that funds permit.

Plans are already well in hand to develop further experiences of flight using simulator rides, hands on exhibits, and interactive computer-



The Mosquito was originally designed as an unarmed bomber which would depend on its superior performance to avoid enemy fighters. It also proved remarkably versatile in other roles, and was a great success for photographic reconnaissance, night fighter, intruder and anti-shiping strikes. Yet the most extraordinary thing about this well-loved and successful aeroplane was the entirely wooden airframe.

captioning capable of interrogation by the public.

## A Great Day Out for All the Family

While a visit to the Hendon RAF Museum may well be a great day out for all the family, it also makes a great educational time out. A substantial number of children visit the museum during term time – many of whom subsequently bring their parents, or grand parents. "In fact," says Director Michael Fopp, "the museum is particularly keen to see itself integrated into the school syllabus." To help this cause there are free preparatory visits for teachers, talks for visiting school groups plus comprehensive activity sheets.

## 'Over-paid, Over-sexed and Over-here'

However, it won't be just school children who will be flocking to the Special Event of 1992. The US Army Air Force Exhibition 'Friendly Invasion' is on display, marking the 50th Anniversary of USAAF in Britain. Based around the existing display of US planes, it is expected that the event will be the focal point for the thousands of US veterans returning to Britain with their families this year, to remind them and ourselves of that time when the two nations flew together against a common enemy. 'Friendly Invasion' apart, the museum stages between six and eight temporary exhibitions every year.

## Major Works Ahead

As if staging all these events was not enough, the museum is currently

undergoing a major re-development programme to further improve walkways, display areas and new additions to the aircraft on display. Also planned is a major re-design of the Bomber Command Hall to coincide with the 1993 Anniversary of The Dam Busters Raid. The museum also hopes to acquire a further four acres of land for the erection of a new exhibition hall. "Basically," says Chris Elliott, "we want our visitors to go away enlightened, but knowing that if they return in six months time, they will see a new display."

So its chocks-away for Hendon. To help speed your path to Hendon, 'Electronics – The Maplin Magazine' has six sets of family tickets (2 adults and 2 children) worth £11, plus a free copy of the Guide Book at £1.50, to give away to the contest-winning readers. So don't delay, get your entries off today and you could be one of the lucky ones!

The Royal Air Force Museum is 20 minutes from central London on the A41, with easy access from M1 Junction 4 and M25 Junction 23. There is a large free car and coach park, and the nearest rail stations are Colindale, Northern Underground line and Mill Hill Broadway on Thameslink. Also a new 303 bus service links Edgware and Mill Hill Broadway via Colindale Underground with the Museum. Prices, at time of compilation, are: adults £4.10, children, senior citizens, students, RAF personnel and registered unemployed £2.05. (All tickets allow free return visit within 6 months.) The Museum is open daily all year from 10am to 6pm, except on 1st January and 24th-26th December. For more details ring (081) 205 2266.

## RAF Hendon Museum Competition

Send your answers to the four questions below, sourced from 'A Junior Guide to the Royal Air Force Museum', to reach us before the 30th September 1992. Please note that multiple entries will be excluded from the draw. Answers on a postcard (or back of a sealed down envelope) please to The RAF Museum Contest, The Editor, 'Electronics – The Maplin Magazine', P.O. Box 3, Rayleigh, Essex SS6 8LR. Tally Ho!

1. Except for gliders, balloons, jets and helicopters, all aircraft have to have one of more of these to drive them through the air:
  - (a) Engine.
  - (b) Tail wind.
  - (c) Duty Free Trolley.
2. In legend, he flew too near the sun and crashed into the sea. Who was he?
  - (a) Hermann Goering.
  - (b) Icarus.
  - (c) Donald Duck.
3. What did fighter command pilots do to get into the air as quickly as possible?
  - (a) Check their maps.
  - (b) Look at the wind sock.
  - (c) Scramble.
4. Which brothers were the first to make a sustained powered flight?
  - (a) Blues Brothers.
  - (b) Wright Brothers.
  - (c) Marx Brothers.

# Twelve great reasons to get Electronics under cover...



Available for the first time! The new Maplin magazine binder that holds twelve issues of Electronics, the Maplin magazine. If you have not got the world of Electronics covered, now's your chance! This great, quality binder comes in hard wearing, laminated art board, that not only looks good on your bookshelf or workshop desk, but is also a great way to build up an Electronics reference library of your own!

Now you can keep all of your copies of Electronics, the Maplin magazine, together and on hand for when you need that extra piece of information. To order your binder simply fill in the order form provided in this issue of Electronics. Only £5.45 (plus £1 handling charge). Order no: XH99H.

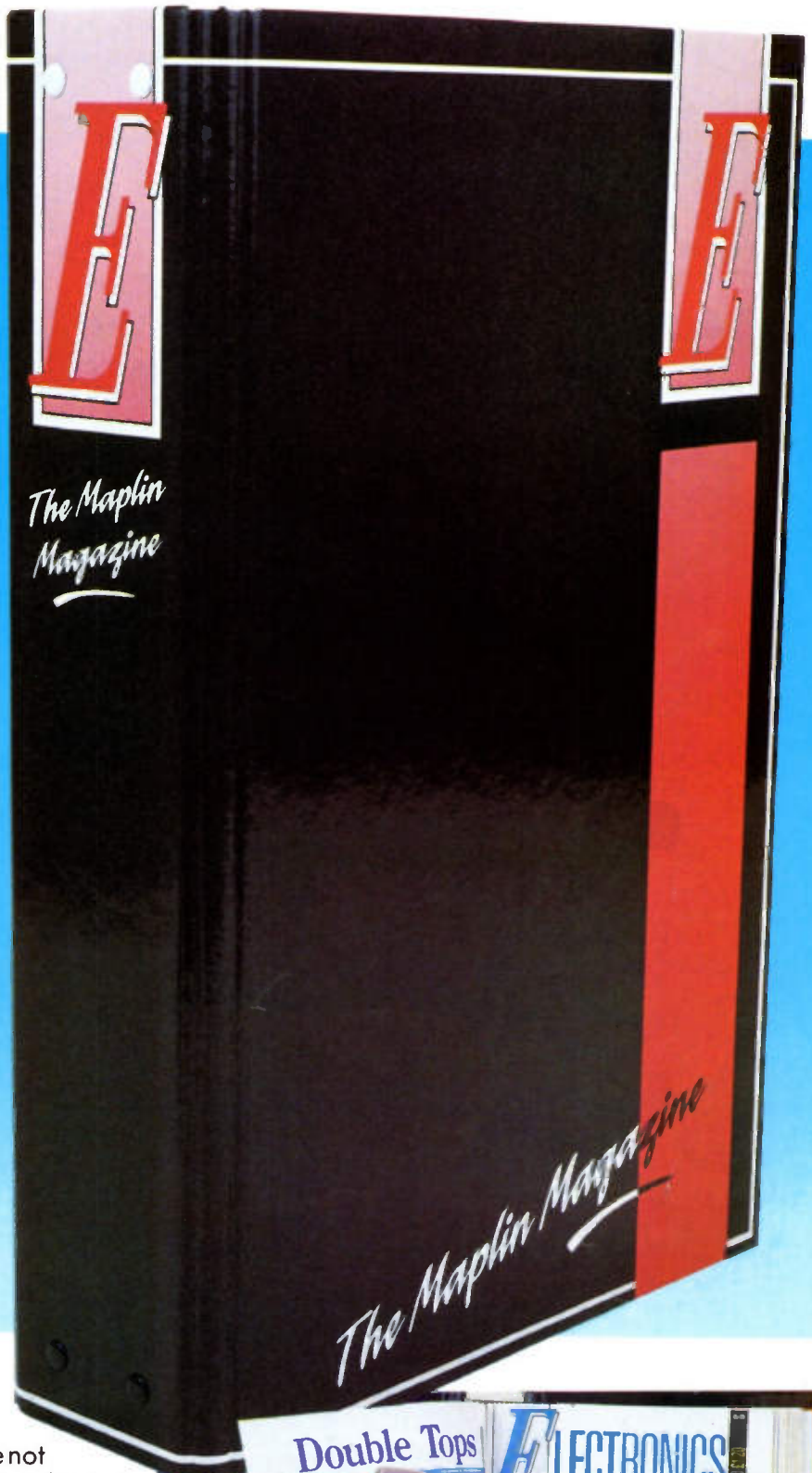

**THE NEW MAPLIN MAGAZINE BINDER...  
A GREAT WAY TO GET THE WORLD OF ELECTRONICS COVERED!**

BUYER'S GUIDE TO ELECTRONIC COMPONENTS 1993

# Maplin



BS 5750  
Part 2 1987  
Level B:  
Quality Assurance  
RS12750

**Order your copy of the New MAPLIN Catalogue on sale 4th September!**  
Pick up a copy from any branch of WHSMITH or from our chain of shops for just £2.95 or  
post this coupon now to receive your copy for just £3.45 inc. p&p. If you live outside the  
U.K. send £5.50 or 14 IRC's for Airmail in Europe/surface mail outside Europe;  
or £10.65 or 27 IRC's for Airmail outside Europe;  
I enclose £3.45/£5.50/£10.65 (delete as applicable).

Name.....  
Address.....  
Post Code.....  
Send to Maplin Electronics,  
P.O. Box 3, Royleigh,  
Essex, England,  
SS6 8LR.  
MM93

Over 700 product packed pages with  
hundreds of brand new products.  
On sale from September 4th, only £2.95

Available from all branches of WHSMITH and  
Maplin shops nationwide. Hundreds of new  
products at super low prices!