

Hobby Electronics

January 79
40p

STARSHIP DAEDALUS

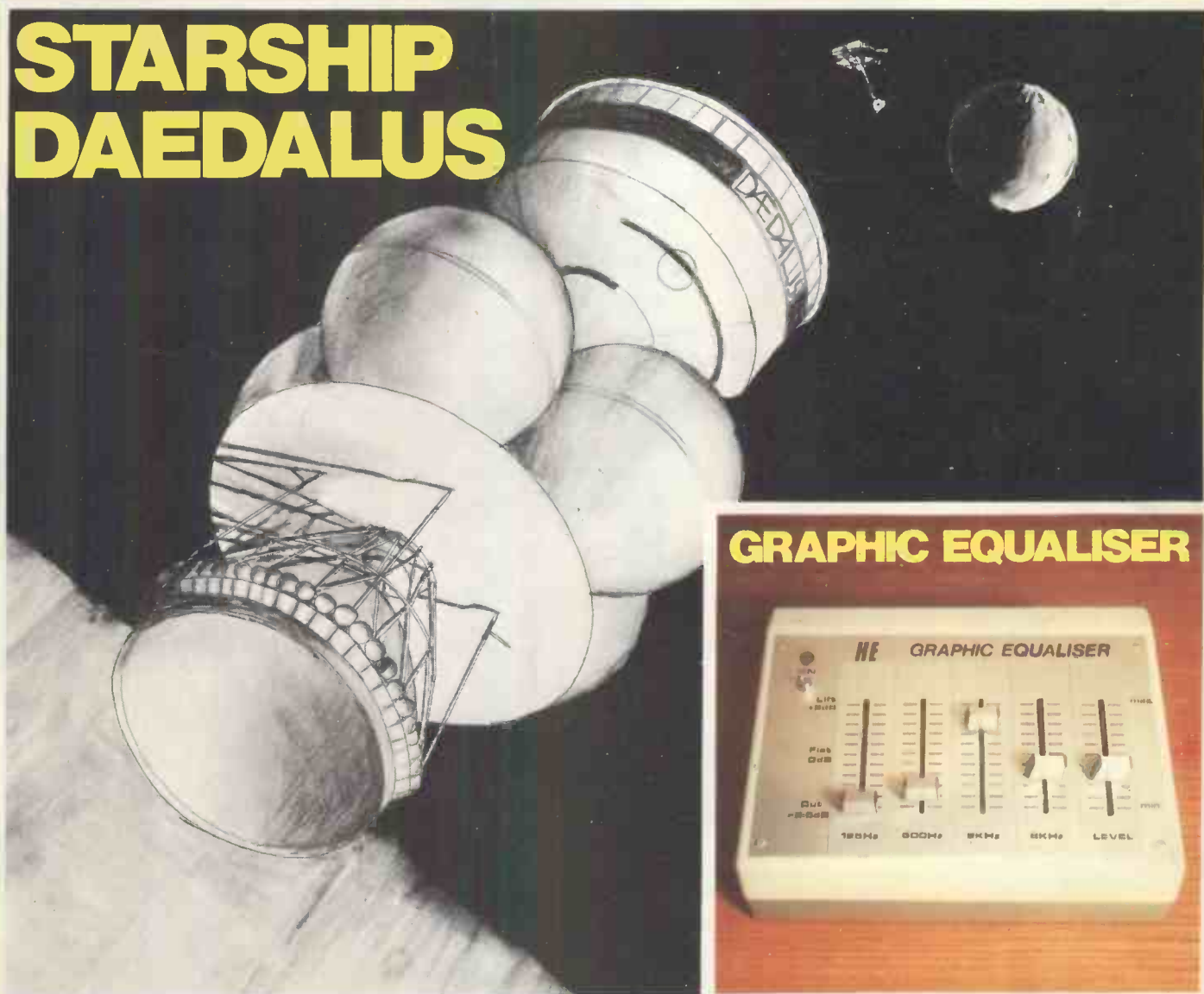

Vari-Wiper Project
Keep your windscreen clean

Viewdata Systems
Coupling your TV to the phone

Touch Switch Project
Fingertip control

Valdemar Poulsen
The early days of tape recording

Slave Flash Trigger
Project for the photographer

Basic Programming
How it's done

Pinball Wizards
A mere bagatelle

Into Electronics
How transistors work

ambit international [®]

Production of the new catalogue has been held up for a few weeks - since we have just been appointed as distributors for two of the most exciting ranges of radio components products yet: The Micrometals range of iron dust torroids cores and formers, and the OKI range of VLSI for digital frequency displays for receivers. We apologize for any inconvenience, but these two ranges are really worth the wait, and include some products you will find hard to believe, like the MSM5523 IC, an IC with less than ten external components that gives AM frequency readout to 1kHz from LW to 39.999MHz, FM frequency readout in 100kHz steps - (all usual IF offsets programmable by diodes), a 24 hour format clock with 12 hour display, independent on and off timers, time signals on the hours, stopwatch facility and a sleep timer. This costs £14 with its timebase crystal, and makes all that has gone before an expensive and time-wasting exercise. Rather like the way the Intersil ICM7216 has revolutionized the instrument counter market. (See the OSTs ad.) And those of you familiar with Amidon and IG dust torroids, favoured in many new RF designs, will be pleased to know Ambit will be stocking a broad range of the Micrometals types for applications from EMI filters to RF PA stages.

OKI frequency counter ICs: details in cat2
MSM5523 for CA LEDs with RHDP such as FND507 £14 inc xtal
MSM5525 for 3 1/2 digit LCD AM/FM with direct segment drive, no clock or timers £11 inc xtal
Other types for fluorescent displays etc OA

Other new semiconductor displays:
KB4437 pilot cancel mpd decoder 4.35
KB4438 muting stereo preamp 2.22
HA1370 supercedes TDA2020 2.99
TDA1090 HiFi AM/FM 3.35
TDA1220 low cost AM/FM 1.45

PRICES DOWN ON VMOS: as expected, this new technology in power transistors is getting cheaper. 120v comp pairs /100W for £10.00

Price reduction on CA3189E ...now £2.20
New varicaps: to add to the biggest range...
KV1211 2.5v bias to tune MW, like the KV1210, but a double diode £1.75

New pilot tone filters from TOKO.....
208BLR series, individual per channel with a 26/38kHz version for pilot cancel decoder applications. Flat to 15kHz £0.90

New crystal filter for amateur NBFM.....
TOYO 10M4B1 with over 90dB adjacent ch. rejection for 2m NBFM, 10.7MHz £14
New ceramic IF filters for 455kHz.....
CFM455H 6kHz/6dB, 15kHz max /60dB ideal for MC3357 etc. £10

A brief summary of some of our range of ICs:
TDA1062/1.95; TDA1083/1.95; HA1197/£1.40
CA3123E/£1.40; TB A651/£1.81; CA3089/1.94
HA1137/£2.20; MC1310/£2.20; HA1196/£3.95
KB4424/£2.75; KB4423/£2.53; SD6000/£3.75
KB4412/£2.55; KB4413/£2.75; KB4417/£2.55
MC1495L/£6.86*; MC1496P/£1.25
LM381N/£1.81; LM1303/£0.99; ULN2283B/£1.00; LM380N/£1; TBA810A/S/£1.09
TCA940E/£1.80; TDA2002/£1.95;
ICL8038CC/£4.50*; NE566/£2.50*; NE567/£2.50*; NE5608/£3.50; NE561B/£3.50;
NE5628/£3.50*; NE565A/£2.50*

SEE THE OSTs ADVERT FOR CMOS/TTL REGULATORS, OPTO DISPLAYS, and other types of linear devices.

Some transistors for RF specifically:
BF256L/B/0.34; 40822/0.43*; 40823/0.51 * 40673/0.55*; BF900/961/0.80*; BF960/1.60*
BF224/0.22; BF274/0.18; BF195/0.18; BF240/0.22; BF241/0.22; BF362/0.70; BF479/0.86; BF6795/0.70; BF990/0.90*

PIN and other Varicap diodes:
BA102/0.30; BA121/0.30; ITT210/0.30
8B104B/0.40; MVAM2/£1.48; MVAM115/£1.05; MVAM125/1.05; KV1210/£2.75
BA479/0.35; TDA1061/0.95; BA182/0.21
METER MADE low cost panel meters: 30 3 x 930 series with blanks and dry transfer sheet of scales and legends for £12.5 *

TERMS etc: CWO please, VAT on Ambit Items is generally 12½%, except where marked (*). Catalogue part 1:45p, part 2 50p all inclusive. Postage 25p per order, carriage on tuner kits £3. Phone Brentwood (0277) 216299/227050 9am-7pm. Callers welcome inc. Saturdays.

At last, DIY HiFi which looks as if it isn't.

That's not to say it doesn't look like HiFi - just that it doesn't look like the usual sort of thing you have come to associate with DIY HiFi. The Mk3 outstrips and outperforms all British made HiFi tuners, and most imported ones too. Certainly at the price, there isn't one near it. But more than that, it looks superb. A small pic here would be an insult, so send an SAE for details on the kit that looks as if isn't. It's something else.....

- ★ Exceptionally high performance - exceptionally straightforward assembly
- ★ Baseband and plug-in construction. Future circuit developments will readily plug in, to keep the MkIII at the forefront of technical achievement
- ★ Various options and module line-ups possible to enable an installation approach to the system

and now previewing the matching 60W/channel VMOS amplifier:

- ★ Matching both the style and design concepts of the MkIII HiFi FM tuner
- ★ Hitachi VMOS power fets - characterized especially for HiFi applications
- ★ Power output readily multiplied by the addition of further MOSFETs
- ★ VU meters on the preamp - not simply dancing according to vol level
- ★ Backed with the usual Ambit expertise and technical capacity in audio

The PW Dorchester-LW, MW, SW, & FM stereo tuner

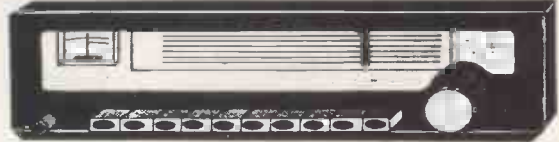

In much the same way as we have swept away the 'old technology' in frequency/timer counters - with the OKI and Intersil single IC counters, we now offer a single IC "All Band" radio tuner. Don't confuse this one chip radio with things like the ZN414 - for this is a genuine superhet receiver with a mechanical AM IF filter, and ceramic IF filters for FM. The AM section employs a balanced input mixer section, covering all broadcast bands - plus a BFO and MOSFET product detector for SSB/CW - though at this price, the tuner is not intended as a "communications receiver" - although we know of many lesser designs that make that claim. The AM sensitivity is nevertheless better than 5uV, and FM sensitivity is 1.2uV for 30dB S/N. As a multiband broadcast superhet receiver, it is a unique constructor project that fulfills the requests we very frequently get for a general coverage circuit that isn't over complicated. The set has CA3089E FM performance, with mute etc., and a PLL stereo decoder with full pilot tone filtering.

The tuner board - with "on board" PCB mounted switching, all components etc. £33.00
The case/cabinet with PSU, meter and mechanics etc. £25.00
An SAE for full details please. See the feature article in Practical Wireless (Dec/Jan)

OSTS

Since AMBIT introduced the "One Stop Technology Shop" to our service, we have been pleased to see just how many users of electronic components appreciate our guarantee to supply goods only from BS9000 approved sources. More than ever, professional and amateur electronics engineers cannot afford to waste time on anything less than perfect pedigree products.

SEE THE AMBIT AD TOO!

CD4000 CMOS

4000	17p	4059	563p	4522	149p
4001	17p	4060	115p	4527	157p
4002	17p	4063	109p	4528	102p
4006	109p	4066	53p	4529	141p
4007	18p	4067	400p	4530	90p
4008	80p	4068	25p	4531	141p
4009	58p	4069	20p	4532	125p
4010	58p	4070	20p	4534	614p
4011	17p	4071	20p	4536	380p
4012	17p	4072	20p	4538	150p
4013	55p	4073	20p	4539	110p
4016	52p	4075	20p	4541	141p
4017	80p	4076	90p	4543	174p
4018	80p	4077	20p	4549	399p
4019	60p	4078	20p	4553	440p
4020	93p	4081	20p	4554	153p
4021	82p	4082	20p	4556	77p
4022	90p	4085	82p	4557	386p
4023	17p	4086	82p	4558	117p
4024	76p	4089	150p	4559	386p
4025	17p	4093	50p	4560	218p
4026	180p	4094	190p	4561	65p
4027	55p	4096	105p	4562	530p
4028	72p	4097	372p	4566	159p
4029	100p	4098	110p	4568	281p
4030	58p	4099	122p	4569	303p
4031	250p	4160	90p	4572	25p
4032	100p	4161	90p	4580	600p
4033	145p	4162	90p	4581	319p
4034	200p	4163	90p	4582	164p
4035	120p	4174	104p	4583	84p
4036	250p	4175	95p	4584	63p
4037	100p	4194	95p	4585	100p
4038	105p	4801	23p		
4039	250p	4502	91p		
4040	83p	4503	69p		
4041	90p	4506	51p		
4042	85p	4507	55p		
4043	85p	4508	248p		
4044	80p	4510	99p		
4045	150p	4511	149p		
4046	130p	4512	95p		
4047	99p	4513	205p		
4048	65p	4514	260p		
4049	55p	4515	300p		
4050	55p	4516	125p		
4051	65p	4517	182p		
4052	65p	4518	103p		
4053	65p	4519	57p		
4054	120p	4520	109p		
4055	135p	4521	236p		

TERMS: CWO use, VAT to be added at 8% (inland), pp 25p per order. When ordering from the OSTs and Ambit - a single combined remittance and pp charge is sufficient. Account details OA.

2 Gresham Road, Brentwood, Essex.

Micromarket

6800 series	8216	1.95	2114	£10
6800P	8224	3.50	2708	£10.55
6820P	8228	4.78		
6850P	8251	6.25		
6810P	8255	5.40		
6852	3.65			
8080 series	2102	£1.70		
8080	6.30	2112	£3.40	
8212	2.30	2513	£7.54	
		4027	£5.78	

Voltage Regs

NEW LOW PRICES
7800 series UC TO220 package 1A all 95p
7900 series UC TO220 package 1A all £1.11
78MLC series TO220 package 1/2A all 90p
78LCP series TO92 100mA all 35p
L200 up to 3A/adjustable V&A 195p
78MG12C 1/2amp adjustable volts 175p
79MG12C 1/2amp adjustable volts 175p
723C precision controller 65p
MAINS FILTERS FOR NOISE/RFI etc
1 amp in IEC connector £4.83
5 amp in 'wire in' case £3.87
NE550A 73p

LINEARS

BIMOS			
CA3130E	84p	LM339N	65p
CA3130T	90p	LM348N	186p
CA3140E	35p	LM3900N	50p
CA3140T	72p	709HC to5	64p
CA3160E	90p	739PC di	36p
CA3160T	99p	710HC to5	65p
		710PC di	59p
		723CN	65p
		741CH to5	66p
		741CN Bdl	77p
		747CN	70p
		748CN	36p
		NE531T	12cp
		NE531N	105p

OPTO

7 seg displays
0.43" High Efficiency HP:
5082 7650 red CA
5082 7653 red CC
5082 7660 yellow CA
5082 7663 yellow CC
5082 7670 green CA
5082 7673 green CC
0.3" Standard HP
5082 7730 red CA
5082 7740 red CC
0.5" Fairchild
FND500 red CC 150p
FND507 red CA 150p

TTL: Standard AND LP Schottky

N'		LSN'		N'		LSN'		N'		LSN'		N'		LSN'	
7400	13	20	7455	35	24	74126	57	44	74185	134		74377	124		
7401	13	20	7460	17		74128	74		74188	275		74378	83		
7402	14	20	7463			74132	73	78	74190	115	92	74379	130		
7403	14	20	7470	28		74133		29	74191			74386	37		
7404	14	24	7472	28		74136		40	74192	105	180	74396	140		
7405	18	26	7473	32		74138		60	74193	105	180	74395	139		
7406	38		7474	27	38	74139		60	74194	105	180	74396	133		
7407	38		7475	38	40	74141			74195	95	137	74398	180		
7408	17	24	7476	37		74142	265		74196	99	110	74399	150		
7409	17	24	7478			74143	312		74197	85	110	74445	92		
7410	15	24	7480	48		74144	312		74198	150		74447	90		
7411	20	24	7481	86		74145	65		74199	160		74490	140		
7412	17	24	7482	69		74147	175		74248			74668	110		
7413	30	52	7483A			74148	109		74249			74670	249		
7414	51	130	7484	97		74150	99		74251			74671	90	MISCELLANY	
7415	24	24	7485	104	99	74151	64	84	74253			NE555	30p		
7416	30	24	7486	40	40	74153	64	54	74257			NE556	78p		
7417	30	24	7489	205		74154	96		74258			NE558	180p		
7420	16	24	7490	33	90	74155	54	110	74259			ICM7217	950p		
7421	29	24	7491	76	110	74156	80	110	74260			ICM7208	1400p		
7422	24	24	7492	38	78	74157	67	55	74261			ICL7106CP			
7423	27	24	7493	32	99	74158	60	60	74266			LCD DVM IC			
7425	27	24	7494	78		74159	210		74273			124			
7426	36	27	7495A	65	99	74160	82	130	74275			312		LCD DVM KIT	
7427	27	29	7496	58	120	74161	92	78	74279			52		2480p	
7428	35	32	7497	185		74162	92	130	74283			120		3 1/2 digit LCD	
7430	17	24	74100	119		74163	92	78	74290			90		display 1150p	
7432	25	24	74104	63		74164	104		74293			95		ICL7107 LED	
7433	40	32	74105	62		74165	105		74298			100		DVM kit 2065p	
7437	40	24	74107	32	38	74166			74298			100		ICM7216 8 digit	
7438	33	24	74109	63	38	74167	20		74324			242		10MHz DFM/	
7440	17	24	74110	54		74168			74325			247		timer £19.82	
7441	74		74111	68		74169		200	74326			237		(for LED C.Cath)	
7442	70	99	74112	88		74170	230	200	74327			237			
7443	115		74113	38		74172	625		74352			100		SCALAR ICs	
7444	112		74114	38		74173	170		74353			100		1829 150MHz	
7445	94		74116	198		74174	87		74362			715		divide by 100	
7446	94		74118	83		74175	87	110	74365			49p		420p	
7447	82</														

Hobby Electronics

January, 1979

Vol. 1. No. 3

Daedalus cover
drawing Gavin Roberts

Monitor 4
What's happening in the world of electronics

Graphic Equaliser Project 7

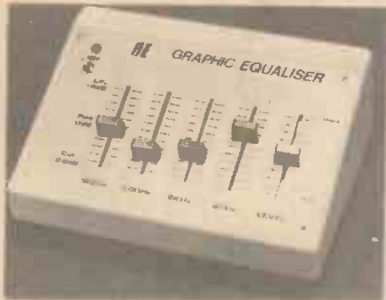

Add quality to your audio system

Valdemar Poulsen 14
How the tape recorder was invented

Touch Switch Project 17



Let your fingers do the work

BASIC Programming 21



Learn a new language — it's easy!

Vari-Wiper Project 27



Slow, slow, quick, quick, slow

HE Book Service 30
Read on

A look at the next HE 31
Some of February's features

Market place 32
Real bargains in time keepers

Short Circuits 26, 33, 37, 70
Circuit to set you thinking

Viewdata 34



What you get by adding a TV to the phone

Starship Daedalus 38

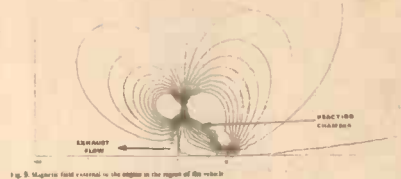

Fig. 8. Magnetic field created in the region of the vehicle

Reaching for the stars

Into Electronics Part 3 46
Getting to understand transistors

Breadboard Report 54
A look at the recent amateur electronics show

Pinball Wizards 57
A mere bagatelle

Flash Trigger Project 59



Freeze the action

Solder 63
Getting it together

Kit Review 67
An inexpensive audio sig genny

Good Evans 73
Our instant jargon language course

Colour Codes 75
Sort out your components

Hobby Electronics
25-27 Oxford Street, London W1R 1RF
01-434 1781
Published by Modmags Ltd,
Distributed by Argus Distribution Ltd,
Printed by Q.B. Ltd, Colchester
Hobby Electronics is normally published
on the second Friday of the month prior
to the cover date

Editor: Halvor Moorshead

Editorial Staff: Phil Cohen B.Sc. Steve
Ramsahadeo, Paul Edwards, Pete Howells

Advertising: Mark Strathern, David Sinfield,
Joy Cheshire.

Admin Staff: Margaret Hewitt, Bren Goodwin,
Kim Hamlin, Val Tregidgo, Tim Salmon.

Copyright. All material in this publication is
subject to world-wide copyright protection.
Permission to reproduce printed circuit board
patterns commercially or marketing kits of
the projects must be sought from the Editor.
All reasonable care is taken in the preparation
of the magazine to ensure accuracy but
Modmags cannot be held responsible for it
legally.

Monitor

Raspberries To EMI!

A fruity tale this. I assure you we are not winding you up. Right? Read on A team of engineers has been disguising acceleration transducers, accelerometers – which convert force into electrical energy – as Raspberries. And hanging them out on bushes.

The number of comments one could make at this point is truly staggering, so one will say nothing at all.

As anyone (?) knows picking raspberries is a sticky process. When ripe they are soft and fragile and liable to squash flat at the drop of a basket. Furthermore they hide beneath leaves upon brittle and lethal canes.

Automation is called for.

Automation has arrived.

Only problem is the prototypes smashed the berries to a pulp in no time flat. Slim pickings, and this is where our men in white coats with the fake raspberries come in. Hang these little fakers out with the real berries and if the machine doesn't smash them to bits too, you know exactly what forces are being produced at the crucial parts, and can adjust your machinery accordingly. Clever eh?

EMI produce the transducers, called Entran, and the Scottish Institute of Agricultural Engineering are the loonies . . . er engineers who produced the model raspberries and went out hanging them (full moon?)

The actual accelerometers are only 3.6mm square, and give out 1mV for every 'g' of acceleration they are subjected to. The false fruits are wired up to both magnetic and pen-recorders to give full details of the fall of the raspberries. I didn't believe it first time either

So You Think You're Nelson?



One of the more interesting games to appear for kiddies (i.e. the entire human race—note the box photo is not an adult!) is this Computer Battleship offering.

The basic game is played in a manner similar to the old paper and pencil game — both players have a fleet cunningly (they hope) distributed across a board upon which the opposition keep dropping bombs. The idea is — of course — to annihilate the enemy while remaining untouched (hah!) yourself.

The machine does all the paperwork for you, and adds little touches like defeating explosions if you actually HIT anything. Based upon a TMS 1000 microprocessor, Random Access Memory (RAM) is used to store the board as seen by the players, and keep track of 'shots' etc.

It is designed in Britain too (oh for a few Dreadnoughts now eh Callaghan?) and lists around £29, from patriotic toy shops everywhere as they say



Our unintentional contributor this month was Pye Electronics Ltd, who have just

landed an order for the \$6.9 million Nova Scotia mobile radio system. The above

photo shows the contract being signed.

News from the Electronics World

Scope For Cost Savings?



A new range of oscilloscopes is on the market, specifically aimed at the home constructor. Calscope is from the House of Scopex as it were, themselves a well-known trace making company. The Calscope 6 is designed to give good performance at a reasonable price. It would make a good instrument for anyone starting to build up a workbench at home.

Sensitivity to inputs can be switched from 50mV to 50V — which means that this is the signal required to produce a trace one inch long on the screen. Bandwidth is quoted at 6MHz — the scope responds to AC between 0 and 6 MHz, and the time base and triggering facilities are claimed as outstanding in this price range.

The Calscope 6 should cost around £160 — it can be bought from Maplin and Marshalls amongst other people.

Oracle Of The Present



Tests will begin next year on the use of Oracle — the ITV's between the lines information service — to provide programme subtitles for deaf viewers. The service could be utilised with a Palantype set-up to give 'real-time' i.e. instant, subtitles while news or sports programmes are being transmitted.

The Palantype produces the shorthand English — misspelt but readable — via a keyboard and processor. Such a system is now in use in the Houses of Parliament by Jack Ashley the deaf MP. Live transmissions will be attempted next year.

The photo shows a typical caption produced by the Palantype/Oracle system.

Technically Speaking

Computer Speech has come a long way since the Daleks first clanked their way across the TV screen. In the USA add-on devices for home systems (peripherals) can be purchased to make the small system talk in a reasonable — at least recognisable manner.

Microspeech is the first such unit to be released in the UK as far as we are aware. As you can see from the photo it is not a massive system at all. The program for the board converts typed in phonetic speech from the keyboard into sets of data which is then transmitted to the synthesiser.

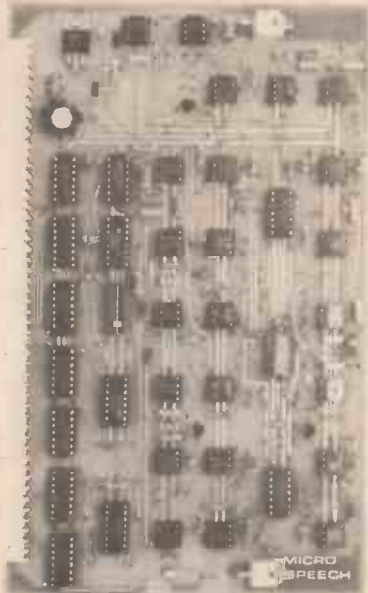

There are nine parameters controlled by the unit which make possible manipulation of the frequency, amplitude and resonance of the final sound, and in this manner male speech can be reasonably imitated.

Microspeech also has an external input which enables it to produce 'talking instrument' effects from guitars and the like. The data coming out is converted back to audio form by an 8-bit digital-to-analogue (DAC) convertor using nine sample and hold circuits which can 'store' information for well over a minute.

Relatively little memory is used up by the system, and any system using BASIC is its language can be adopted to operate with Microspeech. Costronics, 13 Field Heath Avenue, Hillingdon, Middx.

Projected Index

Now this is one of those ideas that someone should have thought of long ago, and now that someone has the rest of us must hang our heads in shame and wonder why we didn't...

A very clever man called M. L. Scaife has compiled a complete index of all electronic projects appearing in all the relevant magazines from 1972-1977. Next year a second listing will appear which will bring

the index completely up to the minute.

Some 2500 projects are listed, all with brief description where applicable, a list of how many components are used in each — and what they are — method of construction PCB, Veroboard etc, and source. Our sister magazine ETI is naturally included as are all ETI Specials.

Subjects are sensibly grouped together to make browsing easy and the listings clearly and precisely done.

This truly amazing piece of work costs only £1.50 a copy from the patient M. L. Scarfe at: Central Library, Northumberland Square, North Shields, Tyne and Wear. Recommended in the strongest possible terms to all who ever intend to build a project again.

DIGEST

The Christmas laser light show was switched on in London's Oxford Street last month, despite attempts by the Westminster Council to ban it for safety reasons.



French viewdata engineers have protested on 'technical grounds' against the British viewdata character set (which includes £ and \$ signs). This is against a background of prospective international agreement on standardisation for viewdata symbols.



Researchers at London's university College are working on the interpretation of the output from acoustic microscopes. These systems use acoustic signals at 3MHz to find a 'map' of the viscosity of plant and animal cells.

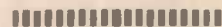

The Science Research Council is putting up £1.6M to set up IC manufacturing facilities at the Rutherford Laboratory and four universities.



At a meeting of the Optical Society of America recently, it was suggested that a laser-carrying satellite could provide detailed information on worldwide wind velocities every 12 hours.

ERRATA: —

Confession time again. Below are the errors which crept into our projects in our last issue. We apologise to our readers for these and will wear our sackcloth and ashes with abashed dignity.

LED DICE: The pinout given for the LED's is not, unfortunately, universal we discover. When buying LEDs check with the supplier as to polarity. Also a 6V or 12V rated tantalum capacitor can be employed for C4, instead of the 35V type specified with a considerable saving in cost!

LIGHT BEAM TELEPHONE: The battery, B1 on the circuit diagram, should be a 12V type.

SHORT CIRCUITS: The item entitled One-Transistor Amplifier in particular. Referring to the circuit, the resistor from the function of R1 and R2 has a value of 100k, and the current flowing through it is 10 uA.

STEVENSON

Electronic Components

LOUDSPEAKERS

56mm dia. 8ohms	70p
64mm dia. 8 ohms	75p
64mm dia. 64 ohms	75p
70mm dia. 8 ohms	100p
70mm dia. 80 ohms	110p



PLUGS AND SOCKETS

1mm plugs and sockets suitable for low voltage circuits. Available in red or black. Plugs 6p each. Sockets 7p each.

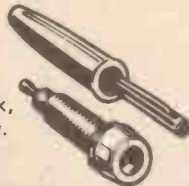

4mm plugs and sockets. Available in black, blue, green, brown, red, white and yellow. Plugs 11p each. Sockets 12p each.

Jack plugs and sockets

	unscreened plug	screened plug	socket
2.5mm	9p	13p	7p
3.5mm	9p	14p	8p
Standard	16p	30p	15p
Stereo	23p	36p	18p

Din plugs and sockets

	plug	socket
2 pin speaker	7p	7p
3 pin	11p	9p
5 pin 180°	11p	10p
5 pin 240°	13p	10p

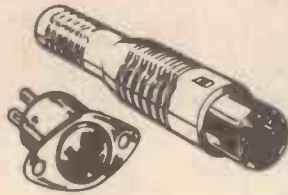

CABLES

Connecting wire Available in packs of 8 metres (one metre of each colour) or packs of forty metres (five metres each colour).

	single	standard
Eight Metre pack	16p	16p
Forty Metre pack	76p	70p

Screened Cable
Single screened 8p
twin individually screened 11p
Ribbon cable
10 way 58p metre
20 way 100p metre

ALUMINIUM BOXES

Boxes complete with lid and screws.



	Length	width	height	
AL1	3	2	1	48p
AL2	4	3	1½	58p
AL3	4	3	2	65p
AL4	6	4	2	70p
AL5	6	4	3	85p
AL6	8	6	2	116p

We now have an express telephone order service. We guarantee that all orders received before 5pm. are shipped first class on that day. Contact our Sales Office now! Telephone: 01-464 2951/5770.

ORDERS
DESPATCHED
BY RETURN
POST

Quantity discounts on any mix TTL, CMOS, 74LS and Linear circuits: 25+ 10%, 100+ 15%. Prices VAT inc. Please add 30p for carriage. All prices valid to 30th April 1979. Official orders welcome.

BARCLAYCARD AND ACCESS WELCOME.

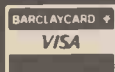

TRANSISTORS

AC127	17p	BCY71	14p	ZTX109	14p
AC128	16p	BCY72	14p	ZTX300	16p
AC176	18p	BD131	35p	2N697	12p
AD161	38p	BD132	35p	3N1302	38p
AD162	38p	BD135	38p	2N2905	22p
BC107	8p	BD139	35p	2N2907	22p
BC108	8p	BD140	35p	2N3053	18p
BC109	8p	BF244B	36p	2N3055	50p
BC147	7p	BFY50	15p	2N3442	135p
BC148	7p	BFY51	15p	2N3702	8p
BC149	8p	BFY52	15p	2N3704	8p
BC158	9p	MJ2955	98p	2N3705	9p
BC177	14p	MPSA06	20p	2N3707	9p
BC178	14p	MPSA56	20p	2N3708	8p
BC179	14p	TIP29C	60p	2N3819	22p
BC182	10p	TIP30C	70p	2N3904	8p
BC184	10p	TIP31C	65p	2N3905	8p
BC184L	10p	TIP32C	80p	2N3906	8p
BC212	10p	ZTX107	14p	2N3908	8p
BC212L	10p	ZTX108	14p	2N3908	8p
BC214	10p			2N3908	8p
BC214	10p	1N914	4p	2N3908	8p
BC477	19p	1N4001	4p	2N3908	8p
BC478	19p	1N4002	4p	2N3908	8p
BC479	19p	1N4004	5p	2N3908	8p
BC548	10p	1N4006	6p	2N3908	8p
BCY70	14p			2N3908	8p

DIODES

1N914	4p	1N4148	3p
1N4001	4p	1N5401	13p
1N4002	4p	1N5402	15p
1N4004	5p	1N5404	16p
1N4006	6p	1N5406	18p
BZY88 series 2V7 to 33V	8p each.		

LINEAR

A SELECTION ONLY! DETAILS IN CATALOGUE.

709	25p	LM324	50p	NE556	60p
741	22p	LM339	50p	NE565	120p
747	50p	LM380	75p	NE567	170p
748	30p	LM382	120p	SN76003	200p
CA3046	55p	LM1830	150p	SN76013	140p
CA3080	70p	LM3900	50p	SN76023	140p
CA3130	90p	LM3909	60p	SN76033	200p
CA3140	70p	MC1496	60p	TBA800	70p
LM301AN	28p	MC1458	35p	TDA1022	650p
LM318N	125p	NE555	25p	ZN414	75p

OPTO

LEDs	0.125in.	0.2in.	
Red	TIL209	TIL220	9p
Green	TIL211	TIL221	13p
Yellow	TIL213	TIL223	13p
Clips	3p		

DISPLAYS

DL704	0.3 in CC	130p
DL707	0.3 in CA	130p
FND500	0.5 in CC	100p



RESISTORS

Carbon film resistors. High stability, low noise 5%.

	E12 series. 4.7ohms to 10M. Any mix:		
	each	100+	1000+
0.25W	1p	0.9p	0.8p
0.5W	1.5p	1.2p	1p

Special development packs consisting of 10 of each value from 4.7 ohms to 1 Megohm (650 res.)
0.5W £7.50. 0.25W £5.70

CAPACITORS

HERE ARE JUST A FEW OF THE CAPACITORS STOCKED

TANTALUM BEAD

0.1, 0.15, 0.22, 0.33, 0.47, 0.68, 1 & 2.2uF @ 35V	9p
4.7, 6.8, 10uF @ 25V	13p
22 @ 16V, 47 @ 6V, 100 @ 3V	16p

MYLAR FILM

0.001, 0.01, 0.022, 0.033, 0.047	3p
0.068, 0.1	4p

RADIAL LEAD ELECTROLYTIC

63V	0.47	1.0	2.2	4.7	10	5p
			22	33	47	7p
						13p
			220			20p
25V	10	22	33	47		5p
						8p
			220			10p
				470		15p
						23p
10V		220				5p
				470		9p
						13p
			2200			23p

74LS

LS00	16p	LS95	65p
LS01	16p	LS123	56p
LS02	16p	LS125	40p
LS03	16p	LS126	40p
LS04	16p	LS132	60p
LS08	16p	LS136	36p
LS10	16p	LS138	54p
LS13	30p	LS139	50p
LS14	70p	LS151	50p
LS16	16p	LS153	50p
LS30	16p	LS155	80p
LS32	24p	LS156	80p
LS37	26p	LS157	45p
LS40	22p	LS164	90p
LS42	53p	LS174	60p
LS47	70p	LS175	60p
LS48	48p	LS190	80p
LS54	16p	LS192	70p
LS73	29p	LS193	70p
LS74	29p	LS196	80p
LS75	44p	LS251	60p
LS76	35p	LS257	55p
LS78	35p	LS258	55p
LS83	60p	LS266	40p
LS85	70p	LS283	60p
LS86	33p	LS290	55p
LS90	45p	LS365	45p
LS93	45p	LS366	45p
		LS367	45p
		LS368	45p
		LS386	35p
		LS670	180p

TTL

7493	34p	7493	34p
7494	52p	7494	52p
7495	52p	7495	52p
7496	50p	7496	50p
7400	12p	74121	25p
7401	12p	74122	33p
7402	12p	74123	40p
7404	12p	74125	35p
7408	14p	74126	35p
7410	12p	74132	50p
7413	25p	74141	56p
7414	48p	74148	90p
7420	12p	74150	70p
7427	24p	74151	50p
7430	12p	74156	52p
7442	43p	74157	52p
7447	55p	74164	70p
7448	58p	74165	70p
7454	14p	74170	125p
7473	25p	74174	68p
7474	25p	74177	58p
7475	32p	74190	72p
7476	28p	74191	72p
7485	70p	74192	64p
7489	145p	74193	64p
7490	32p	74196	55p
7492	35p	74197	55p

CMOS

FULL DETAILS IN CATALOGUE

4001	15p	4029	60p
4002	15p	4040	68p
4007	15p	4042	54p
4011	15p	4046	100p
4013	35p	4049	28p
4015	60p	4050	28p
4016	35p	4066	40p
4017	55p	4068	20p
4018	65p	4069	16p
4023	15p	4071	16p
4024	45p	4075	16p
4026	95p	4093	48p
4027	35p	4510	70p
4028	52p	4511	70p
		4518	70p
		4520	65p

SKTS

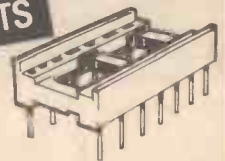

Low profile by Texas			
8 pin	10p	24 pin	24p
14 pin	12p	28 pin	28p
16 pin	13p	40 pin	40p
Soldercon pins: 100: 50p			
1000: 370p			

AT LAST! OUR NEW 40 PAGE CATALOGUE OF COMPONENTS IS AVAILABLE. SEND S.A.E.



Mail orders to: STEVENSON (Dept ET)

236 High St, Bromley, Kent, BR1 1PQ, England

Graphic Equaliser

Another project for those interested in audio work, this will make an excellent companion to the HE Mixer in last month's issue.

A GRAPHIC WHAT, you ask? A graphic equaliser is a complex form of tone control. It can be used to smooth out the frequency response of a Hi-Fi, or as a guitar effects unit. In fact, it will prove useful in any audio application.

FREQUENCY RESPONSE

In order to explain how the equaliser works, first a quick explanation of the term 'frequency response'.

Say we take a circuit (any circuit) and set it up like this:

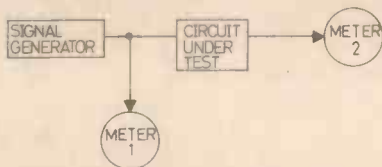

The ratio of the reading of meter 1 to the reading of meter 2 is called the response of the circuit. If the frequency of the signal used is varied, the response varies — because the circuit behaves differently when fed with different frequencies. A graph of response against frequency is called — you guessed it — the frequency response.

The frequency response of a typical amplifier looks something like this:

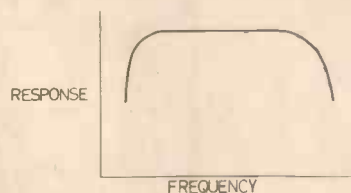

The central section is fairly 'flat' but when it comes to the very high or very low frequencies it loses power — the



reading on meter 2 drops and so the response becomes less.

Once the signal from the amplifier has been passed to the speaker (which has its own frequency response as well), the response of the system overall may look like this:

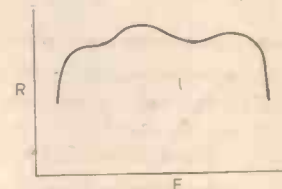

This will be further modified by the response of the room that the Hi-Fi is in — even your curtains have a response curve! By the time the signal finally reaches your ears the overall response will be fairly well mangled.

An equaliser is a device for correcting (equalising) the frequency response of a system.

IRONING OUT THE BUMPS

Say, for instance, that the frequency response looked like this when it reached you (rather exaggerated, perhaps!):

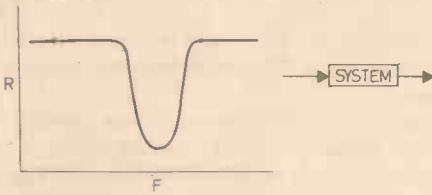

and we would of course like it to look like this:

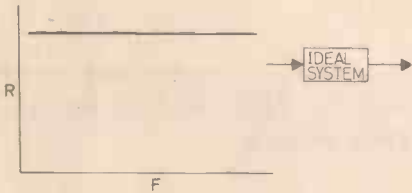

If we have a device (called an equaliser) which has a response like this (the opposite to the one we wish to correct):

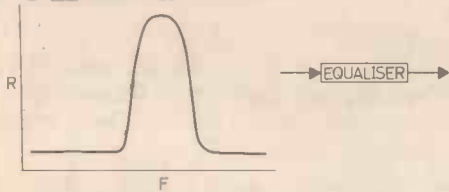

The board. Note the IC sockets and the electrolytic capacitor orientation.

and we put it in series with the system, the overall response would be the sum of the two responses:

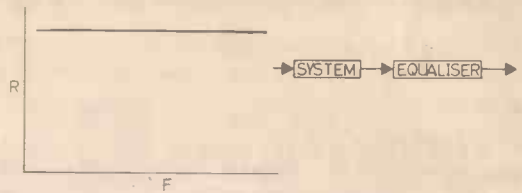

In this way we can take any system, be it a microphone, a telephone line or a Hi-Fi system, and 'iron out' the variations in its response.

There are two ways of finding the right equaliser response — directly or indirectly. The indirect method involves measuring the system curve and then designing an equaliser to fit it. This is fine if you are prepared to do all the sums and build a complete new unit for every application you run across.

The direct method is to build a device which has a variable response, connect it to the system and then vary the equaliser curve to give the desired effect.

The way this is usually done is to build a unit which will split the incoming signal into a number of frequency bands and then remix these in the desired ratios. This will give the device a number of plateaux on its response curve, all of which can be moved up or down independently of each other to give an approximation to the desired shape.

An equaliser of this type is called a graphic equaliser if the controls which determine the positions of the plateaux are of the 'slider' type. The positions of the

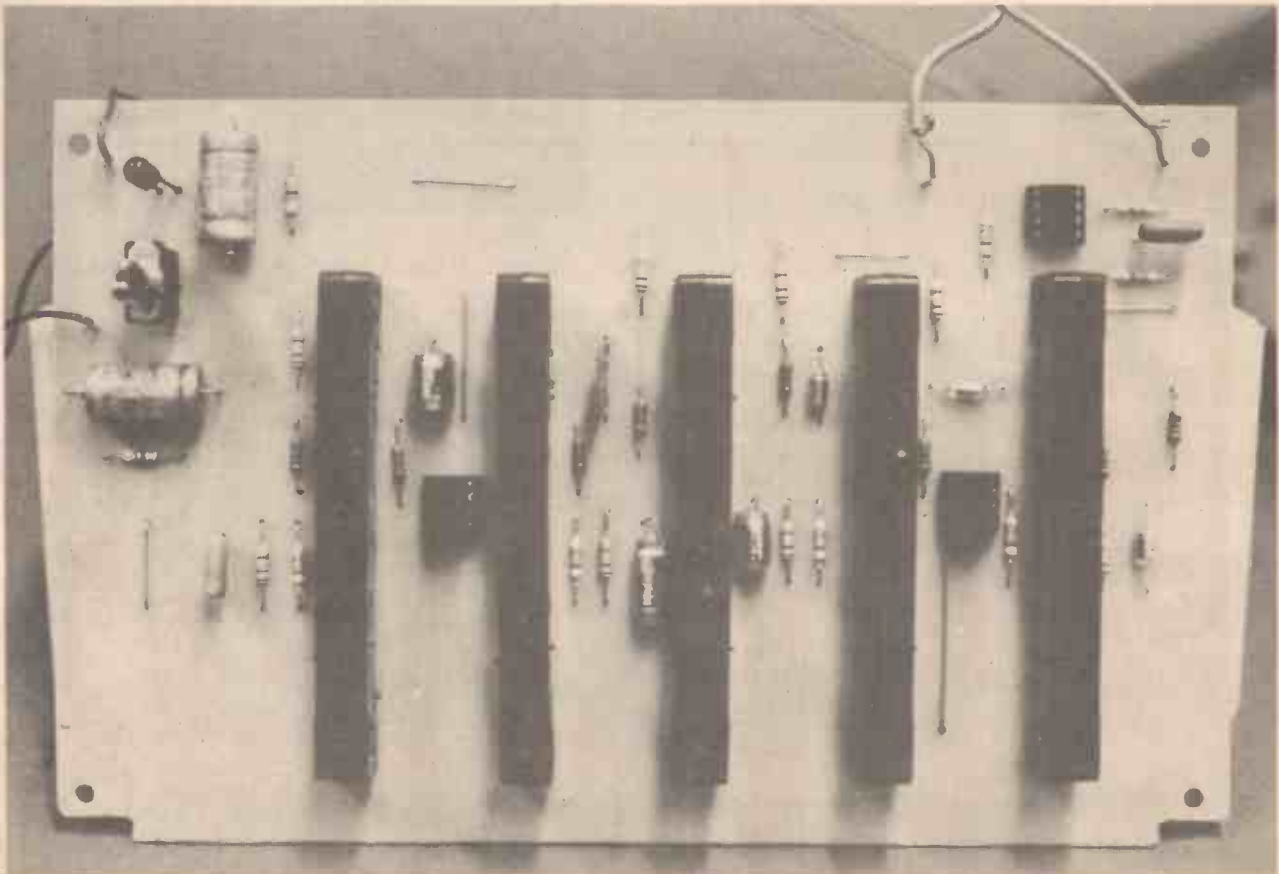

Graphic Equaliser

control knobs will then look like the frequency response graph of the equaliser.

The amount by which the HE Equaliser can vary the level of a particular frequency band is about 8 dB boost or cut.

The dB is a measure of voltage ratio — it measures the response in terms of the output divided by the input.

8 dB should prove sufficient for most applications.

CONSTRUCTION

The equaliser should be fairly easy to build — the only difficult part being the front panel.

Take care to mount all the electrolytic capacitors, the ICs and the LED the right way round and you should be okay. We suggest you use IC sockets to be on the safe side — these solder directly onto the board and the ICs

plug into them.

Don't forget the wire links on the PCB, by the way!

We stuck the batteries on with double-sided adhesive pads (useful things!). The PCB will mount into the case we've specified with the aid of some plastic 'spacers' to increase the distance between the front panel and the board.

After constructing the board, use the positions of the potentiometers, the LED and the switch to mark out the front panel.

The holes for the LED and switch can be drilled simply enough. The holes for the potentiometers can be fairly 'sloppy' as we're using stick-on bezels which go onto the front panel and have cut-outs the right shape for the shafts to run in. Make sure there are no burrs sticking out of the front panel.

Parts List

RESISTORS (all 1/4W, 5% tolerance)

R1, 2	47k
R3, 4, 8, 9, 13, 14, 18, 19	18k
R5, 6, 10, 11, 15, 16, 20, 21	1M
R7, 12, 17, 22, 23	47k
R24, 25	4k7

CAPACITORS (all polyester unless otherwise specified)

C1	0u1
C2	33n
C3	3n3
C4	8n2
C5	820p
C6	2n2
C7	220p
C8	470p
C9	47p
C10, 11	220u 16V electrolytic

SEMICONDUCTORS

IC1, 2, 3	1458
LED1	any red LED

POTENTIOMETERS

RV1	10k logarithmic slider
RV2, 3, 4, 5	100k linear slider

MISCELLANEOUS

One panel-mounting switch (single pole, double throw); Two sockets (see text); Three 8-pin IC sockets; Vero case; PCB; 2 off PP3 batteries with clips.

All of the components in this project should be available from decent stockists. The slider potentiometers we used are RS stereo types — we've only used one channel of each. The box is from the Vero range — in fact it's the same one we used for the mixer last month.

Approximate cost: £20

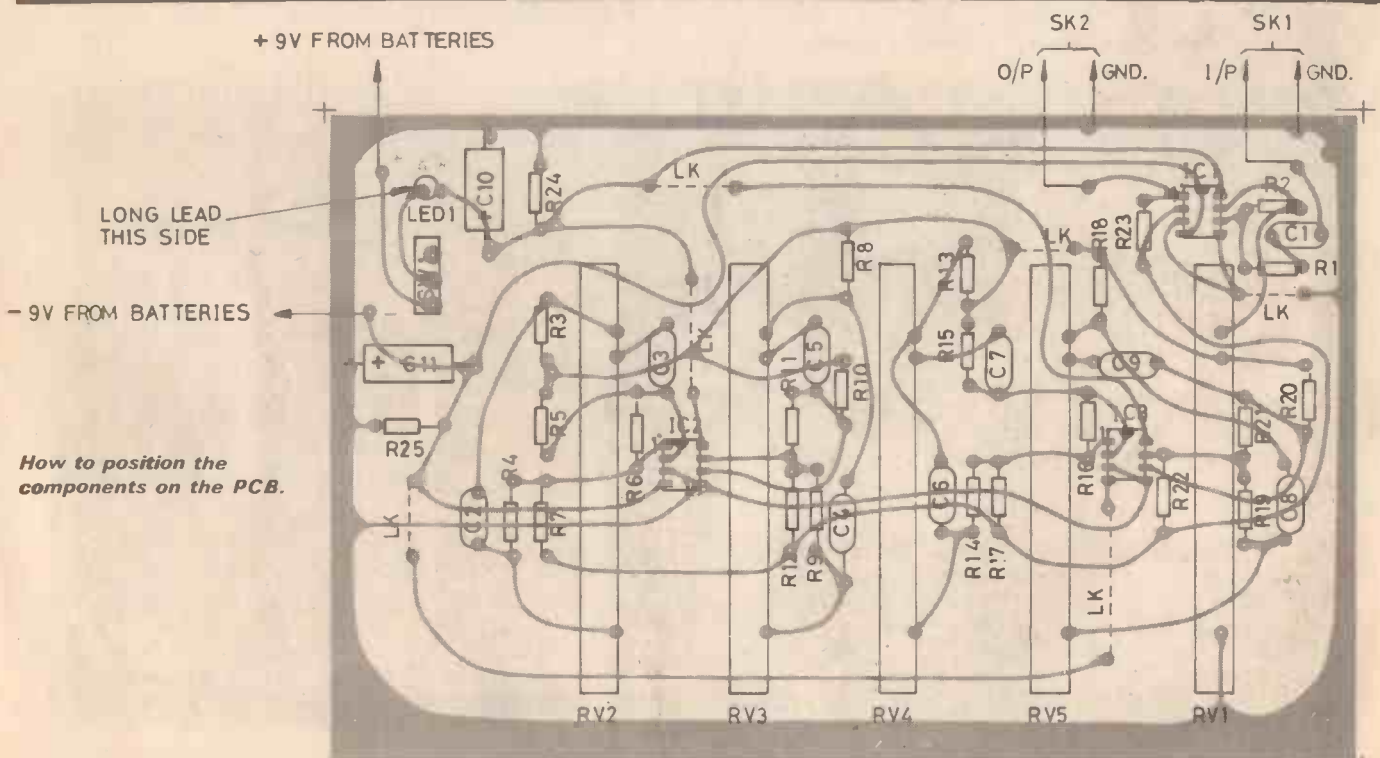

How it Works

The input to the unit is decoupled (to remove DC) by C1 and fed into IC1a, which acts as a 'buffer' — it can be driven from a source with a very small current capability, which would be incapable of providing enough input otherwise. The output of IC1a is sufficiently powerful, however, to drive the rest of the circuit.

The output from IC1a is fed (via RV1, which controls the overall volume) to the four filter stages (ICs 2b, 2a, 3b, and 3a). These each respond to a particular frequency band and their output levels are adjustable by means of RVs, 2, 3, 4 and 5. The outputs from these filters are summed by IC1b, which acts as a virtual earth mixer — the "—" input is held at zero volts by virtue of the feedback through R23 and so the output of the unit is the inverted sum of the voltages at the outputs of the filter ICs.

The individual filters work as follows: the feedback effects will cause the output to be equal to the input times $(-Z_f/Z_{in})$, where Z_f is the impedance from the output to the "—" input and Z_{in} is the impedance from the input to the "—" input.

This is the same situation as in the buffer — IC1a. In its case, $Z_{in} = 47k$ and $Z_f = 47k$. Thus the

output is -1 times the input (i.e. the signal will be 'inverted' — it will sound the same, though).

In the filters, if the variable resistor is at mid-position, with an equal resistance between the wiper and either end, then $Z_{in} = Z_f$. Thus each filter will pass all frequencies with output $= -1 \times$ input when the slider is in mid-position.

When the slider is at the left-hand end on the circuit diagram, however, the impedances of the capacitors will cause the gain of the filter (gain = output/input) to vary with frequency in such a way as to increase the gain in a particular frequency band.

Similarly, moving the slider to the other end of the potentiometer will cause the same band of frequencies to be attenuated.

Thus, by moving the slider from one end to the other, the response of the filter to its particular frequency band can be changed. As the output is the sum of all the filters' outputs, the overall frequency response of the unit will follow the shape the sliders make on the front panel — pushing one of them up will boost that particular frequency band.

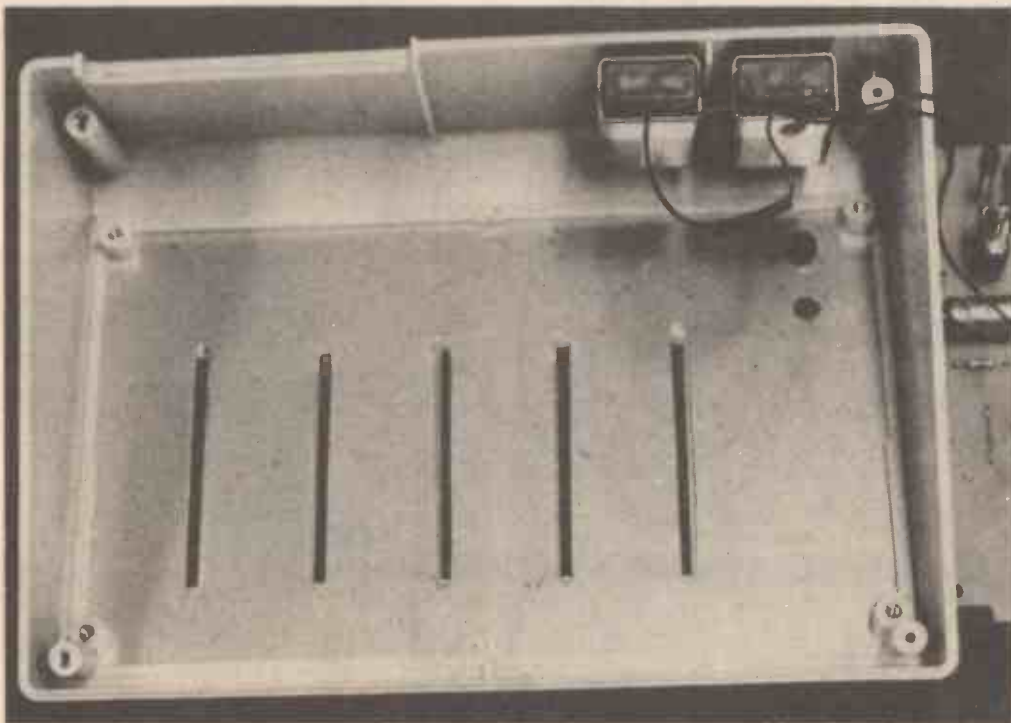

We used phono sockets for the input and output but there's no reason why any sockets suitable for audio signals shouldn't be used if there's room.

Having built the unit, you're now ready to use it — but how? 

The back of the front panel, showing the method of connecting the batteries — with the positive terminal of one connected to the negative terminal of the other. The slightly oversized potentiometer holes can also be seen.

The printed circuit board foil pattern — as viewed from the opposite side of the board to the one the components are mounted on.



EFFECTS UNIT

The input to the equaliser should be of a fairly high level — a microphone or guitar will not do. The output of the HE Mixer would be ideal, however!

Any audio output from a device which either a) requires batteries or b) plugs into the mains should be of a high enough level.

The output from the unit should go wherever the input was going before you built the unit! This could be a PA amplifier or your Hi-Fi or tape recorder.

The sort of effects you can get from this unit are: a telephone line (with the 500Hz slider up and the rest down), a shout from a long way off (with the 8kHz slider up and the rest down), or just a simple bass boost (with the sliders forming a diagonal up at the left).

Of course, by trying the unit yourself, you can adapt it to new applications or use it in conjunction with other effects units to provide a versatile addition to your effects equipment.

HI-FI SMOOTHER

Naturally, if your Hi-Fi is stereo, you'll need two of these units, but that shouldn't prove too much of a stumbling block to a hardened Hi-Fi perfectionist!

The unit should go between your pre-amplifier and power amplifier. The simplest way to adjust it is by ear, although it's not the most accurate method. You can reduce that annoying 'boominess' your speakers have always had, or boost the bass and treble and cut the middle from the signal from your tape recorder.

If you want to do it properly, however, you will need a signal generator (see the kit review in this issue!), a good microphone and an oscilloscope, with the equaliser connected as described above. Assuming the microphone's response is absolutely 'flat' (i.e. the same at all frequencies), you should be able to measure the output of your Hi-Fi at a particular frequency by measuring the signal level with the oscilloscope. Merely adjust the equaliser until the system's response to all frequencies is the same. Make sure the amplifier's tone controls are in mid-position.

This sounds simple enough — but remember that the room's response will change if you move the sofa or open the curtains — so first adjust these to their normal position. Also remember the neighbours! **HE**

OSCILLOSCOPE FULLY GUARANTEED

FEATURES

- Response: DC to 5MHz.
- Sensitivity: 100MV to 50V/division.
- Fully calibrated time-base circuit and automatic blanking.
- 100% solid state
- utilising 13 transistors, 1 FET and 1 specially designed time-base module.
- Stabilised power supplies and active sync circuits.
- Rugged construction together with portability.
- Inexpensive — excellent value and performance.

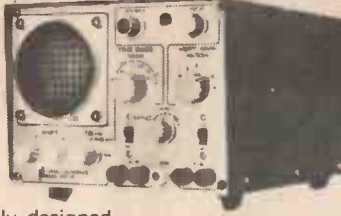

FROM STOCK
£83.25
 Add VAT £6.66
 Carriage £1.50
 EXPORT ADD £5.00

FULL INSTRUCTION & OPERATING MANUAL

SPECIFICATIONS

ELECTRICAL DATA

Deflection Sensitivity — 100mV/division
 Bandwidth (between 3dB points) — DC — 5MHz
 Input Attenuator (calibrated) — 9 steps 0.1, 0.2, 0.5, 1, 2, 5, 10, 20, 50V/div
 Input Impedance — 1 Meg/40pF to shell
 Input Voltage — 60V P-P

HORIZONTAL AXIS [X]

Deflection Sensitivity — 0.400mV/division
 Bandwidth (between 3dB points) — 1 Hz — 350KHz
 Gain Control — Continuous; when time base in EXT position
 Input Impedance — 1 Meg/40pF to shell
 Input Voltage — 60V P-P

TIME BASE

Sweep Range (calibrated) — 100msec/div to 10 sec/div in 5 steps.

Fine Control — Variable between steps — includes fine base calibration position

Blanking — Internal — on all ranges

SYNCHRONISATION

Selection — Internal external
 Synchronisation Level — Continuous from positive to negative

POWER SUPPLY

Input Voltage — 115/220V AC, 10% at 50/60Hz
 Power Dissipation — 15W

CRT DATA

— 3" raster display single beam
 — Maximum high voltage — 750V
 — Fitted with 10 sections bias filter gratings

PHYSICAL DATA

Dimensions — 15cm (h) x 20.5cm (w) x 20cm (d)
 Weight — 3.8kg (approx.)
 Stand — 2 positions. Not set included
 Case — Steel, epoxy assembled
 Colour — Light blue
 Front Panel — Anodised aluminium, epoxy printing

Also at 248 Tottenham Court Road, London, W.1.
 301 Edgware Road, London, W.2



Henry's RADIO

All mail to: Henry's Radio
 404 Edgware Rd. London W2
 PHONE (01)723 1008 ENGLAND

Codespeed

WHERE YOU CAN BE SURE OF A BARGAIN

Full Spec. Devices

- CALCULATOR PACK M4.** Contains a production line reject calculator. Either fix them (not much wrong with some we checked) or strip them for spares (whichever part is defective the rest must be good value for money — case/keyboard/display/chip/PCB). We include all the info. we can find on repairing calculators. What a bargain at £2.50.
- PACK M1.** 2 Calculator keyboards. Each has 17 keys and two switches. Only £1.00.
- PACK M2.** 1 x 2102, a 1024 bit Static R.A.M. The most popular R.A.M. in professional and amateur electronics. With full data. £1.25
- PACK M3.** Build your own calculator! MM5725 calculator chip and data book. £1.00.
- PACK E2.** An 8 digit calculator style Liquid Crystal display. 0.33 high digits with right hand decimal points and overflow indicator. With data. £2.95.
- PACK E3.** Same as Pack E2 but with 0.5 high digits. £4.25.
- PACK E4.** A 1 1/2 digit 0.33 high 7 segment gas discharge display. Requires 180V anode volts but can make an excellent replacement for LEDs in some of your mains operated projects. Fantastic value. With info. 90p.
- PACK E5.** Same as Pack E4 but dual digit. 90p.
- PACK E6.** Contains a brand new 6 digit Texas Instruments type DIS436 LED display. Multiplexed with built-in bubble magnifiers. £1.00.
- PACK E7.** A Genuine Burroughs Panaplex II, 180 volt, 12 digit, 7 segment gas discharge display. 0.3" digits. We include the special socket FREE. With data £1.50.
- PACK T2.** Back again by popular demand. A 0.2 3/4 digit Liquid Crystal wristwatch display with data. £1.00.
- PACK T4.** An 0.8 high red LED clock display. Common cathode. 3 1/2 digit with AM/PM indicator. An excellent display for your digital clock projects at £4.95.
- PACK P1.** An MM5330 Digital Voltmeter I.C. Now build your own digital multimeter or panel meter using this versatile chip. With data and circuit diagrams. £3.95.
- PACK DM1.** 5 x 14 pin dual in line chips, each containing 23 quality matrixed signal diodes. With data. 50p
- PACK C1.** 10 x 12 pin Hybrid circuits each containing 16 resistors/capacitors. Useful values. Ideal for semiconductor circuits and PCB miniaturisation. With data. 10 Hybrid circuits for 50p.
- SPECIAL OFFER PACK DM1/C1** Buy a pack DM1 and a pack C1 for the special price of only 85p for the pair.

Untested Devices

- PACK E1.** (90% Guaranteed Good). 5 x MAN3. 7 segment 0.127" common cathode LED display. Excellent value. £1.00.
- PACK DL1.** (Untested — so no guarantees) Fantastic value for money. A jumbo pack of 30 mixed I.C.s. There could be anything in this pack, linear, digital — who knows. Guaranteed to sell out at only £1.00.
- PACK MU1.** (Untested — so no guarantees) Another bargain. 2 x Upper half of a calculator case with built in keyboard. Most are ex-equipment, but believed to be O.K. A snip at only 60p the pair.
- Your satisfaction is guaranteed or return the complete pack for replacement or a refund.

MAIL ORDER ONLY — NO CALLERS PLEASE
 Postage and Packing please add 25p (Overseas Orders add 60p)

CODESPEED, P.O. Box 23, 34 Seafield Road
 Copnor, Portsmouth, Hants. PO3 5BJ

7400N AND 74LS00N SERIES TTL

74N 74LSN	74N 74LSN	74N 74LSN	74N 74LSN	74N 74LSN	74N 74LSN	Memory	74N 74LSN
7400	10	19	7490	34	60	4012	14
7401	12	19	7491	65		4013	34
7402	12	19	7492	36		4014	80
7403	12	19	7493	32	60	4015	66
7404	13	19	7494	80		4016	36
7405	13	23	7495	52	80	4017	66
7406	24		7496	50		4018	70
7407	24		7497	50		4019	42
7408	14	20	74100	90		4020	58
7409	40	40	74104	42		4021	58
7410	14	22	74105	40		4022	58
7411	19	22	74109	30	38	4023	15
7412	15	23	74110	38		4024	15
7413	25	35	74111	60		4025	15
7414	50	76	74112	30	38	4026	15
7415	24	24	74113	30	38	4027	36
7416	24	24	74114	30	38	4028	58
7417	24	24	74115	125	38	4029	66
7420	12	20	74118	82		4030	66
7421	22	22	74119	130		4031	210
7422	18	23	74120	85		4032	15
7423	22	22	74121	25		4033	180
7425	22	22	74122	40	72	4034	180
7426	24	28	74124	175		4035	180
7428	20	32	74125	35	46	4036	250
7430	12	32	74126	35	46	4037	250
7431	20	32	74127	85		4038	250
7432	23	24	74130	50		4039	250
7433	32	32	74132	40	78	4040	250
7437	22	25	74134	36		4041	250
7438	22	25	74135	68		4042	250
7440	13	25	74136	55	38	4043	250
7441	52	52	74137	80		4044	250
7442	48	48	74138	80		4045	250
7443	74	74	74139	80		4046	250
7444	74	74	74141	56		4047	250
7445	55	55	74142	200		4048	250
7446	62	62	74143	250		4049	250
7447	50	80	74145	250		4050	250
7448	58	95	74146	250		4051	250
7449	100	100	74147	110		4052	250
7450	13	21	74148	90		4053	250
7451	13	21	74149	70		4054	250
7453	13	18	74150	50	65	4055	250
7454	13	18	74151	50	65	4056	250
7455	13	18	74152	50	65	4057	250
7456	13	18	74153	50	65	4058	250
7457	13	18	74154	50	65	4059	250
7458	13	18	74155	50	65	4060	250
7459	13	18	74156	50	65	4061	250
7460	13	18	74157	50	65	4062	250
7461	13	18	74158	50	65	4063	250
7462	13	18	74159	50	65	4064	250
7463	13	18	74160	50	65	4065	250
7464	13	18	74161	50	65	4066	250
7465	13	18	74162	50	65	4067	250
7466	13	18	74163	50	65	4068	250
7467	13	18	74164	50	65	4069	250
7468	13	18	74165	50	65	4070	250
7469	13	18	74166	50	65	4071	250
7470	13	18	74167	50	65	4072	250
7471	13	18	74168	50	65	4073	250
7472	13	18	74169	50	65	4074	250
7473	13	18	74170	50	65	4075	250
7474	13	18	74171	50	65	4076	250
7475	13	18	74172	50	65	4077	250
7476	13	18	74173	50	65	4078	250
7477	13	18	74174	50	65	4079	250
7478	13	18	74175	50	65	4080	250
7479	13	18	74176	50	65	4081	250
7480	13	18	74177	50	65	4082	250
7481	13	18	74178	50	65	4083	250
7482	13	18	74179	50	65	4084	250
7483	13	18	74180	50	65	4085	250
7484	13	18	74181	50	65	4086	250
7485	13	18	74182	50	65	4087	250
7486	13	18	74183	50	65	4088	250
7487	13	18	74184	50	65	4089	250
7488	13	18	74185	50	65	4090	250
7489	13	18	74186	50	65	4091	250
7490	13	18	74187	50	65	4092	250
7491	13	18	74188	50	65	4093	250
7492	13	18	74189	50	65	4094	250
7493	13	18	74190	50	65	4095	250
7494	13	18	74191	50	65	4096	250
7495	13	18	74192	50	65	4097	250
7496	13	18	74193	50	65	4098	250
7497	13	18	74194	50	65	4099	250
7498	13	18	74195	50	65	4100	250
7499	13	18	74196	50	65	4101	250
7500	13	18	74197	50	65	4102	250
7501	13	18	74198	50	65	4103	250
7502	13	18	74199	50	65	4104	250
7503	13	18	74200	50	65	4105	250
7504	13	18	74201	50	65	4106	250
7505	13	18	74202	50	65	4107	250
7506	13	18	74203	50	65	4108	250
7507	13	18	74204	50	65	4109	250
7508	13	18	74205	50	65	4110	250
7509	13	18	74206	50	65	4111	250
7510	13	18	74207	50	65	4112	250
7511	13	18	74208	50	65	4113	250
7512	13	18	74209	50	65	4114	250
7513	13	18	74210	50	65	4115	250
7514	13	18	74211	50	65	4116	250
7515	13	18	74212	50	65	4117	250
7516	13	18	74213	50	65	4118	250
7517	13	18	74214	50	65	4119	250
7518	13	18	74215	50	65	4120	250
7519	13	18	74216	50	65	4121	250
7520	13	18	74217	50	65	4122	250
7521	13	18	74218	50	65	4123	250
7522	13	18	74219	50	65	4124	250
7523	13	18	74220	50	65	4125	250
7524	13	18	74221	50	65	4126	250
7525	13	18	74222	50	65	4127	250
7526	13	18	74223	50	65	4128	250
7527	13	18	74224	50	65	4129	250
7528	13	18	74225	50	65	4130	250
7529	13	18	74226	50	65	4131	250
7530	13	18	74227	50	65	4132	250
7531	13	18	74228	50	65	4133	250
7532	13	18	74229	50	65	4134	250
7533	13	18	74230	50	65	4135	250
7534	13	18	74231	50	65	4136	250
7535	13	18	74232	50	65	4137	250
7536	13	18	74233	50	65	4138	250
7537	13	18	74234	50	65	4139	250
7538	13	18	74235	50	65	4140	250
7539	13	18	74236	50	65	4141	250
7540	13	18	74237	50	65	4142	250
7541	13	18	74238	50	65	4143	250
7542							

Valdemar Poulsen

Although he receives rare credit, Poulsen did much to bring about the tape recorder. We take a look at his experiments carried out at the turn of the century.

ONE OF THE ODDITIES in the history of science is the names that we remember in connection with various inventions. Practically everyone, for example, associates television with Baird, despite the fact that Baird's system was out of date before it was built and had no connection with the TV system which we use. Anyone heard of Campbell Swinton, of Zwyrkin, or Blumlein? These were some, just a few, of the people who really made the modern TV system, yet only a few professionals know these names.

Valdemar Poulsen is another of these less well known names which deserve to be better known. What he invented was the tape recorder, a device which is in use pretty extensively all over the world, yet for many years his work was unknown, his invention a curiosity that was almost forgotten. Poulsen, like many 19th century inventors, was fascinated by electromagnetism, a topic which was well understood by the second half of the century in theory, if not in practice. The basic principles which Poulsen made use of were:

1. A current passed through a coil of wire causes the coil to become a magnet. If the current is an alternating current, the magnetism also is alternating.

2. Some materials, called hard magnetic materials, can be magnetised by being held near a magnet, and will remain magnetised when the magnet is taken away.

3. When a magnet is moved past a coil of wire, a voltage is induced in the wire.

All of these principles had been known in the 1840's, but there's always a gap between discovering a principle and making use of it. Before anyone could think about tape-recording, a method of converting sound-waves into electrical signals had to be invented, and this was achieved by Alexander Graham Bell in 1876; his invention was the telephone. Bell's telephone used a carbon microphone, which makes use of grains of rough carbon held between a conducting plate and a thin metal diaphragm. The two metal plates linked by the carbon grains form part of a circuit in which most of the resistance is the resistance of the carbon grains. When these grains are compressed by pressing the diaphragm, the resistance of the carbon decreases, and more current can flow. When the diaphragm is pulled out, the grains loosen, the resistance increases, and the current de-

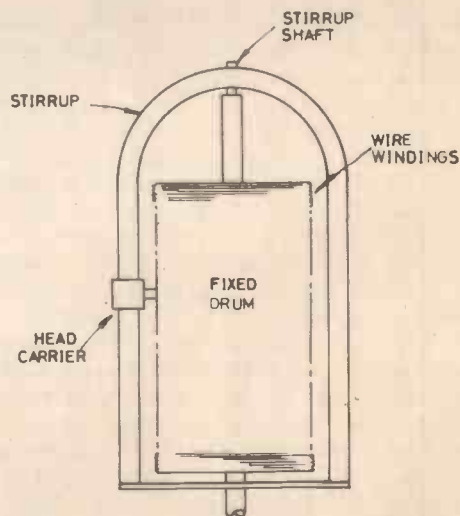
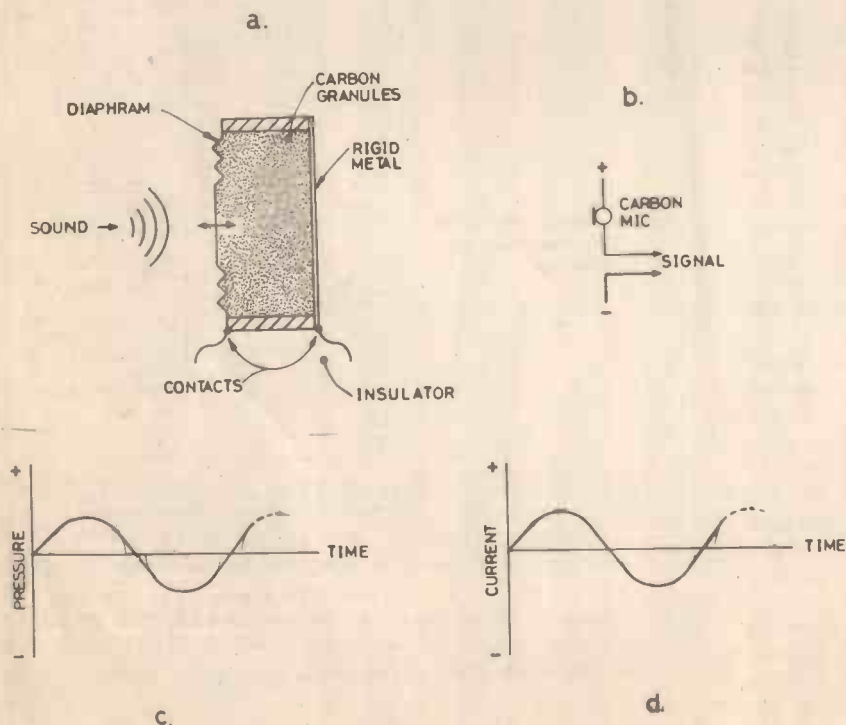

Fig. 1. (left) Carbon-granule microphone (a) Cross-section. (b) Connection in circuit. (c) Sound wave, (d) Corresponding current wave.

Fig. 2. (above) Telegraph diagram — simplified.

creases. The effect of a sound wave on the diaphragm is alternately to compress and pull out the diaphragm, so that the sound wave is converted into a wave of current (Fig. 1). The invention of the carbon-granule microphone was the last link in the chain which was needed before Poulsen could devise a working magnetic recorder. The carbon granule microphone is nowadays almost a museum-piece and is being replaced even for telephone use by modern electret types.

EARLY DAYS

We know very little of what Poulsen was aiming at, or about his early experiments. What we do know with certainty is that he filed a patent in 1898 for a device which seems like an automatic telephone answering machine — well ahead of its time. Almost every feature of tape recording is present in this machine — except for the tape. The technology for manufacturing tape took a lot longer to develop and Poulsen used steel wire, a material which was still used in dictaphones until quite recently.

Poulsen called his invention the Telegraphone, and Fig. 2 shows a diagram taken from the original patent. Let's take a look at how he claimed it worked. Unlike the modern machine in which the tape is reeled past the recording or replay heads, Poulsen's machine used a head which was moved along the wire. This was done by winding the steel wire onto a drum, and revolving the

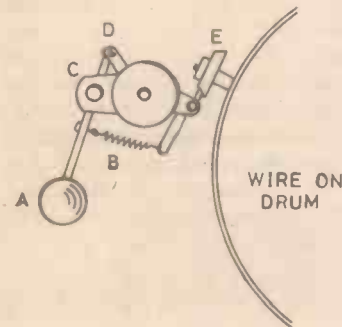

Fig 3. Detail of head construction of Telegraphone.

head around the drum. The head was held on a stirrup-shaped arm, which revolved around the drum, and the head assembly was free to slide up and down one arm of the stirrup. Why such a peculiar arrangement? Well, Poulsen seems to have realised that to get enough recorded signal on steel wire he would have to use thick wire and that made it impossible to wind the wire from one reel to another. The drum idea looks very similar in mechanical detail to another wonder of the age, Edison's Phonograph, the original wax-cylinder gramophone which was by then appearing in homes all over the western world.

The mechanical action of the Telephone is rather ingenious (Fig. 3.). When the stirrup starts to revolve, the weight A tries to keep moving in a straight line (the action that used to be called centrifugal force until someone realised that there is no such force), so that the weight flies outwards, stretching the spring B. As the weight A flies out, the pawl on the end of the hinged arm C pushes the arm D, which in turn presses the recording/replay head, E, against the drum. The head appears to have consisted of a rod of soft iron with a radius machined at the end to match the radius of the recording wire, so that the head was a good fit against the wire. A winding on the soft-iron rod constituted the recording/replay coil, and the wire connections to the



Poulsen's original tape recorder built in 1900.

head were led through the hollow stirrup to a shielded container above the drum in which one wire was earthed to the frame, and the other made a connection through a slip-ring and brush to the lead-out cable. The drum could be turned out at a fairly constant speed by means of a clockwork motor.

FOR THE RECORD

The use of the machine was straightforward. For recording, a carbon microphone, with energising battery, was

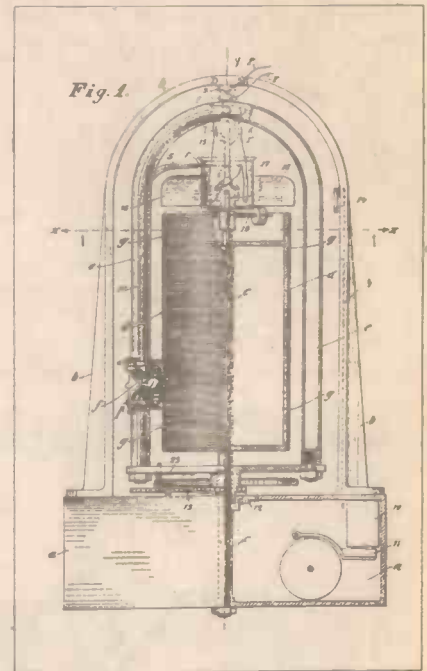

British Patent No. 8761 of 1899, Poulsen's original drawing.

connected to the recording head. The drum was allowed to rotate, so that the head contacted the wire. As the recording was made, the screw action of the wire winding pulled the head assembly steadily higher up the stirrup. At the end of the recording, the machine was switched off, whereupon the head was pulled back from the drum by the spring B, and the whole assembly then fell down to the bottom of the stirrup again — a most

Touch Switch

For turning on equipment sensitive to vibration — photographic enlargers for example — or even just for a doorbell, this circuit is a boon

IF YOU'VE EVER got involved in repairing a transistor radio, you will probably know the trick of dabbing your finger at the input to the audio stage to see if you can hear the hum and/or increase in noise level to prove that the audio stage is working.

It is also possible to make use of this effect to switch a circuit positively. Switching by touch has become quite common in the last two or three years since the IC manufacturers have introduced devices specifically to perform this function. TV sets and lifts are amongst the common users (though some TV sets make use of your finger bridging two terminals and operate differently).

Touch switches may seem highly extravagant but industrially they are far more reliable, than mechanical types. In TV sets, touch switches have the great advantage of enabling the preset pots which control the varicap diodes in the timer to be put at the back of the set.

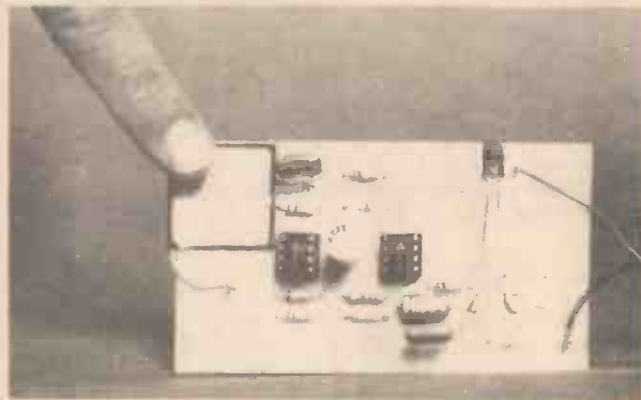

Above: the completed PCB. In this version we did not use a relay connecting a resistor and the LED in series across the output.

Parts List

RESISTORS, All ¼W, 5%
 R1 56k
 R2 100k
 R3 10M
 R4 15k
 R5 15k
 R6 3k3
 R7 100k

CAPACITORS
 C1 100n polyester
 C2 100uF 25 V electrolytic
 C3 2u2 25 V electrolytic
 C4 100n polyester

SEMICONDUCTORS
 IC1, IC2 741 Op Amp
 D1, D2 1N4148 silicon diode

MISCELLANEOUS
 PCB as pattern, Miniature relay (500 ohm or more coil and change-over contacts).

Approximate Cost: £4

On the right is the component overlay for the PCB. Be sure to position the polarised components C2, C3, IC1, IC2, D1 and D2 the right way round. If you're buying a relay get one to fit the holes as shown otherwise extra drilling and soldering may be needed.

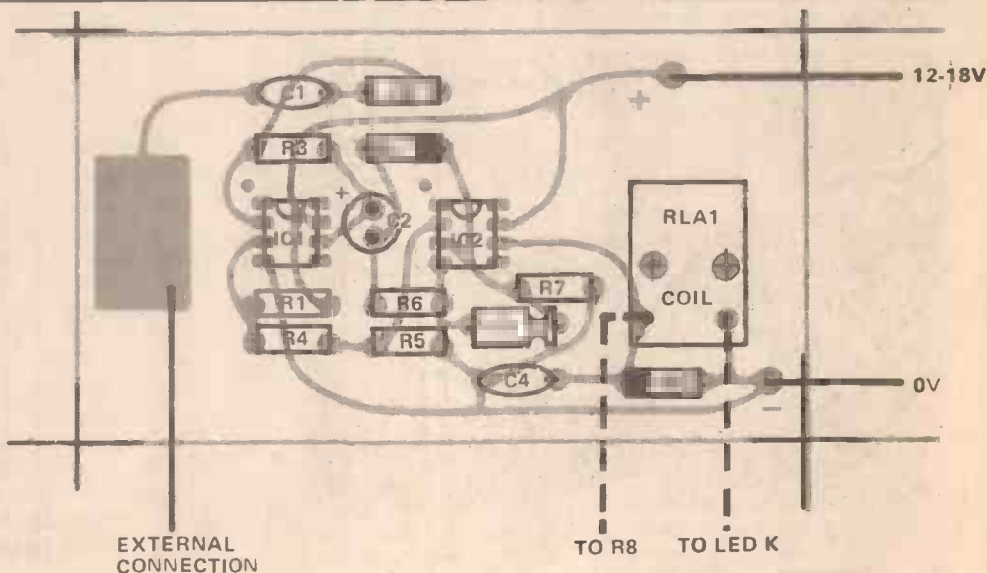

How it Works

When a finger is placed on the touch contact, a low level of mains hum is introduced to IC1 via the DC blocking capacitor C1 and R2. The gain of IC1 is arranged at a very high level and the hum is thus enormous amplified and switches the output of IC1 to about 7 V peak-to-peak. The signal passes through C2 which blocks the DC to diode D1.

When the signal is swung positive, D1 conducts and charges up C3. When the voltage at the non-inverting terminal of IC2 (pin 3) exceeds the voltage at the inverting terminal (pin 2) the output of IC2 goes high and switches the relay.

IC2 acts as a voltage comparator. When the finger is removed, R7 discharges C3 and the output of IC2 goes low and the relay switches off.

D3 and C4 are included to protect IC2 from the very high voltages caused by abruptly turning RL1 off.

If used to switch mains equipment, great care should be taken to isolate the switched mains from the rest of the circuit. R2 and C1 give only a margin of safety and are no substitute for taking care. The power for the circuit itself should only be derived from batteries.

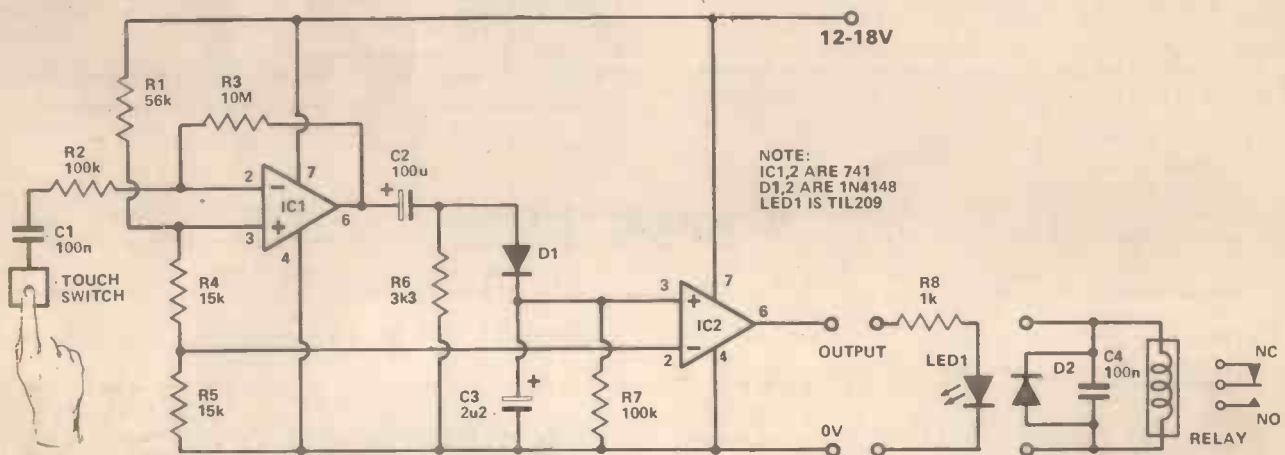

Above is the circuit diagram, showing, on the right, the connections for either an LED (as in the photo on page 17), or a relay.

On the right is the copper foil pattern for the PCB we used, printed actual size.

CONSTRUCTION

We have designed our PCB so that the touch contact is on the board itself but have also allowed a terminal for taking the touch contact to somewhere more remote.

Small relays don't normally come in standard types and for that reason we have only left a general area showing the coil contacts, though these may have to be changed. We have not even attempted to show the switch contacts but there is plenty of room to run the contracts to terminals sited between the supply connections.

Apart from the obvious precautions to ensure that the ICs, diodes and the two electrolytic capacitors (C2, C3) are connected the right way around, construction is easy.

For safety reasons, we strongly recommend that the circuit is battery operated. If it is used to switch a relay, the contacts of the relay can be used to switch a mains supply on.

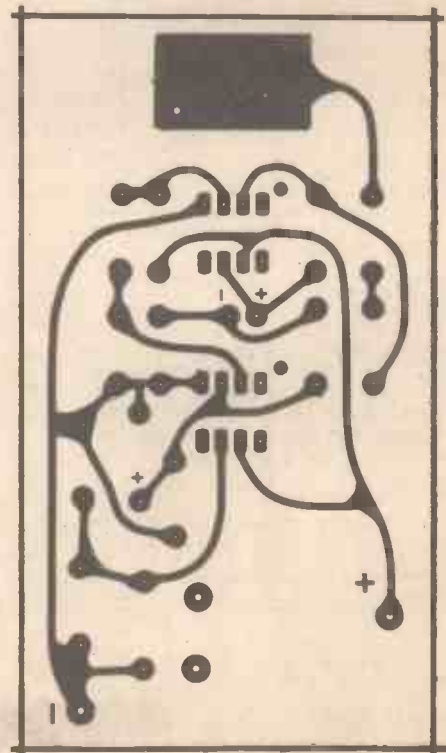

With no previous knowledge you can build this radio

only **£23.55** + P&P

FREE 100 page Instruction Book
FREE BOOK Hamlyn's 150 page 'Electronics'
and 99 other projects as well including:-

- | | |
|--|---|
| Electric Organ | Electronic Gun |
| Automatic Lamp Flashing circuit | 2 Transistor I.C. Electronic Siren |
| Alternating Current Generator | Light and Sound Morse code Practice Circuit |
| 2 Transistor Wireless Microphone | Wireless Morse Telegraph |
| Wireless Water Shortage Warning Device | Electronic Bird (speaker type) |
| 1 transistor - IC Lie Detector | 1 Transistor - IC amplifier signal tracer |
| Basic circuit of Electronic Timer | Wireless water level warning device |
| AC Bridge (for Capacitor) | Physical agility tester |
| Light Control Circuit | Touch buzzer |
| | Electronic horn |

PRICE INCLUDES VAT



Yes. In one Kit, 100 projects... and it's as simple to change from one to the other as it is to build the first, no extra tools are required.

This electronic Kit is educational for the learner while useful to the more advanced student. It's ingenious, it's safe and it's fun! The circuitry is varied by your positional changes of the plug-in blocks on the basic matrix. All blocks are marked with electronic symbols. It's as easy as 'Painting by Numbers', and you're learning all the time.

You must have one of these Kits! Just £23.55 is great value for 100 projects, and the knowledge you gain is priceless.

TECHNICAL SPECIFICATION

- Shock resistant ABS case.
 - Audio Output: 500 mW (from internal output module and loudspeaker).
 - Size: 260mm x 200mm x 50mm.
 - Batteries: 4 x HP7 (Not supplied).
- Accessories provided:
- Crystal Earpiece.
 - Aerial & Connecting Wire (ferrite rod aerial built in).
 - Clips & Test Rods.

REMINDER
The DORAM Electronic Hobbies Catalogue is now available.
FREE

Order now.
Guarantee of Satisfaction.
Send the coupon immediately, Your kit will be delivered within 25 days.
If you are not completely satisfied you may return your purchase within 30 days for a full refund.
Doram Electronics Ltd
PO Box TR8, Leeds LS12 2UF

An Electrocomponents Group Company

OFFER CLOSES
14th February 1979

To Doram Electronics Ltd PO Box TR8 LS12 2UF
Please send60-551 Kit(s) at £24.50 ea. (£23.55 + 95p p&p)
Please send a Hobbies Catalogue

I enclose cheque/PO for £
I am paying via National Giro Centre Bootle Lancs to your Account Number 00/643/7257

Please debit my ACCESS Card No.

I expect delivery within 25 days

Signature

Name (BLOCK LETTERS)

Address

Doram Electronics Ltd Reg 1155856 HE 1.79

BULK PURCHASE - EXCLUSIVE TO HENRY'S ALLOWS US TO SELL AT SUCH FANTASTIC PRICES!

QUALITY ITEMS
Compare performance and specification with units costing 3 times as much!

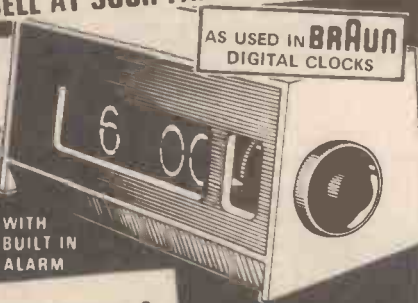

DIGITAL
24 HOUR
CLOCK

WITH BUILT IN ALARM

- SILENT RUNNING
- LARGE ILLUMINATED NUMERALS
- AC MAINS ● SIZE 6 1/4 x 2 1/4 x 2 1/4



MECHANISM ONLY

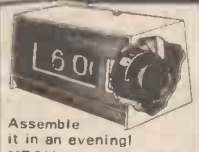

Assemble it in an evening!
MECHANISM & CASE
Inc. assembly instructions



Modern Styling
COMPLETE UNIT

£5.00

£6.99

£7.99

THREE FOR £13.50

THREE FOR £20

THREE FOR £23
POST & VAT INCLUSIVE

Send cheque, P.O./M.O. for the correct amount which includes VAT and P&P or pay by Access/Barclaycard. Send name/card number (if applicable) and address to:

HENRY'S RADIO
404 EDGWARE ROAD,
LONDON W2 1ED

AVAILABLE ONLY FROM

Henry's Radio

DELIVERY FROM STOCK

EXPORT ENQUIRIES INVITED

BUILD-IT-YOURSELF **NEW!** TEST GEAR KIT

BASIC SERVICING INSTRUMENTS WITH EASY STAGE BY STAGE BUILDING INSTRUCTIONS - IDEAL FOR THE AMATEUR

MULTI RANGE TEST METER

A general purpose meter covering all usual ranges of A.C. and D.C. volts current and resistance measurements

AUDIO SIGNAL GENERATOR

New design covering 10Hz to 10KHz and variable output. Distortion less than 0.01% Ideal for HIFI Testing.

OSCILLOSCOPE

A basic 3" general purpose cathode ray oscilloscope for simple testing and servicing work. Sensitivity 0.3 volts/cm

SEND NOW FOR FREE DETAILS

To LERNAKITS, P.O. Box 156, Jersey.

Name

Address

HE 1/79

SPECIALS



TOP PROJECTS

Book 1 + 2: £2.50 + 25p P&P.

Master mixer, 100W guitar amp., low power laser, printmeter, transistor tester, mixer preamp., logic probe, Ni-Cad charger, loudhailer, 'scope calibrator, electronic ignition, car theft alarm, turn indicator converter, brake light warning, LM3800 circuits, temperature alarm, aerial matcher, UHF-TV preamp., metal locator, four input mixer, IC power supply, rumble filter, IC tester, ignition timing light, 50W stereo amp. and many more.

Book 3: SOLD OUT!

Book 4: £1.00 + 25p P&P.

Sweet sixteen stereo amp., waa-waa, audio level meter, expander/compressor, car theft alarm, headlamp reminder, dual-tracking power supply, audio millivoltmeter, temperature meter, intruder alarm, touch switch, push-button dimmer, exposure meter, photo timer, electronic dice, high-power beacon, electronic one-armed bandit ...

Book 5: £1.00 + 25p P&P.

5W stereo amp., stage mixer, disco mixer, touch organ, audio limiter, infra-red intruder alarm, model train controller, reaction tester, headphone radio, STD timer, double dice, general purpose power supply, logic tester, power meter, digital voltmeter, universal timer, breakdown beacon, heart rate monitor, IB metal locator, temperature meter ...

Book 6: £1.00 + 25p P&P.

Graphic equaliser, 50/100W amp. modules, active crossover, flash trigger, "Star and Dot" game, burglar alarm, pink noise generator, sweep oscillator, marker generator, audio-visual metronome, LED dice, skeet game, lie detector, disco light show ...

Graphic Equaliser... Marker Generator
Power Amplifier Modules... £2 Sound
CCTV Camera... Headphone Adaptor
LED Dice... Sound-Light Flash Trigger
Expander-Compressor...
ETI TOP PROJECTS
NO 6 electronics today £1
Alarm... Digital Thermometer
Stars & Dots Logic Game... Lightshow
Active Crossover... Hear and Tell Unit
Pink Noise Generator... GSR Monitor
Sweep Oscillator... Stereo Simulator

ELECTRONICS TOMORROW

Comprised entirely of new material, the edition covers such diverse topics as Star Wars and Hi-Fi! The magazine contains projects for everyone — none of which have appeared in ETI — and a look at the future of MPUs, audio, calculators and video. How can you not read it?

75p + 25p P&P.

electronics tomorrow 75p

A SPECIAL EDITION FROM electronics today



WHAT'S HAPPENING IN PROJECTS, MPUs, Hi-Fi, Calculators, Video, Audio...

Behind the scenes of STAR WARS

TRANSDUCERS IN MEASUREMENT AND CONTROL

This book is rather an unusual reprint from the pages of ETI. The series appeared a couple of years ago in the magazine, and was so highly thought of by the University of New England that they have republished the series splendidly for use as a standard textbook. Written by Peter Sydenham, M.E., Ph.D., M.Inst.M.C., F.I.L.C.A., this publication covers practically every type of transducer and deals with equipment and techniques not covered in any other book. Enquiries from educational authorities, universities and colleges for bulk supply of this publication are welcomed: these should be addressed to H. W. Moorshead, Editor.

£3.00 + 25p P&P.

TRANSDUCERS IN MEASUREMENT AND CONTROL

by PETER H SYDENHAM
M.E., Ph.D., M. Inst. M.C., F.I.L.C.A.

ETI CIRCUITS

Books 1 & 2.

Each volume contains over 150 circuits, mainly drawn from the best of our Tech-Tips. The circuits are indexed for rapid selection and an additional section is included which gives transistor specs, and plenty of other useful data. Sales of this publication have been phenomenal — hardly surprising when the circuits cost under 1p each!

£1.50 + 25p P&P each.

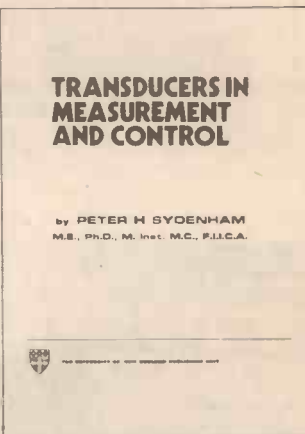

FROM THE PUBLISHERS OF ELECTRONICS TODAY INTERNATIONAL

ETI CIRCUITS No 2

£1.50

ELECTRONICS — IT'S EASY Books 1, 2 & 3.

Our successful beginners series came to an end some time ago now, and the whole series is available from us in reprint form. The three books between them contain all the information presented in the series (sometimes in more detail!) and together form an excellent starting point for anyone interested in learning the art of electronics.

£1.20 + 25p P&P each.

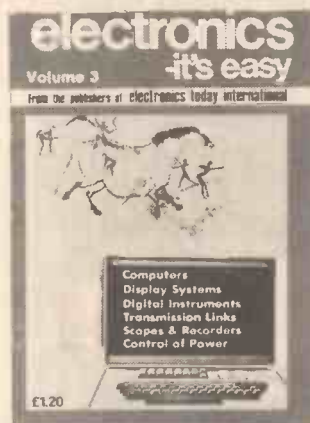

ORDER FROM

Specials
Modmags Ltd
25-27 Oxford Street
London W1R 1RF

Postage and packing also refers to overseas. Send remittance in Sterling only.

Please mark the back of your cheque pr PO with your name and address.

from ETI

Basic Programming

What exactly is involved in computer programming? The easy answer is to say: "Try it and see", but if you don't have access to a computer this can be a trifle difficult. Instead, Jim Perry takes you through the whole thing bit by bit.

THE ENGLISH LANGUAGE contains about 650 thousand words but most people only know a tiny percentage (the average is about 12,000). Even more surprisingly, in conversation we only use a couple of thousand or so words. By learning as few as 200 words in any foreign language, you can make yourself be understood in most situations — but obviously, the words need to be carefully chosen. The main difference between a computer language and any other is that you must obey the grammar rules — otherwise the computer will not understand. English people will smile, but understand, if a foreigner asked "Cinema is you know where?"; bad grammar is not a total barrier to communication.

Computer languages are based around a very small vocabulary, usually less than 100 words. — but if a word is misspelled, or the grammar not obeyed, the computer will either reject the instruction or do something totally different. There are dozens of different computer languages in use, the most common on small computers being called BASIC. The name is an acronym for Beginners All-purpose Symbolic Instruction Code and it was developed by researchers at Dartmouth College in the USA in 1964. BASIC may not be the best computer language, but it can be learned in a few hours and is reasonably powerful (we use the term powerful in relation to computer languages to mean versatile).

Just like any other language BASIC has several, slightly different, 'dialects'. Different computer specialists have developed their own versions of the original Dartmouth BASIC, usually adding extra words and using slightly different grammar rules. As an introduction to the wonderful world of BASIC this article will deal with the dialect spoken (and understood) by Commodore's PET computer.

PARLEZ VOUS BASIC?

To communicate with a computer you need to speak (or rather type) in a language it can understand. The instructions that you give it form a 'program', which the computer will execute when instructed to do so. The instructions (or program) are divided into separate lines

(sentences), with each line having an identification number allocated to it.

When the computer is told to RUN the program, it starts at the line with the lowest number and works up in sequence. To help in modifying programs, the line numbers are usually allocated in multiples of ten — as the computer will only accept whole line numbers, and you may need to insert extra lines as the program is developed.

The line number also tells the computer that you are entering a program, any instructions without a preceding line number will be forgotten after they have been executed. At the end of each program line the 'return' key is pressed, this tells the computer that you have finished the line. The return key is the most used key on every computer, without it every line would have to be the same length so that the computer would know when a line was finished.

WHAT GOES IN . . .

So how can you tell the computer to perform a simple, repetitive, calculation? Suppose you need to calculate the square of any number, a simple enough task! First you need to tell the computer what number you want to square so type in:

```
10 INPUT X (then press RETURN key)
```

The 10 is the line number, the word INPUT is a BASIC instruction meaning 'Ask the outside for a number, call it X, and then go to the next instruction line — but remember the number X'.

```
20 A=X*X (RETURN)
```

An equals sign is a BASIC instruction, as is the * which is the same as a multiplication sign. X times X is the same as X squared.

```
30 PRINT A
```

The PRINT instruction is telling the computer to display the value of A on the screen, as A is X times X (line 20); the number displayed will be the answer we want.

To start the program the instruction RUN is typed into the computer, followed by the return key. The computer's response will be a question mark, which is its way

of asking for an input. If you type in a 4 and then press return the answer 16 will appear instantly, followed by READY.

What has happened is that the computer has started at line 10, asked for a number a number, multiplied it by itself (squaring it), and has assigned the result to a letter A, then moved to the next line. After printing the value of A the computer has found no further instructions and so says that it is READY for more instructions. The screen will look like this:

```
10 INPUT X
20 A=X*X
30 PRINT A
RUN
?4
16
READY
```

This will be followed by a flashing white square on the next line, this is the CURSOR which shows the position of the next position on the screen, anything typed will move the cursor to the next position. If you want to RUN the program again you have to type in the command RUN again, and the program will repeat. To keep the program running an extra line can be added.

```
40 GOTO 10
```

GOTO instructs the computer to jump back to line 10, it is an unconditional instruction — the computer will change the operation sequence to give:

```
RUN
?4
16
?
```

With line 40 the computer will continue to square any number typed into it, if you had told the computer to GOTO a line that had not been allocated it would object — any instruction must be valid.

On a simple program like ours anybody would be able to read it and understand what was happening. However as soon as programs get any longer it can be difficult deciphering them after a period of time, to help the programmer a BASIC instruction REM is used. REM is short for REMark and is used like this:

```
0 REM A PROGRAM TO SQUARE A NUMBER
5 REM ASK FOR A NUMBER
10 INPUT X
15 REM SQUARE THE NUMBER AND CALL IT A
20 A=X*X
25 REM PRINT THE RESULT
30 PRINT A
35 REM GO BACK AND DO IT AGAIN
40 GOTO 10
```

It is very rare that a program would be as well REMed as this example, but REM statements should be used whenever a program goes off from the normal sequence. Another way of squaring a number is as follows:

```
20 GOSUB 100
100 A=X*X
110 RETURN
```

All the previous lines are the same, but in this example the actual squaring operation has been made into a 'subroutine'. The GOSUB instruction is one of the most useful commands in BASIC, without it you would have to include certain sections of program many times. With every GOSUB there must be a RETURN (not the same as the return on the keyboard), the RETURN makes the computer go back to the line after it went off

to the subroutine. As with GOTO, any GOSUB must have an allocated line number that exists. If you had told the computer to GOSUB 99 it would have replied 'UNDEFINED STATEMENT', the modern way of saying 'DOES NOT COMPUTE'.

To demonstrate how precisely you need to tell the computer what to do, line 40 could be missed out (deleted). The computer response would be:

```
RUN
?4
16
RETURN WITHOUT GOSUB IN 110
```

The computer does not like to find RETURNS on their own, without line 40 the computer has 'fallen through the bottom' of the program.

Both X and A are variables, and can be manipulated in any way that numbers can be on a sophisticated calculator. Standard functions that are available in BASIC (arctan) and even exponentiation. By using the exponentiation function (written as X^Y) line 100 could be written:

```
100 A=X^Y
11 INPUT Y
```

Line 0 should also be changed to indicate the new nature of the program, as should line 15. The program will now run as follows (if line 40 is END):

```
RUN
?4
?3
64
READY
```

If the original line 40 is put back in we now get:

```
40 GOTO 10
RUN
?3
?2
9
?
```

We now have a much more useful program that can find any power of any number, within the limits of the computers highest number and lowest number. On most BASICs the largest number is 1.70141×10^{38} which is rather large, and should be enough for most programs!

By using more sophisticated PRINT instructions the answer can be made clearer:

```
30 PRINT A;" IS "X;" ^ "Y
```

The semicolon instructs the computer to continue printing on the same line, all text enclosed in quote marks will be printed exactly as shown. All variables will have their current value printed.

```
RUN
?4
?2
16 IS 4^2
?
```

In the program example we have used A, X and Y as variables but we can use any combination of letters and numbers as a variable. The computer however only looks at the first two characters and the first one must be a letter. Also any variable cannot contain a BASIC command word.

For example, instead of A we can use OFFENCE but

cannot use OFFEND as the BASIC command END is in it. Another common word that cannot be used is TO, which is also a BASIC command word. All the BASIC reserved words are listed below:

ABS, AND, ASC, ATN, CHR\$, CLOSE, CLR, CONT, COS, DATA, DEF, DIM, END, EXP, FN, FOR, FRE, GET, GOSUB, GOTO, IF, INPUT, INT, LET, LIST, LEFT\$, LEN, LOAD, LOG, MID\$, NEW, NEXT, NOT, ON, OPEN, OR, PEEK, POS, POKE, PRINT, PRINT#, READ, REM, RESTORE, RETURN, RIGHT\$, RND, RUN, SAVE, SGN, SIN, SPC(, SQR, STEP, STOP, STR\$, SYS, TAB(, TAN, THEN, TO,USR, VAL, VERIFY, WAIT.

Now suppose we want to find the square, cube and fourth power of a number, we could use our existing program — but would have to keep entering the values for X and Y (2, 3 or 4). A BASIC command DATA can be used to make the job simpler:

```
10 DATA 2,3,4
20 INPUT X
30 READ Y
40 PRINT X^Y; "IS";X;"^";Y
50 GOTO 30
```

Each time that Y is read it takes the next item of DATA as its value, when run this program would act as follows:

```
RUN
?2
4 IS 2^2
8 IS 2^3
16 IS 2^4
OUT OF DATA ERROR IN 30
READY
```

Whoops! Not quite what was wanted! As soon as the DATA has been read the computer has no more to use

and assumes that you have made a mistake — which you have!

To reuse the DATA another statement is used, the RESTORE command. When a program needs to reuse the DATA, the RESTORE makes it start at the first item again. But if RESTORE is used with the program as it is shown where will it go? The answer is simple, nowhere! With the GOTO in line 50 it cannot come after (it would never get reached), and if placed before 50 the answer will always be the same:

```
RUN
?2
4 IS 2^2
4 IS 2^2
```

Etc.

The program will only stop if the BREAK key is pressed. A way round the problem is to check the value of the DATA, IF the DATA is 4 THEN RESTORE:

```
10 DATA 2,3,4
20 INPUT X
30 READ Y
40 PRINT X^Y;"IS"; X;"^";Y
50 IF Y=4 THEN 70
60 TOTO 30
70 RESTORE
80 GOTO 20
```

Now the computer will print the 2nd, 3rd and 4th powers of X, then ask for a new value for X. The IF, THEN is a conditional statement and will be ignored if the condition is not met, a GOTO is not needed at the end of the statement — BASIC assumes you want to GOTO the line number after THEN. You can place a GOSUB or other command after THEN if you want to. DATA can be placed on any line in a program, for example



Checks a program on tape to see if it has any errors.
This will read the status of location I, exclusive OR it with the status of K and then AND the result with J. When the answers is zero the program will restart.
Designates an integer variable.

VERIF
WAIT
%
10 A% = INT(X)

Displays current program.
Displays line 100.
Displays line 100 onwards.
Displays 10 through 100.
Lists up to line 100 only.
Extracts the leftmost A characters from string X\$.
Prints length of X\$, counts spaces as characters.
Loads program from cassette into the computer memory.
Loads named program, ignoring all others.
Gives the natural logarithm of X.
Prints B characters from string X, starting A characters from the left.
Wipes out existing programs from the computer's memory.
Marks the end of a FOR loop.
Without variable ends most recent loop.
Equivalent to NEXTI; NEXT J.
X must be false to transfer to 100.
Branches to line indicated by X, if X = 1 will branch to 20, etc.
The same as GOTO but with a return.
Opens file, numbers indicate what device.
Transfers line if either is true.
Prints the contents of memory location X.

LIST
LIST 100
LIST 100-
LIST 10-100
LIST -100
10 PRINT LEFT\$(X\$,A)
10 PRINT LEN(X\$)
LOAD
LOAD "XYZ"
10 A=LOG(X)
10 PRINT MID\$(X\$,A,B)
NEW
NEXT
20 NEXT
30 NEXT I,J
10 IF NOT X THEN 100
10 ON X GOTO 20,30,40
10 ON X GOSUB 20,30
10 OPEN 1,1
10 IF A OR B THEN 100
10 PRINT PEEK(X)

BASIC Mathematics
You don't have to be a mathematical genius to program a computer in BASIC. The computer obeys strict rules when it evaluates any expression, and all you have to do is learn the rules. Formulae enclosed in brackets are evaluated before anything else, if there are two or more sets of brackets then they are worked out from left to right — this rule also applies to any situation where there is equal priority. As an example 6—3+5 gives 8 as the answer, not —2. As division is more important than addition the expression 5+3/4 gives 5.75 not 2 — if you want to add 5 to 3 and divide the result by 4 you must use the following format (5+3)/4.

The list of precedence is as follows:
1: Formulae in brackets
2: ↑ or exponentiation (X^Y)
3: Negation (—X as a negative number)
4: * and / (multiplication and division)
5: + and —
6: = equal
< > not equal
< > less than
> greater than
< = less than or equal
> = greater than or equal

VERIF
WAIT
%
10 A% = INT(X)

10 DATA 2
11 DATA 3,4
Will give exactly the same result as the previous single line. But
10 DATA 2
11 DATA 4
100 DATA 3
will produce the answers out of order, with the 2nd, 4th and then 3rd power being printed.
The equals sign in the IF THEN statement can also be one of the following <, >, <>, = <, = >, = <, = >.
Two variables can also be compared using the IF THEN statement (remember you can use a variable instead of a number in programs).
As well as the standard greater than, less than and equals (with the combinations shown above) logical comparisons can be made with AND, OR and NOT statements.
IF A = 1 AND B = 2 THEN PRINT "A IS HALF OF B"

Suppose we want a table of squares for each number from 1 to 10, we could use the following program:
10 PRINT 1;1↑2
20 PRINT 2;2↑2
30 PRINT 3;3↑2
This method would work but it's very inefficient, by using the IF THEN statement the program becomes a lot smaller:
10 N = 1
20 PRINT N;N↑2
30 N = N + 1
40 IF N <= 10 THEN 20
This program will produce exactly the same result as the previous one. But what is happening in line 30? Mathematically N=N+1 is nonsense, however in this statement the equals sign is a shorthand for "replace the value of the left side with that of the right side". The statement replaces N with the value N + 1 every time it is executed. As N starts off with a set value of 1 it changes to 2,3,4,5,6,7,8,9 and 10 as the program operates. But when the square of 10 has been printed N becomes 11 and the condition in line 40 is not met — 11 is not less than or equal to 10. The program cannot go back to line 20 and as no more program exists, it will stop.
The technique used in the program above is called 'looping' or 'iteration', and is used extensively in programming. In fact it is such a useful technique that a special BASIC command exists to do it.
10 FOR N = 1 TO 10
20 PRINT N;N↑2
30 NEXT N
The output of this three line program is the same as the previous ten and four line programs. At line 10 N is set at 1, line 20 prints the value of N and the square of N and line 30 adds 1 to the value of N. This continues until N is 10. The variable following FOR is the same as the variable after NEXT, but both could be any valid variable — as long as they are the same.
If only every second square was wanted, a STEP instruction can be added to line 10:
10 FOR N = 1 TO 10 STEP 2
Now the computer will add 2 to the value of N instead of 1, and only every second value will be printed. We can

FOR OUR NEXT TRICK

even get the results printed in reverse order by reversing the FOR conditions and stepping a minus number:

```
10 FOR N=10 TO 1 STEP -2
```

If no STEP is given the BASIC will add 1 to the variable each time. A loop can be placed inside another loop, as long as it is all inside. If two loops overlap then the results are predictable, the computer will say 'NEXT WITHOUT FOR' when it has finished the first loop it finds. Putting one loop in another is called 'nesting'.

STRINGS AND THINGS

So far all the manipulation has been with numeric variables, but BASIC can also cope with alphanumeric variables. All sets of alphanumeric are called 'strings' and denoted by a dollar sign at their end.

```
10 INPUT A$
20 PRINT A$
RUN
?BASIC
BASIC
READY
```

All strings can be up to 255 characters in length.

The strings can be manipulated in many ways, LEN(X\$) gives the total number of characters in X\$. LEFT\$(X\$, I) gives the first I characters of the string X\$, RIGHT\$(X\$, I) gives the last I characters of X\$. The command MID\$ is used in a similar way to extract characters from the middle of the string.

```
10 INPUT X$
20 FOR N=1 TO LEN(X$)
```

```
30 PRINT LEFT$(X$,N)
40 NEXT N
RUN
?BASIC
B
BA
BAS
BASI
BASIC
READY
```

Strings can also be added together after they have been taken apart, the addition sign '+' can add different strings — this is called 'concatenation'.

```
10 INPUT A$
20 B$=A$+A$
30 PRINT B$
RUN
?REPEAT
REPEATREPEAT
READY
```

If all this seems like a maze of jargon then there is only one surefire answer, get hold of a computer and try writing a program! All the BASIC instructions are given here with short explanations. Most small computer systems come with BASIC manuals and some are excellent (the Tandy one in particular). A very good book for beginners is *Illustrating BASIC* by Donald Alcock, available from the HE bookservice for £2.20 (including postage) or most good bookshops; it is published by Cambridge University Press.

Computers are not anything to be afraid of, they are as easy to use as a motorcar — you just have to learn to drive them.

HE

Short Circuit

HF TTL OSCILLATOR

A squarewave oscillator with complementary outputs and with a frequency range of 20 Hz to 10 MHz can be made from one IC, a 7413 which is a TTL dual Schmitt trigger. The oscillator is always self starting and runs from a 5 V supply, current drain 20 to 30 mA. The 7413 is a Schmitt trigger with hysteresis levels (at its input) of +0.9 V and +1.7 V. That is, when the input level exceeds +1.7 V the output jumps to a low condition (+0.2 V). When the input voltage is lowered it needs to fall below +0.9 V before the output jumps back to a high condition (+3.4 V).

When the Schmitt trigger is connected up as shown in the diagram the device will oscillate. Imagine the output is high. C1 is charged up via R1. When the voltage on C1 reaches +1.7 V, the output falls to +0.2 V. C1 is now discharged via R1 in parallel with R2 (D1 is now forward biased) until the voltage on C1 reaches +0.9 V. Then the output jumps to a high state and the process repeats itself. The second Schmitt trigger merely inverts the squarewave output. The

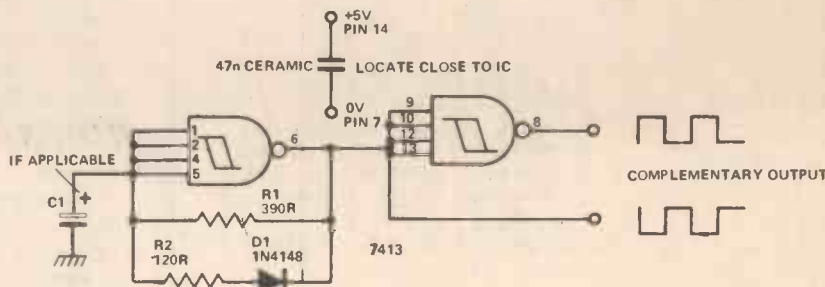

frequency of operation is given by the formula:

$$F_{osc} = \frac{2 \times 10^{-3}}{C1}$$

where F_{osc} is in Hz and C1 is in Farads.

therefore for:

- 10 MHz, C1 = 220 pF (poly-styrene or ceramic)
- 1 MHz, C1 = 2200 pF (poly-styrene)
- 100 KHz, C1 = 22 nF (polyester)
- 10 KHz, C1 = 220 nF (polyester or electrolytic)
- 1 KHz, C1 = 2.2 uF (electrolytic)
- 100 Hz, C1 = 22 uF (electrolytic)
- 20 Hz, C1 = 100 uF (electrolytic)

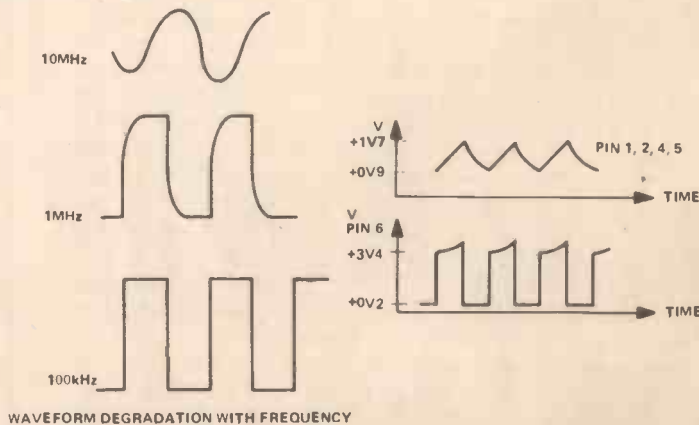

Variwiper

This pulsed windscreen wiping circuit can be used on cars fitted with most types of modern wiper motors.

WHEN OPERATING IN heavy rain windscreen wipers often have difficulty providing adequate visibility. However, during light rain or mist all that is necessary is an occasional sweep of the blades at intervals of a few seconds.

Turning them on and off repeatedly takes the driver's concentration off the road, and his hands off the wheel, increasing the risk of an accident. Alternatively, if the wipers are kept working all the time in such conditions the blades tend to scrape on dry glass, wearing out the rubber inserts, your nerves, and worst still, the screen itself.

The answer is obvious; have the wipers operate intermittently at a duration which can be varied to suit the conditions.

Figure 1 shows the circuit of a modern wiper assembly. Dynamic braking is achieved by applying a short across the armature, by a cam-actuated change-over switch synchronised with the wiper blades. When the wipers are switched off, the change-over switch shorts out the motor armature via the main wiper ON/OFF switch.

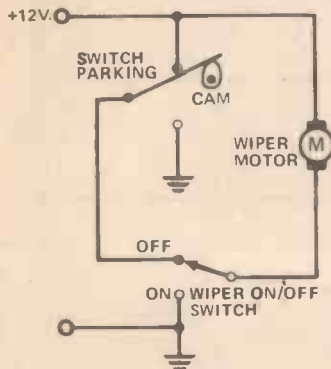

Fig. 1. Circuit of modern wiper motor assembly. Dynamic braking is achieved by applying a short across the armature.

The circuit of Fig. 2 is suitable for use with negative earth cars fitted with permanent magnet motors. Some early model cars are fitted with wound field coil motors and are not suitable for use with this circuit (more about them later).

Some types of permanent magnet wiper motors, especially those on British cars, have a fifth wire extended to the wiper switch. These motors are designed to operate independently of an earth to allow for their use on either positive or negative earth vehicles. The circuit of Fig. 2 can also be used with these motors provided they are fitted to a negative earth car. However, some more cars have wiper motors which are reversed in the parking sequence to lower the blades below the bottom of the windscreen when not in use. The Vari-Wiper unit described cannot be used with these wipers.

Before installing the Vari-Wiper unit make sure that you have one of the types of permanent magnet wiper motors described. If necessary remove the cover of the motor and identify the wire to the centre contact of the cam-operated switch.



NORMAL WIPER OPERATION

Conventional operation of the wipers is obtained by using the vehicle wiper switch in the normal way. Figure 2 shows the sliding contacts of this switch in the correct position for each function. Note that in the OFF position the switch shorts lead B to lead C. In the LOW position the short is removed and an earth is extended to B, while in the HIGH position the earth is removed from B and extended to A. For single speed wipers slide contact A will be omitted.

DELAYED OPERATION

When delayed operation is required, the upper switch is left in the OFF position and the timing circuit energised by operating SW1 which is part of the switch/potentiometer RV1.

After a time which is set by the position of RV1 (0.5-25 secs.) the relay contacts RL1 (1) change over, removing the short circuit from the motor armature before energising the motor by extending an earth via the now closed relay contacts.

As the motor gathers speed the associated cam-operated switch changes over, removing power from the timing circuit (causing the relay to drop out), and

extending an earth to the wiper motor via the wiper switch contacts B and C, the now de-energised relay contacts, and the cam-activated switch.

The wipers continue their sweep across the screen, but on their return the cam-operated switch cuts in just before the end of the sweep. This removes power from the wiper motor and places a short across the armature. The motor is thus dynamically braked and remains stationary until the next relay closure from the timing circuit. When this arrives the sequence is repeated.

WOUND FIELD COIL MOTORS

Because wound field motors do not use dynamic braking, the Vari-Wiper can be made without a relay. Figure 3 shows the simplified Vari-Wiper circuit and its connections to either a positive or negative earth vehicle. The same printed circuit is used for both arrangements. Operation is similar to the previously described unit, having an earth extended through the SCR to start the motor.

CONSTRUCTION

Assemble and solder all components on the printed circuit board as shown in Fig. 5. Do not bend the lugs of the SCR too close to its case and ensure all semiconductors are the right way round.

To connect the unit to the wiper motor circuit, the existing lead from the centre pole of the wiper motor change-over switch to the wiper ON/OFF switch (shown in dotted lines in Fig. 2), should be broken at points X and Y and these leads taken to the normally closed contacts on the relay. Ensure that point X goes to the fixed contact and point Y to the moving one.

The potentiometer should be connected to the unit with just enough wire to allow the printed circuit to be mounted in a convenient position under the dash. The potentiometer can be mounted through a 10 mm hole drilled in the fascia panel or by attaching it to a bracket mounted in a convenient place.

HE

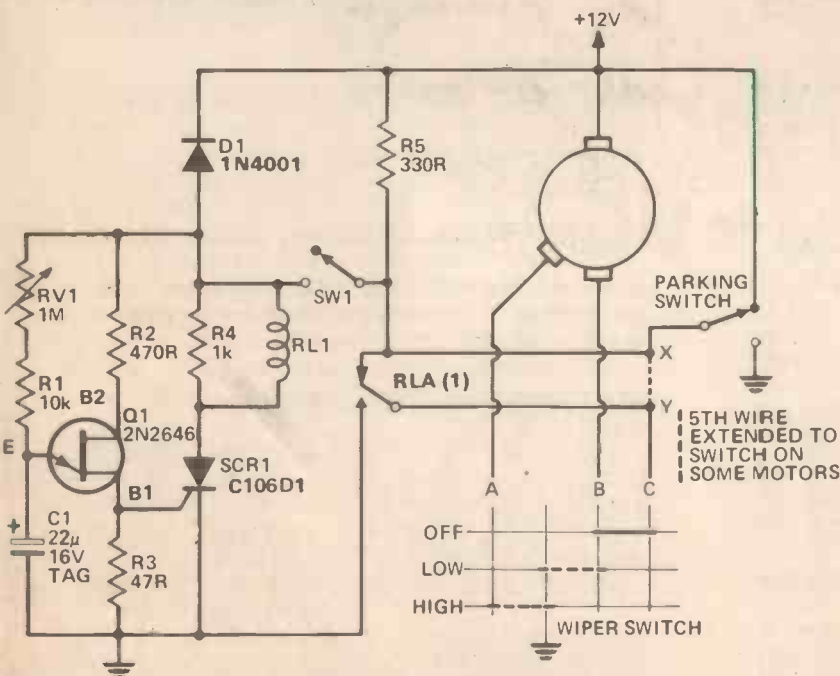

Fig. 2. The Vari-Wiper circuit using relay output for use with permanent magnet motors.

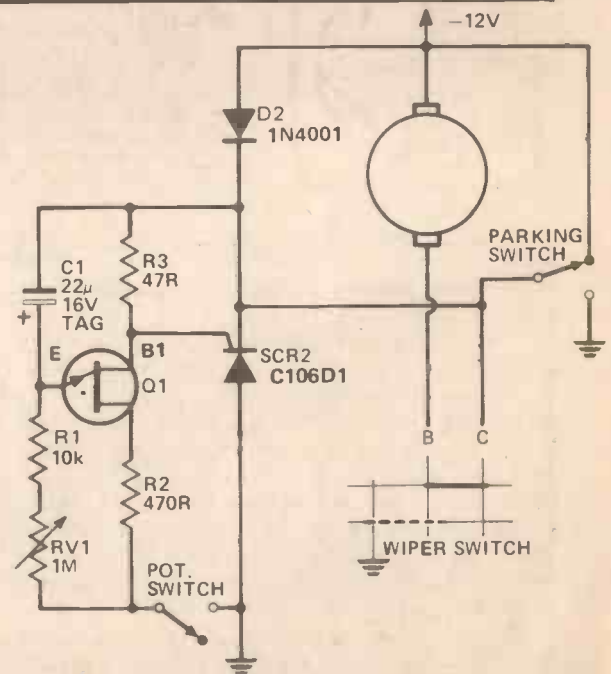

Fig. 3. Simplified Vari-wiper for use with wound field coil motors with positive earth.

Parts List

Relay Output Unit

RESISTORS ALL 1/4W 5%

R1 10k
R2 470R
R3 47R
R4 1k
R5 330R

POTENTIOMETER

RV1 1M switch pot

CAPACITOR

C1 22u 16V electrolytic

SEMICONDUCTORS

D1 1N4001
Q1 2N2646 unijunction
SCR1 C106D (400V, 4A)

MISCELLANEOUS

RL1 Miniature printed circuit board mounting heavy duty 12V relay
PCB Variwiper 2
Nylon terminal strip

SCR Output Unit

All components identical, except:

R5 deleted
D1/2 1N4001
SCR2 C106D (400V, 4A)
RL1 deleted
PCB Variwiper 1

Approximate Cost: £6

Fig. 4. The simplified circuit for negative earth vehicles. Both this and Fig. 3 use the same PCB.

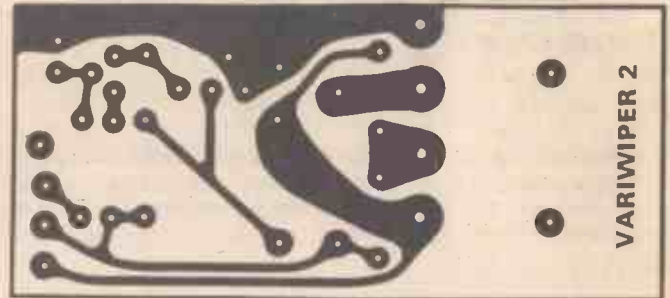
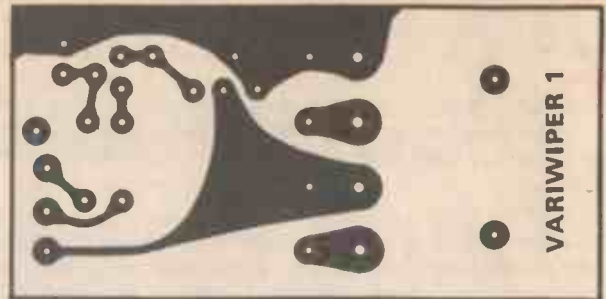
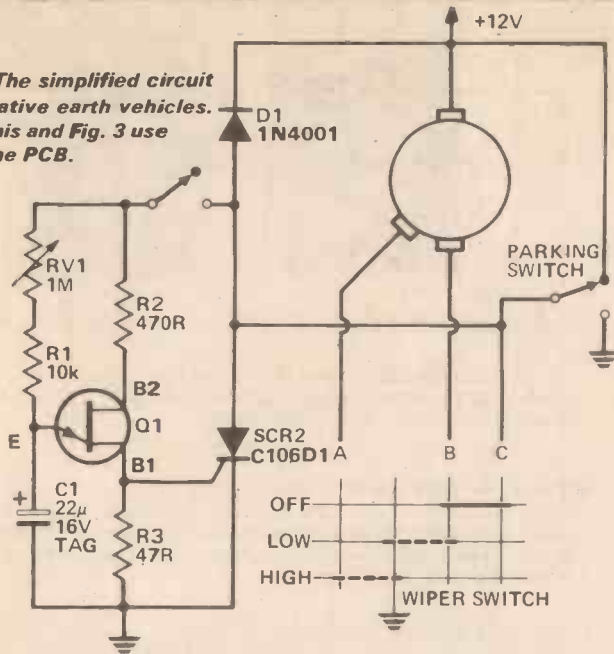

NEG. EARTH	POS. EARTH
+12V	N.C.
PARKING SWITCH	EARTH
N.C.	-12V
EARTH	PARKING SWITCH

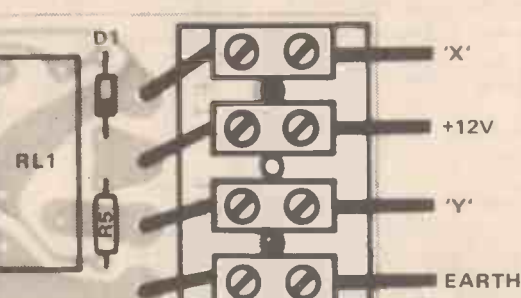
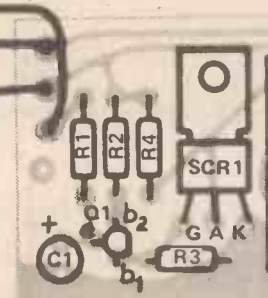
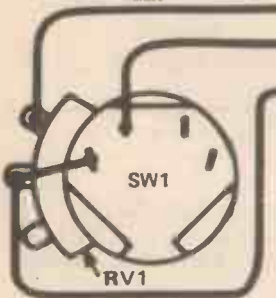
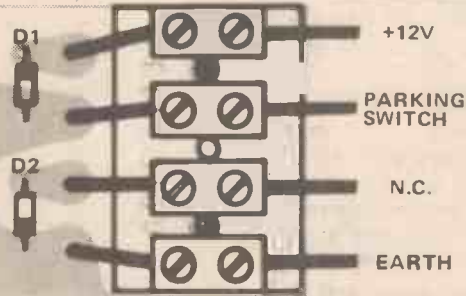
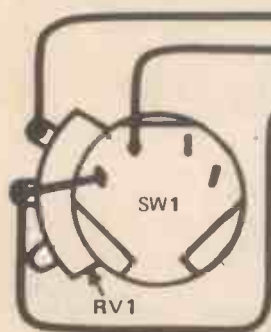

Fig. 5. Component overlays. Note that the same PCB is used for both earth polarities.

How it Works

The timing circuit is energized by operating switch SW1, which is part of switch/potentiometer RV1. This switch applies power to the unijunction/SCR circuit via the still-closed parking switch contacts.

Capacitor C1 charges via RV1 and R1, at a rate determined by the setting of RV1, until the unijunction 'fires', producing a positive going pulse which triggers the SCR into conduction. Resistor R4 ensures that the SCR latches on, thus energizing relay RL1.

Relay contacts RL1 (1) now changeover, removing the short circuit from the motor armature before energizing the motor by extending an earth via the now-closed relay contacts.

As the motor gathers speed, the associated

cam-actuated switch changes over, removing power from the timing circuit (causing the relay to drop out) and extending an earth to the wiper motor via wiper switch contacts B and C, the now de-energized relay contacts, and the cam-actuated switch.

The wipers continue their sweep across the screen, but on their return the cam-actuated switch cuts in just before the end of the sweep. This removes power from the wiper motor and places a short circuit across the armature.

Operation of the unit is similar except the motor, which does not require dynamic braking, can be driven directly from the SCR, saving the cost of a relay. Note that either D1 or D2 become redundant depending on the polarity of the vehicle.

Hobby Electronics Book Service



BUILD-IT BOOK OF OPTOELECTRONIC PROJECTS by Charles Adams £4.75

A 48 project learn-by-building guide to the super-practical world of optoelectronics with thoroughly readable instructions on how to create everything from an LED circuit monitor to an electronic stopwatch.

HOW TO READ ELECTRONIC CIRCUIT DIAGRAMS by Bob Brown and Paul £4.00

This book is for the beginner who wants just enough practical knowledge of electronics to pursue a hobby.

EASY SPEAKER PROJECTS by Len Buckwalter ... £3.75

Explains how to make speaker systems ranging from simple shelfboard and ceiling-mounted enclosures to more advanced bass-reflex and omnidirectional ones.

ELECTRONIC GAMES AND TOYS YOU CAN BUILD by Len Buckwalter £3.75

A 'just-for-fun' book. No complex electronics theory anywhere — just step-by-step instructions, construction photos, and detailed wiring-construction diagrams for building 15 fascinating electronic games and toys.

MICROPHONES: HOW THEY WORK & HOW TO USE THEM by Martin Clifford £4.75

Takes all the mystery out of microphones, shows you how to record almost anything with professional quality, clearly explains how to get different sound effects and better stereo, and fully describes mike positioning techniques.

BASIC ELECTRONICS COURSE by Norman H. Crowhurst £5.50

A self-study text for the novice, hobbyist, student — a perfect reference and brush-up guide for technicians and others who want to advance their knowledge of electronics.

HOW TO TEST ALMOST EVERYTHING ELECTRONIC by Jack Darr £3.50

Practically every testing technique for almost every kind of electronic equipment is laid out for you in easy, highly readable style.

ELECTRONICS FOR THE AMATEUR by Louis M. Dezettel £6.55

Written especially for the radio amateur, discusses radio-wave propagation as it applies to amateur band frequencies, reception and transmission as they pertain to the equipment 'hams' use, and the special field of antennas and how to feed them.

ELECTRICAL SOLDERING (2nd edition) by Louis M. Dezettel £4.45

Teaches the hows and whys of electrical soldering. Tells about solder alloys and fluxes. Discusses the various types of soldering devices. Then concentrates on the principles of good soldering and acquiring the needed skill.

BUILD-IT BOOK OF HOME ELECTRONICS by Graf and Whalen £3.45

Put electronics to work for you in your home. The authors present thirteen interesting and fun projects that use the latest solid-state devices and ICs.

BUILD-IT BOOK OF SAFETY ELECTRONICS by Graf and Whalen £3.45

Contains ideas for building several novel projects to protect toddlers from invading the medicine chest to a motel room from a burglar; and to scare a car thief and more. Thirteen tested safety projects are detailed.

BUILD-IT BOOK OF FUN AND GAMES by Graf and Whalen £3.75

All the projects in this book are designed for fun and game applications. The projects include a sight'n'sound metronome, an electronic football game and stereo balance meter, a sound-activated switch and a metal detector.

IMPROVING YOUR HI-FI £3.50

This book is aimed at the novice who has just purchased his first audio set-up or is about to do so. It begins with details of how to connect the units together to obtain top performance and explains the meaning and proper use of the many control knobs and switches found on modern hi-fi gear.

GUIDE TO PRINTED CIRCUITS by Gordon J. King . £3.50

The Text is angled especially at the keen amateur constructor, the experimenter, the service technician and apprentice.

ELECTRONIC TEST EQUIPMENT by Harry T. Kitchen £5.00

This book is designed to provide interest for almost everyone involved with electronics. The six chapters explore the more general groups of instruments such as test meters of various types, audio and r.f. signal generators, attenuators and oscilloscopes. Each chapter explains the principles and requirements of particular types of test equipment, including typical circuitry, then discusses the choice, care and use of the equipment.

FUN WITH ELECTRONICS by McEntee £3.40

An exciting show-tell-and-build-it book that teaches electronics with plenty of fun in the process.

AUDIO AMPLIFIERS FOR THE HOME CONSTRUCTOR by Ian Sinclair £2.60

Describes in seven chapters the working principles of transistor amplifiers and outlines the steps and circuit design using a modern simplified transistor theory.

INTRODUCING ELECTRONIC SYSTEMS by Ian Sinclair £1.80

This book by author-lecturer Ian Sinclair is intended to provide a basic insight into what makes electronics 'tick'.

INTRODUCING AMATEUR ELECTRONICS by Ian Sinclair £1.55

This is the book for the complete novice of any age, in which author Ian Sinclair assumes no previous knowledge of the subject by the reader.

ABC'S OF FET'S by Rufus P. Turner £3.05

Describes the field effect transistor (FET) in simple language. Deals in detail with the principles of FET operation and stresses the applications of FETs in practical circuits.

ABC'S OF ELECTRONICS (2nd edition) by Farl J. Waters £4.15

An introduction to the ever-expanding field of electronics. Covers the principles of electricity, functions of atoms and electrons, magnetic forces and their relationship to electronics.

Note that all prices include postage and packing. Please make cheques, etc, payable to Hobby Electronics Book Service (in sterling only please) and send to:
Hobby Electronics Book Service,
P.O. Box 79,
Maidenhead, Berks.

Hobby Electronics

Next Month

Short Wave Receiver

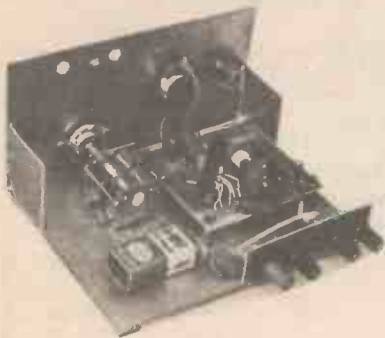

Back in the bad-old-days when there were just valves, and they were expensive, you thought hard before adding another stage of amplification: first you tried to be clever. Our SW radio next month uses just two semiconductors yet will give surprisingly good performance over the range 5.5-25 MHz if used with a reasonable aerial.

Radioactivity



Although most people shudder when they think of radioactivity, there's a lot more to it than fallout from nuclear bombs. Radioactivity is widely used in medicine and in industry and our article describes some of the uses and traces the history of its development.

Sine/Square Wave Generator



An essential part of anybody's test gear and our project next month enables you to add one to your workbench at low cost.

Projects Using The CA3130

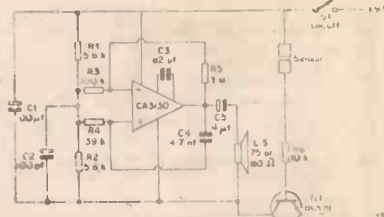

We publish one chapter from R. A. Penfold's '50 Circuits using the CA3130' (brought out by Babani) and mighty interesting they are too. The projects include an electronic organ, metronome, alarm and latching circuits.

Instant Circuit Layout

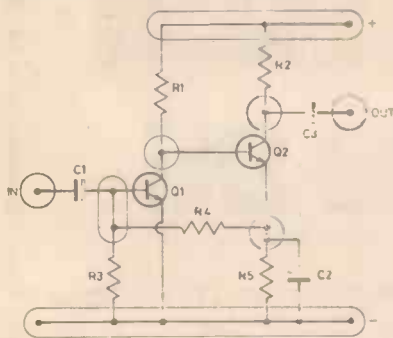

Do you have trouble getting your brain to translate a circuit into a practical layout? If so you're in good company but next month join the elite by overcoming this. We give you practical advice on how to lay out components from practically any circuit diagram.

Video Tape Recorders



The age of the Video Cassette Recorder has arrived and soon they'll be common. However, they are the most complex, sophisticated, pieces of engineering that have ever crossed the doormat in reasonable numbers. Next month we explain how they work and take a look at the different systems being offered.

Holograms

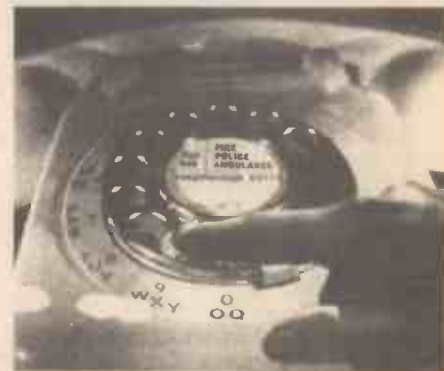

Today they are only a curiosity, shown as exhibits and as special effects but much work has been going on behind the scenes. Today's Holograms really make you wonder if you can believe your eyes.

Scratch/rumble Filter

An add-on circuit to couple to an existing audio system, this project enables you to select the cut-off frequency of the system at both ends of the spectrum.

OST Rules, OK?

Got the hang of Ohms Law? No problem but the world isn't yours yet — have you ever found a problem it can't cope with? The chances are that you have. However, there are two other approaches to help you solve the nasty ones: Superposition and Thevenin's Theorem. They may sound complex but in reality they make life simpler.

The February issue will be on sale on January 12th

The items mentioned here are those planned for the next issue but circumstances may affect the actual content.

Hobby Electronics

Marketplace



Size: 100mm x 130mm x 60mm.

Over 10% of Electronics Today International's readers have purchased a digital alarm clock from offers in that magazine — the offer is now extended to Hobby Electronics readers. This is a first rate branded product at a price we don't think can be beaten.

The Hanimex HC-1100 is designed for mains operation only (240V/50Hz) with a 12 hour display, AM/PM and Alarm Set indicators incorporated in the large display. A switch on the top controls a Dim/Bright display function.

Setting up both the time and alarm is simplicity itself as buttons are provided for both fast and slow setting and there's no problem about knocking these accidentally as a 'locking switch' is provided under the clock. A 9-minute 'snooze' switch is located at the top.

An example of this digital alarm clock can be seen and examined at our Oxford Street offices.

£8.95

(Inclusive of VAT and Postage)



We feel we've got to tell you carefully about this offer which we're introducing for the first time. Why? Because our price is so enormously lower than anywhere else you may suspect the quality.

The exact same watch is currently being offered by another magazine as a special at £24.95 — some of the discounters are selling it at £29.95 the price to HE readers for exactly the same watch is £12.95.

The display is LCD and shows the seconds as well as the hours — and minutes — press a button and you'll get the date and the day of the week.

Press another button for a couple of seconds and you have a highly accurate stopwatch with hundredths of a second displayed and giving the time up to an hour. There is a lap time facility as well — and of course a back light.

Our Chrono comes complete with a high grade adjustable metal strap and is fully guaranteed.

An example of this LCD Chronograph can be seen and examined at our Oxford Street offices.

£12.95

(Inclusive of VAT and Postage)

DIGITAL ALARM

To:
DIGITAL Alarm Offer,
Hobby Electronics,
25-27 Oxford Street,
London W1R 1RF.

Please find enclosed my cheque/P.O. for £8.95 (payable to Hobby Electronics) for my Digital Alarm Clock.

Name

Address

Please allow 14 days for delivery.

LCD CHRONO

To:
LCD Chrono Offer,
Hobby Electronics,
25-27 Oxford Street, London W1R 1RF.

Please find enclosed my cheque/P.O. for £12.95 (payable to Hobby Electronics) for my LCD Chronograph.

Name

Address

Please allow 14 days for delivery.

Short Circuit

A SINGLE OP AMP OSCILLATOR

An op amp can be made to oscillate generating a square-wave output. The circuit is a Schmitt trigger and integrator all rolled into one.

To understand the operation imagine the output is high; C1 is charged up via R3. The voltage at point A is +0.9 V due to the resistor divider network R1, R2. When the voltage at B exceeds this voltage, the output of the op amp flips into its negative (low) state, C1 is therefore discharged by R3. When the voltage on C1 reaches -0.9 V, the reverse process occurs and the op amp output flips back to its high state. Thus the circuit oscillates producing a square wave going from +10V to -10V.

The frequency of operation can be obtained from the voltage changes on C1. This is the truncated section of an exponential charge/discharge curve, but we shall ignore this and assume that the curve is linear (which it almost is).

The frequency can be obtained from the formula $F = I / \Delta V \times C$ Hz where I is the charging current

(approximately 100 μ A), ΔV is the charge across C1 (3.6 V) and C is the capacitance measured in Farads.

Therefore $F = 10^{-4} / 3.6 \times C$ Hz. Thus, if C1 = 100nF, F = 270 Hz; if C1 is 10nF, F = 270 Hz and if C1 is 1nF, F = 27 000 Hz.

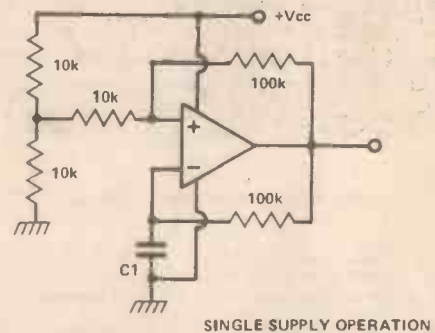
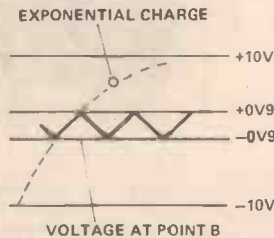
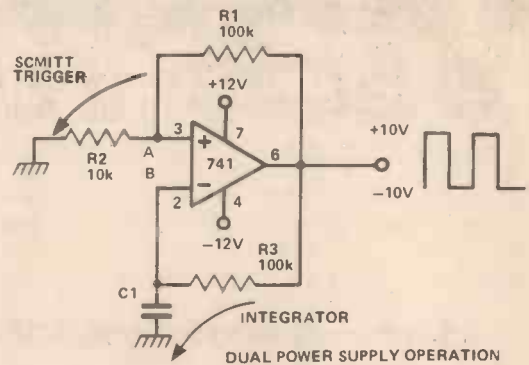

POWER SUPPLY WITH IC REGULATOR

A regulated power supply used to require a fairly complex circuit but the introduction of special ICs has made matters much simpler.

The chart shows the various voltage requirements for four types of voltage regulator. The last two numbers of this range of IC indicate the voltage so the 7812 will give 12V. Care has been taken that the voltage ratings of the regulator are not exceeded as this can blow up the IC.

The secondary voltage from the transformer (it must be an isolating transformer but most are) is full-wave rectified by the diodes and then smoothed by capacitor C1. The voltage here is unregulated and has AC ripple superimposed upon it. The IC removes this and gives an almost ripple free, stable DC voltage. C2 and C3 must be sited close to the regulator to prevent any loss of performance due to high frequency instability. Note that the capacitor and common lead from the IC should be wired to the same point, this helps to reduce instability and current hum problems that can occur due to poor layout.

The 78XX series of regulators which come in a TO220 package generally can supply 500 mA of

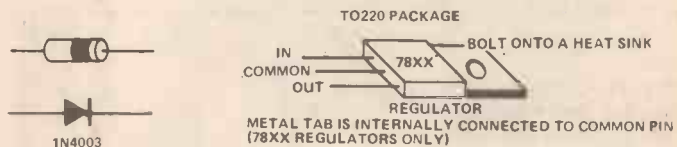
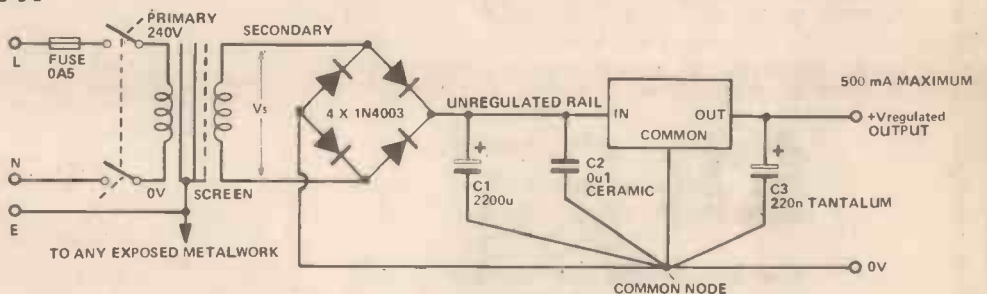

REQUIRED OUTPUT VOLTAGE	REGULATOR 78XX	TRANSFORMER SECONDARY Vs	CAPACITOR VOLTAGE C1	TYPICAL MAXIMUM INPUT VOLTAGE TO REGULATOR
5V	7805	8 TO 9 V RMS	16 TO 25 V	25V
12V	7812	12 TO 15 V RMS	25 TO 35 V	30V
15V	7815	15 TO 16 V RMS	35 TO 63 V	30V
24V	7824	20 V RMS	35 TO 63 V	38V

current. Therefore the maximum power dissipated in them is probably going to be 500 mA times the voltage difference between the input and output terminals. This

might mean that the regulator has to dissipate 5 W of heat. Therefore an adequate heatsink must be used. The 78XX series is current limited which means that if the

maximum current is exceeded, the output voltage drops towards 0V. The regulator is thus short-circuit protected as long as proper heat sinking is provided.

Viewdata

Prestel, the British Post Office's viewdata service, becomes publicly available during early 1979. Angus Robertson takes a look at viewdata's background and its future implications.

MOST READERS will by now have come across teletext, the information service transmitted by both BBC and ITV and called Ceefax and Oracle respectively. These services have been widely promoted through both the TV programme magazines and directly on-air — teletext receivers can be seen at most respectable rental and television showrooms. Basically, a special receiver is used which decodes and displays the digital teletext signals which are transmitted on four of the total 625 lines comprising each television channel. Typical teletext services include news, weather, sport, and such topical subjects — however the maximum number of pages is only a couple of hundred, otherwise the transmission cycle becomes rather extended and the waiting time for pages becomes unacceptable. Viewdata uses the same transmission format as teletext, but instead of information being transmitted on the limited spare lines of a TV signal, telephone lines are used.

In Britain there are some 23 022 000 telephones connected to 14 862 000 lines (allowing for PBXs and extensions) and the capital cost of these, together with cabling to exchanges, is £1 548 100 000. The average number of daily calls per line is only 3.36, and obviously if subscribers can be persuaded to make more calls each day, this investment will be better utilised, thus effectively keeping phone charges down. The speaking clock is one such 'traffic generator' receiving around 400 000 000 calls each year — the Post Office hope that their Prestel viewdata service will be another.



Viewdata systems can appear in many different forms and guises — you don't have to use a domestic TV set. In fact, there's no reason why the system shouldn't be as an accessory to the telephone rather than the TV.

HOW IT'S DONE

Information is stored at the viewdata centre in much the same way as teletext, using a small computer and bulk disc storage. However, with teletext each page is accessed and transmitted every 30 seconds or so, but viewdata pages are only transmitted when a viewer makes a specific request — which makes it a considerably more efficient system and able to handle many millions of pages rather than teletext's few hundred. More importantly, since a telephone line must be established to the viewdata computer to receive information, the computer can then accept other instructions from the home terminal making it totally interactive — in effect it means a commercial computer terminal in ones living room or office. However, unlike a commercial computer terminal, the protocol required to communicate with it is very simple and can be understood even by children after only a few minutes instruction.

Perhaps I should make the rather important point that unlike the free teletext service, charges are made for accessing viewdata pages and these can accumulate rapidly while one browses through the system. One other important difference is that while teletext information is originated by the BBC and ITV, the Post Office is only offering its Prestel viewdata service as a 'medium' in much the same way as the telephone system. In other words, private companies and organisations can rent a telephone, and then transmit whatever information they so wish — the Post Office will originate no pages itself, other than indexing, although certain PO departments may rent pages themselves for various services such as directories, dialing codes, postal charges or whatever.



The works. This shot shows the innards of a Mullard Teletext unit. The size could be reduced even further to fit inside a TV set.

Obviously the normal laws of libel and decency apply, but pages will not be vetted as such by the PO. However, subject matter should be within a specific sphere in order that indexing can be provided.

This might appear rather complex, but in practice is very simple and the system is designed to allow rapid access of information without recourse to directories. Basically, each page provides prompts leading toward other pages in the form of a maximum of 10 choices for further information which are then simply accessed by pressing a single digit on the receiver keypad. This new page should in turn provide further prompts until the required information is reached — the final page has a prompt leading back to the route's beginning so one can start again.

In the initial stages at least, Prestel will be primarily providing 'hard' information such as classified advertisements, houses and cars for sale, stockmarket results, entertainment guides, holiday and travel timetables, hobbies and pastimes, cars, education, agriculture and farming, and employment. In addition to information openly available to all users of Prestel, closed user groups can also be created. This is of particular interest to companies and organisations that need to supply rapidly changing information to a large number of outlets widely scattered around the country (or world), such as travel agents, banks, building societies, chains of shops and wholesalers, service departments and so on. In this case, only preselected users will be permitted access to certain pages — these users might for instance have to pay an additional service charge or simply belong to a particular group of companies.

When Prestel is eventually fully operational, the interactive capability will allow information to be passed back from user to the original information provider. For instance, if one has been examining airline reservations, a booking could be completed through the Prestel system and (potentially) could also be paid for using a credit card (whose number Prestel could conveniently also store). Similarly, one could complete a sales transaction and the system could be on-line to banking computers enabling one to examine up-to-the-minute statements and make transactions directly without paper of any form. Prestel can also be used for tasks such as calculating mortgages (which requires considerable effort on most pocket calculators). One of the first Prestel pages demonstrated almost three years ago was one of interactive games although these are not being initially provided on the public service. The Maze Games provided mazes of seven different complexities and one has to move a marker around using four digit keys — virtually impossible with the most complex!

TOMORROW THE WORLD

Maybe here I should say that eventually there might be many viewdata services operating both in Britain and around the world — the PO Prestel service is just the first and the PO certainly does not have a monopoly over users of its telephone lines. Mullard Research Laboratories have been privately demonstrating their own viewdata system that uses a radically different indexing system. Eventually, this might be made available to the public. Since one of the principle economic necessities of viewdata is that it should be available countrywide for a local telephone charge, thus requiring

a wide network of computers or lines, the PO will have an initial advantage since many different organisations will be using those same computers and lines.

It might be interesting to look at the charges being made for the PO Prestel viewdata service. Users will either buy or rent a viewdata receiver from their local TV shop and this will be plugged into a normal PO jack socket as used for extension telephones. Actual receiver cost is difficult to estimate but will probably initially be about £700 or £18 per month. To contact Prestel, pressing a button automatically dials a special telephone number. The computer answers automatically with a request for the receiver's 'user number', which is stored electronically. When this has been received by the computer, it offers the first indexing page and charging commences.

Apart from the local phone call which works out at 22½p per hour in the evening and at weekends, there is a 2p per minute charge while connected to the computer. Some pages will be free such as indexing and advertisements, while others will carry a charge which is prominently displayed in the top right corner of the screen. This varies between ½p and about 10p although higher charges are possible for valuable information. Most information works out at around ½p to 2p, with only topical news items and such at an extra cost. This charge per page is paid directly to the companies that supplied the information, less a 5% handling charge for the PO. In addition, information providers (as they are

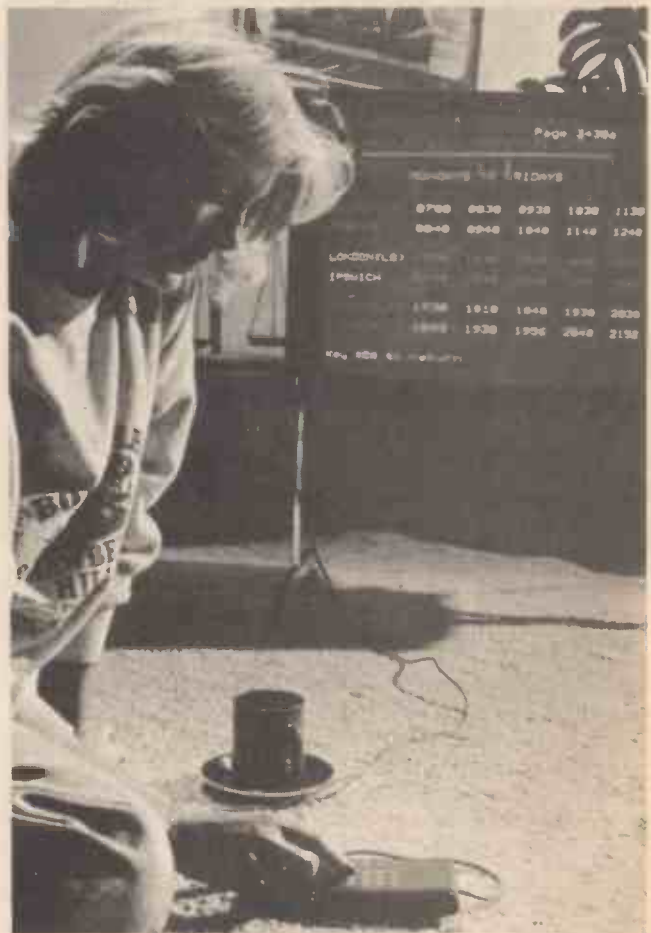

termed), pay additional charges for having their information stored on Prestel in the first place. The 'A' rate applies to regularly updated information and comprises a £4 000 a year service charge with a £4 per frame charge on a one year contract reducing to £2 400 a year and £2.40 per frame on a five year contract. The 'B' rate applies to more archival information that is only occasionally updated for which an annual charge of £1 000 is levied with a £1 per frame storage charge — however, ½p is deducted from each frame access to cover the increased cost of bulk storage. This second rate is appropriate for encyclopedias which might require about 200 000 frames storage and for which a greater waiting time than normal one or two seconds might be acceptable, so that frames could be retrieved from tape or some such system.

IMPLEMENTATION

So how is viewdata actually implemented? The frame format is identical to teletext, 24 rows of 40 characters with seven colours. However, the top line is reserved for page and charging data and the name of the information supplier, while the bottom line is used for computer messages. Information between receiver and computer uses the PO DATEL 600 service which provides a 1 200



One of the many possible applications for a viewdata type system is the fast dissemination of quickly-changing information. This could be financial, advertising or weather information, although some applications won't even be thought of until the system is in common use!

baud (bit/sec) frequency shift modulation circuit between computer and receiver (120 words/sec) and a 75 baud link in the reverse direction for keypad commands.

Although early receivers used standard PO modems, this would have been totally uneconomic for a public service and so the PO has relaxed one of its most stringent rules on the supply of equipment connected to the public switched telephone to allow private industry to develop and sell direct to consumers a vastly simplified modem built into the receiver itself. This change is only part of a broader attitude that the PO has been taking during the past couple of years which should see



One of the many possible configurations for a Viewdata terminal. This one would be suitable for someone with the home computing bug!

other items of telephone equipment and new services becoming available over the next few years (and which I shall be writing about shortly in *Hobby Electronics*).

The computers used for Prestel are GEC 4080 types using 70Mbyte discs (storing about 70 000 pages each) and these operate in pairs at each Prestel computer centre, each with separate memory, but capable of accessing the other. The computer centres will have a large number of 'ports' which comprise telephone line switching answering, modem and a line buffer with a 1 Kbyte memory which temporarily stores a page transferred from disc while it is being transmitted to the receiver. It is hoped that each computer will support some 700 simultaneous users engaged only in information retrieval, while this would have to be reduced for



The system which made it all possible — the widespread use of Ceefax and Oracle systems makes the connection to the phone lines a feasible proposition. It's simply a matter of arranging for the system to get its information from the phone rather than the top few lines of the TV picture.

services requiring more processing time such as games and calculations.

Message services will also become available so that users can send written messages to each other — Prestel is even going to be linked to the international telex network so that users will be able to send messages to any telex users worldwide — and vice versa of course (useful for small businesses that cannot justify the £500-odd rental for a telex). Although initially Prestel will operate from a central London computer centre, in the early years of the project this particular centre will become the national update computer which information providers will access to change their information, while further computer centres in the north and south of London will provide the local Prestel service. Other areas getting computer centres (with twin computers) include Glasgow/Edinburgh, Manchester/Liverpool and Birmingham — further centres will be added as demand is generated. Projections vary, but around 1 000 000 Prestel viewers are anticipated by 1985 although in early years business and commercial users will far outnumber private consumers.

There might be a few stumbling blocks to cross, but viewdata is here to stay. When the various interactive and message services commence operation, demand

should increase considerably. I'm even thinking of becoming a customer myself!

HE



With Viewdata, it will be possible for industrial users to send information to the system for 'publication' via their own terminal.

Short Circuit

RIAA STEREO PREAMPLIFIER

There are two types of record player pickups, ceramic and magnetic. The first type is the cheapest and generally gives a large output voltage (0.5 V). This type of pickup does not usually require any frequency response correction, but the sound quality produced is not as good as that which can be achieved with a magnetic pickup. Records are cut with a frequency response such that when they are replayed with a magnetic pickup and a preamplifier with a RIAA equalisation (Recording Industry Association of America) the reproduced sound will be as similar to the original as possible.

The disc is cut at constant amplitude, except from 500 Hz to 2120 Hz where it is cut at constant velocity. When this disc is replayed with a magnetic pickup, the relative output voltage rises with frequency, this being due to the fact that the magnetically generated voltage is proportional to the velocity of the stylus as it moves sideways in the groove. To restore the original sound quality, a preamplifier with a frequency response that gives decreasing output with increasing frequency is required. This response curve is known as the RIAA equalisation

and it is tailored accurately to fit the cutting and replay processes. The signal level from a magnetic pickup is low, generally 20 mV pp and so a low noise preamplifier is needed.

The circuit shows a realisation of this requirement. The low noise amplifier is the LM381 made by National Semiconductors. A DC bias control is included (RV1, 2), and the feedback components generate the RIAA curve. Use screened cable for the wiring to the pickup, keep the circuit away from transformers (and the pickup and its wiring) and connect all the earths shown in the circuit diagram together, near to the IC.

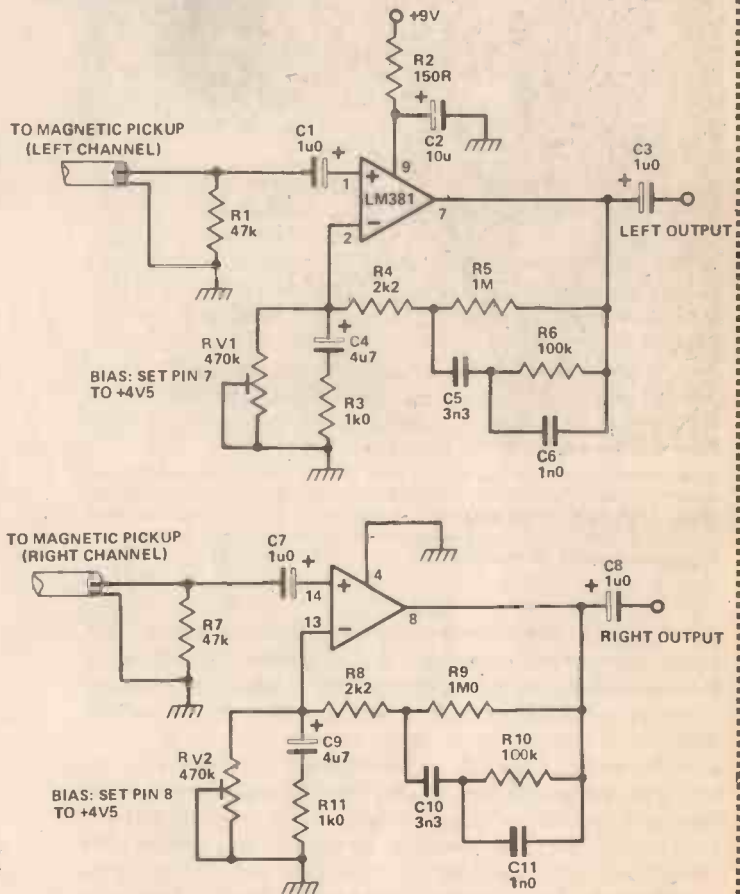
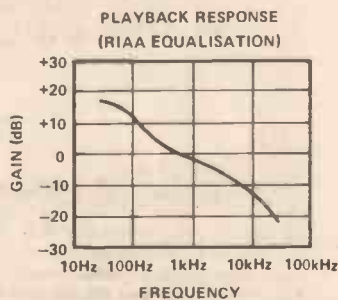

Project Daedalus

Earlier this year the British Interplanetary Society published a report on 'Project Daedalus'. It was nearly 200 pages long and took five years to write. It's packed with detailed calculations for the design of an interstellar craft. These show that the capability is almost within our grasp. Phil Cohen analyses the results of the report.

The DAEDALUS PROJECT is the brainchild of the British Interplanetary Society, founded in 1933 with the aim of advancing the space industry in the UK.

The 'study group' which worked on the project consisted of a small number of professional scientists and engineers from establishments such as the UK Atomic Energy Authority; British Aircraft Corporation, RAF and City University, London. The work was carried out in their spare time over a period of five years and culminated in the publication of a JBIS (Journal of the British Interplanetary Society) report nearly two hundred pages long which contained a *summary* of the results of the study!

The name Daedalus is from the Greek. In legend, Daedalus (meaning 'cunningly wrought') built for himself and his son, Icarus, sets of wings. During their flight, Icarus disobeyed his father's instructions and flew too close to the Sun. The wax holding his wings together melted and he was killed. Daedalus, however, reached his destination without mishap!

The Daedalus craft is an unmanned interstellar probe whose purpose is to gain information about nearby stellar systems — and especially to search for planets, which may contain the first alien life we contact.

THE MISSION

The mission of the probe is to accelerate to about 12% of the speed of light (which works out at 3.6×10^7 m/s, or 20 000 miles per second!) and fly past Barnard's Star (5.91 light years (Ly) away — about 50 years at 20 000 miles per second), dropping probes which will collect data about the star and its (possible) planetary system. This information would then be transmitted back to Earth.

Barnard's Star is not definitely known to have planets. Recent observations have shown that the star 'waltzes' slightly — suggesting that its 'dancing partner' is a massive planet somewhat similar to Jupiter. This 'waltz' is, however, not pronounced enough to prove with any degree of certainty the existence of a planetary system.

Why Barnard's Star, then? There are two other stellar systems closer to us — Proxima Centauri at 4.3 Ly and Alpha Centauri A/B at 4.4 Ly. Alpha Centauri A/B is a double star and must surely be as interesting as Barnard's Star?

The answer is that the Daedalus Project is an attempt, not to design a probe completely, but to provide a design framework for further studies. The design team considered that if it was possible to use a Daedalus-type craft to reach Barnard's Star, it should be possible to get to Alpha or Proxima Centauri also.

One major consideration in deciding on the actual 'mission profile' chosen was that it had to yield some sort of results within a human lifetime. This was because it was considered unlikely that any state would undertake a longer-term project!

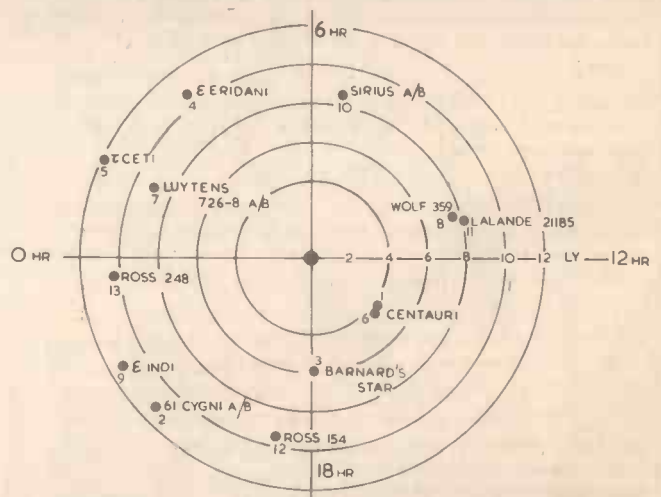

The positions in space of the stars closest to the sun. The figure beside each star is its 'interest' ranking. These were arrived at by taking into account the distance, the 'uniqueness' of the star (how frequently similar types occur) and the probability of habitable planets. The obvious choice for a mission would be Alpha Centauri but the probe was designed to reach Barnard's Star for good measure.

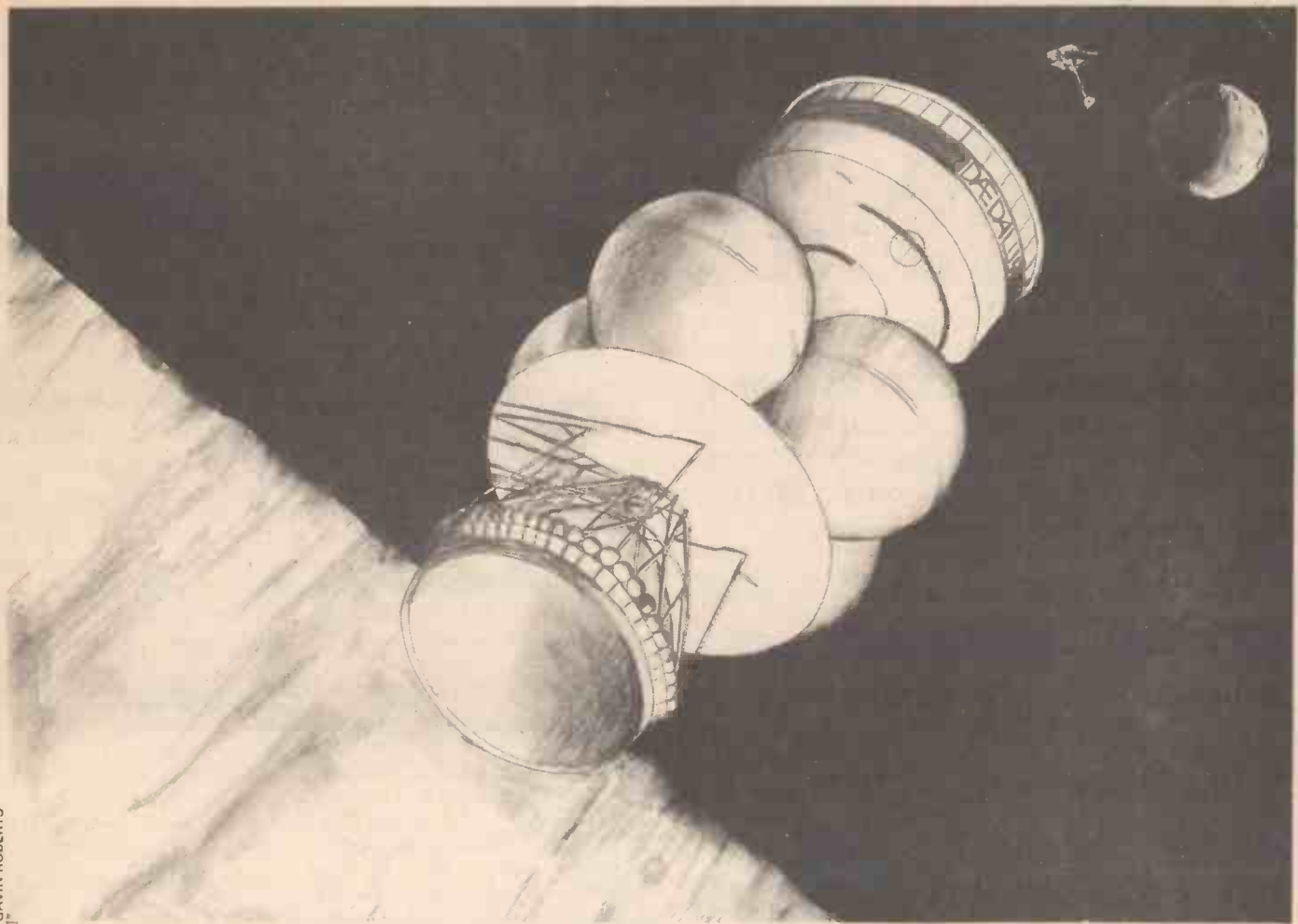

The first twenty years of the project would be spent designing, building and fuelling the craft in orbit around Jupiter (for reasons which will become apparent later). The craft would then accelerate out of the Solar System for 2 years, at which time the first stage would be dropped to save weight. The second stage would then take over for another 1.8 years, accelerating the craft to its final, awesome speed.

There would then come a 40-year wait, with the craft transmitting only data about the interstellar medium — the dust concentration, for instance, which would be invaluable for the design of later craft.

At the end of this period the craft would be close enough to its target to detect the existence of any 'gas giant' planets similar to Jupiter. At about this point it would start to disperse its probes. The dispersal has to take place this soon because it takes a *lot* of power to change course at that sort of speed and the probes would have to fly past the star itself as well as any planets, which may be at wide orbits. The decisions about which direction to send each probe would be taken by the main computer on board the craft. As radio waves would take about 5 years to reach Earth from the ship by this time (and thus a ten-year wait for a reply!), *all* decisions would have to be taken by the ship's computer.

As the craft reached the outer limits of the system, the probes would begin to send back information to it. It

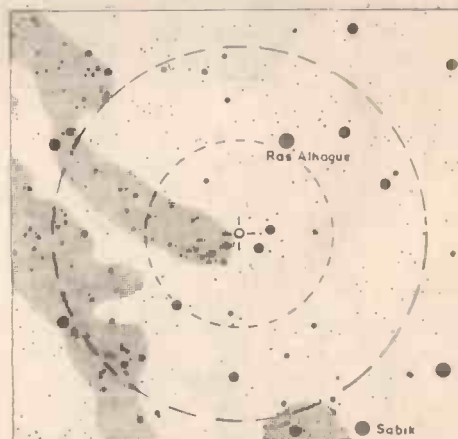

Barnard's Star as seen from the Earth. Unfortunately it's not visible to the naked eye. It appears in the constellation of Ophiuchus.

would relay the information back to Earth, the total transmission time being about 3 years — the beginning of the message would still only be half-way home when the craft stopped transmitting!

THE CRAFT

The *Deadalus* probe has a two-stage engine, the first stage being dropped to save weight when its fuel is finished. These two stages propel the payload of smaller probes, computers for controlling the mission, communications and other equipment.

The first stage weighs over 40 000 tonnes fully fuelled and is about 150 metres long and 190 metres wide. It consists only of a giant motor and six spherical fuel tanks. It 'burns' for about two years continuously at the start of the mission. The designers also took into account which materials would be used for the craft's construction — the materials used for the engine's reaction chamber, for instance, have to stand temperatures from 3°K (3 degrees centigrade above absolute zero) to 1600°K. This means using an exotic alloy. The one chosen was molybdenum with titanium, zirconium and carbon, internally nitrided — you don't come across alloys much more exotic than that!

The fuel tanks are dropped during the course of the 'burn' to save weight. As they weigh over 16 tonnes each this is quite a saving. Remember, the fuel is being used up also — the first stage itself, without fuel and tanks, weighs only 100 tonnes.

The second stage is almost the same as the first, except that it's about 1/10th of the mass and about 1/2 the size. It has four fuel tanks which are also disposable and carries the payload bay. This is about 30 metres long and about 50 metres diameter. It holds (starting at

the front) an erosion shield to protect the craft from interstellar dust erosion, the eighteen disposable self-propelled probes, the main telescopes, the communications equipment and computers and the 'wardens'.

As the craft will be on its own for some decades, and as only the most optimistic would expect there to be no failures on board during all this time, it is necessary to have some form of automatic repair. This is where the wardens come in. Controlled by the main computers, they are multi-purpose self-propelled robots, flexible enough to perform any repair or replacement necessary (within reason). The ship would also carry a large complement of spares — hopefully, the wardens wouldn't have to build anything from scratch.

The ship would be 190 metres long at launch and would weigh over 54 000 tonnes — that's a lot of mass to get moving!

THE PROPULSION SYSTEM

The starship is propelled by a series of very small nuclear fusion explosions, occurring at a rate of 250 per second.

Earlier systems had been proposed by other groups which suggested using conventional atomic bombs ejected from a craft carrying an immense 'pusher plate'. The momentum from the explosions would be transfer-

A diagram of the second stage. This is similar to the first stage but carries the payload — a package of smaller probes to be deployed near the end of the journey.

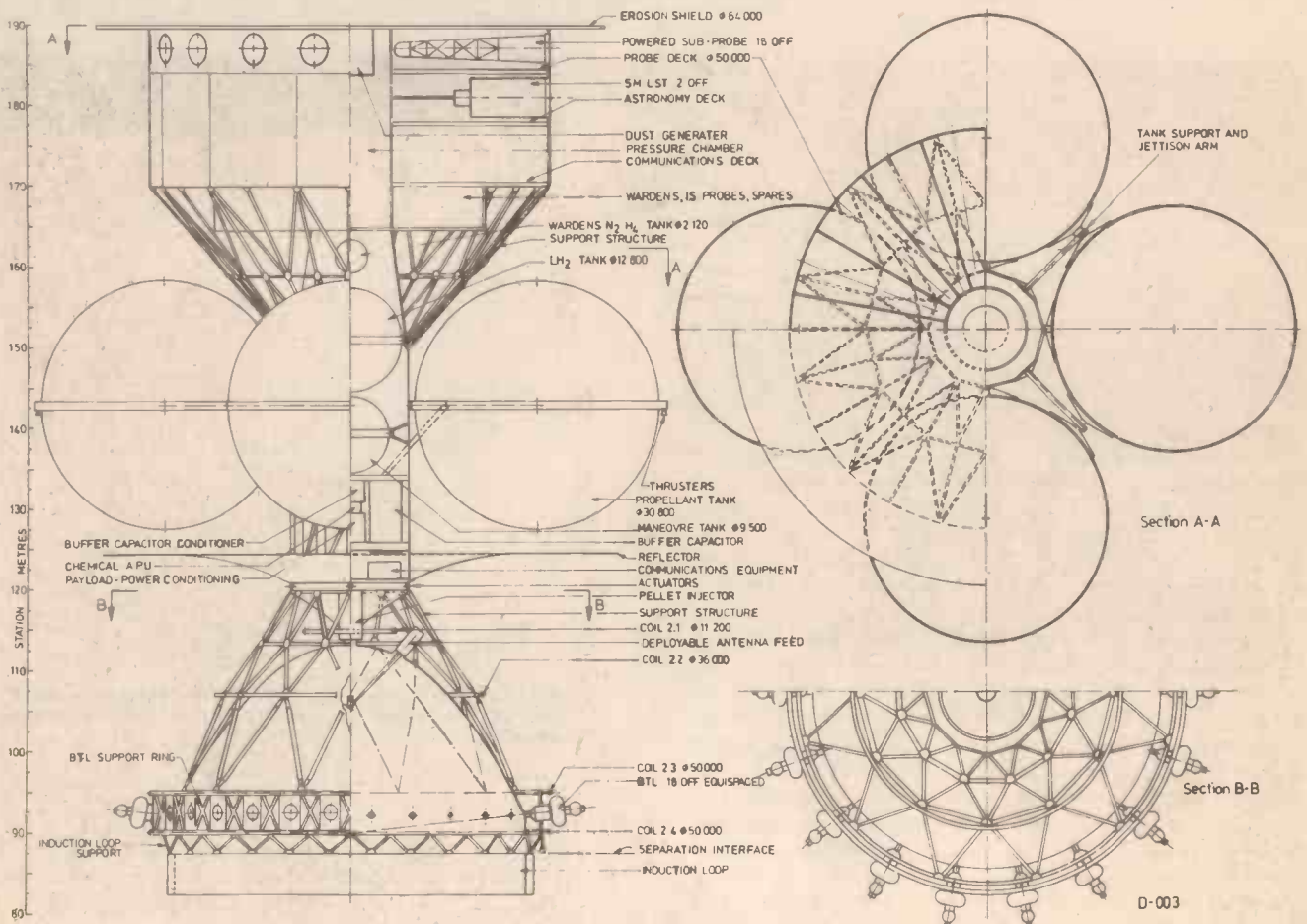

Project Daedalus

red from the pusher plate to the craft at a reasonable rate via a pneumatic spring system. This type of system was dropped because of the required size of the vehicle, "the limitations imposed by the nuclear test-ban treaty and the difficulty of testing the system."!

The Daedalus propulsion system contains the energy of the explosions in a very strong magnetic field and releases it between explosions by squirting out the explosion products at an exhaust velocity of about 10^7 m/s.

The fuel for these explosions is a mixture of isotopes of hydrogen and helium in a solid fuel 'pellet' about 10 to 20 mm across. These are stored in fuel tanks at a temperature of 3°K (3°C above absolute zero) to keep them from melting!

The pellet structure is rather similar to a particular brand of sweet — a thin hard coating and a honeycomb centre. The coating is not made of chocolate, however, but of a superconducting material. This makes it possible to shoot the pellets into the reaction area by magnetic means at an acceleration of about 10^6 g. This phenomenal acceleration is necessary so that they can cross the gap between the pellet ejection system and the ignition point between the time when the last explosion has died down and the next one is required to start. As this happens 250 times a second, this crossing has to be fairly fast.

Once at the ignition point, beams of high-energy electrons are shot at the pellet. This vaporises the outer shell instantaneously, which increases the pressure and temperature of the centre to the levels required to ignite

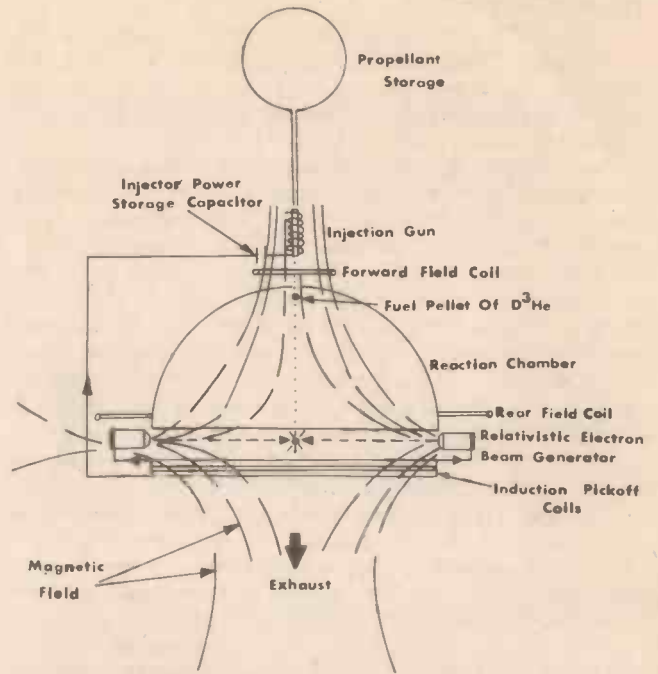

The Daedalus propulsion system. This works by controlled nuclear fusion explosions. Solid pellets of a hydrogen isotope mixture are fired on by electron beams and a magnetic field contains the blast. See the text for a full description.

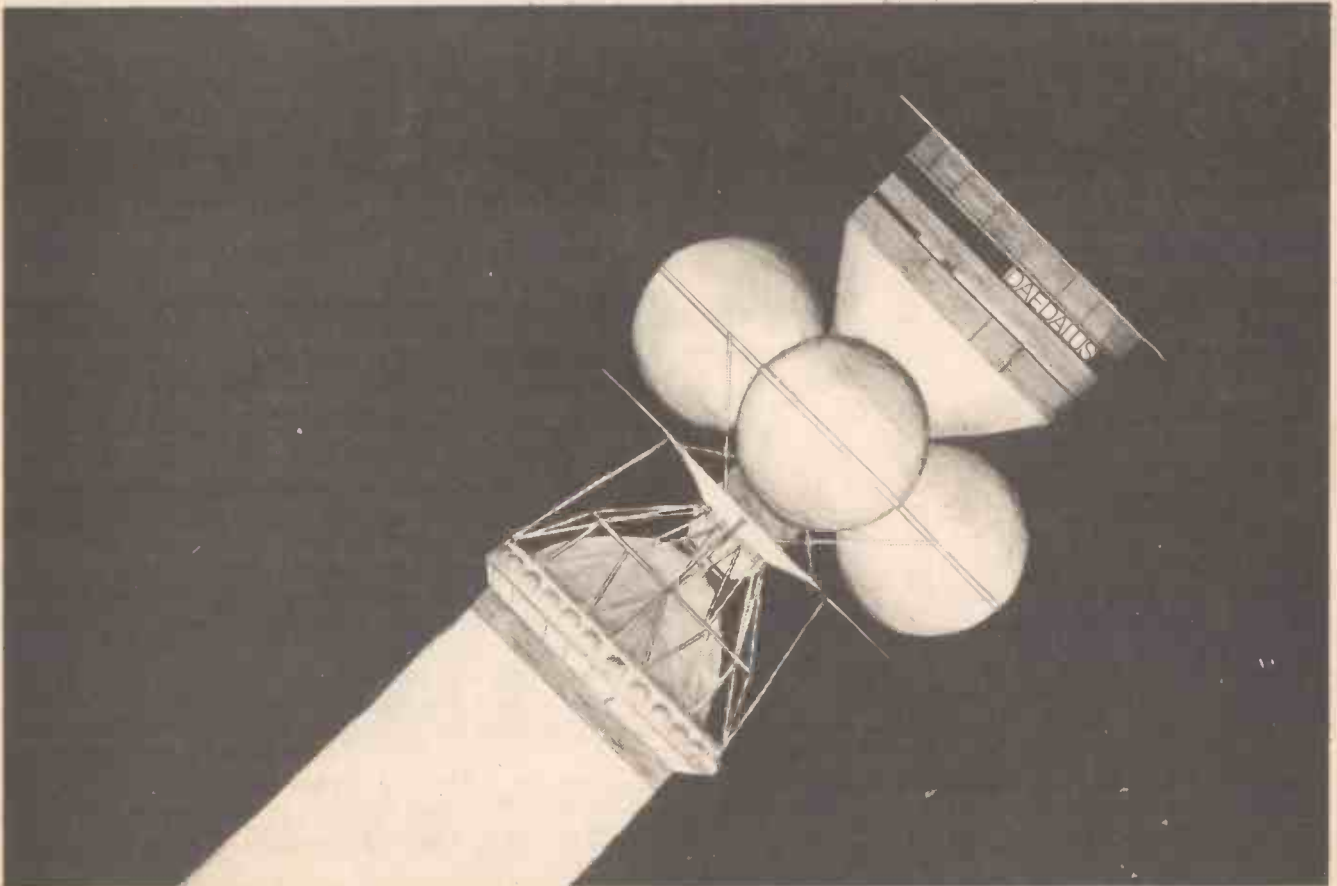

GAVIN ROBERTS

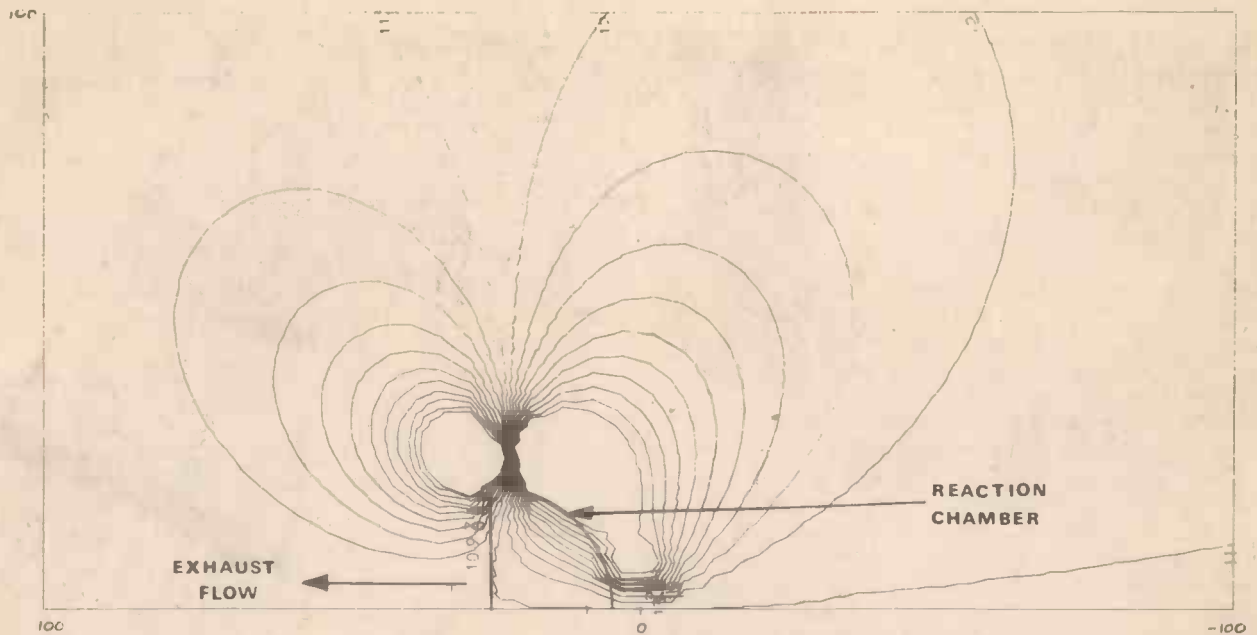

A computer-generated cross-section of the area around the reaction chamber, showing the magnetic field profile. The peak field generated in the coils would be about 14 Tesla.

The fuel pellet structure. The superconducting shell enables the pellet handling system to fire the pellet into the reaction area, where the boiling of the deuterium coat generates enough pressure to detonate the 'trigger' pellet. Each fuel pellet is 1 to 2 cm in diameter.

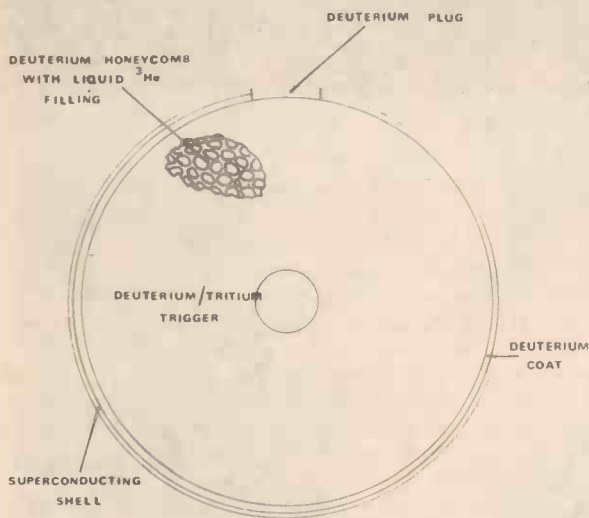

fusion. The ignition is helped by a 'trigger' particle in the centre.

The expanding plasma is trapped by immensely strong magnetic fields set up by two coils surrounding the engine. The coils generate a peak field intensity of around 14 Tesla and are cooled by liquid helium flowing through the hollow conductors to keep the temperature down to 4 K. The field is deformed by the explosion and (hopefully!) contains it and keeps it within the reaction chamber — exactly like the 'magnetic bottle' which can

be used to contain nuclear fusion reactions in terrestrial fusion power generating stations.

One of the reasons for choosing the particular fuel used is that very little of the reaction energy is released as neutrons. This means that the engine is relatively 'cold' (in radioactive terms only!), as the electrons and protons from the reaction can be trapped magnetically, whereas neutrons cannot. This lack of neutrons means that very little shielding is needed to protect the rest of the ship — a weight saving.

Unfortunately, the fuel is rare on Earth and this brings its own problems. For the entire mission, about 3×10^{10} fuel pellets would be required — with a total mass of around 50 000 Tonnes. This would consist mainly of 30 000 Tonnes of helium-3 and 20 000 Tonnes of deuterium. As these are both very rare they have to either be produced artificially on Earth or 'imported' from elsewhere.

MINING JUPITER

One possible source of suitable fuel — the largest such source in the Solar System — is the atmosphere of the planet Jupiter.

While just getting to Jupiter would be a major feat and the prospect of setting up factories around Jupiter to produce 50 000 tonnes of propellant seems daunting the reports points out that once 'mining' had started, the fuel produced could be used to fuel power station reactors on earth. The mining may well have been started due to economic pressures by the time a Daedalus-type probe is built.

As Jupiter has no solid surface, the factories could not be built on Jupiter but they could be built in Jupiter.

One possible design for such a factory would be a giant 'hot air balloon' filled with jovian atmosphere heated by the factory's waste energy.

The skin of the balloon would be woven of carbon fibres or a similar material. It would be 200 odd metres in diameter.

The factory would float in Jupiter at a level which had

Project Daedalus

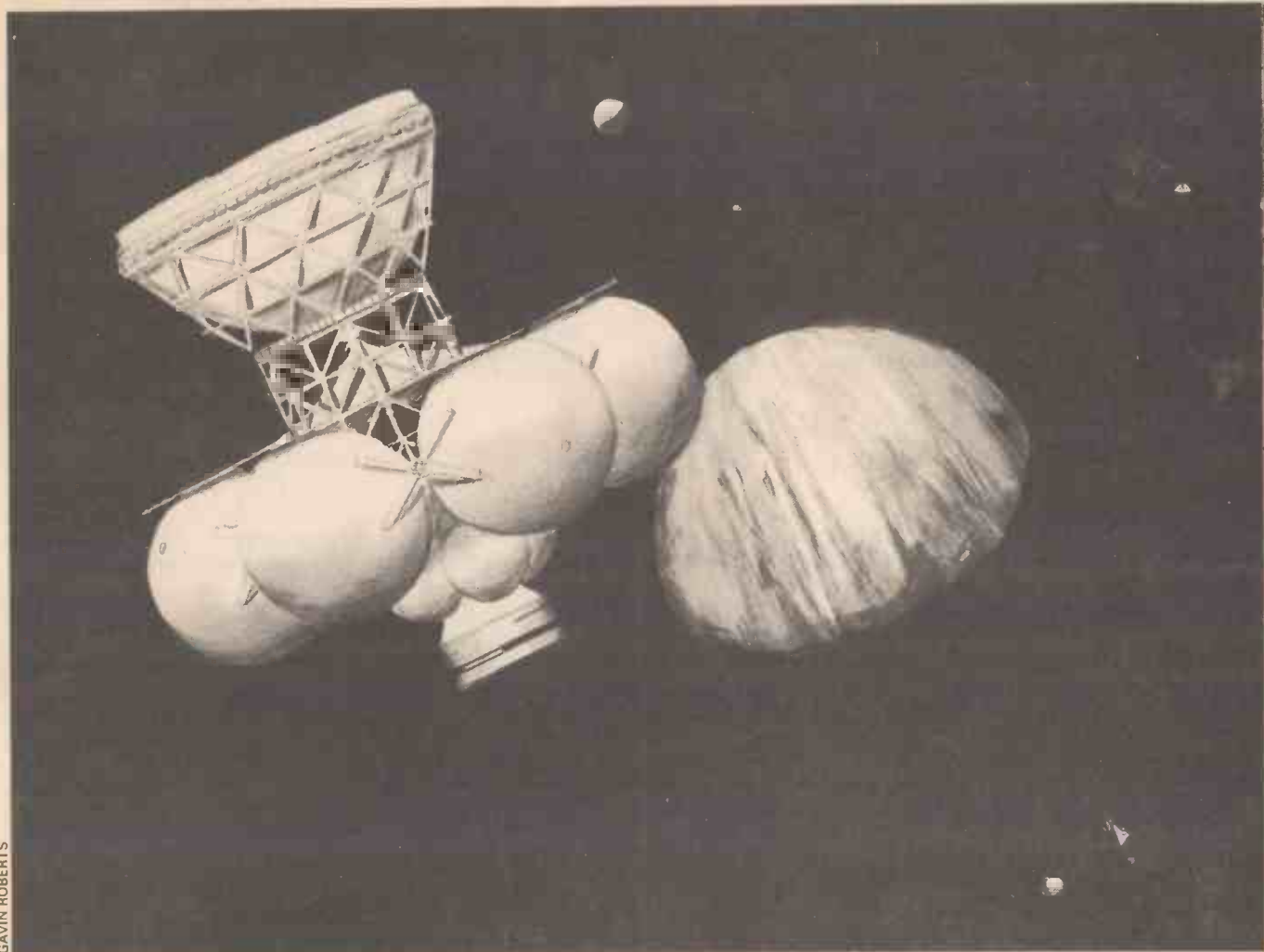

GAVIN ROBERTS

a pressure equal to the pressure of earth's atmosphere. Unfortunately, this would put it in Jupiter's weather, which has been observed to generate 90 m/s winds! Not ideal conditions for a balloon. The vertical atmosphere currents are an unknown quantity but may be even worse. The report suggests sending an atmospheric probe to study the conditions — this could probably be done using present technology.

Another little problem is how to inflate the balloon

when it is initially dropped into Jupiter. One solution to this would be to fuel it with about twelve tonnes of liquid oxygen — which would burn nicely in the hydrogen-rich jovian atmosphere.

The factory itself would hang free of the balloon, with its waste heat directed through a funnel into the neck of the balloon. It would weigh over 100 tonnes. About 128 complete factories would be used in total. These would probably be unmanned. With a 12-second communications gap between the factory and an orbiting platform there would probably have to be a fair degree of autonomy in the factory computer's operation.

The alternative—manning the factories—may, if it proves necessary, be the future equivalent of North Sea Oil drilling, with massive wages and long, dangerous shifts. It wouldn't be possible to fish someone out of Jupiter, though, if the factory collapsed!

The conditions encountered in space would provide problems for the Daedalus probe also, as it sped through space at 12% of light speed.

Preliminary design for a vehicle which would float in the atmosphere of Jupiter, allowing it to be 'mined' to provide the hydrogen isotopes required to fuel the Daedalus craft. The same fuel would be ideal for the production of 'clean' fusion energy for use on Earth.

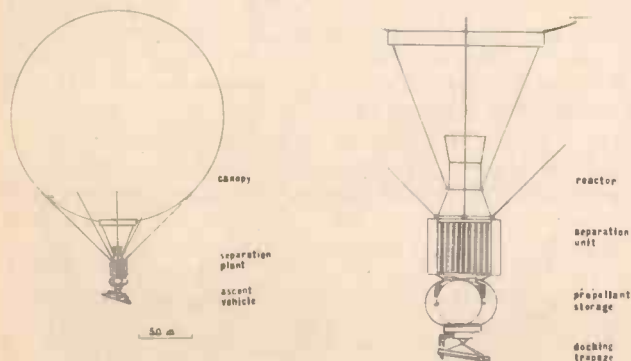

PROBE DEBRIS PROTECTION

The chunks of rock which plagued Dan Dare and his ilk by ploughing through the walls of spacecraft during gaps in the plot are not as numerous in interstellar space as was once imagined.

In the main, the matter which will be encountered between stars consists of ionised and neutral hydrogen clouds and very fine dust grains.

The average mass of the grains is thought to be about 0.1 pg (or 10^{-16} kg). While this is not exactly enormous, the craft will hit quite a large number of them, all at a velocity of 20 000 miles/second!

There are two problems to be countered — the heating effect of the ionised gasses (as large numbers of high energy protons and electrons hit the vehicle) and the erosion caused by the impact of the dust. The designers predict that the erosion shield of the probe will reach a temperature of 193°K — well within reasonable limits.

The material used for the shield will probably be boron and the report concludes that a thickness of 9mm of boron will survive dust erosion long enough to protect the vehicle from the X-rays produced by the impact of protons and electrons (and of course the protons and electrons themselves) during the course of the entire coast period.

When the probe reaches the Barnard's Star System, however, it will encounter the same problem again, but on an entirely different scale.

The target system, if it's anything like our own, will be full of all manner of junk — ranging from material the same size as the interstellar dust all the way up to asteroids weighing up to 10^{12} tonnes! Of course, the likelihood of meeting something large is small, so to speak. The designers of the probe took as a target protection against a 0.5 tonne object.

To protect the vehicle against half-tonne rocks coming towards it at 20 000 miles per second is not as difficult as it sounds, luckily! The system used is to fly a small chemically-propelled vehicle about 200 km ahead of the main probe and use it to deploy a smoke cloud about 100m thick and with a total mass of 6 kg. While this seems rather insubstantial, the calculations show that anything under 500 kg will be totally vaporised on meeting this cloud and that the expanding vapor will be too thin to harm the vehicle when it passes through it, 200km behind the smoke cloud and 0.005 seconds later. It seems that you can stop anything if only it's moving fast enough!

A similar method would be used to protect the smaller probes which are shot into other parts of the target system. The probe couldn't really be said to fly past the Barnard system — it punches several holes in it and flies through it!

SUBPROBES

Most of the information to be gained about the target system will be via the 220 tonnes of smaller probes the mother ship will carry. These will be 'launched' some distance from Barnard's Star and will follow carefully-planned trajectories through the system, transmitting information back to the main vehicle.

The probes (18 in all) would be designed for specific tasks—3 for terrestrial plants, 5 for stellar physics etc.

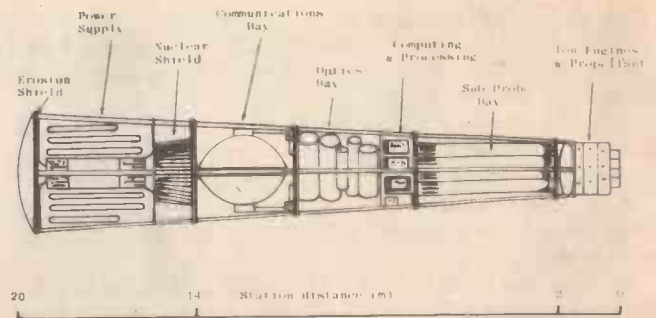

One of the subprobes. These would fly through the target system, sending information to the main craft which would relay it back to Earth.

They would each contain a debris protection system similar to the main ship's. In fact, there would be nineteen holes punched in the target systems detritus! There is an important principle in physics which states that you can't study anything without changing it — that's certainly true here.

The Daedalus craft would also carry five 'interstellar medium probes' for finding the shape of variations in dust concentrations, for example. These would be spread around the mother craft (three at a time, with two in reserve) at a distance of 1000 to 10 000 km. When the craft flies through the edge of a cloud of dust, the information from all four sources (including the main vehicle) would give information about the shape of the edge and how the dust varied throughout the cloud.

COMMUNICATIONS

Naturally, it will be useful for the probe to be in contact with the earth at all times — it should be capable of sending information back and receiving major 'policy change' messages.

During the boost phase, a large plume of plasma (dissociated sub-atomic particles) will trail the vehicle, making microwave communications impossible. For this reason the probe will carry a communications laser for use during the early period of the mission. This system will have a bandwidth (frequency response) of 20 kHz and a range of one light year (20 000 miles/second over one year). This requires a laser with a peak power of 1.3 MW, operating in the infra-red (which the plasma would be transparent to).

When the boost phase finishes, the craft will deploy a microwave transmitter/receiver which will be mounted in what was previously the reaction chamber, using the chamber to focus the microwaves. This would operate at 2.24 — 3.02 GHz and would have a data rate of 864 k baud (864 000 bits/second). The range would be about seven light years — sufficient for the 'Post-encounter' transmissions of data about the interstellar medium on the far side of the target system. One thing which had to be taken into account in designing the system was that transmissions would be received at a lower frequency due to the Doppler effect!

Less powerful transmitters and receivers would also be required for communication with the disposable probes and the wardens.

Project Daedalus

THE COMPUTERS

Perhaps the one aspect of the Daedalus project which will require the greatest extension of present-day capabilities is the self-repair function.

The concept of the multi-purpose 'warden' robots is all very well but these are, after all, only as intelligent as the software (computer programs) which control them.

All the way through the report the wardens crop up as a sort of *deus ex machina* for repair and even improvement of the craft.

As was mentioned before, the speed of radio waves limits the amount of control from the earth to an absolute minimum. The report shows, by extrapolating data from military and commercial aircraft, that a long flight without on-board repair is not feasible.

This means, in effect, that before the project is undertaken there must be a major advance in the state of what is known as 'artificial intelligence'.

The ability of modern computers to deal with predictable repairs — items which will inevitably wear out in a certain way — and such other tasks as will be known in advance is probably adequate when projected to the mission date. However, the complete inability of software as it stands at present to deal with a) un-predictable events and failures and b) failures *in the software itself* is discouraging.

Then again, looking back at the advances in computing in the last few years . . . who knows?

The memory capacity of the system, calculated from

the amount of information to be stored during flypast for transmission back to earth, is about 3×10^{10} bits. Using the latest in high density information storage — the magnetic bubble memory — this would require about 200 000 integrated circuits, weighing 1½ tonnes!

SUMMARY

The Daedalus Project report makes fascinating reading. What is most impressive is the level of *detail* to which everything has been thought out. For instance, the material used for the insulators in the electron beam generators (part of the engine) was chosen to be Berylia, which has the required mechanical and electrical properties. The mere fact that the designers have gone into such detail lends the report much credibility.

The whole thing is written in a clear (if highly technical) manner with references to all sources of data — all in all a very impressive work — but what use is it?

The report will have several effects. One will be to swell the ranks of the British Interplanetary Society — not a bad thing. Another may be the serious consideration at some time in the future of a Daedalus-type project. It's worth noting that the same society produced a feasibility study on a lunar mission some *thirty years* before Appollo 11!

HE

Further information on the BIS is available from:
The Executive Secretary, The British Interplanetary Society, 12 Bessborough Gardens, London, SW1V 2JJ.

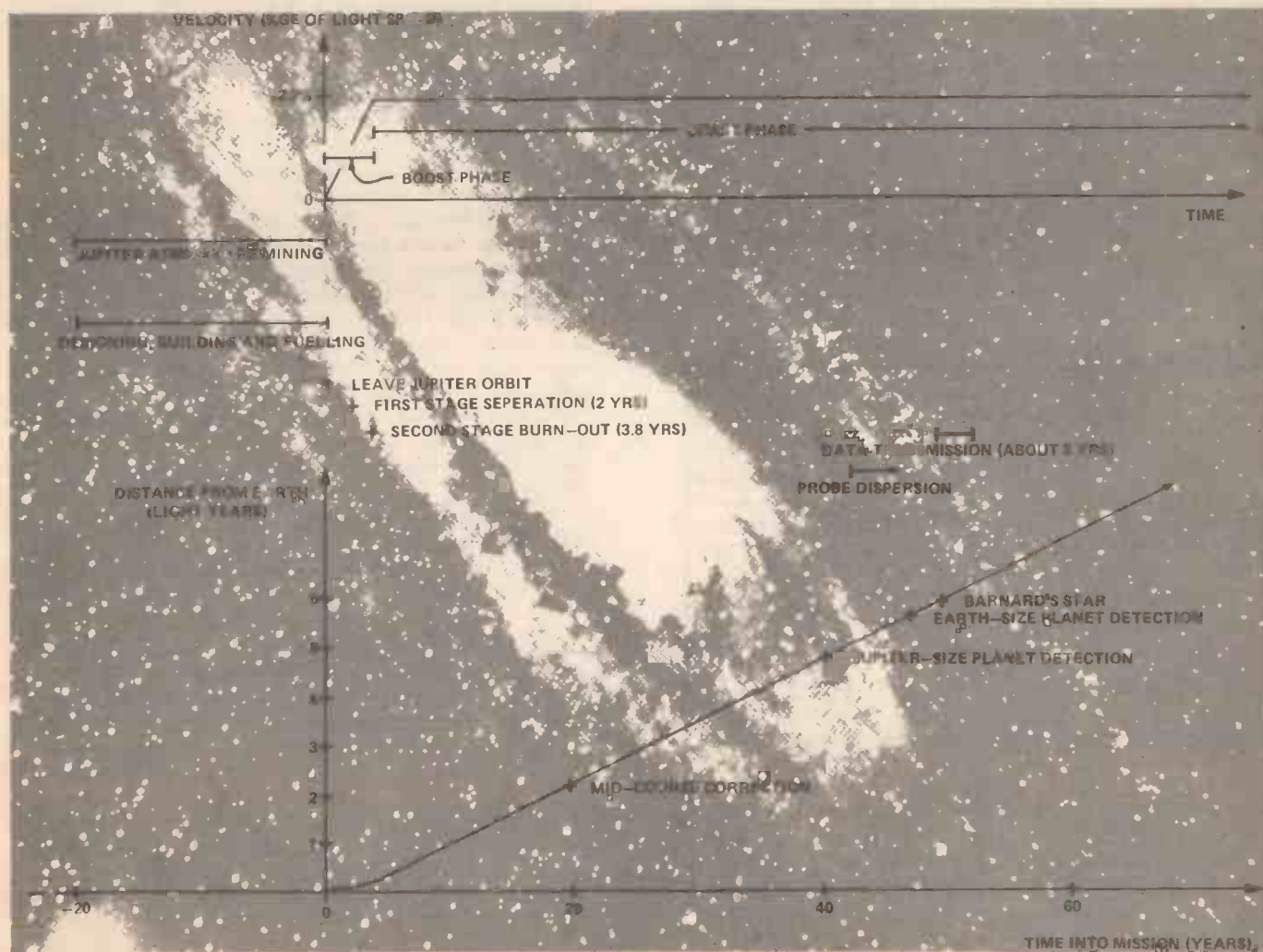

Into Electronics

by Ian Sinclair

Part 3

In this part we enter the field of active components: Semiconductors. First we deal with the materials from which diodes and transistors are made from, then we move on rapidly to applications.

ONCE UPON A TIME, folks, life looked simple. We had conductors, which conducted electric current and insulators which didn't. Then we discovered *why* some materials conduct and others don't, and it's not so simple as we once thought. As usual it all boils down to these electrons. The best conductors, metals, have their atoms arranged so that some electrons are loose, about one electron for each atom. These loose electrons can travel through the material, so that the metal is a conductor. We once thought that this was the only way that electricity was conducted through a solid material, but it's not.

Around the turn of the century, a physicist called Hall, who had set up an experiment to test the sign of charge of the current carriers in metals, found that positive charged particles seemed to carry current also. We now know that these positive particles exist only in materials that form crystals and that they are really gaps in the

regular arrangement of electrons. These gaps can move and behave like positively charged particles. We call them holes. What convinces us that they are not truly particles is that they cannot be removed from the material as electrons can. Inside a metal, though, the hole is as 'real' as the electron.

SEMICONDUCTORS

Between the good conductors, like metals, and the insulators like so many non-metals, there are some curious materials called semiconductors. The difference between semiconductors and other materials is not so much their resistivity (Table 1) but the way in which the value of resistivity can be altered. Take a piece of metal wire, measure its resistance at room temperature, then heat the wire. What happens? The resistance increases by only a few percent. Try the same measurement with an insulator, and the resistance is too high to measure, both times. Now use a chunk of a pure semiconductor material. Whatever value of resistance it had at room temperature, it's a darn sight less when you heat it, not just a few percent but a really big change. A typical result might be a change from 4k to 200R for a temperature rise of 50°C.

That's a very obvious difference, and the other difference is even more important. Compare two bits of wire, one pure copper, the other copper with about 1% zinc. The resistivity values are pretty much the same,

TABLE 1
RESISTIVITY AT 20°C

The resistivity figure for a material is a way of comparing the resistance, R , of samples of standard size. For a wire which is s metres long and A m² cross-section, the resistivity is $\frac{RA}{s}$, units ohm-metres. The resistivity figures for some materials of interest are shown below.

Material	Resistivity in ohm-metres
Aluminium	2.7×10^{-8}
Copper	1.7×10^{-8}
Iron	10.5×10^{-8}
Constantan	45×10^{-8}

(Constantan is an alloy of copper, nickel and manganese used to make wire-wound resistors).

Germanium	about 10^{-7}
Silicon	about 10^4
Diamond	10^{13}
Perspex	10^{19}
Quartz	
(silicon oxide)	10^{20}

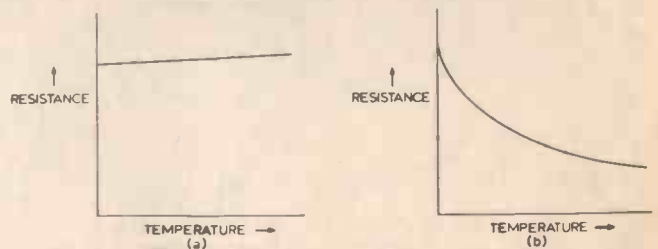

Fig. 1. Resistance/temperature graphs (a) for a metal, (b) for a pure semiconductor.

because the impurity (zinc) has as much effect as you would expect from the quantity — 1%. Try mixing two insulators and you still can't measure any resistance charge.

Semiconductors behave quite differently. Almost immeasurably small amounts of impurity will cause the resistance of a sample of a semiconductor to drop enormously. The amounts of impurity needed are not 1%, or 0.1% but something like one millionth of one percent to make a huge change in the resistance. Difference No. 2, and more to come.

Pure semiconductors, like germanium and silicon, are more like insulators than conductors. Adding other elements to the semiconductors will make them into conductors and we can even choose how they conduct. Elements such as phosphorus make semiconductors conduct mainly by **electron** movement. Elements such as indium make semiconductors conduct mainly by **hole** movement. The addition of impurity is called **doping** and is rather a delicate operation, because we don't exactly operate with bucket loads! Nevertheless, we can now make semiconductors which have whatever resistivity values we want (within reason). What's more important we can make them **N-type** (most of the carriers electrons) or **P-type** (most of the carriers holes) by doping with the appropriate materials. Incidentally because these doped materials have a good supply of electrons or holes, heating them makes little more difference to their resistance value than it does for a metal.

UP THE JUNCTION:

We wouldn't think much of the show so far but for one discovery — one of the discoveries that's changing life around us right now. Take one tiny crystal of silicon or germanium and slice a wafer from it. Now dope it on one side with indium (making P type) and on the other side with phosphorous (making N-type). Heat it up in a vacuum, so that the atoms of the doping materials can spread into the semiconductor and at some stage in the procedure, P and the N bits will meet each other. Logically enough, this meeting place is called a junction. We don't make junctions this way now, but the junction of P and N is the big step forward, because of its behaviour in a circuit.

Try to imagine a junction. Fig 3 is a diagram that helps, showing + and — signs to show which sign of carriers can move. If this junction is made part of a circuit with one wire connected to the P type side of the crystal

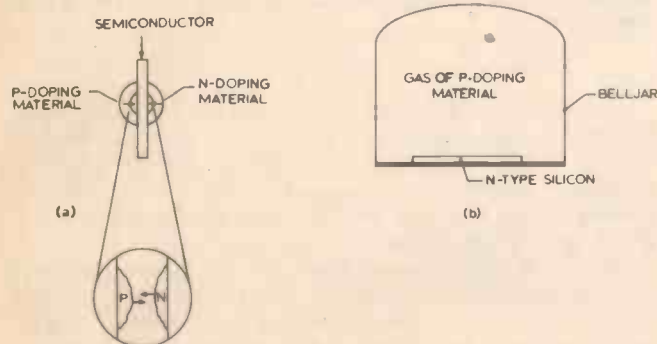

Fig. 2. Creating a junction (a) Diffusing solid material into both sides of a thin crystal, the old-fashioned method. (b) Modern method of diffusing the impurity atoms into oppositely doped material from a hot gas atmosphere.

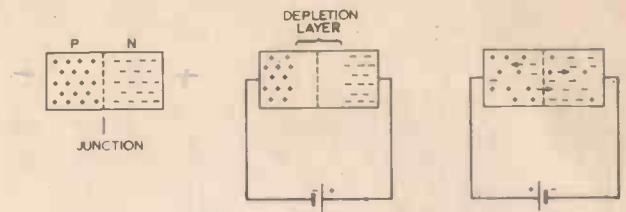

Fig. 3. Junction action. (a) Diagram showing the signs of the mobile charges (b) Action under reverse bias, carriers are drawn away from the junction. (c) With forward bias carriers cross the junction, so that the junction conducts.

and another wire connected to the N-type side, the action of the junction will depend on which way round the circuit is connected. With the N-type side connected to battery + and the P-type side to battery —, no current flows. Why not?

Good old-fashioned 18th century electrostatics, that's why. The battery + attracts the loose electrons of the N-type material away from the junction, and the battery attracts the loose holes of the P-type material away from the junction. Nothing moves right round the circuit, so no current flows. The junction is depleted — drained of electrons and holes, just a chunk of non-conducting material. This connection is called the **reverse bias connection**.

DIODES

Now, think of the battery connected the other way round. This time it's a very different story. The battery + pulls loose electrons across the junction from the N-type side. The battery — pulls loose holes across the junction from the P-type side. Everything is moving, it's all happening, current is flowing; the bias now is **forward**. The whole arrangement of P and N materials meeting at a junction is called a **semiconductor diode**.

The P-type part of the diode is called the **anode**, and the N-type is called the **cathode**. The diode is forward biased when the anode is more positive than the cathode. A germanium diode will just start to conduct when the voltage between anode and cathode is about 0.15 V, a silicon diode will just start to conduct when the voltage between anode and cathode is about 0.55 V.

When the bias is in the reverse direction, there are so few electrons and holes (called the minority carriers) left in the junction that the diode is almost an insulator. A reverse current of only a few nanoamps ($1\text{ nA} = 10^{-9}\text{ A}$) is typical.

We use diodes, as described above, in great quantities; in power supplies, in radio reception, in computing. Details later, folks, but most of the uses for diodes stem from one thing, the current flows one way only. The symbol for a diode shows this direction of



Fig. 4. Diode symbol and terminal names.

current by an arrowhead, using the usual convention of current flowing from battery positive to negative.

ZENER DIODES

One exception is the **zener diode**, though. This type

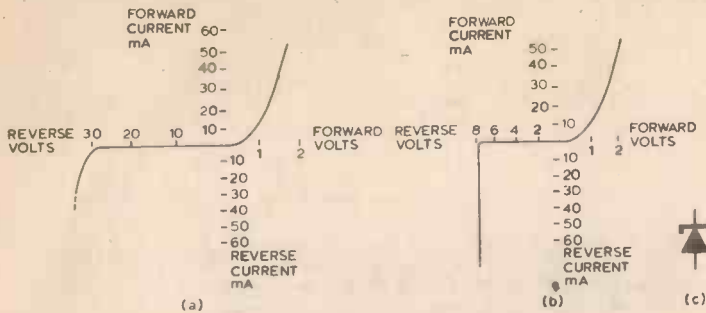

Fig. 5. Diode characteristics. (a) Signal or rectifier diode. Note the difference in the sizes of the voltage and current scales in the reverse direction. (b) Zener diode. The reverse current starts at a definite voltage, and large reverse currents can pass. (c) Zener diode symbol.

of diode (different symbol, too) is always used reverse-biased, but conducting. Reason is that a junction that's heavily doped on each side will break down and start to conduct if enough voltage is put across it on the reverse direction. How much voltage? Well, that's what is so useful. Suitable design and doping will give a range of breakdown voltage from around 3 V to around 200 V. What's more, the voltage is pretty well fixed in any given diode. Whether you pass 1mA or 100mA through the zener diode (reverse direction) the voltage across the diode is the amount written on it — the **zener voltage**. We use them for voltage stabilisation — obtaining a voltage which remains steady despite large changes in current or supply voltage.

DOUBLE YOUR JUNCTIONS

In 1948, Brittain, Bardeen and Shockley made one of the most important discoveries of all time. They managed to make two PN junctions really close together: the first **transistor**. What's so special about two junctions close together? It's like Siamese Twins, that's what, and anything that happens in one affects the other.

Imagine a very thin layer of P-type material as the meat in an N-type sandwich (Fig. 6). By a thin layer we mean just a few hundred atoms thick. Now imagine one N-type layer connected to battery + and the other connected to battery -. From what we know so far there's no way this arrangement could conduct current, its like two diodes connected anode to anode. No matter which way you look at it, one diode is reverse biased and therefore can't conduct. This is where the closeness of the junctions has an effect. Suppose we start one

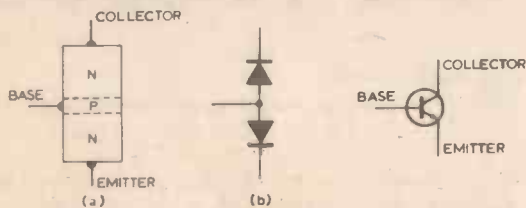

Fig. 6. The transistor. (a) Arrangement of junctions. (b) Two-diode circuit which would give the same readings on an ohmmeter. When two terminals of a transistor are found which do not conduct in either direction, the other terminal must be the base. (c) Symbol of NPN transistor.

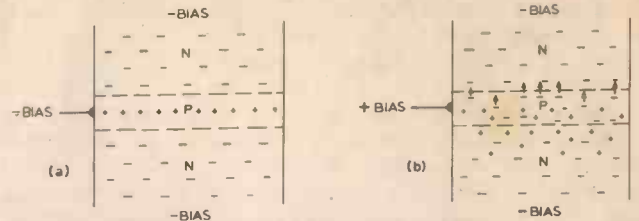

Fig. 7. Transistor effect. (a) With the base-emitter P-N junction unbiased, both junctions are depleted, no current flows. (b) When the base-emitter junction conducts, both junctions are flooded with carriers (electrons in this case) so that both conduct.

junction conducting; the one between the P-type material and the N-type that is connected to battery negative. It won't conduct until the voltage across it is somewhere around 0.55 V (assuming a silicon device), but when it does, the junction is flooded with **carriers**. Because the junctions are so close the other junction also becomes flooded with carriers, though it is reverse biased. This turns the second junction into a conducting junction, despite the reverse bias, so that current flows between the two N-type regions. This current can flow only for so long as carriers are injected from the junction that has been deliberately forward biased.

It's time we put some names to the bits of this device, the bipolar (or junction) transistor. The meat in the sandwich is the part called the **base**, the other two regions are the **collector** and the **emitter**. The reverse biased junction is the junction between collector and base and the forward biased junction is the junction between base and emitter.

Look at it all again. With no bias (or reverse bias) between the base and the emitter, no current flows between the collector and the emitter; reason for that is

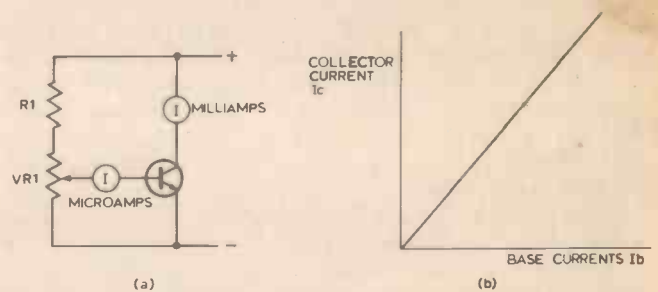

Fig. 8. Current gain. (a) Circuit for measuring base and collector currents. (b) Typical graph of collector current plotted against base current.

the reverse bias between the collector and the base. When the base-to-emitter junction is forward biased, though, the carriers enter the collector junction, so that it conducts. As a result, we can change the collector-emitter circuit from insulating to conducting by altering the base voltage slightly.

We can do even better than this. When we make the base-emitter junction conduct, most of the base carriers are swept across the other junction (base-collector). As a result, much more current flows between the collector and emitter than between base and emitter; a small current between base and emitter controls a large current between collector and emitter. Controls? Yes, controls, because the ratio:

$\frac{\text{collector-emitter current}}{\text{base-emitter current}}$ is fairly constant.

A typical value is 100, meaning that the current between collector and emitter, I_c is 100 times the current between base and emitter (I_b). This ratio is called the **forward current transfer ratio**, common emitter, mercifully shortened to h_{fe} . The phrase '**common emitter**' is used because both the base and the collector conduct to the same terminal, the emitter.

NPN AND PNP

Bipolar transistors can be made in two varieties, **NPN** and **PNP**. The NPN operates with its collector positive to its emitter and will conduct when the base (the P-layer) is about 0.55 V positive to the emitter. The PNP transistor

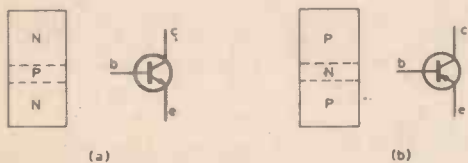

Fig. 9. Junction arrangements and symbols. (a) NPN, (b) PNP.

operates with its collector negative to its emitter and will conduct when the base (the N-layer) is about 0.55 V negative to the emitter. These voltages assume that silicon devices are being used.

GAINING ON THE DEAL

Look at the circuit of Fig. 10a. It has a 6 V, 60 mA bulb in series with a switch and a 6k8 resistor across a 6 V battery. What happens when it's switched on? Nothing noticeable, because 6 V across 6k8 produces less than 1 mA of current, not enough for a 60 mA bulb to glow as bright as a wet rag in the fog. Now try the circuit in Fig. 10b. This time the switch will operate the bulb. The current through the 6k8 resistor is more than enough to make the transistor conduct, passing 60 mA through the bulb. We call this effect **current gain**, and the quantity h_{fe} measures this current again.

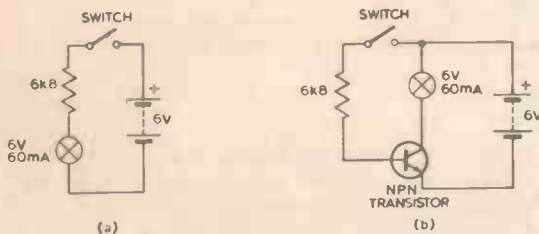

Fig. 10. Current amplification. (a) This circuit cannot pass enough current to light the bulb. (b) The bulb will light when the switch is closed because the base current of the transistor will cause collector current to flow.

Don't get carried away though. The transistor hasn't created this current, just controlled it. If the battery had not been able to supply 60 mA, no cunning tricks with transistors could make the bulb light.

Try the circuit of Fig. 11 for yourself. The bulb will

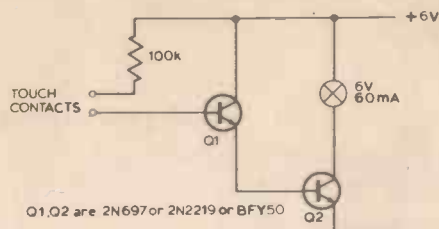

Fig. 11. A touch switch — touching the contacts with your fingers will allow the bulb to light.

light when the two terminals are touched with one finger. The tiny amount of current that flows through you causes a current many times greater to flow in Q1. (We use the abbreviation **Q** for a transistor; an alternative is **Tr**). This greater current flows into the base of Q2, and causes a greater current still, enough to operate the bulb. Suppose we put some sizes to these currents. If the bulb needs 60 mA, then let's suppose, for the sake of simplicity, that Q2 has a current gain (h_{fe}) of 60. Then just 1 mA is needed into the base of Q2 to make the bulb glow. This 1 mA is supplied by Q1. If this transistor also has $h_{fe} = 60$, then only one sixtieth of a milliamp (16 μ A) is needed into the base of Q1. You may have seen this type of touch-detector demonstrated in 'Tomorrow's World' as a way of identifying the end of one selected wire in a bunch of several hundred.

This sort of use of transistors is called **switching**. The bulb, or whatever the transistor is switching on and off, is called the **load**. The load is connected in the collector-emitter circuit, and switched on or off by charges at the base. To switch the lead on:

- the voltage between base and emitter must be more than 0.55 V for a Silicon Transistor (0.15 V for a germanium transistor)
- the current between base and emitter must be enough to ensure that the correct current will flow through the load.

Just to illustrate these conditions, try to explain why the circuits in Fig. 12 will **NOT** work!

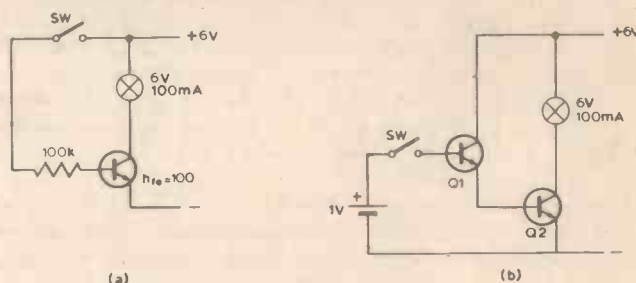

Fig. 12. Two circuits which DON'T work. Can you explain why?

Variations on the theme

Figure 13 shows another circuit which needs some thought. If the load resistor is in the emitter part of the circuit, then the amount of current needed at the base is the same as it would be if the load were connected in the collector part of the circuit. The voltage needed at the base, however, has to be *more* than the normal voltage across the load. The voltage needed at the base, however, has to be *more* than the normal voltage across the



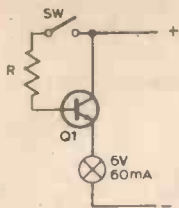

Fig. 13. The emitter-follower.

load. Think of it this way — for the load to operate it needs the correct voltage across it and the correct current through it. Suppose the load is a 6 V 60 mA bulb. In this circuit, the emitter terminal of the transistor must be at 6 V when the bulb glows. For the transistor to conduct, the base voltage must be 0.6 V or so about the emitter voltage which means around 6.6 V. The shift in the position of the load in the circuit makes a large difference to the voltage that is needed at the base. This is, in fact, a rather different type of circuit, the **common collector circuit**.

The differences between these circuits illustrate rather well differences in the behaviour of transistors. Connect as a common emitter circuit (Fig. 10b) and small changes of voltage at the base cause fairly large changes of base current. The input circuit of the transistor (base-emitter) behaves like a low resistance. Connect the transistor in a common collector circuit (Fig. 13) and much larger changes of voltage at the base are needed to cause the same changes of base current. Now the input circuit behaves like a large resistance. We refer to this as the input resistance of the transistor; it's important because we have to be able to supply the correct voltage to this input resistance to turn on the current.

Transistors have an output resistance too. A transistor connected in a common emitter circuit has a high output resistance. This means that changing the collector voltage has very little effect on the collector current. It's a useful feature, because a high value of output resistance means that the current flowing between collector and emitter is controlled only by the base current, not by the collector voltage. Connecting the transistor up into a common collector circuit has the opposite effect; the output resistance is now low. Any change in the emitter voltage now causes a large change in the emitter current (assuming the base voltage is fixed). These input and output resistance values are shown in Table 2, for the common emitter, common collector and also for the common base connection. The common base connection is seldom used now except in high frequency circuits or as a part of other circuits.

Laying it on the line

Take a look at the graph of Fig. 14. It's a graph of silicon transistor collector current plotted against the base voltage (base-to-emitter voltage, that is). What it shows is that very small changes of base voltage will cause larger changes of collector current. We make use of this when we design voltage amplifiers.

A voltage amplifier has an AC voltage signal at its input and produces a copy of the wave, with greater amplitude at its output. The ratio voltage gain equals

$$\frac{\text{signal amplitude at output}}{\text{signal amplitude at input}}$$

How do we use a transistor as a voltage amplifier? To start with, we have to convert the collector currents into voltages. The simplest method is to use a resistor as a load. Take the example of Fig. 15. The load resistor here

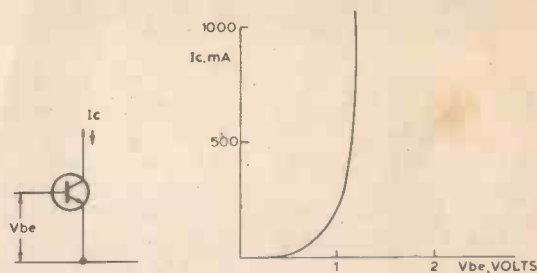
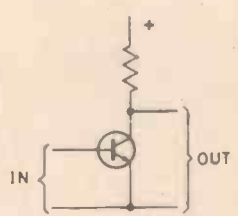
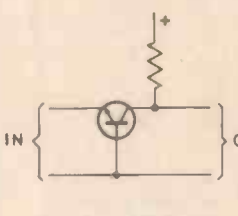
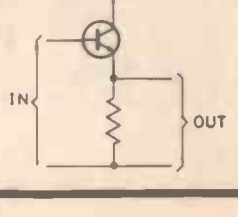

Fig. 14. Mutual characteristic for a medium-current silicon transistor.

is a 1k resistor, and the voltage signal is at the collector of the transistor. When the collector current is zero, the voltage at the collector is 6 V, the supply voltage. When a collector current flows, there is a voltage across the resistor so that the collector voltage drops. The greatest amount of current that could possibly flow in this circuit is 6 mA, because this amount makes the collector voltage zero. We could then get a voltage wave at the output with an amplitude peak-to-peak of 6 V, providing we had enough signal voltage at the input to cause a collector current of 6 mA peak-to-peak. That's where the graph of Fig. 15 comes in, because we can read off the base voltages for the two current limits of zero and 6 mA. Now we have the output voltage (6 V p-p) and the input voltage (0.1 V p-p); so that the voltage gain of this amplifier is 60 times. Easy!

Is the output voltage signal a good copy of the input voltage signal? It can be, but two things can go wrong. One is that the graph of I_c (collector current) against V_{be} may not be a straight line. Any curvature of this line causes a poor copy; we say that there is **distortion**. The other thing is that the base voltage must never drop

TABLE 2
Relative sizes of input and output resistances

	Name	R_{in}	R
	common emitter	medium	high
	common base	low	high
	common collector	high	low

low: below 100R; medium: several k; high: above 10k.

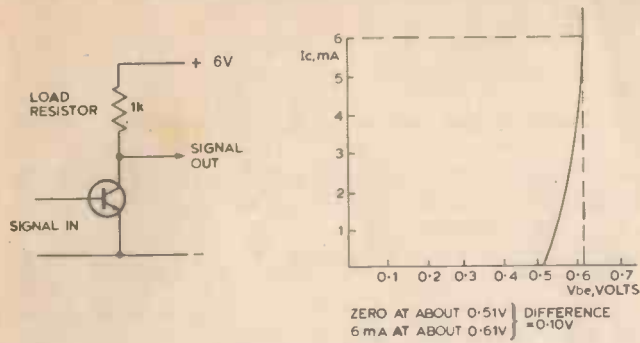

Fig. 15. Voltage amplification using a load resistor.

below the minimum conducting voltage of about 0.55 V. Both problems are tackled by using **bias**. In everyday language, bias is anything that tips things to one side. What we need to tip to one side is the base voltage, to make sure that it can't drop below that figure of about 0.55 V (again assuming a silicon transistor).

A bias circuit does just that. Two common types of bias circuits are drawn in Fig. 16. Fig. 16a shows a circuit using a resistor connected between the base and the collector. We can calculate the value of the resistor so that the collector voltage, with no signal present will be about half supply voltage. This way if we put an AC

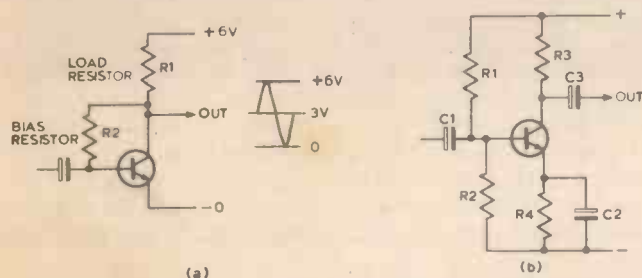

Fig. 16. Two types of bias circuit. (a) Current bias, using a single resistor. (b) Voltage bias, using a potential divider.

signal in at the base, an amplified signal will appear at the collector and its amplitude can be anything up to about half supply voltage without cutting off either peak.

Figure 16b is of another type of bias circuit. In this design, a potential divider sets the voltage at the base. This makes the transistor pass current through the emitter resistor R_4 so that the voltage between base and emitter is set to the correct value, around 0.55 V. If we choose the value of the load resistor R_3 correctly, the collector voltage can be set to about half supply voltage once again. The capacitor C_2 is important. Unless this capacitor is connected, we do not have a true common emitter circuit for signals (because of R_4) and the voltage gain will be very low — more of that later.

Both of these methods of bias are self correcting — if we change the base voltage temporarily with a signal, the voltages will afterwards always return to the value that we set. In addition, slight changes in the values of h_{fe} or resistance will not cause noticeable changes in the bias voltages when these circuits are used.

Bias is not necessarily just a method of preventing the peaks of the signal from being chopped (or clipped). Bias can also be used to ensure that the distortion is as low as we can arrange. The graph of I_c against V_{be} is not usually a perfectly straight line, but some parts of the curve may be more nearly straight than others. If we bias the transistor so that a fairly straight portion of line is used, then the distortion is low. The names '**linear amplifier**'

and '**linear operation**' come from the idea that the best operating conditions are along a piece of the graph which is a straight line.

We can calculate the gain of a transistor amplifier very easily. The ratio

$$\frac{\text{change of collector current}}{\text{change of base voltage}}$$

called **mutual conductance**, symbol g_m , is about 40 mA/V for each 1 mA of collector bias current. For a transistor biased to a collector current of 2 mA, for example, the g_m value would be 80. This value of g_m is also related to the current gain h_{fe} and the input resistance of the transistor h_{ie} by the formula $h_{fe} = g_m h_{ie}$. Now the correct signal out for an input V_{in} must be $g_m V_{in}$, so that the voltage signal is $g_m V_{in} R_L$ (R_L is the value of the load resistance). An even simpler method arises because the DC bias voltage across R_L depends on the bias collector current. The voltage gain of any small signal amplifier using silicon transistors is just $40 \times$ (steady voltage across R_L). For example, if there is 5 V across the load resistor with no signal input, the voltage gain of the transistor is $5 \times 40 = 200$ times.

Up and down the scales

We can measure the voltage gain of a voltage amplifier at any frequency of signal we care to use, but we won't get the same results at each frequency. A simple voltage amplifier such as that of Fig. 17 will have its normal value of voltage gain (around 200) at frequencies ranging from about 100 Hz to several hundred kHz. At very low frequencies, of a few Hz, the measured gain will be less. The transistor is still doing its stuff, but the

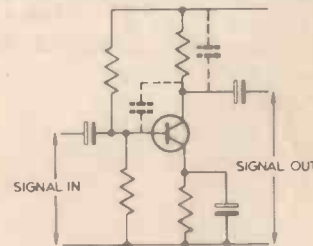

Fig. 17. A complete voltage amplifier stage. The dotted lines indicate important stray capacitances between parts of the circuit.

capacitors that are used in the circuit have such high reactance values at very low frequencies that the signal is potential-divided by each capacitor that is connected to a resistor or the transistor. If we use circuits that eliminate capacitors (direct coupled circuits), the voltage gain remains constant even for DC.

We cannot simply remove the capacitors in a circuit such as that in Fig. 17 because these capacitors are needed to prevent the bias voltages being shorted out or increased by the circuits to which the transistor is connected.

At the high frequencies, it's capacitors again that cause the trouble. This time they're invisible, the type we call **stray capacitance**. Every gap in a circuit is a capacitance, though of small value. In the circuit of Fig. 17 the dotted lines indicate gaps which must have some stray capacitance. The effect of these capacitances is to provide an easier route for high frequency signals than the resistors or even the transistors, so that the voltage gain is, once again, reduced. For audio amplifiers,



FETS

The two-junction, or bipolar, transistor is not the only way of using a semiconductor material for switching or amplification. **Field-effect transistors (FETS)** make use of another way of controlling the movement of electrons or holes in semiconductor without injecting carriers from junctions. The main current path in any FET is called the **channel**, it's a thin narrow strip of silicon, usually N-type. There are no junctions along the length of this channel, so that it behaves like a resistor, allowing current to flow in either direction. The current in the channel is controlled by changing the conductivity of the material, not by injecting carriers into a reverse biased junction.

Two ways of controlling the current are used. One way uses a reverse biased junction, so that the FET is a junction FET. The junction is formed around the strip at one end (Fig. 19a), but the carriers moving through the channel do not pass across the junction. Reverse biasing the junction will deplete it of carriers, so that the conductivity of the silicon around the junction becomes less, and the current in the channel becomes less.

The other type of FET is the MOSFET (Metal-Oxide-Semiconductor FET). A thin layer of silicon oxide (an insulator) is grown on the strip of channel at one end and a layer of metal deposited on top of the insulator. This arrangement forms a capacitor with the silicon of the channel as one plate and the insulated metal as the other. Connecting the metal to a negative voltage causes negative charges to be repelled from the channel, so that the conductivity of the channel becomes less.

In either type of FET, the controlling electrode is called the **gate**; the end of the channel nearest the gate is called the **source**, and the far end of the channel is called the **drain**. A voltage between gate and source controls the current between source and drain, and the ratio

$$\frac{\text{change of channel current}}{\text{change of gate voltage}}$$

is called **mutual conductance, gm**. The values of gm obtained from FETs are pretty low, 1.2-3.5 mA/V usually, as compared to values of 40 mA/V upwards for bipolar transistors. The big advantage of FETs is their very high input resistance. The MOS types have such a high gate resistance that they can be damaged by the electrostatic voltages produced by rubbing materials together! These types of FET (and the MOS types of integrated circuits) must be handled carefully, keeping the leads shorted together until they can be soldered in place in their circuit.

HE

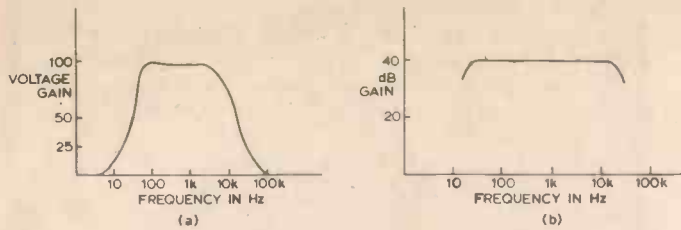

Fig. 18. Frequency response graphs. (a) Using a linear scale for gain. (b) Using a decibel scale for gain.

working with the frequency range 40 Hz-20 kHz, these frequency limits are not usually troublesome. Amplifiers intended for much higher frequencies use tuned (resonant) circuits in place of the load resistor. The stray capacitance then becomes part of the resonant circuit, so that its value does not greatly affect the frequency we can use. At really high frequencies, the transistor itself begins to give up, because the charge does not move fast enough to follow the changes of voltages of high frequency signals. Transistors of rather specialised construction are needed for frequencies of 100MHz or more.

A graph of voltage gain plotted against frequency is called a **frequency response graph**. A typical frequency response graph for an audio amplifier is shown in Fig. 18a. We have to use a logarithmic scale for frequency, with the same distance between 1 kHz and 10 kHz as we have between 100 Hz and 1 kHz. This is because a linear scale would have to be several metres long to show the same frequency points.

The frequency response of an amplifier plotted in this way always looks much worse than we expect from the evidence of our senses. The reason is that the difference between a gain of 100 and a gain of 50 is not so very great when the amplifier drives a loudspeaker or the brightness of a cathode ray tube, it certainly doesn't seem like a 2 : 1 ratio. A better way of showing

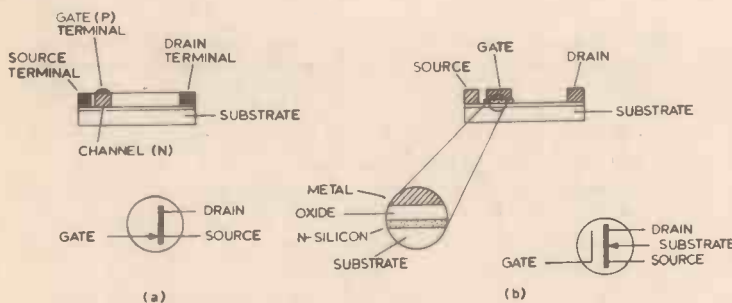

Fig. 19. FETS. (a) Junction type, N channel. (b) MOS type, N channel. The substrate is the silicon layer on which the other layers are deposited.

frequency response is the **decibel (dB)** scale. To convert a voltage gain to decibels, we use $\text{dB} = 20 \log(\text{voltage gain})$ so that a voltage gain of 20 is 26 dB, a gain of 40 is 32 dB, and a gain of 80 is 38 dB. Note that doubling the gain figure causes the dB figure to *increase* by 6 dB, typical of a logarithmic scale.

A frequency response graph plotted in dBs is shown in Fig. 18b.

In Part 4

In the next issue we look much deeper into transistor circuitry and show them in real circuits. We deal with coupling stages together, biasing, negative feedback and the rules-of-thumb that are used in design.

HE-HE!

I DON'T LIKE THE LOOK OF THAT. IT'S TOO WIDE AND TOO SHORT. IT'S NOT DEEP ENOUGH, EITHER. AND YOU'RE JUST ASKING FOR TROUBLE MAKING IT OF ALLOY ANYWAY. YOU'D BE A LOT BETTER.....

THAT'S OUR SUPER-CRITICAL WING DESIGNER!!

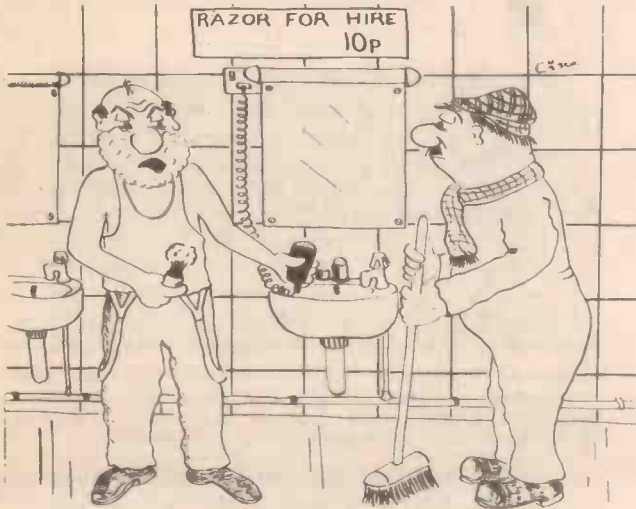
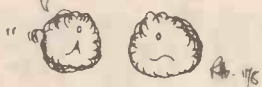

"Hey mate. This razor's dangerous, I've just had a shock."

DID YOU REALISE THAT IF IT WASN'T FOR FARADAY'S DISCOVERIES, THIS MAGAZINE WOULD BE FULL OF BLANK PAGES....?



C'MON M09. BE A GOOD COMPUTER AND EAT UP YOUR FEEDBACK!



WHAT'D YOU CALL A WELSHMAN WHO MAKES DE-IONISED WATER FOR WET-CELL BATTERIES?



DAI-ELECTRIC!!

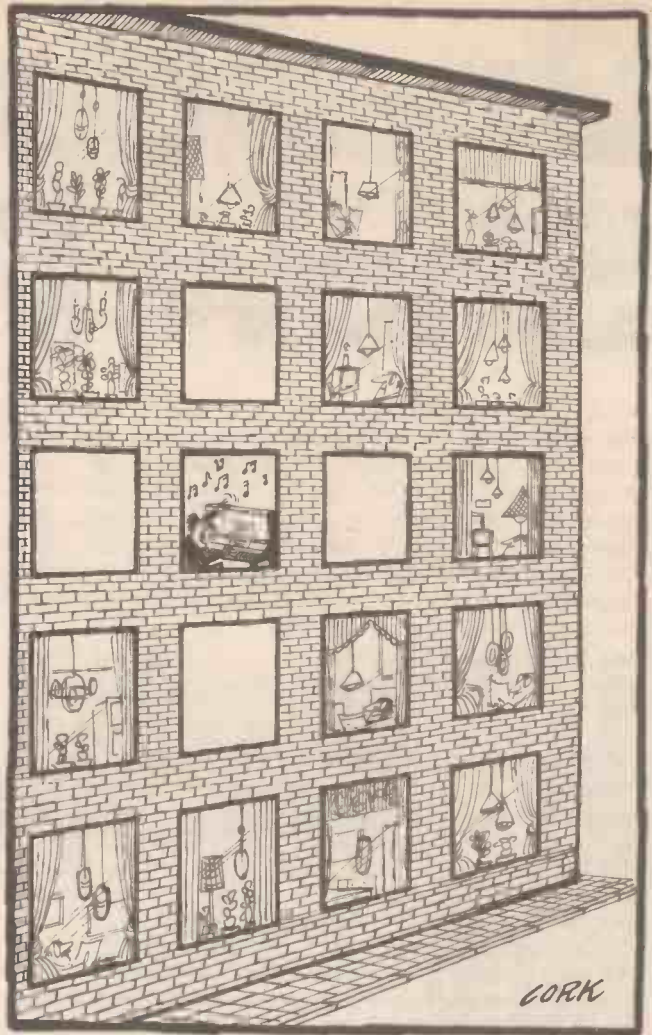
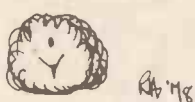

"I can assure you, Miss Jones, that your's is one job that can't be done by a computer!"

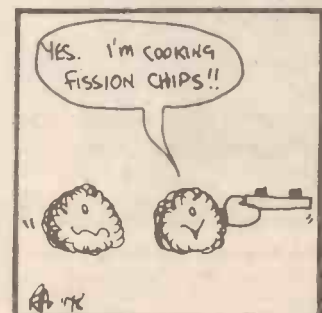
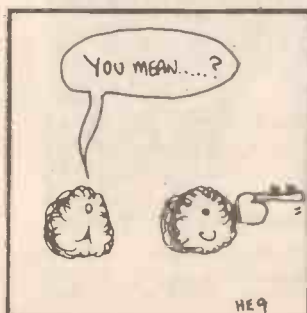
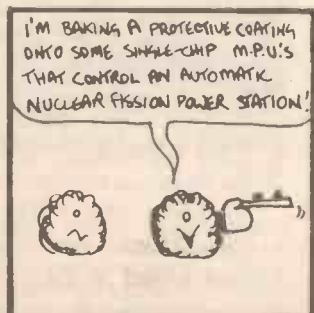
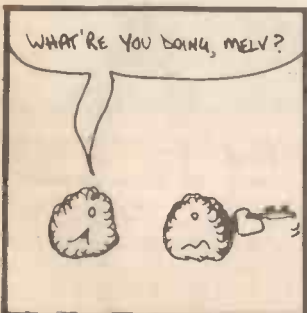

Breadboard Show Report

THE BREADBOARD amateur electronics exhibition was held from 21st to the 25th of November in London. It attracted over 10 000 people. HE had a stand there which it shared with its sister magazine, Electronics Today International. While we were there Phil Cohen fought his way through the crowds with his box brownie to bring us these photos of the more interesting bits and pieces on display.



The Electronics Today Triton. This is a home computer costing less than £300, the design for which was published in our sister magazine. The company which market the machine — Transam — brought several of them along so that prospective buyers could get 'hands-on experience'.



Mike Hughes, the designer of ETI's Triton computer project, giving a talk on its attributes. These talks were so popular that the private hall rented for the occasion was seldom less than full.



Science of Cambridge's PROM blower kit to go with the MK14 microprocessor evaluation kit. This allows the user to build a 'dedicated' microprocessor system — one which is programmed to begin its task as soon as it is switched on.



The MK14 tape interface kit. This allows programs to be stored onto cassette for future recall.



Another Electronics Today project, the Tcholinka chess recorder. This machine was used by the BBC in their coverage of the Korchnoi/Karpov chess match. The name comes from the Russian — Korchnoi named it (he also uses one). The machine is capable of storing an entire game in its memory and can record it onto a cassette tape for future reference. It also allows the game to be played from cassette with a commentary — thus allowing a professional player to review all the common openings, for instance, the day before a game.



The MK14 now has a VDU kit to go with it. This plugs into the aerial socket of a conventional TV set and allows the display of text and symbols.

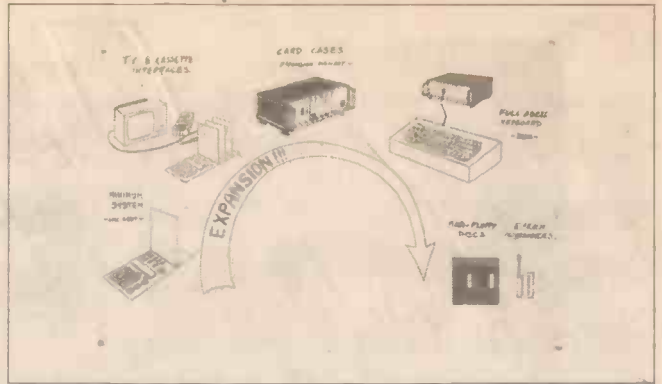

The Watford Electronics microprocessor evaluation kit — soon to be marketed (about a month, they tell us). It uses the Z-80 microprocessor, which is more powerful than the SC/MP processor used by the MK14, and is expandable into a full business system (eventually). The price should be around £70 — only £20 more than the Mk. 14.



In order that people could gauge the performance of the HE Mixer, Graphic Equaliser and Stereo Amp, we connected them in 'series' and fed in a signal. The combination of all the facilities offered by the three units made this a very versatile setup.



Maplin Electronics had on display a small laser. This was set up as a sort of fairground novelty — the idea being that you had to move the cut-out along the beam to the end without cutting the beam. A small electronic counter with a photo-electric input measured the time the beam was interrupted for. The laser was perfectly safe and wouldn't burn a hole in anything — well, that would spoil the purpose of the game!



The Format synthesiser, the design for which was published in *Electron* magazine. There were two of these on display — one by de Boer Components (this one) and one by Elector. Those with sharp eyes may be able to read the notice on the keyboard of this machine saying that a demonstration could be had at the Elector stand. We had to make do with a photo of this one, sign and all, because we couldn't get near the Elector one for people looking at it.



The plant in the background is playing a tune (yes, playing a tune) through the 'Bioactivity Translator' unit in the foreground. The unit gives out a series of musical notes which depend on the electrical conductivity of the plant's leaves. The company which was exhibiting them — Jeremy Lord Synthesisers — claim that amongst other things you can tell a plant's state of health from the tune.





The Integrex system uses a small TV camera to feed information into a microprocessor. This displays (with sixteen levels of grey) the scene which is to be printed, so that it can be reviewed by the customer before it is printed.

This is a photo of Margaret, one of the more attractive of the HE staff (excluding the editorial people of course). The characters used are not letters as in some systems, but a special combination of characters made up from a random pattern of dots. This gives a smoother appearance to the final product.



A MERRY CHRISTMAS & A HAPPY 'VIDEO TIME' NEW YEAR

BARGAIN TV GAMES STAND ALONE KITS

Kits — full instructions, all PCB components. Mini kits — instructions, chip, skt, coil, PCB

	kits	minikits
B&W Tank Battle (AY-3-8710)	£15.90	£9.75
B&W Stunt Rider (AY-3-8765)	£15.90	£9.95
B&W Road Race (AY-3-8603)	£14.90	£8.50
B&W 10 Game B/B (AY-3-8610)	£13.50	£8.50
NEW B&W Submarine/Spacewar (AY-3-8605)	TBA	TBA
B&W Wipeout/Breakout (AY-3-8606)	£14.90	£8.50

LOW COST SOLUTION

MERCURY COMMANDER — Ready Built and Guaranteed

Made in Britain by Teleng — £37.95 with 10 games + accessories



CARTRIDGES — suitable for all Teleng Type Games VAT inc.

Ready-made Road Race	£9.95
Stunt Rider with control	£13.95
Tank Battles with control	£21.50
Wipeout Breakout	£10.95



ATTRACTIVE PRICES

ATARI VIDEO COMPUTER

with big range of Cartridges 7 currently available plus NEW Breakout, Basic Math, Basketball



£139.95 VAT inc. with Combat Cartridge

Just look at these offers! plus we will match any better price offer

£13.45 VAT inc most Cartridges

DETAILS ON REQUEST

UNBELIEVABLE WATCH BARGAINS



VT01 5 FUNCTION LCD. Hour. Min. Sec. Month. Date. S/S strap. Backlight

ONLY £7.95



VT07 12 FUNCTION CHRONOGRAPH Hour. Min. Sec. DATE. Month. 1/100th Sec. Time. 1 or 2 Event.

ONLY £13.85



VT03 SOLAR ALARM Hour. Min. Sec. Month. Date. Day. alarm any time in 24 hour day.

ONLY £22.95

VT08 ALARM ONLY version of VT05

ONLY £21.95



VT05 CHRONOGRAPHY / ALARM Dual Time Zone Chrono lap time alarm

ONLY £35.95

VT09 STOPWATCH Version of VT01

ONLY £8.95



VT06 ALARM/STOPWATCH CLOCK & Snooze Alarm. Stop watch.

ONLY £12.95

★ Prices include VAT, packing & delivery charges and money back guarantee. Send cheque or P.O. to 56 Queens Road, Basingstoke, Hants RG21 1REA Tel: (0256) 56417. Telex: 858747.

VIDEOTIME PRODUCTS

We welcome Barclay & Access Orders by telephone (Trade and Export enquiries welcome)



Pinball Wizards

Long before video games were even a twinkle in any designer's eye, the world had pinball machines. A lot of people (the author included) still think that pinball is more fun to play than even the most advanced video games. How do they work — and what goes wrong? Jim Perry investigates.

THREE NAMES THAT ANY CONNOISSEUR of the finer points of life will recognize are Bally, Williams and Gottlieb. They all make pinball machines, and have brought many a strong man close to tears of both joy and anger — depending on whether the bonus or tilt lit up! The developments that have taken place in the last few years have meant that even pinballs are now succumbing to the onslaught of the microprocessor.

Part of the reason for my 'nostalgia' is that I received my grounding in electronics via repairing pinball machines (working in my uncle's arcade during holidays!), but the main reason is the gradual reduction in mechanical thumps, clangs and dings which were the hallmark of old-fashioned models!

If you look inside an ultra-modern machine you will see very little, apart from a few solenoids and a black box containing a dedicated computer — not a very enlightening experience. So to understand the principles behind the machines let's take a step back in time and see how the older models developed into their modern cousins.

TIME MACHINE...

Originally pintables were little more than extensions of Bagatelle games — with movable flippers to keep the ball in play; the scoring systems were mostly mental! Then some budding genius had the idea of using electrically operated flippers and bumpers; so that the flippers could be positioned anywhere on the playing area, and the bumpers would give more 'action' by physically repelling the ball harder than unassisted rubber could manage.

By positioning switches behind the bumper rubbers, solenoids were activated when the ball hit the rubber — and the solenoid operated a lever to push the rubber towards the ball. From this system it was but a small step to operating electric counters for score-keeping. The next major innovation was the mid-field 'mushroom' which was formed from two bumpers and a solenoid. When the ball hits the mushroom it forces the bottom bumper down; this operates a switch to power the solenoid. When energised the solenoid pulls the upper bumper down sharply — thus forcing the ball away from

the bumpers. Naturally the solenoid circuit is then broken as the lower bumper springs back into place, and the upper bumper also returns to its normal position.

The electrical circuits were connected and disconnected by relays, operated by the bumper switches and 'roll-over' contacts scattered over the playing area. Advantages of using relays included less contact wear on the switches operated by bumpers (as relays con-

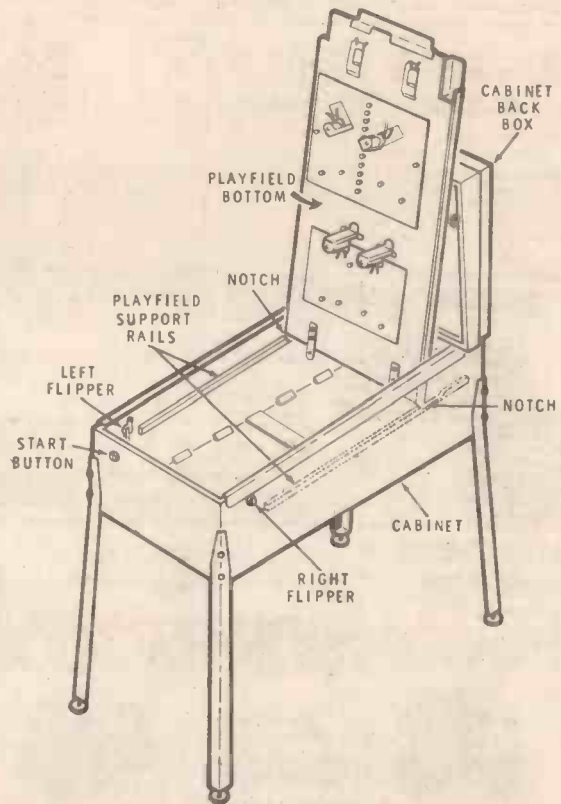

An artist impression of the new Heathkit DIY pintable, the whole machine is MPU controlled — with only four bumper solenoids.

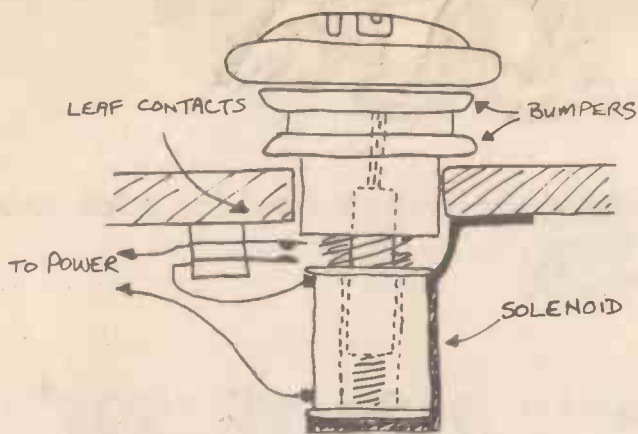

Above is a rough sketch of the midfield 'mushroom' mechanism, found on all pinball machines. Bumper switch mechanism can be seen below, the switch operates a solenoid to force the ball away.

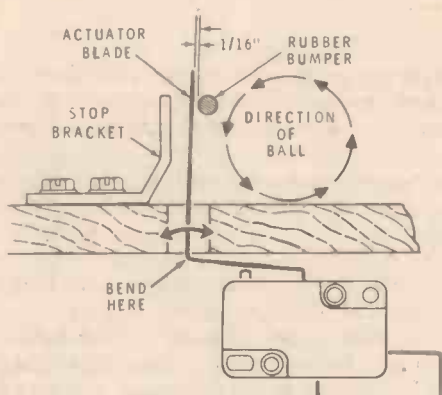

A modern machine from a Spanish company Recel, this one is called 'Mr Evil' and is electronic rather than electro-mechanical.



TILT! The device used to prevent you totally abusing any pinball is elegant but simple in operation. When the hanging bob touches the bob ring a relay is operated, and you lose the game or ball in play.

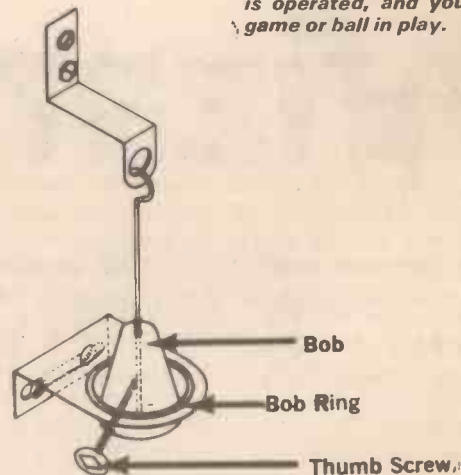

some relatively little current compared to solenoids), and possibilities of more sophisticated switching with the aid of complex interlinking of the multiple contacts available on each relay. In fact the relay systems in pinball machines were the equivalent of dedicated computers (which explains why MPUs have been used to replace them).

... BREAKS DOWN ...

A headache with Pinball machines is when they work — but not quite correctly. Mechanics have been known to spend days on a single machine, trying to trace an elusive intermittent fault. It can be the equivalent of a proverbial needle in a haystack, with upwards of 3000 contacts in an average machine — each one critical to the functioning of the complex logic needed for scoring and bonus awarding, etc. But the big benefit of relay and solenoid control was the ease of fault finding. In most cases it is easy to spot a burning coil, buzzing relay or other similar symptom of catastrophic failure.

If a machine appeared to be in order physically the logic had to be checked through systematically, with checks on all the possible interactions from other parts of the circuit — a very good way of learning about logic control and methodical fault finding!

... NOW AND THEN

So because of the close similarity between what the electromechanical circuitry did, and MPUs are designed to do, the older types of Pinball machine are rapidly being replaced by modern equivalents. The other main factor is that of reliability and ease of repair — MPU systems are inherently more reliable and a single module can be used for several similar but different models.

As a result it is possible to buy second (well, probably fifth or sixth) hand Pinball machines for as little as £20 — well worth it if you fancy learning about complex (yet simple?!) electromechanical devices, and even just to have a good time.

HE

Flash Trigger

Trigger your photo-flash with light, sound, or switch contact with this simple unit.

IT'S NOT TOO HARD for even the amateur photographer to take quite spectacular photographs, freezing motion at a critical stage. To operate the shutter on camera manually, even if this could be done at the critical moment, simply won't work in freezing most fast motion as even the fastest shutter speeds will cause the image to blur.

However, by darkening the subject, opening up the shutter and operating a flash gun we can obtain very, very short effective exposure times because of the high light level for a brief period. In addition we can use an electronic circuit to fire the flash gun which in turn can be triggered by light or sound.

Our project here will operate with any of these triggers and in addition enables you to delay the flash for a small but variable time after the triggering impulse; this will be found very useful for some effects.

Although the circuit will enable spectacular shots to be taken, it is quite simple and makes use of the NE555 Timer IC (often abbreviated to just 555) which is advertised usually for under 40p.

This IC has a very sensitive input and the ability to provide the required variable time delay as well as sufficient output to trigger the SCR (thyristor) which is fitted across the normal contacts for firing the flash.

CONSTRUCTION

Using the PCB pattern shown makes construction very easy, only one thing needs to be watched. The triggering current needed is only 0.5 microamps (this goes into pin 2 of the IC) and with the adjacent pins being the negative supply and the output, leakage across the board can be a problem. Normally excess solder flux, dirty thumb-prints etc. on a PCB don't make much difference to the operation of a circuit but here we have to be careful. Once the PCB is built up, clean it up with methylated spirits. A dirty board will show itself up by continuous triggering; dampness around pin 2 will affect the circuit in a similar way.

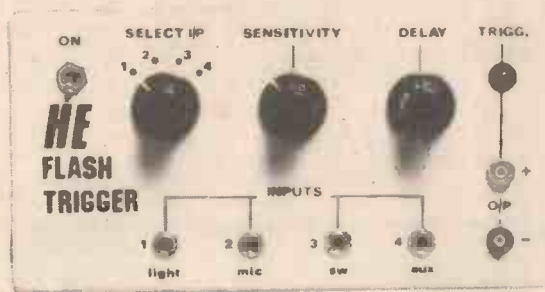
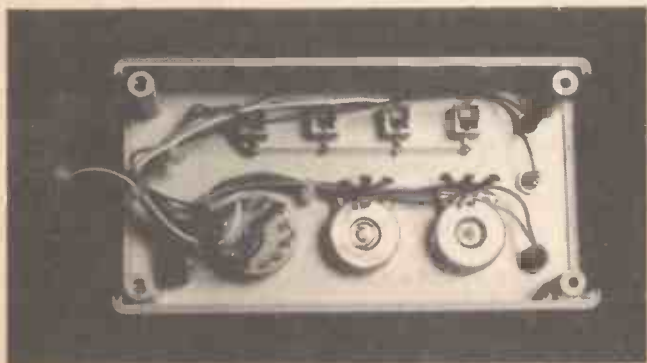

Since flash tubes do not have an unlimited life, it's not a good idea continually to use the flash itself as an indicator that the unit is set up properly; instead the LED serves this function.

It will be necessary to carry out a couple of 'dummy' runs in order to get the sensitivity control (RV1) set correctly.

Connect either a crystal microphone or a loudspeaker across Input 2; due to the sensitivity of the circuit either will give an output of sufficient level to operate.

Start by setting the sensitivity to maximum (this is with RV1 at a minimum); in this state the circuit will probably be triggering continuously. Then back off the control until the LED goes out but comes on again when the required sound is made. There is no advantage in using maximum sensitivity all the time as you will find that the unavoidable noises in resetting the equipment after the first tests have been made will fire the equipment.

LIGHT TRIGGER

Although a light dependent resistor (such as the ORP12) can be used, these are fairly slow to react and you will have a built-in minimum time delay. It is better to use a light sensitive transistor; although this costs more, it will introduce little, if any, time delay.

Light triggering can take one of two forms. With the delay set at minimum, the unit can be used as a slave flash, triggering by the principal flash unit. It is not difficult to set up a light beam which is broken just before the photo is needed. The circuit can be arranged to trigger for both an increase and a decrease in light level.

For an increase in light the phototransistor should be fitted across Input 1 with the resistor across Input 2; for a decrease the two should be reversed.

The unit can also be operated with either a switch closing, or opening. As with the phototransistor, a resistor must be fitted across the other input.

OPERATIONAL TIPS

If you're an experienced photographer the following will be like teaching granny to suck eggs, in that case ignore this section.

As the shutter will have to be open for several seconds awaiting the trigger flash, clearly background light is not desirable but you don't need pitch black (which makes setting up almost impossible).

If you get movement in the developed pictures, try a different flash unit, we have come across at least one cheap flash that doesn't give the highly intense, very short duration flash needed.

You will also find that with a flash you will be operating frequently much more closely to the subject than that allowed for on the tables which you have to consult for aperture settings — in this case move the flash away from the camera.

Oh — and if you want to try breaking light bulbs (which can give beautiful results) don't underestimate the mess created; form a complete 'cup' of paper or material to catch the bits before you start!

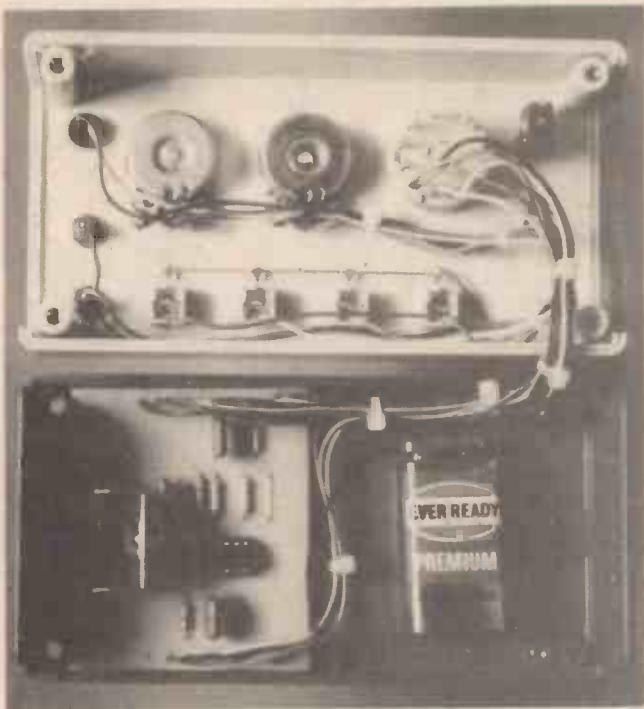

How it Works

A negative pulse at the input is fed via capacitor C1 to the input pin (2) of the IC. Pin 2 is held slightly above its triggering voltage of $1/3 V_{cc}$ by the voltage divider comprising R1, R2, and RV1. The negative pulse triggers the IC and output (pin 3) goes high for a time period controlled by RV2, R3 and C2. When the output goes low again at the end of the time interval capacitor C3 charges through the gate cathode circuit of the SCR switching it on and firing the flash.

Capacitor C1 isolates the input from the voltage divider so that the unit isn't sensitive to the DC level at the input. RV1 acts as a sensitivity control by allowing the voltage to be adjusted to a suitable level so that the input signal will trigger the IC. Resistor R4 limits the discharge current from C2 at the end of the timing cycle so protecting the IC. The LED and its protective resistor R5 act as an indicator to show that the unit has triggered, so simplifying the setting up process and minimising the number of times the flash has to be fired. This means that the flashgun needn't be fired until a photo is to be taken.

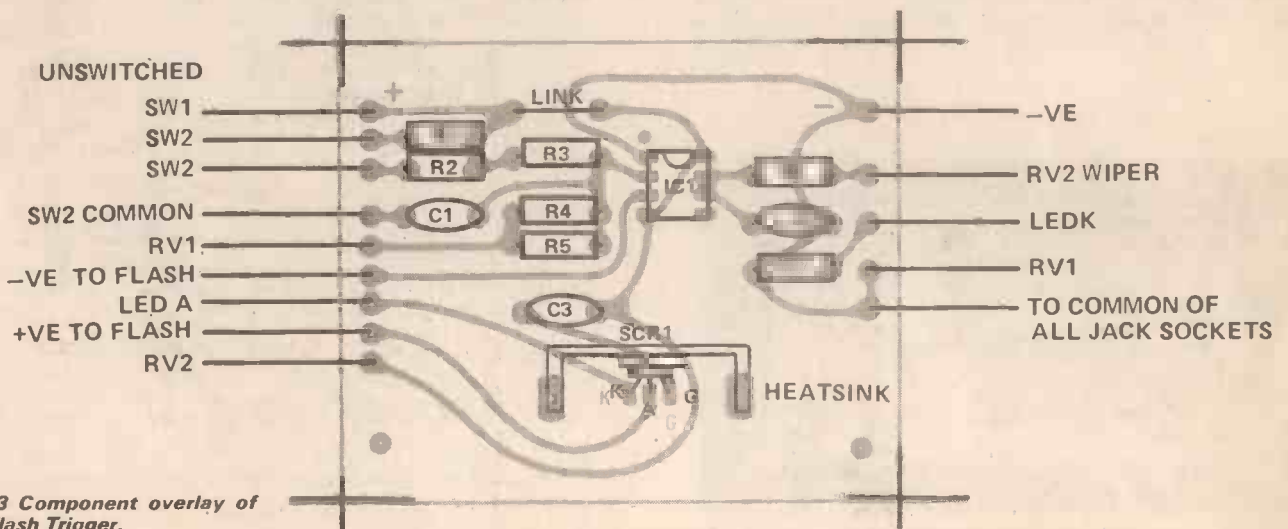
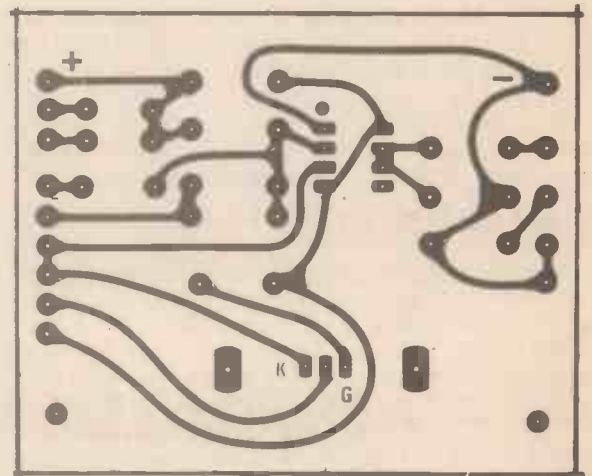
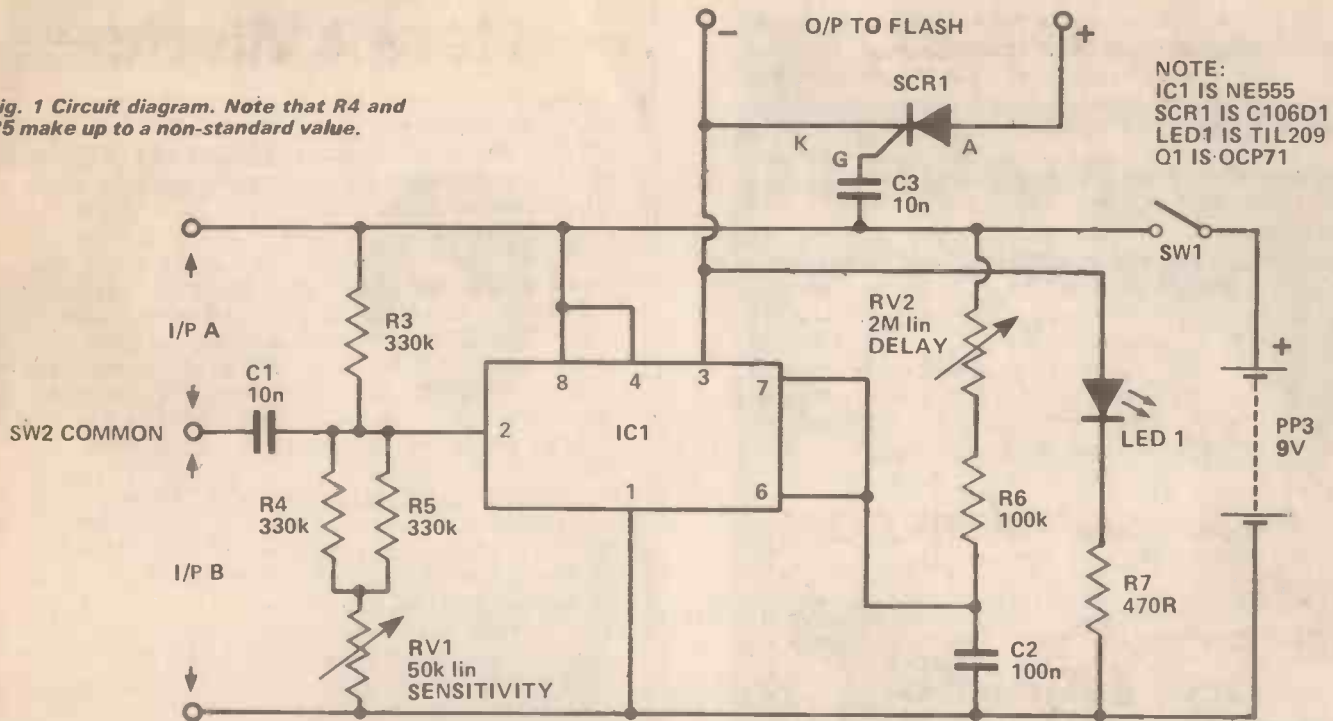

Fig. 3 Component overlay of the Flash Trigger.

Flash Trigger

Fig. 1 Circuit diagram. Note that R4 and R5 make up to a non-standard value.



NOTE:
IC1 IS NE555
SCR1 IS C106D1
LED1 IS TIL209
Q1 IS OCP71

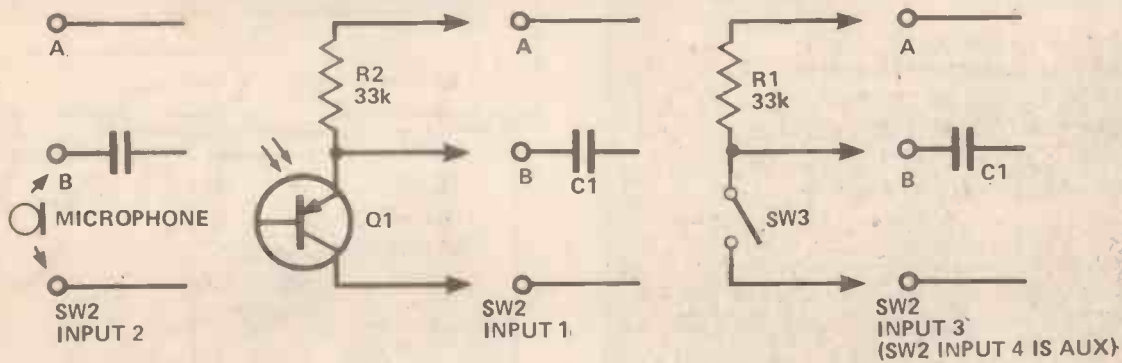

Fig. 2 Alternative input connections.

Parts List

RESISTORS (all 5%, 1/4W)

- R1 330k
- R2 165k (2x330 k in parallel)
- R3 100 k
- R4 10 k
- R5 560 ohm
- R6 33 k (optional depending on input)

CAPACITORS

- C1 10nF ceramic
- C2 100nF ceramic
- C3 10nF ceramic

SWITCH

Any SPST switch suitable

POTENTIOMETERS

- RV2 2 Meg linear
- RV1 50 linear

SEMICONDUCTORS

IC NE 555

SCR C106 D1 or similar with a 400 volt rating

LED Miniature red

INPUT DEVICE

OCP71 transistor
Crystal mike insert etc

OUTPUT DEVICE

Electronic flashgun, preferably computer type as these give a much shorter flash duration at close range

MISCELLANEOUS

Input sockets
Output to suit flash unit being used
Knobs 2 for pots
Battery Connector
PCB



OCP71 NOT USED



CASE TYPE: TQ7

4 JACK SOCKETS

COMMON BUS, TINNED COPPER WIRE

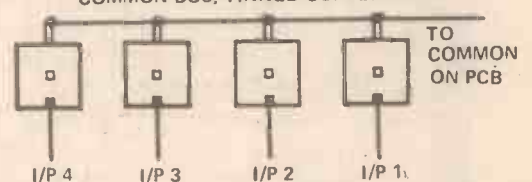

Fig. 4 Jack socket connections.

The latest kit innovation!

from **Sparkrite**

*Sparkrite -
was featured by Shaw Taylor
in "DRIVE IN"*

the quickest fitting
CLIP ON
capacitive discharge
electronic ignition
in KIT FORM

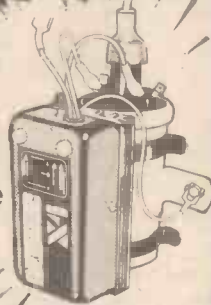

- Smoother running
- Instant all-weather starting
- Continual peak performance
- Longer coil/battery/plug life
- Improved acceleration/top speeds
- Optimum fuel consumption

Sparkrite X4 is a high performance, high quality capacitive discharge, electronic ignition system in kit form. Tried, tested, proven, reliable and complete. It can be assembled in two or three hours and fitted in 1/3 mins. Because of the superb design of the Sparkrite circuit it completely eliminates problems of the contact breaker. There is no misfire due to contact breaker bounce which is eliminated electronically by a pulse suppression circuit which prevents the unit firing if the points bounce open at high R.P.M. Contact breaker burn is eliminated by reducing the current to about 1/50th of the norm. It will perform equally well with new, old, or even badly pitted points and is not dependent upon the dwell time of the contact breakers for recharging the system. Sparkrite incorporates a short circuit protected inverter which eliminates the problems of SCR lock on and, therefore, eliminates the possibility of blowing the transistors or the SCR. (Most capacitive discharge ignitions are not completely foolproof in this respect). The circuit incorporates a voltage regulated output for greatly improved cold starting. The circuit includes built in static timing light, systems function light, and security changeover switch. All kits fit vehicles with coil/distributor ignition up to 8 cylinders.

THE KIT COMPRISES EVERYTHING NEEDED

Die pressed epoxy coated case. Ready drilled, aluminium extruded base and heat sink, coil mounting clips, and accessories. Top quality 5 year guaranteed transformer and components, cables, connectors, P.C.B., nuts, bolts and silicon grease. Full instructions to assemble kit neg. or pos. earth and fully illustrated installation instructions.

NOTE - Vehicles with current impulse tachometers (Smiths code on dial RV1) will require a tachometer pulse slave unit. Price £3.35 inc. VAT, post & packing.

Electronics Design Associates, Dept. HE 3
82 Bath Street, Walsall, WS1 3DE. Phone: (9) 614791

Name _____
Address _____

Phone your order with Access or Barclaycard

including postage and packing UK only

QUANTITY REQD.

Send SAE if brochure only required

I enclose cheque/PO's for

X4 KIT £16.65 inc. VAT

TACHS PULSE SLAVE UNIT
£3.85 inc. VAT

£

Cheque No. _____

Access or Barclaycard No. _____

TEE-HE!

HOBBY ELECTRONICS TEE-SHIRTS

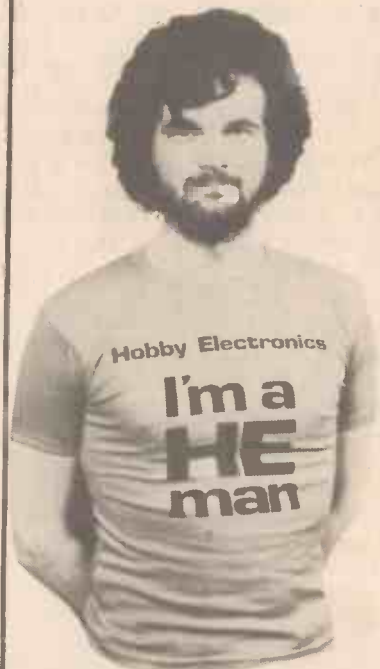

Join the He-men by sporting our cotton Tee-shirts. The photo shows Project Editor Gary Evans wearing a medium-size version - they're also available in Large and Small, please specify which when ordering. All inclusive price is £2.00 from:

HE Tee-Shirts,
Hobby Electronics,
25-27 Oxford Street,
London W1R 1RF.

SPECIAL OFFER ONLY TO HOBBY READERS

5 FUNCTION LCD

Hours, mins, secs,
month, date, auto calendar,
back-light, quality
metal bracelet.

£7.65

Very slim, only 8mm thick



THOUSANDS SOLD 11 FUNCTION SLIM CHRONO

6 digit 11 functions

- * Hours, mins, secs.
- * Day, date, day of week.
- * 1/100, 1/10, secs. 10 x secs. mins.
- * Split and lap modes.
- * Back light, auto calendar.
- * Only 8 mm thick.

This same watch is being sold for £22.00 in newspaper and magazine special offer ads.

Metac Price
£12.65



HANIMEX Electronic LED Alarm Clock

THOUSANDS
SOLD

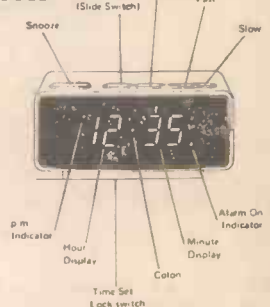

Feature and Specification

- ★ Hour/minute display
- ★ Large LED display with p.m. and alarm on indicator
- ★ 24 Hours alarm with on-off control
- ★ Display flashing for power loss indication
- ★ Repeatable 9-minute snooze
- ★ Display bright/dim modes control

Size 5.15 x 3.93 x 2.36 (131mm x 100mm x 60mm).
Weight: 1.43 lbs (0.65 kg).

£8.65

GUARANTEED SAME DAY DISPATCH

- * All prices include VAT and carry 12 months written guarantee with our 10-day money-back assurance.
- * All watches sent first class post
- * Shops open 9.30 a.m.-6.00 p.m.

Metac electronics have been selling quartz watches probably longer than any other company in the U.K. We carry a very wide range of models and our shops stock most batteries. Fitting is free and this service is open to all.

Please add 30p p&p all orders

Barclay & Access welcome...
Phone or send Card Number



METAC Electronics & Time Centre
67 HIGH STREET Dept. HE
DAVENTRY, NORTHANTS
Tel: (032 72) 76545

327 EDGWARE ROAD
LONDON W2
Tel: (01) 723 4753



Solder

Solder is solder is solder . . . or is it? K. T. Wilson takes a closer look.

SIMPLE ENOUGH, isn't it? You just buy a reel of cored solder and that's it. Or is it? In fact there is no single material called solder, and there's a very wide range of behaviour that you can expect from solder, depending on their composition. Add to that dozens of materials that can be used for a flux core, and it doesn't look so simple.

Basically, solder is a mixture of lead and tin. Pure lead melts at about 327 C, tin at 232 C, but mixtures of tin and lead melt at temperatures which depend on the composition. Fig. 1 is a diagram which shows the melting points of various alloys — the important solders are the alloys which contain up to 60% tin. This type of diagram shows an important point — that there are mixtures of tin and lead which have melting points lower than either tin or lead. This lowest melting point is for a 63% tin mixture, called the eutectic — a name given to any mixture of materials whose melting point is the minimum.

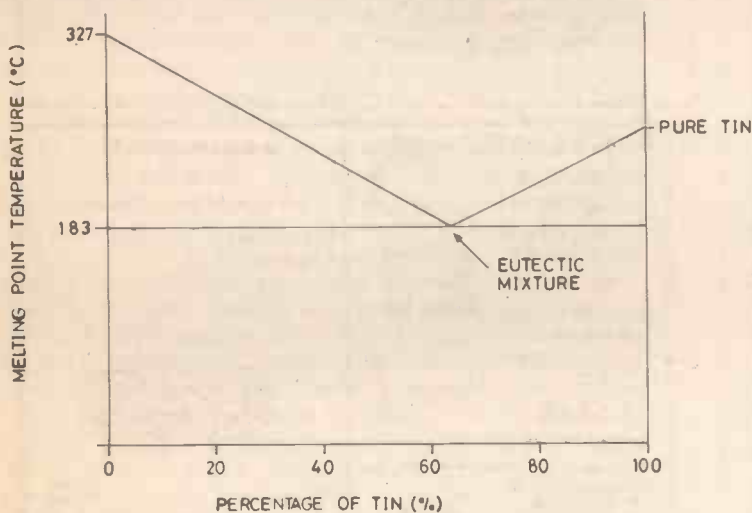

Fig. 1. Graph of melting point plotted against composition for tin/lead mixtures.

The graph of Fig. 1 shows only melting points — but there's more to it than that. Pure materials, such as pure tin or lead, have sharp melting points — meaning that they go from liquid to solid for only a tiny fraction of a degree change in temperature. The eutectic mixture (63% tin) does this also, but all other mixtures of tin and lead which contain more than about 15% tin have a 'pasty' stage (Fig. 2), neither liquid nor solid. This pasty stage is important in soldering, because slight vibration during the setting of solder can cause fractures if there is no pasty stage of temperatures. Fig. 2 shows the temperature range of the pasty stages for the various mixtures — not that these are always completely solid at 183 C, so that this is the final setting temperature of any tin/lead solder.

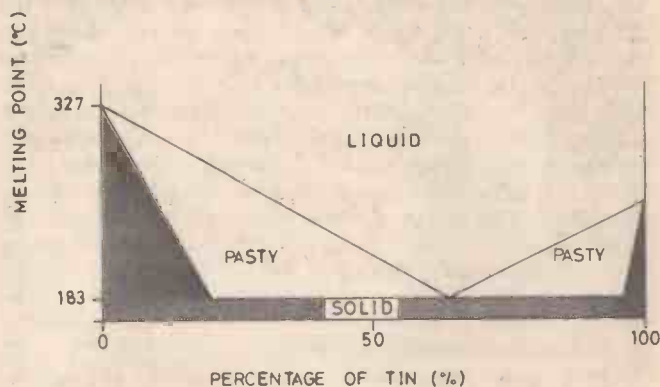

Fig. 2. The pasty part of the temperature/composition graph.

SOLDER ON

The reason for the popularity of the 60/40 alloy (60% tin) is fairly clear. It has a low melting point and a small pasty range; a good combination of qualities for hand-soldering. The low melting point lets us use low-power irons, and also avoids damage caused by the quick burn-off of flux which would occur at higher temperatures. The small pasty range (flux 180 C to 188 C) means that the alloy will set fairly quickly — blow on it once or twice and it's then strong enough to forget about. There are some merits which do not appear in the graph, though. One is that the 60/40 mix is one of the strongest, another is that it is the best electrical conductor of all the tin/lead alloys (about 11.5% of the conductivity of pure copper).

The 60/40 alloy, along with the 50/50, 45/55 and 40/60 alloys are the solders most commonly used for soldering small electrical equipment. Solders with lower tin contents are used for purposes where higher running temperatures are encountered, such as in lamp bases, electric motors, dynamos and fuses.

The lead/tin alloy isn't the only type of solder mixture, though, particularly for the industrial user. A straight lead/tin mixture dissolves copper, and copper is the material that we use for the business end of the soldering iron. The result is that bits of irons wear away very rapidly as the copper of the 'iron' bit dissolves, and the tracks of PCB's can also be dissolved in the same way, causing thinning of the copper layer. This problem is serious for large-scale production soldering work in particular, and can be overcome by making solder which already has a content of about 1.5% of copper. This is about as much copper as a tin-lead solder would normally dissolve, so that the inclusion of copper into the solder virtually puts an end to the dissolving of copper by the alloy from the bit or the PCB. Copper-alloy solder, invented by Multicore, and sold under the trade name of

SAVBIT, is used extensively for large-scale work, and is sufficiently well proven to be approved for soldering work on military equipment.

GOLD SOLDERS NEVER DIE

Not all soldering makes use of 60/40 alloys. For high-temperature soldering, alloys with only 5% tin are available (melting at 301 C); at the other end of the composition scale there is non-toxic solder which has 96.3% tin and the remainder silver. Such lead-free solder can be used when soldering has to be in contact with foodstuffs (as in tin-cans for example, or water pipes). Just for a bit of variety, there is also a low melting point solder, melting at 145 C, which contains 50% tin and 18% cadmium. This is of particular use in soldering onto gold, and the very low soldering temperature is an advantage for IC internal soldering. Another low melting point alloy is 62% tin, 2% silver, 36% lead, which solders particularly well to silver-coated surfaces. It finds particular use in soldering ceramics to metals. Table 1 shows some alloy compositions.

The metal, of course, is only half of the solder process. When we solder metals together, the temperature that has to be used is high enough to enable the oxygen in the air to attack the metals and the solder as well. In addition, we want the solder to spread over the surface of the metals. Now the spreading of a liquid over a solid is greatly affected by the presence of other materials — for example, water will not spread on glass if there is a trace of silicone grease on the glass. Liquid solder is equally fussy, and traces of dirt on metal surfaces will simply prevent solder from spreading.

A flux is a material which is used to avoid both of these problems. A good flux should help to clean up the metal surfaces (though it can't be expected to perform miracles) and should form a protective coating around the solder and the metals being joined so as to avoid oxidation.

For non-electrical soldering, acid fluxes like the traditional 'killed spirit' can be used. These materials are acid enough to dissolve away impurities; the sort of work that is soldered in this way is usually 'pickled' in acid anyway, so that the acidity of the flux is unimportant. For electrical work, however, strongly acid flux of this type has to be avoided like the plague. It's not very often that we can boil our printed circuit boards in water for several hours to get rid of acid, and if we don't remove it then the life of the conductors will be pretty short.

SOLDER GLUE

Electrical fluxes are therefore based on resin, the gummy material which is extracted from wood. Molten resin flows evenly over metals, giving protection for the joint for some time. Any resin which remains on a joint is hard and non-corrosive; a useful protective coating in fact.

Unfortunately, resin by itself does not dissolve a film of oxide from a metal surface, so that it doesn't have the cleaning effect of an acid flux. Fortunately, we can make use here of the fact that soldering is a high temperature operation. Some chemicals, such as the range of salts called halides, will dissociate when heated, meaning that they will release acid vapours which will be neutralised again when the material cools. Chemicals such

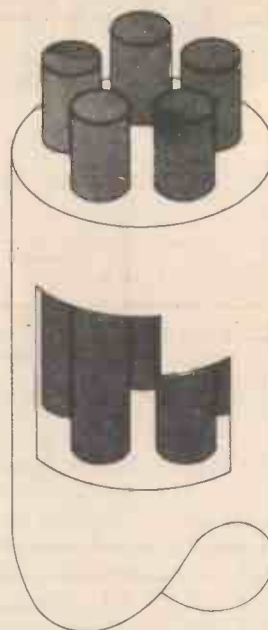

Fig. 3. Cross-section of 5-core solder.

as tin or lead chlorides can be used for the purpose. The addition of such materials, called activators, to a resin has a very noticeable effect on the fluxing ability of the resin. The release of chlorine from a chloride, for example, cleans metal oxides very effectively, but has less adverse effects than acid on the life of the joint because the chlorine is reabsorbed wherever the material cools. Less strongly active materials can be used when there is any risk of contaminating the area around the joint. In general, fluxes for electronics use have a fairly low halide content. A few types of halid-free fluxes have also been developed, and are used for such applications as circuits which are to be encapsulated. For circuits which must have very long corrosion-free life in hot climates, pure resin-flux is available.

In the early days of soldering, the flux was always applied separately from the solder. Since Multicore pioneered the idea of flux-cored solders, the separate-flux system has died out almost completely. Though several manufacturers now make flux-cored solders, Multicore are still unique in offering five cores (Fig. 3), ensuring quick and even dispersion of the flux. In case you were in any doubt, by the way, the resin cored solder is made in the same way as Blackpool rock — a thick rod of solder is cast with five holes running through it, these holes are filled with flux, and the whole thing is drawn out into the fine solder which we use. It's a fascinating process to watch too!

KEEP IT CLEAN

And after all that, let's hope we are soldering correctly. Boards such as Veroboard which have copper tracks should be scrubbed clean — don't let the flux have to do all the job of cleaning the board. Similarly, tarnished leadout wires of components should be cleaned by pulling them through loops of emery-paper. For really good joints, it pays to use leads and tracks that are tinned in advance (like the Blob-board tracks); gold plated leadout wires on transistors will also solder very easily.

Make sure the iron is hot enough. Some irons always seem to run a-bit cool and if a very small bit is used, the heat sinking action of a circuit board can be enough to

ALLOY	GRADE	Melting Temp.		USES
		Solidus °C	Liquidus °C	
2/2/96 Sn/Sb/Pb	"DOUBLE TWO"	305	315	High temperature High creep strength
5/93.5/1.5 Sn/Pb/Ag	HMP	296	301	High melting point
95/5 Sn/Sb	95A	236	243	High melting point Lead free
Pure Tin Sn	PT	232	232	Lead free
15/85 Sn/Pb	W	225	290	Lamps
96/4 Sn/Ag	96S	221	221	Stainless steel Bright, strong, non-toxic
20/80 Sn/Pb	V	183	275	Lamps
30/70 Sn/Pb	J	183	255	Lamps, motors
31.2/67/1.8 Sn/Pb/Sb	L	185	243	Radiators, general purpose Non-electrical
40/60 Sn/Pb	G	183	234	General purpose
45/55 Sn/Pb	R	183	224	General purpose
50/48.5/1.5 Sn/Pb/Cu	SAVBIT 1	183	215	Saves copper erosion
50/49.7/0.3 Sn/Pb/Sb	Sn 50	183	212	General purpose
50/50 Sn/Pb	F	183	212	General purpose
60/39.7/0.3 Sn/Pb/Sb	Sn 60	183	188	Electrical
60/40 Sn/Pb	KP	183	188	Electrical
63/36.7/0.3 Sn/Pb/Sb	Sn 63	183	183	Electrical
62/35.7/2/0.3 Sn/Pb/Sb/Ag	Sn 62	179	179	Silver-plated surfaces
62/36/2 Sn/Pb/Ag	LMP	179	179	Silver-plated surfaces
18/180.1/1.9 Sn/Pb/Ag	ALU-SOL 45	178	270	Aluminium
50/32/18 Sn/Pb/Cd	TLC	145	145	Low melting point, soldering on gold
70/30 Sn/Zn*	—	196	307	Spray wire for metal film capacitors
80/20 Sn/Zn*	—	196	268	
30/70 Sn/Cd*	TC 30	176	240	Low thermal EMF solder

* These alloys are only available as solid wire. For those purposes where solid wire is still used on automatic appliances precision made solid wire can be made in any alloy to special order.

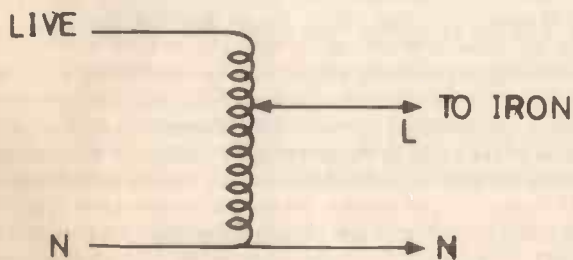

Fig. 4. Using an auto-transformer, such as a Variac, to control iron temperature.

keep the bit too cool to melt the solder properly. A very hot iron, on the other hand, will cause oxidation and burning if it's left on too long. The power output of soldering irons for electronics use is so low that a simple thyristor controller can cope, and excellent heat regulation can be obtained if an auto-transformer is also used (Fig. 4). Incidentally, a lot of awkward problems can be overcome by using ready-formed solder shapes, such as rings and spheres, or by the use of solder and flux mixed in the form of a cream or paint.

May the flux be with you!

HE

The author gratefully wishes to acknowledge the help of Multicore Solders Ltd in providing information for this article.

What to look for in the February issue: On sale Jan 5th

TODAYS 100 WATT AMPLIFIER AT YESTERDAYS PRICES

ETI, Britain's most ingenious magazine has come up with a 100W mixer amplifier, with distortion below 0.1% at all signal levels, S/N ratio greater than 80dB, inputs for four sources, including one or two disc inputs as you wish. Somehow or other the design, by Richard Bekker, cost less than £50 to build

complete with metalwork.

A complete kit of parts will be made available and full constructional details will be given next month. The unit is finished to match the five channel light show presented in the December issue of ETI.

Crowds are expected to throng shops early next month — newsagents are preparing.

BUILD YOUR OWN VCT AND FIND OUT WHAT VCT ME

The revolutionary device that will replace the op-amp.

We got fed up waiting for it to be released. We did something about it.

We show you how to construct your very own VCT next month!

Astound your friends!

Confuse your budgie!

Amuse your boss!

No home dare be without its VCT!

ETI brings home the bacon next month!

VOICE SYNTHESIS CRISIS—

MACHINES SPEAK OUT!

Panic in the streets! Women and children unsafe! Machines can speak! Prime Minister to go on steam radio tonight! From our undercover agent — Tim Orr — comes full details of the invention that could cause a bigger stir than the

double breasted jacket! Several methods are in use, and a new unit is soon to be available which promises to confound us all.

Speech synthesis is here to stay, and Special Agent Orr is right

there in the forefront reporting back for ETI readers exclusively next month. If you value your sanity you cannot afford to miss this! Thinking people everywhere will be talking about this — don't be left out at the dinner table!

SLIDING INTO SYNCH?

OK you guys youse asked for this and now youse gonna get it, see? Youse bin ringing and hassle us boys down at ETI to do youse a slide synchroniser so long now dat the broad on de phone is going bananas see? So we gotta give it to youse see? Nuffin personal see? OK?

NEXT MONTH: COMPUTING TODAY GOES TO 48 PAGES! CAN MANKIND SURVIVE? WILL YOU BYTE OFF MORE THAN WE CAN CHEW? FIND OUT IN COMPUTING TODAY NEXT MONTH!

Composer goes SCAMP

An amazing revelation came to the attention of the British electronics public today. ETI have plans for an MPU composer! Bach and Handel have been heard to revolve in their graves at 2000 RPM at this stunning news! This audacious machine employs a SC/MP processor and an amazingly low component count. All will be finally revealed in the next issue of ETI, and anyone remotely interested in music, synthesisers or electronics is urged not to miss it! A machine that thinks up and plays its own tunes has to be seen to be believed.

Articles mentioned here are in an advanced state of preparation but circumstances may affect the final contents.

SCILLY SCOPE

Make more use of your tele folks! Here is a unit to make the room pulsate with colour in time to your hi-fi! Hooks into music signals to give an oscilloscope type display on a television screen, in full glorious colour! What will they think of next? Pocket calculating machines?

Kit Review

— WEIN BRIDGE OSCILLATOR

A WEIN BRIDGE oscillator is a circuit which produces a sine wave output. This kit makes a test-bench unit which gives a variable frequency sine wave for a variety of purposes.

A sine wave source is very useful in many applications. It is the only waveform which contains only a single frequency. By 'sweeping' it — varying the frequency a little at a time — and finding the response of a particular circuit (how much it reduces the level of the input waveform), the overall frequency response can be found by drawing a graph of response against input frequency.

This procedure requires a sine wave source of a known, but variable, frequency.

This unit will produce a sinewave at frequencies between 15 Hz and 20 kHz, accurate to about 10%. This should prove sufficient for most test applications.

FIRST IMPRESSIONS

The kit cost £7.99 and for this price we expected a small, cheap case. Nothing could be further from the truth. The

The completed unit — very smart, except for the frequency scale (which goes from 15 to 150). White on aluminium is a mistake.

case is *heavy*. It's made (we think) from steel plate — or at least, that's what it feels like!

The front panel is printed in red and white and looks very impressive, with the top painted with grey hammer finish enamel. It wouldn't look out of place on board a battleship.

The components came in two plastic bags, one holding all the board and panel mounting components as well as PCB pins and wire. The other bag contained *more* PCB pins and *more* wire! Very strange. Later we discovered that the pins in the first bag (which was stapled shut) were the wrong size for the holes — the second bag had obviously been added after the first had been sealed — fair enough. Why the extra wire, though? We never did find the answer to that one.

There was also a huge length of solder included — much more than was required.

BUILDING IT

Let me say right at the start that if you can't follow a circuit diagram, you can't build this kit. It's excellent value in terms of the hardware and components provided but it's not easy to build.

The main problem is the book of instructions — it's badly written and produced and, in places, positively

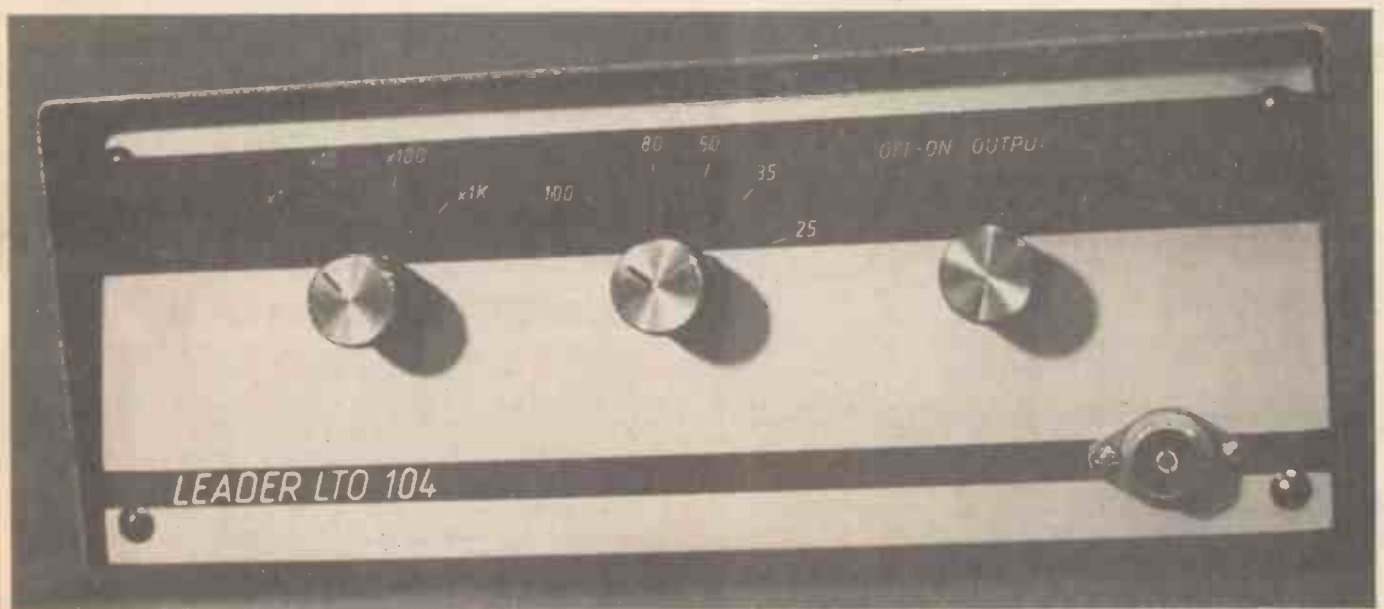

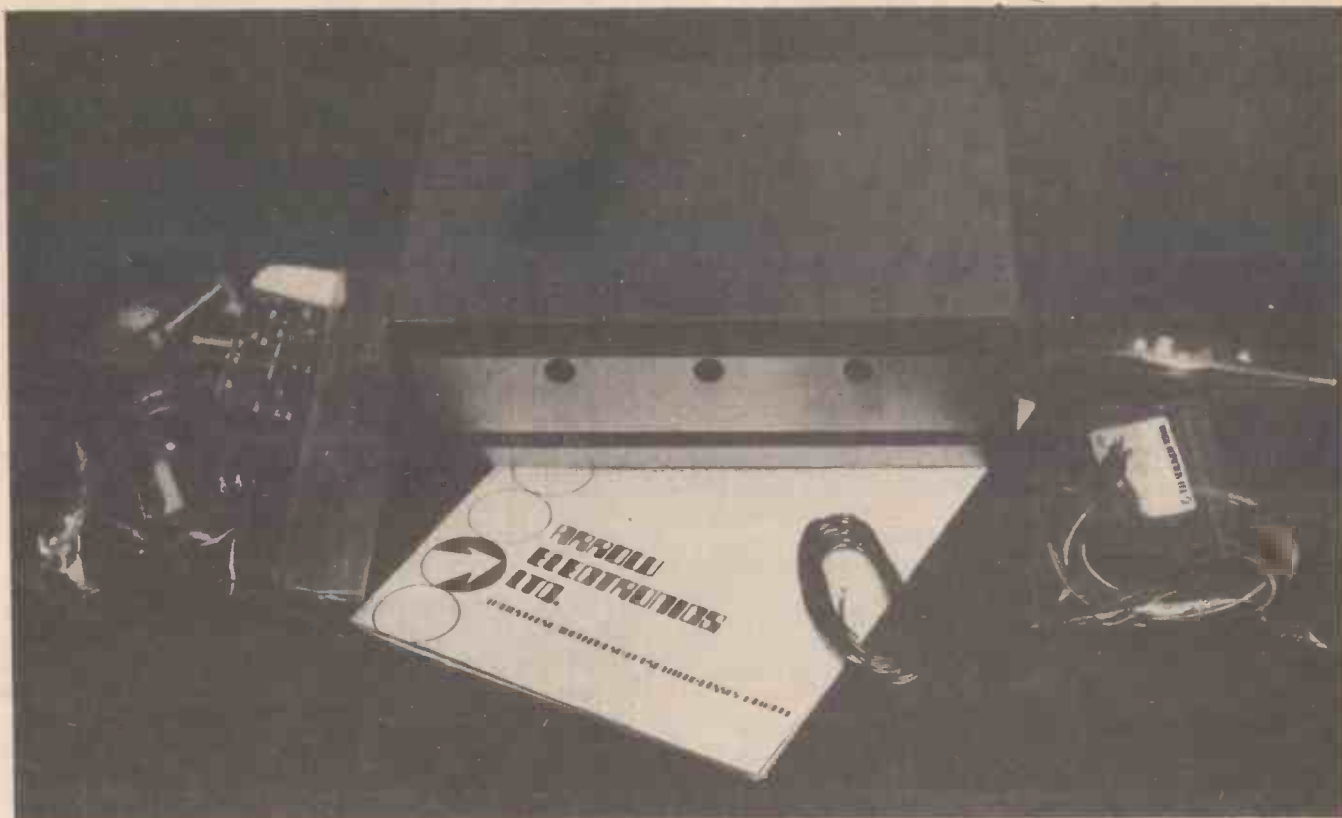

cryptic. Anyone who could build a project from the circuit diagram could find their way round it easily enough but if you want step-by-step instructions then it will give you problems.

COMPONENT CHECK

The first thing we did was to check to components supplied against the parts list in the manual. Surprisingly enough, the instructions gave the resistor and capacitor colour codes where necessary. This is very much at variance with the level of knowledge assumed in the rest of the book.

A couple of components were not as marked in the list — a close value to that required was supplied instead.

The list itself was full of ambiguities:
C6-C10

didn't mean C6 to C10; it meant C6 and C10.

TR1-TR2 BC177-178-179

meant that TR1 and TR2 are both either a BC177, a BC178 or a BC179!

Having come to terms with this sort of thing (and having referred to the circuit diagram once or twice), we discovered that all of the required components were there and so we could proceed with the construction.

PUTTING IT TOGETHER

The board has the component positions printed onto it. While on the one hand this is a good idea, it's also a good

What you get. The case makes up most of the weight.

idea to print the component positions somewhere in the paperwork also. This means that when you've soldered everything down (covering the component position markings as you go, of course) and the manual tells you to solder a PCB pin to a position "alongside C3", you don't have to refer to the circuit diagram and the PCB foil pattern to find out where C3 is!

We had no trouble following the component positioning, however, and managed to get everything in the right place.

The resistors were a bit fiddley — they were of the 'pre-formed' type, with the leads bent ready for insertion into a PCB. The only trouble was, they weren't bent in the right places to fit the board! As the instructions put it, "Resistors are pre-formed. Straighten and re-bend before use". Easier said than done.

The manual is also worth quoting when it comes to D1 and D2. These are wired in parallel, facing in opposite directions or, as the book puts it, "D1-2. 1N4011 Diode. These are fixed in an alternate manner"!

THE FRONT PANEL

The multi-way range switch (a 2-pole, 6-way rotary) has no less than four wires and eight capacitors mounted directly onto it. This is not easy and must make it fault-prone during extended operation. It could have been avoided by making the PCB a little bigger. There was more than enough wire, solder and PCB pins to connect the switch to the capacitors mounted on the PCB.

All three of the front panel components had mounting tags on them. These are designed to poke through a

small hole beside the spindle of the device to stop it from rotating. As there were no such holes in the front panel, the tags had to be clipped off. This was not mentioned in the instructions.

WIRING IT UP

The rest of the construction went off without a hitch. Sleeving was provided for 'flying' connections. A few components mounted directly onto the front panel components. While this is not elegant, it shouldn't cause any problems in building or operation.

The PCB was mounted on plastic pillars which push-fitted into holes in the chassis and the PCB, providing a stable and strong construction.

A piece of paxolin (the stuff PCBs are made of) and another couple of PCB mounting pillars held the batteries (two PP3s) in place fairly securely. The last connection was made and a 'scope plugged into the coax socket on the front panel. The unit was then switched on.

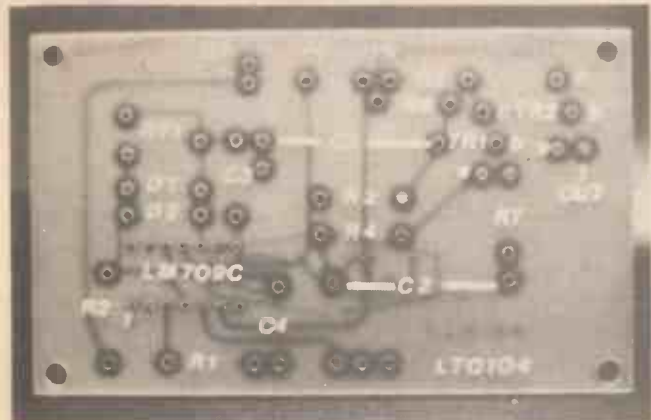

The completed board. Can you follow the component positions through the components? We can't!

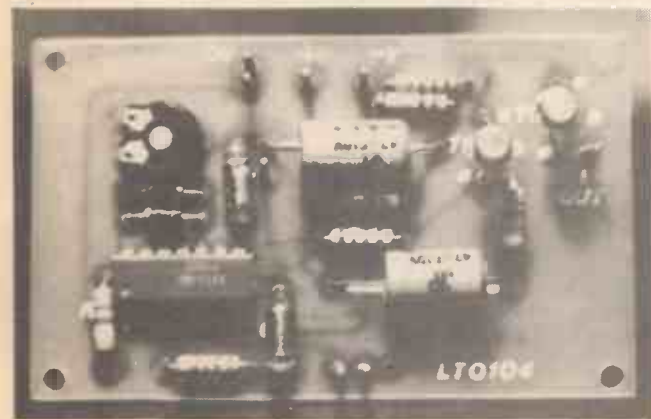

The board before construction. The component position markings are fairly easy to follow.

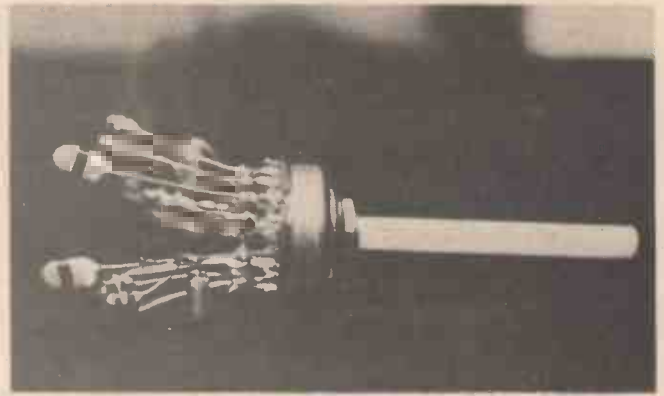

This is what the multi-way switch looks like after everything has been soldered onto it.

OPERATION

It worked first time, the only problem being that the output level control operated in the wrong direction — clockwise rotation *reduced* the signal level. Again the ambiguous instructions had let the product down. Easily enough fixed, though.

The unit produced a range of frequencies from about 30 Hz to over 150 kHz — no doubt the 'nearly correct value' components contributed to the lack of low frequencies.

Another problem was the DC shift on the output. The average value of the signal voltage was not zero volts, even though the output was decoupled by a capacitor!

Replacing the decoupling capacitor revealed the source of the trouble — it was an electrolytic type. These are 'polarised' and have slightly different characteristics to current flowing in one direction, compared to current flowing in the opposite direction.

This means that there is effectively a diode in series with the output. Anyway, replacing the capacitor with a polyester type cured it.

SUMMARY

This is not a kit for the complete beginner. To anyone who is *not* a complete beginner, however, I would recommend this kit highly. When completed it is very rugged, reliable and would prove very useful to anyone interested in (particularly) audio work. It's the best value for money I've seen in a kit for some time. If what you're after in a kit is for someone to do your component buying for you in bulk, then this is for you. If you're looking for something easy to build, buy something else. **HE**

This kit is available from:

**Arrow Electronics,
Leader House,
Coptfold Road,
Brentwood,
Essex,
CM14 4BN**

For £7.99p all inclusive. Order as LTO 104.

Short Circuits

A PREAMP WITH DB STEPPED GAIN CONTROL

A handy little piece of test equipment is a preamplifier with stepped gain control selected by a rotary switch. The circuit here uses a single IC, a 741, 14 resistors and a single-pole, 12-way rotary switch.

The voltage gain of an op-amp (and that is what the 741 is) is determined by the ratio of R_{FB}/R_{in} , thus by having R_{fb} switched, the voltage gain can be varied.

The input impedance of the preamplifier is set by R_{in} to 10k. Having the gain set in decibel (dB) intervals is most useful in audio applications because our hearing, like dBs, is logarithmic. The gain in dB is defined as being equal to $20 \times \log_{10}$ (Voltage Gain) which equals $20 \times \log_{10} (R_{FB}/R_{in})$. Therefore a voltage gain of 1 is $20 \times \log_{10} 1 = 0\text{dB}$ but a voltage gain of 2 is $20 \times \log_{10} 2 = 6\text{dB}$.

Although this may at first seem like a complex approach, the decibel is an easy to use method for describing gain and attenuation since all you have to do is add and subtract them. For instance, say a

DIAL MARKER
OUTER RING - VOLTAGE GAIN AS A MULTIPLIER
INNER RING - VOLTAGE GAIN IN dB

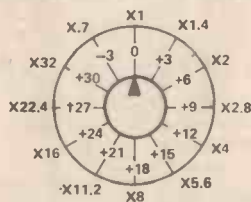

signal passes through four devices with gains of 9dB, 15dB, -3dB and -3dB, the overall signal gain is $9 + 15 - 3 - 3$ which is 18dB (this is a voltage gain of times 8). Note that negative dB means attenuation (reduction in strength). Now consider the same situation without using dB; a signal passes through four devices with gains of 2.8, 5.6, 0.7 and 0.7. The overall signal path is $2.8 \times 5.6 \times 0.7 \times 0.7$ which comes to the same result but a lot more difficult to calculate than adding and subtracting.

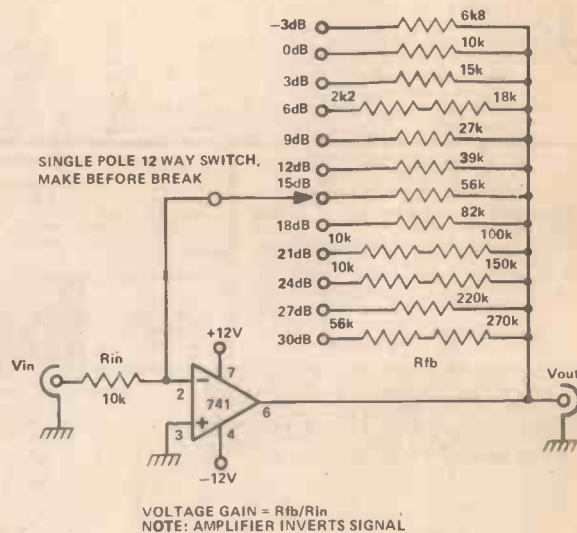

PHASE SHIFT OSCILLATOR

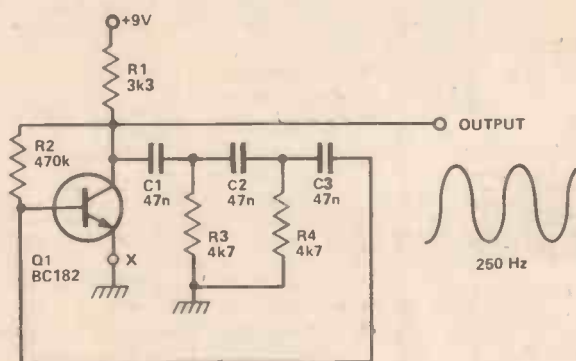

A single transistor can be used to make a simple phase shift oscillator. The output is a sine wave with a 'lump' in it, which means that the distortion content is rather high, about 10%. This is not always a problem, quite often when generating audio tones a high harmonic content will make a more interesting sound. The sine wave purity can be increased by putting a variable resistor (25 ohms) in the emitter lead of Q1 (x). The resistor is adjusted so that the circuit is only just oscillating, then the sine wave

is relatively pure. However, if the power supply level varies, the oscillation may cease altogether. The operating frequency may be varied by putting frequency may be varied by putting a 10k variable resistor in series with R3, or by changing C1, 2, 3. Making C1, 2, 3 equal to 100nF will halve the operating frequency. Also, the operating frequency can be voltage controlled by a FET in series with R3, or optically controlled by an LDR in series with R3.

A LOW FREQUENCY OSCILLATOR

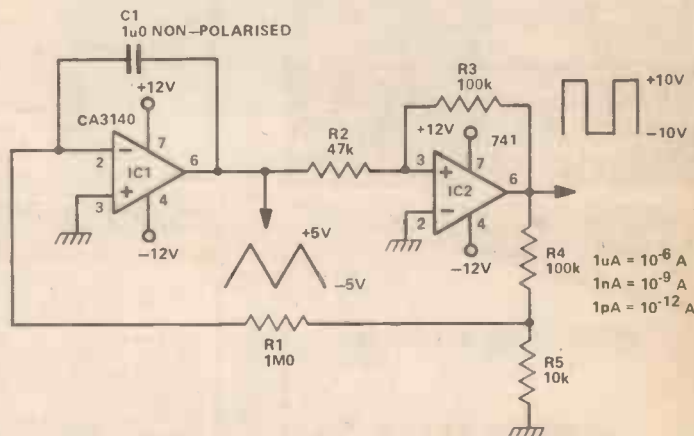

IC1 is a MOSFET OP amp. Thus its input bias current is very low indeed, typically 10 pA as compared with 100 nA for a 741 (10 000 times larger!). This allows very low current designs to be produced. The circuit above shows an integrator (IC1) and a Schmitt trigger (IC2). Imagine that the output of the Schmitt is high (+10 V). The voltage at the junction of R4, R5 is approximately +1 V. This pushes a current of 1 uA through R1 which then charges C1. Thus C1 (the output of IC1) ramps down at a rate of $1/C$ which is in this case 1 V/Sec. When this voltage reaches

-5 V, the Schmitt trigger flips over into its low state (-10 v). Now the current through R1 flows the other way, and so the output of IC1 ramps up at 1 V/sec. This continues until it reaches +5 V (the upper hysteresis level of the Schmitt). The Schmitt trigger then jumps to its high output and so the process repeats itself. The circuit produces a square wave ($\pm 10\text{V}$) and a triangle ($\pm 5\text{V}$) output. Using the components shown the period is 20 seconds. To get 200 seconds make $R1 = 10\text{M}$. To get 2 000 seconds make $R1 = 10\text{M}$, $R5 = 1\text{R}$.

TAMTRONIK LTD. (Dept. HE)

217 Toll End Road, Tipton
West Midlands DY4 0HW. Tel. 021-557 9144

TELEPHONE
OR LETTER



ONE-STOP SHOPPING

PCB's, Components, Hardware, Cases, Part Kits and full Kits. A comprehensive service to the H.E. Constructor. Over 110 kits now available for projects from Electronics Today International, Hobby Electronics & Everyday Electronics. Prices include VAT. P&P 30p per order.

Mag. issue.	Project	Ref.	PCB	Component Pack	Hardware Pack	Case	Total
Dec. '78	Pushbutton Dice	H005	79	3.19	32	45	4.75
Dec. '78	Metronome	H006	61	1.24	1.26	1.65	4.76
Dec. '78	Photon Phone	H007	1.40	3.52	2.66	—	7.58
Dec. '78	HE Mixer	H008	2.95	5.36	4.76	7.35	20.69
Jan. '79	Four Channel Equaliser	H009	TBA	TBA	TBA	TBA	TBA
Jan. '79	HE Slave Flash	H010	TBA	TBA	TBA	TBA	TBA
Jan. '79	Vari Wiper	H011	TBA	TBA	TBA	TBA	TBA
Jan. '79	Touch Switch	H012	TBA	TBA	TBA	TBA	TBA

KITS ARE ALSO AVAILABLE FOR NOV. PROJECTS

THIS MONTH'S BARGAINS

100x½W 1K carbon resistors	30p
10x1W 5% 7k5 resistors	12p
10x1W 5% 1k5 resistors	10p
10x1W 5% 150R resistors	12p
10x6W 5% 390R wirewound	50p
10x47µ 10V Ax. Electrolytic Capacitors	25p
1x10k 1 in Rotary potentiometer	15p
1 plug-in mains PSU 3V/6V/9V/12V DC 300MA, suitable for calculators and TV Games	£2.99

A SPECIAL INTRODUCTORY OFFER

A voucher worth 10% of the advertised prices will be issued to purchasers of full or part kits of H.E. Projects. This offer is valid until 31st December, 1978. The vouchers may be redeemed against future purchases of ANY items offered for sale by Tamtronik Ltd. Send s.a.e. for 2 copies for free catalogue and any kit list, naming kit and kit reference.

TRADE AND EDUCATIONAL ENQUIRIES WELCOME

Visit our shop at
32 Market Place
Great Bridge, Tipton
West Midlands

PARTS FOR PROJECTS IN HOBBY ELECTRONICS

BC107/8	11p	MC3360	130p
BC109	12p	NE555	27p
BC184	10p	TIL209	13p
BC212	12p	ZN414	100p
CD4017	85p	741	24p

Transformer 240V Pr
18V 1A Sec 290p (+50p p&p)

THIS MONTH'S SPECIAL OFFER

2 SN7601B	1 SN76131
1 TIL209	2 Heat Sinks
1 1A 100V Br Rect	£5.40.

We carry **LARGE** stocks of **SEMICONDUCTORS / RES / CAPS / ACCESSORIES**. Send 6"x9" Stamped Addressed Envelope for your free list or see our full advert in E.T.I./PW/PE/WW. Add 25p p&p. All above prices inc. VAT.

TECHNOMATIC LTD.

17 BURNLEY ROAD, LONDON, NW10
(2 mins from Dollis Hill Tube)
Hrs Mon-Fri 9.30-5.30
Sat 10.30-4.30

1.2V NICADS

For UK orders add 50p for post and packing. All prices include VAT

BUTTON CELLS

	Dia.	Hgt.	Price/Cell
225mAh	25.0	7.5	0.65
600mAh	34.5	10.0	£1.25

VENTED CELLS

(for fast charge)

0.45 Ah	17.5	28.0	0.95
0.5 Ah	HP7 or	Size AA	1.10
1.2 Ah	22.5	49.0	1.40
1.8 Ah	HP11 or	Size C	1.95
4.0 Ah	HP2 or	Size D	2.75
6.0V Pack	5x1.2 Ah nicads		7.50

Tags available at extra 10p per cell for 0.5Ah, 1.2 Ah and 1.8 Ah nicads only.
Charger — Suitable for any of the above vented nicads — charges up to twelve similar cells in a series at a 50mA or 200mA rate £9.95

Sizes approx. in mm
Mail order only
V&F SMALLCRAFT (POPLAR) LTD.
38 Stoneleigh Road, Ilford
Essex
01-550 6642

PRINTED CIRCUITS and HARDWARE

Comprehensive range Constructors' Hardware and accessories.

Selected range of popular components. Full range of HE printed circuit boards, normally ex-stock, same day despatch at competitive prices.

P.C. Boards to individual designs.

Resist-coated epoxy glass laminate for the d.i.y. man with full processing instructions (no unusual chemicals required).

Alfac range of etch resist transfers, and other drawing materials for p.c. boards.

Send 15p for catalogue.

RAMAR CONSTRUCTOR SERVICES
MASON'S ROAD
STRATFORD-ON-AVON
WARWICKS. Tel. 4879

BARGAIN PACKS

TTL

7400, 01, 02, 03, 04, 08, 10, 20, 30, 51 ANY MIX 10/£1.00, 100/£9.00.

7433, 48, 104, 105, 109, 122, ANY MIX 10/£1.90, 100/£18.00

7445, 46, 92, 95, 151, ANY MIX 4/£1.00

7443, 83, 96, 156, 160, 162, 163.

74165, 180, 193, 194, ANY MIX 3/£1.30, 10/£5.20.

BC184, 2N711, 12/£1.00. OCP70 5/£1.00

SIMILAR TO 2N2192 20/£1.00. MAN 10 1.27"

4/£3.00

BAX13, IN4151 100/£1.50. TBA 120A 2/£1.00

IN5400 10/£0.80. 74S10 20/£1.00

PANAPLEX 9 DIGIT 7 SEG. DISPLAY 2/£2.50

THYRISTOR 3A 25V 3/£0.50

'L/SP 2½" DIA. 40 OHMS 2/£1.00

RESISTORS 10/£0.09, 100/£0.80, ANY MIX

E12—10 OHMS TO 1 MEG

CAPACITORS

CERAMIC 27P to 8,700P E12 Series 10/£0.30.

POLYESTER 0.01 to .1 10/£0.50, ANY MIX 1 MF

10/£1.00

ELECTROLYTIC 63V 1MF TO 10MF 10/£0.70. 16V

10MF TO 100MF 10/£0.70

TELEPHONE ORDERS: COV. (0203) 611597 USING

ACCESS CARD NO.

V.A.T. add 12½% TO ITEMS MARKED *. TO ALL

OTHERS ADD 8%

IBEK SYSTEMS

32 DUNSVILLE DRIVE
COVENTRY
CV2 2HS

BUILD THE

TREASURE TRACER

MK III

METAL LOCATOR



AS SEEN ON BBC-1 & BBC-2 TV

- Genuine silicon transistor circuit, does not need a transistor radio to operate.
- Incorporates unique varicap tuning for extra stability.
- Search head fitted with Faraday screen to eliminate capacitive effects.
- Loudspeaker or earphone operation (both supplied).
- Britain's best selling metal locator kit, 4,000 already sold.
- Kit can be built in two hours using only soldering iron, screwdriver, pliers and side-cutters.
- Excellent sensitivity and stability.
- Kit absolutely complete including drilled, tinned, fibreglass p.c. board with components sited printed on.
- Complete after sales service.
- Weighs only 22oz.; handle knocks down to 17" for transport.

Send stamped, self-addressed envelope for literature.

Complete kit with pre-built search coil

£15.95
Plus £1.20 P&P
Plus £1.37 VAT (8%)

Built, tested and Guaranteed

£20.95
Plus £1.20 P&P
Plus £1.77 VAT (8%)

MINIKITS ELECTRONICS
6d Cleveland Road, South Woodford,
LONDON E18 2AN
(Mail order only)

**SECOND GENERATION
INDUCTION
BALANCE
METAL
DETECTOR**

**DESIGNED SPECIALLY
FOR THE HOME
CONSTRUCTOR**

**EASY
TO
BUILD**



**EASY
TO
USE**

- A second generation Induction Balance system with improved Variable-Tone detection.
- Designed by professionals for easy assembly by amateurs but with very good performance.
- The search coils are fully assembled and adjusted for you.
- Automatically rejects ground effect

Uses include:

- ★ Treasure hunting — it's amazing what you can find in the garden or on the beach.
- ★ Finding lost metallic items.
- ★ Locating waterpipes and cables under floorboards on in walls.
- ★ Checking old timber for nails before cutting, etc., etc., etc.

**KIT - COMPLETE WITH PRE-
ASSEMBLED SEARCH COILS**
£16.50
Plus £1-00p&p Plus £1-32 VAT

ASSEMBLED & TESTED
£22.50
Plus £1-00p&p Plus £1-80 VAT

Send sae for free components stocklist

Communication Measurement Ltd
15 MALLINSON OVAL, HARROGATE, YORKS.

**Make sure you
don't have to turn
the newsagents
upside down to get
your next copy!**

To: Subscriptions
Hobby Electronics
P.O. Box 35
Bridge Street,
Hemel Hempstead,
Herts

I would like a postal subscription to HE starting with the issue. I enclose payment (£6.50 for UK and Eire, £7.50 elsewhere, £11.50 air mail).

Name

Address

**ETCH RESIST TRANSFER
KIT SIZE 1:1**

Complete kit 13 sheets 6in x 4½in. £2.50 with all symbols for direct application to P.C. board. Individual sheets 25p each. (1) Mixed Symbols (2) Lines 0.05 (3) Pads (4) Fish Plates and Connectors (5) 4 Lead and 3 Lead and Pads (6) DILS (7) BENDS 90° and 130° (8) 8-10-12 T.O.S. Cans (9) Edge Connectors 0.15 (10) Edge Connectors 0.1 (11) Lines 0.02 (12) Bends 0.02 (13) Quad in Line.

**FRONT AND REAR PANEL
TRANSFER SIGNS**

All standard symbols and wording. Over 250 symbols, signs and words. Also available in reverse for perspex, etc. Choice of colours, red, blue, black, or white. Size of sheet 12in x 9in. Price £1.

**GRAPHIC TRANSFERS
WITH SPACER
ACCESSORIES**

Available also in reverse lettering, colours red, blue, black or white. Each sheet 12in. x 9in contains capitals, lower case and numerals ½in kit or ¼in kit. £1 complete. State size.

All orders dispatched promptly.

All post paid

Ex U.K. add 50p for air mail

Shop and Trade enquiries welcome

Special Transfers made to order

**E. R. NICHOLLS
P.C.B. TRANSFERS**

Dept. HE/2

**46 LOWFIELD ROAD
STOCKPORT, CHES.061-480 2179**

ELECTRONIC MUSIC MADE EASY!

Break into this fascinating world and build your own Sound Effects units, even a complete Synthesiser, from ready-built circuit modules. Simple, versatile, low-cost projects, ideal for both experimenting and serious building. Send 2 x 9p stamps for very informative booklet: B. J. Tyler, 21 Beauford Orchard, Norton, Taunton.

AUTOPROGRAMMER remote control equipment. Construction unfinished. Mass of valuable electronic components. Sale due to space shortage. Offer over £25. Phone 352 0015 after 6.30 p.m. or weekend.

AD INDEX

ACE	74
AMBIT	2
ASTRA-PAK	13
BNRS	19
CODESPEED	13
COMMUNICATIONS MEAS	72
DORAM	19
E.D.A.	62
ELECTRONI-KIT	74
HENRY'S	13,19&74
IBEK SYSTEMS	71
MAPLIN	76
METAC	62
MINIKITS	71
NICHOLLS	72
RAMAR	71
STEVENSON	6
SWANLEY	74
TAMTRONIK	71
TECHNOMATIC	71
V&F SMALLCRAFT	71
VIDEOTIME	56

Good Evans

Amaze your friends! It's not necessary to know anything at all about electronics to hold your head up high in the most august circles — simply remember our Gary Evans' jargon generator.

THE BAUD RATE on the CUTS serial I/O connecting my CPU to my background storage medium needs adjusting because at present I am getting a large quantity of read errors.

My Hi-Fi Amp is suffering from HF instability and the LF component of the S/N figure has increased due, I think, to a corresponding increase in the ripple on the LT rails of the system.

Lost in the Jargon Jungle? — well I can help. I may not be able to teach you about all the ins and outs of the technical shorthand that permeates the world of electronics in a few words but at least I'll be able to help you reply in kind when exposed to the talents (sic) of a jargon juggler. The point is you don't have to understand what you're saying, in fact it helps if you don't, you just have to sound convincing in your performance.

Study the ready-made jargon generator below — some of the phrases are more applicable to electronics than others but all should baffle your friends and influence people.

The jargon generator will produce up to 40 000 discrete, well balanced "State of the Art" sentences quickly and simply with very little propagation delay.

To put the generator to work, arrange the modules in W, X, Y, Z order. Next generate a four digit random number, this may be the most difficult phase but if a pseudo-random number generator is not available, you could, at a pinch, use your grey cells to generate said number. The first digit of the number will select a phrase from module W, the second from X etc. The result is a jargon filled sentence. Add more sentences for a paragraph and if you carry on you could soon have a book in print.

After you have mastered the basic technique you can try the advanced version of the generator by altering the order of the modules — be warned though, in these advanced configurations some additional comas may be required.

Jargon Generator Module W

1. in particular
2. on the other hand,

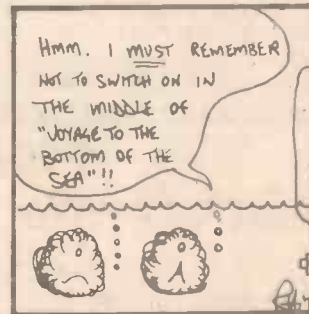
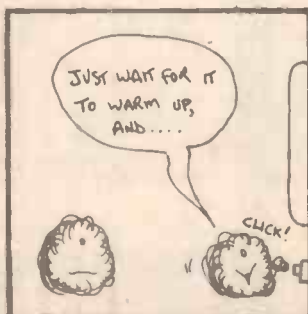

3. however,
4. similarly,
5. in a real time environment,
6. in this connection,
7. as of now,
8. for example,
9. thus,
10. the "State of the Art" implies,

Jargon Generator Module X

1. a large portion of interface coordination communication
2. the concept of electron mobility
3. the characterization of specific criteria
4. the worst case load situation
5. the fully integrated test program
6. the incorporation of DIN requirements
7. any associated supported component
8. a constant data path
9. in independent functional principle
10. a primary interrelationship between system and/or sub system technologies

Jargon Generator Module Y

1. must utilise and be functionally interwoven with
2. maximises the probability of project success and
3. adds explicit performance limits to
4. necessitates that urgent consideration be applied to
5. requires considerable systems analysis to arrive at
6. is further complicated when taking into account
7. presents extremely interesting challenges to
8. recognises the importance of
9. effects a significant improvement in the performance factor of
10. adds over-riding performance constraints to

Jargon Generator Module Z

1. the sophisticated hardware
2. the anticipated fourth generation equipment
3. the sub system compatibility testing
4. the structural design concepts
5. the preliminary qualification limit
6. the evolution of specifications over a given period of time
7. the philosophy of commonality and standardisation
8. the greater fight-worthiness concept
9. any discrete configuration mode
10. the total system rationale.

MAINS OPERATED

ELECTRONIC DIGITAL ALARM CLOCK

IMMEDIATE DELIVERY

£8.95

INCL V.A.T. POST PAID

THREE FOR £26.00 POST FREE

HOBBY ELECTRONICS RECOMMEND THIS MODEL

BARCLAY ACCESS

Just phone in number

- Hanimex HC-1100
- Large Bright LED display
- White case with red display on black background
- Adjustable dim/bright control
- Silent operation, all electronic
- Space age technology L.S.I. circuitry
- Alarm and 9 minute snooze repeater
- P.M. indicator
- Hour and minute display
- Size 100mm x 130mm x 60mm high
- Fully guaranteed

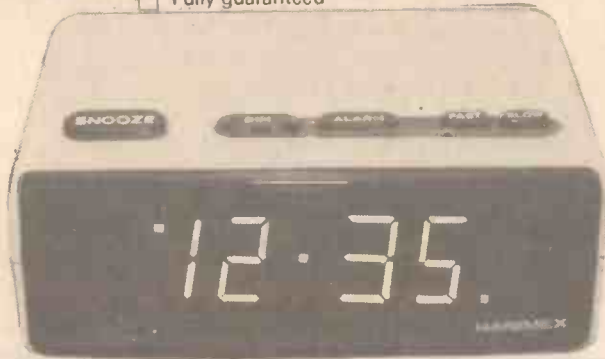

HENRY'S RADIO

HENRY'S RADIO
404 Edgware Rd. London W2
PHONE (01)723 1008 ENGLAND

TOPS THE PACK!

ACE

ACE MAILTRONIX LTD
Dept. HC Tantal Street
Walsfield, W. Yorkshire WF1 5JR

- COMPONENTS** — Now over 1,000 types in stock!
- KITS** — See the new range of low-cost 'ELEKITS'.
- MODULES** — New ready-built functions.
- SERVICE** — 1st Class same day despatch.
- QUALITY** — All guaranteed products.
- PRICES** — Many reductions!
- MAGAZINE PROJECTS** — Trouble-free!

I enclose 30p*, please send catalogue.

Name _____

Address _____

*Refundable with future orders over £5.00.

SINCLAIR PRODUCTS microvision tv £172. PDM35 £27.25. mains adaptor £3.24. case £3.25. DM235 £48.30. rechargeable battery units £8. adaptor/charger £3.70. case £8.50. Cambridge prog calculator £13.13. Prog. library £3.45. Mains adaptor £3.20. Enterprise prog calculator £21.95. DM350. DM450 p.o.s.

COMPONENTS send sae for full list. 1 lb. FeCl £1.05. dolo pen 73p. 60 sq. in. pcb 55p. laminate cutter 75p. small drill 20p. zn414 £1.05. pcb and extra parts for radio £3.95. case £1.1N4148 1.4p. 1N4002 3.6p. 723 29p. 741 15p. NE555 23p. bc182b. bc183b. bc184b. bc212b. bc213b. bc214e 4.5p. plastic equivs bc107. bc109 4.8p. 1/4W 5% E12 resistors 10R to 10M 1p. 0.8p for 50+ of one value. 16v electrolytics 5/1/2/5/1D/22mf 5p. 100mf 6p. 1000mf 10p. polyesters 250v 015. 068. 1mf 15p. ceramics 50v E6 22pf to 47n 2p. polystyrenes E3v E12 10 pf to 10n 3p. zeners 400mW E24 2v7 to 33v 7p.

TV GAMES send sae for data. AY-3-8500 + kit £8.95. AY-3-8600 + kit £12.50. tank battles chip £6.90. kit £7.05. stunt cycle chip £6.90. kit £5.60. rifle kit £4.95.

TRANSFORMERS 6.0-6v 100ma 74p. 1 1/2p £2.35. 6.3v 1 1/2a £1.89. 9.0-9v 75ma 74p. 1a £2. 2a £2.60. 12.0-12v 100ma 90p. 1a £2.49.

IC AUDIO AMPS with pcb JC12 6W £1.60. JC20 10W £2.95. JC40 20W £2.95.

BATTERY ELIMINATORS 3-way type 6/7 1/2/9v 300 ma £2.95. 100ma radio type with press-studs 9v £3.35. 9+9v £4.50. stabilized type 3/6/7 1/2/9v 400ma £6.40. 12v car converters 3/4 1/2/6/7 1/2/9v 800ma £2.50.

BATTERY ELIMINATOR KITS send sae for data. 100ma radio types with press-studs 4 1/2v £1.40. 6v £1.40. 9v £1.40. 4 1/2+4 1/2v £1.80. 6+6v £1.80. 9+9v £1.80. stabilized 8-way types 3/4 1/2/6/7 1/2/9/12/15/18v 100ma £2.80. 1Amp £6.40. stabilized power kits 2-18v 100ma £3.60. 2-30v 1A £6.95. 2-30v 2a £10.95. 12v car converter 6/7 1/2/9v 1a £1.35.

T-DEC AND CSC BREADBOARDS s-dec £3.17. t-dec £4.02. u-deca £4.40. u-decb £6.73. 16 di adaptor £2.14. exp300 £6.21. exp350 £3.40. exp 650 £3.89. exp4b £2.48.

BI-PAK AUDIO MODULES s450 £23.51 AL60 £4.86 pa100 £16.71. spm80 £4.47. bml80 £5.95 stereo 30 £20.12

SWANLEY ELECTRONICS

(Dept HE), 32 Goldsai Rd., Swanley, Kent
Post 30p extra. prices include VAT

ELECTRONIC-KIT

"EDUCATIONAL KITS OF EXCEPTIONAL QUALITY"

(AUDIO magazine)



THIS IS A POWERFUL RADIO RECEIVER!

The same kit is also 150 other different actual working projects e.g.:

Computer & Logic Circuits
Electronic Organ, Timer, Light Control, Agility Tester, Lie Detector, Siren, Horn, Buzzer, Bird, Metronome.
Cds cell light & sound control
Photogun, Light Oscillator
Light Switch, Light and Sound Morse Code.
Field Strength Meter
Hygrometer, Sphygmometer, etc. etc.

Radio Receiver, Transmitter, Amplifier, Audio Generator, Signal Tracer & Injector, Continuity Tester, Telegraph, Photoradio Receiver, Radio Receiver/Microphone Mixer, Illuminometer, Voltmeter, Ammeter, Sound Level Meter, Ohmmeter, Diode & Transistor Tester, Transparency Indicator, etc., etc.

The above is just a *selection* of the circuits available — you can also design your own circuits with these superb new Denshi-Gakken "EX" construction kits.

No previous experience of electronics is required but you learn as you construct and have a great deal of fun too. The kits are completely safe for *anyone* to use.

Kits are *complete* with very extensive construction manuals *PLUS* Hamlyn's "All-Colour" 160 page book "Electronics" (*free of charge whilst stocks last*).

ALL KITS ARE FULLY GUARANTEED. Add-on sets (to increase the scope of each kit) are available, plus spares and accessories as required.

150 PROJECT KIT £39.75	60 PROJECT KIT £25.75
120 PROJECT KIT £33.75	30 PROJECT KIT £18.95
100 PROJECT KIT £29.25	15 PROJECT KIT £16.75

Prices include educational manuals, free book, VAT, p&p (in the U.K.) and free introduction to the British Amateur Electronics Club.

Callers at 20 Bride Lane will be very welcome. Trade and Educational enquiries invited.

Cheque/P.O./Barclaycard/Access No. (or 14p for illustrated literature) to DEPT. HE.

ELECTRONIC-KIT LTD. 20 BRIDE LANE, LUDGATE CIRCUS, LONDON, EC4Y 8DX (01-353 6430)

Hobby Electronics

RESISTOR COLOUR CODE

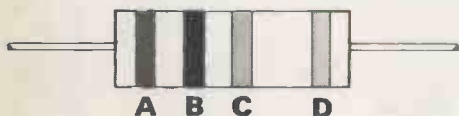

	A and B	C
BLACK	0	-- ohms
BROWN	1	-- 0 ohms
RED	2	- k -
ORANGE	3	-- k
YELLOW	4	-- 0 k
GREEN	5	- M -
BLUE	6	-- M
VIOLET	7	
GREY	8	
WHITE	9	

	D (tolerance)
NONE	20%
SILVER	10%
GOLD	5%
RED	2%
BROWN	1%

CAPACITOR COLOUR CODE



	D (tolerance)
BLACK	20%
WHITE	10%
GREEN	5%

	E (voltage)
RED	250 V

A and B: As for resistors.

EXAMPLES:



A = 1, B = 0, C = -- 0 k, so value is 100 k; D = accuracy = 2%

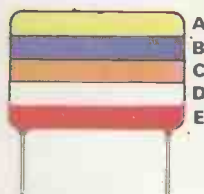

A = 4, B = 7, C = -- n, so value is 47 n; D = accuracy = 10%; E = voltage = 250 V

BRITISH STANDARD COMPONENT MARKINGS

M (pronounced mega) means multiply by 1 000 000,
 k (pronounced kilo) means multiply by 1 000,
 m (pronounced milli) means divide by 1 000,
 u (pronounced micro) means divide by 1 000 000,
 n (pronounced nano) means divide by 1 000 000 000 and
 p (pronounced pico) means divide by 1 000 000 000 000.

So when we write 10 mV, we mean (10 / 1000) V, or 0.01 V. Note: it is usual to leave the "F" and "ohm" out altogether when writing, but as we rarely talk about resistances less than one ohm or capacitances greater than one farad, this does not cause too much confusion.

Examples: 10 uV = (10 / 1 000 000) V = 0.000 001 V; 330 R = 330 ohms (R is used for ohms when no multiplier is needed); 10 k = 10 000 ohms; 3.9 mV = 0.003 9 volts; 3.9 u = 0.000 003 9 farads.

Now, at some stage, someone decided to jazz up the system by putting the suffix in place of the decimal point, so that: 4k3 is 4 300 ohms and 4u9 is 0.000 004 9 farads.

Also, in case one of the digits got lost, it was decided that there should always be at least three numbers or letters in the value, so: 5k is written 5k0, et cetera.

Examples: 3M0 = 3 M ohms = 3 000 000 ohms; 4n5 = 4.5 nF = 0.000 000 004 5 farads.

INTEGRATED CIRCUIT NUMBERS

TTL:



Example: DM 74121

CMOS:

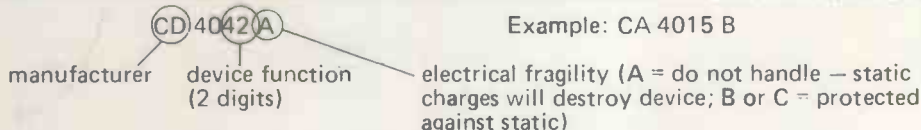

Example: CA 4015 B

OTHER TYPES:

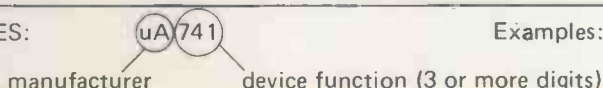

Examples: LM 309, CA 3011, NE 555

MAPLIN

launch their new Catalogue...

A massive new catalogue from Maplin that's even bigger and better than before. If you ever buy electronic components, this is the one catalogue you must not be without. Over 240 pages – some in full colour – it's a comprehensive guide to electronic components with hundreds of photographs and illustrations and page after page of invaluable data.

We stock just about every useful component you can think of. In fact some 5,000 different lines, many of them hard to get from anywhere else. Over 1000 new lines in our new catalogue. And with the service only Maplin provides, you won't regret sending for a copy of our fantastic catalogue. Orders paid before publication date will receive a set of 10 special offer coupons. Big Discounts on popular lines.

MAPLIN

ELECTRONIC SUPPLIES

P.O. Box 3, Rayleigh, Essex SS6 8LR.
Telephone: Southend (0702) 715155.
Shop: 284 London Road, Westcliffe-on-Sea, Essex
(Closed on Monday).
Telephone: Southend (0702) 715157.

Several complete new projects for you to build with full construction details in the catalogue including:
A superb 40W per channel hi-fi stereo amplifier with lots of extra features found only on the most expensive ready-made equipment.
A hi-fi stereo tuner with FM, medium and long wave and UHF TV sound Superb home burglar alarm system including ultrasonic detectors.
A complete home burglar alarm system with inertia control for accelerating and breaking.
A model railway train controller



Post this coupon now for your copy of our 1979-80 catalogue price 75p.

Please send me a copy of your 280 page catalogue as soon as it is published (8th Jan. 1979). I enclose 75p but understand that if I am not completely satisfied I may return the catalogue to you within 14 days and have my 75p refunded immediately. If you live outside U.K. send £1 or ten International Coupons.

NAME _____

ADDRESS _____