

6th MARCH 1963

VOL. 135

NUMBER 3508

THE ORIGINAL
'DO-IT-YOURSELF'
MAGAZINE

HOBBIES *weekly*

FOR ALL
HOME CRAFTSMEN

FREE Design
for making this
very charming picture
in wood veneers

Also in this issue:

MEDIUM WAVE

I-VALVE RADIO

COLLECTORS' CLUB:

STAMPS AND LABELS

DISC BREAK

PRINTING WITH

LINO CUTS

SHIP MODELLING

ANIMAL CUT-OUTS

CHEMISTRY

ETC. ETC

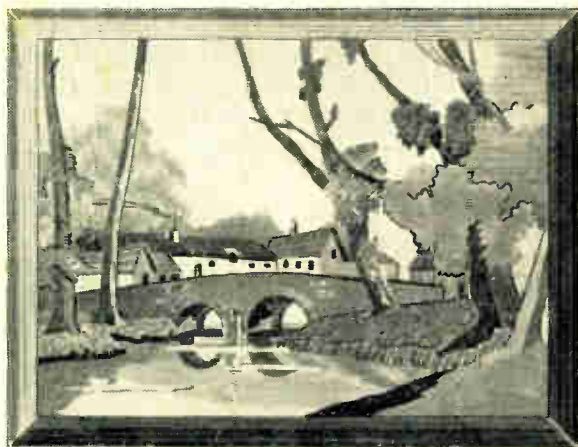

'THE HAMLET'



Up-to-the-minute ideas

Practical designs

Pleasant and profitable things to make

5^p

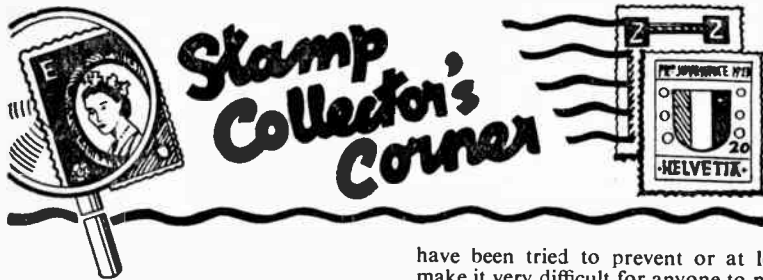

EVER since the adhesive stamp was first introduced the various postal authorities have taken great pains to prevent people abusing them by sending letters without actually paying for the stamp.

There are, of course, two ways in which this could be done. A stamp might be used a second time and there is also the possibility that someone might print stamps and sell them. The main protection against the second risk is the use of printing paper having a particular watermark. To make the paper with the proper watermark and then to print really good imitations would be so costly that unless a very large number of stamps were sold the cost of producing them would be uneconomical. And if a very great number of forgeries were issued then the risk of being found out and prosecuted would be far too great.

The other risk, of course, is that a stamp having been used once might be used a second time; therefore it must be defaced. This is done by an obliteration put on at the post-office. Sometimes this is missed off a stamp and in such cases a postman before delivering a letter is supposed to take an indelible pencil and mark the face of the stamp with that.

Now the most easily seen obliterating ink is black, and that is why you so seldom see a stamp printed in black, and why the British 'penny black' had such a short life. The obliteration did not show up clearly so they changed the stamp to red.

Besides the watermark other ideas

have been tried to prevent or at least make it very difficult for anyone to print a stamp. One such idea was to have a special form of paper called Dickenson or a silk-thread paper. If you take one of the present £1 or 10s. notes and hold it up to the light you will see that there is a dark line formed by a fine ribbon

METHODS OF PROTECTION

By L. P. V. Veale

of metal. The same will be seen if you take one of the Bavarian stamps of 1849. This, of course, is only visible from the back of the stamp; when you look at the front the design masks the thread. In the first illustration a small thread is marked by an arrow. It would not be very easy to introduce such a line into a piece of paper after it has been made; the paper would have to be made purposely.

Some of the early Colonial stamps of King Edward VII's reign had a coating of chalk applied to the surface of the paper after manufacture, the idea being that the printing of the design would be on this coating and if anyone tried to clean the surface then the cleaner would also erase the design and so render the stamp useless.

Similarly a series of shiny bars may be seen on the early stamps of Austria. At first sight it would appear that the stamp was printed and then three or

four shiny bars drawn diagonally across the stamp. But that was not the case; the lines of varnish were put on to the paper and the stamp then printed so that the design is partly on the paper and partly on the bars of varnish. Any attempt to clean the stamp would mean that the design would be cleaned off the shiny bars while the rest of the design would stay on the paper. The second specimen illustrated has been soaked and consequently the shiny bars are clearly visible. If the stamp is left untouched then the bars do not show unless you hold it slanting towards the light and look along the surface.

The practice of looking along a stamp can be very informative and should often be adopted. The surface of a stamp should always appear untouched and if on looking along it you see that the surface is roughened in any way then suspect that the stamp has been tampered with in some manner. If it is a surcharged stamp or has an overprint then be very careful.

This is practically the only way of identifying the grills which appear on some of the early stamps of the United States of America from 1867 to 1873. The idea of the grill was again to prevent anyone using a stamp a second time. After the stamp had been printed a device in the form of a square with many short but sharp pyramids in it was pressed on to the paper so that the tops of the pyramids broke the fibres of the paper. The paper was then smoothed again in a hydraulic press. When the stamp was used on a letter and received the obliteration then some of the ink used would go right through the broken fibres and mark the paper below the design so that it would not be possible to remove all the ink marks.

The third illustration shows a stamp from British Honduras with what appear to be a number of wavy lines across it. This was issued in 1915. The stamps were printed in this country and had to be sent out to British Honduras at a time when German submarines were a menace to shipping. If the Germans had captured the ship carrying the stamps then had they been the regular issue they could have been used without any revenue coming to the British. Accordingly, the pattern shown was printed on all stamps. Had they been captured it would have been easy to say that no stamps overprinted with a moiré pattern would be acceptable for paying postage. In this way, although the cost of printing the stamps would have been lost the revenue that they represented would not.

The last illustration is the back of a Queensland stamp. The faint network marked with an arrow is known as burelage, again to help prevent forgery.



1. Dickenson paper with silk thread. 2. Austria — shiny bars 3. British Honduras — moiré pattern. 4. Queensland — burelage pattern

In 1880 Queensland wanted some stamps very quickly. The normal watermark would have been the letter 'Q' with a crown on top, but as no paper like this was available and they still wanted to make as certain as possible that no forgery was perpetrated, they put a burele band in lilac on the back of the stamp. Now this band is unfortunately soluble in water so that if a used specimen is taken off an envelope by soaking it in water the chances are that the burele band will vanish. So one must use moist blotting paper, which takes a little longer but is much less likely to damage the stamp.

It may come as a surprise to learn that one of our own English stamps has been forged successfully; that is to say

the forger managed to pass his stamps without being caught. And now the forgeries are worth far more than the genuine specimens called the Stock Exchange Forgery. The stamp was the 1s. of the 1870 issue. The genuine stamp is printed on paper watermarked with a spray of roses but the forgery is on plain paper.

The person concerned was a clerk employed by the Post Office in the Stock Exchange from where thousands of telegrams are sent each day. Someone wanting to send a telegram would fill up a form and pass it to the clerk to have the words counted and the price checked. The clerk then gave the form back and the necessary stamps, the cost in those days being 1s. for 20 words.

The sender affixed the stamp and paid the clerk who then cancelled the stamp. After the message had been sent the form would be kept for a time and then destroyed.

This is the usual practice but sometimes some of these forms do come on the market and that was how the forgery was discovered. How long it had been going on is not known exactly but almost certainly for over a year. So the clerk could have sold a good number of stamps to his own advantage.

Possibly we might wonder at anyone going to a lot of trouble to clean a stamp in order to save a penny or two-pence yet we must remember that in former days money was worth much more than it is now.

RUSSIAN MATCHBOX LABELS



Nature - 1962. Selection from a series of match labels from Russia



Soviet industry is featured in this selection of match labels

PEN FRIENDS

PETER COOPER, 42 Mead End, Biggleswade, Beds. Stamps, match, beer and cheese labels.

GEORGE B. HARRIOTT, 17 Dipton Ave., Newcastle-on-Tyne. Stamps.

ASISH KUMAR SIMLAI, 20 1/5, Iswar Ganguly Street, Calcutta — 26, India. Stamps, friendship.

WINIFRED R. S. NKULENU, P.O. Box 220, Parkwa, Ghana, West Africa. Stamps, postcards, records.

EDWARD SHOTTON, 31 Ellison Road, Sidcup, Kent. Postcards, cigarette cards, match labels.

MRS R. J. DANDO AND FAMILY, P.B. 74L, Bulawayo, S. Rhodesia. Stamps and labels.

DEREK COYNE, 26 Leason Park Ave., Appian Way, Dublin 6, Eire. Stamps, postcards.



Dan F. S. Price

D. F. S. PRICE, 8 Engleby Crescent, Ermine Estate, Lincoln, who writes: 'My hobbies are model aircraft, galleon making and toy making. Believe it or not, I can also do crochet-work and embroidery.'

In response to requests

A medium wave 1-valve radio

By

'Radio Mech'

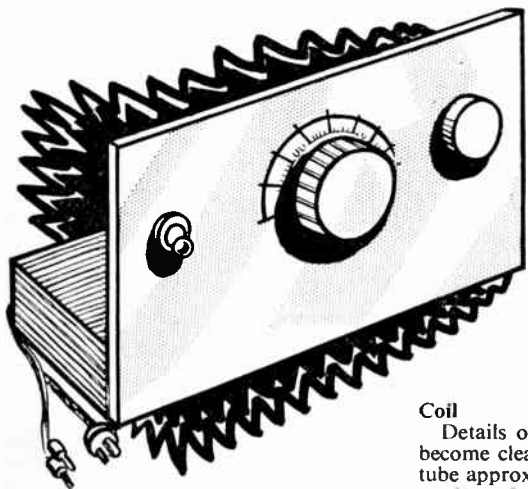

THE circuit of this receiver is shown in Fig. 1, and it uses a 1T4 valve, or any equivalent type, such as the 1F3, DF91, etc. For filament current, a 1½V. dry battery is used, and will have a very long working life. For high tension, a 67½V. or similar battery is satisfactory, and the current taken by the single valve is small.

The receiver tunes medium waves, and is intended to give headphone reception. In these circumstances, good results can be expected, even with a poor aerial.

Component values are not critical, so items to hand may in some cases be satisfactory. For example, the reaction condenser need not be 300pF (·0003μF) as any value from 200pF to 500pF can be used. An air-spaced 500pF (·0005μF) or similar condenser is also suitable for tuning, instead of the solid dielectric component shown. Ready made coils, for medium waves, or both medium and long wave reception, can also be incorporated. Any coil used must have a reaction winding.

Coil

Details of the home wound coil will become clear from Fig. 2. An insulated tube approximately 1½ in. in diameter is used, and the ends of windings are anchored by passing them through small holes. These ends are long enough to reach to the various connecting points.

To begin winding, 32 s.w.g. enamelled wire is anchored to provide lead 1, and 50 turns are wound on tightly, side by side. The small loop 2 is then made, and winding is continued for a further 30 turns. The wire is then anchored to provide lead 3. A space of about ¼ in. is then left, and 50 turns are wound on, between points 4 and 5.

All turns throughout the coil are in the same direction, as in Fig. 2. Slight changes to the coil diameter, number of turns, or gauge of wire will not be important.

The coil can be mounted upright, by means of adhesive.

Panel and chassis

These items are cut from thin wood. The top of the chassis is 4 in. by 6 in., and two side runners are fitted, each 1½ in. deep. A strip 6 in. by 1½ in. fits across the runners at the back, and is drilled for two socket strips. Terminals can be used, if preferred.

The panel is approximately 5 in. high by 6 in. wide, and is fixed to the front of the chassis. A central ¾ in. diameter hole takes the 500pF tuning condenser, as in Fig. 3. The reaction condenser is fitted to the right, and the on/off switch to the left, as shown.

The valvholder is screwed so that its sockets come as in Fig. 4. A screw holds the R.F. choke to the rear runner.

Wiring

Wiring up is very simple, though some wires have to pass through the chassis. Referring to Fig. 4, a lead passes from the earth socket to tag 1 of the valvholder. From this tag, a lead goes through the chassis to Y, which is the moving plates tag of the 500pF variable

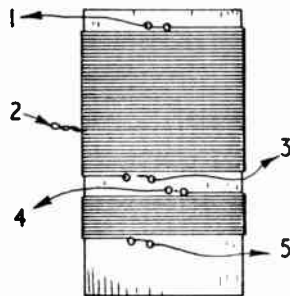

Fig. 2—Tuning coil

condenser. Lead 3 of the coil, and the moving plates tag of the 300pF condenser, are also joined here, as in Fig. 3.

Lead 1 of the coil is taken to the fixed plates of the 500pF tuning condenser at tag X, and a wire passes through the chassis from here to the 100pF (·001μF) condenser. The other coil connections can be seen in Figs. 3 and 4.

The switch is connected from tag 7 of the valvholder, to the LT positive lead. All the battery connections are of thin flex, and they pass through a hole in the rear runner of the chassis.

Wiring should be carefully checked, before inserting the valve. Unused tags on the valvholder should not touch other tags or leads.

Batteries

Any single dry cell will provide a suitable filament supply. A 1½V. dry battery, as used in portable receivers, is

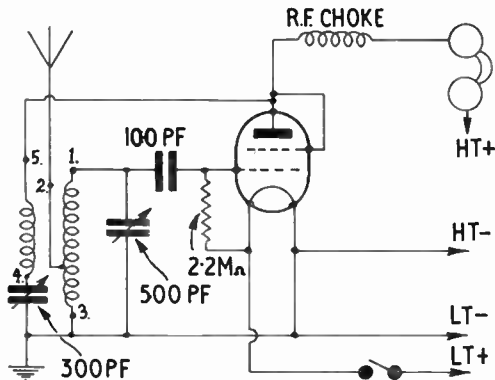

Fig. 1—The receiver circuit

also satisfactory. These batteries have several cells, wired in parallel. More than 1½V. must not be used.

The voltage of the HT supply is not critical, but 67½V. may be used as small HT batteries of this kind are easily obtained. The battery leads should be clearly marked, or equipped with suitable plugs, to avoid any danger of connecting the batteries wrongly.

Phones, aerial and earth

Any ordinary headphones which may be available should prove to be satisfactory. If phones are to be obtained, a good pair of medium or high impedance (500-4,000 ohms) will be most satisfactory.

If an earth is available, it is taken to the earth socket. An earth lead may be taken to a cold water pipe, or to a spike

COMPONENTS LIST

For the guidance of readers, suppliers of components are given in this list, but the items needed can be obtained from many sources.

- 1T4 (3s. 6d., Technical Trading Co., 350-352 Fratton Road, Portsmouth).
- B7G holder (9d., Alpha Radio Supply Co., 103 Leeds Terrace, Wintoun Street, Leeds 7).
- 1½ in. knob 1s. 0d., 1¼ in. knob 9d. (Alpha).
- 40mH R.F. Choke (2s. 8d., Home Radio Ltd, 187 London Road, Mitcham, Surrey).
- 500pF and 300pF variable condensers (3s. 9d., Home Radio).
- 100pF mica condenser (9d., Home Radio).
- 2·2 megohm resistor (red-red-green, 6d., Home Radio).
- Toggle switch (2s. 0d., Home Radio).
- 2oz. 32 S.W.G. enamelled copper wire (2s. 8d., Home Radio).
- Two 2 hole socket strips (1s. 0d., Home Radio).

or metal object in the ground. The lead should not be connected to gas pipes, or to mains wiring. A good earth will give some improvement in range, and the volume obtained with distant stations.

Almost any aerial will be satisfactory. An indoor wire, near the ceiling, can work quite well. An outdoor wire, well insulated at suspension points, and clear of walls, etc, will give greater range.

Tuning and reaction

The centre control is used for tuning, in the usual way. The 300pF condenser is for reaction, which helps to build up the volume of weak stations. This condenser is first opened fully. As it is slowly closed, volume will increase, until a point is reached where the set commences to oscillate. Best long distance reception is obtained when reaction is so adjusted that the receiver is almost oscillating. If the reaction condenser is closed too much, results will be poor. It is thus necessary to adjust reaction quite carefully, except when receiving local stations.

The set should not be allowed to oscillate, as this may cause interference to other receivers.

If a ready-made coil is used, the tags on this should be wired up to agree with the maker's instructions. If a dual-range coil is fitted, for medium and long waves, the wavechange switch can be placed centrally on the panel, under the chassis.

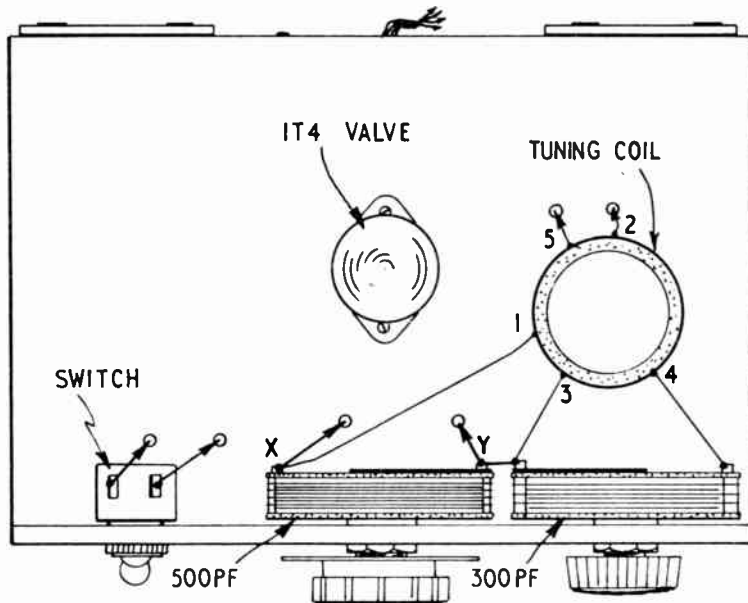

Fig. 3—Top of receiver chassis

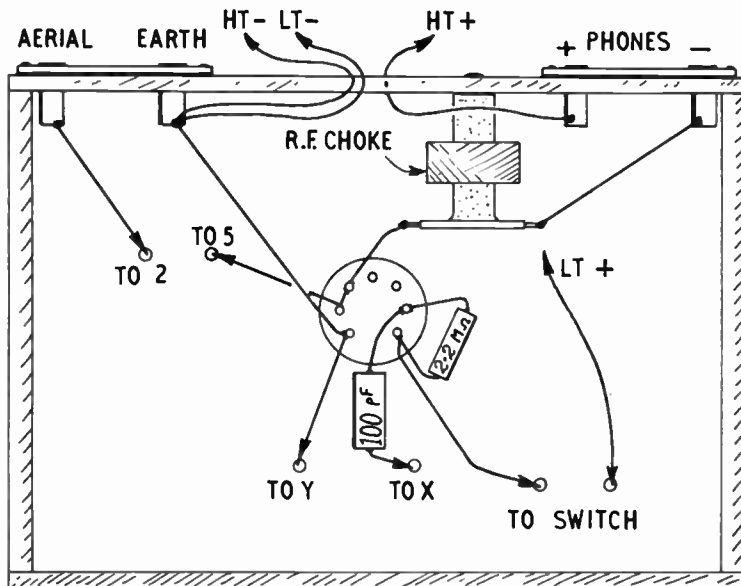

Fig. 4—Components and wiring underneath





KEN KIRKHAM

YOU'VE come into the army to work — not to sing! That was one of the first orders Signaller Ken Kirkham received from his superiors when he joined the 10th Hussars.

Ken, who hails from Preston, had only been in the army for six months, when he was posted to Germany. He applied for, and got an audition with B.F.N., who were so impressed with Ken's singing, that they wanted him to go to Hamburg for special vocal training, and for network programmes. Delighted at the opportunity, Ken applied for a transfer, but the regiment refused to release him. It was at this point that someone informed the disappointed national serviceman that he had come into the army to work.

'I was bitterly disappointed', says Ken. 'But although I was disheartened I wasn't discouraged.'

Three times a week I took singing lessons from the conductor of the Dortmund Opera Company. I couldn't afford the money, so paid him with tins of coffee, which I had sent from home. I didn't mind, and neither did he'.

Then the army's attitude softened slightly, and Ken was allowed to go to Hamburg once a month to record programmes for B.F.N. His singing future brightened.

Caroll Levis 'Discovery'

An ex-pupil of the Deepdale Modern School, Preston, Ken first became interested in music when he left school at the age of 15. 'I used to buy records by Caruso and Gigli, and listen to them for hours', he says. Then when he was 16 he decided to go in for a Caroll Levis talent competition which came to his home town. His fine tenor voice got him through to the finals.

'My family couldn't believe it. I had never had any special voice training, and they thought that I would let them all down'.

Determined to 'keep his hand in', Ken — who was training to be a carpenter — sang at Sunday concerts and local shows, and when he was 21, decided to try for a spot on *Opportunity Knocks* — a well-known talent show on Radio Luxembourg. He won, and apart

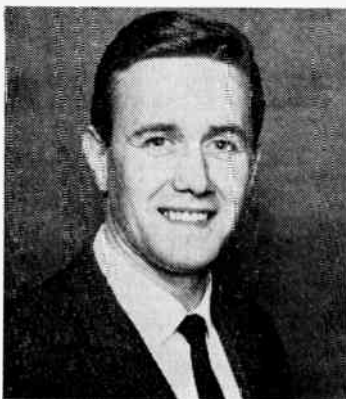

from the prize money was offered a recording test.

By the time he was demobbed, Ken had decided that he would move to London. 'I was determined to break into show business, and thought that London would be the best place to be', he says.

'I went to see an agent, who told me that the sort of 'straight' song I sang had gone out. I was very disappointed, and went back to my old job with a London firm'.

But the old desire to get into show business was still there. Ken decided to try once more, and applied to several record companies in the hope of getting a test. This time he was luckier. Ronnie Aldrich of the Squadronaires, heard a test disc which Ken had made under the direction of Norrie Paramor, and liked

it. He got in touch with Ken, and offered him the job of singer with his band.

A hard time

'I had never visualized myself as a band singer, but decided to try it for a year', he says. 'I stayed for three, then decided it was about time that I tried going solo'.

For the first six months 'going solo' proved very difficult. 'People just didn't seem interested in an ex-band singer', he says, 'and I had quite a hard time trying to convince them that I was capable of doing a completely solo act'.

This was in 1959, and by this time Dick James — an old friend — had agreed to become Ken's manager. After those first six months their luck changed.

Ken managed to break into cabaret, and since then has established quite a name for himself in the London clubs.

Then last year he was chosen for the British singing team which competed in the Knokke Eurovision Song Contest in Belgium. The British team of five vocalists won, and as a result of the publicity Ken received, he has since been doing a lot of television work on the Continent.

Apart from singing, Ken — who is 5 ft. 9 in., has blue eyes and light brown hair — loves swimming and watching football matches. At one time he played for Preston Reserves.

Now he has come back on to the record scene with *Am I Sure That I Love You*, backed by *I'm Sorry I Didn't Say I'm Sorry*. Released on HMV 45 POP 1078.

JEREMY Taylor is the star and co-writer of the smash hit South African show *Wait a Minim*, currently playing to packed houses in Johannesburg. Hit song of the show is *Ag, Pleez Daddy*, and released as a single

England, and on novelty value alone should prove to be a big success.

The song is an amusing, rollicking ditty sung in an original blend of English and Afrikaans accents. It's all about a young boy who is trying to get his father to take him to the fun fair, the park, the

JEREMY TAYLOR

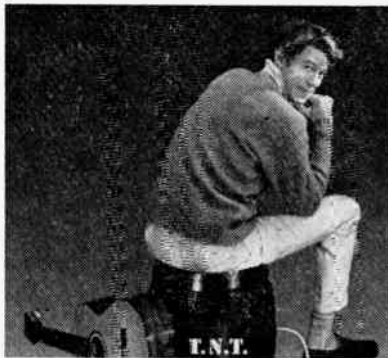

in South Africa it has sold 80,000-plus copies, a fantastic number for that country. Now the disc is to be released in

beach, a wrestling match and other places of amusement. Each verse ends with an amusing chorus.

Jeremy Taylor emigrated to South Africa after leaving Oxford University. He took a post as a school teacher, earning a few extra pounds singing in a tiny Johannesburg coffee bar at night. Then he wrote the show *Wait a Minim*, starred in it and was an overnight sensation. With the success of *Ag, Pleez Daddy* his name is a household word all over South Africa.

PRINTING WITH LINO CUTS

NOVEL prints can be made by engraving blocks of lino when the image may then be printed on paper or cloth. You may use this method for printing your own greetings cards, notices or adding monograms to your personal stationery or wherever you need to reproduce a picture. It is possible to produce such prints in a single colour or you may combine colours by using related blocks for the same design. The method is quite easy and the materials inexpensive.

The printing blocks are made from pieces of lino and these may be obtained from an artists' materials shop in various sizes. The 2 in. square size cost 1s. 2d. per dozen while 6 in. by 4 in. are 6½d. each, and it is advisable to buy these since they are prepared for the work. Patterns are cut on this soft material to make the block, and various cutting tools are required.

Any sharp knife will cut the material but proper tools are so cheap you will find it better to acquire a small set. These take the form of pen-nib cutters which fit into a handle and comprise gouges and cutters. The latter include V shapes and are prepared in different widths, catering for a variety of cuts. They will sharpen quite easily on a stone and should always be kept keen. A set of fine cutters with wooden handles is available from Hobbies price 3s. 6d. (post 6d. extra)

The lino will cut better if it is warmed a little before a fire. Only gentle heat is required to soften the lino sufficiently. A straight cut into the material with a knife will only make an incision and

this would not produce prints. Consequently, we have to cut grooves into the material at least ¼ in. deep, and this can only be done by holding the knife at an angle. This makes a channel and when the block is inked we thus produce a white line or patch wherever the material has been cut away. But there are different methods of handling the tools.

By S. H. Longbottom

The V-shaped tool produces a clean channel and it should be pushed forward, when it will peel away the lino. When we wish to cut a curved line the tool is pushed in the same manner but the block is turned at the same time by the other hand.

A U-shaped tool also cuts a uniform width of line and as stated this can be controlled by using different gauges of tools. Fine lines can be cut with a plain knife but the blade must be held sloping so that a groove is made as distinct from a mere incision.

The pieces of lino used may be mounted on blocks of plywood or left unmounted. Should it be desired to make prints on material it is preferable that the blocks are mounted. Use a piece of 6 mm. plywood for the smaller blocks and ½ in. plywood for the larger, the plywood being cut to the exact size of the lino. Apply a coating of glue to the back of the lino, then affix to the plywood. Place a piece of protective wood over the face of the

lino and clamp together, leaving until the glue sets.

Several mediums are available for the printing, including printer's ink and special lino cut water colours which contain glycerine. The latter slows the drying process, permitting more time when processing. Again, these are quite cheap and the colours used will be at your discretion.

Any type of paper may be used for making prints with the exception of those with a glazed surface. You will find that white Graphic paper is good for this purpose but it is essential to dampen before printing. The plain paper should be dampened and placed between sheets of blotting paper in readiness for processing.

When ready for printing you will require a roller squeegee and a piece of glass for spreading an even coating of ink. A rubbing pad will be helpful but before describing the method it will be better to consider the design.

A drawing is prepared on a piece of paper as decided. It may be for a greetings card or a name label for your books. Do not be afraid of making a bold drawing and it will be better to use a brush rather than a pencil when you will produce large areas of colour.

We now transfer this basic design to the lino but first make a tracing on to transparent tracing paper. When transferring to the block note that the tracing is placed face down on the lino otherwise your finished print would be in reverse. This is most important when lettering is to be included in the design. The lino is usually dark brown in colour and your tracing may not show very well. To obviate this I find it is easier to give the lino block a coating of thin, white poster paint. When this has dried your tracing will show quite clearly and after cutting the paint will wash away without damage to the lino. A pencil may be used for transferring the design to the block and firm strokes are necessary.

If you have followed the above instructions your block should bear a reverse pattern of the original drawing but we should also indicate that we have to prepare the block in reverse. By this we mean that all blank parts in the original design have to be cut out and all those areas which are to print are left intact — apart from lines and textures. Approach the larger black areas first with the V-shape tool, going round the

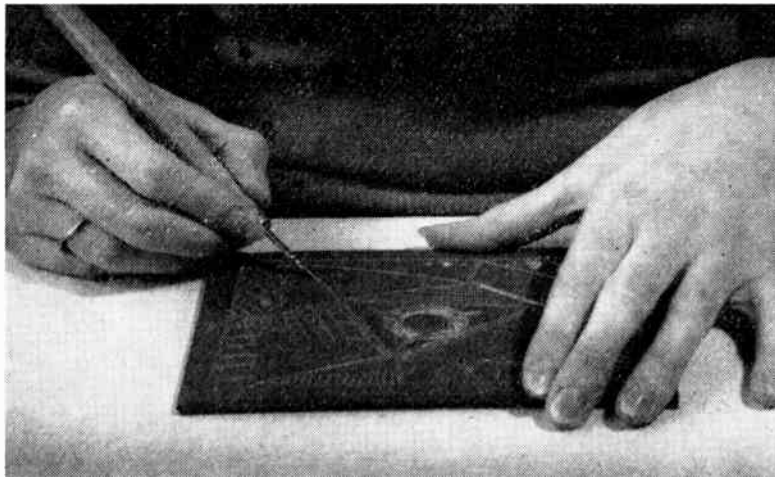

Making the block

Mainly for Modellers

IN some form or another the windlass was used before the capstan for heaving up the anchor, and on many merchant ships and small vessels was used instead of a capstan.

The early windlass shown in Fig. 1, was a large octagonal piece of timber, supported at either end by two frames of wood. These were placed on the opposite sides of the deck near the foremast, and are called windlass-bits.

WOODEN SHIP BUILDING — 27

By 'Whipstaff'

In this position it was turned upon an axis by levers called handspikes, thrust into square holes cut through the centre barrel of the machine. Like the capstans, they were fitted with strong pawls so as to prevent it from turning backwards by the pull of the cable when taking the weight of the anchor. This also served to prevent the cable slipping when at anchor in a rough sea.

The pawls of wood, or iron, fell into notches cut into the surface of the windlass, the notches being lined with iron. The pawls were each hung over a particular part of the windlass, and fell eight times into the notches at each revolution of the barrel, there being eight notches on the circumference of the barrel under the pawls.

Fig. 2 shows a later type, and Fig. 3 is the type found on the brigs used for coastal trade — the collier brigs, and similar vessels.

In modelling the windlass, detail depends on the scale. For small models a simple construction is all that is needed. The side supports can be cut from thin wood, the barrel can be shaped from a piece of stripwood or dowel, and the ratchet in the centre and the holes for the capstan bars marked on in indian ink.

In larger models greater detail is possible, and in later models the use of small gear or ratchet wheels from an old watch will enable us to make a windlass that will actually work.

In many cases our plans on small models do not show the windlass or winch in clear detail because of the scale. Where this is the case, details can

be studied in photographs, especially those of museum models. In later types, the windjammer and other vessels of the nineteenth century, many illustrations are available in books and periodicals.

When considering the winch, we find

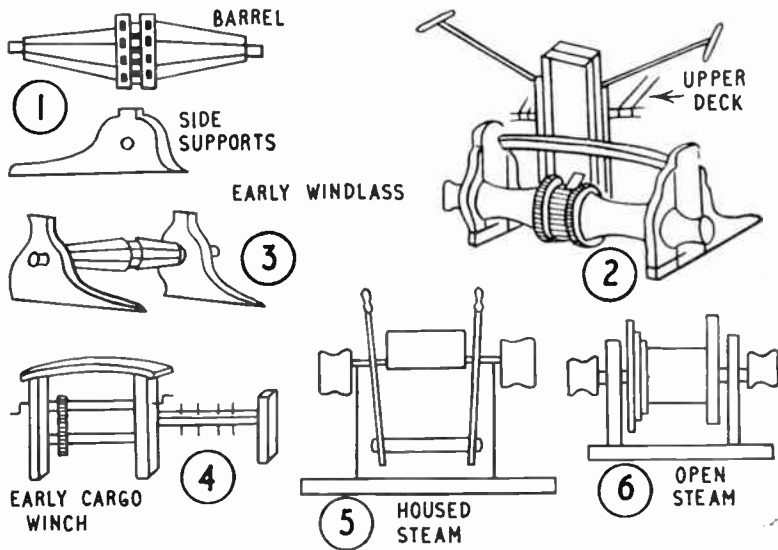

there is a far greater number of types, from the simple winch constructed mainly of wood, to the steam, and later still the electric winches. In this series we are concerned with sailing ships, and so our studies start with the early wood winch, and follow through to the steam winch as used on the later large sailing ships.

In Fig. 4 is shown a simple early type cargo windlass. This could be shown on models of early coasting vessels, schooners, colliers, brigs, etc, where the plan shows a winch. It can be modelled from two posts, a curved toprail, and two wood rollers. Again, if the scale is large enough, the rollers can be fitted with tiny cog wheels from a watch; pins or wire being used to form the handles.

There are two aft uprights, one of which is shown in the sketch. These are joined to the winch by rails pierced to take belaying pins. Most winches adopt a similar form until the introduction of the power winch, types of which are shown in Fig. 5.

As the size of vessels increased, it became necessary to use mechanical means to load and unload the very large cargoes being carried. This was done by means of derricks and winches, driven by steam until the introduction of the modern electric winches.

Both the steam and the electric winch are simple to model. For the smaller ones we can use small blocks of wood, card, and bamboo dowel; the simple housed winch shown is made in this manner. The open winch shown is constructed of wood, dowel, and wire for the axle.

This series is intended as a guide, and

our readers must be governed as to type by the plans they are using. Details for any specific model for any fittings in the present series can be furnished if application is made to the Editor. Please state the type of ship, period, and plans being used, and we will be pleased to help with all details available.

● Continued from page 364

LINO PRINTS

outlines. Next treat the lines in the design, making the cuts $\frac{1}{8}$ in. deep. The large white areas are now undertaken and those may be gouged out.

The illustration shows a block being prepared and you now have sufficient information to enable you to make a block of your own design. In another issue we will describe the method of printing.

To be concluded

CHEMISTRY

AT HOME

IN the last article we saw that carbon dioxide will not support combustion and that it is heavier than and displaces air when poured into it. By careful operation it is possible to prepare a jar containing a layer of air lying upon a layer of carbon dioxide. Proof of this layering also provides a striking conjuring trick.

ABOUT CARBON DIOXIDE — 2

Fill a jar with carbon dioxide and then tilt it at an angle of around 45 degrees. About half of the carbon dioxide is thus spilled out and its place taken by air. Stand the jar on the bench mouth upward. Have ready a stub of candle fixed to a wire, light it and slowly lower it into the jar. At first it continues to burn. Then it is magically extinguished when about half way down the jar. This trick may be repeated several times before the carbon dioxide diffuses into the air.

Such layers occur in places where carbon dioxide issues from the earth, as in a cave near Naples and in Java's Valley of Death. In the former a small dog suffocates, though a man because of his superior height may walk unharmed.

The Valley of Death is truly a valley of death, for animals which venture there quickly suffocate and the floor is strewn with their corpses. Since carbon dioxide is constantly given off from fissures, diffusion of pure air into these localities cannot keep pace and they remain lethal.

An amusing trick is to show a friend that nothing weighs something. Slightly more elaborate but quickly constructed apparatus will be needed. This is shown in Fig. 1 and consists of a simple balance, made from a piece of wood about 10 in. long, pivoted on a needle passing tightly through the wood beam and resting slackly in holes in a bent strip of tin. The weight pan can be a tin lid suspended by thin twine or strong thread, the beaker being similarly suspended.

Counterpoise the beaker with weights, lead shot or sand so that the balance arm is horizontal, slowly pour from the jar what appears to be nothing, but which is in reality carbon dioxide, through the

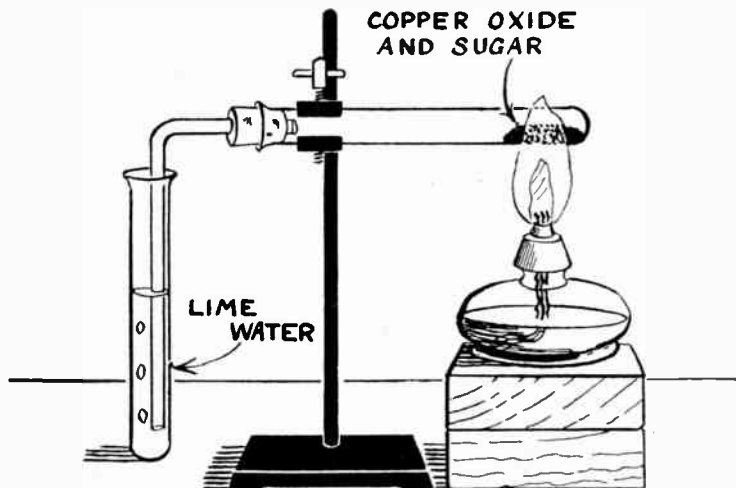

Fig. 2—Using carbon dioxide in testing for an organic compound

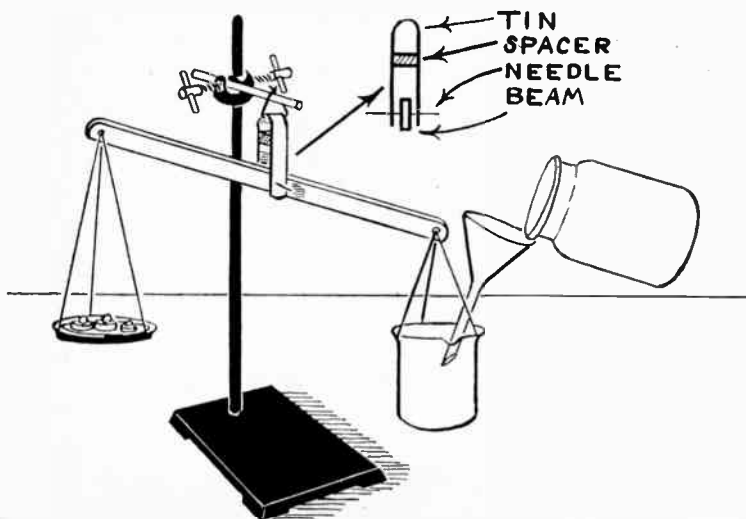
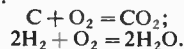

Fig. 1—Weighing nothing!

funnel into the beaker. The beaker descends! To emphasize the trick you can recounterpoise the whole by adding more weights, sand or shot until the beam is again horizontal.

Mammals are not the only source of carbon dioxide. The gas is formed when any carbon-containing substance burns. It is therefore given off by fires, candles, spirit and oil lamps. Candles, for instance, consist of a mixture of substances containing carbon, C, and Hydrogen, H, the oxygen, O, of the air combining with these to form respectively carbon dioxide and water:



Proof of the formation of carbon dioxide may be had by again using the stub of a candle fixed to the wire. Pierce a hole through a tin lid, light the candle and immerse it in a jar of air, sliding down the lid so that it rests on the rim of the jar. Soon the candle flame dims and goes out as it uses up the oxygen. Remove the candle, pour in some lime water, close the jar with a greased glass

NEW FROM

ARCOY!

The SAW & SAW GUIDE SET



A must for the home

HANDYMAN

This set, contained in a most attractive box, comprises the ARCOY 4" Saw and ARCOY Universal Saw Guide. The Saw is designed for use with any make or size of electric drill, and the cutter spindle is mounted on two ball bearings which are sealed and contain an ample supply of grease to last the life of the tool.

From most good retailers

ARCOY PRODUCTS

AN IDEAL PRESENT

Price 7 Gns

Sales Office: 32 Shaftesbury Avenue, LONDON W.C.1.
Works: Knowsley Road, Bootle, LIVERPOOL 20.

Tel.: REGENT 2206
Tel.: BOOTLE 1615

THE WORLD'S LOWEST PRICED ALL TRANSISTOR POCKET RADIO

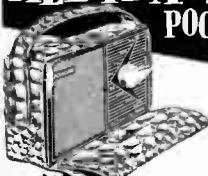

ONLY
32/6
NO MORE
TO PAY

Britain's most popular set — powerful, brilliantly designed — yours for the amazingly low price of

32/6. (Lower than Japanese Home Prices.) Only 1 3/4" x 2 7/8" x 4 1/4". Performs perfectly for months on 1/2d. battery. Assembly easy using our simple A.B.C. plan. Send only 32/6 + 2/6 P. & P. (C.O.D. extra). All parts sold separately. Satisfaction Guaranteed.

CONCORD ELECTRONICS (Dept. BX102/4)
210 Church Road, Hove, Sussex

HEAR ALL CONTINENTS With H.A.C. Short-Wave Receivers

Suppliers for over 18 years of radio S-W Receivers of quality.

One-Valve Kit, Price 25/- Two-Valve Kit, Price 50/-
Improved designs with Denco coils. All kits complete with all components, accessories and full instructions. Before ordering, call and inspect a demonstration receiver, or send stamped addressed envelope for descriptive catalogue.

'H.A.C.' Short-Wave Products (Dept. 22), 44 Old Bond Street, London, W.1.

WOOD BENCH VICE



A strong hardwood vice which can be screwed to the work bench. A real serviceable tool, well made, and fitted with hardwood screws. 12 in. long.

From branches or:
HOBBIES LTD
Dereham, Norfolk

Price 7/6 (Postage 2/-)

the new patent
CLICK VALVE

is here on top
of the new
**CASCO
GLUE-ALL**

to make it easier and cleaner — for you to glue just about anything including: wood · hardboard tiles · fabrics · textiles · mats · lino · leather · cork · ceramics · canvas · plastic laminates · asbestos · glass · plaster

Handy Size 2/- Medium Size 3/6 Large Economy Size 5/-



from Ironmongers, Hardware Stores, Do-it-yourself Shops
LEIGESTER, LOVELL & CO. LTD., North Baddesley, Southampton. Telephone: Rowhams 2131

plate and shake up the whole. The lime water turns milky owing to the formation of calcium carbonate.

Fermentation causes carbon dioxide formation, too. Dissolve 25 grams of sugar, $C_{11}H_{22}O_{11}$, in 100 c.c. of warm water. Let the temperature fall to about 25 degrees Centigrade. Crumble in a pea-sized lump of yeast. Add about 0.2 gram each of ammonium phosphate, $(NH_4)_2HPO_4$, and magnesium sulphate, $MgSO_4 \cdot 7H_2O$, to serve as yeast nutrients. Put the liquid in a bottle or flask fitted with a delivery tube which dips under lime water. Pour a thin layer of benzene, C_6H_6 , on to the lime water to protect it from atmospheric carbon dioxide and set the whole apparatus in a warm room.

After some time bubbles rise in the sugar solution and passing into the lime water turn it cloudy owing to calcium carbonate formation, thus proving that the bubbles are carbon dioxide. The bubbles seen in fermenting home made wine consist of the same gas. Firstly, by the action of an enzyme in the yeast the sugar combines with water and splits into two simpler isomeric sugars glucose,

$C_6H_{12}O_6$, and fructose, $C_6H_{12}O_6$:
 $C_{12}H_{22}O_{11} + H_2O = C_6H_{12}O_6 + C_6H_{12}O_6$.

Another enzyme in the yeast then causes formation of ethyl alcohol, C_2H_5OH , and carbon dioxide:



The presence of alcohol can be shown by letting the fermentation continue until it finishes. Take a little of the liquid, toss it well in a test tube to get rid of dissolved carbon dioxide and then into the test tube fit a cork carrying a short glass tube drawn out to a jet at the end farthest from the test tube. Heat the liquid. As soon as it boils apply a light to the jet. A blue flame appears and burns for a short time. This is caused by the alcohol, which, having a lower boiling point than the water, comes off first.

We have seen that carbon dioxide does not support combustion. There is a special case, however. Substances like wood and coal need free oxygen in order to burn. Magnesium, Mg, however, is so avid for oxygen that it can abstract this from carbon dioxide. Fill a jar with carbon dioxide, light a strip of magnesium ribbon and plunge it into the jar

of gas. It continues to burn, black flocks of carbon, C, appearing and white magnesium oxide, MgO , being formed:

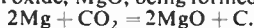

This experiment gives us some proof of the constituents of carbon dioxide.

The formation of carbon dioxide is an important test for organic compounds, that is, most substances which contain carbon. Nearly all organic compounds yield the gas when heated with dry copper oxide, CuO , the oxide being reduced to copper, Cu. To try out the test intimately mix powdered sugar with 8 times its volume of dry copper oxide and heat the mixture in a hard glass test tube, fitted with a cork and delivery tube dipping under lime water in another test tube (Fig. 2). Bubbles soon start to pass through the lime water and turn it milky owing to precipitation of calcium carbonate:

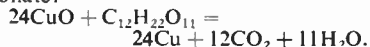

When gas bubbles cease to appear, let the heated tube cool and then shake out the residue on to a sheet of paper. Particles of metallic copper will be seen in it.

NATURECRAFT NOVELTIES

NATURECRAFT figures are always popular, and make most attractive gifts. An endless variety of designs is possible, and a Phone Number Reminder is an excellent example of what can be done. The two owls stand guard over an index of telephone numbers, or instead, the branch

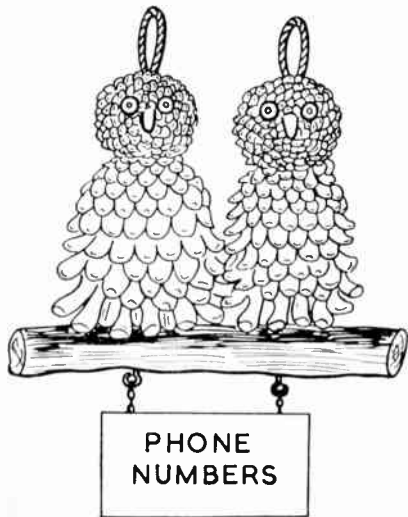

could hold a note pad or calendar.

You will need two medium sized pine cones for the bodies and two small ones for the heads. The body cones should be firm, and the scales tightly closed at the stalk end, but becoming looser, and more open at the bottom.

Cut off the stalk neatly, and drill a small hole through the centre of the cones. This is to take a wire to hold the head in place, and also to fasten the body on to the branch.

The smaller cones for the heads should be chosen with care. They can be pine cones or you may get a better selection from the larch tree. Round cones make the best heads, but if you can only get long ones, then the end must be cut off and rounded to look more like an owl's head. There should be a good length of curved stalk attached to each cone. This is shaped to form the beak of the owl, and if the bark is carefully removed it will look more like the real thing.

The large bright eyes are made with coloured beads held in place with a pin, and secured with a spot of glue.

Fix the heads on to the bodies with wire, and then glue for extra security. Drill two holes through the branch, and fix the bodies of both birds in the same manner. Small loops can be made in the ends of the wires on which to fasten the phone pad. An alphabetically indexed address pad is ideal for the phone numbers, and this is fastened to the loops with a piece of fine cord or ribbon glued to the back of the pad. Similar loops glued to the heads will enable the owls to be hung on a wall. (A.F.T.)

Miscellaneous Advertisements

IF you have taken a lot of care in making a musical box, be sure to make it worthy by including the best Swiss movement — a REUGE. Prices from 14/9. Wide range includes a charming Dancing Ballerina. Many tunes to choose from. Send for details in free booklet 'Profitable Leisure.' — HOBBIES LTD. (Dept. 99), DEREHAM, NORFOLK.

PENFRIENDS home and abroad, all ages. S.a.e. for details. European Friendship Society, Olney, Bucks.

WOULD YOU ENJOY painting flower pictures, etc.? Then read 'PROFITABLE ART' (free). Wonderful opportunities for beginners and others. POPULAR ART (HW), Clun, Salop.

100 DIFFERENT stamps free! Request 1d. upwards discount approvals. — Bush, 53 Newlyn Way, Parkstone, Dorset.

ENJOY WRITING? Then write for Profit. Send for 'Writers' Handbook' (free) detailing countless opportunities for beginner or experienced. — Writers' Ring (HW), 5 Edmund Street, Birmingham.

UNDER 21? Penfriends anywhere — details free. Teenage Club, Falcon House, Burnley.

FRIENDS' WORLD, Postbox 708, Calcutta, India, offers pen friends everywhere.

HOME BILLIARDS FOR FAMILY FUN

Tables in 3 sizes, 4 ft., 5 ft., and 6 ft. from £8. 8s. 0d. to £16. 16s. 0d., including snooker and billiard balls, cues, marker, and rules. Available at all branches. Send for full details from HOBBIES LTD, DEREHAM, NORFOLK.



WOODWORKING LATHES FOR THE KEEN AMATEUR

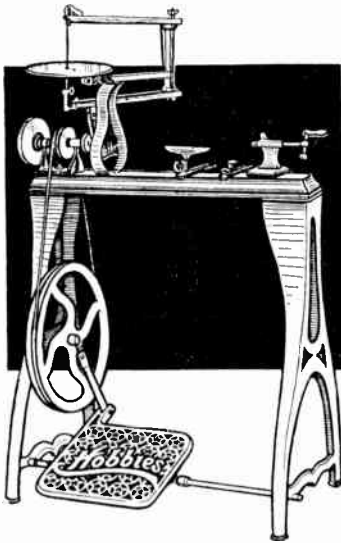

The 'Companion'

The 'Companion' Treadle Lathe. A marvellous combination for the amateur. Obtainable with or without fretsaw attachment shown. The larger driving wheel has two grooves of varying depths to give a change of speed. The headstock is provided with a 2 in. faceplate, a spur centre, and a screw centre for turning cups. It has also a solid emery wheel. The tailstock has a screw feed centre. The lathe is 14 in. between centres and is provided with two rests, designs, saws, etc. The fretsawing attachment is secured to the lathe bed by one bolt, and can be put on or taken off as desired. It is fitted with 19 in. arms and an 8 in. diameter tilting table. A well illustrated book on Wood Turning is included with each lathe.

Cash Price: £15 3s. 6d. (as illustrated) or without fretsaw £11 5s. 0d.

Easy Payments: £3 17s. 6d. down, and 6 monthly payments of £2 1s. 6d.

Without fretsaw, £2 17s. 6d. down and 6 monthly payments of £1 10s. 9d.

The 'Hobbies' Lathe. This lathe has similar features to the 'Companion' but is built for larger work. It stands 6 in. higher, and the distance between centres is 20 in.

Cash Price: £17 7s. 6d. complete. Without fretsaw £13 9s. 0d.

Easy Payments: £4 7s. 6d. down and 6 monthly payments of £2 7s. 8d.

Without fretsaw £3 7s. 6d. down and 6 monthly payments of £1 17s. 0d.

Handy Bench Lathe. This machine is similar to the 'Companion' Treadle Lathe but without the legs, treadle, etc. The headstock spindle has two small 'V' groove pulleys for drive by $\frac{3}{4}$ in. diameter round leather belt. The balance wheel is similarly grooved, so that three speeds are thus provided. An emery wheel, a spur centre and a screw centre are also included. Two centres obtainable.

Cash Price: (14 in. between centres) £6 5s. 0d.

Easy Payments: £1 12s. 6d. down and 6 monthly payments of 17s.

20 in. between centres model, Cash Price: £6 12s. 6d. Or easy payments: £1 15s. 0d. down and 6 monthly payments of 17s. 11d.

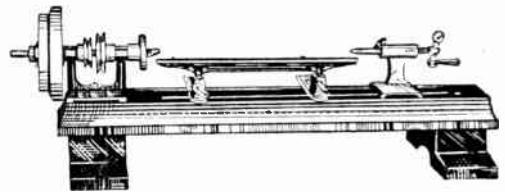

Handy Bench Lathe

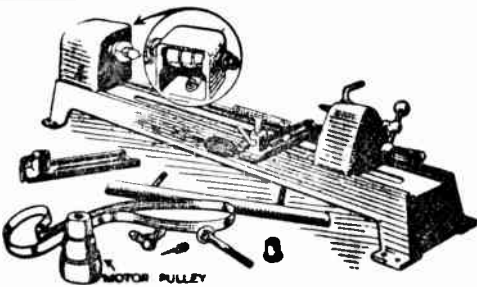

Mark II Bench Lathe

On the **Mark II Bench Lathe** the keen handyman can turn his own stool legs, table lamps, wheels, and 101 things in wood. Unlike some 'cheap' lathes with bed made from steel rods or angle iron, the Mark II is built as a lathe should be built. It has a solid cast bed 32 in. long, machined its entire length. Specification: 22 in. between centres. Height of centres 2½ in. A three-step pulley in conjunction with a similar three-step motor pulley gives speeds of 1,065, 1,420, and 1,890 R.P.M. Drive from motor (*motor not included*) is by $\frac{3}{4}$ in. flat belt provided.

Cash Price: £12 19s. 6d. Easy Payments: £3 5s. 0d. down and 6 monthly payments of £1 15s. 8d.

EASY PAYMENTS. A machine can be dispatched carriage paid after the initial down payment, and subject to the completion of a simple form of agreement. It is impossible for us to allow this system to apply in any part of Ireland, or anywhere outside Great Britain. Agreement forms are obtainable at any Hobbies branch, or you can do the business through the post with Head Office at Dereham, sending your instalments there.

HOBBIES LTD (DEPT.) DEREHAM 99 NORFOLK

Replies to Readers

Models Give TV Interference

I HAVE just started a model railway with Tri-ang. I recently purchased a CKD Princess Elizabeth loco, but find that it is giving me very bad TV interference. I have incorporated two 1 amp suppressors into the loco, also power connecting clip to track, and I wondered if you could please help me any further with this matter, and also two Kitmaster motors with the same trouble. (B.R. — Whitchurch).

THE trouble you mention is likely with model motors, and may be increased by dirty, worn, or wrongly adjusted brushes or commutator, causing bad sparking. The usual form of suppression is to fit by-pass capacitors in parallel with the brushes, or from brushes to frame, or both. Such capacitors may also be added elsewhere, as in parallel with the rails, and from rails to earth, or at the transformer primary and secondary connecting points. Capacitor values are generally around 0.01 μ F. Suppressor chokes in power leads will help keep interference out of mains wiring. Suppressors may be wanted at the receiver, to help reduce mains-borne interference. The by-pass capacitors at the motor are best tried first.

Bronzing Baby Shoes

I WANT to bronze plate some tiny baby shoes and other small articles, transforming them into ornaments. I am told there is a simple method of doing this, and would be most grateful for any help you can give me. (H.A. — Craven Arms).

THE bronzing and hardening of baby shoes is effected by electro-plating with copper. The original method was to fill the shoes with plaster of paris; when dry to apply a coat of linseed oil or quick-drying varnish; to carefully apply a coat of graphite, and then to plate in a solution of copper sulphate. A more recent method dispenses with the plaster, and thus gives a much better appearance. The method is within the scope of the home worker, but the details are too many to be stated here. Full instructions were at one time available in the monograph *How to Metallize Baby Shoes*, which could be had from D. C. Williams, 16 Newton Road, Southampton, price 3s. 0d., but we cannot be sure it is still possible to obtain this.

Mending a Drum

COULD you please advise me on the best way to fix vellum on to each side of a small percussion drum. One of the wooden hoops was thrown away with the old vellum, leaving one hoop, two outer hoops, and six adjustable side screws. (A.C. — Dover).

IT is thought that the vellum could only be replaced effectively by the hoop method. Trying to fix with an adhesive would not, we think, take the strain. You have one of the hoops left which could act as a model for making another, but it is thought that you would be best advised to have this done through a local music shop.

Perfume Spray

I SHOULD be glad of a recipe for a perfume spray for the sick room. (R.M. — Oxford).

PUT into a bottle, 1 fluid ounce of pineneedle oil, 1 fluid ounce formalin, 3 fluid ounces acetone, 10 fluid ounces isopropyl alcohol and shake well. For use, mix 1 ounce of this mixture with 1 pint of water.

Keeping an Aquarium Clean

I AM keeping fish and the aquarium I have is too large to keep emptying, so will you tell me of a way to keep the water fresh and clean? (C.L. — Barnsley).

AQUARIUMS should be cleaned once a week, especially if the main fish diet is dry food. Fish should never be given more food than they can consume within a few minutes. Inevitably, however, a certain amount of food is unconsumed after each feed, and this together with the excreta of the fish, collects at the bottom of the tank to form what is called mulm. Although a certain amount of mulm is essential for plant food, an excess of it is unsightly, and will ultimately contaminate the water. The removal of mulm is fairly simple with a dip tube. A dip tube is a length of glass tubing about 3 in. longer than the depth of the water. One finger is placed over the end of the tube which remains out of the water, and then the rod is submerged in the water until the other end is about $\frac{1}{2}$ in. above the mulm. When the finger is raised from the top of the tube, the pressure of the water in the tank will force water and mulm into the tube. After the tube has filled, replace the finger on the top, and lift the tube of mulm and water out of the tank for emptying. The green algae liable to collect on the inside of the aquarium glass can be removed with a razor blade stuck into the end of a piece of stick. We would recommend a book *The Aquarium* by David Le Roi, published by Nicholas Vane, and obtainable from any bookseller, price 3s. 6d., which we think you will find of great value.

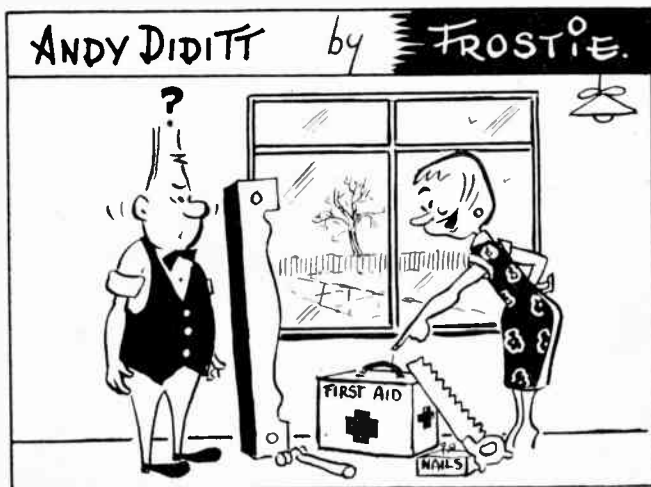

"I'VE PUT OUT ALL THE THINGS YOU'LL NEED TO FIX UP THIS PELMET FOR ME, ANDY."

For your design collection

CUT-OUTS OF ANIMALS

THESE animal cut-outs are cut from thin wood or metal, using a Hobbies fretsaw. They can be used as overlays or can be put on bases for calendars, thermometers, or egg timers, with suitable additions in the way of base and background.

(M.p.)

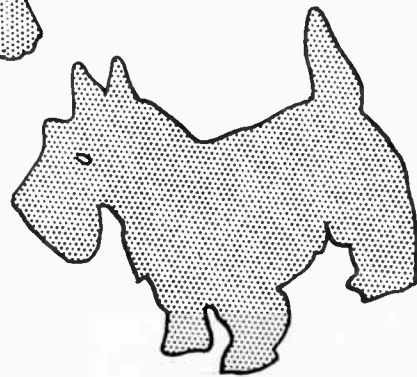
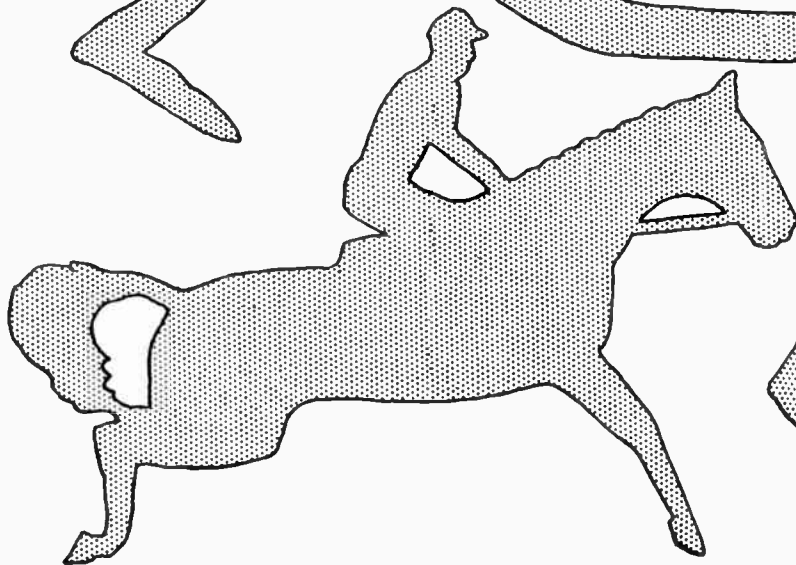
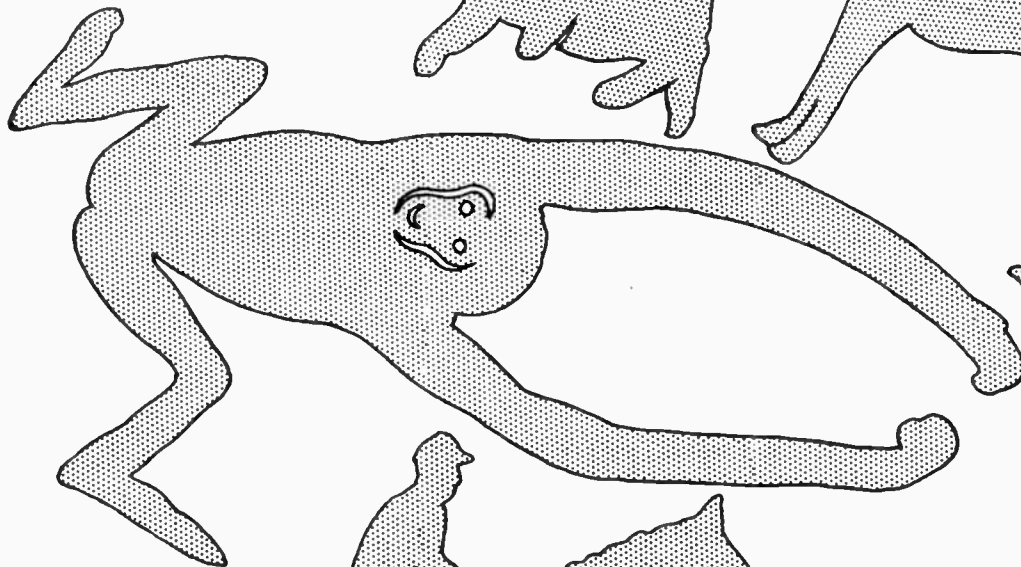
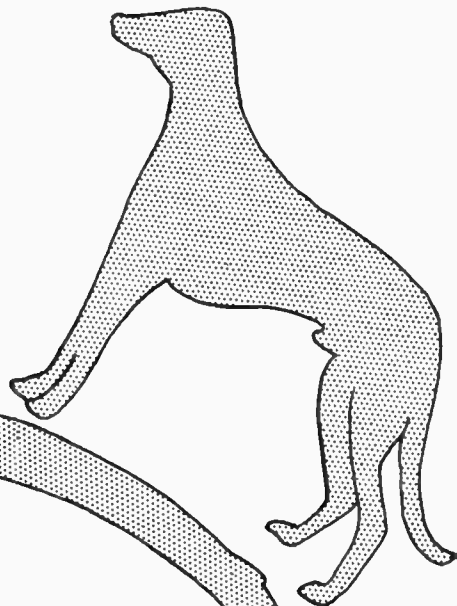
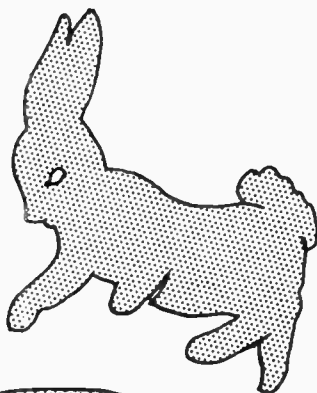



CHARMING MUSICAL BOXES



'GONDOLA' BOX
No. 3388. For trinkets or
cigarettes.

14/6 (post 2/-)

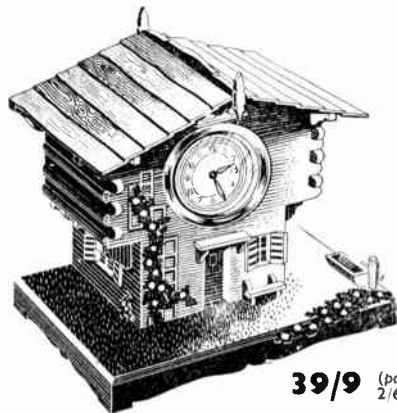

39/9 (post 2/6)

SWISS CHALET CLOCK
No. 263 Special. A 30-hour clock set in a Swiss Chalet, which is also used as a cigarette box. A No. 1 Musical Movement can also be added to play when the roof is lifted for a cigarette. An outstanding novelty.



MUSICAL SWISS CHURCH
No. 3364. Holds about 30 cigarettes.

10/11 (post 2/-)

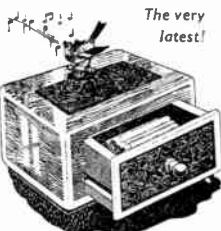

The very latest!

No.261 Special. Bird rotates and whistles when drawer is opened for a cigarette. Kit for Box 14/11 (post 2/3), Mechanism (with bird) 24/9 (post 9d.) extra.



ILLUMINATED MUSICAL SWISS CHURCH

No. 256 Special. Full kit contains materials, paint, glue, electrical fittings, etc.

26/6 (post 2/3)

Kits and Musical Movements from all Hobbies branches or direct by post from

**HOBBIES LTD (Dept. 99),
DEREHAM, NORFOLK**



TREASURE CHEST MUSICAL TRINKET BOX
No. 3312

Charming reproduction of a pirate's treasure chest.

15/9 (post 2/-)

SWISS MUSICAL MOVEMENTS

Choice of 28 Tunes
(One Tune per Movement)
Westminster Chimes
Kiss Me Honey-Honey
The Knick-Knack Song
Anniversary Waltz
Jingle Bells
O My Papa
Blue Danube
Vienna, City of my Dreams
The Harry Lime Theme
Brahms' Lullaby
Parade of the Wooden Soldiers
Church Bells Air
The Bridge on the River Kwai
(Col. Bogey)
Ave Maria de Gounod

Silent Night
Limelight
Moulin Rouge
Greensleeves
Tales from the Vienna Woods
Home Sweet Home
Swedish Rhapsody
Bells of St. Mary's
Blue Bells of Scotland
Irish Eyes are Smiling
Auld Lang Syne
Auf Wiedersehn
On the Street where you live
Some Enchanted Evening

Price 14/11
(post 6d.)

IMPORTANT — When ordering please give 2nd. & 3rd. choice



TWO-STORY MUSICAL SWISS CHALET
No. 255 Special

Kit contains materials, paint, glue, etc. (post 2/3)

21/-



SWISS CHALET MUSICAL CIGARETTE BOX. No. 3152
Kit for chalet

8/6 (post 1/3)

13th MARCH 1963

VOL. 135

NUMBER 3509

THE ORIGINAL
'DO-IT-YOURSELF'
MAGAZINE

HOBBIES *weekly*

FOR ALL
HOME CRAFTSMEN

*A home project
for the handyman*

Also in this issue:

RADIO TESTER
FOR COMPONENTS

COLLECTORS' CLUB:
STAMPS AND LABELS

PRINTING WITH
LINO CUTS

MAKE PICTURES
FROM PAPER

DISC BREAK:
NEIL CHRISTIAN

HANDYMAN TIPS
FROM THE LAB.

ANGLING AND
A NOVELTY

ETC. ETC.

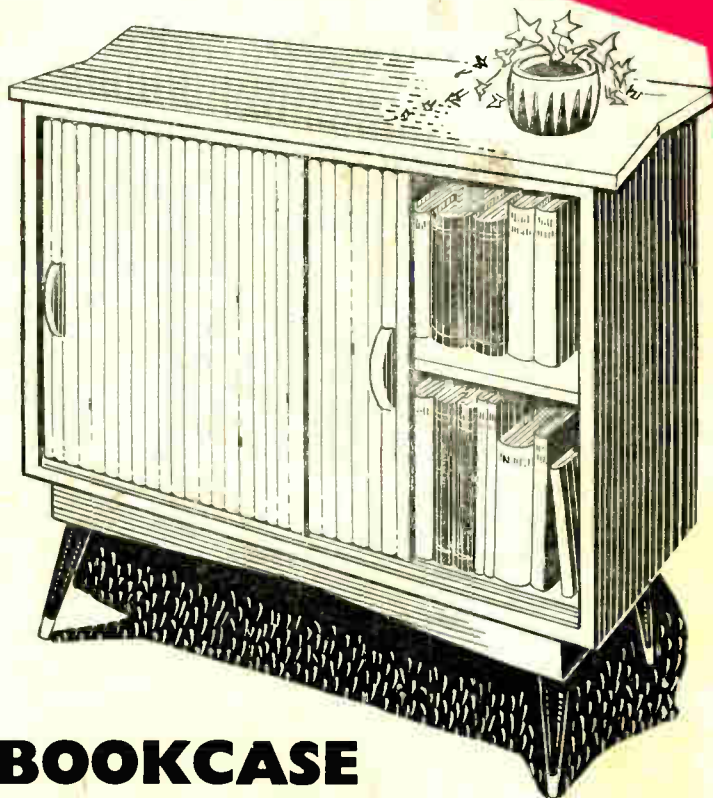

BOOKCASE OR CABINET



Up-to-the-minute ideas

Practical designs

Pleasant and profitable things to make

5^p



Stamp Collector's Corner

'To Pay'. The design has been the same since 1914 although there have been a number of different issues, simply differing in the watermark until 1951, when the colours were changed.

APPROPRIATE DESIGNS

By L. P. V. Veale

The postage due labels of many other countries are just as poor, for example, Canada, South Africa, and Australia. But there is one stamp issuing area which has made some attempt to give a clue to the charge from the design, and that is Hong Kong. Look at the illustration and you can immediately see why it is necessary to pay more for the postal packet.

By looking at a catalogue of British stamps one would get no indication that there was an express letter service. Yet there most certainly is. The service is paid for by means of the ordinary postage stamp. We just state that we wish to express it, pay the extra postage and the clerk sees to the rest.

In general this is true for most countries of the world. There are of course exceptions, for example, Canada. But even here the stamps which are specially made for the service do not give any indication of what is required.

The United States of America, however, have had one or two designs which seem suitable for the job. In 1888 they started a stamp showing a boy running with a letter in his hand. Then in 1902 they changed it to a boy on a cycle. In 1922 this had progressed to a motor cycle, and by 1925 there was an express mail van depicted. So we cannot complain about lack of progress there.

In 1903 New Zealand issued a stamp 'To secure immediate delivery at a special delivery office'. There was no particular design for this but in 1939 there was quite a change and the stamp shows an express mail delivery van moving at speed. Illustrated is an Egyptian express stamp of 1926. The postman on the motor cycle gives as good an idea of speed as possible.

In these days of thematic collections it is not surprising that many people should choose to concentrate on air stamps. Neither is it surprising that there should be a vast number of stamps which show pictures of aircraft. Sometimes these are air mail stamps but frequently they are for ordinary surface mail. In 1933 Egypt had an issue of three designs — an Imperial Airways plane, a Dornier DO.X Flying Boat and a Graf Zeppelin. But these were not air mail at all — they were to commemorate the International Aviation Congress held in Cairo.

The United States of America has produced a great number of stamps showing aircraft. In 1927 Lindberg's Transatlantic Flight was celebrated by showing a map of the North Atlantic with the pilot's plane 'The Spirit of St. Louis' in flight across it. But this was a normal surface stamp. Similarly, the next year two stamps were produced to commemorate the Civil Aeronautical Conference and as this also coincided with the 25th anniversary of the Wright Brothers' first flight, their aeroplane was shown.

One of the most interesting of the air mail stamps and also one of the most appropriate designs was that issued in Newfoundland in 1931. The 1 dollar shows a map of the North Atlantic and on this we find traced out the routes of the seven who up to that time had attempted to cross the Atlantic. The stamp is labelled 'Historic Transatlantic Flights'. At the time there was quite an outburst of indignation against those who should attempt such a foolhardy thing as to try to cross the Atlantic. Now we honour the efforts of these pioneers.

In 1934 France issued a very appropriate design for her air stamp (see

● Continued on page 375

HAVE you ever noticed that some stamps have designs which indicate exactly for what they are used while in other cases there is no indication whatsoever?

The commemorative issue will in nearly every case have something to show what it commemorates. Take for example the Belgian issue of 1939 which was brought out to raise funds for the restoration of Rubens' house. Each stamp was sold at a premium over and above the postal charge, this extra going to the fund, but each of the stamps had something in the design relating to Rubens — such as portraits of his sons, or reproductions of some of his works. The highest value of the set shows a beautiful reproduction of his 'Descent from the Cross'.

Again, in a set from Italy in 1934 commemorating the World Football Championship, each value has a football scene.

But if we consider for a moment those stamps used for such a purpose as collecting the charge for under-stamping a letter there are very few which could be said to tell the story from the design. Our own have a purely conventional design with the words 'Postage Due' or if the amount is over 1s. 0d. then the words are



Reading from left to right the stamps illustrated are:

1. Egypt. 1926. Express letter.
2. Hong Kong. 1924. Postage due.
3. France. 1934. Air Mail.
4. Holland. 1921. Marine insurance.
5. Argentine. 1939. Fonopostal service.

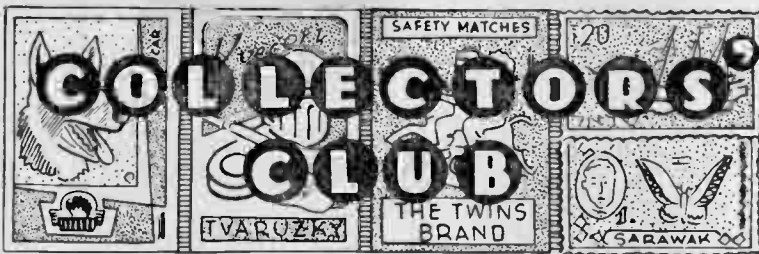

★★★★★★★★★★★★★★★★★★
 ★ NOTE TO ★
 ★ CORRESPONDENTS ★
 ★ All correspondence on any sub- ★
 ★ ject covered in this magazine ★
 ★ must be addressed to: The Editor, ★
 ★ Hobbies Weekly, Dereham, Nor- ★
 ★ folk. If a reply is required, queries ★
 ★ should be accompanied by a ★
 ★ stamped addressed envelope and ★
 ★ reply coupon inside back cover. ★
 ★★★★★★★★★★★★★★★★★★

I WAS interested to read in a report the other day that doll collecting is ranked third in importance among American hobbies after postage stamps, and coins, which are, perhaps, the two most widely practised hobbies in most countries of the world.

DOLLS OF ALL NATIONS

This information was contained in the report of a show held in Paris recently in which dolls were exclusively exhibited, there being about 4,000 on show from seventy-four countries. Most of the dolls, incidentally, excepting for a few precious items lent by collectors, were subsequently sold in aid of a charity, which must have benefited to a great extent, as prices for most of the exhibits ranged from £2 to £4.

Dealers were much in evidence among the buyers, apparently with the idea of selling to collectors of these pieces.

The dolls, it was said, presented a dazzling, colourful display with folk costumes dominating. Included in the forty-one dolls from the United States, there was one called 'Jacqueline Kennedy', modelled upon the President's wife.

A sumptuously-dressed, and bejewelled folk doll sent from Iran was raffled, and brought £650 to the fund.

Belgian dolls included a Queen Fabiola of the Belgians in marriage robes, which was priced at £26, and Canada's display included a skater in clothing knitted by Mrs John Diefenbaker, wife of the Dominion's Prime Minister.

Princess Grace of Monaco had sent a 'Palace Guardsman', and those from the French Provinces made a lavish display.

It is said that American collectors are willing to pay anything up to £75 for a pre-1900 porcelain or wax doll in first-class condition, and bearing the maker's name or mark. There is, incidentally, a women's doll club in nearly every American State, and collectors in that country have their own doll magazine, and an annual congress. (E.)



Match labels with an 'Advert' theme — selection from a Russian issue



'Soviet youth' — examples of match labels from Russia

● Continued from page 374

APPROPRIATE DESIGNS ON STAMPS

illustration). It was also to commemorate the 25th anniversary of the cross Channel flight by Louis Bleriot — another of those who should not have risked his life!

For a special fee a letter or postal packet can be insured but in 1921 Holland hit upon the idea of providing an unsinkable safe for some of its special posts. People who wanted to make quite certain that their letters were not lost — even if the mail vessel carrying the letter was sunk — bought a marine insurance stamp and the postal packet was placed in this unsinkable safe.

Another very unusual service which is available in the Argentine Republic is that of sending messages recorded on discs for transmission by post. There were three special stamps issued in 1939 to cover this charge. Today it is no very remarkable matter as so many people have their own tape recorder and it is a simple matter to send a recording of one's own voice. But to have done this twenty-three years ago would have been considered marvellous. A glance at the illustration of this unusual stamp will indicate how suitable is the design — a dove carrying a fonopostal message.

PRINTING WITH LINO CUTS

WHEN the work of cutting the block has progressed sufficiently it is possible to take a proof, after which further cutting may be made for improvements; but do remember that we cannot replace what has been removed.

We have already stated that your printing paper should be damped with clean water and a sponge will be found suitable for this. If the sheets are left between layers of blotting paper they will remain in working condition for some time without further attention. On no account should the paper be mishandled while damp, for any stretching will cause buckling and cockling on drying. You should also use paper which is larger than the block itself, allowing a margin all the way round of at least 2 in. We can then trim away any tell-tale fingerprints!

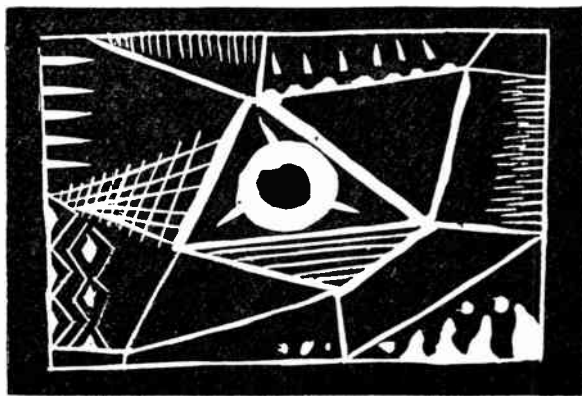

Print from block shown in photograph (part 1)

By S. H. Longbottom

Squeeze a little prepared colour from the tube and place on the glass, our objective being to supply the squeegee with an even coating of colour. Apply your roller squeegee to the glass, spreading the colour in all directions at a brisk pace. Pass the roller across the face of the glass quickly so that the roller still rotates when lifted away since this action helps the process of spreading. When you are satisfied that the roller has accepted an even coating of colour apply to the lino block. Again apply the roller in all directions, allowing it to rotate freely when leaving the block at the edges. Recharge from the glass if necessary. The

block itself must have an even yet thin coating of colour.

Now apply a piece of paper to the block. Place a sheet of dry blotting paper on top of the paper, press down as firmly as possible, rubbing hard with a pad to ensure contact. The paper must be held by one hand while rubbing and not allowed to slip or the print will be blurred. Lift the paper carefully at one corner to determine whether the colour has taken and if so it may be removed. The print is now pinned down at the corners on to a board and left until dry. Any minor defects in the print may be retouched with the same colour when dry. Finally, trim the paper to the size required.

All one-colour prints may be made as described, but when you have acquired some experience you may care to try two-colour printing although the second tint may be only a small addition.

A two-colour pattern requires two

blocks so the best plan is to paint your design in the decided colours. Then make a separate block for each colour in the same way as described. It may well be that one block provides the colour while the other provides the details or outlines in black, so let us consider the tracings for a moment.

Make a tracing of the entire design, ignoring the fact that two colours are to be used, and transfer same to two blocks of the same size. On one the parts to be printed in colour 1 are painted in Indian ink and left intact, but all other parts are gouged away. On the second block that area of the pattern to be printed in colour 2 is treated with Indian ink and the remainder cut away.

Number 1 block is printed in one colour and after drying Number 2 block is applied with the second colour. The blending of the two colours requires some consideration, for in some patterns they may actually overlap and it must be remembered that lighter tones cannot be printed on to darker. It is necessary to print your lighter colours first with the darker on top. Moreover, some care must be taken to ensure perfect register of the two printings. Using the same methods it is possible to add even more colours, but careful preparation of the blocks is necessary as the scheme becomes rather more complicated.

All kinds of attractive pictures may be made for calendars, cards or programmes and the process is extremely fascinating. The specimens shown are abstract designs for repetition over large areas and have been used for fabric printing. Small picture-blocks are made in the same fashion and can be used for numerous items.

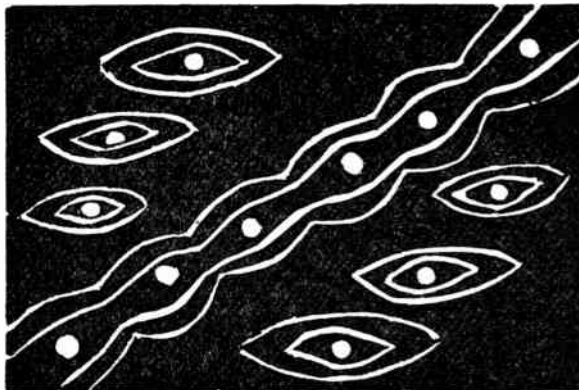

PICTURES FROM PAPER

MARQUETRY is deservedly popular with hobbyists of all ages, but not everyone has the ability to do this type of work neatly at first, and it is not generally realized that for a beginner, effective pictures may be made more easily with paper.

The results, although not to be seriously compared with marquetry, can still be worthy of a place in any home where they will be certain to arouse the curiosity of visitors.

By W. R. Spence

The first step is to collect as many different specimens of brown wrapping paper as possible. This is not difficult because, in addition to pieces saved from parcels, some manufacturers and distributors will forward a complete range of their samples free of charge in response to a courteously worded request.

Any size of picture is, of course, possible, but for best presentation in this medium 8 in. by 6 in. is recommended as the maximum. A rectangle of stiff cardboard or plywood should be chosen as the base, and a piece of

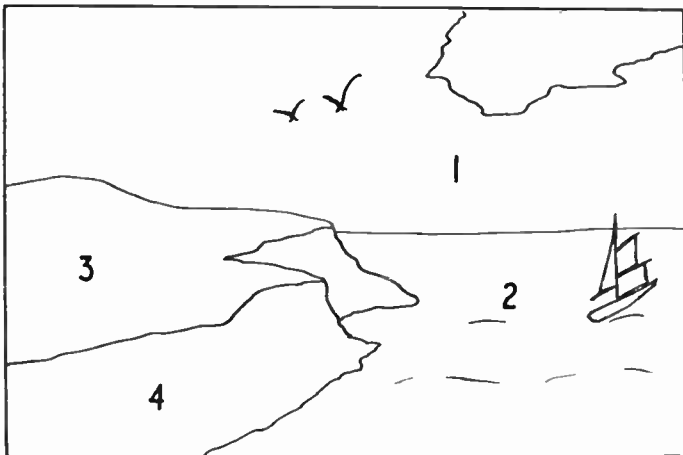

A suggested simple design for a first attempt at picture making. Piece 1 covers the whole area. To this is added piece 2 going right across the picture.

method of overlapping the layers may be adopted. This is not as clumsy a construction as might be imagined, the layers being so thin; and with some designs it is the most effective approach.

Using the 'layer' method, the background goes on first, succeeding items

last-minute changes of design can also be made as the picture is built up.

Fresh paper is unrivalled for obtaining that 'grainy' look which improves the finished appearance, especially if the 'wrong' side of the paper is used occasionally for certain effects. Where

The outline of piece 3, showing the positioning of piece 4.

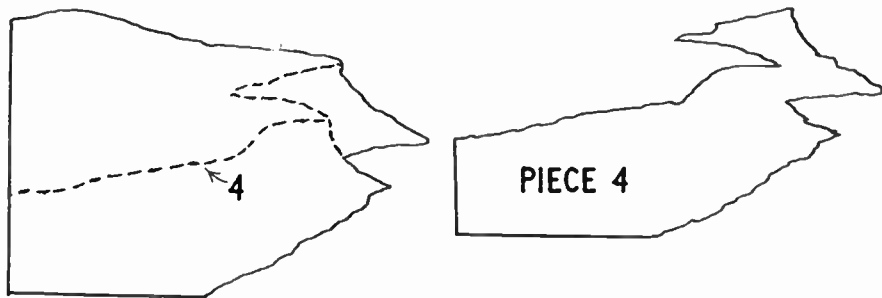

tracing paper of similar size can be used for outlining the design or picture. The different sections of the picture are then easily transferred to papers of appropriate shade and texture, the outlines being simply cut with scissors.

There are two equally acceptable methods of building up the picture and the one to be employed must be decided before any of the outlines are actually cut.

The first is the obvious one, i.e., an imitation of the marquetry procedure, where individual segments are cut precisely, so that they interlock. For those who might find this operation too tedious with paper, the alternative

being superimposed. For example, if a light coloured paper is to be used to represent the sky, then the entire picture area is covered with this paper in the first instance. The sections portraying land masses are then pasted in suitable positions on top of this, and individual trees, etc. are added on top of the land, and so on.

The resulting picture has a three-dimensional quality, which has to be seen to be appreciated. Not only does it allow great freedom of artistic expression but, since the separate pieces are completely independent of each other in respect of boundaries, no great precision of cutting is necessary, and

old used paper is to be employed it becomes necessary first of all to soak it in cold water, afterwards drying it between sheets of blotting paper with a weight on top to prevent wrinkles.

Very small quantities of oil or gum may be applied to areas where a change of tint is desired or a different texture is to be simulated. Trial and error is the only way of discovering precisely what effects may be produced, and a sample book of results could be kept by anyone interested in developing this papercraft work, which is capable of being extended beyond the limits indicated here.

● Continued on page 379

Handy for radio fans

Component Tester

MANY useful tests can be made with a meter able to measure voltages and resistance, and the circuit of a tester of this kind is shown in Fig. 1. Methods of checking components, etc., are described later.

A 1mA meter is required — that is, a meter in which 1 milliampere causes the pointer to move to its full-scale reading. Such instruments are made in many sizes. The actual size is of no importance, but the popular types of 2 in. diameter meter will do well.

By 'Radio Mech'

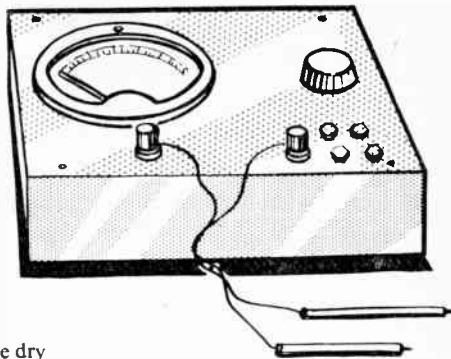

radio sets, accumulators, low voltage dry batteries employed with models, and so on. The 100V. range is useful for HT

carbon, wire-wound, and other fixed and variable resistors and potentiometers.

Instrument scales

The original meter scale will be marked 0–1mA, unless it is a surplus instrument made for some other purpose. For easy reading of voltages and resistances, the scales shown in Fig. 2 can be provided.

The usual moving coil meter has a case held by three small screws and the movement, with dial, can be withdrawn, when these screws are removed. A piece of thin, smooth card can then be cut to match the dial plate, and can be held in position with a touch of adhesive. The new scales are marked on this card.

Care should be taken not to damage the movement, or upset the balance of the coil or pointer. The meter will generally have a screw with pin, which engages with a small arm to which one hairspring is attached. This is used to set the pointer to zero, so the pin must engage with the slot in the arm, when the movement is replaced in its case.

Panel and sockets

A small box, made from thin wood, holds the meter and other parts. For a meter up to about 3 in. in diameter, an insulated panel 4 in. by 6 in., as in Fig. 3, will be satisfactory. A large hole is cut for the meter, which is held by small bolts. Terminals can be used for range selection, though sockets are easily obtained, and are more convenient.

The 'Ohms Zero' potentiometer is mounted in a $\frac{3}{8}$ in. diameter hole, and is fitted with a $\frac{3}{8}$ in. diameter or similar small knob.

The sockets are wired up as in Fig. 4. To obtain accurate voltage readings, the 10K, 100K, and 150K resistors should be of 1 per cent or 2 per cent tolerance. This means that they are actually within 1 or 2 per cent of the marked value. On the 250V. range, the 100K and 150K resistors are in series, to make up 250K, to avoid the full 250V. being applied across only one resistor.

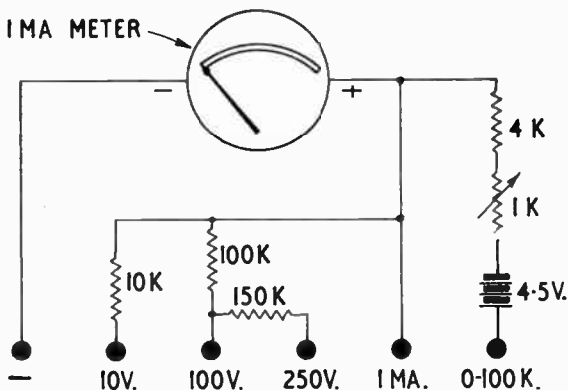

Fig. 1—The test meter circuit

When making tests, one test lead is connected to the negative terminal. The other test lead is equipped with a plug, which can be inserted in any of the sockets provided, to select the required range. With the plug in the 10V socket, the 10K (10,000 ohm) resistor is in circuit, and the meter reads 0–10 volts. The 100V. socket provides a range of 0–100V., while the 250V. socket is for 0–250V. The 10V. range is useful for testing all batteries up to this figure, such as those used with transistor and battery

batteries, etc, most of which are 22½V. to 90V. For over 100V., the 250V. range is used.

With the plug in the 1mA socket, the meter can be used with its original 0–1mA deflection. That is, small currents from zero to 1 milliampere may be read.

When the plug is placed in the 0–100K socket, the meter shows resistances from about 250 ohms to 100,000 ohms. This range is suitable for testing many components, as well as

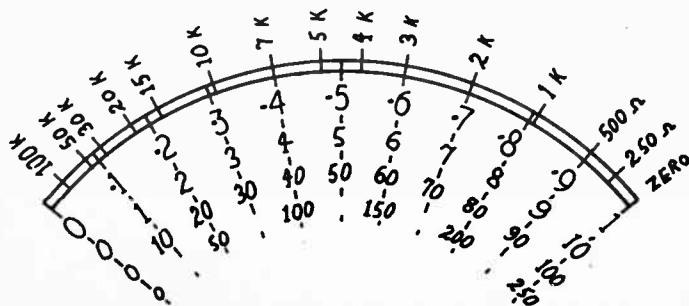

Fig. 2—Scales for the meter

The 4K resistor can be within 5 or 10 per cent of the marked value. It safeguards the meter against possible damage, if the variable resistor should be turned to minimum. It also assures that a new battery must be fitted when the battery voltage has fallen to such an extent that the Ohms range would no longer be correct.

The 4½V. supply is obtained from any 3-cell dry battery, and the battery rests in the case. The current taken is so small that any dry battery in good condition should last at least 6 to 12 months.

Test leads

Lengths of flex, fitted with plugs to suit the sockets, can be used, and insulated prods may be obtained. For low voltages, the insulation is unimportant. But for higher voltages,

Fig. 3 — Panel with sockets for range selection

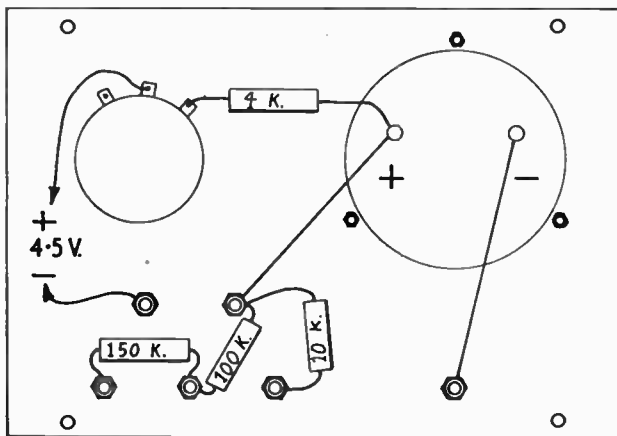
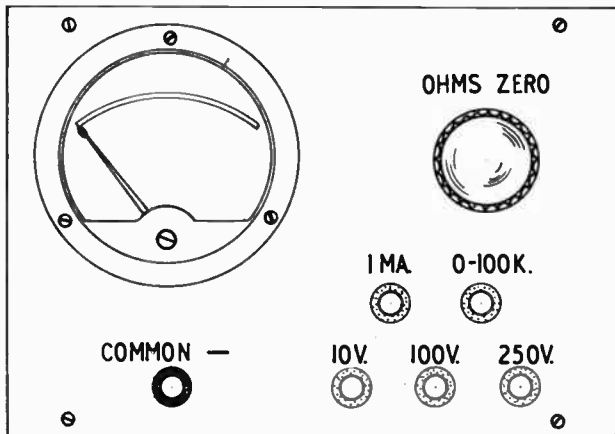

Fig. 4 — Rear of panel

properly insulated leads and prods must be used.

Voltage tests

For all tests, the negative plug remains in the negative socket. The positive plus is inserted in the required socket, for the range wanted. The meter reads direct current.

The voltage of batteries should be checked when the battery is supplying current to the model, radio, or other piece of equipment used. If the battery voltage is about normal with no current being drawn, but falls when the equipment is switched on, this shows that the battery is beginning to fail.

If tests are made on mains receivers, great care must be taken to avoid touching live circuits or metal parts where mains or other high voltages may be present.

Resistance tests

To measure resistance, first short circuit the prods together, and adjust their 'Ohms Zero' knob until the meter pointer shows Zero on the Ohms scale —

that is, 1mA. When the prods are separated, the meter will read 0 — that is, infinite resistance.

Leads equipped with crocodile clips are often convenient for resistance tests, as they can be attached to components easily. Bare clips should not be held in the fingers when actually taking a reading because the body will give a slight error.

Colour coded and other fixed resistors can readily be tested or checked for value. Variable resistors or potentiometers should give a smooth change in value, when operated. An erratic reading, or momentary open circuit, indicates a worn component.

Mica, paper, and similar condensers should show an infinitely high resistance. Condensers larger than about .1µF will give a momentary deflection, as they charge, but a continuous reading shows leakage. Electrolytic condensers pass a small current, so with these a steady reading around 100K is usual.

Mains transformers, speaker transformers, smoothing chokes, and similar items will usually be about 100 ohms to

500 ohms. Broken windings will give no reading. Heater windings, speech coil coupling windings, and other very low resistance windings will show nearly zero resistance, if in order.

Valve filaments and heaters will show near zero resistance, if intact. The current is so low that any filament may be tested, even if the valve has a 1.4 or 2.8V. filament. There should be no reading between any two electrodes, such as a grid and anode, grid and heater, heater and cathode, etc.

Tuning coils and similar winding will have a resistance of only a few ohms. Switches should show Zero resistance when closed, and infinite resistance when open. Headphones may be marked with their resistance, which may be up to 2K or 4K (2,000 or 4,000 ohms). Crystal earpieces show infinite resistance, but should click audibly when connected.

● Continued from page 377

PAPER MARQUETRY

For instance, shades of wrapping paper other than brown, can be tried.

In order to obtain satisfying results from an initial attempt it is suggested that a first design be composed of only a few areas of strong contrast. When the sections have been gummed into place and are quite dry, the joints may, if necessary, be lightly smoothed with glasspaper, care being taken to ensure that the surface of the paper is not damaged, because even minor marks are sufficient to spoil it.

Although competent work will benefit in appearance by being framed, no glass should be used. A coat of varnish or orange shellac, sparingly applied, will complete a job which is guaranteed to give satisfaction at the novel and delightful result obtainable from such unlikely materials.

BOOKCASE OR CABINET

THIS dual-purpose fitment intended as a bookcase or cabinet, has pleasing lines, and if carefully made, will be an attractive addition to any home. Although, perhaps, a little ambitious for the very beginner, it is a suitable project for the handyman with an elementary knowledge of carpentry.

The side view, front view, and plan shown in Fig. 1 give the general layout, and indicate the main measurements. The overall height is about 30 in., and the length 35 in., thus enabling the main part to be made from Hobbies standard furniture panels. Oak or Spanish chestnut can be used mainly, and the back of $\frac{1}{4}$ in. plywood faced with veneer.

In the illustration of the bookcase on the front page the doors shown are of reeded hardboard. These are suitable for bookcase or cabinet, but if a bookcase only is required, the doors could be of glass. These can usually be purchased through an ironmonger, but it would be wise to make inquiries first. It could be that you would have to accept a standard

size, in which case you would, of course adapt the size of the bookcase to suit.

DIAGRAMS ON OPPOSITE PAGE

Commence by making up as shown in Fig. 2. The enlarged detail shows the corner joints, which are screwed and glued together. The sides, top, and bottom of the main structure are all cut from $\frac{3}{4}$ in. wood. Fig. 2 also shows the housing joint made ready for the shelf, which is of $\frac{1}{2}$ in. material. The top finishing piece is also $\frac{1}{2}$ in., and should be screwed in position, inserting the screws from underneath as in Fig. 3. Do this before the shelf is fixed. Fig. 2 also shows how the sides, top, and bottom are rebated to take $\frac{1}{4}$ in. plywood back.

The diagram in Fig. 3 shows how the base is completed. Four pieces of $\frac{3}{4}$ in. wood are mitred together, and strengthened by gluing four blocks of $1\frac{1}{2}$ in. square wood in the corners. These will also serve as a base for the contemporary

legs. The base is glued in place, and strengthened by countersunk screws down through the floor. The sliding door is shown in Fig. 4, the handle being shaped from wood, screwed to the face.

The plastic guides are screwed to top and bottom ready to receive the doors. The plastic guides can be obtained from your ironmongers or D.I.Y. shop. You will find that the top guide is considerably deeper than the bottom, and the doors can be withdrawn by lifting up, and pulling forward at the bottom.

The legs are Hobbies No. 601 plain ferruled beech, 6 in. long at 8s. 3d. per set. They can be obtained from Hobbies Ltd, Dereham, Norfolk (postage and packing 2s. 0d. extra). They can also be obtained from any Hobbies branch or stockist.

The bookcase is finished by staining and polishing or varnishing. The surface should, of course, be sanded, working with the grain, and the grain filled. Careful preparation of the wood before applying the finish is essential. (M.h.)

WEST Berlin police officers have been equipped with cameras to aid in the identification of East German border guards who are guilty of committing inhuman acts against defenceless refugees. Up to now a good many shooting incidents at the Berlin wall were solved by means of photographic evidence.

The police were armed with Voigtlander Bessamatic cameras featuring a standard 50 mm. Septon f/2 lens and the supplementary Voigtlander Super Dynarex f/4 135 mm. telephoto lens after the

CAMERAS ARE ON WALL PATROL

German public and press had been exercising extremely strong pressure because a West Berlin official was kidnapped and held in East German captivity.

In the meantime all 50 West Berlin police patrol cars have been issued with the camera equipment. The handling ease of these cameras enabled the police to permanently record unlawful acts from the Communist side. Defectors from the East German side were in a position to identify the offenders when given a chance to view the photographs. Naturally the cameras are also acting as a deterrent since East German border guards do not want their photographs in the West Berlin file of wanted criminals.

AGED 90—STILL GOING STRONG

WE have received an interesting letter from Mr Will Hunter of Stave Gardens, RRI Ruskin, B.C., Canada, who, although over 90 years of age is still an enthusiastic fretworker. And quite a successful one, too, as he tells us he has received eight first prizes for his work in exhibitions in Canada.

So keen is he on his hobby that Mr Hunter is searching for yet more designs which will tax his ingenuity, and cutting skill. He well remembers the old style fretwork patterns such as trinket and glove boxes, and wall brackets, which were a feature of our publication many years ago. 'Undoubtedly', says Mr Hunter, 'many of your older readers will have some of these tucked away, and which will probably never be used'.

He asks if any reader who is willing to dispose of any of these old designs would get in touch with him at the above address. He suggests that readers submit a list of what they have to dispose of, stating the price required for sending it on to Canada, and he will acknowledge each individually.

We hope that our readers will do their best to help Mr Hunter in his quest, and thereby satisfy the needs of this energetic nonagenarian. (E)

ROLLS Tools Ltd have done model makers in particular a good turn by introducing the 'Zip' Razor Blade Plane. The cutter employed is an old razor blade, and users of safety razors will also welcome this means of getting further value from old blades.

We found this elegantly-manufactured tool a delight to handle. Made to fit comfortably in the palm of the hand, it is particularly effective in trimming up woodwork. Chamfering a panel of wood was child's play, and we gave it a

NEW CRAFT TOOLS

thorough testing on a piece of oak on which it did its job well. The 'Zip' would also appear to be ideal for cleaning down paintwork, plaster, etc, among its many other household and workshop uses.

The Rolls Pad Saw, which comes from the same stable, is another versatile tool which this time makes use of broken hacksaw blades. It consists of a pistol-type handle and two blades — one for metal and all hard materials, and the other for wood. Its ingeniously thought-out grip gives 3-way positioning of the blades depending on the accessibility of the job in hand.

The plane costs 3s. 6d. and the pad saw is 5s. 0d., both available only from Woolworths. (E)

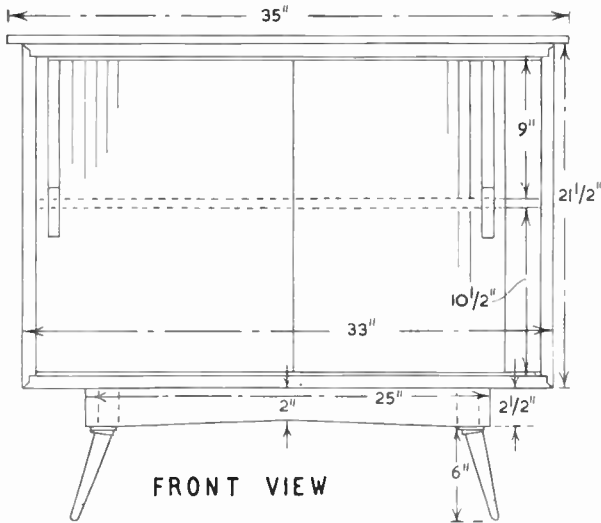
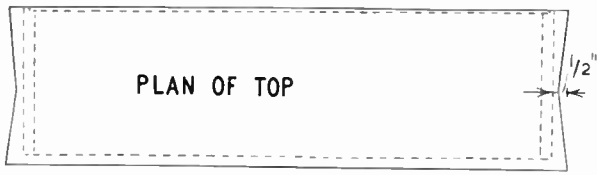

Fig. 1

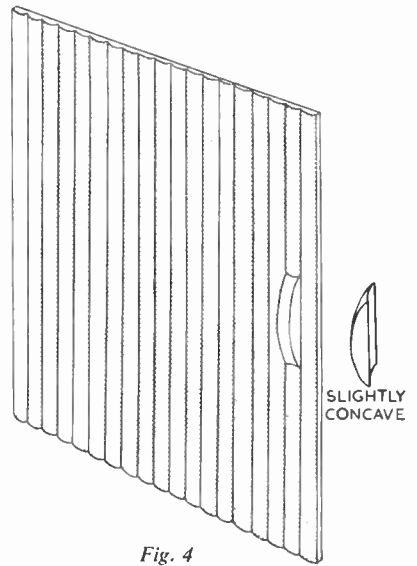
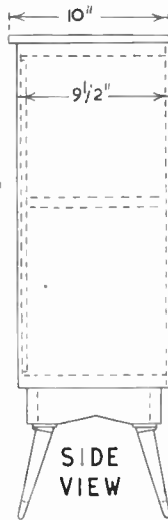
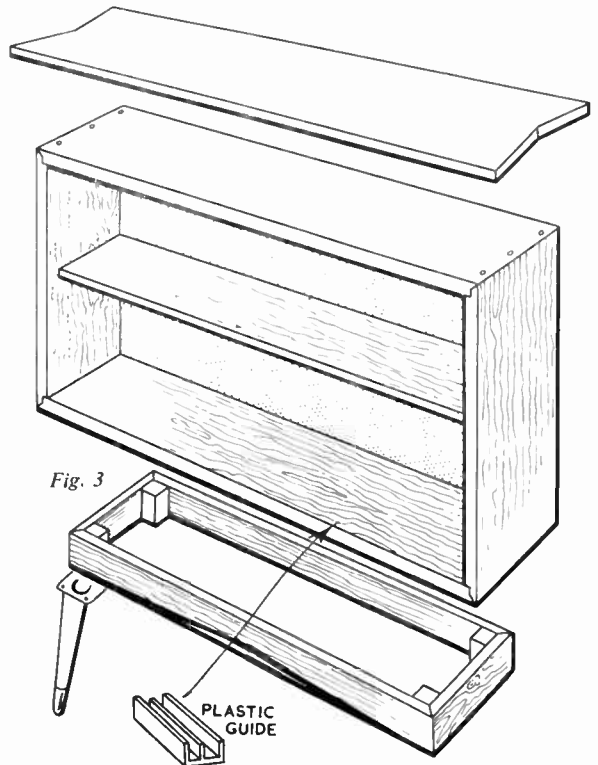
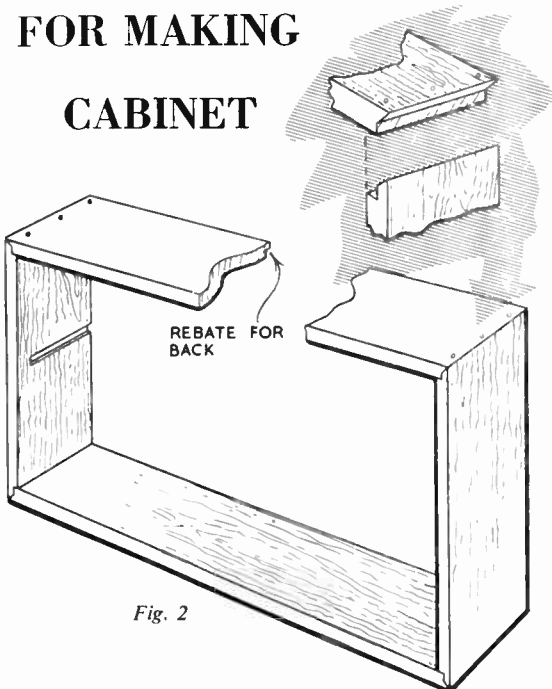

Fig. 4

DIAGRAMS FOR MAKING CABINET





NEIL CHRISTIAN

IT was really no problem at all for young Chris Tidmarsh. With an ever-growing list of professional engagements as a singer — and a recording contract in the offing — he had to find himself a professional name. He settled quickly for — Neil Christian.

'Christian? It was the natural choice,' he explains. 'For years now, I've heard about a tale that's been handed down in our family, that we are descendants of Fletcher Christian of *The Bounty*.

'I remember my old grandfather, who died at the age of 99, telling me about it time and time again. So, when I wanted a professional name, I went straight for "Christian".'

Neil Christian did little or nothing to tread the well-worn path to a recording contract. He did NOT sing in a church choir. He did NOT take part in school concerts. He did NOT have his eye on a show business career when he left school. In fact, he started singing only at the age of 18, and made his disc debut only a short 15 months after that.

Neil Christian was born in London's Shoreditch on 7th August 1943. The only member of his family who had any connections at all with show business was his grandfather (his mother's father), who was a singer-comedian appearing on the same stage as the famous Marie Lloyd.

Neil left school at the age of 17½ — and started work as a draughtsman with a heating and ventilating engineering firm in London's Cavendish Square. He found the work too monotonous, and left to become an apprentice carpenter with a City firm. Then he joined the maintenance staff of Lloyds of London.

Just before he started work at Lloyds he began travelling around with a bunch of school chums who had formed a rock n' roll group. One night the regular singer was taken ill and the boys asked

Neil to take his place.

'I had sung with the group before at rehearsals but, let's face it, it was only for kicks, and I didn't really rate my chances. This first time I sang with them in public was at the '59' Club in Hackney, and it went down so well, that afterwards they persuaded me to sing with them regularly. I was only too happy to do it.

As a matter of fact, I used to see how much 'lolly' they made and it seemed to me to be a very pleasant way of earning money, so I told them they could count me in!

Neil still sings with the same group — now renamed The Crusaders. The lineup has Elmer Twitch on lead guitar, Doc Swift on bass and Tornado Evans on drums. The boys' first real break came when they auditioned at the Astoria Ballroom in Charing Cross Road for Rank ballroom engagements. An agent, sitting in on the audition, liked what he heard and gave them work farther afield than the London clubs and dance halls they had been playing. Their out-of-town dates included a week with singer Eden Kane at the Royalty Theatre, Chester.

Shortly after this, Neil Christian and The Crusaders met John Barlow, and this meeting, too, marked a vital step in their bid for recognition. John Barlow, a company director, who has most successfully turned his attention also to song writing, takes up the story.

'Neil was working with the boys at Walthamstow Town Hall when I met him. I had written several songs in the modern 'pop' idiom, and I had been searching, very unsuccessfully as it happened, for the right singer for them. When I heard Neil I knew immediately my search was over. I was most impressed with him, and his style. The outcome was that as soon as he had finished at Walthamstow, we went back to my flat, and ran through the songs I had in mind, until two or three in the morning.



The song — *Road to Love*. And it was with this song that Neil Christian duly made his debut on the Columbia label in November 1962. The coupling — *The Big Beat Drum*, a Joe Meek composition.

It was soon after he realized the potential of Neil Christian as an entertainer, that John Barlow approached John Kennedy, one of show business's best-known personalities, who helped to guide Tommy Steele to fame. Kennedy, too, liked what he heard. Now he and John Barlow are jointly responsible for the personal management of Neil Christian.

Personally speaking, Neil Christian is 5 ft. 11 in. tall, has brown eyes and light brown hair, weighs 10 st. 9 lb. He still likes swimming, water-skiing — and messing around in boats. Favourite artists are Cliff Richard, Ray Charles, and Gene Vincent.

FOR YOUR LAYOUT



Matchbox king-size 'O' scale model of AVELING-BARFORD diesel road roller, price 3/3, and 'TT' scale model of Aveling-Barford tractor shovel, price 1/9.

3-WAY ROLLS Pad Saw

With one metal-cutting and one wood-cutting blade

ROLLS — the only Pad Saw with the three-way handle.

Can be used as a (1) straight handle or as a (2) pistol grip or may be (3) set upside down which brings the blade close to the floor or sides.

Rolls Pad Saw uses up broken hacksaw blades

Use the green blade for all metal cutting, plastic, fibreglass, asbestos, etc. Use the wood saw for interior frets and scroll cutting, tree pruning, floorboards, etc.

AND FOR 1001 OTHER JOBS IN THE WORKSHOP & AROUND THE HOME.

1. THIS WAY →

2. THIS WAY →

ONLY 5/-
WITH 2 BLADES
AND FULL
INSTRUCTIONS

3. OR THIS
WAY →

'ZIP' RAZOR BLADE PLANE



ONLY
3/6d.

COMPLETE
WITH HEAVY
DUTY BLADE
AND FULL
INSTRUCTIONS

This remarkable plane is not a toy, it is a versatile plane which uses old razor blades as its cutting blade. Saves all re-sharpening costs — when the blade is dull just throw it away! The compact size of the plane enables it to be used in confined spaces. The heavy duty blade, supplied free, adds to the versatility of the plane.

For trimming and shaping models in wood, plastic, etc., cleaning up woodwork, plaster and paintwork. The ideal tool for the balsa — trims in an instant. AND FOR 1001 OTHER JOBS IN THE WORKSHOP AND AROUND THE HOME.

Ideal tools for the practical handyman, hobbyist and modeller.

OBTAINABLE ONLY FROM WOOLWORTHS

FOR PERMANENT RESULTS . . . MODEL IT IN

Plastone

—the self-hardening modelling material. *Regd. Trade Mark*
Send for sample tin and booklet 4/9 (including postage) to Sole
Manufacturers—

Harbutt's Plasticine Ltd., Bathampton, Bath, Somerset.

'LISSAM' Ebonised LEGS

The
NEW
'Slimmer
than
Slim'
Legs



BOXED
IN SETS
OF 4 LEGS

9 in. 14/9 set

12 in. 15/9 set

Complete with Ferrules,
Glides, and fixing plates

15 in. 16/9 set

18 in. 17/9 set

(Postage and Packing 2/- extra)

HOBBIES LTD, (DEPT 99), DEREHAM, NORFOLK



The
STRONGEST
handy glue

STILL ONLY

1/2 a large tube

CHEMISTRY

AT HOME

AMBER is now rated an old fashioned material, plastics having taken its place. For that very reason working with it is becoming a lost art. It does still turn up, however, and the handyman is confronted with problems on which he has no information. One of these may well be the bending of amber.

Careful and uniform heating is the secret. Heat beeswax until it just melts, drop in the amber and continue heating until the wax is at a temperature of 150° Centigrade (about 300° Fahrenheit). After a few minutes remove the amber with forceps, hold it before a fire and attempt to bend it. If it yields easily, carry on with the bending to the desired angle. If it does not yield easily, replace the amber in the wax and increase the heat slowly until it does.

Let the amber grow cold. If difficulty is experienced in rubbing off beeswax, dip the amber in hot water, remove it and rub it clean.

LIQUID FURNITURE POLISH

An excellent polish with a fragrant smell is easily made. In a water bath melt 20 grams of ceresin and 5 grams of beeswax. When a uniform liquid is obtained, remove the vessel from the water bath and let the whole cool to about 70° Centigrade (about 160° Fahrenheit). Stir in slowly 85 c.c. of genuine oil of turpentine and 2.5 c.c. of pine oil. Continue stirring until cold.

IMITATING BRONZE

Brass may be made to look like bronze by a chemical treatment. First dissolve 10 grams of ferrous sulphate in 100 c.c. of warm water, allow to cool and add 1 c.c. of strong hydrochloric acid (caution, corrosive; any on the skin should be flushed off with water and the skin dabbed with wet sodium carbonate). Next dissolve 2 grams of potassium permanganate in 100 c.c. of hot water, allow to cool and mix this with the first solution.

The brass, which should be free from grease or dirt, is then immersed in the liquid for about half a minute. Lift out, rinse well in cold water and allow to dry.

EASING OIL

An excellent oil for easing stubborn threads is easily made by mixing, in a dry bottle, equal volumes of thin lubricating oil and methyl salicylate. Apply a little to the thread and let it penetrate for a

minute or two, when the nut should readily be removable.

CARNAUBA WAX SUBSTITUTE

Those polishes which contain a high proportion of carnauba wax are somewhat expensive. A substitute for carnauba wax, which is almost as good as

HANDYMAN TIPS FROM THE LAB.

By L. A. Fantozzi

the natural product, may be made up from a small proportion of carnauba wax and other ingredients. To prepare a supply, melt together in a water bath 12 grams each of carnauba wax and stearic acid, 36 grams of paraffin wax (candle wax), 6 grams of ceresin and 9 grams of rosin. When evenly melted, pour the liquid into cold water when it will solidify. Remove the substitute, and dry it by drainage on a pad of newspapers.

STONE TO IRON CEMENT

Mix intimately 1 part by weight of ammonium chloride, 30 parts of plaster of Paris and 10 parts of iron filings. Make this into a paste with vinegar, and use immediately.

VERDE ANTIQUE FINISH

That green patina which gives the appearance of authenticity to old bronzes and copper art objects is, of course, nothing but a surface corrosion. Time has been the factor in its production. Chemistry has discovered the mechanism, and the time factor can be immensely shortened. Two simple methods are suitable for the handyman.

For the first, stir 7 fluid ounces of glacial acetic acid into 13 fluid ounces of water. Dissolve in this 2 oz. of copper nitrate and $\frac{1}{2}$ oz. of ammonium chloride. Finally stir in 1 fluid oz. of strong hydrochloric acid. Glacial acetic as well as hydrochloric acid attacks the skin; hence any on the fingers should be flushed off with water and wet sodium

bicarbonate applied. Heat up the solution, and immerse the grease-free article in it until it acquires a dark green colour. Remove the article, allow it to dry, and then let it stand in the air until the patina appears.

For the second method, damp sawdust with a mixture of $\frac{1}{2}$ fluid oz. each of glacial acetic and hydrochloric acids and 1 pint of water. Bury the article overnight in the acid damped sawdust when sufficient patina will usually be imparted. Let the article dry.

In both first and second methods brush the dried articles lightly to remove loose patina.

FIRE RESISTANT CASTING MATERIAL

Intimately mix 87 parts by weight of silicic acid, 7 parts of alumina and 3 parts each of quick lime and ferric oxide. Mix the powder to a paste with sufficient water and put it into the moulds. In a few hours it sets to a hard mass, which should be then allowed to dry out completely.

CHAP REMEDY

An old cure for chapped hands and which is also useful for chilblains is easily made up. Heat in a water bath 1 fluid oz. of almond oil and $\frac{1}{2}$ oz. each of spermaceti and white wax (bleached beeswax) until the waxes have dissolved. Add $\frac{1}{2}$ oz. of camphor and stir until it has in turn dissolved. Lift the vessel from the bath, let the liquid cool down to a comfortable hand heat and pour it into a warmed jar. When set and cold, partially immerse the jar in warm water. This will melt the surfaces of the block in contact with the glass and it may then be removed and wrapped in polythene. For use warm the block near the fire and rub on the hands.

VENETIAN RED

Several grades of this cheap pigment exist. One suitable for cheap distempers may be made by mixing intimately the following ingredients, each in fine powder: ferric oxide 14 oz., whiting 1 lb. 5 oz., gypsum $\frac{3}{4}$ lb.

GUM PRESERVATIVE

Those who make up occasional small quantities of mucilage from gum arabic may have been troubled by mould formation. This can be inhibited by adding a few drops of chloroform and shaking well.

LEARN

RADIO & T/V SERVICING for your OWN BUSINESS/HOBBY

● by a new exciting no-maths system, using practical equipment recently introduced to this country. *FREE Brochure from:—*

RADIOSTRUCTOR

DEPT. 681, READING, BERKS.

13/3/63



be prepared.

... with a tin of
Evo-Stik on your shelf.

There isn't a fixing job around the house or workshop that a tin of Evo-Stik won't tackle: and it usually costs much less than a 'jobs-a-job'.

Table tops, wall panels, ... small jobs and large ... different materials, difficult angles: Evo-Stik fixes them all. Faster, cheaper and a whole sight stronger than the contents of an average size tool chest. And its strength actually increases after use.

No need to scout around either. It's in every Ironmongers and most large stores.

TINS 7 - and 4 3. TUBES 4 9 and 1 9.

a small deposit secures any article

'IMPACT'
EVO-STIK
ADHESIVE

REGD. TRADE MARK

MANUFACTURED BY THE INDUSTRIAL ADHESIVES DIVISION OF EVOGLU LIMITED, COMMON ROAD, STAFFORD, STAFFORDS 2 4J (3 LINES); LONDON OFFICE: 450, 2 EDGWARE ROAD, W.2. AMBASSADOR 2425 (5 LINES)

WITH ROD & LINE

I'VE one or two things to mention in this article which will be of interest to all anglers. First of all is a new spinner I've made up quite cheaply, using the idea of the fish which always heads my articles in this magazine.

This spinner can be made to suit your own idea with regard to size, but I've used the size of the illustration.

KINGFISHER'S NEW SPINNER

The material is coloured Perspex, and you can get off-cuts quite cheaply from many of the handicraft stores. Stick the fish from this page heading to the Perspex, and cut it out, omitting the tail, which can be cut later, and to a slightly different shape.

This body does not spin, but goes along on an even keel in the manner of a fish. To ensure that it remains upright a small strip of thin lead is folded and riveted to the belly part for its whole length.

The shape of the tail is amended as

shown in the illustration, and this enables you to bend the 'forks' by heating, so that the tail will spin as the lure is brought through the water. The tail is attached to the body by drilling holes, and I suggest you rivet small eyelets in the holes as a safety measure against breakage when a fish is on. A swivel is connected to split rings in tail and body. In addition I run trace wire up to the split ring in the nose of the fish, so that if the body breaks away entirely, the fish is still on the hooks, and firmly held.

You can use either the opaque colours or transparent Perspex, and provide quite an assortment, so that you have a colour to suit according to the light on the day of fishing.

With holidays in mind I've just got three additions to my library.

THE BROADS BOOK

This is a fine edition, which printed on art paper, and selling at 5s. 0d., is just impossible to beat. It contains fifty large-scale maps of the Broads, so that every drop of water in the area is fully covered. There are articles on boat management, and a tide computer, which will help to save a lot of time. Literally hundreds of photographs and

many other articles are all helpful to people who like to holiday afloat.

THE THAMES BOOK

As its title suggests, this is devoted entirely to the River Thames, and this vast waterway is covered from its start to where it enters the sea.

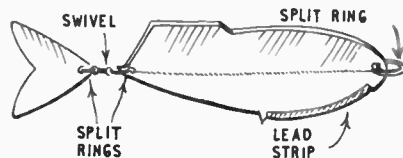

Heights of bridges and clearances at high tides are given; fishing information is shown on the maps. Places of interest along its course, and hotel and boat services are shown for every section of the river. Again printed on art paper, and selling at 5s. 0d., this is a book you shouldn't miss.

THE WATERWAYS ANNUAL

Again presented in the same quality, this book covers a great many parts of the country, and, in addition, you will find one or two places on the Continent well covered. There are articles of all kinds on what the yachtsman wants to know, and a chapter on skin diving is included.

At the same price as the other books this makes a total of 15s. 0d. for the three, and you'll find them a real addition to your fishing library. The publishers are George Goodwin Ltd, of London, and, no doubt, your local bookshop will be able to obtain them for you.

Miscellaneous Advertisements

NO BRIBES. (Stamp Value) — Harris Approvals, 74 Rosaville Road, London, S.W.6.
PENFRIENDS home and abroad, all ages. — S.a.e. for details. European Friendship Society, Olney, Bucks.

WOULD YOU ENJOY painting flower pictures, etc.? Then read 'PROFITABLE ART' (free). Wonderful opportunities for beginners and others. **POPULAR ART** (HW), Clun, Salop.

100 DIFFERENT stamps free! Request 3d. upwards discount approvals. — Bush, 53 Newlyn Way, Parkstone, Dorset.

ENJOY WRITING? Then write for Profit. Send for 'Writers' Handbook' (free) detailing countless opportunities for beginner or experienced. — Writers' Ring (HW), 5 Edmund Street, Birmingham.

UNDER 21? Penfriends anywhere — details free. Teenage Club, Falcon House, Burnley.

FRIENDS' WORLD, Postbox 708, Calcutte, India, offers pen friends everywhere.

LEARN RADIO & ELECTRONICS the NEW Practical Way! Very latest system of experimenting with and building radio apparatus — 'as you learn'. FREE Brochure from: Dept. H.W.10, Radiostructor, Reading.

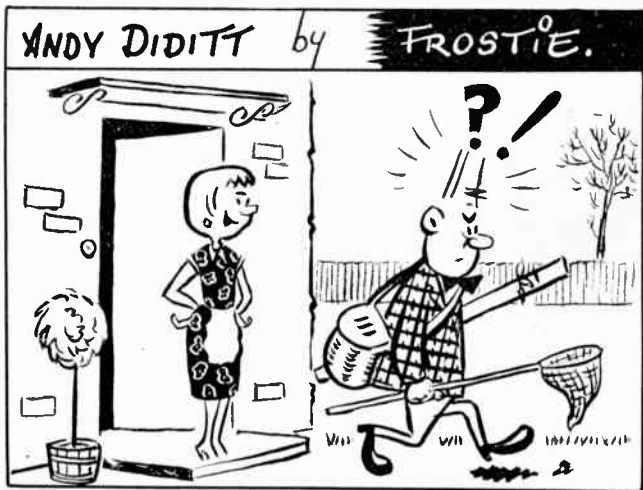

"TRY AND CATCH A FILLETED ONE, THIS TIME!"

Patterns for a Swimming Fish

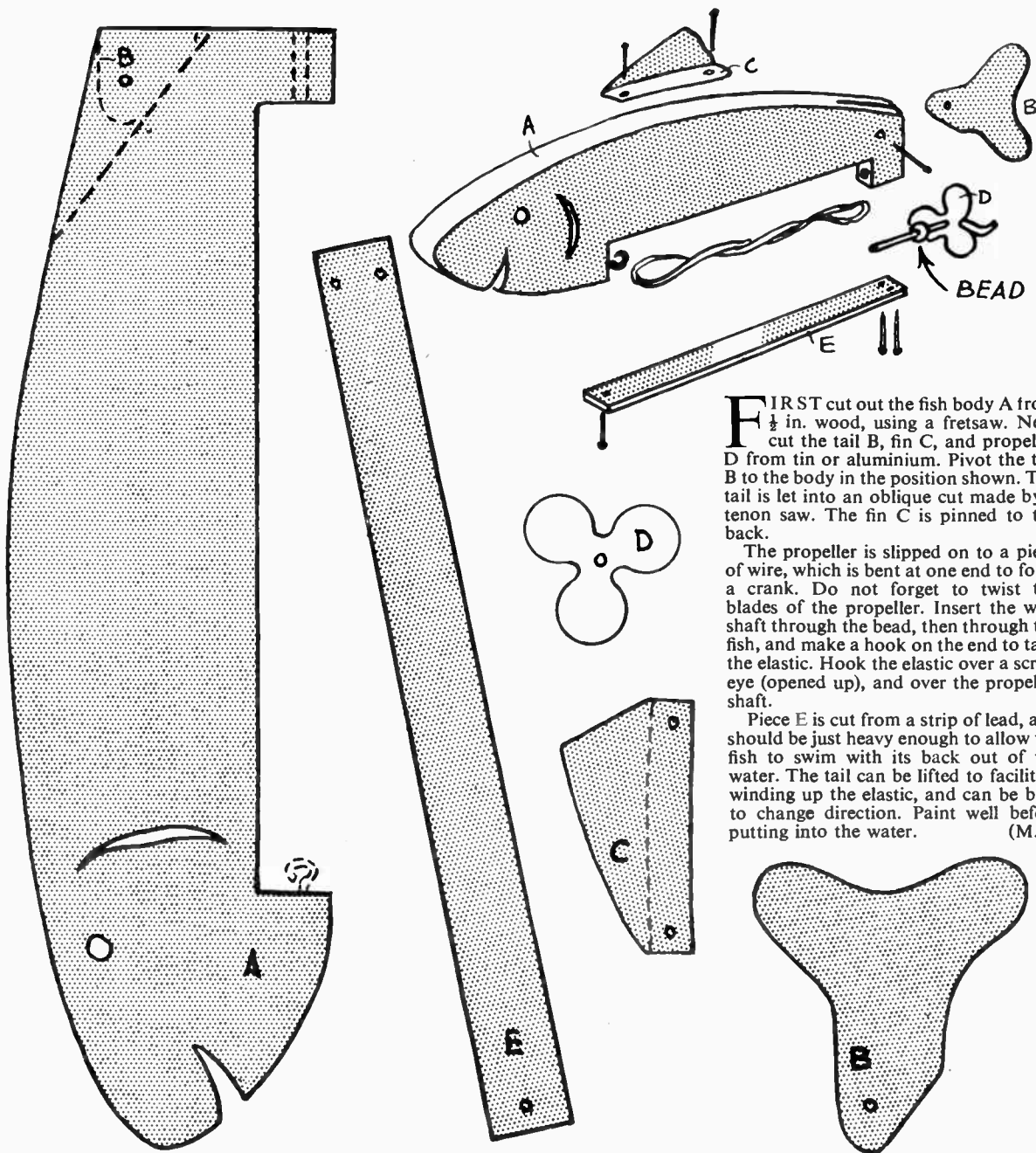

FIRST cut out the fish body A from $\frac{1}{2}$ in. wood, using a fretsaw. Next cut the tail B, fin C, and propeller D from tin or aluminium. Pivot the tail B to the body in the position shown. The tail is let into an oblique cut made by a tenon saw. The fin C is pinned to the back.

The propeller is slipped on to a piece of wire, which is bent at one end to form a crank. Do not forget to twist the blades of the propeller. Insert the wire shaft through the bead, then through the fish, and make a hook on the end to take the elastic. Hook the elastic over a screw eye (opened up), and over the propeller shaft.

Piece E is cut from a strip of lead, and should be just heavy enough to allow the fish to swim with its back out of the water. The tail can be lifted to facilitate winding up the elastic, and can be bent to change direction. Paint well before putting into the water. (M.p.)

GRAND READY-TO-ASSEMBLE KITS

THESE
SUPERB
DOLLS'
HOUSES
MAKE
IDEAL
GIFTS

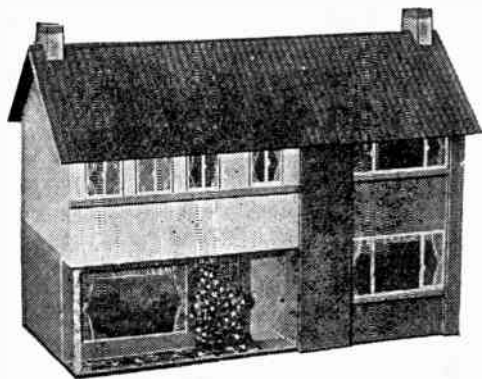

Kit R.T.A.6 The 'ROYAL'

Double door opening at back gives access to a modern lounge, hall entrance, kitchen/dining room, 2 bedrooms, bathroom and landing. Size 26 in. by 12 in. by 19 in. high.

98/6d.
(carr. free)

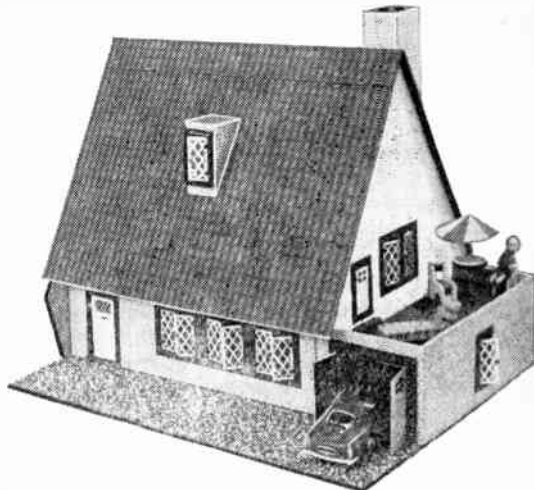

Kit R.T.A.10 The 'CONTINENTAL'

Two openings at front give access to all three floors containing dining room/lounge, kitchen, hall, two bedrooms, bathroom, and large play attic. Garage with sun deck. Size 24 in. by 19 in. by 20 in. high.

99/6d.
(carr. free)

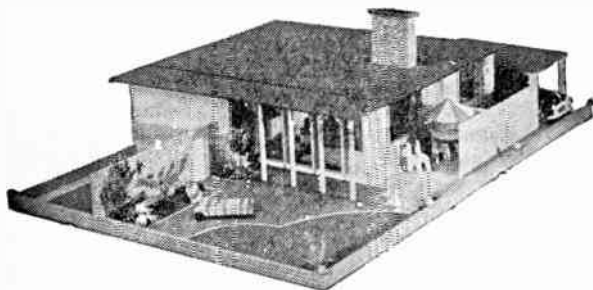

Kit R.T.A.7 The 'CELEBRITY'

Flat roof lifts off for easy access to each room. Ultra modern layout with five main rooms, including lounge with dining recess. Gardens, car port, service area, sun trap, etc. Size 36 in. by 24 in. by 8 in. high.

79/11d.
(carr free)



- *ALL PARTS
PRE-CUT
- *ALL MATERIALS
INCLUDED
- *NO TOOLS
REQUIRED

Kit R.T.A.12 'Lindy' Play House

Designed for the larger scale of dolls' house furniture and maximum play value. Sliding front gives access to all three floors. Rigid construction. Size 15 in. by 9½ in. by 2 ft. 9 in. high.

44/11d.
(carr. 4/- extra)

THESE BEING READY-TO-ASSEMBLE KITS, NO DESIGN IS REQUIRED, BUT FULL ASSEMBLY INSTRUCTIONS ARE INCLUDED IN EACH KIT. THE FURNITURE IS NOT INCLUDED, BUT CAN BE PURCHASED OR MADE FROM OUR DESIGNS.



To Hobbies Ltd. Dept. 99
Dereham, Norfolk.

Please send Kit No. R.1.A. for which I enclose

Name

Address

20th MARCH 1963

VOL. 135

NUMBER 3510

THE ORIGINAL
'DO-IT-YOURSELF'
MAGAZINE

HOBBIES *weekly*

FOR ALL
HOME CRAFTSMEN

Also in this issue:

A 1-TRANSISTOR
AMPLIFIER

COLLECTORS' CLUB:
NEW STAMPS

FULL-SIZE PLANS
FOR NURSERY LAMPS

DISC BREAK:
GARDEN FRANKS

A MACHINE TO
TEACH CHILDREN

TOY AIRSHIP
FROM A BALLOON

PATTERNS FOR A
ZOO CAGE

ETC. ETC.

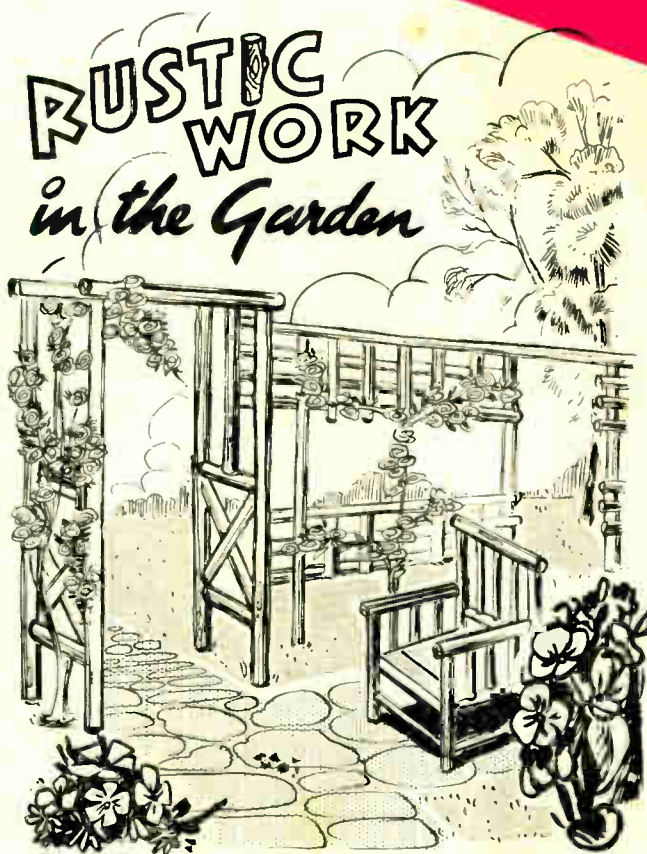

Up-to-the-minute ideas

Practical designs

Pleasant and profitable things to make

5^p



THE designs of the 15 new stamps in a new general issue for the Cayman Islands include the Annigoni portrait of Her Majesty the Queen with the St. Edward's Crown, and the central theme of the stamps is the portrayal of various scenes and aspects of life on the Cayman Islands. Brief details of the issue are:

1d. Cayman Parrot — This handsome little parrot is one of the forms peculiar to Grand Cayman. It nests in holes in trees or in old ants' nests.

1d. Catboat — The Cayman built catboats are sturdy, highly manoeuvrable craft much used by local fishermen. Traditionally the timbers are cut from trees which are naturally shaped by the prevailing trade winds. To watch a fisherman sailing his craft single-handed, observing the sea bottom through a water-glass, and proging at the same time for crayfish or conch with a 12 ft. pole is to appreciate the art of boat-handling.

1½d. Orchid. — One of the unique orchids to be found in the Islands, where it grows in profusion in some areas.

2d. Map. — The present Admiralty chart was published in 1882. Aerial photography of the Islands was com-

pleted late in 1958, and modern maps of the Islands are expected to be published probably in 1963, based on the aerial photographs, and a ground survey.

2½d. Fisherman casting net. — 'Sprats' as they are called locally are small fish used as bait for the larger fish such as wahoo.

THE CAYMAN ISLANDS

3d. West Bay Beach — Grand Cayman. — This six mile uninterrupted stretch of pure white coral sand beach is probably the most striking feature of the island.

4d. Green Turtle. — The Islands were once famous for the vast numbers of green turtle that could be found in the surrounding waters, and laying eggs in the sand of the quiet beaches. By the end of the eighteenth century the ruthless exploitation of Cayman turtle had so far reduced their number that their extermination was made certain, and the inhabitants of Grand Cayman (who had practically no alternative resources) were compelled to go further afield in search of new turtle fisheries. They first went

north to Cuba, where their tendency to supplement fishing with wrecking and brigandage did little to commend them to the Spaniards, who as late as 1798 appealed to the Spanish Government to 'wipe out the Pirate's nest' which was Grand Cayman. The Cuban turtle suffered the same fate as those in Grand Cayman, and before 1850 Caymanians had turned south to the Central American coast, where turtle fishing continues to the present day.

6d. Cayman Schooner. — The schooner illustrated, the *Lydia Wilson* is the last of the old Cayman-built vessels still operating under sail in the turtle catching industry.

9d. Angler with Kingfish. — Game fishing is one of the attractions of the Islands, and fish up to 500 lbs. have been caught. Visiting enthusiasts, usually from the United States, claim that certain types of fishing off the Cayman Islands are unsurpassed in their experience.

1s. 0d. Iguana. — The illustration represents an adult female iguana, which inhabits Cayman Brac. These lizards sometimes attain a length of 5 ft., and many have been mistaken for alligators or crocodiles by the early explorers, giving rise to the name 'Caymanes'.

1s. 3d. Swimming Pool, Cayman Brac. — It has a lovely setting among the palm trees lining the north shore.

1s. 9d. Water Sports. — A view of West Bay which is ideal for water-skiing and small boat sailing.

5s. 0d. Fort George. — No records now exist describing the origins of this fort, which is situated close to the shore in Georgetown, the capital. It is made of coral limestone, and is a crude hollow square with embrasures in which were mounted the cannon, many of which



A selection of the new Cayman Islands issue showing the colourful detail incorporated.

exist today. The large cotton tree shown in the picture was used during the 1939-45 war as a look-out for German submarines, and was manned by the local equivalent of the Home Guard. Thus the site of the old fort which was used to repel invaders in the eighteenth century was also used to guard against invaders in the twentieth.

10s. 0d. Coat of Arms. — The Coat of Arms was granted by Her Majesty the Queen on the 14th of May 1958.

£1. — Annigoni Portrait of Her Majesty the Queen.

An 'Ancient Emperors' Set from Ethiopia

EMPERORS of ancient Ethiopia are depicted on a series of seven stamps issued by that country. Brief details of these personalities are:

10c BAZEN — When Christ was born in Bethlehem, the King who was in power in Ethiopia was Bazem, famous for his administrative ability. According to the historical Chronicle, the Glory of Kings, Jesus was born in the eighth year of the reign of Bazem.

15c EZANA (ABRAHA) The King whose name and reign was most outstanding in the history of ancient Ethiopia was Ezana who came to power between 320 and 325 A.D. There are many coins on which his face is engraved; half of these coins were engraved at the time when he worshipped idols, with discs, and the moon as signs of the idolatry of South Arabia, and others, engraved after he became a Christian, had the sign of the Cross.



At the time of Ezana, the Ethiopian Kingdom was vast: Christianity was preached and it was the epoch when civilization and commerce flourished. Foreign writers called Ezana 'The Constantine of Ethiopia'.

20c KALEB — After Ezana, Kaleb is one of the most outstanding kings who sat on the Ethiopian Throne. The Government was respected and feared by foreign countries as Ethiopia found herself in a good position both administratively and economically. The Eastern Roman Government sent many delegations which concluded agreements with Ethiopia.

At the time when Christians were persecuted in South Arabia, the King crossed over on two occasions to wipe out the revolt in that country, and returned to his capital in triumph. Thereafter, he abdicated in favour of his son, Gabre Maskal, and gave his Crown to the Altar of the Holy Sepulchre, and died after living as a hermit. His name is commemorated not only by the Ethiopian Church but also by the Greek and Roman Catholic Churches. In fact,

there is no Ethiopian other than Kaleb who is considered as a Saint by foreign churches.

50c LALIBELA — After Kaleb, the King who came to power, and became outstanding in Ethiopia was Lalibela, who reigned for forty years between 1190-1230. It is known that, during his long reign, he worked for the development of his country in both culture and administration. His relations with Egypt were friendly at the time of the Crusades. At that time, the Sultans and Khaliphs of Egypt exercised a measure of oppression against the Christians, many of whom they compelled to leave the country. The refugees left for Ethiopia, where they found asylum with their Christian brothers.

What enhanced Lalibela's fame more than anything else was the building of ten churches at Roha. These are unique in that they were carved out of solid rock.

60c YEKUNO AMLAK — After Lalibela, the Zagué Dynasty does not seem to have commanded much respect. In many parts of the country people rose against the Government. One of the reasons for the unrest seems to be that the Emperors of the Zagué Dynasty were not descendants of the ancient and respected Solomonic Dynasty.

Yekuno Amlak revolted against the Government, and attracted many persons in his struggle to regain the Crown of his ancestors. Seeing that bloodshed was inevitable by Christian fighting against Christian, the Church intervened as mediator, and Yekuno Amlak gained the crown.

75c ZARA YACOB — During the reign of Zara Yacob, 1434-1468, Ethiopia was much advanced in culture, administration, and living standard. At that time, the kingdom was vast; its boundaries were the Red Sea on the north and the Indian Ocean on the east and south.

Like all other Ethiopian Kings, Zara Yacob was a devout believer, and had close relations with the Church. In his

time, education was much developed. He was himself a learned man who encouraged writers, and the publication of books.

1\$ LEBNA DENGEL — Lebna Dengel came to power at the end of the Dynasty, which reigned in Shoa, and which lasted for 270 years (1270-1540). At the beginning of his reign, he was a minor, and consequently his grandmother acted as regent.

Subsequently, a war which was started by the Chiefs of Adal amongst themselves spread to the whole of Ethiopia. Lebna Dengel was not only beaten on the battle field, but this was followed by the burning of churches, houses, and books, and the sacrilege of holy places and things. Lebna Dengel continued the war by moving from place to place; nevertheless, due to shortage of arms, he could not withstand the enemy.

HAMMARSKJOLD INVERT TO BE REPRINTED

SO that all collectors may share in possession of the philatelic curiosity that resulted from the first inversion error of American postage stamps since 1918. The Hammarskjold invert will be reprinted and placed on sale at face value.

Unlimited quantities of the deliberately reprinted error will be available, produced from the same plate numbers of the stamps which were sent backwards through the second of two printing impressions. An inverted plate number resulted, and there was a horizontal white area around the United Nations building as seen in the illustration.



The decision to reprint the error is in line with Postmaster General J. Edward Day's policy of avoiding production of rare or overvalued stamps. Some 400 of the inversion errors are known to be in circulation, and these have had estimated values placed on them as high as \$5,000. Because of the decision to reprint they are now devaluated to 4c.

A 1-TRANSISTOR AMPLIFIER

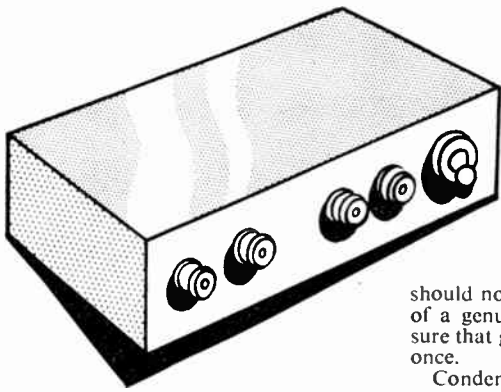

By 'Radio Mech'

THIS small transistor amplifier can be used for a number of purposes, as described later. It runs from a 9V. dry battery, which is incorporated, so that the amplifier is completely self contained.

A small case for the amplifier is easily made from $\frac{1}{8}$ in. thick wood. Two pieces $2\frac{1}{2}$ in. by $1\frac{1}{2}$ in. form the sides, and a strip 4 in. by $1\frac{1}{2}$ in. is used for the back. The front is best made of Paxolin or similar insulating material, and is also 4 in. by $1\frac{1}{2}$ in. If $\frac{1}{16}$ in. Paxolin is used here, both top and bottom will be 4 in. by $2\frac{3}{16}$ in. The finished case is thus $3\frac{1}{2}$ in. by $2\frac{1}{2}$ in. by $1\frac{1}{2}$ in. inside dimensions.

The amplifier circuit is shown in Fig. 1, and is intended for an OC71 transistor. These are easily obtainable, at quite low cost, and resistor values are intended for this particular transistor. Many other transistors will work satisfactorily in this circuit, so there is no reason why transistors of similar type

should not be tried, if to hand. The use of a genuine OC71 does, however, assure that good results will be achieved at once.

Condenser values are not too important, though those shown are most generally suitable. For coupling purposes (that is, in the $8\mu\text{F}$ position) values from $2\mu\text{F}$ to $25\mu\text{F}$ or so are general.

Fig. 1—Transistor amplifier circuit

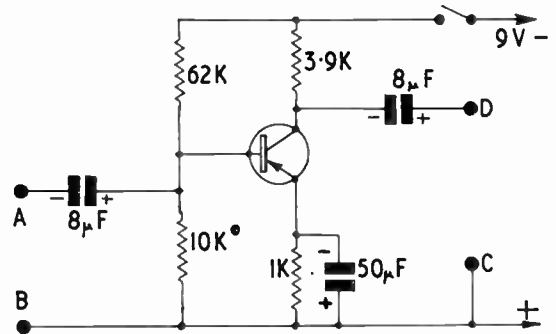

The remaining condenser may be $25\mu\text{F}$ to $100\mu\text{F}$, if such a component is to hand.

Resistor values should be as shown. 62K is blue-red-orange, while 10K is brown-black-orange. The 1K resistor

will be colour coded brown-black-red, while the 3.9K resistor is orange-white-red.

Wiring up

A piece of $\frac{1}{8}$ in. Paxolin is cut slightly smaller than the inside dimensions of the case, so that it will fit as in Fig. 2. The amplifier is constructed on this Paxolin panel, which is afterwards inserted in the case and secured with a screw.

All wiring will be clear from Fig. 2. Small holes are drilled to take the wire ends of resistors, etc, so that all the parts are secure. The three fixed condensers have positive and negative ends, which must be connected in the polarity indicated in Fig. 2.

The transistor leads are left full length, and are kept well apart, or may be insulated with 1 mm. sleeving. A red spot indicates the collector lead. This is marked 'C' in Fig. 2, and is taken to the 3.9K resistor, and $8\mu\text{F}$ condenser. The centre lead is for the base connection, marked 'B'. The remaining wire is the emitter lead, 'E' in Fig. 2. Connections should be soldered rapidly, with an iron at the correct temperature, and the iron is removed quickly. Prolonged soldering will cause heat to travel up the transistor wires, and this can damage the transistor. Each wire may be gripped with flat-nosed pliers, just below the transistor body, to help prevent heat reaching the transistor.

When wiring is finished, any projecting leads at the other side of the panel should be cut short, and bent over. The panel can then be inserted in the case, which should be complete except for the top.

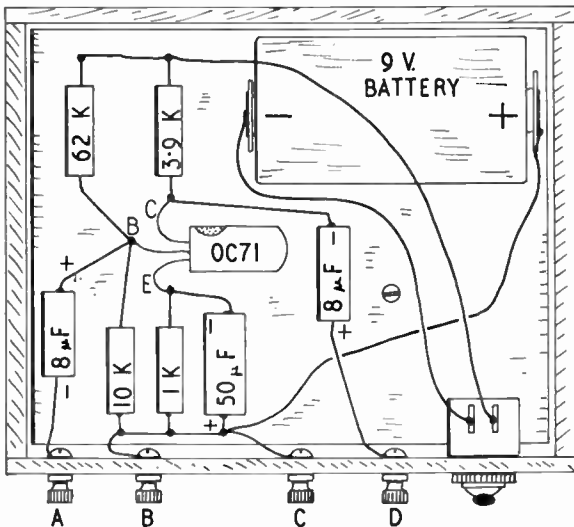

Fig. 2—Wiring diagram

Four 6BA or similar terminals are fitted as in Fig. 2, and wired as shown. The small toggle switch is also secured and wired. Two short pieces of thin flex form battery connections, and positive and negative snap clips are soldered to these leads. The battery must always be connected in the polarity shown. Clips can easily be obtained for this purpose. Alternatively, the clip and round pin may be taken from an old battery. These will snap into place on the new battery. In this case, take particular care to observe the polarity on the new battery, not that of the old battery clips, which will be reversed. That is, the old battery negative connector will clip to the battery positive, while the old positive connector fits the new battery negative.

Crystal set amplifier

The amplifier can be used with a crystal set, and will greatly increase volume. To do this, terminal A is taken to the crystal detector, and terminal B is wired to earth on the crystal set. The phones are removed from the crystal set, and wired to terminals C and D of the amplifier.

Using the amplifier in this way can give really good results, if the crystal set provided a reasonable signal. If the signal from the crystal set was too weak for comfort, adding the amplifier should give good headphone volume.

As pre-amplifier

If a 2 or 3-transistor amplifier has been made for use with a pick-up, the 1-transistor amplifier may be added between pick-up and main amplifier, to boost volume.

Terminals A and B are wired to the pick-up. One connection is normally

made by means of an outer screened brading, and this is taken to B. Terminal C is wired to the earth (positive) side of the main amplifier. A lead is then taken from D to the input socket of the main amplifier; that is, transistor base.

The 1-transistor amplifier is particularly suitable for this purpose. If a high impedance crystal pick-up is being used for record playing, a 220K resistor may be added between pick-up and A.

Fig. 3—Amplified 2-way intercom

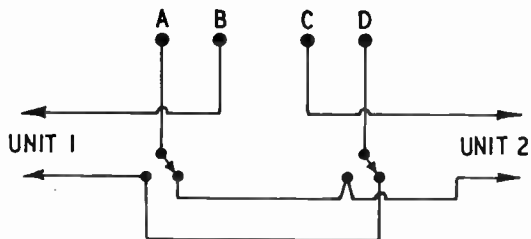

The amplifier can also be used with a microphone, and any medium impedance microphone may be taken to terminals A and B. A screened lead is necessary, with the brading connected to B, exactly as for the gram pick-up.

Two-way intercom

Simple room to room home telephones are sometimes made up, using an earphone as microphone and receiver. These usually suffer from rather poor volume. This can be overcome by using the amplifier, with a change-over switch.

Connections for this purpose are shown in Fig. 3. Unit 1 is a medium impedance headphone, situated at any convenient point. Unit 2 is a similar phone, at the amplifier. The change-over switch is also at the amplifier.

When the switch is in one position, Unit 1 acts as microphone, and Unit 2 as reproducer. With the switch in the second position, Unit 2 works as microphone, with Unit 1 as reproducer. The switch can thus be marked 'Speak', and 'Listen'. Any 2-pole 2-way switch is suitable. Rotary and toggle switches of this kind are easily obtained, and also spring loaded switches, which are held down while speaking, and released when listening.

As extra amplifier

If a single transistor receiver is in use, the amplifier can be added to this. Terminal B is joined to the positive (earth) line of the receiver, and A is taken to the original transistor collector circuit. If phones were wired from collector to battery negative, a 3-9K resistor is used to replace them, and the phones are taken to terminals C and D.

Home built receivers of fairly simple kind, using from 3 to 6 transistors, sometimes fail to give enough volume in unfavourable conditions, or from weak stations. If the receiver has only two audio amplifier stages, it is in order to introduce the 1-transistor amplifier by connecting it between the detector and 1st audio stage.

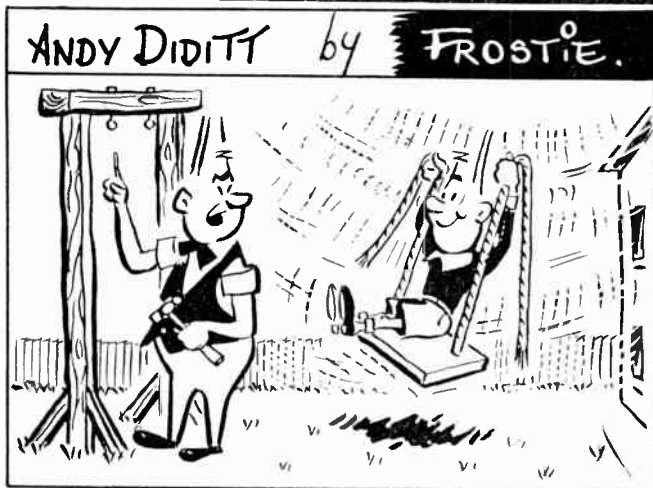

"YOU JUST CAN'T WAIT UNTIL YOUR SWING'S FINISHED, CAN YOU?"

LEARN

RADIO & T/V SERVICING for your OWN BUSINESS/HOBBY

● by a new exciting no-maths system, using practical equipment recently introduced to this country. FREE Brochure from:—

RADIOSTRUCTOR

DEPT. G81, READING, BERKS. 20/3/63



MATCHBOX POLICE CAR

The new 'Matchbox' series Police Car (No. 55) which is an 'OO' scale model having many authentic features for such a tiny vehicle. It measures 2½ inches overall and costs 1/9d.

Illustrated on front page

MAKING RUSTIC WORK

ALL kinds of garden features and furniture can be made from rustic poles, including anything from fences, screens, archways and pergolas to bird tables, chairs or hanging baskets.

There are numerous advantages in using this material. It is reasonably cheap to buy since it needs no processing; many of the smaller pieces which result from cutting can be utilized for filling. Rustic features fit into any garden scheme quite naturally and most items

By H. Mann

may be made by hammer and nails carpentry. In some instances you may be able to gather suitable material from topplings of trees and this will provide for fillings.

Most timber merchants can supply rustic poles varying in cost according to the diameter of the butts. Fir and larch poles are best for straight jobs such as fencing or screens, while ash is strong and good for tougher work. Oak, beech

sized butts where sturdy uprights are required to bear the weight.

When the material has been purchased you will then have to decide whether to leave the bark intact or whether it should be peeled and a varnished finish applied. If the material has been winter felled and has assumed a nice grey tone it seems a pity to disturb the bark, which offers natural protection. Consequently, whenever erecting garden features such as pergolas or screens it is as well to leave the bark untouched. At the same time, knots should be trimmed and smoothed with a rasp or Surform plane.

However, should you be contemplating some pieces of garden furniture it would be as well to strip the bark for this does harbour insects and their eggs, especially if cracked and broken in places. The question of comfort would also arise if used for making seats.

In any case, if the bark varies a great deal or is cracked it will be advisable to strip it away. This can be done with the aid of a spokeshave and the weather. Work the tool down the length of the pole in two or three places then leave out in the rain for a week or so. The incisions

carpentry it is possible to make some simple joints to give strength and these are shown in Fig. 1. These should be helpful whatever the project providing you use some discretion.

To increase the length of a crosspiece when fencing is being constructed it may be necessary to make a half-lap joint as shown in Fig. 1A. Endeavour to use similar diameters of poles, preparing the joint as shown. You may also apply waterproof glue and fasten by means of clenched nails through the joint.

Butt joints will always be more secure if cupped as shown in Fig. 1B. This is usually effective whenever it is wished to join horizontal with vertical poles.

When fitting a horizontal to a vertical, between the top and bottom of the job,

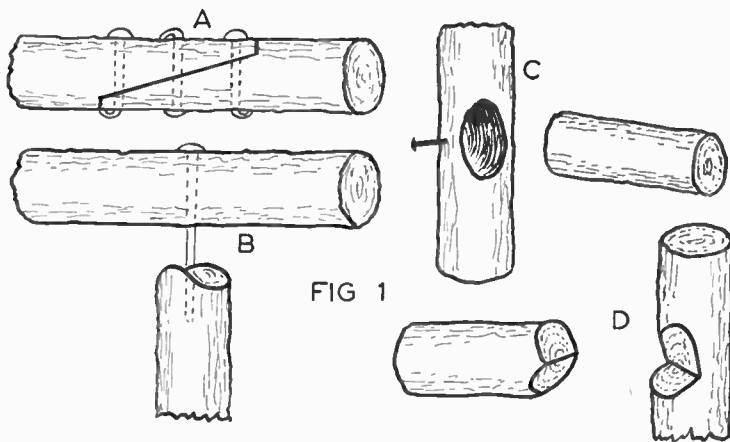

FIG 1

and chestnut topplings will provide all kinds of attractive shapes for fillings whenever you wish to make something out of the ordinary. Sycamore and maple may give a little trouble unless holes are bored for the nails, since they are brittle and may split.

Any job you may contemplate should be planned as far as possible and particular attention given to the basic structure. Much will depend on the size of a structure and whether you should order larger

you have made will help to loosen the bark which will then peel away without difficulty. This done the poles should be washed in a strong soda solution, swilled with clean water, dried off and smoothed with glasspaper. Be sure to trim off any spurs and knots. Two or three coats of brown copal varnish will give a good finish but this can be left until the carpentry has been completed.

While we have said that construction is merely a matter of hammer and nails

drill shallow holes in the vertical to fit the thinner one as shown in Fig. 1C, which is really a mortise joint. Here again drive a nail through the joint. Alternatively, use a mitre joint as shown in Fig. 1D. Both these joints are useful whenever thinner material has to be housed in thicker as it avoids any possibility of splitting the wood.

Bracing struts may always be fixed across the internal angle where horizontals and verticals meet and again

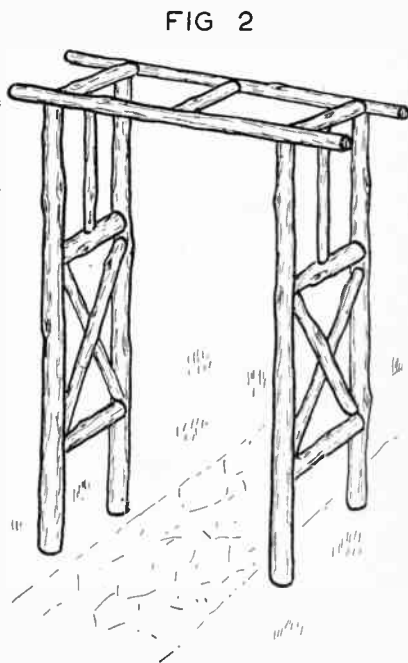

FIG 2

fastened by nailing. Use galvanized round headed clout nails, 1½ in., 2 in. and 3 in. according to the work. Clench the nails by using another hammer as a shock absorber and should the material be hard it will assist if you start a small hole with a drill at the proper angle. Whenever confronted with the necessity for a strong joint it will be better to employ a ½ in. nut and bolt. Drill the hole accordingly and after tightening the nut saw off the surplus of the bolt then burr up the end to lock the nut.

Uprights for pergolas, screens and fences must be firm and vertical. We have the choice of setting these directly into the ground or into concrete. When setting into the ground it is advisable to first char the end of the poles for about 1½ ft. or 2 ft. from the base in a coke fire or with a blow lamp. Creosote will also help to preserve them but it may be better to apply a proprietary brand of preservative which is harmless to plants if these are to be planted nearby.

Make a hole by driving a crowbar into the ground — or a stout metal pipe — working round and round until a suitable hole has been formed. This should con-

solidate the soil around, making a neat firm hole. Drop the pole into position, give a few light taps at the top, placing a protective piece of wood on top of the pole, and then test for vertical with a plumb line. Once the vertical has been checked you may hammer the soil firm all the way round the base.

Concrete bases are sometimes used for setting the poles but a little reflection will show that this is not altogether wise. Concrete is porous and attracts moisture. To set a pole directly into concrete may be inviting trouble since decay will soon start if the pole is constantly subjected to dampness. The alternative is to dig a hole about 9 in. square and fill with concrete made up from four parts of gravel to one part cement. Before this sets insert an angle iron or bar which has been drilled for bolts. Allow about one foot of this bar to be above the ground and after the concrete has set the upright may be bolted to the bar.

When making screens or the like the maximum span between uprights should be not more than 10 ft. Should this measurement be adopted it will be advisable to fix intermediate uprights, al-

though these need not be inserted in the ground. Spans of 7 ft. are reasonable, since this will eliminate joints in horizontals and the necessity for intermediate uprights.

As mentioned earlier it is wise to plan the basic structure and fillings can then be added as desired. Even so, it is advisable to make temporary fittings before nailing in position. All such fillings should be tied with string or tacked temporarily and the effect judged before final fixing.

Rustic archways as shown in Fig. 2 always look well and are ideal for climbers. They may be used as an entrance to the garden, at the end of a path at the gateway or end of the lawn. They may be used as an opening in a fence or hedge or at the beginning of a walk — or anywhere to produce a visual break.

Uprights for these should be at least 7 ft. from the ground level to the top of the arch, which may be horizontal, pointed or rounded. There should be at least 5 ft. between the sidepieces otherwise it will look skimpy. Short horizontals can always be used as fillings and climbing plants or roses will quickly cover.

New Power Unit for Airfix Motor Racing

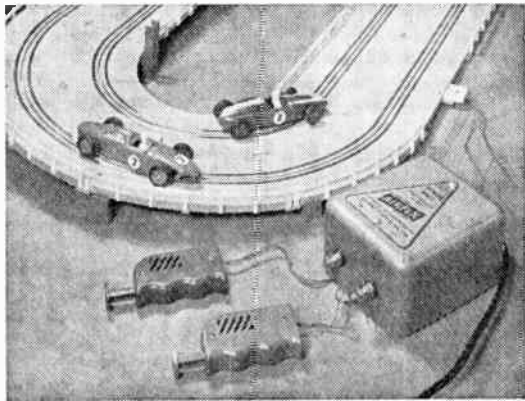

To complete their current range of accessories for the tremendously popular Motor Racing set, Airfix announce this new transformer power unit. Robustly made and completely safe in operation, the power unit transforms A.C. mains current at 200-240 volts to a D.C. output of 12 volts at 1.5 amps, which is the ideal power for the set. An automatic thermal cut-out is fitted to deal with overloading. The price of the unit is 42s. 0d.

Miscellaneous Advertisements

PENFRIENDS home and abroad, all ages. S.a.e. for details. European Friendship Society, Olney, Bucks.

WOULD YOU ENJOY painting flower pictures, etc.? Then read 'PROFITABLE ART' (free). Wonderful opportunities for beginners and others. **POPULAR ART** (HW), Clun, Salop.

100 DIFFERENT stamps free! Request 4d. upwards discount approvals. — Bush, 53 Newlyn Way, Parkstone, Dorset.

ENJOY WRITING? Then write for Profit. Send for 'Writers' Handbook' (free) detailing countless opportunities for beginner or experienced. — Writers' Ring (HW), 5 Edmund Street, Birmingham.

UNDER 21? Penfriends anywhere — details free. Teenage Club, Falcon House, Burnley.

FRIENDS' WORLD, Post box 708, Calcutta India, offers pen friends everywhere.

LEARN RADIO & ELECTRONICS the NEW Practical Way! Very latest system of experimenting with and building radio apparatus — 'as you learn'. FREE Brochure from: Dept. H.W.10, Radiostructor, Reading.

NYLON · P.T.F.E.
BRASS · COPPER · BRONZE
ALUMINIUM · LIGHT ALLOYS
 ROD, BAR, SHEET, TUBE, STRIP, WIRE
No Quantity too Small List on Application
H. ROLLET & Co. Ltd.
 6 Chesham Place, S.W.1 BELGRAVIA 4300
ALSO AT LIVERPOOL, BIRMINGHAM
MANCHESTER, LEEDS

Easy to Make **NURSERY**

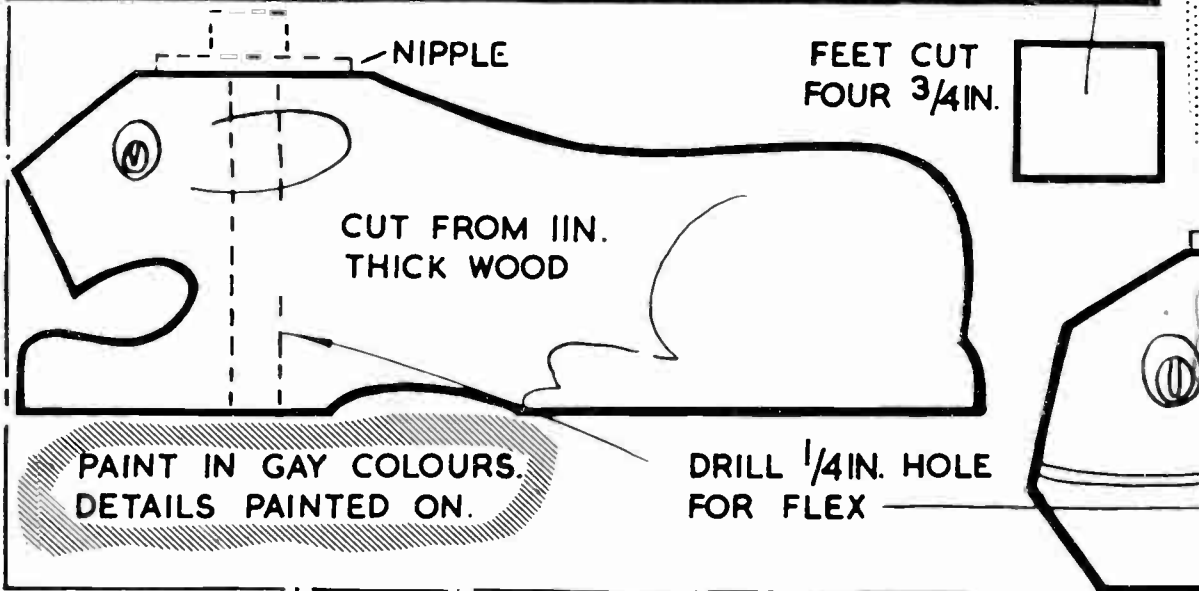
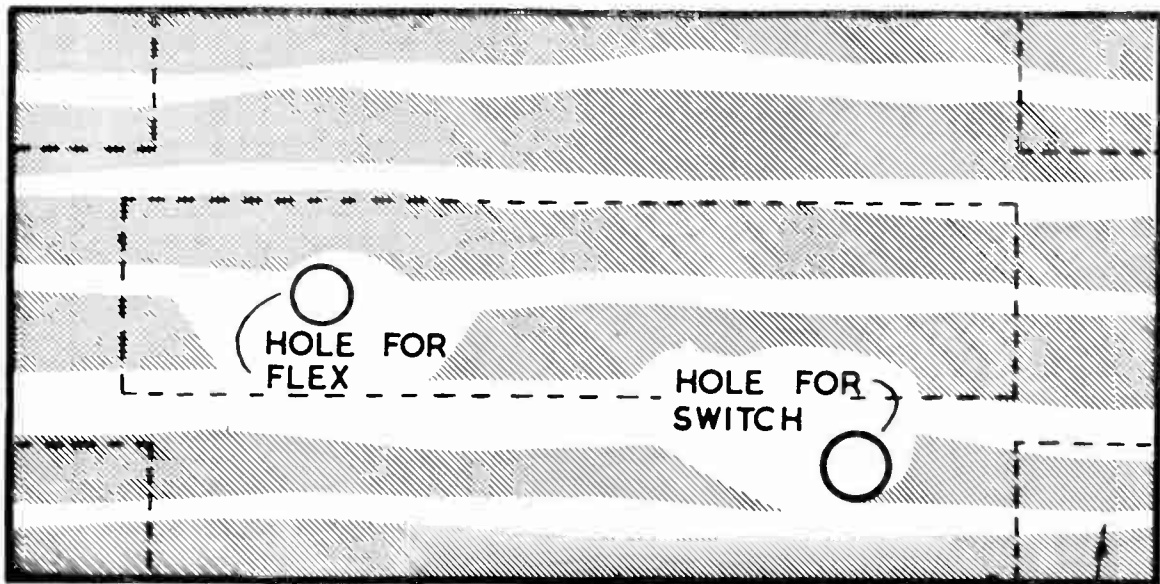

LAMP

15 WATT
"PYGMY" BULB OBTAIN
FROM ELECTRICAL SHOP

HOBBIES MINIATURE
LAMP HOLDER 1/9D.*

NIPPLE 4D.*

* POSTAGE 6D. FOR
SET OF FITTINGS

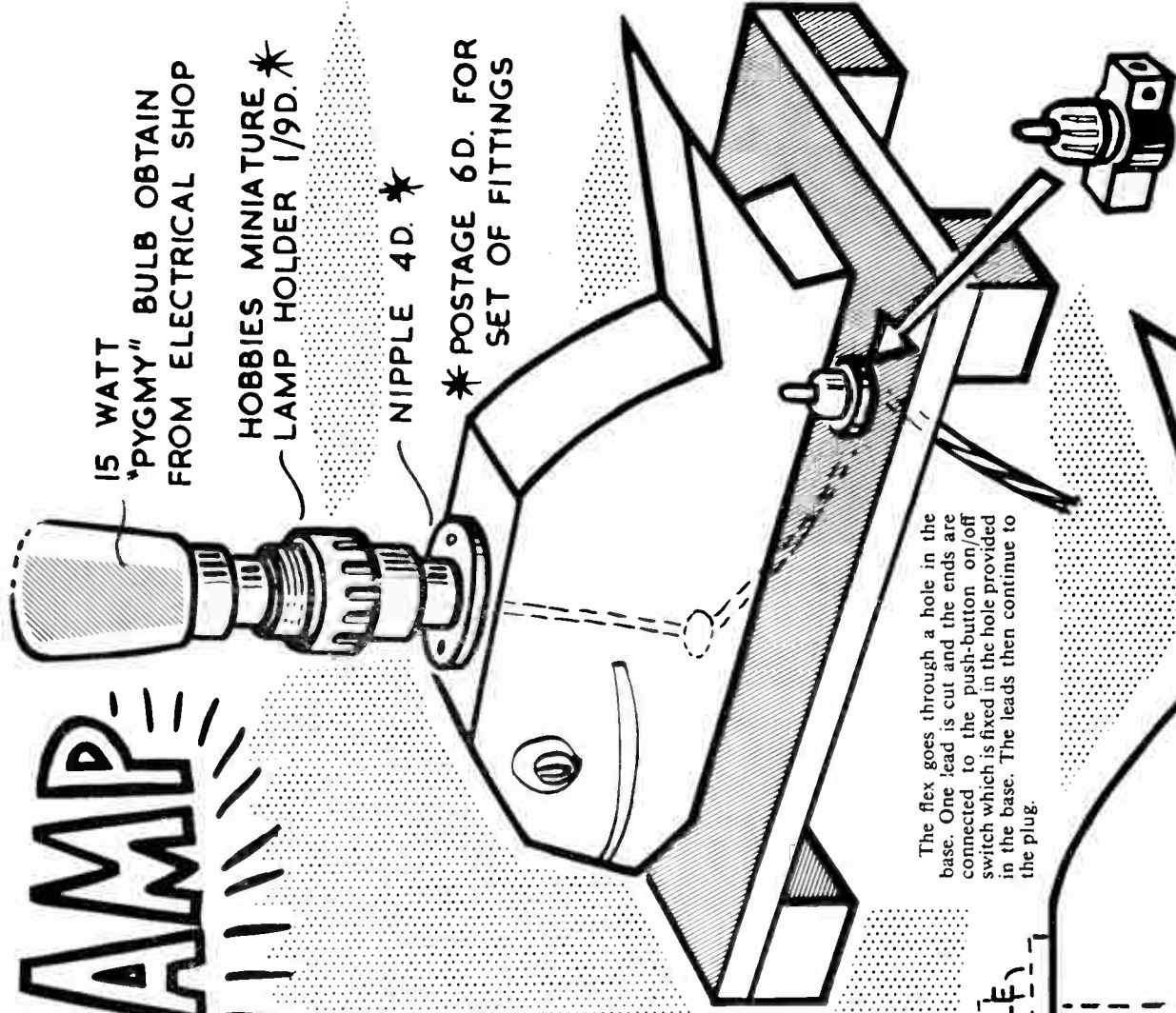

The flex goes through a hole in the base. One lead is cut and the ends are connected to the push-button on/off switch which is fixed in the hole provided in the base. The leads then continue to the plug.

HOBBIES *
PUSH/PUSH
SWITCH 2/-

ANIMAL SHAPE
CUT FROM 1IN. THICK WOOD

NIPPLE

A Teaching Machine for Children

TEACHING machines are now widely used in the United States, and have also been introduced to this country, where their use will no doubt become more widespread within a few years.

A simple teaching machine is not difficult to make; basically, it is a box containing a roll of paper with questions and spaces for answers. As each question is answered and checked, the paper is moved on, like the film in a camera, to the next question.

The dimensions are not critical — the box illustrated here is made of plywood, and is 6 in. by 6 in. by 12 in. One side is removable, and is held in place by wing nuts and bolts fixed to an interior lip of $\frac{1}{4}$ in. square stripwood. This is shown in

By
A. Liston

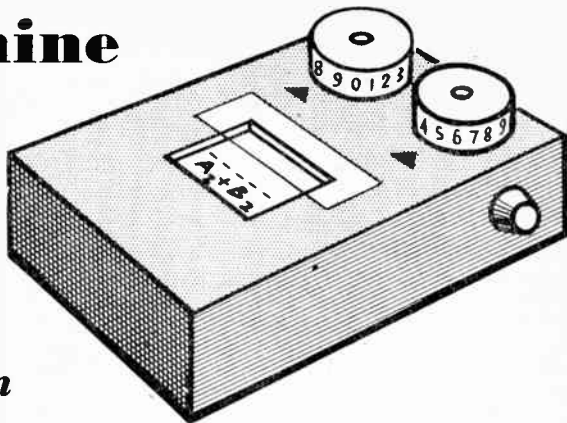

Fig. 1. A 2 in. square hole is made in the middle of the top of the box, and a $\frac{1}{2}$ in. wide section at one end of this hole is covered by a piece of clear plastic glued in place A.

A 4 in. square of $\frac{1}{2}$ in. thick wood is fitted below the opening, using washers as distance pieces so that there is a gap of

about $\frac{1}{4}$ in. between the box lid and the wood. Fig. 2. The ends of this wooden section are rounded off as shown so that the paper roll slides smoothly over them.

Two holes are then drilled in each side, 2 in. down and 2 in. in from the corners, to take the $\frac{1}{4}$ in. diameter dowel rod spindles on which the paper spool is wound. These spindles are shown in Fig. 3. Each one is 7 in. long, and the take-up spindle A has two 3 in. diameter plywood discs glued to it to form a spool, and a plastic knob is fitted to it on the fixed side of the box. The discs should be a little over $2\frac{1}{2}$ in. apart, to accommodate the paper roll comfortably. The second spindle B is also fitted with plywood discs.

Pieces of metal rod or plastic tubing are fitted to the spindles as distance pieces to keep the spools in line, so that a roll of paper passing from one to the other over the wooden panel is directly below the window in the top of the box. The end of spindle B is filed square and sawn off flush with the side of the box. A simple tinplate key C is used to rewind the spool when all the questions have been answered.

The paper used for the machine is a roll of adding machine paper, $2\frac{1}{2}$ in. wide. This can be bought at a good stationer for less than a shilling. Other widths of roll can be used, of course, if the dimensions are altered accordingly.

At this stage, the working of the machine should be tested with a short length of paper. Using pieces of adhesive tape, wind it on to the rear spool, feed it under the window, then tape it to the front spool. Replace the side and turn the knob. The paper should wind on evenly, and any tendency to jam will probably be caused by the spindles not being parallel. This can be corrected by enlarging the appropriate hole slightly. The paper roll can only be wound one

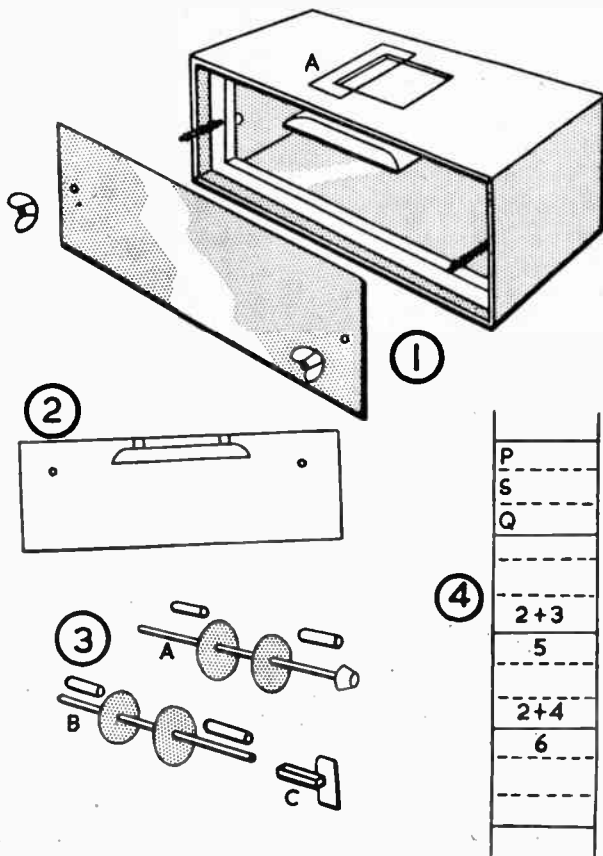

● Continued on page 400

THE HIGHLAND 'LOCH' CLASS

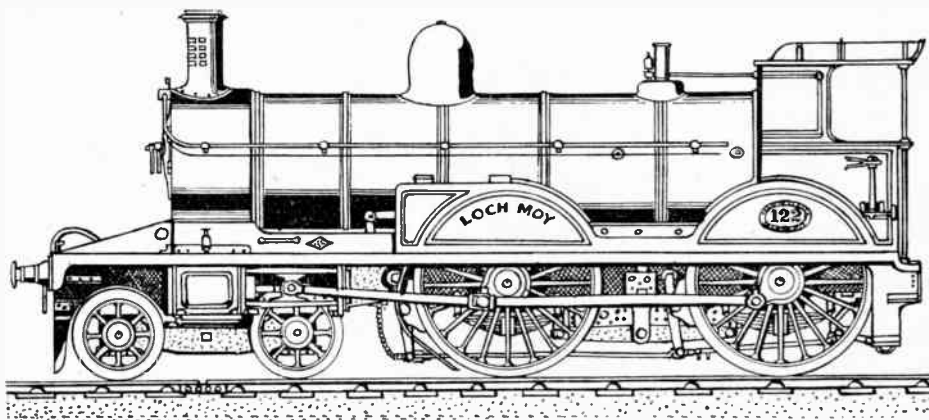

Coupled bogie passenger locomotive 'LOCH' class, Highland Railway

THE 4-4-0 locomotives of the *Loch* class were the last and final design by David Jones for the Highland Railway prior to his retirement as chief of the Locomotive Dept. in October 1896. They were intended for fast passenger work and at the time of their introduction they possessed many notable features which made them somewhat outstanding.

They were among the first engines in this country to be provided with piston valves whilst the first one of the class, No. 119, was equipped with Smith's patent feed-water heater. (The piston valves however did not prove altogether satisfactory and they were replaced from 1899 onwards by the balanced slide valve.) The class comprised 18 engines and the table gives the details.

The last three, Nos. 70-72 were ordered by Christopher Cumming from the original drawings of 1896 which comprised the following details: cylinders, 2 outside, 19 in. diameter and 24 in. stroke. Wheel diameters: bogie 3 ft. 3 in., coupled 6 ft. 3 in.; wheelbase: 6 ft. 6 in.

+ 7 ft. 0 in. + 9 ft. 0 in., total, 22 ft. 6 in. Boiler diameter, 4ft. 4½ in., containing 244 tubes of 1½ in. diameter. Heating surface: tubes 1,176 sq. ft., firebox 119 sq. ft., total 1,295 sq. ft. Grate area 20.5 sq. ft. Working pressure 175 lb p.s.i. Weight in working order: on bogie 17 tons 12 cwt, on driving wheels 15 tons 10 cwt, on trailing coupled

wheels 14 tons 9 cwt, total, 47 tons 11 cwt.

The tenders were of the usual Highland Railway six wheel type of the period. At the time of their introduction the 'Loch' class were the most powerful passenger engine to be put on the line, and for many years they were employed on the principal duties on all parts of the line.

No.	Maker and No.	Date Built	Date Withdrawn	Name	LMS No. in 1923
119	Dübs & Co. 3392	1896	1948	Loch Insh	14379
120	Dübs & Co. 3393	1896	1941	Loch Ness	14380
121	Dübs & Co. 3394	1896	1940	Loch Ericht	14381
122	Dübs & Co. 3395	1896	1940	Loch Moy	14382
123	Dübs & Co. 3396	1896	1934	Loch-An-Dorb	14383
124	Dübs & Co. 3397	1896	1938	Loch Laggan	14384
125	Dübs & Co. 3398	1896	1948	Loch Tay	14385
126	Dübs & Co. 3399	1896	1938	Loch Tummel	14386
127	Dübs & Co. 3400	1896	1930	Loch Garry	14387
128	Dübs & Co. 3401	1896	1930	Loch Luichart	14388
129	Dübs & Co. 3402	1896	1931	Loch Maree	14389
130	Dübs & Co. 3403	1896	1937	Loch Fannich	14390
131	Dübs & Co. 3404	1896	1941	Loch Shin	14391
132	Dübs & Co. 3405	1896	1947	Loch Navar	14392
133	Dübs & Co. 3406	1896	1934	Loch Laoghal	14393
70	N.B. Loco Coy. 21456	1917	1936	Loch Ashie	14394
71	N.B. Loco Coy. 21457	1917	1935	Loch Garve	14395
72	N.B. Loco Coy. 21458	1917	1934	Loch Ruthven	14396

COLLINS NUTSHELL BOOKS

WE have received six titles in the Collins Nutshell Books series, which should interest our readers, depending on their particular hobbies. These well produced volumes are of a handy pocket size and contain valuable information on the subject in hand. Very well illustrated, they are strongly bound in hard covers with distinctive wrappers. Altogether they are good value for a modest 5s. each volume.

Titles include:

'*Gardening Month by Month*,' by Ian G. Walls, in which modern aids to gardening are discussed and work throughout the year planned for you.

'*Small Boat Sailing*,' by Commander D. A. Rayner, written especially for those who intend to take up sailing for the very first time.

'*Tenpin Bowling*,' by John Sawyer, contains all the information needed to

make a start in this pastime.

'*Colour Photography*,' by Christopher Trent, is written in easy to follow non-technical language, and deals particularly with the choice of camera and film to use.

'*Stamp Collecting*,' by E. H. Spire, will be of interest to all age groups, both beginner and specialist.

'*Week-End Jobs*,' by Kenneth Gee, describes how to do many of the tasks in the home, capable of being undertaken by the average handyman.

Made from a Balloon

TOY AIRSHIP

DURING the war, barrage balloons holding aloft tough steel anti-aircraft cables helped to defend our cities against German bombers. Early in the war toy versions

By A. E. Ward

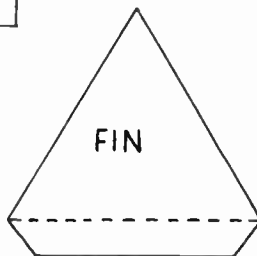
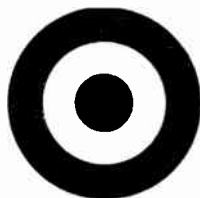
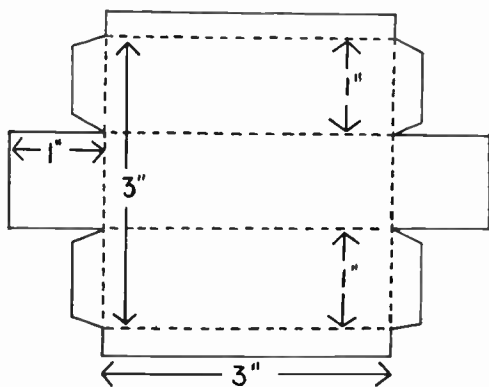

them to the underside of the balloon.

Cut out four fins of suitable sizes, as suggested by the triangular pattern. Bend aside the tabs and paste the fins to the rear of the balloon.

Paint two large circular symbols upon paper, as illustrated, and paste these upon the 'sides' of the balloon. Letters, numbers and wording cut out of magazines will provide neat bold markings which you may cut out and paste to the balloon.

The completed airship may be 'flown' by simply suspending it by a thread from the ceiling. Threads may be fixed to the toy with Sellotape or you may like to attach the toy to a cotton 'hoist' running through a bent pin stuck in the ceiling. A youngster will love taking the airship up and down by merely pulling and paying out the end of the hoisting thread.

of these weapons were available. Large elongated fourpenny balloons were sold with sets of cardboard fins to be attached when the models were inflated. Recently the toy reappeared in the guise of an 'atom' space ship. The novel balloons sold like hot cakes at the 1962 Farnborough air show. You can quickly make up another form of the toy if you follow these instructions for constructing the 'Scout' airship.

Purchase a large plain 'sausage' balloon and inflate it to nearly full size. Tie the neck tightly with cord to prevent any air escaping. Study the three patterns before making the various attachments for the balloon in light stiff paper. A 'gondola' measuring 1 in. by 1 in. by 3 in. will be suitable for a small balloon, but these dimensions should be doubled for a larger balloon. Mark out the pattern for the gondola in pencil before cutting it out with sharp scissors. Fold along the lines shown dotted and paste the small tabs behind the end pieces to form a box shape.

Paint the gondola blue or black and paste on pieces of white paper to suggest windows. Tiny faces cut out of comic papers may be pasted upon the gondola windows to resemble passengers. Bend

● Continued from page 398

A TEACHING MACHINE

way, there being no knob for winding back. This is intentional — to prevent cheating by discovering the answer before writing it down. The tinplate key should not, of course, be kept in place.

The paper roll is divided into 'frames' by drawing lines across it at 2 in. intervals, and it is then programmed. The principle on which the machine works is that one question at a time appears in the window, with a space above it for the answer. When this has been written, the knob is turned until the answer given is below the plastic shield, and cannot be altered. The correct answer now appears below the question, and the written answer can now be checked. The two numbered discs indicate how many questions have been correctly answered, and are numbered and

screwed to the top of the box.

Fig. 4 shows how the frames are divided. The upper half-inch of the frame shows the correct answer to the previous frame P, the middle section S is the space for the answer to be written in, and the lower section Q contains the written question.

Copying this example on to a piece of paper roll will soon show how the method works, if there is still any doubt.

Most subjects can be programmed for use in a teaching machine, but it is obviously pointless for the same person to write out the programme and then use it himself — with the exception of work which can later be used as revision. Two people working together, however, can find one of these machines both rewarding and entertaining.



All sets contain a book of instructions

CHEMISTRY SETS

No. 13. An excellent low-price set containing a bunsen burner with rubber tubing, flask, and a good supply of chemicals, test tubes, filter funnel, paraffin burner, etc

16/11d.
Post 2/-

No. 14. Contains an ample supply of chemicals and apparatus, including bunsen and paraffin burners, flask, test-tube holder, brush, pipette, asbestos square, test-tube stand, funnel, rubber and glass tubings, etc.

23/11d.
Post 2/3d.

No. 15. (Illustrated) A very popular set containing the new detachable sloping rack for the tubes of chemicals. Contents also include test tubes, brush, holder, stand, tripod and gauze. U-tube, pipette paraffin and bunsen burners, flask, funnel, filter papers, etc.

37/6d.
Post 2/6d.

No. 17. A really fine chemistry set containing an excellent selection of chemicals and apparatus to enable the young chemist to carry out the many interesting experiments set forth in the splendid new book of instructions especially written by an experienced Science Master.

55/-
Post 2/9d.

Get these modern Science Sets from
HOBBIES LTD, (Dept. 99), DEREHAM, NORFOLK

MAGNET - TRICITY

No. 1. This beginner's set contains everything necessary for elementary experiments in Magnetism and Electricity, including a powerful magnet, compass, rheostat, Morse tapper, etc.

30/-
Post 1/9d.

No. 2. (Illustrated) A fine set for experiments. Contents include a powerful magnet, compass, rheostat, Morse tapper, fire-alarm, etc.

50/-
Post 2/-

No. 3. A splendid set which includes a powerful magnet, compass, rheostat, Morse tapper, fire-alarm, electric motor, pliers, Crocodile clips, electro-magnet, galvanometer, and other apparatus.

79/6d.
Post free



All sets contain a book of full instructions but no batteries

The name DAVIES is synonymous with all that is best in Roller Skates. Strong, speedy, light and durable, they are fully guaranteed as to workmanship and materials.

DAVIES Roller Skates

No. 10

Junior model with girder-type construction and rubber composition wheels. Self-lubricating nylon bearings. Amazing value.

18/11 pair
Post 2s. 6d.

No. 4

Senior model with double ball bearings and rubber composition wheels. Electro-plated with oscillating cushion. Very good skates, indeed.

27/9 pair
Post 2s. 6d.

1A SPECIAL

The best of all! Chromium-plated chassis, rubber toe brakes, extra wide rubber composition wheels with 192 precision ball bearings.

37/6 pair
Post 2s. 6d.

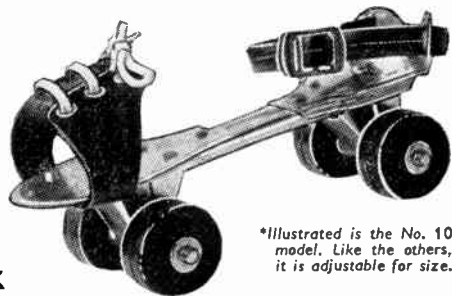

*Illustrated is the No. 10 model. Like the others, it is adjustable for size.

HOBBIES LTD, (Dept. 99), DEREHAM, NORFOLK



GORDON FRANKS

GORDON FRANKS was born in Glastonbury, Somerset, on 4th November 1923. He was six years old when he started playing the piano — and eight when he started having lessons. There was a lot of music around the Franks' home. Gordon's mother was a pianist, his father a singer, and brother Alan is a well-known trumpet player.

'When I was 10', says Gordon, 'I took up percussion, joining Glastonbury Town Silver Band. I learned all the percussion instruments and Alan, playing cornet, was in the band with me. Then when I was about 11 years old I started studying orchestration, and did my first orchestration when I was 12. It was a hymn for the band'.

Gordon Franks left school when he was 16, and went to work at an electronics firm near Glastonbury, staying there for one year. Then he joined Waldini's Gypsy Band (on percussion and piano), moving on after a year to the Billy Gold Band in Exeter.

'We were bombed out after I had been with the band three months, so I came up to London to work for Jack Hylton. I went with the touring version of the *Garrison Theatre* show, later went into Ensa for two months, and was then called up for service in the Army'.

Gordon served in the Royal Army Tank Corps — he was nearly 19 years old at the time. 'They put me in the 9th Lancers' Band on piano and percussion. I was also doing orchestrations for them, and we played in North Africa, Italy, and Greece. Then I was put on teaching'.

Gordon was demobilized in 1947, and immediately joined up with the late Leslie 'Jiver' Hutchinson, and the remainder of the Ken 'Snakehip' Johnson band, which had survived the bombing

of the Cafe de Paris in London. They played West End clubs, restaurants, and hotels in the late 1940s, and early 1950s — but without a lot of success or financial gain.

The next move Gordon made was to freelance. At this time he was also playing vibraphone, and became one of the circle of London's freelance musicians. Later he took up musical direction, and he soon became well-known for his work on the Bernard Braden television shows, *Citizen James*, *The Eric Sykes Show*, and *The Rag Trade*.

He has also worked on the orchestration of such films as *The River Plate*, and *Bachelor of Hearts*, and more recently composed, orchestrated, and directed the music for the film *The Seven Keys*.

Gordon is 5 ft. 7 in. tall, weighs 13½ stone, has hazel eyes, and is married,

with two children, Melvyn (5), and Yvonne (9). He likes the works of Tchaikovsky, and admires the artistry of Ella Fitzgerald, and Frank Sinatra.

Talk to Gordon Franks about his most embarrassing moment, and he will tell you it was in Czechoslovakia when he was playing with the Ken Johnson band. The piano just collapsed on top of him. He supported it with his knees as long as he was able to, and then the rest of the band rallied round him and lifted it off.

Gordon Franks made his bow on E.M.I.'s Parlophone label in May 1962, with his own composition, the theme from B.B.C.-TV's *The Rag Trade*, called *Rag Trade Rag* (45-R.4910). The coupling was *Sid's Tune* from the *Citizen James* series.

HUMBROL

really brings
your models
to life!



Make the most of your models and give them a really authentic finish with HUMBROL Enamel. Humbrol comes in a wide range of glorious colours and is not spoiled by water, oil or diesel fuels. Ask for one-hour-dry Humbrol, the paint that'll give your models a super-smooth finish without any brushmarks. It's recommended by all the leading kit manufacturers. Get it at your local model or Hobbies shop. ¼ oz. tin only 9d.

Humbrol complies with Safety Code B.S.3443:1961.

Ask also for Britfix 77 Polystyrene Cement, Britfix 66 Balsa Cement, Humbrol Authentic Railway Colour, Humbrol Scenic Enamels and Humbrol Universal Cleaner.

A CAGE FOR ZOO ANIMALS

THIS small cage is intended for use with the many small zoo animals which are so popular with children as toys. Cut one each of A and B, and two of D from $\frac{1}{4}$ in. wood. The lid C is cut from the piece B. Assemble as shown in the sketch, using short lengths, about $2\frac{1}{2}$ in., of medium gauge wire. The lid is hinged back in place, and a small knob and stop provided.

Cut the wheels E from $\frac{1}{4}$ in. wood, or use ready-made aeroplane wheels. Paint the cage cream, and decorate with red and yellow. (M.p.)

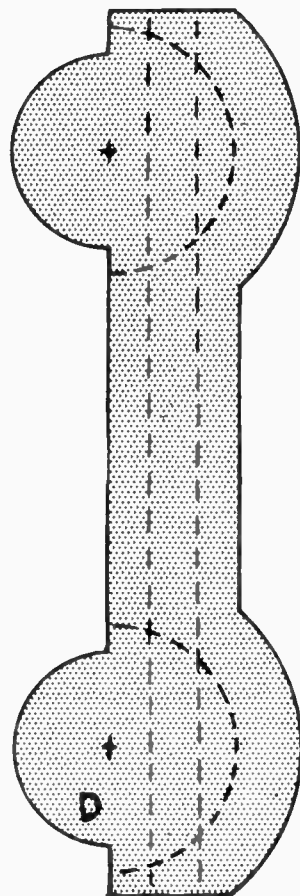
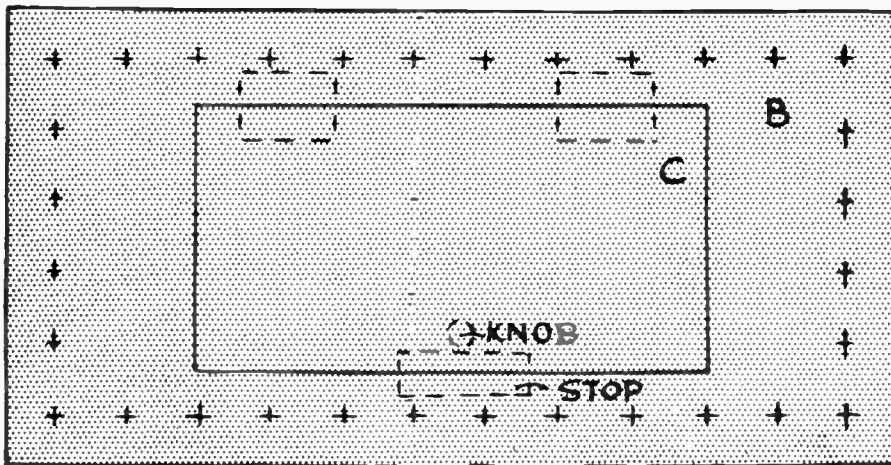
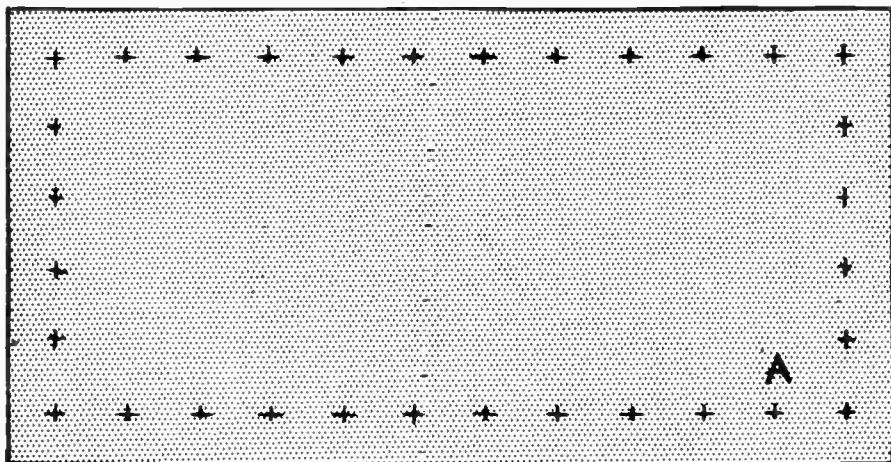
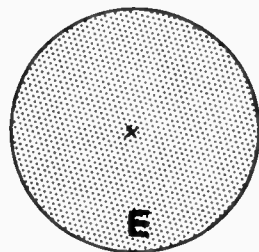
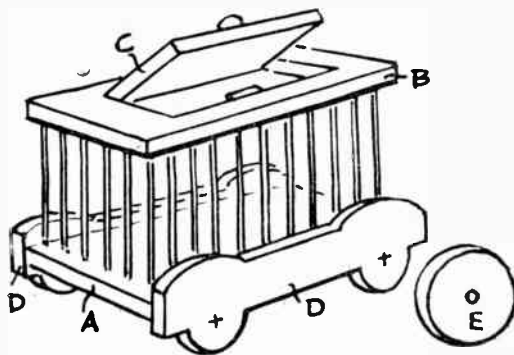

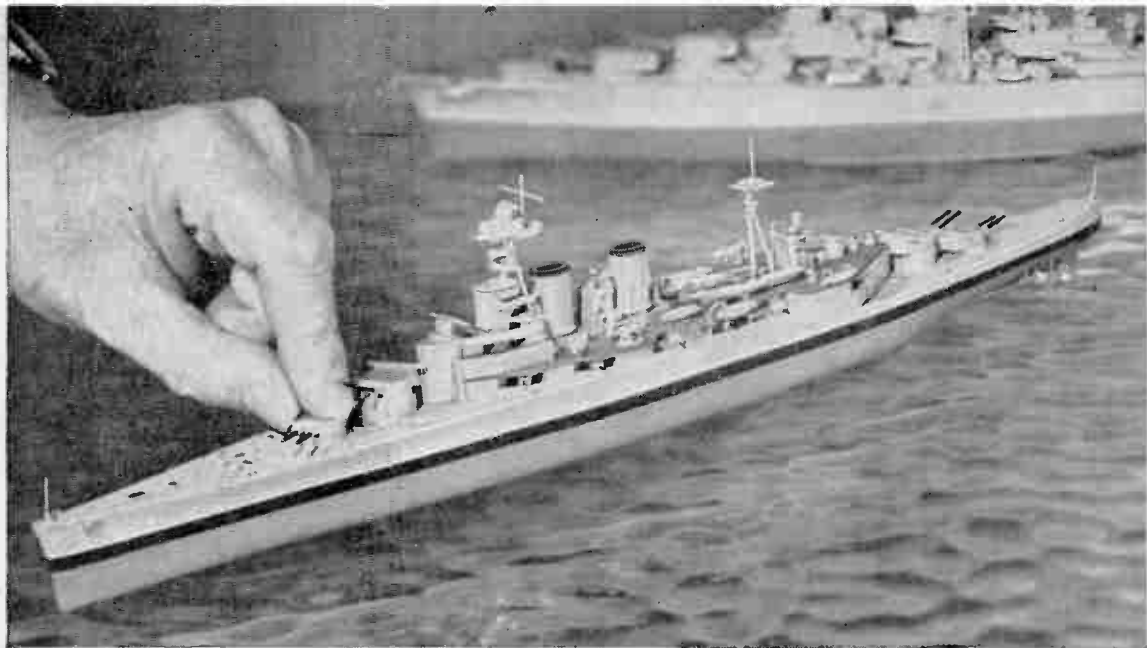

... even the turrets rotate!

This Airfix 1/600 scale H.M.S. HOOD is an exact replica of the battleship sunk in 1941. It bristles with detail — and guns. 17" long — 133 part kit 6/-. It's typical of the realism you get with Airfix models. They're just like the real thing! More than that, though, Airfix give you constant

scale, so that the models of every series are proportionately right; and a great ever-increasing range — there are 11 series now, with over 150 kits. At prices from 2/- to 12/6, Airfix are great on value too.

For endless modelling fun — make it Airfix.

**JUST LIKE
THE REAL THING!**

AIRFIX

**CONSTANT SCALE
CONSTRUCTION KITS**

From model and hobby shops, toy shops, and F. W. Woolworth.

STOP PRESS !

LATEST AIRFIX PRODUCTION TANK TRANSPORTER

A realistic HO/OO model, 8 ins. long, of the Scammell 30-ton vehicle used for tank movement and recovery. 108-part kit complete with markings and drivers

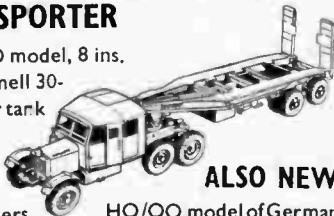

ALSO NEW

HO/OO model of German

75 mm Panzer Assault Gun 2/-.

3/-. 1.118

GET YOUR CATALOGUE

28 pages of models, facts and kit details from your dealer - only 9d



27th MARCH 1963

VOL. 135

NUMBER 3511

THE ORIGINAL
'DO-IT-YOURSELF'
MAGAZINE

HOBBIES *weekly*

FOR ALL
HOME CRAFTSMEN

PROJECTS USING PICTURE FRAMES

Also in this issue:

'RADIO HIGH' ON
METER RANGES

COLLECTORS' CLUB:
ARRANGING CARDS

MORE RUSTIC
GARDEN PROJECTS

INDIAN ART
IN FRETWORK

PHOTOGRAPHS WITH
THE 'HALF FRAME'

INDOOR GARDEN
FEATURE

DISC BREAK:
CAROLE DEENE

BIRD OVERLAY
PATTERNS

ETC. ETC.

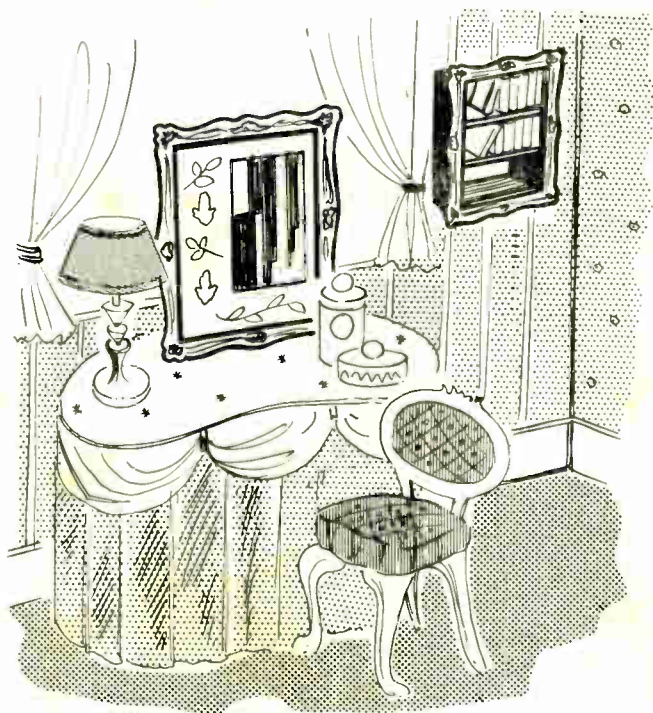

Up-to-the-minute ideas

Practical designs

Pleasing and profitable things to make

5^p



ARRANGING A COLLECTION OF CARDS

WE receive many inquiries concerning the arranging of a post-card collection, especially from readers just starting the hobby.

There are many ways to arrange a collection, and the best way for each individual depends on many things, including the size of the collection, how much one can invest in accessories, the purpose to which a collection is put, etc.

Of course, the nicest way in which to keep and display a collection of cards is in albums, but this can be quite expensive if one has a large number. Most of the regular postcard albums are of the slotted type, in which there are slots in the pages through which the corners of the cards are placed to keep them in position. Some collectors use scrapbooks and mount cards with art corners such as are used in photograph albums. Albums are the best if you like to show your cards to friends, as it makes it possible for the cards to be seen but not touched.

Box Files

Some collectors use boxes in the size used by business houses for filing 4 in. by 6 in. cards. These are available in metal, and each box or drawer will hold about 1,000 cards. Files of cardboard may also be used, and are, of course, much less expensive. If one has a large collection and does not care to invest in files or albums, one of the most popular methods is to file cards in shoe boxes. When filed this way, the boxes should be marked, and the cards separated by subjects or states or companies, or whatever categories one is collecting. Ready-made blank guide cards can be used, or the collector can make his own 'guides'.

Now the question arises: 'What shall I collect?' There are many advanced collectors who like to take it upon themselves to tell others what they should or should not collect. That is not the purpose of this article. We feel that every

new collector should decide for himself. Cards which may interest us may be of no interest to anyone else.

There are such varieties of subjects on view-cards that everyone should be able to find a subject or subjects of interest. Our advice to beginners would be to start as a general collector, that is, to collect all kinds of cards they can get their hands on. After they have a thousand or so, they will have a pretty good idea as to just what subject is of the most interest to them.

NOTE TO
CORRESPONDENTS
All correspondence on any subject covered in this magazine must be addressed to: The Editor, Hobbies Weekly, Dereham, Norfolk. If a reply is required, queries should be accompanied by a stamped addressed envelope and reply coupon inside back cover.

May we make one suggestion? When you consider the subject you want to specialize in, remember to pick one which is not so narrow in scope that you will soon have your collection complete, and there is nothing more to look for. Remember, in any hobby, half the fun is in the SEARCH.

For your pleasure, collect something that interests you, not what someone else thinks you *should* be interested in. It's your collection, so make it to suit yourself and enjoy your hobby.

STAMP NEWS FROM FIJI



IN 1961 the Government of Fiji issued eight new postage stamps as the first step in the improvement and standardization of the definitive series. On the 3rd December last another six new stamps were released and the 2½d value, which was withdrawn in November 1961, was reintroduced, in a new colour.

Details of the new stamps are as follows: 1d., 1½d., and 2½d values, recess printed by Bradbury Wilkinson & Co. Ltd., on CA (block capitals)

watermarked paper in size 26 mm. × 21 mm., perforation to perforation, in vertical format, in sheets of sixty stamps. 3d., 1s. 6d., 2s. and 5s. values, printed by photogravure by Harrison & Sons Ltd. The 3d. value is 30 mm × 26 mm, perforation to perforation, and the other values size 38 mm × 26 mm, perforation to perforation. The 3d. and 2s. values are in vertical format and the 1s. 6d. and 5s. values in horizontal format. All four values are in sheets of sixty stamps.

RUSTIC WORK IN THE GARDEN

IN a previous article we described the general principles governing the production of rustic garden features and we will now consider other small items. These will be of interest either for your own garden or making for sale.

HANGING BASKET

This is of simple construction, made entirely from rustic material of $\frac{3}{4}$ in. diameter. Twenty-one pieces each 10 in. long are required although the basket may be made to any specification. No doubt you will be able to use many short, surplus pieces left over from other work. In this instance larch is to be recommended and the bark should be left intact.

The basket is suspended by means of four cords and all but three of the rods are drilled with a small hole about $\frac{1}{2}$ in. from the ends. That is all the preparation that is needed.

By H. Mann

Lay two of the rods parallel to each other with a further two placed at the ends on top at right angles. We now nail on the three rods which have not been drilled, to the crosspieces, making the floor of the basket (see illustration). The two outer rods are loose but these are fastened to the others by passing a wire or strong nylon cord through the holes. Continue building up the basket by threading rods first one way and then the other. Tie large knots at the four bottom corners to secure the rods, allow some surplus at the top ends of the cords and tie to a suitable ring which may then be used for suspending the basket from a hook.

This item may be made for your own garden but if for sale you might wish to advise your customer on the best method of filling for growing plants.

First fill the spaces between the bars with moss, which will show on the outside, and cover this inside with old newspaper. If you have any old sponges lay these at the bottom, covering with a piece of muslin or thin sacking. Now fill up with good soil to which some peat moss has been added and the basket will be ready for setting out with geraniums and other suitable plants. Alternatively, the plants may be left in their pots but the filled basket looks much better.

GARDEN CHAIR

The chair shown illustrated requires a little more attention and in this instance we make use of the joints mentioned in

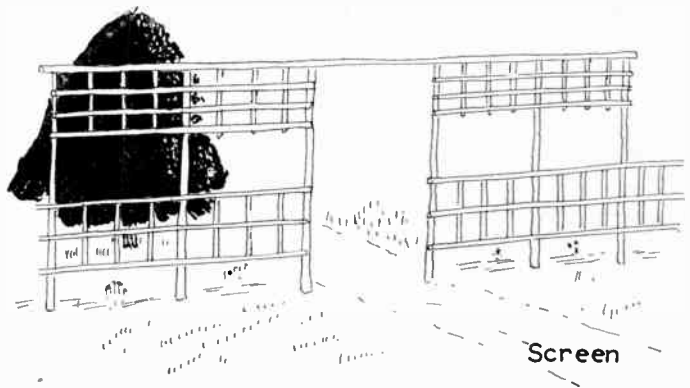

the previous article. It is advisable to strip the bark from the poles to avoid damage to clothing apart from the fact that the chair will be more comfortable.

We require two straight pieces of 3 in. diameter and 3 ft. long for the back leg, and two pieces of the same diameter 2 ft. 3 in. long for the front legs. Cut two pieces 22 in. long and of 2 in. diameter for the front and back rails of the seat and two more for the side rails.

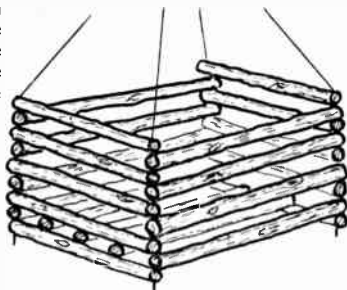

Take the two front legs and prepare a mortise by making holes 16 in. from the bottom. Make this mortise about 2 in. in diameter and $\frac{1}{2}$ in. deep. Insert one end of the front seat rail and secure with a long nail through the other side of the leg.

Now cut two pieces a little over 21 in. long and of 1 in. diameter. Make cupped joints at the ends and these will make additional supports for the front and back legs. Take one of the pieces, sliding into position so that the joints will fit snugly on the insides of each leg, nailing through the latter so that the rails are 4 in. from the bottom.

Fit the seat and bottom supporting rails to the back legs. Take a second piece of wood cut for the seat support, preparing mortises 2 in. in diameter and $\frac{1}{2}$ in. deep on the insides of the back legs. These should be 16 in. from the bottom of the legs as with the front ones. Secure the seat rail with nails, slide the bottom rail down the legs until 4 in. from bottom and nail.

We now prepare mortises 2 in. in diameter and $\frac{1}{2}$ in. deep and 16 in. from the bottom in the sides of the front legs next to the seat rail. Similarly with the back legs when we can fit the two side rails of the seat. Nail these members with long, strong nails remembering that they have to bear the full weight of the sitter.

Two further rods 1 in. in diameter and just over 19 in. long are prepared with cupped ends. Slide one down between front and back legs on each side and until 4 in. from the bottom and nail securely.

The two arms are cut from 2 in. diameter material each 22 in. long. The outside ends remain flat but should be smoothed, while the other ends are cupped so that they will fit to the back legs. Nail the joints securely. Cut another

● Continued on page 408

INDIAN ART IN FRETWORK

WE often get letters from readers saying that they cannot obtain sufficient patterns to engage them on their fretwork hobby, and we commend to them the idea sent to us from India and illustrated by the photographs herewith.

In his letter enclosing the photographs, Mahendra Sen Jaini of Manoranjan Bhavan, 11 Darya Ganj, Delhi, India, emphasizes the interest of himself and his children in fretwork. Designs, however, are very scarce in his country, and he has therefore resorted to the exploration of fresh avenues and experimentation with his own designs.

The question arises, if such appealing pieces can be thought out and worked on so successfully by this correspondent, there may be others of our readers who have attempted similar work. If so, we should like to know of their activity and if possible see a photograph suitable for publication, as we think that in this way the idea might commend itself to other readers in formulating designs of their own. Unfortunately our publication cannot satisfy the demands of readers by producing such designs because of the limitations in the size of the design sheet.

As readers can see, the work has been beautifully executed and put to very good use by providing artistic and novel decoration. Following are the notes on each project given by the author.

A wardrobe with a difference

An artistic situation from the great epic *Mahabharata* has been transferred

to the eight panels of the two doors. The design has been cut with a hand-frame on $\frac{1}{4}$ in. thick teak ply and mounted on to the door frame backed by white glass-panes. Each panel is 12 in. wide by 10 in. high. A $\frac{1}{4}$ in. border provided all round each panel is covered by the four sides of the frame. Note the string of the bow

ILLUSTRATIONS ON OPPOSITE PAGE

which, though running through all the four panels on one side, has been fitted in a way that it looks quite straight and gives the impression that it is in one whole piece. The pieces have been polished with the other woodwork of the almirah-like furniture.

Wall decoration

In the same style has been worked out by my daughter this adaptation of a painting of *raga-todi* (a musical note) from the famous school of Kangra Valley Painting. Like the former design, this also has a $\frac{1}{4}$ in. border running round each panel to hold support behind the frame. Each of the four panels is again 12 in. high by 10 in. wide, in $\frac{1}{4}$ in. thick plywood, cut by a hand-frame. There is no background, which is provided by the wall surface on which it is

hung. The effect of the 'painting' changes with a change in the colour of the wall. The whole piece, including the frame, has been polished with furniture spirit-polish.

Artistic table decoration

This is an adaptation of an ivory statue of exquisite beauty. The subject is the four-armed Goddess of Learning and Fine Arts, holding a mace, a veena (musical string instrument), a dove and a swan. The lotus and the Goddess have been cut in $\frac{1}{4}$ in. thick plywood in one piece, about 12 in. high. The base depicts a lotus leaf in $\frac{3}{8}$ in. thick five-ply. The slot in the stand has been cut so that the figure tilts back a little. With the halo painted in gold, the rest of the figure in white, the lotus in pink and the leaf (base) in green, it gives a beautiful effect. White is, incidentally, the colour traditionally associated with Goddess Saraswati.

Triangular corner table

Designed and cut by my daughter in $\frac{3}{8}$ in. thick rose-wood, it is a pretty addition to the drawing room and can hold small pieces of decoration or an ash-tray. The vertical figure constitutes a three piece Lion set together and fixed into the foliage base by small slots and glued in position. The top has a triangular floral design, under which another small triangular piece has been provided to hold the vertical pillars through slots and then fixed to the top by screws and glue. Spirit polished like furniture. (P.P.)

● Continued from page 407

RUSTIC WORK IN THE GARDEN

piece of 2 in. diameter material 30 in. long to fix across the top of the seat at the back, overlapping at each end as shown. Smooth off both ends. Note that it will be an advantage to cup the tops of the back legs to take this top rail.

The remainder of the material required is for filling between the main rails and 1 in. diameter will be suitable. In the illustration you will see that we have used vertical rods but the design may be amended in many ways. Cut two lengths a little over 19 in., cup jointing the ends. Slide one down between the back and front legs above the seat and

under the arms until about 3 in. above the seat rail, nailing secure. Now prepare six pieces 5 in. long and 1 in. diameter. Cup joint at both ends and fit vertically, three at each side of the chair, between the arms and the rail, arranging at equal distances.

We now require three pieces 1 in. diameter and 14 in. long and one a little over 21 in. long. Cup joint the ends. Slide the 21 in. piece down between the back legs until 3 in. from the back rail of the seat. Secure this piece, fitting three 14 in. rods vertically between the horizontal bar and top rail of the chair back.

For your guidance I must mention that I made the seat itself from rustic poles, which proved to be most uncomfortable! Consequently, I found it necessary to replace these rods with 2 in. by $\frac{3}{4}$ in. planed material.

Three coats of brown copal varnish will complete the job making a fine chair for the garden.

You will no doubt realize that the same idea can be used for making a larger garden seat, since it only requires to be a little wider. In this case it is better to arrange for bracing struts to be fitted across the angles of the front legs and seat rail, using 2 in. by 1 in. material for the seat.

Bird tables, birdhouses and the like may also be constructed from rustic material, while screens, fences and pergolas will make attractive garden features.

**PROJECTS IN
FRETWORK
DESIGNED AND
EXECUTED
BY AN INDIAN
READER
AND FAMILY**
(see text opposite)



The wardrobe



Artistic table decoration

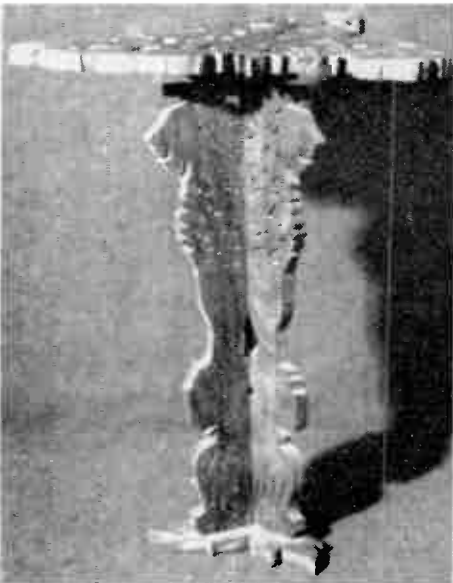

Corner table



Panelled wall decoration

FUN AND FANTASY*

Projects Galore with PICTURE FRAMES

THOSE old frames lying in the loft or junk room are just the thing for the useful projects shown in these illustrations. Glass is not essential, only the frames being required for the various ideas. If you cannot find what you want at home you can buy old pictures for a shilling or two at sales or from secondhand dealers. Maybe your friends would be glad to get rid of some of their 'junk'.

If the frames are in good condition they can be cleaned with turpentine, and varnished. If on the other hand the finish has deteriorated, then they should be lightly glasspapered and repainted.

The first suggestion is for a small open wall cabinet suitable for sports trophies, glass ornaments, flowers or even a fish bowl. The diagram in Fig. 1 shows how a small box can be made from wood and hardboard glued and pinned together. The frame will, of course, be glued to the front to give it a nice setting. On the size of the frame will, of course, depend the size of the box.

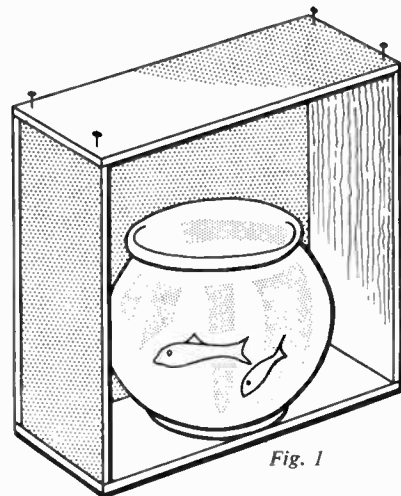

Fig. 1

The ornament in Fig. 2 is suitable for a hall or landing. The 'picture' consists of a delicate floral print — they are often given away in periodicals — or suitable piece of embroidery. The background should be of a bright contrasting colour, either painted or a piece of material stuck down to card.

To the front of the frame fix a small shelf to which are screwed two or three Hobbies wooden balls. Holes are bored in these before fixing, to take ornamental candles.

Continuing with the same idea for decoration, Fig. 3 indicates another way

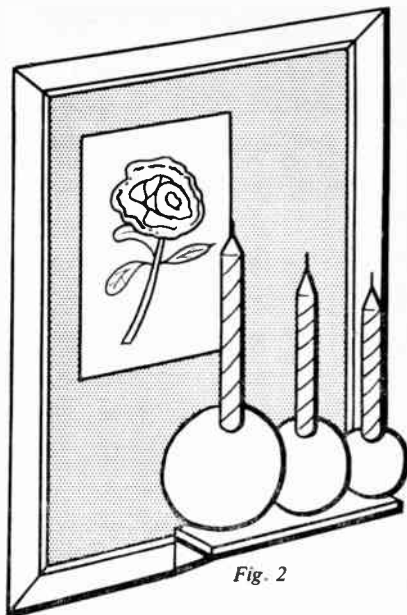

Fig. 2

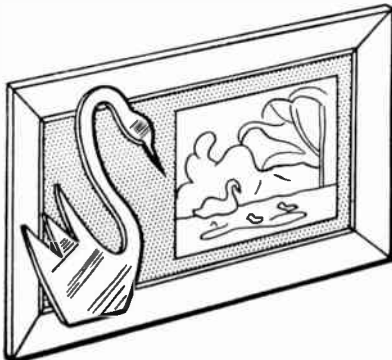

Fig. 3

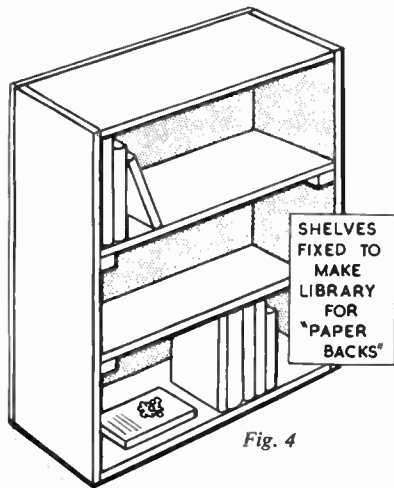

Fig. 4

of adapting a frame. In this case a 'wild life' picture, say, a birthday card, is glued to a bright contrasting background, and a cut-out silhouette in copper or brass screwed or pinned over one end as shown. Of course, wood or coloured plastic could be used in lieu of brass if desired. The 'swan' shape can be enlarged to any size by the square method.

To use a large, heavy frame, small hanging shelves can be made as in Fig. 4. Make them of wood and hardboard, strengthening the shelves with battens as indicated. These shelves can



Fig. 5

be used for knick-knacks or books such as paperbacks or pocket editions. The front will be framed and wall hangers added.

The last and most ambitious idea is to use a large gilt frame as a dressing table mirror. The design in Fig. 5 shows a mirror let into a backing of card, which should be of a light brown or orange shade. The leaves are pressed between pages in a book, and glued to the card as indicated. The mirror is hung direct on to the wall.

The diagram in Fig. 6 suggests a way of making a simple dressing table of the popular kidney shape, and suitable for use with the mirror, as shown in the illustration on the front page. Since the drapes will hide the actual construction it is not essential to make any elaborate joints. Plain pieces of wood and hard-board can be glued and nailed together to form shelves and supports. The top should be of $\frac{1}{2}$ in. plywood, covered with a hard wearing plastic such as Warerite, and the drapes could be any suitable material or plastic. (M.h.)

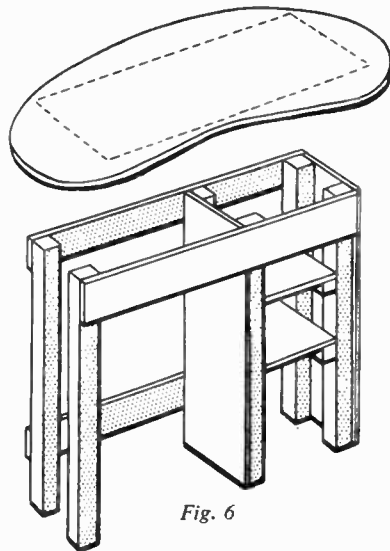

Fig. 6

TRANSFORMED PORTRAITS

YOU can transform a pig into an alligator, a boy into a girl, or merely make an elephant vanish, with the aid of a simple toy made with a large envelope, a stiff white card and some pictures removed from old magazines.

Prepare a rectangular piece of card-board which will slip easily into a large stout envelope. Use a pencil and ruler to mark out a series of $\frac{1}{2}$ in. wide 'slots', half an inch apart, across the narrow dimensions of the envelope.

The slots should begin about one and a half inches from the 'bare edge' and finish an inch from the beginning of the flap. Cut out the slots tidily with sharp pointed scissors, and paint this face of the envelope with black Indian ink.

Slide the card into the envelope. If you are anything of an artist you will be able to draw a pig between the cross pieces, as it would appear inside a cage. When the drawing is complete, pull the card out half an inch.

Of course the pig will have disappeared behind the black bars and the 'cage' will seem empty. Now draw an alligator behind the bars in the same manner as you depicted the pig. You will see that by sliding the card in and out, you will be able to bring about the metamorphosis of a pig into an alligator and vice versa.

If you are not an artist, you can contrive your subjects in a different way. Acquire a pair of photographic portraits

which will fit into the envelope. Select a male and a female picture from magazines. It will be interesting if the man is in 'black and white' and the young woman is in colour.

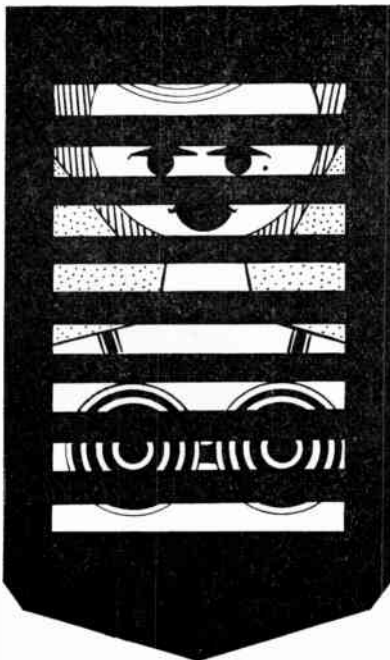

Rule off the pictures into $\frac{1}{2}$ in. wide slices, cut out the strips, then paste alternate slices of the pictures upon the cardboard. Think a moment about this arrangement. This card will produce a startling 'sex change' in your magic envelope, similar to the transformation of animals.

To make an elephant 'vanish' will now be easily accomplished. You will use alternate slices of only one picture. At the start of your little illusion the elephant will be visible between the bars. But after you pull out the card slightly, the strips of picture will be hidden behind the bars and only the white card will be seen. (A.E.W.)

KITE MAKING AND FLYING

By Harold Ridgway

WHAT do you know about a Tonking, Pegtop or Double Butterfly? These are some of the names given to types of kite flown in one of the world's oldest pastimes.

This book describes 20 different kites to make and will be of interest to all readers, irrespective of age. Much useful information is given on getting the most from this hobby, including notes on the determination of weather conditions. The use of kites through the ages in war and in peace makes interesting reading. Published by Arco Publications, 9 Grape St., London, W.C.2.—Price 15s. 0d.

INCREASE METER RANGES

MANY experimenters and radio constructors have a milliamperemeter. As it stands, such an instrument will have a single current range, so it can be used for measuring currents in this range, but not for other purposes. Such a meter can, however, be converted to read voltages, or higher currents. It can thus be used as the basis for a multi-range voltmeter or test-meter. Multi-range meters, such as sold for radio testing, etc, actually consist of a single range milliamperemeter, with resistors for voltage measurement, and so on.

The meter

If this item is already at hand, resistor values can be chosen to suit it. But if a meter is to be purchased, one of sensitive type will be best for most purposes. A meter reading 0-0.5mA. will do very well. Meters reading 0-1mA. are also often used. Surplus meters are much less expensive than new instruments. Suitable meter movements are also found in many surplus aircraft and other units, such as electrical temperature gauges, bank and climb indicators, etc.

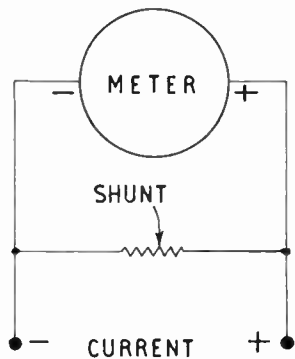

Fig. 2 — Using a shunt resistor to measure current

The actual size of the meter is not very important. It may be flush mounting, to fit in a hole the same size as the meter case. Or it may be of projecting type, in which the case stands above the panel.

A neat wooden box should be made, to house the meter, resistors, and other items. Thin sheet Paxolin is easily obtained, and will do well for the panel. Terminals or sockets are fitted to the panel, so that flexible test leads can be connected.

It is not possible to reduce the current range of a meter, though the current range can easily be increased. This is one

reason for having a sensitive instrument. A sensitive meter will also draw less current, when measuring voltages, and this is an advantage.

Volts ranges

The milliamperemeter is arranged to read voltages by adding a resistor in series with it. This resistor is R1 in Fig. 1. To measure voltages in this range, test

By 'Radio Mech'

leads are taken to sockets marked Negative and A. The meter and single resistor are all that will be required for a single range voltmeter.

As other ranges can be obtained by adding other resistors, the resistor R2

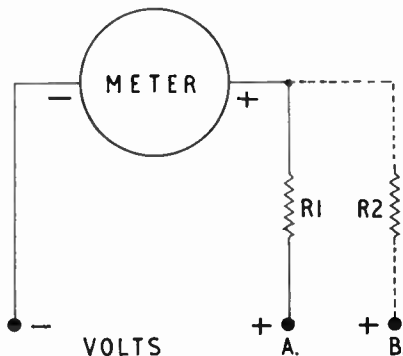

Fig. 1 — Circuit for a voltmeter

may be added, with socket B. Connecting to Negative and B then gives a second voltage range. It is thus easy to provide a single range, or as many ranges as wanted, using one extra resistor and socket, for each range.

The resistor value, for any meter and voltage range, is easily found. To do this, divide the voltage range required by the current taken by the meter, to obtain the answer in ohms. For example, a range of 0-10V. is wanted, with a 1mA. meter. There are 1,000 milliamperes in 1 ampere. So 1mA. = 0.001 ampere.

$$\frac{10}{0.001} = 10,000 \text{ ohms}$$

Therefore R1 can be 10,000 ohms (10K.) for 0-10V. If preferred, current can be expressed in mA., and the result is then in thousands of ohms (K-ohms).

For example, 10/1 = 10K., which is the same result as before.

The following are examples of resistor values, for various meters and voltage ranges.

1mA. meter. 5V., 5K. 10V., 10K. 50V., 50K. 100V., 100K. 250V., 250K. or $\frac{1}{4}$ megohm.

2mA. meter. 5V., 2,500 ohms or 2.5K. 10V., 5K. 50V., 25K. 100V., 50K. 250V., 125K.

5mA. meter. 5V. 1,000 ohms or 1K. 10V., 2K. 50V., 10K. 100V., 20K. 250V., 50K.

About 3 ranges, covering about 10V. to 250V. will do for many purposes. It is convenient to choose ranges to suit the meter scale. For example, 0-5V., 0-50V., and so on can easily be read on a meter marked 0-5, while 0-10V. and 0-100V. would be easily read on a scale marked 0-1 or 0-10.

Current ranges

The current which may be read can be increased by adding a resistor across the meter. This is called a shunt, as in Fig. 2. The resistance of the shunt can be calculated, or found by trial.

To calculate the shunt value, in ohms, first decide how many times the meter reading is to be increased. For example, if the meter reads 1mA., and a range of 0-10mA. is wanted, this number is 10. Take 1 from this number, and divide the

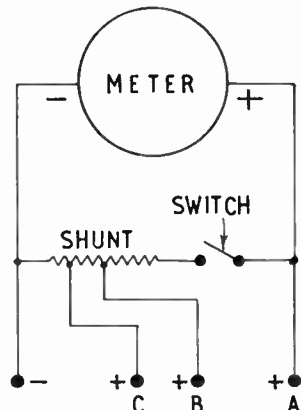

Fig. 3 — Meter with several current ranges

meter resistance by the result. As example, assume a 10mA. range is wanted with a 1mA. meter of 100 ohms resistance.

$$\frac{100}{(10 - 1)} = \frac{100}{9} = 11.1 \text{ ohms.}$$

So when a 11.1 ohm resistor is added as in Fig. 2, the meter will read 0-10mA.

To make low resistance shunts, some resistance wire is handy. Assume 36 s.w.g. Eureka resistance wire, having a resistance of 1 ohm per 2.4 in. is used. For 11.1 ohms, the length is $11.1 \text{ by } 2.4 = 26.64 \text{ in.}$ The required wire is cut off and wound on a strip of insulating material.

Shunt values can also be found by trial, using one of the following methods:

Battery and variable resistor. Connect a dry battery and suitable variable resistor in series with the meter, such as 5K. and $4\frac{1}{2}\text{V.}$ for 1mA. Adjust the

Next week 'Radio Mech' will describe how to make a Wave Trap to reduce or eliminate interference from unwanted stations. Make sure of your copy of Hobbies Weekly.

variable resistor until the meter reads full scale, that is, 1mA. Connect the shunt and adjust its value until the meter shows 0-1mA. This shunt will now provide a 0-10mA. range.

With second meter. If a multi-range meter can be borrowed, wire it in series with the meter being constructed. Connect a battery and variable resistor, adjusting the latter until the multi-range meter indicates some suitable current, and adjust the shunt until the new meter shows the same current.

Using known current. From Ohm's Law, current = voltage divided by resistance. It is thus possible to obtain various currents, from one or two resistors, and a tapped battery in good condition.

Valve heaters also furnish quite accurate calibration currents, when the valves are used with the battery voltage intended. For fairly large currents, .2A., .3A. and similar bulbs may be used.

In all cases it is only necessary to obtain one calibration point on each range, because the whole range is then automatically correct. The shunt value is readily adjusted by altering the length of wire, only winding this wire to form a resistor, as explained, when the length has been found.

Excess current must not be passed through the meter, so the battery must be disconnected each time the shunt is changed, when experimenting to find the value necessary.

To provide a number of ranges, two or more shunts can be connected as wanted, using a switch, or plug and sockets.

Universal shunt

Another method of obtaining several current ranges is shown in Fig. 3. With the switch open, taking leads to Nega-

Fig. 4—A complete 7-range test meter

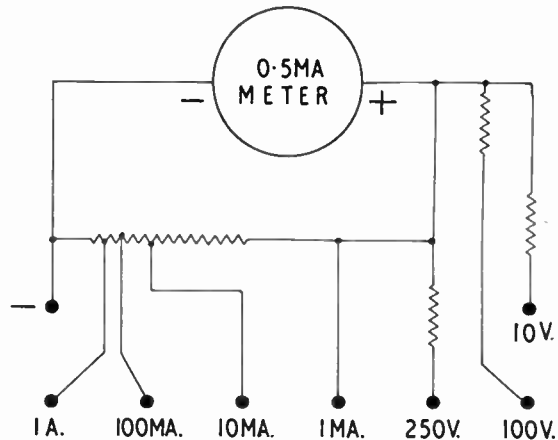

tive and A will allow the meter to be used with its original range.

When the switch is closed, the shunt is across the meter, giving an increased range, such as 0-2mA. When the one lead is transferred from A to B, a further increased range is obtained, such as 0-10mA. Using Negative and C gives yet another range.

Shunt values are more easily found, with this circuit. For example, with the switch closed, it is only necessary to slide lead C along from Negative, until the meter reads 0-100mA., or as required, and a wire may then be soldered to the shunt. Point B is similarly found, and there is no danger of passing excess current through the meter. Nor need the battery be disconnected. When all tappings are soldered on, the shunt wire is wound on insulating material, as mentioned.

This type of circuit is often used. The switch is often omitted, though this means that the most sensitive range (meter unshunted) is never available.

Complete test meter

A meter with 7 ranges is shown in Fig. 4. Though the ranges shown are convenient, it will have become clear that any ranges wanted can be provided.

The permanent shunt is adjusted until the meter reads 1mA. That is, a current originally moving the pointer to full-scale will only cause it to move to half-scale. This is the most sensitive range — 0-1mA.

For 0-10V., the resistor is 10K., with 100K. for 0-100V. and 250K. for 0-250V. ranges. For accurate readings, 1 per cent or 2 per cent resistors are used.

1mA. is then passed through the meter, as shown by the full-scale reading. The 10mA. lead is then moved along the shunt until the meter reads $\frac{1}{10}$ of full-

scale. This lead is soldered on, for the 10mA. tapping.

The series resistance and battery are then adjusted until the meter reads 10mA. (again full-scale). The 100mA. tapping point is then found by moving this connection until the meter shows $\frac{1}{10}$ of full-scale (that is, 10mA. on the 0-100mA. range). This lead is soldered on, and wired to the 100mA. socket.

The 1 ampere tapping can be found in the same way, but is best checked by means of a lamp, or other meter, to avoid errors. The amount of resistance between negative and 1A. sockets is so small that ordinary 20 s.w.g. copper wire may be used for this end of the universal shunt.

The whole instrument may be constructed with terminals or sockets located approximately as in Fig. 4. One test lead is always taken to the Negative socket. The other lead is equipped with a plug, and is inserted in any of the other sockets, according to the voltage or current to be read.

All moving coil meters of this type read direct current only. That is, dry batteries, accumulators, the output of DC generators, battery and mains receiver H T voltages, and so on.

LEARN

RADIO & T/V SERVICING for your OWN BUSINESS/HOBBY

● by a new exciting no-maths system, using practical equipment recently introduced to this country. FREE Brochure from:—

RADIOSTRUCTOR

DEPT. G81, READING BERKS

27/3/63

Good results with 'Half-Frame'

NEGATIVE sizes have been getting appreciably smaller and smaller in recent years. Not so very long ago $3\frac{1}{2}$ in. by $2\frac{1}{2}$ in. was the popular amateur size, but with the popularity of the smaller cameras taking perforated 35 mm. film and producing negatives measuring 24 by 36 mm. the old size is almost obsolete today.

By C. Robinson

Recently, however, a further reduction in negative size was introduced; one which is becoming increasingly popular. This is due, no doubt, among other factors, to its economy in regard to film used. This camera is known as 'The Half-Frame' and as the name suggests, its negative size is half the normal 35 mm. format. The same width 35 mm. perforated film is used, but the camera is designed to produce a negative measuring 18 by 24 mm. This means that on a normal 36 exposure 35 mm. cassette one now gets 72 exposures and on a 20 exposure colour film there will be 40 colour transparencies — an appreciable economy of 50%.

Other advantageous factors are that the camera itself is very small and compact and can be carried in the pocket as easily as a packet of cigarettes. Also, the focal length of the lens necessary to cover so small a negative size can be much

shorter than on a larger sized camera and thus gives a considerably greater depth of field. This means that larger apertures can be used more easily and without the fear that the subject will be out of focus should you have made a slight inaccuracy in estimating the distance between subject and camera.



'A hole in the roof', taken at a range of 2 ft. Ilford Pan F film 1/100 th, f4. Johnson's Definol Developer.

For example, with the camera set at 7 ft. and the lens stopped down only to $f/5.6$, all shots from $4\frac{1}{2}$ ft. to $12\frac{1}{2}$ ft. will be acceptably sharp. By altering the camera setting to 15 ft. and retaining the same aperture, the depth of acceptable sharpness will be increased from $7\frac{1}{2}$ ft. to infinity. It will thus readily be seen just how much this can help in the ease of camera operation.

The main questions, however, which some of you may be asking are: Will such a camera produce results of reasonable quality and are special processing techniques necessary?

I have now used one of these cameras for a reasonable period and my answer to the first query would be 'yes' without hesitation, bearing in mind that the amateur's usual requirements are for good, sharp album prints up to postcard size, and again, good, sharp 10 in. by 8 in. or whole-plate glossies for competitions and reproduction purposes. Larger sizes for exhibitions are of course also possible, bearing in mind that they are usually viewed from a greater distance than the smaller ones and that a lustre or stippled paper is normally used. These factors of course tend to minimise any grain that may be evident.

To the other question I would say that no special processing technique is required other than the normal care usually



'Fun on the climbing frame'. 1/200th, f5.6.

taken with miniature work. That means correct exposure and development, times and temperatures, and being particularly careful to guard against dust in cameras, cassettes, and at the film drying stage, as any abrasions, however small on the film, will be visible on a finished enlargement due to the degree of magnification necessary.

Perhaps I should also say that for all normal work with so small a camera it is advisable to use one of the slower speed fine grain films in the 25-50 ASA group (Ilford Pan F, Kodak Panatomic X, Adox KB14 and KB17, Agfa IFF, etc.).

These, when used in conjunction with a high definition developer, can be re-rated at twice their marked speed and will give fine grain and good definition results. These films are quite adequate in the way of speed for as I mentioned previously, wider apertures can be used more frequently than with a larger-sized camera.

Camera shake is, of course, one of the bogies of photography regardless of negative size, and it is advisable to use the highest shutter speed possible at all times to guard against this.

The accompanying illustrations will, I

think, add weight to my words. Incidentally, one of these it should be noted, was taken at a range of 2 ft. which is possible with the half-frame camera without the use of supplementary lens. This is most useful enabling one to fill the frame easily and tackle close-ups without resorting to additional accessories and conversion tables.

These cameras are available in various price ranges, the cheapest being the Olympus Pen at £16. 16s. 0d. (which is the one I use). There are of course other manufacturers with models in the £20-£30 price range.

For all-the-year-round greenery

AN INDOOR GARDEN

By A. Liston

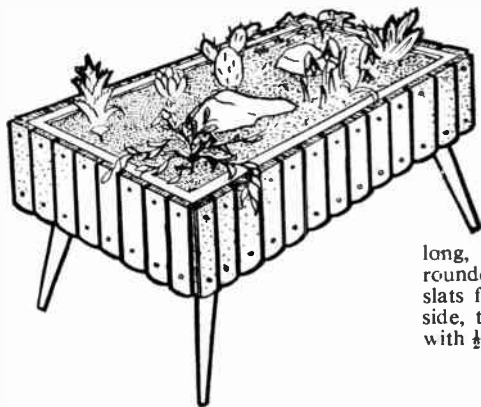

long, with the lower end of each slat rounded off over its last $\frac{1}{2}$ in. Using six slats for each end and twelve for each side, they are first laid out in position with $\frac{1}{2}$ in. spaces between them, then any

AN impressively large plant container, big enough to arrange with rocks and plants as an indoor garden, is an attractive fitting, which is easy to make. The one shown here has a smart black and white finish, contrasting with the varnished wooden slats which cover the sides.

The illustration shows the very simple method of construction. The base **A** is made of $\frac{3}{4}$ in. thick blockboard, and measures 15 in. by 30 in. It is fitted with a set of 15 in. beechwood screw-in legs, which may be of the ebonized variety, if desired.

A frame of 2 in. by 1 in. wood **B**, the outside measurements of which are the same as those for the base, is then screwed together.

The four sides **C** are of hardboard, and are 7 in. high, measuring 15 in. by 30 in. The sides are lightly tacked to the base with panel pins, and also to the frame, which should be flush with the top of the sides, as shown at **D**. At this stage, the hardboard sides are painted matt black, using emulsion or flat oil paint, and the inside, including the wooden frame, is enamelled white.

When the paint is thoroughly dry, the slats **D** can be added. These are made from 2 in. by $\frac{1}{2}$ in. wood, and are $7\frac{1}{2}$ in.

necessary adjustments are made to ensure that the distance between each pair of slats is the same. They are then screwed in place to the upper frame and the base board. The heads of the screws are countersunk, and the screw holes filled. The circles of filler can be painted with black enamel to give a decorative touch, and to disguise them completely.

The slats are then varnished or coated with clear wood sealer, being careful to prevent any varnish from marking the matt black surface between the slats.

When the trough is completely dry, it is half-filled with dry peat, then the plants, complete with pots, are arranged so that the rims of the pots are 1 in. or so below the top of the trough. A mixture of house plants, bowls of bulbs, cacti, and succulents can all be used, according to one's fancy, and changed when necessary, for a continuous show.

A polythene bag round each pot will prevent the surrounding peat from becoming soaked if plants are watered while in position. As a further precaution, a large polythene sheet can be used as a lining for the trough. Pinned to the underside of the frame, it will be hidden by the peat.

After the plants are in position, the trough is filled with peat, making sure that the pots are covered. Attractive pieces of stone can now be laid in place, and allowed to settle, the peat below them being packed more tightly, if necessary, to prevent their sinking too much. Other decorative objects which can be added as an alternative to stones are pieces of smooth driftwood, lichen-covered logs, or even small china ornaments.

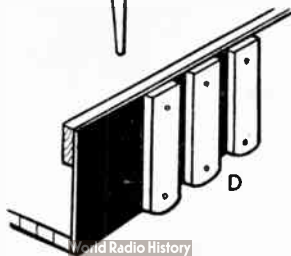
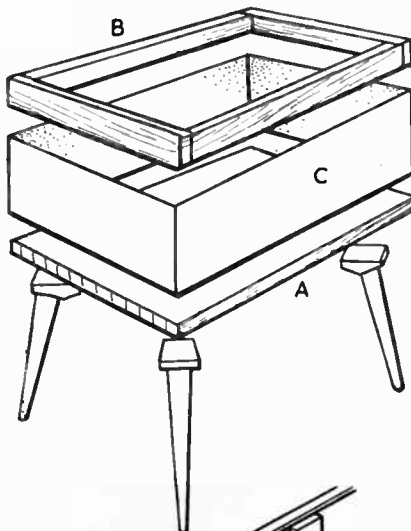

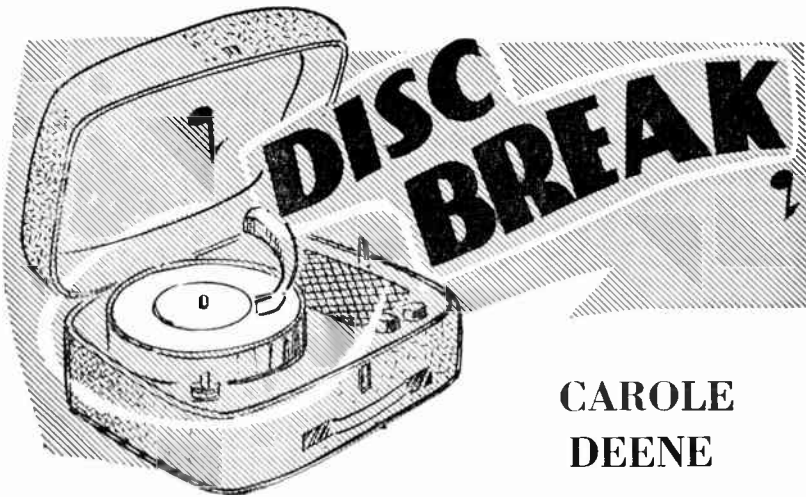

CAROLE DEENE

IT was her singing miner Dad who was no doubt responsible for young Carole Carver deciding on a show business career. As a singer, of course!

But Jeff Carver, who works at the coal-face of a Yorkshire mine by day and sings Crosby-styled songs at local clubs and concerts by night, was determined that Carole would have the opportunity to find success that he himself had never had.

So he arranged for her to have singing lessons in London. The result? She passed a B.B.C. Audition, appeared on television, and made a record.

And there was just one other outcome . . . Jeff Carver passed a BBC-TV audition, too!

It happened like this. Carole had been taking lessons from well-known singing teacher Freddy Winrose, now her personal manager. Last Whitsun Jeff Carver arrived in Guildford to sign a contract on behalf of Carole.

'Jeff stayed with us for the week-end', explains Freddy, 'and while he was there he sang a couple of songs for me. I passed on a tip here and there to him and before long we had recorded some songs on tape.'

Some time afterwards the BBC telephoned me to ask if I had any new voices, so I played the Jeff Carver tapes to them over the 'phone. The result was that Jeff went for an audition, which he passed, and is now to make a television film for the benefit of producers as Carole has done before him'.

So, an excited Jeff Carver returned to the coal mine — the only job he had known since leaving school — and daughter Carole made her disc debut — as Carole Deene and on the H.M.V. Label — with *Sad Movies* and *Don't Forget* on 45-POP-922.

Carole Deene was born in Thurnscoe, just outside Doncaster, on 3rd August 1944. She started singing lessons with a local teacher when she was seven, and went on to win her share of medals, plaques, and cups at concerts and festivals.

At one time or the other Carole had been interested in enrolling at an art college — and taking a hairdressing course. But, finally, all roads led back to singing.

Freddie Winrose might have been excused for wondering whether her mind was really made up when first he heard her sing. 'After she had sung a couple of songs for me I told her, 'I am very sorry, my dear, you have got a good voice, but you have no idea of how to use it. You will have to learn to breathe properly, and to phrase correctly. You've got a tough job ahead of you'.

At once she burst into tears, and rushed out of the studio, and it took us more than an hour to persuade her to return. Three weeks later I had a letter

from her apologizing for the scene — and asking for lessons'.

Why 'Carole Deene'? Freddy Winrose telephoned the BBC to ask them to arrange an audition for her. 'What', he was asked, 'is the girl's name?'

'As a matter of fact, we haven't yet fixed one', Freddy replied.

'Well', said the voice at the other end, 'why not call her after me?' The speaker was Deene Moray, then an assistant in BBC-TV's Audition Unit.

So Carole Carver became Carole Deene. She made her BBC-TV debut on 4th June, in the Joan Regan Show, and has since appeared regularly in the *Show Train* series. And she has passed her BBC sound radio audition.

Carole—5 ft. 2 in., and eyes of blue — has already realized two ambitions with her television appearances and her record. And now she wants nothing more than to go on to become a first-class artiste.

Miscellaneous Advertisements

PENFRIENDS home and abroad, all ages. S.a.e. for details. European Friendship Society, Olney, Bucks.

WOULD YOU ENJOY painting flower pictures, etc? Then read 'PROFITABLE ART' (free). Wonderful opportunities for beginners and others. POPULAR ART (HW), Clun, Salop.

ENJOY WRITING? Then write for Profit. Send for 'Writers' Handbook' (free) detailing countless opportunities for beginner or experienced. — Writers' Ring (HW), 5 Edmund Street, Birmingham.

UNDER 21? Penfriends anywhere — details free. Teenage Club, Falcon House, Burnley.

125 COPIES HOBBIES WEEKLY, excellent condition, 25/- — 32 Aitkenbrae Drive, Prestwick.

LEARN RADIO & ELECTRONICS the NEW Practical Way! Very latest system of experimenting with and building radio apparatus — 'as you learn'. FREE Brochure from: Dept H.W. 10, Radiostrutor, Reading.

FRIENDS' WORLD, Postbox 708, Calcutta India. Offers pen friends everywhere.

FOR PEN PALS and Collectors read 'World Youth Correspondence Club Bulletin'. Sample copy 2/- — O'Brien, Killenaule, Thurles, Ireland.

100 DIFFERENT stamps free! Request 4d. upwards discount approvals. — Bush, 53 Newlyn Way, Parkstone, Dorset.

100 FREE DIFFERENT STAMPS! Request discount approvals. S Cutler, 2 Harpsden Hill, Henley-on-Thames, Oxon.

• IF YOUR INTERESTS ARE

Lathework or Welding

TAKE ADVANTAGE OF THIS
FREE OFFER

Every technician knows — and you know — that there are big opportunities for skilled craftsmen. Newnes proved and trusted **TECHNICAL AIDS** will help you to make your future secure. Examine the set you need free of charge for a week, without obligation to buy!

Newnes COMPLETE LATHEWORK

It contains all the essential information for operating CENTRE, CAPSTAN, TURRET and AUTOMATIC LATHES.

OVER 500 PAGES. 2 volumes and Case of Charts. Also Free Turret Lathe Setters Pocket Book. 2 Years' Free Postal Advice. Contents include: Differential Threading. Trepan boring. Back facing. Tool design, multi-cut. Camshafts, machining. Gear cutting. Profile turning. Grinding carbide tools. End-train. Eccentric turning. High-speed screwcutting, etc.

NEWNES COMPLETE GAS & ARC WELDER

Packed with data and with illustrations, it explains techniques used in general engineering, motor industry, loco workshop. Incorporates U.S.A. techniques.

OVER 500 PAGES. 2 Volumes and Case of Charts. Free—Welding Engineer's Pocket Book. 2 Years' Free Postal Advice. Contents include: Gas Welding and Cutting: equipment. Rods. Fluxes. Joints. Welding sheet steel, cast iron, alloy steels, aluminium, magnesium, copper, etc. Electric Welding and Cutting: Equipment, transformers, generators. Electrodes. Joints. Testing, etc.

POST COUPON NOW

To George Newnes Ltd., 15-17 Long Acre, London, W.C.2

Without obligation to purchase, please send: Complete Lathework

Gas and Arc Welder Tick your choice

I will return it in 8 days or send 10/- deposit 8 days after delivery then 12 monthly payments of 10/-, paying 130/- in all. Cash in 8 days, £6. 5s.

Mr. _____
Mrs. _____
Miss _____
Address _____
Occupation _____
Signature _____
Parent's _____
Signature if you are under 21. _____
(GA) 567/9 (CL) 568/9

Tick ✓ where applicable

The address on left is—

My Property
Rented unfurnished
Parents' Home
Furnished Accom.
Temporary Address

MAKE YOUR OWN

GUITAR

Kit 3209

All wood (including partly shaped neck) full-size plan, six strings, etc.

59/6

(Post 3/3)

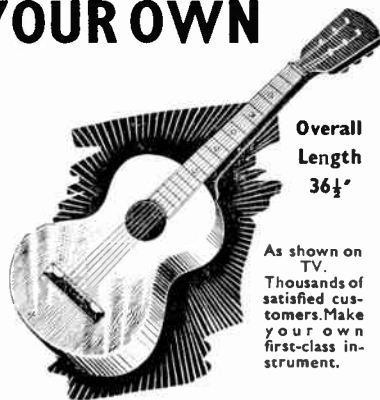

Overall Length 36½"

As shown on TV. Thousands of satisfied customers. Make your own first-class instrument.

UKULELE

Kit No. 3260

Contains all wood, wire, strings, etc., for full-size instrument

24/11 Post 2/-

To Hobbies Ltd., Dept 99, Dereham, Norfolk. Please send Kit No. _____

P.O. for _____ enclosed

Name _____

Address _____

From branches, etc., or by post



A NEW RANGE OF JOHNSON DO-IT-YOURSELF OUTFITS

Here's excitement! The new Johnson range of "Do-it-yourself" outfits makes it so easy to develop and print your films at home.

These outfits contain everything you need. They range from sets for the beginner, to outfits for the more advanced enthusiast. And full instructions go with every outfit.

Prices from £1-17-6 to £5-12-6.

JOHNSONS
OF HENDON LTD.

FOR CONFIDENCE
IN PHOTOGRAPHY

THE G.C.R. 2-8-0 ENGINES

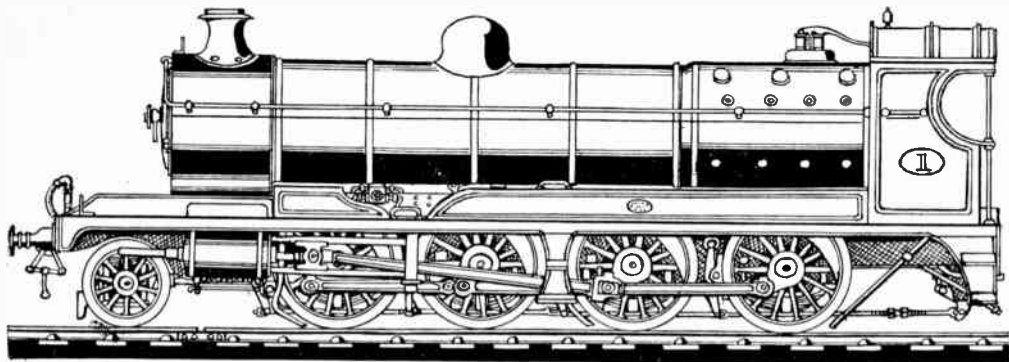

Great Central Railway. Mr J. G. Robinson's 2-8-0 mineral engine built Gorton works 1911

THE first 2-8-0 type goods tender engine to appear in this country was designed by Mr G. J. Churchward for the G.W.R. and built at Swindon in 1903. This engine No. 97 became the forerunner of a numerous class of engine (the 28XX) which were used for working the South Wales coal trains to London, subsequently becoming the principal G.W.R. goods and mineral type.

On the Great Central Railway in 1911 Mr J. G. Robinson produced a somewhat similar engine (both types having outside cylinders) for the principal coal and mineral traffic of the line. These were in reality a development of his earlier 0-8-0 engines of 1902 and were classified 8K by the G.C.R. and when taken over by the L.N.E.R. in 1923 reclassified 04.

The G.C.R. built 127 of the type for the line, the leading features being: Cylinders, 21 in. diameter & 26 in. stroke with 10 in. piston-valves behind the frames. The central lines of the cylinders and the valve chambers seen in elevation were all in the same plane and inclined at an angle of 1 in 24. Stephenson link motion actuated the valves, the eccentrics being attached to the driving axle, the expansion links being centre-suspended 18 in. ahead of the second coupled axle.

The boiler, made in three rings, had an inside diameter of 4 ft. 10½ in. and contained 110 fire tubes of 2 in. diameter and 22 superheater flues of 5½ in. diameter giving a combined heating surface of 1,349 sq. ft. The firebox added 154 sq. ft., making the total heating surface 1,503 sq. ft. Grate area was 26.24 sq. ft. and working pressure

180 lb. p.s.i. Length between tube-plates was 15 ft. 5½ in. and centre line 8 ft. 6½ in. above rails.

Wheel diameters: leading 3 ft. 6 in. and coupled 4 ft. 8 in. Wheelbase: 8ft. 4 in. + 5 ft. 8½ in. + 5 ft. 5½ in. + 5 ft. 11 in., total 25 ft. 5 in. Weight in working order was 73 tons 4 cwt of which 66 tons 4 cwt was available for adhesion, the tractive effort being 31,326 lb.

The tender was of the usual G.C.R. type running on six 4 ft. 4 in. diameter wheels having a tank capacity of 4,000 gallons, coal space of 6 tons and weighing

full 48 tons 6 cwt giving a total for engine & tender of 121 tons 10 cwt.

During the 1914-18 war, a total of 521 of these engines were built in Great Britain to the order of the Railway Operating Dept. of the War Office for overseas military railway service being employed on heavy goods, munition and troop trains. They were provided with the Westinghouse air brake in order to conform with Continental practice. After the War many were returned to this country, being purchased by various British railway companies. (A.J.R.)

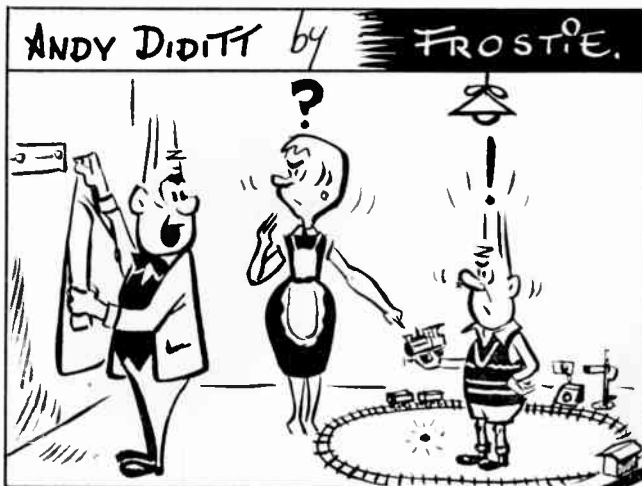

"BROKEN HIS TRAIN? — I SUPPOSE HE'S BEEN PLAYING WITH IT AGAIN!"

For your collection

OVERLAYS FEATURING BIRDS

THE shapes shown on this page are intended for use as decorative overlays. They may be traced and transferred to wood, metal or plastic by means of carbon paper. They may be pinned or glued in place according to the material used. Use an ordinary Hobbies saw blade for wood and plastic, but use a Hobbies metal cutting blade for metal.

(M.p.)

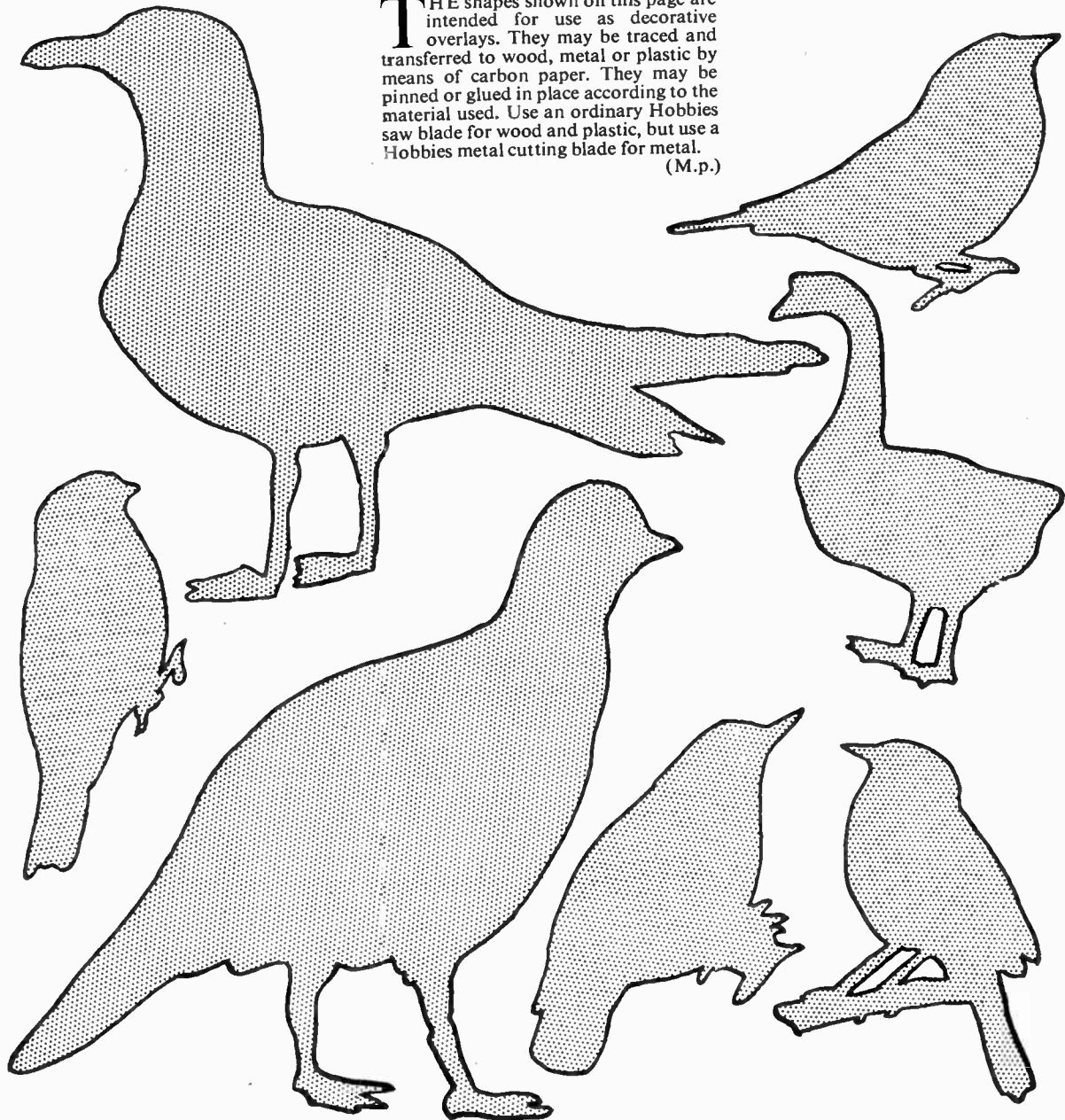

418

Printed by BALDING + MANSELL, LTD., London and Wisbech, and Published for the Proprietors, HOBBIES LTD., by HORACE MARSHALL & SON, LTD., Temple House, Tallis Street, E.C.4. Sole Agents for Australia and New Zealand: Gordon & Gotch (A'sia.) Ltd. For South Africa: Central News Agency Ltd. Registered for transmission by Canadian Magazine Post.

READER'S REPLY
HW
MAR.
1963

Plans to make your own Craft

Much of the cost for a professionally built boat is for time. As this costs the amateur nothing he can, solely for the price of the materials used, achieve first-class results if he is prepared to be patient and careful. The plans of the craft specified below are by the expert, P. W. Blandford and provide all the information you need to build from scratch. Shaped parts are shown full size and there are detailed instructions. Hobbies Ltd, can also supply kits for the canoes PKB10 and 20 and for the Runabout 'Zip'. Send for details. A list of firms supplying materials and kits is provided with each plan.

CANOES (Rigid fabric-covered)

PKB10. The shortest satisfactory canoe, carrying a man and camping kit. Very economical in size and building costs. Suitable for most waters, 11 ft. long, 28 in. beam, 48 in. cockpit, draught 5 in. Normal maximum load 300 lb. Price 12/6

PKB14. Roomy single for the big man or a two-seater for an adult and child or two young people. A popular tourer, but only room for light weight gear when used as a two-seater. Has crossed Channel as a single-seater. 14 ft. long, 29 in. beam, 76 in. cockpit, draught 5 in. Normal maximum load 500 lb. Price 12/6

PKB15. Fast touring single-seater, suitable for rapid rivers and the open sea in capable hands. Safe and stable. The adult enthusiast's canoe. Many Channel crossings. 14 ft. 6 in. long, 26 in. beam, 48 in. cockpit, draught 4 in. Normal maximum load 400 lb. Price 12/6

PKB20. Very stable and scaworthy two-seater, with sufficient beam to carry an efficient sail plan. Very roomy and popular tourer on most waters, 15 ft. long, 32 in. beam, 7 ft. cockpit, draught 6 in. Normal maximum load 600 lb. Price 12/6

PKB26. Fast and stable single-seater with a shorter cockpit than the other single-seaters, and a rockered keel, making it a good boat for rapid rivers. Many successes in long-distance racing. 14 ft. long, 26 in. beam, 39 in. cockpit, draught 4 in. Normal maximum load 400 lb. Price 12/6

CANOES (Folding)

PKB24. A short single-seater of similar lines to PKB10, but with a longer cockpit. The only canoe which packs into one bag small enough to go on a bus. (42 in x 16 in. diam.), 11 ft. long, 28 in. beam, 55 in. cockpit, draught 4 in. Normal maximum load 300 lb. Price 12/6

CANOES (Rigid plywood skinned)

PKB16. A two-seater, flat bottom, safe and robust. Capable of standing up to hard work, as in hire fleets. May be left afloat. 16 ft. long, 32 in. beam, 7 ft. cockpit, draught 5 in. Normal maximum load 700 lb. Price 12/6

PKB23. A single seater with the same main dimensions as PKB15, but with V-bottom and hard-chine section. Roomy and stable, may be left afloat. 14 ft. 6 in. long, 26 in. beam, 48 in. cockpit, draught 4 in. Normal maximum load 400 lb. Price 12/6



GOBLIN PRAM DINGHY

DINGHIES

WENSUM. A fast 11 ft. sailing dinghy, suitable for general touring and family sailing as well as racing. Construction is double-chine, built upside-down on frames with a plywood skin. The rig is a sloop, with gunter main-sail. Length 11 ft. 0 in., beam 4 ft. 8 in., sail area 66 sq ft.. Draught hull only, about 6 in. or with centreboard down, about 30 in. Weight complete about 220 lb. Rowing positions for two oarsmen and will take an outboard motor of up to 4 h.p. Price 16/-

GOBLIN. Plywood pram dinghy, light enough to be easily lifted on to the roof of a car, yet able to carry two or three adults, and with a sailing performance that makes it suitable as an economy class single-handed racer. Length 9 ft. 10 in., beam 4 ft. 6 in., weight 120 lb. complete, sail area 52 sq. ft. Construction easy and quick. Good foredeck, and buoyancy is built in under side benches. Price 16/-

GREMLIN. A 7 ft. by 46 in. plywood pram dinghy of special form. This is the longest hull that can be got out of standard sheets of marine plywood. Fitted with rudder, dagger board and gunter rig. For its size it gives excellent performance under sail, oars and outboard motor. Price 14/-

PETE. A 6 ft. 0 in. by 44 in. flat bottomed pram dinghy. The cheapest and simplest practical boat, intended to be built from one 8 ft. x 4 ft. sheet of hardboard and the minimum amount of wood. Will carry two adults or one adult and two children. Popular as a single-handed angler's boat. May be carried or lifted single-handed on to a car roof. With sails it makes an excellent children's playboat. Price 10/-

ZIP RUNABOUT. Length 7 ft. 8½ in., beam 2 ft 10½ in., weight 80 lb. Skinned with oil-tempered hardboard and suitable for a small h.p. outboard engine. Will carry an adult and one or two children. Price 16/6 'ZIP' is Hobbies Ltd design.

Postage 9d. extra on each plan from Dept. 99

HOBBIES, DEREHAM, NORFOLK