

4th OCTOBER 1961

VOL. 133

NUMBER 3434

THE ORIGINAL
'DO-IT-YOURSELF'
MAGAZINE

HOBBIES *weekly*

FOR ALL
HOME CRAFTSMEN

Also in this issue:

MAKING A
SOLITAIRE RING

COLLECTORS' CLUB

FISHING FOR
LARGE TENCH

TABLE TOP
PHOTOGRAPHY

PATTERNS FOR
A STUD BOX

GARDENING HINTS
FOR OCTOBER

ETC. ETC.

FREE
plans
for



Details of our
£200 FREE
CONTEST



THERMOMETER PLAQUES



Up-to-the-minute ideas

Practical designs

Pleasing and profitable things to make

World Radio History

5^p

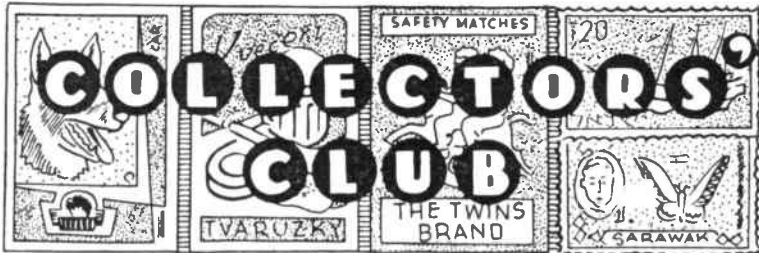

I HAVE just received a nice set of playing cards from America, depicting famous authors. Three of them are shown at the bottom of the page.

Charles Dickens, who was born in 1812, was the most popular novelist of the nineteenth century. From very humble beginnings he worked himself up to the highest position in the world of

CARDS IN CIRCULATION AUTHORS

letters. His literary output was enormous. From the time of the publication of the Pickwick Papers to his death in 1870, covering a period of thirty-three years, he produced novel after novel, all possessing the original Dickensian characteristics, yet each wonderfully different from the rest, and his popularity continues undiminished.

Robert Louis Stevenson (1850-94), was the Scottish author of a remarkable series of essays, stories, and poems, including *Travels with a Donkey*, *Virginibus Puerisque*, *Treasure Island*, *Kidnapped*, *Dr Jekyll and Mr Hyde*, and *A Child's Garden of Verse*. He always suffered from delicate health, and travelled extensively, finally settling in Samoa with

his Californian wife, formerly Mrs Osbourne. His literary influence was considerable.

Alfred, Lord Tennyson (1809-92), was Poet Laureate from 1850 to his death. Born at Somersby, in Lincolnshire, he showed poetic gifts while quite young, and in 1827, joined his brother, Charles, in the publication of *Poems by Two Brothers*. In 1847 he published *The Princess*; in 1850 *In Memoriam*, a poem of great beauty and depth of thought, in which he enshrined his affection for the memory of his friend Arthur Hallam; and in 1855 *Maud* appeared. His other works include *The Idylls of the King*, *Enoch Arden*, *Queen Mary*, *Harold*, and *Becket*.



This special stamp commemorating the twenty-fifth anniversary of Aer Lingus — *Irish International Airlines* — was issued on 26th June. The design features the original and the latest type of aircraft used by the Company — a De Havilland Dragon and a Boeing Jet.

'Pop' fan

'I collect stamps and cigarette cards', says LAURENCE STANLEY HARKER of 'Rose Cottage', Hennock, Nr. Newton Abbot, Devon. 'My sister Maureen is keen on stamps, cards, autographs, reading, and pop records. We both enjoy television. We would like pen friends throughout the world.'

Regular reader JOHN WILSON of Bedford Road, Bootle, Lancs, will answer all letters sent.

C. A. E. GREEN of 43 Gainsborough Avenue, Tilbury, Essex, is eager to meet new friends — 'I thought the best way to start was for you to publish my name in Collectors' Club', he writes. 'My hobbies are cricket, stamps, cycling, and gardening. I am 14 years old.'

From Scotland

'I am a 16-year-old boy who would love pen friends', says DUNCAN MACDONALD, 10 Milton Terrace, Jamestown, Dunbartonshire, Scotland. 'My hobbies include photography, cars, tape recording, and television.'

D. SINGH of Calcutta — 22, India, and David Sievewright of Shipley, Yorkshire, have sent us photographs since their names appeared in Collectors' Club.

L. N. DUKIN of CCCP — U.S.S.R. — Russia, Moscow B — 186, Hazopnov Y1, G-5, Diokung, A.H. is a keen philatelist. 'I will send novelty stamps of Russia in exchange for those of Great Britain and the Commonwealth', he says.

'I wonder if it would be possible for me to contact some new pen friends through *Hobbies Weekly*', asks GEORGE M. GRACE of 55 Dun Drum Road, Dromara, Co. Down, N. Ireland. 'I am 23 years old, and have been collecting stamps for about fourteen years.'



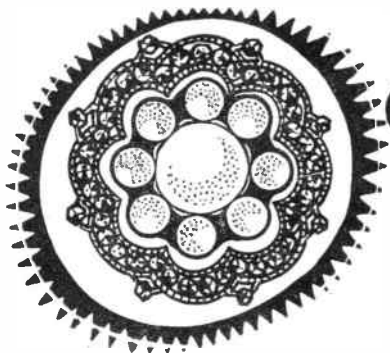

Hand-Made JEWELLERY

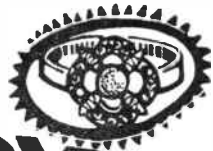

A JEWELLER, using only hand tools, can easily compete with the most accurate machinery. Generally he produces something far more beautiful — though not, of course, for the same price. Often it pays the craftsman to use certain parts which have been roughly fashioned by machine.

This is true of all modern-style settings, which weigh very little and are cut away in order that plenty of light may reach the lower parts of gemstones.

Such settings are to be had in silver, gold or platinum, and are sold by weight, plus a fashion charge which varies according to the complexity of the design. Decorative shoulders for rings can be bought in the same way.

Making the ring described in this article, using setting and shoulder blanks, means absolutely no wastage of metal, and this compensates for the fashion charge — besides saving a great deal of labour.

This ring is made with a 9ct. yellow gold shank and 9ct. white gold setting and shoulders. If you wish, you can make it entirely from silver, in which



case the cost of the metal will be only a few shillings. The stone is a blue zircon of 6 mm. diameter, costing 30s. You could instead use a topaz, which might cost about 10s.

Begin by buying the stone. Then order the setting, shoulders and ring shank wire. This shank material is known as half-round, and is 3 mm. wide. These details must be specified. The length required can be checked by bending a piece of soft wire of about 2 mm. diameter round a mandrel to give the size of ring wanted, allowing a little over for safety.

Send either the stone or mention of its exact diameter with your order for a Light-weight Rex setting and under-bezel. A small sketch of the shoulders should be good enough, though they

could be filed quite easily from a small piece of sheet metal. If the ring is to be made from yellow and white gold, you will need a small slip of 9 ct. white gold solder. If the ring is to be made from silver, substitute silver solder where the instructions mention gold solder.

Setting and under-bezel

The under-bezel must first be soldered to the setting (Fig. 1). Thoroughly coat the join with borax and tie the parts together with fine iron binding wire. Use five or six turns, passing it outside and up through the centre of the setting and bezel. Apply a minute panel of 9 ct. white solder where each lower prong of the setting touches the bezel, drying very gently with the blowpipe flame. Bring the lower part of the setting and all the bezel to red heat until all the joins are completed.

The binding wire removed, take a piece of dowel rod the size of a pencil and sharpen one end until you can push the setting on to the taper. Holding it on the

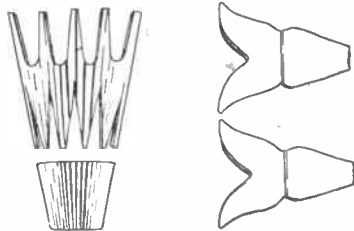

Fig. 1

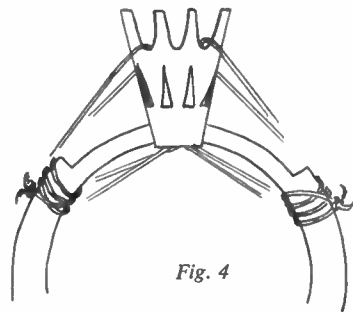

Fig. 4

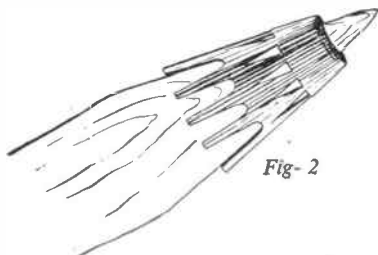

Fig. 2

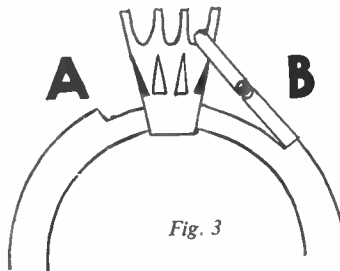

Fig. 3

bench-pin, file the under-bezel all round until it becomes a perfect continuation of the setting and blends into it. (Fig. 2). Now, with the point of a triangular needle-file, clean up any irregularities in the V-shaped cut-away portions of the setting.

The shank wire must be annealed (softened) before bending, so bring it to red heat and quench it in water. Then bend it round a piece of rod used as a mandrel. As the metal will spring back very slightly, you must use a mandrel a shade smaller than the size you wish the ring to be. Use your fingers first, and finally the mallet. The ends will need the

most hammering, and, if too long, the ring should be sprung slightly sideways to allow them to lie side-by-side.

With a jeweller's saw, cut the shank to size, leaving a gap half the width of the base of the setting. This gap is now filed with a round file until it exactly fits the setting.

The shank, on either side of the setting, will need to be reduced to about half its thickness to accommodate the white gold shoulders. At this stage, however, file only the ends for a length of 4 mm. or 5 mm. and to a depth equal to the thickness of one of the shoulders, Fig. 3A.

Spring the shank together at the ends until it grips the setting quite firmly of its own accord and holds it upright when viewed from all angles. This is most important. Then borax the joints and wire it in position, Fig. 4. First take several tight turns round the shank on either side, about $\frac{3}{8}$ in. from the setting. This will prevent the next wires from slipping. Take a new length of wire round these first turns, then down through the setting and back again. Use plenty of wire and re-check the position of the setting. Now take several turns round the setting

and bezel alone, just as you did when joining these two together. This is necessary because you will probably remelt the original joints. Make sure that a little of the bezel projects just below the circle of the shank; the bezel will later be filed to complete a perfect circle.

Coat all joints with borax (including joints of setting and bezel) and prop the ring upright on the charcoal block, laying it against another piece of charcoal. Lay a panel of white gold solder on each joint of shank and setting and solder them with the blowpipe. Remove the binding wire, but replace the few turns used for safety on the setting and bezel. Extend the file-cuts started on the shank until they are long enough to accommodate the shoulders when these are held in position, Fig. 3B. The tips of the shoulders, which must be filed slightly to give the correct angle, must rest against the two claws on each side to leave 1.5 mm. of claw projecting above the joint.

Flux these joints with borax and tie the shoulders tightly to the shank with fine binding wire. First solder the shoulders where they join the shank. Do this with the ring propped upright on the charcoal and lay the panels of solder in the angles

formed by the junction of shank and shoulders. You can use 9 ct. yellow solder here if you wish. Heat the shank first, slightly below the joint, for the shank will absorb the most heat; then, when the shank is nearly red, play the flame on the actual joint, moving it about slightly until the solder melts and flushes. This is one of the easiest joints, but make sure that you use enough solder, for the area to be joined is comparatively large and strength here is vitally important.

Now solder the four joints of shoulders and claws. Make sure that there is good contact at these points. Solder with the ring upside-down against the supporting piece of charcoal. Apply borax to the joints and a very small piece of white gold solder in each angle. Solder with a small flame.

Test for a good joint by prising the shoulders gently upwards; it is better to find a fault at this stage, when it can easily be remedied. Next remove all binding wire and pickle the ring. A solution of 1 part nitric acid added to 8 parts of water is rather better for gold than the sulphuric solution used for silver.

(To be concluded)

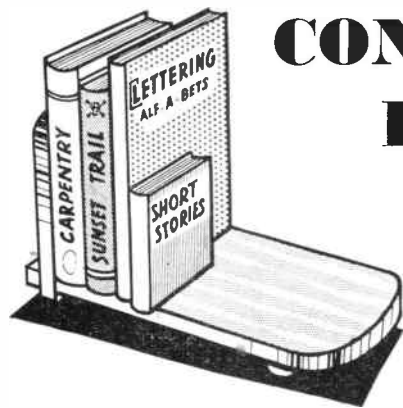

CONTEMPORARY STAND FOR YOUR BOOKS

the upstand, which is 7 in. long. Here again the surfaces should be made smooth and the top end rounded off.

The tenons at the bottom should be made to fit accurately into the notches and mortice previously formed in the base piece. Note that the two outer tenons are made so that they will form two small projecting 'feet' to the book-stand. Apply a little strong glue when assembling these two members.

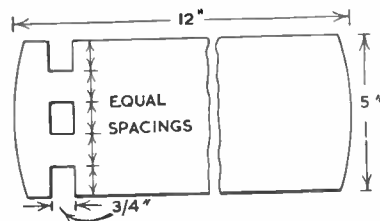

It is generally accepted that contemporary fittings and furnishings need not balance in design or shape so the book-stand illustrated should please those who favour this type of design. The stand has only one end upstand and the books are kept in place merely because the base is set at a slight slant. The construction is very simple and the project can be completed in an evening. For best results use a choice hardwood such as oak, beech or mahogany.

The base piece measures 12 in. by 5 in. and a suitable thickness would be $\frac{3}{4}$ in. All surfaces should be planed perfectly smooth and for added appearance the ends can be shaped to a pleasing curve. Two notches and a mortice should be formed in the manner shown to receive

By Finlay Kerr

It now only remains to make two more 'feet' $\frac{3}{4}$ in. thick to fix on to the opposite end of the stand to produce the necessary slant. If the book-stand is to be placed on top of a polished surface then the underside of the four 'feet' should be covered with thin felt or similar material.

Complete by applying a few coats of french polish to produce an attractive lustre.

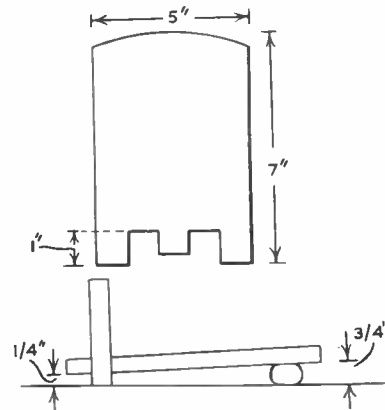

WITH ROD & LINE

ONE of the most pleasant ways of spending a warm evening is to visit some quiet lake or sluggish stream and try to catch a few tench. This fish is usually in very good condition about now, though not of the same class as a fighter as the dace it can, nevertheless, put up quite a struggle on light tackle. A tench hooked is by no means a tench landed!

Tench are very fond of a water where the bottom is composed of mud or soft silt, so it is these places you have to look for. In still water you should use your groundbait sparingly. On your first visit it will attract fish, but a couple of days of hot weather which warms up the water will soon make the groundbait turn sour and taint the surrounding water. The result is that on your next visit you'll most likely be wasting your time as the fish will not go near where this 'local pollution' is taking place.

Fish near weedbeds, and also watch the surface of the water for little strings of bubbles, which is a sign that the tench are feeding. So far as groundbait is concerned, it is far better to throw in samples of your hook bait; and if this happens to be maggots, then those which escape will not do any harm to the water. If you are using bread, or a paste made from bread, then be sparing with it; a few small pellets from time to time will help to keep the fish around and on the alert for more.

I've heard about lots of tench being caught on worms, but I write from my own experiences and I've caught far more fish on a single maggot than on a worm. Looked at sensibly, it is just like someone offering you a lunch when you've just had one — but you wouldn't refuse a coffee. It's the same with the fish, they may have just fed, and the sight of a large worm is enough to put them completely off. Whereas a small maggot is just a little something to firtish off with.

Never fish under the tip of the rod. If lake fishing, you can cast out a few yards or to your left or right so that you are not visible to the fish so much. Many anglers seem to think that their fish swim in from midstream or the middle of a lake to take the bait. Nothing could be further from the truth. Very often the fish may be living under your side of the bank and will thus swim out to it. Therefore it is essential that your shot is at least 18 in. from the hook. Should the

fish rub the line with its body it may get a scare. The least that can happen is that this action will be reflected by your float, which will dip, and you'll strike so that the bait suddenly jumps away from the fish just as he is about to pick it up.

TRY FOR THE LARGE TENCH By 'Kingfisher'

Any tench with a particle of sense — and believe me, they have quite a lot — knows that a bit of bread paste can't suddenly leap towards the surface and this will put it off such food for the rest of the day.

Although I've heard of long rods for fishing over weeds I don't use anything

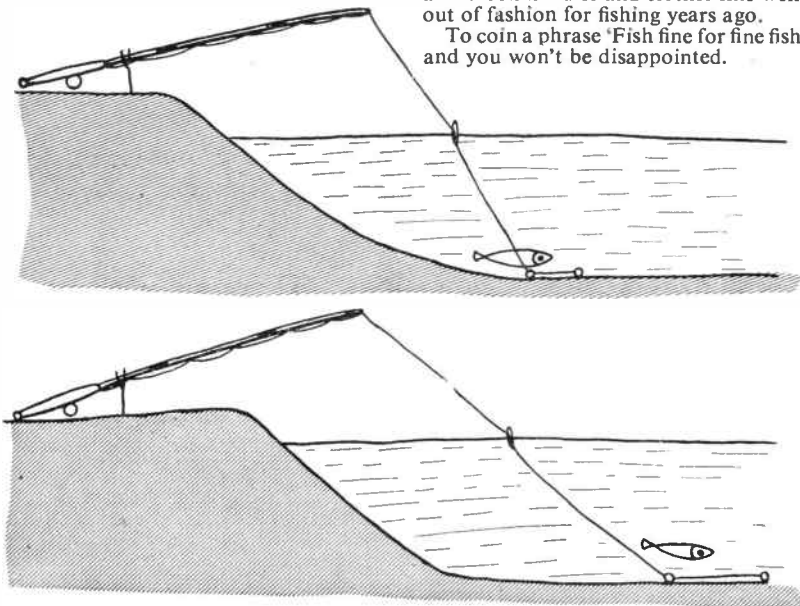

The top illustration shows how the fish rubs the line, as the bait is too near. The float dips and the 'strike' scares the fish. The bottom illustration shows the fish well clear of the line before reaching the bait. Never 'strike' at first tremble of float

except my usual bottom rod of 10 ft. 6in. in length and if I look around I can always find a swim or easily make one which will be suitable for my rod. Even the longest rod won't lift the fish over a weedbed when you are about to bring it to the net.

My favourite baits are cheese paste and maggots. Garden peas are an excellent standby to which tench are very partial. In fact this bait will often be the downfall of the fish when all other baits fail. These must be fished on the bottom and near to weeds.

All this business of early morning or late evening I ignore unless I happen to be on the water at those times. I don't go specially at late evening for tench and I find that fine tackle will account for big fish during the day. Coarse tackle with thick lines puts them off far more easily than the time of day.

My line is of 3 lb. breaking strain even in very weedy waters and if the fish tries to make for the weeds I let him go on the principle that the more I try to pull him away the harder he'll try to get there. Whereas if I let him take line easily he will imagine himself free and stopping his run will turn about to get back to the feeding area where the rest of his shoal is.

The largest I use in hook sizes is a '12' and the smallest a size '16', which is fine for a single maggot. You can't bully a fish on such fine tackle but if you are an angler you should have no qualms about landing him, even in a weedy water. After all, you want to enjoy some sport and brush handles and clothes line went out of fashion for fishing years ago.

To coin a phrase 'Fish fine for fine fish' and you won't be disappointed.

TABLE TOP PHOTOGRAPHY

TABLE top photography is a fascinating branch of the hobby whereby you can enjoy devising, making and taking pictures in your own miniature studio. It is a novel change from the usual idea of photography — taking views and snapshotting friends — and this is probably due to the fact that the main interest is in the production of the settings. Moreover, you do not have to rely on perfect weather conditions, or on catching that smiling face at the right moment, for everything is entirely under your control. We are thus given an opportunity of using our own ingenuity for making models or properties, while we can also experiment with equipment and lighting.

By S. H. Longbottom

It is, however, necessary to distinguish between mere still life pictures and the table top variety. The former may be anything from vases of flowers to books but the latter can approach the whimsical cartoon, or a picture story made by an arrangement of toys in an appropriate setting. We may copy landscapes in our miniature studio, make buildings from cardboard, use dolls for human beings or ornaments when required along with many other odds and ends.

There is a vast field to explore and sets may be either simple or elaborate, dependent on your own skill and patience. For example, a background can be made from your own drawing, a picture, an enlarged photograph or a transparency back-projected on to a screen — a method frequently used for television productions.

It is doubtful whether you will possess an old fashioned type of camera which has a viewing screen along with other refinements such as a rising front. This type is ideal for table top work for you are able to see the scene through the camera lens and test the accuracy of the focusing. But we can use any type of camera and by a little ingenuity take a peep at the scene. First of all remove the back of the camera as though you were inserting a new film. Take a piece of old, clear film or celluloid of the same size as the film you use. Lay this on the table, scraping away the shiny surface with a razor blade held at right angles. You could also use some very fine glasspaper.

Viewing the scene

This action will produce a piece of celluloid having the appearance of ground glass and when fixed in position

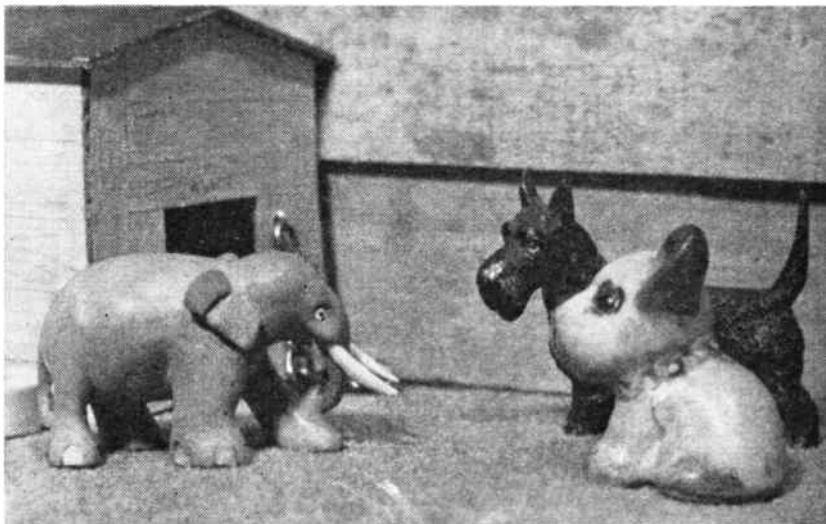

A title to this picture could be 'The Stranger'. The dog kennel was made from cardboard, the visible sides only, the boarding being lined in with pencil. The background is composed of some odd pieces of wood, while it will be quite obvious that the subjects are ornaments. A piece of plain carpeting was used to represent the grass

in the camera where the film would lie — dull side towards the lens — you will be able to view the scene. You must cover your head and camera with a dark cloth and open the shutter. If your camera

permits time exposures so much the better for the lens will remain open as long as required. If it has only a B, or brief, setting you will have to keep the lens open by retaining pressure on the trigger.

Table top work is necessarily close-up photography and you may experience some difficulty in getting near enough for a good picture. This difficulty is easily overcome by the addition of a supplementary lens which will cost only a few shillings. A number 1 or a number 2 lens will permit pictures to be taken at close range, and if the aperture is reduced to the smallest stop the depth of field will be sufficiently increased. A firm stand is also essential, since most of the exposures will be made with the aid of electric light and at least of one second duration.

Viewing the scene through the prepared celluloid is the most accurate method of checking the focusing, after which careful measurements should be made of the distance between the objects and the camera lens. The camera can then be loaded and the shot taken. A piece of cut film can be attached to the pressure plate in the back of the camera by means of 'Scotch tape', but loading must be done in the darkroom, hence the necessity for the measurements if the instrument has to be moved. If you prefer to load an ordinary film, again note the measurements as suggested.

You will also find that there is a chart

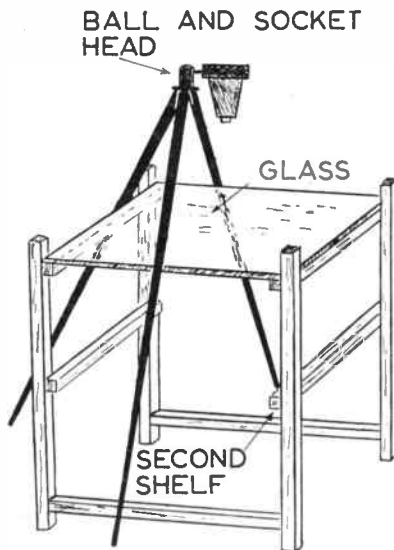

This diagram shows the arrangement for glass shelves. These shelves should be 3 or 4 in. apart, and any number may be fitted. For the sake of convenience it is best to make the fitting about 1½ ft. high

supplied with each supplementary lens indicating accurate distances for arranging the camera and these can be used with every confidence if you do not wish to go to the trouble of viewing. At the same time, if viewing is omitted you must remember to point the lens directly at the subject, since the scene observed through the normal viewfinder is misleading at close quarters due to the latter being fitted either above or at the side of the lens.

Making the sets

The foregoing should be of assistance so far as the technical aspect is concerned but there is little doubt that most of the fun of table top photography is in the making of the sets. And from the start we must remember that since we are working in monochrome our sets need only to be tinted in black, white or tones of grey. You may use water colours, indian ink, charcoal or pencil on thin cardboard, or you may use a pale grey pastel paper as a base. These materials will help to make backgrounds or model buildings and in many cases you may only have to make that portion which is visible. Enlarged photographs of landscapes are very useful for they can be toned down a little or strengthened with colour as required.

The really ambitious worker with a projector may like to try back projection. Here the picture is first taken but with a black background and normal lighting. A second exposure is then made without lights, the background being projected from behind on to a translucent screen.

Your stage can be a card table and the treatment of the base will depend on your theme. It could be a desert, requiring sand, or a snow scene with salt. A piece of carpeting or towelling will

represent grass, but let us now turn our attention to the actors.

Ornaments, toys and figurines are the most useful of all and even domestic articles can be transformed by means of a little Plasticine or modelling wax. For example, an egg cup can quickly be made into a garden flower pedestal if covered with a layer of Plasticine and suitably ornamented with a design. Dolls can be used, but if necessary you can model figures to your own requirements and even clothing can be made from thin layers of Plasticine or wax. Glass ornaments are useful as well as toy motor cars, fire engines and similar miniatures. But these do not exhaust our range of actors for along with a few other odds and ends we can make humorous table top pictures from onions and potatoes! When it is necessary to model human figures they should be about 8 in. high if you wish to add details such as eyes, nose and mouth.

Lighting

Some subjects may be taken out of doors but otherwise we resort to artificial lighting, using a 150 or 200 watt lamp in a suitable holder. A table lamp or reading lamp will be quite handy but here again some experiments are advisable to ascertain the best position. If approached in a logical manner you will soon find the answer. For example, if we are dealing with a snow scene remember that the sun is in a low position during the winter. Moreover, the most interesting pictures are produced by a side, back lighting which casts oblique shadows in the foreground. You should experiment both with height and angle of the light for best results, the exposure for an average scene with a medium speed film being approximately one second at $f/16$. It is better to make one or two test shots as a trial, using different apertures and speeds and noting which produces the best negative.

To help you further we add a list of common materials which make useful properties.

Snow: Salt is recommended. You can also use a white towel with crumpled newspaper beneath. For trees, smear with glue in places and sprinkle with salt.

Water: Crinkled cellophane, glass, mirrors or celluloid. Can be 'rippled' by crinkling greaseproof paper and covering same with glass. Foam made by shaving soap lather.

Trees: Pieces of twigs or even roots upside down.

Grass: Tufts taken from brooms or coconut matting.

Rocks: Coke or coal or small pebbles.

Earth: The real stuff, sieved to remove stones. For a ploughed field cover corrugated cardboard.

Sand: Use fine silver sand.



Here we have another simple example of the use of ornaments, the title being 'What a Surprise'

Buildings: Cardboard painted with emulsion paint, plaster or poster paint.

Doors cut out, windows made from cellophane. Domes may be table tennis balls, light bulbs. Pillars from tubes.

Ice: Glass or tin plate smeared with soap.

Lumps of washing soda for icebergs. Icicles made from wax.

There are lots of other tricky modifications you may care to try. One method involves the use of a sheet of plate glass supported by four legs, the camera being arranged so that it can operate vertically from above. For this you will need a tripod with a ball and socket head, while an upturned stool will support the glass. Objects are laid on the glass, a background being laid underneath on a shelf. We can now photograph things which would roll or cannot be otherwise supported, producing the effect of pictures taken in the air! This idea can be extended even further if a frame is made to hold two or three sheets of glass, when the objects can be placed in the different planes. You may also do odd tricks with the shadows, separating them from the objects.

Using the same glass and a black background underneath, double exposures on the same film become possible and modifications are almost unlimited. Remember that everything is within your control from start to finish so go ahead and enjoy some table top photography.

Details for making a handsome 2-tier tea trolley, suitable as a special Christmas gift, will be given in next week's issue. Make sure of your copy.

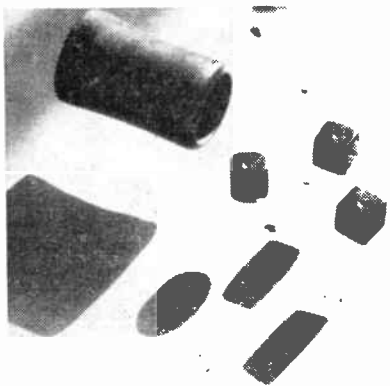

This picture was taken with the dice laid on a sheet of plate glass with a piece of white cartridge paper some 4 in. below. The effect is to separate the shadows from the objects

1962 COMPETITION DETAILS

OVER the past few years the standard of entries in Hobbies Annual Fretwork Competition has been consistently high. Many is the time the judges have pondered for a long while over this or that piece of work, examining minutely the cutting in order to exactly determine the placings. And often there has been little to choose between those who receive prizes and the 'also rans', leaving us with the impression that excellent work has in some cases not been adequately rewarded.

In order to give a greater number of competitors a prizewinning chance, it has therefore been decided to amend the annual awards. For the 1962 Competition in the Open section there will be the usual First Prize of a cheque for 15 guineas, the winner also holding the magnificent Silver Challenge Cup for a year and retaining a replica as a permanent memento. Second and Third Prizes in this section will be cheques for 10 guineas and five guineas respectively.

In the Junior section, which is open to those of 15 years and under, the three

main awards will be cheques to the value of seven guineas, five guineas and three guineas.

For many other competitors, however, there will be prizes of Hobbies Gift Vouchers for £1, and it is in this category that the number of prizes will be considerably extended. With these Gift Vouchers, winners are able to obtain any Hobbies goods to the value of £1, and in previous years we have received many letters indicating the recipients' appreciation of this valuable consolation award. The number of other consolation awards consisting of Hobbies saws will also be considerably increased, and in this way we hope to please many more of our competitors.

It has also been decided to allocate separate designs for the two sections — Open and Junior. A study of the design sheet will show that although the projects are substantially the same, i.e. — a Thermometer Plaque — the Senior motif will demand more exacting cutting, particularly in the lettering of the word 'Britannia'. For the Junior competitors

we have chosen an attractive 'Galleon' motif which should not present many difficulties, and we hope that this choice will result in a greater number of entries in this section.

In choosing this type of subject it is also hoped to obviate the breakages which occurred when the Wheelbarrow Pincushion, which was last year's design, was sent through the post for judging. The Thermometer Plaque should travel quite safely with a little extra packing over the glass tube of the thermometer.

In the Junior section, incidentally, it must be thoroughly understood that competitors shall receive no help from an adult, and receipt of an entry in this section will be taken as an honourable guarantee that it is in fact their own work.

All competitors should read thoroughly the Rules concerning entry, and don't forget that the Competition closes on 30th April 1962.

Entry is free and all submissions will be thoroughly scrutinized by the judges. There are hundreds of prizes to be awarded so do not hesitate to enter.

PRIZES

OPEN SECTION

(Winner also receives Challenge Cup)

1st Prize	Cheque for £15	15	0
2nd Prize	" "	£10	10 0
3rd Prize	" "	£5	5 0

JUNIOR SECTION

(Open to those 15 years of age and under)

1st Prize	Cheque for £7	7	0
2nd Prize	" "	£5	5 0
3rd Prize	" "	£3	3 0

Many vouchers for £1 will be awarded for the next best entries

In addition, dozens of other valuable prizes and Certificates of Merit will be awarded. Winners of the vouchers may choose any Hobbies goods to the value of the voucher.

RULES

1. All entries must be made from Hobbies Design No. 3434. Open — 'Britannia'; Juniors, — 'Galleon'.
2. Points will be awarded for the quality of the fretcutting, plus the excellence of the finish.
3. An entry must be the unaided effort of the competitor. This rule must be strictly adhered to.
4. Entries must be sent to the Competition Dept., Hobbies Ltd, Dereham, Norfolk, not later than 30th April 1962.
5. A label bearing the name and address of the competitor, age, and Section of the Competition for which the entry is to be judged, must be firmly affixed to the entry. Competitors who wish their entries returned must include a 1/- P.O. towards cost of repacking and postage.
6. Because of Customs restrictions, etc, entries are confined to those from Gt. Britain and Northern Ireland.
7. Prizewinners will be notified by 30th June 1962, and details will also be given in *Hobbies Weekly*.
8. Hobbies Ltd cannot accept responsibility for any loss or damage to entries, but all reasonable care will be taken with them.
9. The judges' decisions are final, and no correspondence can be entered into.

...was evenly on the paper... to know if you could... wish to make some plan... mitter? (R.P. — Wolverhampton.)
 ...light and hang to dry under... to go over the wallpap... on the... Channel ID would

Replies to Readers

...of... is a brush pot...
 ...to charge a 12V. battery, as... was made by fixing... board over a stu...

Lamp for Chemistry

MY son wishes to carry out some simple experiments in chemistry. Unfortunately we are not connected to a gas supply, so he cannot use a bunsen burner. Do you know of any simple alternative? (B.T. — Wisbech).

A METHYLATED spirit lamp will answer well. A glass spirit lamp is specially made for laboratory use, and serves for all ordinary heating, such as boiling test tubes, flasks, beakers, and also for simple glass working and crucible heating where very high temperatures are not needed. The intensity of the heat can be regulated by pulling up or pushing down the wick. A spirit lamp may be had from any laboratory furnisher for a few shillings.

Hardening Lead Soldiers

I HAVE cast lead soldiers from moulds, but found that although they turned out very good, they have been too soft, and bend very easily. Can you advise me as to what other metal (low melting) I could use with lead to harden it? (B.E. — Liverpool).

THERE are many compositions with lead that are used for small castings. One consists of 80% lead, 20% tin; another substitutes zinc for the tin, which would probably be the most convenient for you. The addition of 2% to 5% of antimony toughens a lead base mixture, while one comprising 20% lead, 30% tin, 25% antimony, and 25% bismuth is particularly hard — tending to brittleness.

Building an Aviary

I WOULD be glad if you could advise me of a non-poisonous rot-proofer to use on a wooden aviary for budgerigars. Also the best thing for water-proofing the hardboard of the roosting shelter, and the most suitable glue to use. (G.J. — Tunbridge Wells).

ALL preservations are poisonous when wet, but when they have dried and ceased to smell strongly you should find them safe. Cuprinol is one sort that should do. Any hardboard for outside should be oil-tempered type. If this is painted it will have a good life. For gluing we suggest Aerolite 306 or Cascamite One Shot.

Staining Pigskin

I HAVE some white pigskin and would like to stain it blue. Could you give me any information? (R.W. — Ware).

YOU should buy some of the dye known as Soluble Blue, from a laboratory furnisher, or through your dispensing chemist, who can order it from British Drug Houses Ltd. Dissolve enough of this in hot water to produce a deep blue solution. Dampen the leather so that it is wet through to the flesh side, and then brush the dye solution evenly on. Allow to dry, and buff with a soft cloth. A point to be remembered in shade judgment is that the wet pigskin will appear much darker than when dry. Allowance should be made for this. Should the dye appear to go on patchily, fine grease films are present. A trial should, therefore, be made on a small piece. The grease films are removable by sponging with dilute detergent, followed by rinsing.

Canoe Storage and Transport

HAVE you any useful hints as to storage, transport of canoes, etc, which might prove helpful? (C.L. — Finchley).

A CANVAS canoe is best stored under cover. A common method is to hang it from the roof of the garage in two slings. Inverted on a rack is a good way. Keep the cockpit open to ventilate inside. The canoe may be carried short distances or wheeled on a trolley. It will travel the right way up on a car roof rack, preferably of the type consisting of two crossbars. Lashing down to the crossbars is usually sufficient, but other ropes may be put at the ends.

Cobbler's Wax

WILL you please tell me how to make cobbler's brown wax for making brown threads for sewing boots and shoes by hand? (A.C. — Wanstead).

MELT together 2 ounces beeswax, 1½ ounce Japan wax, and 7½ ounces paraffin wax. Stir in enough raw umber to give the desired depth of shade. This gives a yellowish brown; for tan, use burnt umber.

Reclaiming Rubber

HOW can I melt rubber? (M.R. — Neath).

THERE is no way of melting the ordinary rubber we meet with in everyday life. As soon as the softening point is reached by heating, the rubber begins to decompose, and does not return to its original texture on cooling.

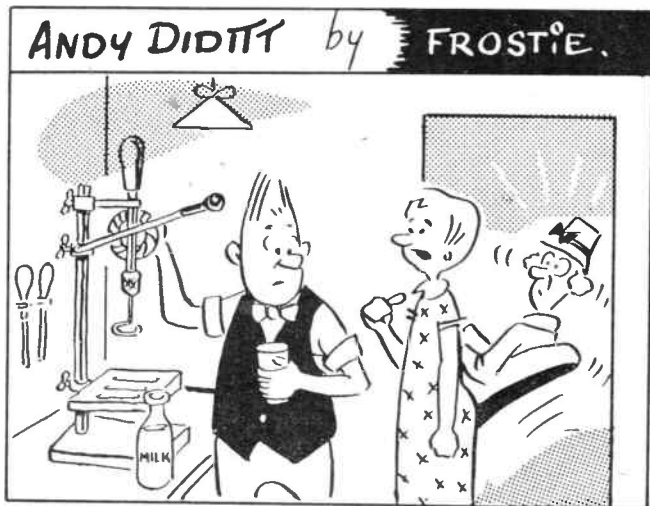

"MRS. WEST SAYS SHE DOESN'T THINK SHE'LL BOTHER ABOUT THAT MILK SHAKE AFTER ALL, ANDY."

full industrial strength

CASCAMITE 'ONE-SHOT' RESIN GLUE

waterproof and heat resistant

Table-tops, worktops and kitchen cabinets . . . bathroom panels and fittings . . . wherever you need strong, waterproof and heat-resistant bonds, use CASCAMITE "One Shot"—the resin glue that has proved its worth in the furniture, joinery, boatbuilding and many other industries. With CASCAMITE "One Shot" you have ample time to position your work before the glue begins to set.

for permanently bonding WOOD
HARDBOARD · FORMICA · WARERITE
FABLONITE and other plastic laminates. Also for model making and general repairs.

3½-oz. tin 2/6d.
7-oz. tin 4/-d.
18-oz. tin 8/6d.



CASCO 'CONTACT' INSTANT ADHESIVE

For practically everything that needs to be stuck instantly, without pressure. Ideal for handicrafts. In a handy hang-up pack. Tubes 1/- and 1/9d.



MANUFACTURED BY LEICESTER, LOVELL & CO. LTD., NORTH BADDESLEY SOUTHAMPTON



141

HANDBOOKS on Photography, Model Aircraft, Lampshade Making, Painting, Sketching, Conjuring, etc. 4/6 post free. Or send S.A.E. for lists. — John Reade, 11 St. Michael's Gardens, Shrewsbury.

WILL PAY worth while for one or more compass lens combination, sandwich type, stamped. Made in England. New, used. — Alexei Zardzke, 340 Bowery, New York 12, New York, U.S.A.

'MUSCLES IN A MONTH'. Complete Body-Building Course, 10/6. Post Free. — Pioneer Publications (Dept. XI.), 9 Courtland Terrace, Merthyr Tydfil, Glam.

PAINTING offers relaxation and profit. Even beginners can make art pay, painting their preferences. Endless demand. Exciting free brochures. Popular Art Services (HW), Clun, Shropshire.

EARN EXTRA MONEY with your sewing machine by making cushion covers. Profitable and interesting. Regular work guaranteed. Apply Dept. 28, Arnold Company, 10 Shelley Road, Worthing, Sussex.

LEARN

RADIO & T/V SERVICING

for your OWN BUSINESS/HOBBY

● by a new exciting no-maths system, using practical equipment recently introduced to this country
FREE Brochure from:—

RADIOSTRUCTOR

DEPT. G81, READING, BERKS. 4/10/61

100 DIFFERENT stamps free! Request ½d. upwards discount approvals. — Bush, 53 Newlyn Way, Parkstone, Dorset.

ENJOY WRITING? Then write for Profit. Send for 'Writers' Handbook' (free) detailing countless opportunities for beginner or experienced. — Writers' Ring (HW), 5 Edmund Street, Birmingham.

PERSONAL COLUMN LTD. Falcon House, Burnley, Lancs. — Pen Friend — all hobbies. Correspondents in almost every Country. All ages. S.A.E. for details.

HULL

DO YOU KNOW?

HOBBIES LTD. have a branch at

42 SAVILE STREET

(Removed from Ferenway)

where the manager and staff are always willing to give you the benefit of their experience with any of your handicraft problems. Why not pay a visit?

No. 2 Corner Cramp

Made of cast iron. Will take mouldings up to 4 ins.

30/-

(post free)

HOBBIES LTD, (DEPT. 991), DEREHAM, NORFOLK



HEAR ALL CONTINENTS With H.A.C. Short-Wave Receivers

Suppliers for over 18 years of radio S-W Receivers of quality. One-Valve Kit, Price 25/- Two-Valve Kit, Price 50/- Improved designs with Denco coils. All kits complete with all components, accessories and full instructions. Before ordering, call and inspect a demonstration receiver, or send stamped addressed envelope for descriptive catalogue. 'H.A.C.' Short-Wave Products (Dept. 22), 11 Old Bond Street, London, W.1



YOU should take precautions against frost this month. Any tender plants such as bedding begonias, geraniums etc, should be covered if frost is likely, or better still lifted and brought into a greenhouse or shed. Begonias will be dried off for storing and geraniums can be boxed closely with soil packed around the roots.

October is undoubtedly the best month for planting out polyanthus and wall-

flowers and every effort should be made to get them out as soon as possible. For the sake of the spring display it is advisable to take out summer bedding plants even before they have finished blooming.

Be prepared with labels when lifting plants for storing. Dahlias should have labels attached to the stems *before* lifting and heights and colour should be marked on the backs of the labels. Tip the roots

Work to do this month

Take cuttings of gooseberries and currants

Plant out new raspberry rows

Cloche outdoor tomatoes early

Perpetual strawberries can be cloched if they are still fruiting

Lift and store beetroot

Use peat or sand for storing

Plant fruit trees and perennial bedding plants

Lift gladioli corms, dry off and store

Divide peonies and montbretias

Plant spring flowering bulbs such as crocuses, snowdrops, hyacinths, daffodils, etc. (Leave tulips until November)

Lift potatoes, dry off and store

Lift and store onions

Sow sweet peas for early flowering next year

Sow lettuce for over wintering under cloches

Collect and store stakes and canes.

THESE NOTES REFER CHIEFLY TO MIDLAND GARDENS — DUE ALLOWANCE SHOULD BE MADE FOR CHANGE OF LATITUDE.

upside down when drying off, so that moisture can run out of the stems. Dust with flowers of sulphur to help prevent mildew while in storage.

From now on shrubs and roses can be planted when the weather is suitable. The ground should of course be prepared by enriching with compost or old stable manure. Protect from cold freezing winds by surrounding with old sacking.

In the warm and cool greenhouse

Increase heat for cold nights

Ventilate when possible

House all chrysanthemums not already in

Pot on cinerarias, calceolarias and schizanthus

Pot up tulips for forcing

Stop watering cacti in general.

In the cold house

Ventilate for chrysanthemums when possible

Prick out lettuces for spring crops

Scrape and paint woodwork if the house is empty.

Lots of detail in this Model Layout

TWO young Brentford children, Peter Ivermee (10) and his sister Elizabeth (13) have built an intricate model layout in just three months, using 30 Airfix plastic models. Though the layout, in their living room, measures a compact 8 ft. by 4 ft. it includes two railway stations, two trains, an airport, a canal, dock, goods yard and warehouse plus a host of ingeniously detailed features.

Among the Airfix models used are a girder bridge, signal box, thatched cottage, bungalow, level crossing, airport control tower, cranes, general shop, railway bridges, booking hall, two sets of civilians, engine shed, water tower, mixed animal set, two helicopters and an aeroplane.

Further detail is added by a petrol storage depot, barges, scenic effects and advertisements, a taxi rank and a camping ground. In fact, the amount of detail, on an area measuring only 32 sq. ft., is a lesson in how to cram the proverbial quart into a pint pot. (E.)

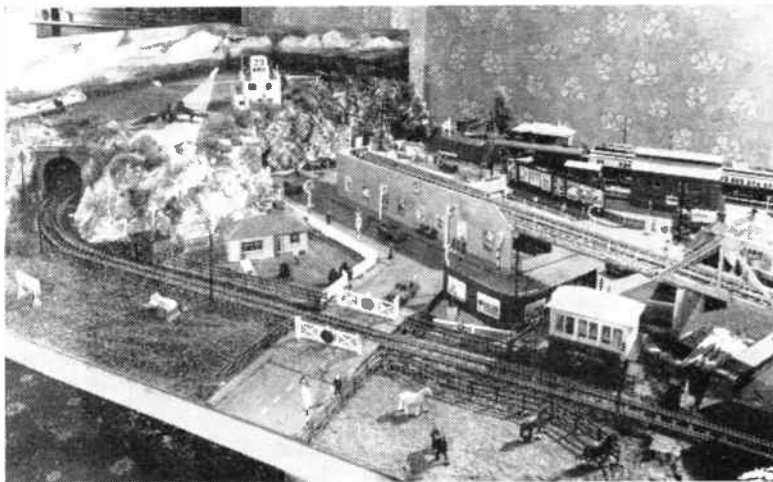

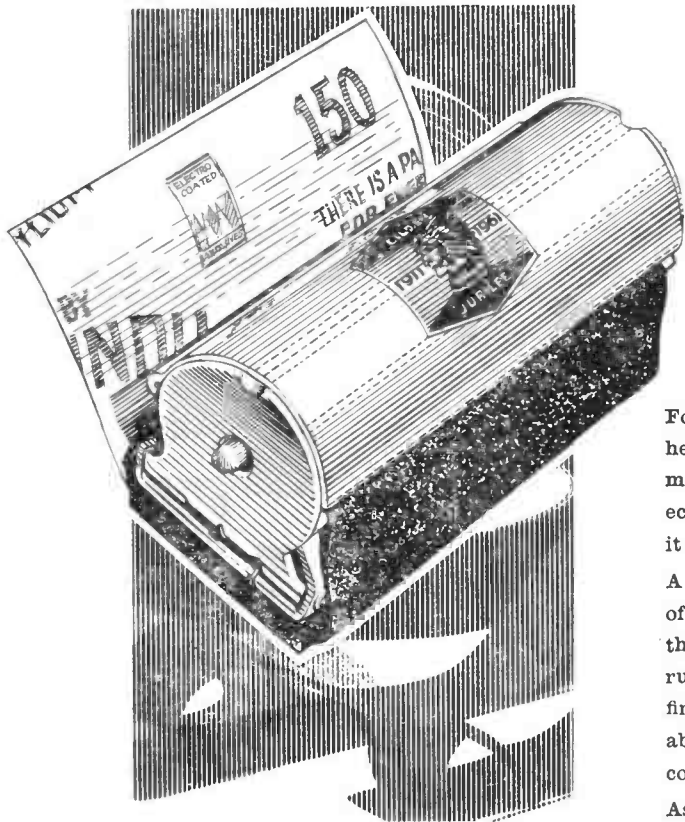

For the professional or amateur handyman here is a device that was really needed. It makes sand papering easier, quicker, more economical and gives a better result too—it uses all the abrasive paper uniformly.

A steel cylindrical container holds a roll of abrasive paper which is withdrawn through a slot and folds round the resilient rubber base where it is firmly held by fingers and thumb—the rubber base enables the abrasive to make a better all-over contact.

As each portion is used to the limit, the roll is pulled out just the width of the base again — no waste in time or material.

the new **SLIK**

sander



Refill rolls of Cabinet paper in fine, medium and coarse grades are available

From Ironmongers, Hardware and Do-it-Yourself Shops.

THE
CARBORUNDUM
COMPANY LTD
TRAFFORD PARK
MANCHESTER 17





Every handyman's right hand man for over 60 years

There's nothing like real SECCOTINE! For over sixty years Seccotine has been indispensable to every handyman. For sheer adhesive power buy Seccotine with the efficient new "pop-on" seal and open-nozzle tube ready for use.

STILL ONLY
SECCOTINE 1/3
PER TUBE

Sole Manufacturers — **McGAW, STEVENSON & ORR LTD., BELFAST**

HANDSOME VENEERED PANELS

ON $\frac{3}{8}$ in. PLYWOOD, in oak, sapele or walnut.

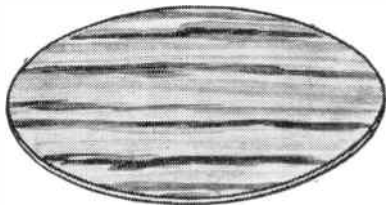

ROUND
 Veneered both sides
 22 in. diameter.

21/-
 (post 2/9)

SQUARE & OBLONG
 Veneered both sides.
 20 x 20 in. and
 30 x 15 in.

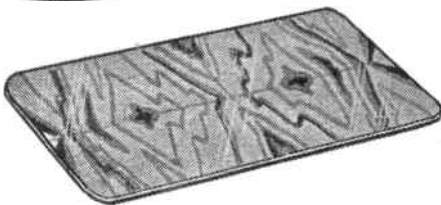

18/6
 (post 2/6)

CURVED ENDS

Veneered one side.

28 x 15 in. 27/6
 36 x 15 in. 35/-
 48 x 15 in. 52/6

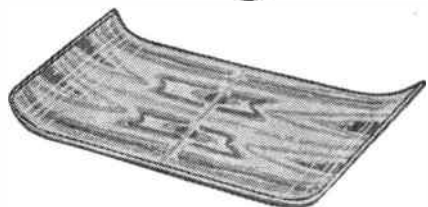

HOBBIES LTD (Dept. 991), DEREHAM, NORFOLK

The present for the future!

Here's an inexpensive way to teach your son or daughter the fascinating hobby of taking photographs.



coronet



Presentation Outfit

A complete and perfect gift that will ensure sparkling results from the very beginning. The kit includes, camera, coro-flash gun with batteries and bulbs, roll film, close-up lens and anti-dazzle lens hood.

The smart Triumph flash gun is for use with the Coronet Victor and Viscount Cameras and for any camera fitted with Compur-Prontor type synchronization.

Price 25/-

Supplied by Photographic Dealers, Chemists, Opticians, Co-ops, and Mail Order Organizations.
 Prices, plus a surcharge of 3½d. in 20/-
SEND FOR ILLUSTRATED LEAFLETS TODAY!

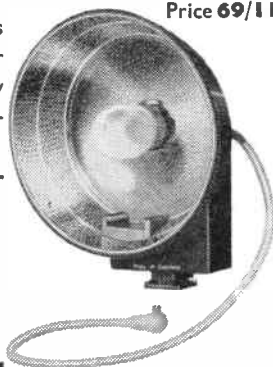

Price 69/11

coronet

cameras

CORONET LTD., 308-310, SUMMER LANE, BIRMINGHAM, 19

A STUD BOX

ALL parts are cut from $\frac{1}{4}$ in. wood using a fretsaw. You will need one each of C, F, and G and two each of A, B, D, and E. Glue them together as shown by the diagrams and by the dotted lines on the various pieces. Make up the stud from a piece of $\frac{3}{8}$ in. diameter round rod (H) a plain circle of wood (G) and a Hobbies No. 19 toe. Shape and paint. Finish off the box by staining and varnishing. (M.p.)

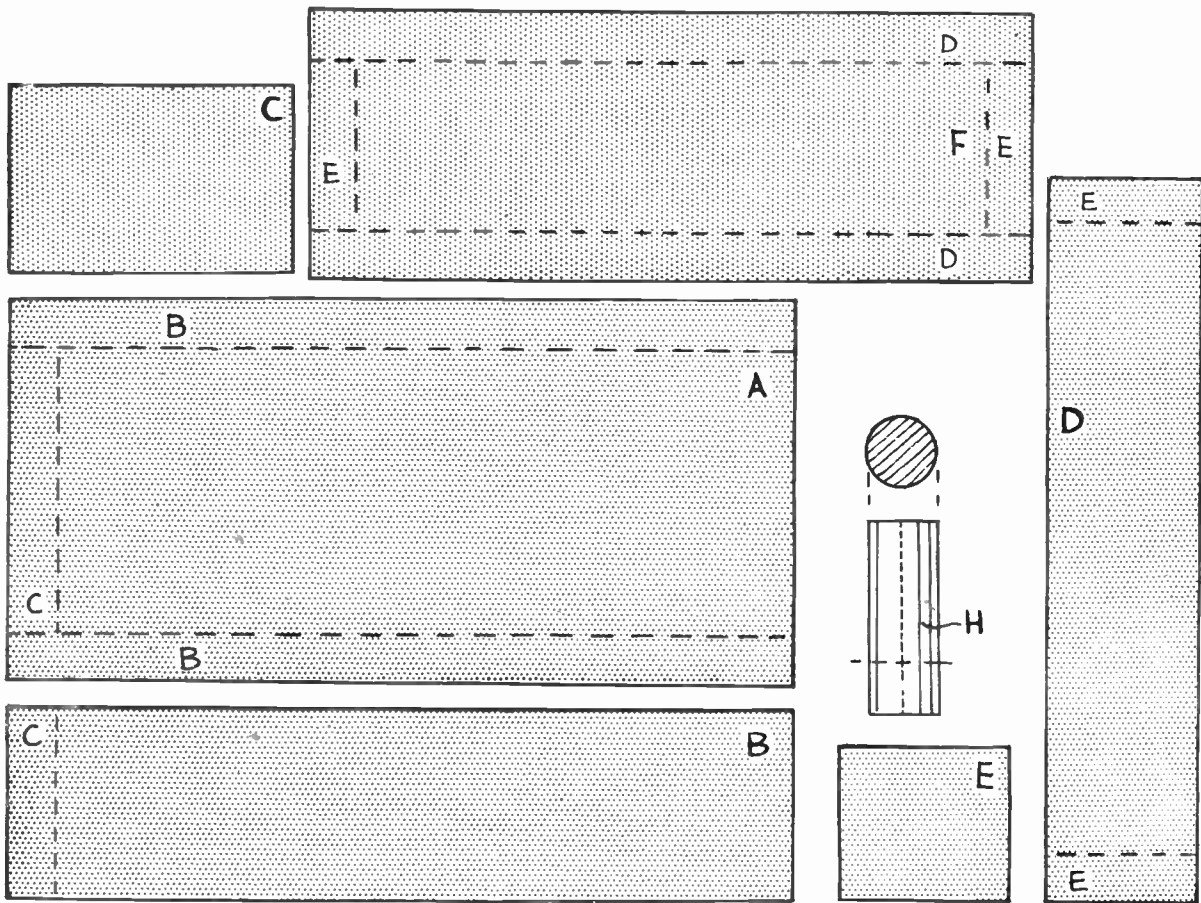
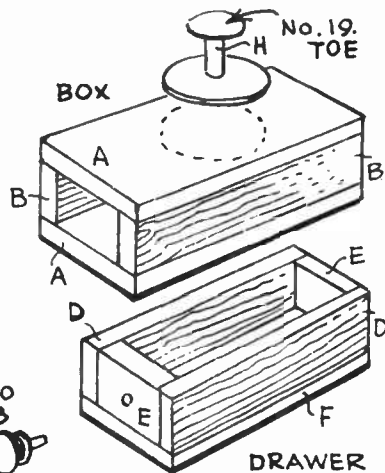
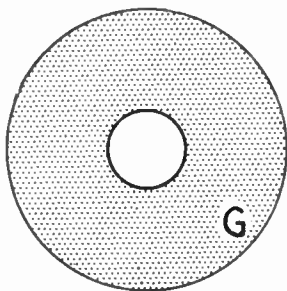

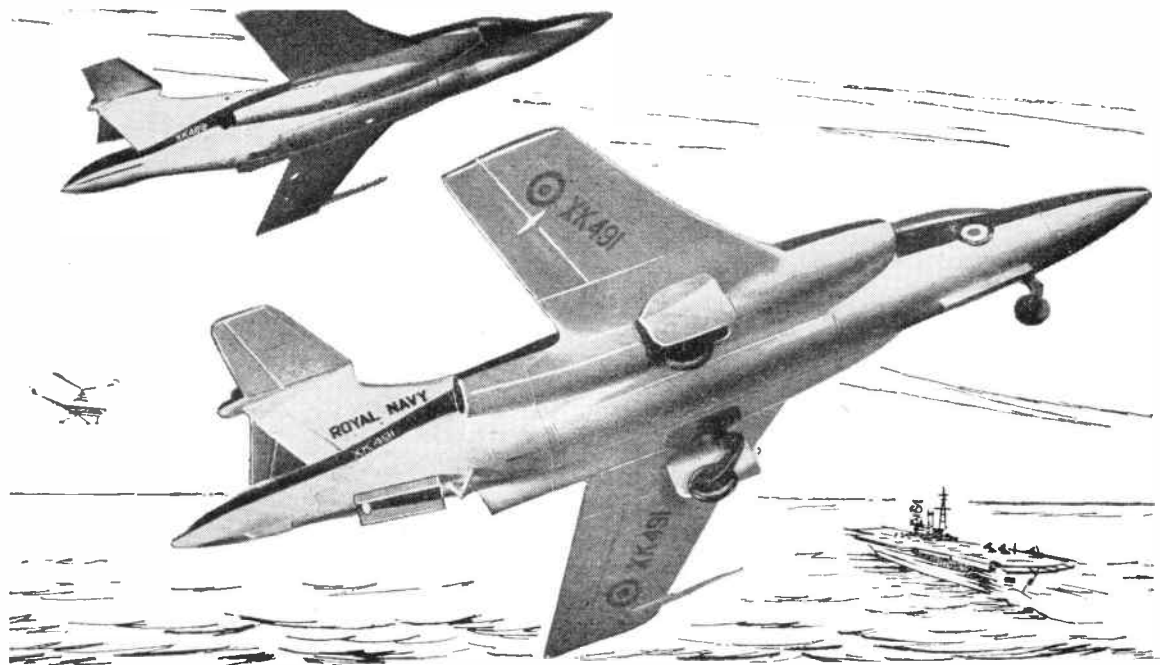

Just like the real thing!

Believe it or not, the nearer one is the Airfix model of the Blackburn Buccaneer (N.A. 39), 1/72nd scale (Kit 4/6). Behind it is a picture of the real thing.

That's how wonderfully realistic Airfix models are. Close attention to every detail gives them their faithful-to-the-original look—makes them true collector's pieces. And every Airfix series is to a constant scale. This means Airfix models look proportionally right, one against another, because *they are right!* You can't beat Airfix for realism—or value.

AIRFIX

Constant Scale Construction Kits

From Model & Hobby Shops, Toy Shops and F. W. Woolworth

There are over 100 Airfix models from 2/- to 10/6.

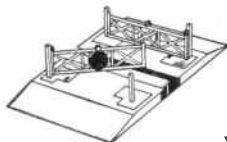

TRACKSIDE SERIES
Level Crossing 2/-

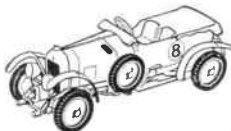

VINTAGE CARS
1930 Bentley 2/-



MODEL FIGURES
Lifeguard 2/-

BRITISH WARSHIPS

H.M.S. Cossack 2/-



A.160

STOP PRESS!

Latest Airfix Production

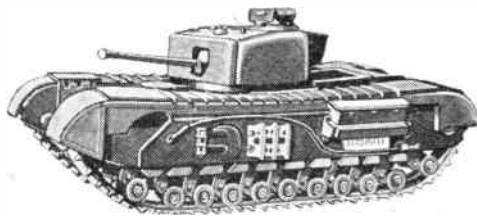

CHURCHILL Mk VII TANK

Another model in the new Airfix OO/HO scale tank series. This finely detailed model measures 3 3/8" long, has an 80 part running gear; revolving turret; the 75 mm. gun raises and lowers; 11 piece transfer set. 104 part kit . . . 2/-

Also New: Drewry Shunter. OO/HO scale locomotive in magnificent detail. 67 part kit . . . 2/-

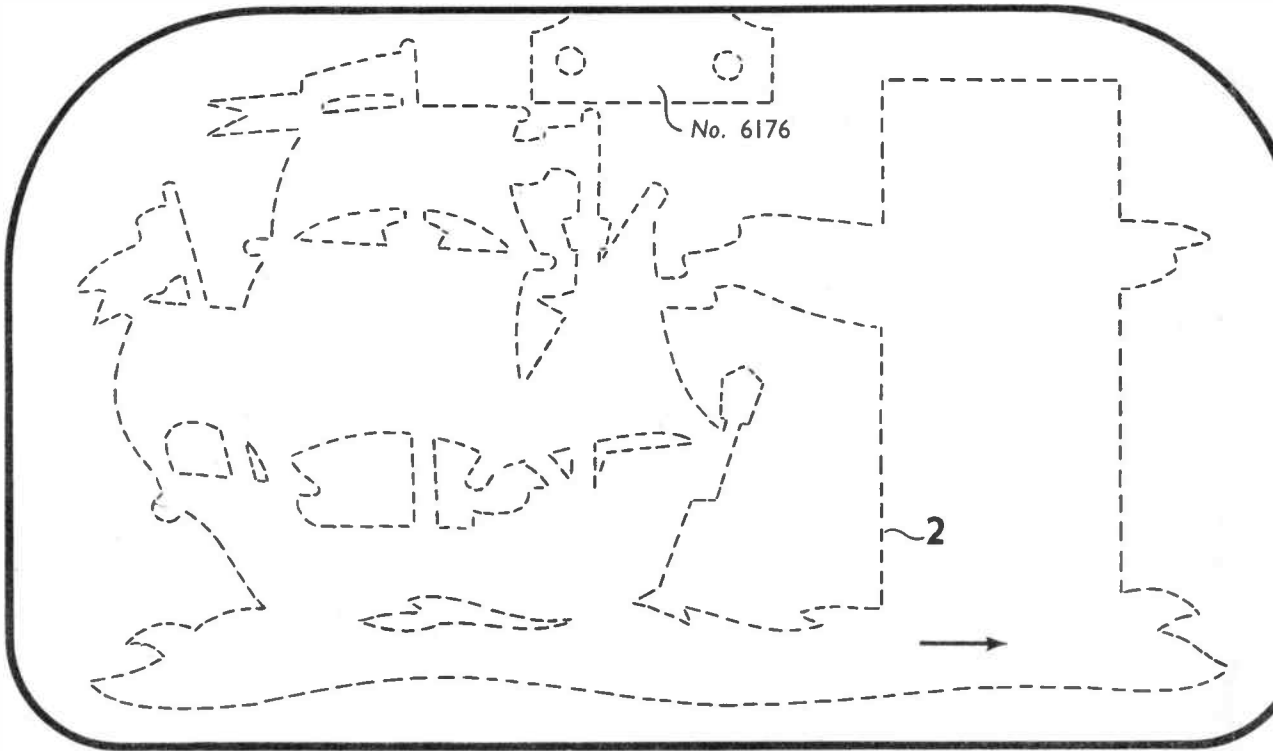

PIECE 1. CUT ONE 1/4 in.

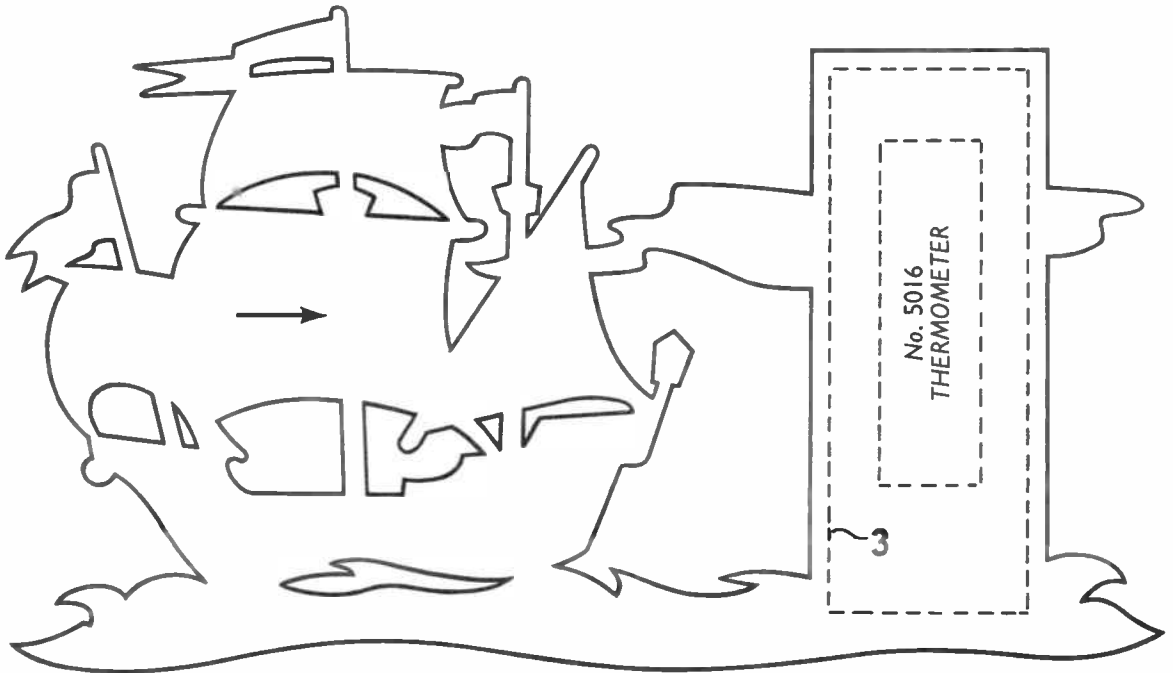

PIECE 2. CUT ONE 1/8 in.

NOTE:
THE KIT
CONTAINS
SUFFICIENT
WOOD AND
FITTINGS
FOR ONE
DESIGN
ONLY



TWO
THERMOMETER
PLAQUES
'BRITANNIA'
AND
'GALLEON'

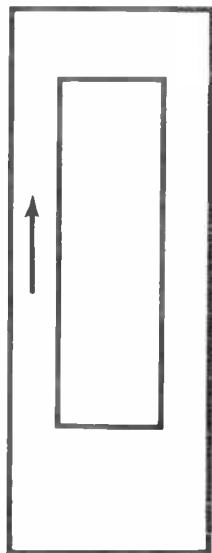
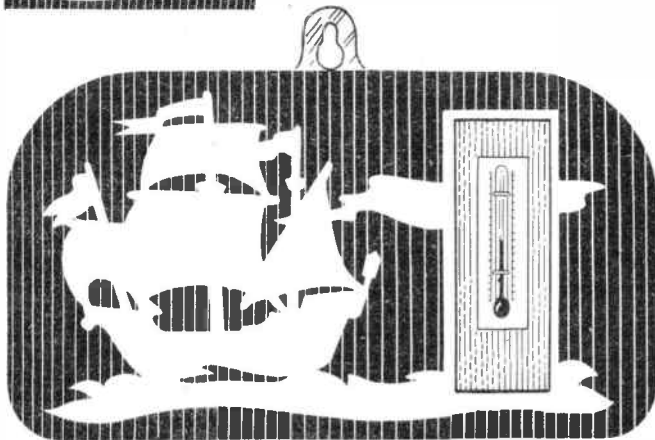

PIECE 3.
CUT ONE 1/8 in.

SIZES:
GALLEON
6 3/4 in. WIDE
4 in. HIGH

BRITANNIA
4 in. WIDE
6 in. HIGH

PANELS OF WOOD REQUIRED
FOR ONE DESIGN.
ONE G2 **ONE G4**
A KIT OF MATERIALS FOR MAKING THIS
DESIGN IS SUPPLIED BY
HOBBIES LIMITED, DEREHAM, NORFOLK.
PRICE ON APPLICATION.

Hobbies **FRETSAW BLADES ARE THE BEST BLADES**

For
WOOD. LEATHER.
PLASTIC. CARD.
BAKELITE.
PERSPEX



PIECE 2. CUT ONE 1/8 in.

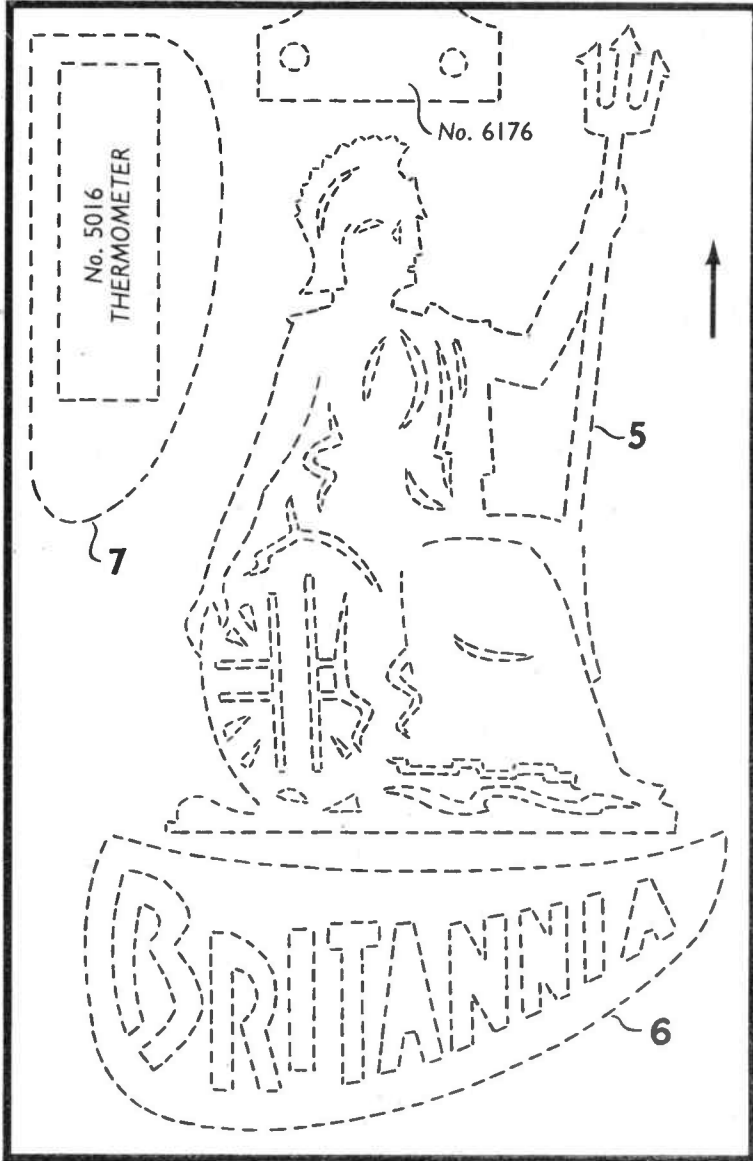

PIECE 4.
CUT ONE
1/4 in.



PIECE 5. CUT

THE ARROW
DIRECTION
OF WO

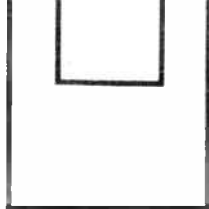

PIECE 3.
CUT ONE 1/8 in.

BRITANNIA
4 in. WIDE
6 in. HIGH

DESIGN IS SUPPLIED BY
HOBBIES LIMITED, DEREHAM, NORFOLK.
PRICE ON APPLICATION.



CUT ONE 1/8 in.

NOTE. CUT TO THE
OUTSIDE OF THICK
LINES

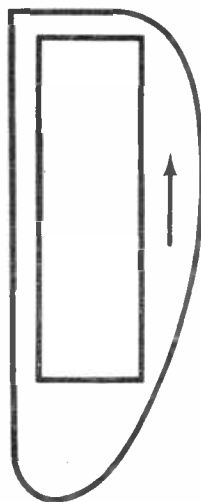

PIECE 7.
CUT ONE
1/8 in.



PIECE 6. CUT ONE 1/8 in.

ARROWS INDICATE
DIRECTION OF GRAIN
OF WOOD.

PRINTED IN ENGLAND.