

10th AUGUST 1960

VOL. 130

NUMBER 3374

THE ORIGINAL
'DO-IT-YOURSELF'
MAGAZINE

HOBBIES *weekly*

FOR ALL
HOME CRAFTSMEN

FREE plan supplement

Also in this issue:

RESULTS OF 1960
COMPETITION

RECIPES FOR
WINE MAKING

COLLECTORS' CLUB

FIT A RADIO
TONE CONTROL

AN ELECTRIC
BOMBING GAME

USE OF FILTERS
IN PHOTOGRAPHY

PLAN FOR 'COTTON
REEL' LINER

ETC. ETC.

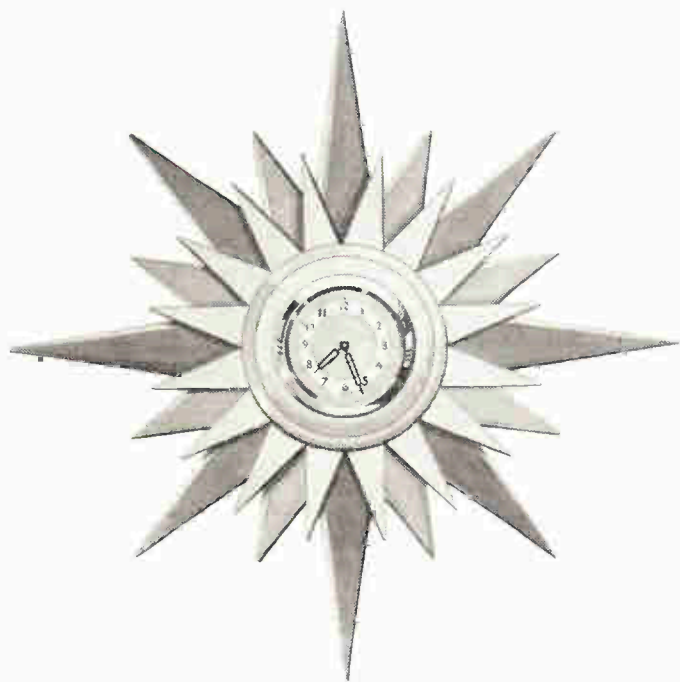

STELLAR CLOCK



Up-to-the-minute ideas

Practical designs

Pleasant and profitable things to make

World Radio History

5^D



LABELS from Scotland are popular abroad, particularly those with pictures of Highland chieftains.

The Otago Centennial stamps of New Zealand are beginning to rise in price. But you'll get them for 2/9 if you buy now. There's much to be learned from these stamps. The 1d. shows arrival of immigrant ships at Port Chalmers in

YOU'LL never guess the life ambition of movie actor James Cagney. His chief hobby is farming, and he wants to rear a new breed of cattle — a breed that can live on practically nothing.

'I have a farm in New York State', he said in a recent letter. 'It's 750 acres. I rear horses and ponies. And I'm trying to achieve a new breed of cattle.'

He has taken selected beasts from the shaggy Scottish Highland breed. Mixed them up with Herefords. And then again with Aberdeen Angus.

'Now I'm waiting to see what I get', he says. 'I hope it will be a cow that can be put out to graze on scrub. A cow that takes very little looking after. A tough, hardy cow. A Cagney cow.'

In real life, James Cagney is a quiet, likeable man. He has been in pictures since about 1928.

This hobby world

ANNA BELLASIS of Bracknell, Berks., a regular reader of *Hobbies Weekly* has made hobby news. 'When I go to the pictures I buy an ice-cream', she says. 'On the spoon I write the name of the film, the stars appearing in it, and the date. I have hundreds of spoons.' Anna's collection is probably the only one of its kind in the world.

'Collecting vehicle registration plates is a swell hobby', writes Peter Colby of New Hampshire, U.S.A. 'The walls and ceiling of my room are lined with over 1,500 plates of many colours and varied features.' Peter has plates from Alaska, Hawaii, Puerto Rico, Canada, Europe,



The cup presented for competition by Guinness Exports in the Label of the Year contest. Organised by the Society of Trollogists, the trophy was won this year by W. A. Gilbey.

and Africa. The plates came from all types of vehicles. The prize one is an old taxi plate used in Hong Kong. He started collecting four years ago, and still the plates keep coming from all over the world.

From Czechoslovakia

LAST December I sent a set of Scottish Brewery labels to Czechoslovakia, and have just received all the latest stamp issues in exchange — see illustrations below.

Most firms are generous with labels. So save all your spares. Send them to foreign pen friends. You'll get many surprises.

1848; 2d., Cromwell, an early gold-mining area; 3d., First Church, and 6d., Otago University.

Pen friends

MR W. C. ZUBAY of 3117 — 36th St., L.I. City 6, N.Y., U.S. America, collects playing cards. He will answer all letters from readers.

Leslie Burden writes: 'I would like a pen friend who is interested in fretwork, photography, and sports.' Write to 13 Mount Gilbert, Wellington, Shropshire.

Andre Prinsloo says: 'All my friends have pen pals, so I would like some, too. I am thirteen years of age and collect stamps, match labels, and cards. My address is 43 Van Riebeeck Dr., Stilfontein, Transvaal, South Africa.'

Sam Busuttill (fifteen) of 28 Mater Boni Consilii Str., Paola, MALTA, G.C., writes: 'I wish to correspond with a boy or girl in England. My hobbies are fretwork, stamps, and music.'

W. M. Anderson would like to exchange beer labels with fellow readers. Write to: 119 Manor Road, Knaresborough, Yorkshire.

Do you collect model soldiers? If so, write to reader R. White, 22 Swallow Street, Longsight, Manchester 12, Lancs. Mr White has a large collection.



Straining Home-made Wines

STRAINING plays a very important part in the making of home-made wine. During the whole process most wines need to be strained many times, and when properly carried out, this can often turn a muddy concoction into a crystal clear sparkling drink.

Straining is a job that must not be hurried, and all liquids should be allowed to trickle through the material on their own account. Squeezing will produce a muddiness which will be very difficult to correct later on; therefore it is certainly best to start right in the first place.

The first straining, and probably the one that matters most, takes place after the fruit, flowers or vegetables have been soaked in water for several days. You will need several thicknesses of material for this operation. Muslin is the usual straining medium, and it can be augmented with one or more tea towels.

Using a chair

As this part of the process will take quite a time we must have some means of holding the cloths undisturbed. Our illustration shows a way of suspending the cloths between the legs of an up-turned chair or stool.

Several thicknesses of material can be tied together or two or three cloths hung at intervals down the legs, so that the straining is done in stages.

The jelly bag can also be used with equal success, and probably the best type for general work is to use about three thicknesses of muslin made into a bag. The top is fastened to a circle of stout wire or cane, and this is suspended by strings from a convenient nail or hook.

When the wine has been made and has finished its major fermentation, it must be strained again, and this is a much quicker operation. At this stage there will usually be a large quantity of sediment at the bottom of the bottle or jar, and it must first be carefully decanted so as not to disturb it.

Two thicknesses of muslin in a funnel will usually be sufficient, but with a wine that is very cloudy, a wad of cotton wool, placed in the bottom of the funnel, as well as the muslin, may help matters.

After this straining there may be a little secondary fermentation taking place, and the wine should not be corked down tightly. In most cases this will not last long, and after about three months a further straining can take place.

Some ingredients are apt to produce a muddy wine unless care is taken in the making, and this applies especially to the various straining processes. Potato

wine made by boiling is liable to produce a 'mushy' mixture, but here we have a recipe for a good potato wine that can be made without boiling the ingredients.

By A. F. Taylor

Potato Wine

1½ lb. Potatoes
1 pint Wheat
2 lb. Raisins
4 lb. Demerara Sugar
1 gall. Water
½ oz. Yeast

The potatoes are not peeled or cut up, but should be well scrubbed and put aside to dry. They are then grated and put into a jar together with the wheat, the chopped-up raisins, and sugar. On to this is poured a gallon of boiling water. Stir well until the sugar is completely dissolved.

The yeast is added when the temperature drops to blood heat (98°), and is prepared by placing it in water of that temperature and stirring until dissolved. Leave the mixture to ferment for about 3 weeks, after which it may be bottled and lightly corked.

Sake Wine

This wine comes from the Far East, and is made from rice.

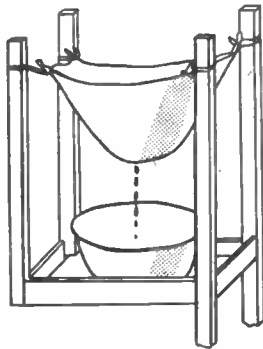

Types of strainer

3 lb. Rice
1 lb. Raisins
3 lb. Sugar
1 oz. Yeast
1 gall. Water

Boil the rice gently in the water for about 15 minutes, but do not allow it to get 'mushy', or you will end up with a thick mixture that will be very difficult to clear. Then strain it while still warm, add the chopped-up raisins and sugar, and stir until dissolved. The yeast is mixed as

before and then added to the mixture, which is allowed to ferment for about 3 weeks.

Strain again, bottle, and stand in a cool place. Continue the process of straining periodically when sufficient sediment has collected in the bottom of the bottles to warrant this.

Parsnip Wine

Here again we have another vegetable which can produce a thick wine unless care is taken in its preparation. A good parsnip wine can be likened to a sherry, and can even be made dry or sweet as desired. This one should only be allowed just to simmer for a short time.

5 lb. Parsnips
3 lb. Sugar
1 gall. Water
½ oz. Yeast

The parsnips are much better after a good frost has attacked them. Well scrub them and trim off any bad parts before cutting into small pieces, and place into cold water. Bring to the boil and simmer until tender. If any water is lost in the process it should be replaced.

Now strain off the liquid through muslin, add the sugar, and stir until dissolved. While still warm (98°), add the yeast, and allow to ferment for 3 weeks.

Raisin Wine

This is a wine that is liable to be thick and muddy, and some times it can be rather difficult to clear properly. Making wine from dried fruits presents a bit of a problem, and in order to get as much goodness as possible from the fruit it is necessary to well boil the ingredients. It is this continued boiling that can do the damage. Here then is a very simple recipe which should give good results.

1½ lb. Raisins
2 lb. Sugar
1 gall. Water
½ oz. Yeast

Remove all stalks from the raisins, and chop them up into small pieces. If you can mince them it will give better results, but it is not absolutely necessary. Pour on the boiling water, and leave to soak overnight. Next day simmer gently for about an hour.

Now strain through muslin and allow it to drip through of its own accord. You can then add the sugar. Stir well until dissolved, and warm up to 98° before adding the yeast. Allow to ferment for 3 weeks, and bottle up.

FITTING A TONE CONTROL

A TONE control circuit can be added to most amplifiers and receivers, especially if the equipment has been home constructed. With such an addition, it is possible to adjust the 'tone' of reproduction by means of the tone control knob. Simple tone controls are often fitted to commercial receivers, so that users may adjust the character of the sound (particularly music) to their liking. With amplifiers, more complicated tone control circuits are often used, to allow adjustment of the bass and treble from records, etc.

Speaker tone control

This kind of circuit is often used, and it allows treble to be reduced so that reproduction from the speaker becomes more 'mellow'. The circuit is very simple, a condenser of about .05 mfd. and a variable resistance (or volume control) being wired together, and connected across the primary of the loudspeaker transformer. The variable resistance is sometimes an ordinary potentiometer with switch, and the switch can then be wired to switch the set or amplifier on and off.

When this kind of tone control is not present, a fixed condenser is often wired across the transformer, as shown by the dotted lines in Fig. 1. When a variable

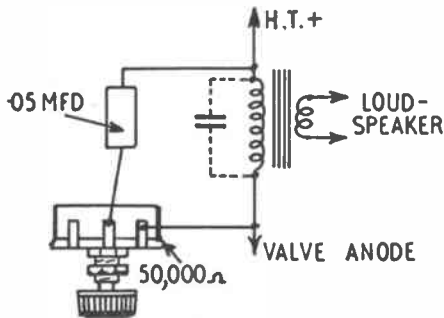

Fig. 1—Loudspeaker tone control

control is added, this condenser should be disconnected.

Most receiver circuits emphasize the treble parts of the musical scale, and the condenser is originally provided to cor-

By 'Radio Mech'

rect this. Results will thus be most brilliant in tone when the 50,000 ohm control has all its resistance in circuit, and will become more and more mellow as the knob is turned to reduce the resistance. Such a control is often called a 'top cut' tone control, because it reduces the top register.

Between valves

A similar result is achieved if a condenser and variable resistance or potentiometer are wired from the anode of an earlier stage to the earth line as in Fig. 2. Here the condenser is smaller than in Fig. 1, and the resistor is much larger ($\frac{1}{2}$ megohm). The other parts of the circuit, used to couple the valves together, are not changed.

This circuit is often fitted in powerful amplifiers and receivers where the signal

strength at the output transformer would be too great. It can also be used in the first stage of large amplifiers which have negative feedback connected from the output transformer.

As with the other tone control circuits, the values of resistors and condensers can be varied somewhat. In general, using larger value condensers will make reproduction stronger at the bass (low notes) end of the musical scale. On the other hand, smaller condensers will generally make the treble more noticeable.

Increasing treble

The circuits in Figs 1 and 2 reduce treble so that bass seems louder. Circuits are also used which reduce bass, so that the treble (high notes) sounds more powerful.

One simple and popular method of doing this is to reduce the value of the coupling condenser, which is marked 'C' in Fig. 2. The smaller the condenser the more noticeable will treble become. A switch is often fitted so that three or four condensers can be switched into circuit, giving varying degrees of tone. If a 4-way switch is used, four condensers can be employed. Suitable values would be .0005, .002, .01, and .05 mfd. With this type of treble control, it is best to have the other control (which reduces treble) in another part of the circuit. For example, Fig. 1 may be used for treble cut, and four condensers in position 'C' in Fig. 2 for bass cut.

A simple variable treble control is shown in Fig. 3 and is used in conjunction with the volume control, which is wired to the .05 mfd. condenser. If volume is reduced by turning down the volume control, treble volume can be increased by turning up the other 1 megohm control. It is thus possible to get greater 'brilliance'.

A three-control circuit

A circuit which can be used for playing records, or between a radio tuner unit and an amplifier, is shown in Fig. 4. The first 1 megohm control, at the left, acts as volume control. The other 1 megohm potentiometer allows the strength of the lower register to be adjusted, while the $\frac{1}{2}$ megohm potentiometer controls treble.

With a circuit of this kind, more pleasing results can often be obtained from records. For example, some records are defective in the low register, and this can be brought up in volume. Or, if a bad scratch or hiss is present, this can be reduced by cutting treble.

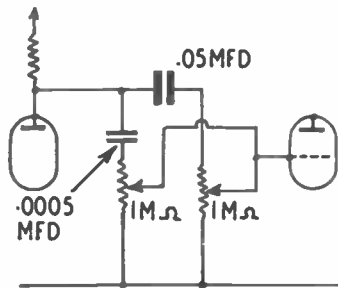

Fig. 3—Control to increase treble

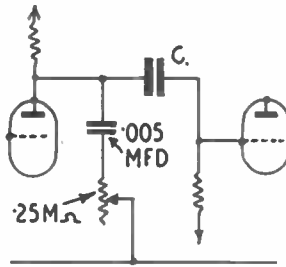

Fig. 2—Tone control between valves

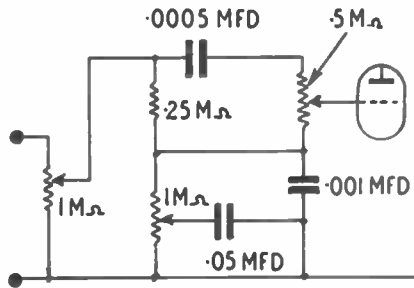

Fig. 4—A 3-control circuit for records

MAKE AN ELECTRIC BOMBING GAME



A TOY 'jet' V bomber which slides down a pair of wires and which can be made to release a bomb, by means of a remotely controlled electro-magnetic device, is the main apparatus needed to play an exciting modern game.

The strong guide wires for the bomber are preferably made of copper, though rust-free iron wire would serve. Thick

fuse wire is ideal if this is available. Have the twin guide wires as long as possible. 20 ft. would be admirable. Rig up the wires in a long room, or out of doors, so that they slope at an angle of about 45 degrees. The wires should be strung 'level' and parallel, about 1½ in. apart, between two pairs of eyelet screws driven firmly into strong supports. Delay actually securing the wires at the base of the proposed aerial 'run' until the bomber is made.

Make the bomber, using ½ in. dowel and stout cardboard, and basing your own design on one of the famous V-bombers, now in service with the R.A.F. Fig. 1 will serve as a guide when marking out the wings and tailplane. Balsa wood may be used if you wish. Shape one end of a 9 in. length of dowel to form a rounded 'nose', by means of a penknife and glasspaper. The dowel will form the fuselage of the bomber. Cut out the wings and tail pieces.

Now commence work upon the electro-magnet. Cut off the heads of two 4 in. iron nails, using a hacksaw, and bind these together with Sellotape, to form a bobbin-like object, roughly 1½ in. in length. This will be the core of the magnet. Wind 200 turns of thin insulated copper wire on to the core and then secure the coil in place upon the core by covering the outer windings with Sellotape. Bare the ends of the wire.

Assemble the bomber as follows: Bind the electro-magnet beneath the dowel fuselage, using a strip of gummed paper. At this stage the ends of the copper wire coil should protrude from the magnet for about 4 in. Use balsa cement to fix the wings and tail pieces securely in place. Insert pairs of eyelet screws, pointing obliquely outwards and upwards, in positions just behind the wings and below the tail, to serve as a means of suspending the bomber from the guide wires. Join the bared ends of

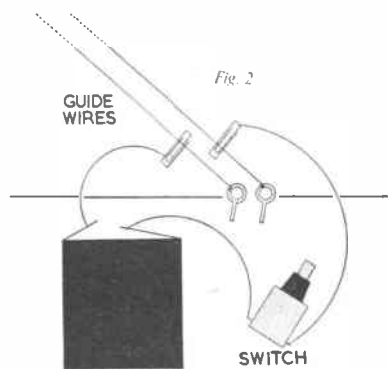
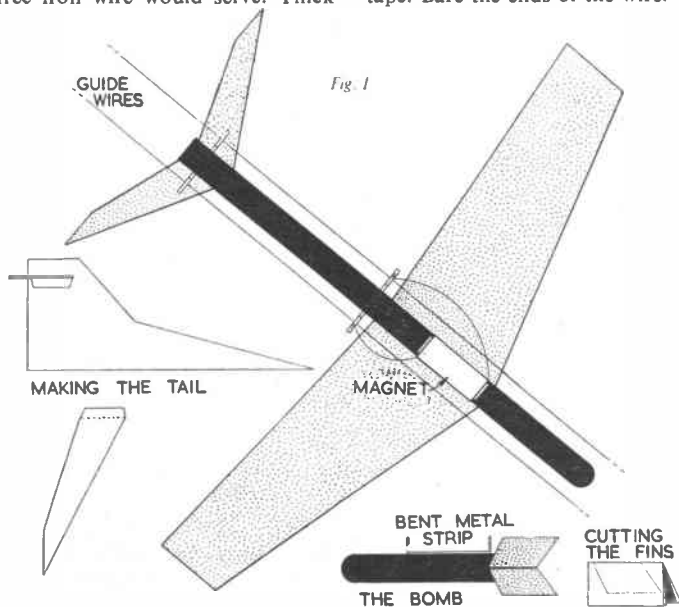

the copper magnet coil to the eyelets behind the wings. It will be advisable to solder the wires to the eyelets if bad contacts are to be avoided. Paint the model, using dope. Poster paints will be satisfactory if the colours are afterwards protected by a coat of clear varnish. The appearance of the bomber can be further improved by the application of a set of aircraft roundels.

Suspend the bomber from the wires, as illustrated in Fig. 1, and attach the two guide wires to the eyelet screws at the end of the 'run'. Now you must make a bomb from a 2½ in. length of ½ in. dowel, as shown in the drawings. Round off the nose of the bomb, using a penknife and glasspaper, then make cross cuts at the 'top' end, into which cardboard fins can be firmly inserted. Obtain a 2 in. long strip of ¼ in. wide metal and bend up the ends so that the shape can be fitted loosely on to the electro-magnet. Nail the metal strip to one side of the bomb, which can be painted in bright colours.

Obtain a 4½ in. volt flat torch battery and a small pressure operated switch, such as are sold for use with table lamps. Join together the battery and switch, with a copper wire. Fix a wire to the free terminal of the battery and attach

● Continued on page 33 I

FUN WITH SMUDGEGRAPHS

INK blots need not necessarily be ugly untidy things that disfigure an otherwise clean sheet of paper. Sometimes, by accident, a spilt blot of ink resembles a recognizable object and you are surprised, or you are tempted to doodle a simple ink blot into an interesting silhouette. However, if, hitherto, ink blots have annoyed you, try experimenting with smudgegraphs, or ink urchins.

By A. E. Ward

A smudgegraph is a symmetrical pattern made by folding a piece of paper through the middle of an ink blot, and then opening out the paper again. The design produced is never exactly predictable, and often pictures of incredible beauty will be formed. You will find that the pastime will prove absorbing and irresistible, and you will soon learn by experience that skill can be acquired whereby the likelihood of a really artistic result can be ensured.

Provide yourself with a bottle of black ink and some white scrap paper. Fold a sheet of paper in half, open it out flat, and make a wet ink blot or smear in the middle, using a pen or watercolour brush. Fold the paper again and press it lightly with your fingers. When your paper is opened out a pattern of regular appearance will be revealed. Your first efforts will probably be a trifle messy. The secret of success is not to press too heavily. Before the paper is folded the ink marks must be as wet as possible if elaborate designs are to be obtained. Try making several small blots or gently flick ink on to the paper and fold it quickly, before the smallest ink mark can dry.

Fantastic shapes

Fantastic 'other-world' animals, weird portraits, exotic flowers, bizarre insect forms and curious dancing figures will all be created in due course. Dragons, butterflies, beautiful Oriental ladies, kings, and clowns will combine to comprise a lively gallery of strange pictures. In order to obtain man-like figures you should roughly represent one side of a human body on half of your paper, adjacent to the centre crease, before folding the paper and pressing gently. You will make fairy characters, warriors, wild leaping figures, skeletons, and ghosts. Select your most successful subjects and paste them in an album. Invent exciting titles for your new works

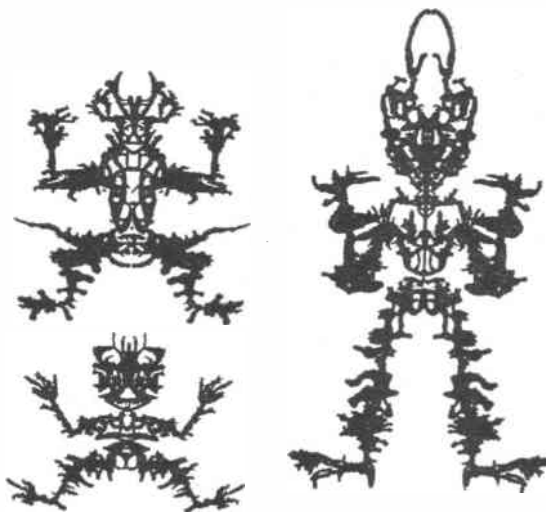

of art, and write the names tidily underneath the pictures.

Mixing the colours

You will wish to experiment with several colours at once. Splash red, blue, and black blots together, and observe what patterns are produced. Such vari-coloured pictures may not always be satisfactory, but occasionally a really lovely effect will result. Mix the ink blots in different proportions so that a certain colour will predominate each time. Another variation of technique is to apply each colour in turn, letting the ink dry before subsequent applications.

Fifty years ago ink blot pictures were used by the Swiss doctor Herman Rorschach to measure the personality traits of people who were mentally ill. Ten cards bearing ink blot patterns were displayed, in sequence, to the patient, and the sick person's descriptions of the various designs were noted and studied. Every person saw the pictures differently. Some people saw clouds, trees, maps or faces, and others responded to minute details or textures. This was the famous Rorschach Test, which is still used by psychologists today.

Some smudgegraph patterns will be fine enough to use upon very original greetings cards, though much perseverance may be necessary to gain suitably pleasing effects. Youngsters will obtain a lot of pleasure by starting a 'Book of Phantoms'! For this old pastime, which is seldom met with nowadays, you will need a small pad of 'soft finish' plain white paper. Make a bright cover and write its title boldly in

large eerie-looking red letters. Fold the pages vertically in half and open them out flat. Now begin your collection of ghostly autographs. Let your friends select pages in your book and sign their names, in ink, along the creases, before folding the pages and pressing hard prior to opening them out again. Make sure that the ink is very wet. The resulting 'phantoms' will be a source of great amusement.

● Continued from page 330

ELECTRIC BOMBING GAME

another wire to the second contact of the switch. Fasten paper clips to the ends of these wires and press one clip on to each of the bomber guide wires. Fig. 2 should make these directions quite easy to follow. You are now ready for a trial run.

Ask a friend to hold the bomber high up the wire. Turn on the switch and let your friend hang the bomb on the now alive electro-magnet, beneath the toy plane. The coil of the electro-magnet will have completed an electric circuit which flows, via the front eyelet screws on the aeroplane. When your friend releases the bomber, it will begin to slide down the wire and the electric circuit will remain unbroken. Cause the bomb to fall by pressing the switch and breaking the circuit, so that the electro-magnet ceases to function.

Build a toy boat from scrap wood and float it in a bowl of water, to serve as a target. (A.E.W.)

1960 COMPETITION RESULTS

LAST year I had the pleasure of congratulating Mr D. H. Goddard of Ealing, London, who won the title of 'Champion Fretcutter' for an excellent piece of work. And now congratulations are again in order for the same person because Mr Goddard has succeeded in retaining his title for 1960, despite intense competition.

He thus retains the Hobbies Silver Challenge Cup for a further year, and receives another replica together with a voucher for 15 guineas enabling him to obtain Hobbies goods to that value.

The main winners in the 1960 Competition are detailed on page 333 and among them will be found several names who have been knocking on the championship door for the past few years. None, however, was good enough to topple Mr Goddard from his perch, and it remains to be seen whether he can make it a hat-trick of successes. Incidentally, previous to his win last year, Mr Goddard was placed second in 1958 — a truly remarkable performance.

I also commented last year on the fact that J. Ratcliffe, who was the Junior champion, should do well when he entered the Senior lists. Lo and behold he accepted my challenge with a vengeance, and it will be seen that the judges have awarded his latest effort the fifth Senior prize. Quite a grand performance from a 16-year-old youth who has thus well justified previous comments on his work.

As a contrast (on the age question) I am pleased to report that W. Asplin, who is aged 70, has made his obvious experience count to good effect by being placed in ninth position.

Welcome, Ladies!

Another pleasing result is the 12th place gained by Miss Catherine Sauer whose success proves that fretcutting is not indeed a man's prerogative. Incidentally there were other honourable entries from the ladies, and without going into detail we can also state that there are many other up-and-coming 'youngsters' who have graduated from the Junior section. Their work has been noted and we shall watch with interest their future development in this competition.

Of the other chief prizewinners, their good work has merited awards in previous years. The runner-up to the champion, G. J. Gibbins was placed 11th in 1959 — a notable advance. Perhaps he will be the one to topple Mr Goddard from his pedestal next year. W. J. Hart, third this year, was second in 1959 — another consistent performer — and

R. Wines, who was placed fourth, was seventh in 1959 and is a former holder of the cup. R. H. Watts maintained his same placing as in the previous year, and C. Southwell dropped back a few places from fourth in 1959 to seventh this year. A. Johnson (eighth) and H. Cuthbert (tenth) enter the main lists for the first time, and will no doubt be keen to improve on their positions in forthcoming contests.

Immaculate cutting

As regards the entries, it can be said that the standard was well above average. Mr Goddard's piece was a standard of perfection, his immaculate hairline cutting really turning the scales in his favour. All edges were neat and perfectly clean, and the mirror-like cellulose finish further enhanced his work. This competition was judged particularly on fretcutting and due note was taken of those competitors who had attempted the outline cuts particularly on the policeman's clothing. These lines gave the judges a good indication of the standard of the work, and points were forfeited by those who had merely painted in the features. Specific instructions were not given in the rules for the contest, and it was left to the discretion of the worker. We felt that where it had been attempted and nicely achieved, higher marks should be given.

On the other hand, some competitors had added to the design, giving the policeman a truncheon and stripes etc. Again, in these cases when nicely done, we thought the work merited some distinction and higher marks were assessed accordingly. Essentially, however, the competition was judged on the fretcutting and the finish. Some of the painting was beautifully done — in other cases competitors lost marks for putting it on too thickly. Some had, in fact, obscured the fretcutting by a mass of paint.

We were particularly impressed by the high standard of the cutting, particularly the lettering, and nobody will say that this is easy. In some instances the work was received in a damaged condition, due to lack of careful packing to come through the post. We always have to comment on the fact that overlays tend to come unstuck and must again emphasise that this would not happen if some of the paint was scraped away from the background before applying the overlay with glue. You must give the glue a key to hold on to. Gluing over paint merely means that in the case of any tension the paint, and consequently the

overlay, will come away from the wood. In cases where mishaps occurred to the entries, these were repaired by our own staff before judging took place to give all an equal chance.

We have said something about the different types of work submitted, but in particular we must mention the entry from J. Styles of Taunton, Somerset. After fretcutting out the various pieces, he had meticulously inlaid each section, a most difficult job to do, particularly on the lettering. Even the policeman's tiny buttons were inlaid and a neat drawer was included at the back to catch the shavings from the sharpened pencil. This won for him a special prize voucher, many of which were awarded in addition to the main prizes detailed.

Other competitors whose work was not quite up to the general standard also received consolation prizes, and here again we hope that improved work will result in a main award for them in future contests. The judges were also pleased to award Certificates of Merit according to the standard of cutting achieved.

Skilful juniors

Pride of place in the Junior section went to Roger Bacon for an outstanding example in cutting and finish. Roger, who is aged 15, came sixth in 1959 and here again we hope to see him doing well in future Senior contests.

The age of most of the competitors in this section was from 13 to 15, but we were particularly pleased to award special vouchers to Brian Nye of Sharnbrook, Nr Bedford, and Richard Jones of Farnborough, Kent, two nine-year-old boys whose work elicited favourable comment. In this section G. L. Barrett, who was placed eighth, would have been higher in the list but for a mistake in assembling the car — the mudguards were glued on the inside. Worthy of particular mention (on the question of age) are G. R. Phillips (second) and Ian Strugnell (fourth) both of whom are only 11. Obviously they will be among the main contenders for Junior championship honours in the next few years.

For the 1961 Competition, details of which will be published later in the year, the main prizes will be in cash. Many suggestions have been received as to the type of subject we should choose for the competition. Some readers contend that the design should be made more difficult, but our purpose is to encourage the not-so-skilled workers rather than cater exclusively for the expert—an opinion which we think most of you will appreciate.

THE MAIN WINNERS

OPEN SECTION

FIRST PRIZE

Silver Challenge Cup, Replica and Voucher for £15 15 0

D. H. GODDARD, 157 GUNNERSBURY PARK, POPE'S LANE, EALING, LONDON, W.5.

Second Prize

Voucher for £12 12 0

G. J. Gibbins, 43 Green Leys,
St. Ives, Huntingdon.

Fourth Prize

Voucher for £7 7 0

R. Wines, 41 Northville Road,
Bristol 7.

Seventh Prize

Voucher for £3 3 0

C. Southwell, Gull Road,
Guyhirn, Nr. Wisbech, Cambs.

Tenth Prize

Voucher for £2 2 0

H. Cuthbert, 13 Oaklands,
Chapelcross, Annan, Dumfriesshire.

Fifth Prize

Voucher for £5 5 0

John Ratcliffe, Post Office,
Grayrigg, Nr. Kendal, Westmorland.

Eighth Prize

Voucher for £2 2 0

A. Johnson, The City,
Bishopstone, Swindon, Wilts.

Eleventh Prize

Voucher for £1 10 6

R. A. Wood, 34 Morris Ave.,
Wyken, Coventry.

Third Prize

Voucher for £10 10 0

W. J. Hart, 41 Waterlow Road,
London. N.19.

Sixth Prize

Voucher for £4 4 0

R. H. Watts, 52 Gaunts Road,
Chipping Sodbury, Bristol.

Ninth Prize

Voucher for £2 2 0

W. Asplin, 'St. Davids',
King Edward Road, Birchington, Kent.

Twelfth Prize

Voucher for £1 10 6

Miss Catherine Sauer,
146 Sunningvale Avenue,
Biggin Hill, Kent.

JUNIOR SECTION

FIRST PRIZE

Voucher for £12 12 0

ROGER BACON, 53 PARKSIDE, SOMERCOTES, DERBYSHIRE.

Second Prize

Voucher for £7 7 0

Glyn Roger Phillips, 40 Delville Rd.,
Wednesbury, Staffs.

Third Prize

Voucher for £5 5 0

Tony Gort, 9 Abbot's Rd.,
Leicester.

Fourth Prize

Voucher for £3 3 0

Ian Strugnell, 22 Hatfields,
Loughton, Essex.

Fifth Prize

Voucher for £2 2 0

J. A. Brown, 131 Park Ave.,
Gosforth, Newcastle-on-Tyne.

Sixth Prize

Voucher for £2 2 0

R. Davies, 15 Thornton Road,
Ilford, Essex.

★

AT HANDICRAFTS EXHIBITION

A representative selection of the winning entries, together with the Silver Challenge Cup which goes with the main Senior award, will be on display at Hobbies Stand at the International Handicrafts and Hobbies Exhibition at Olympia, London, from September 8th to 23rd. It is hoped that as many of our readers as possible will take this opportunity of seeing some of the fine work submitted for this competition.

★

Seventh Prize

Voucher for £2 2 0

J. Daniels, 17 Cotswold Gardens,
Ilford, Essex.

Eighth Prize

Voucher for £1 10 6

G. L. Barret, 29 Hogarth Ave.,
Rosehill, Burnley.

Ninth Prize

Voucher for £1 10 6

Adrian Bomback, 46 Woodberry Ave.,
North Harrow, Middlesex.

Tenth Prize

Voucher for £1 10 6

Mervyn Olver, Alma Cottage,
Rilla Mill, Callington, Cornwall.

SOME FACTS ABOUT FILTERS

*There are three main colours,
Red, green and blue.
Any one of these
Will absorb the other two.*

CONTRARY to what you may expect, this jingle has nothing to do with colour photography, but is a memory aid for the black and white enthusiast who occasionally uses filters.

We are told that the modern panchromatic film is sensitive to all colours, rendering them in different tones of white and grey to black, but generally speaking they are inclined to be over-sensitive to blue. The earlier films were sensitive to blue light only, but the incorporation of dyes in the modern emulsion makes it practicable for other colours to be more faithfully rendered.

But if we wish to emphasize colours in terms of black and white tones, we usually resort to filters; the most noticeable effects being to bring out the out-

By
H. Mann

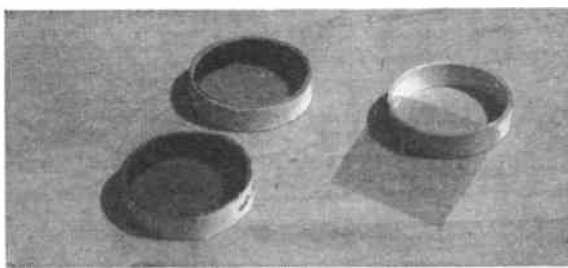

Fig. 1—Two gelatine filters in regular use, green on the left and yellow in the centre with the cardboard ring on the right and a new filter. It is a good plan to write exposure details on the filter number on the rim

ing behind the clouds as in Fig. 2, well worth waiting for and, of course, aided by a filter.

All we have to do to capture these wonderful skies is to place an appro-

prate filter before the lens and compensate by a little increased exposure, although this can be effected by opening the stop a little wider.

A pale yellow filter or a yellow-green filter will absorb blue light, darkening the blue sky, and you will probably have to double the exposure. The yellow filter has the additional advantage of eliminating unwanted ultra-violet light, and penetrates haze to some extent.

Orange or red filters absorb more blue than the yellow ones, but require six to four times the exposure. Consequently, they are mostly used for showing wood graining to best advantage. Accurate exposure and development are still essential, for the filters can hardly be expected

to correct processing errors. The red filter will render red colours almost white, while greens and blues appear almost black. The medium green filter will darken red and blue, and will counter-



Fig. 2—This sunset picture was taken with the aid of a yellow filter. FP3 film, f8, 1/50 sec. Time 9 p.m.



Fig. 3—Example of how a green filter increases cloud contrast

standing appearances of clouds against a blue sky.

Care must be taken in the choice of film, however, for we are confronted with the problem of grain, which will produce a mottled effect in an enlargement. For this reason it is an advantage to use a medium or slow speed film, such as FP3, which has an extremely fine grain.

Apart from the fact that a fine rendering of the sky adds distinction to a picture, and is such an improvement on those bald skies we often see, cloud studies can be interesting in themselves. There are cotton wool type cumulus, the nimbus rain clouds, and the mackerel skies in many formations. We have the dramatic sunsets with the sun disappear-

ing behind the clouds as in Fig. 2, well worth waiting for and, of course, aided by a filter.

All we have to do to capture these wonderful skies is to place an appro-

prate filter before the lens and compensate by a little increased exposure, although this can be effected by opening the stop a little wider.

act ultra-violet rays considerably. It can be used for landscapes below blue skies, when it will lighten the tone range of the foliage. Pale blue filters may be used for portraits in conjunction with panchromatic film and photoflood lamps.

Gelatine filters are available at 1s. each, and some of these were used for the accompanying pictures, so there is no reason why you could not make a couple of experimental ones for yourself.

Fig. 1 shows the two filters used, and a spare lens rim prepared for attaching another gelatine. Cut strips of thin card $\frac{1}{8}$ in. in width, rolling into the form of a shallow ring to fit the lens barrel of your camera. Alternatively, you may use a suitably sized pill box with the bottom

SPOT ON with the ILFORD Sporti 4

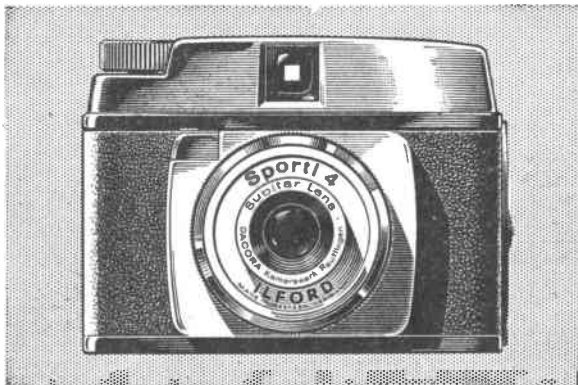

This new 'Sporti 4' is certainly some camera. A really smart job, strongly made, with a big eye-level viewfinder. Even if you've never had a camera before, you can't go wrong with the Ilford 'Sporti 4'. In daylight, set the aperture to SUNNY or CLOUDY and squeeze the button.

And you can easily take flash pictures, too, with the 'Sporti 4'. You get twelve pictures from every roll of 127 film. Spot-on—every time.

What a wonderful present the 'Sporti' would make! Or you could soon save your pocket money and buy it yourself—it'll give you a lifetime of fun, and it costs so little.

ILFORD SELOCHROME PAN

That's the film to ask for—whether you have a 'Sporti 4' or any other roll-film camera. Selochrome Pan is the all-purpose film made by Ilford, who also make the special films for nuclear research. So remember always to say "Ilford Selochrome Pan, please".

You'll get super pictures from this class camera
ILFORD LIMITED · ILFORD · ESSEX

ONLY 49'8 EVER-READY CASE 17/5

Make sure of your copy of

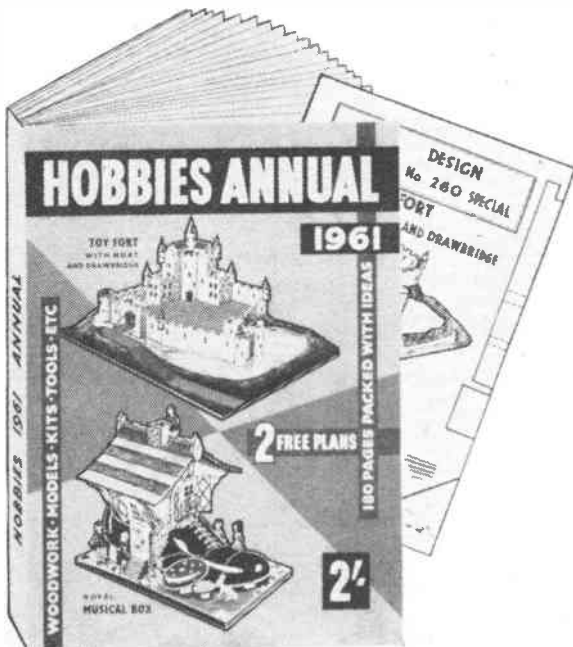

HOBBIES 1961 ANNUAL

Enlarged to 180 pages—and still only 2/-

Two free plans with each copy, for making

TOY FORT (with moat and drawbridge)

MUSICAL BOX (The Old Woman who lived in a Shoe)

Hundreds of exciting projects for all ages

From Hobbies branches, stockists, newsagents, bookstalls, etc., or send NOW for your copy by post (6d. extra)

To Hobbies Ltd., Dept. 99, Dereham, Norfolk

Please send.....copy/copies Hobbies 1961 Annual containing two free plans

Name.....

Address.....

P.O. for.....enclosed

removed. The strips are coated with gum and rolled round and round until a reasonably substantial ring is made as shown. Lay a piece of fine glasspaper on the table, then rub the edges of the ring until a flat rim is produced. Smear the rim with nail varnish, or china fixative, lay on the filter, turn over and leave under a weight until dry. Surplus material can be trimmed away with a pair of scissors.

The best filter for capturing clouds is a medium yellow filter which darkens the blue sky, although you may like to try the green one (see Fig. 3) which is useful for giving the nearest true rendering of all colours. White clouds are really cream coloured when compared with the steam from a railway engine, and a test by observation through a piece of yellow cellophane, or a filter, will show that all objects of the same colour appear much lighter in tone. Briefly, that is what really happens on the film. The cream coloured

clouds are actually made to register several tones lighter on the negative material, while the blue sky is darkened. In view of the small cost, and the simplicity of making the holders, it is suggested that you experiment with both yellow and green filters. You can buy special filters made from optical glass, but these are more expensive. Moreover, you may buy special sky filters so treated that only the sky portion is affected.

The adjoining list is intended to help in the choice of the correct filter for different conditions, and whether you prefer true renderings or crisper results.

It will be seen that you have different alternatives for capturing beautiful cloud effects in your pictures, but we may also mention that filters can be used for copying old, faded or stained photographs. A yellow filter will absorb the discoloration and improve the contrast, so remember the jingle we quoted at the beginning and that green is a secondary colour made

Type of sky	Natural Rendering	Crisp Results
Very dark sky, brilliant contrasts	No filter	Pale yellow
Clear, but little contrast	Pale yellow	Dark yellow
Blue sky, good contrast	Pale yellow	Med. yellow or green
Hazy	Med. yellow	Dk. yellow or green
Sunset, blue sky	Pale yellow	Medium yellow

from yellow and blue.

There are times when the skies are cloudless and it is not a bad idea to collect cloud negatives of all types, when they may be incorporated in other pictures when printing. For the time being you should experiment with these cheap filters, and you will find them a good investment.

A 'Galleon' Wall Plaque in Plywood



waves (C). This piece should be slightly larger than the part B underneath so that it hides the joint between the hull and the lower 'layer' of sea.

The sails are cut as shown at D and fixed in place, three to each mast. The illustration shows how the sails are graded in size. A triangular jib sail at the bow is optional. Short pieces of dowelling between the sails represent the parts of the masts showing.

Other projecting details are then added to help make the picture stand out. These include three strips along the hull (one amidships and two at the

stern), the muzzles of cannon (discs of dowelling glued in place), and a scroll on which the ship's name can be painted (E).

Other details which can be made of plywood are the flags and pennants and an anchor.

Paint the sky and sea in shades of blue, the sails white and the hull in dark strong colours such as black and brown. Finally, flags, pennants and decoration on the hull can be picked out in bright colours. The name scroll and small details on the hull look most effective finished in gilt. (A.L.)

ATTRACTIVE wall plaques can be made from plywood, using layers of wood to build up a picture which looks most realistic, since it really has depth.

The base is a circle of plywood about 15 in. in diameter. Alternatively, for a modern subject, the base can be given a rounded barrel shape, like a television screen.

There are many possible subjects for a plywood picture; the one shown here is an old sailing ship. First, the shape of the hull (A) is drawn on plywood and cut out. Next, the sea (B) is made, using a piece of plywood which is part of a circle of the same diameter as the base.

These are glued and pinned to the base, and the upper 'layer' of sea is made, this time with a wavy edge to represent

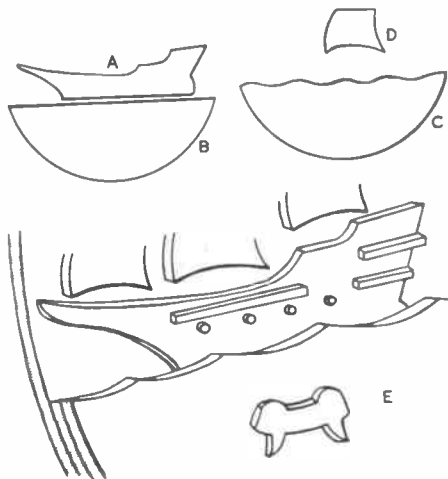

NEW!

LEARN RADIO & T/V SERVICING and ELECTRONICS

and how to make and build your own equipment — using an exciting new Practical apparatus course. Ideal for starting your own business or as a fascinating hobby.

FREE Brochure, without obligation, from

RADIOSTRUCTOR Dept.
READING . BERKS G.81

Britain's leading radio training organization

50 EMPIRE Stamps; 5/- each; stamp magazines 1/- each, post free. Try our 7 days stamp approvals.—E. C. F. Townsend (H), 92 Tenby Road, Edgeware, Middx.

100 STAMPS FREE — request ¼d., ¼d., 1d., etc. discount approvals. — Croft, Pigdown, Hever, Edenbridge, Kent.

PERSONS (either sex). Soft toy assembling. The ideal profitable pastime. Experience unnecessary. Everything supplied. Apply, enclosing s.a.c. Dept. H.W. Cuddycraft Supplies, East Road, London, N.1.

BUYING OR SELLING?

Classified advertisements on this page are accepted at a cost of 6d. per word prepaid. Use of a Box No. is 1/- extra. Send P.O. with advertisement to *Hobbies Weekly*, Advert. Dept., Dereham, Norfolk. Rates for display advertising on application.

KUKLOS ANNUAL. Indispensable cyclists' handbook. Tours, resthouses, money-saving hints. 3/- post free. — Burrow, Publishers, 2 Imperial House, Cheltenham.

100 DIFFERENT stamps free! Request ¼d upwards discount approvals. — Bush, 53 Newlyn Way, Parkstone, Dorset.

MODELS. You can make lasting stone-hard Models with Sankey's Pyruma Plastic Cement. Supplied in tins by Ironmongers, Hardwaremen and Builders' Merchants. Ask for instruction leaflet.

WORKERS with sewing machines required for making cushion covers. Regular work guaranteed. Apply enclosing s.a.c., Dept. 28, Arnold Trading, 10 Shelly Road, Worthing, Sussex.

PEN PROFIT. If you like writing send for 'Writers' Guide' (free). Thousands of words to interest beginner or experienced. Typewriter unnecessary under our system. Writers' Ring (H.W.), 5 Edmund Street, Birmingham 3.

AGENTS WANTED

Large private Christmas Card Company has few vacancies for agents (spare time). Tremendous scope and excellent profits to be made by keen agents; wide range of best selling designs; reasonable prices. Write for further details without obligation to: **GARRICK CARD CO. DEPT. 6, AVENHAM STREET, PRESTON, Lancs.**

BARGAIN—1,000's of stamps, 9d. 100; 14th B catalogue value.—Pearson, 8a The Broadway, Kingsbury, London. N.W.9.

DO YOU DOODLE? Then you have creative ability. Read 'MAKE ART PAY' (sent free). This fascinating booklet shows how doodling can be turned to profitable artistry, quickly, easily. —**VALLEY FEATURES**, Castle Gallery, Clun, Shropshire.

WHEELS (Hardwood and Rubber Tyred Metal). Cot, Pram and Doll's house Fittings and Papers. Beads, Transfers, Prints and other accessories. Stamp for new lists. (Trade supplied.) New address — **JOYDEN CO.**, 91 Peplins Way, Brookmans Park, Herts.

LEARN RADIO & ELECTRONICS the NEW Practical Way! Very latest system of experimenting with and building radio apparatus — 'as you learn'. FREE Brochure from: Dept. H.W.10, Radiostructor, 40 Russell Street, Reading, Berks.

'THE PLOUGHMAN' Bracket or Pipe Rack



Size 13½ in. long

Kit No. 3056 contains wood panel, backing, bracket eyes, design sheet with instructions.

Price 3/3 plus 9d. postage

To **HOBBIES LTD.** (Dept. 99)
DEREHAM, NORFOLK

Please send me Kit No. 3056.

Name

Address

P.O./Cheque for 4/- enclosed.

WOOD BENCH VICE

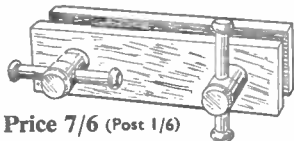

Price 7/6 (Post 1/6)

A strong hardwood vice which can be screwed to the work bench. A real serviceable tool, well made, and fitted with hardwood screws. 12 in. long.

From branches or:
HOBBIES LTD.
Dereham, Norfolk

HEAR ALL CONTINENTS With H.A.C. Short-Wave Receivers

Suppliers for over 18 years of radio S-W Receivers of quality.

One-Valve Kit, Price 25/- Two-Valve Kit, Price 50/-

Improved designs with Denco coils. All kits complete with all components, accessories and full instructions. Before ordering, call and inspect a demonstration receiver, or send stamped addressed envelope for descriptive catalogue.

'H.A.C.' Short-Wave Products (Dept. 22), 11 Old Bond Street, London, W.1

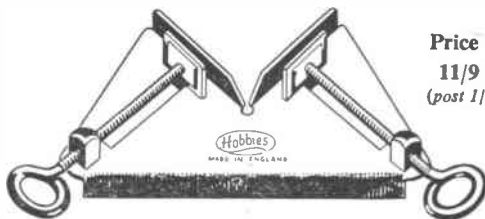

Price
11/9
(post 1/3)

A Picture Frame Cramp made from steel and practically unbreakable. It is well made and finished and will take work up to 2½ in. wide. For ordinary moulding it is a very serviceable article. From branches or:—

HOBBIES LTD, DEREHAM, NORFOLK

...ab evenly on the paper in... to know if you could... wish to make some plan... mitter? (R.F. — Wolverhampton.)
 ...ht and hang to dry under... to go over the wallpap... on the same... Channel 11 would

Replies to Readers

...re... is a brush posit... to charge a 12V. battery, as... was made by j... board over a stu... and 15V... more.)

Channel 11 TV Aerial

WILL you please let me know the length of a dipole element for an Anglia television aerial (Channel 11)? (B.S. — Dunmow.)

FOR Channel 11 the dipole should be 4 ft. 7 in. If you need a reflector this can be at 12½ in. distance from the dipole, being 2 ft. 5 in. A 2 ft. 2½ in. director may be at 10½ in. if more signal strength is required. The dipole is normally folded so that the ends are about ½ in. apart.

Finishing Plastic Ornaments

I WONDER whether you could give me advice on decorating small ornaments, and I should like to know a little more about how to obtain an ivory finish on castings made out of ordinary casting material. (G.P. — Bethel.)

YOU do not say what your ornaments are made from, but we assume it is plaster of paris. This may be coloured with poster colours which are then sealed with one or two coats of a quick-drying varnish, particularly a cellulose type. You can give plaster an ivory effect by treating with wax. Paraffin wax may be melted and brushed on or the article dipped in it. This will fill the pores of the plaster, which may be given a dull polish with a cloth or soft brush. Further coats of dry wax may be needed to build up a satisfactory polish. The best results come if the waxing is done at intervals of several days. Ordinary furniture wax may be used.

Putting Eggs into Bottles

PLEASE can you tell me how to soften the shell of an egg so that it will fit down the neck of a bottle, and when inside will regain its original hardness and shape? (R.R. — Woodbridge.)

TO soften the shell, dilute strong hydrochloric acid by stirring it into three times its volume of water and put in the egg. This process in itself furnishes an additional trick, for the egg first sinks, then moves up and down owing to the carbon dioxide bubbles forming on its surface. Rinse the egg when the gas evolution ceases and it may now be pushed easily into a bottle. We know of no process whereby hardness may be restored under these conditions, but the egg will resume its original shape.

Balsa Cement Formula

PLEASE could you tell me how to make a clear waterproof balsa cement which doesn't continually need heating up? And what sort of container will I require? (M.L. — Stretford.)

BALSA cement is made by dissolving celluloid in amyl acetate. Make sure it is celluloid, which is inflammable, and not the cellulose acetate used for sidecar windscreens and similar purposes, which is non-inflammable. Put the amyl acetate in a jar with a lid and drop in bits of celluloid until it will dissolve no more. Do this outdoors or in a well-ventilated room. The typical pear-drop smell should not be inhaled any more than you can help.

Sterilizing Vinegar Barrel

I HAVE an old vinegar barrel with a very strong odour, so could you please tell me of a way in which I can get it purely clean and sterilized for keeping wine in? (M.B. — Heage.)

THE use of an old vinegar cask is most ill-advised, since malt vinegar (as distinct from that made from pure acetic acid) will contain an organism which turns the alcohol of wine into the acetic acid of vinegar. The result would be to turn the wine into vinegar and thus produce the very result you wish to avoid. If you are prepared to take this risk, you may successfully sterilize by the treatment suggested, though the organism may still lurk in the cracks and emerge on storing the wine. Fill the cask with a solution containing two ounces of washing soda per gallon, leave overnight, empty out, rinse thoroughly, fill with plain water and stand overnight. Empty out the water and lower a tin containing burning sulphur into the cask. Cover with a wet cloth and leave a few hours. Sulphur dioxide is formed by the burning sulphur and is poisonous if inhaled in quantity. Hence the operation should be conducted out-of-doors. Remove the cloth, turn the cask on its side while standing to windward so as to allow the sulphur dioxide to escape, fill the cask with water and stand overnight, then drain.

Blackthorn Walking Sticks

I HAVE been lucky enough to cut myself a pair of really fine blackthorn (walking) sticks. Unfortunately there is a small bend in each of them. Could you please tell me the best and safest method of straightening them out? Perhaps you would also recommend what you consider to be the best filler for small defects in the knob-type handles. (R.F. — Strabane.)

THE sticks may be straightened after soaking in water, by tying to a bench or fixing in a vice between boards and pulling with cords. Arrange the pull so that the wood is pulled a little past the required position to allow for spring. Probably the best filler for the handles is Brummer green label stopping. This is a waterproof putty-like material, obtainable in many colours. It bonds to the wood and may be sanded down flush with it, and may be polished with the wood.

Making Copper-coloured Paint

I AM interested in making some copper-coloured paint, and understand that mixing copper dust with clear cellulose lacquer gives a good finish. Could you please tell me the proportions of copper dust and cellulose to use? (P.H. — Birmingham.)

COPPER dust would not be suitable for the paint, since it would have a dull appearance. A larger grain would be needed. For copper paints it is usual to employ aluminium bronze or anodised aluminium dyed suitably. These are available in various shades from gold through copper to bronze. Many oil and colour shops stock them. Cellulose lacquer is quite suitable as the medium. The proportion of metal to lacquer varies with the viscosity of the lacquer and the covering power of the metal pigment. It may vary from 1 to 10 ounces of the metal to 1 pint of lacquer, and consequently is a matter for trial with the materials at hand. We suggest mixing in first 1 ounce to the pint, making a brushing trial and continuing the addition with repeated trials until the desired effect is obtained. Thinning can be done with a mixture of equal volumes of amyl acetate and acetone, though this should be kept to a minimum; the thicker the lacquer film the more durable the metal pigment. If smaller quantities are desired, it will be convenient to know that there are 20 fluid ounces in 1 pint. Should there be difficulty in acquiring the metal pigment, James Beard Ltd, 16 Great Ancoats Street, Manchester, should be contacted.

A 'COTTON REEL' LINER

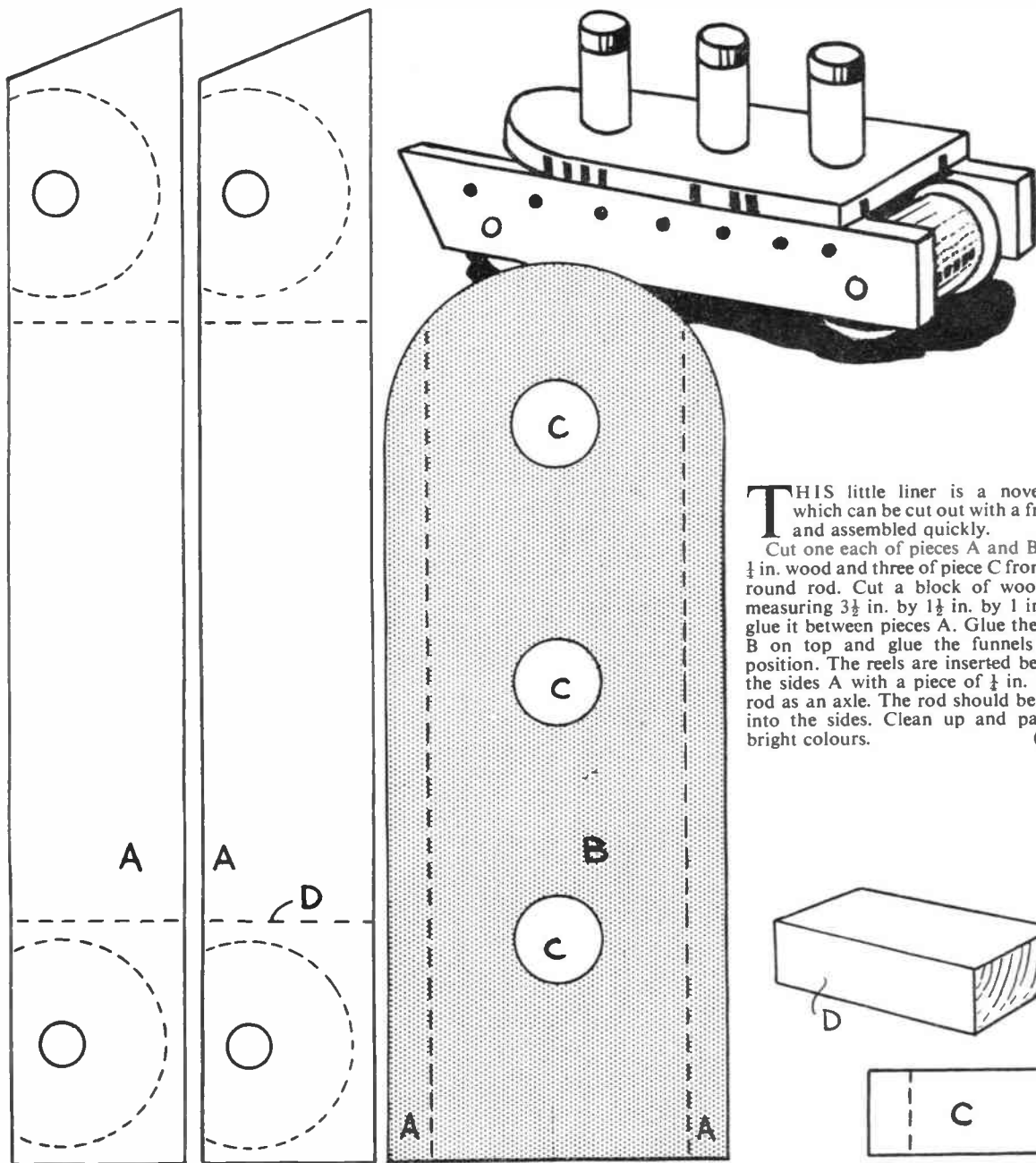

THIS little liner is a novel toy which can be cut out with a fretsaw and assembled quickly.

Cut one each of pieces A and B from $\frac{1}{4}$ in. wood and three of piece C from $\frac{1}{8}$ in. round rod. Cut a block of wood (D) measuring $3\frac{1}{2}$ in. by $1\frac{1}{2}$ in. by 1 in. and glue it between pieces A. Glue the piece B on top and glue the funnels C in position. The reels are inserted between the sides A with a piece of $\frac{1}{8}$ in. round rod as an axle. The rod should be glued into the sides. Clean up and paint in bright colours. (M.p.)

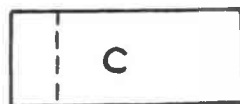
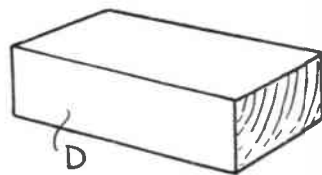

start a-

NEW

hobby with.....



Photography is fun! And it's easy with the NEW Coronet 6x6 camera. No mathematical calculations, no range finding difficulties — everything is perfectly simple. With its brilliant ultra-modern styling and eye-level viewfinder the 6x6 is the last word in low priced cameras. What's more, it's fully synchronized for use with a Coronet flash gun.

The Coronet 6x6 takes twelve big album size pictures on easily obtainable 120 roll film. You can take black-and-white snaps by day or night: also pictures in colour. A handsome ever-ready carrying case is available, also a wallet containing a special close-up lens and lens hood.

PRICE **37/6**

the

NEW

coronet



**Send
this
NOW!**

Please send me a free illustrated leaflet
on the new Coronet 6x6 camera

NAME.....

ADDRESS.....

CORONET LTD., 72 SUMMER LANE, BIRMINGHAM 19

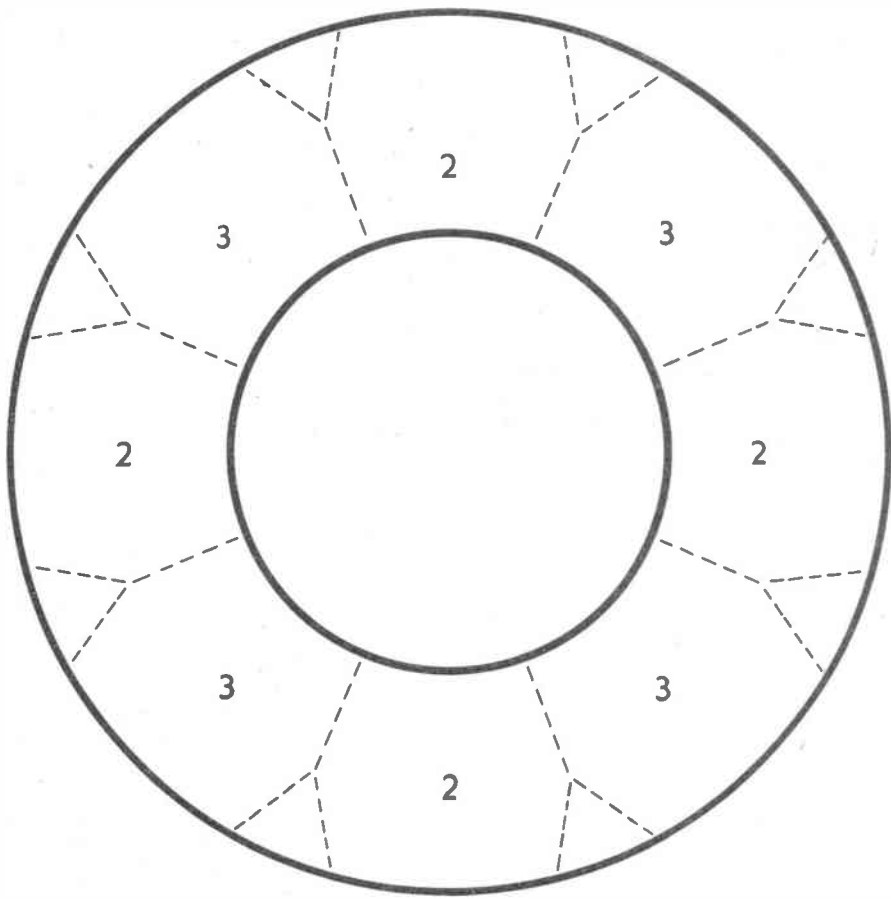

PIECE 1. CUT ONE 1/4 in.



PIECES 2. CUT FOUR 1/4 in.



PIECES 3. CUT FOUR 1/4 in.

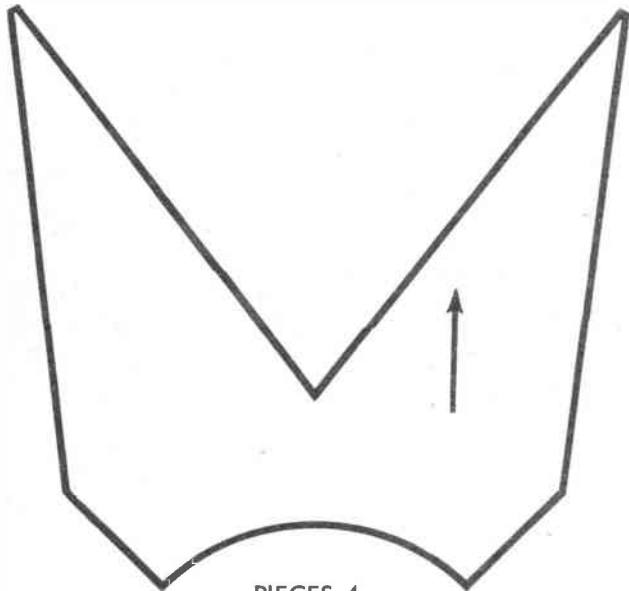

PIECES 4. CUT FOUR 1/4 in.

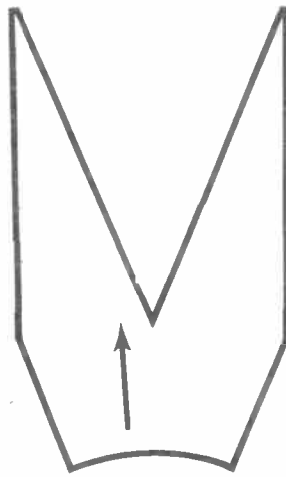

PIECES 5. CUT EIGHT 1/4 in.

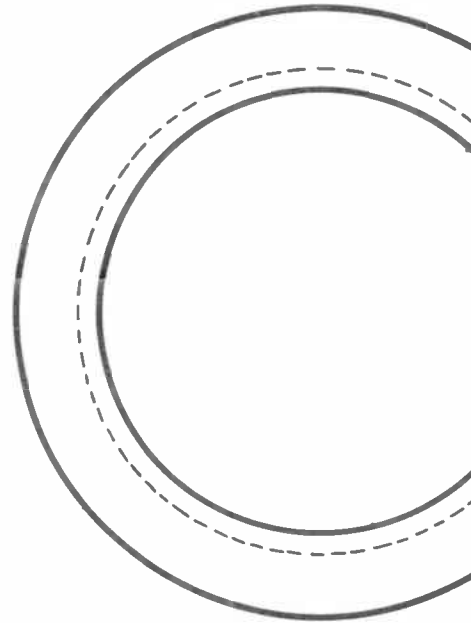

CUT SHA

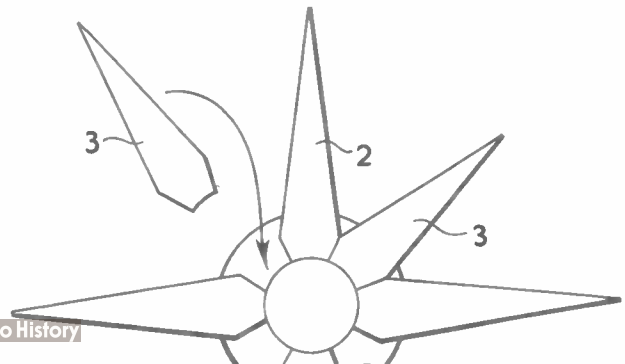
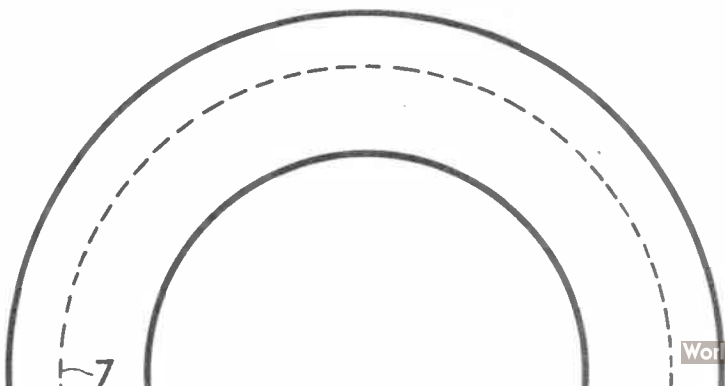



DESIGN

No. 3374

THE "STELLAR" CLOCK

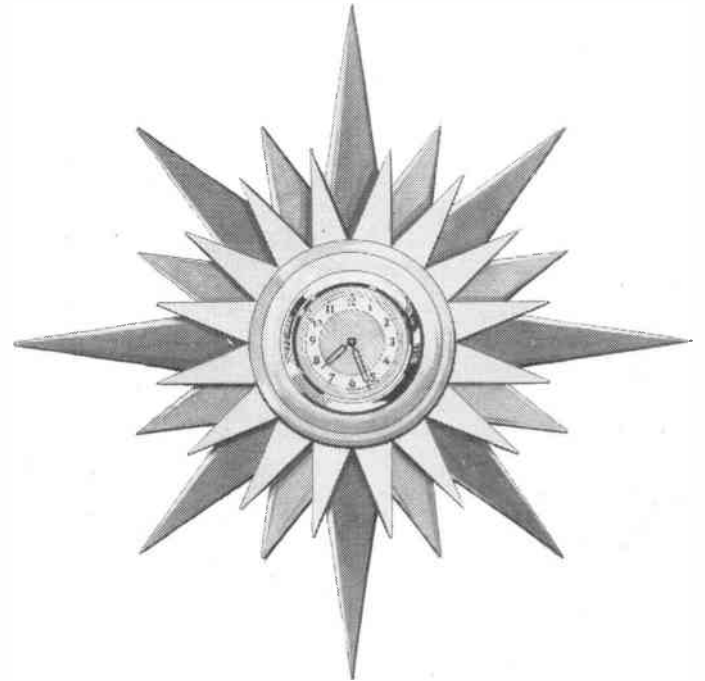

SIZE — 12 ins. DIAMETER (from tip to tip)

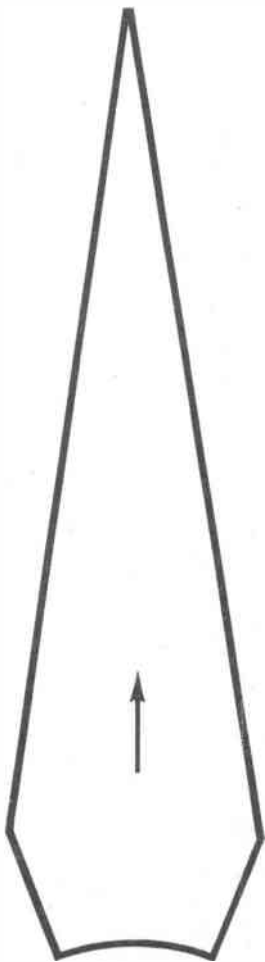

PIECES 2.
CUT FOUR
1/4 in.

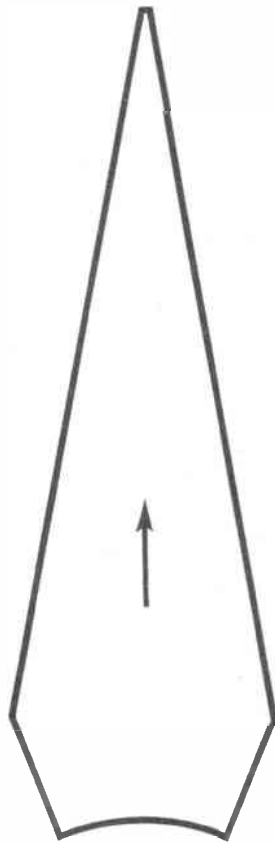

PIECES 3.
CUT FOUR
1/4 in.

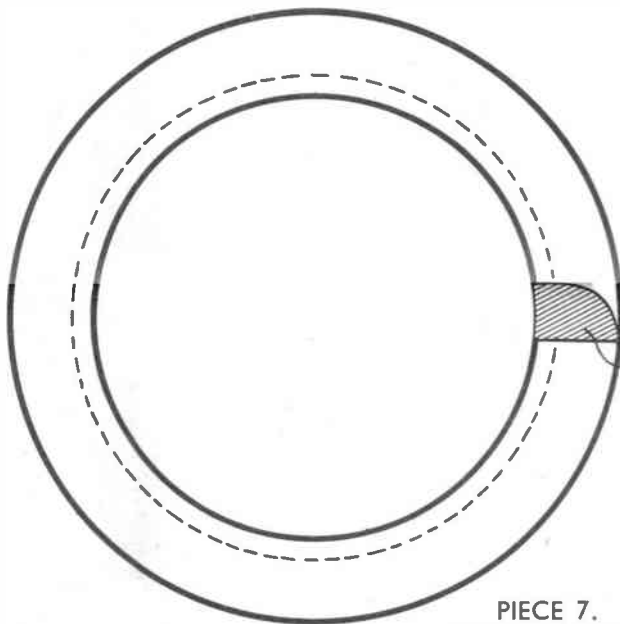

PIECE 7.
CUT ONE 1/4 in.
SHAPE TO SECTION.

PANELS OF WOOD REQUIRED
FOR THIS DESIGN

THREE Q4

A KIT OF MATERIALS FOR MAKING THIS
DESIGN IS SUPPLIED BY HOBBIES LIMITED
DEREHAM, NORFOLK.
PRICE ON APPLICATION.



**NEW
HUMBROL
MINI KIT**

Here's the latest addition to the Humbrol range, the new Mini Kit. 6 phials of Humbrol Enamel, and mixing palette; ideal for handicrafts and all small jobs. Buy one today from your stockist!

THE HUMBER OIL COMPANY LTD., MARFLEET, HULL, YORKSHIRE

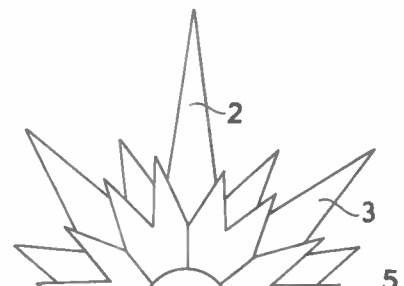
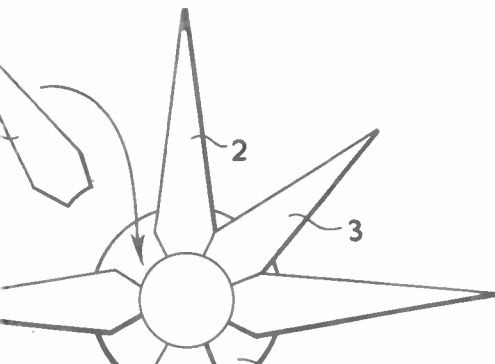

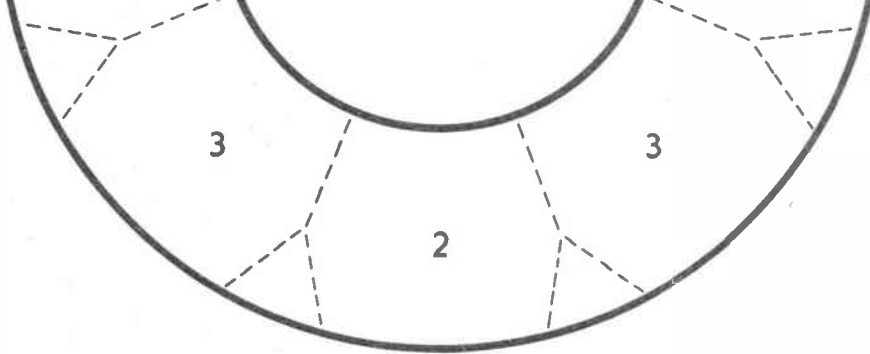

PIECE 1. CUT ONE 1/4 in.

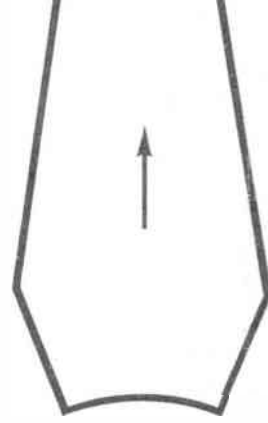

PIECES 2. CUT FOUR 1/4 in.

PIECES 3. CUT FOUR 1/4 in.

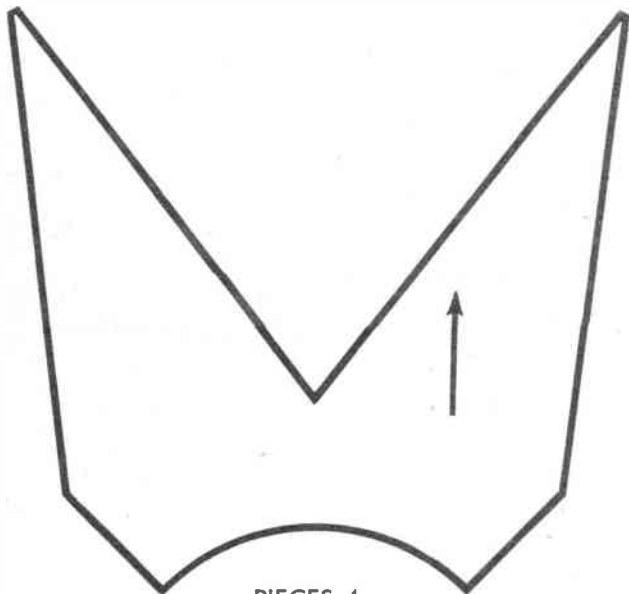

PIECES 4. CUT FOUR 1/4 in.

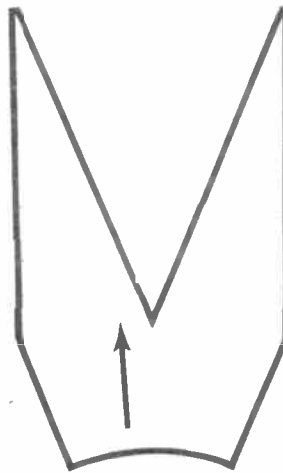

PIECES 5. CUT EIGHT 1/4 in.

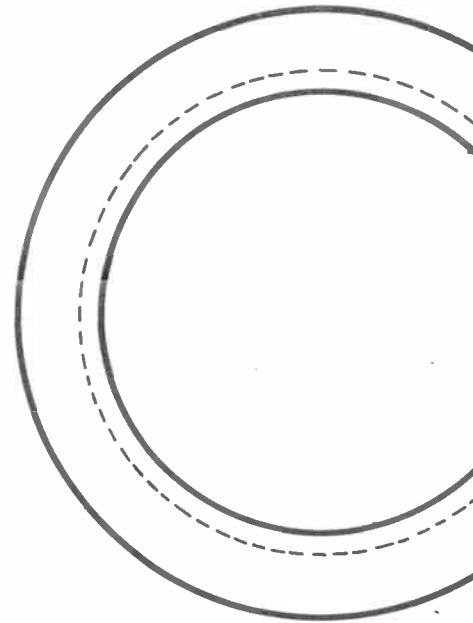

C SHA

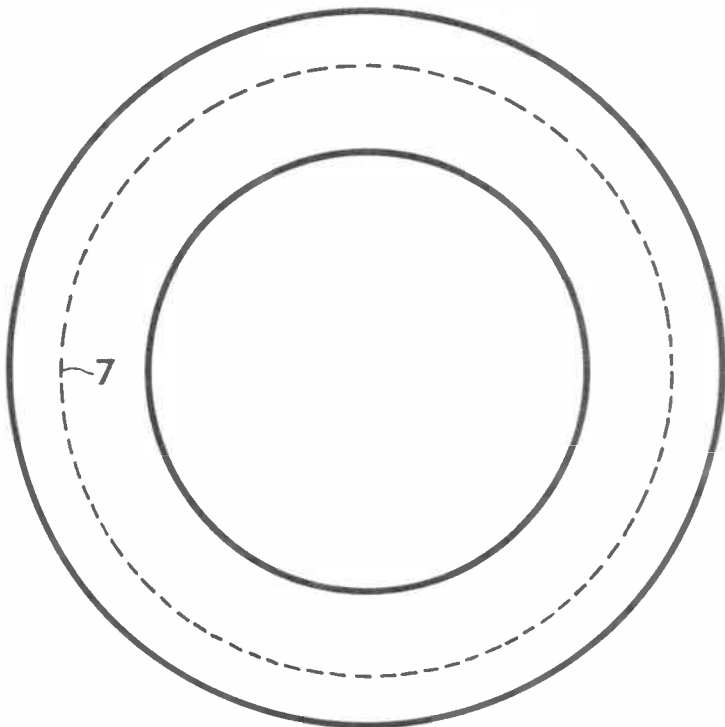

PIECE 6. CUT ONE 1/4 in.

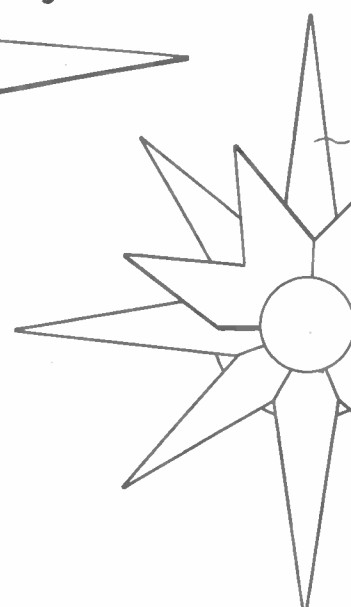
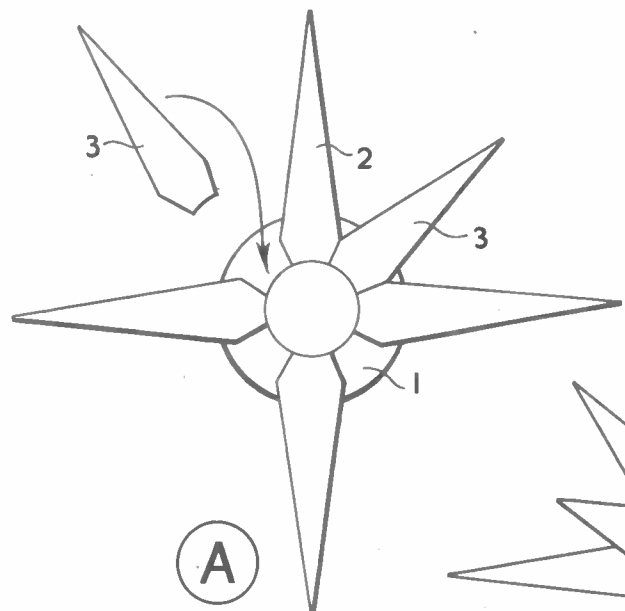

THE ARROWS INDICATE DIRECTION OF GRAIN OF WOOD.



SIZE — 12 ins. DIAMETER (from tip to tip)

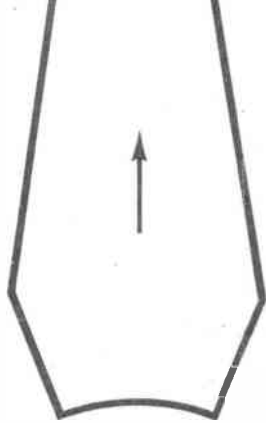

PIECES 2.
CUT FOUR
1/4 in.

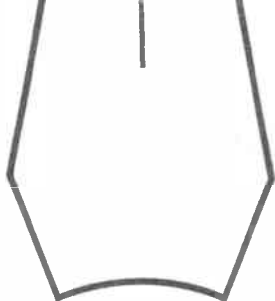

PIECES 3.
CUT FOUR
1/4 in.

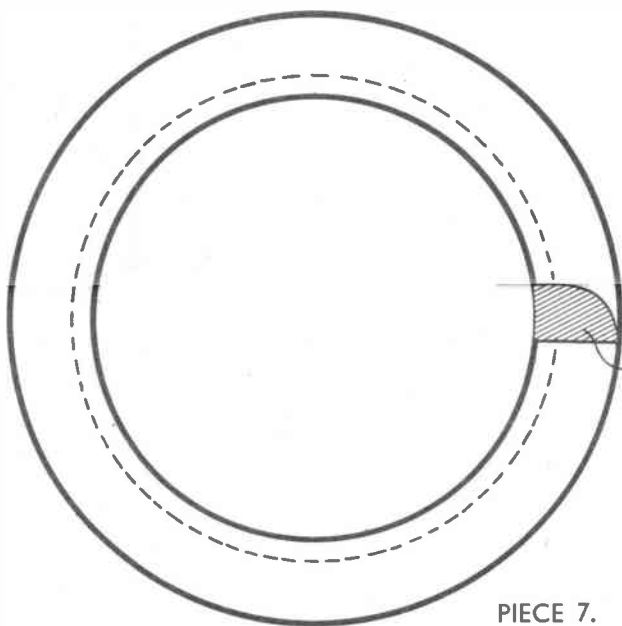

PIECE 7.
CUT ONE 1/4 in.
SHAPE TO SECTION.

PANELS OF WOOD REQUIRED
FOR THIS DESIGN

THREE Q4

A KIT OF MATERIALS FOR MAKING THIS
DESIGN IS SUPPLIED BY HOBBIES LIMITED
DEREHAM, NORFOLK.
PRICE ON APPLICATION.

**NEW
HUMBROL
MINI KIT**

Here's the latest addition to the Humbrol range, the new Mini Kit. 6 phials of Humbrol Enamel, and mixing palette; ideal for handicrafts and all small jobs. Buy one today from your stockist!

THE HUMBER OIL COMPANY LTD., MARFLEET, HULL, YORKSHIRE

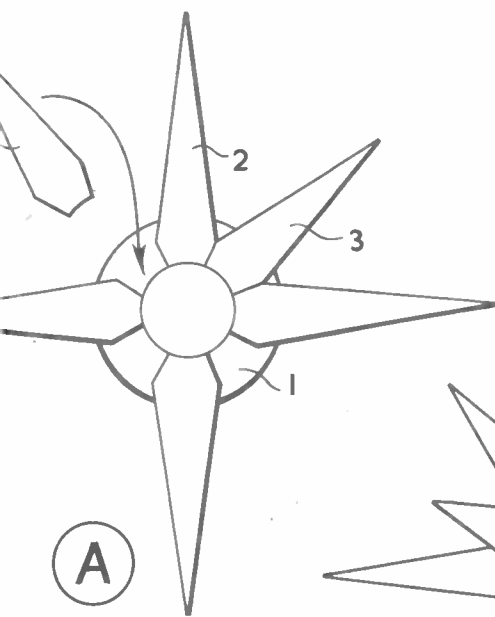

A

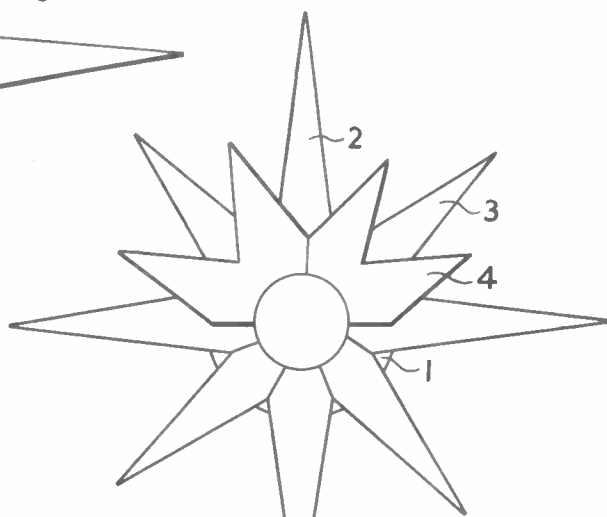

B

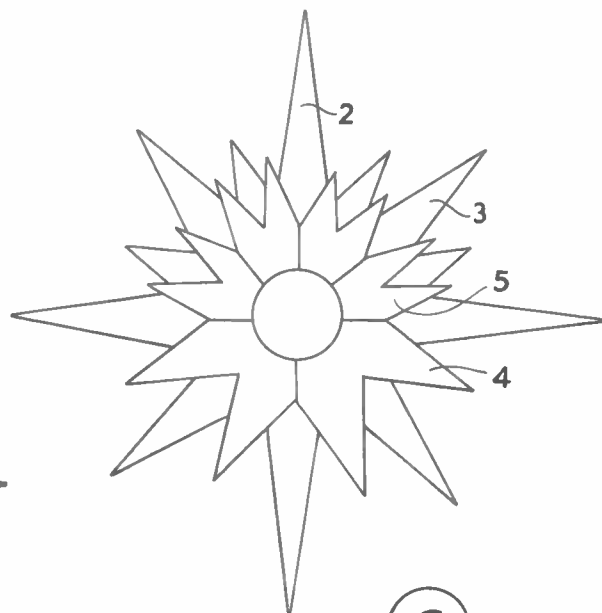

C

ARROWS INDICATE
DIRECTION OF
GRAIN OF WOOD.

PRINTED IN ENGLAND.