

8th APRIL 1959

VOL. 128

NUMBER 3310

THE ORIGINAL
'DO-IT-YOURSELF'
MAGAZINE

HOBBIES *weekly*

FOR ALL
HOME CRAFTSMEN

Also in this issue:

BEGINNER'S TWO-
VALVE RADIO

HOW TO MAKE
KALEIDOSCOPES

WOOD TURNING

INFORMATION FOR
INVENTORS

COLLECTORS' CLUB

'BIRTHDAY CARD'
IN WOOD

ETC., ETC.

*FREE design
supplement . . .*

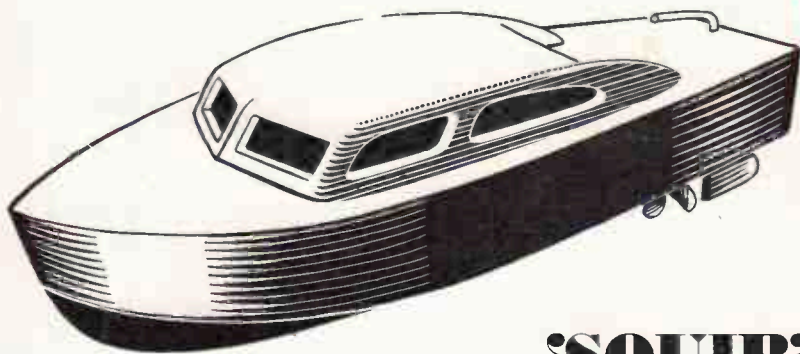

'SQUIB'

**BALSA
CABIN
LAUNCH**



Up-to-the-minute ideas

Practical designs

Pleasant and profitable things to make



5^D

Instructions for making MODEL CABIN LAUNCH 'SQUIB'

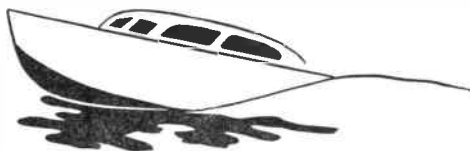

LIGHT and speedy, the model cabin launch 'Squib' will prove to be the pride of every boy. Quick off the mark, it skims along at a spanking pace, propelled by a 'Mighty Midget' electric motor.

It is made entirely from balsa, which is very easy to work with a modelling knife and a fretsaw and also included in Hobbies' kit besides the motor is the propeller unit which motivates this 12in. craft.

Most of the parts are shown full size on the design sheet. Note that the cabin top (12) is the correct width, but it must be extended in length to 5½ins. The full-size side view on the design sheet will also greatly assist in assembling the various parts.

Use carbon paper to trace and transfer the shapes from the design sheet on to the appropriate thicknesses of balsa indicated. Some parts can be cut with a modelling knife or razor blade, but the shaped portions such as the cabin sides (11) are best cut with the fretsaw. Use a fine blade and exert the very lightest of pressure when cutting, to prevent 'tearing' the balsa. When cutting out the parts, keep as close to the outlines as possible to ensure good fitting.

Balsa cement is used throughout in assembly. To commence construction,

lay the two deck pieces (1) together on a flat surface and cement them as shown in Fig. 1, being fairly liberal with the adhesive.

The addition of the transom (piece 4), and bulkheads (pieces 5, 6 and 7) are shown in Fig. 2, being positioned according to the dotted lines on piece (1) on the design sheet. Note the two holes which are provided in piece (6) through which will pass the wires connecting the battery to the motor.

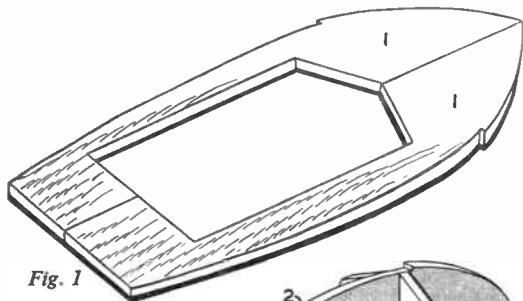

Fig. 1

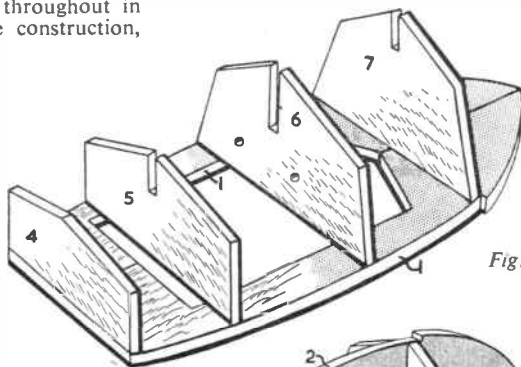

Fig. 2

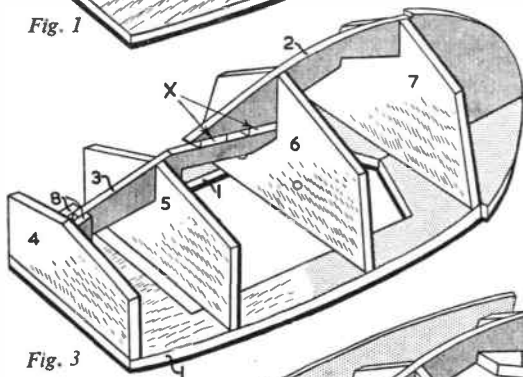

Fig. 3

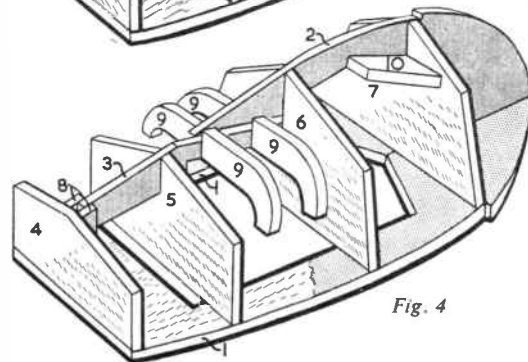

Fig. 4

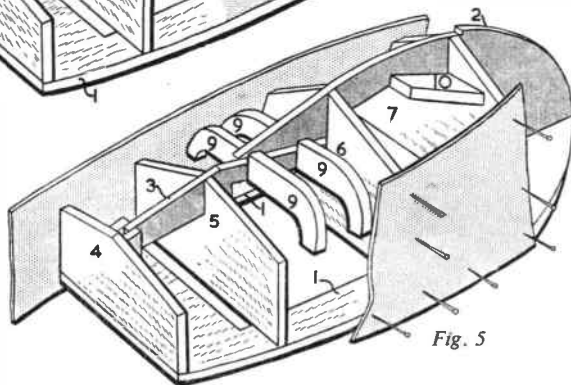

Fig. 5

As shown on the design sheet, the keel consists of pieces (2) and (3) which should initially be cut as one piece and then the slot for the propeller removed. From this piece which is removed, cut two small blocks and lightly glue them back in place as shown by the shaded portions (X) on the design sheet, thus temporarily making the keel one piece again.

Now glue the keel in position as shown in Fig. 3, adding the spacers (8) near the transom. The pieces (X) can be removed after the cement has dried.

Continue by adding the battery rests (9) and the motor bed (10) as seen in Fig. 4.

The sides can now be skinned by covering with $\frac{1}{8}$ in. balsa. Allow plenty of overlap as shown in Fig. 5. Apply plenty of cement and pin the balsa in position until the cement is dry. To

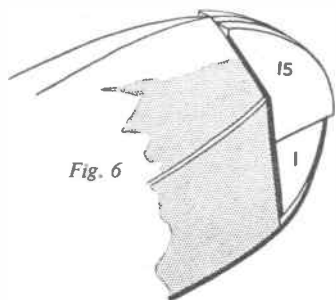

Fig. 6

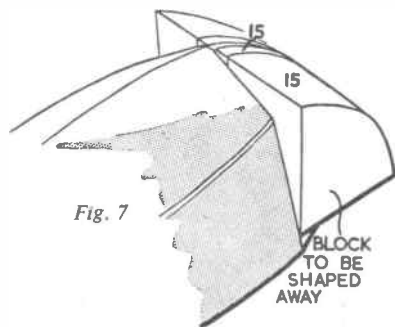

Fig. 7

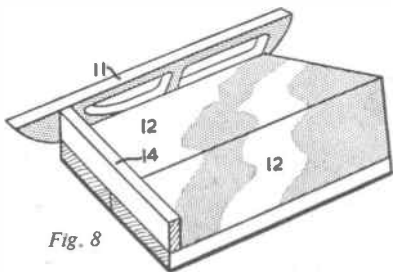

Fig. 8

assist adhesion at the bow, cord can be wound round and round until the cement is set.

Follow on by trimming the waste wood from the sides, and then add sheet balsa to the bottom in the same way as for the sides. This is in two pieces which join along the keel.

Next glue in place the $\frac{1}{2}$ in. bow blocks (15), one on each side of the keel (Fig. 6). Now the two $1\frac{1}{2}$ in. thick blocks (15) are glued in place as seen in Fig. 7. When the cement is dry, shape away with a modelling knife and glasspaper down so as to maintain the contour of the hull and the deck.

Lay pieces (12) forming the cabin, on a flat surface, and cement together (Fig. 8). Add the sides (11) and cross strut (14). When dry, turn the cabin assembly

over and cement in place the two windows (13) as seen in Fig. 9.

Finish shaping by rounding off all edges to give a pleasing streamlined shape to the cabin. The cabin top will be a neat fit over coaming which should next be glued round the inside of the deck opening. It consists of strips $\frac{1}{2}$ in. wide cut from $\frac{1}{8}$ in. sheet balsa and fixed so as to leave approximately $\frac{1}{8}$ in. protruding over the deck level.

Pierce the hull and insert the propeller shaft in position as shown in the side view on design sheet. Seal off the shaft with balsa cement to prevent the ingress of water after ensuring that the propeller does not foul the bottom of the craft.

Use $\frac{1}{4}$ in. screws and a dab of cement to secure the motor to its bed (10) as indicated on the side view on the design sheet.

The connections between the battery and motor are made by means of thin covered wire. Connections at the battery ends can be made by means of paper clips twisted to the wire and then clipped over the battery terminals. Note that the engine direction will be reversed if the battery connections are changed over. In action, the cabin top is removed to make the connections and start the motor, and then replaced for the trip.

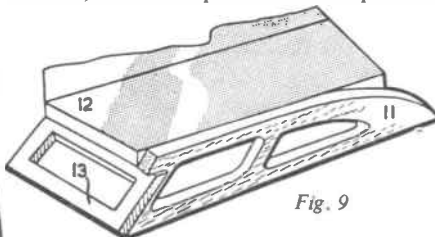

Fig. 9

KIT FOR 30/-



Kit No. 3310 contains balsa wood, and other materials for making the 'Squib' Cabin Launch. The price is only 30/- and also included is the motor and propeller unit. Kits from branches and Hobbies Ltd., Dereham, Norfolk (post free)

GET ONE TODAY !

Pierce the deck and bottom to take a 2 in. length of brass tube which is cemented in position and which locates the tiller and rudder. The position of this tube is shown in the side view on the design sheet. The tiller consists of a piece of wire which goes through the tube through the rudder (16) and is then bent and returned into the rudder which is thus fixed as shown in the side view.

In our prototype model a good finish was obtained by filling the grain with 'Celestor' woodfiller. Rub down with fine glasspaper, apply two flat undercoats and then a top coat of high-gloss enamel. With battery and motor fixed in position, the model was found to be perfectly balanced.

Lively Mothballs

MOTHBALLS that dance sedately up and down in a jar of water are sure to provide an entertaining mystery. The 'miracle' is made possible by means of a teaspoonful of bicarbonate of soda and a small quantity of hydrochloric acid.

Prepare for the demonstration by almost filling a large glass jar with water and adding a little hydrochloric acid. If the acid is very strong only a small amount will be required. Avoid spilling the acid on your hands. Then place a heaped teaspoonful of bicarbonate of soda in the jar. As the resulting gas bubbles rise to the surface with a fizzing sound, drop about a dozen mothballs into the liquid.

At first the mothballs will sink, but soon they will become covered with bubbles of gas and will be buoyed upwards. When the mothballs break surface a few of the bubbles will be knocked off

and some of the buoyancy will be lost. Consequently the mothballs will sink. They will remain on the bottom of the jar until a sufficient quantity of gas bubbles have formed to raise them again. This up and down movement may continue for hours and the mothballs will not be harmed by the chemicals. When the activity of the mothballs slows down you can quicken them up again by adding small quantities of acid and bicarbonate of soda to the water.

The gas generated when hydrochloric acid and bicarbonate of soda react together is carbon dioxide and gas bubbles form easily on the rough surfaces of the mothballs.

The effect can be greatly enhanced by colouring the mothballs with ordinary wax crayons. A glass vessel containing brightly coloured dancing mothballs will provide an unusual and beautiful table decoration. (A.E.W.)

ADJUSTABLE COVER FOR A VENTILATOR

IN many older types of houses it is common to find wall ventilators situated in bedrooms to provide a permanent means of ventilation. In fact, at one time it was compulsory to have permanent ventilators in bedrooms which did not have an open fire.

Although this by-law no longer applies many builders still provide them in present day houses. These ventilators are very efficient and effective but it has

on the inside face of the wall as illustrated. The cover enables the ventilators to function freely during normal weather conditions but when there is any likelihood of draughts then the small door at the front can be slid along to cover up the air holes. This is much better than stuffing paper into the vent holes, as so many people do.

The illustrations at Fig. 1 show how the cover is constructed. The back

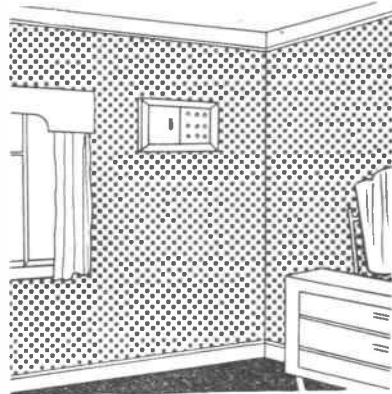

By K. Finlay

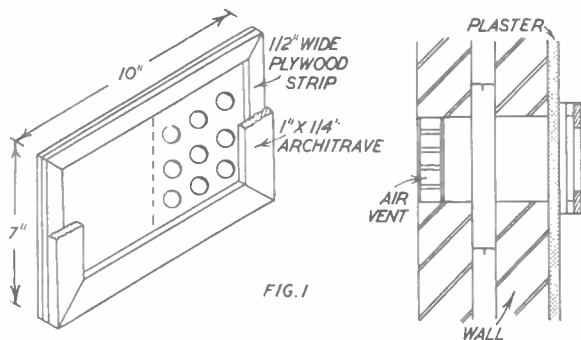

FIG. 1

around the outside which will form a rebated channel for the door. Use mitred joints at the corners. However, before nailing the architrave completely in position make a plywood (or hard-board) door to fit in the channel provided. Ensure that the door slides freely in the channel. Glasspaper the material thinner, if necessary. The handle for the door can be made from a piece of $\frac{1}{2}$ in. by $\frac{1}{2}$ in. timber about 3 ins. long and screwed in position from the back.

Once the cover is made plug it in position on the wall, keeping the half of the cover with the holes opposite the ventilator hole. If there is a plaster ventilator on the wall then remove this carefully to give a flat surface for securing the cover in position.

Finish off by painting the cover to match the existing room decorations.

been experienced that during stormy and windy weather they can be rather draughty, often to the discomfort of the occupants of the room.

A simple remedy for this is to provide the ventilators with an adjustable cover

consists of a piece of 3-ply which should be cut 10 ins. by 7 ins. Bore a number of $\frac{3}{8}$ in. diameter holes on one half of this member as shown. Then fix a $\frac{1}{2}$ in. wide strip of plywood around the edge and attach an 1 in. by $\frac{1}{2}$ in. wood architrave

Interesting Locos - No. 18

IN 1886 William Dean built at Swindon two 4-cylinder 4-4-0 (inside cylinder) Tandem Compound locomotives for express work. They were numbered 7 and 8, and were built for the standard and broad gauges respectively.

Our illustration shows the latter engine No. 8, and from the external appearance there was nothing to show that the engine was a 4-cylinder Compound. The following were the principal features. Wheels diameter coupled 7ft., leading 4ft. In order to carry the four inside cylinders at the front, the leading wheels were placed well forward, being 10ft. 2 ins. from the driving wheels. The coupled wheelbase was 8ft. 4 ins., total wheelbase being 18ft. 6 ins. Total heating surface = 1,258 sq. ft., the firebox with water pockets contributing 137.7 sq. ft. Working pressure 180 lbs. per sq. in. Grate area = 18.33 sq. ft. Cylinders, high press, 14 ins. diameter. Low press 22 ins.

diameter by 21 ins. stroke. Cylinder ratio = 2.47. The Stephenson link motion provided a direct drive.

Mr. Dean built both engines purely as an experiment, but it appears that after several trials the tandem system did not

give the best results, and both engines were later completely rebuilt to the standard (4ft. 8 $\frac{1}{2}$ ins. gauge) 4-4-0 type. No. 7 being named 'Armstrong' and No. 8 'Gooch'.

(A.J.R.)

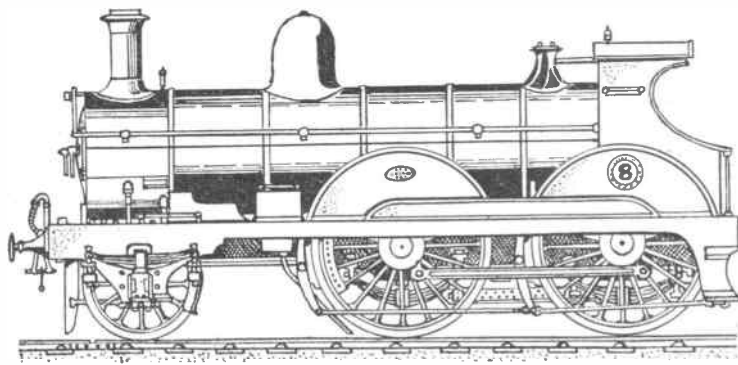

Designed for beginners

TWO-VALVE BATTERY SET

A RECEIVER operating entirely from dry batteries is very popular, especially with the beginner, and it is understandingly a first choice with many in the remoter rural areas. The set described here (see circuit in Fig. 1), may be relied upon to give good results, especially when used with an efficient aerial and earth system, and, moreover, it has the great advantage, from the young constructor's point of view, of being one of the simplest to make to give good loudspeaker volume.

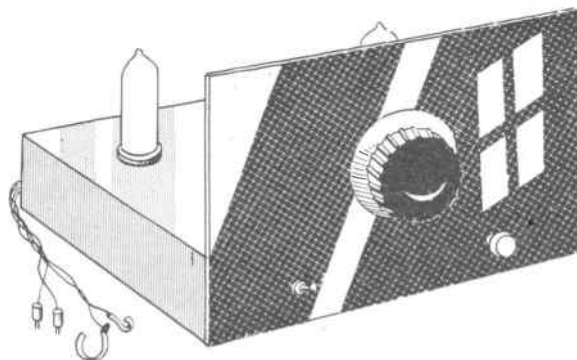

By 'Radio Mech'

With such a circuit there is a lot of latitude in the parts actually used. In the detector position, where a 1S5 is shown, equivalents such as the ex-service CV784, ZD17, or DAF91 may be used. If to hand, a DL92 or CV820 may be inserted instead of the 3S4. No changes to wiring or other modifications are necessary when fitting these equivalent valve types.

For high tension, a 67½V. battery of the kind used in small portables will be satisfactory. For the filament supply a 1½V. dry battery is needed. This can be one of the 1½V. batteries made for all-dry portables, or torch or flashlamp battery cells, wired in parallel, can be used. More than 1½V. must never be fitted here, because the valve filaments would be damaged.

Grid bias is developed across the 800 ohm resistor, so that no separate bias battery is necessary. This simplifies connecting up and replacing the batteries.

For the valves mentioned, two B7G holders are required. The bias resistor can be 800 to 850 ohms. The bias condenser may be 25µF, 25V., as these are so easily obtainable, though any value from 6µF upwards will do. The small fixed condenser (·0002µF) may be anything from ·0001µF to ·0005µF, and the larger fixed condenser can be ·005µF or ·01µF.

For reaction, a ·0003µF or ·0005µF variable condenser will be satisfactory. The full value of ·0005µF is necessary for tuning. This condenser may be solid dielectric or air-spaced, the latter being more efficient. A medium wave tuning coil can be wound as described, or single wave or dual wave (medium and long) coils can be fitted instead.

The coupling transformer is an important item, and should be of good quality, with a step-up ratio of 1:3 or 1:5. Some ex-service transformers are suitable, but if there is any doubt about this, a new coupling transformer, in-

tended for such circuits, should be obtained, as it has considerable effect on the results.

An on/off switch is needed, and a knob for the reaction condenser, with pointer knob or dial for tuning. Some 22 S.W.G. wire will be satisfactory for connecting purposes, with a few feet of thin flex for battery leads. Four terminals, or two 2-way socket strips, are required for aerial, earth and speaker.

The chassis can be of wood or metal. A ready-made aluminium chassis may be purchased, or one can be made by bending 2in. deep runners upon a sheet of reasonably stout aluminium, to form a chassis about 5½ins. by 7ins. The chassis can also be made from 3-ply, with a ply panel and rear strip, ¼in. thick wood being used for the side runners, so that the other pieces can be attached with small panel pins.

The various holes should be drilled before fixing any parts in position. Large holes for the valveholders can be made with a fret saw or washer-cutter, or by drilling a number of small holes in a ring, and cleaning up with a file.

The tuning coil

This is shown in Fig. 2, the insulated tube being a push-fit on a strip of wood bolted or screwed to the chassis. With a tube 1½ins. in diameter, 80 turns of 32 S.W.G. wire can be used, from points 1 to 3, with the tapping 2 at about 50 turns from point 1. A ¼in. space is then left, and 50 turns are wound on between points 4 and 5. For this section, thinner wire (about 36 S.W.G.) may be used, if to hand.

All turns must be in the same direction, as shown. The exact gauge of wire and size of tube are not critical. If the tube has a rather larger diameter, fewer

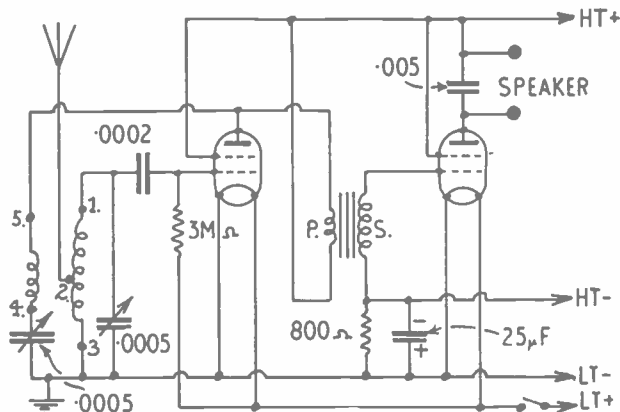

Fig. 1—The receiver circuit

turns will be needed, while a smaller tube will need more turns.

The windings are connected as follows: 1 to fixed plates of tuning condenser; 2 to aerial; 3 to earth line; 4 to fixed plates of reaction condenser; 5 to detector anode. These leads are also numbered in the other diagrams.

If a ready-made coil is fitted, the maker's leaflet will show tag connections, and these should be followed. A coil with reaction winding, intended for such circuits, should be used. Some have an aerial coupling winding instead of the tapping 2. If so, this is used for the aerial connection:

Building and wiring

Fig. 3 shows the layout of parts on top of the chassis. The two valveholders should be so bolted that the sockets come as illustrated, and that the wiring plan can be followed. Some holders have the fixing lugs at an angle, so the positions of the lugs themselves can be ignored.

The modern type of air-spaced tuning condenser usually has small feet or brackets, which can be bolted to the chassis. The spindle then projects through a clearance hole. Older air-spaced condensers, or solid dielectric condensers of the reaction type, usually require a $\frac{3}{16}$ in. diameter hole in the panel, to which they are secured with a lock nut.

A dial marked 0-100 will be satisfactory, or a knob with pointer can be used, a dial or scale being fixed to the panel.

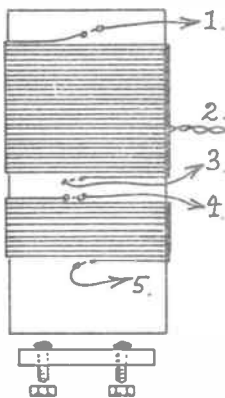

Fig. 2—Coil and mounting strip

Two leads pass through the chassis from the tuning condenser. One goes from frame (or moving plates) to the earth line. The second, from the fixed plates, is connected to the .0002 μ F fixed condenser. These points are indicated in the diagrams. Point 1 on the coil also goes to the fixed plates, as described.

Four leads from the coil pass down through holes in the chassis, these have been explained, and are shown in the diagrams.

All wiring underneath is given in Fig. 4. Soldered joints will be necessary at many points, and these can be made quite easily if both tags and leads are scraped clean. Cored solder should then

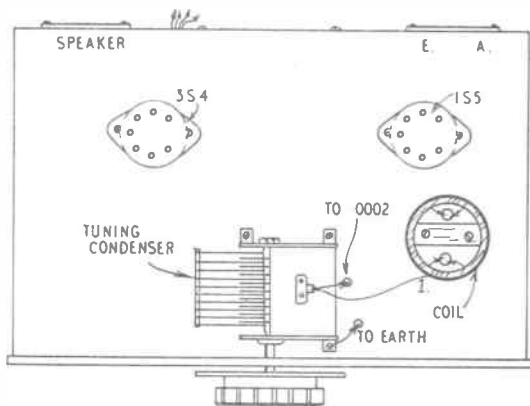

Fig. 3—Top of Chassis

be placed in contact with the joint, and melted with a hot iron until the joint fuses. Leads or tags must not touch each other, or the chassis.

In Fig. 4, 'P' 'P' indicates the two primary connections of the transformer. These may be marked 'IP', 'OP' or 'A' (anode) and 'H.T.' (high tension). In the same way 'S' and 'S' shows the secondary tags or terminals, which may be marked 'G' (grid) and 'G.B.' (grid bias). The letters 'IS' and 'OS' are also sometimes used instead.

If the transformer has H.T. and G.B. markings, take the H.T. terminal to H.T. positive, and the G.B. terminal to H.T. negative and 25 μ F condenser. If the transformer only has P and S markings, it is worth while trying the effect of reversing the secondary connections, to find which way round gives best results.

It will be noted that the 25 μ F condenser has positive and negative markings, and the negative end must be taken to H.T. negative, as in the diagram.

A careful check should be made of wiring before inserting the valves, to see that there are no wrong connections or short circuits.

Loudspeaker

The usual permanent magnet moving coil speaker, with transformer, will give good results. The transformer should be one intended for 'battery pentode' working. The size of the speaker is not very important, but a unit with a $4\frac{1}{2}$ in. or larger cone will be best, as very small speakers or transformers do not usually give such good results.

The speaker should be fitted in a cabinet, which may also house the receiver and batteries. A moving coil speaker cannot function, with such a circuit, unless the usual transformer is present.

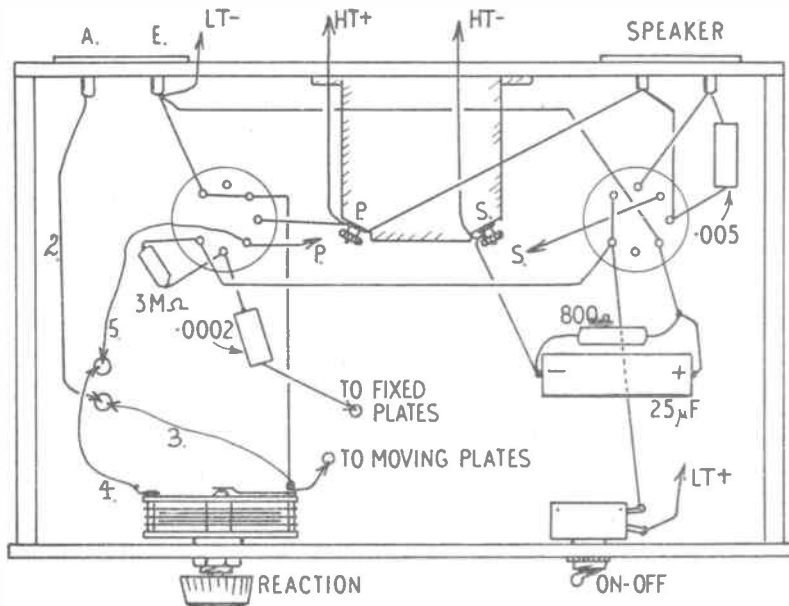

Fig. 4—Wiring plan

TYPES OF KALEIDOSCOPE

THERE are many different kinds of kaleidoscopes, but all depend on the multiple reflections from mirrors inclined to one another at an angle. The making of simple kaleidoscopes provides much pleasure and amusement, and they are of considerable use, especially to artists and designers.

The kaleidoscope illustrated in Fig. 1 is built up inside a short piece of cardboard tubing, the inside of which should be painted dead black. Three rectangular mirror pieces of mirror are placed together as shown by the dotted lines. The sizes of the pieces of mirror must be worked out after a suitable piece of cardboard tubing has been found. The mirrors are bound together at the edges with Sellotape, and after they have been placed in position in the tube, the end (A) is closed up with a circular piece of cardboard painted dead black and with a hole about $\frac{1}{4}$ in. in diameter in the centre.

Beautiful patterns

Close to the other ends of the mirrors, and inside the tube, position a circular piece of glass or other transparent material (B). A circular piece of ground glass, tracing paper or similar material (C), is fixed to the other end of the tube. Between (B) and (C), a distance of about half an inch, are placed a number of small pieces of different coloured colour-filters. The hole in the end (A) is placed near the eye and the other end is turned towards a window or electric lamp. The tube is turned round and a succession of beautiful patterns is seen.

The kaleidoscope illustrated in Fig. 2 consists of three pieces of glass, two, like the piece (A), inclined to each other at 45° and another piece (B), bound together at the edges with Sellotape. The bottom (C), consists of a piece of thick white card and the eyepiece (D) is a piece of cardboard with a small circular hole in the centre. The whole of the outside of the apparatus with the exception of the aperture (E) is painted with black paint or covered with dark paper.

A number of pieces of coloured wool or, better still, coloured silver paper, are placed inside the apparatus which, is held in a vertical position with the window (E) turned towards a window or an electric lamp. As the apparatus is gently shaken a great variety of beautiful coloured patterns is seen.

The kaleidoscope illustrated in Fig. 3 consists of two rectangular pieces of mirror inclined to each other at 45° or 60° and a rectangular piece of hardboard painted dead black. These are bound together with Sellotape. The eyepiece

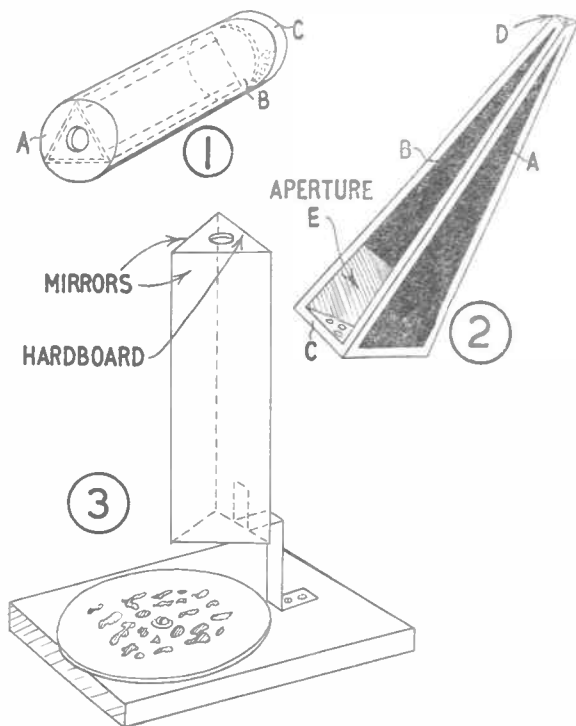

consists of a piece of cardboard with a circular hole in the centre. The mirrors and hardboard are supported by a brass strip fixed with two nuts and bolts to the hardboard, and at the other end to a piece of wood which carries a circular piece of hardboard fixed with a screw at the centre so that it can be turned.

The upper surface of the circular piece of hardboard is painted white or covered with white paper. An assortment of pieces of coloured silver paper or coloured wool is placed on the circular table. This is turned slowly and the observer sees a succession of beautiful coloured patterns. (T.A.T.)

● Continued from page 6

Two-Valve Battery Set

Reasonable results can be expected with no earth, but if an earth connection can be arranged, this will improve volume, especially from distant stations. A clip attached to a water pipe, or a metal rod or spike driven in the ground, can be used for an earth.

Sufficient volume can usually be expected with an indoor aerial, but a good out-door wire will, naturally, give better results. If a very short indoor aerial should be used, best volume will be had if it is connected directly to the fixed plates of the tuning condenser. This is not satisfactory with a longer wire, as tuning will become very flat or unselective.

The reaction condenser should be set with its plates fully out of mesh, then closed as necessary to increase volume. With weak or distant stations, the reaction control will have a considerable influence on volume. As the condenser is closed, oscillation will commence, and the most sensitive position is just before this happens. The receiver should not be left oscillating, as this can cause interference to neighbours.

If an uncontrollable howling arises when the receiver is first switched on, connections to the secondary of the transformer should be reversed, as explained.

Help from an expert

STARTING WOOD TURNING

WATCHING the chips fly away and the wood take shape under your tools while it is spinning round on a lathe is a fascinating thing, and any keen amateur woodworker will find turning a very good addition to his hobby. A simple lathe is not expensive — either an independent one powered by treadle or motor, or one based on an electric drill power unit. Power drive is worth having — the steady high speed without effort on your part will produce better tool control.

The wood is driven by a spindle in the headstock. For long work the other end is supported by the tailstock. The tool is supported on a tool rest (A). Shallow

for roughing to shape and the chisel for finishing cuts, both straight and curved. Where there is sufficient room it is easier to use a wide tool than a narrow one.

By P. W. Blandford

Almost any wood may be turned. In general soft woods are more difficult than hard woods, as they tend to splinter and break out. The favourite turning wood is beech. Oak is rather harsh but quite a lot of turning is done

in it. If possible, choose a wood with a close even grain for your early attempts.

For the first trials have a piece of wood about 1½ ins. square and maybe 10 ins. long. Plane the corners off and prepare the ends for the centres. Give the wood a slight tap towards the headstock, so that it fits on to the driving centre. Bring up the tailstock and lubricate the centre. Press it into the wood and start the lathe. The centre will wear in a little and should be tightened. You may have to tighten again later, depending on the hardness of the wood.

Bring the tool rest fairly close to the wood. Start with the gouge. Have one hand at the end of the handle and the

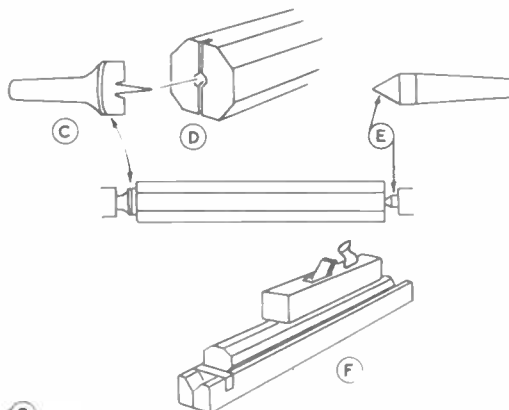
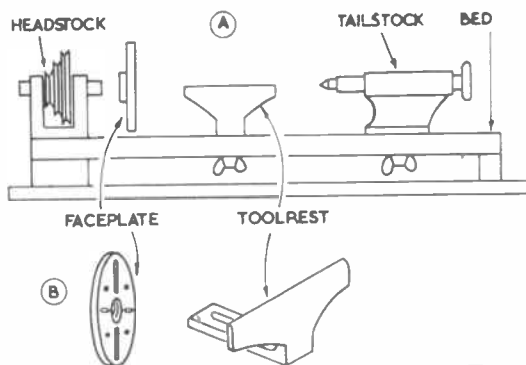

circular work is fixed to a faceplate (B) and the tailstock is not used. The usual method of driving long work is by a spur centre (C). A saw cut and centre-punch mark in the wood locate it (D). The other end is supported by a plain centre (E) in the tailstock. A little candle grease or oil on this centre prevents squeaking. It is best to plane the corners off square stuff before turning, and a wooden trough to hold the wood is worth making (F).

Gouges and Chisels

Nearly all wood turning is done with two tools — a gouge (G) and a chisel (H). It is an advantage to have several sizes of each, but you can start with one of each ½ in. wide. Turning tools are long and have long handles, because they need a good leverage. The chisel has a skew end and is sharpened both sides. Do not try to turn with an ordinary chisel. The gouge is sharpened outside and has rounded corners.

The beginner might expect the gouge to be used for curves and the chisel for straight cuts. In fact, the gouge is used

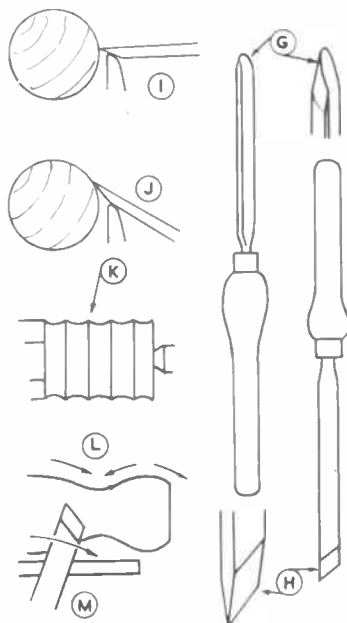

other resting against the tool rest and around the blade. For light cuts some workers prefer to have their thumb on top and the rest of the hand underneath, but do not be tempted to use a light grip because the cut is to be light — a firm grip is needed at all times. Normally your hand is on top of the blade and all of the fingers around it, with the little finger against the tool rest.

Obtaining cleaner cuts

At first you will want to cut with the gouge nearly horizontal (I). This is not wrong, but the result is a scrape. If you lower the handle so that the blade points upwards the tool will cut cleaner (J). The first job is to reduce the wood to round. At first you will make a series of gouge cuts (K), but after some practice you can swing the handle and blend the cuts into each other. The turning wood looks smooth, but when you stop the machine you will find it quite rough.

Use the gouge to make some hollows, then change over to the chisel. This has to be used with a slicing action so that

the skew end actually cuts off shavings. Have the hands as on the gouge, but let the lower side of the skew end face the way you are to cut. To avoid tearing out the grain, all cuts are made downhill, into the hollows (L). Be careful that the long point does not touch the work. Let the sharpening bevel rest on the work and tilt the tool to bring the cutting edge on to the surface, then swing and slide the tool along (M). At first you may do short strokes, but you will progress to long sweeps. Most finished turning is done in this way, so practise it well.

Working a narrow bead

A common decoration on turned work is a narrow bead (N). To turn this, mark its width with the chisel on edge and the long point forward (O), then turn down the sides of the bead with the normal cut, but tilting the tool to follow the desired curve (P).

Faceplate work is done in a different way. The wood for a bowl or lamp standard has to be fixed to the faceplate. It is usually sawn into a circle first. The simplest mounting

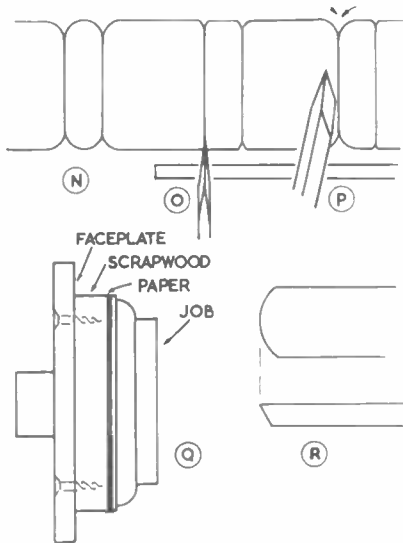

is by screwing through the holes of the plate, if the screws can be located where they will not matter. Another way is to screw scrap wood on to the plate and fix the job to it by gluing with paper between (Q). After the work is finished, the joint can be broken without damaging the wood by levering apart with a chisel.

Finishing on the lathe

When turning on the faceplate keep the tool rest close to the part being turned. Rough to shape with a gouge held horizontally. With the grain going across the wood there would be too much risk of breaking out if the gouge was held up at an angle. Finishing is also done by scraping. It is possible to use the normal turning chisel held flat, but this is not as good as a scraping tool — a flat chisel, curved on the broad surface and given only a slight bevel across the end (R). Despite its very obtuse angle, this needs frequent sharpening.

Turned work may be glasspapered while it is revolving, but keep the paper moving, as the heat generated will soon soften the glue holding the particles of glass. Wax and french polishing are easily done on the lathe, as the machine provides the motion in place of the usually laborious rubbing.

perfect partners...



CASCAMITE

"One Shot"

the gap-filling powdered resin glue with hardener incorporated. Easy to use (simply mix with cold water), this outstanding wood glue will fill gaps in joints of $\frac{1}{8}$ ". And what is more, it is heat and mould resistant, non-staining and waterproof. Especially recommended for furniture making and repairs, joinery, boat-building and the gluing of decorative plastic laminates to wood. Packed in 3½, 7 & 18 oz. tins (2/6d., 4/-d. & 8/6d. respectively). Also in larger sizes.



CASCO

"Stopper"

the new high quality material for filling cracks, knots, screw and nail holes, etc.—essential for any first class woodworking job. CASCO Stopper sets rapidly and gives a hard surface which takes stain, polish or paint. Packed in 8 oz., 2 & 8 lb. tins (2/-d., 4/-d. & 10/6d. respectively) and available in white, cream and 8 wood colours.

Stocked, like CASCAMITE "One Shot", by Ironmongers, Builders' Merchants, Handicraft Shops etc.

...for gaps and cracks in wood

the NEW combination



LEICESTER, LOVELL & CO LTD
NORTH BADDESLEY SOUTHAMPTON



MISS F. Bladen of 5 Leatham Street, Longside Lane, Bradford 7, Yorks, has been a regular reader of *Hobbies Weekly* for the past 40 years.

Recently she wrote: 'At 9 a.m. on Wednesdays, I cycle to my newsagent for my copy of *Hobbies*, and woe betide

Pen Friends—By R.L.C.

him if he can't produce it. I have completed many *Hobbies* designs as shown in my photo', which was taken some time ago. I had to carry all my models to the photographer on the carrier of my



Robert Oakley

cycle. On the way home I had a puncture. But it was well worth the trouble.'

Miss Bladen is a keen philatelist. She would like to open friendly correspondence with home and overseas readers who follow the same hobbies.

Our Australian friend Bill Robinson is well known to many readers. The last exchange packet sent out by him contained the new 'Flag' set. Bill, who is very reliable, lives at 35 Hartley Street, Cairns, North Queensland, Australia.

Robert Oakley of 12 Edgcombe House, The Octagon, Plymouth, Devon, (age 12) would like to hear from readers of his own age. He collects stamps and match labels.

Victor George Briffa, 48 Dee Park, Holt, Wrexham, Denbighshire, began collecting stamps about 38 years ago in Malta and has been collecting ever since. In a recent letter he explains: 'I have two other hobbies — fretwork and fishing. I have made the Coach (complete with

horses and passengers), the Farm, and the Garage out of designs from *Hobbies Weekly*. I originally started fretwork when I was 11 and had a septic foot. I could not move about, so made calendars and photo' frames as my first attempts. During the war I was an Aircraft Recognition instructor and my fretwork and model making came in handy to repair and make models for instructional purposes.'

Since the war Victor has bought a fretwork machine and spends most of his spare time using it. He is married with two sons.

I have received some interesting letters from all these readers. So why not drop them a line? You will find them reliable and sincere.



Victor G. Briffa



Miss F. I. Bladen



Bill Robinson

1958 CHAMPION

Pictured on the left is the reigning Hobbies fretwork champion, Mr R. M. Edwards, of Reading, Berks., who won first prize, valued at 15 guineas, in our 1958 Competition, and who also holds the magnificent silver challenge cup for this success.

Entries for the 1959 Competition, for which prizes to the value of £200 will again be awarded, close on April 30th., and judging will commence soon after that date. Full details can be obtained from Hobbies Ltd., Dereham, Norfolk, and Kit No. 3280 for cutting out the competition piece — a 'Viking' Wall Plaque which incorporates a Thermometer — costs only 3/3 (post 9d.) extra. Send for a Kit immediately and enter this grand free competition.



AT LAST!

PLASTIC SCALE MODEL

RAILWAY KITS

Authentic Models with Moving Parts

Can be used on OO and HO Gauge Tracks

Brand-New! Exciting! Just what you've always wanted! Assemble these thrilling new Kitmaster railway kits yourself . . . you'll get hours of pleasure and satisfaction. No ordinary models these. They move . . . are built to scale . . . finely detailed—look just like the real thing. That's why you get that professional finish every time with all Kitmaster models. Start your collection now . . . you'll find plenty of thrills and fun with these authentic new Kitmaster plastic scale models.



No.1. Stephenson's "Rocket" 4/6d.

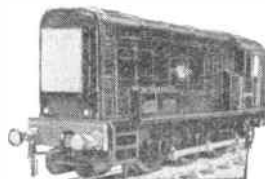

No.2. Diesel Electric Shunter 4/6d.



No.3. Early American "General" 6/6d.



No.5. Schools Class "Harrow" 7/6d.

ROSEBUD

Kitmaster REGD TRADE MARK

PLASTIC SCALE MODELS

- * A fresh, new model is coming out every month
- * Step by step instructions, coloured leaflet and transfers included
- * Special plastic cement is enclosed for a rigid, lasting fit
- * Supplied in all good model shops and toy shops.

ROSEBUD KITMASTER LIMITED
RAUNDS • NORTHAMPTONSHIRE

Get yours today!

World Radio History

KMCI

PROTECTING YOUR INVENTION

EVERYONE has heard the expression, 'There's nothing new under the sun'. It sounds a truism, but try it out on an amateur inventor who has just devised a workable, breath-taking gadget. He won't be convinced. . . .

Very few inventions, however, turn out to be completely new. In fact it will be almost three years at the least before an invention can be officially declared new and thus warrant a patent.

Only a fool, or an eccentric millionaire, would invent something and not bother to see if it was worth developing into a commercial success.

If he decides it has distinct possibilities he would be a bigger fool not to patent it. He can, of course, see a manufacturer and sell him the idea. All very nice if the manufacturer is scrupulous. What if he is otherwise? There is no law against him telling the inventor he is not interested and then to take immediate steps to start producing the idea even before the inventor is outside the factory gates.

Apart from this, who is to advise the inventor on just what price to sell his brain-child? How is he to know the value of it to a manufacturer? It may be £10 — it could even be £1,000.

Use of an agent

Most inventors have neither the facilities nor the capital to produce the invention themselves in saleable quantities. Quite possibly they have not even the means of testing it commercially. Obviously, therefore, some other people will have to be consulted if the invention is likely to be a success. Until, however, the inventor has some protection over his idea he should be particularly wary. Plans and specifications should be locked away and on no account should the invention be discussed with anyone.

The inventor must decide whether to obtain a patent himself or to conclude the negotiations through a patent agent. There will probably be at least one agent in your town. Most of them have their headquarters in London and a glance through a classified telephone directory will give you a dozen to choose from.

It is perfectly safe to be open with an agent about your invention. In fact you must. Patent agents, like lawyers, have a professional code of conduct and your idea is absolutely safe with them. Any of them will give free preliminary advice to an inventor on obtaining a patent.

By B. Wise

New gadgets are usually easy to patent but if the idea is too complicated, its advantages over similar and simpler ideas already on the market, may defeat its own purpose, especially if the new gadget costs more to produce. Therefore, the inventor must realize that he will not make money from his idea unless it sells quickly and at a reasonable price.

An inventor wishing to patent an invention and thus stop other people from making, selling, or using his idea, must first fill out what is called a Complete Specification and forward it to the Patent Office in London. It is most important that the specification gives absolutely full details. Otherwise, the patent office will refuse to file the claim until the details have been fully made out.

The drafting of such a specification is skilled work and is undoubtedly best undertaken by a patent agent. He will however, charge around £25 for his work. This will include submitting the claim to the patent office.

This may appear a heavy fee for such work and perhaps more than most people can afford. It is, however, a safe and sure way of finding out if the idea is really new and thus qualifies for a patent.

The inventor can, of course, prepare and submit his own Complete Specification on payment to the patent office of £4 for stamp duty. But supposing the drafting made is not of the required type and form? The patent office cannot be expected to give advice to every inventor on how to draft specifications. Therefore if a patent agent must finally be consulted the inventor's own attempt at filing a specification has been just so much waste of time and money.

Beware of pitfalls

Fortunately, there is a compromise. A simple, general description of the invention, together with any suitable drawings, can be submitted to the patent office at a cost of £1 only for stamp duty. On receipt of this a Provisional Specification certificate is issued to the inventor. A patent agent will prepare, submit and obtain a Provisional Specification for a client for around seven guineas.

The inventor must not think his

troubles are over once he has a Provisional Specification filed with the patent office. True, he is in a much stronger position in negotiating a sale of his idea to a manufacturer for now he is protected, if only provisionally.

He must watch for two pitfalls. One, to get a full patent a Complete Specification must be filed with the patent office within twelve months of filing the Provisional Specification. Two, if he markets his idea under a Provisional Specification only to find that another inventor has devised previously, a similar gadget, and has obtained a full patent on it, it is an offence in law and heavy damages can be incurred.

Manufacturers will of course be also wary of this happening and may refuse to even talk about an invention until a full patent has been obtained. The wise inventor, therefore, will go ahead and take out a Provisional Specification but spend the next say, nine months, on improving and perfecting the idea in order to give himself more confidence in deciding whether to go ahead for a full patent or not.

A Royalty basis

On the other hand, once a full patent has been obtained, a manufacturer really interested in the idea may even agree to pay the inventor a royalty on each of the gadgets produced and sold. The inventor, therefore, may find himself much richer than if he had accepted a lump sum for the rights of his brain-child. Incidentally, most manufacturers would be more interested if the inventor offered to work on a small royalty payment. It would show that the inventor had good faith in his idea.

Once a Complete Specification has been filed the inventor must expect to await from two to three years before a patent is granted or refused. This time lapse is due to the search the patent office must make to be sure the invention is entirely new.

In conclusion, whether the inventor decides to sell his invention or endeavour to market the idea himself, he should not hesitate to claim for a patent. He may have a fortune in his hands — it is worth the trouble of protecting it.

FOR OUTSIDE JOBS

Plywood is a material which is extensively used nowadays for many jobs around the house. For outside jobs, however, remember to use only resin-bonded plywood because this is fully resistance to the weather. Similarly, oil-tempered hardboard should be specified when ordering for outside use.

Next week's issue will contain four extra pages and will be filled with interesting projects and articles. 'Radio Mech' will start a series on 'Radio Control for models', there will be full-size patterns for toys, and home craftsmen will also be well catered for.

MAKE SURE OF YOUR COPY

Get ahead *faster* in the R.A.F. team

...through an
APPRENTICESHIP at 15 to 17!

R.A.F. Apprentices learning to service a jet fighter at their Technical Training School.



Today the R.A.F. has one of the biggest technological jobs to do in this country. New jet aircraft, new missiles and electronic equipment are now coming into service.

And the R.A.F. Aircraft Apprentice of today will become one of the skilled, highly paid N.C.Os.—or even officers—looking after this new equipment. If you are technically-minded and between 15 and 17, get yourself a front place in a great team! With a satisfying career, good pay, plenty of sport, it's a *full* life in the Royal Air Force. *Send for the details today!*

R.A.F. Aircraft Apprentices learn about the NEW things

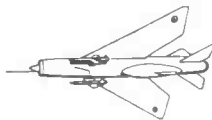

NEW JET AIRCRAFT



NEW MISSILES



NEW RADARS

R.A.F.

POST BEFORE 15th APRIL —or you may be too late for the next entry!

Apprenticeships 15 to 17

Send for FREE booklet! To: R.A.F. H.S. 83a, Victory House, London, W.C.2.

I am under 17, and British. Please send WITHOUT OBLIGATION the R.A.F. Apprenticeships booklet.

NAME _____ ADDRESS _____

Date of Birth _____

If you're under 15—join the Air Training Corps!



BUYING OR SELLING?

Classified advertisements on this page are accepted at a cost of 6d. per word prepaid. Use of a Box No. is 1/- extra. Send P.O. with advertisement to *Hobbies Weekly*, Advert. Dept., Dereham, Norfolk. Rates for display advertising on application.

FREE — Homeworkers' opportunity. S.A.E. — Esprey, 29 Newman's Grove, Rugeley, Staffs.

PYGMY TREES — MINIATURE GARDENS. Complete outfits of either 20/-, 100 varieties trees. Resale orders £4 for £3. Garden ornaments supplies.

FLOWER DYES (Esther Reads etc.) 4 colours, instructions 16/-. Wreath and bouquet materials, artificial flowers etc. Stamp all lists — Station Nurseries (H) Oakengates (Salop).

10,000 FORMULAS. Trade secrets, recipes, processes. Remarkable 900 page book. Only few available. Money back guarantee. 27/6 p. pd. — S. P. Ltd., 28(H.B.) Dean Road, London, N.W.2.

MAKE A MUSICAL BOX for as little as 21/-. New kits and tunes available. Movements 13/- post free. Please send 3d. stamp for free illustrated catalogue. — The Swisscross Co., Dept. B, 202 Tulse Hill, London, S.W.2.

WHEELS (Hardwood and Rubber Tyred Metal). Cot, Pram and Doll's House Fittings and Papers, Beads, Transfers, Prints and other accessories. Stamp for new lists. (Trade supplied.) New address — JOYDEN CO., 91 Peplins Way, Brookmans Park, Herts.

HOW TO STOP SMOKING

and permanently overcome that ceaseless craving for tobacco. Save money, safeguard health. Send stamp for details of the world-famous inexpensive Stanley Treatment for tobacco habit.

THE STANLEY INSTITUTE LTD Dept. 30
12 Bridewell Place, London E.C.4

* GREAT CAMPING OFFER * RIDGE TENT SENT FOR 4/-



Complete. Ideal Cyclists, Campers. Length 7' 3" sleeping base x 4' 6" wide x 3' 6" high x 12" walls, all approx. Weight 3½ lbs. Cash 55/-, or 4/- deposit and 9 monthly payments 6/-, 1 of 2/6. WITH FLYSHEET 83/6, or 9/3 deposit and 8 monthly payments of 9/9, 1 of 4/9. Both carriage 2/6. FREE LISTS TENTS, MARQUEES, CAMPING EQUIPMENT, WATCHES, BINOCULARS, GUITARS, CABINETS, RINGS, JEWELLERY, ETC., TERMS.

One large FULLY ZIPPED Com-part-ment. **R.A.F. NEW WATERPROOF BACK PACKS** One ditto same size back to back, 4 Buttoned-off separate side-by-side superimposed Pockets, 2 strong adjustable webbing back straps with easy-release press-studs. Made of genuine R.A.F. 100% waterproof material, all brand new. Ideal for Motor Cyclists, Hikers, Fishermen and a 100 uses. 4/11 only. post, etc., 1/1. Send at once. LISTS TENTS, CAMPING EQUIPMENT, BINOCULARS, CLOTHING, FOOTWEAR, ETC. TERMS. Headquarter & General Supplies Ltd. (HOBW/57) 196-200 Coldharbour Lane Loughboro Junc., London, S.E.5 Open Sat.



EARN extra money at home. 3d. stamp brings full details, without obligation. — Newdale, 25A Heys Road, Thongsbridge, Huddersfield.

EXCITING MODERN BOOKS! Latest titles, cheap editions, Half-price offers etc., List 3d. — Newdale (H), Thongsbridge, Huddersfield.

YOU CAN BUILD an efficient Crystal Receiver with our complete kit. Easy instructions. Soldering unnecessary. Good reception anywhere. Reduced price 14/6 post free. Send P.O. now while stocks last. — Radio Components, Accessories, Transistor Kits supplied. Send 3d. stamp for Bargain List. — RADIOMATIC, Dept. C., 26 Blackburne Drive, Hunts Cross, Liverpool.

BRAND-NEW MAGAZINES, terrific selection at greatly reduced prices, Body Building, Rock and Roll, Cartoons, Western, Detective, Mystery, Pin-ups, Art magazines. List 3d. Large sample parcel (any subject) 5/-. — Newdale (H), Thongsbridge, Huddersfield.

FREE stamp album and 20 stamps. Request approvals, enclosing 6d. Additional gifts given. — Beeze, 8 Langland Villas, Mumbles, Swansea.

KUKLOS ANNUAL. Indispensable cyclists' handbook. Tours, resthouses, money-saving hints, 3/- post free. — Burrow, Publishers, 2 Imperial House, Cheltenham.

100 DIFFERENT stamps free! Request 4d upwards discount approvals. — Bush, 53 Newlyn Way, Parkstone, Dorset.

MODELS. You can make lasting stone-hard models with Sankey's Pyruma Plastic Cement. Supplied in tins by Ironmongers, Hardwaremen and Builders' Merchants. Ask for instruction leaflet.

STAMPS FREE — Empire Packet including Pictorials and Victorians with approvals. — Robert J. Peck, 7A Kemp Road, Bournemouth.

PERFECTLY SIMPLE. Simply Perfect. CLAY MODELLING BY COLOUR. These sets of six delightful miniatures are obtained by carefully removing coloured layers of clay. The soft, workable clay figure remaining, appears like magic. May be coloured, may be kilned. Sculptoring is simple with CLAY MODELLING BY COLOUR. All prices include p. & p. The models available are: Venus de Milo 9/6d. Horse 6/10d. Spaniel, Puppy and Squirrel 4/7d. each. Kitten and Duck 6/4d. each. Seamer Products (Sculptorcraft) Ltd., 23/27, Eastbourne Street, Hull.

APPARATUS AND CHEMICALS. Gigantic price reductions. Save pounds! Special offers. Catalogue free. New premises and better service — Scientific and Technical Supplies (Nottm) Ltd., 286 Alfred Street Central, Nottingham.

MEN/WOMEN with spare time, required for new simple weaving work. For details, send S.A.E. — Dept. 4, Weava Products, 10 Shelley Rd, Worthing.

LEARN RADIO and ELECTRONICS the NEW practical way! Very latest system of experimenting with and building radio apparatus — 'as you learn'. FREE brochure from — Dept. HW 10, Radiostrutor, 46 Market Place, Reading, Berks.

BUILD YOUR OWN HI-FI at home! At last, for reasonable cost — the chance to make your own quality HI-FI audio equipment and to gain the knowledge to service and maintain it. FREE brochure from — Dept. HW 20, Radiostrutor, 46 Market Place, Reading, Berks.

STICK TO SECCOTINE

it sticks everything



1/3 PER TUBE

Sole Manufacturers —

McGAW, STEVENSON & ORR LTD., BELFAST

HEAR ALL CONTINENTS With H.A.C. Short-Wave Receivers

Suppliers for over 18 years of Radio S-W Receivers of quality. One-Valve Kit, Price 25/- Two-Valve Kit, Price 50/- Improved designs with Denco coils. All kits complete with all components, accessories and full instructions. Before ordering, call and inspect a demonstration receiver, or send stamped addressed envelope for descriptive catalogue.

'H.A.C.' Short-Wave Products (Dept. 22), 11 Old Bond Street, London, W.1

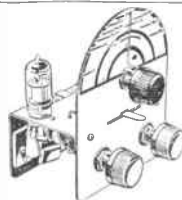

ARE YOU INTERESTED IN RADIO ?

Then build the amazing DSB one valve receiver. Simple to build with our easy-to-follow diagrams. Highly instructive. Will work anywhere with a short aerial and earth. Receives Luxembourg, Dutch, French, Italian and many other stations.

Send P.O. 1/6 and 2d. stamp, for circuit drawings, wiring diagrams, full instructions and list of parts to — OCEAN RADIO, (Dept. H/W) 38 Uppate, Louth, Lincs.

NOVEL BIRTHDAY 'CARD'



SURPRISE and please your friends with this unusual card. It is made from two pieces of wood glued together. Piece (A) is $\frac{1}{4}$ in. thick and the overlay (B) is $\frac{1}{8}$ in. The strut at the back is $\frac{1}{4}$ in. thick and is hinged in place as shown below.

Finish by painting the background with black enamel and the overlay in bright colours. The trumpeter should be bright red with yellow and black decorations. Shoes are black and trumpet yellow or gold. Paste a piece of paper on the back for signing your name. (M.p.)

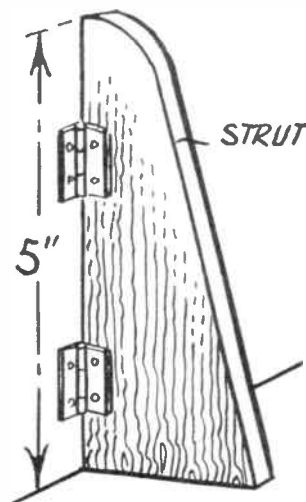

Whatever your speciality

You'll get a far better finish—far quicker—

with **NEW FORMULA**
HUMBROL
PLASTIC ENAMEL

NEW FORMULA
HUMBROL
PLASTIC ENAMEL

is available in 34 colours—
matt and gloss

½ oz tins 8d. Sizes up to ½ pint
Handy multiple painting kits 3/-12/11
from all good model shops and
hardware stores.



Specially formulated for the exacting standards of professional model makers, new formula Humbrol gives a superlatively fine finish to wood, metal, perspex, polystyrene, pottery, aircraft tissue and paper.

- *dual purpose: replaces colour dope*
- *dries in one hour*
- *lead free in most colours*
- *proof to diesel fuel*
- *brushes on easier*
- *consistently matching shades*
- *long lasting*

AIRCRAFT
SHIPS
GALLEONS
CARS
TRAINS
ARCHITECTURE
PUPPETS
MACHINERY
HANDICRAFTS

HUMBROL

A product of the paints division,
THE HUMBER OIL COMPANY LTD.

MARFLEET · HULL · ENGLAND

BULKHEAD 6.
CUT ONE
1/8 in.

BULKHEAD 5.
CUT ONE 1/8 in.

BULKHEAD 7.
CUT ONE 1/8 in.

NOTE

**ALL PARTS
CUT FROM
BALSA**

TRANSOM 4.
CUT ONE 1/8 in.

PIECE 10.
CUT ONE
1/8 in.
(HALF
ONLY
SHOWN).

KEEL 2.
CUT ONE
1/8 in.

CABIN
TOP 12.
CUT TWO
1/4 in.

CABIN SIDES 11.
CUT TWO 1/4 in.

BOW BLOCK 15.
CUT TWO 1/4 in.
AND TWO 1 1/2
THICK.
(CUT FROM
1 1/2 ins. BY 2 1/2
BLOCK.)

PIECES 9.
CUT FOUR
1/4 in.

THE ARROWS INDICATE
DIRECTION OF
GRAIN OF WOOD.

WINDOWS 13.
CUT TWO 1/8

13

12

11

CABIN LAUNCH 'SQUIB'

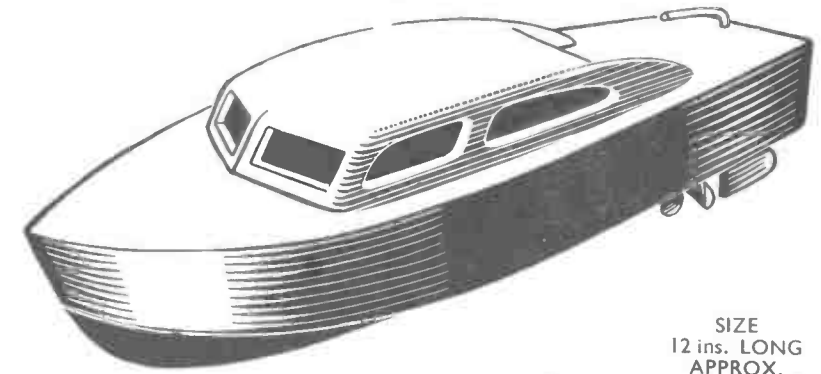

SIZE
12 ins. LONG
APPROX.

A KIT OF MATERIALS FOR MAKING THIS DESIGN IS SUPPLIED BY HOBBIES LIMITED DEREHAM, NORFOLK. PRICE ON APPLICATION.

FINEST VALUE EVER! The **HUMBROL** Economy kit

Perfect for small jobs. Contains 8 intermixable Art Oil Enamels (including gold and silver), thinners and flattening agent, plus brush, palettes, colour guide and mixing instructions.

only **3'-**

MADE BY THE HUMBER OIL CO. LTD. · MARFLEET · HULL

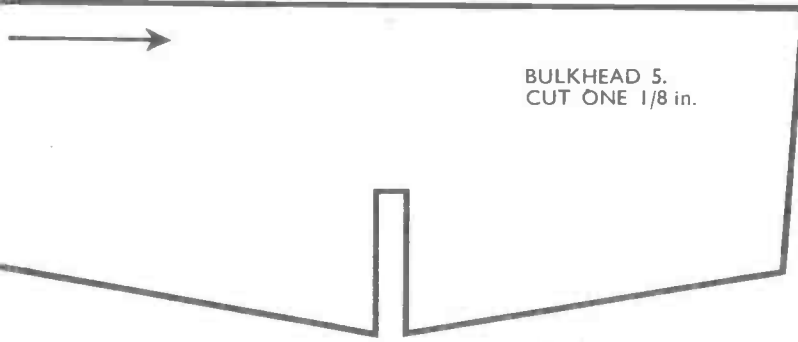
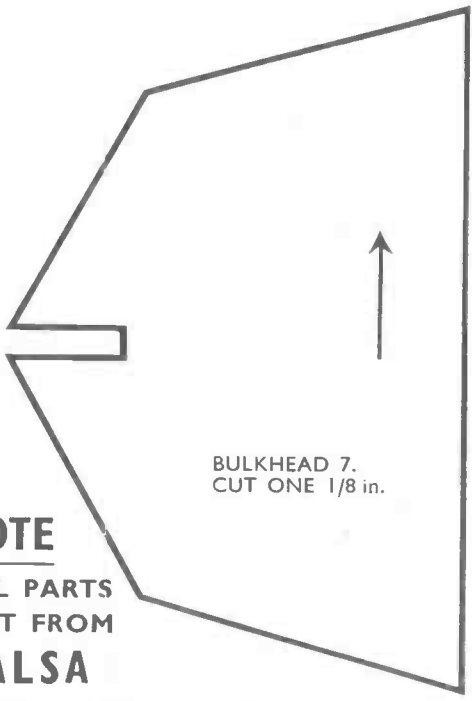
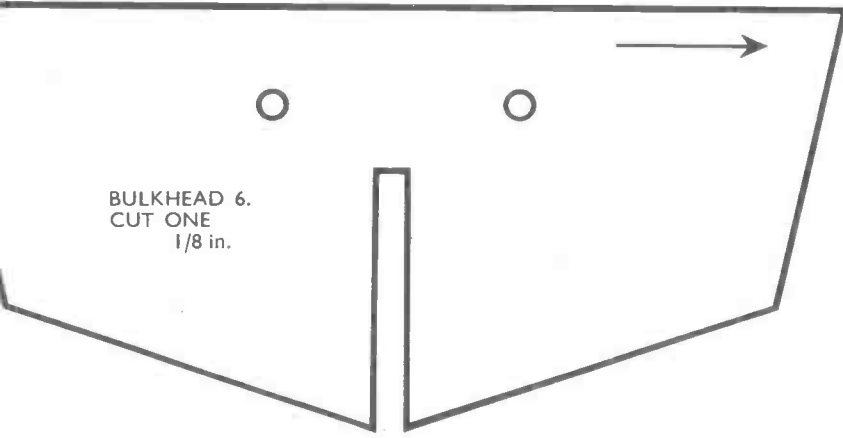

NOTE
ALL PARTS
CUT FROM
BALSA

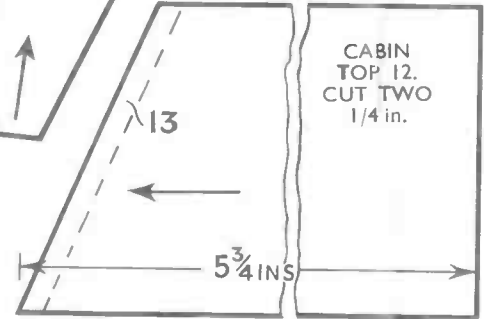
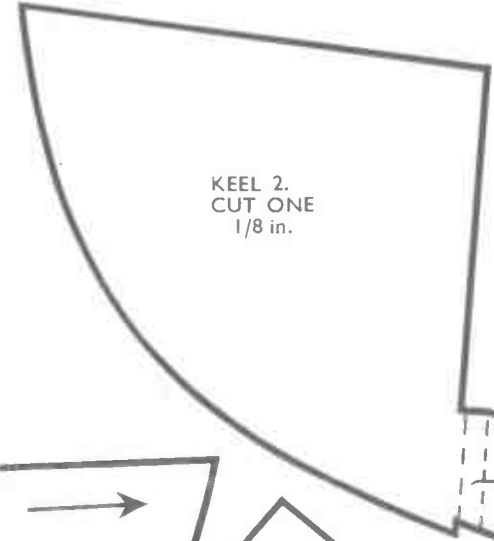
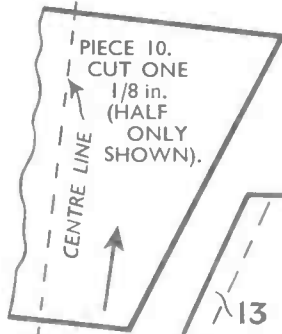
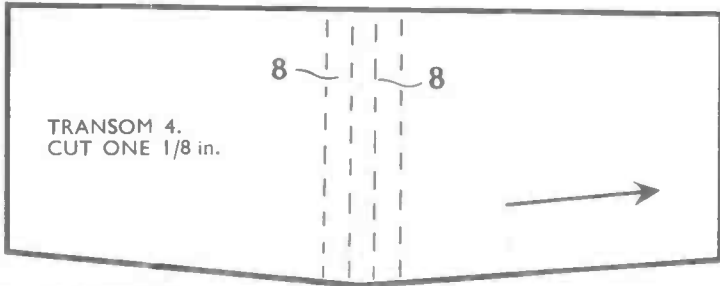

CABIN SIDES 11.
CUT TWO 1/4 in.

palettes, colour
guide and mixing
instructions.
MADE BY THE HUMBER OIL CO. LT

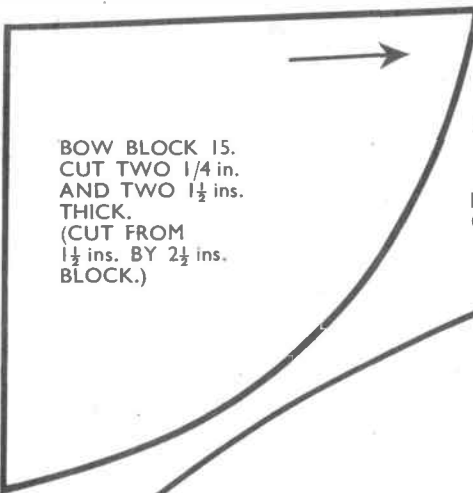

BOW BLOCK 15.
CUT TWO 1/4 in.
AND TWO 1 1/2 ins.
THICK.
(CUT FROM
1 1/2 ins. BY 2 1/2 ins.
BLOCK.)



PIECES 9.
CUT FOUR
1/4 in.

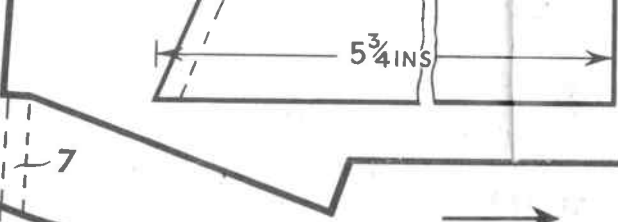

5 3/4 IN

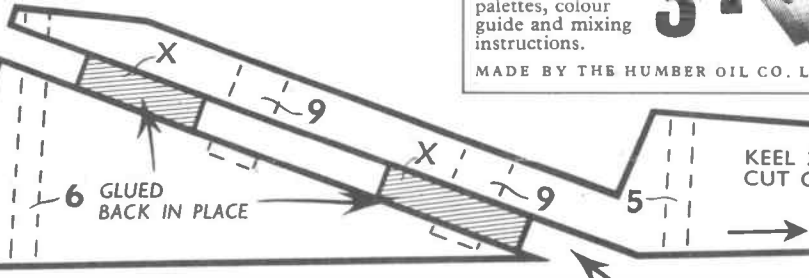

6 GLUED
BACK IN PLACE

PROPELLER
SLOT

KEEL 3.
CUT 0

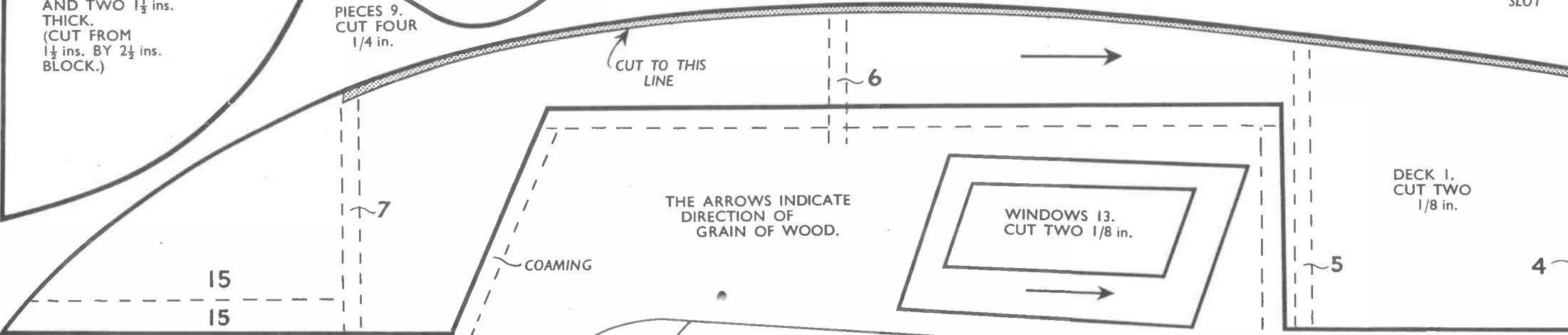

CUT TO THIS
LINE

THE ARROWS INDICATE
DIRECTION OF
GRAIN OF WOOD.

WINDOWS 13.
CUT TWO 1/8 in.

COAMING

DECK 1.
CUT TWO
1/8 in.

15
15

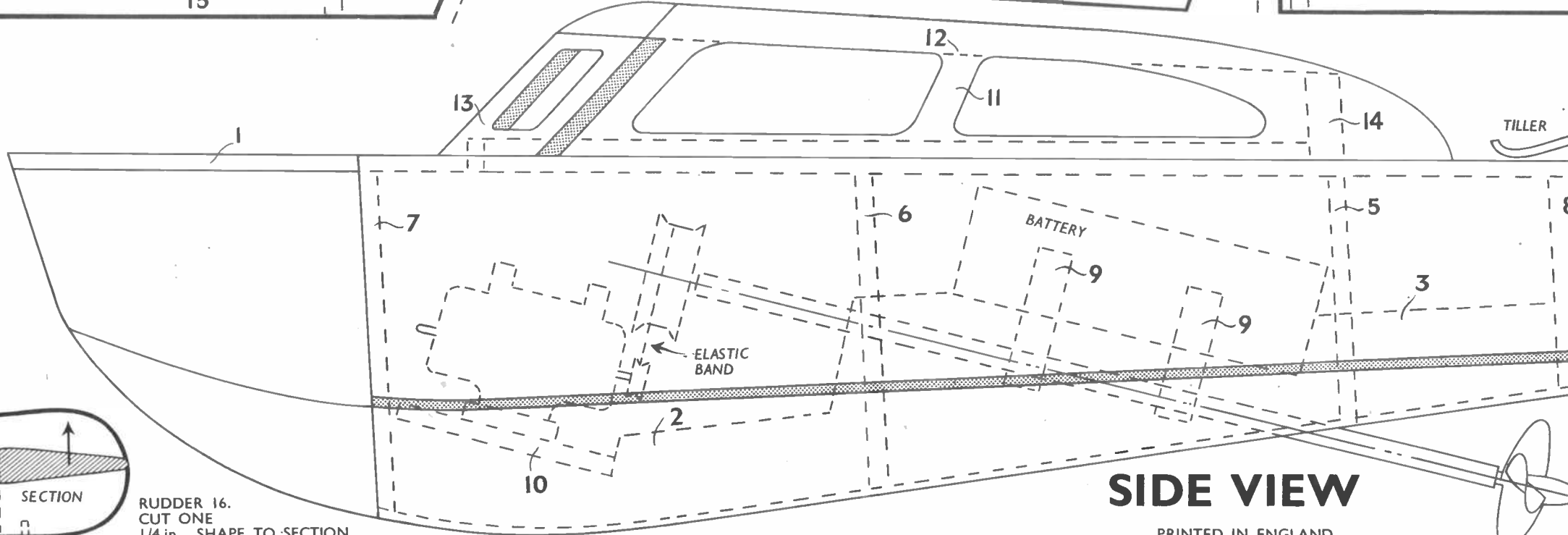

TILLER

BATTERY

ELASTIC
BAND

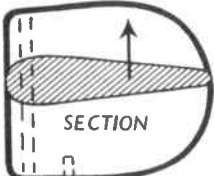

RUDDER 16.
CUT ONE
1/4 in. SHAPE TO SECTION.

SIDE VIEW

PRINTED IN ENGLAND.

ALL PARTS
CUT FROM
BALSA

SIZE
12 ins. LONG
APPROX.

A KIT OF MATERIALS FOR MAKING THIS DESIGN
IS SUPPLIED BY HOBBIES LIMITED
DEREHAM, NORFOLK.
PRICE ON APPLICATION.

FINEST VALUE EVER! The **HUMBROL**
Economy kit

Perfect for small jobs. Contains 8 intermixable Art Oil Enamels (including gold and silver), thinners and flattening agent, plus brush, palettes, colour guide and mixing instructions.



only
3'-

MADE BY THE HUMBER OIL CO. LTD. · MARPLET · HULL

TRANSOM 4.
CUT ONE 1/8 in.

CABIN
TOP 12.
CUT TWO
1/4 in.

SPACERS 8.
CUT TWO 1/8 in.

KEEL 3.
CUT ONE 1/8 in.

6 GLUED
BACK IN PLACE

PROPELLER
SLOT

THE ARROWS INDICATE
DIRECTION OF
GRAIN OF WOOD.

WINDOWS 13.
CUT TWO 1/8 in.

DECK 1.
CUT TWO
1/8 in.

PIECE
14.
CUT ONE
1/4 in.

BATTERY

TILLER

ELASTIC
BAND

TUBE

SIDE VIEW

PRINTED IN ENGLAND.