

HOBBIES WEEKLY

NOVEMBER 26th 1958

VOL. 127

NUMBER 3291

IN THIS ISSUE

| | Page |
|---------------------------------------|------|
| Combined Hut and Greenhouse - - - - - | 129 |
| Doll's Tea Table - - - - - | 131 |
| Some easy-to-make Gifts - - - - - | 132 |
| Toy Gun for Junior - - - - - | 133 |
| Adding Current Ranges - - - - - | 134 |
| Home of the Music Box - - - - - | 135 |
| Patterns for Lino-Cuts - - - - - | 136 |
| Properties of Fabrics - - - - - | 138 |
| Collectors' Club - - - - - | 140 |
| Patterns for Clown Key Rack - - - - - | 143 |



All correspondence should be addressed to the Editor, Hobbies Weekly, Dereham, Norfolk

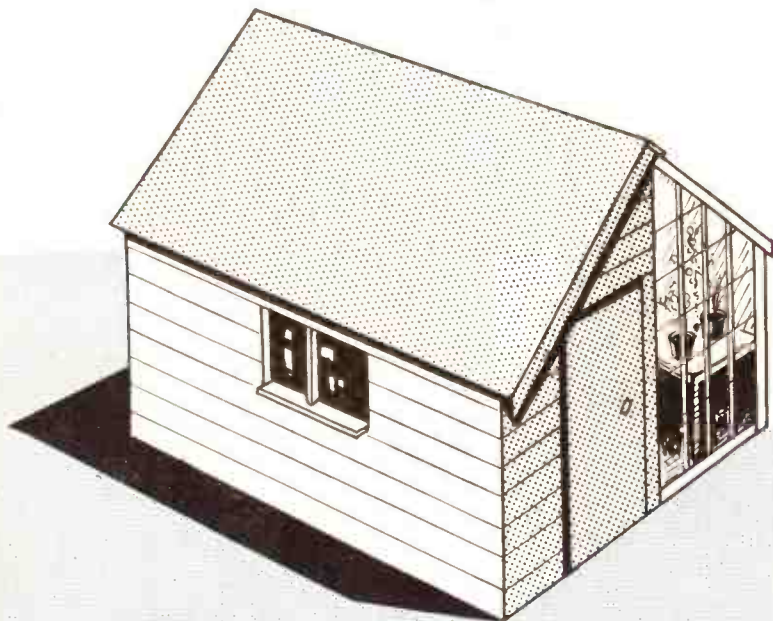

COMBINED HUT AND GREENHOUSE

129

*This novel
dual-purpose
building can be
made by any
handyman*

IT isn't often that one can have both a hut and a greenhouse in the garden. So why not have a structure that serves both purposes. A dual purpose building like this is extremely convenient, and saves space and money.

It is not at all difficult to build and the average handyman will find it well within his scope. The construction has been kept as simple as possible, and consideration has been given to economy of materials.

The design shown can be altered to accord with one's particular needs. All that is necessary is to grasp the principles of the construction, and after that alter the size of the whole or of one part (hut or greenhouse) as desired.

The dimensions of the spars, etc., are not critical. Any wood at hand that approximates to the suggested dimensions can be pressed into service, provided it is not too weak to do the job.

FOR ALL HOME CRAFTSMEN
Over 60 years of 'Do-it-Yourself'

World Radio History

4¹⁰/₂

BUILDING THE HUT/GREENHOUSE

The most important preliminary, once you have decided on the exact size, is the establishment of the foundation for the building. It is quite useless to set up the structure directly on to plain beaten-down earth. This would soon rot the wood.

So, mark out the exact shape of the building on the ground, and dig a trench to fit this. This can be (at least) 6ins. wide and 9ins. deep. Fit boards along the sides of the trench, so that the top edge of the boards is 1in. or 2ins. above the ground level. Work section by section, and use a spirit level to get the boards exactly level in both directions.

Fill in with broken brick, stones, rubble, etc., and finish off with concrete, level with the tops of the boards. After

In Fig. 2 we see how the three members (B, C, D) of the frame are articulated. (B) and (C) are joined by simple half-lap joints, a shoulder being sawn off the upright (C), so that it fits snugly into the spar (D). The cut-out in (D) is easily done with saw and chisel, the angles being 45°. A hole is bored through all the members to take a bolt (T) of at least 1/4 in. diameter. This bolt will hold the three spars firmly together. (See Fig. 2, inset).

The bottom sections of the frame (A, C, F) are connected as in Fig. 3. (A) and (C) are half-lapped and a long nail is driven through both into the end of (F), which butts up against (C).

The glazing bars of the roof are of 3/4 in. by 1 1/2 ins. sparring with 1/2 in. by 3/4 in. or 1/2 in. strip nailed on to hold the glass. Slots are made in the eaves beam (B) to hold the bars. See Fig. 4. These slots should be positioned so that their distance apart allows easy fitting of the glass. (This drawing also shows strip-

wood nailed to the inside of (D) for the glass to rest on.) The glazing bars are nailed through into the slots.

The vertical sashbars of the front are most easily fixed by nailed T-pieces over each end and nailing this on to the (A) and (B) members. These T-pieces can be of wood or metal. 3/4 in. thick wood is quite adequate. Fig. 5 shows the method.

(H) and (B) and (K) members are joined in the same way as (D), (B) and (C), while the bottom of (K) is half-lapped to member (A), and held with a nail.

Moving towards the roof, the members (D), (R) and (E) are joined as shown in Fig. 6. (D) and (E) are connected by means of a simple halved joint and held with a nail. It must be noticed that these members are at 45° angle to each other, and therefore the ends of each must be sawn off at this angle, also.

The ridge (R) which connects the two gables and middle section (D, D, H), is of 1in. or 1 1/2 ins. thick wood of about 4ins. depth. In length, it comes 1in. short of each end of the building, to allow for member (L) to sit in. (R) is nailed on to (D) and (E) as shown in

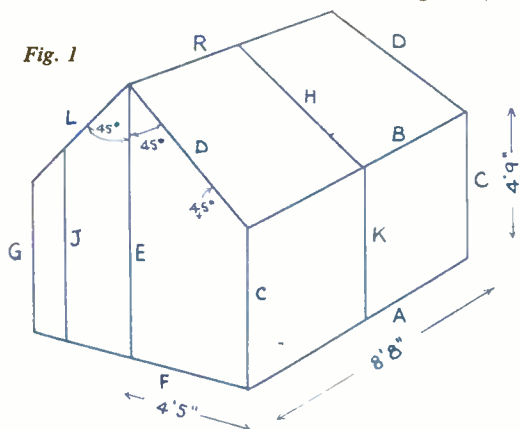

Fig. 1

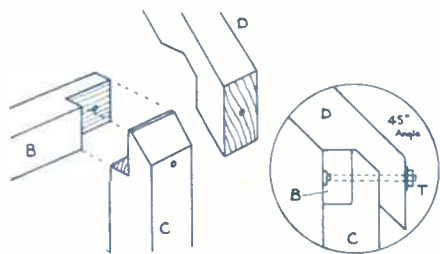

Fig. 2

the concrete has set, the boards may be removed, but in the meantime, the construction of the building can be started.

The frame of the building is the important thing. This should be of at least 2ins. by 2ins. sectioned wood. Fig. 1 is a small sketch of the frame, showing suggested approximate dimensions of the members. For later instruction, these members are lettered.

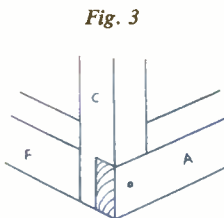

Fig. 3

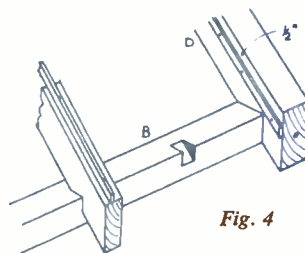

Fig. 4

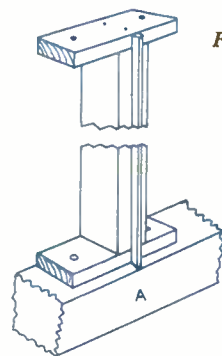

Fig. 5

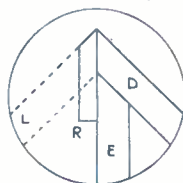
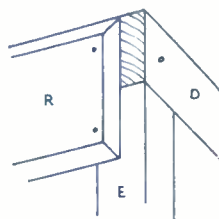

Fig. 6

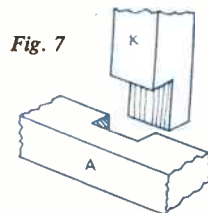

Fig. 7

Fig. 6. The top of (R) must be planed off to make a 45° chamfer.

The member (E) is joined to the bottom (F) by a half-lap joint, in the same way as (K) and (A). See Fig. 7.

The (L) section of the hut roof, as already indicated, butts up against (R) and (D) and (E), and is nailed to (R). See Fig. 8. The spar should be 1in. by 2ins. in section. The junction of (L) with (G), and (G) with (F) is straightforward, being halved jointing.

(J) is 2in. by 2in. section and is half-lapped to (L) and (F). It represents the left-hand door jamb.

Although a spar could be joined (for the eaves) between (G, G), this was omitted because the boarding across the back and roof of the hut serves the same purpose.

The top (ridge) end of the middle member (H) of the greenhouse roof is fixed by a nail through the opposite side of the ridge board (R). Similarly, with the glazing bars, although these could also be fixed by the T-piece method used in the front side of the greenhouse.

A partition divides the middle of the building, separating the hut from the glass section, and it has a door in it leading from the hut to the greenhouse. This door is at the back of the hut, at the opposite end to the outside door. This avoids draughts entering the greenhouse. For the partition and door it is necessary to fix the post (P), see Fig. 9. (P) is of 2in. by 2in. section, and is nailed to the inside of the ridge (R). The bottom can be sunk into the ground, preferably into concrete.

The boards of the partition are nailed to the same side of the post (P) as (R). Instead of boards (which can be about ½in. thick), one could use asbestos sheet, or, perhaps, even hardboard. (The door will be dealt with later.)

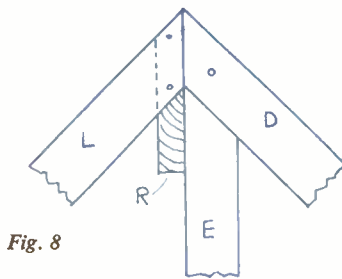

Fig. 8

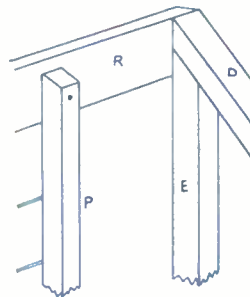

Fig. 9

In assembling the building, the frame must, of course, be erected first. Begin by laying out the base members (A, A), (F, F) on the concrete foundation. Then nail into position the uprights at each corner (C, C, G, G). Follow these with the middle uprights (K), (E), (E) and (J). The member (B) (eaves) can then be placed in position on (C, C) and (K). At one corner add the gable member (D) and while someone holds this up for you, bolt the three members (B, C, D) together. Once bolted they can be left quite safely, and the opposite corner attended to in the same way. Then add the middle section (H) to (B, K). (Ignore the glazing bars for the time being.)

If the members have been cut correctly it should be found that (D) and (E) fit nicely together as in Fig. 6. This being so, nail these two together, at each end of the building.

Next attach the ridge beam (R), nailing it on to (D) and (E), and remembering it comes in. short at each end (see Fig. 6). After this, nail the upper end of (H) to the ridge beam (R).

Next week A. Fraser will describe other features of the Hut/Greenhouse and complete the instructions for building.

DOLL'S TEA TABLE

THE sizes of the finished table are given in Fig. 1. Construct the top frame from the 1½in. wide material using open housing joints at the corners as shown by the exploded view in Fig. 2. The long sides should protrude ½in. at each end when the joints are cut. After gluing and nailing with 1in. ovals these ends are planed flush. No planing or other form of cleaning up should take place until the glue has set.

A ½in. shoulder is cut out of two adjacent sides of each leg. Care should be taken in doing this so that the leg fits

snugly into the corner of the framework. The legs are then glued and screwed to the frame by means of four 1in. by 8 countersunk screws at each corner.

Clean up the edges of the plywood and after rounding the corners fix to the frame using a few dabs of glue and then 1in. ovals at about 3in. intervals. Paint in bright colours and add two animal transfers if desired. (K.J.)

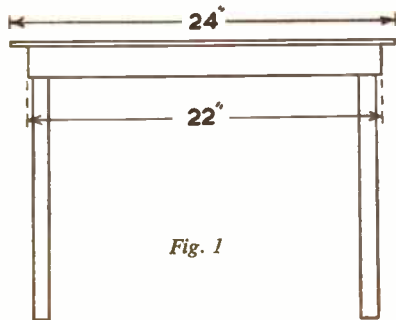
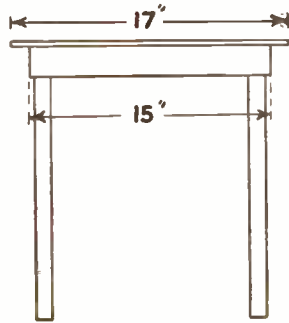

Fig. 1



| CUTTING LIST | |
|-----------------------------------|----------|
| Finished sizes: | |
| 4 at 16in. by 1in. by 1in. | |
| 2 at 22½in. by 1½in. by ½in. | Softwood |
| 2 at 14½in. by 1½in. by ½in. | |
| 1 at 24in. by 17in. by 6 mm. ply. | |

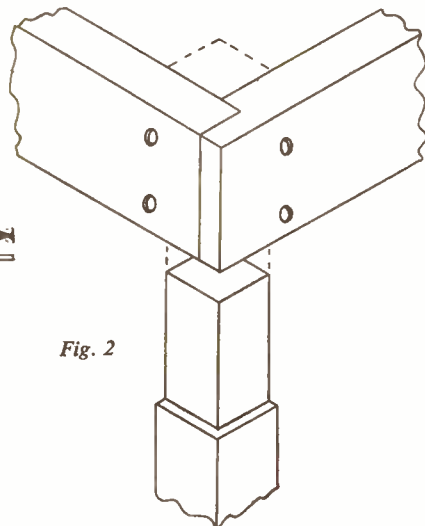

Fig. 2

Some easy-to-make Gifts

IMITATION parchment forms the basis of the many easy to make gifts now to be described, and the only tools you will require are scissors, sharp knife and a measure. You may be able to buy oddments of parchment from a crafts store suitable for all or a few of these articles. It will also be appreciated that several gifts can be cut out at the same time, ready for assembly.

The principle of construction is the same in each case, involving the punching of holes at the seams, fastening the joints together by means of silk corded thonging threaded in and out. Any knotting of the cord, due to joins, should be arranged at the back of the work to preserve a neat appearance. There are also many varieties of plastic thonging available in dainty shades, and you may use this material for binding purposes if you wish.

When preparing the holes for the thonging it is advisable to mark a pencil guide line approximately $\frac{3}{8}$ in. to $\frac{1}{2}$ in. from the edge, punching holes along this line $\frac{1}{4}$ in. apart with a leather punch. It is easiest to mark these points in pencil on one part, holding the two together with a bulldog clip while punching and when they will be in exact register. Thonging is done by threading the cord in a bodkin and any tendency for the ends to fray can be obviated by an application of an

amyl acetate cement, i.e., china, film or jewellers' cement, or nail varnish.

Easiest among these gifts to make is probably the bookmark, consisting of two identical pieces with a pointed end as shown in the sketch. The pieces measure $6\frac{1}{2}$ ins. long by $1\frac{1}{2}$ ins. wide, and are fastened together by thonging at the top and each side to a depth of $1\frac{1}{2}$ ins.

If you are reasonably efficient at lettering in Indian ink, it is suggested you add the words 'I Mark Your Page' or something similar. Here again you will find it helps to plan the position of the wording in pencil and you are strongly recommended to make several trials on scrap paper of the same size. These remarks apply equally to all other articles where lettering is indicated, for attention to detail makes all the differ-

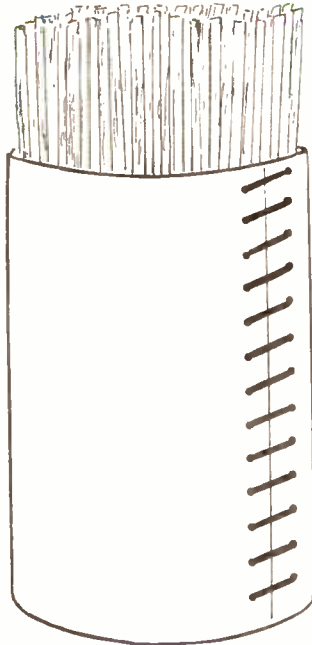

apply a coat of paint inside. Measure the circumference and depth of the tin, carefully cutting out a piece of parchment to the requirements. In this instance the holes are punched down the two edges on the material, the seams thonged and then eased on to the tin. Any lettering is best done before thonging, and here you could add the words 'Have A Light?' or something similar. Instead of thonging down the side it is possible to attach the parchment by means of coloured Scotch tape. Strips are attached around the top and bottom of the holder after making an overlapping joint. In the latter instance you must remember to allow $\frac{1}{2}$ in. extra on the circumference measurement for this overlap to permit gluing, and that this should be done with the material wrapped tightly round the tin. A few rubber bands will hold the parchment in position until the glue sets and then the decorative bands may be attached.

Letter rack

The letter rack is also another useful gift for hanging on the wall, and is composed of two parts to make a pocket holder. The normal letter and postcard measures $3\frac{1}{2}$ ins. by $5\frac{1}{2}$ ins., but

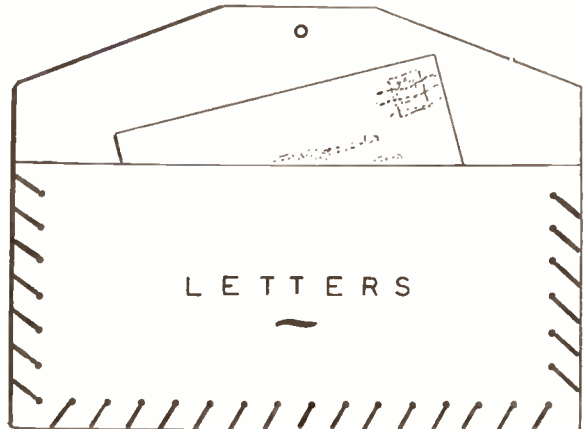

ence in the ultimate appearance of any handicraft job. Moreover, it is often advisable to complete the lettering while the material is flat, and before thonging the seams together.

Spillholders

Spillholders make useful gifts, but here we require an empty round cocoa tin for use as a base. Strip off the old label, making certain that the inside is quite clean, and if desired you may

we must make allowance for binding and slightly different sizes, so you are recommended to cut out a piece of parchment for the back measuring $8\frac{1}{2}$ ins. by $7\frac{1}{2}$ ins., and one for the front measuring $5\frac{1}{2}$ ins. by $7\frac{1}{2}$ ins. The former is shaped as shown in the sketch, and has a hole punched for a tape hanger. The two parts are clipped together for punching the thonging holes and the word 'Letters' neatly printed in a central position. We should mention that it is

ADDING CURRENT RANGES

THE two spare switch positions in the simple D.C. multimeter described in previous issues can now be used to switch into circuit two current ranges. When this moving coil meter is used as an ammeter, it is necessary to pass most of the current being measured through a shunt, since 1 mA only must pass through the meter.

Consider the circuit in Fig. 1. Let I amps be the current to be measured, I_g the current passing through the meter, and I_s the current passing through the shunt. Further, let G be the resistance of the meter and S the resistance of the shunt. Then by applying Ohm's Law it can be shown that the resistance of the shunt is given by:

$$S = \frac{I_g \times G}{I - I_g}$$

Let us suppose that a 10 mA range is required. Then $I = 10 \text{ mA} = 10/1000$ amp. $I_g = 1 \text{ mA} = 1/1000$ amp., and we know G to be 50 ohms.

$$\text{Therefore, } S = \frac{1/1000 \times 50}{10/1000 - 1/1000}$$

$$= \frac{50}{9} = 5.556 \text{ ohms.}$$



Fig. 1



Fig. 2

Now let us suppose that the second range is to be 100 mA. Then the value of the shunt is given by:

$$S = \frac{1/1000 \times 50}{100/1000 - 1/1000}$$

$$= \frac{50}{99} = 0.505 \text{ ohms.}$$

Shunts of these values can be obtained commercially, but many constructors would prefer to wind their own

shunts by trial and error. The best way to make shunts is to wind them round old carbon resistances, the free ends being soldered to the resistance tags (Fig. 2). A loop can be left twisted at one end so that a sensitive adjustment may be made to its value when wired in the instrument. For the first shunt, a piece of resistance wire having a value of 6 ohms would be a starting point, and for the second shunt a length of resistance wire having a resistance of just over half an ohm would do. A friend possessing an accurate milliammeter would be able to adjust the finished instrument by passing a current through your instrument and his in series when your meter is adjusted by twisting or untwisting the

loops so as to read the same as his instrument.

Fig. 3 shows the complete circuit, values being: $S_1 - 5.556$ ohms. (10 mA range); $S_2 - 0.505$ ohms. (100 mA range). The two spare switch positions on the front panel should now be labelled 10 mA and 100 mA respectively.

A final word of warning — always return the instrument to the 500 volt range after use. If in error you leave the instrument switched to the 10 mA range and then later connect the instrument to a source of high voltage, you will burn out the moving coil or snap off the pointer, or both. There is always the danger, too, that you will damage the apparatus under test. (D.A.C.)

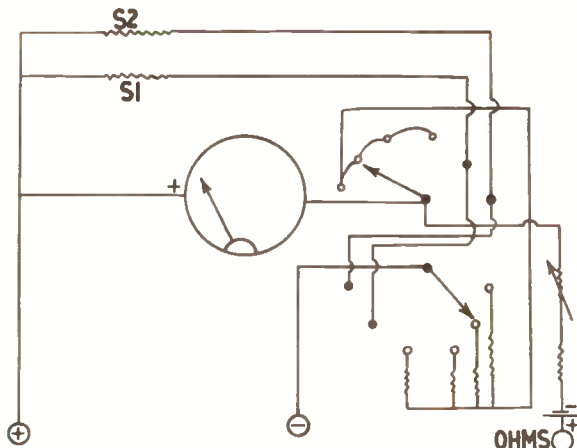

Fig. 3

Early (and successful) Start

THIRTEEN years of age seems quite early in life to be making furniture, and consequently we are pleased to record the success of Paul N. Wilkinson of 47 Moss Road, Northwich, Cheshire, in a local handicrafts competition. He was awarded second prize for his entry of a Combined Table and Firescreen (illustrated here) which was made from Hobbies Design No. 3050. Paul writes to thank us 'for an excellent design and instructions to make a well finished article', and we, in turn, think that he should be heartily congratulated on its execution.

The kit for this dual purpose piece of furniture costs 37/6 and the table top

measures 24ins. by 18ins. The design and instructions separately cost 1/3 (postage 2d.) from branches or Hobbies Ltd, Dereham, Norfolk.

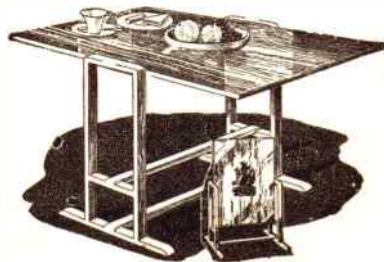

HOME OF THE MUSIC BOX

The musical movements supplied for Hobbies kits are manufactured by the famous Swiss firm of Messrs Reuge, whose development in this field is here recalled.

THE making of music by mechanical means is one of the oldest forms: organs worked by pressure date from before the Christian era, and mechanically-operated chimes existed in the fourteenth century.

But movements with combs which work the music boxes did not come into being until 1796 at Geneva, through the efforts of a simple workman, who little thought that his invention would bring about such a revolution in the world of music.

The first examples of these small movements 'without bells or hammers' — reports an account of the period — were used in snuff-boxes, jewels and watches. However, they only played short and not very tuneful melodies. A whole series of detailed technical inventions were necessary to make these new mechanisms into real musical instruments which, as a result of continual improvement, eventually became an important export industry.

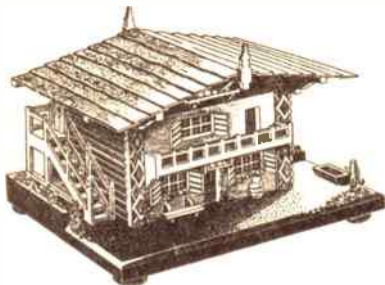

Essentially Swiss in character, this 2-storey chalet is in great favour as a novel gift. There is a compartment to hold 50 cigarettes and the kit (No. 255 Special) contains all materials for making and finishing, including paint, glue, etc. The kit costs 19/11 (postage 1/9) and if a musical movement is required, this of course is extra.

Sainte-Croix which, at the end of twenty years, already occupied second place in this activity, has been in the foremost position since the middle of the nineteenth century. This was attained by a new organisation. The work ceased to be done entirely in the homes of the Swiss people. With the exception of the

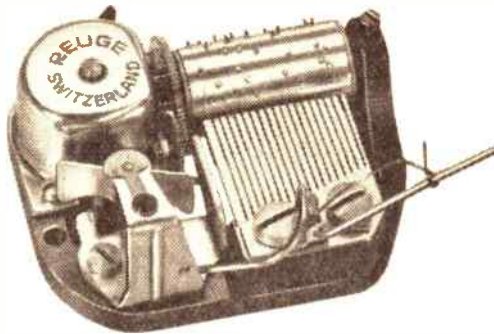

This movement (Hobbies No. 1) is the 'plunger' type, ideal for such models as cigarette and trinket boxes where the raising and lowering of the lid starts and stops the tune. These fine products of Swiss craftsmanship cost only 15/6 (post 6d.) and over 20 different tunes are available. The titles cover all moods — from the merry 'Jingle Bells' to the lovely 'Brahms' Lullaby'

actual music department, manufacturers gathered together nearly all the workers they needed in ever-expanding businesses.

It was from 1890 to 1900 in this district that the large music boxes (or 'cartels') were made, some of which had changing cylinders and could give real concerts. It was thought that the gramophone and other modern inventions would kill this industry. But nothing of the sort has happened, and Sainte-Croix, more than ever before, supplies enormous quantities of musical movements fitted in hundreds of different objects.

Some with 72 notes

Large factories, alongside the small workshops, are provided with the most modern technical means and some, such as Messrs Reuge, produce very carefully-made articles containing movements with eighteen to seventy-two notes.

The activity of this firm in this field dates from 1880. In that year Charles Reuge, whose family had previously specialised in watchmaking, undertook the manufacture of a series of watches with musical movements intended for export, in particular to the Far East.

These were the beginnings of Messrs Reuge, who, in the space of seventy-five years passed from a simple workshop to a semi-industrial business to become a large modern factory. Provided with the most up-to-date machines, this firm has been able to achieve a degree of quality and good workmanship never before attained.

The industrialisation of the making of musical movements formerly executed by craftsmen in their own workshops, has posed problems of great complexity. This firm can claim the distinction of

having moulded together these two forms of production, in combining the most complicated technique with tradition and work in the home, which they have happily been able to maintain. On the other hand, in the constant search for new applications for musical movements, they have brought out a key holder with or without a watch, a cigarette lighter and an alarm clock, all with music, which have met with an enthusiastic reception. People have recognised, in these articles in particular, the seal of the artist and the harmonious forms of classical works of art.



This Swiss Church (No. 256 Special) is the subject of the free design given in each copy of Hobbies 1959 Annual (2/- from newsagents, etc., or by post 2/6). Designed as a cigarette or trinket box and with musical movement, an added feature is the incorporation of electric light. Kits from branches and stockists cost 25/- (by post 1/9 extra) and are complete down to the brass bell in the clock tower. This model also takes a No. 1 movement costing 15/6 extra.

LINO-CUT

SUITABLE FOR THE BEG



PHOTO' PASTED DOWN



FOR XMAS CARDS

INNER...



PROPERTIES OF FABRICS

EXAMINE wool, silk and cotton fibres under the microscope. You will find that wool fibres are cylindrical and their outer surfaces are covered with scales which overlap like the scales of a fish. Silk fibres are like glass rods and cotton fibres are flat, and spirally twisted with thickened edges.

The two outstanding properties of wool, its elasticity, and its capacity for absorbing and retaining moisture may next be examined. Note how a few fibres gently stretched between the fingers return to their original length when the stretching ceases. Wool is more elastic than any other textile fibre. Note how the fibres are even more elastic when moistened with water.

Take a bundle of wool fibres, previously dried in a current of warm air and then weighed, and place them in a current of steam for a time. On weighing again you will find that the wool is capable of absorbing and holding moisture to the extent of about 33 per cent of its original weight without feeling very damp. If you repeat the experiment with cotton and silk fibres you will find the increase in weight is about 8 per cent and 20 per cent respectively.

Next you can try the test of relative strengths of fibres using the apparatus illustrated in Fig. 1. Apparatus required: Wool, cotton, and silk fibres; microscope, balance, clip, cotton.

The air content

Examine a piece of new woollen fabric with a magnifying glass. Cut it into two pieces, wash one piece in a tepid solution of soap flakes and the other in a hot soda solution. Rinse and dry both pieces, examine them again with a magnifying glass and you will see how the air spaces have shrunk in the piece washed in soda.

The amount of stabilized air in samples of different fabrics can be measured by means of the apparatus shown in Fig. 2. This is a very important test, for the warmth of clothing made from these fabrics depends on the enclosed air. Apparatus required: Samples of cotton, silk, wool, artificial silk, linen, flannel, flannelette, balance, magnifying glass, flask, rubber bung, glass tube.

A strip of the fabric to be tested should be rolled up tightly so that it will pass into the flask which is filled with water. When the bung is pushed into the neck of the flask the water rises up the glass tube. A small weight fastened to the fabric acts as a sinker.

The original level of the water in the glass tube should be noted, and when the fabric has soaked for a considerable time the final level should be noted. It will be lower than at first, the missing water having taken the place of the air which was originally enclosed in the fabric. Strips of approximately equal area should be used.

Clothing and fire

Cut small pieces from samples of material. Hold each in crucible tongs over a tin tray and put a light to it. Watch carefully what happens, noting whether the material bursts into flame, burns quickly or slowly, smoulders or produces any smell. You will see that some of these materials used for clothing are highly inflammable.

Articles required for this experiment are pieces of the following materials (each labelled): cotton, silk, wool, artificial silk, linen, flannel, flannelette,

crucible tongs, matches, tin plate tray, scissors.

Make a table of the various materials tested and details of how they burn.

Colour in cold weather

Apparatus required: Two tins of the same size, having lids with holes in them — one painted dead black and the other glossy white, two thermometers.

Heat up sufficient water to fill both tins. Pour equal quantities of this water into the tins and quickly take the starting temperature of the water in each tin and read the temperature of the water in both tins after each minute for about fifteen minutes, tabulating your results (see Fig. 3).

This experiment will enable you to decide which colour you should choose for clothing in cold weather.

Colour in hot weather

By suspending a piece of gas fire radiant above a Bunsen burner, by means of wire attached to a retort stand clamp between the two tins each filled with cold water, you can check the rise in temperature of the water in each tin, and you will then discover that it is better to wear light coloured clothing in hot weather, if you wish to avoid becoming too hot (Fig. 4). (T.A.T.)

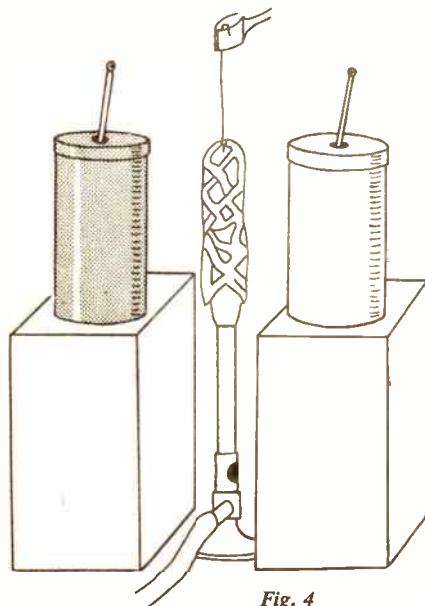
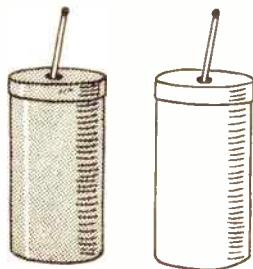
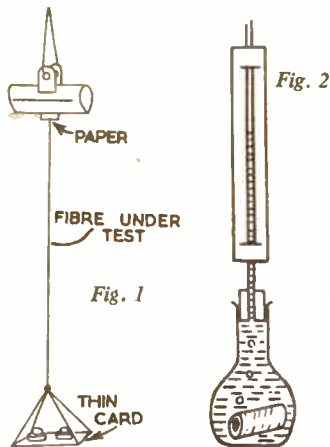

Fig. 3

Fig. 4

You'll have more fun with **MECCANO**

Meccano is more fun because it is a whole lot of toys in one. Starting from quite simple models that can be made with the smallest Outfit No 00, you can add extra parts and accessory Outfits with which you can build large working models that represent major feats of engineering. Enjoy the fun and excitement of building your own Meccano models - it's the greatest hobby in the world.

SEE MECCANO AT YOUR
LOCAL DEALERS TO-DAY

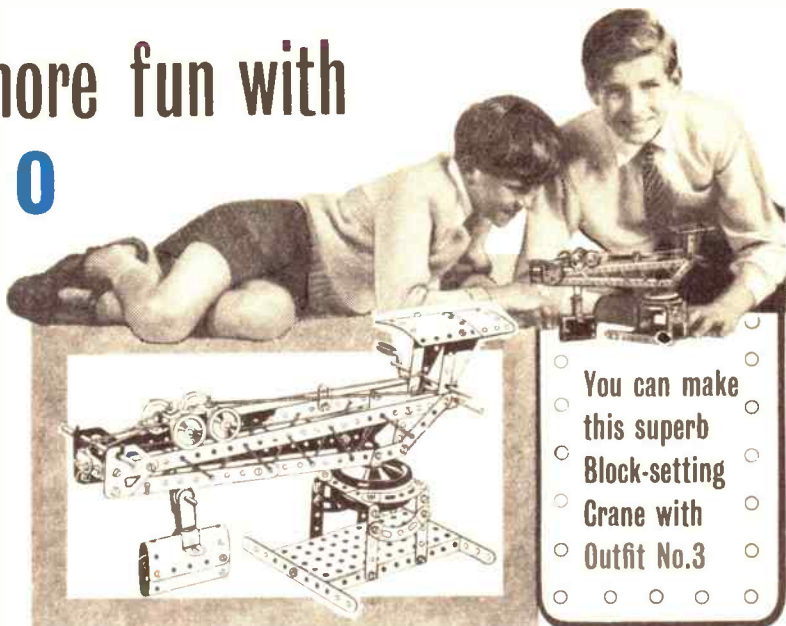

You can make
this superb
Block-setting
Crane with
Outfit No.3

MECCANO - so much more than a toy

MECCANO LTD BINNS ROAD LIVERPOOL 13

PHOTOGRAPHERS!

**DO YOUR OWN
DEVELOPING**



Here's a quick way to the mastery of developing photographic films. The Roto One tank is designed for easy loading. You have everything under control from the outset. Adjustable to take 120, 127 and 88 roll films or 20 exposure 35 mm. films. From Photographic Dealers with full instructions £1 10s. od.

IT'S EASY AND EXCITING WITH
JOHNSON Roto ONE
DEVELOPING TANK



MODELS FOR BOYS

No. 251 Spl.
TUG 'CLIMAX'
16ins. long

53/6



Make them with a
Hobbies Kit

No. 253 Spl.
TRAWLER
'ANGLIAN'
18ins. long

54/6



Electric motor
and propeller
included

No. 3206
'EMPRESS
OF
BRITAIN'
24ins. long
56/5

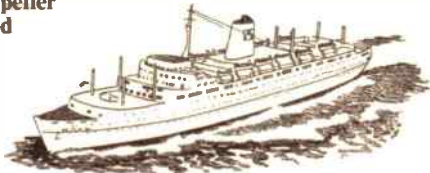

Hobbies Ltd, Dept. 992 Dereham, Norfolk

THE Royal Bengal Tiger belongs to India. Everybody knows how fierce, cruel, and strong is this creature, a far-off cousin of our domestic pussy cat.

In some parts of India tigers are killed in a curious way. Many broad leaves smeared with a kind of glue like birdlime are strewn in the tiger's way. When he steps on any of them they stick to his paws; he rubs his paws on his head to get them off, and the leaves stick to his face; the harder he works to get them off the worse is his plight, until he gets blinded and rolls on the ground howling with rage. The hunters hear the noise and come and shoot him.



In China a large box-trap with a mirror is set with the door open. The tiger, seeing his own image in the glass, and thinking it to be another tiger, goes in, the door closes and he is caught. This kind of trap is very old, being shown in ancient sculptures.

LIONS AND TIGERS

Lions sometimes show fondness for other animals, especially when they are of use to them. An old lioness in the Dublin Zoological Gardens was taken sick, and during her illness was troubled by rats, which she was unable to drive away. A terrier dog was put into her cage, but she, not knowing that he could aid her, received him with a surly growl. But when she saw him kill a rat, she coaxed the little dog to her, fondled him, and every night after that he slept beside her with her paws folded round him.



IRELAND is called 'the Emerald Isle' because it is so green. The west winds blowing from across the Atlantic Ocean bring so much rain that the fields are even greener than English fields; in fact, until you go to Ireland, you do not know what green really is.

'Stamps: 1931. 2d. blue — Reaper — 1d. used. 1945. 2½d. blue — Youth Sowing Seeds — 1d. used. 1946. 2½d. red — 'Country and Homestead' — 1d. used'.

IRISH ISSUES

Dublin (the capital) stands at the mouth of the Liffey, and at the head of Dublin Bay, which stretches between Howth Head and Kingstown.

Londonderry, a beautiful city on the Foyle, is celebrated for its great siege of 105 days, when the inhabitants, having used up all their cannon-balls, fired brickbats cased in lead, upon their besiegers.

Belfast is the chief manufacturing town. It is noted for cotton weaving and spinning, bleaching, dyeing, and iron foundries.

St. Patrick (patron saint of Ireland) is depicted on a 2/6 stamp of 1937—3/- used.

The following stamps are worthy of note.

'1922. Overprinted with T.I. (date in thin figures). 2/6 brown — 15/- mint, 20/- used. 5/- red — 20/- mint, 40/- used. 10/- blue — 42/- mint, 80/- used'.



This model farm cost less than 2/6

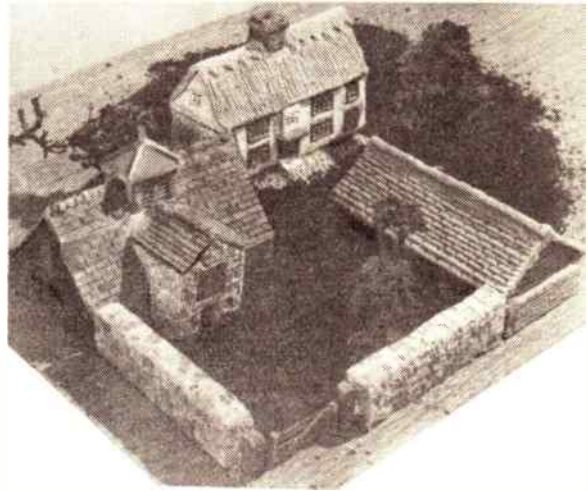

It was made from a half-crown tin of Sankey's PYRUMA — farmhouse, barn, implement shed, walls and gate — and there was still plenty of this grand modelling material left to build many more farm features, by simple methods described in the Instruction Book (see Coupon below). PYRUMA, plastic and ready-for-use, becomes stone hard after drying or baking, and can be painted in natural colours. For permanent modelling —

MAKE IT AND BAKE IT IN



Obtainable from your local Ironmonger or Hardwareman and many Art Material dealers. Ideal for making —

**Model Railway Buildings and Accessories.
Harbours. Ship Models. Airport Buildings
and Features. Houses. Bookends. Ashtrays.
Animals and Figures. Plaques, etc.**

Post this Coupon today for your Instruction Book.

J.H. SANKEY & SON, L^{TD}

Established over a century
Dept. H, ILFORD, ESSEX

Please send ILLUSTRATED INSTRUCTION BOOK with full colour pages on Pyruma Modelling.

Enclosed Postal Order value 6d. (not stamps)

NAME (Block letters) _____

ADDRESS _____

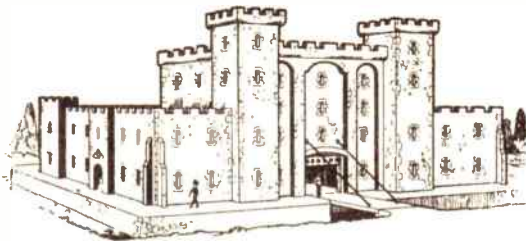

GIFTS

Kit No. 3274
GRAND MODEL FORT
Base 19ins. x 13ins.
28/6
(post 3/3)



FOR

Kit No. 2910
DOLL'S HOUSE
17ins. wide.
Four rooms, hall, landing.
65/-

GIRLS



Kit No. 254 Spl.
DOLL'S HOUSE
Rigid hardboard construction.
Open back.
47/11

AND

BOYS

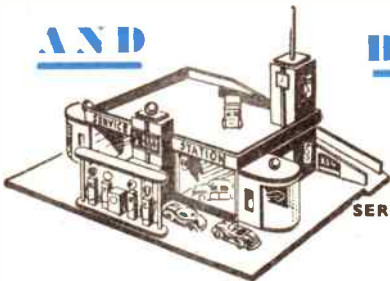

Kit No. 3129.
SERVICE STATION
Very modern.
Base 24ins. x 18ins.
43/11

To Hobbies Ltd., Dept. 992, Dereham, Norfolk.
Please send free booklet illustrating kits available
and kit indicated here.

Kit No.

Name

Address

P.O. for enclosed.

(Orders value 30/-
and over, post free)

FULLY TRANSISTORIZED

THE VOXETTE TAPE RECORDER

NOW a brand new EXPENSIVELY TRANSISTORIZED tape recorder and play back machine AT EVERYBODY'S PRICE. Complete outfit ready to record and play back. £11. 19. 6., carr. 5/-.



No more to buy. Records anything — music, outdoor sound effects, sing-songs, parties. Ideal reporters, dictating, etc. Permanent recordings or tape can be used again and again. Further 3 in. spools obtained anywhere. With standard batteries (cost 1/8d. — months of normal use) you can record outdoors — anywhere! Perfect reproduction. Portable. Written guarantee. Or sent for £4, bal. 18 fnly. payts. 10/10d. LISTS. GUITARS, WATCHES, RINGS, CABINETS, JEWELLERY, etc. TERMS.

Headquarter & General Supplies Ltd. (HOBW/39) 196-200 Coldharbour Lane Loughboro Junc., London, S.E.5. Open Sat.

BECOME CHIROPODIST MASSEUR. Postal Schools (Dept. 27), 48A Abbey Street, Accrington.

'PAINTSPRAYING' HANDBOOK. Covers Car, Industrial & Flock Spraying. 3/6, post 4d. Catalogue of our Cellulose and Paints and all Allied Sundries 3d. — Leonard Brooks Ltd., 81 Oak Road, Harold Wood, Essex.

CLUB PRINTING AND DUPLICATING. Samples and prices 3d. — Bernard Salmon, 107 Shearer Road, Buckland, Portsmouth.

MAKE A MUSICAL BOX for as little as 21/- New kits and tunes available. Movements 13/- post free. Please send 3d. stamp for free illustrated catalogue. — The Swisscross Co., Dept. B, 202 Tulse Hill, London, S.W.2.

MUSICAL MOVEMENTS. The largest selection of tunes in England. — Richardson & Forder, 5 Chapel Place, London, N.17.

XMAS PRESENTS

Stamp collecting is the King of Hobbies, the Hobby of Kings.

Give him stamps! he can select from approvals up to the amount you wish to give. Albums @ 6/- & 11/- book on collecting 3/- or beginners outfit (ten items) 3/6, all post included.

H. LENNARD BUTTLE
83 Thames Side, Staines, Middlesex

SAVE THIRTY SHILLINGS!

ELECTRIC DRILL ACCESSORY KITS

Sanding Discs — Backing Pad — Lambswool Bonnet — Grinding, Buffing and Wire Wheels with Arbor — Masonry Drill and Wallplugs — 3 Drills for Wood — 3 Drills for Metal — Postage Paid — 24/6 — (Usually 54/6). — Lists Free.

BARKERS, 70 WEST STREET, LEEDS 1

Completely new 54 page Edition

WHERE'S THAT CAR FROM?

Price 1/- (Postage 4d.)

Of all Booksellers

or

RALEIGH PRESS, Exmouth, Devon

MOONSCOPES £5.19.6!!!

See Moon at close quarters, Jupiter's Moons, Saturn's Rings, etc. Amateur's Astro. Kits £9-7-0 or 10/- weekly. Ideal Xmas gifts. Stamp for lists. Photos 1/- set (returnable). WORLD WIDE TESTIMONIALS.

J. K. M. HOLMES & CO. LTD. (Dept. H1) Scientific Instrument Makers, Martins Bank Chambers, 33 Bedford Street, North Shields, Northumberland.

BUYING OR SELLING?

Classified advertisements on this page are accepted at a cost of 6d. per word prepaid. Use of a Box No. is 1/- extra. Send P.O. with advertisement to *Hobbies Weekly*, Advert. Dept., Dereham, Norfolk. Rates for display advertising on application.

CUPPED PUNCHES

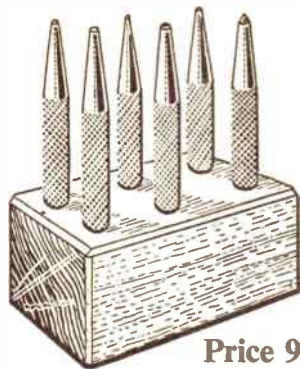

Price 9/6

(Post 1/3)

A set of six round-head punches with polished wood stand. There are five cup or brad punches from 1/8 in. to 3/8 in. and one centre punch. A most useful set for the handyman.

From branches or:—

HOBBIES LTD., (Dept. 29), Dereham, Norfolk

STAMPS FREE — Empire Packet including Pictorials and Victorians with approvals. — Robert J. Peck, 7A Kemp Road, Bournemouth.

100 DIFFERENT stamps free! Request 1d. upwards discount approvals. — Bush, 53 Newlyn Way, Parkstone, Dorset.

15/6 CRYSTAL RADIO kit. Easy-to-build with only a screwdriver and pliers. Post free — send 15/6 P.O. ALSO — 1 and 2 valve kits, headphones, etc. — send stamped addressed envelope for complete list to — Blanchard's Radio, Dept. HC8, 13 Gainford Gardens, Manchester, 10.

OLYMPIC Games stamp and 10 beautiful Pictorials free! Five Continents represented. Send 3d. postage requesting bargain approvals. — Greenwood (HA), 9 Moor View Road, Sheffield 8.

MEN-WOMEN with spare time, required for new simple weaving work. For details send S.A.E. (Dept. 4) Weava Products, 10 Shelley Road, Worthing.

SHIP Photographs. Liners. Send 1/3 List, Specimen.—Elder, 38 Westview Road, Barrow-in-Furness.

ALL-STEEL CORNER CRAMP



Price
11/9
(post 1/3)

A Picture Frame Cramp made from steel and practically unbreakable. It is well made and finished and will take work up to 2 1/2 in. wide. For ordinary moulding it is a very serviceable article. From branches or:—

HOBBIES LTD, DEREHAM, NORFOLK

YOU CAN BECOME A HANDY-CRAFTS INSTRUCTOR

EXPERIENCE NOT ESSENTIAL

Men who enjoy making things in wood or metal can turn their hobby into a permanent and interesting Career. Short hours, long holidays and security in a job you would really enjoy, can be yours if you become a Handicrafts instructor. Let us send details of the easiest and quickest way to get the necessary qualification.

We guarantee "NO PASS — NO FEE"

If you would like to know about our unique method of preparing you for one of these appointments, write today, and we will send you our informative 144 page Handbook—free and without obligation. Mark your letters "Handicrafts Instructor".

BRITISH INSTITUTE OF ENGINEERING TECHNOLOGY BIET

595 College House, Wright's Lane Kensington, London, W.8

CLOWN KEY BACK

TRACE the outline of the pattern and transfer to $\frac{3}{16}$ in. or $\frac{1}{4}$ in. wood by means of carbon paper. Cut round the outline with the fretsaw, making sure that the saw is upright. Clean up with glasspaper and prepare for painting by rubbing all over with woodfiller.

Give one undercoat of white, allow to dry and then transfer the face. Paint in bright colours and give two coats in all.

Three cup hooks are screwed in place on the collar as indicated and a wall hanger is screwed on the back. (M.p.)





KITS WHICH WILL MAKE GRAND GIFTS FOR ALL MEMBERS OF THE FAMILY

Gifts made by yourself have that 'personal' touch which make them all the more appreciated. Here are a few kit suggestions from Hobbies which will delight both giver and receiver. Many more ideas in Hobbies free 20-page booklet. Send for one today and save yourself £££'s.

KITS CONTAIN ALL MATERIALS AND FULL INSTRUCTIONS FOR MAKING WITH A FEW SIMPLE TOOLS.

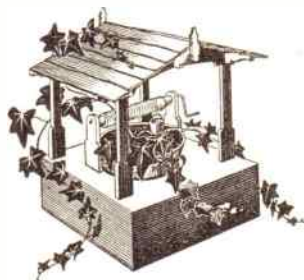

'OLD WELL' PLANT HOLDER

Kit No. 3248
10/3 (post 1/6)

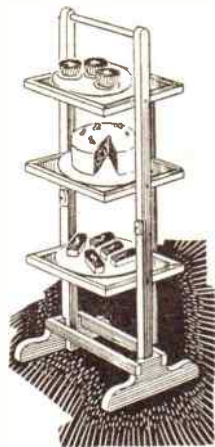

FOLDING CAKE STAND
Kit No. 3226. All wood, hardboard, etc.

20/- (post 1/9)



'LIGHTHOUSE ELECTRIC LAMP'

Kit No. 3252. Lampfittings, printed window material, etc.

22/6 (post 1/9)

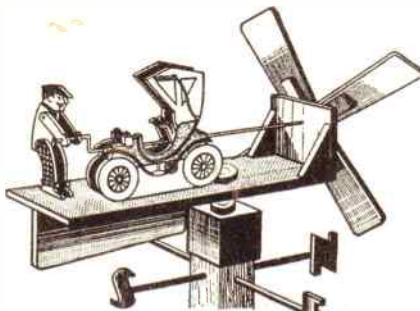

NOVEL WINDVANE

Kit No. 3258. Wood, wire, steel, etc.

16/- (post 2/-)

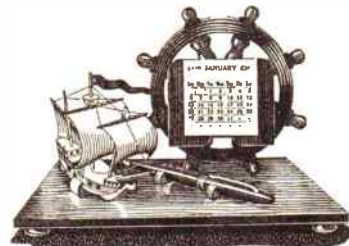

GALLEON CALENDAR 5/9 (Post 1/-)
No. 3188 Graceful and practical.

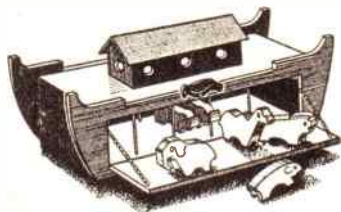

NOAH'S ARK
No. 3270. With animals.

13/11 (post 1/6)



AUTOMATIC CIGARETTE BOX
No. 3272. Open the drawer for a cigarette.

5/6 (post 1/-)

**GET STARTED ON SOME
OF THESE RIGHT AWAY!**

To Hobbies Ltd., Dept. 992, Dereham, Norfolk.

Please send free copy of 'Profitable Leisure' and

KIT NO.....

Name.....

Address.....

P.O. for..... Orders totalling 30/- and enclosed. over, post free