

HOBBIES WEEKLY

IN THIS ISSUE

	Page
Portable Wireless	287
A Handy Drying Rack	291
A Book to Read	291
Convert It to Capacitor Flash	292
The Shipmodeller's Corner	293
A Brooch from a Toothbrush	294
Fly Whip Control for Fun	295
How to Renovate a Shabby Suitcase	295
Patterns for Making Model Motor Lorry	296
A Pin-Vice Is a Useful Tool	298
Making Inlaid Table Mats	298
Replies of Interest	300
Patterns for Inlaid Table Mats	303



FEBRUARY 9th 1955

VOL. 119

NUMBER 3093

Detailed instructions for making a

PORTABLE WIRELESS

FOR HEADPHONE
RECEPTION

★ *By F. G. Rayer*

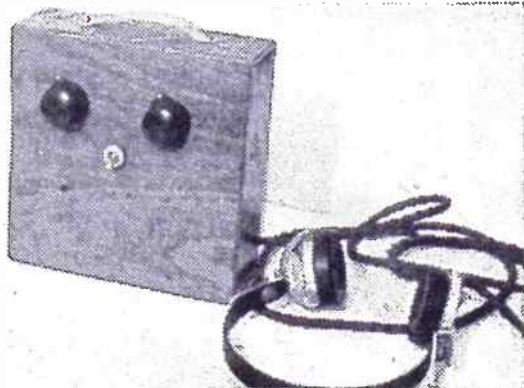

THIS receiver has been designed for the constructor who wishes to build a fairly compact and simple portable wireless for headphone reception. It is quite small, and contains batteries and phones, the latter being withdrawn from the case when required for listening.

There are several advantages in this method. For example, the set can be used anywhere without disturbing other people. The circuit can also be much simplified, as less power is required for phones than would be so if a speaker were incorporated. As a result, weight and initial and running costs are kept down. If, on the other hand, an external loudspeaker and larger battery are

available upon occasion, then quite good speaker results can be had from the local station.

The Circuit

The circuit is shown in Fig. 1. Automatic bias is provided to avoid the need for a G.B. battery. Actually, quite good phone results can be obtained in most parts of the country with one valve and frame aerial, and if it is desired to try this, then the L.F. coupling transformer, 600 ohm resistor, 25 μ F condenser, and output valve, with holder, are omitted. The phones are wired from H.F. choke to H.T. positive, H.T. negative being wired to L.T. negative. 1S5 and 1S4 valves are used. A 1S5 and

1T4 are equally suitable, for phone reproduction only; a further 1T4 may also be employed instead of the 1S5. If the valves are changed, valveholder wiring must be modified to suit.

The other components required will be seen from the diagrams. A further 0.0005 μ F variable condenser can be used for reaction, if available, instead of the 0.0003 μ F shown. Any H.F. choke for medium and long waves is suitable. This item can be made by fitting two discs of paxolin $\frac{1}{4}$ in. in diameter on a piece of wood or bakelite rod $\frac{1}{4}$ in. in diameter, spaced so that $\frac{1}{4}$ in. is left between the discs. This space is wound full of 38 to 42 S.W.G. silk-covered wire.

Results are considerably influenced by the L.F. transformer, and an efficient component, designed for this purpose,

All correspondence should be addressed to The Editor, Hobbies Weekly, Dereham, Norfolk

*For Modellers, Fretworkers
and Home Craftsmen*

4^D

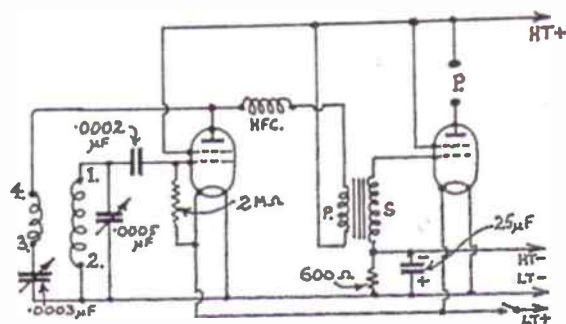

Fig. 1—The circuit

is required. Its ratio may be between 1:3 and 1:5, and it *must* be a genuine L.F. coupling transformer. Ex-service transformers are satisfactory, if of this type. But 1:3 to 1:5 transformers which are really intended for other purposes should be avoided, as though of suitable ratio they have insufficient

Fig. 4—Back view of the receiver

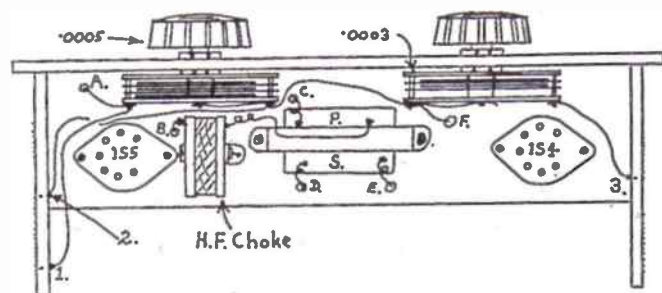

Fig. 2. Layout of top of baseboard.

turns, and volume will be very greatly reduced.

Base and Frame Aerial

Exact dimensions are not critical, but depend largely on the headphones. Before actually building the receiver, it would be wise to check that these can be accommodated. The dimensions given are, however, suitable for average phones.

The receiver is built on a 3-ply baseboard 1½ ins. by 6½ ins. as shown in Fig. 2. Holes for the valveholders can be cut with a fretsaw. This baseboard is nailed to a frame 6½ ins. by 6½ ins. and 2½ ins. wide, as shown in Fig. 4. Frame and baseboard are also nailed to the panel, which is ½ in. larger all round. With careful marking out and drilling, and the use of very small nails, the whole should be rigid, with no splitting. The whole receiver is built on panel, baseboard and frame, and can be operated and tested in this form before fitting in the cabinet. The headband of the phones is accommodated in the space behind the baseboard.

In Fig. 2, the top piece of the frame is assumed to be removed, to show wiring.

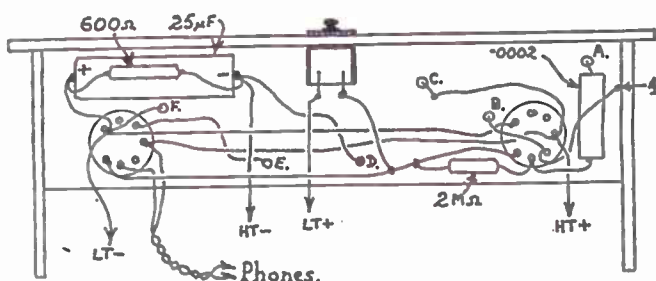

Fig. 3—Underneath view of wiring etc.

In Fig. 3, the bottom piece is similarly omitted. Wiring between components may be done before these pieces are fixed in position.

Several wires pass through the baseboard, and these are lettered. Referring to Fig. 2, 'A' passes to the .0002μF condenser. 'B' goes to detector anode and '4' on frame aerial. 'C' goes from transformer primary to H.T. positive. 'D' is from secondary to H.T. negative. 'E' is from secondary to output valve grid. 'F' goes from moving plates of condensers to L.T. negative line. The

should go to two terminals fitted conveniently to a small strip of insulated material. The positive phone lead should go to the H.T. positive side of the circuit.

Winding the Frame

When all components are wired up, the frame can be wound. A small hole is made at '1' in Fig. 2, and the end of a reel of 28 D.C.C. wire plugged in it, the wire being joined to the fixed plates

● Continued on page 293

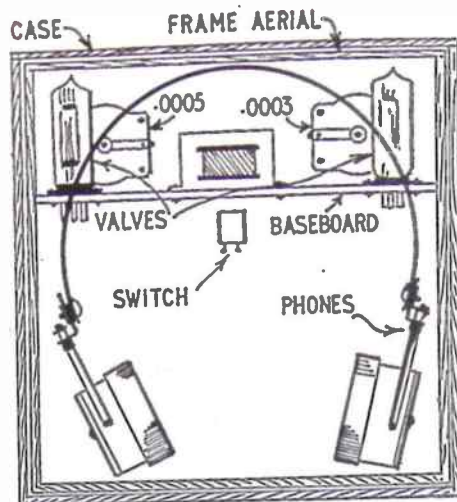

25μF condenser will have polarity marked on it, and this should be observed as in Fig. 3. Some of the valveholder sockets or tags are not used, but no leads or other parts must touch these. To arrange the sockets in the positions shown in the diagrams, it may be necessary to turn some holders one way or the other as all manufacturers do not place the fixing holes in the same relative positions.

Any insulated wire of 22 to 20 S.W.G. can be used for wiring up. Flex is required for battery connections. If the phones are to be used elsewhere, then the leads marked 'Phones' in Fig. 3

FOR THE HOME

A Handy Drying Rack

OIL convection heaters are becoming increasingly popular to provide that little extra warmth in spare rooms, hallways, etc., during the winter months. They give out, at low cost, a large volume of warm air which circulates the room. One of the popular makes of convection heater is

Can be fitted to an oil convection heater

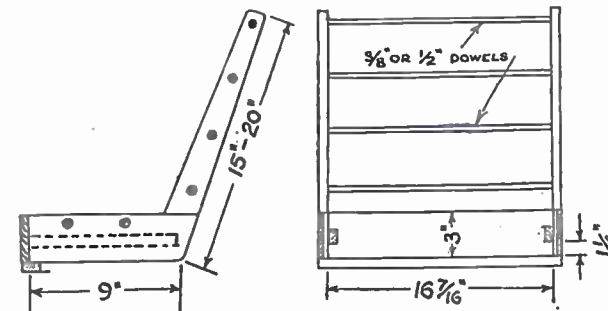

Fig. 1

enclosed in an attractive-looking metal casing, the top of which becomes quite warm; the writer has found this warm metal top very useful for drying out the odd kitchen tea-towel, or the airing of a pair of socks, and many other small items of clothing.

The main stream of warm air issues in a sloping direction upwards from the grid opening in front of the heater casing, and best drying results were obtained when the items were suspended in this stream of air: from this fact was evolved the simple drying rack shown in the illustration. The rack simply fits on top of the casing, a strip of wood fitting closely under the overhanging rear edge and preventing the rack from tipping forward under the weight of clothes.

The sizes given in the drawings suit

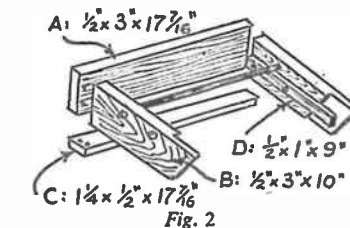
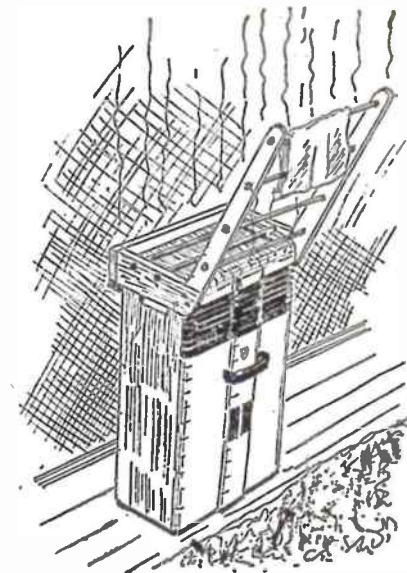

Fig. 2

the particular model of heater shown; it will be a fairly simple matter to modify the sizes to suit other metal-encased heaters. Perhaps a slightly different means of holding the rack in place would also be required, and the capable handyman will have no difficulty in evolving a suitable method of attachment without drilling, or other-



wise cutting, the heater casing. Whatever method is used the hot metal top should be kept free of pieces of wood, as this is a valuable drying area.

Construction

Fig. 1 shows a side and front view of the rack with dimensions. 16 7/16 ins. is the size of the top of the convection heater, or rather just slightly larger, allowing the rack to just slip on. When placed in position the rack is pulled forward so that piece (C) (Fig. 2) fits in under the projecting top of the heater.

Make up the two side pieces, consisting of two sides (B)—refer now to Fig. 2—and the two long sloping arms which are half-jointed to sides (B). These arms can be anything from 15 ins. to 20 ins. long, 2½ ins. wide at bottom and tapering to 1½ ins. wide at top. All wood should be ½ in. thick, but ¾ in. stuff will do, making a somewhat heavier-looking job. Any hardwood will suit, beech, perhaps, being the most suitable. Glue and screw the halving joints.

On the inside of the sides, glue and screw pieces (D), ½ in. by 1 in. by 9 ins. long, fixing them exactly 1½ ins. from the bottom edge of the sides. These prevent the rack from dropping right over the heater.

Now, clamp both side frames together with thumb-screws and bore the six holes, ½ in. or ¾ in. diameter, to take the dowel rod rails. Unclamp, and screw and glue piece (A) across the back of the sides, and glue and pin the six dowels in position. Finally glue and screw piece (C) in place. Glasspaper all rough edges. One or two coats of brushed french polish will make a good-looking job. (R.C.)

A Book to Read

TV Inventors' Club

by Leslie Hardern

MR HARDERN has always believed that there is more inventive talent in Great Britain than in any other country in the world. He believes, too, that we have given it far too little encouragement. He has done much to help the British inventor with his TV programme, which has now been running for some six years, and has examined more than 7,000 inventions and ideas submitted from all parts of Great Britain and the Commonwealth.

Of these, some 500 have been shown to viewers and Mr. Hardern has had the satisfaction of seeing more than a quarter of these inventions taken up by manufacturers, and placed on the market. This book will not show you how to become an inventor, but it will tell you the fascinating story of the Inventors' Club, and some of the people who have appeared in it. Published by Rockliff Publishing Corporation, 1 Dorset Building, Salisbury Square, Fleet Street, London, E.C.4—Price 12/6.

If you have an old photographic Flash-Gun —

Convert it to Capacitor Flash

reflector of the usual size (about 4 to 5 ins. in diameter) could be made from polished metal. Such a gun could be as reliable as a commercially-made model.

Capacitor Firing

The simple battery-type of gun uses two or more dry cells exactly as in a torch or hand-lamp. The circuit to the

depend on the state of the battery, as even a battery in poor condition can give out a slow current to charge the condenser. So long as the latter becomes charged (which usually takes 5 to 10 seconds) its stored energy will fire the bulb. This gives more certain results, and one battery can be used six months or more.

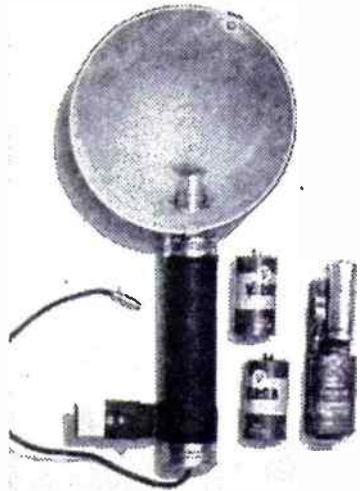

Flash-gun and capacitor unit. The latter is to the right of the two cells normally used in the gun

THE old type of photographic flash-gun which fires bulbs directly from a 3 to 6 V battery has been almost wholly replaced by the capacitor type of gun. The older type can, however, be converted to capacitor firing quite easily, and in all but exceptional cases the required components can be housed in the space which was used to hold the 3 to 6 V battery originally employed.

bulb is completed to fire the latter, when a high current flows, igniting the magnesium wire or foil it contains. If the dry cells are not fresh and in good condition, the bulb may not fire at all, or may only fire after a delay. (With a synchronised camera the latter is worst of all, as the shutter may already have closed again.)

The circuit for capacitor firing is shown in Fig. 1, and is actually very easy to understand. When the bulb is inserted in the gun, the circuit from battery to condenser is completed, through bulb and resistance. The

The Slip-In Unit

This is shown in Fig. 2, and dimensions are not given because flash guns are of many sizes, according to the type and number of dry cells used. If the gun holds two or three large cells, there will be ample space for the capacitor unit. But with small guns using only two Baby Torch type cells, it will be necessary to keep the unit as compact as possible, and to use a condenser of small external dimensions.

The unit is built upon a strip of plywood or paxolin cut to slip inside the gun. Two small clips are cut from brass

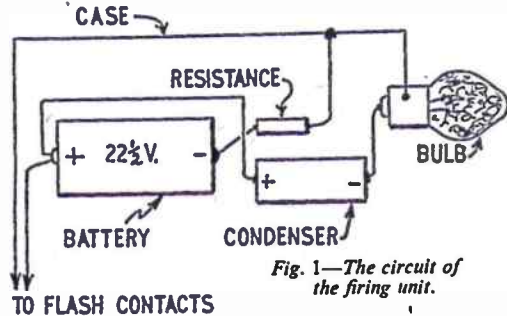

Fig. 1—The circuit of the firing unit.

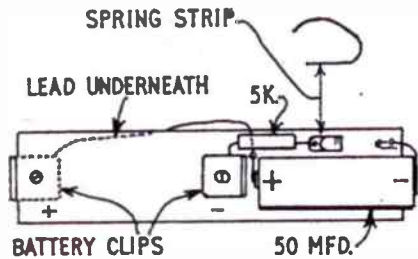
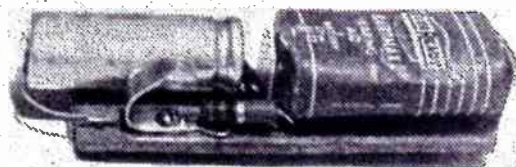

Fig. 2—The wiring plan of capacitor unit.



The capacitor firing unit.

The idea of making such a conversion, therefore, becomes feasible, the unit being made to slip in to replace the dry cells normally used.

It would also be possible to make up a complete flash-gun with the circuit shown. The components could be housed in a small wooden case, and a

resistance prevents a high current flowing, so the bulb does not fire when inserted. The condenser remains charged up to the full voltage of the battery. When the camera flash contacts close, the condenser discharges abruptly through the bulb, firing it.

The firing of the bulb does not

to hold the battery—a 22½ V 'deaf aid' type. These slips are bolted to the strip. If the gun held three cells, it will be possible to use a longer strip and fix a third bracket at the negative end of the condenser. But with the small two-cell guns, space is lacking for this. The negative

Continued on page 300

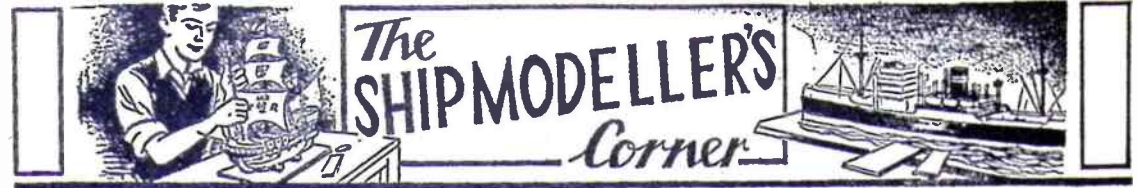

NAUTICAL AND SHIPBUILDING TERMS

By 'Whipstaff'

FOLLOWING publication of some of my articles, it has frequently happened that readers have inquired the meaning of some of the terms used. To help them, we are presenting a selection of such terms, together with their meanings and usage.

Here are some old nautical terms, many of which are still in use.

Acorn: A small ornamental piece of wood, fixed on the masthead. Its purpose is to hold the wind vane securely in position.

Back Stays: Ropes from the mastheads to the sides of the ship (aft of the mast) to hold the masts against the pull of the sails.

Balcony or Stern Walk: The projecting gallery for the use of officers, at the stern of old-time ships.

Bands: Strips of canvas sewn across the sails to strengthen them.

Beak-head: Platform in the fore-part of the ship.

Binnacle: Case containing compass and navigating instruments.

Bits: Timber posts and frames for the securing of cables and ropes.

Blocks: Pulleys used with ropes on board ship.

Beams: Strong, thick pieces of timber, stretching across the ship from side to side. They support the deck and retain the sides at their proper distance. See *Knees*.

Beds: For cannon. Pieces of wood having a stool at one end to support the rear axle-trees.

Bees: Pieces of elm bolted to the upper end of the bowsprit.

Belaying Pins: First of turned wood (ash) and later of iron. They are 16 ins. long and 1 1/4 ins. in diameter at the upper end. For 3/7th of the upper end they are turned to form a handle. The iron ones were made in various sizes, and used to belay ropes to the pin rails.

Bibbs: Brackets of elm, bolted to the hounds of the masts to support the trestle-trees.

Bollards: Mooring posts usually in pairs on deck or on the quay-side.

Capping: The moulding on top of a rail or bulwark.

Cat-heads: Stout timbers projecting horizontally on each side of the bow, usually at an angle of 45 degrees to the centre line of the ship, and used to secure the anchors.

Chain-plates: Plates bolted to the ship's sides and connected by chains and dead-eyes to the shrouds.

Clew: The lower corners of square sails. In other sails it is the lower free corner.

Clew Lines: Ropes from the clews to haul the square sails up to the yard.

Crutch: Forked end of a boom. It rests on the mast.

Cheeks: Knee pieces of timber, fastened to the ship's bow and to the knee of the head.

Cheeks: Of a block. The two sides forming the shell.

Cheeks: Of a mast. The faces, or projecting parts, on either side of the mast to support the trestle-trees.

Dead-eye: The wooden blocks at the foot of the shrouds. The true dead-eye has three holes.

Earrings: Ropes used for securing the upper corners of sails to their yards.

Freeboard: The part of the hull above the waterline.

Falling-home or Tumble-home: This term was used by shipwrights to denote the inward and upward fall of the ship's sides away from the perpendicular.

Gaff: A similar spar to a boom, but fixed at the top of a fore-and-aft sail.

Gammoning: This is applied to the ropes used to bind the inner quarter of the bowsprit and hold it down securely.

Continued overleaf

Continued from page 290

Portable Wireless

terminal of the tuning condenser, as shown. Twenty-two turns of the wire are then wound tightly on the frame, each turn being separated from its neighbour by the diameter of the wire, which is finished off at '2'. This point goes to the moving plates tag of the tuning condenser.

A space of about 1/4 in. is left, and some 32 S.W.G. wire anchored at '3', this point going to the fixed plates of the reaction condenser. Ten turns are wound on, in the same direction as the twenty-two-turn winding, and the wire taken on round to '4', where it is connected to the detector anode.

The wooden frame may be varnished before winding, but it should not be varnished or painted after winding. A strip of stout brown paper, 2 ins. wide and about 28 ins. long, can be wound

completely round the frame, on top of the windings, to prevent turns being moved when the whole is slid into the cabinet.

Batteries and Cabinet

The cabinet may be made from 3-ply. When the receiver is found to be in proper working order, it should be slid into the cabinet and the panel secured in place by very small screws or nails. The back of the cabinet is removable, to gain access to batteries and phones, and the general appearance of the set, with back removed, will be as in Fig. 4. The back may be hinged or fitted in place with clips.

The valves mentioned require a 1.4 V L.T. supply, and this can be obtained from a single dry cell, or several such cells wired in parallel.

With such cells, the central carbon rod (with metal cap) is positive, the zinc case being negative.

The H.T. voltage can be up to 67½ V and small 'layer' 67½ V batteries are made. This voltage is recommended if a speaker is to be used. With this in view, an external aerial really becomes necessary. It is connected to '1' on the frame. For phones, a 22½ V or 45 V H.T. battery is suitable, though volume will be reduced as the H.T. voltage is reduced.

Tuning and reaction will be found quite sharp. Reaction should build up volume until oscillation commences. If this is not possible, the reaction circuit should be checked, as proper reaction is essential for good reception. The set may be turned about to make use of the directional properties of the aerial. Care should be taken that the H.T. battery never makes contact with L.T. leads, or the valve filaments will be destroyed.

A Brooch from a Toothbrush

By P. W. Blandford

COLOURED toothbrush handles are made from a plastic which can be easily worked with a few tools, so do not discard an old toothbrush—keep it, and see what you can make from it. Here is one idea for a brooch.

Saw pieces from the handle with any fine saw. If the saw sticks, moisten it. File the strips straight. It is also possible to plane them with a small, finely set steel plane. If you use a metal vice, cover the jaws with cardboard. Round the edges slightly with fine glasspaper or emery cloth.

Polish the parts before shaping. After rubbing out scratches with very fine emery cloth, use a damp rag and some pumice powder, or one of the domestic cleaning powders. This will

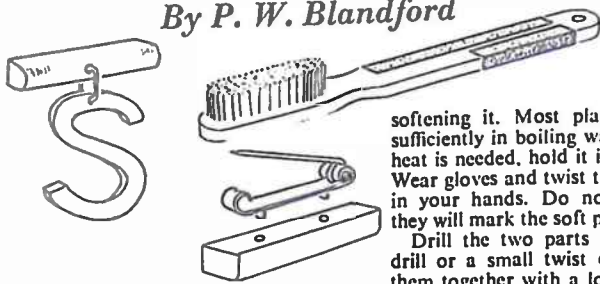

leave the surface with an eggshell finish. Bring this to a high gloss by rubbing with metal polish. Prepare the strip for bending by

softening it. Most plastics will soften sufficiently in boiling water, but if more heat is needed, hold it in front of a fire. Wear gloves and twist the strip to shape in your hands. Do not use pliers, as they will mark the soft plastic.

Drill the two parts with a fretwork drill or a small twist drill, and fasten them together with a loop of wire. Get a pin with two lugs from a craft shop. Drill undersize holes in the back of the brooch and squeeze the lugs in with the corner of a vice or with padded pliers.

Continued from previous page

Shipmodeller's Corner

Usually consists of seven or eight turns of a rope around the bowsprit and through the gammoning hole in the stem.

Grommet: A rope ring fastened to a sail as a guide when raising or lowering the sail.

Halyard: Ropes used for hauling up the sails.

Jeers: Tackles or ropes used to haul up the yards.

Knight-heads: Heavy timber supports for the inboard end of the bowsprit.

Lanyards: Small ropes used to draw the deadeyes together to tighten up the shrouds.

Parrel: Rope fitting passed around the mast and yard, to hold the yard in position against the mast.

Pillow: A block of wood on which the inner end of the bowsprit is supported.

The following list consists mainly of terms which are still in current use.

Apple Bowed: Bluff in the bow, as in the old collier brigs.

Beads or Beading: Narrow strips of wood running along the ship's side at deck level and bulwark level.

Beam: The broadest part of the ship.

Bilge: The lowermost part of the ship; that which curves up from the keel.

Bobstay: Stout rope or chain from the bowsprit to the stem at waterline level.

Bolsters: Cushions to prevent the stays chafing the mast.

Brace: Rope used for squaring the yard.

Bulkhead: Partition dividing one part

of the interior of the ship from another.

Boom: Spar at foot of sail to extend its wind area.

Companionway: Staircase from the deck to the interior of the ship.

Carlings: Short pieces of timber between the deck beams, to give added strength.

Carvel Built: This term denotes that the hull planks are butted together flush, leaving the hull with a smooth outer surface.

Cleats: Pieces of wood with small arms used for securing ropes.

Clincher Built: A hull with the lower edge of each plank laid over the top edge of the plank below is clincher built.

Fair-lead: A claw of metal through which a sheet, hawser or other rope is passed to avoid or lessen chafing.

Fashion or Quarter Piece: A small piece of timber fitted on to the edge of a ship where the transom joins the bulwark.

Fore-peak: Hatchway in the bow of the ship.

Hatch Coaming: The border of a hatch.

Hawse Holes: Holes in bow through which the anchor cable passes.

Jib-boom: Light spar fixed on the bowsprit to add length.

Lubber's Hole: A square hole in the platform of the lower masts so called because the inexperienced sailor would reach the platform through this opening. The sailor's way was to go up over the futtock shrouds.

L.O.A.: Length overall.

L.W.L.: Load water-line.

Pintles: Vertical pins on rudder post to carry the rudder.

Poop: Highest deck at rear (or aft) of ship.

Reefs: Horizontal areas of the lower parts of sails. They can be bunched together in rough weather, to lessen the sail area.

Robins: Small rope lengths with a loop at one end, used to secure the sail to the yard.

Scroll Board: A false transom, decorated with ship's name and port of registration.

Scuttle: Door or lid to give access to the ship.

Sheer: The curve of the ship from bow to stern, the degree making for the beauty of appearance when looking at a ship broadside on.

Sheet: A rope used to control and trim the sail.

Skids: Shaped pieces of timber used to support the ship's boats.

Stanchion: Small posts used for various purposes, such as supports for lashing ropes, supporting sails, etc.

Taffrail: The extreme top of the stern.

Topsides: The portion of the ship above the waterline.

Tricks: The wood cap on the top of the mast or flagstaff through which the signal halyard is rove.

Wales: Stout timbers along the ship's sides to act as buffers and also strengthen the hull. Usually they are not separate pieces added on the outside of the hull, as in a model. They are usually built in by using a plank several inches thicker at that part when planking the hull.

Water-line: The line up to which the hull of a ship is submerged.

Wooding: Rope bindings around the mast for strengthening purposes.

FLY WHIP-CONTROL FOR FUN

By R. H. Warring

YOU can knock up a tough whip-control model in less than half an hour from pieces found in the scrap box. Constructed of hardwoods throughout, it will be difficult to damage, and can be flown in restricted spaces or in winds which would ground most normal models.

Cut Wings from Ply

A wing span of about 10ins. is best, with a chord approximately 2ins. The tail should be about one-quarter of the wing area. Cut both wings and tail parts from ply. The fuselage is a 12ins. length of hardwood, tapered towards the tail. Cement and screw the wings and tail in place and cement on the fin. No dihedral is needed on the wing.

The attachment point for the line is a hole bored near one wing tip, as shown. Use stout towline or fishing line and tie the other end securely to the tip of a long bamboo pole. If you have an old fishing rod, this will be better still.

Fit a screw to the nose and round this screw mould the ballast weight of plasticine. The completed model should balance on the leading edge of the wing.

Simple Manœuvres

For a start, use a relatively short length of line—say, 8ft. to 10ft. As you get more proficient at 'whipping' the model round, you can increase line length to 20ft. or more and control the model through various simple manoeuvres. To launch with a long line, double up the line and hold alongside the pole. Pay off bit by bit as the model is flying until all the line length is released.

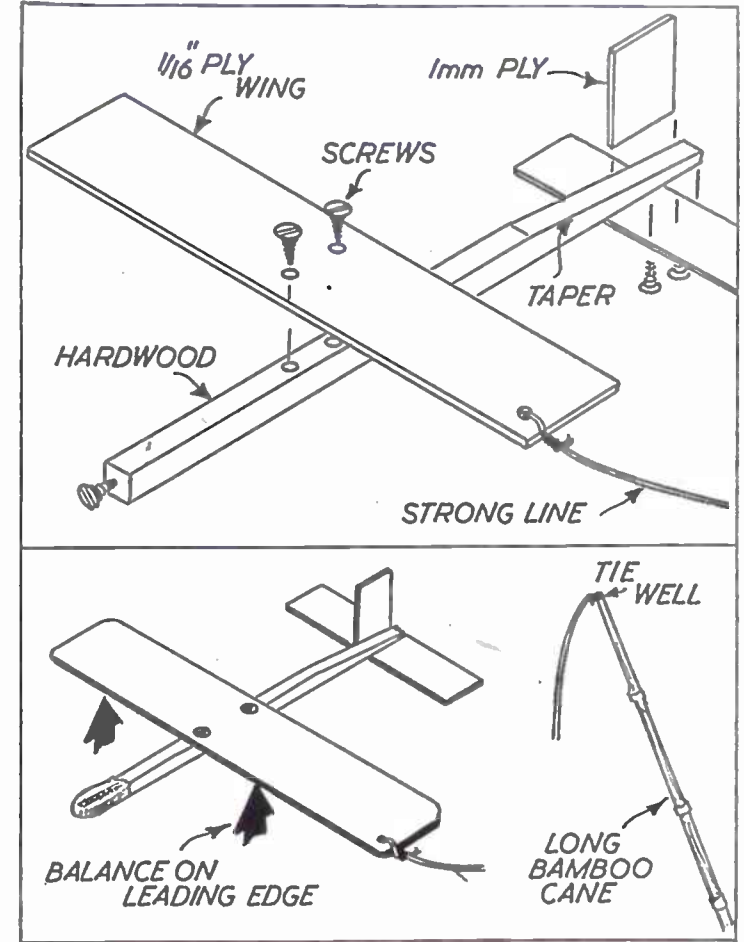

How to Renovate a Shabby Suitcase

TO cover the case first cut a piece of cloth large enough to cover the bottom and sides right up to the level of the lid. Casement, hessian or canvas is the best to use. Any desired colour can, of course, be selected, but the renovation will look best, when completed, in either brown, navy blue or dark green.

Fit the material closely by pinning right angle tucks at each of the corners,

then stitch these firmly and cut off the surplus material.

Cut the edge a little lower in the front to clear the locks and handle. Then cut a similar cover for the top, allowing enough material at the back for a seam joining the two sides.

Narrow Binding

After sewing this join, fold in single turns and bind all round with a narrow

binding. Or, two pieces of material can be cut in larger all round than the bottom and lid of the case. These can be piped to straight strips, coming from the back and passing round the sides and the top, with bound slits to let the locks and the handle through.

Two matching belts to make good straps will complete the renovation and your case will again be fit for a good deal more service. (E.M.B.)

HOBBIES PICTORIAL GUIDE
TO MAKING A

Model MOTOR LORRY

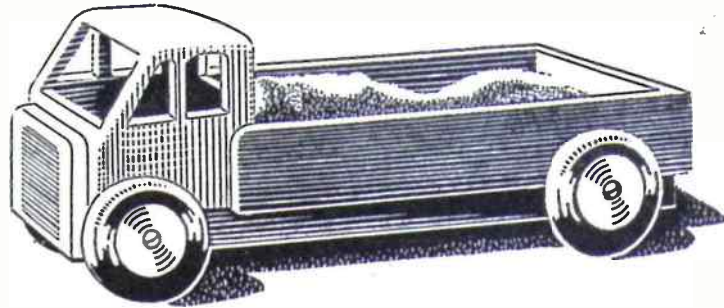

NOTE: DISC C IS GLUED TO
BACK OF FRONT WHEELS

WHEELS CAN BE ROUNDED
AND THE TYRES PAINTED ON

1/4IN. WOOD IS
USED THROUGHOUT

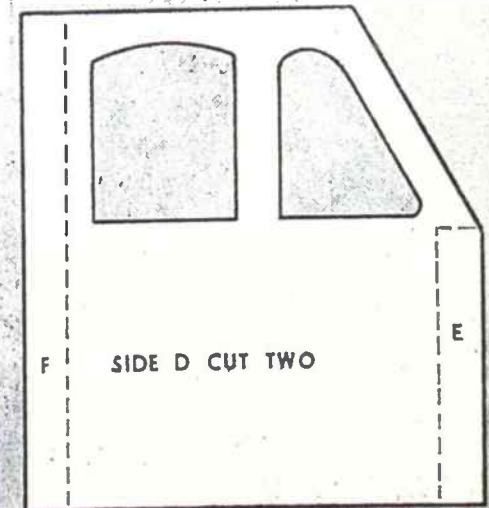
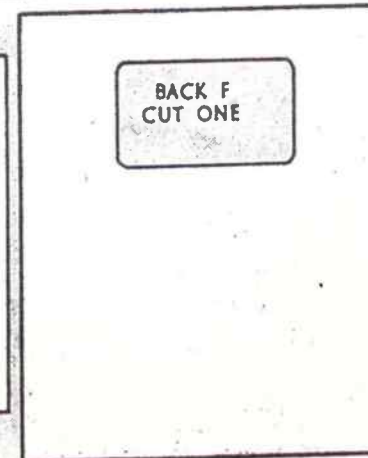
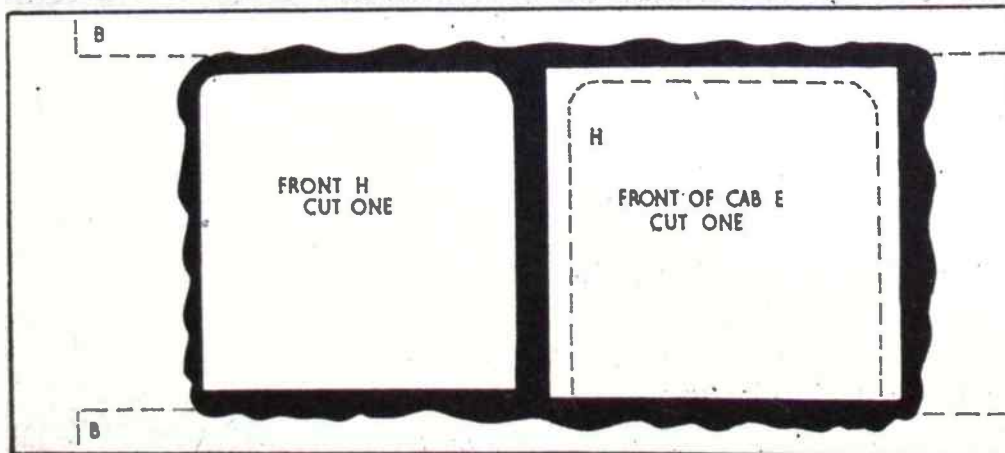
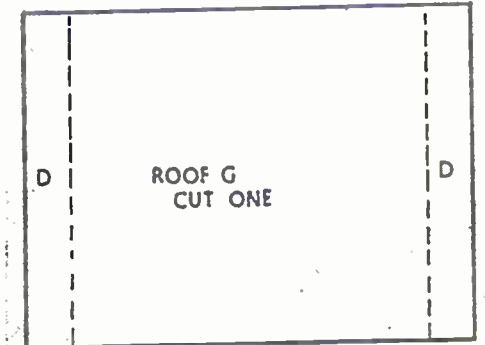
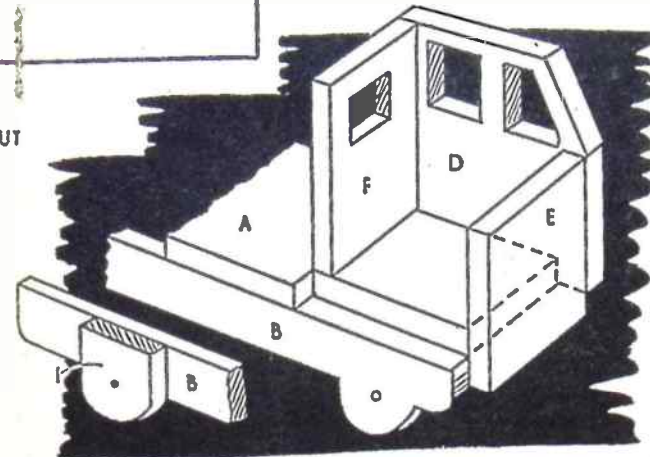
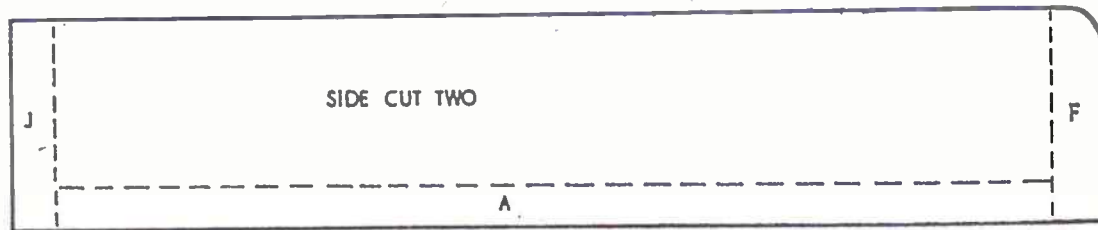
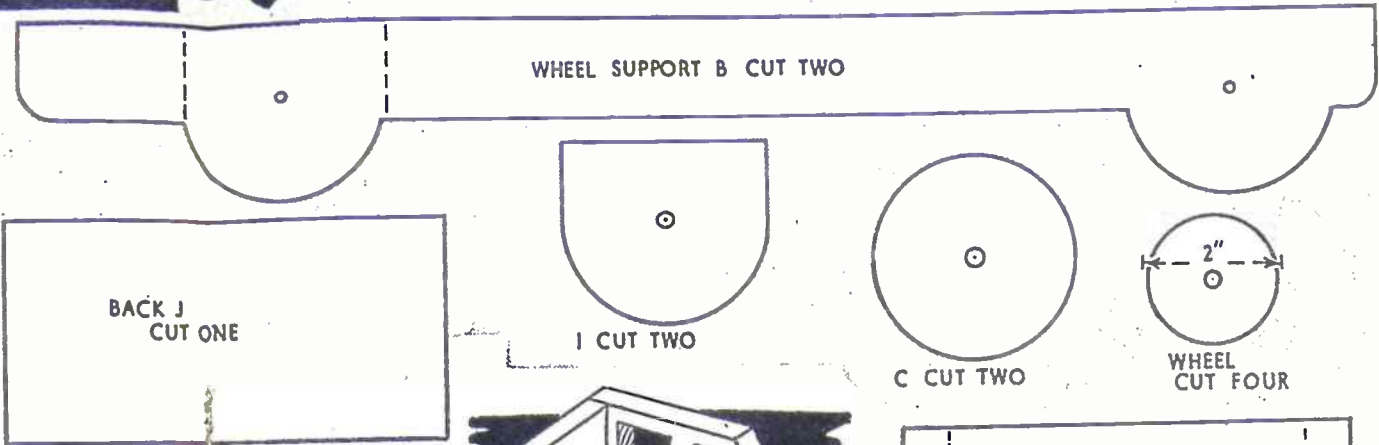

A Pin-Vice is a Useful Tool

THE pin-vice, or vise as it used to be written, is an extremely useful tool for the model maker or anyone engaged in small engineering work. It is essentially a watch and clockmaker's tool and for instrument making it is constantly in demand.

As its name implies it is a vice for holding small articles—pins, arbors and such-like. Round taper pins for instance are extensively used in all kinds of instruments and it is very easy to file these to shape with a pin-vice.

For working on, or shaping, small or awkward articles, a pin-vice is really indispensable and is much more convenient besides being less cumbersome than the ordinary bench-type vice.

It is quite easy to make a pin-vice and the person who does much small work will, no doubt, want to possess several different sizes and with jaws of various patterns.

Material Required

Many different kinds of metal may be used to make the tool, including brass, copper, aluminium and steel. For most general purposes hard brass will be found the easiest to work, and if used with care will withstand a considerable amount of hard wear.

Steel, however, is the ideal metal and will be found more difficult to work, but if you do not mind spending more time and care on the job, the result will be a tool to be proud of and will last a very long time. Start by making a small brass one first, and then you can try a piece of mild steel.

The size of the tool will depend on the type of work to be done and you must determine this for yourself. A very useful vice can be made from a strip of hard springy brass about 5ins. long and 3/16 in. wide, and this is shown in Fig. 1.

Carefully bend it to shape, leaving about 3/16 in. in the centre where the handle is attached. It is a good idea to drill the hole and rivet on the handle before bending the strip to the required shape. Make the handle from a 4ins. length of brass or iron rod about 3/16 in. to 1/4 in. in diameter. File a shoulder on the end as shown at (A) in Fig. 1, and rivet it tightly on to the strip.

Now it can be bent to shape, and the two holes drilled about half-way along for the adjusting screw, which is an ordinary cheese or round-headed screw, size about 4 B.A. or 3/16 in. Whitworth having a wing-nut.

Unless the screw has been threaded in the first part of the vice it will probably turn when the wing-nut is moved, and

it is a good idea to solder a piece of wire so that it rests in the screw slot as shown at (B) in Fig. 1. The screw itself could be soldered in position or even a thin nut screwed on, but it is better to let the screw have a little play and not be fixed rigid.

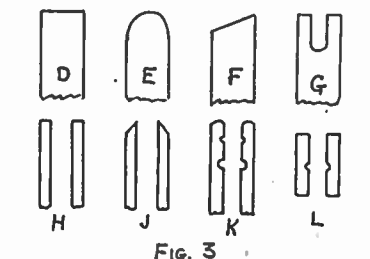
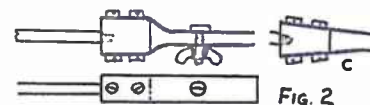

When more substantial jaws are needed for the vice, then the model shown in Fig. 2 should be made. Instead of using one strip of sheet metal, we have two pieces which are

screwed to a square block with the handle attached to one end: It is, therefore, possible to use much thicker metal and steel can be used, which would have been difficult to bend at right angles as in Fig. 1.

Tapering the block as shown at (C) Fig. 2 might be an advantage in some cases, especially when using thick metal for the jaws, as it would not have to be bent so much.

The shape of the jaws can vary quite a lot, and this will depend on the type of work you are doing. Several examples are shown in Fig. 3, and there are many more which you can devise to meet some special requirement.

Flat, round and skew ends as (D) to (F) are most useful, while various widths and lengths of the slot in (G) will hold special work in an efficient manner. The tips of the jaws also come in for a variety of shapes, as at (H) and (J), and the grooves in (K) will hold pins and similar objects quite securely.

A groove on the end of the jaws (L) can be used for filing up taper pins and this will be found extremely useful.

Many other materials besides metal can be used and even thin wood can be tried. For some jobs it is advisable to face the jaws with a protective material, such as rubber or leather, and this can be easily cemented in position.

A wooden handle may be more convenient to hold and this can be drilled and slipped over the metal rod if desired. (A.F.T.)

Making Inlaid Table Mats

YOU will enjoy making these attractive inlaid table mats from wood. A good polishing with wax brings out the colour and grain, giving a colourful effect.

The usual procedure with fretsaw inlay is followed and we suggest using Hobbies No. 1 Inlay Panels, price 3/6 per set of four. These panels, of contrasting woods, are 1/4 in. thick, measuring 10 3/4 ins. by 7 1/4 ins.

Trace the pattern and transfer to the piece of whitewood. Pin the four panels together round the margin and drill a small hole in one corner. Thread the fretsaw through and cut out all the pieces. Now sort out the pieces and stick them to paper as shown.

The letters indicate the shade of the wood. A light, B medium light, C dark, D medium dark. Having made two to this pattern you proceed to make up

Full-size patterns are on page 303

others with the pieces left over, but in different colours. This will give you four identical pairs of mats.

Having stuck the pieces to paper they are now glued face downwards on to bases 3/4 in. thick and of the same measurements. Place under weights until dry.

Finish off by removing the paper with glasspaper until the surface of the wood is perfectly smooth. Wax polish is then applied until a good result is obtained. (M.P.)



P.V.A. (Polyvinyl Acetate) glue, so popular in the U.S.A. for both industrial and home gluing, is now available here — and CASCO P.V.A. Glue really is amazing. So clean and white, it hardly looks like glue, it doesn't smell like glue, it isn't sticky like glue . . . yet CASCO P.V.A. will glue a whole variety of materials (wood, paper, leather, cloth, etc.) and the bond has tremendous strength. No heat whatsoever is required; it spreads smoothly, washes easily from brushes or fingers, is quick setting, non-staining and when set is almost transparent. CASCO P.V.A. Glue has been tested by the Good Housekeeping Institute and awarded their Seal of Guarantee — so why not get a jar and test it for yourself?

Obtainable from Ironmongers, Hardware Stores, etc. Price 2/- per jar (approx. 2-oz.)

CASCO P.V.A. GLUE

Manufactured by: LEICESTER, LOVELL & CO. LTD. · NORTH BADDESLEY · SOUTHAMPTON
Main Distributors: Charles Cleeve & Co. Ltd. · 45 Great Peter Street · London S.W.1

MISCELLANEOUS ADVERTISEMENTS

KUKLOS ANNUAL. Indispensable cyclist's handbook. Tours, resthouses, money-saving hints, 2/10, post free. — Burrow, Publishers, 2 Imperial House, Cheltenham.

NEW AND USED Correspondence Courses for sale. List. — Courses, 28 Dean Road, London, N.W.2.

STAMPS FREE — Empire Packet including Pictorials and Victorians with approvals. — Robert J. Peck, 7A Kemp Road, Bournemouth.

'PAINTSPRAYING' HANDBOOK (1954 Ed.). Covers Car, Industrial & Flock Spraying. 3/6, post free, including catalogue of our Cellulose and Synthetic Paints and all Allied Sundries and Plant Hire. — Leonard Brooks Ltd., 81 Oak Road, Harold Wood, Essex.

PLYWOOD — HARDBOARD — at amazing low prices. Send S.A.E. for samples and prices to — N. Gerver, 10 Mare Street, Hackney, London, E.8.

STOP SMOKING!! Quick guaranteed remedy. Free Testing Sample! — Triumph Remedies (H.2), Exeter.

SWISS MUSICAL Mechanisms for cigarette boxes, etc., 18/- post free. S.A.E. for illustration and list of tunes available. — Dept. HW, Metwood Accessories, Church St., Wolverton, Bucks. (Trade supplied.)

RUBBER MOULDS for plaster casting, 3 sample 3/11. Trade supplied. S.A.E. — Burrell Supplies, 13 Burrell Street, Hull.

SEA SHELLS for all types of shellcraft. Large lot, post free, to — Sea Shell Supplies, Braye Rd., Alderney, C.I.

10/6! CRYSTAL Radio Kit. Send 5d. for building instructions. — Blanchard's (H6), 13 Gainsford Gardens, Manchester, 10.

A GRAND BOOK FOR ALL THE FAMILY. The "Kaylee Year Book of Bright Ideas". A really helpful guide to home planning, decoration, Hobbies, toys, etc. Showing famous Kaylee Transfers in brilliant colours, and most effective uses. From "Hobbies" stockists 1/- or direct. **KAYLEE TRANSFERS** Postage 3d. LTD., (HW) Long Eaton Nottingham.

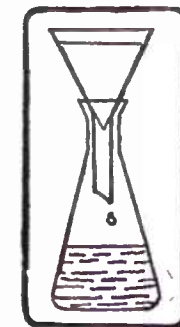

A.D.P. CHEMICALS AND APPARATUS
WE CAN OFFER A WIDE SELECTION OF EQUIPMENT SUITABLE FOR BEGINNERS AND STUDENTS. SEND STAMP FOR LISTS TO: — 14, (D/H) SURREY ROAD, BARKING, ESSEX.

BUILD your own T/V and learn about its operation, maintenance and servicing. Qualified engineer-tutor available whilst you are learning and building. Free Brochure from — E.M.I. Institutes, Dept. HW.58, London, W.4. (Associated with H.M.V.)

100 DIFFERENT stamps free. 4d. upwards approvals. — Bush, 53 Newlyn Way, Parkstone, Dorset.

* GREAT CAMPING OFFER *

RIDGE TENT SENT FOR 4/-
BRAND NEW de luxe Para. Tent. All colours. Complete. Ideal Cyclists, Campers. Length 7 ft. 3 in., sleeping base x 4 ft. 6 in. wide x 3 ft. 6 in. high x 12 in. walls, all approx. Weight 3 1/2 lb. £2 15s. or 4/- deposit and 6/- monthly. With fly-sheet £4 2s. 6d. or 10/- deposit and 9/9 monthly. Both carr. 1/6. Lists of other models. Terms. Send now for this wonderful offer.

TELESCOPE QUICK ACTION! See this telescope in action. Up in a flash!
2/6 POST ETC. WITH INSET MAGNETIC COMPASS

with special single draw that cuts down focusing time. You have the object you wish to view at close quarters, in a split second. Boy Scouts, Hikers, Cyclists, etc., like this useful telescope because let into the body there is an accurate compass which gives you bearing of view. The price of this absolutely super bumper bargain 2/6 only plus 6d. post, etc. NO MORE TO PAY. Black grained body with nickel finish. FREE LISTS WATCHES, BINOCULARS, TENTS, TARPULINS, MARQUEES, TERMS. Open Sat. 1 p.m. Wed. Headquarter & General Supplies Ltd. (Dept. HOBW/38), 196/200 Coldharbour Lane, Loughboro Junction, London, S.E.5

FOR SALE—Hobbies' Gem treadle fret-machine, in good condition; £3. "Selecta" portable gramophone, £4/10/-; Meccano set and other parts (approx. 250 pieces including two motors); £2.—Stone, 27 Whitehill Lane, Gravesend, Kent. Phone: Gravesend 5917.



REPLIES OF INTEREST

Model Village

I AM contemplating constructing a model village to be erected out of doors. I have been told that hardboard is a suitable material to use as long as the cut ends are well sealed with some substance, such as Bostic C. Will this be satisfactory? (J.B.—Withington).

FOR outdoor models, made from hardboard, Bostic C would serve to seal the edges, but a thick mix of Casco glue would be cheaper, we think, if much sealing becomes necessary. We also suggest you size the wood before painting with a standard mix of the glue, diluted with three times its bulk of water. When dry, paint the model with Valspar lacquer to protect against the weather.

Creaking Stairs

IS there any cure for creaking stairs? (F.S.—Bristol).

THE creaking of stairs is generally caused through shrinkage of the wood and consequent looseness inside grooves, and possibly between treads and risers. It can usually be cured by nailing or gluing strips of wood in the angles at the rear of the stairs, between treads and sides, and treads and risers. Also a few nails driven in the treads to fasten them firmly to the risers underneath will help.

Continued from page 292

Converting to Capacitor Flash

metal end of the condenser thus bears directly on the centre pip contact of the lampholder. In Fig. 2 a stout wire also passes from this end of the condenser and is pinched through two small holes in the base strip, to hold the condenser in place.

A lead passes from the positive end of the condenser to the battery clip, as shown. When the unit is inserted in the gun and the bottom screwed on, this clip is also pressed upon by the spring in the bottom of the case, normally used to hold the dry cells in place. The 5K (5,000 ohm) resistor is wired between the negative battery clip and a spring strip which bears against the metal body of the gun, inside. Comparing Figs. 1 and 2 will make this clear. The metal body of the gun also completes the circuit to the bulb holder. As

the positive end of the condenser must not touch the negative battery clip, a piece of insulating material may be placed between these points, if necessary.

When the unit is inserted in the gun, the negative end of the condenser must touch the centre contact of the bulb holder. The spring strip must touch the metal case, and the positive bracket the bottom spring of the case, as explained. No other parts should touch each other, or the case. If danger of this kind arises, the whole unit may be inserted in a cardboard tube, with the spring strip projecting.

For Other Guns

If the gun uses a flat 4½ V type battery, the unit will have to be made up accordingly, the condenser being at the side of the battery. With bakelite guns,

but still reasonably flat, you could cover it with Waverite. This is similar to Formica, but already stuck to a thin plywood backing. If you want the plastic to conform to the shape of the draining board, use thin celluloid, say, rather less than ¼ in. thick. Soak this in boiling water until it becomes absolutely limp. Fairly quickly drape it over the board and leave it to set. If possible, turn the edges under the board, then there will be no need for an adhesive. If you have to stick the celluloid, use Durofix or similar adhesive, such as balsa cement.

Query About Polish

PLEASE inform me whether there is any difference between french polish and white garnet polish. I have quite a lot of french polishing to do, and would appreciate it if you would instruct me as to quantity of shellac and meths. to mix up in order to make my own polish. (C.B.—Durham).

THE difference between french polish and white garnet polish lies in the shellac used mostly, the ordinary button shellac being for french polish and bleached shellac for the white variety. The latter is necessary where light wood is to be treated and the beauty of the grain brought out in the process. For hard woods, 4ozs. of shellac are dissolved in methylated spirits; for soft woods, 6ozs.

Plastic for Draining Board

I HAVE a mahogany sink draining board and wish to cover it with plastic (white) to match up with glazed tiles. Please advise me what to do, and where to obtain the necessary mixtures, etc. (G.M.—Malta).

THE simplest treatment for the draining board is to give it two coats of a heat and water resisting enamel, such as Valspar. If the surface of the board is flat, you could stick on a sheet of Formica. If the surface is worn

Suppressor for Electric Motor

WHAT capacity of condensers should I use to suppress my electric motors against television and radio? I use ½ h.p. Brook's Cub on my bench saw, and ¼ h.p. Brook's Cub on my lathe; the latter is wired for reversal. Can you also tell me how to connect such condensers? (W.O.—Shiremoor).

FOR the purpose mentioned, condensers of about .05 mfd. are usually employed. One from each mains lead to earth may be sufficient. In some cases, further condensers may need wiring from the motor brushes to the motor frame. The latter should be earthed. The condenser leads should be short and direct. High-voltage working condensers are necessary—preferably 750 V working rating, though 500 V condensers may be employed. Interference may be increased by excessive sparking at the brushes, due to dirty or worn commutator or brushes, or brushes sticking in their holders. This should be investigated if the motors have seen much use.

it will be necessary to add a short flexible lead to complete the circuit to the end of the 5K resistor.

The actual layout of parts is of no importance, provided matters are so arranged that the circuit in Fig. 1 is followed. With other guns, this circuit should, therefore, be used.

The gun is operated exactly as with the 3 to 6 V type, except that the bulb should be inserted at least ten seconds before making the shot, to give time for the condenser to charge. An unused bulb should never be left in the gun, or it may be fired when the synchro-flash contacts are connected up. It is essential both condenser and battery be wired in the correct polarity, as in Fig. 1.

To test the circuit without expending a bulb, short the spring strip in Fig. 2 to the negative end of the condenser for a few seconds, to charge it. Then short positive and negative ends of the condenser, when a spark should be seen as contact is made. (F.G.R.)

Picture Marquetry



EACH
INN SIGN
SET CONTAINS
MATERIAL
FOR TWO
COMPLETE
SIGNS

Size of each sign
Approx. 4½" x 4",
including frame



Here is another subject in the popular Modelcraft series of Picture Marquetry Kits. The designs will form the basis of an interesting collection and provide excellent home decorations.

No. 1 Set "King's Head" and "Red Lion"
No. 2 Set "Cross Keys" and "White Hart"
No. 3 Set "Rose & Crown" and "Cock & Bottle"
Price of each set (including Purchase Tax) 7/-
Postage and packing 6d. extra

From all Model, Hobby and Handicraft shops or send S.A.E. for full details to—

MODEL CRAFT LTD

77(F) GROSVENOR ROAD, LONDON, S.W.1



BRANCHES: LONDON
78a New Oxford St., W.C.1
(Phone MUSeum 2975)
87 Old Broad Street, E.C.2
(LONDON Wall 4375)
81 Streatham Hill, S.W.2
(TULse Hill 8796)

GLASGOW: 324 Argyle Street
(Phone CENTral 5042)

Head Office & Factories—HOBBIES LTD., DEREHAM, NORFOLK

MANCHESTER
10 Piccadilly
(Phone CENTral 1787)
BIRMINGHAM
14 Bull Ring
SHEFFIELD
4 St. Paul's Parade
(Phone 24071)

LEEDS
10 Queen Victoria Street
(Phone 28639)

HULL
10 Paragon Square
(Phone 32959)

SOUTHAMPTON
25 Bernard Street
BRISTOL

30 Narrow Wine Street
(Phone 23744)

FLEXIMOULD

For PLASTER CASTING

The all-family hobby
WALL PLAQUES, GIFTS and
ORNAMENTS, etc.

No special equipment needed.
Adds pounds to your income.

'FLEXIMOULD'

Illustrated Leaflet from

DOHM Ltd.

Dept. H, 167 VICTORIA ST., LONDON, S.W.1



ELECTRIC PAINT STRIPPER

4/-
DEPOSIT
3 monthly payments of 10/-
Cash price 30/-
Old paint peels off like magic with the Horvell electric paint stripper. Easy, even strokes, remove paints, varnish, etc. Four-sided blade for angles and corners. A.C./O.C. mains-state voltage.
P.&P. 1/- Send for leaflet

ELECTRIC PAINT SPRAYER

for 5/- deposit
Cash 75/- Or 5/- deposit and 6 monthly payments of 13/6
Paint easily, evenly, twice as fast with the Burgess Electric Sprayer. Sprays paint, varnish, etc. Complete with sturdy glass container, flex, nozzles for ceiling spraying and extra nozzle discs for different liquids. A.C. mains only - state voltage. Fully guaranteed. Illustrated leaflet free.

DRILL FASTER

with a Black & Decker ELECTRIC DRILL 12!
DEPOSIT
A first-class tool, the Black & Decker U-1 Portable Electric Drill saves hours on home and workshop jobs. Drills wood, steel, brick, etc. Steel capacity up to 1". Also drives sanding discs, polisher pads, etc. Weighs 3½lb. Fully suppressed. £5. 19. 6. or 12/- deposit and 6 monthly payments of £1. Sent on receipt of the deposit. A.C./O.C. motor, voltages 110 to 250. State voltage required.

5 inch SAW ATTACHMENT ONLY

£3-5-0
Or 5/- down and 6 monthly payments of 11/-
Here's a brand-new inexpensive attachment that changes the Black & Decker Orill into a portable electric saw. Cuts without guide lines from 0" to 1½" depth. Bevels up to 45°. Fitted with telescopic safety guard. Invaluable in home and workshop.

Send for complete list of Tools
BARGAIN DISTRIBUTORS
(Dept. 124), 5 Silver Street, Luton

DECRA-LED

Converts plain windows into lovely Leaded Lights

Lead your own windows first - EARN MONEY doing others afterwards.

No glass to cut or take out - no capital outlay - no previous experience. Begin NOW to supply the demand for Decra-Led Windows

The NEW Trial Kit to do approx. 3 panes includes 7 suggested designs and full instructions, 10/- complete.

Obtainable from Handicraft & Woodwork Supply Stores, Ironmongers & Decorators

If unobtainable locally, direct from
T. BROWN & CO. LTD., Dept 1, 50 Wood St.
ASHTON-UNDER-LYNE, LANCASHIRE

HARDHITTING ACCURATE

Webley AIR PISTOLS

AIR RIFLES · ACCESSORIES

Write for Catalogue
WEBLEY & SCOTT Ltd., 166 WEAMAN ST., BIRMINGHAM, ENGLAND

KITS for OLD TIME SHIPS

Hobbies range of Ship Models includes Elizabeth Jonas, Cutty Sark, Victory, Mayflower, etc. Complete kits of wood, sail material, guns, pulleys, cord, etc. with full-size patterns of parts and planned wood ready to cut out, shape and construct. A fascinating pastime. Kits for models 7ins. long and upwards.

Ask for free illustrated lists at Hobbies Branches or from Hobbies Limited, Dept. 89, Dereham, Norfolk.

NEW! EXPERIMENTAL KITS

LEARN THE PRACTICAL WAY

Here is home study of the most effective kind under expert tutors. There is no better way of studying for an examination for a career in industry or starting a new hobby. Our Practical courses comprise the most modern methods of postal tuition, combined with a practical kit of parts (which is supplied upon enrolment and remains your property).

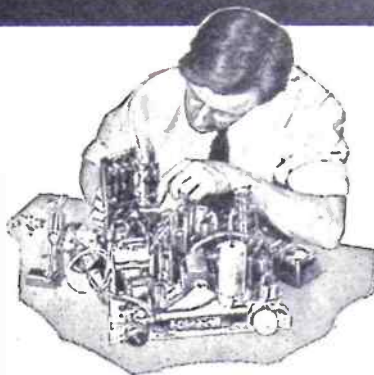

COURSES FROM 15/- A MONTH

COURSES WITH KITS INCLUDE: Radio, Television, Mechanics, Electricity, Chemistry, Photography, Carpentry; also Draughtsmanship, Commercial Art, Amateur S.W. Radio, Languages, etc.

EMI INSTITUTES
The only Postal College which is part of a world-wide Industrial Organisation.

POST THIS COUPON TODAY

E.M.I. INSTITUTES, Dept. 31X, Grove Park Road, London, W.4. Please send me your free book.

Subject(s) of Interest _____
NAME _____
ADDRESS _____
9/2/55 _____ IC.SI

GLUED TO LAST WITH CRAFTEX

Jig-saw puzzles stand tough handling longer when you glue them with CRAFTEX—the quick-sticking, extra strong dextrine adhesive, made for the purpose. Clean to use. The ideal mountant for all similar hobbies and handicrafts.



★ And Remember —
Croid AERO GLUE

Is recommended for use with woodworking patterns.

CROID LIMITED IMPERIAL HOUSE, KINGSWAY, LONDON, W.C.2

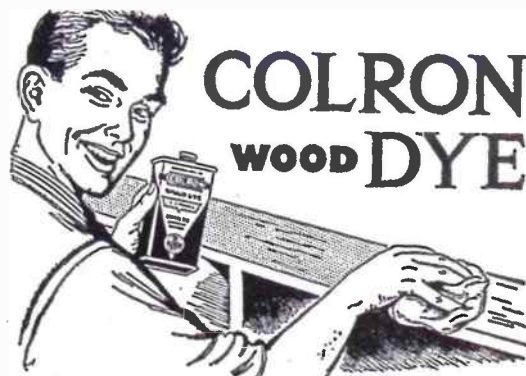

COLRON WOOD DYE

the first step to the perfect finish

Colron Wood Dye is safe, quick and simple to use. Safe, because COLRON enhances the beauty of the wood *without raising the grain*—quick, because you simply wipe on a single coat of any one of the 12 lovely shades which you can mix for any colour effect—and remember, waxing with RONUK gives you the perfect finish.

Colron is available in all sizes from 1/2-pint upwards.

From all good decorators' stockists.

Write for COLRON COLOUR GUIDE

RONUK LTD., PORTSLADE, SUSSEX. Hove 40631

SEE PAGE 298

Patterns for Inlaid Table Mats

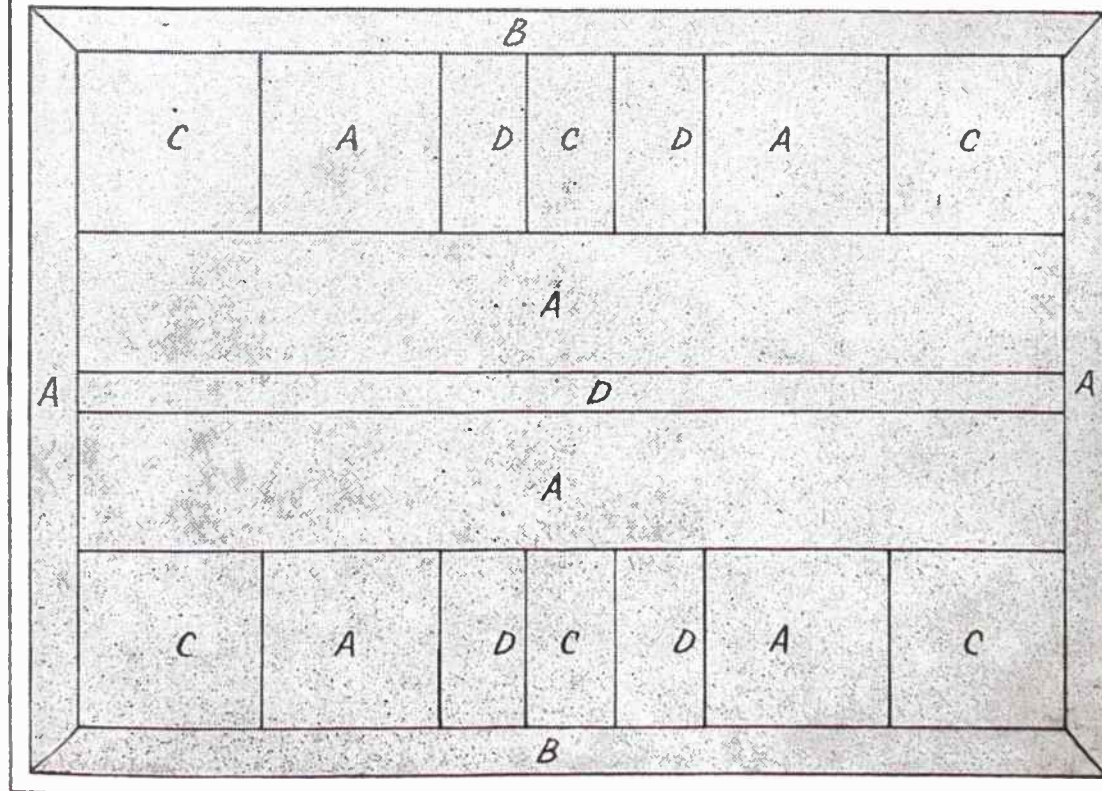
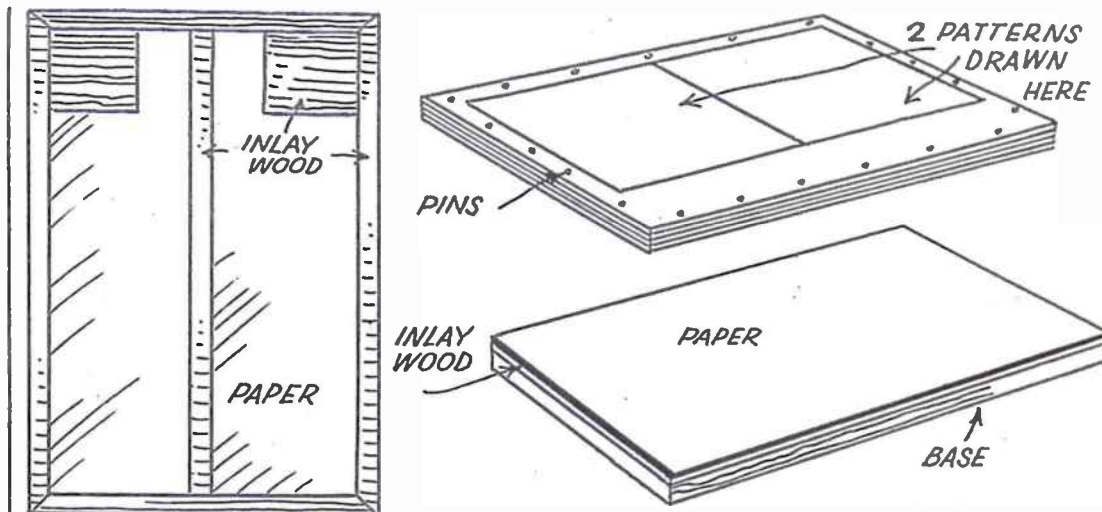

YOU MAKE THE BRICKS



TO BUILD
THE HOUSE
*this simple
way—*

Just a simple wood mould with a tape or paper strip base—and there's your home-made brickworks, ready to supply you with "Pyruma" bricks for building houses, walls, farm buildings, model railway stations, etc. Just one of the ways of modelling in Sankey's "Pyruma" plastic cement explained more fully in the Instruction Book offered below. Other and simpler ways of modelling are also described, showing how to make many useful, permanent stone-hard objects which can be painted in colour, from



Pyruma is ready for use from its airtight tin—to be modelled while plastic. It dries or bakes to stone hardness and, after treatment as instructed, can then be painted or enamelled. Pyruma is ideal for modelling Houses, Railway and Airport Buildings, Farms, Docks, Figures and for making Ashtrays, Bookends, Plaques, Dolls Furniture, Relief Maps, Animals, etc.

Sankey's, PYRUMA and TILUMA are inexpensive and obtainable in air-tight tins from Ironmongers, Art Material Dealers, Hobbies Shops, etc.

POST
THE
COUPON
TO-DAY



To: **J.H. SANKEY & SON, L^{TD}**

Estd. 1857

Dept. H.W., ILFORD, ESSEX.

Enclosed 4d. in stamps for PYRUMA MODELLING INSTRUCTION BOOK addressed to:

NAME (Block letters)

ADDRESS



Take up the best hobby in the world—PHOTOGRAPHY

It's easy to produce good results, once you know the way of it, and your snapshots will get better and better as you progress. The thrill of seeing a piece of white paper gradually built up, in the developer, and become a picture must be experienced to be believed.

THE JOHNSON JUNIOR HOME PHOTOGRAPHY PRINTING OUTFIT comprises an 8-oz. bottle of UNIVERSAL Developer, a 250-gram tin of ACID HYPO FIXING, **15/6** Two Xylonite Dishes, a Plastic Printing Frame, a packet of SEE-THRU Printing Masks, a Plastic Measure and a 2-oz. Glass Measure, together with a booklet giving full instructions.

Get one from your dealer, today.

JOHNSONS OF HENDON LIMITED

The sparkling enamel PAINT IN TUBES!

Handy, Economical



STARLON in handy, economical tubes is just right for all small or multi-coloured painting jobs; cycles, prams, etc. No wasteful 'left-overs'. Easy to apply. Quick drying. No brush marks. Brilliant lasting finish.

1/-
IN 14
LOVELY
COLOURS

Trade Enquiries
welcomed by
the makers

Starlon

PLASTIC ENAMEL PAINT

Obtainable at Handicraft shops everywhere

STARLINE, SOUTHEND-ON-SEA, ESSEX