

Hobbies

WEEKLY

FREE DESIGN
FOR A
PULL - ALONG
TOY LINER
(See Inside)

VOL. 115

NUMBER 2978

How you can make A COMPACT BOOKCASE

THE bookcase shown in the sketch on this page has been designed with a view to accommodating a large number of books in the smallest possible space and will appeal particularly to those who live in flats or in other circumstances where space is at a premium. How far this object has been achieved is left to the reader to decide, but it is of interest to note that the bookcase shown provides space for nearly two hundred books in an overall space 40ins. by 27ins. by 12ins.

Construction

As will be seen from the sketches on this page, the principle of construction involved is that of making an open framework braced with a plywood backing. This gives the required degree of rigidity without recourse to elaborate and difficult joints.

The sizes shown in the sketches and Part List are only intended as a guide and can be varied within reasonable limits either up or down to suit the reader's personal requirements.

Whatever sizes are decided on, however, one or two things must be remembered—all the work must be

IDEAL
FOR THE
MODERN HOME

planned square and true and all the joints carefully and accurately made. The joints should all be glued and screwed with the screw-heads countersunk below the surface of the work.

When it is ascertained that the units

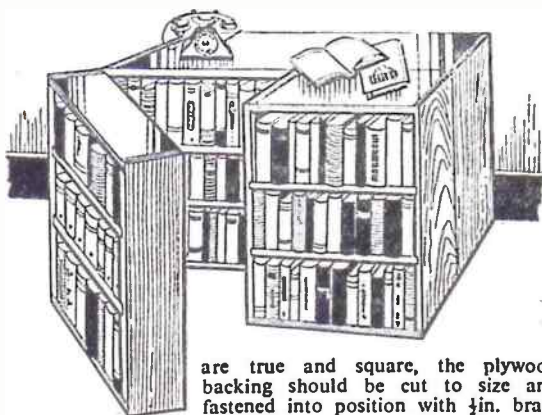

are true and square, the plywood backing should be cut to size and fastened into position with 1/4in. brass countersunk screws.

The two handles referred to in the Part List are merely rectangular blocks with a 1/4in. chamfer planed on the rear lower edge to provide a comfortable grip when opening the front units. The handles are, of course, on the sides of the units furthest from the hinges and are each secured with two good brass screws.

Fittings

Very little now remains of the constructional work proper. First, there is the fitting of the ornamental mouldings shown in the sketches and, second, the fitting of the hinges—three on each side of the rear unit. The mouldings can be sawn to size and glued and pinned into position but the fitting of the hinges is best left until the finishing process is complete.

IN THIS ISSUE

	Page
A Compact Bookcase	129
A Simple Folding Table	131
How to Make Seasonal Greetings	132
A Pull-along Toy Liner	133
Home-made Shove Ha'penny Board	134
Buffers for a Toy Railway	135
Christmas Lighting	136
An Attractive Gift	137
A Sturdy Log Rack	138
Meet 'George' the Duck	139
Keep the Home Bright this Winter	140
Some Experiments with Epsom Salt	142

All correspondence should be addressed to The Editor, Hobbies Weekly, Dereham, Norfolk.

THE MAGAZINE FOR MODELLERS,
HANDYMEN AND HOME CRAFTSMEN



All the work, except the mouldings, must be carefully smoothed with glass-paper and then given a liberal coat of wood-filler. When the wood-filler has dried, the work should be rubbed down again, this time using fine or at least worn glasspaper.

Finishing must of necessity depend to a large extent on the furniture already contained in the room which will accommodate the bookcase. If it is desired to rely on natural wood finishing, the bookcase can be given one coat or more of good stain and when this has dried the work can be either varnished or french-polished according to the skill of the maker. On the other hand, the shape of the bookcase lends itself to a more modern style of finish if such is preferred. Enamelling looks quite well if two or three undercoats are given first. Alternatively, a very pleasing finish can be achieved by finishing in stain and varnish in the main but relieving the scheme in part by enamelling the top edges of the front units in a pastel shade in the predominant colour of the room furnishing.

Last of all there is the fitting of the hinges which should be countersunk so that the units will lie flat one against the other.

The bookcase is not suitable for use on a heavily carpeted floor. (V.A.G.)

PART LIST	
REAR UNIT	
A. Top.	1 39ins. by 6ins. by 1in.
B. Shelves.	4 19ins. by 6ins. by 3/4in.
C. Bottom.	1 39ins. by 6ins. by 1in.
D. Centre.	1 26ins. by 6ins. by 1in.
E. Sides.	2 27ins. by 6ins. by 1in.
F. Back.	1 40mm. by 27mm. by 4mm.
G. Feet.	6
FRONT UNITS	
H. Top.	2 19ins. by 6ins. by 1in.
I. Shelves.	4 19ins. by 6ins. by 3/4in.
J. Bottom.	2 19ins. by 6ins. by 1in.
K. Sides.	4 27ins. by 6ins. by 1in.
L. Back.	2 27mm. by 20mm. by 4mm.
M. Handles.	2 3ins. by 1in. by 1in.
N. Feet.	8
Mouldings to choice.	

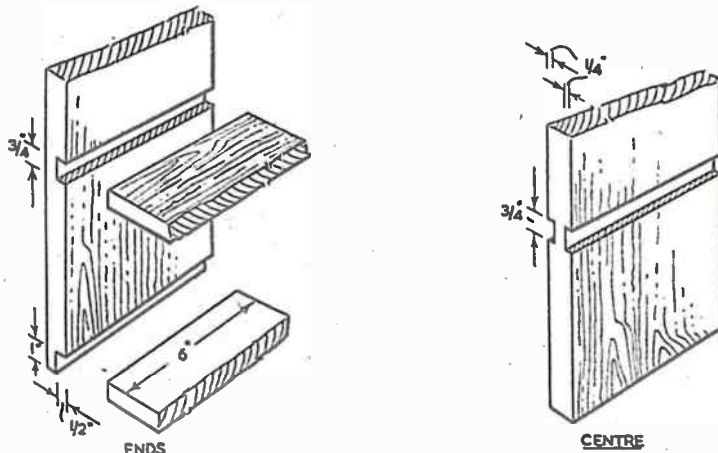
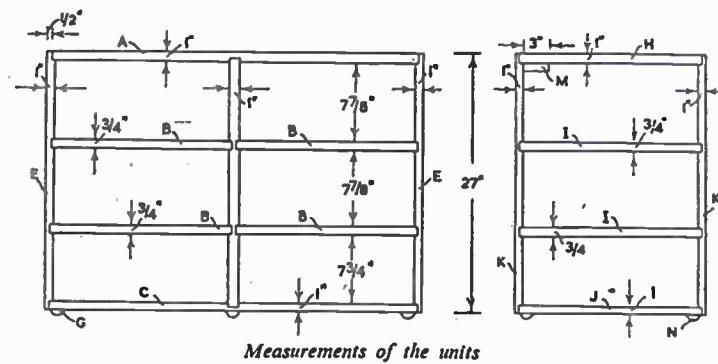
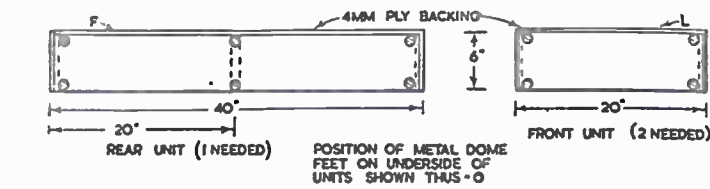

Details of the joints

A Simple Folding Table

(Continued from page 131)

quite flush as in detail Fig. 4. It will be noticed that it is necessary now to cut out a narrow strip from the top rail of each swinging leg to allow it to clear the knuckles of the hinges.

Cut six strips of the 3/4 in. wood, 1 in. wide, and glue and screw these against the end and outside edges of the leaves to lessen any chance of them warping. The side strips should be, at their inner ends, bevelled off to 45 degrees, and where they join the outside strips, be

neatly mitred. Fig. 4 shows these details. This completes the work of construction.

If any of the hardwoods have been used for making up the table readers will, of course, stain and varnish or polish as preferred. If deal, give the work an undercoat, then follow with hard gloss paint, or paint over with a flat colour, and finish with a coat of copal varnish. Colour is a matter of choice, naturally, but a rich red brown can be recommended, if a suggestion is

deemed useful. Alternatively, readers who have some knowledge of graining, would find the table an excellent subject on which to exercise their craft.

CUTTING LIST	
Centre stand, sides.	(2). 2ft. 3ins. by 6ins. by 1/2in.
Centre stand, rails.	(4). 2ft. 8ins. by 2 1/2ins. by 1/2in.
Parts (C).	(2). 8ins. by 1in. by 1in.
Swing legs, uprights.	(4). 2ft. 3ins. by 1 1/2ins. by 3/4in.
Swing legs, rails.	(4). 1ft. 1in. by 2ins. by 3/4in.
Centre top.	2ft. 9ins. by 8ins. by 1in.
Leaves.	(2). 2ft. 9ins. by 14ins. by 1in.
Edging strips.	(2). 2ft. 9ins. by 1in. by 1/2in.
Edging strips.	(4). 1ft. 2ins. by 1in. by 1/2in.
2 pairs 3in. butt hinges, 2 pairs 1 1/2in. backflaps.	

A Simple Folding Table

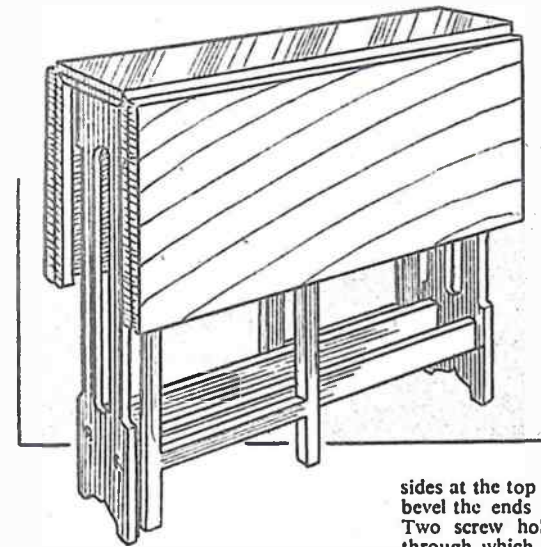

Glue the rails between the sides, and drive in 1 1/2 in. oval nails just above and below the tenons into them. A strong joint should result. Cut two pieces of 3/4 in. wood to 8 ins. long and 3/4 in. wide. With the 3/4 in. width horizontal, glue and nail these to the sides at the top as at (C) in Fig. 2, and bevel the ends of them to 45 degrees. Two screw holes are bored in them through which the screws, which fix the top in position, can afterwards be driven. For the same purpose, a piece of wood, say, 2 ins. long, is nailed between the rails as shown at (D). Be careful here to make sure that parts (C) and (D) are level on top with sides and rails, and that parts (C) extend over the sides just 3/4 in. each way.

The swinging legs which support the leaves are detailed in Fig. 3. Details of sizes of timber used are given in the cutting list, and need not be repeated here. Join the rails to the uprights with the usual mortise and tenon joints, and shoulder the tenons for the top rails as in the inset drawing. These legs are hinged to the rails of the centre stand with 1 1/2 in. backflaps as in Fig. 2, and should be so positioned, that when swung out, they will be in the middle.

The complete table top consists of a fixed centre part, and two leaves hinged to it. The lengths are given as stated in the cutting list, but in case any slight inaccuracy in cutting or jointing the stand occurs, it will be as well to actually measure across the stand, the measurement being taken from parts (C), not the sides. Cut the centre top and lay face downwards on the bench. Invert the stand and lay it on top. See that the ends are exactly level with the outer

THIS is a pattern of table with much to recommend it. Ordinarily it folds up to occupy a small compass, but can be opened out to seat four persons when needed. Not in use, it makes a neat stand for flowers, plants or what you will. It could, of course, be constructed in any of the hardwoods, but could be made of deal, and enamelled to suit existing furniture.

Construct the centre stand first. This consists of two sides, joined together with two pairs of horizontal rails. To save repetition, wood 3/4 in. thick is suggested for all parts except the table top and leaves, for which timber of 1 in. thickness is recommended.

Fig. 1 shows the pattern for the sides (A) and rails (B). Cut the sides and shape up as in the drawing. The four mortise slots shown are 1 in. long and 3/4 in. wide, both pairs are in true alignment. Cut the rails to the length given, plus 1 in. extra each end for the tenons. These are cut, of course, to fit tightly the mortises in the sides, and are positioned centrally. The tenons will project outside the sides by 3/4 in. and these projections should be chiselled to diamond shape, then, instead of looking somewhat unsightly, they will have a decorative effect.

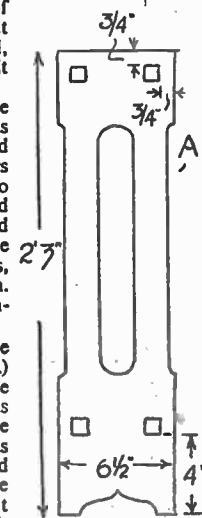

Fig. 1

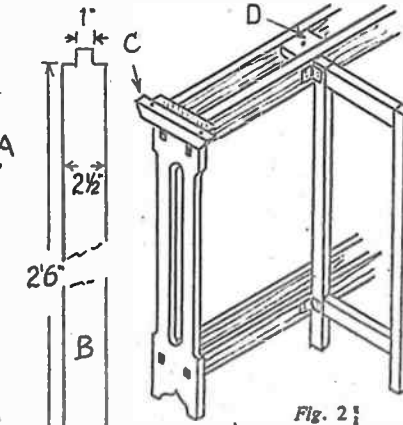

Fig. 2

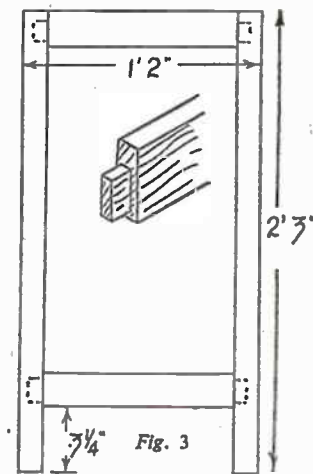

Fig. 3

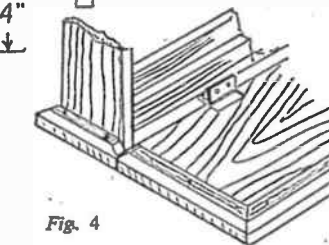

Fig. 4

face sides of parts (C), and then drive the screws through the holes already bored in (C) into the top. A screw is also driven in through centre block (D). This should fix the top securely enough to the stand.

Cut the two leaves to exactly the same length as the centre top, and hinge to it either side with 3 ins. butt hinges. The leaves of these hinges should be recessed

(Continued on page 130)

HOW TO MAKE YOUR Seasonal Greetings

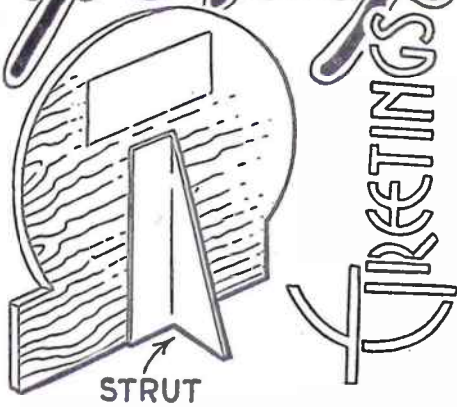

THE feature of these Christmas greeting cards is that they are quickly and cheaply made from odd pieces of wood. We have shown two designs on this page and they each consist of a background and overlays.

In the top design the background is a plain piece with no frets. It is cut from 1/4 in. wood. The holly spray and ribbon are cut as one piece from thin plywood. Our PPM panels are suitable for this purpose. The idea is to pin about six pieces together and cut six overlays at a time.

Polish or paint the background and glue the overlay in place. Paint the leaves green, with a darker green for the shaded portions. The berries and parts of the ribbon shown black are painted red, while the dotted portion of the ribbon is yellow. The rest of the holly twig is white and the stem of the holly twig brown.

The word GREETINGS is written on in ink or stencilled on by means of the lettering in the top right-hand corner. Trace the lettering on to a post-card and cut it out with a broken razor blade. For stencilling use an old water colour brush with the hairs trimmed to about 1/4 in. long.

The second card has a circle cut from the background to frame the candle flame. The berries, leaves and candle are all overlays cut from thin wood and are coloured up as just described. In this case the word greetings is an overlay with the letters cut out. The word could be stencilled if desired.

To finish off the cards you will need to glue cardboard struts to the back as shown in the diagram. Small slips of paper gummed on the back will serve for writing your Christmas message to your friends. (M)

DESIGN 2978

A Pull-along Toy Liner

THOSE who made up the novel toy tug and barge published on May 14th, this year, will have found the system of using internally hidden rollers, instead of the usual ugly outside wheels, worked perfectly, and they will welcome this toy liner which works on the same principle. From above, the rollers are quite invisible but the toy will run quite easily even on a rough surface such as that provided by a carpet.

Construction is quite easy, and anyone with a fretsaw can undertake it with confidence.

To begin, trace the patterns on to the wood and cut out the various pieces. Assembly is straightforward and can be followed clearly from the detailed drawing Fig. 1.

First pieces 1 and 2 are glued together,

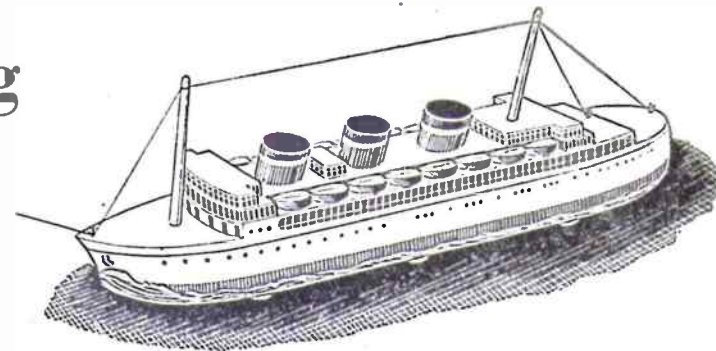

COMPLETE KIT FOR 4/7

For making this attractive toy, a kit containing all necessary wood, round rod, nails, screws and cord, can be obtained from any Hobbies branch, or post free from Hobbies Ltd., Dereham, Norfolk, price 4/7, including tax.

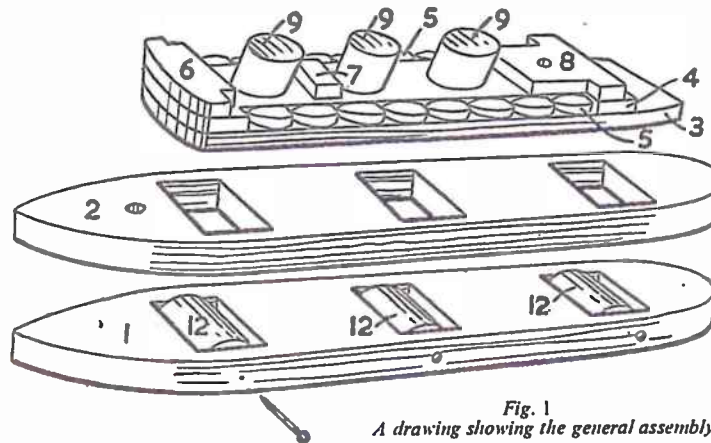

Fig. 1
A drawing showing the general assembly

and then parts 3, 4, 5, 6; 7 and 8 are glued in position one on top of the other. The boats (5) can be shaped a little if desired, but this is hardly necessary in a toy.

The funnels (9) which are cut from 1/4 in. round rod are next glued in position. When all is dry, the hull can be slightly shaped as shown in the side view on the design sheet. Note the gentle rounding of the underside of the bow and stern.

The rollers are added next, using 1/4 in. fret pins to hold them. When the holes for the pins are drilled in the sides of the ship, make sure that they are large enough to allow the pins to revolve easily. The pins have to be driven centrally into the rollers, and as a guide for the pins, holes can be started in the rollers with a burnishing awl.

To complete construction, fix the masts and rigging in place. Note the rake of the masts.

For painting the toy, follow the colour guide given on the design sheet, and add a few windows and portholes, etc., if desired. Before painting, of course, the job should be properly cleaned up and finished. The colours used should be as bright as possible.

A piece of thin cord attached to the screw on the bow of the vessel completes the toy, which is ready for use and should give many hours of enjoyment to any small child.

Two Replies to Readers' Queries

Mould on Tent

ON opening up my tent which has been wrapped up for about six months, I found it covered with grey mould. How can I remove this mould? (P.R.—Llanhilleth).

MOULD on stored-away tents is a thing to be avoided. In future always see that your tent is thoroughly dry before storing, and it pays to examine it periodically and give it an airing. If the mould is not too ingrained, it can be dealt with by brushing off with a fairly stiff bristled brush. If, however, parts have been badly affected, it may be

necessary to cut away the rotting canvas and patch with new material. After giving the whole surface of tent a good brushing and a good airing, it may be advisable to give it a coat of proofing solution. Granger's Solution or Mesowax, obtainable from camping stores and Army & General Stores, used according to directions on the container, is recommended for the purpose. Do the job on what is referred to as 'a good drying day', in the backyard or on the lawn or other suitable place, and leave tent to dry well before folding it up again.

Painting Ties

COULD you tell me what kind of paint to use for hand painting satin ties? (J.H.—Morpeth).

SATIN can be painted with poster colours (which will not be waterproof), or with ordinary artist's oil colours (which will be waterproof), provided the material is suitably prepared. A simple preparation is to paint over the design with a solution of gum arabic, or with gum tragacanth, and when dry, applying the colours.

Amuse yourself this Winter with a Home-made Shove Ha'penny Board

FOR an indoor game that does not require the floor area necessary for darts or billiards, it would be rather difficult to beat shove ha'penny. Until the game is actually tried, the amount of skill necessary in sliding a coin into its proper 'bed' is not appreciated, and close finishes in shove ha'penny are equally as exciting as they are in more popular sports.

The game has another advantage in that the board can be home-made at a fraction of the cost of the shop-bought article, and the work of making it is well within the novice woodworker's scope.

For the board a piece of wood 2ft. 3ins. long by 1ft. 2ins. wide will be needed. Probably the best way of

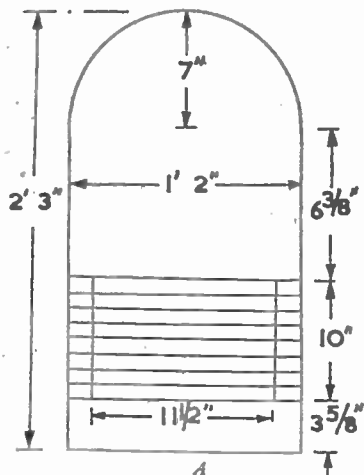

obtaining such a width is to use five-ply, or some 3/4in. thick hardboard. One end of this is taken off to a semi-circular shaping as shown in the plan at (A), and the sawn edges smoothed with a spokeshave.

A series of nine lines have then to be made across the width of the board, these being at 1 1/2ins. apart. The first line of the series is 3 1/2ins. from the bottom edge of the board.

It is advisable to use a guide when sawing these lines. The latter are first marked out in pencil, then a narrow strip of wood is laid alongside each line in turn. This strip is held down on the baseboard by means of a fretwork

cramp at each end as shown in the sectional drawing at (B). By pressing the saw-blade hard against the edge of the strip the teeth will be unable to wander away from the line. All saw-cuts should be made to a depth of about 1/4in.

When these cross-lines have been cut the top and bottom lines are connected by two cuts, each being parallel to the long edge and at 1 1/2ins. from it (see A). Again, a saw-guide can be used, but this time the cutting can be done only with the 'heel' of the tool.

A wood batten 1ft. 2ins. long, 1in. wide and 1/2in. thick is screwed to the underside of the board, flush with the bottom edge. This strip acts as a fence to hold the board against the edge of the table.

At this stage the surface of the board should be thoroughly glasspapered, and can be lightly wax polished.

The Rim

Plywood 1/4in. thick and about 1 1/2ins. wide is used for the semi-circular rim. The strip, 1ft. 1in. long, is given a quarter-round shaping at the top outside edges, and is fastened round the semi-circular shaping. It is nailed into place so that its lower edge is flush with the bottom of the baseboard. Fine brass nails may be used for the fixing (see drawing C).

This completes the construction of the actual board.

The only other equipment needed is five half-pennies or thin brass metal discs of the same size. The discs should be filed flat and polished on one face so that they slide easily. Some chalk for marking is also needed.

The game is played by two players, each of whom takes one of the sets of small squares at the side of the board to mark his score.

In turn, each player takes his five discs, lays them one at a time at the end

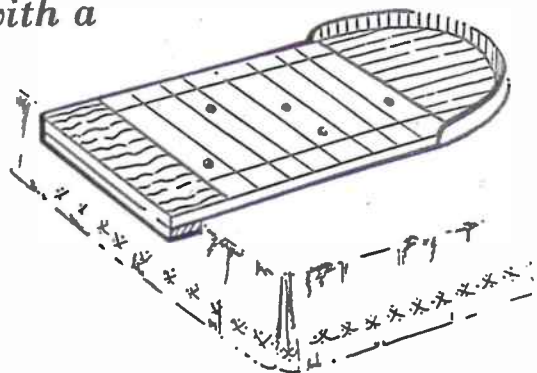
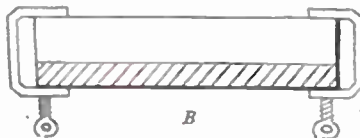

of the board (slightly overhanging the edge) and gives it a sharp tap with the flat of the hand to send it sliding up the board.

To score, a coin must rest in a 'bed' without touching either the cross-lines or the two long upright lines. At the end of each set of five shots (and not before) a chalk mark is made in the scoring space at the side of the appropriate bed.

Each bed has to be filled three times (i.e. twenty-four scoring shots). If, however, one player has already filled his bed with three shots and lands a fourth in that bed, his opponent can count it as a score for himself if he has not already got that bed filled.

Most players agree that a hard shot that hits the rim and rebounds back



into a scoring bed shall not be allowed to count, but the opponents can make their own rules on this point. If a weak shot is made with the idea of going into the first bed, and the coin does not touch the first cross-line, it can be replayed, but this can only be done three times with the same coin, after which the shot is forfeited.

A coin that cannons off another and lands in a scoring bed counts as a score for the player, as it also does if a coin is pushed into a bed by a nudge from a second coin that has been played in the correct manner. Coins that go over the side of the board cannot be replayed.

The winner is the first player to fill all the scoring beds.

To keep the board in good condition it should be dusted occasionally with french chalk. (F.H.T.)

Old film spools make these

BUFFERS FOR A TOY RAILWAY

MUCH of the fun and enjoyment to be obtained from a model railway system is in the planning of new lay-outs and in the making of new gadgets and apparatus to improve the general working.

Quite a lot of this can be made from odds and ends to be found about the house or in the junk box in the shed. Very often some really elaborate model railway gadgets can be built up at no cost whatever and giving many hours of pleasure for the work entailed.

The very realistic buffer described and illustrated in this article is an excellent example of what can be done in this way, and although simple to make, is a really efficient piece of apparatus.

The working part of the buffer is made from an old photo film spool, and as these are available in a variety of sizes it is possible to fit nearly all the different gauges of model railways. For this reason no definite measurements have been given, but just sufficient information to enable you to plan one to fit your own particular gauge.

Working Parts First

It is best to make the working part of the buffers first and then to fix them on to a support at the correct height above the rails.

Some film spools are made of all metal, while others have a wooden spindle with metal end flanges. It does not matter which type is used, although the all metal ones will make a neater job and generally work better.

Cut off the ends of two spools just beyond the centre slot as shown at (B), and well smooth so that there are no rough edges to prevent them sliding easily in the tubes. All this is clearly shown at (C).

The tubes are made from a suitable size piece of dowel rod drilled down its centre so that the film spool plunger is an easy fit. If you have not got a drill of the exact size, make the hole slightly smaller, and with a piece of glasspaper wrapped round a piece of rod, carefully polish it out to the correct size.

Wire Pins

A small hole is then drilled in the tubes to take a wire pin which is inserted through the centre slot of the plunger to prevent it from being withdrawn. Before fixing this pin, a short length of spiral spring must be slipped over the plunger to give the necessary set-up to the buffer.

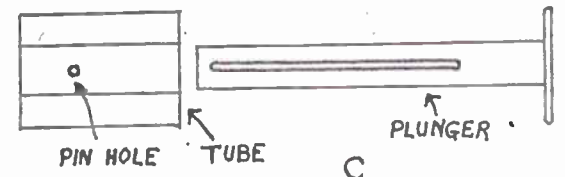
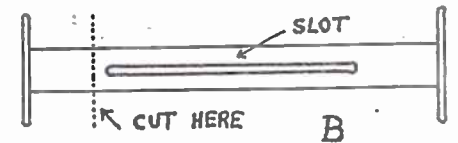
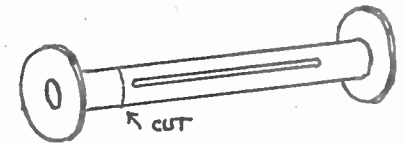
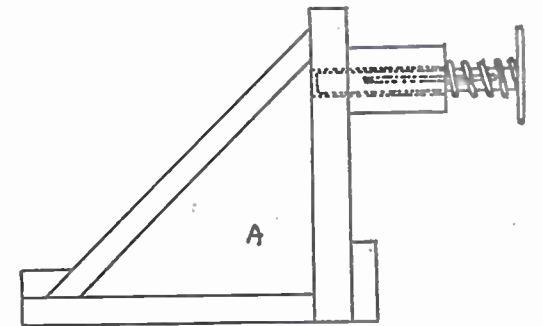

To make the spiral spring, take a length of springy wire, such as thin steel piano wire or even a good hard brass wire, and carefully coil it tightly round a piece of dowel rod rather smaller than the size required. When the pressure of winding is released this will spring out, increasing both in length and diameter.

Stripwood Framework

Stripwood can very conveniently be used to make the framework of the buffers, a general idea of which is shown at (A). Ample support should be given and the whole should have some means

of firmly fixing them to the rails. This will, of course, depend on how the rails are constructed, and as there are so many different sizes and types, no definite plans can be given here, but no difficulty should be experienced at all.

A coat of paint or hard drying enamel will help to preserve the apparatus, besides making it quite attractive. (A.F.T.)

Remember the advertisement pages of Hobbies Weekly—they are worthy of your attention.

It isn't too early to think about

CHRISTMAS LIGHTING

WITH the approach of Christmas, numbers of readers appear to be interested in circuits for tree and decorative lighting. Quite a lot can be done in this way with relatively little expense, and the bulbs and other fittings can be kept until another year—they can, indeed, prove serviceable for a very long time, if safely stored.

A number of arrangements are possible, both mains and battery operated. If mains supplies are available it is best to use these, so that no

necessary to remove each bulb in turn, replacing it by the new one, until the string lights. Alternatively, the bulbs may be tested with a battery of 4.5 V. upwards, when each will glow dimly, if the filament is intact.

Bulbs of different voltage ratings can be wired in series, if their current rating is similar. This means that an ordinary electric bulb of 15 to 60 watts can be used to make up a chain. For example, if only half-a-dozen fairy lights were to hand, they could be wired in series with a full-sized lamp holder,

series provided they pass approximately the same current, and that the total voltage of all, added together, equals or exceeds the mains voltage.

Mains Wiring and Switch

Proper care should be taken with all wiring, etc., connected to the mains. Good quality insulated flex should be used, with no bare or twisted joints.

The correct way to wire a switch and power plug is shown in Fig. 2. On the power plug the Neutral (N) terminal, which is at lowest potential with respect to earth, is taken to the lights. The Line (or positive) terminal goes to the switch. Accordingly the bulbs are not left at high potential when switched off.

When wiring the switch, the leads are taken round the small projections which will be found present on most such switches. These take the strain off the terminal connections.

Bulb holders with bare terminals or contacts should not be used with mains circuits. The proper type of holder is of insulated material, with insulated leads issuing from the back. It is as well to withdraw the mains power plug when leaving the lights unused, or making changes to the position of bulbs, etc.

Parallel Circuits

These can be driven from a low voltage supply, such as obtained from a battery, accumulator, or the secondary of a small mains transformer. (Transformers can only be used on A.C. mains). With such circuits, all the bulbs should be of approximately the same voltage rating. If any bulb fails, the others will remain burning.

Small holders can be used, as shown at (A) in Fig. 3. It is also quite easy to solder the leads directly to the bulbs, as shown at (B), and this saves expense. Insulated wire must be used. The two

leads may then be twisted together, and almost any quantity of bulbs can be used, if sufficient current is available.

The average 2.5 V. or 3.5 V. torch bulb consumes about .3 amp. Ten such bulbs would consume 3 amps. An accumulator could supply this, or a mains transformer. With dry batteries it would be desirable to use fewer bulbs, or bulbs of lower current consumption. Bulbs rated at .06 amp. are available. Ten of these would only consume .6 amp., and could be driven from a fairly large dry battery.

The voltage of the bulbs would depend upon the voltage of the supply. 2.5 or 3.5 V. bulbs can be lit from a 2 V. accumulator or 3 V. dry battery. For a 6 V. battery, 6.3 V. bulbs would do. A large number of such bulbs, of .3 amp. rating, could be lit from a 6 V. accumulator. Such bulbs would also be suitable for a 6 V. mains transformer.

Connecting a Transformer

A switch should be included in one lead to the battery. If a transformer is used, the primary should be connected to the mains (with a switch in one lead), and the secondary should be wired to the bulbs. A small wireless 'heater' transformer can be obtained for 5/- to

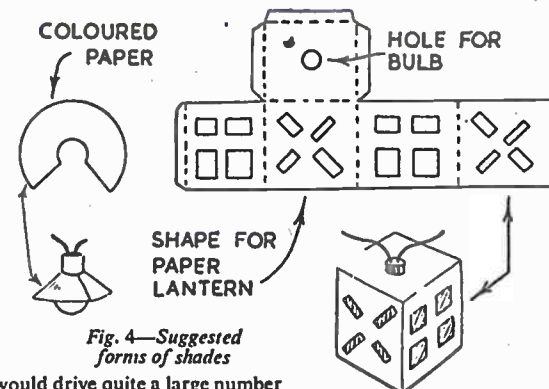

Fig. 4—Suggested forms of shades

6/- and would drive quite a large number of bulbs.

Decorative Fittings

'Fairy' lights are coloured, and, therefore, decorative, but torch bulbs require a little attention in this direction if the best effect is to be created. If clear transparent paint in various colours is to hand, the bulbs can be dipped in this. Ordinary oil paint, unless very thin, is not very suitable, as it prevents light passing.

Small shades of coloured paper may be made in a few moments as shown in

Fig. 4, by cutting a circle, drawing it round the bulb, and gluing. Cellophane and other transparent or tinted papers can also be used, according to what is to hand.

Small lanterns can be cut from paper as shown, and only need to be about 1 in. square, for small bulbs. The 'windows' may be cut with a razor blade and coloured paper stuck over inside, so that the bulb shines through. Other arrangements will, doubtless, come to mind, and could usually be employed with success. (F.G.R.)

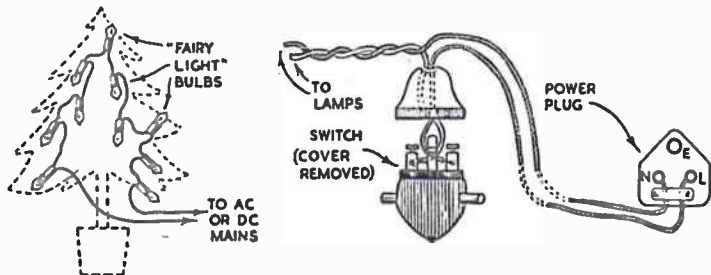

Fig. 1—A popular series-connected circuit

Fig. 2—The correct way to fit a pear-switch and plug

batteries need be purchased. In addition, the number of bulbs which can be lit from batteries is limited, unless an accumulator is available.

Series Circuits

With such circuits all the bulbs are wired in series, so that current passes in turn through each, as shown in Fig. 1. Chains of coloured bulbs may be purchased for this purpose, and are most satisfactory, though other bulbs can be used with success. Such chains of bulbs may be driven from either A.C. or D.C. mains.

With such an arrangement all the bulbs must be of the same current-carrying capacity. (If a reliable brand of 'fairy light' bulbs are purchased, this will be so). The total voltage of all the bulbs should be equal to, or greater than, the mains voltage. Most such bulbs are 25 volt ones. This means that ten such bulbs would total 250 V., and could be driven from 200 to 250 V. mains. With 200 V. mains each bulb would receive only 20 V., but this would not make any appreciable difference, since the bulbs would still light brightly.

With such a circuit the whole string will go out if one bulb fails. Accordingly, it is wise to have a spare bulb in hand, to use if one fails. As there will be no indication of the faulty bulb, it will be

and an ordinary 200 to 250 V. lamp inserted in the latter. A lamp of small wattage should be tried here, first. If the fairy lights do not light with sufficient brightness, a lamp of larger wattage can be inserted. Such a lamp can usually be borrowed from another room, for this purpose. It will not light at full brilliance, as the voltage to it will be reduced. Instead, it acts as a resistance. It may be used to illuminate the foot of the Christmas tree, etc.

A string may be made up from other bulbs; for example, a 45 watt, 200 V. bulb, and a number of .3 amp. (2.5 or 3.5 V.) torch bulbs. As mentioned, any bulbs of any voltage can be wired in

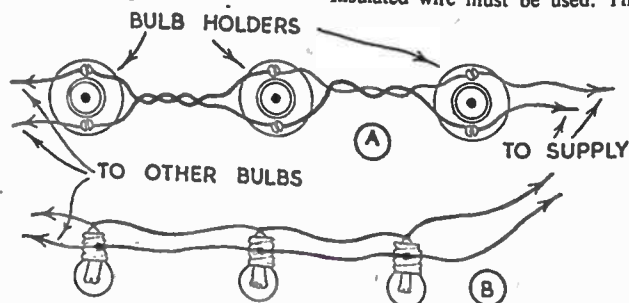

Fig. 3—Parallel connection for low voltages

MAKE IT FOR CHRISTMAS

An Attractive Gift

YOU can quite easily make a very attractive pair of book-ends from an ordinary log and a panel of good-grained wood about 3/4 in. thick. Choose the log with care. This needs to be between 6 ins. and 7 ins. long and some 5 ins. to 6 ins. in diameter. The bark should be intact and firm, the wood itself free from splits or faults and the rings clearly defined. Clean thoroughly by scrubbing and then allow to dry out in a warm dry place. Do not dry in fierce heat, as this may scorch the wood and cause the bark to start peeling away.

Now cut a panel from the 3/4 in. stock the same width as the diameter of the log and about 10 ins. long. Glue the log to the centre of this piece and reinforce the joint with woodscrews, counter-sinking the heads of the screws into the underside of the base. When this assembly has set, part carefully down the middle by sawing.

The faces of the pair of book-ends so formed are covered with aluminium or tinfoil panels, as shown, tacked in place with small nails or pins. The base itself can then be glasspapered down perfectly smooth and the ends rounded off.

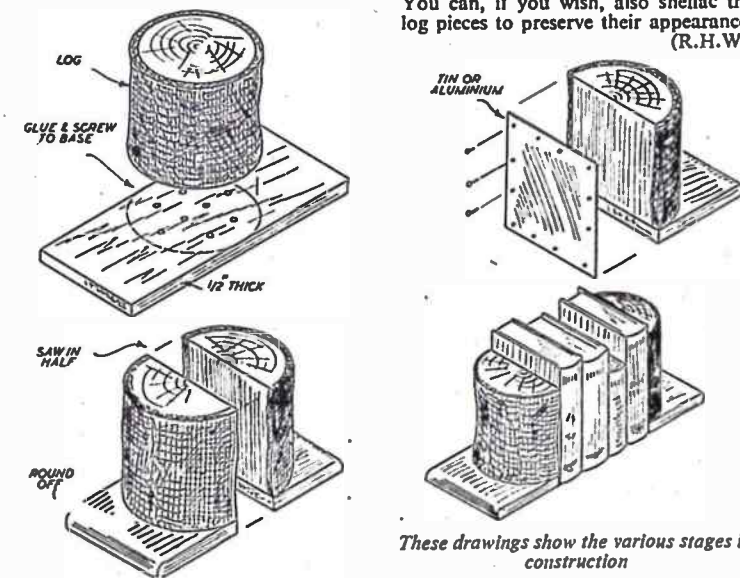

These drawings show the various stages in construction

If the wood used for the base is of somewhat indifferent stock it will probably be best to paint the whole of the base green or black. If the base wood has a good grain, however, smooth well down and stain and polish. You can, if you wish, also shellac the log pieces to preserve their appearance. (R.H.W.)

A Sturdy Log Rack

EASILY MADE
BY ANYONE
HANDY WITH
TOOLS

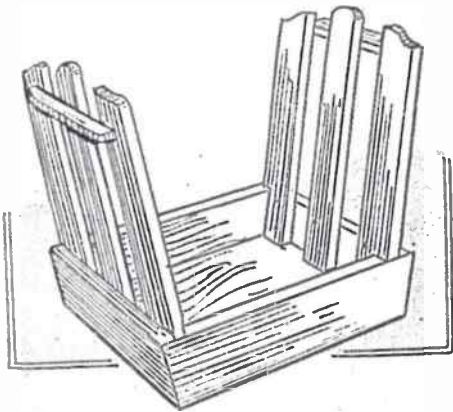

WITH the advent of winter, and the accumulation of some logs to eke out the coal supply, it would be a good idea to make up a simple rack for their accommodation instead of an untidy pile in the fender. The design of rack, illustrated, would meet the case nicely, and is quite easily constructed of any wood available, say, about $\frac{1}{2}$ in. thick. It holds sufficient logs for daily consumption, and is furnished with a closed base to catch those little bits of sawdust and stuff

end slopes, these must be beveled at top and bottom, and are then glued under the bottom of the tray portion of the rack. This completes the tray portion of the rack. The extreme corners should be slightly rounded off, only a little, and all nails punched down level.

End Supports

For the sloping end supports for the logs, cut six pales, three to each end. The cross section of the rack, Fig. 4, shows these, and how they are shaped up. It will be seen, of course, that the outer ones are cut $\frac{1}{2}$ in. shorter than the middle one, also that the outer pales are cut away at their bottom ends to fit over the sides of the base. Place each in

quite strong enough if glue is added to the joint as well. Alternatively here brass handles can be fitted, and would look rather nice, and, perhaps, provide a better grip.

Finish

· Clean up the work with glasspaper. Stain it to match existing furniture (if you like, of course), and finish off with two coats of clear varnish, or two coats of varnish stain would do quite well for an article of this description. While in no ways essential, it would provide a decorative finish to add turned wood feet to the base, or even simple square blocks, one to each corner would suffice, to lift the rack clear of the floor. (W.J.E.)

Fig. 3

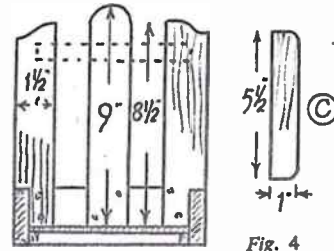
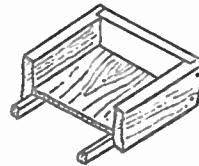

Fig. 4

Renovating Candlesticks

I HAVE a pair of very old candlesticks (telescopic) which have not been used for many years and have become very tarnished—almost black. What can I use to clean them? (C.M.H.—Leicester).

As you do not state the metal of which the candlesticks are made, we can only suggest that if of brass, the tarnishing can be removed by washing with a dilute solution of nitric acid, followed at once by boiling in soda water to neutralize the action of the acid. The resultant surface will be bright but slightly matt, and will need repolishing. If made of silver, a good boiling in a detergent such as Tide, followed by well washing in hot clean water and then vigorously polishing with rottenstone and water—or with rouge or plate powder moistened with methylated spirits.

position, as seen in the drawing, and run a pencil along the top edges of the sides to mark the correct angle on each pale for sawing away the cut-out, to ensure a neat and close fit.

Now glue and screw the pales to their respective ends, and make a strong joint, as some strain comes on them when the rack is lifted up, laden with its load of logs. It would be best here to employ round-headed screws, and to partly drive in the screws first, then to remove each pale in turn, glue it, and rescrew tightly back.

Handles

The handles (C), two of which are needed, can be cut to the shape from similar thickness wood to that employed for the rest. These are glued and screwed across where shown, at 2 ins. down from the top. One screw at each end should prove sufficient, and be

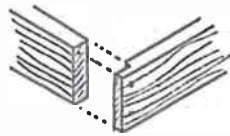

Fig. 2

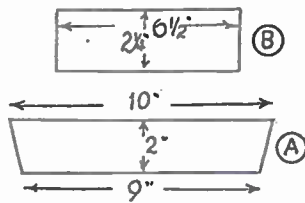

Fig. 1

which cling to logs and make a mess on the carpet or rug.

Tray-Shaped Base

From the drawings, the rack will be seen to consist of a tray-shaped base, with rising sides, quite simple in fact. Parts of the tray are detailed in Fig. 1. Cut two each of sides (A) and ends (B). The sloping ends of the sides are rebated to half thickness, to receive the end parts, as in Fig. 2. Now plane the top and bottom edges of the ends, which obtrude themselves owing to the slope, level with the sides.

On the inside, nail and glue $\frac{1}{2}$ in. square strips of wood along at the bottom. On these the bottom of the tray will rest, as in detail sketch, Fig. 3. Cut this bottom from plywood, a tight fit is desirable, and nail it to the side strips below. Cut two similar strips to go across between the sides. Owing to the

EASY
TO
MAKE

MEET 'GEORGIE' THE DUCK

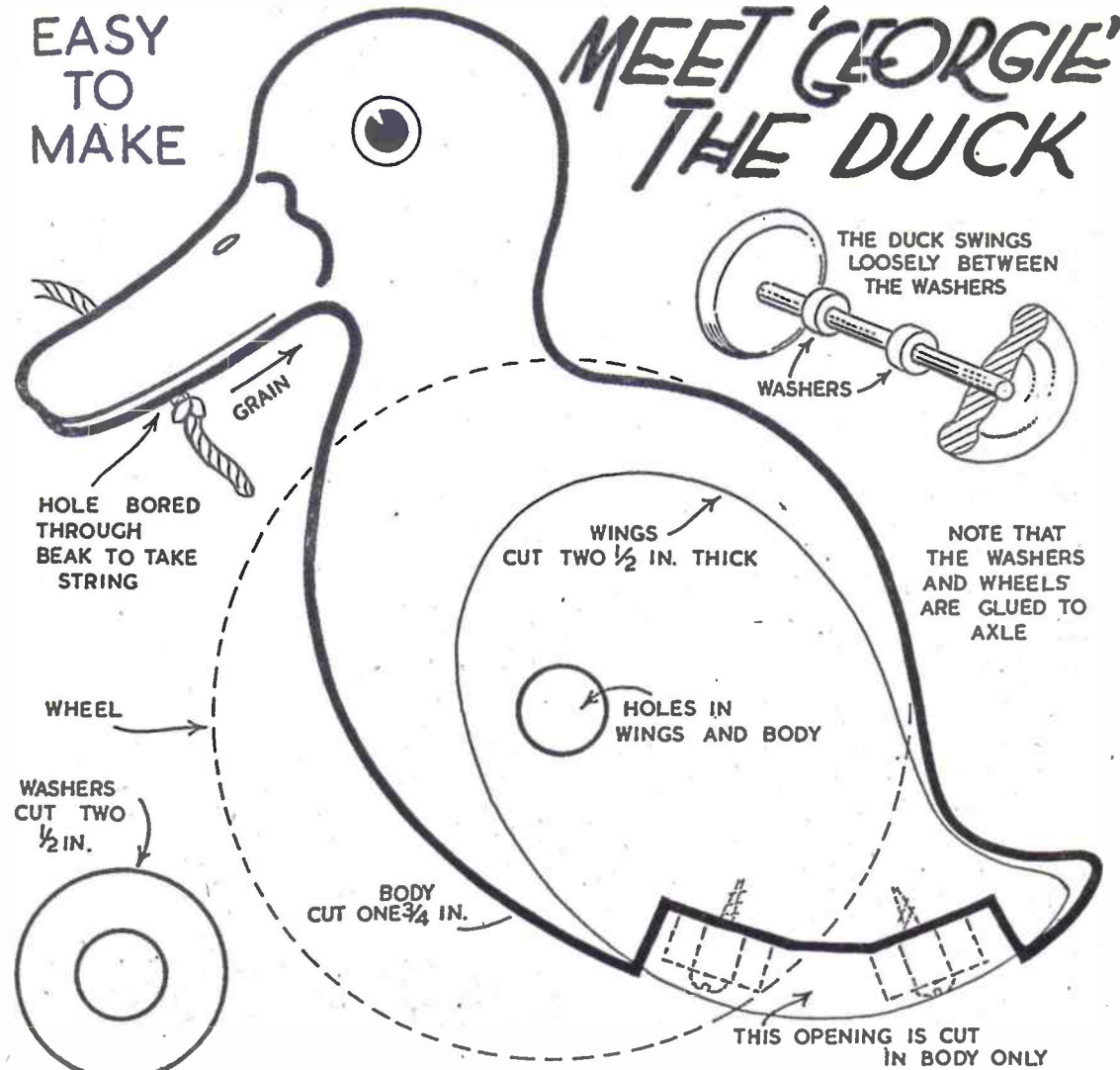

WHEN pulled along, this toy gives a nodding and waddling effect which will amuse the children. The body, swinging freely on the axle, is weighted at the bottom so as to bring the duck upright. By jerking the string slightly as it is pulled along, the head will move backwards and forwards realistically.

The Body
Cut the body from $\frac{3}{4}$ in. wood and the wings from $\frac{1}{2}$ in. Glue the wings on either side of the body, making the holes coincide. Note the direction of the

grain shown by the arrow. In the opening at the bottom you should screw a lump of lead or two or three nuts. The weight must be sufficient to bring the body smartly upright.

Axle
The axle is cut from $\frac{1}{2}$ in. round rod and is about 5 ins. long. The wheels are 4 ins. diameter and can be obtained from Hobbies Ltd., Dereham, Norfolk—price 2/9 per pair, post paid. The hole in the wheel must be enlarged with a fretsaw to take the $\frac{1}{2}$ in. diameter axle. Glue one wheel in position, then a

washer, slip the duck on and then fix the other washer and wheel. To finish off, drill a hole through the beak to take the string as shown.

Painting
The duck should be painted with glossy white enamel and the beak bright orange. The eye is orange and black. Wheels should be treated similarly, being white with a bright orange band round the outside. (M.)

If your friends like making things, tell them about 'Hobbies' Weekly and its real value-for-money contents.

Keep the Home Bright this Winter

FLOWERS are expensive during the winter months but one can gather all sorts of oddments from woods, trees and hedgerows to make an attractive show indoors. All you need are some small pots of enamel in red, yellow, blue and orange, and if you add to these some aluminium, old gold, copper bronze and black, you have enough material to make all the decorations you need for Christmas also.

Heather

First of all, heather. When collected, arrange this neatly in vases by securing a piece of potato into which you must punch plenty of holes with a metal meat skewer. Each hole will hold a stem of heather, and with water in the vase, the heather will keep for months. Be careful where you pick it, because in some places, there is a by-law prohibiting its picking.

Cut flowers should not be allowed to stand in hot places or in direct draughts.

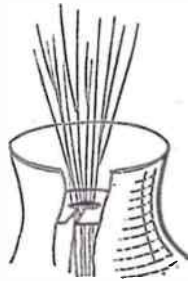

A device for preventing flowers from 'flopping about' in wide-necked vases

The water in vases should be frequently changed—preferably every day. The stems of some flowers get woody and hard. Roses are like this, and you should take them out and peel them up a little way. When cut, the water ducts become filled with air bubbles. To avoid this, recut to a shorter length whilst holding the stems under water. This is a trick learned from the Japanese who are world-famed for their flowers.

Keeping Flowers Fresh

A pinch of soda or salt in the water will keep flowers fresh. When posting flowers to friends, wrap them in wet newspaper and seal up the ends with a little sealing wax.

Containers for flowers are expensive and there are few suitable ones for the

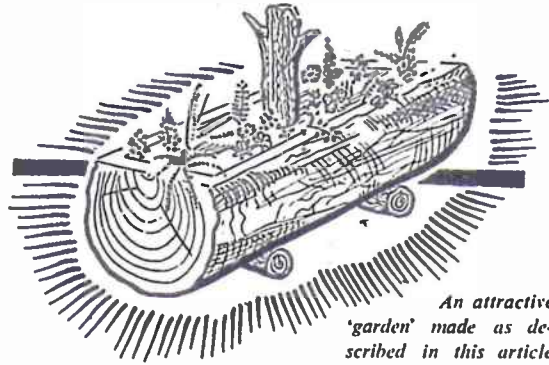

An attractive 'garden' made as described in this article

purpose of having both a summer and winter show. In the sketch is shown a piece of silver birch log which is suitably cut to a flat section on top, cut out inside with a chisel and mounted on two short lengths of rustic branch. Other trees can be utilised but choose something with a naturally good finish. The log can be filled with fine soil, fibre or small stones and planted with little trees, flowers or other attractive items. Keep the garden well watered, as that is half the secret of this idea.

Flowers have a habit of flopping about in a tall necked vase but one can overcome this with a cardboard disc as shown in the little sketch. Have a circular hole and a slit to push the flowers in by. A milk bottle top will do if you have no other thick cardboard.

Brightly painted twigs can be used to hold tufts of coloured felt, pine cones, beads, fluffy bunches of rug wool, and other oddments. Odd scraps of tinsel from the Christmas stock can be added in small quantities.

If your flowers will not stay put, get some fairly stout garden wire and paint this green. Have it in short lengths of 9ins., with 2ins. for a turnover bend to grip the flowers. It is easy to push into pots and cannot be seen when painted. This applies to potted flowers, of course.

Beech Leaves

From a decorative angle, one of the great standbys of the winter are dried beech leaves. Take a walk into the country and find a tree that is just beginning to change colour, but be careful to select sprays that are still green.

See that the leaves are quite soft, with no hint of the brittleness that

means they are about to fall. Choose branches that are long and artistically shaped, bearing in mind the sort of vessels you mean to place them in.

Treatment

When you bring your leaves home, peel the stems 2ins. or 3ins. up from the bottom and then stand them in a solution of one part glycerine to three parts of water, making sure that the solution comes above the peeled part. Leave the stems in this for about a week till the stalks have absorbed the liquid. Take the branches out, wash them and arrange in the vases to suit your own taste. During the advancing months they will change to a very attractive copper shade. Change the water at regular intervals.

Choose your vases carefully. Some of the newer pottery types are most attractive in their natural shades with designs in red, orange and fawn. These leaves will look most attractive if used with a background of copper or pewter articles, well polished.

Preserving

Leaves and berries are at their best at this time of year and it is not really difficult to preserve them. Dissolve half-ounce of shellac in five table-spoonfuls of methylated spirits. This takes several days to dissolve, so it is a good plan to have it ready beforehand. The fresher the sprays are varnished, the more attractive they will look when done. The liquid should be strained before being used, to ensure the varnish being quite clear. The leaves and berries are then given a coating of the varnish and left to dry undisturbed. (V.S.)

HURRY!

Send NOW to be sure of getting your copy of

HOBBIES 1953 HANDBOOK

2/3 Post Free from HOBBIES LTD, DEPT. 99 DEREHAM, NORFOLK

WANTED

Anyone having for sale a Hobbies 4-corner picture framing cramp (as shown on page 107 of Hobbies 1953 Handbook) is invited to write to the address given below stating the price required. The tool must be complete, in good condition, and proper working order.
Box No. 4 HOBBIES WEEKLY DEREHAM, NORFOLK

SPARE TIME WORKERS

Full and spare time workers are required to make up simple "Prestaplasta" novelties. Regular all the year round home employment with weekly (or when work is received) payments. Materials are supplied and no experience is required. The whole family can join in and enjoy this pleasant and profitable full or spare time occupation. Stamped addressed envelope for particulars from:

PRESTAPLASTA PRODUCTS
(Outwork HW) BCM/125 London, WC1



Laurel & Hardy 'Way Out West'. Mystery of Flying Saucers. Lash La Rue in 'Outlaw Country'. Adventures of Charlie Chaplin. Hopalong Cassidy in 'Sunset Trail'. P. & P. 1/6
Animal Antics. Cinderella. John Wayne in 'New Frontier'. The Royal Tour of Canada. Rex Allen 'Arizona Cowboy'.

Send Cash or Postal Order or C.O.D. 1/- extra.
FOWDEN FILM & OPTICAL SERVICE
2 HASTINGS STREET, LUTON, BEDS.

STOCKS LIMITED!



Build this Realistic Model Village with

BRICKPLAYER
Bricks and Mortar Building Kit and Accessories

ENTER FOR THE BRICKPLAYER COMPETITION

Prizes of £10 10s., £5 5s., and £3 3s. and a number of consolation prizes of Brickplayer Accessories will be awarded for winning models.

Write for full details.



The Brickplayer Kit contains miniature bricks in all required shapes, mortar, roofing, metal or plastic windows and doors, plans and instruction booklet. All models are architect designed to 'O' gauge scale. Buildings can be permanent or dismantled by merely soaking in water, and the bricks used again and again.

Brickplayer Kits at 28/6 and 52/6 and Accessories are available from good toyshops and stores.

If your dealer cannot supply, write for address of nearest stockist to:

J. W. SPEAR & SONS LIMITED

Dept. "H", Enfield, Middlesex

YOUR IDEAL CHRISTMAS GIFT

Some Experiments with Epsom Salt

AS its name implies, Epsom salt occurs naturally at Epsom—in a mineral spring. To extract the salt from this spring is not profitable, however. Instead, the mineral magnesite (which is magnesium carbonate) is dissolved in sulphuric acid and the solution evaporated. Crystals of Epsom salt are deposited on cooling.

Epsom salt (whose chemical name is magnesium sulphate), besides being an aperient, is the starting point for making the indigestion remedies basic magnesium carbonate, magnesium oxide and magnesium hydroxide. Specimens of all three of these can be made easily in the home laboratory.

White Precipitate

Basic magnesium carbonate is formed as a white precipitate on adding sodium carbonate (washing soda) solution to Epsom salt solution. This is best done with hot solutions, for the precipitation is more complete. The precipitate is also denser and so more easily filtered and washed.

Boil both solutions, remove them from the source of heat, and stir the sodium carbonate into the Epsom salt until no more precipitate forms. Let the precipitate settle. Then decant off the clear liquid and filter off the precipitate.

Wash it well on the filter, until the wash waters no longer give a white turbidity with barium chloride solution. Dry filter paper and basic magnesium carbonate on a saucer in the oven. Besides being used as an indigestion remedy, this compound is used in some tooth-pastes. Dispensing chemists call it magnesia alba.

Magnesium Oxide

Magnesium oxide is the white ash formed when magnesium ribbon is burned. This is an expensive way of making it. It is much more cheaply made from basic magnesium carbonate.

To prepare it, nearly fill a crucible with basic magnesium carbonate and heat it with a bunsen flame until it is red hot. Water vapour and carbon dioxide will be given off and the powder will shrink. On letting the crucible cool you will find left a white powder of magnesium oxide. This is the ordinary magnesia of the chemist's shop.

Magnesium oxide will stand a very high temperature without melting and so is sometimes used for lining furnaces.

To prepare magnesium hydroxide add sodium hydroxide solution to Epsom salt solution until no more white

precipitate forms. Filter off the white precipitate of magnesium hydroxide, and wash it until the wash waters no longer give a turbidity with barium chloride solution. Then dry it in a cool oven.

A Test

To show how indigestion remedies solve our tummy troubles, take half a test tube full of water and add a drop or

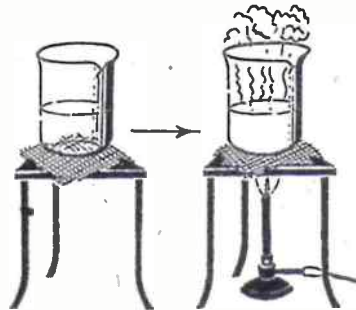

The 'water into milk' trick

two of hydrochloric acid. Blue litmus paper will redden if you dip it in the liquid, showing it is acid in reaction—as is the suffering stomach.

Now add gradually any one of the compounds you have just prepared. At first it will dissolve, then later you will find no more will dissolve. Dip blue litmus paper into the liquid. It will not now redden. The acid has been neutralised and in the case of the tummy, harmony restored.

Most insoluble salts of metals are produced by precipitation and are precipitated immediately. But there is a salt of magnesium which, though insoluble, is not at once precipitated. This is magnesium hydrogen orthophosphate. When it does at length appear it is in the form of beautiful needle-like crystals.

To prepare it, dissolve 5 grams of Epsom salt in 30 c.c. of water, and 11 grams of sodium phosphate in 175 c.c. of water. Then mix the two solutions. Nothing happens except that the liquid becomes opalescent in a few moments.

Set the solution aside for a few hours, when you will find the magnesium hydrogen orthophosphate has been deposited. The crystals often group together in glistening tufts. Filter these off, wash them with a little cold water, and then tip them out on to a porous

tile to dry at room temperature.

No precipitate is absolutely insoluble in water. Some need a vast bulk of water to dissolve them, but many dissolve appreciably in fairly small amounts. Magnesium hydrogen orthophosphate is one of the latter.

Powder about 1 gram of this salt and shake it vigorously in a corked bottle with 400 c.c. of water. All or most of it will dissolve, according to how long you shake it.

Interesting Experiment

With this solution you can perform another interesting experiment. Filter and then boil it. It will become cloudy and full of tiny white flocks. These are magnesium orthophosphate, the magnesium hydrogen orthophosphate having been decomposed by the boiling.

Magnesium, the metal contained in Epsom salt, is of tremendous importance to our food supply. Imagine a farmer with no green food for his cattle! Yet without magnesium, grass and kale could not grow, for it is an essential constituent of chlorophyll, the green colouring matter of herbage. By means of chlorophyll green plants convert the water they obtain from their roots and the carbon dioxide they extract from the air through their leaves, into food for their growth.

Plants usually find enough magnesium in the soil, but Epsom salt is sometimes used as a fertiliser for clover.

An interesting laboratory use for Epsom salt is in distinguishing a soluble bicarbonate from a carbonate. Add Epsom salt solution to sodium carbonate solution. White basic magnesium carbonate will be precipitated at once. Repeat the test with sodium bicarbonate solution. No precipitate forms. Then boil the solution, when the white basic magnesium carbonate will appear.

Foot Your Friends

And there lies a conjuring trick to astonish your friends—converting 'water' into 'milk' by boiling it! Just produce a mixed solution of Epsom salt and sodium bicarbonate, boil it and leave them guessing! (L.A.F.)

GOT YOUR INDEX?

The index to Volume No. 114 is now ready, and can be obtained from the Editor, price 1/-, post free. Binding cases for the volume are also obtainable price 4/6, post free.

TURN YOUR SPARE TIME INTO CASH

Men and Women wanted to make Bennett Model Bungalows at Home. Fascinating, Clean, Remunerative. No Selling involved.

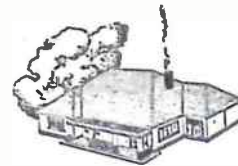

Money back within seven days guarantee.

Send stamped addressed envelope for full details.

BENNETT MODELS, 3 Lower George St., Richmond, Surrey

You too can know the thrill of building and operating your own model railway

The RAILWAY MODELLER

Monthly 1/6

will show you how!

Obtainable from Hobbies Stores, Newsagents and Model Shops everywhere.

Specimen Copy 1/8 from

DEPT. H.W., PECOWAY, STATION ROAD, SEATON, DEVON

FLEXIMOULD

FOR PLASTER CASTING

CORONATION SOUVENIRS, XMAS GIFTS, WALL PLAQUES, FIGURES, ETC. The All-Family Hobby That Adds to Your Income.

Write for

FLEXIMOULD

ILLUSTRATED LEAFLET TO DOHM LTD. (DEPT. H) 167 VICTORIA STREET LONDON, S.W.1

YOU CAN BECOME A HANDICRAFTS INSTRUCTOR

EXPERIENCE NOT ESSENTIAL

Men who enjoy making things in wood or metal can turn their hobby into a permanent and interesting Career. Short hours, long holidays, and security in a job you would really enjoy, can be yours if you become a Handicrafts instructor. Let us send details of the easiest and quickest way to get the necessary qualification.

We guarantee "NO PASS—NO FEE"

If you would like to know about our unique method of preparing you for one of these appointments, write today, and we will send you our informative 144 page Handbook—free and without obligation. Mark your letters "Handicrafts Instructor".

BRITISH INSTITUTE OF ENGINEERING TECHNOLOGY

BIET

595 Shakespeare House, Stratford Place, London, W.1

PLEASURE AND PROFIT



This is the BARGAIN OF THE YEAR COMPARE THE VALUE SEE

SILK SCREEN PRINTER with ACCESSORIES & SUPPLIES & FREE COURSE!

PRINTS IN SIX COLOURS CARDS, NOTICES, POSTERS

This is the great new printing and colouring process for amateurs or professionals alike and all handicraft workers. Its versatility is enormous. It will print a few copies, or hundreds, to a professional standard, in solid colours or intricate designs, on cloth, paper, wood, etc. Print notices, greeting cards, drawings, paintings in full colour, photographs, type-script. Fluorescent colours, suede flock and novelty finishes, transfer papers for printing your own transfers also available. Can also be used as first-rate duplicator with any typewriter. Nowhere else is such a large and comprehensive outfit offered for so little money. Hundreds of customers testify to the quality and amazing value. Do not miss this opportunity.

—ON PAPER, WOOD, CLOTH, PLASTICS, Etc.

WHAT YOU GET!
Large 16" x 12" PRINTING FRAME
Stout Laminated WOODEN BASE

Patented ADJUSTABLE HINGES (for printing on material up to 1" thick)
Fine Quality SQUEEGEE
SIX CONTAINERS COLOURS—Red, Blue, Yellow, Green, Black, White

STENCIL FILM (design traced and applied with hot iron)

STENCIL CUTTERS and HOLDER, Register Guides, Masking Tape, etc., etc. And FREE 10/- COURSE giving step by step procedure for every application of process, including PHOTO STENCILS, DAY-GLO, FLOCK finishes, etc.

to: 4716 post paid

REFUND GUARANTEED IF NOT APPROVED

AMERICAN PUBLISHERS SERVICE (Graphic Arts Div.), DOCKING RD., SEDGEFORD, KING'S LYNN, NORFOLK

Micromodels

BUILD YOUR OWN MICRO MUSEUM

Three-dimensional volumetric. Locos; Ships; Architecture; Engineering; Aero, and other subjects.

COTTON BLOSSOM



Send stamped addressed envelope for ILLUSTRATED CATALOGUE OF 100 MODELS
MICROMODELS Ltd., 3 (H) Raquet Court, Fleet Street, London, E.C.4



SLÉRIOT MONOPLANE
WRIGHT BIPLANE

H.A.C. SHORT-WAVE EQUIPMENT

Suppliers for over 18 years of Radio S.W. Receivers of quality.

One Valve Kit, Price 25/- Two Valve Kit, Price 50/-
Improved designs with Denco coils. All kits complete with all components, accessories and full instructions. Before ordering, call and inspect a demonstration receiver, or send stamped addressed envelope for descriptive catalogue.

'H.A.C.' Short Wave Products, (Dept. 22.) 11 Old Bond Street, London, W.1

KITS for OLD TIME SHIPS

Hobbies range of Ship Models includes Elizabeth Jonas, Curry Sark, Victory, Mayflower, etc. Complete kits of wood, sail material, guns, pulleys, cord, etc., with full size patterns of parts and planned wood ready to cut out, shape and construct. A fascinating pastime.

Kits for models 7ins. long and upwards.
Ask for free illustrated lists at Hobbies Branches or from Hobbies Limited, Dept. 99, Dereham, Norfolk.



Build this beautiful DOLL'S HOUSE

for your
daughter

Kit 2910

52/4

(Carriage
paid U.K.)

Any handyman will enjoy making one of these doll's houses from Hobbies kit No. 2910. The completed house is 1ft. 5ins. wide and 1ft. 4½ins. high. Everything necessary to build it is included in the kit—wood, metal 'open and close' windows, door, staircase, chimneys, hinges, catches and covering paper for inside and outside. And, of course, complete detailed instructions that anyone can follow. Other doll's house kits are described in the booklet mentioned below.

or a grand fort for the boy

This sturdy Fort is truly the boy's answer to his sister's Doll's House, and will keep him (and his father!) amused for hours on end. Assembled for use, it is 36ins. wide, 27ins. deep and 21ins. high, but packs for storage to 18ins. wide, 14ins. deep and 13ins. high. Kit is complete with all necessary materials and instructions.

Kit 248

Special

57/-

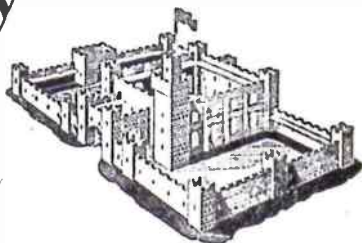

(Carriage paid U.K.)



Hobbies kits and tools are obtained at good stores, Hobbies branches in London, Glasgow, Manchester, Birmingham, Sheffield, Leeds, Hull, Bristol and Southampton, or carriage paid from Hobbies Ltd., Dept. 99, Dereham, Norfolk. Illustrated two-colour booklet of complete range FREE on request.



THE FLUXITE QUINS AT WORK

'And now let's begin
Lesson Two.

Heat the bit is the next
thing to do.

And when it is seen
That the flame's
showing green.

The bit's nicely heated
right through.'

See that FLUXITE is always by you—in the house—garage—workshop—wherever speedy soldering is needed. Used for over 40 years in Government works and by leading Engineers and manufacturers. OF ALL IRONMONGERS, IN TINS 1/- upwards

TO CYCLISTS! Your wheels will not keep round and true unless the spokes are tied with fine wire at the crossing AND SOLDERED. This makes a much stronger wheel. It's simple—with FLUXITE—but IMPORTANT!

FLUXITE

SIMPLIFIES ALL SOLDERING

Write for book on the art of 'SOFT' SOLDERING and for Leaflets on CASE HARDENING STEEL and TEMPERING TOOLS with FLUXITE Price 1½d. each.
FLUXITE LTD., BERMONDSEY STREET, S.E.1

The Woodworking Lathe for the Home Workshop

MYFORD

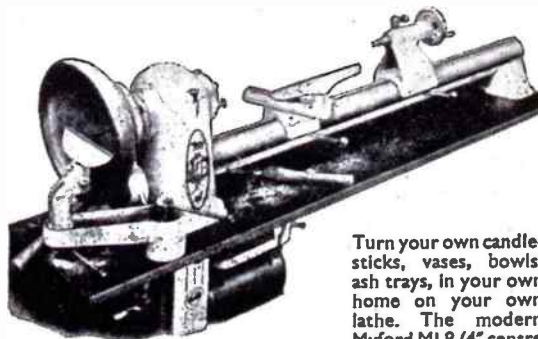

Turn your own candlesticks, vases, bowls, ash trays, in your own home on your own lathe. The modern Myford MLB (4" centre

height) will give you good work right from the start. Modern but inexpensive, strongly-made but easy to operate, the high-speed MLB is Britain's finest lathe value.

The MLB Lathe is supplied through leading Tool Merchants. Your nearest shop? Write Myford—and ask for the MLB illustrated leaflet and price.

MYFORD
ENGINEERING CO LTD
BEESTON NOTTINGHAM