

# Hobbies

## WEEKLY

### CONTENTS

	Page
Kite Designs - - -	133
Tubular Door Bell -	135
A Camera Tripod -	136
Harp Hat Pin Holder	137
Small Baby Trolley -	138
Tablet Weaving - -	139
Paper Aeroplanes -	140
Olympic Games on Stamps -	141
Hat Pin Holder Patterns - -	143

July 7th, 1948

Price Threepence

Vol. 106 No. 2749

## Some of the popular KITE DESIGNS

**M**ARCH winds, of course, are too powerful and gusty for the flying of kites. April is too wet, and sometimes rather gusty. June is a better month for kite-flying. The weather is milder and dependable with light breezes. It must be borne in mind, however, that while there is no apparent breeze near the ground, there is probably a strong breeze high in the sky. A mountain slope often throws wind current skywards.

And with these preliminaries, let us view the design of five popular kites, all of which are of a good medium size, with exception of the model shown in our illustration. It is a giant size, about 30ins. by 20 ins.

The making and flying of larger sizes of kites is just as simple as the smaller types, but due to the strain, a strong tow line, such as cord, is wanted. A large flying field is also required, and before attempting to fly the mammoth kites, the reader should make himself fully conversant with the smaller models.

### Kite Design "A"

This is an oblong type, 20ins. by 18ins., which is fairly large, but not difficult to handle. It, like most kites, consists of  $\frac{1}{2}$ in. square strips of wood, crossed with thread at the middle and around the ends. Small notches, for the thread, are made at each end of the frame strips with a knife.

Having secured the thread, the framing is covered on one side with paper, this being cut to the size shown

at Fig. 1. Light coloured tissue paper may be used, or brown paper. The use of newsprint paper is not advised, as this, when wet, is liable to tear easily.

The framing is set over the prepared paper and the hems pasted and folded over the threads. For flying purposes, a belly band is arranged at the face side, as shown, using a strong thread, or fine glace twine. The tail line is then attached and the tails (folded pieces of paper) added, using the

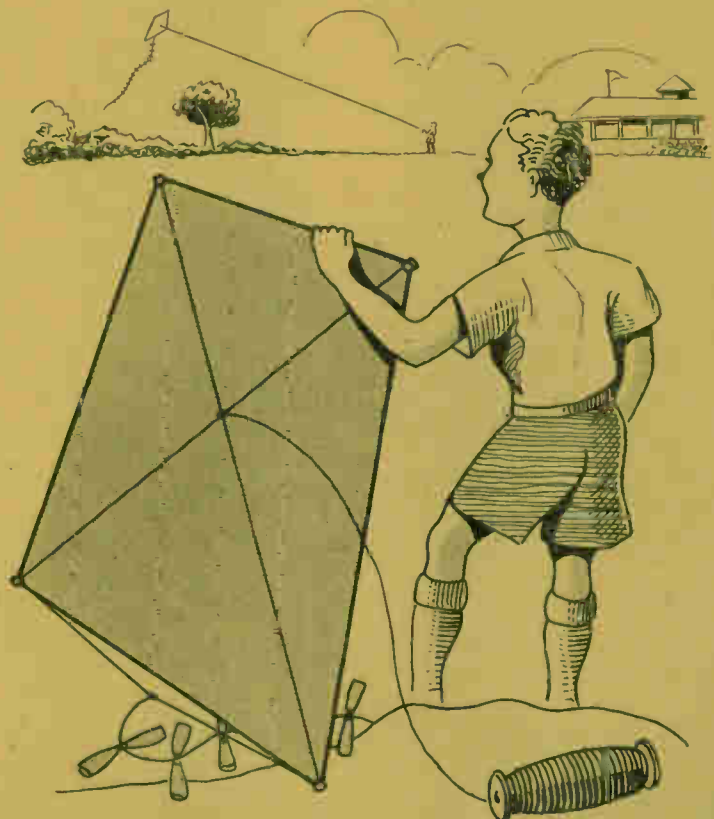

All correspondence should be addressed to The Editor, Hobbies Weekly, Dereham, Norfolk.

special loop shown in the enlarged detail.

The towing line, preferably a glace cord or twine, is added. The knot, although tight, must be able to slip up or down to give the best flying angle to the kite.

### Kite Design "B"

The kite, B, Fig. 2, is a good flyer, due to its shape. It is made similar as A, but is smaller at the top than the bottom. The tow line should be tied exactly where the belly bands cross

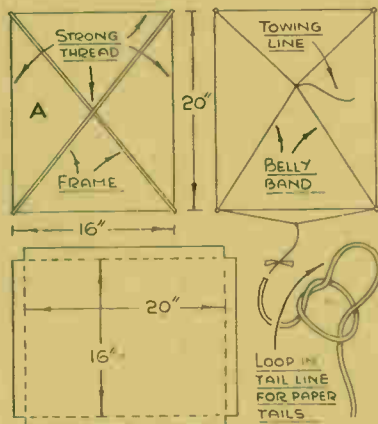

Fig. 1—Size and detail of square kite

has an extra cross piece, as shown, same being added after binding the main sticks together.

It is a strong kite, easily flown, but is liable to spin or dart about if the tail is of insufficient length. On the other hand, the tail must not be so long that it weighs the kite down too much; a compromise must be made.

C is made in exactly the same way as the previous models. If made the size shown, use brown parcel paper for a covering. A strong thread is not strong enough. The fine twine, known

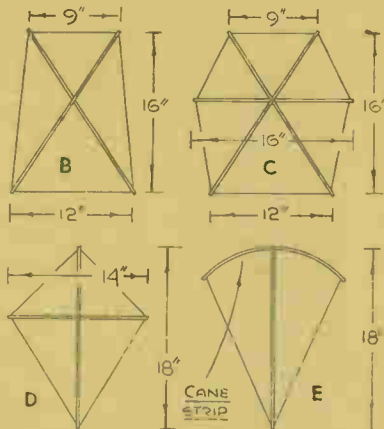

Fig. 2 Four popular designs easily made up

over each other. This is usually the best flying position, giving the correct slant to the kite.

A kite flies by virtue of its slant against the wind. The greater the slant, the higher the kite flies. When the tow line is too low, the kite is liable to dart from side to side. The best flying position is usually to be found by trial and error methods. B could be reduced to 14ins. by 10ins., but there is really no set rule regarding dimensions.

### Kite Design "C"

This model is known as a "star" kite. It is made up similar as B, but

as glace cord, is excellent for kite brace lines, tow lines, etc.

It is usually brightly coloured and sold pile-wound on cardboard tubes. Warehouses selling hemp cord, fibre rope, sash cord, etc., usually stock it, including firms who cater for the requirements of upholsterers.

### Kite Design "D"

D is the simplest of all kites, and an excellent flyer, too. It is known as a diamond kite, since its shape resembles the "pip" of the ace of diamonds. Note, however, that it has a long tail end. If the cross piece is 14ins. long, this is invariably tied half of its length

(7ins.) from the top end of the spine strip.

When the belly bands are attached, these will cross in exactly the same way as the wooden strips, and by tying the tow line at the cross-over, this will be found to be the best flying position.

### Kite Design "E"

This kite is similar as D, but is known as a "bender", due to its bent top cross piece. This is usually prepared from a piece of school cane, or twig. A piece of ash would serve; ash bends easily.

To make the frame, cut the spine piece to length, including the top piece, this being about 10ins. or 12ins. long. Nail the top piece to the spine, using a gimpin. Notch the ends, tie the thread to one end of the cane, bring it down and around the spine end, up to the opposite end, meanwhile getting a bend into the cane. The thread will hold the bent wood, following which the framing is covered with paper in the usual way and the accessories added.

On account of the bend, it will be necessary to snip the hem of the paper with scissors. The paper will then paste down more flatly, with less wrinkles. The bender, owing to its high belly band cross-over, if two bands are used, is not a good flyer.

Therefore, a single belly band, from one end of the spine stick to the other, is used. If desired, a cross-over band could be added, but this should be slack so a lower tow-line position is possible.

The wood, for all kites, can be strips of deal. It need not be square in section. In fact, stuff  $\frac{1}{4}$  in. by  $\frac{1}{4}$  in. is ideal for smaller kites. Larger (medium) sizes need sticks  $\frac{3}{4}$  in. by  $\frac{1}{2}$  in. Giant models need sticks  $\frac{1}{2}$  in. by  $\frac{3}{4}$  in., preferably made from a hardwood.

The best place for flying a kite is an open field, or a park. When the breeze is not powerful enough to "life" the kite skywards, running backwards will create the necessary force. Be sure to look around frequently where you are running.

## A Reader's Splendid Model Locomotive

**T**HIS splendid replica of a "Great Northern" 4-6-2 Pacific Locomotive was made by Mr. G. Duncan whose picture is given here, of Greenlaw Place, Woolwich, London, S.E.18. It is an outstanding example of what can be done with fretwork tools and a Hobbies kit of materials. The design, readers will remember, was presented with Hobbies 1947 Handbook, but those readers who were not fortunate enough to get a copy can still procure the design sheet and kit of material. The large sheet is No. 234 Special with pattern for making this 2ft. model, obtainable for 9d. The parcel of

planed wood for all parts costs 12 2 (postage 9d). No doubt many readers will want to follow the example of Mr. Duncan.



# Fit your hall or house with a modern TUBULAR DOOR BELL

**S**HOULD you own an old electric door bell, with a rusty gong or a gong that does not ring properly, we show how the device can be converted into a modern type. Door chimes, of course, are operated by an electric-magnetic mechanism similar as the common electric door bell.

There are, however, two tubular chimes or bells which give forth a sweet, harmonious sound in the hall—a vast difference, indeed, from the sudden, shocking, harsh, tremolo ringing of the average door bell.

Now, a single tubular bell is easily fitted to the gong arm on door bell cases. It is hung in position with a cord and two small felt pads, or washers. The hammer, striking rapidly upon the tube, creates a sound reminiscent of a church bell. The pitch of the note can be high or low according to the diameter and length of the tubing.

## Brass Tubing

The best tubing to use is of brass, without a join. Brass curtain tubing, it must be pointed out, is sometimes made from sheet iron, with a join, covered with thin brass. While this will produce a sound, when struck, a solid tube will give much better results.

A piece of light, metal pipe, such as used for gas and electrical wires, made from iron, will give a ringing note when struck. The pipe is either galvanised or black-japanned. Another substitute is the aluminium tubing used in aircraft construction. This, although made from a light metal, gives a pleasing ringing note. Brass, however, produces best results, particularly when hard-drawn.

The lovely chimes in clocks, for example, are created by a series of tuned lengths of solid brass rod about 3/16in. thick. Any length of solid rod, whether brass, iron or mild steel, is liable to ring sweetly if suspended by a cord and struck gently with a small hammer.

In the case of a tubular rod, there is less weight, with a greater vibration. So, this kind of bell is desirable, and for the purpose in hand, you need a piece about 10ins. long by 3/4in. or 1in. in diameter. This size happens to suit the gong arm of most door bells and the length of the back-board required. You are not so confined to the length, as the diameter.

## The Back-board

In order to incorporate the new tubular bell, you need a wooden back-board, cut to the size and shape shown at Fig. 1. A piece of deal, 16ins. long by 5ins. wide by 1/4in. thick makes the back-board. When you have this

prepared, remove the old gong from the door bell arm. This arm, you will find, has a bend in it to support the gong properly.

It will, or may, be necessary to bend it more squarely with pliers so it accommodates the tubing easily, as seen in the side elevation. The threaded hole in the arm must be brought up so it will be possible to drill a hole directly beneath it in the bakelite case, the drill bit being

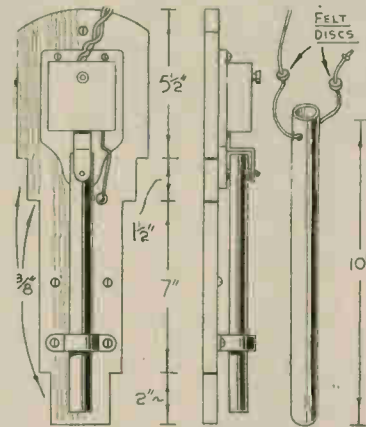

Fig. 1—A front and side view of the finished bell, with detail of sizes, etc.

inserted and worked through the gong arm hole.

## The Tubular Bell

At this point, you need to prepare the tubular bell. When cut to length, drill a hole through the tubing, near one end. The hole must penetrate both sides of the tubing so the suspension cord can be threaded through it, as shown.

Any soft cord may be used, but a small piece of braided or window-blind cord is preferred. To prevent wear, the rims of the holes in the tube should be countersunk slightly, or else rubbed with a "poke" of emery paper to remove the sharpness.

Having inserted the cord, slip on a felt washer at each side, then thread one end of the cord through the gong arm hole and tie a knot in it. Thread the other end of the cord through the hole in the casing, bring the tubular bell into position and tighten up the cord, then secure it by forming a knot at its end.

There will, owing to the difficulty of getting the knot tied close enough to the bakelite case, be a slight amount of sagging, but this does not matter, providing the felt pads remain between the case and the arm.

You may, perhaps, wonder why cord, instead of a nail, is used. You

may also wonder why the felt washers are inserted between the tubular bell and its mooring points. The reason is that the tube must be free to vibrate. A nail, or a screw, would "kill" vibration, and the same effect would arise should the tube touch the gong arm and the case. Therefore, the tube must be isolated as much as possible.

## The Finishing Touches

When you have got the tubular bell suspended correctly and are satisfied with its ringing note, the mechanism is screwed to its back-board, as at Fig. 1. The hammer, or beater, requires to be bent in the manner indicated so it strikes correctly against the bell.

To prevent the bell swinging about, like a pendulum, assuming the back-board is to be affixed to the central upright of a front door, at the inside, a staple, made from hat felt, must be screwed to the back-board to go over the lower end of the bell, as shown. Brass, or any other sheet metal, could be used for making the staple, but the felt will not be inclined to deaden the vibration of the bell if the latter touches it.

Wires, from the bell mechanism, are taken to a battery and thence to the door push-switch. To wire up correctly, simply connect a length to one terminal of the door bell mechanism and bring it along to one terminal of the battery. Connect another length to the second battery terminal and bring it to the door switch.

A further length is taken from the switch along to the bell mechanism, i.e., its second terminal or connecting point. The circuit, broken by the switch contacts, is closed as soon as the switch contacts are pressed together, thereby sending a current through the electro-magnets, these causing the hammer to beat on the tubular bell.

## To Prevent Wood Splitting

**W**HEN nailing very thin wood it usually splits. This is very inconvenient at times, and to prevent it, the nails should be flattened out until they are like a knife, and then driven in with the chisel-like edge at rightangles to the grain.

## Parting a Glued Joint

**T**HE best way to get over the difficulty of parting two pieces of wood which are glued together is to rub a little methylated spirits round the joint. After a few minutes the two pieces will separate quite easily.

# How the enthusiastic photographer can make for himself A CAMERA TRIPOD

A TRIPOD is an essential accessory where stand, box and folding cameras are concerned, if one is to take good indoor and outdoor time exposures. Of course, any kind of temporary support will serve, but such supports are not so convenient as a proper tripod. There are various kinds of metal telescopic tripods, with swivelling ball-and-socket heads which enable the camera to be set at any angle desired.

As some difficulty, however, is sure to be experienced in obtaining such a tripod, a good makeshift, for home use, can be made from builders' lath, odd pieces of wood, a few bolts, etc.

## Cameras Suitable

It is rather difficult to copy the metal, folding, portable types in wood, and the "head" requires to be somewhat large to be adjustable. It will, however, take all types of cameras provided with sockets for attachment to tripods.

The tripod to be described is of sensible height, light and rigid. The camera can be adjusted to any up-and-down tilt or swivelled on a horizontal plane, side angle being obtained by adjustment of the legs. The leg tips are spiked and are non-slipping; if desired, one can make the leg portions adjustable so the camera can be raised or lowered to the maximum and minimum of height.

The tripod is an exact model of one made and used by the writer; having sufficient scrap wood at home, the tripod cost very little to construct.

## Leg Construction

The legs should be constructed first. These—one of which is detailed at Fig. 1—resemble lightly-made crutches, consisting of two "thigh" pieces, with the "leg" portion fixed between them and a cross strut and a pivoted shoulder block at the top.

The thighs, leg and strut pieces are cut to length from  $\frac{3}{4}$  in. wide by  $\frac{1}{2}$  in.

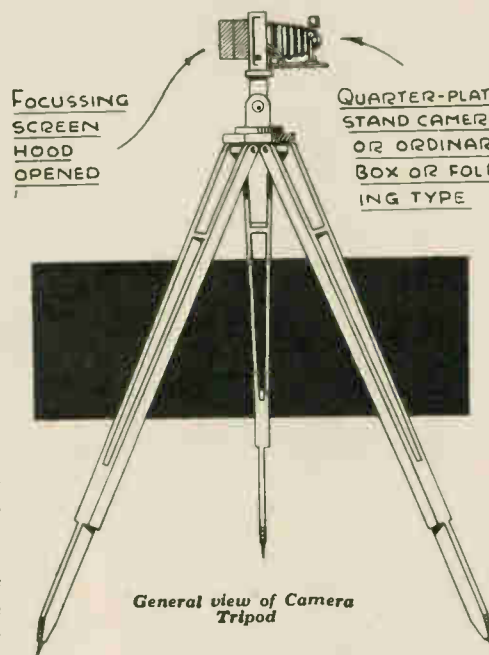

thick strips of wood. These strips can be very easily rip-sawed from  $\frac{3}{4}$  in. thick deal shelving board, the edge be planed as each strip is removed, this keeping the edge true and square and saving the worker from having to trim two sides of the strips when all have been cut.

If you are not able to do this, an alternative, as stated, is builders' lath. These laths measure about  $1\frac{1}{2}$  in. wide by  $\frac{1}{2}$  in. thick. The edges and surfaces of the laths are usually rough and require to be trimmed with a smoothing plane; the width should be reduced to  $\frac{3}{4}$  in.

The leg pieces are 18 ins. long and pointed slightly at one end, as suggested at Fig. 1. They are glued and affixed between the  $3\frac{3}{4}$  in. long thigh pieces with 1 in. oval nails, points of same being clinched on the

opposite side with a hammer, or you might prefer to use  $\frac{3}{4}$  in. by 6 flathead iron screws.

The cross struts are  $2\frac{1}{2}$  ins. long. Attach them 9 ins. down from the top ends of the high pieces. The top ends, as can be seen, are rounded over and centrally bored for the pivot screws. The top shoulder block is  $2\frac{1}{2}$  ins. long by  $\frac{1}{2}$  in. square. It is held in place by means of 1 in. by 6 roundhead screws, the heads being based with thin washers to prevent wear. The screws should be a tight fixture in the shoulder block and the shanks free to turn in the thigh holes.

Having made three identical leg frames, make holes in the leg tips with a bradawl for the spikes. The spikes are 2 in. wire nails driven 1 in. deep, the heads being cut off and the projection filed to a sharp point. Small, half-round, rubber-headed nails could be used, but these may be hard to obtain.

## Adjustable Leg Pieces

If you want adjustable leg pieces, the 18 in. long leg is cut, diagonally, to be 15 ins. long, as shown at Fig. 2. The remaining portion is a fixture between the thigh pieces.

It will be necessary to bore  $\frac{1}{4}$  in. holes in the leg and the thigh pieces for the bolts, the latter being  $1\frac{1}{2}$  in. long by  $3/16$  in. thick roundhead carriage bolts, with suitable washers and bat-wing nuts. It is advisable to mark the bolt hole position on the thigh pieces, put the leg in position, then drill the bolt holes.

Note that the diagonal cut serves a purpose. It prevents the leg from moving outwardly. In other words, the packing piece is made to serve as a stop for the leg and keeps the leg straight with the thigh.

The legs can thus be returned to "normal" quickly, following which the bat-wing nuts are screwed tight to hold the leg in place. Carriage bolts, as you know, are square-shanked at the head. It is only necessary to push the bolts through, slip on a washer,

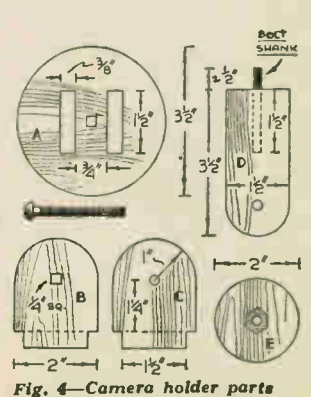
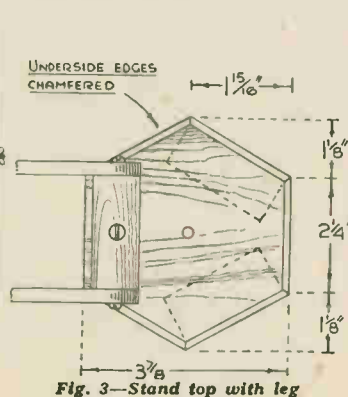
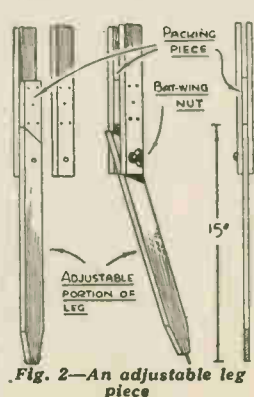
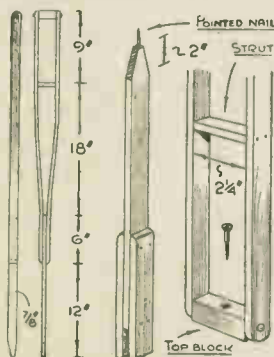

then screw on the nut. By tightening up the nut, the square-shanked portion of the bolt is forced into the wood and keeps the bolt from turning around with the nut.

### The Top Piece

The top piece to which the legs are attached is hexagonal in shape, as shown at Fig. 3. It is cut from  $\frac{1}{2}$  in. deal, the edges at the underside being chamfered with a plane.

Having bored a  $\frac{3}{16}$  in. central hole, the legs are screwed to the underside of the top piece, using glue and single  $1\frac{1}{2}$  in. by 8 flathead iron screws. The leg shoulder blocks are kept level with the chamfered edge (see dotted lines).

Be sure to have the legs attached the right way about, i.e., so the adjustable leg piece (if made adjustable) can be only moved inwards, not outwards, because the thighs are able to move outwardly.

If the leg portions also move outwardly, there will be too much of a "splay" and the spikes will obtain a poor grip on the ground. It is better to have the movable, adjustable portion almost upright, with the thigh at the outward angle, and this will not be possible if the leg portions can only

move outwardly.

### Camera Holder Parts

While plywood would be the best, plain wood,  $\frac{3}{8}$  in. thick, may be used to make the camera holder. It is essential that the grain runs in the direction of piece A, as shown at Fig. 4.

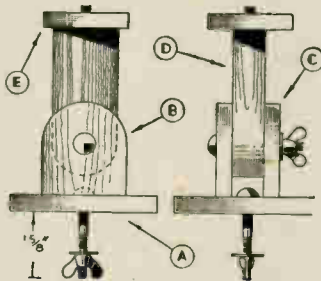

Fig. 5—Side and end view of holder

The other parts, B, C and E are cut from  $\frac{3}{8}$  in. stuff, with part D from  $\frac{1}{2}$  in. stuff. The top end of piece D is centrally bored  $1\frac{1}{2}$  ins. deep with a  $\frac{3}{16}$  in. drill or bit. This hole is for a bolt shank.

The bolt—a roundhead machine type—is shown; it is driven into the hole with a screwdriver and its head

removed to leave a  $\frac{1}{2}$  in. threaded projection.

The disc, E, is screwed over the bolt projection, but before doing so, it will be necessary to cut a neat recess in the centre of part E for a nut which is a flush fit. The underside of the disc is smeared with glue, then screwed on part D.

Parts B and C are glued to the mortises cut in part A. As soon as the glue sets, insert a 2 in. by  $\frac{3}{16}$  in. carriage bolt in part A, then fit part D between parts B and C. Insert a 2 in. by  $\frac{3}{16}$  in. carriage bolt through the three pieces, fit on a washer and a bat-wing nut and tighten the latter to draw the bolt into part B.

### Final Work

This completes the holder, or rather, the tripod head, and helpful side and end elevations are shown at Fig. 5. The completed head, of course, is secured to the tripod top by means of the bolt in part A.

To finish the work, it can be stained light oak or jet black. However, you might prefer to keep it in the natural state. By the way, do not have the camera socket projecting too much. The camera must screw down firmly on piece E.

## Full size patterns printed on page 143 for this NOVEL HAT PIN HOLDER

THIS is a distinctly novel type of hat-pin holder. The actual holder, of course, is in the form of a harp. When the hat pins are inserted, they form the "strings" of the harp.

The whole thing can be made from panel of wood measuring 9 ins. by 4 ins. by  $\frac{1}{2}$  in. Although the main harp shape measures  $4\frac{1}{2}$  ins. at its narrowest width, the panel can be used by cutting the main harp shape in three separate pieces which fit together. This must be done, incidentally, even though you may have a scrap piece of material which would enable the entire shape to be cut out in its complete form.

By having the shapes cut separate, one can get at the drilling of the hat pin holes much better, following which the parts are fitted together. You will understand all this more clearly if you turn to the patterns shown full size on page 143 of this issue.

### The Main Body Shape

The main body shape, it will be seen, is shown with its three parts fitted together. It is only a matter of tracing out the parts separately on the  $\frac{1}{2}$  in. thick fretwood and cutting them out.

When tracing out the parts, be sure to mark on the vertical lines where

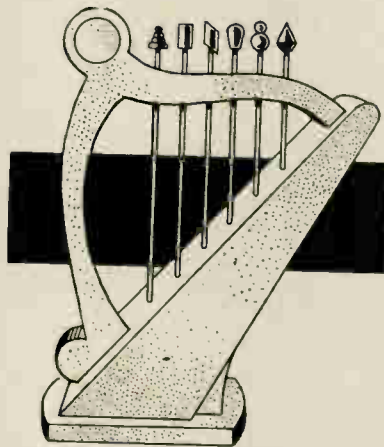

they cross the top "peg arm" piece and the slanting "sound-box" piece. When the parts are cut to shape, the lines are carried over the edges with a small set square and pencil, then a central line gauged across them on the edge.

### Drilling the Holes

The six hat pin holes are best made with a  $\frac{1}{16}$  in. twist drill. When drilling, keep the drill in line with the side pencil marks. Having made the holes, the rims are countersunk

slightly to facilitate the entry of the hat pins.

Glue the pieces, after fitting them neatly together first of course, together, then cut out two side shapes. These are glued to the main piece so that the tenons project evenly at the bottom end.

### Mortise and Tenon

The tenons fit into the mortises cut in the base piece which can be cut out and attached. To complete the novelty, give it a light rubbing with No. 1  $\frac{1}{2}$  glasspaper, then apply a coat of gold paint. A single application should suffice, but if not, brush on a second coat.

The discs can be omitted, but if you wish to include them, they should have been attached to each side of the work prior to painting. They can be cut from  $\frac{1}{2}$  in. or  $\frac{1}{4}$  in. wood. In the latter case, they should be pared and rounded at one side to make them dome-shaped. The discs, or buttons, can be silver, including the base.

By the way, hat pins are not all the same length. The harp takes most sizes. If you are making the novelty as a gift for a lady and buy  $\frac{1}{2}$  dozen hat pins all the same length, it would be easy to vary the lengths of the stems suitably and re-point by rubbing on an oilstone.

# For garden or holiday use this is a splendid BABY TROLLEY

**H**ERE is a splendid little trolley to make up for giving the youngsters rides in the garden. It is a lightweight, but sturdy in construction, and when painted in gay colours would make an acceptable gift for any youngster. Wood  $\frac{1}{2}$  in. thick is used throughout, and the simple shaping of the various parts can be done with the fretsaw, using a coarse saw.

The length of the trolley is 16 ins., and its height 11 ins. The seat, which is of ample size, measures 9 ins. long by 6 ins. wide. The construction of the article can be plainly seen in the open diagrams, Figs. 2 and 3.

## The Body Work

The floor, A, is a piece 16 ins. long by 10 ins. wide. As it is unlikely a single board this width can be obtained, two 5 in. boards must be glued or doweled together. When these two boards are connected with the cross rails, C and E, a very firm flooring would result. The two side edges of the floor should be rounded off and made smooth.

The two lower side rails, B, are next prepared from wood 16 ins. long by  $3\frac{1}{2}$  ins. wide. The curve cut in this is drawn to a radius of 7 ins. (see Fig. 2). The centre lines of the wheel-axles, C, are 2 ins. in from the ends of the rails (see Fig. 2) and from the line of the front axle the slope of the front rail can easily be gauged.

They will be spaced 7 ins. apart on the underside of the floor, see cross section, Fig. 3. Countersunk screws  $1\frac{1}{2}$  ins. long should be driven in.

The two axles, C, are 7 ins. long by  $3\frac{1}{2}$  ins. wide, and may be heightened in appearance by cutting the arc shown with a radius of  $3\frac{1}{2}$  (see Fig. 3). Screw the axles to the floor and to the sides, B.

The two upper sides, D, are each 16 ins. by  $3\frac{1}{2}$  ins., and having first

cut the two pieces square to these measurements, set out a number of 1 in. squares from one end as seen in diagram, Fig. 4. Through these squares the curve can be drawn, using the diagram as a guide.

The front of the decorative panel suggested for painting on can be also drawn in from the outline given. After cutting out and cleaning up the panel it can be used as a template for drawing round to produce the second side, D. The cross rail, E, measures 8 ins. by 2 ins., and with the two sides, D, can be screwed to the floor.

The seat, F, is a plain oblong 9 ins. by 6 ins. Its long edges are rounded off and the upper surface made clean and smooth. It is screwed to the tops of the side rails, D (Fig. 2). The two outer sides, G, will now be made, and some careful preparatory work will be necessary to make a really satisfactory job of these prominent additions.

## Drawing an Ellipse

They are elliptical in shape, and we give here the method of describing an ellipse. The plan, Fig. 5, gives the size of the piece of wood required, but it would be best to allow a  $\frac{1}{2}$  in. or so all round for working in the ellipse by the method suggested. Divide the piece and mark in the two axis shown by dotted lines in Fig. 5.

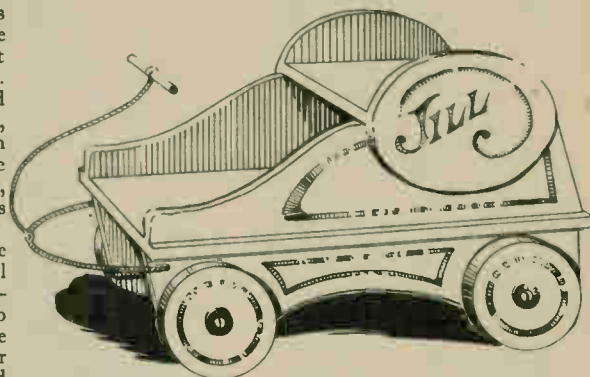

Fig. 1--The handy little Trolley with name painted on

With a pair of compasses or dividers, take half the major axis, which is 3 ins., and strike it through the major axis, using the end of the minor axis as the point from which the arc is struck.

In the two points so obtained, stick pins and also a pin at the point from which the arc was struck. Fig. 6 explains this very simply, and the method of tying a piece of thin twine round the three pins or points. Any proportion ellipse can be set out using this method. Having then drawn in our ellipse on the panel or prepared board, cut it round and clean up its edges. The second outer side can be drawn in from this, using it as a template.

Now screw the pieces to the sides, D, and here screws should be countersunk and the heads covered with putty ready for painting over. All surfaces of the wood should be given a thorough cleaning with coarse and fine glasspaper before the priming coat of paint is applied.

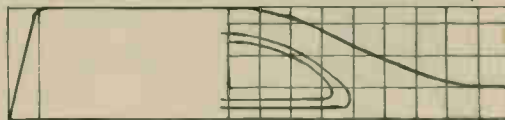

Fig. 4--Squared shape of main side

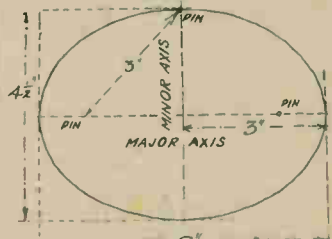

Fig. 5--The side ellipse required

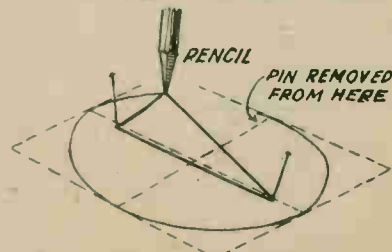

Fig. 6--How to mark out an ellipse

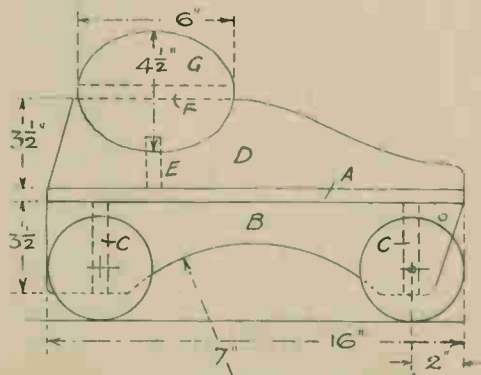

Fig. 2--Side view with lettered parts

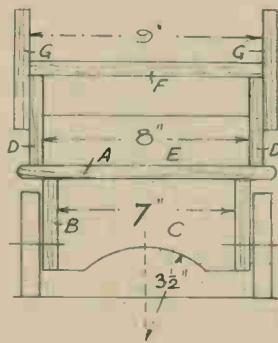

Fig. 3--End view and dimensions

# For making a number of interesting articles you should TRY TABLET WEAVING

**R**EADERS of Hobbies Weekly, interested in home crafts, may like to try their hand at the ancient pastime of tablet weaving. Ancient is the right term, because it was practised in Egyptian times. The tools necessary are few, and simple, and some pleasing artistic results are possible. The craft is limited in its scope as only narrow work is possible, but within such limits much useful work is possible.

The tools are detailed in Fig. 1. The tablets, A, can be cut from any thin but tough material, Celluloid, 1/16in. thick would do nicely, but other similar material would serve. For a start about 12 tablets would be enough, others could be added, as desired, later on.

Cut out a 3/16in. hole in the centres and a 3/16in. or 1/8in. hole near the corners. Slightly round the corner angles and glasspaper the whole to smoothness, especially the sharp edges of the corner holes.

A strip of wood, B, is planed up to fit the square centre hole, it can be some 8 ins. long. In this bore a few holes along, and provide a pair of stiff wire pins to fit the holes. Make from 3/16in. fretwood a shuttle, C, for the weft thread, and from the celluloid cut a strip to size at D.

## Material to Use

For the warp threads you can employ a good mercerised silk, or other suitable material. Even a strong knitting yarn will do for some purposes. For the weft it is more usual to use something thinner, such as a strong linen thread.

Four warp threads will be required for each tablet. These should be cut a little longer than the proposed length of the braid. Tie the ends together and thread through the holes in the tablets, as in Fig. 2. Then tie the other ends.

As each tablet is threaded push it on the stick, B, first pushing one of the wire pins in a hole to prevent the tablets working off. When all the tablets are threaded, and on the stick, push the second pin in the hole nearest

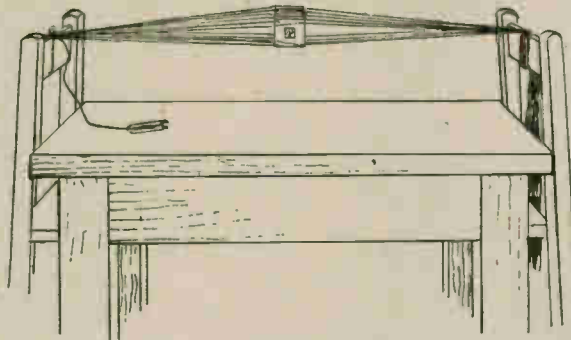

to them, so keeping all in place on the stick.

The warp threads must be stretched between some supports while the work progresses. A good and simple method here is to tie it to the back of two chairs, with a table between, as shown in the general view, but readers may have other methods they can use for themselves. As long as the warp is reasonably taut, and there is room below it for passing the shuttle to and fro, nothing else matters.

A plan view of the warp, thus stretched and ready for weaving is given in Fig. 3. The threads are drawn together at one end and tied to the chair back. At the opposite end, what we may call the "working" end, a piece of cord is drawn through the threads and then tied round the chair back, as shown.

## Working

For convenience in working, the celluloid strip, D, is pushed through the threads, alternately under and over them, and then is forced up to the cord, so as to spread out the threads a little instead of leaving them jumbled close together.

Take the shuttle, C, and wind a sufficiency of the weft thread on it. Tie one end to the warp, against the celluloid, then slip the stick out of the tablet. All is now ready for weaving.

Take the tablets in the hand, all together and give them a quarter turn,

so that threads 2 come to the bottom, and threads 3 take the place of 4. (See diagram, Fig. 2). Pass the shuttle in the opening between the threads, just at the front, or left, of the tablets.

Push the weft up to the celluloid strip, with a paper knife, or similar thin-bladed tool. Now give the tablets another quarter turn and bring the shuttle through, back again. Repeat this procedure, and do not omit to press the weft threads up tightly each time.

When the warp threads are so twisted that further work is impossible, untie both ends from the chair back, unravel the twisted threads and then retying in position continue until the work is finished. When done, cut off the unwanted warp threads and tie them in pairs. Leave enough to form a fringe at each end.

## Pattern Variety

Using a combination of colours the variety of patterns possible are almost endless. Longitudinal stripes follow if, for example, tablets 1, 2, 3, 7, 8, 9, are threaded in blue, and tablets 4, 5, 6, and 10, 11, 12, in red, and so in such arrangement as desired.

For cross stripes; in each tablet threads 1, 3 and 4 are one colour and thread 2 another. Using say black for 1, 3, and 4, and white for 2, cross stripes of white will appear in the braid, as at Fig. 4, E.

For producing a chequer pattern, F, thread every alternative tablet with black threads in holes 1 and 3, and white threads in holes 2 and 4, and the remainder between with black threads in holes 2 and 4 and white in holes 1 and 3.

In all cases, the tablets must be placed on the stick in correct order. In most fancy designs of braid, the first and last two tablets are threaded in one colour to produce a border and thus show up the pattern between.

Much interest results in working out fresh designs for oneself, which, with a little experience becomes quite easy in time.

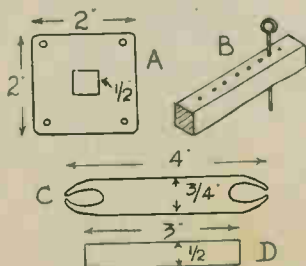

Fig. 1—The necessary tools

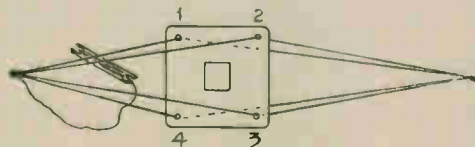

Fig. 2—The warp threads through the tablet holes



Fig. 3—Plan view of warp ready for weaving

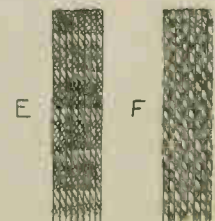

Fig. 4—Varied patterns

# How to make, fold and fly PAPER AEROPLANES

**H**OW do you fancy the modern paper aeroplane shown here-with? Better than the long-pointed type, isn't it? And it flies much better, too! The folding procedure is not so difficult as it seems at first glance.

To avoid confusion and vague writing, we provide nearly all of the various folding stages. Naturally, it is very hard to describe clearly just how the paper is folded up; we would rather get a sheet of paper and actually show you the simple method so you could follow each move as we made it.

To make a success of the first attempt, do your folding neatly and exactly and thus avoid confusing yourself. Do not hurry—take your time. Any sort of paper can be used, but for the best results, you should try to find a sheet of paper measuring 10ins. by 8ins.—the size of typewriter paper.

## The First Folds

Having managed to secure the size of paper required, it is folded diagonally as shown at Fig. 1. The 2in. bottom margin is cut away with the scissors, this serving as a tail piece later on.

You are left with an 8in. square piece of paper which is then creased neatly four times as shown at Fig. 2.

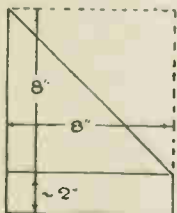

Fig. 1

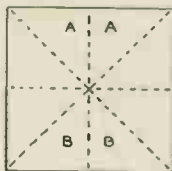

Fig. 2

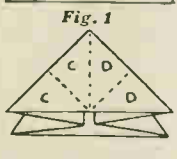
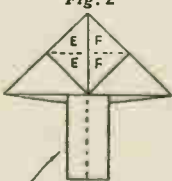

Fig. 3



TAIL IN POSITION

Fig. 4

The sections marked A and A are folded face to face, including those marked B and B, the paper thus being folded as shown at Fig. 3.

Having folded the tail-piece in the manner depicted (it is merely a matter of folding the strip down the centre and then folding one end into a point, the corners meeting on the folded central line as indicated by the dotted

lines), the pointed end is inserted in under the wing part (see Fig. 4), pushing it right up to the corner.

## Complicated Folds

We now come to the more complicated folds, as at Fig. 3. Press the triangle of paper quite flat with the fingers, then fold over section D on D, then C on C. The paper takes the form shown at Fig. 4.

The point of the triangle is then folded over in the direction of the tail-piece so that sections E and F meet. Turn the fold back to its original shape again, as shown, the dotted lines indicating the fold thus made.

To obtain the point jutting from the centre of the wings as at Fig. 8, certain creases have to be made so as to get correct folds. Therefore, section G (see Fig. 5) is folded over as shown, then brought back to its original position again. It is folded over in the opposite way, as shown at Fig. 6, then folded back again. The same folding operations apply to section H.

The resultant creases are shown by the dotted lines at Fig. 7. At this stage, portion G is tucked into itself in the centre, as suggested by the recent folding shown at Figs. 5 and 6. Section G then appears as shown at Fig. 7. The other section, H, is folded similarly, then the nose of the work folded over (as at Fig. 8) and brought

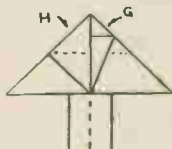

Fig. 5

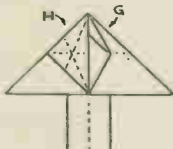

Fig. 7

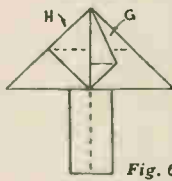

Fig. 6

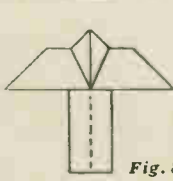

Fig. 8

round to the reverse side of the work, as at Fig. 9.

## A Different Tail-piece

Reading these instructions, without actually following them out faithfully with a piece of paper, makes them seem unintelligible and difficult. However, after you have made one aeroplane, you can make the second one almost entirely from memory.

The actual folds in the paper, plus

the diagrams and the drawings of the finished models (at Fig. 11) will make it all clear to you. It is worth while getting a clear understanding of the "nose" folds right at the beginning, for not only is the nose part of the shape of the plane, but the model is heavier there, due to the many folds and so helps the plane to glide in a correct manner.

## How to Fly

And if desired, a less plain sort of tail-piece can be fitted, this taking the shape shown at Fig. 10. The end (the tail-less end) is pointed as at Fig. 3 and inserted in the wings in the same manner.

These new type of paper fliers can be flown in still air, or gusty breezes, with good effect. To set one in flight, it is held (by the underside of the wings) in the centre and launched up into the air with a swing of the arm. It should fly up a good distance, then drop earthwards in a power dive, then flatten out just prior to reaching the ground.

It will probably skim along the ground for a short distance and then make another effort to rise higher. Much depends on the wings and the wind. Sometimes the plane will, upon being launched, fly up straight, then come down in wide circles and strike the ground with full force—but luckily,



Fig. 9

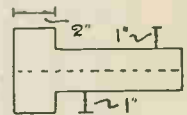

Fig. 10

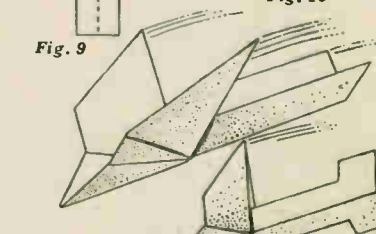

Fig. 11

without doing any damage beyond denting the nose a little, and this can always be straightened out again.

Incidentally, the paper aeroplane can be any size, but not too big, as it becomes rather flabby, unless stiffer paper is used.

Please lend your copy of **Hobbies Weekly** to a friend who cannot obtain one for his own use





## STAMPS AND THE OLYMPIC GAMES

**B**Y now all stamp collectors will have specimens of the 2½d. stamp issued in connection with the Silver Wedding of their Majesties the King and Queen. The lucky ones will also have the £1 stamp, too! Well, it is seldom that Great Britain issues a commemorative set of stamps, but this year three such sets are being issued.

In addition to the Silver Wedding stamps we have a set in connection with the anniversary of the issue of stamps in the Channel Islands and also one to commemorate the Olympic Games being held in London. We cannot illustrate these particular stamps because at the time of writing they are not available.

However, as the values are only 2½d., 3d., 6d. and 1/-, there is no reason why each one of you should not add them all to your collections. As to the stamps for the Channel Islands, there is a difference of opinion as to the wisdom of having such a set.

If you look through the pages of a good stamp collection you will see that a number of countries have issued stamps in connection with the international games. Of course, the original Olympic Games were held ages before stamps were ever thought of.

The first of the present series of games was held in 1896 in Athens. In commemoration of these, Greece issued a set of twelve stamps showing pictures of some of the events which used to take place in olden times,



Fig. 1—Greek Contests



Fig. 2—German Contests



Fig. 4—Queer Football

such as discus throwing (still an event) chariot racing and (the specimen chosen here) gladiators fighting.

The Olympic Games are held every four years. In 1900 Paris received the athletes, 1904 St. Louis, U.S.A., while London took them in 1908 instead of Rome. Then they visited Stockholm. In 1916 the Great War was in progress, so there was no contest. In 1920 the struggle was held in Antwerp, followed by Paris, Amsterdam, Los Angeles and Berlin in 1936.

Again war stopped the contest (1940) and London takes up the series this year. As, no doubt, you know the winter games—skating, ice hockey, ski-ing, bobsledding and so on—have already taken place in Switzerland and a special set of stamps was issued by that country in commemoration.

There were four stamps in the set. One shows what a goalkeeper in an ice-hockey team has to put on to protect himself, another shows a picture of a ski-runner.

Germany in 1936 issued a set of eight stamps, the designs showing various athletes in action, diving, football, javelin throwing, relay running, fencing, rowing, steeple-chasing, and (as the picture shows), a gymnast in action.

Germany had had the Winter games the year before and in celebration of these, issued three stamps showing skating, ski-jumping and bobsledding. One of the best of the Olympic Games Winter stamps which has been issued was the 1932 from the United States of America, showing the picture of a man ski-ing at Lake Placid.

The Summer Games stamps in connection with Los Angeles gave an excellent picture of a sprinter getting on his mark and also a discus thrower of ancient times.

It is not easy to make a large collection of Olympic Games stamps, but if one was to include other athletic contests, then a very wide

jumping and Jugoslavia adds pole vaulting, and putting the weight. In 1932, for the European Rowing Championship, she issued a set of eight stamps each showing a team in action.

Russia in 1935 for the Spartacist Games had ten stamps of diamond shape with running, diving, football, ski-running, cycling, tennis, skating, hurdling—all illustrated.

Tennis also comes from the Philippine Islands set of



Fig. 3—Russian Sprinting

1934, together with basket ball and baseball. The United States of America in 1939 issued a special stamp to commemorate the centennial of baseball showing a game in progress.

Some of the best association football pictures (Rugby does not appear to figure on stamps), come in the 1934 World Championship set from Italy. It shows a goalkeeper tipping a ball over the bar, players heading the ball and a defender tackling. Roumania also depicts football among the 1937 set, whilst France in 1938 issued a single stamp showing a fine action picture of goal-keeping.

Surely the most curious football picture is the one illustrated here, which comes from Uruguay. The Uruguayan team won the football contest at the Olympic Games in 1924 and again in 1928. The first of these victories was commemorated by a stamp showing a picture of "Victory" of Samothrace.

The one illustrated issued in 1928 commemorated both victories. As you can see, it shows a very primitive set of goalposts, a football apparently resting on the top of the crossbar and a bird perched on the top of that. Small footballs form the top corner ornaments.

# MISCELLANEOUS ADVERTISEMENTS

The advertisements are inserted at the rate of 3d. per word prepaid. Name and address are counted, but initials or groups, such as E.P.S. or £1/1/6 are accepted as one word. Postal Order and Stamps must accompany the order and advertisements will be inserted in the earliest issue. Announcements of freetrack goods or those shown in Hobbies Handbook are not accepted. Orders can be sent either to Hobbies Weekly, Advert. Dept., Dereham, Norfolk, or Temple House, Temple Avenue, London, E.C.4

**ONE HUNDRED** different, really worth-while British Colonials. Catalogue value 10/-. My price 2/6 post free.—Arkley, 2 Slieve Coole Park, Newcastle, Co Down, N.I.

**WIRELESS** parts, dismantled 5v. set, including L.S. unit, no valves, 25/- the lot.—Appletree Cottage, Ovington, Sudbury, Suffolk.

**STAMPS FREE!!** Twenty unused (2½d.).—G. H. Barnett, Limington, Somerset.

**WANTED**—complete or part complete set of "Astounding Science Fiction", from January 1939 to December 1944. Good price offered. Write—47 Grove Park, S.E.5

**FREE** Stamps, liberal discount to all approval applicants enclosing postage.—J. Lindsay, 17 Johnston St, Paisley, Renfrewshire.

**LONELY?** Join Friendship Circle. Details 6d.—Secretary, 34 Honeywell Road, London, S.W.11.

**PERSPEKIT!** The really profitable pastime. Outfit includes tools, lessons, plans, polishes, transfers, adhesive, clear and coloured Perspex for making the articles. Make your own gifts. Stamped addressed envelope brings full particulars.—White, 2 Alexander St., Coatbridge.

**PERSONS** required immediately to make leather shopping bags in spare time. Write—Dept. 11., Empire Co., 117 Nottingham Road, Loughborough.

**CHARGING** Sets — Petrol — new condition—288 watts. J.A.P. air-cooled engine Model 2A.—governed—complete with switchboard £14 10 0, carr. paid.—Parker, St. Peter's Power House, Jersey, C.I.

**LICENCE** Free. Beautifully veneered panels 24ins.—24ins. x 3in. oak 13/6, mahogany 14/-. Carriage extra. Also Plimberwood in all sizes, Perspex from 6/- per foot, Veneered Plastics, etc. Please send for price lists.—Drew & Co., 78 Princes Road, Liverpool 8.

**WANTED**—unusual or patented design toothbrushes of years ago. Folding, double-end, silver handles, etc. 7/- offered for each specimen.—Dr. Francis Blauston, 33 West 42 Street, New York 18, N.Y., U.S.A.

**URGENTLY** required—spare time workers to make leather goods. Apply—Dept. Y 3, Somat Plastic Co., 8 Middlemarsh, Nottingham.

**HAPPY** Circle pen-pals bulletin, H1/3. Contacts everywhere—176a Shoreham Road, Hove.

**NEW** waterproof cycling jackets 10/-. American army lumber jackets 15/-. No coupons, war surplus.—BM/GMKT, London, W.C.1.

**WOODWORKERS'** and Engineers' tools. The largest selection in the West. Band saws, circular saws, band and disc sanders. Fractional electric motors. A.C. single phase 1/20th to 1½ h.p. Grinding stones, cutting tools, micrometers, verniers, calipers, all gauges. Angle plates, centres, squares, etc.—Edwards and Drage (Tools) Ltd., 131 Magdalen Road, Exeter. 56134 and 67645.

**SMOOTHING** planes 5ins. and 7ins., a really efficient tool at 7/- and 9/- each respectively. Satisfaction guaranteed. Cheques and postal orders (to include 6d. for postage and packing) to—Branker Ltd., 50 Brighton Road, Purley, Surrey.

**BE TALLER.** Quickly! Safely! Privately! No appliances—no tablets—no dieting. Details 6d. stamp.—Malcom Ross, Height Specialist, BCM/HYTE, London, W.C.1.

**LONELY?** Then write Secretary L.U.C.C., 5B.B. Hay St., Braughing, Herts. Genuine. Est. 1905.

**MODELS:** you can make lasting stone-hard models with Sankey's Pyruma Plastic Cement. Supplied in tins by Ironmongers, Hardwamen and Builders Merchants. Ask for instruction leaflet.

**TRANSFERS** for decorating toys, trays, furniture, fancy goods. Selection 10/- 20/-. Flowers, pixies, dogs, nursery rhymes.—H. Axon Harrison, Jersey.

**FEW** Bound Volumes (6 months period) of Hobbies Weekly, with index, available, 27/6 post free. Dates available on request.—Hobbies Weekly, Dereham, Norfolk.

**PERSONS** required make fancy goods at home. Write for details—Melton Manufacturing Co., Southgate Street, Leicester.

**PROFITABLE** spare time ideas, money-making offers etc., free with 28 page "Opportunity" Magazine. 9d. post free.—Hazlehurst, 25 Melrose Avenue, Hoylake, Wirral.

**CANADIAN** Silver Jubilee set, free to all requesting approvals (without approvals 9d.) Postage please.—H. A. Smith, 13 New Road, Scole, Diss, Norfolk.

**GOOD** Printing moderate cost, prompt attention. Note-paper headings (four line address) on good quality Bond or Bank paper (according to availability) 4/6d. per 100. Send stamp for catalogue.—The Zodiac Company, BCM/Crucis, London, W.C.1.

**FREE.** Extra special Br. Col. packet scarce Jubilee, Coronation, Victory, Zoological new issue stamps. Request approvals (2½d.)—Thompson, 2 Western Gardens, London, W.5.

**THE** interest in car numbers never ceases. "Where's That Car From?" containing all the car index marks, alphabetically arranged. 54 pages 6d. Now in its sixth edition. From all newsgagents.—Raleigh Press, Exmouth.

**W. McGARRIGLE** for aeroplane and ship kits. All accessories. Stamps lists 3d. wholesale lists 4d.—64 Hillcrest Road, Romford.

**SPECIAL** Offer. Attractive stamp album, 50 stamps, packet of mounts. Post free 3/-.—Gamut (Dept. C.) Supplies Co., 24 Gunnersbury Avenue, London, W.5.

**TOY** casting Moulds, farm animals, soldiers, wallplaques, ornaments, dogs etc. The largest selection of metal and plaster moulds available. 6d. illustrated catalogue, S.A.E. for list.—Nuthall, 69 St. Marks Road, Hanwell, W.7.

**BOYS.** Learn Magic. The boy who does tricks is always popular. Send stamp for illustrated catalogue of tricks specially arranged so that you can do them.—The Boys Magic Service, Prestatyn, North Wales.

**DOLL'S** House fittings and papers, send S.A.E. for list. Doll's House plan, special, send 2/6d. Trade supplied.—Zimplan, 88 Ware Road, Hoddeston.

**ALL** Metal Chassis designed for mounting animal etc., cut-outs. Green platform (6ins. x 2ins.) fitted with 1½ins. red or yellow wheels. Stove enamel finish. 1/9d. each post paid, reduction for quantities.—Joyden Toy Co., 193 Chase Side, London, N.14.

**INDEX** for Vol. 105—Hobbies Weekly Oct. to March.—Useful for binding or reference. Price 1/- post free.—Hobbies Weekly, Dereham, Norfolk.

**DOLL'S** House papers, model supplies, kits, plans, engines and motors. Full lists 1/-.—Sutton, Hill House Drive, Billericay.

**SPOKE** Wheels, treaded tyres 8ins. 9ins. and 12ins. overall diameter. Also rubber tyred metal disc wheels ranging from 2ins. to 9ins. Small or large quantities supplied. Write requirements—Joyden Toy Co., 193 Chase Side, London, N.14.

**"POWER** Tools You Can Make". Famous "Popular Mechanics" plans and constructional details for building drilling machine, jig-saw, band-saw, lathe etc., all from readily available materials. 12/6d. only, post 7d. Illustrated lists 3000 American Homecraft books, plans, magazines 6d.—BCM/PUBLICATIONS (H) London, W.C.1.

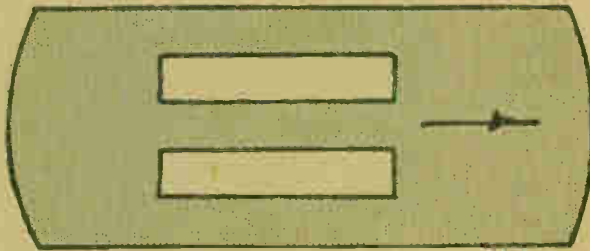

BASE - CUT  
FROM 1/4 IN.  
WOOD.

DISC - CUT TWO  
FROM 1/8 IN. WOOD.

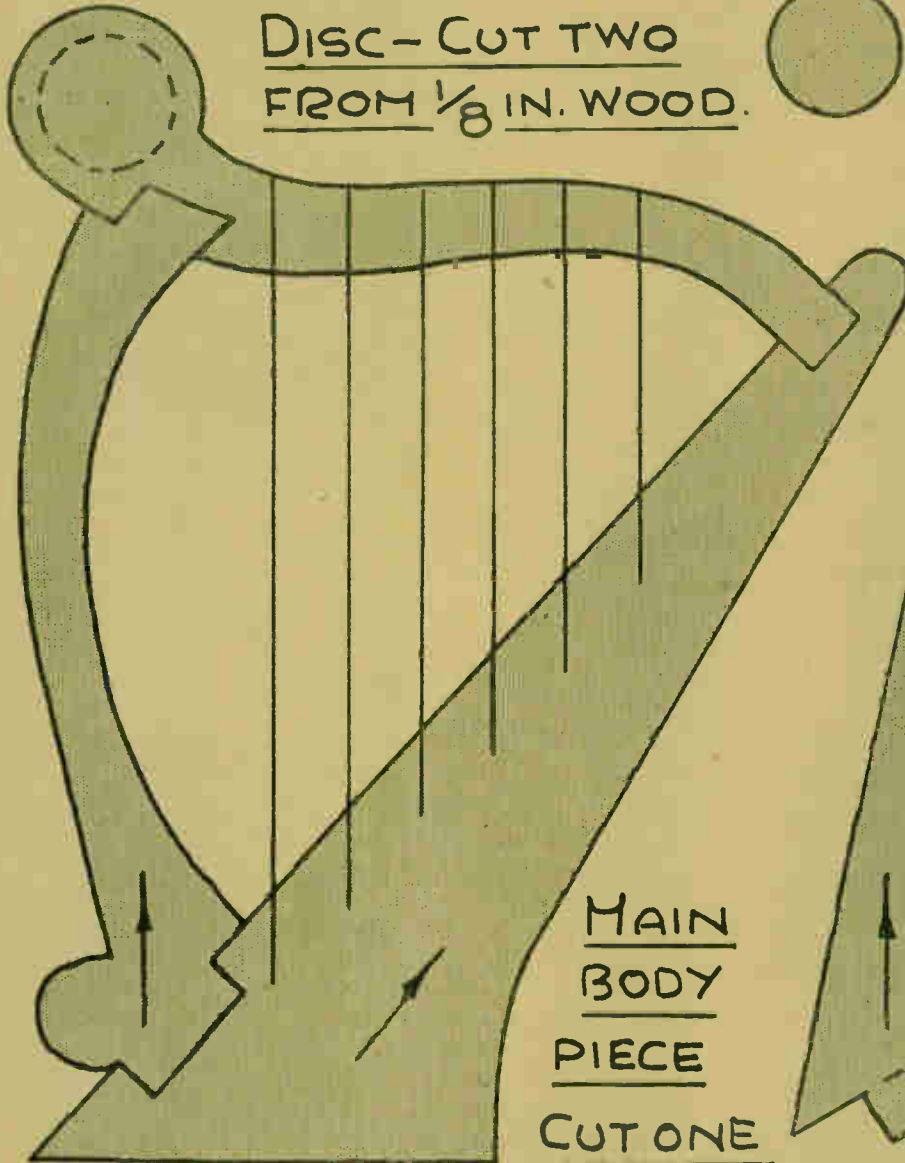

MAIN  
BODY  
PIECE  
CUT ONE  
FROM 1/4 IN. WOOD

SIDE PIECE  
CUT TWO FROM 1/4 IN. WOOD.

She might be **YOUR** ship

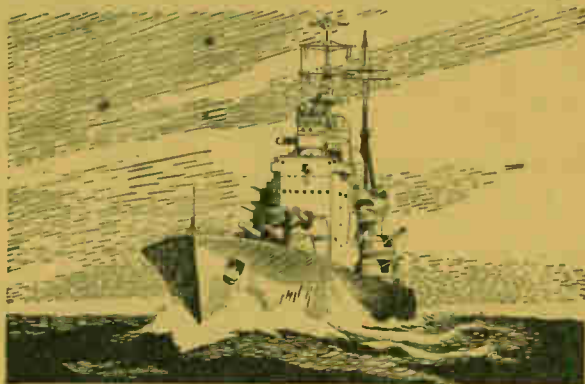

## BATTLESHIP

She's a 35,000 tonner, her armour plate is 16 inches thick at the waterline and she mounts ten 14-inch guns. In the Navy she's known as a 'battle-wagon' and she's a very tough customer. Whatever the ship that takes you on your travels in the Royal Navy, she'll be a home to be proud of. In her you'll find plenty of pals and plenty of sport. You'll do a worthwhile job with good pay and fine prospects.

If you are between the ages of 15-16 or 17-23 call at any Combined Recruiting Centre or write to D.N.R. Dept. AR/148, Admiralty, London, S.W. 1.

Make the

## ROYAL NAVY

*your career*

*Brilliant England and Middlesex bat, and Arsenal winger . . .*

## Denis Compton

SAYS

**"I cross roads like THIS . . ."**



'Many a cricket match has been won by running singles—and in Soccer, of course, you need all your speed. But the road's no place for running—it's criminal to risk your life and other people's. I cross roads the proper way, like this:

- 1 At the kerb—*halt.*
- 2 Eyes—*right.*
- 3 Eyes—*left.*
- 4 Glance again—*right.*
- 5 If all clear—*quick march.*

"I don't believe in rushing; it's better to wait till there's a real gap in the traffic.

"In both Soccer and cricket, there are sometimes risks you ought to take. But in traffic—never! It's just stupid to take risks where the results are so serious. To be a good Road Navigator, do your Kerb Drill as I do—and never try to sneak runs!"

*Denis Compton*

Issued by the Ministry of Transport

**Mars**  
ARE  
MARVELLOUS



You'll certainly agree! Just taste these chunks of sheer delicious goodness made with *chocolate* to sustain, *glucose* to energise, *milk* to nourish you. Ask your sweet shop for Mars.

**Mars** 4d.

MARS LTD., SLOUGH, BERKS.

## SUPER TOY PLANS

- 10044 Engine and Tender
- 20044 Mechanical Shovel
- 30044 Tipping Lorry
- 40044 Paddle Steamer
- 60044 Toy Fortress

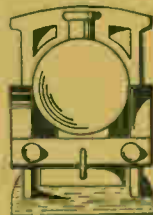

9d each from **HOBBIES** branches and principal stores or 1/- post free, from

**ZIMPLAN** 88 Ware Road  
Hoddesdon, Herts

## MODEL-MAKER'S KIT

This set of tools has been specially selected for model makers in wood. There is a complete range of reliable necessary tools, a full size pattern sheet from which to make a small model galleon, and a 24-page book of instructions for the beginner, and hints for the experienced.



**HOBBIES Ltd.**  
Branches  
or Dereham,  
Norfolk.

**18/6**  
Post 8d.

# Hobbies

## WEEKLY

### CONTENTS

	Page
A Folding Garden Chair -	145
Cellulose Finish -	147
Two Small Trays -	148
Books to Read -	149
Mount Cutter's Knife	150
A Plastic Candlestick	151

SUPPLEMENT DESIGN  
SHEET FOR FRETWORK  
FLOWER HOLDER

July 14th, 1948

Price Threepence

Vol. 106 No. 2750

## For house or garden, make this sturdy and comfortable FOLDING CHAIR

ORDINARY folding chairs have a hard back rest, and to give comfort, the chair illustrated was devised. It folds quite flat when not in use. It is a form of arm-chair for a garden, etc., and a conventional

size is 3ft. high, by about 22ins. wide, with a seat height of 18ins., and a depth of 17ins.

The chair consists of a small folding seat fitted with special side frames which carry the back rest. Apart from the joint pivots, small metal connec-

tion strips are fitted to ensure rigidity, prevent splaying and facilitate folding.

There is thus not much difficulty in making such a chair. The main drawback is the wood required. This, of course, should be a hardwood, such as oak or birch, but deal, free from knots, could be used, or a hard pine. The parts must be of the thickness stated, otherwise you may introduce weakness at the vital places.

### The Side Frames

The two side frames could be the first parts to prepare, and one of these is detailed at Fig. 1. The legs are made from 1½in. by 1in. stuff, 26ins. long. Between these is doweled a bottom rail 14ins. by 2½ins. by ½in. The edge of the rail, including the underside of the arm piece, needs to be bored for ½in. dowel rods.

The depth of the holes is ½in., and consequently, the rod length is about 16ins. Note, from the sectional view, Fig. 2, how the bottom rail is kept central, whereas the arm goes flush at the inside side. The dowel rails must be kept in alignment with the bottom rail.

### Arm Rest

A view of the arm rail is provided at Fig. 1. One end is checked for the back rest uprights (1½in. by 1in.). When the parts are ready for assembly, glue the bottom rail between the legs, glue in the dowel rods, then add the arm piece.

A sash cramp should be used to press the parts home, then the frame tested for squareness. The other side frame is made in the same way. But, make sure one is right-handed and the other left-handed, as the sides cannot be reversed.

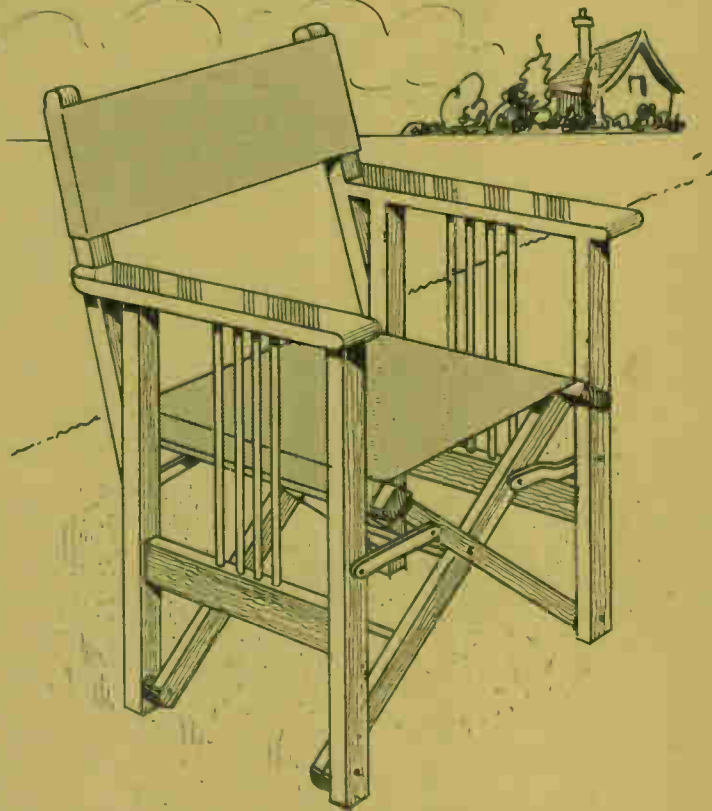

All correspondence should be addressed to The Editor, Hobbies Weekly, Dereham, Norfolk.

The back rest uprights measure 20ins. by 1½in. by 1in. and are bevelled slightly at the lower end to fit snugly against the rear end of the arm and its leg, as shown in the elevation. The wood is glued and screwed in place to project 9ins. for the canvas material.

The top end should be rounded over; there should be no sharp edges. Use a 2½in. by 8 roundheaded screw

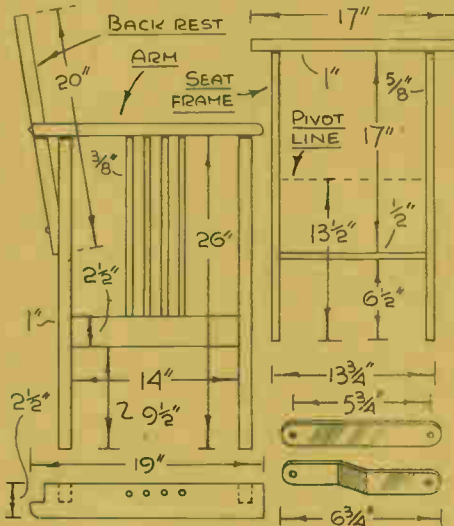

Fig. 1 - Side elevation and seat frame details

by 1½in. by 1in. The legs are 24ins. by 1½in. by ½in.

The legs are kept 13½ins. wide to fit between the side frame legs, with an ½in. clearance at each side. The second seat frame is made to fit between the first seat frame legs; therefore, its width is about 12½ins.

The top corners of the seat rails are rounded over so that there are no sharp corners to fray the canvas

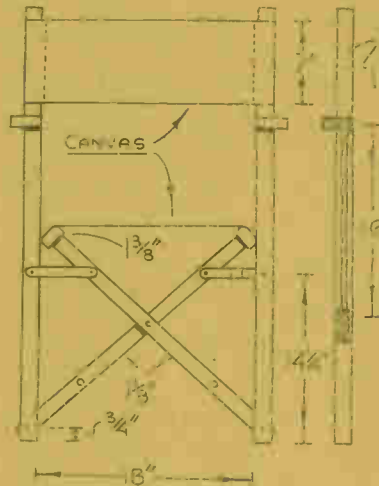

Fig. 2 - Front elevation with sectional views

The bottom ends of the seat frames are pivoted to the side frame legs with rivets and burrs. It will be necessary to fit ½in. thick wooden washers to the inner frame legs to pack them between the side frame legs.

The metal fixing strips are made from ½in. by ½in. mild steel or iron strip. The strips are straight and cranked. The former are attached to the outer seat frame legs and the latter to the inner seat frame legs, as shown at Fig. 2 and in the illustration. Use roundhead brass screws. The approximate fixing position is 14½ins. upwards, as shown at Fig. 2. Try folding the work prior to adding the canvas.

### The Canvas

Assuming the frames fold neatly together, a piece of canvas is tacked to the seat frame rails (it may be necessary to remove the fixing plates to get at the tacking properly). For the seat, you will need a piece of material about 22ins. by 16ins. For the back rest, a piece of canvas about 24ins. by 7ins. is wanted. This may be tacked to the uprights, or can be hemmed at the ends to slip over the uprights.

As a finish, give the work a coat of spirit stain, then two thin applications of trench polish. Mahogany, or walnut, or oak, is a suitable finish. If the wood used is real oak, then a light or dark oak finish is desirable. If birch is used, any of the three above-mentioned finishes are suitable.

at the arm, and an 1½in. by 8 screw at the leg.

### The Seat Frames

The seat frames are of identical size, as detailed at Fig. 1. The outer frame is shown. The canvas seat rail is 17ins.

material. The seat frames have a ½in. dowel rail, and the pivot position is 13½ins. upwards from the bottom of the legs. For pivots, use suitable copper rivets and burrs, with a washer between the wood to prevent undue rubbing.

The method of making a hectograph was described to me some little time ago, so I am passing it on for readers who have some hectograph ink available and would like to make up the jelly compound. The materials required are two parts of glue to one part of glycerine by weight, in quantities according to the size required.

## Printing Pictures on Tomatoes

AN idea suggested to me some little time ago may appeal to readers who grow tomatoes and also take an interest in photography. Though I have not yet had an opportunity to give it an actual test, the novel experiment certainly seems worth trying.

Now, as you will be wondering what connection there is between gardening and photography, the idea is this—to print a photograph on a tomato. The procedure is to attach a negative containing, say, a scene with clear outlines, firmly in position on a tomato still in its green state, leaving it on the plant, of course. Then, as ripening proceeds, the theory is that the picture should leave its impression in various shades.

Not having tried it I cannot say whether the scheme works out successfully. However, I pass it on so readers with an experimental turn of mind and a greenhouse, may try their hand at producing something unusual and decorative for the amusement of their friends.

## A Home-Made Duplicator

CLUB secretaries and others sometimes have occasion to duplicate notices and letters for circulation among members, but where only a dozen or so copies are required, the use of a home-made duplicator may be worth considering.



The kit of wood (No. 2750) for this Flower Stand is supplied by Hobbies Branches for 3/10 or sent post free from Hobbies Ltd., Dereham, Norfolk, for 4/7 post free.

Break the glue into small pieces, cover with cold water, and leave for several hours till quite soft. Then strain off the water, stir the glycerine with the glue, and boil gently in a water bath for about three hours until the glue is melted. The water bath, of course, is simply a matter of standing the vessel in a saucepan of boiling water over a slow heat.

Pour the melted mixture into a shallow tray ready for use when cold. The matter to be copied is written out in hectograph ink on smooth paper, from which an impression is made on to the jelly, copies then being taken by rubbing sheets of paper into contact.

The matter to be copied is written out in hectograph ink on smooth paper, from which an impression is made on to the jelly, copies then being taken by rubbing sheets of paper into contact.

The Craftsman

# How you can complete your models with a brilliant CELLULOSE FINISH

**D**O you know that it is possible to apply cellulose paint on wood much in the same way as french polish? The process is almost similar, and the results are similar, too, except that the cellulose finish will withstand greater heat—which makes it particularly ideal where table tops are concerned.

If, therefore, you have any experience of french polishing, the more modern finish will present no difficulties. Wood is stained and filled in the usual way. On no account, however, should oil stains be used, as the presence of oil has a tendency to keep the finish soft and slow-drying. Water or spirit stains are the best, especially the latter.

## Staining and Filling

Assuming the smoothed, prepared wood surface has been stained, allow this to dry thoroughly. Then apply a grain filler. The latter usually consists of a plaster-of-paris paste or whitening mixed with some of the stain.

It is rubbed across and into the grain with a clean piece of rag or linen, allowed to dry, following which the surface is smoothed lightly with fine glasspaper, dusted, then, if necessary, the surface re-stained. When in the damp state, of course, the filler appears darker. It becomes lighter in colour when dry, and re-staining is frequently necessary.

When this dries, the surface is lightly glasspapered again, using No. 0 or "flour" grade glasspaper to skim off slight roughnesses and raised grain, then the surface dusted and rubbed down with hessian. The latter helps to burnish the surface if a fair pressure is used, thus paving the way for the ultimate finish.

## Applying the Cellulose

There are two ways in which cellulose finish can be applied. A spraying-gun is the best and quickest article to use, but a brush may be used. Herein, however, lies a difference in the method of application. Obviously, the spraying method is the more advantageous. The surface is not touched in the same way as with a brush, and the latter can create awful marks and, if precautions are not taken, spoil a good finish.

Unlike shellac, cellulose cannot be brushed over the same spot twice, because the fresh application reacts quickly on the older application and the brush "wears" into the foundation. This is specially the case when the first application has not been given long enough time to set and harden.

Take the spraying method first. So

far, you have the surface prepared. Now you need the paint. This is, for wood, known as "wood finish". It tinted to the same colour as the staining, it may not be necessary to re-stain the filled grain surface, as explained earlier on. The finish will do this to some extent, much like "coloured" polishes.

Wood finish is usually a clear, transparent cellulose lacquer. It is obtainable thin, or thick, for spray or brush use, and one or the other must be specified when buying. In time, the spraying stuff gets thicker, and must be diluted with cellulose thinners—a special solvent, differing entirely from *paint thinners* which must not be used.

The spraying cellulose is put into the spraying-gun jar or container, with thinners added, if necessary, well stirred in, then a preliminary "mist" sprayed on the wood at a pressure of approximately 20 to 40 lbs. per square inch.

Half-an-hour or so later, by which time the application will be dry and sunk into the surface, apply a second coat and allow to dry. Then add a third coat, following which the work should be left over-night to sink and harden.

## Using the Spraying-gun

Now, to use the spraying-gun, it is not just a matter of filling the container, pressing the trigger and aiming the fine jet of spray at the work, with the gun at arm's length, swinging from side to side from the shoulder. If facing the work, and doing this, the centre will receive a heavier application than the extreme ends of the work.

No—the nozzle of the gun must be kept equidistant with the work as much as possible, and it is wrong to go over the same parts twice. It is so easy, you see, to "build up" the lacquer if certain parts receive more than their share of the fine spray.

## Pulling Over

The three preliminary applications, while resulting in a fairly high finish, are insufficient as a finish. In the morning, inspection will show that the high gloss will have diminished to some extent. The thinners will have evaporated, including some of the cellulose, the latter sinking into the wood and filler.

Therefore, two further applications will be necessary, and when these have thoroughly dried, the surface is finished off. This is done by flatting and pulling over. Flatting is done with 320-grade abrasive paper, used wet.

The paper is dipped in water, a little soap rubbed on it to check its

action and give lubrication. Rub down the sprayed surface with the paper until all gloss and spray marks are removed, then wash off the residue and dry with a chamois leather.

## A Special Solution

Pulling over is similar as the spiriting-off stage in french polishing, except that a special "pull over" solution is required, which may be thinners, with a drop of castor oil added to check its rapid drying action. The polishing pad, unlike the french polisher's pad, consists of a ball of wadding covered with a piece of fine chamois leather—not linen.

Soak the wadding (or cotton wool) with the solution, wisp it up with the leather to make a flat, smooth, rubbing side, then gently stroke (do not rub) the flat finish in one direction, using a moderate pressure. This finally produces a semi-gloss which, when absolutely hard, is highly polished with Karpol or any car polish.

## For a Brushed Surface

As stated, a different process is necessary if a brush is used to apply cellulose lacquer. Having, if necessary, re-stained the filled wood surface, and rubbed it down, two thin coats of *french polish* are applied with a mop or pad in order to "seal" the stain and filler against the action of the cellulose which, moreover, if spoiled, can be easily removed without injury to the stain and filler.

For the brush coats, take 1 pint of cellulose finish and add an eggcupful of castor oil (the sweet smell of the finish, fortunately, kills the sickening odour of the latter!), stirring both together thoroughly. Put the finish in an old cup and use it immediately, in small cupfuls. Flow the finish on—do not try to brush it into the wood.

## For Good Results

The whole secret of good cellulose polishing lies in the flatting stage, plus the pulling over stage. For best results keep the finish as thin as possible, but not without some base, or rather, body, i.e., celluloid. The brushed work is finished off in the same way as the sprayed work. As the coats, however, are sure to be much thicker than the sprayed coats, a longer drying and sinking period should be allowed.

Incidentally, coloured cellulose lacquers are available so that the finish, as seen on non-utility pencils, can be made on pieces of furniture, novelties, etc. Bright red, green, blue, etc., make attractive finishes.

A little experiment with them on waste wood will soon bring you ability to use them with excellent results.

# Bright and easy to make for the nursery use — TWO SMALL TRAYS

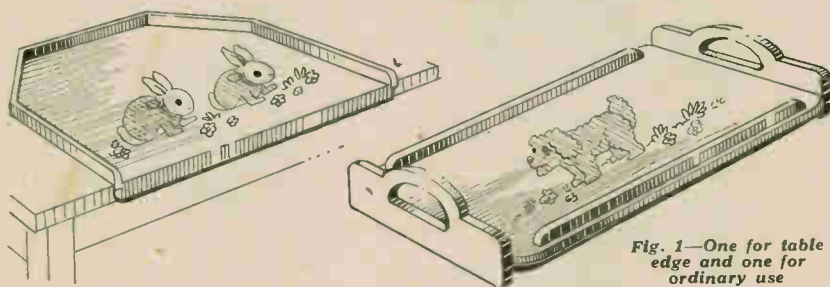

Fig. 1—One for table edge and one for ordinary use

HERE are two useful trays for household use, of light construction but convenient in size for handling. The table tray shown at the top of illustration, Fig. 1, is intended for use for children who are able to sit up and have their meals with the rest of the family.

Such a tray as this will keep the tablecloth clean, and, to a good extent, the contents of cups, etc., which get overturned will be confined to the tray which can easily be cleaned up.

The second tray is plain in character, and would be useful for carrying things from larder to table. The child's tray outline is given in Fig. 2, and the base for it may consist of one piece of wood or composition board 15ins. by 10ins. cut to the shape shown.

Along the front edge of the panel and screwed underneath it is a narrow section of rail about  $\frac{1}{2}$ in. deep by  $\frac{3}{8}$ in.

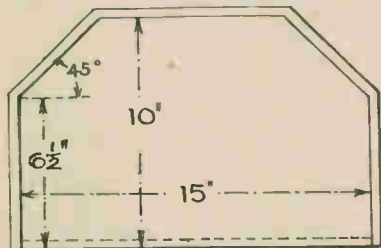

Fig. 2—Outline shape and edging

wide, see Fig. 3. If a strip 15 $\frac{1}{2}$ ins. long is unobtainable, then it can be in two parts and halved and screwed together as seen in the detail, Fig. 4. The actual edging to the tray should be of  $\frac{3}{8}$ in. thick wood lin. or so deep and with rounded top as in the detail at top of Fig. 3.

Mitred around inside the edging are five pieces of angle fillet which, not only strengthen it, but facilitate the sponging out and cleaning of the tray itself. Brass screws should be used for all fixing including the angle fillet.

### Suitable Finish

Whether ordinary wood or a composition board be used for the tray, the finish can be the same, and the edges also can be smoothed up to take the under rail and the edging. If the interior of the tray, or the whole of it be painted up, this seems the best and most durable finish, and an attractive addition can also be introduced in the

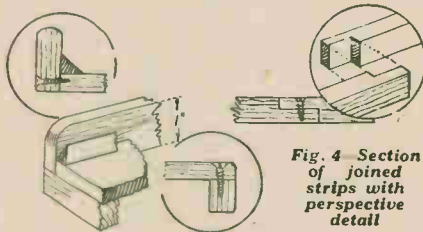

Fig. 4—Section of joined strips with perspective detail

Fig. 3—The edging strips

way of an animal transfer such as suggested in the picture.

The second tray needs but little explanation, as the detail, Fig. 5, gives full dimensions and method of construction. Here again a wood or composition panel can be used for the base of the tray with hard-wood for the ends bearing the handles.

To get a really firm fixing between base and ends we suggest that the latter be tenoned as shown in the smaller detail in Fig. 5. Set out the tenons carefully in pencil and then cut them with the fretsaw, after which a cleaning up should be given before the ends, A, are made.

### The Ends

Each end is 9ins. long by 2ins. wide in the middle where the handhole comes. Measure up and draw a line across the ends  $\frac{3}{8}$ in. up from their lower edges and above this line set out the mortises direct from the tenons on the base, B.

When cutting the mortises keep the fretsaw inside the drawn lines so that a tight fit follows when the tenons are knocked home. Do not, however, have too tight a fit or the wood each end of the tenons will split. Round off the edges of the handle sections and make smooth with fine glasspaper.

The joints between ends and base can be much strengthened by adding a square strip of wood or angle fillet as at, C, in Fig. 5. This tray can be finished in the same way as the other.

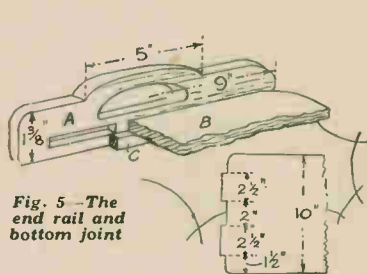

Fig. 5—The end rail and bottom joint

## RHODESIAN ROYAL VISIT FREE

WE will send you ABSOLUTELY FREE this lovely green and black two-colour stamp, which shows both our Royal Princesses (Princess Elizabeth and Princess Margaret Rose). This very beautiful stamp was only issued in April, 1947, to commemorate the Royal Visit to SOUTHERN RHODESIA during the African Royal Tour. This attractive historic stamp was on issue for a very short time only, and is now scarce. We managed to

obtain a small supply, and now have pleasure in offering one to you, ABSOLUTELY FREE, for you to add to and improve your own collection. Just send us 3d. in stamps to cover our posts, and ask for free Rhodesian Royal Visit stamp. It will be immediately sent to you with our interesting approvals.



WINDSOR STAMP CO. (Dept. 12), UCKFIELD, SUSSEX



## CANADA 1947 CITIZEN COMMEMORATIVE FREE!

We have been fortunate enough to obtain a small supply of this scarce, 1947, large, blue, 4 cent. pictorial, fine used; the symbolical design represents Canadian Citizenship; and we are giving one specimen ABSOLUTELY FREE to every applicant for our famous approvals. Obtain your copy now! (Enclose 2 $\frac{1}{2}$ d.).

D. J. HANSON, (Dept. H.30)  
EASTRINGTON, GOOLE, YORKS., ENGLAND



SUPPLEMENT TO HOBBIES No. 2750.

**STAND FOR BOWL OF FLOWERS OR BULBS**



—SIZE—  
1 1/2 in. SQUARE.  
4 1/2 in. HIGH.

NOTE:—This design sheet is only presented free with the current issue of Hobbies and not with back numbers. Further copies may be obtained.

PANELS OF WOOD REQUIRED FOR THIS DESIGN  
**TWO H3 TWO G3**  
The price is shown in Hobbies Weekly, July 16th, 1948, but is subject to revision. See the current edition of Hobbies Handbook, or write for prices to Hobbies Limited, Dereham, Norfolk.

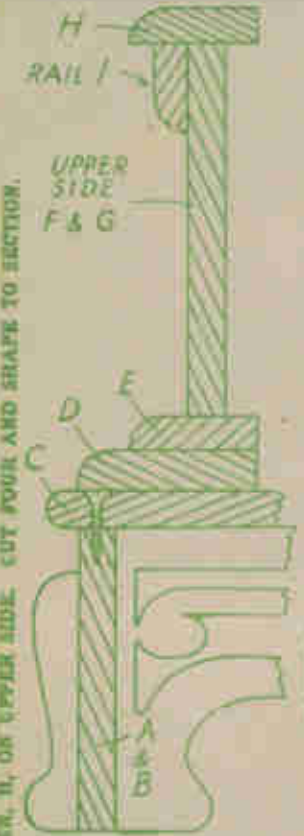

SECTION SHOWING POSITION OF THE VARIOUS MEMBERS.

TOP MEMBER, H, ON UPPER SIDE. CUT FOUR AND SHAPE TO SECTION.

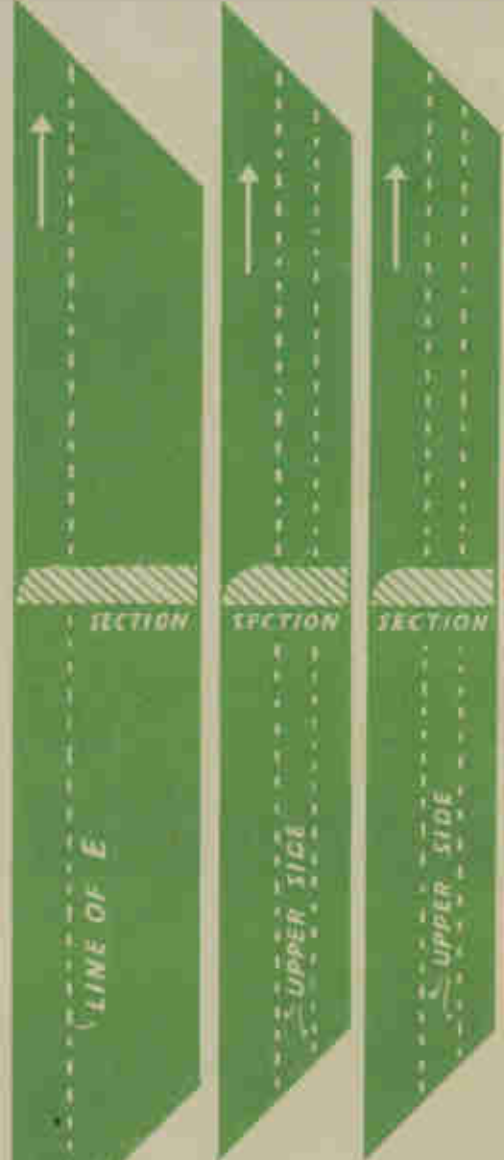
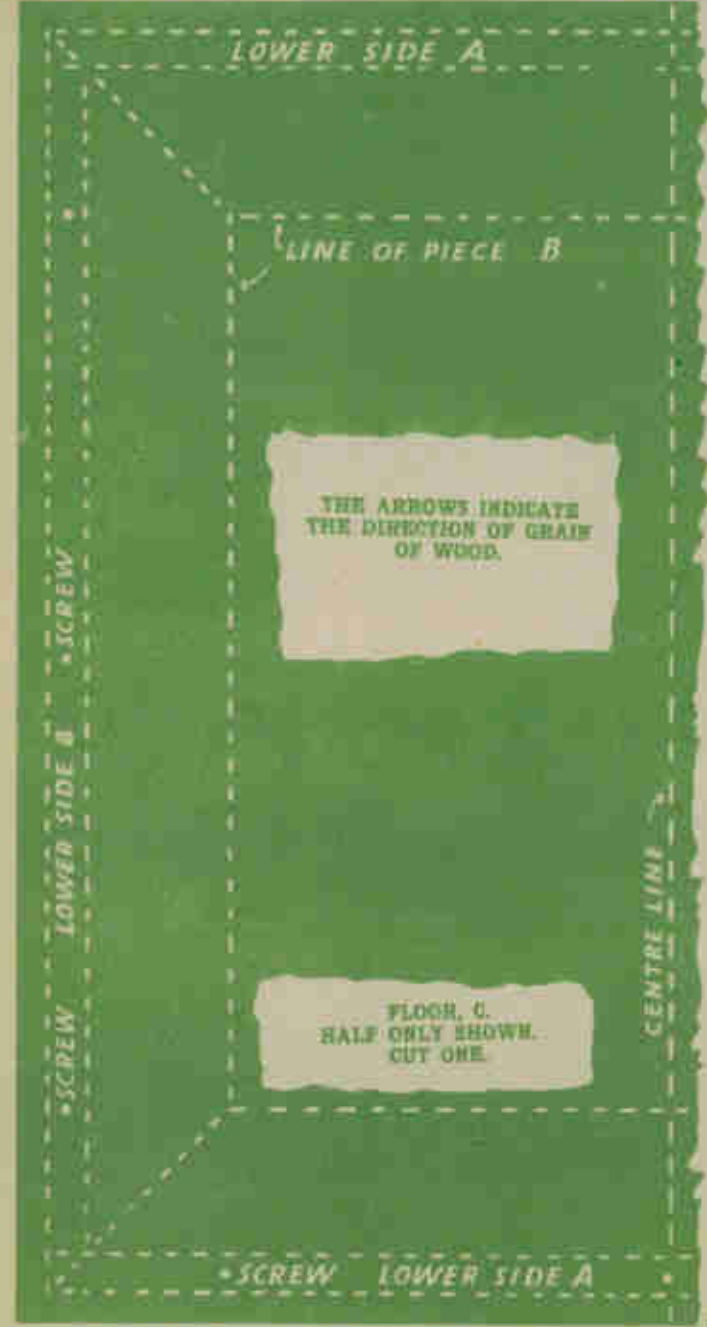

FLOOR RAIL, E. CUT FOUR AND SHAPE TO SECTION.

FLOOR RAIL, D. CUT FOUR. SHAPE TO SECTION.



## Design parts No. 2750 for a FLOWER STAND

THE patterns shown on the other side should be marked out on to the wood. The fretted designs, however, would be best pasted down to the boards to save a lot of trouble in tracing. Note in the case of the floor that half only is shown. This, however, is a piece 6½ ins. square, so it can be marked off with rule without trouble.

The pattern of that part clearly indicates by dotted lines adjoining pieces of the sides and lower sides, and should be kept for reference for this purpose. A sectional detail is also given at the top righthand, which indicates the position of the various lettered parts. Cut pieces out with the fretsaw and clean up with glasspaper for assembly. Construction is quite straightforward, and to conserve material, many of the parts are strips only.

### The Base Framework

Commence by making the lower framework of parts A and B. The two latter are glued between the two former, and then the two false feet (J) added to come in line on the outside. Stiffen up the inside corners with small fillet blocks, either before or after adding the main floor, C. This has a rounded edge and projects evenly on the fretted framework.

On top of this floor comes the frame, D. It consists of four rails, the ends of which are mitred to make a good corner joint. The top edge is chamfered and rounded as shown by the sectional drawing on the pattern itself. As shown by the sectional

drawing, you can drive small screws down through the floor (C) into the upright rails beneath. This must be done before the D rails are added.

The square frame (E) is similar to D, the inside edge coming in line, and the outer edge being slightly rounded. It is probably best to make up this frame of E and the upper fretted portions so the whole lot can be glued down as a box on to D.

### Upper Sides

The upper sides (F and G) are dealt with in the same way as the lower fretted ones. The two short sides are glued square between the two longer ones, and little blocking pieces glued in the corner to stiffen. An ornamental rail is cut and glued on these sides with the top edge level. The ends of these narrow rails (I) are chamfered (see section), to a good fit.

You now have a broad edge on which to glue the uppermost framework (H). Like the others, it is mitred at the corners and should be tested out and glued before being fitted to the box frame with an equal projection all round.

It will add considerably to the attractiveness of the article if a lining material is put behind the fretted sides. It should at least be done in the upper compartment so that the vase or bowl is not seen inside.

Apart from the fretted decoration, much of the beauty of this work is made or marred by the nicely rounded edges of the various rails and floor. Take care, therefore, to get these suitably done before finally polishing or varnishing the whole thing.



DECORATED RAIL, 1, UNORN SHOWN.  
CHANGE THE SIZES TO SUITE UP.



# Books to Read!

These recently—published books are of particular interest to readers and can be obtained through booksellers or direct (by mentioning Hobbies) from the address of the publishers given.

## The British Journal Photographic Annual

FOR those who are really serious with their Photography, this annual Handbook is undoubtedly 5/- well spent. Its technical articles are written by experts, whilst its 32 pages of photogravure subjects give pictures which repay long study for their composition, lighting, etc. The index alone occupies 6 pages, so you may imagine the range of subjects covered. Tables, formulæ, glossary and instructions are provided for the expert and would-be expert and there is something of interest on every one of its 490 pages—including the advertisements.

(Published by Henry Greenwood & Co., Ltd., 24 Wellington Street, Strand, London, W.C.2—Price 5/-).

## The Right Way to Use a Camera

by "Reflex"

AS more material for photography becomes available, so wider interest and growing enthusiasm will be created. Unfortunately so many beginners treat a new camera as a toy instead of a precision instrument, and disappointing "snaps" dull the keenness. With so many books available, one is able to obtain a thorough knowledge, before putting the camera in practice. Every beginner can save time, labour, films and prints as well as obtain good results right away by a study of just such a book as this. It is written in simple language by a practical photographer. It covers the whole art so far as the average amateur is concerned, and its prints give pictorial presentation of the practical points raised. The author deals with handling the camera right, selection of suitable subjects, lighting and exposure, accessories, and finally developing, printing and enlarging.

(Published by The Rolls Publishing Co., Ltd., 2 Breems Buildings, Fetter Lane, London, E.C.4—Price 5/-).

## Be Clever with Leather

by C. W. Read

THIS paper-covered book packs into its 62 pages of small print as much information as you would find in many double its size. The whole subject of leather work for the amateur is dealt with in progressive chapters. Commencing with explanation of purpose and tools required, the chapters explain in clear detail the work which can be

undertaken from simple thonging to tea cosies and ladies handbags. Apart from straightforward work on the leather with its suggestion of numerous things to make, chapters are devoted to embossing, tooling, dyeing and other operations which help to make the craftsman complete in his knowledge and practical in his output.

(Published by Bear Hudson, Ltd., 63 Goldhawk Rd., London, W.12—Price 2/6).

## Home Guide to Repair, Upkeep and Remodelling

by William H. Grouse

THIS is one of the most useful books for the home handyman which we have seen for some time. It is essentially for the home owner, or anyone who has a house which he is pleased and proud to maintain and improve by odd jobs. The book covers the whole range of needs in house, garage and garden, and a full index makes reference easy. It deals with those every-day problems most of us have some time or other when we are trying to effect repairs or add improvements to our home. There is hardly a job you are likely to have to undertake which is not dealt with, shortly, efficiently, and simply in this well-bound well-printed 358-page book. The home handyman should have one on his shelf not only for present interest but for reference against the time when something needs to be done at once for repair or replacement. You can find what to do on almost any occasion in the home on repair or construction in carpentry, painting, concrete, plumbing, electrical, outside walls, roofs, attics, garage or basement or many more supplementary needs as covered in the 26 different chapters. We can recommend the Home Guide confidently to the thrifty home owner.

(Published by McGraw-Hill Publishing Co., Ltd., Aldwych House, W.C.2—Price 22/6).

## The Trains we Loved

by Hamilton Ellis

THE kind of book deserving a place on any home library shelf because of its lasting interest and knowledge providing pages. Now that Nationalization has engulfed our railways we shall lose much of the variety of colour, classification, and type which has proved of such interest during the 100 years of

competitive progress. The pictures and pages will produce nostalgic remembrance of happy comfort and speed of recent years, even if we cannot realize or visualize the discomfort and slowness of the early railroad trains. Mr. Ellis has been a life-long collector of things of interest in the railway world, and here we have a book full of his memories shown by the printed word, the photographic picture and the coloured work of Mr. Ellis's own paint brush. The book, the author says is "a sympathetic attempt to recall what the old British systems, and their trains were really like". Journeys, companies, carriages, locomotives, and even a chapter on "Oddities" provide absorbing reading. (Published by George Allen & Unwin, Ltd., 40 Museum St., London, W.C.1—Price 15/-).

## Bench Notes, Woodwork

by E. B. Darlington, A.T.D., F. Coll. H

THE name of Pitmans as publishers is sufficient to guarantee a worth-while book, and this book is no exception. It is different from most manuals on woodwork, but equally satisfying and helpful. Practical line illustrations occupy most of its 32 pages, but the letterpress is clear, concise and sufficient to make the construction and instruction simple and straightforward. It is a book for the beginner, showing in easy stages, tools and their use, wood and its joints, drawing and its instruments and simple articles built for strength and everyday usefulness. (Published by Sir Isaac Pitman & Sons, Ltd., Parker St., Kingsway, W.C.2—Price 2/-).

## The Amateur's Lathe

by L. H. Sparey

WE frequently receive letters from readers anxious to undertake turning, but uncertain how to begin. Well, this book is certainly one of the best we have seen to give them all the "gen." Indeed any user of a lathe—whether amateur craftsman, garage mechanic or light engineer, will find much in its 232 pages to enable him to do better work, more efficiently and with less difficulty. Its pages are well printed on art paper with clear photographic and line reproductions and a comprehensive index, contents list, and tables to make reference easy for any knowledge needed or problem to be

solved. It deals, of course, with metal turning and not woodwork, but so many of our readers have interest in that sphere that they would find it worth while to have a book among their home-handyman's collection. Tools, processes, installations, equipment and all forms of use and care, are detailed by an author (Editor of "The Model Mechanic") who has the unusual combination of being a practical engineer with years of experience and the ability to write and pass on the resulting information in terms which the average amateur can easily follow.

(Published by The Harborough Publishing Co., Ltd., Edward Buildings, Rutland St., Leicester).

### Gifts you can make Yourself

A BOOK like this makes you realize what marvellous opportunities

are now provided for a whole family to find interesting occupation in the home for their spare time. Surely an interest in something to do or make would overcome the restless uselessness which seems to affect so many in our present day. The joy, and restfulness of handwork in creative effort are certainly needed now as much as ever. A book such as this would surely give the urge to any member of a family, until they all combine in competitive effort in making gifts for their friends, practical articles for the home, or articles for their own use and adornment. In this book are 256 pages with explanatory details of 50 things for the home craftsman to make. The subjects are tabulated "For Men", "For Women", "For the House", etc., and the article is dealt with methodically to show materials needed and how to use them. In addition there is a full page photograph of the finished products. Most

of the suggestions would appeal to the woman of the home to make, covering knitting, dressmaking, crocheting, leatherwork, etc., but there are plenty of articles involving the use of wood, plastic, string, papier maché, felt, etc. A very wide range of suggestions is provided, making gifts suitable for Christmas, weddings, birthdays and other special occasions. A large sheet measuring 22½ ins. by 35 ins. (something like our own Design Sheets) is also included, containing full-size outline patterns of making the articles concerned. The instructions are clear for the actual making, although they do not include details on the actual tools and how to use them. But, altogether, a book to buy and keep, to provide many happy hours of craft work for pleasant, charitable or money-saving results.

(Published by Odhams Press, Ltd., Long Acre, London, W.C.2—Price 8/6).

## You will find lots of uses for this easily-made MOUNT-CUTTER'S KNIFE

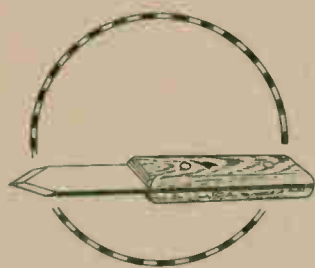

THIS particular pattern of knife is used largely for mount cutting, but is equally useful for trimming cardboard and paper, and is altogether an invaluable tool. They may be hard to buy nowadays, so some instructions on making one for oneself may be welcome, especially as the job is not a difficult one.

A piece of steel is wanted for the blade. Within reason it can be any width from ½ in. to 1 in. and about 9 ins. long. At 1 in. from one end two holes are drilled through, 2 ins. apart, large enough to admit stout brass screws, wood pattern, 1 in. long.

The opposite end of the blade is ground to an angular shaped edge, as at A in Fig. 1. This particular shape is the best for the purposes the knife is intended to be used for.

### Use a T Hinge Blade

Suitable steel for the blade may, however, be difficult to get, but if a T hinge of the large kind, say 12 ins. long, is obtained, a strip of steel ½ in. to 1 in. and about 9 ins. long, can be cut from it, as in Fig. 1, and will make a good substitute.

The hinge must be of mild steel, not the wrought iron variety, and can be cut quite easily with a hack saw.

When cut, drill the holes and cut the opposite ends sharply off to point the blade. It should then be ground, or filed to a sharp edge.

Being mild steel it should be hardened to keep its edge longer. This job is done by heating the blade to redness and plunging it immediately into cold water.

It is unnecessary to add, perhaps, that the blade should be quite straight, before hardening. After cutting with the hacksaw, it should be tested against a flat surface to see that the work of cutting the steel has not bent the metal.

Any irregularity from straightness should be corrected by lightly hammering the blade on a flat piece of metal. After hardening, the blade should be cleaned and brightened by a good rubbing with emery cloth.

### The Handle

For a handle, cut two pieces of ½ in. thick fretwood, (or ¾ in. would do), to a length of 4 ins. and a width equal to that of the blade. The blade is to be sandwiched between the two pieces of wood, as in Fig. 2, so holes for the screws must be bored in both to suit those already drilled in the blade.

Holes in the upper piece of the handle should be large enough to allow the screws to enter freely, as in the blade, and should be countersunk to sink the heads quite level. In the lower half of the handle the holes should be smaller, to allow the threads of the screws to bite into the wood.

Not too small, however, or the force of driving home the screws may split the wood.

Better test the size of holes in a spare scrap of wood first.

The blade and handle parts can now be firmly screwed together, as in detail, B. Finish off the handle by rounding off all the corners and sharp edges, filing off any screw parts sticking out, and glasspaper to smoothness. If the varnish pot is handy, complete the article with a coat of varnish over the handle.

### A Straightedge

To go with this knife a metal straightedge is invaluable. One with one of its edges bevelled like a ruler is the kind wanted, so that the knife can be held at the slant necessary when cutting the mounts—the edges of which are cut to a bevel.

In emergency you can use a hardwood straightedge, but owing to the shape of the blade it will probably be cut a little sometime and so spoiled. You can, however, get a wood straightedge, with a strip of metal embedded in it, and this would serve for a long while if care is taken when using it.

Bring up the edge of the knife on an oilstone, and in use keep it sharp so that it cuts the paper and not tears it.

In cutting take note of the pressure used. If you press too hard you are more likely to tear than to cut clean. Keep an even pressure, with a little extra when you begin and end at the edges.

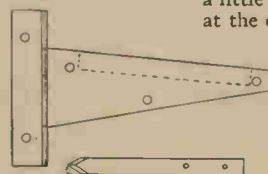

# It does not take much material for this attractive PLASTIC CANDLESTICK

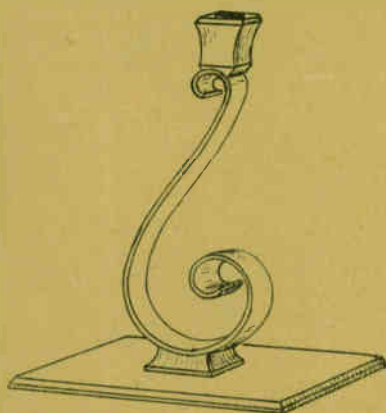

**C**ANDLESTICKS put the finishing touches to the dinner table, and the type shown are easily made. They would look equally well in coloured transparent, or opaque Perspex.

Fig. 1 shows the shaping of the scroll, and should be drawn full size to act as a check when bending the material. Cut a strip of Perspex about 15ins. long by  $\frac{1}{2}$ in. wide and  $\frac{1}{8}$ in. thick. Plane the sides smooth and then polish them.

## The Standard

Heat the strip and bend each end round a piece of  $\frac{1}{8}$ in. diameter dowel rod (which of course should be glass-papered perfectly smooth). This is shown in Fig. 2, and you will notice that the curls are made in opposite directions. You will now find that by warming the piece and manipulating

it with the fingers, you can easily form the rest of the scroll.

## The Holder

Fig. 3 shows how the candle socket and the foot are made up. The foot is filed to shape from a thick piece of Perspex. To make the candle socket, cut five pieces of  $\frac{1}{8}$ in. thick Perspex, each  $1\frac{1}{2}$ ins. square. In four of these pieces bore a  $\frac{1}{8}$ in. diameter hole. To do this, first find the centre of each piece, mark a  $\frac{1}{8}$ in. diameter circle, then drill the largest hole you can, finishing with a round file until the correct sized hole is reached.

These four pieces together with the fifth are cemented face to face to form the block. To ensure that the holes are in register, cut a piece of  $\frac{1}{8}$ in. dowel rod  $\frac{1}{4}$ in. long, wrap a piece of paper round it until it fits easily into the holes, then stick the end of the paper down.

Brush Perspex cement on the pieces, slip them over the paper coated dowel, swivel them until they are all square, and add the bottom piece

to the pile. Now clamp them firmly together in the vice and leave until the cement has set. The dowel is then removed and the paper pulled out. The block is next filed to shape, smoothed and polished.

## The Base

The base is cut from  $\frac{1}{4}$ in. or  $\frac{3}{16}$ in. thick Perspex and the edges bevelled with a block plane. Smooth and polish them, then assemble and cement all the parts together, and your candlestick is ready for use.

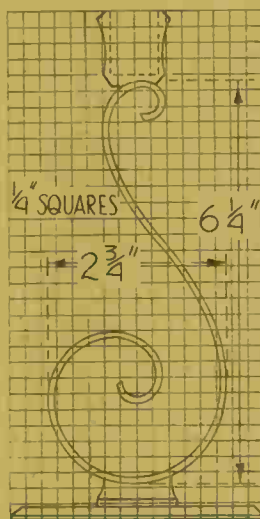

Fig. 1—Squared section of complete article



Fig. 2—Forming the curve

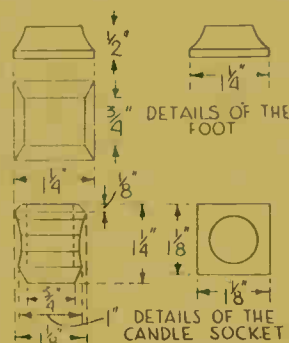
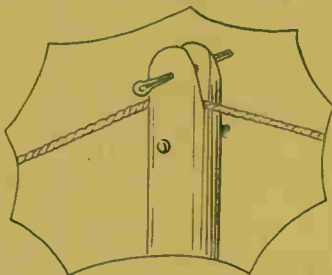

Fig. 3—Details of foot and socket

## A Non-Slip Clothes Prop

**I**NSTEAD of having a simple V-shaped notch in the top of the prop for the line to fit into, it is an improvement to use a prop-head as shown in the diagram. A split pin is



passed through the notch, thus acting as a lock and obviating the annoyance of the laundry falling in the wind, acting on the garments attached to line, causes the line to lift.

## How to Sharpen a Gimlet

**F**IRST bore a hole in a piece of hard wood, using the gimlet which is to be sharpened, then fill in the hole with a mixture of emery and oil. The gimlet should be inserted and turned to and fro in the mixture. Change the emery and oil from time to time, and to give a good final polish, bore a hole in soft wood, fill it with flour or brick-dust and give the gimlet a few turns in this, when it will come up like new.

## How to Repair a Knife Handle

**T**O refix a knife handle, take a teaspoonful of powdered resin, and mix with it the same quantity of powdered chalk in a saucer. Having done this, fill the hole in the handle with the mixture. Then warm the end of the blade, and fit it into the handle as tightly as possible. In ten minutes it will be quite firm, as the

heat of the blade melts the resin which joins the blade to the handle.

## Improved Cramp

**V**ERY often a cramp is not obtainable, and a very suitable substitute is to tie a double piece of strong string round the tea-tray, picture frame, or whatever it might be, and then get a piece of wood about

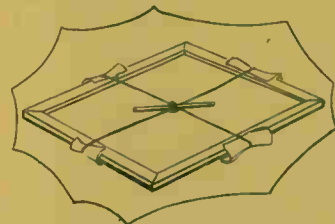

6ins. by 1in. by  $\frac{1}{2}$ in., and put this through the doubled string; then turn the wood round and this will hold the work tight and firm.



## A good strong job... soundly joined... HE USED CROID...

it's REAL GLUE—but scientifically prepared, ready for use without messy preparation. You get the best results every time and *all the time*.

Croid Aero glue for the big job.

Croid No. 3 in handy tubes for light work.



CROID LTD. 109, KINGSWAY, LONDON, W.C.2

## The Bristles won't come out...!

To tell you the truth it has been known for a faulty brush to slip through. Shame on us! If you should get one send it back and we'll replace it at once.

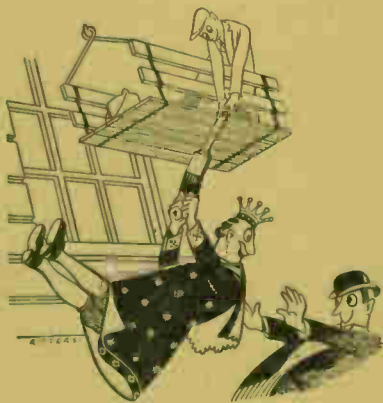

Production up - Prices down!



**Harris**—the paint brush with a name to its handle

L. G. HARRIS & CO. LTD., STOKES PRIOR, WORCESTERSHIRE

## CUT YOUR OWN HAIR

TRIMS AS IT COMBS

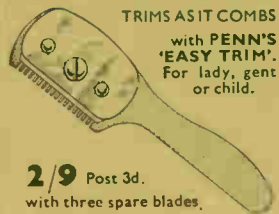

with PENN'S 'EASY TRIM'. For lady, gent or child.

**2/9** Post 3d.  
with three spare blades.

This superior, unbreakable SELF-TRIMMING COMB with blade ready for use keeps your hair always neatly trimmed.

Send NOW 3/- P.O. or stamps to:  
Wm. PENN LTD. (Dept. THB),  
585 High Road, Finchley,  
LONDON, N.12

## PENN'S RUG MAKER

Recommended in 'Hobbies Weekly' 30-7-47

Makes full-size Rug on ANY machine in a few hours. Enables wool to be stitched on canvas without waste.

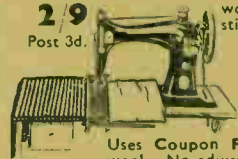

Uses Coupon Free rug wool. No adjustment to machine. Profitable hobby. With simple directions. Send 3/- P.O., cheque or stamps. Direct only from:

Wm. PENN LTD. (Dept. HBR)  
585 High Road, Finchley,  
LONDON, N.12

## BOYS! ELECTRIC-MOTOR OUTFIT

**3/6**  
Post Free

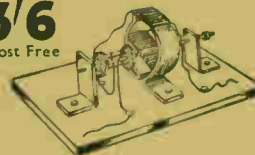

WORKS FROM ORDINARY TORCH BATTERY

**6,000 REVS. PER MINUTE**  
EASILY ASSEMBLED

This outfit comprises ALL necessary parts and base ready for simple assembly by any boy to make this working Electric Motor exactly as illustrated.

Apart from its novelty, this has very considerable technical and constructive value. More can be learnt from it regarding Electric Motors than by reading volumes. A most instructive and entertaining toy for boys. Complete with diagrams and very easy instructions. Send P.O. 3/6. Direct only from:

Wm. PENN LTD. (Dept. EMD),  
585, HIGH ROAD, FINCHLEY, LONDON, N.12

## Modelcraft's PLANS FOR 1/2"-1" SCALE PERIOD FURNITURE

These plans are "isometrically" drawn so that they not only provide dimensions which can be pricked off to the wood but give that good general picture, which is so important if the worker is to get the spirit of the design. We shall be introducing further plans in this series to coincide with our period model house plans.

ELIZABETHAN PERIOD  
QUEEN ANNE PERIOD **2/6**  
GEORGIAN PERIOD Post 2d.

## Modelcraft's GALLEON WOOD PARCELS

The first two of these are the 'Golden Hind' and the 'Santa Maria'. Each pack consists of 26 roughly-shaped wood parts (and in the case of the 'Santa Maria' some sail parchment) in good clean knot-free timber. They are not 'kits' in the full sense, but they fill the need of most modellers.

**21/-**  
Post 1/-



## MAGAZINE & LIST

The June issue lists nearly 500 plans, etc., and in addition has more editorial matter than previous issues. In fact this little book is packed full of good things for the model maker.

## Modelcraft Ltd.

77 (F) GROSVENOR ROAD, LONDON, S.W.1



# Hobbies

## WEEKLY

### CONTENTS

	Page
Modern Tea Trolley	- 153
A Sailing Boat	- 155
Carpenter's Shooting Boards	- 156
Toy Noah's Ark	- 157
Tree Leaf Printing	- 158
Small Model Buffers	- 159
Long Handled Bellows	160
Bench Tool Rack	- 161
Cut-out Animal Patterns	- 163

July 21st, 1948

Price Threepence

Vol. 106 No. 2751

## A MODERN TYPE TEA TROLLEY

**T**HIS modern, baby-carriage style of tea trolley has large 4in. diameter rubber-tyred wheel castors which enable it to be used in the garden or indoors. The trolley has two good shelves, or tiers, and a bottom tray. It has been designed on lines which save some amount of timber.

Construction is quite straightforward, and the work, for convenience and cheapness, could be built from deal boards, or red cedar. The end frames save using solid wood, and these frames could be assembled first.

### Frame Construction

To make one frame, you need two upright members 27ins. by 2ins. by  $\frac{3}{4}$ in., two cross rails 12ins. by 2ins. by  $\frac{3}{4}$ in. and a bottom cross rail 12ins. by 4ins. by  $\frac{3}{4}$ in., as shown at Fig. 1. The cross rails are dowelled between the uprights, spacing the 2in. rails in the manner shown. Have two dowel stumps in the ends of the 2in. rails and three dowel stumps in the 4in. rail.

Prior to gluing together, decide whether you prefer to have three dowel rails (cut from  $\frac{3}{4}$ in. dowelling) between the centre and top cross rail, as in the end elevation. If required, the dowel rails are, of course, glued between the two rails concerned before the uprights are added. The dowel rails should be  $\frac{1}{2}$ in. deep or thereabouts in the rails.

Having constructed both end frames, which are identical in every

way, the special handle bars are added. These bars are two 14in. lengths of  $1\frac{1}{2}$ in. diameter curtain pole, or lengths of fairly thick broomstick.

The lengths of pole or broomstick

are checked 2ins. by  $\frac{7}{8}$ in. at the ends for fitting against the top ends of the trolley end frames. When fitted, the wood is secured with glue and single, thin, flathead screws, the heads of which should be countersunk a trifle more than necessary for concealing with plastic wood.

The top inside ends of the frames require to be rounded over to conform with the diameter of the broomstick or pole handles. This can be easily done by paring away most of the waste wood with a chisel, roughly, then by rasping and glasspapering.

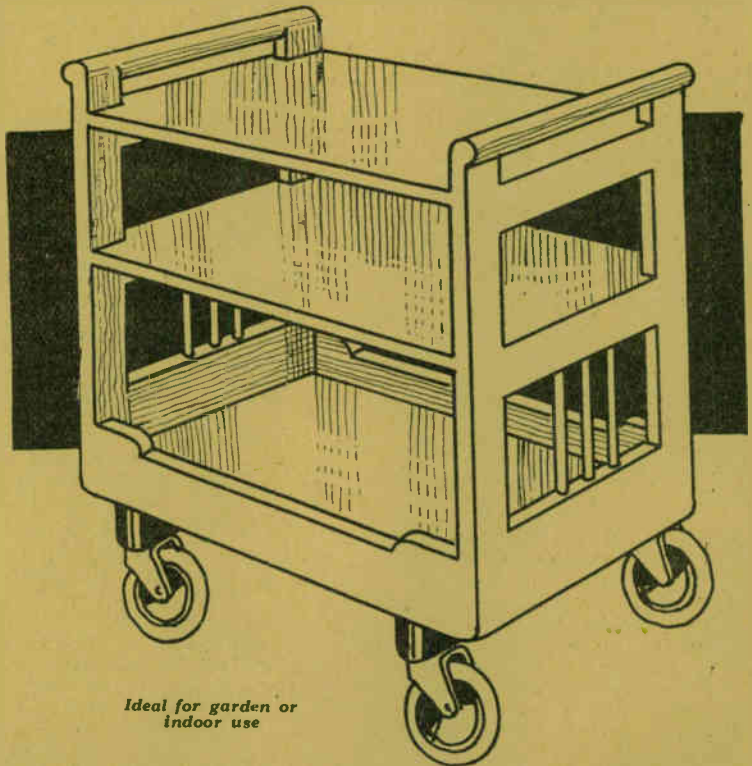

*Ideal for garden or indoor use*

All correspondence should be addressed to The Editor, Hobbies Weekly, Dereham, Norfolk.

When the end frames are prepared, make the bottom and side rails. The bottom consists of two 8in. wide by  $\frac{7}{8}$ in. boards glued and dowelled together. The exact size is 5 $\frac{1}{2}$ ins. long by 16ins. wide by  $\frac{7}{8}$ in. thick. When the joint has been levelled and the ends trimmed squarely to size, the end frames are attached on the bottom ends with glue and 2in. oval nails, to be flush, as in the side elevation.

This is a rough but ready way of attaching the parts together. Nail heads are sunk later and concealed with plastic wood, and nobody will know the difference, once the finish has been applied. The side rails, which

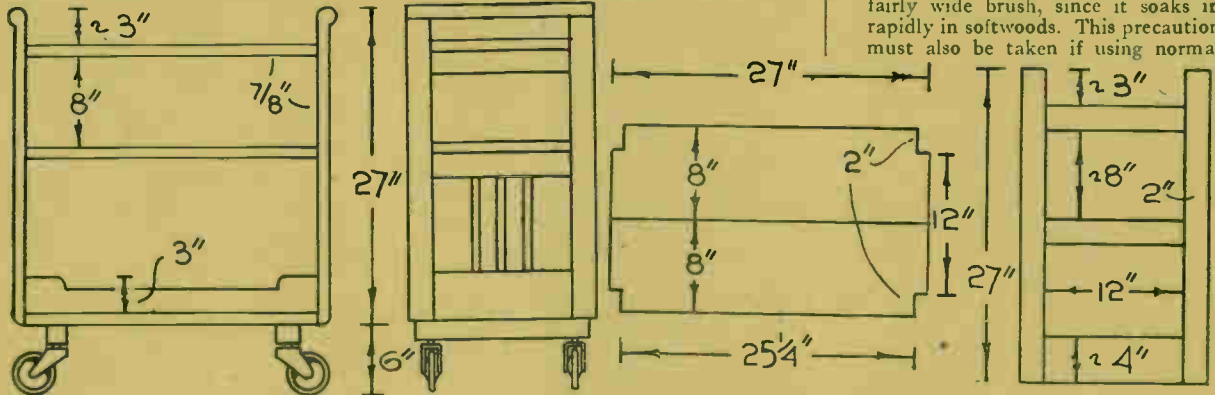

Fig. 1—Side and end elevation with details of end frame and shelves

measure 25 $\frac{1}{4}$ ins. by 3ins. by  $\frac{7}{8}$ in., are shaped as shown and attached with glue and nails. Keep these rails flush at the outside of the work, and try to have the end cut and trimmed neat and square.

You will require two shelves, prepared from  $\frac{7}{8}$ in. stuff, the size and shape shown at Fig. 1. These shelves fit in to rest upon the central cross rail of the trolley. When fitted, they are secured with screws, and there are

three ways this can be done.

One simple way is to use round-headed, or raised-head wood screws, driving these into the rails through the ends of the shelves. Being round-headed, or raised, no one will object to them being visible. By the way, similar screws should be driven through the end frame uprights into the end grain of the shelves, at each side. One screw in the centre of each upright, where required, will suffice.

Another plan is to cut pockets at the inside of the cross rails so screws can be driven up into the shelves. If preferred, holes could be bored in the shelves and the uprights which are

countersunk for flathead screws. These, when driven in, are concealed with plastic wood.

#### Rounding the Bottom Corners

It will be noticed that, in conformity with the general design, the bottom corner edges of the carcass are rounded over. This should be done with a smoothing plane and glasspapering block before the castor batters are added.

These battens measure 15ins. long by 1 $\frac{1}{2}$ ins. square, or 2ins. by 1 $\frac{1}{2}$ ins. They are affixed, 3ins. in from the ends, with a few screws, plus glue. Before doing so, however, the ends require to be rounded.

When attached, bore a  $\frac{3}{8}$ in. socket hole for the sockets of the 4in. peg castors required. The metal sockets are driven home, then secured with a small wire nail or a screw. The pegs of the castors simply push in, and the work is ready for its finish.

Whether deal or red cedar is used, or a mixture of both, the trolley looks best if stained and polished ebony. Use a spirit stain, and apply it with a fairly wide brush, since it soaks in rapidly in softwoods. This precaution must also be taken if using normal

coloured stain, i.e., walnut, mahogany, etc., as patchiness in application can be more easily avoided.

A light walnut trolley looks attractive. Another finish is light oak, with ebony castor battens. Alternatively, enamel paint, of a bright colour, such as light green or red, can be applied. The wood surface will need to be filled or primed before applying the first coat of enamel. A second application will bring up a good finishing gloss.

## From the Editor's Notebook—

JUST an example of the value of reading Hobbies, as expressed by A. W. Clark, a reader from Hook, Surrey. "I would congratulate you on the details of the Rocking Horse in a recent issue. I saw an inferior article priced at £8, which could in no way compare with Hobbies model, and yours could be made for about £1". Hobbies Weekly really saves you money!

IN these days of materials so many people when talking of a hobby immediately ask "What use is it?" or "How much do you make out of it?" That, surely is quite the wrong attitude to adopt, and one which you must not let creep in. A hobby is a pleasing recreation for spare time relaxation. It brings its own reward in happiness and contentment. It must not be commercialized according to time, labour and cost. I know a

reader who enjoys studying live moths and butterflies—of which there are 2,000 different types of the former in England. That particular hobby has no commercial value—but remember that the Panama Canal exists only because somebody studied the life history of the mosquito, and a large area of Queensland, Australia, can be cultivated because some one knew that a particular type of moth lived on prickly pear.

BEFORE the War our Hobbies League had many members in Burma and Malaya. A number of them have again become readers, but between times have suffered more than we realize. Low Hock Hoon, of Malacca, wrote me recently, for instance, asking if I could replace his League Certificate. "When the invasion of Malaya took place" he writes "I destroyed my books and

Certificate for the fear that the Japanese might execute me for being a member of a British Club—many members of Allied charitable associations were executed." Fear was one of the Four Freedoms for which we fought.

HOW a hobby—and an unusual one at that—can become the beginning of a career is shown by a Coventry engineer, who has turned commercial artist in a novel way. As an amateur painter he overcame the difficulty of paper for the wall of his home by putting on pastoral scenes and landscapes over the distemper. Now he has given his hobby full play, with profits, and gone into business to paint Italian and English scenes on walls of anyone's home. A pleasing, as well as profitable piece of work, brought about from a hobby.

The Editor

# Imagine the joy to be indulged in by making A SAILING BOAT

**T**HIS is not a racing boat, of course. It is just a simple, yet realistic, miniature type, based on nothing in particular. Its construction is very simple, the body consisting of three main pieces of wood, cut to shape, then glued together and—after truing up—the keel fitted, and the accessories added.

Nothing in it, really. Yet, the result is shapely, and a youngster is sure to get much pleasure from the model craft. It is not too small—14ins. long, 3½ins. wide, with an overall height of about 16ins—a decent size for lakes or calm waters inland or at the shore.

The jib and mainsail can be adjusted to catch every patch of wind with advantage. The weighted keel is a necessity to keep the craft properly balanced. The body is a half-shell type and thus quite buoyant.

A blunt bow, with port holes, gives the impression of a below deck, forward cabin. So, despite the size, or design, it is a good enough sailing boat—and most of all, it is new.

## Construction of Body

The bodywork is tackled first. Fig. 1 gives the top and side plan. It will be seen that the cabin piece can be taken from the hull shape plotted in the 1in. squares. Both these shapes are cut from ½in. wood, such as deal. The keel piece is cut from ¾in. material to the same shape and size.

Therefore, the shape, as shown in the squares, should be drawn out on paper carefully and used as a template for marking out the repeat shapes. A sheet of black carbon (duplicating) paper and a sharp pointed pencil will be wanted, so the shapes can be drawn directly on the wood.

The three parts are glued together,

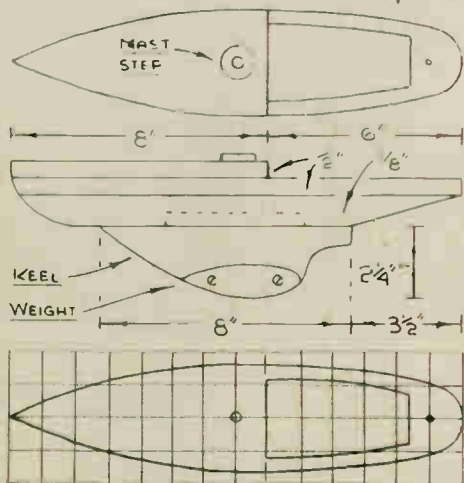

Fig. 1—Deck plan and side with hull shape in 1in. squares for marking out

using a casein or resin glue, such as Aerabond and similar makes. If the work is well enamelled, ordinary glue will serve, such as Durafix, etc., or a hot Scotch glue. It would not do, of course, if the parts came apart once subjected to dampness, hence the protection afforded by a good enamel finish.

## The Keel

The keel is cut to the shape shown in ¾in. wood. Note the tenon indicated by the dotted lines. This tenon fits into a suitable mortise carved in the bottom of the keel piece if preferred, the keel could be cut from ¾in. wood and be glued and nailed to the boat bottom.

Note, also, the shape of the keel weight. You need two, cast ½in. thick. It is merely a matter of cutting the desired shape in ½in. wood and pouring molten lead into the aperture. The cut wood is, naturally, nailed on another piece of wood to form the mould.

Alternatively, the weights could be cut from ½in. lead sheeting or water piping. Gas pipe could be beaten out to the desired thickness. The weights, when shaped, are drilled and countersunk for small screws. The particular pointed shape of the weights, incidentally, helps to make them cut through the water easily, without much drag.

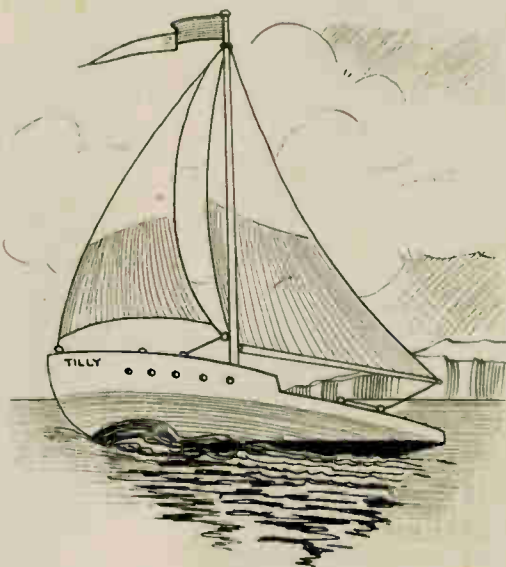

The mast is a pointed length of dowelling rod, 14ins. by ¼in. in diameter. A hole for same is bored in the deck at the position shown. A small ring of wood is glued over the hole to form a step, or collar, for the mast base. The hole depth is 1½ins. or thereabouts.

A rudder, or tiller, if wanted, is made from bent wire and tin, as shown. The wire should be bent to shape after being inserted through its hole at the aft end of the hull. This is not a necessary addition, however, and can be omitted.

In practice, it will have little steering effect upon the craft; it simply adds to the appearance and the detail, if included, is sure to please. It is left to you to decide.

The main mast carries a boom 6½ins. by ¼in., made from a piece of dowel rod. The thick end is connected to the main mast with small wire eyes. These eyes may be bought or can be bent from wire. In the latter case, they are a force fit.

The sails are prepared from thin white linen. An old handkerchief, washed and ironed, makes good sail cloth. The jib has plain handkerchief hems, with the running lines tied on at the corners. The main sail is open hemmed for the boom. The adjusting lines are brought through the

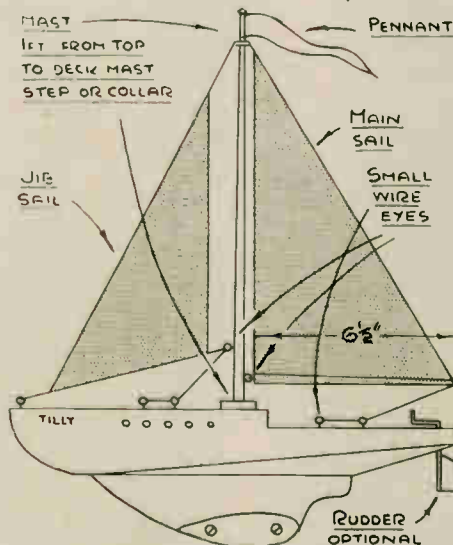

Fig. 2—Side elevation with sail details

(Continued foot of page 157)

# The home handyman carpenter can make his own SHOOTING BOARDS

**S**HOOTING boards are indispensable to the woodworker. For trimming the ends of boards, etc., neatly and truly, he needs the plain type shown at Fig. 1. The wood to be trimmed is set on the fence, close against the stop. The latter acts as a sort of try-square, and by holding the work against it, with the edge to be trimmed projecting over the fence slightly, the edge is trued by running the plane against it.

The plane is set on its side, with the sole facing the edge of the fence. A jack plane or trying plane may be used for "shooting" the edges or ends of the board. To trim the wood, the plane is moved backwards and forwards, pressing the cutter against the edge to be trimmed. The shavings are removed in an easy, accurate manner. The wood, lying on its side, enables guide lines to be seen.

## For Accuracy

The shooting board is very useful when it is necessary to rub-joint thin panels of wood together. Although the planing is fairly square, as a test with the try-square will show, it often happens that the body of the plane, especially the body of wooden planes, is slightly out of square, due, possibly, to a slight casting.

While the plane body can be squared with a second plane, the slight inaccuracy may be overcome by reversing one of the two pieces of wood which are to be trimmed on the board. Thus, the slight angle produced on the board edges becomes cancelled out, the boards being quite flat with each other at the joint.

If one of the boards is not reversed, of course, they will not join together flat; there will be a slight bend at the centre. Be sure, then, to make a habit of reversing one board when shooting the edges with a plane having a slight curve in its body. Metal planes are usually quite square and true.

## Making the Board

We have chosen a medium size of board which will suit the requirements of most home workers. To construct the board, you need a base piece 18 ins. by 6 ins. by  $\frac{7}{8}$  in. The fence is 18 ins. by  $3\frac{1}{2}$  ins. by  $\frac{7}{8}$  in. or  $\frac{3}{4}$  in. The base and fence must be cut and planed true to size.

The fence is glued and screwed (via the underside) to the top of the base piece, flush along one edge. Before doing so, however, take the arris of the corner edge of the fence (see inset detail). The chamfer provides a groove for dust, etc., thus ensuring that the corner is clear for the corner of the body of the plane.

The stop at the top of the fence is

$3\frac{1}{2}$  ins. by  $1\frac{1}{2}$  ins. by  $\frac{7}{8}$  in. Its position is marked accurately (with a try-square) on the top of the fence. The fence is recessed (about  $\frac{1}{8}$  in. deep) for the stop, as shown. The stop must be a neat, tight fit. It is fixed in place with glue and a couple of  $1\frac{1}{4}$  in. by 8 flathead iron screws.

The best wood to use is a hardwood, such as oak or beech. However, deal will make a reasonable good shooting board. Flooring material could doubtless be used, if available. There is no need to stick to the particular sizes stated. Make up the board according to what material is available. Small planes, such as metal block planes, require boards which need not be too wide.

## Mitre-Shooting Board

It is generally difficult to cut moulding, etc., to the precise length. Moreover, the mitres, cut with a tenon

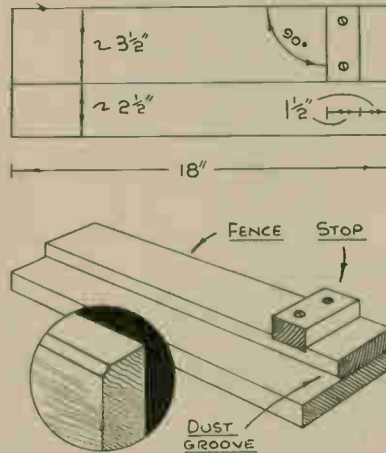

Fig. 1—An ordinary shooting board

saw and a mitre block, have a ragged edge. Mitres must, therefore, be trimmed quite clean so they meet properly together, with an almost invisible joint.

Trimming is done on a special shooting board. This, as shown at Fig. 2, is like a common shooting board, but instead of a plain stop, there is a central block. This block is cut to give a right and left 45 degree angle. These are the usual mitring angles, and while they can be marked out with a mitre square, the block can be marked out as shown and the waste wood removed as per the dotted lines.

When you have shaped the block, the edges are trimmed neatly with a block plane. Having prepared the base and fence, the block is set upon the fence and its position scribed with a pencil. The wood is cut across with a tenon saw to a depth of  $\frac{1}{8}$  in., then recessed. The block is fitted and affixed with glue and screws. Like the

plain shooting board, the mitre-shooting board must have a dust groove.

## Using the Board

The mitre-shooting board is used similar as the plain board. However, as you are dealing with mitres, it will be necessary to have the work reversed, including the plane, for trimming the "opposite" mitres on mouldings. The plane, preferably a trying plane, finely-set and keenly sharpened, is pushed up towards the projecting moulding and a little removed at a time until the correct length is obtained.

When cutting the moulding in a mitre box, or block, it is always best to allow  $1/16$  in. or  $\frac{1}{8}$  in. in the length for trimming purposes. Of course, if dealing with picture rail moulding, one need not care so much about the mitres being neat and tidy.

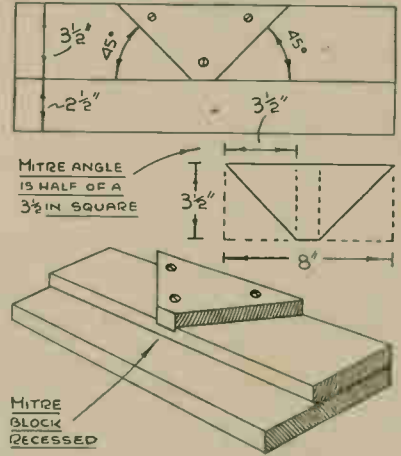

Fig. 2—A board for mitring

But, in the case of picture frames, beading, mitre joints, etc., one must exercise every care. The mitre-shooting board is really a substitute for a trimming machine, or a guillotine, as it is sometimes called.

The board enables mouldings, i.e., light mouldings, to be trimmed to within a fraction of an inch. As so much depends on the mitring angles of the block, this must be made accurately. Any fault in this will always cause repeated inaccuracies in the trimmed moulding. It must be dead true, thereby always ensuring that the mitres will be trimmed dead true.

Should your wooden planes slide along the boards stiffly, a rubbing of candle on the base and side of the plane will ease matters. Remember that the plane cutter must be set finely. It is liable to splinter the wood badly if projecting too much.

# Full size animal patterns on page 163 for this simple TOY NOAH'S ARK

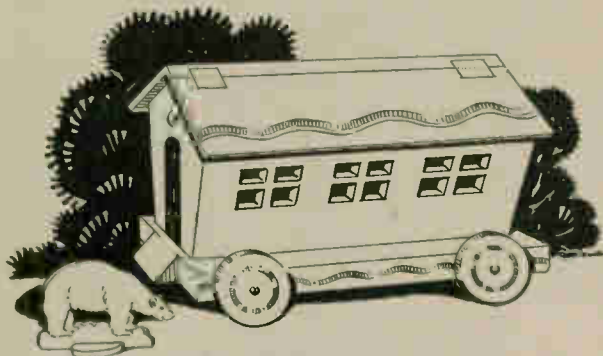

Fig. 1—A simple little wheeled toy complete with animals

THE attractive little Ark shown in our illustration Fig. 1, measures 9½ ins. long on the base, about 6 ins. wide and 6½ ins. high. It is made with a hinged roof so it can be easily opened for keeping all the animals in. The ark is mounted on wheels so it can be pulled about, which should please any youngster.

Wood ¼ in. thick is used throughout for the ark, and the 2½ in. wheels for it can be purchased from Hobbies at 1/6 the set of four, postage extra.

### Animal Patterns

A whole page in this issue has been given up to patterns for making half-a-dozen animals—cut from almost any thickness of wood and mounted on circular disc stands, one pattern for which is also supplied.

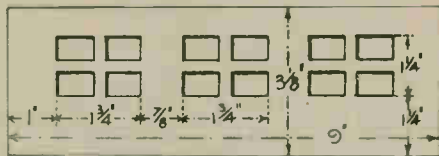

Fig. 3—Outline of sides and sizes

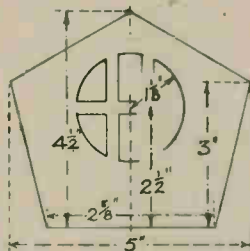

Fig. 2—Details of end piece

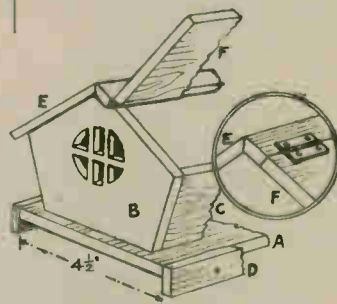

Fig. 4—How to build the parts

fretted "window" to the ¼ in. wood. After cutting both the ends, clean them with glasspaper and then proceed with the sides. Full dimensions for the setting out of these are given in Fig. 3.

When they have been cut and cleaned, a piece of coloured paper or card should be pasted

on the inside of each piece over the "window" openings to make a colourful and attractive article. The lower edge of each side piece should be slightly chamfered to meet the base of the ark.

Nail the sides to the ends and glue in small fillets of odd wood in the angles to give added strength.

Turning to Fig. 4 we see a sectional diagram showing the assembly of the various parts, lettered in the manner of fixing. The four walls can now be glued to the base and a few small wire nails or fret pins added from beneath to strengthen the joint.

The side rails, D, are next added. These are to take the screws of the

filling, and a shaped angle block added at one end where the door will be represented (see Fig. 1).

The two roof slopes measure 9½ ins. by 3¼ ins. each, and one long edge of each piece must be chamfered to an angle of 45 degrees to meet at the ridge as seen in Fig. 4. One of the pieces will also have to be cut through lengthways about ¼ in. from the chamfered edge.

Hinge the rail so cut, to the wider piece, making, as it were, a flap to open as seen in Fig. 4. A pair of brass hinges may be fastened on as shown, or a very efficient hinge can be made with tape glued over each piece.

### Coloured Finish

The whole Ark should be painted in bright colours and very little decoration to make it look effective and to take away from the plainness of just the body colour. Little need be said about the animals except that the patterns given should be pasted down to the wood and the cutting out done with a fine fretsaw.

The shallow recess on the ground work of each animal is intended to receive the circular base to which they must be securely glued. If desired, the paper may remain on the

The base for the ark measures 9½ ins. long by 4½ ins. wide, and on this will stand the four walls.

At Fig. 2 the necessary dimensions and outline of one of the ends are given. Draw this out first on paper and then transfer the outline and the

wheels, small blocks of spare wood being added to the base to take the ends of the screws. The rails are 9½ ins. long and ¼ in. wide and are nailed and glued on strongly.

Two small pieces of wood can be glued between the side rails as

wood of the animals and water-colour paint added on this.

Or the patterns could be cleaned off with fine glasspaper and the animals then finished with oil paint which would make them more durable.

### Sailing Boat—(Continued from page 155)

mooring eyes several times to allow for adjustment.

To finish the work, apply a white primary paint to the hull, deck and keel plate. When this dries, apply a white enamel to the deck top and hull sides. The keel plate and rudder is painted light green. The weights and mast may be black, including the mast step.

Five port-holes are painted, with black, on the hull sides, as shown.

Alternatively, you would obtain a more realistic effect by boring the holes and plugging them with lace eyelets removed from old boots or shoes. The eyelets make excellent port-hole flanges. They should be a push-in fit.

A pennant can be added to the mast, but is not absolutely essential. If added, it should have the initial of the name of the boat marked on it, such as T for Tilly. Details of this nature

give an added interest to the boat—so far as kiddies are concerned, at least.

If, in strong winds, the sailing boat proves to be somewhat top-heavy, thicker keel weights could be added. While this will doubtless correct the top-heaviness, some amount of buoyancy is lost, and consequently, if possible, extra weight must be avoided. The mast could be reduced in length considerably. This, however, means a loss of wind force.

# A simple and interesting hobby is that of TREE LEAF PRINTING

**L**EAF printing is a most interesting hobby, and it is surprising how few people know anything about it. Besides being interesting it is exceedingly cheap, and requires no materials except a few sheets of carbon paper and a loose leaf notebook.

The common varieties of trees in the British wayside and woodland number about forty; those usually found in small gardens amount to about forty more, and those in

other hard surface. A plain piece of paper is then placed over the leaf and rubbed hard, so every part of the leaf is firmly pressed into the carbon.

The rubbing is best carried out with the fingernail and tip of the right forefinger, the fingers of the left hand being used to hold the leaf in position. Once rubbing is complete the top paper should be removed and the leaf lifted. It should then be examined to ensure that all the back of it is thoroughly covered with carbon.

The second part of the job is similar to the first. A page of the album is substituted for the carbon, the leaf is placed on it, covered with a clean piece of paper, and rubbed as before. Since this second rubbing produces the final print, extra care must be taken to ensure that the leaf is held absolutely still

useless.

Choice of a suitable album may present a certain amount of trouble. The best type of paper is a smooth type of writing paper, white, glossy, and without lines. It is essential that loose leaves should be used, so that smudged pages can be removed and destroyed.

For the same reason it is not usually desirable to print more than one leaf on a sheet. One bad print can spoil the effect of several good ones, and it is too much to hope that every print will be perfect.

## Album Size

The size of sheets for the album depends on personal taste. The writer would suggest quarto or even foolscap. The leaves themselves should be clean, but not too young and green. Dirt, dust and cobwebs spoil the carbon paper, but young green leaves are liable to shed juice on the final print and disrupt the beautiful blue effect. Deformed and bug-eaten leaves should be avoided for obvious reasons.

Certain leaves have multiple leaflets on one stalk—the ash, rowan, walnut, rose and raspberry. All the leaflets on a stalk should be treated as one leaf and printed as such, but it is often very hard to hold every leaflet still. The horse chestnut, in which all the leaflets radiate from the stalk at the same place, is probably the most difficult of all.

Some of the coniferous trees, such as the fir, pine, and cedar, have leaves which are almost impossible to print. One of the hardest evergreens to reproduce satisfactorily is the holly,



A sample of common woodland leaves from the garden

botanical gardens and private parks are innumerable.

The intending collector would do well to start by printing the leaves from his own garden in the early summer, during which time he can learn the technique. Then in the country, he can collect all the wilder varieties, and finally by visits to botanical gardens and other places where rarer trees are found.

## Printing Method

The method of printing is very simple. It consists first in pressing the back of each leaf on to carbon paper so this side of the leaf becomes covered with carbon. The leaf is then removed from the carbon paper and pressed onto a plain sheet of paper so the outline and veins of the leaf are printed in carbon on the paper. The result should be a beautiful blue reproduction of the leaf.

The detailed procedure is as follows: Take the leaf and place it face upwards on a piece of carbon paper, which should itself have been placed, carbon side upwards, on a magazine or



Example of good and poor printing of oak

with the left hand and that every part of the leaf gets an equal share of rubbing.

This is most important, since failure to hold the leaf still results in smudging or double impression, which spoils the print as effectively as moving the camera during exposure

spoils a photograph, whereas uneven rubbing tends to produce a blotchy effect with some parts of the leaf printed much more darkly than others.

The carbon paper must be of the type used for reproducing handwriting; it is usually coloured blue. Typewriting carbon paper (usually coloured black) is



Of the hazel, chestnut and birch, only the first is good

simply because it is so difficult to press flat. There are other special difficulties attendant on printing certain varieties, but the collector will find these out as he goes along and will devise means to overcome them.

One of the most delightful prints is from a fig leaf. This leaf has a very powerful and pleasant smell which passes to the print and stays on the paper for several months.

(Continued foot of page 159)



The rose and currant leaf from the garden

# Add to your terminal station realism by having SMALL MODEL BUFFERS

**A**LTHOUGH model railways are not quite so much to the fore at the moment due to shortage of equipment, many readers still have their lines and are looking for easily-made, but realistic line-side items. Here, then, is a set of those very long hydraulic buffers you often see at the end of platforms in terminal stations.

This type of buffer is made with a special long thrust to help reduce the impact should a train over-run the distance when coming into the platform. In our case the buffers are only imitation and are made with two of those long spike nails.

## Use 3in. Nails

First cut the nails to 3ins. long and then cover a distance of 1½ins. from the end with a layer of insulating tape, followed by a strip of heavily glued paper, rolling as shown, to produce the raised section (A). Roll the paper tightly, and this together with the inner layer of tape, it will be found, holds the nails quite firmly when fitted in the wood.

Next cut the block (B) 2½ins. by 1in. by 1½ins. and also a piece (a) to go on top 2½ins. by 1in. by ½in.

Now shape the block as shown with two slots along the top which will tightly hold the widened ends of the nails at 1½ins. apart. Also make two slots below at such a height they will just take the ends of a piece of your tin-plate rail.

Now fill the top channel with glue, press in the nails, put on the top and make all secure by the large screw (b) which goes down the centre. Some careful fitting is needed here, the idea being that when the top piece is put

on and screwed down, it holds the nails rigidly in position. Like other fitting jobs, it is quite likely that you may have to take the pieces apart once or twice to secure a really good result. The buffers, too, should be quite parallel.

The cuts in the block were, of course, square and the nails round, the intervening space, therefore, is filled up with a little plastic wood, pressed well in, or some filling made of a mixture of glue and sawdust.

Now put the block on the base (D) which is a thin piece of plywood 2½ins. by 3ins. held by sprigs and glue.

The short piece of rail (K) can next be fitted. This is merely an odd length from any tin-plate section cut to the right size. On the inner side the rail ends (there is only one sleeper required) go into the two lower channels cut in the block.

At the outer end the single sleeper is bored and held to the base by a short screw. Everything is then made quite tight by the strip of wood (C) which just joins under the rails and presses them tightly against the top of the cuts in the block.

Finally the back (H) is put on to cover the ends of the rails. This is

merely a rectangle of thin wood held in position by sprigs and glass-papered off neatly flush with the block.

## Painted Parts

With regard to finish, the shanks of the nails and the heads should be painted aluminium colour, while the face of the block should be red and the rest buff, or any other colour you have to hand.

The rails can be left as shown in the sketch, but they can be surrounded,

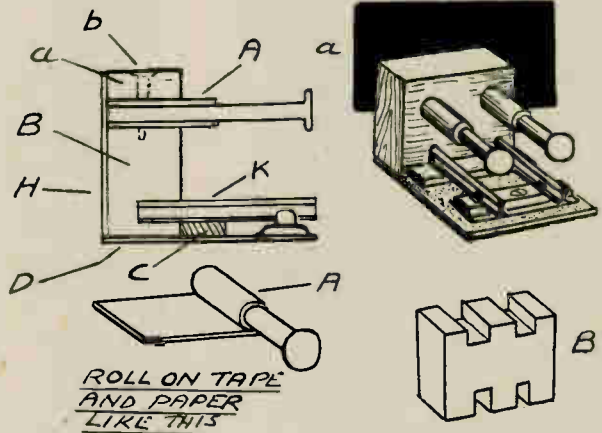

to sleeper-top level, with very fine stone mixed with glue. This gives a really nice ballasted effect and certainly should be done if the buffers are to be connected with scale track. If with tin-plate it is as well to leave the rails as they are.

## Tree Leaf Printing—(Continued from page 158)

The filing and cataloguing of prints must be done according to the collector's fancy. A collection can be filed alphabetically under the English names of the trees. The only other details given are the Latin name, the place where the tree was found, and the date.

## Cataloguing

For the collector who wishes to be more elaborate, a list may be made of the countries and climates in which the tree grows, or of the uses of the fruits and timber. Better still, the collector who is also an artist may improve his collection with drawings or paintings of the flowers and nuts of each tree, and the photographer has ample scope for inserting snapshots of the tree or close-ups of the flowers, fruits, or bark.

Beginners should either buy or

borrow a good textbook, to assist them with identification of leaves and to advise them what to look for. One of the best books for amateur use is "Wayside and Woodland Trees" by Edward Step, F.L.S. (Frederick Warne

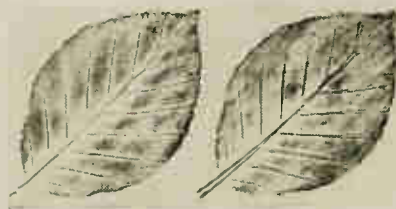

A good and bad print of a beech leaf

and Co., London), but there are several other good ones on the market. "Trees shown to the Children" by

Janet Harvey Kelman and C. E. Smith, (T. C. and E. C. Jack, London) is very useful for beginners.

## Permission First

It is most advisable that collectors should not take any leaves from trees in private or botanical gardens without first obtaining permission. This will usually be granted willingly to collectors who promise not to take more than one leaf from each tree.

The more one goes in for leaf printing, the more fascinating the hobby becomes. Collectors who take it up and persevere will never regret it. The illustrations attached will give an idea of the results that can be obtained and the common mistakes that will need to be overcome, but nothing that can be reproduced in print will adequately convey the beauty of the original carbon.

# For ornament as well as use, you should make these LONG HANDLED BELLOWS

FOR making this useful domestic article a board of  $\frac{1}{2}$  in. thick deal, or hardwood, is required, 2ft. long and 7ins. wide. The pattern can be set out direct on the wood quite easily. Draw a line down the centre of the board and on it, with radius of  $3\frac{1}{4}$  ins., strike a semi-circle, as in Fig. 1.

The remainder can be put in with pencil and ruler, being straight lines—the diagram shows this. Having marked and cut out the two sides of the bellows, on one side only saw off the piece marked A.

Now cut a second piece (A) from the scrap remaining. Through the centre of this, lengthwise, bore a  $\frac{3}{16}$  in. hole for the nozzle, which should be a  $\frac{1}{4}$  in. piece of  $\frac{3}{16}$  in. brass tube. Take some care when boring this hole.

It will be as well to bore halfway through from each end, and if a preliminary pilot hole is first drilled through, it will help to keep the drill bit from wandering. The bored piece is then glued to the bottom end of the other side piece of the bellows, and

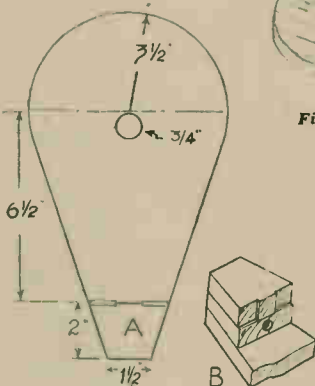

Fig. 1—Side shape and hinged toe

piece A glued on top of it. Through the bottom side piece, just touching the half circle, a  $\frac{3}{16}$  in. hole is bored through to allow air to enter. The hole is shown in Fig. 1.

The top half of the bellows is now hinged to piece A, two lin. stout brass hinges being used for the job, positioned as in the drawing. Recesses are cut out in the ends of both side piece, and A, for these hinges, as in detail B, so that where the two ends of the wood meet at the centre there is little or no gap left for air to leak out.

## Air Inlet

The air inlet hole, already bored has now to be covered with a valve. The arrangement for this is sketched in Fig. 2, D showing the valve in posi-

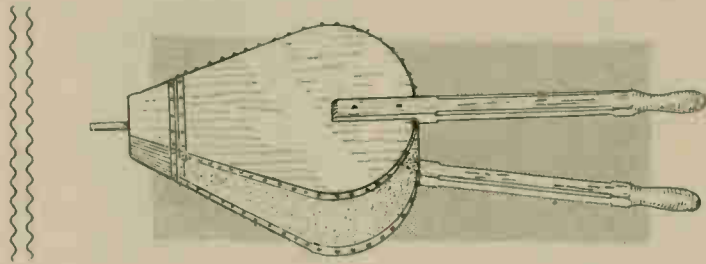

tion, and C a section through it and how it covers the hole.

To make the valve, cut a piece of thin leather (wash-leather would do)  $1\frac{1}{2}$  ins. wide and 2 ins. long. Glued to this is a lin. square of thin fretwood. Next to this is glued a thicker piece of wood,  $1\frac{1}{2}$  ins. long and  $\frac{1}{2}$  in. wide. It should be  $\frac{3}{16}$  in. thick.

A space of some  $\frac{1}{16}$  in. should be allowed between both pieces of wood, to allow freedom of movement. The thick piece is screwed to the bellows side, letting the thinner part cover the hole completely.



Fig. 2—Interior showing valve

This thinner part, which is the flap, of course, should move easily, but to prevent it falling too low a bent strip of brass, as in the detail, C is fitted to act as a catch.

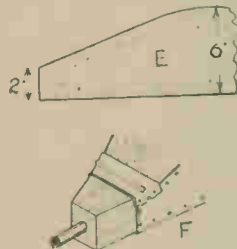

Fig. 3—Details of nozzle

This should not rise above the wood more than  $\frac{1}{16}$  in., which will allow enough movement of the flap and yet not be in danger of being flattened down when the bellows are

closed. It is important to see this portion of the bellows works smoothly, as it cannot be afterwards dealt with.

The open sides of the bellows are now to be covered in with leather. A strip of soft, pliable leather should be used for this part of the work. Cut it to the shape given at E, in Fig. 3 (half only shown). The length is not given, as this is best measured from the bellows sides itself. A tape measure will do this part, measurement being taken right round the edges to  $\frac{1}{16}$  in. past the hinged joint.

Mark the centre of the leather first, then fix it at its centre to the centre of the semi-circular ends. Get an assistant to keep the sides fully extended while the leather is glued and tacked round.

Press the leather well down to the

wood edges, as tacking proceeds, to seal the joints. Now leave for awhile for the glue to get hard, then trim off any surplus leather remaining.

A weak spot is the hinged joint, so this must also be sealed against leakage. This is effected by gluing a strip of leather over the hinge, as in F, the strip also extending over the side edges  $\frac{1}{16}$  in. as well. Avoid getting any of the glue on the hinges themselves, or they may stick.

It is as well to slightly damp the leather here first, also to snip it a trifle at the edges that go over the sides, but only just enough to allow the bellows to open, no more. If the leather, while damp, is stretched a trifle, the actual snipping need be but little—in fact it may be avoided altogether.

## Brass Nozzle

The brass tube nozzle is then glued tightly in its place. If the hole is a good fit, the glue will make an airtight joint here. Notch the tube a little with a file to enable the glue to “key” itself to the brass. To finish off the nozzle part, the sharp corner angles of the wood portion can be smoothed off. Then the whole is glasspapered to smoothness.

For the long handles cut two to the shape and dimensions given at Fig. 4, from wood  $1\frac{1}{2}$  in. wide and  $\frac{3}{16}$  in. thick. Cut away to half thickness at the lower ends, which fit over the bellows, and shape up the upper ends for a comfortable grip for the hands.

The main parts of the rest can be stop chamfered, it imparts a lighter and more pleasing finish to the whole article. Fix the handles on with round-

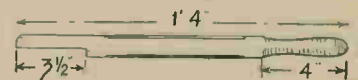

headed brass screws, and glue the joints as well.

This practically completes the article, which can be stained and varnished to taste. The tacked edges however, do look rather unfinished, and a great improvement results if a strip of banding, such as can be bought at any upholsterer's stores, is neatly tacked round.



# Keep them clean and tidy in this STAND TOOL RACK

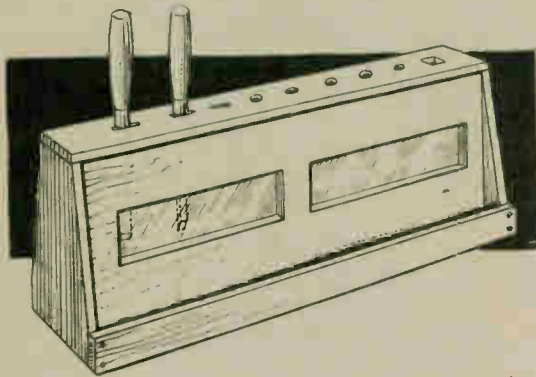

**T**HIS pattern of tool rack can be recommended, as it keeps the tools free from dust and protects the edges. Tools are so dear nowadays, besides being hard to get, that it behoves everyone to take care of them.

The rack is intended to stand at the rear of the bench, but, if space on the bench is too limited to accommodate it, it could be placed on a narrow shelf above it. Alternatively, if the back edges of the rack were cut straight down, instead of sloping, it could be screwed direct to the wall.

The ends of the rack can be cut from moderately thick deal, the dust-proof side panels from  $\frac{1}{2}$  in. wood, and the remainder from  $\frac{1}{4}$  in. wood. The ends are shown at A. Cut to the shape and chisel out two grooves,  $\frac{1}{4}$  in. deep to admit the panels.

## The Construction

The simple construction will be understood by reference to detail B. The top piece, holding the tools, is cut to any convenient length, long enough to house the tools suitable to the rack. The sketch shows a rack 18 ins. long, and will hold quite a number of tools.

In the top piece cut out openings to suit the particular tools to be held. Slots for wide chisels and square, for example,  $\frac{1}{2}$  in. holes for smaller chisels, and perhaps, a square hole to receive the marking gauge.

Then cut a 1 in. wide strip of wood the same length as the top, which is required along the front, with a  $\frac{1}{2}$  in. wide strip to go between the ends. These two pieces form a narrow rack, as at B, convenient to hold pencils, files, and such like tools not easily accommodated elsewhere.

Now nail the top piece across,

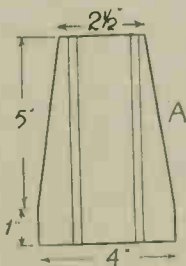

Details of the end, the method of construction and the glass fixing

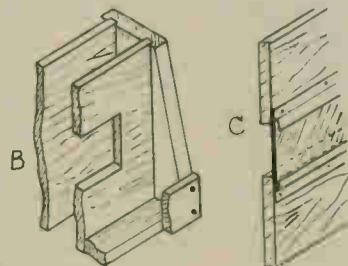

then the front rack strip; the required length of the panels can then be measured off, and should prove a smooth sliding fit in the grooves.

In the front panel only, saw out two openings, as shown in the sketch. These are covered on the inside with glass, kept in place by bent tin strips, as in the detail, C. Fit this panel in first, then push the bottom rack strip in place and nail the

panel to it.

## Screw Fixing

Fix the back panel in with a single screw each side, driven in through the ends of the rack. Two or three screws should now be driven into the front strip into the bottom rack strip behind.

No glue is needed anywhere. It will be understood by this arrangement that by withdrawing the front screws the glass-pannelled front can be drawn out any time it may be necessary should the glass be broken and replacement necessary.

It may be added, that the glass panels can be omitted not being essential to the rack, but, as in this style of rack the blades of the tools are hidden from view the glass-pannelled front enables all the tools to be seen and picked out unerringly. It is certainly an advantage.

## Glass Substitute

If you cannot get glass the correct size, however you can easily substitute some of the transparent material now more or less easily obtainable. Fix it inside with narrow strips of wood overlapping the edges so the nails can hold all in place.

The finished stand should be neatly cleaned and coloured. If odd wood has been used it can be stained all the same colour, or the whole thing can be given a coat of paint.

# Two replies of General Interest

## Fixing Pins to Perspex

*HOW can one undertake the fitting of a pin or clasp to brooches and trinkets made from Perspex? (M.B.—Parkstone).*

**T**HE type of pin you should use depends on the size of the brooch. If it is small, use a miniature safety pin, but if the brooch is large enough, a small tie pin can be used. Special brooch pins are sometimes obtainable, having two projecting tongues on the back of the pin, which are clasped round some suitable part of the brooch. As you may have some difficulty in obtaining these, here is a good method of mounting either safety or tie pins.

Cut a small groove in the back of the brooch, just wide enough to take the flat part of the tie pin, or the back of the safety pin. Smooth and polish the groove, otherwise it will look unsightly from the front of the brooch. Run a little cement into the groove, and lay the pin in position.

A very thin cover piece is now cemented over the pin, and overlaps the metal so that in effect the pin is buried in the plastic. This method makes a very strong and reliable job.

## Moulds in Gelatine

*I AM interested in making small scale ship models, so would you please inform me how you use gelatine for making moulds? (H.P.—London-derry).*

**G**ELATINE can be used for making moulds for small castings—in plaster or the like—under suitable conditions. A model of the desired article is prepared and the location and number of moulds decided upon, according to the shape of the model. Undercut parts should, of course, be avoided.

The model is then placed in a small box or container, with the top edges thereof level with that part of the model where the divisions between the moulds are to come.

A suitable quantity of gelatine is then placed in a clear vessel which is placed in a pan of boiling water. As soon as the gelatine becomes liquid, it is poured into the box and the model held in place while the gelatine cools and sets. The surface is then coated with grease, and the remainder of the mould is made in a similar way by placing another box on top of the first, securing the edges with adhesive tape to keep it in place, and the gelatine poured in through a suitable hole or holes in the top.

As gelatine dissolves with heat, its use for moulds for lead castings is impracticable.

# MISCELLANEOUS ADVERTISEMENTS, etc.

The advertisements are inserted at the rate of 3d. per word or group of letters prepaid. Postal Order and Stamps must accompany the order, and the advertisements will be inserted in the earliest issue. Freetwork goods or those shown in Hobbies Handbook not accepted. Orders can be sent to Hobbies Weekly, Advertisement Dept., as below.

**S**MOOTHING planes, 5ins. and 7ins. A really efficient tool at 7/- and 9/- each respectively. Satisfaction guaranteed. Cheques and postal orders (to include 6d. for postage and packing) to—Branker, l.t.d., 50 Brighton Road, Purley, Surrey.

**L**ONELY? Join Friendship Circle. Details 6d.—Secretary, 34 Honeywell Road, London, S.W.11.

**F**REE Stamps. Liberal discount to all approval applicants enclosing postage.—J. Lindsay, 17 Johnston St., Paisley, Renfrewshire.

**S**TAMPS FREE!! Twenty unused (2½d.).—G. H. Barnett, Limington, Somerset.

**S**UPER quality translucent plastic Sand chrome bracelets, in red, green and yellow pastel shades, 2/6 each, post free.—Cailes, 210 Stewart Road, Bournemouth, Hants.

**F**REE with Approvals ten Switzerland. Postage 2½d.—Fantozzi (HW), Whitegate, Northwich, Cheshire.

**H**OW high could you fly the Habrey Spineller? Have a try. Send 5/6 Postal Order today for one of these fascinating outdoor flying propellers and launching machines. Full instructions included.—Abrey Engineering, Greys Road, Henley-on-Thames.

**P**ERSONS required immediately to make leather shopping bags in spare time. Write—Dept. 11, Empire Co., 117 Nottingham Road, Loughborough.

**P**ERSPEKIT! The really profitable pastime. Outfit includes tools, lessons, plans, polishes, transfers, adhesive, clear and coloured Perspex for making the articles. Make your own gifts. Stamped addressed envelope brings full particulars.—White, 2 Alexander St., Coatbridge.

**C**HARGING Sets. Petrol, new condition 288 watts. J.A.P. air-cooled engine Model 2A, governed complete with switchboard. £14/10/0 carr. paid.—Parker, St. Peter's Power House, Jersey, C.I.

**U**RGENTLY required, spare time workers to make leather goods. Apply—Dept. Y3, Somat Plastic Co., 8 Middlemarsh, Nottingham.

**N**EW waterproof cycling jackets 10/-. American army lumber jackets 15/-. No coupons, war surplus.—BM/GMKT, London, W.C.1

**B**E Taller. Quickly! Safely! Privately! No appliances—no tablets—no dieting. Details 6d. stamp.—Malcolm Ross, Height Specialist, BCM/HYTE, London, W.C.1.

**L**ONELY? Then write Secretary L.U.C.C., 5B.B. Hay St., Braughing, Herts. Genuine. Est. 1905.

**M**ODELS: you can make lasting stone-hard models with Sankey's Pyruma Plastic Cement. Supplied in tins by Ironmongers, Hardwaremen and Builders' Merchants. Ask for instruction leaflet.

**T**RANSFERS for decorating toys, trays, furniture, fancy goods. Selection 10/- 20/-. Flowers, pixies, dogs, nursery rhymes.—H. Axon Harrison, Jersey.

**P**ERSONS required make fancy goods at home. Write for details—Melton Manufacturing Co., Southgate Street, Leicester.

**G**OOD Printing, moderate cost, prompt attention. Note-paper headings (four line address) on good quality Bond or Bank paper (according to availability) 4/6 per 100. Send stamp for catalogue.—The Zodiac Company, BCM/Crucis, London, W.C.1.

**B**OYS! Learn Magic. The boy who does tricks is always popular. Send stamp for illustrated catalogue of tricks specially arranged so that you can do them.—The Boys Service, Prestatyn, North Wales.

**D**OLL'S House fittings and papers. Send S.A.E. for list. Doll's house plan special, send 2/6. Trade supplied.—Zimplan, 88 Ware Road, Hoddesdon.

**W**HEELS for toys in metal, wood and plastic. Numerous sizes and types. Write for list stating requirements to The Joyden Toy Co., 193 Chase Side, London, N.14.

**"POWER Tools You Can Make".** Famous "Popular Mechanics" plans and constructional details for building drilling machine, jig-saw, band-saw, lathe, etc., all from readily available materials. 12/6 only, post 7d. Illustrated lists 3,000 American homecraft books, plans, magazines 6d.—BCM/PUBLICATIONS (H), London, W.C.1.

**A**LL Metal Chassis designed for mounting animal, etc., cut-outs. Green platform (6ins. by 2ins.) fitted with 1½in. red or yellow wheels. Stove enamel finish. 1/9 each post paid. Reduction for quantities.—Joyden Toy Co., 193 Chase Side, London, N.14.

**H**APPY Circle pen-pals bulletin 1/3. Contacts everywhere.—176a, Shoreham Road, Hove.

**M**INIATURE Naval Ship Packet of Designs for complete Fleet and Base. Price 1/- (postage 1d.).—Hobbies Ltd., Dereham, Norfolk.

**N**OVELTY packet of unusual stamps free to approval applicants sending 3d. postage.—M. Edwards (N.3), Westcroft, Northchurch Common, Berkhamsted, Herts.

**T**HE interest in car numbers never ceases. "Where's That Car From?" Containing all the car index marks alphabetically arranged. 54 pages. 6d. Now in its sixth edition. From all newsgates.—Raleigh Press, Exmouth.

**G**ALEON Designs. Range of well-known historical models. Plans, materials and instructions. Write for list.—Hobbies Ltd., Dereham, Norfolk.

**W.** McGARRIGLE for aeroplane and ship kits. All accessories, stamps, lists 3d. Wholesale lists 4d.—64 Hillcrest Road, Romford.

**S**PECIAL offer. Attractive stamp album, 50 stamps, packet of mounts. Post free 3/-.—Gamut (Dept. C), Supplies Co., 24 Gunnersbury Avenue, London, W.5.

**M**ODELS of all kinds made from Hobbies designs. Leaflet from Branches and Dereham, Norfolk.

**F**REE! Extra special Br. Col. packet scarce Jubilee, Coronation, Victory, Zoological new issue stamps. Request approvals (2½d.).—Thompson, 2 Western Gardens, London, W.5.

**S**HORTHAND in one week. Test lesson 3d.—Dutton's (H.B.), 92 Gt. Russell St., London, W.C.1.

**I**NDIX for Vol. 105—Hobbies Weekly Oct. to March.—Useful for binding or reference. Price 1/- post free.—Hobbies Weekly, Dereham, Norfolk.

## ELECTRIC MOTORS

TYPE 47 GM. Dimensions 11¼ x 4¼ x 4½ ins.

Converted into a Motor 220v. A.C., 50-Cycle, Single-Phase. Fitted with reduction gear box with 3 intermittent cams and 1 slow drive. Air blower at the other end. Ideal for displays, experimental purposes and driving your model.

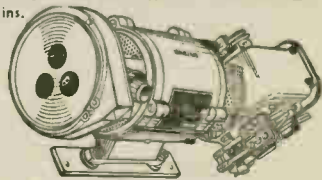

OUR PRICE 27'6

Plus 2/6 Postage and Packing

**DOUGLAS HOUSE LTD.**  
WARREN WORKS, UPPER CULHAM,  
NEAR WARGRAVE, BERKSHIRE.

**Cut-out Figures for the  
Noah's Ark on page 157**

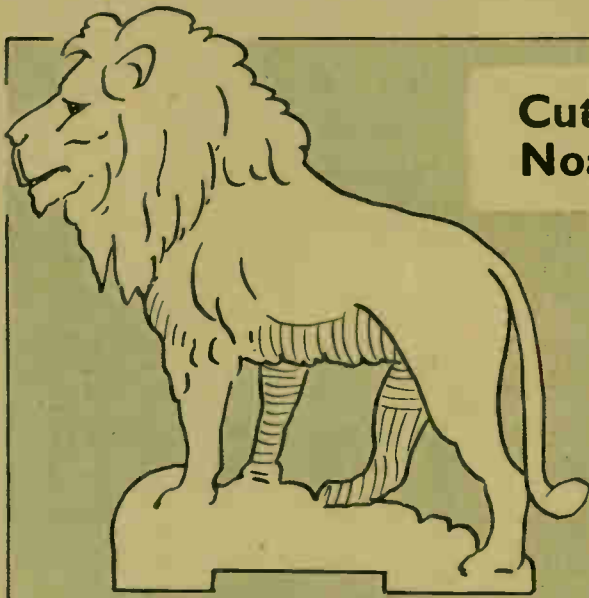

**LION**

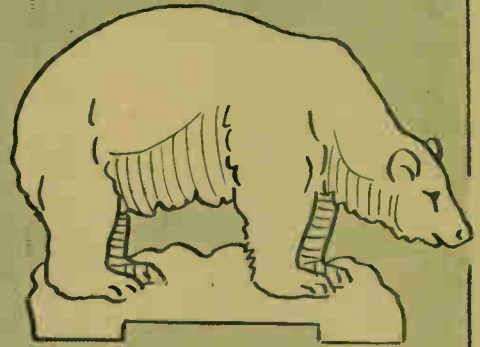

**POLAR  
BEAR**

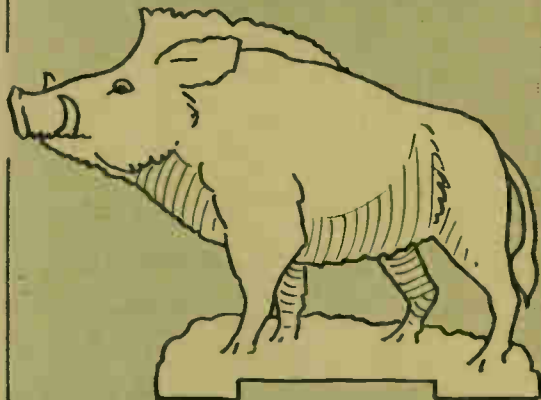

**WILD BOAR**



**REINDEER**

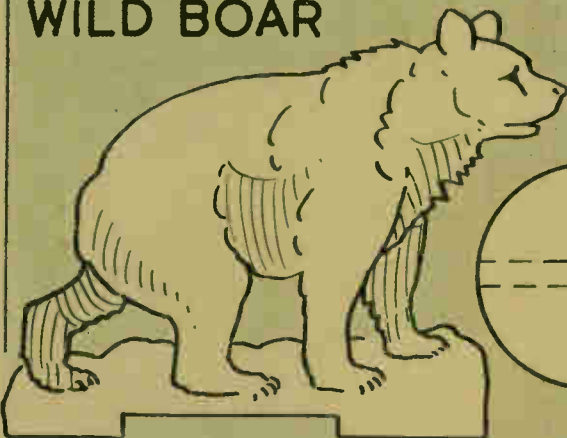

**BROWN BEAR**

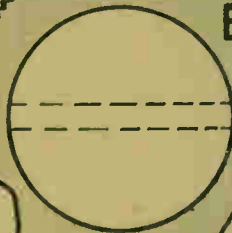

**BASE.  
MAKE SIX**

**WALLABY**





*Get this book  
- make these  
MODELS*

HOUSES · SHIPS · ASHTRAYS · BOOKENDS  
SIGNAL CABINS · RAILWAY STATIONS  
AIRPORTS · DOCKS · RELIEF MAPS · PLAQUES  
MODEL FURNITURE · INKSTANDS · PAPER  
WEIGHTS · MODEL FIGURES & ANIMALS etc.

**SIMPLE TO HANDLE · INEXPENSIVE**

The instruction book illustrated tells you how to make such models as above, without special tools or skill, in Sankey's "Pyruma" Plastic Cement. This material, modelled while plastic, dries or bakes to stone-hardness, ready for painting according to instructions. Obtainable at local ironmongers, hobby shops and art material dealers.

Get Instruction Book by sending 4d. in stamps to the address below



Dept. 3

**J. H. SANKEY & SON, L<sup>TD</sup>**

ILFORD

Est. 1857

ESSEX

## QUALIFY FOR A BETTER POST —BY POST!

Let the most progressive, most successful College in the world coach you by correspondence. Choose your career or be advised by us. We take a personal interest in all our students and provide the friendly individual training that quickly leads to success. Make the first move NOW—write for free particulars.

**CHOOSE YOUR CAREER—  
WE WILL TRAIN YOU QUICKLY**

Blue Prints.  
Book-keeping, Accountancy  
and Modern Business  
Methods.  
Building, Architecture  
and Clerk of Works.  
Cambridge Senior  
School Certificate.  
Carpentry and Joinery.  
Civil Engineering.  
All Commercial subjects.  
Sanitation.  
Shorthand (Pitman's).  
Concrete and Structural  
Engineering.

Draughtsmanship,  
all Branches.  
Heating and Ventilating.  
Institute of Housing.  
Languages.  
Mathematics.  
Matriculation.  
Municipal & County  
Engineers.  
Plumbing.  
Quantity Surveying—  
Institute of  
Quantity Surveyors Exams.  
Structural Engineering.  
Surveying.  
Teachers of Handicrafts.

If you do not see your own requirements above, write to us on any subject. Full particulars free.

Direct Mail to **Dept. 62**

**THE BENNETT COLLEGE Ltd.  
SHEFFIELD, ENGLAND**



**FOR A  
REAL  
Professional  
'FINISH'**

'FINISH' is the true test of craftsmanship. It's easy to impart a real professional 'finish' to woodwork and furniture you make at home with "COLRON" WOOD DYE—the finest stain for all practical purposes.

One coat of "COLRON" is all that is required to emphasise the natural beauty of the wood grain. No smears—no 'overlaps'—no trouble. Leave from two to three hours, burnish with rough dry cloth and you have a perfect base for french polishing or for waxing with "RONUK" FLOOR POLISH.

**COLRON** WOOD  
DYES

12 SHADES—ALL SIZES

Write for colour guide and full details to :

**RONUK LTD. (Dept. 62) Portslade, Sussex**

## BOYS — MEN!



*Give your  
varnishing &  
polishing that  
professional  
look!*

**10/6**

Here is a unique new woodworkers' Varnishing and Polishing kit produced

by specialists for you. It contains 1 Jar Rustin's Stain, 1 Jar Varnish, 1 Jar French Polish, 1 Jar 'Kwiksolv' Paint Remover, 1 Bottle Linseed Oil, 1 Bottle Thinners, 1 Bottle Methylated Spirit, 2 Sticks Wood Stopper, 1 Tin Woodfiller, 1 Polishing Rubber, 2 Sheets Glass Paper and Full Instructions. Complete from your local store or carriage paid 10/6d. Get your outfit to-day.

FROM STORES  
OR

CARR.  
PAID

from

**Rustin's**

WATERLOO RD. LONDON · NW2

# Hobbies

## WEEKLY

### CONTENTS

	Page
A Canopied Deck Chair	- 165
Craftsman's Notes	- 166
Handy Cramps	- 167
Radio Auto Bias	- 168
Photography	- 169
Handy Scissor Sharpener	- 170
Home-made Watering Can	- 171

SUPPLEMENT DESIGN  
FOR LADIES'  
COMPANION SET

July 28th, 1948

Price Threepence

Vol. 106 No. 2752

It is nice to relax in a deck chair and bask in the health-giving sunlight.

Too much exposure to strong sun rays is bad for the eyes and head, however, and as few individuals desire to wear a hat, or a handkerchief, the convenience and protection of a canopy attachment is sure to be appreciated.

We have, therefore, designed a simple deck chair, with canopy attachment, and some idea of the work can be gathered from the illustration. The frames are easily constructed and not too much wood is necessary. Thick dowel rod has been suggested for rails.

## A CANOPIED DECK CHAIR

Flat laths are required for the canvas, of course, as the laths makes stronger rails.

The chair is of usual proportions and folds up compactly when not in use.

A clear idea of the frame construction and the various sizes is provided at Fig. 1. The rails used should be of hardwood 1½ ins. wide by ½ in. thick. Deal, while it can be employed, is rather soft for the purpose, and may be weakened in places with knots.

### Making the Frames

The first frame to make is A. The lath is 2 ins. by ½ in. The bottom rail is ½ in. or 1 in. diam. dowel rod. The rail is tenoned into the uprights and the tenons wedged for additional strength. The dowel rail is cut at the ends to form ½ in. pins. Holes for the pins (see small detail) are ½ in.

Do not have the tenon mortises or pin holes too near the ends of the frame uprights. Note that the ends of the latter are rounded over slightly. The edges of the uprights should be slightly rounded, this also applying to the top cross rail lath. Note the position of the pivot holes. Drill these with a 3/16 in. bit.

Frame B is made similarly as A. but the uprights are racked as shown. Pay particular attention to the overall width of the frames, by the way. B is only 19 ins. wide to fit between frame A.

### Support Strut

C is the supporting strut framework for frame A. Note how the cross rail is shaped so it takes a good grip on the racks of frame B. D is the frame strut for the canopy. It fits over frame E. All the frames must be strongly made, with the pins and tenons wedged in the upright pieces.

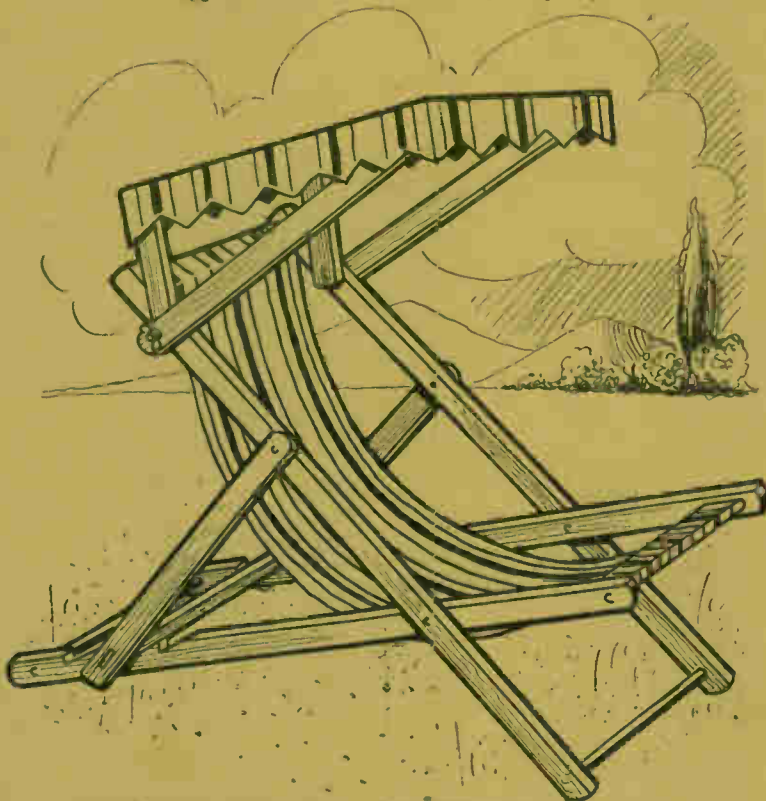

All correspondence should be addressed to The Editor, Hobbies Weekly, Dereham, Norfolk.

See, too, that each frame is quite square and without any twist.

### Assembling the Frames

The illustration shows how the frames go together. But, begin with frame A and B. B is riveted between A. Use 3/16in. copper rivets, with burrs. The latter are small thin

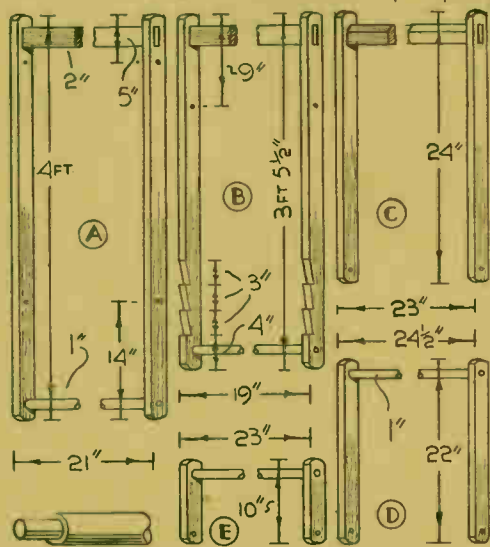

Fig. 1—The various frames with their dimensions

washers which are a force fit over the stems of the rivets; as the washers are hammered on, the metal bends over them and thus binds the wooden parts together.

Have an ordinary washer between each frame to facilitate movement. If you have used 7/8 in. thick stuff, there will be sufficient clearance for the washers.

The rivets should be roundheaded. The heads need to be supported on some form of anvil, such as the head of a heavy hammer. It is imperative that you have the rivet holes bored equidistant on each of the uprights, otherwise the frames will not fold properly, becoming "bound" at some quarter.

Having A and B fixed together and tested them for folding, attach frame C, using similar rivets, washers and burrs. Test the frame in its racks to see that adjustment is easy, and that the bottom rail takes a good, firm grip in the racks. There must be no slipping out, of course, nor too much side slackness. The rivets should make the parts move easily yet stiffly and firmly.

Slackness will come later on, after the chair has been in use. The parts should, therefore, move stiffly at the beginning; a little oil will help to ease the frames if moving too stiffly, or squeaking unduly. Apply little oil, however, if you intend to stain the work with a water stain, the oil preventing the wood from taking such a stain. An oil stain can be used without trouble.

The canopy support, E, and its strut, D, are affixed to the top of frame A with 3/16in. roundhead carriage bolts, 3ins. long, with washers and winged nuts. The latter enable the canopy to be removed at any time, or to be tilted at an angle.

It will be necessary, perhaps, to cut a square hole for the head square of

the bolts. This square prevents the bolt from turning around with the winged nuts. Keep the nuts to the outside, as shown.

Having completed the assembly of the frames, the wood can be oil stained and, allowing this to dry (after wiping off the excess stain with a rag), a coat of copal varnish brushed on. Spirit varnish may be used, including clear shellac polish.

The former, however, is easily scratched, and a church varnish, or french polish, is recommended, including copal varnish. The latter is an outside varnish which makes it ideal for the chair.

### The Canvas Seat

You will need a length of good striped canvas. This, when the size has been found, is hemmed at the ends for fixing laths. These laths are put into the hems and should project slightly beyond the widths of frames A and B.

To attach, the canvas is draped over the top rails, the lathed ends brought underneath and the ends inserted over the uprights of A and B. Thus, the laths become locked to the framing, and when necessary, the canvas can be removed for cleaning purposes. Alternatively, the canvas can be tacked to the rails permanently, but this is not advised.

### Canopy

The canopy is made up from similar material as the canvas seat. It simply fits down over the support and strut. It could be provided with cords so it may be tied to the strut and support. To find the length of the canvas for the seat, drape a length of cord over the rails of A and B, and make allowance for the hems.

### When Framing Pictures

NOW and then I come across such attractive pictures on out-of-date calendars that I hesitate to throw them away, with the result that more than once I have made a smart wood frame so that the best may hang on the walls.

Usually it is necessary to remove the picture from the calendar and re-mount it on a fresh piece of card or thick paper, and others who contemplate doing likewise, may be interested in one or two suggestions on this matter.

A white, brown, or other pleasing shade of mount is chosen, and the picture arranged so that there is an attractive narrow border all round to set it off to best advantage. But the picture ought not to be absolutely central on the mount. The margins at the sides should be equal, but for the finished work to look its best, the margin at the foot ought to be rather deeper than that at the top.

The framed picture will then look much more nicely balanced. When placed perfectly central an optical

illusion tends to give one the impression that the picture has slipped downwards a little.

It is unnecessary to coat the entire back of the print with paste when fixing it in position on the mount. In fact it is better not to do this, as there will then not be any risk of the mount cockling out of shape when the paste dries and pulls it taut. I merely fix it in position with a couple of dabs near the top and another somewhere about the middle, and when it is framed, the pressure of the glass holds it flat.

\* \* \*

### Whittling

DURING a country ramble I picked up a thick fallen twig. Having a penknife with me, I cut into the wood and found it smooth and soft. So, settling for a while on a fallen log, I tried my hand at whittling.

The incident seems worth mentioning here because whittling offers scope for real craftsmanship and will appeal to many readers, yet it has the advantage that it can be practised almost

anywhere—outside the tent when camping, or by the fireside at home—and in any odd moments of leisure.

A sharp pocket-knife is the main tool for this work, though for more elaborate efforts it may be desirable to bring one or two others into use. A saw will facilitate matters when cutting the first rough outline, and file and glasspaper will impart a perfect smooth finish. A small chisel may come in handy.

Whittling is a job that should not be hurried, and a start at the craft is best made with something plain—say a spoon or egg cup—using fairly soft wood that can be easily worked. With experience more elaborate objects can be tackled, and they may be either useful or purely ornamental, small animal shapes offering scope for more experienced workers.

Wooden chains are popular with many whittlers, and they provide an attractive means of fastening curtains back, to suggest one use to which they may be put. They are, however, only done by the expert after hours of actual experience on easier pieces of work.

The Craftsman

# The handyman should know of the various types of HANDY CRAMPS

THE handyman and amateur craftsman who is keen to get the best results should certainly appreciate the value of the different types of cramps which can help him in his efforts. Generally the beginner has a single cramp and tries to do all kinds of jobs with that.

He should realise that one cramp by itself is of little value, because there are many occasions when a number of a variety of these useful tools is essential. Most of us know the occasion when we are gluing up work and have it in a cramp, only to find



Fig. 1 - A steel cramp

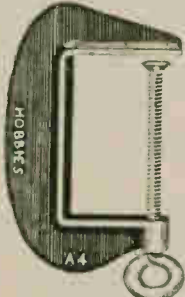

Fig. 2 - The cast cramp

that another one is required, and one either is not available, or already in use.

Even if you are unable to buy these things yourself you can often suggest them as a suitable present for a birthday or Christmas. A friend who knows your enthusiasm will realise your need and keenness, and probably reward it accordingly.

A few cramps which you should certainly accumulate are illustrated here. Each has its own particular job, but at the same time each can be brought into use on many other occasions, and will often help what might otherwise have been a difficult problem.

## A Light Steel Cramp

The most generally useful, of course, is the simple light metal cramp shown at Fig. 1, and most readers know how this is helpful in gluing up all kinds of work. It is built of a strong metal strip and obtainable in various sizes. The one illustrated is an ordinary 2in. small cramp. The measurements are the extreme width of work which can be used.

For larger work, then, you can obtain either cramps in  $\frac{1}{2}$ in. increases. If you have four of any one of these it is certainly not too many. You know the job when you have a large flat panel to glue down to another piece of wood, and have not enough cramps to hold it. One of these in each corner will just do the trick.

The screws, of course, can be turned up when the work is in position in the jaw, until a firm grip is obtained.

Unfortunately the firmer the grip, the more you will mark the work by the loose head at the top of the screw. Remember this before you put the cramp in position, and provide for it by having a waste piece of wood or a thick piece of card. This will take the impression and any mark which may be made by the extreme pressure.

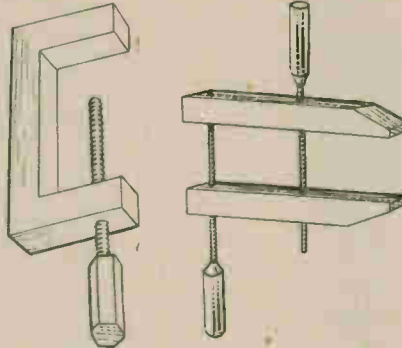

Fig. 3 - The wooden hand cramp

Whilst these cramps are quite strong, there is no doubt that on occasion, with a good deal of tightening you can extend the jaw and throw the whole thing out of true. This is the case particularly when you get the longer cramp and the strain on the back strip enforces bending.

## A Cast Metal Cramp

If you are likely to undertake work

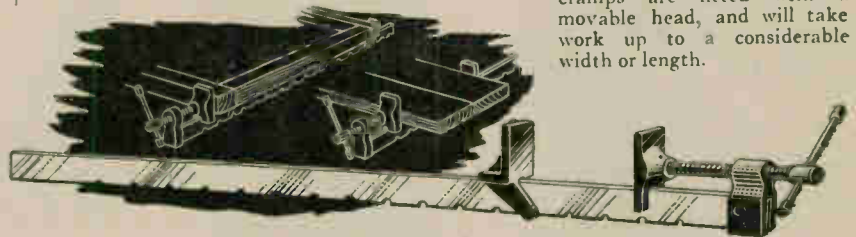

Fig. 4 - A sash cramp with extended bar for wide work as shown in details

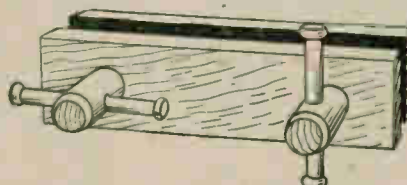

Fig. 5 - A carpenter's bench vice

of this kind where extreme pressure must be obtained, then you should certainly have the cast metal cramps shown at Fig. 2. They, of course, are used in the same method and for the same purposes, but being cast, there

is no possibility of the jaws opening. You cannot, indeed, make any impression no matter how tight you screw the work into it.

## A Wooden Hand Cramp

Before this more modern metal cramp came into being, the usual general-purpose one was the hand screw cramp shown at Fig. 3. This, indeed, is still found in many carpenters' kits, as well as the double cramp shown in the same detail.

This hand screw cramp is not necessarily for holding glued parts, but is also very useful for keeping small parts in position whilst they are being shaped with chisel or glass-paper, etc. You see, you can hold the part comfortably by means of the straight handle and yet go to work on it with the other free hand.

The double cramp is also useful on occasions, and can be put right over an article and cramped up quite tightly. Before the war this type of cramp was also obtainable in metal, being made by Hobbies Ltd. with two universal joints so it could be used on awkward corners and in angles which would not be accessible by the ordinary tool.

## The Sash Cramp

The sash cramp at Fig. 4 is essential for long or wide work, and the details given in that picture illustrate how useful it can be on the specialised occasions. The name "sash cramp", of course, suggests its original use when the frames of sash windows had to be glued together. These sash cramps are fitted with a movable head, and will take work up to a considerable width or length.

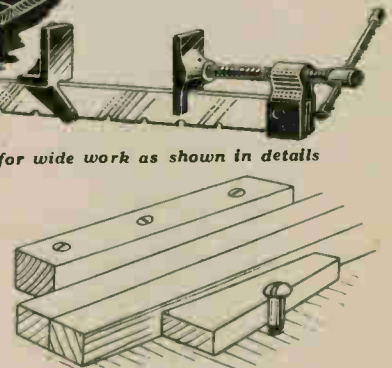

Fig. 6 - A home-made bench cramp

The holes along the strong straight bar allow for adjustment every 2ins. or 3ins. and if the desired width comes between these holes, then the

(Continued foot of page 171)

# Some helpful notes for the radio amateur about AUTO BIAS AND H.T.

It is apparent some readers are curious to know how Grid Bias may be obtained from an Eliminator so no battery is necessary. Actually the circuit is quite simple, and it may also be used with a receiver operated from a H.T. battery so that no G.B. supply is needed. Many modern sets are built in this way.

As the user of an Eliminator is often puzzled how to obtain additional H.T. tappings to correspond with those he may previously have used on his battery, this is also described.

## Voltage Drop

Free, or Automatic Bias, is obtained by adding a resistor in the H.T. Minus line. The resistor is arranged to cause

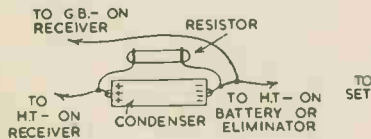

Fig. 1—Obtaining free bias

a voltage drop equal to the Bias required. By connecting as shown in Fig. 1, G.B. is then provided.

The G.B. Plus lead (previously taken to the battery) is no longer needed, and the plug is removed from G.B. Minus, so that it can be connected as illustrated.

If a proper bias condenser is used any value from 10 to 50 mfd. about 25 volts working, is suitable, and the polarity should be as shown. With simple sets no condenser is required, though results will be improved slightly if one of any capacity from 1 mfd. upwards is added.

If a H.T. battery is used, the bias developed will fall as the H.T. runs down, so that the correct bias is always applied. If the receiver consumes 10 milliamps (as do most 3 and 4 valvers) a 500 ohm resistor will provide 5 volts bias, a 750 ohm resistor 7.5 volts bias, and so on. Most

2-valve sets consume only about 5 milliamps, so 1000 ohms must be used to obtain 5 volts bias, with 1,500 for 7.5 volts, and so on.

As resistors are only a few pence each, various values may be tried, or a 2,000 ohm variable resistor can be used, and adjusted for best results. With almost all receivers a value of about 700 or 800 ohms does nicely, as the circuit is not critical.

## For Two Tappings

If two G.B. tappings must be used (say 4.5 volts and 9 volts) then two resistors and two condensers are necessary (see Fig. 2). The voltage obtained at G.B.1 will be that developed across the resistor R2. The

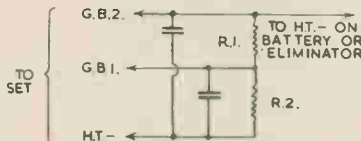

Fig. 2—For two tappings

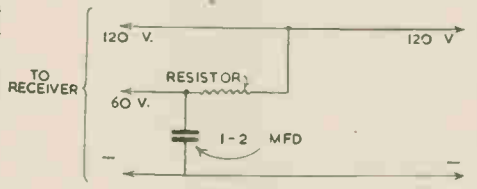

Fig. 3—Circuit showing H.T. tappings

voltage at G.B.2 will be that developed across both R1 and R2.

So to obtain 4.5 volts at G.B.1 and 9 volts at G.B.2, with 10 milliamps flowing, R2 should be 450 ohms, and R1 450 ohms also (not 900 ohms, since the extra 450 ohms is provided by R1). Both condensers should be 25 or 50 mfd.

## H.T. Tappings

Many Eliminators only provide one voltage—say 120 volts. If the user has previously been inserting one plug on his receiver in, say 60 volts on the battery, he may get oscillation and distortion if he takes this plug to H.T. 120, after adding the Eliminator. Therefore a resistor should be added to drop the unrequired 60 volts, and the way to do this is shown in Fig. 3. Usually the

H.T. 60 plug feeds the Detector and about 1 milliamp will pass. A 60,000 ohm resistor will therefore drop 60 volts, reducing the 120 volts provided by the Eliminator to 60.

Likewise a 30,000 ohm resistor would drop only 30 volts; a 40,000 ohm resistor 40 volts, and so on. So by selecting a suitable value any desired high tension voltage can be obtained.

A condenser of about 1 or 2 mfd. should be connected as shown to bypass low-frequency currents.

If other intermediate tappings are required a condenser and resistor should be provided to obtain each one, the value of the resistor being decided as mentioned.

## Screen Grid Tapping

A few receivers may have had a plug which feeds a Screen Grid. As an extremely small current would pass here, little voltage drop would be produced in the resistor shown in Fig. 3. Therefore the connections in Fig. 4 should be used.

The slider on the variable resistor

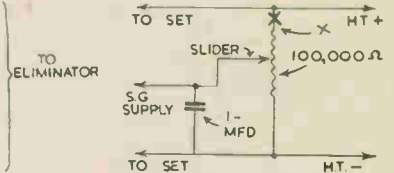

Fig. 4—Screen grid tapping

may be adjusted to supply any voltage to the screen grid. Actually, this will act as a volume control and in some receivers it is built into the circuit in this way, volume being at zero when the slider is near H.T. Minus and no voltage is applied to the screen grid.

## Resistor Added

If the volume reaches maximum with the control in a midway position, then a 100,000 ohm resistor may be added at the point marked with a cross. This will mean the control has to be fully turned for maximum volume, in the proper way. If the control is not going to be used as a volume control, then there is, of course, no need for this extra resistor.

Though 100,000 ohms is shown, values from 50,000 ohms upwards can be used. It is also possible to use two fixed resistors of the same value connected in series with the S.G. lead taken to the junction, this having the same result as when the slider of the control shown is in a central position.

Once connections have been made no further adjustment is required, of course, and no batteries need be bought.

## Homecrafts PERFECT PASTIMES

# Homecrafts

## Modern Materials for CRAFTS AT HOME

Plastercraft — Leatherwork — Lampshade making — Plastics  
Models — Toys — Patterns

Send 1/- for specimen copy of the magazine "Craftworker" & Catalogue  
of instructions, tools and materials.

# Homecrafts

(Dept. 17), Albion Street, BROADSTAIRS, Kent



# How amateur photographers can prepare successful COMPETITION PRINTS

**H**AVING made a picture from one of your negatives, trimmed and mounted it in accordance with certain modern standards, you are almost sure to find quite a thrill in perching it on a suitable shelf so as to be able to examine it at a short distance and to criticise it. You might go further and get friends to give you their opinion. But, if you do so, be sure to invite only those who have a fair knowledge of pictorial composition and know what to look for in a picture, whether a painting, etching or a photograph.

Now if this judgment and criticism is favourable, what do you purpose doing with the print? It is evidently too good to be put away in a drawer or cupboard. You should be able to live with it for quite a long time and so it deserves framing and hanging on one of your walls.

## Exhibition Purposes

There is, however, another purpose to which it can be put with considerable pleasure to yourself. Why not send it to your local photographic exhibition or enter it in one of the photographic competitions which some firms and photographic journals and magazines are regularly running?

Perhaps you may be asking yourself why you should do so? Well, quite apart from any question of winning a prize, it is one of the most expedient and helpful uses to which you can put a finished picture. One or two illustrations will serve to convince you of the value of such a course.

If you set out to make a print for a competition or exhibition it follows that you are determined to do the best possible work on the specimen. It is possible that when it is finished you will not be altogether satisfied and you will settle down to do another. That will be decidedly better than the first and you will have learnt something in the course of the making which will help you in all future efforts.

## 43 for 1!

It is on record that one of our very best exhibitors made no less than forty-three prints from one of his best negatives before he got one that he considered could not be further improved and that final result proved a real gem. It is now in a permanent collection of famous pictures.

Again, if you are successful in getting a print accepted and hung at the exhibition it should not be difficult for you to listen to the criticisms made by visitors to the show, probably persons unknown to yourself. Such may be of a controversial nature but any genuine

criticism will probably help you. You can best decide that, but the remarks might be concerning technique or pictorial details which should at any rate interest you.

## Competition Hints

So much for exhibitions. Now for a few hints relating to competitions. The possibility of success in these is very remote, as compared to acceptance for exhibiting, simply because of the small number of prizes that are usually offered and the enormous number of entries received.

If the competition has been well advertised, the entries might easily run into thousands. If it is only a local effort, then probably only up to 500 might be received. But do not let the numbers deter you, for, from an experience of judging extending over many years and embracing quite a number of both large and small examples of competitions, it is most surprising what a large number of prints are so poor and inferior in quality that one wonders what could have induced the owners to have spent even the few pence on postage.

These are very quickly sorted out and eliminated from those that are to be considered further, and usually this pile consists of anything up to 50 or 60 per cent of the whole. When judging the remainder there are three or four points which the judge will have in mind and, as they are so important, they will be worth your while to note when preparing any print you have in mind.

These "qualities" can be classified as Pictorial, Technique, Originality and Finish, and when the remaining prints have all been sorted, it can be reckoned that each has a fairly high number of marks in two or more of the qualities mentioned. The final winning prints for the big prizes are outstanding examples of good work

of an all-round character.

Let us try very briefly to explain what is meant by the classifications. Many will have got a fairly good idea of what "Pictorial" means and you will agree it is largely a matter of composition of a subject that is pleasing to the eye.

## Study Composition

For example, when you were influenced to make an exposure on a certain landscape there was a "something" in the scene which attracted and pleased you. You probably stood still and considered it for a few moments, and in your mind you wished that a certain tree or fence was not there. Or if that man and dog were only a few yards nearer, how much better the whole scene would be. You then moved a few feet to the left and while getting the camera ready, the man and dog had come nearer and the whole became much more of a picture.

Simply because the objects making up the whole scene had become co-related and had composed themselves, so your eye took in the whole

(Continued foot of page 170)

A NEW AND ECONOMICAL TANK  
FOR AMATEUR PHOTOGRAPHERS  
TAKES THE POPULAR SIZE 20 FILM

## J-20 For Developing Roll Film Spools Easily

**W**HEN once the film has been loaded into the Spiral in the dark room, and the lid has been put on the tank, all the rest of the work is done in daylight. Only four

working parts. A one-piece spiral for holding the film. A tank body which requires only ten ounces of solution. A lid which locks on by a half turn and makes the interior absolutely light tight. A stirring rod for keeping solutions active. Several quite new features are incorporated. The deep central tube makes it easy to fill the tank. This tube is large enough to allow a thermometer to be inserted. A pouring lip enables solutions to be easily and cleanly emptied. The spiral is very sturdy and is ALL IN ONE PIECE. See this tank at your dealers and you will want to buy one. PRICE COMPLETE



**JOHNSONS OF HENDON**

Photographic Chemicals and Apparatus

# The handyman can easily make and use this SCISSOR SHARPENER

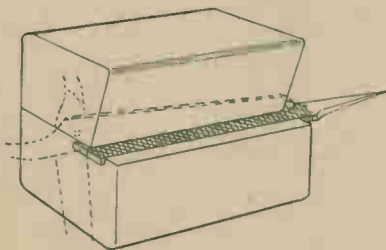

The file in place with dotted lines showing scissor blade

**W**HY take your household scissors to be ground when you can sharpen them yourself with this easily made gadget? It is shown in the illustration, and is simply constructed with a small piece of wood and a file. A plain flat file is required, one 4ins. long will serve.

A piece of hardwood is the best to use, if you own it, but if not, just a piece of deal will do. It should be 1in. thick, but two or more pieces could be glued together to make the required thickness if necessary.

A piece, 6ins. long and 2ins. wide will be enough; this is sawn into two equal sized parts to make the two halves of the gadget, A and B, shown in Fig. 1.

In part A, which is the bottom half, at 1/4in. from one edge, cut and chisel out a groove just the size to let the file lie in almost level. Make this a

good fit as the file must remain firm and not shift about during use.

In the space to the left of the groove, bore a couple of holes for screws, large enough to allow the screws to be pushed through with the thumb. Countersink these screw holes well underneath.

The top half of the gadget, B, has one edge planed to a bevel of 70 degrees, as shown. Set a bevel to this angle and mark it on the end edges of the wood as a guide to ensure correctness. Place the two parts, A and B together, with the bevelled edge of B just half covering the groove in A, as seen in Fig. 2.

Fix in the vice to prevent shifting, and screw home. When fixed firmly, plane the back edge of B level with A, and at the same time just take a shaving or two off all the sharp outside edges to make the article comfortable to hold in the hands.

Give it a good rub over with glass-paper to make all smooth, and finish it, if you like, with a coat of clear varnish. The varnish finish improves it a lot and it does not show dirt so much.

When the varnish is quite dry, loosen the screws a trifle, insert the file, and tighten up again. The file should then be securely held and will not shift in operation.

To sharpen the scissors, press one blade against the sloping edge of B, as shown by the dotted outline in the general view, and rub it along,

pressing firmly on the file at the same time. Take care to keep it flat against B all the time, so that the cutting edge of the scissors is sharpened at the same angle. This is important.

## Sharpening

A few seconds rubbing should be enough, unless the scissors are very blunt. Then turn the scissors and sharpen the other blade similarly. The whole operation is soon done with satisfactory results.

It is most convenient to keep the file in the sharpener permanently, but should the file be required for other uses, it can easily be removed by loosening the screws again. For permanent use it would be best to break off the sharp tang. The sharpener can be held between the fingers and allowed to rest on the knees during use, or laid on the table as preferred.

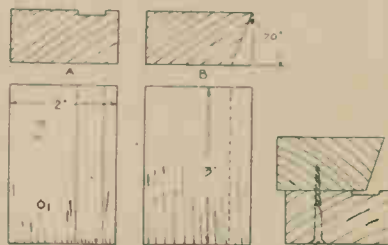

Fig. 1 Plan of the two parts

Fig. 2 End section to show screw

## Photography—(Continued from previous page)

ensemble without being unduly attracted by any one of the units.

The second quality—Technique—is one which, for the purpose of this article, concerns the manipulation of negative making and the printing to secure the best possible rendering of the subject. The print should have a good range of gradation. There should not be any hard contrasts, and there should be a long line of half-tones. There should be details in the shadows and if there is an open sky then clouds must be present. Bald-heads are taboo.

## Paper Selection

A negative with these qualities must obviously have been correctly exposed and correctly developed. Care must be taken to print on paper that will bring out the tone values. It may be that a soft medium grade with a matt surface will prove much better than a hard, glossy or semi-glossy grade.

Again, the greatest care must be given in the actual printing, shading any part that becomes overprinted before other sections have received

the right exposure and full development must be given also to ensure that the good qualities in the negative are being reproduced in the print.

Originality of subject. This, of course, explains itself and one can only suggest that at all times the camerist must be on the watch for

securing a picture that in design, subject or treatment has a note of originality.

In the last few chapters you have had several hints on Toning, Mounting, Titling, etc. Let us add a few words on the question of spotting. In the course of making the print you may have had the misfortune to get one or two airbells in the developing bath. They are white spots on the print, and must be spotted out before the print is despatched. A small bottle of Spotting Ink will do this quite easily.

All dirty marks on a print or mount should be removed. Remember, the judge is examining the print; he does not want to see how clever you are with the pen or pencil in making lines or ornamental titles. These may seem hints of very little value to you, but you would be surprised how many entries are spoiled in the last stages.

Although this article may make you think that to enter a competition means a lot of hard work, please dispel such a thought and make an effort. You will find it is well worth your while.

## PRESENTATION GIFT CASE FOR LADIES

A kit of wood for making this article from the supplement Design Sheet is obtainable from Hobbies Branches for 3/4 or sent post free for 4/1 from Hobbies Ltd., Dereham, Norfolk.

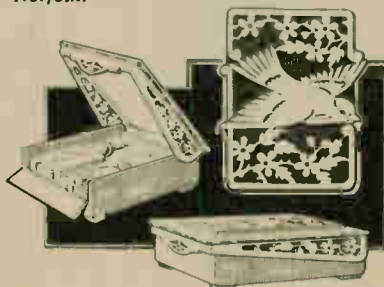

TOP RAIL OF BACK GLUED UNDER

SIDE RAIL GLUED UNDER



OVERLAY ON LID.  
CUT ONE 3/16in.

FRONT EDGING GLUED UNDER

SECTION

LID. CUT ONE 5/16in. SHAPE EDGES TO SECTION.  
GLUE ON THE OVERLAY  
IN THE POSITION SHOWN.

THE ARROWS INDICATE  
THE DIRECTION OF GRAIN  
OF WOOD.



DESIGN

No.  
2752  
28-7-48

SUPPLEMENT TO HOBBIES No. 2752

# PRESENTATION OR GIFT CASE

SUITABLE FOR CONTAINING PERFUME, FACE POWDER  
AND TOILET SOAP.

PANELS OF WOOD REQUIRED  
FOR THIS DESIGN  
**TWO H3 ONE G3**

The price is shown in Hobbies Weekly,  
July 28th, 1948, but is subject to revision.  
See the current edition of Hobbies Hand-  
book, or write for price to Hobbies  
Limited, Dereham, Norfolk.

NOTE—This design sheet is  
only presented free with the  
current issue of Hobbies and  
not with back numbers.  
Further copies may be  
obtained.



SIZE OF CASE  
—COMPLETED—  
6 1/2 in. BY 4 1/2 in.  
BY 2 1/2 in. HIGH.

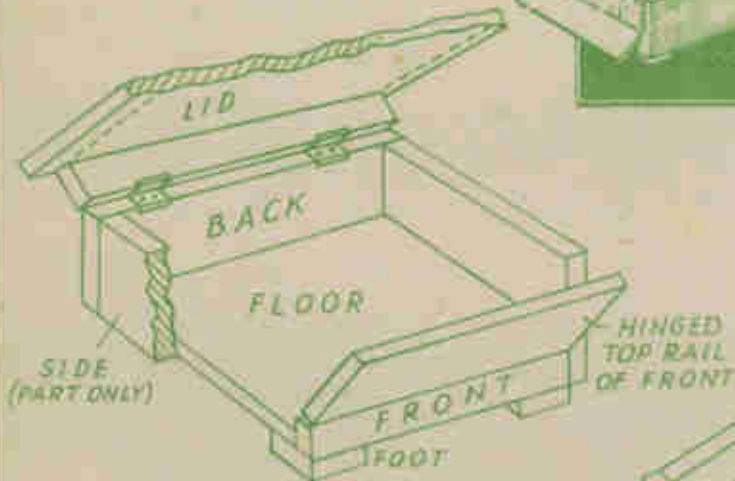

DETAIL, SHOWING CONSTRUCTION  
OF CASE. THICKNESSES OF WOOD  
EXAGGERATED.

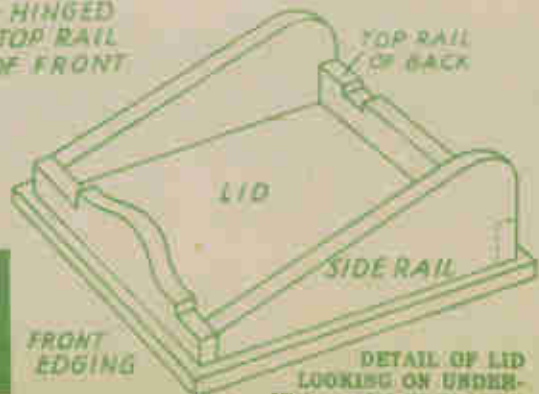

## Patterns No. 2752 for making a **PRESENTATION CASE**

**P**ATTERNS are provided full size on the opposite side for the case illustrated. It is cut entirely in 3/16in. wood, with an attractive bird overlay on its lid. If you prefer a plainer cover, then this can be omitted and a simple monogram or shield incorporated in its place. The lid, as can be seen, lifts from the back, and allows a short flap front to drop forward.

Apart from the cutting, the actual construction must be carefully undertaken. The parts should be tested out carefully after they are cut to see that they fit correctly. Sides should be compared together to see they form proper pairs, etc. The lid is a drop piece on three sides, and it is essential in fitting to see that these do not bind on the sides of the case itself. All this is done by careful measurement.

The positions of parts are shown by dotted lines on the patterns concerned, and notes should be made of these in the construction. The diagrams containing fretted work should be pasted down, but in other cases it is a simple matter to lay the patterns on the wood and mark them through at the corners with a tiny hole, which is afterwards linked up on the board with pencil marks. Having done that, use a ruler and square to ensure accuracy before cutting.

### **General Construction**

The actual construction is shown by the detailed drawings on the other side. The back and two sides cover the three edges to the floor, but the front comes between the sides. This front having been cut as a plain rectangle, has a saw line cut across it 1/4in. from the bottom edge to provide the strip which is glued to the front edge of the floor itself.

The remaining portion is hinged

lid, snugly in place or the other parts will not fall into place correctly. The lid is shown upside down in the detail, which makes the construction simple. The top back rail goes between the sides, and then the front edging is placed at the other end.

### **Rails**

The position of these drop rails under the lid is indicated by the dotted lines on the pattern of the lid itself. Glue them securely to the lid and to each other, testing to ensure that the whole thing will drop easily over the sides and front. The edge of the lid is rounded in itself, and the other three parts have a little fretted decoration as ornament.

The back rail under the lid is hinged to the main portion of the back itself, the hinge plates being recessed slightly to allow the parts to bed together in a single straight line.

The final decoration on the lid is the overlay shown in 3/16in. wood. If, however, you have a piece of thinner material such as 1/4in. or 1/16in., it will be better to cut it in this to make a more dainty finish.

If you are going to polish the box, do this before the overlay is glued on. Or you can make an attractive background for the overlay by staining or enamelling the background to the fretted part a jet black.

The great point, as previously mentioned, is to get the angles right and the joints satisfactory. Use the rule and square to ensure this. Needless to say, all edges must be straight and true, otherwise they will not butt up to any adjoining ones. If you cannot be certain of this with the fretsaw, use a tenon saw where possible.

Clean all parts lightly with glass-paper, but do not use it so the edges become round or irregular. The four



SIDE RAILS OF LID. CUT THE TWO FROM 3/16IN.

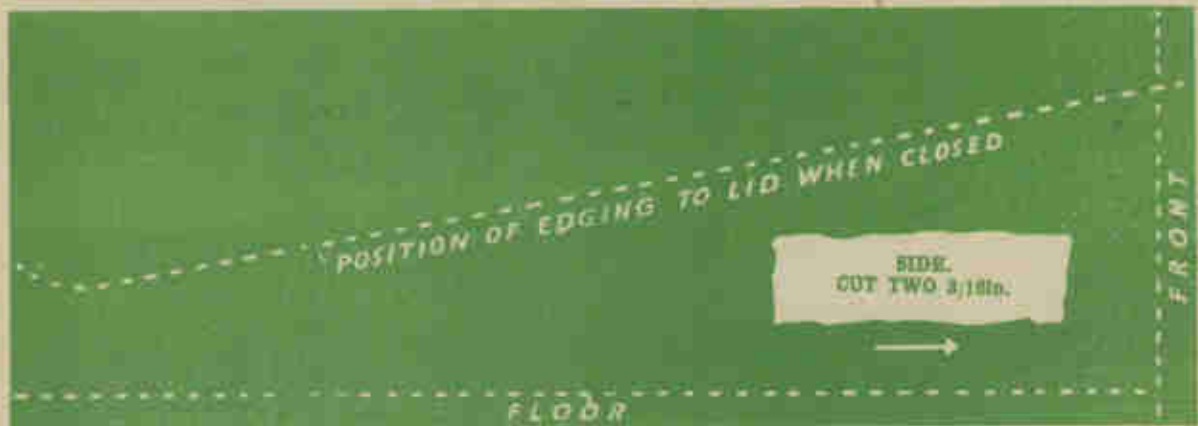

FRONT. CUT FROM 3/16IN.

WOOD EXAGGERATED.



PRINTED IN ENGLAND.

shown by the recessed marks. Get  
these hinges, as well as those on the

under each corner, either in line or  
set back a little from the edge itself.

# With a few odds and ends the handyman can easily make A WATERING CAN

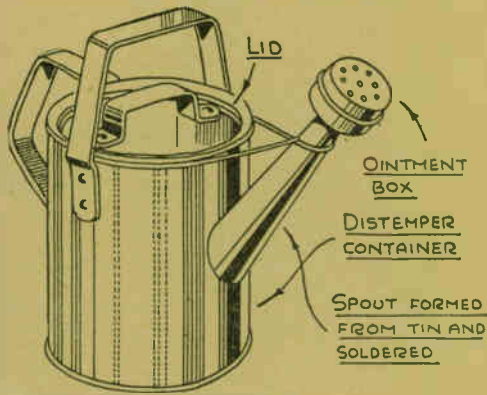

**I**N this new, short series of articles, we hope to show you how empty tins can be utilised in various ways to make useful items for the home. This week we start off by showing how an empty distemper paint container, with lid, an ointment box and a few pieces of strip metal or tin can be converted into a practical gardening item, namely, a watering can.

First of all, you need the empty tins mentioned. Distemper containers are usually fairly large and, owing to the nature of their contents, are waterproof. The empty container should be washed out in hot water to remove all traces of the distemper.

Now the lid is a rather tight fit. For a watering can, it should be fairly loose. Therefore, slacken it by filing at the inside of the lip of the container. Alternatively, do not have the lid fitting down tightly so that, when

it is necessary to fill the container with water, the lid can not be removed.

To facilitate this, a handle could be riveted to the lid so it can be lifted out. But, if you wish to save filing at the container rim, fitting a handle to the lid and giving yourself extra trouble, a simple idea is to bore an  $\frac{1}{4}$ in. hole in the lid, near one side (not in the centre). This can be done with an old centre bit.

Have the lid resting on a piece of scrap wood. Put the bit in a brace and, allowing the point to penetrate the lid by turning the brace in the usual

way, gently apply the scribe of the bit to the metal. This will mark the tin and cut it. A neat circular hole will result. The lid is forced on the container tightly, tapping in gently with a hammer.

However, before you attach the lid, the spout and handles need to be attached to the container. The handles will present little difficulty. They are formed from strips of metal, or alternatively, strips of tin, folded along the edges.

The strips, when bent to the desired shape, are attached with rivets, such as small roundheaded aluminium rivets, the ends being kept to the inside for clinching over the burr. This can be done by using a large hammer as an anvil and tapping upon the rivets at the outside. You may find it more convenient to have the heads at the interior of the container.

The spout is bent to shape from tin the edge being neatly soldered. To the top end an ointment tin is soldered. The lid of this is perforated with a drill, as shown. For connection to the spout top, a suitable hole is made (with an old centre bit) in the base of the tin to fit tightly on the spout. It is then soldered. The lid is attached and soldered.

The bottom end of the spout is soldered against the outside of the container. It is first positioned, then the position perforated with holes prior to soldering the spout; this saves the necessity of cutting a hole in the container, i.e., for the spout. The spout is braced at the top with wire, as shown.

## Painted Green

The work, when completed, should be painted bright green at the outside, and black at the inside. The interior coating is to prevent rust attacking the tin.

There are no loose lids to watering cans, of course, and the fixed lid, with tap hole, is sufficient. If you cannot have the metal bored, the loose-fitting lid, with handle, is a second alternative.

By the way, use a reliable flux when soldering. Tinman's solder should be used. Cored solder is hard to beat, and if you own an electric soldering iron, the job is greatly simplified. Be sure to select a fairly large distemper container; some containers only measure  $5\frac{1}{2}$ ins. in diameter by about 6ins. high. These, although small, make neat little watering cans.

## Handy Cramps—(Continued from page 167)

turned screw at one end will bring the work between the cramp plates.

### A Woodwork Bench Vice

The handyman who is again taking up his home carpentry and light woodwork, should certainly have a bench vice such as illustrated at Fig. 5. Fortunately these are now on the market again and are really essential. They are usually made in beech, which is a strong, smooth wood and generally obtainable 12ins. or 15ins. long. The cramping action is quite simple and holds almost any work very securely for planing or chiselling, etc.

The backboard of the vice has to be screwed to the side of the bench or worktable, two countersunk holes being provided for the purpose. In this part there are two fretted holes which take the moving handles when turned through the second piece of the vice. The outer piece of wood is loose on the two turning handle

spindles, and presses up to the work which is being fixed.

In order to allow the spindles through the fretted portion it is, of course, necessary to bore a couple of holes for them in the table side or work bench. This may sound a lot to undertake, but even if you cannot leave the vice in place always, it can easily be removed once you have arranged its position and screw holes as mentioned.

Finally, as a simple home-made vice we have the method of holding shown in Fig. 6—a simple, rather

primitive way which may on occasion serve your purpose. A fairly solid block of wood is screwed down to the work bench to serve as a stop. The work to be glued together is

laid alongside. A large strong round-headed screw is then driven in a little distance away from this, and the intervening space filled by a wedge-shaped piece of wood.

You will realise that as this wedge is driven up tight, it forces the two longer pieces together and so serves as a cramp. We are not suggesting, of course, that this is satisfactory for all occasions, because the wood may jump or the boards being glued may spring just at the wrong moment. This little suggestion should be borne in mind, when it may save the situation.

## WEBLEY AIR PISTOLS

Marvellously accurate for target practice.

No license required to purchase.

Senior Mark I Junior Webley Air Rifle

Write for List. WEBLEY & SCOTT LTD., 166 WEAMAN STREET, BIRMINGHAM, ENG.

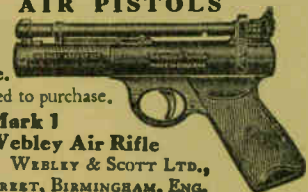

# ANORMA

## Constructional Kits for Model Buildings

4 MM. SCALE FOR OO GAUGE.

No.		Price	No.		Price
1	Bungalow	5/-	20	Corner Shops (2)	5/6
2	Windmill	3/-	21	Semi-det. Houses	6/6
3	Modern Villa "A"	7/6	22	Farmstead	10/6
4	Country Station "A"	11/6	23	Det. Villa and Garage	7/6
5	Signal Cabin	4/-	24	Factory	11/6
6	Timber Mill	6/6	25	Country Goods Depot	8/6
7	Modern Villa "B"	8/-	26	Telegraph Poles, Kiosk and Bus Shelter	7/6
8	Shops and Flats	8/6	27	4 Extension Platforms	7/6
9	Semi-det. with Garage	7/6	28	Loco Water Tower	3/-
10	Semi-bungalow	5/6	29	Airport Control Tower	10/-
11	Church	10/6	30	Hangar	8/6
12	Public House	11/6	31	Loco Shed	7/6
13	Country Station "B"	10/-	32	Coal Office and Cattle Pen	4/6
14	Georgian Mansion	9/6	33	Café and Bank	5/6
15	Service Station	7/-	34	Rly. Footbridge "A"	2/9
16	Cinema	7/6	35	Post Office	4/6
17	Walk-round Store	5/6	36	Rly. Footbridge "B"	3/6
18	Town Shops	5/6			
19	Arcade	8/6			

Please write for full illustrated price list of the above and of the "Airyda" Model Aircraft and "Aquila" Model Ship Constructional Kits to:

## MODELLERS SUPPLY LIMITED

AIRYDA WORKS, ASPLEY, HUDDERSFIELD.  
Tel. 5511 (2 lines).



Whatever your soldering job, in your home or workshop, you will prefer to use Ersin Multicore Solder. No extra flux is required. Multicore is the simple and precision method of making sound soldered joints for all household purposes. Just apply it simultaneously with the soldering iron; the three cores automatically provide correct proportions of flux to solder.

**6**  
d.  
CARTON  
Shown above

WORKSHOP SIZES 4/10 - 6/9 each.  
MULTICORE SOLDERS LTD.  
Mellier House, Albemarle Street, London, W.1  
Tel.: REGent 1411

## HOW A GASWORKS WORKS



It's easy to make gas. Put coal in a corked test-tube and heat it. You can light the gas as it is given off.

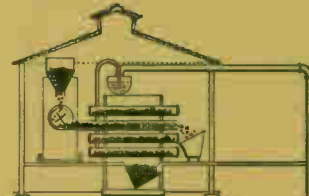

In a gasworks, these ovens (called "retorts"), each holding up to 15 cwt. of coal, take the place of the test tube.



From the retort, the gas goes to a condenser, where ammonia and tar are taken out, then to washers and purifiers which remove benzole, sulphur and the rest of the ammonia. The tar, ammonia and benzole are run into storage tanks for further treatment. The solid residue left in the retort is coke.

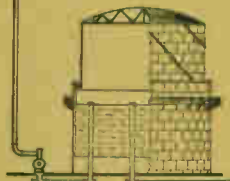

The cooled and purified gas is measured in large meters and stored in gasholders. The gas-holders are generally made in 2 or 3 storeys, which are telescopic.



Here are a few examples of over 2000 valuable things that can be made from the tar and ammonia.

Issued by the BRITISH GAS COUNCIL, 1 GROSVENOR PLACE, LONDON, S.W.1

Genuine **BRITISH NAVAL** Telescopic Gun Sight

Naval Telescopes. Powerful day and night lenses with modern micrometer automatic range focus apparatus. Splendid object lens. Approx. 15ins. in length. Picks out objects with clarity and precision at many miles range. Made by famous instrument manufacturers. To clear, 35/- only. Post and packing 1/6. Two or more carr. free.

**EX ARMY BELL TENTS**  
£8.15.0.  
MARQUEES. 30ft. by 20ft. Height 14ft. £38/15/- complete. Also larger sizes. EX-RAILWAY & SHIP TARPULINS. Good condition and Waterproof. 70 sq. ft., 20/-; 140 sq. ft., £2/10/-; 280 sq. ft., £5; 360 sq. ft., £6; 720 sq. ft., £12. All carr. free.

All types camping equipment. Send 1d. for List.  
HEADQUARTER & GENERAL SUPPLIES LTD. (Dept. HOB.),  
196-200 COLDHARBOUR LANE, Loughborough Junction,  
LONDON S.E.5.

A V & W Hobby Book :

## METALCRAFT

by Wm. A. Bagley

A new edition of an old favourite.

How to make decorative and useful articles without a special workshop or expensive tools.

paper **2/6** covers

**VAWSER & WILES (London) LTD.**

555, Lea Bridge Road, London, E.10