

Hobbies

WEEKLY

February 2nd, 1944

Price Twopence

Vol. 97. No. 2520

A WORKING MODEL REVOLVER

A DESIGN page is given this week for making the novel, realistic, working-model revolver shown at Fig. 1. The model is, of course, built from fretwood throughout, but even so, it looks genuine and formidable—like the Lone Eagle type on which it is based.

The revolving magazine has eight chambers for eight small wooden bullets. Instead, however, of the trigger action working the magazine as in real revolvers, the magazine requires to be turned by hand, each turn being automatically "gauged" and held in an accurate position by a catch which is part of the trigger.

Firing Action

Thus, assuming the gun is fully loaded (this is done by inserting the shells, one by one, through a hole provided at the rear, left-hand side of the magazine), one draws the firing rod (plunger) backwards by means of the "lug" showing at the top of the model. When drawn back to its fullest extent, the plunger becomes "locked" back automatically and, to release it, a slight pressure on the trigger is all that is necessary.

In a way, then, it is a "hair-trigger" model. As soon as the plunger is released, it clicks forward, actuated by an elastic band at each side, and its conical point strikes against the bullet in line with it,

sending the bullet forward with considerable force.

That operation empties one chamber in the magazine. To bring a fresh bullet into line with the plunger and "bore" of the barrel, the plunger rod is drawn back and the magazine given one slight turn in an anti-clockwise direction with the thumb and finger of the left hand.

Now, as you can see by the view at Fig. 4, there is a tiny sem-circular groove cut along the outside of the

magazine in line with each bullet chamber. The catch on the trigger engages with each groove, thus keeping the chambers dead in line with the bore of the barrel until the trigger is pressed.

Bullet Process

The movement of the trigger raises a toothed, eccentric-moving cam which, in turn, lifts the plunger rod "lugs" out of their notches and thus releases it. Briefly, in order to fire

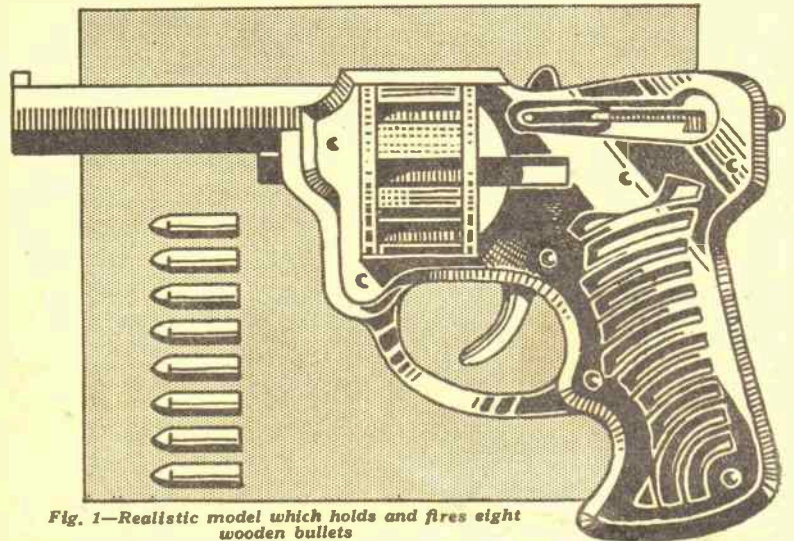

Fig. 1—Realistic model which holds and fires eight wooden bullets

a single shot, a bullet is pressed into the empty chamber at the side of the gun, then brought into the accurate firing position by turning the magazine round (after drawing the trigger back) and fired by pressing the trigger.

The plunger must always be drawn back first after firing a shell, because its rounded point penetrates half-way into the shell chambers and would prevent the magazine from being turned, as you will see by the drawing at Fig. 3.

The Construction

To make the model, paste or trace the centre pieces on 3/16in. fretwood, these—with exception of the trigger, being grouped together. The trigger and eccentric-moving cam should, for strength purposes, be cut from 3/16in. plywood.

Owing to lack of space, we printed the outer cover piece on top of the cover piece. You require two of each, cutting the cover pieces from 3/16in. stuff and the outer covering

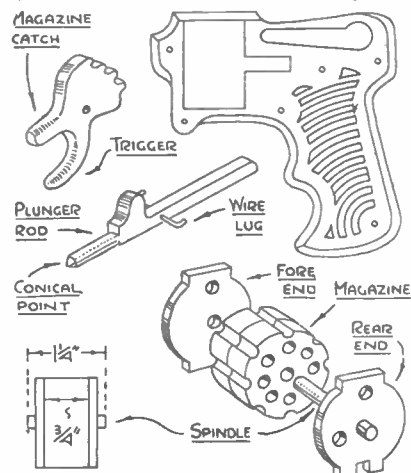

Fig. 4—Some helpful constructional details

pieces (as shown in black) from 1/4in. stuff. One of the latter is plainly seen at Fig. 4, incidentally, with its edges chamfered.

Having cut out the various parts mentioned, the central pieces are neatly and accurately glued upon one of the cover pieces, as shown at Fig. 2. As you will understand, the parts must be exact and neatly in line. Use a strong tube glue, heating it if rather chilled.

The trigger and eccentric-moving cam is held in position temporary with small screws (3/16in. by 4 flatheads), countersinking the holes so the heads lie flush. A flat spring is bent from 1/8in. wide by 1/32in. thick steel, such as a curling pin, clock (watch) spring or a corset rib, the actual size and shape appearing on the pattern page.

Fit the spring as shown at Fig. 3. Have its ends bent out more than shown to provide sufficient tension against the "ear" on the eccentric moving cam. The plunger rod,

which is shaped up as detailed at Fig. 4, is then fitted.

The nose end of the rod, you will notice, is rounded to 3/16in. diameter and given a conical point. Fit a wire lug in the hole provided, bending the ends at right angles, as shown. The wire should be a tight fit, and the plunger rod should, for preference, be made from a hard wood.

Preparing the Magazine

The magazine must now be made. It consists of two fixed end pieces (cut in 1/4in. wood) and a drum (made up from two shaped discs cut from 3/8in. wood or four shaped discs cut from 3/16in. stuff) and a wooden spindle 1 1/4ins. long by 3/16in. diam.

Glue the spindle truly into the rear end piece to project 1/4in. (see constructional detail at Fig. 4). Glue the drum pieces evenly together. To ensure accuracy, the discs can be glued on a piece of 3/16in. dowelling, this running right through the central holes. Another length is inserted into one of the chamber

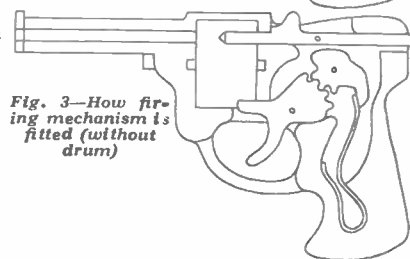
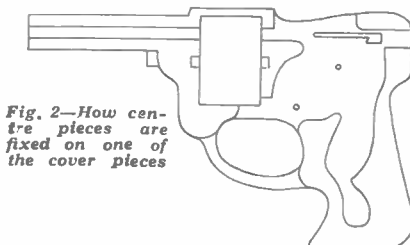

Fig. 3—How firing mechanism is fitted (without drum)

holes to "draw" them into line.

When dry, it is advisable to run a 3/16in. drill through the eight holes to clear them of excess glue and minor inaccuracies. The outside of the drum is neatly glasspapered and the grooves corrected. The spindle is put through the drum centre and the fore end piece glued to it. The cylinder of wood must, of course, turn freely on the spindle, but not too freely or loosely.

To distinguish the fore end from the rear end pieces, one of these—the rear end—has a side loading hole. Be sure, then, not to get them mixed or turned the wrong way.

Fitting the Magazine

Having prepared the magazine, it is fitted to its aperture, the spindle projections engaging with suitable slots provided by the centre pieces. When fitted to satisfaction, attach the other cover piece.

At this point, the mechanism can

be tested for accuracy and free movement. This means that small elastic bands are put on the plunger rod lugs and connected to small round-head screws driven into the cover piece where small holes are provided for the purpose.

If working and firing satisfactorily, as the mechanism will do if made accurately, the outer covering pieces are added. These cover pieces need to be chamfered at certain edges, as shown at Fig. 4. By the way, please note how the trigger, and the magazine catch, are rounded over. This is important to correct working.

The nose piece is glued on the barrel and the latter neatly rounded to the same diameter. If desired, the barrel could be eight-sided, as shown at Fig. 1. Be sure to run a 3/16in. drill into the bore of the barrel to clear it.

Finishing Off

When made and smoothly glasspapered, the work could be finished off in ebony black. It is better to use a polish rather than varnish or paint. A coat of ebonying spirit stain, followed with two thin coats of black polish should suffice, allowing the first application to dry, following which it is rubbed down with fine glasspaper and the second coat applied.

The second coat could be rubbed down with a "flour" grade of glasspaper to produce a dull matt finish. The grooves in the magazine could be lined with silver paint, but this is not absolutely necessary nor may you like it. All black is the best plan.

If you make a really workmanlike model and finish it off patiently, the revolver, although a wooden one, will amaze those friends to whom you proudly exhibit it. In respect to the eight bullets, these are cut and shaped from 3/16in. dowelling.

It is wise to rub the length of dowel down slightly with a piece of glasspaper prior to cutting the bullets to length. Elastic bands, about 1in. long or less, are used, one at each side of the plunger rod.

CIGARETTE BOX

This design (No. 2520) free with this issue. Planed wood for making supplied by Hobbies Ltd. for 1/11, or sent post free for 2/6.



How the handyman can make himself useful with HOUSEHOLD REPAIRS

THE difficulties of obtaining material should not deter the handyman from making himself generally useful in a number of odd jobs about the house, and we are frequently showing in these pages methods by which he can prove his ability, and at the same time be practically useful in the home.

The long hours of the evening should provide the opportunity of looking round to find those jobs of mending and repairing which are so often neglected, and which equally frequently lead to final destruction in the article concerned. In these days of scarcity of furniture, the matter is more particularly important, and the old adage of "A stitch in time . . ." is more applicable than ever.

Damaged Corners

The possibility is that the housewife will be able to tell you of odd corners knocked off pieces of furniture, little bits of moulding which need repairing, chair legs which have become loose, or shelves which are needing some firmer fixing. These jobs should not be undertaken lightly, or rushed at with the idea of getting them done as quickly as possible.

We are constantly saying that it is better to do a good job than a shoddy one. Take as an example, as so frequently occurs—the odd corner of a small side table may become damaged or splintered, and, by the way, the operation described here can be followed in many other instances.

Matching Wood

The first point is, of course, that you must find a suitable small piece of wood which will match up in the staining and polishing with the actual part damaged. It should be a little thicker than the piece needed, and is cut off much larger than the part which it will replace.

The end of the corner will probably be splintered, so first of all you must cut back a little further into the wood to make a straight joint. Do not cut into this at right angles, but rather at a little more than 45 degrees. This will provide a wedge-like joint when the strip is put into place along the edge, and will also serve as a better holding for the glue than if a right angle is maintained across the end grain.

Saw and plane the wood about $\frac{1}{16}$ in. larger than the part into which it is to be placed, and mark off the exact angle by using the damaged portion as a template. Saw the two edges accurately so the slip of wood slides

close up to the damaged table corner, and see it beds in snugly.

Then glue it in place, and if necessary add headless nails across the two pieces. You can drive a thin panel pin into the table portion, first file off the head to a point, and then drive on and in the strip concerned. The nails must be driven in at an angle so that the wedge slides tightly into the piece cut out.

Shape after Fixing

Leave the part until the glue has thoroughly hardened before you commence to shape, then very carefully plane the strip down to the moulded edge of the table itself, finishing off equally carefully with glasspaper. The same curve or angle as the rest of the work must be maintained and, of course, the polish on the original table will be taken away with the glasspaper a little over the new part.

This will allow you afterwards to stain the new piece to the original colour. It is best done by using a lighter shade first, and applying several coats until you are satisfied that it is like the original. Finally, the polish is rubber over and into

the wood so that the finished result will be an unseen joint and almost a perfect job.

Repairing Veneer

Very often, too, the veneered base of a piece of furniture will have become damaged. The veneer, which is usually about 1/16 in. thick, will have become lifted at the edges, and possibly splintered also. Here again the broken edges must be cut away to make a good joint for the new part.

You will probably be able to get hold of a small piece of plywood and strip off one thickness of it to provide the necessary veneer piece for the repair. This is cut the same shape as the piece taken out of the damaged part, and replaced in a similar manner to the operation previously mentioned.

Owing to the thinness of the veneer piece it will probably be necessary—and in any case desirable—to hold the part down firmly until the glue is hardened. When the veneer is fitted in, lay a piece of newspaper over it then a small block of wood with another piece of wood on the underside, and hold the whole lot together with a light steel clamp.

The need for the piece of newspaper

ALPHABETICAL HINTS

KEY chains prevent one from losing keys by virtue of the fact that the keys are "anchored" to one's person. Bunches of small keys are generally lost by setting them down somewhere and forgetting about them. Men are more inclined to be absent-minded like that, either going off to business minus the keys or leaving them on the office desk—much to their discomfort and peace of mind.

However, it is the smaller keys we are most concerned with—the keys easily lost or mislaid by anyone, such as Yale keys, attache case keys, safe keys, watch keys, etc. If all are put on a single split ring, they can be hitched forever to a button on your trousers!

How to make a Key Chain

A simple key chain can be made in the following way. Get an old strap from a pair of trouser braces. Carefully remove the rivet holding the leather strap to the adjustable metal fitting ring. Cut the strap smaller, to the shape shown, then bend it around a split ring and tap in the rivet, turning the prongs well over and flat by the hammer.

A piece, or rather, a length of fine picture chain is now wanted. Insert one end to the split ring, then add another split ring to the opposite end. A useful chain length is 12 ins. to 14 ins.

If you wish, a key ring could be attached to the end of the chain. Should the picture chain be found rather heavy and uncomfortable, picture cord could be used, including

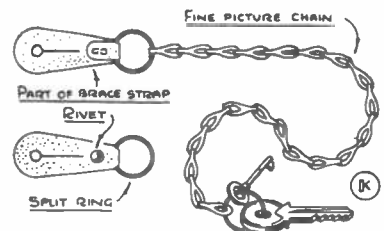

a boot lace. The latter will probably be found to be the most comfortable.

The strap of the key chain is affixed to the trouser button nearest the pocket in which the keys are kept. A special button could be sewn to the waist band of the trousers for the key chain, but that is seldom essential.

s in case the glue has oozed out. The paper can be torn away and the whole part carefully rubbed down flat with glasspaper. If the wooden block was put on direct to the other one, it would, of course, have fixed itself and could not be cleaned off as is the case with the paper.

Veneer Blisters

If the veneer on the piece of work has raised itself in the form of a bubble or large blister, it is because the air has got underneath owing to shrinkage or dampness somewhere. In this case, you have to let the air hubble out.

Take the point of a sharp knife and carefully run it through the veneer with the grain. The length of the air bubble determines the length of the cut, but it must be sufficiently long to allow you to get the flat portion of the knife underneath. The cut concerned is run through the centre of the bubble.

Press one side of it down in order to get the knife flat under the raised portion on the other side. Carefully apply glue to the knife blade and insert it under the wood to transfer it to that material. Withdraw the knife, and press the veneer flat, then raise the other side and repeat the operation.

Endeavour to get the glue as far in as possible, and spread thinly and

evenly inside. Here again, the operation is completed by laying a piece of paper on top, then a piece of wood and finally weighting the whole lot down to keep the veneer as a good joint until the glue has hardened.

Chair Leg Repair

In the case of chair legs, the most commonly damaged are the kitchen ones which usually have a strut between the legs. These occasionally fall out, and should be replaced at once or the whole leg will be broken off.

The cross bar should have its end cleaned thoroughly, and the bored hole in the leg itself should also be roughed out with a knife to take away any glue remaining. Make a slight tapered cut in the end of the cross piece to allow the air to get out when you put it back into the leg.

Apply glue to this end, and then force it firmly into the leg itself, doing the other end in a similar manner by springing that corner open to take it. If there is more than one of these cross bars requiring attention, do them all at the same time, and having replaced them in position, hold them temporarily firmly by tying a piece of thick string or thin rope round the legs, and pulling it as tightly as possible.

The string should be passed round over the point where the cross bars

have been fixed. If you put it on the ends of the legs you will be apt to spring them open, and so affect the joint made.

Loose Shelves

We mentioned earlier, the question of loose shelves, and this can well form an evening's work for the handyman. Too often these points are overlooked until the shelf is so loose it falls, with consequent damage to important or irreplaceable articles.

If the shelves are fixed to the usual support metal brackets, see that the screws holding them are still firm. If they are loose in the wall, have them out and replace.

Plug the wall with a piece of rope before returning the screw, and if you wish, add a touch of glue for further strengthening. If the shelves have become warped, and are apt to twist on end brackets fixed to a wall, plane one end down until it beds itself firmly on the support piece.

Pantry shelves are often the holders of hooks for cups, and here again the handyman will notice if any need renewing or altering to be in a more convenient position.

Odd jobs like this provide a happy change sometimes from model making or the ordinary pastime, and in addition, provide practical service which the housewife particularly will appreciate.



FROM ODDS AND ENDS



INKING pads, for various sizes of rubber stamps, can be bought, of course. If not, such pads can be easily made from a few odds and ends, thereby saving money.

If you possess a very small rubber stamp, a date stamp, for instance, a good little pad can be made for it from a gramophone needle box. These neat, tin boxes have a hinged lid and are ideal for the purpose.

To make the pad itself, cut a piece of stiff cardboard to fit neatly, but freely in the bottom of the box. Glue a 1/4 in. deep layer of cotton wool on top, then trim the surplus away with the scissors to the size of the cardboard base.

A suitable piece of muslin, or linen,

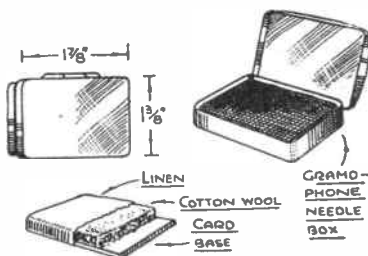

is placed over the top of the cotton wool, the sides and ends being folded over and glued down on the underside of the base. Have the folds at the corners neatly brought together; the linen should be stretched—free from wrinkles—over the cotton wool.

When dry, place the pad in its box, then saturate the pad with purple copying ink (indelible ink), this being obtainable in small bottles from most stationer's shops. Avoid putting too much of the ink on the pad.

Using the Pad

The pad should be well-covered with the ink, but at the same time, it should only be "damp" with it, not dripping, so that letters in the rubber stamp become clogged with ink. An almost dry pad is far better than a pad that is too wet.

Incidentally, do not always press the stamp on the pad for every impression. One application of ink usually gives three impressions. And if, sometime later, you wish to use the stamp once more, just "haw-haw" your breath on the face of the stamp. This permits a fourth impression without going to the trouble of bringing out the pad.

By the way, if the cotton wool surface tends to be lumpy, a very even

AN INKING STAMP PAD

surface is obtainable by cutting a piece of soft blotting paper to the size of the pad and putting it on top of the cotton wool prior to adding the covering of linen.

Suitable Boxes

Other suitable boxes for pads are typewriter ribbon boxes, medicine tablet boxes and so forth. Should the gramophone needle box prove to be too short in length for the date stamp, try using the stamp cornerwise on the pad.

You should use an old piece of linen—not a new piece, as the latter is sure to contain too much starch. Starch, or any other stiffening in the linen keeps the ink from seeping through. Soft, washed linen is the best. Muslin may be too open, but if over blotting paper is ideal.

We have suggested the use of purple indelible stamping ink because it gives more impressions. But, black ink, or green ink may, of course, be used. Always keep the lid closed to prevent evaporation.

An excellent little spotlight in colours for model

STAGE LIGHTING

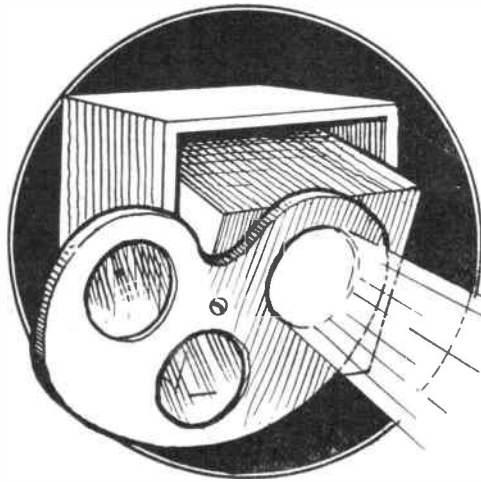

A FEW weeks ago we published two articles on the making of a Model Theatre. We treated them with certain lighting effects for footlights and toplights for the proscenium. In this article we are going to tell how to make a "lime" or spotlight for stage-lighting in three colours.

Such lighting greatly adds to the interest of the different scenes and we propose red, blue and amber as being most suitable.

The spotlight is intended to take the place of either of the electric lights suggested, to be placed in the angle formed between one of the sides and the back of the proscenium. Instead of the bulb being fixed in the wood of the side wall, it will be fitted in the back of the lime itself, the whole thing being held and pivoted in an outer case or frame so it can be tilted at almost any angle.

Separate Units

The work of making can be divided up into three sections, and each can be made up independently. Section No. 1 consists of the lantern itself, No. 2, the movable colour-reflector and No. 3, the fixed frame in which the lantern is pivoted. The lantern is seen in the lower illustrations at Fig. 1, with a back and front view. Wood $\frac{1}{4}$ in. thick, and preferably plywood is used throughout excepting for parts B and C which might be $\frac{3}{16}$ in. thick.

The front A has its dimensions given, as also have the sides. The circle in this piece A is 1 in. in diameter and the inside edge should be chamfered so as to interfere as little as possible with the light which will be carried through. The sides are $1\frac{1}{2}$ in. square, and the top and bottom fit between.

Looking at the back view in Fig. 1 we see how two narrow slots are cut midway in the back edges of the sides. In these slots fit two round-head screws which are run partly into the side edges of the back B of the lantern.

This facilitates the removal of the back when necessary to add a new bulb or make new flex connections to it. All one need do to remove the back is to loosen each screw and pull the back out.

Glue up the parts of the lantern after cutting them out with the fretsaw and cleaning them up, and see from the diagrams how the parts are joined up.

It would be well to mark the top edge of back B and the edge which comes above it when fixed so that the back may be returned correctly and easily after removal. Near the centre of each side is glued a disc about 1 in. in diam. to take the pivot screws of the frame.

Fitting Hints

The centre of each disc measures 1 in. back from the front edge of the lantern. At the front of the disc and on one side only, is glued a semi-circular lug C to receive the pivoting screw of the colour-reflector. (see Fig. 1). Four short lengths of $\frac{1}{4}$ in. fillet are next cut and glued $\frac{3}{16}$ in. in inside the lantern for the back to rest upon.

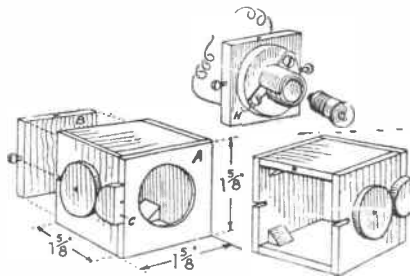

Fig. 1—Constructional detail of separate parts

The bulb-holder must be fixed, as seen in the upper diagram in Fig. 1. These holders are very easy to screw on, and the wiring connections thus simplified. The flex consisting of either japanned-covered copper wire or just silk or cotton-covered stuff is led through holes made at H and twisted round the screws on each side of the bulb socket.

The free ends of the wire on the outside of the end of the lantern, of course, connect with the switch and the circuit.

The reflector containing the three colour discs is shown in Fig. 2. First draw on a piece of $\frac{1}{4}$ in. plywood the plan shown. Before cutting out the three holes draw additional circles nearly $\frac{1}{4}$ in. diameter larger round each.

Cut out the circles to the inner lines and then to cut down with a pocket knife to the depth of one thickness of the plywood along this outer line. Clean away the waste wood, leaving a shallow rebate into which later will be laid the coloured discs.

Colour Discs

Coloured celluloid discs are ideal for the purpose. To hold them in place glue over the whole surface a piece of thin card, having the holes cut to the same size as the actual hole in the plywood.

It will be found that a halfpenny laid on the celluloid can be held rigidly while it is scratched round with a metal point. The disc will break away easily from the surrounding celluloid if this method is adopted.

The Swing Arrangement

The reflector is pivoted to the lantern with a round-head screw, and should move freely round the screw.

The frame for holding the lantern is made up as Fig. 3 shows. Here again $\frac{1}{4}$ in. wood is used and the dimensions for the sides A are included in Fig. 3. Holes for the pivot screws in these pieces are $\frac{3}{16}$ in. from the front edge and $1\frac{1}{2}$ ins. down

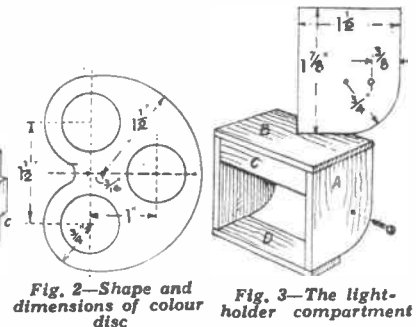

Fig. 2—Shape and dimensions of colour disc

Fig. 3—The light-holder compartment

from the top edge. The sizes of pieces B, C and D respectively are $2\frac{1}{2}$ ins. by $1\frac{1}{2}$ ins. $1\frac{1}{2}$ ins. by $\frac{3}{4}$ in. and $2\frac{1}{2}$ ins. by $\frac{3}{4}$ in.

All the wooden parts may be stained or painted dark excepting the inside of the lantern which should be painted matt white.

The completed box must be put in the wings, usually on the prompt side, high up. Fix it, of course, sideways to the stage so the spot may be directed down and across to any point.

An economical and easy method of making a FANCY FAIR STALL

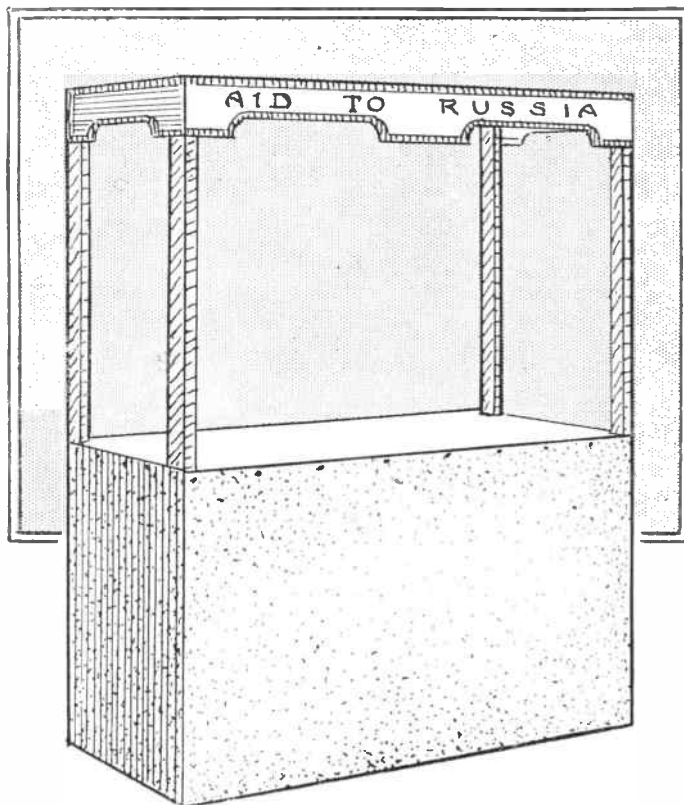

SUCH a stall as that illustrated is just the thing for readers who are interested in helping and organising sales of work for war and charitable objects. It is portable, so can be erected and taken apart quickly, occupying little space when not in use.

Quite a small quantity of wood is wanted—rather fortunate just now, wood being scarce, and such wood as is necessary need not be new stuff provided it is cleaned up well.

Fig. 1 shows a view of the complete framework—the stall itself in fact, denuded of its covering. The sides are of 1in. by 5in. wood, and consist of two uprights and three cross rails nailed together.

Rails

The bottom rail is 2ins. up from ground level, the middle one at the distance shown. Get these sides square and both alike, the following simple method will help.

Square lines across the uprights where the rails will come, and nail the rails to touch these lines—one nail to each joint, only as a start. Make sure the frame is now square and when satisfied add two more nails to each joint to fix it so.

The second frame is treated in the same way for the preliminary nailing, then is laid on top of the first to ensure both being alike before adding the extra nails.

The Counter

For the counter, tongued and grooved boards are best, in any reasonable thickness available, say $\frac{3}{4}$ in. to 1in. Join together to make up the width, and cut to length. The side with the headed edges will be underneath, leaving the top surface flat. At each end, underneath, nail a 1in. by 3in. batten across, and note that these battens are nailed to the counter edgewise, not flat. Then they will come up against the middle rails of the sides and are bolted to them, holes being bored through both for the bolts.

At each corner of the counter cut out a piece to fit round the uprights of the sides. Fig. 2 shows these details, part of the middle rail being

cut away to show the counter batten behind it and to which it is bolted.

The struts for stiffening are now prepared. They can be cut from 1in. by 2in. deal, and are joined by bolts to the counter at A and to the bottom side rails at B. Details of the joint at A are given in Fig. 3.

A piece of wood is cut to 5ins. long and about 2ins. wide. This is bored where shown for the bolts and is screwed to the centre of the counter, underneath. The struts are also bored for the bolts, and have their ends rounded off, as shown, by dotted outline.

At B, on the bottom rails, a lug piece is fixed each side, as shown in Fig. 4. This is 2ins. by 3ins. and has its face edge rounded off, and is also bored for the bolts. Fix firmly in the centre of the rails with screws. The struts are then connected to both and should stiffen the structure, making it stand quite firm.

The actual length of the struts should be measured off with the stall erected—a tape measure will do this. Measure the distance between the bolt holes, and add $\frac{3}{4}$ in. at each end, the total being the full length of the struts.

The bolts can be $\frac{1}{2}$ in. by 3in. ones, complete with nuts and washers. This finishes the stall, ready to be draped for decoration.

The most suitable material for this part of the job is the stuff known as bunting, made in various colours. Readers who have some, or are lucky enough to buy it, can proceed to drape the stall. The side posts and rails above the counter are covered

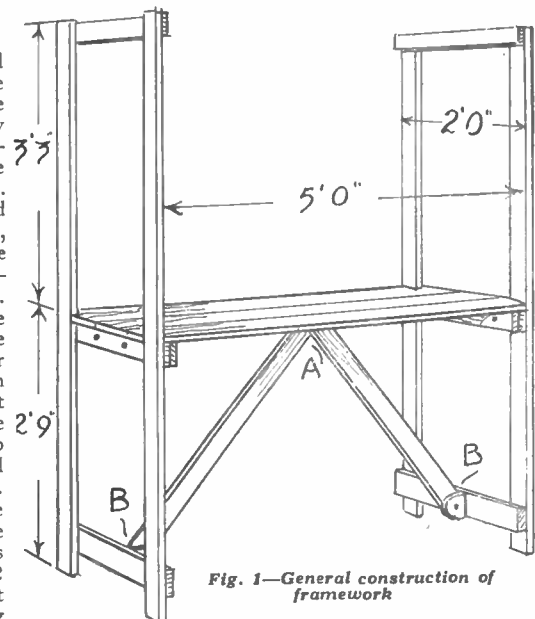

Fig. 1—General construction of framework

with strips wound spirally round and fastened top and bottom with drawing pins.

In the absence of suitable stuff plain or coloured paper strips could be used.

The counter can be covered either with the bunting, or plain calico. Paper could also be used, but would be better pasted on. It would be as well not to use a light paper as it soon gets dirty. A green, or brown wrapping paper would wear longer. Do not forget to cover the edges.

The material covering the front and sides below the counter, is simply draped round and fastened with the drawing pins. It would not be advisable to use paper here in the absence of more suitable stuff.

If the material is too long, or too wide, there is no need to cut it, any surplus can be doubled over on the inside and tacked with cotton.

For this reason many things could be used for draping, long cretonne curtains for example, and returned for use afterwards.

The fascia strip is the last. This can be of paper and should be about 8ins. wide and shaped up a little at the bottom edge. A suggestion to this effect is given in the finished view of the stall.

The fascia strip can be cut from white paper, and a border marked round, coloured with crayon or poster paint. Any lettering desired is better done on a separate strip and fixed to the fascia with gum. It can then be removed and a freshly lettered strip attached when the stall is erected for some other object.

Fix the fascia by stretching the

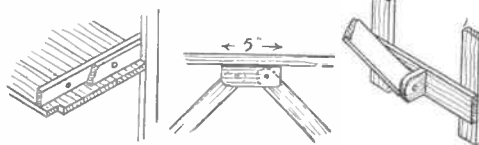

Fig. 2—Counter fixing Fig. 3—Stiffeners Fig. 4—Rail joint

A piece of tape is stitched to the strip along the top edge, to prevent tearing. If tape cannot be got, a string can be substituted.

tape round and fastening the ends inside the frames with pins. A drawing pin at each corner in front will prevent the strip slipping down.

ATLANTIC WAR STAMP FREE!



On November 1st, 1943, the FREE POLISH GOVERNMENT IN LONDON issued a new set of pictorial postage stamps for use by the FREE POLISH FORCES in this country and by POLISH SAILORS at sea. We have been fortunate in obtaining a supply of these historic War Stamps and have pleasure in offering YOU same ABSOLUTELY FREE. The stamp, as illustrated, depicts an actual incident of a Wellington bomber of a Polish Coastal Command Squadron sinking a German Submarine in the Atlantic. It is inscribed in Polish of course, "Polish Air Force in the Battle of the Atlantic"; and the stamp is printed in pink colour. You can get your copy of this most interesting stamp from us ABSOLUTELY FREE by writing to us and asking for our Lists and a selection of our stamps "on approval." This Polish issue can only be supplied FREE with an approval selection and if you send us 3d. in stamps also (to cover cost of List and postage of approvals to you). Do not delay; write immediately for this wonderful FREE OFFER to:— WINDSOR STAMP CO. (Dept. 12), UCKFIELD, SUSSEX.

Books of Designs

Simple designs for everyday subjects to cut from small pieces of wood. Brackets, pipe racks, boxes, frames, calendars, etc. All printed full size, ready to paste down.



FOUR BOOKS
A and B Books have 20 Designs each. Books C and D each contain 14 Designs of slightly larger subjects.
1/6 each, postage 1d.
HOBBIES LIMITED, DEREHAM & BRANCHES



MISCELLANEOUS ADVERTISEMENTS, etc.

The advertisements are inserted at the rate of 3d. per word or group of letters prepaid. Postal Order and Stamps must accompany the order, and the advertisements will be inserted in the earliest issue. Fretwork goods or those shown in Hobbies Handbook not accepted. Orders can be sent to Hobbies Weekly, Advertisement Dept., as below.

BE TALLER. Quickly! Safely! Privately! No Appliances—No Tablets—No Dieting. Details 6d. stamp.—Malcolm Ross, Height Specialist, BM/HYTE, London, W.C.1.

SCIENTIFIC AND ELECTRICAL EXPERIMENTS. First steps and experiments in elementary science and electricity, 2/-. Obtainable from booksellers, or Guardian House, Walthamstow, London, E.17.

SIMPLE HOME CHEMISTRY. Simple, thrilling experiments with home materials, 2/-. Obtainable from booksellers, or Guardian House, Walthamstow, London, E.17.

GENUINE Wartime Formulas! Haircream, or Setting Lotion, Table Jellies, Lemon Cheese, Coffee Essence, Fruit Salts. All for 2/6 post free.—C. Womersley, "Northview," New Road Side, Rawdon, Leeds.

STAMPS FREE!! Twenty unused (2½d.)—G. H. Barnett, Limington, Somerset.

RAILWAYS. A new "Planbook" by P. R. Wickham. "Scenic Railway Modelling" will add a new interest to constructing and operating miniature railways. **AIRCRAFT.**—"Making Miniature Aircraft" is another new "Planbook," by R. H. Warring. It tells how to make realistic solid scale models. **YACHT** "Planbook" tells how to make and race model. New simple time-saving method of construction. **GAS ENGINE** "Planbook" gives instructions and drawings for working model which runs on air. Made with simple tools and materials. New technique. **GALLEONS.**—All the secrets of making lovely models of these old-time ships are in this "Planbook" with working drawings. **AIRCRAFT, SHIPS and RAILWAYS.** Use "Scaleline" plans. SEND 3d. and unstamped addressed envelope for list of over 100 Plans and details of above Modelcraft "Planbooks."—77(H) Grosvenor Road, London, S.W.1.

LONELY? Join Friendship Circle. Details 6d.—Secretary, 34 Honeywell Road, London, S.W.11.

FREE to approval applicants enclosing S.A.E. Free French Colonials.—Ramsey, 168 Legsley Avenue, Grimsby.

WANTED. Designs for Doll's House and Furniture. Nos. 186 Special, 1988B, 1989, 1998, 2003.—Smalley, New Lumford, Bakewell, Derby.

BARGAIN STAMP Packets Free! Including used and unused British Colonials and Foreign to all applicants for my low priced approvals. All post free.—Ronald Bibb, 45 Windsor Street, Walsall.

APPROVALS ON REQUEST.—Warrington, Letham, Bearsden, Glasgow.

WANTED 100 Galleon Guns (brass), ¾"—2" long. Particulars—Walker, 6 South Holme, Liversedge, Yorks.

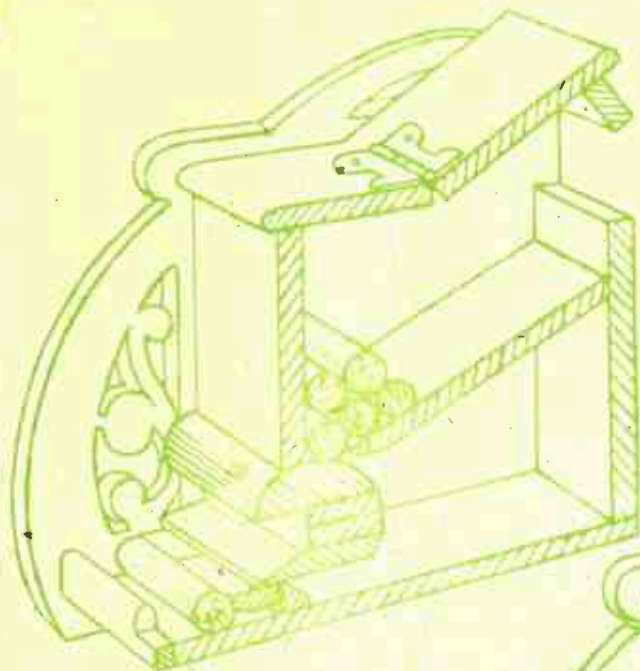

SECTION THROUGH BOX SHOWING FRONT OPEN AND CIGARETTE READY FOR PICKING UP. LID ALSO OPEN FOR FILLING WITH CIGARETTES.

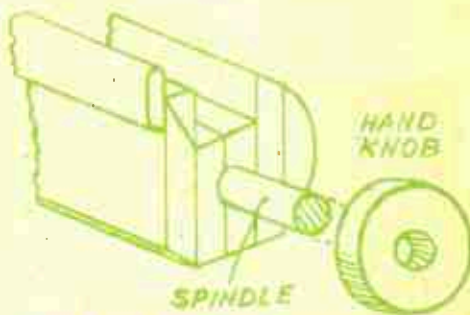

SHOWING HOW HAND KNOB AND SPINDLE ARE FITTED TO MOVING FRONT.

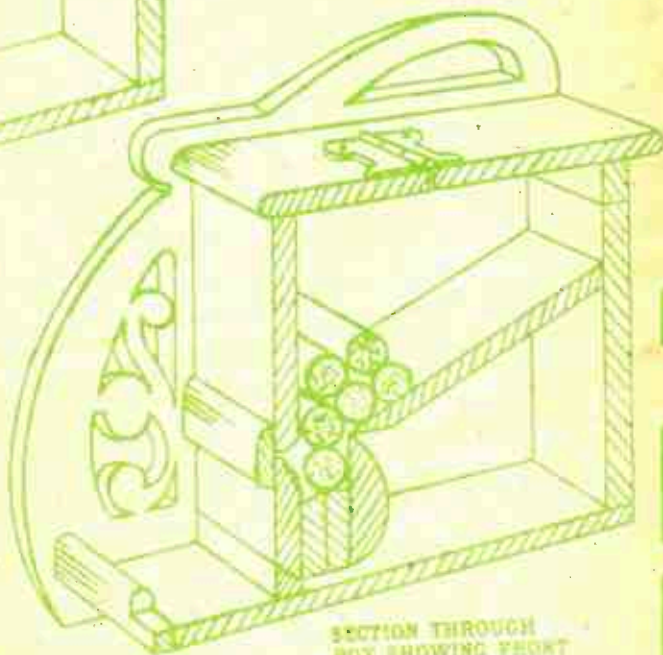

SECTION THROUGH BOX SHOWING FRONT CLOSED.

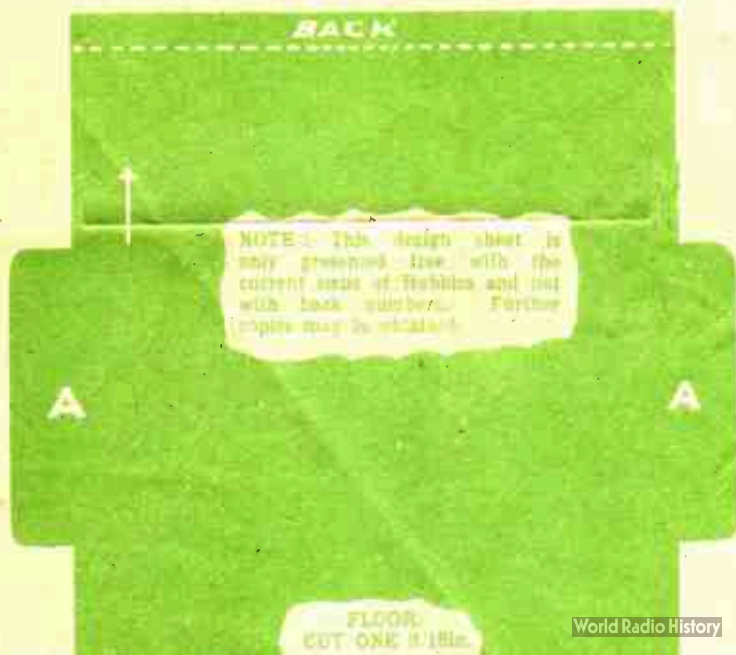

NOTE: This design sheet is only presented here with the current issue of *Radio* and not with back numbers. Further copies may be obtained.

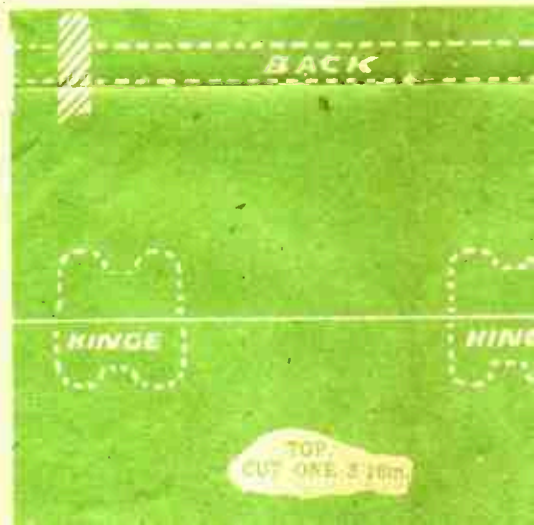

The screws influence the direction of grain of wood.



DESIGN

No. 2520
2-44

SUPPLEMENT TO HOBBIES No. 521

AUTOMATIC CIGARETTE BOX

SIZE - 4 1/2" BY 2 1/2" BY 1 1/2" HIGH

PANELS OF WOOD REQUIRED FOR THIS DESIGN

ONE G3 ONE H3

The price is shown in Hobbies Weekly, Feb. 2nd, 1944, and is subject to revision. See the current edition of Hobbies Handbook, or write for price to Hobbies Limited, Hertsford, Herts.



OUTSIDE FRONT RAIL. CUT ONE 2 1/2" BY 1 1/2" AND RUN DOWN TO 1/2" AND SHAPE UP TO SECTION.



CIGARETTE REST. CUT TWO 2 1/2" BY 1 1/2" AND GLUE TOGETHER. See detail.



CIGARETTE REST. CUT TWO PIECES 2 1/2" BY 1 1/2" AND GLUE TOGETHER AND SHAPE UP TO SECTION. See detail.



FRONT. LOWER RAIL GLUED TO FLOOR. CUT ONE 2 1/2" BY 1 1/2" AND CHAMFER TOP EDGE TO SECTION.



CUT ALONG THIS LINE



LINE OF OUTSIDE RAIL

CHAMFER

FRONT. CUT FROM 1/2" IN. THE LOWER PORTION IS MADE MOVABLE. See detail.

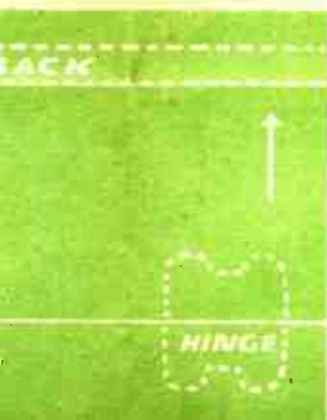

BACK

HINGE



CUT ALONG THIS LINE

BOX CATCH



TURNING KNOB. CUT ONE OF EACH 2 1/2" BY 1 1/2" AND GLUE TO SPINDLE.

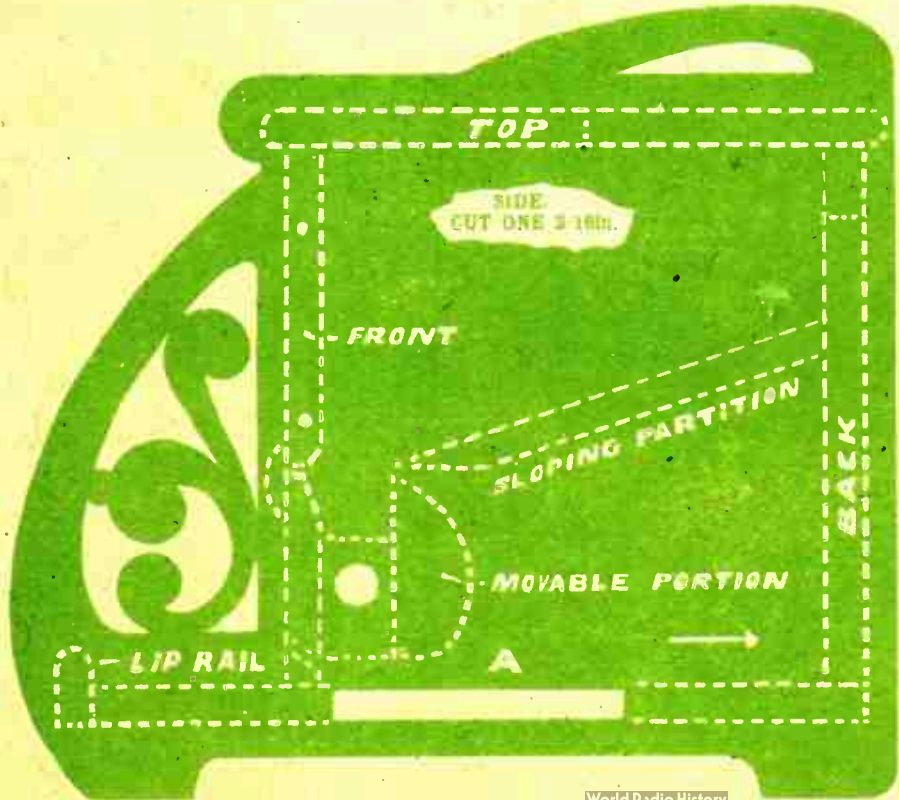
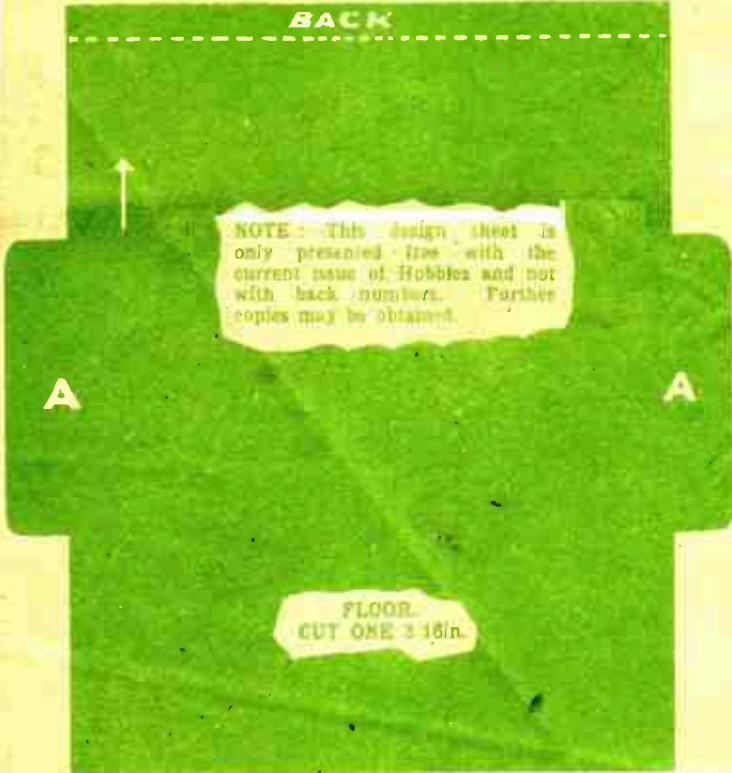

CUT TWO 2 1/2 IN. AND GLUE TOGETHER. See 4950b.

CIGARETTE REST. CUT TWO PIECES 2 1/2 IN. AND GLUE TOGETHER AND SHAPE UP TO SECTION. See 4951a.

UGAR

CUT ALONG THIS LINE

LINE OF OUTSIDE RAIL

CHAMFER

FRONT. CUT FROM 2 1/2 IN. THE LOWER PORTION IS MADE MOVABLE. See detail.

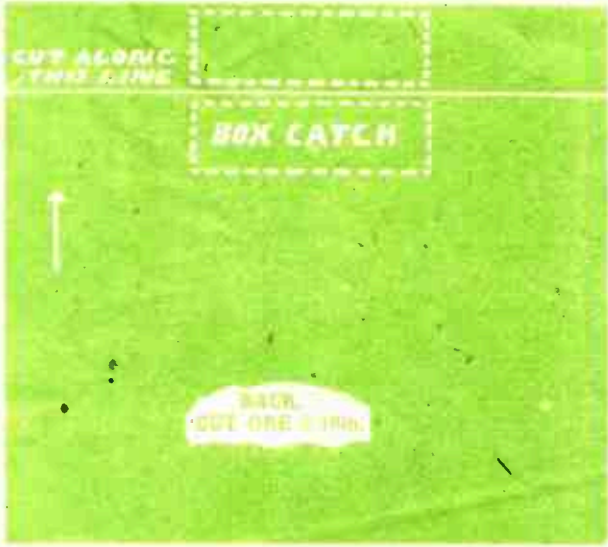

TURNING KNOB. CUT ONE OF EACH SIDE AND GLUE TO SPINDLE.



SPINDLE. CUT TWO AND SHAPE UP FROM 2 1/2 IN.



THE FINISHED KNOB READY FOR FIXING TO MOVABLE FRONT.

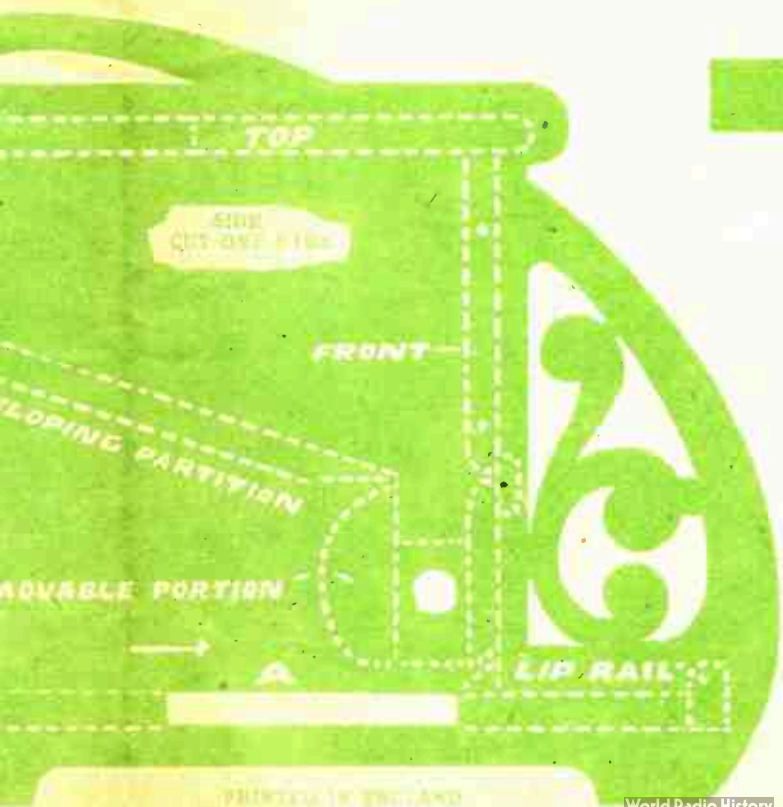

LIP RAIL. CUT ONE 2 1/2 IN. AND ROUND OFF TOP EDGE TO SECTION.

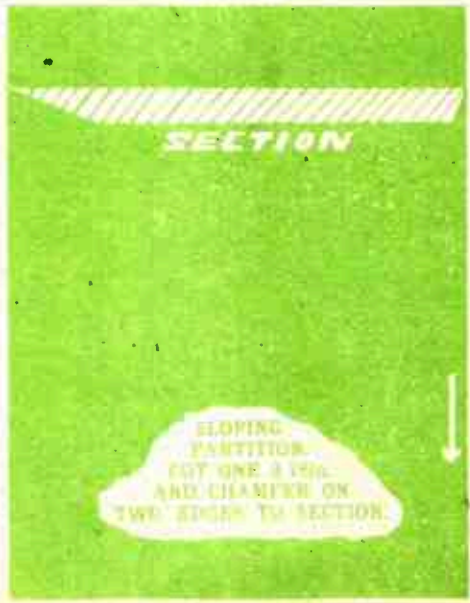

SLOPING PARTITION. CUT ONE 2 1/2 IN. AND CHAMFER ON TWO EDGES TO SECTION.

CIGARETTE HOLDER

THE mechanical cigarette delivery box shown on the other side, is a novel piece of work to cut out with the fretsaw from pieces of wood $\frac{3}{16}$ in. and $\frac{1}{4}$ in. thick. All the patterns required are shown, as well as two details which make the mechanism clear.

The box holds a number of cigarettes and when the knob on the righthand side is turned, one of them is delivered into the hollow platform at the front. Each time the knob is turned backwards and forwards it brings a cigarette, until the box is empty. The principal work is in the delivery mechanism, and time and care should be spent to see that this works smoothly and operates satisfactorily each time.

The parts shown should be cut out by marking the patterns on to the wood, and cleaning them with glass-paper afterwards. The parts are quite straightforward although several of them have to be shaped up.

Two-piece Front

Notice, too, how the front is cut into two pieces along the line just below the word "Cigarettes." This lower portion must also have one long edge chamfered deeply, and the other edge chamfered to a more slight angle. The actual slope of this chamfer is shown by the shaded section, and this angle must be carefully maintained to ensure satisfactory delivery.

When all parts are all ready, the construction should be proceeded

with in this way. First of all get the two sides, the floor and the top. The position of them is shown by the dotted lines on the pattern of the side. The lower portion of the front, of course, fits to the movable cigarette delivery portion, and the upper portion of the part of the front comes immediately above it.

The Holder

The actual cigarette holder piece is shown in the details on the sheet. Two $\frac{3}{16}$ in. pieces of the cigarette rest are glued together, and to the front of this is fixed the lower and chamfered portion of the front. Notice that the chamfered piece is inwards. Immediately above this is glued the outside front rail which projects slightly above to form a stop against the main front.

At the back of this piece is the rounded portion. This is made from two $\frac{3}{16}$ in. boards (or one $\frac{1}{2}$ in. piece) and then filed and glasspapered to the curve shown so it may turn round easily in the aperture of the front. Into the end of the solid block a spindle on a short rounded piece is glued to project at each end through the sides.

Turning Handle

It must project far enough to allow the circular disc to be glued on to form a turning handle. The spindle portion, by the way, cannot be finally glued in until the whole thing has been tested in place and found satisfactory.

The two cutaway diagrams on the

sheet illustrate the two positions. The lower one shows the cigarettes running down the sloping floor, and one in the grooved holder. The diagram above shows the holder turned, and the cigarette rolled out down the chamfered slope.

The sloping floor can be fitted between the two sides either by gluing in place, or gluing on to two support strips fitted to the inner face of the sides. The back is not yet in place near the other hinged portion of the top because this will allow trial to be made with the mechanism to get it right. When satisfactory, the other portion of the top is hinged on with its glued block of the back below.

The Back

The back, in the first instance, can be cut as a plain rectangle, and then the top strip cut off. Fit the back in by gluing to the sides and floor, then see that the top strip is glued to the underside of the top so it comes down on to the upper edge of the back.

By the way, the sloping floor, you will note, has had to be chamfered slightly to rest snugly against the back, and the other end has also to be chamfered to allow the turning of the cigarette holder portion. The top is hinged by two small fancy hinges, and if necessary, a little catch can be put on the back to keep the lid from falling open.

The only other remaining piece is a narrow lip rail glued along the front of the floor to prevent the cigarettes rolling off when ejected.