

# Hobbies

## WEEKLY

December 15th, 1943

Price Twopence

Vol. 97, No. 2513

A QUEER sort of aeroplane, isn't it? In the future, however, we may expect to see even more unorthodox aircraft flying in the skies. The pterodactyl—pronounced "ter-o-dak-til"—is really nothing new and startling. Our model is, for example, based on a type designed by a man called Dunne, in 1911, who wanted an aircraft possessing inherent stability, a feature lacking in most of the usual design of aeroplane in these days. We give you an improved idea of the early pterodactyl—futuristic conception of it as a peacetime aircraft, to be more exact.

### Fuselage Parts

As usual, a page of full-size patterns is provided on Cover iv to simplify the

Patterns on  
Cover iv

construction. It will be seen that the fuselage is merely built up from shaped layers of wood. Cut out these parts first, from the different thickness of wood, as instructed on the pattern page.

When cutting, you will notice incision lines to be made at the back of the pilot's cabin in the centre cover

## A MODEL PTERODACTYL

A non-flying model  
in wood

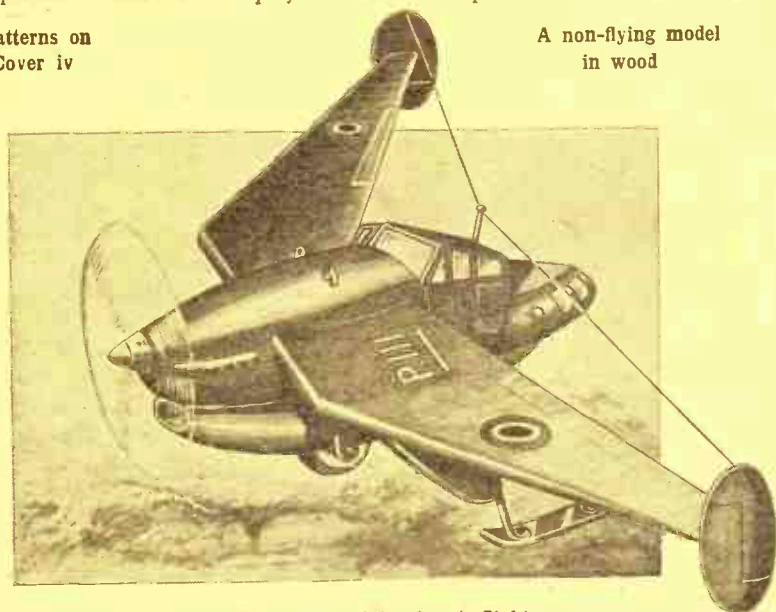

Fig. 1—An artist's picture of the plane in flight

pieces and outer fuselage pieces. These incisions ease matters in shaping up the rear of the fuselage later on. Meanwhile, glue the cover pieces to each side of the centre piece, then add the outer fuselage covering pieces.

To ensure accuracy for the main wing root-slots and keep the parts held together, a piece of wood about 3ins. long by 1½ins. wide by ¼in. thick should be inserted through the slot. This is removed when the glue has set.

### Wings and Fins

While waiting, prepare the main wings. When cut out, the underside is planed to taper to ¼in. at the tips. The leading edges are rounded over. The bi-planes are also made to taper, from ½in. to 1/16in. The edges can be rounded over by glasspapering.

The tail fins are cut to shape, then neatly paired on both sides to give a "wafer" edge all round, following which the surfaces are neatly smoothed out by glasspapering. The fins are then glued to the main wing tips. The tenon will likely project a trifle, but can be easily pared flush and glasspapered to be almost invisible.

Regarding the wire supports which go between the bi-planes and main wings, the holes for same are drilled at a suitable angle (see side elevation at Fig. 2). Four headless wire nails would make ideal supports, otherwise brass wire could be used. The

smaller holes marked on the wings are for connecting the skid shafts.

### Shaping the Fuselage

Proceed with the shaping of the fuselage, helpful half sections being provided at Fig. 2. Most of the "rough" work is done with a sharp penknife. Before starting, however, mark out, in pencil, the top shape, as shown. The propeller hub will give you the diameter of the nose of the fuselage.

Having pared away the wood to shape, start paring the corners away. Note how the front of the cabin is "pointed" (see top plan, Fig. 3).

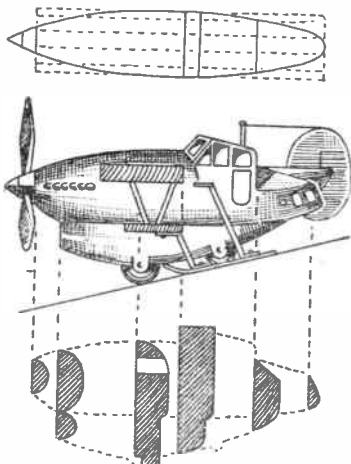

Fig. 2—Top shape of fuselage, with side elevation and shaping sections

The construction view of the back of the cabin shows up much of the rear shaping. The incision cuts mentioned earlier will save "poking" about to get a neat corner on both sides; the waste wood will slice away easily.

Refer to the half sections again. The engine radiator, situated beneath the nose, is oval in shape. An actual aperture could be formed in the radi-

tor by drilling a series of small  $\frac{1}{8}$  in. holes  $\frac{1}{2}$  in. deep in the wood, then by "chopping" out the waste with the point of the penknife or, better still, by burning it out with a red-hot poker or metal rod.

Note how the wheel "lugs" are left flush with the "belly" of the radiator. This calls for careful nicking, paring and glasspapering. A coarse, flat file and an ordinary half-round file will be found useful; a wood rasp might be too coarse to use.

Attach the main wings and biplanes to the fuselage, seeing that

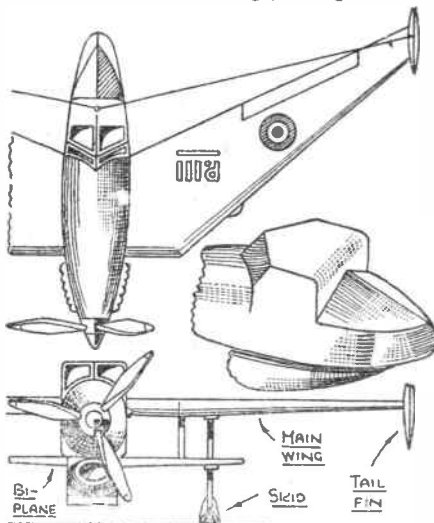

Fig. 3—Part of top plan, and front view with detail of cabin

the leading edges of the former are in a straight line. The wheels, when rounded over, are fixed in their respective slots (one wheel is slightly larger than the other) by means of pins. The wheels must be free to turn on their pin axles, of course.

The skids are made from wire and thin brass strips. The wire is bent to shape, then flattened out at the ends

and drilled with a fine fretwork drill bit for fixing nails. The flat gliders are drilled and countersunk on the underside so the shafts can be fixed with rivets, or one could solder the gliders and shafts together.

Having attached the skids, make the propeller. You need three blades cut from  $\frac{1}{4}$  in. wood and a hub and spinner cut from  $\frac{1}{4}$  in. stuff. Three equidistant holes,  $\frac{1}{8}$  in. diam., are made in the hub. Shape the blades in the usual manner and glue to the hub.

The airscrew spindle is an ordinary plain pin or panel pin about  $\frac{3}{4}$  in. long. A hole for the head of it is countersunk in the face end of the hub, following which the spinner is adhered over the latter. The hub and spinner are, naturally, shaped up prior to fixing on the blades.

### Other Details

The exhausts are glued at the sides of the engine, in the position shown. A large plain pin serves as an aerial mast, it being situated on the cabin top, near the back. Thread or fine wire provides an aerial. Run it from one tail fin, to the aerial mast, then to the other tail fin.

As a finish, give the whole work a coat of grey poster paint. Two applications may be necessary. Light grey, or dark grey, may be used. Outlines are drawn on with black ink. The various wires, including the skid gliders, or runners, are enamelled black, this also applying to the airscrew blades.

While the spinner and hub could also be black, silver paint would make the airscrew look better. The blade tips are touched with it, too, if desired. The windows are done up with white paint, then shaded with light blue. The usual "target" is painted on the top of the main wings the marking "P.111" being done in white.



## Hobby Work on an A.A. Site

**T**HIS photograph was sent by the Cambridge Y.M.C.A., showing a popular result of their activities in the district. The Anti-aircraft sites are usually isolated and lonely, and you can imagine what a godsend it is to be able to use hand and brain on such a pleasing hobby. Evidently these keen Army men have ability as well as enthusiasm. Notice the pleasing range of models, boxes and rings, which are shown in the foreground. Obviously the picture was taken in the summer, but no doubt the men are just as keen now in the warmth of the huts.

# How to use an earphone piece as speaker in making this NOVEL CRYSTAL SET

A CRYSTAL set is not to be despised merely because it is a simple type of wireless receiver. Indeed, many people in our midst prefer crystal sets to the most modern valve sets. Few care much about selectivity. Providing they can tune in a couple of frequencies and hear the news bulletins, they are more than satisfied. The chief drawback with crystal sets is that only earphones can be used for reproduction, and these, unless properly adjusted, are uncomfortable on the ears.

## An Auxiliary Earphone

Considering this point, we have thought of incorporating an auxiliary earphone in the set we have designed, as will be seen at Fig. 1. When properly tuned, the set will work the single earphone sufficiently to be heard a short distance away.

The volume will not be great, but it could be vastly increased with a small horn fitted to the cap of the earphone, the horn resembling the mouth-piece found on old-fashioned telephones, but preferably much longer to magnify the sound waves considerably.

The auxiliary earphone is ideal if one intends to build the set for listening-in after retiring to bed. Many are probably dance music enthusiasts, so rather than sit up, wasting gas or electric light, you can tumble into bed, tune up your small receiver, and lie snugly between the sheets, to hear Jack Payne, Ambrose, Geraldo, etc., do their stuff.

One important thing you will need is a good aerial, including a good earth connection.

## The Front Panel

As all the components, as listed, are mounted on the back of the front

panel, this—detailed at Fig. 2—is cut out to size and shape right away. Now, assuming you have been able to obtain a second-hand, mica-spaced variable condenser about 2ins. square and  $\frac{3}{16}$ in. thick, it will be necessary to mount it upon a suitable block of wood so the spindle will not project too much.

A block of wood 2ins. square by  $\frac{3}{16}$ in. thick will serve. A  $\frac{3}{16}$ in. hole is bored in the centre of it, following which the block is glued centrally on the back of the panel so its spindle hole corresponds with the spindle hole in the panel (see dotted lines at Fig. 2).

The variable condenser is then affixed on top with a suitable round-head screw driven in at each corner (see back view at Fig. 5). The switch, which is optional, but worth including, is attached by pushing its threaded spindle through its hole and screwing on the bakelite nut; the switch (detailed at Fig. 4) is an automatic-action push type, i.e., one merely

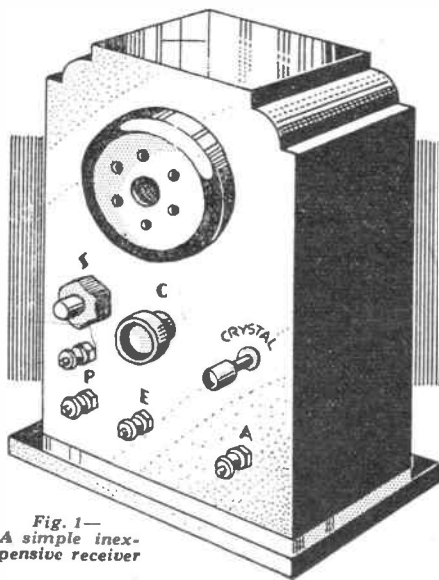

Fig. 1—  
A simple inexpensive receiver

## COMPONENTS REQUIRED

- 1 variable mica-spaced condenser, 2ins. square.
- 1 perikon (semi-perm.) crystal detector.
- 1 small fixed condenser (optional).
- 1 automatic-action push switch.
- 1 earphone piece.
- 4 small wireless terminals.
- 1 small tuning coil.

presses the button down to switch on, then pushes it down again to switch off.

## Coil and Crystal Detector

The tuning coil is easily made. All you require is a cardboard tube  $2\frac{1}{2}$ ins. long by lin. diam. The better the insulating properties of the tube, or former, as it is known, the better the coil. Cardboard tubes, if coated with shellac varnish, serve, but if you

have fibre, ebonite or Paxolin tubing of suitable diameter, use it.

Drill two terminal bolt holes and two pin holes in the tube as shown. Insert the terminal bolts (these are about  $\frac{3}{16}$ in. long) and, having bared one end of a piece of fine coil wire (enamelled stuff), insert it through one of the pin holes and loop it around the head of the neighbouring terminal bolt, then tighten up same with its nut.

## The Coil

The coil wire is then wound around the tubing neatly and tightly. Get each winding closely against the preceding one. Failure in that respect will affect the inductance capacity of the coil. When you have wound on the wire, connect the free end to the second terminal bolt and the coil is ready from mounting on the front panel.

To do so, insert the bolt shanks through the holes provided and screw on two more nuts. Proceed by mounting the crystal detector. The type shown (Fig. 4) costs 2/6. complete. A special thin, brass support is made for it, the shape it has to be bent being given.

To mount the detector, first connect the support to it by means of the crystal cup bolt, as you can see at Fig. 5, in the side elevation. Now remove the adjustable spring contact part by withdrawing the cork end in the glass tube. In the cork you will find an elongated eyelet which is removed and pushed into the respective hole in the front panel.

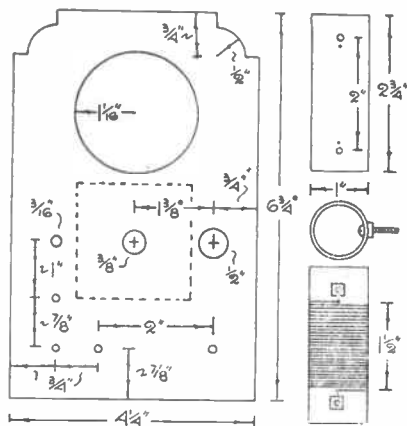

Fig. 2—Front panel sizes

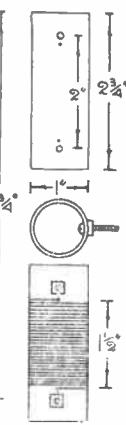

Fig. 3—The tuning coil

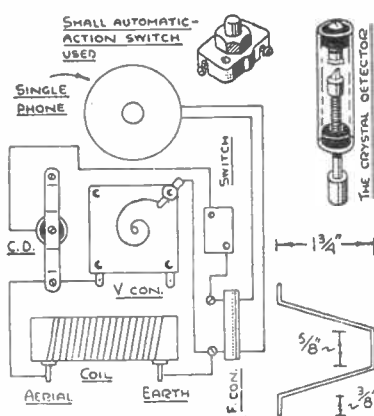

Fig. 4—Wiring circuit with switch and crystal details

To remove the cork, the "handle" on the cat's whisker rod is unscrewed. Incidentally, the cat's whisker is no longer a fine spiral of wire. It is a jagged piece of stony material which seems to do the job much better, with less twiddling.

To assemble the detector, press the cork end over the eyelet projection, insert the rod and screw on its handle. The crystal tube is then pressed over the cork and the support screwed to the panel. If the screw points project, file them flush;  $\frac{3}{16}$  in. by 4 roundhead brass screws should be used.

A small fixed condenser (a tiny tube, with wires projecting at the ends) is fixed to the 'phone terminals. This, however, could be omitted from the circuit.

### Wiring the Parts

There is no need to give a full explanation of the wiring. The circuit diagram at Fig. 4 is easily followed. Regarding the single earphone, two short lengths of flexible wire are connected to its contacts, the free ends going to the 'phone terminals on the inside.

When wired, test the circuit by connecting the aerial and earth wires to their respective terminals. Place the ear-phone against your ear and tune up the coil by means of the variable condenser. If results seem

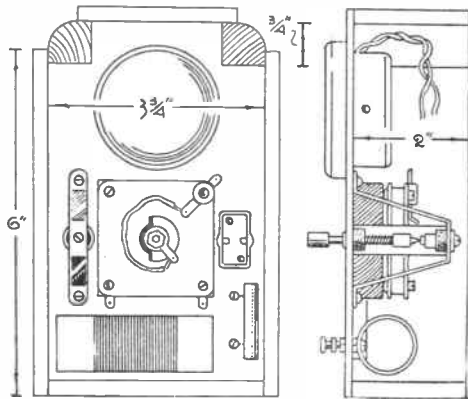

Fig. 5—Back and side details and dimensions

weak, shift the "cat's whisker" about on the crystal until a more sensitive spot is found. If you have followed the circuit correctly, you

will hear excellent results right away as soon as the wave-length has been tuned in.

If results are weak, your aerial or earth is at fault. A 50ft. aerial is essential for crystal sets, with a proper earth connection, such as a water-pipe.

### The Case

The case of the set is constructed from  $\frac{1}{4}$  in. and  $\frac{3}{8}$  in. fretwood, with  $\frac{1}{2}$  in. square blocking for the top corners. The main dimensions are shown in the front and side views. To assemble, glue the blocks (cut exactly 2ins. long) to the side pieces, adding a few pins, if necessary. A bottom piece is nailed between the sides, then a top piece added. A back, cut the same size and shape as the front panel is added, then the front panel, complete with components; the block corners are rounded over to correspond with the front and back pieces.

The auxiliary earphone is a tight fixture in its circular aperture. Be sure, therefore, to find the correct size of the hole to be cut. You should be just able to press the 'phone into the aperture. A base,  $\frac{1}{4}$  in. bigger all round, is fixed to the work which is then enamelled or polished.

## Cotton reels and evergreen make little trees for XMAS TABLE NOVELTIES

IN spite of war-time rationing we are still able to have a few parties for grown-ups and the children. Lack of decorations for the table in the way of eatables can be compensated by the introduction of a few simple and easily made novelties from cotton reels, pine cones, twigs, etc. These few suggestions would enable you to make quite a few in a good variety.

The straight-shaped cotton reels make attractive miniature flower pots and need only to have the labels removed and the rims cut off. Most reels are made of soft wood and yield to a hard rub with medium glasspaper.

### The Base Reel

When cleaned and prepared drive a stick of soft wood into the centre of the reel to block up the hole. If you only have the recessed shape reel, then make a covering of stiff fancy paper, as shown in Fig. 1., which should extend  $\frac{1}{2}$  in. above the reel at one end. Add any ornamental paper for additional effects.

It is a good plan to prepare all the reels first and then you can do the more difficult part indoors during the dark evenings. Oddments of paint in bright shades of red, green, yellow, turquoise or silver will be the best shades to use and poster colours will also take quite well.

Failing this, some scraps of crepe

paper will enhance the look of the other pots. Other suggestions will come to the worker, once he has the idea.

### Tree Material

All manner of materials can be used to make miniature trees. Perhaps you can find some pine cones and you will find these quite good to paint. Paint the lower parts of the petals in a light shade and then tip the tops of the petals with silver, scarlet or yellow. If you can find any of the taller types of cones they will make ideal trees.

To fit the cones in the pots, bore a small hole in the base of the cone with a bradawl and another one in the centre. Drive a piece of wire about 2ins. long into the cone and then the other end into the pot. If you have no wire, chop the heads off some fine nails with the pliers.

If you have no cones, collect some twigs about 9ins. long and similar to those shown in Fig. 2. Get these twigs with nice shaped offshoots and paint them in silver, turquoise or red and you will have to shape off the lowertip so that they can be driven into the reel. In this case there will be no need to block up the centre of the reel. For decoration, tiny flowers from crepe paper or any fancy paper will do. Coloured beads suspended

on wire is another suggestion. If you are able to find any acorns paint these in bright colours, with yellow cups and bright red eggs and fit on to the twigs with thin wire.

A most attractive and very dignified selection of novelties can be made by getting short lengths off the cypress tree (see Fig. 3). If you

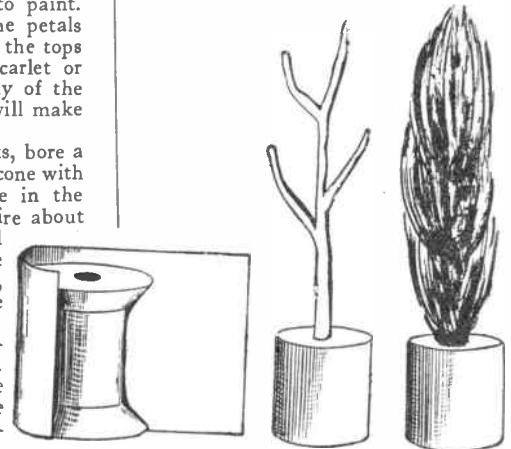

Fig. 1—Covering the reel Fig. 2—Twig tree Fig. 3—From cypress

dry these and then paint them with silver or green with tips in another shade they will retain their shape and can be forced into the centre of the reel. These are rather brittle so do not attempt to add novelties.

# Make a smart job of it by completing an ALARM CLOCK CASE

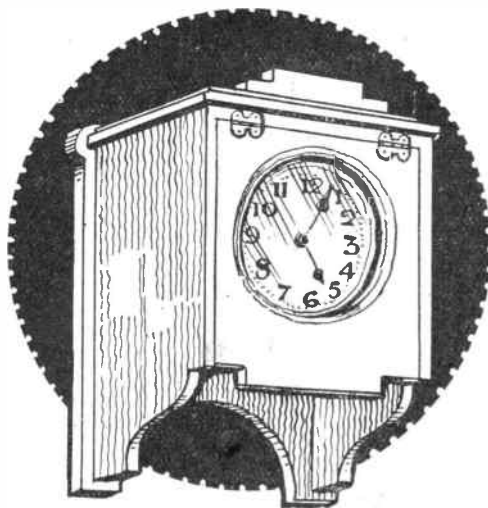

Fig. 1—The completed clock case

THE attractive hanging clock case shown in Fig. 1 is intended to house one of the cheaper makes of clock which at one time were easily obtainable, and which at the present time are most difficult to get. The greater number, were fitted with an alarm bell on the top, while others had a bell on the inside of the metal casing.

The disadvantage of these clocks is that they turn a bad colour after a time and thus become rather unsightly. So we have thought out a way of making a wooden case which might hang conveniently on the wall.

## Extracting the Clock

All one need do when the clock needs winding is to lift the front which is in the form of a hanging lid, take out the clock and wind it up, and then replace it on its shelf in the case taking

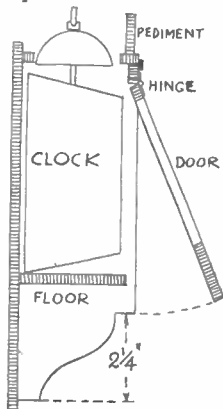

Fig. 2—Side section

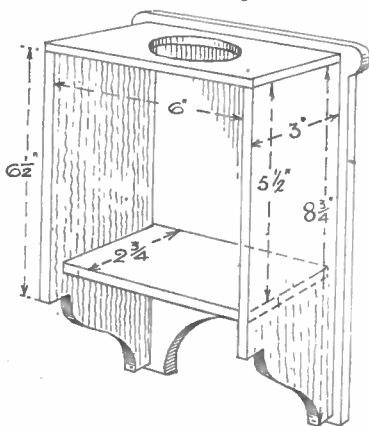

Fig. 3—Constructional details

care to push the bell through the hole in the top of the case.

Almost any kind of wood may be used, providing it has a smooth surface is flat and not warped or twisted. Fig. 1 gives a section of the case and shows the clock supported by the floor and the door swung partly out.

The general construction of the case is shown in Fig. 3. It consists of a back, two sides, a top and a floor all cut from 1/2 in. wood. All parts are simply glued and screwed together.

The fretsaw will be used for all the cutting, and the shapes and sizes of the various pieces can be set out quite simply from the measurements supplied here. The outline of the back of the case is given in Fig. 4 and the dotted lines

shown on this diagram should be transferred to the wood also the screws may be centred accurately when putting the case together.

## The Sides

The two sides are each 8 3/4 ins. long by 3 ins. wide, shaped at the lower end to the simple curve shown in Fig. 2. The top, which rests on the two sides, and is flush with them, is 6 1/2 ins. long by 3 ins. wide. The hole in the middle is made about 2 1/2 ins. in diameter, with a space of 3/8 in. from the front edge.

The floor measures 6 ins. long by 2 3/4 ins. wide. It stands 5 1/2 ins. down inside measured from the underside of the top as seen in Fig. 4. The outline of the front is given, in Fig. 5 with all necessary dimensions for setting it out on the wood.

It will be observed that the top of this piece has been cut through and

refixed to the lower portion with a pair of brass hinges. This narrow top rail is eventually fitted between the two sides and beneath the top to which it is secured with screws from above.

## Joint Covering

To form a suitable finish and covering to the joints between the top of the cabinet and its sides and front rail, a narrow fillet of wood is mitred at the corners and glued on. This fillet is shown in the section of the case in Fig. 2.

## CUTTING LIST

All 1/2 in. Wood

Back—one piece 9 1/2 ins. by 8 ins.  
Sides—two pieces 8 3/4 ins. by 3 ins.  
Top—one piece 6 1/2 ins. by 3 ins.  
Floor—one piece 6 ins. by 2 3/4 ins.  
Fillets—one piece 6 ins. by 1/2 in.  
Fillets—two pieces 3 1/2 ins. by 1/2 in.

A simple shaped pediment to add a finish to the top of the case is shown in the sketch, this pediment being about 4 ins. long and 1 in. wide. It helps to hide the brass ring and the bell of the clock when the case is hung on the wall.

## Suitable Finish

The finish to the case will, of course, depend upon the variety of wood that has been used. A soft wood could be coated with ebonizing solution and then polished or varnished.

If you have had to use odd pieces of wood of various colour, it will be best to cover them all with paint. Use a pleasing colour, such as light blue or cream, and get a nice glossy finish to the article.

If oak, then it could be lightly stained and wax polished or simply varnished over.

The whole article may be made from two of Hobbies standard panels of wood, viz., one H4 and one K4, cost and postage of which are obtainable on request.

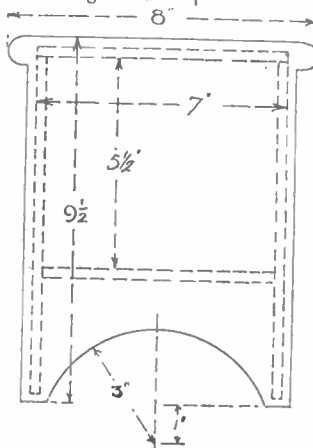

Fig. 4—Plan of back portion

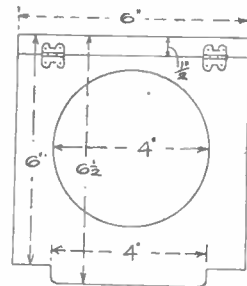

Fig. 5—The hinged front

# Home photographers should read these hints on how TO IMPROVE NEGATIVES

**A**T this time of the year, when weather conditions are not always favourable for taking the camera out, it is a good opportunity for going carefully through your collection of negatives to sort out those which, for various errors in exposure or development fail to give satisfactory prints.

It is also the season when it is most difficult for those who are able to use their cameras to judge the true value of the light and so secure correct exposure.

The actual value of November and December and January light is approximately only one quarter that of May to July and it has the habit of changing so quickly and so frequently that it is necessary to carry some form of reliable exposure meter to avoid mistakes.

## An Interesting Occupation

Even expert amateurs make mistakes, and if you are in the habit of taking your films to a chemist to be developed and printed—you should be doing the work yourself now—you may have been told by the chemist that some of the films are under—and others over-exposed and that that is why they are not giving first-class prints.

It is these negatives that you should pick out to receive, what is termed after-treatment. The work is really very simple, requiring practically no skill or previous experience and is a pleasant occupation for a wet evening. It can be done in artificial light such as the dining room or kitchen.

Many amateurs destroy negatives that are under—or over-exposed or developed but this is quite wrong. Especially in these days when films are not plentiful. And, also, as there are two or three methods by which they can be partially improved.

## For under Exposure

If a film is grossly under exposed it is wrong to assume that after-treatment will make it perfect. The perfect negative is one that has been correctly exposed and correctly developed. The work now suggested can only produce an improvement and cannot correct the errors completely.

Intensification is the process of building up or increasing the density of the image. This may be very thin through under-exposure, or because it has not been in the developer for

the full time, or because the solution is too cold or too weak. Such a negative is inclined to give a very dark or muddy "flat" print and by building or adding density more contrast can be obtained in the print.

Reduction is the reverse. It is for cutting down or reducing the density of the image. Such a negative is very black, it is very difficult to print, requiring longer exposure than a normal one and often a stronger light, quite frequently the print shows an absence of detail in the high lights.

## Intensifying Bath

For the intensification process one of the most popular formulae today is the Uranium bath. The solution can be obtained of any dealer, or if it is preferred to make your own solution, here is a formula that is perfectly satisfactory.

- A. Uranium Nitrate .. 50 grains.  
Water to make .. 5 ounces.
- B. Potassium Ferricyanide 50 grains.  
Water to make .. 5 ounces.

Take four parts of both A and B and add one part of acid acetic. After soaking the negative in this for a few minutes you will notice that it is stained an orange but do not overdo the staining unless the negative is very thin. Wash it in four or six changes of still water. If you wish to remove the stain then immerse the negative in a weak Soda carbonate solution.

Another popular formula is the Johnson's Redevelop Intensifier sold in two bottles. One solution is for bleaching the image, the other for redeveloping it. This has a special advantage as it can be used a second or third time on the negative, until the desired density is reached.

For the reduction process, there are two popular formulas. One is the

Howard Farmer for increasing contrast while reducing the density. It has a greater effect on shadow detail than on the dense parts of the negative. Two solutions have to be made as follows—

- A. Hippo Soda .. 1 ounce.  
Water to make .. 8 ounces.
- B. Potassium Ferricyanide 1 ounce.  
Water to make .. 10 ounces.

To each ounce of "A" add about 30 drops of "B", the more of "B" the quicker the action. The mixed solution will not keep, it must be used at once, it is ineffective in a few minutes and becomes a blue-green colour. It should be a lemon colour. Watch its action and when the reduction is complete wash the negative thoroughly.

## Reducing Contrast

The "Persulphate" formula is one which acts on the heavy high-lights of the negatives first without much effect on the shadow details, these reducing contrast.

- Ammonium Persulphate 200 grains  
Water to make .. 5 ounces

A drop of sulphuric acid in each 2 ounces of solution is recommended for making the action more regular.

*(Continued at foot of page 87)*

## These publications are yours—for 3d.

Send us your name and address and enclose 3d. in stamps for the following. A 32 page booklet entitled Home Photography. This will teach you how to develop your own negatives, how to make prints on gaslight or bromide paper, how to make enlargements and how to do Flashlight Photography. Five well-known experts have written full, easy-to-follow directions on these subjects. Then there is a folder giving the Time and Temperature tables for dish or tank development with AZOL and a lot of very useful hints. The other booklet is a fully illustrated list of chemicals, sundries and accessories which will be helpful to you in your hobby.

FOR 3d. IN STAMPS WE WILL SEND  
YOU THESE THREE PUBLICATIONS

*To save time, be sure you mark your  
envelope HOBBIES DEPARTMENT*

JOHNSON & SONS Manufacturing Chemists Ltd. HENDON, N.W.4

# A printed alphabet is provided for making these SIMPLE LETTER BLOCKS

SOME children are always fond of playing with alphabet blocks, and in an interesting manner in this way pick up the formation of simple words, and learn their alphabet under pleasant conditions. The making of such an alphabet as this is made possible by the specially printed pictures provided in a sheet by Hobbies Ltd., at a cost of 5d. post free.

An illustration of some of the letters is given herewith, and they are all printed quite plainly ready for pasting down and cutting out with a fretsaw. A further feature is that each letter incorporates the name and picture of an animal or bird as a further easy reminder of the actual letter itself.

## A Handy Size

The printed letters are 2½ ins. high and the widest of them measures 2¼ ins. They are thus a handy size for any youngster to use.

Now for the instructions for cutting out to form the finished letter blocks.



The letters as they appear on the printed sheet supplied by Hobbies

As the letters themselves are fairly large, it is advisable to have comparatively thick wood. If you can obtain ½ in. plywood that will do very well. If not, ordinary wood of this thickness will do.

If, however, you think the cutting of such thickness is beyond your ability, there is no objection to having thinner material although it should certainly not be less than ¼ in. Get plywood if you can, because the thinner wood is apt to split and get broken across the grain if used in the ordinary fretwood.

Use a good strong paste, too, in putting the paper down to the wood. Flatten it out so there are no air bubbles, and do not commence cutting until the paste and paper are thoroughly dry. Remember to have clean hands so that no grease or dirt

is transferred to the paper in cutting.

In pasting down, too, put the letters on with the grain running up and down the letter to reduce any likelihood of breaking. You will see that round the printed letter provided, is printed a very thick line. Before commencing decide how you are going to cut round this.

That is to say, whether you are keeping the fretsaw on the outer edge or whether down the middle of the line. The former is better, but the same thickness of line must be preserved right through. Be sure to hold the fretsaw upright and take it steadily round the cutting line until it returns to its starting point.

If there is any interior work as in B, D, etc., a drill hole can easily be made near the cutting line, and the fretsaw threaded through it before cutting out the little piece needed. Hold the work to the table with the fingers as close to the sawblade as possible. This will help to hold the paper firmly and to provide less likeli-

hood of it being turned up in the process of cutting.

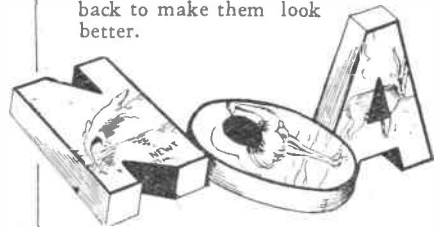

Three cut-out letter blocks

The Hobbies Blackboard Black or Eggshell Black provides a flat edged surface and is easily applied with a soft brush. Remember to be careful along the front edge, not to let any of the paint get over on to the paper. You can hold the letter for painting by sticking a knitting needle or similar sharp pointed instrument into the edge of the wood, and using it as a handle.

To preserve the face of the paper, you can apply a good carriage varnish. Try it out on a piece of the spare alphabet paper first, however, to ensure it is not too thin. If it is, it will merely be absorbed by the paper, and not produce a hard surface such as required.

hood of it being turned up in the process of cutting.

## Cleaning and Smoothing

As each letter is completed, it is advisable to clean it with glasspaper. This will give a little change of operation from the cutting. Notice that the edges are all clean, and that the paper on the front has not been turned up.

Rub it slightly over the edge if possible with the fingers, and paste down any which has become raised. The back edge of the wood should be given a light rubbing with glasspaper in case any tiny shiver or saw burr has been pulled up.

The completed letters can be left in their natural state if they are cut

## For Complete Words

Of course, the use of one alphabet sheet will only provide one of each letter. The owner, therefore, will be only able to make simple words containing one of each. You will accordingly be well advised to cut two or three alphabets to overcome this, or if you do not want to cut all the alphabet, you can cut the more used letters and leave out such little wanted ones as Q, X, Z, etc. The vowel E, by the way, is in more demand than any other letter.

To finish the whole thing properly, it would be nice to have it put in a box, which in turn could be covered with fancy paper and a suitable name pasted on a label on the front.

## Improve Negatives—(continued from page 68)

Keep the dish well packed and watch for a "milky" appearance in the solution. Continue for a further ½ minute unless heavy reduction is required. When the time can be increased but when the solution becomes opalescent it is useless and must be thrown away and fresh prepared.

After reducing, wash the negative rapidly for three minutes and

immerse it for 10 minutes in a weak fixing bath of 1oz. Hippo dissolved in 20 ounces of water; then wash well.

You will be surprised how many poor quality negatives can be improved with one or another of these solutions and you will find it is a good plan to make one or two experiments with negatives which you do not wish to retain. Take one of these and cut it into two pieces, intensify or reduce

one of the pieces and when it is dry compare it with the untouched portion. You will then be able to realise how the chemicals can react on the image.

In order to get regular action all negatives must be thoroughly soaked for several minutes in plain water beforehand. Endeavour also to keep the temperature of the solution at about 65° Fah.

# Patterns for Making a Model Pterodactyl

See page 81

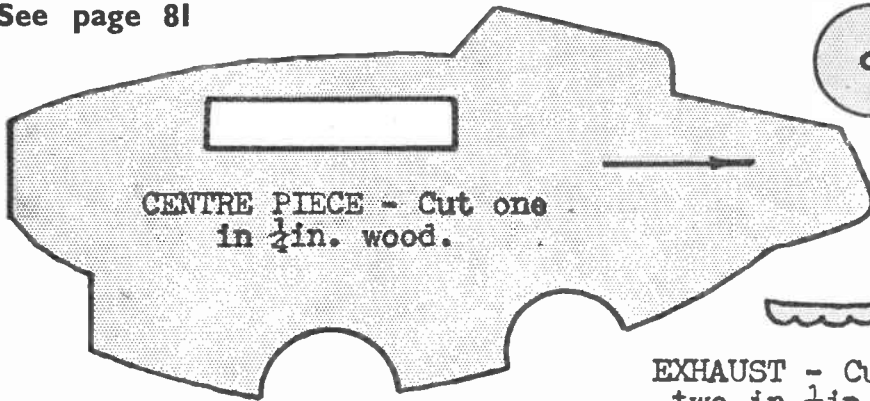

CENTRE PIECE - Cut one in  $\frac{1}{4}$  in. wood.

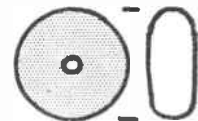

EXHAUST - Cut two in  $\frac{1}{8}$  in. wood.

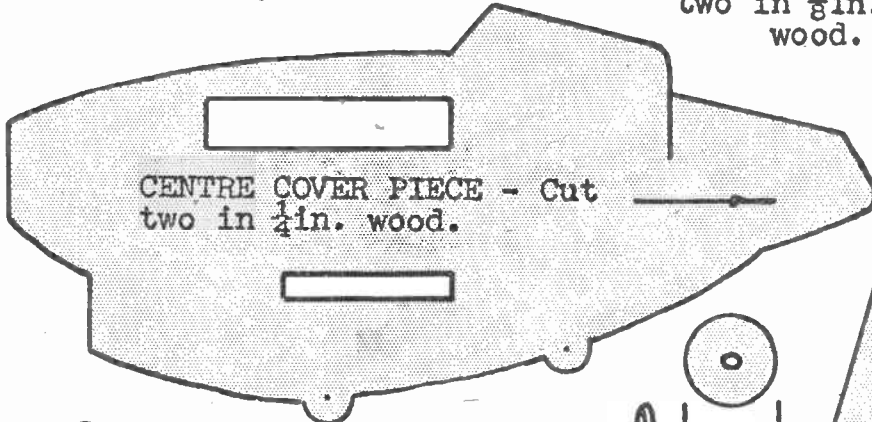

CENTRE COVER PIECE - Cut two in  $\frac{1}{4}$  in. wood.

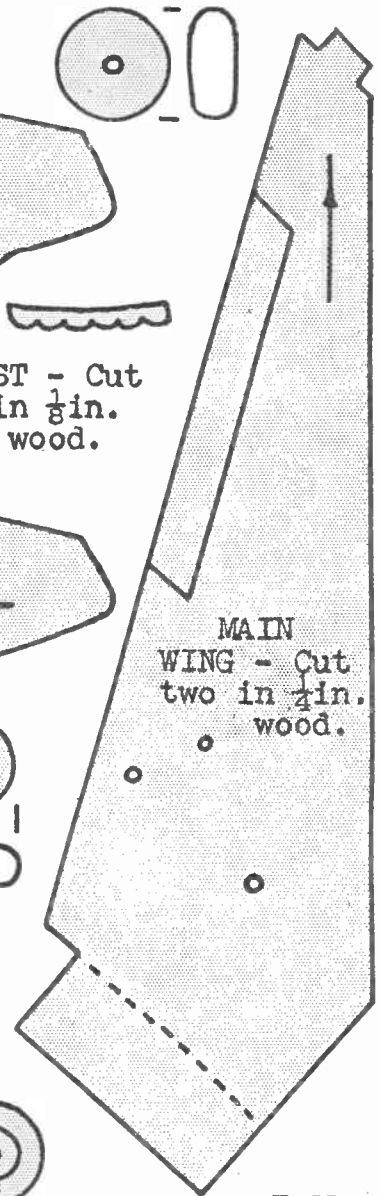

MAIN WING - Cut two in  $\frac{1}{4}$  in. wood.

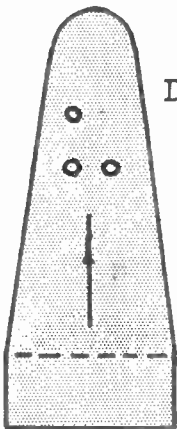

SKID DETAILS.

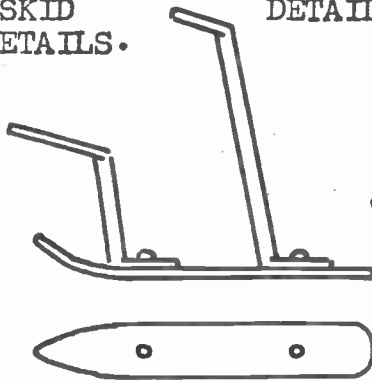

AIRSCREW DETAILS.



BI-PLANE Cut in  $\frac{1}{8}$  in. wood.

TAIL FIN - Cut two in  $\frac{1}{8}$  in.



BLADE

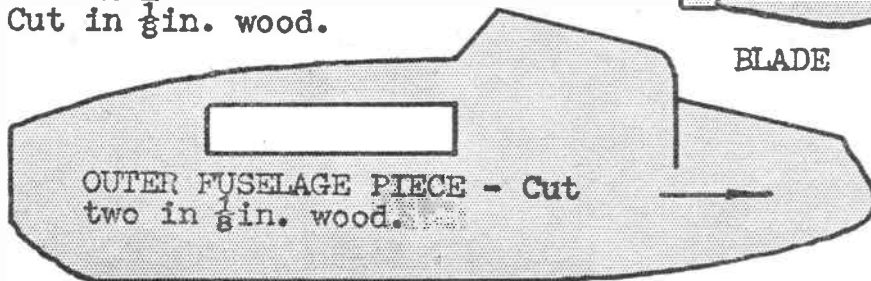

OUTER FUSELAGE PIECE - Cut two in  $\frac{1}{8}$  in. wood.

