

# Hobbies

## WEEKLY

October 13th. 1943

Price Twopence

Vol. 97 No. 2504

## Plug in and you get the answer from this ELECTRIC ENCYCLOPEDIA

**T**HIS novel article is just the thing to make for a youngster. It is interesting and instructive giving correct answers to a series of questions on the subject chosen. The idea is quite simple and intriguing. You put one plug in for the question and by trying the other plug in the various numbers you get the correct answer when the appropriate lamp lights up.

Animals is the subject selected for example here, and the model will show what country any particular animal comes from.

### For Plane Recognition

The interest in the model can be greatly extended by replacing animals by other subjects, natural products for example, and birds, insects, reptiles, and so forth. Or why not have a range of aeroplane names, with the answers showing whether bombers, fighters, etc., and their makers?

In use, the bottom plug is pushed into any hole 1 to 20, and kept there with a pressure of the finger. The centre plug is then tried in any of the holes 21 to 39 and when the lamp lights up the correct answer is shown.

On a sheet of white, good

quality paper, mark a rectangle to the dimensions given in Fig. 1. Run a line across the centre and in the middle of the line mark A. At the top draw the cut-out B, and below this mark point C. At A strike the 4in. dia. circle.

Divide this into 24 equal parts, and omitting the top 5, mark the remaining 19 points clearly on the circle. Draw the side lines across the paper and divide the spaces into divisions of  $\frac{1}{2}$ in. wide each. Cut out the paper pattern and paste to a panel of  $\frac{1}{8}$ in. fretwood.

The panel should be 7ins. by 14ins. Paste the paper to it with one side and end level with a side and end of the panel so that when cut out a strip 14ins. by 2ins. and 5ins. by 3ins., will be left over. These pieces will be wanted later on for rims so take care of them.

A second panel will be wanted.

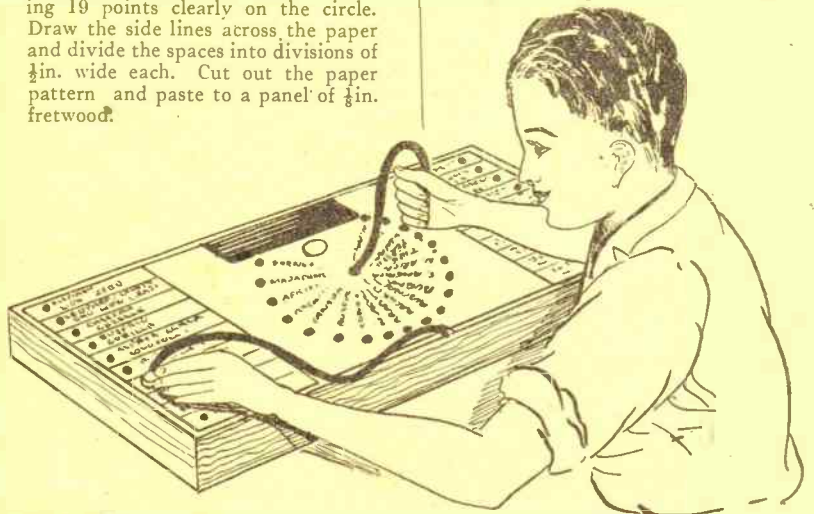

This is a soft wood one, 5ins. by 11ins. and  $\frac{1}{2}$ in. thick, the same size as the pattern so no waste will ensue. The  $\frac{1}{2}$ in. panel, which will be called the cover, is now temporarily nailed to this.

Get a  $\frac{1}{8}$ in. drill bit, and on a line drawn  $\frac{1}{2}$ in. from each end of the panel drill a hole in the centre of each division and also on the 19 points marked on the circle. These holes should penetrate the cover and enter the panel below about half way.

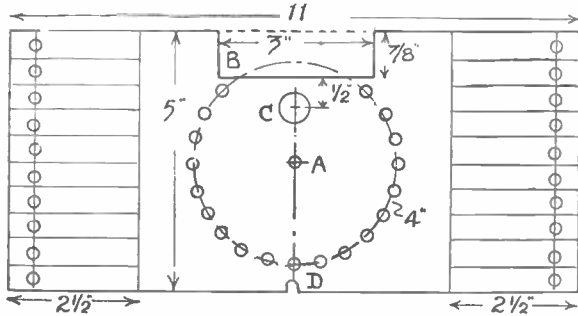

Fig. 1—How to mark out the top

Now saw out the cut-out B. At point C drill a very fine hole through both panels, they are then separated.

In the cover alone, drill a  $\frac{1}{8}$ in. hole through at A and a  $\frac{1}{2}$ in. hole through C, and at the bottom cut out the notch D,  $\frac{1}{2}$ in. square. The  $\frac{1}{2}$ in. thick panel which is the base, is shown at Fig. 2.

In each of the  $\frac{1}{8}$ in. holes drive a  $\frac{1}{8}$ in. No. 4 round-headed brass screw. These, for reference, are numbered 1 to 39, as shown. At point C, bore a  $\frac{1}{8}$ in. hole through for the lamp, a 2-5 volt one.

Electrical connections for this lamp are made as follows. Cut a right-angled notch in B to within  $\frac{1}{8}$ in. of the lamp hole, and in this drive a brass screw far enough to make contact with the lamp, when the latter is in. Fig. 4 shows this screw.

### Contacts

For the second contact, cut a strip of springy brass (terminal of a flash lamp battery). Turn the base over and chisel out a recess  $\frac{1}{8}$ in. deep, as in Fig. 3, in which the brass strip can lie and cover the lamp hole, as shown. Fix in position with a  $\frac{1}{8}$ in. long brass screw.

This screw will stick out above the base, of course, and should have its tip filed to a flat. To this top solder a length of single flex, marked on the diagram as flex 1.

The battery connections can now be made. These are two strips of springy brass again, about  $1\frac{1}{2}$ ins. long. They are bent as shown in Fig. 4, and fixed, one at each end of B with brass screws.

Connect the screw contacting the lamp with one of these, and to the other solder a second length of flex, marked flex, 2. Fix a lamp in the hole and a battery in B. Bring the ends of the flex leads together and the lamp should light up. Get this right by adjusting the contact screw of the lamp or the battery contacts if necessary.

From the pieces of wood laid aside for the rims cut two strips  $1\frac{1}{2}$ ins. long and two 5ins. long, and as near

screws 1 and 35 being connected together, press the bared ends of the flex leads to them, one to each, and the lamp should light up. Note that screws 1 and 19 are both connected to the same point.

Now cover the bottom of the base with a sheet of cardboard, glued over. Trim the edges of this to the base and fix the rim pieces round with glue and nails. These rims will stand up above the base from  $\frac{1}{2}$ in. to  $\frac{3}{4}$ in. Give the rim a coat of stain and varnish.

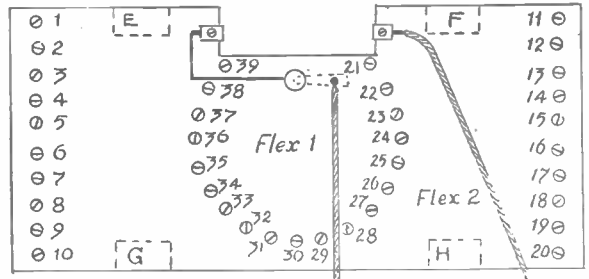

Fig. 2—The numbered contacts and flex leads

to  $\frac{1}{2}$ in. wide as the wood allows. The remaining bit left over is cut into 8 pieces, the pieces being glued together in pairs to form 4 spacing blocks.

These are glued to the base where shown in E, F, G and H. The screw heads should now be pencilled 1 to 39 to assist in connecting up correctly.

These connections are not shown in Fig. 2, they might prove rather con-

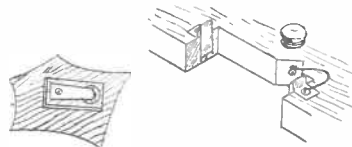

Fig. 3—The strip recess

Fig. 4—Contacts to the lamp

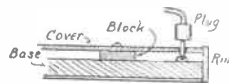

Fig. 5—Section showing plug

fusing, so are enumerated as follows. 1 to 35, 2 to 21, 3 to 33, 4 to 36, 5 to 30, 6 to 25, 7 to 37, 8 to 38, 9 to 22, 10 to 32, 11 to 39, 12 to 29, 13 to 26, 14 to 31, 15 to 28, 16 to 23, 17 to 34, 18 to 24, 19 to 35, and 20 to 27.

Connecting is easy enough. Get some thin D.C.C. or enamelled copper-wire, such as would be used to make electric bell coils, and cut into suitable lengths. Bore the ends of each and slip the bared ends under the correct screw heads, and tighten up.

It will be as well to test each connection as made. For example,

Now push flex 1 through the centre hole in cover and flex 2 in notch D. Press the cover down to the base and screw it to blocks E to H. Cut the flex to suitable lengths, flex 1 being long enough to contact any screw 21 to 39, and flex 2 screws 1 to 20.

Fit each flex with a wander plug, such as is used in wireless sets to connect to H.T. and grid bias batteries. The sectional view, Fig. 5, shows the toy and how the plugs, inserted in the holes in the cover, can contact with the screw heads below.

### Suggested Questionnaire

The following names, or group of names, should now be neatly printed against each hole in the cover:—

- 1—Elephant; 2—Lion, Zebu; 3—Leopard, Cheetah, Gnu, Lion, Giraffe, Hyena, Hartbeest; 4—Buffalo, Caribou, Marsh Deer, Moose; 5—Alpaca, Llama, Colocolo, Guanaco; 6—Chimpanzee, Gorilla; 7—Orang-outang, Banteng; 8—Lemur; 9—Coyote, Elk, Skunk, Caribou; 10—Tufted Deer, Yak; 11—Puma, Jaguar; 12—Banteng, Sambar; 13—Camel, Dromedary, Hartbeest; 14—Camel, 15—Kangaroo, Opossum, Koala, Wallaby, Platypus; 16—Reindeer, Saiga; 17—Eland; 18—Okapi; 19—Panther, Cheetah; 20—Viscacha; 21—Africa; 22—Canada; 23—Russia; 24—Congo; 25—W. Africa; 26—Arabia; 27—Argentina; 28—Australia; 29—Burma; 30—S. America; 31—N. Africa; 32—Tibet; 33—Persia; 34—S.W. Africa; 35—India; 36—N. America; 37—Borneo; 38—Madagascar; 39—America.

## OUR FREE DESIGN FOR A NON-FLYING MODEL LANCASTER

Our Pattern Sheet this week is for making in wood a simple model of the famous Lancaster Heavy Bomber. The work is easily undertaken from the full-size patterns and complete instructions as printed. A kit of planed boards for all parts is also supplied by Hobbies Ltd. It is obtainable (ask for No. 2504) at Branches for 3/2, or from Dereham, Norfolk for 3/9 post free.

# A number of practical hints contained in these FRETWORK NOTES

**T**HE cutting of thin fretwood is often a disastrous undertaking for the beginner, but if carried out properly there is no reason why it should be. Wood 1/16in. thick is usually put on as overlays or for bending to shape on models, but such thin material is naturally very fragile and needs handling with care.

One way out, of course, is to use the thin plywood, but a disadvantage as in the case of all plywood—is that the edges always show the grain of ply. Moreover, plywood cannot always now be obtained. So it is best to use the real wood whenever possible, even though it takes more care in using.

First and foremost, be sure to have a sharp blade for your handframe or

on the underside. Put the thin board on top with the pattern pasted on in the usual way. Drive the nails round outside the design of the part to be cut with a few more in the frets which are later to be cut out.

## Frame for Cleaning

In cutting the part leave these until the others have been taken out, and then go round the outer edge last of all. The outer part which is cut away should be kept as a whole piece if possible. Then, when the pattern is to be cleaned, it can be used as a framework to hold during glasspapering.

article where it has been cut through. A section is always cut through the centre so that in certain cases overlays or parts which are not in the middle of the article are not shown. A perspective drawing of the actual thing is shown at B which illustrates the principle quite clearly.

This sectional view is also often given in a drawing of a part to show its edge must be rounded, as illustrated at Fig. 3. Here you see the pattern as it is pasted on the wood, with the sectional drawing incorporated. In the same illustration is a picture of the part cut out

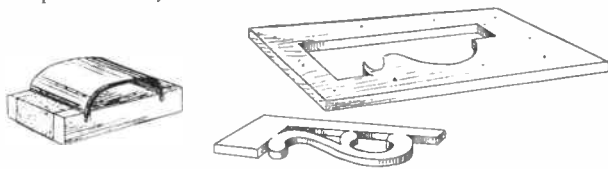

Fig. 1—The waste wood used as a frame for glasspapering

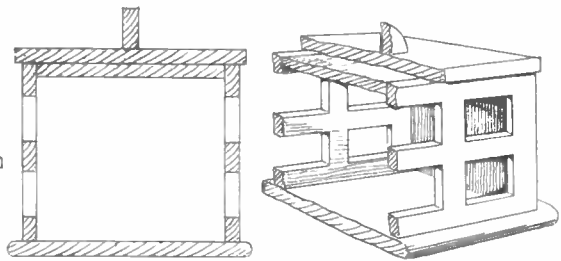

Fig. 2—An elevation drawing and the same article in perspective

machine and do not force the saw through wood too quickly. Naturally the blade cuts such thin material very easily, and is apt to run away with you. Have perfect control.

Take an even, steady stroke, working the saw quickly up and down without actually pressing forward too fast. Remember as you turn into the grain of the wood, the saw is apt to run forward quicker than it does across the grain, and keep a restraint on it accordingly.

## Stiffening Parts

It is a good plan, always to fasten another piece of wood to the thin piece. This makes the part stiffer, and so renders it less likely to break. A piece of 1/4in. wood is used, and it is nailed to the thin piece with some of those thin fretnails which are quite cheap.

Have the nail longer than the combined thickness of both pieces, in order that some of it can be bent over

Nail this frame to the bench, and lay the design in it. It will then be quite flat and easily cleaned with the glasspaper used on a block or the proper holder (see Fig. 1).

There are some readers apparently who cannot always understand the detail drawings on a design sheet, or know the meaning of technical terms in instruction articles. A few words of explanation will soon put them wise, and be helpful in making them understand construction more easily.

One of the most common drawings is a "section" and a typical example is shown at Fig. 2. Now this drawing is merely a side view of the article if it were cut in two through the middle. You will see certain parts in the section at A are shaded and others are not.

Those in outline are parts which help to form the whole piece, but have no actual portion in the centre of the

showing the edge properly rounded off to the shape provided by the section.

## To "Read" Drawings

A plan is a straightforward drawing looking down on the article and usually drawn to show positions of various parts. An excellent illustration is given at Fig. 4 which shows the plan of a base composed of four parts. In the second detail of the drawing these same parts are shown in perspective as they would appear when completed.

An elevation, on the other hand, is a flat front view of any piece of work, usually in plain outline. It is generally given to provide an illustration of where the various parts have to be put.

The detail at Fig. 5 is an elevation of a small hut. Such an elevation cannot, of course, show the thick-

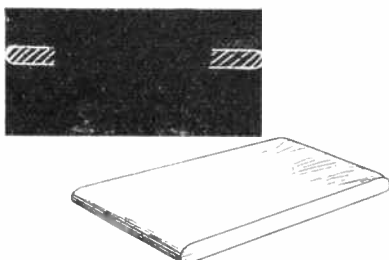

Fig. 3—Shaded section shows rounded portion as in lower drawing

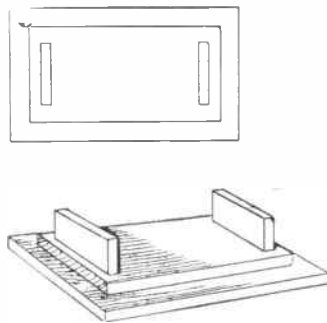

Fig. 4—Top detail is a plan of the article shown below

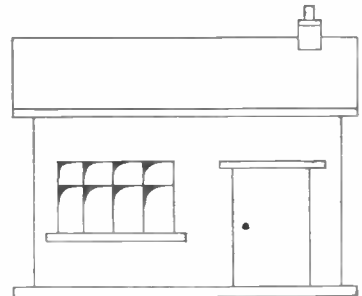

Fig. 5—Illustration to show an elevation drawing

nesses of the various parts, nor the shape of the protruding or recessed portions.

It is very often the case that a design sheet is not large enough to show a part full size. The parts, however, contain certain portions which are difficult to draw, but which in the main, are only the ends of an otherwise plain shape.

### Extended Parts

This is often the case in tenons on the ends of shelves, or shaped portions of the front of a base. The parts which are shaped are usually printed full size, but the complete length is not given.

The plain portion between is, therefore, broken in two—the break being indicated by a wavy or jagged edge. To show the complete length, however, a line is drawn from end to end, and the dimension given to which the actual part must be extended. The two parts of the pattern are thus cut as separate pieces, and one pasted down to the wood.

Rule pencil lines as a continuation of the sides as far as necessary to

complete the length. Then take the second part of the pattern and paste it at the other ends, taking care to measure up the required length when it is down.

Be careful to get the pencil lines

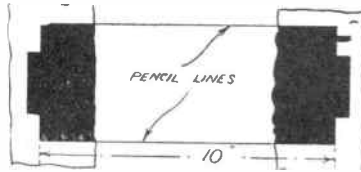

Fig. 6—How to draw parts extended

straight and the correct distance apart. Test them out before pasting the second portion of the design down, or the part, when cut, will not be accurate. An illustration of this method is given at Fig. 6.

### Squared Work

Another method of transferring work which cannot be printed full size is by means of squares. This is often given in the articles in these pages, and is quite simple to follow. The outline required is shown (as at

Fig. 7) drawn through a number of squares. These squares are always stated to be a certain size. To transfer them to the wood is thus a simple matter. Measure off marks on the material on two sides, the distance apart stipulated—usually  $\frac{1}{2}$  in. or 1 in. and with a square and rule draw pencil lines through to make a chequer-board effect of a number of squares.

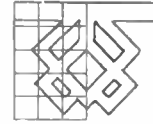

Fig. 7—How to enlarge

Then with the small drawings in front of you, sketch in the outline of the design, taking particular care that your pencil marks pass through the various lines of the squares at the same point as in the original drawing.

If, of course, a portion of the pattern is more intricate or elaborate, these inch squares can be sub-divide again into half or a third. This will make the drawing of the design much more easy and accurate.

The pencil lines should not be too thick, but the pattern itself should be quite distinct.

## Economical and straightforward way of making POULTRY SHELTERS

THE great difficulty in making up poultry houses or shelters is the limited supply of wood and for that reason the writer has had to adopt the idea shown. It will probably be equally acceptable to others in the same position.

The A shaped poultry shelter shown at Fig. 1 and Fig. 3 is simple in con-

struction and satisfactory in service. If straight poles are available they may be used for the framing and skids (Fig. 5).

Placing the joists 5 ins. above the skids keeps them clear of uneven ground (Fig. 2) when the shelter is dragged to new positions in the field. Anything equal to 3 ins. by 2 ins. is suggested for rafters and joists if the

shelter is built to the dimensions of the drawing. Allowing 6 ins. perch space per bird this size would shelter close on a 100 birds.

If it is made smaller, lighter poles or timber would do. The poultry netting is placed on the joists with a strip of wood at each side and the netting turned up to meet the roof covering.

The upright netting encloses the shelter at the sides. Then 2 in. by 2 in. poles are placed on the wire floor for roosting as shown at Fig. 2.

### Roof Covering

The rafters are covered with poultry netting and roll roofing. In addition to the door at the front a small door for the poultry to run out is built at the rear, as shown at Fig. 4.

The front and rear of the shelter is covered with poultry netting and roll roofing. Should poultry netting be limited, wooden strips may be used for the front and rear to form a support for the roll roofing. Wood strips may be used with satisfaction on the joists if wire is not to be had.

### Inexpensive Shelter

These poultry shelters can be built of old timber, too poor to use for other structures. Sizes called for in the plan may be changed to suit wood at hand. This construction is especially suitable for a small flock of birds. The shelter is light, inexpensive and easy to build.

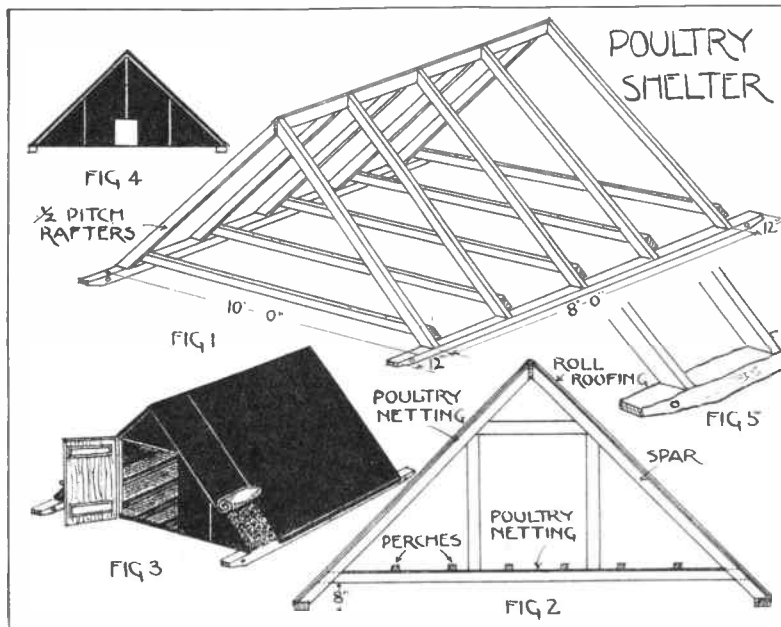

# Whatever your interests here are some everyday



## THINGS you SHOULD KNOW



**WHAT'S** in a gas-lighter flint ? For a change, that is what the writer would like to know ! You see, here's a very queer thing about flints. If you attach one to a piece of thin wire and hold it in a fire for a few minutes and then withdraw it and look at it, it will probably be a dull-reddish colour.

Keep looking at it and, strange to say, the flint starts to glow to a bright red and keeps glowing, mysteriously, for a long time.

It reminds one of an element charged with electricity. Suddenly, however, the bright glow dies away and all you have left on the wire is a few ashes ! Bit costly, this flint experiment, so you will have to take somebody's word for it ! Incidentally, the "ashes" will glow again for a short period if heated. The ashes are twice the size of the flint.

\* \* \*

**ONE** of the things you should not know is that old ruinous tip of sharpening scissors by trying to cut a sewing needle with the blades. The action does not sharpen the cutting edges—it merely *turns over* the edges, producing a "burr" on the flat sides of the blades. Consequently, as both blades rub against each other, they each cut away the burr, leaving the edges worse than ever.

Try it—and you will feel the burr being cut away. A much better plan is to file the edges or rub them on a small oilstone slip, or failing that, use a piece of roof slate, dipping it in water. Fine machine oil could be

used as a lubricant, but water does the trick just as well. The sharpening is of course, slow, so take your time.

An alternative idea, is to use a steel knitting needle. The blades are sharpened by drawing the needle down the cutting edges at the angle ground on them.

This tends to turn over the edges in the same way as the sewing needle tip, but rather than leave the burr projecting, this is straightened by rubbing the needle on the flat side of the blades.

Thus, the blades are sharpened much in the same way as a cabinet-maker's wood scraper is sharpened.

\* \* \*

**DICTIONARY** is a household book that is always used. When in a hurry to find a certain word, pages are flicked over recklessly, some becoming turned over and almost turn out. Why not be wise and "thumb-slot" the book ?

This is easy to do, using a  $\frac{1}{2}$  in. wide inside cutting wood gouge. To begin, get all the "A" pages together and put a piece of plywood beneath. Then, with the aid of the gouge, cut a thumb slot in all the pages, starting off near the top of the page, at the right-hand side.

Now get all the "B" pages together, put the wood underneath, make another thumb slot that will be directly below the first thumb slot. Do the same thing with all "C" pages, "D" pages, "E" pages and so on until you reach the "Z" pages. These pages, please note, do not require to be slotted.

**DO** you know, or rather, realize that ordinary hair-oil is ideal for oiling your fret-machine, including your oilstone ? It is just as cheap, too, and not quite so nifty as the usual fish oil most woodworkers use now when sharpening tools.

The hair-oil is almost as thin as knife oil. It is, of course, faintly perfumed. You will prefer that to the awful, sickening odour of the fish oil; the smell of this seems to cling lovingly to the hands, apron and woodwork implements for days on end. Sweet lavender or attar of roses is to be preferred by all, no doubt !

\* \* \*

**DO** you know, by the way, that you can find the weight of hay by measuring it ? Well, it can be done, and if ever you find yourself working on the land for some farmer, here is the way to go about things—

First of all, multiply the length by the breadth of the stack of hay in feet; then take the height to the eaves; and add to it half the height from the eaves to the top for the taper. Multiply the other product by this, and divide by 27, the number of cubic feet in a yard.

The number of stones supposed to be in every cubic yard of new hay is 6 stones of 22lbs. avoirdupois each; if the hay has stood for some time 8 stones, and if old hay, 9 stones to the cubic yard. So, now you know—*or do you ?*

\* \* \*

**NOW**, how would you like to be able to tell a farmer the weight of cattle, etc. using nothing more than a rule ? Wouldn't old Giles be surprised ! Right, then, take the measurement of the girth of the animal where smallest (around the body, close behind the shoulder); take the length from the front of the shoulder to the insertion of the tail. Multiply the square of the girth in feet and inches, with the length in feet and inches, and the product by .24, .26, .28 or .30, according to the fatness of the animal; the result will be the weight of the carcase in imperial stones. The weight of the carcase is to the live weight of an animal as 1 to 2, or a little more in cattle; as roughly 4 to 7 in fat sheep; as about 2 to 3 in fat pigs. These proportions will vary according to the condition and breed of the animal.

## A Simple Cross Word Puzzle

### CLUES ACROSS

- 1 Corrupt (6). 5 Smallest (5). 9 Describe clearly (3). 10 Dread (3). 13 Battlefield (5)  
15 Model (7). 17 Renominate (6). 19 Attack (4). 20 Match (5). 23 Artist's studio (7).  
26 Fruit (5). 29 Railway-wagon (5). 31 Cover (5). 34 Promiser (7). 37 Accompany (5).  
39 Verily (4). 41 Keeper (6). 45 Tone (7). 48 Convey over water (5). 49 Clothe (3)  
50 Request (3). 51 Period (3). 52 Foe (5). 53 Make angry (6).

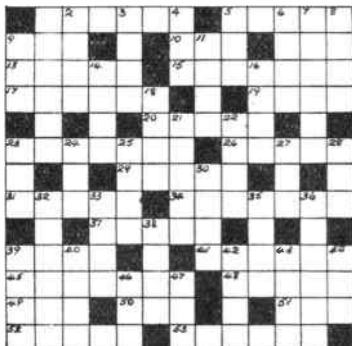

### CLUES DOWN

- 1 Father (6). 2 Frank (4). 3 Bang (4).  
4 Short sleep (3). 5 Permit (3). 6 Extent (4).  
7 Periodically (6). 8 Contribute (4).  
11 Wits (4). 14 Claw (4). 16 Ambush (4).  
18 Always (4). 21 Burst (5). 22 Capture (4).  
23 Help (3). 24 Memorable date (3).  
25 Detail (4). 27 Pin (3). 28 Sin (3).  
30 Indication (4). 32 Stay (6). 33 Plate of glass (4). 35 Venture (4). 36 Come forth (6).  
38 Curves (4). 39 Measure of land (4).  
40 Brink (4). 42 Far away (4). 43 Draw (4).  
44 Kind of grain (3). 46 No. (3). 47 Lengthen (3).

Solution Next Week





glued to the front as in the section Fig. 2.

To the front of K a shaped handle piece L is glued for pulling the drawer forward.

The completed drawer should slide smoothly into its place in the box, then, turning the whole thing upside-down a large diameter round-headed screw should be put through the slot in the floor of the drawer, quite near to the back edge as in the section Fig. 2. This prevents the drawer lifting and from pulling out altogether.

Two strips of wood glued underneath the floor, one at the rear and one at the front of the box form feet for the box, and make for clearance for the head of the screw in the slot of the floor.

Thirty or more cigarettes may be put into the box by first inserting it and removing the round-headed screw from the drawer. By removing or drawing out the latter it is a simple matter to drop the cigarettes through the front slot in the floor down into the box and past the inner partition

and the front triangular fillet. Finally reinsert the drawer and replace the screw.

The box, after a general clean up, should be stained and polished or varnished. The cross-sectional view, Fig. 5, shows all the parts in place and the slots in the floor.

Hobbies prepared standard panels of wood will be found economical for such articles as this, and all parts for this box can be got from two H3 panels.

The price of these panels is given in Hobbies Handbook or can be supplied.

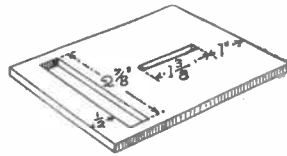

Fig. 4—The slotted floor

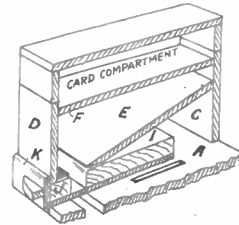

Fig. 6—Cut away view

## CYPRUS & MOROCCO FREE

One of the stamps that you can get from THE WINDSOR STAMP CO. ABSOLUTELY FREE, has been issued by the British Crown Colony of CYPRUS, the historic little island in the Mediterranean, and shows the ruins of the Theatre at Soli as well as small portrait of H.M. King George VI. The MOROCCO stamp is another interesting stamp to add to your collection and another which we also think that neither you nor your friends will already possess. It is overprinted and surcharged and has been issued by the British Post Office in North Africa for use in French Morocco.

We will give you these stamps ABSOLUTELY FREE. If you want them you should send immediately and comply with all the following simple conditions: (1) Write clearly your name and full address; (2) Ask for Cyprus & Morocco Free Packet; (3) Ask to see our Approval Selections and Price List; (4) Enclose 3d. in stamps, and (5) post your application to:

**WINDSOR STAMP CO. (Dept. 12), Uckfield, SUSSEX**

## HOBBIES HANDBOOK for 1944

The new edition is now on sale. Revised and brought up to date. 68 pages. Large free design for making model Liberator Bomber. Coloured sheet of Miniature Planes. Interesting articles and instructions. All for **6d.**



From Hobbies Branches, newsagents, bookstalls, etc., or sent post free for 8d. from Hobbies Ltd., Dereham, Norfolk.

## MISCELLANEOUS ADVERTISEMENTS, etc.

The advertisements are inserted at the rate of 3d. per word or group of letters prepaid. Postal Order and Stamps must accompany the order, and the advertisements will be inserted in the earliest issue. Fretwork goods or those shown in Hobbies Handbook not accepted. Orders can be sent to Hobbies Weekly, Advertisement Dept., as below.

**L**ONELY? Then write Secretary U.C.C., 5 B.B. Hay Street, Braughing, Herts. Genuine. Est. 1905.

**B**E TALLER. Quickly! Safely! Privately! No Appliances—No Tablets—No Dieting. Details, 6d. stamp.—Malcolm Ross, Height Specialist, BM/HYTE, London, W.C.1

**G**AS ENGINE. "Planbook" gives instructions and drawings for working model which runs on air. Made with simple tools and materials. New technique. **YACHT.** "Planbook" tells how to make and race Model. New simple timesaving method of construction. **GALLEONS.** All the secrets of making lovely models of these old-time ships are in this "Planbook" with working drawings. **AIRCRAFT and SHIPS.** Use "Scaleline" plans. SEND 2d. and addressed envelope for list of over 60 plans and details of above Modelcraft "Planbooks."—77(H) Grosvenor Rd., London, S.W.1.

**STAMPS FREE!!** Twenty Used (2½d.).—G. H. Barnett, Limington, Somerset.

**L**ONDON County Council—Wanted at the Council's Evening Institutes, instructors for simple handicraft work such as the making of plain handbags, gloves, slippers, toys and other useful articles from new or salvaged material; rate of pay 12s. 6d. for two hours' attendance and a war-time allowance of 2s. 6d. a day for not less than two hours' instruction; application forms from the Education Officer, T.7, The County Hall, S.E.1. (Enclose stamped addressed envelope). Canvassing disqualifies.

**M**ODEL MAKERS. Birch Veneer Offcuts. 1/40in. thick. Send stamped addressed envelope for List.—A. Stephenson, Villiers Street, West Hartlepool.

**L**ONELY? Then write Secretary, S.V.C.C., 34 Honeywell Rd., London, S.W.11. Genuine. Stamp.

**B**OYS' Books Wanted. Rovers, Wizards, etc. Dated before 1941. Excellent price given.—Box No. 456, Hobbies Weekly, Dereham, Norfolk.

**A**PPROVALS on Request. Postage Essential.—Warrington, Ictham, Bearsden, Glasgow.

**M**OULDs for Casting Concrete Garden Ornaments—Rabbit, Squirrel 10/-; Dwarf 15/- plus 1/6 post. Progress Sheets on Mould Making 3/-. Enquiries for List of Moulds. Stamped addressed envelope.—Windridge, Bell Lane, Bedmond, Watford, Herts.

**'MAKE** Your Own Torch Batteries." Send for this book now. Full Instructions. Easy, satisfactory. 1/9 post free.—Cross P.O. to W. H. Tucker, 84 Wiston Road, Brighton, 7, Sussex.

**A**NY Handyman can make a satisfactory Toy or Model Makers LATHÉ at a cost of 40/- to 50/- from my diagrams and clear instructions. Price 3/-. All materials easily obtainable. Parts stocked.—H. Barham, Hilltop, Bradmore Green, Coulsdon, Surrey.



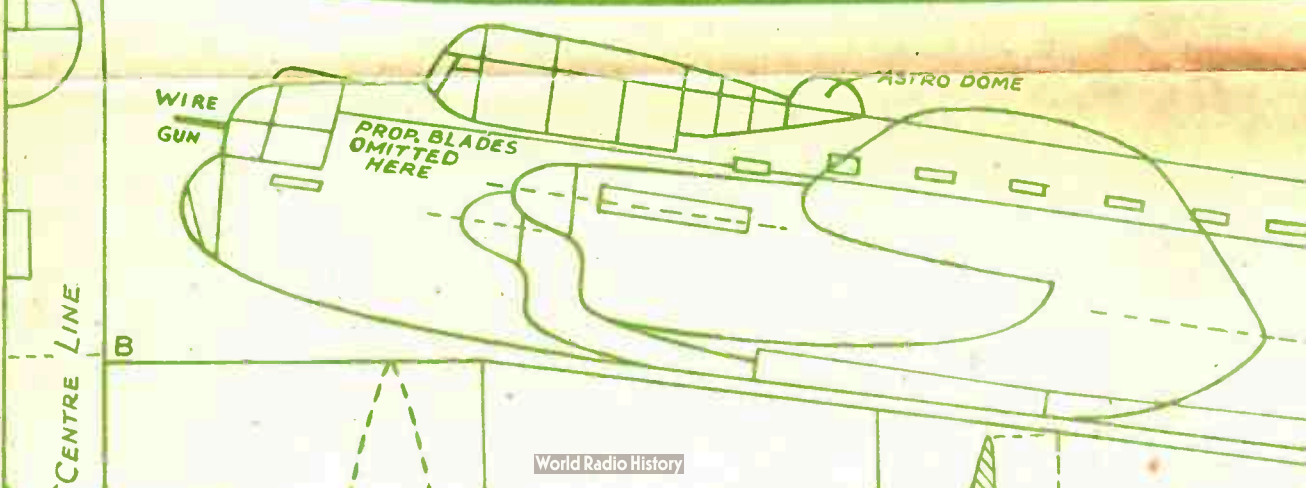
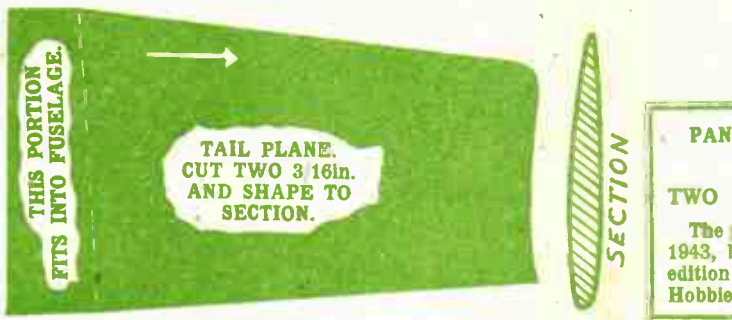
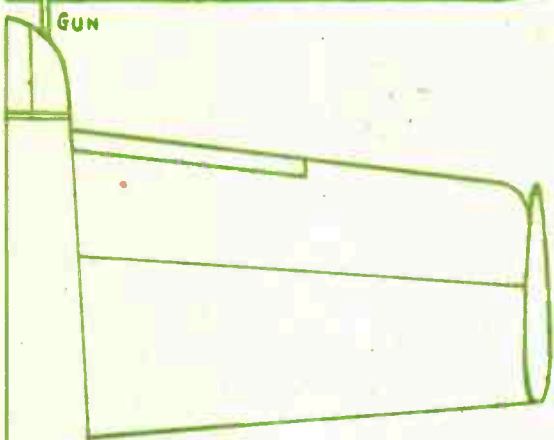
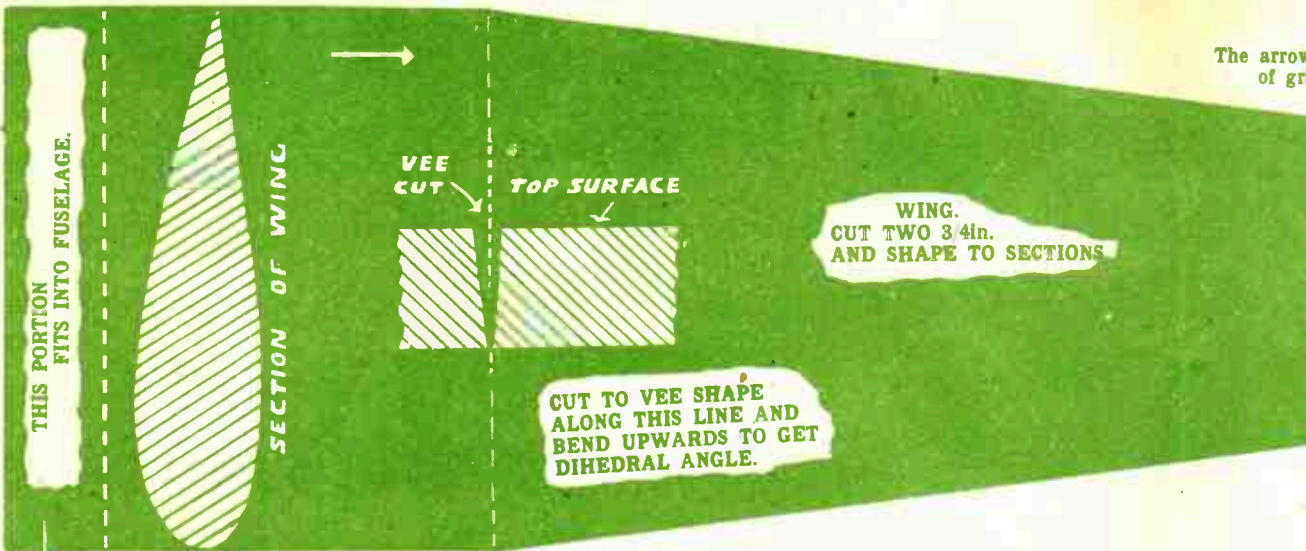

The arrows indicate direction of grain of wood.

**Hobbies** DESIGN

No. 2504  
13.10.43

SUPPLEMENT TO HOBBIES No. 2504.

**MODEL OF THE AVRO "LANCASTER" HEAVY BOMBER**  
SPAN 102 FT. LENGTH 69 FT. 6 INS.

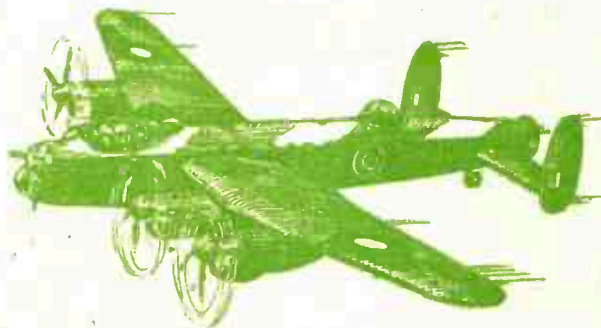

**PANELS OF WOOD REQUIRED FOR THIS DESIGN**  
TWO ND12 ONE MD8 ONE G3  
The price is shown in Hobbies Weekly, Oct. 13th, 1943, but is subject to revision. See the current edition of Hobbies Handbook, or write for price to Hobbies Limited, Dereham, Norfolk.

SIZE OF MODEL.  
SPAN 17ins.  
LENGTH 11½ins.



**FUSELAGE.**  
CUT TWO PIECES 1/2in. TO THE OUTLINE AND GLUE TOGETHER AND AFTERWARDS SHAPE TO SECTIONS A, B AND C.

INSERT TAIL PLANE HERE

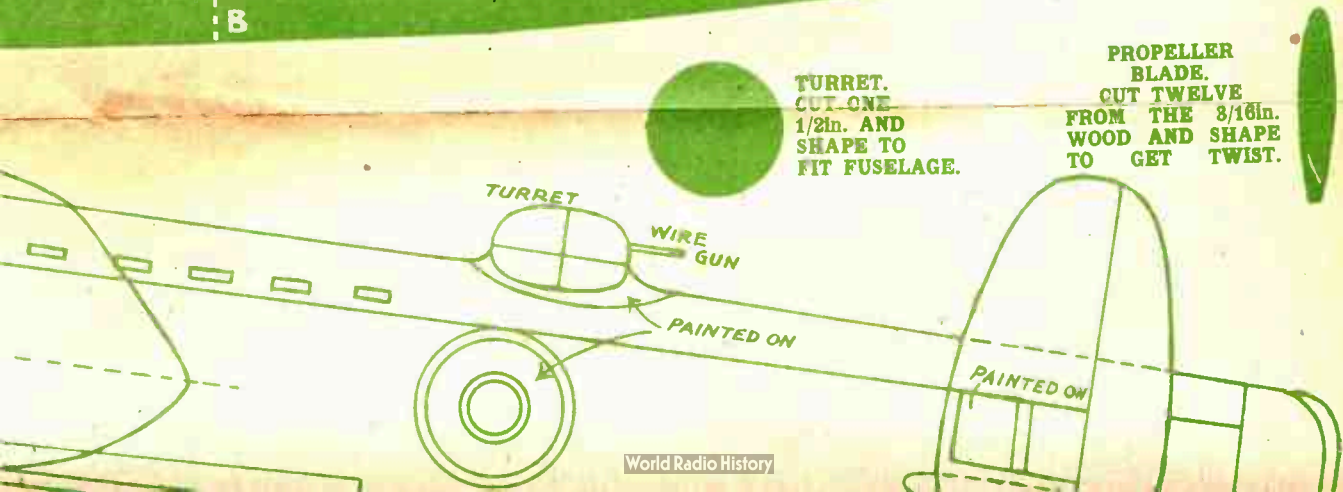

**TURRET.**  
CUT ONE 1/2in. AND SHAPE TO FIT FUSELAGE.

**PROPELLER BLADE.**  
CUT TWELVE FROM THE 3/16in. WOOD AND SHAPE TO GET TWIST.

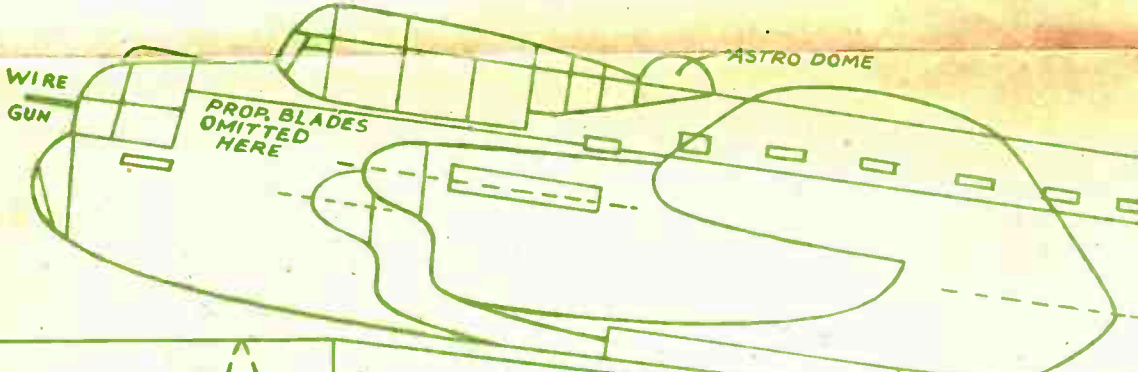

CENTRE LINE

B

ASTRO DOME

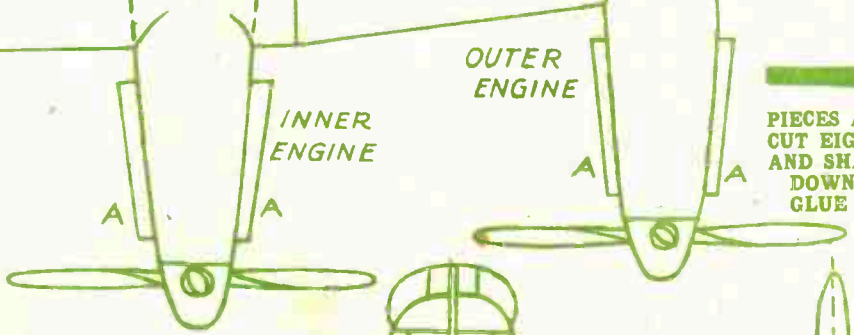
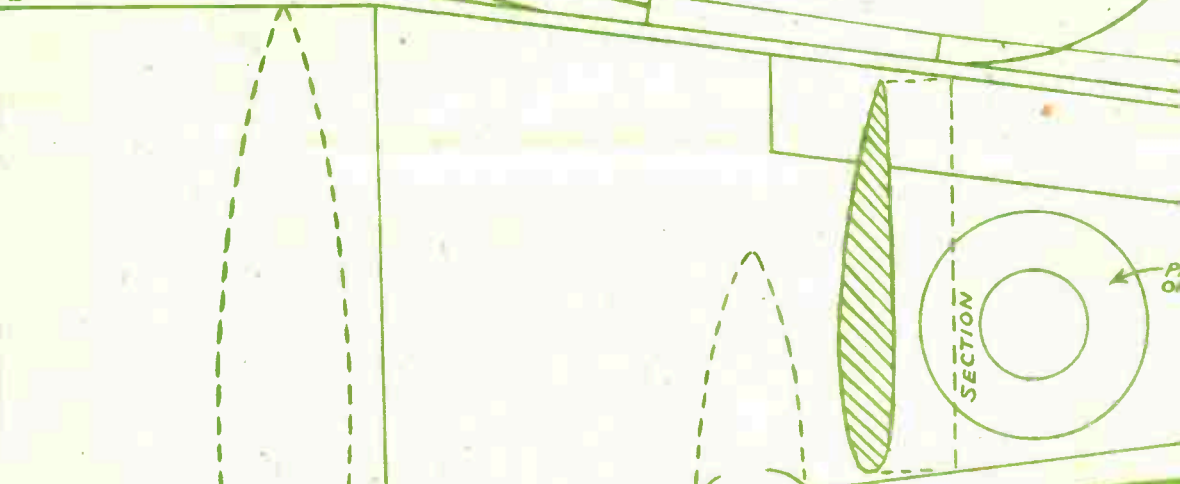

PIECES A.  
CUT EIGHT 3/16in.  
AND SHAPE  
DOWN AND  
GLUE ON.

:PLAN:  
HALF ONLY  
SHOWN

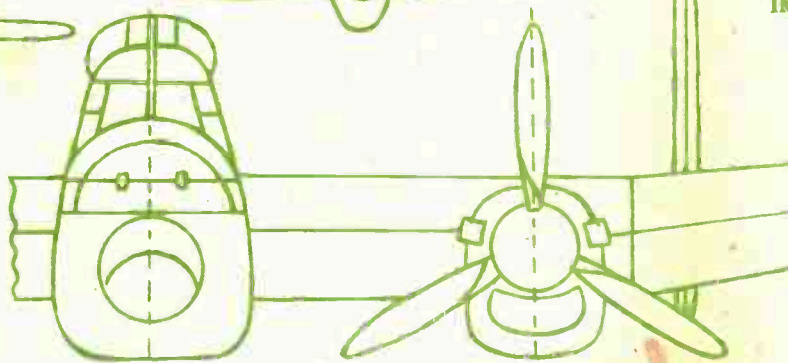

PRINTED IN ENGLAND.



**FUSELAGE.**  
 CUT TWO PIECES  
 1/2in. TO THE OUTLINE  
 AND GLUE TOGETHER  
 AND AFTERWARDS SHAPE  
 TO SECTIONS A, B AND C.

INSERT TAIL PLANE HERE

**TURRET.**  
 CUT ONE  
 1/2in. AND  
 SHAPE TO  
 FIT FUSELAGE.

**PROPELLER  
 BLADE.**  
 CUT TWELVE  
 FROM THE 3/16in.  
 WOOD AND SHAPE  
 TO GET TWIST.

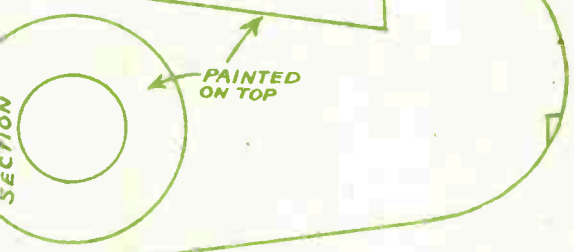
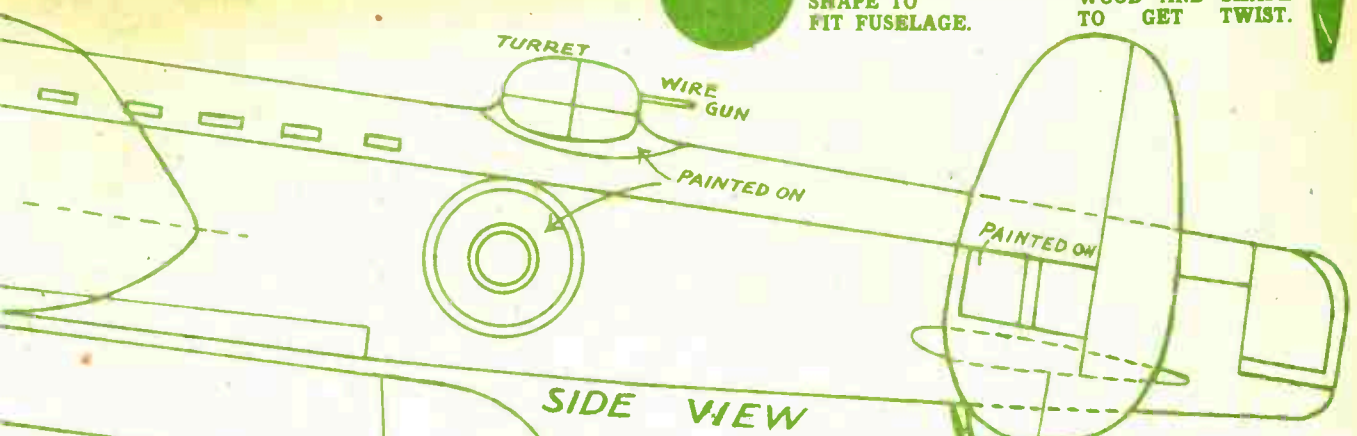

**FIN AND  
 RUDDER.**  
 CUT TWO  
 3/16in. AND  
 SHAPE TO  
 SECTION.

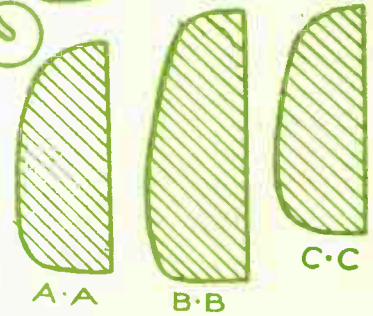

SHAPING TO FUSE-  
 LAGE CROSS SECTIONS  
 ON THE LINES SHOWN  
 ON PLAN, ETC.

T 3/16in.  
 PE  
 ND  
 N.

**OUTER ENGINE.**  
 CUT TWO 3/4in. AND  
 SHAPE TO THE  
 OUTLINE SHOWN  
 IN PLAN AND  
 SECTION.

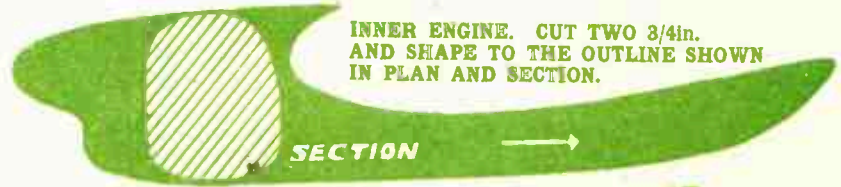

**INNER ENGINE.** CUT TWO 3/4in.  
 AND SHAPE TO THE OUTLINE SHOWN  
 IN PLAN AND SECTION.

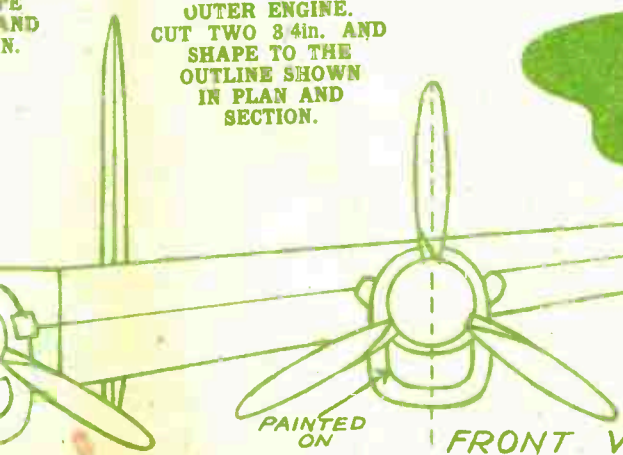

**WHEEL**  
 READY FOR  
 FIXING TO  
 FUSELAGE.

**STIRRUP**  
 FOR WHEEL  
 MADE FROM  
 WIRE.

**TAIL WHEEL.**  
 CUT ONE 3/16in.  
 AND SHAPE  
 TO SECTION.

ONLY SHOWN

# Details for construction of a model non-flying LANCASTER

**T**HE patterns on the other side of the sheet provide all the necessary details for building a non-flying model of the famous heavy bomber. The necessary wood is provided in the Hobbies standard panels, the price of which is given in Hobbies Weekly or obtainable on request.

The completed model has a 17in. span and an overall length of just 12ins. The patterns are shown full size, and there is a side, top and front view which can be studied during the operation of construction. Although half the plan only is shown, it can be easily traced to the opposite outline if needed.

The shape should be transferred to the wood in the thickness required, by means of tracing paper or carbon paper. It is not advisable to paste the patterns down, but to retain them for reference.

## The Fuselage

Cut the fuselage first in two pieces each  $\frac{1}{2}$ in. thick, and notice the apertures for the wing and the tail. Glue the two parts together, and then shape to a gradual taper towards the tail. Notice the dotted lines at AA., BB. and CC. The shape at these points is given at the cross shaded sections shown lower down on the sheet.

This shaping is done with a rasp, file, and finished off with glasspaper. The astro-dome will be made half round, and the pilot's cockpit and bomb-aimer's place at the front must be carefully rounded according to the shapes shown in the side view, front view, etc.

## Wings

The wings are cut from  $\frac{3}{4}$ in. wood shaped to the shaded section on the pattern, with the taper towards the trailing end. To get the dihedral or lifting angle towards the outer end a sawcut must be made almost through the wood at the line shown, then the part is carefully pressed upwards until you get the angle shown in the front view. Be sure to get both wings to the same angle.

When completed, the wings are glued in place to meet in the centre of

the fuselage. The tailplane consists of the cross plane and the two end rudder fins. All the parts are shaped carefully and then the tailplane inserted through the fuselage. The end upright fin is then glued on and should be strengthened with two or three fretnails or fine pins driven through the ends as shown on the pattern.

The gun turret on the top of the fuselage is a separate piece cut to a circle and shaped round at the top. The under edge, of course, will have to be shaped slightly concave, and this can be done by laying a piece of

propellers, although the actual holes for their insertion should be made first.

## Engine Details

The engine exhausts are shown as pieces A, and eight will be required. Their inner edge must be curved so they bed snugly to the engine nacelle, and they are later painted or just cut round to indicate the various pipes of which the whole thing is composed.

Notice that the outer engines are shorter than the inner engines, and mark off carefully their position along the length of the wing.

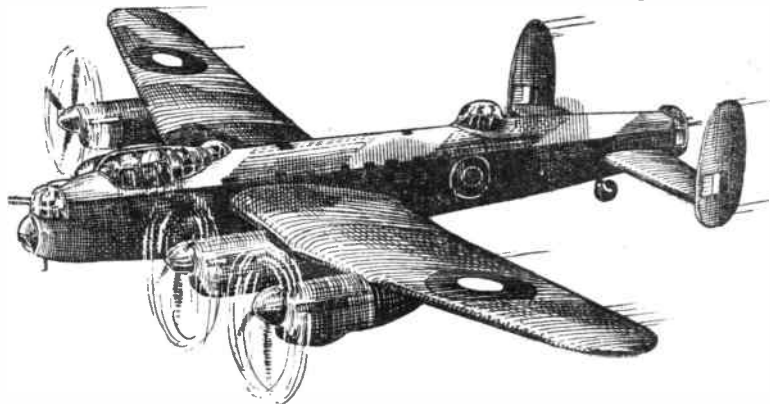

glasspaper on the fuselage itself and rubbing the turret part along it to get the correct curve.

The tailwheel is the only one shown in the model, and the construction of this is as given on the details at the bottom of the sheet. A little circular wooden wheel of  $\frac{3}{16}$ in. wood is put on a stirrup shaped piece of wire, and then a bracket soldered from it to lead upwards to the underside of the fuselage near the tail.

## Propellers

Twelve propeller blades will be required. They are cut from  $\frac{3}{16}$ in. wood shaped correctly, and then glued into the front of the engine at the points shown by the front view.

The engines themselves are made as four separate units shaped on the underside to fit the wing, and rounded according to the section. It is best to glue them in place before fitting on the

The completed model must be carefully cleaned up and painted. A first coat of dull paint is given, and allowed to harden, then the final coat added. These night bombers are usually black all over, with red and blue roundels above the wings, and red, white, blue and yellow on the underside as well as on the side of the fuselage. They do not have a large individual letter, but numerals in the usual positions.

The Perspex of the cabins can be painted on with light blue or grey, the framing of the metal work being brown or black. The flaps, windows, etc. can also be painted on, care being taken to get the lines even, steady and straight.

The excellence of the model is, indeed, made by the manner in which it is finished. In this respect the drawing of the finished model is helpful.