

# Hobbies

## WEEKLY

May 12th. 1943

Price Twopence

Vol. 96. No. 2482

### Waterline model in wood of an EARLY PADDLE STEAMSHIP

**T**HIS interesting ship model is of the steamship "Sirius," the first vessel relying entirely upon steam to cross the Atlantic in 1838.

We have included with the illustrations, a side view and plan with scale beneath. The model overall is 14ins. and 3½ins. across the paddle-boxes.

#### The Hull

The hull will be the first part of the model to make, and this consists of the solid part just above the waterline, the deck, which is glued in it, the bow and stern blocks and the sides which stand above the deck level. All these parts are shown in position ready for assembly in Fig. 1.

The lowermost piece consists of a solid layer of wood ½in. in thickness and measuring 11ins. by 1½ins. It is shaped hollow at the bow where it meets the deck, and at the stern it is undercut and shaped round to a wide chamfer as it were.

The deck is the next layer, and its true shape is in the plan Fig. 2. It is 11½ins. long, and its width takes in the two paddle wheel extensions one on each side. The deck overhangs the thick lower hull piece at bow and stern and is shaped to meet it at the

former place and chamfered to meet the stern block which will be glued upon it.

The bow and stern blocks (see Fig. 1) are each ¾in. thick and their widths can be scaled off on the plan. Paddle-box blocks are glued in place on the deck.

The raised sides are cut from thin 1m.m. wood or from cardboard. The paddle-box blocks are simply semi-

circular pieces cut to the measurements shown in Fig. 3 from ¾in. wood. Note from Fig. 1 that the raised sides are brought up to the paddle boxes where they are shaped to it and glued, little strips of the thin stuff being added to stiffen up the gluing at these points. The positions of the paddle boxes are shown by dotted lines on the plan Fig. 2.

The deck is painted and lined to represent planking and this work should be done now. Rub the deck smooth with fine glasspaper and give it a coat of buff-tinted matt paint. When this is quite dry add the planking by ruling lines not more than ¼in. apart the whole length of the deck.

A sharp-pointed hard lead pencil will be found to make quite suitable lines or of course a fine ink line would perhaps be better, put in with Indian ink.

The deck fittings, boats, masts, etc. can now be added. The first piece to make will be the block which fixes

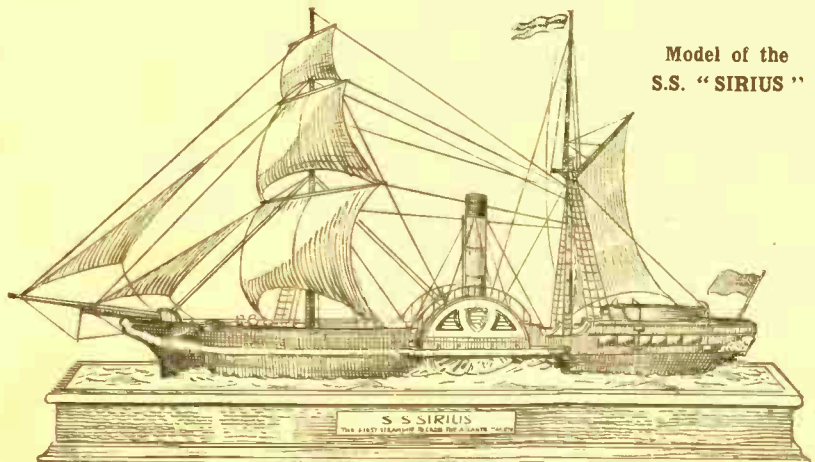

Model of the  
S.S. "SIRIUS"

between the two paddle boxes, see Fig. 4. It is cut the full width between the boxes and is  $1\frac{1}{2}$  ins. wide and  $\frac{1}{2}$  in. thick. On top of this piece is a square of wood measuring 1 in. by  $\frac{1}{2}$  in., and upon this stands the funnel. This last-named, however, should not be fixed until the masts are being added. It consists of  $\frac{3}{8}$  in. round rod  $2\frac{1}{2}$  ins. long.

Leading from the deck to the top of the engine-room casing are four sets of steps seen again in Fig. 4 and in the plan made from triangular blocks  $\frac{3}{8}$  in. sided and  $\frac{1}{2}$  in. wide. Other deck

Details for carving the boats are given in Fig. 5 together with the wire davits for supporting them. The little blocks marked "S" and "E" are glued to the sides of the ship, "S" being the socket for the lower end of the davit while "E" is the eyelet through which the davit passes.

Guard rails are put to the paddle boxes as shown in Fig. 6. These rails are to be made from brass wire of suitable gauge, the uprights being soldered to the curved rail at the top while the bottom can be let into the wood.

pieces of brass cut off for these and put in the holes and carried up to the underside of the curved rail. Here a touch of liquid glue was given to each junction, and this when almost hard, was formed into small round pin-head lumps which when painted gave a most realistic appearance of actual railings.

The bowsprit is shown in Fig. 7. piece A is let into the shaped block and glued there, and the top tapered piece B glued and bound to this.

The short length of wire is held in place with glue and the connecting

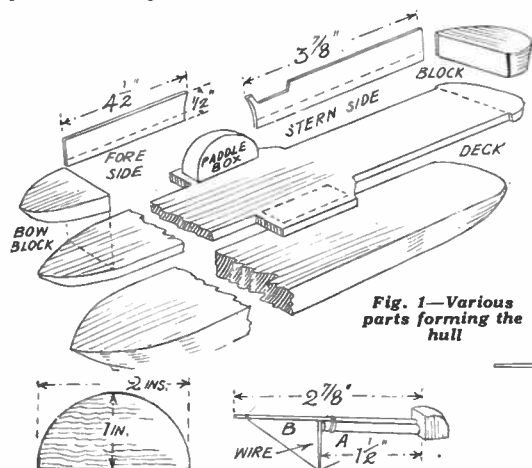

Fig. 1—Various parts forming the hull

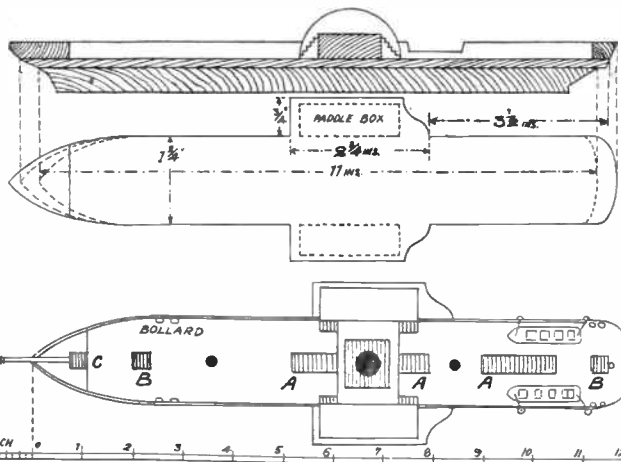

Fig. 2—Section of the boat and plan views of deck, with scale

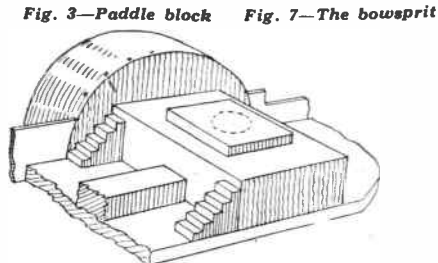

Fig. 3—Paddle block

Fig. 7—The bowsprit

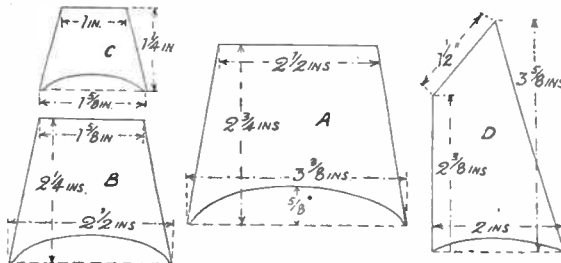

Fig. 8—Shape and sizes of the set of sails

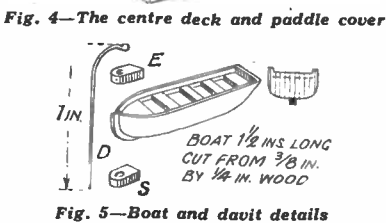

Fig. 4—The centre deck and paddle cover

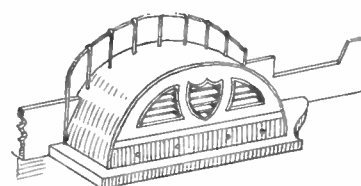
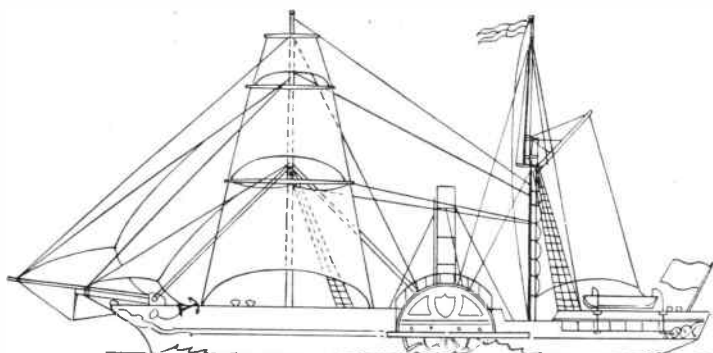

Fig. 5—Boat and davit details

Fig. 6—The finished paddle box fittings include the simple blocks A, seen on the plan and these can be of  $\frac{1}{4}$  in. wood. The two pieces B are plain squares of  $\frac{1}{4}$  in. wood, while the block C carries the inner end of the bowsprit. It is  $\frac{5}{16}$  in. square and cut from  $\frac{1}{2}$  in. stuff. It has a rounded top and a shallow hole made in its front into which fits the bowsprit.



A general side view showing rigging, sails, small boats, etc.

A good way of making this type of handrail was recently seen by the writer, where soldering was found to be difficult. The curved part of the rail was first set out, the two ends being bent down square and run into holes prepared for them below.

The holes were next made for the intermediate uprights, and short

cord will be formed to stiffen up the whole when, in addition, the remaining rigging cords are added.

The general arrangement of the masts and sails is shown in the side view of the ship just above the plan. The foremast is  $\frac{7}{16}$  ins. long of  $\frac{3}{16}$  in. drain dowelling tapered off slightly towards the top.

The rear mast is in two lengths. The lower one is  $\frac{3}{16}$ in. diameter, not tapered,  $4\frac{1}{2}$ ins. long. The top mast is a piece of  $\frac{1}{4}$ in. rod, 3ins. long, glued and bound with cord to the lower mast in the manner shown.

The four sails of the ship may consist of a stiffish white or cream paper cut to the shape and measurements given in Fig. 8. Now in the three sails of the foremast (A, B and C) sufficient depth has been allowed for them to bellow with the wind. Each of the three sails is glued to a spar of  $\frac{1}{4}$ in. wood tapered slightly from the centre to the ends.

Each spar should be a little longer than the top measurement of their respective sails, and in fastening them to the mast be sure to get their correct position by measurement say, from the top of the mast downwards.

#### Spar Details

Thus, spar A is  $3\frac{1}{2}$ ins. down spar B,  $1\frac{1}{2}$ ins. down and spar C,  $\frac{1}{2}$ in. down. A very shallow groove is filed in the mast where the spars are to come.

Measurements for the rear sail D are given in Fig. 8, and the spar to support

this at the top should be  $1\frac{1}{2}$ ins. long. The two fore-sails are quite simple in outline and their measurements may be scaled off direct from the side view of the ship. They are creased along their long edges to take the rigging rope to which they are glued.

The position of the top ropes supporting the spar of this sail are seen in the side view of the ship, as also are the rigging ropes to both masts. Use, again the fine thread for all the ropes, and fasten them on the decks to tiny staples made from pins driven in as necessary.

The four sets of shrouds—that is, the ladders reaching from the sides of the ship to half-way up the masts, are again made from thread. They can be fastened to the outer sides of the ship and carried up and fixed with glue to the masts.

Paint the hull of the ship, before the masts are erected and the sails and rigging added. Coat the whole with flat black paint except the bow and stern of the ship which should be touched up with white and gold as suggested in the sketch.

A banding of white and gold runs

almost the length of the ship, and the stern is treated in more or less a decorative manner and a figurehead formed in the scheme with white and gold paint.

The painting of the paddle-boxes is seen in Fig. 6 and they may be panelled in light blue with gold edging, louvre boards being represented by the addition of black as shown.

#### A Base

A box-base would set the model off nicely and we think would be better than an ordinary flat base. Cut a simple hollow frame  $\frac{1}{2}$ in. deep by  $\frac{1}{2}$ in. thick stuff if a solid piece of  $\frac{1}{2}$ in. wood is difficult to get. A simple name plate might be added to the front of the base giving the name of the ship and her performance.

Glue the model to the base, and then mould some modelling wax round it to represent waves, the wash at the bow and the stern of the ship and around the paddle-wheel box. At the back of the paddle boxes carry up the wax well to the underside of them to represent the high wash of the waves just at those points.

## A penknife and patience can help to make some COTTON REEL CHESSMEN

**C**HESSEMEN are very difficult and expensive to obtain these days but quite a serviceable set can be made with little trouble by any handyman from a number of old cotton-reels. Even if you are not a chess fan yourself, they are well worth making, for men in the Services are crying out for sets with which to play and everywhere the game is on the increase.

queen, knight, etc. on the lines of the drawings herewith where the dotted lines indicate the shape of the original reel. Slight variations of shape may, of course, be made, but the simpler your designs are the more effective will be the result.

Straight-forward patterns are also much easier to carve out. This is done with several tools, but the writer finds the pen-knife the best for the more intricate work.

As for the other pieces, the castles require the notches cut only; the sides may be left as they are. The kings and queens should be made from the larger reels, the king being the largest. The cross surmounting this piece is made out of an odd bit of wood with a short peg to fit into the hole at the top. Similar pieces may be shaped for the knobs on top of the queens and bishops, but old cribbage pegs make excellent ones if they are of the right colour.

The holes in the remaining pieces can easily be filled in with neatly-made pegs or stops of plastic wood. The pawns should not be made too large.

In all the pieces the base of the reel should form the base of your piece. It should not require reducing in size and then all the men will stand upright without toppling over in the course of play. If you are lucky enough to possess a small lathe then they can all be turned up on it with ease, with the exception of the knights.

When the shaping is all done give your men a good smoothing with a not too coarse glasspaper. Keep the dust out of the notch cut into the side of the bishops. Then paint the pieces red or black. A dark reddish stain looks very effective.

Alternatively the men may be enamelled according to your choice. To complete the job give each piece two coats of thin varnish, and you will then have a set of chessmen that will last for years.

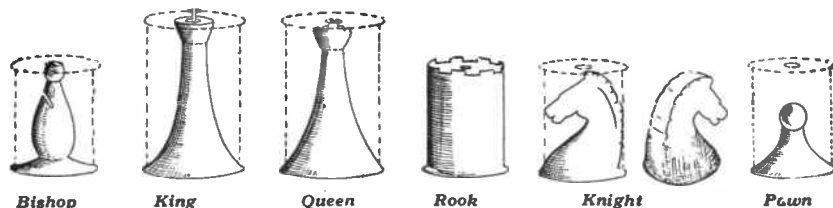

First 32 old cotton-reels are required. These can usually be obtained from the female members of your family, or friends or on request to a tailor or dressmaker. If you can get hold of some reels that are larger than the rest, so much the better.

A full set consists of 16 carved pieces and 16 small pawns, 8 of each white, and 8 black or red. The carved pieces need most attention as they are the distinctive chessmen, but simplicity of design should be aimed at throughout.

Having removed the paper labels which adorn the reels when in use, the next thing to do is to mark out the shapes of the various men, bishop,

As for the individual pieces the knight is the most difficult to carve. You can either cut away the waste wood on both sides of the horse's head (which should be about  $\frac{1}{2}$ in. thick or less), or you can make a wooden silhouette with a fretsaw and glue it to the base of the reel. The former method looks better although it requires more care.

Two knights of each colour are needed, as are two each of castles (or rooks), bishops and knights. One king and one queen together with eight pawns of a colour make up the set. The bishops are quite easy to shape, care being taken not to make them too portly.

# The home craftsman should try his hand at a SIMPLE BREAD BASKET

**R**EADERS who desire a change of hobby might try their hand at the simple basket illustrated. No knowledge of basket work is required, and the materials, cane or osiers, can usually be got without difficulty, the latter especially in country districts.

Though the article is described as a bread basket, it can be used, of course, for many other purposes besides, and of course, need not be confined to the dimensions given.

The base is a circle of deal or common box wood. Cut it to the size given in Fig. 1 and give it a thorough rubbing all over with glasspaper. The thickness, within limits, is immaterial, about  $\frac{1}{2}$  in. is enough.

## Marking the Base

Draw a line across the centre, and with the aid of a protractor divide the circle into 30 equal parts of 12 degrees, as shown. Square these marks over the edge. Hold the base in a vice, and with a saw and chisel, at each mark cut out a slot wide and deep enough to just admit two pieces of the cane side by side.

These slots should slope inwards a little so that the cane loops splay outwards slightly instead of standing.

The thickness of the cane or osier is not important, but it should not be too thick or the basket may appear rather clumsy. At the ends of the centre line, each side, the handle will come.

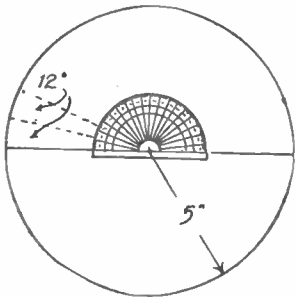

Fig. 1—Marking the base circle

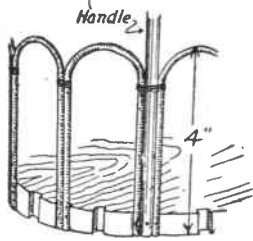

Fig. 2—Fixing the ends and handle

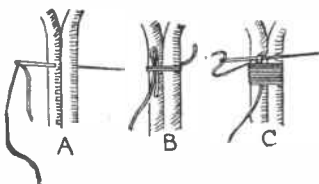

Fig. 3—The process of binding



Fig. 4—The handle

Here the slot must be a little larger to admit not only the cane loops but also the handle, which comes between. As this handle cane is thicker, it should be shaved off a little at the bottom, back and front, so as not to stick out beyond the edge of the base.

The loops are in two rows, 15 in. each row. The long ones stand 4 in. high. The cane for these should be cut into equal lengths to ensure a level result.

Bend a piece double and fix in

place, cut off any surplus and use this piece as a gauge for cutting the remainder to regular length. Fix the loops, side by side, in alternate slots, as in Fig. 2. A thin nail, or panel pin to each will fix them. The handle cane, which should be of stout stuff, is fixed between the loops at each centre, as already mentioned.

## Coloured Thread

When the long loops are fixed they should be bound together at the points shown with thin twine or strong thread. Coloured thread would look nice if available.

To do a neat job of binding, use this method. Thread a good length of the twine or whatever is used in a darning needle. Push the needle through the cane as at A, Fig. 3, leaving about 2 in. of the thread sticking out.

This piece is doubled to form a loop and is laid along the cane and kept there by pressure of the thumb.

Now wrap the thread round the canes over the loop as at B. When, say, a  $\frac{1}{2}$  in. of binding is done, pass the needle through the loop as at C, draw tight, and taking hold of the beginning of the thread (that which forms the loop), draw it down until the loop disappears beneath the binding.

## Finishing Binding

Now cut off the thread against the binding. No ends will be visible and a neat finish results. It will be noticed that where the handle comes between the loops the binding here embraces all three.

The short loops, which can stand about 2  $\frac{1}{2}$  in. high can now be cut and



meet together and show no bulge. Fix with a few fine nails.

## The Handle

The handle is thickened with two lengths of thin cane twisted round. This makes for a more secure grip. Cut the lengths of cane, allowing for the extra amount needed for twisting. Fix to one side of the handle near the loops with a strong binding as shown in Fig. 4.

There may be a tendency here for the cane to slip round, instead of lying on opposite sides, and this can be prevented by adopting the following precaution.

Fix the canes temporarily in position with two pins, driven sideways through all three, then bind as usual very strongly and remove the pins.

The canes can now be twisted round the handle and bound together at the opposite side. Some of the

thin cane should now be taken and split down to make half-round section.

This is woven in and out between the loops at the bottom as seen in the view of the finished basket. About two layers of such weaving may be enough, though more can be added if liked. The ends should be bound together with thread to fix securely.

The basket can be stained and varnished, or, if for bread, just varnished. For other purposes it can be painted or enamelled in pleasing colours.

Those who are desirous of taking up the hobby will find many things can be made for home use. There are several books for amateurs which we can recommend. Send a stamped addressed envelope to the Editor.

# Everything to hand for emergencies by making this UTILITY MEDICINE CABINET

THE advantage of this cabinet is in the top compartment which is hinged and opens upwards just as seen in the smaller sketch of Fig. 1. This saves a good amount of wood over the usual method of having a drawer inside the cabinet.

The size of the cabinet allows it to contain all the materials required for the usual household. The length overall is 13ins., its height 11ins. and the depth 5ins. Hobbies standard panels of wood are adapted throughout and here the wood is all nicely planed and prepared ready for cutting.

The two sides A should first be marked out, and the dimensions for these are shown in Fig. 2. Note that the front edges measure 10ins. whereas the back edges are 11ins. This allows for sufficient slope of the hinged top.

The two housings in each side can be cut down to a depth of 3/16ins. with a fine-tooth tenon saw, the waste-wood being afterwards cleaned away with a 1/4in. chisel. The lower-most housing is 3/4in. up from the bottom edge of the board, and then there is a clear distance of 7ins. in between that and the top housing.

## Simple Construction

Note that for simplicity in cutting, the housings may run right across the width of the boards, and this entails no extra work in forming stopped-ends to the housings. The two shelves B are next prepared. The housings in the sides are coated with glue and the shelves then knocked home. See all angles are square and correct before leaving the parts to dry.

A space of 3/16in. is left at the back of the two sides to allow the backing-board C to lie flush with the edges of them.

The back of the cabinet is a plain square piece of 3/16in. stuff carefully cut to fit neatly between the sides. It should rise 2 3/4ins. above the top surface of the upper shelf as seen in Fig. 2. Countersunk screws or fret-pins fix the backing board to the back edges of the shelves (see Fig. 3).

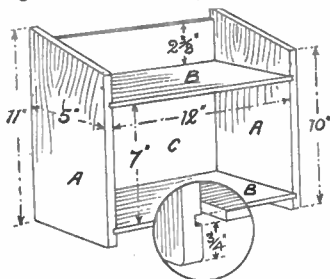

Fig. 2—The cabinet framework

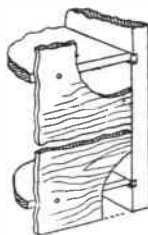
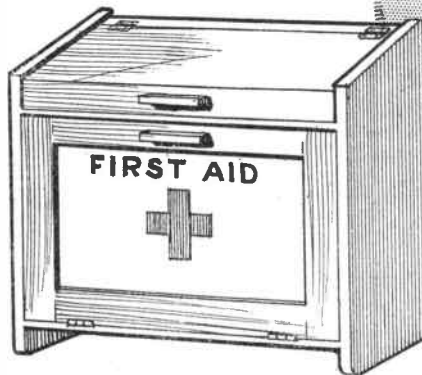

Fig. 3—Cut-away detail of back

The construction of the lifting top can be seen in Fig. 4. Cut the pieces to the sizes given in the cutting list and chamfer with the plane the top edge of piece E and the back edge of piece D where the latter fits against the backing board C.

A fixed back hinge-rail is formed



on piece D by cutting through a strip 3/4in. wide. This is fixed ultimately to the main flap by two strong hinges as in Fig. 4. This diagram also shows how the parts may be strengthened by the addition of angle fillets planed up and glued in.

When the lid has been made up it should be put in position on the shelf and made to fit accurately by marking in pencil and filing away the wood until a satisfactory job has been made.

A plain strip of wood forms a good handle for lifting the lid. It could be about 3ins. long and rounded off smoothly on three edges and glued centrally to rail E.

The door is made up of four rails glued and screwed to a main panel. The panel measures 12ins. by 7ins. and is 3/16in. thick, trimmed to fit the opening of the cabinet.

All four rails are 1 1/4ins. wide and 3/16in. thick and are glued up in the manner shown in Fig. 5. The two

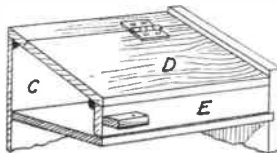

Fig. 4—Top lid, shelf, handle

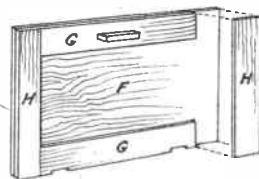
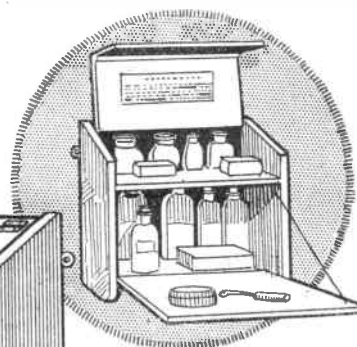

Fig. 5—Detail of the drop front



upright rails H should be put on first and then the horizontal ones cut and fitted between them. After applying the glue and putting the rails in place the whole should be weighted down for a time and then a few screws run through from the back of the door into the rails.

The door is hinged along its bottom edge, with the hinges recessed into it so a close fit is made when it is closed. The recesses for the hinges are seen in the detail Fig. 5. The hinges are first screwed with these recesses and then the door held in place between the cabinet sides and the remaining hinge-flaps screwed to the lower shelf.

## Cleaning and Painting

In conclusion all the woodwork should receive a good glasspapering before the undercoat of paint is applied. The final coating may consist of paint or enamel either white or a pale shade of blue being appropriate.

The wording and the cross should be in bright vermilion. A handle similar in pattern to that above the door should be finally screwed on.

A length of link brass chain must be secured to the inside of one of the sides of the cabinet and carried down to be fixed to the back of the door.

## Hanging Plates

Two brass hanging plates are to be screwed to the back edges of the sides and in fixing the cabinet to the wall it will be found the ideal height if the top shelf comes just below the level of the eyes.

## CUTTING LIST

- A—2—11 by 5ins. by 1/4in.—two ND8 panels.
- B—2—12 1/2 by 4 1/2ins. by 1/4in.—one J4 panel.
- C—1—12 by 10ins. by 3/16in.—one J3 panel.
- D—1—12 by 5 1/2ins. by 1/4in. } one H4
- E—1—12 by 1 1/2ins. by 1/4in. } panel.
- F—1—12 by 7ins. by 3/16in. } one J3
- G—2—9 1/2 by 1 1/2ins. by 3/16in. } panel.
- H—2—7 by 1 1/2ins. by 3/16in. }



## A Review of some of the War Issues

**R**EADERS will no doubt welcome, some notes on the most interesting stamps which have been issued, shall we say, during the period in which it has been almost impossible to get them. Obviously we cannot illustrate specimens of these for you, but we can describe them so you will know what to look out for when stamps are available once more.

We did illustrate some time ago stamps from the Cameroons, the Free French Issue. But do not forget the set of two issued in 1941 from the same place. These had the overprint "Spitfire General de Gaulle" and were surcharged ten francs. The postal value of these two were 1fr. 25c. and 2frs. 25c.

### A High Premium

The same year the same types of stamps were overprinted "Ambulance Laquintinie" and surcharged the same amounts in each case. Of charity premiums, the War Charity of the Belgian Congo is a high one. The postal value of the stamp is ten francs and the charity premium it bears is forty francs. The same remark applying to the stamps from Ruanda Urundi.

The difficulty about having such a high premium with a stamp is that so few people can afford to buy. A smaller premium would very probably bring in just as much money.

If, however, they intend to have a considerable number of charity stamps then one such high value is rather a distinguishing feature and is sought after by the more wealthy.

### Chinese Issues

China has had a number of issues in the past year or so, Martyr's issues, Air Mail stamps and a Thrift issue. These last bear designs depicting Chinese Industries and are rather an attractive set of stamps to possess. Particularly when one considers the various industries of China, which are quite a change from the normal Western types of industry.

You all probably heard of the Dutch Indies Bomber Fund stamps. There were only three of them, and the values were quite low, being 5c., 10c., and 1g. The premium was the same amount for each stamp, making the price just double face value. Well, these three stamps today would cost you as much as 25/- unused or about half that used. Now you see how prices do jump in a short while.

The picture of Marshal Petain appears on a set of 16 French stamps, which also have a Seamen's charity. Postal value is 1fr., the premium being 9frs., and the design a French Fisherman.

### German Occupation Stamps

Holland and Poland both have stamps issued for the German Occupation. The first Dutch set is similar to the portrait designs of 1939, and the second Dutch set is like the 1924 set with numerals in the circle.

The Polish stamps—two in number—show views of buildings with the inscription "General Gouvernement" at the bottom. Then, of course, there is the Free Polish Issue, mainly for use on Polish ships working with the Allies. This set was described in these columns at the time of issue.

Hungary commemorated the return of Yugoslavian territory to Hungary by overprinting two stamps "Del Uisszater." The design of these two is the familiar "Crown of St. Stephen" type.

### Führer and Duce

Hitler and Mussolini appear on stamps from Libya. One, an Air Mail, is inscribed "Due popoli una Guerra" The other set of seven has the same design as the air mail except that the aeroplane and the words "Posta aerea" are omitted.

Norway had a single charity stamp bearing a portrait of Quisling, and later the same stamp was overprinted 1-2-1942. Those stamps will be much sought after when they are available.

We illustrate the Switzerland stamp for salvage! There are three of these, all of the same value, the only difference being the wording. Each is printed in a different language, one in French, one in German, and one in Italian. The stamp shown is, of course, the German wording.

### Mixed Languages

The stamps are so printed that you might buy three stamps, and have one of each language; not as one would imagine, one sheet being all French, one all German and one all Italian. The reason why there are three language stamps is that all three are spoken in Switzerland according to the part of the country. About 71% speak German, 21% French and 8% Italian.

It is going to be an enormous task for anyone to obtain specimens of all these stamps when the war does stop.

It would seem that this is a period when serious collectors must specialise in certain countries and forgo the attempt to collect all the stamps from all over the world. The outlay would be beyond the pockets of the vast majority.

You see, with the New Issue Services run by the big stamp dealers, one can buy at a small cost over the face value all the stamps as they are issued. But with this period of



Swiss Salvage Stamp

halting it means that when we do start again some of the stamps will have gone up in price tremendously, and some will not be obtainable.

You realise that all postal stationery should be kept. For example have you all got an Airgraph? You certainly should have one and also one of the many examples of the "Passed by Censor" labels—on the entire envelope, of course. It would be useless removed from the cover.

Most of these you should be able to obtain quite easily. Very likely you have some great friend or relation who has already sent you one, if not remind them of their oversight.

### A Good Story

Rather an amusing story concerns the Airgraph letter. The recipient of one of these interesting photographs of handwriting was saying that they had heard from their relation and that the writing was exactly like the writers.

They were told that it was called an Airgraph and that it came by air. "Oh no," the owner replied, "the postman brought it with the other letters." Can it be that they thought that an Airgraph or Airmail Letter was delivered to the house by an aeroplane landing on the front lawn?

After all the Airgraph idea is somewhat similar to the idea of the stamps of the 1939 issue from Argentine Republic. The Fonopostal service stamps which were issued to pay the postage on messages which were recorded on gramophone records. You could, by this means send, say, Birthday Greetings in your own voice.

# A fascinating and interesting piece of work is an ELECTRIC RAINBOW TOP

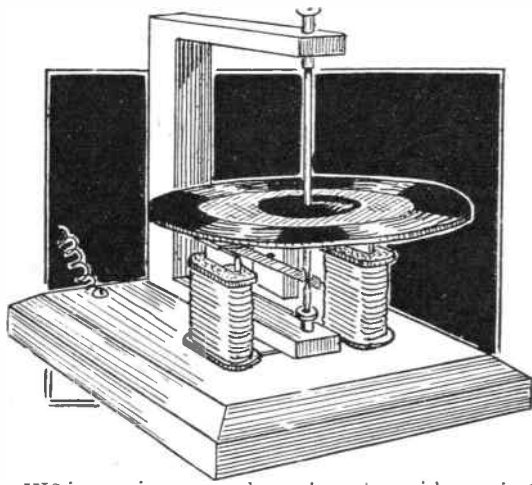

**T**HIS interesting toy can be made with a few yards of copper wire and odds and ends. Really it is a very simple form of electric motor carrying a colour changing disc as an added attraction.

A plan view is given in Fig. 1. From this the dimensions of the baseboard can be got. Cut it from a piece of  $\frac{1}{2}$  in. deal and bevel off the edges. The armature frame, Fig. 2 consists of two pieces of  $\frac{1}{4}$  in. fretwood joined to a piece of  $\frac{1}{2}$  in. square wood.

Both these are fixed with screws, or at least the top one should be, to enable it to be removed, as required, for subsequent operations.

## Screw Fittings

At  $\frac{1}{2}$  in. from the ends bore holes for two screws, these are  $\frac{3}{4}$  in. round-headed brass ones, and care must be taken to get them both in line, otherwise the armature will not revolve level.

Drive the top screw in and give it a few turns to form a thread in the wood. Then remove it, file the point flat, mark the centre of this flat with a punch and drill a cup-shaped recess in it to admit the pointed end of the spindle as in inset.

Now unscrew the top piece of the frame. Drive the second screw in the bottom hole, leaving it sticking up about  $\frac{1}{4}$  in. File off any bit of the

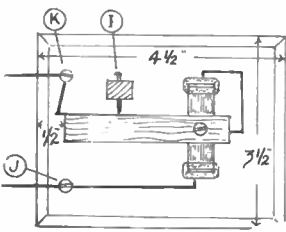

Fig. 1—Looking down on the article

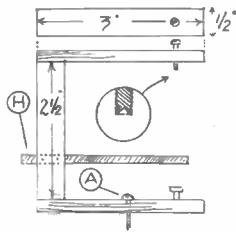

Fig. 2—The framework

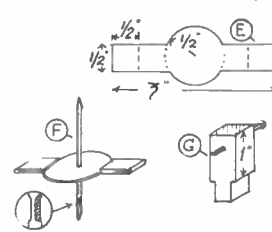

Fig. 4—Parts of the armature

screw projecting beneath, then give the screw a half turn to the left.

This will raise the bottom of the screw to a trifle above the surface of the wood, the underneath surface of course. File the slot of the screw away, and in the middle of the flat thus left centre tap, and drill a recess, as for the top screw. These form the bearings for the armature spindle.

Fix the frame to the baseboard, where shown in the plan, with a single screw, driven in at A, and rescrew the top piece back again.

For the magnets, cut three strips of tinplate to the size given in B, Fig. 3. Lay these together, and bend the ends up at the dotted cross lines, as at C. Trim these ends level, they should both be exactly the same height.

## Bobbins

Make bobbins to fit over the ends in this way. First wrap paper round the poles, as the upright ends are called, about twice round is enough and stick down. Cut four pieces of cardboard, 1 in. long and  $\frac{1}{4}$  in. wide. In these cut slots large enough to slide over the tapered ends, and glue two to each as shown at D.

A few yards of D.S.C. or enamelled copper wire, thin, will be needed for the coils. Allow about a foot for connections, then wind evenly in a clockwise direction, round one bobbin, at least four layers.

Then, without cutting the wire, carry it across to the other bobbin, and wind that, this time in an anticlockwise direction. Tie off and leave a few inches for connection.

Loosen the screw at A, press the magnet beneath the frame and see it is just under the bottom bearing screw. Tighten screw A to hold the magnet in place. Now run a pencil round the magnet, where it rests on

the baseboard. Remove both magnet and armature frame, and inside the pencil marks chisel out a very shallow recess into which the magnet can fit.

The recess should just admit the three thicknesses of tin, no more, then replace the armature frame and screw down. This should hold the magnet safely, the recess in which it fits preventing any possibility of side shifting.

## Armature Parts

For the armature spindle, get a 2 in. wire nail, and cut it down to a full 2 ins. Carefully file both ends to a smooth point. At about  $\frac{1}{4}$  in. above the bottom point, file a small flat each side of the nail, as shown at inset F, in Fig. 4.

For the armature itself, cut a piece of tin-plate to the shape, E Fig. 4. Punch a hole in the centre to be a tight fit on the spindle, and bend each end, at the dotted lines, right over. Press the armature on to the spindle, as at F, taking care that the folded ends are in line with the flats filed on the spindle.

Now loosen the top bearing screw of the frame, and slip the spindle between its bearings. Adjust the top screw until the spindle can rotate easily and level.

## Testing the Armature

Press the armature down until it just clears the magnet poles, and no more. Lift the spindle out, and fix the armature to it with a spot of solder. Then replace and test the magnet to see all is right so far.

Just connect the ends of the coils to a dry battery, when the armature should swing to over the poles. If the armature is at right angles to the poles the attraction may not be strong enough, but just give it a touch with the finger to help it.

The brush H, Fig. 2 is a narrow strip of thin, springy brass, or even a piece of watch main spring would

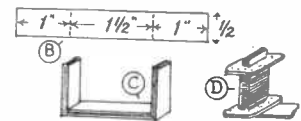

Fig. 3—Magnet details

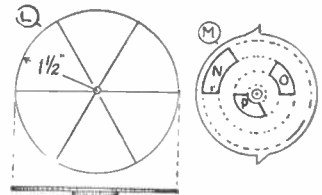

Fig. 5—The card colour discs

do. Fix it with a small nail to the frame, at such a height as will bring it level with the filed flats on the spindle.

Adjustments of pressure against the spindle, which is rather critical, is provided by a screw driven through a block of  $\frac{1}{2}$  in. wood, G, Fig. 4. This block is tenoned, or just nailed if you like, to the baseboard, at approximately the position shown at I, in Fig. 1. Now connect up.

The connections are shown by thick black lines in Fig. 1. First, near the rear end of the baseboard, drive in two round-headed brass screws, as at J, K.

Then carry the long connection wire from the coils to J and twist under it. Leave enough to spare to make connection afterwards to a battery. The second wire from the coils is bored at its end and twisted

round the bottom bearing screw.

The final connection is a length of wire, bared and twisted round the rear end of brush H, and carried to screw K, twisted round it and its end left spare for connecting to the battery.

Now connect these wires, leading from screws J and K to a flash lamp battery. Carefully adjust the screw, which presses against the brush, until the motor runs satisfactorily. The motor will not always be self-starting but a touch with the fingers will set it in motion.

For the changing colour discs, cut a circle of thin card to the size given at L, Fig. 5. To the bottom of this glue a thin disc of cork. Then divide the disc into 6 parts, and colour each part differently.

This can be done with water colours, or crayons, or, what is perhaps better

paste coloured paper on each division. The gaily coloured printed wrappers on canned food will help here.

From thin card or stiff white paper, cut a second disc, M. This, though shown smaller for reasons of space, is the same size as L. Leave a tooth-shaped piece projecting at opposite sides as shown.

On it mark and cut out the openings N, O, and P, and cut a small hole in the centre. Now take the spindle out and push the disc down on it until it nearly touches the armature. Drop disc M on top and replace the spindle.

When set in motion, the disc will show three rings of colour, giving a pretty effect. By bringing the finger against the top disc (M), thus checking it for a moment; the colours of the rings will be changed.

The varieties of tint thus resulting make the toy most interesting.

## ABSOLUTELY FREE!

We will give you—absolutely free—the very attractive stamp which the Free Dutch Government in London have just issued (February 1st, 1943) for the Dutch West Indies Islands of Curacao. This extremely handsome stamp is in two colours and shows the Dutch flag flying over the old Fort at Saint Eustatius. Three old cannon can be seen in the foreground of the stamp while inset is a portrait of Her Royal Highness Queen Wilhelmina of the Netherlands (Holland) who is now in London. The Dutch Government have told us that no more stamping and historical issue should be in every collection. This very interesting and historical issue should be in every collection. It will increase the value and interest of any collection, and you can get this stamp from us Absolutely Free by asking to see one of our Approval Selections. Also you must send us 3d. in stamps to cover cost of our postages. Only one of these Gifts can be sent free to each applicant. Write now to:

Windsor Stamp Co. (Dept. 12), Uckfield, Sussex

## STAMPS AT WAR DISCOUNTS

### COLONIALS, FOREIGN OR AIR MAILS

Pick any from our celebrated APPROVALS

20/- worth as priced for 5/-, and *pro rata*

OLD AND RARE STAMPS BOUGHT

SAUNDERS & CO., 51 DRAYCOTT AVENUE, HARROW

## Materials for the STAG PHOTO FRAME—

For making the design presented with this issue Hobbies Ltd. supply a parcel of planed wood for 2/10 at any of their Branches. If sent by post from Dereham, Norfolk, the cost is 3/5. A special piece of glass (No. 5840) also obtainable for 3d., postage 4d. extra if sent separately.

## MISCELLANEOUS ADVERTISEMENTS, etc.

The advertisements are inserted at the rate of 3d. per word or group of letters prepaid. Postal Order and Stamps must accompany the order, and the advertisements will be inserted in the earliest issue. Fretwork goods or those shown in Hobbies Handbook not accepted. Orders can be sent to Hobbies Weekly, Advertisement Dept., as below.

**L**ONELY? Then write Secretary U.C.C., 5B.B. Hay St., Braughing, Herts. Genuine. Est. 1905.

**B**E TALLER! Quickly! Safely! Privately! Increased my own height to 6ft. 3 $\frac{1}{2}$ ins. Ceylon Client, age 20, gains Eight inches! Enclose 6d. stamp for Details.—Malcolm Ross, Height-Specialist, BM/HYTE, London. W.C.1.

**T**OY BRICKS—Advertiser wishes to purchase Children's wood bricks, preferably with coloured designs. Condition immaterial, but must be complete sets. Send details and price including postage.—Box 187, c/o Pool's, Aldwych House, W.C.2.

**S**TAMPS FREE! Twenty unused (2 $\frac{1}{2}$ d.).—G. H. Barnett, Limington, Somerset.

**W**ELL Tested simplified Diagrams (+) and clear instructions for any handy man to construct a satisfactory Woodworkers or Toy Makers Lathe from obtainable materials and 'scrap' at approximate cost of 30/-, 40/. Price 3/3.—H. R. Barham, "Hilltop", Bradmore Green, Coulsdon, Surrey.

**E**EARN 5/- weekly selling stamps at school. Send 1d. for details.—Arkle (H.W.11), Carmel, Caernarvon.

**L**ONELY? Then write confidentially, Secretary, V.C.C. 34 Honeywell Rd. London, S.W.11. Stamp.

**M**ODEL Makers Birch Veneer Offcuts. 1/40in. thick, send stamped addressed envelope for list.—A. Stephenson, Villiers Street, West Hartlepool.

**W**ATERMARK Detector, perforation gauge and stamps free! Request approvals.—Fantozzi (HW), Hillside, Whitegate, Northwich.

**W**ORKING gun model patterns free with Hobbies 1943 Handbook—Also colour jigsaw sheet of dogs. Model making, toymaking, fretwork, etc. Marvellous value 6d. only. Newsagents and Hobbies Agents.—Or from Hobbies Ltd. Dereham, Norfolk. 8d post free.

**G**ALLEONS, WARSHIPS and other old-time Ship Models. Easy to build from Hobbies KITS. Send 1d. for list.—Hobbies Ltd. Dereham.

**F**RETWORK OUTFITS. Prices from 5/- to 20/-. Ask for particulars of stock available before ordering.—Hobbies Ltd. Dereham.

Hobbies Weekly—2d. every Wednesday—Subscription Rate 14/- per year or 7/- half year. Editorial Offices, Dereham, Norfolk. Advertising Dept., Dereham or Temple House, Tallis Street, London, E.C.4. Hobbies Branch shops at 78a New Oxford Street, London. W.C.1. 87 Old Broad Street, London, E.C.2. 326 Argyle Street, Glasgow. 10 Piccadilly, Manchester. 4 St. Paul's Parade, Sheffield. 10 Queen Victoria Street, Leeds. 14, Anlaby Road, Hull. 14 Bull Ring, Birmingham.

Printed by BALDING & MANSSELL LTD., London and Wisbech, and Published for the Proprietors, HOBBIES LTD., by HORACE MARSHALL & SON, LTD., Temple House, Tallis Street, E.C.4. Sole Agents for Australia and New Zealand: Gordon & Gotch (A'sia) Ltd. For South Africa: Central News Agency Ltd. Registered for transmission by Canadian Magazine Post.





BRACKET.  
CUT ONE 3/16".

BACK.  
CUT ONE 3/16".  
DOTTED LINES INDICATE  
POSITION OF OVERLAY.  
THE PIECE OF WOOD CUT FROM  
THE MIDDLE WILL BE CHAMFERED  
ROUND THE OUTSIDE EDGE AND THEN  
REPLACED BEHIND THE GLASS  
AND PICTURE. STOUT BROWN  
PAPER SHOULD BE PUT OVER  
THE BACK.  
GLASS NO. 5440.

Hobbies

DESIGN

No.  
2482  
12.5.43

SUPPLEMENT TO HOBBIES NO. 5482.

## THE STAG PHOTO FRAME & BRACKET

The arrows  
indicate the  
direction of grain  
of wood.



SIZE.  
14 1/2 ins. LONG.  
10 1/2 ins. HIGH.  
2 1/2 ins. PROJECTION.

PANELS OF WOOD REQUIRED  
FOR THIS DESIGN

ONE G3 ONE J3

The wood supplied for this design is composed of standard panels as detailed above. The price is shown in Hobbies Weekly, dated MAY 12th, 1943, but is subject to change after that date, when the current edition of Hobbies Handbook should be consulted, or application made direct to Hobbies Limited, Dersham, Norfolk.

BACK.  
CUT ONE 3/16in.  
DOTTED LINES INDICATE  
POSITION OF OVERLAY.  
THE PIECE OF WOOD CUT FROM  
THE MIDDLE WILL BE CHAMFERED  
ROUND THE OUTSIDE EDGE AND THEN  
REPLACED BEHIND THE GLASS  
AND PICTURE. STOUT BROWN  
PAPER SHOULD BE PUT OVER  
THE BACK.  
GLASS NO. 5841.

NOTE.—This design  
sheet is only presented  
free with the current  
issue of *Hobbies* and not  
with back numbers. Further  
copies may be obtained.

BRACKET,  
CUT ONE 3/16in.

B

above. The price is shown in Hobbies Weekly, dated MAY 12th, 1943, but is subject to change after that date, when the current edition of Hobbies Handbook should be consulted, or application made direct to Hobbies Limited, Dereham, Norfolk.



PRINTED IN ENGLAND.

OVERLAY.  
CUT ONE 3/16in.  
AND CHAMFER THE  
INSIDE EDGE AS SECTION.

# PHOTO FRAME

ALL patterns shown can be pasted straight away down to the wood of the thickness required for each, taking care that the grain runs in the direction indicated by the arrow. Cut out all the parts carefully with the fretsaw and clean off the remains of the pattern design with glasspaper.

Take care in cleaning the back to keep the glasspaper on a solid block of wood so the edges of the work do not become tapered. In cleaning the portion of the stag at the top, it is as well to replace a piece of the wood from which it was cut. This will make a solid frame and so prevent the likelihood of breaking the parts off during cleaning.

The part cut away as waste wood can just be replaced temporarily like a jigsaw puzzle round the outline of the animal, and will hold in place the antlers.

The overlay has its inner opening chamfered down to the angle shown by the shaded section. This work is best done before the actual outline of the part is undertaken. Cut the centre out first and then with a file clean away the edge to a slope after

marking a pencil all round to the distance to which the chamfer is to go.

Be careful not to clean the shelf supports too much or the tenons at B will be too thin to fit securely into the back mortises. The same applies to the tenon A on the shelf.

See all these pieces fit securely, and when finally cleaned up, glue them in place. Add a touch of glue along the top of the shelf support so it may help to hold the underside of the bracket piece as well.

The rim overlay round the central opening is glued flat and provides a little projection behind in which the elliptical glass can lie. This is 5840.

The picture, of course, is placed behind the glass, and then a piece of card or several thicknesses of brown paper put in behind to fill up the thickness of the wood. A piece of brown paper is pasted to the back afterwards, to hold the whole lot in place.

It is not advisable to hang the frame by the fretted work, but to add two small wall hangers on the extreme right where the solid piece of wood rises just above the shelf.