

HIFI YEAR BOOK 1977

HIFI YEAR BOOK 1977

Pickups/Motors/Tuners/Amplifiers/Microphones
Recorders/Speakers/Cabinets/Audio Systems



Eagle.

Everything from a jack plug
to a receiver.

HIFI YEAR BOOK 1977

Edited by Kenneth Ellmore
Manager IPC Ancillary Publications and Year Books

Note: VAT rate change

Where prices are shown as inclusive of VAT readers should contact manufacturers or suppliers before purchase. The VAT rate changed from 25 per cent to 12½ per cent just as this book was going to press and it was not possible to ascertain the correct new selling prices in every case.

© IPC Electrical-Electronic Press Limited 1977

Published by

IPC Electrical-Electronic Press Limited
Dorset House, Stamford Street, London SE1 9LU 01-261 8000

Publishers of Wireless World, Electrical & Radio Trading,
Electrical and Electronic Trader

Printed in Great Britain by
Chapel River Press, Andover, Hants.

Contents

Articles

- 7 Aerials for Stereo Radio Reception
by Ralph Stallworthy
- 12 Choosing Your First Hi-Fi System
by Donald Aldous
- 16 How to Up-date Your Hi-Fi
by Gordon J. King
- 23 Headphones
by John Dwyer
- 27 Abbreviations

Directory Sections

- 29 Aerials FM/VHF
- 37 Amplifiers and Control Units
- 75 Cassette Recorders and Decks
- 97 Constructional Kits
- 107 Headphones and Accessories
- 131 Hi-Fi Cabinets
- 141 Magnetic Tape
- 153 Microphones and Accessories
- 181 Music Centres
- 195 Pickup Accessories
- 211 Pickups and Arms
- 235 Radio Tuners
- 249 Receivers
- 283 Record Decks
- 311 Recordings of the Year
- 323 Speakers Accessories
- 329 Speaker Drive Units
- 339 Speaker Enclosures
- 403 Surround Sound
- 407 Tape Accessories and Components
- 421 Tape Amplifiers and Mixer Units
- 425 Tape Decks and Recorders
- 439 Test Tapes and Discs
- 444 Tape Playing Times
- 445 Unit Audio — Records Systems
- 459 Unit Audio — Tape Systems
- 463 Stop Press
- 469 Directory of Brand Names
- 473 Directory of Makers and Suppliers
- 483 Advertisers' Index
- 484 Directory of Hi-Fi Dealers

Best buy of the day.



626 AM-FM hi-fi stereo receiver.

How would you like an AM-FM hi-fi stereo receiver with an amplifier delivering more than 40 watts per channel (both channels driven) and an FM tuner section designed to achieve a specification very close to the theoretical performance limits of the FM broadcasting system?

It's called the Armstrong 626.

And it costs £207.00. (You'll find systems costing double that and performing less well.)

Said reviewer F. C. Judd in 'Audio': "Go out and buy the 626." And Gordon J. King in 'Hi-Fi News': "How encouraging to see that British hi-fi is taking the lead once again."

Please write for full information on the complete range of Series 600—you could also choose the 621 Stereo Amplifier (£118.00), the 623 AM-FM Stereo Tuner (£125.00), the 624 FM Stereo Tuner £(98.00) or the 625 FM Stereo Receiver (£179.00).

Prices are R.R.P., include V.A.T. @12½% and are correct at time of going to press.

Armstrong

Armstrong Audio Ltd., Warlters Road, London N70RZ. Telephone: 01-607 3213.

**For quality,
for service,
for reliability,
for choice**



**QAS
LEADS**

QAS

Ariel Pressings Limited Wollaton Road Beeston Nottingham
Telephone: Nottingham 256141

Foreword

This is the second edition of the Hi-Fi Yearbook to be compiled by my department and the sales of the previous edition were most gratifying, breaking all existing records.

The economic crisis has hit the Hi-Fi Industry like everything else, but if manufacturers are down they are certainly not out! Accent over the past year has been on quality, especially in the area of loudspeakers, where great improvements have been effected for very little extra cost.

It goes without saying that the Hi-Fi Yearbook is constantly changing to meet new markets and public tastes. This year I have made two major changes. The Music Centre with facilities for records, tapes and radio, is here to stay and now warrants a spot on its own. This leaves Unit Audio broken down into Record or Tape Systems. I am well aware that the very words Unit Audio make the true enthusiast recoil in horror, but nevertheless some of the packaged equipment available is of fine quality and worthy of mention.

The other change is the incorporation of a Record and Tape Review in the main Directory Section. In previous books we have usually featured a music review among the specialist articles but I feel that this is the very heart of the industry and should be featured more strongly.

I would repeat my warning on prices. In these days of economic upheaval, prices and tax rates are constantly changing and prices quoted should be taken as a guide only. Please check with your manufacturer or supplier before ordering.

Specifications are supplied by manufacturers or importers and we haven't facilities for verifying statements or testing equipments. My staff has made every effort to ensure the accuracy of the information given in the following pages, but no responsibility can be accepted for any error or omission. In this connection I thank Frank Jones for his help in checking proofs.

Finally, I would ask readers not to write asking for information on products. Much as we like to receive your comments, we cannot answer general enquiries.

KENNETH ELLMORE

there's a good deal for you ~ at IMHOFS

Yes! There's a good deal to see and a good deal to hear. For here at Imhof House we now have a number of specialised showrooms, each devoted to one of the world's leading manufacturers - Bang & Olufsen, Dual Dynatron, Eddystone, Hacker, Radionette, Sony, Tandberg and Telefunken. Not only can you see the most comprehensive selection of equipment, you will also have the advantage of manufacturer trained representatives to advise and serve you.

Of course, we still have our famous hi-fi demonstration room on the 4th floor and our world renowned record departments are on the ground floor. Then there is the Service Shop on the 2nd floor and here, besides selling our famous IM styli and other accessories they will look after the servicing of all equipment purchased from us.

And a point to remember is that any new item of equipment bought from us is covered by the "Imhof Sales Charter" which includes the first 12 months service completely free of charge. So, if you are in town, pop into Imhofs - there's a "full house" waiting for you.

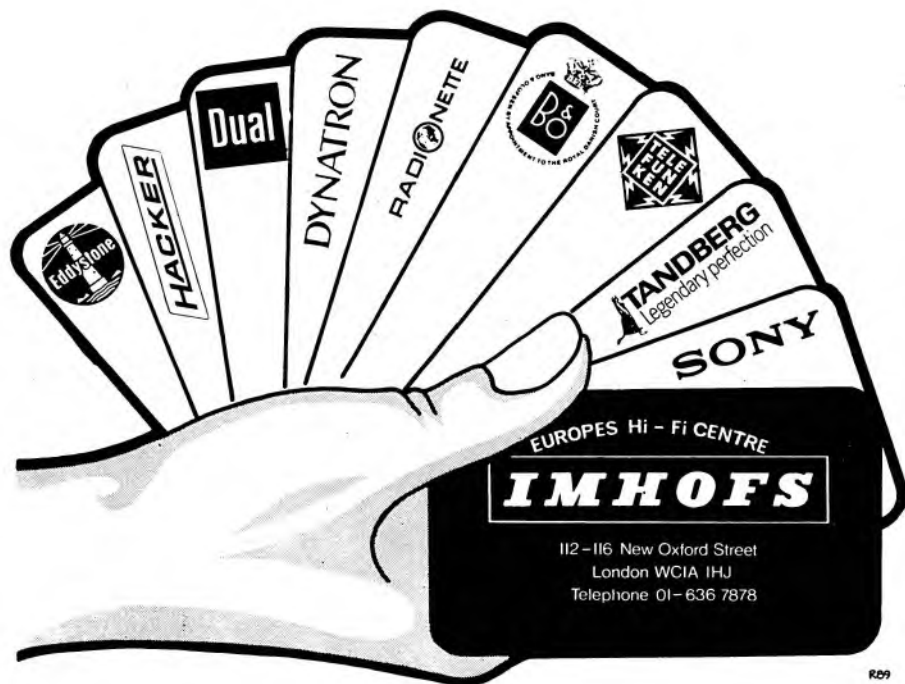

Aerials for Stereo Radio Reception

by R. Stallworthy*

IT IS not surprising for the newcomer to FM-Stereo radio to be doubtful, or even suspicious, about aerial requirements, having been conditioned by years of 'steam radio' reception apparently without aerials. He wonders why his modern, expensive FM tuner suddenly requires an aerial – or is it all a 'big con' by the aerial manufacturers to make a bit out of the growing Hi-fi market?

An examination of the facts is, however, re-assuring and many a Hi-fi enthusiast will be delighted at the improvement in results that a correctly designed and installed aerial can give. The FM aerial proves to be very good value for money indeed, ensuring that FM stereo sound is, as it should be, actually better than disc or tape recordings.

What then are these facts? First of all one must know that FM sound in the U.K. is transmitted in the VHF Band II between 87.5 and 100 MHz which means utilising wavelengths of between 3 and 3.5 metres. Now radio waves are similar to light waves, their only differences being longer wavelength. As radio waves get shorter they tend to behave more and more like light waves, so it is easy to understand that they will be obstructed by objects in their path; reflecting off those which are large in relation to their wavelength and also refracted in just the same way as their light-wave cousins. And, believe it or not, they tend to come into the house only through the windows.

This fundamental behaviour of radio waves means that, in the path between transmitter and receiver a great deal can happen to attenuate or mar the quality of the signals they carry. These propagation effects can, however, be minimised by well sited transmitters and receiving aerials which have a clear unobstructed view towards the transmitter. Except in the strongest signal areas this does mean having an efficient aerial system outdoors. Indoor aerials, even in the loft, cannot give the same results as a good outdoor aerial.

* Product Group Manager, Communications Division, Antiference Limited.

Water tanks, pipes and electrical wiring as well as the roof all obstruct the signals. As we shall see later in this article, the receiving aerial also has a lot to do besides collecting enough signal to operate the tuner. For this reason simple wire aerials, such as those often supplied free by tuner manufacturers, have limited use and for the same reason old TV aerials are not a good start either. How many Hi-fi enthusiasts would consider using old gramophone needles in their modern stereo cartridges?

Most FM aerials are designed around the well-known 'Yagi', which comprises a half-wave 'driven' dipole (to which the cable is connected) plus a number of 'parasitic' elements, usually a reflector (longer than the dipole) and one or more directors (shorter than the dipole). The relative lengths and spacing of dipole, reflector and directors affect the gain, bandwidth, beamwidth and front-back ratio of the aerial and considerable know-how goes into the design of the various commercial aerials available. Examples of typical FM aerials are given in Figs 1 and 2.

The FM-Stereo band is capable of accommodating up to 50 transmitters which are receivable in any one area and the broadcasting authorities are busy fully exploiting this capability with an increasing number of National and Local radio stations. To avoid interference from all these transmitters the receiving aerial has to play a vital role. It has to have the necessary qualities to discriminate between the transmissions the listener wants and those he doesn't want.

Let us consider next the advantages of the FM Radio Service. Because the signals are *frequency modulated* and of constant amplitude the tuner eliminates a great deal of noise and interference which is generally amplitude modulated. FM Radio reception is therefore relatively noise- and interference-free compared to AM. Because wider channel bandwidths are utilized than in the long, medium and short wave AM bands, better quality signals, including stereo, can be accommodated. The behaviour of the VHF

waves in their similarity to light waves is taken into account in the geographical location of transmitters – ranges of mountains and hills can be used to prevent interference by one transmitter with another. Furthermore, the FM tuner has the happy knack of always selecting the stronger of any two signals in one channel. This ‘capture effect’ as it is called, automatically eliminates weaker, interfering signals.

But all these advantages can easily be lost, particularly where stereo reception is concerned, if the tuner has an inadequate aerial. In the FM tuner a certain level of signal is required to operate the ‘limiter’ which gives a

quiet background. As the level of signal is raised no increase in audio output takes place but the background noise continues to be reduced, as will be seen in Fig. 3.

Assuming that the signal-to-noise ratio of 40 dB is acceptable, a mono signal of only 10 microvolts might be sufficient to give good quality with a quiet background. With stereo, however, the multiplexing circuit which is required to decode the stereo signals degrades the signal-to-noise ratio to such an extent that a further increase in signal level of 20 dB (ten times) or more is required. (Fig. 3). All of this increase in signal strength cannot be provided by a larger aerial. So how is this greatly in-

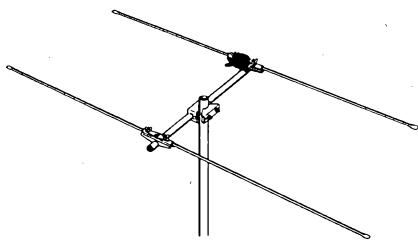

Fig 1 The familiar ‘H’ type aerial for FM stereo reception comprising a half-wave dipole with reflector. (The reflector elements are longer than the dipole.) Courtesy: Antiference Ltd.

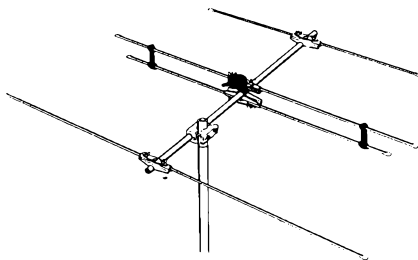

Fig 2 A three element ‘Yagi’ array comprising ‘Trumatch’ dipole, reflector and director. The director (shortest element) should be positioned nearest to the transmitter. Courtesy: Antiference Ltd.

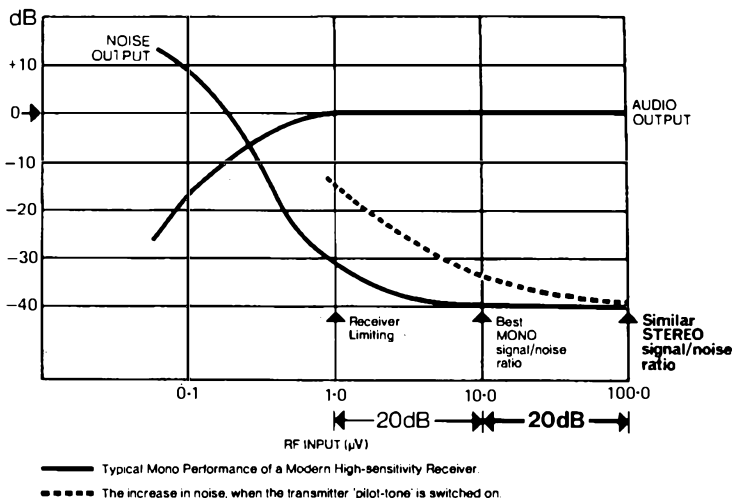

Fig. 3. The above diagram illustrates the need to have as much as 20dB (i.e. ten times more signal for good stereo reception than is required for mono.

creased signal to be obtained?

The answer is by good siting of the aerial and getting it up as high as possible. The aerial should be positioned with its dipole broadside to the direction of the transmitter and its shortest element (end director) nearest to the transmitter. The aerial should be in a clear, unobstructed position as far away as possible – at least two feet – from other aerials. The B.B.C. define the normal service area as where there is a minimum of 1 millivolt per metre of signal at 30ft. They suggest at least a two element aerial, the familiar 'H' array, mounted outside. If it is not possible to have the aerial outside and one resorts to the loft, then the number of elements should be increased to 3 or more. As one gets out into the 'fringe' areas where there is as little as 250 microvolts per metre, an aerial with a gain of 9dB or more is required and this would have six to eight elements.

But remember, 'gain' is not the only function of the aerial. Directivity is also of great importance. This is the quality that enables the aerial to enhance the signals you want and reject the ones you don't want, whether these be distant transmitters on the same channel or other types of interference causing hiss, burbles, buzzes or crackles. Despite 'capture effect', the tuner will not perform miracles when interfering signals are on the same channel, so the aerial must be directional to help to eliminate them. The various types of interference and the remedies are discussed in greater detail later.

The programmes available in any one area and the location of the relevant transmitters must be taken into account when selecting the

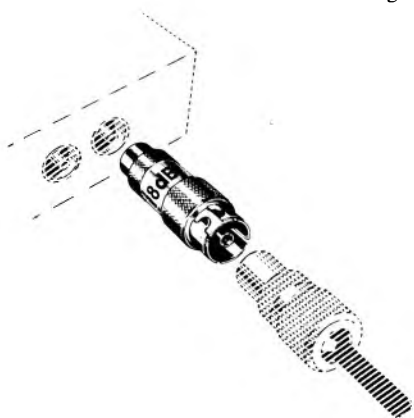

Fig 4 Plug-in attenuator to reduce high-level signals which can sometimes cause troubles known as 'intermodulation' close to the transmitter. Courtesy: Antiference Ltd.

aerial. In some places the situation may be complicated by the National Radio 2, 3 and 4 transmitters being at different sites to the local B.B.C. or Independent Local Radio Stations. Or maybe the listener wants to receive distant or foreign stations as well as the local ones.

There are four ways to tackle the problem of 'non co-sited' transmitters as they are called. The first way is the simplest. One selects the main ones from the same direction and ignores the rest. Secondly, one can choose an aerial with a broad enough beamwidth to get adequate signal from all the options if they are in the same general direction. Thirdly, and this applies if the wanted stations are situated more than 45 degrees apart, use two or more aerials. In this case some effective method of combining the downloads without signal loss must be found. (See below). Last but not least, one can have an aerial with a rotator and turn it to any selected station.

When signals are weak an amplifier or 'signal booster' is sometimes fitted. But the rule is not to use an amplifier as a substitute for aerial gain because it amplifies noise as well as signal. Signal-to-noise ratio can be worse with an amplifier than without, and unless the signal-to-noise ratio is increased very little is gained.

In weak signal areas it is worth paying special attention to downloads and other accessories, to conserve signal. Good low-loss coaxial cable with a centre-core of at least 1 millimetre (0.040 ins) diameter should be used. Don't attempt to join downloads without specially designed units, otherwise massive losses can occur. Always use good quality socket-outlets and plugs too, and make sure they are correctly fitted and soldered where necessary. Coaxial cables should not be kinked or heavily stapled.

Overcoming various types of interference often requires a great deal of patience and fortitude. Unwanted signals such as police, fire service and taxi radio telephones can be very troublesome, particularly if you are situated close to one of these transmitters. This problem can often be minimised by selecting an aerial which has been designed to have a sudden 'drop-off' above 100MHz where these transmitters operate.

Persistent interference should of course be reported to the Post Office who are extremely tactful in their handling of complaints. But be sure you have done all *you* can in the way of having a proper aerial installed before you complain.

Reflected signals which are the counterpart of 'ghosts' on TV often produce buzzing noises on FM. The procedure for eliminating this type of interference is to use a highly directive aerial

with a 'clean' polar diagram and to carefully orientate it to reject the reflected signal (but at the same time retaining the true direct signal one wants).

Too much signal, surprisingly, produces the same effect as not enough. Although a comparatively rare complaint, this can happen in close proximity to a transmitter, when the harmonics of the various transmissions cause what is called 'intermodulation'. On stereo this usually manifests itself as a hiss or 'burbles' in the background. The remedy is to fit an attenuator. (Fig. 4). Handy plug-in types of different dB values are available in good Hi-fi and Tv shops. By purchasing one 6dB and one 18dB type one can use them individually or together to provide 6, 18 or 24dB attenuation on a trial and error basis until the required value is found.

The purchaser of an imported FM stereo tuner (and believe it or not some British types) is sometimes baffled to find that the aerial connections are for a 240 or 300 ohm twin feeder and not the 75 ohm coaxial type. Some tuners now have both types of aerial input provided and most European countries have changed to

the 75 ohm coaxial standard. Whatever type of aerial input is provided it is best to use 75 ohm coaxial downlead. 300 ohm ribbon feeder is very difficult to obtain in the U.K. and presents considerable problems in installation.

If one connects a 75 ohm coaxial cable (which is unbalanced) into a 240/300 ohm balanced input a serious mismatch can occur and a great deal of signal is lost. The simplest way to avoid this is to connect the centre core of the coaxial cable to one aerial terminal and connect the braid to the chassis or an earth terminal, *ignoring the other aerial terminal*. Better still, purchase one of the specially designed 75/300 ohm receiver transformers (Fig. 5) which will correctly match your downlead into the tuner. A word of warning, however, some makers of FM aerials already have a balun in their cable junction units to 'match' the folded dipole into the downlead. The addition of

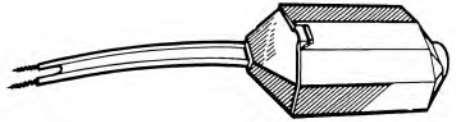

Fig 5 75/300 ohm receiver transformer to match 75 ohm coaxial downlead into a 240/300 ohm twin 'balanced' input. Courtesy: Antiference Ltd.



Fig. 6 A six-element array required for fringe area reception.

another balun at the receiver end sometimes proves incompatible. The aerial manufacturer should be consulted in this case if the method described above is not effective.

An increasing need arises to combine two or more aerials or to 'split' the signals on one downlead between two or more receivers. Because of the nature of radio waves and their behaviour it is not advisable to try to combine or divide signals without special devices such as diplexers, combiners or splitters. Some typical examples are:

Combining Two FM Aerials – Frequency conscious diplexers operating within one band such as FM Radio Band II are rather rare and costly, but a simple splitter can often do the job satisfactorily. If it is of the resistive type then at least half the signal (6dB) will be lost in the process. More expensive 'professional' combiner/splitters employing ferrite transformers can reduce this loss to only 4dB. If even this is unacceptable, then the use of an aerial switch is recommended.

Combining TV/FM Aerials – This is often done merely to reduce the multitude of wires that TV and Hi-fi creates. Cheap effective diplexers for combining TV and FM aerials are readily available, as well as a selection of flush or surface outlets with built-in diplexers or filters to separate the signals at the receiver end.

Splitting Signals to Two or More Receivers – The problem is merely to divide all the signals equally between two receivers. The resistive splitter can again be used if the 6dB insertion loss can be tolerated. With simple resistive splitters the effects of connecting or disconnecting one or other of the receivers is sometimes a problem unless an unused outlet is 'terminated' by inserting a coaxial plug with a 75ohm resistor across its connections. The transformer type of splitter obviates this need

as there is a high degree of 'isolation' between the two outlets. In some cases it is necessary to replace splitter losses with some form of amplification but this is where complications can arise. There are now a number of multi-outlet amplifiers available which simplify the matter and can cope with both TV and FM signals. These provide a very simple to install 'distribution system' for two or more outlets.

To sum up: it is necessary, except in the strongest signal areas, to have an adequate well designed aerial, preferably outdoors, in a clear unobstructed position. This aerial should be designed to receive a sufficient level of wanted signal and to reject unwanted signals and interference. The aerial must be 'matched' into its downlead and the downlead correctly connected into the tuner. If aerials or their downleads are to be combined or divided, properly designed units must be used to avoid losses or other troubles. Attention to the aerial installation will be very rewarding to the Hi-fi enthusiast; his FM-Stereo radio reproduction will be as good as it should be – better than disc or tape recordings.

Choosing your first hi-fi system

A basic guide by Donald Aldous

ONCE the decision has been made to acquire a hi-fi sound system for the home, there are several options open to you. So many, in fact, that many budding audiophiles get so confused that they decide to keep their old stereogram, or the wrong choice is made for their particular requirements and pocket.

Let me explain the approaches available. If the lady of the household insists that several cabinets and interconnecting wiring are not acceptable, and the listening room is small anyway, you may plump for—what is called—a 'music centre', which usually means a one container assembly including tuner-amplifier (also known as a receiver), a disc turntable/pickup, a tape cassette deck, and two separate loudspeakers. What is often referred to as an 'audio compact' unit consists only of a disc turntable, plus amplifier or radio receiver in one box. Loudspeakers to be added to taste and budget.

Of course, these systems are not high fidelity in the purist's use of the term, but the latest combinations from the widely known names—like B & O, Sony, Dynatron, JVC, Philips, Toshiba, National Panasonic, Sanyo—can offer a most pleasing sound performance, and no problems of compatibility exist for the purchaser. This question of matching and intercoupling 'audio separates' does seem to bother some potential enthusiasts, but a good hi-fi store can resolve any misgivings on the spot. Here we have the key to most of the problems—find the right dealer in your area or go further afield, if necessary, as the initial advice and installation will pay dividends for a long time.

There are many outlets for audio equipment these days, from the local branch of the big multiple brown and white goods shops, W.H. Smiths and Books' branches, discount stores, to the furniture emporiums, but the installation and service side at these places is an unknown or variable quantity in my experience. Usually, if the item fails, it has to be sent back to the manufacturer or UK distributor.

Specialist advice is not easily found, and unbiased advice is even more difficult to ob-

tain, with the pressures of advertising and eager store salesmen making their impact. But the fact that you are reading this Year Book means that your purchases will not be casual but backed with knowledge of the available products. Another useful source of information, close to my heart as an audio journalist, are the reviews in hi-fi magazines, which in most cases reach a high standard of independence. The importance of such reviews and test reports cannot be ignored, as the desire for favourable comment by known reviewers is considerable by the manufacturers (as reprints of the material indicate), linked to the fact that many customers tour hi-fi stores clutching such reviews in their hands, or certainly referring to them in conversations with the sales staff.

At the beginning we mentioned the integration of a record turntable, plus cassette mechanism, and associated amplifier, in one neat box of tricks, but these upgraded record players—as they've been described—do have an inbuilt limitation. If the overall sound quality offered begins to pall after a period of use, as is not uncommon with one's listening faculties becoming more critical, it is not practicable to improve the module by exchanging components. So the initial purchase of separate components in the hi-fi chain may well be a good investment right from the start.

This is perhaps the moment to consider how to apportion your planned budget for the hi-fi system, as the ratio of money spent on the essential components is vitally important. There can be no hard and fast rules, but some guide lines, based on experience, can be suggested: for a modest system (comprising a stereo receiver, with a disc turntable, and two loudspeakers) the breakdown could be 25 per cent for the record section, 40 per cent for the heart—the tuner-amplifier—and 35 per cent for the loudspeakers. For a complex quadraphonic layout, the ratio might be of the order of 25 per cent for the 4-channel receiver, 20 per cent for the multi-track open reel tape deck, 10 per cent for the cassette deck, with 10 per cent for the record unit (or preferably 20 per cent for

an even better disc player, and omit the cassette unit at the start), leaving 35 per cent for the four loudspeakers. Of course, today with the continuous improvements in tape cassette performance, a domestic hi-fi system could forgo the open reel machine, unless the ultimate in fidelity and signal/noise performance is demanded.

As you go up the rungs of the hi-fi ladder, in my opinion, the components to which one should pay most attention—and money—are the front-end (pickup cartridge/turndtable) and rear-end (loudspeakers). Let's look at the loudspeaker requirements first: there must be more brands and types of loudspeakers than any other component, coupled with flamboyant advertising claims for this or that design feature.

The variations among the better systems are considerable, for instance, sound quality, sound handling capacity, power amplifier demands, shape, size appearance and price, so choosing a speaker system is difficult. The only answer is to learn how to listen, and find a supplier who either has an audition room, with comparator, permitting immediate switching from one pair of speakers to another combination, or, preferably, will arrange a demonstration in your home surroundings. The final listening quality and your ultimate pleasure are determined not only by the loudspeakers, but the relationship of these systems to your particular room shape and furnishings, not to mention your ears and musical preferences.

Loudspeakers have their own 'character', although the perfect transducer would simply reproduce the input signal without coloration, and so it is necessary to train one's ears to distinguish between what may, at the outset, sound impressive, bordering on exaggeration, but which can soon cause aural fatigue. In the search for a good loudspeaker, which really means trying to assess the realism of a reproduced record or broadcast, it helps to hear a familiar voice speaking, as well as singing, and listen to string and piano tone, not forgetting massed orchestral sounds. Classical music is desirable for these checks, as who knows what 'pop' music—complete with synthesised sounds reproduced electronically—should sound like? Keep your ears clean by attending 'live' symphony or small ensemble concerts whenever available in your district. The original natural sounds must be your standard of reference.

During your investigation of loudspeakers, you will come across many terms, for instance, 'coloration' has already been mentioned. Transient and frequency response (meaning the ability to follow sudden changes in sound

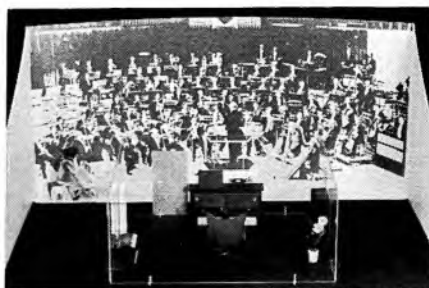

Model of Bang and Olufsen system showing loudspeaker layout in relation to the seated listener.



KEF Speaker series 104

level and the range of frequencies the unit can reproduce) are well known, but other words like 'dispersion' (describing the ability of a speaker to spread its sound throughout a wide angle) and 'efficiency' which, in this context, is most often used to estimate the power needed to drive a loudspeaker, may be less familiar to the novice.

Again, in choosing a system that is right for you, it will help to know the meaning of the different types of loudspeaker enclosure and loading in current use. Using simple language, here are descriptions of a few types: *bass reflex*, a system in which a moving-coil speaker's backwave is radiated through a port at the front

of the enclosure to reinforce bass output. *Acoustic suspension*, a small speaker design relying on a floppy cone and trapped air to develop extended bass response. *Infinite baffle*, I.B., an enclosure in which the 'backwave' of the mechanism is totally isolated from the front radiation; mounting a speaker unit in the wall of a room is one way. *Acoustic labyrinth*, type of cabinet with partitions producing a long convoluted path between rear of drive unit and outlet, lined with damping material to limit resonances. *Transmission line*, a type of loudspeaker enclosure resembling a labyrinth but filled with absorbent material. *Folded horn* system, a straight horn design would need to be nearly 9 ft. long to radiate 32Hz sound, so the horn enclosure is folded back on itself to reduce its physical dimensions. Straight horn designs are employed for high frequency 'tweeters' or in some mid-range elements.

Two other terms it might be useful to understand: *omni-directional*, which means 'all round' radiation by using multiple driver units specifically oriented, and *crossover frequencies*, which are the points in the frequency spectrum where woofer (bass), mid-range, and tweeter (treble) units divide the work load. These are determined by an inbuilt crossover network, and so largely irrelevant to most consumers. All these terms have related to moving-coil designs, and, of course, the electrostatic principle (as incorporated in the QUAD model, or several American designs of ELS) uses the attraction and repulsion of static charges to move a flat diaphragm.

One other factor in speaker specifications you ought to know about—this is the nominal impedance, which is usually rated at 4, 8 or 16 ohms. With today's transistor amplifiers, the available power rises approximately in proportion as the load impedance falls, and so the manufacturer usually states the tolerable lower load limit. If your LS spec sheet states that the unit is suitable for 8 and 16 ohms, this puts out of court 4 ohm models. The rule is that an amplifier will drive into an impedance higher than specified, although a match is desirable, but coupling to a lower load could damage an amplifier, where a protection device is not fitted.

Turning now to the amplifier, often referred to as the 'heart' of a sound system, a rule of thumb for hi-fi installations is to get power outputs of the order of 12 to 15 watts r.m.s. from both channels for each 1,000 cubic feet of listening room size. Loudspeakers do, of course, have different efficiencies, but 1% efficiency is common for domestic drive units. Incidentally, r.m.s. stands for *root-mean-square* and refers to the continuous sine-wave



Trio KD 5033 Turntable

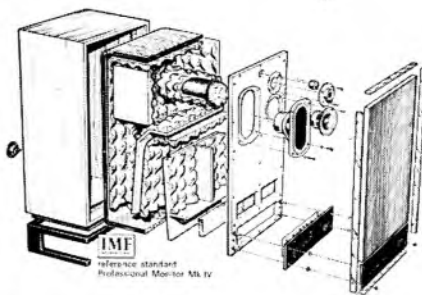

IMF International Professional Monitor Mk IV



Rotel RX7707 Receiver

power output from an amplifier, rather than short bursts, for a specified distortion level over a stated frequency range. Ignore the inflated figures under such headings as 'music power', 'peak power' or 'instantaneous peak power' when making amplifier comparisons. This is a good moment to remind you that the loudspeaker chosen must be able to handle the electrical input (watts) of the loudest sound signal you are likely to require.

The record playing equipment proper comes into several categories: an elegant pickup cartridge/arm can be assembled on a suitable platform with a manual turntable of high grade, offering low rumble, wow and flutter figures, and mechanical noise. This is the recommended way for the dedicated hi-fi enthusiast, but perhaps you prefer a fully automatic record changer? Until recently, none of these could measure up in performance to a manual model, but well made automatics nowadays can provide a most respectable performance, with a top class cartridge fitted. One of the latest releases is the BSR Accutrac 4000, which is a direct drive turntable having an electronic cueing system for the arm. This refinement is a cordless digital transmitter unit similar to those fitted on some TV sets, which allow the user full remote control from his armchair. This unit does cost about £300, including VAT, but it should become an export moneyspinner.

If you are a collector of old 78 shellac records, it is useful to know that a few turntables are still available rotating at this speed—apart from the modestly priced BSR and Garrard units (often fitted on record players)—there are the Garrard 401, the Goldring-Lenco models, and the latest Fons unit, made in Scotland, which has a variable speed control.

The pickup cartridge/stylus assembly has one of the most prodigious tasks in the entire sound chain, and to reproduce the microscopic waveforms in the groove with accuracy it pays dividends to obtain a good arm. Arm mass and friction in the pivots are merely two of the limitations imposed by the 'tonearm', which in fact do determine the grade of cartridge that can be fitted.

A term that you will come across is 'compliance units' (CU), which indicates the ability of a cartridge to track large low frequency modulations in the groove. At the other end of the scale, the limits are set by, what is called, the 'effective tip mass of the stylus'. With high grade cartridges, these parameters permit playing weights down to 1 gram (demanding a superb arm), at which pressure record wear and diamond stylus wear is negligible for several thousand LP sides.

But it must be borne in mind that a cartridge with a high CU figure (say 18 to 20) will not be suitable for cheap integrated playing decks. Similarly, tracking pressures recommended indicate the standard of equipment necessary, as modest players will not cope with tracking cartridges at less than 2 grams. In any case, it is always wise to set the arm tracking pressure at the top end of its tolerances, for the particular cartridge.

If you are wondering what to do about quad-

raphonic systems, of which four techniques (apart from Hafler pseudo-quadraphony, and Fellgett's 'ambisonics' or surround sound) are in use—SQ, QS, CD-4 and UD-4, it is likely that eventually a matrix system (like the QS method) will be chosen, but it is certainly desirable that a single, standard system should be adopted. It must be compatible (so that listeners can hear it if they only possess stereo or mono gear) and able to be employed in broadcasting. The BBC is, in fact, now experimenting with its own matrix circuitry. Unless you get one of the systems able to cope with all 'quadro' methods, it is probably best to wait and see.

Lastly, if you are a do-it-yourself hobbyist, several firms cater for your interests—for example, KEF Helme, and Peerless have speaker kits for home assembly, and similar package systems are marketed by Richard Allan and Eagle International. Heathkit offer several of their AM/FM stereo receivers, etc, in kit form, but you must be able to use a soldering iron with modest skill.

To sum up: there are many ways of purchasing your first hi-fi system, not forgetting mail order suppliers and discount houses, but the specialist dealer can offer practical advice, A/B tests with a comparator, but preferably audition of selected equipment at one's home, proper installation on the spot for the system, and service if and when things go wrong later.

How to up-date your hi-fi

by Gordon J. King

THE MOST dramatic change in the auditioning of a hi-fi system is undoubtedly attained by changing the loudspeakers — closely followed by changing the pickup. Until fairly recently the hi-fi amplifier itself was regarded as a comparatively neutral part of the system, having only minimal influence on the sound produced by the loudspeakers, but this viewpoint has been somewhat shattered by detailed objective/subjective investigations^{1,2,3,4,5,6} and by the group testing of amplifiers using a listening panel as conducted by some of the hi-fi magazines^{7,8}. Work in addition to that indicated by these references has also been pursued, and is still being pursued, along similar lines by other authorities.

During the last decade the technological advancement of hi-fi equipment has been nothing less than fantastic, and some of the parameters of the specifications relating to latter day equipment were little more than fantasia in the minds of the hi-fi pioneers. So far as amplifiers and tuners are concerned, the transistor and integrated circuit are the main components upon which the technology has so dramatically advanced. We can now buy a hi-fi FM tuner of mono signal-to-noise (S/N) ratio no worse than 50dB from an aerial input signal as small as $2.5\mu\text{V}$ (μ means one-millionth) and of usable sensitivity down to $1.5\mu\text{V}$, which is bordering on the physical limits imposed by the noise of cosmic sources and of the random movement of electrons in the aerial itself. To much improve upon this we would need to immerse the input amplifier in liquified gas and likewise cool the aerial! One such recent tuner in this category is the *Pioneer TX-9500*, which I have recently been using at Brixham in Devon to receive Capital Radio from London!

While the FM tuner has certainly benefited from solidstate technology, including the resolution of some of the input overload problems by the use of field effect transistors (fets)

and enhanced front-end selectivity (the *Pioneer TX-9500*, for example, is equipped with four variable-tuned circuits from aerial to mixer), what of the amplifier? Listening panel tests indicate that an advancement of parameter does not necessarily result in more acceptable reproduction; indeed, there is reason to believe that certain parameters can be taken too far, detracting from rather than improving upon the reproduction¹⁰. Contemporary technology makes it possible to design amplifiers of very fine *electrical* parameters; but it is now being questioned as to whether this channel of advancement is that required to get the amplifier to audition more favourably.

Listening panel tests^{7,9} incorporating early valve amplifiers with state-of-art transistor designs have shown that from the musical point of view the improvement of parameters has not been matched by the subjective results, and that relative to early valve designs the sound is lagging behind the meter readings. The term *musicality* is now drifting into hi-fi circles which, as judged by a selected listening panel, endeavours to provide a comparative measure of the 'sounding' of different amplifiers, as distinct from or relative to the measured parameters.

It is also being discovered that the auditioning of a hi-fi amplifier/loudspeaker combination can be influenced significantly by the electrical compatibility of these two parts. Excluding acoustical factors, some amplifiers can certainly audition less desirably with some loudspeakers than others, and *vice versa*.

When the time comes to up-date your hi-fi system, therefore, the lack of correlation between ears and meters should not be forgotten, and it would appear prudent after making a choice of loudspeaker pair to judge the musicality relative to one or two amplifiers before making a final choice in this area. It is also best to do this in one's own listening room, and

most devoted hi-fi dealers are only too happy to participate in such selection.

Electrical power required from the amplifier for hi-fi-scaled listening room sound intensity depends on both the acoustics — size and furnishings — of the listening room and on the efficiency of the loudspeakers. Thus, if the plan is to up-date the loudspeakers one must ensure that the efficiency of the new ones selected is compatible with the amplifier power. For example, if, say, a 20+20W amplifier has been working with a pair of loudspeakers of, say, 0.5% efficiency (which, so far as loudspeakers are concerned, is a good efficiency in an average size lounge of 63m³; the sound intensity is surely going to be curtailed by peak clipping and hence bad distortion of the amplifier when driving loudspeakers of, say, 0.15% efficiency.

To realise the full dynamic range potential of hi-fi programme material the system should be capable of producing a sound pressure at the listening position corresponding to 96dBA on music peaks (i.e., *fff*) without running into overload distortion. In an environment of particularly low ambient noise level (in the country, for example) one might be able to peak at a lower level without noise masking of the lower level sounds (i.e., *ppp*).

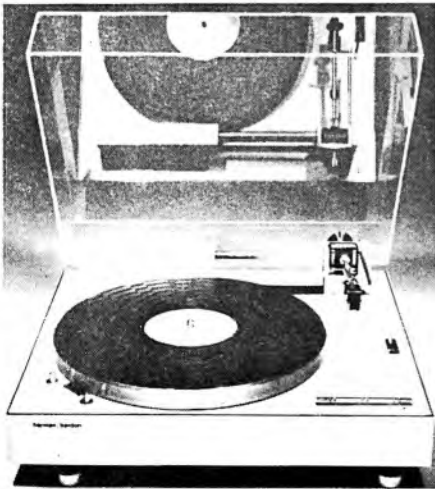

Fig. 1. Recent radial tracking record deck, the Radco ST7 by Harmon/Kardon. This employs a belt-driven turntable and arm of 6g effective mass. For tracking details see Fig. 2.

The sound pressure at 96dBA is some 63,000 times greater than that corresponding to the threshold of hearing. The suffix 'A' merely indicates that the instrument used for the sound pressure measurement is equipped with a weighting filter to give some correlation to the way we hear. The pressure in real terms around the threshold of hearing is a mere 0.0002 dyne/cm² (microbar) or, in SI units, 0.00002 N/m², which corresponds to 20μPa, where Pa is short for pascal. Thus at 96dB the pressure is around 1.26 Pa or 12 μbar.

Although this may seem rather technical, it is important because the efficiency or, more accurately, the *sensitivity* of loudspeakers is often expressed as the average power in 1 watt (on noise signal measured in a non-reverberant — anechoic — enclosure) required for 12μbar sound pressure level (SPL) at 1m. Thus a loudspeaker which requires 10W input for 96dB at 1m is *less* sensitive than another which requires, say, 5W input for the same output. From this sort of loudspeaker specification which, incidentally, is a German DIN one, it is possible roughly to determine the power of the amplifier required to obtain the 96dBA SPL at the listening position in a room of average size and furnishings by multiplying the DIN loudspeaker power by 8.5. With a 5W (for 12μbar or 96dB spl at 1m) loudspeaker, therefore, the total amplifier power (average or so-called 'rms' power) will need to be about 42W — or 21+21W stereo. With the 10W loudspeaker example just given we get 85W, or about 42+42W stereo. Although rough and ready, this rule is surprisingly consistent in the average type of room. A smaller room would need less amplifier power for a given loudspeaker sensitivity, while greater power would be more comfortable in a larger room and/or one of particularly heavy furnishings and thick carpets, etc.

Having determined the amplifier power, the next thing is to make sure that the chosen loudspeaker is capable of handling that sort of power. Although there are numerous ways of expressing loudspeaker power handling capacity, that mostly favoured refers the power handling capacity of the loudspeaker to the rated per-channel power of the amplifier *when the drive is music signal*. For example, a loudspeaker with a 60W power rating usually implies that it will accommodate the power delivered by a 60W amplifier channel on music

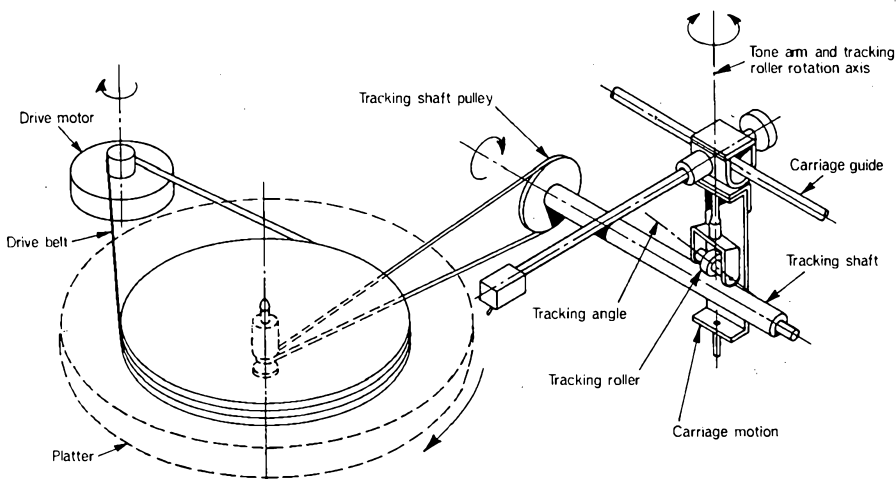

Fig. 2. Mechanical aspects of the HIK Rabco straight-line tracking system. The ratio of the tracking roller relative to the tracking shaft changes with tracking angle, thereby maintaining the arm tracking in correlation with the groove spiral of the record, irrespective of variable groove spacing used during recording.

signal. If 60W of steady-rate (i.e., sinewave) signal were applied, then the loudspeaker might well protest, probably blowing its tweeter if not its bass and/or mid-range unit, depending on the frequency of the signal. The net result of all this is that a large and well furnished room calls for loudspeakers of greater power handling capacity (along with a suitably rated amplifier) than a smaller, sparsely furnished room of hence 'brighter' (more reverberent) acoustics¹¹.

The electrical impedance of the loudspeakers also needs to be taken into account when determining the amplifier power requirement. Most contemporary amplifiers will accept loudspeakers over the impedance range 4-16 ohms; but as the impedance rises so the power falls. Provided the protection circuits do not limit the drive prematurely an amplifier will deliver virtually twice the 8-ohm power into 4-ohm loads and half the 8-ohm power into 16-ohm loads. This, however, applies to resistive loads; because a loudspeaker contains components of inductive and capacitive reactance, as well as resistance, producing an *impedance*, the power drawn by a loudspeaker at

many frequencies is less than that which would be drawn by a pure resistance of the same ohmic value from a given value of signal voltage across it.

While the current through a pure resistance is in phase with the voltage across it (the two being in step, so to speak), the power drawn is the product of the voltage and current. With an impedance the current leads or lags the voltage (depending on the nature of the reactance) in time, this being known as the phase-angle. At some frequencies a loudspeaker may have a phase-angle of 40deg. or perhaps more, the power then being drawn being the product of the current and voltage times the cosine of the phase-angle. If an amplifier is delivering 50W, say, to a resistive load of 8 ohms, an 8-ohm impedance of 40deg. phase-angle connected in place of the resistive load would draw only about 76% of the 50W at that particular frequency (the cosine of 40deg. is 0.766), or 38W, even though the signal voltage across the impedance is exactly the same as that across the resistance.

This is one reason why it would be more logical for amplifiers to be rated in voltage that can be obtained across defined loads, rather than watts into non-representative resistive loads!

The impedance quoted by loudspeaker manufacturers is a nominal value only, sometimes measured at 400Hz or 1kHz. As is well known the impedance can rise to many times its nominal value at the bass resonance fre-

quency. While many firms give details of the impedance over the frequency range, very few give information on the phase-angle — its magnitude and how it changes with frequency — which could be very useful to amplifier designers and laboratories geared to assess the performance of amplifiers.

To summarise, the impedance of a loudspeaker is not very important — less important than some people appreciate; provided it is in the range 4-16 ohms, then most good amplifiers will accommodate it without distress. A loudspeaker of low nominal impedance does not *necessarily* produce more sound than a counterpart of higher impedance, even though the amplifier will produce greater power into a lower value load. This is because loudspeakers of low impedance are often less sensitive than counterparts of higher impedance. This is logical when you come to think of it since a higher impedance usually means that more turns of wire are used on the driver voice coils, which automatically puts up the sensitivity, other things being equal! Thus, apart from how they sound, there are two primary parameters to take into account when up-dating, which are sensitivity and power handling capacity related to the size of the room.

Turning now to the radio tuner there are, again, two main points to consider: one the prevailing signal conditions at the reception site and two the quality of programme signal delivered by the tuner. A good FM tuner (and only FM can be considered from the hi-fi aspect; although some tuners incorporate AM bands, these are bands of 'convenience' and incapable of real hi-fi) operating from a well engineered live transmission can yield a programme signal of quality in advance of that of any other source — apart from microphone direct. A well designed tuner (or tuner-amplifier) is thus a good hi-fi investment.

The radio-frequency (rf) section of a tuner defines its performance in the particular reception area, while the audio-frequency (af) section controls more the resulting quality of the programme signal applied to the amplifier. FM stereo listeners in particularly difficult reception areas — which include not only 'fringe areas' (for example, those removed by 50 miles or more from a stereo transmitter) but also location *close to* powerful transmitters — should consider carefully the rf performance of

a tuner when up-dating in this programme signal part of the hi-fi system.

Some tuners which might well operate adequately at locations within the service area of a transmitter are not unknown to overload badly when sited fairly close to a transmitter or produce undue background noise on stereo operating towards the limit of the service area or in a fringe area. The strength of the FM signals falls inversely as the square of the distance from a transmitter (i.e., quarter the strength at twice the distance), so to 'capture' sufficient signal at fair distances from the transmitter a well designed outside aerial mounted as high as possible, clear from other aerials and metal-work, should be used and coupled to the FM tuner or receiver through low-loss feeder cable. The aerial will have at least two elements — possibly three or more — which means that it will be directional and thus need to be 'beamed' on to the required station group for maximum response. The simple, flexible dipole type of indoor aerial sometimes supplied with a tuner or receiver is totally incapable of giving the best results in all but a few favourable reception areas.

For low-noise stereo reproduction the tuner must receive a minimum level of aerial signal, dictated by the sensitivity and noise performance of the tuner. *Unless this signal level is reached low-level intervals of the music will be*



Fig. 3. Stereo headphones may also be considered in a hi-fi up-dating. The latest models are capable of very high performance from even small amplifiers. The assessment by the author's wife.

plagued by a disconcerting background 'hiss'. Listeners so troubled would be advised first to check that the aerial installation is adequate, and up-date here if necessary, and then to ensure that the tuner or receiver is of sufficiently high sensitivity and low noise performance for the reception area. If the background 'hiss' is cleared from a stereo transmission by translating it to mono — that is by switching the tuner or receiver to the mono mode — this is a fair indication that the aerial signal is too small or that the tuner or receiver is unsuitable for the fringe area. *It is important to embrace the aerial installation in any up-dating exercise, for this is often the weakest link in the FM stereo hi-fi chain.*

At the other end of the scale very strong aerial signals fed to a tuner or receiver can cause overloading. This does not mean that the af output of the tuner is so strong that the amplifier is overloaded. Indeed, the af output of a hi-fi tuner remains constant above a certain aerial signal input threshold, irrespective of how strong the aerial signal is made. What it does mean, however, is that the various and strong signals in the rf section intermix and produce spurious interfering signals which may coincide with the frequency of a wanted station or produce phantom signals over the tuning range. Once this happens the signals cannot be separated or the phantom signals removed without reducing the strength of the aerial signals. Overloading of this kind can also produce a particularly nasty brand of distortion — a sort of 'tizzly' noise on high-level treble sounds, particularly on piano music.

Simple plug-in aerial attenuators can be obtained from dealers specialising in aerial and tuner equipment; they come in various dB attenuation ratios. A value should be selected which eliminates the overloading symptoms without adding background noise to stereo transmissions. However, it must be noted that such attenuation will also reduce the strength of all the other signals from the aerial. Thus, if some of these are relatively weak to start with, when tuned in with the attenuator they will almost certainly be accompanied by background 'hiss'.

An enthusiast requiring to receive weak, distant signals in an area close to powerful transmitters must select a tuner or receiver which does not overload readily on strong signals, so that aerial signal attenuation will not then be

necessary.

It has also been known for some FM receivers to respond to very strong medium-frequency signals in the AM bands. Depending on the distance from the interfering station, this sort of thing is indicative of poor design or inadequate filtering or screening within the receiver.

While the quality of the af signal delivered by a tuner can be affected by the aerial signal, some tuners when operating under *ideal* conditions may produce better or worse quality signals than other tuners, depending on the design and adjustment of the af section, including the stereo decoder and the filtering associated with this. The distortion produced by a well designed FM tuner at full modulation level and on stereo should not exceed 0.5%, which is considerably less than the distortion on the signal from a gramophone pickup playing a fairly highly modulated record, which can be higher than 10%.

Tuner up-dating, then, should take account of the audio quality, which includes stereo separation, signal-to-noise (S/N) ratio, background hum, etc. as well as distortion. The accuracy of the de-emphasis is another quality affecting factor. De-emphasis is necessary to equalise for the pre-emphasis applied at transmission as an artifice for enhancing the overall FM S/N ratio, since the noise as well as the audio signal is subjected to de-emphasis at the tuner. Pre and de-emphasis are defined by a time-constant, the European standard being



Fig. 4. An unusually styled tuner-amplifier (hi-fi receiver) by British Nytronics Ltd, the Nytech CTA-252, which has a good FM tuner section and is moderately powered.



Fig. 5. *The British Armstrong Hi-Fi Receiver (600 series) which tunes the whole of the LW and MW bands without switching also with press-button station selection, including FM. Medium power delivery.*

50 μ sec. If a tuner designed for or adjusted to the American 75 μ sec. standard is used in the UK the top treble will be attenuated and the treble control at the amplifier will need to be turned up a point or two to restore the correct frequency response. With correct de-emphasis, tone controls 'flat', the upper-frequency response should not be much more than 2dB down at 15kHz.

A tuner with poor stereo separation will not only impair the stereo image, but distortion on the breakthrough signal will tend to detract from the overall quality of sound. A stereo separation ratio of 30 to 40 dB is essential since the distortion on the breakthrough signal can be as high as 30%!

For all the good things, one obviously has to pay a higher price for a tuner; but since a tuner can be critical of the prevailing reception conditions, the choice is prudently finalised at one's own home under the actual reception conditions and in partnership with the proposed aerial installation. This, again, is where a friendly local hi-fi dealer can be a blessing. There is usually no undue problem in coupling almost any latter day tuner to any contemporary amplifier — the inter-coupling compatibility here is good. Hi-fi magazine reviews constitute an excellent source of information at hi-fi up-dating time.

Finally, a few points on pickups. Overall smoothness of quality is dictated by the pickup/loudspeaker partnership — assuming the amplifier to be a 'neutral' link in the chain. Most dramatic subjective changes in sound result from sharp undulations in the overall frequency response characteristics. If such undulations occur together in the same frequency range from the pickup and the loudspeakers, then the net sound can be far from 'smooth'. For example, it would be undesirable to

employ a pickup cartridge noted for 'over bright' treble with a loudspeaker exhibiting similar characteristics. By the same token, one could expect a lack of 'presence' by using a pickup cartridge having a 4.5 dB treble 'suck out' around 5kHz with loudspeakers also with a dip in response in the same octave.

The best plan is to leave the pickup up-dating until the amplifier, loudspeakers and tuner have been chosen. It is less easy to secure a home dem of pickup cartridges than of amplifiers, loudspeakers and tuners, so more reliance needs to be placed on reviews for pickup selection.

While a cartridge that tracks adequately at a very small downward force is probably of top-flight mechanical design, this parameter should not be made the criterion of choice. More important are factors such as freedom of high-frequency resonance, smooth overall frequency response, good separation over 100Hz to 10kHz at least and compatibility with reasonable arms. One would, of course, expect a cartridge to track all reasonable modulation levels within the useful spectrum at no greater weight than, say, 2 grams. A much higher tracking weight tends to accelerate record wear.

There is not much point in becoming involved in such technical things as effective tip mass, compliance, dc resistance, impedance, etc. While these parameters are of great interest to the engineer, the main things that an intending purchaser needs to know are compatibility, tracking weight, frequency response and stereo separation. It is worth noting that the very low tracking weight cartridges may not perform as well as they should in arms of relatively high effective mass, high bearing friction, inadequate sidethrust correction, etc. In other words, the more 'delicate' the cartridge, the more technically advanced needs to be the arm to partner it.

When the loudspeakers and amplifier are up-dated for improved bass performance, for example, rumble which may have previously



Fig. 6. *British Goodmans 150 Hi-Fi Receiver. At 100+100W this includes a high-power audio section and unique FM section with 'digital' circuit techniques for FM tuning lock.*

been inaudible might well tend to figure in the equation. This is then a pointer towards the need for turntable unit or record deck updating. Some of the latest direct-drive turntable units are capable of very quiet, low-rumble operation; but the same can be said *equally* of well designed belt-driven units.

Rumble and acoustical feedback (howl round when the amplifier's volume control is advanced when a record is playing) are also encouraged by arm/cartridge incompatibility. The effective mass of the arm and the compliance of the cartridge establish a mechanical resonance condition at low-frequency, the frequency falling with increase in effective mass and compliance. If the resonance frequency happens to coincide with the rumble frequency, then the rumble will be boosted. Howl round is also encouraged by the bass resonance of the loudspeakers correlating with that of the pickup; also by low-frequency standing waves in the listening room, which is a room resonance effect. Some of the more expensive amplifiers are equipped with low-frequency filters which decrease the output at the low resonance frequencies; some such filters, in fact, are termed 'subsonic' since they take effect below the lowest music octave, around 15Hz.

Some of the more recent record playing decks are adequately decoupled mechanically to defeat the causes of acoustical feedback, a good example being the Leak 2001.

Most arms still adopt the pivot principle; though, including the B&O 'computer' type player, one or two arms are appearing based on true radial tracking (playing in the same way as the record was cut in the first place); a recent example being the Harman-Rabco ST7 (see the photo and the illustration of the mechanical

'servo' mechanism). A true radial tracking system avoids the lateral tracking error of the pivoted arm and hence reduces the distortion from this cause but, as already noted, the inherent distortion is high anyway, and this cannot be reduced. The system also makes it possible to reduce the effective mass of the arm, which is a good point in its favour.

There we have it, then. Equipment is in abundance by which you may up-date your hi-fi system. Avoid being pressurised, up-date progressively and logically as detailed in this article, keep up-to-date with the equipment by studying reviews, and not only will you save money, you will do the right thing and enjoy doing it!

References

- 1, 2, 3. Linsley Hood J. L., *Wireless World*, June 1970; Settling Time in Audio Amplifiers (letters), *Wireless World*, Jan. and March 1975.
4. Gordon J. King, Settling Time in Audio Amplifiers (letter), *Wireless World*, March 1975.
5. Gordon J. King, Does Every Amplifier Have a Different Sound, *Practical Hi-Fi and Audio*, August 1975.
6. Gordon J. King, Amplifier Distortion, *Electronics Today International* (British Edition), March 1976.
7. F. M. Hughes, A New Look at Testing Amplifiers — by Listening to Them/Final Test Results, *Hi-Fi For Pleasure*, Dec. 1975 and March 1976.
8. Gordon J. King, Ten Amplifiers Tested — Group Review, *Practical Hi-Fi and Audio*, May 1976.
9. Gordon J. King, Comparison of Valve Amplifier with Transistor Amplifier, *Practical Hi-Fi and Audio*, June 1976.
10. Gordon J. King, Three Amplifier Obscurities, *Hi-Fi News and Record Review*, February 1976.
11. Gordon J. King, *The Audio Handbook*, published by Newnes-Butterworths, 1975.

Headphones

by John Dwyer

EVEN BEFORE Concorde was banging about above, most households weren't exactly the havens of peace depicted in the Kosset carpet ads. If little Rodney and Charlotte aren't screaming at one another across a snakes and ladders board the vacuum cleaner is droning like a demented dentist's drill up and down the hall and some spotty Erbert is revving his motor bike outside the front room window. At times the nest is anything but the place to enjoy a little well-reproduced music. And isn't it strange how, as soon as you reach for the amp's on/off switch, the rest of them, even in all the din, turn on you in unison and say, 'Can't you turn that thing down?' A good set of headphones can get you out of a spot like that and, with some luck, they'll cut out a lot of the audible flak too.

It isn't much good having a set of headphones that performs brilliantly but weighs enough to carve a groove in your skull. Phones must be light and comfortable. Usually foam or liquid filled ear pads surround the working part of the phones, and these should prevent the phones squeezing or pinching your ears. Nevertheless if you hang your head the phones shouldn't fall off. They should be a firm fit since any change in their position on your head may alter the sound you hear. There is usually one correct position for the headphone in relation to your ear and once you've found it the improvement should be noticeable compared with the sound you get in other positions.

Broadly there are two types of drive unit in headphones: moving coil and electrostatic drivers. These are the two dominant types in loudspeakers as well as headphones and this is not surprising since all a headphone may be said to be is two miniature loudspeakers held against the ears. The more common type, also like loudspeakers, is the moving coil head-

phone. This is easier and cheaper to make than the electrostatic type and, unlike a few electrostatic headphones, does not require a polarising voltage and a separate power supply.

The electrostatic type gives superior reproduction, though it may be susceptible to moisture, which produces a deterioration in the signal to noise ratio. Some electrostatic phones are powered by an external power pack but the tendency is to use 'electret' powering from the permanent voltage which appears across a certain type of crystal. Electrostatic headphones work on the principle that, if the voltage across a pair of capacitor plates varies, the force between those plates varies and so they move. The distance between the plates is proportional to the plate voltage divided by the charge on the plates. The charge on the plates must therefore be made constant if the response is to be linear, and so the plates are charged through a high resistor, keeping the charge current low.

The moving coil headphone is usually much more electrically efficient than the electrostatic variety. This means that it needs much less input power to give the same sound output level. Most electrostatic units need about 8 to 10 watts of input, compared with about half a watt for most dynamic or moving coil units. Electrostatic units usually have a single diaphragm covering the entire audio range, but moving coil phones often have a separate high and low frequency units, just as loudspeakers have. Probably a unique variation is the design used in the Wharfedale Isodynamic headphones, where a diaphragm is used similar to that in an electrostatic headphone but the physical principle behind it is more akin to that in the moving coil headphone. The principle used is, of course, much less important than how the headphones sound.

At first it would seem that, when compared

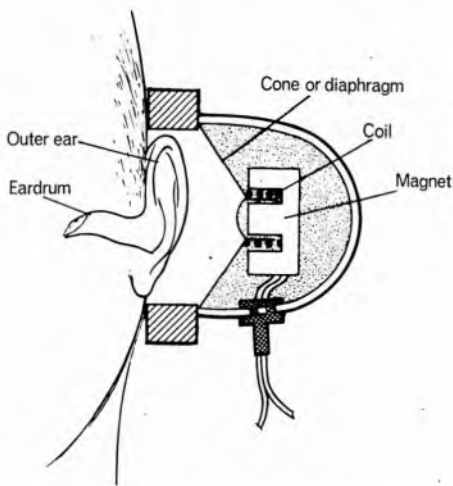

Fig 1 *Moving coil headphones*

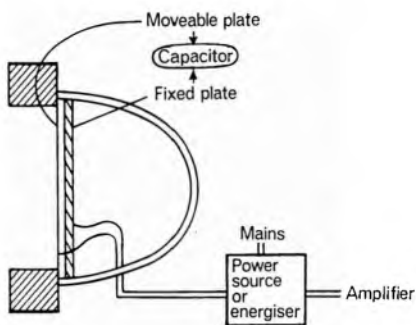

Fig 2 *Simple capacitor or electrostatic headphone*

with a loudspeaker, the small size of a headphone driver unit, whichever type it is, would make it impossible to produce a good bass response. Like a loudspeaker, the bass response is improved by isolating the front of the driver unit from the back. In a speaker this is done by putting the speaker in a box. In a headphone the earpads stop the sound from the outside of the driver unit from cancelling out the direct sound which is supposed to go to your ear. Again, a loudspeaker has difficulty in pushing bass into a room because the air into which the speaker is feeding has such a low impedance compared with that preferred by the speaker. There is an impedance mismatch,

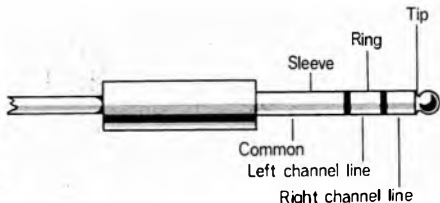

Fig 3 *Typical headphone jack plug showing the connections for correct stereo operation*

in other words between the air in a room and the cone of the speaker, and so the transfer of power from cone to sound waves is poor. In a headphone there is only a very small volume of air to be moved, and that air is enclosed. Thus its impedance is higher and nearer the cone's natural impedance. The efficiency of transfer is greater and results in better bass.

The kind of headphone you choose depends on the job you want them to do. Most people want good sound quality headphones for listening to music at home. Power handling is not a prime requirement and neither is mechanical robustness, but these last two qualities are of prime importance if you want to use the phones for monitoring during recording. Whichever use you want them for they should be stereo headphones, each earpiece being electrically independent of the other, and they should be electrically balanced.

The importance of acoustic isolation varies, and many headphones which are otherwise good in fidelity differ from one another widely in the extent to which they stop sound getting into and out of the headphone. The noisier the place where you buy the headphones the better for this, but take someone with you and ask them to speak to you with the headphones on. That way you can tell how well isolated the headphones are. And if you speak to your companion he or she will also be able to tell by how loud you shout at them, thinking they can't hear you. Then play music through the headphones and place them over the head of your companion. Judge how loud the quiet scraping noises that emerge are.

You should make sure that the point where the lead enters the headphone is able to take some physical punishment. Some otherwise very good phones have a plug at both ends of the lead, with a plug and socket on the headphone itself. It's perhaps a personal prejudice, but I don't think this is a good idea.

There is also an appalling tendency these

days to add knobs and twiddly bits to headphones. These add to the weight and complexity of the headphones, making them less reliable. Most of these knobs give the game away by being marked in numbers, just as a volume or tone control on an amplifier is, thus betraying that they are for twiddling in shops rather than adjusting during use. I don't know where your eyes are, but mine make it difficult to see my ears without a mirror, and so I can't adjust the tone or volume controls by sight. And the numbers are never printed backwards for use with a mirror.

The place for adjusting volume and tone is on the amplifier. The phones should be as 'flat' with frequency as possible. They shouldn't have a sound of their own. In any case a survey of headphones some years ago showed that the impedance of all those with volume controls varied as the volume control was adjusted.

Another worse sales gimmick is 'quadraphonic' or 'four channel' headphones. There are various ways of introducing phase distortions and frequency response changes to alter the effect of what is being put through the headphones, but there is no way that you can hear four channel information without being able to make those slight imperceptible and involuntary movements of the head in relation to the sound source which allow us to tell from which direction a sound is coming.

When you look at the specification of a set of headphones there are various terms which you should understand. The frequency response is one you will probably be familiar with. As with all other hi fi equipment the response should not just be between X Hz and Y Hz, but X Hz to Y Hz, $\pm ZdB$. It is probably better to settle for a narrower, but flatter frequency range, such as 50Hz to 15kHz $\pm 2dB$, rather than a wider response with a greater degree of error, such as 40Hz to 22kHz $\pm 5dB$.

The impedance of the headphones will usually be stated as eight ohms, and therefore the implication is that the phones are meant to be driven from the speaker terminals of an amplifier, possibly via an attenuator. A better solution is a properly built headphone amplifier with 600 ohm matching. This will give better results, particularly with regard to noise performance. Series resistances in the ordinary loudspeaker circuit affect the resonance-damping performance of the headphone and if this is what you have

available—most headphone sockets work on this principle—then the headphone itself should be well-damped, though this will make it less efficient.

There is no reason to regard high efficiency or sensitivity as necessarily a good thing. Efficiency is, as we have seen, a comparison between the electrical power put in and the power in the form of sound taken out. Sensitivity is a measure of the sound pressure level obtained for a given input voltage. Most manufacturers quote the voltage input for an output level of 95 SPL (Sound Pressure Level decibels). Maximum output should be 110 dB upwards at a distortion of 1 per cent or less, otherwise the phone may not be able to handle sustained high inputs. Too much listening at that kind of level, I should add, gives you a headache, and some say it makes you deaf.

A very sensitive headphone used with a power amp and series resistor, as in a headphone socket, may give too much noise with the output. It might be better to choose one less sensitive, though it does depend on how much power you have available in your amplifier. If you choose badly, and get a highly insensitive headphone with a low powered amplifier you may, ironically, get better results than other people by using the headphone directly on the loudspeaker terminals, but do be very careful. To avoid blowing the headphones up, connect them with the volume control at zero.

Some manufacturers make a box which acts as a buffer between amplifier and headphones. This is usually little more than a few high-wattage resistors, but it may be much cheaper and tidier than making the thing yourself. What you should watch is that, even though the headphone adaptor is made by the phone manufacturer, the two are compatible. Some years ago a dealer wrote to a magazine saying a customer had complained that, although the headphones could handle the maximum sound levels the customer wanted to hear, the adaptor unit had started to smoke.

Some amplifiers, such as the Ferrograph, do not have common ground connections for the two stereo channels. The two ground channels should not be connected together, and some headphone adaptors, if not most, will connect them together. The Ferrograph has an adequate phone socket, but if it didn't the only way to provide headphone facilities would be with two isolating transformers, one for each

channel. In this, as in general, the outputs to the two channels should be the same, and should result in equal sound levels in each earpiece.

It should be clear from looking at the headphones which earpiece goes on which ear. Most amplifier headphone sockets are connected so that the tip of the jack plug is the right channel line, the ring is the left channel line and the sleeve, the contact nearest the handle of the plug, is the common ground for each channel. Don't ignore other small points such as the possibility of adjusting the phones to fit you; usually the head strap has some sort of slider. The lead from the phones should be long enough to allow reasonable movement.

When you take the phones home prepare yourself for something of a shock. If you've chosen them well those records you had become so attached to may sound alarmingly different. Any imperfections in the records will become immediately apparent. The effect of stereo heard through headphones is artificial unless, as on the Sennheiser dummy head recordings, they were specially recorded for headphone listening. But it is impressive if your records are in good condition. A lot more impressive than that vacuum cleaner.

Abbreviations

A	-- ampere	L.P.	-- long play (records or tape)	UHF	-- ultra high frequency (approx 470-854MHz)
A-R	-- comparison test	LW	-- long waves (approx 1100-2000m)	VAT	-- value added tax
AC	-- alternating current	m	-- metres	VHF	-- very high frequency (VHF) radio approx 88-108MHz, VHF TV approx 174-216MHz)
AFC	-- automatic frequency control	MΩ	-- megohms (millions of ohms)	V	-- volts or voltage
AGC	-- automatic gain control	mA	-- milliamps (0.001A)	VA	-- volt/ampere
AM	-- amplitude modulation	mag	-- magnetic	vci	-- voice coil impedance
ASA	-- Acoustical Society of America	ME	-- magic eye	VU	-- volume units
aux	-- auxiliary	MC	-- moving coil	W	-- watts
RAF	-- bonded acetate fibre	mg	-- milligram	W and F	-- wow and flutter
CCIR	-- International Radio Consultative Committee	MHz	-- megahertz (see Hz)	xfl	-- crystal (pickup or microphone)
char	-- characteristic	mic	-- microphone	Z	-- impedance
cm	-- centimetre	mos	-- metal oxide semiconductor	Miscellaneous	
cm/sec	-- centimetres per second	mpx	-- multiplex	μ	-- mu (micro or millionth)
c/n	-- cut-off frequency	mV	-- millivolts (0.001V)	μA	-- microamp
coax	-- coaxial	MW	-- medium waves (approx 185-570m)	μV	-- microvolt
		N	-- newton (SI unit of force)	μbar	-- microbar (air pressure equal to 1 dyne/cm ²)
dB	-- decibel	NAR	-- National Association of Broadcasters (see also NARTB)	Symbols	
dBm	-- decibel/milliwatt	NARTB	-- National Association of Radio and Television Broadcasters (USA)	%	-- per cent
DC	-- direct current	NL	-- noise level	>	-- greater than
deg	-- degrees	Pat.	-- power available for tuner	<	-- less than
det	-- detector	pF	-- picofarad (10 ⁻¹² farad)	±	-- plus or minus
DIN	-- Deutscher Industrie Normen (German audio standards)	PPM	-- peak programme meter	≥	-- equal to or greater than
disc	-- discriminator	Psn	-- power supply needed	≠	-- equal to or less than
DNL	-- dynamic noise limiter	PU	-- pickup cartridge	∞	-- infinity
FET	-- field effect transistor	Pw	-- playing weight		
f/s	-- full frequency stereo sound (Decca)	Q	-- Q-factor (quality of tuned circuit)		
fi oz	-- fluid oz	rcf	-- recommended crossover frequency		
FM	-- frequency modulation	rec load	-- recommended load		
FR	-- frequency response	Replay			
		char	-- replay characteristic		
gm	-- gramme	RIAA	-- Record Industry Association of America		
HC	-- handling capacity	RMS	-- root mean square (0.707 peak value of AC)		
HD	-- harmonic distortion	rpm	-- revolutions per minute		
HF	-- high frequency	sec	-- second (time)		
H & N	-- hum and noise	SEC	-- sound equalisation control		
Hz	-- hertz (cycles per second)	sel	-- selector switch		
IC	-- integrated circuit	S/N	-- signal-to-noise ratio		
IEC	-- International Electrotechnical Commission	SW	-- short waves (approx 10-60m)		
IF	-- intermediate frequency	THD	-- total harmonic distortion		
IHFH	-- Institute of High Fidelity (USA)	thou	-- thousandths of an inch (0.001in)		
IM	-- intermodulation distortion	tpi	-- turns per inch (screw threads)		
imp	-- impedance				
in	-- inches				
ind	-- inductor				
in/s	-- inches per second				
K	-- kilohms (thousands of ohms)				
kHz	-- kilohertz (see Hz)				
lb	-- pound (weight)				
L/C	-- inductance/capacitance				

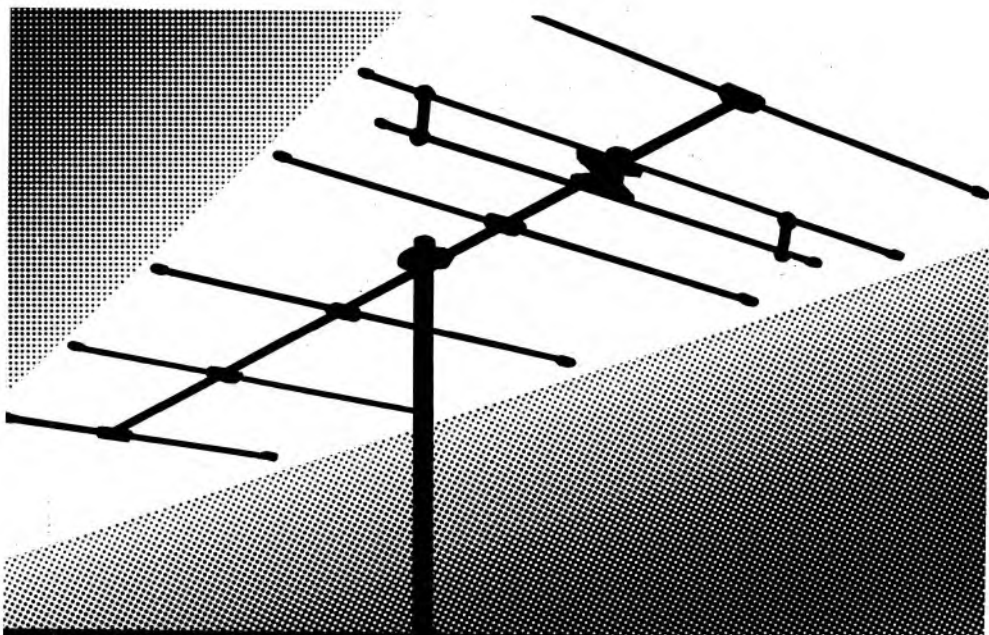

Antiference ***mush*killers** for better FM stereo reception

Specially designed to bring in the strong clear signal that FM stereo needs. Mushkiller FM aerials are available in various sizes to suit differing locations. The unique Tru-match dipole gives even better all-round performance; wide, even bandwidth and low VSWR

New do-it-yourself models of the three and five element Mushkillers are available, each individually packed with both loft *and* outdoor mountings.

Send for literature to:

Antiference 

Antiference Ltd Aylesbury Bucks HP19 3BJ Tel 82511 Telex 83666

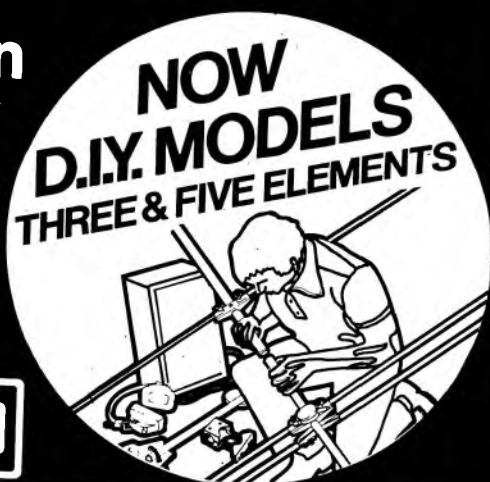

Aerials FM/VHF

★ Indicates entry is illustrated
Abbreviations used in this section are given on page 27.

■ AERIALITE

Aerialite Aerials Ltd, Radnor Park Trading Estate, West Heath, Congleton, Ches CW12 4PX. Tel: Congleton 3892.

Aerialite also manufacture a range of vertical rod-type aerials and anti-static systems for AM reception.

FMS100

FM/stereo single dipole with straight stand-off arm and 1-2in bracket. Price: £3.36 (plus VAT).

FMS200

FM/stereo dipole and reflector array with 1-2in mast attachment bracket. Price: £4.28 (plus VAT).

FMS300

FM/stereo three-element array with 1-2in mast attachment bracket. Price: £6.56 (plus VAT).

FMS400 ★

High power stereo four-element array with 1-2in mast attachment bracket. Price: £7.10 (plus VAT).

FMS600

Six-element extra high power (array only) stereo/Fm, with 1-2in mast attachment bracket. Price: £10.91 (plus VAT).

■ ANTIFERRENCE

Antiferrence Ltd, Bicester Road, Aylesbury, Bucks HP13 3BJ. Tel: Aylesbury 82511.

FM224 Mushkiller

Dipole and reflector 'H' type array. Complete with universal mast/boom clamp. For use in good reception areas. Price: £4.70 (plus VAT).

FM234T Mushkiller

Three-element array with Trumatch dipole, complete with universal mast/boom clamp, for medium range FM stereo reception. Price: £7.00 (plus VAT).

FM244T Mushkiller

Four-element array with Trumatch dipole, complete with universal mast/boom clamp. The most popular FM stereo array. Price: £7.60 (plus VAT).

FM264T Mushkiller ★

Six-element array with Trumatch dipole, complete with universal mast/boom clamp. Suitable for medium and long-range FM stereo reception. Price: £11.50 (plus VAT).

FM284T Mushkiller ★

Eight-element array with Trumatch dipole complete with universal mast/boom clamp. Price: £14.50 (plus VAT).

FM235T Mushkiller

Three-element array with Trumatch dipole



Aerialite FMS400

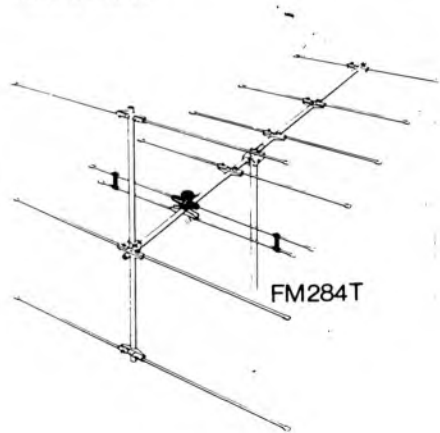

Antiferrence FM284T Mushkiller



Antiferrence FM264T Mushkiller



Tune into Aerialite's new range of Stereo Aerials

If you've invested in top class audio equipment or recently bought an expensive tuner, you've the right to expect perfection. Unfortunately, you may still have neglected one vital aspect of stereo radio. The aerial. Without the right aerial, your equipment can be operating way below potential. FM stereo needs up to ten times the level of signal required for mono. Given this plain fact, even the world's finest FM tuner is totally dependent on the strength and quality of the received signal.

To give you the finest stereo reception possible from your equipment, Aerialite have designed a superb range of stereo aerials. They'll eliminate background noise, cut out unwanted signals and interference, and just as important, give high directional selectivity to minimise multipath reception. Flawless stereo reception is a rewarding experience. The sooner you contact your nearest hi-fi/radio centre or Aerial Contractor, the sooner you'll achieve perfection.

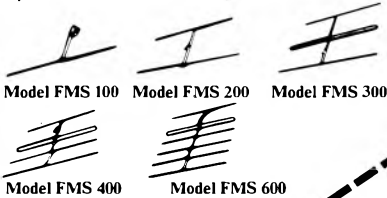

Aerialite Aerials Ltd.

Whitegate, Broadway, Chadderton, Oldham, OL9 9 QG Lanes. Tel: 061-652 1111



Please send your new Stereo Aerials leaflet
Name _____
Address _____
HFYB101

suitable for outdoor or loft fitting. Supplied with loft mounting arm bracket and clamp plus a universal clamp for outdoor fixing. Price: £6.75 (plus VAT).

FM255T D.I.Y. Mushkiller

Five-element array with Trumatch dipole suitable for outdoor or loft fitting. Supplied with loft mounting arm bracket and clamp plus a universal clamp for outdoor fixing. For medium to long range reception. Price: £9.25 (plus VAT).

RTA 175 Rotenna

Fully automatic standard aerial rotator suitable for carrying a standard size antenna. Price: £41.20. (plus VAT).

RTA 200 Rotenna ★

Fully automatic heavy duty rotator designed to support large FM and TV arrays. Price: £45.50 (plus VAT).

MA102 FM Mast Head Amplifier

Masthead amplifier in fully weatherproof housing complete with perforated strip and bracket for mast or surface mounting. Typical gain: 15dB. Price: £8.00 (plus VAT).

PU102 Power Unit

Power unit for MA102 FM. Fully insulated housing. Price: £7.00 (plus VAT).

TRR/V/SP Receiver Transformer

Matches 75 ohms coaxial input feeder into 300 ohms aerial sockets on imported tuners and tuner/amplifiers. Price: £1.72 (plus VAT).

UF2/SP TV&FM Aerial combiner

In fully weatherproof housing complete with perforated strip and bracket for mast or surface mounting. Price: £2.20 (plus VAT).

Y12SP TV/FM Aerial Outlet

With built-in diplexer to separate TV and FM signals from a common download. Can also be used indoors to combine TV and FM aerials. Surface mounting. Price: £1.40 (plus VAT).

812/SP TV/FM Aerial Outlet

Similar to Y12 but designed for flush-mounting. Price: £2.20 (plus VAT).

■ EAGLE

Eagle International, Heather Park Drive, Wembley HA0 1 SU. Tel: 01-902 8832.

FMA 10

Band II dipole for loft mounting. Price: £2.30 (plus VAT).



Antiference TYA 200 Potenna



Eagle FMA 20

FMA 20 ★

Band II FM aerial outdoor or loft mounting. 3dB gain. Front to back ratio of 6dB. Price: £3.60 (plus VAT).

FMA30

Band II FM aerial outdoor or loft mounting. 6dB gain, front to back ratio 8dB. Acceptance angle 40 degrees. Price: £5.20 (plus VAT).

FMA 40

Band II aerial, 4-element, outdoor or loft mounting, 7.5dB front to back ratio 25dB, acceptance angle 35 degrees. Price: £7.00 (including VAT).

FMA 50

Band II aerial, 2-director, double reflector, 8dB gain, front to back ratio 32dB, acceptance angle 35 degrees. Price: £10.00 (plus VAT).

DA1 ★

Complete 75Ω indoor aerial with lead. Price: £1.90 (plus VAT).



Eagle DA1 and LK1/AM1



Jaybeam Stereobeam SBM2



Jaybeam Stereobeam SBM3

LKI & AMI ★

AMI aerial mast. 4ft mast for securing aerials to all types of chimney stack. Price: 80p (plus VAT).

■ JAYBEAM

Jaybeam Ltd,
Sandfield Close, Moulton Park
Industrial Estate, Northampton NN3 1QQ.
Tel: Northampton 46611.

Stereobeam SBM2 ★

Band II folded dipole and reflector on boom. Supplied complete with fixing clamp for masts up to 2in diameter. Gain: 3dB. Reduces interference from rear. Price: £4.97 (including VAT).

Stereobeam SBM3 ★

Band II aerial comprising folded dipole, reflector and director on boom. Supplied complete with clamp to fit masts up to 2in diameter. Gain: 6dB. Gives protection against signals

★ Indicates entry is illustrated

more than 40° off bearing. Price: £7.07 (including VAT).

Stereobeam SBM4 ★

Band II aerial comprising folded dipole, reflector and two directors on boom. Supplied complete with clamp to fit masts up to 2in diameter. Suitable for medium fringe areas where large input signal is required for optimum performance. Gain: 7dB. Price: £7.67 (including VAT).

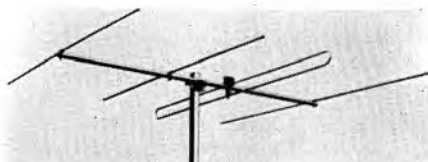

Jaybeam Stereobeam SBM4

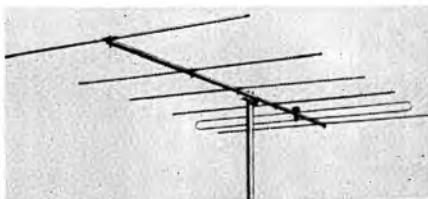

Jaybeam Stereobeam SBM6

Stereobeam SBM6 ★

High-gain Band II aerial comprising folded dipole, reflector and four directors on boom. Supplied with clamp to fit masts up to 2in diameter. Suitable for use over the whole of the FM/VHF band, including the more powerful continental stations in favourable locations. Gain: 8.5dB. Price: £11.72 (including VAT).

Stereobeam room aerial ★

Band II compressed dipole using inductive loading. Suitable for areas of high signal strength. Can be stood on base or fixed to wall. Supplied complete with lead and plug. Price: £3.62. (including VAT).

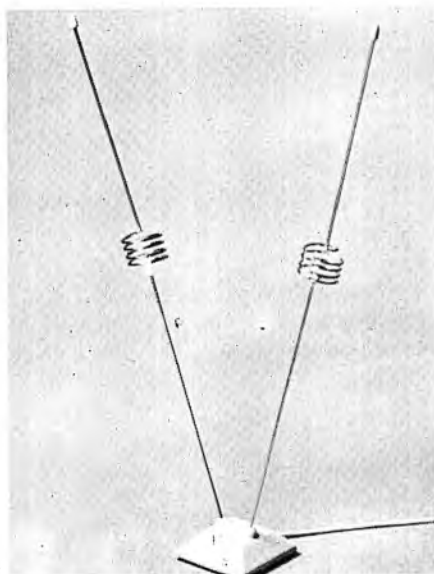

Jaybeam Stereobeam room aerial

FM9S Superfringe Area FM Antenna ★

Consists of folded dipole, five directors and triple reflector unit with universal mast clamp. Price: £20.52 (including VAT).

Stacking Kit PM3

For extreme long range reception two SBM4 or SBM6 arrays can be stacked together using phasing and matching harness PM3. Price: £4.21 (including VAT).

2010/220 Aerial Rotator

Control unit with position selector knob, plus motor unit for driving aerial. Operation indicated by signal lamps. Motor 20V 65W. 360° rotation. Suitable for 220-240V AC only. Speed: one revolution in 50 sec. Magnetic disc brake and self-restraining worm-gear drive hold aerial in chosen position. Five-core control cable available separately (see below). Price: £40.50 (including VAT).

2030/220 Multimatic Aerial Rotator

Control unit with position selector knob, direction indication shown by flashing light that follows to position set. Motor 20V 65W. 360° rotation, suitable for 220-240V AC only. Speed: one revolution in 50 secs. Magnetic disc brake and self-restraining work gear drive hold aerial in chosen position. Four-core control cable available separately (see below). Price: £45.90 (plus VAT).

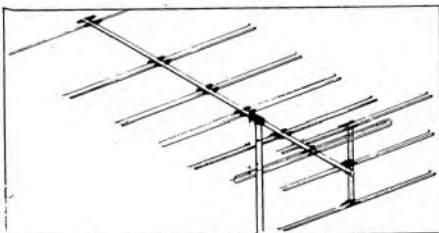

Jaybeam FM9S

Control cable

Five-core colour-coded control cable available in 20 metre or 50 metre lengths. Price: C5/20 £4.27; C5/50 £10.80 (both including VAT).

RZ100

Alignment bearing suitable for use with the above-mentioned equipment. Price: £9.90 (including VAT).

FM4S

Four-element stereo antenna. Price: £12.69 (including VAT).

FM6S

Six-element stereo antenna. Price: £18.36 (including VAT).

■ MAXVIEW

Maxview Aerials Ltd, Maxview Works, Setch, King's Lynn, Norfolk.
Tel: Watlington 376/591.

Maxview D/DW

Band II wall-mounting dipole with stand-off arm and adjustable swivel fitting. Price: £3.00 (plus VAT).

Maxview D/DM

Band II dipole array with bracket for mast fitting. Price: £2.88 (plus VAT).

Maxview D/HM

Band II array comprising dipole and reflector on boom. Bracket for mast mounting. Price: £3.85 (plus VAT).

Maxview D/S3

Band II three-element array comprising director, dipole and reflector. Bracket for mast mounting. Price: £4.50 (plus VAT).

Maxview D/FD3 ★

Band II three-element array comprising director, folded dipole and reflector. Bracket for mast mounting. Price: £5.00 (plus VAT).

Stereomax 4

Tripole, two directors and reflector. Price: £6.50 (plus VAT).

Stereomax 6 ★

Tripole, four directors and reflector. Price: £9.60 (plus VAT).

■ PREMIER

Premier Industries Ltd, 343/345 High Street, Cheltenham Spa, Gloucestershire GL50 3HS.
Tel: Cheltenham 27782.

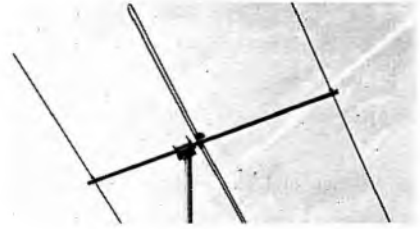
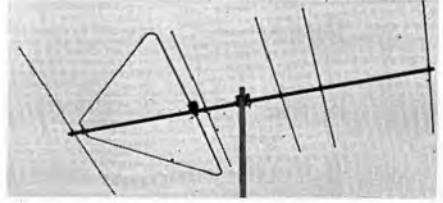
*Maxview D/FD3**Maxview Stereomax 6***C4ST**

Four-element Band II array comprising two directors, folded dipole and modified reflector with wider folded back end and easier assembly. Price: £7.12 (plus VAT).

C6ST

Six-element Band II array comprising four directors, folded dipole and modified reflector with wider folded back end and easier assembly. Price: £9.24 (plus VAT).

Clarity PH/ST

Phasing harness for coupling two C4 or two C6 arrays for extra long distance reception. Price: £2.16 (plus VAT).

2/SD/S

Single dipole Band II array. Supplied with 2 ins. universal mast clamp. Price: £2.00 (plus VAT).

2/H/H

H Band II array. As above. Price: £3.20 (plus VAT).

2/3/H

Three element array, folded dipole. Price: £5.32 (plus VAT).

■ STOLLE

Karl Stolle, 29 Church Street, Ilkley, Yorks. Tel: Ilkley 2193.

US-1

FM dipole with AM rod. Supplied with win-



Greatly improved stereo reception

Wolsey, for many years the experts on reception problems, now offer a comprehensive range to meet all requirements. The new 6 element



Super Gain Array, coupled with the Clearsound Masthead Amplifier, is probably the finest combination of its type for use in the more difficult signal areas. Send for full details.

Wolsey clear sound

FM aerials & amplifiers

Wolsey Electronics,
Cymmer Road, Porth,
Mid Glamorgan CF39 9BT Gt. Britain.
Telephone: (044 361) 2711.



dow/loft mounting bracket. Connection 300 ohms. Price: on application.

US-3

Three-element high power FM array. Universal mast clamp. Built-in balancer for 240 or 750 ohms down leads. Forward gain: 5.5dB. Front/back ratio: 13dB. Acceptance angle: horizontal 68 degrees, vertical 110 degrees. Price: on application

US-5

Five-element high power FM array with double reflector. Universal mast clamp. Built-in balancer for 240 or 75 ohms down leads. Forward gain: 7.5 dB. Front/back ratio: 20dB. Acceptance angle: horizontal 60 degrees, vertical 90 degrees. Price: on application.

US-8

Eight-element high power FM array with treble reflector. Universal mast clamp. Built-in balancer for 240 or 75 ohms down leads. Forward gain: 10dB. Front/back ratio: 22dB. Acceptance angle: horizontal 50 degrees, vertical 70 degrees. Price: on application.

US-14V

Fourteen element, high power FM array. Universal mast clamp. Built-in balancer for 240 or 75 ohm downleads. Forward gain: 12dB. Front/back ratio: 20dB. Acceptance angle: horizontal 44 degrees, vertical 60 degrees. Connection box designed to accommodate a plug-in module amplifier. Price: on application.

Stereo Set-top (indoor) Aerials

Apollo. Model Z.1912. With built-in amplifier. 8dB. Model Z.1906. Model Z.1942. With built-in amplifier. 14dB gain. Orion. Z.1956. With built-in amplifier. 8dB gain. Model Z.1955. Model Z.1960. With built-in amplifier. 14dB gain. Further details and prices of models on application.

FM Masthead Amplifiers

Model TRA.3552. Supplied complete with remote power unit. 14dB gain. (Also a complete range of ultra broadband Masthead amplifiers, suitable for FM or TV reception. 14 to 30dB gain. Further details and prices of models on application.

FM Amplifier

Model TRA.3652. For indoor use only. With built-in amplifier. 14dB gain. Price: on application.

Receiver Balancer

Model SG.1200. Matching transformer 300/75 ohms. Price: on application.

FM Module Amplifier

For use with US-14V. SAV 3325. Use with power unit SW 3307. Gain: 15dB. Price: on application.

FM Set back Amplifier

Fully screened with integrated power units. SAV 3303 — gain 12dB, SAV 3304 — gain 18dB, SAV 3308 — gain 24 dB. Price: on application.

Variable attenuator

0-20 dB. SD 3201. Price: on application.

■ VORTA

Vorta Systems (UK), 297/299 High Street, Cheltenham Spa, Glos GL50 3HS. Tel: Cheltenham 31166.

Vorta Mk VI

Dome antenna. Omni-directional stereo enclosed aerial. Price: £16.50 (plus VAT).

Octophonic-OST8

Continental style 8-element Band II aerial, comprising 5 directors, folded dipole (75/300 ohms matching transformer built-in), and a 2-element fish tail type of reflector. Robustly constructed on a 25mm sq section boom. Complete with mast fixing clamp. Price: £16.45 (plus VAT).

Quinphonic-QST5

Continental style 5-element Band II aerial, comprising 2 directors, folded dipole (75/300 ohms matching transformer built-in), and a 2-element fish tail type of reflector. Robustly constructed on a 25mm sq section boom. Complete with mast fixing clamp. Price: £12.66 (plus VAT).

VS1

Single dipole. Deluxe Band II aerial. Dipole mounted on 25mm sq section stand-off arm 30mm in length. Complete with mast fixing clamp. Price: £3.12 (plus VAT).

VS2

Dipole and reflector ('H' type) deluxe Band II aerial. Robustly constructed on 25mm sq section boom. Complete with mast fixing clamp. Price: £5.50 (plus VAT).

VS3

3-element deluxe Band II aerial. Comprising 1 director, folded dipole, folded reflector. Robustly constructed on 25mm sq section boom. Complete with mast fixing clamp. Price: £8.94 (plus VAT).

■ WOLSEY ELECTRONICS

Cymmer Road, Porth, Rhondda, Glamorgan CF39 9BT. Tel: Porth 2711.

FM/DD ★

Band II single dipole for loft or room mounting. Price: £2.68 (plus VAT).

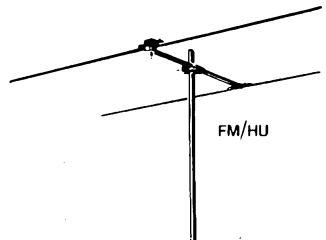
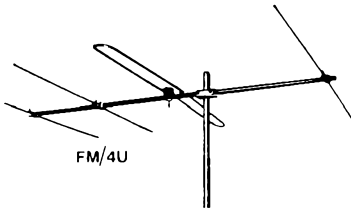
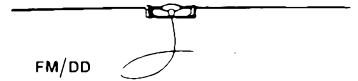
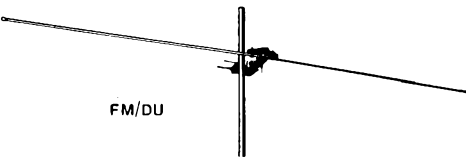

Wolsey Electronics

★ Indicates entry is illustrated



Wolsey Clearsound

FM/DU ★

Band II single dipole for outside masthead mounting. Supplied with fixing clamp. Price: £3.07 (plus VAT).

FM/HU ★

Band II dipole with reflector for outside mounting. Supplied with fixing clamp. Price: £4.43 (plus VAT).

FM/4U ★

Band II four-element array comprising folded dipole, two directors, one reflector. Supplied with fixing clamp. Price: £7.19 (plus VAT).

Clearsound FM Amplifier ★

Signal booster for use with any Band II aerial array to boost wanted weak station without introducing distortion from strong unwanted stations. Designed to be fitted to aerial mast, weatherproofed. Supplied with power unit. Price: £19.17 (plus VAT).

Amplifiers and Control Units

★ Indicates entry is illustrated

Abbreviations used in this section are given on page 27

■ ACCUPHASE

Belmont A/V Ltd, Fircroft Way, Edenbridge, Kent TN8 6HA. Tel: Edenbridge 4116.

P-250

Dual channel power amplifier. 36 transistors, 34 diodes. Power output: 100W RMS continuous per channel into 8 ohms (both channels operating simultaneously at any frequency from 20Hz-20kHz). THD: not more than 0.1% at rated power output. Intermodulation distortion: 0.1% at rated power output. FR: 20Hz-20kHz. Slewing rate: more than 15V/ μ s. Damping factor: 20 at 8 ohms load, 20Hz-20kHz. Input sensitivity and impedance: 1V 100K for rated output at maximum level control. Hum and noise: 94dB below rated output. Output load impedance: 4, 8 and 16 ohms. Cut-off frequency: low 17Hz 18dB/Oct; high 24kHz 18dB/Oct. Mains: 100, 117, 220 μ 240V AC 50/60Hz. Controls: Left level-right level speakers, speaker damping. Power consumption: 70W at zero signal output. Size: 445 x 152 x 355mm. Weight: 19.5kg. Price: £320 (plus VAT).

E-202 ★

Integrated stereo amplifier. 53 transistors, 4 FET's, 44 diodes, 2 thermistors. Power output 100W RMS continuous per channel into 8 ohms (both channels operating simultaneously at any frequency from 20Hz-20kHz). THD: not more than 0.1% at rated power output. Intermodulation distortion: 0.1% at rated power output. FR: 20Hz-20kHz +0dB, -0.2dB. Damping factor: 20 at 8 ohms load, 20Hz-20kHz. Headphone jack: for listening with low impedance (4-32 ohms) dynamic stereo headphones. Hum and noise: 94dB below rated output. Controls: 10-step rotary switch for both channels with on/off switch. Tone is varied in 2dB steps. Bass turnover frequency: 400Hz \pm 10dB at 100Hz; treble turnover frequency: 2.5kHz \pm 10dB at 10kHz. Volume

control: less than 1dB tracking error. Output load impedance: 4, 8 and 16 ohms. Mains: 110, 117, 220, 240V AC 50/60Hz. Power consumption: 70W at zero signal output. Size: 455 x 152 x 355mm. Weight: 19.5kg. Price: £375 (plus VAT).

P-300 ★

Dual channel power amplifier, 73 transistors, 1 IC, 88 diodes, 2 thermistors. Power output: 150W RMS continuous per channel into 8 ohms (both channels operating simultaneously at any frequency from 20Hz-20kHz). THD: not more than 0.1% at rated power. Intermodulation distortion: not more than 0.1% at rated output. FR: 20Hz-20kHz + 0dB, -0.2dB. Slewing rate: more than 15V/ μ s. Damping factor: 20 at 8 ohms load. Input sensitivity and impedance: 1V 100K for rated output at the maximum level control. Hum and noise: 100dB below rated output. Output load impedance: 4, 8 and 16 ohms. Mains: 100, 117, 220, 240V AC 50/60Hz. Power consumption: 100W at zero signal output. Size: 445 x 152 x 355mm. Weight: 25kg. Price: £450 (plus VAT).

C-200

Stereo pre-amplifier. 80 transistors, 35 diodes. FR: 20Hz-20kHz +0dB, -0.2dB. Distortion: lower than 0.05% at rated output level. Inputs: disc (1) 2-6mV 30K, 47K; disc (2) 2-6mV 47K, mic 2mV 47K, tuner 200mV 130K, aux (1 & 2) 200mV 130K, tape play (1 & 2) 200mV 130K. Maximum output level: 10V at 0.05% distortion. Hum and noise: tuner, aux tape play 90dB below rated output; disc, mic 74dB below



Accuphase P-300



Accuphase E-202

* Indicates entry is illustrated

10mV input. Tone controls: 10-step rotary switch for each channel with turnover frequency switches. Volume control: less than 1dB tracking error control down to -60dB. Mains: 100, 117, 220, 240V AC50/60Hz. Power consumption: 36W. Size: 445 × 152 × 55mm. Weight: 14kg. Price: £330 (plus VAT).

M-60

Monophonic power amplifier. Output 300W. THD: 0.1%. FR: +0 -0.2dB over 20Hz-20kHz; +0-3dB over 2Hz to 90kHz range. Input sensitivity and impedance 2V, 100K Ω . Damping Factor 45. Controls 1dB step attenuator type volume control. Power Level meter. Dimensions 48.2 × 34.5 × 17cm. Features/Facilities: Heavy duty large energy power supply. Subsonic Filter to eliminate noise below audible range.

■ AKAI

Rank Audio Visual Ltd, PO Box 70,
Great West Road, Brentford TW8 9HR.
Tel: 01-568 9222.

AA5810

Integrated stereo amplifier. Inputs: phono 2.5mV 50K, tuner 150mV 60K, aux 150mV 60K, tape (DIN/pin) 150mV 60K, mic 2.5mV 50K. Rated output power: 50W RMS per channel, both channels driven at 8 ohms. THD: 0.3% from 1-4W to rated output, 8 ohms. Power bandwidth (IHF): 15Hz-35kHz at 8 ohms, both channels fully driven. FR: 7Hz-100kHz +0dB, -3dB. S/N ratio: phono better than 81dB, mic better than 80dB, aux, tuner, tape better than 90dB. Channel separation: better than 50dB. Equaliser (phono): ± 1 dB. Tone controls: bass 100Hz ± 10 dB, treble 10kHz ± 10 dB, loudness 100Hz +7dB, 10kHz +4.5dB. Low filter 50Hz -8dB, high filter 10kHz -8dB. 45 transistors, 21 diodes. Mains: 100-240V AC 50/60Hz. Size: 450 × 118 × 285mm. Weight: 10.2kg. Price: £175.60 (plus VAT).

AA5510

Integrated stereo amplifier. Rated output power: 30W RMS per channel, both channels driven into 8 ohms. THD: 0.5% from 1-4W to rated output, 8 ohms. Power bandwidth: (IHF) 10Hz-60kHz at 8 ohms. FR: 7Hz-100kHz +0dB, -3dB. Inputs: phono 3mV 50K, tuner 150mV 70K, aux 150mV 70K, tape (DIN/pin) 150mV 70K, mic 2.5mV 50K. Main amp 650mV 50K. S/N ratio: (phono) better than 82dB, aux better than 90dB. Channel separation: better than 50dB (phono at rated output). Equaliser (phono): RIAA ± 1 dB. Tone controls: bass 100Hz ± 10 dB, treble 10kHz



Alba 700A

± 10 dB, loudness 100Hz +7dB, 10kHz -10dB. Low filter 50Hz -10dB, high filter 10kHz -10dB. 30 transistors, 6 diodes. Mains: 100-240V AC 50/60Hz. Size: 450 × 115 × 290mm. Weight: 9.3kg. Price: £140.40 (plus VAT).

AA5210

Rated output power: 15W RMS per channel, both channels driven into 8 ohms or 18W RMS per channel, both channels driven into 4 ohms. Harmonic distortion: 0.8% from 1-4W to rated output (8 ohms). Power bandwidth: (IHF) 15Hz-90kHz at 8 ohms, both channels fully driven. FR: 8Hz-100kHz -3dB. Input sensitivity and impedance: phono 3mV 50K, tuner 150mV 80K, aux 150mV 80K, tape (DIN/pin) 150mV 80K, mic 3mV 50K. Main amp: 600mV 50K. S/N ratio: (IHF) phono better than 78dB, aux better than 80dB. Channel separation: better than 45dB (phono at rated output). Equalizer (phono): RIAA ± 1 dB. Tone controls: Bass 100Hz ± 10 dB, treble 10kHz ± 10 dB. Low filter 50Hz -8dB, high filter 10kHz -9dB. 23 transistors, 10 diodes. Mains: 100/240V AC 50/60Hz. Power consumption: 120W. Size: 459 × 108 × 290mm. Weight: 7.2kg. Price: £106.80 (plus VAT).

AA5210DB

Incorporates a Dolby noise reduction circuit which facilitates Dolby recording and playback with an ordinary tape recorder or tape deck. Rated output power: 15W RMS per channel, both channels driven into 8 ohms or 18W RMS per channel, both channels driven into 4 ohms. Harmonic distortion: 0.8% from 1-4W to rated output (8 ohms). Power bandwidth: (IHF) 15Hz-90kHz at 8 ohms, both channels fully driven. FR: 8Hz-100kHz -3dB. Input sensitivity and impedance: phono 3mV 50K, tuner 150mV 80K, aux 150mV 80K, tape (DIN/pin) 150mV 80K, mic 3mV 50K. Main amp: 600mV 50K. S/N ratio: (IHF) phono better than 78dB, aux better than 80dB. Channel separation: better than 45dB (phono at rated output). Equalizer (phono): RIAA ± 1 dB. Tone controls: Bass 100Hz ± 10 dB, treble 10kHz ± 10 dB. Low filter 50Hz -8dB, high

filter-10kHz -9dB. 43 transistors, 2 FET's, 26 diodes. Mains: 100/240V AC 50/60Hz. Power consumption: 150W. Size: 529 × 108 × 340mm. Weight: 9.6kg. Price: £140.40 (plus VAT).

■ ALBA

Alba (Radio & Television) Ltd,
Bull Lane, Edmonton,
London N18 1SD.
Tel: 01-803 4451.

900

Integrated stereo amplifier. 40W per channel. THD: less than 0.1%; FR 20Hz-20kHz. Inputs, magnetic p.u. 2.7mV/47k; tuner, tape replay 150 mV/1ma; quadrophonic adaptor. Damping Factor greater than 200 at 50Hz; S/N ratio, p.u. 69dB (77dB weighted) other input 79dB (82dB weighted). Dimensions: 46 × 24 × 10cm. Features: var. channel separation for quad. adaptor. L/S switching (A, A+ B, B). Scratch and rumble filter. Price on application.

UA700 ★

Integrated stereo amplifier. 10W per channel. THD: less than 0.1%. FR 30Hz-18kHz ±1dB. Input imped. p.u. (mag.) 5mV/50K, (cer) 50mV; mic 2.3mV/50K; aux (high) 2V/3M; other aux 3.75mV/500K. S/N ratio: tuner (aux) 63dB, mag p.u. 55dB. Controls: level, bass, treble, loudness and balance calibrated in dB's. Dimensions: 41.5 × 19.5 × 10cm. Price on application.

■ ALPHA

Highgate Acoustics, 38 Jamestown Road,
London NW1 7EJ.
Tel: 01-267 4937.

AX 500

Integrated amplifier. Output: 25W RMS per channel. THD: 0.15%. FR: 30Hz-40kHz. Inputs: mag PU 2.5mV 47K, radio 100mV 100K, tape 150mV 150K. Damping Factor: 30:1. S/N Ratio: 65dB. Controls: volume, bass, treble, balance. Dimensions: 44 × 21 × 10cm. Price: £63.50 (excluding VAT).

FA 600

Integrated amplifier. Output: 32W RMS per channel. THD: 0.5%. FR: 15Hz-40kHz. Inputs: mag PU 3mV 47K, xtal 260mV 500K, aux 260mV 500K, tape 260mV 500K. S/N Ratio: 65dB. Controls: bass, treble, balance, volume. Dimensions: 41 × 30 × 13cm. Price: £89 (excluding VAT).



Amcron D150A



Amcron D60

■ AMCRON

Macinnes Laboratories Ltd,
Macinnes House, Carlton Park
Industrial Estate, Saxmundham,
Suffolk IP17 2NL.

Tel: Saxmundham 2262/2615.

D150A ★

Stereo power amplifier. Output: 100W RMS per channel into 8 ohms (200W RMS per channel into 2.5 ohms). THD: below 0.05%. Frequency response: ±0.1dB DC-20kHz, ±1dB DC-100kHz. Inputs/Impedance: unbalanced 20K, 1.19V for full output. Damping factor: greater than 400, DC-400Hz into 8 ohms. Controls: two front panel input level controls and power switch. Stereo/mono switch on rear. DC-coupled throughout. Can be converted from stereo to mono by single switch. Dimensions: 43 × 22 × 13.7cm. Rack mounting kit available. Price: on application.

D60 ★

Stereo power amplifier. Output: 62W RMS per channel into 4 ohms, 42W RMS per channel into 8 ohms, 100W RMS into 8 ohms mono. HD: <0.05%. Intermodulation distortion: <0.05% from 10mW to 30W. FR: 5Hz-30kHz ±1dB at 30W. Damping factor: >200 from 0-1kHz. H and N: -106dB at 30W. Input: 0.775V for 30W into 8 ohms. Mains: 117, 234V 50Hz. Size: 17 × 8¼ × 1¾in. Weight: 10lb. Fully protected against short circuit or mismatch. Outlet socket for headphones on front panel. Price: on application.

★ Indicates entry is illustrated

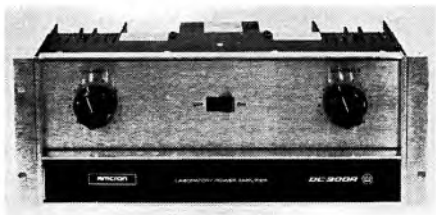

Amcron DC300A



Amcron IC-150

DC300A ★

Stereo power amplifier. Output: 500W RMS per channel into 2.5 ohms, 350W RMS per channel into 4 ohms, 200W RMS per channel into 8 ohms, 650W RMS into 8 ohms or 4 ohms mono. HD: <0.05% from 0-20kHz. Intermodulation distortion: <0.05% 10mW to 150W into 8 ohms. FR: DC to 20kHz ± 0.1 dB. Damping factor: >200 from DC to 1kHz. H and N: -110dB at 150W. Input: 1.75V for 150W output. Mains: 117, 234V, 50Hz. Size: 19 x 7 x 9 3/4 in. Price: on application.

IC-150 ★

Stereo preamplifier and tone control unit incorporating IC circuitry. Inputs: 2 phono, 1 tuner, 2 aux, 2 tape. Output: 2.5V, max 10V into 600 ohms. H and N: 90dB below rated output. FR: high-level into high impedance load, 3Hz-100kHz ± 0.6 dB; into IHF load, 10Hz-20kHz ± 0.1 dB. Volume, loudness, stereo panorama, bass and treble controls. Rumble and scratch filters. Mains: 120, 240V 50-400Hz AC. Size: 17 x 5 1/4 x 8 1/4 in. Price: on application.

AMSTRAD

AMS Trading (Amstrad) Ltd,
89 Ridley Road, Dalston, London E8 2NH.
Tel: 01-249 5237/8/9.

I.C. 2000Mk III ★

Integrated amplifier. Output: 25W RMS per channel. THD: <0.1% at rated output. FR: 15Hz-30kHz. Inputs: mag PU 3mV 47K,

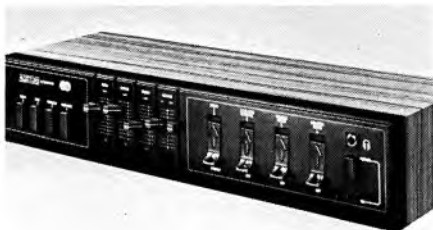

Amstrad IC2000MkIII



Amstrad 8000 MkIII

ceramic PU (velocity loaded), tape 70mV 150K, radio 70mV 150K. S/N Ratio: 60dB. Controls: bass, middle, treble, left and right volume, mono/stereo switch, loudness, rumble filter, scratch filter. Dimensions: 429 x 163 x 92mm. Features: headphone socket, extension loudspeaker outlets, slider controls, tape recording signal output. Price: £48 (excluding VAT).

8000 Mk III★

Integrated amplifier. Output: 10W RMS per channel. THD: <0.5% at rated output. FR: 20Hz-30kHz. Inputs: mag PU 3mV 47K, ceramic PU 75mV 1 M Ω (velocity loaded), tape 700mV 150K, radio 70mV 150K. S/N Ratio: 60dB. Controls: bass, treble, left and right volume, rumble filter, scratch filter, loudness, mono/stereo switch, input select, mains switch. Dimensions: 33 x 216 x 76mm. Features: tape recording signal output, extension loudspeaker sockets, headphone socket, slider controls, three filter. Price: £31.66 (excluding VAT).

■ A/R/D

Audio Research & Development Ltd,
Navas House, The Maultway, Camberley,
Surrey GU15 1QE.
Tel: Camberley 24684.

A/R/D Mk IV

Integrated amplifier. Output: 35W RMS per channel. THD: 0.08% at rated output. FR: 20Hz-20kHz ± 1 dB. Inputs: PU 2.5mV 47K, radio (1) 90mV 47K, radio (2) 90mV 47K, tape

(1) 90mV 47K, tape (2) 90mV 47K, tape monitor. Damping Factor: 100 at 8 ohms. S/N Ratio: -68dB at 35W. Controls: volume, bass, treble, balance. Dimensions: 260 × 352 × 112mm. Low pass filters 6kHz and 9kHz. Two switched headphone outlets. Plug-in circuit boards for up-dating and simple factory servicing. Price: £95 (excluding VAT).

■ ARMSTRONG

Armstrong Audio Ltd, Warlters Road,
London N7 0RZ.
Tel: 01-607 3213.

621 ★

Integrated stereo amplifier. 40W per channel into 8 ohms. THD: 0.08% at rated output. FR: 20Hz-20kHz ±1dB. Inputs: disc (1) 3.0mV 47K; disc (2) 6.0mV 47K; tape 250mV 68K; tuner 120mV 68K; auxiliary 120mV 68K. Damping factor better than 50. S/N ratio: -65dB unweighted. Controls: volume, bass, treble, balance, input selector, loudspeakers 1+2. Loudness, monitor, mono/stereo, filter 1 & 2, slope and low filter. Dimensions: 31.2 × 28.5 × 8.2cm. Features include electronic gate switching on inputs, teak or rosewood case. Price: £92.58.

■ ATRON

Teledyne Acoustic Research, High Street,
Houghton Regis, Dunstable, Beds.
Tel: 0582 603151.

KA 2015 ★

Solid state integrated stereo amplifier. 15W per channel into 8 ohms. THD: 0.1% at rated power. FR: 25-35000Hz. Input impedances: phono 2.5mV (50K); aux. 160mV (100K); tape mon., 160mV (100K); tape recorder (DIN) 160mV (100K). Damping Factor 25 at 8 ohm load. S/N ratio: phono, better than 60dB; auxiliary better than 70dB. Controls: Bass ±10.5dB at 100Hz, treble ±10.5dB at 100Hz. Loudness ±7dB at 100Hz. Dimensions: 43(w) × 13(h) × 32(d)cm. Pushbutton controls for mute, hi-lo filters, loudness, stereo, mono, tape monitor, tuner, aux, AM/FM, Quadro, remote power. Price: £56 (excluding VAT).

■ BGW SYSTEMS

Webland Electronics Ltd, Mirabel House,
117-121 Wandsworth Bridge Road,
London SW6.
Tel: 01-736 0980.

BGW Model 500D ★

Power amplifier. Power output: 200W RMS per channel with both channels driven into 8



Armstrong 621



Atron KA2015

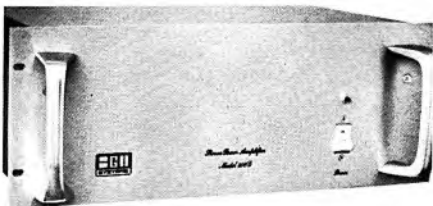

BGW 500D

ohms at 25kHz to 15kHz. THD: not more than 0.2% at any power level from 250mW to 200W into 8 ohms. FR: 20Hz-20kHz +0dB, -0.2dB. Noise and hum level: better than 110dB below rated output into 8 ohms. Input sensitivity: 2V for 40V output. Voltage gain: 26dB. Input impedance: 47K. Damping factor: greater than 1000 at low frequencies into 8 ohms. Load impedance: ≥2 ohms. Facilities include electronic crowbar circuitry, circuit breaker, thermal trip. Size: 19 × 7 × 12in. Finish: standard brush silver rack panel with handles. Weight: 49lb. Price: £550.00 (plus VAT).

BGW Model 250B

Power amplifier. Power output: 85W RMS per channel with both channels driven into 8 ohms at 20Hz-20kHz. THD: 0.1% at any power level from 250mW to 85W. FR: 20Hz-20kHz +0dB, -0.25dB. Noise and hum level: better than 110dB below rated output. Input sensitivity: 1.5V for 30V output. Voltage gain: 26dB. Input impedance: 47K. Damping factor: greater than 500 at low frequencies into 8 ohms. Load impedance: ≥2 ohms. Facilities include electronic crowbar circuitry, circuit breaker, thermal trip. Finish: standard brush silver rack panel. Weight: 27lb. Price: £325.00 (plus VAT).

BGW Model 750A

Power amplifier. Power output: 200W RMS per channel with both channels driven into 8 ohms at 5Hz-15kHz. THD: not more than 0.2% at any power level from 250mW to 200W into 8 ohms. FR: 20Hz-20kHz +0dB, -0.25dB. Noise and hum level: better than 100dB below rated output into 8 ohms. Input sensitivity: 2V for 4V output. Voltage gain: 26dB. Input impedance: 47K. Damping factor: greater than 1000 at low frequencies into 8 ohms. Facilities include electronic crowbar circuitry, circuit breaker, thermal trip. Fan cooled. Size: 10 × 7 × 12in. Finish: standard black rack panel with handles. Weight: 49lb. Price: £650 (plus VAT).

BGW pre-amplifier 202

Contains an advanced phono preamplifier design. Output: Line out 8 volts RMS into 600 ohms. Phono at tape output: 10 volts RMS into 5 kohms. Rated Output: 4 volts into 5 kohms. THD: less than 0.01% at rated output 20-20,000Hz. Noise: Phono equivalent input noise: 0.8 microvolt with input shorted over 20-20,000Hz. S/N: 82dB. FR: 20-20,000. Dimensions: 5.25 × 19 × 10.75ins. Price: £395.00 (plus VAT).

■ **BOSE**

Bose (UK) Ltd, Gas Road, Milton Regis., Sittingbourne, Kent. Tel: Sittingbourne 75341.

Model 1801

Power amplifier. Output: 250W RMS per channel into 8 ohms or 400W RMS per channel into 4 ohms. FR: 20Hz-20kHz ±1dB. Input impedance: greater than 50K. Input sensitivity: 1.5V RMS for 250W into 8 ohms. Damping factor: greater than 40. S/N ratio: 120dB. Controls: input gain controls. 1/2 channel selection switch, speaker selection A and B, on/off, LED and meter display switch. Current limiting. Built-in thermal heat sensors. Dimensions: 18 × 18½ × 7½in. Price: £540 (excluding VAT).

4401

Solid-state four channel pre-amplifier. Inputs: phono (1) 2mV 1kHz, phono (2) 2mV 1kHz, tuner 200mV, aux 200V, tape (1) 200mV, tape (2) 200mV. Rated output: 2V RMS (7V RMS before overload). Output impedance: 600 ohms. Input impedance: high level 100K, phono (except CD-4 mode) 47K, phono (CD-4 mode) 100K. FR: 20Hz-20kHz ±0.2dB. THD: ≤0.2%, 20Hz-20kHz at rated output. IM distortion: ≤0.2% at rated output. H and N: high level min 80dB below rated output, noise typically 90dB down. Low filter: -3dB at 70Hz,

6dB/Oct attenuation, high filter -3dB at 7kHz, 12dB/Oct attenuation. Tone controls: bass ±15dB at 50Hz, treble ±15dB at 20kHz. Volume muting: -20dB. Mains: 105-130V or 210-260V AC 50/60Hz, 30W. Size: 6in high, 18in wide, 13½in deep. Weight: 12lb. Price: £298 (excluding VAT).

Both models covered by a 5-year parts and labour guarantee.

■ **BRADMATIC LTD**

338 Aldridge Road, Streetly, Sutton Coldfield, West Midlands B74 2DT. Tel: 021-353 3171.

Manufacturers of solid state mono and stereo power amplifiers. Details on request.

■ **CAMBRIDGE AUDIO**

Cambridge Audio Ltd, 111 Chertsey Road, Byfleet, Surrey KT14 7LA. Tel: Byfleet 41131.

P60

Integrated stereo amplifier. 30W per channel into 8 ohms. THD: less than 0.05% at 1kHz. FR: 25Hz-25kHz ±0.5dB. Inputs for phono 3mV 47K, radio 250mV 180K, cassette 150mV 100K, aux 150mV 100K, tape 1 & 2 400mV. Tape 1 & 2 cassette outputs 400mV. Damping factor 780 into 8 ohms. S/N ratio: phono 60dB tuner <70dB unweighted. Controls: balance, input selector, pre-amp volume control, treble, bass, power amp level. Dimensions: 41.9 × 24.4 × 5.1cm. Features include variable gain front end. Visual monitoring of signal levels.

■ **CERWIN VEGA**

Cerwin Vega (UK), 281 Balmoral Drive, Hayes, Greater London. Tel: 01-573 1566.

A-1800 S

Power amplifier. Power output: 225W RMS into 8 ohms per channel. Distortion: less than 0.08% (IM or THD) at 250W RMS (typically less than 0.008%). FR: 20Hz-100kHz +1dB (DC -100kHz +1dB without low frequency roll-off). Damping factor: 500 at 1W. Hum and noise: 105dB below maximum output. Load impedance: 10K. Input sensitivity: 1V RMS. Power requirements: 25VA at no signal, 1100VA at maximum output. Size: 19 × 5½ × 6in. Weight: 25lb. Finish: brushed satin aluminium and walnut case. Price: £450 (plus VAT).

A1800 I

As above plus dB meters and crossover at 250Hz. Price: £550 (plus VAT).

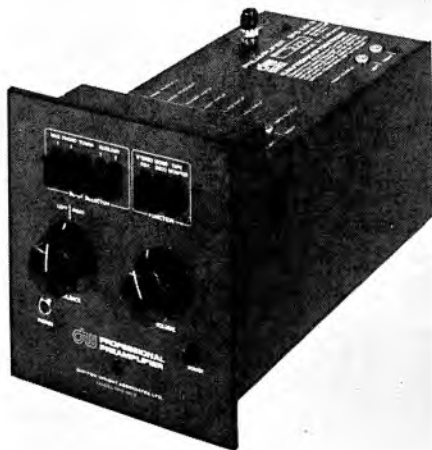

Dayton Wright SPS Mk3

A-3000

Power amplifier. Power output: 400W RMS into 8 ohms per channel. Distortion: less than 0.08% (IM or THD) at 400W RMS. Damping factor: 500 at 1W. Hum and noise: 105dB below maximum output. Load impedance: 4 ohms or higher. Input sensitivity: 1V RMS. Input impedance: 10K. Power requirements: 30VA at no signal, 1500 at maximum output. 120V AC 60Hz. Controls: input level, on/off switch, over temperature indicator. Size: 19 × 9 × 9in. Weight: 40lb. Finish: brushed satin aluminium enclosed in walnut case. Price: £795 (plus VAT).

A-3000 I

As above plus dB meters and electronic cross-overs at 250Hz. Price: £895 plus VAT.

DAYTON WRIGHT

Exposure Electronics, Richardson Road, Hove, Sussex BN3 5RB.
Tel: Brighton 777912.

SPS Mk 3 ★

Pre-amplifier. Output: 25V peak to peak. IM distortion: under 0.002% at 1.5V output. FR: (high level) ±1dB at 4Hz-0.7MHz, RIAA phono ±0.2dB at 40Hz-20kHz. Inputs: phono 1, phono 2, tuner, aux 1, aux 2, tape. Controls: balance, volume, input selector, stereo reverse, stereo/mono, tape monitor, on/off. Dimensions: 5 × 5½ × 10in. Weight: 9lb. Output jack for medium impedance headphones. Price: on application.

SPL

Professional pre-amplifier. Outputs: 25V peak

to peak. IM distortion: under 0.002% at 1.5V output. FR: (high level) ±1.6dB at 1Hz-0.7MHz. Inputs: low level magnetic 30mV for 1.5V output, normal magnetic 1.5mV, tape 400mV. S/N ratio: better than 70dB. Controls: balance, volume, left and right channel controls for headphone input, input selector pushbutton, tape monitor 1 and 2, tape dub 1-2, 2-1. Dimensions: 11 × 5½ × 10in. Price: on application.

DUNLAP-CLARKE

Exposure Electronics, Richardson Road, Hove, Sussex BN3 5RB.
Tel: Brighton 777912.

Dreadnought 1000

Power amplifier. Output: 250W RMS into 8 ohms, 500W RMS into 4 ohms, 1,000W RMS into 2 ohms. THD: 0.25% maximum, typically 0.025%. FR: 20Hz-20kHz ±0.5dB. Inputs: 1.75V for full output. Input impedance: 100K. S/N ratio: at least 100dB minimum. Controls: meter calibrated. Dimensions: 19 × 7 × 12in. Price: on application.

Dreadnought 500

Power amplifier. Output: 150W RMS into 8 ohms, 300W RMS into 4 ohms, 600W RMS into 2 ohms. FR: 20Hz-20kHz ±0.5dB. Inputs: 1.75V for full output. Input impedance: 100K. S/N ratio: at least 100dB minimum. Controls: meter calibrated. Dimensions: 19 × 7 × 12in. Price: on application.

EAGLE

Eagle International, Precision Centre, Heather Park Drive, Wembley HA0 1SU.
Tel: 01-902 8832.

A 2004 ★

Integrated amplifier. Output: 20W RMS per channel at 8 ohms. THD: >0.2%. FR: 15Hz-36kHz ±2dB. Inputs: phono (1) 3mV 47K, phono (2) 3mV 47K, tuner 180mV 100K, aux 180mV 100K, tape 180mV 100K. Damping factor: 35 at 8 ohms. S/N ratio: phono 68dB (weighted), aux 80dB (weighted). Controls: in-

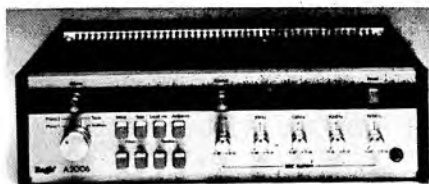

Eagle International A2004

★ Indicates entry is illustrated

put, volume, bass, treble, balance, mono/stereo, tape, loudness, ambience, 7kHz filter, 10kHz filter, speaker (1), speaker (2). Dimensions: 38 × 27 × 10.5cm. Inputs for two turntables. Facility for two pairs of speakers and ambience. Two HF filters. Price: £69.50 (excluding VAT).

A 2006 ★

Integrated amplifier. Output: 20W RMS per channel, both channels driven at 8 ohms. THD: >0.2%. FR: 15Hz-36kHz ±2dB. Inputs: phono (1) 3mV 47K, phono (2) 3mV 47K, tuner 180mV 100K, aux 180mV 100K, tape 180mV 100K. Damping factor: 35 at 8 ohms. S/N ratio: phono 63dB (weighted), aux 80dB (weighted). Controls: input, volume, balance, 5 SEC (Sound Equalisation Controls) mono/stereo, tape, loudness, ambience, 7kHz filter, 10kHz filter, speaker (1), speaker (2). Dimensions: 38 × 27 × 10.5cm. Inputs for two turntables. Facility for two pairs of stereo speakers and ambience. Two HF filters, SEC system at 40Hz, 200Hz, 1200Hz, 6000Hz and 15000Hz (all controls ±10dB). SEC controls may be used for recording. Price: £79.80 (excluding VAT).

AA6 S

Integrated amplifier. Output: 20W RMS per channel, both channels driven at 8 ohms. THD: >0.2%. FR: 15Hz-36kHz ±2dB. Inputs: mag 3mV 47K, cer 80mV 100K, aux 180mV 100K, tape 180mV 100K, tape monitor 180mV 100K. Damping factor: 35 at 8 ohms. S/N ratio: mag 64dB (weighted). Controls: input selectors, volume, bass, treble, balance, mono/stereo, loudness, source/monitor, SEC (Sound Equalisation Controls) at 40Hz, 200Hz, 1200Hz, 6000Hz, 15000Hz (all controls ±10dB), tone control/SEC switch. Dimensions: 37.5 × 27 × 11.4cm. SEC tone control system at five frequencies to adjust source material. Tape monitor on 2-head machines. Price: £69.20 (excluding VAT).

AA 2

Integrated amplifier. Output: 10W RMS per channel, both channels driven at 8 ohms. THD: >0.5%. FR: 25Hz-20kHz ±2dB. Inputs: mag 3mV 47K, cer 80mV 100K, tuner 180mV 100K, tape 180mV 100K. Damping factor: 25 at 8 ohms. S/N ratio: mag 58dB (weighted). Controls: input selectors, volume, bass, treble, balance, mono/stereo, scratch filter, rumble filter. Dimensions: 27.5 × 22 × 9.6cm. Price: £43.90 (excluding VAT).

AA 4

Integrated amplifier. Output: 20W RMS per

channel, both channels driven at 8 ohms. THD: >0.2%. FR: 15Hz-36kHz ±2dB. Inputs: mag 3mV 47K, cer 80mV 100K, tuner 180mV 100K, tape 180mV 100K. Damping factor: 35 at 8 ohms. S/N ratio: mag 64dB (weighted). Controls: input selectors, volume, bass, treble, balance, scratch filter, rumble filter. Dimensions: 33 × 27 × 10cm. Price: £59.90 (excluding VAT).

FF2 ★

Pre-amplifier. Output: 200mV at 100K. FR: 20Hz-20kHz variable limits. Inputs: phono 3mV 47K, aux 200mV 100K, tape 200mV 100K. S/N ratio: better than -50dB. Controls: power on/off, input selector, tone controls. Dimensions: 25 × 18 × 4.6cm sloping to 2.8cm. Boost/cut controls (±10dB) at 40Hz, 200Hz, 1200Hz, 6000Hz and 15000Hz, enabling recordings etc to be equalised or modified. Price: £34 (excluding VAT).

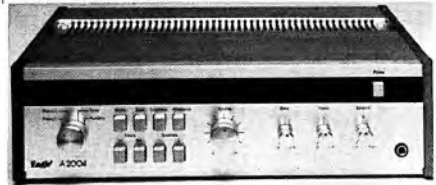

Eagle International A2006



Eagle International FF2

■ ENVIRONMENTAL SOUND

JB Manufacturing, Acoustics and Design Ltd,
London House, Mayfield,
Sussex TN20 6AQ.

KM PR5

Stereo pre-amplifier designed to drive the company's ESKM motional feedback range of loudspeakers which incorporate their own main amplifiers (see speaker enclosure section). Outputs: Tape 600mV, 10K, headphones 1.2V 400 ohms THD: less than 0.25% at 1kHz. FR: 30Hz-35kHz \pm 1dB. Inputs: Phono 1.5mV at 47 ohms with HF radio filter. Auxiliary (1 & 2) 300mV at 40K. Controls: loudness combined with volume. Tone — treble at 10kHz +16dB -10dB, bass at 40Hz +15dB -19dB. Dimensions: 40.8 x 17.5 x 9.7cm. Price £88.75 (inc. VAT).



Environmental Sound KM50

KM 2002

Professional standard mixer pre-amplifier for use with either external amplification systems or directly into the company's ES KM motional feedback speaker systems. Tape monitor 600mV 10K; direct feed into standard power amplifiers; headphone 3V 400 ohms; lighting synchronisation 1V max 100K. Six inputs: via slider controls consisting of 2 x 0.9-1.4 cm/sec RIAA phono; 2 x tape 350mV at 47K; 1 x aux 350mV at 47K; 1 mic/mic-mixer 1mV at 47K/350mV at 47K. Controls: pre-fade listening, tape monitoring, master volume (with loudness), bass and treble controls, stereo balance, stereo/mono changeover/headphone volume/twin VU meters and the mic mixer-selector switch. Price: £238.18.

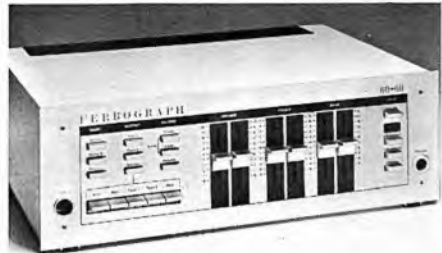

Ferrograph F608



Ferrograph F208

■ FERROGRAPH

The Ferrograph Company Ltd,
Auriema House, 442 Bath Road,
Cippenham, Slough SL1 6BB.
Tel: Burnham 62511.

F208 ★

Stereo amplifier. Output: 20W RMS per channel, both channels driven into 8 ohms. Distortion: less than 0.18%. THD at 1kHz at all levels up to rated output power (both channels driven into 8 ohms). FR: mag PU to RIAA characteristic \pm 1.5dB, all other inputs 20Hz-25kHz \pm 1dB, 15Hz-30kHz +1, -3dB. Inputs: ceramic PU 100mV 2M, mag PU 3mV 47K, tape 150mV 50K. Controls: bass up to 17dB boost or cut at 50Hz (ref. 1kHz), treble up to 13dB boost or cut at 15kHz (ref. 1kHz). Volume, bass and treble controls are dual concentric types, giving easy simultaneous adjustment of left and right channels, or independent adjustment if required. Filters: low-pass,

selected by pushbuttons, giving steep cut of frequencies above 5, 7 or 10kHz. Slope approx. 30dB per octave. Mode selection: pushbuttons give stereo, either one signal (left or right) applied to both output channels, or the two channels combined for mono reproduction. Suitable for selecting upper, lower or combined tape track signals. Mains: 117, 220, 240V AC 50/60Hz, 80W max. Dimensions: 457 x 127 x 222mm. Weight: 8.1kg. Price: £94 (excluding VAT).

F608 ★

Stereo amplifier. Output: 60W RMS per channel, both channels driven into 8 ohms. Distortion: less than 0.08% (50Hz-10kHz) at all levels up to rated power output (both channels driven

★ Indicates entry is illustrated

into 8 ohms). FR: mag PU to RIAA characteristic $\pm 1.5\text{dB}$, all other inputs 25Hz-20kHz $\pm 1\text{dB}$. Filters: pushbutton selected. Turnover frequencies: 5kHz, 7kHz, 10kHz. Rumble: pushbutton selected, -1dB at 65Hz. Slider controls: bass 0-12dB boost or cut at 50Hz (ref. 1kHz), treble 0-12dB boost or cut at 20kHz (ref. 1kHz). Volume, bass and treble controls are sliders mounted in pairs, giving independent adjustment for left and right channels, or easy simultaneous operation. Mains: 110-120V or 220-250V 50/60Hz, 240W max. Dimensions: 450 x 145 x 350mm. Weight: 13.1kg. Price: £162 (excluding VAT).

■ GOODMANS

Goodmans Loudspeakers Ltd,
Downley Road, Havant,
Hants PO9 2NL. Tel: Havant 6344.

Model Forty-forty ★

Stereo integrated amplifier. Inputs: magnetic pick-up 2mV into 50 Kohms, aux 60mV into 600 Kohms, tuner 60mV into 600 Kohms, tape 320mV into 50Kohms. S/N: phono 60dB, all other 75dB; all ref. to rated power. Outputs: 35W channel into 4 ohms. Damping factor: 80 into 8 ohms. THD: less than 0.1% both channels driven 60W. FR: 30Hz-20kHz $\pm 1.5\text{dB}$. Controls: power on/off, local LS, remote LS, headphones, surround sound, balance, treble, bass, volume, filters, loudness compensation, reverse LS. Features include output for conventional stereo reproduction, plus facility for four loudspeakers surround sound. Size: 56 x 30 x 9.4cm. Price: £90.13 (plus VAT).

■ HARMON KARDON

Highgate Acoustics, 38 Jamestown Road,
London NW1 7EJ.
Tel: 01-267 4937.

A 401

Integrated amplifier. Output: 20W RMS per channel. THD: 0.5%. FR: 10Hz-80kHz. Inputs: aux, tuner 150mV 20K, phono 47K, tape monitor 150mV 20K. Damping factor: 30:1. S/N ratio: 65dB. Controls: volume, bass, treble, balance. Dimensions: 33 x 27.5 x 13.4cm. Price: £105 (excluding VAT).

Citation 16

Power amplifier. Output: 150W. THD: 0.05%. FR: 5Hz-110kHz. Impedance: 22K Ω . Damping factor: 300:1. S/N ratio: 100dB. On power display. Dimensions: 48.3 x 35.6 x 23.5cm. Price: £465 (excluding VAT).

Citation 11

Pre-amplifier. Output: 6V. THD: 0.05%. FR:



Goodmans forty-forty .

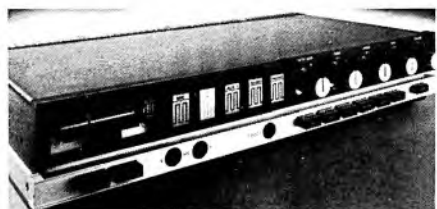

Harrison S200

10Hz-30kHz. Inputs: phono (1 & 2), aux (1, 2, 3), tape monitor (1+2). S/N ratio: 90dB. Controls: volume, balance, function, mode, audio equalizer. Dimensions: 40.6 x 30.5 x 12cm. Price: £228 (excluding VAT).

Citation 12 De Luxe

Power amplifier. Output: 60W RMS per channel. THD: 0.2%. FR: 0.5Hz-100kHz. Impedance: 22K Ω . Damping factor: 40:1. S/N ratio: 100dB. Dimensions: 31.1 x 31.7 x 14cm. Price: £209 (excluding VAT).

■ HARRISON

Gimar Ltd, 10 Museum Street,
London WC1A 1JS. Tel: 01-836 3222.

S200 ★

Stereo integrated amplifier. Incorporates touch sense function switching, an LED output level meter and full output protection which is self-restoring. Inputs: mic 110mV 68K, phono 2.5mV 47K, two aux and radio adjustable 100mV 50K. Noise level: mic and phono 60dB ref 100W, aux and radio 70dB ref 100W. Output: 100W into 4 ohms, 75W into 7.5 ohms. Disc input overload margin 40dB. Damping factor: 100. THD: 0.05% at 100W, 1kHz. FR: 20Hz-20kHz $\pm 0.5\text{dB}$ at 50W. Mains: 110-240V preset internally. Size: 17 x 10½ x 3⅞in. Price: £205 (plus VAT).

■ HITACHI

Hitachi Sales (UK) Ltd, Hitachi House,
Station Road, Hayes UB3 4DR.
Tel: 01-848 8787.

ALBA 900

"One of the best British amplifiers"

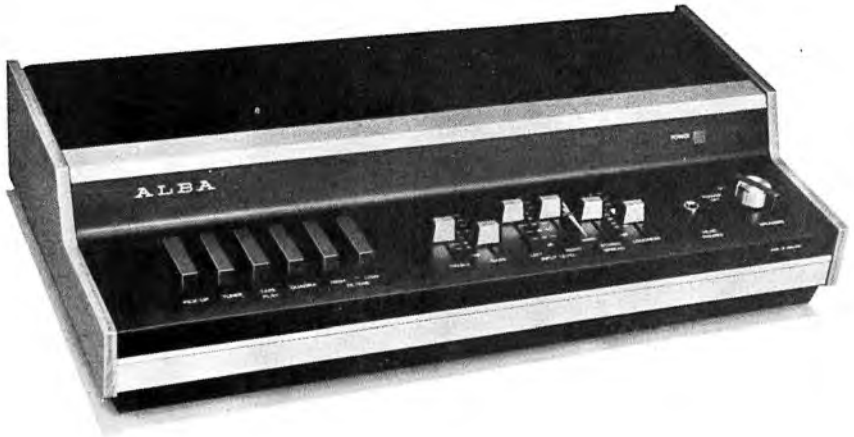

“ This is without doubt one of the best British amplifiers that I have had the pleasure of evaluating. I still cannot get over the very low distortion figures which reflect very good power amplifier design. The amplifier is nicely presented, well made and being man enough to handle my protracted and sometimes high-frequency tests it should take the domestic demands easily in its stride. An amplifier which I can thoroughly recommend and one of which Alba can be truly proud. ”

Gordon King 'Hi-Fi Sound'

Write now for the complete specification and full Test Reports of Alba units, and for the comprehensive colour booklet featuring the complete Alba range.

ALBA

Alba (Radio & Television) Ltd
Bull Lane, Edmonton, London N18 1SD

Amcron

NEW!

STATE OF THE ART



New Amcron IC-150A Pre Amplifier

A new phono circuit incorporates an exclusive complimentary parallel discrete input, driving an operational amplifier output. This combination results in extremely low distortion, wide dynamic range, and a noise level 85dB or more below a 10 millivolt input. Audibly, the results extend from clean, controlled bass reproduction to precisely accurate music transient response all the way to the top of the audio band.

The IC-150A by itself can control and route signals among two turntables, two tape decks, a tuner, and three auxiliary components.

Detailed Brochures are available on request, and the equipment can be seen, and heard at

REW (AUDIO VISUAL) LTD.,

CENTREPOINT, LONDON, W.C.2

and

KJ LEISURE SOUND

101 ST. ALBANS RD., WATFORD, HERTS.



MACINNES LABORATORIES LTD.

MACINNES HOUSE, CARLTON PARK INDUSTRIAL ESTATE,
SAXMUNDHAM, SUFFOLK IP17 2NL
TEL: (0728) 2262 2615

Design Council Award 1976

QUAD 405

Once again* Quad's ability to combine outstanding technical development and good design has won a Design Council Award

Once again, the design is all our own work, and we are justifiably proud of it.

For further details of the QUAD 405 current dumping amplifier and other QUAD products write to: Dept. HF, The Acoustical Manufacturing Co. Ltd., Huntingdon, Cambs. PE18 7DB. Telephone (0480) 52561

QUAD

for the closest approach to the original sound
for twenty-five years

QUAD is a Registered Trade Mark

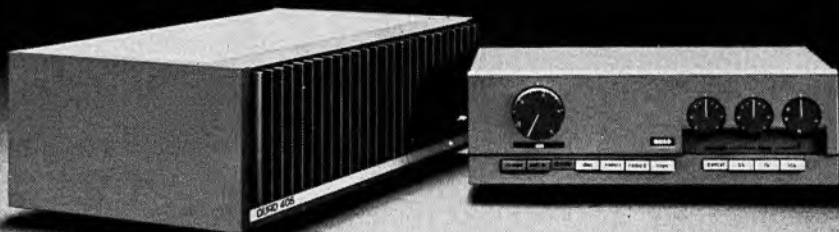

*The previous Award was for the Quad 33 control unit (seen here with the Quad 405) the Quad 303 power amplifier and Quad FM stereo tuner in 1969.

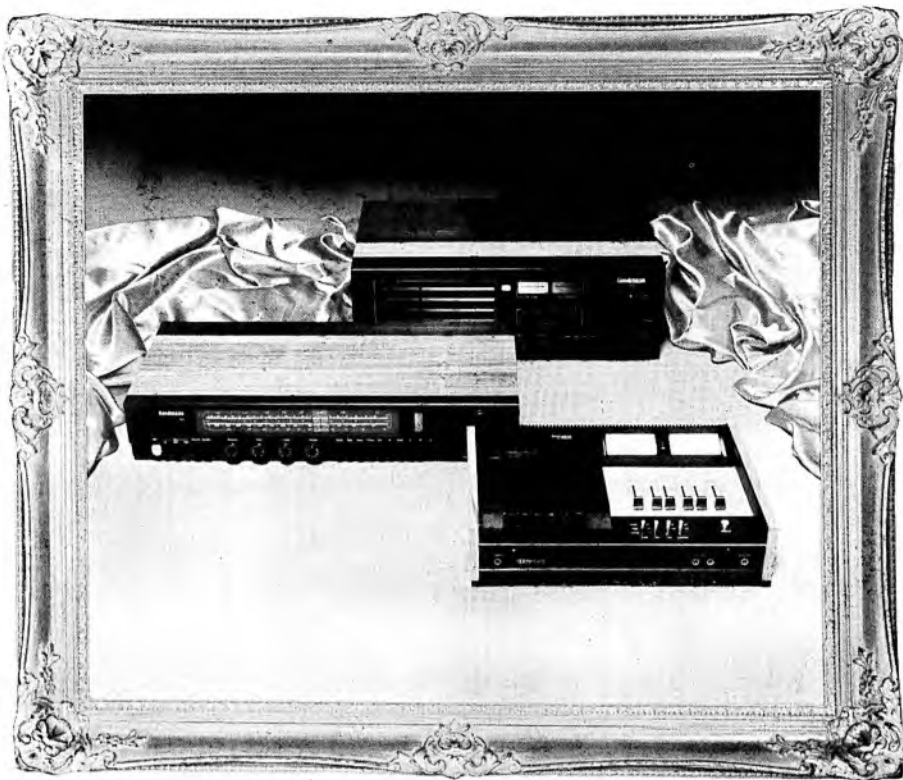

A reproduction masterpiece by Goodmans

To match our loudspeaker systems, the highly acclaimed Model 150 receiver takes its place flawlessly at the heart of any high fidelity system with high output (110 Watts per channel) and low distortion (typically 0.02%), and push button FM station selection.

The Model 1—20 with 50 watts per channel shares the same high performance of its larger counterpart.

The SCD 100 Stereo cassette tape deck with Dolby noise reduction system compliments both our receivers and

speakers and leads the field in the modern generation of cassette recorders.

For details of these products and the full range of Goodmans associated high fidelity equipment write to the Technical Assistance department.

Goodmans Loudspeakers Limited
Downley Road, Havant
Hampshire, PO9 2NL, England

Goodmans High Fidelity

HA 300

Stereo amplifier. Output: 20W RMS per channel into 8 ohms at 1kHz. FR: 20-30.000 Hz ± 2 dB. Power bandwidth: 30-20.000Hz. Distortion: 0.8% RMS. Damping factor: 55 at 8 ohms. Input sensitivity and impedance: mic 4.8mV 8K, phono 2.4mV 45K, tuner/aux 140mV 50K, tape (1 & 2) 140mV 50K, DIN 400mV 160K. Tone controls: bass ± 10 dB (100Hz), treble ± 10 dB (10kHz). Loudness control: +10dB (100Hz); +5dB (10kHz). Equaliser: ± 2 dB(RIAA). S/N ratio: phono 74dB, aux/tuner 94dB. Residual noise: 0.4mV.

Mains: 220-240V AC 50Hz, 120W max. Size: 39 x 12.1 x 31.8cm. Weight: 6.7kg. Loudness switch, tape monitor switch, headphone jack and microphone jack. Facility for mic mixing. Price: on application.

HA 610

Stereo amplifier. Output: 60W per channel into 8 ohms. THD: 0.3%. FR: 10Hz-30kHz. Inputs/impedance: phono 1-2mV 50K, phono (2) 1.7-6mV/50K; aux (1) 100mV/55K, aux (2) 100mV/55K; tuner 100mV/55K; tape PBI 100mV/55K. Damping factor: 70 at 8 ohms. S/N ratio: phono 75dB, aux 90dB. Controls: tuner, tape, phono, aux, tone, loudness. Dimensions: 43.5 x 144 x 38.8cm. Price: on application.

IA1000

Integrated stereo amplifier. Inputs: mag PU (1) 2mV 50K, mag PU (2) 5mV 50K, aux (1) 140mV 100K, aux (2) 140mV 100K, radio 140mV 100K, mic 2mV 35K. 37 transistors, 18 diodes, two ICs. Output: 50W RMS per channel into 4 ohms (both channels driven). HD: $< 0.1\%$ FR: 10Hz-100kHz. Damping factor: 50 at 8 ohms. Tone controls: bass ± 12 dB at 100Hz, treble ± 12 dB at 10kHz, high filter -10dB at 10kHz, low filter -8dB at 50Hz. Size: $17\frac{1}{8} \times 5\frac{3}{8} \times 13$ in. Weight: 27 $\frac{1}{2}$ lb. Two VU meters. Microphone input mixing. Two-system speaker connections. Finish: rosewood side panels and drawn aluminium control panel. Price: £146 (including VAT).

IA600

Integrated stereo amplifier. Inputs: mag PU (low) 2.5mV 50K, mag PU (high) 6mV 50K, aux (1) 220mV 100K, aux (2) 220mV 100K, mic 2.5mV 25K, tape 220mV. 19 transistors, 13 diodes, two ICs. Output: 27W RMS per channel into 4 ohms (both channels driven). HD: $< 0.1\%$ FR: 10Hz-100kHz. Damping factor: 50 at 8 ohms. Tone controls: bass ± 12 dB at 100Hz, treble ± 12 dB at 10kHz, high filter -8dB at 10kHz. Size: $16\frac{1}{4} \times 4\frac{1}{4} \times 12\frac{3}{8}$ in.



Heathkit AP1615



Heathkit AA1640

■ HEATHKIT

Heath (Gloucester) Ltd.
Gloucester GL2 6EE. Tel: 0452 29451.

AP 1615 ★

Stereo amplifier/control centre. Input sensitivity: phono, 2mV. Hi-Level (Tuner, tape, aux, tape mon and tap dub), 180mV. Input overload: phono, over 100mV. Hi-level, over 10V. Hum and noise: phono -65dB (2mV input); Hi-level -85dB (180mV input). Input impedance: phono 47K ohms shunted by 65 pF. Hi-level 50K ohms shunted by 80 pF. FR: phono ± 0.5 dB, 30Hz to 15kHz. Hi-level, ± 0.2 dB, 20Hz to 20kHz. Rated output: 1.5V at rated sensitivity. Output impedance: 500 ohms. Tape output: 180mV. Harmonic distortion: less than 0.05% from 20Hz to 20kHz at 1.5V output. Channel separation: 50dB at 1kHz. Filters: low -3dB at 15Hz, -12dB octave/slope. High -3dB at 7kHz, -12dB octave/slope. Headphone amplifier: harmonic distortion: 0.1% (4V min. into 100 ohms). Dimensions: $4\frac{1}{2}$ H x $17\frac{1}{2}$ W x $8\frac{1}{8}$ in. D. Power requirement: 120/240V AC. 60/50Hz. Price: £75.20 (plus VAT).

AA-1640 power amplifier ★

Frequency response: -1dB, 7Hz to 50Hz; -3dB, 5Hz to 100kHz. Intermodulation distortion: less than 0.1% from 0.25 to 200W. Damp-

★ Indicates entry is illustrated

ing factor: greater than 50. Hum and noise: less than $400\mu\text{V}$ or 100dB below full output. Channel separation: 50dB, min. Input impedance: 50K ohms, min. Input sensitivity: 1.5V. Net weight: 58lbs. Dimensions: 19 W \times 7 $\frac{1}{4}$ H \times 18in. D. Power requirement: 120/240V AC, 60/50 Hz. Price: £272.00 (plus VAT). Optional extra: AAA-1640-1 output metres. Price: £40.00 (plus VAT).

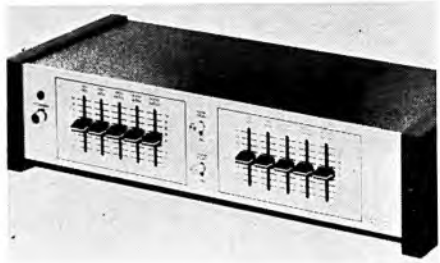

Heathkit AD1305

AD-1305 two-channel audio equalizer ★

Input impedance: 100K ohms shunted by 200 pF. Output impedance: 100 ohms. Rated output: 1.5V RMS. Overload: 5V RMS. Noise: 90dB below 1.5V. THD: 0.05% from 20Hz to 20kHz at 1.5V output. IM distortion: .05% at 1.5V. Frequency control ranges (separate controls for each channel): 30-125Hz, 125-500Hz, 500-2,000Hz, 2,000Hz to 8kHz, 8kHz-32kHz. Overall gain (flat): zero dB (unity gain). Slope of filters: 12dB per octave. Power requirement: 120/240 VAC, 60/50Hz. Dimensions: 4 $\frac{7}{32}$ H \times 17 $\frac{1}{2}$ W \times 8in. D. Price: £70.40 (plus VAT).



JVC 4VN 990

■ JVC

JVC (UK) Ltd, Eldonwell Trading Estate, Staples Corner, 6-8 Priestley Way, London NW2. Tel: 01-450 2621.

JA-X9

Integrated amplifier with built-in CD4 demodulator. Output: 4 \times 25W RMS at 8 ohms. THD: 0.05%. FR: 5Hz-200kHz -3dB. Impedance: 8-16 ohms BTL. Damping factor: 30 at 8 ohms. S/N ratio: phono 76dB, aux 96dB, tape play 96dB. Four independent level controls. Four-channel matrix. Loudness and muting. Dubbing 1 & 2. Subsonic/high filter. Dimensions: 42 \times 36.2 \times 13.8cm. Price: £293 (excluding VAT).



JVC SEA 10

4VN-990 ★

Integrated amplifier. Output: 4 \times 35W RMS at 8 ohms. THD: 0.5%. FR: 10Hz-50kHz \pm 1dB. Impedance: 8-16 ohms. Damping factor: 50 at 8 ohms. S/N ratio: phono 65dB, aux 75dB, tape play 75dB. Sound Effects Adjustment system (5 section). Four independent level controls. Dimensions: 42.2 \times 39 \times 13.7cm. Price: £293 (excluding VAT).

Sound Effects Adjustment rec/playback. Dimensions: 42 \times 33.3 \times 13.8cm. Five section SEA system. Price: £204 (excluding VAT).

SEA-V7E

Graphic equalizer. THD: less than 0.02% at 3V output. FR: 20Hz-20kHz. Input impedance: 100K. S/N ratio: better than 85dB. Controls: 2 \times 7 section graphic control. Dimensions: 17 \times 12 \times 5 $\frac{1}{2}$ in. Price: £140.50 (excluding VAT).

JA-58

Integrated amplifier. Output: 55W RMS per channel, both channels driven at 8 ohms. THD: 0.05% at 50W. Fr: 10Hz-150kHz -3dB. Impedance: 4-16 ohms. Damping factor: 30 at 8 ohms. S/N ratio: 92dB. Controls: loudness, muting, subsonic/high filter, tape dubbing,

SEA-10 ★

Graphic equalizer. THD: less than 0.1%. FR: 20Hz-30kHz. S/N ratio: better than 70dB. Controls: five section graphic control. Dimen-

sions: 19.1 x 25.4 x 13.4cm. Price: £67.50 (excluding VAT).

■ **KLARK-TEKNIK RESEARCH LTD**
 Summerfield, Kidderminster, Worcs.
 Tel: Kidderminster 64027/63467

DN27 ★

Mono graphic equaliser with 27 variable filters giving 12dBs of boost or cut at the following frequency centres: 40, 50, 63, 80, 100, 125, 160, 200, 250, 315, 400, 500, 630, 800, 1K, 1.25K, 1.6K, 2K, 2.5K; 3.15K, 4K, 5K, 6.3K, 8K, 10K, 12.5K, and 16kHz. Each filter has a band width of two-thirds of an octave. Specification: Distortion: <0.01% 1kHz at +4dBm into a 600 ohm load; <0.05% 20Hz at +18dBm into a 600 ohm load. Calibration accuracy: ±0.5dB. Hum and noise: 20Hz-20kHz unweighted <-90dBm. Centre frequency accuracy: ±2%. Input impedance: Unbalanced 10K ohm nominal. Output impedance: unbalanced <10 ohms, short circuit protected. Operating level: -20dBm to +24dBm input protection -60V RMS. Balanced floating inputs and outputs available. Input: 10K ohms. Output: 600 ohms. Output clipping point: +22dBm into 600 ohm load. 6dB of gain is available adjusted by the front panel control. This can be increased to 20dB by an internal preset. Panel controls include a mains on/off switch with LED indicator, level control and equalization bypass switch. Mains: 110/120-220/240 AC. 50/60Hz. Size: 19 x 5¼ x 8½in. Price: on application.

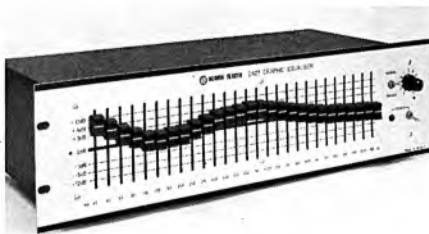

Klark Teknik DN27

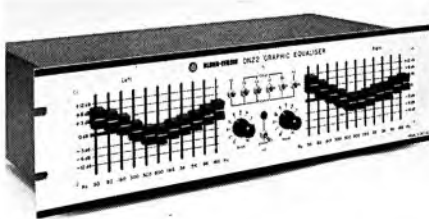

Klark Teknik DN22

DN22 ★

Two channel graphic equaliser. Each channel has 11 variable filters and is particularly suitable for room acoustic correction. A separate high pass and low pass filter, bypass control and a main level control are included on each channel. A maximum of 12dB of boost or cut is available on each of the 11 individual controls which have frequency centres at: 50, 90, 160, 300, 500, 900, 1.6K, 3K, 5K, 9K and 16kHz. Specifications as in DN27.

DN15 ★

Stereo 11 band graphic equaliser which includes a stereo preamplifier. Graphic equaliser section is similar to the DN22. Preamplifier includes the following switchable inputs: phono, auxiliary, tuner, tape 1, tape 2. Input impedance: phono 47K, other 47K. S/N: phono 80dB, others 90dB. Outputs: +21dBm into a 600 ohm load. Distortion: <0.1% at all levels and frequencies. Mains: 110/120-220/240 AC. 50/60Hz. Size: 19 x 5¼ x 8½in. Price: on application.

■ **LEAK**

Rank Radio International Ltd,
 PO Box 70, Great West Road, Brentford,
 Middlesex TW8 9HB.
 Tel: 01-568 9222.

2200 ★

Stereo integrated amplifier. Inputs: phono 2.5mV or 6.5mV 47K switchable, tape 150mV 100K, cassette 150mV 100K, tuner 150mV 100K, mic. 2.4mV 47K, main amp 1V 47K; all at 1kHz for 50W output. S/N: phono 65dB,



Klark Teknik DN15



Leak 2200

★ Indicates entry is illustrated

tape/cassette/tuner 80dB, main amp 90dB. Outputs: tape/cassette 150mV, DIN 1.5mV/K, speakers 45W channel into 8 ohms, 50W channel into 6 ohms, 60W channel into 4 ohms.

Both channels sine wave driven at 1kHz. High power single channel mode 120W. Damping factor: 40 at 80Hz. THD: 0.1% at 45W. Power bandwidth: 10Hz-40kHz at 50W - 3dB. Mains: 240V AC 50-60Hz. Size: 16.3 x 12½ x 5¼in. Price: £173.33 (plus VAT).



LG Sound Systems L2800

■ L.G. SOUND SYSTEMS

5 Eden Grove, London N7 8EQ.

L 2800 ★

Integrated with output of 50W RMS per channel. THD: 0.05%. FR: 10-50,000 Hz. S/N: phono: 65dB, others 75dB. Controls include subsonic, low-cut, high cut filters, frequency roll-off monitor, dubbing. Dimensions: 44 x 27 x 15cm. LED power read out, dubbing tape monitoring. Price: £208.00 (plus VAT).



LG Sound Systems L2600 amp

L 2600 ★

Integrated with output of 40W RMS per channel. THD: 0.2% FR: 10-50,000Hz. S/N: <63dB. Standard controls. Dimensions: 37 x 25 x 13cm. Price: £92.00 (plus VAT).

L 2600G ★

Integrated with output of 40W RMS per channel. THD: 0.2% rated o/p. FR: 10-50,000Hz. S/N: <63dB. Standard controls. Dimensions: 37 x 25 x 13 cm. Price: £120.00 (plus VAT).



LG Sound Systems L2600G amp

L2400G

Integrated with output 27W RMS per channel. THD: 0.5%. FR: 10-50,000Hz. S/N: 63dB. Dimensions: 37 x 25 x 13cm. Price: £104.00 (plus VAT).

L 2400

Integrated with output 27W RMS per channel. THD: 0.5%. FR: 10-50,000 Hz. S/N: 63dB. Dimensions: 37 x 25 x 13. Price: £82.00 (plus VAT).

■ LUX

Howland-West Ltd, 3-5 Eden Grove, London N7 8EQ. Tel: 01-609 0923/6.

L309

Integrated stereo amplifier. Inputs: phono (1 & 2) 2.5mV, aux (1 & 2) 100mV, 100mV tuner input (level adjustable). Output: 75W RMS per channel into 8 ohms, both channels driven. FR: 10Hz-50kHz. Size: 485 x 300 x 165mm. Finish: rosewood. Price: £310.00 (plus VAT).

CL350 ★

Preamplifier. Input impedance: phono (1 & 2)



Lux CL350

2mV, three aux inputs 110mV, mic 2-3mV, two tape inputs 110mV. Size: 476 × 244 × 182mm. Finish: rosewood. Price: £198 (plus VAT).

M150 ★

Main amplifier. Output: 75W RMS per channel into 8 ohms, both channels driven. FR: 10Hz-90kHz to within 1dB. Size: 476 × 244 × 182mm. Finish: rosewood. Matches the CL350 pre-amplifier. Price: £242 (plus VAT).



Lux M150

L 100 ★

Integrated with output of 100W RMS per channel. THD: >0.05%. FR: 5-50,000. S/N: 65dB phono, 80dB others. Controls include linear equaliser, filters, monitor and dubbing. Dimensions: 48 × 35 × 17cm. Price: £500.00 (plus VAT).

L 80V

Integrated with output of 50W RMS per channel. THD: >0.05%. FR: 5-50,000 Hz. S&N: Phono 65dB, others 80dB. Price: £210.00 (plus VAT).



Lux L100

L80

Integrated with output of 40W RMS per channel. THD: >0.1%. FR: 10-50,000Hz. S/N: 63dB phono, 78dB others. Dimensions: 45 × 30 × 16cm. Price: £175.00 (plus VAT).

L 30

Integrated with output of 32W RMS per channel. THD: >0.05%. FR: 15-50,000Hz. S/N: phono 67dB, others 83dB. Dimensions: 44 × 22 × 16cm. Price: £120.00 (plus VAT).

M4000

Power amplifier with output 200 into 8 ohms, 20-20,000Hz. THD: 5-50,000Hz. S/N: 108dB. Dimensions: 48 × 39 × 17cm. Price: £850.00 (plus VAT).

M6000

Power amplifier. THD: 0.05%. FR: 5-50,000Hz. S/N: -100dB. Dimensions: 22 × 16 × 8cm. Price: £1,375.00 (plus VAT).

C1000

Pre amplifier. THD: 0.007%. FR: 2-80,000Hz. S/N: better than 65dB. Dimensions: 48 × 24 × 17cm. Lux type turnover frequency selection tone controls. Price: £475.00 (plus VAT).

3600

Stereo pre-amplifier/control console. FR: 20Hz-20kHz ±0.25dB. THD: 0.02% at or below rated output. IM distortion: 0.01%. Tone controls: bass ±15dB at 50Hz, mid ±8dB

at 700Hz, treble ±10dB at 10kHz. Output level and impedance: 3V 150 ohms. Input sensitivity and impedance (high level) 300mV 25K, (phono) 2mV 40K. Equivalent noise input: (phono) 0.775µV. Overload voltage: 100dB. (Front panel) six input selector push-switches, mode, tape monitor, turnover push-switches for 250Hz and 4kHz, three filter push switches (30Hz, 5kHz and 9kHz), left and right mic input jacks, dubbing input and output jacks, main and remote speaker push-switches, headphone jack and power. Separate bass, mid-range and treble controls for left and right channels, tone in/out switch and a horizontal straight-line balance control. (Rear panel) features include two tape output and two tape input jacks, six AC sockets (four switched, two unswitched), left and right speaker switching inputs, tuner, phono and aux input jacks, and two sets of pre-out jacks to power two separate power amps. Price: £346 (plus VAT).

3800

Specifications the same as 3600 but with Dolby B and tape equaliser. Price: on application.

Model 1200B

Stereo integrated amplifier. Inputs: phono (1 & 2), tuner, mic and aux (1 & 2). Ratio of input

★ Indicates entry is illustrated

overload to equivalent noise (phono): 100dB. Sensitivity and impedance: 1.35mV 47K. Input sensitivity and impedance (high level): 134mV 50K. Tone controls: bass 50Hz \pm 10dB, mid 700Hz, treble 10kHz \pm 10dB. Output level and impedance: 3V 600 ohms. THD: 0.05%. IM distortion: 0.05%, 20Hz-20kHz. FR: (high level) 20Hz-20kHz. Power output. 100W RMS per channel, both channels driven at 20Hz-20kHz into 8 ohms. Power bandwidth: 10Hz-40kHz, both channels driven. Damping factor: 100 at 8 ohms. Price: £472 (plus VAT).

Model 1120

Integrated stereo amplifier. Inputs: mag PU 1.38mV 47K, mic 1.38mV 47K, aux 138mV 125K. Overload capability: (low level inputs) 100mV. Output: 60W RMS per channel, both channels driven from 20Hz-20kHz at 0.08% distortion. Controls: six-position input selector, high filter 9kHz slope 12dB/octave, low filter 50Hz slope 12dB/octave, four slider type graphic tone controls (one for each channel), tape monitor pushbuttons, loudness switch, muting switch, main remote speaker switch. Tape dubbing jacks. HD: 0.08% 20Hz-20kHz. Load impedance: 8 ohms. FR: 5Hz-50kHz +0.5dB, -3dB at 1W, 20Hz-20kHz +0.3dB at 1W. Mains: 120, 220, 240V AC. Size: 15 $\frac{1}{8}$ \times 5 $\frac{1}{4}$ \times 14in. Finish: simulated walnut with gold anodised front panel. Automatic overload protection for circuit and speakers. Price: £317 (plus VAT).

■ MACEL ELECTRONICS LTD

PO Box 64, 14 High Street, Ipswich IP1 3LR. Tel: Ipswich 215465.

Brown Mark I

Stereo integrated amplifier. Output: 70W RMS per channel guaranteed (typically 85W per channel), both channels driven into 8 ohms at 20Hz-20kHz. IM and harmonic distortion: less than 0.1% at 20Hz-20kHz (typically less than 0.05% at 1kHz). Tone controls: Bass \pm 12dB at 80Hz, treble \pm 12dB at 10kHz. Low filter 30Hz cut-off (18dB/Oct), high filter 7kHz cut-off (12dB/Oct). S/N ratio: phono 78dB (10mV), aux, tuner, tape 90dB (250mV). Damping factor: greater than 150. Input sensitivity and impedance: phono 2.5mV 47K, aux, tuner, tape 0.25mV 100K. RIAA accuracy: \pm 1/2dB. Size: 15 \times 12 \times 5in. Weight: 20lb. Price: £290 (plus VAT).

■ MARANTZ

Pysers Ltd, Fircroft Way, Edenbridge, Kent TN8 6HA. Tel: Edenbridge 4111.

510M

Professional stereo power amplifier. Output: 256W RMS per channel, both channels driven at 8 ohms from 20Hz-20kHz. Power bandwidth: 20Hz-20kHz. THD: less than 0.1%. Load impedance: 8 ohms. FR: (high level input) 20Hz-20kHz \pm 1dB. Input sensitivity and impedance: 2.0V 25K. Damping factor: 100. Price: on application.

510

Stereo power amplifier. Output: 256W RMS per channel, both channels driven at 8 ohms from 20Hz-20kHz. Power bandwidth: 20Hz-20kHz. THD: less than 0.1%. Load impedance: 8 ohms. FR: (high level input) 20Hz-20kHz \pm 1dB. Input sensitivity and impedance: 2.0V 25K. Damping factor: 100. Price: on application.

250

Professional power amplifier. Output: 126W RMS per channel, both channels driven at 8 ohms from 20Hz-20kHz. Power bandwidth: 20Hz-20kHz. THD: less than 0.1%. Load impedance: 8 ohms. FR: (high level input) 20Hz-20kHz \pm 1dB. Input sensitivity and impedance: 2.0V 100K. Damping factor: 100 ohms. Price: £387 (excluding VAT).

240

Power amplifier. Output: 125W RMS per channel, both channels driven at 8 ohms from 20Hz-20kHz. Power bandwidth: 20Hz-20kHz. THD: less than 0.1%. Load impedance: 8 ohms. FR: (high level input) 20Hz-20kHz \pm 1dB. Input sensitivity and impedance: 1.5V 100K. Damping factor: 100. Price: £258 (excluding VAT).

Model 1030

Integrated stereo amplifier. 22 transistors and 14 diodes. Inputs: mag PU 2.1mV 47K, mic 2.1mV 47K, aux 150mV 100K. Noise level: (PU input) -93dB. Overload capability: (PU input) 100mV. Output: 15W RMS per channel, both channels driven. Load impedance: 8 ohms. Tone controls: bass \pm 12dB at 50Hz, treble \pm 12dB at 15kHz, high filter 16dB/octave from 5kHz, low filter 16dB/octave from 100Hz. HD: 0.5% from 40Hz-20kHz. FR: 20Hz-20kHz \pm 1dB at 1W. Output circuits automatically protected. Mic input on front panel. Main and remote speakers and headphones. Size: 14 $\frac{1}{2}$ \times 4 $\frac{1}{4}$ \times 12in. Finish: gold anodised front panel. Price: £89.50 (plus VAT).

Model 1060

Integrated stereo amplifier. 35 transistors and



Marantz 3200



Marantz 1040



Marantz 1070

14 diodes. Inputs: mag PU 1.8mV 47K, mic 1.8mV 47K, aux 180mV 100K. Noise level: (PU input) -96dB. Overload capability: (PU input) 100mV. Output: 30W RMS per channel, both channels driven. Load impedance: 8 ohms. Tone controls: bass ± 15 dB at 50Hz, treble ± 12 dB at 15kHz, high filter 16dB/octave from 5kHz, low filter 16dB/octave from 100Hz, middle control ± 6 dB at 700Hz. HD: 0.5% 20Hz-20kHz. FR: 20Hz-20kHz ± 0.5 dB at 1W. Automatic protection of output circuits. Three-zone tone controls. Front panel sockets for mic and aux. Size: 14 1/4 x 4 1/4 x 14in. Finish: gold anodised front panel. Price: £137 (plus VAT).

Model 4140

Integrated stereo amplifier with power mode switch for quadraphonic sound. Facilities for two 4-channel tape recorders with dubbing back and forth, a CD-4 adaptor, matrix decoders, 4-channel scope and separate pre-out/main-in jacks. Ratio to input overload voltage to equivalent noise (phono): 96dB. Equivalent noise input: 1.9 μ V. Sensitivity and impedance: 1.8mV 47K. Input sensitivity and impedance (high level): 180mV 100K. Tone controls: bass 50Hz ± 10 dB, mid 700Hz, treble 15kHz ± 10 dB. Output level and impedance: 1V 900 Ω . Power output: 70W RMS per channel, both channels driven at 20Hz-20kHz into 8 ohms or 4 x 25W RMS per channel, all channels driven at 20Hz-20kHz into 8 ohms. THD: 0.3%. IM distortion: 0.3%. FR: 20Hz-20kHz ± 5 dB. Power bandwidth: 7Hz-70kHz (IHF). Damping factor: 40 at 8 ohms. Price: £365 (plus VAT).

4000

Four channel pre-amplifier adaptor. High level input sensitivity and impedance: 180mV 100K. Tone controls: Bass at 50Hz ± 10 dB, treble at 15kHz ± 10 dB. Output level and impedance: (front) 180mV (rear) 2.1V. FR: 20Hz-20kHz ± 5 dB. Finish: metal chassis with optional walnut cabinet (model WC2). Price (without cabinet): £177 (plus VAT).

Model 4070

Integrated four-channel amplifier. Inputs: mag PU 1.8mV 47K, high level 180mV, radio, aux. Overload capability: 100mV. Output: 2 x 35W RMS total into 8 ohms (4 x 15W RMS all channels). Controls: five-position mode switch, slider vari-matrix control, slider for balance (left, right, front, rear), separate sliders for bass and treble (front and rear). Pushbuttons for main/remote speakers and headphones, tape monitor, remote control, loudness. HD: 0.25% 20Hz-20kHz. Load impedance: 8 ohms. FR: 20Hz-20kHz ± 1 dB at 1W. Size: 14 1/4 x 4 1/4 x 12in. Finish: simulated walnut metal chassis with gold-anodised front panel. Pocket in base for plug-in SQ decoder. Price: £226 (plus VAT).

3200 *

Pre-amplifier. THD: 0.05%. FR: phono 30-15,000Hz, aux 20-20,000Hz. S/N: phono inputs 75dB, high level inputs 86dB. Dimensions: 36 x 28 x 12cm. Price: £137.00 (plus VAT).

1040 *

Integrated console amplifier with output of 20W. THD: 0.3%. FR: 20-20,000Hz. Dimen-

★ Indicates entry is illustrated

sions: 36 × 28 × 12cm. Price: £137.00 (plus VAT).

1070★

Integrated console amplifier similar to 1040 but with 35W output. Price: £154.00 (plus VAT).

140

Power amplifier with output of 75W per channel. THD: 0.1%. FR: within ±0.25dB at 1W output. Dimensions: 36 × 27.5 × 12cm. Price: £206.00 (plus VAT).

■ MONOGRAM PROFESSIONAL AUDIO

281 Balmoral Drive, Hayes,
Middlesex, Greater London.
Tel: 01-573 1566.

RA1

Pre-amplifier equalizer. Output: 0-11V, 100 ohms-150Kohms. THD: 0.008%. FR: 2-130,000Hz. S/N: -85 DIN A, -95 DIN B. Dimensions: 19 × 8 × 5¼in. Price: £425.00 (plus VAT).

PA1

Power amplifier with output: 140W RMS. THD: 0.05%, typically 0.005%. FR: 1-80,000Hz. S/N: -100Db, typically -110dB. Dimensions: 19 × 11⅞ × 5¼in. Price: £425.00 (plus VAT).

■ MUSTANG COMMUNICATIONS

Mustang Communications, Nelson Street,
Scarborough, North Yorks YO12 7SZ.

SS.50

Power amplifier. Output: 80W RMS per channel. THD: less than 0.5% (typically 0.1%). FR: (Ref. 1kHz) -0.2dB at 10Hz and -0.2dB at 20kHz. Inputs/impedance: standard jack (others to order) 0.775V into 10K. Damping factor: 200. S/N ratio: 90dB. Controls: gain control, VU meter and mains illuminated on&off switch. Output fully protected. Unit is rack mounted in open chassis form. A range of steel cabinets are available. Dimensions: 48.3 × 33.7 × 8.9cm. Price: £83.20 (excluding VAT).

SS.100

Power amplifier. Output: 150W RMS per channel. Details as per SS.50. Price: £110.08 (excluding VAT).

■ NIKKO

Distributors: Howland-West Ltd.
3-5 Eden Grove, London N7 8EQ.
Tel: 01-609 0293/6.



Nikko TRM 210



Nikko TRM 230



Nikko TRM 500



Nikko TRM 600

TRM-210 ★

Integrated stereo amplifier. Output power: 16W per channel into 8 ohms. Inputs: phono 1.8mV 50K, tuner 200mV 100K, tape and aux 200mV 100K. Price: £66.50 (plus VAT).

TRM-230 ★

Integrated stereo amplifier. Output power: 20W per channel into 8 ohms. Inputs: phono (1 & 2) 1.8mV 50K, tuner 200mV 100K, tape and aux 200mV 100K. Main in 850mV 150K. Price: £78.50 (plus VAT).

TRM-500 ★

Integrated stereo amplifier. 29 transistors, 9 diodes. Inputs: mag PU 2mV 47K, tape 150mV 50K, aux 150mV 50K, radio 150mV 50K. Noise level: (mag PU input) -60dB, (other inputs) -80dB. Output: 26W RMS per chan-

nel. Controls: bass ± 10 dB at 70Hz, treble ± 10 dB at 10kHz, loudness +11dB at 70Hz +7dB at 10kHz, low filter -8dB at 70Hz, high filter -7dB at 10kHz, speaker switch (A, A + B, B), tape dubbing. HD: 0.2% at 1W, 0.8% at rated output. Output impedance: 8 ohms. FR: 20Hz-30kHz ± 2 dB. Mains: 100, 120, 220, 240V 50-60Hz. Size: 15 x 8 $\frac{1}{8}$ x 11 $\frac{1}{8}$. Finish: wood cabinet with metal trim. Price: £112.00 (plus VAT).

TRM-600 ★

Full technical specification not available as this edition of the Year Book closed for press. Integrated stereo amplifier. Finish: wood cabinet with metal control panel. Price: £134.00 (plus VAT).

TRM-800

Integrated amplifier with output of 65W. THD: 0.3%. FR: 10-40,000Hz. S/N: 65dB phono; 80dB others. Dimensions: 45 x 34 x 15cm. Price: £185.00 (plus VAT).

■ **NORDMENDE**

Vessco Vision and Radio Ltd,
Vessco House, Unit 4, Blackwater Way,
Ash Road, Aldershot, Hants GU12 4DL.
Tel: Aldershot 312661/4.

Stereo 500S

Stereo tuner-amplifier, waveband coverage FM, L, M, S. Price: on application.

Stereo 6005ST

Stereo tuner-amplifier with four wavebands FM, L, M, S. Five pre-programmed selection switches for FM, four sliding regulators for control of volume, balance, treble, bass, stereo indicator lamp. Output: 30W. Price: on application.

7020ST

Stereo tuner-amplifier with four wavebands FM, L, M, S. Features include sliding controls for bass, treble, volume, and balance. Dimensions: 58 x 11.5 x 32cm. Price: on application.

■ **PHILIPS**

Philips Electrical Ltd, Century House,
Shaftesbury Avenue, London WC2H 8AS.
Tel: 01-437 7777.

RH 551 ★

Stereo pre-amplifier suitable for use with Philips motional feedback speakers. Inputs: MD PU 2mV 50K, tuner 100mV 100K, tape (1) 250mV 100K, tape (2) 250mV 100K, monitor 250mV 100K, mic 1mV 2K (all DIN sockets).



Philips RH551



Pioneer SA-9900

Output: 2 x 1V. Controls: rumble -3dB at 80Hz (12dB/Oct), scratch -3dB at 7kHz (12dB/Oct), slide controls for bass ± 14 dB at 50Hz, presence ± 6 dB at 2kHz, treble ± 15 dB at 10kHz, rotary volume control. FR: 10Hz-40kHz +0.5dB -3dB. S/N ratio: -70dB. Price: £155 (including VAT).

AH 561

Integrated amplifier with output 2 x 30W RMS into 4 ohms. THD: <1% for 2 x 30W. FR: 15-40,000Hz linear, 20-20,000Hz linear. Damping factor: >20 at 4 ohms. S/N: better than -90dB (2 x 30W). Controls for balance, rumble, scratch, treble, bass, presence, three position contour. Dimensions: 47 x 28 x 11.7cm. Price: £152.00 (plus VAT).

■ **PIONEER**

Shriro (UK) Ltd, Shriro House,
The Ridgeway, Iver, Bucks SL0 9JL.
Tel: Iver 652222/7.

SA-9900 ★

Stereo integrated amplifier. Output: 110W RMS per channel from 20Hz-20kHz, both channels driven into 8 ohms. THD: not more than 0.1% at rated output, 20Hz-20kHz. FR:

★ Indicates entry is illustrated

10Hz-80kHz +0dB, -1dB. Inputs: phono (1) 2.5mV 50K, phono (2) 2.5mV/10mV 35, 50, 70, 100K (variable), mic 6mV/24mV 85K, tuner 150mV 50K, aux (1) 150mV 50K, aux (2) 150mV 50K, tape playback (1) 150mV 50K, tape playback (2) 150mV 50K, tape rec (1) 150mV, tape rec (2) 150mV. Load impedance: 50K and above. Damping factor: 30 (20Hz-20kHz at 8 ohms). S/N ratio: main amp 110dB, phono 70dB, mic 65dB, tuner, aux, tape playback 95dB. IHF short circuited A network. Controls: (twin tone control system) bass (main) 100Hz ± 7.5 dB, (sub) 50Hz ± 4.5 dB; treble (main) 10kHz ± 7.5 dB, (sub) 20kHz ± 4.5 dB. Dimensions: 42 \times 40.3 \times 16.5cm. Stepped volume attenuator control. Tape to tape duplication. 12dB/Oct filters at 15Hz, 30Hz, 8kHz, 12kHz. RIAA equalization 30Hz-15kHz $\times 0.2$ dB. Price: on application.



Pioneer SA-9500



Pioneer SA-8500



Pioneer SA-7500

SA-9500 ★

Stereo integrated amplifier. Output: 80W RMS per channel from 20Hz-20kHz, both channels driven into 8 ohms. THD: not more than 0.1% at rated output, 20Hz-20kHz. FR: 10Hz-80kHz +0dB, -1dB. Inputs: phono (1) 2.5mV 50K, phono (2) 2.5mV/10mV 35, 50, 70, 100K (variable), mic 6mV/24mV 85K, tuner, aux (1), aux (2) 150mV 50K, tape-playback (1) 150mV 50K, tape playback (2) 150mV 50K, tape rec (1) 150mV, tape rec (2) 150mV. Load impedance: 50K and above. Damping factor: 30 (20Hz-20kHz at 8 ohms). S/N ratio: main amp 100dB, phono 70dB, mic 65dB, tuner, aux, tape playback 90dB. IHF short circuited A network. 3-position turnover tone controls — 100Hz, 200Hz, 400Hz ± 5 dB, 2kHz, 4kHz, 8kHz ± 5 dB. Dimensions: 42 \times 40.3 \times 16.5cm. Stepped volume attenuator control. Tape to tape duplication. 12dB/Oct filter at 15Hz, 30Hz, 8kHz, 12kHz. RIAA equalization 30Hz-15kHz ± 0.2 dB. Price: on application.

SA-5300

Stereo integrated amplifier. Output: 10W RMS per channel from 40Hz-20kHz, both channels driven into 8 ohms. THD: not more than 0.8% at rated output. FR: aux input 20Hz-30kHz +0.5dB, -1dB (DIN). Inputs: phono 2.5mV 50K, tuner 150mV 50K, aux, tape PB, tape PB (DIN) 150mV 50K, tape rec (DIN) 30mV 80K, tape rec (line) 150mV 50K. Load impedance: 50K and above. Damping factor: 30 (40Hz-20kHz at 8 ohms). S/N ratio: phono 70dB, tuner, aux 85dB. Controls: bass +9dB, -8dB at 100Hz, treble ± 6 dB at 10kHz, loudness contour +8dB at 100Hz, -5dB at 10kHz. Dimensions: 35 \times 28 \times 12.5cm. RIAA equalization 30Hz-15kHz +0.5dB. Switching for two

sets of speaker loudness control. Loudness control. Price: on application.

SA-6300

Stereo integrated amplifier. Output: 20W RMS per channel from 40Hz-20kHz, both channels driven into 8 ohms. THD: not more than 0.8% at rated output. FR: aux input (DIN) 20Hz-20kHz (0.5-1dB). Inputs: phono 2.5mV 50K, tuner, aux, tape PB, tape PB DIN connector 150mV 50K, tape rec (DIN) 30mV 80K, tape rec line 150mV. Load impedance: 50K and above. Damping factor: 25 (20Hz-20kHz at 8 ohms). S/N ratio: phono 70dB, tuner, aux 90dB. HF short circuited A network. Controls: bass +9dB, -8dB (100Hz), treble +6dB (10kHz), loudness contour +8dB (100Hz), +5dB (10kHz). Dimensions: 35 \times 28.2 \times 12.5cm. Speaker A+B, A+B switching. Click stop tone controls. RIAA equalization 30Hz-

The 1976 Eagle catalogue lists every thing we sell, from a complete hi-fi system to a jack plug. Study the merchandise; scrutinise the prices. You may discover you can get the hi-fi things you need for a lot less than you thought. Write to us today for your catalogue.

It's free. Mistakes, unfortunately, aren't.

It costs you nothing. It could save you plenty.



Eagle International, Dept. HFY, Precision Centre, Heather Park Drive, Wembley, Middx. HA0 1SU

Monogram Professional Audio

CREATIVE SOUND FOR THE TRUE AUDIOPHILE

Designed and Handcrafted
in England



Products meet full studio and broadcast standards (Studio series)

For release in June 1976. Semi-professional Hi-Fi series including new 7-way 4-channel decoder pre-amplifier plus world's first pre-amplifier equalizer incorporating sound enhancement systems.



Monogram Professional Audio
LONDON ENGLAND

281 BALMORAL DRIVE HAYES
MIDDLESEX (01) 573 1566

IN USA (213) 393 8037

15kHz +0.5dB. Optional cabinet details on request. Price: on application.

SA-8500 ★

Stereo integrated amplifier. Output: 60W RMS per channel from 20Hz-20kHz, both channels driven into 8 ohms. THD: not more than 0.1% at rated output, 20Hz-20kHz. FR: 10Hz-80kHz +0dB, -1dB. Inputs: phono (1) 2.5mV 50K, phono (2) 2.5mV 50K, mic 75mV/15mV 85K, tuner, aux 150mV 50K, tape playback (1) 150mV 50K, tape playback (2) 150mV 50K, tape rec (1) 150mV, tape rec (2) 150mV. Load impedance: 50K and above. Damping factor: 30 (20Hz-20kHz at 8 ohms). S/N ratio: main amp 110dB, phono 70dB, mic 65dB, tuner, aux, tape playback 90dB. IHF short circuited A network. Twin tone control network. Bass 100Hz \pm 8dB (50Hz \pm 6dB, treble 10kHz \pm 8dB (90kHz \pm 6dB). Dimensions: 42 x 34.5 x 15cm. Tape duplicate switching. 12dB/Oct filters at 30Hz-8kHz. RIAA equalization 30Hz-15kHz +0.3dB. Price: on application.

SA-7500 ★

Stereo integrated amplifier. Output: 40W RMS per channel from 20Hz-20kHz, both channels driven into 8 ohms. THD: not more than 0.3% at rated output, 20Hz-20kHz. FR: 10Hz-80kHz +1.0dB, -1dB. Inputs: phono (1) 2.5mV 50K, phono (2) 2.5mV 50K, mic 7.5mV 85K, tuner 150mV 50K, aux (1) 150mV 50K, tape playback (1 & 2) 150mV 50K, tape rec (1 & 2) 150mV. Load impedance: 50K and above. Damping factor: 25 (20Hz-20kHz at 8 ohms). S/N ratio: main amp 100dB, phono 70dB, mic 65dB, tuner, aux, tape playback 90dB. IHF short circuited A network. Tone controls with selectable turnovers. Bass 200Hz, 400Hz, treble 2.5kHz, 5kHz. Dimensions: 42 x 34.5 x 15cm. Tape duplication switching. Filters 6dB/Oct at 30Hz, 8kHz. RIAA equalization 30Hz-15kHz +0.3dB. Price: on application.

SA-7300

Stereo integrated amplifier. Output: 35W RMS per channel, both channels driven from 20Hz-20kHz into 8 ohms. THD: not more than 0.3% at rated output. FR: aux input (DIN) 10Hz-50kHz +0dB, -1dB. Inputs: phono 2.5mV 50K, tuner 150mV 50K, aux 150mV 50K, tape PB 1/2 150mV 50K, tape PB 2(DIN) 150mV 50K, tape rec 1/2 150mV, tape rec 30mV 80K (DIN connector). Load impedance: (line) 50K and above. Damping factor: 25 (20Hz-20kHz at 8 ohms). S/N ratio: phono 70dB, tuner, aux 90dB. Short circuited IHF A network. Tone controls: bass 100Hz \pm 9dB, treble 10kHz +8dB, -6dB. Dimensions: 35 x 28.2 x 12.5cm. Deck (1) to deck (2) dubbing switch.

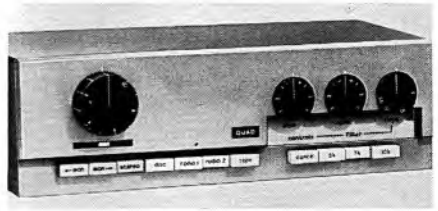

Quad 33

Loudness switch. Speaker selector switching. RIAA equalization 30Hz-15kHz +0.5dB. Optional cabinet details by request. Price: on application.

■ PLUSTRON

Plustronics Ltd, Hempstalls Lane, Newcastle, Staffs ST5 0SW.
Tel: Newcastle 615131.

QA10

Four-channel adaptor. Boosts stereo into 4-channel sound using two pairs of speakers. Special effect switch for surround and "hall" reproduction. Mode control for two or four channels. Sound level control. Price: on application.

■ QUAD

The Acoustical Manufacturing Co. Ltd, St. Peters Road, Huntingdon PE18 7DB.
Tel: Huntingdon 52561.

Quad 33 ★

Pre-amplifier. Output: 0.5V into not less than 10K (3.7mV, 20mV or 100mV to recorder). THD: 0.02%. FR: 30Hz-20kHz \pm 0.5dB. Inputs/impedance: radio (\times 2) 100mV into 100K; tape 100mV, 400mV or 1V pre-set, 40K; disc pre-set for cartridges of 0.2-3mV/cm/sec magnetic or 25-80mV/cm/sec ceramic. S/N ratio: (0-30 phon weighting 15.7kHz bandwidth) -90dB. Controls: volume/on-off, balance, bass, treble, filter slope and frequency, channel selection, source selection. Features/facilities: variable slope filter switched at half octave intervals 5-10kHz; pre-set adjustments on plug-in boards for pick-up and tape parameters. Dimensions: 26 x 9.2 x 16.5cm. Price: £68 (excluding VAT).

Quad 303 ★

Power amplifier. Output: 45W RMS per channel into 8 ohms. THD: 0.03%. FR: (within 1dB) 30Hz-35kHz into 8 ohms and 20Hz-35kHz into 16 ohms. Inputs/impedance: 0.5V RMS 22K in parallel with 60pF. Damping factor: output source 0.3 Ω in series with 2000 μ F and 6 μ H.

★ Indicates entry is illustrated

S/N ratio: -100dB. Features/facilities: unconditional stability, triple output circuit; output protected by current and voltage limiters. Dimensions: 12 × 15.9 × 32.4cm. Price: £74 (excluding VAT).

Quad 405 ★

Power amplifier. Output: 100W RMS per channel. THD: 0.01%. FR: (Ref. 1kHz) -1dB at 20Hz, -0.5dB at 20 kHz, -3dB at 50kHz. Inputs/impedance: 0.5V RMS 20K in parallel with 50pF. Damping factor: source 0.03Ω in series with 3.3μH. S/N ratio: ('A' weighted) -95dB, (unweighted) -90dB (15.7kHz bandwidth). Features/facilities: new current damping circuit, instantaneous recovery up to +20dB overload, unconditional stability, output current limiter, pre-set power limiter for 50W, excellent input slew and output offset. Dimensions: 11.5 × 34 × 19.5cm. Price: £115 (excluding VAT).

Quad 50E

Power amplifier. Output: 50W RMS per channel. THD: 0.1% at 1kHz. FR: (unbalanced input) -1dB at 30Hz and 20kHz, (balanced input) -2dB at 30Hz and 20kHz (Ref. 1kHz). Inputs/impedance: 0.5V RMS., (unbalanced) 14-50K depending on pre-set gain, (balanced) >14K in parallel with 50H. Damping factor: source 0.5Ω in series with 2.5μH for 17V output. S/N ratio: -80dB. Controls: continuously variable screwdriver pre-set gain. Features/facilities: input bridging for monitoring 600Ω lines; output adjustable for any load 4-200Ω; unconditional stability. Dimensions: 12 × 32.4 × 15.9cm. Price: £62 (excluding VAT).

■ RADFORD

Radford Audio Ltd, Ashton Vale Road, Bristol BS3 2HZ. Tel: Bristol 662301.

ZD22. Stereo Pre-amplifier Control Unit

A stereo pre-amplifier of virtually zero distortion. Inputs for disc, tuner and two tape machines providing comprehensive recording and reproducing facilities. Sensitivities: Disc 1mV and aux 50mV for 1V output. Exceptional signal/noise ratio. Output at clip level 18V. Size: 43 × 12 × 25cm. Price: £165.00 (plus VAT).

HD250. Stereo Integrated Amplifier

Uses ZD22 pre-amplifier with power amplifier having a power output in excess of 50W per channel RMS sine wave into 4-8 ohms. Distortion: less than 0.02% at rated power, typically less than 0.01%. True complementary symmetry output having low crossover distortion. Headphone output. In-



Quad 303 power amp

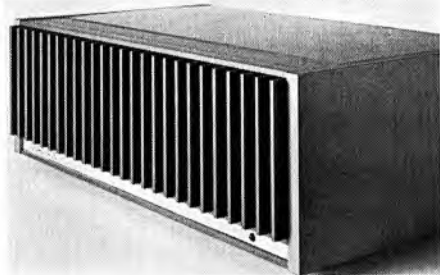

Quad 405

puts: Disc, tuner and two tape machines. Sensitivities: disc 1mV, aux 50mV for 50W output. Size: 43 × 12 × 28cm. Price: £220 (plus VAT).

ZD25. Pre-amplifier Control Unit

A stereo pre-amplifier of unmeasurable distortion constructed entirely of aluminium. Inputs for disc, tuner, and two tape machines. Input sensitivity: disc 1mV and aux 50mV for 1V output. Output at clip level 18V. Size: 43 × 12 × 25cm. Price: £210.00 (plus VAT).

ZD25H. Pre-amplifier Control Unit

As ZD25 but fitted with a headphone amplifier with independent volume control.

ZD2-100. Integrated Amplifier

A stereo integrated amplifier of all aluminium construction using the ZD25 pre-amplifier and the ZD100 power amplifier circuitry. Power output 125W per channel RMS sine wave into 4 ohms and 75W per channel into 8 ohms at, virtually zero distortion. Headphone output.

Inputs for disc, tuner and two tape machines. Input sensitivity for 125 watts into 4 ohms: disc 1mV, aux 50mV. Size: 43 x 12 x 35cm. Price: £325.00 (plus VAT).

ZD100. Power Amplifier

A stereo-power amplifier of all aluminium construction with high thermal mass. Designed for continuous operation at high output level. Provides 150 watts per channel continuous sine wave into 4 ohms and 90 watts per channel into 8 ohms at virtually zero distortion. Sensitivity: 1V for rated power output. Size: 43 x 14 x 35cm. Price: £275.00 (plus VAT).

ZD200. Power Amplifier

Characteristics as ZD100 amplifier but provides an output of 250W per channel into 4 ohms and 150W per channel into 8 ohms. Size: 43 x 20 x 35cm. Price: £400.00 (plus VAT).

ZD100 Pro. Power Amplifier

Construction and performance as ZD100 amplifier but fitted with 10K ohms line bridging transformers, input level controls and XLR input sockets. Price on application.

ZD200. Power Amplifier

Characteristics as ZD100 amplifier but provides an output of 250W per channel into 4 ohms and 150W per channel into 8 ohms. Size: 43 x 20 x 35cm. Price: £400.00 (plus VAT).

■ RADIONETTE

9 Hawksworth Trading Estate, Swindon, Wilts SN2 1DZ. Tel: Swindon 31287.

SM240C ★

Basically the SM340EC music centre without gram section. Amplifier 2 x 25W into 4 ohms. Tuner: FM/AM with four pre-sets on FM plus free tuning scale. Physiological volume control switchable to give linear output. Available in teak or rose finish. Price: £223.20 (plus VAT).

■ REVOX

Distributors: C. E. Hammond & Co Ltd, Lamb House, Church Street, London W4 2PB. Tel: 01-995 4551.

Revox A78 ★

Stereo amplifier. Output: 40W RMS per channel into 4-8 ohms, 25W RMS per channel into 16 ohms. HD: less than 0.1% at 1kHz, 0.3% 40Hz-15kHz. FR: 20Hz-20kHz \pm 1dB. Inputs: mag PU 3mV, ceramic PU 230mV, tape 100mV, aux 100mV, radio 100mV, tape monitor 250mV. Treble control: \pm 12dB at

12kHz. Bass control: \pm 12dB at 60Hz. Mains: 110, 130, 150, 220, 240, 250V AC 50-60Hz. 30 silicon transistors, 3 rectifiers, 14 diodes. Size: 6¼ x 16½ x 9¾in. Weight: 18lb. Price: £229.00 (plus VAT).

A722 ★

Stereo power amplifier. Inputs: 0.75V 20K for (60W/4 ohms). Outputs: speakers 60W per channel into 4 ohms, 45W per channel into 8 ohms, 30W per channel into 16 ohms. THD: greater than 0.1% at rated power into 4 ohms, 1kHz. FR: 20Hz-20kHz - 1dB, into 4 ohms. Power bandwidth: 10Hz-50kHz (DIN) into 4 ohms. S/N ratio: less than 90dB (Ref. 60W/4 ohms). Price: £205.00 (plus VAT).

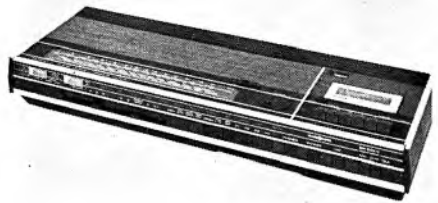

Radionette SM 240 C



Revox A78



Revox A722

★ Indicates entry is illustrated

■ ROGERS

Swisstone Electronics Ltd, 4-14 Barmeston Road, London SE6 3BN. Tel: 01-697 8511.

Ravensbrook Mk III

Solid state stereo amplifier and control unit. Power output: 15W per channel into 10 ohms. 10W per channel into 8 ohms. THD: less than 0.1% at 10W into 10 ohms, less than 0.25% at 10W into 15 ohms. 100Hz-10kHz. FR: 20Hz-50kHz -3dB. S/N ratio: disc -53dB, radio -80dB. Power consumption: quiescent 22W; 10W/15 ohms 50W. Inputs: disc, sensitivity 2, 4, 25 50mV impedance 47K. Controls: pushbutton input selector, function, bass and treble, balance, high pass filter switch, low pass filter/slope. Output facility for headphones. Output matching: 4-8 ohms and 8-16 ohms. Dimensions: 14 $\frac{3}{4}$ × 9 $\frac{7}{8}$ × 5in. Price: (in teak cabinet) £63.50 (plus VAT).



Rogers Panthera A75

Panthera A75 ★

Integrated stereo amplifier. 22 silicon transistors. Power output: 2 × 37.5W continuous into 8 ohms. THD: less than 0.06% up to 20W into 15 ohms at 1kHz. (0.1% average at 32W). Output impedance: 4, 8 and 16 ohms. Damping factor: 60 at 1kHz into 15 ohms. Power frequency response: -3dB 25Hz-35kHz into 15 ohms. S/N ratio: volume control minimum better than -80dB, volume control maximum, tuner, tape, aux inputs better than -75dB. Disc inputs, short circuit or 10K load, 2.5/3.5mV better than -60dB, 55/80mV better than -65dB, all relative to 32W into 15 ohms. Crosstalk: tuner, tape, and aux better than 45dB, 1kHz better than 30dB, 10kHz. Disc input short circuited better than 40dB up to 25kHz. Bass control: ±16dB at 40Hz. Treble control: ±16dB at 10kHz. High pass filter: built-in 20Hz 30dB per octave. Low pass filter: switched 6 or 9kHz. Balance control: range 9dB. Mains: 110, 125, 220, 240V 50/60Hz. Size: 14 $\frac{1}{4}$ × 11 $\frac{1}{4}$ × 4 $\frac{5}{8}$ in. Weight: 15 $\frac{1}{2}$ lbs. Price: £95 (plus VAT) with optional teak or walnut end trim.



Ross Elec Stereo pre-amp

■ ROSS ELECTRONICS

32 Rathbone Place, London W1P 9AD.
Tel: 01-580 7122.

Stereo pre-amplifier ★

Permits use of magnetic cartridges with amplifiers providing inputs for ceramic or crystal only. Shielded case. Phono input and output. FR: 30Hz-20kHz. Input impedance: 50K. Gain: 10mV to 0.5V output. Maximum input: 30mV. Price: £6.09 (plus VAT).

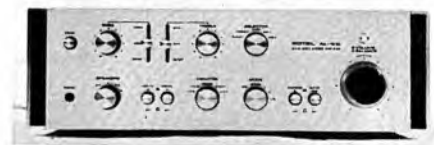

Rotel RA1210



Rotel RA 312

■ ROTEL

Rank Audio Visual Ltd, Great West Road, Brentford TW8 9HR. Tel: 01-568 9222.

RA 211

Integrated stereo amplifier. Inputs: phono (1) 2.7mV 45K, phono (2) 140mV/170mV 100K, aux (1) 150mV 50K, aux (2) 330mV 100K. Damping factor: 35 at 8 ohms. Output: 10W RMS per channel, both channels driven into 8 ohms. THD: less than 1%. Power bandwidth: (IHF) 20Hz-35kHz. S/N ratio: phono 65dB, tape 70dB. Phono overload: 80mV. Speaker impedance: 4 to 16 ohms. Size: 13 × 4½ × 6½in. Weight: 9lb. Price: £58.00 (plus VAT).

RA 1210 ★

Stereo pre-main amplifier. Inputs: mag PU (1) 1mV 100K, PU (2) 1-4mV 30-100K, radio 200mV 45K, aux 200mV 45K, tape 200mV 45K, tape (DIN) 330mV 100K. Output: 60W RMS per channel, both channels driven into 8 ohms. THD: less than 1%. Controls: loudness +10dB at 50Hz and +6dB at 10kHz, low filter -10dB at 50Hz, bass ±10dB at 50Hz, treble ±10dB at 10kHz. Load impedance: 4 to 16 ohms. Power bandwidth: 5Hz-50kHz. S/N ratio: phono 70dB, tape 80dB. Phono overload: 130mV. Mains: 100, 117, 220, 240V AC 50/60Hz. Size: 16½ × 5½ × 12in. Weight: 30lb. Price: £212.00 (plus VAT).

RA 212

Integrated amplifier with output of 10W at rated power, bandwidth 50-20,000Hz at rated THD. THD: 1%. FR: 20-60,000Hz. S/N: >80dB. Dimensions: 33.5 × 24 × 11.5cm. Features: 2 pairs of speaker facilities. Tape monitor, rotary knobs for balance, volume, treble, bass; function selection. Price: £58.00 (plus VAT).

RA 312 ★

Integrated amplifier with output of 18W at 50-20,000Hz. THD: 1%. FR: 15-60,000Hz. S/N: >85dB. Dimensions: 40 × 24 × 11.5cm. Price: £69.20 (plus VAT).

RA 412

Integrated amplifier with output of 25W at 20-20,000Hz. THD: 0.5%. FR: 15-90,000Hz. S/N: >85dB. Dimensions: 40 × 24 × 11.5cm. Features include split power supply. Audio muting, simulated four channel sound, tape dubbing facilities, high and low filters. Price: £86.00 (plus VAT).

RA 612

Integrated amplifier with output of 35W at 20-20,000Hz. THD: 0.5%. FR: 5-95,000Hz.

S/N: >90dB. Dimensions: 43 × 33 × 14cm. Electronic circuitry protection, full tape dubbing and audio muting. Separate right and left controls, simulated four channel matrix. Price: £116.40 (plus VAT).

RA 812

Integrated amplifier with output of 45W at 20-20,000Hz. THD: 0.3%. FR: 5-100,000Hz. S/N: >90dB. Dimensions: 43 × 33 × 14cm. Three stage direct coupled equaliser amp with high gain ICs. Audio muting, tape dubbing and mic mixing. Subsonic, low, high filters. Two direct reading watt meters. Price on application.

RA 1212

Integrated amplifier with output of 70W 20-20,000Hz. THD: 0.3%. FR: 4-100,000Hz. S/N: >95dB. Dimensions: 43 × 38 × 14cm. Two power transformers. Full tape dubbing, audio muting, simulated four channel matrix. Price: £109.00 (plus VAT).

RA 1412

Integrated amplifier with output of 110W 20-20,000Hz. THD: 0.1%. FR: 3-100,000Hz. S/N: >95dB. Dimensions: 54 × 43 × 18cm. Full tape dubbing, mic mixing. Price: £316.00 (plus VAT).

■ SANSUI

Vernitron Ltd, Thornhill, Southampton SO9 5QF. Tel: Southampton 444811.

AU2200

Stereo amplifier. Output: 2 × 15W RMS into 8 ohms. THD: less than 0.8% at rated output. Damping factor: 30 at 8 ohms. Output impedance: 4-16 ohms. FR: 30Hz-40kHz + 1dB -2dB. Inputs: phono 2.5mV, mic 2.5mV 10K, tuner 150mV 50K, aux 150mV 50K, tape monitor 150mV 50K. S/N ratio phono better than 65dB. Aux inputs better than 75dB. Controls: Pushbutton input selectors, provision for two sets of speakers, high filter and loudness switches. Size: 400 × 120 × 240mm. Finish: brushed aluminium. Price: To be announced.

AU4400

Stereo amplifier. Output: 2 × 26W RMS into 8 ohms or 2 × 36W RMS into 4 ohms. FR: 20Hz-30kHz + 1dB -2dB. Damping factor: 50 at 8 ohms. Output impedance: 4-16 ohms. Inputs: phono 2.5mV 50K, tape monitor 150mV 50K, mic 2.5mV 10K. S/N phono better than 70dB. Aux inputs better than 85dB. Controls: Pushbutton input selectors, provision for two sets of speakers, low and high filters, loudness and stereo&mono switches. THD: less than

★ Indicates entry is illustrated

0.3% at rated output. Size 400 × 120 × 240mm. Finish: brushed aluminium with black enamelled casing. Price: To be announced.

AU550

Stereo amplifier. Total output: 2 × 26W RMS into 8 ohms. Output impedance: 8 ohms. FR: 10Hz-35kHz +0.5dB -1dB. THD: less than 0.1% at rated output. Inputs: phono 2.5mV 50K, tuner 100mV 50K, aux 100mV 50K, tape monitor 100mV 50K, power amplifier output 800mV 50K. S/N tuner better than 75dB, aux better than 85dB, power amplifier inputs better than 100dB. Facility for two sets of speakers, tape to tape reprint, triple tone control. Size: 434 × 130 × 315mm. Finish: black. Price: To be announced.

AU7700 ★

Stereo amplifier. Output: 2 × 54W RMS into 8 ohms. Damping factor: 30 at 8 ohms. FR: 10Hz-50kHz +0.5dB -1dB. THD: less than 0.1% at rated output. Inputs: phono one 2.5mV (30K, 50K, 100K), phono two 2.5mV 50K, tuner 100mV 50K, aux 100mV 50K, tape monitor 100mV 50K, power amplifier output 800mV 50K. S/N: tuner better than 75dB, aux better than 85dB, power amplifier inputs better than 100dB. Facility for two sets of speakers, tape to tape reprint, triple tone control. Size: 434 × 130 × 315mm. Finish: black. Price: To be announced.

AU9500

Integrated stereo amplifier. Inputs: mag PU (2) 2.5mV 50K, mic 2.5mV 50K, radio 100mV 50K, aux 100mV 50K, tape (3) 100mV 50K, four-channel adaptor 100mV 50K, noise reduction unit 100mV 50K, power amplifier 800mV 50K. Noise level: (mic) better than 65dB (PU inputs) better than 75dB, (other inputs) better than 85dB. Overload capability: (PU inputs) 300mV. Output: 2 × 80W RMS into 8 ohms. Controls: bass ±15dB at 20Hz (3dB steps), mid-range ±5dB at 1.5kHz (1dB steps), treble ±15dB at 20kHz (3dB steps), bass selector defeat -150Hz, 300Hz, 600Hz, mid-range selector defeat -750Hz, 1.5kHz, 3kHz, treble selector defeat -2kHz, 3.5kHz, 6kHz, loudness +10dB at 50Hz +8dB at 10kHz, low filter -3dB at 50Hz -3dB at 100Hz, high filter -3dB at 12kHz -3dB at 6kHz. HD: <0.1%. Output impedance: 4-16 ohms. FR: 15Hz-40kHz +0dB -1dB at 1W. Mains: 100, 117, 127, 220, 240, 250V 50-60Hz. Finish: matt black cabinet and front panel with satin chrome trim. Four AC outlets. Two headphone jacks. Two microphone jacks. Size: 500 × 140 × 347mm. Price: £311.46 (plus VAT).



Sansui AU7700



Shure Safephone SA2E



Shure MS4-2E

■ SANYO

Sanyo Marubeni (UK) Ltd,
Sanyo House, Bushey Mill Lane,
Watford, Herts. WD2 4UQ.
Tel: Watford 30421.

DCA200

Stereo amplifier. Output: 15W RMS per channel, both channels driven into 8 ohms. HD: 0.8%. Power bandwidth: 20Hz-100kHz. FR: 20Hz-100kHz ±3dB. Input level/impedance: aux 150mV 50K, phono 2.5mV 50K, Tape (RCA) 150mV 50K, tape (DIN) 150mV 50K. Tone controls: bass ±10dB 100Hz, treble ±10dB 10kHz. Loudness control: +8dB 100Hz, +3dB 10kHz. S/N ratio: aux 85dB, phono 75dB, tape 85dB. Speaker impedance: 4-16 ohms. Size: 350 × 295 × 120mm. Controls: power, speakers, mode, filter, loudness, mic level, tape 1 and 2, bass, treble, volume, balance, function selection, micmix. Connections: headphones, mic, speakers, phono, tuner, aux, tape playback, DIN. Price: on application.

■ SHURE ELECTRONICS

Shure Electronics Ltd,
Eccleston Road, Maidstone,
Kent ME15 6AU. Tel: Maidstone 59881.

Solophone SA-2E ★

Provides personal stereo listening for one or two people. Gives sufficient amplification to accept output from any high quality cartridge (for example Shure Stereo Dynetic range), tape deck or FM tuner. There are input selector switch, separate volume controls for each channel and two headphone jacks mounted on the front panel. Size: $10\frac{1}{4} \times 3\frac{1}{2} \times 3$ in. Weight: 2lb. Mains: 240V 50Hz. Price: £30.00 (plus VAT).

M64-2E ★

Stereo pre-amplifier designed to furnish voltage gain and equalisation to enable amplifiers not equipped with necessary input facilities to be used with magnetic pickup cartridges and tape heads. Can also be used for microphones and as buffer amplifiers. FR: 20Hz-20kHz ± 2 dB. Input impedance: 50K at 1kHz. Load impedance: (high) 22K minimum; (low) 600 ohms optimum. Separation: 50dB at 1kHz. H and N: 71dB minimum below 10mV input from 20Hz-20kHz. Optional battery power unit. Price: £35.10 (plus VAT).

■ SKANTIC (UK) LTD

Station Road, Edenbridge, Kent TN8 6EY.
Tel: Edenbridge 5231.

25412.25422

Tuner amplifier, two channels ambiphonic stereo. FR: 20-20,000Hz. Four preset programmes. Decoder. Full details and Price: on application.

■ SONAB LTD

214 Harlequin Avenue, Brentford TW8 9EW.
Tel: 01-568 295213.

P4000

Integrated stereo amplifier. Inputs: mag PU (2) 2mV 68K RIAA, mic 2.1mV 68K flat, aux 100mV 100K, tape 100mV 100K, line 500mV 47K. Output: 70W RMS per channel into 4 ohms, 50W RMS per channel into 8 ohms, 55W per channel into 4 ohms with both channels driven, 40W per channel into 8 ohms with both channels driven. Controls: input selector, mono/stereo, tape monitor, loudness, high filter, volume, balance, bass ± 12 dB at 50Hz, treble ± 8 dB at 10kHz. HD. less than 0.1% at 1kHz with both channels operating and up to 35W into 8 ohm load. Output impedance: 4-16 ohms. FR: 15Hz-25kHz ± 1.5 dB. Mains: 110,



Sony TA70/ST70

130, 220, 240V 50/60Hz. Size: $18\frac{3}{4} \times 9\frac{7}{8} \times 4\frac{1}{2}$ in. Weight: 18 $\frac{3}{4}$ lb. Provision for two pairs of stereo headphones with impedance 8-600 ohms. Price: on application.

■ SONY (UK) LTD

Pyrene House, Sunbury Cross,
Sunbury-on-Thames.
Tel: Sunbury 87644

TA 70★

Integrated stereo amplifier. Output: 8W per channel, both channels operating at 1kHz into 8 ohms. Harmonic distortion: 5% at rated output power. Input sensitivity and impedance: phono 3.5mV 50K, phono (I) 300mV (switchable) 1M, tuner 250mV 100K, aux 250mV 100K, tape 440mV 100K, DIN 440mV 100K. Output level and impedance: rec out 250mV 10K, DIN 30mV 80K. Tone controls: bass ± 10 dB 100Hz, treble ± 10 dB 10kHz; loudness +8dB 100Hz, +4dB 10kHz (attenuation -30dB), filter (high) 3dB/Oct above 5kHz. Quasi-complementary symmetry circuit system, 20 transistors, 2 diodes. Mains: 240V AC 50Hz. Power consumption: 70W. Size: 330 \times 87.5 \times 245mm. Weight: 3.8kg. Price: £46.25 (plus VAT). Optional accessories: DR9 stereo headphone, DR15 stereo headphone, RC2 DIN (Rec/PB) connecting cord, RK81 connecting cord, RK74 connecting cord. Price: £47.96 (plus VAT).

TA 88 ★

Integrated stereo amplifier. Output: 10W RMS per channel, both channels operating at 1kHz into 8 ohms, 40Hz-12.5kHz. Power bandwidth: 20Hz-20kHz IHF. Harmonic distortion: 0.5% at 1W. IM distortion: 1% at rated output power. FR: 15Hz-50kHz ± 1 dB, -3dB, tuner, tape, aux, rec/PB input. S/N ratio: 60dB phono, 80dB other inputs. Damping factor: 35 at 8 ohms. Input sensitivity and impedance: phono 3mV 50K, tuner 250mV 50K, aux 250mV 50K, tape 250mV 50K, DIN 250mV 50K. Outputs: rec out 250mV 10K, headphone

★ Indicates entry is illustrated

8K, DIN 30mV 80K. Tone controls: bass ± 10 dB 100Hz, treble ± 10 dB 10kHz, filter (high) 6dB/Oct above 5kHz. Quasi-complementary symmetry direct circuit system. 22 transistors, 8 diodes. Mains: 110, 220 and 240V AC 50/60Hz. Power consumption: 80W. Size: 130 \times 230 \times 165mm. Weight: 3.2kg. Price: £55.51. Optional accessories: DR9, DR15 stereo headphone, RC2 DIN (Rec/PB) connecting cord, RK81, RK74 connecting cords. Price: £58.36 (plus VAT).



Sony TA88/S188



Sony TA5650



Sony TA8550

TA 5650★

Output: 65W RMS per channel, both channels operating at 1kHz into 8 ohms, 20Hz-20kHz. Harmonic distortion: 0.1% at 1kHz rated output power. IM distortion: 0.1% at rated power. S/N ratio: 100dB. Damping factor: better than 100 at 1kHz into 8 ohms. Pure complementary direct-coupled circuit system (main amp). Mains: 240V AC. Price: £183.96 (plus VAT).

TA 8650 ★

Output: 90W RMS per channel, both channels operating at 1kHz into 8 ohms, 20Hz-20kHz. Harmonic distortion: 0.1% at 1kHz rated output power. IM distortion: 0.1% at rated output power. S/N ratio: 100dB. Damping factor: better than 100 at 1kHz into 8 ohms. Inputs: phono (1) 2.5mV 50K, phono (2) 2.5mV 50K, mic 0.2mV 50K, aux 1, 2, 3 150mV 100K, tuner 150mV 100K, tape (1 & 2) 150mV 100K. FR: (RIAA equalisation curve ± 0.2 dB) phono (1 & 2) 10Hz-100kHz ± 0.2 dB, aux 1, 2, 3, tuner, tape (1 & 2). Tone controls: bass 250/500Hz ± 10 dB, treble 2.5/5kHz ± 10 dB, filters (high) 12dB/Oct 9-20kHz (turnover), (low) 12dB/Oct 10-40Hz (turnover). S/N ratio: 70dB phono (1 & 2), 90dB aux 1, 2, 3, tape (1 & 2). Pure-complementary triple push-pull direct-coupled circuit system. Mains: 240V AC. Power consumption: 30W. Size: 440 \times 170 \times 425mm. Weight: 20.8kg. Price: £479.96 (plus VAT).

TA 3140F

Power amplifier. Rated output: 35W per channel, both channels operating into 8 ohms at 20Hz-20kHz RMS. Power bandwidth: 6Hz-35kHz IHF. Harmonic distortion: 0.1% at rated output power, 0.05% at 1W output power. IM distortion: 0.1% at rated output power. FR: 10Hz-200kHz ± 0 , -2 db at 1W output. S/N ratio: 110dB. Damping factor: 100 at 8 ohms. Input sensitivity and impedance: 0.85V 70K. Mains: 100, 117, 220 and 240V AC 50/60Hz. Power consumption: 210W. Size: 200 \times 149 \times 320mm. Weight: 6.5kg. Price: £97.17 (plus VAT).

■ J. E. SUGDEN

J. E. Sugden & Co Ltd, Carr Street, Cleckheaton, Yorks BD19 5LA.
Tel: Cleckheaton 2501.

C51 control unit ★

Transistorised stereo control unit designed for use with P51 power amplifier. Inputs: radio, tape and aux, each 150mV into 250K for flat response. PU (1) 2.5mV 47K RIAA. PU (2) same as PU (1) or any characteristic to choice with basic sensitivity 0.25mV. Plug-in adap-



J. E. Sugden C51



J. E. Sugden P51

tors available for various cartridges, microphones, etc. Controls: bass ± 14 dB at 40Hz, treble ± 14 dB at 10kHz, volume ± 1 dB per channel, balance ± 6 dB for 180° rotation fade out at full rotation. Rumble filter: 12dB/octave below 30Hz. Treble filter: 4kHz, 7kHz and 10kHz. Treble filter slope: gradual 6dB/octave, steep 18dB/octave. HD: better than 0.1% at rated output. S/N: better than 85dB on 150mV inputs, better than 75dB on PU inputs. Pushbutton selection of inputs and operating mode. Power: obtained from P51 amplifier. Size: 11 \times 3 $\frac{1}{2}$ \times 7in. Price: £67.20 (plus VAT).

A21 Series Three ★

Integrated stereo amplifier. 28 transistors, 13 diodes. Inputs; mag PU 2.5mV 47K, radio 100mV 200K, aux 100mV 200K, tape 100mV 200K. Noise level: (PU input) -73dB, (other inputs) -85dB. Overload capability: (PU input) 130mV, (other inputs) infinite. Output: 20W RMS per channel into 8 ohms, 25W per channel into 4 ohms. Controls: bass ± 14 dB at 40Hz, treble ± 14 dB at 10kHz, balance ± 6 dB for 180° rotation, fade out at full rotation, volume, input selectors, HF filter 7kHz at 12dB/octave, stereo/mono, left/right outputs. HD: <0.1%. FR: 30Hz-20kHz ± 1 dB at all power levels. Mains: 110, 120, 220, 240V 50-60Hz. Size: 16 \times 5 $\frac{3}{4}$ \times 11 $\frac{1}{8}$ in. Finish: teak with anodised front panel. Special class AB output stage. Price: £95.20 (plus VAT).

A48 Series Two

Integrated stereo amplifier. 34 transistors, 17 diodes. Inputs: mag PU 2.5mV 47K, radio 100mV 200K, tape 100mV 200K, aux 100mV 200K. Noise level: (PU input) -70dB, (other inputs) -82dB. Overload capability: (PU input) 100mV, (other inputs) infinite. Output: 40W RMS into 8 ohms. Controls: bass ± 14 dB at 40Hz, treble ± 14 dB at 10kHz, balance ± 6 dB at 180° rotation, fade out at full rotation, volume, input selectors, LF filter 18dB/octave from 70Hz, HF filter at 4, 7 or 10kHz, pushbutton selection of slope (steep 18dB/octave, gradual 6dB/octave), quiet button (-16dB loudness compensated), mono/stereo, left or right output. HD: <0.1%. FR: 30Hz-20kHz ± 1 dB at all output levels. Mains: 110, 120, 220, 240V 50-60Hz. Size: 16 \times 5 $\frac{3}{4}$ \times 11 $\frac{1}{8}$ in. Finish: teak with anodised aluminium panel. Special output stage. Price: £140.00 (plus VAT).

P51 ★

Mono or stereo power amplifier. 21 transistors, 20 diodes. Input: 500mV 300K. Noise level: -90dB. Output: 50W RMS into 8 or 4 ohms, or with mono connection 100W into 8 ohms. Mono/stereo switch. HD: 0.05% at 8 ohms, 0.1% at 4 ohms. FR: 30Hz-20kHz ± 0.75 dB at all power levels. Mains: 110, 120, 220, 230, 240V 50-60Hz. Finish: case finished in embossed PVC with matt PVC facing on aluminium panel. Price: £92 (plus VAT).

■ TANDBERG

Farnell-Tandberg Ltd, Farnell House,
81 Kirkstall Road, Leeds LS3 1HR.
Tel: Leeds 35111.

TA300M

Integrated stereo amplifier. 33 transistors, 13 diodes. Inputs: mag PU (2) 2.5mV 48K, tape (2) 200mV 100K. Noise level: (PU inputs) 60dB, (other inputs) 83dB. Overload capability: 25dB. Output: 35W RMS per channel. Controls: treble ± 17 dB, high filter -3dB at 7kHz, bass ± 15 dB, loudness +7dB at 10kHz, low filter -3dB. HD: 0.2% at 1dB below rated output. Load impedance: 4-8 ohms. FR: 15Hz-50kHz -1.5dB. Mains: 115, 220, 240V AC 50-60Hz. Size: 16 $\frac{1}{8}$ \times 3 $\frac{1}{2}$ \times 9 $\frac{1}{8}$ in. Finish: teak or rosewood. Headphones jacks on front plus microphone input. Input mixing capability. Price (teak or rosewood): £116.00 (plus VAT).

■ TELETON

Teleton Electro (UK) Co Ltd,
Teleton House, Waterhouse Lane,
Chelmsford, Essex CM1 1BD.
Tel: Chelmsford 62442.

★ Indicates entry is illustrated

A400 ★

Stereo amplifier. Twin VU meters. Output power: 20W RMS per channel, both channels driven. HD: 0.3% at 10W 1kHz. IM distortion: 1%. FR: 25Hz-30kHz ± 1.5 dB (Ref. 1kHz). Power bandwidth: 15Hz-30kHz. Input sensitivity: mag PU 3mV 47K, crystal/ceramic PU 150mV 700K, tape 250mV 100K, aux 200mV 100K. Tone controls: bass ± 11 dB (100Hz), treble ± 11 dB (10kHz). High cut filter: -8dB at 10kHz. Hum and noise: (vol/bass/treble max) less than 20mV. Outputs: speakers 8 ohms. Headphones: 8 ohms (500mV at 20W). Crosstalk: -50dB at 1kHz. Damping factor: 20. Mains: 240V AC 50/60Hz 100W max. Size: 90 x 422 x 230mm. Weight: 4kg. Price: £64.50 (plus VAT).



Teleton A400

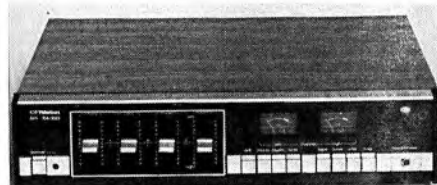

Teleton GA203

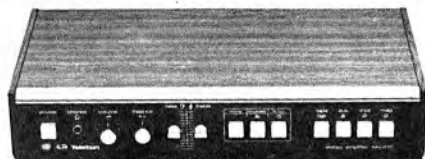

Teleton SAQ307D

GA203 ★

Stereo amplifier with twin VU meters. Output power: 20W RMS per channel, both channels driven. HD: 0.3% at 10W 1kHz. IM distortion: 1%. FR: 25Hz-30kHz ± 1.5 dB (ref. 1kHz). Power bandwidth: 15Hz-30kHz. Input sensitivity: mag PU 3mV 47K, crystal/ceramic PU 150mV 700K, tape 250mV 100K, aux 200mV 100K. Tone controls: bass ± 11 dB (100Hz), treble ± 11 dB (10kHz). High cut filter: -8dB at 10kHz. Hum and noise: less than 20mV. Outputs: speakers 8 ohms, headphones 8 ohms. Crosstalk: -50dB at 1kHz. Damping factor: 20. Mains: 240V AC 50/60Hz. Size: 90 x 422 x 230mm. Weight: 4kg. Price: £64.50 (plus VAT).

SAQ307D ★

Stereo amplifier. Output power: 8W RMS per channel, both channels driven. HD: 0.4% at 6W. FR: 30Hz-20kHz ± 1.5 dB (ref. 1kHz). Input sensitivity: phono mag 3mV, phono xtal 150mV, aux 200mV, tape 250mV. Tone controls: bass ± 10 dB (100Hz), treble ± 10 dB (10kHz). High cut filter: -8dB at 10kHz. Hum and noise: less than 20mV. Crosstalk: -50dB at 1kHz. Damping factor: 20. Smooth slider control for balance with rotary volume bass and treble controls. Flip switches for stereo/mono, loudness and hi-cut filters. Rotary function switch selects mag, crystal, aux or tape. Exceeds DIN 45 500. Mains: 110/240V AC 50/60Hz 60W max. Size: 80 x 388 x 230mm. Price: £55.60 (plus VAT).

ohms. THD: 0.2% at rated output. IM distortion: 0.2% at rated output. FR: 10Hz-70kHz -1dB. Damping factor: 100 at 8 ohms. Speaker impedance: 8-16 ohms. Input sensitivity and impedance: phono (1) 20mV 47K, phono (2) 2mV 70K, phono (3) 2mV 47K, tuner 150mV 47K, aux 1 (4-ch) 150mV 47K, aux 2 (4-ch) 150mV 47K, 4-channel tape 150mV 47K. Tone controls: bass ± 10 dB 100Hz, treble ± 10 dB 10kHz. Equalising curve: ± 0.2 dB RIAA. Mains: 100, 120, 220, 240V AC 50/60Hz. Power consumption: 230W (16W at no signal). 74 transistors, 38 diodes. Size: 450 x 376 x 126mm. Weight: 11.5kg. Price: £278.00 (plus VAT).

SB-220

Integrated amplifier with output 22 x 2 RMS at 8 ohms, 40-20,000Hz. THD: 0.8% rated power. FR: 15-70,000Hz. S/N: phono 66dB, aux 80dB. Dimensions: 40 x 31.2 x 12.6cm. Price: on application.

SB-420

Integrated amplifier with output 42 x 2 RMS at 8 ohms, 20-20,000Hz. THD: 0.3% rated power. FR: 10-80,000Hz. S/N: phono 70dB, aux 80dB. Dimensions: 45 x 37.5 x 14.8cm. Price: on application.

■ TOSHIBA

Toshiba (UK) Ltd. Toshiba House,
Great South West Road, Feltham,
Greater London. Tel: 01-751 1281.

SB-514

Output: 35W RMS all channels driven into 8

■ TRIO

Distributors: B. H. Morris & Co (Radio) Ltd, Trio House, The Hyde, London NW9 6JP. Tel: 01-205 6441.

KA 1200G ★

Integrated stereo amplifier. Output: 13W RMS per channel both channels driven into 8 ohms at 1kHz (16W RMS per channel, both channels driven into 4 ohms at 1kHz). THD: 0.8% at rated power into 8 ohms. Power bandwidth: 20Hz-40kHz. S/N ratio: 50dB at 50mW. Damping factor: 30 at 8 ohms. Inputs: phono 2.5mV 50K, tuner 150mV 50K, aux 150mV 50K, tape play 150mV 50K, mic 3mV 50K. FR: phono RIAA standard curve +1dB, tuner, aux, tape play 20Hz-40kHz +0dB, -2dB. Controls: bass ± 10 dB at 100Hz, treble ± 10 dB at 1kHz, loudness +8dB at 100Hz or +5dB at 1kHz. Facilities for tape monitoring, two sets of loudspeaker outputs, loudness switch. Power consumption: 120W full power, 9W no signal. Mains: 240V AC 50/60Hz. Size: 372 \times 125 \times 251mm. Weight: 4.9kg. Finish: brushed gold and teak. Price: £57 (plus VAT).

KA 1200B

Identical in performance to the KA 1200G but with an attractive matt black fascia. Price: £57 (plus VAT).

700C ★

Stereo pre-amplifier. THD: 0.04% at rated output: Inputs: (1 & 2) 2.5mV 50K, tuner 150mV 100K, aux (1 & 2) 150mV 100K, tape play 150mV 100K, mic 2.5mV 600 Ω . S/N ratio: phono (1 & 2) 70dB, tuner, aux (1, 2, 3) RIAA standard curve +0.3dB, tuner, aux, tape play 20Hz-20kHz -0.3dB, +0dB. Controls: bass, treble, loudness, low filter, high filter, phones out. Power consumption: 10W. Size: 440 \times 145 \times 300mm. Weight: 9.5kg. Price: £353.00 (plus VAT).

700M ★

Stereo power amplifier. Power output: 170W RMS per channel, both channels driven into 8 ohms at 20Hz-20kHz. THD: 0.1% at rated power into 8 ohms. IM distortion: 0.1% at rated power into 8 ohms. Power bandwidth: 5Hz-30kHz. S/N ratio: 100dB. Input sensitivity and impedance: 1V 50K. Damping factor: 40 at 8 ohms. FR: 20Hz-20kHz +0dB, -0.5dB. Speaker impedance: 4-16 ohms. Power consumption: 73W at no signal. Size: 440 \times 200 \times 360mm. Weight: 27kg. Price: £496.00 (plus VAT).

KA 3300

Integrated amplifier with output 30+30W from

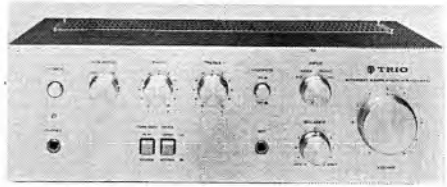

Trio KA1200G



Trio 700C

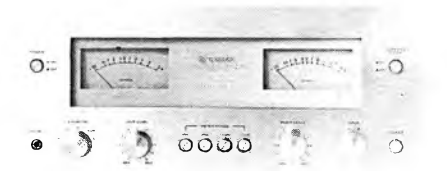

Trio 700M

20-20,000Hz. THD: 0.8% rated power. 0.08% at -3dB. Power bandwidth: 10-40,000Hz. S/N: phono 70dB, aux, tuner, tape 90dB. Controls: bass, treble, volume, loudness, tape dubbing, monitor. Dimensions: 38 \times 25 \times 14cm. Click-stop bass, treble and volume control. Direct coupled FET input stage, modular output stage. Price: £78.40 (plus VAT).

KA 5500

Integrated amplifier with output 55+55W from 20-20,000Hz. THD: 0.1 at rated power, 0.06 at 1W. Power bandwidth: 5-40,000Hz. S/N: 100dB input shorted. Controls: bass, treble, volume, balance, low filter, audio attenuator. Dimensions: 38 \times 25 \times 14cm. Adjustable sensitivity power meters. Speaker selector, tape dubbing, monitoring switches. Price: To be announced.

KA 7300

Integrated amplifier with output 65+65W from 20-20,000Hz. THD: 0.1% at rated power, 0.04% at 1W. Power bandwidth: 5-60,000Hz. S/N: 110dB input shorted. Controls: bass, treble, volume, balance, loudness, subsonic filter, low filter, high filter, presence. Dimensions: 43 \times 37 \times 15cm. Audio attenuator, separate power supplies for each channel, direct coupling FET amps. Price: To be announced.

★ Indicates entry is illustrated

KA 8300

Integrated amplifier with output 80+80 W from 20-20,000Hz. THD: 0.1% rated power, 0.04% at 1W. Power bandwidth: 5-40,000Hz. S/N: 100dB input shorted. Controls: volume, bass, treble, loudness, balance, low-Hi filters, presence. Dimensions: 43 × 37 × 15cm. Features include switchable turnover tone controls, dual sensitivity power meters, direct coupling FET amps. Price: To be announced.

Model 600

Integrated amplifier with output 130+130 W from 20-20,000Hz. THD: 0.08% at rated power, 0.03% at 1W. FR: DC to 70,000Hz. S/N: 115dB input shorted. Controls: bass, treble, loudness, volume, low filter, high filter, presence. Dimensions: 44 × 38 × 15cm. Features include direct coupling FET amps. DC power amplifier, separate power supplies for each channel. Price: To be announced.

■ YAMAHA

Natural Sound Systems Ltd, Strathcona Road, North Wembley, London HA9 8QL. Tel: 01-904 0141.

CA400

Integrated stereo amplifier. Inputs: phono

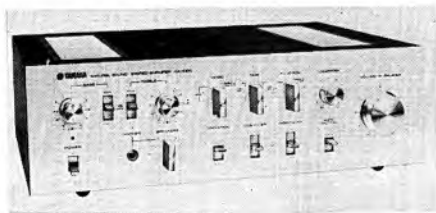

Yamaha CA1000

3mV into 47K. Noise level: 75dB. Output: 20W RMS into 8 ohms. Load impedance: 4-16 ohms. Damping factor: 50. THD: 0.02% at rated power. FR: 10Hz-100kHz +0 -1dB. Dimensions: 438 × 146 × 324mm. Mains: 110-240V. Price: £110.40 (plus VAT).

CA600

Integrated stereo amplifier. Phono input: 3mV into 47K. Noise level: 80dB. Output: 30W per channel into 8 ohms. Load: 4-16 ohms. Damping factor: 70. THD: 0.02% at rated power. FR: 10Hz-100kHz +0dB -1dB. Dimensions: 438 × 146 × 324mm. Mains: 110-240V. Price: £159.20 (plus VAT).

CA800

Integrated stereo amplifier. Phono input: 3mV into 47K. Noise level: 80dB. Output: 45W per channel into 8 ohms. Load: 4-16 ohms. Damping factor: 70. THD: 0.02% at rated power. FR: 10Hz-100kHz. Mains: 110-240V. Dimensions: 438 × 146 × 324mm. Price: £204 (plus VAT).

CA1000 ★

Integrated stereo amplifier. Phono input: 3mV into 47K. Noise level: 80dB. Output: 70W from 20Hz-20kHz into 8 ohms. Load: 4-16 ohms. Damping factor: 70. THD: 0.016% (Class B) not measurable in Class A. Distortion measured at 10W. FR: 10Hz-100kHz +0dB ±1dB. Mains: 110-240V. Dimensions: 438 × 146 × 324mm. Price: £292.80 (plus VAT).

BI

All FET power amplifier. Output: 150W RMS per channel. THD: less than 0.05% at all powers. FR: 5Hz-100kHz ±0.5dB. Damping factor: 80. S/N ratio: >100dB. Dimensions: 46 × 39 × 15cm. Electric and thermal protection. Price: £710.40 (excluding VAT).

CI

Pre-amplifier for BI. S/N ratio: >90dB. Dimensions: 47 × 35 × 17cm. All FET. Built-in oscillator. Price: £799.20 (excluding VAT).

**NAMEPLATES - CONTROL
PANELS - LABELS - BADGES
ENGRAVING - DECORATIVE
WINDOW DISPLAYS AND
LAMINATED SWING TICKETS**
OF ALL DESCRIPTIONS IN ALL MATERIALS

Cast in metal, injection moulded in any plastic, silk screen printing on aluminium (and other materials), hot blocking, engraving, industrial gifts, advertising, novelties, trade promotion articles available and can incorporate your trade emblem or other details.

Catalogue on request:

I. MARKOVITS LTD.

1, 2, 3 COBBOLD MEWS, LONDON W12

Telephone: 743 1131/2; 743 1313

Cassette Decks and Recorders

view/cue control for speedy replay. Oil damped elevation. Mic/line input mixing. 4-track, 2-channel. FR: 30-16,000Hz (F, CrO₂ tape), S/N ratio: 60dB (Dolby on CrO₂ tape). W and F: 0.07%. Separate bias and equalisation switches. 2 VU meters. Inputs for mic, line, Rec/PB. Dimensions: 42.3 × 29.5 × 15.2 cm. Price: £167.25 (plus VAT).

★ Indicates entry is illustrated

Abbreviations used in this section are given on page 27.

■ AIWA

Johnsons of Hendon Ltd, 14 Priestley Way, London NW2 7TN. Tel: 01-450 8070.

AD 1800 ★

Stereo cassette deck. Double noise reduction circuitry, Dolby and DNL. 3-step tape selector. Automatic CrO₂ tape selector built in. Ferrite record head aligned by four points for extra stability. Quick review/cue controls. Oil-damped cassette eject elevation. Memory rewind system. MPX filter. Mic/line mixing. FR: 30Hz-18kHz (F/Cr tape). S/N ratio: 65dB (Dolby and DNL on, CrO₂ tape). W and F: 0.05% (WRMS). Separate bias and equalisation switching. VU meters and +3dB and +7dB peak lights. Dimensions: 42.3 × 29.5 × 15.2 cm. Inputs: mic, line, Rec/PB. Hinged and removable acrylic dust cover. Price: £224.89 (plus VAT).

AD 6500 ★

Front loading Dolby cassette deck. Features include: Dolby noise reduction system, motor driven cassette tape loading mechanism, 3-step tape selector (LH, CrO₂ and FeCr), quick review/cue controls, two large VU meters, 2-step peak indicator (3dB and 7dB). Mechanical pause. Two mic/line input selectors and memory rewind mechanism. FR: 30 Hz-16kHz (FeCr tape). S/N ratio: 62dB (FeCr tape, Dolby on) 58 dB DIN. W and F: 0.07% (WRMS). Separate bias and equalisation switching. VU indicators +3dB and +7dB peak lights. Inputs for mic, line, Rec/PB. Dimensions: 45 × 30 × 15.5 cm. Price: approx. £189.27 (plus VAT).

AD 1600 ★

Stereo cassette deck. Fitted with Dolby noise reduction. 3-step tape selector. Automatic CrO₂ tape selector built-in. Ferrite record head. Full automatic stop system. Quick re-

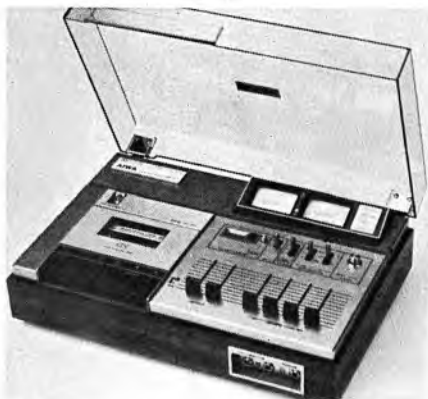

Aiwa AD1800



Aiwa AD6500



Aiwa AD1600

★ Indicates entry is illustrated

Model AD 1300

Stereo cassette deck. Fitted with Dolby noise reduction. 3-step tape selector. Automatic CrO₂ tape selector built in. Ferrite record head. Quick review/cue control. Fäuse. Automatic shut off. 4-track, 2-channel. FR: 30-16,000Hz (FeCr). S/N ratio: 58dB (Dolby on CrO₂). W and F: 0.09% (WRMS). Separate bias and equalisation switches. 2 VU meters. Dimensions: 40.7 × 26.1 × 10.2 cm. Price: £131.85 (plus VAT).

■ **AKAI**

Rank Audio Visual, PO Box 70, Great West Road, Brentford, Middlesex TW8 9HR. Tel: 01-568 9222.

CS 34 D

Stereo cassette deck with Dolby noise reduction. W and F: less than 0.13%. S/N: better than 52 dB. FR: 40 to 13,000 Hz ± 3dB, 40-15,000Hz using chrome. Bias switch for low noise and chrome. Inputs for mic and line. Dimensions: 14.9 × 4.3 × 8.9 ins. Price: £116.40 (plus VAT).

GXC 39D

Stereo cassette deck using Dolby noise reduction. W and F: less than 0.08%. S/N: better than 47 dB but improves with Dolby up to 10dB above 5kHz. FR: 30-17,000. Bias switch for low noise, chrome and Ferrochrome. Inputs for microphone and line. Dimensions: 17.3 × 4.6 × 9ins. Price: £155.60 (plus VAT).

GXC 310 D

Stereo cassette deck using Dolby noise reduction. W and F: 0.07%. S/N: 50dB or 18dB with Dolby. FR: 30-17,000. Switch for noise control, chrome and Ferrochrome. Inputs for mic and line. Dimensions: 17.3 × 5.6 × 11.8 ins. Price: £188.40 (plus VAT).

GXC 510 D

Similar to GXC 310 D except W and F: 0.08% and FR: 30-16,000Hz. Dimensions: 16.4 × 10.1 × 5.2 ins. Price: £203.60.

GXC 710 D

Stereo cassette deck with Dolby noise reduction. W and F: 0.08%. S/N: better than 50dB, with Dolby 10dB better above 5kHz. FR: 30-17,000Hz. Inputs for mic and line. Size: 17.3 × 5.6 × 12 ins. Price: £211.60 (Plus VAT).

GXC 75 D

Stereo cassette deck with Dolby noise reduction. W and F: less than 0.1%. S/N: better than 50dB, without Dolby. FR: 30-16,000Hz. Inputs for mic and line. Dimensions: 18.1 × 5.8 × 11.9

ins. Price: £219.60 (plus VAT).

GXC 325 D

Stereo cassette deck with Dolby noise reduction. W and F: less than 0.055%. S/N: better than 51dB with Dolby improves 10 dB. FR: 30-19,000Hz. Inputs for mic and line. Dimensions: 17.4 × 5.6 × 11.9 ins. Price: £243.60 (plus VAT).

GXC 740 D

Stereo cassette deck with Dolby noise reduction. W and F: better than 0.07%. S/N: better than 50dB, with Dolby improves up to 10dB. FR: 30-18,000. Inputs for mic and line. Dimensions: 17.3 × 5.6 × 12 ins. Price: £287.60 (plus VAT).

GXC 760 D

Similar to GXC 740 D except: W and F: 0.06% and FR: 30-19,000Hz. Price: £359.60 (plus VAT).

■ **ALPHA**

Highgate Acoustics Ltd., 38 Jamestown Road, London NW1 7EJ. Tel: 01-267 4937.

CD 1000

Stereo cassette deck. W and F: 0.3%. S/N ratio: 35dB. FR: 50Hz-10kHz ± 3dB. VU meter. Inputs: mic 1mV 600 ohms, aux (phono) 100mV 220K, aux (DIN) 30mV 220K. Slave unit. One motor. Mains: 240V AC. Dimensions: 26.7 × 22.5 × 9.3cm. Price: £44.50 (excluding VAT).

CD 2000

Stereo cassette deck. W and F: 0.13%. S/N ratio: 45dB. FR: 45Hz-12kHz ± 3dB. VU meter. Inputs: mic 1mV 600 ohms, aux (phono) 100mV 220K, aux (DIN) 30mV 220K. Slave unit. One motor. Mains: 240V AC. Dimensions: 40 × 25 × 10cm. Price: £69 (excluding VAT).

■ **AMSTRAD**

AMS Trading (Amstrad) Ltd, 89 Ridley Road, Dalston, London E8 2NH. Tel: 01-249 5237/8/9.

6000 ★

Stereo cassette deck with top cut filter. W and F: 0.17%. S/N ratio: 42dB. FR: (CrO₂) 40Hz-14kHz ± 3dB, (Fe₂O₃) 40Hz-11kHz ± 3dB. Bias switch. Two illuminated VU meters. Inputs: mic 0.5mV, line 60mV 33K, DIN 2.5mV 3.3K. Outputs: DIN/phono 600mV 47K min, phones 250mV 8 ohms. DC motor. 3-digit manual reset tape position indicator. Mains: 240V AC. Dimensions: 31.4 × 23.1 × 11.1cm.

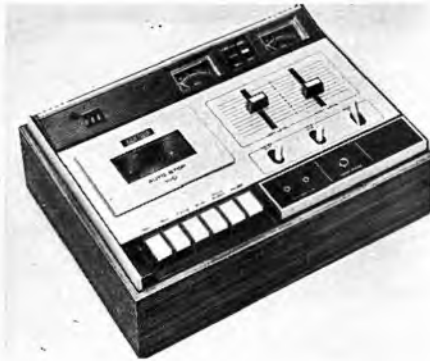

Amstrad 6000

Electronically driven solenoid operated automatic stop mechanism. Independent left and right channel record level slider controls. Switched noise reduction circuit complete with indicator light. Automatic switching. Two separate inputs for stereo mics. Stereo headphone output jack socket. Pause control key. Price: £61.32 (excluding VAT).

7000

Stereo cassette deck with Dolby noise reduction circuit. W and F: 0.17%. S/N ratio: 55dB. FR: (CrO₂) 40Hz-14kHz, (Fe₂O₃) 40Hz-11kHz. Bias switch. Two illuminated VU meters. Inputs: mic 0.5mV, line 100mV 47K, DIN 10mV 47K. Outputs: DIN/phono 600mV 47K min, phones 250mV 8 ohms. DC motor. Mains: 240V AC. Dimensions: 31.4 × 23.1 × 11.1cm. Electronically driven solenoid operated automatic stop mechanism. 3-digit manual reset tape position indicator. Independent left and right channel record level slider controls. Variable output level controls to facilitate matching to any stereo system. Automatic switching. Stereo headphone output jack socket. Two separate inputs for stereo mics. Pause control key. Price: £79.66 (excluding VAT).

■ BASF

BASF United Kingdom Ltd, Audio/Video Tape Division, PO Box 473, Knightsbridge House, Knightsbridge, London SW7 1SA. Tel: 01-584 5080

BASF CC Recorder 9202 CrO₂

Battery or mains operated mono cassette recorder. Automatic switching to CrO₂ when DIN-CrO₂ cassette is inserted. Built-in condenser microphone. DIN connections for external remote control microphone, amplifier, radio, tape recorder and loudspeaker or headphones. Automatic or manual recording level control. Tape index counter. Meter for record-

ing level and battery check. Fast review button. Automatic stop and cassette ejection. Mains: 110/240V. Battery: 6V, 4 cells SP2. FR: 80Hz-10kHz (Fe₂O₃), 80Hz-12.5kHz (CrO₂). W and F: ≤0.3%. S/N ratio: ≥45dB (Fe₂O₃), 50dB (CrO₂). Output: approx 1.5W RMS. Size: 296 × 68 × 203mm. Weight: 2.5kg. Price: on application.

Model 8200

Stereo cassette deck. W and F: less than 0.2%. Fitted with both Dolby and DNL noise reduction. S/N: better than 45dB (ferric oxide, NR out), better than 58dB (CrO₂ NR out). FR: 40Hz-10kHz (ferric oxide), 40Hz-12.5kHz (CrO₂) DIN. CrO₂ switch alters bias and record/replay equalisation. Two VU meters. Inputs: mic 70dB 1 K, line 0.1-2mV 50K. Outputs: line 0.5-2V 2.5K, phones 8 ohms. Mains: 110/220-240V. Size: 407 × 147 × 270mm. Price: to be announced.

BASF CC Radio-Recorder 9302 CrO₂

Battery or mains operated, 4 waveband radio (VHF, MW, SW, LW), mono cassette recorder. Telescopic FM/SW aerial. Built-in ferrite rod aerial. Dial light. Slide controls for volume and tone. Manual recording level and mixing facility while recording from built-in radio. Other recordings with automatic recording level only. Monitor facility. Ratings and features as recorder CC 9202 CrO₂ except fast review button. Size: 299 × 251 × 90mm. Weight: 3.15kg. Price: on application.

BASF 8100 Hi-Fi Stereo Deck CrO₂

Automatic switching to CrO₂ cassettes conforming to the DIN standard. DNL noise limiter. Two illuminated recording level meters. Automatic or manual recording level. Pause key. Tape index counter and automatic switch off. Fast review key. DIN and phono connectors. FR: 20Hz-10kHz (Fe₂O₃), 20Hz-14kHz (CrO₂). S/N ratio: ≥48dB (Fe₂O₃ with DNL), ≥52dB (CrO₂ with Dolby). W and F: ≤0.25%. Size: 327 × 114 × 259mm. Weight: 3.9kg. Price: on application.

BASF 8200 Hi-Fi Stereo Deck CrO₂

Dolby system with DNL noise limiter. Automatic switching to CrO₂ cassettes. Two illuminated recording level meters. Automatic or manual recording level, tape index counter with memory to find a pre-set passage. Pause key and automatic switch-off. DIN and phono connectors. FR: 20Hz-12.5kHz (Fe₂O₃), 20Hz-14kHz (CrO₂). S/N ratio: ≥54dB (Fe₂O₃ with Dolby), ≥58dB (CrO₂ with Dolby). W and F: 0.5%. Size: 407 × 147 × 270mm. Weight: 5.4kg. Price: on application.

★ Indicates entry is illustrated



Beltek M1150



Beacord 2200

■ **BELTEK**

Eagle International, Precision Centre,
Heather Park Drive, Wembley HA0 1SU.
Tel: 01-902 8832.

M 1150 ★

Stereo cassette deck. W and F: 0.15%. Fitted with Dolby noise reduction. S/N ratio: 58dB (Dolby in). FR: 50Hz-12kHz \pm 3dB (Fe). Bias switch for chrome and ferro-chrome cassettes plus low noise. Twin VU meters. Inputs: line/mic 200mV 100K (line), 30mV 100K (DIN). Output: 88mV 100K (max). Regulated DC motor. Mains: 240V AC. Dimensions: 40 \times 32 \times 15cm. Price: £158 (excluding VAT).

■ **BEACORD**

Bang & Olufsen (UK) Ltd,
Eastbrook Road, Gloucester GL4 7DE.
Tel: Gloucester 21591.

Beacord 2200 ★

Stereo 1/4-track cassette tape deck incorporating Dolby noise reduction system. Speed: 17 1/2 i/s. W and F: 0.12% (JIS). FR: 30Hz-15kHz. S/N ratio: >62dB (with Dolby on), >53dB (without Dolby). Switched characteristics for CrO₂ or standard tapes. Rewind time: 70 seconds for C60. High density ferrite heads. Inputs: mic 100 μ V 1K, radio 4mV 47K, aux 200mV 2.2M. Outlets: 660mV 6.3K and headphones 0.5-0.8mW. 3-digit tape counter. Mechanical auto-stop plus preset memory on rewind. Mains: 110-130 and 220-240V 50-60Hz. Size: 19.7 \times 9.1 \times 2.9in. Price: on application.

Beacord 1100

Stereo cassette deck with mono mic. W and F:

0.3% DIN. Dolby noise reduction system. S/N: 52dB or 60dB with Dolby. FR: DIN 45-511, 40-12,500Hz. Dual VU meters. Inputs for mic, radio. Dimensions: 40 \times 24 \times 8.5cm. Price: on application.

■ **BUSH-ARENA**

Rank Radio International Ltd, PO Box 596,
Power Road, Chiswick, London W4 5PW.
Tel: 01-994 6491.

C445

Stereo cassette deck. W and F: 0.3% WRMS. S/N: 45dB (Ferric oxide tape), 50dB (CrO₂). FR: 50Hz-9kHz (Ferric oxide tape). CrO₂ switch fitted. Twin VU meters. Inputs: Two stereo mic, DIN and line. Outputs: line, headphones. Size: 13.7 \times 3.5 \times 9.1in. Cassette deck fitted with auto-stop and supplied with microphones. Price: £90.85 (including VAT).

■ **DANSK**

Plustronics Ltd, Hempstalls Lane, Newcastle,
Staffs. Tel: Newcastle 615131.

1802 ★

Cassette deck, compact and slim featuring LED light system for record level control. W and F: less than 0.2%. FR: Ferric 30-14kHz, Chrome 30-15kHz. S/N: better than 48dB. Dolby noise reduction system. Inputs for mic, radio, line. Price: £166.26.

■ **DECCA**

Decca Radio & Television Ltd,
Neachells Lane, Willenhall,
Wolverhampton, Staffs.
Tel: Wolverhampton 67367.

DC 2000

Stereo cassette deck with Dolby B. Tape speed 17 1/2 i/s. FR: (playback) \pm 2dB 100Hz-8kHz. Bias frequency: 83kHz. W and F: 0.18% linear RMS. Twin VU meters. Slider controls: record level (left and right). Pushbutton controls: mains on/off, CrO₂ on/off, Dolby noise reduction on/off, memory rewind switch, tape counter reset. Piano key controls: record, rewind, fast forward, play, pause, stop/eject. Input sockets: mic jacks, aux, DIN inputs.



Dansk SD 1802

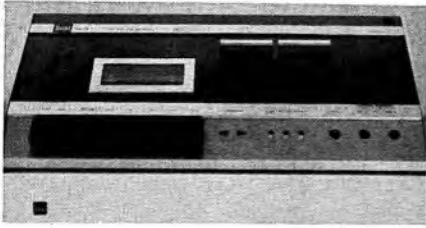

Dual C901

Output sockets: stereo headphones, line outputs, DIN outputs. Mains: 240V 50Hz. Power consumption: 6W. Size: 350 × 240 × 110mm. Finish: teak. Price: £95.92.

DC 1100

Stereo cassette deck. Tape speed: 1 7/8 i/s. FR: (playback) ±2dB 100Hz-8kHz. Bias frequency: 83kHz. W and F: 0.18% linear RMS. Twin VU meters. Slider controls: record level (left and right). Pushbutton controls: mains on/off, CrO₂ on/off tape counter reset. Piano key controls: record, rewind, fast forward, play, pause, stop/eject. Input sockets: microphone jacks, aux, DIN inputs. Output sockets: stereo headphones, line outputs, DIN outputs. Mains: 240V 50Hz. Power consumption: 6W. Size: 350 × 240 × 110mm. Finish: teak. Price: £66.00 (plus VAT).

■ **DUAL IMPORTERS Audiodecks LTD**

Sales and enquiries to:
A. C. Farnell Ltd, Kenyon Street,
Sheffield 1. Tel: 78901.

C901 ★

Stereo cassette deck with record and playback in both directions. W and F: better than ±0.12% DIN. Drift: better than 1%. FR: 30Hz-14kHz (ferric oxide tape), 30Hz-10kHz (CrO₂ tape). S/N: better than 50dB (IEC Curve-A). Fitted with Dolby noise reduction. Inputs: mic 0.15mV, DIN 0.15mV, line 40mV. Outputs: phones, DIN 0.75V, line 0.75V. Size: 16 1/2 × 4 3/4 × 1 1/2 in. Automatic tape reversal, auto stop after both directions have been replayed. Continuous play override switch. Automatic selection for CrO₂ cassettes. Automatic level control or manual. Twin VU meters. Overload indicator. Fittings available for vertical mounting. Alternative walnut or white enamel (C901W) finish. Price: £247.37 (including VAT).

■ **DYNATRON**

Dynatron Radio Ltd, St Peters Road,
Maidenhead, Berks SL6 7QY.
Tel: Maidenhead 23331.

Model CP3

Stereo cassette deck. W and F: 0.35%. Fitted with DNL noise reduction. S/N: better than 45dB (DIN). FR: 60Hz-10kHz ±6dB (DIN). Twin VU meters. Inputs: mic 0.2mV 2K, DIN (1) 35mV 220K, DIN (2) 3.5mV 22K. Outputs: DIN (1) 500mV 30K, DIN (2) 35mV 10K. Mains: 110-240V, 50-60Hz. Size: 12 × 4 × 9in. Auto-stop. Price: £100.00.

CP2 The Jewel Case

Stereo cassette tape deck housed in period style cabinet with cassette storage space. Tape deck unit: Dynatron CR 102-D. Features: DNL (switchable); auto chrome tape switching; twin VU type recording level meters; twin recording level controls. Controls: piano key operation of record, rewind, start, fast forward, pause, stop/eject. W and F: 0.2%. S/N typically: 50dB weighted dependent on tapes used; DNL operating. Overall distortion: 2.5% relative to 100% modulation. Channel separation: 40dB at 1kHz. Outputs: 0.8V nominal (100% level). Mains: 240V AC 50Hz. Power consumption: 7.8W. Finish: walnut using selected burr veneers. Size: 363 × 265 × 142mm. Price: £124.00.

■ **FERGUSON**

Thorn Consumer Electronics Ltd,
Thorn House, Upper St. Martins Lane,
London WC2H 9ED.
Tel: 01-836 2444

3280

Stereo cassette deck with Dolby system. FR: CrO₂: 60Hz-12kHz, Ferric 60Hz-10kHz. W and F: 0.2%. S/N: 45dB or 50dB with Dolby. Twin VU meters, slider record level controls, left and right channels, manual or auto recording. LED function indicators, digital tape position indicator, mechanical auto stop. Sockets for 5 pin DIN and phono. Stereo mic and headphones. Finish in black and silver with teak base. Dimensions: 7.7 × 32.7 × 20cm. Price: on application.

3272

Stereo cassette deck. FR: 40Hz to 16kHz (CrO₂) or 40Hz-14kHz (ferric). W and F: 0.2%. S/N: 43dB ferric, 46dB CrO₂. CrO₂ and bias equalisation switches. Twin VU meters. Left and right channel slider controls, noise suppression switch. Mechanical auto-stop and digital tape counter. Dimensions: 13.3 × 38.4 × 27.9cm. Finish in black and silver with teak base. Price: £74.32 (plus VAT).

This new Toshiba PC-6030 contains all we know.

“Overall the Toshiba PC-6030 was undoubtedly most satisfying to use and returned excellent sound quality. It’s easy and fast to operate, whilst the deck performs complex operations with silky-quiet precision.”

— a quotation from Philip Mount’s review of three top cassette decks, Hi-Fi Sound, June.

Drive System DC servo-motor, with PLL control and dual capstan drive.
Second DC servo-motor for reel drive.
Noise Reduction System DOLBY NR with built-in calibration system

PERFORMANCE

Frequency response:
20Hz to 15kHz (FE Tape)
20Hz to 17.5kHz (chrome tape)
Tape Speed deviation: 0.1%
Wow and Flutter: 0.07% wrms
Total harmonic distortion: 1% wrms
Cross talk: 70 dB (1kHz + 10b)
Channel Separation: 35 dB (1kHz + 10dB)
S/N Ratio: 58 dB (FE tape Dolby off)
60 dB (Chrome tape, Dolby off)
Bias frequency: 85kHz



So does the PC-5060,

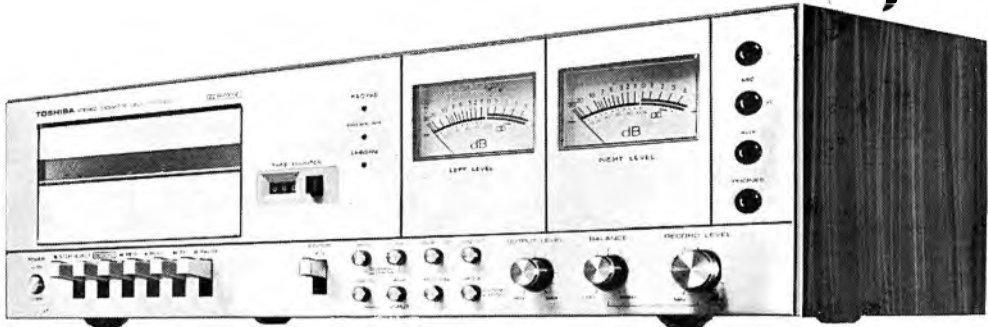

PC-5060 Dolby Front Loading Stereo Cassette Deck.

Frequency response: 40Hz to 12kHz (FE tape) 40Hz to 15kHz (Chrome tape)

Wow and flutter: 0.08% wrms

and the PC-4030

PC-4030

Dolby Stereo Cassette Deck.

Frequency response:

40Hz to 12kHz (FE tape)

40Hz to 15kHz

(Chrome tape)

Wow and flutter:

0.12% wrms



And the PC-4020

And the PC-3110

The same expertise that makes the incredible PC-6030 outstanding in its class, makes the others outstanding in their respective classes.

What isn't always realised, is that it often takes more ingenuity and resourcefulness to perfect the smaller products in the range than the range leader.

The quality of the PC-6030 is enviable, and we'd all have one if we could afford it.

But if you're just a beginner, or you're steadily building up your hi-fi system, we'd like you to know that we are just as proud of what we achieved in building the rest of the range.

Call in and see the superb Toshiba range of cassette decks at your local stockist. One deck is just right for you, and everything we know went into it.

TOSHIBA
...In Touch with Tomorrow

★ Indicates entry is illustrated

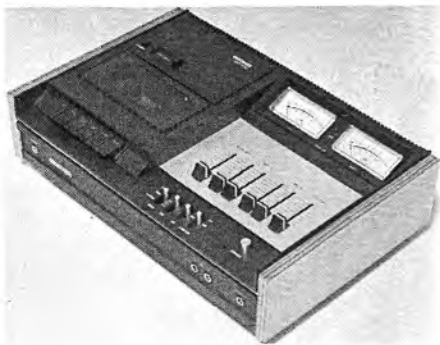

Goodmans SCD100

3274

Stereo cassette deck with Dolby. FR: 40Hz-16kHz (CrO₂), 40-14kHz (ferric). W and F: 0.2%. S/N: Ferric 50dB, CrO₂ 55dB, or without Dolby 45dB ferric, 50dB CrO₂. Bias and equalisation switches. Twin VU meters, left and right channel slider controls, electronic auto-stop and digital tape counter. Dimensions: 13.3 × 38.5 × 28cm. Finish in black and silver with teak base. Price: £109.60 (plus VAT).

■ GOODMAN'S LOUDSPEAKERS LTD

Downley Road, Havant, Hants PO9 2NL.
Tel: Havant 6344.

SCD 100 ★

Stereo cassette tape deck with Dolby noise reduction system. W and F: less than 0.16% (DIN), FR: CrO₂ tape 40-15kHz. Low noise tape 40-15kHz. S/N: CrO₂ tape: 50dB or 56dB with Dolby. Low noise and normal tape: 48dB or 54dB with Dolby. Inputs: line (phono and DIN); stereo plus centre mic. Features: Limiter and MPX filter. Dimensions: 38.5 × 25.5 × 12cm. Price: £156.56 (plus VAT).

■ GRUNDIG

Grundig International Ltd, Newlands Park, London SE26 5NQ. Tel: 01-659 2468.

CN 730 ★

Stereo cassette deck with CrO₂ facility. Fitted with Dolby B and DNL. W and F: ±0.2%. S/N ratio: (Fe₂O₃) 46dB, (CrO₂) 56dB. FR: (CrO₂) 30Hz-14kHz ±3dB, (Fe₂O₃) 30Hz-12kHz. Automatic switching. Two recording level meters, CrO₂ lamp, tape pilot and auto/manual recording lamps. Inputs: mic 1mV 33K, radio diode 1mV 33K, phono 60mV 2.2M. Outputs:

0.5-1.5V 20K adjustable high impedance. One motor. Mains: 110-240V. Dimensions: 23.7 × 10.3 × 26.1cm. Price: £173 (including VAT).

CN 700 ★

Stereo cassette deck fitted with DNL. W and F: ±0.2%. S/N ratio: 48dB. FR: 30Hz-12.5kHz. Auto switching. Recording level meter, DNL pilot, record pilot, tape pilot. Inputs: mic 1mV 100K, radio diode 5mV 50K, phono 40mV 2.2M. Output: 0.5-1.5V 20K adjustable high impedance. Mains: 110-240V. Dimensions: 23.7 × 10.3 × 26.1cm. Price: £105 (including VAT).

■ HACKER

Hacker Radio Ltd, Norreys Drive, Cox Green, Maidenhead, Berks SL6 4BP.
Tel: Maidenhead 22261.

HCD1000

Stereo cassette deck with Dolby noise reduction system. Tape speed: 4.8cm/sec. W and F: less than 0.2% (wtd peak). FR: -20dB level (CrO₂) 30Hz-16.5kHz ±3dB; (Fe₂O₃) 30Hz-15kHz ±3dB. S/N ratio: CrO₂ Dolby out 53dB wtd (CCIR) nominal, Dolby in 60dB wtd (CCIR) nominal ±3dB. THD: less than 2%

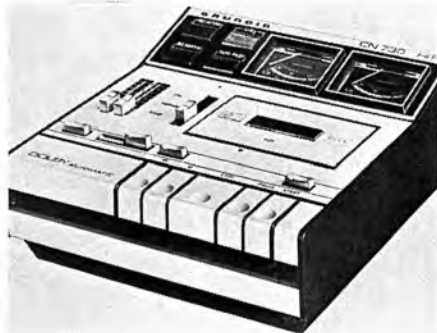

Grundig CN700

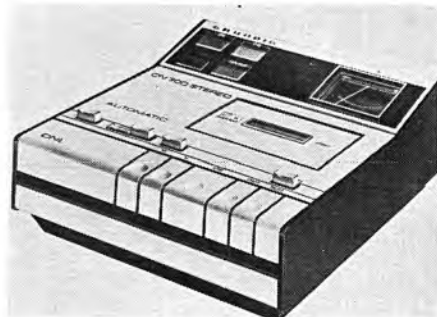

Grundig CN730

nominal at 1kHz. Inputs: DIN 20mV 30K, mic 0.2mV 600 ohms, line 100mV 100K. Outputs: DIN and line 580mV \pm 3dB into 10K or more. Bias Frequency: 107kHz \pm 5kHz. Erase Ratio: better than 60dB. Channel separation: better than 35dB nominal. Incorporates closed loop servo DC motor with automatic motor stop and twin illuminated VU meters. Dimensions: 10 \times 18.5 \times 29cm. Weight: 3.3kg. Finish: styled in matt black and selected teak veneers.

HCD 1000

Stereo cassette unit with Dolby system for use in conjunction with hi-fi audio equipment. Tape speed: 4.8cm/sec (1 $\frac{7}{8}$ ips). W and F: less than 0.2%. FR: 30Hz-16,500 (CrO₂) or 30Hz-15,000 (ferric). S/N: 53dB or 60dB Dolby. Inputs for DIN, mic, line. Outputs: DIN and line. Dimensions: 10 \times 18.5 \times 29cm. Price: £198.00 (inc. VAT).

■ HANIMEX (UK) LTD

Faraday Road, Dorcan, Swindon, Wilts SN3 5HW.
Tel: Swindon 26211.

HCD 1010

Stereo cassette deck. W and F: 0.15%. S/N: 45dB. FR: 40-12,000 or chrome 40-15,000. VU meter (L and R). Inputs for line, mic, DIN. Dimensions: 37 \times 25.5 \times 9cm. Price: on application.

HCD 1020

As above plus Dolby. Price: on application.

■ HARMAN KARDON

Highgate Acoustics Ltd, 38 Jamestown Road, London NW1 7EJ. Tel: 01-267 4936.

HK 2000

Stereo cassette deck. W and F: 0.07%. Fitted with Dolby noise reduction. S/N ratio: 53dB OVU. FR: 15Hz-17kHz \pm 3dB. Bias switch for chrome cassettes. VU meters and LED. Inputs: mic 0.2mV 600 ohms, low 50mV 50K, high 200mV 50K. One motor. Mains: 117, 220, 240V AC. Dimensions: 38.1 \times 26 \times 13.6cm. Price: on application.

■ HITACHI

Hitachi Sales (UK) Ltd,
Hitachi House, Station Road,
Hayes UB3 4DR. Tel: 01-848 8787.

D2330

4-track, 2-channel stereo record/playback. FR: 40-12,000Hz with normal tape, 40-14,000Hz with CrO₂ tape. S/N: Dolby off: 50dB; Dolby on: 58dB. W and F: less than

0.18% WRMS. Output: More than 0.5V. Dimensions 31.9 \times 9.2 \times 22.3cm. Accessories: DIN lead, head cleaning stick. Price: £79.20 (plus VAT).

D2310

4-track, 2-channel stereo record/playback. FR: 40-12,000Hz with normal tape, 40-14,000Hz with CrO₂ tape. S/N: 50dB. W and F: Less than 0.2% WRMS. Output: More than 0.5V. Dimensions: 31.9 \times 9.2 \times 22.3cm. Accessories: DIN lead, head cleaning stick. Price: £55.20 (plus VAT).

D3500

4-track, 2-channel stereo record/playback. FR: 20-15,000Hz on normal tape: 20-20,000Hz on CrO₂ tape. S/N: better than 55dB at Dolby off; better than 63dB at Dolby on. W and F: 0.05% WRMS. Output: better than 0.5V (variable). Dimensions: 43 \times 14 \times 28.3cm. Accessories: DIN lead, head cleaning bar. Price: £200.00 (plus VAT).

D2750

4-track, 2-channel, stereo record/playback. FR: 30-14,000Hz DIN45511 with normal tape, 20-15,000Hz DIN 45500 with CrO₂ tape, 20-16,000Hz DIN 45511 with CrO₂ tape. S/N: Dolby off: better than 45dB DIN with normal tape; better than 48dB DIN 45500 with CrO₂ tape; Dolby on: improves up to 9dB over 4kHz. DNL on: improves up to 10dB over 4kHz. W and F: less than 0.15% DIN 45500. Dimensions: 43 \times 14 \times 28.3cm. Accessories: DIN lead, head cleaning bar. Price: £156.00 (plus VAT).

■ ITT CONSUMER PRODUCTS (UK) LTD

Maidstone Road, Footscray, Sidcup, Kent DA14 5HT.
Tel: 0-300 7733.

SR88A

Stereo cassette deck with Dolby system. W and F: \pm 0.2%. S/N: better than 48dB with Dolby or 43dB without. FR: 40-12kHz (ferric) or 40-14kHz (CrO₂). Bias switch for CrO₂. Level meters for each channel with lamps indicating Dolby, record, superimpose. Inputs: mic and direct recording. Dimensions: 40 \times 28 \times 11.5cm. Price: £153.64 (plus VAT).

ST 720

Stereo Cassette Deck. W and F: \pm 40dB. FR: 60-1000Hz (ferric) or 60-12,500 (chromium dioxide). Bias switch for CrO₂. Level meters displaying recording level for each channel and

★ Indicates entry is illustrated

battery condition. Inputs: mic, direct recording. Dimensions: 25 × 27 × 85cm. Price: £63.87 (plus VAT).

SL58

Mono cassette deck. W and F: 0.35%. S/N: better than 40dB. FR: 80-10kHz. Inputs: mic and direct recording. Dimensions: 18.3 × 6.9 × 6.9cm. Price: £30.80 (plus VAT).

■ JVC

JVC (UK) Ltd, Eldonwell Trading Estate, Staples Corner, 6-8 Priestley Way, London NW2. Tel: 01-450 2621.

CD-1669-2 ★

Stereo cassette deck. W and F: 0.07% WRMS. Fitted with ANRS. S/N ratio: 53dB at 1kHz (from peak level) without ANRS. Improved by 5dB at 1kHz and 10dB at 5kHz with ANRS. FR: 30Hz-16kHz ±3dB, (chrome) 30Hz-19kHz. Bias switch for chrome and ferro-chrome cassettes. VU meters and peak level lamps. Inputs: mic 2 × 0.3mV 600 ohms, line × 280mV 100 ohms, DIN 30mV 10 ohms. Outputs: line out 2 × 0.5V, reference 0.3V, 8K, headphones 0-0.8mW 8 ohms, DIN 0-0.5V, reference 0.3V, 5K. Hysteresis synchronous AC motor for capstan. DC motor for reels. Mains:

240V AC. Dimensions: 423 × 307 × 143mm. Price (includes remote control): £286 (excluding VAT).

CD-1740

Stereo cassette deck with Dolby noise reduction. W and F: 0.13% WRMS. S/N ratio: 50dB at 1kHz (from peak level) without Dolby. FR: 40Hz-14kHz ±3dB, (chrome) 30Hz-15kHz. Bias switch for chrome and ferro-chrome cassettes. VU meters and peak level lamps. Inputs: mic 2 × 0.45mV 10K, line in 2 × 100mV 220K, DIN 15mV 84K. Outputs: line out 2 × 0.42V 1K, DIN 0.42V 1K, headphone 0.3mW 8 ohms. Electrical governor DC motor. Mains: 240V AC 50Hz. Dimensions: 405 × 217 × 97mm. Price: £79.80 (excluding VAT).

CD-1635 ★

Stereo portable cassette deck. Fitted with ANRS. W and F: 0.08% WRMS. S/N ratio: 54dB at 1kHz (from peak level) without ANRS. FR: 45Hz-16kHz ±3dB (chrome) 25Hz-18kHz. Bias switch for chrome and ferro-chrome cassettes. Level indicator and two VU meters. Inputs: mic × 2 0.14mV 200 ohms 10K, line in 2 × 78mV 100K, DIN 11mV 9K. Outputs: line out 2 × 500mV 2K, DIN 500mV 2K, headphones 0.3mW 8 ohms. DC coreless motor. Mains: 240V AC 50Hz. 9V batteries. External DC 8-16V. Dimensions: 360 × 242 × 100mm. Price: £149.50 (excluding VAT).



JVC DC-1635



JVC CD-1669-2

■ Lenco

Goldring Ltd, 10 Bayford Street, Hackney, London E8. Tel: 01-986 6411/2.

C-2003

Stereo cassette deck with Dolby system. W and F: to DIN 0.15%, WRMS linear 0.3%, 0.08%. S/N: 50dB or 58dB with Dolby. FR: 30-18kHz. Illuminated panel shows all functions as selected. VU level indicators. Inputs: mic DIN, line. Price: to be announced.

■ NAKAMICHI

Natural Sound Systems Ltd, Strathcona Road, North Wembley HA9 8QL. Tel: 01-904 0141

TT 1000

Stereo cassette deck fitted with Dolby noise reduction and DNL. W and F: <0.1%. S/N ratio: >60dB. FR: 20Hz-20kHz ±3dB. Bias switch for chrome and ferric cassettes. Peak level meters. Inputs: mic 0.5mV 600 ohms, line 100mV 100K. Output: 0-1.2V. Phonic wheel

DC servo, separate rewind motor. Mains: 100, 220, 240V. Dimensions: 528 × 220 × 300mm. Price: £675.20 (excluding VAT).

TT 700 ★

Stereo cassette deck fitted with Dolby noise reduction. W and F: <0.1%. S/N Ratio:>60dB. FR: 20Hz-20kHz±3dB. Bias switch for chrome and ferric cassettes. Peak level meters. Inputs: mic 0.5mV 600 ohms, line 100mV 100K. Output: line 0-1.0V. Phonic wheel DC servo motor, separate rewind motor. Mains:- 100, 117, 220, 240V. Dimensions: 520 × 130 × 270mm. Price: £444 (excluding VAT).

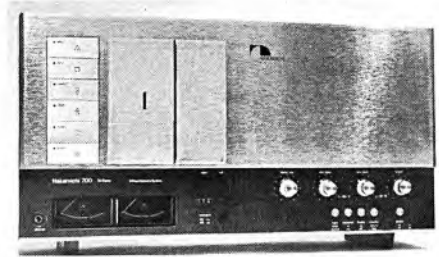

Nakamichi TT 700

DT 550 ★

Stereo cassette deck fitted with Dolby noise reduction. W and F: <0.1%. S/N Ratio:>60dB. FR: 40Hz-17kHz. Bias switch for chrome and ferric cassettes. Peak level meters. Inputs: mic 0.2mV 600 ohms, line 70mV 150K. Output: 580mV. Pulse control DC servo motor. Batteries and separate transformer. Dimensions: 311 × 350 × 89mm. Price: £239.20 (excluding VAT).



Nakamichi DT 550

DT 600 ★

Stereo cassette deck fitted with Dolby noise reduction. W and F: <0.8%. S/N Ratio:>68dB. FR: 20Hz-20kHz ±3dB. Bias switch for chrome and ferric cassettes. Peak level meters. Inputs: line 60mV 50K. Output: 580mV. DC servo-controlled motor. Mains: 240V. Dimensions: 400 × 237 × 170mm. Price: £239.20 (excluding VAT).



Nakamichi DT 600

■ **NEAL**

North East Audio Ltd, 5 Charlotte Square, Newcastle-upon-Tyne NE1 4XF. Tel: Newcastle-Upon-Tyne 26660.

Model 102 Mk II/Mk IIV

Transcription cassette recorder. Dolby B. 3M Wollensak deck. Two illuminated peak reading meters. Chrome and ferric equalisation and bias. Controlled headphone output. Separate input amplifiers for mic, DIN and line. W and F: less than 0.09% RMS (DIN weighted). Record amp distortion: less than 0.1% at 0dB. Inputs: mic 500µV 2K, high level line 50mV 200 K, DIN 2.5mV 10K. Outputs: Line and DIN 600mV 5K, phones variable to 2.5V 10Ω. Overload margin on all inputs 40dB. Replay amp distortion: less than 0.1% at 0dB. Equalisation: CrO₂ 70/3180µsec. Outputs: (102 Mk IIV as for 102 Mk II, but with built in Dolby calibration oscillator, fully variable bias in ferric and chrome positions, and provision for reading bias on the meters). Output levels referred to 220nWb/m flux density. FR: (ferric

tape) 35Hz-12kHz + 1dB - 3dB; CrO₂ tape 35Hz-15kHz + 1dB - 3dB. S/N ratio: CrO₂ (Dolby off) 55dB, CrO₂ (Dolby on) 63dB, ferric low noise (Dolby off) 53dB, ferric low noise (Dolby on) 61dB. Price: £225.00 (plus VAT); 102 Mk IIV £245.00 (plus VAT).

Model 103 ★

Transcription cassette recorder. Dolby B with built-in Dolby calibration oscillator. 3M Wollensak deck. Two illuminated peak reading meters. Chrome and ferric equalisation and fully variable bias for both. Bias level may be displayed on meters. Controlled headphone output. Separate amplifiers and input mixing for mic, DIN and line. W and F: less than

★ Indicates entry is illustrated



Neel 103

0.09% RMS (DIN weighted). Record amp distortion: less than 0.1% at 0dB. Inputs: mic 200 μ V 2K, high level line 80mV 2M, DIN 5mV 10K. Replay amp distortion: less than 0.1% at 0dB. Inputs: mic 200 μ V 2K, high level line 80mV 2M, DIN 5mV 10K. Equalisation: CrO₂ 70/3180 μ sec, ferric oxide 120/3180 μ sec. Equalisation calibration controls externally accessible. Outputs: monitor 600mV 5K, DIN 600mV 5K, phones variable to 2.5V, 10 ohms. F.R. (ferric tape) 35Hz-12kHz + 1dB - 3dB, CrO₂ tape 35Hz-15kHz + 1dB - 3dB. S/N ratio: CrO₂ (Dolby off) 55dB, CrO₂ (Dolby on) 64dB, ferric low noise (Dolby off) 53dB, ferric low noise (Dolby on) 62dB. Price: on application.

Model 104

Replay only machine. Dolby B. 3M Wollensak deck. Chrome and Ferric equalisation. Outputs, line and phone 2V variable, load 10 Ω . W and F: less than 0.09% RMS. (DIN weighted). F.R. from DIN Test Tape (455 13/6) corrected to 3,180 μ S, \pm 1dB. S/N ratio CrO₂ (Dolby off) 55dB, CrO₂ (Dolby on) 64dB, ferric low noise (Dolby off) 53dB, ferric low noise (Dolby on) 62dB. Price on application.

Model 110

Audio visual format cassette recorder. Mono audio with synchronising track. 3M Wollensak deck. Dolby B. Two illuminated peak reading meters. Chrome and ferric equalisation and bias. Separate recording/replay on each track. W and F: less than 0.09% RMS. (DIN weighted). Inputs: audio 100mV 10K Ω , sync 100mV 10K Ω . Equalisation audio track: CrO₂ 70/3180 μ sec, ferric oxide 120/3180 μ sec. Outputs: audio, line 600mV 100 Ω fixed, head-phone 2.5V 10 Ω variable, sync, phono 600mV 100 Ω fixed, line 2.5 10 Ω variable. F.R. (audio) ferric tape 35Hz-12KHz +1 -3dB, CrO₂ tape 35Hz-15kHz +1 -3dB, (sync) 100Hz-5kHz +1

-3dB. S/N ratio CrO₂ (Dolby off) 55dB, CrO₂ (Dolby on) 63dB ferric low noise (Dolby off) 53dB, ferric low noise (Dolby on) 61dB. Price: on application.

Model 102AV

Stereo audio visual format cassette recorder. Audio details as for 102 Mk IIV above. Sync/Audio tracks can be recorded/replayed separately. Fully compatible with mono audio visual format and with standard stereo cassette format. Sync track details: Inputs, line 100mV 10K Ω , DIN 100mV 10K Ω . Outputs line 600mV fixed 200 Ω , DIN 600mV fixed 200 Ω . F.R. 100Hz-5kHz +1-3dB. Price: on application.

Model 103AV

Stereo audio visual format cassette recorder. Audio details as for 103 above. Sync/Audio tracks can be recorded/replayed separately. Fully compatible with mono audio visual format and with standard stereo cassette format. Sync track details: Inputs, line 100mV 10K Ω , DIN 100mV 10K Ω . Outputs line 600mV fixed 200 Ω , DIN 600mV fixed 200 Ω . F.R. 100Hz-5kHz +1-3dB. Price: on application.

Professional Options

An extensive range of professional variants of these machines is available. Facilities and options to special order include: 3 $\frac{3}{4}$ ips tape speed, remote pause, balanced inputs and outputs, four channel operation. Details and prices on application.

■ NORDMENDE

Vessco Vision & Radio Ltd,
Unit 4, Blackwater Way, Ash Road,
Aldershot, Hants GU12 4DL.
Tel: Aldershot 321661.



Nordmende 6000

6000Hi-Fi ★

Stereo cassette recorder. W and F: $\pm 0.25\%$ DIN. FR: 40Hz-12.5kHz, DIN. One synchronous motor fitted. Twin VU meters. Dolby noise reduction fitted; automatic level control CrO₂ switch. Conforms to DIN Hi-Fi standard. Size: 245 × 95 × 230mm. Memory counter. Price: £102 (plus VAT).

■ PHILIPS

Philips Electrical Ltd, City House, London Road, Croydon, Surrey CR9 3QR. Tel: 01-689 2166.

N2515

Stereo cassette deck fitted with DNL. W and F: $\pm 0.2\%$. S/N ratio: (Fe₂O₃) ≥ 46 dB, (CrO₂) ≥ 48 dB. FR: (Fe₂O₃) 40Hz-10kHz within 6dB, (CrO₂) 40Hz-12.5kHz within 6dB. Automatic switching. Two illuminated moving coil meters. Inputs: mic 0.12mV 2K, phono 100mV 1M, tape 2mV 20K. Output: external amplifier 1V 20K. Single motor. Mains: 110, 127, 220, 240V. Dimensions: 37 × 24 × 9cm. Price: £108 (excluding VAT).

N2520

Stereo cassette deck fitted with DNL. W and F: $\leq \pm 0.2\%$ (DIN 45 500), $\leq \pm 0.14\%$ (NAB). S/N ratio: (Fe₂O₃) ≥ 45 dB (DIN 45 511) and ≥ 53 dB (NAB), (CrO₂) ≥ 48 dB (DIN 45 500) and ≥ 55 dB (NAB). FR: (Fe₂O₃) 40Hz-12kHz (DIN 45 511) and 30Hz-14kHz (NAB), (CrO₂) 25Hz-14kHz (DIN 45 500) and 20Hz-16kHz (NAB). Automatic switching. Two illuminated moving coil meters. Inputs: mic 0.2mV 2K, diode 2mV 20K, phono 100mV 1M. Outputs: diode 0.5V 20K, monitor record 350mV 13K, monitor playback 600mV 10K. Single motor. Mains: 110, 127, 220, 240V. Dimensions: 39.6 × 21.8 × 8.5cm. Price: £171.30 (excluding VAT).

N2507 ★

Stereo cassette deck fitted with DNL. W and F: $\leq \pm 0.35\%$. S/N ratio: (Fe₂O₃) ≥ 45 dB, (CrO₂) ≥ 47 dB. FR: (Fe₂O₃) 60Hz-10kHz within 6dB, (CrO₂) 40Hz-12kHz within 6dB. Automatic switch. Illuminated moving coil meter. Inputs: diode 0.2mV 2K, phono 100mV 1M, mic 0.2mV 2K. Output: external amplifier 0.5V 20K. One low voltage DC motor. Mains: 220, 240V. Dimensions: 21.7 × 20.3 × 9cm. Price: £69.44 (excluding VAT).

■ PIONEER

Shriro (UK) Ltd, Shriro House, The Ridgeway, Iver, Bucks SL0 9JL. Tel: Iver 652222/7.



Philips N2507



Pioneer CTF2121

CTF 2121★

Stereo front loading cassette deck. W and F: 0.19% (DIN). Fitted with Dolby noise reduction system. S/N ratio: 48dB (Dolby off), 58dB (Dolby on). FR: (LH tape) 40Hz-11kHz ± 3 dB, (chrome) 40Hz-12kHz ± 3 dB. Switchable EQ and bias for LH and chrome tape. Two VU meters. Inputs: mic 2 × 0.3mV/63mV 20K, line 2 × 63mV/12V 50K, DIN 1 × 10mV/2V 10K. Outputs: headphone 80mV 8 ohms, line 2 × 450mV 50K, DIN 1 × 450mV 50K. Electronically controlled DC motor. Full auto stop mechanism. Cassette compartment illumination. Permalloy solid rec/playback head. Rosewood, teak or walnut cabinets an optional extra. Mains: 110-240V switchable. Dimensions: 35 × 28.2 × 14.2cm. Price: on application.

CT 3131A ★

Stereo cassette deck (with mono switching, top loading). W and F: 0.19% (DIN). S/N ratio: 47dB at 250nWb/m. FR: (LH tape) 63Hz-10kHz ± 3 dB, (chrome) 63Hz-12kHz ± 3 dB. Bias switch for chrome cassettes. Two VU meters. Inputs: mic 2 × 0.5mV/90mV 20K, line 2 × 50mV/7V 300K, DIN 15mV/22V 10K. Outputs: headphone 40mV 8 ohms, line 2 × 300mV 50K, DIN 300mV 50K. Electronically controlled DC motor. Full auto stop



Pioneer CT3131A

mechanism. Large tape run pilot indicator. Permalloy solid rec/playback head. Mains: 220/240V. Dimensions: 39.6 × 24.2 × 9.6cm. Price: on application.

CT 4141A ★

Stereo cassette deck (with mono switching, top loading). W and F: 0.19% (DIN). Fitted with Dolby noise reduction. S/N ratio: 48dB (Dolby off) at 250 nWb/m, 58dB (Dolby on) at 250 nWb/m. FR: (LH tape) 63Hz-10kHz ±3dB, (chrome) 63Hz-12kHz ±3dB. Switchable bias and EQ for LH and chrome tape. Two VU meters. Inputs: mic 2 × 0.5mV/90mV 200K, line 2 × 50mV/7V 300K, DIN 15mV/2.2V 10K. Outputs: headphones 40mV 8 ohms, line 2 × 300mV 50K, DIN 300mV 50K. Electronically controlled DC motor. Full auto stop mechanism. Skip button and tape run pilot. Permalloy solid rec/playback head. Mains: 220/240V. Dimensions: 39.6 × 24.2 × 9.6cm. Price: on application.

CT 5151

Stereo top loading cassette deck. W and F: 0.15% DIN. Fitted with Dolby noise reduction. S/N ratio: 48dB (Dolby off) 58dB (Dolby on). FR: (LH tape) 63Hz-12kHz ±3dB, (chrome) 63Hz-13kHz ±3dB. Switchable EQ and bias for LH and chrome tape. Two VU meters. LED peak indicator. Inputs: mic 2 × 0.5mV/90mV 20K, line 2 × 50mV/7V 300K, DIN 15mV/2.2V 10K. Outputs: headphone 40mV 8 ohms, line 2 × 300mV 50K, DIN 300mV 50K. Electronically controlled DC motor. Full auto stop mechanism. Skip button, level limiter, tape run pilot, ferrite recording head. Mains: 220/240V. Dimensions: 39.6 × 24.2 × 9.6cm. Price: on application.

CTF 6161

Stereo front loading cassette deck. W and F: 0.19% (DIN). Fitted with Dolby noise reduction. S/N ratio: 48dB (Dolby off) at 250 nWb/m, 58dB (Dolby on) at 250 nWb/m. FR: (LH tape) 40Hz-11kHz ±3dB, (chrome) 40Hz-12kHz ±3dB. Switchable bias and EQ for LH and

chrome tape. Two VU meters. Inputs: mic 2 × 0.2mV-90mV 20K, line 2 × 60mV/9V 470K, DIN 6mV/2.7V 10K. Outputs: headphones 40mV 8 ohms, line 2 × 300mV 50K, DIN 300mV 50K. Electronically controlled DC motor. Full auto stop mechanism, cassette compartment illumination. Mains: 110-240V switchable. Dimensions: 44.2 × 33 × 13.8cm. Price: on application.

CTF 7171

Stereo front loading cassette deck. W and F: 0.19% (DIN) Fitted with Dolby noise reduction. S/N ratio: 48dB (Dolby on) at 250 nWb/m, 58dB (Dolby off) at 250 nWb/m. FR: (LH tape) 40Hz-12kHz ±3dB, (chrome) 40Hz-13kHz ±3dB. Switchable bias and EQ for LH and chrome tape. Two VU meters. LED peak indicator. Inputs: mic 0.2mV/90mV 20K, line 60mV/9V 470K, DIN 6mV/2.7V 10K. Outputs: headphone 40mV 8 ohms, line 300mV 50K, DIN 300mV 50K. Electronically controlled DC motor. Full auto stop mechanism. Memory rewind switch. Recording limiter, skip button. Independent record and playback controls, cassette illumination light and switch. Mains: 110-240V switchable. Dimensions: 43 × 31 × 13.8cm. Price: on application.

CTF 9191

Stereo front access cassette deck. W and F: 0.12% (DIN). Fitted with Dolby noise reduction. S/N ratio: 52dB (Dolby off) at 250 nWb/m, 62dB (Dolby on) at 250 nWb/m. FR: (LH tape) 35Hz-13kHz ±3dB, (chrome) 30Hz-14kHz ±3dB. Switchable bias and EQ for LH and chrome tape. Two VU meters (-40dB) and +3dB. LED peak indicator. Inputs: mic 2 × 0.22mV/100mV 30K, line 4 × 65mV/00100K, DIN standard. Outputs: headphone 40mV/65mV 8 ohms, line 4 × 315mV/530mV 100K, DIN standard. Electronically controlled DC motor. One DC torque motor. Mic and line mixing. Switchable MPX filter. Auto tape selector for CrO₂ tape. Full memory rewind start function. Memory markers. Mains: 110-240V switchable. Dimensions: 45.7 × 31.5 × 19.7cm. Price: on application.

■ PYE

Pye Ltd, PO Box 49,
St Andrews Road, Cambridge CB4 1DS.
Tel: Cambridge 58985.

9147 ★

Stereo cassette deck. W and F: ≤ ±0.2% peak. Fitted with DNL noise reduction. S/N ratio: (CrO₂) ≥47dB, (Fe₂O₃) ≥45dB. FR: (CrO₂) 50Hz-14kHz, (Fe₂O₃) 50Hz-11kHz, both to DIN 45 511. Automatic switch for CrO₂. Twin



Pye 9147



Pye 9148



Pye 3507

illuminated VU meters. Inputs: crystal PU 100mV 1M, radio 100mV 1M, record player 2mV 2K, mic 0.2mV > 2K. Output: main amplifier 1V 20K. Motor: electronic, hysteresis magnetic clutch. Controls: interlocked piano-key controls for record, rewind, start, stop, fast wind. Pushbutton on/off mains switch, cassette eject button. Slider-type controls for left and right channel recording levels. Mains: 110-127, 220-240V AC 50Hz. Dimensions: 36.8 x 23.8 x 8.3cm. Price: £100 (excluding VAT).

9148 ★

Stereo cassette deck. W and F: $\leq 0.2\%$ peak. Fitted with DNL noise reduction. S/N ratio: (CrO₂) ≥ 48 dB (DIN 45 500), (Fe₂O₃) ≥ 45 dB (DIN 45 511). FR: (CrO₂) 25Hz-14kHz (DIN 45 500), (Fe₂O₃) 40Hz-12kHz (DIN 45 511). Automatic switch for CrO₂. Twin illuminated VU meters. Inputs: mic 0.2mV 2K, radio 2mV 20K, record player 100mV 1M. Outputs: radio 0.5V 10K, monitor 400mV 10K. Motor: electronic, servo-controlled, hysteresis clutch, auto stop. Controls: interlocked pushbutton for record, rewind, start, stop, wind. Pushbutton on/off mains switch. Pause button. DNL switch and cassette eject button. Slider-type recording level controls. Sliding cover over microphone sockets. Mains: 110-127, 220-240V AC 50/60Hz. Dimensions: 39.4 x 21.6 x 8.6cm. Price: £134.26 (excluding VAT).

3507 ★

Stereo cassette deck. W and F: 0.35% peak. Fitted with DNL noise reduction. S/N ratio: (CrO₂) ≥ 47 dB. (Fe₂O₃) ≥ 45 dB. FR: (CrO₂) 40Hz-12kHz, (Fe₂O₃) 60Hz-10kHz, both to DIN 45 511. Automatic switch for CrO₂ and lamp. Inputs: mic 0.2mV 2K, radio/PU 100mV 1M, record player 2mV 20K. Output: main amplifier 0.5V 20K. Motor: electronic, hysteresis magnetic clutch, autostop. Controls: interlocked piano-key controls for record, rewind, start, stop, fast wind. Pushbutton on/off mains switch. Cassette eject switch. DNL switch. Pause switch. Single slide operated recording level for both left and right channels. Mains: 110-127, 220-240V AC 50Hz. Dimensions: 20.3 x 21.6 x 7.6cm. Price: £71.92 (excluding VAT).

■ **ROTEL**

Rank Audio Visual, PO Box 70, Great West Road, Brentford, Middlesex. Tel: 568 9222.

RD20

Stereo cassette deck with Dolby 'B'. W and F: 0.07%. S/N: 53dB (or 60dB Dolby) for CrO₂, 50dB (or 59dB Dolby) for FeCr, 48dB or 58dB Dolby for L.N. FR: Normal 30-15,000Hz but 22-15,000Hz FeCr and 22-16,000Hz CrO₂. Three tape selector switches. VU meters with indicators for record/Dolby/Three types of tape. Inputs for mic, line and DIN. Electronic governor DC motor. Dimensions: 45.8 x 24.5 x 7.5cm. Price: £158.00 (plus VAT).

■ **SANSUI**

Vermtron Ltd, Thornhill, Southampton SO9 5QF. Tel: Southampton 444811.

★ Indicates entry is illustrated

SC636

Stereo cassette tape deck. Twin VU meters. Facility for left/right and centre mic mixing. Has chrome/standard and Dolby facility. Input sensitivity: mic 0.5mV 600 ohms to 10K, line 70mV 100K. Output level: line 0.56V. FR: 30Hz-13kHz (standard tape), 30Hz-16kHz (chromium dioxide tape). Size: 408 × 118 × 295mm. Price: £135.63 (plus VAT).

SC737 ★

Stereo cassette tape deck. Twin VU meters. Facility for left/right and centre mic mixing. Has chrome/standard and Dolby facility. Input sensitivity: mic 0.5mV 600 ohms to 10K, line 70mV 100K. Output level: 0.56V. FR: 30Hz-13kHz (standard tape), 30Hz-16kHz (chromium dioxide tape). Size: 464 × 121 × 294mm. Price: £159.95 (plus VAT).

SC2000

Front loading stereo cassette deck with Dolby. W and F: 0.1%. FR: 30-13,000Hz, 35-11,000Hz ±3dB normal or 30-15,000Hz, 35-12,000Hz ±3dB chromium. S/N: 50dB or 60dB Dolby. Inputs: Mic, line, DIN. Dimensions: 44 × 29 × 15.8cm. Price: £155.08 (plus VAT).

SC3000

Front loading stereo cassette deck with Dolby. W and F: 0.09%. FR: 30-13,000Hz, 35-11,000Hz ±3dB normal or 30-16,000Hz, 35-



Sansui SC737



Sansui SC737



Sanyo RD4600



Sanyo RD4250

13,000Hz ±3dB chromium. S/N: 50dB or 60dB Dolby. Inputs: Mic (left, right), line, DIN. Dimensions: 44 × 29 × 15.8cm. Price: £173.96 (plus VAT).

SC3003

Front loading stereo cassette deck with Dolby. W and F: 0.09%. FR: 30-13,000Hz, 35-11,000Hz ±3dB normal or 30-16,000Hz, 35-13,000Hz ±3dB chromium. Inputs: mic (left and right), line, DIN. Dimensions: 44 × 29 × 15.8cm. Price: £173.96 (plus VAT).

■ SANYO

Sanyo Marubeni (UK) Ltd, Sanyo House, Bushey Mill Lane, Watford, Herts WD2 4UQ. Tel: Watford 30421.

RD4600 ★

Cassette deck with switchable Dolby noise suppression circuit. For recording and playback through a hi-fi system. Near perfect speed accuracy is obtained with direct drive from a saturable magnetic core type ultra low-speed DC brushless motor. Separate left-right adjustments for input and output levels, 3 position tape selector switch for chrome, low noise and normal tapes, super ferrite heads. Auto-stop and auto-return rewinds tape to original position, auto repeat gives continuous music. Input select switch and tilt-up panel with two VU meters. Memory rewind system. FR: 30Hz-16kHz on CrO₂. W and F: 0.06% RMS. S/N: 50dB (58dB with Dolby). Size: 104 × 468 × 284mm. No recommended retail price.

RD4250 ★

Dolby cassette deck incorporating a super ferrite head to provide a flat frequency response with negligible wear when using any kind of tape. For hiss-free recording and play-back a Dolby suppression is incorporated. Servo controlled drive mechanism assures almost perfect speed accuracy. Other facilities include VU recording level meters, tape counter and eject button with seven control buttons including cueing and pause function in a keyboard arrangement. Auto-stop facility, sliding adjustable recording levels that provide optimum recording with standard, high-energy cobalt or CrO₂ tape. Finish: teak and brushed aluminium. Price: £126.95 (including VAT).

■ SHARP ELECTRONICS (UK) LTD

107 Hulme Hall Lane,
Manchester M10 8HL.
Tel: 061-205 7321.

RT-3500

Stereo cassette deck with Dolby system. W and F: 0.3% weighted peak DIN. S/N: 52dB (250 Pw/mm), Dolby 58dB (250 Pw/mm). FR: CrO₂ 25-16kHz. Fe₂O₃ 25-14kHz. Built in bias switch, recording equalisation, 70 μS play back, equalisation for CrO₂ tapes. Three digit counter, twin VU meters, Dolby, CrO₂, APFS, pause indicators, peak level indicator (two coloured). Inputs: mic 2 × (0.1mV 120K ohms), DIN r/p. DC servo motor. Dimensions: 42.8 × 11.4 × 26.8cm. Price: £115.96 (plus VAT).

RT-1200

Stereo cassette deck. W and F: 0.3% weighted peak (DIN). S/N 50dB or 55dB with suppressor on. FR: CrO₂ 45-12kHz, normal 45-10kHz. Built-in bias switch, recording equalisation, playback equalisation for CrO₂ tapes. 3 digit counter, level meters, recording indicator. Inputs: mic and DIN. DC servo motor. Dimensions: 40.6 × 11.2 × 25.6cm. Price: £67.90 (plus VAT).

RT-2000H

Stereo cassette deck with Dolby system. W and F: 0.3% weighted peak (DIN). S/N: 50dB or with Dolby 56dB. FR: CrO₂ 40-14kHz, Fe₂O₃ 40-12kHz. Built-in bias switch, recording equalisation switch, 70 m/sec playback equalisation for CrO₂ tapes. Inputs: mic, DIN, r/p. DC servo motor. Dimensions: 40.6 × 25.6 × 11.2cm. Price: £84.00 (plus VAT).

RT-2500H

Stereo cassette deck with similar spec. to RT-2000H except S/N: 52dB or 58dB with Dolby.

Dimensions: 42.8 × 26.8 × 11.4cm. Price: £101.56 (plus VAT).

■ SONAB LTD

214 Harlequin Avenue, Brentford,
Middlesex TW8 9EW.
Tel: 01-569 2952.

C500 ★

Stereo cassette deck with Dolby 'B'. W and F: ±0.15%. S/N: 45dB or 52dB Dolby standard tape; 48dB or 52 dB Dolby for CrO₂ tape. FR: 40-12,500 Hz standard, 40-15,000 Hz chrome. 2× quasi peak reading level meters, three figure tape counter with memory rewind. Inputs: mic left and right and centre, DIN, line. Servo controlled DC motor. Dimensions: 38 × 25 × 10.5cm. Price: £187.00 (plus VAT).

■ SONY (UK) LTD

Consumer Information, Sony Showroom,
Regent Street, London W1R 6DJ.
Tel: 01-439 3874.

TC 135 SD

4-track, 2 channel stereo cassette deck with Dolby system. W and F: 0.12% WRMS, ±0.22% DIN. S/N 53dB. FR: 50-13,000Hz, 40-12,000Hz (DIN). Equalisation switch. Normal, FeCr, CrO₂, automatic bias switch for CrO₂. Level indicators: 2× VU meters. Inputs for mic, line, DIN. Dimensions: 39 × 24.8 × 10.8cm. Price: £91.96 (plus VAT).

TC 136 SD

4-track, 2 channel stereo cassette deck with Dolby system. W and F: 0.1% WRMS, ±0.2% DIN. S/N: 52dB normal, 54dB FeCr, CrO₂. FR: 40-14,000 Hz (DIN on FeCr), 30-16,000Hz ±5dB (FeCr). Equalisation switch. Inputs: mic, line, DIN. Dimensions: 38.6 × 24 × 12.6cm. Price: £115.96.

TC 138 SD

4-track, 2 channel stereo cassette deck with Dolby system. W and F: 0.07% WRMS. S/N: 55dB improvement with Dolby in. FR: 30-



Sonab C500

★ Indicates entry is illustrated



Sony TC153SD



Sony TC177SD



Sony TC204SD

15,000Hz. Equalisation switch, automatic bias switch for CrO₂. 2× VU meter and peak level indicator. Inputs for mic, line, DIN. Dimensions: 44.1 × 29.4 × 13.8cm. Price: £159.96 (plus VAT).

TC 177 SD ★

4-track, 2 channel stereo cassette deck with Dolby system. W and F: 0.07% WRMS, ±0.18% DIN. S/N: 53dB normal, 55dB (FeCr, CrO₂). FR: 30-13,000 Hz normal, 30-17,000 FeCr, CrO₂. Bias switch: low, medium, high. 2× VU meter and peak level indicator. Inputs:

mic, line, DIN. Dimensions: 43.5 × 32.5 × 15.5cm. Price: £311.96 (plus VAT).

TC 204 SD ★

4-track, 2 channel stereo cassette deck with Dolby system. W and F: 0.1% WRMS ±0.2% DIN. S/N: 53dB normal, 55dB with FeCr, CrO₂. FR: 40-12,000 normal, 40-15,000 FeCr, CrO₂. Bias switch: low, normal, high. Equalisation switch: normal, FeCr, CrO₂. 2× VU meter plus peak level indicator. Inputs: mic, line, DIN. Dimensions: 43 × 32.5 × 16cm. Price: £127.96 (plus VAT).

TC 209 SD

4-track, 2 channel stereo cassette deck with Dolby system. W and F: 0.07% WRMS, ±0.18% DIN. S/N: 61dB at peak level. 53dB (FeCr, DIN). FR: 30-15,000Hz. Bias switch, equalisation switch, 2× VU meter plus peak level indicator. Inputs: mic, line, DIN. Dimensions: 43 × 32 × 17cm. Price: £199.96 (plus VAT).

TC 153 SD ★

4-track, 2 channel stereo cassette deck with Dolby. W and F: 0.15% WRMS. S/N: 53dB normal, 55dB (FeCr, CrO₂). FR: 30-15,000 Hz (FeCr), 40-12,500 Hz (DIN, FeCr). Equalisation switch. 2× VU meter. Inputs: mic, line, DIN. Dimensions: 37.8 × 23.8 × 10.8cm. Price: £143.47 (plus VAT).

TC 117

4-track, 2 channel stereo cassette deck. W and F: 0.2% WRMS. S/N: 46dB. FR: 40-13,000 Hz. Inputs: mic, line, DIN. Dimensions: 36.2 × 23.8 × 10.5cm. Price: £63.96.

■ TANDBERG

Farnell-Tandberg Ltd, Farnell House,
81 Kirkstall Road, Leeds LS3 1HR.
Tel: Leeds 35111.

TCD310 ★

Cassette stereo tape deck, ¼ track. Speed: 17 1/2 i/s. Compact cassette. W and F: 0.2%. S/N: 52dB. FR: 40Hz-12.5kHz (ferric oxide tape),

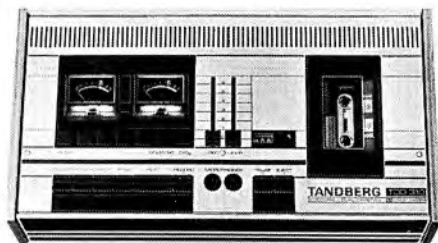

Tandberg TCD310



Teac A400

40Hz-13.5kHz (CrO₂ tape). CrO₂ switch. Re-play char: NARTB. Two meter level indicators. Four-digit tape position indicator with PB reset. Inputs: mic 0.1mV at less than 700 ohms, line 40mV 100K, radio 8mV 47K. Outlet: line 0.775V 10K. All DIN sockets. Three motors (synchronous hysteresis for capstan, precision fastwind reel motors). Size: 16 $\frac{7}{8}$ × 4 $\frac{1}{8}$ × 9 $\frac{1}{8}$ in. Weight: 14 $\frac{1}{2}$ lb. Pause. Monitoring on record. Parallel track replay. Hot-pressed ferrite heads. Dolby noise reduction system. Dual-capstan closed loop tape transport. Electronic controls. Auto-stop. Operates horizontally or vertically. Can be wall mounted. AC mains. Price: £181 (plus VAT).

TCD330

Stereo cassette deck with Dolby system. W and F: 0.15%. S/N: 53dB. Peak level record meters. Inputs: mic, line, radio. Price: not yet known.

TEAC

Teledyne Acoustic Research, High Street, Houghton Regis, Dunstable, Beds.
Tel: 0582 603151.

A400 ★

Stereo cassette deck with Dolby system. W and F: 0.08%. S/N: 50dB, improved with Dolby. FR: 30Hz-16kHz (CrO₂), 30Hz-13kHz. Fitted with peak level indicator. Outputs: 2 line, stereo headphones. Dimensions: 44 × 15.5 × 28.5cm. Price: £160.00 (plus VAT).

A650

Stereo cassette deck with Dolby system. W and F: 0.06%. S/N: 57dB, improved with Dolby. Inputs: 2 mic and 2 line. Dimensions: 44 × 17.7 × 32.5cm. Price: on application.

A170

Stereo cassette deck with Dolby system. W and F: 0.09%. S/N: 50dB, improved with Dolby. FR: 30Hz-13kHz. VU meter. Inputs for mic and line. Dimensions: 43 × 13.6 × 22.5cm. Price: £133.00 (plus VAT).

TELEFUNKEN

AEG-Telefunken (UK) Ltd, Bath Road, Slough SL1 4AW. Tel: Slough 33311.

MC2100 Hi-Fi

Stereo cassette deck. W and F: better than 0.2%. Fitted with DNL noise reduction. S/N: 52dB (CrO₂ tape), 50dB (Ferric oxide tape). FR: 30Hz-10kHz (Ferric oxide tape), 30Hz-12.5kHz (CrO₂ tape). Automatic selection for CrO₂. Twin VU meters. Inputs: radio 0.2mV 2.2K, mic 0.2mV 2.2K, ceramic PU 200mV 2.2M. Outputs: radio 0.8V 15K, phones 0.4V 3.3K. One electronic controlled DC motor. Mains: 110-220V AC. Size: 320 × 72 × 270mm. Memory counter. Automatic level control. Price: £115.00 (including VAT).

MC2200 Hi-Fi

Stereo cassette deck. W and F: better than 0.2%. Fitted with Dolby noise reduction. S/N: better than 56dB (CrO₂ tape), better than 54dB (Ferric oxide tape). FR: 30Hz-12.5kHz (ferric oxide tape), 30Hz-14kHz (CrO₂ tape). Automatic selector switch for CrO₂. Two VU meters. Inputs: radio 0.2mV 2.2K, mic 0.2mV 2.2K. Ceramic PU 200mV 2.2M. Outputs: radio 0.8V 4.7K. Phones 2.5V 400 ohms. One electronic controlled DC motor. Mains: 110-220V AC. Size: 390 × 85 × 300mm. Memory counter. Slider volume control for headphones, and recording. Manual or automatic record level control. Price: £160 (including VAT).

Magnetophon C 3300 Hi-Fi

Stereo cassette tape deck (DIN 45 500). Dolby system, featuring integrated circuitry and with selector switch. Electronic CrO₂ tape selector. HNS audio head. Automatic stereo recording level control with manual override. Speech/music change-over switch coupled with radio/mic input selector. Two illuminated peak voltage meters, also operated during playback. Three slide controls for record left/right and headphones volume. Headphones socket. Magnetic movement control with electronic touch buttons. Illuminated signals for record, playback, forward, rewind, stop, pause, Dolby and CrO₂. FR: 30Hz-15kHz (CrO₂). S/N: ≥57dB. W and F: ≤ ±0.18%. Five rocker switches for electrical function selection. Electronically-governed direct-current motor. Three digit memory tape counter (memory can be cut out). Electronic end-of-tape and interference detector with stop feature. Pause button. CrO₂ cassette C60 and stereo transcription lead included. Finish: plastic, black and silver. Size: 17 × 4 $\frac{1}{4}$ × 12in. Price: £260.00 (including VAT).

★ Indicates entry is illustrated

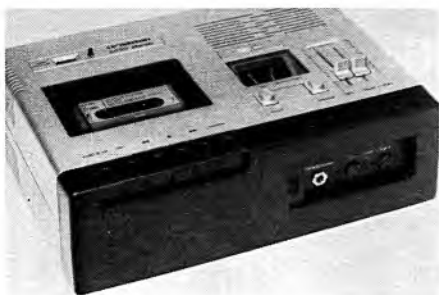

Teleton CD50



Teleton STC 126

Stereosound Tape Recorder

4 track stereo cassette recorder including speakers. Can be connected to a record player to serve as amplifier. Mains warning light, 3 digit counter. 2 x 15W music power. Price: £109.80 (plus VAT).

■ TELETON ELECTRO (UK) LTD

Teleton House, Waterhouse Lane,
Chelmsford, Essex.
Tel: Chelmsford 62442.

CD 50 ★

Stereo cassette deck, 4-track, 2 channel, driven by electronically stabilised DC motor, equipped for CrO₂ operation. W and F: 0.2%. FR: 60-10kHz normal, 40-12.5kHz CrO₂. Dimensions: 11.5 x 33 x 24.5cm. Price: £87.65 (including VAT).

STC 126 ★

Stereo cassette deck with piano key controls and three position monitor switch controlling VU meter, monitoring both channels simultaneously or left and right individually. Spec as for CD50 except Dimensions: 10.8 x 30 x 24.3cm. Price: £86.00 (including VAT).

■ TOSHIBA

Toshiba (UK) Ltd, Toshiba House,
Great South West Road,
Greater London. Tel: 01-751 1281.

PT-415

Cassette deck. 4-track, 2-channel. Tape speed: 17 1/2 i/s. 4-pole synchronous motor. FR: 30Hz-15kHz (chrome). S/N ratio: more than 49dB (chrome) W and F: 0.1% WRMS. Mains: 100, 120, 220, 240V 50/60Hz. Size: 42.5 x 29 x 14cm. Weight: 4.6kg. Price: £81.60 (plus VAT).

PC4030

Stereo cassette deck with Dolby. W and F: 0.09%. S/N: 55dB normal. Equalisation/bias switches. dB meter. Inputs: line in, mic, DIN. DC servo motor with AC generator. Dimensions: 40 x 30 x 13.5cm. Price: on application.

PC 6030 ★

Stereo cassette deck with Dolby. W and F: 0.07%. S/N: 58dB normal. Separate bias/equalisation switches. Peak reading meters. Inputs: line in, mic, DIN. Dimensions: 40.3 x 19.9 x 25.2cm. Price: on application.

PC 3060

Stereo cassette deck with Dolby. W and F: 0.09%. S/N: 50dB normal. Separate bias/equalisation switch, dB meter. Inputs: line in, mic, DIN. Bridge servo DC motor. Dimensions: 40 x 30 x 14.5cm. Price: on application.

PC 5060 ★

Stereo cassette deck with Dolby. S/N: 56dB normal. Separate bias/equalisation switch, dB meter. Inputs: line in, mic, DIN. DC servo motor with AC generator. Dimensions: 45 x 33.3 x 15cm. Price: on application.

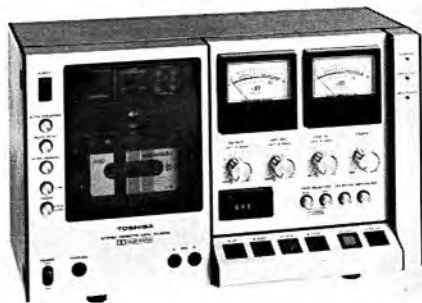

Toshiba PC6030

CASSETTE DECKS/RECORDERS



Toshiba PC5060



Trio KX620

PC 3110

Stereo cassette deck. W and F: 0.25%. S/N: 42dB normal. VU meter. Inputs: line in, mic, DIN. DC servo motor. Price: on application.

PC 4020

Stereo cassette deck with Dolby system. W and F: 0.09%. S/N: 52dB normal. dB meter. Inputs: line in, mic, DIN. DC servo motor. Dimensions: 40 × 30 × 13.5cm. Price: on application.

TRIO

B. H. Morris & Co (Radio) Ltd, Trio House, The Hyde, London NW9 6JP. Tel: 01-205 6441.

KX710

Dolby cassette deck. Facilities: Dolby 'B' system, auto tapé switching, auto stop, cue and review, memory rewind, tape run indicator, tape counter, auto level control, peak level indicator, Dolby FM/copy. DC servo controlled motor. Tape system: 4-track, 2-channel stereo. Tape speed: 17/8i/s. Heads: super ferrite record/playback and erase. W and F: less than 0.09%. S/N: 58dB Dolby. FR: 30Hz-16kHz (CrO₂), 30Hz-13kHz (low noise). Recording system: AC bias 85kHz. Erasing system: AC bias. Input sensitivity: (variable) mic 0.24mV 10K, line 77.5mV 47K. Output voltage: (variable) 490mV 100K. Power consumption: 23W.

Mains: 240V AC. Size: 40 × 25 × 12cm. Price: £153.60 (plus VAT).

KX 620 ★

Stereo cassette deck with Dolby. W and F less than 0.09%. S/N: 61dB Dolby. Separate bias and equalisation switching permitting six permutations. Two VU meters. Inputs: line, DIN, mic. DC servo motor. Dimensions: 43 × 30 × 14cm. Price: £134.40 (plus VAT).

KX 910

Stereo cassette deck with Dolby 'B'. W and F: less than 0.08%. S/N: 58dB Dolby. FR: 30Hz-16,000Hz (CrO₂), 30Hz-13,000Hz (low noise). Auto tape switching with manual override. Two VU meters augmented by peak level indicator. Inputs: mic, line. Dimensions: 40 × 25 × 12cm. Price: £185.60 (plus VAT).

UHER

Uher (UK) Ltd, Peas Home House, St. Saviour Place, York. Tel: York 30421.

CG360 ★

Mains operated 3-motor stereo cassette recorder with touch sensitivity digital drive control, and Dolby noise reduction. 1/4-track, 17/8i/s. W and F: 0.2%. Hum and noise: -56dB (CrO₂ with Dolby). FR: 20Hz-15kHz (CrO₂), 20Hz-12.5kHz (FeO₂). All figures to DIN specification 45 500. Inputs: mic 0.2mV- 100mV 500



Uher CG360



Uher Power Output stage for CG360

★ Indicates entry is illustrated

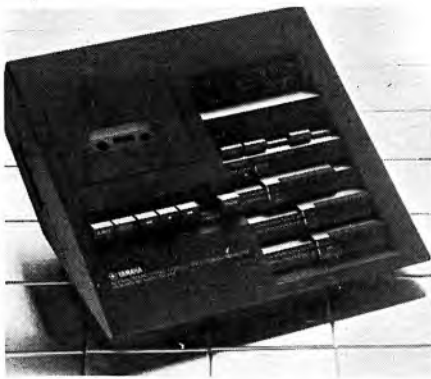

Yamaha TC 800 GL

ohms, radio 2mV-600mV 22K, phono 300mV-6V 1M, recorder 300mV-6V 1M. Outputs: line 0.775V 15K, rerecording 0.775V 15K, headphones 2V 4 ohms (with addition of output stage accessory W 319). Digital drive control with 3 motors giving touch sensitive operation and full remote control facility (accessory F 113), automatic CrO₂ switching, automatic reverse and continuous play facilities, separate bass, treble, balance, volume, two record levels (mixed) and record balance controls, optional 10W (sine) per channel output stage (W 319), twin peak programme reading record meters and switchable Dolby noise reduction circuitry. Weight: 7kg. Price: £581.20 (plus VAT).

■ YAMAHA

Natural Sound Systems Ltd, Strathcona Road, North Wembley HA9 8QL.
Tel: 01-904 0141.

TC 800 GL ★

Stereo cassette deck. W and F: 0.06%. Fitted with Dolby noise reduction. S/N ratio: >63dB. FR: 30Hz-16kHz \pm 3dB. Bias switch for chrome and ferro-chrome cassettes. Two VU meters and peak lights. Inputs: line 50mV 50K, mic 0.5V 10K. Output: 0.4V. DC servo motor. Mains: 240V or batteries. Dimensions: 312 \times 312 \times 98mm. Price: £179 (excluding VAT).

■ WOLLENSAK

3M United Kingdom Ltd, 3M House, Wigmore Street, London W1A 1ET.
Tel: 01-486 5522.

4766

Cassette recorder. Speed: 4.76cm/sec. W and F: typically 0.1% DIN peak weighted. Forward/rewind: typically 45 seconds for C60 cas-

ettes. Inputs: mic 0.15mV 5K, aux (line) 125mV 100K, DIN 1.5mV 10K. Outputs; line with output level control at maximum output level 1V at 0 VU tape level. DIN as line, headphones 0.2mV into 8 ohms adjustable. FR: 40-15,000Hz \pm 3dB, chrome and ferrochrome tape. Record/play: 40-13,000Hz \pm 3dB, ferric tape reference 0dB at 1kHz. Distortion: typically less than 0.1%. Dolby oscillator: 400Hz for Dolby 'B' system calibration. Twin volume unit meters with separate peak programme indicators. S/N ratio: better than 50dB with ferric tape. Noise reduction: (Dolby on) 10dB at 4kHz and above, 9dB at 2.4kHz, 6dB at 1.2kHz, 3dB at 600Hz. Crosstalk attenuation: better than 65dB. Stereo channel separation: better than 38dB at 1kHz. Stereo channel balance: within 2dB. Bias and erase oscillator: 110kHz \pm 5kHz. Erase efficiency: better than 70dB. 33 transistors, 20 diodes, 2 FETs. Mains: nominal 230V AC 50Hz. Power consumption: less than 25W. Size: 43.8 \times 26.04 \times 16.5cm. Weight: 7.26kg. Price: £230.56 (plus VAT).

8075

8-track cartridge recorder with Dolby noise reduction. W and F: 0.2% DIN. FR: 50-13,000kHz. Inputs: mic, line, DIN. Dimensions: 50 \times 26 \times 12.5cm. Price: £182.87 (plus VAT).

Constructional Kits

★ Indicates entry is illustrated Abbreviations used in this section are given on page 27.

■ RICHARD ALLAN

Richard Allan Radio Ltd,
Bradford Road, Gomersal,
Cleckheaton, Yorkshire BD19 4AZ.
Tel: Cleckheaton 2442.

Twin Assembly ★

Speaker kit comprising CBF8 bass/mid-range driver and CB4 treble unit. CN54 crossover, BAF wadding, Vynair fret material (with choice of three patterns), foam backing sheet, detailed assembly instructions, fixing screws, terminals, etc. FR: 40Hz-17kHz. HC: 15W RMS. Impedance: 8 or 15 ohms. Recommended cabinet size: 20 × 12 × 9in. Design based on Richard Allan Chaconne series II enclosure. Price: £15.00 (plus VAT).

Triple-8 Assembly

Speaker kit comprising CF8L bass driver, CF5 mid-range unit, CB4 treble unit, 1/4-section printed circuit crossover, BAF wadding, Vynair grille material (with choice of three patterns), foam backing sheet, detailed assembly instructions, fixing screws, terminals, etc. FR: 40Hz-17kHz. HC: 20W RMS. Impedance: 8 or 15 ohms. Recommended cabinet size: 20 1/2 × 13 × 8 1/2in. Design based on Richard Allan Flamenco series II enclosure. Price: £23.00 (plus VAT).

Triple-12 Assembly

Speaker kit comprising CG12 bass driver, CP8 mid-range unit, CB4 treble unit, 1/4-section printed circuit crossover, BAF wadding, Vynair fret material (with choice of three patterns), foam backing sheet, detailed assembly instructions, fixing screws, terminals, etc. FR: 30Hz-17kHz. HC: 30W RMS. Impedance: 8 or 15 ohms. Recommended cabinet size: 25 × 15 1/2 × 12 1/2in. Design based on Richard Allan Pavane series II enclosure. Price: £28.00 (plus VAT).

Super-12 Assembly

Speaker kit comprising CG12 Super bass driver, CP8 mid-range unit, CB4 treble unit, 1/2-section crossover network. FR: 30Hz-17kHz. HC: 45W RMS. Impedance: 8 or 15 ohms. Recommended cabinet size: 25 × 15 1/2 × 12 1/2in. Design based on Richard Allan Sardana enclosure. Price: £33.00 (plus VAT).

■ CONNOISSEUR

A. R. Sugden & Co (Engineers) Ltd,
Connoisseur Works, Atlas Mill Road,
Brighouse, Yorks HD6 1ES.
Tel: Brighouse 2142.

BDI Turntable Kit

Description and specification as for BDI motor unit (See Record Decks section). Easy one-hour assembly. No soldering. Price: £18.62 (including VAT).

Plinth and cover for BDI:
£15.00 (plus VAT), plinth only;
£9.50 (plus VAT), cover only;
£5.50 (plus VAT).

■ DORAM ELECTRONICS LTD.

PO Box TR8, Leeds LS12 2 UF.
Tel: Leeds 34222.

International 25

Complete kit to build a 25W RMS per channel amplifier. Power: 25W. THD: 0.16% (12.5W)



Richard Allan Twin Assembly

★ Indicates entry is illustrated

1kHz) Hum/Noise 67dB below full output.
Price: £29.95 (plus VAT).

■ EAGLE

Eagle International, Precision Centre,
Heather Park Drive, Wembley HA0 1SU.
Tel: 01-902 8832.

SK 210

Speaker kit (two-way) complete with cross-over and terminals. No soldering required. HC: 10W RMS at 8 ohms. FR: 150Hz-14kHz ± 5 dB. Drive units: 165mm bass and high-range. Price: £6 (plus VAT).

SK 215

Speaker kit (two-way) complete with cross-over and terminals. No soldering required. HC: 15W RMS at 8 ohms. FR: 120Hz-20kHz ± 4 dB. Drive units: 203mm bass and high-range. Price: £10.00 (plus VAT).

SK 320

Speaker kit (three-way) complete with cross-over and terminals. No soldering required. HC: 20W RMS at 8 ohms. FR: 90Hz-20kHz ± 4 dB. Drive units: 203mm bass mid and high-range. Price: £14.00 (plus VAT).

SK 325

Speaker kit (three-way) complete with cross-over and spring terminals. No soldering required. HC: 25W RMS at 8 ohms. FR: 80Hz-20kHz ± 4 dB. Drive units: 254mm bass mid and high-range. Price: £22.00 (plus VAT).

SK 335 ★

Speaker kit (three-way) complete with cross-

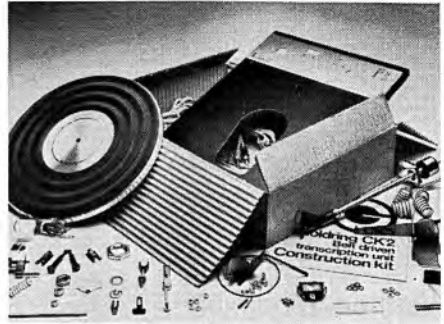

Goldring CK2



Goodmans Kits

over and spring terminals. No soldering required. HC: 35W RMS at 8 ohms. FR: 75Hz-20kHz ± 4 dB. Drive units: 305mm bass mid and high-range. Price: £28.00 (plus VAT).

■ GOLDRING LTD.

10 Bayford Street, Hackney London E8.
Tel: 01-986 6411.

CK2 Transcription Unit ★

Complete with instruction for easy assembly. 2 speed belt driven turntable with 33 $\frac{1}{3}$ and 45 rpm. Viscously damped pick-up lifting and lowering device. 16 pole synchronous motor, counter balanced pick-up arm with adjustable stylus pressure from 0.5gm. Removable plug-in headshell bias compensation. W and F: 0.15%. Motor Plate 37.8 \times 28.3cms. Turntable diameter 25.4 cms. Price: £25.70 (plus VAT).

■ GOODMAN'S LOUDSPEAKERS LTD.

Downley Road, Havant, Hants PO9 2NL.
Tel: Havant 6344.



Eagle SK335

DIN 20 Kit ★

All parts supplied except timber to make complete loudspeaker system, which should be used with amplifier rated between 10 and 40 watts. FR: 45-22,000 Hz. Power Handling: 20W DIN. Recommended amplifier music-power: 10-40 watts. Sensitivity: 4.4 Watts (96 dB at 1m). Rec. amp imp: 4 or 8 ohms. Crossover frequency: 4,000Hz. Price: £16.79 (plus VAT).

Mezzo Twin Kit ★

Parts to make Mezzo SL, which should be used with amplifiers having music power rating in range 10-60 Watts. FR: 40-20,000Hz. Power Handling: 50 Watts (DIN), Recommended amplifier music power: 10-60 Watts, Sensitivity: 7 Watts (96dB at 1m), Recommended amplifier imp: 4 or 8 ohms. Crossover frequency: 2,000Hz. Price: £58.86 (plus VAT).

■ HEATHKIT

Heath (Gloucester) Ltd,
Bristol Road, Gloucester GL2 6EE.
Tel: Gloucester 29451.

AR-1500

AM/FM stereo receiver. Range: FM 88-108MHz, MW 185-560m. IHF sensitivity: FM 1.8 μ V, AM 50 μ V. Aerial input: 75 ohms coaxial and 300 ohms balanced. Built-in ferrite rod for MW. Stereo decoder fitted. Tuning meter. Stereo beacon. Variable tuning. Pushbutton waveband selectors. Output: 60W sine wave into 8 ohms per channel. HD: <0.5%. H and N: -75dB. Inputs: mag PU 1.8mV, tape 140mV, aux 140mV. Two AC outlet sockets. Size: 18½ × 5½ × 13¾in. Mains: 120 or 240V 50-60Hz. Price: (kit) £302.40. Carriage included within UK.

AR-1302

AM/FM stereo receiver. Range: FM 88-108MHz, MW 185-560m. Sensitivity: FM 1.9 μ V, MW 300 μ V. Aerial input: 75 ohms coaxial and 300 ohms balanced. Built-in ferrite rod for MW. Stereo decoder fitted. Stereo beacon. Tuning meter. Inputs: mag PU 2.4mV, tape and aux 180mV. Variable tuning. Slider controls for bass, treble, balance and volume. Pushbuttons for waveband selection, mode and speakers. Output: 20W per channel sine wave into 8 ohms. Two AC outlet sockets. Mains: 120 or 240V 50-60Hz. Size: 16¾ × 5½ × 14½ in. Price: (kit) £208.00. Carriage included within UK.

AR-1214 ★

AM/FM stereo receiver. Range: FM 88-

108MHz, MW 185-560m. Sensitivity: FM 2 μ V, AM 100 μ V. Aerial input: 75 ohms coaxial or 300 ohms balanced. Built-in ferrite rod for MW. Stereo decoder fitted. Stereo beacon. Variable tuning. Pushbutton waveband and mode selection. Output: 15W per channel sine wave into 8 ohms. Inputs: mag PU 2mV, tape 190mV. Two AC outlet sockets. Mains: 120 or 240V 50-60Hz. Size: 17 × 3¾ × 13in. Price: (kit) £87.84. Carriage included within UK.

AR-2000

Multi-waveband AM/FM stereo receiver. Range: 88-108MHz, MW 185-560m, LW 860-2000m, SW 26-52m. Variable tuning. Aerial input: 75 ohms coaxial and 300 ohms balanced. Sensitivity: FM 2 μ V, SW 15 μ V, MW 25 μ V, LW 50 μ V. Input: mag PU 2.8mV, crystal PU 200mV, tape 200mV. Output: 20W sine wave per channel into 8 ohms. HD: <0.25% at 20W. FR: 10Hz-30kHz \pm 1dB. Output impedance: 4-16 ohms. Tape outlet socket: 1V adjustable at 100 K. Treble control: +14dB -16dB at 20kHz, bass control + 16dB -20dB at 20Hz. Mains: 110, 130, 220-230, 240-250V AC. Size: 24¾ × 4½ × 11½in. Finish: walnut or teak. Price: (kit) £107.84. Carriage included within UK.

AR1118

AM/FM stereo receiver. Range: FM 88-108MHz, MW 185-560m. Sensitivity: FM 18 μ V, AM 50 μ V. Aerial input: 75 ohms coaxial and 300 ohms balanced. Built-in ferrite rod for MW. Stereo decoder fitted. Tuning meter. Stereo beacon. Variable tuning. Pushbutton waveband selectors. Bass and treble controls, slide controls for volume, speaker on/off and stereo/mono switches, terminals for external FM antenna and headphone jack. Output: 4.5W RMS per channel into 8 ohms at less than 1.0% THD from 50Hz-15kHz. FR: 30Hz-15kHz \pm 3dB. Input sensitivity: ceramic phono 140mV, high level inputs 120mV. Hum and noise: -60dB FM. Selectivity: 60dB. Channel separation: 35dB. Mains: 120/240V AC 60/50Hz. Size: 4½ × 16¾ × 15in. Price: £84.00 (plus VAT).



Heathkit AR-1214

★ Indicates entry is illustrated



Heathkit AS-9560 AS-9520 AS-9515 AS-9530

AA-1214

Stereo integrated amplifier. Specification the same as amplifier section of AR-1214. Size: $12\frac{3}{4} \times 3\frac{7}{8} \times 12$ in. Finish: teak or walnut end panels. Price: (kit) £54.56. Carriage included within UK.

AJ-1214

AM/FM stereo tuner. Specification the same as tuner section of AR-1214. Output: AM 0.6V nominal, FM 1V nominal. Size: $12\frac{3}{4} \times 3\frac{7}{8} \times 13$ in. Finish: teak or walnut end panels. Price: (kit) £54.56. Carriage included within UK.

AS-9560 ★

Speaker system with units. HC: 60W RMS. FR: 25Hz-27kHz. Crossover: 650Hz and 5kHz. Infinite baffle. Impedance: 8 ohms. Finish: teak or walnut. Size: $32 \times 16 \times 12$ in. Weight: 60lb. Price: (kit) £86.40. Carriage included within UK.

AS-9530 ★

Infinite baffle enclosure with units, KEF B139 $13 \times 9\frac{1}{2}$ in bass driver, KEF B110 $5\frac{1}{2}$ in mid-range unit, KEFT27 dome tweeter. Crossover: 600Hz and 3kHz. Impedance: 8 ohms. HC: 30W RMS. FR: 30Hz-27kHz. Size: $26 \times 16 \times 12$ in. Weight: 32lb. Finish: teak or walnut. Price: (kit) £66.00. Carriage included within UK.

AS-9520 ★

Infinite baffle enclosure with units. KEF B200 bass driver, KEF T15 mid-range and HF unit. HC: 20WRMS. FR: 35Hz-20kHz. Impedance: 8 ohms. Crossover: 3kHz. Size: $20 \times 12 \times 10$ in. Weight: 23lb. Finish: teak or walnut. Price: (kit) £38.80. Carriage included within UK.

AS-9515 ★

Infinite baffle enclosure with units. One full-range Peerless E396M elliptical driver. HC: 15W RMS. FR: 50Hz-16kHz. Impedance: 8 ohms. Size: $7 \times 12 \times 6$ in. Finish: teak or wal-

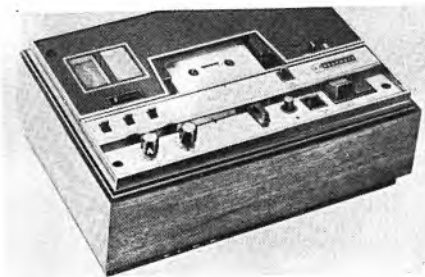

Heathkit AD-1530E

nut. Weight: 6lb. Price: (kit) £15.52. Carriage included within UK.

AS-1140

Infinite baffle enclosures. Each enclosure houses a $4\frac{1}{2}$ in full-range speaker with a foam suspension and 3oz magnet. Useful response extends from 70Hz-16kHz. For use with amplifiers of up to 10W output. Size: $12 \times 7 \times 6$ in. Impedance: 8 ohms. Finish: walnut-grain vinyl. Price: £25.52 per pair (plus VAT).

AD-1530E ★

Dolby cassette deck. Individual bias adjust controls for regular and CrO₂ tape. Individual record level controls with separate VU meters. Large three-digit resettable counter for indexing selections within a tape. Input selector switch for either mic or high-level source input. Modular plug-in circuit board design in the amplifier and Dolby circuits simplify construction and servicing. FR: regular (iron oxide) tape 40Hz-12kHz ± 3 dB typical, CrO₂ (chromium dioxide) tape 40Hz-14kHz ± 3 dB typical. Distortion: less than 0.5%. Hum and noise: (Dolby switch off) 10dB at 4kHz, -9dB at 2.4kHz, -6dB at 1.2kHz, -3dB at 600Hz. W and F: less than 0.25% RMS. Tape speed: 1781/s. Mains: 120/240V AC 50/60Hz 15W. Size: $5\frac{1}{2} \times 9\frac{1}{2} \times 14$ in. To help check-out and adjustment, a built-in test circuitry and blank C60 cassette tape are included. Price: £183.92 (plus VAT); dust cover (model ADA-1530-I) optional extra £5.60.

AA-2005

Four channel amplifier with built in decoder for matrixed 4-channel records and FM broadcasts. Output: 15W per channel into 8 ohms. Power bandwidth: 5Hz-30kHz. FR: ± 1 dB 7Hz-50kHz, ± 3 dB 5Hz-70kHz. HD: less than 0.5% from 20Hz-20kHz at 15W output. Output impedance: $< \frac{1}{2}$ ohms. Inputs: phono 2.2mV, tuner, aux, tape 200mV. Input overload: phono greater than 5V with level control tuner,

aux; tape greater than 3V. H and N: phono -60dB, tuner, aux, tape -70dB. Channel separation: phono 40dB, tape 45dB. Input impedance: phono 49K (RIAA equalised), tuner, aux, tape 100K. Mains: 120 or 240V 50/60Hz AC. Size: $4\frac{7}{8} \times 10\frac{3}{4} \times 12$ in. Price: £172.80 (plus VAT).

AJ-29

FM stereo tuner. Sensitivity: 1.8μ V. Selectivity: greater than 70dB. Built-in AM rod antenna. Price: £156.00 (plus VAT).

AA-29

Stereo amplifier. Output: 70W. Outputs for two stereo speaker systems. Input level controls for both channels of all inputs including tape monitor allow adjustments of levels so volume remains constant when switching sources. Price: £112.40 (plus VAT).

AR-29

AM/FM Receiver. Output: 30W into 8 ohms. Frequency Response (1W): -1dB, 7Hz to 60kHz. HD: 0.25% from 20Hz to 20kHz at 35W RMS, 0.1% at 1000Hz at 1W. IM Distortion: 0.2% at 35W, 60 and 6,000Hz mixed 4:1. 0.1% at 1W. Damping factor: 50. Input sensitivity: phono: 2.2mV (overload 155mV), tape aux and tape mon, 180mV (overload 10V). Hum and noise: phono (10mV ref.), -65dB tape and aux (0.25V ref.), -75dB. Channel separation: phono: 50dB, tape and aux, 60dB. Output impedance: (each channel): 4 to 16 ohms. Tape output Channel separation: 45dB at mid-frequencies. FR: ± 1 dB from 20 to 15,000 Hz. HD: 0.5% at 1000 Hz with 100% modulation. 19kHz and 38kHz. Suppression: 55dB. AM Section: Tuning: 535 to 1620kHz. AM antenna: Adjustable rod. Connections for external ant. grd. THD: 2%. Hum and noise: -35dB. AC outlet sockets: one switched (350W max.), ant. impedance: 50 ohms. Input impedance: phono, 49k ohms (RIAA equalised). aux, tape and mon, 100k ohm. Tape output: 1 V with 0.2 V input. FM, 3.8V with 100% modulation. FM section: (monophonic): tuning range: 88 to 108 MHz. Antenna: balanced for external 300 ohm antenna, unbalanced 75 ohm. FR: ± 1 dB 20 to 15,000Hz. Sensitivity: 70dB. Image rejection: 90dB. Capture ratio: 1.5dB. AM suppression: 50dB. THD: 0.4%. Hum and noise: -60dB. AC Outlets. Mains: 120/240V AC 50/60 Hz-240 watts at full output. Dimensions: (Overall): $5\frac{1}{8} \times 16\frac{1}{8} \times 14\frac{1}{2}$ ins. Price: £252.00. Optional cabinet £16.64 (plus VAT).

AJ-1510

Digital tuner: stereophonic: Tuning range: 88.1 to 107.9MHz. Tuning: digitally synthesized.

Intermediate frequency: 10.7MHz. Antenna: 75 or 300 ohm. FR: Discriminator: 10-60,000Hz, ± 0.5 dB. Audio: 20-15,000 Hz, ± 1 dB. Sensitivity: Less than 1.8μ V. Selectivity (alternate channel): greater than 95dB. Capture ratio: less than 1.5dB. HD: Less than 0.3%. IM distortion: less than 0.1% Image rejection: greater than 90dB. IF rejection: greater than 95dB. Spurious rejection: greater than 90dB. Signal-to-noise ratio (100% mod): greater than 65dB. AM suppression: greater than 60dB. Channel frequency accuracy: Better than 0.005%. Stereophonic: channel separation: 1,000 Hz, 40dB; 80Hz, 25dB; 10kHz, 25dB; 15kHz, 20dB. THD: (100% mod): 0.35%. FR: (± 1 dB): 20 to 15,000Hz. 19kHz and 38kHz suppression: greater than 60dB. SCA suppression: greater than 60dB. Audio output: audio output level: (fixed): 1.2V rms nominal (with 100% mod.). Output impedance (fixed): Approx. 4,700 ohms. Power requirements: 120/240V AC, 50/60Hz, 50W. AC outlet socket: unswitched, 350W max. Dimensions: $6 \times 16\frac{1}{8} \times 14\frac{1}{8}$ ins. Weight 23 lbs (less cabinet). Price: £384.00 (plus VAT). Optional cabinet £18.80 (plus VAT).

AD-1013

Audio scope: Input impedance: 100k Ω . FR: 5Hz to 200kHz ± 3 dB. Audio oscillator output: range: 20Hz to 20kHz. Voltage level: 2mV to 3 volts (RMS) (variable). Output variations: 25dB 20Hz to 20kHz. Output impedance (front panel jack): Approx. 600 Ω . FR: 5Hz to 200kHz, ± 3 dB. 4-channel Input: Sensitivity: 1 volt P-P/cm. Triggered sweep generator: range: 10Hz to 100kHz. Mains: 120 or 240volts AC, 50/60Hz, 15 watts with no accessory load. AC Outlet (on rear panel): unswitched. Dimensions (overall): $5\frac{1}{8} \times 18\frac{1}{2} \times 13\frac{1}{2}$ ins. Price: £148.80 (plus VAT): optional cabinet £18.00 (plus VAT).

AR-2020

AM/FM receiver: FM section (monophonic): Tuning range: 88-108MHz. Intermediate Frequency (IF): 10.7MHz. FR: ± 1 dB, 20 to 15,000Hz. Sensitivity: 2μ V. Selectivity: 60dB. Image rejection: 50dB. IF rejection: 75dB. Capture ratio: 2dB. AM suppression: 50dB. HD: 0.5%. IM Distortion 0.5%. Hum and Noise: 60dB. Spurious rejection: 70dB. FM section: (stereophonic): Channel separation: 40dB typical. FR: ± 1 dB from 20 to 15,000Hz. THD: 75% at 1000Hz with 100% modulation. 19kHz and 38kHz suppression. 60dB. SCA suppression: 55dB typical. AM section: tuner range: 535 to 1620kHz. Intermediate Frequency (IF): 455kHz. Sensitivity: 100mV per metre. Selectivity: 40dB (alternate channel).

★ Indicates entry is illustrated

Image rejection: 75dB at 600kHz. 70dB at 1400kHz. IF rejection: 70dB. HD: 2%. Hum and noise: 35dB. Amplifier: Dynamic Power Output per channel: (music power rating) 25 watts (8Ω load); 30 watts (4Ω load); 14 watts (16Ω load). Continuous power output per channel: 15 watts (8Ω load); 20 watts (4Ω load); 10 watts (16Ω load). Power bandwidth for constant 0.5% THD: 5Hz to 30kHz. FR: (1 watt level): ±1dB 7Hz to 50kHz. ±3dB, 5Hz to 70kHz. 1HD: less than 0.5% from 20Hz to 20kHz at 15 watts output. Less than 0.25% at 1000Hz with 1 watt output. Intermodulation Distortion: less than 0.5% with 15 watts output, using 60 and 6000 Hz mixed 4:1. Less than 0.25% at 1 watt output. Damping factor: greater than 30. Input sensitivity: phono: 2.2 mV. Tape: 200 mV. Input overload: phono: greater than 5 volts with level control. Tape: greater than 2.5 volts. H. and N: phono (10 millivolt reference) +60dB. Tape (200 millivolt reference) -70dB volume control in minimum position -85dB referred to rated output. Channel separation: phono 40dB. Tape: 45dB. Load impedance: 4Ω, 8Ω, or 16Ω. Tape output impedance: approx. 50. Input impedance: phono 49K (RIAA equalized). Tape 100K. Tape monitor 100K. Tape output: 4 volt output with 2 volt input. AC outlet sockets: Two, one switched (350 watts max.) and one unswitched (350 watts max.). Power requirements: 120 or 240 volts 50/60Hz AC. Dimensions: 5 × 20 × 14ins. Price: £232.00 (plus VA1).

AD-110 ★

Cassette deck with Quadraphonic sound. FR: 30-12,000. W and F: less than 0.25% WRMS. Price: £114.00 (plus VA1). Microphone set extra £14.80 (plus VA1).

Modulus Unit Audio System ★

Comprising digital AM/FM tuner (AN 1016). Price: £440.00 (plus VA1); medium power Stereo Power Amplifier (AA 1505) Price: £100.00 (plus VAT); High power Stereo Power Amplifier (AA 1506) Price: £120.00 (plus VAT);

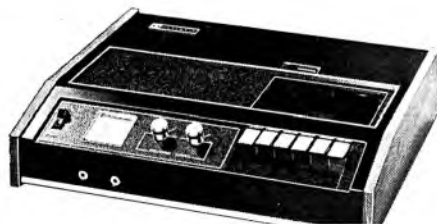

Heath Kit AD-110



Heath Kit Modulus System

FM Dolby (AD 1504) Price: £27.20 (plus VAT); CD-4 demodulator (AD1507) Price: £48.00 (plus VAT); SQ 4-channel decoder (AM1503) Price: £30.40 (plus VAT).

■ HELME AUDIO PRODUCTS LTD.

Summerbridge, Harrogate HG3 4DR, North Yorks.
Tel: Darley 279

Range of easy to build hi-fi loudspeaker kits for the home constructor.

Five high grade stereo speaker kits are offered, two of which require no soldering. All are complete with accessories and fully detailed instructions for assembly. As an additional aid, assembled cabinets are available to suit most of the kits.

KIT XLK-30

8 in bass/midrange with plastic coated cone and 4 in tweeter. HC: 30W DIN. FR: 45Hz-18kHz. Cross-over Frequency: 5.5kHz. Price: £18.68 per pair (plus VAT).

KIT XLK-35

8 in bass/midrange with plastic coated cone and 4 in tweeter. HC: 35W DIN. FR: 35Hz-18kHz. Cross-over frequency: 2.4kHz. Price: £23.90 per pair (plus VAT).

KIT XLK-40

8 in bass/midrange with plastic coated cone and 3 in aluminium cone tweeter. HC: 40W

DIN. FR: 35Hz-40kHz (± 4 dB). Cross-over frequency: 4kHz. Price: £34.60 per pair (plus VAT).

KIT HYPO-60

Two 8 in bass/midrange drivers and two 3 in aluminium cone tweeters. HC: 60W DIN. FR: 35Hz-40kHz. Cross-over frequency: 4kHz. Price: £67.50 per pair (plus VAT).

KIT HYPO-100

Four 8 in bass/midrange drivers and four 3 in aluminium cone tweeters. HC: 100W DIN. FR: 30Hz-40kHz. Cross-over frequency: 4kHz. Price: £132.75 per pair (plus VAT).

■ KEF ELECTRONICS LTD

Tovil, Maidstone, Kent ME15 6QP.
Tel: Maidstone 57258.

Kefkit I ★

B200, T27 and DN13 units supplied mounted on polyurethane foam baffle. Complete with ready-for-fitting fabric grille. Pre-formed acoustic damping foam blocks, insulating strip, terminal plates. For use with an amplifier of up to 25W per channel. Impedance: 8 ohms (nominal). FR: 50Hz-30kHz ± 3 dB. Sensitivity: 17W into nominal 8 ohms for 96dB/m. Price: £29.50.

Kefkit 3

B139, B110 and T27 units supplied mounted on 28 x 14 x 10½ in baffle. Complete with grille fabric, mounting bolts, BAF padding, speaker terminals and full mounting instructions. HC: 30W. FR: 30Hz-30kHz. Impedance: 8 ohms. Price: £53.50 (plus VAT).

■ MACEL ELECTRONICS LTD.

PO Box 64, Commerce Buildings,
14 High Street, Ipswich, Suffolk IP1 3LR.

This company is responsible for importing the European SEAS range of loudspeaker kits, the details of which are given below. All the kits come complete with wiring diagrams and detailed cabinet plans to DIN 45 500.

Type 91H

Two drive units: 6½in high compliance and a chemically treated 3½in. unit. 2 element crossover. Frequency response: 75-16000Hz ± 3 dB. Power handling: 10W rms. Sensitivity: 1 watt gives 92dB. RRP: £7.35 each kit (plus VAT).

Type 94H

3 drive units: 11 x 6½ in high compliance, 3½

in. and 2 in. chemically treated. 3 element crossover. Frequency response: 60-18000Hz ± 3 dB. Power handling: 25W rms. Sensitivity: 1 watt gives 90dB. RRP: £13.25 each (plus VAT).

Type 10-2

2 drive units: 6½ in neoprene and 1 in dome. 5 element crossover. Frequency response: 70-20000Hz ± 3 dB. Power handling: 30W rms. Sensitivity: 1 watt gives 88dB. RRP: £15.35 each (plus VAT).

Type 18

2 drive units: 8 in Neoprene and 1½ in dome. 3 element crossover. Frequency response: 60-18000Hz ± 3 dB. Power handling: 35W rms. Sensitivity: 1 watt gives 87dB. RRP: £16.30 each (plus VAT).

Type 30

2 drive units: 10 in Neoprene and ½ in dome. 3 element crossover. Frequency response: 55-18000Hz ± 3 dB. Power handling: 45W rms. Sensitivity: 1 watt gives 88dB. RRP: £16.95 each (plus VAT).

Type 35

2 drive units: 2 x 8 in Neoprene and 1½ in dome. 4 element crossover. Frequency response: 45-18000Hz ± 3 dB. Power handling: 70W rms. Sensitivity: 1 watt gives 90dB. RRP: £25.30 each (plus VAT).



KEF KEFKIT 1

★ Indicates entry is illustrated

Type 60

3 drive units: 10 × 2 in Neoprene, 6 × 4 in and 1½ in dome. 10 element crossover. Frequency response: 40-18000Hz ± 3dB. Power handling: 80W rms. Sensitivity: 1 watt gives 91dB. RRP: £34.95 each (plus VAT).

Although the cabinets are not supplied, a unit consisting of baffle, frame and cloth can be supplied to any of these kits.

■ PEERLESS

Distributor: Ross Electronics.
32, Rathbone Place, London W1P 1AD.
Tel: 01-580 7112.

Peerless Loudspeaker Kits comprise expertly chosen and accurately matched drive units which are arranged to operate over their optimum frequency ranges through specially designed dividing networks. All Peerless kits contain: speaker fixing clamps, sealing strip, solderless connecting cables, and comprehensive instructions on system connection and cabinet construction. All kits have an input impedance of 8 ohms.

Kit 20-2 ★

8in. woofer with rubber roll surround. 2¼ in sq. cone tweeter. HC: 50W. FR: 40-20,000Hz. Crossover: 2500 Hz. Rec. cabinet vol: 20 litres. Price (each kit): £18.88 (plus VAT).

Kit 20-3

8in. woofer with rubber roll surround. 5in. enclosed midrange. 2¼in. sq. cone tweeter. HC: 50W. FR: 40-20,000Hz. Crossover: 1500 and 6000Hz. Rec. cabinet vol: 20 litres. Price (each kit): £28.50 (plus VAT).

Kit 30-2

10in. woofer with rubber roll surround. 1in. dome tweeter. HC: 50W. FR: 35-20,000Hz. Crossover: 3000Hz. Rec. cabinet vol: 30 litres. Price: (each kit): £26.63 (plus VAT).

Kit 50-4 ★

10in. woofer with rubber roll surround. 7 × 5in enclosed midrange. 2 × 2½in. cone tweeters. HC: 50 W. FR: 30-20,000 Hz. Crossover: 500 and 3500 Hz. Rec. cabinet vol: 50 litres. Price (each kit): £44.00 (plus VAT)

Kit 1060 ★

8¼in. woofer with foam roll surround. 1in. dome tweeter. HC: 50 W. FR: 30-22,000 Hz. Crossover: 1600 Hz. Rec. cabinet vol: 20 litres. Price (each kit): £30.12 (plus VAT)

Kit 1070 ★

2 × 7in. woofer with foam roll surround. 4in.



Peerless Kit 20-2



Peerless Kit 50-4

enclosed midrange. 1in. dome tweeter. HC: 60W. FR: 25-22,000 Hz. Crossover: 500 and 4000 Hz. Rec. Cabinet vol: 30 litres. Price (each kit): £51.80 (plus VAT)

Kit 1120 ★

2 × 10in. woofer with foam roll surround. 4in. enclosed midrange. 1in. dome tweeter. HC: 100W. FR: 20-22,000 Hz. Crossover: 500 and 4000 Hz. Rec. cabinet vol: 60 litres. Price (each kit): £58.46 (plus VAT)

■ SINCLAIR

Sinclair Radionics Ltd, London Road,
St Ives, Hunts PE17 4HJ.
Tel: St Ives 64646

System 4000

Stereo integrated amplifier. Inputs: mag PU



Peerless Kit 1050

3mV 47K, ceramic PU 30mV 220K (Switchable), radio 100mV 100K, aux 100mV 100K, tape replay 100mV to 47K. Output: 100mV 10K. Output: 17W RMS into 8 ohms, both channels driven. Output load requirement: any impedance between 3 and 16 Ω protected against continuous short circuit. Distortion: 0.05%. THD: -3dB at 1kHz. FR: 20Hz-25kHz \pm 3dB. Controls: all inputs selected by pushbuttons. Headphone outlet switched for automatic loudspeaker muting. S/N: 65dB, gain at max. Mains: 110/120 or 220/240V. Size: 12 \times 6 \times 2in. Finish: matt black. Price: on application.

System 4000

FM stereo tuner. Range: 88-108MHz. Sensitivity: 5 μ V for 30dB signal to noise. Aerial input 75 or 300 ohm utilizes varicap tuning and quadrature detection, together with a ceramic filter. Contains integral stereo decoder. Price: on application.

Q16

FR: 60Hz-16kHz with a loading of up to 14W RMS and input impedance of 8 ohms. Size: 246mm square, 120mm deep. Solid teak surround and a black cellular foam front. Price: on application.

Project 80

Preamplifier and control unit Size: 260 \times 50 \times 20mm (10 $\frac{1}{4}$ \times 2 \times $\frac{3}{16}$ in). Finish Black, with white markings Inputs Mag PU 3mV R1AA corrected; ceramic PU 300mV; radio 100mV; tape 30mV. Signal to noise ratio: 60dB. Frequency range 20Hz to 15KHz \pm 1dB; 10Hz to 25KHz \pm 3dB. Power requirements 20 to 35 volts. Outputs: 100mV + AB monitoring for tape. Controls: press button for tape, radio and PU selection; volume, bass + 12dB to -14dB at 100Hz; treble + 11dB to -12dB at 10kHz. Price: on application.

Project 80 Quadraphonic decoder

Size: 260 \times 50 \times 20mm. Input sensitivity 40mV for rated output. Rated output 100mV. Frequency response: 15Hz to 25kHz \pm 3dB. Overload factors +20dB at 1kHz on all inputs. Distortion: 0.1%. Signal to noise ratio: 58dB. Bass control \pm 10dB at 100Hz; treble control \pm 10dB at 10kHz. Output load impedance not less than 25K. Power requirements: 22 to 35 volts (15mA at 30 volts). Phase shift network 90 $^\circ$ \pm 10% 100Hz to 10kHz. Provision is included for 4-channel discrete input. The decoder has 10-40 blend included, which aids front to back separation. Price: on application.



Peerless Kit 1070



Peerless Kit 1120

★ Indicates entry is illustrated

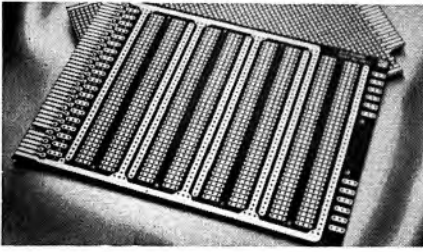

Vero printed boards

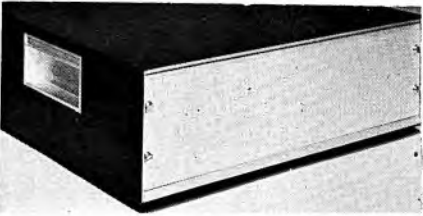

Vero Type D Case

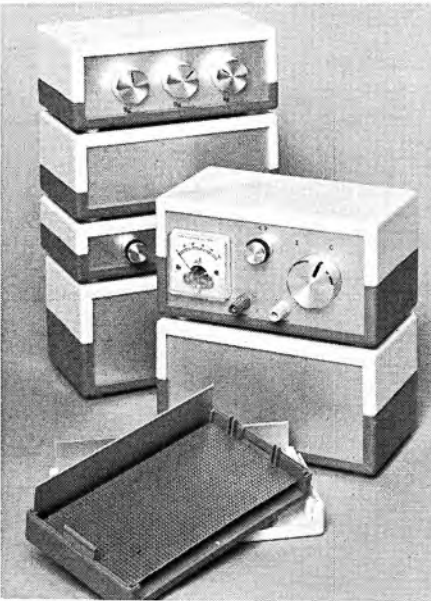

Vero

PZ20

This power supply is specifically for the IC20 stereo amplifier, and consists of a transformer, bridge rectifier, and reservoir capacitor. The bridge rectifier and capacitor should be mounted on the IC20 pcb in the positions provided, and the transformer mounted separately, wherever convenient.
Price: on application.

FM tuner

Tuning range 88 to 108 MHz. Detector IC balanced coincidence, for good AM rejection. AFC Switchable, with thermistor control to prevent drift. One 26 transistor IC. Dual varicap tuning distortion 0.3% at 1kHz for 75 kHz deviation. Output 100mV for 30% modulation ceramic filter in IF section. Aerial impedance 75Ω or 240-300Ω sensitivity 5 microvolts for 30dB. S/N power requirements 23-35 volts. Size: 85 × 50 × 20mm. Price: on application.

Project 80 Decoder

One 19 transistor IC power requirements 23-35 volts. Size: 47 × 50 × 20mm. Price: on application.

PZ5

A simple unstabilized supply suitable for a pair of Z40's in a simple system. Output voltage 30 volts. Price: on application.

■ VERO

Vero Electronics Ltd, Industrial Estate, Chandler's Ford, Eastleigh, Hants SO5 3ZR. Tel: Chandler's Ford 2952.

Audio Equipment Cases ★

Wide range of equipment cases suitable for hi-fi units, tuners, power supplies and test gear. Available in various panel heights and with or without anodised aluminium front handles. Made in light gauge steel finished in Raf blue/grey vinyl paint. Integral aluminium trim. Neat slim-line appearance. Ventilation slots incorporated. Full list of sizes, accessories and prices, available on request. Ask for Vero 'D' series cases.

Printed circuit boards ★

Vero circuit boards comprise resin-bonded paper laminate clad on one side with 1oz copper foil of nominal thickness 1.5mm. Base material cut to width and punched with a matrix of holes. Copper foil is in parallel strips along the lines of holes. Enables small electronic assemblies to be built easily and quickly. Vero boards are produced in various sizes, also double-sided, in strips, with plug-in terminations, edge-connectors, breadboards and in plain non-coppered versions. Accessories include connector contacts, D-I-L sockets, terminal pins, pin insertion tool, spot face cutter and numerous design-aid sheets. Catalogue on request.

New cases ★

Six sizes injection moulded in ABS and provided with aluminium front and rear panels, ideally suited to housing small amplifiers and tuners. Prices on request.

Headphones and Accessories

★ Indicates entry is illustrated

Abbreviations used in this section are given on page 27.

■ ADASTRA

Adastra Electronics Ltd, Unit N22,
Cricklewood Trading Estate,
Claremont Road, London NW2 1TU.
Tel: 01-452 6288.

H7

Mono headphones. Impedance: 16 ohms. Maximum input: 250mW. FR: 20Hz-10kHz. Weight: 15oz. 5ft. lead. Fitted with dynamic boom mic. Two-tone grey. Adjustable headband. Washable ear cushions. Price: on application.

H10

Stereo headphones. Impedance: 8-16 ohms. Maximum input: 500mW. FR: 20Hz-18kHz. Weight: 10oz. 6ft. lead, fitted plug. Adjustable earpieces, foam cushioned. Price: on application.

H13

Stereo headphones. Impedance: 8-16 ohms. Maximum input: 650mW. FR: 25Hz-18kHz. Weight: 13oz. 9ft coiled lead. Moulded stereo jack plug. Individual volume controls. Adjustable headband. Washable ear cushions. Mono/stereo slide switch. Price: on application.

H11

Stereo headphones. Impedance: 4-16 ohms. Maximum input: 200mW. FR: 20Hz-12kHz. Sensitivity: 115dB. Weight: 8oz. 6ft lead fitted. Stereo plug. Adjustable headpieces, foam cushioned ear pads. Finish: two-tone grey. Price: on application.

H15

Stereo headphones. Impedance: 8 ohms. Maximum input: 650mW. FR: 50Hz-19kHz.

Weight: 19oz. 10ft coiled lead. White moulded earpieces with black and silver fittings. Control box in lead with volume controls and mono/stereo switch. Adjustable leather padded headband. Washable ear cushions. Price: on application.

H17

Stereo headphones. Impedance: 4-16 ohms. Maximum input: 500mW. FR: 15Hz-25kHz. Weight: 21oz. 15ft coiled cord. Stereo plug. Satin white earpieces with black trim. Open back housings with 3/2in units. Slide volume controls. Adjustable headband. Washable ear cushions. Price: on application.

H19/G3500

Stereo headphones. Impedance: 4-16 ohms. Maximum input: 900mW. FR: 15Hz-25kHz. Weight: 24oz. 8ft coiled lead. Moulded stereo jack plug. Black moulding with chrome trim. 3/2in and 1/2in units in each earpiece. Wire-wound Volume Controls. Adjustable headband and washable ear cushions. Price: on application.

H20/G8030

Stereo electrostatic headphones. Impedance: 4-16 ohms. Normal listening input: 8W. Maximum input: 10W. FR: 20Hz-19kHz. Weight (headphones only) 19oz; (headphones and energiser unit) 5/2lb. 8ft coiled lead. Black moulding with black leather headband. Adjustable padded headband. Price: on application.

H40 "Sprite"

Featherweight stereo headphones. Impedance: 4 ohms. Maximum input: 200mW. FR: 30Hz-13kHz. Weight: 5oz. One-piece moulded headband in brilliant red. Black padded ear cushions. Fully adjustable. Mylar reproducer units. Price: on application.

H36/G3600

Quadraphonic headphones with two full-range 2in units in each earpiece. Impedance: 8-16 ohms. Maximum input: 200mW. FR: 20Hz-20kHz. Weight: 2lb 10oz. Stereo/quadraphonic switching. 15ft coiled lead. Padded ear cushions and headband. Price: on application.

H63/61305

Headphone remote control unit. Provision for connecting headphone leads and includes slider controls for volume/balance adjustment. Switching for mono/stereo. 10ft coiled lead. Finish: black moulded case with silver coloured fascia. Price: on application.

★ Indicates entry is illustrated

H61

3-way stereo junction box with loudspeaker and headphone connecting facility, with switching for function of either or both, amplifier protective circuitry, coded leads. Rating: 20W. Moulded case for free standing or wall mounting location. Size: 72 × 28 × 78mm. Price: on application.

H62/G1301

Free standing remote control listening station with stereo gain controls, dual stereo headphone input sockets, and loudspeaker muting switch. Operates from 4, 8 and 16 ohms. Price: on application.

H65

Compact stereo adaptor providing instant loudspeaker/headphone switching. Jack plug entry for 2 stereophones, DIN speaker sockets, loudspeaker connecting leads fitted with DIN plugs. Three position function switch. Rating: 3W. Moulded case for free standing or wall mounting location. Price: on application.

■ AKAI

Rank Audio Visual Ltd, PO Box 70,
Great West Road, Brentwood TW8 9JR.
Tel: 01-568 9222.

ASE11 ★

Stereo headphones with acoustic control. Impedance: 8 ohms. Maximum input: 500mW. FR: 25Hz-15kHz. Weight: 18oz approx. Length of cord: 6ft. Price: £12.75 (plus VAT).

ASE20

Stereo headphones with acoustic loudness control. Impedance: 8 ohms. Maximum input: 500mW. FR: 25Hz-18kHz. Weight: 17oz approx. Length of cord 6ft. Price: £15.75 (plus VAT).

ASE22 ★

Stereo headphones. Built-in mechanical two-way system. Mylar film diaphragms. Impedance: 8 ohms. FR: 20Hz-10kHz. Normal input: 1mW. Maximum input: 500mW. Weight: 18oz approx. Price: £17.75.

■ AKG

AKG Equipment, 182-184 Campden Hill
Road, Kensington, London W8 7AS.
Tel: 01-229 3695.

K140

Dynamic stereo headphones. FR: 20Hz-20kHz. 50mW per channel for 112dB SPL. Distortion: less than 1% max. loading. Impedance:



Akai ASE11



Akai ASE22

600 ohms \pm 20% per channel. Fitted with 3m coiled cable and 6.3mm dia. stereo jack plug. Adjustable headband. Price: £18.00 (plus VAT).

150

Lightweight stereo headphones with easy interchangeable ear cushions type Z64. Fitted with 2m cable without connector. Impedance: 600 ohms. Price: £16.00 (plus VAT).

K154

Lightweight headphone/microphone combination for educational use. Noise-cancelling microphone (230 ohms) and 600 ohms headphone system connected in parallel to give 300 ohms. Supplied with 1.4 metres (4.6ft) cable without connector. Price: £17.00 (including VAT).

K160

Dynamic stereo headphones. Double headband, detachable ear cushions. High quality transducer system offers distortion free reproduction even at very high volume. FR: 16Hz-20kHz. 1mW per channel for 112dB SPL. Distortion: less than 1% max. loading. Impedance: 600 ohms per channel \pm 20%. Fitted with 2m coiled cable and 6.3mm dia. stereo jack plug. Weight: 330gm. Price: £24.00 (plus VAT).

K35/2

Professional quality headset. Noise cancelling close-talk microphone (240 ohms) and wide-range headphone systems (600 ohms per channel). Supplied with 1.5 metre (4.9ft) 4 pole screened cable fitted with 3 pin DIN plug for microphone and 5 pin DIN plug for headphones. Weight: 470gm (16.6oz). Price: £43.00 (including VAT).

K158

Headphone/microphone boom combination. Noise cancelling microphone (230 ohms) and headphone system (600 ohms) connected in parallel to give 300 ohms. Cable length 2 metres (6.6ft). Weight: 320gm (11.3oz). Price: £19.00.(including VAT).

K240

Six additional diaphragms to stabilise frequency response. Price: £29.00 (plus VAT).

K2000/3

Single ear piece for use with radio and cassettes. DIN. Price: £4.50 (plus VAT).

KX2

Dynamic organ headphone for use with electronic organs. Price: £26.00 (plus VAT).

K10

Lightweight monaural phones. Price: £12.00 (plus VAT).

■ **AUDIO TECHNICA**

Shriro (UK) Ltd, Shriro House, The Ridgeway, Iver, Bucks SL0 9JL. Tel: Iver 652222.

AT701 ★

Dynamic headphones. Impedance: 4-16 ohms. FR: 30Hz-20kHz. Maximum input power: 200mW at 200Hz. Weight: 250gm. Diaphragm: mylar. Copper coated aluminium voice coil. Price: on application.

AT702

Dynamic headphones. FR: 20Hz-20kHz. Maximum input power: 200mW at 200Hz. Weight: 250gm. Diaphragm: mylar. Copper coated aluminium voice coil. Price: on application.

AT703

Dynamic headphones. Impedance: 4-16 ohms. FR: 20Hz-20kHz. Maximum input power: 200mW at 200Hz. Weight: 250gm. Diaphragm: mylar. Copper coated aluminium voice coil. Price: on application.



Audio Technica AT701



Audio Technica AT 706

AT706 ★

Electrostatic headphones. Impedance: 4-16 ohms. FR: 10Hz-25kHz. Maximum input power: 10W at 200Hz. Weight: 220gm. Diaphragm: push/pull electret. Adaptor with two headphone outlets, speaker switch and attenuator. Price: on application.

AT707

Electret condenser headphones. Impedance: 4-16 ohms. FR: 20Hz-25kHz. Maximum input power: 800mW at 200Hz. Weight: 310gm. Price: on application.

■ **BEYER**

Beyer Dynamic (GB) Ltd, 1 Clair Road, Haywards Heath, Sussex. Tel: Haywards Heath 51003.

DT96A ★

Lightweight moving coil stereo headphones. FR: 30Hz-17kHz. Impedance: 50 ohms or 400 ohms per earpiece. Max power: 100mW. Various cable lengths and terminations available. Also available with coiled cable. Price: £15.80 (plus VAT).

★ Indicates entry is illustrated

DT100 ★

Moving coil stereo headphones. Sensitivity: 110dB. FR: 30Hz-20kHz. Various impedances and cable terminations available. Price: £18.86 (plus VAT).

DT100RR

Similar to the DT100 but fitted with individual volume controls. Price: £24.29 (plus VAT).

DT48

Moving coil stereo headphones. FR: 16Hz-20kHz. Impedance: 8 ohms, 25 ohms, 200 ohms per earpiece. Rated input: (8 ohms) 80mV, (25 ohms) 150mV, (200 ohms) 450mV. Cable: 6½ft open end. Price: £57.07 (plus VAT).

DT480

Moving coil stereo headphones. FR: 20Hz-20kHz. Various impedances available. Rated input: 350mW, max 1W. Cable: 10ft. Various terminations offered. Price: £37.74 (plus VAT).

DT900 ★

Moving coil stereo headphones. FR: 30Hz-18kHz. Impedance: 600 ohms per earpiece. Maximum input: 200mW. Lightweight, gaily coloured. Price: £13.45 (plus VAT).

DT900RR

Similar to the DT900 but fitted with individual volume controls. Price: on application.

DT49

Telephone type handset with coloured replaceable ear pads. FR: 30-13,000Hz. Impedance: 15 ohms. Weight: 220gm. Finish in black, red, grey. Price: £16.03 (plus VAT).

DT98A/B and DT99A/B

Specification as DT96 for headphone. FR: 40-15,000Hz. Impedance: 200 ohms. Price: £26.80 (plus VAT).

DT109

Dynamic headphones-microphones combination. FR: 30-20,000 headphone and 40-12,000 microphone. Hypercardioid mic available as DT109V fitted with induction loop receiver. On-off switch and separate volume controls for phone and mic. Price: £34.44; DT109V £57.65 (plus VAT).

DT1202

Stereo dynamic transducer. FR: 20-2,000Hz. Impedance: 400 ohms. Weight: 360gm. Straight or coiled leads available with choice of terminations (extra). Price: £29.22 (plus VAT).

DT204

Quad/stereo moving coil. FR: 20-20,000Hz. Impedance: quad 200 ohms, stereo 100 ohms. Weight: 435gm. Quad/stereo switch and two volume controls for front to rear balance. Price: £44.51 (plus VAT).

DT302

Stereo moving coil. FR: 20-20,000Hz. Sen-

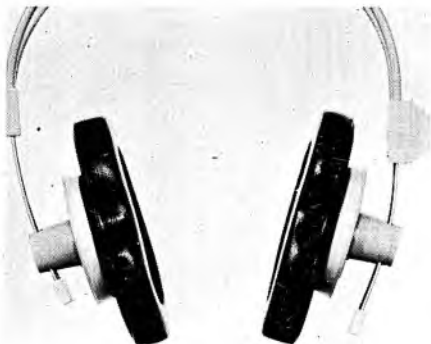

Beyer DT96



Beyer DT100

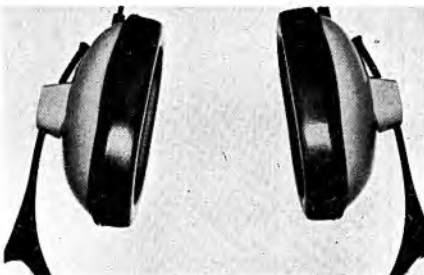

Beyer DT900

sitivity: 110dB. Impedance: 600 ohms. Weight: 66gm. Price: £9.06 (plus VAT).

DT440

Open high velocity dynamic transducer. FR: 20-20,000Hz. Impedance: 600 ohms. Weight: 260g. Suitable for connection to source impedances from 4-1,000 ohms. Complete with lead. Price: £29.00 (plus VAT).

Accessories

Monitoring units/voltage divider/passive simulator unit when connected stereo system gives four channel effect/headphone output transformer for DT48. Prices: on application.

■ **BINATONE**

J. Parkar & Co (London) Ltd, Parkar House, Beresford Avenue, Wembley HA0 1YX. Tel: 01-903 5211.

Model 01/3943 ★

Stereo headphones with padded headband and ear pads. Coil lead. Jack plug. Sliding volume control. Price: on application.

■ **BUSH**

Rank Radio International Ltd, PO Box 596, Power Road, Chiswick, London W4 5PW. Tel: 01-994 6491.

YX9003

Stereo headphones. FR: 40Hz-15kHz. Nominal impedance: 6-22 ohms. Cushioned earpieces and headband finished in black. Individual volume controls and coiled connecting lead. Price: on application.

YX 9002

Stereo headphones. FR: 20Hz-15kHz. Nominal impedance: 4-22 ohms. Individual slider volume controls, mono/stereo switch, removable ear-muffs, coiled removable connecting lead. Price: on application.

■ **DYNATRON RADIO LTD**

Ditton Walk, Cambridge CB5 8QD. Tel: Teversham 2781.

SP3

Stereo moving coil headphones with separate bass and treble units. FR: 16Hz-22kHz. Sensitivity: 100dB at 600Hz at 1mV input. Max input: 0.5W. Impedance: 8-16 ohms each channel. Price: £19.60 (plus VAT).

SP4

Stereo moving coil headphones with individual



Binatone 01/3943



Eagle H2008/H2009

volume controls to each unit. Padded earpieces. Impedance: 8 ohms. FR: 20Hz to 20,000Hz. Price: £15.60 (plus VAT).

■ **EAGLE**

Eagle International, Precision Centre, Heather Park Drive, Wembley HA0 1SU. Tel: 01-902 8832.

H 2009 ★

Moving coil reflex stereo headphones. FR: 30Hz-20kHz ±5dB. Impedance: 8-16 ohms. Weight: 0.35kg. Finish: black/brushed metal. Adjustable padded headband. Reflex enclosure. Lift/flat/cut bass switch (acoustic) on both earpieces. Controls: ±5dB at 100Hz acoustic switches on both earpieces. Price: £15.60 (excluding VAT).

H 2008 ★

Moving coil reflex stereo headphones. FR: 30Hz-20kHz ±5dB. Impedance: 8-16 ohms. Weight: 0.35kg. Finish: black/brushed metal. Padded adjustable headband and earpieces. Price: £12.90 (excluding VAT).

★ Indicates entry is illustrated

SE 70

Moving coil reflex stereo headphones. FR: 25Hz-20kHz. Impedance: 8-16 ohms. Finish: black/chromium. Nylon-mesh covered earpieces. Padded. Adjustable. Price: £10.90 (excluding VAT).

SE 75

Moving coil reflex stereo headphones. FR: 20Hz-20kHz. Impedance: 8-16 ohms. Finish: black/chromium. Nylon-mesh covered earpieces with large surface area for comfort. Padded. Adjustable. Price: £11.60 (excluding VAT).

SE 30

Moving coil stereo headphones. FR: 25Hz-16kHz. Impedance: 8-16 ohms. Finish: black/chromium. Fully padded and adjustable. Separate left/right level controls. Mono/stereo switch. Price: £8.60 (excluding VAT).

SE 60 ★

Moving coil stereo headphones. FR: 25Hz-18kHz. Impedance: 8-16 ohms. Finish: black/grey. Porous headband for long periods of use. Padded earpieces. Adjustable stirrups. Price: £11.40 (excluding VAT).

FF 6

Moving coil stereo headphones. FR: 20Hz-20kHz. Impedance: 8-16 ohms. Finish: black/white with chrome stirrups. Fully padded and adjustable with control box. Separate left and right levels, mono/stereo switch. Control box in lead. Price: £14.00 (excluding VAT).

G 3000

Moving coil stereo headphones. FR: 25Hz-18kHz. Impedance: 8-16 ohms. Finish: black/white with chromium stirrups. Fully padded and adjustable with control box. Lead plugs into earpiece. Separate left and right levels, mono/stereo switch. Control box in lead. Price: £12.20 (excluding VAT).

G 6000

Moving coil stereo headphones. FR: 20Hz-20kHz. Impedance: 8-16 ohms. Finish: black/white with chromium stirrups. Fully padded and adjustable. Volume control on each earpiece (slider type). Mono/stereo switch on left earpiece. Price: £9.80 (excluding VAT).

FF 29 ★

Stereo/quadrasonic headphones. Moving coil (4 transducers). Impedance: 8-16 ohms per channel. Finish: black/white with chromium stirrups. Contoured earpads and padded head-



Eagle SE60



Eagle FF29

band, fully adjustable. Connection is via two coded stereo jack plugs. Compatible with all quadrasonic systems. Stereo/4-channel switch on left earpiece. Price: £18.00 (excluding VAT).

■ ECHO

Sole Distributors: Adastra Electronics Ltd, Unit N22, Cricklewood Trading Estate, Claremont Road, London NW2 1TU. Tel: 01-452 6288.

H6/HS 606M

Dual impedance mono headphones. Specially designed for monitoring, electronic musical in-

struments, language laboratories, etc. Instant switching from 8-16 ohms to 4K. Adjustable earpieces. Soft padded ear cushions. FR: 25Hz-17kHz. Power handling capacity: 0.5W. Supplied with 10ft coiled cord lead fitted with jack plug. Price: on application.

H71/JB400

Quadraphonic remote control unit. Hand size control unit with 4-slide controls for adjustment of individual channel gain on quadraphonic headphones. 6ft lead fitted with two standard stereo jack plugs. Price: on application.

H70/JB40

Quadraphonic remote control unit. Free standing moulded case in black and silver with individual slider channel controls and twin mode headphone/speaker switching headphone sockets. Rear tag terminals. Price: on application.

■ ELECTROPHONIC

J. Parkar & Co (London) Ltd,
Parkar House, Beresford Avenue,
Wembley HA0 1YX. Tel: 01-902 8991.

01/3978

Volume control on each channel. Coiled cable and jack. Price: on application.

01/3994

Complete with coiled cable and jack. Price: on application.

01/3986

Separate volume and tone controls on each channel. Slider controls. Complete with coiled cable and jack. Price: on application.

■ GRUNDIG

Grundig International Ltd, Newlands Park,
London SE26 5NQ. Tel: 01-659 2468.

221 6DHS

Moving coil stereo headphones. FR: 20Hz-20kHz. Impedance: 220-426Ω. Distortion Factor: 0.5% at 120 phn. Fitted with stereo plug (DIN 45 327). Weight: 550gm. Finish: black. Price: £50.44 (including VAT).

215/ADR

Moving coil stereo headphones. FR: 20Hz-20kHz. Impedance: 400Ω. Distortion Factor: 1% at 100 phn. Fitted with stereo plug (DIN 45 327) and supplied with 279 plug adaptor (5-pin DIN to 2-pin DIN). Weight: 500gm. Finish: white casing, black ear pads. Price: £25.22 (including VAT).

212/ADR

Moving coil stereo headphones. FR: 50Hz-20kHz. Impedance: 400Ω. Supplied with stereo plug (DIN 45 327) and Grundig adaptor 279 (5-pin to 2-pin DIN). Finish: satin metallic casing, black ear pads. Price: £16.50 (including VAT).

■ HACKER RADIO LTD

Norrey's Drive, Cox Green, Maidenhead,
Berks SL6 4BP. Tel: Maidenhead 22261.

Stereo Headphones HPI

Light and comfortable to wear. Supplied complete with coiled lead and jack plug. Impedance: 8-16 ohms. Price: £11.00 (plus VAT).

■ HITACHI

Hitachi Sales (UK) Ltd, Hitachi House,
Station Road, Hayes.
Tel: 01-848 8787.

HD 404

4-channel moving coil headphones with built-in switch for 2-channel listening. FR: 20Hz-20kHz. Input power: 1mW. Maximum rated power input: 0.1W. Impedance: 8 ohms. Distortion: less than 1%. Cord length: 2m. Weight: (with cord) 610gm. Price: £27.92 (including VAT).

HD 60

Moving coil stereo headphones. FR: 20Hz-20kHz. Input power: 1mW. Maximum rated power input: 0.5W. Impedance: 8 ohms. Distortion: less than 1%. Cord length: 1.5m. Weight: (with cord) 420gm. Price: £11.92 (including VAT).

HD 50

Moving coil stereo headphones. FR: 20Hz-20kHz. Input power: 1mW. Maximum rated power input: 0.3W. Impedance: 8 ohms. Distortion: less than 1%. Cord length: 1.5m. Weight: (with cord) 380gm. Price: £9.20 (including VAT).

■ HOWLAND-WEST

Howland-West Ltd, 3-5 Eden Grove,
London N7 8EQ.
Tel: 01-609 0293/6.

CIS.200

Stereo headphones. Impedance: 8 ohms. Maximum input: 200mW. FR: 20Hz-15kHz. Weight: 12oz. Fitted stereo jack plug. Finish: grey with black pads. Price: £9.90 (plus VAT).

★ Indicates entry is illustrated



Howland West CIS 800



Howland West Headphone Doubler

CIS.250

Stereo headphones. Impedance: 8 ohms. Maximum input: 500mW. FR: 20Hz-20kHz. Weight: 14oz. Special stretch cord. Standard jack. Finish: black. Price: £10.20(plus VAT).

CIS.300

Stereo headphones. Supplied complete with standard stretch cable and alternative remote control cable featuring left and right-channel volume controls and mono/stereo switch. FR: 18Hz-21kHz. Impedance: 8 ohms. Price: £15.50 (plus VAT).

CIS.800 ★

Stereo headphones. Impedance: 8 ohms. Maximum input: 400mW. FR: 20Hz-17kHz. Weight: 14oz. Fitted stereo jack plug. Finish: available in red, yellow or white, with black earpads. Price: £9.60.

CIS.800V

Similar to the CIS.800 but fitted with independent volume control on each earpiece. Price: £10.60 (plus VAT).

Headphone Doubler ★

Splits headphone outlet and permits two pairs of stereo phones to be used. Mono/stereo switch. Independent volume controls for left and right channels. Stretch cord connection



Howland West CIS 1100 Waferlite

with standard jack plug fitted. Neat moulded box with control panel on top and outlet sockets for headphones. Price: £3.60 (plus VAT).

CIS.4000 Quadraphonic

Virtually two headphones built into one. Each earpiece contains two speakers, one angled towards the ear from a forward position and the other angled towards the ear from a rear position, simulating the placing of four loudspeakers. The double stretch cord is terminated in two jack plugs. The left-hand earpiece is fitted with a stereo/four-channel switch. Finish: white and black padding and headband. Price: £18.50 (plus VAT).

CIS.600

Impedance: 8 ohms. FR: 20Hz-20kHz. Max. input 0.4W. Weight: 15oz. Incorporates three controls, volume for left and right and a stereo/mono switch on the left-hand earpiece. Finish: black headband and earpieces with white border. Price: £12.50 (plus VAT).

CIS.1100 Waferlite ★

Lightweight stereo headphones. Max. input: 0.1W. Impedance: 4-150 ohms. FR: 18Hz-22kHz. Rare earth magnet transducer with super thin 25 micron diaphragm. Headphone weight (less cord) 4.6oz. Price: £19.50 (plus VAT).

CIS.900

Impedance: 8 ohms. FR: 20Hz-22kHz. Max. input: 0.3W. Weight: 17½oz. Coiled lead and jack. Colouring in black and white. Price: £11.60 (plus VAT).

Headphone Control Mk III

The unit's function is to enable two pairs of stereo headphones to be used simultaneously with each listener being able to obtain his own preferred listening level, by use of the volume control on the front panel. The loudspeakers which are also connected via the unit can be switched on or off. Price: £7.10 (plus VAT).

CIS.7000 ★

Stereo moving coil headphones. FR: 20-20,000. Impedance: 8 ohms. Power handling: 0.5W. Weight: 7½oz. Finish in black/white. Price: £17.20 (plus VAT).

■ **JECKLIN**

Belcaire Trading, 59 Cheriton High Street, Folkestone, Kent CT19 4EZ. Tel: Folkestone 76834.

Jecklin Float ★

Stereo headphones. Construction: electrostatic. FR: linear throughout the audible field. Sensitivity: 103dBA for 10W RMS input. Impedance: 80W at 8 ohms. Controls: the power supply/switch box has two headphone sockets, headphone to loudspeaker switch. Weight: 650gm (power box 1000gm). Finish: metallised acrylic glass with plastic foam cushioning. Price: £97.90 (excluding VAT).

■ **JVC**

JVC (UK) Ltd, Eldonwell Trading Estate, Staples Corner, 6-8 Priestley Way, London NW2. Tel: 01-450 2621.

5944

Four channel/two channel moving coil headphones. FR: 20Hz-20kHz. Impedance: 8 ohms at each individual channel. Power handling: nominal input 1mW, maximum output 100mW. Weight: 1.3lb. Finish: grey plastic with padded headrest. Price: £26.00 (excluding VAT).

HP-1000

Stereo moving coil headphones. FR: 20Hz-20kHz. Impedance: 1000 ohms. Weight: 330gm. Finish: brown plastic and chrome. High velocity. Price: £26.50 (excluding VAT).

HP-150

Stereo moving coil headphones. FR: 20Hz-

20kHz. Impedance: 150 ohms. Weight: 310gm. Finish: grey plastic and chrome. High velocity. Price: £19.00 (excluding VAT).

HP-20

Stereo moving coil headphones. FR: 20Hz-20kHz. Impedance: 8 ohms. Weight: 440gm. Finish: brown plastic and chrome. Independent volume controls. Price: £17.00 (excluding VAT).

■ **KOSS**

Tape Music Distributors Ltd, 114 Ashley Road, St Albans, Herts AL1 5JR. Tel: St Albans 64337.



Howland West CIS 7000

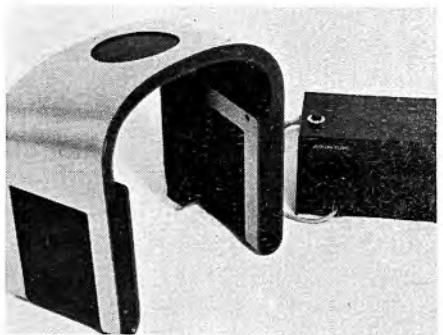

Jecklin Float

★ Indicates entry is illustrated

K6

Stereo headphones. Suitable for outputs of 4-600 ohms. Normal listening input: 95dB SPL @ 18mV. Maximum input: 3.7V. FR: 10Hz-16kHz. HD: unmeasurable at 95dB SPL. Weight: 450gm. Special coiled cord, 3ft coiled, 10ft extended. Standard stereo jack plug. Bronze finish. Washable ear cushions. Adjustable headband. Price: £13.95 (plus VAT).

K6LC

Stereo headphones. Suitable for outputs of 4-600 ohms. Normal listening input: 95dB SPL @ 73mV. Maximum input: 1.25V. FR: 10Hz-16kHz. HD: unmeasurable at 95 dB SPL. Weight: 480gm. Special coiled cord: 3ft coiled, 10ft extended. Standard stereo jack plug. Bronze finish. Washable ear cushions. Individual volume adjustment for each ear. Adjustable headband. Price: £15.95 (plus VAT).

K711 and KRD711

Stereo headphones. Suitable for outputs of 4-600 ohms. Normal listening input: 95dB SPL @ 1.4V. Maximum input: 29V. FR: 10Hz-17kHz. HD: <0.5% at 110dB SPL. Weight: 340gm. Special coiled cord: 3ft coiled, 10ft extended. Standard stereo jack plug. Finish: (K711) black moulding; (KRD711) red moulding. Adjustable headband. Price: £12.50 (plus VAT).

KO727B

Stereo headphones. Suitable for outputs of 4-600 ohms. Normal listening input: 95dB SPL @ 12mV. Maximum input: 2.6V. FR: 10Hz-18kHz. HD: unmeasurable at 95dB SPL. Weight: 480gm. Special coiled cord: 3ft coiled, 10ft extended. Standard stereo jack plug. Black finish. Washable ear cushions. Adjustable headband. Price: £18.00 (plus VAT).

KO747 ★

Stereo headphones. Suitable for outputs of 4-16 ohms. Wired for mono and stereo with changeover switch. Weight: 500gm. Special coiled cord: 3ft coiled, 10ft extended. Standard stereo jack plug. Finish: two-tone brown. Washable ear cushions. Individual volume adjustment. Adjustable headband. Fluid-filled ear cushions. Frequency response is 30 to 20,000Hz with a distortion of less than 1% at maximum output of 110dB SPL. Impedance is nominally 300 ohms each channel but can be used with systems having output taps of 4, 8, or 16 ohms as well as with stereophone jacks at resistance values to 600 ohms. 10ft coiled cord. Prices: on application.

PRO4AA

Stereo headphones. Suitable for outputs of



Koss ESP9

4-16 ohms. Normal listening input: 95dB SPL @ 260mV. Maximum input: 4.1V. FR: 10Hz-20kHz. HD: negligible at 95dB SPL. Weight: 650gm. Special coiled cord: 3ft coil, 10ft extended. Standard stereo jack plug. Finish: beige with black cushions. Washable ear cushions. Adjustable headband. Fluid-filled cushions. Price: £31.50 (plus VAT).

PRO-5LC

Professional dynamic headphones. FR: 10Hz-20kHz. Designed to work from amplifier outputs of 4-1000 ohms impedance. Input: not to exceed 5V RMS. THD: < 1% at 95dB SPL. Driver units: 1in diameter voice coils, 4 sq in radiating area. 10ft coiled cable. Fluid filled vinyl ear cushions. Extendable headband with pivoting yokes in stainless steel. Headband covered with soft moulded PVC and sponge rubber cushioning. Finish: beige with black cushions and cord, brushed chrome trim. Weight: 19oz. Price: £34.50 (plus VAT).

ESP6

Electrostatic stereo headphones. Suitable for outputs of 4-16 ohms. Normal listening input: 1V at 80dB SPL. Maximum input: 20V. FR: 30Hz-19kHz \pm 5dB. HD: <0.2% at 110dB SPL. Weight: 850gm. Special coiled cord: 3ft coiled, 10ft extended. Standard stereo jack plug plus connector box. Finish: black. Washable fluid-filled ear cushions. Neon level indicators. Adjustable headband. Carry case included in price. Price: £59.00 (plus VAT).

ESP9 ★

Electrostatic studio monitor stereo headphones. Suitable for outputs of 4-16 ohms. Normal listening input: 1V at 80dB SPL. Maximum input: 20V. FR: 15Hz-15kHz \pm 2dB (10Hz-19kHz \pm 5dB). Weight: 590gm. 6ft cord. Supplied with speaker output terminals.

Finish: black. Fluid-filled ear cushions. AC or self-energised selector switch. Price: £79.00 (plus. VAT).

K2 + 2

Four-channel dynamic headphones. Wired for stereo and quadraphonic. Suitable for outputs of 3-600 ohms. Normal listening input: 1.4V at 95dB SPL. Maximum input: 29V. FR: 10Hz-20kHz. HD: negligible at 95dB SPL. Weight: 600gm. Special coiled cord: 3ft coiled, 10ft extended. Two headphone jack plugs. Black finish. Washable fluid-filled ear cushions. Adjustable headbands. Switch for two or four-channel operation. Price: £49.00 (plus VAT).

Two-way adaptor TPA

For connecting two pairs of headphones to single output. Extends length by 3ft. Price: £3.25 (plus VAT).

Extension cable EC25KK

25ft coiled cord terminated with stereo jack plug and socket. Price: £4.00 (plus VAT).

T3 Switchbox

Speaker/headphone switchbox. Jack socket for phones, terminals for speaker and connection to amplifier output. Switch selects speakers on or off. Price: £4.00 (plus VAT).

T4A Connector box

Accepts up to five pairs of stereo headphones. 14ft extension lead with jack plug for amplifier. Simulated rosewood base with black trim, spun aluminium panel. Price: £7.50 (plus VAT).

T-5D

Remote control station suitable for running two pairs of stereo headphones. Speaker on/off switch incorporated, but headphones are always on. The volume of headphones plugged into left-hand jack individually controlled (other set of headphones controlled by volume knob on amplifier). Fitted DIN sockets for amplifier and speaker connections. Matches any amplifier with 4, 8 or 16 ohms output. Finish: black with simulated walnut top. Connecting cable seven-core colour-coded 3ft long. Size: 3 1/8 x 3 1/8 x 2 5/8in. Weight: 10 1/2oz. Price: £8.50 (plus VAT).

T10A

Chairside listening station. Provides separate volume controls for two pairs of stereo headphones, also speaker on/off switch. Wires directly to amplifier output. Seven-core flat cable suitable for under carpet installation. Tinted plastic cover. Price: £11.50 (plus VAT).



Koss PRO-5Q



Koss KO-747Q

Continental adaptor leads

For use with amplifiers having DIN output sockets instead of jack sockets. Comprises: two DIN speaker plugs with lead and stereo jack socket. Two 100-ohm resistors inserted for attenuation. Price: £1.50 (plus VAT).

K-6LCQ

Quadraphonic headphones with 4 drivers. Operate from 3.2 ohms to 600 ohms impedance. Power for normal listening level (1kHz): 160mW. Max. input: 5V RMS with provision for 14dB transients above this. FR: 20Hz-17kHz. THD: 0.5% at 109dB SPL. Sensitivity: 90dB SPL/100mV (2-channel) 96dB SPL/100mV (4-channel). Cord length: 120in. Two stereo jacks. Brown finish. Price: £29.00 (plus VAT).

PRO-5Q ★

Quadraphonic headphones with four drivers.

★ Indicates entry is illustrated

Operate from 3.2 ohms to 600 ohms. Power for normal listening level (1kHz): 160mW. Max. input: 5V RMS with provision for 14dB transient peaks beyond this. FR: 20Hz-20kHz. THD: <0.5% at 109dB SPL. Sensitivity: 90dB SPL/100mV (2 channel). 96dB SPL/100mV (4-channel). Weight: 21oz. Cord length: 120in. Two stereo jack plugs. Brown finish. Price: £45.00 (plus VAT).

KO-747Q ★

Quadraphonic headphones with four drivers. Operate from 3.2 ohms to 600 ohms. Power for normal listening level (1kHz): 160mW. Max. input: 5V RMS with provision for 14dB transient peaks beyond this. FR: 20Hz-19kHz. THD: <0.5% at 109dB SPL. Sensitivity: 90dB SPL/100mV (2-channel) 96dB SPL/100mV (4-channel). Weight: 22oz. Cord length: 120in. Two stereo jack plugs. Brown finish. Price: £42.00 (including VAT).

HV/ILC

High velocity stereo headphones. Specifications: Elements: 2in diameter velocity operated. Source impedance: 3.2 to 600 ohms. FR: 15Hz-20kHz; Distortion: 0.5% at 109dB SPL. Sound pressure level: 95dB SPL 0.6V RMS. Power handling: 5V RMS continuous. Ear cushions: soft acoustical foam. Volume/balance controls: one miniature rotary type per earcup. Weight: 280gm. Price: £29.95 (plus VAT).

HV-1A ★

High velocity stereophones with new decilite drivers, reproducing all ten audible octaves. Operates from 3.2 to 600 ohms impedance. FR: 15Hz-20kHz. 10ft coiled cable. Weight: (less cord) 9.3oz. Price: £26.50 (plus VAT).

Phase 2

Stereo dynamic headphones with panoramic source controls and ambience expander. Comparator switch to compare ordinary stereo with phase 2. FR: 10Hz-20kHz. Operates from 3.2 to 600 ohms impedance. Finish: beige with black air-filled cushions. Price: £42.00 (plus VAT).

Easy Listener ★

Stereo moving coil dynamic headphones. FR: 20-20,000. Impedance: 16 ohms at 1kHz designed to operate from outputs with source impedances of 3.2 to 600 ohms. Finish in blue denim. High velocity lightweight open-back stereophone supplied complete with mono adapter. Soft acoustical sponge ear-cushions. Extendable headband with self-adjusting



Koss HV-1A



Koss Easy Listener



Koss HV-2

pivoting yokes and soft denim cover. Price: £25.90 (plus VAT).

HV-2 ★

Stereo moving coil dynamic velocity operated headphone. FR: 20-20,000. Designed to operate from source impedances of 3.2 to 600 ohms. Weight (with cord) 0.340kg. Black finish. 4 conductor, straight 'Y' cord. Soft acoustical sponge ear-cushions, flexible, high-strength Acetal headband with soft padded sponge and self-adjusting pivoting yokes. Price: £13.95 (plus VAT).



Koss Phase 2+2

Phase 2+2 ★

Moving coil dynamic velocity Quadrafone. FR: 20-20,000. Impedance: designed to operate from outputs with source impedances of 3.2 to 600 ohms. Weight: 0.535kg including V-cord from headset to programmer. Black finish. 127 listening perspectives. Can be used to monitor both 2-channel and 4-channel source material. Incorporates one 50mm dia. decilite and one 38mm dia. high velocity dynamic element per cup. Soft acoustical sponge ear-cushions. Extendable headband with pivoting self-adjusting yokes. V-cord 1m from headset to programmer. Pal size programmer controls. Price: £85.00 (plus VAT).



Koss Technician (VFR)

Technician/VFR ★

Moving coil dynamic stereo headphone. FR: 10-22,000. Impedance: 230 ohm at 1kHz. Designed to operate from outputs with source impedances of 3.2 to 600 ohms. Weight less cord 0.483kg. Black finish. 4-conductor, coiled, 3m extended corder. Pneumalite ear-cushions for high ambient noise isolation. Wide extendable stainless steel headband with self-adjusting yokes and stitched vinyl cover. Boom mount. Variable frequency response controls. Price: £42.00 (plus VAT).

K-7 ★

Moving coil dynamic stereo headphones. FR: 20-16,000. Impedance 100 ohms at 1 kHz. Designed to operate from outputs with source impedances of 3.2 to 600 ohms. Power handling: 4 V-RMS continuous. Weight: 0.310kg less cord. Mushroom finish with black ear-cushions. 4-conductor, straight 'Y' cord, 2.4m length. Foam-filled vinyl ear-cushions. Flexible, high-strength polypropylene headband with sponge cushion. Price: £10.00 (plus VAT).



Koss K-7

■ Lenco

Goldring Ltd, 10 Bayford Street,
London E8 3SE.
Tel: 01-985 1152

★ Indicates entry is illustrated

K110

Moving coil stereo headphone. FR: 16-22,000 Hz. Sensitivity: 91dB. Imp: 200 ohms. Price: £18.00 (plus VAT).

K105

Moving coil stereo headphone. FR: 18-20,000. Imp: 4-16 ohms. Price: £13.80 (plus VAT).

■ MARANTZ

Pyser Ltd, Fircroft Way, Edenbridge, Kent TN8 6HA.

Tel: Edenbridge 4111.

SD-1 ★

Electrostatic headphones. FR: 20Hz-20kHz \pm 3dB. Distortion: 0.5% at all frequencies from 40Hz-20kHz and up to 100dB SPL. Automatic limiting of very loud passages. Impedance: 30 ohms. Weight: 14oz. Supplied with EE-1 energiser which has built-in speaker/headphone switching and will accept up to two headphones. EE-1 switches off if severely overdriven. Price: £62.00 (plus VAT).

SD-5 ★

Stereo headphones. Impedance: 8 ohms. FR: 30Hz-15kHz. Finished in gold and brown leather ear cushions. Fully adjustable headband. Weight: 16oz. Price: £18.00 (plus VAT).

■ MICRO

Howland-West Ltd, 3-5 Eden Grove, London N7 8EQ.

Tel: 01-609 0293/6.

MX1

Comprises headset MS2 and power source MP1. Stereo electrostatic headphones. Impedance: 8ohms. Maximum input: 8V at 1kHz RMS. FR: 20Hz-20kHz \pm 1dB. HD: <1% at 115dB sound pressure level. Sensitivity: 98dB sound pressure level at 1kHz. Cord: 8ft approx. Finish: metallic and black. Extension cable available to enable two sets of headphones to be used from a single power source. Power supply: single PP9 battery gives about 2000 hours listening. Price: £48.00 (plus VAT).

■ PEERLESS

Ross Electronics,
32, Rathbone Place, London, W1P 1AD
Tel: 01-580 7112

PMB-6 ★

Direct connection, Orthodynamic stereo headphones utilizing a special thin film diaphragm uniformly driven to provide near linear

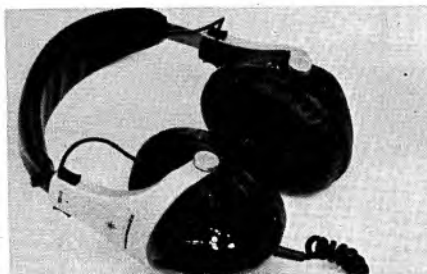

Marantz SD-1



Marantz SD-5



Peerless PMB-6

frequency characteristics. Fitted with stainless steel headframe and adjustable, contour fitting headband, and swivel mounted earcups with supra-aural earpads. FR: 16Hz-20kHz. Impedance: 140 ohms (suitable for all Hi-Fi amplifiers). Sensitivity: 90dB. S.P.L./0.001W. Handling capacity 2W. Total harmonic distortion: less than 1%. Price: £32.29 (including VAT).

■ PHILIPS

Philips Electrical Ltd,
City House, 420-430 London Road,
Croydon CR9 3QR.
Tel: 01-689 2166.

N6310

Moving coil stereo headphones. FR: 20Hz-20kHz. Sensitivity: 92dB at 1mW. Impedance: 600 ohms each channel. Power handling: 20mW each channel. Weight: 160gm. Finish: black/silver. Meets DIN 45 500 standard. 3m cable attached. Incorporates "open air" principle. Available in three versions: (N6310/00) 360° DIN plug; (N6310/02) 6.3mm jack plug; (N6310/03) loudspeaker DIN plugs. Price: £11.00 (plus VAT).

N6302

Moving coil stereo headphones. FR: 16Hz-20kHz. Sensitivity: 112dB at 1mW. Impedance: 600 ohms each channel. Power handling: 20mW each channel. Weight: 450gm. Finish: black/silver. 6½ft curled connecting cord. Price: £21.99 (plus VAT).

For connection to a 240° DIN headphone socket an adaptor is available (code number 4822 263 50054) from: Combined Electronic Services, 604 Purley Way, Waddon, Croydon CR9 4DR. Tel: 01-686 0505

■ PICKERING

Highgate Acoustics Ltd,
38 Jamestown Road, London NW1 7EJ.
Tel: 01-267 4937.

OA-3

Stereo moving coil headphones. FR: 20Hz-20kHz. Sensitivity: 100dB SPL at 0.10V input at 1kHz each channel. Impedance: 15 ohms. Power handling: 0.2W per channel. Weight: 0.215kg. Finish: brown. Price: £18.50 (plus VAT).

OA-2

Stereo moving coil headphones. FR: 30Hz-19kHz. Sensitivity: (specific response) 100dB at 600Hz. Impedance: 8 ohms. Power handling:



Pioneer SE-700

ing: 0.3W per channel. Finish: brown. Price: £11.00 (plus VAT).

PH-4955

Stereo moving coil headphones. FR: 10Hz-22kHz. Sensitivity: 100dB SPL at 0.10V at 1kHz. Impedance: 8 ohms. Power handling: 0.15W. Weight: 0.785kg. Finish: brown. Price: £28.00 (plus VAT).

■ PIONEER

Shriro (UK) Ltd, Shriro House,
The Ridgeway, Iver, Bucks SL0 9JL.
Tel: Iver 652222.

SE-505

Dynamic headphones. Impedance: 4-16 ohms. Maximum power input: 500mW. FR: 20Hz-20kHz. Distortion: 1%. Sensitivity: 108dB at 300mV. Weight: 690gm. Cord length: approximately 60in. Jack plug. Two-way speaker volume/tone controls. Price: to be announced.

SE-305

Dynamic headphones. Impedance: 4-16 ohms. Maximum power input: 500mW. FR: 20Hz-20kHz. Distortion: 1%. Sensitivity: 113dB at 300mV. Weight: 435gm. Cord length: 60ins. Jack plug. Price: to be announced.

SE-205

Dynamic headphones. Impedance: 4-16 ohms. Maximum power input: 500mW. FR: 20Hz-20kHz. Distortion: 1%. Sensitivity: 115dB at 30mV. Weight: 450gm. Cord length: 84in. Jack plug. Price: to be announced.

SE-700 ★

Piezoelectric headphones. Impedance: 4-16 ohms. Static capacity: 0.1µF. FR: 20Hz-

★ Indicates entry is illustrated



Pioneer SE-Q404

20kHz. Sensitivity 100dB 3V. Maximum input power: more than 30V. Price: to be announced.

SE-500

Piezoelectric headphones. Impedance: 4-16 ohms. Static capacity: 0.08 μ F. FR: 20Hz-20kHz. Sensitivity 100dB 3V. Maximum input power: 30V. Price: to be announced.

SE-300

Piezoelectric headphones. Impedance: 4-16 ohms. Static capacity: 0.08 μ F. FR: 20Hz-20kHz. Sensitivity 100dB 3V. Maximum input power: 30V. Price: to be announced.

SE-Q404 ★

4-channel dynamic headphones. Impedance: 4-16 ohms. FR: 20Hz-20kHz. Sensitivity: 105dB 0.3V (4-channels driven) 111dB 0.3V (2-channels driven). Maximum input power: 500mW (each channel). Price: to be announced.

SE-255

Carbon fibre blend moving coil stereo headphone. FR: DIN 20-20,000. Sensitivity: 100dB/mv. Imp: 4-8 ohms. Power handling: more than 500mw each channel. White leather-like vinyl with aluminium metal trim. High efficiency carbon fibre drive units, 4m coiled lead. Price: on application.

Monitor 10

Moving coil stereo headphones. FR: DIN 20-20,000. Sensitivity: 100dB/mw. Imp: 4-16 ohms. Power handling: 700mw per channel. Finish in black leather. Low sound leakage design, High efficiency drive units. Head band has clock stop locking adjustment. Price: on application.

■ PLUSTRON

Plustronics Ltd, Hempstalls Lane,
Newcastle, Staffs ST5 0SW.
Tel: Newcastle 615131.

T300

Stereo/mono switch. Individual volume controls for each headphone speaker. FR: 20Hz-18kHz. Impedance: 8 ohms. 10ft coiled connecting cord with 3-circuit stereo phone plug. Price: on application.

T340

Stereo/mono switch. Individual volume controls for each headphone speaker. FR: 20Hz-18kHz. Impedance: 8 ohms. 10ft coiled connecting cord with 3-circuit stereo phone plug. Black finish. Price: on application.

■ REVOX

C. E. Hammond and Co Ltd,
105-109 Oyster Lane, Byfleet, Surrey KT14
7LA.
Tel: Byfleet 41131.

RH 31

Stereo headphones. FR: 20-20,000. Impedance: 600 ohms. Power handling: 50mW per channel. Weight: 200gm. Soft foam earpads, lightweight PVC headband with soft cushioning. Price: £16.50 (plus VAT).

■ ROSS ELECTRONICS

32 Rathbone Place, London W1P 1AD.
Tel: 01-580 7112.

RE-220

Budget stereo headphones. Lightweight headband, padded earmuffs. FR: 20Hz-20kHz. Maximum input: 200mW. Impedance: 8 ohms. 10ft lead. Price: £3.57 (plus VAT).

RE-225

Stereo headphones with lightweight adjustable headband, padded earmuffs. FR: 20Hz-20kHz. Maximum input: 200mW. Impedance: 8 ohms. 3-metre spiral cord. Price: £4.80 (plus VAT).

RE-230

Stereo headphones with fully padded adjustable headband and earmuffs. Independent volume controls. FR: 20Hz-20kHz. Maximum input: 200mW. Impedance: 8 ohms. 3-metre spiral cord. Price: £6.47 (plus VAT).

RE-236 ★

Features two high-flux density drive units

Puzzled about headphones?



RE-237

RE-270



RE-260

You've no need to be!

There's one cut out just for you in the new Ross Electronics range



RE-252

RE-237. Extended range
Reflex (15-22000 Hz).
RRP £10.60 + VAT.

RE-252. Interchangeable
remote volume control and
stereo/mono switch.
RRP £12.30 + VAT.

RE-260. Two-way stereo
headphone. Mylar cone
tweeter and woofer.
RRP £15.47 + VAT.

RE-270. Electret Condenser,
direct connection type.
£25.32 + VAT.

These are just four of the
thirteen stereo headphones
in the complete Ross
Electronics range. See them
at your dealer or write for
information.

 **ROSS
ELECTRONICS**
Quality Hi-Fi from beginning to end.
32 Rathbone Place, London W1P 1AD. Tel: 01-580 7112/3

★ Indicates entry is illustrated

operating in specially designed acoustic chambers. Softly padded adjustable headband and earmuffs. With 3-metre spiral cord and jack plug. FR: 20Hz-20kHz. Impedance: 8 ohms. Price: £10.31.

RE-237

Reflex stereo headphones featuring drive units



Ross RE-236

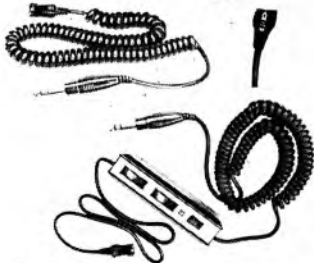

Ross RE-252

with high velocity mylar diaphragms for wide-range, distortion-free response and ported earcups that provide a controlled awareness of ambient sound. Other features include a universally adjustable headband with leather grain cover, foam-filled ear cushions and a 3-metre coiled lead with moulded jack plug. Impedance: 8 ohms. FR: 15Hz-20kHz. Maximum input: 500mW. Sound Pressure. Level: 115dB/mW. Price: £10.60 (plus VAT).

RE-240

Stereo headphones with leather grain padded headband and earmuffs. Fitted 3in diameter wide-range loudspeakers and slide volume controls. FR: 20Hz-20kHz. Maximum input: 1W. Impedance: 8 ohms. 3-metre spiral cord. Price: £8.72 (plus VAT).

RE-245

Mono/stereo headphones. Leather grain padded headband and earmuffs. Fitted 3in diameter loudspeakers, slide controls for volume and bass/treble. Maximum input: 1W. Impedance: 8 ohms. 3-metre spiral cord. Price: £10.22 (plus VAT).

RE-250

Semi-professional stereo headphones. Lightweight headband, padded earmuffs. Fitted with specially designed 60mm mylar cone loudspeakers. Independent slide volume controls. FR: 20Hz-22kHz. Maximum input: 500mW. Sensitivity: 130dB at 800Hz for 1mW. Impedance: 8 ohms. 3½-metre spiral cord. Price: £10.22 (plus VAT).

RE-252 ★

Stereo headphones featuring detachable, remote control box with left and right volume controls and stereo/mono switch. Remote control may be simply unplugged and replaced by 3-metre spiral cord and jack plug. Wide range drive units operate in acoustically damped earcups. Padded stainless steel headband and earmuffs. FR: 20Hz-20kHz. Impedance: 8 ohms. Price: £15.38 (including VAT).

RE-255

Semi-professional stereo headphones. Padded adjustable headband and earmuffs. Fitted high-grade, wide-range loudspeakers and recessed, vertically-operated slide controls for volume and bass/treble. FR: 20Hz-20kHz. Sensitivity: 108dB at 1000Hz for 1mW output. Impedance: 8 ohms. 3-metre spiral cord. Price: £13.68 (plus VAT).

RE-264

Stereo/quadrasonic headphones. Padded

headband and earmuffs. Fitted with 50mm front and rear loudspeakers angled to provide realistic 4-channel listening from discrete or matrix systems. Maximum input: 200mW per channel. Impedance: 8 ohms. Price: £9.84 (plus VAT).

RE-260

Two-way stereo headphones employing a 35mm woofer and 15mm tweeter with dividing network in each earcup. Finished matt black and satin silver with softly padded headband and earmuffs. With 3-metre spiral cord and jack plug. FR: 20Hz-20kHz. Impedance: 4-32 ohms. Sensitivity: 100dB/mW at 1,000Hz. Price: £19.34 (including VAT).

RE-270 ★

Electret condenser stereo headphones utilising a high-molecular thin-film element that provides a low-distortion, extended frequency range. Direct connection, external adapters or polarizing equipment not required. Functional styling with softly padded headband and earmuffs. FR: 18Hz-22kHz. Impedance: 1.3K ohms at 1kHz. Matching impedance: 4-32 ohms. Sensitivity: 100dB/V at 1,000Hz. Max. input: 10V. Price: £33.40 (including VAT).

RE-208 Stereo Headphone Junction Box

Provides 3-way switched selection of headphones only, loudspeakers only or both fitted with 2-pin DIN plug connectors and input sockets, and twin headphone sockets. Price: £2.45 (plus VAT).

RE-202 Stereo Headphone Extension Lead

Spiral lead fitted with stereo jack plug one end, jack socket at other. Lead extends to 25ft. Price: £1.50 (plus VAT).

■ **ROTEL**

Rank Audio Visual Ltd, PO Box 70, Great West Road, Brentford TW8 9HR. Tel: 01-568 9222.

RH630

Stereo headphones. FR: 20-19,000Hz. Impedance: 4-16 ohms. All black finish. Spring steel headband. Elastic sponge ear cushions. Price: £9.95 (plus VAT).

RH700

Stereo headphones. Impedance: 8-16 ohms. Maximum input: 500mW. FR: 20Hz-20kHz. 10ft coiled cord. Black headband and ear cushions. Adjustable headband. Price: £14.72 (plus VAT).



Ross RE-270



Sansui SS10



Sansui SS50

★ Indicates entry is illustrated

RH430

Stereo headphones. Impedance: 4-16 ohms. FR: 40-15,000. All black finish. Flexible plastic headband. Elastic sponge ear cushions. Price: £6.25 (plus VAT).

■ SANSUI

Vernitron Ltd, Thornhill,
Southampton SO9 5QF.
Tel: Southampton 444811.

SS10 ★

Stereo headphones. Impedance: 8 ohms. Normal listening input: 1mW. Maximum input: 500mW. FR: 20Hz-20kHz. HD: <0.8%. Sensitivity: better than 110dB. Crossover frequency: 1kHz (6dB/Oct). Weight: 625gm. Three-pole jack plug. Washable ear cushions. Individual volume adjustment. Black headband, white earpieces. Price: £18.76 (plus VAT).

SS20

Stereo headphones. Impedance: 8 ohms. Normal listening input: 1mW. Maximum input: 500mW. FR: 20Hz-20kHz. THD: <0.8%. Sensitivity: 110dB at 200Hz. Crossover frequency: 1kHz (6dB/Oct). Weight: 780gm. Individual volume adjustment. Individual tone adjustment. Adjustable headband. Dual extension lead. Two drive units in each earpiece. Black headband and ear cushions, white earpieces. Price: £25.08 (plus VAT).

SH5

Stereo headphones. Impedance: 25 ohms nominal. FR: 20Hz-20kHz. Maximum input power: 65mW. Sensitivity: 97dB. Weight: 245gm. Price: £18.47 (plus VAT).

SS50 ★

Stereo headphones, woofer 7.5cm, tweeter 3.3cm. Impedance: 8 ohms. FR: 20Hz-20kHz. Maximum input: 500mW. Sensitivity: 106dB at 200Hz. Crossover frequency: 1kHz (6dB/Oct). Weight: 800gm. Price: £36.39 (plus VAT).

QH44

2/4 channel headphones. Impedance: 25 ohms. FR: 20Hz-20kHz. Maximum input power: 100mW. Sensitivity: 98dB. High velocity full range dome type speakers. Weight: 430gm. Price: £36.39 (plus VAT).

SH 15

Stereo dynamic headphones. Imp: 4-32 ohms. FR: 20-20,000Hz. Weight: headphones only 260gm. Price: £22.51 (plus VAT).

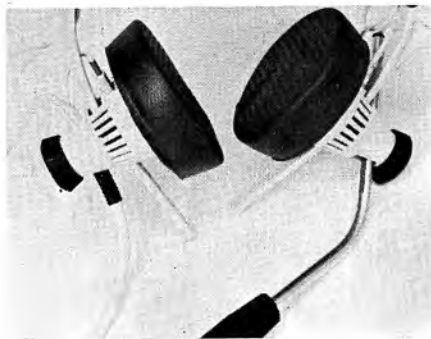

Sennheiser HMD 414

■ SENNHEISER ELECTRONIC

Distributors: Hayden Laboratories Ltd,
Hayden House, Churchfield Road,
Chalfont St. Peter, Bucks SL9 9EW.
Tel: Gerrards Cross 88447.

HD.414

Stereo headphones. Wired for mono or stereo. Lightweight robust design. Removable washable sponge ear pads. FR: 20Hz-20kHz. Impedance: 2000 ohms per capsule. Weight: 5oz. Price: £18.80 (plus VAT).

HMD.414★

Stereo headset HD.414 with close-talking boom microphone located near corner of mouth. Especially high ratio of desired sound to background noise. Sensitivity: 0.1mV/ μ bar. Impedance: 200 ohms. Price: £45.45 (plus VAT).

HD.44

Ultra light stereo headphones with volume control on each capsule. Can be used mono. FR: 40Hz-15kHz. Impedance: 640 ohms. Weight: 33gm. Price: £12.00 (plus VAT).

HD.424

Stereo headphones (can be used mono) with good low frequency response. FR: 16Hz-20kHz. Impedance: 2K. Weight: 170gm. Price: £27 (plus VAT).

HD.412

Stick type headphone designed for use in record booths, etc. FR: 20Hz-20kHz. Impedance: 2K. Price: £20.35 (plus VAT).

HD.4004

Lightweight mono stethoset. Weight: 19gm.



Sonab H20

FR: 100Hz-6kHz. Impedance: 17 ohms. Price: £8.35 (plus VAT).

HD 400

Moving coil stereo headphone. FR: 20-18,000Hz. Imp: 600 ohms. Price: to be announced.

HD 224

Stereo moving coil headphone. FR: 20-20,000Hz. Imp: 200 ohms. Weight: 250 gms. Price: to be announced.

■ **SHARP**

Sharp Electronics (UK) Ltd,
107 Hulme Hall Lane, Manchester M10 8HL
Tel: 061-205 7321.

HP100

Stereo headphones. Fully adjustable slide fittings. Double headband. Padded comfortable earpieces. FR: 30Hz-18kHz. Complete with lead and jack plug. Price: £7.19 (plus VAT).

HP200

Stereo headphones. Fully adjustable slide fittings. Single headband. Padded comfortable earpieces. FR: 30Hz-17kHz. Complete with lead and jack plug. Price: £5.40 (plus VAT).

HP400

Stereo headphones. Fully adjustable slide fit-

tings. Extra thick padding for comfort. Twin units in each earpiece. Independent volume controls. FR: 30Hz-20kHz. Complete with lead and jack plug. Price: £17.50 (plus VAT).

■ **SKANTIC**

Skantic (UK) Ltd, Station Road,
Edenbridge, Kent TN8 6EY.
Tel: Edenbridge 5231.

Type AH-27

Stereo headphone complete with coiled lead and jack. FR: 20Hz-20kHz. Price: on application.

Type SM-220

Stereo headphones complete with cable and jack. FR: 20Hz-18kHz. Price: on application.

■ **SONAB**

Sonab Ltd, 214 Harlequin Avenue,
Brentford TW8 9EW.
Tel: 01-568 2952.

H20 ★

Stereo moving coil headphones. FR: 20Hz-14kHz ±2dB. Requisite operating power for 100dB 0.18mW. Impedance: 400 ohms. Power handling: 250mW at 1kHz. Weight: 450gm. Finish: black/non-glossy nickel plated. Completely encloses the ears to keep out external noises. Adjustable vertically and sideways. Price: £28.00 (plus VAT)

H10

Stereo moving coil headphones. FR: 20Hz-14kHz ±3dB. Requisite operating power for 100dB 0.22mW. Impedance: 400 ohms. Power handling: 100mw at 1kHz. Weight: 450gm. Finish: red/black. Completely encloses the ears to keep out external noises. Adjustable vertically and sideways. Price: £22.00 (plus VAT).

■ **SONY**

Sony (UK) Ltd, Pyrene House,
Sunbury Cross, Sunbury-on-Thames.
Tel: Sunbury 87644

DR9

Stereo headset with slider controls. Impedance: 8 ohms. FR: 30-18,000Hz. Max. input: 0.3W. Weight: 520g. Price: £10.88 (plus VAT).

DR15 ★

Stereo headset. FR 20Hz-20kHz. Impedance:

★ Indicates entry is illustrated



Sony DR15



Sony ECR400



Sony Electret ECR500

4-16 ohms. Open back construction, light-weight diaphragm. Price: £14.77 (plus VAT). Distortion: 0.8% (500Hz, 101dB). 2m cable. Weight: 350gm. Price: on application.

ECR 400 ★

Electret condenser stereo headphone. FR: 20Hz-20kHz. Imp: 30 ohms. Power handling: max. input to adaptor 12 VRMS. Finish in black and chrome. Weight: 430g, adaptor 970g. Adaptor includes switch for headphone or speakers. Price: £39.96 (plus VAT).

ECR 500 ★

Electret condenser stereo headphone. FR: 20Hz-20kHz. Imp: 30 ohms at 1kHz. Power

handling: max. input 12V 1kHz. Weight: 350g, adaptor 1kg. Adaptor includes switch for headphone or speakers. Price: £57.56 (plus VAT).

HS 25

Mono LL headset with microphone for TC 96L. Price: £15.69 (plus VAT).

■ STAX

Wilmex Ltd, Import Division
Crompton House, New Malden, Surrey KT3 4DE.

Tel: 01-949 2545.

SR5/SRD6

Stereo electrostatic headphones. FR: 30Hz-25kHz. Sensitivity: 96dB at 100V RMS input. Impedance: 130K ohms at 10kHz. Power handling: 8W continuous. Weight: 390gm. Finish: white, black leather, stainless steel. Supplied with SRD 6 mains energiser. Controls: switch on SRD6 headset or loudspeakers. Price: £67.50 (plus VAT).

SR44

Stereo electret headphones. FR: 25Hz-25kHz. Sensitivity: 95dB at 100V RMS. Impedance: 150K at 10kHz. Power handling: 5W continuous, 30W momentary. Weight: 250gm. Finish:

HEADPHONES AND ACCESSORIES



Stax SRX Mk2 Headphone and
Stax SRD-7 Electrostatic energiser

black. Supplied complete with SRD4 adaptor box for connection to loudspeaker output on amplifier. Controls: switch on SRD4 to select between headset and loudspeaker. Price: £52.50 (plus VAT).

SRX3/SRD7 ★

Stereo electrostatic headphones FR: 30Hz-27kHz. Sensitivity: 97dB at 100V RMS. Impedance: 130K at 10kHz. Power handling: 8W continuous. Weight: 380gm. Finish: black/stainless steel. Supplied with SRD7 mains energiser. Controls: switch on SRD7 for speakers or headset. Price: £135 (excluding VAT).

■ SUPEREX

Webland Electronics Ltd,
Mirabel House, 117-121 Wandsworth Bridge
Road, London SW6 2NA.
Tel: 01-736 0987/8/9/0.

PEP-81

Electrostatic isolation type stereophone complete with deluxe walnut energiser which is AC and self energised, providing two phone jacks and volume control. FR: 10-18,000Hz. Impedance: 4-16 ohms. Weight: 8.5oz. Padded aluminium headband. Price: £87.60 (plus VAT).

PEP-79E

Electrostatic stereophone complete with fully protected energiser. FR: 15-18,000Hz. Impedance: 4-16 ohms. Weight: 8.6oz. Padded aluminium headband. Price: £47.60 (plus VAT).

PRO-VII

Woofertweeter stereophone. FR: 15-

23,000Hz. Imp: 80 ohms. Weight: 18oz. Padded steel headband. Price: £37.60 (plus VAT).

CL-1

Isolating professional stereophone finished in cordovan and gold design. FR: 10-20,000Hz. Impedance: 35 ohms. Weight: 10.6oz. Headband of padded steel/aluminium. Price: £30.00 (plus VAT).

TL-3

Translinear finished in black with brushed chrome trim. FR: 25-20,000Hz. Impedance: 70 ohms. Weight: 10oz. Covered aluminium headband. Price: £21.60 (plus VAT).

ST-N

Lightweight dynamic stereophone. FR: 30-15,000Hz. Impedance: 8 ohms. Weight: 13oz. Vinyl covered headband. Price: £11.00 (plus VAT).

■ TOSHIBA

Toshiba (UK) Ltd, Toshiba House,
Great South West Road, Feltham,
Greater London. Tel: 01-751 1281.

HR50

Stereo headphone with channel changeover switch for binaural and cross-field stereo sounds. Price: £16.40 (plus VAT).

HR80

Cross-field stereo headphone with removable, washable earpieces. Prices: £8.00 (plus VAT).

HR710

Electrostatic stereo headphones. FR: 20-35kHz. Sensitivity: 8-500 ohms. Power handling: 100V RMS. Weight: 0.24kg. Extra lightweight headset, electrostatic without need for power supply. Price: on application.

■ UHER

Uher (UK) Ltd, PO Box 53, York.
Tel: York 30421.

W674

Stereo moving coil headphones. FR: 20Hz-20kHz. Fitted with DIN loudspeaker plugs. Price: £25.20 (plus VAT).

W675

Stereo moving coil headphones. FR: 20Hz-20kHz. Fitted with DIN 5-pin headphone plug. Price: £25.20 (plus VAT).

★ Indicates entry is illustrated

■ UNISOUND

Condor Electronics Ltd, 100 Coombe Lane, London SW20 0AY. Tel: 01-946 0033.

S444 ★

Stereo headphones with mono switch. FR: 20Hz-18kHz. Sensitivity: 105dB at 1000Hz. Impedance: 8-16 ohms. Power handling: 0.5W. Weight (with cord): 370gm. Adjustable padded headband. Padded earmuffs. Independent volume controls, mono/stereo switch. 10ft coiled lead. Finish: polished black plastic. Price: £6.90 (plus VAT).



Unisound KS208/S444



Wharfedale isodynamic headphones

KS208 ★

Stereo headphones with padded earpiece and 3m lead. Sensitivity: 110dB at 1000Hz. Impedance: 8-16 ohms at 1000Hz. FR: 20Hz-12kHz. Power handling: 0.2W. Weight: 285gm. Price: £2.95 (plus VAT).

■ WHARFEDALE

Rank Audio Visual, PO Box 70, Great West Road, Brentford, Middlesex TW8 9HB. Tel: 01-568 9222.

Isodynamic Headphones ★

High quality headphones using an electromagnetic technique which distributes the drive over the whole of the diaphragm in the manner of an electrostatic system. Impedance: 40 ohms per capsule but suitable for connection to the output terminals of amplifiers with impedance of 8 ohms. Response down to 35Hz without need for strong side force to seal the cups to the head. Light weight. Adjustable padded headband. Coiled lead. Soft ear pads. Modern white plastic appearance. Price: £31.11 (plus VAT).

■ YAMAHA

Natural Sound Systems Ltd, Strathcona Road, North Wembley HA9 8QL. Tel. 01-904 0141.

HP-900

Sensitivity: 105dB at 600Hz. FR: 18Hz-22kHz. Matching impedance: 4-16 ohms. Max. input: 0.3W. Built-in separate left and right volume controls. Fitted with 2m coiled cable and stereo jack plug. Weight: 440gm. Price: on application.

HP-500

Sensitivity: 104dB at 600Hz: 18Hz-20kHz. Matching impedance: 4-16 ohms. Max. input: 0.5W. Fitted with 3m coiled cable and stereo jack plug. Weight: 450gm. Price: on application.

Hi Fi Cabinets

★ Indicates entry is illustrated.

Abbreviations used in this section are given on page 27.

■ ABSTRACTA

Abstracta Construction Ltd, Unit C, Staples Corner Trading Estate, Edgware Road, Cricklewood, London NW2. Tel: 01-450 2511.

Home Frames

A range of slim-line chromium-plated steel tubular frameworks with white melamine-faced shelves to accommodate hi-fi equipment. Twelve suggested layouts for audio storage, including space for records, tapes and books. Can be adapted for most types and makes of equipment. Sizes range from 33in to 71in and system can be extended as required. Supplied in flat packs for easy assembly. Additional shelves can be added if needed. Home Frames hi-fi leaflet available on request from makers.

■ ACCUPHASE

Belmont A/V Ltd, Fircroft Way, Edenbridge, Kent. Tel: Edenbridge 4111.

A2

Walnut cabinet for Accuphase models C200 pre-amp, P300 power amp. Price: £37.50 (plus VAT).

A3

Walnut cabinet for Accuphase models E202 amp, T101 tuner. Price: £37.50 (plus VAT).

■ A/R/D

Audio Research & Development Ltd, Navas House, The Maultway, Camberley, Surrey GU15 1QE. Tel: Camberley 24684.

2000 Mk IV

Contemporary table top cabinet designed to match the A/R/D amplifier and tuner. Accommodates most player decks, lift up or lift off lid.

Finish brush-anodised aluminium. Price: £18 (plus VAT).

■ ARNEX

Arnex Products (1975) Ltd, Arnex House, Alma Park Industrial Estate, Grantham, Lincs. Tel: Grantham 66581.

E60 Adaptable

An adaptable trolley/table with addition of chrome extension arms if required. Price: £16.30 (plus VAT).

E56 Chrome Hi-Fi Occasional Table ★

Chrome hi-fi occasional table that can be used for a variety of applications—a hi-fi stand, trolley, etc. Teak veneer top and castors. Price: £11.00 (plus VAT).

E54 TV Occasional Table

Useful mobile table which can transport a sewing machine or television and yet can still be used as a conventional coffee table. Dimension: 26 × 16 u09 17in. high. Price: £7.50 (plus VAT).

■ BSR

BSR Ltd, Monarch Works, Cradley Heath, Warley, Worcs B64 5QH. Tel: Cradley Heath 69272.

Plinths ★

Designed specially for the BSR 810 and 710 record decks. Finish: wooden plinth with teak veneer. Polished aluminium trim with opaque black brushed satin insert. Price: £12.18 (plus VAT).

Designed to fit the BSR MP60 and HT70 turntables. Finish: simulated teak plinth with black baseboard. Price: £5.67 (plus VAT).



Arnex E56 Hi-Fi table

★ Indicates entry is illustrated



BSR Plinth for 710 & 810

Covers

Designed for the BSR 810 and 710 record decks. Finish: smoke-tinted low line Perspex dust cover. Price: £5.58 (plus VAT).

Designed to suit the BSR MP60 and HT70 turntables. Finish: smoke-coloured styrene dust cover. Price: £3.96 (plus VAT).

■ A. DAVIES & CO

56 Wellesley Road, London NW5.

Tel: 01-485 5775.

Handmade Cabinets

Equipment cabinets finished in period styles, to customers' exact requirements.

■ DYNATRON

Dynatron Radio Ltd, Ditton Walk,
Cambridge CB5 8QD.

Tel: Teversham 2781.

RSU 6

Teak veneered cabinet with vertical storage space for approximately 275 LP records. Storage dividers are removable if required and the pull down front opening door is held horizontally for maximum convenience when selecting records. Size: $38\frac{3}{4} \times 17\frac{1}{8} \times 25\frac{1}{4}$ in. Price: £50.93 (plus VAT).

RSU 8

Contemporary style record storage cabinet with two doors providing vertical storage space for approximately 150 LP records. Shelf for accessories. Size: $23\frac{3}{8} \times 16\frac{7}{8} \times 21\frac{5}{8}$ in. Finish: teak veneers. Price: £41.67 (plus VAT).

RSU 10

Period storage unit in Queen Anne style with two lockable vertically hinged doors. Accommodates approximately 150 LP records with shelf for accessories. Size: $21\frac{1}{4} \times 16\frac{1}{4} \times 23\frac{1}{2}$ in. Finish: walnut using selected burr veneers. Price: £82.87 (plus VAT).

RSU 11

Period record storage unit in Regency style with two lockable vertically hinged doors. Accommodates approximately 150 LP records with shelf for accessories. Size: $21\frac{1}{4} \times 16\frac{1}{4} \times 23\frac{1}{2}$ in. Finish: flame mahogany veneers. Price: £89.35 (plus VAT).

RSU 12

Period style record storage unit in Queen Anne style with two vertically hinged doors and antiqued drop handles. Accommodates approx. 150 LP records with shelf for accessories. Fitted with castors. Size: as RSU 10. Finish: walnut using selected burr veneers with hand-tooled leather inlay top. Price: £101.20 (plus VAT).

RSU 13

Period style record storage unit in Regency style with two vertically hinged doors with boxwood inlay and antique ring handles. Accommodates approx. 150 LP records, with shelf for accessories. Fitted with castors. Size: as RSU 11. Finish: flame mahogany veneers with hand-tooled leather inlay top. Price: £101.20 (plus VAT).

ST 27

Metal-framed, two-tier trolley fitted with castors. Shelves finished in plastics laminate, one teak, the other walnut. Can be fitted to suit equipment. Top shelf designed to accept Dynatron audio separates, lower shelf for speakers. Record rack. Size: $26\frac{3}{8} \times 16\frac{3}{8} \times 27\frac{7}{8}$ in. Finish: frame finished in matt black. Price: £22.00 (plus VAT).

ST 28

Queen Anne style table stand with cabriole legs. Finish: walnut. Accommodates HFC 208 Empress. Size: $17\frac{1}{4} \times 26\frac{3}{4} \times 18\frac{3}{4}$ in. Price: £34.26 (plus VAT).

■ EDWARDS CONSTRUCTION CO

4 Brunswick Drive, Harrogate, Yorks.

Tel: Harrogate 60921.

Handmade record cabinets and cupboards holding up to 1,500 LP records. Matching bookshelves. Cabinets of various designs and sizes to accommodate almost any combination of hi-fi equipment, records, cassettes, tapes and sheet music. Special designs considered for individual quotation.

DN Range ★

Contemporary styled cabinets designed for any combination of hi-fi equipment. Internal

partitioning can be made adaptable for cassettes, tapes and sheet music. Sizes: 26in, 32in, 40in, 46in, 48in, 64in. Finish: teak, sapele, walnut and oak. All but teak can be stained to customer's requirements at a small extra charge. Price: from £106 (including VAT). Price includes delivery in the UK.

Brunswick Range ★

De luxe record cabinet, contemporary styled with 12in LPs in mind. Internal partitioning can be adapted to tapes, cassettes, etc. Sizes: 24in, 32in, 40in, 48in, 56in, 64in. This cabinet can be made in two-tier and three-tier versions. Finish: teak, sapele, walnut and oak. All but teak can be stained to customer's requirements at a small extra charge. Price: from £133 (including VAT). Price includes delivery in the UK.

■ **GOODMANS**

Goodmans Loudspeakers Ltd,
Downley Road, Havant, Hants PO9 2NL.
Tel: Havant 6344.



Edwards Construction 48 DN



Edwards Construction "48" New Brunswick Range 2

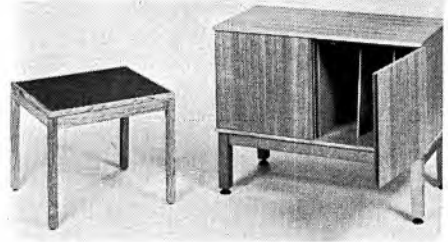

Hacker T45 and SR 1000 Record Cabinet

Cabinet Stand-CS2

Chromium-plated stand for compact units. Fits Model 1-10Z compact. Packed flat. Size: 15 3/8 x 21 1/8 x 15 3/4 in. Price: £16.96 (plus VAT).

Loudspeaker Stand-CS3

Black, tubular stand for floorstanding loudspeaker systems, especially for use with Achromat 400, packed in pairs. Optional flat or 5° upward tilt. Size: 6 1/8 x 11 3/4 x 11 1/4 in. Price: £17.29 per pair (plus VAT).

■ **HACKER RADIO LTD**

Norreys Drive, Cox Green, Maidenhead,
Berks SL6 4BP. Tel: Maidenhead 22261.

T45 Teak Table ★

Frame and legs suitable for record player or audio unit. Teak finish with top inset and covered in grained black leathercloth. 16 1/4 high x 19 1/4 wide x 17 3/4 in. deep. Price: £11.25 (inc. VAT).

SR 1000 Record Cabinet ★

Sturdy craftsman finished record storage cabinet in selected teak veneers. Legs and underframe are solid timber. Holds approx. 240 records. Measures 24 3/8 high x 32 wide x 16 1/2 in deep. Price: £47.52 (inc. VAT).

■ **HOLDER PEARCE LTD**

66 Grove Road, Eastbourne
Sussex BN21 4UH.
Tel: Eastbourne 26565.

Built-in or free-standing equipment cabinets designed and built to meet customers' exact requirements. Lift-up or drop-down lids, accommodation to suit any equipment, all standard finishes to blend with furnishing. Details and prices on application.

Jevington ★

Elegant Regency style cabinet in four finishes,

★ Indicates entry is illustrated

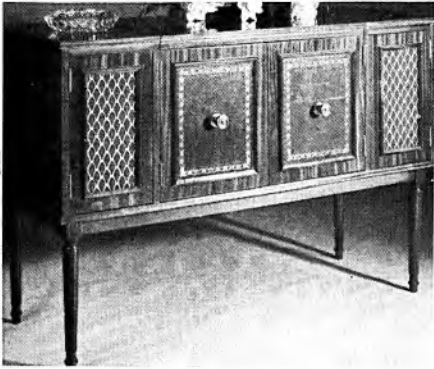

Holder Pearce Jevington



Holder Pearce Vulcan

with reeded legs, front opening doors and lift-up lid to centre section. Provision for speakers each side could be used for record storage if preferred. Interior allows provision for player decks and receiver under lift-up lid for easy access. Adjustable shelf can accommodate units of varying heights. Weight: 31kg.

Folkington

A small version of the Jevington, it could be adapted for record storage, if preferred, or to house tape recorder and cassette storage. Weight: 19kg.

Vulcan ★

Distinctive and unusual cabinet in smoked glass with black iron frame. Sliding doors provide easy access for record storage section, which is fitted with metal rod supports. Shelf, plinth and back are in polished mahogany.

Wilmington

Two-door top section has a lift-up lid for easy

access to player deck housed on adjustable shelf, with receiver below. Two-door lower section has capacious storage for 12in records. Weight: 33kg.

Alfriston

Special features are the lift-up lid and pull-down flap to top section, and the two-door record compartment below. Weight: 31kg.

Berwick ★

In rich yew tree veneers, Berwick has full width continuous top shelf to house record-player and tape recorder side by side, space below for amplifier and tuner units and two lift-up lids above shelf for easy access to both units. Bottom section has record divisions in right hand cupboard and one removable adjustable shelf at left, although this space may be used alternatively for record storage if required.

Mayfield ★

For comprehensive hi-fi equipment. Mayfield is an extended version of Alfriston model, but in this case allows record player and tape recorder to be placed side by side on one level. Finished in yew tree veneers, special features include two lift-up lids and double pull-down flaps below which provide access to front controls. The lower section has two adjustable, removable shelves for housing amplifiers and



Holder Pearce The Berwick



Holder Pearce The Mayfield

tuner units, or record storage. Right hand lower cupboard is fitted with three record divisions with useful accessory storage shelf above. Price: on request.

■ **HOWLAND-WEST LTD**

3-5 Eden Grove, London N7 8EQ.
Tel: 01-609 0293.

Clearview HWI

Cabinet in teak, walnut or rosewood. Takes gram unit or tape deck. Lift-off Perspex lid. Overall size: 18 1/4 x 16 1/2 x 8 1/2 in. Clearance above board 3 3/4 in, below board 4 1/2 in. Price: £20 (plus VAT).

■ **MARANTZ**

Pyser Ltd, Fircroft Way, Edenbridge, Kent.
Tel: Edenbridge 4111.

WC 14

Walnut sleeve for Marantz models 125 tuner, 150 tuner, 1120 amp, 1200 amp, 4140 four channel amp. Price: £28.00.

WC 2

Walnut sleeve for Marantz models 3600 pre amp, 240 power amp, 250 power amp, 4000 pre amp four channel adaptor. Price: £26.00.

WC 10/20

Walnut sleeve for Marantz models 112 tuner, 1030 amp, 1040 amp, 1070 amp, 2015 receiver, 4070 four channel amp, 4220 four channel receiver. Price: £16.00.

TC 10/20

Teak sleeve for Marantz models as for WC 10/20. Price £16.00.

SC 22/42

Walnut sleeve for Marantz receivers: 2220, 2230, 2240, 2245, 2275, 4220, 4230, 4240, 4270. Price: £18.00.

TC 22/42

Teak sleeve as above. Price: £18.00

WC 43

Walnut sleeve for Marantz 4300 and 4400 four channel receivers. Price: £30.00.

■ **NEW CLASSIC**

J. W. (W.) Company, 14-16 Walton Street, Walton-on-the-Hill, Surrey.
Tel: Tadworth 3778.

Anti-warp record storage

Features of the New Classic storage system include spring-loaded panels that keep records flat, upright and easy to withdraw and replace. Also all models have built-in press for dealing with badly warped records.

Compact 100

Contemporary style storage unit with accommodation for 100 LP records, Incorporates anti-warp storage equipment as listed above. Size: 16 1/2 x 13 7/8 x 13 3/4 in. Finish: meranti (to blend with teak finishes). Price: £9.10 (plus VAT).

Major 200

Traditional style record storage cabinet on



New Classic Music Console

★ Indicates entry is illustrated



New Classic Compact 100 plus



Pageantry Cabinet

legs. Accommodation for 200 LP records and record-press built-in (as described above). Size: $36\frac{1}{4} \times 27\frac{1}{2} \times 15\frac{1}{2}$ in. Finish: selected teak veneers hand polished to satin finish. Price: £58 (plus VAT).

Music Console ★

Contemporary style record storage unit with accommodation for 200 LP records and record press built-in. Designed to be large enough to house all transcription equipment. Size: $34 \times 38\frac{3}{4} \times 18\frac{1}{4}$ in. Finish: selected teak veneers. Price: £41.50 (plus VAT); optional extras (sliding doors) £4.60 (plus VAT); (castors) £2.50 (plus VAT).

Compact 100 Plus ★

Compact 100 Plus is the latest version of the Compact 100 making it into a highly versatile dual storage cabinet for LP records and cassettes, Contemporary style design with facilities for storing 100 LP records and 48

boxed cassettes (in drawer below record storage). Size: $16\frac{1}{2} \times 13\frac{3}{4} \times 17\frac{3}{4}$ in. Weight: 15 $\frac{3}{4}$ lb. Finish: brown meranti to match teak finishes. Price: £12.75 (plus VAT).

■ PAGEANTRY RADIO & TV CO LTD

104 Felsham Road, Putney SW15 1DQ.

Tel: 01-788 5588.

Custom-built cabinets ★

Hand-made cabinets to house hi-fi systems. Two standard designs. Typical is antique reproduction model in selected walnut veneers hand-finished with traditional French polish. Features include intricate hand-carved mouldings on front side panels. Size: 54in wide, 21in deep, 32in high. Lower centre front houses record storage drawer running on precision runners. Size of drawer: 17in wide, 15 $\frac{1}{2}$ in deep, 13in high. Full details of hi-fi cabinets including prices and delivery available on request.

■ RECORD HOUSING

17a Newnham Road, London N22 5SS.

Tel: 01-888 7487.

President Cabinet ★

Will house both a player unit and a tape recorder side by side under the lift-up lid. Below is a two-tier section for amplifiers, tape storage, etc. Additional storage capacity for approx. 100 LP records. Size: (overall) 37in. wide, 26in high, 18in deep; (upper shelf) 35 $\frac{1}{2}$ in wide, 17in deep, with clearance of 7 $\frac{1}{2}$ in below lid; (two-tier section) 20in wide, 6in high, 16in deep.



Record Housing President Cabinet



Record Housing Transcription Trolley



Record Housing Capricorn Cabinet

Finish: natural afrormosia. Price: £66.00 (plus VAT).

Stereo Trolley

Upright style equipment cabinet on wheels. General purpose equipment/record cabinet. Accommodation for turntable, amplifier (or tuner/amplifier) plus approx 125 LP records. Size: 19in wide, 18in deep, 23in high (including castors); top measures 19in by 18in; amplifier section 18in wide, 18in deep, 6in high. Finish: natural teak. Price: £33.00 (plus VAT).

Transcription Trolley ★

Upright style equipment cabinet on wheels. General purpose equipment/record cabinet. Accommodation for turntable, amplifier (or tuner/amplifier) plus 150-175 LP records. Size: (overall) 27in high (including castors). 16¼ in deep, 25in wide; (top) 16¼in deep, 24in wide;

(internal tuner/amplifier section) 6in high, 15in deep, 24in wide. Finish: natural teak. Price: £45.00 (plus VAT).

Capricorn Cabinet ★

Contemporary equipment cabinet on legs. Front-opening doors. Vertical record partitions which are removable and can function as shelves, providing flexible arrangement for housing records and equipment. Size: (overall) 32in wide, 16½ deep, 16in high, plus 12in legs and frame; inside height 15in, inside depth 15in. Distance between partitions 7½in. Finish: natural afrormosia. Price: £39 (plus VAT).

Scan Record Unit

Contemporary style record storage cabinet. Accommodation for 100 LP records in each cabinet. Designed as add-on units permitting users to build up a library. Size: (overall) 19¾in high, 15in wide, 16¾in deep; (black plinth) 19in wide, 14in deep, 3in high. Finish: natural afrormosia. Price: £18 (plus VAT).

Audiflex Cabinet

Contemporary style equipment/record storage cabinet. Front-opening doors in lower section holding records. Accommodation for turntable (or tuner/amplifier) and amplifier (or tuner). Size: (overall) 24in high, 15¾in deep, 25in wide; (top) 15¾in deep, 24in wide; (amplifier section) 6in high, 15¾in deep, 24in wide. Finish: teak. Price: on application.

Rolaflex Trolley

Upright style equipment cabinet on castors. General purpose equipment/record cabinet. Accommodation for player unit, tape recorder, amplifier and tuner. Below there is storage for over 200 LP records. Size: (overall) 36in long, 24in high, 15¾in deep; (top) 36in by 15¾in; (amplifier section) 6in high, 15¾in deep, 36in long. Finish: teak. Price: on application.

The Music Centre

Will take virtually any piece of audio equipment including records and tapes with room to spare. The centre section is 25in wide for those with large equipment. Fitted with castors. Overall size: 59¾in wide by 24in high by 16½in deep. Top measure: 59½in wide by 15¾in deep with drawer, cupboard, section for amplifier, open storage section, tape storage section and record storage for approx. 100 records. Price: on application.

★ Indicates entry is illustrated

Congreve

Elegant period-style cabinet designed to take either records or a TV set. Internal partitions and back are removable and doors fold back flat against cabinet sides to allow maximum vision. Overall size: 32½in high by 28in wide by 15¼in deep. Record capacity approx. 175 records. Finish in French walnut or mahogany. Price: £69.00 (plus VAT).

Kingston

Reproduction cabinet taking a complete "Audio Centre" on top and a large tuner/amplifier on the internal shelf behind doors. Lower section will take approx. 150 records but the partitions can be removed to make a clear area 14¾in high by 15¼in deep by 24in high. Overall size: 26½in high by 16½in deep by 25½in wide. Finish in mahogany. Price: £75.00 (plus VAT).

■ SELMOR

Selmor Engineering Industries Ltd,
24 Mulberry Street, Tower Hamlets,
London E1 1EH. Tel: 01-247 3344.

Hi-Fi Trolley Stand

Mounted on castors with shelves and fitted dividers for record storage. Teak finished

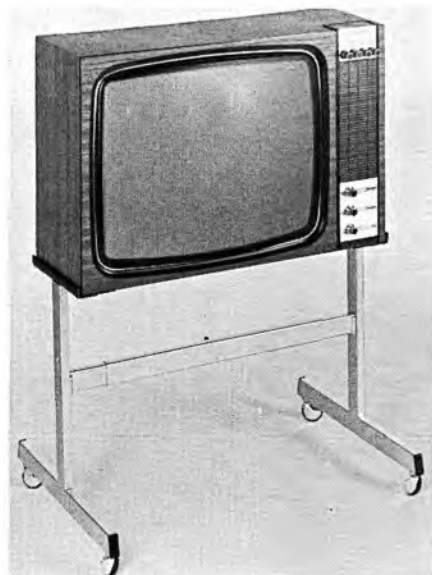

Merlin Stand

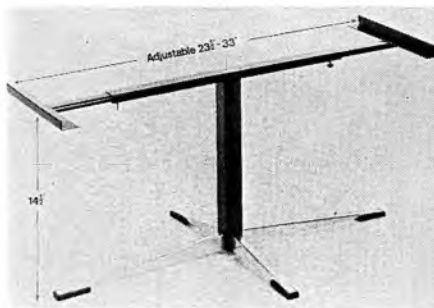

Sonic Stand

shelves and five removable metal dividers. Price: £9.00 (plus VAT).

Sonic Stand ★

With long low look for added stability and smarter appearance, designed to take full range of width and weight of modern Music Centres and larger Hi-Fi Units. Made of high grade steel with ribbed plastic edging and legs of polished chrome. Easily assembled. Price: £5.40 (plus VAT).

Merlin Adjustable Stand ★

For TV or Hi-Fi equipment. Steel with silver finish to simulate brushed aluminium. Stand consists of three parts, two uprights and adjustable crossbar. Height: 40 cm. Price: £4.50.

■ SONY (UK) LTD.

Sony Showroom Consumer Information,
134 Regent Street, London W1R 6DJ.
Tel: 01-439 3874.

TAC 1N

Walnut wood case for Sony models TA1130, TA1140, TA1150, ST5150, ST5130, SQD2010, SQD2020. Price: £11.20 (plus VAT).

TAC 5N

Walnut wood case for Sony models STR7055A, STR7065A, STR6055. Price: £12.00 (plus VAT).

TAC 6

Walnut wood case for STR6200F. Price: £13.38 (plus VAT).

TAC 16

Cabinet for TC209SD. Price: £7.16 (plus VAT).

SU234 Audio Stand

For use with Sony music centres HMK30, HMK40, HMK40A, HMK20. Complete with record and cassette rack and mounted on castors. Finish: teak and chrome. Price: £13.84 (plus VAT).

TIDI-FI

Joyce and Co (PM) Ltd, 29 Clerkenwell Green, London EC1R 0DT. Tel: 01-253 7355.



Joyce & Co Tidi-Fi

Basic 1 ★

White melamine ends and teak veneered shelves. Record and tape decks stand on top shelf, middle shelf takes most amplifiers and tuners. Easy access to rear wiring with adjustable divider. Bottom space gives ample storage for records, cassettes and sundries. Basic model can be varied by addition of doors, castors, drawers and drop flaps. Price: £39.54 (plus VAT).

■ **VERO**

Vero Electronics Ltd, Industrial Estate, Chandler's Ford, Eastleigh, Hants SO5 3ZR. Tel: Chandler's Ford 2952.

Wide range of equipment cases suitable for hi-fi units, tuners, power supplies and test gear. Available in various panel heights and with or without anodised aluminium front handles. Made in light gauge steel finished in RAF blue/grey vinyl paint. Integral aluminium trim. Neat slim-line appearance. Ventilation slots incorporated. Full list of sizes, accessories and prices available on request. Ask for catalogue of Vero 'D' series cases.

PEM gives you the pros without the cons.

Agfa-Gevaert's PEM Series gives you a professional tape to match the high quality of your machine without the serious disadvantages you may find when you use studio tapes at home.

PEM 368 Long Play and PEM 268 Double Play. They give you the pros without the cons.

A matt black back for better winding.

The matt black coating on the back of each tape provides firm, even winding, particularly on the new generation of semi-professional machines. And it prevents static build-up, so your tapes are always dust-free.

Needle-shaped oxide for sharper sound.

PEM tapes have a ferric oxide layer, very fine needle-shaped particles which give a better high-frequency performance, lower HF distortion and 40% less tape hiss than conventional low-noise tape.

**Join the
Sound Improvement Movement
with PEM tapes from
Agfa-Gevaert**

Because the oxide coat is compressed and polished, it reduces head wear and flutter due to friction.

Hearing is Believing.

Agfa PEM Professional tape is available on 10½in., 7in. and 5in. spools in either plastic or metal. The PEM series is especially suitable for high-quality machines like Revox, Teac and Nagra.

If your machine has pressure pads, like the Ferrograph, Tanberg and Uher, Agfa PE 36 Low-Noise tape is more suitable.

If you want full specifications, simply send us the coupon.

But the better way to find out about Agfa's Professional tape is to try it for yourself.

All the words in the world can't describe the difference you'll hear.



Agfa-Gevaert Ltd., 27 Great West Road, Brentford, Middlesex TW89AX
Please send me the specifications of the Agfa PEM tapes.

Name: _____ Address: _____



Magnetic Tape

★ Indicates entry is illustrated
Abbreviations used in this section are given on page 27.

■ AGFA-GEVAERT LTD

Great West Road, Brentford, Greater London. Tel: 01-560 2131.

PE36

Low-noise, long play tape supplied in plastic library case, 13cm 270m £2.65½; 15cm 360m £3.04½; 18cm 540m £4.39; 26cm 1280m £10.91; 26cm 1280m £12.53½. All prices include VAT.

PE46

Low-noise, triple-play tape supplied in plastic library case. 13cm 360m £3.14; 15cm 540m £4.39; 18cm 720m £5.42½. All prices include VAT.

PE66

Low-noise, triple-play tape supplied in plastic library case. 13cm 540m £4.55; 15cm 720m £5.51; 18cm 1080m £6.83½. All prices include VAT.

PEM368 ★

Low-noise, long-play, matt backed tape supplied in plastic library case. Metal spools: 13cm 270m £3.57; 18cm 540m £5.92; 26cm 1100m £14.72½; Plastic spools: 13cm 270m £3.08; 18cm 540m £5.10½; 26cm 1100m £12.70. All prices include VAT.

PEM268

Low-noise, double-play, matt-backed tape supplied in plastic library case. Metal spools: 13cm 320m £4.24½; 18cm 640m £7.32; 26.5cm 1280m £15.46. Plastic spools: 13cm 320m £3.66; 18cm 640m £6.32, 26.5cm 1280m £13.31½. All prices include VAT.

Compact Cassettes

Conventional and colour. C60 (2 × 30min) 98p; C90 (2 × 45min) £1.36; C120 (2 × 60min) £2.04. All prices include VAT.

Cassette Album

Three C60 plus three C90 cassettes £6.98. 10-pack (10 × C60) in case £8.41½. 10 pack (10 × C90) in case £12.24½. All prices include VAT.

Stereochrome ★

Chromium dioxide tape cassette. C60 (2 × 30min) £1.71½; C90 (2 × 45min) £2.24½; C120 (2 × 60min) £3.18½. All prices include VAT.

Super Cassettes ★

Super C60 +6 (2 × 33min) £1.13½; Super C90



Agfa Professional



Agfa Stereo Chrome

★ Indicates entry is illustrated



Agfa Super Cassettes

+ 6 (2 × 48min) £1.47½; Super C120 (2 × 60min) £2.04. All prices include VAT.

For empty library boxes and spare spools see Tape Accessories Section.

■ AMPEX GREAT BRITAIN LTD

Acre Road, Reading, Berks RG2 0QR.
Tel: Reading 85200.

Magnetic recording tape for every domestic and professional application, in various cassette, open-reel and cartridge configurations. Prices and details of specifications on request.

■ BASF UNITED KINGDOM LTD

Audio/Video Tapes Division, PO Box 473,
Knightsbridge House, 197 Knightsbridge,
London SW7 1SA. Tel: 01-584 5080.

LP35 LH Long Play Tape

Long play, low noise, high output. In plastic swivel box: 5in 900ft £2.34; 5¾in 1200ft £2.70; 7in 1800ft £3.86; In cardboard box: 10in 3280ft £7.16; 10½ 4200ft £9.62. All prices exclude VAT.

DP26 LH Double Play Tape

Double play, low noise, high output. In plastic swivel box: 5in 1200ft £2.78; 5¾in 1800ft £3.88; 7in 2400ft £4.78. All prices exclude VAT.

TP18 LH Triple Play Tape

Triple play, low noise, high output. In plastic swivel box: 5in 1800ft £4.02; 5¾in 2400ft £4.84; 7in 3600ft £6.02. All prices exclude VAT.

LP35 LH Super Long Play Tape

Super low noise, high output, long play. In plastic swivel box: 5in 900ft £2.66; 5¾in 1200ft

£3.20; 7in 1800ft £4.54. All prices exclude VAT.

DP26 LH Super Double Play Tape

Super low noise, high output, double play. In plastic swivel box: 5in 1200ft £3.50; 5¾in 1800ft £5.80; 7in 2400ft £6.28. All prices exclude VAT.

LPR35 LH Matt Back Long Play Tape

Long play, low noise, high output tape with conductive matt back for professional or semi-professional use with fast winding machines. In cardboard box, plastic spool 5in 900ft £4.13. In soft plastic box, metal spool 7in 1770ft £5.94; 10½in 3610ft £11.55. All prices exclude VAT.

DPR26 LH Matt Back Double Play Tape

As LPR35 LH Matt Back, but double play tape. In soft plastic box, metal spool 7in 2100ft £6.93; 8¾in 3000ft £10.23; 10½ 4200ft £13.53. All prices exclude VAT.

Compact Cassettes

BASF LH tape in snap pack box: C30 68p; C60 91p; C90 £1.26; C120 £1.73. All prices exclude VAT.

BASF LH Super Tape ★

Incorporates BASF special mechanics for smooth winding and avoidance of jamming, in snap pack box: C60 £1; C90 £1.30; C120 £1.80. All prices exclude VAT.



BASF LH



Contek LN

BASF Chromium Dioxide Tape

Incorporated BASF special mechanics, CRO₂ tape, better dynamic range, lower background noise, when used with suitable machines, in snap pack box: C60 £1.50; C90 £1.90; C120 £2.50. All prices exclude VAT.

8-track Cartridges (unrecorded)

45min £1.60; 64min £1.75; 90min £2. All prices exclude VAT.

Special Requirements Tapes

See details in Tape Accessories Section.

■ **CONTEK MAGNETICS LTD**

32 Eveline Road, Mitcham, Surrey.
Tel: 01-648 5156.

Contek L.N. ★

Low noise cassettes available in: C60 89p; C90 £1.20; C120 £1.60. All prices exclude VAT.

Contek U.H.E. ★

Ultra Hi-Energy low noise cassettes available in: C60 £1.08; C90 £1.37; C120 £1.88. All prices exclude VAT.

Contek Chrome CrO₂ ★

Chromium dioxide cassettes available in: C60 £1.46; C90 £1.85; C120 £2.45. All prices exclude VAT.

■ **EMI TAPE LTD.**

Tape House, Dawley Road, Hayes UB3 1BT.
Tel: 01-573 3888.

HSP Standard Play

5in 600ft. £2.14; 5³/₄in 900ft £2.46; 7in 1200ft £3.11. All prices include VAT.

HLP Long Play

5in 900ft £2.46; 5³/₄in 1200ft £3.42; 7in 1800ft £4.02. All prices include VAT.

HDP Double Play

5in 1200ft £3.42; 5³/₄in 1800ft £4.02; 7in 2400ft £5.27. All prices include VAT.

Emitape Hi-Dynamic

Is supplied in transparent hinged library case. A pre-folded index card is included. Card is designed to provide maximum space for titling with easily visible reference without opening the box.

Compact Cassettes (Soundhog)

C60 (1 hour playing time) 86p; C90 (1½ hours playing time) £1.18; C120 (2 hours playing time) £1.66. All prices include VAT.

Compact Cassettes (Hi-Dynamic)

C30 75p; C60 £1.06; C90 £1.46; C120 £2.00. All prices include VAT.

Compact Cassettes (X-1000) ★

C60 £1.36; C90 £1.84. All prices include VAT.

EMI Cassettes are supplied in library case with index sheet.

Trio Packs of Three

Soundhog—C60 £2.59; C90 £3.53; C120 £4.99.
Hi-Dynamic—C60 £3.18; C90 £4.37; C120 £5.99.
X1000—C60 £4.08; C90 £5.51.



EMI Compact Cassette

■ **GRUNDIG INTERNATIONAL LTD**

Newlands Park, London SE26 5NQ.
Tel: 01-659 2468.

GL13 Hi-Fi

Long Play: 5in 900ft.

GD13 Hi-Fi

Double Play: 5in 1200ft.

★ Indicates entry is illustrated



Maxell

GL15 Hi-Fi

Long Play: 5 $\frac{3}{4}$ in 1200ft.

GD15 Hi-Fi

Double-play: 5 $\frac{3}{4}$ in 1800ft.

GL18 Hi-Fi

Long-play: 7in 1800ft.

GD18ME Hi-Fi

Double-play: 7in 2400ft

C60 HE

Compact cassette. 60 minutes playing time.

C90 HE

Compact cassette. 90 minutes playing time at.

C60CR

Compact cassette. 60 minutes playing time.

C90CR

Compact cassette. 90 minutes playing time.

C120CR

Compact cassette. 120 minutes playing time.
Price list on request.

■ **LENNARD DEVELOPMENTS LTD**

206 Chase Side, Enfield EN2 0QX.
Tel: 01-363 8238.

Playfair Compact Cassettes

Available in C60, C90 and C120 sizes. Price: to be announced.

Playfair 8-track cartridge blanks

60 mins: £1.05 each (plus VAT).

■ **MASTER TAPE**

Audiō Devices (UK) Ltd,
Elstree Studios, Boreham Wood, Herts.
Tel: 01-953 1600.

Reels

7in/1800ft £3.70.

Cassettes

C45 90p; C60 £1.00; C90 £1.29; C120 £1.75.

Cartridges

8T-45 £1.50; 8T-90 £1.80.

Prices exclude VAT.

■ **MAXELL**

Natural Sound Systems,
Strathcona Road, North Wembley,
Middlesex HA9 8QL.
Tel: 01-904 0141.

Super Low Noise ★

SLN C60 £0.95; SLNC C90 £1.25; SLNC 120
£1.70; All prices excluding VAT.

Ultra Dynamic Cassettes ★

UDC 46 £1.27; UDC 60 £1.43; UDC 90 £1.87;
UDC 120 £2.42; UDXL C60 £1.87; UDXL C90
£2.34. Prices exclude VAT.

Ultra Dynamic Open Reel Tape Matt-Back

UD 35-90B 7in-1800ft £5.08; UD 50-120B
10 $\frac{1}{2}$ in-2500ft £10.80; UD 35-180B 10 $\frac{1}{2}$ in.-
3600ft £11.60. Prices exclude VAT.

Ultra Dynamic Open Reel Tape

UD 35-90 7in-1800ft £4.60; UD 50-120 10 $\frac{1}{2}$ in-
2500ft £8.95; UD 35-180 10 $\frac{1}{2}$ in-3600ft £9.90.

■ **MEMOREX**

Memorex (UK) Ltd, Hoechst House,
50 Salisbury Road, Hounslow West,
Greater London. Tel: 01-570 7716.

MRX₂ Cassettes

C30 77p; C45 95p; C60 £1.15; C90 £1.60; C120
£2.20. All prices exclude VAT.

CrO₂ Cassettes

CC45 £1.24; CC60 £1.55; CC90 £2.20. All
prices exclude VAT.

Standard Play Tapes

5in 600ft £2.15; 7in 1200ft £3.10. Both prices
exclude VAT.



We've taken the lid off new Scotch High Energy Cassettes to show you an invisible revolution

This is the part of a cassette you never see. But we thought you'd like to take a good look at the inside story of the most advanced of the new "super" ferric oxide cassettes.

Count the improvements of new High Energy cassettes.

- 1 A unique new small-particle gamma ferric oxide tape. The uniformity and size of the needle-like crystals is controlled, during manufacture, to the highest standards of accuracy. The result is a high performance coating which provides an extended response at all frequencies. A high frequency response up to 9dB better than standard cassettes.
- 2 New High Energy is one of the family of Scotch cassettes; all with a number of features that ensure smoother performance. Features like Posi-Trak anti-static back coating for a smoother wind and jam-free playing, and therefore gives better tape transport across the heads.
- 3 And features like fixed metal roller guides that do away with plastic moving parts.
- 4 And a larger pressure pad to make the tape track better against the playing head, and deliver a cleaner sound.
- 5 Finally, all Scotch cassettes have rigorous, built-in quality controls at all stages of manufacture. This together with the new high precision automated assembly, ensures uniformity of quality and minimises jamming problems.

The Scotch family of cassettes

There is now a complete range of Scotch cassettes. One for every kind of cassette deck or recorder there is.

For instance, if you have a chrome bias switch on your machine, there's new Scotch Chrome cassettes which are coated with chromium dioxide giving you a vastly better signal-to-noise ratio than ordinary cassettes and pure, crystal-clear sound.

There's the new Scotch Dynarange "Jam-buster" cassettes for your everyday recording needs.

And of course, High Energy cassettes with new small-particle gamma ferric oxide tape, gives you fine performance at a very reasonable cost.

Discover the Scotch family of cassettes the next time you go into your hi-fi shop.



For further details write to Paul Edelston, 3M United Kingdom Limited, 3M House, Wigmore Street, London W1A 1ET. Telephone: 01-486 5522.

Name.....

Address.....

3M2293 3M, Scotch, Dynarange and Posi-Trak are trademarks.



Sony SLH tape using Sony TC756 open reel tape deck at 7 1/2 IPS (frequency response - 20VU)

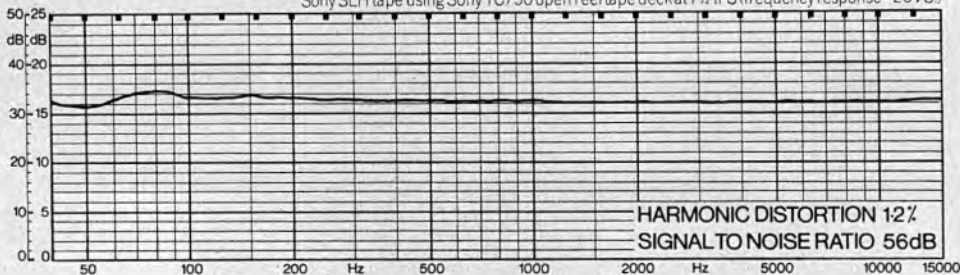

Our open reel tape.

Sony Ferri-chrome tape using Sony TC177SD cassette deck with Dolby system 'out' (frequency response - 20VU)

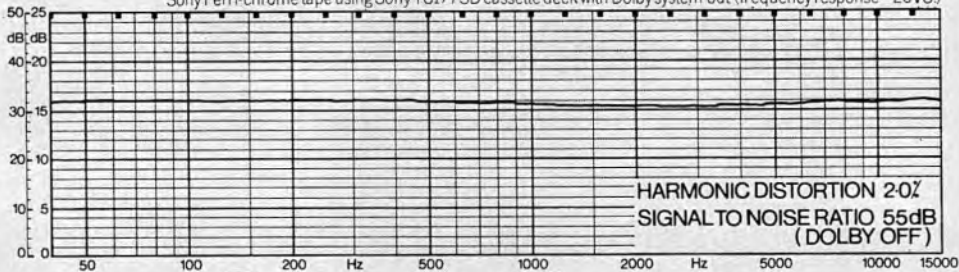

Our cassette tape.

Or is it the other way round?

We must admit we'd be hard put ourselves to tell which was which.

After all, there's not a lot to choose between their signal to noise ratios.

All our tests run between 40 Hz and 15 KHz (or in other words the working range of the human ear). On frequency response, they come out Even Stephen.

As for harmonic distortion they're very close.

For an open reel tape they're everything you'd expect from a Sony Open Reel.

For a cassette tape they're everything you wouldn't expect.

We owe it to our new Ferri-chrome cassette tape.

Firstly, we lay down a layer of Ferric Oxide which gives better results at low frequencies.

Secondly, we lay down a very thin coating (1 micron) of Chromium Dioxide giving better high frequency response.

The two combine to give optimum results in both areas.

You can get excellent results from Ferri-chrome tape using tape decks set up for normal tape.

But if you really want to get the most out of the tape, you should have a deck with a Ferri-chrome switch (All the latest Sony cassette decks now have one).

If the deck to be used has a tape select with normal and Chromium Dioxide positions the normal setting should be used.

Needless to say, we actually produce tape, hub and case (which is the screw type) in our factory.

After all, when you're up against a tape like Sony Open Reel, you cut distortion.

Not corners **SONY.**



Long Play tapes

5in 900ft £2.25; 7in 1800ft £3.85. Both prices exclude VAT.

Double Play tapes

5in 1200ft £3.10; 7in 2400ft £5.10. Both prices exclude VAT.

Blank 8-Track

45 mins £1.70; 60 mins £1.80; 90 mins £1.95.

■ **MUSONIC**

Musonic Ltd, 34-38 Verulam Road, St Albans, Herts AL3 4 DF. Tel: St Albans 50611.

MT1 ★

C60 Professional low noise cassette. Price: 80p (plus VAT).

MT2 ★

C90 Professional low noise cassette. Price: £1.02 (plus VAT).

MT3 ★

C120 Professional low noise cassette. Price: £1.24 (plus VAT).

MT4

8-track cartridge. 80 minutes. Price: £1.98 (plus VAT).

MT21

C60 Chromium Dioxide Cassette. Price: £1.40 (plus VAT).

MT22

C90 Chromium Dioxide Cassette. Price £1.80 (plus VAT).

MT24

C30 Low Noise Cassette in postal pack. Price: 60p (plus VAT).

■ **NAKAMICHI**

Natural Sound Systems Ltd, Strathcona Road, North Wembley HA9 8QL. Tel: 01-904 0141.

Ex ferric cassettes in snap packs. Prices: C60 £1.50; C90 £1.85. Also available in album sets of six cassettes at £11.90 for C60s and £17 for C90s. All prices exclude VAT.

■ **PHILIPS**

Philips Electrical Ltd, Century House, Shaftesbury Avenue, London WC2H 8AS. Tel: 01-437 7777.

Long Play (Red) in library case

Coercivity 26A/m, retentivity 950G, tensilised polyester base, S/N at 3³/₄i/s better than -58dB, print-through less than 55dB, relative frequency response 333Hz-125kHz. Price: 5in 900ft £3.48; 5³/₄in 1200ft £4.29; 7in 1800ft £5.53. All prices include VAT.

Double Play (Blue) in library case

Coercivity 26A/m, retentivity 950G, tensilised polyester base, S/N at 3³/₄i/s 58dB, print-through less than -55dB, relative frequency response 333Hz-12.5kHz. Price: 5in 1200ft £4.29; 5³/₄in 1800ft £5.53; 7in 2400ft £6.96. All prices include VAT.

10¹/₂in cine centre

Red LP26 3600ft £8.95 including VAT).

Compact Cassettes

Double tensilised polyester/mylar base, bias adjustment 0dB, maximum output level (MOL) at 333Hz +2dB, maximum output level (MOL) at 8kHz -15.5dB, relative frequency response (RFR) at 10kHz -4dB, relative tape sensitivity (RTS) at 333Hz 0dB, S/N 53dB. C60 (one hour playing time) £1.03, C90 (1¹/₂ hours playing time) £1.40; C120 (2 hours playing time) £1.89. All prices include VAT.

CrO₂ Hi-Fi Cassettes

Chromium dioxide tape in compact cassettes. Bias adjustment: +5dB. Max. output level: (333Hz) +4dB; (8kHz) -9.5dB. S/N ratio: 59.5dB. Suitable for recorders with facilities for recording with chromium dioxide tape, preferably models that conform to DIN 45 500 standards. C60 (one hour playing time) £2.14. All prices include VAT.

EL 1907/52 Endless Loop cassette CE. 10

Approximate playing time: 40 minutes at 1⁵/₄i/s. Approximately 195ft. Price: £3.77 (including VAT).



Musonic

★ Indicates entry is illustrated

Hi-Ferro

Polyester base. Bias adjustment. 0dB maximum output level (MOL) at 333Hz +2.5dB. Maximum output level (MOL) at 8 kHz -9dB. Relative frequency response (RFR) at 10kHz +1.0dB. Relative tape sensitivity (RTS) at 333Hz 0dB S/N 55dB. Prices: C60 £1.27; C90 £1.61; C120 £1.89. All prices include VAT.

PRECISION TAPES LTD

Precision House, 11 Denmark Street, London WC2H 8NR.
Tel: 01-836 3104/2534.

Eight-track stereo, cartridges, mono compatible tapes, both blank and pre-recorded. Catalogue and price list on request.

PYRAL (UK) LTD

Airport House, Purley Way, Croydon, Surrey CR0 0XY.
Tel: 01-681 2272.

CJ86 Matt Back (Professional)

Available in ¼in, ½in, 1in and 2in widths: ¼in 180m plastic spool 83p; 375m £1.55; 750m £3.50. Also available CJ87 Super professional.

Standard Play (SD82)

750m £3.77; 375m £1.81; 180m £1.01. Long play and double play also available.

Cassettes (Hi-Fi Low Noise)

C60 85p; C90 £1.15; C120 £1.45.

Maxima (Cobalt Active)

C60 £1.20; C90 £1.60.

Optima

C60 £1; C90 £1.35.

Super Ferrite

C60 £1.45; C90 £2.

All prices exclude VAT.

ROSS ELECTRONICS

32 Rathbone Place, London W1P 1AD.
Tel: 01-580 7112.

Ross 66 Series Compact Cassettes

High output, low noise. Super-calendered for consistent performance with minimum wear. Five-screw fixing. Supplied with library case and index. Prices: C30 33p; C60 45p; C90 65p; C120 81p. All prices exclude VAT.

SCOTCH

3M United Kingdom Ltd, 3M House, Wigmore Street, London W1A 1ET.
Tel: 01-486 5522.

Cassette:

Low Noise Dynarange

C60 91p; C90 £1.26; C120 £1.76 (plus VAT).

High Energy

C45 £1.03; C60 £1.28; C90 £1.56 (plus VAT).

Chrome

C45 £1.19; C60 £1.50; C90 £1.88; C120 £2.59 (plus VAT).

Classic Ferrichrome

C45 £1.30; C60 £1.62; C90 £2.16 (plus VAT).

Reel to Reel:

Super Life

SP175 Standard Play. 5in 600ft £2.29; 5¾in. 900ft £3.19; 7in 1200ft £2.81 (plus VAT).

LP215

Long Play. 4in 450ft £1.33; 5in 900ft £2.14; 5¾in 1200ft £2.96; 7in 1800ft £3.72 (plus VAT).

DP220

Double Play. 5in 1200ft £2.96; 5¾in 1800ft £3.95; 7in 2400ft £4.91 (plus VAT).

Hi-Fi Range in Library Box:

SP222

Standard Play. 5in 600ft £2.73; 5¾in 900ft £3.58; 7in 1200ft £4.71 (plus VAT).

LP223

Long Play. 5in 500ft £3.19; 5¾in 1200ft £3.88; 7in 1800ft £5.10 (plus VAT).

DP224

Double Play. 5in 1200ft £3.88; 5¾in 1800ft £5.10; 7in 2400ft £6.43 (plus VAT).

TP225

Triple Play. 5in 1800ft £5.10; 5¾in 2400ft £6.43; 7in 3600ft £9.32 (plus VAT).

Classic

7in 1200ft £4.62; 7in 1800ft £5.75; 7in 2400ft £7.79; 10½in 2400ft £11.07; 10½in 3600ft £13.32; 10½in 4800ft £17.51 (plus VAT).

Cartridge:

High Output—low noise

8 Track. 45mins £1.69; 90mins £2.01 (plus VAT).

Classic

45mins £1.90; 90mins £2.30 (plus VAT).

Video/cassette (compatible with Philips System)

VC30 £12.70; VC45 £15.95; VC60 £18.70 (plus VAT).

■ **SONY (U.K.) LTD.**

Sony Showroom, Consumer Information,
134 Regent Street, London W1R 6DJ.
Tel: 01-439 3874.

K series Compact Cassettes

Low noise ferric oxide tape. May be used on all types of cassette recorder for general use. C60 69p, C90K 97p, C120K £1.26. All prices exclude VAT.

HF series Compact cassettes ★

High performance ferric oxide tape. May be used on all types of cassette recorder. Particularly recommended for music recording. C60HF £1.02, C90HF £1.34, C120HF £1.57. All prices exclude VAT.

CR series Compact Cassettes ★

Chromium dioxide tape for improved treble response. For cassette recorders having a 'chrome' position tape select switch. C60CR £1.53, C90CR £2.08. All prices exclude VAT.

FeCr series Compact Cassettes

Top performance dual layer ferri-chrome tape. Combines the brightness in the high frequency range attributable to chromium dioxide, and the depth and steadiness in the low and middle frequency range inherent in ferric oxide. C60FeCr £1.71. C90FeCr price on application. All prices exclude VAT.

Open Reel Tapes ★

SLH 72-370BL Super low noise high output tape—370m, £3.10; SLH 7-550 BL Super low noise high output tape—550m, £4.40; SLH 7-740B Super low noise high output tape—740m, £6.71; SLH 11-740B Low noise 740m. 10½in NAB Spool, £7.36; SLH 11-1100BL Low noise 1100m. 10½in NAB Spool, £8.56. All prices exclude VAT.



Sony C60HF



Sony C90CR



Sony SLH-11-1100-BL

★ Indicates entry is illustrated

■ SYNCHROTAPE

Sole distributors: Adastra Electronics Ltd, Unit N22, Cricklewood Trading Estate, Claremont Road, London NW2 1TU. Tel: 01-452 6288.

Specification of Synchrotape includes the following: Coercivity 270 oersteds, remanent induction 0.75 maxwell per 6.25mm width. At 7½i/s ½-track biased to give max output at 1kHz, with DIN 70µ Sec playback equalisation, main characteristics are: recorded flux for 2% third harmonic distortion 0.2 maxwell, unweighted RMS noise referred to 0.2 maxwell -65dB, print-through after 72 hours at 20C -58dB.

Standard Play

PVC base. 3in 150ft 30p; 5in 600ft 90p; 5¾in 900ft £1.05; 7in 1200ft £1.45. All prices exclude VAT.

Long Play

PVC base. 3in 225 ft 33p; 4in 450ft 75p; 5in 900ft £1.05; 5¾in 1200ft £1.27; 7in 1800ft £1.87. All prices exclude VAT.

Double Play

Tensilised polyester base. 3in 300ft 45p; 4in 600ft £1.12; 5in 1200ft £1.68; 5¾in 1800ft £2.18; 7in 2400ft £2.92. All prices exclude VAT.

Syncassettes

Compact cassettes. C60 60p; C90 75p; C120 £1.08. All prices exclude VAT.

Synchrotape Editing Kit

Instant cut and trim splicer, four reels coloured leader tape, one reel metallic stop-foil, one reel adhesive tape, six coloured tape-securing clips and 28 self-adhesive titling labels. Presented in see-through crush-proof carton. Complete with 12-page instruction and information booklet. Price: £2.85 (plus VAT).

■ TDK

Tape Distributor (UK) Ltd, 341 Brighton Road, South Croydon, Surrey CR2 6EQ. Tel: 01-688 7372.

Cassettes

New HUDVA range of cassettes: C45 £1.50; C60 £1.66; C90 £2.36. Super-Dynamic cassettes available in: C45 £1.10; C60 £1.22; C90 £1.66; C120 £2.36. Dynamic Cassettes available in C45 94p; C60 £1.04; C90 £1.50; C120 £1.98; C180 £4.80. Super Avilyn cassettes available in C45 £1.50; C60 £1.76; C90 £2.50. All prices exclude VAT.

8-Track Cartridges

8T45SD £1.94; 8T90SD £2.54. All prices exclude VAT.

Audua

L1800 1800ft £4.62; L3600 3600ft £12.68. All prices exclude VAT.

Endless Loop

EC 30S £2.20; EC1M £2.20; EC3M £2.52; EC 6M £2.82; EC12M £4.52. All prices exclude VAT.

Cassette Head Cleaner HC-1

Head cleaning tape, loaded into a standard cassette. Price: 84p (plus VAT).

Open Reel Spools

7in metal spool AMR7 £4.26; 10½in metal spool AMR 10½in £6.90; NAB hub NAB2 £2.86. All prices exclude VAT.

■ TELEFUNKEN

AEG-Telefunken (UK) Ltd, Bath Road, Slough. Tel: Slough 33311.

Telefunken Endless Tape Cassette

Price: £3.36 (plus VAT).

•

■ TMT

Tape Marketing Technology Ltd. 8 Green Street, London, W1. Tel: 01-493 4205.

Blank Cassette Tapes

Lengths available: C60, C90, C120. Price: on application.

You'll hear a lot of good sounds from Contek!

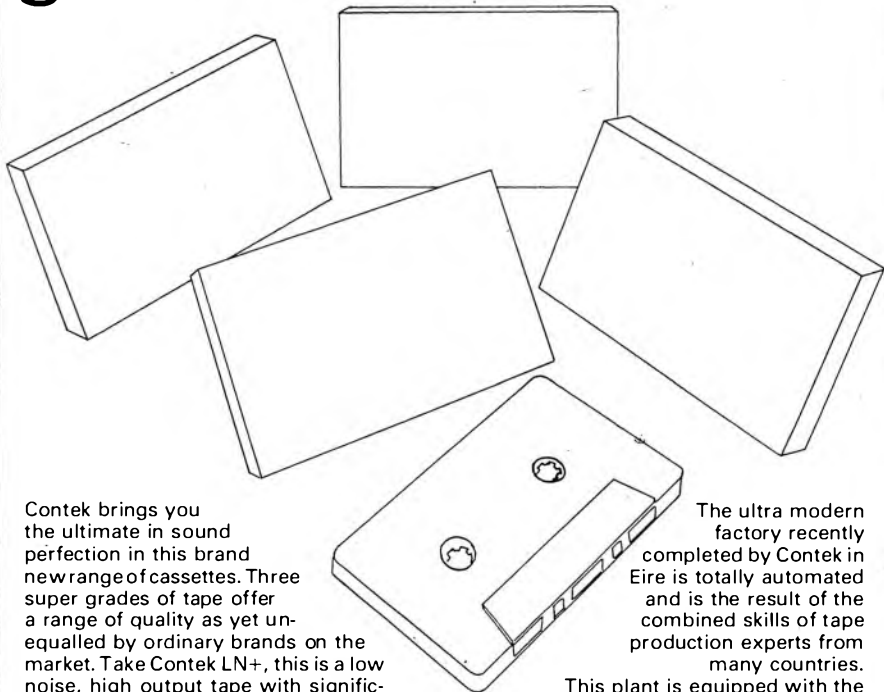

Contek brings you the ultimate in sound perfection in this brand new range of cassettes. Three super grades of tape offer a range of quality as yet unequalled by ordinary brands on the market. Take Contek LN+, this is a low noise, high output tape with significantly improved signal to noise ratio. Contek UHE is an ultra high energy tape coated with specialised formulations of oxide particles which provide a greatly improved quality and clarity by comparison with similarly priced alternatives. Contek Krom is perfection for the sound perfectionist, the best possible cassette tape available today.

The ultra modern factory recently completed by Contek in Eire is totally automated and is the result of the combined skills of tape production experts from many countries.

This plant is equipped with the most modern coating, moulding and assembly machinery available in the western world and as such will produce in ever increasing volume, tape which will establish a new standard of excellence in Britain. Contek Magnetics Ltd., Eveline Rd., Mitcham, Surrey. Tel: 01-648 5156.



CONTEK

pure listening pleasure



Famous Entertainer

ROGER WHITTAKER chooses AKG C45I
Condenser mic's for stage.

AKG the popular choice for Radio,
Television and Theatre.



**AKG Equipment Ltd 182/4 Campden Hill Road
London W8 7AS. Telephone 01229 3695.**

Microphones and Accessories

★ Indicates entry is illustrated

Abbreviations used in this section are given on page 27.

■ ADASTRA

Adastra Electronics Ltd,
Unit N22, Cricklewood Trading Estate,
Claremont Road, London NW2 1TU.
Tel: 01-452 6288.

Imp-Verta ★

Matches low impedance microphones, PU cartridges and tape heads into high impedance amplifier inputs. Solid state printed circuit device using silicon transistors. Automatically switched internal 9V battery. Negligible drain. Conversion factor approximately 20 (depending on load). Virtually no hum or signal loss. Metal case, black crackle finish. Size: $5 \times 1\frac{1}{2} \times 1\frac{1}{2}$ in. Price: on application.

M.12/EX.220

Condenser, cardioid pattern, with on/off switch, and battery (1½V) contained within die-cast aluminium body. Satin finish, supplied with U bracket and stand fitting stem, Busby type slip-on windshield, 6m lead fitted plug. Current drain 0.8mA. FR: 50Hz-15kHz. Impedance: 600 ohms. Sensitivity: -70dB. Price: on application.

M.14/B.7107

Condenser, cardioid pattern with on/off switch. Satin silver aluminium body housing

1½V battery cell providing approximately 10,000 hours life. Supplied with U bracket and stem, windshield and 6m special lead. Current drain: 0.2mA. FR: 30Hz-16kHz. Impedance: 600 ohms. Sensitivity: -70dB. Price: on application.

M.16/B.1238

Pencil slim condenser microphone in machine turned aluminium with 1½V internally located power cell. On/off switch. Omnidirectional performance. Supplied with push-on ball windshield, chrome and white moulded stant; and 3m lead. FR: 20Hz-13kHz. Impedance: 600 ohms. Sensitivity: -74dB. Price: on application.

M.19

Uni-directional cardioid microphone with dual impedance of 50K and 600 ohms. On/off switch. Heavy duty aluminium and steel body in spun silver and black finish. Wire mesh protected diaphragm. Impedance change effected by connections of 6m lead. Supplied with U bracket and stem. FR: 80Hz-13kHz. Sensitivity: -600 ohms -73dB, 50K -54dB. Price: on application.

M.20

Electret condenser microphone with omnidirectional pick-up pattern. 1.5V power cell. On/off switch. Satin and matt black finish. Fitted with 5m lead and moulded plug. Supplied with vari-angle U bracket for stand fitting, and removable windshield. FR: 50Hz-13kHz. Impedance: 600 ohms. Sensitivity: -68dB. Price: on application.

M.21

Of similar conception to Adastra M.20, this electret condenser microphone has a uni-directional polar pattern and substantial cast diaphragm protective housing. On/off switch, U bracket. FR: 50Hz-14kHz. Other details as M.20. Price: on application.

M.124

Portable microphone stand with folding tripod legs and 2-piece chromed stem extending to give 50in height. Adjustable stem locking device. Price: on application.

M.125/B.1411

Studio microphone floor stand with easy-grip stem locking device, microphone lead retaining clip, 3-way coupling adaptor, 2-section extending to 63in. Supplied with heavy steel screw-in tripod legs fitted with rubber ferrules. Price: on application.



Adastra Imp-Verta

★ Indicates entry is illustrated

M.126/B.1415

Microphone boom arm 33in long with easy fitting clamp allowing tilt, length and lateral adjustment. Finished black and chrome. Price: on application.

M.127/B.1416

Boom arm extending to 32in with instant key locking and adjustment bracket. Black moulded finger grip, multi-adaptor termination for acceptance of most microphones and accessories. Price: on application.

M.129/B.1430

Three-section microphone floor stand adjustable for height up to 72in. Dual adaptor fittings. Case metal tube. Price: on application.

M.130

Microphone stand with unique boom arm, counter balanced and rotatable through 360°. Additional slide adjuster will accept second microphone. Screw-in tripod legs with rubber ferruled ends. Maximum height: 5ft. Weight: 11lb. Price: on application.

M.131 and M.132

Model M.131 is a portable 2-section floor stand featuring a moulded polypropylene base which receives the three 15in tubular support legs both for assembly and transportation. Chrome plated stem, height adjustable, rubber ferruled legs, cable retaining clip. Model M.132 has the addition of 32in boom arm fully adjustable through 360°. Prices: on application.

M.150/B.7101

Anti-shock microphone suspension cradle with slip-in mount accepting most microphones. Aluminium frame with covered elasticated cord and adjustable angled bracket for fitting on to stands, etc. Price: on application.

M.161/M.163/M.165

A range of goosenecks with 5/8in male and female termination. Fully hollow flexible tube finished in tough grey PVC covering. M.161 10in long; M.163 15in long; M.165 20in long. Prices: on application.

■ **AIWA**

Johnsons of Hendon Ltd,
14 Priestley Way, London NW2 2TN.
Tel: 01-450 8070.

CM-2000A

One-point stereo electret condenser microphone. Directivity: Uni-directional. Semi-

conductors: 1 FET. Output impedance: 250 ohms. Sensitivity: -74dB ±3dB (0dB 1V/μbar). Frequency response: 50-17,000Hz. Channel balance 2dB. Dimensions 50 × 215mm. Price: on application.

DM-68N

Dynamic microphone. Directivity: Uni-directional. Impedance: 250Ω or 10kΩ. Sensitivity: -73dB (250Ω), -59dB (10kΩ). Frequency response: 50-15,000Hz. Switch: Built-in tone selection switch. Price: on application.

DM-85

Dynamic microphone. Directivity: Non-directional. Impedance: 250Ω. Sensitivity: -82dB. Frequency response: 150-10,000Hz. Price: on application.

DM-91

Dynamic microphone. Directivity: Non-directional. Impedance: 250Ω. Sensitivity: -80dB. Frequency response: 70-10,000Hz. Switch: Built-in talk switch. Price: on application.

DM-503

Dynamic microphone. Uni-directional. Dual impedance 600Ω or 50K. Socket switchable. Sensitivity: -76dB (600Ω), -58dB (50K). FR: 100Hz-12kHz. Built-in talk switch. Price: on application.

DM-504

Dynamic microphone. Uni-directional. Impedance: 600Ω or 50K. Sensitivity: -77dB (600Ω), -58dB (50K). FR: 100Hz-10kHz. Built-in talk switch. Price: on application.

DM-506T

Moving coil microphone. Uni-directional. Impedance: 250Ω. Sensitivity: -78dB ±3dB. FR: 150Hz-10kHz. Built-in talk switch. Price: on application.

■ **AKAI**

Rank Audio Visual, PO Box 70, Great West Road, Brentford, Middlesex TW8 9HB.
Tel: 01-508 9222.

ACM 100

Electret. FR: 40Hz-16,000Hz. Supplied with two different coloured mufflers. Price: £18.01 (plus VAT).

ADM 20

Moving coil. FR: 80-13,000Hz. Stand or hand. Price: £8.00 (plus VAT).

ADM 80

Moving coil. FR: 70-15,000Hz. Stand or hand.
Price: £9.04 (plus VAT).

■ **AKG**

AKG Equipment Ltd, Eardley House,
182-184 Campden Hill Road,
Kensington, London W8 7AS.
Tel: 01-229 3695.

C414E/Comb. ★

FET Studio Condenser Microphone with large capsule. Four switchable directional characteristics: Cardioid, Omni-directional, Figure-of-eight and Hypercardioid. Supplied with combined stand adaptor and connector and 20m (65.6ft) cable terminated in a Cannon XLR-3-12C connector. Price: £194.00 (plus VAT).

C451E/Comb.

FET Microphone Pre-amplifier C451E with Cannon 3 pin socket XLR-3-50 complete with Cardioid Capsule CK1 and Stand Adaptor SA15/1. Specify as: C451E/CK1/SA15/1. Price: £69.70 (plus VAT).

C451C/Comb.

As C451E/Comb. but Pre-amplifier fitted with DIN 3 pin socket T3262. Specify as: C451C/CK1/SA15/1. Price: £69.70 (plus VAT).

C451EB/Comb.

As C451E/Comb. but Pre-amplifier has 3 position switch: "flat" and bass Roll-off from 75Hz and 150Hz. Specify as: C451EB/CK1/SA15/1. Price: £80.70 (plus VAT).

C451CB/Comb.

As C451EB/Comb. but Pre-amplifier fitted with DIN 3 pin socket T3262. Specify as: C451CB/CK1/SA15/1. Price: £80.70 (plus VAT).

C452E/Comb.

As C451E/Comb. but designed for 48 volt operation. Specify as: C452E/CK1/SA15/1. Price: £69.70 (plus VAT).

C452C/Comb.

As C452E/Comb. but Pre-amplifier fitted with DIN 3 pin socket T3262. Specify as: C452C/CK1/SA15/1. Price: £69.70 (plus VAT).

C451E

Microphone Pre-amplifier. Price: £41.00 (plus VAT).

C451C

Microphone Pre-amplifier. Price: £41.00 (plus VAT).

C451EB

Microphone Pre-amplifier. Price: £52.00 (plus VAT).

C451CB

Microphone Pre-amplifier. Price: £52.00 (plus VAT).

C452E

Microphone Pre-amplifier. Price: £41.00 (plus VAT).

C452C

Microphone Pre-amplifier. Price: £41.00 (plus VAT).

CK1

Cardioid (Unidirectional). Price: £25.50 (plus VAT).

CK1S

Cardioid, with presence rise for added brilliance. Price: £25.50 (plus VAT).

CK2

Omni-directional. Price: £25.50 (plus VAT).

CK5

Cardioid. Capsule elastically suspended in robust windshield. Price: £42.00 (plus VAT).

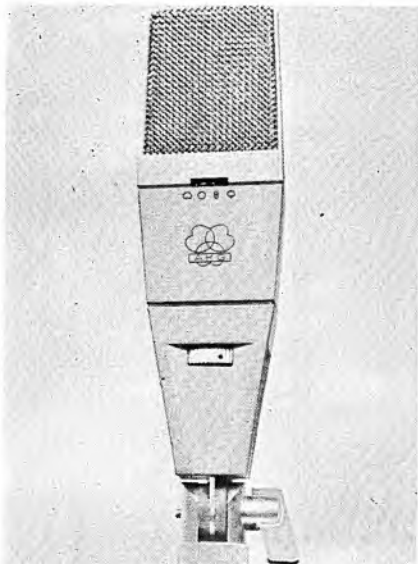

AKG C414

★ Indicates entry is illustrated

CK8

Short, (210mm/8.3inch) Hypercardioid "Gun" attachment. Price: £47.00 (plus VAT).

CK9

Long, (610mm / 24.5inch) "Gun" attachment. Price: £54.00 (plus VAT).

C505E

Detachable Cardioid Capsule CE5 with Feeding Unit SE5E with built-in Cannon connector. Price: £56.80 (plus VAT).

C505C

As above but with DIN connector. Price: £56.80 (plus VAT).

CE5

Elastically suspended Cardioid Capsule. Price: £32.80 (plus VAT).

SE5E

Feeding Unit for all Capsules of CMSE with built-in Cannon connector. Price: £24.00 (plus VAT).

SE5C

As above but with DIN connector. Price: £24.00 (plus VAT).

C510E

Miniature Electret Lavalier Microphone comprising inconspicuous capsule CE10 and Feeding Unit SE5E with built-in Cannon connector. Price: £74.90 (plus VAT).

C510C

As above but with DIN connector. Price: £74.90 (plus VAT).

CE10

Miniature Lavalier Microphone with 7m (23ft.) 2-pole screened lead terminated with screw cap for connection to SE5E or SE5C Feeding Units. Price: £50.90 (plus VAT).

DST11/41

Miniature Paging Unit comprising Directional Microphone mounted on Stand Base ST41 with on/off pushbutton switch, signal lamp and facilities for relay operation. 5 metre (16.4ft.) attached cable. Price: £26.00 (plus VAT).

DST11/43

As DST11/41 but mounted on Stand Base ST43 with three pushbutton switches giving additional facilities. Price: £30.00 (plus VAT).

D12

Unidirectional Microphone for PA and Studio

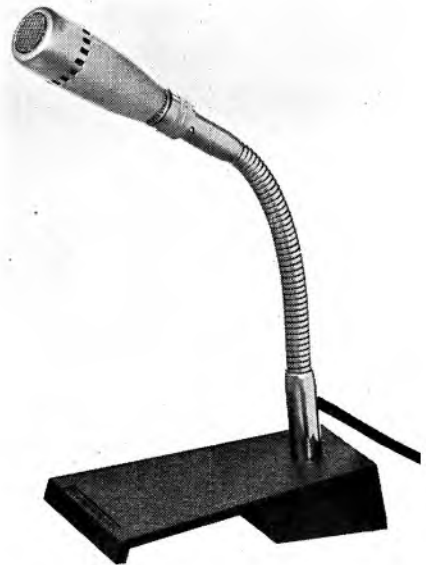

Beyer M 64 SH

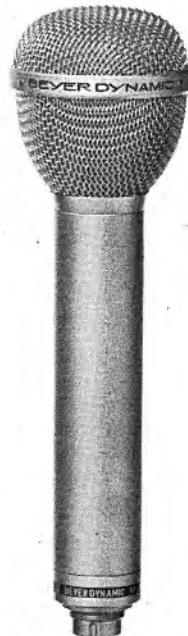

Beyer M88N



Beyer 101 (C)

use with 5 metre (16.4ft.) attached cable. Available in 60 or 200 ohms impedance. Price: £51.00 (plus VAT).

D14S

Economical Directional PA microphone with 5 metre (16.4ft.) attached cable. For stand mounting only. Available in 60 ohms. Price: £14.00 (plus VAT).

D109

Slim, lightweight Lavalier Microphone. Supplied complete with Lavalier cord and clip. Fitted with 5 metre (16.4ft.) attached cable. Impedance: 60 or 200 ohms. Price: £21.50 (plus VAT).

DM-576

Dynamic microphone. Uni-directional. Dual impedance 600 Ω or 50K. Socket switchable. Sensitivity: -76dB (600 Ω), -57dB (50K). FR: 100-12,000Hz. Built-in talk switch. Price: on application.

■ BEYER

Beyer Dynamic (GB) Ltd,
1 Clair Road, Haywards Heath, Sussex.
Tel: Haywards Heath 51003.

M55LM

Mono moving coil omni-directional. FR:

70Hz-16kHz \pm 4dB. Sensitivity: (low Z) 0.17mV; (high-Z) 1.5mV. Impedance: (low Z) 500 ohms; (high Z) 50K. Rec. load: (low Z) 2K; (high Z) 200K. Hand mic with plastic table stand and clamp. Polished metal finish. Price: £15.18 (plus VAT).

M57

Mono moving coil omni-directional. FR: 300 Hz-4kHz. Sensitivity: -146 dBm. Impedance: 600 ohms. Hand mic waterproof and shock resistant. Price: £20.10 (plus VAT).

M64 SH ★

Mono moving coil cardioid. FR: 100Hz-10kHz. Sensitivity: -146 dBm. Impedance: 200ohms Gooseneck with rigid baseplate. Price: £32.45; M £20.55 (plus VAT).

M67N(C)

Mono moving coil cardioid. FR: 40Hz-18kHz \pm 2.5dB. Sensitivity: -148 dBm. Impedance: 200 ohms. Rubber suspended hand mic. Suitable for any climatic conditions. Built-in speech/music switch. Price: DIN £49.97; Cannon £54.16.

M69 N (C)

Mono moving coil uni-directional cardioid. FR: 50Hz-15kHz \pm 3dB. Sensitivity: 144 dBm. Imp: 200 ohms. Rec. load: 1K. Hand mic with optional speech-off-music switch. Steel case finished blue stove enamel. Price: DIN £40.50; Cannon £42.80; SM £42.80 (plus VA1)

M81 LM

Mono moving coil cardioid. FR: 15Hz-16kHz. Impedance: 500 ohms. Supplied complete with plated table stand and clamp. Price: £19.60 (plus VAT).

M88 N (C) ★

Mono moving coil hypercardioid. FR: 30Hz-20kHz. Sensitivity: 144 dBm. Impedance: 200 ohms. Hand mic available with Cannon plug. Price: DIN £81.05; Cannon £83.34 (plus VAT).

M101N (C) ★

Mono moving coil omni-directional. FR: 40Hz-20kHz \pm 2.5dB. Sensitivity: 150 dBm. Impedance: 200 ohms. Rec. load: 1K. Hand mic with windshield. Anodised aluminium case. DIN £44.70; Cannon £48.24 (plus VAT).

M111N

Mono moving coil omni-directional. FR: 60Hz-15kHz. Sensitivity: -155 dBm. Impedance: 200 ohms. Lavalier mic. Anodised aluminium case. Price: £53.89 (plus VAT).

★ Indicates entry is illustrated



Beyer M810N

M160N (C)

Mono double-ribbon super cardioid. FR: 40Hz-18kHz ± 2.5 dB. Sensitivity: 152 dBm. Impedance: 200 ohms. DIN £96.07; Cannon £98.37 (plus VAT).

M260 N (C)

Mono ribbon super cardioid. FR: 50Hz-18kHz ± 3 dB. Sensitivity: -153 dBm. Impedance: 200 ohms. Price: DIN £47.16; Cannon £55.73 (plus VAT).

M410

Mono moving coil cardioid. FR: 300Hz-12kHz. Sensitivity: -144 dBm. Impedance: 200 ohms. Gooseneck hand mic designed for heavy duty use. Price: £27.15 (plus VAT).

M411N (C) S

Mono moving coil uni-directional cardioid. FR: 200Hz-12kHz. Sensitivity: -149 dBm. Impedance: 200 ohms. Rec. load: 1K. Hand Gooseneck mic. Designed for close-talking applications. Price: £29.24 (plus VAT).

M500 N (C)

Mono ribbon hypercardioid. FR: 40Hz-18kHz. Sensitivity: -153 dBm. Impedance: 200 ohms. Price: DIN £61.45; Cannon £64.30 (plus VAT).

M818LM

Stereo moving coil cardioid. Comprises pair of matched M81HL. FR: 15Hz-16kHz. Impedance: 500 ohms. Price: £44.18 (plus VAT).

M550LM

Omni-directional moving coil. FR: 70Hz-18kHz. Sensitivity: -152 dBm. Impedance: 500 ohms. Price: £14.70; M550 LMS £16.35 (plus VAT).

M810N ★

Cardioid moving coil. FR: 50Hz-16kHz. Sensitivity: -148 dBm. Impedance: 500 ohms. Supplied complete with case, widescreen, spring mic clamp, detach. cable. Price: £31.75 (plus VAT).

M201NC

Hypercardioid moving coil. FR: 40Hz-18kHz. Sensitivity: -149 dBm. Impedance: 200 ohms. Hand-held or stand-mounted type. Price: DIN £53.23; Cannon £54.87.

M412N(T)S

Moving coil cardioid. FR: 200Hz-12,000 Hz. Imp: 200 ohms. Sensitivity: -149 dBm. Hand or gooseneck mounting. PA mic with flexible rubber housing. Price: £29.65 (plus VAT).

X1N (C)

Moving coil cardioid. FR: 30Hz-18,000 Hz. Imp: 200 ohms. Sensitivity: -146 dBm. Stand, built-in pop filter. Available with DIN connectors or Cannon. Price: DIN £30.35, Cannon £31.84 (plus VAT).

X1HL(C)

As above. Price: DIN £35.98. Cannon £37.44 (plus VAT).



Coles Eng 4038

■ COLES

Coles Engineering (Hoddesdon) Co,
Pindar Road, Hoddesdon, Herts.
Tel: Hoddesdon 66685.

Distributor: Hampstead Hi-Fidelity,
91 Heath Street, Hampstead, London, NW3.
Tel: 01-435 0099.

4037

Omni-directional moving coil stick microphone for field work and P.A. Extremely rugged in construction. FR: 80Hz-10kHz. Impedance: 30 ohms or 300 ohms. Sensitivity: -76dB. Long (A) or short (C) models available. Available in colours for use in discos and on colour television. Price: £52.53 (plus VAT).



Coles Eng 4104

4038 ★

Studio ribbon microphone. Accurate figure-of-eight response. Flat frequency response 30Hz-15kHz. Impedance: 30 ohms or 300 ohms. Sensitivity: -85dB. Non-linear distortion 0.1%. Controlled transient response. Price: £127.36 (plus VAT).



Coles Eng 4136

4104 ★

Broadcast quality commentator's noise-cancelling ribbon lip microphone. Output: -82dB. Impedance: 30 or 300 ohms. Price: £84.93 (plus VAT).

4105A

Cardioid moving coil microphone specially designed for speech. Flat response 60-10,000Hz. Impedance: 30 ohms. Sensitivity: -82dB. Front to back ratio 15-20dB. Price: £52.53 (plus VAT).

4136 ★

Condenser cardioid microphone, uniform polar frequency response. Front/back ratio better than 20dB. FR: 40Hz-18k Hz. Impedance: 30 or 300 ohms. Sensitivity: -50dB at 300 ohms. FET head amplifier. Phantom power supply for combined mains and battery supply unit. Complete system with windshield and connecting cable. Price: £204.65 (plus VAT).



Eagle UD 50 HL

■ EAGLE INTERNATIONAL

Heather Park Drive, Wembley HA0 1SU.
Tel: 01-902 8832.

DM18HL

Mono moving coil. Omni-directional. FR: 60Hz-12kHz \pm 3dB. Sensitivity: -57dB. Impedance: 600 ohms and 50K. Built-in impedance switch. Rec load: 600 ohms and 50K.

Stick mic for hand or stand. Fitting: 15.5 \times 1mm thread. Complete with desk stand. Finish: black anodised aluminium. Price: £10.90 (plus VAT).

UD50HL ★

Mono moving coil. Cardioid. FR: 40Hz-14kHz \pm 3dB. Sensitivity: -54dB at 50K, -74dB at 600 Ω . Hand and stand mic. Fitting: 15.5 \times

★ Indicates entry is illustrated



Eagle PRO-M5

Imm thread. Built-in on/off switch. Finish: satinised stainless steel. Price: £12.00 (plus VAT).

Model DM94

Omni-directional dynamic, supplied with windshield. Impedance: 50K. FR: 80Hz-10kHz. Sensitivity: -50dB. Price: £10.00 (plus VAT).

PRO-M5 ★

Mono omni-directional capacitor microphone. FR: 50Hz-13kHz. Sensitivity: -65dB. Impe-

dance: 600 ohms. Lapel type. Sub-miniature FET circuitry built into mic capsule. Price: £16.00 (plus VAT).

PRO-M20 ★

Mono uni-directional capacitor microphone. FR: 30Hz-17kHz. Sensitivity: -60dB. Sub-miniature FET circuit built into mic capsule. Impedance: 600 ohms balanced (floating). Hand or stand type. Supplied with stand adaptor. Built-in switch, windshield. Price: £32.00 (plus VAT).

CO96

Mono electret condenser microphone. Powered by single cell. Cardioid response: better



Eagle PRO-M20

Microphones and Mixers



The Eagle PRO range of microphones is for Professionals. (But we've got a lot of different mikes for less exacting jobs as well). They're all meticulously engineered, guaranteed and cost less than any others of the same quality. Omni- and uni-directional capacitor mikes. Lavalier capacitor mikes. And a lot of other studio equipment you're sure to need.



Write to us today for your free copy of the full catalogue with details and prices of mikes, mixers and studio equipment.

Eagle International,
Dept. HFY,
Precision Centre,
Heather Park Drive,
Wembley,
Middx. HAO 1SU.

Eagle

than 20dB. Impedance: 600 ohms. FR: 30Hz-16kHz. Sensitivity: -70dB. Price: £18.00 (plus VAT).

MDF 619

Cardioid dynamic microphone. Dual impedance: 600 ohms or 50K. FR: 200Hz-10kHz. Output: 2.2V 50K. Stand mounting complete with windshield. Price: £18.40 (plus VAT).

Wide range of desk stands, floor stands, boom arms, goose-necks, shock-mounts—and matching units also available.

■ ELECTRO-VOICE

Gulton Europe Ltd, Special Products Division, The Hyde, Brighton BN2 4JU. Tel: Brighton 66271.

635A ★

Moving coil omni-directional hand/stand microphone. FR: 80Hz-13kHz. Sensitivity: -149dB EIA rated. Output: -55dB (ref 1mW/10 dynes/cm²). Impedance: 150 ohms. Supplied with 312A stand adaptor. Built-in pop filter. Fitted with Switchcraft connector and cable. Finish: non-reflecting steel case.

RE10

Moving coil super cardioid hand or boom microphone. FR: 90Hz-13kHz. Sensitivity: -150dB EIA rated. Output: -56dB (ref 1mW/10 dynes/cm²). Impedance: 150 ohms. Supplied with 312A stand adaptor, or 307 boom mounting. Fitted with Switchcraft connector and cable. Finish: non-reflecting Micomatte finished steel case.

RE11

Moving coil super cardioid hand or boom microphone. FR: 90Hz-13kHz. Sensitivity: -150dB EIA rated. Output: -56dB (ref 1mW/10 dynes/cm²). Impedance: 150 ohms. Supplied with 312A stand adaptor, or 307 boom mounting. Built-in pop filter. Fitted with Switchcraft connector and cable. Finish: non-reflecting Micomatte finished steel case.



Electro-Voice 635A



Electro-Voice RE20

RE15

Moving coil super cardioid hand or boom microphone. FR: 80Hz-15kHz. Sensitivity: -150dB EIA rated. Output: -56dB (ref 1mW/10 dynes/cm²). Impedance: 150 ohms. Supplied with 312A stand adaptor, or 307 boom mounting. Fitted with Switchcraft connector and cable. Bass tilt switch incorporated. Finish: fawn beige with Micomatte non-reflecting finish.

RE16

Moving coil super cardioid hand or boom microphone. FR: 80Hz-15kHz. Sensitivity: -150dB EIA rated. Output: -56dB (ref 1mW/10 dynes/cm²). Impedance: 150 ohms. Supplied with 310A stand adaptor, or 307 boom mounting. Fitted with Switchcraft connector and cable. Built-in pop filter. Bass tilt switch incorporated. Finish: non-reflecting Micomatte finished steel case.

RE20 ★

Moving coil wide range cardioid stand or boom microphone. FR: 45Hz-18kHz. Sensitivity: -150dB EIA rating. Output: -57dB (ref 1mW/10 dynes/cm²). Impedance: 50, 150 and 250 ohms selectable. Supplied with 302 stand adaptor, or 309 boom mounting. Fitted with Switchcraft connector and cable. Built-in pop filter. Finish: non-reflecting satin nickel steel case.

RE55

Moving coil omni-directional hand, stand or boom microphone. FR: 40Hz-20kHz. Sensitivity: -149dB EIA rated. Output: -55dB (ref 1mW/10 dynes/cm²). Supplied with 310S stand adaptor and metal carrying case. Fitted with Switchcraft connector and cable. Finish: non-reflecting satin nickel steel case.

670, 670V Top Brass

Moving coil cardioid hand or stand mic-

★ Indicates entry is illustrated

rophone. FR: 60Hz-14kHz. Sensitivity: -150dB EIA rated. Output: -58dB (ref 1mW/10 dynes/cm²). Impedance: 150 ohms or high Z selectable. Model 670 has built-in switch and pop filter. Model 670V has built-in volume control and pop filter. Fitted with Switchcraft connector. Finish: anodised aluminium.

DS35

Cardioid dynamic microphone with built-in pop filter. Switchcraft connector. Impedance: 150K. FR: 60Hz-17kHz. Sensitivity: -56dB (0dB = 1mV/10 dynes/cm²). Supplied with stand adaptor and cable. Finish: non-reflecting grey.

Model 660

Super cardioid dynamic microphone with Switchcraft connector. Impedance: 120K or Hi-Z selectable. FR: 90Hz-13kHz. Sensitivity: Low-Z -56dB, High-Z -55.5dB (0dB = 1mV/10 dynes/cm²). Finish: chrome.

Model 671

Cardioid dynamic microphone with Switchcraft connector. Impedance: 150K or High-Z. FR: 60Hz-14kHz. Sensitivity: Low-Z -61dB, Hi-Z -60dB (0dB = 1mV/10 dynes/cm²). Supplied with stand adaptor and cable. Prices: on application.

■ ENVIRONMENTAL SOUND

London House, Mayfield, Sussex TN20 6AQ.
Tel: Mayfield 3419/2495.

KM M6ST Micromixer ★

Professional standard microphone mixer for 6 mic inputs with panoramic balance on input 1 and left/right switching at inputs 2-6. Possible to feed an additional ES KM M6ST unit into the first to give a total of 12 inputs, if required. Six symmetrical inputs 50-600 ohms impedance giving six microphones which can be combined in stereo or mono each with an individual treble and bass control. Sensitivity:

Input 1-1mV for output voltage of 1.1V; Inputs 2-6 -2mV for output voltage of 1.1V. FR: 20-25kHz. S/N: better than 60dB. Outputs: 2.5V maximum per channel for dynamic impedance of 220 ohms. Price: £157.32 (plus VAT).

■ FOSTER

Distributors: Adastra Electronics Ltd,
Unit N22, Cricklewood Trading Estate,
Claremont Road, London NW2 1TU.
Tel: 01-452 6288.

M53/MDF623C

Mono moving coil cardioid stick microphone. FR: 200Hz-10kHz. Impedance: 600 ohms and 50K. Sensitivity: (600 ohms) -82dB, (50K) -63dB. Adjustable cradle fitting. Microphone holder and neck cord. Satin metal case. Price: £14.25 (plus VAT).

M58/MDF619BC

Mono moving coil cardioid stick microphone. FR: 200Hz-10kHz \pm 6dB. Impedance: 600 ohms and 50K. Sensitivity: (600 ohms) -76dB \pm 3dB, (50K) -58dB \pm 3dB. Adjustable cradle fitting. Built-in switch. Windshield. 16ft cord. Satin gold finish with chrome trim. Price: £20.60 (plus VAT).

M50

Dynamic microphone with on/off switch. FR: 400Hz-5kHz \pm 6dB. Sensitivity: -72dB \pm 3dB at 600 ohms, -54dB \pm 3dB at 50K. Dual impedance. Black moulded case. Heavy duty 1.5m (extended) coiled cord. Price: £7.50 (plus VAT).

M51/DF1X

Dynamic stick/hand microphone offered in three impedance versions: 50K, 600 and 50 ohms. FR: 100Hz-10kHz. Sensitivity: -57dB. Omni-directional polar pattern. Supplied with matching base, adjustable U bracket and lavalier cord. Price: £6.40 (plus VAT).

■ GARDNERS

Gardners Transformers Ltd,
Christchurch, Dorset BH23 3PN.
Tel: Christchurch 2284.

Audio Transformers ★

Wide range of miniature microphone transformers, standard microphone and A.F. line matching transformers, wide band microphone and A.F. line matching transformers, extra wide band microphone and A.F. line matching transformers, super fidelity wide band microphone and line matching transformers, high-voltage-proof A.F. line matching trans-

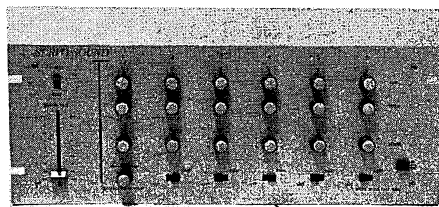

Environmental Sound Micro Mix

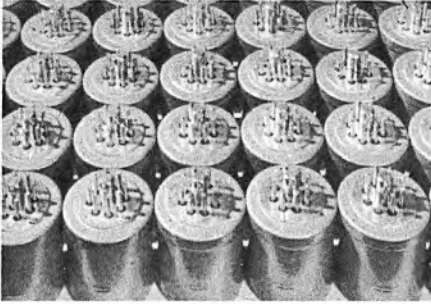

Gardner Mic Transformers

formers, high-level A.F. line matching transformers, sub-miniature A.F. matching transformers, miniature open-type microphone transformers and miniature open A.F. line matching transformers. Specifications and prices on request.

■ **GRAMPIAN REPRODUCERS LTD**

19 Hanworth Trading Estate,
Hampton Road West, Feltham TW13 6EJ.
Tel: 01-894 9141.

DP4

Moving coil. FR: 50-15,000Hz. Sensitivity: -52dB, -70dB, -86dB, for high, medium and low impedance, 50,000, 600 and 25 ohms. Tubular case. Price including lead, high or medium impedance: on application; low impedance on application.

DP6 ★

Moving coil. Omni-directional. FR: 200Hz-15kHz. Sensitivity: -87dB (25 ohms), -75dB (200 ohms), -50dB (600 ohms), -52dB (50K). Built-in transformers fitted to all but low impedance model. Price: on application.

GC2 and GC3

Mono moving coil microphone for hand (GC2) or desk mounting (GC3). Uni-directional response. FR: 70Hz-14kHz. Impedance: (L) 25 ohms; (X) 200 ohms; (M) 600 ohms; (H) 50K. Sensitivity: (L) -86dB 50µV, (X) -75dB 180µV (M) -70dB 300µV (H) -52dB 2.5mV. All sensitivity figures per microbar. Easily replaceable diaphragm and coil assembly. GC2 has on/off switch and is supplied with swivel holder for fitting to floor or table stand. Prices: on application.

GR1

Ribbon. Unequal figure-of-eight. Response: 40Hz-15kHz. Sensitivity: -90dB (25 ohms), -81dB (200 ohms), -76dB (600 ohms), -58dB

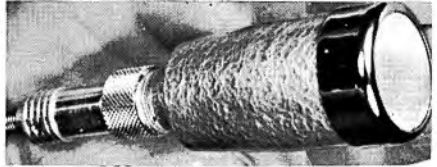

Gramplan DP6



Gramplan DP4

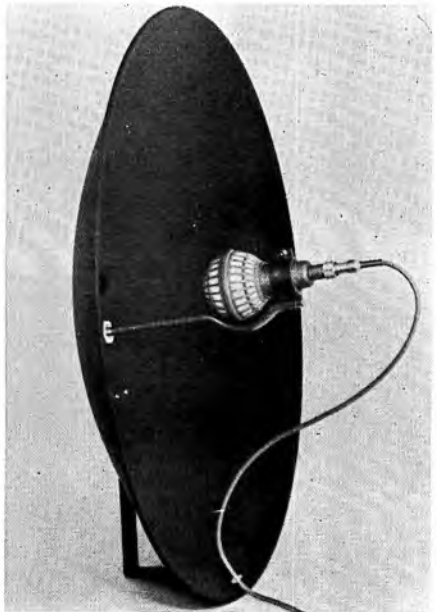

Gramplan Parabolic Reflector

★ Indicates entry is illustrated

(50K). Impedance: 25, 200, 600 ohms, 50K. Built-in transformer. Easily replaceable ribbon. Price: on application.

GR2

Details as for GR1, but equal figure-of-eight response.

DP8 series ★

Moving coil omni-directional microphones. FR: 50Hz-15kHz \pm 5dB. Built-in on/off switch. Interchangeable leads. Hand type with swivel holder for stand use. Sensitivities, impedances and rec loads as for DP4 series. Prices: on application.

Boom arm

Suitable for use with various types of mics and stands. The clamp, locked by a single lever, allows the reach and angle to be readily adjusted as required. Length: 34in. Weight: 1 $\frac{3}{4}$ lb. Thread termination for mic $\frac{1}{16}$ in BSF male, thread termination for stand $\frac{5}{16}$ in \times 27tpi female. Supplied with adaptor to $\frac{1}{16}$ in BSF female. Adaptors for other sizes available. Price: on application.

Grampian Parabolic Reflector ★

Diameter 24in, depth 5in. Gain 14dB 500Hz-5kHz. Takes Grampian DP4 and DP6 microphones. Weight: 4 $\frac{3}{4}$ lb. Price: on application.

■ GRUNDIG

Grundig International Ltd,
Newlands Park, London SE26 5NQ.
Tel:01-659 2468.

GDM 305 ★

Mono moving coil hand microphone. FR: 80Hz-12.5kHz. Sensitivity: -74dB. Impedance: 500-700 ohms. Stop/start switch. Price: £11.56 (including VAT).

GDM 312 ★

Mono moving coil hand microphone. FR: 150Hz-15kHz. Impedance: 200 ohms and 100K. Finish: moulded black and grey body. Price: £11.20 (including VAT).

GDM314

Mono moving coil hand microphone. Omni-directional. FR: 80Hz-15kHz. Impedance: 200 ohms and 10K. Table stand supplied. 3-pin DIN plug. Extension cable (MEC 10) available. Finish: black and metallic. Price: £13.32 (including VAT).

GDM 318SC

Mono moving coil hand microphone. FR:



Grundig GDM 305

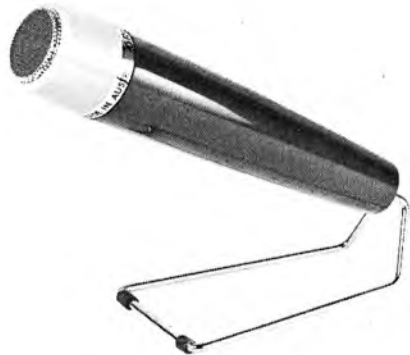

Grundig GDM 312

100Hz-15kHz. Sensitivity: -72dB. Impedance: 700 ohms. Finish: moulded black and silver trim. Stop/start switch fitted. Price: £27.10 (including VAT).

GDSM 331

Stereo dynamic moving coil microphone. FR: 150Hz-15kHz. Sensitivity: -10dB. Impedance: 200 ohms and 11K. Price: £23.63 (including VAT).

■ HEATHKIT

Heath (Gloucester) Ltd,
Gloucester GL2 6EE.
Tel: Gloucester 29451.

TM-1626 ★

Stereo mike mixer. Details of kit on applica-

tion. Price: £78.80 (plus VAT).

■ LAWTRONICS

Lawtronics Ltd, 139 High Street,
Edenbridge, Kent TN8 5AX.
Tel: Edenbridge 5191/2.

LM23

A subminiature electret microphone weighing 7.5gm. FR: 30Hz-10kHz \pm 3dB. Impedance: 600 ohms. Sensitivity: -72dB, \pm 4dB @ 1kHz. Hand or lapel mounting. External power adaptor. FET amplifier. Supplied with adaptor and case. Price: £23.95 (excluding VAT).

■ LEM

Distributors: Douglas A. Lyons and Associates Ltd, 99 Larkhall Lane, London, SW4. Tel: 01-622 0287.

DH80

Miniature moving coil. Omni-directional. FR: 70Hz-14kHz \pm 4dB. Impedance: 50 ohms or 80K. Sensitivity: (low impedance) -82dB, (high impedance) -52dB. May be used as hand microphone, desk stand, or attached to floor stand. Price: from about £12.00 (plus VAT).

DO35

Miniature lavalier moving coil microphone. Omni-directional. FR: 80Hz-12kHz \pm 3dB. Sensitivity: -80dB. Impedance: 200 ohms. Can also be used as hand or stand microphone. Size: 2 1/2in long, 3/8in diameter. Weight: 1 1/4oz. Price: approximately £28.00.

DO21B

Studio-quality omni-directional moving coil microphone. FR: 30Hz-16kHz \pm 3dB. Impedance: 50 ohms or 200 ohms. Sensitivity: (200 ohms) -77dB. Individually calibrated re-

sponse curves. Suitable for hand or stand use. Price: approximately £28.00 (plus VAT).

DO20

Hand or stand type coil microphone. Omni-directional. FR: 40Hz-15kHz. Impedance: 50 ohms, 200 ohms or 80K. Sensitivity: 50 ohms -82dB, 200 ohms -76dB, 80K -50dB. Internal element resiliently mounted to avoid mechanical shock. Price: approximately £20.00 (plus VAT).

DO42

Miniature lavalier. Similar specification to type DO35 but incorporates special features to avoid rubbing noises. Price: approximately £30.00 (plus VAT).

■ MELODIUM

Keith Monks (Audio) Ltd,
26-30 Reading Road South, Fleet,
near Aldershot, Hants.
Tel: Fleet 7316 and 3566.

76A

Moving coil, cardioid. FR: 100Hz-15kHz (3dB). Sensitivity: -63dB (0dB = 1mW/10 μ Bar) 30 ohms or 200 ohms impedance. Windshields available.

78A or 78A/108

Moving coil cardioid. FR: 50Hz-15kHz \pm 3dB. Sensitivity: -67dB (0dB = 1mW/10 μ Bar, 0.042 mV/ μ Bar), 30 ohms or 600 ohms impedance. Stick, head removable for fitting to swan neck. Clamp or swan neck fitting, 1/2in Whit. Switch available on microphone or swan neck. Windshields available. Steel.

RM6

Ribbon bi-directional. FR: 30Hz-18kHz \pm 2dB. Sensitivity: (200 ohms) -56dB 0.1mV/ μ Bar, (50 ohms) -61dB 0.09mV/ μ Bar (0dB = 1mV/10 μ Bar), 50 ohms or 200 ohms impedance. Stick. Clamp fitting. Four position sensitivity and on/off switch.

C121

Moving coil, cardioid. Noise-cancelling miniature. FR: 150Hz-14kHz \pm 3dB. Sensitivity: -89dB (0.036mV). Removable head for fitting to swan neck for use as stick mic. With 3-pin DIN connector.

C133

Moving coil, cardioid. Stick type mic. FR: 50Hz-15kHz \pm 3dB. Sensitivity: -83dB (0.072mV) at 30 ohms, -71dB (0.28mV) at 600 ohms. Built-in pop shield. With or without

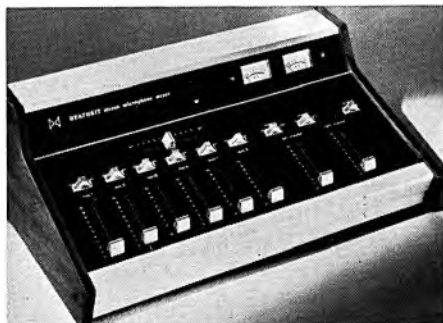

Heathkit TM-1526

★ Indicates entry is illustrated

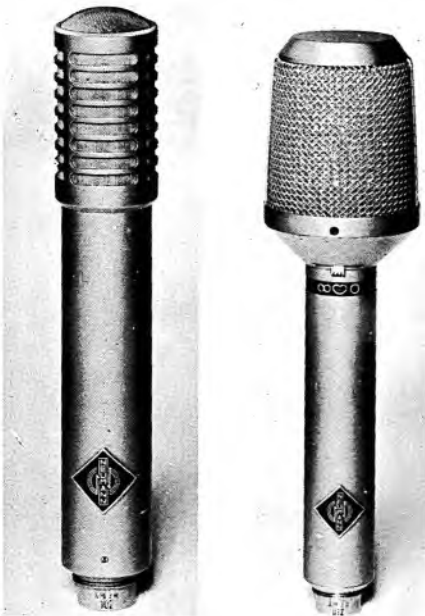

Neumann KM74

Neumann KM76

on/off switch. Melodium or 3-pin DIN screened plug.

Optional accessories

Wide range of plugs, sockets, adaptors, clamps, goosenecks, stands, stereo bars, mounting blocks, windshields, lavalier cords, transformers and adaptors. Full details on request.

79A

Omnidirectional miniature dynamic. FR: 60-16,000Hz. Small compact and robust with unusually wide frequency response to suit lavalier operation with performance equivalent to stand operation.

88

Omnidirectional dynamic. Compact high quality intended to direct mounting on gooseneck or floor stand, rugged construction. FR: 50-17,000Hz.

All prices on application.

■ NEUMANN GMBH

Sole UK Agents. F.W.O. Bauch Ltd,
49 Theobald Street, Boreham Wood,
Herts WD6 4RZ. Tel. 01-953 0091.

KM73

Transistor (FET) condenser. Omnidirectional. FR: 40Hz-16kHz ± 2 dB. Sensitivity across 1K: 2.5mV/dyne/cm². Impedance: 200 ohms without transformer. Printed circuit. Miniature pressure mic. Price: on application.

KM74 ★

Transistor (FET) condenser. Cardioid. FR: 40Hz-16kHz ± 2 dB. Sensitivity across 1K: 2.5mV/dyne/cm². Impedance: 200 ohms without transformer. Printed circuit. Miniature pressure-gradient mic. Price: on application.

KM76 ★

Transistor (FET) condenser. Switchable: omni-directional, cardioid, figure-of-eight. FR: 40Hz-16kHz ± 2 dB. Sensitivity across 1K: 2.6mV/dyne/cm². Impedance: 200 ohms without transformer. Printed circuit. Miniature pressure-gradient mic. Price: on application.

KML

Lavalier transistor (FET) condenser. Cardioid. FR: 40Hz-16kHz ± 2 db. Sensitivity across 1K: 0.5mV (18V) or 1.8mV (45V) per dyne/cm². Impedance: 50 or 200 ohms. Built-in transformer. Printed circuit. Battery driven (18V or 45V). Miniature pressure-gradient mic. Price: on application.

U77

Condenser FET. Switchable omni-directional or cardioid or figure-of-eight. FR: 40Hz-16kHz. Sensitivity across 1K: 2.6mV/microbar (omni), 5mV/microbar (figure-of-eight), 3mV/microbar (cardioid). Impedance: 200 ohms. Pressure-gradient mic. Bass cut and sensitivity switch of -10 dB. Price: on application.

KM83

FET condenser. Omnidirectional. FR: 40Hz-16kHz. Sensitivity: 0.5mV/microbar. Impedance: 50 or 200 ohms. Built-in transformer. Sensitivity switch: -10 dB. Price: on application.

KM84

FET condenser. Cardioid. FR: 40Hz-16kHz. Sensitivity: 0.5mV/microbar. Impedance: 50 or 200 ohms. Built-in transformer. Sensitivity switch: -10 dB. Price: on application.

KM86

FET condenser. Cardioid. FR: 40Hz-16kHz. Sensitivity: 0.5mV/microbar. Impedance: 50 or 200 ohms. Built-in transformer. Sensitivity switch: -10 dB. Price: on application.

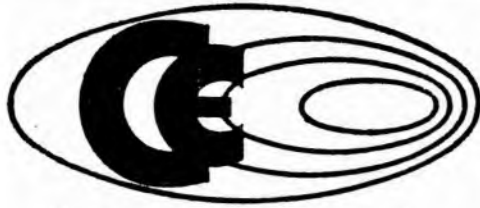

ACOUSTIC PRODUCTS



Coles have for the past few years manufactured the range of microphones formerly made and distributed by S.T.C. In April 1974 Coles acquired the full rights from ITT S.T.C. and have since under their own name, manufactured and distributed direct, and through their stockist "HAMPSTEAD HI-FI LTD" this well-known range of acoustic products throughout the world, satisfying the ever increasing demand for quality and reliability.

Coles Engineering (Hoddesdon) Co.

Pindar Road

Hoddesdon

Herts EN11 0BZ

Telephone Hoddesdon 66685

★ Indicates entry is illustrated

U87

FET condenser. Switchable to omnidirectional, cardioid or figure-of-eight. FR: 40Hz-16kHz. Impedance: 50 or 200 ohms. Built-in transformer. Bass cut and sensitivity switch of -10dB. Price: on application.

KM88

FET condenser. Switchable to omnidirectional or cardioid. FR: 40Hz-16kHz. Impedance: 50 or 200 ohms. Sensitivity across 1K: approx 0.7mV/microbar. Built-in transformer. Sensitivity switch - 10dB. Price: on application.

SM69 FET

Stereo transistor condenser. Both systems separately remote controlled: omnidirectional, cardioid or figure-of-eight. FR: 40Hz-16kHz. Sensitivity across 1K: 2mV/microbar. Impedance: 50 or 200 ohms. Built-in transformers. Pressure-gradient. Price: on application.

U47 FET ★

Mono condenser. Cardioid. FR: 40Hz-16kHz. Sensitivity: 0.8mV/ μ bar. Impedance: 150 ohms balanced. Recommended load: \geq 750 ohms. Stand swivel with thread adaptor. Continues the tradition of the U47 produced from 1947-1960. Elastically mounted capsule and various switches. Finish: matt nickel plated. Price: on application.



Neumann U47 FET



Neumann KMS 85

KMS 85 ★

Mono condenser. Cardioid. FR: 40Hz-16kHz. Sensitivity: 0.6mV / μ Bar. Impedance: 150 ohms balanced. Recommended load: \geq 750 ohms. Hand type. Multistage mechanical filter in front of condenser capsule provides protection against close-talking, popping noises and other explosive sounds. Finish: matt nickel plated. Price: on application.

KMA

Mono condenser. Cardioid. FR: 40Hz-16kHz. Sensitivity: 0.5mV open circuit. Impedance: 800 ohms balanced. Recommended load: \geq 2.7K. Lavalier type. Tie-clip fitting. Low sensitivity to noise of clothing etc. Finish: dark satin nickel plate. Price: on application.

■ PEARL

Allotrope Ltd, 90 Wardour Street,
London W1V 3LE.
Tel: 01-437 1892.

M-68

Mono ceramic microphone. Noise-cancelling type. FR: 500Hz-5kHz, -6dB. Sensitivity: 0dBm for normal voice $\frac{1}{2}$ in from microphone. Impedance: 600 ohms. Hand type. Military specification with built-in on/off switch and four transistor pre-amplifier. External metal parts non-ferrous and black anodised. Price: on application.

CL-3

Sub-miniature omnidirectional tie-pin capacitor microphone. FR: 80Hz-17kHz, -3dB. Sensitivity: 32mV/Pascal. Impedance: 200 ohms. Recommended load: \geq 200 ohms. Size: $\frac{1}{2} \times \frac{5}{16} \times \frac{1}{4}$ in. Finish: brass and satin chrome. Price: on application.

HM49

Moving coil omnidirectional stand microphone. FR: 50Hz-18kHz -6dB. Sensitivity: -74dB. Impedance: 200 ohms. Rec. load: \geq 200 ohms. Fitting: $\frac{5}{16} \times 27$ tpi. Finish: black anodised alloy. Price: on application.

HM47

Moving coil omnidirectional lavalier microphone. FR: 100Hz-10kHz -6dB. Sensitivity: -76dB. Impedance: 200 ohms. Rec. load: \geq 200 ohms. Fitting: lavalier neck cord. Polyester diaphragm. Finish: brass, satin chrome. Price: on application.

RD34/36

Moving coil cardioid stand microphone. FR: 40Hz-16kHz -6dB. Sensitivity: -74dB. Impedance: (RD34) 200 ohms; (RD36) 200 ohms and high Z. Rec. load: \geq 200 ohms. Fitting: $\frac{5}{16}$ in

× 27tpi adaptor. Polyester diaphragm. Finish: black anodised alloy. Price: on application.

RD16

Moving coil cardioid lavalier or stand microphone. FR: 80Hz-12kHz -6dB. Sensitivity: -70dB. Impedance: 200 ohms. Rec load: ≥ 200 ohms. Fitting: $\frac{5}{16}$ in × 27tpi adaptor. Polyester diaphragm. Finish: black anodised alloy. Price: on application.

LD18/19

Moving coil omni-directional stand microphone. FR: 80Hz-16kHz -6dB. Sensitivity: -74dB. Impedance: (LD18) 200 ohms; (LD19) 200 ohms and high Z. Rec. load: ≥ 200 ohms. Fitting: $\frac{5}{16}$ in × 27tpi. Polyester diaphragm. Finish: black anodised alloy. Price: on application.

D44LS/BS

Moving coil cardioid lavalier or stand microphone. FR: 100Hz-13kHz -6dB. Sensitivity: -71dB. Impedance: (D44LS) 200 ohms; (D44BS) 200 ohms and high Z. Fitting: $\frac{5}{16}$ in × 27tpi. Built-in on/off switch and windshield. Finish: anodised black alloy. Price: on application.

ST 8

Capacitor stereo microphone with variable response pattern. FR: 30Hz-18kHz. Sensitivity: -61dB. Impedance: 200 ohms. Rec load: ≥ 200 ohms. Stand fitting: $\frac{5}{16}$ in × 27tpi. Variable pattern with remote control, one capsule may be rotated through 180 deg. Finish: brass, satin chrome. Price: on application

FP92C/FP92K

Capacitor mono stand microphone. Response: (FP92C) cardioid; (FP29K) omni-directional. FR: 30Hz-16kHz -3dB. Sensitivity: -66dB. Impedance: 200 ohms. Rec load: ≥ 200 ohms. Fitting: $\frac{5}{16}$ in × 27tpi. Permanent pre-polarisation. Built-in 6V battery supply. Weight: 6oz. Finish: brass, satin chrome. Price: on application.

TCV4V

Capacitor stand microphone with variable remote-control response pattern. FR: 40Hz-18kHz -3dB. Sensitivity: -56dB. Impedance: 200 ohms. Rec load ≥ 200 ohms. Fitting: $\frac{5}{16}$ in × 27tpi. Finish: brass, satin chrome. Price: on application.

DC96

Capacitor stand microphone with cardioid response. FR: 30Hz-18kHz -3dB. Sensitivity:



Pearl DC73

-61dB. Impedance: 200 ohms. Rec load: ≥ 200 ohms. Fitting: $\frac{5}{16}$ in × 27tpi. Finish: brass, satin chrome. Price: on application.

DC73★

Capacitor hand or stand cardioid microphone. FR: 40Hz-17kHz -3dB. Sensitivity: -60dB. Impedance: 200 ohms. Rec load: ≥ 200 ohms. Fitting: $\frac{5}{16}$ in × 27tpi. Switchable pop filter. Shockproof elastic suspension. Finish: brass, satin chrome. Price: on application.

DC63

Capacitor stand microphone with variable response pattern. FR: 30Hz-18kHz -3dB. Sensitivity: -60dB. Impedance: 200 ohms. Rec load: ≥ 200 ohms. Fitting: $\frac{5}{16}$ × 27tpi. Variable response pattern gives 44 combinations. Switchable bass cut. Switched attenuator. Finish: polished alloy and brass, satin chrome. Price: on application.

DC20/DC21

Capacitor stand microphone. Response: (DC20) omni-directional; (DC21) cardioid. FR: 30Hz-18kHz -3dB. Sensitivity: -56dB. Impedance: 200 ohms. Rec load: ≥ 200 ohms. Fitting: $\frac{5}{16}$ in × 27tpi. Miniature microphone measuring $\frac{27}{16}$ in long and $\frac{3}{16}$ in diameter. Finish: polished alloy or brass, satin chrome. Price: on application.

VM40/41

The VM40 (omni-directional) and VM41 (cardioid) condenser microphones combine new design and construction with increased facilities: A four position ring switch mounted near the microphone head selects 10dB attenuation and/or low frequency roll off. Rec load: 200 ohms. FR: 30Hz-18kHz, 48V symmetrical signal cable powering. Price: on application.

★ Indicates entry is illustrated

VM40/12 and VM41/12

Condenser Microphones as VM40/41 above, but can be operated by a symmetrical signal cable supply of between 10 and 48V. Price: on application.

SP84/85

The SP84 (omni-directional) and SP85 (cardioid) are self-powered versions of the VM40/41 condenser microphones above. An internal 15V battery operates an a.c. to d.c. converter providing the capsule polarising voltage. The supply is controlled by a plunger on/off switch in the microphone body operated by the mating connector. Price: on application.

■ PHILIPS

Philips Electrical Ltd, City House,
420-430 London Road, Croydon CR9 3QR.
Tel: 01-689 2166.

N8500

Hyper-cardioid electret microphone. FR: 100Hz-16kHz. Sensitivity: 0.25mV/ μ bar at 1kHz. Impedance: 1000 ohms. S/N ratio: 28dB. Finish: silver/black. Meets DIN 45 500 standard. 10ft cable with 3-pole 180° DIN plug. Table stand with quick release holder. Detachable wind shield. Price: £17.60 (excluding VAT).

■ PYE

Pye Business Communications Ltd,
Cromwell Road, Cambridge CB1 3HE.
Tel: Cambridge 45191.

LBB 9019/10

Cardioid microphone. FR: 150Hz-18kHz. Impedance: 500 ohms. Front-to-back ratio: 14dB at 1kHz. On/off switch. 2-core screened cable, 3m.

LBB 9005/06

Cardioid microphone. FR: 50Hz-16kHz. Impedance: 200 ohms. Front-to-back ratio: 20dB. Complete with on/off switch and quick release fixed angle adaptor. Hum compensation coil. 2-core screened cable, 3m.

LBB 9007/06

Cardioid microphone. FR: 50Hz-16kHz. Impedance: 200 ohms. Front-to-back: 20dB. Complete with on/off switch and 3m cable.

LBB 9008/07

Cardioid microphone. FR: 50Hz-16kHz. Impedance: 200 ohms. Front-to-back ratio: 20dB. 3m cable.

LBB 9023/10

Cardioid microphone. FR: 250Hz-12.5kHz. Impedance: 500 ohms. Front-to-back ratio: 17dB. On/off switch. Supplied with 2m cable, 3-pin DIN 180 plug, complete with wall mounting suspension bracket.

LBB 9018/05

Noise-cancelling microphone. FR: 200Hz-12.5kHz. Impedance: 250 ohms. Front-to-back ratio: 16dB. Supplied with 4-core and screened cable and complete with on/off button and suspension bracket. Cable length 0.6m coiled, 2.6m extended.

All prices: on application.

■ RESLOSOUND LTD

Eagle Road, Rye, Sussex TW31 7NR.
Tel: Rye 2988.

UD1 ★

Uni-directional hand or stand microphone. FR: 50Hz-17kHz (-4dB at 100Hz, +8dB at 16kHz). Rear pick-up -10 to -20dB between 200Hz-15kHz. Sensitivity: -88dB at 30-50 ohms. Output: average voice 6in from front of mic 150 μ V (low imp), 250-450 μ V (medium imp), 2-4mV (high imp). Output increases approximately 10 times at one inch from microphone. Impedance: UD.1/L 30-50 ohms or 600 ohms; UD.1/M medium impedance, 200-300 ohms; UD.1/MT, 600-1000 ohms; UD.1/H, high impedance. Finish: main case beige nylon, top case satin silver.

Superstar 80

Moving coil cardioid hand or stand microphone. FR: 50Hz-15kHz. Sensitivity: -58dB (50K). Impedance: (S80L) 30 or 600 ohms, (S80H) 250 ohms or 50K. Optional accessories: carry case, dual impedance cable set.

UD3 ★

Moving coil super cardioid stand microphone. FR: 100Hz-16kHz. Sensitivity: -58dB (50K). Impedance: (UD3/LM) 30 or 600 ohms, (UD3/MH), 200 ohms or 50K. Terminated with



Reslo UD1



Reslo UD3

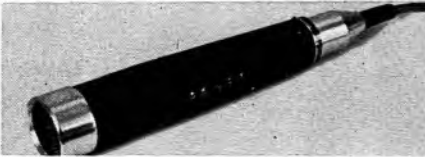

Reslo PD3

Reslo connector and suitable for use with any of the six flexible stems.

PD3 ★

Moving coil omni-directional pencil microphone. FR: 30Hz-17kHz. Sensitivity: -88dB (30 ohms). Impedance: (PD3/L) 30 ohms, (PD3/M Dual) 200 or 600 ohms (PD3/H) 50K. Supplied with 16ft directly-connected cable. Optional extras: SA6019 stand holder MS500 desk base.

MPD

Moving coil omni-directional miniature pencil stand or lavalier microphone. FR: 50Hz-15kHz. Sensitivity: -88dB (30 ohms). Impedance: 30 ohms. Available as head only (MPD/HD), lavalier type (MPD/L) and desk version (MPD/D) with 8in flexible stem and desk base.

MPD/L

Dynamic, omni-directional, lavalier. FR:

50Hz-15kHz -12dB at 100Hz. -4dB at 14kHz. Sensitivity: 88dB below. Impedance: low. Finish: satin anodised.

MPD/D

Dynamic, omni-directional, desk base fitted with 8in flexible stem. FR: 50Hz-10kHz. Sensitivity: 88dB below. Impedance: low. Finish: satin anodised microphone, chrome stem, grey enamel base.

Silverstar S91

Cardioid electret microphone. Impedance: 50-600 ohms and high impedance. FR: 40Hz-20kHz. Sensitivity: -76dB. Stand mounting type. Switched version available.

MS.110B

Adjustable floor stand. Minimum height: 40in, maximum height: 62in. Grey hammertone base, chrome outer and inner stem.

Reslo radio microphones

Range of radio microphones for all purposes. Full details on request.

All prices on application.

■ **ROSS ELECTRONICS**

32 Rathbone Place, London W1P 1AD.
Tel: 01-580 7112.

RE-320

Dynamic, omni-directional ball type. Impedance: 50K. Response: 50Hz-12kHz. Sensitivity: -54dB at 50K. Satin finish, diecast case. On/off switch. Price: £8.53 (plus VAT).

RE-325

Uni-directional, cardioid dynamic. Dual impedance: 600 ohms and 50K. Satin and black anodised finished, diecast case. On/off switch. Price: £9.66 (plus VAT).

RE-330

Uni-directional, cardioid dynamic. Dual impedance: 600 ohms and 50K. Response: 50Hz-15kHz. Sensitivity: -55dB at 50K. Satin finished diecast case. On/off switch. Price: £12.10 (plus VAT).

RE-335

Dynamic, omni-directional slimline type with detachable foam windshield. Dual impedance: 600 ohms and 50K. Response: 50Hz-17kHz. Sensitivity: -57dB at 50K. Satin finish, diecast case. On/off switch. Price: £12.10 (plus VAT).

★ Indicates entry is illustrated

RE-345

Uni-directional, cardioid dynamic. Switched dual impedance: 600 ohms and 50K. Response: 50Hz-15kHz. Sensitivity: -72dB at 600 ohms, -56dB at 50K. Diecast casing finished matt silver with parallel flutes and black mesh screen. On/off switch. Price: £13.00 (plus VAT).

RE-350

Uni-directional, cardioid dynamic. Switched dual impedance: 600 ohms and 50K. Response: 50Hz-15kHz. Sensitivity: -72dB at 600 ohms, -56dB at 50K. Case and machined head with deep drawn wire mesh screen. Price: £13.59 (plus VAT).

Gooseneck

$\frac{5}{8}$ in diameter. Minimum bend radius 1½in. Male/female threaded ends. Available in 13in and 21in lengths. Prices: (13in) £2.45 (plus VAT); (21in) £3.57 (plus VAT).

B.2004 Mixer

4-channel transistorised audio mixer with mono/stereo selector switch. High impedance inputs into standard jack sockets; phono plug output. Max input 1V. Output 1.3V. Noise ratio: -60dB. Gain approximately 3dB. Price: £6.56 (plus VAT).



Ross Electronics RE-311

RE-360

Omni-directional, dual-impedance, electret condenser type with FET pre-amplifier, dual-impedance transformer and battery all housed in microphone body, together with on/off switch. FR: 30Hz-18kHz. Impedance: 600 ohms and 50K. Sensitivity: -62dB at 600 ohms (1kHz), -48dB at 50K (1kHz). SPL: 130dB max. With stand holder, foam windshield, 20ft lead and jack plug. Price: £13.59 (plus VAT).

RE-361 ★

Electret condenser, omni-directional slimline type with built-in on/off switch and detachable foam windshield. Impedance: 600 ohms. Response: 30Hz-16kHz. Sensitivity: -66dB at 1000Hz. S/N ratio: -44dB. In brushed, spun aluminium housing with FET amplifier and HP-7 Battery. Supplied with 6-metre lead and standard jack plug. Price: £14.18 (including VAT).

RE-362 ★

Electret condenser cardioid slimline microphone with built-in on/off switch and detachable foam windshield. Impedance: 600 ohms. Response: 30Hz-16kHz. Sensitivity: -66dB at 1000Hz. S/N ratio: -44dB. With built-in FET amplifier operated by HP-7 battery. Supplied with 6-metre lead and standard jack plug. Price: £15.48 (including VAT).

RE-365

Uni-directional cardioid, dual-impedance electret condenser microphone, similar in construction to RE-360. FR: 20Hz-20kHz. Sensitivity: -68dB at 600 ohms (1kHz), -52dB at 50K (1kHz). SPL: 132dB max. With stand holder, foam windshield, 20ft lead and jack plug. Price: £14.91 (plus VAT).



Ross RE-361



Ross RE-362

RE-367

Omni-directional tieclasp type with built-in FET pre-amplifier operated from a mercury cell. Fitted with 3m lead and moulded jack plug. Impedance: 600 ohms. FR: 50Hz-16kHz. Sensitivity: -60dB at 1kHz. SPL: 120dB max. Price: £12.09 (plus VAT).

Desk stands ★

RE-311. Weighted, black plastic base with fixed chrome pillar. Standard screwed end for microphone holder. Size: 5in dia. by 3in high. Price: £2.25 (plus VAT); RE-312. Base as RE-311 but fitted with single draw telescopic centre rod and friction grip. Size: 12in high (closed) 19 $\frac{3}{4}$ in (extended). Price: £3.75 (plus VAT).

■ SENNHEISER ELECTRONIC

Distributors: Hayden Laboratories Ltd, Hayden House, Churchfield Road, Chalfont St. Peter, SL9 9EW. Tel: Gerrards Cross 88447.

Audio equipment showroom, service department and despatch department:
6 Bendall Mews, Bell Street, London, NW1.

MD21

Omni-directional moving coil hand or stand microphone. FR: 40Hz-18kHz \pm 3dB. Sensitivity: 0.2mV/ μ bar \pm 3dB. Impedance: 200 ohms. Rec load: 1K. Light alloy case finished hammer stove enamel. Windshield MZW421 optional extra. Price: (microphone) £37.85 (plus VAT); (windshield MZW421) £4.10 (plus VAT); (desk stand MZT21) £4.55 (plus VAT).

MD21HL

Dual-impedance version of MD21. Price: £39.65 (plus VAT).

MD211N

Omni-directional moving coil miniature studio microphone. Hand or stand use. FR: 30Hz-20kHz \pm 2.5dB. Sensitivity: 0.13mV/ μ bar \pm 2.5dB. Impedance: 200 ohms. Rec load: 1K. Metal case with satin chrome finish. Windshield MZW201 optional extra. Price: (microphone) £53.80 (plus VAT); (windshield MZW201) £3.65 (plus VAT); (small tripod desk stand MZT104) £3.65 (plus VAT).

MD214 ★

Omni-directional moving coil lavalier microphone. Built-in 'natural voice' equaliser to studio standards. FR: specially designed for lavalier operation. Sensitivity: 0.10mV/ μ bar \pm 2.5dB. Impedance: 200 ohms. Rec load: 1K.



Sennheiser MD214

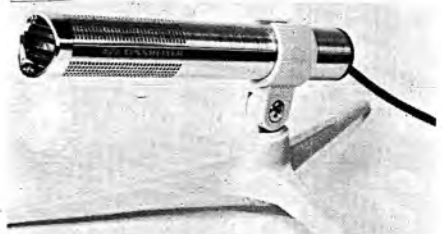

Sennheiser MD402LM

Metal case finished special 'non-glare' enamel. Price: £63.10 (plus VAT).

MD408N

Super cardioid moving coil microphone with flexible shaft. Specially suitable for PA applications. FR: 50Hz-15kHz \pm 3dB. Impedance: 200 ohms. Sensitivity: 0.13mV/ μ bar \pm 3dB. Case of light gauze woven wire cloth. Price: £28.00 (plus VAT).

MD420-2

Super-cardioid noise cancelling moving coil mono microphone. FR: 200Hz-10kHz (special response curve for noise cancellation). Impedance: 200 ohms. Rec load: 1K. Sensitivity: 0.18mV/ μ bar. Hand or stand microphone with large Tuchel plug. Metal case with silver finish. Price: (MD420-2) £29.75 (plus VAT); (MD420-2T with switch) £33.35 (plus VAT).

MD420-9

Shorter version of MD420 for gooseneck mounting. Price: £29.75 (plus VAT).

MD402LM ★

Mono moving coil super cardioid microphone. FR: 80Hz-12.5kHz. Sensitivity: 2.3mV/ μ bar. Impedance: 750 ohms. Rec load: 4K. Hand mic with stand and clip. Rugged construction. Fre-

★ Indicates entry is illustrated

quency response tailored for domestic applications. Finish: satin chrome. Price: £17.05 (plus VAT).

MD409N

Mono moving coil super cardioid. FR: 50Hz-15kHz. Sensitivity: $0.18\text{mV}/\mu\text{bar}$. Impedance: 200 ohms. Rec load: 200 ohms or greater. Stand mounted musicians' microphone. Finish: black and gold. Price: £42.00 (plus VAT).

MD421

Mono moving coil cardioid microphone. FR: 30Hz-17kHz. Sensitivity: $0.2\text{mV}/\mu\text{bar}$ at 1kHz. Impedance: (HL series) 200 ohms and 24K; (N, U and 2 series) 200 ohms. Rec load: (high Z version of HL series) 50K, (all others) 1K. Hand/stand microphone $\frac{3}{8}$ in thread fitting. Built-in bass cut switch. Low handling noise. Finish: (standard versions) grey plastic body with chrome grille. Price: (MD421N & MD421U) £59.95; (MD421HL) £61. All plus VAT.

MD441

Mono moving coil super cardioid microphone. FR: 30Hz-20kHz. Sensitivity: $0.2\text{mV}/\mu\text{bar} \pm 3\text{dB}$. Impedance: 200 ohms. Rec load: 1K. Hand microphone, with optional mounting clip available. Choice of ten switchable frequency responses. Low handling noise. Polar diagram constant over frequency range. Finish: shock resistant metal case. Silver-plated metal grille on matt black body. Price: (MD441N, MD441U & MD441-2) £85.60 (plus VAT).

MKH105T

Mono capacitor omni-directional microphone. FR: 20Hz-20kHz. Sensitivity: $2\text{mV}/\mu\text{bar}$. Impedance: 20 ohms. Rec load: 200 ohms or greater. Hand/stand microphone. Table stands MZT104 and 105 available. Low self noise. Windshield (MZW201) optional extra. Finish: satin chrome on brass. Price: £121.55 (plus VAT).

MKH124

Mono capacitor omni-directional. FR: 40Hz-20kHz. Sensitivity: $0.32\text{mV}/\mu\text{bar}$. Impedance: 150 ohms. Rec load: 200 ohms or greater. Lapel or lavalier microphone with clip or lanyard. Small size: flat frequency response. Presence lift. Finish: matt grey enamel. Price: £161.65 (plus VAT).

MKH125

Mono capacitor omni-directional microphone. FR: 40Hz-20kHz. Sensitivity: $2\text{mV}/\mu\text{bar}$. Impedance: 10 ohms. Rec load: 200 ohms. Lapel/lavalier microphone with lanyard or

clip. Small size. Flat frequency response. Presence lift. Finish: matt grey enamel. Price: £171.90 (plus VAT).

MKH415T/TU

Mono capacitor super cardioid microphone. FR: 40Hz-20kHz. Sensitivity: $2\text{mV}/\mu\text{bar}$. Impedance: 20 ohms. Rec load: 200 ohms. Hand or stand microphone. Table stand MZT415 available. Low self noise. Good wind noise rejection. Windshield MZW415. Finish: satin chrome on brass. Price: £149 (plus VAT).

MKH815T/TU

Mono capacitor uni-directional (narrow beam) microphone. FR: 50Hz-20kHz. Sensitivity: $4\text{mV}/\mu\text{bar}$. Impedance: 20 ohms. Rec load: 200 ohms. Gun microphone. Fittings: boom MZS-805 or pistol grip MZP805. Low self noise. Very narrow beam. Windshield: MZW804 and MZW815. Finish: satin chrome on brass. Price: £198 (plus VAT).

MD412LM

Moving coil super cardioid mono microphone. FR: 50Hz-12.5kHz. Impedance: 800 ohms. Sensitivity: $0.2\text{mV}/\mu\text{bar} \pm 3\text{dB}$. Built-in roll-off filter. With desk stand. Price: £25.10 (plus VAT).

MKH435T/TU

Studio quality capacitor microphone. Cardioid polar diagram. FR: 40Hz-20kHz. Sensitivity: $2\text{mV}/\mu\text{bar} \pm 1\text{dB}$. Impedance: 200 ohms. Hand/stand type microphone. Price: £142.45 (plus VAT).

MD416NU

Moving coil mono microphone. Cardioid polar diagram. Insensitive to handling or mechanical vibration. Designed for vocal or instrumental soloists. FR: 50Hz-15kHz. Sensitivity: $0.13\text{mV}/\mu\text{bar} \pm 3\text{dB}$. Impedance: 200 ohms. Hand or stand microphone. Low sensitivity to pop and wind noises. Price: £49.00 (plus VAT).

MD413NU

Moving coil mono microphone. Cardioid diagram. FR: 50Hz-15kHz. Impedance: 200 ohms. Sensitivity: $0.13\text{mV}/\mu\text{bar} \pm 3\text{dB}$. Rec load: 200 ohms or greater. Hand or stand microphone. Built-in 'pop' protector. Good immunity to feedback. Finish: solid brass with satin chrome finish. Price: £39.00 (plus VAT).

MKH416P/48

Capacitor microphone super cardioid. FR: 40-20,000Hz. Phantom powered 48V cannon or tuchel versions available. Price: £149.00 (plus VAT).

TAPE RECORDING ENTHUSIASTS.
 CHURCHES.
 SPEAKERS.
 FILM STUDIOS.
 THEATRES.
 REPORTERS.
 CLUBS AND CABARET ARTISTS.
 RECORDING STUDIOS.
 P.A. ENGINEERS.
 SINGERS.
 DANCE BANDS.
 ORCHESTRAS.
 RADIO AND TV COMPANIES.



Which is YOUR line?

Beyer Dynamic have a microphone to fully satisfy most customer requirements. Their vast range has been built up over the years, from the days when the company catered for the needs of a few specialised customers, to a great enterprise now serving a world market with products of quality that are universally recognised.



Beyer Dynamic also manufacture headsets. Ideal for Industrial Teaching, Schools, Film Studios, Broadcast Studios, and home use.

For further information and illustrated brochure of BEYER DYNAMIC microphones, headsets and full range of accessories, please write to:

**BEYER
 DYNAMIC**
 [GB] LIMITED
 1, CLAIR ROAD, HAYWARDS HEATH, SUSSEX.
 TELEPHONE: HAYWARDS HEATH 51003.



Shure SM33

■ SHURE ELECTRONICS LTD

Eccleston Road, Maidstone,
Kent ME15 6AU. Tel: Maidstone 59881.

SM33 ★

Ribbon microphone. Super cardioid. FR: 40-15,000Hz. Impedance: 50 and 150 ohms. Stand mounted. Smooth warm response with switchable low end roll off. Price: £99.00 (plus VAT).

SM51

Omni-lavalier microphone. FR: 70-12,000Hz. Low impedance with sensitivity: -82dB. Small size. Price: £47.40 (plus VAT).

SM54

Cardioid microphone. FR: 70-16,000Hz. Impedance: 150 ohms. Sensitivity: -81dB. Hand, stand or boom. Versatile with switchable low end roll-off. Price: £106.80 (plus VAT).

SM58

Cardioid microphone. FR: 50-15,000Hz. Impedance: 50 and 150 ohms. Sensitivity: -84 and -77dB. Rugged construction with Built-in wind shield. Price: £63.60 (plus VAT).

SM57

Cardioid microphone. FR: 40-15,000Hz. Impedance: 50 and 150 ohms. Sensitivity: -82 and -76dB. Good feedback suppression. Price: £49.80 (plus VAT).

SM62

Cardioid microphone. FR: 100-10,000Hz. Impedance: 150 ohms. Sensitivity: -82dB. Price: £49.80 (plus VAT).

300

Ribbon microphone with polar patterns figure of 8. FR: 40-15,000Hz. Impedance: 50, 150 and high. Switchable low end roll off. Price: £68.40

515SA

Cardioid microphone. FR: 80-13,000Hz. Impedance: High, but low version available. Price: £18.00 (plus VAT).

545 ★

Cardioid microphone. FR: 50-15,000Hz. Impedance: low/high. Slim style, true cardioid. Price: £37.80 (plus VAT).

548

Cardioid microphone. FR: 40-15,000Hz. Impedance: low/high. Price: £45.00 (plus VAT)

565 ★

Cardioid microphone. FR: 50-15,000Hz. Im-

MKH816P/48

Capacitor microphone super directional. FR: 50-20,000Hz. Phantom powered 48V cannon or tuchel versions available. Price: £198.00 (plus VAT).

MKE802

Electret microphone super cardioid. FR: 50-15,000Hz. Impedance: 200 ohms. Cannon or tuchel plug versions available. Price: £75.00 (plus VAT).

MKH406P/48

Capacitor microphone. FR: 40-20,000Hz. Cannon or tuchel plug versions available. Price: on application.

MKE2002

Electret omni-microphone. FR: 50-15,000Hz. Impedance: 200 ohms. Cannon or tuchel plug versions available. Price: £54.00 (plus VAT).

MKE402

Electret cardioid microphone. FR: 50-15,000Hz. Impedance: 200 ohms. Cannon or tuchel plug versions available. Price: £63.00 (plus VAT).

pedance: low/high. Built-in wind shield. Price: £42.60 (plus VAT).

579SB

Omni-microphone. FR: 50-15,000Hz. Impedance: low. Price: £30.00 (plus VAT).

588SA

Cardioid microphone. FR: 80-13,000Hz. Impedance: High; but low version available. Built-in wind shield. Price: £25.80.

589S

Cardioid microphone. FR: 90-13,000Hz. Impedance: low/high. Price: £30.00 (plus VAT).

A95U

High quality series line transformer making it possible to connect low impedance (25-50 ohms and 150-250 ohms) lines to a high impedance amplifier input. Comes complete with all connectors. Size: 2 1/2in x 3/4in. Price: £8.80.

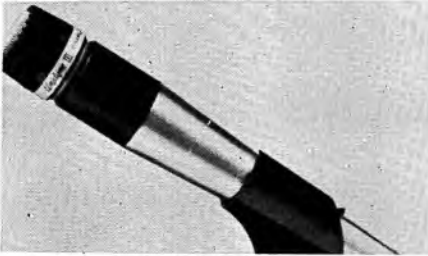

Shure 545 Unidyne 111



Shure 565 Unisphere 1

A97A

As above but designed to match 150-600 ohm microphone outputs to medium impedance (1-10K ohm) devices, such as those frequently used in cassette recorders. Price: £8.00.

A15 Series

Attenuators, Equalizers and Adaptors. In-line plug-in components to solve sound problems without rewiring. Connections are made via professional three-pin audio connectors. Nine models available. Price: £8.80.

S33 Series Stands

Low silhouette heavy duty desk stand for any Shure microphone. Satin black or dark grey to match Shure 'SM' series microphones. Size: 1 5/16in H x 5 3/16in W x 6in D. Price: £6.40.

S55P

Low profile microphone stand for distant microphone pickup. Holds the microphone a fraction of an inch above the floor for better sound quality by minimizing reflections. Ideal for 'footlight' recordings of choral, orchestral or ensemble musical events and dramatic presentations. Effectively isolates mechanical noise from floor vibrations. Height: 4 3/4in. Price: £10.40.

■ **SONY (UK) LTD**

Consumer Information, 134 Regent Street, London W1R 6DJ.
Tel: 01-439 3874.

ECM 95S

Electret uni-directional. FR: 70-10,000Hz. Impedance: 1.5K. Sensitivity: -54.0dB. Includes remote switch. Built-in windscreen. Price: £6.34 (plus VAT).

ECM 99/A

Electret uni-directional one point stereo microphone. FR: 50-12,000Hz. Impedance: 250 ohms. Hand mounted. Built-in wind shield. Price: £14.77 (plus VAT).

ECM 200/S

Electret unidirectional. FR: 50-10,000Hz. Impedance: 1.5K ohms. Sensitivity: -53.0dB. Supplied with microphone holder. Weight: 160g. Price: ECM200 £8.29, ECM200S £8.80 (plus VAT).

ECM 170

Electret omnidirectional. FR: 20-16,000Hz. Impedance: 200 ohms. Sensitivity: -56.0dB. Hand mounting. A15 table stand available. Bass roll off switch. Price: £21.76 (plus VAT).

★ Indicates entry is illustrated

ECM 220

Electret unidirectional. FR: 50-12,000Hz. Impedance: 200 ohms. Built-in wind screen. On/off talk switch. Price: £18.80 plus VAT).

ECM 250

Electret unidirectional. FR: 50-14,000Hz. Impedance: 200 ohms. Built-in wind screen. Price: £16.62 (plus VAT).

ECM 270

Electret uni-directional. FR: 40-16,000Hz. Impedance: 200 ohms. Removable wind screen. Price: £21.76.

ECM 280

Electret unidirectional. FR: 30-18,000Hz. Impedance: 200 ohms. Removable wind screen, bass roll-off switch. Price: £29.95 (plus VAT).

■ TTC

Doram Electronics Ltd,
PO Box TR8, Leeds LS12 2UF.
Tel: Leeds 34222.

995-037

Electret cardioid. FR: 30-16,000Hz. Impedance: 600 ohms. Sensitivity: -70dB. Bracket for stand included, wind shield, stand-holder. Price: £14.95 (plus VAT).

994-438

Moving coil cardioid. FR: 100-12kHz. Impedance: 600 ohms. Sensitivity: -73dB (-54dB). Stand bracket included. Price: £7.50 (plus VAT).

995-021

Moving coil cardioid. FR: 100-10kHz. Impedance: 200/250 ohms. Sensitivity: -77dB. Stand mic. Price: £3.15 (plus VAT).

■ UHER (UK) LTD

Peas Home Hse., St. Saviour Place, York.
Tel: York 30421.

M136

Omni-directional dynamic microphone with detachable table stand. FR: 50Hz-15kHz. Sensitivity: 0.32mV/ μ bar. Plug wiring: unbalanced 3/2. Price: £11.70 (plus VAT).

M154 ★

Dynamic microphone with remote control switch providing: record, stop, start, rewind. FR: 50Hz-20kHz. Impedance: 200 ohms. For use with Uher 5000 tape recorder. Price: approximately £33.10 (plus VAT).



Uher M154



Uher M534

M517

Dynamic cardioid microphone for use with Uher battery portable. Remote stop/start switch. Speech/music switch. FR: 70Hz-14kHz. Price: £33.10 (plus VAT).

M534

Dynamic cardioid microphone with speech/music switch. Sensitivity: 0.23mV/ μ bar. FR: 50Hz-16kHz. Impedance: 500 ohms. For recording under adverse acoustic conditions. Pressure diecast case. Includes table stand (M923). Plug wiring: unbalanced 3/2. Price: £27.50 (plus VAT).

M537

Dynamic cardioid microphone with speech/music switch. Sensitivity: 0.23mV/ μ bar. FR: 40Hz-18kHz. Impedance: 500 ohms. Flexibly supported microphone system. Includes stand connecting piece (M937) and table stand (M923). Supplied without connecting lead. Plug wiring: unbalanced 1-2/3. Price: £69.70 (plus VAT).

M538

Dynamic cardioid studio microphone. Sen-

sitivity: $0.14\text{mV}/\mu\text{bar}$. FR: 30Hz-18kHz. Impedance: low Z. Sintered bronze head. Separate bass and treble systems incorporated. Includes stand connecting piece (M937) and table stand (M923). Supplied without connecting lead. Plug wiring: 1-2/3. Price: £106.80 (plus VAT).

M539

Dynamic omni-directional studio microphone. Sensitivity: $0.18\text{mV}/\mu\text{bar}$. FR: 40Hz-17kHz. Low impedance. Flexibly supported microphone system. Includes stand connecting piece (M937) and table stand (M923). Supplied without connecting lead and windshield. Plug wiring: balanced 1-2/3. Price: £71.25 (plus VAT).

M634 (stereo) ★

Dynamic cardioid stereo microphone system. Sensitivity: $0.23\text{mV}/\mu\text{bar}$. FR: 50Hz-16kHz. Impedance: 500 ohms. Comprises two M534 microphones, one M925 stereo bar and one M923 table stand. Speech/music switch. Price: £54.50 (plus VAT).

M640

Dynamic stereo microphone. Omni-directional characteristic, also suitable for mono recordings. Sensitivity: $0.25\text{mV}/\mu\text{bar}$. FR: 70Hz-15kHz. With stop/start switch for Uher cassette recorders. Price: £38.20 (plus VAT).

■ UNISOUND

Condor Electronics Ltd, 100 Coombe Lane, London SW20 0AY.
Tel: 01-946 0033.

EM82 Mk II ★

Omni-directional electret condenser microphone. FR: 40Hz-18kHz. Impedance: 500 ohms. Sensitivity: -48dB . On/off switch. Stand holder. Foam wind shield. Detachable 5m lead. Hand or stand mounting. Price: £15.00 (excluding VAT).

EM82M Mk II

Omni-directional electret condenser microphone. FR: 40Hz-18kHz. Impedance: 5K. Sensitivity: -43dB . On/off switch. Stand holder. Foam windshield. Detachable 5m lead. Hand or stand mounting. Price: £15.00 (excluding VAT).

EM82H Mk II

Omni-directional electret condenser microphone. FR: 40Hz-18kHz. Impedance: 40K. Sensitivity: -39dB . On/off switch. Stand holder.



Unisound

der. Foam windshield. Detachable 5m lead. Hand or stand mounting. Price: £15.00 (excluding VAT).

EM82D Mk II

Omni-directional electret condenser microphone. FR: 40Hz-18kHz. Impedance: 40K/500 ohms. Sensitivity: -39dB -48dB . On/off switch. Stand holder. Foam wind

★ Indicates entry is illustrated

shield. Detachable 5m lead. Hand or stand mounting. Price: £19.00 (excluding VAT).

EM83 Mk II ★

Uni-directional electret condenser microphone. FR: 40Hz-18kHz. Impedance: 1000 ohms. Sensitivity: -54dB. On/off switch. Stand holder. Foam wind shield. Detachable 5m lead. Hand or stand mounting. Price: £17.50 (excluding VAT).

EM83M Mk II

Uni-directional electret condenser microphone. FR: 40Hz-18kHz. Impedance: 5K. Sensitivity: -50dB. On/off switch. Stand holder. Foam wind shield. Detachable 5m lead. Hand or stand mounting. Price: £17.50 (excluding VAT).

EM83H Mk II

Uni-directional electret condenser microphone. FR: 40Hz-18kHz. Impedance: 40K. Sensitivity: -46dB. On/off switch. Stand holder. Foam wind shield. Detachable 5m lead. Hand or stand mounting. Price: £17.50 (excluding VAT).

EM83D Mk II

Uni-directional electret condenser microphone. FR: 40Hz-18kHz. Impedance: 40K/1000 ohms. Sensitivity: -46dB/-54dB. On/off switch. Stand holder. Foam wind shield. Detachable 5m lead. Hand or stand mounting. Price: £21.00 (excluding VAT).

EM85D ★

Uni-directional electret condenser microphone. FR: 30Hz-20kHz. Impedance: 50K/1K. Sensitivity: -51dB/-68dB. Hand or stand mounting. On/off switch. Tone switch. Stand holder. Detachable 5m lead. Price: £21 (excluding VAT).

EM86D ★

Uni-directional electret condenser microphone. FR: 40Hz-18kHz. Impedance: 50K/1K. Sensitivity: -51dB/-68dB. Hand or stand mounting. On/off switch. Stand holder. Detachable 5m lead. Price: £17.50 (excluding VAT).

EM84 ★

Omni-directional electret condenser microphone. FR: 40Hz-16kHz. Impedance: 1K. Sensitivity: -51dB. Tie tack/lapel mounting. Price: £13.50 (excluding VAT).

Music Centres

(see also Unit Audio sections)

★ Indicates entry is illustrated

Abbreviations used in this section are given on page 27.

■ AIWA

Johnsons of Hendon Ltd,
14 Priestley Way, London NW2 7TN.
Tel: 01-450 8070.

AF 5080

Stereo music centre with Dolby noise reduction circuitry. Record deck: speeds 33 $\frac{1}{3}$, 45 rpm. W and F: 0.1%. Moving magnet cartridge with 2-2.5 stylus. Amplifier: output 24+24W. FR: 20-30,000Hz. THD: 0.08% 22+22W (8 ohms). S/N: 58dB. Radio tuner: four waveband (AM/FM/LW/SW). FR: 20-15,000Hz. THD: 0.7% stereo. Tape deck: Dolby cassette. W and F: 0.2% DIN. S/N: 58dB DIN. FR: 30-15,000Hz (CrO₂ tape). Speakers: recommended speakers with HC 30W x 30W. Imp: 8 ohms. Dimensions: 27.8 x 19.3 x 48cm. Walnut finish. Main Unit: dimensions 59 x 38.2 x 14.8cm. Finish: walnut. Features: Dolby unit. Oil-damped cassette key controls and cassette elevation. Synchronous mechanism between tone arm and cassette motor. Price: £256.56 (plus VAT).

■ ALBA (RADIO AND TELEVISION) LTD

Bull Lane, London N18 1SD.
Tel: 01-803 4451.

9070

Three piece unit-audio comprising tuner-amp, record player, cassette tape recorder (all in one cabinet) and separate pair of speaker enclosures. Record deck: BSR C123 R1.A2. Speeds: 33 $\frac{1}{3}$, 45, 78 rpm. Rumble better than -29dB. W and F: less than 0.35%. Ceramic cartridge with sapphire stylus. Amplifier: output 5W+5W. Radio tuner: band coverage VHF/L/M. FR: 162-580kHz. Tape deck: W and F: less than 0.6%. FR: 60-10kHz on Fe, 60-12kHz on C/O. Speakers: Imp: 8 ohms. Crossover drive units: 20.3 x 12.7cm. Dimensions: 27.6 x 16 x 37.8cm. Teak veneer finish. Main unit: dimensions: 80.6 x 37.1 x 17.8cm. Teak veneer finish in black and silver. Cassette storage. Stand available. Price: on application.

9071

Record deck: BSR 172 D1. Speeds: 33 $\frac{1}{3}$, 45, 78 rpm. Rumble: better than -29dB. W and F: less than 0.2%. Ceramic cartridge with sapphire stylus. Amplifier: Output: 7.5W+7.5W. THD: 5%. Radio tuner: band coverage: VHF/L/M. FR: 150-530kHz. Tape deck. W and F: less than 0.35%. S/N: better than 35dB. Speakers: Imp: 8 ohms. Crossover drive units: 20.3 x 12.7cm. Teak finish. Main unit: 55 x 41 x 18.5cm. Price: on application.

■ AMSTRAD

AMS Trading (Amstrad) Ltd,
89 Ridley Road, Dalston,
London E8 2NH.
Tel: 01-249 5237/8/9.

MC20 ★

Record deck: Garrard deck. Speeds: 33 $\frac{1}{3}$, 45 rpm. Goldring G800 cartridge. Amplifier: Output: 20W RMS per channel. FR: 15Hz-20kHz. THD: 0.1% at rated output. S/N ratio: 45dB. Radio tuner: band coverage: FM 88-104MHz; LW 150-330kHz, MW 520-1605kHz, SW 6-10MHz. Cassette deck: W and F: 0.15%. S/N ratio: 50dB. FR: 40Hz-10kHz standard tape. Speakers: Amstrad 2500 speakers. HC: 25W. Imp: 8 ohms. Crossover: 4-element 2nd order. 165mm woofer, 85.7cm mid-range/tweeter. Dimensions: 25.7 x 24.1 x 48.9cm. Weight: 9.1kg. Finish: teak veneered cabinet with black fabric front. Main unit: dimensions: 66.5 x 41 x 19.5cm. Weight: 20kg. Finish: teak effect cabinet with black front. Features: stereo microphones. Slider controls. CrO₂ facility. Tuning meter. Record level meter. Full width dust cover. Price: £239.37 (plus VAT).

■ CROWN RADIO CO LTD

Russell Gardens, Wickford,
Essex SS11 8RT.
Tel: Wickford 63414.

SHC 3100

Stereo music centre complete with speakers.



Amstrad MC20

★ Indicates entry is illustrated

Record deck: BSR P129 R1 with speeds of 33 $\frac{1}{3}$, 45, 78 rpm. W and F: below 0.35%. Ceramic cartridge with diamond stylus. Amplifier: Output: 7.5+7.5 RMS. FR: 50-20kHz. Radio tuner: Coverage: FM/L/M. Tape deck: W and F: 0.25%. FR: 100-10kHz. Speakers: Imp: 8 ohms. Drive units: woofer, tweeter. Dimensions: 13 × 10.75 × 5.5in. Walnut finish. Main unit: Dimensions: 24 × 13.5 × 6.5in. Finish in simulated wood and black. Price: £152.00 (plus VAT).

SHC 3200

Three piece record player, radio and stereo cassette recorder with matching 24W speaker system. Record deck: BSR P141 R1 with speeds 33 $\frac{1}{3}$, 45, 78 rpm. W and F: below 0.2 RMS. Magnetic cartridge with diamond stylus. Amplifier: output: 20+20 RMS. FR: 40-20,000Hz. THD: 1%. Tape deck: W and F: 0.25%. S/N: 45dB. FR: 40-12kHz. Speakers: Imp: 4 ohms. Crossover drive units: 20cm and 7.7cm. Dimensions: 39 × 29 × 20.5cm. Main unit: dimensions: 23.5 × 16 × 8.5in. Finish in black and silver. Price: £245.00 (plus VAT).

■ DECCA RADIO & TELEVISION LTD

Neachells Lane, Willenhall,
West Midlands WV13 3RW.
Tel: Willenhall 67367.

Audio 20 Music Centre DS 5355

Complete three-piece music centre. Record deck: Garrard 35SB with speeds of 33 $\frac{1}{3}$ and 45 rpm. Rumble: -55dB. Shure M75-6S cartridge with diamond spherical stylus. Amplifier: output: 25W per channel. FR: 20-30,000Hz. THD: 1% at 1kHz. S/N: >60dB. Radio tuner: band coverage: FM/L/M. Tape deck: W and F: <0.3% RMS. S/N: 50dB. FR: 40-12,000Hz (Fe₂O₃). Speakers: Imp: 8 ohms. Crossover drive units: 8in bass and tweeter. Dimensions: 30 × 25 × 60.4cm. Teak finish. Main unit: dimensions: 65.5 × 42 × 14.4cm. Teak finish. Features: mute/AFC, high filter, mono external tape switching, erase oscillator frequency shift, four-speaker facility for ambiphonic sound. Price: to be announced.

DS 5339

Music centre. Record deck: Garrard 6200CP with speeds of 33 $\frac{1}{3}$, 45, 78 rpm. Ceramic cartridge with Acos GP104 diamond stylus. Amplifier: Output: 12W per channel. FR: 20-30,000Hz. THD: 0.2% max at 1kHz. S/N: -60dB. Radio tuner: coverage: FM/L/M. Tape deck: W and F: <0.3% RMS. S/N: 50dB. FR: 40-12,000Hz (Fe₂O₃). Speakers: HC: 20W DIN. Imp: 8 ohms. Drive units: 1 at 8in. Di-

mensions: 24 × 14.4 × 42cm. Teak or walnut finish. Main unit: dimensions: 65.5 × 14.4 × 42cm. Teak or walnut finish. Features: four speaker facility for ambiphonic sound. Twin stereo microphones supplied, headphone socket, mute/AFC, high filter. Price: to be announced.

DS 5347

Three piece music centre. Record deck: BSR C141/R with speeds of 33 $\frac{1}{3}$, 45, 78 rpm. Ceramic cartridge with Sonotone 3559 diamond stylus. Amplifier: output: 12W per channel. FR: 30-30,000Hz. THD: 0.2% max at 1kHz. S/N: -70dB. Radio tuner: coverage: FM/L/M. Tape deck: W and F: 0.3% RMS. S/N: 48dB. FR: 40-12,000Hz (Fe₂O₃). Speakers: Imp: 8 ohms. Crossover drive units: 1 at 5in. Dimensions: 21.5 × 14 × 31.5cm. Teak finish. Main unit: dimensions: 90 × 36.5 × 22.5cm. Teak finish. Features: four speaker facility for ambiphonic sound, stand supplied, headphone socket, mute, AFC, high filter. Price: £215.00 (plus VAT).

■ DYNATRON

Dynatron Radio Ltd, Ditton Walk,
Cambridge CB5 8QD.
Tel: Teversham 2781.

HFC 205 Buckingham Music Centre

Integrated tuner-amplifier and record player unit, as HFC 203 plus stereo cassette deck. Tape deck: Dynatron CR 102-D. Tape deck specification as Dynatron Model CP2. Size and finish: as HFC 203. Price: £383.00.



Dynatron Beaufort



Dynatron Carlton

HFC 206 Carlton Music Centre ★

As HFC 204 plus stereo cassette tape deck. Tape deck: Dynatron Model CR 102-D. Tape deck specification: as Dynatron Model CP2. Size and finish: as HFC 204. Price: £383.00.

HFC 209 Concerto Music Centre

Integrated stereo tuner/amplifier (top presentation), record player and stereo cassette tape deck housed in compact contemporary style cabinet. Specification as HFC 205/206. Finish: teak veneers. Size: 638 × 400 × 205mm. Price: £280.00.

RG94 Beaufort Music Centre ★

Integrated stereo tuner/amplifier (top presentation), record player and stereo cassette tape deck housed in Queen Anne style cabinet. Specification: as HFC 205/206. Record and cassette storage. Built-in infinite baffle enclosures housing 2 × 8in and 2 × 2in loudspeaker units. Finish: walnut using selected burr veneers. Price: £516.00.

■ EUROPHON

Europhon UK Ltd, 70 Caledonian Road, London N1 9DN.
Tel: 01-817 3045/6.

RGR9003A

Record deck: Europhon deck. Speeds: 33 $\frac{1}{3}$, 45 rpm. LPS 3C stylus. Stroboscope. Dual belt drive. Variable fine speed control. Amplifier: output: 5W RMS. FR: 40Hz-20kHz \pm 2dB. THD: 2% at rated output. S/N ratio: 50dB. Radio tuner: bands: LW/MW/SW/FM. Cassette deck; W and F: 0.3%. FR: (Fe₂O₃) 40Hz-8kHz. Automatic recording level. Phase locked loop mpx. Speakers: HC: 10W. Imp: 4 ohms. Dimensions: 23 × 11.5 × 23cm. Weight: 1.25kg. Main unit: dimensions: 50 × 28 × 19cm. Weight: 6kg. Finish: wood effect foil print. Price: £128 (excluding VAT).

■ FERGUSON

Thorn Consumer Electronics Ltd.
Thorn House, Upper St. Martin's Lane,
London WC2H 9ED.
Tel: 01-836 2444.

3471

Record deck: BSR PI46 R2 with ceramic cartridge and sapphire stylus. Amplifier: output: 5W RMS. FR: 60-15,000Hz. THD: <2%. Radio tuner: band coverage: FM/L/M/S. Tape deck: S/N: 46dB. FR: 40-10,000Hz (ferric). Speakers: Imp: 15 ohms. Crossover drive units: 8 × 5in elliptical. Teak finish. Main unit: dimensions: 56 × 34.3 × 17cm. Black finish with teak surround. Features: switchable AFC tuning indicator. FM stereo beacon, auto stop and automatic level control on cassette. Price: on application.

3494

Record deck: BSR P170. Magnetic cartridge with diamond stylus. Amplifier: Output: 10W RMS. FR: 25-30,000Hz. THD: <0.5%. Radio tuner band coverage: FM/L/M/S. Tape deck: W and F: 0.3%. S/N: 50dB. FR: 40-14,000Hz (ferric). Speakers: Imp: 8 ohms. Crossover drive units: 6 $\frac{1}{2}$ in. Teak finish. Main unit: 62 × 49 × 22cm. Finish in black with teak surround. Features: single play or automatic record deck, AFC automatic switching for CrO₂ tape, auto stop, auto or manual record with two VU meters. FM stereo beacon, noise suppressor. Price: on application.

■ FIDELITY RADIO LTD

Victoria Road, London NW10 6ND.
Tel: 01-965 8771.

MC2 ★

Music centre incorporating radio, record player and cassette deck with matching speakers. Record deck: BSR three speed deck. W and F: 0.25% RMS. Stereo ceramic cartridge with turnover stylus. Amplifier: output: 4W (Sine wave). FR: 40-15,000Hz. THD: less than 1% at 4W. S/N: 55dB. Radio tuner: Band



Fidelity MC2

★ Indicates entry is illustrated

coverage: FM, L, M, FR: 40-15,000Hz. Tape deck: W and F: 0.25% RMS. S/N: 45dB. FR: 35-12,000Hz (standard) or 35-16,000Hz (chrome). Speakers: HC: 10W RMS. Imp: 8 ohms. Crossover drive units: 6.5in. woofer. Dimensions: 25.4 × 15.2 × 38.1cm. Teak finish. Main unit: Dimensions: 19.05 × 53.34 × 41.27cm. Teak finish. Features: provision for cassette storage; removable transparent lid. Price: £158.40 (plus VAT).

■ GOODMAN'S

Goodmans Loudspeakers Ltd,
Downley Road, Havant,
Hampshire PO9 2NL. Tel: Havant 6344.

Module 90 Compact ★

AM/FM stereo receiver with transcription record player. Facilities: two stereo head-phone sockets, stereo beacon, tuning indicator, two output meters. Amplifier: 45W per channel into 4 ohms, 30W per channel into 8 ohms. THD: <0.1% at 35W into 4 ohms. FR: 25Hz-30kHz, -3dB. S/N: . (Tape input)



Goodmans Module 90



Goodmans 1-10z compact

-75dB. Radio bands: MW 525-1605kHz, FM 87.5-108MHz variable, 87.5-101MHz on 4 pre-sets. FM sensitivity: typically 2µV into 240 ohms or 1µV into 75 ohms, for 30dB S/N with 75kHz deviation. THD: typically 0.5% for 75kHz deviation. Transcription unit. Garrard Zero 100SB; W and F: 0.12% peak, rumble -63dB DIN. Cartridge: Shure M93E, elliptical stylus. Mains: 122V or 220-245V 50-60Hz. Size: 24½ × 15¾ × 8½in. Price: £254.56 (plus VAT); (white) £259.51 (plus VAT).

Model 1-10z Compact ★

AM/FM stereo receiver in case with transcription record player. Motor unit: Garrard Zero-100SB. Speeds: 33½ and 45 rpm. Die-cast zinc turntable, 292.1mm diameter. Belt drive. Tangential tracking pickup. Cartridge: Shure M93E magnetic. Stylus: diamond, elliptical 0.7 × 0.4thou. Tuning range: FM 87.5-108MHz, MW 187-572m, LW 1130-2000m, SW 48-51m. Variable tuning. Switched AFC. Signal strength meter. Usable sensitivity: FM 1µV in 75 ohms/2µV into 24 ohms, AM 20µV MW and SW, 40µV LW. Stereo decoder included, with indicator beacon. 89 semi-conductors. Inputs: ceramic PU 200mV IM, tape play 200mV 100K. Noise level: mag PU -70dB, other inputs -80dB. Overload capability: 30dB. Output 50W RMS per channel into 4 ohms. Controls: bass, treble, volume, balance, plus 17 tab controls. HD: <0.01% at 30W output, <0.1% at any power up to rated maximum. FR: 20Hz-20kHz ±1dB at rated power. Mains: 115-125V or 200-250V AC 50/60Hz. Suitable for use on Goodmans CS2 stand. Price: (teak or walnut) £272.74 (plus VAT); (white) £278.31 (plus VAT).

■ GRUNDIG

Grundig International Ltd,
Newlands Park, London SE26 5NQ.
Tel: 01-659 2468.

Studio 3000 ★

AM/FM stereo receiver in cabinet with Dual 1224 record deck, cassette deck and two separate speakers. Range: FM 87.5-108MHz, LW 2069-857m, MW 588-185m, SW 51.3-18.5m. Stereo decoder with beacon. Variable tuning with five pre-set stations (FM) and AFC. Tuning meter. Output: 15W RMS per channel into 4 ohms. Accepts compact cassettes up to C120. 1⅞ i/s. FR: 60Hz-12.5kHz. Automatic switching for CrO₂. W and F: ±0.25%. S/N ratio: 46dB. Three digit tape position indicator. Size: 63.5 × 21 × 52cm. Price: £362.73 (including VAT).



Grundig 3000



Hacker MC600

■ **HACKER RADIO LTD**
 Norreys Drive, Cox Green,
 Maidenhead, Berks SL6 4BP.
 Tel: Maidenhead 22261.

MC600 ★

Record deck: Garrard 35SB with speeds of 33 $\frac{1}{3}$ and 45 rpm. Rumble: -55dB (DIN). W and F: 0.20%. Vernitron V100 magnetic cartridge with diamond stylus. Amplifier: Output: 14W+ 14W into 8 ohms, both channels driven. FR: 25-40,000Hz. THD: 0.075% at 1Hz. Radio tuner: band coverage: FM/L/M THD: better than 0.5%. Tape deck: W and F: less than 0.25%. S/N: 47dB. FR: 50-12,000Hz (CrO₂) and 50-10,000Hz (Fe₂O₃). Speakers: designed to operate with any high quality loudspeaker of 8 ohms including Hacker range. Main unit: dimensions: 67 x 43.2 x 19.6cm. Teak veneer finish. Features: Built-in facilities for immediate connection of rear speakers for ambiphonic reproduction. Programme material from disc and radio can be recorded and played back. Material from external sources can be similarly recorded and played back. Record-

ings can be made from disc and radio on external equipment. Voice can be mixed with recording. Facilities for chromium dioxide tape. Price: £300.00 (plus VAT).

■ **ITT CONSUMER PRODUCTS (UK) LTD**
 Maidstone Road, Footscray, Sidcup,
 Kent DA14 5HT. Tel: 01-300 7733.

KA 2030

Three piece music centre. Record deck: BSR P128R with speeds of 33 $\frac{1}{3}$, 45, 78 rpm. Sonotone 3559 cartridge with Sonotone CD single tip diameter styles. Later units are fitted with BSR SCM12M/ST21D. Amplifier: output: 8.5W per channel. FR: 40-50,000Hz. THD: 0.5%. Radio tuner: band coverage: FM/L/M. Tape deck: W and F: 0.35%. S/N -3dB at 40Hz and 50 kHz. Speakers: LS30 with HC of 20W. Imp: 4 ohms. Crossover drive units: double section LC 5in bass/mid-range, 3 $\frac{1}{4}$ tweeter. Dimensions: 23 x 17.8 x 38.2cm. Finish in teak/black acoustic cloth with edge trim. Main unit: Dimensions: 80 x 40 x 19cm. Teak veneered cabinet with black base and dust cover. Price: £220.00 (plus VAT).

■ **JVC (UK) LTD**

Eldonwell Trading Estate, Staples Corner, 6-8 Priestley Way, London NW2.
 Tel: 01-450 2621.

MF-1845L ★

Record deck: JVC with speeds of 33 $\frac{1}{3}$ and 45 rpm. Moving magnet cartridge with diamond CDT-33H stylus. Amplifier: Output: 15W RMS at 4 ohms. THD: 1%. Radio tuner Wavebands: FM/L/M. Tape deck: Noise cut filter. W and F: 0.1% WRMS. S/N: better than 50dB. FR: 30-13,000Hz normal, 30-



JVC MF-1845L

★ Indicates entry is illustrated

15,000Hz chrome. Main unit: dimensions: 50 × 43.8 × 19.3cm. Weight: 16kg. Features: auto stop on cassette. Cassette storage space included. Price: £224.00 (plus VAT).

■ Lenco

Goldring Ltd, 10 Bayford Street, Hackney, London E8. Tel: 01-985 6411.

L3000

Lenco L65 with speeds of 33½ and 45rpm. Unweighted to DIN -40dB, weighted -60dB. G800 stylus. Amplifier: Output: 12W RMS. FR: 25-40,000Hz. THD: 1kHz 2 × 12W 0.2%. Radio tuner: wavebands covering FM/L/M. Tape deck: W and F: ±0.3% playback, 45dB rec/PB -42dB. FR: 53-10,000Hz -6dB rec/PB 63-10,000 -8dB. Speakers: HC: 20W DIN. Imp: 5 ohms. Crossover: 3.5kHz. Drive unit. 13cm bass, middle range 70-3500Hz. 3cm treble, 3,500-20,000Hz. Dimensions: 38.5 × 21.5 × 18.5cm. Weight: 3.5kg. Matching wood finish. Features include amplifier with 2 × 12 sine wave power, all: front operation, cassette mechanism fitted next to turntable protected by dust cover. Price: £225.00 (plus VAT), speakers extra.

■ MARCONIPHONE

Thorn Consumer Electronics Ltd, Thorn House, Upper St Martin's Lane, London WC2H 9ED. Tel: 01-836 2444.

4494

Record deck: BSR P170. Speeds: 33½, 45, 78 rpm. Magnetic cartridge with diamond stylus. Amplifier: Output: 10W RMS per channel into 8 ohms. FR: 25-30,000Hz. THD: <0.5%. Radio tuner: band coverage: FM/L/M/S. Tape deck: W and F: <0.3%. S/N: 50dB (CrO₂). FR: 40-14,000 (CrO₂). Speakers: Imp: 8 ohms. Drive units: 6½in. Teak finish. Main unit: dimensions: 62 × 49 × 22cm. Black finish with teak surround. Features: single or automatic deck. AFC automatic switching for CrO₂ tape. Auto-stop. Auto or manual record with two VU meters. FM stereo beacon. Noise suppressor. Price: on application.

■ OMEX PRODUCTS LTD

Hereford House, Wandle Mills, Beddington, Croydon, Surrey CR0 4SB. Tel: 01-686 9022.

MC006 ★

Record deck: BSR C123 R1 with speeds 33½,



Omex MC006

45, 78 rpm. SC 12M cartridge with ST16 stylus. Amplifier: output: 5W RMS per channel. FR: 100-10,000Hz. THD: 1% at 5W. S/N: 55dB. Radio tuner: band coverage: FM/L/M. Tape deck: W and F: 0.25% RMS. S/N: 38dB. FR: 100-10,000Hz (low noise tape). Speakers: HC: 7W RMS. Imp: 8 ohms. Drive units: 8 × 5in. Dimensions: 23 × 15 × 36cm. Weight: 3kg. Teak finish. Main unit: dimensions: 60.7 × 20 × 38.7cm. Weight: 11kg. Teak finish. Features: auto record level, switchable AFC, cueing device. Price: £152.82 (plus VAT).

MC007

Record deck: BSR C123 R1. Speeds: 33½, 45, 78 rpm. SC12M cartridge with ST16 stylus. Amplifier: output: 10W per channel. FR: 30-15,000. THD: 1%. S/N: 55dB. Radio tuner: band coverage: FM/L/M. FR: 30-15,000Hz. THD: 1.25%. Tape deck: W and F: 0.25% RMS. S/N: 45dB. FR: 80-10,000Hz (low noise tape). Speakers: HC: 15W RMS. Imp: 8 ohms. Drive units: 6½in duo cone. Dimensions: 27 × 21 × 43cm. Weight: 5kg. Teak finish. Main unit: dimensions: 60.7 × 20 × 39.7cm. Weight: 12kg. Teak finish. Features: slider controls, CrO₂ switching. Auto record level. Mics provided. Cueing device on changer. Pause control and auto stop on cassette. Price: £187.50 (plus VAT).

MC 011

Record deck: BSR C123 R1 with speeds of 33½, 45, 78 rpm. SC12M cartridge with ST16 stylus. Amplifier: output: 7.5W per channel. FR: 40-20,000Hz. THD: less than 1%. S/N: -65dB. Radio tuner: band coverage: FM/L/M. THD: less than 1%. Tape deck: W and F: 0.25% RMS. S/N: 38dB. FR: 100-10,000Hz (low noise tape). Speakers: HC: 15W RMS. Imp: 8 ohms. Drive units: 6½in duo cone. Dimensions: 27 × 21 × 43cm. Weight: 5kg. Teak finish. Main unit: dimensions: 56 × 39 × 20cm. Weight: 9kg. Teak finish. Features:

THE TECHNOLOGY OF PLEASURE CREATES **MC3**

Music Centre versatility at a Unit Audio Price.

The commitment to technology that has made Fidelity the best-selling British made brand of sound systems now creates another breakthrough: the combination of full music centre versatility and quality sound reproduction at no more than the cost of a good unit audio system.

Fidelity's MC3 offers complete radio, record playing and cassette facilities in a sleek, superbly styled unit with complementary speakers.

A glance at the specifications will prove the MC3's superiority of design; only when you hear it in action will you fully appreciate that superiority of performance.



MC3 £145.00*

DESIGN:

Soft line ultra modern unit with complementary speakers and a hinged, removable, transparent lid

OPERATION:

Push Button Controls On/Off, LW, MW, FW, AF, Frequency Shift, Tuner, Phono, Tape, Microphone.

Slider Controls Volume Left Volume Right, Treble and Bass.

BSR Single Play Autodeck fitted with a cueing device and a stereo ceramic cartridge with a turn-over stylus.

AM Radio MW 525-1625 KHz 184-572 metres. LW 150-250 KHz 1200-2000 metres. Sensitivity 400 μ V/metre at 1 MHz for 20 dB signal to noise ratio.

FM Radio 87.5-108 MHz Sensitivity better than 15 μ V for 3 dB from limiting.

FM Stereo Channel Separation 25 dB at 1 KHz

Output 8 watts RMS per channel into 4 ohms with thermal and current overload protection.

Cassette Piano Keys—Record, Rewind, Fast Forward, Play, Stop/Eject, Pause.

Signal to Noise Ratio 45dB.

Erase Ratio 70 dB.

Wow and Flutter less than 4% RMS.

Frequency Response 50 Hz to 10 KHz +3 dB.

Power Supply—200-250 volt AC 50 Hz 3 core mains lead.

Power Consumption 60 watts.

Speakers—Two units, each 20.3mm x 129 mm (8" x 5") Loudspeaker lead length approx. 3.6 metres (12') terminated with a Din plug 2 pin

Extra Facilities: Sockets for microphone, AM aerial, FM aerial, loudspeakers. Stereo headphone jack socket. Minimum impedance 4 ohms internal ferrite rod aerial for LW and MW. Automatic FM Stereo indicator light. Auxiliary recording input. The

cassette player and recorder has an automatic level recording and push-button control to eliminate oscillator whistle on direct radio recording. Automatic tape position indicator. A cassette auto stop, blank cassette, 2 stereo microphones and indoor FM aerial are provided



Fidelity Radio Limited

Victoria Road, London NW10 6ND.

Telephone: 01-965 8771 (20 lines) Telex: 923355 Cables: Amplify London.

Service Department: Victoria Road, London NW10 6ND

Telephone: 01-965 9235/6

UNIT AUDIOS, RADIO/CASSETTE RECORDERS, TRANSISTOR RADIOS, RECORD PLAYERS

*Recommended Retail Price including VAT @ 12 1/2% (Correct at May 1976)



Music centres needn't cost the earth....

We'll give you everything you need:

The latest technical innovations.

Superb European styling.

Simulated teak finish.

Twin matching speakers.

Stereo microphones.

Optimum performance

All at easily affordable, budget prices.

Ask to see Sanyo

-or write for further details.



SANYO

a world of difference

Sanyo Marubeni (U.K.) Limited, 8 Greycaine Estate, Watford WD2 4UQ Tel: Watford 30421

two meters. Auto level control. AFC, switchable. Price: £172.50 (plus VAT).

MC 020

Record deck: BSR P163. Speeds: 33 $\frac{1}{3}$, 45 rpm. W and F: $\pm 0.2\%$, typical 0.13%. ADC K8 cartridge with diamond stylus. Amplifier: output: 25W per channel. FR: 30-15,000Hz. THD: better than 1%. S/N: -60dB. Radio tuner: band coverage: FM/L/M. FR: 30-15000Hz. THD: 1.25%. Tape deck: Noise reduction system: DNL. W and F: 0.2% RMS. S/N: 45dB. FR: playback 63-10,000Hz (TEAC MTT-116L), rec/playback 80-10,000Hz (low noise). Speakers: HC: 30W. Imp: 8 ohms. Drive units: 8in woofer, 2 $\frac{1}{2}$ in tweeter. Dimensions: 27 x 21 x 43cm. Weight: 6kg. Teak finish. Dimensions: 60 x 40 x 17cm. Weight: 20kg. Teak finish. Features: Noise reduction system, pause, auto-stop, level meter, microphones supplied, tuning meter, radio, four speaker output (switched), belt drive, record deck, magnetic cartridge. Price: £318.74 (plus VAT).

■ PHILIPS ELECTRICAL LTD

City House, 420-430 London Road,
Croydon CR9 3QR.
Tel: 01-689 2166.

AH 963

Record deck: Philips GC027 with speeds 33 $\frac{1}{3}$ and 45 rpm. Rumble: <-55dB. W and F: <0.2%. Philips GP215 ceramic cartridge. Amplifier: Output: 2 x 10W. FR: >20-15,000Hz. THD: <1%. S/N: -50dB. Radio tuner: band coverage: FM/L/M/S. THD: FM <1% at 75kHz deviation. Tape deck: noise reduction system: DNL. W and F: < $\pm 0.35\%$. S/N: >48dB for CrO₂ tape with DNL. Speakers: HC: 20W RMS. Impedance: 4 ohms. Drive units: 8in dia. Dimensions: 24.6 x 17.6 x 34.4in. Weight: 3.5kg approx. Black ash finish. Main unit: dimensions: 57.6 x 37.7 x 18cm. Weight: 9.6kg. Black and silver finish. Features: tape pause control, hinged lid, headphone output. Price: to be announced.

RH 953

Record deck: Philips GC027 with speeds of 33 $\frac{1}{3}$, 45 rpm. Rumble: <-55dB. W and F: <0.2%. Philips GP400 magnetic cartridge. Amplifier: output: 2 x 10W. FR: >20-15,000Hz. THD: <1%. S/N: -50dB. Radio tuner: band coverage: FM/L/M/S. THD: FM: <1% at 75kHz deviation. Tape deck: noise reduction system: DNL. W and F: < $\pm 0.35\%$. S/N: >48dB for CrO₂ tape with DNL. Speakers: HC: 20W RMS. Imp: 4 ohms. Crossover: 3,000Hz. Drive units: 8in + 1in dia. Dimensions: 24.6 x 17.6 x 34.4cm. Weight: 3.8kg approx.

Black ash finish. Main unit: dimensions: 57.6 x 37.7 x 18cm. Weight: 9.5kg approx. Black and silver finish. Features: mic input and headphone output on front panel. Switchable contours. Automatic tape switching. Three digit tape counter, tape pause control, hinged lid. Price: £300.00 (plus VAT).

AH 967

Record deck: Philips GC018 with speeds 33 $\frac{1}{3}$, 45 rpm. Rumble: <-60dB. W and F: <0.14%. Philips GP400 magnetic cartridge. Amplifier: output: 2 x 25W. FR: 30-25,000Hz. THD: <0.1% for 2 + 20W. S/N: <-56dB. Radio tuner: band coverage: FM. THD: <0.2% at 4kHz deviation. Tape deck: noise reduction system: Dolby and DNL. W and F: <0.2%. S/N: <-62dB with Dolby for chromium tape. Main unit: dimensions: 72 x 40 x 15. Weight: 14kg approx. Black finish. Features: stereo four surround sound. Presets for five FM stations. Automatic record diameter selection and arm return. Speakers of customer's choice. Price: to be announced.

RH953

Stereo tuner/amplifier/record player/cassette recorder combination. Range: FM 87.5-104MHz, SW 5.95-9.78MHz, MW 520-1605kHz, LW 150-345kHz. Output: 10W per channel. Distortion: less than 1%. FR: 20Hz-15kHz ± 3 dB. S/N ratio: better than -50dB at rated output. Tone controls: bass +12 to -10dB at 50Hz, treble +11 to -12dB at 10kHz. Cassette deck fitted with DNL. Two-speed turntable with Philips GP 400 pick-up cartridge. Power supply: 110, 127, 200 and 240V ac. Power consumption: 52W max. Size: 576 x 180 x 377mm. Price: £300 (plus VAT).

■ PLUSTRONICS

Hempstalls Lane, Newcastle-under-Lyme,
Staffs ST5 0SW.
Tel: Newcastle-under-Lyme 61531.

Plustron

Record deck: P 128R with speeds 33 $\frac{1}{3}$, 45, 78 rpm. Cartridge: SC12M with ST17 stylus. Amplifier: output: 8W at 1kHz. Radio tuner: band coverage: FM/L/M/S. Tape deck: W and F: less than 0.35%. S/N: 40dB overall. FR: standard 100-7,500Hz. Chrome: 10-15,000Hz. Speakers: Imp: 8 ohms. Dimensions: 25 x 14 x 40cm. Weight: 2.75kg. Teak finish. Price: on application.

■ PYE

Pye Ltd, PO Box 49, St Andrews
Road, Cambridge CB4 1DS.
Tel: Cambridge 58985.

★ Indicates entry is illustrated

5024 ★

Record deck: turntable unit: BSR C129R or Glenburn AT 100E. Speeds: 33 $\frac{1}{3}$, 45, 78 rpm. W and F: <0.35% RMS and <0.08% RMS. Cartridge: BSR SC12M or Tetrad 251 S. Stylus: sapphire turnover. 3-speed auto-changer with cueing lever, stylus adjustment and side thrust compensation. Amplifier. Output: 9W RMS per channel. FR: 60Hz-25kHz \pm 3dB. THD: <2% at 1kHz for 2 \times 5W continuous output power. S/N ratio: better than -50dB. Power bandwidth: 60Hz-20kHz at 1dB below max power. Tone controls: bass \pm 10dB at 100Hz, treble \pm 10dB at 10kHz. Channel separation: better than 40dB. Radio tuner. Band coverage: LW 146-262kHz, MW 525-1625kHz, VHF 87.5-104MHz. Tuning system: Varicap with fixed AFC on FM and automatic stereo decoder and manual override. Aerials: IEC socket for external FM aerial, internal ferrite rod for AM, socket for external aerial and earth. Cassette recorder: switchable Dynamic Noise Limiter (DNL). W and F: <0.25% RMS. S/N ratio; 45dB without DNL. FR: (CrO₂) 60Hz-13kHz, (Fe₂O₃) 60Hz-10kHz. Speed: 1 $\frac{1}{8}$ i/s. Storage space for six boxed cassettes. Speakers. HC: 10W. Imp: 8 ohms. Drive units: 203mm \times 127mm. Dimensions (each speaker): 24.5 \times 17.8 \times 36.2cm. Weight: 3.4kg. Finish: simulated teak. Main unit: dimensions: 53.9 \times 47.7 \times 19.8cm. Finish: black/simulated teak. Features/facilities: Fe₂O₃/CrO₂ tape facility with auto switching. Interference filter switch. Tape and headphone sockets. Electronic tape auto stop. Pause control. Friction hinged lid. Price: £199.20 (excluding VAT). Price includes stand.

ZU540 ★

Record deck: turntable unit: Philips GC 008. Speeds: 33 $\frac{1}{3}$, 45 rpm. Rumble: <-38dB (DIN A), <-58dB (DIN B). W and F: <0.2%. Cartridge: Philips GP400 magneto-dynamic. Stylus: 15 micron diamond. Amplifier: output: 20W RMS per channel. FR: 30Hz-25kHz \pm 1.5dB. THD: <0.2% at 2 \times 18W. S/N ratio: 55dB. Channel separation: >55dB at 1kHz. Tone controls: Bass +12, -8dB at 100Hz, treble +12, -10dB at 10kHz. Radio tuner: band coverage: 87.5-104MHz. Tuning system: Varicap with five push-button pre-selectors plus free tuning. Aerial: IEC socket (300 ohm). Cassette recorder: Dolby system noise reduction on record and playback. W and F: < \pm 0.2% (DIN 45 507). S/N ratio: >48dB without Dolby. FR: (CrO₂) 40Hz-12.5kHz, (Fe₂O₃) 40Hz-10kHz. Speed: 1 $\frac{1}{8}$ i/s. Speakers: HC: 20W. Imp: 4 ohms. Drive units: one 8in bass/mid-range unit and one 1in dome tweeter.



Pye ZU540



Pye SX0940

Dimensions (each speaker): 28.6 \times 21 \times 43.8cm. Finish: teak. Main unit. Dimensions: 57.2 \times 37.5 \times 14.7cm. Finish: black/silver. Features/facilities: exceeds hi-fi requirement of DIN 45 500. Built-in stereo decoder and beacon indicator. CrO₂/Fe₂O₃ tape facility with auto switching. Auto contour control. Price: £399.20 (excluding VAT).

SX 6955

Record deck: turntable unit: Philips GC 007. Speeds: 33 $\frac{1}{3}$, 45rpm. Rumble: \leq -58dB. W and F: \leq 0.16%. Cartridge: Philips GP 400 magneto-dynamic. Stylus: diamond. Amplifier: output: 15W RMS per channel. FR: 30Hz-20kHz \pm 1.5dB. THD: <0.1% at 2 \times 12W. S/N ratio: better than 50dB. Radio tuner: band coverage: 87.5-104MHz. FM tuner with built-in stereo decoder. Switchable AFC. Pre-select tuning on four FM stations. Cassette recorder: Dynamic Noise Limiter (DNL). W and F: < \pm 0.35%. S/N ratio: better than 48dB (CrO₂) with DNL. FR: (Fe₂O₃) 60Hz-10kHz. speakers: HC: 20W. Impedance: 4 ohms. Drive units: one 8in bass/mid-range unit and one 1in dome tweeter. Dimensions (each speaker): 23.3 \times 21 \times 43.5cm. Finish: black ash. Main unit: dimensions: 57.4 \times 37.7 \times 14cm. Finish: black. Features/facilities: slide controls. Auto contour control. Disc jockey and dubbing facility. Auto switching between Fe₂O₃ and CrO₂ tapes. Auto recording level

control. Auto tape-end stop. Price: to be announced.

SX0940 ★

Record deck: turntable unit: Philips GC 014. Speeds: 33 $\frac{1}{3}$, 45, 78 rpm. Rumble: <-51dB. W and F: <0.25% RMS. Cartridge: Philips GP 214. Stylus: 18 micron diamond. Slide cueing control and click-stop stylus pressure adjustment. Amplifier: output: 5W RMS per channel. FR: 40Hz-20kHz \pm 3dB. THD: <2% at 1kHz for 2 \times 3.5W. S/N ratio: better than -50dB. Radio tuner: band coverage: LW 150-255kHz, MW 520-1605kHz, SW 5.95-6.2MHz, VHF 87.5-104MHz. Tuning system: free tuning with full-vision illuminated scale over all wavebands. Aerials: Ferroceptor for MW and LW, wire aerial for SW and VHF. Cassette recorder: W and F: < \pm 0.35%. S/N ratio: <-40dB. FR: (Fe \times O $_3$) 60Hz-10kHz \pm 3dB. Speed: 1 $\frac{1}{8}$ i/s. Speakers: HC: 7W. Imp: 4 ohms. Drive unit: one 203mm in each enclosure. Dimensions: 24.2 \times 10 \times 26.5cm. Finish: black/silver. Main unit: dimensions: 51.2 \times 36 \times 10.5cm. Finish: black/silver. Features/facilities: built-in stereo decoder and beacon indicator. AFC on FM. Slide controls. Auto recording level control. Switchable interference filter. Auto tape-end stop. Price: £164 (excluding VAT).

■ RADIONETTE

Norse Audio Systems Ltd,
9 Hawksworth Trading Estate,
Swindon, Wilts SN2 1DZ.
Tel: Swindon 22592/31287.

SM 340 EC ★

Record deck: PE with speeds 33 $\frac{1}{3}$, 45 rpm. Rumble: >56dB weighted, >37dB linear. W and F: \pm 0.15% DIN. Shure M75 type D cartridge with 15 μ spherical stylus. Amplifier: output: 2 \times 20W into 4 ohms. FR: 20-

15,000Hz. THD: 0.3%. S/N: better than 60dB. Radio tuner: band coverage: FM/L/M. FR: 148-270kHz, 515-1630Hz, 87-104mHz. THD: 0.2% DIN. Tape deck: noise reduction system: DNF. W and F: <0.2%. S/N: 50dB DIN. FR: Standard tape \pm 3dB, 35-12,000 Hz, CrO $_2$ \pm 3dB, 35-14,000Hz. Speakers: HC: 30W continuous, 50W peak. Imp: 4 ohms. Crossover: 2,500Hz. Drive units: 8in, 2 $\frac{1}{2}$ in. Dimensions: 14 $\frac{1}{2}$ \times 11 $\frac{1}{4}$ \times 8 $\frac{3}{4}$ in. Teak or rosewood finish. Main unit: dimensions: 64.5 \times 35 \times 17.5cm. Weight: 13kg. Teak, rose, black finish. Features: four pre-sets on FM. AFC. Inter station muting, stereo beacon. Built-in ambio facility. Physiological volume control. Bass lift. Extra tape input giving AB monitoring. Two headphone sockets. Switchable microphone socket. CrO $_2$ switch. Dynamic noise filter. Storage for nine cassettes. Price: £207.20, speakers extra £65.60 (plus VAT).

■ SHARP ELECTRONICS (UK) LTD

107 Hulme Hall Lane, Manchester
M10 8HL.
Tel: 061-205 7321.

SG 309/CP 130

Stereo receiver combined with stereo cassette tape deck, record player and two-way speaker system. Record deck: Sharp with speeds of 33 $\frac{1}{3}$, 45 rpm. Fixed ceramic cartridge with sapphire stylus. Amplifier: output: 10W RMS per channel (both channels driven). FR: 30-35,000Hz. THD: 0.5% at 2.5W. Radio tuner: band coverage: FM/L/M/S. FR: FM 30-15,000Hz. THD: FM 1% at mono. Tape deck: W and F: 0.35% DIN. S/N: 46dB. Speakers: HC: 10W RMS. Imp: 4 ohms. Crossover: 5kHz. Drive units: 8in base, 2in tweeter. Dimensions: 26.5 \times 15.4 \times 37.8cm. Weight: 3.6kg. Walnut or black finish. Main unit: dimensions: 75.5 \times 34 \times 19.1cm. Weight: 13kg. Walnut or black finish. Features: top control floor type stereo. Large dial scale and tuning meter. Built-in AFC. Built-in loudness control. Automatic CrO $_2$ tape selector and CrO $_2$ indicator. Mechanical autostop capability for record and playback made at end of tape. Semi-lead-in/cut out and auto return disc player with 30cm turntable. Price: £175.96 (plus VAT).

■ SKANTIC

Skantic (UK) Ltd, Station Road, Edenbridge,
Kent TN8 6EY. Tel: Edenbridge 5231.

39332

Record deck in cabinet with built-in cassette



Radionette SM 340 GC

★ Indicates entry is illustrated

DNL noise reduction system. Output: 10W RMS per channel. FM tuner with pushbutton selection of 4 pre-set stations. Stereo radio decoder. Record player incorporates ceramic cartridge. FR: 40Hz-20kHz. Available in teak, rosewood, walnut, white or black lacquer. Price: on application.

■ SONY (UK) LTD

Consumer Information, Sony Showroom,
134 Regent Street, London W1R 6DJ.
Tel: 01-439 3874.

HMK 20

Unit audio system with cassette recorder. Record deck: Sony with speeds $33\frac{1}{3}$, 45 rpm. Ceramic VX24P cartridge with sapphire NS 128P stylus. THD: 5%. Radio tuner: band coverage: FM/AM. Stereo 2% at 400Hz. Tape deck: W and F: less than 0.22%. FR: 40-12,000Hz with normal Sony FH tape. Speakers: Imp: 8 ohms. Drive units: 16cm full range cone. Dimensions: $25 \times 12.9 \times 34$ cm. Weight: 2.3kg. Teak finish. Main unit; dimensions: $57 \times 35 \times 16.5$ cm. Weight: 13.9kg. Teak finish. Features: Separate volume controls for left and right channels. Variable tone control. Microphone mixing facility. Pause control, tape counter and automatic recording level on cassette recorder. Price: £159.96 (plus VAT).

HMK 30 ★

Record deck: Garrard with speeds $33\frac{1}{3}$ and 45 rpm. Rumble: S/N ratio 53dB DIN. W and F: $\pm 0.2\%$ DIN. Magnetic cartridge with diamond stylus. Amplifier: output 8W RMS rated per channel operating at 1kHz into 8 ohms. THD: 5% at 1kHz rated output power. S/N: tape 45dB, phono 35dB. Radio tuner: band coverage: FM/L/Mm. FR: 50-15,000Hz. Tape deck: W and F: 0.22% WRMS. S/N: 45dB CrO₂. FR: 40-12,000Hz -15dB normal tape. Speakers: HC: 10W max. Imp: 8 ohms. Drive units: woofer 16cm, tweeter 5cm. Dimensions: $28 \times 14 \times 38.5$ cm. Weight: 2.1kg. Teak finish. Main unit: dimensions: $57 \times 36.3 \times 17.5$ cm. Weight: 10.5kg. Teak finish. Features: separate controls for volume, balance, bass, treble. Stereo indicator light, cue facility on record deck. Pause control, tape counter, and automatic recording level on cassette recorder. Price: £199.96 (plus VAT).

HMK 40A

Record deck: Garrard M355B belt drive with speeds $33\frac{1}{3}$, 45 rpm. Magnetic VL 30G cartridge with diamond ND 133G stylus. Amplifier: output: continuous RMS 10W per channel both channels operating 1kHz into 8 ohms. FR: 70-40,000Hz at 1W output power.



Sony HMK 30



Sony HMK 70

THD: 1% at 1kHz rated output power. S/N: tape 75dB, DIN 75dB. Tape deck: W and F: 0.22% RMS weighted. S/N: 45dB CrO₂. FR: 30-17,000Hz-15dB CrO₂ tape. Speakers: imp: 8 ohms. Drive units: woofer 16.5cm, tweeter 5cm. Dimensions: $25.5 \times 18.5 \times 40.5$ cm. Weight: 4kg. Teak finish. Price: on application.

HMK 70 ★

Record deck: Sony belt drive with speeds $33\frac{1}{3}$ and 45 rpm. S/N ratio -63dB DIN. Wand F: $\pm 0.09\%$. DIN. Magnetic VL 30G cartridge with diamond ND 133G stylus. Amplifier: output: RMS rated output 20W per channel at 1kHz into 8 ohms 40-13,500Hz, 20W at 0.9% distortion. FR: 40-20,000kHz at continuous RMS output power. THD: 0.9% at 1kHz rated output power. S/N: tape 75dB, DIN 75dB. Radio tuner: band coverage: FM/L/M. 20-15,000Hz. Tape deck: Dolby 'B' noise reduction system. W and F: 0.1% WRMS. Speakers: HC: 20W RMS, 35W DIN. Imp: 8 ohms. Crossover: 3,000-5,000Hz. Drive units: 3-way, 22cm woofer, 9cm mid range, 5cm tweeter. Dimensions: $28.5 \times 24 \times 49.5$ cm. Weight: 5.5kg. Teak or walnut finish. Main unit dimensions: $62.6 \times 43 \times 19.1$ cm. Weight:

19.4kg. Teak or walnut finish. Features: loudness control and high filter. Facility for two pairs of speakers. Signal strength and stereo indicator on tuner. Manual recording level and limiter switch. Tape switch for normal, chrome, and ferrichrome tapes, ferrite and ferrite heads, Dolby switch and pause control on cassette deck. Price: £319.95 (plus VAT).

■ **TOSHIBA (UK) LTD**

Toshiba House, Great South West Road, Feltham, Middlesex.
Tel: 01-751 1281.

SM 3500

Record deck: Toshiba with speeds of 33½ and 45rpm. W and F: 0.12% WRMS. Magnetic C52M cartridge and N-14D diamond stylus. Amplifier: 12+12 RMS 1kHz, 8 ohms. THD: better than 1%. Radio tuner: band coverage: FM/L/M. Tape deck: Dolby noise reduction. W and F: 0.23 WRMS. S/N: 55dB. Main unit: Dimensions: 69 × 36 × 20cm. Features: full ASO mechanism, memory system, auto CrO₂ normal tape selector. Price on application.

SM-2900

Record deck: Toshiba 33½, 45 rpm. W and F: 0.12% WRMS. Ceramic C37C cartridge. Amplifier: 8+8W RMS at 1kHz. FR: 8-50,000Hz -6dB. THD: 1.5%. Radio tuner: band coverage: FM/L/M. FR: 50-15,000Hz. THD: stereo 0.85%. Tape deck: W and F: 0.23% WRMS. S/N 55dB. Speakers: two way. Imp: 8 ohms. Drive units: 16cm, 6cm. Dimensions: 21.5 × 16 × 38cm. Main unit: Dimensions: 69 × 38 × 17cm. Price: on application.

SM3100 ★

Record deck: Toshiba with speeds 33½ and 45 rpm. W and F: 0.1%. Magnetic C29M cartridge with N-14D diamond stylus. Amplifier: output:

12+12WRMS at 1kHz 8 ohms. FR: better than 1% rated. Radio tuner: band coverage: FM/L/M. FR: 50-15,000Hz. THD: stereo 0.85%. Tape deck: W and F: 0.23% WRMS. S/N: 55dB. Speakers: 12W RMS. Imp: 8 ohms. Drive units: 16cm and 5cm. Dimensions: 27.5 × 19 × 47cm. Main unit: dimensions: 69 × 38 × 17cm. Features: Dolby noise reduction with auto shut-off. MQS-autoplay, auto CrO₂ tape selector. Price: on application.

SM-3200

Record deck: Toshiba with speeds 33½ and 45 rpm. Magnetic C52M cartridge with N14D diamond stylus. Amplifier: 12W × 2 RMS 1kHz 8 ohms. FR: better than 1% rated. Radio tuner: band coverage: FM/L/M. Tape deck: noise reduction: D.N.L. Wand F: 0.23% WRMS. S/N: 55dB. Speakers: HC: 55-200 recommended. Main unit: dimensions: 69 × 38 × 20cm. Features: full A.S.O. mechanism with auto CrO₂/normal tape switching. Price: on application.

■ **VIDEOTONE**

Perdix Comps, 98 Crofton Park Road, London SE4. Tel: 01-690 1914.

K8005

Record deck: Garrard 35SB with speeds 33½ and 45 rpm. Rumble: -57dB (DIN B), W and F: 0.15%. Magnetic cartridge with diamond elliptical stylus. Amplifier: output: 18W per channel into 8 ohms. FR: 20-20,000Hz. THD: 0.1% at full output. S/N: -65dB. Radio tuner: band coverage: FM/L/M/S. FR: 20-15,000Hz. THD: 0.5%. Tape deck: W and F: 0.25%. FR: 60-13,000Hz (chrome). Speakers: HC: 20 WRMS. Imp: 8 ohms. Crossover: 3.2kHz. Drive units: 1 × 200mm, 1 and 100mm. Dimensions: 23.5 × 22.5 × 39.5cm. Weight: 5.7kg. Teak finish. Main unit: dimensions: 63.5 × 36 × 20.6cm. Weight: 16.5kg. Features: normal/chrome tape quadrosound with front/back volume. Five waveband radio, semi auto turntable, full filters. Price: £218.30 (plus VAT).

K800T

Record deck: Garrard 86SB with speeds 33½ and 45 rpm. Rumble: >60dB (DIN B), W and F: <0.1%. Magnetic cartridge with elliptical diamond stylus. Other features: otherwise identical to K8005. Cartridge is superior. Price: £233.70 (plus VAT).

■ **WALTHAM**

Telerenters (London & Provincial Ltd, 155-159 Queens Road, Watford, Herts WD1 2QH.
Tel: Watford 24543.



Toshiba SM-3100

★ Indicates entry is illustrated



Waltham STM30

STM30 ★

Record deck: turntable: BSR autochange C123R. Speeds: 33 $\frac{1}{3}$, 45, 78 rpm. W and F: 0.2% WRMS. Cartridge: SC 7 M2. Stylus: sapphire ST16. Amplifier: output: 8W RMS. FR: 20Hz-20kHz. Radio tuner. Band coverage: MW 535-1620kHz, FM 88-108MHz, SW 5.8-16.3MHz, LW 148-255kHz. Switchable AFC. Tuning level meter. Cassette deck: W and F: 0.2% WRMS. Crosstalk: 32dB. FR: 100Hz-15kHz. Single VU meter. Auto level record speech/music. Manual record level. Auto switching. Speakers: HC: 10W. Imp: 8 ohms. 6 $\frac{1}{2}$ in dual cone drive unit. Dimensions (each speaker): 15 × 23 × 35.5cm. Weight: 2.9kg. Finish: simulated teak/walnut. Main unit: dimensions: 40 × 65 × 20cm. Weight: 13.6kg. Finish: simulated teak/walnut. Price: £148.03 (excluding VAT).

■ WYE ELECTRONICS LTD

27 Station Road, Brimington, Chesterfield, Derbyshire. Tel: 0246 70297.

Audio 803

Record deck: BSR 129 with speeds 33 $\frac{1}{3}$, 45, 78 rpm. SC12M cartridge with SS stylus. Amplifier: Output: 5W. FR: 20-18,000Hz. THD: >2%. S/N: <54dB. Radio tuner: band coverage: FM/L/M. Tape deck: noise reduction system: CrO₂. W and F: 0.15%. S/N: 50dB. FR: 100-10,000kHz. Speakers: HC: 5W. Imp: 5 ohms. Drive units: 8 × 5in. Dimensions: 20.6 × 15 × 35cm. Teak finish. Main unit: dimensions: 69 × 39 × 17.4cm. Teak finish. Features: auto stop, pause, CrO₂, separate record level controls and meters. Price: £163.16 (plus VAT).

■ WYNSOR

Wyndor Recording Company Ltd, Wyndor Works, Bellevue Road, Friern Barnet, London N11 3ES. Tel: 01-368 2226/7.

MC555

Three-unit system with stereo cassette recorder, stereo radio and stereo cassette recorder. VHF/LW/MW. Automatic record changer with cueing device. Recorder has twin meters and separate record level controls. Output: 5W RMS per channel at less than 2% distortion. 203mm speakers. Imp: 8 ohms. Price: £179 (plus VAT).

MC424

Three-unit system with stereo cassette recorder, stereo radio VHF/LW/MW and automatic stereo record changer with cueing device. Recorder has twin meters and separate record level controls. Output: 5W RMS per channel at less than 2% distortion. 8 × 5in elliptical speakers. Imp: 8 ohms. Price: £153.00 (plus VAT).

S5000

Compact three-unit system combined record deck and tuner/amplifier plus speakers. VHF/LW/MW. Output: 5W RMS per channel. Price: £92.00 (plus VAT).

S2000

Compact three-unit system combined with auto changer/amplifier plus speakers. Output: 5W RMS per channel. Price: £55.95 (plus VAT).

■ YAMAHA

Natural Sound Systems, Strathcona Road, Wembley, Middlesex. Tel: 01-904 0141.

MS 2B

Record deck: Yamaha with speeds of 33 $\frac{1}{3}$ and 45 rpm. Rumble: 48dB. W and F: 0.08%. Cartridge: Yamaha vertical magnetic with conical diamond stylus. Amplifier: output: 18+18. FR: 50-30,000Hz. THD: 0.1%. Radio tuner: Band coverage: FM/AM; FR: 30-15,000; THD: <0.5. Tape deck: DC electronic governed noise reduction system. W and F: <0.15%. S/N: >50dB. FR: 30-13,000 Maxell UD, 30-15,000 Nakamichi CrO₂. Main unit: Dimensions: 69 × 36.7 × 17cm. Weight: 20kg. American walnut finish. Features: auto return turntable. CrO₂ switch, loudness switch. Price: £266.40 (plus VAT).

MS2B/NS430

As MS2B plus speakers with HC of 25W. Imp: 4-8 ohms. Drive units: tweeter 2in, woofer 10in. Dimensions: approx. 32 × 27 × 58in. Weight: approx 12kg. American walnut finish. Price: £310.40 (plus VAT)

Pickup Accessories

★ Indicates entry is illustrated

Abbreviations used in this section are given on page 27.

■ ACOS

Cosmocord Ltd, Eleanor Cross Road,
Waltham Cross, Herts EN8 7NX.
Tel: Lea Valley 716666

Dust Jockey ★

Record cleaner comprising brush to sweep the grooves and a plush pad to lay a film of anti-static solution. Suction base for easy fitting. Automatic action. Designed to fit most single playing units and auto-changers when used manually. Price: on application.

■ ADASTRA

Adastra Electronics Ltd,
Unit N22, Cricklewood Trading Estate,
Claremont Road, London NW2 1TU.
Tel: 01-452 6288.

Imp-Verta

Matches low impedance PU cartridges, microphones and tape heads into high impedance amplifier inputs. Solid state printed circuit device using a silicon transistor. Automatically switched internal 9V battery. Negligible drain. Conversion factor approximately 20 (depending on load). Virtually no hum or signal loss. Metal case, black crackle finish. Size: 5 × 1½ × 1½in. Price: on application.

Discoduster

A comprehensive record cleaning kit with balanced aluminium arm, impregnated cylinder and superfine groove brush. The weighted base can be permanently fixed or used free standing, and the two pivots with choice of arm location enable the Discoduster to be used with a wide variety of automatic, or transcription type decks. Supplied with two replacement treated cylinders, and fluff removing brush. Price: on application.

Audio Leads

Over 40 different audio leads are now available

in the Adastra hanging pack covering practically all audio applications.

A.111/E.1300

Transistorised pre-amplifier with RIAA equalisation circuitry, 47dB gain with FR of 30-20,000Hz. Internal 9V operation for amplifying signals from low output phono cartridges, tape heads, microphones, etc. Metal case. On/off switch. Price: on application.

A.112/E.1310

Stereo, solid state, 4 low-noise silicon transistors pre-amplifier with built-in RIAA equalisation, gain of 34dB and FR of 30-20,000kHz. Input load 50K, output from 50K-500K. Amplifies signals from 3mV to 38mV. Internal 9V operation. Channel separation over 50dB. Twin phono input and output sockets. On/off switch. Silver and black metal case. Price: on application.

A.114/E.1306

Completely cabinetted mains operated stereo pre-amplifier suitable for low output magnetic cartridges, tape head, etc. On/off switch. Tape/phono input selection, pilot lamp. Input impedance: upto 70K, cross-talk: -40dB, noise ratio-45dB. Input: 60mV max. Output: 2V. Price: on application.

■ AUDIO PACKS

Tape Recorder Spares Ltd,
206-210 Ilderton Road, London SE15 1NS.
Tel: 01-639 7844.

Audio Packs

Pre-packed spares and accessories.

Connecting cords

Cables of various types with plugs, sockets and other terminations covering all equipment in use for domestic radio.

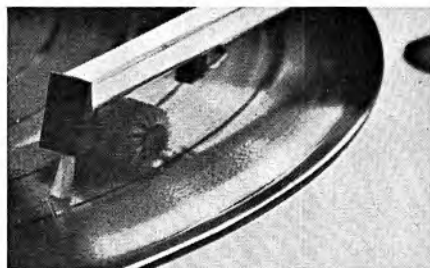

Acos Dust Jockey

★ Indicates entry is illustrated



Audio Pack 441

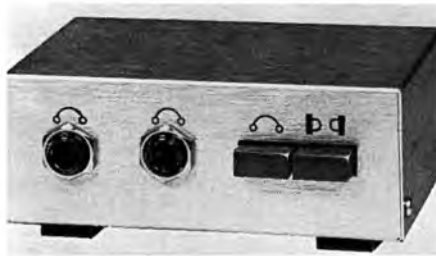

Audio Pack 790



Audio Technica ATS



Audio Technica AT 6002

Adaptors

Convert from any type of plug or socket termination to any other type.

Audio spares

Plugs, sockets, chassis mounted components, fuses and audio accessories. Pre-packed for counter or showroom display.

Mains units ★

Five different 4.5-12V battery eliminators complete with connecting leads for use with all standard battery-operated tape recorders and radios. Full specifications on request.

Sound selector units ★

A range of five units for routing signals to phones, speakers and amplifiers. Four of the units provide for the selection of up to three pairs of stereo headphones or up to three pairs of speakers. The fifth unit, model HZ793, provides facilities for connecting any three signal sources to any three amplifiers. Particularly suitable for demonstration purposes in showrooms and for comparative tests. Prices on request.

■ AUDIO TECHNICA

Shriro (UK) Ltd, Shriro House,
The Ridgeway, Iver, Bucks SL0 9JL.
Tel: Iver 652227.

AT 6008 Rotary Disc Cleaner

Complete with cleaning solution reservoir with special double layered padding construction which enables you to apply cleaner evenly over entire record. Price: on application.

AT 6010 Record Cleaning Kit

Special cleaning solution AT 6008, included in kit, is effective in loosening coagulated dirt in the groove. Price: on application.

AT 6003 Tri Capsule

Stand with thick acrylic covers which will hold up to three spare cartridges in headshells. Price: on application.

ATS Standard Headshell ★

For 1005 arm. Weight: 8gm. Price: on application.

AT UL Ultra Light Standard Headshell Fitting

Will fit AT1005 and 1009 arms. Weight: 6gm. Price: on application.

AT. D Headshell for AT1009 Arm

Weight: 7gm. Price: on application.



Audio Technica AT 6005

which effectively cleans the stylus. Small brush is attached to bottle cap for convenience. Price: on application.

AT 6005 ★

Air lift. Remote control. Tone arm lift utilising compressed air which unlike oil is not affected by changes in temperature. The lifting and lowering action is smooth and constant. Price: on application.

AT L2

Oil lift, for use in conjunction with AT 1005 II arm. Price: on application.

Details on other Audio Technica accessories (headshells, cleaners, etc) on request.



Bib 49

■ **BIB**

Bib Hi-Fi Accessories Ltd, PO Box 78, Hemel Hempstead, Herts. HP2 4RH. Tel: Hemel Hempstead 61291.

Model 42

Record cleaner consisting of an aluminium arm with integral rest, fitted to a self-adhesive base with a brush and velvet roller attached. Price: £1.82 (plus VAT).

Model 45 Auto-changer Groov-Kleen

Finished in chrome and fits most units with flat top cartridge housings. Complete with velvet and stylus cleaning brush. Adaptor available for Garrard Zero 100. Price: 98p (plus VAT).

AT 6001

Autocleanica. Sweep arm. Double action soft bristle brush and anti-static treated plush roller. Weighted base. Replacement brush/pad kit. AT 601. Price: on application.

AT 6002 ★

Improved autocleanica. Sweep arm. Conducting arm and brush with grounding wire, dissipates static charges. Supplied with record cleaning solution. AT 608. Price: on application.

AT 605

Acoustic insulators. For use with turntable or speakers, will effectively neutralise both vertical and horizontal vibrations and minimise acoustic feedback. Adjustable for height, set of four complete with turntable spirit level. Price: on application.

AT 607

Stylus cleaner. Powerful cleaning solution,

Model 50 Groov-Kleen

Has all the features of the Model 60 but made in high quality plastic. The base is black and the cranked arm is white. Price: £1.08 (plus VAT).

Model 43 Record care kit

Contains Groov-Kleen in chrome finish, record dust off, spirit level, stylus and turntable cleaner. Price: £2.76 (plus VAT).

Model 60 Groov-Kleen

Chrome finished with armrest and counter weight to ensure light tracking. Price: £1.72 (plus VAT).

Model 32A Stylus balance

Made from non-magnetic material and fitted with non-scratch base. Measures from ¼ to 5gm and calibrated to be accurate to within ¼gm. Simple to use and supplied with full instructions. In presentation case. Price: £1.28 (plus VAT).

★ Indicates entry is illustrated



Bib 2000



Bib 79

Model 56 Hi-Fi stereo hints and tips

Book for hi-fi enthusiasts describing how to make the most of audio equipment. Contains illustrations, diagrams and reference tables. Written by John Borwick, B.Sc. Price: 48p (VAT exempt).

Model 36A Record and stylus cleaning kit

A kit for removing dust from records and stylus. Comprises two record cleaning cloths and a stylus cleaning brush. Price: 32p (plus VAT).

Record Dust-off Ref: 48 ★

Record cleaning pad mounted on plastic handle. Size: 3½in long, 1in wide. Velvet cleaning pad with foam backing. Is applied to record on turntable while rotating to remove dust and dirt. Price: 26p (plus VAT).

Model 2000 Groov-Kleen ★

Cleans records while you play them. Improves reproduction and reduces record and stylus wear. Fitted with adjustable counterweight and arm rest. Finished in chrome. Spare replacement roller and tracking brush provided. For low level turntables (model 2000/L.). Price: £2.72 (plus VAT).

Ref: 71. Record Dust-Off

For removing dust and dirt quickly and simply from records to reduce record and stylus wear. Measuring just over 5in, it is convenient to hold in the hand and covers the full width of record grooves, making it easy to remove surface dust by applying gently to the record as it revolves. Supplied with protective cover. Price: 66p (plus VAT).

Ref: T/5

Cassette colour-coded title labels. Pack of 45 in three colours, self-adhesive. Price: 39p per pack (plus VAT).

Ref: 45. Cassette Re-Record Kit

Ideal for converting Musicassettes for further recordings and to make your own recorded cassettes erase-proof. Kit contains special tab removing and winding tool, 24 re-record tabs and 27 self-adhesive colour-coded title labels. Supplied in plastic container with instructions. Price: 80p (plus VAT).

Ref: 51. Cassette Care Kit

Containing splicing tape, tape splicer, salvage cassette, tape head cleaner, title labels, re-record kit. Price: on application.

Ref: 40 Record Cleaning Cloth

Completely lint-free and washable. Supplied in handy dust-free container. 26p (including VAT).

Ref: 49 Turntable Levelling Kit ★

For preventing undue wear of records and stylus. Kit comprises three adjustable feet and turntable spirit level. £3.00 (including VAT).

Ref: 69 Anti-Static Liquid

Non-flammable, non-toxic, ideal for cleaning tape heads, record styli, glass, plastic and colour TV screens. 26p including VAT.

Ref: 70 Stylus and Turntable Cleaning Kit

Essential for maintaining stylus and turntable free from dirt. Comprising: cleaning brush, ab-

sorbent cloth, anti-static cleaner and stylus inspection mirror, packed in wallet. 71p (including VAT).

Ref: 75 Indexa Record

Gramophone record filing and index system. Finds 1-100 discs instantly. 100 pairs of numbered sleeve labels. Pad of coded printed pages.

Ref: 76 Stylus Cleaner.

A special purpose stylus cleaning brush and bottle of stylus liquid cleaner, packed in a dust-free container. Essential for maintaining stylus free from dust and dirt. 39p (including VAT).

Ref: 79 'Golden' Record Care Kit ★

This attractive kit comprises: Model 2000 Groove-Kleen, stylus cleaner in dust-free container, record handler, stylus inspection mirror, stylus balance, record dust-off, complete with full instructions. £6.63 (including VAT).

Ref: 80 3-Way Record Care Kit

Another handy care kit which includes the Model 42 Groov-Kleen, Record Handler and Record Dust-Off, which can be used dry or moist. Price: on application.

Ref: 81 Auto-Changer Care Kit

Comprising: Auto-Changer Groov-Kleen, Stylus Cleaner in dust-free container, Record Handler, Record Dust-Off, Cleaning Brush, with full instructions. Price: on application.

■ **B+J IMPORTS**

56 Woodcock Hill, Kenton,
Harrow HA3 0JF.
Tel: 01-907 6667.

Stereo Stamp

Rubber stamp enabling records and tapes to be labelled for easy recognition. Price: 50p including postage.

■ **BSR**

BSR Ltd, Powke Lane, Cradley Heath,
Warley, West Midlands B64 5QH.
Tel: Cradley Heath 69272.

Cartridge Carrier

Quick-change slide-in carrier. Permits changing or inspecting cartridge easily and quickly without interfering with wiring. Models to suit all BSR McDonald pick-up arms (except 210 mini-changer). Price: £1.20 (plus VAT).



Colton ElectroDuster

■ **CLENDISC (Mail Order) LTD**
7 Trinity Court, Gray's Inn Road,
London WC1X 8JX.
Tel: 01-837 9088.

Clendisc

An anti-static cleaner and preservative for records, photographic and optical lenses, copying machines, tape heads and computers. 4 fl oz bottles. Price: 28p (plus VAT).

Clendisc Cleaning Pad

Pad impregnated with Clendisc fluid which assists in the removal of dust and dirt and also neutralises any electrostatic charges present. Price: 20p (plus VAT).

■ **COLTON**

Musonic Ltd, 34-38 Verulam Road,
St. Albans, Herts AL3 4DF.
Tel: St. Albans 50611

Electroduster ★

A pad of soft but firm fibres traverses the record, lifting dust and dirt out of the groove. It is then deposited on to a separate felt pad. Airborne dust settling on a record while it is playing is instantly picked up. Price: £7 (plus VAT). Spare Pads 54p (plus VAT). Replacement Belt £1.11 (plus VAT).

Variscale ★

A precision engineered stylus balance for determining stylus pressure from ½ to 5 gm (adequate to cover all modern lightweight

★ Indicates entry is illustrated

pick-ups). Finished in silver on black base. Price: £1.40 (plus VAT).

Magnalift (MC102)

An automatic centre lift off for pick-up arms, and designed to meet the need on professional turntables where no provision is made for the arm to leave the record when the stylus reaches the run-out groove. When the pick-up has completed the playing cycle the Magnalift will lift the pick-up arm clear of the record thereby obviating stylus wear. Price: £3.90 (plus VAT).

Varilift (MC104)

A precision instrument designed to meet the needs of those requiring a 'hydraulic' pick-up control. It employs a silicon damped piston for slow descent. Finished in black and chrome. Price: £6.05 (plus VAT).

Antistatimat (MC106)

This all-rubber 12in turntable mat is so made that when a record is brought into contact with the mat, it drains off the static charge from the record, thereby freeing the reproduction from static induced noises, without the aid of fluid or cloths. Price: £1.94 (plus VAT).

Precision Turntable Level (MC107)

A circular spirit bubble level accurately made and mounted in plastic with a transparent plastic dome. Accurate levelling ensures correct tracking and minimises stylus and record wear and assists stereo balance. Can be stuck or screwed to any turntable or autochange unit. Price: 66p (plus VAT).

Times Fifty (MC108)

A pocket microscope of $\times 50$ magnification and specifically designed for stylus inspection and as such, has a special slotted hood to accommodate stylus assemblies. Provides an amateur enthusiast with a visual check on the condition of his stylus. Price: £1.23 (plus VAT).

Gripex (MC109)

An anti-slip dressing for drive-belts and idler wheels, it is a spirit suspended solution supplied in 1 fl oz bottles with a special applicator brush. When applied thinly to drive surfaces of belts or friction wheels it will dry off in 15-20 minutes leaving a powerful anti-slip surface. Gripex is ideal for turntables, tape recorders or even car fan belts. Price: 30p (plus VAT).

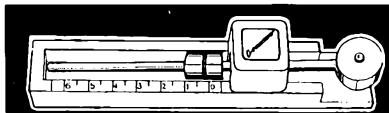

Connoisseur stylus balance

■ CONNOISSEUR

A.R. Sugden & Co (Engineers) Ltd,
Connoisseur Works, Atlas Mill Road,
Brighouse, Yorks HD6 1ES.
Tel: Brighouse 2142.

Connoisseur Stylus Balance ★

Precision stylus balance with sliding weight adjustment. Scale calibrated 0-6gm. Simple operation giving accurate stylus pressure settings. Price: £1.50 (including VAT).

■ DECCA

Decca Special Products, Ingate Place,
Queenstown Road, London SW8 3NT.
Tel: 01-622 6677.

Magnetic bias compensator

Neat, simple, unobtrusive device using magnetism precisely to neutralise the force which draws a pickup towards the centre of the turntable. Type A for Mk I and Mk I 'Super' *ffss* arms, and for Deram ARI arm. Price: £1.03 (plus VAT).

Central locator

Fits on *ffss* arm like *ffss* head. Pickup arm is correctly positioned when the locator moulding fits the turntable centre spindle. Price: 28p (including VAT).

Deccalift

Motorising lifting and lowering device which can be controlled at the turntable and/or remotely. Supplied with 6.3V AC transformer (suitable for 110/230V). Price: £7.70 (plus VAT).

London cartridge adaptors

Type A. Simple slide-on adaptor for use with *ffss* arms (Mk I, Mk I Super and Professional) to accommodate the London cartridge. Automatically adjusts playing weight. Price: £1.29 (plus VAT). Type B. Simple slide-on adaptor for use with International arm to accommodate the London cartridge. Collar arrangement to adjust for correct playing weight. Price: 2½p (plus VAT).



Pixall

Pat. Pend.

CITATION:
Messrs. Milty Products Limited

PIXALL
The above product of your company has been chosen as the top product in the Foreign Products Division by the selection committee of the Fifth Japan Stereo Components Grand Prix.

We hereby praise you for the high honour, and hope at the same time that you will continue to contribute to the development of the audio world in the future.

January 1976.

Japan Stereo Components Grand Prix
Selection Committee - Isamu Asano, Chairman.

Radio Technique Ltd.
Eikichi Ishihara, Representative Director.



THE GRAND PRIX COMMITTEE OF THE STEREO ART MAGAZINE OF JAPAN HAVE AWARDED PIXALL THE HONOUR IN THE CATEGORY OF ACCESSORIES



Pixall

The revolutionary record cleaner

Pat. Pend.

"It's like starting afresh with a new record collection!"

Too many music lovers are putting up with second-rate performances..... distortion, crackly interference, sound track hiss, and tickety tack in their L.P.s, and it can even happen with records that are only weeks old. Instead of blaming your equipment, or records, try the unique Pixall record cleaning treatment.

Pixall is the only revolutionary cleaner that penetrates right down into the delicate serrations inside a micro-groove, holding and lifting out every particle of dust and foreign matter, therefore leaving your record in a scrupulously pristine clean condition.

The treatment takes less than a minute. Each Pixall cleaner has 5 ft. of special adhesive tape, sufficient to allow ten fresh cleaning surfaces to be utilised. *Inexpensive refills are available when required.*

"A highly efficient cleaner. . . it really does clean the record. . . All parts of the groove right down to the bottom. . . glad to be able to recommend it".
B. WEBB. HI-FI NEWS.

"It certainly does remove dust with meticulous thoroughness to leave a gleaming clean record surface. . . in pristine condition. . . can be confidently recommended!"
J. BORWICK, THE GRAMOPHONE.

MILTY PRODUCTS LIMITED

New Mansion House, 173/191, Wellington Road South, Stockport, Cheshire SK1 3UA
Telephone: 061 480 8142/3 · Telex: 667700

★ Indicates entry is illustrated

Record Brush ★

One million conductive man-made bristles, each 8-9 microns in diameter. Cleans the record of dust and static. No anti-static fluids required. Price: £4.50 (plus VAT).

Record Cleaner

An electrically conducting arm carrying a brush made from 20,000 conducting man-made bristles. Can be accommodated on most turntables. Requires no anti-static fluid. Price: £4.50 (plus VAT).

■ EAGLE

Eagle International, Precision Centre,
Heather Park Drive, Wembley HA0 1SU.
Tel: 01-902 8832.

PRE402 ★

Mains-powered stereo pickup pre-amplifier for magnetic cartridges including Eagle LC 05 and LC 07. Provided with dual phono sockets. RIAA equalization. Price: £5.50 (excluding VAT).

FF2 Stereo pickup amplifier

Designed for use with magnetic cartridges, having RIAA equalization. Fitted with phono socket input and outputs. Powered by a PP3 battery or equivalent. Price: £6 (excluding VAT).

■ EXPERT PICKUPS LTD

PO Box No. 3, Ashted, Surrey KT21 2QD.
Tel: Ashted 76604.

Replacement stylus service

For detachable cantilever systems using client's own stylus assembly. Radius to choice; from 0.5 thou (stereo) to 4 thou (78 oversize). Ellipticals where suitable. Radius checked using x 500 magnification.

Grade A transcription diamond styli

Finest quality, highly polished, giving minimum background noise and optimum results. Spherical or elliptical tip.

Grade B

Commercial standard, 0.5 thou to 2.5 thou only. Oversize sapphires and diamonds (Grade A only) for Pathe and Edison reproducers formed and fitted. Expert Pickup diamonds are manufactured only to customers' specifications.

To collectors of 78rpm records

Advice available as to the best method of reproducing from old 78rpm records.



Decca Record brush



Eagle PRE 402

Replacement styli

Complete range of new replacement styli in sapphire and commercial diamond, also professional Grade A diamonds of our own manufacture.

Leak pickup servicing

Sole agents for the servicing of Leak Mk I and Mk II pickups.

EMI pickup servicing

Sole agents for the repair of the EMI EPU 100 pickup head and arm.

■ GROOVAC

R.I. Audio, Kernick Road, Penryn,
Cornwall TR10 9DQ.
Tel: Penryn 72753.

Vacuum record cleaner ★

Consists of a precision lightweight arm and a suction unit acoustically isolated in a special enclosure. Fitted with mains switch and indicator (unit inaudible at a distance of 2 metres). Tracking force 0.6gm. Fine hairs incorporated in nozzle to facilitate removal of dust from bottom of grooves. Counterbalanced. Fixes by magnetic base, or self-adhesive pad. Adjustable height. Integral rest incorporates new



Groove Vac Rec. Cleaner

Complete with template for easy installation. Screw adjustment of horizontal arm. Damped adjustable rate of descent ensures accurate lowering and cueing. Price: on application.

GH 228 Super Arm ★

Allows best performance by providing low bearing friction of 6mgm and extra low mass construction. Accepts all cartridges down to 6grm. Weights assemblies interchangeable so that models can be converted by simply changing weights. Silicon fluid damping, bias adjustment by thread and weight, tracking force adjustment by vernier for accuracy. Counterweight double decoupled, alignment protractor provided. Price: on application.



Hadcock GH 228 Super Arm

■ **HOWLAND-WEST LTD**

3-5 Eden Grove, London N7 8EQ.
Tel: 01-609 0293.

Howland-West Alignment Protractor

Made in laminated Perspex. Provides facilities for checking: (1) vertical tracking angle, (2) lateral tracking angle and (3) channel balance and separation. Price: 60p (plus VAT).

Discduster ★

Record cleaning instrument comprising light-weight arm equipped with brush and cylindrical pad. Balance and height adjustable. Heavy stand permits full operation without need for permanent fixing to motor board. Supplied with two spare brushes and two spare cylinders. Price: £2.15 (plus VAT).

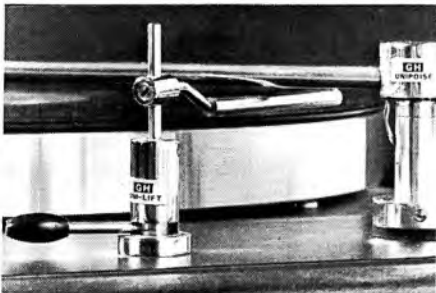

Hadcock Uni Lift Mk III

■ **LENCO**

Goldring Ltd, 10 Bayford Street, Hackney, London E8 3SE.
Tel: 01-985 1152.

Lencoclean

Record cleaning device mounted on turntable. Tracks in front of the pickup, dispensing a narrow band of special fluid. Leaves no deposit on record, cleans the groove and cools the point contact. Keeps stylus point clean. Price: £5.70 (plus VAT).
Replacement Brushes for Lencoclean 50p (plus VAT).

Lencoclean super refill

Price: £1.20 (plus VAT).

Goldring/Lenco VV7

Stereo preamplifier for magnetic cartridges.

anti-skate device. Price: £16.70 (inc. VAT and Postage).

■ **G. F. C. HADCOCK**

Audio Division, The Old Vicarage, Doveridge, Derby DE6 5NN.
Tel: Uttoxeter 2452.

GH Uni-lift Mk III ★

Raising and lowering device suitable for most pickup arms. Two-hole fixing for stability.

★ Indicates entry is illustrated

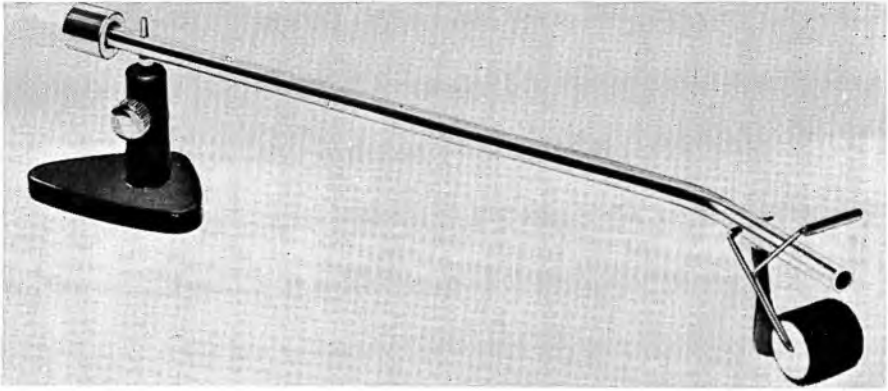

Howland West Discduster

Input: 1mV 47K. Noise level: -60dB. Output: 100mV RMS. Mains: 200-240V 50Hz. Size: $4\frac{1}{4} \times 2 \times 1\frac{1}{2}$ in. Price: £13.20 (plus VAT).

■ LENNARD DEVELOPMENTS LTD

206 Chase Side, Enfield EN2 0QX.

Tel: 01-363 8238.

Play-fair Stylus Timer

Manually operated device which indicates when stylus is due for replacement. Self-adhesive to attach to motor board if desired. Swiss mechanism. Neat plastic case with instructions. Two models: one for sapphires, one for diamonds. Price (either model): 85p (plus VAT).

Play-fair Cleaning Pad

Anti-static. Price: 12p (plus VAT).

Play-fair Stylus Cleaner

Cleaning fluid with separate brush. In presentation case. Price: 36p (plus VAT).

Play-fair Antistatic Cleaning Fluid

30cc polythene bottle. Price: 24p (plus VAT).

Play-fair Discoda

Record sleeve indexing device for quick identification of records. Price: 3f or 12p, 12 for 39p (plus VAT). Bulk prices on application.

Micro-Diamond replacement styli

Comprehensive range. Also retipping service. Price: on application.

Micro-Sapphire replacement styli

Comprehensive range. Also retipping service. Price: on application.

Play-fair Discoduster

Record cleaning device. Two models; one for single play record decks, one for auto-changers. Price: (single) £1.10; (record changer) 52p. All prices exclude VAT.

Play-fair Record Cleaners

Play-fair 60p each (plus VAT); Senior 60p (plus VAT); Junior 40p; Play-fair Record Care Kit 70p; Play-fair Record Handle and Cleaner 30p.

■ LINN PRODUCTS LTD

235 Drakemire Drive, Castlemilk, Glasgow G45 9SZ.

Tel: 041-634 3860.

Clean-ol

A natural fibre (Angora goat hair) disc cleaning device, used dry without antistatic fluids or water. Does not generate static and removes smallest particles from the bottom of the groove. Price: £2.25.

■ METROCARE

Metrosound Audio Products Ltd, Audio Works, Cartersfield Road, Waltham Abbey, Essex EN9 1JF.

Tel: Lea Valley 712712.

M.3 Record Care Kit No. 1

Comprising bottle of Metro-Spray spirit-based anti-static record cleaning fluid; special texture sponge applicator with moulded handle; and soft stylus cleaning brush. Price: 56p (plus VAT).

M10 Metro-Mat

A carbon molecule loaded rubber anti-static



Metrasound M54

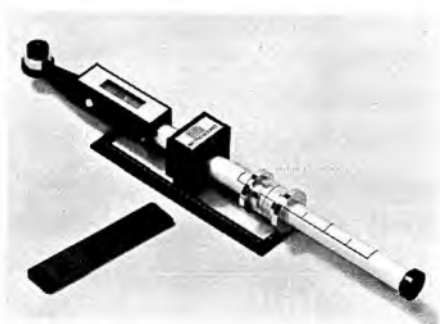

M45 Percy Wilson Discmaster

Dual purpose record cleaning arm; includes wet cleaning version for pre-cleaning badly contaminated discs and dry version similar in specification to the M43 Groovemaster. Held in presentation tray complete with 100cc record cleaning fluid. Price: £3.40 (plus VAT).



Metrosound M64

M52 Metrocare Hi-Fi Kit No. 2

Moulded record cleaner with plush velvet foam backed pad held in protective tray. Bottle of record/stylus cleaning fluid and stylus cleaning brush. Price: 80p (plus VAT).

M53 Metrocare Hi-Fi Kit No. 3

Metrocare Ioniser, record/stylus cleaning fluid and stylus cleaning brush contained in permanent moulded storage case with tinted transparent cover. Price: £1.30 (plus VAT).

M54 Metrocare Hi-Fi Kit No. 4 ★

Metrocare Super Groovemaster, Ioniser, record/stylus cleaning fluid and stylus cleaning brush contained in permanent moulded storage case with tinted transparent cover. Price: £3.36 (plus VAT).

M55 Autochange Groovemaster

Record cleaning device attached to pickup headshell by means of self-adhesive shoe. Finished in bright chrome plate. Whole unit weighs less than 1½gm. Price: £1.10 (plus VAT).

M60 Junior Groovemaster

Record cleaning arm finished in bright chrome plated plastic, pivoted on adjustable self-adhesive base. Price: £1.40 (plus VAT).

M64 Phono Cartridge Kit ★

Comprising microscope, screwdriver, tweezers, stylus cleaning fluid and brush. An essen-

turntable mat to neutralise the negative static charge on records. Price: £1.00 (plus VAT).

M11 Hi-Fi Stylus Cleaning Kit

Bottle of specially developed mild solvent fluid. Moulded plastic retaining clip on bottle for soft nylon cleaning brush. Price: 50p (plus VAT).

M26 Ioniser

High-fidelity record cleaner. Permanently anti-static humid soft velvet enclosed in plastic moulding. Price: 60p (plus VAT).

M43 Super Groovemaster

High quality record cleaning arm finished in satin anodised aluminium and contrasting black; pivoted on dye-cast free standing base. Brush supplied for cleaning velvet roller after use. Price: £2.10 (plus VAT).

★ Indicates entry is illustrated

tial for the safe installation and maintenance of pickup cartridges. Price: £2.00 (plus VAT).

M66 Stylus Balance ★

A professional stylus balance calibrated to within $\frac{1}{20}$ gm with scale divisions at $\frac{1}{10}$ gm between 0 and 3gm. Ensures accurate tracking weight of pickup in tone arm. Price: £2.50 (plus VAT).

M72 Turntable Care Kit.

Comprises spirit level, oiler of advanced design with special oil to reach and lubricate all bearings and moving parts, cleaning brushes and cloth and fluid for cleaning stylus and deck. Housed in a special purpose permanent storage case. Price: £2.50 (plus VAT).

M80 Turntable Spirit Level

A very accurate spirit level, specially designed to set up turntables correctly. Price: 70p (plus VAT)

M81 Duostatic Record Cleaner

A world patented record cleaner incorporating two cleaning surfaces. One consists of polyester with conductive interwoven yarn for static release and the other of thick pile rayon velvet for dust removal. Price: £2.00 (plus VAT).

■ MICRO

Howland-West Ltd, 3-5 Eden Grove,
London N7 8EQ.
Tel: 01-609 0293.

MSB-1 ★

Micro shock absorber. Microsorber employs air-damped high efficiency materials to eliminate acoustic feedback to the record playing deck. Adjustable for height to equalise unbalanced weight of turntable. Price (set of four): £6.30 (plus VAT).

■ KEITH MONKS (AUDIO) LTD

26-28 Reading Road South, Fleet,
near Aldershot, Hants.
Tel: Fleet 7316.

Professional Record Cleaning Machine ★

Used by broadcasting companies, sound studios, record retailers and gramophone libraries. Special washing, scrubbing and suction action leaves record clean and dry. Retail price: (single) £365.48 (plus VAT); (double) £501.95 (plus VAT).

KMAL/S/SL

Spirit level. High quality level with adhesive base. Metal. Price: £1.30 (plus VAT).



Micro MSB-1



Keith Monks Professional Cleaning Machine



Keith Monks KMAL/S/TFL

KMAL/S/TFL ★

Set of 3 adjustable feet for turntable and spirit level. All items have adjustable base. All metal construction with felt pads on feet. Price: £3.92 (plus VAT).

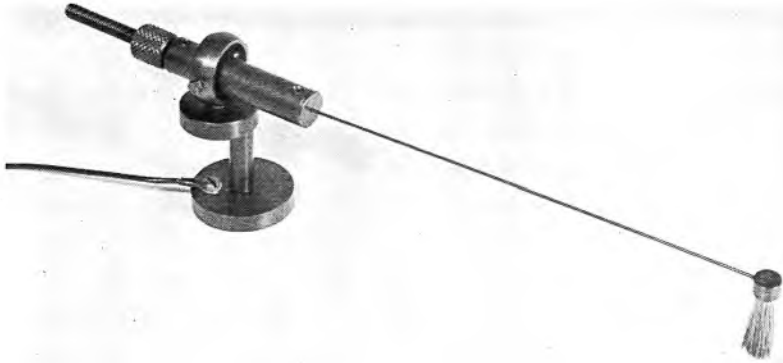

Keith Monks KMAL/S/BA

KMAL/S/BA ★

Record sweeper. High quality brush assembly with squirrel hairs, copper threads and connection for static record deck. Price: £7.05 (plus VAT).

KMALS/BAL

Record sweeper with stylus gauge. As KMAL/BA but with built-in stylus gauge with adjustment up to 1/100gm. Price: £10.35 (plus VAT).

KMAL/S/SG

Stylus pressure gauge with built-in adjustment as little as 1/100gm. Each full turn of the adjustment screw is 1/100gm and every stylus gauge is hand calibrated. At the end of the small arm is a metal cup to take the stylus from the cartridge and give accurate readings. Price: £7.05 (plus VAT).

■ **MUSONIC LTD**

34-38 Verulam Road, St. Albans, Herts. AL3 4DF.

Tel: St. Albans 50611.

DiscRack (MR1) (MR2) (MR3) (MR4)

A range of high quality record racks constructed of heavy gauge steel, welded at all joints. Fitted with plastic feet, available in two sizes, with or without handles, to hold 50 12" records or 36 7" records. Six colours, blue, black, red, grey, gilt or copper. Small No Handle 7" (MR1) Small with Handle 7" (MR2) Large No Handle 12" (MR3) Large with Handle 12" (MR4). Prices: MR1 £1.05; MR2 £1.10; MR3 £1.61; MR4 £1.67. (All plus VAT).

DisCase (MR5) (MR6) (MR7)

A sturdy, elegant case in wood and plastic. Three sizes (MR5) which holds up to 60 7" records, the (MR6) which holds up to 30 12" records, and the (MR7) which holds up to 60 12" records. There is a choice of 10 colours. Prices: MR5 £2.00; MR6 £2.51; MR7 £2.84. (All plus VAT).

DisClens (MR8)

A soft cloth impregnated with an anti-static preparation. One wipe removes dust and dirt from the record, leaving it clean and static free. This helps increase stylus and record life. Price: 20p (plus VAT).

Stylus Cleaner (MR9)

A specially prepared solution which when applied to the stylus tip with the brush provided, cleans and renders it antistatic for longer stylus and record life. Attractively packed in a re-usable plastic wallet. Price: 39p (plus VAT).

Discentres (MR10)

These are record centre adaptors moulded in black high impact polystyrene, designed to convert 7in 45 rpm records from large to standard spindle size. They are easy to fit by simply springing into position, and are almost unbreakable. Available in packs of 10. Price: 24p (plus VAT).

DiscSleeves 12in (MR12)

Discsleeves are made from 200 gauge polythene, specifically to protect stereophonic or monophonic microgroove records from dust and damp. The round cut base ensures that the disc fits snugly and safely for maximum pro-

★ Indicates entry is illustrated

couplers, screw terminals, slider switches, connecting leads with all types of terminations, tecton. For sale in packs of 12. Price: 60p (plus VAT).

DisCovers (MR13)

Discovers are made from 200 gauge polythene to protect colourful and elaborate LP record sleeves against scratching and rubbing. Available in packets of 12 or in bulk for the record retailer. Price: 60p (plus VAT).

DisClosures (MR14)

Special heavy duty welded sleeves made from glass clear PVC. The clarity and strength of these sleeves make them ideal for record shop browsers or for protecting private record collections. Price: £1.02 (plus VAT).

Disc Guards (MR15)

In plain white paper with see-through centre and lined throughout with polythene. Designed to fit snugly inside the printed LP sleeve and provide extra protection for valuable LP records. Price: 47p (plus VAT).

Super Active 30cc (MR16) 15cc (MR17)

This is the famous formula anti-static fluid which produces excellent results in cleaning and neutralising static in records and other plastic products. The fluid can be applied with a sponge or cloth, and is ideal for re-charging all anti-static cleaning devices. Supplied in dropper bottles of either 30cc fl oz or 15cc fl oz approximately. Prices: MR16, 26p (plus VAT); MR17, 20p (plus VAT).

Steel Needles (MR18)

Steel needles in packs of 20. Price: 33p (plus VAT).

Stroboscope (MR19)

Enables you to check accuracy turntable speed. Price: 12p (plus VAT).

Styli

Large range manufactured at Musonic factory. Details on request. Many products above supplied in bulk for dealers.

■ QAS

Quality Audio Supplies, Wollaton Road, Beeston, Nottingham NG9 2PB.
Tel: Nottingham 256141.

Wide range of individually blister-packed audio accessories including phono plugs, DIN plugs and sockets, 4mm and wander plugs,

audio switching units and remote control stations.

Dusta-Disc

Counterbalanced arm to mount alongside turntable for cleaning records while playing. Comprises base with height adjustment, arm with counterbalance weight, super-fine brush for cleaning grooves, plus a soft fabric roller for applying anti-static fluid.

See Speaker Accessories Section for details of other QAS equipment.

■ ROSS ELECTRONICS

Ross Electronics Ltd, 32 Rathbone Place, London W1P 9AD.
Tel: 01-580 7112.

Connecting Leads

Purpose made connecting leads with a variety of end fittings that permit instant connection or extension between pickup sources and amplifiers with dissimilar input/output connectors. Display packed with header card.

Shielded Adaptors

One-piece, male/female interconnectors to provide direct connection between a wide variety of dissimilar plugs and sockets.

Connectors

Plugs and sockets, chassis mounting an inline, to DIN and USA standards.

■ SHURE ELECTRONICS LTD

Eccleston Road, Maidstone, Kent ME15 6AU.
Tel: Maidstone 59881.

SFG2 Stylus Force gauge ★

Accurate beam balance type gauge designed for measuring tracking force in the range of 0.5gm to 3gm. Measures existing playing weight of arm, or can be used to adjust arm to a desired tracking force. Price: £3.30 (plus VAT).

M64-2E

Preamplifier for use with magnetic pickup head and amplifier not having sensitive enough input. Full specification and price in Amplifier Section.

■ SONY (U.K.) LTD

Consumer Information, Sony Showroom, 134 Regent Street, London W1R 6DJ.
Tel: 01-439 3874

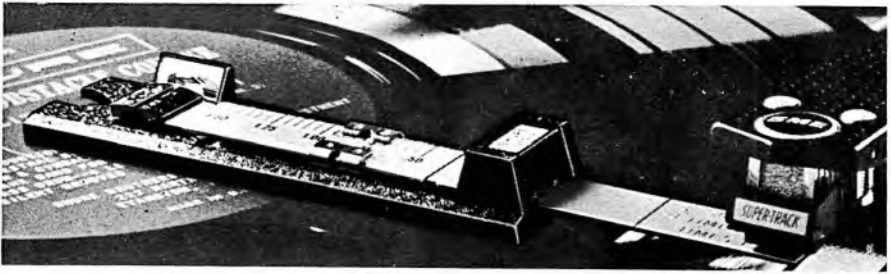

Shure SFG2

Head Shells

SH135 for PS1350/PS 2350 Shell weight 7.5g, £2.36; SH150 for PS4750 / PS6750 / HMK70 / HMP70 Shell weight 10.5g, £3.16; SH160 for PS4750 / PS6750 Carbon Clad £14.36. All prices exclude VAT.

■ **CECIL E. WATTS LTD**

Darby House, Sunbury-on-Thames,
Tel: Sunbury-on-Thames 83252.

PLAY-FAIR

Record Accessories, Stylus Timers, Stylus Cleaners, Antistatic Cleaning Pads, Antistatic Fluid, Discodods, Discodusters (Record Changer and Single Player models), Record Care Kits, Record Cleaners, Tape Accessories, Tape Cassettes and Cartridges, Cassette and Cartridge Cleaners, Cassette Index Cards, Tape Head and Capstan Cleaners, Cassette and Cartridge Carrying Cases.

**MICRO-DIAMOND
MICRO-SAPPHIRE**

Replacement Styli. Most comprehensive range, best quality, reliable service, keen prices; also MICRO-DIAMOND retipping service.

**DRY-SPLICE and
TAPE ACCESSORIES**

(Tapes, Spools and Plastic Tape Boxes).

WOELKE - Tape Heads
(formerly Miniflux).

Manufacturers and Distributors:

LENNARD DEVELOPMENTS LTD
206, CHASE SIDE,
ENFIELD, Middx. EN2 0QX
Tel. (01) 363 8238

Watts Dust Bug

Claimed to be the most efficient method of removing static and dust from records as they are played. Instantly fitted, suitable for all types of records. Record quality is improved, surface noise and wear reduced. Price: £1.36 (including VAT).

Watts Disc Preener

For record maintenance where anti-static agents are not desirable (where stylus force is less than 2gm). Price: 54p (including VAT).

Watts Manual Parastat with Humid Mop ★

Manual model Parastat record cleaning machine. For cleaning and applying anti-static agents to LP records. Complete with humid mop for cleaning bristles and velvet pads. Price: £3.57 (including VAT).

Watts Manual Parastat

Available separately (without Humid Mop). Price: £3.24 (including VAT).

Watts Humid Mop

Available separately. Price: 33p (including VAT).

Hi-Fi Parastat Model Mk 4

Gramophone record maintenance and stylus cleaning kit. Designed for use on records in new condition which are played with pickups requiring very low tracking pressures. Price: £2.97 (including VAT).

Watts Stylus Cleaner

As included with Hi-Fi Parastat kit. Price: 33p (including VAT).

Watts Spares and Replacements

Dust bug nylon bristle and plush pad. Price: 14p (including VAT).

New Formula Dispenser. Price: (1/2oz) 20 1/2p (including VAT); (1oz) 33p (including VAT).

★ Indicates entry is illustrated

Preener Wicks. Price: (packet of four) 14p (including VAT).

Manual Parastat Brush. Price: 87p (including VAT).

Parastat Nylon Velvet Pad Covers. Price: 27p (including VAT) a pair.

Parastat White PVC Sponge. Price: 6½p (including VAT).

Humid Mop (sponge and four wicks). Price: 20½p (including VAT).

Hi-Fi Parastat Distilled Water Dispenser. Price: 27p (including VAT).

Hi-Fi Parastat pad cover and ribbons. Price: 14p (including VAT).

■ WILSON STEREO LIBRARY LTD

104-106 Norwood High Street,
London, SE27.
Tel: 01-670 6394.

W.S.L. Blank Disc

Highly polished blank vinyl disc for adjusting side thrust and alignment. Indicates the amount of side thrust to be corrected. Mirror-like surface reflects underside of cartridge and stylus and assists in accurate alignment. Supplied with instructions for correcting side

thrust. Price: 95p, postage and packing included.

W.S.L. Side Thrust Corrector

Pulley device which may be fitted to any pick-up to correct side thrust. Should be used in conjunction with W.S.L. Blank Disc for precise elimination of side thrust. Price: 60p, postage and packing included.

■ ZEROSTAT

Zerostat Instruments Ltd,
9 Station Road, Huntingdon, Cambs.
Tel: St Ives 62225.

Anti-Static Pistol

Where static is a problem, the use of the Zerostat pistol in conjunction with existing record care products assists the cleaning process and eliminates the subsequent attraction of airborne dust particles, reducing background noise and disc wear. The pistol which is hand-operated uses a high energy piezo-electric element to produce a high corona discharge at the barrel of the device. The ions produced are attracted to oppositely-charged surfaces until the surface charge is neutralised. The pistol produces positive ions on squeezing the trigger, negative ions on release. Price: £6.99 (including VAT).



Record care

A first class way to remove bothersome dust from hi-fi records is to immerse them in hot, soapy water and scrub them vigorously with a scouring pad. One annoying side effect of this method is that severe tracking problems may be experienced due to the absence of grooves.

A better procedure is to prevent the dust getting on to the disc in the first place. Dust is attracted by static. The Zerostat anti-static pistol neutralises static, without contact, in seconds.

Don't get into a lather over record care, get yourself a Zerostat from your local hi-fi dealer, or, write to Department X, Zerostat Ltd., 9 Station Road, St Ives, Huntingdon, Cambs (telephone St Ives 62225) for a data sheet and dealer list.

Yes, the Zerostat pistol costs only £6.99 (including VAT).

ZEROSTAT



Pickup, Cartridges and Arms

★ Indicates entry is illustrated
Abbreviations used in this section are given on page 27.

■ ACOS

Cosmocord Ltd, Eleanor Cross Road,
Waltham Cross, Herts EN8 7NX.
Tel: Lea Valley 716666.

GP91-1 SC ★

Mono/stereo compatible crystal cartridge. Turnover dual stylus. Pw: 3-6gm. Tip mass: 2.5mg (sapphire). 2.8mg (diamond). Dynamic compliance: vertical 2×10^{-6} cm/dyne, lateral 4×10^{-6} cm/dyne. FR: 50Hz-12kHz. Output: 178mV. Min load 1M. Price: (diamond) £1.91 (plus VAT); (sapphire) £1.48 (plus VAT).

GP92-1 SC

Mono ceramic cartridge. Turnover stylus assembly. Stereo/LP 0.6/0.8 thou diamond or sapphire, 78 2.5 thou sapphire. Pw: 4-10gm. Tip mass: 2.5mg dynamic. Compliance: 2.5×10^{-6} cm/dyne. FR: 150Hz-16kHz ± 3 dB, 12dB down at 30Hz relative to 1kHz. Output: 100mV. Load impedance 1M. Low temperature coefficient. Price: (diamond) £2.32 (plus VAT); (sapphire) £1.82 (plus VAT).

GP93 ★

Stereo crystal cartridge. Turnover dual stylus. Stylus 0.6/0.8 thou diamond or sapphire, 2.5 thou sapphire. Pw: 4-8gm. Tip mass: 2.5mg dynamic. Compliance: vertical 2.2×10^{-6} cm/dyne, lateral 2.2×10^{-6} cm/dyne. FR: flat 250Hz-18kHz 3dB down at 100Hz relative to 1kHz. Output: 250mV. Rec load: 1M. Low temperature coefficient. Price: (diamond) £2.69 (plus VAT); (sapphire) £2.23 (plus VAT).

GP94

Stereo ceramic cartridge. Turnover dual stylus. Stylus 0.6/0.8 thou diamond or sapphire, 2.5 thou sapphire. Pw: 2-4gm. Tip mass: 2.5mg dynamic. Compliance: lateral 5×10^{-6} cm/dyne, vertical 6×10^{-6} cm/dyne. FR: flat



Acos GP91-1SC



Acos GP93

100Hz-12kHz, 7-8dB at 30Hz relative to 1kHz. Separation 20dB at 1kHz, 8dB at 10kHz, minimum. Output: 80mV average. Load impedance: 1M each channel. High capacity ceramic elements (1000pF). Low temperature coefficient. Price: (diamond) £3.29 (plus VAT); (sapphire) £2.78 (plus VAT).

GP104

Stereo ceramic cartridge. Two versions; turnover and single-sided. Stylus: 0.5/0.7 thou and 2.5/3 thou. Sapphire or diamond. Pw: 3-4gm. Tip mass: 2-3mg. Compliance: (static) lateral 20×10^{-6} , vertical 17×10^{-6} ; (dynamic) lateral 6×10^{-6} , vertical 5×10^{-6} . Separation: 20dB at 1kHz, 7dB at 10kHz. FR: 70Hz-15kHz +5dB. Output: 100mV. Rec load minimum 1M. Prices: (diamond) £3.46 (plus VAT); (sapphire) £3.02 (plus VAT).

GP104 Transcription

Stereo ceramic cartridge. Single sided. Diamond stylus 0.5/0.7 thous. Pw: 2-5gm. Tip mass: 1.6-2.6gm. Compliance: (static) lateral 20×10^{-6} cm/dyne, vertical 17×10^{-6} cm/dyne; (dynamic) lateral 6×10^{-6} cm/dyne, vertical 5×10^{-6} cm/dyne. FR: 70Hz-12kHz ± 5 dB. Channel separation not less than 20dB at 1kHz. Output: 100mV. Rec load: 1M. Price: (diamond) £3.71 (plus VAT).

★ Indicates entry is illustrated

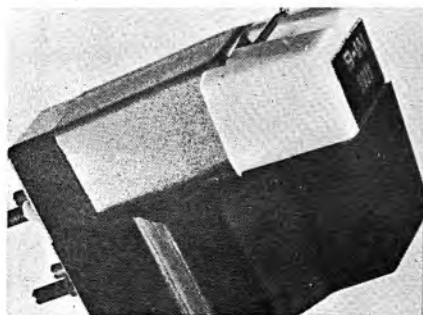

Acos M6

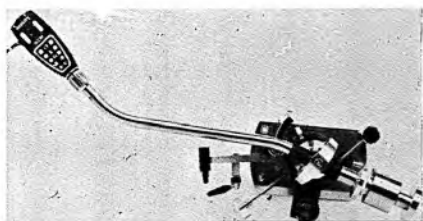

Acos Lustre arm

M6 ★

Stereo magnetic cartridge. Sensitivity: 1.25mV at 1cm/sec. Rec load: 47K. Separation: >15dB at 1kHz. FR: 20Hz-20kHz. Stylus: 0.5/0.7 thou. Pw: 1½-2½gm. Price: (diamond) £6.25 (plus VAT).

M6E

Stereo magnetic cartridge. Sensitivity: 1.25mV at 1cm/sec. Rec load: 47K. Separation: >18dB at 1kHz. FR: 10Hz-25kHz. Stylus: 0.25 × 0.8 thou. Pw: 1¼-2gm. Price: (diamond) £13.50 (plus VAT).

M6EX

Stereo magnetic cartridge. Sensitivity: 0.8mV at 1cm/sec. Rec load: 47K. Separation: >18dB at 1kHz. FR: 10Hz-30kHz. Stylus: 0.25 × 0.8 thou. Pw: 1-2gm. Price: (diamond) £17.25 (plus VAT).

Lustre ★

Transcription pickup arm with headshell. Magnetic bias compensation. Easy height and overhang adjustment. Direct reading stylus pressure gauge with ½gm calibrated marks. Machine finish. Supplied with two headshells. Price: on application.

■ ADASTRA

Adastra Electronics Ltd, Unit N22,
Cricklewood Trading Estate,
Claremont Road, London NW2 1TU.
Tel: 01-452 6288.

D.1 Crystal Turn-over (J.2005)

This well proved cartridge is suitable for a wide range of pick-up heads and its high output matches most record players and phono equipment. Turnover clip-on sapphire styli, 33/45 (LP) and 78 rpm with standard replacements easily obtainable. Supplied with miniature connectors and individually boxed. Output at 1kHz: 2.0V. Compliance: 2.0×10^{-6} cm/dyne. Frequency: 30-15,000Hz. Stylus pressure: 5-8gm. Size: 19 × 20 × 46mm. Weight: 9 gm.

D.2 Mono/Stereo Compatible Crystal

An almost universal replacement cartridge enabling 'pre-stereo' equipment to play stereo records monaurally without damaging effects. 0.7mm sapphire styli 'flipover' 33/45 (LP) and 78 rpm. Moulded carrying bracket with fixing slots, centre hold and clip-on shield. Individually boxed. Output at 1kHz: 2.0V. Compliance: 1.5×10^{-6} cm/dyne. FR: 30-15,000Hz. Stylus pressure: 4gm. Size (less shield): 18 × 21 × 32mm. Weight: 4.6gm.

D.5 Crystal Turn-over (J.2006S)

Intended as the stereo version of Model D.1, this versatile high output cartridge is an ideal replacement for both mono and stereo equipment. Standard fitting bracket; clip-on 33/45 (LP) and 78 rpm sapphire styli. Individually boxed. Output at 1kHz: 1.5V. Compliance: 1.5×10^{-6} cm/dyne. FR: 30-15,000Hz. Stylus pressure: 4-6gm. Size: 18 × 20 × 51mm. Weight: 10gm.

D.6 Ceramic

Will fit most head shells and features sapphire 'flip-over' styli with 33/45 (LP) and 78 rpm selection and protective shield. Individual casket presentation. Output at 1kHz: 0.5V. Compliance: 1.5×10^{-6} cm/dyne. FR: 20-15,000Hz. Stylus pressure: 4-6gm. Size (less shield): 18 × 22 × 32mm. Weight: 3.0gm.

D.11 Magnetic High Fidelity (J.2203)

Diamond tipped moving magnet cartridge. Black and white moulded body with polarity markings and simple slide-out housing for easy stylus replacement. Individually boxed presentation with connectors, fitting screws and data sheet. Sensitivity: 5mV/cm/sec at 1kHz. Compliance: 10×10^{-6} cm/dyne. FR: 20-

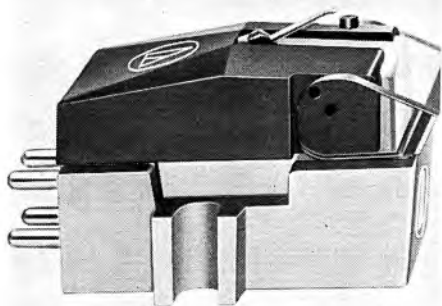

Audio Technica AT15SA

20,000Hz. Channel separation: 20dB. Load: 47K. Stylus pressure: 2gm \pm 0.5gm. Size: (less shield): 15 \times 18 \times 31mm. Weight: 5gm.

D.12 Replacement Stylus for D.11 Cartridge (JSP.1)

Genuine replacement diamond LP stereo styli already assembled in slide-in housing available in see-through plastic box presentation.

D.13 Elliptical High Fidelity (J.2203E)

This model has been introduced with a diamond tipped elliptical stylus 0.3 \times 0.8mm diameter. All other details as D.11. Stylus life of approx. 4/5 years.

D.14 Magnetic High Fidelity with Spare Elliptical Diamond Stylus (J.3000E)

This is the highly developed version of the D.11 fitted with elliptical diamond stylus together with spare stylus already assembled in slide-in housing. Presentation is in a smart moulded case with metal inlay and strong clear cover. This model will fit into most quality pick-up heads and is supplied complete with fitting and connecting accessories. Sensitivity: 5mV/cm/sec at 1kHz. Compliance: 12 \times 10⁻⁶cm/dyne. FR: 20-20,000Hz. Channel separation: 20dB. Load: 2 megohms. Stylus pressure: 2gm. Size (less shield): 15 \times 18 \times 35mm. Weight: 6gm.

D.21 Tone Arms (J.1111)

This tone arm although supplied with the diamond tipped D.11 moving magnetic cartridge already fitted, has a headshell which will accept most other high quality cartridges. Easily adjustable for playing weight and bias compensation. Overall length: 285mm. Effective

length: 223mm. Overhang: 10mm. Offset angle: 24°. Tracking error: 5°. Cartridge: Specification as for D.11. Mechanics: High quality precision turned stainless steel arm and weight/bias adjustment pivoting on self-lubricating ball-bearing block.

■ AUDIO TECHNICA

Distributors: Shriro (UK) Ltd, Shriro House, The Ridgeway, Iver, Bucks SL0 9JL. Tel: Iver 652222.

AT-14SA

Stereo/CD-4 V-magnet cartridge. Stylus: nude Shibata diamond. FR: 10Hz-45kHz. Channel separation: 32dB at 1kHz. Channel balance: 1.5dB. Output: 2.7mV at 5cm/sec. Compliance: 28 \times 10⁻⁶cm/dyne.

AT-15SA ★

Stereo/CD-4 V-magnet cartridge. Stylus: nude Shibata diamond. FR: 10Hz-50kHz. Channel separation: 33dB at 1kHz. Channel balance: 1.5dB. Output: 2.7mV at 5cm/sec. Compliance: 30 \times 10⁻⁶cm/dyne. Channel separation: 33dB. Channel balance: 1.5dB. Output: 2.7mV at 5cm/sec.

AT-11

Stereo dual moving magnet cartridge. Stylus: 0.7 spherical diamond. FR: 15Hz-25kHz. Output: 4.8mV at 5cm/sec. Compliance: 22 \times 10⁻⁶cm/dyne.

AT-10

Stereo V-magnet cartridge. Stylus: 0.7 spherical diamond. FR: 20Hz-20kHz. Channel separation: 30dB at 1kHz. Channel balance: 2dB. Output: 4.8mV at 5cm/sec.

AT11E

Stereo V-magnet cartridge. Stylus: 0.4 \times 0.7 elliptical diamond. FR: 15Hz-28kHz. Channel separation: 30dB at 1kHz. Channel balance: 2dB. Output: 4.8mV at 5cm/sec.

AT12S

Stereo/CD-4 V-magnet cartridge. Stylus: Shibata diamond. FR: 10Hz-45kHz. Channel separation: 30dB at 1kHz. Channel balance: 1.5dB. Output: 2.7mV at 5cm/sec.

AT13EA

Stereo dual moving magnet cartridge. Stylus: 0.2 \times 0.7 nude elliptical diamond. FR: 10Hz-35kHz. Channel separation: at 10kHz 20dB, at 1kHz 25dB. Output: 4.2mV.

★ Indicates entry is illustrated



Audio Technica AT1005 II



Audio Technica AT1009

AT12E

Stereo dual moving magnet cartridge. Stylus: 1.2 to 2gm. FR: 10Hz-45kHz. Channel separation: at 10kHz 17dB, at 1kHz 22dB. Output: 4.2mV at 5cm/sec.

AT-20SL

Stereo/CD-4 V-magnetic cartridge. Stylus: nude Shibata diamond. FR: 10Hz-50kHz. Channel separation: 35dB. Channel balance: 1dB. Output: 2.7mV at 5cm/sec.

Prices for cartridges range from around £8 to £50. Full details on request.

AT1005 II ★

Tubular counter-balanced pickup arm. Overall length: 323mm. Effective length: 240mm. Tracking force: 0.3gm. Cartridge weight: 5.24gm. Effective mass: 20gm (with AT14S). Bias compensation: calibrated weight. Hydraulic lift and lowering.

AT1009 ★

Tubular counter-balanced pickup arm. Overall length: 330mm. Effective length: 240mm. Tracking force: 0-2.5gm. Cartridge weight: 4-12gm. Effective mass: 15gm (with AT14S). Pneumatic lift and lowering with remote control.

Prices for tone arms range from around £25 to £60. Full details on request.

■ BANG & OLUFSEN

Bang & Olufsen UK Ltd,
Eastbrook Road, Gloucester GL4 7DE.
Tel: Gloucester 21591.

MMC 4000

Stereo magnetic integrated cartridge. Factory sealed assembly and therefore no replacement stylus available. Stylus: 0.2 × 0.65 thou diamond. Pw: 1gm. Compliance: 30 × 10⁻⁶cm/dyne. FR: 50Hz-20kHz ±1.5dB. Separation: 24-30dB at 1kHz, 20dB at 500Hz-10kHz. Output: 0.6mV. Rec load: 47K. Ring mounting bracket available. Price: on application.

■ COLTON

Musonic Ltd, 34-38 Verulam Road, St Albans, Herts AL3 4DF.
Tel: St Albans 50611.

MC101 ★

Pick-up arm with lateral balance and anti-skate bias adjustment. Tracking error: +1.5°, -0.5°. Price: £28.00 (plus VAT).

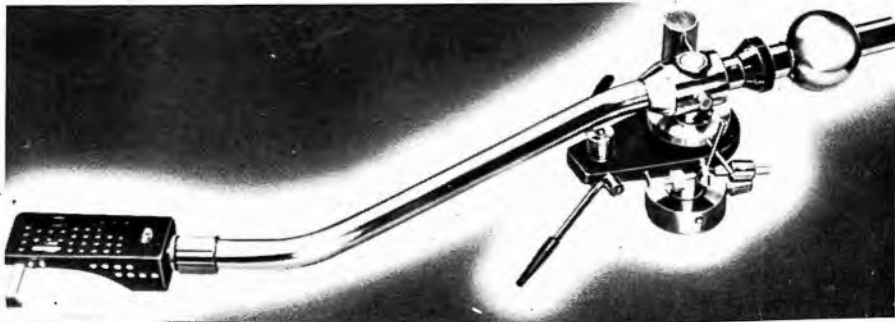

Colton MC 101



Connoisseur SCU1

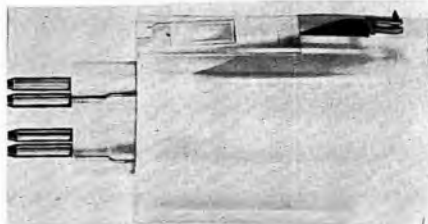

Decca Deram

■ CONNOISSEUR

A. R. Sugden & Co (Engineers) Ltd,
Connoisseur Works, Atlas Mill Road,
Brighouse, Yorks HD6 1ES.
Tel: Brighouse 2142.

SCU1 ★

Stereo ceramic cartridge with 1/2in fixing centres. Stylus diamond 0.5-0.6 thou or 1 thou for mono. Pw: 2-4gm. Tip mass: 1mg. Compliance: lateral 12×10^{-6} cm/dyne; vertical 8×10^{-6} cm/dyne. Range: 25Hz-18kHz ± 3 dB. Separation (1kHz) 25-30dB; (10kHz) 18dB. Output with rec load of 100K, 50mV per channel, RIAA equalisation required. Output with 2M load, 150mV per channel, no equalisation required. Features: four-terminal output, easily replaceable diamond stylus. Price: £7.02 (including VAT).

SAU2

Pickup arm with gimbal mountings on ball bearings set at 45/45. Automatic bias compensator. Hydraulic lowering device. Decoupled counter balance weight. Additional weight supplied to accommodate different cartridges. Single hole fixing. Height adjustable from 1in to 2in. Lightweight shell with 1/2in fixing

centres. Five-pin plug connection to base of pick-up. Low resistance self-cleaning contacts. New head shell allows backward-forward horizontal adjustment so that minimum tracking error is obtained with all cartridges. Alignment protractor provided. Supplied with set of leads and separate precision balance with range 0.6gm. Price: £20.00 (including VAT). Extension stem for use with high turntables. Price: 56p (including VAT).

■ DECCA

Decca Special Products, Ingate Place,
Queenstown Road, London SW8 3NT.
Tel: 01-622 6677.

Deram ceramic (New series)

Stereo/mono cartridge. White shell transcription quality. Pw: 2.5gm. Tip mass: 0.6mg. Compliance: 9×10^{-6} lateral, 5×10^{-6} vertical. FR: 18Hz-18kHz ± 3 dB. Separation better than -20dB at 1kHz. Output: 200mV at 5cm/sec. Rec load impedance: 2M. Stylus: diamond. Price: (spherical stylus) £4.31 (plus VAT); (elliptical stylus) £5.17 (plus VAT).

Deram ceramic ★

Mono cartridge. Stylus 1 thou diamond. All

★ Indicates entry is illustrated

other details as for stereo/mono cartridge.
Price: £4.31 (plus VAT).

NOTE

All Deram cartridges are of transcription quality, the black shell range intended primarily for cheaper auto-changers is discontinued.

Deram heads are suitable for use with amplifiers having a sensitivity of 100mV at 2M.

Replacement Deram diamond styli: Double Deram pack (2 stereo styli) £2.22 (plus VAT); or £1.25 each (plus VAT); elliptical £2.15 each (plus VAT).

London

Stereo magnetic cartridge: *ffss* sum-and-difference system. Stylus: 0.6 thou spherical diamond. Pw: 3gm. Effective tip mass: <1mg. Compliance: (lateral) 12×10^{-6} cm/dyne, (vertical) 5×10^{-6} cm/dyne. FR: 20Hz-20kHz. Channel separation: better than 20dB. Output: 7.5mV for 5cm/sec. Rec load: 47K. Price: £29.09 (plus VAT).

London cartridge adaptors

Type A. Simple slide-on adaptor for use with *ffss* arms (Mk 1, Mk 1 Super and Professional) to accommodate the London cartridge. Automatically adjusts playing weight. Price: £1.29 (plus VAT). Type B. Simple slide-on adaptor for use with International arm to accommodate the London cartridge. Collar arrangement to adjust for correct playing weight. Price: 21p (plus VAT).

■ EAGLE INTERNATIONAL

Precision Centre, Heather Park Drive, Wembley HA0 1SU.
Tel: 01-902 8832

FF12E ★

Moving magnet stereo cartridge. Stylus: Elliptical 0.3 x 0.8 mil. Playing weight: 1.5-2 gms. Compliance: 15×10^{-6} cm/dyne FR: 20-25,000 Hz. Output: 5mV at 5 cm. Rec. Load: 47 K ohms. Supplied complete with stylus brush, guard, screws, washers, nuts and screwdriver. Replacement stylus: FF12S. Price: £14.00 (plus VAT). FF12S: £9.60 (plus VAT).

LC07★

Moving magnet stereo cartridge. Stylus: conical 0.7 mil. Playing weight: 1.5-2.5 gms. Compliance: 12×10^{-6} cm/dyne, FR: 20-21,000 Hz. Output: 7mV at 5 cms⁻¹. Rec. Load: 47 K ohms. Price: £6.80. Replacement stylus LCS07: £5.80 (plus VAT).

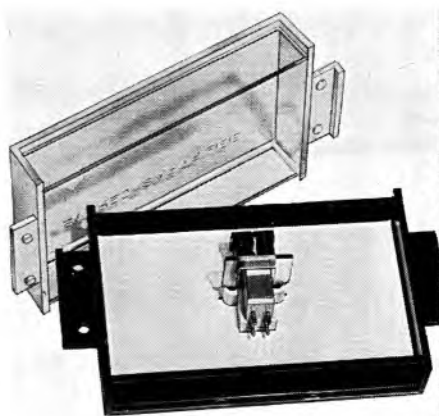

Eagle FF12E



Eagle LC07

LC05 ★

Moving magnet stereo cartridge. Stylus: conical 0.7 mil. Playing weight: 2-4 gms. Compliance: 9×10^{-6} cm/dyne FR: 30-18,000 Hz. Output: 6mV at 5 cms⁻¹. Rec. Load: 47 K ohms. Price: £5.60 (plus VAT). Replacement stylus LCS05: £3.60 (plus VAT).

■ ELAC

Ambionic Sound Reproducers Ltd.
Omal House, North Circular Road,
London NW10 7UF, Tel: 01-965 8787.

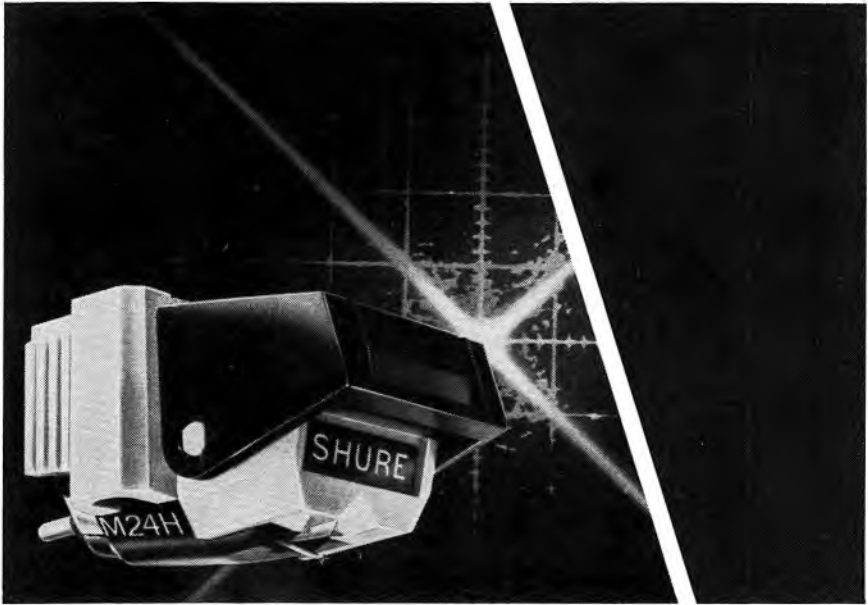

M24H: A superb new stereo cartridge ...but that's only half the story.

Shure's new M24H stereo + quadraphonic cartridge offers uncompromised stereo with the bonus of state-of-the-art full four-channel capability for the hi-fi enthusiast in transition from stereo to quadraphony. It features several breakthroughs by Shure: the M24H has exceptionally low (0.39 mg) effective stylus mass for truly outstanding trackability at minimal forces . . . its optimized 20 to 50,000 Hz frequency response curve is essentially flat in the

stereo range and rises smoothly to accommodate CD-4's supersonic FM carrier frequencies . . . its hyperbolic "long-contact" stylus tip geometry results in a solid groove-tip interface . . . it has a new "Dynetic® X" high-energy magnet assembly and low-loss laminated electromagnetic structure . . . and high-performance trackability at 1 to 1½ grams. If you are considering adding CD-4 capability, but intend to continue playing your stereo library, this is the one cartridge for you.

2+4

MODEL M24H
STEREO +
QUADRIPHONIC
CARTRIDGE

Shure Electronics Limited
Eccleston Road, Maidstone ME15 6AU
Telephone: Maidstone (0622) 59881





ACOS tips for sound enjoyment

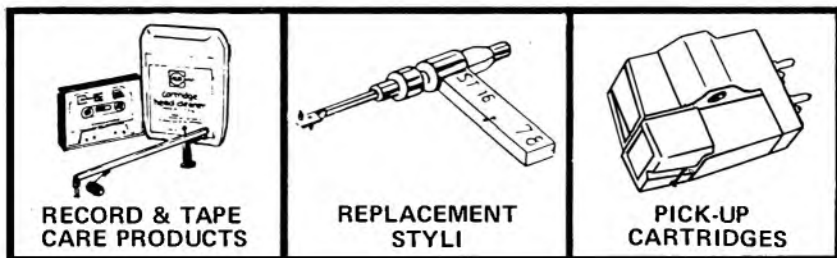

TIP 1. EXAMINE YOUR STYLUS – REPLACE WHEN WORN

The stylus is one of the smallest yet most important components in your audio system since it is the only actual contact between your record and your sound enjoyment. Because it is in contact with the playing surface after a time it becomes worn. Sapphire tips will only last for 25 hours and diamonds for 500 hours, approximate playing time, before wear becomes dangerous to your records. Most replacement styli cost less than one L.P. and are easily fitted in a few seconds.

TIP 2. CHECK YOUR PICK-UP CARTRIDGE PERFORMANCE

Before replacing your existing audio system, check it out, using one of the readily available test records. Ensure that the Tone Arm is set-up for correct balance and stylus tracking weight. Replacing your present cartridge with the latest Acos compatible equivalent, will almost certainly give you sounds like new from your old system.

TIP 3. CLEAN-UP AND KEEP GOOD SOUND

Record, stylus and tape head cleaners come in various shapes and sizes from Acos-care. Remember that airborne dust, vapours from smoking, plus hair, insect and deodorant sprays are all attracted towards electrical equipment, where high static attraction is present. Clean-up and keep good sound with Acos Care record, stylus and tape head cleaning accessories.

ACOS CARE FOR SOUND ENJOYMENT

Cosmocord Ltd., Eleanor Cross Road, Waltham Cross, Hertfordshire, EN8 7NX

Telephone: Lea Valley 716666 Telex: 24294

STS 155-17

Stereo/mono magnetic cartridge. Diamond stylus radius 17μ conical. Playing weight: 1.5 to 3gm. Effective tip mass: 0.8mg. Compliance: 20×10^{-6} cm/dyne. FR: 20Hz-16kHz ± 2 dB. Channel separation: < 2 dB at 1kHz. Output voltage: 2mV. Rec load impedance: 47K. Price: £10.00 (plus VAT).

STS 255-17

Stereo/mono magnetic cartridge. Diamond stylus radius 17μ conical. Playing weight: 1.5 to 3gm. Effective tip mass: 0.75mg. Compliance: 20×10^{-6} cm/dyne. FR: 20Hz-20kHz ± 2 dB. Channel separation: < 2 dB at 1kHz. Output voltage: 1.8mV. Rec load impedance: 47K. Price: £15.00 (plus VAT).

STS 355-17

Stereo/mono magnetic cartridge. Diamond stylus radius 17μ conical. Playing weight: 1 to 2gm. Effective tip mass: 0.60mg. Compliance: 30×10^{-6} cm/dyne. FR: 20Hz-22kHz ± 2 dB. Output voltage: 1.1mV. Rec load impedance: 47K. Price: £18.00 (plus VAT).

STS 355-E

Stereo/mono magnetic cartridge. Diamond stylus elliptical $6/18\mu$. Playing weight: 1 to 2gm. Effective tip mass: 0.60gm. Compliance: 30×10^{-6} cm/dyne static. FR: 20Hz-22kHz ± 2 dB. Output voltage: 1.1mV. Rec load impedance: 47K. Price: £24.00 (plus VAT).

STS 455-12

Stereo/mono magnetic cartridge. Diamond stylus radius 12μ conical. Playing weight: 0.75 to 1.50gm. Effective tip mass: 0.5gm. Compliance: 40×10^{-6} cm/dyne static. FR: 10Hz-25kHz ± 1.5 dB. Channel separation: < 1.5 dB at 1kHz. Output voltage: 1mV. Rec load impedance: 47K. Price: £24.00 (plus VAT).

STS 455-E

Stereo/mono magnetic cartridge. Diamond stylus elliptical $6/18\mu$. Playing weight: 0.75 to 1.5gm. Effective tip mass: 0.5mg. Compliance: 40×10^{-6} cm/dyne static. Channel separation: < 1.5 dB at 1kHz. Output voltage: 1.1mV. Rec load impedance: 47K. Price: £29.00 (plus VAT).

STS 555-12

Stereo/mono magnetic cartridge. Diamond stylus radius 12μ conical. Playing weight: 0.5 to 1gm. Effective tip mass: 0.5mg. Compliance: 45×10^{-6} cm/dyne static. FR: 10Hz-27kHz + 1.5dB. Output voltage: 1mV. Channel separation: < 1.5 dB at 1kHz. Price: £34.00 (plus VAT).

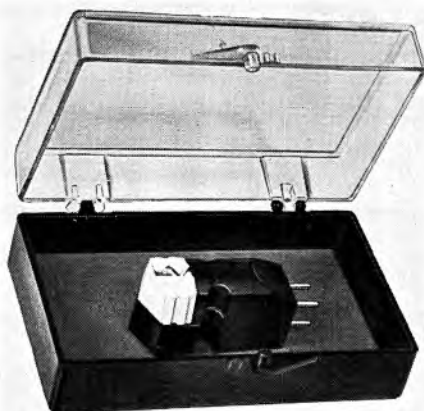

Eagle LC05

STS 555-E

Stereo/mono magnetic cartridge. Diamond stylus elliptical $6/18\mu$. Playing weight: 0.5 to 1gm. Effective tip mass: 0.5mg. FR: 10Hz-27kHz + 1.5dB. Output voltage: 1mV. Channel separation: < 1.5 dB at 1kHz. Rec load impedance: 47K. Price: £39.00 (plus VAT).

STS 655-D4

Quad/stereo magnetic cartridge. Diamond stylus—Shibata. Playing weight: 1 to 2gm. Effective tip mass: 0.35mg. Compliance: 30×10^{-6} cm/dyne static. Channel separation: < 1.5 dB. Output voltage: 0.8mV. (Rec load impedance: 47-100K. Price: £49.00 (plus VAT).

■ EMPIRE SCIENTIFIC CORP

Hayden Laboratories Ltd, Hayden House, Churchfield Road, Chalfont St. Peter SL9 9EW.

Tel: Gerrards Cross 88447.

2000

Diamond cartridge 0.7 mil. Playing weight: $1\frac{1}{2}$ -3 gms, tip mass 1 mg. Compliance: 14×10^{-6} cm/dyne. FR: 20-20,000kHz ± 3 dB. Output: 7mv. Rec. Load: 47K ohms. Price: £8.00 (plus VAT).

2000E

Diamond cartridge 0.3×0.7 mil. Playing weight: $1\frac{1}{4}$ -2 $\frac{1}{2}$ gm. Tip mass 0.9 mg. Compliance: 16×10^{-6} cm/dyne. FR, Output and load as 2000. Price: £9.50 (plus VAT).

2000E-1

Diamond cartridge 0.2×0.7 mil. Playing

★ Indicates entry is illustrated

weight: 1-2 gms. Tip mass: 0.6 mg. Compliance: 17×10^{-6} cm/dyne. FR, output and load as 2000. Price: £12.50 (plus VAT).

2000E-II

As per 2000E-I except Playing weight is $\frac{3}{4}$ -1½ gm and compliance 18×10^{-6} cm/dyne. Price: £15.00 (plus VAT).

2000E-III

As per 2000E-I except compliance: 20×10^{-6} cm/dyne and Output: 4.5 mv. Price: £13.00 (plus VAT).

2000Z

Stereo cartridge. As per 2000E-I except Playing weight: $\frac{3}{4}$ -1¼ gm. Compliance: 30×10^{-6} cm/dyne. Output: 3 mv. Price: to be announced.

4000D-I

Quad/stereo cartridge 0.2 mil tracing radius. Playing weight: 1-1¼ gm. Tip mass: 0.4 mg. Compliance: 30×10^{-6} cm/dyne. FR: 15-45,000Hz \pm 3dB. Output: 3 mv. Rec load: 100K ohms. Price: £45.00 (plus VAT).

4000D-II

Similar to 4000D-I except Playing weight: $\frac{3}{4}$ -1 gm. FR: 15-50,000Hz \pm 3 dB. Price: £67.00 (plus VAT)

4000D-III

Same as 4000D-II except playing weight is $\frac{3}{4}$ -1¼ gm. Price: £78.00 (plus VAT).

■ FIDELITY RESEARCH

Wilmex Ltd, Compton House, New Malden, Surrey KT3 4DE.
Tel: 01-949 2545

FR1 Mk2 + FRT3 transformer

Magnetic moving coil cartridge. Stylus: 0.2 \times 0.8 elliptical. Playing weight: 0.75-1.5 gms. FR: 20 Hz-20 kHz 0.5 dB. Output: 0.1mv 5 cm sec at 45. Rec load on transformer 47K-50K. State of the Art cartridge supplied with FRT3 transformer for coupling to normal magnetic input on amplifier. Price: £79.95 (plus VAT).

■ FORMULA 4

Mayware Ltd.
15 Heather Walk, Edgware, Middx. HA8 9TS.
Tel. 01-958 9421

PLS4/D Tone Arm

Viscous Pivot Damping with variable low ef-

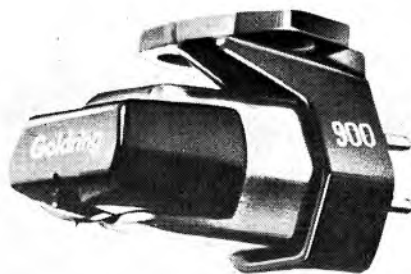

Goldring G900 Super E

fective mass ensures natural sound without 'listening fatigue' enabling high and low compliance cartridges to reach their 'Linear Region' of best performance, absolutely essential for perfect Stereo and Quadraphonic transcription due to the suppression of instantaneous tracking-force which reduce record wear and high frequency playback distortion. Viscous silicone damping means better tracking even of warped records the sound having exceptionally good definition rich full and clean bass with a dramatically improved solid stereo image and near-pinpoint localisation. Jewelled uni-pivot friction below 0.005 gm. VTF 0-3 gm. Bias Control. Stylus-to-pivot 224 mm. Suitable cartridges weighing 2-10 gm. Price: £44.00 plus VAT).

■ GOLDRING LTD

10 Bayford Street, Hackney, London E8.
Tel: 01-985 1152.

G900 Super E ★

Micro mass moving magnet cartridge. Stylus: Elliptical 0.007 \times 0002. Playing weight: 0.75-1.5 gm. Tip mass: 0.32 mg. Compliance: Lat 40×10^{-6} cm/dyne ver 20×10^{-6} cm/dyne. FR: 20Hz -20 kHz \pm 2dB. Output: at 5cm/sec, 1K Hz 5mV RMS. Rec. Load: 47 K/150 -200 pF. Because of its extraordinarily low mass, the G900 tracking at less than 1 gm, provides extremely low intermodulation distortion. Because of micro mass it offers very flat frequency response with excellent tone burst response. Price: £36.00 (plus VAT).

G800

Stereo magnetic cartridge. Stylus: 0.0005in. Playing weight: 1½-2½ gms. Tip Mass less than 1 mg. Compliance: 20×10^{-6} cm/dyne. FR: 20 Hz-20kHz \pm 3 dB. Output: 8mV at 5 cm/sec 1 kHz. Rec. Load: 47K. Separation: 20dB at 1K Hz. Price: £7.50 (plus VAT).

G800H

Stereo magnetic cartridge. Stylus: 0.0007in. Playing weight: 2½-3½ gm. Tip mass: 1.2 mg. Compliance: 18×10^{-6} cm/dyne. FR: 8 mV at 5 cm/sec 1 kHz. Rec. Load: 47K. Separation: 20dB at 1 kHz. Price: £7.50 (plus VAT).

G800E

Stereo magnetic cartridge. Stylus: Elliptical: 0.0007×0.0003 ($18 \times 8\mu$). Playing weight: ¾-1½ gm. Tip mass: less than 1 mg. Compliance: 30×10^{-6} cm/dyne. FR: 10Hz-23kHz ± 3 dB. Output: 5 mV at 5 cm/sec 1 kHz. Rec. Load: 47 K. Separation: 20dB at 1 kHz. Price: £11.40 (plus VAT).

G800 Super E

Stereo magnetic cartridge. Stylus: Elliptical 0.07×0.03 ($18 \times 8\mu$) Playing weight: ½-1¼ gm. Tip mass: less than 1 mg. Compliance: 35×10^{-6} cm/dyne. FR: 10Hz-23kHz. Output: 4mV at 5 cm/sec 1 kHz.

G820★

Stereo magnetic cartridge. Stylus: 0.0005. Playing weight: 1.5-4gm. Tip mass: 1 mg. Compliance: 20×10^{-6} cm/dyne. FR: 20Hz-20kHz. Output: 5mV at 5 cm/sec 1 kHz. Rec. Load: 47 K. Separation: 1 kHz 20 dB. Price: £10.50 (plus VAT).

G820/E

Stereo magnetic cartridge. Stylus: Elliptical 0.0007×0.0003 ($18\mu \times 80\mu$). Playing weight: ¾-2 gm Tip mass: 1mg. Compliance: 25×10^{-6} cm/dyne. FR: 10Hz-25kHz. Output: 5 mV at 5 cm/sec 1-kHz. Rec. Load: 47 K. Separation: 1 kHz 20 dB. Price: £15.00 (plus VAT).

G820/SF

Stereo magnetic cartridge. Stylus: Elliptical 0.0007×0.0003 ($18 \times 8\mu$). Playing weight: 0.6-1.75 gm. Tip mass: 0.9 mg. Compliance: 35×10^{-6} cm/dyne. FR: 10 Hz-25 kHz. Output: 4mV at 5 cm/sec. Rec. Load: 47K. Separation: at 1kHz 25dB. Price: £21.00 plus VAT.

G850

Stereo magnetic cartridge. Stylus: Spherical 0.0007. Playing weight: 2½-4 gm. Tip Mass: 1.2 mg. FR: 20 Hz-18 kHz. Output: 8mV at 5 cm/sec RMS. Rec. Load: 47K. Separation: 20 dB at 1kHz. £5.25 (plus VAT).

G850

Magnetic diamond stylus. Playing weight: 2½-4 gms. FR: 20Hz-18kHz. Output: 8mV at 5 cm/sec. Rec. Load: 47-100 kHz. Price: £3.40 (plus VAT).



Goldring 820

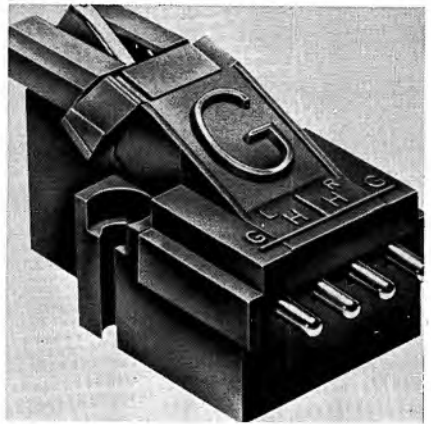

Grado F

G800

Magnetic diamond. Playing weight: 1½-2½ gm. Compliance: 20×10^{-6} cm/dyne. FR: 20 Hz-20 kHz. Output: 5 mV at 5 cm/sec. Rec. Load: 47-100 kHz. Price: £4.50 (plus VAT).

G820F

Magnetic diamond. Playing weight: 0.75-2 gm. Tip mass: 1mg. Compliance: 25×10 cm/dyne. FR: 20Hz-20Hz. Output: 5mV at 5 cm/sec. Rec. Load: 47kHz-100kHz. Price: £11.20 (plus VAT).

■ **GRADO**

Distributors: Howland-West Ltd,
3-5 Eden Grove, London N7 8EQ.
Tel: 01-609 0293.

F3E ★

Stereo magnetic cartridge. Stylus: 0.7×0.3 thou diamond. Pw: 1½-3½ gm. FR: 10Hz-35kHz. Output: 3mV. Price: £17.00 (plus VAT).

★ Indicates entry is illustrated



Hadcock GH Uni-lift



Hadcock GH Super Arm

F2 ★

Stereo magnetic cartridge. Stylus: 0.6 × 0.3 thou diamond. Pw: 1-2 gm. FR: 7Hz-60kHz. Output: 3mV. Price: £28.00 (plus VAT).

FTR ★

Stereo magnetic cartridge. Stylus: 0.6 thou spherical diamond. Pw: 1½-3½gm. FR: 10Hz-35kHz. Output: 3mV. Price: £8.60 (plus VAT).

FTE ★

Stereo magnetic cartridge. Stylus: 0.7 × 0.3 thou diamond. Pw: 1½-3½gm. FR: 10Hz-35kHz. Output: 3mV. Price: £13 (plus VAT).

■ G.F.C.HADCOCK

Audio Division, The Old Vicarage,
Doveridge, Derby DE6 5NN.
Tel: Uttoxeter 2452.

GH Super arm ★ provides exceptionally low bearing friction of 6mgm and ultra mass construction.

Accepts all cartridges down to 4 grm weight. Suitable for Decca London cartridge with Type D counterweight. Weights assemblies interchangeable so that models can be converted by simply changing the weights. Silicon fluid damping provided. Bias adjustment by thread and weight. Tracking force adjustment by vernier for supreme accuracy. Counterweight double decoupled. Alignment protractor provided. Single hole fixing. Overall length 289.6mm (11.40in) Height 43mm (1.70in) 90mm (3.5in). Pivot stem length to top of arm 86.4mm (3.4in). Pivot to stylus point 228.6mm (9.0in). Pivot to centre of turntable 212.85mm (8.38in).

Offset angle 23°. Rear overhang 60.9mm (2.40in) maximum Headshell mounting 12.7mm (.50in) centres. Bearing friction 6 mgm. Length of leads 1219mm (48in). Price: on application.

GH Uni-Lift Mk 3 ★

Raising and lowering device introduced to minimise any risk to records or stylus. The rate of descent is fully adjustable so it is suitable for mounting on all turntables including any sprung pick-up mounting boards. The unit comes complete with template for easy installation.

Features include: A universal model for all pick-up arms and turntables. Superb finish, brass based chromium plated. Two hole fixing for stability. Screw adjustment of horizontal arm. Accurate lowering and easy cueing. Unique screw adjustment for rate of descent. Adjustable rate of descent. Overall height 60mm (2.36in). Height of horizontal arm 28mm (1.10in) min. 66mm (2.60in) max. Two hole fixing for stability. Length of horizontal arm 97mm (3.8in). Screw adjustment for height of horizontal arm and rate of descent. Price: on application.

■ JVC

JVC (UK) Ltd, Eldonwell Trading Estate,
Staples Corner, 6-8 Priestly Way, London
NW2. Tel: 01-450 2621.

X-1

Four channel/two channel stereo cartridge with Shibata Stylus. Playback of CD-4 discrete 4-channel or 2-channel discs. Structure: moving magnet. Stylus: CD-4 Shibata. FR: 10-60,000 Hz. Stylus Pressure: 1.5-2 gm. Price: on application.

4MD-20X

Four channel/two channel stereo cartridge

with Shibata stylus. Play-back of CD-4 discrete 4-channel or 2-channel discs. Structure: V-shaped magnetic. Stylus: Shibata 4DT-20X. Stylus Pressure: 1.5-2 gm. Price: on application.

4MD-10X

Four channel/two-channel stereo cartridge with Shibata stylus. Playback of CD-4 discrete 4 channel or 2 channel discs. Structure: moving magnet. Stylus: Shibata 4DT-10X. Stylus pressure: 1.5-2 gm. Price on application.

■ **LENCO**

Goldring Ltd, 10 Bayford Street, London E8
Tel: 01-986 6411.

L75 Arm

Transcription pick-up arm, calibrated stylus pressure adjustment, removeable plug-in shell with adjustable stylus position. Anti-skating bias compensator. Price: £16.50.

L69

Pick-up arm—calibrated stylus pressure adjustment. Removeable plug-in shell with adjustable stylus position. Anti-skating bias compensator. Price: £13.50.

■ **LINN PRODUCTS LTD**

235 Drakemire Drive, Castlemilk,
Glasgow G45 9SZ.
Tel: 041-634 3860.

Supex SD-900/E

Stereo cartridge, moving coil type 0.3 × 0.8 mil elliptical stylus. Frequency range: 5-40,000Hz ± 1.5dB. Employs low compliance cantilever and tracks at 1½gm. If a suitable pre-amplifier is not available, as the output voltage is 0.2mV, a matching transformer should be employed. Price: £54.00 (including VAT).

Supex SDT-77

Transformer for use with SD-900/E stereo cartridge. Price: £50.00 (including VAT).

Supex SDT-180

Transformer for use with SD-900/E stereo cartridge. Price: £110.50 (including VAT).

The Supex SD-900/E cartridge is available with a Shibata stylus giving a frequency range up to 60kHz. Price: £75.00. (including VAT).

Supex SM-100

Stereo conical cartridge tracking at 1½gm with a 4mV output. Price: £13.44 (including VAT).

Supex SM-100/E

Elliptical cartridge tracking at 1½gm with a 4mV output. Price: £44.00 (including VAT).

Grace F-9E

Stereo cartridge stylus. 0.2 × 0.8 mil elliptical diamond stylus. Playing weight: 1gm. Output: 3.5mV. Price: £52.50 (including VAT).

Grace PM-1 Stylus Balance

An extremely accurate genuine balance giving maximum flexibility and ease of operation. Supplied complete with full range of weights and manipulatory tweezers. Price: £7.25 (including VAT).

Grace G-707

Pick-up arm. 9in quadmaster fixed headshell tone arm, complete with bias compensation and arm lift/lowering device, and low capacitance shielded cord for optimum CD-4 performance. Effective length: 237mm. Stylus overhang: 15mm. Stylus pressure adjustment calibrated to 0.1gm calibration. Price: £55.00 (including VAT).

Grace G-940

9in multi-master damped uni-pivot arm, complete with super lightweight detachable headshell, bias adjustment and lift/lowering device. Low capacitance shielded cord. Price: £93.75 (including VAT).

A range of broadcast and professional arms is also available. Full details and prices on application.

The Grace G 707 series of tone arms were designed specifically for use with CD-4 cartridges. All the Grace range of tone arms have low mass and geometric accuracy as features. The G-707 and G 840 F employ gimbal bearings utilising aircraft micro-pivots giving friction resistance of less than 20mg in all planes. The uni-pivot of the G-940 arm employs a jewelled pivot. All arms are resonance free within the audio frequency range. The G-707 arm is free of tube resonance to above 50kHz.

■ **MICRO**

Howland-West Ltd, 3-5 Eden Grove,
London N7 8EQ.
Tel: 01-609 0293.

VF3200/6

Stereo variable flux cartridge. ½in fixing centres. Stylus: 0.6 spherical diamond. Pw: 1.5gm. Compliance: 30 × 10⁻⁶cm/dyne. FR: 5Hz-35kHz. Separation: 30dB at 1kHz. Out-

★ Indicates entry is illustrated

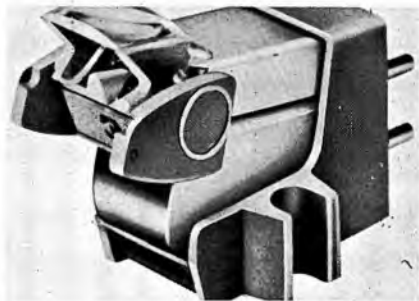

Micro VF3200E

put: 3mV at 1kHz at 3.54cm/sec. Rec load: 47-50K. Price: £8.00. (plus VAT).

VF3200XE

Stereo variable flux cartridge. $\frac{1}{2}$ in fixing centres. Stylus: 0.3×0.8 thou diamond. Pw: 1.5gm. Compliance: 30×10^{-6} cm/dyne. FR: 5Hz-35kHz. Separation: 30dB at 1kHz. Output: 3mV at 1kHz at 3.54cm/sec. Rec load: 47-50K. Price: £12.00 (plus VAT).

VF3200E ★

Stereo variable flux cartridge. $\frac{1}{2}$ in fixing centres. Stylus: 0.3×0.8 thou low-mass diamond. Pw: 1.5gm. Compliance: 30×10^{-6} cm/dyne. FR: 5Hz-35kHz. Separation: 30dB at 1kHz. Output: 3mV at 1kHz at 3.54cm/sec. Rec load: 47-50K. Price: £15.00 (plus VAT).

■ MICRO ACOUSTICS

Webland Electronics Ltd, Mirabel House, 117-121 Wandsworth Bridge Road, London SW6.

Tel: 01-736 0987.

QDC-1e

American electret cartridge. FR: 5-20kHz. Effective tip mass: 0.35mg. Tracking force range: 0.75-1.5gm. Load recommendations: 47K ohms. Price: £39.60 (plus VAT).

■ N. MIERS & CO LTD

28 Piercing Hill, Theydon Bois, Epping, Essex CM16 7LE.

Tel: 037-881 2611.

SX6M

Stereo crystal cartridge. LP/78 diamond stylus. Pw: 4-6gm. Output: 280mV. Price: £2.60 (plus VAT).

SX6H

Stereo crystal cartridge. LP/78 diamond

stylus. Pw: 7gm. Output: 700mV. Price: £2.60 (plus VAT).

X5M

Monaural crystal compatible cartridge, sapphire stylus. Pw: 3-6gm. Output: 400mV. FR: 40Hz-10kHz. Price: £1.50 (plus VAT).

X5H

Monaural crystal compatible cartridge, sapphire stylus, Pw: 5-9 gm. Output: 1V. FR: 40Hz-10kHz. Price: £1.50 (plus VAT).

SC12M

Stereo ceramic cartridge. Output: 100mV. Stylus pressure: 2-6gm. Sapphire or diamond stylus. Price: (sapphire) £3.02 (plus VAT); (diamond) £3.62 (plus VAT).

SC12H

Stereo ceramic cartridge. Output: 170mV. Stylus pressure: 4-6gm. Sapphire or diamond stylus. Price: (sapphire) £3.02 (plus VAT); (diamond) £3.62 (plus VAT).

■ KEITH MONKS

Keith Monks (Audio) Ltd, 26-28 Reading Road South, Fleet, Aldershot, Hants.

Tel: Fleet 7316.

M9BA Mk 2 & 3 ★

Pick-up arm. 9in arm length pivot to stylus. Designed for low mass ultra high compliant cartridges tracking at very low stylus pressures. Damped unipivot with mercury contact pins and no lead out wires. Bias correction and anti-skating built-in. Damped lift/lowering device. Effective mass: 9gm. LF res: 10Hz for 5gm cartridge. Friction lateral and vertical: 4mg approx. Torque: 25 to 35mg. Price: on application.

■ ORTOFON

Distributed in the UK by Metrosound (Sales) Co Ltd, Cartersfield Road, Waltham Abbey, Essex EN9 1JF.

Tel: Lea Valley 712712.

SL15/E

Moving coil stereo cartridge. Pw: 1-2gm. Tip mass: 0.9mg. Compliance: 25×10^{-6} cm/dyne. FR: 10Hz-40kHz. Separation: 20-30dB. Output: 0.04mV/cm/sec (loaded). Output impedance: 2 ohms. Matching transformer required for most amplifiers (see transformer below). Stylus diamond 0.6×0.3 thou. Tracking angle: 15°. Price: £46.00 (plus VAT).

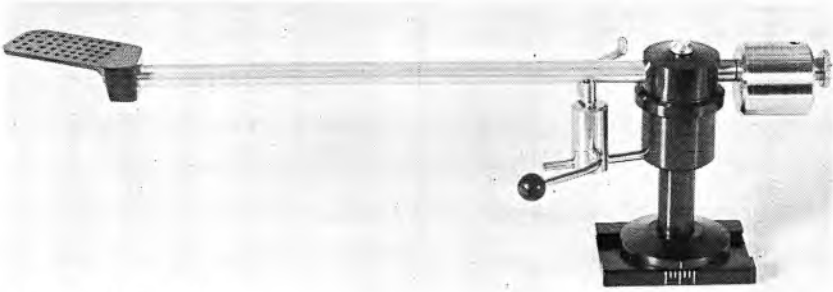

Keith Monks M9BA Mk III



Ortofon M15E

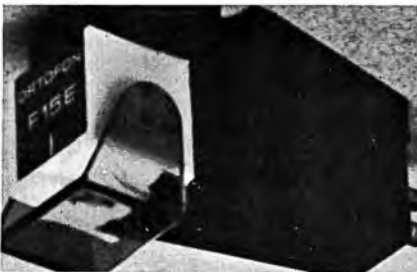

Ortofon F15E

SL15

Similar specification to SL15/E but with spherical 0.6 thou diamond stylus. Price: £38.50 (plus VAT).

Transformer module

Primary impedance: 2 ohms. Secondary impedance: 15K. Load: 10K to 50K without change in frequency response. FR: 20Hz-40kHz. Price: £17.50 (plus VAT).

M15E Super ★

Moving magnet stereo cartridge. Compliance:

(horizontal) 50×10^{-6} cm/dyne; (vertical) 30×10^{-6} cm/dyne. Trackability: $80\mu\text{m}$. Output: 0.8mV. FR: 20Hz-20kHz. Pw: $\frac{3}{4}$ -1 $\frac{1}{2}$ gm. Separation: better than 25dB at 1kHz. Price: £46.00 (plus VAT).

M15 Super

Moving magnet stereo cartridge. Compliance: (horizontal) 50×10^{-6} cm/dyne; (vertical) 30×10^{-6} cm/dyne. Trackability: $80\mu\text{m}$. Output: 0.8mV. FR: 20Hz-20kHz. Pw: $\frac{3}{4}$ -1 $\frac{1}{2}$ gm. Separation: better than 25dB at 1kHz. Price: £38.50. (plus VAT).

F15E ★

Stereo cartridge. Compliance: (horizontal and vertical) 25×10^{-6} cm/dyne. Trackability: $60\mu\text{m}$. Output: 1mV. FR: 20Hz-20kHz. Separation: better than 25dB at 1kHz. Pw: 1-2gm. Price: £18.00 (plus VAT).

F15

Stereo cartridge. Compliance: (horizontal and vertical) 25×10^{-6} cm/dyne. Trackability: $60\mu\text{m}$. Output: 1mV. FR: 20Hz-20kHz. Separation: better than 25dB at 1kHz. Pw: 1-2gm. Price: £15.00 (plus VAT).

FF15E

Stereo cartridge. Compliance: (horizontal and vertical) 20×10^{-6} cm/dyne. Trackability: $60\mu\text{m}$. Output: 1mV. FR: 20Hz-20kHz. Separation: better than 25dB at 1kHz. Pw: 1-3gm. Price: £15.00 (plus VAT).

FF15

Stereo cartridge. Compliance: (horizontal and vertical) 20×10^{-6} cm/dyne. Trackability: $60\mu\text{m}$. Output: 1mV. FR: 20Hz-20kHz. Separation: better than 25dB at 1kHz. Pw: 1-3gm. Price: £12.00 (plus VAT).

Replacement styli

SL15E elliptical diamond. Price: £25.00 (plus VAT); SL15 0.6 thou spherical diamond.



Good, better, best...

All things are a matter of compromise and superlatives must take account of it. Few will dispute the slogan under which our precision pick-up arms are sold. In this context 'best' is not only a reference to quality in design and manufacture, but extends to service which we believe is unequalled.

Every week we send out hundreds of letters providing detailed advice and answering customers' queries in a way that only specialisation permits.

Spares are despatched promptly to all parts of the world, usually the same day, and a recently introduced exchange service provides new arms for old on very attractive terms.

Because of these things demand sometimes exceeds supply but delivery is yet another matter in which we should be able to help if you write to

SME Limited · Steyning · Sussex · England

SME

The best pick-up arm in the world

We used an electron microscope to prove to you a Shibata Stylus is the finest you can own.

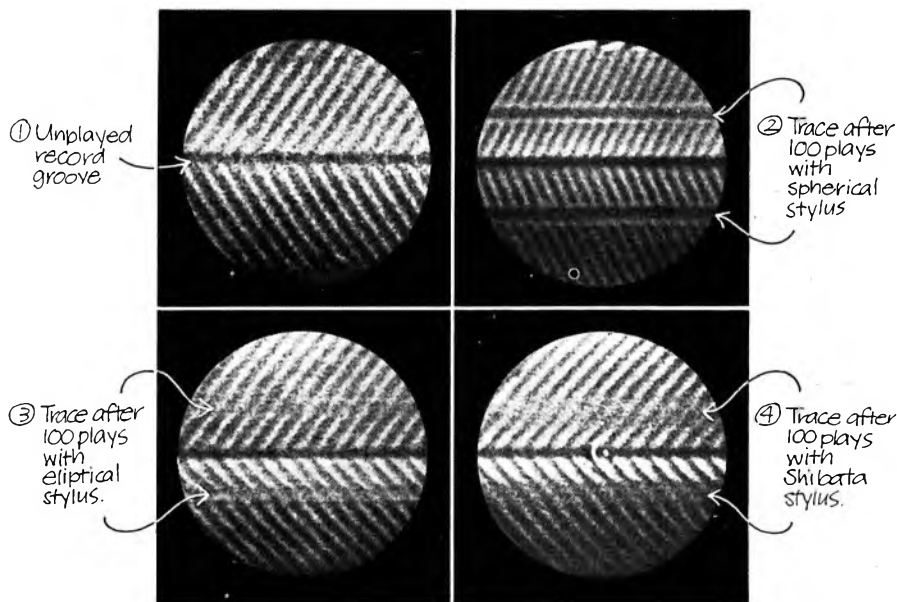

Unretouched photographs.

The Shibata reduces pressure to one quarter of that with any other stylus, because it's shaped more like the groove itself.

Less wear, longer record life, truer sound.



audio-technica®

Shiro (UK) Ltd., Shiro House,
The Ridgeway, Iver, Bucks SL0 9JL. Tel. Iver (0753) 652222.

Goldring.

The Great British Cartridge.



After 40 years' research into sound, Goldring have developed a superb range of cartridges to suit everyone. Cartridges like the G800, a million-seller worldwide. Like the G820 series, another dramatic advance towards technical perfection.

And the latest development – the new G900SE micro mass cartridge.

Goldring Cartridges –
a great British
sound achievement.

 **Goldring**
Sound pure and simple

Anglian Lane, Bury St. Edmunds IP32 6SS
For further details ring: 0284 64011

Price: £17.50 (plus VAT); M15E Super elliptical diamond stylus. Price: £26.50 (plus VAT); M15 0.6 thou spherical diamond. Price: £19.00 (plus VAT); F15. Price: £8.00 (plus VAT); F15E. Price: £11.00 (plus VAT); FF15. Price: £6.00 (plus VAT); FF15E. Price: £9.00 (plus VAT); N20E elliptical. Price: £22.00 (plus VAT); VMS20E elliptical. Price: £20.00 (plus VAT); VMS20S elliptical. Price: £15.50 (plus VAT).

Note: SL15 Series styli are factory-replaceable only and the charge includes reconditioning the cartridge.

AS212

12in pickup arm for stereo and mono cartridges. Playing weight: adjustable 0-3gm. Magnetic anti-skating device. Hydraulic lifting, lowering and cueing. Easy to mount. Arm base to turntable centre: 8³/₁₆in. Height adjustable: 1¹/₄-2⁵/₁₆in. Effective length: (stylus to pivot) 9in. Optimum overhang: ⁵/₁₆in. Maximum tracking error: 0.16 deg/cm. Price: £55.00 (plus VAT).

M Shell

Type M metal shells for 15 Series cartridges. Price: £6.00 (plus VAT).

VMS20E

Moving magnetic stereo cartridge. Compliance: (horizontal) 40 × 10⁻⁶cm/dyne; (vertical) 30 × 10⁻⁶cm/dyne. Trackability: 70μm. Output: 1mV at 1kHz. FR: 20Hz-20kHz. Price: £26.50 (plus VAT).

VMS20S

As VMS20E but with spherical stylus. Price: £22.00 (plus VAT).

■ PHILIPS

Philips Electrical Ltd,
Century House,
Shaftesbury Avenue, London WC2H 8AS.
Tel: 01-437 7777.

GP400 Super M Pickup Cartridge

Type: stereo magnetic, 1/2in fixing. Stylus: 7 × 18μm diamond profiled for supersonic tracking. Compliance: 32 × 10⁻⁶cm/dyne. Separation: ≥25dB at 1kHz. Sensitivity: 0.7mV/cm/sec at 1kHz. Stylus pressure: 0.75-1.5gm. Weight: 6.9gm. Price: on application.

GP401 Super M Pickup Cartridge

Type: stereo magnetic 1/2in fixing. Stylus: 7 × 18μm diamond (elliptical). Compliance: ≥

20mm/N lateral. ≥16mm/N vertical. Separation: ≥24dB. Sensitivity: 1.2mV/cm/sec at 1kHz. Stylus pressure: 1.5-3gm. Weight: 7gm. Price: on application.

GP412 Super M pickup Cartridge

Type: stereo magnetic 1/2in fixing. Stylus: 7 × 18μm diamond (elliptical). Compliance: ≥30mm/N lateral. ≥20mm/N vertical. Separation: ≥25dB at 1kHz. Sensitivity: 1.2mV/cm/sec at 1kHz. Stylus pressure: 0.75-1.5gm. Weight: 7gm. Price: on application.

GP422 Super M Pickup Cartridge

Type: stereo magnetic 1/2in fixing. Stylus: 7 × 18μm diamond profiled for supersonic tracking. Compliance: 32 × 10⁻⁶cm/dyne. Separation: ≥25dB at 1kHz. Sensitivity: 0.7mV/cm/sec at 1kHz. Stylus pressure: 0.75-1.5gm. Weight: 6.9gm. Price: on application.

■ PICKERING

Distributors: Highgate Acoustics,
38 Jamestown Road, London NW1 7EJ.
Tel: 01-267 4937.

Large range. Details on request.

■ RS COMPONENTS

Doran Electronics, PO Box TR8, Leeds LS12 2UF.
Tel: Leeds 34222.

GP 104 Ceramic cartridge with diamond stylus

Playing weight: 3-4gm. FR: 30Hz-20kHz. Output: 100mV at 1cm/sec. Price: £2.40 (plus VAT).

GO 93-1 Crystal cartridge with diamond stylus

Playing weight: 4-8gm. FR: to 18kHz. Output: 280mV at 1cm/sec. Price: £2.40 (plus VAT).

■ SHURE

Shure Electronics Ltd, Ecclestone Road,
Maidstone ME15 6 AU.
Tel: Maidstone 59881.

M3D

Stereo Dynetic cartridge. Moving magnet. 1/2in fixing centres. Stylus: 0.7 thou diamond. Pw: 3-6gm. Compliance: 4 × 10⁻⁶cm/dyne. FR: 20Hz-15kHz. Separation: 20dB at 1kHz. Output: 1mV. Load impedance: 47K. Price: £6.00 (plus VAT).

M44C

Stereo dynetic cartridge. Moving magnet. 1/2in

★ Indicates entry is illustrated



Shure M55E



Shure M75ED



Shure V15-III

fixing centres. Stylus: 0.7 thou diamond (1 thou and 3 thou styli available). Pw: 3.5gm. Compliance: 7.5×10^{-6} cm/dyne. FR: 20Hz-20kHz. Separation: 25dB at 1kHz. Output: 1.8mV. Load impedance: 47K. Price: £7.50 (plus VAT).

M44E

Stereo Dynetic cartridge. Moving magnet. $\frac{1}{2}$ in fixing centres. Stylus: 0.7×0.4 thou bi-radial diamond (3 thou stylus available). Pw: $1\frac{3}{4}$ -4gm. Compliance: 15×10^{-6} cm/dyne. FR: 20Hz-20kHz. Separation: >25dB at 1kHz.

Output: 1.8mV. Rec load: 47K. Price: £8.10 (plus VAT).

M44G

Stereo Dynetic cartridge. Moving magnet. $\frac{1}{2}$ in fixing centres. Stylus: 0.6 thou diamond (1 thou and 3 thou styli available). Pw: $\frac{3}{4}$ -1 $\frac{1}{2}$ gm. Compliance: 25×10^{-6} cm/dyne. FR: 20Hz-20kHz. Separation: 25dB at 1kHz. Output: 1.4mV. Load impedance: 47K. Price: £7.50 (plus VAT).

M44-7

Stereo Dynetic cartridge. Moving magnet. $\frac{1}{2}$ in fixing centres. Stylus: 0.7 thou diamond (1 thou and 3 thou styli available). Pw: $1\frac{1}{2}$ -3gm. Compliance: 20×10^{-6} cm/dyne. FR: 20Hz-20kHz. Separation: 25dB at 1kHz. Output: 2.2mV. Load impedance: 47K. Price: £7.50 (plus VAT).

M55E ★

Stereo Dynetic cartridge. Moving magnet. $\frac{1}{2}$ in fixing centres. Stylus: 0.7×0.2 thou elliptical diamond (3 thou stylus available). Pw: $\frac{3}{4}$ -2gm. Compliance: 15×10^{-6} cm/dyne. Output: 1.3mV. Load impedance: 47K. Price: £9.00 (plus VAT).

M75B Type 2

Stereo Dynetic cartridge. Moving magnet. $\frac{1}{2}$ in fixing centres. Stylus: 0.6 thou conical diamond (3 thou stylus available). Pw: $1\frac{1}{2}$ -3gm. Trackability (see note at end) at 2gm in SME 3009 arm: 400Hz 28cm/sec, 1kHz 35cm/sec, 10kHz 20cm/sec. FR: 20Hz-20kHz. Separation: >25dB at 1kHz. Output: 1mV. Rec load: 47K per channel. Price: £12.60 (plus VAT).

M75ED Type 2 ★

Stereo Dynetic cartridge. Moving magnet. $\frac{1}{2}$ in centres. Stylus: 0.7×0.2 thou elliptical diamond (3 thou stylus available). Pw: $\frac{3}{4}$ -1 $\frac{1}{2}$ gm. Trackability (see note at end) at 1gm in SME 3009 arm: 400Hz 22cm/sec, 1kHz 33cm/sec, 5kHz 28cm/sec, 10kHz 19cm/sec. FR: 20Hz-20kHz. Separation at 1kHz: 25dB. Output: 5mV. Rec load: 47K per channel. Price: £17.10 (plus VAT).

M75G Type 2

Stereo Dynetic cartridge. Moving magnet. $\frac{1}{2}$ in fixing centres. Stylus: 0.6 thou conical diamond (3 thou stylus available). Pw: $\frac{3}{4}$ -1 $\frac{1}{2}$ gm. Trackability (see note at end) at 1gm in SME3009 arm: 400Hz 20cm/sec, 1kHz 28cm/sec, 10kHz 18cm/sec. FR: 20Hz-20kHz. Separation: >25dB at 1kHz. Output: 1mV. Rec load: 47K per channel. Price: £13.50 (plus VAT).

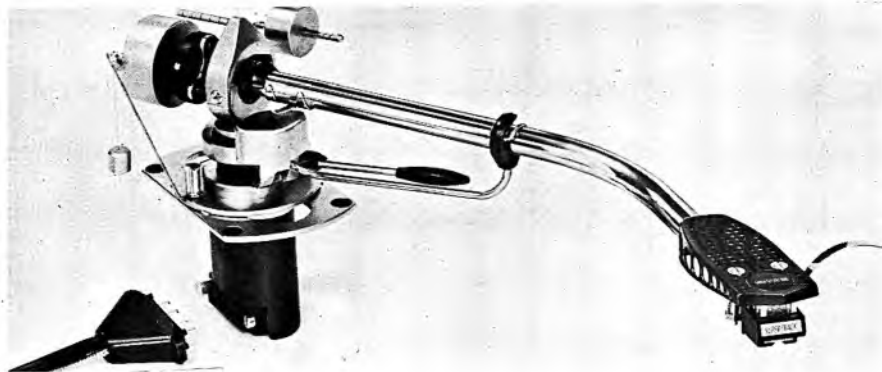

SME 3009

M75EJ Type 2

Stereo Dynetic cartridge. Stylus: 0.7×0.4 thou bi-radial diamond. Pw: $1\frac{1}{2}$ -3gm. Trackability at 2gm in SME 3009 arm: 400Hz 28cm/sec, 1kHz 35cm/sec, 10kHz, 20cm/sec. Price: £14.70 (plus VAT).

V15-Type III ★

Stereo Dynetic cartridge. Moving magnet. $\frac{1}{2}$ in fixing centres. Stylus: 0.7×0.2 thou bi-radial diamond (0.6 thou and 2.5 thou spherical tips also available). Pw: $\frac{3}{4}$ -1 $\frac{1}{2}$ gm. Trackability (see note at end) at 1gm in SME 3009 arm: 400Hz 26cm/sec, 1kHz 38cm/sec, 5kHz 35cm/sec, 10kHz 26cm/sec. FR: 10Hz-25kHz. Separation: 25dB at 1kHz, 20dB at 10kHz. Output: 3.5mV at 1kHz (5cm/sec peak recorded velocity). Recload: 47K. Price: £44.70 (plus VAT).

M95ED

Stereo Dynetic cartridge. Moving magnet. $\frac{1}{2}$ in fixing centres. Stylus 0.7×0.2 thou bi-radial diamond. (2.5 thou spherical 78 rpm tip also available). Pw: $\frac{3}{4}$ -1 $\frac{1}{2}$ gm. Trackability (see note at end) at 1gm in SME 3009 arm: 400Hz 24cm/sec, 1kHz 33cm/sec, 5kHz 28cm/sec, 10kHz 19cm/sec. FR: 20Hz-20kHz. Separation: 25dB minimum at 1kHz. Output: 4.7mV per channel at 1kHz, 5cm/sec peak recorded velocity. Rec load: 47K ohms per channel. Price: £22.20.

M95EJ

Stereo Dynetic cartridge. Moving magnet. $\frac{1}{2}$ in fixing centres. Stylus 0.7×0.4 thou biradial diamond. (2.5 thou spherical 78 r.p.m. tip also available). Pw: $1\frac{1}{2}$ -3gm. Trackability (see note at end) at 2gm in SME 3009 arm: 400Hz 28cm/sec, 1kHz 35cm/sec, 5kHz 30cm/sec,

10kHz 20cm/sec. FR: 20-20kHz. Separation: 20dB minimum at 1kHz. Output: 47mV per channel at 1kHz, 5cm/sec peak recorded velocity. Rec load: 47K ohms per channel. Price: £15.30.

NOTE

Trackability is a term introduced by Shure to give a measure of the total performance of a cartridge. It takes into account the mechanical design parameters of tip mass, inertia, compliances throughout the system, tracking pressure, recorded velocity, etc. Explanatory leaflet available on request.

■ SME

SME Ltd, Mill Road, Steyning, Sussex BN4 3GY.
Tel: Steyning 814321.

Model 3009

Series II Improved precision pick-up arm. Non-detachable shell. Pivot to stylus: 9in nominal. Effective mass: 5.5gm. Low-friction pivots. Vertical axis: high precision fully pivoted ball races. Horizontal axis: knife edges. Less than 0.02gm applied at the stylus will deflect the arm in either plane. Low inertia: fixed elements of the balance system are light, movable elements are heavy and close to the fulcrum. Low distortion geometry. Bias adjustable to correspond with tracking force. Base slides on bedplate for tracking adjustment with protractor. Arm mass divided by elastic coupling. Tracking force: 0.15gm applied precisely without the use of a gauge. Lever operated hydraulically damped lowering and raising control. Shell accepts all car-

★ Indicates entry is illustrated

tridges with 1/2in (12.7mm) fixed centres, weighing 4-9gm. 4ft (1.22m) audio lead, low capacity for magnetic cartridges. SME phono plugs are standard, DIN 5-pole supplied on request. Camera finish in satin chrome, gun black anodised alloy and polished stainless steel. Complete with mounting template, alignment protractor, shell hardware, fixing screws and fully illustrated instruction book. Price: £45.81 (excluding VAT).

Model 3009/S2 ★

Series II Improved precision pick-up arm. Detachable shell. Effective mass: 9.5gm. Other details as above. Price: £50.22 (excluding VAT).

■ SONOTONE

Vernitron Ltd, Thornhill, Southampton, Hants SO9 5QF.
Tel: Southampton 444811.

Details and prices of range on application.

■ SONY (U.K.) LTD

Consumer Information, Sony Showroom, 134 Regent Street, London W1R 6DJ.
Telephone: 01-439 3874.

Cartridges

VM 26 G Cartridge for PS5520/PS230/HP511A/ SQP20/ PS5550/ HMP70/ HMK70 £7.36. VL 30 G Cartridge for HMP40/ HMK40/ HMK40A/ HMK70/ HMP70 £7.36. VL 32 G Cartridge for PS1350/ PS2350 £13.56. VM 10P Cartridge for HP211A/ HP239A £5.88. VX 24P Cartridge for HMP20/ HMW20/ HMK20 £2.80.

Styli

ND 132G Stylus for PS5520/ PS230/ HP511A/SQP20/PS5550/HMP70/HMK70 £5.09. ND 133G Stylus for HMP40/HMK70/ HMK30 £5.09. ND 134G Stylus for PS1350/ PS2350 £5.56. ND 114P Stylus for HP211A& HP239A £3.60. ND 150P Stylus for PS5011 £5.09. NS 128P Stylus for HMP20/HMW20/ HMK20 (pair) £1.16. (All prices exclude VAT).

■ SOUTH WESTERN AGENCIES

Spring Gardens, Bigbury, Kingsbridge, Devon.TQ7 4AP.
Tel: 054 881 323.

Diamond and Sapphire Styli

Range exceeding 750 types, augmented by manufacturers' original styli, and large range of cartridges. Prices on application.

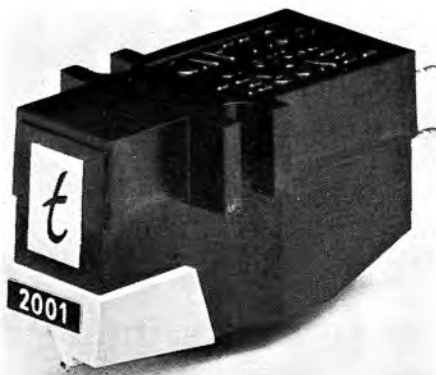

Tenorel 2001 ED

■ TENOREL

Condor Electronics Ltd, 100 Coombe Lane, London SW20 0AY.
Tel: 01-946 0033.

T.2001

Stereo magnetic cartridge. Separation: more than 25dB at 1kHz. FR: 15Hz-25kHz. Com-

STYLUS SERVICE?

We make a point of it!

- our own range of over 800 types
- sapphires – diamonds – double diamonds
- also many manufacturers' originals
- and all at competitive prices

ASK US ABOUT OUR GREAT INTRODUCTORY OFFER ON SWA STYLII!



E. and W. MAGEE LTD.
SPRING GARDENS,
BIGBURY,
KINGSBRIDGE,
DEVON TQ7 4AP
BIGBURY-ON-SEA 323
STD CODE: 054 881 323

SWA means Styli With Assurance

PICKUP, CARTRIDGE AND ARMS

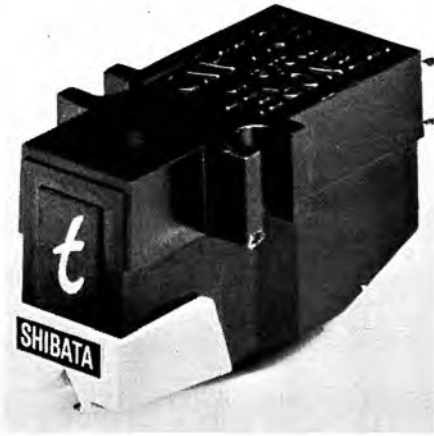

Tenorel 2001 SD

pliance: 25×10^{-6} cm/dyne. Output: 5.5mV at 1000Hz 5cm/sec. Playing weight: $\frac{3}{4}$ -2.5gm. Channel balance: 1.2dB at 1000Hz. Tip mass: <0.8mg. Stylus radius: Shibata (nude). Load: 47K. Inductance: 550mH. DC resistance 520 ohms. Price: £17.50 (excluding VAT).

■ TOSHIBA

Toshiba (UK) Ltd, Toshiba House, Great South West Road, Feltham, Greater London. Tel: 01-751 1281.

■ C401S ★

Direct electret transducer cartridge. FR: 20Hz-35kHz. Modulator and demodulator unnecessary. Used with SZ-200Y equalization amplifier where necessary. Price: (C401S) £54.40; (SZ-200Y) £22.80 (plus VAT).

■ ULTIMO

Chave Innovations Ltd, The Granary, Jackass Lane, Keston, Kent BR2 6AH. Tel: 0689-66 52051.

■ DV38/20A

Moving coil cartridge with diamond stylus, playing weight 1.5 ± 0.3 gm. Compliance: $8-17 \times 10^{-6}$ cm/dyne. FR: 20Hz-30kHz. Output: 2mV at 1kHz 5cm/sec. Rec load: 47K. No transformer required. Suitable for quadraphonic records. Price: £43.00 (plus VAT).



Toshiba Electret

pliance: 20×10^{-6} cm/dyne. Output: 5.5mV at 1kHz 5cm/sec. Playing weight: $1\frac{1}{2}$ -3gm. Channel balance: 2dB at 1kHz. Tip mass: 1mg. Stylus radius: $0.0006-15\mu$. Load: 47K. Weight: 7gm. Inductance: 550mH. DC resistance: 520 ohms. Price: £5.45 (excluding VAT).

■ T.2001ED ★

Stereo magnetic cartridge. Separation: more than 25dB at 1000Hz. FR: 15Hz-32kHz. Compliance: 25×10^{-6} cm/dyne. Output: 5.5mV at 1000Hz 5cm/sec. Playing weight: $\frac{3}{4}$ -2.5gm. Channel balance: 1.2dB at 1000Hz. Tip mass: <0.8mg. Load: 47K. Weight: 7gm. Inductance: 550mH. DC resistance: 520 ohms. Stylus: N.2001ED. Elliptical stylus radius 0.0002×0.0007 (nude). Price: £10.50 (excluding VAT).

■ T.2001SD ★

Stereo magnetic cartridge. Separation: more than 25dB at 1000Hz. FR: 15Hz-45kHz. Com-

HAMPSTEAD HIGH FIDELITY HAVE TAKEN OVER THE POST OFFICE!

Our new showrooms in the old Hampstead post office are now open. We are stockists of high quality audio equipment including: Quad, Linn Sondek, Yamaha, Celef, Monitor Audio, Technics, Lecson, Gale, Orpheus, Denon, Exact, Sony, Revox, Nakamichi, Supex, Shure, Micro Acoustics, ADC, C.E. microphones to name but a few! Our enlarged Export and Mail Order Departments can handle orders for complete systems or even replacement styli promptly and efficiently.

Don't miss our fantastic Record Departments and separate Accessory Bar. All under one roof at 63 Hampstead High Street and only 50 yards from Hampstead Tube Station (Northern line). We are open Monday-Friday 9.30-6.00, Saturday 9.30-5.30.



Hampstead High Fidelity Ltd,

63 Hampstead High Street,
Hampstead, London NW3 1QH.
Tel: 01-435 0999/6377



Radio Tuners

★ Indicates entry is illustrated

Abbreviations used in this section are given on page 27.

■ ACCUPHASE

Belmont A/V Ltd, Fircroft Way, Edenbridge, Kent TN8 6HA.
Tel: Edenbridge 4116.

T101

Stereo FM tuner. Tuning range: 88 MHz-108MHz. Sensitivity: $20\mu\text{V}$ for 40dB quieting. S/N: 70dB at 2mV input. THD: not more than 0.2% at 1kHz. Audio FR: 20kHz-15kHz - 1dB. Stereo separation: 35dB at 100Hz, 45dB at 1kHz. Stereo and muting threshold: $5\mu\text{V}$. Output impedance: 200 ohms (fixed), 2.5K (controlled). FM antenna inputs: 300 ohms balanced, 75 ohms unbalanced. Signal strength meter, centre tuning meter and multipath meter. Mains: 100, 117, 220, 240V AC 50/60Hz. Consumption: 26W. 2 FETs, 7 ICs, 25 transistors, 24 diodes. Size: 455mm wide, 152mm high, 355mm deep. Weight: 11.1kg. Price: £245 (plus VAT).

T100 ★

Stereo AM/FM tuner. Tuning range: 88MHz-108MHz. Sensitivity: $15\mu\text{V}$ (distance), $150\mu\text{V}$ (local). S/N: 50dB. THD: not more than 0.1% at 1kHz. Stereo separation: 45dB at 1kHz. FM antenna inputs: 300 ohms balanced, 75 ohms unbalanced. Signal strength meter, centre tuning meter, multipath meter. Mains: 100, 117, 220, 240V AC 50/60Hz. Power consumption: 26W. 7 FETs, 45 transistors, 9 ICs, 43 diodes. Size: 445mm wide, 152mm high, 355mm deep. Weight: 14kg. Price: £350 (plus VAT).

■ AKAI

Rank Audio Visual, Rank Hi-Fi,
PO Box 70, Great West Road,
Brentford TW8 9HR.
Tel: 01-368 9222.

AT 550 ★

AM/FM stereo tuner. Tuning range: FM 88MHz-108MHz, AM 535-1605kHz. FR: 50-15,000Hz $\pm 1.5\text{dB}$. HD: 0.8%. S/N ratio: better

than 70dB. Selectivity: (IHF) better than 70dB. Aerial input impedance: 300 ohms balanced/75 ohms unbalanced. Mains: 100-240V AC 50/60Hz. Power consumption: 15W. Size: 17.1 \times 5.6 \times 12.6in. Weight: 16.9lb. Price: £106.80 (plus VAT).

AT 580

AM/FM stereo tuner. Tuning range: FM 88-108MHz, AM 535-1605kHz. FR: 50-15,000Hz $\pm 1.5\text{dB}$. HD: less than 0.8%. S/N ratio: better than 70dB. Selectivity: (IHF) better than 80dB. Aerial input impedance: 300 ohms balanced/75 ohms unbalanced. Mains: 100-240V AC 50/60 Hz. Power consumption: 15W. Size: 17.1 \times 5.6 \times 12.6in. Weight: 17.2lb. Price: £148.40 (plus VAT).

■ ALBA

Alba Radio & Television Ltd, Bull Lane, Edmonton, London N18 1RA.
Tel: 01-803 445.

UA 800 ★

AM/FM stereo tuner with multiplex decoder designed for use with the Alba UA 700 amplifier. Tuning range: MW 1640-535kHz, LW 280-162kHz, FM 87-104MHz. Switchable AFC. Pushbutton switching for wavebands.



Accuphase T100



Akai AT550



Alba UA800D

★ Indicates entry is illustrated



Amstrad 3000 MkII



Armstrong 623



Armstrong 624

Rotary tuning control. Stereo beacon. Stereo broadcast muting facility. THD: less than 1%. VHF aerial impedance: 75 ohms. Price: on application.

■ ALPHA

Highgate Acoustics, 38 Jamestown Road, London NW1 7EJ.
Tel: 01-267 4937.

TX 500

AM/FM tuner. Tuning range: 87.5-108MHz, 550-1,600kHz. Variable tuning. Manual (pushbutton) AFC. Sensitivity: 1.5 μ V. Image frequency rejection: -50dB. Signal strength meter. Capture ratio: 2dB. Fixed output: 50mV-500mV. Aerial input impedance: 75 Ω unbalanced. Dimensions: 21 x 44 x 10cm. Mains: 240V AC. Price: £63.50 (plus VAT).

FT 650

Tuning range: 87-108MHz, 540-1,600kHz. Variable tuning. Automatic AFC. Sensitivity: 2 μ V. Signal strength and centre tuning meters. Capture ratio: 2dB. Fixed output: 200mV. Aerial input impedance: 75 Ω unbalanced. Dimensions: 42 x 5 x 24.8 x 14.2cm. Mains

voltage tapings: 240V AC. Price: £99.00 (plus VAT).

■ AMSTRAD

AMS Trading (Amstrad) Ltd, 89 Ridley Road, Dalston, London E8 2NH.
Tel: 01-249 5237/8/9.

3000 Mk II ★

AM/FM radio tuner. Tuning range: MW 525-1600kHz, LW 150-270kHz, FM 88-108MHz. Variable tuning. Switchable AFC. Sensitivity (mono): 2.0 μ V. Image frequency rejection: 54dB. IF rejection: 72dB. Illuminated tuning meter. Capture ratio: 1.5dB. S/N ratio (mono): 63dB. Variable output: 0-1V RMS. Aerial input impedance: 75 Ω FM. Dimensions: 365 x 155 x 95mm. Mains: 240V AC. Price: £48 (excluding VAT).

■ A/R/D

Audio Research and Development Ltd, Navas House, The Maultway, Camberley, Surrey GU15 1QE.
Tel: Camberley 24654.

A/R/D MkIV

Tuning range: 87.5-104.5MHz. Variable electronic tuning plus six pre-set push buttons. AFC: \pm 400kHz. Sensitivity: 1.2 μ V stereo. Image frequency rejection: 80dB. IF rejection: 85dB. Signal strength and tuning meters. Selectivity: 55dB. S/N stereo: 67dB. Fixed output: 150mV RMS. Aerial input impedance: 75 Ω . Dimensions: 26 x 35.2 x 56cm. Mains: 240, 220, 200, 117. Price: £70 (plus VAT).

■ ARMSTRONG AUDIO LTD

Walters Road, London N70RZ.
Tel: 01-607 3213.

623 (AM-FM) ★

Tuning range: FM: 87.5-108MHz. AM: 145-1,625kHz. Variable and three presets on FM and three presets on AM. AFC Sensitivity: 1.5 μ V. Image frequency rejection: 50dB. IF rejection: 100dB. Signal strength and tuning meters. Capture ratio: 1.75dB. Selectivity: 56dB. S/N: 65dB mono. Fixed output: High: 0dB (.775V) 600 Ω . Low: 100mV. Aerial input impedance: 75-80 Ω and 240-300 Ω . Dimensions: 31.2 x 28.5 x 8.2cm. Mains: 105-135 and 215-250V. Price: £98.42 (plus VAT).

624 (FM) ★

FM only, otherwise similar to 623 (AM-FM). Price: £73.74 (plus VAT).

■ **ATRON**

Teddyne Acoustic Research, High Street, Houghton Regis, Dunstable, Beds. Tel: 0582 603151.

K1-1000 ★

AM/FM stereo tuner with range 88-108 MHz FM and 535-1.605kHz AM. Pushbuttons for AM, FM, FM-Auto, Mute, Hi-Filter, power. Sensitivity: FM (30dB quieting) $3\mu\text{V}$ (1HF) $3\mu\text{V}$. AM $400\mu\text{V}$. Image frequency rejection: FM 40dB at 98MHz. IF rejection: FM 50dB at 98MHz. AM better than 40dB. Capture ratio: (HF) 35dB. Selectivity: FM better than 40dB at 98MHz. AM better than 20dB. S/N: Stereo better than 55dB. Aerial input impedance: 75 ohm and 300 ohms balanced. Dimensions: 43 x 13 x 32cm. Mains: 110, 117, 220, 240V 50-60Hz. Price: £63.00 (plus VAT).

■ **CAMBRIDGE AUDIO**

11 Chertsey Road, Byfleet, Surrey. Tel: Byfleet 41131.

T55

FM Stereo Tuner with range 88-108MHz. Variable tuning with remote tuning facility. Switchable AFC. IF rejection: 84dB. Tuning indicator with provision for remote meter. Capture ratio: 0.5. S/N ratio: mono 70dB. Aerial input impedance: 75 ohms coaxial or 300 ohms balanced. Dimensions: 41.9 x 24.4 x 5.1cm. Price: on application.

■ **CHAVE INNOVATIONS LTD**

The Granary, Jackass Lane, Keston, Kent BR2 6AH. Tel: Keston 52051.

US-1

Tuning range: 1V Band IV, V. Variable tuning. AFC. Image frequency rejection: 55dB. IF rejection: 80dB. Signal strength and tuning meter. Capture ratio: 0.85dB. Selectivity: $6\mu\text{V}$. S/N: 65dB mono. Aerial input impedance: 75. Dimensions: 26 x 20 x 9cm. Mains: 240, 110, V. Price: £70.00 (plus VAT).

VUS-1

VHF Band II. UHF IV, V. Push button tuning. AFC. Image frequency rejection: 60dB. IF rejection: 80dB. Signal strength and tuning meters. S/N: 65dB both mono and stereo. Pre-set outputs. Aerial input impedance: 75. Dimensions: 35 x 22 x 10cm. Mains: 240, 110 V. Price: £90.00 (plus VAT).



Atrion Kit 1000

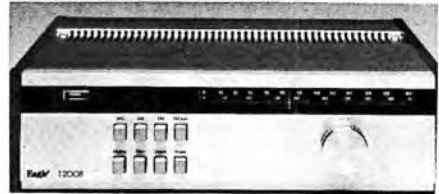

Eagle T2008



Eagle A48

■ **EAGLE**

Eagle International, Precision Centre, Heather Park Drive, Wembley HA0 1SU. Tel: 01-902 8832.

T2008 ★

AM/FM stereo tuner matching Eagle A2004 and A2006 amplifiers. Range: FM 88-108MHz. MW 187-560m. Variable tuning, switchable AFC, meter tuning indicator, tuning arrows, inter station muting. Sensitivity: FM $3\mu\text{V}$ for 30dB quieting, AM $150\mu\text{V}$ for 20dB quieting. Stereo separation: 30dB at 1kHz. Aerial input: 75 ohms coaxial or 300 ohms balanced. Also MW aerial and internal MW aerial. Capture ratio: 3dB at rated sensitivity. AM rejection: 53dB. Image rejection: FM 50dB MW 45dB, IF rejection: FM 60dB, MW 40dB FR: FM 20Hz-15kHz $\pm 2\text{dB}$ Output: 0-1V adjustable. Size: 15 x 10 1/2 x 4 1/8 in. Finish: teak cabinet with metal fascia. Price: £78.60 (excluding VAT).

AA 8 ★

AM/FM stereo tuner. Tuning range: AM 540-1600kHz, FM 88-108MHz. Variable tuning. No pre-sets. Switchable AFC. Sensitivity: (mono) AM $150\mu\text{V}$ (for 20dB quieting),

★ Indicates entry is illustrated

(stereo) FM $3\mu\text{V}$ (for 30dB quieting). Image frequency rejection: 50dB. IF rejection: 60dB. Signal strength meter. Capture ratio: 3dB. S/N ratio: (stereo) >60dB. Variable output: 0-1000mV. Aerial input impedance: 75 ohms, 300 ohms. Dimensions: 33 × 27 × 10cm. Mains: 110-120, 220-240 AC. Price: £64 (excluding VAT).

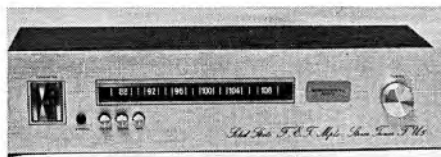

Environmental Sound KMTU5

AA 102

AM/FM stereo tuner. Tuning range: AM 540-1600kHz, FM 88-108MHz. Variable tuning. No pre-sets. Sensitivity: (mono) AM $150\mu\text{V}$ (for 20dB quieting), (stereo) FM $7\mu\text{V}$ (for 30dB quieting). Image Frequency Rejection: 45dB. IF Rejection: 50dB. Capture Ratio: 5dB. S/N Ratio: > (stereo) 54dB. Variable output: 0-1000mV. Aerial input impedance: 75 ohms, 300 ohms. Dimensions: 27.5 × 22 × 9.6cm. Mains: 110-120, 220-240V AC. Price: £47.20 (excluding VAT).

■ ENVIRONMENTAL SOUND

London House, Mayfield, Sussex TN20 6AQ.
Tel: Mayfield 3419/2495.

TUS ★

Stereo FM tuner. Range 87-108MHz, variable tuning, switchable AFC, squelch circuit, FM discriminator, meter tuning indicator giving centre of signal and signal strength, mono/stereo switch and stereo beacon. Usable sensitivity: $0.9\mu\text{V}$ for 30dB signal to noise ratio at 100% modula. Aerial Input: 240-300 ohms balanced. Output: 1V including stereo decoder. Dimensions: 41 × 17.5 × 9.7cm. Black finish. Price: £146.50 (inc. VAT).

■ FERROGRAPH

The Ferrograph Company Ltd,
Auriema House, 442 Bath Road, Crippenham,
Slough, Bucks SL1 6BB.
Tel: Burnham 62511.

SFM 1 Mark 2

VHF stereo tuner. Range: 88-108MHz, variable. AFC: switched. Tuning and signal strength meters. Sensitivity: $1.5\mu\text{V}$ (IHF). Aerial: 300 and 75 ohm. VHF S/N: 60dB at 1mV input. Distortion: 1.0%. Output: 200mV for 25kHz deviation into 300 ohms. Mains: 100-120V, 200-240V AC. Size: 45.8 × 23 × 10.7cm. Finish: teak, walnut or white cabinet with brushed aluminium fascia. Continuously adjustable mute threshold and adjustable stereo separation control from 40dB (1kHz) to zero (mono) Price: £114 (including VAT).

■ HARMON KARDON

Highgate Acoustics, 38 Jamestown Road,
London NW17EJ.
Tel: 01-267 4937.

Citation 15

FM stereo receiver. Bands: 88-108MHz. Manual tuning, meter. Sensitivity: $2.0\mu\text{V}$ IHF. Aerial: 75 or 300 ohms. THD: mono 0.25%, stereo 0.35%. Output: (voltage) 2V fixed and 2V variable into 100K. Mains: 110-240V. Size: 16 × 13¾ × 4¾in. Fitted with a patented signal-to-noise ratio meter. Price: £279 (plus VAT).

■ HITACHI

Hitachi Sales (UK) Ltd, Station Road,
Hayes UB3 4DR.
Tel: 01-848 8787.

FT600

AM/FM stereo tuner. Range: FM 88-108MHz, MW 187-572m. Usable sensitivity: FM $1.8\mu\text{V}$, MW $15\mu\text{V}$. Tuning light indicator. Capture ratio: 1.5dB. Output: 1.5V (fixed) and 0-1.5V adjustable. Quiet tuning facility. Noise filter. Stereo decoder with auto switching and beacon. 28 transistors, 21 diodes, three ICs, one FET. Variable tuning and pushbutton selectors. Size: 16¼ × 4¾ × 12¾in. Weight: 16¼lb. Price: £98 (including VAT).

FT 920

FM section: Usable sensitivity (IHF): $1.6\mu\text{V}$. Selectivity (IHF): 80dB. Capture ratio: 1dB. Image rejection: 80dB. IF rejection: 90dB. AM suppression: 55dB. Harmonic distortion: Mono 0.15%; Stereo 0.25%. Signal-to-noise ratio: 74dB. Aerial impedance: 75Ω, 300Ω. AM section: Sensitivity: Ferrite $300\mu\text{V/m}$; IHF $15\mu\text{V}$. Selectivity: 40dB. Image rejection: 65dB. IF rejection: 85dB. Signal-to-noise ratio: 50dB. Dimensions: 435 × 144 × 394mm. Weight: 17¾lb. (7.8kg). Price: on application.

FT 300

Solid-state stereo tuner. Circuitry: AM/FM 2-band super-heterodyne. Semiconductors: 2 ICs, 9 transistors (1 FET). 14 diodes. FM section: Frequency range: 88-108MHz. Usable sensitivity: $2.2\mu\text{V}$ (IHF), $1.9\mu\text{V}$ (S/N 30dB, 30% modulation). Image rejection: 50dB. IF rejection: 95dB. Distortion: Monaural 0.2% (400Hz); Stereo 0.5% (400Hz). Signal-to-noise ratio: 70dB. Selectivity: 58dB. Stereo separation: 50dB (1kHz). Capture ratio: 1.5dB. Aerial input impedance: 300Ω (balanced type), 75Ω (unbalanced type). AM section: Frequency range: 530-1605kHz. Usable sensitivity: $20\mu\text{V}$ (IHF), $250\mu\text{V/m}$ (bar aerial). Image rejection: 55dB. IF rejection: 45dB. Selectivity: 30dB. Signal-to-noise ratio: 43dB. Output voltage: 300mV (400Hz, 30% modulation). Power source: AC 220V-240V, 50Hz. Power consumption: 15W. Dimensions: $39 \times 12.1 \times 36.3\text{cm}$. Weight: 12.1 lbs (5.5kg). Accessory circuits: FM/AM combination meter. Mode/muting switch. AM bar aerial. FM stereo indicator. Stereo/monaural auto changeover. Price: on application.

■ **JVC (UK) LTD.**

Eldonwell Trading Estate,
Staples Corner, 6-8 Priestley Way,
London, NW2
Tel: 01-450 2621.

JT-V6

AM/FM tuner. Variable tuning. Sensitivity: $2\mu\text{V}$. Image frequency rejection: 45dB. IF Rejection: 45dB. Capture ratio: 1dB (muting on). Selectivity: 60dB. S/N mono: 70dB. S/N Stereo: 60dB. Fixed Output: 400mV. Variable Output: 800mV. Aerial Input Impedance: 300 ohms balanced, 75 ohms unbalanced. Dimensions: $42 \times 29.8 \times 13.8\text{cm}$. Price: £124.00 (plus VAT).

■ **LEAK**

Rank Audio Visual,
PO Box 70, Great West Road,
Brentford, Middlesex TW8 9HB.
Tel: 01-568 9222.

Model 2300 ★

FM/MW/LW stereo tuner. Bands: 87.5-108MHz FM, 150-350kHz LW, 510-1650kHz MW. Manual tuning, switched AFC, centre tuning meter. Sensitivity: $1.6\mu\text{V}$ IHF (FM), $20\mu\text{V}$ AM. Aerial: 75 and 300 ohms. S/N: > -65dB. Distortion: 0.5% at 1kHz. Output: 400mV 600 ohms for 30% modulation. Mains: 240V 50-60Hz AC. Size: $5.2 \times 16.3 \times 12.2\text{in}$.



Leak 2300 tuner



LG Sound Systems T1200

Weight: 13.2 lb. Teak finish. Variable mute level, quasi stereo control. Price: £138.60 (plus VAT).

■ **LG SOUND SYSTEMS**

5 Eden Grove, London N7 8EQ.
Te.: 01-609 0293/6.

T1200G

Tuning range: 88-108Hz, 525-1,605kHz. Variable tuning. Sensitivity: $200\mu\text{V}/\text{AM}$. $2\mu\text{V}/\text{FM}$ stereo. Image Frequency Rejection: 60dB, IF rejection: 70dB. Signal strength and tuning meters. Capture ratio: 1.5dB. Selectivity: 60dB. S/N ratio: 68dB Stereo. Fixed output: 1V. Aerial Input Impedance: 75-300 Ω . Dimensions: $37 \times 25 \times 13\text{cm}$. Mains voltage: 220-240V. Price: £112.00 (plus VAT).

T1200 ★

Similar specifications to T1200 G. Price: £94.00 (plus VAT).

T1400

Tuning range: 88-108Hz, 525-1605kHz. Variable tuning. Sensitivity, mono: $230\mu\text{V}$. AM, Sensitivity, Stereo: $2\mu\text{V}$ FM. Image Frequency Rejection: 90dB. IF Rejection: 90dB. Signal strength and tuning meters. Capture ratio: 2dB. Selectivity: AC 60dB. S/N stereo:

★ Indicates entry is illustrated

70dB. Fixed output: 1.6V. Aerial Input Impedance: 75-300Ω. Dimensions: 44 × 27 × 15cms. Mains: 220-240 V. Price: £201.00 (plus VAT).

■ LUX

Howland-West Ltd,
3-5 Eden Grove, London N7 8EQ.
Tel: 01-609 0293/5.

T33

Tuning range: FM 87.5-109Hz, AM 522-1640kHz. Variable tuning. Sensitivity: 2μV. IF rejection: 70dB. Combined signal strength and tuning meter. Capture ratio: 1dB. Selectivity: 50dB. S/N mono: 70dB. Fixed output: 1V. Aerial Input Impedance: 75-300Ω. Price: £110.00 (plus VAT).

TV 88V

Tuning range: 88-108Hz. Variable tuning. IF Rejection: 85dB FM, 40dB AM. Signal strength and tuning meters. Capture ratio: 1.8dB. Selectivity: 60dB FM, 35dB AM. S/N mono: 72dB FM, 50dB AM. S/N stereo: 68dB. Fixed output: 1.6V FM, 450mV. AM. Variable output. Aerial Input Impedance: 15-300Ω. Dimensions: 45 × 30 × 16cm. Mains Voltage tapping: 220-240V. Price: £116.00 (plus VAT).

T110

Tuning range: 88-108MHz FM only. Variable tuning. Sensitivity: 1.6μV. IF Rejection: 100dB. Signal strength and tuning meters. Capture ratio: 1.3dB/1mV. Selectivity: 70dB at 400kHz. S/N mono: 78dB. Fixed output: 1.5V. Variable output: 0-1.5V. Aerial Input Impedance: 75-300Ω. Dimensions: 48 × 24 × 11cm. Mains: 220-240V. Price: £295.00 (plus VAT).

■ MOTION ELECTRONICS

Addlestead Farm, Tonbridge Road,
East Peckham, Kent.
Tel: East Peckham 871354.

Television Sound Monitor ★

Tuner unit designed to receive VHF and UHF television sound broadcasts. Varicap tuning with six preset pushbuttons, all manually adjustable. Ratio detector for FM, diode detector for AM. Centre-zero tuning meter. Sensitivity: 10 microvolts. Aerial input: 75 ohms coaxial or 300 ohms balanced. Output adjustable up to 0.5V. Mains: 110-240V AC. Consumption: 5W. Available in cabinet or chassis form for building-in. Cabinet teak veneered with finely grained silver finished front panel. Suitable for vertical or horizontal mounting. VHF



Motion Electronics TV Tuner



Nikko FAM 220



Nikko FAM500

coverage: 41-66.75MHz and 176-215MHz. UHF coverage: 470-846MHz. Prices: (VHF-only chassis) £38.00, (VHF-only in cabinet) £42.00; (UHF-only chassis) £36.40; (UHF-only in cabinet) £40.00; (VHF/UHF chassis) £46.00; (VHF/UHF in cabinet) £46.00.

Television Sound Monitor plus VHF Radio

Television section similar to specification for Sound Monitor listed above. Radio section employs vari-cap tuning. Built-in stereo decoding with automatic switching. Centre-zero tuning meter. Stereo beacon. Mono over-ride control. Pushbutton programme selection. AFC. Separation: better than 45dB at 1kHz. Sensitivity: 5μV for 35dB signal-to-noise. Ultrasonic frequency rejection: (19kHz) 40dB. (38kHz) 40dB. Output impedance: 5K per channel. Output: 0-1.5V balanced to within 1dB. Aerial input: 75 ohms coaxial. Available in chassis form or in teak or walnut veneered cabinet.

Mains: 110-120V AC and 210-240V AC. Size: (chassis) $5\frac{1}{8} \times 3\frac{3}{8} \times 10\frac{1}{4}$ in. deep; (cabinet), $6\frac{1}{4} \times 5 \times 11\frac{1}{4}$ in. deep. Price: (UHF/VHF stereo radio chassis) £53.65; (UHF/VHF stereo radio in cabinet) £57.20. All prices plus VAT.

■ **NIKKO**

Howland-West Ltd,
3-5 Eden Grove, London N7 8EQ.
Tel: 01-609 0293/3

FAM 220 ★

Tuning range: FM 88-108MHz, AM medium. Variable Tuning. Sensitivity stereo, $2.3\mu\text{V}$. Image Frequency Rejection: 50dB, IF rejection: 80dB, Signal strength and tuning meters. Capture ratio: 3.0dB. Selectivity: 40dB. S/N: 60dB. Fixed output: 775mV. Aerial Input Impedance: 75-300Ω. Dimensions: $32 \times 27.4 \times 11$ cms. Mains: 220-224 Volts. Price: £78.50 (plus VAT).

FAM 500 ★

Solid state AM/FM stereo tuner. Range: FM 88-108, AM Medium. Variable Tuning. Sensitivity: $2.0\mu\text{V}$. Image Frequency Rejection: 80dB. Signal strength and tuning meters. Capture ratio: 2.0dB. Selectivity: 50dB. S/N: 60dB. Fixed Output: 1,000mV. Aerial Input Impedance: 75-300Ω. Dimensions: $38 \times 32 \times 12$ cm. Mains: 220-240V. Price: £99.00 (plus VAT).

FAM 800

Tuning range 88-108, AM Medium wave. Variable tuning. Sensitivity, mono: $150\mu\text{V}$. AM. Sensitivity, stereo: $1.8\mu\text{V}$. FM. Signal Strength and tuning meters. Capture ratio: 1.0dB. Selectivity: 80dB. Dimensions: $45 \times 37 \times 15$ cms. Price: £145.00 (plus VAT).

■ **PHILIPS ELECTRICAL LTD.**

City House, 420 London Road,
Croydon Surrey.
Tel: 01-689 2166.

RH 640

Tuning range: FM/L/M/S. Variable tuning. Switchable AFC. Sensitivity: AM $80\mu\text{V}$ for 26dB. FM $2.5\mu\text{V}$ (300 ohms), 26dB. Selectivity: AM 37dB for 9kHz, FM 25dB for 300kHz. Fixed output: 500mV-10k ohms. Aerial Input Impedance: 300 ohms. Dimensions: $36 \times 20.4 \times 9.2$ cm. Mains: 110, 127, 220, 240 Volts. Price: £79.60 (pus VAT).



Pioneer TX-9500

RH651

Tuning range: FM/L/M/S. Variable tuning plus five pre-sets. Switchable AFC. Sensitivity: AM $80\mu\text{V}$ for 26dB, $30\mu\text{V}$ for 50mV RMS. FM $1.4\mu\text{V}$ at 300 ohms, $0.7\mu\text{V}$ at 75 ohms for 26dB. Signal strength and tuning meters. Selectivity: AM 40dB, FM 46dB. Fixed output: AM 350mV at 30%, FM 600mV at 40kHz dev. Aerial Input Impedance: 300 ohms. Dimensions: $42.2 \times 30 \times 12$ cm. Mains: 110, 127, 220, 240V. Price: £140.00 (plus VAT).

■ **PIONEER**

Shriro (UK) Ltd, Shriro House,
The Ridgeway, Iver, Bucks SL0 9JL.
Tel: Iver 652222/7.

TX-9500 ★

AM/FM stereo tuner. Tuning range: FM 88-108MHz, AM 550-1650kHz. 5-ganged variable tuning. Sensitivity: (mono) $2.5\mu\text{V}$ for 50dB quieting, (stereo) $35\mu\text{V}$ for 50dB quieting. Image frequency rejection: 110dB. IF rejection: 110dB. Signal strength and centre tuning meters. Capture ratio 1.0dB. Selectivity: 85dB ($\pm 400\text{kHz}$), 55dB ($\pm 300\text{kHz}$). S/N ratio: (mono) 80dB, (stereo) 75dB. Fixed output: 650mV 5K. Variable output: 70mV to 2V 3.5K. Aerial input impedance: 75 ohms and 300 ohms. Dimensions: $42 \times 36.5 \times 15$ cm. Mains: 110 to 240V. Built-in record signal level check. PLL decoder 2-step muting. Price: on application.

TX-7500★

AM/FM stereo tuner. Tuning range: FM 88-108MHz, AM 550-1600kHz. 4-ganged variable tuning. Sensitivity: (mono) $4\mu\text{V}$ for 50dB quieting, (stereo) $50\mu\text{V}$ for 50dB quieting. Image frequency rejection: 85dB. IF rejection: 90dB. Signal strength and centre tuning meters. Capture ratio: 1.0dB. Selectivity: 80dB ($\pm 400\text{kHz}$). S/N ratio: (mono) 73dB, (stereo) 68dB. Fixed output: 650mV 5K. Variable out-

★ Indicates entry is illustrated



Pioneer TX-7500



Pioneer TX-5300



Revox A76



Quad FM3

put: 50mV to 1.5V 2.5K. Aerial input impedance: 75 ohms and 300 ohms. PLL decoder and MPX filter. Dimensions: 42 × 36.5 × 15cm. Mains: 110 to 240V. Price: on application.

TX-5300 ★

AM/FM stereo tuner. Tuning range: FM 88-108MHz, AM 550-1600kHz. 3-ganged variable tuning. Sensitivity: (mono) 4.5μV for 50dB quieting, (stereo) 50μV for 50dB quieting. Image frequency rejection: 60dB. IF rejection:

90dB. Centre tuning meter. AM signal strength meter. Capture ratio: 1.0dB. Selectivity: 60dB (±400kHz). S/N ratio: (mono) 70dB, (stereo) 68dB. Fixed output: 750mV 5K. Aerial input impedance: 75 ohms and 300 ohms. PLL decoder. FET equipped FM front end. Dimensions: 39.9 × 36.6 × 16.5cm. Mains: 110 to 240V. Price: on application.

■ QUAD

The Acoustical Manufacturing Co. Ltd,
St. Peters Road, Huntingdon PE18 7DB.
Tel: Huntingdon 52561.

Quad FM3 ★

Stereo FM tuner. Range: 88-108MHz. Variable tuning. High stability tuned stages maintain accuracy without AFC. Sensitivity: 2μV for full limiting. Aerial input: 75 ohms coaxial and 300 ohms balanced. Output: 100mV per channel for 30% modulation. Stereo decoder fitted. Image rejection: 56dB. IF rejection: 80dB. Capture ratio: 3dB. FR: 20Hz-15kHz ±1dB. Separation: 40dB at 1kHz. Distortion: 1kHz at 40kHz deviation, 0.3%. Recommended load: greater than 50K. De-emphasis: 50μSec or 75μSec as required. Mains: 100-125V 200-250V 50-60Hz. Dual gate MOSFET input stage. Integrated circuits (ICs) in IF and decoder. Ceramic filters in IF chain. Output via 5-pin DIN connector. Size: 26 × 16.5 × 9.2cm. Price: £74 (plus VAT).

■ RADFORD AUDIO LTD.

Ashton Vale Road, Bristol BS3 2HZ.
Tel: Bristol 662301.

Model FMT 5

FM tuner with varicap tuning, FET front end. Uses varicap front end having two radio frequency stages of five tuned circuits and four field effect transistors. Intermediate frequency amplifiers contain ceramic ladder filters and high gain integrated circuits. Incorporates phase locked stereophonic decoder. Size: 17 × 4¾ × 11in. Price: £200 (plus VAT).

■ REVOX

Distributors: C. E. Hammond & Co Ltd,
Lamb House, Church Street,
London W4 2PB. Tel: 01-995 4551.

Model A76 ★

Stereo tuner, VHF only: 87.5-108MHz, variable tuning. Two tuning meters. Sensitivity: 1μV mono (IHF), 10μV stereo (IHF). Aerial: 60 ohms. VHF S/N: 70dB at 75kHz deviation. VHF distortion: 0.2% at 1kHz, 40kHz deviation.



Revox Digital FM Tuner/Preamp A720



Ravensbrook tuner

tion mono or stereo. Output: 1V at 75kHz deviation. Mains: 110-250V, 50-60Hz AC. Price: £267.00 (plus VAT).

Model A720 Digital Tuner/pre-amp ★

Stereo tuner and preamplifier combined. VHF only, tuning range: 87-107.95MHz in 50kHz steps. Tuner uses frequency synthesiser. Sensitivity: 1µV mono (IHF), 10µV stereo (IHF). Tuning indication by digital readout on Nixie tubes. Aerial: 75 ohms, BNC socket or 300 ohms DIN. VHF S/N: 70dB weighted ASA-A. Distortion: 0.2% at 1kHz, 40kHz deviation. Output: 1.5V at 40kHz deviation. Pre-amp section; Inputs: Aux, 100mV/100K sensitivity variable over 20dB range. Tape 1, 100mV/100K sensitivity variable over 20dB range. Tape 2, 100mV/100K sensitivity variable over 20dB range. Phono 1, (RIAA) 3mV/50K ±5dB. Phono 2, (RIAA) 3mV/50K ±5dB. Overload margin on all inputs >30dB. Outputs: 1 and 2: 1.5V into load >10K. Tape out, front panel and two rear: 200mV into load >50K. Phono socket, bass, treble and presence controls. Low, high and loudness filter. Distortion: 0.1% at 1.5V output. FR: 20Hz-20kHz ± 1dB. S/N: phono, 65dB. Other inputs: 85dB. Price: £650.00 (plus VAT).

■ ROGERS

Swisstone Electronics Ltd,
4-14 Barmeston Road, Catford, London SE6 3BN.
Tel: 01-697 8511.

T75 P.L.L. Panthera

Stereo Tuner. Range: 88-108MHz. Sensitivity: 2µV. Capture ratio: 1.5dB. IF Rejection:

80dB. Signal strength meter. Nominal output: (30% modulation) 200mV O/P, 20-15,000Hz < 0.5%. S/N: mono 68dB, Stereo 65dB. Price: £87.00 (plus VAT).

Ravensbrook FET FM Tuner, SERIES II ★

Range: 88-108MHz. Variable tuning. Quadrature detector. Centre-zero meter. Sensitivity: better than 5µV (IHF). Aerial impedance: 75 ohms coaxial and 300 ohms balanced. Output: 200mV for 30% modulation. Phase lock loop stereo decoder. Switchable AFC. Three-gang FET front-end. Dual ceramic IF filters using IC techniques. Built-in 55kHz filter. Switchable interstation noise suppression. Mains: 105-125V, 200-250V, 50-60Hz. Consumption: 9W. Size: (chassis) 3¼ × 10¾ × 10in; (cabinet) 5 × 11½ × 10in. Prices: (chassis) £45 (plus VAT); (in cabinet) £50 (plus VAT).

■ ROTEL

Rank Audio Visual, Rank Hi-Fi, PO Box 70, Great West Road, Brentford TW8 9HR.
Tel: 01-368 9222

RT 824

Tuning range: FM 88-108MHz, AM 550-1,600kHz. Variable rotary knob tuning. Sensitivity mono: AM/IHF 150µV. FM/IHF 1.6µV. Image frequency rejection: >110dB. IF rejection: >110dB. Signal strength and tuning meters. Capture ratio: 1.0dB. Selectivity: 80dB. S/N: >70dB. Fixed output: 775mV. Variable output: 0-1.5 Volts. Aerial input impedance: FM 300 ohms balanced, 75 ohms unbalanced. AM ferrite loopstick. Dimensions: 43 × 33 × 14cm. Price: £143.92 (plus VAT).

RT 624

Features similar to RT 824 except: Sensitivity: AM/IHF 180 µV, FM/IHF 1.8mV. Image frequency rejection: >80dB. IF rejection: >90dB. Selectivity: 75dB. Price: £114.80 (plus VAT).

RT 324

Tuning range: AM 550-1,600kHz, FM 88-108MHz. Rotary knob for variable tuning. Sensitivity mono: AM/IHF 250 µV. Sensitivity stereo: FM/IHF 1.9µV. Image frequency rejection: >55dB. IF rejection: >70dB. AM/FM tuning meter. Capture ratio: 2dB. Selectivity: 50dB. S/N: 765dB. Fixed output: 775mV. Aerial input impedance: FM 300 ohms balanced, 75 ohms unbalanced. Dimensions: 40 × 24 × 11.5cm. Price: £79.92 (plus VAT).

RT 224

AM 550-1, 600kHz, FM 88-108 MHz. Rotary

★ Indicates entry is illustrated

knob for variable tuning. Sensitivity mono: AM/IHF 250 μ V. Sensitivity stereo: FM/IHF 4mV. Image frequency rejection: >40dB. IF rejection: >70dB. Signal strength meter. Capture ratio: 4dB. Selectivity: 45dB. S/N: >60dB. Fixed output: 775mV. Aerial input impedance: FM 300 ohms balanced, 75 ohms unbalanced. Dimensions: 33.5 x 24 x 11.5cm. Price: £62.00 (plus VA1).

■ SANSUI

Vernitron Ltd, Thornhill,
Southampton SO9 5Q1.
Tel: Southampton 444811.

TU5500

AM/FM stereo tuner. Tuning range: FM 88-108MHz, MW 535-1606kHz. Signal meter and tuning meter, aerial input for 300 and 75 ohms. FM sensitivity: 1.9 μ V. S/N ratio: better than 70dB. Size: 434 x 130 x 243mm. Price: £137.69 (plus VA1).

TU7700

AM/FM stereo tuner. Tuning range: FM 88-108MHz, MW 535-1605kHz. Signal meter and tuning meter, aerial input for 300 and 75 ohms. LED indicator switch to enable signal meter to be used as multi-path signal indicator. FM sensitivity: 1.8 μ V. S/N ratio: better than 75dB. Selectivity: better than 80dB. Size: 434 x 130 x 243mm. Price: £169.76 (plus VA1).

■ SONY (UK) LTD.

Consumer Information, Sony Showroom, 134
Regent Street, London W1R 6DJ.
Tel: 01 439 3874.

ST 70

Tuning range: FM 87.5-108MHz, MW 530-1,605kHz. Variable tuning. AFC. Sensitivity: 2 μ V (S/N: 30dB). Image frequency rejection: 40dB (IHF). IF rejection: 90dB. Signal strength meter. Capture ratio: 4dB IHF. Selectivity: 35dB, IHF. S/N: 65dB, IHF. Fixed output: High - 2V, normal 750mV. Aerial input impedance: (FM) 300 ohms balanced. Dimensions: 33 x 24.5 x 87.5 (including projections) cms. Price: £47.96 (plus VA1).

ST 88

Tuning range: FM 87.5-108MHz, MW 530-1,605kHz. Variable tuning. Sensitivity: 2.2 μ V (IHF). 1.7 μ V (S/N: 30dB). Image frequency rejection: 45dB. IF rejection: 90dB. Signal strength meter. Capture ratio: 2.5dB, IHF. Selectivity: 50dB, IHF. S/N: 65dB. Fixed output: High 1.5V (3.3k ohms) normal 750mV



Sony ST4950



J. E. Sugden R51

(4.5k ohms). Aerial input impedance: (FM) 300 ohms balanced. Dimensions: 12.8 x 21 x 23.2cm including projecting parts. Mains: AC 110, 127, 220, 240V. Price: £58.36 (plus VAT).

ST 4950 ★

Tuning range: VHF 87.5-108MHz, MW 530-1,605 kHz. Variable tuning. AFC. Sensitivity mono: 1.9 μ V, IHF. Image frequency rejection: 75dB. IF rejection: 100dB. Signal strength meter, centre tuning. Capture ratio: 1.0dB. Selectivity: 80dB, IHF. S/N: 70dB. Fixed output: 750mV, 10k Ω . Variable output: 0-2V, 3 k Ω . Aerial input impedance 300 Ω balanced, 75 Ω unbalanced. Dimensions: 46 x 32.3 x 16.8cm. Mains: AC 110, 120, 220, 240V. Price: £135.96 (plus VAT).

■ J. E. SUGDEN & CO LTD.

Carr Street, Cleckheaton, Yorks BD19 5LA.
Tel: Cleckheaton 2501.

R51 ★

FM stereo tuner. Range: 88-104MHz. Variable and pre-set tuning. Ratio detector. Centre-zero tuning indicator. Sensitivity: 2 μ V for 20dB quieting. Aerial input: 75 ohms coaxial and 300 ohms balanced. Output: 0.5V. Stereo decoder fitted. AFC. Mains: 110, 120, 220, 230 and 240V AC. Thermometer type tuning dial. Special decoder filter to prevent spurious responses. Switchable decoder filter for low-level transmissions. Size: 29 x 25 x 14cm. Price: £87.20 (plus VA1).

R48

Tuning range: 88-108MHz. Six push buttons. AFC. Sensitivity mono: $2.0\mu\text{V}$. Sensitivity stereo: $6.0\mu\text{V}$. Image frequency rejection: 70dB. IF rejection: 80dB. Capture ratio: 2.5dB. Selectivity: 40dB. S/N mono: 70dB. S/N stereo: 66dB. Fixed output: 1 volt. Aerial input impedance: 75 or 300 ohms. Dimensions: $16 \times 28 \times 13\text{cms}$. Mains: 110, 120, 220, 230, 240 Volts. Price: £63.20 (plus VAT).

TEAC

Teledyne Acoustic Research, High Street, Houghton Regis, Dunstable, Beds.
Tel: Dunstable 603151.

AT100

Tuning range: 88-108MHz. Rotary control. AFC. Sensitivity stereo: $2.0\mu\text{V}$ (IHF). Image frequency rejection: better than 90dB (98MHz). Capture ratio: below 1.5dB. Selectivity: $65\text{dB} \pm 400\text{kHz}$. Fixed output: 1V (400 Hz 100% modulation). Variable output same. Aerial input impedance: 75Ω , 300Ω . Dimensions: $41 \times 32.8 \times 14.1\text{cm}$. Price: on application.

TELETON

Teleton Electro (UK) Ltd; Teleton House, Waterhouse Lane, Chelmsford, Essex CM1 3DW
Tel: Chelmsford 62442

GT 203 Stereo Tuner ★

Wavebands: VHF/FM 87.5-104MHz; MW 510-1630kHz; LW 145-350kHz. Aerial impedance: FM 300 ohms; AM 75 ohms. Sensitivity: VHF/FM $2\mu\text{V}$ for 30dB S/N (measured at 22.5kHz dev.). Image rejection: FM -45dB. Capture ratio: 2dB. Stereo Separation: -30dB. Output: 200mV into 100 ohms. Power requirements: 240V AC 50/60Hz 10W max. Dimensions: 98mm (H) \times 422mm (W) \times 230mm (D). Net weight: 3.5kg approx. Price: on application.

T300 Stereo Tuner

Wavebands: VHF/FM 88-104MHz; MW 510-1605kHz; LW 150-350kHz. Aerial impedance: FM 240 ohms. AM 75 ohms. Sensitivity: VHF/FM $3.5\mu\text{V}$ for 30dB S/N ratio on mono (measured at 22.5kHz Dev.). Image rejection: FM -50dB. Capture ratio: 2dB. Crosstalk: 35dB at 1kHz. Power requirements: 105-125V/210-250V AC 50/60Hz 10W max. Dimensions: 422mm (W) \times 98mm (H) \times 230mm (D). Price: on application.

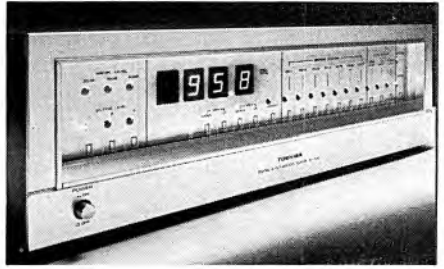

Toshiba ST 910



Teleton GT 203

GT 202 Stereo Tuner

Wavebands: VHF/FM 88-104MHz; MW 520-1600kHz; LW 150-350kHz. Aerial impedance: (FM) 75 or 300 ohms. (AM) 75 ohms. Sensitivity: VHF/FM $3.5\mu\text{V}$ for 30dB S/N ratio on mono (measured at 22.5kHz Dev.). Image rejection: FM -50dB. Capture ratio: 2dB. Crosstalk: -35dB at 1kHz. Power requirements: 115/240V AC 50/60Hz. Dimensions: 76mm (H) \times 388mm (W) \times 248mm (D). Price: on application.

TOSHIBA

Toshiba (UK) Ltd, Toshiba House, Great South West Road, Feltham, Greater London. Tel: 01-751 1281.

ST-500

FM/AM stereo tuner. Tuning range: FM 88-108MHz, AM 530-1605kHz. RF amplification and double stage AGC. High blend switch. Signal, strength and centre channel meters. Output terminal for 4-channel broadcast decoder. FM muting. Price: £99.20 (plus VAT).

ST-910 ★

Tuning range: 87.5-107.9MHz. Touch sensi-

★ Indicates entry is illustrated

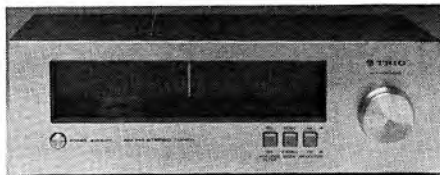

Trio KT1300G

tive controls with seven pre-sets. Sensitivity: $1.8\mu\text{V}$. (stereo). Image frequency rejection: 100dB, IF rejection: 100dB. Signal strength and tuning meters. Capture ratio: 1.5dB. Selectivity: 85dB. S/N: 75dB. Fixed output: 650mV. Variable output: 0-2V. Aerial input impedance: 75 ohms, 300 ohms. Dimensions: $45 \times 34 \times 13\text{cm}$. Price: on application.

ST-220

Tuning range: FM/AM. Variable tuning. Sensitivity $2.0\mu\text{V}$ stereo. Image frequency rejection: 55dB. IF rejection: 75dB. Signal and FM Centre tuner in one. Capture ratio: 1.5dB. Selectivity: 55dB. S/N stereo: 70dB. Fixed output: 450mV. 400Hz 200%. Variable output: 0-600mV, 400Hz 100%. Aerial input impedance: 300 ohms 75 ohms. Dimensions: $40 \times 31.8 \times 12.6\text{cm}$. Mains: 220-240V. Price: on application.

ST-420

Tuning range: FM/AM. Sensitivity: $1.9\mu\text{V}$ stereo. Image frequency rejection: 85dB. IF rejection: 90dB. Special large scale for tuning. Capture ratio: 1.0dB. Selectivity: 70dB. S/N stereo: 75dB. Fixed output: 450mV 400Hz 100%. Variable output: 0-600mV 400Hz 100%. Aerial input impedance: 300 ohms-75 ohms. Dimensions: $45 \times 34 \times 13.5\text{cm}$. Mains: 220-240V. Price: on application.

■ TRIO

Distributors: B. H. Morris & Co (Radio) Ltd, Trio House, The Hyde Industrial Estate, The Hyde, London NW9 6JP. Tel: 01-205 6441.

KT 1300G ★

Tuning Range: FM: 88-108MHz, AM: 540-1,600kHz. Variable tuning. Automatic AFC. Image frequency rejection: better than -40dB. IF rejection; better than -80dB. Dual function meter for AM/FM. Capture ratio: 3dB. Selectivity: better than 41dB (IHF). Fixed output:

AM 30% Mod 150mV, FM 100% Mod 1V. Aerial input impedance: 300 ohms balanced, 75 ohms unbalanced. Dimensions: $37 \times 25 \times 12\text{cm}$. Mains: 240V AC. Finish-in brushed gold and teak. Price: £73.50 (plus VAT).

KT 1300 B.

Identical to KT 1300G but with matt black fascia. Price: £73.60 (plus VAT).

KT 3300

Tuning range: 88-108MHz, 535-1,605kHz. Variable tuning. Automatic AFC. Sensitivity: $1.9\mu\text{V}$. Image frequency rejection: 50dB, IF rejection: 90dB. Dual purpose meter for AM and FM wavebands. Capture ratio: 1dB. Selectivity: 60dB. S/N: 70dB. Fixed output: FM (400Hz 100% Mod); 0.7V. AM (400 Mz 30% Mod); 0.15 V. Aerial input impedance: 300 ohms balanced, 75 ohms unbalanced. Dimensions: $38 \times 29 \times 14\text{cm}$. Mains: 240 Volts AC. Price: £78.40 (plus VAT).

KT 5300

Tuning Range: 88-108MHz FM, 535-1,600kHz AM. Variable tuning. Automatic AFC. Sensitivity: $1.9\mu\text{V}$. Image frequency rejection: 50dB, IF rejection: 90dB. Signal strength meter. Capture ratio: 1dB. Selectivity: 60dB. S/N mono: 70dB. Fixed output: average 300mV. Dimensions: $38 \times 30 \times 14\text{cm}$. Mains: 240 Volts AC. Price: to be announced.

KT 8300

Tuning range: 88-108MHz FM, 535-1,600kHz AM. Variable tuning. Automatic AFC. Sensitivity: $1.6\mu\text{V}$. Image frequency rejection: 110dB, IF rejection: 110dB. Separate meters for signal strength and tuning. Capture ratio: wide band 1dB, narrow band 1.5dB. Selectivity: Wide band 40dB, narrow band 110dB. S/N mono: 78dB. S/N stereo: 75dB. Fixed output: average 300mV. Variable output: 0-300mV average. Aerial input impedance: 75 ohms unbalanced, 300 ohms balanced. Dimensions: $43 \times 38 \times 15\text{cm}$. Mains: 240. Price: to be announced.

KT 7300

Tuning range: 88-108MHz, 535 - 1,600kHz. Variable tuning. Automatic AFC. Sensitivity: $1.8\mu\text{V}$. Image frequency rejection: 85dB. IF rejection: 90dB. Separate signal strength and tuning meters. Capture ratio: 1dB. Selectivity: 80dB. S/N mono: 73dB. S/N stereo: 68dB. Variable output: 0-300mV at 2.5K. Aerial input

impedance: 300 ohms balanced, 75 ohms unbalanced. Dimensions: 43 × 37 × 15cms. Mains: 240V AC. Price: to be announced.

■ **YAMAHA**

Natural Sound Systems Ltd,
Strathcona Road, North Wembley MA9 8QL.
Tel: 01-904 0141.

CT 7000

Tuning range: 88-108MHz. Variable tuning. AFC (automatic on touching tuning knob). Sensitivity: (mono) 0.8µV. IF rejection: >120dB. Image frequency rejection: >120dB. Signal strength and tuning meter. Capture ratio: >0.7dB. Selectivity: >85dB. S/N ratio: (mono) >78dB, (stereo) >75dB. Fixed output: 775mV. Variable output: 70mV-2V. Aerial input impedance: 75 ohms and 300 ohms. Dimensions: 436 × 318 × 144mm. Mains: 117/240V 50/60Hz. Price: £444 (plus VAT).

CT 800

Tuning range: 88-108MHz. Variable tuning. AFC (automatic on touching tuning knob). Sensitivity: (mono) >1.1µV. IF rejection: 100dB. Image frequency rejection: >90dB. Signal strength and tuning meter. Capture ratio: 1.0dB. Selectivity: 80dB. S/N ratio:

(mono) 75dB, (stereo) 72dB. Fixed output: 775mV. Variable output: 70mV-2V. Aerial input impedance: 75 ohms and 300 ohms. Dimensions: 436 × 323 × 144mm. Mains: 117/240V 50/60Hz. Price: £177.60 (plus VAT).

CT 600

Tuning range: 88-108MHz. Variable tuning. AFC (automatic on touching tuning knob). Sensitivity: (mono) 1.3µV. IF rejection: 95dB. Image frequency rejection: 90dB. Signal strength and tuning meter. Capture ratio: 0.5dB. Selectivity: 75dB. S/N ratio: (mono) 70dB, (stereo) 66dB. Fixed output: 775mV. Variable output: 70mV-2V. Aerial input impedance: 75 ohms and 300 ohms. Dimensions: 436 × 323 × 144mm. Mains: 117/240V 50/60Hz. Price: £132.80 (plus VAT).

CT 400

Tuning range: 88-108MHz. Variable tuning. AFC. Sensitivity: (mono) 1.3µV. IF rejection: 75dB. Signal strength and tuning meter. Capture ratio: 1.5dB. Selectivity: 75dB. S/N ratio: (mono) 70dB, (stereo) 66dB. Fixed output: 775mV. Variable output: 70mV-2V. Aerial input impedance: 75 ohms and 300 ohms. Dimensions: 436 × 300 × 144mm. Mains: 117/240V 50/60Hz. Price: £97.60 (plus VAT).

TWO FINE UNITS
Elegantly styled
and assembled by

MIERS

Made
by

B.S.R.

for

*YOUR MODERN, FORWARD LOOKING HI-FI SYSTEM
Up-date your present Record Player with either or both.*

**"THE MIERS LYRICHORD"
8-TRACK CARTRIDGE TAPE
PLAYER AND PREAMPLIFIER**

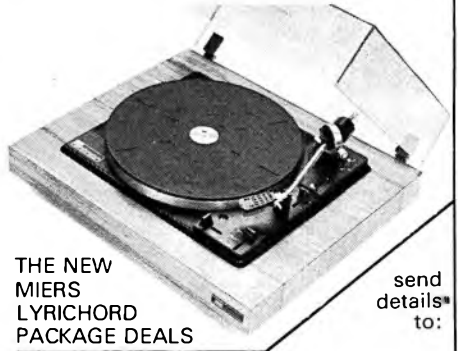
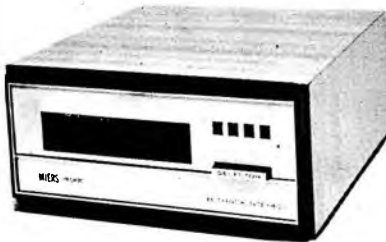

THE NEW
MIERS
LYRICHORD
PACKAGE DEALS

send
details
to:

N. MIERS & COMPANY LTD.

28 Piercing Hill, Theydon Bois, Epping, Essex CM16 7LE
Tel: Theydon Bois 2611/2/3 (STD 037 881) Telex 897076

Clip coupon and mail to us for details and name of nearest stockists.

Name

Address

.....
.....
.....

You've asked for it!

Time and again we are asked for reprints of Wireless World constructional projects: tape, disc, radio, amplifiers, speakers, headphones. Demand continues long after copies are out of print. To meet the situation we have collected fifteen of the most sought after designs and put them in one inexpensive book. And we've updated specifications where necessary to include new components which have become available. A complete range of instruments is presented, from the Stuart tape recorder and Nelson-Jones f.m. tuner, through the Bailey, Blomley and Linsley Hood amplifiers, to the Bailey and Baxandall loudspeakers – some of which have been accepted as standard in the industry.



high fidelity designs

£1 from newsagents and bookshops. A book from

WirelessWorld

Receivers

★ Indicates entry is illustrated

Abbreviations used in this section are given on page 27.

■ AKAI ■

Rank Audio Visual, Rank Hi-Fi, PO Box 70, Great West Road, Brentford, Middlesex TW8 9HR.
Tel: 01-568 9222.

AA 810

Amplifier

Power output: 10 watts per channel. THD: 0.8%. FR: 20-65,000Hz. Power bandwidth: 20-40,000Hz. Inputs for phono, tape.

Tuner

Sensitivity: 2 μ V. Capture ratio: 3dB. Image rejection FM: better than 65dB at 98MHz. Image rejection AM: Better than 55dB at 1MHz. Spurious rejection FM: less than 43dB. IF rejection FM; better than 90dB at 98MHz. Stereo separation: better than 40dB. THD: less than 0.8%. Wavebands: FM/AM.

General

Dimensions: 53 × 11 × 30cm. Price: £119.60 (plus VAT).

AA 1020

Amplifier

Power output: 20 watts per channel. THD: 0.4%. Inputs: phono (2), Aux, tape (2).

Tuner

Sensitivity FM: 20 μ V. Sensitivity AM: 5 μ V. Image rejection FM: better than 65dB. Image rejection AM: better than 55dB. Spurious rejection: less than 43dB. IF rejection: better than 90dB. Stereo separation: better than 40dB. THD: less than 0.8%. Wavebands: FM/AM.

General

Dimensions: 44 × 14 × 35cm. Price: £154.00 (plus VAT).

AA1030

Amplifier

Power output: 30 watts per channel. THD: 0.3%. Power bandwidth: 10-60,000Hz. Inputs: phono (2), Aux, tape (2). Bass and treble tone controls, scratch filter, rumble filter.

Tuner

Sensitivity FM: 1.0 μ V. Sensitivity AM: 5 μ V. Image rejection FM: better than 65dB. Image rejection AM: better than 55dB. Spurious rejection FM: better than 70dB. IF rejection: better than 90dB. Stereo separation: better than 40dB. THD stereo: 0.4%. Waveband coverage: FM/AM.

General

Dimensions: 44 × 14 × 35cms. Price: £167.70 (plus VAT).

AA 1050

Amplifier

Power output: 50 watts per channel. THD: 0.15%. Power bandwidth: 7-70,000Hz. Inputs: phono (2), aux, tape (2). Bass and treble controls. Scratch filter, rumble filter.

Tuner

Sensitivity FM: 1.8 μ V. Sensitivity AM: 8 μ V. THD stereo: less than 0.3%. Waveband coverage: FM/AM.

General

Dimensions: 48 × 16 × 39cm. Price: £227.60 (plus VAT).

AS 1080 DB

Amplifier

Power output: 80 watts per channel (2 channels) 40 watts per channel (four channels). THD: 0.2%. Power bandwidth: 10-60,000Hz. Inputs: phono, CD-4, Aux, tape (2). Bass and treble controls. Scratch filter. Rumble filter.

Tuner

Sensitivity FM: 1.9 μ V. Sensitivity AM: 5 μ V. THD: less than 0.4%. Waveband coverage: FM/AM.

General

Dimensions: 52 × 18 × 41cm. Price: £504.00 (plus VAT).

■ ALBA (RADIO AND TELEVISION) LTD

Bull Lane, Edmonton, London N18 1SD.
Tel: 01-803 4451.

1500

Amplifier

Power output: 10+10 watts continuous. THD: less than 0.1%. Total Music Power: 40W. FR: 30-18,000Hz. Power bandwidth: 20-30,000Hz. Inputs: P.U. mag 2.5mV/50K, cer 60mV. Overload capability: P.U. 130mV; Tape 10V. Tape output (DIN): 120mV. Tone controls, Bass \pm 13dB at 100Hz. Treble \pm 10dB at 10kHz. Crosstalk: better than -38dB.

★ Indicates entry is illustrated



Armstrong 626

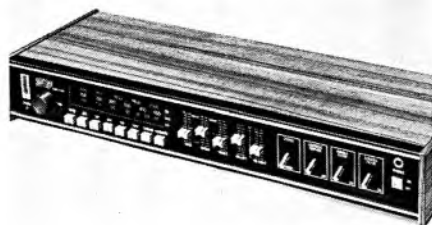

Amstrad 5000

Tuner

Sensitivity FM: $2\mu\text{V}$ (IHF). Sensitivity AM: better than $500\mu\text{V}$. Image rejection FM: greater than 60dB. Image rejection AM: 40dB. IF rejection FM: greater than 75dB. Stereo separation: 34dB at 1kHz.

General

Dimensions: $44.2 \times 19.6 \times 13.7$ cms. Finish in teak veneer. Black and silver trim. Price: on application.

■ ALPHA

Highgate Acoustics, 38 Jamestown Road, London NW1 7EJ.
Tel: 01-267 4937.

FR5000

Stereo VHF/AM receiver. VHF 88-108MHz, MW 535-1605kHz. Variable tuning. AFC. Sensitivity: VHF (IHF) $3\mu\text{V}$, AM $25\mu\text{V}$. Aerial impedance: 300(75) ohms. S/N ratio: (VHF) IHF 50dB. Output voltage: 250mV. Load impedance: 100K. Mains: 110-240V AC. Loudness control, low filters, high filters. Size: $16\frac{1}{2} \times 11\frac{3}{4} \times 5\frac{1}{2}$ in. Finish: teak with brushed aluminium front. Price: £99 (plus VAT).

FR6000

Stereo VHF/AM receiver. VHF 88-108MHz, MW 535-1605kHz. Variable tuning. AFC. Sensitivity: VHF (IHF) $2\mu\text{V}$. AM $25\mu\text{V}$. Aerial impedance: 300(75) ohms. S/N ratio: (VHF)

IHF 50dB. Output voltage: 250mV. Load impedance: 100K. Mains: 110-240V AC. Loudness control, low filters, high filters. Size: $17\frac{1}{2} \times 11\frac{3}{4} \times 6\frac{3}{16}$ in. Price: £115 (plus VAT).

■ AMSTRAD

AMS Trading (Amstrad) Ltd,
89 Ridley Road, Dalston, London E8 2NH.
Tel: 01-249 5237/8/9.

5000 ★

Stereo receiver. Output: 25W RMS per channel. THD: less than 0.1% at rated output. FR: 15Hz-30kHz ± 3 dB. Inputs: mag PU 3mV 47K, ceramic PU 55mV (velocity loaded), tape 700mV 150K. Mag input overload factor: 30dB. Tone controls: bass ± 10 dB at 100Hz, middle ± 7 dB at 1kHz, treble ± 15 dB at 10kHz, loudness 16dB at 1kHz. Scratch filter: -6dB at 20kHz. Rumble filter: -26dB at 20Hz. Crosstalk: better than 60dB on any input. Stereo separation: 34dB at 1kHz. THD (stereo): 0.5% at rated output. Band coverage: FM 88-102MHz, MW 525-1600kHz, LW 155-270kHz. Dimensions: $23\frac{3}{4} \times 8\frac{3}{4} \times 3\frac{3}{16}$ in. Finish: teak style cabinet affixed to 'black anodised fascia. Price: £86.87 (plus VAT).

■ ARMSTRONG AUDIO LTD.

Warlters Road, London N7 0R7.
Tel: 01-607 3213

625(FM)★

Amplifier

Power output: 40 watts into 8 ohms. THD: 0.08% at rated output. FR: 20-20,000Hz. Power bandwidth: 25-45,000Hz. Damping factor: better than 50. Inputs: Disc (2), tape, aux. Tape output (DIN): 0-250mV.

Tuner

Sensitivity FM: $1.5\mu\text{V}$ IHF. Capture ratio: 1.75dB. Image rejection FM: 50dB. IF rejection FM: 100dB. Stereo separation: 40dB at 1kHz. Pilot tone rejection: 65dB. Pilot har-

monic rejection: 65dB. THD Stereo: <0.2%. Waveband coverage: 87.5-108MHz.

General

Dimensions: 50 × 28.5 × 8.2cms. Teak or rosewood finish. Price: £132.62 (plus VAT).

626(AM-FM) ★

AM-FM versions of 625 with similar specifications. Price: £163.94 (plus VAT).

■ ATRON

Teledyne Acoustic Research, High Street, Houghton Regis, Dunstable, Beds.
Tel: Dunstable 603151.

KR215 ★

AM/FM stereo receiver.

Amplifier

Power output: 2 × 15 watts into 8 ohms. THD: 0.1% at rated power. FR: 25-35,000Hz. Power bandwidth: 25-35,000Hz. Damping factor: 25 into 8 ohms. Inputs: Phono, aux, tape (mon), tape recorder (DIN). Load impedance: 4-16 ohms. Tape output (DIN): 60mV. Loudness: +7dB at 100Hz.

Tuner

Sensitivity FM: 30dB quieting 3μV (HF) 3μV. Sensitivity AM: 400μV. Capture ratio: 3.5dB. Image rejection FM: 40dB at 98MHz. IF rejection. FM: 50dB at 90MHz. stereo separation: better than 30dB. THD stereo: less than 1%.

General

Dimensions: 43 × 13 × 32cm. Price: £89.00 (plus VAT).

KR-220 ★

AM/FM stereo receiver.

Amplifier

Power output: 2 × 20 watts into 8 ohms. THD: 0.1% at rated power. FR: 25-35,000Hz. Power bandwidth: 25-35,000Hz. Damping factor: 25 into 8Ω. Inputs: Phono, Aux, tape mon, tape rec (DIN). Load impedance: 4-16 ohms. Tape output (DIN): 60mV. Loudness: ±7dB at 100Hz.

Tuner

Sensitivity FM: 30dB quieting 3μV. Sensitivity AM: 400μV. Capture ratio: 3.5dB. Image rejection FM: 40dB at 98MHz. IF rejection FM: 50dB at 98MHz. Stereo separation: better than 30dB. THD stereo: less than 1%.

General

Dimensions: 43 × 13 × 32cms. Price: £109.00 (plus VAT).

■ AUDIO TECHNICA

Shriro (UK) Ltd, Shriro House, The Ridge-



Atron V-R 215



Atron KR 220

way, Iver, Bucks SL0 9JL.
Tel: Iver 652222.

SX 1010

Amplifier

Power output: 20Hz-20kHz 100 + 100 watts at 8 ohms. THD: Less than 0.05% at rated output. Frequency response: Aux, input (DIN) 10 Hz-40kHz + 0dB -1dB. Power bandwidth: 10Hz-40kHz. Damping factor: more than 50 (1kHz at 8 ohms). Inputs: Phono 1.2, 2.5. mv/50K ohms, mic 2mv/50K ohms, aux, tape PB 1.2, tape PB (DIN), 150mv/70K ohms. tape rec 1.2, 150mv, tape Rec 2 (DIN) 30mv/80K ohms. Overload capability: Phono (RMS/RP) 250mv/700mv. Tone controls: bass ±10dB (100Hz) Main control ±5dB (50Hz); sub control. Treble ±10dB (10kHz) main control; ±5dB (20kHz) sub control. Scratch filter: -9dB (10kHz) 6dB/oct. Rumble filter: -8dB (50Hz) 6dB/oct.

Tuner

Sensitivity FM: 1.7μV (HF). Sensitivity AM: 300μVM (HF ferrite antenna). Capture ratio: 1.0dB Image rejection: 110dB (98mHz). Image rejection: 65dB. Spurious rejection: 110dB. IF rejection: 110dB (98mHz). Stereo separation: more than 40dB 1kHz. Pilot tone rejection: 65dB. THD (stereo): less than 0.3%. Waveband coverage: FM 88-108MHz; AM 550-1600kHz.

General

Dimensions: 52 × 44 × 17.5cm. Finish: Walnut finish cabinet. Price: on application.

SX 939

Amplifier

Power output: 20Hz-20kHz 70+70 watts at 8 ohms. THD: less than 0.3% at rated output. Frequency response: Aux. Input (DIN) 10Hz-40kHz+0dB-1dB. Power bandwidth:

★ Indicates entry is illustrated

10Hz-40kHz. Damping factor: more than 45 (1kHz, 8 ohms). Inputs: phono 1.2 2.5mv/50K ohms; mic 2mv/50K ohms; aux, tape PB 1.2, tape PB DIN, NR adaptor in: 150mv/70K ohms; tape Rec 1.2 150mv; tape Rec 2 (DIN) 30mv/80K ohms; NR adaptor out 150mv. Overload capability: Phono (RMS/PP) 250mv/700mv. Tone Controls: Bass ± 10 dB (100Hz) main control, ± 5 dB sub control; Treble ± 10 dB (10kHz) main control, ± 5 dB (20kHz) sub control. Loudness: +8dB (100Hz) + 4dB (10kHz). Scratch filter: -9dB (10kHz) 6dB/oct. Rumble filter: -9dB (50Hz) 6dB/oct.

Tuner

Sensitivity FM: 1.8 μ V (IHF). Sensitivity AM: 300 μ V/m (IHF ferrite antenna). Capture ratio: 1.0dB (IHF). Image rejection: 85dB (98MHz). Image rejection: 65dB. Spurious rejection: 100dB. IF rejection: 100dB (98MHz). Stereo separation: more than 40dB at 1kHz. Pilot tone rejection: 65dB. THD (stereo): less than 0.4%. Waveband coverage: FM 88-108MHz; AM 550-1600kHz.

General

Dimensions: 52 \times 52 \times 17.5cm. Finish: Walnut finish cabinet. Price: on application.

SX 838

Amplifier

Power output: 20Hz-20kHz 50+50 watts at 8 ohms. THD: less than 0.3% at rated output. Frequency response: Aux. Input (DIN) 15Hz-40kHz+0.5dB - 1dB. Power bandwidth: 10Hz-40kHz. Damping factor: more than 45 (1kHz 8 ohms). Inputs: Phono: 1.2 2.5mv 50K ohms; mic 2mv/50K ohms; aux, tape PB 1.2, tape PB DIN: 150mv/80K ohms; NR adaptor in 150mv/80K ohms; tape Rec 1.2. 150mv; tape Rec 2 DIN 30 mv/80K ohms; NR adaptor out 150mv. Overload capability: Phono (RMS/PP) 170mv - 480mv. Tone controls: turnover frequencies: bass 200Hz. 400Hz, treble 5kHz 2.5kHz. Loudness: +8dB (100Hz)+4dB (10kHz). Scratch filter: -9dB (10kHz) 6dB/oct. Rumble filter: -8dB (50Hz) 6dB/oct.

Tuner

Sensitivity FM: 1.8 μ V (IHF). Sensitivity AM: 300mv (IHF antenna ferrite). Capture ratio: 1.0dB. Image rejection: 85dB (98MHz). Image rejection; 65dB. Spurious rejection: 100dB. IF rejection: 100dB (98MHz). Stereo separation: more than 40dB at (1kHz). Pilot tone rejection: 65dB. THD (stereo): less than 0.4%. Waveband coverage: FM 88-108MHz. AM 550-1600kHz.

General

Dimensions: 52 \times 42 \times 17.5cm. Finish: Walnut finish cabinet. Price: on application.

SX 737

Amplifier

Power output: 20Hz-20kHz 35+35 watts at 8 ohms. THD: less than 0.5% at rated output. Frequency response: Aux. Input (DIN) 15Hz-40kHz+0.5dB - 1dB. Power bandwidth: 10Hz-40kHz. Damping factor: More than 40 (1kHz 8 ohms). Inputs: Phono: 2.5mv/50K ohms; mic 2.5mv/50K ohms; Aux, tape PB 1.2, tape PB DIN: 150mv/50K ohms; tape record 1.2. 150mv; tape record 2 DIN 30mv/80K ohms; Overload capability: Phono (RMS/PP) 190mv - 480mv. Tone controls: Bass ± 10 dB at 100Hz. treble ± 10 dB at 10kHz. Loudness: +8dB at (100Hz)+3dB (10kHz). Scratch filter: -9dB (10kHz) 6dB/oct. Rumble filter: -9dB (50Hz) 6dB/oct.

Tuner

Sensitivity FM: 1.9 μ V IHF. Sensitivity (AM): 300 μ V/ (IHF Ferrite antenna). Capture ratio: 1.0dB. Image rejection (FM): 80dB; Image rejection (AM) 40dB; Spurious rejection (FM); 100dB; IF rejection (FM) 100dB. Stereo separation: more than 40dB at (1kHz). Pilot tone rejection: 40dB. THD (stereo): less than 0.4%. Waveband coverage: FM 88-108MHz. AM 550-1600kHz.

General

Dimensions: 50 \times 41 \times 15.8cm (W \times D \times H). Finish: Walnut finish cabinet. Price: on application.

SX 636

Amplifier

Power output: 20Hz-20kHz 25+25 watts at 8 ohms. THD: less than 0.5% at rated output. Frequency response: Aux. Input (DIN) 20Hz-30kHz \pm 1dB. Power bandwidth: 10Hz-60kHz. Damping factor: more than 35 (1kHz 8 ohms). Inputs: Phono: 2.5mv/50K ohms; mic 7mv/85K ohms; Aux, tape PB 1.2, DIN PB 2: 150mv/60K ohms; tape record 1.2. 150mv; tape record 2 DIN 30mv/80K ohms; Overload capability: Phono - (RMS/PP) 110mv/310mv. Tone controls: Bass ± 10 dB at 100Hz treble \pm at 10kHz. Loudness: +9dB at 100Hz + 5dB at 10kHz. Scratch filter: -9dB at 10kHz 6dB/oct.

Tuner

Sensitivity (FM): 1.9 μ V (IHF). Sensitivity (AM): 300 μ V/M (IHF ferrite antenna). Capture ratio: 1.0dB. Image rejection (FM): 60dB (98MHz). Image rejection (AM); 40dB. Spurious rejection (FM): 75dB. IF rejection (FM): 90dB (98MHz). Stereo separation: more than 40dB (1kHz). Pilot tone rejection: 40dB. THD (stereo): less than 0.4%. Waveband coverage: FM 88-108MHz. AM 550-1600kHz.

General

Dimensions: 48 × 40.5 × 14.7cm (W×D×H). Finish: Walnut finish cabinet. Price: on application.

SX 535**Amplifier**

Power output: 20Hz to 20kHz 18+18 at 8 ohms. THD: less than 0.8% at rated output. Frequency response: Aux. input (DIN) 20Hz-30kHz±1dB. Power bandwidth DIN: 10Hz-50kHz. Damping factor: more than 30 (1kHz 8 ohms). Inputs: Phono: 2.5mv/50K ohms; mic 7mv/85K ohms; Aux, tape PB 1, DIN PB 2: 150mv/75K ohms; tape record 1.2. 150mv. Tape record 2 DIN 30mv/80K ohms; Overload capability: Phono (RMS/PP) 110mv/310mv. Tone controls: Bass +9dB -8dB (100Hz) Treble +6dB -6dB. Loudness: +10dB (100Hz), +5dB (10kHz).

Tuner

Sensitivity (FM): 1.9μV (IHF). Sensitivity (AM): 300μV (IHF ferrite antenna). Capture ratio: 1.0dB. Image rejection (FM): 90dB (98MHz). Image rejection (AM); 40dB. Spurious rejection (FM): 75dB. IF rejection (FM): 90dB (98MHz). Stereo separation: more than 40dB at 1kHz. Pilot tone rejection: 40dB. THD (stereo): less than 0.4%. Waveband coverage: FM 88-108MHz. AM 550-1600kHz.

General

Dimensions: 48 × 40.5 × 14.7cm. Finish: Walnut finish cabinet. Price: on application.

SX 434**Amplifier**

Power output: 40Hz-20kHz, 15+15 watts at 8 ohms. THD: less than 0.8% at rated output. Frequency response: Aux. input (DIN) 30Hz to 25kHz±1dB. Power bandwidth DIN: 10Hz-40kHz into 8 ohms. Damping factor: more than 25 (1kHz 8 ohms). Inputs: Phono: 2.5mv/50K ohms. Mic 10mv/90K ohms. Aux 150mv/80K ohms; Tape PB 150mv/80K ohms; Tape PB DIN 150mv/80K ohms; Tape record 150mv; Tape record DIN 30 mv/80K ohms; Overload capability: Phono (RMS/PP) 100mv/280mv. Tone controls: Bass +9dB -8dB (100Hz) Treble +5dB -7dB (10kHz). Loudness: +10dB (100Hz) +5dB (10kHz).

Tuner

Sensitivity FM: 1.9μV (IHF). Sensitivity (AM): 300μV/M (IHF Ferrite antenna). Capture ratio: 1.0dB (IHF). Image rejection (FM): 60dB (98MHz). Image rejection (AM); 40dB. Spurious rejection (FM): 75dB. IF rejection (FM): 90dB (98MHz). Stereo separation: more than 40dB. Pilot tone rejection: 40dB. THD

(stereo): less than 0.4%. Waveband coverage: FM 88-108MHz. AM 550-1600kHz.

General

Dimensions: 43 × 34.7 × 14cm. Finish: Walnut type finish sleeve. Price: on application.

LX 434 FM, AM and Long Wave**Amplifier**

Power output: 20Hz-20kHz 15+15 watts at 8 ohms. THD: less than 0.8% at rated output. Frequency response: Aux. input 30Hz-25kHz±1dB. Power bandwidth: 10Hz-40kHz. Damping factor: more than 25 at 1kHz. Inputs: Phono: 2.5mv/50K ohms; mic 10mv/90K ohms; Tape monitor, aux: 150mv/80K ohms; Loudness.

Tuner

Sensitivity (FM): 1.9μV (IHF). Sensitivity (AM): 10μV. Sensitivity (long wave): 25μV. Capture ratio: 1.5dB. Image rejection (FM): 60dB. Image rejection (AM); 40dB. Spurious rejection (FM): 75dB. IF rejection (FM): 90dB (98MHz). Stereo separation: more than 40dB. Pilot tone rejection: 40dB. THD (stereo): 0.4%. Waveband coverage: FM 88-108MHz. MW 550-1600kHz, Long Wave 150-350kHz.

General

Dimensions: 43 × 14 × 34.7cm. Finish: Walnut finish cabinet. Price: on application.

SX 300**Amplifier**

Power output: at 1kHz both channels driven into 8 ohms 7+7 watts. THD: less than 1% at rated output. Frequency response: Aux. Input (DIN) 30Hz to 20kHz±1dB. Power bandwidth DIN: 40Hz to 30kHz both channels driven into 8 ohms. Damping factor: more than 20 (1kHz 8 ohms). Inputs: Phono: 2.5mv/50K ohms; aux, 150mv/100K ohms; Tape monitor 150mv/100K ohms; Tape monitor (DIN connector) 150mv/100K ohms; Tape record 150mv; Tape record (DIN) 30mv/80K ohms. Tone controls: Bass 9dB -9dB (100Hz) Treble +6dB -11dB (10kHz). Loudness: Yes.

Tuner

Sensitivity (FM): 2.3μV (IHF). Sensitivity (AM): 300μV/M (IHF ferrite antenna). Capture ratio: 3.5dB (IHF). Image rejection (FM): more than 80dB (98MHz). Image rejection (AM); more than 45dB. Spurious rejection (FM): more than 70dB. IF rejection (FM): more than 80dB. Stereo separation: more than 40dB (1kHz). Pilot tone rejection: 35dB. THD (stereo): 0.8%. Waveband coverage: FM 88-100MHz. AM 550-1600kHz.

★ Indicates entry is illustrated

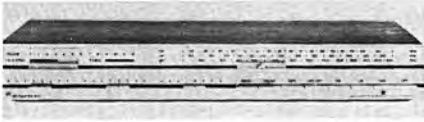

Beomaster 901



Beomaster 6000

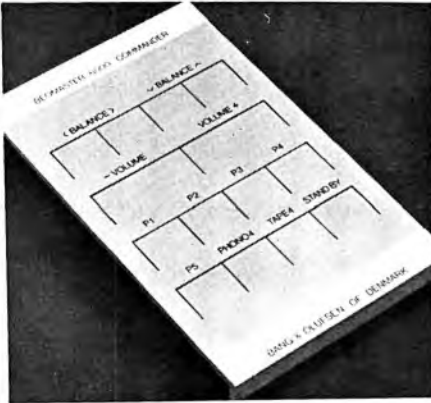

Beomaster 6000 Commander

General

Dimensions: 44.1 × 32.4 × 13.2cm. Finish: Walnut type finish sleeve. Price: on application.

■ BEOMASTER

Bang & Olufsen (UK) Ltd, Eastbrook Road, Gloucester GL4 7DE.
Tel: Gloucester 21591.

Beomaster 901 ★

20W per channel tuner/amplifier. Tuning range: FM 87.5-104MHz, LW 147-350kHz, MW 520-1610kHz. Variable tuning. 'Balanced light' tuning indicator. Sensitivity: $1.8\mu\text{V}$ FM; $15\mu\text{V}$ LW; $20\mu\text{V}$ MW. AFC. Aerial input: 75 ohms coaxial and 300 ohms balanced. FR: 20Hz-30kHz $\pm 1.5\text{dB}$. HD: 5% at full output. S/N ratio: mag PU >55dB, other inputs > 55dB. Inputs: mag PU 2.5mV 47K, tape 150mV 470K. Outputs: 4 ohms and headphones 100 ohms minimum. Mains: 110-130

and 220-240V AC 50/60Hz. Size: 19.6 × 9 × 2.95in. Price: on application.

Beomaster 1100

Stereo FM tuner/amplifier with four pre-set stations. Tuning range: 87.5-108MHz. Variable tuning. Power output: 22W RMS per channel. AFC. Sensitivity: $2.5\mu\text{V}/75$ ohms IHF. FR: 20Hz-30kHz $\pm 1.5\text{dB}$ (DIN). HD: 0.5% at full output. Inputs: mag PU 2.5mV/47K. Speakers: 4 ohms. Headphones: max 10V/200 ohms. Mains: 110-240V AC switchable. Two sets of speaker connections. Finish: black anodised fascia. Size: 19 $\frac{3}{4}$ × 3 $\frac{1}{2}$ × 10 $\frac{1}{4}$ in. Price: on application.

Beomaster 2000

Stereo FM/AM tuner/amplifier with five preset FM stations. Output: 40W RMS per channel. Variable tuning. 'Balanced light' tuning. AFC. Sensitivity: $2\mu\text{V}/75$ ohms IHF, 85 μV LW. FR: 20Hz-30kHz $\pm 1.5\text{dB}$. HD: 0.1% at 40W per channel. Speakers: 4 ohms. Headphones: max 8V/200 ohms. Tape: (× 2) 15mV/20K. Inputs: mag PU 2.5mV/47K at 1kHz. Tape: (× 2) 175mV/1M. Anodised aluminium control panel with white finish, black anodised aluminium with teak or rosewood finishes. Size: 27 × 3 × 10 $\frac{1}{2}$ in. Price: on application.

Beomaster 4000

Stereo 60W per channel FM tuner/amplifier. Tuning range: 87.5-104MHz. Variable tuning plus six preset stations. Meter indicator plus 'balanced light' tuning. AFC. Sensitivity: $1.4\mu\text{V}$. Aerial inputs: 75 ohms coaxial and 300 ohms balanced. FR: 20Hz-30kHz $\pm 1.5\text{dB}$. HD: 0.2% at 60W. S/N ratio: mag PU >62dB at full output, tape >75dB at full output. Inputs: mag PU 3mV 47K variable, tape (1) 250mV 1M variable, tape (2) 250mV 1M variable. Outputs: speakers 4 ohms, ambiphonic speakers 4 ohms, plus headphones. Special features include ambiphonic reproduction via side or rear speakers, black anodised panel. Mains: 110-130 and 220-240V AC 50-60Hz. Size: 22.4 × 10.6 × 3.7in. Price: on application.

Beomaster 6000 ★

4-channel FM tuner/amplifier with remote control capable of reproducing mono/stereo/SQ and discrete. Variable tuning with five pre-set stations. FM tuning range: 87.5-104MHz. Cordless remote control unit. Feather-touch controls with large illuminated scales. AFC. Sensitivity: $2\mu\text{V}/75$ ohms IHF. FR: 20Hz-30kHz $\pm 1.5\text{dB}$. HD: 0.1% at 40W. Power output: 40W RMS all channels. Inputs: phono (4) 200mV 470K, aux (2) low 2.5mV 47K

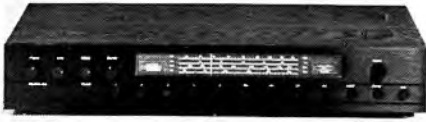

Dansk 2100



Dansk 5000

switchable to high 200mV 470K, tape (4) 200mV 470K. Outputs: tape (4) 15mV 10K. Stereo headphones: (2 pairs) 13V/200 ohms. Speakers: 4 ohms each channel. Size: (Beomaster 6000) 26¼ × 3¼ × 12½in. Price: on application.

Beomaster 6000 Commander ★

Remote control unit for Beomaster 6000 receiver. Price: on application.

3400 (Type 2802)

Amplifier

Power output: 2 × 20 watts RMS or 4 × 20 watts RMS. THD: <0.06% at 50mW or 0.1% at full power. Total music power: 160 watts. Power bandwidth: 10-40,000Hz. Damping factor: >36/ikHz/4Ω. Inputs: phono low Z, 2 channel, low Z, 4 channel, Hi z, 2 channel, Hi z, 4 channel. Tape output: 30mV 22k ohms. Crosstalk: >40 dB 250-10,000Hz.

Tuner

Sensitivity FM: <2.5μV/75Ω IHF. Sensitivity AM: <1.5μV/75 Ω 26dB. S/N 40kHz DIN. THD stereo: <0.5%. Waveband coverage: 87.5-104mHz.

General

Dimensions: 68.5 × 27 × 7.5cms. Teak or rosewood finish, white and oak to special order. Price: on application.

■ DANSK

Plustronics Ltd, Hempstalls Lane, Newcastle, Staffs ST5 0SW.

Tel: Newcastle (Staffs) 615131.

2100 ★

Receiver unit with book-shelf design low line styling. Power output is 2 × 30W, there is variable FM/AM tuning with 5 pre-select stations. Will integrate with a turntable and tape deck.

Amplifier

Power output: 2 × 30W sinus/4 ohm, 2 × 45W music/4 ohm. Distortion: less than 0.8%/max., output/1kHz. Frequency response: 20-25,000Hz. Effective band width: 10-60,000Hz. Signal-to-noise ratio: better than 85dB max. output. Channel separation: better than 50dB/1kHz. Inputs: DIN 45.500.

FM Section

IF: with ceramic filters. Tuning range: 87-104MHz. Pre-select stations: 5 diode tuned. IHFM Sensitivity: 1.8μV. Lighting: 1.8μV/3dB. S/N ratio: 1.8μV for 30dB/100% mod. 1kHz. Distortion: 0.4% for 100% mod. 1kHz. Capture ratio: 2dB. Channel separation: better than 35dB, 1kHz. Frequency response: 50-15,000Hz ± 1.5dB. Pilot suppression: 19kHz better than 30dB, 38kHz better than 40dB.

AM Section

Tuning range LW: 145-360kHz. Tuning range MW: 510-1660kHz. Sensitivity: 1μV/3dB signal-to-noise ratio. S/N ratio: 53dB/1mV.

Connections

FM aerial: 300 ohm balance. AM aerial and earth wire: Phono, 2mV/47K ohm; Tape, 200mV/470K ohm; Speakers, 2 × stereo (4-16 ohm). Finish in black or teak. Price: on application.

2200

Receiver unit with output of 2 × 22W. Features a range of connections so that it is possible to use this as the basis for a sophisticated hi-fi system incorporating record and tape decks.

Amplifier

Power output: 2 × 22W sinus/4 ohm. Distortion: less than 0.5% max. output/1kHz. Frequency response: 20-25,000Hz. S/N: better than 70dB max. output. Channel separation: better than 50dB/1kHz. Inputs: Phono/tape.

FM Section

IF: with ceramic filters. Tuning range: 87-104MHz. Pre-select stations: diode tuned. Sensitivity: 1.8μV/26dB. S/N ± 75kHz. Distortion: 0.4% for 100% mod. 1kHz. Channel separation: better than 40dB, 1kHz. Frequency response: 50-15,000Hz ± 1.5dB. Pilot suppression: 19kHz better than 50dB, 38kHz better than 60dB.

★ Indicates entry is illustrated

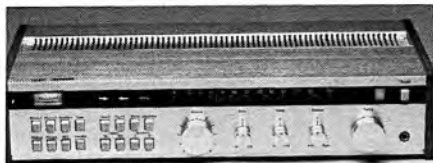

Eagle R20



Eagle AA30

AM Section

Tuning range LW: 145-360kHz. Tuning range MW: 510-1660kHz. Sensitivity: $1\mu\text{V}/3\text{dB}$ S/N ratio. Signal-to-noise ratio: 53dB/1mV.

Connections

FM antenna: 75 ohm. Phono: 2mV/47K ohm. Tape: 200mV/1m ohm. Speakers: 2 × stereo (4-16 ohm). Black finish. Price: on application.

5000 ★

7 pre-select stations and FM tuning. Output: 2 × 40W. Special feature is finger-touch sensor controls, one of the very latest developments in electronics.

Amplifier

Power output: 2 × 40W sinus/4 ohm. Distortion: less than 0.1% max. output/1kHz. Frequency response: 25-30,000Hz. Effect and width: 15-40,000Hz. S/N ratio: better than 75dB/max. output. Channel separation: better than 50dB/1kHz.

FM Section

Tuning range: 87.5-108MHz. Limiting: $1.5\mu\text{V}/3\text{dB}$. S/N ratio: $1.8\mu\text{V}$ for 62dB/100%, mod. 1kHz. Distortion: 0.3% for 100% mod., 1kHz. Capture ratio: 1.5dB. Channel separation: better than 40dB, 1kHz. Frequency response: 20-15,000Hz $\pm 1.5\text{dB}$. Pilot suppression: 19kHz better than 55dB. 38kHz better than 52dB.

Connections

FM antenna: 75/300 ohm. AM antenna with earth wire: phono, 2mV/47K ohm. Tape, 200mV/470K ohm. Speakers, 2 × stereo (4-8 ohm)/m. pushbutton. Finish in black or teak. Price: on application.

■ EAGLE INTERNATIONAL

Precision Centre, Heather Park Drive, Wembley HA0 1SU, Middlesex.
Tel: 01-902 8832.

R 2020 ★

Amplifier

Power output: 20 + 20 watts RMS at 8 ohms. THD: less than 0.2%. Total music power: 80 watts. FR: 15-36,000Hz. Power bandwidth: 13-50,000Hz. Damping factor: 30 at 8 ohms. Inputs: Phono (2), Aux, tuner, tape (2). Overload capability: 70mV (phono 1). Tape output: both 180mV at 100 ohms. Tone controls: $\pm 10\text{dB}$ at 12kHz, $\pm 12\text{kHz}$ at 40Hz. Loudness: +6dB at 100Hz and 10kHz. Scratch filter. Crosstalk: better than -56dB.

Tuner

Sensitivity FM: $3\mu\text{V}$ for 30dB quieting. Sensitivity AM: $150\mu\text{V}$ for 20dB quieting. Capture ratio: 3dB at $3\mu\text{V}$. Image rejection FM: 50dB. Image rejection AM: 46dB. IF rejection FM: 60dB. Stereo separation: 30dB at 1kHz. Pilot tone rejection: 60dB. THD: less than 0.5%. Waveband: 88-108MHz, 540-1,600kHz.

General

Dimensions: 53 × 27 × 10.5cms. Teak, brushed metal finish. Price: £126.40 (plus VAT).

AA30 ★

Power output: 30 + 30 watts RMS at 8 ohms. THD: less than 0.2%. Total music power: 120 watts. FR: 15-36,000Hz. Power bandwidth: 13-50,000Hz. Damping factor: 35 at 8 ohms. Inputs: mag, Aux, tape monitor. Overload capacity: 70mV (Mag). Tape output: 180mV at 100K ohms. Scratch filter. Crosstalk: better than -56dB.

Tuner

Sensitivity FM: $3\mu\text{V}$ for 30dB quieting. Sensitivity AM: $150\mu\text{V}$ for 20dB quieting. Capture ratio: 3dB at $3\mu\text{V}$. Image rejection FM: 50dB. Image rejection AM: 46dB. IF rejection FM: 60dB. Stereo separation: 30dB at 1kHz. Pilot tone rejection: 60dB. THD stereo: less than 0.5%. Wavebands: 88-108MHz, 540-1,600kHz.

General:

Dimensions: 42.5 × 34.5 × 14cms. Teak with black fascia. Price: £140.00 (plus VAT).

■ GOODMAN'S LOUDSPEAKERS LTD.

Downley Road, Havant, Hants.
Tel: Havant 6344.

150 ★

Amplifier

Power output: 110 + 110 watts RMS into 4



Goodmans 150

Tuner

Sensitivity FM: less than $1\mu\text{V}$ into 75 ohms. Sensitivity AM: $20\mu\text{V}$ MV, $40\mu\text{V}$ LW. Capture ratio: better than 1.5dB. Image rejection FM: 75dB. Image rejection AM: 65dB. Spurious rejection FM: 80dB. IF rejection FM: 90dB. Stereo separation: 40dB at 1kHz. Pilot tone rejection: better than 65dB. Pilot harmonic rejection: better than 75dB. Overload capability: 120dB above $1\mu\text{V}$ input. THD Stereo: 0.5% (67.5kHz deviation). Wavebands 87.5-108MHz, 148-350kHz, 520-1,625kHz.

General

Dimensions: $54 \times 36 \times 20\text{cms}$. Black fascia, teak or walnut veneer case. Price: £239.20 (plus VAT).

120 and One-Ten ★**Amplifier**

Power output: 50 + 50 watts RMS into 4 ohms. THD: 0.01%. Total music power: 110 watts. FR: 20-20,000Hz $\pm 1\text{dB}$. Power bandwidth exceeds response bandwidth. Damping factor: 80 into 8 ohms. Inputs: magnetic, aux, tape. Overload capability: +30dB any input. Tape output (DIN) 100mV into 10K ohms (for 10mV into mag. input). Scratch filter, rumble filter. Crosstalk: -45dB.

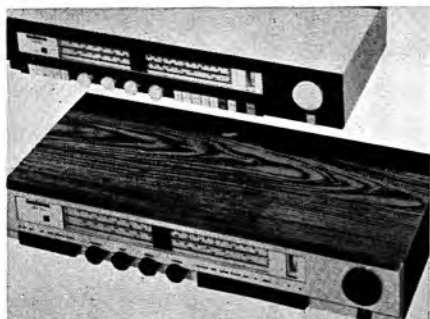

Goodmans Model One Ten

Sensitivity FM: $1\mu\text{V}$ into 75 ohms. Sensitivity AM: $20\mu\text{V}$ MV, $40\mu\text{V}$ LW, $20\mu\text{V}$ SW. Image rejection AM: better than 55dB. Image rejection FM: 90dB. Stereo separation: 35dB. Pilot tone rejection: better than -50dB. Overload capability: 120dB alone, $1\mu\text{V}$ input. THD stereo: 0.2% (75kHz deviation). Waveband coverage: 87.5-108, 150-265kHz, 525-1,605kHz, SW 5.9-6.25MHz bandspread.

General

Dimensions: $58.4 \times 30.5 \times 11.5\text{cms}$. Model 120 has black fascia with teak or walnut sleeve. Model One-Ten has brushed aluminium fascia with teak or walnut sleeve. Price: £163.77 (plus VAT).



Goodmans 120

Module 90 ★**Amplifier**

Power output: 45 + 45 RMS into 4 ohms. THD: less than 0.1%. Total music power: 120 watts. FR: 25-30,000Hz, +0.3dB. Inputs: magnetic pickup, aux, tape. Overload capability: +23dB any input. Tape output (DIN): for 10mV into mag input: 10mV into 10K ohms. Scratch filter, rumble filter. Crosstalk: 45dB.

Tuner

Sensitivity FM: $1\mu\text{V}$ into 75 ohms. Sensitivity AM: $50\mu\text{V}$. Capture ratio: better than 1.5dB. Image rejection FM: better than 60dB. IF re-

ohms. THD: 0.02%. Total music power: 275 watts into 4 ohms. FR: -3dB at 20Hz and 20kHz. Power bandwidth: 10-30,000Hz. Damping factor: 50 into 8 ohms. Inputs: magnetic pickup, aux (tape 2), tape. Overload capability: +38dB any input. Tape output (DIN) has four levels: 250mV into 100 K ohms, 50mV into 10K ohms, $2 \times 8\text{mV}$ into 10K ohms. Scratch filter, rumble filter. Crosstalk: -50dB.



Goodmans 90

★ Indicates entry is illustrated



Grundig RTV 901

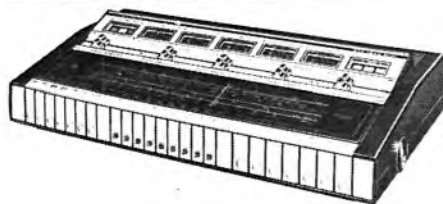

Grundig RTV 1040 Quadrophonic

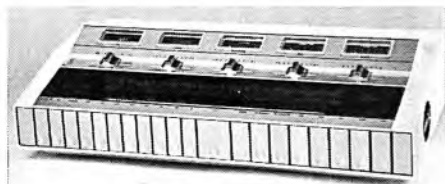

Grundig RTV 820

jection FM: better than 80dB. Stereo separation: -35dB at 1kHz. Pilot tone rejection: better than -40dB. Overload capability: 120dB. THD stereo: 0.5% for 75kHz deviation. Waveband coverage: 87.5-108MHz, 52.5-1.650kHz: Four presets on FM.

General

Dimensions: 61.6 × 40 × 21cms. Black fascia with teak, walnut or white case. Price: £144.37 teak, walnut; £146.84 white (plus VAT).

■ GRUNDIG

Grundig (Great Britain) Ltd, Hi-Fi Division, Newlands Park, London SE26 5NQ.
Tel: 01-659 2468

RTV 901 ★

FM/AM stereo and synthesized four channel receiver. Bands: 87.5-108MHz FM, 145-350kHz LW, 510-1620kHz MW, 5.4-16.2MHz SW. Seven pre-set selectors for FM, manual for AM. Sensitivity: 1.9µV DIN (FM), 12-25µV MW, 21-21.5µV LW, 4.7-5.2µV SW.

Aerials: 240 ohms (FM) wire (AM). Inputs: phono (mag) 3.3mV 470K, phono (ceramic) 300mV 470K, tape 300mV 470K. Output: 25W per channel into 4 ohms. Damping factor: 20. THD: 0.5% at 1kHz and full rated power. FR: 40Hz-16kHz ±2dB. Size: 23½ × 5¼ × 1½in. Price: £236.50 (plus VAT).

RTV 1040Q ★

Four-channel receiver. Bands: FM 87.5-108MHz, LW 145-350kHz, MW 510-1620kHz, SW 5.4-16.2MHz. Seven pre-set selectors for FM Sensitivity: 1.6µV 240Ω. FM, 4-12µV MW, 11-25µV LW, 5-6.5µV SW. AFC. Stereo decoder. Aerial sockets: FM VHF dipole 240K. AM external aerial and earth. Distortion: ≤0.3% at 1kHz. Output: 30W per channel, 25W all channels. FR: 20-20,000Hz ±1dB (discrete/stereo), 40-20,000Hz ±1.5dB (matrix). Damping factor: 28.5 at 4 ohms. Mains: 110, 130, 220 and 240V AC 50/60Hz. Size: 61 × 15 × 33cm. Price: £452.50 (plus VAT).

RTV 820 ★

Stereo receiver, with facilities for 4D stereo. Automatic stereo decoder built-in. Bands: FM 87.5-108MHz, LW 145-350kHz, MW 510-1620kHz, SW 5.4-16.2MHz. Sensitivity: FM 2.2µV 240Ω, MW 8µV, LW 11µV SW 5µV. Aerial sockets: FM VHF dipole 240Ω, AM external aerial and earth. A switch allows the VHF aerial to be used on AM. Distortion: ≤0.5% at 1kHz. FR: 40-16,000Hz ±1.5dB for input tape/phono crystal and ±2dB for input phono magnetic. Price: £193.30 (plus VAT).

■ HACKER RADIO LTD.

Norry's Drive, Cox Green, Maidenhead, Berks SL6 4BP.

Tel: Maidenhead 22261.

Black Knight RP 76 MB

Portable mono VHF radio design to provide FM reception with stereo tuner for use with high fidelity audio system or tape recorder. The specially developed stereo radio decoder is brought into operation only when the radio is connected, as a tuner, to the amplifier of a high fidelity audio system or to a tape recorder.

Features

A ceramic filter in the IF amplifier for improved selectivity. Two tuned circuits before the mixer to improve rejection of image and other spurious responses. A stereo radio decoder operational only when the radio is used as a tuner to a high fidelity audio system or tape recorder. A stereo indicator light on the tuning scale; the light glows red when a stereo broad-

cast is received. Mains/battery operation; insertion of the mains plug automatically disconnects the batteries. Local station markers colour coded for BBC and IBA stations. Waveband: VHF: 87.5-101MHz. Audio amplifier: Power output: mean level 1.5 watts; speech and music 2 watts. Distortion less than 1%. Frequency response: 40Hz-20kHz \pm 2dB. Loudspeaker dimensions 177mm \times 127mm (7in \times 5in). Tone control, Bass: \pm 10dB at 50Hz; Treble: \pm 12dB at 10kHz. FM tuner Sensitivity 2.5 μ V (PD) for 30dB S/N (30kHz deviation). Image rejection greater than 50dB. IF rejection greater than 50dB. AM rejection below noise level. Automatic frequency correction, Switchable AFC. Stereo Radio Decoder: Separation typically 30dB at 80Hz; 30dB at 1kHz; 30dB at 5kHz. The decoder becomes operational only when the DIN 5-pin plug is inserted. Sockets: (a) External aerial: 75 ohms; (b) Mains input: 200-250V, 50Hz, AC; (c) Tuner output/tape recording DIN 5-pin; Output for 75kHz deviation; Stereo: 500mV at 600 ohms impedance; Mono: 500 mV at 20K ohms impedance; (d) External loudspeaker, headphones or personal earphone: 4-8 ohms. Dimensions: 25.7 \times 34.4 \times 11.1cm. Price: £59.20 (plus VAT).

■ HANIMEX (UK) LTD.

Hanimex House, Dorcan, Swindon, Wilts.
Tel: Swindon 26211.

KR 801

Amplifier

Power output: 2 \times 30 watts into 8 ohms. FR: 20-40,000Hz. Inputs: phono (2), aux, tape. Tape output (DIN): 20mV.

Tuner

Sensitivity FM: 1.5 μ V (IHF). Sensitivity AM: 20 μ V. Image rejection FM: 70dB. Image rejection AM: 45dB. Stereo separation: 40dB-1kHz. THD: 0.35%. Waveband coverage: 87.5-108MHz.

General

Dimensions: 45 \times 33 \times 14.5cm. Price: on application.

SR 887

Amplifier

Power output: 2 \times 50 watts. THD: 0.1% at 48 watts. FR: 10-45,000Hz. Inputs: phono, aux, tape. Tape output (DIN): 170mV. Scratch filter, Rumble filter.

Tuner

Sensitivity FM: 1.5 μ V (IHF). Sensitivity AM: 20 μ V. Image rejection FM: 90dB. Image re-

jection AM: 70dB. Stereo separation: 40dB-1kHz. THD stereo: 0.3%. Waveband coverage: 87.5-108.

General

Dimensions: 46 \times 36 \times 14.5cm. Price: on application.

■ HARMAN-KARDON

Highgate Acoustics, 38 Jamestown Road,
London NW1 7EJ.
Tel: 01-267 4937.

730

Amplifier

Power output: 40+40 WRMS. THD: 0.2%. FR: 4-140kHz. Power bandwidth: 10Hz-40kHz. Damping factor: 40. Inputs: Aux (2), Phono (2), Tape (2). Scratch filter, rumble filter.

Tuner

Sensitivity FM: 2 μ V. Image rejection FM: 80dB. Spurious rejection FM: 80dB. IF rejection FM: 90dB. Stereo separation: 40dB. Waveband coverage: 87-108, 540-1,160kHz. Price: £249.00 (plus VAT).

430

Amplifier

Power output: 25+25 WRMS. THD: 0.5%. FR: 4-140kHz. Power bandwidth: Aux, phono, tape. Scratch filter, rumble filter.

Tuner

Sensitivity FM: 1.9 μ V. Capture ratio: 1.7dB. Image rejection FM: 60dB. Spurious rejection FM: 82dB. Stereo separation: 39dB. Waveband coverage: 87-108MHz, 540-1,600kHz.

General

Dimensions: 43.2 \times 36.8 \times 14cm. Price: £179.00 (plus VAT).

330B

Amplifier

Power output: 20+20 watts RMS. THD: 0.5%. FR: 20-20kHz. DampMFR: 20-20kHz. Damp factor: 30. Inputs: Aux tape phono.

Tuner

Sensitivity FM: 2.5 μ V. Sensitivity AM: 50 μ V. Capture ratio: 3dB. Image rejection FM: 40dB. Image rejection AM: 40dB. Spurious rejection FM: 60dB. IF rejection (FM): 60dB. Stereo separation: 25dB. Wavebands coverage: 87-108MHz, 540-1,600kHz.

General

Dimensions: 38.7 \times 33 \times 11cms. Price: £125.00 (plus VAT).

★ Indicates entry is illustrated

■ HITACHI SALES (UK) LTD.

Hitachi House, Station Road,
Hayes, UB3 4DR.
Tel: 01-848 8787.

SF 302

Amplifier

RMS power: Both channels driven (1kHz, 0.8% THD) 16W × 2 (8Ω); (1kHz, 0.8% THD) 20W × 2 (4Ω); (40-20,000Hz, 0.8% THD) 15W × 2 (8Ω). Music power (IHF): 25W × 2 (8Ω); 28W × 2 (4Ω). Frequency response: 20Hz - 30kHz (± 1dB). Power bandwidth (IHF): 20Hz - 40kHz (0.8% THD). Harmonic distortion: At rated output 0.8%; at -3dB output less than 0.1%. IM distortion: At rated output, 0.8%; at -3dB output, less than 0.1%. S/N ratio (IHF): 70dB (phono). Damping factor: 30 (8Ω). Input sensitivity: 2.5mV (50Ω) (phono); 200mV (50kΩ) (aux); 200mV (50kΩ) (tape). Output sensitivity: 200mV (10kHz) (tape); 40mV (80kHz) (DIN). Tone control: ±10dB (100Hz) (bass); ±10dB (10kHz) (treble). Loudness (volume at -30dB: +9dB (100Hz); +4dB (10kHz).

Tuner

FM Section: Frequency range: 88-108MHz. Usable sensitivity: 1.9μV (IHF). Selectivity: 46dB. Capture ratio: 1.2dB. Image rejection: 55dB. IF rejection: 90dB. AM suppression: 56dB. Harmonic distortion: 0.2% (mono); 0.4% (stereo). Stereo separation: 40dB (1kHz). S/N ratio: 65dB. Aerial impedance: 300Ω. AM Section: Frequency range: 530-1605kHz. Sensitivity: 20μV (IHF). Selectivity: 36dB. Image rejection: 50dB. IF rejection: 40dB. S/N ratio: 50dB.

General

Dimensions: 42.4 × 13.6 × 34.7cm. Weight: 7.6Kg. Loudness Sw. Feh. Headphone Jack. Price: No rec. retail price.

SR 502

Amplifier

FR: 20-30KH ± 1dB. HD: at rated output 0.8% at -3dB output, less than 0.1%. S/N ratio (IHF): 70dB (phono). Damping factor: 30 (8Ω). Input sensitivity: 2.5mV (50kΩ) (phono); 200mV (50kΩ) (aux); 200mV (50kΩ) (tape). Output sensitivity: 200mV (10kHz) (tape); 40mV (80kHz) (DIN). Tone control: ±10dB (100Hz (bass); ±10dB (10kHz) (treble). Loudness (volume at -30dB): +9dB (100Hz) + 4dB (10kHz).

Tuner

FM Section: Frequency range: 88-108MHz. Usable sensitivity: 1.9μV (IHF). Selectivity:

46dB. Capture ratio: 1.2dB. Image rejection: 55dB. IF rejection: 90dB. AM suppression: 56dB. Harmonic distortion: 0.2% (mono); 0.4% (stereo). Stereo separation: 40dB (1kHz). Signal-to-noise ratio: 65dB. AM Section: FR: 530-1605kHz. Sensitivity: 20μV; Selectivity: 36dB. Image rejection: 50dB. IF rejection: 40dB. S/N: 50dB.

General

Dimensions: 42.4 × 13.6 × 34.7cm. Weight: 8.4kg. Features: Loudness switch, tape monitor switch, 1.2, speaker selector A, B and A+B. Headphone jack. Price: No rec. retail price.

SR 802

Amplifier

RMS Power: (both channels driven) (20-20,000Hz, 0.5% THD) 50W × 2 (8Ω); (1kHz, 0.5% THD) 60W × 2 (8Ω); (1kHz, 0.5% THD) 70W × 2 (4Ω). Music Power (IHF): 80W × 2 (8Ω); 90W × 2 (4Ω). Frequency response: 10Hz - 30kHz ± 1dB. Power bandwidth (IHF): 10Hz - 40kHz. Harmonic distortion: at rated output 0.5%, at -3dB output 0.05%. IM distortion: at rated output 0.3%; at -3dB output 0.2%. S/N ratio (IHF): phono 70dB; tape 85dB; aux 85dB. Damping factor: 50Ω. Input sensitivity: phono 2.5mV/47kΩ; aux 150mV/50kΩ; tape 150mV/50kΩ. Output sensitivity: tape 150mV/1kΩ; DIN 40mV/80kΩ. Tone control: bass 100Hz (±10dB); treble 5kHz (-8dB). Low filter: 100kHz (-8dB). High filter: 10kHz (±10dB). Loudness (volume at -30dB): 100 (+9dB) 10K (+4dB).

Tuner

FM Section: Frequency response: 20Hz - 15kHz (± 1dB). Usable sensitivity (IHF): 1.7μV. Selectivity: 80dB. Capture ratio: 1.0dB. Image rejection: 85dB. IF rejection: 100dB. AM suppression: 55dB. Harmonic distortion: mono 0.15%; Stereo 0.25%. Stereo separation: 45dB (1kHz) S/N ratio: 74dB. Aerial impedance: 75Ω, 300Ω. AM Section: Sensitivity: 20μV (IHF), 300μV/m (Ferrite). Selectivity: 35dB. Image rejection: 50dB. IF rejection: 50dB. S/N ratio: 50dB.

General

Dimensions 490 × 144 × 400mm. Weight: 12.5kg. Price: No rec. retail price.

SR 6100

Amplifier

RMS power (both channels driven): (1kHz, 0.8% THD) 25W × 2 (8Ω); (1kHz, 0.8% THD) 30W × 2 (4Ω); (40-20,000Hz 0.8% THD) 20W × 2 (8Ω). Music power (IHF): 37W × 2 (8Ω); 45W × 2 (4Ω). Frequency response: 20Hz - 40kHz (± 1dB). Power bandwidth (IHF): 20Hz - 40Hz (0.8% THD). Harmonic distortion: at

rated output: 0.8%; at -3dB output; less than 0.1%. IM distortion: at rated output; 0.8%; at -3dB output; less than 0.1%. S/N ratio (IHF): phono 67dB; aux 87dB; tape 87dB. Damping factor: 30 (8 Ω). Input sensitivity: phono 2.4mV (47k Ω); aux 145mV (47k Ω); tape 145mV (47k Ω). Output voltage: tape 45mV (80k Ω). Tone control: bass \pm 10dB (100Hz); treble \pm 10dB (10kHz). Loudness (volume at -30dB): +9dB (100Hz); +5dB (10kHz). Dimensions: 38.4 \times 12.1 \times 31.0cm. Weight: 7.5kg. Features: Loudness switch, tape monitor switch 1.2, headphone jack.

Tuner

FM Section: Frequency range: 88-108MHz. Usable sensitivity: 2.2 μ V (IHF). Selectivity: 50dB (IHF). Capture ratio: 1.0dB (IHF). Image rejection: 46dB. IF rejection: 80dB. AM suppression: 50dB. Harmonic distortion: mono 4%; stereo 0.6%. Stereo separation: 40dB (1kHz). S/N ratio: 65dB. Antenna impedance: 300 Ω /75 Ω . Price: No rec. retail price.

■ JVC

JVC (UK) Ltd, Eldonwell Trading Estate, Staples Corner, 6-8 Priestley Way, London NW2. Tel: 01-450 2621.

4VR5456 X ★

FM/AM stereo and quadrasonic receiver. Bands: 88-108MHz FM, 525-1605kHz AM. Sensitivity: 1.8 μ V IHF (FM), 30 μ V AM. Tuning meter, manual tuning. Inputs: phono (1) 3mV, phono (2) 1.5mV, aux (1 & 2) 200mV, tape play 200mV. Output: 45W per channel (4) into 8 ohms at 1kHz. THD: 0.5% 10Hz-50kHz \pm 1dB. Size: 20 \times 7 $\frac{1}{8}$ \times 15 $\frac{1}{8}$ in. Sound effects amplifier: CD-4 demodulator and matrix decoder. Price: £444.50 (plus VAT).

4VR5446 X

FM/AM stereo and quadrasonic receiver. Bands: 88-108MHz FM, 525-1605kHz AM. Sensitivity: 2.0 μ V IHF (FM), 30 μ V AM. Tuning meter, manual tuning. Inputs: phono (1) 3mV, phono (2) 1.5mV, aux (1 and 2) 200mV, tape play 200mV. Output: 22W per channel (4) into 8 ohms at 1kHz. THD: 0.5%. FR: 10Hz-30kHz \pm 1dB. Size: 20 \times 6 $\frac{1}{8}$ \times 15 $\frac{1}{8}$ in. Sound effects amplifier. CD-4 demodulator and matrix decoder. Price: £336.00 (plus VAT).

4VR-5426X

Amplifier

Power output: 17 watts RMS \times 4. THD: 1.0%. FR: 20-30,000Hz. Power bandwidth: 10-40,000Hz. Inputs: phono, aux tape.



JVC 4VR-5456X

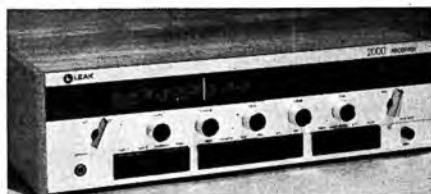

Leak 2000

Tuner

Sensitivity FM: 2.2 μ V. Sensitivity AM: 30 μ V, 200 μ V/M. Capture ratio: 2.0dB. Image rejection FM: 55dB. Image rejection AM: 45dB. Stereo separation: 40dB. THD stereo: 0.8%. Waveband coverage: 88-108mHz, AM 525-1,605kHz.

General

Dimensions: 47.6 \times 39.1 \times 16.3cms. Price: £220.50 (plus VAT).

■ LEAK

Rank Audio Visual, PO Box 70, Great West Road, Brentford, Middlesex TW8 9HB. Tel: 01-568 9222.

Leak 2000 ★

AM/FM stereo tuner/amplifier. Range: FM 87.5-108MHz, MW 510-1650kHz, LW 150-350kHz. Variable tuning: Sensitivity: FM 1.6 μ V (IHF). Inputs: phono 2.2mV or 6mV 47K switchable, tape 140mV 100K, tuner 140mV 100K (all at 1kHz for 35W output). Outputs: tape/cassette 140mV. DIN 1.4mV/K. Speakers: 30W per channel into 8 ohms, 40W per channel into 4 ohms, both channels sine wave driven at 1kHz. High power single channel mode 80W. Damping factor: 40 at 80Hz. THD: 0.1% at 30W into 6 ohms. Power bandwidth: 10Hz-40kHz -2dB at 35W. Mains: 240V AC 50/60Hz. Tone controls: treble \pm 13dB at 15kHz, bass \pm 13dB at 50Hz, filter -3dB at 5kHz (-10dB at 10kHz), loudness +10dB at 50Hz (-40dB volume setting). Input resistance: 47K. FR: 20Hz-50kHz -2dB. Crosstalk: -90dB at 10kHz. Special facilities

★ Indicates entry is illustrated

include normal/matrix switch, pre-amp and main amp normal/separate switch, variable level FM muting control, quasi stereo. Size: 132 × 471 × 292mm. Weight: 9.7kg. Finish: teak. Price: £223.96 (plus VA1).

R800

Specifications: Unless otherwise stated, these specifications apply for 6 ohm speakers, and values are typical. Noise measurement bandwidth 20Hz-20kHz. Distortion Limited Output Power: 4 ohm speakers: greater than 28+28 watts, 6 ohm speakers: greater than 25+25 watts. 8 ohm speakers: greater than 20+20 watts. (Both channels sine wave driven at 1kHz, 0.5% THD). Total harmonic distortion: All powers up to 20 watts; less than 0.1%. At 20 watts: 0.1%. Intermodulation distortion: (70Hz and 5kHz in ratio 4 to 1): 0.1%. Power bandwidth: 2dB down relative to 25W: 0.5%. THD: 10Hz-40kHz. (Both channels driven). Damping factor: Measured at 80Hz: 40. Residual Hum and Noise: Volume control minimum: 1mV. Control amplifier: Treble control: ±13dB at 15kHz. Bass control: ±13dB at 50Hz, Filter (high): -3dB at 4kHz. -10dB at 10kHz. Filter (low): -3dB at 70Hz. -10dB at 20Hz. Disc Input: Sensitivity at 1kHz for 25 watts: 2.3mV. Input impedance: 47K ohms. Frequency response: Compensated to IEC 98 fine groove characteristic. Hum and Noise: -65dB. Input overload margin: +35dB. Crosstalk at 10kHz: -35dB. Tape Input: Sensitivity for 25 watts: 120mV. Input impedance: 50K ohms. Frequency response (±1.5dB): 25Hz-40kHz. Hum and Noise: -80dB. Crosstalk at 10kHz: -40dB. Tape Output: 1.2mV/k ohm based on above sensitivity. FM Tuner: Frequency Range: 87.5 to 108MHz. Sensitivity for 30dB signal/noise: 2μV. (IHF method, 75 ohms). Mono distortion at 1kHz: 0.5%. Stereo distortion at 1kHz: 0.5%. Hum and noise: -65dB (relative to 75kHz deviation, 1mV RF input). Channel separation at 1kHz: 35dB. Channel separation at 10kHz: 30dB. Image rejection (IHF) 45dB. IF rejection (IHF): 60dB. Alternate channel rejection (IHF): 50dB. AM rejection: 50dB. Capture ratio: 1.5dB. Mute level: 5μV. De-emphasis: 50 micro seconds. Frequency response (±1.5dB): 40Hz to 14kHz. 19 and 38kHz rejection: 60dB. SCA rejection: 70dB. AM tuner: Frequency ranges: medium wave 510 to 1650kHz. Sensitivity for 20dB signal/noise: 20μV. Image rejection: 40dB. IF rejection: 35dB at 1MHz. Selectivity (IHF): 25dB. AF bandwidth: 3kHz (-3dB). Dimensions: 471 × 292 × 130mm. Weight: 9.75kg (21.5 lbs). R.R.P. inc. VA1 £189.95.

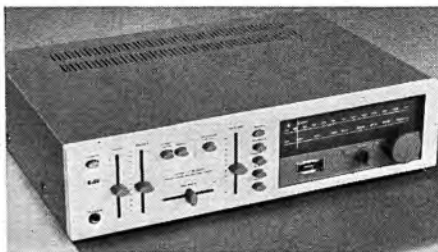

LG Sound Systems R3400 Receiver



LG R3600

■ L G SOUND SYSTEMS

5 Eden Grove, London N7 8EQ.
Tel: 01-609 0293/6

R3400 ★

Amplifier

Power output: 25W. THD: 0.5%. Total music power: 60W. FR: 20-40,000Hz. Inputs: phono, aux.

Tuner

Sensitivity FM: 2.8μV; Sensitivity AM: 200μV. Capture ratio: 2dB. Image rejection FM: 60dB. Image rejection AM: 45dB. IF rejection FM: 70dB. Stereo separation: 38dB. THD stereo: 0.5%. Waveband coverage: 88-108, 525-1,605kHz.

General

Dimensions: 43 × 30 × 13cms. Blue and white finish. Price: £128.00 (plus VA1).

R3400G

As above but in teak finish. Price: £157.00 (plus VA1).

R3600 ★

Amplifier

Power output: 36 watts. THD: 0.5% at rated output. Total music power: 90W. FR: 10-50,000Hz. Inputs: phono, aux. Scratch filter, rumble filter.

Tuner

Sensitivity FM: 2.2μV. Sensitivity AM:

200 μ V. Capture ratio: 2dB. Image rejection FM: 80dB. Image rejection AM: 46dB. IF rejection FM: 90dB. Stereo separation: 38dB.



LG Sound Systems R3600G



Lux R800



Lux R600



Lux R1500

THD stereo: 0.5%. Waveband coverage: 88-108, 525-1,605kHz.

General

Dimensions: 43 x 30 x 13cms. Blue and white finish. Price: £154.00 (plus VAT).

R3600G ★

As above but in teak finish. Price: £184.00 (plus VAT).

■ LUX

Distributors; Howland-West Ltd,
35 Eden Grove, London N7 8EQ.
Tel: 01-609 0293/6.

R1500 ★

Amplifier

Power output: 75 RMS per channel. THD: >0.05%. FR: 15-35,000Hz. Power bandwidth: 5-40,000Hz. Damping factor: 40. Inputs: phono (1+2), Aux (1+2), tape monitor (1+2), mic. Overload capability: up to 130mV 1kHz. Scratch filter, rumble filter.

Tuner

Sensitivity FM: 1.8 μ V. Sensitivity AM: 16 μ V. Capture ratio: 1.3dB. Image rejection FM: 90dB. Image rejection AM: 72dB. Spurious rejection FM: 90dB. IF rejection FM: 90dB. Stereo separation: 40dB at 400Hz. THD stereo: 0.4% at 400Hz. Waveband coverage: 88-108 plus medium wave.

General

Dimensions: 52 x 35 x 15cms. Boxwood finish. Price: £350.00 (plus VAT).

R600 ★

AM/FM stereo tuner/amplifier. Range: FM 88-108MHz, MW 187-540m. Variable tuning. AFC. Signal strength meter and centre-zero tuning meter. Usable sensitivity: FM 1.8 μ V, MW 200 μ V. Aerial input: 300 ohms balanced twin, 75 ohms coaxial. Stereo decoder fitted. Inputs: mag PU (2), aux (2), tape (2), mic (2). Noise level: (mic) 60dB, (PU) 65dB, (other inputs) 80dB. Overload capability: (PU) 130mV. Output: 30WRMS per channel. Controls: treble \pm 10dB at 10kHz, bass \pm 10dB at 300Hz, low cut 20Hz-70Hz 6dB/Oct, high cut 6kHz-12kHz 6dB/Oct. HD: <1% at 40W. Output impedance: 8 ohms. FR: 10Hz-40kHz +1dB. Mains: 100, 120, 220, 240V 50/60Hz. Finish: rosewood cabinet. Price: £205.00 (plus VAT).

R800 ★

AM/FM stereo tuner/amplifier. Range: FM 88-108MHz, MW 187-540m. Variable tuning. AFC. Signal strength meter and centre-zero

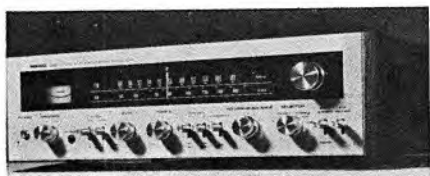

Nikko STA-7070

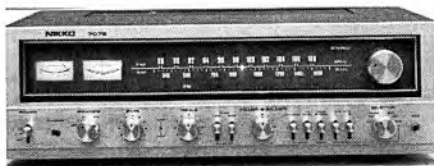

Nikko 7075



Nikko 3035



Nikko 5055

tuning meter. Usable sensitivity: FM $1.8\mu\text{V}$, MW $200\mu\text{V}$. Aerial input: 300 ohms balanced twin, 75 ohms coaxial. Stereo decoder fitted. Inputs: mag PU (2), aux (2), tape (2), mic (2). Noise level: (mic) 60 dB, (PU) 65dB, (other inputs) 80dB. Overload capability: (PU) 130mV. Output: 40W RMS per channel. Controls: treble $\pm 10\text{dB}$ at 10kHz, bass $\pm 10\text{dB}$ at 300Hz, low cut 20Hz-70Hz 6dB/octave, high

cut 6kHz-12kHz 6dB/octave. HD: $< 1\%$ at 40W. Output impedance: 8 ohms. FR: 10Hz-40kHz $\pm 1\text{dB}$. Mains: 100, 120, 220, 240V 50-60Hz. Finish: rosewood cabinet with champagne panel. Price: £240.00 (plus VAT).

■ NIKKO

Distributors: Howland-West Ltd, 3-5 Eden Grove, London N7 8EQ. Tel: 01-609 0293/6.

STA-8080

AM/FM stereo tuner/amplifier. Range: FM 88-108MHz, MW 182-556m. Variable tuning. AFC. One signal strength meter, one center-zero tuning meter. Usable sensitivity: FM $2\mu\text{V}$, MW $150\mu\text{V}$. Aerial input: 300 ohms balanced twin, 75 ohms coaxial. Stereo decoder fitted. 78 transistors. Inputs: mag PU (2) 2.2mV 50K, aux (1) 160mV 100K, aux (2) 320mV 120K, tape 160mV 100K. Output: 55W RMS per channel. Controls: bass $\pm 10\text{dB}$ at 70Hz, treble $\pm 10\text{dB}$ at 10kHz, loudness +9dB at 70Hz +5.5dB at 10kHz, speaker switch (A, A+B, B), balance, mono/stereo, FM muting, low filter -8dB at 70Hz, high filter -7dB at 10kHz, tape/dubbing. HD: 0.1% at 1W, 0.5% at rated output. Output impedance: 8 ohms. FR: 10Hz-50kHz $\pm 1\text{dB}$. Mains: 120, 220, 240V 50-60Hz. Size: $18 \times 14\frac{1}{2} \times 5\frac{3}{4}\text{in}$. Finish: wood cabinet with metal trim. Price: £195.00 (plus VAT).

STA-7070 ★

AM/FM stereo tuner/amplifier. Range: FM 88-108MHz, MW 182-556m. Variable tuning. AFC. Meter tuning indicator. Usable sensitivity: FM $2\mu\text{V}$, MW $150\mu\text{V}$. Aerial input: 300 ohms balanced twin, 75 ohms coaxial. Stereo decoder fitted, 76 transistors. Inputs: mag PU (2) 2.2mV 50K, aux (1) 160mV 100K, aux (2) 320mV 120K, tape (2) 160mV 100K. Noise level: (mag PU input) -65dB, (other inputs) -80dB. Output: 40W RMS per channel into 8 ohms. Controls: bass $\pm 10\text{dB}$ at 70Hz, treble $\pm 10\text{dB}$ at 10kHz, loudness +9dB at 70Hz +5.5dB at 10kHz, speaker switch (A, A+B, B), balance, mono/stereo, FM muting, low filter -8dB at 70Hz, high filter -7dB at 10kHz, tape/dubbing. HD: 0.1% at 1W, 0.5% at rated output. Output impedance: 8 ohms. FR: 10Hz-50kHz $\pm 1\text{dB}$. Mains: 120, 220, 240V 50-60Hz. Size: $18 \times 14\frac{1}{2} \times 5\frac{3}{4}\text{in}$. Finish: wood cabinet and metal trim. Price: £170.00 (plus VAT).

STA-5050

AM/FM multiplex stereo receiver. Tuning

range: FM 88-108MHz, AM 540-1600kHz. Variable tuning. Double function tuning meter. FM muting. Stereo separation FM: 38dB at 1kHz. Output: 24W RMS per channel, both channels driven into 8 ohms (26W per channel into 4 ohms). FR: 20Hz-30kHz \pm 1dB. Distortion: 0.8% at rated output. Input sensitivity/impedance: phono 2.0mV 50K, aux 200mV 50K, tape monitor 200mV 50K. S/N: phono 60dB (other) 75dB. Tone controls: bass \pm 12dB at 70Hz, treble \pm 12dB at 10kHz, +10dB at 70Hz, loudness +10dB at 70Hz. Damping factor: 30 into 8 ohms. 35 transistors, 21 diodes, 1 FET, 1 IC. Power consumption: 110W. Mains: 120V (or 220/240V AC) 50/60Hz. Size: 450 \times 380 \times 135mm. Weight: 9kg. Price: £145.00 (plus VAT).

3035 ★**Amplifier**

Power output: 20W THD: 0.8%. Damping factor: 15. Overload capability: 100mV.

Tuner

Sensitivity FM: 2.0 μ V. Image rejection FM: 60dB. IF rejection FM: 80dB. Stereo separation: 40dB. Wavebands: FM/Medium.

General

Dimensions: 48 \times 35 \times 15cms. Teak finish. Price: to be announced.

7075 ★**Amplifier**

Power output: 47W RMS per channel. THD: 0.5%. Damping factor: 35. Overload capability: 150mV. Scratch filter, rumble filter.

Tuner

Sensitivity FM: 1.9 μ V. Image rejection FM: 80dB. IF rejection FM: 90dB. Waveband coverage: FM/Medium.

General

Dimensions: 48 \times 35 \times 15cms. Teak finish. Price: to be announced.

5055 ★**Amplifier**

Power output: 30W RMS per channel. THD: 0.8%. Damping factor: 20. Overload capability: 100mV. Scratch filter.

Tuner:

Sensitivity FM: 2.0 μ V. Image rejection FM: 60dB. IF rejection FM: 90dB. Waveband coverage: FM/Medium.

General

Dimensions: 48 \times 35 \times 15cms. Teak finish. Price: to be announced.

■ NORDMENDE

Vessco Vision & Radio Ltd, Unit 4,

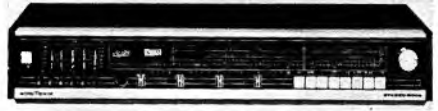

Nordmende 6005 ST

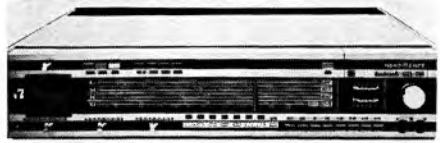

Nordmende Quadronado QXL 160

Blackwater Way, Ash Road, Aldershot,
Hants GU1 4DL.

Tel: Aldershot 312661.

6005 ST ★

Stereo tuner/amplifier. Ranges: VHF, LW, MW, SW and 49 metre band. Electronic mono/stereo switching with indicator. Five VHF pre-sets. Signal strength meter. Output: 15W RMS per channel. Price £98.00 (plus VAT).

Quadronado QXL 160 ★

Quadraphonic tuner/amplifier. Ranges: VHF, LW, MW, SW with seven VHF pre-sets. Illuminated 4-channel balance control, stereo beacon and signal strength meter. Output: 120W RMS (4 \times 30) all channels driven. SQ Quadraphonic + CD4 using external encoder. Price: £261.20 (plus VAT).

Quadronado QX 80

As QXL 160 except power output 60W RMS (4 \times 15W RMS). Price: £224.40 (plus VAT).

■ PHILIPS ELECTRICAL LTD.

City House, 420 London Road,
Croydon, Surrey.

Tel: 01-689 2166.

RH 752**Amplifier**

Power output: 2 \times 30 watts RMS THD: < 1% for 2 \times 30 watts. Total music power: 2 \times 40 watts. FR: 20-25,000Hz. Power bandwidth: 20-50,000Hz. Damping factor: 20 \times 4 ohms. Inputs: Recorder (2), aux, mic. Crosstalk: better than -40dB at 1000Hz and better than -30dB between 250-10,000Hz.

Tuner

Sensitivity FM: 2 μ V term. volt for 26dB at 40kHz deviation. Sensitivity AM: 90 μ V EMF

★ Indicates entry is illustrated

for 26dB S/N. Stereo separation: -40dB at 1kHz. Pilot tone rejection: -35dB at 19kHz. Pilot harmonic rejection: -35dB at 38kHz. THD: <1% at 75kHz deviation. Waveband coverage: FM/L/M/S.

General

Dimensions: 63 × 34.4 × 12.2cms. Matt silver and black finish. Price: £220.00 (plus VAT).

RH 743

Tuner pre-amplifier for use with motional feedback speakers.

Amplifier

Power output: 1 volt per channel in 1k ohms. THD: <0.1% at 1 volt. FR: 20-25,000Hz at 1.5-3dB. Tape output (DIN): 2mV/20k ohms. Crosstalk: better than -40dB at 1,000Hz. -30dB between 250 and 10,000Hz.

Tuner

Sensitivity FM: 2μV for 26dB S/N at 40kHz deviation. Sensitivity AM: 90μV EMF for 26dB S/N. Stereo separation: -40dB at 1kHz. Pilot tone rejection: -35dB at 19kHz. Pilot harmonic rejection: -35dB at 38kHz. THD: <1% at 75kHz deviation. Waveband coverage: FM/L/M/S.

General

Dimensions: 60.3 × 29.5 × 11.7cms. Black finish. Price: £148.00 (plus VAT).

RH 741

Amplifier

Power output: 2 × 10 watts RMS. THD: <1% for 2 × 6 watts. Total music power: 30 watts. FR: 20-20,000Hz linear at +1 -3dB. Power bandwidth: 30-30,000Hz at -3dB. Tape output (DIN): 2mV/20k ohms. Crosstalk: better than -40dB at 1,000Hz. Better than -30dB between 250-10,000Hz.

Tuner

Sensitivity FM: 2.5μV terminal voltage for 26dB S/N ratio 40kHz deviation. Sensitivity AM: 80μV EMF for 26dB S/N ratio. Stereo separation: >-40dB at 1kHz. THD stereo: <1% at 75kHz deviation. Waveband coverage: FM/L/M/S.

General

Dimensions: 52.8 × 22.9 × 10.5cms. Walnut veneer finish. Price: £159.20 (plus VAT).

RH 742

Amplifier

Power output: 2 × 15 watts RMS. THD: <1% for 2 × 15 watts <0.1% for 2 × 9 watts. Total music power: 44 watts. FR: 20-25,000Hz linear +1.5 -3dB. Power bandwidth: 20-50,000Hz at -3dB. Damping factor: 20 × 4 ohms. Tape

output (DIN): 2mV/20k ohms. Crosstalk: better than -40dB at 1,000Hz, -30dB between 250-10,000Hz.

Tuner

Sensitivity FM: 2μV terminal volt for 26dB S/N ratio 40kHz deviation. Sensitivity AM: 90μV EMF for 26dB S/N ratio. Stereo separation: > -40dB at 1kHz. THD stereo: <1% at 75kHz deviation. Waveband coverage: FM/L/M/S.

General

Dimensions: 60.3 × 29.5 × 12.2cm. Black finish. Price: £180.00 (plus VAT).

■ PIONEER

Distributors: Shiro (UK) Ltd, Shiro House, The Ridgeway, Iver, Bucks SL0 9JL. Tel: Iver 652222.

QX 646

FM/AM stereo-quadrasonic receiver. Bands: 88-108MHz FM, 550-1600kHz AM/MW. Manual tuning. Signal strength meter. Sensitivity: 2.2μV IHF (FM), 15μV AM. Aerial: 75 or 300 ohms. Inputs: phono 2.5mV 100K, aux 180mV 90K, tape monitor (2-channel, 4-channel) 180mV 100K. S/N: 65dB FM, 50dB AM, ref to full power. Output: 10W (4-channel) into 8 ohms. 11W (4-channel) into 4 ohms. Damping factor: 40 at 1kHz into 8 ohms. THD: 1% ref to full power. FR: 10Hz-30kHz power bandwidth. Size: 20 × 5⁷/₈ × 14in. All regular matrix. SQ and CD-4 systems decoded. Price: on application.

QX 747

FM/AM stereo quadrasonic receiver. Bands: 88-108MHz FM, 550-1600kHz AM/MW. Manual tuning. Centre tuning meter. Sensitivity: 1.9μV IHF (FM), 15μV (AM). Aerial: 75 or 300 ohms. Inputs: phono 2.2mV 50K, aux 140mV 100K, tape monitor 140mV 100K, tape rec (2) 140mV 100K. S/N: 70dB FM, 50dB AM. Output: 25W (4-channel) into 8 ohms, 30W (4-channel) into 4 ohms. Damping factor: 35 at 1kHz into 8 ohms. THD: 0.2%. Power bandwidth: 7Hz-40kHz. Size: 21 × 6 × 16in. All regular matrix, SQ and CD-4 sources decoded. Price: on application.

QX 949

FM /AM stereo-quadrasonic receiver. Bands: 88-108MHz FM, 550-1600kHz AM. Manual tuning. Centre tuning and signal strength meters. Sensitivity: 1.8μV IHF (FM), 15μV (AM). Aerials: 75 or 300 ohms. Inputs: phono (1 & 2) 2.5mV 50K, aux 150mV 100K, tape mon (1) 150mV 100K, tape rec 150mV. S/N: 70dB FM, 50dB AM reffull power output.

Output: 44W (4-channel) into 8 ohms, 58W (4-channel) into 4 ohms. Damping factor: 35 at 1kHz into 8 ohms. THD: 0.3% at full power. Power bandwidth: 7Hz-40kHz. Size: 21 × 6 × 17in. All regular matrix, SQ and CD-4 sources decoded. Price: on application.

LX-424

Three band stereo receiver.

Amplifier

Music power output (IHF): 50 watts (4 ohms), 37 watts (8 ohms). Continuous power output: 12 watts + 12 watts (8 ohms), (1kHz, both channels driven: 13 watts + 13 watts (4 ohms). Continuous power output: 14 watts/14 watts (8 ohms). (1kHz, each channel driven): 18 watts/18 watts (4 ohms). Harmonic Distortion: Less than 1% (continuous power output), less than 0.1% (1 watt + 1 watt output). Intermodulation Distortion: less than 1% (continuous power output), less than 0.5% (1 watt + 1 watt output). Power bandwidth: 20Hz to 60kHz (IHF, both channels driven). Output: speaker: A, B, A+B (4 to 16 ohms); Headphone: 4 to 16 ohms. Damping factor: 40 (1kHz, 8 ohms). Residual hum and noise: less than 0.5mV (8 ohms, pre and power amp.). Input sensitivity/impedance: phono: 2.5mV/50 k ohms. mic: 6.5mV/50 k ohms. Aux: 150mV/100 k ohms. Tape monitor: 150mV/100 k ohms. Tape monitor (DIN connector), 150mV/100 k ohms. Output level/impedance: Tape rec: 150mV. Tape rec (DIN connector); 30mV/80 k ohms. Frequency response: phono (RIAA equalization); 30Hz to 15kHz \pm 1dB. Aux, tape mon: 20Hz to 70kHz \pm 3dB. Tone control: bass: +9dB, -9dB (100Hz) treble: +6dB, -9dB (10kHz). Loudness contour (volume control set at -40dB position): +9.5dB (100Hz); +5.5dB (10kHz). Hum and noise (IHF, short-circuited A network): phono; more than 75dB Aux, tape mon: more than 85dB.

FM Tuner

Frequency range: 88 to 108MHz. Usable sensitivity (IHF): 1.9 μ V. Sensitivity: 1.3 μ V (S/N 26dB, 40kHz deviation). Capture ratio (IHF): 1.5dB. Selectivity (IHF): 60dB. S/N ratio: 70dB. Image rejection: more than 60dB (98MHz). IF rejection: more than 90dB (98MHz). Spurious rejection: more than 75dB. AM suppression: 50dB. Harmonic distortion: mono: less than 0.2%, stereo: less than 0.4%. Frequency response: 20Hz to 15kHz +0.2dB, -2.0dB; 50Hz to 10kHz +0.2dB, -0.5dB. Stereo separation: more than 40dB (1kHz); more than 30dB (50Hz to 10kHz). Sub carrier suppression: 60dB. Antenna input: Impedance 300 ohms balance and 75 ohms unbalanced.

AM tuner

MW: Frequency range: 525 to 1,605kHz. Sensitivity (ferrite antenna): 170 μ V (S/N 20dB), 600 μ V (S/N 30dB); (ext. antenna): 15 μ V (S/N 20dB), 40 μ V (S/N 30dB). Selectivity: 40dB. Signal-to-noise ratio: 50dB. Image rejection: 35dB. IF Rejection: 35dB. Antenna: Built-in ferrite loopstick antenna. LW: Frequency range: 150 to 350kHz. Sensitivity (ferrite antenna): 560 μ V (S/N 20dB), 2mV (S/N 30dB); (ext. antenna): 45 μ V (S/N 20dB), 160 μ V (S/N 30dB). Selectivity: 45dB. S/N ratio: 45dB. Image rejection: 45dB. IF Rejection: 30dB. Antenna: built-in ferrite loopstick antenna.

General

Power requirements: 110, 120, 130, 220, 240V (switchable); 50-60Hz. Power consumption: 110W. AC outlets: switched; 1, Unswitched; 1. Price: on application.

SX-535

Amplifier

20W per channel, min. RMS, at 8 ohms from 40Hz to 20kHz, with no more than 0.8% total harmonic distortion. Continuous power output 40Hz to 20kHz (both channels driven): 22W + 22W (4 ohms); 20Hz to 20kHz (both channels driven): 18W + 18W (8 ohms); 1kHz (both channels driven): 22W + 22W (8 ohms), 25W + 25W (4 ohms) THD: less than 0.8% (continuous power output); less than 0.08% (1 watt + 1 watt, power output). Intermodulation distortion: less than 0.8% (continuous power output); less than 0.08% (1W +1W, power output). Power bandwidth: 10Hz to 70kHz (HD 0.8%) (IHF, both channels driven). Output: Speaker: A, B, A+B (4 to 16 ohms); Headphones: 4 to 16 ohms. Damping factor: more than 30 (1kHz, 8 ohms). Residual H & N: less than 0.5mV (8 ohms, pre and power amplifier). Input sensitivity/impedance: phono: 2.5mV/50K ohms; phono overload level (RMS/P-P): 110mV/310mV; mic: 7mV/85K ohms; aux: 150mV/75K ohms; tape PB 1, 2: 150mV/75k ohms; tape PB 2 (DIN connector): 150mV/75k ohms. Output level/impedance: tape rec 1, 2: 150mV; tape rec 2 (DIN connector): 30mV/80K ohms. FR: phono (RIAA equalisation): 30Hz to 15kHz \pm 0.5dB; aux, tape PB: 20Hz-30kHz \pm 1dB. Tone control: bass: + 9dB, -8dB (100Hz); treble: +6dB, -6dB (10kHz). Loudness contour: +10dB (100Hz), +5dB (10kHz) (volume control set at -40dB position). H & N (IHF, short-circuited A network): phono: more than 70dB; mic: more than 65dB.

FM Tuner

Usable sensitivity (IHF): 1.9 μ V. Capture

★ Indicates entry is illustrated

ratio (IHF): 1.0dB. Selectivity (IHF): 60dB. S/N ratio: 70dB. Image rejection (98MHz): 60dB. IF rejection (98MHz): 90dB. Spurious rejection: 75dB. AM suppression: 50dB. THD: mono, less than 0.2%; stereo, less than 0.4%. FR: 20Hz-15kHz +0.2dB -2.0dB; 50Hz-10kHz +0.2dB -0.5dB. Stereo separation: more than 40dB (1kHz); more than 30dB (50Hz-10kHz). Sub carrier suppression: 40dB. Antenna input: 300 ohms balanced and 75 ohms unbalanced. Muting: on-off.

AM Tuner

Sensitivity: 300 μ V/m (IHF, ferrite antenna), 15 μ V (IHF, ext. antenna). Selectivity: 35dB. S/N ratio: 50dB. Image rejection: 40dB. IF rejection: 70dB.

General

Power consumption: 130W (KCU), 180W (FVGN). Price: on application.

LX-626

Amplifier

Music power output (IHF): 110W (4 ohms), 76W (8 ohms). Continuous power output (1kHz, each channel driven): 40W/40W (4 ohms) 32W/32W (8 ohms); Continuous power output (1kHz, both channels driven): 30W + 30W (4 ohms); 27W + 27W (8 ohms). Power output in the range of 20-20,000Hz (both channels driven): 20W + 20W (8 ohms, THD less than 1%). THD: Less than 1% (continuous power output); less than 0.09% (8 ohms, 16W/16W power output). Intermodulation distortion: less than 1% (continuous power output); less than 0.4% (8 ohms, 16W/16W power output). Power bandwidth (IHF): 10-70,000Hz (8 ohms, THD less than 1%). FR: 5-80,000Hz \pm 1dB. Input sensitivity/impedance (1kHz, continuous power output): 500mV/60K ohms (power 1W). Speakers: 3 pairs (A, B, C) 4 to 16 ohms. Headphone jack: 4 to 16 ohms. Damping factor: 40 (8 ohms, 1kHz).

FM Tuner

Frequency range: 88-108MHz. Usable sensitivity (IHF): 1.9 μ V. Capture ratio (IHF): 1.5dB. Selectivity (IHF): more than 80dB. Image rejection: more than 80dB (98MHz). IF rejection: more than 100dB (98MHz). Spurious rejection: more than 90dB. AM suppression: 55dB. S/N ratio: 70dB. THD: mono less than 0.2% (100% mod.) stereo less than 0.4% (100% mod.). Tuning indicator: signal strength type (AM); centre tuning type (FM). Muting: switchable to on-off. Stereo separation: more than 40dB (1kHz). Sub carrier suppression: more than 65dB. Antenna input: impedance 300 ohms balanced and 75 ohms unbalanced.

AM Tuner

MW: Frequency range: 525-1,605kHz. Usable

sensitivity (IHF): 10 μ V. Selectivity (IHF): More than 40dB. Image rejection: more than 65dB (1,000kHz). IF rejection: more than 85dB. S/N ratio: 50dB. Antenna: built-in ferrite loopstick antenna. LW: Frequency range: 150-350kHz. Usable sensitivity (IHF): 25 μ V. Selectivity (IHF): more than 50dB. Image rejection: more than 80dB. IF rejection: more than 60dB. S/N ratio: 50dB. Antenna: built-in ferrite loopstick antenna.

Preamplifier

Output voltage: 500mV (rated output), 3V (max.). HD: less than 0.5%. FR: 15-20,000Hz \pm 1dB. Input sensitivity/Impedance (1kHz, for rated output): Phono 1 mag 2.5mV/45K ohms; phono 2 2.5mV/45K ohms; mic 2.2mV/22Kohms; aux 1, 2: 200mV/100K ohms.

SX-950 Amplifier

Continuous power output is 85W per channel, min. RMS at 8 ohms or 110W per channel at 4 ohms from 20Hz-20,000Hz with no more than 0.1%. THD: (20Hz-20,000Hz, from aux): no more than 0.1% (continuous rated power output); no more than 0.05% (43W per channel power output, 8 ohms); no more than 0.05% (1W per channel power output, 8 ohms). Intermodulation distortion (50Hz-7,000Hz = 4:1, from aux): no more than 0.1% (continuous rated power output); no more than 0.05% (43W per channel power output, 8 ohms); no more than 0.05% (1W per channel power output, 8 ohms). FR: 7Hz-90,000Hz +0dB, -1dB. Input sensitivity/impedance: 1V/50K ohms (power-amp in). Output: Speaker: A, B, C, A+B, B+C, A+C. Headphone: Low impedance. Damping factor: 25 (20Hz-20,000Hz 8 ohms). H & N: 100dB (IHF, short-circuit A network).

Preamplifier

Input sensitivity/impedance: phono 1: 2.5mV/50K ohms; phono 2: 2.5mV/50K ohms; mic: 6.5mV/50K ohms; aux: 150mV/50K ohms; Tape play 1: 150mV/50K ohms; Tape play 2: 150mV/50K ohms; Tape play 3 (DIN connector): 150mV/50K ohms. Phono overload level (THD 0.1%) phono 1: 200mV (1kHz); phono 2: 200mV (1kHz). Output level/impedance: tape rec 1: 150mV; tape rec 2: 150mV; tape rec 2 (DIN connector): 30mV/80K ohms. Pre out: 1V/100 ohms. THD: no more than 0.05% (20Hz to 20kHz, 1V output). FR phono (RIAA equalisation): 30Hz-15kHz, \pm 0.2dB) aux, tape play: 15Hz-40kHz, +0dB, -1dB. Tone control: bass: \pm 7dB/ \pm 10dB (100Hz); turnover frequency 200Hz/400Hz. Treble: \pm 7dB/ \pm 10dB (10kHz). Turnover frequency 5kHz/2.5kHz. Filter: low: 30Hz (12dB), high: 6kHz (12dB). Loudness contour: +6dB (100Hz), +3dB (0kHz). (volume control set at

-40dB position). H & N (IHF, short circuited A network, rated power). Phono: 75dB; aux, tape play: 90dB. Muting: -20dB.

FM Tuner

Usable sensitivity: Mono: 10.3dBf (3.6 μ V/300 ohms), Stereo: 22.2dBf (14.1 μ V/300 ohms). Usable Sensitivity (IHF): Mono: 1.8 μ V. 50dB Quieting Sensitivity: Mono: 17.2dBf (8.0 μ V/300 ohms), Stereo: 38.0dBf (87 μ V/300 ohms). S/N Ratio (at 65dBf): Mono: 72dB, Stereo: 67dB; Distortion (at 65dBf), 100Hz: 0.15% (mono), 0.3% (stereo); 1KHz: 0.15% (mono), 0.3% (stereo); 6KHz: 0.4% (mono), 0.4% stereo. FR: 30Hz to 15kHz \pm 0.2dB, -2.0dB. Capture Ratio: 1.0dB; Alternate channel selectivity: 8.0dB; Spurious response ratio: 100dB; Image response ratio: 85dB; IF response ratio: 100dB; AM suppression ratio: 55dB; Muting threshold: 14dBf (5.5 μ V/300 ohms); Stereo separation: 40dB (1KHz), 30dB (30Hz-15kHz). Subcarrier product ratio: 62dB. SCA rejection ratio: 62dB. Antenna input: 300 ohms balanced, 75 ohms unbalanced.

AM Tuner

Sensitivity: 300 μ V/m (IHF, antenna ferrite), 15 μ V (IHF, ext. antenna). Selectivity: 40dB. S/N ratio: 55dB. Image response ratio: 65dB. IF response ratio: 85dB. Antenna: Built-in ferrite loopstick antenna.

SX 1250

Power amplifier

Continuous power output is 160W per channel, min. RMS at 8 ohms or 200W per channel at 4 ohms from 20 Hz-20,000 Hz with no more than 0.1%. THD: (20 Hz-20,000 Hz, from AUX). No more than 0.1% (continuous rated power output). No more than 0.05%, (80 W per channel power output, 8 ohms). No more than 0.07%, (1W per channel power output, 8 ohms). FR: 5 Hz-100,000 Hz. + 0dB, -1dB. Input sensitivity/impedance: 1V/50 K ohms (Poweramp. in) Output speaker: A, B, C, A+B, B+C, A+C. Headphone: Low impedance. Damping Factor: 30 (20 Hz-20,000 Hz, 8 ohms). Hum and noise: 100dB. (IHF, short-circuited A network).

Preamplifier

Input sensitivity/impedance. Phono 1: 2.5mV/50 K. Phono 2: 2.5mV/50 K ohms. Mic: 6.5mV/50 K ohms. Aux: 150mV/ 50 K ohms. Tape play 1: 150mV/50 K ohms. Tape play 2: 150mV/50 K ohms. Tape play 2 (DIN connector): 150mV/50 K ohms. Phono overload Level (THD 0.1%). Phono 1: 500mV (1kHz). Phono 2: 500mV (1kHz). Output level/impedance: Tape rec 1: 150mV. Tape rec 2: 150mV. Tape rec 2 (DIN connector): 30mV/80 K ohms. Pre out: 1V/1 K ohms. Total harmonic distortion:



Rogers Ravensbrook

No more than 0.02%. (20Hz-20,000Hz, 1V output). FR: Phono (RIAA equalization): 30Hz-15,000Hz \pm 0.2dB. Aux. tape play: 10Hz-50,000Hz + 0dB, -1dB. Tone control. Bass: \pm 10dB (100Hz) main control. \pm 5dB (5 kHz) sub control. Treble: \pm 10dB (10kHz) main control. \pm 5dB (20kHz) sub control. Filter: Low: 30Hz (12dB/oct.). High: 8kHz (12dB/oct.). Loudness contour: +6dB (100Hz), +3dB (10kHz). (volume control set at -40dB position) Hum and noise (IHF, short circuited A network, rated power). Phono: 75dB. Aux, tape play: 90dB. Muting: -20dB.

FM Tuner section

Usable sensitivity: Mono: 8.7dBf (3.0 μ V/300 ohms), Stereo: 14.5dBf (5.8 μ V/300 ohms). Usable sensitivity (IHF) 1.5 μ V. 50dB quieting sensitivity: Mono: 11.5dBf (4.1 μ V/300 ohms), Stereo: 36.0dBf (69 μ V/300 ohms). Signal-to-noise ratio (at 65dBf): Mono: 80dB, Stereo: 74dB (Max. 75dB). Distortion (at 65dBf). 100Hz: 0.1% (mono), 0.25% (stereo). 1kHz: 0.1% (mono), 0.2% (stereo). 6kHz: 0.3% (mono), 0.3% (stereo). Frequency response: 30Hz-15,000Hz + 0.3dB, -1.0dB. Capture ratio: 1.0dB. Alternate channel selectivity: 83dB; Spurious response ratio: 110dB. Image response ratio: 110dB. IF response ratio: 120dB. AM suppression ratio: 60dB. Muting threshold: 13dBf (4.9 μ V/300 ohms). Stereo separation: 50dB (1kHz), 35dB (30Hz-15kHz). Subcarrier product ratio: 74dB. SCA rejection ratio: 74dB. Antenna input: 300 ohms balanced, 75 ohms unbalanced.

AM Tuner Section

Sensitivity: 300 μ V/m (IHF, ferrite antenna), 15 μ V (IHF, ext. antenna). Selectivity: 40dB. Signal-to-noise ratio: 55dB. Image response ratio: 65dB. IF response ratio: 85dB. Antenna: Built-in ferrite loopstick antenna.

ROGERS

Swisstone Electronics Ltd,
4-14 Barmeston Road, Catford,
London SE6 3BN.
Tel: 01-697 8511.

★ Indicates entry is illustrated

Ravensbrook ★

Integrated stereo tuner/amplifier. Range: 88-108MHz. Variable tuning. Quadrature detector. Aerial input: 75 ohms coaxial and 300 ohms balanced. Phase lock loop stereo decoder. Three-gang FET front end. Dual ceramic IF filters using IC techniques. Inter-station quiet tuning. Output: 13W RMS per channel into 15 ohms, 20W RMS per channel into 8 ohms. HD: <0.1% at rated output. FR: 20Hz-50kHz -3dB. S/N: PU input -53dB. Pushbutton input selector. Controls: bass, treble, volume, balance, high filter, low filter. Tuning meter. Price: £107.50 (plus VAT).

■ ROTEL

Rank Audio Visual Ltd, PO Box 70,
Great West Road, Brentford TW8 9HR.
Tel: 01-568 9222.

RX-802 ★

AM/FM stereo receiver. Tuning range: FM 88-108MHz, AM 550-1600kHz. Variable tuning. Sensitivity: (IHF) FM 1.5 μ V, AM 15 μ V. S/N ratio: FM 70dB, AM 55dB. IF rejection: FM 100dB, AM 75dB. Output: 55W RMS per channel, both channels driven into 8 ohms at less than 1% THD IM distortion. S/N ratio: phono/tape 70dB/80dB. Phono overload: 130mV. Controls: bass \pm 10dB 50Hz, treble \pm 10dB 10kHz, loudness +8dB/+4dB 50Hz/10kHz, high filter 12dB/Oct 50Hz, low filter 12dB/Oct 10kHz. Audio muting -20dB at 1kHz. Residual noise: 0.5mV. Speaker impedance: 4-16 ohms. Size 24 \times 5 $\frac{3}{8}$ \times 15in. Weight: 28.6lb. Finish: teak or rosewood. Price: £289.92 (plus VAT).

RX-254 ★

4-channel stereo receiver. Discrete 4-channel and built-in CD-4 demodulator plus SQ matrix. Tuning range: FM 88-108MHz, AM 550-1600kHz. Variable tuning. Sensitivity: (IHF) FM 2.9 μ V, AM 20 μ V. S/N ratio: FM 65dB, AM 50dB. IF rejection: FM 70dB, AM 45dB. Output: 24WRMS per channel, both channels driven or 12W RMS all channels driven into 8 ohms at less than 1% THD. IM distortion: 0.3%. S/N ratio: phono/tape 65dB/80dB. Phono overload: 80mV. Residual noise: 0.5mV. Speaker impedance: 4-16 ohms. Controls: bass \pm 10dB 50Hz, treble \pm 10dB 10kHz, loudness +10dB/+4dB 50Hz/10kHz. Volume selector, mode, treble, and bass for separate front and back operation, 4-balance controls (one for each channel), CD-4 separation controls, twin speaker switches, tape monitor, loudness, two headphone jacks for stereo and 4-channel, rear panel CD-4 carrier level control. Size: 21 $\frac{1}{2}$ \times 5 $\frac{1}{2}$ \times 13in. Weight: 22.7lb. Price: £239.92 (plus VAT).



Rotel RX-802



Rotel RX-254



Rotel RX-202

RX-152

AM/FM stereo receiver. Tuning range: FM 88-108MHz, AM 550-1600kHz. Variable tuning. Sensitivity: (IHF) FM 4 μ V, AM 20 μ V. S/N ratio: FM 65dB, AM 50dB. IF rejection: FM 65dB, AM 45dB. Output: 10W RMS per channel, both channels driven into 8 ohms at less than 1% THD IM distortion. S/N ratio: phono/tape 65dB. Phono overload: 80mV. Speaker impedance: 4-16 ohms. Controls: bass \pm 10dB 50Hz, treble \pm 10dB 50Hz/10kHz, loudness +10dB/+5dB 50Hz/10kHz, balance, selector, tape monitor. Two speaker switches for operating two pairs of speakers plus a simulated 4-channel switch for surround sound. Inputs: phono, tape, aux, tape monitor. Residual noise: 0.5mV. Terminals: For two pairs of loudspeakers, for balanced 300 ohm and unbalanced 75 ohm FM antenna, for external AM antenna (AM loopstick antenna built-in). AC outlet and front panel headphone jack. Size: 18 $\frac{3}{8}$ \times 4 $\frac{1}{2}$ \times 11in. Weight: 11lb. Price: £93.20 (plus VAT).

RX-202 ★

AM/FM stereo receiver. Tuning range: FM 88-108MHz, AM 550-1600kHz. Variable tuning. Sensitivity: (IHF) FM 2.9 μ V, AM 20 μ V. S/N ratio: FM 65dB, AM 50dB. IF rejection: FM 70dB, AM 45dB. Output: 15W RMS per channel, both channels driven into 8 ohms at



Rotel RX 602

less than 1% THD IM distortion. S/N ratio: phono/tape 65dB/78dB. Phono overload: 80mV. Speaker impedance: 4-16 ohms. Controls: bass \pm 10dB 50Hz, treble \pm 10dB 10kHz, loudness +10dB/ +4dB 50Hz/10kHz, high filter -9dB 50Hz, balance. Terminals for two pairs of speakers, for balanced 300 ohm and unbalanced 75 ohm FM antenna connection (built-in AM ferrite loopstick antenna), headphone jack. Simulated 4-channel switch. Size: 18 $\frac{1}{8}$ \times 4 $\frac{1}{2}$ \times 11in. Weight: 13lb. Price: £103.92 (plus VAT).

RX-402

AM/FM stereo receiver. Tuning range: FM 88-108MHz, AM 550-1600kHz. Variable tuning. Sensitivity: (IHF) FM 2.0 μ V, AM 20 μ V. S/N ratio: FM 67dB, AM 50dB. IF rejection: FM 80dB, AM 45dB. Output: 24W RMS per channel, both channels driven into 8 ohms at less than 1% THD IM distortion. S/N ratio: phono/tape 65dB/80dB. Phono overload: 85mV. Speaker impedance: 4-16 ohms. Controls: bass \pm 10dB 50Hz, treble \pm 10dB 10kHz, loudness +8dB/+5dB 50Hz/10kHz, high filter -10dB 50Hz, balance, selector. Separate left and right control for bass and treble. Simulated 4-channel switch. Two speaker switches. FM muting. Residual noise: 0.5mV. Terminal for external AM antenna. AM ferrite loopstick antenna. Front panel headphone jacks. AC outlets. Size: 18 $\frac{1}{8}$ \times 4 $\frac{1}{2}$ \times 13in. Weight: 15lb. Price: £142.00 (plus VAT).

RX-602 ★

AM/FM stereo receiver. Tuning range: FM 88-108MHz, AM550-1600kHz. Variable tuning. Sensitivity: (IHF) FM 1.8 μ V, AM 20 μ V. S/N ratio: FM 70dB, AM 50dB. IF rejection: FM 80dB, AM 50dB. Output: 40W RMS per channel, both channels driven into 8 ohms at less than 1% THD IM distortion. S/N ratio: phono/tape 65dB/80dB. Phono overload: 130mV. Speaker impedance: 4-16 ohms. Controls: bass \pm 10dB 50Hz, treble \pm 10dB 10kHz, loudness +8dB/+4dB 50Hz/10kHz, high filter -10dB 50Hz, audio muting switch, tape monitor, balance, selector. Simulated 4-channel switch. Terminals for FM antenna and AM antenna connections. AM ferrite loopstick antenna on rear of panel. Front

headphone jack. AC outlets. Finish: teak or rosewood. Size: 22 $\frac{1}{2}$ \times 5 $\frac{1}{8}$ \times 13in. Weight: 22.7lb. Price: £186.00 (plus VAT).

RX 102

Amplifier

Power Output: 5.5 Watts. THD: 1% FR: 20-50,000 Hz. Damping factor: 30 Inputs: phono, tape, aux, tape monitor, two speakers. Tape Output (DIN): 5 mV: 100 mV/90 k ohms. Crosstalk: 50 dB/10 kHz.

Tuner

Sensitivity FM: IHF/4 μ V. Sensitivity AM: IHF/300 μ V. Capture Ratio: 4dB. Image Rejection: 740dB. Spurious Rejection FM: >55dB. IF rejection FM: >60dB. Stereo separation: 35dB. Wavebands: 88-108MHz, 525-16,000kHz.

General

Dimensions: 47.5 \times 27 \times 11.5cms. Black fascia, teak surround. Price: £84.40 (plus VAT).

■ SANSUI

Vernitron Ltd, Thornhill, Southampton SO9 5QF.

Tel: Southampton 444811

221

FM/AM Stereo Receiver. Audio Section: Music Power (IHF) 40 watts into 4 ohms at 1,000Hz, 30 watts into 8 ohms at 1,000Hz. THD: Overall (Aux to speaker terminals) less than 1.0% at rated power output. IHF Power Bandwidth: 20 to 30,000Hz at rated distortion. Frequency Response (at 1 watt): Overall (AUX to power output) 25 to 30,000Hz +2.0dB. -3.0dB. Damping Factor: approximately 30 into 8 ohms load. Channel Separation (at rated output 1,000Hz), Phono: better than 45dB, Aux, Tape, better than 45dB. IHF Hum and Noise: Phono: better than 70dB, Aux, better than 80dB. Input Sensitivity and Impedance (at rated output 1,000Hz): Phono: 2.5mV (50k ohms), Max. input capability 120mV RMS (THD: less than 0.5%). Aux: 150mV (50k ohms). Tape Monitor (PIN): 150mV (50k ohms). Tape Monitor (DIN): 150mV (50k ohms). Tuner FM Section: Tuning Range: 88 to 108MHz. Sensitivity (IHF) 2.5 μ V (DIN) 1.3 μ V. THD: Mono less than 0.8%, Stereo less than 1.0%. S/N Ratio: better than 65dB. Selectivity: better than 60dB. Capture Ratio: less than 1.5dB. Image Frequency Rejection: better than 50dB at 93MHz. IF Rejection: better than 70dB at 93MHz. Spurious Response Rejection: better than 70dB at 93MHz. Spurious Radiation: less than -34dB. Stereo Separation: better than 35dB at 1,000Hz. Frequency Response: 30 to 12,000Hz +1dB,

★ Indicates entry is illustrated

—3dB. Antenna Input Impedance: 300 ohms balanced, 75 ohms unbalanced. AM Section: Tuning Range: 535 to 1,605kHz. Sensitivity (Bar Antenna): 50dB/m at 1,000kHz. Selectivity (± 10 kHz): better than 40dB at 1,000kHz. Image Frequency Rejection: better than 80dB/m at 1,000kHz. IF Rejection: better than 80dB/m at 1,000kHz. Dimensions: 424 × 125 × 266mm. Price: £95.99 (plus VAT).

331

Audio Section: Music Power (IHF) 50 watts into 4 ohms at 1,000Hz, 40 watts into 8 ohms at 1,000Hz. THD: Overall (Aux to speaker terminals) less than 1.0% at rated power output. IHF Power Bandwidth: 20 to 30,000Hz at rated distortion. Frequency Response (at 1 watt): Overall (AUX to power output) 25 to 30,000Hz + 2.0dB — 3.0dB. Damping Factor: approximately 30 into 8 ohms load. Channel Separation (at rated output 1,000Hz), Phono: better than 45dB, Aux, Tape, better than 45dB. IHF Hum and Noise: Phono: better than 70dB, Aux, better than 80dB. Input Sensitivity and Impedance (at rated output 1,000Hz): Phono: 2.5mV (50k ohms), Max. input capability 120mV RMS (THD: less than 0.5% distortion). Aux: 150mV (50k ohms). Tape Monitor (PIN): 150mV (50k ohms). Tuner FM Section: Tuning Range: 88 to 108MHz. Sensitivity (IHF) 2.5 μ V (DIN) 1.3 μ V (at 1,000Hz, 30% mod, S/N 26dB). THD: Mono less than 0.8%, Stereo less than 1.0%. S/N Ratio: better than 65dB. Selectivity: better than 60dB. Capture Ratio: less than 0.5dB. Image Frequency Rejection: better than 50dB at 98MHz. IF Rejection: better than 70dB at 98MHz. Spurious Response Rejection: better than 70dB at 98MHz. Spurious Radiation: less than 34dB. Stereo Separation: better than 35dB at 1,000Hz. Frequency Response: 30 to 12,000Hz + 1dB, —3dB. Antenna Input Impedance: 300 ohms balanced, 75ohms unbalanced. AM Section: Tuning Range: 535 to 1,605kHz. Sensitivity (Bar Antenna): 50dB/m at 1,000kHz. Selectivity (± 10 kHz): better than 40dB at 1,000kHz. Image Frequency Rejection: better than 80dB/m at 1,000kHz. IF Rejection: better than 80dB/m at 1,000kHz. Dimensions: 424 × 125 × 266mm. Price: £106.64 (plus VAT).

551

Audio Section: Music Power (IHF) 70 watts into 4 ohms at 1,000Hz, 50 watts into 8 ohms at 1,000Hz. THD: Overall (AUX to speaker terminals) less than 0.8% at rated power output. IHF Power Bandwidth: 25 to 30,000Hz at rated distortion. Frequency Response (at 1 watt): Overall (Aux to power output) 15 to 30,000Hz + 1.0dB. —2.0dB. RIAA Curve Deviation:

(Phono): +1.5dB —1.5dB (30 to 15,000Hz). Damping Factor: approximately 20 at 8 ohms load. Channel Separation (at rated output 1,000Hz), Aux, better than 45dB. Input Sensitivity and Impedance (at rated output 1,000Hz): Phono: 2.5mV (50k ohms), Max. input capability 90mV (THD: less than 0.5%). Aux: 150mV (50k ohms). Tape Monitor (PIN): 150mV (50k ohms). Tape Monitor (DIN): 150mV (50k ohms). Filter: High —10dB at 10,000 Hz (6dB/oct). Tuner FM Section: Tuning Range: 88 to 108MHz. Sensitivity (IHF) 2.5 μ V. THD: Mono less than 0.4%, Stereo less than 0.7%. S/N Ratio: better than 65dB. Selectivity: better than 60dB. Capture Ratio: less than 2.5dB. Image Frequency Rejection: better than 55dB at 98MHz. IF Rejection: better than 75dB at 98MHz. Spurious Response Rejection: better than 65dB at 98MHz. Spurious Radiation: less than 34dB. Stereo Separation: better than 40dB at 1,000Hz. Frequency Response: 30 to 15,000Hz. Antenna Input Impedance: 300 ohms balanced, 75ohms unbalanced. AM Section: Tuning Range: 535 to 1,605kHz. Sensitivity (Bar Antenna): 53dB/m at 1,000kHz. Selectivity (± 10 kHz): better than 30dB at 1,000kHz. Image Frequency Rejection: better than 80dB/m at 1,000kHz. Dimensions: IF Rejection: better than 80dB/m at 100 kHz. 424 × 135 × 285mm. Price: £139.34 (plus VAT).

661

Audio Section: Power Output (at rated distortion) continuous RMS power: both channels driven, 20W + 20W into 8 ohms (20-20,000Hz), 27W + 27W into 8 ohms at 1,000Hz; each channel driven, 40/40W into 4 ohms at 1,000Hz, 32/32W into 8ohms at 1,000Hz. Music Power (IHF) 110 watts into 4 ohms at 1,000Hz, 75 watts into 8 ohms at 1,000Hz. THD: Overall AUX to amp power output less than 0.5% at rated output. Power Bandwidth (IHF): 15—40,000Hz. Frequency Response Aux to power amp output 15—30,000Hz + 1.0dB. —2.0dB. Equalization. (at Rec out) RIAA Curve 30—15,000Hz \pm 1.0dB. Load Impedance: 4—16ohms. Damping Factor: approximately 60 at 8 ohms load. Channel Separation (at rated output 1,000Hz), Phono to power amp output: better than 45dB, Aux to power amp output, better than 45dB. Hum and Noise (IHF): Phono: to power amp output, better than 70dB, Aux to power amp output, better than 80dB. Input Sensitivity (for rated output at 1,000Hz): Phono: 2.5mV 50k ohms, Overload capacity: more than 150mV at 0.5% distortion. Aux: 100mV 50k ohms. Tape Monitor 1, 2 (4-ch) 100mV 50k ohms. Output Level: Tape Monitor (DIN): 30mV, (PIN):

100mV. Tuner FM: Tuning Range: 88 to 108MHz. Sensitivity (IHF) 2.2 μ V THD: Mono 0.5%, Stereo 0.7%. S/N Ratio: better than 60dB. Selectivity: better than 50dB. Capture Ratio: 2.5dB. Image Rejection: better than 55dB at 98MHz. IF Rejection: better than 60dB at 98MHz. Spurious Response Rejection: better than 60dB at 98MHz. Spurious Radiation: less than 34dB. Stereo Separation: better than 35dB at 400Hz. Frequency Response: 30 to 12,000Hz + .1dB, -3.0dB. Antenna Input Impedance: 300 ohms balanced, 75ohms unbalanced. AM: Tuning Range: 535 to 1,605kHz. Sensitivity (Bar Antenna): 50dB/m at 1,000kHz. Selectivity: better than 80dB at 1,000kHz \pm 10kHz. Image Frequency Rejection: better than 80dB/m at 1,000kHz. IF Rejection: better than 80dB/m at 1,000kHz.

General:

Voltage: 100, 117, 220, 240V 50/60Hz. Dimensions: 444 \times 135 \times 300mm. Price: £178.60 (plus VAT).

771

Audio Section: Power Output (at rated distortion) continuous RMS power: both channels driven 32W + 32W into 8 ohms (20—20,000Hz), 40W + 40W into 8 ohms at 1,000Hz, each channel driven 55/55W into 4 ohms at 1,000Hz, 45/45W into 8 ohms at 1,000Hz, Music Power (IHF) 140W into 4 ohms at 1,000Hz, 110W into 8 ohms at 1,000Hz. THD: Aux to power amp output less than 0.5% at rated output. Intermodulation Distortion (70Hz: 7,000Hz=4:1 SMPTE method) Aux to power amp output less than 0.5% at rated output. Power Bandwidth (IHF): 15 to 40,000Hz. Frequency Response: AUX to power amp output 15 to 30,000Hz +1.0dB. -2.0dB. Load Impedance: 4—16ohms. Damping Factor: approximately 60 at 8ohms load. Channel Separation (at rated output at 1,000Hz), Phono to power amp output, better than 45dB, Aux to power amp output, better than 45dB. Tuner FM: Tuning Range: 88 to 108MHz. Sensitivity (IHF) 2.0 μ V. THD: Mono 0.4%, Stereo 0.6%. S/N Ratio: better than 60dB. Selectivity: better than 60dB. Capture Ratio: 2.0dB. Image Rejection: better than 75dB at 98 kHz. IF Rejection: better than 90dB at 98MHz. Spurious Response Rejection: better than 80dB at 98MHz. Stereo Separation: better than 35dB at 400Hz. Frequency Response: 30 to 12,000Hz + 1.0dB, -3.0dB. AM: Tuning Range: 535 to 1,605kHz. Sensitivity (Bar Antenna): 50dB/m at 1,000kHz. Selectivity: better than 28dB at 1,000kHz \pm 10kHz. Image Frequency Rejection: better than 80dB/m at 1,000kHz. IF Rejection: better than 80dB/m at 1,000kHz. General: Voltage, 100,

117, 220, 240V 50/60Hz. Dimensions: 480 \times 135 \times 300mm Price: £221.69 (plus VAT).

881

Audio: Power Output: 60W per channel, min. RMS, both channels driven into 8 ohms from 20Hz to 20kHz, with no more than 0.3% total harmonic distortion. 64W per channel, min. RMS, both channels driven into 8 ohms at 1kHz, at rated total harmonic distortion. IHF Music Power total 150W into 8 ohms, total 200W into 4 ohms. Total Harmonic Distortion: Overall (Aux to speaker terminals) less than 0.3% at rated min. RMS power output. Power Bandwidth: 20 to 20,000Hz at rated min. RMS power output and total harmonic distortion. Load Impedance: 8 ohms. Frequency Response Overall (AUX to power output) 10 to 30,000Hz \pm 1.0dB. Damping Factor: approximately 45 at 8 ohms load. Tuner Section FM: Tuning Range: 88 to 108MHz. Sensitivity (IHF) 1.8 μ V. THD: Mono 0.3%, Stereo 0.5%. S/N Ratio: better than 70dB. Selectivity: better than 70dB. Capture Ratio: 1.5dB. Image Rejection: better than 75dB at 98MHz. IF Rejection: better than 90dB at 98MHz. Spurious Response Rejection: better than 80dB at 98MHz. Frequency Response: 30 to 15,000Hz + 0.5dB, -3.0dB. AM: Tuning Range: 535 to 1,605kHz. Sensitivity (Bar Antenna): 53dB/m at 1,000kHz. Selectivity: better than 30dB at 1,000kHz \pm 10kHz. Image Rejection: better than 80dB/m at 1,000kHz. IF Rejection: better than 80dB/ at 1,000kHz. Voltage: 100, 117, 220, 240V 50/60Hz. Dimensions: 480 \times 135 \times 300mm. Price: £286.78 (plus VAT).

8080

Audio Section: Power Output (at rated distortion). Music Power (IHF) 250W into 4 ohms at 1,000Hz, 230 watts into 8 ohms at 1,000Hz. Continuous RMS Power: both channels driven 110W per channel into 4 ohms at 1,000Hz, 90W per channel into 8 ohms at 1,000Hz, 80W per channel into 8 ohms from 20 to 10,000Hz, THD: Overall (Aux to speaker terminals) less than 0.2% at rated power output. Power Bandwidth (IHF): 5 to 45,000Hz at rated distortion. Frequency Response (at 1 watt): Overall (from Aux) 10Hz to 30kHz + 1.0dB, -1.0dB. Damping Factor: approximately 10 at 8 ohms load. FM Section: Tuning Range: 88 to 108MHz. Sensitivity (IHF) 1.7 μ V (DIN) 0.9 μ V. Quieting Slope (Mono): 3 μ 50dB. THD: Mono less than 0.2%, Stereo less than 0.3%. S/N Ratio (Mono): better than 70dB. Selectivity: better than 85dB. Capture Ratio: less than 1.5dB. Image Frequency Rejection: better than 75dB at 98MHz. IF Rejection: better than 100dB at 98MHz. Spurious Response

★ Indicates entry is illustrated

Rejection: better than 90dB at 98MHz. Stereo Separation: better than 40dB at 1,000Hz. Frequency Response: 30Hz to 15kHz + 0.5dB, -2dB. AM Section: Tuning Range: 535 to 1,605kHz. Sensitivity (Bar Antenna): 50dB/m at 1,000kHz. Selectivity: better than 50dB at 1,000kHz. Image Rejection: better than 80dB/m at 1,000kHz. IF Rejection: better than 80dB/m at 1,000kHz. General: AC Outlets: switched max. 100W, unswitched total 150W. Power Voltage: 100, 120, 220, 240V. 50/60Hz. Dimensions: 540 × 182 × 397mm. Price: £362.27 (plus VAT).

9090

Audio Section: Power Output (at rated distortion). Music Power (IHF) 450W into 4 ohms at 1,000Hz. 300 watts into 8 ohms at 1,000Hz. Continuous RMS Power: both channels driven 150W per channel into 4 ohms at 1,000Hz, 120W per channel into 8 ohms at 1,000Hz, 110W per channel into 8 ohms from 20 to 20,000Hz. THD: Overall (Aux to speaker terminals) less than 0.2% at rated power output. Power Bandwidth (IHF): 5 to 45,000Hz at rated distortion. Frequency Response (at 1 watt): Overall (from Aux) 10Hz to 30kHz + 1dB -1dB. Damping Factor: approximately 10 into 8 ohms load. FM Section: Tuning Range: 88 to 108MHz. Sensitivity (IHF) 1.7μV (DIN) 0.9μV. Quieting Slope: (mono): 3μV 50dB. THD: Mono less than 0.2%, Stereo less than 0.3%. S/N Ratio (Mono): better than 70dB. Selectivity: better than 85dB. Capture Ratio: less than 1.5dB. Image Frequency Rejection: better than 75dB at 98MHz. IF Rejection: better than 100dB at 98MHz. Spurious Response Rejection: better than 90dB at 98MHz. Stereo Separation: better than 40dB at 1kHz. Frequency Response: 30Hz to 15kHz + 0.5dB, -2dB. AM Section: Tuning Range: 535 to 1,605kHz. Sensitivity (Bar Antenna): 50dB/m at 1,000kHz. Selectivity: better than 50dB at 1,000kHz. Image Rejection: better than 80dB/m at 1,000kHz. IF Rejection: better than 80dB/m at 1,000kHz. General: AC Outlets: switched max. 100W, unswitched total 150W. Power Voltage: 100, 120, 220, 240V. 50/60Hz. Dimensions: 540 × 182 × 397mm. Price: £398.32 (plus VAT).

■ SHARP

Sharp Electronics (UK) Ltd,
107 Hulme Hall Lane,
Manchester M10 8HL.
Tel: 061-205 7321.

SA606

Stereo AM/FM tuner/amplifier. Range: FM 88-108MHz, MW 189-560m, LW 1000-2000m,

SW 16-50m. Variable tuning plus FM presets. AFC. Ratio detector. Meter tuning indicator. Usable sensitivity: FM 5μV, AM 100μV. Aerial input: 300 ohms balanced. Decoder included. Output: 4W RMS per channel DIN. Output impedance: 8 ohms. Mains: 110, 220, 240V AC. Finish: Cabinet PVC laminated veneer, front panel aluminium. Size: 18¾ × 13¾ × 4½in. Price: £111.96 (plus VAT).

■ SKANTIC (UK) LTD.

Station Road, Edenbridge,
Kent TN8 6EY.

Tel: Edenbridge 5231.

39342

Four band receiver with FM/L/M/S. FM section has pushbutton selection of 4 pre-set stations and stereo decoder. Record player with ceramic cartridge. Output 2 × 10 watts RMS. Pair of Hi-Fi 2-unit loudspeakers. Ready for connection to an Ambiophonic box. Available in teak, rosewood, walnut, white or black lacquer. Technical specifications and price: on application.

■ SONAB LTD

214 Harlequin Avenue, Brentford,
Middlesex TW8 9EW.

Tel: 01-568 2952.

R3000

Amplifier

Power Output: 2 × 28 watts RMS into 8 ohms both channels driven. THD: less than 0.1%. FR: 30-20,000Hz. Power bandwidth: 30-20,000Hz. Inputs: DIN, Mag P/U, Aux, tape monitor. Tape output (DIN): 100 mV/10k ohms. Treble filter.

Tuner

Sensitivity FM: DIN 3.0 μV. Capture ratio: 1dB. Spurious Rejection FM: 50dB. Stereo separation. 30dB. Pilot tone rejection: 30dB. Pilot harmonic rejection: 35dB. THD stereo: 0.4%. Waveband coverage: 87.5-108mHz.

General

Dimensions: 43.5 × 35 × 9.7cm. Black finish. Price: £195.00 (plus VAT).

R4000

Amplifier

Power Output: 2 × 40 watts RMS into 8 ohms both channels driven. THD: less than 0.1% at 1 kHz 35 watts. FR: 15-25,000Hz. Power bandwidth: 15-25,000Hz. Damping factor: 100. Inputs: DIN, Magnetic P/U, Aux, tape monitor. Overload capability: p/u input over-

load greater than 36dB. Tape output (DIN): 150 mV/10k ohms. Crosstalk: at 1 kHz better than 50dB at 20-10,000Hz better than 40dB.

Tuner

Sensitivity FM: better than $1.0\mu\text{V}$ (75 ohms) according to DIN. Capture ratio: 2dB. Image rejection: better than 65dB. Spurious rejection FM: better than 55dB. IF rejection FM: better than 65dB. Stereo separation better than 30dB. THD stereo: less than 0.3%. Waveband coverage: 87.5-104MHz.

General

Dimensions: 47.5 × 25 × 11cm. Black finish. Price: £230.00 (plus VAT).

■ SONY

Sony (UK) Ltd, Pyrene House,
Sunbury Cross, Sunbury-on-Thames.
Tel: Sunbury 87644.

STR 7055A ★

AM/FM stereo tuner/amplifier. Tuning range: FM 87.5MHz, AM 530-1605kHz. Output: 40W RMS per channel, both channels operating into 8 ohms at 20Hz. Power bandwidth: 15Hz-35kHz. HD: less than 0.2% at rated output. Inputs: phono 3mV 47K, all other inputs 250mV 50K. S/N ratio: phono 72dB, aux 1, 2 90dB, tape 90dB. Damping factor: 50. Tone controls: bass $\pm 10\text{dB}$ at 100Hz, treble $\pm 10\text{dB}$ at 10kHz. Mains: 110, 127, 220, 240V AC 50/60Hz. Size: 440 × 148 × 375mm. Price: £185.14 (plus VAT).

STR 7065A ★

AM/FM stereo tuner/amplifier. Tuning range: FM 87.5-108MHz, AM 530-1605kHz, Output: 50W RMS per channel, both channels operating into 8 ohms at 20Hz-20kHz. Power bandwidth: 15Hz-35kHz. HD: less than 0.2% at rated output. S/N ratio: 110dB. Inputs: phono 3mV 47K, mic 1.6mV 47K, all other inputs 250mV 50K. Aerial terminals: 300 ohms balanced, 75 ohms unbalanced. Damping factor: 50. Mains: 110, 127, 220, 240V AC 50/60Hz. Size: 440 × 148 × 375mm. Weight: 16.9kg. Price: £231.43 (plus VAT).

STR 7015 ★

Amplifier

Power Output: 15W per channel. THD: 0.8% at 1kHz rated output power. 0.1% at 1kHz, 1W output power. Power Bandwidth: 10-25,000Hz. Damping factor: 25 (8 ohms) at 1 kHz. Inputs: phono, mic, aux, tape, DIN

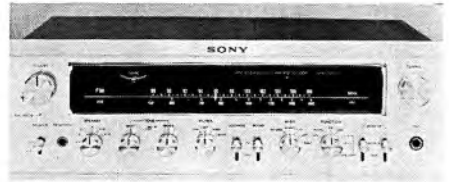

Sony STR 7055A



Sony STR 7065A



Sony STR 7015

Tuner

Sensitivity FM: $2.2\mu\text{V}$ IHF. Sensitivity AM: 48dB/m built-in aerial. Capture ratio: 3dB. Image Rejection FM: 55dB. Image Rejection AM: 56dB at 1,000kHz. Spurious Rejection FM: 78dB. IF Rejection FM: 90dB. Stereo separation: 35dB at 400Hz. THD stereo: 0.8% at 400Hz. Waveband coverage: 87.5-108MHz, 530-1,605kHz.

General

Dimensions: 42.7 × 34.5 × 14.9cm. Brushed aluminium fascia and walnut case. Price: £111.96 (plus VAT).

STR 7025

Amplifier

Power Output per channel: 18W. THD: 0.8 at 1kHz, 0.17 at 1kHz. Power bandwidth: 10-25,000Hz. Other main specs as per STR 7015. Price: £127.96 (plus VAT).

STR 7035

Amplifier

Output: 24W per channel. Other main specs as per STR 7015. Price: £146.96 (plus VAT).

★ Indicates entry is illustrated

■ **J. E. SUGDEN & CO. LTD.**

Carr Street, Cleckheaton,
West Yorkshire.
Tel: Cleckheaton 872501

AR 48★

Amplifier

Power Output: 45W RMS per channel. THD: less than 0.1%. Total music power: 190W. FR: 30-20,000Hz. Power bandwidth: 8-35,000kHz. Damping factor: 32. Inputs disc (2), tape (2). Scratch filter, rumble filter. Crosstalk: approx. 40dB.

Tuner

Sensitivity FM: 2.0 μ V. Capture Ratio: 2.5dB. Image rejection FM: 70dB. IF Rejection FM: 80dB. Stereo separation: 30dB. Pilot tone rejection: 40dB. Pilot harmonic rejection: <60dB. THD: stereo: 0.25% at 30% mod. Waveband coverage: 88-108MHz.

General

Dimensions: 56 × 28 × 13cm. Price: £199.20 (plus VAT).

■ **TANDBERG (UK) LTD.**

Farnell House, 81 Kirkstall Road,
Leeds LS3 1HR.
Tel: Leeds 35111.

Huldra 10 ★

AM/FM stereo tuner/amplifier. Range: FM 87.5-108MHz, MW 187-579m, LW 1120-2000m, SW1 30-90m, SW2 15-30m, SW3 10-15m. Variable tuning plus four presets. AFC. Meter tuning indicator. Usable sensitivity: FM 1 μ V, AM 2 μ V. Aerial input: 75 ohms coaxial. Stereo decoder fitted. Inputs: mag PU 2mV 47K, tape 200mV 100K. Noise level: -70dB. Overload capability: 25dB. Output: 35W RMS per channel. Controls: bass \pm 17.5dB at 50Hz, treble \pm 15dB at 10kHz, loudness +12dB at 50Hz. HD: 0.2% at 35W RMS. Output impedance: 4-8 ohms. FR: 20Hz-20kHz \pm 2dB. Mains: 220-240V 50-60Hz. Size: 21 × 4 $\frac{3}{4}$ × 12in. Finish: teak or rosewood cabinet with black dials and satin finished metal panel. Outputs for four speakers. Quiet tuning facility. Price: (teak or rosewood) £212.50 (plus VAT).

TR1055 ★

FM/AM stereo tuner/amplifier. Output: 55W RMS per channel, both channels driven into 8 ohms. Tuning range: FM 87.5-108MHz, AM 518-1600kHz. Variable tuning. Tone controls: treble \pm 15dB at 10kHz, bass \pm 16dB at 50Hz, loudness +7dB/ \pm 12dB at 10kHz/50Hz. Sig-



J. E. Sugden AR48



Tandberg Huldra 10



Tandberg TR-1055



Tandberg TR 220

nal/hum and noise: tape (1 and 2) 82dB 250mV. Separate bass and treble controls for each channel. Size: 17 $\frac{1}{2}$ × 5 × 12 $\frac{1}{4}$ in. Finish: walnut. Price: £245.00 (plus VAT).

TRP1040P

Stereo FM receiver/amplifier. Pre-tuning for five stations. Output: 40W RMS per channel, both channels driven into 8 ohms. Tuning range: 87.5-108MHz FM. Treble control \pm 15dB at 10kHz, bass \pm 16 dB at 50Hz. Size: 17 $\frac{1}{2}$ × 5 $\frac{3}{8}$ × 12 $\frac{1}{4}$ in. Price: £205.00 (plus VAT).

TR 220 ★

Amplifier

Power Output: 13W. THD: 0.2%. Total music power 20W. FR: 30-30,000Hz.

Tuner

Sensitivity FM: 20 μ V. Capture Ratio: 1.3dB. Image rejection FM: 70dB. IF rejection FM: 95dB. THD stereo: 0.4%. Waveband coverage: 87.5-108MHz.

General

Dimensions: 56.7 \times 11.7 \times 31.2cm. Teak or rosewood finish. Price: £130.00 (plus VAT).

Solysuper 12**Amplifier**

Power Output: 12W. THD: 0.2%. Total music power: 20W. Power bandwidth: 30-25,000Hz. Damping factor: 30 at 1kHz.

Tuner

Sensitivity FM: 40 μ V. Sensitivity AM: 50 μ V. Capture Ratio: 1.5dB. Image rejection FM: 46dB. Image rejection AM: 46dB. IF Rejection: 90dB. Stereo separation: 40dB. Pilot Tone rejection: 50dB. THD stereo: 0.5%.

General

Dimensions: 49.5 \times 11.7 \times 25.7cm. Teak or rosewood finish. Price: £136.00 (plus VAT).

TR 2075**Amplifier**

Power output: 75W per channel. THD: 0.08%. Total music power: 100W. FR: 6-80,000Hz. Inputs: Tape (2), phono. Loudness compensation button.

Tuner

Sensitivity FM: 20 μ V. Sensitivity AM: 20 μ V. Capture ratio: 0.9dB. Image rejection FM: 70dB. Image rejection AM: 70dB. IF rejection FM: 95dB. Stereo separation: 40dB. Pilot Tone rejection: 70dB. THD stereo: 0.15%. Waveband coverage: 87.5-108MHz.

General

Dimensions: 51 \times 15.3 \times 35.3cm. Teak or rosewood finish. Price: £236.00 (plus VAT).

TEAC

Teledyne Acoustic Research, High Street, Houghton Regis, Dunstable, Beds.
Tel: Dunstable 603151.

AG 6500**Amplifier**

Power output: 50/50 RMS. THD: 0.05% into 8 ohms. Total music power: 80W both channels operating. Power bandwidth: 10-40,000Hz. Inputs: Aux, phono. Scratch filter, rumble filter.

Tuner

Sensitivity FM: 1.8 μ V (IHF). Sensitivity AM: 200 μ V (IHF). Capture Ratio: below 2.0dB.

Image rejection FM: 85dB. Image rejection AM: 60dB. Price: £299.00 (plus VAT).

TELEFUNKEN

AEG-Telefunken (UK) Ltd, Bath Road, Slough.
Tel: Slough 33311.

Hymnus 5050

FM/AM stereo receiver. Bands: 88-108MHz (FM), 145-330kHz (LW), 515-1645kHz (MW), 5.75-15.55MHz (SW). Seven presets plus manual tuning. Signal strength meter. Sensitivity: 2.4 μ V DIN (FM), 20 μ V DIN (AM). Aerial: 240 ohms. Inputs: phono 1.8mV 47K, phono (ceramic) 240mV 470K, tape, 240mV 470K. Outputs: 2 \times headphones, 6 \times loudspeakers (4-16 ohms), tape 1.7mV. Power output: 30W per channel. THD: 0.5%. FR: 20Hz-20kHz \pm 5dB. Selector switches for four speakers, room 1 (four channel stereo); two speakers, room 2. Adjustable muting. Price: £225 (including VAT).

Concerto 4040

FM/AM stereo receiver. Bands: 87.6-108MHz (FM), 520-1630kHz (MW), 5.75-15.55MHz (SW), 145-330kHz (LW). Output: 22W RMS per channel. Five presets plus manual tuning. Signal strength meter. Sensitivity: 2.4 μ V DIN (FM), 8 μ V DIN (SW), 12 μ V DIN (MW), 30 μ V (LW). Inputs: phono (mag) 3mV 47K, phono (ceramic) 220mV 600K, tape 220mV 600K. Outputs: headphones >200 ohms, speakers 4 ohms, tape 700mV/K. Power output: 40W per channel. FR: 20Hz-20kHz. Size: 21 $\frac{3}{4}$ \times 4 $\frac{3}{4}$ \times 10 $\frac{1}{2}$ in. Price: £178 (including VAT).

Electronic centre 6001 hifi

4 wavebands: FM, MW, LW, SW. 7 FM pre-selectors. Sensor switches for all functions (16). 7 rocker switches. Incorporates S500 record player. 2 \times 35W. 6 loudspeaker sockets 4 ohms. 2 headphone sockets. Input: phono (mag) 2.5mV/47K. Input: ceramic (200mV/600K. Input: tape recorder 200mV/600K. FR: 22Hz-20,000kHz \pm 5dB. Distortion factor: \leq 0.2%. Price: £475.00 (including VAT).

Compact Centre 6002

4 wavebands: FM, MW, LW, SW. 7 FM presets. 13 sensor functions. 12 rocker switches. Incorporates MC 3300 cassette recorders. Other information as 6001. Price: £549.00 (including VAT).

Opus 6060

4 wavebands: FM, MW, LW, SW (AFC). 7 FM

★ Indicates entry is illustrated

presets with 7 sensor controls. Other tuner spec. as Hymnus 5050. $2 \times 35W$ RMS. Inputs: phono (mag) $2.5mV/47K$, (crystal) $200mV/600K$. Tape $200mV/600K$. 6 speaker sockets 4 ohms. 2 headphone sockets. Servo-tonic selector switch filters. Linear, rumble and monitor. Price: £265.00 (including VAT).

Quadro 1000

Tuner specification as Hymnus 5050. Built in SQ matrix decoder. External connection of a CD4 system possible. Output on stereo: $2 \times 30W$ RMS. Output on quadro: $4 \times 15W$ RMS. Price: £318.00 (including VAT).

Allegretto 1010

Amplifier

Power output: $2 \times 10W$. Total music power: $2 \times 10W$. Inputs for tape recorder, p/u, loudspeaker, dipole and aerial. Bass-treble tone controls.

Tuner

Wavebands: FM, L, M, S.

General

Dimensions: $48 \times 21 \times 11cm$. Light wood and matt walnut. Price: £108.80 (plus VAT).

Concertino 3520

Amplifier

Power output: $2 \times 35W$. Total music power: $2 \times 10W$. Inputs for tape recorder, p/u, loudspeakers, dipole and aerial. Bass and treble controls.

Tuner

Wavebands: FM, L, M, S.

General

Dimensions: $54.7 \times 27 \times 11.8cm$. Light matt walnut with black side panels or white with black side panels. Price: £137.60 (plus VAT).

Opus 1050

Amplifier

Power output: $2 \times 70W$. Total music power: $2 \times 50W$. FR: 20-22,000Hz. Inputs for tape, p/u, loudspeakers, headphone, monitor. Rumble filters.

Tuner

Waveband: FM, L, M, S.

General

Dimensions: $61.8 \times 30 \times 11.8cm$. Light matt walnut, black side panels or white or black and silver. Price: £246.40 (plus VAT).

Stereoline 1010

Amplifier

Power output: $2 \times 10W$. Inputs: p/u, tape, speaker, headphones, monitor. Bass and treble controls.

Tuner

Waveband: FM, L, M, S.

General

Dimensions $49.8 \times 24.4 \times 10.5cm$. Light matt walnut or white finish. Price: £119.20 (plus VAT).

TELETON

Teleton Electro (UK) Company Ltd, Teleton House, Waterhouse Lane, Chelmsford, Essex CM1 3DW.

Tel: Chelmsford 62442.

TA 3000 ★

AM/FM stereo tuner/amplifier. Tuning range: FM 87.5-104MHz. AM 510-1605kHz. Aerial impedance: FM 300 ohms. Sensitivity: FM $10\mu V$. Crosstalk: $-46dB$. Output: 7W per channel. THD: 0.3% at 3.5W. FR: 20Hz-20kHz $\pm 1.5dB$. Inputs: phono mag 3mV, aux 200mV, tape 250mV. Tone controls: bass $\pm 11dB$ at 100Hz, treble $\pm 11dB$ at 10kHz. H and N: less than 20mV. Mains: 115/240V AC 50/60Hz. Size: $120 \times 417 \times 310mm$. Price: on application.



Teleton TA 3000

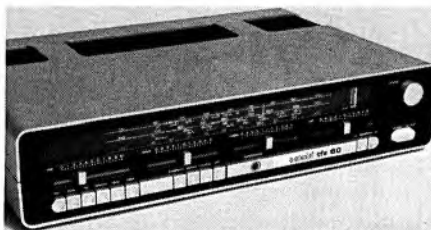

Teleton TFS 60

TFS 60 ★**Amplifier**

Output power: continuous sine wave both channels driven 15W per channel. Dynamic music power 25W per channel. HD: 0.4% at 10W. FR: 30Hz-25kHz ± 1.5 dB. Input sensitivity: phono mag 3mV, aux 200mV, tape 200mV. Tone control: bass ± 13 dB (100Hz), treble ± 13 dB (10kHz). Hum and noise: volume max. mag 30mV, others 15mV. Crosstalk: 40dB at 1kHz. -35 dB at 250Hz-10kHz. Damping factor: 30.

Tuner

Wavebands: VHF/FM87.5-104.5MHz. MW 510-1630kHz. LW 145-350kHz. Aerial impedance: FM 300 ohms. Sensitivity: VHF/FM 2.5 μ V for 30dB S/N ratio on mono (measured at 22.5kHz dev.). Image rejection: FM -45 dB. Capture ratio: 4dB. Crosstalk: 28dB at 1kHz. Power requirements: 115/240V A.C. 50/60Hz, 130W max. Dimensions: 107 \times 495 \times 330mm. Price: on application.

TFS 70**Amplifier**

Output power: Continuous sine wave both channels driven 30W per channel. Dynamic music power 50W per channel. HD: 0.4% at 6W. FR: 30Hz-25kHz ± 1.5 dB (Ref 1kHz). Input sensitivity: phono mag 3mV, xtal phono 250mV, aux 200mV, tape 350mV. Tone control: Bass ± 13 dB (100Hz), treble ± 11 dB (10kHz). Hi cut filter: -8 dB at 10kHz. H & N: (volume max) mag 50mV, others 30mV. Crosstalk: 55dB at 1kHz -45 dB, 205Hz -10 kHz. Damping factor: 20.

Tuner

Wavebands: VHF/FM 87.5-104.5MHz. SW 5.8-12.5MHz. MW 510-1710kHz. LW 145-350kHz. Aerial impedance: FM 300 ohms. Sensitivity: VHF/FM 2.5 μ V for 30dB S/N ratio on mono (measured at 75kHz dev.). SW 450 μ V/m for 20dB S/N ratio. MW 350 μ V/m for 20dB S/N ratio. LW 750 μ V/m for 20dB S/N ratio. Image rejection: FM -70 dB. Capture ratio: 3dB at 22.5kHz deviation. Power requirements: 120/240V. AC 50/60Hz 200W max. Dimensions: 107 \times 490 \times 331mm. Price: on application.

TA 3000 Stereo Tuner Amplifier**Amplifier**

Output power: continuous sine wave both channels driven 7W per channel. Dynamic music power, 9W per channel. HD: 0.3% at 3.5W. FR: 20Hz-20kHz ± 1.5 dB (Ref. 1kHz). Input sensitivity: phono mag 3mV, aux

*Toshiba SA-220L*

200mV, tape 250mV. Tone control: bass ± 11 dB (100Hz), treble ± 11 dB (10kHz). H & N: less than 20mV (volume, bass, treble, max). Crosstalk: -40 dB at 1kHz, -30 dB 250Hz-10kHz. Damping factor: 20.

Tuner

Wavebands: VHF/FM 87.5-104MHz. MW 510-1605kHz. Aerial impedance: FM 300 ohms. Sensitivity: VHF/FM 10 μ V for 30dB S/N ratio on mono (measured at 22.5kHz dev.). Image rejection: 46dB. Crosstalk: 30dB at 1kHz. Power requirements: 115/240V AC 50/60Hz. Dimensions: 120 \times 417 \times 310mm. Price: on application.

■ TOSHIBA (UK) LTD

Toshiba House, Great South West Road, Feltham, Middlesex.
Tel: 01-751 1281.

SA-220L ★**Amplifier**

Power output: 11W \times 2 RMS at 8 ohms. THD: 0.8%. Total music power: 32W. FR: 30-30,000Hz. Power bandwidth: 20-50,000Hz. Damping factor: 30 (8 ohms 1kHz). Inputs for phono, tape, aux. Overload capability: 90mV 0.08%. Tape output (DIN): 30mV. Bass and treble tone controls.

Tuner

Sensitivity FM: 2.3 μ V. Sensitivity AM: 15 μ V. Capture ratio: 3.5dB. Image rejection FM: 55dB. Image rejection AM: 45dB. Spurious rejection FM: 70dB. IF rejection FM: 70dB. Stereo separation: 35dB. THD stereo: 0.8%. Waveband coverage: FM, L, M, S.

General

Dimensions: 44.5 \times 27 \times 13cm. Woodgrain finish. Price: on application.

SA-320L**Amplifier**

Power output: 15W \times 2 RMS. THD: 0.8%

★ Indicates entry is illustrated

rated. Total music power: 50W. FR: 30-30,000Hz. Power bandwidth: 10-60,000Hz. Inputs for phono, tape, aux. Overload capability: 100mV at 8%. Tape output (DIN) 30mV. Bass and treble controls. Loudness: +10dB +5dB. Scratch filter.

Tuner

Sensitivity FM: 1.9 μ V. Sensitivity AM: 15 μ V. Capture ratio: 1.0dB. Image rejection: 60dB. Image rejection AM: 40dB. Spurious rejection: 75dB. IF rejection AM: 90dB. Stereo separation: 40dB. Pilot tone rejection. 40dB. Pilot harmonic rejection: 40dB. THD stereo: 0.4%. Waveband coverage: FM, L, M.

General

Dimensions: 50 × 38.7 × 16.3cm. Woodgrain finish. Price: on application.

SA-420

Amplifier

Power output: 25W × 2 RMS. THD: 0.4% rated. Total music power: 70W. Other details as per SA320L plus rumble filter. Tuner and General details as per SA-320L.

SA-520

Amplifier

Power output: 40W × 2RMS at 8 ohms. THD: 0.4% rated. Total music power: 100W. FR: 20-30,000 Hz. Power bandwidth: 5-60,000 Hz. Damping Factor: 45 (8) ohms at 1kHz. Inputs: phono, tape, aux. Overload capability: 150mV 0.4% THD. Tape output (DIN) Tape 2 30mV. Scratch and rumble filters.

Tuner

Sensitivity FM: 1.8 μ V. Sensitivity AM: 15 μ V. Capture ratio: 1.0dB. Image rejection AM: 40dB. Spurious rejection FM: 100dB. IF rejection FM: 100dB. Stereo separation: 40dB. Pilot tone rejection: 40dB. THD stereo: 0.4%. Waveband coverage: FM, M.

General

Dimensions: 53 × 38.7 × 16.3cm. Woodgrain finish. Price: on application.

SA-620

Amplifier

Power output: 60W × 2 RMS. THD: 0.4% rated. Total music power: 140W. Other details as per SA-520.

■ TRIO

Distributors: B. H. Morris & Co (Radio) Ltd, Trio House, The Hyde, London NW9 6JP. Tel: 01-205 6441.

KR 2600

Amplifier

Power output: 15 + 15W. THD: 0.8% at rated power. Power bandwidth: 10-70,000Hz. Damping factor: 30 at 8 ohms. Inputs for phono, aux, tape. Overload capability: phono 140mV. Scratch filter.

Tuner

Sensitivity FM: 2.5 μ V. Sensitivity AM: 25 μ V. Capture ratio: 2.5dB. Image rejection FM: 50dB. Image rejection AM: 45dB. Stereo separation: 33dB at 1kHz. Pilot tone rejection: 40dB. THD stereo 0.5%. Waveband coverage: 88-108MHz, 535-1,600kHz.

General

Dimensions: 44 × 30 × 136cm. Teak finish. Price: to be announced.

KR 3600

Amplifier

Power output: 22 +22W. THD: 0.8% at rated power. Power bandwidth: 7-35,000kHz. Damping factor: 35 at 8 ohms. Inputs: phono, aux, tape. Overload capability: phono 150mV. Tape output (DIN): 30mV. Scratch filter.

Tuner

Sensitivity FM: 2.3 μ V. Sensitivity AM: 25 μ V. Capture ratio: 2dB. Image rejection FM: 50dB. Image rejection AM: 45dB. Spurious rejection FM: 80dB. IF rejection FM: 90dB. Stereo separation: 35dB from 50-10,000Hz. Pilot tone rejection: 40dB. THD stereo: 0.4%. Waveband coverage: 88-108mHz FM.

General

Dimensions: 50 × 30 × 14cm. Brushed aluminium finish. Price: to be announced.

JR 4600

Amplifier

Power output: 30 +30W. THD: 0.8% at rated power. Power bandwidth: 7-35,000Hz. Damping factor: 40 at 8 ohms. Inputs: phono (2), aux, tape (2). Overload capability: phono 170mV. Tape output (DIN): 30mV at 80K ohms. Scratch filter.

Tuner

Sensitivity FM: 1.8 μ V. Sensitivity AM: 20 μ V. Capture ratio: 1.5dB. Image rejection: 85dB. Image rejection AM: 45dB. Spurious rejection FM: 85dB. IF rejection FM: 100dB. Stereo separation: 35dB from 50-10,000Hz. THD stereo: less than 0.25%. Waveband coverage: 88-108MHz, 535-1.600kHz.

General

Dimensions: 50 × 34 × 14cm. Brushed aluminium finish. Price: to be announced.

KR 5600**Amplifier**

Power output: 40 + 40W. THD: 0.5% at rated power. Power bandwidth: 7-35,000Hz. Damping factor: 40 at 8 ohms. Inputs: phono (1) (2), aux, tape (A), (B). Overload capability: mono 170mV. Tape output (DIN): 30mV at 80 K. Scratch filter.

Tuner

Sensitivity FM: 1.8 μ V. Sensitivity AM: 20 μ V. Capture ratio: 1.5dB. Image rejection FM: 85dB. Image rejection AM: 45dB. Spurious rejection FM: 85dB. IF rejection FM: 100dB. Stereo separation: 35dB from 50Hz-10,000Hz. THD stereo: less than 0.25%. Waveband coverage: 88-108MHz, 535-1,600kHz.

General

Dimensions: 50 x 34 x 14cm. Brushed aluminium finish. Price: to be announced.

KR 7600**Amplifier**

Power output: 80 + 80W. THD: 0.3% at rated power. Power bandwidth: 7-50,000Hz. Damping factor: 45 at 8 ohms. Inputs for phono (2), aux, mic, tape (2). Overload capability: phono 180mV. Tape output (DIN): 30mV at 8 ohms. Scratch filter. Rumble filter.

Tuner

Sensitivity FM: 1.7 μ V. Sensitivity AM: 20 μ V. Capture ratio: 1.5dB. Image rejection FM: 85dB. Image rejection AM: 45dB. Spurious rejection AM: 85dB. IF rejection FM: 100dB. Stereo separation: 40 at 1,000kHz. Pilot tone rejection: 65dB. THD stereo: less than 0.25%. Waveband coverage: 88-108MHz, 535-1,600kHz.

General

Dimensions: 53 x 37 x 15cm. Brushed aluminium finish. Price: to be announced.

VIDEOTONE

Perdix Components, 98 Crofton Park Road, London SE4.
Tel: 01-690 1914.

VRI/VA1**Amplifier**

Power output: 18W RMS into 8 ohms, 20-20kHz. THD: >0.1%. FR: 25-20,000Hz. Damping factor: 50 at 1kHz. Inputs: tape, tuner, aux. Overload capability: 30dB. Tape output (DIN): 100mV average. Scratch filter. Rumble filter. Crosstalk: 40dB.

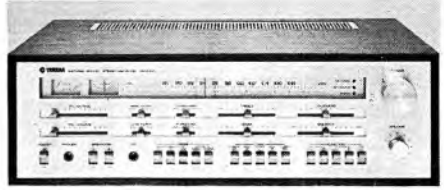

Yamaha CR 1000

Tuner

Sensitivity FM: 1.5 μ V for 26dB S/N. Sensitivity AM: 2 μ V for 20dB S/N. Capture ratio: 2dB. Image rejection AM: 60dB. Spurious rejection FM: 50dB. Stereo separation: 40dB. Pilot tone rejection: 45dB. Frequency coverage: 87.5-108MHz. Price: to be announced.

YAMAHA

Natural Sound Systems Ltd,
Strathcona Road, North Wembley,
London HA9 8QL.
Tel: 01-904 0141.

CR400

FM/AM stereo receiver. Bands: 88-108MHz (FM), 550-1600kHz (MW). Sensitivity: 2.5 μ V (IHF) (FM). Auto-touch AFC (off when tuning knob touched) signal strength and tuning meters. Aerial: 75 and 300 ohms. Inputs: phono 3mV 50K, mic 3mV 50K, tape A & B 150mV 100K. S/N: phono 72dB, mic 65dB, tape 85dB. Outputs: 16W per channel into 8 ohms, 20Hz-20kHz. Damping factor: 40. THD: 0.07% at any power up to full rated power. FR: 20Hz-50kHz + 0.5dB -3dB. Size: 17 $\frac{1}{2}$ x 6 $\frac{1}{4}$ x 11 $\frac{3}{4}$ in. Price: £141.60 (plus VAT).

CR1000 ★

FM stereo receiver. Bands: 88-108MHz. Manual tuning, auto-touch AFC (off when tuning knob touched), signal strength and tuning meters. Sensitivity: 1.7 μ V (IHF) (FM). Aerial: 75 and 300 ohms. Inputs: phono (1 & 2) 3mV 50K, mic 3mV 50K, tape 150mV 40K. S/N: phono 80dB, mic 70dB, tape 90dB. Outputs: 70W per channel into 8 ohms, 20Hz-20kHz. Damping factor: 70. THD: <0.04% at any power up to rated output. FR: 10Hz-50kHz + 0.5dB -1dB. Size: 20 x 6 $\frac{1}{4}$ x 13 $\frac{1}{4}$ in. Five gang front end, variable muting and loudness. Price: £399.20 (plus VAT).

CR800

FM/AM stereo receiver. Bands: 88-108MHz (FM), 550-1600kHz (MW). Manual tuning, auto-touch AFC (off when tuning knob touched), signal strength and tuning meters. Sensitivity: 1.7 μ V (IHF) (FM). Aerial: 75 and 300 ohms. Inputs: phono (1 & 2) 3mV 50K, mic

★ Indicates entry is illustrated

3mV 50K, tape A & B 150mV 45K. S/N: phono 75dB, mic 70dB, tape 90dB. Output: 45W per channel into 8 ohms, 20Hz-20kHz. THD: <0.06%. FR: 10Hz-50kHz +0.5dB -1dB. Size: 18¾ × 6¼ × 11¾. Price: £266.40 (plus VAT).

CR600

FM/AM stereo receiver. Bands: 88-108MHz (FM), 550-1600Hz (MW). Manual tuning, auto-touch AFC (off when tuning knob touched), signal strength and tuning meters. Sensitivity: 2.0µV (IHF) (FM). Aerial: 75 and 300 ohms. Inputs: phono (1 & 2) 3mV 50K, mic 3mV 50K, tape A & B 150mV 100K. S/N: phono 72dB, mic 70dB, tape 90dB. Output: 16W per channel into 8 ohms at 1kHz. Damping factor: 70. THD: 0.06%. FR: 10Hz-50kHz +0.5dB -1dB. Size: 18¾ × 6¼ × 11¾in. Price: £204 (plus VAT).

CR200

Amplifier

Power output: 15 + 15W. THD: <0.1%. Power bandwidth: 20-50,000. Damping factor: 40. Inputs for phono, tape, aux. Overload capability: 135mV. Tape output (DIN) 150mV (50K ohms).

Tuner

Sensitivity FM: 2.5µV. Sensitivity AM: 52dB. Capture ratio: 2.0dB. Image rejection FM: 55dB. IF rejection FM: 75dB. Stereo separation: 40dB. THD stereo: 0.3%. Waveband coverage: 88-108MHz. 525-1,605kHz.

General

Dimensions: 40 × 29.3 × 13.3cm. Simulated American walnut finish. Price: £99.95 (plus VAT).

CR450

Amplifier

Power output: 25 + 25W. THD: <0.1%. FR: 20-20,000Hz. Damping factor: >50. Inputs for phono, tape, aux. Overload capability: 150mV. Tape output (DIN): 150mV (<500 ohms). Scratch filter. Rumble filter. Crosstalk: 65dB.

Tuner

Sensitivity FM: 1.5µV. Sensitivity AM: 50dB. Capture ratio: 1.5dB. Image rejection FM: 45dB. Image rejection AM: 40dB. Spurious rejection, FM: 45dB. IF rejection, FM: 60dB. Stereo separation: 40dB. Pilot tone rejection: 40dB. THD stereo: >0.3%. Waveband coverage: 88-108MHz. 525-1,605kHz.

General

Dimensions: 46.5 × 33.5 × 15.7cm. American walnut finish. Price: £168.00 (plus VAT).

Record Decks

★ Indicates entry is illustrated

Abbreviations used in this section are given on page 27.

■ ACOS

Cosmocord Ltd, Eleanor Cross Road,
Waltham Cross, Herts EN8 7NX.
Tel: Waltham Cross 27331.

Rega

Modern planetoid design replaces conventional turntable thus providing reduced static attraction for airborne dust. Dimensions: 44.5 × 35.6 × 12.7cm. Motor: 24 pole synchronous 200/250V AC. 50Hz (FA 9159) or 90/120V AC 60Hz (FA 9164). Belt drive. Speeds: 33 $\frac{1}{3}$, 45 rpm. Power consumption: less than 4W. Manual on/off switch. W and F: 0.08%. Rumble typically 43dB unweighted, 65dB weighted. Pickup arm. Overall length: 330mm. Effective length: 237mm. Overhang: 15mm. Offset angle: 21°. Tracking error angle less than 1.5°. Stylus pressure up to 3gm. Direct reading magnetic repulsion bias compensation. Low capacity connecting leads fitted with phono plugs. Accepts all cartridges with 12.5mm fixing centre.

■ ADC

BSR Ltd, Powke Lane, Cradley Heath,
Warley, West Midlands B64 5QH.
Tel: Cradley Heath 69272/8.

Accutrac 4000 ★

The Accutrac 4000 is a computerised turntable operated by remote control, and consists of three separate but interrelated component pieces, the automatic direct drive electronic turntable, a sleek and sculptured space-age remote receiver and a hand-held cordless transmitter. By selection of tracks indicated numerically on the transmitter a message can be transmitted to the receiver which is located in convenient proximity to the turntable and the receiver in turn activates the turntable's arm which places the stylus precisely at the beginning of the track selected. The receiver's L. E. D. (light emitting diode) winking 'eye' lets the listener know that the information has been received and held in total memory. Up to twenty-four commands can be programmed in

any order required. The transmitter can also be programmed to reject, cue, repeat and clear, as well as play. Turntable system. Type two-speed direct drive. Motor drive system: low speed, electronically controlled, DC brushless direct drive motor. Speeds: 33 $\frac{1}{3}$ and 45 rpm (electronic speed change). Build up time: within two seconds to full speed. Variable pitch controls: 5% range (individual control for each speed). Turntable platter: die-cast aluminium alloy, dynamically balanced, diameter 306.4mm 12 $\frac{1}{16}$ in. Weight: 1.4kg (3lb 2oz). W and F: less than 0.03% WRMS (DIN 45507) \pm 0.042% weighted zero to peak. Rumble: better than -70dB (DIN 45539B), -50dB (DIN 45539A). Tonearm. Type: Tubular S-shaped, statically-balanced arm direct read-out, decoupled counter-weight, electronically controlled cue, pause and muting operation, anti-skate control. Effective length: 237mm (9 $\frac{5}{16}$ in) pivot to stylus tip. Overhang 15mm (1 $\frac{1}{2}$ in). Friction: 5-7mg horizontally and vertically. Offset angle: 21°. System resonance: 8-10Hz (with ADC LMA-1 cartridge supplied). Tracking force range: 0-4gm (with ADC LMA-1 cartridge supplied, operated at $\frac{3}{4}$ -1 $\frac{1}{2}$ gm). Wire capacitance: less than 20pF per channel. Compatible with CD-4. Cartridge. Type: ADC LMA-1 low mass, induced magnet (U.S. Patent 3294405) electro-optical sensing system, high energy magnet structure. Output: 3.5mV/5.5cm/sec. Tracking force range: $\frac{3}{4}$ to 1 $\frac{1}{2}$ gm. FR: 10Hz to 24kHz \pm 2dB. Channel separation: 28dB. Load resistance: 47K ohms. Stylus tip: nude .0003in × .0007in elliptical diamond. General. Power requirements: Model 4000/EW-1 120v AC 50/60Hz. Model 4000/EW-2 240V AC 50/60Hz. Model



Accutrac 4000

★ Indicates entry is illustrated

4000/EW-3 100V AC 50/60Hz. Model 4000/EW-4 220V AC 50/60Hz. Power consumption: 12W. Accessories included: ADC TX-1 remote control transmitter with 9V battery. ADC SX-1 remote control receiver with connecting cable. Removable hinged dust cover. Wood veneer cabinet. 45 rpm record spindle adaptor. 48in dual phono cables. Dimensions: 47 × 44.1 × 15.2cms. Price: £299.25 (inc. VAT).

■ AIWA

Johnsons of Hendon Ltd, 14 Priestley Way, London NW2 7TN.
Tel: 01-450 8070.

AP-2060

Automatic return belt-drive record player. 4-pole hysteresis synchronous motor. Stylus pressure indication scale attached to the high frequency static balance tone arm. Automatic return and automatic power cut system. Anti-skating device. Speeds: 33 $\frac{1}{3}$ and 45rpm. Turntable platter: aluminium alloy die-cast, 30cm diameter. W and F: 0.09% (WRMS). S/N: 48dB. Tone arm. Static balance type tubular arm. Cartridge: moving magnet type. Channel separation: 20dB. Output voltage: 2.5mV (at 1kHz). Load impedance: 47-100K. Stylus pressure 2.5gm. Mains: 110-120V/220-240V AC, 50/60Hz. Power consumption 10W. Size: 480 × 355 × 187mm (with dust cover). Weight: 6.8kg. Price: £70.30 (plus VAT).

■ ALBA (RADIO AND TELEVISION) LTD

Bull Lane, Edmonton, London N18 1SD.
Tel: 01-803 4451.

220

Plinth mounted with hinged and lift-off top cover. PU arm included with BSR P163 single



Amstrad TP12D



ARXB1

auto/manual record deck. Speeds: 45 and 33 $\frac{1}{3}$ rpm. Wow: typically 0.13%. Flutter: typically 0.13%. Rumble: greater than -55dB weighted, greater than -35dB unweighted. Synchronous motor. Turntable measures 27.9cm. Belt drive. Motor: dynamically balanced, high torque synchronous 4-pole 200-240V, 50Hz. Pick-up arm: S-shaped, low resonance, floating on concentric gimbal style mount, counter balanced. Satin black and polished aluminium finish. Viscous cueing control and click suppressor and muting. Price: on application.

■ AMSTRAD

AMS Trading (Amstrad) Ltd, 89 Ridley Road, Dalston, London E8 2NH.
Tel: 01-249 5237/8/9.

TP12D ★

Integrated turntable fitted with pickup arm, mounted on base with transparent dust cover. Speeds: 33 $\frac{1}{3}$, 45rpm. W and F: less than 0.1% WRMS. Rumble: better than -47dB. Speed constancy: No change with $\pm 40\%$ supply volts variation. Turntable 300mm diameter. Weight: 0.75kg. Aluminium platter. Belt drive. Motor: 16-pole/shaded pole 220V synchronous motor 240V. S-shaped pickup arm. Offset angle 22°, length 220mm. Fully adjustable counterbalance and bias compensation. Standard detachable headshell. Viscous cueing device. Finish: teak veneered base with removable hinged transparent dust cover. Price: £49.09 (excluding VAT).

■ AR

Acoustic Research International, High Street, Houghton Regis, Dunstable, Beds LU5 5QJ.
Tel: Dunstable 603151.

XB1 ★

Complete fitted pick-up arm. Hinged lid. Speeds: 33 $\frac{1}{3}$, 45rpm. Wow: 0.03%. Flutter: 0.03%. Rumble: less than -40dB. Turntable: 29.8cm. Belt drive, synchronous motor 220-240V 50Hz. Pickup arm made of light alloy. Walnut base with transparent plastic dust

cover. Price: £56.00 without cartridge, £64.00 with cartridge (plus VAT).

■ BEOGRAM

Bang & Olufsen (UK) Ltd,
Eastbrook Road, Gloucester GL4 7DE.
Tel: Gloucester 21591.

Beogram 3400 Type 5703

Integrated record deck with plinth, arm, pickup and dust cover. Shibata stylus. Speeds: 33 $\frac{1}{3}$, 45rpm. Wow: $\pm 0.07\%$. Rumble: $>42\text{dB}$ DIN unweighted, $>62\text{dB}$ DIN weighted. Speed constancy: $\pm 0.1\%$ for $\pm 6\%$ mains volts variation. Turntable: 30cm made of aluminium alloy. Belt drive with synchronous 110-220V motor. Pickup arm: ultra low mass—magnesium alloy—integrated bias compensation. Optional CD4 demodulator can be fitted (available late 1976). Teak or rosewood white finish. Price: on application.

Beogram 6000 Type 5505

Integrated stereo/CD4 record deck, tangential tracking, including CD4 pickup and dust cover. Speeds: 33 $\frac{1}{3}$, 45rpm. W and F: $\pm 0.05\%$. DIN. Rumble: $>-45\text{dB}$ DIN unweighted, $>-65\text{dB}$ DIN weighted. Speed constancy: $<0.02\%$ for $\pm 6\%$ change in mains volts. Turntable: 30cm aluminium alloy. Belt drive with synchronous motor driven from Wien Bridge oscillator, 6V. Aluminium low mass pickup arm with tangential tracking, servo driven. White/rosewood finish and fitted with CD4 demodulator. Full automatic operation. Price: not quoted.

Beogram 1203

Plinth-mounted motor unit with arm, cartridge

and separate dust cover. Speeds: 33 $\frac{1}{3}$ and 45rpm. W and F: $<0.15\%$. Rumble: 58dB (DIN). Turntable: 12in aluminium alloy with conical studs instead of disc matt. Belt drive. Two-pole asynchronous motor. B and O pickup arm with built-in bias compensation and stylus pressure adjustment. Fully automatic operation with single master control. Price: not quoted.

Beogram 2000

Plinth-mounted motor unit with arm, SP 10A cartridge and hinged dust cover. Speeds: 33 $\frac{1}{3}$ and 45rpm. W and F: $<0.12\%$ (DIN). Rumble: -60dB (DIN). Turntable: 12in aluminium alloy with conical studs. Belt drive. Two-pole asynchronous motor. 110-240V AC switchable. B and O pickup arm with built-in bias compensation. Stroboscopic disc. Fully automatic motor/arm/speed/record size action. Price: not quoted.

Beogram 4002

Plinth-mounted motor unit with tangential arm and MMC 4000 integrated cartridge. Hinged translucent dust cover. Servo driven tone arm plus detector arm for automatic record size and speed sensing. Computer-like data unit gives completely automatic operation. Speeds: 33 $\frac{1}{3}$ and 45rpm (with 6% fine speed adjustment). W and F: better than $\pm 0.05\%$ DIN ($\pm 0.025\%$ RMS). Rumble: better than -65dB (DIN B). Turntable: 12in aluminium alloy radially ribbed. Belt drive. Individual speed indicator lights. Power supply: 110, 130, 220 and 240V AC 50/60Hz. Price: not quoted.

■ BIC

Belmont A/V Ltd, Fircroft Way, Edenbridge, Kent TN8 6HA.
Tel: Edenbridge 4116.

BIC 960

Automatic belt drive turntable complete with base, cover and tone arm. Speeds: 33 $\frac{1}{3}$ and 45rpm. W and F: less than 0.05%. Rumble: better than -65dB . 24-pole synchronous motor. Tubular aluminium tone arm. Price: £69.50 (excluding VAT); (with Stanton 681EE cartridge) £94.50 (excluding VAT).

BIC 980 ★

Automatic electronic drive turntable complete with base, cover and tone arm. Pitch adjustment: $\pm 3\%$. W and F: less than 0.03%. Rumble: better than -65dB . 24-pole synchronous motor. Tubular aluminium tone arm. Built-in stroboscope. Price: £89.50 (excluding VAT); (with Stanton 681EE cartridge) £114.50 (excluding VAT).



BSR MP 60

★ Indicates entry is illustrated



BSR BDS 90



BSR BDS 80

■ BSR

BSR Ltd, Monarch Works, Cradley Heath, Warley, Worcs B64 5QH.
Tel: Cradley Heath 69272.

MP60 ★

Three-speed single player. Wow: 0.2% RMS. Flutter: 0.06%. Speed constant down to 16% reduction in mains volts. 11in diecast turntable. Pulley drive, 4-pole motor. Double ballrace pickup arm. Plug-in headshell. Counter-balanced pick-up arm. Bias compensator calibrated for spherical and elliptical, styli. Viscous damped cue control. Calibrated stylus pressure gauge. Muting switch. Price: Module/K8 £35.23, Module £29.73. Chassis/K8 £24.68. Chassis £19.18 (plus VAT).

BDS80 ★

Transcription-engineered single player with resilient belt drive giving silent power transmission. Speeds: 33 $\frac{1}{3}$ and 45rpm. Total wow and flutter: within DIN weighted specification. Rumble: better than -55dB weighted (measured according to DIN 45 500). 11in diameter, 4lb precision machined diecast alloy turntable with integral rotating record spindle. Dynamically balanced, high torque, synchronous, 4-pole motor. Low mass, square section aluminium tone arm with counter balance adjustment and automatic lock. Anti-skate bias compensator calibrated for spherical and elliptical styli. Lightweight cartridge shell with finger lift has slide-in cartridge carrier. Calibrated stylus pressure control. Unit will accommodate crystal, ceramic or magnetic cartridge. Linear controls. Corner mounting springs. Click suppressor. Muting switch. Capacity: 7in, 10in and 12in records. Size: 286

× 334 × 81mm. Mains: 100-120V AC 60Hz or 200-240V AC 50Hz. Finish: satin black mainplate and a combination of black and silver on tone arm, turntable and control panel. Price: Module K5E £46.33, Module £39.94. Chassis/K5E £34.10. Chassis £27.72 (plus VAT).-

BDS90 ★

Transcription-engineered belt drive single play turntable. Speeds: 33 $\frac{1}{3}$ and 45rpm. Total wow and flutter: within DIN weighted specification. Rumble: better than -55dB weighted (measured according to DIN 45 500). Resilient belt drive giving completely silent power transmission. Dynamically-balanced, high torque, synchronous, 4-pole motor. 11in diameter, 4lb, precision-engineered diecast alloy turntable with integral rotating record spindle. Low resonance aluminium tone arm floats in a concentric gimbal style mount. Calibrated stylus pressure control 0-4gm. Primary counter balance adjustment for tonearm with second control for ultra-fine balance. Bias compensator calibrated for spherical and elliptical styli. Lightweight cartridge shell with finger lift has slide-in cartridge carrier. Unit will accommodate most crystal, ceramic or magnetic cartridges. Automatic tone arm lock. Silicone damped viscous cueing device. Slider controls. Corner mounting springs insulating unit against vibrations whilst playing. Click suppressor. Muting switch. Capacity: 7in, 10in or 12in records. Size: 286 × 334 × 91mm. Mains: 100-120V AC 60Hz or 200-240V AC 50Hz. Finish: satin black mainplate and a combination of black and silver on tone arm, turntable and control panel. Price: Module K5E £51.04.

Module £44.22. Chassis/K5E £38.81, Chassis £31.99.

BDS95

Single play, belt driven turntable, fitted with pickup arm. Supplied mounted on a slimline plinth with smoky-grey cover, and complete with ADC K5E magnetic cartridge. Can also be supplied in chassis form. Speeds: 33 $\frac{1}{3}$, 45rpm. Wow: $\pm 0.2\%$. Flutter: $\pm 0.13\%$. Rumble: weighted $> -55\text{dB}$, unweighted $> -35\text{dB}$, typically -58dB weighted. 11in turntable of diecast alloy. Belt drive, 4-pole synchronous motor. Counterbalanced pickup arm, S shaped, tubular aluminium on gimbal style mount. Satin black mainplate and control panel with combination of black and polished aluminium on tonearm and turntable. Price: Module/K5E £52.69, Module £45.87, Chassis/K5E £40.46, Chassis £33.66 (plus VAT).

CONNOISSEUR

A. R. Sugden & Co (Engineers) Ltd,
Connoisseur Works, Atlas Mill Road,
Brighouse, Yorks HD6 1ES.
Tel: Brighouse 2142.

BD1 ★

Two-speed motor unit supplied as motor only. Two fixed speeds, 33 $\frac{1}{3}$ and 45rpm. Wow: $< 0.1\%$. Flutter: $< 0.1\%$. Rumble: -50dB measured at RIAA characteristics ref 7cm/sec at 1kHz. No change in speed for 20% variation in



Connoisseur BD1



Connoisseur BD2

supply voltage. 10 $\frac{1}{4}$ in non-ferrous lathe-turned turntable. Precision ground belt drive. Unique drive arrangement eliminates transmission noise. Simple manual speed change. Low hum field. Slim line construction. Only 1 $\frac{3}{4}$ in required below mounting platform. Mains: 100-120V and 200-240V 50 or 60Hz. Price: £22.75 (including VAT).

BD2 ★

Integrated transcription unit. Includes a BDI motor unit (mounted on a larger platform and fitted with pressbutton speed change) and a type SAU2 pickup arm. Hydraulic arm lift, operated from front. Anti-vibration mounted. Supplied either chassis only or plinth mounted. Acrylic cover. Size: 12 $\frac{1}{4}$ × 14 × 4 $\frac{3}{4}$ in (2in below and 2 $\frac{1}{2}$ in above the platform). Price: (chassis model) £45.75 (including VAT); (assembly mounted on plinth complete with acrylic cover) £60.62 (including VAT).

BD3

9V DC servo controlled motor with electronic speed variation on all 3 speeds - 33 $\frac{1}{3}$, 45 and 78rpm. Externally housed power source, eliminating hum fields, convertible for 120 or 230V mains supply. Belt drive. Studio type turntable, 11 $\frac{1}{2}$ in diameter. Neon illuminated stroboscope underneath turntable viewed through mirror at front of platform available with either 50 or 60Hz stroboscope. Adjustable magnetic bias, calibrated for spherical and elliptical stylus. Stylus balance. Hinged acrylic dust cover. Price: £106.25 (plus VAT).

CEC

Plustronics Ltd, Hempstalls Lane, Newcastle,
Staffs ST5 0SW.
Tel: Newcastle Staffs 615131.

BD 100

Turntable with speeds 33 $\frac{1}{3}$, 45rpm. Turntable diameter 30cm. W and F: 0.12% DIN. External rumble: -42dB . Rumble: -62dB . Tone arm 215mm long with 0.4 tracking force. MC11 cartridge. Dimensions: 43.5 × 34.8cm. Walnut, white, palisander, teak, graphite black. Price: £63.86.

BD 2000 ★

Similar specifications but with Ortofon F150 cartridge. Dimensions: 43.5 × 37cm. Price: £75.51.

BA 300

Similar to BD 2000 but with additional automatic shut-off. Price: £87.17.

BA600 ★

Similar to BD 2000. Hydraulic tonearm lift.

★ Indicates entry is illustrated



CEC BD 2000



CEC BA 600



CEC BD 7000

Can be operated as an unlimited repeat player.
Price: £93.21.

BD 7000 ★

Special electronic circuit makes motor independent of line fluctuations in voltage and frequency. W and F: 0.05%. Weighted rumble 65dB. Ortofon F20 EO cartridge. Dimensions: 45.5 × 35.5cm. Price: £137.01.

■ DANSK

Plustronics Ltd, Hempstalls Lane, Newcastle, Staffs ST5 0SW.

Tel: Newcastle Staffs 615131.

Dansk 1702-1 ★

Ultra slim styling – total height is only 100mm. Transparent lid hinges within its own width so that it can be fitted flush up to a wall. Pick-up arm has a low friction factor which teams with the gyroscopic suspension of the turntable to ensure high quality sound reproduction. Gramophone motor. Voltage 110/220V AC, 50/60 c/s. Motor: 32 pole synchronous motor. Speeds: 45 and 33½rpm. Speed adjustment: ±3%. Speed control: stroboscope, illuminated by neon lamp. Transmission: space drive with flat neoprene belt. W and F: less than 0.08% (DIN 45507). Rumble: better than 45dB unweighted, better than 60dB weighted (DIN 45539). Turntable: diameter 300mm. Pickup arm. Type: Dansk. Overhang: 16mm. Stylus pressure adjustment: 0.2gm/0.20mN. Pick-up lift: viscosity damped. Anti-skating: magnetic action. Pickup. Type: Ortofon F 15 O. Frequency range: 20-18,000c/s ±1dB. Channel separation: 20-20,000 c/s better than 25dB at 1kc/s. Output voltage: 1mV ±1dB at 1kc/s 1cm/sec. Stylus pressure: 0.75-2gm/7.5-20mN. Stylus angle: 15°. Compliance: 25 × 10⁻⁶ cm/dyne. Stylus-tip-radius: 15µm (0.015mm). Cabinet. Dimensions: 100 × 450 × 360mm. In teak or black. Price: £144.10.

■ DUAL

A. C. Farnell Ltd, Kenyon Street, Sheffield S1 4BD.

Tel: Sheffield 78901.

601

Belt drive, two-speed turntable fitted with Shure V 15 Mark 3 LM cartridge, plinth and cover. Dual 8-pole synchronous motor through precision flat belt to platter base. Non-magnetic, dynamically-balanced platter. Speeds: 33½ and 45rpm. Speed control: with illuminated stroboscope for platter speeds 33½ and 45rpm, adjustable to 50 or 60Hz. W and F: < ±0.08%. Rumble: unweighted: >42dB, un-

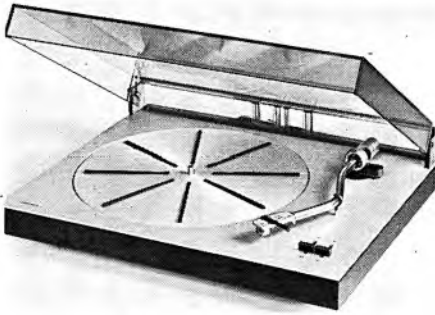

Dansk SD 1702



Dual CS 510

weighted: $>63\text{dB}$. Tonearm: torsion-resistant tubular aluminium tonearm in self-adjusting pivot bearing. Effective length: 222mm. Cartridge holder: removable, accepting any cartridges with $\frac{1}{2}\text{in}$ mounting and weighted from 2-10gm (including mounting hardware). Adjustable overhang: 5mm. Size: $420 \times 147 \times 365\text{mm}$. Weight: approx. 7.4kg. Line voltage: 110-130V or 220-240V. Ac 50/60Hz. Power input: approx. 8W. Price: £124.30 (excluding VAT).

701

Direct drive, two-speed turntable fitted with Shure V 15 Mark 3LM, plinth and cover. Platter: non-magnetic, dynamically-balanced, 2.9kg, 305mm dia. Speeds: $33\frac{1}{3}$ and 45rpm. Automatic tonearm lowering coupled to speed change. Speed check with illuminated strobe for platter speeds of $33\frac{1}{3}$ and 45rpm, adjustable for 50 or 60Hz. Overall speed variation:

$\pm 0.03\%$. S/N Ratio: rumble unweighted 50dB, weighted 70dB. Tonearm: torsion-resistant, extra-long tubular aluminium tonearm in four-point gimbals suspension, tonearm counter balance with two mechanical, anti-resonance filters. Effective tonearm length: 222mm. Pick-up head: (cartridge holder) detachable, suitable for all pick-up cartridges with $\frac{1}{2}\text{in}$ mounting and a dead-weight of 2-10gm (including mounting material). Adjustable overhang: 5mm. Size: $420 \times 147 \times 365\text{mm}$. Weight: approx. 10.9kg. Price: £192.00 (excluding VAT).

CS510 ★

Single-play turntable with mechanical sensor to tell when the tonearm is lined up precisely over the lead-in groove. When the record finishes the tonearm is lifted by cue-control and the motor shuts off automatically. Belt driven. A simple system which filters out motor vibration. Features include: 8-pole synchronous motor. 12in dynamically balanced 2-speed platter with inbuilt gear cut strobe. Viscous-damped cue-control. Multi-scale antiskate. Low mass gimbal tonearm and Shure M95D cartridge. Weighted rumble according to DIN 45 500 is better than -63dB . Wow and flutter is better than 0.08% according to DIN 45 507. Price: £116.41 (inc. VAT).

CS1225/1

For universal use as a manual, fully automatic or changer. Rim-drive system. The CS1225/1 has a single phase 4-pole induction motor and a die-cast platter. The tonearm is of torsion-resistant tubular aluminium fitted with Shure M75D cartridge and mounted in a self-adjusting pivot bearing. Other features include: pitch control, anti-skating and cue-control. Wow and flutter is better than $\pm 0.12\%$. Rumble is better than -57dB weighted. Price: £82.51 (inc. VAT).

■ EAGLE

Eagle International, Precision Centre, Heather Park Drive, Wembley HA0 1SU. Tel: 01-902 8832.

D2005

Belt driven, two-speed record deck in plinth with cover, 4-pole synchronous motor. Rumble: -55dB . W and F: 0.18% RMS. Static balance S-type tone arm. Tracking weight: 0-3gm. Fixed mechanical torque bias. Turntable weight: 1.1kg. Size: $7\frac{1}{4} \times 18\frac{1}{2} \times 14\frac{3}{4}\text{in}$. Finish: teak with smoked acrylic dust cover. Price: £51.90 (excluding VAT).

★ Indicates entry is illustrated



Eagle D2006

D2006 ★

Belt driven, electronically-monitored two-speed record deck in plinth and cover. Speed control: $\pm 2.5\%$. Speed stabilization: electronic (tachometer) $\pm 10\%$ mains variation. Rumble: -55dB . W and F: 0.18% RMS. Tone arm: static, balance, S-type. Tracking weight: 0.3gm . Fixed mechanical torque bias. Turntable weight: 1.1kg . Size: $7\frac{1}{4} \times 18\frac{1}{2} \times 14\frac{1}{4}\text{in}$. Finish: teak with smoke acrylic dust cover. Price: $\pounds 88$ (excluding VAT).

EMPIRE SCIENTIFIC CORP

Hayden Laboratories Ltd, Hayden House, Churchfield Road, Chalfont St. Peter SL9 9EW.

Tel: Gerrards Cross 88447.

Troubador 598111

Complete with PU arm, plinth and cover but excluding cartridge. Speeds $33\frac{1}{3}$, 45rpm . W and F: 0.03% . Belt driven Hysteresis synchronous motor, self cooling and high torque. Low mass arm suitable for tracking cartridges at $\frac{1}{4}\text{gram}$. Deck and P/U arm finished in satin gold mounted in walnut plinth with Plexiglas dust cover. Price: $\pounds 199.00$ (plus VAT).

ENVIRONMENTAL SOUND

London House, Mayfield, Sussex TN20 6AQ.

Tel: Mayfield 3419

Planet

Gives maximum inertia with lowest possible weight, mounted on slimline plinth with hinged perspex lid. Speeds: $33\frac{1}{3}$, 45rpm . W and F: 0.08% . Rumble: typically -43dB unweighted, 65dB weighted. 24-pole synchronous 200-250 Volts AC 50 Hz or 90-120 Volts AC 60 Hz motor. Belt drive. Tone arm length 33cm . Adjustable tracking weight with calibrations of 0.3gm . Direct reading magnetic repulsion bias compensation. Dimensions: $44.4 \times 35.6 \times 12.7\text{cms}$. Price: $\pounds 97.50$ (inc. VAT).

ERA

Wilmex Ltd, Import Division, Crompton House, New Malden, Surrey KT3 4DE.

Tel: 01-949 2545.

Era Mk6X

Complete with plinth and cover, without arm. Armboard precut for SME 3009 supplied free of charge. Speeds: $33\frac{1}{3}$, 45rpm . Wow: 0.04% . Rumble: -73dB (DIN). 12in turntable. Weight: $2\frac{1}{2}\text{lb}$. Neoprene belt drive. Double 48-pole synchronous motor. Finish: black with walnut sides and armboard. Price: $\pounds 65$ (excluding VAT).

FONS

Fergus Fons Ltd, 1 Society Street, Maybole, Ayrshire KA19 7BH, Scotland.

Tel: Maybole 82424

C30★

Variable speed transcription record deck complete with plinth and cover. Speeds: 29-100rpm (variable). Wow and Flutter: $\pm 0.03\%$. Rumble: -48dB unweighted relative to a 10cm/sec tone. Speed constancy: better than 0.09% . Turntable: 12in aluminium. Turntable weight: 5lb (1.82kg). Belt drive. DC servo-controlled motor. Finish: plinth available in walnut or rosewood (extra). Tone arm not supplied. Price: (walnut) $\pounds 82.50$ (excluding VAT); (rosewood) $\pounds 85$ (excluding VAT).

GARRARD ENGINEERING LTD

Newcastle Street, Swindon, Wilts SN1 1DA.

Tel: Swindon 5381.

86SB Mk II

A belt drive turntable with own pick-up arm,



Funs C30

DOES YOUR TURNTABLE LEAVE ITS MARK ON YOUR RECORDS?



Even today there are still a lot of turntables around that don't do enough to make your LPs live up to their name.

With Trio's KD 2033 turntable and our KP 1022 turntable pictured here though, they'll have a much better chance.

Everything on our turntables, you see, is geared not just for perfect reproduction.

But to make sure that that performance and with it your records, really lasts over the years.

The KD 2033 for instance has an anti-skate pulley that virtually defies centrifugal force.

Instead of the natural tendency of the arm to be pulled towards the centre of the platter it stays where it should: fair and square in your groove.

The KD 2033 has high damping rubber feet too. And though their main purpose is to isolate the turntable from transmitted sound, they're also perfect shock absorbers of bumps and knocks.

So much for the present.

How will your turntable be treating your records in twenty years' time?

Well unlike a lot of turntables, both the KP 1022 and the KD 2033 have been put together to age gracefully.

Built with parts we make and design ourselves, subjected to constant quality checks and sometimes even put through 40 days of continuous use, we make sure they'll not wear out even as time wears on.

Your records will be the same after 500 plays as they were after the first.

The only mark you'll be able to recognise them by will be the fact they haven't any



Please send me details of your range of turntables.

Name

Address

B H Morris and Co (Radio) Ltd, Two House, The Hyde,
London NW9 6JP Tel 01-205 6841
Agents in Eire: Peat Wholesale Ltd, Dublin

See and hear us at the High Fidelity '76 Exhibition

Guess who makes Hi-Fi as well as Hitachi make TV?

Not surprisingly, Hitachi do. And a very wide range of high quality hi-fi at that.

Amplifiers, tuners, tuner-amps, turntables, cassette decks, speakers and headphones. Something for everyone, really, from beginner to ambitious enthusiast.

In short, a full product range. Not one we've introduced overnight—rather, a range built up gradually and carefully with performance and reliability the objectives at every step.

Now we've reached the stage where Hitachi and hi-fi mean business in a big way.

Play your part by highlighting it in your store and it could also mean big business for you.



PS 38 Direct Drive Turntable with 8-pole, 24-slot DC servo motor. S-shape Tone Arm with vertical magnet cartridge, precision anti-skating device and arm lifter.

For more details and our latest catalogue, write to: The Hi-Fi Division, Hitachi Sales (UK) Ltd., Hitachi House, Station Road, Hayes, Middlesex UB3 4DR. Telephone: 01-848 8787.

complete with base, cover and friction hinges, automatic. Speeds $33\frac{1}{3}$ and 45rpm. W and F: 0.12% (RMS Din); Rumble: -63dB (Din. B). Die-cast zinc alloy dynamically balanced platter. Motor: 4-pole synchronous. Low mass 'S' shape arm with combination jewel and ball bearings, slide-in cartridge carrier, calibrated stylus force and separately calibrated spherical/elliptical bias compensation. Cue control viscous damped for both lowering and lifting. Price: £73.95 (Excluding VAT) complete with Shure M75/6S cartridge.

125SB

A belt drive turntable with own pick-up arm complete with base, cover and friction hinges, automatic with the facility of repeat play. Speeds $33\frac{1}{3}$ and 45rpm. W and F: 0.16% (RMS DIN); Rumble: -59dB (DIN B). Deep formed aluminium platter. Motor: 4-pole synchronous. Low mass 'S' shape pick-up arm, slide-in cartridge carrier, calibrated stylus force and separately calibrated spherical/elliptical bias compensation. Cue control viscous damped. Price: £55.95 (Exc VAT) complete with Shure M75/6S cartridge.

SP25 Mk IV

A turntable fitted with own pickup arm complete with base, cover and friction hinges, automatic. Speeds $33\frac{1}{3}$, 45 and 78rpm. W and F: 0.2% (RMS DIN); rumble: -55dB (Din B). Aluminium platter. Motor: 4-pole synchronous. Slide-in cartridge carrier, calibrated stylus force and bias compensation. Resiliently mounted counterbalance weight. Price: £42.50 (excluding VAT) complete with Shure M75/6S cartridge.

401

Precision idler wheel transcription motor. Speeds $33\frac{1}{3}$, 45 and 78 rpm. W and F: 0.10% (RMS Din); rumble: -63dB (Din B). Dynamically balanced 6lb cast aluminium platter with gear-cut illuminated markings on rim. Die-cast aluminium unit plate. Completely screened spring mounted shaded pole motor with adjustable eddy current speed control. Size $13\frac{3}{4}$ inch wide, $14\frac{1}{8}$ inch front to rear, $2\frac{1}{8}$ inch above and $3\frac{1}{16}$ inch below lower edge of unit plate. Price: £69.00 (excluding VAT).

■ GOLDRING LTD

10 Bayford Street, Hackney,
London E8 3SE.
Tel: 01-985 1152.

Goldring 103

Two speed unit on plinth with cover, pickup arm. Speeds: $33\frac{1}{3}$, 45rpm. W and F: 0.15%



Goldring Lenco L90

peak. Rumble: -60dB weighted. 10 ins. turntable, belt driven. 16 pole synchronous motor. Counter balanced pickup arm. Removable shell. Bias compensation, viscous damped lowering device. Modern functional styling in lowline wooden cabinet. Price: £48.00 (plus VAT).

Lenco L90 ★

Two speed motor unit with pickup arm, on plinth with cover, illuminated stroboscope. Viscously damped spring suspension, viscously damped lift/lowering device. Speeds: $33\frac{1}{3}$, 45rpm with electronic fine speed adjustment of $\pm 7.3\%$. W and F: weighted $\pm 0.08\%$. Rumble: unweighted -45dB weighted -63dB. 31.6cm dia. turntable with belt drive by 16 pole synchronous motor. Counter balanced, mounted on four sets of precision ball bearings. Stylus pressure adjustable 0.5gm. Equipped with IC electronics ensuring trouble free switch off and lifting off of pick up arm. Price: £128.00 (plus VAT).

Lenco GL72

Turntable unit with pickup arm available in chassis form only. Speeds: 30-86rpm continuously variable with click stops at $16\frac{2}{3}$, $33\frac{1}{3}$, 45, 78rpm. W and F: 0.12%. Rumble: unweighted -37dB, weighted -60dB. Speed variation 0.3% for 10% change in mains voltage. Turntable dia. 30cm. Idler wheel driven by 4 pole motor 110/220 volts 50Hz. Viscous damped lowering device. Removeable shell. Bias compensation. Price: £52.00 (plus VAT).

Lenco L80 ★

Two-speed motor unit with special light S type tone arm on plinth with cover. Speeds: $33\frac{1}{3}$,

★ Indicates entry is illustrated



Goldring L80



Goldring L84

45rpm. W and F: 0.08%. Rumble: unweighted -40dB, weighted -60dB. Turntable diameter 30cm. Belt driven by 16 pole synchronous motor 110/220 volts 50-60Hz. Counter balanced arm, bias compensation, removeable headshell. Price: £59.60 (plus VAT).

Lenco L84 ★

Transcription unit on plinth with cover. An improved version of L82 with special light tone arm fully automatic. Speeds: 33 $\frac{1}{3}$, 45rpm. W and F: -0.12%. Rumble: unweighted -38dB. Weighted -57dB. Turntable diameter 30cm. Belt driven by 16 pole synchronous motor 110/220 Volts, 50-60 Hz. Counter balanced arm, bias compensation, removeable headshell. Price: £79.60 (plus VAT).

Lenco L82

Transcription unit on plinth with cover, improved version of L80. Price: £69.60 (plus VAT).

■ HITACHI

Hitachi Sales (UK) Ltd, Hitachi House,
Station Road, Hayes.
Tel: 01 848 8787.

PS33★

Two-speed belt-drive turntable in plinth with arm and cartridge. 12in aluminium alloy turntable. Four-pole outer rotor motor. Speeds: 33 $\frac{1}{3}$, 45rpm. W and F: <0.1%. Plug-in headshell. Magnetic cartridge. Pw: 0.4gm. FR: 20 Hz-20kHz. Stylus: 0.7 thou diamond. Finish: walnut veneer. Size: 19 $\frac{1}{4}$ × 7 $\frac{1}{4}$ × 15 $\frac{1}{4}$ in. Price: on application.

PS77

Two-speed belt/drive idler turntable in plinth with arm. Four-pole hysteresis synchronous motor. 12 $\frac{1}{2}$ in aluminium diecast turntable. Weight of turntable: 5.6lb. Built-in strobe. Zinc diecast motor board. Speeds: 33 $\frac{1}{3}$, 45rpm. W and F: <0.05%. Tubular arm with static balance and cueing device. Plug-in headshell. Finish: oiled walnut. Size: 22 $\frac{1}{2}$ × 11 $\frac{3}{4}$ × 17 $\frac{3}{4}$ in. Weight: 33lb. Price: on application.

PS12

Two-speed, belt drive auto player. 16-pole condenser phase-shift synchronous motor. S/N ratio: 50dB. W and F: less than 0.08% WRMS. Static balance type pipe arm, head shell change type. Cartridge: VM-type VFS-260. FR: 20Hz-20kHz. Output voltage: 2-4.5mV (1kHz, 50mm/sec). Stylus pressure: 3gm. Oil-damp type arm lifter, auto-return mechanism. Lateral balancer. Size: 49 × 18 × 38cm. Weight: 8kg. Price: on application.

PS10

Motor: 16-pole synchronous motor. Drive system: Belt drive. Speeds: W and F, 33 $\frac{1}{3}$, 45rpm, 0.1% WRM. SS/N: 50dB. Turntable platter: 300mm (11.8in): Aluminium die-cast. Tone arm: Static balance. Effective length: 220mm. Overhang: 0.6in (15mm). Max. usable cartridge. Weight: 0.4oz (12gr) Cueing device: Oil damper. Dimensions 476 × 159 × 374mm.



Hitachi PS33

Weight: 15 lbs. (800g). Price: on application.

PS38

Phono motor: Drive system: Direct-drive. Speeds: $33\frac{1}{3}$, 45rpm. Pitch control range: $\pm 3\%$. W and F: 0.04% (WRMS). Signal-to-noise ratio: 60dB. Turntable platter: 305mm \varnothing aluminium die-cast.

Tone Arm

Type: Static-balance-type S-shape pipe arm. Head shell: plug-in type. Arm length: 301mm. Effective length: 220mm. Overhang: 15mm. Tracking error: 2° . Stylus pressure range: 0-3g. Max./usable cartridge. Weight: 4-10g.

Cartridge

Type: VM type (VFS-260). Frequency response: 20-20,000Hz. Output voltage: 2-4.5mV (1kHz 50mm/sec). Channel balance: 2dB. Crosstalk: 20dB. Stylus pressure: 2g. Stylus: 0.5mil diamond stylus (DS-S126). Dimensions 476 x 157 x 368mm. Weight: 18lbs. (8.3kg). Price: on application.

■ JVC

JVC (UK) Ltd, Eldonwell Trading Estate, Staples Corner, 6-8 Priestley Way, London NW2.

Tel: 01-450 2621.

JL-B44 ★

Direct-drive stereo turntable. Four-channel adaptable. Fitted with arm but not cartridge. Speeds: $33\frac{1}{3}$, 45rpm. W and F: less than 0.05%. 12in die cast aluminium alloy platter. DC servo-controlled motor. Statically balanced tubular tonearm. Finish: walnut or rosewood. Price: £165 (excluding VAT).



JVC JL-A1



JVC JL-B44 DC direct drive turntable



Leak 2001 transcription unit

JL-A1 ★

Auto return stereo turntable. Speeds: $33\frac{1}{3}$, 45rpm. W and F: less than 0.06%. 12in die cast aluminium platter. Belt drive. 4-pole synchronous motor. Statically balanced S-shaped tubular arm. Finish: walnut. Price: £58.50 (excluding VAT).

■ LEAK

Rank Radio International Ltd, Power Road, Chiswick, London W4 5PW.

Tel: 01 994 6491.

2001 ★

Turntable with pickup arm, plinth and hinged transparent cover. Unique spherodynamic damped turntable suspension. Isolates against external shock, vibration and acoustic feedback. Speeds: $33\frac{1}{3}$ and 45rpm. Speed accuracy: $\pm 0.5\%$. Wow: typical 0.08%. Flutter: typical 0.02%. Rumble: typical -65dB (DIN B). Platter: 320mm diameter. Weight: 2.03kg. Motor: 10-pole synchronous, 600rpm at 50Hz. Belt drive to turntable rim. Tonearm: static balance, professional, precision engineered. Length: 323mm, effective length: 240mm. Dynamic balancing by counter-weight, adjustable stylus pressure 0.3gm, direct reading. Bias compensation. Pivot friction: 18mgm typ-

★ Indicates entry is illustrated



LG Sound Systems AP 13/AP 14 G

ical, lateral and vertical. Remote control, viscous damped arm raise/lower device. Plug-in headshell. Size: 494mm wide, 391mm deep, 170mm high. Price: £167.83 (plus VAT).

■ LG SOUND SYSTEMS

5 Eden Grove, London N7 8EQ.
Tel: 01-609 0293/6

AP13 ★

Turntable with arm and cartridge in plinth with perspex cover. Speeds: 33 $\frac{1}{3}$, 45rpm. W and F: 0.08%. Rumble: 55dB. Turntable: 31cms. Belt driven, 4 pole synchronous motor. Static balance pickup arm. White finish. Price: £96.00 (plus VAT).

AP14G ★

Turntable with pick-up arm and cartridge in plinth with perspex cover. Details as AP 13 with teak finish. Price: £100.00 (plus VAT).

■ LINN-SONDEK

Linn Products Ltd, 235 Drakemire Drive, Castlemilk, Glasgow G45 9SZ.
Tel: 041-634 3860.

LP12 ★

Single speed (33 $\frac{1}{3}$ rpm) transcription record deck available as chassis only; with plinth and cover and also with plinth, cover and Grace G-707 arm or SME 3009 Series II arm. Standard plinth finish afrormosia, various other solid timber plinths available. 12in diecast platter driven by ground flat belt from a 24-pole synchronous motor. Patented external bearing assembly for low noise and a patented steel point control bearing running in an oil bath. W and F: 0.04% RMS unweighted. Rumble: -60dB with ref. to 10cm/s at 1kHz unweighted. Price £90.00 (chassis only), £115.00 (with plinth and cover), £170.00 (with plinth, cover and arm). All including VAT.

■ LUX

Howland-West Ltd, 3-5 Eden Grove, London N7 8EQ.
Tel: 01-609.0293/4.

PD131 ★

Mounted on rosewood with anodised aluminium plinth. No arm supplied but bayonet fitting ready to take SME arm. Speeds: 33 $\frac{1}{3}$, 45rpm. W and F: >0.03%. Rumble: 70dB. Turntable: 30cms diameter. Direct drive. Brushless DC servo motor. Black light strobe system. Price: £195.00 (plus VAT).

■ LYRICHORD

N. Miers & Co Ltd, 28 Piercing Hill, Theydon Bois, Epping, Essex CM16 7LE.
Tel: 01-849 2611/2.

BDS80

Single player with low mass PU arm available in chassis form or plinth mounted. Speeds: 33 $\frac{1}{3}$ and 45 rpm. W and F: typically \pm 0.13%. Rumble: typically -58dB. Turntable: precision machined alloy, weighing 4lb. Belt drive.



Linn-Sondek LP12



Lux PD 131

★★MAHLER: *Symphony No. 1 in D*. London Symphony Orchestra conducted by James Levine. RCA ARLI-0894. Price: £2.99

A remarkable feature of the last decade is the revival of Mahler's symphonies, neglected for so long. Detractors label them banal, childlike and vulgar, consisting only of longwinded unconnected fragments. I admit to subscribing to that view myself but, on the other hand, Mahler represents a great technical advance in orchestration. These same criticisms also apply to Tchaikowsky and, like Tchaikowsky, the actual musical sound of Mahler can be tremendously exciting. In this first symphony, Mahler conforms almost to a classical pattern, and here is served by a brilliant recording of the virtuoso London Symphony Orchestra. Conductor James Levine is obviously a specialist in this music and his reading is expansive and beautifully phrased.

In the first movement I enjoyed the clarity of the woodwind bird calls with every instrument perfectly clear without being unnaturally spotlighted. Even the triangle appears to sound from its proper position instead of being unnecessarily prominent. The opening of the Funeral March is absolutely faithfully reproduced and only for a few moments in the Finale does the balance seem to favour the brass unduly. Full marks to RCA!

★ MAHLER: *Symphony No. 2 in C Min 'Resurrection'*. Vienna Philharmonic Orchestra and State Opera Chorus. Ileana Cotrubus (Soprano), Christa Ludwig (Mezzo), conducted by Zubin Mehta. Decca SXL 6744-4. (Cassette KSZC2 7037). Price: Record £6.50, tape £5.75

This superb recording was made in the Sofiensaal Vienna and captures the glowing warmth of this famous hall. The glory of the set is the playing of the Vienna Philharmonic, although Mehta does not make full use of the sensuous strings which in some passages seem positively undernourished. Only in the first movement do they sound opulent.

Christa Ludwig is in fine voice and her *Wunderhorn* solo *Der Mensch lieg't in grosser Not!* is exemplary. The chorus is beautifully controlled and particularly impressive in quieter passages. Both soloists are good, but Ludwig steals the limelight.

I found the long finale rather disjointed and frankly boring as Mehta lost the thread of the argument.

MENDELSSOHN: *String Quartet No. 2 in A*/SCHUMANN: *String Quartet No. 3 in A*. Albeni Quartet. CRD 1017. Price: £2.99.

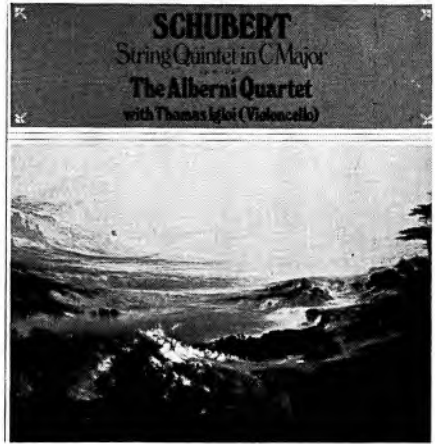

Surprisingly the first recording of both works. The Mendelssohn was composed in 1842 during his period of Bach study, but reveals the influence of Beethoven more than anyone else. It is a charming piece with a particularly engaging Scherzo. The Schumann was written twelve years later and, again, it is the Scherzo which makes the most impact at first hearing, being unusually constructed as a theme and variations. Some slight surface noise at the beginning of the Mendelssohn spoils an otherwise perfect recording. The young Albeni Quartet play well except for a lapse of intonation in the final bars of the Schumann.

★ MONTEVERDI: *Vespro Della Beata Vergine 1610*. Conducted by John Eliot Gardiner. Decca SET 59134.

Line-up for this masterpiece reads like a musical *Who's Who*. Monteverdi Choir and Orchestra, Salisbury Cathedral Boys' Choir, Philip Jones Brass Ensemble, David Munrow Recorder Consort, six continuo, with soloists Jill Gomez, Felicity Palmer, James Bowman, Robert Tear, Philip Langridge, John Shirley-Quirk, and Michael Rippon. Recorded in St. Jude's-on-the-Hill, Hampstead Garden Suburb, produced by James Mallinson with engineers Kenneth Wilkinson and Colin Moorefoot.

Monteverdi was primarily a theatrical composer, but his Vespers of 1610, a service of prayer and praise, comprise a veritable compendium of 17th Century sacred musical techniques. Lasting two hours, the work is

split into solos, duets, complex choruses, instrumental solos and diverse orchestral interludes even introducing dance rhythms.

The producer has resisted the temptation to introduce stereo gimmickry, and the recording is a model of clarity combined with warm ambience making for comfortable home listening.

MOZART: *The Magic Flute (Complete)*. Original Sound recording of Ingmar Bergman's film with Sveriges Radio Symphony Orchestra and Radio Chorus conducted by Eric Ericson. BBC REV 223. Price: £6.25.

On the face of it, a film version of *Magic Flute* with cuts, scene transpositions, sung in Swedish, would not seem an attractive proposition. However, this three-record set turns out to be a useful acquisition to any record library. Apart from the leading tenor, the cast are all Swedish and, under the guidance of conductor Eric Ericson, reveal an intelligent grasp of Mozart's operatic style. This is a lightweight *Flute* stressing the Pantomime element and keeping mysticism well in the background.

Austrian Josef Kostlinger is an outstanding Tamino with a strong, sure tenor showing only a hint of strain in the top register. Hakerno Hagegard makes an engaging Papageno with a light pleasant Baritone. Ulrik Cold's benign Sarastro only reveals a slight vibrato on top notes.

The ladies are less successful except for Irma Urrilla's Pamina which is sure and pleasing. I have heard better Queens of the Night, but Birgit Nordin does not disgrace this technically difficult role. The recording is reverberant and pleasing to the ear, and the three records come in attractive presentation box complete with libretto in English and notes by Ingmar Bergman on the production.

MOZART: *Piano Concerto No. 23 in A, K.488/ Symphony No. 41 in C 'Jupiter'*. Michael Roll (Piano), London Mozart Players conducted by Harry Blech. Abbey ABY 746. Price: £2.79.

Michael Roll won the first Leeds International piano competition in 1963 at the age of 17, and has developed into a first-class musician with fine sense of feeling especially in the classics. To this warm and gentle concerto he contributes fine sensitive playing showing affection and affinity for Mozart, and is well supported by the hand-picked small band.

In the *Jupiter* Harry Blech adopts a pedantic attitude to one of Mozart's greatest symphonies. First two movements are devoid of sympathy and the Minuet is taken much too fast. Only the finale takes wings and then, un-

fortunately, the sound deteriorates, this being a well-filled side. On the whole, however, the recording made in St. Giles, Cripplegate, is satisfactory and should please the many fans of this popular small orchestra.

MOZART: *Piano Concerto No. 9 in E flat K271/No. 21 in C K467*. Nina Milkina with Orchestra of St. John's Smith Square conducted by John Lubbock. Pye Nixa Stereo Quad PCNH1 (Cassette 2PCNH 1).

Nina Milkina gives her dependable musical interpretations to two favourite Mozart concerti. The early work is a masterpiece with many unusual features. Soloist plunges straight in at bar 2, thereafter assists the orchestra during the exposition, and keeps up support right to the end of the movement. No. 21 has gained popularity recently through the cinema but, of course, it is a wondrous work of the mature Mozart showing more than a hint of romanticism. The limpid clear tones of Miss Milkina make her unrivalled in this music and she is ably supported by the orchestra making its recording debut.

ORFF: *Carmina Burana. Judith Blegen (Sop), Kenneth Riegel (Ten), Peter Binder (Bar), Cleveland Orchestra, Chorus and Boys' Choir* conducted by Michael Tilson Thomas. CBS 76372 Price: £2.99.

This German-made pressing has odd moments of surface noise, which spoil an otherwise good recording.

Peter Binder makes the most of his chances, especially as the drunken Abbot of Cucany, tenor Kenneth Riegel declaims in operatic manner, but Judith Blegen could have been more seductive, although the indecision of '*In tontina mentis*' is nicely caught.

Sound is rather distant but one gets used to this and I must admit that the overall ambience simulates the effect of the back seat of a concert hall. Everything comes over clearly without being distorted or unnaturally spotlighted. The chorus has some exciting moments especially in '*In Taberna*' section.

★★**RACHMANINOV: *Symphony No. 3 in A Min.* Desmar DSM 1007. Dist by Rediffusion. Price: £3.49.**

The new label from America retails at £3.49 and, if this recording is typical, is worth every penny. For a man in his nineties, Stokowski produces a performance calculated to keep an audience rivetted to its seats. National

Philharmonic is a recording orchestra comprising hand-picked musicians such as John Georgiadis, Max Salpeter, Alan Civil and John Wilbraham to name just a few.

Recording by Bob Auger is superb with every note crystal clear and pleasant ambience. West Ham Pentecostal Mission Hall is reverberant, and the orchestra was divided into instrumental choirs placed apart to give maximum spaciousness and clarity. This has paid dividends in at least two places: horn echo motif which ends the development section of the first movement, and bassoon figure in the last movement after the first lyrical episode. The finale is terrific.

★ **RACHMANINOV:** *24 Preludes. Vladimir Ashkenasy. Decca 5BB221-2. Price: £5.50. (Cassette: KSXC2 7038).*

I have great admiration for Ashkenasy and this two-record set is a fine achievement. Recording made at All Saints Church, Petersham, is warm, pleasant and natural.

I tend to compare any Rachmaninov recording with discs cut by the composer himself, or those of his favoured interpreter Benno Moiseiwitsch. Take, for example, *the* famous Prelude Op. 3 No. 2. The composer really punches out the melody while the huge accompanying chords are unevenly timed as per the practice of the day. He also takes the trio section at terrific speed with panache. Moiseiwitsch follows the same pattern but his accompanying chords are more even with a beautiful mellow tone. Like Rachmaninov he makes a gradual acceleration in the Trio section but keeps his tone to a more subdued murmur. Ashkenasy is slower than either. The first two opening bars are punched out so savagely as to be positively ugly, but thereafter he adopts a more subdued tone. The Trio section is much slower and more deliberate, quite contrary to the composer.

The most noble piece of all, Op 32 No. 10 is depicted as a hopeless tragedy and boredom creeps in. In the popular G sharp Min No. 12 of the same set, Ashkenasy is less rhythmic than his distinguished ancestors. Certainly the passionate numbers seem to elude him. On the whole he excels in the quiet Chopinesque pieces such as Op. 23 No. 4.

★ **SCHUBERT:** *String Quintet in C. Alberni Quartet with Thomas Igloi (cello). CRD 1018. Price: £2.99.*

A warm, glowing account of Schubert's loveliest chamber work by the young Alberni Quartet with Thomas Igloi as additional cellist. Igloi

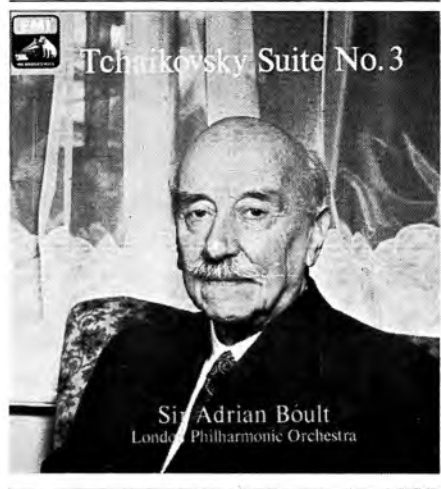

was, at the tender age of 29, Professor at Royal Academy of Music and a prominent soloist. His four colleagues form the resident Quartet to Harlow New Town. Igloi's death, soon after this record was released, is a tragic loss to music.

The C Major Quartet was one of Schubert's last pieces, dating from the last year of his life and coming after a lean period when he composed only trifles. It is a difficult work to perform and record because two cellos overweight the bass. By and large, this danger is overcome in this version, made in the Church of St. George the Martyr, Queen Square, London.

★★ **RICHARD STRAUSS:** *Also Sprach Zarathustra/Don Juan/Till Eulenspiegel. Chicago Symphony Orchestra conducted by Sir Georg Solti. SXL6749: £3.25 (Cassette KSXC6749 £3.50).*

A superb recording, broad and spacious, with both sides playing for more than half-an-hour without loss of quality. The Chicago Symphony Orchestra excel themselves and I rate this one of their finest performances on disc. Horns, so important in Strauss, are splendid, and the lush strings remind me of the Vienna Philharmonic, high praise indeed.

Sir Georg Solti shows himself a first-rate Strauss conductor, emphasising the romantic melodies and yet generating tremendous excitement. Karajan is direct competitor in all three pieces and he produces even greater thrills from the Berlin and Vienna Orchestras. Choice must be personal and I would not care to influence you in either direction. Although *Zarathustra* is too bombastic and banal for my

taste, I enjoyed wallowing in the sheer luxurious sound of this recording. *Zarathustra* and *Till* were recorded in 1975 at Medinha Temple, Chicago and *Don Juan* at Krennert Centre two years earlier.

★ **STRAVINSKY:** *Ballet 'The Firebird' (complete)*. New York Philharmonic Orchestra conducted by Pierre Boulez. CBS 76418. Price: £2.99 (Cassette: 40-76418. Price: £2.99).

Good stereo recording with every detail crystal clear; in fact some people may consider harps and percussion too clear to be natural. Boulez is patchy in this score. The introduction is suitably awesome with good woodwind, but the strings are not as silky as some European orchestras.

Side Two introduces King Kastchei with stereo used to good effect. Trumpet calls seem to echo all around striking terror into both the Princesses and the listener. Other parts of the score drag and I cannot give this version whole-hearted approval although the sound is first-class.

★★ **TELEMANN:** *Don Quichotte Suite/ Viola Concerto in G/Overture in D. Academy of St. Martin-in-the-Fields* directed by Neville Martiner. Argo ZRG 836. Price: £3.25. (Cassette: KZRC 836).

Rich silent recording made at St. Mary's, Rotherhithe, produced by Michael Bremner with Stanley Goodall engineer.

The *Don Quichotte Suite* is a wonderfully descriptive piece in galante style starting with an attractive Overture in the French style. Overture in D, scored for two oboes, two horns and strings is similar to Handel's *Fireworks Music* being written in the Military manner. Telemann was not an enthusiastic concerto writer and the G major work for viola is the least interesting piece on the disc, although Stephen Shingles provides some elegant playing. A most attractive selection, well played and well recorded.

★ **TIPPETT:** *String Quartets 1-3. Lindsay Quartet. L'Oiseau-Lyre DLSO-10*. Price £3.35.

Lindsay Quartet studied these works with the composer, who was present at the recording sessions and provided insert notes. Presumably these must be regarded as definitive versions.

Tippett found his individual style in the first

Quartet of 1935 and it came to fruition with the Third, one of the major Quartets of modern English music. Recommended.

★ **TSCHAIKOWSKY:** *Opera 'Eugene Onegin'*. Teresa Kubiak, Bernard Weikl, Stuart Burrows, Nicolai Ghiaurov, John Alldis Choir, Covent Garden Orchestra conducted by Sir Georg Solti. Decca SET 596/8.

Firm hand of Sir Georg Solti produces one of the most convincing performances of this rather tricky opera. Tchaikowsky's most popular stage work is a far cry from the verisimo blood and thunder of Verdi. It is an attempt to portray normal situations and should be played on low-key level. Only the passionate outbursts of young Lenski are in conventional operatic fashion.

The cast are impressive. This is a fine performance by Weikl, matched by Kubiak who manages to prevent her letter scene from becoming a big 'set' piece. In the third scene of Act 1, Bernard Weikl conveys the correct attitude of righteousness while Kubiak shows apt realisation that her youthful impetuosity has carried her beyond the bounds of propriety.

All small parts are excellent. Enid Harle as the nurse is a tower of strength in the scene with Tatyana preceding the Letter Song. Michael Senechal dodders aptly as the old Frenchman Toiquet, while Nicholai Ghiaurov as Prince Gremlin makes the most of his single aria. What a noble voice this is, in true Russian Bass tradition.



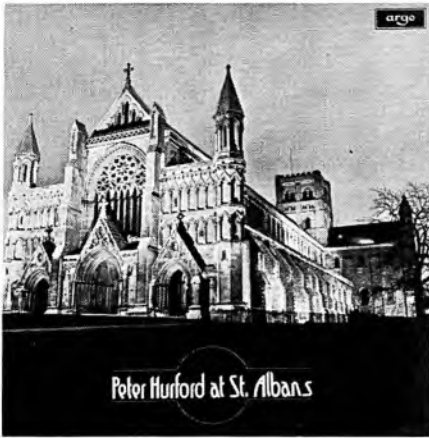

Eugene Onegin was recorded in Kingsway Hall, produced by Ray Minshull, engineered by Kenneth Wilkinson and James Lock.

TSCHAIKOWSKY: *Nutcracker Ballet* (complete). National Philharmonic Orchestra, Finchley Children's Music Group, conducted by Richard Bonyge. Decca SXL 6688-9. Price: £5.98.

Bonyge invites comparison with complete set conducted by Andre Previn on EMI, who has the crack LSO and professional Ambrosian Singers at his disposal. Bonyge conducts the National Philharmonic, a recording orchestra consisting of our finest free-lance musicians, and in *Waltz of the Snowflakes* uses a choir of children.

In the *Waltz of the Snowflakes* Bonyge stresses middle registers with a resulting muddy sound. Previn spotlights the upper woodwind, and the pure professionalism of the Ambrosian Singers outshine the Bonyge children.

In the *Waltz of the Flowers*, I prefer Bonyge. He keeps good steady tempo and his thicker textures hide Tchaikowsky's mundane unimaginative rhythm. He is also good in the *Pas-de-Deux* and *Finale*.

If pressed to judge I would plump for Previn because he seems to give more loving care to the music, and the LSO have the advantage of playing together continuously under a permanent conductor.

But if you buy Bonyge you will not regret it as differences are marginal. *Nutcracker* was recorded in Kingsway Hall and produced by Michael Woolcock.

★**TSCHAIKOWSKY:** *Suite No. 3 in G Op 55*.

London Philharmonic Orchestra conducted by Sir Adrian Boult. EMI ASD 3135 Stereo/Quad.

A work of mature Tchaikowsky rarely heard complete in concert. Admittedly *Valse Melancolique* is a miserable piece, but the opening *Elegie*, after an unpretentious opening, works up to something akin to the great ballet scenes, and the *Scherzo* is a brilliant tarantella.

However, the Theme and Variations stand head and shoulders above the rest and are inevitably played separately.

A virtuoso performance under Sir Adrian who, as always, gives a fine reading of the score. Leader Rodney Friend is the elegant soloist in the 9th and 10th variations and opening *Elegie*. Recording producer: Christopher Bishop. Balance Engineer: Robert Good. Recommended.

★★ **VIVALDI:** *Violin Concertos Op 12 Nos 3-6*. Salvatore Accardo (Violin) with I Musici. Philips 6500 937.

Concerto in D Op. 12 No. 3 is a *ripieno* concerto for strings without soloist with brilliant fugal finale. Others are conventional concertos featuring Salvatore Accardo as solo violin. Vivaldi wrote over 230 violin concertos, more than a third of his total output, and all are minor miracles providing fascinating listening.

The record is a delight with silent surfaces and, for once, a well-balanced Harpsichord – audible but not too prominent.

Classical Collections

★ *Cantilena* – Grange Records SRG 1124. Price: £1.95.

First record from Grange presents the disc debut of Cantilena, a group comprising key players from the Scottish National Orchestra directed by Adrian Shepherd.

Apart from the Corelli *Christmas Concerto* and Vivaldi G major *Sinfonia*, we can hear the Farina *Pavane*, Three Dances of Widmann, and ensemble version of Ferrabosco *Pavane*. I find the newcomers of academic interest only, but the group play extremely well and recording is first-class. I hope this is the first of many appearances on record of Cantilena.

★★ *Fascinating Rhythm*. Yehudi Menuhin, Stephane Grappelli. EMI EMD 5523 Stereo/Quad.

Messrs. Menuhin and Grappelli from opposite poles of the musical world come together again to dispense their particular magic with songs of

Gershwin, Kern, and Cole Porter, supported by rhythm group of top session men. Each artist plays a solo, both composed by Stephane Grappelli. I hate to be harsh on such a fine artist, but Mr. Grappelli just cannot compete with the three finest song writers produced by Tin Pan Alley. If anything this new record is better than the first collaboration and will be a winner. Recording is faultless, the playing marvellous.

Peter Hurford at St. Albans. Argo ZRG 807.

Absolutely faithful organ tone produced by Chris Hazell with engineers Michael Miles and Ronald Cohen. Peter Hurford's programme raises doubts. Apart from *Voluntary in C* by blind Londoner John Stanley and Hurford's own *Suite*, the music was uninteresting to me. Frank's Chorale (No. 1) is the duller of the three. The pieces of Bosso and Gigout are mundane and even Hurford's exemplary technique could not warm me to William Mathias and Jean Langlais.

Organ Music from Canterbury Cathedral played by Alan Wicks. Polydor Select 2460 252 (Cassette 3170 240).

An impressive recording of popular organ music played by Alan Wicks on the Father Willis organ at Canterbury. Built in 1883 and rebuilt in 1939, 1948 and 1968 it features four manuals and a pedal board of 32 with 30 couplers making a total of 98 registers. Side one contains Bach's *Dorian* toccata and fugue plus Mendelssohn's lovely Sonata in B flat. The second side opens with a Widor March, and continues with Franck's *Pastorale*, and the fussy Scherzo by Bossi.

★ *The Kings' Singers Concert Collection. EMI CSD 3766. Stereo/Quad. Price: £2.99. (Cassette: TC-C5D 3766. Price: £3.25).*

Kings' Singers defy description. I cannot recall any other vocal group able to tackle a programme ranging from Tudor Songs through Renaissance Motets, French Chansons, Grieg Songs, to pop tunes like *Puppet on a String*. Also included is an original piece written for the singers, *History of the Flood* by Alan Ridout.

The Tudor Group is exemplary although I doubt if Tomkins, Morley and company would have envisaged two counter-tenors.

It goes without saying that the Singers respond to all moods in virtuoso fashion. Recording, produced by John Willan and engineered by Christopher Parker is very good.

Music of Old Vienna. Reader's Digest.

This appears to be a mixture of old reprocessed tracks side by side with newer recordings by the recently-formed National Philharmonic and London Festival Orchestra. Naturally sound quality varies but none of the items fall below an acceptable level. All in all, this is a highly desirable selection including music by Schubert, Lehar, Oscar Straus and Suppé, as well as the famous Strauss family.

I confess to be mystified by some tracks. *Blossom Time*, for example, is labelled as being arranged by Sigmund Romberg and certainly the music has a Romberg flavour about it. However the *Blossom Time* I remember was arranged by G. H. Clutsam and John Drinkwater. The story outlined on the sleeve seems to be that of *Lilac Time* also arranged by Clutsam but to lyrics by Adrian Ross. I can only presume that Romberg made yet another version of the Schubert story which I have not encountered.

Similarly the track announced as the *Count of Luxembourg Waltz* is a lovely piece, but I cannot match it with the score. Tracks made by the London Festival Orchestra are poor. Sad to say, conductor Eric Rogers just hasn't the right Viennese feeling. Perhaps he tries too hard but only succeeds in getting effects in the wrong places.

There are better versions of the operettas, but I was delighted to find that lovely old weepy-weepy *A Waltz Dream*. I consider it Oscar Straus's finest score and thoroughly enjoyed the long selection nicely sung and conducted by Lehman Engel.

Complete set costs £11.95 including a bonus record of popular overtures, available only from *Reader's Digest*, 25 Berkeley Square, London W1X 6AB.

★ *A Victorian Musical Evening. William Bennett (flute), Trevor Wye (flute), Clifford Benson (Schmidt piano). Pearl SHE 501. Price: £2.99.*

Apart from Chopin's lovely Nocturne in F sharp major, most of the music on this disc is sheer rubbish – and I enjoyed every minute of it! Right away the *Valse des Fleurs* by Italian born Ernesto Kohler charms, being a *morceau de salon* of the period impeccably played by William Bennett and Trevor Wye on flutes. *Concert Duet* by the same composer is more contrived. Other works for flute by Godard and Doppler are enjoyable and Clifford Benson plays a Schmidt piano sounding delightfully empty and typical of the poor quality instruments used in most homes.

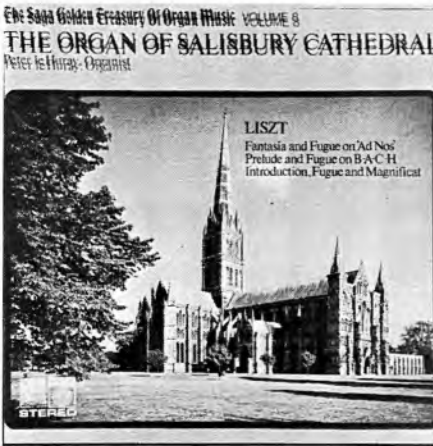

A record of immense charm and fascination, beautifully recorded.

Bargain Labels

Classics for Pleasure

CFP continues to produce high-quality recordings retailing at only £1.25.

Only complaint against the Tchaikowsky Overtures *Hamlet* and *Francesca da Rimini* (CFP 40223) is short measure as *Hamlet*, a twenty-minute work, takes up the whole of one side. Apart from that Vernon Handley directs the LPO in two splendid performances, well-recorded with only slight loss of pitch during some woodwind solos.

Beethoven's *Piano Concerto No. 1* and *Choral Fantasia* (CFP 40232) is a mixed bag. The orchestra's confident opening of the Concerto is marred by the pedantic C-Minor entry of soloist John Lill, who appears strangely uninspired. However, he soon warms to his task and turns in a lyrical Largo and robust Rondo. *Choral Fantasia* Op 80 is a unique setting of Burger's song *Gegenliebe* in the form of a Theme and Variations. Piano opens solo with orchestra gradually joining in and full chorus swelling the finale. Lill here plays with strength and is well supported by the Scottish National Chorus and Orchestra under Alexander Gibson.

Saga Records

Originally formed to market budget priced material the current Saga catalogue includes many new discs mostly of recitals or small ensembles, and in this field there are bargains to be picked up at a RRP of £1.25.

I enjoyed Livia Rev's first hook of Debussy *Preludes* (5391). I am not attracted to Debussy, but Miss Rev won me over completely with her excellent interpretations. She is both sharp and incisive (*Minstrels*) or muzzy and mysterious (*La Cathedrale Engloutie*). Recording is only fair and my copy had more than its share of surface noise, but Livia Rev produces some of the best Debussy playing I have heard.

**Elizabeth de la Porte* is a young harpsichordist from South Africa who on her first disc (5402) shows fine musical sense and attack. She uses two instruments, both by Michael Johnson. Mainly she plays on a two-manual copy of Couchet-Taskin which combines best characteristics of French and Flemish workmanship. When performing Elizabethan pieces she wisely changes to a single manual copy with two eight foot stops. Her programme is varied and enjoyable and the good recording makes this a most desirable issue.

Lisztomania (5405) is named to catch film-goers, but in reality is a straightforward recital given by David Wilde. He is a Liszt specialist with good technique and confident attack marred only by poor pedalling. He produces some exciting playing of the popular 2nd and 14th *Hungarian Rhapsodies* but, for me, the high spot is the breathtaking way he tackles the fearsome left-hand octaves in *Funerailles*.

Peter Le Huray at the Organ of Salisbury Cathedral (5401) plays three major organ works by Liszt: *Ad nos, ad salutarem undam*, *Prelude and Fugue on Bach*, and *Introduction Fugue and Magnificat* arranged by Gottschlag. All were composed for the Merseburg Cathedral organ which has similar specification to the Father Willis at Salisbury. Peter Le Huray gives a grand musical account and recording is good.

In Schubert's *Best Loved Songs* (5404), tenor Martyn Hill displays sound technique and excellent breath control. All the old favourites are here except for those unsuitable for tenor voice. Hill and his partner, Nina Walker, give pleasing performances which only lack the ultimate intensity needed to illuminate Schubert's genius.

Pickwick International

A new series launched last summer, Camden Classics Victrola, features re-issues of RCA

labels up to twenty years old. Sound is acceptable if not of the highest quality, but interest centres on performances of crack American orchestras. In nearly every case performance overcomes any reservations on dated sound. Selling at £1 these are first-rate bargains and all are available on cassette at £1.75.

Big attraction for me was the Mozart *Clarinet Concerto* and *Quintet* (CCV 5006) played by that old Master of Swing Benny Goodman. He gives a good account of the concerto if a little closely recorded. Quintet is better-balanced and Goodman is at his best in the expressive *Larghetto*.

Bolivian violinist Jaime Laredo plays both *Bach A minor* and *Mozart G major* on CCV 5041. His Mozart is lyrical and happy and he is supported here by Howard Mitchell with the National Symphony Orchestra. The Bach is less praiseworthy. Opening ritornello is taken at a deliberate pace by Munch who appears to have the whole weight of the Boston Strings behind him. Not for the purists, although Laredo copes well with the solo arabesques of the slow movement. This side is short measure at only 15 minutes, but at £1 it would be pointless to complain.

Chicago Symphony conducted by Fritz Reiner give a fine performance of the Strauss bombastic tone poem *Also Sprach Zarathustra* (CCV 5040). Recording falls short of modern standards but is adequate for cheaper equipment.

Band music

Regimental Band of the Queen's Own Hussars. Grosvenor GRS 1036. Price: £2.50

This sounds a moderate-sized band slightly overweighted in the bass. Side One is devoted to Regimental Calls and traditional tunes culminating in *Evening Hymn* with *Cavalry Last Post*, a slight variation on the usual theme. Side Two comprises a typical concert in which several bandsmen are given a chance to shine. The band plays with zest and the enterprising programme contains delightful numbers such as *Polka Party* and *Rimbalzello*, a swing setting à la Joe Loss. *Wonderland by Night* features the impressive trumpet of L'Cpl Steve Croney, who also plays the Calls on Side One. There is obviously a large public for military bands, but this gay and happy record should appeal to all lovers of light music. Recording is good, but my copy had some surface noise.

★ *Colonel Bogey On Parade Vol. 2. Polydor Super 2382 362 (Cassette 3170 262). Price: £2.95*

The Band of HM Royal Marines in a fine re-

recording of music by Kenneth Alford. My only moan is the inclusion of the inevitable 'Musical Switch', a speciality of Alford. Here we have not one, but three! However, the remainder of the programme is varied including my favourite Alford March *The Mad Major* and one of his last—*Eagle Squadron*, together with a couple of popular xylophone solos and the waltz *Thoughts*. The recording, a Chandos production, was made in the Guildhall, Portsmouth.

Electronic and New Music

★ *MUSSORGSKY: Pictures at an Exhibition. Isao Tomita on electronic synthesiser. RCA ARL1-0838. Price: £2.99*

Isao Tomita follows up his successful synthesis of Debussy with similar treatment of Mussorgsky. Somehow this does not seem such a sacrilege. Perhaps Mussorgsky's robust tunes can take it more than delicate Debussy. This can be fun in small doses and makes an excellent demonstration disc, although as a work of art it is inferior to the rock version by Emerson, Lake and Palmer.

Tomita simulates the human voice both solo and in choir to great effect and the *Ballet of the Unhatched Chickens* is a riot.

GEORGE CRUMB: Music for a Summer Evening. Makrokosmos 2. Nonesuch H71311. Price: £1.85

This is a long piece for two amplified pianos



Motor: four-pole dynamically-balanced high torque synchronous 240V 50Hz. PU arm: low mass square section aluminium, viscous cueing device ensures featherlight touchdown of stylus. Finish: satin black mainplate and a combination of black and silver on tonearm, turntable and control panel. Price: (chassis unit) £27.72 (excluding VAT); (complete with plinth) £45 (excluding VAT).

BDS90

Transcription engineered unit with gimbal style tonearm. Slider controls. Chassis or plinth mounted with ADC-K5E magnetic cartridge. Speeds: 33 $\frac{1}{3}$ and 45rpm. W and F: typically $\pm 0.13\%$. Rumble: typically -58dB . Turntable: precision machined non-magnetic alloy, weighing 4lb. Belt drive. Motor: dynamically balanced high torque, synchronous four-pole motor. PU arm: low resonance tubular aluminium located in a concentric gimbal style with calibrated balance adjustments. Finish: satin black mainplate and a combination of black and silver on tonearm and control panel. Price: (chassis unit) £33.57 (excluding VAT); (with plinth and cartridge) £52.05 (excluding VAT).

MP60

Single player with low mass PU arm available in chassis form and with plinth and dust cover. Speeds: 33, 45, 78rpm. Wow: better than 0.2%. Flutter: better than 0.06%. Turntable: 11in. diameter, diecast alloy. Motor: four-pole, 240V 50Hz. Features include slide-in cartridge carrier, bias compensator, cue/pause lever, automatic pick-up arm lock, simple linear controls. Price: £19.18 (excluding VAT).

■ MICRO

Howland-West Ltd, 3-5 Eden Grove, London N7 8EQ.

Tel: 01-609 0203.

DD5 ★

Mounted on solid plinth with perspex cover, fitted shock absorbent feet. Speeds: 33 $\frac{1}{3}$, 45rpm. W and F: 0.03%. Rumble: 60dB. Turntable diameter 31cms. Direct drive, brushless DC servo motor. Static balance pickup arm. Price: £150.00 (plus VAT).

Solid 1★

Mounted on solid plinth with perspex cover complete P/U arm. Speeds: 33 $\frac{1}{3}$, 45rpm. W and F: $>0.06\%$. Rumble: 48dB. Turntable diameter 30cms. Belt drive, 4 pole synchronous motor. Static balance p/u arm. Price: £58.00 (plus VAT).



Micro DD5



Micro Solid 1

MB300

Turntable unit only. Speeds: 33 $\frac{1}{3}$ and 45rpm. W and F: $<0.1\%$. Rumble $<-48\text{dB}$. Turntable: 12in diecast alloy, 2 $\frac{1}{2}$ lb. Belt drive. Four-pole hysteresis motor. Pushbutton speed selection. Price: £48 (plus VAT).

MB600

Turntable only. Speeds: 33 $\frac{1}{3}$ and 45rpm. W and F: $<0.05\%$. Rumble: $<-52\text{dB}$. Turntable: 12 $\frac{1}{2}$ in cast aluminium alloy, 3lb. Belt drive. Eight-pole hysteresis synchronous motor. 100-240V AC. Pushbutton speed selection. Price: £60.00 (plus VAT).

MR-322

Belt drive turntable assembly. 4-pole hysteresis synchronous outer rotor motor. Two

★ Indicates entry is illustrated

speeds. 30cm aluminium platter weighing 1kg. Power consumption: 12W. W and F: less than 0.08%. S/N ratio: better than 48dB. Size: 45.9 × 36.5 × 17.1cm. Total weight: 8.5kg. Static balance tone arm. Tracking error: below 1.5 degrees. Cartridge weight: 4-11gm. Tracking weight: 0.4gm. Lift/lower tone arm adjusted by slide control. Individually height adjustable shock absorbers fitted to plinth. Price: £90.00 (plus VAT).

DD-1

Direct drive turntable assembly. Two speeds. 30cm 1.2kg diecast aluminium turntable. Power consumption: 5.4W. W and F: less than 0.045%. S/N ratio: more than 55dB. Static balanced type tone arm. Max. tracking error: less than 1.5 degrees. Incorporates brushless direct drive motor and DC servo mechanism. Price: £130.00 (plus VAT).

■ MONOGRAM (MPA)

281 Balmoral Drive, Hayes, Middlesex.
Tel: 01-573 1566

Manually operated and fitted with hinged cover. Aluminium die-cast platter 50-60 Hz. Direct drive. DC servo-controlled motor with speeds 33½ and 45rpm. W and F: 0.03%. Rumble: -70dB. SME 3009 tone arm (export only); Price: Mechanical speed control Price: £125.00, Electronic solenoid operated with SME: £195.00, electronic solenoid operated no arm: £140.00 (all plus VAT).

■ NORDMENDE

Vessco Vision and Radio Ltd, Vessco House, Unit 4, Blackwater Way, Ash Road, Aldershot, Hants. GU12 4DL.
Tel: Aldershot 312661.

Quadronada PII

Automatic turntable chassis using Dual 1228 and Shure M91 MG-D. Manual and auto with

auto-change facility. Speeds: 33½ and 45rpm. Pitch control variation. Turntable 27cm diameter. Magnetic pickup. Speed accuracy variation. Turntable 27cm diameter. Magnetic pickup. Speed accuracy variation <0.09%. Rumble: >59dB Price: on application.

Quadronado PIII

Automatic player deck, interchangeable manual or auto play. Speeds: 33½, 45, 78rpm. Variable pitch adjustment. Dual synchronous continuous pole motor. Turntable diameter 30.5cm. Stroboscopic light. Speed accuracy deviation <0.09%. Rumble >59dB. Price: on application.

■ OMEX PRODUCTS LTD

Hereford House, Wandle Mills, Beddington, Croydon, Surrey CR0 4SB.
Tel: 01-686 9022.

Discomex 1000

BSR P152 with speeds 33½, 45 and 78rpm. SC12M cartridge with ST16 stylus. Output: 13 Watts. Leather in black and grey. Dimensions: 76 × 43 × 18.5cms. Mixing and fade controls. Cueing device, mic sockets and tape sockets. Price: £163.14 (plus VAT).

■ PHILIPS

Philips Electrical Ltd, Century House, Shaftesbury Avenue, London WC2H 8AS.
Tel: 01-437 7777.

GA209 ★

Turntable complete with pickup arm, GP 412 magnetic cartridge, plinth and transparent cover. W and F: ≤0.08%. Rumble: ≤-43dB (DIN A), ≤-65dB (DIN B). Arm friction: ≤10mg force horizontal and vertical. Side thrust compensation: tension spring principle, adjustable for spherical and elliptical styli. Stylus force: 0.75-3gm adjustable, calibrated. Speeds: 33½, 45 rpm. Belt driven. Speed adjustment range: ±3%. Turntable diameter: 294mm (11½in.). Turntable weight: 1.17kg (2.56lb). DC motor, combined with tachogenerator and electronic speed control. Headshell: slide-in carrier for standard ½in fixing cartridges. Cartridge: GP 412 magnetic with diamond elliptical LP stylus. Signal output: 1.2mV/cm/sec. Controls: mains on/off. PU lift and lower illuminated touch sensitive controls. Servo motors: 2 × DC motors for automatic and manual movement of PU arm. Mains: 110, 127, 220, 240V AC 50/60Hz. Dimensions: 445 × 340 × 165mm. Weight: 9kg (19½lb). Price: £132.00 (plus VAT).



Philips GA209

The new PL-112D will take a lot of knocking.

Why?

Because like the rest of the new range, the PL-112D's tonearm and platter are now both independently sprung from the cabinet in a revolutionary 'Double Floating' system. So if you knock the cabinet while you're playing a record, the tonearm won't jump — your records and stylus last longer.

Other features include a new rubber material in the counter weight which cuts out howling and adverse tonal effects. Plus a new anti-vibration cabinet.

For more details on the PL-112D and the rest of the Pioneer turntable range, write to: Shriro (UK) Ltd., Shriro House, The Ridgeway, Iver, Bucks. SL0 9JL. Telephone: Iver (0753) 652222.

 **PIONEER®**





The turntable that's revolutionised hi-fi.

It's been a long time since anything revolutionary happened in hi-fi. But now we have the world's first automatic direct drive turntable with electronic track selection and computerised memory bank.

The ADC Accutrac 4000.

Once your record is in place, you can walk across the room with the cordless transmitter, casually operating it and selecting the tracks in any order you like.

We could talk for hours about the superb sound reproduction and the many remarkable features, but there's nothing so convincing as a demonstration.

That says it all.

ADC AccutracTM 4000
It remembers everything.

Distributed by BSRLimited, Powke Lane,
CradleyHeath Warley, West Midlands B64 5QH.

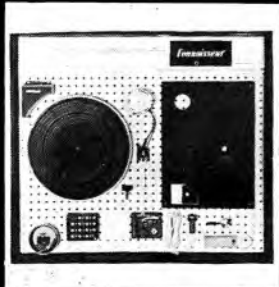

Connoisseur Sound Design



Top left: The BD1 Turntable Kit.
Right: The BD3 Transcription Unit.



Top: The SAU2 pick up arm.
Top Right: The BD2 Turntable Assembly.

New From Connoisseur - BD3 Transcription Unit

With a studio style rising turntable giving accurate cueing. Run up time is only a fraction of a second. Other important features include an external power source and consequently no hum field. A belt driven turntable with neon illuminated stroboscopic disc with 3 speeds, 33, 45 and 78 - all featuring variable control. The BD3 arm is lightweight and incorporates a unique method of magnetic stabilisation with an interchangeable head shell tracking cartridge down to 0.6 grams. The unit features brushed aluminium trim and is mounted on a matched wooden plinth complete with acrylic dust cover.

BD2 Turntable Assembly

The famous BD2 belt drive turntable features push button speed change, an SAU2 pick up arm with damped lowering device, brushed aluminium trim, and specially designed turntable mat. It is available in chassis form, or as illustrated mounted on a slimline wooden plinth, with acrylic cover which features an easy hinged on hinged off movement.

BD1 Turntable Kit

The BD1, well known for its excellent performance and superb quality is available in kit form, which allows greater freedom of choice for the practical enthusiast with regard to mounting, selection of arm etc. Construction is simplicity itself with no soldering required. Now it's easy to own the best.

SAU2 Pick Up Arm

Recognised as one of today's most advanced pick up arms. Among its star features is an Auto Bias compensator, hydraulic lowering device, precision balance and an adjustable head shell which can be matched to a wide variety of decks and pick up cartridges, ideal for the demanding practical audiophile. For further details of all Connoisseur products, the BD3 or BD2, the BD1 kit or SAU2 arm, to the still popular SCU1 cartridge and our precision stylus balance, please contact your dealer or send a stamp for brochure.

Manufactured by:-
A. R. Sugden & Co. (Engineers) Ltd.
Atlas Mill Road, Brighouse,
Yorkshire, HD6 1ES.
Telephone: Brighouse (04847) 2142
Telegrams & Cables: Connoisseur, Brighouse.

Connoisseur



Philips GA212

GA212 ★

Integrated turntable, pickup arm and cartridge mounted on walnut veneered plinth with hinged tinted plastic lid. Speeds: 33 $\frac{1}{3}$, 45rpm. Fine speed adjustment: $\pm 2\%$. W and F: $< 0.1\%$. Rumble: $< 62\text{dB}$ (DIN B). Turntable: 11 $\frac{1}{4}$ in diameter steel, 2 $\frac{1}{2}$ lb. Belt drive. Motor: DC type with tachogenerator giving electronic control, obviates the need for a heavy flywheel type platter. Lightweight tubular gimbal-mounted pickup arm. Decoupled counterweight. Bias compensation. Stylus pressure adjustment. Standard $\frac{1}{2}$ in headshell, with slide-in cartridge carrier. Electronic touch controls for speed selection, start and stop. Light beam operated auto-stop. Viscous damped pickup arm raising and lowering device. Supplied complete with Philips GP400 cartridge. Mains: 110, 127, 220, 240V 50-60Hz. Size: 15 $\frac{1}{4}$ \times 6 \times 14 $\frac{1}{2}$ in. Price: £85.60 (plus VAT).

GA227

Two-speed turntable complete with arm and cartridge. Speeds: 33 $\frac{1}{3}$ and 45rpm. Motor: 24-pole synchronous. W and F: 0.2%. Rumble: $\leq 35\text{dB}$ (DIN A), $\leq -55\text{dB}$ (DIN B). Side-thrust compensation: adjustable both for spherical and elliptical (bi-radial) styli. Pick-up cartridge: GP 400, Super M. Pickup lift: viscously damped. Mains: 110, 127, 220, 240V AC 50Hz only. Power consumption: 5W. Size: 360 \times 123 \times 290mm. Cabinet: polystyrene base, silver finish (friction hinged cover). Weight: 3.5kg approx. Price: £44.80 (plus VAT).

GA418

Two-speed turntable complete with arm and cartridge. Speeds: 33 $\frac{1}{3}$ and 45rpm. W and F: 0.14%. Rumble: $\leq -40\text{dB}$ (DIN A), $\leq -60\text{dB}$ (DIN B). Side-thrust compensation; adjustable both for spherical and elliptical (bi-radial) styli. Pickup cartridge: GP 400, Super M. Hydraulically-damped pickup lift. Synchronous motor. Mains: 110, 127, 220, 240V AC 50Hz. Power consumption: 1.7 W. Cabinet: polystyrene base, silver finish (friction hinged

cover) Size: 415 \times 142 \times 355mm. Weight: 5.9kg. Price: £68.00 (plus VAT).

GA427

Turntable complete with arm and cartridge. It features a 254mm (10 $\frac{3}{8}$ in) dia. belt-driven turntable with anti-static mat, driven from a low-speed synchronous motor. The pick-up arm is complete with GP400 magnetic cartridge mounted on a slide-in carrier, and a calibrated gauge allows easy adjustment of stylus pressure. Side thrust compensation is effected by means of a tension spring below the deck, and is fully adjustable by using a calibrated rotary control on the top surface of the deck. W and F: $\leq 0.2\%$. Rumble: $\leq -35\text{dB}$ (DIN A), $\leq -55\text{dB}$ (DIN B). Stylus pressure: 2-4gm adjustable, calibrated. Speeds: 33 $\frac{1}{3}$ and 45rpm, belt-driven. 24-pole synchronous motor. Controls: speed change, stop, pickup lift/lower, stylus pressure, sidethrust compensation. Size: 390 \times 338 \times 127mm. Weight: 4kg. Mains: 110, 127, 220, 240V AC 50Hz, 5W. Price: £52 (plus VAT).

GA222

Complete with plinth, arm, cover and GP 401 magnetic cartridge. Speeds: 33 $\frac{1}{3}$, 45rpm. W and F: $< 0.08\%$. Rumble: -62dB . Speed adjustment range $\pm 3\%$. Drift $< 0.2\%$. Turntable: 29.5cm diameter with stroboscopic rings. Belt drive. DC motor with frequency controlled tachogenerator. Stylus force adjustable to 0.3gm. Touch controls. Automatic arm return. Price: to be announced.

■ PIONEER

Shriro (UK) Ltd, Shriro House,
The Ridgeway, Iver, Bucks SL0 9JL.
Tel: Iver 652222/7.

PL-112D ★

Integrated turntable and arm with plinth and cover. Speeds: 33 $\frac{1}{3}$ and 45rpm. W and F: not more than 0.07% WRMS. S/N ratio: 50dB. Aluminium alloy die cast turntable, 12in (300mm) diameter. Belt drive. 4-pole synchronous motor. Static balance type S-shaped pipe arm. Usable cartridge weight 4gm (min) to 10gm (max). Anti-skating device, plug-in headshell. Viscous damped cueing device. Lateral balance. Free adjustable hinges. Price: on application.

PL-117D ★

Fully automatic integrated turntable with plinth and cover. Speeds: 33 $\frac{1}{3}$ and 45rpm. W and F: not more than 0.07% WRMS. S/N ratio: 50dB. Aluminium alloy die cast turntable, 12in (300mm) diameter. Belt drive system. 4-pole



Pioneer PL-112D



Pioneer PL-117D

synchronous motor. Static balance S-shaped pipe arm. Usable cartridge weight 4gm (min) to 10gm (max). Double floating suspension system. Fully automatic arm mechanism. Free adjustable hinges. Price: on application.

PL-510

Integrated turntable and arm with plinth and cover. Speeds: 33 $\frac{1}{3}$ and 45rpm. W and F: not more than 0.03% WRMS. S/N ratio: more than 60dB. Aluminium alloy die cast turntable, 12in (300mm) diameter. Direct drive system. Brushless DC servo-controlled motor. Static balance type S-shaped pipe arm. Usable cartridge weight 4gm (min) to 10gm (max). Double floating suspension system. Fine speed adjustment. Plug-in type headshell. Free adjustable hinges. Price: on application.

ROTEL

Rank Audio Visual Ltd,
Great West Road, Brentford TW8 9HR.
Tel: 01-568 9222.

RP-1000 ★

Belt-driven turntable with tone arm, plinth and cover. 4-pole hysteresis synchronous motor. 12in diameter aluminium diecast platter. W and F: less than 0.2% WRMS. S/N ratio: better than 45dB overall. Speeds: 33 $\frac{1}{3}$ and 45rpm. Stylus pressure: 0.4gm. Power consumption: 10W. Size: 47 × 35 × 20cms. Total weight: 8kg. Price: £75.60 (plus VAT).

RP-3000

Direct-drive driven turntable with arm, plinth and cover. Pulse-determinant AC servo motor. Speeds: 33 $\frac{1}{3}$ and 45rpm. Speed control change: $\pm 5\%$. W and F: less than 0.05% WRMS. S/N ratio: better than 60dB. Full-size aluminium alloy diecast platter (310mm) with embossed strobe markings on trim. Static balanced S-shaped tone arm, with plug-in headshell, oil-damped cueing device, direct readout stylus gauge counter-weight, anti-skating device. Mains: 100-120V 50/60Hz or 220-240V 50/60Hz. Power consumption: max. 10W. Size: 470 × 35 × 19cms. Total weight: 7.7kg. Horizontal spirit level meter, 45rpm EP adaptor with overhang readout, height adjustable insulator legs, removable free-stop hinge dust cover, low capacitance phono cords, strobe light housing. Price: £119.92. Without arm £98.00 (plus VAT).

RP-2500

Semi-automatic deck. Speeds: 33 $\frac{1}{3}$, 45rpm. W and F: less than 0.05%. Speed controls variable by $\pm 5\%$. Turntable 12in diameter. Belt drive. FG DC servo motor. Static balanced S-shaped pipe arm, plug-in headshell. Counter weight. Anti-skating device. Teak finish. Semi-



Rotel RP-1000

★ Indicates entry is illustrated

automatic. Reject facilities. Strobe markings. Five speed controls. Strobe light. Price: £84.40 (plus VAT).

RP-1500

Manual versions of RP 2500. Price: £70.00 (plus VAT).

■ SANSUI

Vermtron Ltd, Thornhill,
Southampton SO9 5QF.
Tel: Southampton 444811.

SR212

Semi-automatic return complete with pickup arm, plinth and cover. Speeds: 33 $\frac{1}{3}$ and 45rpm. W and F: 0.1% RMS. S/N: 45dB. Platter: aluminium alloy diecast, 300mm. Motor: 4-pole synchronous. Belt drive. Tonearm: statically balanced tubular. Length: 215mm, overhang: 100mm, bias compensation. Cueing device. Fitted with induced magnet cartridge SC-37. Size: 442 × 166 × 352mm. Price: £62.88 (plus VAT).

SR313 ★

Two-speed, belt-driven turntable. Four-pole synchronous motor. W and F: less than 0.6% RMS. S/N ratio: better than 50dB. Statically balanced S-shaped tubular tonearm with anti-skating device. Supplied complete with dust cover and cartridge. Size: 464 × 380 × 185mm. Price: £134.26 (plus VAT).

SR222

Manual 2-speed belt-drive turntable, 33 $\frac{1}{3}$, 45 rpm. W and F: 0.07%. Rumble: better than -60dB. S-shaped tone arm. Price: to be announced.

SR525

Direct-drive electronic transcription turntable. Manual single play. W and F: 0.03%. Rumble: better than -72dB. Statically balanced S-shaped tone arm. Price: £145.49 (plus VAT).



Sansui SR313



Sanyo TP700SA

■ SANYO

Sanyo Marubeni (UK) Ltd,
Bushey Mill Lane, Watford WD2 4UQ.
Tel: Watford 30421.

TP700SA ★

Transcription unit, two speeds, 33 $\frac{1}{3}$ and 45rpm. 4-pole synchronous motor. Belt driven. S bend static balance tone arm with a double counterweight for easy adjustment when changing cartridge. Die cast aluminium platter weighing 2.4lb. Fitted with magnetic cartridge and diamond stylus. Finish: teak with smoked perspex lid. Price: £85.95 (including VAT).

■ SKANTIC

Skantic (UK) Ltd, Station Road, Edenbridge,
Kent TN8 6EY.
Tel: Edenbridge 5231.

42212

Semi-automatic two-speed turntable. 16-pole synchronous motor. Anti-skating device. Stylus pressure: 1.5-3gm. W and F: 0.05%. S/N ratio: -62dB. Belt drive. Switchable automatic stop. Single lever operation of start, stop and tonearm lift. Fitted with Shure M75MB type 2 magnetic cartridge with diamond stylus. Transparent lid. Cabinet finished in teak, walnut, rosewood and white or black lacquer. Price: on application.

■ SONAB

Sonab Ltd, 214 Harlequin Avenue,
Brentford TW8 9EW.
Tel: 01-568 2952/3.

855

Counter-weighted pickup arm, plinth, hinged dust cover and Ortofon F15EO cartridge. Speeds: 33 $\frac{1}{3}$, 45rpm. W and F: less than ±0.08%. Rumble: better than -60dB. Speed constancy: less than ±1%. Non-magnetic alloy turntable, 300mm diameter. Weight: 1.2kg. Belt-drive. 4-pole synchronous motor. Statically and dynamically balanced adapted for



Sonab 67S

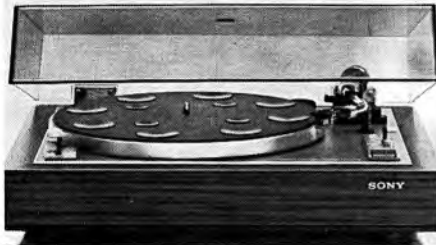

Sony PS1350

minimum distortion due to angle deviation. Auto bias and cue. Finish: black matt. Price: £88 (excluding VAT).

67S ★

Counter-weighted pickup arm, plinth, hinged dust cover and Shure M75ED II cartridge. Speeds: 33 $\frac{1}{3}$, 45rpm. W and F: less than 0.08%. Rumble: better than -60dB. Speed constancy: less than $\pm 1\%$. Non-magnetic alloy turntable, 300mm diameter. Weight: 1.2kg. Belt drive. 24-pole synchronous motor. Needle and ball bearing statically balanced, free from resonances. Adjustable anti-skating and damped cue. Finish: black matt. Price: £88 (excluding VAT).

■ SONY

Sony (UK) Ltd, Pyrene House, Sunbury Cross, Sunbury-on-Thames. Tel: Sunbury 87644.

PS 5011

Manually operated turntable unit with variable speed control. Drive system: idler drive. Motor: induction. W and F: $\pm 12\%$ DIN. S/N ratio: 59dB weighted. Static balance tonearm. Anti-skating adjustment. Channel separation: 21dB at 1kHz. Load impedance: 47K. Output voltage: 4mV at 1kHz. Tracking force: 2-4gm. Stylus: conical, 0.7mil diamond. Mains: 240V AC 50Hz. Size: 446 x 162 x 361mm. Price: on application.

PS 4750

Servo controlled direct drive turntable unit. Two-speed. W and F: $\pm 0.045\%$ DIN. S/N ratio: 70dB DIN. Static balanced tonearm. Built-in illuminated stroboscope. Mains: 110, 127, 220 and 240V AC 50/60Hz. Size: 477 x 175 x 420mm. Weight: 8.9kg. Price: on application.

PS 1350 ★

Semi-automatic integrated turntable, mounted on walnut plinth with tinted perspex lid, complete with VL32G cartridge. Speeds: 33 $\frac{1}{3}$, 45rpm. Wow: 0.08%. Flutter: 0.06%. S/N ratio: 63dB. Turntable: 30cm. Belt-drive, 4-pole semi-synchronous motor. Static balance tone-arm, stylus force adj. range 0-3g. Anti-skating. Cueing facilities. Newly designed discmat for effective damping of disc vibration. Price: £63.96 (plus VAT).

PS 2350

Main details as per PS 1350. Lateral balance weight on pickup. Detachable head shell and dust cover. Price: £71.96 (plus VAT).

PS 6750

Manual integrated direct drive turntable, mounted on plinth complete with dust cover. Supplied without cartridge. Speeds: 33 $\frac{1}{3}$, 45rpm. W and F: 0.045%. S/N: 70dB. Speed control range: $\pm 4\%$. Turntable 32cm diameter. Direct drive. DC servo controlled motor. Static balanced tone arm made from carbon fibre. New low resonance construction, fluid filled platter mat for disc isolation, built-in illuminated stroboscope, anti-static grid on dust cover prevents static influencing tone arm tracking performance. Price: £147.96 (plus VAT).

■ SOUND IDEAS

216 Brampton Road, Bexleyheath, Kent. Tel: 01-303 9272.

Specialists in manufacture of turntable plinths. All plinths include a special de-coupled and suspended motor board designed to minimise rumble/acoustic feed back.

DC 1 Plinth ★

For Garrard 301/401 motor and any arm combined. Price: £27.50. Others from £17.50 (plus VAT).

■ STRATHEARN

Strathearn Audio Ltd, Kennedy Way Industrial Estate, Belfast, N. Ireland. Tel: Belfast 663335.

STA4

Integrated automatic/manual electronic servo

★ Indicates entry is illustrated

direct-drive turntable with plinth fitted with low mass arm. Speeds: 33 $\frac{1}{3}$, 45rpm. W and F: 0.11% weighted peak, 0.2% unweighted peak. Rumble: -60dB DIN B (Ref: 10cm/sec). Aluminium turntable, 277mm diameter. Weight: 1.6kg. Motor: electronic servo controlled 110/240V 50/60Hz. Low mass pivoted arm. Semi-automatic single play deck. Price: on application.

SMA2 ★

Integrated manual turntable with electronic servo direct-drive, touch controls and low mass arm. Speeds: 33 $\frac{1}{3}$, 45rpm. W and F: 0.08% weighted peak, 0.15% unweighted peak. Rumble: -65dB DIN B (Ref: 10cm/sec). Aluminium turntable, 300mm diameter. Weight: 0.82kg. Electronic servo controlled 110/250V 50/60Hz. Low mass friction pivoted arm. Electronic touch switch control, electronic strobe, variable speed, low profile. Price: on application.



Sound Ideas DC 1 Plinth



Strathearn SMA2



Telefunken W258

■ TELEFUNKEN

AEG-Telefunken (UK) Ltd, Bath Road, Slough, Bucks.

Tel: Slough 33311.

W258 ★

Record changer complete with plinth and cover. Speeds: 33 $\frac{1}{3}$, 45 and 78rpm. Fine speed adjustment $\pm 3\%$. W and F: better than $\pm 0.1\%$ DIN. Rumble: better than 59dB DIN. Platter: 10 $\frac{1}{2}$ in, 4 $\frac{1}{2}$ lb, diecasting. Pulley drive. Motor: induction-type, 110-220V. Tonearm: tubular with adjustable counterweight, anti-skating device separately calibrated for conical and elliptical styli. Fitted with Shure M91ME cartridge. Stroboscope, antic-static mat, changer spindle, damped cue control, single and auto changer. Price: £119.50 (including VAT).

S500

Two-speed record deck. Opto-electronic end-of-play cut-out and pick-up arm lift. Pressure diecast turntable 12in diameter, 5 $\frac{1}{4}$ lb. Fine speed adjustment ($\pm 5\%$). Illuminated stroboscope on outer rim of turntable. Belt drive with tachometer governed direct-current motor. Studio transcription arm (Ortofon AS212). Manual lift. Magnetically acting anti-skating adjustment with setting scale. Adjustable stylus pressure with counterweight. Foot-fall sound absorption by joint-spring-mounting of the turntable and pickup arm. Tinted cover. Casing: metal, black and silver. Size: 17 \times 5 $\frac{1}{2}$ \times 14in (including cover). Price: £145 (including VAT).

W240

Turntable complete with pickup arm, plinth and cover. Two speeds 33 $\frac{1}{3}$ and 45rpm. Heavy balanced turntable, spring mounted chassis. Pickup arm with adjustable counterweight. Manual pickup arm lift. Automatic record size selector. Shure M75-6SM cartridge. Fine speed adjustment ($\pm 3\%$). Price: £79.20 (plus VAT).



Teleton S 100G

Liftomat G

Fitted with pickup arm, tinted cover. Speeds: 33 $\frac{1}{3}$, 45, 78rpm. Large, heavy turntable. 240V motor. Pickup arm fitted with sapphire cartridge. Cabinet styled in metal look, black and silver. Price: £27.40 (plus VAT).

■ **TELETON ELECTRO (UK) CO LTD**

Teleton House, Waterhouse Lane,
Chelmsford, Essex CMI 3DW.
Tel: 01-857 7633.

S 100G ★

Record deck mounted in silver and black cabinet with hinged plastic lid. Speeds: 33 $\frac{1}{3}$, 45 rpm. W and F: 0.1%. Turntable: 12in aluminium die cast, belt driven. Bias compensated arm with fine stylus force adjustment. Magnetic cartridge with 0.5 mil diamond stylus and plug-in headshell. Price: on application.

S 200 W ★

as S100G but in teak-grain wood finish. Price: on application.

■ **THORENS**

Metrosound Audio Products Ltd,
Cartersfield Road, Waltham Abbey,
Essex EN9 1JF.
Tel: Lea Valley 712712.

TD125 Mk 11

Transcription turntable. Three speeds: 33 $\frac{1}{3}$, 45 and 16 $\frac{2}{3}$ rpm. With $\pm 2\%$ electronic speed control. Low speed synchronous motor, belt driven. Motor is transistor governed. Neon-lit strobe. 12in non-ferrous turntable. W and F: 0.09%. Plinth and cover available, also mounting frame if cabinet mounted. Price: £106.50 (plus VAT).

TD125AB Mk 11

Details as for TD25 but complete with TP16

pickup arm and plinth. Price: £165.00 (plus VAT).

TD160C

Transcription turntable with integrated pickup arm. Speeds: 33 $\frac{1}{3}$ and 45rpm. TP16 pickup arm. Pw: adjustable 0.5 to 4gm. Magnetic bias compensation device. Complete with smoke grey cover. Price: £91.00 (plus VAT).

TD160BC

As TD160C but without TP16 tonearm. Fits mounts suitable for SME 3009 tone arm. Price: £74.50 (plus VAT).

TD145 ★

Transcription turntable with integrated TP16 tone arm. Two speeds: 33 $\frac{1}{3}$ and 45rpm. W and F: 0.06%. Rumble: -65dB. Turntable diameter 12in. With automatic shut and lift-off. Complete with plinth and cover. Price: £115.50 (plus VAT).

TD166

Plinth mounted with cover and pickup arm. Speeds: 33 $\frac{1}{3}$ and 45rpm. W and F: 0.06%. Rumble: -65dB weighted. Turntable 12in diameter. High torque belt drive. 16-pole synchronous motor 110-125V, 210-240V AC 50/60Hz convertible. Pickup arm: TP11 dynamically balanced with bias compensator. Teak finish. Price: £79.00 (plus VAT).

TD126AB

Plinth mounted with pickup arm and cover. Speeds: 33 $\frac{1}{3}$, 45, 78rpm. Belt drive. TP16 dynamically balanced magnet with bias compensator. Teak finish. Electronic auto stop and lift. Functions selected by user. Price: to be announced.

■ **TOSHIBA (UK) LTD**

Toshiba House, Great South West Road,
Feltham, Middlesex.
Tel: 01-751 1281.



Thoren TD145

★ Indicates entry is illustrated



Toshiba SR-355

SR220

Plinth mounted with arm but without cartridge. Speeds: 33 $\frac{1}{3}$ and 45rpm. W and F: 0.08% WRMS. Rumble: 48dB. Turntable 30cm diameter. Belt drive. 16-pole hysteresis synchronous motor. S-shaped pickup arm, spring adjusted. Bias compensation. Cueing lever. Woodgrain plinth with smoked acrylic cover. Price: on application.

SR355 ★

Plinth mounted with arm but without cartridge. Speeds: 33 $\frac{1}{3}$, 45rpm. W and F: 0.04%. Rumble: 60dB. Turntable 30cm in diameter. Direct drive. DC servo motor. S-shaped arm, spring adjusted. Cueing lever. Woodgrain plinth. Smoked acrylic cover. Price: on application.

SR370

Plinth mounted without arm. Speeds: 33 $\frac{1}{3}$, 45rpm. W and F: 0.04%. Rumble: 60dB. Turntable 30cm diameter. DC servo motor. Designed to take SME pickup arm. Price: on application.

SR255

With arm on A.D. Solid steel base with A.D. solid platter - without cartridge. Speeds: 33 $\frac{1}{3}$, 45rpm. W and F: 0.05% WRMS. Rumble: 58dB. Turntable 33cm diameter. Direct drive DC servo motor. S-shaped spring adjusted arm. Bias control and cueing device. Direct reading tracking weight. Smoked acrylic cover. Price: on application.

■ TRIO

B. H. Morris and Co Ltd, Trio House,
The Hyde, London NW9 6JP.
Tel: 01-205 6441.

KD 500

Pickup arm not supplied. Cutout for SME.

Plinth mounted. Speeds: 33 $\frac{1}{3}$, 45rpm. W and F: less than 0.03% WRMS. Rumble: more than 70dB. 12in dia. turntable. Direct drive, 8 pole 24 slot brushless DC servo controlled motor. High compression ARCB base which has the feel and looks of granite. Price: to be announced.

KD 550

Details as per KD 500 plus static balance S-shaped pickup arm with lightweight detachable headshell. Price: to be announced.

KD5033 ★

Pickup arm fitted. Plinth mounted. Speeds: 33 $\frac{1}{3}$, 45rpm. W and F: less than 0.05%. Rumble: more than 58dB. Turntable: 12in solid die cast aluminium alloy. Direct drive. S-shaped pickup arm with detachable lightweight headshell. Variable strobe speed control. Anti-feed back legs. Walnut finish. Price: £163.20 (plus VAT).

KP 1022

Fitted with pickup arm and cartridge. Plinth mounted. Speeds: 33 $\frac{1}{3}$, 45rpm. W and F: less than 0.07% WRMS. Rumble: more than 47dB. Turntable: 12in solid die cast aluminium alloy. Belt drive. 4-pole synchronous motor. S-shaped tone arm with lightweight detachable headshell. Anti-feedback legs. Walnut finish. Price: £51.20 (plus VAT).

KD 2033

Fitted with pickup arm. Plinth mounted. Speeds: 33 $\frac{1}{3}$, 45rpm. W and F: less than 0.06% WRMS. Rumble: more than 49dB. Turntable: 12in solid die cast aluminium alloy. Belt drive. 4-pole synchronous motor. S-shaped with lightweight detachable headshell. Automated arm manoeuvres. Anti-feedback legs. Price: £73.60 (plus VAT).



Trio DK5033

Lenco advance into the 80s.



Lenco

Introduce your ears to the sound of the new Lenco 80s series of transcription units—the L80, L82 and the automatic L84

They're all belt-driven, of course, with power drive via a 16-pole synchronous motor giving a wow and flutter reading of only 0.08% and a weighted rumble reading of -60dB on the L80 and L82.

Stylus pressure is adjustable from 0.5 to 5p with antiskating adjustment calibrated from 0 to 3p for spherical styli and 0 to

5p for elliptical styli.

All have 33 $\frac{1}{3}$ and 45 rpm speed selector, the L82 has automatic stop and lift-off while the L84 has automatic return as well as 3-position record diameter selection

The pick-up arm on each has a viscous-damped cueing action.

Superb, faultless sound reproduction starts with the quality of the Lenco turntable. Which is why you're strongly recommended to listen to the sound of the 80s right now.

Please send me full details on the Lenco 80s series.
To: Goldring Limited,
10 Bayford Street, Hackney,
London E8 3SE.

Name _____

Address _____

HYB 77

 **Goldring**
Sound pure and simple

for doubting Thomas's.. ..hearing is believing

It's incredible but amazingly true that most people just don't appreciate the different effects that a turntable has on the overall performance of a Hi-Fi system. They only look for strobes, frills and fancy knobs. Others. Well, they choose the Linn Sondek L.P. 12 because of its simplicity. Because they know it audibly improves their system more than any other turntable. Tall statement? You don't believe it? There's

only one real way to find out. And that's listen to it for yourself. Try an A-B comparison between a Linn Sondek L.P. 12 and any other turntable (irrespective of it's price) using the same arm and cartridge through any system. We're willing to bet once you hear the Linn Sondek L.P. 12 you'll believe all we say about it. Find out for yourself. Call in at any Linn Sondek authorised dealer. They will be pleased to arrange a demonstration.

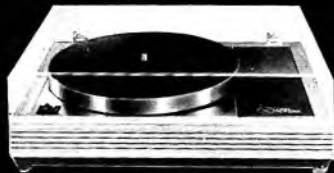

simply better!

LINN PRODUCTS LIMITED Sondek Division, 235 Drakemire Drive, Glasgow G45 9SZ. Tel: 041-634 3860 Cables: EURODECK

Recordings of the year

A personal selection chosen by the Editor

Prices are those applicable when going to press. Asterisks (★) denote recording quality. All records mentioned are presumed to be of reasonable standard, but those marked with one Asterisk (★) are of slightly superior sound, while two Asterisks (★★) denotes first-class recording worthy of demonstration.

Record numbers quoted are for Stereo Discs with Tape and Quad references added where applicable.

Classical releases

★ **ARRIAGA:** *String Quartets. Chilingirian Quartet.* CRD 1012/3. Price: £2.99.

When Arriaga died at the early age of twenty, victim of consumption, he already had an impressive list of compositions to his credit. This attractively-boxed set presents the three Cuartetos composed when he was sixteen. In spite of warnings in Roy Carter's intelligent sleeve notes, I still consider the music Mozartian, but it nevertheless shows remarkable ability from one so young.

A young man's work played by a young quartet, the Chilingirian, now resident at Liverpool University, recorded in the Church of St. George the Martyr, Queens Square, London WC1.

The music is attractive, easy-on-the-ear, and occasionally, as in the finale of the No. 2 in A, inventive. Playing is good, and recording absolutely impeccable.

★ **J. S. BACH:** *Flute Sonatas (complete).* Stephen Preston (flute), Jordi Savall (bass viol), Trevor Pinnock (harpsichord). CRD 1014/5. Price: £2.99 each.

Bach's sonatas are among the earliest works for transverse flute, and some are of doubtful authenticity. On this disc three young artists perform on original or copy instruments.

Stephen Preston uses a boxwood Glatt copy of J. G. Rottenburg (1735), Trevor Pinnock an Adlam Burnett harpsichord after Ruckers (1630), and the bass viol of Jordi Savall is an original Barak Norman of 1697.

The advantages seem doubtful to me. Only Trevor Pinnock seems totally at ease and his is a magnificent performance. Stephen Preston would be more expressive on a modern instrument because he is obviously a talented musician. His solo sonata is a veritable *tour de force*.

Personally I recommend the C Maj Sonata BWV 1033, a most unusual work. The opening andante leads to a cadenza, while the ensuing allegro is a real showpiece for flute. After a short adagio it ends with two minuets. Authenticity is in doubt but C. P. E. Bach attributed it to his father. Recording, engineered by Bob Auger, was made at St Andrew's Church, Fontwell Magna, Dorset, and is excellent.

BEETHOVEN: *Choral Music. London Symphony Orchestra and Ambrosian Singers conducted by Michael Tilson Thomas.* CBS 76404. Price: £2.99. (Cassette 40-76404. Price: £2.99)

Main work is the *King Stephen* incidental music. Michael Tilson Thomas cannot erase memories of Klemperer in the Overture but other orchestral interludes are well done, especially the Andante Maestoso of Movement Seven.

Beethoven came to choral music late in life and I find his inspiration slightly under par in this field. The choral songs on side two are all hymnlike in construction without much variation. *Elegaic Song* dates from 1814 and is a tribute to the wife of Baron Pasqualati. *Fellowship* is a Masonic piece and *Song of Sacrifice* a soprano solo, here sung by Lorna Haywood. *Calm Sea and Prosperous Voyage* was a deliberate attempt, which failed, to bribe Goethe to subscribe to the *Missa Solemnis*. Best music on record comes from *King Stephen* where the singers show their quality particularly in quieter passages. The sound is recorded at a low level but is pleasing to the ear.

BERLIOZ: *Harold in Italy. Daniel Benyamini with the Israel Philharmonic Orchestra conducted by Zubin Mehta.* Decca SXL 6732. Price: £2.99

Harold in Italy is a curious work, a pastiche with tenuous connections which cannot make up its mind whether it is a symphony or a viola concerto. Paganini commissioned it to show off his new Stradivarius viola and sub-

sequently rejected *Harold* as being too symphonic. He was right – all the best moments are given to the orchestra.

Mehta does his best to keep this episodic piece together and concentrates, rightly, on effect and colouring. Recording made in the Binyanei Ha'ouma Jerusalem was produced by Ray Minshull and is warm and particularly kind to the brass. My one complaint concerns the sleeve notes which are set in such small type that my middle-aged eyes found it difficult to decipher.

BRITTEN: *Variations and Fugue on theme of Purcell* / **PROKOFIEV:** *Excerpts from ballet 'Cinderella'*. London Symphony Orchestra conducted by Andrew Davis. CBS 76453. Price: £2.99 (Cassette 40-76453. Price: £2.99)

At first glance a strange coupling. Presumably the link is that both pieces date from 1945 and are happy works reflecting relief at cessation of hostilities. Andrew Davis takes the Purcell theme slowly and lingers lovingly over many variations, but holds the music together so that it never flags.

Cinderella is one of my favourite ballet scores and Davis doesn't disappoint. Only in the apotheosis does he let Prokofiev's magic slip away. The music is driven too hard and the ethereal celesta can hardly be heard. Recording is free of surface noise and recommended.

ELGAR: *Symphony No. 2 in E flat*. London Philharmonic Orchestra conducted by Sir Georg Solti. Decca SXL 6723.

It is always interesting to hear a foreign approach to a great English work. Solti tackles this as any other piece of music, without the reverent awe which overcomes most British conductors approaching Elgar. The Second symphony, which frankly I have always considered a bore, emerges fresh as a daisy, even lighthearted at times. The first movement is pushed along with panache, and the same sense of urgency pervades the *Larghetto*. Probably not in British Elgarian tradition but alive and, above all, never dull. Full marks to Solti. The recording made in Kingsway Hall, London was produced by Ray Minshull with Engineer Kenneth Wilkinson.

ELGAR: *Music for Violin and Piano*. John Georgiadis (violin), John Parry (piano). Pearl SHE 522. Price: £2.99

Early salon music mostly composed at Worcester and surprisingly good. Elgar was a keen

amateur violinist and these *morceaux* show intelligent grasp of the instrument's capabilities. Obviously the quality of music varies, but most is enjoyable. Some pieces – *Salut d'Amour*, *Chanson de Matin*, *Chanson de Nuit* and *Sospiri* – are old friends. Others are little gems, like the Bachian *Gavotte* with an enterprising middle section, the Tschaikowskian *Romance* and the syncopated Chopinesque *Gedje Allegretto*. John Georgiadis and John Parry are persuasive advocates and this record will give much pleasure.

FAURE: *Requiem Op 48/Pavane Op 50*. Elly Ameling (Soprano), Bernard Kraysen (baritone), Daniel Chorzempa (organ).

Netherlands Radio Chorus and Rotterdam Philharmonic Orchestra conducted by Jean Fournet. Philips 6500 968. Price: £3.10

Gabriel Fauré's middle name was Urbain, and 'urbane' sums up his musical character. The Requiem is a quiet reflective piece. Although full symphony orchestra is used, Fauré generally utilises small groups of instruments at a time. The organ has an important role and with a player of Chorzempa's calibre at the keyboard it is not surprising that the recording engineer has tended to emphasise this instrument.

Elly Ameling is her usual assured self, and the Netherlands Radio Choir is accurate and tonefully pleasing. Only Bernard Kraysen shows a baritone voice too prone to vibrate for comfort.

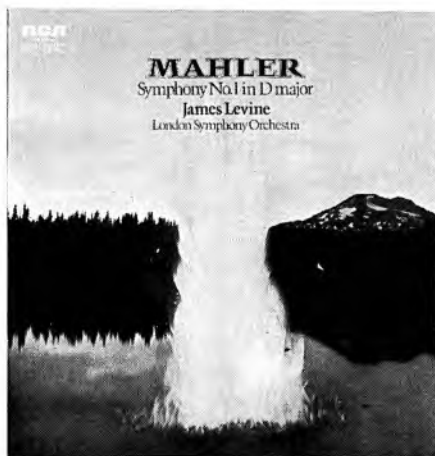

and percussion performed by American artists Gilbert Kalish, James Freeman (pianos), Raymond Desrodes and Richard Fitz (percussion). Of the five movements, three are inspired by poems of Quasimodo, Pascal and Rilke. Variety of percussion include slide whistle, African log drum, jaw bone of an ass, Tibetan prayer stones, and a musical jug. I cannot decide whether or not Crumb is serious or if this is one big con trick. If you enjoy these modern sounds, the recording is clear and free from surface noise.

LORIS TJEKNAVORIAN: *Suite from Ballet 'Simorgh'*. Soloists of the Rouadki Hall conducted by the composer. Unicorn RHS 333

Thirty-nine-year-old Persian composer is no stranger to Britain having conducted at the Proms and recorded with members of the LSO. He has researched old Middle East instruments and this ballet, premiered by the New London Ballet, is the result of his study. It involves a group of 14 Middle Eastern instruments with fascinating names such as Ney, Santur, Gheichek, Tar, Ud. Most interesting.

Popular and light

The third venture of American Sheffield into direct-to-disc recording, bypassing usual intermediate tape process, is ★★ *Lincoln Mayorga and Distinguished Colleagues Vol. 3* (Sheffield LAB-1). There can be no re-takes or superimposition, so the only sounds heard are those made by the artists without interference. The result is a perfectly natural sound, absolute clarity, and silent surfaces.

The disc was made in Los Angeles in 1973 with Bill Schnee recording engineer and Arnie Acosta lathe operator. Stereo separation is superb and, in short, this is a demonstration disc in every sense of the word. Price is £7.49 and it can be ordered from retailers or direct from sole distributor, Regent Acoustics, Carington House, 130 Regent Street, London W1R 6BR.

Some wonderful albums are to be had from *Reader's Digest*. ★ *Stereo Spectacular* undoubtedly lives up to its name. Tracks are taken from Decca Phase 4 and programmes are varied and entertaining, adding up to eight discs of sheer delight.

My personal favourite is *Swing Spectacular* starring Ted Heath and His Music playing old favourites of Glenn Miller, Tommy Dorsey, etc, offering three-quarters of an hour of nos-

algia wallowing. *Silver Screen Spectacular* presents popular film music shared between the orchestras of Stanley Black, Frank Chacksfield and Roland Shaw. Stanley Black has *Broadway Spectacular* to himself and *Light Classics* is beautifully done, especially Ilona Vered's limpid interpretation of the Rachmaninov Variation. Sound quality falls off slightly in *March Slav*, but Stokowski's expansive account is enough to quell any criticism.

G & S Spectacular is a bonus taken from the Malcolm Sargent recordings of *Pinafore*, *Mikado* and *Pirates*. I may be a lone Jeremiah, but Sargent's tempi are much too slow for my tastes. Nevertheless these are first-rate recordings of John Reed, Philip Potter, Donald Adams, Valerie Masterson, with the D'Oyly Carte Opera Company and the Royal Philharmonic Orchestra. Price: £14.95, also available in Dolby cassette form. Apply direct to *Reader's Digest*, 25 Berkeley Square, London W1X 6AB.

To me, the price of *Command Performance* would be offset by the bonus disc, twelve tracks from great voices of the past, including Caruso, John McCormack, and Kirsten Flagstad. Everyone will have personal favourites, but I was bowled over the great Galli-Curci singing *I am Titania*, almost matched by Elizabeth Rethburg's magnificent Czardus from *Die Fledermaus*. And of course, who can resist Nellie Melba, here singing the Jewel Song from *Faust*. Each record concentrates on a specific aspect of opera, the first being a collection of overtures. Arias are dominated by Robert Merrill's fine *Largo al factotum*, and features Richard Tucker, Leontyne Price, Placido Domingo, and Anna Moffo. All eight tracks of duets are good but I particularly liked Price and Tucker in the Love Duet from *Butterfly*, and Price and Bergonzi in the Love Duet from *Masked Ball*.

Highspots disc contains Caballe's *Casta Diva* and Corelli's *Flower Song* amongst other treasures.

Most tracks on the Chorus record are by the Robert Shaw Chorus and I find them too concertised and not theatrical enough. Orchestral excerpts include the fine *Faust* ballet from Almeida.

This collection gave me hours of enjoyment and I recommend it to all opera lovers. Price: £13.50 direct from *Reader's Digest*, 25 Berkeley Square, London W1X 6AB.

Art of the Minstral, (Grosvenor GRS 1013. Price: £2.50) is a charmer. Martin Best sings

and plays lute and guitar assisted by Edward Flower also on lute and guitar. There are four lute duets, two by John Johnson, a little-known Elizabethan composer, and anonymous Rossignol, and the ubiquitous *Greensleeves*, given here in its original lively dance form.

Songs from England, France, and Spain, range from pieces of great antiquity through Purcell to modern settings by Best himself, who sings with great conviction if somewhat harshly. I would have welcomed a softer approach. Nevertheless this is great stuff.

Grosvenor Records specialise in electronic organ music and devotees are well served. *John Norris Plays* (Grosvenor GRS 1037. Price: £2.50) displays the capabilities of the Baldwin Fantasia domestic organ. Few amateurs will manage the expertise and understanding shown here by young John Norris who uses a straightforward style without gimmicks or multi-tracking.

Personally I found the automatic rhythm mechanism monotonous, but the record is ideal for background music at cocktail parties, etc. John is director of Home Counties Organ Centre where he must be a most persuasive advocate. Recording is first-class.

The BBC caters for light music middle-of-the-road people. ★★ *Hits on the Harp* (BBC REC 178. Price: £1.79. Cassette MRCM 015. Price: £1.95) presents David Snell with backing group in a most unusual sound. We rarely hear the elegant harp playing pop, but Snell, previously with the Bournemouth Symphony and Covent Garden Orchestras, really knows how to swing it. All tracks are good but I particularly liked *You are the sunshine of my life*, *Top of the World* and *Tie a Yellow Ribbon*. Recording is in the demonstration class.

★★ *Radio 2 Top Tunes Vol. 2* BBC REB 202 Price £2.95. Cassette RMC 4022 Price £3.25) provides an entertaining selection of light music played by the Midland Radio Orchestra conducted by Norrie Paramor. Norrie directs his tip-top band with a sure hand and the excellent recording is clear without spotlighting any particular section. A good number for demonstration is *Pop Corn* where the tune is stated in unison by xylophone from left speaker and electronic organ (right). *Take Your Partners* BBC REB 216 Price: £2.95. Cassette RMC 4029 Price: £3.25) and *Come Dancing* with Sydney Thompson and

His Orchestra. Good value-with 18 tracks of ballroom dances played to strict tempo in typical Thompson fashion. The maestro first broadcast in 1945 and quickly became a firm favourite on radio and TV. Recording is good. Heading the latest batch of pops from CBS is *Rupert Holmes* (CBS EPC 80942) a young man unknown to me but obviously talented. I am told he writes songs for Barbra Streisand and here he presents his work, both words and music, self orchestrated and self conducted with a pop group and forty-piece orchestra. I found both words and music undistinguished but the recording is of demonstration standard.

Another first-class recording is *Born To Run* featuring Bruce Springsteen (CBS 69170), the latest rock sensation from America who turns out to be another mumbling, husky-voiced type. *Three Degrees Live* (CBS PIR 69197) is a good live recording with true atmosphere complete with extraneous introductions. The audience at Blighty's in Leicester obviously enjoyed every minute.

Back to more conventional fields, Johnny Mathis' *Feelings* (CBS 69180) needs no introduction. Personally I find his excessive vibrato irritating but no doubt his countless admirers will disagree. This collection includes the popular *Solitaire* and will be a good seller.

The break-up of a double-act usually results in the demise of the artists; but since Paul Simon parted company with Art Garfunkel he has gone from strength to strength. *Still Crazy After All These Years* (CBS 86001) presents songs typical of their kind and not quite up to past standards, but fans will ensure good sales. I liked *My Little Town* where Art Garfunkel joins his old partner. Recording is fierce with over-prominent soloists.

If your budget is limited, some good bargains can be picked up for £1 from the Pickwick International labels. *Stereo Spectacular Vol. 4* (RCA Camden CDS 1149 Price £1 Cassette CAM 460, Cartridge CAM 8460 both priced £1.75) more than lives up to its name being a gimmicky record with all tunes divided up into four-bar phrases emerging alternately from left and right speakers. Cyril Orndel directs an orchestra accenting zither, harp, xylophone and electronic organ, all placed well forward. When more conventional backing instruments join in the sound is rather thin.

Speaker Accessories

★ Indicates entry is illustrated

Abbreviations used in this section are given on page 27.

■ RICHARD ALLAN

Richard Allan Radio Ltd, Bradford Road, Gomersal, Cleckheaton, Yorks BD19 4AZ. Tel: Cleckheaton 2442.

CN54 Crossover Unit

Two-way quarter section. Recommended for use with CR5 bass unit and CB4 tweeter. Crossover frequency: 5kHz. Imp: 8 or 15 ohms. Price: (twin) £2.75; (triple) £3.00. All plus VAT.

CN104 Crossover Unit

A two-way half-section parallel network. Crossover frequency: 5kHz. Imp: 8 or 15 ohms. Price: £6.25 (plus VAT).

CN1284 Crossover Unit

A three-way crossover with main crossover operating from half-wave parallel network and subsidiary crossover capacity fed. Crossover frequencies: 1.1kHz and 5kHz. Imp: 8 or 15 ohms. Price: £8.50 (plus VAT).

CN1220 Crossover Unit

Three-way half-section. Crossover frequencies: 700Hz and 7kHz. Price: £11.25 (plus VAT).

CN820 Two-way Crossover

Frequency 3.5kHz. Low pass 12dB/Oct. High pass 18dB/Oct. Nominal imp: 8 ohms. Price: £2.85 (plus VAT).

CN8280 Three-way Crossover

Frequencies: 250Hz, 3.5kHz. Low pass 6dB/Oct, band pass 12dB/Oct and 18dB/Oct. High pass 24dB/Oct. Nominal imp: 8 ohms. Price: £18.00 (plus VAT).

■ AUDIO PACKS

Tape Recorder Spares Ltd, 206-210 Iliderton Road, London SE15 1NS. Tel: 01-639 7844.

Sound selector units ★

A range of five units for routing signals to phones, speakers and amplifiers. Four of the units provide for the selection of up to three pairs of stereo headphones or up to three pairs of speakers. The fifth unit, model HZ793, provides facilities for connecting any three signal sources to any three amplifiers. Particularly suitable for demonstration purposes in show-rooms and for comparative tests. Price: on request.

■ CELESTION

Rola-Celestion Ltd, Ditton Works, Foxhall Road, Ipswich, Suffolk IP3 8JP. Tel: Ipswich 73131.

CO3K Crossover

Designed specially for use with HF1300 Mk2 units but equally suitable for use with any efficient bass and treble combination. Air-tight terminal assembly with flange mounting. Full half-section filter network. Imp: 8 ohms. 12dB per octave cut-off at 3kHz. Size: 3⁷/₁₆in long, 2⁷/₁₆in diameter of body, 3³/₁₆in diameter of flange. Price: £4.47 (plus VAT).

■ DECCA

Decca Special Products, Ingate Place, Queenstown Road, London SW8 3NT. Tel: 01-622 6677.

Acoustic Lens

Device for obtaining optimum dispersion of the higher audio frequencies produced by the Decca Mk II ribbon speaker or the Decca DK30 ribbon speaker. Price: on application.

CO1/8 Crossover

Crossover network specially designed for use with the DK30 ribbon speaker. Ferrite cored inductors and close tolerance capacitors. Low-pass section is constant 12dB/octave, high-pass section is variable slope multi-stage network of novel design. Price: on application.



Audio Pack Sound Unit 790

★ Indicates entry is illustrated

CO/1000/8

Crossover network designed for use with London ribbon speaker. Mounted on printed circuit board. Close tolerance carbon polyester capacitors and inductors. Low-pass section is standard constant-impedance 6dB/octave filter, high-pass section attenuates at 12dB/octave. Crossover frequency: 1kHz. Negligible intermodulation distortion. Price: on application.

■ EAGLE INTERNATIONAL

Precision Centre, Heather Park Drive, Wembley, Middx. HA0 1SU.
Tel: 01-902 8832.

CN28 ★

L/C 2-way crossover. Nominal imp: 8 ohms. Nominal capacity: 15W RMS. Crossover frequency: 3kHz. Price: £1.20 (plus VAT).

CN212

L/C 2-way crossover. Nominal imp: 8 ohms. Nominal capacity: 40W RMS. Crossover frequency: 3kHz. Price: £2.00 (plus VAT).

CN216

L/C 2-way crossover. Nominal imp: 16 ohms. Nominal capacity: 15W RMS. Crossover frequency: 3kHz. Price: £1.20 (plus VAT).

CN312

L/C 3-way crossover. Nominal imp: 8 ohms. Nominal capacity: 40W RMS. Crossover frequency: 800Hz/3kHz. Price: £3.80 (plus VAT).

FF5

L/C 3-way crossover. Nominal imp: 8 ohms. Nominal capacity: 25W RMS. Crossover frequency: 1kHz/5kHz. Price: £2.90 (plus VAT).

FF30

L/C/R 3-way crossover. Nominal imp: 8 ohms. Nominal capacity: 25W RMS. Crossover frequency: 1kHz/5kHz. Variable resistance controls to midrange and tweeter. External mounting. Price: £7.60 (plus VAT).

SN75

2-way crossover. Nominal Imp: 8 ohms. Nominal capacity: 15W RMS. Crossover frequency: 3kHz. Variable resistance to tweeter. External mounting. Price: £2.50 (plus VAT).

CN412 ★

4-way crossover. Nominal imp: 8 ohms. Nominal capacity: 40W. Crossover frequency 800, 3,000, 7,000Hz. Price: £5.00 (plus VAT).

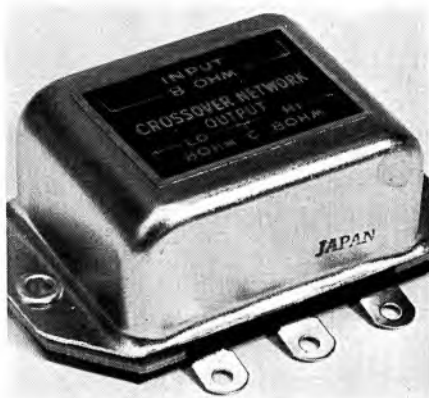

Eagle CN28



Eagle CN412

■ GOODMAN'S

Goodmans Loudspeakers Ltd,
Downley Road, Havant,
Hampshire PO9 2NL. Tel: Havant 6344.

Loudspeaker stand type CS3

Packed in pairs. Price: £17.29 per pair (plus VAT).

■ HOWLAND-WEST LTD

3-5 Eden Grove, London N7 8EQ.
Tel: 01-609 0293/6.

Headphone control Mk III ★

For operating two sets of stereo headphones simultaneously from the same source. Independent volume controls for each earpiece (four in all). On/off switch and jack sockets on front panel. Amplifier and speaker connections to colour coded terminals at rear. Teak finish. Size: 6 × 2⁷/₈ × 3¹/₂in. Weight: 18oz. Price: £7.00 (plus VAT).

Headphone Doubler

A simpler version of the Headphone Control Mk III which whilst not quite so versatile will still enable two people to enjoy headphone listening. It is connected via a stretch cord to the amplifier via the headphone socket. Volume of the right and left-hand channels can be adjusted. Stereo/mono switch fitted. Price: £4.50 (plus VAT).

Remote Control ★

Supplied with 5m of cable. Enables volume of speakers to be controlled individually at this distance from the amplifier. Will also accept headphones which are also individually controlled. Ideal for balancing speakers from central position between speakers. Price: £7.00 (plus VAT).

■ KEF

KEF Electronics Ltd, Tovil, Maidstone, Kent ME15 6QP. Tel: Maidstone 57258.

Crossover networks ★

DN 12 (SP1004) combines B139, B110 and T27. Price: £7.00. DN 13 (SP1017) combines B110 and T27. Price: £4.50. DN 13 (SP1015) combines B200 and T27. Price: £5. All prices shown exclude VAT which must be added.

104F

Loudspeaker stand. Price: £19.00 per pair.



Howland-West Headphone Control Mk III



Howland-West Remote Control



KEF B110

See Constructional Kits section for details of KEF crossover inductors, capacitors, terminals and BAF wadding.

■ KOSS

Tape-Music Distributors Ltd, 114 Ashley Road, St Albans, Herts AL1 5JR. Tel: St Albans 64337.

T10A

Chairside listening station. Comprises control box with separate volume controls for two sets of stereo headphones, plus on/off switch for speakers. Wires directly into amplifier. Seven-core flat connecting cable suitable for under-carpet installation. Tinted plastic cover. Price: £11.50 (plus VAT).

T3

Speaker/headphone switchbox. Incorporates jack socket for stereo headphones, connections for speakers and terminals for connecting to stereo amplifier. Switch selects speakers on or off. Price: £4 (plus VAT).

T5D

Remote control station suitable for running two pairs of stereo headphones. Speaker on/off switch incorporated, but headphones are always on. The volume of headphones plugged into left-hand jack individually controlled (other set of headphones controlled by volume knob on amplifier). Fitted DIN sockets for amplifier and speaker connections. Matches any amplifier with 4, 8 or 16 ohm output. Finish: black with simulated walnut top. Connecting cable seven-core colour-coded 3ft long. Size: $3\frac{1}{8} \times 3\frac{3}{8} \times 2\frac{1}{8}$ in. Weight: $10\frac{1}{2}$ oz. Price: £8.50 (plus VAT).

See Headphone and Accessories section for details of full range of Koss headphones and accessories.

★ Indicates entry is illustrated

■ QAS

Quality Audio Supplies, Wollaton Road,
Beeston, Nottingham NG9 2PB.
Tel: Nottingham 265141.

Wide range of audio accessories including phono plugs, DIN plugs and sockets, 4mm and wander plugs, couplers, screw terminals, slider switches, connecting leads with all types of terminations, audio switching units, record cleaner and remote control stations. All items individually blister-packed for over-the-counter or self-service sales.

Audio Switch

For use with two sets of stereo speakers and two sets of headphones. Pushbuttons provide any combination of speakers and phones. Headphones attenuated by 100 ohms. Connections by DIN and jack sockets. Size: $5\frac{1}{2} \times 1\frac{1}{4} \times 2\frac{3}{4}$ in. Finish: brushed aluminium. Price: £6.75 (excluding VAT).

De Luxe Audio Switch

Provides for two sets of headphones and two sets of stereo speakers. Pushbutton switches permit any combination to be used. Monitor socket for adjusting level of remote speakers. Level controls for left and right channels. Headphones attenuated by 100 ohms. Wire-wound potentiometers handle up to 35W. Size: $7\frac{1}{2} \times 1\frac{1}{2} \times 2\frac{3}{4}$ in. Finish: brushed aluminium. Fixing brackets provided. Price: £8.75 (excluding VAT).

Phone Switch

Designed to cater for two sets of stereo headphones and one set of speakers. Pushbutton switches provide any combination. Headphones attenuated by 100 ohms. Connections by DIN and jack sockets. Size: $5\frac{1}{2} \times 1\frac{1}{4} \times 2\frac{3}{4}$ in. Finish: brushed aluminium. Fixing brackets included. Price: £4.75 (excluding VAT).

Output Selector

For connecting three sets of stereo speakers from one source. Suitable for retailers' show-rooms for comparison of speakers. Also for supplying three sets of speakers in different rooms in the home. Units can be stacked to provide additional facilities. Pushbutton switches. Size: $5\frac{1}{2} \times 1\frac{1}{4} \times 2\frac{3}{4}$ in. Finish: brushed aluminium. Fixing brackets included. Price: £6.75 (excluding VAT).

■ RADFORD

Radford Acoustics Ltd, Ashton Vale Road,
Bristol BS3 2HZ. Tel: Bristol 662301.

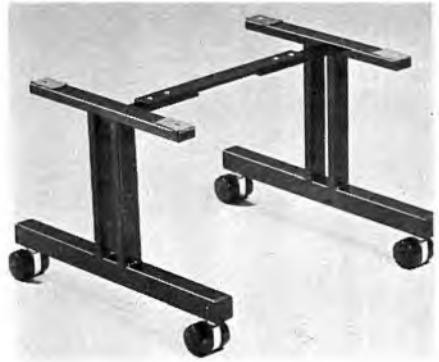

Tristan 22C

FN11

Three-way 17-element crossover network. Impedance: 8 ohms in four types to match various drive unit combinations. HC: 100W. FR: 25Hz-25kHz. Crossover frequencies: 500Hz and 4.2kHz. Price: £10 (plus VAT).

FN831

Filter network 3-way. Crossover frequencies 600Hz and 7kHz. Rating 150 watts. 8 ohms or 4 ohms for Radford designs A90, M90, T90, M180 and A270. Price: £13.50 (plus VAT).

FN832

Filter network 3 way. Crossover frequencies 600Hz and 7kHz. Rating 150 watts. 8 ohms or 4 ohms for Radford designs S360 and ISO360. Price: £13.50 (plus VAT).

FN831

Filter network 2 way. Crossover frequency 3kHz. Rating 100 watts for Radford designs B90 & B180. Price: £9.50 (plus VAT).

■ TRISTAN

Danil Engineering Co, Old Teme Bridge,
Lower Wick, Worcester WR2 4BY.
Tel: Worcester 425595.

Tristan 12

Speaker stand suitable for larger bookshelf type speakers where it is required to have them floor mounted. All steel, finished in semi-matt black enamel. To suit speaker 7-10in (178-245mm) deep by 10in (254mm) wide. Holds speaker 8in (203mm) above floor. Price: £7.88 per pair (excluding VAT).

Tristan 15

Speaker stand suitable for small and medium floor standing units up to 12in (305mm) wide by 12in (305mm) deep. All steel, finished in semi-matt black enamel. Holds speaker 8½in (216mm) above floor. Price: £9.48 per pair (excluding VAT).

Tristan 15T

Speaker stand. Details as Tristan 15 but holds speaker 10½in (267mm) above floor. Price: £9.80 per pair (excluding VAT).

Tristan 22C ★

Speaker stand. All steel, finished in semi-matt black enamel. Adjustable for width. With castors. Suitable for monitor type loudspeakers with a depth of 10in (254mm) or more and a width between 12in (305mm) and 17in (432mm). Holds speaker 9½in (244mm) above floor. Price: £15.60 per pair (excluding VAT).

■ WOOLLETT

Woollett Audiostatics, Anerley Station Road, London SE20 8PY. Tel: 01-699 5296.

XSI ★

Speaker matching transformer. Converts 16 ohms to 8 ohms, and 8 ohms to 4 ohms. Bifilar wound. Grain orientated laminations. Ratio 1:0.707 auto. FR: 16Hz-30kHz ±0.6dB. Price: on application.

XS2 ★

Speaker isolating and matching transformer. Matches 16 ohms. Bifilar wound. Grain orientated laminations. Ratio 1:1 double wound. FR: 16Hz-100kHz ±100.6dB. May be used to attenuate -6dB and -12dB while maintaining heavy damping on speaker and offering correct load to amplifier. Suitable for operating stereo

system comprising two high frequency, or full range, speakers with common bass speaker. *Note:* Not suitable for mains isolation in live chassis equipment. Price: on application.

Speaker Chokes

Details and prices on application.

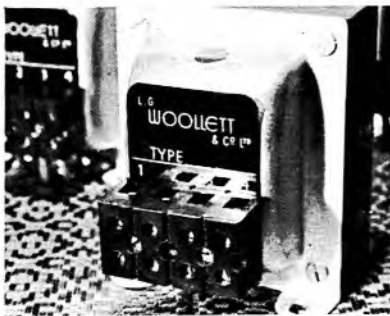

Woollett XSI and XS2

Sabre Loudspeaker Stands



SABRE LOUDSPEAKER TROLLEY STANDS

Loudspeaker design today has advanced to such a degree that very high quality reproduction of music is possible. But so often this quality is not achieved because the speakers are placed on the floor.

A SABRE STAND IS THE ANSWER

SABRE MARK II TROLLEY STAND

Manufactured from high grade steel coated in high durability nylon. Platform lined in slip proof neoprene.

SPECIFICATIONS

	Sabre Loudspeaker Trolley stand	Sabre Mark II Trolley
Platform height	10in 254mm	10in 254mm
Platform depth	9½in 242mm	12in 305mm
Platform width	10in 254mm	12in 305mm

Available from all leading hi-fi dealers

MANUFACTURED IN THE U.K. BY EUROPE'S LEADING STAND MANUFACTURERS, SQUIRREL HOLLOWARE MANF. CO. LTD.

Trade and export enquiries to

GRABERN AUDIO

13 FAMET AVENUE,
PUBLEY, SURREY CR2 2DN.
TELEPHONE: 01-660 4780



Speaker Drive Units

★Indicates entry is illustrated
Abbreviations used in this section are given on page 27.

■ RICHARD ALLAN

Richard Allan Radio Ltd, Bradford Road,
Gomersal, Cleckheaton, Yorks BD19 4AZ.
Tel: Cleckheaton 2442.

CB4

4in tweeter. Paper cone. Doped cambric surround. Ceramic magnet. Voice coil $\frac{9}{16}$ in. Gap flux 8000 gauss. Total flux 12,000 maxwells. HC: in systems up to 25W. vci: 8 or 15 ohms. FR: 2kHz-17kHz. ref: 5kHz. Price: £2.75 (plus VAT).

DT20

20mm dome tweeter. Low mass, plastic foil dome. Ceramic magnet. Voice coil 20mm. Gap flux 12,000 gauss. Total flux 24,500 maxwells. FR: 3kHz-25kHz. HC: in systems up to 70W. vci: 8 or 15 ohms. rcf: 7kHz. Price: £6.25 (plus VAT).

CF5

5in mid-range unit. Coated paper cone with PVC surround. Ceramic magnet. Voice coil 1in. Gap flux: 8000 gauss. Total flux: 32,000 maxwells. HC: in systems up to 30W. FR: 250Hz-15kHz. vci: 8 or 15 ohms. Price: £5.00 (plus VAT).

CB5

5in mid-range unit. Coated paper cone with PVC surround. Ceramic magnet. Voice coil 1in. Gap flux: 12,000 gauss. Total flux: 48,000 maxwells. HC: in systems up to 30W. FR: 250Hz-15kHz. vci: 8 or 15 ohms. Price: £5.75 (plus VAT).

CR5

5in bass/mid-range unit. Paper cone with PVC surround. Ceramic magnet. Voice coil 1in. Gap flux: 14,000 gauss. Total flux: 56,000 maxwells. HC: 15W. vci: 8 or 15 ohms. FR: 30Hz-8kHz. Specially designed for use in small volume infinite baffle enclosure. Price: £7.00 (plus VAT).

CP8

8in mid-range unit. Paper cone. Doped cambric surround. Ceramic magnet. Voice coil: 1in. Gap flux: 10,000 gauss. Total flux: 40,000 maxwells. HC: 10W. vci: 8 or 15 ohms. FR: 100Hz-12kHz. Price: £5.25 (plus VAT).

CB8

8in paper cone. Doped cambric surround. Ceramic magnet. Voice coil: 1in. Gap flux: 12,000 gauss. Total flux: 48,000 maxwells. HC: 15W. vci: 8 or 15 ohms. FR: 45Hz-10kHz. Price: £6.00 (plus VAT).

CB8T

8in paper cone plus tweeter inner. Doped cambric surround. Ceramic magnet. Voice coil: 1in. Gap flux: 12,000 gauss. Total flux: 48,000 maxwells. HC: 15W. vci: 8 or 15 ohms. FR: 45Hz-17kHz. Price: £6.50 (plus VAT).

CBF8

8in bass/mid-range unit. Paper cone. Moulded polyurethane surround. Ceramic magnet. Voice coil: 1in. Gap flux: 12,000 gauss. Total flux: 48,000 maxwells. HC: 15W. vci: 8 or 15 ohms. FR: 40Hz-10kHz. Price: £6.25 (plus VAT).

CG8

8in paper cone. Doped cambric surround. Ceramic magnet. Voice coil: 1in. Gap flux: 14,000 gauss. Total flux: 56,000 maxwells. HC: 20W. vci: 8 or 15 ohms. FR: 45Hz-10kHz. Price: £8.00 (plus VAT).

CG8T

8in paper cone with tweeter inner. Doped cambric surround. Ceramic magnet. Voice coil: 1in. Gap flux: 14,000 gauss. Total flux: 56,000 maxwells. HC: 20W. vci: 8 or 15 ohms. FR: 45Hz-17kHz. Price: £8.50 (plus VAT).

CF8L

8in bass unit. Coated paper cone. Moulded polyurethane surround. Ceramic magnet. Resonance 25Hz. Voice coil: 1in. Gap flux: 14,000 gauss. Total flux: 56,000 maxwells. HC: 20. vci: 8 or 15 ohms. FR: 35Hz-2.5kHz. Price: £8.50 (plus VAT).

CG10

10in paper cone. Doped cambric surround. Ceramic magnet. Voice coil: $1\frac{1}{2}$ in. Gap flux: 14,000 gauss. Total flux: 105,000 maxwells. HC: 30W. vci: 8 or 15 ohms. FR: 35Hz-10kHz. Price: £13.00 (plus VAT).

*Indicates entry is illustrated

CG10T

10in paper cone with tweeter inner. Doped cambric surround. Ceramic magnet. Voice coil: 1½in. Gap flux: 14,000 gauss. Total flux: 105,000 maxwells. HC: 30W. vci: 8 or 15 ohms. FR: 35Hz-15Hz. Price: £13.50 (plus VAT).

CG12

12in paper cone. Doped cambric surround. Ceramic magnet. Voice coil: 1½in. Gap flux: 14,000 gauss. Total flux: 105,000 maxwells. HC: 30W. vci: 8 or 15 ohms. FR: 25Hz-9kHz. Price: £14.00 (plus VAT).

CG12T

12in paper cone with tweeter inner. Doped cambric surround. Ceramic magnet. Voice coil: 1½in. Gap flux: 14,000 gauss. Total flux: 105,000 maxwells. HC: 30W. vci: 8 or 15 ohms. FR: 25Hz-15Hz. Price: £14.50 (plus VAT).

CG12 Super

12in paper cone. Doped cambric surround. Ceramic magnet. Voice coil: 2in. Gap flux: 14,000 gauss. Total flux: 186,000 maxwells. HC: 75W. vci: 8 or 15 ohms. FR: 25Hz-5kHz. Price: £18.50 (plus VAT).

CG15

15in paper cone. Doped cambric surround. Ceramic magnet. Voice coil: 2in. Gap flux: 17,000 gauss. Total flux: 220,000 maxwells. HC: 75W. vci: 8 or 15 ohms. FR: 20Hz-5kHz. Price: £30.00 (plus VAT).

Richard Allan full-range speaker modules are included in Speaker Enclosure section. Twin Assembly, Triple-8 Assembly speaker kits are in the Constructional Kits section.

LP8B

8in Bextrene. PVC roll surround. Ceramic magnet. Voice coil: 25mm. Flux density: 1.2 tesla. HC: 20W vci: 8 or 15 ohms. FR: 40Hz-5.5kHz. Price £8.95 (plus VAT).

HP8B

8in Bextrene cone. PVC roll surround. Ceramic magnet. Voice coil: 38mm high temperature winding. Flux density: 1.3 tesla. HC: 45W at 60Hz. vci: 8 or 15 ohms. FR: 25Hz-4.5Hz. Price: £13.00 (plus VAT).

HP12B

12in Bextrene cone. PVC roll surround. Ceramic magnet. Voice coil: 50mm high temperature winding. Flux density: 1.35 tesla. HC: 75W. vci: 8 or 15 ohms. FR: 25Hz-1kHz. Price: £21 (plus VAT).

ATC

Executive Audio Ltd. Unit 5A, Pier House Laundry, Strand-on-the-Green, Chiswick, London W4.
Tel: 01-995 3654.

PA75-75

Midrange dome. 7.5cm nominal diameter. Damped soft formed cone material. Dual suspension fabric surround. Voice coil diameter: 7.5cm. Voice coil material: Aluminium/nomex former copper ribbon wire coil. Impedance: 8 ohms. Total flux: 255,000 maxwells. Gap flux: 12,500 gauss. Nominal capacity: 150 watts. R up to 5kHz. Cross-over frequency 300(+)Hz. Resonant frequency: 240Hz. Price: on application.

PA75-314 Studio bass drive

28cm nominal diameter. Plasticized PVC damped material. Rubber roll surround. Voice coil diameter 7.5cm. Voice coil material: Aluminium/Nomex former copper ribbon wire coil. Nominal Impedance: 8ohms. Total flux: 233,000 maxwells. Gap flux: 11,000 gauss. Nominal capacity 150watts. R up to 3kHz. Cross-over frequency 300Hz-1kHz. resonant frequency 18Hz. Price £70.00 (plus VAT).

PA75-314 Long coil Bass

28cm nominal diameter. Paper cone. Fabric surround. 7.5cm coil diameter. Voice coil material: Aluminium former copper ribbon wire. Nominal Impedance 8 or 12 ohms. Total flux: 242,000 maxwells. Gap flux: 11,500 gauss. Nominal Capacity: 75watts. FR: up to 3kz. Cross-over frequency: 300Hz to 3kHz. Resonant frequency: 35Hz. Price: £67.50 (plus VAT).

PA75-314 Bass

28cm nominal diameter. Paper cone. Fabric surround. Voice coil diameter: 7.5cm. 4, 8 or 15 ohms. Total flux: 242,000 maxwells. Gap flux: 11,500 gauss. Capacity: 75 watts. R: up to 5kHz. Cross-over for frequency: 300Hz-5kHz. Resonant frequency: 40Hz. Price: £67.50 (plus VAT).

PA75-314 Linen surround

28cm nominal diameter. Paper cone. Fabric surround. Voice coil diameter: 7.5cm. Voice coil material: Nomex former copper ribbon wire. Nominal Impedance: 4, 8 or 15 ohms. Total flux: 255,000 maxwells. Gap Flux: 12,000 gauss. Capacity: 75 watts. R. up to 60kHz. Cross-over frequency: 2kHz-6kHz. Resonant frequency: 55Hz. Price: £65.00 (plus VAT).

PA75-314 Standard

28cm nominal diameter. Paper cone. Paper surround. Voice coil diameter 7.5cm. Voice coil material: Nomex former copper ribbon wire. Nominal Impedance: 4, 8 or 15 ohms. Total flux: 255,000 maxwells. Gap flux: 12,000 gauss. Capacity: 75 watts. up to 6kHz. Cross-over frequency: 2kHz-6kHz. Resonant frequency: 65Hz. Price £65.00 (plus VAT).

■ BAKER

Baker Loudspeakers Ltd, Bensham Manor Road, Passage, Thornton Heath, Surrey. Tel: 01-684 1665.

Regent

Full range 12in cone speaker. Paper cone with roll surround. Voice coil: 1½in. Copper voice coil. VCI: 3, 8 or 15 ohms. Gap flux: 12,000 gauss. HC: 20W. FR: 45Hz-13kHz. Price: £12.00 (plus VAT).

Major ★

Full range 12in speaker with built-in tweeter cone. 14,000 gauss magnetic gap. FR: 40Hz-14.5kHz. HC: 25W. vci: 3, 8 or 15 ohms. Cast aluminium chassis. Weight: 6lb. Price: £14.00 (plus VAT).

Deluxe Mk II

Full range 12in cone speaker. 15W. Bass resonance: 30Hz. Gap flux: 14,000 gauss. Copper voice coil: 1½in diameter. VCI: 8 or 15 ohms. Paper cone with foam plastic surround. Built-in tweeter cone. FR: 25Hz-16kHz. Cast aluminium chassis. Depth: 6in. Weight: 6lb. Price: £16.00 (plus VAT).

Superb Twelve ★

Full range 12in speaker with built-in tweeter cone. Foam plastic surround. Coil diameter: 1½in. vci: 8 or 15 ohms. Gap flux: 16,500 gauss. HC: 25W. FR: 20Hz-17kHz. Bass resonance: 25Hz. Copper speech coil. Diecast aluminium chassis. Weight: 10lb. Price: £21.00 (plus VAT).

Auditorium 12

Full range 12in cone speaker suitable for bass unit multi-speaker system. HC: 35W. Bass resonance: 35Hz. Gap flux: 15,000 gauss. Copper voice coil: 1½in diameter. vci: 8 or 15 ohms. FR: 25Hz-16Hz. Paper cone with roll surround. Cast aluminium chassis. Depth: 7in. Weight: 10lb. Price: £19.00 (plus VAT).

Auditorium 15

High power 15in speaker suitable for bass unit in multi-speaker system. HC: 45W. Bass resonance: 35Hz. Gap flux: 15,000 gauss. vci: 8

*Baker 12in Major**Baker Superb Twelve*

or 15 ohms. FR: 20Hz-14kHz. 2in diameter voice coil. 35W. Depth: 8in. Weight: 15lb. Price: £25.00 (plus-VAT).

Group 25

12in cone speaker with heavy duty suspension for electronic music, guitars, etc. HC: 30W. vci: 3, 8 or 15 ohms. Bass resonance: 55Hz. FR: 30Hz-13kHz. Gap flux: 12,000 gauss. Voice coil: 1½in. Depth: 6in. Weight: 5lb. Price: £9.50 (plus VAT).

Group 35

12in cone speaker with heavy duty suspension for electronic music, guitars, etc. HC: 40W. vci: 3, 8 or 15 ohms. Bass resonance: 55Hz. FR: 55Hz-13kHz. Gap flux: 14,000 gauss. Voice coil: 1½in. Depth: 6½in. Weight: 6 lb. Price: £10.50 (plus VAT).

Group 50

15in cone speaker with heavy duty suspension for electronic music, guitars, etc. HC: 75W. vci: 8 or 15 ohms. Bass resonance: 45Hz. FR: 30Hz-13kHz. Gap flux: 17,000 gauss. Voice coil: 2in. Depth: 8in. Weight: 15lb. Price: £22.00 (plus VAT).

★Indicates entry is illustrated



Decca DK30 Ribbon



Decca London Ribbon Speaker

Group 50/12

12in cone speaker with heavy duty suspension for electronic music, guitars, etc. vci: 8 or 15 ohms. Max. power: 60W. Bass resonance: 55Hz. Flux: 15,000 gauss. Voice coil: 1½in. Depth: 4¼in. Weight: 10lb. Price: £16.00 (plus VAT).

■ CASTLE ACOUSTICS LTD

Shortbank Road, Skipton, N. Yorks.
Tel: Skipton 5333.

8 RS DD

Full Range. Cone diameter 20cm. Coil diameter 2.5cm. Impedance: 8 ohms. Flux: 54,000 maxwells. Gap Flux: 15 watts. Peak Cap: 25 watts. FR: 50-20,000 ± 6dB. Resonant Frequency: 37Hz. Price £10.00 (plus VAT).

■ COLES

Coles Engineering (Hoddesdon) Co,
Pindar Road, Hoddesdon, Herts EN11 0RZ.
Tel: Hoddesdon 66685.

4001G

High frequency pressure unit. Nominal cone diameter 3cm. Plastic cone, steel surround.

VCI: 2cm. Voice coil material: copper, Impedance: 8 and 15 ohms nominal. Flux density: 14,000 Gauss. Peak capacity: 3W RMS. FR: 6kHz-20kHz±3dB. Price: £5.63 (plus VAT).

■ DECCA

Decca Special Products, Ingate Place,
Queenstown Road, London SW8 3NT.
Tel: 01-622 6677.

DK30 Ribbon★

Horn-loaded high frequency ribbon speaker. Size: 6½ × 3½ × 2in. Aluminium ribbon element. Impedance: 8 ohms constant. HC: 30W maximum. FR: 2.5kHz-25kHz. rcf: 2.5kHz. Price: on application.

London Ribbon ★

Horn-loaded high frequency ribbon speaker. Size: 9½ × 4½ × 7½in. Aluminium ribbon element. Impedance: 8 ohms constant. HC: 30W maximum. FR: 1kHz-25kHz. Rec cross-over: 1kHz. Price: on application.

Decca Acoustic lens

Device for obtaining optimum dispersion of higher audio frequencies produced by Decca Mk II ribbon speaker or the Decca DK30 ribbon speaker. Price: on application.

■ EAGLE INTERNATIONAL

Precision Centre, Heather Park Drive,
Wembley, Middlesex. HA0 1SU.
Tel: 01-902 8832.

FR10

Full range/bass. 22cm nominal cone. Paper cone material. Roll surround. Nominal Impedance: 8 ohms. Gap flux: 12,000 gauss. Nominal Capacity: up to 25 watts. FR: 25-20,000Hz. Cross-over frequency: 1.5kHz. 2.5cm cone tweeter with own 11,000 gauss magnet. Price: £15.40 (plus VAT).

FR8

Full range/bass. 18cm nominal cone. Paper cone material. Roll (fibre) surround. Nominal Impedance: 8 ohms. Gap flux: 12,000 gauss. Capacity: up to 15 watts. FR: 75-17,000 Hz. Cross-over frequency: 3kHz. Parasitic HF cone. Price £12.20. (plus VAT).

FR65

Full range/bass. 15cm cone diameter. Paper cone. Roll surround. Nominal Impedance: 8 ohms. Gap flux: 11,000 gauss. Nominal Capacity: up to 10 watts. FR: 35-17,000 Hz. Cross-over frequency: 3kHz. Parasitic HF cone. Price: £9.60 (plus VAT).



Eagle MS 33

FF24

Midrange dome. 5.5cm cone diameter. Paper cone. Corrugated fibre surround. Voice coil diameter: 5.5cm. Nominal Impedance: 8 ohms. Total flux: 10,000 gauss. Nominal Capacity: 20 watts RMS. FR: 350-9,000Hz. Cross-over frequency: 1kHz and 5kHz. Price: £9.50.

MS33★

Midrange. 5cm diameter paper cone. Roll surround. Nominal Impedance: 8 ohms. Total flux: 10,000 gauss. Nominal Capacity: 30 watts RMS. Frequency response: 450-10,500Hz. Cross-over frequency: 1kHz and 5kHz. Cone/magnet assembly is completely enclosed and protected. Price £9.20.

FF26

Midrange. 13cm diameter. Paper cone. Roll surround. Nominal Impedance: 8 ohms. Total flux: 10,300 gauss. Nominal Capacity 20 watts RMS. Frequency Response: 700-8,500Hz. Cross-over frequency: 1kHz and 5kHz. Price: £7.00 (plus VAT).

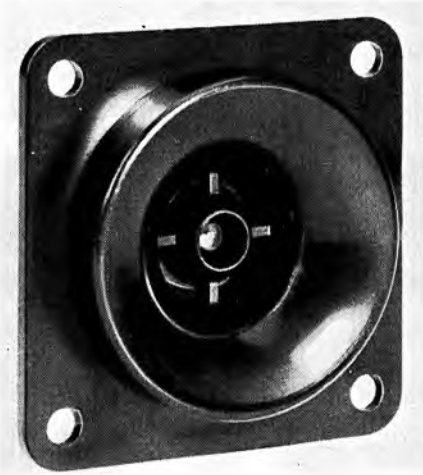

Eagle ST 54

AA12

Midrange. 11.5cm cone diameter. Paper aluminium cone material. Corrugated surround. 2.5cm coil diameter. Nominal Impedance: 8 ohms. Total flux: 9,000 gauss. Capacity: 15 watts RMS. FR: 350-13,000Hz. Cross-over frequency: 1kHz and 5kHz. May be used as tweeter in low cost systems. Price: £4.94 (plus VAT).

DT48

Tweeter/(dome type) super tweeter. 3cm cone diameter. Fibre cone, corrugated surround. 3cm voice coil. Nominal Impedance: 4 ohms. Gap flux: 11,000 gauss. Nominal Capacity: 3-way systems up to 40 watts. FR: 1,500-21,000 Hz. Cross-over frequency: 3-7kHz. Price £6.95 (plus VAT).

FR4

Full range. 8.5cm cone diameter. Paper cone. Roll surround. Nominal impedance: 8 ohms. Gap flux: 10,000 gauss. Nominal capacity: up to 5 watts. FR: 0-16,000Hz. Price: £5.60 (plus VAT).

FF23

Elliptical full range. Cone diameter 20 × 13cm. Paper cone. Roll surround. Nominal Impedance: 8 ohms. Gap flux: 11,500 gauss. Capacity: up to 15 watts. FR: 80-16,000Hz. Parasitic HF cone. Price £6.80 (plus VAT).

DT33

Tweeter (dome type). 2.8cm cone. Foil plastic cone material. Spiral section surround. 2.8cm Voice coil diameter. Nominal Impedance: 8 ohms. Gap flux: 14,000 gauss. Nominal Capacity: up to 40 watts. FR: 2,600-17,500 Hz. Cross-over frequency: 3kHz-5kHz. Diffuser. Price: £6.30 (plus VAT).

FF27

Midrange. 2.9cm nominal cone. Foil plastic cone material. Flat suspension surround.

★Indicates entry is illustrated

Voice coil diameter: 2.9cm. Nominal Impedance: 8 ohms. Gap flux: 10,000 gauss. Nominal capacity: 30 watts. FR: 1,800-21,000Hz. Cross-over frequency: 3kHz-5kHz. Price: £7.00.

FF28

Midrange (flared horn). Voice coil diameter: 2.5cm. Nominal Impedance: 8 ohms. Gap flux 10,000 gauss. Nominal Capacity: up to 20 watts. FR: 1,500-17,000Hz. Cross-over frequency: 3kHz-5kHz. Cellular horn construction 120° spread in 5 sections for wide polar response. Price: £5.80. (plus VAT).

HT21

Horn tweeter. Nominal Impedance: 8 ohms. Gap flux: 14,000 gauss. Nominal Capacity: up to 40 watts. FR: 18,000-31,000Hz. Cross-over frequency: 3kHz-5kHz. All-metal construction with integral diffuser. Matt silver finish. Price £4.60 (plus VAT).

MHT10

Tweeter. 1.8cm cone diameter. Fibre plastic cone material. Flat surround. Voice coil diameter: 1.8cm. Nominal Impedance: 8 ohms. Gap flux: 13,000 gauss. Nominal Capacity: suitable for systems 25-50 watts. FR: 2,000-21,000Hz. Cross-over frequency: 3kHz-5kHz. Flat response 5kHz to 18kHz. used in studio loudspeakers. Price: £4.00 (plus VAT).

HT15

Tweeter. 2cm cone diameter. Fibre plastic cone material. Voice coil diameter: 2cm. Nominal Impedance: 16 ohms. Gap flux: 13,000 gauss. Nominal Capacity: up to 30 watts. FR: 2,100-21,000Hz. Cross-over frequency: 3kHz-5kHz. Price: £4.00 (plus VAT).

CT10/8

Tweeter. 2.5cm cone diameter. Foil plastic cone material. Voice coil diameter: 2.5cm. Nominal Impedance: 8 ohms. Gap flux: 10,000 gauss. Nominal capacity: up to 20 watts. FR: 1,700-14,000Hz. Cross-over frequency: 3-5kHz. Price £3.40 (plus VAT).

CT5

Tweeter (cone type). 9cm cone diameter. Paper cone material. Fibre surround. Voice coil diameter: 2.5cm. Nominal Impedance: 8 ohms. Gap flux: 9,000 gauss. Nominal Capacity: up to 10 watts. FR: 3,000-15,000Hz. Cross-over frequency: 3kHz-5kHz. Price: £1.80 (plus VAT).

ST54★

Super tweeter. 1.7cm cone diameter. Plastic cone material. Voice coil diameter: 1.7cm. Nominal Impedance: 8 ohms. Total flux 10,000 gauss. Capacity: 4-way systems up to 50 watts. FR: 5,000-22,000Hz. Cross-over frequency: 7kHz. Integral diffuser. Price: £3.80 (plus VAT).

■ ELECTRO-VOICE

Gulton Europe Ltd, Special Products Division, The Hyde, Brighton, Sussex BN2 4JU. Tel: Brighton 66271.

EVM15B

Bass driver. Nominal cone diameter: 38.13cm. Paper cone. Cloth surround. Voice coil diameter: 6.5cm. Nominal impedance: 8 ohms. Nominal RMS capacity: 100W. Resonance frequency: 40Hz. Price: on application.

EVM15L

Bass driver. Nominal cone diameter: 38.13cm. Paper cone. Cloth surround. Voice coil diameter: 6.35cm. Nominal impedance: 8 ohms. Nominal RMS capacity: 100W. Resonance frequency: 50Hz. Price: on application.

EVM12L

Bass driver. Nominal cone diameter: 30.95cm. Paper cone. Cloth surround. Voice coil diameter: 6.35cm. Nominal impedance: 8 ohms. Nominal RMS capacity: 100W. Resonance frequency: 50Hz. Price: on application.

EMV18B

Bass driver. Nominal cone diameter: 47.72cm. Paper cone. Cloth surround. Voice coil diameter: 6.35cm. Nominal impedance: 4 ohms. Nominal RMS capacity: 100W. Resonance frequency: 40Hz. Price: on application.

12TRXB

Full range integrated 3-way driver. Nominal cone diameter: 30.95cm. Paper cone. Cloth surround. Voice coil diameter: 6.35cm. Nominal impedance: 8 ohms. Peak RMS capacity: 60W. FR: 35Hz-20kHz. Price: on application.

SP12

Full range unit. Nominal cone diameter: 30.95cm. Paper cone. Cloth surround. Voice coil diameter: 6.35cm. Nominal impedance: 8 ohms. Peak RMS capacity: 80W. FR: 30Hz-15kHz. Price: on application.



Goodmans Twin Axiom 8

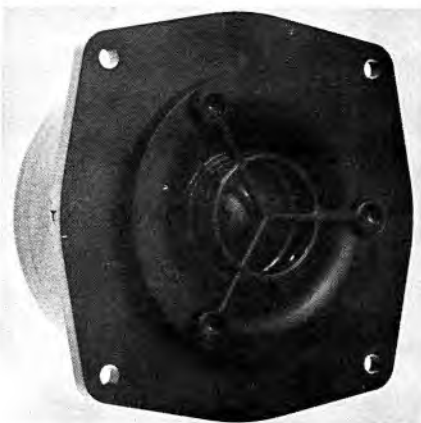

Goodmans Axiom 100

SP8B

Full-range unit. Nominal cone diameter: 20.3cm. Paper cone. Cloth surround. Voice coil diameter: 5cm. 5cm. Nominal impedance: 8 ohms. Peak RMS capacity: 40W. FR: 35Hz-15kHz. Price: on application.

30W

Bass driver. Nominal cone diameter: 76.26cm. Polystyrene cone. Cloth surround. Voice coil diameter: 6.35cm. Nominal impedance: 8 ohms. Nominal RMS capacity: 60W. Resonance frequency: 15Hz. Recommended crossover: 100Hz. Price: on application.

T35

VHF tweeter. Voice coil diameter: 2.6cm. Nominal impedance: 8 ohms. FR: 5kHz-20kHz. Recommended crossover: 3.5kHz. Price: on application.

T350

VHF tweeter. Voice coil diameter: 2.6cm. Nominal impedance: 8 ohms. FR: 3.5Hz-23kHz. Recommended crossover: 3.5kHz. Price: on application.

■ **GOODMANS**

Goodmans Loudspeakers Ltd,
Downley Road, Havant, Hants PO9 2NL.
Tel: Havant 6344.

Twin Axiom 8 ★

8in full-range twin-cone driver. Paper cone. Rubber surround. Voice coils: 1in diameter copper wound. Impedance: 8 ohms. Gap flux: 13,500 gauss. Total flux: 53,000 maxwells. HC: 15W (DIN). FR: 40Hz-18kHz. Price: £10.91 (plus VAT).

Axiom 100★

Domed diaphragm high-frequency direct radiator with built-in filter network. Plastic cone. Voice coil: 1in diameter copper wound. Impedance: 8 ohms. HC: for use in systems rated at not more than 30W. FR: typically 2kHz-22kHz. Crossover: cut-off of 12dB/octave from 3kHz down. Price: £8.80 (plus VAT).

Audiom 10P

10in heavy duty. HC: 15W. Impedance: 8 or 15 ohms. Price: £7.35 (plus VAT).

Audiom 12P

12in heavy duty. HC: 50W. Impedance: 8 or 15 ohms. Price: £18.26 (plus VAT).

Audiom 18P

18in. Voice coil diameter: 3in. vci: 8 or 15 ohms. HC: 100W. Fundamental resonance: 45Hz. Flux density: 13,500 gauss. Baffle hole diameter: 16¹/₄in. Depth: 8³/₄in. Weight: 26lb. Recommended sealed enclosure (per speaker): 7000 cu in. Price: £45.59 (plus VAT).

Audiom 12P-G

12in heavy duty. HC: 50W. Impedance: 8 or 15 ohms. Price: £19.79 (plus VAT).

Audiom 12P-D

12in heavy duty twin-cone. HC: 50W. Impedance: 8 or 15 ohms. Price: £20.86 (plus VAT).

Audiomax 12AX

Bass drive unit. Nominal diameter: 12in. (312mm). Nominal impedance: 8 or 15 ohms. Nominal power handling: 100W. Resonance frequency: 55Hz. Sensitivity (96dB at 1m):

★Indicates entry is illustrated

0.12W. 10cm diameter edge wound voice coil.
Price: £47.07 (plus VAT).

Audiomax 15AX

Bass drive unit. Nominal diameter: 15in. (395mm). Nominal impedance: 8 or 15 ohms. Nominal power handling: 100W. Resonance frequency: 55Hz. Sensitivity (96dB at 1m): 0.25W. 10cm diameter edge wound voice coil. Price: £53.30 (plus VAT).

Hifax 750P

High power HF horn unit. Nominal impedance: 8 or 15 ohms. Designed for systems rated at 50W. FR: 1kHz-10kHz. Recommended crossover: 2kHz. Price: £19.40 (plus VAT).

Twin Axiom 10/11

10in. full range drive unit. Nominal cone diameter 250cm. Paper cone. Impedance: 8 or 15 ohms nominal. Total flux: 53,000 maxwells. Gap flux: 13,500 gauss. Nominal capacity: 40W DIN. Peak capacity: 40W DIN. FR: 50Hz-16kHz. Resonant frequency: 60Hz. Price: £11.11.

Audiom 200 ★

10in. long throw bass unit recommended for use with Axent 100. Nominal cone diameter 250cm. Paper cone, rubber surround. Impedance: 8 ohms nominal. Total flux: 68,750 maxwells, Gap flux: 7,500 gauss. Peak capacity: 60W DIN. Resonant frequency: 24Hz. Crossover frequency: 3,000Hz. Price: £14.39 (plus VAT).

Audiom 15P

15in. heavy duty drive unit. Paper cone. Impedance: 8 or 15 ohms nominal. Peak capacity: 75W. Resonant frequency: 60Hz. Price: £26.83 (plus VAT).

Axiom 402 ★

12in full range twin-cone driver. Nominal cone diameter 30.5cm. Paper cone, plastic surround. Voice coil diameter: 4.5cm. Impedance: 8 and 15 ohms nominal. Total flux: 164,750 maxwells, Gap flux: 14,500 gauss. Nominal capacity: 60W DIN. FR: 40-11,000Hz. Resonant frequency: 30Hz. Price: £22.57 (plus VAT).

Audiom 8PA

8in heavy duty. 20cm cone diameter. Paper cone material. Paper surround. Nominal impedance: 8 or 15 ohms. Capacity: 15 watts. FR: 50-9000Hz. Resonant frequency: 85Hz. Price: £3.14 (plus VAT).

■JORDAN-WATTS

Benlow Works, Silverdale Road,
Hayes UB3 3BW.
Tel: 01-573 6928.

Jordan-Watts Module Mk II ★

15cm square frame. Aluminium diaphragm with plastic surround. Voice coil: 1½in. Ceramic magnet. VCI: 4, 8 or 16 ohms. HC: 15W. FR: 25Hz-20kHz. Price: £18.78 (including VAT).

Qubige ★

Reflex cuboid enclosure 30cm³ using rigid ceramic side panels. FR: 35-20kHz. HC: 15 watts. VCI: 4, 8 and 16 ohms. Weight: 16kg. Price: £58.50 (including VAT).

■ KEF

KEF Electronics Ltd, Tovil, Maidstone,
Kent ME15 6QP.
Tel: Maidstone 57258.



Jordan-Watts speaker drive module

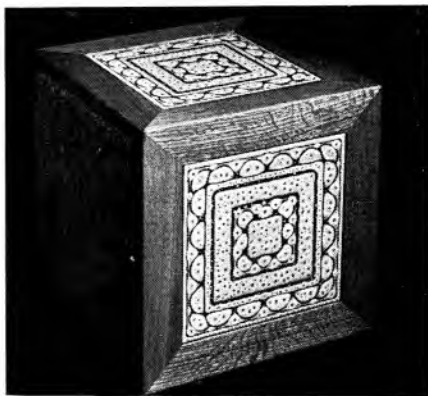

Qubige - Jordan - Watts

B139 SP1044 ★

11.82 × 8.25in. 8lb. HC: 50W. Resonance: 23Hz. Impedance: 8 ohms. FR: 20-1,000Hz. Price: £19.50 (plus VAT).

B200 SP1014

8³/₄in dia × 4in. 3³/₄lb. HC: 25W. Resonance: 25Hz. Impedance: 8 ohms. FR: 25-3,500Hz. Price: £9.75, (plus VAT).

B110 SP1003

5¹/₂ dia × 3¹/₈in. 3.6lb. HC: 20W. Resonance: 30Hz. Impedance: 8 ohms. FR: 55-5,000Hz. Price: £8.25 (plus VAT).

T27 SP1032

4¹/₄ dia × 1³/₈in. 1.4lb. HC: 8W. Resonance: 900Hz. Impedance: 8 ohms. FR: 3,500-40,000Hz. Price: £6.00 (plus VAT).
See also entry in Constructional Kits section and Speaker Accessories section.

■ PEERLESS

Distributor: Ross Electronics,
32, Rathbone Place, London W1P 1AD.
Tel: 01-580 7112.

All units are 8 ohms impedance

MT 20 HFC

Cone tweeter. 51 × 51mm. HC (System Max.): 50W. FR: 3000-18,000Hz. Impedance: 8 ohms. Price: £2.74 (plus VAT).

MT 225 HFC ★

Cone tweeter. 58 × 58mm. HC (System Max.): 50W. FR: 1500-20,000 Hz. Impedance: 8 ohms. Price: £2.85 (plus VAT).

MT 25 HFC

Cone tweeter. 68 × 68mm. HC (System Max.): 50W. FR: 2000-18,000 Hz. Impedance: 8 ohms. Price: £2.85 (plus VAT).

DT 10 HFC

Dome tweeter. 75 × 115mm. HC (System Max.): 50W. Cone resonance: 1000 Hz. FR: 1,500-20,000Hz. Impedance: 8 ohms. Price: £8.54 (plus VAT).

KO 10 DT

Dome tweeter. 80 × 115mm. HC (System Max.): 50W. Cone resonance: 1000Hz. FR: 1,500-20,000Hz. Impedance: 8 ohms. Price: £7.09 (plus VAT).

KO 40 MRF

Enclosed Midrange. 122 × 122 × 110mm. deep. HC (System Max.): 50W. Cone resonance: 230Hz. Rec. FR: 500-5,000Hz. Impedance: 8 ohms. Price: £9.77 (plus VAT).

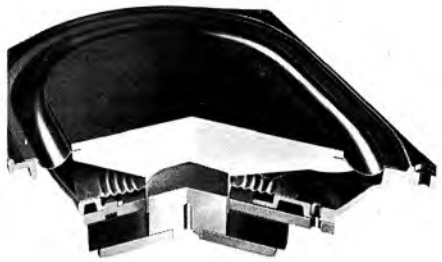

KEF B139 SP1044



Peerless MT 225 HFC

KO 65 WG

Woofer, rubber roll surround. 165mm. diam × 84mm. deep HC: 20W. Cone resonance: 35Hz. Upper freq. limit: 4,000Hz. Impedance: 8 ohms. Price: £8.14 (plus VAT).

L 825 WG

Woofer, rubber roll surround. 210mm. diam × 108mm. deep. HC: 50W. Cone resonance: 25Hz. Upper freq. limit: 2,500 Hz. Impedance: 8 ohms. Price: £11.44 (plus VAT).

L 100 WG

Woofer, rubber roll surround. Impedance: 8 ohms. 250mm diam × 127mm deep. HC: 50W. Cone resonance: 20 Hz. Upper freq. limit: 2,500 Hz. Price: £12.23 (plus VAT).

■ RADFORD

Radford, Ashton Vale Road,
Bristol BS3 2HZ.
Tel: Bristol 662301.

★ Indicates entry is illustrated

BD35

Bass driver, nominal 15in. Cast frame. Twin cone diaphragm. 2in diameter aluminium former voice coil. 8 ohms impedance only, for use in 120 W rating systems. Price: £45.00 (plus VAT).

BD25

Bass driver, nominal 12in. Cast frame heavy plasticised diaphragm for use up to 1kHz with a 1½in aluminium former voice coil. Impedance 8 ohms or 4 ohms for use in 75W rating systems. Price: £24.50 (plus VAT).

BD15

Bass driver, nominal 8in. For 2-way systems with a crossover frequency up to 2.5kHz. Pressed steel frame 1in diameter aluminium voice coil. For use in systems up to 50W. Impedance 8 ohms or 4 ohms. Price: £16.00 (plus VAT).

MD6

Midrange driver. 6cm diameter soft dome unit for use in the frequency range 500Hz-10kHz. 1½in aluminium former voice coil. Impedance 8 ohms or 4 ohms, for use in 75W rating systems. Price: £13.20 (plus VAT).

MTD4

Mid-treble driver. 4cm diameter soft dome unit designed for 2-way systems with a crossover frequency down to 1500Hz. 1½in aluminium former voice coil. For use in systems up to 50W rating. Price: £10.50 (plus VAT).

TD3/2

Treble driver. 3cm diameter soft dome unit designed for 2 or 3-way systems operating up to 25kHz. Aluminium former voice coil. Impedance 8 ohms or 4 ohms for use in 75W rating systems. Price: £7.80 (plus VAT).

TD3/3

Treble driver. 3cm diameter soft dome unit designed for use in high efficiency 2 or 3-way systems operating up to 18kHz with a crossover frequency down to 2.5kHz. Aluminium former voice coil. This unit is approximately 3dB more sensitive than the TD3/2 driver. Impedance 8 ohms or 4 ohms for use in 75W rating systems. Price: £7.00 (plus VAT).

TD2

Treble driver. 2cm diameter soft dome unit designed for 3-way systems operating up to 30kHz. Aluminium former voice coil. Impedance 8 ohms or 4 ohms for use in 75W rating systems. Price: £7.00 (plus VAT).

■ R. S. COMPONENTS

Doram Electronics Ltd. P.O. Box T.R.8,
Leeds. LS12 2UF
Tel: Leeds 34222.

248-886

Bass unit. 18cm cone diameter. Paper cone material. Foam surround. Voice coil diameters: 2.5cm. Copper coil material. Nominal Impedance: 8 ohms. Gap flux: 10,000 gauss. Nominal Capacity: 25 watts. FR: 30Hz-4kHz. Cross-over frequency: 2.8kHz. Resonant frequency: 30Hz. Price: £5.76 (plus VAT).

248-870

Tweeter. 2.5cm cone diameter. Polycarbonate cone material. 2.5cm coil diameter. Copper coil material. Nominal Impedance: 8 ohms. Gap flux: 10,000 gauss. Nominal Capacity: 8 watts. FR: 1.5kHz-22kHz. Cross-over frequency: 2.8kHz. Resonant frequency: 1kHz. Price: £5.06 (plus VAT).

249-031

Full range. 14.2cm cone diameter. Paper cone material. Foam surround. Voice coil diameter: 2.5cm. Copper coil material. Nominal Impedance: 8 ohms. Gap flux: 10,000 gauss. Nominal capacity: 10 watts. FR: 70Hz-16kHz. Resonant frequency: 50Hz. Price: £4.05 (plus VAT).

249-047

Full range. 14.2cm cone diameter. Paper cone material. Foam surround. Voice coil diameter: 2.5cm. Copper coil material. Nominal Impedance: 15 ohms. Gap flux: 10,000 gauss. Nominal Capacity: 10 watts. FR: 70Hz - 16kHz. Resonant frequency: 50Hz. Price: £4.05 (plus VAT).

248-892

Bass unit. 14.2cm cone diameter. Paper cone material. 2.5cm Voice coil diameter. Copper coil material. Nominal Impedance: 8 ohms. Gap flux: 7,500 gauss. Capacity: 15 watts. FR: 50Hz-10kHz. Cross-over frequency: 6.5kHz. Resonant frequency: 75Hz. Price: £3.76 (plus VAT).

248-763

Tweeter. 7.7cm cone diameter. Paper cone material. Voice coil diameter: 1.4cm. Copper coil material. Nominal Impedance: 8 ohms. Gap flux: 7,000 gauss. Capacity: 2 watts. FR: 1.5kHz-18kHz. Cross-over frequency: 6.5kHz. Resonant frequency: 1kHz. Price: £1.32 (plus VAT).

Speaker Enclosures

★ Indicates entry is illustrated.

Abbreviations used in this section are given on page 27.

■ AKAI

Rank Audio Visual, Rank Hi-Fi, P.O. Box 70, Great West Road, Brentford, Middlesex, TW8 9HR.
Tel: 01-568 9222.

SA 800

Infinite Baffle speaker with 8in woofer and 3in tweeter. Crossover frequency: 2.5 kHz. FR: 40-20,000 Hz. Impedance: 8 ohms. Amplifier requirements: 10-40 Watts. Dimensions: 25 × 47 × 24 cms. Weight: 7.5 kg. Walnut veneer finish. Price per pair: £98.80 (plus VAT).

SA 1000

Infinite Baffle speaker with 8in woofer, 3in mid-range, and 3in tweeter. Crossover frequency: 1.2 kHz, and 12 kHz. FR: 35-20,000 Hz. Impedance: 8 ohms. Amplifier requirements: 10-40 Watts. Dimensions: 32 × 59 × 26cms. Weight: 12.3 kg. Walnut veneer finish. Price per pair: £158.00 (plus VAT).

SA 1200

Infinite Baffle speaker with 12in woofer, 3in mid-range, 3in tweeter. Crossover frequency: 1.2 kHz, 12 kHz. FR: 35-20,000 Hz. Impedance: 8 ohms. Amplifier requirements: 10-40 watts. Dimensions: 36 × 67 × 27 cms. Weight: 16.2 kg. Walnut veneer finish. Price per pair: £207.60 (plus VAT).

■ ALBA (RADIO AND TELEVISION) LTD

Bull Lane, Edmonton, London, N18 1SD.
Tel: 01-803 4451.

300A

Infinite Baffle speaker with 16.5mm bass and 86mm tweeter. Impedance: 8 ohms. Dimensions: 21.3 × 15.2 × 42.5 cms. Weight: 3.7 kg. Teak veneered with black fabric finish or alternative white (optional). Price: on application.

901

Infinite Baffle speaker with 200 mm bass and

25.4mm dome tweeter. FR: 20-22,000 Hz. Impedance: 4 ohms. Dimensions: 31.6 × 21 × 53.6 cms. Weight: 10 kg. Teak veneered with black fabric finish. Price: on application.

■ RICHARD ALLAN

Richard Allan Ltd, Bradford Road, Gomersal, Cleckheaton, West Yorkshire BD19 4AZ.
Tel: Cleckheaton 2442.

Minette series II

Infinite baffle bookshelf 15W enclosure. 5in bass unit, 4in tweeter. FR: 50Hz-17kHz. HC: 10W. Size: 11½ × 7 × 6½in. Weight: 11lb. Price: £21.00 (plus VAT).

Chaconne series II

Full range two-way 15W system comprising 8in bass unit and 4in tweeter. FR: 45Hz-17kHz. HC: 12W. Size 20 × 12 × 8½in. Weight: 21lb. Price: £24.00 (plus VAT).

Flamenco series II

Full range three-way 120W system. One 8in bass driver, one 5in mid-range unit, one 4in tweeter. FR: 40Hz-17kHz. HC: 15W. Size: 20 × 12 × 8½in. Weight: 21lb. Price: £34.00 (plus VAT).

Pavane series II

Full range three-way 30W system comprising 12in bass driver, 8in mid-range unit and 4in tweeter. FR: 30Hz-17kHz. HC: 20W. Size: 27 × 15½ × 12in. Weight: 39lb. Price: £48.00 (plus VAT).

RA8

Compact enclosure designed to fit on bookshelves and room dividers. Impedance: 8 ohms. FR: 50Hz-20kHz. Crossover: 3.5kHz. Handling capacity: 20W. Finish: teak or walnut. Size: 395 × 266 × 247mm. Price: £60.00 per pair (plus VAT).

RA82

Large bookshelf speaker to give improved bass response, also suitable for floor standing. FR: 50Hz-20kHz±3dB. Crossover: 3.5kHz. Handling capacity: 45W. Size 546 × 278 × 247mm. Price: £96.00 per pair (plus VAT).

RA82L

Floor standing constricted labyrinth enclosure. Electrically the same as RA82. FR: 40Hz-20kHz ±3dB. Size: 724 × 345 × 292mm. Finish: teak or walnut. Price: £116 per pair (plus VAT).

RA828LP

Floor standing labyrinth enclosure. Crossover

★Indicates entry is illustrated



Alpha HT17 MkII



Amstrad Acoustra 2500

frequencies: 250Hz, 3.5kHz. Handling capacity: 45W. Size: 749 × 381 × 292mm. Finish: teak or walnut. Price: £180.00 per pair. (plus VAT).

■ ALPHA

Highbate Acoustics Ltd, 38 Jamestown Road, London NW1 7EJ. Tel: 01-267 4937.

HT12

Infinite baffle omni-directional speaker enclosure. One drive unit. FR: 50Hz-18kHz. Impedance: 8 ohms. Dimensions: 16 × 16 × 24cm. Finish: teak. Price: £16.00 per pair (excluding VAT).

HT17 Mk2 ★

Infinite baffle speaker enclosure. Two drive units. Crossover frequency: 3.5kHz. FR: 50Hz-18kHz. Impedance: 8 ohms. Dimensions: 25 × 14 × 36cm. Weight: 4.2kg. Finish: teak. Price: £15.00 per pair (excluding VAT).

HT20 Mk3

Infinite baffle speaker enclosure. Three drive units. Crossover frequencies: 750Hz and 3kHz. FR: 35Hz-20kHz. Dimensions: 28 × 22

× 44cm. Weight: 9.2kg. Finish: teak. Price: £29.00 per pair (excluding VAT).

HT50

Infinite baffle speaker enclosure. Two drive units. Crossover frequency: 3kHz. FR: 45Hz-20kHz. Impedance: 8 ohms. Dimensions: 25 × 20 × 36cm. Weight: 5.5kg. Finish: teak. Price: £18.00 per pair (excluding VAT).

HT60

Infinite baffle speaker enclosure. Four drive units. Crossover frequencies: 750Hz and 4kHz. FR: 30Hz-20kHz. Impedance: 8 ohms. Dimensions: 36 × 30 × 59cm. Weight: 17kg. Finish: teak. Price: £49 per pair (excluding VAT).

HT90

Bass reflex speaker enclosure. Three drive units. Crossover frequencies: 700Hz and 4kHz. FR: 27Hz-20kHz. Impedance: 8 ohms. Dimensions: 40 × 30 × 72cm. Weight: 22kg. Finish: teak. Price: £69.00 per pair (excluding VAT).

■ AMSTRAD

AMS Trading (Amstrad) Ltd, 89 Ridley Road, Dalston, London E8 2NH. Tel: 01-249 5237/8/9.

1500

Fully sealed speaker enclosure. 165mm bass unit and 85.7cm mid-range/treble. Crossover frequency: 1,200Hz. FR: 45Hz-17kHz. Impedance: 8 ohms. HC: 15W. Dimensions: 26 × 22.2 × 36.8cm. Weight: 6.8kg. Finish: teak veneered cabinet, black fabric front. Price: £36.00 per pair (excluding VAT).

2500★

Fully sealed speaker enclosure. 303mm bass unit and 85.7 mid-range/treble. Crossover frequency: 1,200Hz. FR: 35Hz-17kHz. Impedance: 8 ohms. HC: 25W. Dimensions: 25.7 × 24.1 × 48.9cm. Weight: 9.1kg. Finish: teak veneered cabinet, black fabric front. Price: £42.32 per pair (excluding VAT).

■ AR

Teledyne Acoustic Research, High Street, Houghton Regis, Dunstable, Beds, LU5 5QJ. Tel: Dunstable 603151.

AR-LST ★

Acoustic suspension enclosure with units and crossover. One 12in bass driver, four 1½in hemispherical dome mid-range units, four ¾in

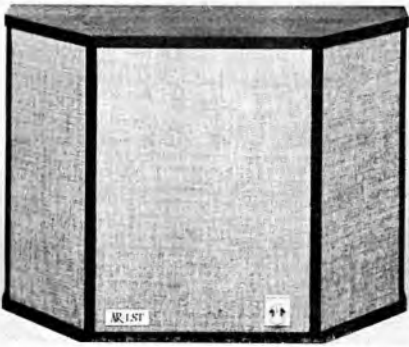

AR-LST

hemispherical dome tweeters. FR: choice of six energy output characteristics (spectral energy profiles) by means of a switch mounted on front of cabinet. Crossovers: 525Hz, 5kHz. Impedance: 4-16 ohms, depending on switch position. HC: details on request. Size: 68.9 × 50.8 × 24.8cm. Weight: 40.5 kg. Five-year guarantee. Price: £477.00 per pair (plus VAT).

AR-MST

Infinite Baffle speaker with 203mm acoustic suspension woofer, three 32mm cone/dome mid and high ranges. Crossover frequency: 1,600 Hz, 5,000 Hz. Impedance: 8 ohms nominal. Amplifier requirements: minimum 25 W per channel. Dimensions: 53.2 × 36 × 15.9. Walnut finish. Price: £130.00 (plus VAT).



AR11

AR7X

Infinite Baffle speaker with 203mm acoustic suspension woofer, 32mm high-frequency cone. Crossover frequency: 2,000 Hz. FR: Woofer resonance—free air 25 Hz, in enclosure 68 Hz. Impedance: 8 ohms nominal. Amplifier requirements: Up to 100 W per channel. Dimensions: 24.7 × 40 × 14.6 cm. Weight: 5 kg. Teak or Walnut finish. Price: £65.00 per pair (plus VAT).

AR-11 ★

Infinite Baffle speaker with 305mm acoustic suspension woofer, 38mm hemispherical dome midrange, 19mm hemispherical dome high range. Crossover frequency: 525 Hz 5,000 Hz. FR: Woofer 18Hz (free air), midrange 400Hz, high range 2,000Hz. Impedance: 4 ohms nominal. Amplifier requirements: min. 25 W per channel. Dimensions: 35.4 × 63.5 × 27.3 cm. Weight: 24.9 kg. Walnut finish. Price per pair: £242.00 (plus VAT).

AR-10TR

Infinite Baffle speaker with 305mm acoustic suspension woofer, 38mm hemispherical dome/midrange, 19mm Hemispherical dome highrange. Crossover frequency: 525Hz 5000 Hz. FR: Woofer 18 Hz (free air), midrange 400 Hz, Highrange 2,000 Hz. Impedance: 4-16 ohms nominal. Amplifier: 25 W. Dimensions: 35.4 × 63.5 × 27.3cm. Weight: 24.9 kg. Walnut finish. Price per pair: £346.00 (plus VAT).



AR12

AR 12★

Infinite Baffle speaker 25.4cm acoustic suspension woofer, 65mm midrange with integral rear loading cavity and magnetic fluid suspension, 19mm Hemispherical dome highrange. Crossover frequency: 700 Hz, 4000 Hz. FR: Woofer 26 Hz (free air), midrange 500 Hz, High range 2000 Hz. Impedance: 8 ohms nominal. Amplifier requirements: Min. 25 W per

★ Indicates entry is illustrated

channel. Dimensions: 35.4 × 63.5 × 27.3 cm. Weight: 15.9 kg. Walnut or teak finish. Price: £216.00 (plus VAT).

AR 14

Infinite Baffle speaker with 25.4cm acoustic suspension woofer, 25mm Hemispherical dome highrange. Crossover frequency: 1,300 Hz. FR: Woofer 26 Hz (free air), highrange 1,000 Hz. Impedance: 8 ohms nominal. Amplifier requirements: Min. 25 W per channel. Dimensions: 35.4 × 63.5 × 27.3 cm. Teak or walnut finish. Price: to be announced.

AR 16

Infinite Baffle speaker with 200mm acoustic suspension woofer, 25mm dome highrange. Crossover frequency: 1,300 Hz. FR: Woofer 25 Hz (free air) high range 1,000 Hz. Impedance: 8 ohms nominal. Amplifier requirements: Min. 25 W per channel. Dimensions: 24.9 × 50 × 21.7cm. Weight: 9.5kg. Teak or walnut finish. Price per pair: £106.00 (plus VAT).

■ BEOVOX

Bang & Olufsen (UK) Ltd, Eastbrook Road, Gloucester GL4 7DE. Tel: Gloucester 21591.

Beovox S22

Uniphase pressure chamber with 2.5cm treble and 16cm bass units. Crossover frequency: 3 kHz. FR: 50-20,000 Hz. Impedance: 4 ohms. Amplifier requirements: 22 Watts maximum. Dimensions: 22 × 14 × 41cm. Weight: 4 kg. White, oak finish to special order. Standard in teak or rosewood. Price: not quoted.

Beovox 530

Uniphase pressure chamber enclosure with 2.5cm treble and 16cm bass drive units. Crossover frequency: 3 kHz. FR: 40-20,000 Hz. Impedance: 4 ohms. Amplifier requirements: 30 max. Dimensions: 22 × 14 × 41 cm. Weight: 4 kg. White, oak, teak or rosewood. Price: not quoted.

Beovox P30

Phase linear pressure chamber with 2.5 cm treble and 16 cm bass drive units. Crossover frequency: 3 kHz. FR: 49-20,000 Hz. Impedance: 4 ohms. Amplifier requirements: 30 max. Dimensions: 30 × 9 × 54 cm. Weight: 5 kg. White or oak to special order, but standard finish in teak or rosewood. Price: not quoted.

Beovox P45

Phase linear pressure chamber with 2.5 cm treble, phase link 9 cm, 2 × 12.5 cm bass.

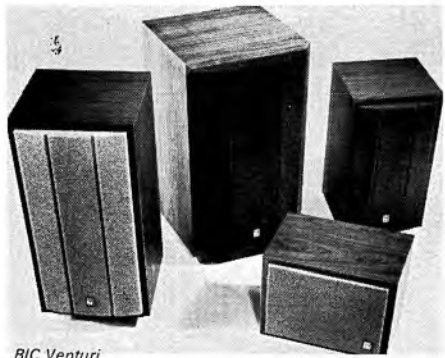

BIC Venturi

Crossover frequency: 2 kHz. FR: 40-20,000 Hz. Impedance: 4 ohms. Amplifier requirements: 45 max. Dimensions: 35 × 14 × 65 cm. Weight: 8 kg. White or oak, teak or rosewood finish. Price: not quoted.

S45

Phase linear with 2.5 cm treble, phase link 9 cm, 20cm bass drive units. Crossover frequency: 2,000 Hz. FR: 40-20,000 Hz. Impedance: 4 ohms. Amplifier requirements: 45 max. Dimensions: 26 × 18 × 48. Weight: 7 kg. Standard teak or rosewood finish with white or oak to special order. Price: not quoted.

S60

Phase linear speaker with 2.5 treble, 5 cm Mid, phase link 12.5 cm, 25 cm bass. Crossover frequency: 36-20,000 Hz. Impedance: 4 ohms. Amplifier requirements: 60 max. Dimensions: 32 × 20 × 59 cm. Weight: 11 kg. Standard teak or rosewood finish with white or oak to special order. Price: not quoted.

Beovox M70

Phase linear pressure chamber with 2.5 cm treble, 6 cm mid, phase link 12.5 cm, 25 cm bass drive units. Crossover frequency: 500-4,000 Hz. Impedance: 4 ohms. Amplifier requirements: 70 max. Dimensions: 35 × 29 × 65 cm. Weight: 25 kg. Standard finish teak or rosewood with white or oak to special order. Optional stand available. Price: not quoted.

■ BIC VENTURI

Belmont A/V Ltd, Fircroft Way, Edenbridge, Kent TN8 6HA. Tel: Edenbridge 4116.

Formula 1★

Reflex bass enclosure with 2 units, plastic cone and roll surround. Bass driver diameter: 20cm.

Nominal capacity: 50W. FR: 50Hz-18kHz. Size: 27.5 × 25.5 × 42cm. Weight: 20lb. Finish: walnut. Price: £48.00 (excluding VAT).

Formula 2 ★

Reflex bass enclosure with 2 units, plastic cone and cloth surround. Bass driver diameter: 20cm. Nominal capacity: 75W RMS. FR: 40Hz-20kHz. Size: 30.5 × 29 × 50 cm. Weight: 34½lb. Finish: walnut. Price: £70.00 (excluding VAT).

Formula 4 ★

Reflex bass enclosure with 2 units, plastic cone and cloth surround. Bass driver diameter: 25.4cm. Nominal capacity: 100W. FR: 35Hz-20kHz. Size: 33.5 × 33 × 63.5cm. Weight: 48lb. Finish: walnut. Price: £86.50 (excluding VAT).

Formula 6

Reflex bass enclosure with 5 units, plastic cone and cloth surround. Bass driver diameter: 27.8cm. Nominal capacity: 125W RMS. FR: 30Hz-20kHz. Size: 40 × 37.5 × 66.7 cm. Weight: 64 lb. Finish: walnut. Price: £210.00 (excluding VAT).

■ BOSE

Bose (UK) Ltd, Gas Road, Milton Regis, Sittingbourne, Kent.
Tel: Sittingbourne 75341.

Bose 901

Infinite baffle enclosure with high acoustic coupled drivers. Nine 100mm high compliance paper cone speakers (one forward facing, eight on rear baffles). No crossover network. Impedance: 8 ohms. Amplifier requirements: 40W minimum. Active equaliser corrects response shape and adjusts for room acoustics (Frequency range not quoted). Direct reflecting. 300W RMS handling. Dimensions: 20⁹/₁₆ × 12⁷/₈ × 12³/₄in. Weight: 38lb each. Various finishes. Sold in matched pairs. Price: £340.00 per pair (excluding VAT).

Bose 501

Infinite baffle enclosure with units and crossover. One forward-facing 10in bass driver, two rear-angled 3in tweeters. Impedance: 4 ohms. Amplifier requirements: 10W. HC: 100W RMS. Dimensions: 14½ × 14½ × 24in. Weight: 45lb each. Direct reflecting. Finish: ebony gull cloth and walnut grain effect veneer. Sold in matched pairs. Price: £185.00 per pair (excluding VAT).

Bose 301

Ported bass reflex enclosure plus variable high



B & W DM4

frequency deflection 'sound paddle'. One 8in bass unit and one 3in tweeter. Crossover frequencies: 1kHz and 3kHz. Impedance: 8 ohms. Amplifier requirements: 10W. HC: 60W RMS. Dimensions: 17 × 10½ × 9½in. Weight: 17lb each. Finish: walnut effect veneer with foam grille coverings. Asymmetrical direct/reflect. Bookshelf speaker. Sold in matched pairs. Price: £120.00 per pair (excluding VAT).

All models covered by a 5-year parts and labour guarantee.

■ B & W

B & W Electronics, Meadow Road, Worthing, Sussex BN13 1QA.
Tel: Worthing 205611.

DM2A

Eighth-wave acoustic line bass enclosure with units and crossover. One 8in bass driver with Bextrene cone, one HF1300 mid-HF unit, one ¾in low mass plastic dome tweeter. Crossover: 3kHz. FR: 30Hz-25kHz (±4dB 60Hz-20kHz). Impedance: 8 ohms at 400Hz. Size: 64.4 × 35.3 × 34.5cm. Weight: 52lb. Finish: teak, rosewood, satin white or walnut. Every model individually pen tested and calibration certificate supplied. Price: teak, satin white or walnut. Price: £78.12 each (plus VAT); rosewood £82.14 each (plus VAT).

DM4 ★

Three-unit monitor speaker system suitable for bookshelf or wall mounting. One DW200/4 bass/mid-range driver with Bextrene cone, one



R & W DM6



C.A.S range

Celestion HF1300 upper mid-frequency unit. One $\frac{3}{4}$ in low-mass plastic dome tweeter. FR: 30Hz-25kHz (± 5 dB 80Hz-20kHz). HC: 30W. Impedance: 8 ohms at 400Hz. Size: 53 × 25.5 × 25.6cm. Weight: 24lb 6oz. Finish: teak, rosewood, satin white or walnut. Every model individually tested and calibration certificate supplied. Price: teak, satin white or walnut £55.68 each (plus VAT); rosewood £58.22 each (plus VAT).

DM5

Two-unit Bookshelf monitor speaker system. Sensitivity 6-8 watts into nominal impedance (i.e. 7.4 volts for sound pressure of 95 dB pink). Bass/Midrange Driver type MW150/M with overload protection with amplifiers above

25 watts. 1 × 19mm Upper Mid and High Frequency units TW20/5. Frequency Range: ± 5 dB 100Hz to 20kHz (Free field). Handling Capacity: Suitable for amplifiers from 10 and 25 watts r.m.s. under normal domestic conditions. Impedance: 8 ohms at 400Hz (Nominal). Size: 45 × 22.7 × 24.1in. Weight: 7.25kg. Cabinet Finish: teak, walnut, rosewood and satin white. Price: Teak, walnut or satin white £39.29 each (excluding VAT); Rosewood £41.97 each (excluding VAT).

DM6 ★

Monitor loudspeaker with 224mm bass unit. 131mm midrange. 19mm high frequency unit. Both bass and midrange units are loaded into independent irregularly-shaped totally sealed enclosures. FR: 50-20,000Hz. Sensitivity: 7.6 W into nominal impedance (i.e. 7.8 volts) for pink noise sound pressure of 95dB at 1 metre (anechoic conditions). Power Handling: suitable for amplifiers between 25 and 350 W RMS under normal domestic conditions. Crossover frequencies: 500Hz, 5kHz. Impedance: 8 ohms. Dimensions: 93.1 × 41 × 38cm. Weight (including stand): 36.2kg. Satin white, teak veneer, walnut or rosewood finish. Prices: Rosewood £182.14 (plus VAT), other finishes £167.87 (plus VAT).

■ C.A.S.

City Audio Services Ltd, Rush Hill Mews, London SW11.
Tel: 01-223 2496.

D-25 ★

Sealed enclosure. Three drive units. Crossover frequencies: 5kHz and 9kHz. Impedance: 8 ohms. Amplifier requirements: 12W RMS (min). Dimensions: 10½ × 8 × 18½in. Weight: 18lb. Finish: walnut. Price: £42.90 per pair (excluding VAT).

M-40 ★

Sealed enclosure. Three drive units. Crossover frequencies: 250Hz and 5kHz. FR: 40Hz-22kHz. Impedance: 4-8 ohms. Amplifier requirements: 15W RMS (min). Dimensions: 10½ × 8 × 18½in. Weight: 22lb. Finish: walnut. Price: £61.31 per pair (excluding VAT).

M-80 ★

Sealed enclosure. Three drive units. Crossover frequencies: 250Hz and 5kHz. FR: 35Hz-25kHz. Impedance: 4-8 ohms. Amplifier requirements: 15W RMS (min). Dimensions: 12 × 8½ × 22in. Finish: walnut. Price: £93.52 per pair (excluding VAT).

M-100 ★

Sealed enclosure. Three drive units. Cross-

over frequencies: 250Hz and 5kHz. FR: 25Hz-25kHz. Impedance: 4-8 ohms. Amplifier requirements: 20W RMS (min). Dimensions: 14 × 15 × 34½in. Finish: walnut. Price: (per pair) £171.60 (excluding VAT).

■ CASTLE

Castle Acoustics Ltd, Park Mill, Shortbank Road, Skipton, Yorks. Tel: Skipton 5333.

Conway

Three-speaker, three-way system for use with amplifiers requiring 4 to 8 ohms load. Power handling capacity: 50W (DIN 45 500). Crossover frequencies: 800Hz and 4kHz. Low frequency cut-off: -3dB at 45Hz. Size: 25 × 14 ×

14in. Finish: teak, walnut or mahogany. Price: teak £140 per pair (plus VAT); walnut £147.00 per pair (plus VAT); rosewood £160.00 per pair (plus VAT). Period Styling £170.00 upwards.

Howard ★

Five-speaker, three-way system for use with amplifiers requiring 4 to 8 ohms load. Power handling capacity: 50W (DIN 45 500). Crossover frequencies: 800Hz and 4kHz. Low-frequency cut-off: -3dB at 40Hz. Size: 26 × 19 × 15in. Finish: teak, oak, walnut or mahogany. Price: teak £182.00 per pair (plus VAT); walnut, oak, mahogany £192.00 per pair (plus VAT); period styling £222.00 per pair (plus VAT).

Richmond

Reflex loaded, diaphragm bass and mid-range unit for use with amplifiers requiring 4 to 8 ohms load. Power handling capacity: 25W (DIN 45 500). Crossover frequency: 3.5kHz. Low frequency cut-off: -3dB at 55Hz. Size: 16½ × 9 × 9½in. Weight: 18¾lb. Finish: teak or walnut. Price: £68.00 per pair (plus VAT);; Teak £70.00; walnut £77.00 rosewood.

Kendal

Drive units: 30mm tweeter, 20cm bass/mid range. Crossover frequency: 3.5kHz. FR: 48-20,000Hz. Imp: 4-8 ohms. Amplifier requirements: 10-40W. Dimensions: 29 × 28 × 52.5cm. Weight: 11kg. Teak, walnut, oak, mahogany, rosewood. Veneered baffle back. Hand finished. Price: £95.00 teak, £99.00 walnut, oak, mahogany, £108.00 rosewood (all plus Vat).

■ CELEF

Celef Audio, 130 Thirsk Road, Borehamwood, Herts. Tel: 01-207 1150.

Celef Micro

Infinite baffle enclosure. FR: 100Hz-20kHz ±2dB. Imp: 8 ohms. Power handling capacity: 60W. 2 drivers. Distortion: less than 1% for 90dB SPL. Size: 12 × 6½ × 9½in. Weight: 11½lb. Finish: teak, walnut, or white. Price: on application.

Celef Mini Professional

Twin resistive loading with symmetrical flow paths. Imp: 8 ohms. FR: 60Hz-20kHz ±2dB. Power handling capacity: 80W. 2 drivers. Distortion: less than 1% for 96dB SPL. Size: 25 × 12 × 13in. Weight: 50lb. Finish: teak, walnut or white. Price: on application.

Celef Mini ★

Resistively loaded reflex port. One 5in bass unit. FR: 90Hz-20kHz ±2dB. Imp: 8 ohms.

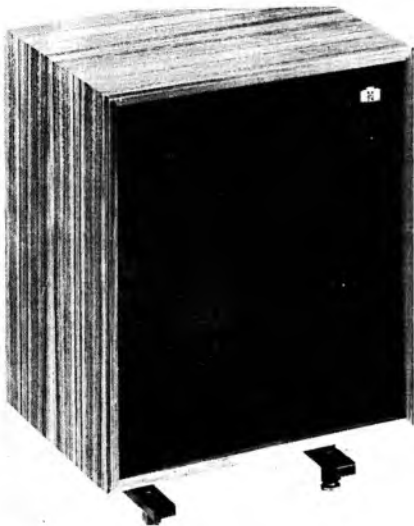

Castle Howard



Celef mini (left) & Celef Monitor (Right)



Celestion Ditton 25



Celestion Ditton 44

Power handling capacity: 60W. 2 drivers. Distortion: less than 1½% for 90dB SPL. Size: 16 × 9½ × 8in. Weight: 13lb. Finish: teak, walnut or white. Price: on application.

Celef Monitor ★

Resistively loaded reflex port. FR: 70Hz-20kHz ±2dB. Impedance: 8 ohms. Power handling capacity: 80W. 2 drivers. Distortion: less than 1% for 90dB SPL. Size: 20½ × 11 × 9½in. Weight: 24lb. Finish: teak, walnut or white. Price: on application.

Celef Domestic

Two drivers totally enclosed, high efficiency speaker. Crossover: 3kHz. FR: 40-20,000Hz. 8 ohms. Distortion: less than 1% for 90dB. Finish in teak, walnut, Rosewood, Walnut. Dimensions: 22 × 12 × 10in. Weight: 28lb. Price: on application.

Celef Studio Professional Transducer

Special damped tapering bass chamber with rear resistive reflex loading. Impedance: 8 ohms. Power handling: 100W. FR: 20-20,000Hz. Crossover: 250Hz and 5kHz. Distortion: less than 1% for 96dB. Size: 31 × 14 × 15in. Weight: 80lb. Price: on application.

■ **CELESTION**

Rola-Celestion Ltd, Ditton Works, Foxhall Road, Ipswich, Suffolk IP3 8JP. Tel: Ipswich 73131.

Ditton 25 ★

FR: 20Hz-40kHz, -6dB at 40Hz. Impedance:

4-8 ohms. Max. continuous input: 60W (DIN). SPL: 7W for 96dB at 1m. Crossover frequencies: 2kHz and 9kHz. THD: (at 96dB) 0.8% 100kHz, 0.7% 400Hz, 0.7% 1kHz, 1.0% 4kHz, 0.8% 10kHz, 0.9% 15kHz. Weight: 19kg. Finish: teak or walnut. Size: 81 × 36 × 28cm. Price: £216.40 per pair (plus VAT).

Ditton 44 ★

Floor-standing enclosure with units. One 12in bass driver, one 6in HF unit and HF2000 tweeter. FR: 30Hz-40kHz, -8dB at 40Hz. Imp: 4-8 ohms. Max. continuous input: 44W (DIN). SPL: 5.5W for 96dB at 1m. Crossover frequencies: 500Hz and 5kHz. THD: (at 96dB) 0.8% 100Hz, 0.8% 400Hz, 0.8% 1kHz, 1.4% 4kHz, 1.1% 10kHz, 0.9% 15kHz. Weight: 20.4kg. Finish: teak or walnut. Size: 76 × 37 × 25cm. Price: £183.48 per pair (plus VAT).

Ditton 15

Compact infinite baffle enclosure. FR: 30Hz-15kHz, -12dB at 40Hz. Impedance: 4-8 ohms. Maximum continuous input: 30W (DIN). SPL: 3.8W for 96dB at 1m. Crossover frequencies: 2.5kHz. THD: (at 96dB) 1.1% 100Hz, 0.9% 400Hz, 0.7% 1kHz, 0.9% 4kHz, 1.7% 10kHz. Weight: 7.6kg. Finish: teak or walnut. Size: 53 × 24 × 23cm. Price: £102.26 per pair (plus VAT).

Ditton 66

FR: 16Hz-40kHz, -4dB at 40Hz. Imp: 4-8 ohms. Max. continuous input: 80W (DIN). SPL: 10W for 96dB at 1m. Crossover frequencies: 500Hz and 5kHz. THD: (at 96dB) 0.6% 100Hz,

0.6% 400Hz, 0.7% 1kHz, 0.7% 4kHz, 0.9% 10kHz, 1.1% 15kHz. Weight: 30kg. Finish: teak or walnut. Size: 100 × 38 × 29cm. Price: £294.69 per pair (plus VAT).

Ditton 11

Dimensions: 24 × 35 × 25cm. FR: 90Hz-25kHz. Teak or walnut finish, containing 1in HF and 6in L.F. Power handling: 25W peak music power. Sensitivity: 90dB at 1m for 6V input. Imp: 4-8 ohms amplifier matching. Crossover dividing frequency: 2.5kHz. Weight: 5.9kg. Price: £63.00 (plus VAT).

Ditton 22

New model. Provisional information only. FR: 30Hz-25kHz. Max. continuous input: 30W (DIN). Further details and price to be announced.

Ditton 33

Teak or walnut finish. Weight: 15.3kg. 40-25kHz. Peak music power: 40W. Sensitivity: 96dB at 1m for 10V input. Imp: 4-8 ohms amplifier matching. Drive: 1in HF, 10in L.F. Dividing frequencies: 500Hz and 2.5kHz. Size: 61 × 35.5 × 26.7cm. Price: £151.10 (plus VAT).

UL6 ★

Speaker enclosure with units. One pressure dome tweeter HD1000, one 152mm dia. mid-bass unit, one 152mm dia. ABR. Power handling: 20W continuous RMS sine wave (40W peak). Sensitivity: 15.4V RMS pink noise input for 96dB at 1m. Crossover frequency: 2.5kHz. Frequency: 35Hz-28kHz. Response: ±3.5dB 80Hz-20kHz. Weight: 10.1kg. Size: 292mm high, 412mm wide, 222mm deep. Price: £94.60 per pair (plus VAT).

UL8 ★

Speaker enclosure with units. One pressure-dome tweeter HD1000, one 205mm dia. mid-bass unit, one 205mm dia. ABR. Power handling: 25W continuous RMS sine wave (50W peak). Sensitivity: 12V RMS pink noise input for 96dB at 1m. Crossover frequency: 2kHz. Frequency: 30Hz-28kHz. Response: ±3dB 70Hz-20kHz. Weight: 12.5kg. Size: 584mm high, 280mm wide, 235mm deep. Price: £118.80 per pair (plus VAT).

UL10 ★

Speaker enclosure with units. One HF2000 super tweeter, one MD700 pressure-dome mid-range unit, one 254mm bass drive unit. Power handling: 50W continuous RMS sine wave (100W peak). Sensitivity: 15.2V RMS pink noise input for 96dB at 1m. Crossover

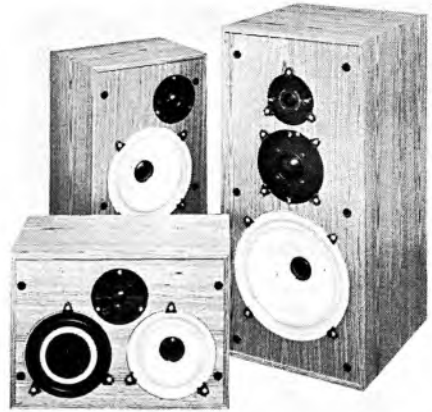

Celestion ULS. 8. 10

frequencies: 700Hz and 5kHz. Frequency: 20Hz-40kHz. Response: ±2dB 40Hz-20kHz. Weight: 23.5kg. Size: 673mm high, 317mm wide, 380mm deep. Price: £176.00 per pair (plus VAT).

■ CERWIN VEGA

Cerwin Vega (UK), 281 Balmoral Drive, Hayes. Tel: 01-573 1566.

15T

FR: 30-20,000Hz ±3½dB. Efficiency: 103dB at 1W at 1m on axis. Configuration: Direct+reflecting 4-way 'tower'. Power handling: 150W average continuous programme power. Max. output level (at 1m): 124dB. Driver complement: L.F: special 15in woofer, 12lb magnet system, 13Hz resonance. MF: 8in cone driver in sealed sub-chamber, 5lb magnet system. MF: (reflective) rear-radiating horn driver, 1in diaphragm. HF: 5in superhorn tweeter, 1in diaphragm, 17,500 Gauss. Crossover frequencies: 200, 1500, and 4000Hz. Controls: Rotary level controls for all drivers except woofer. Tweeter protection: resettable circuit breaker. Overall protection: user-replaceable fuse. Dimensions: 16½inD × 16½inW × 40inH. Weight: 95lb. Finish: oiled walnut with black grille. Minimum recommended amplifier power: 2W RMS (for sound levels comparable to 25W with low efficiency speakers). Price: £812.50 per pair (including VAT).

12T

FR: 32-20,000Hz ±3½dB. Efficiency: 100dB at 1W at 1m on axis. Configuration: Direct-radiating 3-way 'tower'. Power handling: 100W average continuous programme

★ Indicates entry is illustrated

power. Max. output level (at 1m) 119dB. Driver complement: LF: special 12in woofer, 6lb magnet system, 15Hz resonance. MF: 8in cone driver in sealed sub-chamber, 4lb magnet system. HF: 2½in horn tweeter, 1in diaphragm, 16,000 Gauss. Crossover frequencies: 200 and 4,000Hz. Controls: Separate rotary midrange and high frequency level controls. Tweeter protection: resettable circuit breaker. Overall protection: user-replaceable fuse. Dimensions: 13½inD × 13½inW × 40inH. Weight: 75lb. Finish: oiled walnut with black grille. Minimum recommended amplifier power: 4W RMS (for sound levels comparable to 25W with lower efficiency speakers). Price: £487.50 per pair (including VAT).

Model 26

Speaker enclosure with units and crossover. Max. power input: 60W RMS (120W peak). FR: 38Hz-20kHz ±4dB. Dynamic range: 69dB. Crossover frequency: 2.5kHz. Dispersion: 100 degrees. Imp: 4-8 ohms. Size: 12 × 14½ × 25in. Finish: oiled walnut. Others special. Price: £79.00 each (plus VAT).

Model 211

Speaker enclosure with units and crossover. Max. power input: 100W RMS (200W peak). FR: 32Hz-20kHz ±3.5dB. Dynamic range: 72dB. Crossover frequency: 2.5kHz. Dispersion: 100 degrees. Imp: 4-8 ohms. Size: 15½ × 15 × 26in. Finish: oiled walnut, other special. Price: £135.00 each (plus VAT).

Model 211R

Speaker enclosure with units and crossover. Max. power input: 100W RMS (200W peak). FR: 32Hz-20kHz ±3.5dB. Dynamic range: 76dB. Crossover frequencies: 1.5kHz and 3kHz. Dispersion: 100 degrees. Imp: 4-8 ohms. Size: 15½ × 15 × 26in. Finish: oiled walnut. Price: £195.00 each (plus VAT).

Model 217R

Speaker enclosure with units and crossover. Max. power input: 150W RMS (300W peak). FR: 30Hz-20kHz ±3.5dB. Dynamic range: 78dB. Crossover frequencies: 1.5kHz and 3kHz. Dispersion: 100 degrees. Imp: 4-8 ohms. Size: 17 × 20 × 27½in. Finish: oiled walnut. Price: £255.00 each (plus VAT).

V8

Max. power input: 30 RMS, 60 peak. FR: 50-20,000Hz. Crossover frequency: 2,800Hz. Speaker elements: 8in low, 1in dome high. Imp: 4-8 ohms. Price: £57.00 (plus VAT).

V10

Max. power input: 40 RMS, 80 peak. FR: 40-

20,000Hz. Crossover frequency: 2,500Hz. Speaker elements: 10in low, 1in dome high. Imp: 4-8 ohms. Price: £68.00 (plus VAT).

V12

Max. power input: 45 RMS, 90 peak. FR: 35-22,000Hz. Crossover frequency: 2,300Hz. Speaker elements: 12in low, 1in dome high. Imp: 4-8 ohms. Price: £79.00 (plus VAT).

25

Max. power input: 50 RMS, 180W peak. FR: 30-25,000Hz. Crossover frequency: 2,500Hz. Imp: 4-8 ohms. Price: £88.00 (plus VAT).

36R

Max. power input: 100 RMS, 200 peak. Effective FR: 25-25,000Hz. Crossover: 2,500Hz. Imp: 4-8 ohms. Price: £97.00 (plus VAT).

■ CHARTWELL

Chartwell Electro-Acoustics Ltd,
Alicric Avenue, London NW10 8RA.
Tel: 01-451 1442/1452.

PM 400

Bass reflex enclosure. Drive units: bass 305mm Chartwell, mid-range 127mm Chartwell, HF unit KK10/8 Isophone (modified). Crossover frequencies: 500Hz and 3.5kHz. FR: 30Hz-30kHz. Imp: 8 ohms nominal. Sensitivity: 12W RMS for 96dB SPL at 1m. Dimensions: 86.4 × 33 × 38.1cm. Weight: 29.9kg. Finish: teak, walnut or rosewood. Price per pair: (teak) £257; (rosewood) £285.60; (walnut) £271.40. All prices are excluding VAT.

PM 200

Bass reflex enclosure. Drive units: Bass 203mm Chartwell, HF unit KK10/8 Isophone (modified). Crossover frequency: 3.5kHz. Power handling: 50W RMS suitable for amplifier rated 125W on speech and music. Sensitivity: 12W RMS for 96dB SPL at 1m. Imp: 8 ohms nominal. Dimensions: 66 × 28.6 × 34.3cm. Weight: 15kg. Finish: teak, rosewood. Price per pair: (teak) £149.00; (rosewood) £171.40. All prices are excluding VAT.

LS3/5A

Infinite baffle enclosure with units and crossover. Drive units: 110mm bass/mid-range driver with Bextrene cone and Neoprene roll surround, and a modified T27 dome treble radiator. The voice coil diameters are 25mm and 19mm respectively. Crossover frequency: 3kHz. Imp: 15 ohms. Amplifier requirements: 15-25W. Dimensions: 30.5 × 19 × 16cm. Weight: 5.3kg. Finish: teak or rosewood. Price: £125 per pair (plus VAT).



When talk
gets around to speakers...
...there's one name on
everyone's lips

Monitor Audio



Symbol of Quality

Monitor Audio Ltd

347F Cherry Hinton Road
Cambridge CB1 4DJ
Telephone (0223) 42898



Selected for the Design Centre London

Write for ^{free} colour brochures and test reports
Name
Address

Lowther

the finest
in the
world

Lowther is for the listener of impeccable taste — for the listener ready to apply the most critical standards of judgement and make no compromise with quality. The outcome of Lowther design is breathtakingly beautiful reproduction of sound, and with finely styled cabinets, these loudspeakers create new elegance to capture both ear and eye.

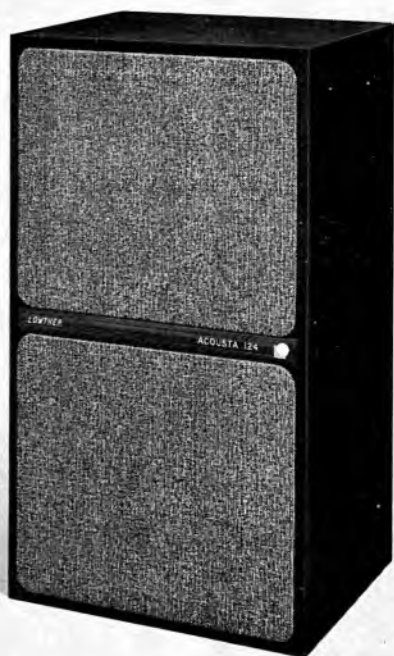

Lowther Onlife Developments Ltd. 41 Masons Hill Bromley Kent BR2 9HQ

Tel 01-460 5225

■ CLARK

Clark Speakers, 122 Hull Road, Anlaby,
North Humberside HU10 6UV.
Tel: Hull 656706.

A1-21

Critically damped transmission line enclosure. Drive units: bass/mid-range 140mm cone (KEF B110), tweeter 25mm soft fabric dome (Peerless KO10). Undamped line length 2.21m. Continuously variable level control on tweeter. Crossover frequency: 1.75kHz. FR: 28Hz-20kHz. Imp: 8 ohms. Efficiency: 16W for 96dB. Amplifier requirements: suitable for 10-60W RMS per channel amplifiers. Dimensions: 53 × 28 × 24cm. Weight: 15kg. Finish: medium to dark teak, others to special quotation. Price (per pair): £97.00 (including VAT).

A1-31H

Critically damped transmission line enclosure. Drive units: bass 207mm cone (Richard Allan HP8B), 122mm precisely damped mid-range (Peerless KO40), 25mm soft fabric dome tweeter (Peerless KO10). Crossover frequency: 450Hz and 3.3kHz. FR: 25Hz-20kHz. Imp: 8 ohms. Efficiency: 20W for 96dB. Amplifier requirements: suitable for 15-135W RMS per channel amplifiers. Dimensions: 78 × 45 × 38cm. Weight: 34kg. Finish: medium to dark teak, others to special quotation. Continuously variable level control on tweeter. Price (per pair): £210.00 (including VAT).

A1-31L

Critically damped transmission line enclosure. Drive units: 222mm cone (KEF B200) bass, 122mm precisely damped mid-range (Peerless KO40), 25mm soft fabric dome tweeter (Peerless KO10). Crossover frequency: 450Hz and 3.3kHz. FR: 20Hz-20kHz. Imp: 8 ohms. Efficiency: 20W for 96dB. Amplifier requirements: suitable for 25-90W RMS per channel amplifiers. Dimensions: 78 × 45 × 38cm. Weight: 31kg. Finish: medium to dark teak, others to special quotation. Continuously variable level control on tweeter. Price (per pair): £191.00 (inc VAT).

A1-35/11

Critically damped transmission line enclosure. Drive units: 300 × 210 flat polystyrene diaphragm bass (KEF B139), 207mm precisely damped mid-range (R. Allan HP8B), 25mm soft fabric dome tweeter (Peerless KO10), 18mm hard dome super tweeter (Coles 400IG). Undamped line length: 2.71m. Crossover frequencies: 450Hz, 3.3kHz and 13kHz. FR: 17Hz-25kHz. Imp: 8 ohms. Efficiency: 20W for 96dB. Amplifier requirements: suitable for 25-150W RMS per channel amplifiers. Dimen-

sions: 89 × 45 × 38cm. Weight: 41kg. Finish: mid/dark teak, others to special quotation. Continuously variable level control on tweeter. Price (per pair): £281 (inc VAT).

■ DANSK

Plustronics Ltd, Hempstalls Lane,
Newcastle, Staffs.
Tel: Newcastle Staffs 615131.

HT-25

Volume: 10 litres. FR: 50-19,000Hz. Nominal level: 30W. Overload level: 40W. Efficiency 96dB/1kHz: 3.2W. Crossover: 9,000Hz. Design system: pressure chamber. Units: tweeter 38mm, bass 215mm. Dimensions: 18cm deep × 23cm wide × 33cm high. Price: £24.83.

A-25

Volume: 25 litres. FR: 30-20,000Hz. Nominal level: 45W. Overload level: 90W. Efficiency 96dB/1kHz: 5W. Crossover: 1,500Hz. Design system: aperiodic valve. Units: Dome 38mm, bass 254mm. Dimensions: 25cm deep × 29cm wide × 50cm high. Price: £48.77.

A-10

Volume: 10 litres. FR: 45-20,000Hz. Nominal level: 30W. Overload level: 60W. Efficiency 96dB/1kHz: 6.3W. Crossover: 1,000Hz. Design system: aperiodic valve. Units: Dome 38mm, bass 177mm. Dimensions: 20cm deep × 21cm wide × 38cm high. Price: £35.48.

A-30

Volume: 30 litres. FR: 30-20,000Hz. Nominal level: 50W. Overload level: 100W. Efficiency 96dB/1kHz: 5W. Crossover: 1,500Hz. Design system: aperiodic valve. Units: dome 38mm, spec bass 254mm. Dimensions: 25cm deep × 32cm wide × 57cm high. Price: £55.43.

A-20

Volume: 17 litres. FR: 35-20,000Hz. Nominal level: 35W. Overload level: 70W. Efficiency 96dB/1kHz: 6.3W. Crossover: 1,500Hz. Design system: aperiodic valve. Units: dome 38mm, bass 215mm. Dimensions: 25cm deep × 25cm wide × 43cm high. Price: £39.90.

■ DAYTON WRIGHT

Exposure Electronics, Richardson Road,
Hove, Sussex BN3 5RB.
Tel: Brighton 777912.

XG-8 Mk 3

Full-range electrostatic loudspeaker enclosure. Drive units: 10 electrostatic units with piezo-electric ultra sonic tweeters. Roll-off to ultra sonic areas above 16kHz. FR: 32Hz-

THE

CHARTWELL

RANGE

'the best of British'



PM400



PM200



AND THE
FAMOUS
LS3/5A



CHARTWELL

... A NAME WORTH LISTENING TO

CHARTWELL ELECTRO ACOUSTICS LTD.
2-10 COMMONSIDE EAST, MITCHAM, SURREY

24kHz \pm 4dB. Imp: 4 ohms nominal. Amplifier requirements: 200W RMS. Dimensions: 42 x 39 x 9 1/2 in. Weight: 80lb. Electrostatic units are placed inside the loudspeaker in heavier than air gas. Price (per pair): £1,650 (plus VAT).

■ DECCA SPECIAL PRODUCTS

Ingate Place, Queenstown Road,
London SW8 3N1.
Tel: 01-622 6677.

London Enclosure ★

Infinite baffle speaker. Drive units: ribbon (London), high flux 203mm bass. Crossover frequency: 1.6kHz. FR: 50-25,000Hz. Imp: 8 ohms. Amplifier requirements: 25W nominal. Dimensions: 35.4 x 28.1 x 58.5cm. Weight: 19kg. Teak, white, rosewood, or walnut. Price: on application.

■ DYNATRON RADIO LTD

Ditton Walk, Cambridge CB5 8QD.
Tel: Teversham 2781.

LS 1018

Infinite baffle with 1 x 152 x 102mm drive units. Fr: 60-18,000Hz. Imp: 8 ohms. Max. power handling capacity: 15W DIN. Dimensions: 14.5 x 23.7 x 20.4cm. Weight: 2.3kg. Teak veneer finish. Wall or shelf mounting complete with DIN connecting lead. Price (per pair): £30.56 (plus VAT).

LS 1428

Infinite baffle with 1 x 203mm (LF) and 1 x 51mm (HF) drive units. Crossover frequency: 2,500Hz. FR: 40-20,000Hz. Imp: 8 ohms. Max. power handling capacity: 50W (DIN). Dimensions: 23.6 x 17.8 x 44.6cm. Teak veneer finish. Shelf mounting complete with DIN connecting lead. Price (per pair): £56.00 (plus VAT).

LS 3038

Infinite baffle with 1 x 203mm (LF), 1 x 127mm (mid), 1 x 51mm (HF) drive units. Crossover frequency: 1,500 and 6,000Hz. FR: 45-20,000Hz. Imp: 8 ohms. Max. power handling capacity: 50W (DIN). Dimensions: 28 x 23.5 x 54.9cm. Weight: 7.5kg. Finish in teak veneers. Floor standing. Price (per pair): £76.00 (plus VAT).

LS 4138

Infinite baffle with 1 x 254mm (LF), 1 x 127mm (mid), 1 x 51mm (HF) drive units. Crossover frequency: 500 and 5,000Hz. FR: 25-20,000Hz. Imp: 8 ohms. Max. power handling capacity: 50W (DIN). Dimensions: 36.5 x

30.5 × 67cm. Weight: 18kg. Teak veneers. Floor standing. Price (per pair): £131.48 (plus VAT).

LS 5128

As LS 1428. Dimensions: 36.8 × 25 × 58.4cms. Weight: 8.5kg. Walnut finish with burr veneers. Floor standing Queen Anne period style enclosure complete with DIN connecting lead. Price per pair: £124.00 (plus VAT).

LS 5228

As LS 5128. Dimensions: 36.8 × 25 × 58.4cm. Weight: 8.6kg. Flame mahogany veneer finish. Floor standing Regency style enclosure complete with DIN connecting lead. Price (per pair): £120.00 (plus VAT).

■ EAGLE

Eagle International Precision Centre,
Heather Park Drive,
Wembley HA0 1SU. Tel: 01-902 8832.

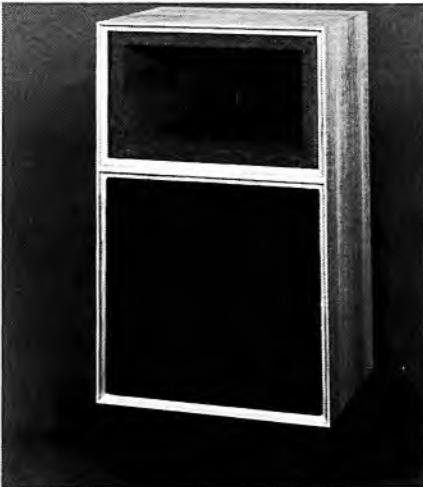

Decca London Enclosure

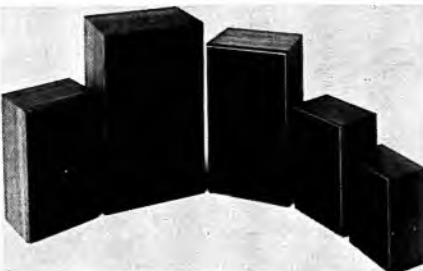

Eagle 2000 Series Speaker Range

S2002 ★

Infinite baffle enclosure. FR: 50Hz-17.5kHz. Imp: 8 ohms. HC: 10W. One 8in bass unit, one 2in tweeter. Crossover: 5kHz. Size: 11¼ × 8 × 5½in. Finish: teak with hardwood lipping. Price (per pair): £42.00 (plus VAT).

S2003 ★

Infinite baffle enclosure. FR: 45Hz-17.5kHz. Imp: 8 ohms. HC: 15W. One 8in bass unit, one 2½in tweeter. Crossover: 5kHz. Size: 15 × 9¼ × 7¼in. Finish: teak with hardwood lipping. Price (per pair): £56.00 (plus VAT).

S2004 ★

Infinite baffle enclosure. FR: 35Hz-19kHz. Imp: 8 ohms. HC: 20W. One 8in bass unit, one 2½in mid-range, one 2in tweeter. Crossover: 1.5kHz and 5kHz. Size: 21¼ × 10½ × 8¼in. Finish: teak with hardwood lipping. Price (per pair): £68.00 (plus VAT).

S2005 ★

Infinite baffle enclosure. FR: 30Hz-20kHz. Imp: 8 ohms. HC: 25W. One 10in bass unit, one 5in mid-range, one 2½in tweeter. Crossover: 1.5kHz and 5kHz. Size: 20½ × 12½ × 10¼in. Finish: teak with hardwood lipping. Price (per pair): £118.00 (plus VAT).

S2006 ★

Bass reflex enclosure. FR: 20Hz-20kHz. Imp: 8 ohms. HC: 35W. One 12in bass unit, one 5in mid-range, one 2½in tweeter. Crossover: 1.5kHz and 5kHz. Size: 25¾ × 14¼ × 11¼. Finish: teak with hardwood lipping. Price (per pair): £158.00 (plus VAT).

■ ECHONICA

Ambionic Sound Reproducers Ltd,
Omni House, North Circular Road,
London NW10 7UF. Tel: 01-965 8787.

Echonica

Speaker system which has the appearance of an interior picture panel. Imp: 8 ohms. FR: 40Hz-12kHz. Nominal input: 10W. Size: 690 × 490 × 30mm. Weight: 3.4kg. Price: £20.00 (plus VAT).

■ EDWARDUS

J. R. Edwards Electronics Ltd,
783 Romford Road, Manor Park,
London E12. Tel: 01-553 4349.

LS 150

Power handling capacity: 20W. FR: 45Hz-20kHz. Units: Goodmans 8in long-throw bass unit, Goodmans 3¼in mid-range treble unit.

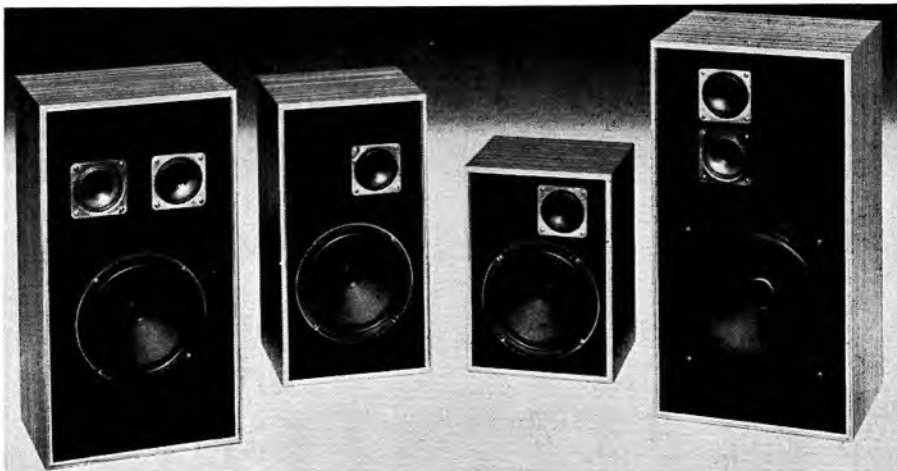

Edwardus range

Imp: 8 ohms. Cabinet size: 14 × 10 × 8³/₄in. Price (per pair): £32.30 (including VAT).

LS 200

Power handling capacity: 20W. FR: 35Hz-20kHz. Units: Goodmans 8in long-throw bass unit, Goodmans 3³/₈in mid-range treble unit. Imp: 8 ohms. Cabinet size: 19 × 10 × 9¹/₂in. Price (per pair): £46.20 (including VAT).

TD151

Now with improved power handling and extended high frequency response. Nominal power handling: 20W. FR: 40-22,000Hz. Sensitivity: (for 96dB at 1m) 5W. Imp: 8 ohms. Recommended amplifier power (per channel) 8-25W RMS. Drive units: 8in bass, 1in dome radiator. Crossover components: 2 chokes, 1 capacitor. Interior volume: 12 litres. Finishes: teak and walnut veneers, white. Size: 14 × 10 × 8³/₄in deep (356 × 254 × 223mm). Net weight (per pair): 26lb (11.5kg). Price (per pair): £42.60 (plus VAT).

TD 201

Nominal power handling: 20W. FR: 35-22,000Hz. Sensitivity (for 96dB at 1m): 5W. Imp: 8 ohms. Recommended amplifier power (per channel): 8-25W RMS. Drive units: 8in bass, 1in dome radiator. Crossover components: 2 chokes, 1 capacitor. Interior volume: 19 litres. Finishes: teak and walnut veneers, white. Size: 19 × 10 × 9¹/₂in deep (483 × 254 × 241mm). Net weight (per pair): 32lbs (14.5kg). Price (per pair): £48.60 (plus VAT).

TD 251

A new version of the TD251 will comfortably

handle all forms of music from amplifiers with only 10W output per channel. Nominal power handling: 25W. FR: 35-22,000Hz. Sensitivity (for 96dB at 1m): 6W. Impedance: 8 ohms. Recommended amplifier power (per channel): 10-30W RMS. Drive units: 8in bass, 3³/₈in upper mid-range, 1in dome radiator. Crossover components: 3 chokes, 2 capacitors. Interior volume: 25 litres. Finishes: teak and walnut veneers, white. Size: 22 × 11 × 9¹/₂in deep (558 × 280 × 241mm). Net weight per pair: 37lb (17kg). Price (per pair): £57.60 (plus VAT).

TD 401

New low resonance woofer for improved bass response, together with a new upper mid-range unit and dome tweeter. Nominal power handling: 40W. FR: 30-22,000Hz. Sensitivity (for 96dB at 1m): 8W. Imp: 8 ohms. Recommended amplifier power (per channel): 15-50W RMS. Drive units: 10in bass, 3³/₈in upper mid-range, 1in dome radiator. Crossover components: 3 chokes, 2 capacitors. Interior volume: 35 litres. Finishes: teak and walnut veneers, white. Size: 24 × 12¹/₂ × 11in (610 × 320 × 280mm). Net weight (per pair): 55lb (25kg). Price (per pair): £93.60 (plus VAT).

LS 250

New version, refining performance still further with an addition of an upper mid-range unit and subtle alterations to the integrating network. Nominal power handling: 25W. FR: 35-20,000Hz. Sensitivity (for 96dB at 1m): 6W. Imp: 8 ohms. Recommended amplifier power (per channel): 10-30W RMS. Principle of system: infinite baffle. Drive units: 8in bass, 3³/₈

upper mid-range, 3³/₈in treble. Interior volume: 25 litres. Finishes: teak, walnut, white. Size: 22 × 11 × 9¹/₂in deep (558 × 280 × 241mm). Net weight (per pair): 37lb (17kg). Price (per pair): £42.00 (plus VAT).

LS 400

New low resonance woofer for improved bass response, together with a new upper mid-range and treble unit. Nominal power handling: 40W. FR: 30-20,000Hz. Sensitivity (for 96dB at 1m): 8W. Imp: 8 ohms. Recommended amplifier power (per channel): 15-50W RMS. Principle of system: infinite baffle. Drive units: 10in bass, 3³/₈ upper mid-range, 3³/₈in treble. Interior volume: 35 litres. Finishes: teak, walnut, white. Size: 24 × 12¹/₂ × 11in (610 × 320 × 280mm). Net weight (per pair): 55lb (25kg). Price (per pair): £78.00 (plus VAT).

ME2

Drive units: Coles 4001G. Celestion HF1300. Peerless bass unit (165mm). Imp: 8 ohms. Dimensions: 406 × 229 × 203mm. Finish: teak, walnut. Price (per pair): £90.00 (plus VAT).

ME4

Drive units: Coles 4001G. Celestion HF1300. KEF B200 bass unit (210mm). Imp: 8 ohms. Size: 559 × 305 × 254mm. Finish: teak, walnut. Price (per pair): £105.00 (plus VAT).

ME6

Drive units: Coles 4001G. Celestion HF1300. Peerless bass unit (210mm). Imp: 8 ohms. Size: 597 × 318 × 267mm. Finish: teak, walnut. Price (per pair): £135.00 (plus VAT).

■ ELECTRO-VOICE

Gulton Europe Ltd, Special Products Division, The Hyde, Brighton BN2 4JU. Tel: Brighton 66271.

Interface A

Full-range loudspeaker system with equaliser. Fitted with one 10in bass unit and two tweeters. Imp: 8 ohms nominal. FR: 32Hz-18kHz ±3dB. Size: 55.9 × 35.6 × 19.8cm. Price: on application.

Sentry III

Full range loudspeaker with 10in bass unit. Imp: 8 ohms nominal. FR: 40Hz-18kHz ±3dB. Size: 87.6 × 72.4 × 52.1cm. Price: on application.

■ EMPEROR

M.M.G. Associates, 19 St Andrews Road, Great Malvern, Worcs WR14 3PR. Tel: Malvern 63555.

101

Infinite baffle speaker enclosure. 13 × 8in elliptical driver with coaxially mounted high frequency unit. Crossover frequency: 5kHz choke-capacitor network. FR: 50Hz-16kHz. Imp: 8 ohms. Amplifier requirements: 20W. Adjustable high frequency balance. Dimensions: 31 × 17 × 9in. Weight: 39.5lb. Finish: teak effect in Melamine. Price (per pair): £75.00 (plus VAT).

102

Infinite baffle speaker enclosure. 13 × 8in elliptical driver with coaxially mounted high frequency unit. Crossover frequency: 5kHz choke-capacitor network. FR: 50Hz-16kHz. Imp: 16 ohms. Amplifier requirements: 20W. Adjustable high frequency balance. Dimensions: 31 × 17 × 9in. Weight: 39.5lb. Finish: teak effect in Melamine. Price (per pair): £75.00 (plus VAT).

Emperor Mk III

Infinite baffle speaker enclosure. FR: 50Hz-18kHz. Imp: 8 or 16 ohms. High efficiency. Amplifier requirements: 25W. Adjustable high frequency balance. Dimensions: 35 × 17 × 19in. Weight: 42lb. Finish: teak, mahogany or to order. Price (per pair): £150.00 (plus VAT).

Emperor Studio Monitor

Full specifications and prices of the Emperor Studio Monitor systems available on request.

Emperor Custom Series

Full specifications and prices of the Emperor Custom Series systems available on request.

■ ENVIRONMENTAL SOUND

JB Manufacturing, Acoustics and Design Ltd, London House, Mayfield, Sussex TN20 6AQ. Tel: Mayfield 3419/2495.

VT15 ★

Infinite baffle completely disguised as an elegant Victorian table. Drive units: 1 × 8in (low), 1 × 4in (mid), 1 × 3in (treble). Crossover frequency: 1,000 and 5,000Hz. FR: 35-20,000Hz. Imp: 8 ohms. Designed to operate with amplifiers 10-25W RMS. Dimensions: 38 × 48cm. The structure of the table is covered in a variety of shades of beize and the whole object enveloped in a large tablecloth which is acoustically transparent. These are omni directional units designed to blend with the decor of the home while reproducing pure uncoloured sound, giving flexibility of positioning. Price: £155.00 (inc VAT).

VT24

Infinite baffle disguised as an elegant Victorian

★ Indicates entry is illustrated

table. Drive units: 1 × 10in (bass), 1 × 8in (special cone), 1 × 4in (mid), 1 × 3in (tweeter). Crossover frequency: 1,000 and 50,000Hz. FR: 30-20,000Hz. Imp: 8 ohms. Designed to operate with amplifiers from 15-35W RMS. Dimensions: 69 × 71cm. The structure of the table is covered in a variety of shades of beige and the whole object enveloped in a large tablecloth which is acoustically transparent. These are omni directional units designed to blend with the decor of the home while reproducing pure uncoloured sound, giving flexibility of positioning. Price: £260.00 (inc. VAT).

KM30

Motional feedback with high efficiency bass unit, electronically controlled passive radiator and dome tweeter. Crossover frequency: 60Hz



Environmental Sound VT15



Environmental Sound Larson

and 7,000Hz. FR: 37-20,000Hz. Built-in electronic impedance adaptor. Dimensions: 22.8 × 35.5 × 19cm. Teak, brushed black or brushed aluminium finish. Price (per pair): £224.50 (inc VAT).

KM50

Motional feedback electro pneumatic. Drive units: passive unit, main unit, dome tweeter. Crossover frequencies: 60Hz, 7,000Hz. FR: 30-20,000Hz. Built-in impedance transformer. Dimensions: 36.8 × 27 × 17.2cm. Teak, brushed aluminium finish. Price (per pair): £395.00 (inc VAT).

E. S. Larson ★

Omni directional infinite baffle with 254mm bass and 38.1mm dome tweeter. Crossover frequency: 1kHz. FR: 37-20,000Hz. Imp: 8 ohms. Designed to operate with amplifiers 10-40W RMS. Dimensions: 60.9 × 30.4 × 30.4cm. Teak, white, walnut and rosewood finishes. Rigid pyramid construction. Price (per pair): £176.00 (inc VAT).

ESKM 21

Motional feedback speaker with one bass driver and one tweeter. Crossover frequency: 1kHz. FR: 35-35,000Hz. Built-in impedance transformer. Teak finish. Price (per pair): £185.25 (inc VAT).

Rondo ★

Rigid cylinder with acoustical transparent top. Infinite baffle. Drive units: 200mm long throw low resonance, special cone, roll surround bass unit, 56mm cone tweeter. FR: 40-18,000Hz. Imp: 8 ohms. Designed to operate with amplifiers from 10-25W RMS. Dimensions: 25 × 39.5cm. Constructed in ABS shatterproof plastic in white, red, green and yellow. Design Centre Award for construction, design and performance. Sound project in the vertical plane to give maximum number of locations for the units in the home. Price (per pair): £79.50 (inc VAT).

Tower

Infinite baffle made in high density veneered chipboard. Drive units: 200mm long throw, low resonance, special cone, roll surround bass unit, 76.2mm dome tweeter. Crossover frequency: 3,000Hz. FR: 35-20,000Hz. Imp: 8 ohms. Dimensions: 27.3 × 27.3 × 47.6cm. Teak, mahogany or pine finish. Features as Rondo. Price (per pair): £99.00 (inc VAT).

KM A110 Attenuator

A sophisticated attenuator capable of adjusting individually the level of 10 different ES KM

motional feedback loudspeakers driven from either the ES KM2002 mixer or the PA5 pre-amplifier. Electronic filter system lowers the individual level of each loudspeaker in the medium and high frequency ranges whilst retaining low frequency response in all speakers. This is necessary to keep the sound balance in the whole installation. It is possible to adjust individual level of each speaker throughout its whole frequency range or turn it off completely. Inputs: two stereo inputs from either ES KM 2002 control desk or the ES KM PA5 amplifier. Outputs: A - 10 attenuators with loudness correction. B - 10 special changeable

filters for loudspeaker response maintenance at extremely low frequencies with 10 push buttons. Dimensions: 40 × 15 × 70cm. Price: £157.50 (inc VAT).

■ FERROGRAPH

The Ferrograph Company Ltd, Durban Road, South Bersted, Bognor Regis, Sussex. Tel: Bognor Regis 25811.

Model S1 ★

Reflex system enclosure with units and crossover. One LF driver, one mid-range unit and one tweeter. 18-element steep-cutting crossover network. Imp: 8 ohms nominal. HC: 25W RMS. FR: 45Hz-20kHz ±3dB. Crossover: 400Hz, 3.5kHz. Size: 35 × 44 × 64cm. Weight: (cabinet) 25kg, (stand) 2.7kg. Finish: simulated walnut with aluminium trim, white surround and folk weave fabric grille. Connections via recessed press terminals in rear. Price: £228.00 (plus VAT).

■ GOODMAN'S

Goodmans Loudspeakers Ltd, Downley Road, Havant, Hampshire PO9 2NL. Tel: Havant 6344.

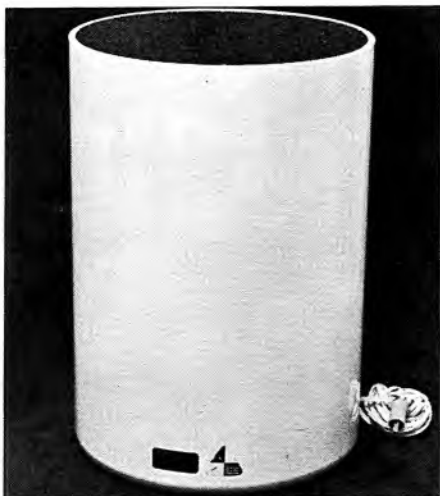

Environmental Sound Rondo



Ferrograph S1



Goodmans Achromat 400 on CS3 stand and Achromat 100

★ Indicates entry is illustrated

Havant SL

Reflex enclosure with units and crossover. One 8in bass driver, one 3³/₄in mid-range unit, one 1in dome tweeter. Crossovers: 2kHz and 8kHz. Interior volume: 18 litres. FR: 45Hz-22kHz (DIN 45:500). HC: 20W (DIN). Imp: 8 ohms. Finish: teak, walnut or white. Size: 19 × 10¹/₂ × 9³/₄in. Weight: 18³/₄lb. DIN connector with cable. Price: £35.87 or £36.00 in white (plus VAT).

Mezzo SL

Reflex enclosure with units and crossover. One 10in bass driver, one 1¹/₂in dome tweeter. Crossover: 2kHz. FR: 40Hz-22kHz. HC: 60W (DIN). Imp: 4-8 ohms. Size: 24¹/₂ × 15 × 11³/₄in. Finish: teak or walnut. Price: £53.13 (plus VAT).

Magnum SL

Infinite baffle enclosure with units and crossover. One 12in bass driver, 4in back-loaded mid-range unit, 1in dome tweeter. Crossover: 2kHz and 6kHz. FR: 35Hz-22kHz. HC: 60W (DIN). Imp: 4-8 ohms. Size: 24¹/₂ × 15 × 11³/₄in. Finish: teak or walnut. Price: £66.90 (plus VAT).

Minster SL

Bookshelf enclosure with units and crossover. 8in bass driver with plastic coated diaphragm, dome type tweeter. HC: 20W (DIN). Imp: 4-8 ohms. FR: 45Hz-22kHz. Finish: teak or walnut. Size: 19 × 10¹/₂ × 9³/₄in. Supplied in matched pairs. Price: £26.54 (plus VAT).

Achromat 400 ★

Closed box with 260mm bass, 45 and 25mm domes drive units. Crossover frequency: 900 and 3,500Hz. FR: 40-22,000Hz. Imp: 4-8 ohms. Amplifier requirements: 25-75W. Dimensions: 32.7 × 29.2 × 65.7cm. Weight: 16.5kg. Teak, walnut or white finish. For use with Goodmans CS3 stand. Price (per pair): £174.02 (plus VAT).

Achromat 250 ★

Closed box with 203mm bass and 25mm dome HF drive units. Crossover frequency: 3,500Hz. FR: 47-22,000Hz. Imp: 4-8 ohms. Amplifier requirements: 25-60W. Dimensions: 27.2 × 27.8 × 54cm. Teak or walnut finish. Packed in pairs. Price (per pair): £132.14 (plus VAT).

C.H.B. SUPPLIES LTD

SPARES ARE IMPORTANT

**B. S. R.
GLENBURN
A. D. C.**

AS MAIN DISTRIBUTORS WE STOCK
SPARES — CARTRIDGES — UNITS — STYLI
IF B.S.R. OR GLENBURN FIT IT — WE SUPPLY IT

C.H.B. SUPPLIES LTD.

Oldington Trading Estate, Stourport Road
Telephone: KIDDERMINSTER 4861 or 3293

Achromat 100 ★

Closed box with 175mm bass and 38mm dome drive units. Crossover frequency: 3,000Hz. FR: 58-22,000Hz. Imp: 4-8 ohms. Amplifier requirements: 25-50W. Dimensions: 21.2 × 23.3 × 35cm. Weight: 6kg. Teak or walnut finish. Packed in pairs. Price (per pair): £89.98 (plus VAT).

■ GRUNDIG

Grundig International Ltd, Newlands Park, London SE26 5NQ. Tel: 01-659 2468.

Audiorama 4000 ★

Infinite baffle enclosure with units and crossover. Two bass/mid-range units and two treble. FR: 45Hz-20kHz. Impedance: 4 ohms. HC: 10W. Finish: white globe with satin silver stand. Price: (per pair) £192.25 (including VAT).

403 Compact

Infinite baffle enclosure with units. Two bass/mid-range units and one tweeter. FR: 45Hz-26kHz. Impedance: 4 ohms. HC: 10W. Dimensions: 33.5 × 51 × 9cm. Finish: light matt wood effect. Price: £100.45 per pair (including VAT).

106M

Infinite baffle enclosure with unit. One full range 12.75mm. FR: 70Hz-12kHz. Impedance: 4 ohms. HC: 10W. Dimensions: 30 × 19.25 × 10cm. Weight: 2.47kg. Finish: light matt wood effect. Price: (per pair) £48.70 (including VAT).

210a

Infinite baffle enclosure with units and crossover. One bass/mid-range and one tweeter. Crossover frequency: 4.5kHz. FR: 50Hz-20kHz. Impedance: 4 ohms. HC: 15W. Dimensions: 19.25cm diameter. Finish: satin metal with black grille. Optional free standing, wall mounting or ceiling suspended. Price: £63.70 per pair (including VAT).

■ HACKER

Hacker Radio Ltd, Norreys Drive, Cox Green, Maidenhead, Berks SL6 4BP. Tel: Maidenhead 22261.

LS550

Infinite baffle enclosure. FR: 85Hz-17kHz ±3dB. Impedance: 8 ohms. HC: 30W DIN. Double drive units. Crossover frequency: 2.5kHz. Res. frequency: 85Hz. Size: 16½ × 10⅞ × 8½in. Sold only in matched pairs. Price: £64.00 per pair (plus VAT); Optional stands £10.00 per pair (plus VAT).



Goodmans Achromat 250



Grundig Audiorama 4000



Hacker 1100

★ Indicates entry is illustrated

LS1100 ★

Infinite baffle enclosure. FR: 78Hz-17kHz \pm 3dB. Impedance: 8 ohms. HC: 60W DIN. Triple drive units, including pressurised mid-range speakers. Crossover frequencies: 1.7kHz and 4.7kHz. Res. frequency: 55Hz. Size: 20 $\frac{1}{4}$ \times 13 $\frac{3}{8}$ \times 11 $\frac{1}{4}$ in. Finish: teak. Price: £86.40 per pair (plus VAT). Optional stands £12.00 per pair (plus VAT).

LS1300

Infinite baffle enclosure. FR: 38Hz-21kHz \pm 2dB. Impedance: 8 ohms. HC: 20W DIN. Three drivers including dome tweeter and pressurised mid-range speaker. Crossover frequencies: 550Hz and 3.5kHz. Res. frequency: 48Hz. Size: 24 $\frac{1}{2}$ \times 15 $\frac{3}{8}$ \times 12in. Finish: teak. Price: £126.00 per pair (plus VAT). Optional Stands: £14.00 per pair.

■ HI-BALL

Executive Audio Ltd, Unit 5A, Pier House Laundry, Strand-on-the-Green, Chiswick, London W4. Tel: 01-995 3654.

Hi-Ball 750 ★

Spherical infinite baffle enclosure. One drive unit, 4 $\frac{1}{2}$ in diameter. FR: 50Hz-16kHz. Impedance: 8 ohms. HC: 35W. Dimensions: 7 $\frac{1}{2}$ in sphere. Weight: 5kg per pair. Finish: red, black, purple, white, dark brown or orange. Price: £40 per pair (excluding VAT).

■ HITACHI

Hitachi Sales (UK) Ltd, Hitachi House, Station Road, Hayes UB3 4DR. Tel: 01-848 8787.

SS 52

Acoustic suspension two-way speaker system with units and crossover. One 8in woofer, one 2 $\frac{1}{2}$ in cone tweeter. FR: 65Hz-20kHz -8dB (45Hz-20kHz-15dB). Crossover frequency: 4.5kHz. Impedance: 8 ohms. Maximum input power: 25W music. Sound pressure level: 92dB. Size: 30.6 \times 53.6 \times 24cm. Weight: 6.5kg. Cabinet finish: simulated teak. Price: £49.00 per pair (including VAT).

HS 220T

Air suspension type speaker system with units and crossover. One 8in bass driver, one 2 $\frac{1}{2}$ in tweeter. FR: 60Hz-20kHz -8dB (40Hz-20kHz -15dB). Crossover frequency: 4kHz. Impedance: 8 ohms. Maximum input power: 20W music, 8W RMS. Output sound pressure level: 90dB. Size: 28 \times 48.5 \times 25cm. Weight: 7kg. Cabinet finish: simulated teak. Price: £54.00 per pair (including VAT).

HS 320

Reflex enclosure with units and crossover. One 8in bass driver, one horn-type tweeter. Crossover frequency: 4kHz. FR: 50Hz-20kHz -8dB (35Hz-20kHz -15dB). Impedance: 8 ohms. Maximum input power: 20W music, 8W RMS. Output sound pressure level: 90dB. Size: 32 \times 58 \times 25cm. Weight: 11kg. Cabinet finish: walnut open-pore veneer. Price: £39.00 each (including VAT).

HS 420

Reflex enclosure with units and crossover. One 9 $\frac{1}{4}$ in bass driver, one 5in mid-range unit, one horn-type tweeter. Crossover frequency: 2kHz, 8kHz. Impedance: 8 ohms. FR: 45Hz-20kHz -8dB (30Hz-20kHz -15dB). Maximum input power: 40W music, 15W RMS. Output sound pressure level: 91dB. Size: 37 \times 67.5 \times 25cm. Weight: 15kg. Cabinet finish: simulated teak. Price: £58.00 each (including VAT).

HS350

Ducted port two-way speaker system with units and crossover. One 8in bass driver, one tweeter. Crossover frequency: 3.5kHz. Impedance: 8 ohms. FR: 40Hz-20kHz. Maximum input: 50W music, 20W RMS. Output sound pressure level: 90dB. Size: 36.5 \times 59.3 \times 25cm. Weight: 15kg. Cabinet finish: walnut open-pore veneer finish. Price: £78.00 each (including VAT).

HS 500

Reflex enclosure with units and crossover. One 8in super bass driver, one 8in bass driver, one 5in mid-range unit, one horn type tweeter. Crossover frequency: 3kHz. Distortion: less than 2.7% at 10W output. FR: 25Hz-20kHz. Input impedance: 8 ohms. Rated input: 60W music, 20W RMS. Sensitivity crossover: 94dB. Acoustic control high level: \pm 4dB (2dB step). Size: 36 \times 61 \times 34.7cm. Weight: 21.8kg. Cabinet finish: oiled walnut. Price: £137.00 each (including VAT).

HS 1400WA

Acoustic super-woofer three-way speaker system with units and crossover. One 8in super bass driver, one 8in bass driver, one 5in mid-range unit, one horn type tweeter. Crossover frequency: 100Hz, 4kHz. FR: 35Hz-20kHz -8dB. Impedance: 8 ohms. Maximum input power: 20W music. Sound pressure level: 90dB. Level control: high range \pm 3dB. Size: 43.8 \times 115.7 \times 37cm. Weight: 34kg. Cabinet finish: walnut open-pore veneer finish with removable grey saran front cover. Price: £127.00 each (including VAT).



PHILIPS

Philips prove brains beat brawn.

The most serious problem in getting beautiful sound out of a loud-speaker enclosure is to stop the woofer going out of control.

You can try bigger and bigger enclosures. But you'll be far better off with a new idea developed by Philips. It ensures true bass response, in correct proportion to the rest of the tonal range. And reduces enclosures to a quarter of their previous size.

Philips Motional Feedback (MFB) System.

How does it work?

A solid-state electronic brain monitors the woofer cone and *instantly stifles the slightest tendency to vibrate incorrectly.*

The woofer can therefore only vibrate in strict accordance with the incoming signal.

It is virtually *incapable* of distorting the sound. Even in a small enclosure.

Built-in amplifiers.

The nature of the MFB system demands built-in amplification. The RH544 has two amplifiers, one driving the woofer, the other for the squawker and tweeter. The output is 60 watts (continuous sine wave).

The squawker and tweeter are domes, which give a much better spread of the frequencies they handle.

And a continuously variable treble roll-off filter enables you to adjust to the acoustics of your room, thus avoiding the harshness possible with other speakers when reproducing high tones.

Philips MFB enclosures can be used with virtually any amp or pre-amp unit, such as the Philips RH551.

For full details of Philips Motional Feedback Enclosures please write to Philips Electrical Limited, Audio Division, 420/430 London Road, Croydon CR9 3QR.



Simply
years ahead.

From the range of Philips
high-technology Hi-Fi.

STUDIO ELECTRONIC 85

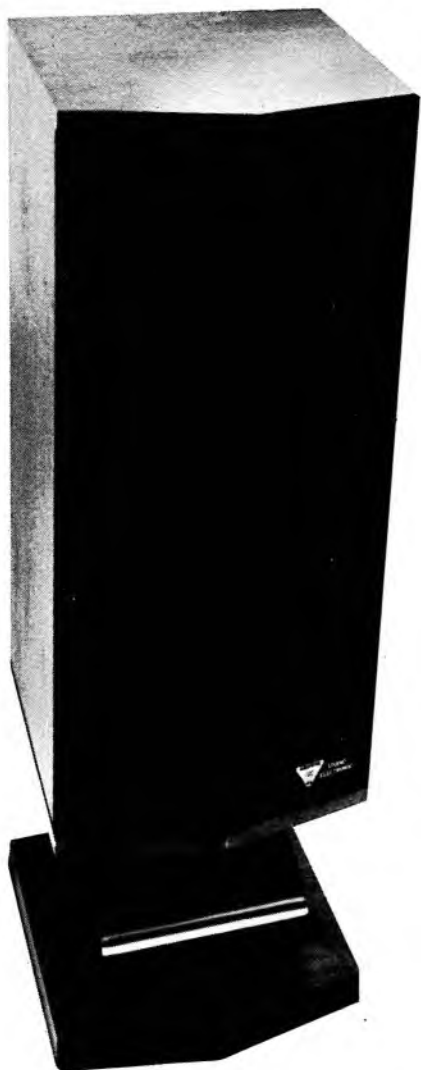

LOUDSPEAKER

This unit is a five-speaker system with three built-in power amplifiers, one for bass, one for mid-range and one for treble. It features variable enclosure damping, level controls, and has a unique (patent applied for) bass system.

The use of amplifiers built into the loudspeaker, each tailored to suit the units they are driving, results in a response that can be controlled to within fine tolerances.

The firm, well-controlled bass is a result of the tandem line bass system. The bass notes are well able to be distinguished from each other, making the loudspeaker both an accurate acoustical instrument, and a sound source that aids easy listening.

The system is primarily intended for reference purposes, the unit being capable of high pressure levels with low distortion, and accurate response to transients. In these respects the design is a great advance on conventional speaker systems.

Manufacturers:
H. K. Griffin & Co. (Electronics)
Siddons Factory Estate
Howard Street
West Bromwich
West Midlands B70 0SU
Tel: 021-556 0559/0752



IMF ALS 40II

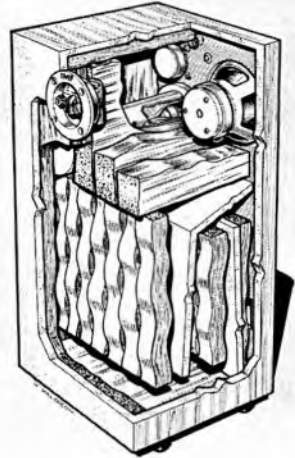

IMF TLS 50I

HS 300

Enclosure type. Vented floor type. Enclosure volume: 30 litres. Speaker system: 2-way woofer: 8in (20cm) gathered-edge suspension; Tweeter: 2 $\frac{1}{2}$ in (6.5cm) cone type. Frequency response: 55~16,000 Hz (-8 dB); 45~19,000 Hz (-15 dB); Crossover frequency: 3,800 Hz; Impedance: 8 Ω ; Maximum input power: 50W (Music); Sound pressure level: 88dB (1W, 1m); Dimensions (W×H×D): 11 $\frac{1}{2}$ × 27 × 10 $\frac{3}{8}$ in (29.2 × 68 × 27 cm); Weight: 28.6 lbs. (13 kg); Price: on application.

HS 335

Enclosure: Damp based reflex; Volume of enclosure: 38 litres; Speakers: Woofer 9 $\frac{3}{4}$ in. (25 cm); Mid range: 4 $\frac{3}{4}$ in. (12 cm); Tweeter: Titanium Domed 1 in. (2.5 cm); Frequency response: 45-18,000 Hz (-8 dB); 40-20,000 Hz (-15 dB); Crossover frequency: 700 Hz, 3,000 Hz; Impedance: 6 Ω ; Maximum input power: 50 watts maximum; Output sound pressure level: 91 dB (1W, 1m); Dimensions (W × H × D): 12 $\frac{1}{2}$ × 21 $\frac{1}{16}$ × 12 $\frac{7}{16}$ in. (31.5 × 55 × 31.5 cm); Weight: 28.6 lbs. (13 kg); Cabinet: Simulated teak finish. Price: on application.

SS 8310 G

Infinite baffle; Interior volume: 20 litres; Frequency range: 40-20,000 Hz; Sensitivity: 4 watts; Music power rating: 10-40 watts; Impedance: 4 Ω ; Drive units; 8in base unit. 3 $\frac{3}{8}$ in mid range unit. 3 $\frac{3}{8}$ in tweeter unit. Crossover frequencies: 1.5 kHz and 7 kHz; Size: (W × H × D): 10 $\frac{1}{4}$ × 18 $\frac{15}{16}$ × 9 $\frac{7}{16}$ in. (260 × 479 × 249mm); Price: £42.36 per pair (plus VAT).

■ IMF

IMF Electronics Ltd, Westbourne Street, High Wycombe, Bucks. Tel: High Wycombe 35576.

Compact II

Reflex enclosure with units and crossover. 16.5 bextrene mid-range and bass unit with domed tweeter. Crossover frequency: electrical two way at 4kHz. FR: 35Hz-20kHz. Impedance: 4-8 ohms. Efficiency: 99dB via Pink Noise at 1m on axis for 40W. Amplifier requirements: 15-40W. Dimensions: 38 × 23 × 24cm. Weight: 6kg each. Finish: teak or walnut woodgrain. Price: £69.50 per pair (excluding VAT).

Super-Compact

Reflex enclosure with units and crossover. 20.5cm bextrene bass unit and 10cm rolled surround impregnated cone mid-range with domed tweeter. Crossover: electrical three-way at 375Hz and 3kHz. FR: 30Hz-20kHz. Impedance: 4-8 ohms. Efficiency: 100dB via Pink Noise at 1m on axis for 40W. Amplifier requirements: 20-50W. Dimensions: 46 × 28 × 30cm. Weight: 9 kg each. Finish: teak or walnut woodgrain. Price: £103.95 per pair (excluding VAT).

Studio ALS 40 II ★

Active line loudspeaker with units and crossover. 20.5cm bextrene bass unit, 20.5cm bextrene sub-bass unit and 10cm rolled surround impregnated cone mid-range with domed tweeter. Crossover: electrical four way at 150Hz,

★ Indicates entry is illustrated

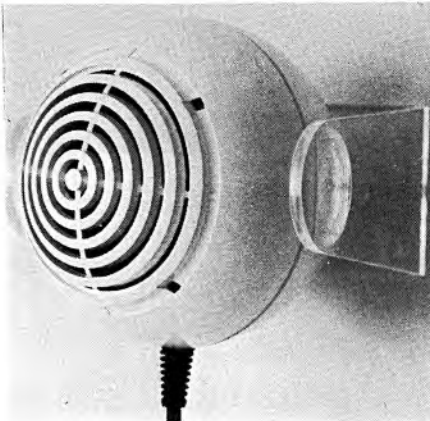

Isophon-Werke Isonetta

375Hz and 3kHz. FR: 28Hz-20kHz. Impedance: 4-8 ohms. Efficiency: 98dB via Pink Noise at 1m on axis for 40W. Amplifier requirements: 25-60W. Dimensions: 35 × 35 × 68cm. Weight: 18½kg each. Finish: walnut. Price: £214.50 per pair (excluding VAT).

Studio TLS 50 II ★

Transmission line loudspeaker with units and crossover. 20.5 bextrene bass unit, 10cm rolled surround impregnated cone mid-range with domed tweeter and super tweeter. Crossover: electrical four way at 375Hz, 3kHz. FR: 23Hz to beyond audibility. Impedance: 4-8 ohms. Efficiency: 97dB via Pink Noise at 1m on axis for 40W. Amplifier requirements: 30-70W. Dimensions: 36 × 38 × 96cm. Weight: 27kg each. Finish: walnut. Price: £248.00 per pair (excluding VAT).

Monitor TLS 80 ★

Transmission line loudspeaker with units and crossover. Bass unit 31 × 21cm flat polystyrene diaphragm loaded by transmission line, mid-range 15.2cm plastic cone containing in separate line, 5cm tweeter and 2cm chemical dome super-tweeter. Crossover: electrical four way at approximately 375Hz, 3.5kHz and 13kHz. FR: 20Hz to beyond audibility. Impedance: 4-8 ohms. Efficiency: 96dB via Pink Noise at 1m on axis for 40W. Amplifier requirements: 40-80W. Dimensions: 46 × 41 × 97cm. Finish: walnut. Supplied in matched 'mirror-image' pairs. Price: £355.00 per pair (excluding VAT).

■ ISOPHON-WERKE

Hayden Laboratories Ltd, Hayden House, Churchfield Road, Chalfont St. Peter, SL9 9EW. Tel: Gerrards Cross 88447.

Isonetta ★

Spherical enclosure with unit. One full-range 2½in unit. FR: 200Hz-20kHz. HC: 5W. Impedance: 4 ohms. Size: 3½in diameter. Weight: 12oz. Finish: white, black, red, orange. Scratch resistant finish. Price: £7.99 (plus VAT).

HFB 100

Spherical enclosure housing high-frequency unit. Designed for use with other speaker systems. One 3½in tweeter unit. FR: 3kHz-20kHz. For use with up to 50W systems. Impedance: 8 ohms. Size: 3½in diameter. Weight: 1¾lb. Finish: white or black with white base. Price: £12.55 (plus VAT).

Prominent 2002

Speaker enclosure with units and crossover. 12in bass driver, 8in mid-range unit and two tweeters. FR: 25Hz to over 20kHz. HC: 70W. Impedance: 8 ohms. Size: 30 × 50 × 42cm. Weight: 27kg. Finish: walnut or matt black. Price: to be announced.

B40/8

5½in bass, 1 dome tweeter. FR: 50-20,000 Hz. Impedance: 8 ohms. Amplifier requirements: 20 W RMS. Dimensions: 27 × 18 × 20cm. Finish: Walnut vinyl. Price: £50.00 per pair (plus VAT).

SKB 5030S/8

6½ in bass, 1 dome tweeter. FR: 50-20,000 Hz. Impedance: 8 ohms. Dimensions: 35.5 × 21 × 17 cm. Finish: Walnut vinyl. Price: £62.00 per pair (plus VAT).

SKB 60/8

1 × 8in bass, 1 midrange, 1 dome tweeter. FR: 35-20,000 Hz. Impedance 8 ohms. Amplifier requirements: 40 W RMS. Dimensions: 48 × 24 × 24 cm. Finish: Walnut vinyl. Price: £99.00 per pair (plus VAT).

■ ITT

ITT Consumer Products (UK) Ltd, Maidstone Road, Sidcup, Kent DA14 5HT. Tel: 01-300 7733.

LS 15

Drive Units: 100mm round. Impedance: 8 ohms. Amplifier requirements: 6 W musical power. Dimensions: 23.4 × 38.2 × 17.8 cm. Weight: 3 kg. Teak appearance. Bass reflex. Sold in pairs Price: on application.

LS 30

Drive Units: bass, mid, tweeter. Im-

pedance: 8 ohms. Amplifier requirements: 20 Watts. Dimensions: 23.4 × 38.2 × 17.8 cm. Weight: 4 kg. Teak appearance. Ported bass reflex enclosure. High flux bass/mid range unit neoprene surround. Half section 6 element crossover network. Not available separately. Price: on application.

■ JBL

C. E. Hammond & Co, Ltd, Chertsey Road, Byfleet, Surrey. KT14 7LA.
Tel: Byfleet 41131.

JBL Decade L16

Reflex enclosure. 20cm bass driver. 3.6cm HF. Direct radiator. Crossover frequency: 2,500Hz. Impedance: 8 ohms. Minimum 10 W. Size: 27 × 26 × 49cm. Weight: 13kg. Natural Oak finish. Brown grille. Price per pair: £178.00 (plus VAT).

JBL Decade L26

Reflex enclosure. 2.5cm low frequency loudspeaker. 3.6cm high frequency direct radiator. Crossover frequency: 2,000Hz. Impedance: 8 ohms. Minimum 10 Watts. 32 × 34 × 61cm. Weight: 19kg. Natural Oak finish. Grille colour: Orange, Blue or Brown. Price per pair: £226.00 (plus VAT).

JBL Decade L36

Reflex enclosure. 25 cm low frequency loudspeaker. 13 cm Midrange unit. 3.6 cm High frequency direct radiator. Crossover frequency: 1,500 and 6,000 Hz. Impedance: 8 ohms. Minimum 10 watts. 34 × 35 × 61cm. Weight: 20kg. Natural Oak finish with grilles in Orange, Blue or Brown. Price per pair: £280.00 (plus VAT).

LBL Horizon L166

Reflex Enclosure. 20 cm low frequency loudspeaker. 13cm midrange transducer. 2.5 cm high frequency hemispherical radiator. Crossover frequency: 1,000 and 6,000 Hz. Impedance: 8 ohms. Minimum 10 Watts. 36.2 × 33 × 59.7cm. Weight: 25kg. Oiled Walnut finish. Black grille. Price per pair: £516.00 (plus VAT).

JBL Century L100 ★

Reflex Enclosure. 20 cm low frequency loudspeaker. 13 cm midrange transducer. 3.6 cm high frequency direct radiator. Crossover frequency: 1,500 and 6,000 Hz. Impedance: 8 ohms. Minimum 10 watts. 36 × 35 × 60cm. Weight: 25kg. Oiled Walnut finish. Grille colour: Ultra Blue, Chocolate, Brown or Burnt Orange. Price per pair: £440.00 (plus VAT).



JBL Century L100

JBL Aquarius Q L120

Reflex enclosure. 25 cm low frequency loudspeaker. 13 cm midrange transducer. 3.6 cm high frequency direct radiator. Crossover frequency: 1,000 and 8,000 Hz. Impedance: 8 ohms. Minimum 10 watts. Size: 31 × 31 × 112cm. Weight: 31kg. Oiled walnut or Satin white finish. Grille colour: Brown with oiled walnut or Blue with satin white finish. Price per pair: £860.00 (plus VAT).

LBL Jubal L65

Reflex enclosure. 30cm low frequency loudspeaker. 13cm midrange transducer, ultra high frequency horn loaded slot radiator. Crossover frequency: 1,000 and 6,500 Hz. Impedance: 8 ohms. Minimum 10 watts. 61 × 33 × 44cm. Weight: 30 kg. Oiled Walnut finish. Grille colour: Midnight Blue, Earth Brown or Rust Red. Price per pair: £590.00 (plus VAT).

JBL Studio Master L200B

Reflex Enclosure. 38cm low frequency loudspeaker. High frequency compression driver. Crossover frequency: 800 Hz. Impedance 8 ohms. Minimum 10 watts. Size: 61 × 54 × 83cm. Weight: 59 kg. Oiled Walnut finish. Grille colour: Grey, Black, Blue or Burgundy. Price per pair: £990.00 (plus VAT).

JBL Summit L300

Reflex enclosure. 38cm low frequency loudspeaker, high frequency compression driver ultra-high frequency horn loaded slot radiator. Crossover frequency: 800 Hz and 8,500 Hz. Impedance: 8 ohms. Minimum 10 W. Size: 58 × 57 × 80cm. Weight: 66kg. Oiled walnut finish. Grille colour: Blue, Black, Brown or Camel. Price per pair: £1250.00 (plus VAT).

★ Indicates entry is illustrated

JBL Aquarius S109-4

Reflex enclosure. Low frequency loudspeaker. 20cm dia. 1 High frequency Radiator 5cm dia. Crossover frequency: 6,000Hz. Impedance: 8 ohms. Minimum 10 W. Size: 25 × 25 × 102cm. Weight: 26kg. Oiled walnut or satin white finish. Grille: Charcoal or Brown fabric. Price per pair: £296.00 (plus VAT).

■ JORDAN

E. J. J. Sales Ltd, 17 Castle Street, Banbury, Oxon. OX16 8NU. Tel: Banbury 53620.

Co-Planar Suite

Complete stereophonic ensemble of loudspeakers which utilize the formation of coordinated plane-wave radiation from left and right channels to provide wall-to-wall sound distribution. The basic system comprises two Co-planar radiators housed in figured glass for shelf or wall mounting each having dimensions of 12 × 10 × 6in, together with a combined channel bass radiator to handle the extreme bass. HC: 50W. Can be extended to surround sound or quadraphonic applications. Price: £430.00 (including VAT).

■ JORDAN-WATTS

Jordan-Watts Ltd, Benlow Works, Silverdale Road, Hayes UB3 3BW. Tel: 01-573 6928.

GT

Reflex enclosure. One Jordan-Watts module and HF dome tweeter. Treble control fitted. Size: 68 × 32 × 17cm. FR: 30Hz-22kHz. HC: 15W. Finish: teak. Price: £45.00 each (plus VAT).

Jodrell

Reflex enclosure. Twin Jordan-Watts module. Treble control fitted. FR: 40Hz-22kHz. Size: 76 × 35 × 22cm. HC: 30W. Finish: teak. Weight: 25kg. Price: £64.80 each (plus VAT).

Jumbo

Infinite baffle. Power handling 15W. Forward facing. Shelf or wall mounting. Incorporates one Jordan-Watts modular unit. FR: 70Hz-20kHz. Size: 40 × 20 × 9cm. Weight: 7kg. Finish: teak. Price: £27.60 each (plus VAT).

Janet

Infinite baffle. One full-range Jordan-Watts module. FR: 70Hz-20kHz. HC: 15W. Compact shelf-mounting full range speaker system.



Jordan-Watts Juno

Finish: teak with green Vynair. Size: 30 × 20 × 15cm. Weight: 7kg. Price: £27.60 each (plus VAT).

Juno ★

Reflex enclosure. Power handling 15W. Forward facing. Incorporates one Jordan-Watts modular unit. FR: 40Hz-20kHz. Size: 61 × 30 × 16cm. Weight: 14kg. Price: £36.90 each (plus VAT).

Juliet

Reflex cabinet. One full-range Jordan-Watts module. FR: 40Hz-20kHz. HC: 15W. Compact shelf-mounting full range speaker system. Finish: teak with green Vynair. Size: 40 × 25 × 23cm. Weight: 13kg. Price: £36.90 each (plus VAT).

Jupiter Centurion

Reflex enclosure. Power handling 30W. Forward facing. Incorporates four Jordan-Watts modular units and two HF unit. FR: 30Hz-22kHz. Size: 88 × 38 × 27cm. Weight: 41kg. Price: £82.50 each (plus VAT).

Jupiter TLS/ABR

Transmission line speaker system. HC: 30W. Forward-facing. Incorporates two Jordan-Watts modular units. Treble control incorporated. Enclosure lined with sheet lead. FR: 30Hz-22kHz. Size: 88 × 38 × 27cm. Weight: 80lb. Price: £99.00 each (plus VAT).

Flagon

Ceramic infinite baffle loudspeaker. 65Hz-20kHz. HC: 15W. Exclusive decorative pottery enclosure. Size: 36cm diameter. Weight: 13kg. Price: £44.00 each (plus VAT).

Jericho

Reflex enclosure. Power handling capacity: 50W. Forward facing. Incorporates two Jordan-Watts modular units and 13 × 9in extra bass driver. FR: 40Hz-20kHz. Size: 76 × 34 × 22cm. Weight: 56lb. Price: £87.50 each (plus VAT).

Quadrasonic

Reflex. one drive unit. Frequency range: 40-20kHz. Impedance: 4, 8 or 16 ohms. 10-25 W. Size: 33 × 21 × 40cm. Weight: 12kg. Teak finish. Non directional rear channel loudspeaker. Price: on application.

JVC

JVC (UK) Ltd, Eldonwell Trading Estate, Staples Corner, 6-8 Priestley Way, London NW2.
Tel: 01-450 2621.

SX-7 ★

Three-way (three-speaker) acoustic suspension enclosure. Drive units: 30cm cone, 7.5cm dome, 3cm dome. Crossover frequencies: 500Hz and 5kHz. FR: 25Hz-20kHz. Impedance: 4 ohms. Efficiency: 91dB/W at 1m. Amplifier requirements: 100W (peak). Dimensions: 335 × 322 × 635mm. Weight: 25kg. Finish: walnut and spruce. Removable grille. Price: £389.00 per pair (excluding VAT).

SX-5 ★

Three-way (three-speaker) acoustic suspension enclosure. Drive units: 25cm cone, 6.5cm soft dome, 3cm soft dome. Crossover frequencies: 800Hz and 5kHz. FR: 30Hz-20kHz. Impedance: 8 ohms. Efficiency: 90dB/W at 1m. Amplifier requirements: 60W (peak). Dimensions: 13 × 12 × 22in. Weight: 17kg. Finish: walnut and spruce. Removable grille. Price: £248.00 per pair (excluding VAT).

SX-3

Two-way hermetically sealed speaker enclosures. Drive units: 25cm free edge woofer, 51mm soft dome. Crossover frequency: 2kHz. FR: 35Hz-20kHz. Impedance: 8 ohms. Efficiency: 88dB/W for 1m. Amplifier requirements: 50W (peak). Dimensions: 315 × 290 × 520mm. Weight: 13.3kg. Finish: spruce and walnut. Price: £158.00 per pair (excluding VAT).

GB-IE ★

Acoustic suspension globular speaker system. Drive units: 13cm free edge cone, 7cm cone. Crossover frequency: 3.5kHz. FR: 35Hz-20kHz. Impedance: 8 ohms. Efficiency:



JVC SX-7



JVC SX-5

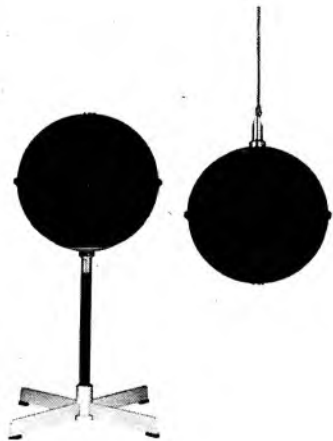

JVC GB-IE

★ Indicates entry is illustrated



KEF 103

88dB/W for 1m. Amplifier requirements: 100W (peak). Dimensions: 34cm diameter. Weight: 9.5kg. Finish: black. Price: £248.00 per pair (excluding VAT).

VS-5323

Three-way (three-speaker) variable bass reflex system. Drive units: 25cm woofer, 10cm cone, multi-cellular horn tweeter. Crossover frequencies: 5kHz and 8kHz. FR: 40Hz-20kHz. Impedance: 8 ohms. Amplifier requirements: 50W peak. Dimensions: 32 × 30 × 58cm. Weight: 8kg. Price: £104.00 per pair (excluding VAT).

SK-33

Two-way (two-speaker) acoustic suspension system. Drive units: 20cm free edge woofer, 5cm cone tweeter. Crossover frequency: 3kHz. FR: 40Hz-20kHz. Impedance: 8 ohms. Efficiency: 91dB/W for 1m. Amplifier requirements: 50W peak. Dimensions: 25.3 × 20.5 × 45.6cm. Price: £50.50 per pair (excluding VAT).

JSP-310

Drive units: 8in free edge woofer, 1in soft dome. Crossover frequency: 4kHz. FR: 40Hz-20kHz. Impedance: 4-8 ohms. Efficiency: 96B/W for 1m. Amplifier requirements: 25W. Dimensions: 25.5 × 45.5 × 21cm. Weight: 5.5kg. Price: £54.00 per pair (excluding VAT).



KEF 104

■ KEESONIC

Keesonic Audio Developments Limited, Halldore Hill, Cookham, Maidenhead, Berks (All customer enquiries to Keesonic Audio Sales Limited). Tel: Bourne End 22726.

Keesonic KBS

Tuned port system: FR: 60-20KHz±4dB: Impedance, 8 ohms: HC 30 W. Two drive units. Size 33 × 21 × 21cm. Finish Teak, Walnut or White. Price: £100.00 per pair (inclusive of VAT).

Keesonic KRF

Tuned port system: FR 45-20kHz±3dB: Impedance, 8 Ohms: HC 50 W. Three drive units. Size 61 × 28 × 31cm. Finish: Teak, Walnut or White. Price: £200.00 per pair (inclusive of VAT).

■ KEF

KEF Electronics Ltd. Tovil, Maidstone, Kent. ME15 6QP
Tel: Maidstone 57258.

Catata

Free standing, supplied in mirror image pairs. Elliptical low frequency, 110mm mid frequency, 52mm high frequency. Crossover frequency: 250 and 3000Hz. Impedance: 8 ohms. 15-150 W. Size: 34 × 39 × 81cm. Teak or Walnut finish. Switchable controls for mid and

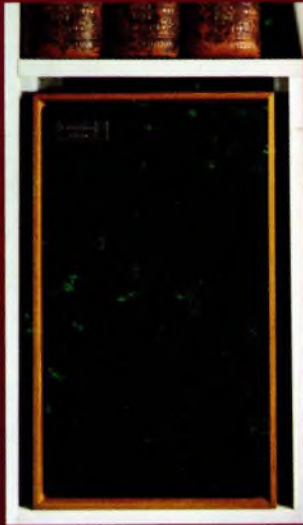

**Celestion
loudspeakers...**

...the choice of the perfectionist

DITTON
range

Ditton 66

Ditton 25

Ditton 33

Ditton 44

Ditton 11



Take a look into a Celestion loudspeaker and you will appreciate the skill and care which goes into the design and manufacture of Celestion's marvellous high-fidelity loudspeakers.

Meticulous attention to detail from the superb furniture finish right through to the precision engineering at the heart ensures the quality for which Celestion are well renowned.

Illustrated on this leaflet are both the well-established Ditton range of speakers

and the newer UL range altogether giving the audiophile a choice from nine superb designs.

More information about Celestion speakers may be obtained from your local stockist, or write direct to the manufacturers.

Celestion



UL 10



UL
range

UL8



Ditton 15



UL6



Model	Measurements		Sensitivity Pink Noise W at 1M = 90 dB	Power handling Peak music	Suggested Amp Watts RMS		Frequency Response
	Centimetres	Inches			Min	Max	
Ditton 11	35 × 20 × 25	14 × 8 × 10	9.9	25w	15	30	35 Hz–28 KHz
Ditton 15	53 × 24 × 23	21 × 9½ × 9½	4.2	30w	10	30	30 Hz–15 KHz
Ditton 33	61 × 35 × 26	24 × 14 × 10½	5.5	40w	20	50	40 Hz–28 KHz
Ditton 44	76 × 37 × 25	30 × 14½ × 10	4.0	44w	20	50	30 Hz–40 KHz
Ditton 25	81 × 36 × 28	32 × 14 × 11	2.9	60w	15	60	20 Hz–40 KHz
Ditton 66	100 × 38 × 29	40 × 15 × 11½	4.8	80w	20	80	16 Hz–40 KHz
UL 6	29 × 41 × 22	11½ × 16 × 8¾	13.0	40w	20	40	35 Hz–28 KHz
UL 8	58 × 28 × 23	23 × 11 × 9¼	8.4	50w	15	50	30 Hz–28 KHz
UL 10	67 × 31 × 38	26½ × 12½ × 15	18.0	100w	25	100	20 Hz–40 KHz

All models match 4 to 8 ohm amplifiers + finish available Teak or Walnut + Dittons are stocked by most good Hi-Fi dealers. See our list for UL stockists.

The Celestion policy is one of continuous improvement and the Company reserves the right to modify specifications without notice.



Rola Celestion Limited, Ditton Works, Foxhall Road, Ipswich, Suffolk IP3 8JP, England
 Telephone: Ipswich (0473) 73131 Cables: Voicecoil Ipswich, Telex: 98365

high frequency. Price: £260.00 per pair (plus VAT).

Calinda

Free standing. Mechanical reflex. 200mm low frequency, 27mm high frequency, Elliptical bass radiator. Cross over frequency: 45Hz acoustically coupled and 3,500Hz. Frequency range: 40-30,000Hz. Impedance: 8 ohms. 15-100 W. Size: 28 × 35 × 70cm. Teak or Walnut finish. Computer developed filter section. Price: £190.00 per pair (plus VAT).

Corelli

Compact, IB shelf enclosure. 200mm low frequency 27mm high frequency. Crossover frequency: 3,500Hz. Frequency range: 50-30,000Hz. Impedance: 8 ohms. 15-50 W. Size: 28 × 22 × 47cm. Teak or Walnut finish. Supplied in matched pairs. Price: £110.00 per pair (plus VAT).

Reference Series Model 103 ★

Compact, IB shelf enclosure. 200mm low frequency, 52mm high frequency. Crossover frequency: 3,000Hz. Frequency range 30-20,000Hz. Impedance: 8 ohms. 25-100 W. Size: 33 × 22 × 50cm. Weight: 19kg. Teak or Walnut finish. Steel, rotatable baffle provides optimum stereo image in horizontal or vertical use. Price: £145.00 per pair (plus VAT).

Reference Series Model 104 ★

Compact, floorstang mechanical reflex. 200mm low frequency, 27mm high frequency, Elliptical bass radiator. Crossover frequency: 45Hz acoustically coupled and 3,600Hz. Frequency Range: 30-40,000Hz. Impedance: 8 ohms. 15-75 Watts. Size: 33 × 26 × 63cm. Weight: 16kg. Teak, Walnut or White finish. Optional stand available. Price: £185.00 per pair (plus VAT).

■ KLH

Webland International Ltd, Mirabel House, 117/121, Wandsworth Bridge Road, London SW6

Tel: 01-736 0989/9410.

KLH 331

Size: 16 × 12 × 8.75in. Weight: 21lb. Impedance: 8 ohms. Minimum 8 W RMS. Max 90 W short duration. 8in woofer, 2.25in cone tweeter. Frequency: 50-18,000Hz. Price: £97.00 per pair (inclusive of VAT).

KLH 317

Size: 23 × 12 × 9.75in. Weight: 30lbs. Impedance: 8 ohms. Min. 10 W. RMS Max 100 W short duration. 10in woofer, 2.25in cone tweeter.

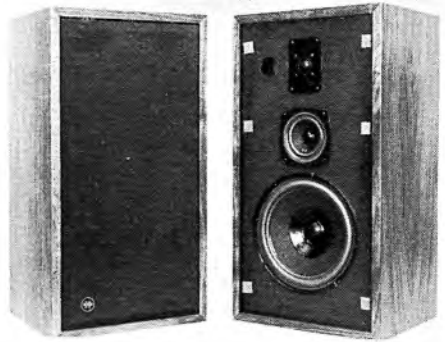

KLH CL4

ter. Frequency: 45-18,000Hz. Price: £147.00 per pair (inclusive of VAT).

KLH 363

Size: 24 × 13 × 12.5in. Weight: 42lb. Impedance: 8 ohms. Min. 15 W. RMS Max. 150 Watts short duration. 3-way speaker system. 12in woofer, 5in midrange, 2.25in cone tweeter. Frequency: 30-22,000Hz. Price: £220.00 per pair (inclusive of VAT).

KLH CL3

Size: 26 × 14 × 11.5in. Weight: 53lb. Impedance: 8 ohms. Min. 20 W. RMS max 100 W RMS. 10in megaflux woofer, 2.5in cone tweeter, 2in cone tweeter. Frequency: 35-20,000 Hz±3.5dB. Price: £275.00 per pair (inclusive of VAT).

CB8

Size: 19.5 × 11 × 7.25in. Weight: 27lb. Impedance: 8 ohms min. 8 W RMS. Max 75 W RMS. 8in megaflux woofer, 2.5in cone tweeter. Frequency: 47-18,000 Hz±4dB. Price: £169.00 per pair (inclusive of VAT).

CB10

Size: 19.5 × 14.75 × 7.25in. Weight: 35lb. Impedance: 8 ohms. Min. 10 W RMS. Max. 100 W RMS. 10in megaflux woofer, 2.5in cone tweeter. Frequency: 40-18,000 Hz±4dB. Price: £240.00 per pair (inclusive of VAT).

CL4 ★

Size: 27 × 14.25 × 13in. Weight: 59lb. Impedance: 8 ohms. Min. 25 W RMS. Max 150 W RMS. 10in megaflux woofer, 4.5in cone midrange, 1in dome tweeter. Frequency: 30-22,000Hz±3dB. Price: £360.00 per pair (inclusive of VAT).

SCX2

Size: 27 × 14 × 21in. Weight: 82lb. Impedance:

★ Indicates entry is illustrated



KLH SCX3

8 ohms. Min. 25 W RMS. Max. 200 W RMS. 2 DVR tweeters. 4, 5in cone midrange. 12in megaflux woofer. Frequency: 30-30,000Hz \pm 2.5dB. Price: £599.99 per pair (inclusive of VAT).

SCX3 ★

Size: 38 × 13.5 × 15in. Weight: 96lb. Impedance: 8 ohms. Min. 30 W RMS. Max. 400 W RMS. 3 DVR tweeters, 2 × 4.5in cone midranges, 12in megaflux woofer. Frequency: 26-33,000 Hz \pm 2dB. Price: £799.00 per pair (inclusive of VAT).

KLH 9

Full range electrostatic loudspeaker system. Impedance: 16 ohms nominal. Amplifier requirements: 40W RMS per channel minimum. Weight: approx. 100lb. Finish: oatmeal grille with walnut frame. Price: £2,250 per pair (inclusive of VAT).



Leak 2030

LEAK

Rank Audio Visual P.O. Box 70,
Great West Rd,
Brentford, Middx. TW8 9HR.
Tel: 01-568 9222.

2030 ★

Reflex enclosure. FR: 50Hz-20kHz \pm 3dB. Voice coil impedance: 6 ohms nominal. HC: 35W (DIN). Size: 19 $\frac{1}{2}$ × 11 × 10in. Weight: 24 $\frac{1}{2}$ lb. Three drive units. Crossover: 700Hz and 3.5kHz. Finish: teak. Price: £122.38 per pair (plus VAT).

2060

Acoustic suspension enclosure. FR: 45Hz-20kHz \pm 3dB. Voice coil impedance: 6 ohms nominal. HC: 50W (DIN). Size: 25 $\frac{1}{2}$ × 15 × 12 $\frac{1}{2}$ in. Weight: 5lb. Three drive units. Crossover: 600Hz and 3.5kHz. Finish: teak. Price: £198.30 each (plus VAT).

2075 ★

Transmission absorber. FR: 35Hz-20kHz \pm 3dB. Voice coil impedance: 6 ohms nominal. HC: 100W (DIN). Size 50 × 19 $\frac{1}{2}$ × 15in. Weight: 112lb. Four drive units. Crossover: 450Hz, 2kHz and 5kHz. Finish: teak. Price: £502.00 each (plus VAT).

LENTEK MONITOR

Lentek Audio Ltd, 9 Station Rd,
St. Ives, Huntingdon.
Tel: St. Ives 62225.

Lentek ★

Transmission line. 1 × 11.82/8.7



Leak 2075

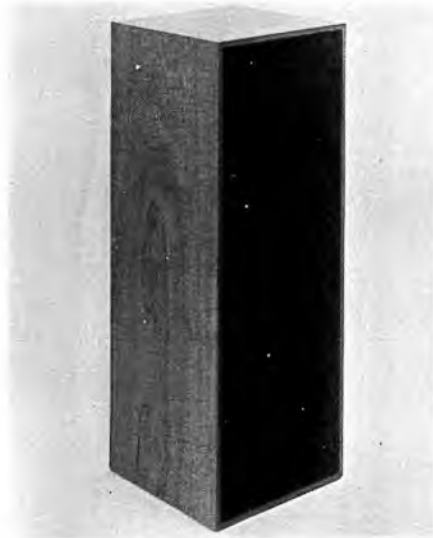

Lentek

driver. 1 x 5.5in MR, 2 x 4.25in and 4in dome tweeter. Crossover frequency: 400Hz. 3.5kHz 10kHz. min 30Hz-high 25kHz.40Hz-20kHz±dB. Impedance: 8 ohms. 25 W per channel. Size: 39.4 x 40.6 x 107.3mm. Weight: 38.2kg. Teak or white finish. Price: £260.00 per pair (plus VAT).

■ **LG**

L. G. Sound Systems, 5 Eden Grove, London N7 8EQ
Tel: 01-609 0293/6.

S209

2 speaker bookshelf. Infinite baffle. Drive units: 200mm. Crossover frequency: 1,500Hz. Frequency Range: 45-17,000Hz. Impedance: 8 ohms. 12-30 Watts. Size: 28 x 22 x 48cm. Weight: 7kg. Wood/Grey finish. Price: £126.00 per pair (plus VAT).

S20

2 speaker bookshelf. Infinite baffle. Drive units: 200mm, 35mm. Crossover frequency: 1,500Hz. Frequency range 45-17,000 Hz. Impedance: 8 ohms. 12-30 Watts. Size: 28 x 22 x 48cm. Weight: 7kg. White finish. Price: £138.00 per pair (plus VAT).

S25G ★

3 speaker bookshelf. Infinite Baffle. Drive units: 250mm, 35mm and 25mm. Crossover frequency 1,500-5,000Hz. Frequency range: 35-20,000Hz. Impedance: 8 ohms. Size: 32 x

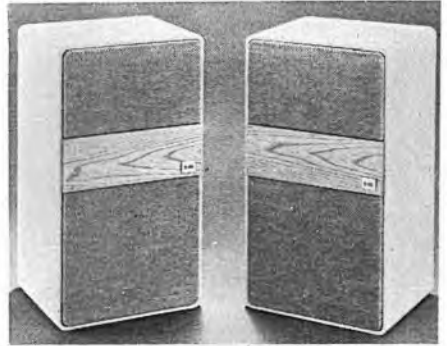

LG S25

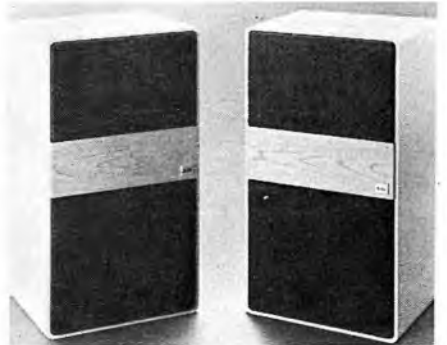

LG S25

28 x 58cm. Weight: 10kg Wood/Grey finish. Price: £162.00 per pair (plus VAT).

S25

3 speaker bookshelf. Infinite baffle. Drive units: 250mm, 35mm and 25mm. Crossover frequency: 1,500-5,000Hz. Frequency Range: 35-20,000Hz. Impedance: 8 ohms. Size: 32 x 28 x 58cm. Weight: 10kg. White finish. Price: £172.00 per pair (plus VAT).

■ **LNB**

LNB Audio Ltd, Duke Street, Loughborough, Leics.
Tel: Loughborough 61229.

LNB Para-Lab-20

Labyrinth loaded loudspeaker enclosure. 20cm bextrene cone bass unit Kef T27 and STC. FR: 30Hz-25kHz. Impedance: nominal 8 ohms at 400Hz. Efficiency: 96dB at 1m on axis in anechoic conditions for 12.5W into 8 ohms. Amplifier requirements: 20-30W per channel. Dimensions: requirements: 20-30W per chan-

★ Indicates entry is illustrated

nel. Dimensions: 28 × 28.5 × 78.8cm. Weight: 14.1kg. Finish: teak or walnut with complementary baffle and trim. White or Jacobean oak on request. Price: £125.00 per pair (plus VAT).

LNB Para-Lab-40

Labyrinth loaded loudspeaker enclosure. 20cm bextrene cone bass unit plus Rola HF1300 and STC. FR: 30Hz-25kHz. Impedance: nominal 8 ohms at 400Hz. Efficiency: 96dB at 1m on axis in anechoic conditions for 11.75W into 8 ohms. Amplifier requirements: 20-40W per channel. Dimensions: 28 × 28.5 × 78.8cm. Weight: 14.98kg. Finish: teak or walnut with complementary baffle and trim. White or Jacobean oak on request. Price: £155.00 per pair (plus VAT).

LNB Mini-Lab ★

Labyrinth loaded loudspeaker enclosure with units. 16.5cm long throw bass and 2.5cm dome treble. FR: 50Hz-25kHz. Impedance: nominal 8 ohms at 400Hz. Efficiency: 96dB at 1m on axis in anechoic conditions for 12.5W into nominal 8 ohms. Amplifier requirements: 15.20W per channel. Dimensions: 22.8 × 20.3 × 47cm. Weight: 6kg. Finish: teak or walnut with complementary baffle. White or Jacobean oak on request. Stand available. Price: £64.00 per pair (plus VAT).

LNB Para-Lab-Super ★

Labyrinth loaded loudspeaker enclosure with units. 16.5cm long throw bass and 2.5cm dome treble. FR: 40Hz-25kHz. Impedance: nominal 8 ohms at 400Hz. Efficiency: 96dB at 1m on axis in anechoic conditions for 10W into nominal 8 ohms. Amplifier requirements: 15-20W per channel. Dimensions: 22.8 × 26 × 59.7cm. Finish: teak or walnut with complementary baffle and trim. White or Jacobean oak on request. Stand available. Price: £80.00 per pair (plus VAT).

■ LINN-ISOBARIK

Linn Products Ltd, 235 Drakemire Drive, Castlemilk, Glasgow G45 9SZ.
Tel: 041-634 3860.

DMS ★

Infinite baffle enclosure with units and cross-over. HC: 100W. Impedance: 4 ohms nominal. Size: 15 × 15 × 30in. Suitable for amplifiers delivering over 60W per channel into 4 ohms, and up to 100-250W per channel. FR: 20Hz-20kHz ±1.5dB. Employs new bass generator concept (Patent pending). Weight: (approx) 100lb. Price: (per pair) £625.00 (inclusive of VAT).



LNB Mini Lab

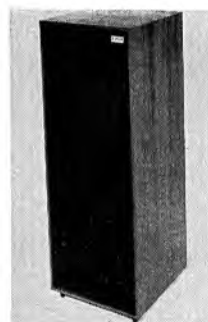

LNB Para Lab 40

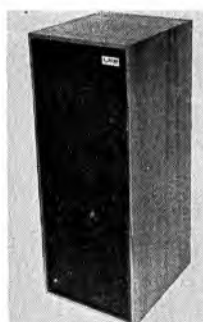

LNB Para Lab Super

■ LOWTHER ONLIFE

Lowther Onlife Developments Ltd,
41 Masons Hill, Bromley, Kent BR2 9HQ.
Tel: 01-460 5225.

Super Acousta

Folded bass horn. Frequency range: 45Hz-20kHz. Impedance: 8 ohms. Size: 46 × 36 × 84cm. Weight: 28kg. Teak or walnut veneer finish. Price: £195.00 per pair (plus VAT).

Acousta

Folded bass horn. Frequency range: 45Hz-20kHz. Impedance: 15W. Size: 46 × 36 × 84cm. Weight: 25kg. Teak or walnut veneer finish. Price: £160.00 per pair (plus VAT).

Auditorium Acousta

Folded bass horn. Frequency range: 45Hz-

20kHz. Impedance: 8 ohms. Size: 24 × 48 × 81cm. Weight: 18kg. Teak or walnut veneer finish. Control of forward facing unit for control of depth of image. Price: £208.00 per pair (plus VAT).

Dual Position Acousta

Folded bass horn. Frequency range: 45Hz-20kHz. Impedance: 8 ohms. Size: 24 × 46 × 81cm. 5-25W. Weight: 20kg. Teak or walnut veneer finish. Corner position or 45°; indirect sound. Price: £185.00 per pair (plus VAT).

Mini Acousta

Folded bass horn. Frequency range: 45Hz-2kHz. Impedance: 15 ohms. Size: 38 × 33 × 68cm. Weight: 22kg. 5-25W. Teak or walnut veneer. Usable in any position. Price: £140.00 per pair (plus VAT).

TP1 Model D

Compound folded horns. PM3. Single drive unit. Frequency range: 45Hz-20kHz. Impedance: 15 ohms. 5-30W. Size: 81 × 58 × 119cm. Weight: 41kg. Teak and walnut, other finishes available. Design for use in corner only. Price: £452.00 per pair (plus VAT).

TP1 Model A

Compound folded horns. PM3/5 single drive unit. Frequency range: 45Hz-20kHz. Impedance: 15 ohms. 5-30W. Size: 81 × 58 × 119cm. Weight: 41kg. Teak and walnut, other finishes available. Design for use in corner only. Price: £540.00 per pair (plus VAT).

Argus

PM6 Mk1 152. Single drive unit. Frequency range: 45Hz-20kHz. Impedance: 16 ohms. 5-30W. Size: 48 × 35 × 19cm. Weight: 7kg. Walnut or teak. Slave diaphragm prevents cabinet resonance. Price: £75.00 per pair (plus VAT).

Apollo

Drive units: mid 7.5cm, HF 4.5cm. Crossover frequency: 200Hz. Frequency range: 45Hz-20kHz. Impedance: 8 ohms. Amplifier: 5-30W. Size: 20 × 18 × 30cm. Weight: 5kg. Walnut, teak finish. Retains balance at low level. Price: £70.00 per pair (plus VAT).

■ MARANTZ

Pyser Ltd, Fircroft Way, Edenbridge, Kent. Tel: Edenbridge 4111.

4G

Two-way bookshelf. Drive units: 1 × 8in woofer, 1 × 1½in tweeter. FR: ± 5dB, 60Hz-15kHz. FR: 40Hz-18kHz. Impedance: 8 ohms.

Size: 28.5 × 21.25 × 48.5cm. Weight: 20lb. Teak or walnut finish. Price: £80.00 per pair (plus VAT).

5G

Two-way bookshelf. 1 × 8in woofer, 1 × 3½in tweeter. FR: ± 5dB, 45Hz-16kHz. Frequency range: 35Hz-20kHz. Impedance: 8 ohms. Size: 30.5 × 24 × 58.25cm. Weight: 23.5lb. Teak or walnut finish. 3 position. High frequency level selector switch. Price: £108.00 per pair (plus VAT).

6G

Two-way bookshelf system. 1 × 10in woofer, 1 × 2in tweeter. FR: ± 5dB, 40Hz-18kHz. Impedance: 8 ohms. Frequency range: 35Hz-20kHz. Size: 36 × 29.5 × 65cm. Weight: 40lb. Teak or walnut finish. 3 position. High frequency level selector switch. Price: £148.00 per pair (plus VAT).

7G

Three-way bookshelf system. 1 × 12in woofer, 1 × 3½in mid range, 1 × 1¼in tweeter. FR: ± 5dB, 40Hz-20kHz. Frequency range: 30Hz-20kHz. Impedance: 8 ohms. Size: 36 × 29.5 × 65cm. Weight: 45lb. Teak or walnut finish. 3 position high frequency level selector switch. 3 position mid-range level selector switch. Price: £184.00 per pair (plus VAT).

8G

Floor standing. 1 × 12in woofer. Rotatable air-coupled array of 3 mid-range transducers, 2 tweeters. FR: ± 5dB 30Hz-20kHz. Frequency range: 30-20,000Hz ± 3dB. Impedance: 8 ohms. Size: 47.5 × 36.75 × 68.5cm. Walnut finish. Variable density woofer with 4 layer voice coil. Price: £360.00 per pair (plus VAT).

9G

Floor standing. 2 × 10in woofers. Air coupled array of 4 mid-range and 2 tweeters. FR: 30Hz-20kHz ± 3dB. Frequency range: 30-20,000Hz ± 5dB. Impedance: 8 ohms. Size: 61 × 45.75 × 77.5cm. Walnut finish. Two position crossover with variable controls. Air-coupled array is symmetrical, allowing mirror imaging. Price: £500.00 per pair (plus VAT).

■ MIRSCH OF SWEDEN

Tape Music Distributors Ltd, 114 Ashley Road, St Albans, Herts. AL1 5JR. Tel: St Albans 64337/9.

OM 2.17 ★

Infinite baffle. Two-way system. 18cm bass/mid range, 2.5cm tweeter. Crossover fre-

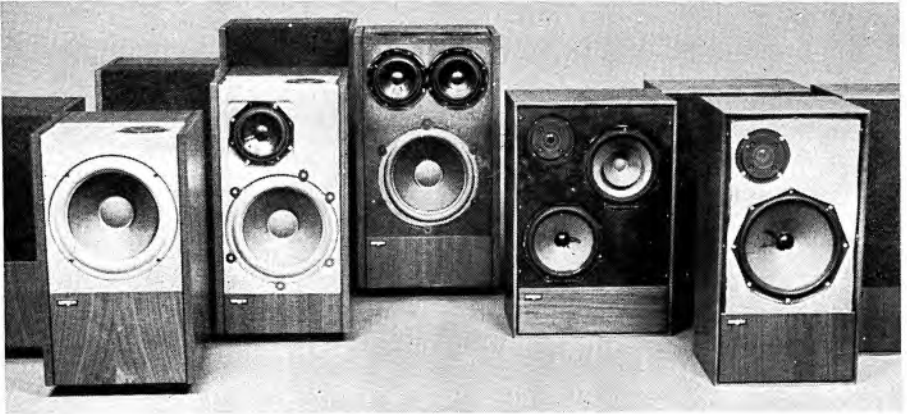

Mirsch OM2.17/2.21/3.23/3.28/5.32

quency: 4,000Hz. Frequency range: 50-20,000Hz. Impedance: 4-8 ohms. 35W. Size: 25 × 48 × 21cm. Weight: 6kg. Teak, rosewood, walnut, white or black oak finish. Price: £74.97. Rosewood £76.75 per pair (plus VAT).

OM 2.21 ★

Infinite baffle. Two-way system. 23cm mid-range/bass. 2.5cm tweeter. Crossover frequency: 4,000Hz. Frequency range: 40-20,000Hz. Impedance: 4-8 ohms. Handling power: 40W. Size: 25 × 46 × 29cm. Weight: 8kg. Teak, rosewood, walnut, white or black oak. It has an upward firing dome tweeter which gives height to the music and a wide distribution of high frequency. The mid-range bass is forward facing. This gives the correct proportions of direct and reflected sound. Price: £118.96. Rosewood: £121.61 per pair (plus VAT).

OM 3.23 ★

Infinite baffle. Three-way system. 2 × 15cm bass/mid-range, 1 × 2.5cm dome tweeter. Crossover frequency: 3,000Hz. Frequency range: 40-20,000Hz. Impedance: 4-8 ohms. Handling power: 35W. Size: 31 × 46 × 22cm. Teak, rosewood, walnut, white or black oak. The two 15cm drivers work together as a pair for bass and one doubles as a mid-range unit. Also the dome tweeter gives a wide dispersion of high frequency sound. Price: £151.60. Rosewood: £154.20 per pair (plus VAT).

OM 3.28 ★

Infinite baffle. Three-way system. 23cm bass, 15cm mid-range, 2.5cm dome tweeter. Crossover frequency: 700-4,000Hz. Frequency range: 35-20,000Hz. Impedance: 4-8 ohms.

Handling power: 50W. Size: 25 × 51 × 32cm. Weight: 9kg. Teak, rosewood, walnut, white, or black oak finish. High frequency unit is upward firing to give height to the reproduction, while the mid-range and bass are forward facing, giving the correct proportion of direct and indirect sound. Price: £159.68. Rosewood: £162.49 per pair (plus VAT).

OM 5.32 ★

Infinite baffle. Three-way system. 2 × 23cm bass, 2 × 15cm mid-range, 2 × 1.5cm dome tweeter. Crossover frequency: 700 + 4,000Hz. Frequency range: 32-20,000Hz. Impedance: 4-8 ohms. Handling power: 90W. Size: 30 × 56 × 29cm. Weight: 12kg. Teak, rosewood, walnut, white or black oak finish. Two upward firing dome tweeters give height to the music and wide dispersion of high frequency sound. The bass and mid-range are forward facing giving the correct proportions of direct and indirect sound. Six metres of cable can be stored at base of speaker. Price: £215.20. Rosewood: £219.00 per pair (plus VAT).

■ MONITOR AUDIO

347 Cherry Hinton Road,
Cambridge CB1 4DJ. Tel: Cambridge 42898.

MA 1 series II

Reflex enclosure with units and crossover. One 13 × 9in reinforced polystyrene wedge bass driver, one 7in plastic cone mid-range, one synthetic dome, 1in tweeter. Crossover frequencies: 400Hz and 2.9kHz. FR: 45Hz-19kHz ±3.5dB. HC: 60W programme. Min. power: 20W. Impedance: 8 ohms. Size: 30 × 13.5 × 15in. Weight: 60lb. Stand: 10in high, steel frame with castors. Price: £250.00 per pair (plus VAT). Stand extra.

MA 3 series II ★

Reflex enclosure with units and crossover. One 13.5 × 9.2in bass driver, one 7in plastic cone mid-range driver, one damped mylar dome 1in tweeter. Crossover frequencies: 400Hz and 3.5kHz. FR: 45Hz-18kHz ±3dB. HC: 100W programme. Impedance: 8 ohms. Size: 27¼ × 13¼ × 12½in. Highly damped enclosure with above average translation efficiency. Price: £324.00 per pair (plus VAT). Stand available.

MA 4

Reflex enclosure with units and crossover. One plastic cone base/mid-range driver 8in dia. One synthetic dome tweeter 1in. Frequency crossover: 3.2kHz. FR: 50Hz-18kHz ±3dB. Impedance: 8 ohms (nominal). Sensitivity: 12W for 96dB at 1m. HC: 60W programme. Size: 23.5 × 12.5 × 11in. Weight: 32lb. Price: £198.00 per pair (plus VAT). Stand available.

MA 5 series II ★

Infinite baffle enclosure with units and crossover. One plastic cone bass/mid-range driver 8in in diameter, one synthetic dome tweeter 1in. Crossover: 2.9kHz. FR: 55Hz-19kHz ±3dB. HC: 40W programme. Min. power: 15W. Impedance: 8 ohms. Size: 22 × 12 × 10in. Weight: 26lb. Price: £120 per pair (plus VAT). Stand available.

MA 7 ★

Compact reflex enclosure with units and crossover. One 6.5in bass driver, one mylar dome 1in dome tweeter. Crossover: 3kHz. FR: 70Hz-20kHz ±4dB, (overall) 40Hz-22kHz. HC: 25W programme. Min. power: 8W. Impedance: 8 ohms. Size: 16 × 9 × 8in. Weight: 15lb. Price: £74.50 per pair (plus VAT).

■ KEITH MONKS

Keith Monks (Audio) Ltd, 26-28 Reading Road South, Fleet, near Aldershot, Hants. Tel: Fleet 7316/3566.

Elf De Luxe ★

Bookshelf reflex enclosure with three units. Built-in filter system, 6½in bass driver, two 3in tweeters. HC: 20W. FR: 35Hz-18kHz. Impedance: 8 ohms. Size: 22.5 × 37.5 × 24.8cm. Weight: 6.35kg. Price: £32.80. Rosewood: £39.65 (plus VAT).

Super Elf ★

Bookshelf enclosure with units and crossover. One 8in long-throw bass driver, two 3in high response tweeters. FR: 35Hz-18kHz. Impedance: 8 ohms. HC: 25W RMS. Size: 44.5 × 28 × 25.4cm. Weight 6.80kg. Finish: teak, walnut

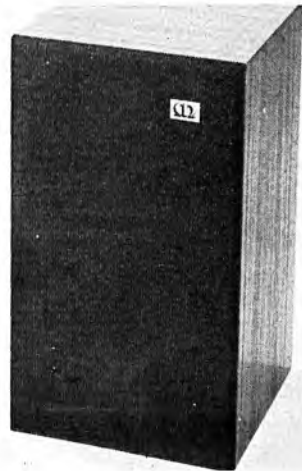
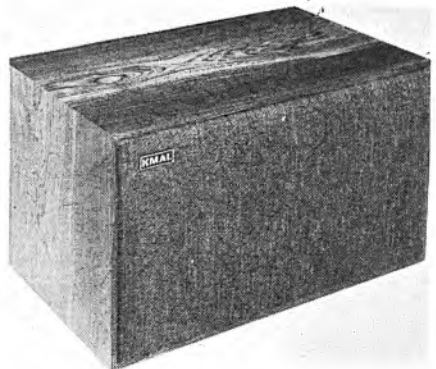
*Monitor Audio MA5 Series II**Monitor Audio MA7**KMAL Elf*

★ Indicates entry is illustrated

or rosewood. Price: £49.50. Rosewood: £57.85.

Pixie

Bookshelf, infinite baffle enclosure with one 6½in bass driver, one 3in tweeter. HC: 15W. Impedance: 8 ohms. Size: 31.1 × 21 × 15.3cm. Weight: 2.8kg. Finish: teak or walnut. Price: £19.55 (plus VAT).

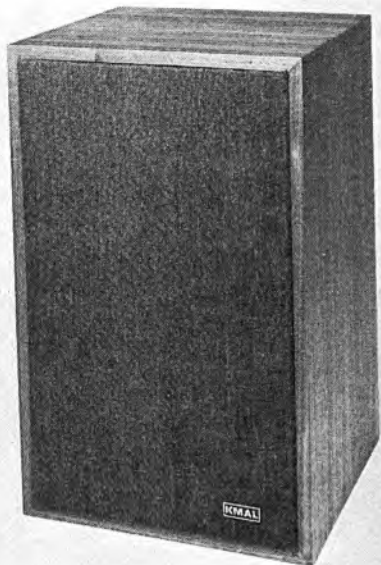

KMAL Super Elf

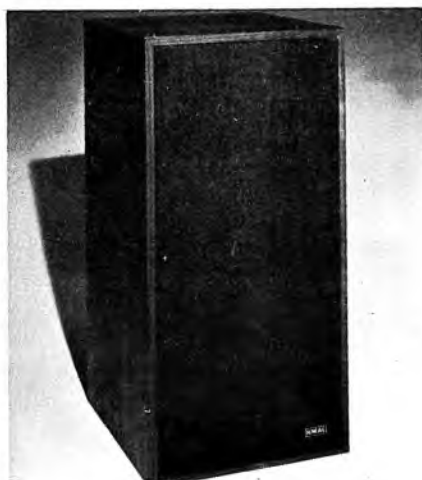

Keith Monks Elf Major

Elf Minor

Bookshelf bass reflex enclosure with 8in special treated bass unit, 4in damped mid-range, 3in dome tweeter. HC: 40W. Finish: teak, walnut or rosewood. Impedance: 8 ohms. Price: £62.90 (plus VAT).

Elf Major ★

Floor standing, bass reflex enclosure with 8in special treated bass unit, 4in damped mid-range, 3in dome tweeter. HC: 50W. Impedance: 8 ohms. Size: 63.7 × 30.6 × 33.1cm. Weight: 12.6kg. Finish: teak, walnut or rosewood. Price: £88.10. Rosewood: £99.20 (plus VAT).

MONOGRAM (MPA)

Monogram Professional Audio,
281 Balmoral Drive, Hayes, Middx.
Tel: 01-573 1566.

MS 1

Reflex tuned Helm Holz. 12in bass, 3in mid-range, 1in dome. Crossover frequency: 800Hz, 2,500Hz, 4,000Hz. Frequency range: 30Hz-22kHz ±3dB. Impedance: 4-8 ohms. Size: 15 × 16 × 29.5in. Weight: 60lb. Walnut or teak finish. Adjustable mid fully fused HF. Price: £280.00 per pair (plus VAT).

MS 2

Reflex/horn loaded. 12in bass, 4in mid-range, 2in horn/dome. Crossover frequency: 200Hz, 1,500Hz, 4,000Hz. Frequency range: 28-25kHz ±3dB. Impedance: 4-8 ohms. Size: 15 × 16 × 29½in. Weight: 70lb. Walnut or teak finish. Adjustable mid/high fully fused circuit breaker. Price: £370.00 per pair (plus VAT).

MORDAUNT-SHORT

Mordaunt-Short Ltd, Durford Mill,
Petersfield, Hampshire GU31 5AZ.
Tel: Rogate 721/2.

Carnival Series 2 ★

Infinite baffle. Bookshelf enclosure. 68mm cone high frequency unit. Crossover frequency: 3,500Hz. Frequency range: 45-20,000Hz, 85-17,000Hz ±3dB. Impedance: 8 ohms. 10-80W per channel. Size: 24.1 × 14.5 × 40cm. Weight: 5.9kg. Teak/walnut veneer. Other finishes to special order. Dual DIN/push-button connectors. Price: £62.80 per pair (plus VAT).

Festival Series 2

Infinite baffle. Bookshelf enclosure. 19mm dome high frequency unit. Crossover frequency: 3,500Hz. Frequency range: 35-



Mordaunt Short Carnival Series 2

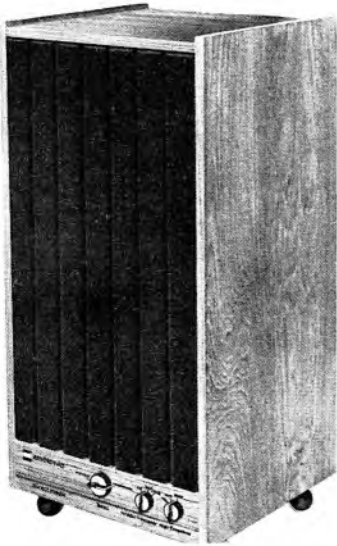

Omni Ambionic TL6 Monitor

25,000Hz, 75-20,000Hz \pm 3dB. Impedance: 8 ohms. 10-90W per channel. Size: 27.9 \times 18.5 \times 45.4cm. Weight: 7.2kg. Teak/walnut veneer. Other finishes to special order. Price: £79.00 per pair (plus VAT).

Pageant Series 2

Reflex enclosure. 25mm dome high frequency unit. Crossover frequency: 3,500Hz. Frequency range: 25-25,000Hz. 65-20,000Hz \pm 3dB. Impedance: 8 ohms. 15-100W per chan-

nel. Size: 33 \times 23 \times 53.3cm. Weight: 10.1kg. Teak/walnut veneer. Other finishes to special order. Mid and upper frequency ranges controlled by separate switches. Dual DIN/push-button connectors. Price: £124.00 per pair (plus VAT).

■ **NORDMENDE**

Vessco Vision & Radio Ltd,
Vesco House, Unit 4, Blackwater Way,
Ash Road, Aldershot, Hampshire GU12 4DL.
Tel: Aldershot 312661/4.

LB21

Bass unit 16cm, domed tweeter. Impedance: 4 ohms. Nominal load 15W, peak load 20W. Frequency range: 50-20,000Hz. Size: 26 \times 41 \times 10.4cm. Walnut or white finish. Price: on application.

LB15

Bass unit 16cm. 5.2cm tweeter. Impedance: 4 ohms. Nominal load: 12W, peak load: 15W. Frequency range: 50-18,000Hz. Size: 25 \times 36 \times 15cm. Walnut or white finish. Price: on application.

LB20

Bass unit 16cm, 7 \times 13cm tweeter. Impedance: 4 ohms. 20-30W. Frequency range: 40-22,000Hz. Size: 45 \times 25 \times 17.6cm. Walnut or white finish. Price: on application.

LB46

Two bass units, 1 mid-range unit. Impedance: 4 ohms. 35-45W. Frequency range: 50-25,000. Slim construction. Size: 50 \times 30 \times 10.2cm. Walnut or white finish. Price: on application.

LB45

Bass unit 17.5cm, mid-range 10cm, domed tweeter 9cm. Impedance: 4 ohms. 30-60W. Frequency range: 35-25,000Hz. Compact enclosure. Size: 46.5 \times 23 \times 22.4cm. Walnut or white finish. Price: on application.

LB22

Bass unit 13cm, tweeter 8.7cm. Impedance: 4 ohms. Load: 15-20W. Frequency range: 50-20,000Hz. Compact enclosure. Size: 26 \times 15.5 \times 17cm. Walnut or white finish. Price: on application.

LB47

One bass unit 20cm, one mid-range 13cm, one mid treble unit 7 \times 13cm, one domed tweeter 9cm. Impedance: 4 ohms. Load: 35-70W. Frequency range: 30-25,000Hz. Size: 66 \times 32 \times 25.2cm. Walnut or white finish. Price: on application.

★ Indicates entry is illustrated

■ OMAL

Ambionic Sound Reproducers Ltd,
Ambal House, North Circular Road,
London NW10 7UF. Tel: 01-965 8787.

Omali Ambionic TL6 Monitor ★

Variable transmission line monitor speaker system with adjustable damping, resonance and polar response. Fitted with one bass driver, two mid-range and two treble units. FR: 20Hz-50kHz. Power handling: 50W DIN. Amplifier requirement: minimum 15W RMS per channel. Distortion: less than 1%. Impedance: 8 ohms nominal. Crossover frequencies: 400Hz and 5kHz. Controls: bass, mid-range and treble. Size: 870 × 420 × 420mm, including castors. Weight: 31kg. Price: £370 per pair (plus VAT).

■ ORTOFON

Metrosound Audio Products Ltd,
Audio Works, Cartersfield Road,
Waltham Abbey, Essex EN9 1JF.

P45

19mm dome tweeter, 13cm midrange with 38mm voice coil, 25cm woofer with 42mm voice coil. Crossover frequency: 800-2,800Hz. Frequency range: 30-40,000Hz. Sensitivity: 94dB. Power rating: 70W. Music power: 150W. Impedance: 4-8 ohms. Size: 59 × 34 × 30cm. Weight: 18kg. Acoustic resistance vents for woofer and midrange in back of cabinet. Price: on application.

P75

19mm dome tweeter, 38mm dome tweeter, 13cm midrange with 38mm voice coil, 21cm internal woofer, 25cm external woofer with 42mm voice coil. Frequency range: 28-40,000Hz. Sensitivity: 93dB. Power rating: 100W. Music power: 200W. Impedance: 4-8 ohms. Size: 65 × 37 × 32cm. Weight: 26kg. Special acoustic resistance vent in back of cabinet. Price: on application.

H15

19mm dome tweeter. 18cm woofer with 42mm voice coil. Crossover frequency: 2,500Hz. Frequency range: 40-40,000Hz. Sensitivity: 91dB. Power rating: 40W. Music power: 80W. Impedance: 4-8 ohms. Size: 41 × 24 × 25cm. Weight: 8.5kg. Acoustic resistance vent in front of cabinet. Walnut finish. Price: on application.

P15

19mm dome tweeter. 38mm mid range, 18cm woofer with 42mm voice coil. Crossover frequency: 1,500-2,500Hz. Frequency range: 40-

40,000Hz. Sensitivity: 91dB. Power rating: 45W. Music power: 90W. Impedance: 4-8 ohms. Size: 41 × 24 × 25cm. Weight: 9kg. Acoustic resistance vent in back of cabinet. Walnut finish. Price: on application.

P20

19mm dome tweeter, 38mm mid range. 21cm woofer with 42mm voice coil. Crossover frequency: 1,500/3,500Hz. Frequency range: 35-40,000Hz. Sensitivity: 91dB. Power rating: 50W. Music power: 100W. Impedance: 4-8 ohms. Size: 48.8 × 28 × 25cm. Weight: 11kg. Acoustic resistance vent in front of cabinet. Walnut finish. Price: on application.

P30

19mm dome tweeter. 13mm midrange with 38mm voice coil. 21cm woofer with 42mm voice coil. Crossover frequency: 1,000/2,800Hz. Frequency range: 32-40,000Hz. Sensitivity: 92dB. Power rating: 60W. Music power: 120W. Impedance: 4-8 ohms. Size: 51 × 29 × 25cm. Weight: 11.5kg. Acoustic resistance vents for woofer and mid-range in back of cabinet. Walnut finish. Price: on application.

■ PHILIPS

Philips Electrical Ltd, Century House,
Shaftesbury Avenue, London WC2 8AS.
Tel: 01-437 7777.

RH541 ★

Motional feedback loudspeaker enclosure. 7in woofer, 1in dome tweeter. FR: 35-20,000Hz. Amplifier output: 30W. HD: <1% at 30W. Power bandwidth: 14-50,000Hz. Crossover frequency: 1.4kHz. Input sensitivity: 1V at 10k, for connection of pre-amplifiers: 7.5V at 100 ohms, for connection of low power amplifiers, 19V at 100 ohms, for connection of high power amplifiers. 19 transistors, 14 diodes. 5-pin DIN sockets. Pilot lamp. Mains: 110, 127, 220 and 240V AC 50/60Hz. Size: 23 × 18 × 29.5cm. Weight: 6.8kg. Motional feedback system. Built-in 30W RMS amplifier. Black ash veneer finish. Price: £168.00 (plus VAT).

RH532★

Motional feedback loudspeaker enclosure. Drive units: 8in bass (with motional feedback), 5in mid-range, 1in treble. FR: 35Hz-20kHz. Amplifier output: bass amp 40W RMS, mid/treble amp 20W RMS. Distortion: bass amp ≤ 0.1% at 30W, mid/treble ≤ 0.1% at 15W. Electronic crossover filter at 500Hz at input of bass and mid/treble amplifiers. Passive crossover filter at 3.5kHz to feed mid-range and treble drive units. Mains: 110, 127, 220, 240V

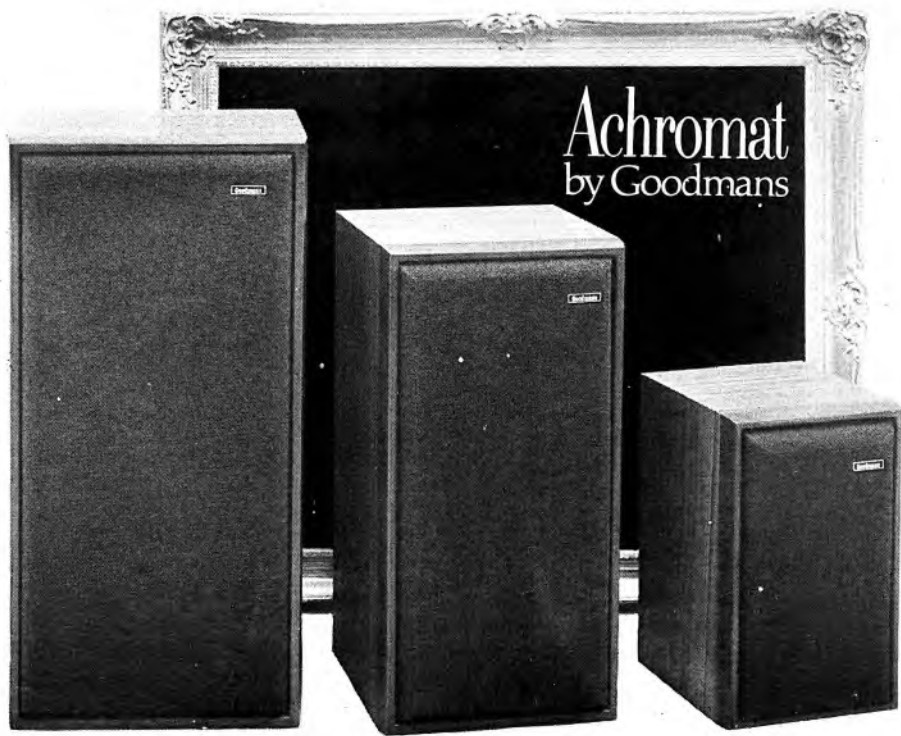

A reproduction masterpiece —with no colouration

To match our receivers we developed the Achromat range of high fidelity speaker systems, each sharing the same superb performance but differing in size and power handling capacity.

Achromat speakers will recreate music and speech with unsurpassed accuracy. This degree of quality has been obtained by giving attention to each and every component and design detail so that colouration—exhibited by all loudspeakers—is negligible.

Although the technical development

took place in the laboratory, the final tests were carried out in living room conditions to ensure constant energy distribution over the operating range.

For details of these products and the full range of Goodmans associated high fidelity equipment write to the Technical Assistance department.

Goodmans Loudspeakers Limited
Downley Road, Havant
Hampshire, PO9 2NL, England

Goodmans High Fidelity



The Opus range

Speakers that work from experience

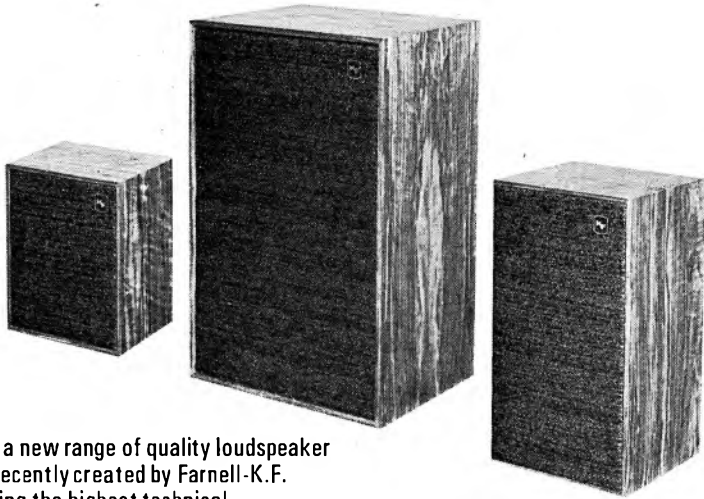

Opus is a new range of quality loudspeaker systems recently created by Farnell-K.F.

Combining the highest technical specifications with outstanding workmanship and design. Available matched in identically grained pairs with teak or walnut finish.

Producing the quality of sound reproduction normally associated with far larger and costlier systems.

Built by specialists with years of experience in speaker design and manufacture, to provide countless hours of listening pleasure.

Opus — a new range of speakers, whose remarkable performance commands such an unremarkable price.

Opus 20 : Drive unit: 1 x 170 mm twin cone. Music power: 20 Watts. Impedance: 4 to 8 ohms. Frequency response: 100 Hz – 20000 Hz \pm 4 dB. Sensitivity: 1 Watt produces 91 dB at 1 metre. Amplifier power compatibility: 2.5 W (RMS) to 12 W (RMS). Size: 11" x 8 $\frac{1}{2}$ " x 7".

Opus 45 : Drive units: 1 x 200 mm, 1 x 100 mm, 1 x 30 mm. Crossover at 1.1 kHz and 4 kHz. Music power: 45 Watts. Impedance: 4 to 8 ohms. Frequency response: 45 Hz – 20000 Hz \pm 4 dB. Sensitivity: 1 Watt produces 87 dB at 1 metre. Amplifier power compatibility: 3 W (RMS) to 25 W (RMS). Size: 19" x 10 $\frac{1}{2}$ " x 9 $\frac{1}{2}$ ".

Opus 55 : Drive units: 1 x 250 mm, 1 x 100 mm, 1 x 30 mm. Crossover at 1 kHz and 8 kHz. Music power: 55 Watts. Impedance: 4 to 8 ohms. Frequency response: 43 Hz – 20000 Hz \pm 4 dB. Sensitivity: 1 Watt produces 90 dB at 1 metre. Amplifier power compatibility: 3 W (RMS) to 30 W (RMS). Size: 24" x 15" x 11 $\frac{1}{2}$ ".

Farnell-K.F. Limited

Ashton Road, Bredbury, Stockport, Cheshire.

Specialist Manufacturers of High Quality Loudspeakers



Philips RH541

50/60Hz AC, 150W. Dimensions: 380 × 283 × 220mm (15 × 11¹/₈ × 8³/₄in). Weight: 11¹/₂kg (25¹/₄lb). Price: £165 (including VAT).

RH544

Motional feedback loudspeaker enclosure. 8in woofer, 2in dome squawker, 1in dome tweeter. Amplifier output: 60W. Crossover frequencies: electronic crossover at 500Hz and passive crossover at 3kHz. Input sensitivity: 1-22V at 100K (continuously variable). 25 transistors, 16 diodes. 5-pin DIN sockets. Mains: 110, 127, 220 and 240V AC 50/60Hz. Power consumption: 150W max. Size: 28.7 × 22.5 × 38.7cm. Black ash veneer finish. Motional feedback system. Two built-in amplifiers. 20W (treble), 40W (bass) RMS. Price: £264.00 (plus VAT).

RH457

Loudspeaker enclosure with units and crossover. HC: 50W. 8in woofer, 8in radiating cone, 2in dome squawker, 1in dome tweeter. Crossover frequencies: 580Hz and 3kHz. Impedance: 4 ohms. FR: 30-20,000Hz. Resonance frequency: 22 and 55Hz. Size: 42.2 × 22.5 × 55.5cm. Weight: 13kg. Black ash veneer finish. Price: £142.40 (plus VAT).

RH456

Loudspeaker enclosure with units and crossover. HC: 40W. 8in woofer, 2in dome squawker, 1in dome tweeter. Impedance: 4 ohms. Crossover frequencies: 580Hz and

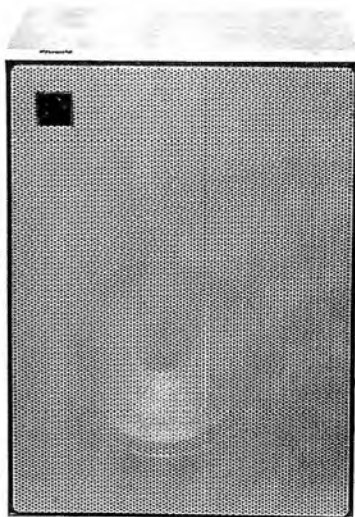

Philips RH532

3kHz. FR: 35-20,000Hz. Resonance frequency: 55Hz. Size: 35.5 × 22.5 × 47.5cm. Weight: 10.5kg. Black veneer finish. Price: £108.00 (plus VAT).

RH453

Loudspeaker enclosure with units and crossover. HC: 35W. 8in woofer, 1in tweeter. Impedance: 4 ohms. Crossover frequency: 1.5kHz. FR: 45-20,000Hz. Resonance frequency: 85Hz. Size: 28.5 × 21 × 38cm. Weight: 6.2kg. Black ash veneer finish. Price: £76.00 (plus VAT).

■ PIONEER

Shriro (UK) Ltd, Shriro House, The Ridgeway, Iver, Buckinghamshire SL0 9JL. Tel: Iver 65222/7.

HPM 60

Bass reflex. Woofer 25cm, mid-range 10cm, tweeter 4.5cm. Super tweeter high polymer type. Crossover frequency: 1,200Hz/4,000Hz/12,000Hz. Frequency range: 35Hz-25kHz. Impedance: 8 ohms. Max. power: 60W. Size: 35 × 32.1 × 61cm. Weight: 17.5kg. Walnut finish. Price: on application.

HPM 40

Bass reflex: Woofer 25cm, tweeter 4.5cm, super tweeter - high polymer type. Crossover frequency: 4,000Hz/10,000Hz. Frequency range: 35Hz-25kHz. Impedance: 8 ohms. Max.

★ Indicates entry is illustrated

input: 40W. Size: 32.5 × 31.7 × 57cm. Weight: 13kg. Walnut finish. Bass and mid range speaker use carbon fibre drive units. Price: on application.

CST 61

Infinite baffle. Woofer 25cm, mid-range 10cm, tweeter 6.6cm. Crossover frequency: 950Hz/4,700Hz. Frequency range: 35Hz-20kHz. Impedance: 8 ohms. Nominal power: 30W DIN. Size: 35 × 29.7 × 61cm. Weight: 17.5kg. Teak finish. Carbon fibre woofer and mid-range with soft cone tweeter. Price: on application.

CS 515 ★

Bass reflex type. Bass 25cm, mid-range 12cm, tweeter 2.5cm. Crossover frequency: 700Hz/5,000Hz. Frequency range: 35Hz-20kHz. Impedance: 8 ohms. Max. power: 50W. Size: 34.5 × 30.3 × 58.5cm. Weight: 16kg. Walnut finish. Price: on application.

CS-313 ★

Bass reflex enclosure. Bass 20cm, tweeter 7.7cm. FR: 50Hz-20kHz. Sensitivity: 1W for 93dB at 1m. Maximum input power: 20W. Impedance: 8 ohms. Two drive units. Crossover frequency: 5kHz. Size: 27 × 50 × 23cm. Weight: 64kg. Finish: walnut. Price: on application.

CS E830

Infinite baffle. Woofer 30cm, mid-range 4.8cm, 2.5cm tweeter. FR: 35Hz-20kHz. vci: 8 ohms. HC: 75W. Size: 38 × 31.7 × 66cm. Weight: 22kg. Three drive units. Crossover: 760Hz and 5.6kHz. Resonant frequency: 55Hz. Distortion: 5% at 1kHz. Sensitivity: 1W for 90.5dB at 1m. Finish: walnut. Price: on application.

CS-E220

Air suspension. FR: 50Hz-20kHz. vci: 4-8 ohms. HC: 20W. Size: 20 × 17 × 30cm. Weight: 6kg. Two drive units. Crossover frequency: 4,000Hz. Resonant frequency: 90Hz. Distortion: 3% at 1kHz. Sensitivity: 1W for 86dB at 1m. Woofer 16cm cone, tweeter 2.5cm dome, infinite baffle. Finish: walnut. Price: on application.

CS-E320

Air suspension. FR: 45-20kHz. vci: 4-8 ohms. HC: 30W. Size: 24 × 22 × 45cm. Weight: 9kg. Two drive units. 20cm woofer, 2.5cm tweeter. Crossover frequency: 3,300Hz. Resonant frequency: 73Hz. Distortion: 3% at 1kHz. Sensitivity: 1W for 86dB at 1m. Finish: walnut. Price: on application.



Pioneer CS-515

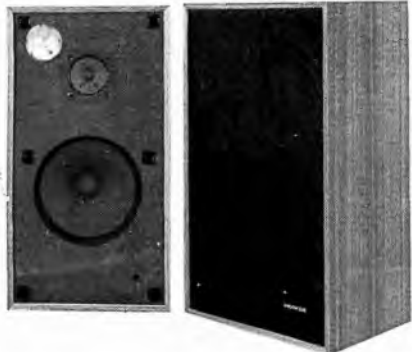

Pioneer CS-313

CS E420

Air suspension: 20cm cone woofer, 2.5cm tweeter. FR: 35Hz-20kHz. vci: 4-8 ohms. HC: 40W. Size: 26 × 24.5 × 50cm. Weight: 12kg. Two drive units. Crossover: 1.6kHz. Resonant frequency: 60Hz. Distortion: 2% at 1kHz. Sensitivity: 1W for 87dB at 1m. Finish: walnut. Price: on application.

CS E530

Infinite baffle. Woofer 25cm, mid-range 12cm, tweeter 2.5cm. FR: 35Hz-20kHz. vci: 8 ohms. Size: 33 × 30 × 57cm. Weight: 16.5kg. Three drive units. Crossover: 800Hz. Resonant frequency: 53Hz. Distortion: 2% at 1kHz. Sensitivity: 1W for 89dB at 1m. Finish: walnut. Price: on application.

CS E730

Infinite baffle. Woofer 30cm, mid-range 4.8cm, tweeter 2.5cm. FR: 35Hz-20kHz. vci: 8 ohms. HC: 60W. Size: 38 × 30 × 66cm. Weight: 21.5kg. Three drive units. Crossover: 650Hz and 5kHz. Resonant frequency: 53Hz. Distortion: 2%. Sensitivity: 1W for 91dB at 1m. Finish: walnut. Price: on application.

■ QUAD

The Acoustical Manufacturing Co. Ltd.
St Peters Road, Huntingdon PE18 7DB.
Tel: Huntingdon 52561.

Quad Electrostatic ★

Full range electrostatic loudspeaker. FR: 45Hz-18kHz. Impedance: 15 ohms. Amplifier requirements: 15W min. 33 peak volts max. Dimensions: 88 × 27 × 79cm. Weight: 18kg. Finish: black or bronze anodised grille. Price: £240 per pair (plus VAT).

■ QUASAR

Eagle International. Precision Centre.
Heather Park Drive, Wembley HA0 1SU.
Tel: 01-902 8832.

QS1 ★

Studio monitor loudspeaker. Ported cabinet. Reinforced and braced. Drive units: 38mm super tweeter, 50mm tweeter, 100mm mid-range unit, 305mm woofer. Crossover frequencies: 600Hz, 4.5kHz, 18kHz. FR: 45Hz-20kHz ± 3dB. THD: 0.16% at 1kHz. Impedance: 8 ohms (stable). Efficiency: 90dB for 3.1W at 1m. Amplifier requirements: 20-50W RMS (will accept higher output). Dimensions: (approx) 39 × 29 × 66cm. Finish: teak veneers, a formosia, black grille. 3-position switch for -3dB, -6dB HF cut at 10kHz. Price: £168.00 per pair (plus VAT).

QS2

Monitor loudspeaker. Ported cabinet. Reinforced and braced. Drive units: 50mm tweeter, 100mm mid-range unit, 305mm woofer. Crossover frequencies: 600Hz (12dB/octave), 4.5kHz (18dB/octave). FR: 55Hz-18kHz ± 3dB. Impedance: 8 ohms (stable). Efficiency: 90dB for 3.1W at 1m. Amplifier requirements: 20-50W RMS (will accept higher output). THD: 0.16% at 1kHz. Dimensions: (approx) 33 × 29 × 62cm. Finish: teak veneers, a formosia panels, black grille. 15-element crossover. Three-position switch for -3dB, -6dB HF cut at 10kHz. Price: £136.00 per pair (plus VAT).

QS3

Compact monitor loudspeaker. Infinite baffle cabinet. Drive units: 50mm tweeter, 100mm mid-range unit, 203mm woofer. Crossover frequencies: 600Hz (12dB/octave), 4.5kHz (18dB/octave). FR: 60Hz-16kHz ± 3dB. Impedance: 8 ohms. Efficiency: 90dB for 3.1W at 1m. Amplifier requirements: up to 30W RMS. Dimensions: (approx) 30 × 22 × 60cm. Finish: teak veneers, a formosia panels, black grille. 15-element crossover. Three-position switch

for -3dB, -6dB HF cut at 10kHz. Price: £108.00 per pair (plus VAT).

■ REVOX

C. E. Hammond & Co Ltd, 105-109 Oyster Lane, Byfleet, Surrey KT14 7LA.
Tel: Byfleet 41131.

AX4-3

Woofer 24.5cm, mid-range 3.8cm, tweeter 2.5cm. Crossover frequency: 900/6,000Hz. Frequency range: 30-20kHz. Impedance: 4 ohms. 8-60W. Size: 315 × 250 × 560mm. Weight: 14.1kg. Mid-walnut colour with matching acoustic foam front. Price: £250.00 per pair (plus VAT).

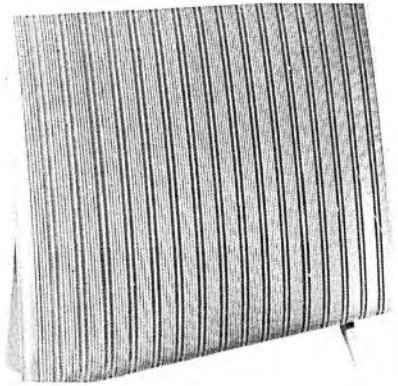

Quad Electrostatic

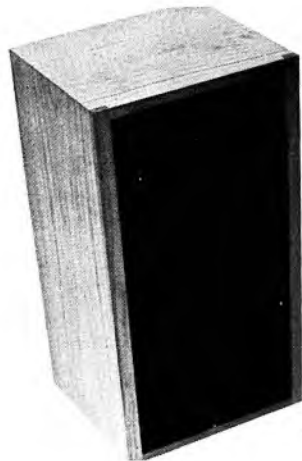

Quasar QS1 Studio

★ Indicates entry is illustrated

AX3-3

Woofer 2cm, mid-range 3.8cm, tweeter 2.5cm. 1,000/4,500Hz crossover frequency. Frequency range: 30-20kHz. Impedance: 4 ohms. 8-40W. Size: 264 × 214 × 474mm. Weight: 10.7kg. Mid-walnut colour with matching acoustic foam front. Price: £198.00 per pair (plus VAT).

■ JIM ROGERS

Tape Music Distributors Ltd,
114 Ashley Road, St Albans, Herts. AL1 5JR.
Tel: St Albans 64337/9.

JR149★

Heavy gauge aluminium in a near cylindrical shape with discs at each end held under tension by a steel rod. 13cm bass unit, 2cm treble unit. Crossover frequency: 3kHz. Frequency range: 75Hz-20kHz ± 3dB, 55Hz-20kHz ± 4dB. Impedance: nominally 15 ohms, minimum 8 ohms. Size: 37cm high, 23cm dia. Weight: 5.5kg. Declon foam circular grill capped top and bottom with decorative discs. Enclosure virtually non-resonant. Price: walnut, teak or aluminium £110.00. Rosewood, yew or leather £114.00. Acrylic black £153.00 per pair (plus VAT).



JR 149

■ ROGERS

Swisstone Electronics Ltd,
4-14 Barmeston Road, London SE6 3BN.
Tel: 01-697 8511.

Export Monitor

Three drive unit. Crossover with precision tapped inductors and low loss capacitor. Impedance: 15 ohms. Size: 12 × 12 × 25in. Height with stand: approx 35in. Teak or walnut finish. Power handling: 35W speech and music. Price: £195.00 per pair (plus VAT).

BBC Monitor LS3/5A ★

Infinite baffle enclosure. FR: 80Hz-20kHz ± 3dB. vci: 15 ohms. Size: 7½ × 6¾ × 12in. Weight: 11lb. Two drive units. Crossover: 3kHz. Finish: teak. Price: £125.00 per pair (plus VAT).

NOTE: Made under licence from the BBC. Distribution of the Rogers BBC Monitor speaker system is through a very limited number of selected audio retailers. Full list of appointed retailers available from the manufacturers.

■ ROTEL

Rank Audio Visual, PO Box 70,
Great West Road, Brentford, Middx.
TW8 9HR. Tel: 01-568 9222.

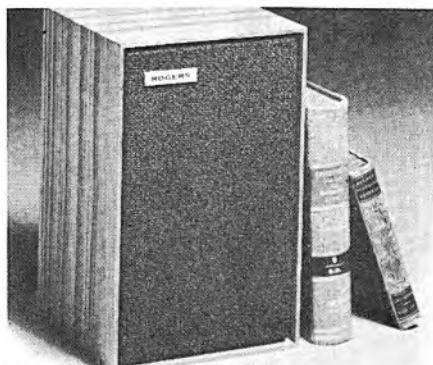

Rogers BBC Monitor LS3/5A

RL200

Infinite baffle. 1in dome tweeter, 8in bass driver. Crossover frequency: 2kHz. Impedance: 6 ohms. 10W. Size: 45 × 25 × 23.5cm. Weight: 8.5kg. Teak veneer or black grille cloth finish. Price: £71.60 per pair (plus VAT).

RL400

Infinite baffle. 1in dome tweeter, 1½in mid-range, 8in bass driver. Crossover frequency: 1kHz and 6kHz. Impedance: 6 ohms. 10W. Size: 52 × 24.5 × 26.5cm. Weight: 12.5kg. Teak veneer or black grille cloth finish. Price: £87.60 per pair (plus VAT).

RL600

Infinite baffle. 1in tweeter, 1½in mid-range, 10in bass driver. Crossover frequency: 1kHz and 6kHz. Impedance: 6 ohms. 25W. Size: 58.5 × 26 × 31.5cm. Weight: 16kg. Teak veneer or black grille cloth. Price: £130.00 per pair (plus VAT).

RL800

Infinite baffle. 1in tweeter, 1½in mid-range. Crossover frequency: 1kHz and 6kHz. Impedance: 6 ohms. 30W. Size: 67 × 28.6 × 36cm. Weight: 16kg. Teak veneer or black grille cloth finish. Price: £159.60 per pair (plus VAT).

■ SANSUI

Vernitron Ltd, Thornhill,
Southampton.
Tel: Southampton 444811.

ES30

Woofers 16.5cm, tweeter 5.8cm. Max. power: 35W. Nominal Power: 20W. Impedance: 4 ohms. Frequency range: 50-20,000Hz. Crossover frequency: 2,500Hz. Two-way system. Size: 24.3 × 43. × 15.2cm. Walnut finish. Weight: 4.6kg. Price: £31.44 (plus VAT).

ES50

Woofers 20cm, tweeter 1.9cm. Max Power: 35W. Nominal Power: 20W. Impedance 8 ohms. Frequency range: 45-20,000Hz. Crossover frequency: 3,000Hz. Semi-damped bass reflex type. Size: 25 × 48 × 24cm. Weight: 7.8kg. Walnut, Teak and Palisander finish. Price: £45.56 (plus VAT).

ES200

Woofers 25.5cm, Midrange 3.5cm, Tweeter 1.9cm. Max. Power: 50W. Nominal Power: 35W. Impedance: 8 ohms. Frequency range: 30-20,000Hz. Crossover frequency: 1,500Hz, 6,000Hz. Size: 31.4 × 59.6 × 29.3cm. Weight: 20kg. Price: £73.73 (plus VAT).

ES100

Woofers 25.5cm, Tweeter 3.5cm. Max. Power: 45W. Nominal Power: 30W. Impedance: 8 ohms. Frequency range: 35-20,000Hz. Crossover frequency: 3,000Hz. Size: 30.8 × 52.3 × 24.3cm. Weight: 15.5kg. Price: £55.03 (plus VAT).

LM330

Woofers 25.5cm, Tweeter 6.5cm. Power rating: 60W. Impedance: 8 ohms. Frequency range: 31 to 20,000Hz. Crossover frequency: 1,500Hz. Size: 31 × 71 × 30.4cm. Weight: 20.7kg. Walnut grain finish. Price: £114.62 (plus VAT).

LM220

Woofers 20.5cm, tweeter 6.5cm. Power rating: 45 Watts. Impedance: 8 ohms. Frequency range: 32-20,000Hz. Crossover frequency: 2,000Hz. Size: 27.8 × 62 × 25cm. Weight: 13.6kg. Walnut grain finish. Price: £85.96 (plus VAT).

LM110

Woofers 16.5cm, tweeter 6.5cm. Power rating: 35W. Impedance: 8 ohms. Crossover frequency: 2,000Hz. Frequency range: 38-20,000Hz. Size: 24.8 × 53.4 × 19.4cm. Weight: 18.2kg. Walnut grain finish. Price: £68.77 (plus VAT).

■ SCANSONIC

Howland-West Ltd, 3-5 Eden Grove,
London N7 8EQ. Tel: 01-609 0293/6.

H-10

FR: 45Hz-20kHz. Power rating: 20W. Sensitivity: 90dB/1W/1m. Impedance: 4-8 ohms. Size: 440mm high, 275mm wide, 170mm deep. Weight: 7kg. Price: £44.50 (plus VAT).

H-20

FR: 40Hz-20kHz. Power rating: 35W. Sensitivity: 91dB/1W/1m. Impedance: 4-8 ohms. Size: 515mm high, 320mm wide, 220mm deep. Weight: 9kg. Price: £47.50 (plus VAT).

HP-30

FR: 35Hz-20kHz. Power rating: 40W. Sensitivity: 91B/1W/1m. Impedance: 4-8 ohms. Size: 550mm high, 340mm wide, 250mm deep. Weight: 11kg. Price: £57.00 (plus VAT).

P25

Three-way system. 8in bass, 5in mid-range, 1½in tweeter. Frequency range: 40-30,000Hz. Impedance: 4-8ohms. 35 Watts. Size: 32 × 24 × 51cm. Weight: 11.5kg. Teak, Rosewood finish. Price: £137.00 per pair (plus VAT).

P35

Three-way system. 10in bass, 5in-midrange, 1½in tweeter. Frequency range: 35-20,000Hz. Impedance: 4-8 ohms. 45W. Size: 34 × 25 × 55cm. Weight: 13.5kg. Teak or Rosewood finish. Price: £157.00 per pair (plus VAT).

P55 ★

Compound system. 2-12in bass, 1-mid-range, 1-tweeter. Frequency range: 30-20,000Hz. Impedance: 4-8 ohms. 80W. Size: 39 × 30 × 63cm. Weight: 22kg. Teak, or Rosewood finish. Price: £270.00 per pair (plus VAT).

S-02

FR: 65Hz-15kHz. Power rating: 10W. Sen-

★ Indicates entry is illustrated



Scan Sonic P55



SMC Saturn

sitivity: 92dB/1W/1m. Impedance: 4-8 ohms. Size: 340mm high, 210mm wide, 130mm deep. Weight: 2.5kg. Price: £16.30 (plus VAT).

S-12

FR: 60Hz-20kHz. Power rating: 12W. Sensitivity: 92dB/1W/1m. Impedance: 4-8 ohms. Size: 440mm high, 275mm wide, 170mm deep. Weight: 5.5kg. Price: £24.50 (plus VAT).

S-22

FR: 45Hz-20kHz. Power rating: 20W. Sensitivity: 92dB/1W/1m. Impedance: 4-8 ohms. Size: 515mm high, 320mm wide, 220mm deep. Weight: 9kg. Price: £35.00 (plus VAT).

■ SHURE

Shure Electronics Ltd. Eccleston Road, Maidstone. ME15 6AU
Tel: Maidstone 59381

VA305-HF

Power rating: 100W. Impedance: 16 ohms. FR: Flat ± 5 dB 50Hz to 18kHz. Crossover frequency: 5kHz. Size: $6\frac{3}{4} \times 14\frac{3}{4} \times 8\frac{3}{4}$ in. Weight: 11lb 4oz. Price: £61.34 (plus VAT).

■ SMC

Monitor Distribution Co Ltd, 76 Bedford Road, Kempston, Beds MK42 8BB.
Tel: Bedford 854133.

Saturn ★

Drive units: 8in Bextrene cone PVC roll surround LF unit and 1in doped fabric dome HF unit. FR: 55Hz-20kHz ± 4 dB (40Hz-25kHz DIN). Power rating: 25W DIN. Impedance: 8 ohms. Sensitivity: 96dB for 12W for 96dB at 1m. Crossover frequency: 3kHz. Size: $255 \times 465 \times 240$ mm. Weight: 8kg. Price: £71.43 per pair (plus VAT)..

AL12

Acoustic labyrinth system, 8in bass unit and $\frac{3}{4}$ in tweeter. FR: 45Hz-40kHz (DIN 45: 500). HC: 30W into 8 ohms. Efficiency 20W pink noise for 96dB at 1 metre. Size: $23\frac{1}{2} \times 11\frac{1}{2} \times 11\frac{1}{2}$ in. Finish: teak. trolley T12 available. Price: £118.80 per pair (plus VAT).

AL22

Acoustic labyrinth system, 8in bass unit and $\frac{3}{4}$ in tweeter. FR: 35Hz-40kHz. (DIN 45: 500). HC: 30W into 8 ohms. Efficiency 20W pink noise for 96dB at 1 metre. Size: $32\frac{1}{2} \times 13\frac{1}{2} \times 13\frac{1}{2}$ in. Finish: teak, supplied on plinth for floor standing. Price: (per pair) £142.40 (plus VAT).

AL30

Acoustic labyrinth system, bass unit and two HF units. FR: 3Hz-40kHz (DIN 45:500). HC: 40W into 8 ohms. Efficiency 20W pink noise for 96dB at 1 metre. Size: $35\frac{1}{2} \times 14\frac{1}{2} \times 13\frac{1}{2}$ in. FR: 30Hz-40kHz. Finish: teak. Price: £191.18 per pair (plus VAT). Other finishes available to order.

AL50 Studio Monitor

Acoustic labyrinth system. 12 × 8in bass unit. 5in mid-range and 3/4in treble unit. FR: 55kHz ± 3dB. Power Rating: 100W programme. Efficiency 15W pink noise for 96dB at 1 meter. Size: 29 × 15 × 17in. Finish Teak. Weight 80lbs. Heavy duty trolley supplied. Price £380.00 per pair (plus VAT).

■ SKANTIC

Skantic (UK) Ltd, Station Road, Edenbridge, Kent TN8 6EY
Tel: Edenbridge 5231.

60362

13cm Mid-range, 2.5cm dome tweeter treble. 25cm Bass Unit. Crossover frequency: 1000, 3000Hz. Frequency response: 20-20,000Hz. Power handling: 50W. Sensitivity: 5W Impedance: 4ohms. Size: 35 × 60 × 23cm. Weight: 13kg. Price: Teak: £45.52, Walnut £48.59, Rosewood £53.15 (plus VAT).

68312

Bass unit 20cm, Mid-range 20cm, Treble 4 × 5cm. Crossover frequency: 1500Hz. Frequency response: 30-20,000Hz. Power: 40W. Sensitivity: 5W Impedance: 4 ohms. Size: 27.5 × 44 × 27.5cm. Weight: 9kg. Omnidirectional. Price: Teak £46.26. Walnut £49.17. Rosewood £52.05 (plus VAT).

40412

Bass unit 20cm, Mid-range 20cm, Treble 2.5cm dome tweeter. Crossover frequency: 1000,

3000Hz. Frequency response: 40-20,000Hz. Handling power: 40W. Sensitivity: 4 Watts. Impedance: 4Watts. Size: 50 × 30 × 27cm. Weight: 8.5kg. Price: Teak £27.45. Walnut £28.99. Rosewood £32.07 (plus VAT).

30412

Bass unit 20cm, mid-range 20cm, treble 2.5cm dometweeter. Crossover frequency: 3000Hz. Frequency response: 40 × 40 × 20cm. Weight: 5kg. Price: Teak £23.60. Walnut £25.14. Rosewood £28.22 (plus VAT).

■ SONY

Sony (UK) Ltd, Consumer Information, Sony Showroom, 134, Regent St, London W1R 6DJ
Tel: 01-439 3879

SS70 ★

Infinite baffle. Woofer and Mid-range 13cm cone type. Tweeter 6cm cone type. Frequency range: 95-18,000Hz DIN. Impedance: 8 ohms. Handling power 10 W. Weight: 1.9kg. Teak finish. Price: £19.20 (plus VAT).

SS5088 ★

Infinite baffle. Woofer and mid-range 17cm. Tweeter 5cm. Crossover frequency: 6.5kHz. FR: 80-20,000Hz DIN. Impedance: 8 ohms. Handling power: 12W, 25W Music DIN. Size: 23 × 13.5 × 38cm. Weight: 3.5kg. Walnut finish. Price: £44.72 (plus VAT).

SS5177 ★

Infinite baffle. Woofer 22cm, mid-range 9cm,



Sony SS 70, SS 5088, SS 5177, SS 5300A, SS 3050

★ Indicates entry is illustrated

tweeter 5cm. Crossover frequency: 3,000-5,000Hz. FR: 50-20,000Hz DIN. Impedance: 8 ohms. Handling Power: 20W RMS. 35W max DIN. Size: 28.5 × 24 × 49.5. Weight: 5.5kg. Teak or Walnut finish. Price: £55.92 (plus VAT).

SS5300A ★

Infinite baffle. Woofer 25cm. Mid-range 9cm, tweeter 5cm. Crossover frequency: 1,500Hz, 4,000Hz. FR: 30-20,000Hz DIN. Impedance: 8 ohms. Handling Power: 35 W RMS. 50 W DIN max. Size: 33 × 30.5 × 56cm. Weight: 12kg. Walnut finish. Removable front grille. Price: £87.92 (plus VAT).

SS3050 ★

Infinite baffle. Woofer 25cm, tweeter 6cm, super tweeter. Crossover frequency: 2.5kHz, 12kHz. FR: 40-20,000Hz. 8 ohms. Output sound pressure 91dB/W/m. Handling power: 70 W max DIN. Size: 31.5 × 29 × 5.8cm. Price: £127.92.

SS5050

Infinite baffle. Woofer 30cm, mid-range 3.5cm, Tweeter 2.5cm. Crossover frequency: 800Hz (-12dB/octave) 9kHz (-12dB/octave). FR: 40-20,000Hz DIN. Impedance: 8 ohms. Handling Power: 80 W RMS. Size: 36.5 × 31.8 × 63cm. Weight: 20kg. Walnut finish. Price: £199.92 (plus VAT).

SS8150

Bass reflex type. Beech tree plywood. Woofer 30cm, mid-range 4cm, tweeter 2cm. Crossover frequency: 1kHz (-12dB/octave) 6.5kHz (-12dB octave) FR: 30-25,000Hz. Impedance: 8 ohms. Handling Power: 100 W RMS. Size: 43 × 38.5 × 91cm. Weight: 60kg. Grey and Black finish. Push post terminals. Three developed diecast frame speaker drive units with carbon fibre cones. Price: £1,120.00 (plus VAT).

■ SPENDOR

Spendor Audio Systems Ltd, Unit 12, Station Road, Industrial Estate, Hailsham, Sussex. Tel: Hailsham 843474.

BCI

Reflex enclosure with units and crossover. One 8in plastic cone bass driver, one Celestion HF1300 mid-range unit, one STC 4001G tweeter. Crossover: 3kHz and 13kHz. FR: 45Hz-25kHz (±3dB 60Hz-14kHz). HC: 40W peak programme. Impedance: 8 ohms. Main driver based on BBC design with resin-bonded voice coil. Size: 25 × 11¼ × 12in. Weight: 31lb. Finish: teak standard (rosewood, walnut or



Spendor BCIII

white to order). Price: on application. Trolley optional extra.

BCII

Reflex enclosure with units and crossover. One 8in plastic cone bass driver, one Celestion HF1300 mid-range unit, one STC 4001G tweeter. Crossover: 3kHz, 13kHz. FR: 45Hz-25kHz (60Hz-14kHz ±3dB). HC: 50W peak programme. Impedance: 8 ohms. Bass driver developed by Spendor with 1½in diameter resin-bonded voice coil. Size: 25 × 11¼ × 12in. Weight: 33lb. Finish: teak standard (rosewood, walnut or white to order). Price: on application. Trolley optional extra.

BCIII ★

Reflex enclosure with units and crossover. One Spendor 12in bass driver, one 8in mid-frequency unit, one Celestion HF1300 HF unit, one Celestion HF2000 tweeter. Crossover: 700Hz, 3kHz and 13kHz. FR: 30Hz-20kHz (50Hz, 14kHz ±2½dB). HC: 70W peak programme. Impedance: 8 ohms nominal. Size: 31½ × 15½ × 15½in. Weight: 75lb. Finish: teak (white, walnut, rosewood to order). Price: on application. Trolley optional extra.

Spendor speakers also supplied with 25W or 50W power amplifier built-in (Models BCIA and BCIIA). Amplifier inputs balanced or unbalanced. Designed for professional market. Prices and specifications on request.

I AM THE GREATEST

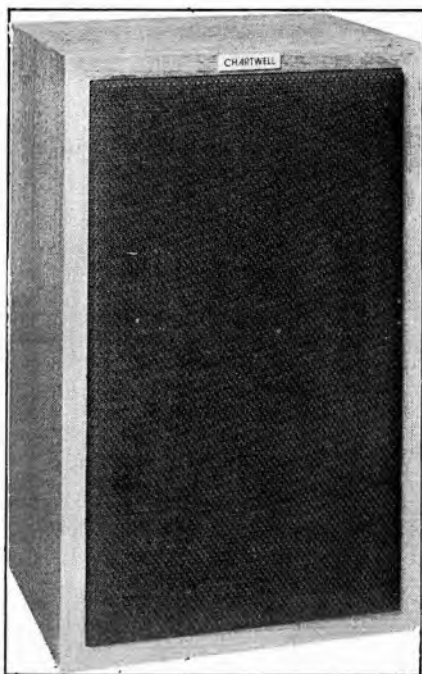

Miniature Monitoring Loudspeaker

THE FAMOUS

LS3/5A

This Loudspeaker, designed by the British Broadcasting Corporation, is used where space is at a premium and some small sacrifice of Bass Response is justified for the sake of achieving compactness.

Maximum output is greater and the quality higher than that obtainable from loudspeakers of comparable size, especially in the lower frequency range.

MADE IN ENGLAND BY

CHARTWELL

the loudspeaker specialists



**CHARTWELL ELECTRO ACOUSTICS LTD., 2-10, COMMONSIDE EAST
MITCHAM, SURREY, ENGLAND**



Living Sound

Whatever your taste in music, with today's high technical standard in record production, it's not asking too much to expect "living sound" from a really good loudspeaker system. Richard Allan have gone a long way in producing speakers, with you in mind, by incorporating the most up-to-date developments into their highly acclaimed Bextrene speaker range. All speakers are finished in teak or walnut in sizes ranging from the Compact Bookshelf loudspeaker to the Labyrinth Floor Standing Unit, all manufactured to reproduce "concert hall" performance. If you buy any loudspeaker system, regardless of your room size or budget, without first listening to a pair of speakers from the Richard Allan Range, you will be doing your ear and your music system an injustice.

Richard Allan

For full details of all our loudspeaker systems, please write to
Richard Allan Radio Limited, Department HF1, Bradford Road, Gomersal, Cleckheaton BD19 4AZ, Yorkshire, England.
Telephone: Cleckheaton 872442/3, Cables: Acoustics, Bradford.

Broadcast Standard Loudspeakers and Amplifiers

Spendor's reputation for setting a new standard in audio design is well established. The expansion in 1975 of the Spendor manufacturing facility has allowed more of these high grade loudspeaker systems to be produced, whilst maintaining the independent handmade production techniques and extensive testing procedure which is the hallmark of each Spendor product. The range of Spendor equipment has now been widened to include high quality amplifiers designed to match Spendor loudspeakers.

spendor

Spendor Audio Systems Limited

Station Road Industrial Estate Hailsham Sussex England BN27 2ER

Cerwin-Vega FOR THE ORIGINAL SOUND



SYSTEM SPECIFICATIONS

	24	26	211
MAXIMUM POWER INPUT	40 watts RMS 80 watts peak	60 watts RMS 120 watts peak	100 watts RMS 200 watts peak
EFFECTIVE FREQUENCY RANGE	30-25 000Hz	30-25.000Hz	25-25 000Hz
FLAT FREQUENCY RANGE	38-20 000Hz ± 4dB	38-20.000Hz ± 4dB	32-20.000Hz ± 3½dB
ONE WATT SENSITIVITY* (measured at 1 meter on axis)	94dB	96dB	98dB
MAXIMUM SOUND LEVEL* (at 1 meter at rated power)	109dB	113dB	117dB

INSIDE:

- 1) **BASS YOU CAN FEEL.** Cerwin-Vega woofers combine high efficiency and high power handling ability for more low-distortion output below 50 Hz and quicker transient attack than sluggish acoustic suspension units
- 2) **CRISP, ACCURATE HIGHS.** Our exclusive dhorn tweeters feature extremely high flux densities and low mass diaphragms. The result — superior transient response and flat evenly dispersed output to beyond 20 kHz
- 3) **CONTROLLABLE IMAGING.** A reflective mid-hi horn in the 211R and 217R adds spatial dimension and presence, eliminates "holes" due to poor room acoustics.
- 4) **UNIQUE "INFRASONIC" TUNING.** Basic enclosure resonance of 5-10 Hz eliminates response peaks and "boom" from the audible range

OUTSIDE:

- 1) **RUGGED COMPONENTS.** Extra heavy frames and specially treated cones and voice coils maintain flawless performance under demanding use
- 2) **QUALITY CABINETS.** All cabinets are premium hardwood on hi-density ¾" particle board, with solid inlays and hand rubbed natural oil finishes for lasting beauty and easy maintenance
- 3) **EASY COMPONENT ACCESS.** Snap-on grille (except 24) and removable cabinet back allow field-replacement of all components.
- 4) **ADJUSTABLE BALANCE.** Rotary crossover controls allow precise tailoring of high frequency balance to suit any room and any music. (fixed crossover on 24)

**CERWIN-VEGA. (U.K.). 281 BALMORAL DRIVE
HAYES MIDDLEX 01-573-1566
Trade Enquiries Invited**



Cerwin-Vega

■ **STEEPLETONE**

Steeplestone Products Ltd,
Station Approach, Bicester, Oxon OX6 7DP.
Tel: Bicester 42031.

S36

Price: £19.57 per pair (plus VAT).

S43

Price: £27.24 per pair (plus VAT).

S50

Price: £45.09 per pair (plus VAT).
No further details available at time of going to press.

■ **STUDIOCRAFT**

Bose (UK) Ltd, Gas Road, Milton Regis,
Sittingbourne, Kent.
Tel: Sittingbourne 75341.

Model 110

Ported reflex enclosure with two drive units.
Impedance: 4 ohms. Amplifier requirements:
5W. Dimensions: 9 × 7½ × 14in. Weight: 13lb
each. HC: 40W RMS. Sold in matched pairs.
Finish: walnut grained effect veneer. Price:
£65.00 per pair (plus VAT).

Model 220

Ported reflex enclosure with two drive units.
One 8in bass and one 1¾in tweeter. Impedance:
8 ohms. Amplifier requirements:
8-10W. Dimensions: 12 × 8 × 20in. Weight:
16lb each. Finish: walnut grained effect ven-

eer. HC: 50W RMS. Sold in matched pairs.
Price: £92.00 per pair (plus VAT).

Model 330

Ported reflex enclosure with three drive units.
One 8in bass and two 1¾in tweeter in convex
array. Impedance: 8 ohms. Amplifier require-
ments: 10W. Dimensions: 13½ × 9 × 21½in.
Weight: 20lb each. Finish: walnut grained ef-
fect veneer. HC: 60W RMS. Sold in matched
pairs. Price: £119.50 (plus VAT).

Model 440

Infinite baffle enclosure with three units. One
10in bass and two 3in tweeters in convex array.
Impedance: 4 ohms. Amplifier requirements:
15W. Dimensions: 15½ × 11½ × 25½in.
Weight: 24lb each. Finish: walnut grained ef-
fect veneer. HC: 100W RMS. Sold in matched
pairs. Price: £169.50 (plus VAT).
All models covered by a 5-year parts and
labour guarantee.

■ **TANDBERG**

Tandberg (UK) Ltd, Farnell House,
81, Kirkstall Road, Leeds. LS3 1HR
Tel: Leeds 35111

TL3520

Closed cabinet. Drive Units: 10, 3¾, 1in dome.
FR: 40-20,000Hz. Impedance 8 ohms. Max
Power: 50 W. Size: 35 × 20 × 50.5cm. Teak
and Rosewood finish. Price: Teak £158.00
Rosewood £173.00 per pair (plus VAT).

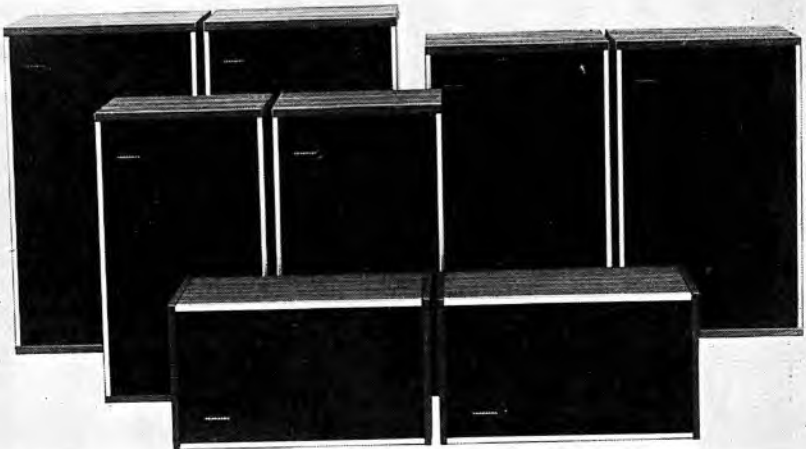

★ Indicates entry is illustrated

TL2520

Closed cabinet. Drive Units: 8, 3 $\frac{3}{8}$, 2in. FR: 45-20,000Hz. Impedance: 8 ohms. Max Power: 40 W. Size: 26 × 18 × 46.2cm. Teak and Rosewood finish. Price: Teak £112.00 Rosewood £126.00 (plus VAT).

TL8020

Closed cabinet. 12in, 2in dome, tweeter 2 × 1in dome. Crossover frequency: 600, 35,000Hz. FR: 25-20,000Hz. Impedance: 8 ohms. Max Driving Power: 100 W. Black or Teak finish. Price: £428.80 per pair (plus VAT).

TL5020

Closed cabinet. 12in, 5in, 2 × 1in, drive units. FR: 35-20,000Hz. Impedance: 8 ohms. Max Driving Power: 60 W. Size: 31 × 22.2 × 58cm. Teak and Rosewood finish. Price: Teak £210.00 Rosewood £233.00 per pair (plus VAT).

TI.1520

Closed cabinet. 7in woofer, 2in tweeter. FR: 50-20,000Hz. Impedance: 4 ohms. Max Driving Power: 30 W. Size: 22 × 18 × 35cm. Teak and Rosewood finish. Price: Teak £80.00 Rosewood £92.00 per pair (plus VAT).

Fasett

Closed cabinet. 5in woofer 2 $\frac{1}{4}$ in tweeter. FR: 50-20,000Hz. Impedance 4 ohms. Max driving power: 25 W. Size: 22 × 18 × 24cm. Orange, Black or White finish. Price: £64.00 per pair (plus VAT).

■ TANNOY

Tannoy Products Ltd, High Fidelity Div,
Canterbury Grove, London SE27 0PW.
Tel: 01-670 1131

Arden ★

Power handling: 85 W. Impedance: 8 ohms. FR: 30-20,000Hz ±4dB. Sensitivity: 3W input at 400Hz for 96dB at 1 metre. Crossover frequency: 1000Hz at 12dB per octave. Size: 99 × 66 × 37cm. Weight: 56kg. Walnut, Ash/teak with Brown grille finish. Optional extra Sand or Blue grille. Price: £160.00 (plus VAT).

Berkeley

Power handling: 85 W. Impedance: 8 ohms. FR: 35-20,000Hz ±4dB. Sensitivity: 3W input at 400Hz for 96dB at 1m. Crossover frequency: 1000Hz. Size: 84 × 54 × 31cm Weight: 41kg Walnut, Ash/Teak with Brown grille finish. Optional extra Sand or Blue grille. Price: £140 00 (plus VAT)



Tannoy Arden

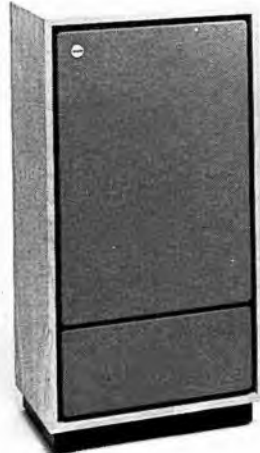

Tannoy Cheviot

Cheviot ★

Power Handling: 60 W. Impedance: 8 ohms. FR: 40-20,000Hz ±4dB. Sensitivity 5W at 400Hz for 96dB at 1m. Crossover frequency: 1000Hz 12dB per octave. Size: 85 × 45 × 26cm. Weight: 30kg. Walnut, Ash/Teak with Brown grille finish. Optional extra Sand or Blue grille. Price: £110.00 (plus VAT)

Devon

Power Handling: 60 W. Impedance: 8 ohms. FR: 45-20,000Hz ±4dB. Sensitivity: 5W at 400Hz for 96dB at 1m. Crossover frequency: 1000Hz 12dB per octave. Size: 58 × 40 × 26cm. Weight: 21kg Walnut, Ash/Teak with Brown grille finish. Optional extra Sand or Blue grille. Price: £104.00 (plus VAT).

Eaton

Power Handling: 50 W. Impedance: 8 ohms. FR: 50-20,000Hz \pm 4dB. Sensitivity: 7 W at 400Hz for 96dB at 1m. Crossover frequency 1000Hz at 12dB per octave. Size: 52 x 35 x 25cm. Weight: 18kg. Walnut, Ash/Teak with Brown grille finish. Optional extra Sand or Blue grille. Price: £94.00 (plus VAT).

■ **TELEFUNKEN**

AEG-Telefunken (UK) Ltd, Bath Road, Slough. Tel: Slough 33311.

TL400

FR:44Hz-20Hz. HC: 20W; 30 W music power. Two drive units; 6 $\frac{1}{4}$ in woofer, 3 x 5in mid-range and tweeter. Size: 19.7 x 14 x 27.5cm. Finish: light matt walnut softline. Price: £55.00 per pair (plus VAT).

TL500

FR: 40Hz-20kHz. HC:35W; 50W music power. Size: 26.3 x 17.5 x 35.7cm. Two drive units: 8in woofer, 1 $\frac{1}{2}$ in tweeter. Crossover: 2kHz. Finish: light matt walnut anthracite. Price: £95.20 per pair (plus VAT).

TL600

FR: 40Hz-20kHz. HC:35W; 50W music power. Size: 33 x 12.5 x 46.5cm. Three drive units: 8in woofer, 4 $\frac{1}{2}$ in mid-range, 1in tweeter. Crossovers: 800Hz and 1500Hz. Finish: light matt walnut softline. Price: £119.20 per pair (plus VAT).

TL700

FR: 30Hz-20kHz. HC: 45W; 60W music power. Size: 33x 23.5 x 46.5cm. Three drive units: 8in woofer, 4 $\frac{1}{2}$ in mid-range, 1 $\frac{1}{2}$ in tweeter. Crossovers: 600Hz and 3kHz. Finish: light matt walnut softline. Price: £140.00 per pair (plus VAT).

TL800

4-way performance standard speaker with 4 loudspeaker systems including 2 spherical loudspeakers. Rated capacity: 60W. Max capacity: 100W. FR: 25Hz-20kHz. Crossover frequencies: 500Hz, 900Hz and 6kHz. One 9 $\frac{1}{2}$ in woofer, one 5in medium-level loudspeaker, one 1 $\frac{3}{4}$ in diameter medium-level loudspeaker, one 1 $\frac{1}{4}$ in diameter spherical tweeter. Size: 42 x 30.7 x 58cm. Finish: light matt walnut with genuine veneer or pearl-white finish. Stand included. Price: £128.00 (plus VAT).

TL100

Spherical speaker with two-way system. FR: 55Hz to 20,000Hz. Woofer 6in, Tweeter 1in.

Crossover frequency: 3,200Hz. Rated capacity: 30 W. Music Capacity: 60 W. Price: £41.60 (plus VAT).

L20

Frequency Range: 48-20,000Hz. Rated capacity: 15 W. Music Cap: 30 W. Size: 24.8 x 10.9 x 19.6cm. Plastic with anthracite or White finish. Price: £35.92 (plus VAT).

L6000

Crossover frequency: 1,800Hz. FR: 45-20,000Hz. Rated Capacity: 30 W. Music Cap: 50 W. Size: 27 x 19 x 47.5cm. Light matt walnut finish. Price: £69.60 (plus VAT).

L7000

Crossover frequency: 600-4,500Hz. FR: 40-20,000Hz. Rated capacity: 40 W. Music Capacity: 60 W. Size: 27 x 24.5 x 52cm. Light matt walnut finish. Price: £76.00 (plus VAT).

■ **TELETON**

Teleton Electro (UK) Ltd, Teleton House, Waterhouse Lane, Chelmsford, Essex. CM1 3DW.

Tel: Chelmsford 62442.

ND25S

Infinite baffle. Frequency range: 50Hz-22kHz. Power Handling Capacity: 15 Watts RMS-25 W music. Impedance: 8 ohms. Drive Units: 5in bass and mid-range, plus tweeter. Size: 27 x 17 x 11cm. Price: on application.

ND40S

Infinite baffle. FR: 45Hz-25kHz. Power Handling Capacity: 25 W RMS-40 W music. Impedance: 8 ohms. Drive Units: 6 $\frac{1}{4}$ in bass and mid-range, 3 $\frac{1}{2}$ in upper range. Size: 35 x 21.5 x 11cm. Price: on application.

LS203 ★

Infinite baffle. FR: 40Hz-22kHz. Rec Amp

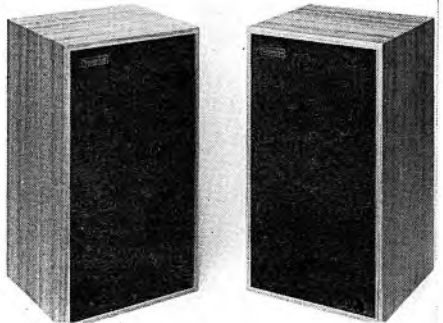

Teleton LS203

★ Indicates entry is illustrated

Music Power rating: 10-40 W. Sensitivity: 4.4 W 96dB at 1m. Impedance: 4-8 ohms. Drive Units: 8in Bass and mid range, 3¹/₂in upper range. 2 pin DIN plug. Size: 48 × 26 × 25cm. Price: on application.

■ TOSHIBA

Toshiba (UK) Ltd, Toshiba House, Great South West Road, Feltham, Greater London. Tel: 01-751 1281.

SS-200

Two-way infinite baffle system. 2 drive units. FR: 50Hz-20kHz. HC: 15W. Impedance: 8 ohms. Size: 250 × 495 × 195mm. Price: £52.00 per pair (plus VAT).

SS-350

Three-way pressure balance system. 3 drive units. FR: 35Hz-20kHz. HC: 20W. Impedance: 8 ohms. Size: 320 × 560 × 270mm. Price: £129.20 per pair (plus VAT).

SS-415

Three-way pressure balance system. 3 drive units. FR: 25Hz-20kHz. HC: 25W. Impedance: 8 ohms. Size: 320 × 540 × 310mm. Price: £176.00 per pair (plus VAT).

SS-2200

Two-way system. Infinite baffle. Drive units: 16cm low cone, 5cm high cone. Crossover frequency: 9,000Hz. FR: 50Hz-20kHz. Impedance: 8 ohms. Size: 27.5 × 19 × 47cm. Weight: 4kg. Silver vinyl finish. Price: on application.

SS-220

Two-way system. Pressure balance. Drive units: low 20cm, high 5cm concave. Crossover frequency: 4000Hz. FR: 35Hz-20kHz. Impedance: 8 ohms. Size: 30 × 29 × 59.5cm. Weight: 11kg. Woodgrain finish. Removeable grille. Price: on application.

SS-470

Three-way system. Pressure balance. Drive units: Low 25cm, Mid 10cm, high 2cm. Crossover frequency: 1,000Hz-6,000Hz. FR: 35Hz-25kHz. Impedance: 8 ohms. Size: 30.8cm. × 29.4 × 54.8, Weight: 15kg. Woodgrain finish. Removeable grill, level control. Price: on application.

■ TRIO

B. H. Morris & Co Ltd, Trio House, The Hyde, London NW9 6JP. Tel: 01-205 6441.

LS-202

Infinite baffle. Drive units: Bass 16cm, Tweeter 7cm. Crossover frequency: 3,000Hz. FR: 40Hz-20,000Hz. Impedance: 8 ohms. 10-20 W RMS. Size: 26 × 19 × 42cm. Oil rubbed walnut. Price: £64.00 (plus VAT).

LS 203

Infinite baffle. Bass 19.5cm tweeter 1.9cm dome drive units. Crossover frequency: 3,500Hz. FR: 38Hz-25,000Hz. Impedance: 8 ohms. 10-30 W RMS. Size: 28 × 20 × 46cm. Oil rubbed walnut finish. Price: £96.00 (plus VAT).

LS 205

Infinite Baffle. Drive Units: Bass, 24.5cm, mid 3.7cm tweeter 2.5cm. FR: 30Hz-25,000Hz. Impedance: 8 ohms. 15-45 Watts RMS. Size: 33 × 24 × 54cm. Oil rubbed walnut. Built in controls for mid-range and HF adjustment. Price: £129.60 (plus VAT).

■ VIDEOTONE

Perdix Components, 98 Crofton Park Road, London SE4. Tel: 01-690 1914.

Minimax 1 (D131E)

Infinite baffle loudspeaker enclosure. Drive units: one 130mm woofer. FR: 50Hz-12.5kHz. Impedance: 8 ohms. Amplifier requirements: up to 50 W. Dimensions: 15 × 22 × 26cm. Weight: 3.9kg. Finish: teak, orange, white or walnut. Cane or black front grille. Price: £30.00 per pair (plus VAT).

Minimax 2 (D132E)

Infinite baffle loudspeaker enclosure. Drive units: one 130mm woofer, one 100mm tweeter. Crossover frequency: 3.2kHz. FR: 50Hz-20kHz. Impedance: 8 ohms. Amplifier requirements: up to 50 W. Dimensions: 15 × 22 × 26cm. Weight: 4.3kg. Finish: teak, walnut, white or orange. Cane or black front grille. Price: £40.00 per pair (plus VAT).

Saphir 1 (DP202E)

Infinite baffle loudspeaker enclosure. Drive units: one 200mm woofer, one 100mm tweeter. Crossover frequency: 3.2kHz. FR: 45Hz-20kHz. Impedance: 8 ohms. Amplifier requirements: up to 40W. Dimensions: 23.5 × 22.5 × 39.5cm. Weight: 5.7kg. Finish: teak. Black or cane grille. Price: £48.00 per pair (plus VAT).

Saphir 2 (DF202E)

Infinite baffle loudspeaker enclosure. Drive units: one 200mm woofer, one 100mm tweeter. Crossover frequency: 3.2kHz. FR: 45Hz-

20kHz. Impedance: 8 ohms. Amplifier requirements: up to 40W. Dimensions: 33 × 14 × 53cm. Weight: 6.7kg. Finish: teak. Black or beige grille. Price: £48.00 per pair (plus VAT).

Midimax (D204E)

Infinite baffle loudspeaker enclosure. Drive units: one 200mm woofer, one 25mm tweeter. Crossover frequency: 1.9kHz. FR: 30Hz-20kHz. Amplifier requirements: up to 70W. Dimensions: 30 × 24 × 55cm. Weight: 14kg. Finish: teak with brown front. Price: £80.00 per pair (plus VAT).

Supermax (D402E)

Infinite baffle loudspeaker enclosure. Drive units: two 250mm woofers, two 100mm mid-range units, two 25mm tweeters. Crossover frequency: 1.9kHz. FR: 30Hz-20kHz. Impedance: 8 ohms. Amplifier requirements: up to 150W. Dimensions: 36 × 26 × 67cm. Weight: 21.5kg. Finish: teak with brown grille. Price: £120.00 per pair (plus VAT).

■ VOXSON

DSC (Audio Products) Ltd, Colwyn Bay, North Wales LL28 5HD. Tel: Colwyn Bay 49275.

B311

FR: 45Hz-18kHz. Maximum input power: 60W. Impedance: 8 ohms. Size: 665 × 382 × 302mm. Weight: 15kg. Price: £65.66 each (plus VAT). Speaker housing units: left (Cat. no. 1096) £88.26 (plus VAT); right (Cat. no. 1097) £88.26 (plus VAT).

■ WHARFEDALE

Rank Radio International Ltd, PO Box 596, Power Road, Chiswick, London W4 5PW. Tel: 01-994 6491.

Chevin XP

Drive units: 20cm dual cone. Power handling: 20 W DIN. Frequency response: 70-22,000Hz DIN. Sensitivity: 6 W 96dB at 1m. 1 watt 88dB at 1m. Impedance: 4-8 ohms. Size: 30.5 × 24 × 22cm. Teak or Walnut finish. Price: £41.50 per pair (Inclusive of VAT).

Denton 2 XP ★

Acoustic suspension enclosure with units and crossover. One 8in bass, one 2in mid-range/treble. Power handling capacity: 25W DIN. FR: 65Hz-20kHz DIN. Crossover type: 12dB/Oct. Crossover frequency: 1.4kHz. Impedance: 6 ohms nominal. Sensitivity: 6W for 96dB SPL. Size: 355 × 246 × 222mm. Finish: teak, walnut or white. Price: £58.56 per pair (inclusive of VAT).



Wharfedale Denton 2 XP

Linton 3 XP

Acoustic suspension enclosure with units and crossover. One 8in bass, one 4in mid-range unit, one 1in treble. Power handling capacity: 30W DIN. FR: 50Hz-20kHz DIN. Crossover type: 12dB/Oct. Crossover frequencies: 1kHz and 4kHz. Sensitivity: 8W for 96dB SPL. Impedance: 6 ohms nominal. Size: 476 × 264 × 240mm. Finish: teak, walnut or white. Price: £83.65 per pair (inclusive of VAT).

Glendale 3 XP

Acoustic suspension enclosure with units and crossover. One 10in bass, one 4in mid-range unit, one 1in treble. Power handling capacity: 40W DIN. FR: 40Hz-20kHz DIN. Crossover type: 12dB/Oct. Crossover frequencies: 800Hz and 4kHz. Sensitivity: 10W for 96dB SPL at 1m. Impedance: 6 ohms nominal. Size: 565 × 305 × 265mm. Finish: teak, walnut or white. Price: £109.07 per pair (inclusive of VAT).

Dovedale SP

Max flat reflex. Drive units: Bass 2 × 17cm, mid-range 10cm, treble 2.5cm. Power handling: 60 W DIN. Frequency response: 35Hz-20kHz at -3dB. Crossover frequency: 800Hz. 5kHz. Sensitivity: 6 W 96dB at 1m, 1 W 98dB at 1m. Impedance: 4-8 W. Teak or Walnut with detachable brown jersey grille. Price: £192.79 per pair (inclusive of VAT).

Airedale SP

Max flat reflex. Drive units: Bass 25cm lower mid-range 17cm upper mid-range 10cm treble 2.5cm. Power handling: 100 W DIN. Frequency response: 27Hz-20kHz. Crossover frequency: 450Hz. 2.5kHz. 6kHz. Sensitivity: 9 W 96dB 1m. 1 W 86dB 1m. Impedance: 4-8

★ Indicates entry is illustrated

ohms. Teak or Walnut with detachable brown jersey grille. Price: £300.30 per pair (inclusive of VAT).

■ WORDEN

Worden Audio Developments Ltd,
54 Chepstow Road, London, W2 5BE.
Tel: 01-229 4996.

Panosona Reproducer

Double horn with diffusing chamber. Corner reproducer, designed for near plane-wave distribution from single speaker unit. Available in three versions: Model A size 54in high, 24in wide, 14½in to corner. FR with Lowther PM6 Mk1 or PM7 20Hz to over 18kHz. Model B size 48in high, 21½in wide, 12½in to corner. FR with Lowther PM6 or PM6 Mk1 30Hz to over 18kHz. Model C size 27in high, 24in wide, 13in to corner. FR: with Lowther PM6 or PM6 Mk1 40Hz to over 18kHz. Prices: Model A (speaker enclosure only) £100; Model B (enclosure only) £88.00; Model C (enclosure only) £68.00.

Panosona Bookshelf Speaker

Designed in accordance with the principles of the Panosona Corner Reproducers. Size: 16 × 9 × 9½in. Standard finish: teak. Other finishes to order. Contrasting Tygan or Vynair front covering. Price: £45.00 complete, including full range drive unit.

■ WYE

Wye Electronics Ltd, 27 Station Road,
Brimington, Chesterfield, Derbyshire S43 2JJ.
Tel: Chesterfield 70297.

801

Infinite baffle speaker enclosure. Two drive units. Crossover frequency: 3kHz. FR: 40Hz-18kHz. Impedance: 8 ohms. Amplifier requirements: 15W. Dimensions: 33 × 20 × 55.6cm. Finish: teak. Price: £54.96 (per pair) (plus VAT).

■ YAMAHA

Natural Sound Systems Ltd,
Strathcona Road,
North Wembley HA9 8QL.
Tel: 01-904 0141.

NS 1000

Speaker enclosure with units. Drive units: 300 × 88 × 30mm. Crossover frequencies: 500Hz and 6kHz. FR: 40Hz-20kHz. Impedance: 8 ohms. Amplifier requirements: 70-200W. Dimensions: 395 × 326 × 710mm. Weight: 39kg.

Finish: ebony. Two level controls. Price: £532.80 (per pair) (plus VAT).

NS 1000M

Speaker enclosure with units. Drive units: 300 × 88 × 30mm. Crossover frequencies: 500Hz and 6kHz. FR: 40Hz-20kHz. Impedance: 8 ohms. Amplifier requirements: 70-200W. Dimensions: 375 × 326 × 675mm. Weight: 31kg. Finish: black. Two level controls. Price: £444.00 (per pair) (plus VAT).

NS 690

Speaker enclosure with units. Drive units: 300 × 75 × 30mm. FR: 35Hz-20kHz. Impedance: 8 ohms. Amplifier requirements: 20-100W. Dimensions: 350 × 291 × 630mm. Weight: 22kg. Finish: American walnut. Two level controls. Price: £266.40 (per pair) (plus VAT).

NS 670

Speaker enclosure with units. Drive units: 250 × 60 × 30mm. FR: 40Hz-20kHz. Impedance: 8 ohms. Amplifier requirements: 20-80 W. Dimensions: 320 × 269 × 577mm. Weight: 19kg. Finish: American walnut. Two level controls. Price: £204.00 (per pair) (plus VAT).

NS 645

Speaker enclosure with units. Drive units: 250 and 45mm. FR: 40Hz-20kHz. Impedance: 4 ohms. Amplifier requirements: 20-60W. Dimensions: 300 × 259 × 540mm. Weight: 14.6kg. Finish: American walnut. Tweeter level control. Price: £141.60 (per pair) (plus VAT).

NS 625

Speaker enclosure with units. Drive units: 200 and 45mm. FR: 45Hz-20kHz. Amplifier requirements: 20-50W. Dimensions: 280 × 249 × 500mm. Weight: 11.6kg. Finish: American walnut. Tweeter level control. Price: £106.40 (per pair) (plus VAT).

NS 430

Bass reflex enclosure with units. Drive units: 250 and 40mm. FR: 50Hz-20kHz. Impedance: 8 ohms. Amplifier requirements: 10-25W. Finish: American walnut with black front. Price: £79.20 (per pair) (plus VAT).

NS 410

Infinite baffle enclosure with units. Drive units (mm): 200 and 30. FR: 60Hz-18kHz. Impedance: 8 ohms. Amplifier requirements: 5-15W. Finish: American walnut with white front. Price: £52.80 (per pair) (plus VAT).

Surround Sound

(Four channel and synthesisers intended for use with four speakers)

★ Indicates entry is illustrated

Abbreviations used in this section are given on page 27.

■ BANG & OLUFSEN

Bang & Olufsen (UK) Ltd, Eastbrook Road, Gloucester GL4 7DE.

Tel: Gloucester 21591.

Ambio Control Unit

Ambiophonic adaptor for use with most conventional amplifiers to facilitate the use of two side loudspeakers in conjunction with main stereo loudspeakers. Enables greatly enhanced reproduction to be obtained from stereo programme sources. Features 6kHz filter switch to limit ambiophonic signals above this frequency. Size: 1.4 × 1.9 × 4.3in. Price: on application.

■ EAGLE

Eagle International, Precision Centre, Heather Park Drive, Wembley HA0 1SU.
Tel: 01-902 8832.

AA 26

Four-channel quadraphonic synthesiser. The AA 26 plus two extra speakers provides two additional information channels from ordinary two-channel stereo. Self-contained matrix system with level controls and speaker check switches. Rating: 35W RMS per channel. Input impedance: 8 ohms. Output impedance: 8 ohms. Output jacks for four channel headphones. Dimensions: 8⁷/₈ × 2³/₄ × 5⁷/₈in. Finish: teak cabinet. Price: £20.00 (plus VAT).

■ FERGUSON

Thorn Consumer Electronics Ltd, Thorn House, Upper St. Martin's Lane, London WC2H 9ED.

Tel: 01-836 2444.

3491

Four channel tuner/amplifier with integral decoder for multiplex stereo FM and SQ quadraphonic system. FM coverage 87.5MHz-104MHz. Switchable AFC. Six FM presets. FM stereo beacon inputs. Magnetic PU 3mV 50K, ceramic PU 140mV 660K, 2 channel tape input 140mV 500K, 4 channel tape 110mV 50K. Output: 4 × 20W RMS into 4 ohms, 4 × 14W RMS into 8 ohms. THD < 0.1% up to rated power. F.R. 30-20kHz + 0dB, -3dB. Damping factor 20, S/N Ratio-60dB. Controls: sliders for treble, bass, volume, 14 tabs for functions balance: pan lever with 4 illuminated power output meters. Dimensions: height 5in. (13cms), width 20¹/₂in. (51.5cms), depth 14in. (36cms). Finish, black cabinet with teak surround. Price: £168.28 (plus VAT).

■ GRAMPIAN REPRODUCERS LTD.

Hanworth Trading Estate,

Feltham TW13 6EJ.

Tel: 01-894 9141

666 Ambiophonic unit

Enables from one to four speakers to be fed with amplified and delayed signal from main amplifier output. Delay device comprises two transducers and parallel springs as used in Gramplan reverberation unit. Volume of delayed signal controlled by listener. Twin high-impedance line-bridging connections. Output: 2.5W into 5 ohms and 600 ohms. Mains: 200-250V AC. Size: 18 × 4¹/₄ × 5¹/₂in. Weight: 7lb. Price: on application.

■ GRUNDIG

Grundig International Ltd,
Newlands Park, London SE26 5NQ.

Tel: 01-659 2468.

Studio 1600a ★

AM/FM stereo receiver in cabinet with Dual 1225 record deck fitted with Shure H75D cartridge. Provides Grundig 4D stereo entertainment with optional extra speakers. Variable tuning and pushbutton waveband selectors and sliding controls for volume, bass, treble, stereo balance and 4D stereo balance. Output: 15W RMS per channel into 4 ohms. Incorporates tuning meter and 5kHz filter for AM. Dimensions: 54 × 37 × 18cm. Finish: silver and black. Price: £229 (including VAT).

Studio 2040a Quadraphonic

AM/FM quadraphonic receiver in cabinet with Dual 1228 record deck. Variable tuning with 7 pre-set stations on FM. AFC. Quadro and stereo decoder fitted. Slider controls for quadro balance, stereo balance, bass, treble

★ Indicates entry is illustrated



Grundig Studio 1600a

and volume. Tuning meter for AM and FM with pushbutton waveband selection. Output: $4 \times 12.5\text{W RMS}$ into 4 ohms or $2 \times 16.5\text{W RMS}$ into 4 ohms. THD: 0.2% at $4 \times 10\text{W}$. Power bandwidth: 10Hz-50kHz. FR: 40Hz-16kHz $\pm 1.5\text{dB}$. Crosstalk: 45dB at 1 kHz, 40dB at 0.25-10kHz, 40dB at 16kHz. CD4 option. SQ fitted. Sensitivity: FM $2.4\mu\text{V}$. Capture ratio: 3dB for -3dB interference. THD: 0.7%. Dimensions: $65 \times 18 \times 39\text{cm}$. Finish: silver and black. Price: £426.60 (including VAT).

■ HACKER

Hacker Radio Ltd, Norreys Drive, Cox Green, Maidenhead, Berks SL6 4BP. Tel: Maidenhead 22261.

Ambiophonic Unit Model QC1

The QC1 is designed to re-create all-round sound reality as far as possible from two-channel programme material. As the input to the unit is taken from the existing loudspeaker outlets on the amplifier, no additional amplification is required. Power handling: 12W RMS. Sensitivity: (rear channel) -8dB max. FR: (quad) 20Hz-20kHz $\pm 1\text{dB}$. (stereo) 20Hz-5kHz. $\pm 1\text{dB}$, -3dB at 7kHz. Size: 81mm high, 190mm wide, 60mm deep. Weight: 510gm. Price: £18.75 (including VAT).

■ NORDMENDE

Vessco Vision and Radio Ltd, Vessco House, Unit 4, Blackwater Way, Ash Road, Aldershot, Hants GU12 4DL. Tel: Aldershot 312661.

Quadronado

Controlled power: 150 W. Uses a sound localiser like a radar screen, pinpointing the central hearing area of the room. Full details and price on application.

■ PHILIPS

Philips Electrical Ltd, City House, 420/430 London Rd., Croydon CR9 3QR. Tel: 01-689 2166.

RH832

Quadraphonic tuner pre-amplifier record player combination. Range: FM 87.5-104MHz, MW 520-1605kHz, LW 150-345kHz, SW 5.95-9.78MHz. Record player: GCO12 (two speed). Pickup cartridge: GP 422, suitable for 4-channel discrete reproduction. FR: 20-45,000Hz $\pm 4\text{dB}$. Distortion: $<0.1\%$. Tone controls: bass +15 to -15dB at 50Hz, treble +12 to -15dB at 10kHz. Power consumption: 32W. Mains: 110, 127, 220 and 240V AC. Finish: silver top-deck and black front. Speakers: Philips RH532MFB. Price: (complete system) £636.00.

■ SANSUI

Vernitron Ltd, Thornhill, Southampton SO9 5QF. Tel: Southampton 444811.

QRX 7500

AM/FM comprehensive 4-channel decoder tuner/amplifier. Output: 25W all channels driven into 8 ohms. THD: less than 0.3% at rated output. Will synthesize 2 to 4 channel, will decode QS, SQ and CD4 material. 4VU meters indicate decoder output. Facilities for phono (2), a 2-channel tape deck, two 4-channel tape decks. FM sensitivity: 1.9mV. Controls: front bass and treble, rear bass and treble, speaker switch, A, B, A. + B. Balance controls for front main and rear, volume, decoder function, input selector, CD4 adjustment. Push switches power on/off, front high and low filters, rear low and high filters, loudness, 2-channel tape monitor, 4-channel tape monitor 1, 4-channel tape monitor 2 and FM muting. Size: $594 \times 203 \times 370\text{mm}$. Price: £543.55 (plus VAT).

QRX 7001

All sources FM/AM 4-channel receiver. Audio Section: power output: 35 W per channel, min. RMS, all channels driven into 8 ohms from 20Hz to 20kHz, with no more than 0.4% total harmonic distortion. 43 W per channel, min. RMS, all channels driven into 8 ohms at 1kHz, at rated total harmonic distortion. IHF music

power: Total 220 W into 8 ohms at 1,000Hz; total 280 W into 4 ohms at 1,000Hz. Total harmonic distortion: overall (aux to speaker terminals): less than 0.4% at or below rated min. RMS power output. Power Bandwidth: 20 to 20,000Hz at or below rated min. RMS power output and total harmonic distortion. Load impedance: 8 ohms. Frequency response: Overall (aux to power output): 15 to 30,000Hz ± 1.0 dB. Equalization (at Rec out) RIAA curve, 30 to 15,000Hz ± 1.0 dB. Damping factor: approximately 10 at 8 ohms load. 4-channel Decoder Section (type-A QS Vario-matrix): Frequency response: 20-30,000Hz. Distortion: less than 0.1% (at 1,000Hz). Separation: QS decoder: 20dB (adjacent channels); 30dB (diagonal channels). QS synthesizer: equivalent to QS decoder. SQ function (phase matrix) 20db (front left/right channels), 12dB (centre front/back channels). CD-4 Demodulator: Frequency response (STD Test signal at Rec out): 30-15,000Hz Main-ch. Separation (STD Test Signal: 40dB (left/right channels), 25dB, (front/back channels). Tuner Section, FM: Tuning range: 88 to 108MHz. Sensitivity (IHF): 1.9 μ V, max. input capability more than 120dB. Total harmonic distortion: Mono, less than 0.3%, Stereo, less than 0.5%. Selectivity: better than 70dB. Capture ratio (IHF) less than 1.5dB. Image rejection: better than 75dB at 98MHz. IF rejection better than 90dB at 98MHz. Spurious response rejection: better than 80dB at 98MHz. Signal to noise ratio (mono): better than 70dB. Stereo separation: better than 40dB at 1,000Hz. Frequency response: 30 to 15,000Hz, +0.5dB, -3.0dB. Antenna impedance: 300 ohms balanced, 75 ohms unbalanced. AM: Tuning range: 535 to 1605kHz. Sensitivity (Bar Antenna) 53dB/m at 1,000kHz. Selectivity: better than 30dB at 1,000kHz ± 10 kHz. Image rejection: better than 80dB/m at 1,000kHz. IF rejection: better than 80dB/m at 1,000kHz. General: Dimensions: 540mm (21 $\frac{1}{2}$ in.)W, 161mm (6 $\frac{1}{2}$ in.) H, 403mm (15 $\frac{1}{2}$ in.) D. Price: £491.11 (plus VAT).

QX 949A

4-Channel receiver with built in CD4, SQ full logic and regular matrix. Amplifier Section: Power output: 40 W \times 4 (20Hz to 20kHz, 8 ohms), 60 W \times 2 (with 2 channel boosting circuits). THD: Not more than 0.3%. Damping factor: 35 at 1kHz. Inputs: Phono 1, 2 2.5mV/50K ohms, Aux 150mV/100K ohms, tape monitor (2CH 4CH) 150mV/100K ohms, Tape record (2CH 4CH) 150mV. Overload capability: Phono 100mV (RMS). Tone controls: Bass ± 10 dB (100Hz, Treble ± 10 dB (10kHz). Loudness control: + 6dB (100Hz) +

3dB (10kHz), low 50Hz (6dB/oct), high 10kHz (6dB/oct). CD4 Demodulator section: Input sensitivity: 2.5mV (1-5mV adjustable). Input impedance: 100K ohms. Harmonic distortion: 0.15%. Signal to noise: More than 70dB. Separation: (STD test signal at 1kHz): Left to right 50dB, front to rear 30dB. Tuner Section: Sensitivity (FM): 1.8 μ V (IHF). Sensitivity (AM): 300 μ V/M (IHF Ferrite antenna). Capture ratio: 1dB. Image rejection (FM): 85dB (98MHz). Image rejection (AM): 65dB. Spurious rejection (FM): 100dB. IF rejection (FM): 100dB 98MHz). Stereo separation: 40dB at 1kHz. Pilot tone rejection: 65dB. THD (stereo): 0.4%. Waveband coverage: FM 88-108MHz, AM 550-1600kHz. General: Dimensions W \times D \times H: 55 \times 44 \times 15cm. Finish: Walnut finish cabinet. Price: on application.

QX 747A

A Channel receiver with built in CD.4, SQ full logic and regular matrix. Amplifier section: Power output: 25 W \times 4 at 1kHz 8 ohms. 45 W \times 2 (with 2 ch boosting circuit). THD: Not more than 0.5% at rated output. Damping factor: 35 at 1kHz 8 ohms. Inputs: Phono 2.4mV 50K ohms, aux 140mV 100k ohms, tape monitor 140mV 100K ohms, tape record 140mV. Overload capability: Phono 100mV RMS. Tone controls: Bass ± 10 dB (100Hz, Treble ± 10 dB (100kHz). CD4 demodulator section: Input sensitivity: 2.5mV (1 to 5mV adjustable). Input impedance: 100K ohms. Distortion: 0.15%. Signal to noise: 70dB (IHF A network). Separation: Left to right, 50dB, Std test signal at 1kHz, Front to rear 30dB. Tuner Section: Sensitivity (FM): (IHF) 1.9 μ V. Sensitivity (AM): 300 μ V/M (IHF Ferrite antenna). Capture ratio: (IHF) 1.0dB. Image rejection (FM): 80dB. Image rejection (AM): 40dB. Spurious rejection (FM): 100dB. IF rejection (FM): 100dB. Stereo separation: 40dB 1kHz. Pilot tone rejection: 65dB. THD (stereo): 0.4%. Waveband coverage: FM 88-108MHz, AM 550-1600kHz. General: Dimensions W \times D \times H: 55 \times 42 \times 16cm. Finish: walnut finish cabinet. Price: on application.

■ SANYO

Sanyo Marubeni (UK) Ltd, Sanyo House, Bushey Mill Lane, Watford, Herts.
Tel: Watford 30421.

DCX 2000K

A stereo receiver combining a pre-main amplifier and tuner in one compact unit. Incorporated speaker matrix. Advanced hybrid ICs

★ Indicates entry is illustrated

and OTL circuitry in the amp section plus ICs, FET and ceramic filters on the tuner side, giving distortion-less sound with high sensitivity and selectivity. Loudness, tape monitor, stereo/mono mode and audio muting pushbuttons. Separate mic volume control for professional sound blending. Output: 15W RMS per channel. Includes an IC-equipped double-balanced demodulator. Price: £113.95 (including VAT).

■ SONY (UK) LTD.

London Showroom, Consumer Information Service, 134 Regent Street, London W1R 6DJ.

SQA 2030 ★

SQ decoder amplifier. Rated output power: 18W RMS per channel into 8 ohms between 20Hz-20kHz, both channels operating 22W per channel, both channels operating, 1kHz into 8 ohm load. Power bandwidth: (1HF) 10Hz-25kHz. FR: 20Hz-20kHz ± 3 dB SQ. RMTX, 20Hz-20kHz +0, -3dB others. HD: 0.8% at rated output. Inputs: 2-channel (SQ, RM, 2-4) low 75mV 75K, normal 250mV 90K, high 500mV 100K. (2-channel tape) low 250mV 50K, normal 750mV 80K, discrete (4-channel) 250mV 100K, DIN 250mV 80K. Tone controls: bass ± 10 dB at 100Hz, treble ± 10 dB at 10kHz. Loudness control: 50Hz +10dB, 10kHz +4dB (att -30dB). S/N ratio: 85dB. Circuit system: full logic IC SQ decoder, hybrid power amplifier (rear channel) tone, loudness controls (rear channel). 27 transistors, 5 ICs, 14 diodes. Mains: 110, 127, 220, 240V AC 50/60Hz. Size: 226 \times 156 \times 307mm including projecting parts. Weight: 6.9kg. Price: £111.06 (plus VAT).

SQD 2010 Decoder

Circuit system: Full logic controlled, SQ, R-M decoder. SQ separation: Lf - Rf 35dB, Lb - Rb 13dB, Lf-Lb 17dB, R - Rb 17dB, Lf-R 13dB, RF-Lb 17dB, Cf-Cb 20dB. Frequency response: SQ, RM, 24:20Hz to 20kHz ± 3 dB. 2-4. Discrete, 4 channel tape, 2 channel 110Hz to 100kHz ± 3 dB. SQ-R-MTX 2-4, 80dB. Discrete 4 channel tape, 2 channel 10Hz to 100kHz ± 3 dB. S/N ratio: Harmonic distortion: 0.1% (input signal) 250mV at 2kHz. Inputs: (from record out), Tone controls (rear ch.) 3: bass ± 10 dB 100Hz, treble ± 10 dB 10kHz. Semiconductors: 41 transistors, 2 FETs, 4 ICs, 35 diodes. Power requirements: AC 110, 127, 220 and 240V (factory set 240V, 50/60Hz). Dimensions (approx.): 15 $\frac{3}{8}$ (W) \times 5 $\frac{7}{8}$ (H) \times 12 $\frac{7}{8}$ (D) in (400 \times 149 \times 327mm. Weight (approx.): 13lb (5.9kg). Supplied accessories: 3 \times RK-7Q

connecting cord. Ac mains lead. Price: £127.96 (plus VAT).



Sony SQA 2030

■ J. E. SUGDEN & CO. LTD.

Carr Street, Cleckheaton, West Yorkshire. Tel: Cleckheaton 872501.

Q51 Four Channel Matrix Control Unit

Intended for adding to C51/P51 based system with additional P51 power amplifier, but will work equally well with any system. There are two basic sections - matrix decoder and tape facility section.

Tape Facility Section: Not 4-channel, being included only to increase versatility of the basic P51/C51. Permits connection of three tape recorders which can be played separately or simultaneously. Q51 is fitted with 6dB amplifier on tape monitor circuits together with closely matched volume control enabling user to adjust monitor level to match original signal level to render AB monitoring accurate and valuable. Tape Post Filter permits recordings to be made after the tone and filter controls should it be desired to doctor the frequency response prior to recording. Matrix Decoder: Will decode SQ, QS and BMX matrices for producing four channel from two channel encoded discs, tape or radio. It is equipped with a difference matrix, similar to the Hafler configuration and a Schieber matrix. Three balance controls. General: Styled to match C51 with brushed silver facia. Power is supplied from P51 power amplifier driving rear channels or, in the event of use with other amplifiers, any smooth 16-19 volt source or two PP9 batteries. Price: £99.00 (inc. VAT).

Tape Accessories/ Components

★ Indicates entry is illustrated

Abbreviations used in this section are given on page 27.

■ ADASTRA

Adastra Electronics Ltd, Unit N22,
Cricklewood Trading Estate,
Claremont Road, London NW2 1TU.
Tel: 01-452 6288.

Tape Editing Kit

See entry under Synchronotape.

R101 Cassette Carrying Case

30 cassette version of above with double opening front and individual moulded tray holders. Size: 14½ × 3½ × 9in. Price: on application.

R51

Tape splicer. Self-contained with instant cut and trim action. Spring-loaded arms secure tape to padded cutting block. Price: on application.

R52

Tape head defluxer. AC mains. For removing residual magnetism from tape heads, capstan, guides and other parts of recorders. Hand-shaped moulded body with 1¼in probe. 3ft mains lead. 200-250V. Price: on application.

R100 Cassette Carrying Case Mk II

Designed to hold 15 compact cassettes in rigid drop-front case. Finished in padded simulated leathercloth. Snap-fast closing. Slotted compartments and moulded handle. Finish: red, tan or black. Size: 14½ × 4¾ × 3¼in. Price: on application.

R.54

De-luxe tape head demagnetizer. Operates from AC mains 220-240V. Removes residual magnetism from recording heads, etc. Features extra long probe for access to difficult parts. Complete with 1m lead. Heavy duty 'Torpedo' shaped body. Overall length: 6½in. Price: on application.

R.105 Casseten-Bar

Rotating storage unit which houses 20 cased or 32 uncased cassettes in spillage-proof compartments. Units can be stacked on each other and are made of high gloss finished mouldings in black/white or black/orange combinations. Price: on application.

R.110/R.111 Stako-Tape

Vertical and horizontal interlocking storage system in two versions: (R.110) holding 10 cassettes; (R.111) containing 8 8-track cartridges. Moulded cabinets in orange, white or black. Can be wall-mounted or used free-standing. Price: on application.

R.120/R.121

Two wood storage cabinets designed to take 32 compact cassettes (R.120), or 24 8-track cartridges (R.121). Both models feature lift-off/hinged smoked cover, moulded compartment tray and rubber protective feet. Finish: (R.120) rosewood, teak or white; (R.121) teak. Price: on application.

Tape Spools

First grade plastic tape spools with standard tape threading facilities and of a design enabling them to fit all tape recorders. In sizes 2¾, 3, 4, 5, 5¾, 7in. Price: on application.

R40 Cassette Library Cases

Standard design to accommodate all compact cassettes with the flip lid moulded in clear material. Size: 110 × 70 × 17mm. Price: on application.

R45 Cassette Tape Tension Winders (M.1111)

For manual winding of compact cassettes for editing and repair purposes. Neat moulded knobs in black with silver trim have hexagon shaped projections for fitting into the hub recesses of compact cassettes packed in pairs in top card see-through presentation. Price: on application.

■ AGFA-GEVAERT

Agfa-Gevaert Ltd, Great West Road,
Brenford, Greater London.
Tel: 01-560 2131.

Editing Accessory Kit

Price: £3.15½ (including VAT).

Splicing Tape Outfit ★

Price: 56p (including VAT).

Splicing Tape

33ft ¼in wide. Price: 34½p (including VAT).

★ Indicates entry is illustrated



Agfa Cutter-Set



Agfa Compact Cassette

Leader Tape

80ft $\frac{1}{4}$ in tape in red, green, white. Price: 31p (including VAT).

Silver Stop Foil

33ft $\frac{1}{4}$ in. Price: 50 $\frac{1}{2}$ p (including VAT).

Plastic library boxes

No. 13 (5in) 50p; No. 15 (5 $\frac{3}{4}$ in) 67 $\frac{1}{2}$ p; No. 18 (7in) 83 $\frac{1}{2}$ p. All prices include VAT.

Plastic spools

No. 13 (5in) 34p; No. 15 (5 $\frac{3}{4}$ in) 40p; No. 18 (7in) 40 $\frac{1}{2}$ p; No. 26 (10 $\frac{1}{2}$ in) £1.56 $\frac{1}{2}$. Prices include VAT.

Metal spools

No. 13 (5in) £1.71; No. 18 (7in) £2.14; No. 26 (10 $\frac{1}{2}$ in) £3.83. Prices include VAT.

Cassette head cleaner

Price: 78p (including VAT).

Empty album ★

Price: £1.33 (including VAT).

Publications

Tape Recording Technique. Price: 45p.

Tape Recorder Manual. Price: 35p.

Recording with Compact Cassettes. Price: 65p. Prices exclude postage and packing.

■ AKAI

Rank Audio Visual, PO Box 70,
Great West Road, Brentford, Middlesex TW8
9HR.

Tel: 01-568 9222.

AK700 Accessory Kit

Includes leader tape, chlorothane, cleaning tape, tape splicer and splicing tape. Price: £4.91 (plus VAT).

Head Cleaning Kits

HC500: includes head cleaning fluid, leading tape and brush. Price: £1.88 (plus VAT).

CHC600: includes cleaning fluid and pen. Price: £1.58 (plus VAT).

Head Demagnetiser

AH9B. Price: £12.42 (plus VAT).

Remote Control Unit

RC-17. Price: £22.86 (plus VAT).

Tape Splicer

AS-3. For secure and instantaneous tape splicing. Price: £2.65 (plus VAT).

Splicing Tape

ST-2A. Designed for sufficient adherence. Price: 34p (plus VAT).

Metal Reels

R-7M. 7in reel, 1800ft. LP tape. Long lasting, made of aluminium. Price: £3.50 (plus VAT).

Dust Covers

DC44 for 4000DS Mk. II and 4000DB. Price: £6.50. DC34 for CS34D. Price: £6.86. DC39 for GXC39D. Price: £7.33. DC310 for GXC310D. Price: £9.30. All plus VAT. (Other dust covers are retained for some past models.)

■ ALPHA

Distributors: Highgate Acoustics,
38 Jamestown Road, London NW1 7EJ.
Tel: 01-267 4937.

DB6

Noise reducing unit for use between any tape recorder or tape deck and main hi-fi amplifier. Phono and DIN sockets inputs and outputs. Inputs: two line inputs (>20K) with level control. Input sensitivity: 30mV for Dolby level (0 VU). Slider type level controls. Two VU meters. Outputs: 580mV for 0 VU at 1K impedance. HD: <0.5% at Dolby level at any frequency 20Hz-20kHz. Noise reduction: 8dB at 2kHz, 10dB at 5kHz. With noise reduction switched out the unit becomes a unity gain amplifier. MPX 19kHz filter, response < 1dB down at 15kHz, >30dB down at 19kHz and >20dB down at 38kHz. Mains: 117, 220, 230, 250V AC. Price: £48 (plus VAT).

■ **AVEL-LINDBERG**

Avel-Lindberg Ltd, Arisdale Avenue, South Ockendon, Essex RM15 5TD. Tel: South Ockendon 3444.

MP3 DC/AC inverters

A range of four DC to AC electronic inverters. Suitable for operating tape recorders and other similar equipment from DC supplies. Input voltages: 20-30V DC, 41-60V DC, 100-125V DC, 200-250V DC. Output: 217-227V 50Hz for first two models, 215-225V 50Hz AC for second two models. Efficiency: greater than 70%. Output frequency 50Hz sinewave ±1%. No moving parts. Electrically and mechanically robust. Protected against overload, short circuit and incorrect polarity. Full details and prices on request.

■ **BASF**

BASF United Kingdom Ltd, Audio/Video Tapes Division, PO Box 473, Knightsbridge House, 197 Knightsbridge, London SW7 1SA. Tel: 01-584 5080.

Technical Look Spools

Standard sizes: 2¼in, 3in, 3½in, 4in, 4¼in, 5in, 5¾in, 7in, 8¼in, 8¾in, 10in, 10½in.



BASF Cassette Hobby Box

Metal Spools

7in, 8¾in, 10½in.

Profi NAB adaptor

Price: on application.

Leader Tape

Green, red or white. Plastic centre spools; 984ft, 80ft.

Leader Tape Set

Containing red and green leader tapes, 25 strips of metalised foil and spare spool labels.

Splicing Tape

¼in × 8ft; ½in × 8ft; ¾in × 32ft.

Splicing Set

Plastic box with bonding groove and 33ft of ½in splicing tape.

Metalised foil

¼in × 80ft.

Plastic Clips

Box of 10.

Hobby Box (reel-to-reel)

Contains splicer, marking pencil, 33ft splicing tape, 80ft each of red, white and green leader tapes, 50 pieces of metalised foil, 25 spool labels, 3 tape clips.

Hobby Box (Cassette) ★

Contains splicing block, scissors, tweezers, Philips screwdriver, flat-blade screwdriver, 5m splicing tape dispenser, 10m leader tape, 3 clips, pressure springs and screws.

BR Reel-to-reel Cleaning Tape

Details on application.

CR Cleaning Cassette

Details on application.

Cassette Library Box

Details on application.

Hinged lid plastic Boxes

5¾in and 7in reels.

Head alignment tape

Details on application.

All prices on application.

■ **BIR**

Rib Hi-Fi Accessories Ltd, PO Box 78, Hemel Hempstead, Herts HP2 4RH. Tel: Hemel Hempstead 61291.



BIB Cassette Care Kit

Ref. J. Compact tape and cleaning kit

Price: 90p (including VAT).

Ref: 65. Cassette storage rack

Holds 30 cassettes in their library cases. Finished in simulated teak. Price: £5.18 (including VAT).

Ref: 78. Cassette fast hand winder

Very simple and easy to use, it winds a C90 cassette in 60 seconds. Saves batteries. Price: £1.06 (including VAT).

Ref: 86. Cassette cabinet

Holds 30 cassettes in their containers. Fitted with a smoked coloured hinged acrylic lid. Finish: simulated teak. Fitted with protective rubber feet. Price: £7.13 (including VAT).

Ref: 51. Cassette care kit ★

Contains: head cleaner, salvage cassette and re-record kit, editing and joining kit. Price: £4.00 (including VAT).

Ref: 31. Cassette head cleaner

Price: 75p (including VAT).

Ref: 73. Cassette rotarack

Holds 40 cassettes in their containers. Price: £4.26 (including VAT).

26A Cassette Tape Recorder Care Kit

Contains: 1/8in splicer, splicing tape, tape piercer, 9 cassette labels, 3 tape winders, 2 tape cutters, polishing cloth and cassette head cleaner. Price: £2.38 (plus VAT).

53 Stereo Test Cassette

Devised by BIB and recorded by Decca the cassette contains: channel identification, balance control, speaker phasing, adjusting record volume controls, reducing tape hiss and eliminating hum, wow and flutter. Also includes music, brass band, Grand Organ, etc. Price: £2.40 (plus VAT).

34 Cassette Case

High quality black padded PVC case, with carrying handle. For 12 cassettes. Price: £1.84 (plus VAT).

D/2 Flex Tidies

Shortens without cutting inter-unit cables, speaker leads and mains flex. Price: (pack of 5) 34p (plus VAT).

20 Recording Tape Splicer

For use with 1/4in tape. Fitted with clamps for holding tape for diagonal or butt splices. Price: £1.34 (plus VAT).

24 1/8in Cassette Editing and Joining Kit

Complete kit to enable cassette tapes to be edited and joined. Price: £1.99 (including VAT).

Ref: 83. Cassette title and container labels

Contains 20 cassette body labels and 10 library container edge labels. Price: 39p per pack (including VAT).

29A Salvage Cassette

Enables damaged tape to be transferred to new cassette. The tape may be joined with BIB splicer model 30 or BIB kits (Ref: 24, 26A or 51). Nine replacement title labels are included. Price: 44p (plus VAT).

Ref: 54. Cassette Re-Recorded Kit

Ideal for converting Musicassettes for further recordings and to make your own recorded cassettes erase-proof. Kit contains special tab removing and winding tool, 24 re-record tabs and 27 self-adhesive colour-coded title labels. Supplied in plastic container with instructions. Price: 86p (including VAT).

Ref: 23 Tape Editing Kit

Essential for quick and accurate editing. Kit contains 1/4in (6.3mm) tape splicer, 12 tape reel labels, razor cutter, splicing tape, tape marker and instructions, all in plastic wallet. Price: £1.94 (inc VAT).

Ref: 30. Cassette Tape Splicer

For use with 1/8in (3.2mm) tape. With full instructions. Price: £1.45 (including VAT).

Ref: 37. Luxury Cassette Carrying Case

Fitted with a moulded inner tray to hold 30 cassettes in their containers for easy selection. Covered in a simulated pig-skin PVC with carrying handle. Approximate size: 15in long x 8½in wide x 3¼in high. Price: £3.89 (including VAT).

Ref: 39. Cassette Wallet

Holds six cassettes in their containers for quick and easy selection. Ideal for home or car. Folds to convenient size 9¼ x 4½in (249 x 115mm). Finished in high quality brown PVC. Price: £1.10 (including VAT).

Ref: 62. Cassette Head Cleaner

Essential for regular cleaning of tape heads, capstan and roller. Pack contains blue tape head applicator and white tape head polisher tools, bottle of special formula cleaning fluid and full instructions. Price: 60p (including VAT).

Ref: 84. Cassette Editor and Winder Unit ★

For easy, trouble-free editing, splicing and

tape transfer, including fast tape winding. Made in metal, measures approximately 9¼ x 6¼in (23 x 16cm), fitted with four protective feet. Complete with splicing tape, tape cutter, spare empty cassette and full instructions. Price: £4.97 (including VAT).

Ref: 85. Cassette Album ★

Holds 12 cassettes in their containers and is designed in book form so that the two halves close together on each other. The cover is made from a tan PVC material. Price: £3.02 (including VAT).

■ B + J IMPORTS

66 Woodcock Hill, Kenton,
Harrow HA3 0JF. Tel: 01-907 6667.

Stereo stamps

Small rubber stamp enabling tape recording enthusiasts who record in stereo to label their tapes making them easily identifiable. Price: 50p including postage.

■ BRADMATIC LTD

338 Aldridge Road, Streetly,
Sutton Coldfield, West Midlands
B74 2DT. Tel: 021-353 3171.

Magnetic recording heads manufactured to order. Enquiries welcomed and full details of service offered provided on request.

■ CONTEK MAGNETICS LTD

32 Eveline Road, Mitcham, Surrey.
Tel: 01-648 5156.

Contek head cleaner. Price: 60p (plus VAT).

■ CROWN MERTON

Hancock, Corfield & Waller Ltd,
Station Road, Merton Abbey,
London SW19 2NJ. Tel: 01-542 1012.

Cassbar Ref. 5066 ★

Modern plastic, revolving cassette storage unit. Holds 21 cassettes designed for multiple stacking. Price: £5.40 (including VAT).

Keyboard Cassette 5067 ★

Modern plastic cassette storage unit. Holds 10 cassettes, special add and stack feature to form library system. Price: £2.70 (including VAT).

Cassette 24 5056 ★

Compact brass plated wire cassette holder. Holds 24 cassettes. Also available for 36 cassettes. Price: £2.24 and £3.34 respectively.



BIB Cassette Editor and Winder Unit



BIB Cassette Album

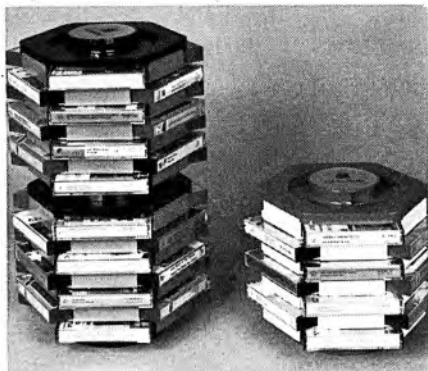

Crown Merton Cassbar 5066

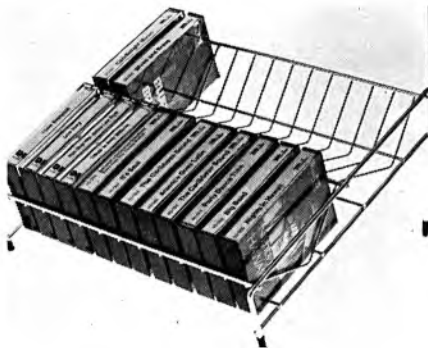

Crown Merton Cassbar 24 5056 brass plated wire cassette holder

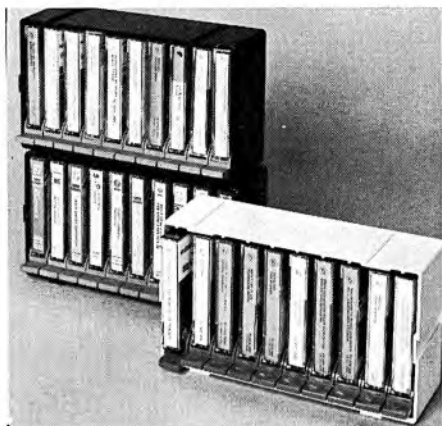

Crown Merton Keyboard Cassette 5067

■ **EAGLE**

Eagle International. Precision Centre, Heather Park Drive, Wembley HA0 1SU. Tel: 01-902 8832.

TD79 Tape Head Demagnetiser

250V AC mains operation. Price: £2.50 (plus VAT).

TD 83★

Cassette head demagnetiser. 240V AC operation, suitable for compact cassette recorders and players. Price: £2.96 (plus VAT).

■ **FERROGRAPH**

Ferrograph Co Ltd, Auriema House, 442 Bath Road, Cippenham, Slough SL1 6BB. Tel: Burnham 62511.

Defluxer

For depolarising heads, capstans and guides. Ensures maximum signal/noise ratio. Prevents hiss and protects tapes from cumulative background noise. Price: £5.00 (plus VAT).

Carrying case for Series 7 recorders

Waterproof canvas case with zip fastener. Price: £7.56 (plus VAT)

Plugs

JPS-401 screened plug with aluminium body, and cable clamp. Price: 40p (plus VAT).

Endless loop cassette

Permits Ferrograph to be operated continuously on an endless loop of 8 min duration at 7½i/s. Price: £10.00 (plus VAT).

Ferrrotape spools

Aluminium, anodised grey. Prices: 7in £1.20 (plus VAT); 8¼in £1.35 (plus VAT).



Eagle TD 83 tape head demagnetiser

■ GARDNERS TRANSFORMERS LTD

Christchurch, Dorset BH23 3PN.
Tel: Christchurch 2284.

DC/AC Inverters 107 (A, B and D) ★

Provide 240V AC squarewave output from DC input. Output: 300VA and 400VA (107D) at 220-240V nominal. Frequency: 50Hz \pm 1Hz. Efficiency: >80% at full load. Input: (107A) 11-15V DC; (107B) 22-30V DC; (107D) 22-30V DC. Size: 9½ × 8¼ × 8½in. Weight: 28¼lb. Full specification sheet on request. Price: 107A and B £72.03 (plus VAT), 107D £91.38 (plus VAT).

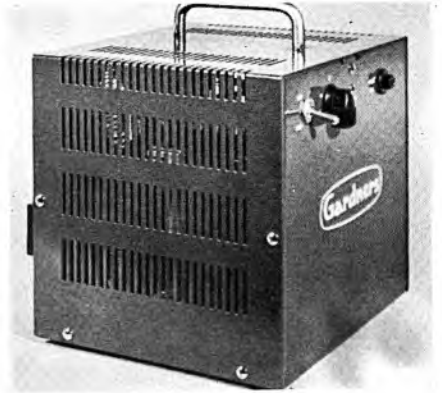

Gardners 107 inverter

■ GRAMPIAN REPRODUCERS LTD

Hanworth Trading Estate,
Hampton Road West, Feltham TW13 6EJ.
Tel: 01-894 9141.

Grampian G.7 ★

Matching units, consisting of double-wound transformer in a Mu-metal case with jack socket on the primary and a screened lead on the secondary. Dimensions: 3¾ × 1¼in diameter. Versions available for matching 15/30 ohms, 600 ohms and 50,000 ohms or greater. Price: on application.



Grampian G7 matching unit

Type G16

As G.7 but with balanced input.

Grampian Parabolic Reflector

Diameter 24in, depth 5in. Gain: 14dB over range of 500Hz-5kHz. To take Grampian DP4 and DP6 mics. Weight: 4¼lb. Price: on application.



Leevers-Rich LR71 with Leevers-Rich LR70

Grampian Reverberation Unit

Self-contained portable unit, transistorised and operated from internal dry batteries. Independent input channels, low-level and high level. Output: 1V, 600 ohms. Size (including detachable lid): 17½ × 5¼ × 6¼in. Weight: 12lb. Price: on application. Main/s unit available.

■ LENNARD DEVELOPMENTS LTD

206 Chase Side, Enfield EN2 0QX.
Tel: 01-363 8238.

■ LEEVERS-RICH

Leevers-Rich Equipment Ltd,
319 Trinity Road, Wandsworth,
London SW18 3SL. Tel: 01-874 9054.

Leeraser LR70, LR71 ★

Bulk tape demagnetisers. Model LR70 for tapes up to 8¼in diameter. Price: £44.00 (plus VAT). Model LR71 for tapes up to 11¼in diameter. Price: £66.00 (plus VAT).

Dry-splice

Precut adhesive tape for splicing and mending without the aid of a splicing block. Envelopes of 24. Price: 21p (plus VAT).

Playfair antistatic cleaning fluid

30cc polythene bottle. Price: 24p (plus VAT).

Playfair cassette cleaners

48p (plus VAT).

Playfair cassette carrying cases

Price: £1.95 (plus VAT).

Bib®

Over 80 items for Hi-Fi, Record and Tape Care

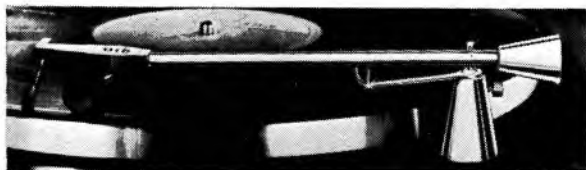

▲ Model 200



▲ Model 42



▲ Model 45

Model 45 AUTO-CHANGER GROOV-KLEEN

Finished in chrome - fits most units with flat top cartridge housings. Adaptor available for Zero 100. Velvet and stylus cleaning brush included.
Pat. App. No. 1361732
Reg. Des. No. 958457

£1.06

STYLUS BALANCE

Precision built Calibrated. Measures stylus pressure within 1/4 gramme.

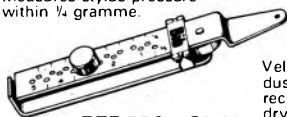

REF 32A £1.44



RECORD DUST-OFF - WITH COVER

Velvet pad gently collects and removes dust from delicate grooves. Reduces record and stylus wear. Can be used dry or moist.

REF 71 71p

Record Care

GROOV-KLEEN automatic record cleaners

ALL GROOV-KLEENS remove and collect dust whilst records are played. Improve reproduction and reduce record and stylus wear. Quick and simple to fit.

Model 200 This has it all - efficiency, styling and chrome finish. Complete with stylus brush, plus spare velvet roller, self-adhesive base pad and tracking brush. Des. Reg. App. No. 967842 **£2.94**

Model 42 Finished in chrome, bright anodised aluminium and shiny black. **£1.99**

STYLUS AND TURNTABLE CLEANING KIT

Contains stylus cleaning brush absorbent cleaning cloth, bottle of approved, non-flammable, anti-static cleaner and stylus inspection mirror, in PVC wallet.

REF 70

71p



Cassette Care

CASSETTE FAST TAPE WINDER

Very simple and easy to use. The BIB cassette fast winder enables you to wind tape in one cassette whilst you are listening to another cassette. If you have a battery recorder, always use the Fast Winder to save the high battery consumption when fast winding. It winds a C90 cassette in 80 seconds - faster than most recorders. Patent Pending.



REF 78 £1.06

CASSETTE CABINET

This elegant unit with hinged acrylic tinted cover complements any equipment. Provides individual accommodation for 30 cassettes. Attractive teak-finish base fitted with protective feet. Dimensions 15" long by 10" wide by 4" high, approx.

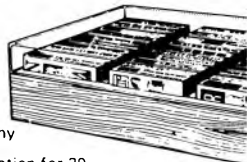

REF 86 £7.13

CASSETTE HEAD CLEANER

For all cassette machines. Removes oxide and dirt from heads. Packed in plastic "library" case



REF 31 68p

Other lines include:

	Ref.	Price
Cassette Tape Editing & Joining Kit	24	£1.99
Hi-Fi Stereo Test Cassette	53	£2.60
Tape Care		
Tape Head Cleaning Kit	J	£0.81p

■ Please write for fully illustrated catalogue showing our comprehensive range of Hi-Fi Accessories.

■ All prices shown are recommended retail, inc. VAT.

Bib Hi-Fi Accessories Limited

P.O. Box 78, Hemel Hempstead, Herts. HP2 4RH. Telephone. 61291.

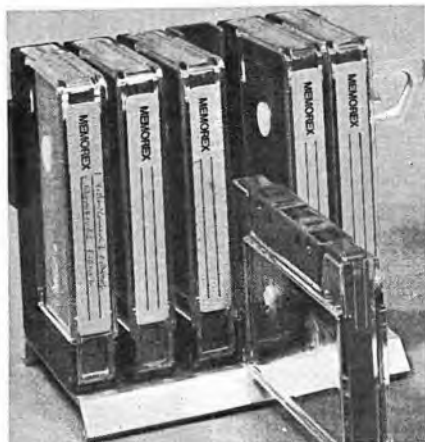

Memorex library holder

Cassette bars (20/32)

Revolving type. Price: £4.75 (plus VAT).

Playfair Tape (cassette) library cases

Pack of three. Price: 30p (plus VAT).

Playfair Cartridge Cleaners

Price: 75p each (plus VAT).

Playfair Cartridge Carrying Cases

Price: £2.30 each (plus VAT).

Cassette Index Cards

Packets of 20. Price: 36p each (plus VAT).

■ **LYRICHORDS**

N. Miers & Co Ltd, 28 Piercing Hill,
Theydon Bois, near Epping,
Essex CM16 7LE. Tel: 037-881 2611.

Tape Accessories

8-track cartridge demonstration and test tape £2.48 (plus VAT); 8-track cartridge tape head cleaner £1.10 (plus VAT); tape head cleaning kit for reel-to-reel and cassette recorders 90p (plus VAT); 1/8in cassette splicing and editing kit £1.99 (plus VAT); cassette salvage kit 48p (plus VAT); universal modification kit £1.50 (plus VAT).

■ **MAGNETIC COMPONENTS**

Penryn, Cornwall TR10 8AR.
Tel: Penryn 2267.

Manufacturers of high quality audio magnetic recording heads. Range consists of mono and

stereo heads for use in cartridge and cassette tape recorders in addition to existing reel-to-reel heads.

■ **MEMOREX**

Memorex (UK) Ltd, Hoechst House,
50 Salisbury Road, Hounslow West,
Greater London. Tel: 01-570 7716.

Cassette cleaner

Details on application.

Cartridge cleaner

Details on application.

Cassette Library Holder ★

Details on application.

Audio Training Cassette kits

Available in boxes of 50 in C30, C45, C60, C90 and C120 sizes. Further details and prices on application.

■ **METROSOUND**

Metrosound Audio Products Ltd, Audio Works, Cartersfield Road, Waltham Abbey, Essex EN9 1JF. Tel: Lea Valley 712712.

M.4 Klentzape kit

Patented head cleaner. Kit comprises ribbed cleaning tape, two special spools and bottle of Klentzape fluid. Price: 98p (plus VAT).

M.17 Metro-Splicing Block

Professional precision metal splicing block for 1/4in tape, supplied with non-magnetic cutter blade. Price: £1.10 (plus VAT).

M.18 Leader tapes

Choice of six colours, approximately 40ft of leader tape, wound on to plastic mini-spool. Price: 37p (plus VAT).

M.19 Stop foil

Metallic tape for actuating electronic auto stop mechanisms for tape recorders. Approximately 15ft on mini-spool. Price: 37p (plus VAT).

M.20 Jointing tape

1/4in wide; approximately 12ft on mini-spool. Price: 37p (plus VAT).

M.24 Lubricating Kit

Suitable for tape recorders and mechanical moving parts. Comprises small bottles of each of R.O.B. and R.O.G. oil and container of Starfax. Price: 50p (plus VAT).

★ Indicates entry is illustrated

M.30 Accessory Pack

For radio and audio retailers. Wire display rack with assortment of Metrosound accessories in packs. Full details and prices on request.

M.46 Test Cassette and Sampler

Compact cassette containing directions for cassette tape recorder maintenance and setting up procedure. Includes test music and recorded stereo works. Price: £2.44 (plus VAT).

M.69 Cassette Edit Kit

Presented in permanent storage case containing professional machined splicing block, roll leader tape, roll splicing tape and two splicing cutters. Price: £1.50 (plus VAT).

M.71 Cassette Deck Care Kit

Presented in special purpose permanent storage case containing head cleaner, cassette head cleaning spatula with brush and velvet polisher, cassette head cleaning fluid, multi-purpose duster and spare spatula velvets. Price: £1.50 (plus VAT).

M32 Head Cleaner Cassette

Complete cassette conforming to international specification; loaded with silicone impregnated, non-abrasive, fibrous tape; contained in plastic library case. Price: 55p (plus VAT).

M39 Cartridge Head and Capstan Cleaner

8-track cartridge moulding containing fluid tank with soft felt pad activated by sprung lever in rear cavity. Bottle of specially formulated cleaning fluid and nylon tuft brush for cleaning pad. Price: £1.20 (plus VAT).

M48 Dolby Tone Test Cassette

A very carefully produced pre-recorded tape for correct setting up, alignment and calibration of high quality Dolby cassette players. Price: £2.00 (plus VAT).

M62 Cassette Salvage Kit ★

Kit contains one complete compact cassette, splicing block, editabs, hub key and cutter to facilitate easy and economical repair of damaged cassettes. Price: 56p (plus VAT).

■ MUSONIC

Musonic Ltd, 34-38 Verulam Road,
St Albans, Herts AL3 4DF.
Tel: St Albans 50611.

MT5

Cassette cleaner in library box. Price: 66p (plus VAT).



Metrosound Cassette Salvage Kit



Caseset (MT8)



Cassette Library (MT11)



Cartridge Library (MT17)



Cartridge Carousel (MT15)



Cassette Library Box (MT16)



Add 'N' Stac Cartridge Storage (MT13)

Musonic Accessories

MT6

Cartridge head cleaner. Price: 99p (plus VAT).

MT7

Cartridge head and capstan cleaner. Price: £1.44 (plus VAT).

MT8 Case set ★

Case for 16 cassettes. Price: £1.59 (plus VAT).

MT9 Cartahout

Case for 15 cartridges. Price: £1.92 (plus VAT).

MT10

Cassette library for 30 cassettes. Price: £2.51 (plus VAT).

MT11 ★

Cassette library for 15 cassettes. Price: £1.83 (plus VAT).

MT12

Add 'n' stac for 8 cassettes. Price: 77p (plus VAT).

MT13 ★

Add 'n' stac for 6 cartridges. Price: 90p (plus VAT).

MT14

Cassette carousel for 32 cassettes. Price: £8.09 (plus VAT).

MT15 ★

Cartridge carousel for 24 cartridges. Price: £8.09 (plus VAT).

MT16 ★

Empty cassette library box. Price: 14p (plus VAT).

MT17 ★

Cartridge library for 24 cartridges. Price: £3.00 (plus VAT).

MT18

Cassette cleaner without library box. Price: 59p (plus VAT).

MT20

Pack of 10 spare cassette index cards. Price: 27p (plus VAT).

MT25

Cassette library case for 48 cassettes. Price: £6.48 (plus VAT).

■ OSMABET

Osmahet Ltd, 46 Kenilworth Road, Edgware HA8 8YG. Tel: 01-958 9314.

Bulk Tape Eraser and Recording Head Demagnetizer

Operates from AC mains to provide rapid and complete erasure of tapes and cassettes prior to making quality recordings. In addition, the eraser can be used for the instant removal of residual magnetisation of recording heads. In

the majority of cases without the removal of recording head protective covering. Is suitable for all sizes of tape reels or cassettes. Weight: 18oz. Price: £3.75 (plus VAT).

■ QAS

Quality Audio Supplies, Wollaton Road, Peeston, Nottingham NG9 2PB. Tel: Nottingham 252222.

Wide range of audio accessories including phono plugs, DIN plugs and sockets, 4mm and wander plugs, couplers, screw terminals, slider switches, connecting leads with all types of terminations, audio switching units and remote control stations. New additions to the range are screw fixing blank cassettes, cassette head cleaners and dynamic microphones. All items individually blister-packed for over the counter or self-service sales.

Tape Selector

Designed to permit two tape recorders to record and play back without being disconnected from the amplifier. Size: 5½ × 1¼ × 2¾in. Finish: brushed aluminium. Price: £6.75 (plus VAT).

See Pickup Accessories and Speaker Accessories Sections for details of other QAS equipment.

■ ROSS ELECTRONICS LTD

32 Rathbone Place, London W1P 1AD. Tel: 01-580 7112.

Cassette Head Cleaner

Lint-free cleaning tape in a compact cassette package removes oxide residue and dirt from record and erase heads. Price: 42p (plus VAT).

Cassette Carry Case ★

Tough, attractive PVC construction with carrying handle and fastening clip. Holds 12 cas-



Ross cassette carry case

★ Indicates entry is illustrated



Ross RE 527K Tape Head Demagnetiser



Ross RE-528K

settes in library cases. Packs flat for storage. Colour red. Price: £1.41 (plus VAT).

8-Track Cartridge Carry Case

Similar to above. Holds 10 cartridges. Price: £1.50 (plus VAT).

RE527K Tape Head Demagnetiser ★

Removes gradual build-up of residual magnetism from tape heads by briefly applying tip to heads in cassette and reel-to-reel recorders. Operates from mains supply. Totally enclosed and insulated. Price: £1.97 (plus VAT).

RE528K ★

Construction and operation similar to RE-527K but equipped with specially shaped pole piece designed to reach into cassette recorder head without dismantling case parts. Price: £2.35 (plus VAT).

■ SCOTCH

3M United Kingdom Ltd, 3M House, Wigmore Street, London W1A 1ET. Tel: 01-486 5522.

Empty Hi-Fi Boxes

5in 50p; 5½in 57p; 7in 72p (plus VAT).

Empty Hi-Fi Spool

5in 31p; 5½in 39p; 7in 46p (plus VAT).

Empty Clear Spool

5in 28p; 5½in 31p; 7in 35p (plus VAT).

41 Splicing Tape

½in × 150in 37p (plus VAT).

Miscellaneous

Audio Index Book in 7in box £1.27 (plus VAT).

Empty Metal Nab Spool 10½in £2.31 (plus VAT).

Tape Clips 14p (plus VAT).

Leader Tape ¼in × 50in 19p (plus VAT).

Cartridge Head Cleaner £1.20 (plus VAT).

Cassette Head Cleaner 90p (plus VAT).

■ SONY

Sony (UK) Ltd, London Showroom, Consumer Information Service, 134 Regent Street, London W1R 6DJ.

Tel: 01-439 3874.

Tape Spools

R3A empty spool 3¼in 24p. R5A empty spool 5in 36p. R6A empty spool 5½in 55p. R7A empty spool 7in 59p. R11A empty 10½in NAB spool £3.60.

Recorder, Cassette Accessories

RA1 10½in NAB reel adaptor £5.09. RE3 endless cassette, size 90m £3.24. RE4 endless cassette, size 46m £1.25. TF3 spool clip 3¼in 19p. TF5 spool clip 5in 19p. TF7 spool clip 7in 19p. BE7 cassette eraser £11.99. CE3 high Z impedance 96p. DP2A dust cover for TC280 £7.20. DP11 dust cover for CF610/620 £8.00. BP15 dustcover for TC134SD £4.80. DP16 dust cover for TC377 £8.00. DP19 dust cover for TC131SD £6.40. DP20 dust cover for TC755/756-2 £11.20. DP21 dust cover for TC458 £9.60. DP24 dust cover for TC138SD £6.40. DP25 dust cover for TC177SD £14.40. DP27 dust cover for TC645 £9.60. DP28 dust cover for TC135/136SD £7.96. FS6 foot switch £4.80. FS7 foot switch for TC96L £17.55. HE2 tape head demagnetiser £8.10. KB1 case extension strap 54p. LC28 carry case for TC152SD £13.19. LC29 carry case for TC153SD £13.19. LC1110 carry case for CF310L £4.35. LC1600 carry case for CF320 £4.91. LC1780 carry case for CF420L £5.56. LC2100A carry case for TC146A £4.58. ME26 8 ohms stethoscope headset stereo £2.80. RM15 remote control switch £2.27.

■ SYNCHROTAPE

Sole Distributors: Adastra Electronics Ltd, Unit N22, Cricklewood Trading Estate, Clarendon Road, London NW2 1TU. Tel: 01-452 6288.

Synchrotape Editing Kit

Instant cut and trim splicer, four reels coloured leader tape, one reel metallic stop foil, one reel

adhesive tape, six coloured tape-securing clips and 28 self-adhesive titling labels. Presented in see-through crush-proof carton. Complete with 12-page instruction and information booklet. Price: on application.

■ **TAPE RECORDER SPARES LTD**

206-210 Ilberton Road, London SE15 1NS.
Tel: 01-639 7844/5/6/7.

Large range of spares and accessories for all makes of tape recorder. Catalogue and details on request.

■ **THORN**

Thorn Consumer Electronics Ltd,
Thorn House, Upper St Martin's Lane,
London WC2 9ED.
Tel: 01-366 1155.

Foot switch TA/19

Facilitates use of recorder as dictating machine. Recorder runs when switch is depressed. For models with remote pause facility. Price: on application.

Monitoring Stethoset TA/29

Stethoscope type earpiece to monitor programme during recording. Fitted with Continental speaker plug. Price: on application.

Stereo headphones TA/39

General purpose stereo headphones. Fitted with 3/4in standard jack plug. Price: on application.

Stereo headphones TA/41

Stereo headphones. High impedance. High quality performance. Price: on application.

The tape recorder accessories listed above are primarily for use with machines marketed under the Thorn brand names Ferguson and Marconiphone. Prices on application.

■ **VALRADIO LTD**

Browells Lane, Feltham TW13 7EN.
Tel: 01-890 4837/4242.
Service Agents: Vibro Supply, 57 Fortress Road, London NW5.
Tel: 01-485 5165.

DC converters

Designed for operating tape recorders, video recorders and similar mains equipment from ship's supply or car battery. Input voltage from 12V to 220V DC. Output from 30W to 1,000W AC. Prices from £21.



Valradio C12/30S Transverter

Transverter C12/30S ★

Input 12V DC. Output 50Hz \pm 1/4Hz sine wave at 30W. Suitable for positive or negative earthed input. Built-in switch and socket. Supplied complete with input lead. Size: 8 x 6 x 6in. Weight: 8lb. Price: approximately £40.

Transverter D12/120S

Input 12V DC. Output: 115-230V 50Hz \pm 1/4Hz sine wave at 120W. Price: approximately £83.

Transverter D12/200S

Input 12V DC. Output: 115-230V 50Hz \pm 1/4Hz sine wave at 200W. Price: approximately £110.

Transverter D12/400S

Input 12V DC nominal. Output 115-230V 50Hz \pm 1/4Hz sine wave at 400W. Price: approximately £220.

Frequency changer

AC-DC. Suitable for records, films, television programme special effects. Price: (200W) from about £95.

■ **WAL**

A. C. Farnell Ltd, Kenyon Street,
Sheffield S1 4BD.
Tel: 0742 78901.

Wal Bulk Tape Eraser

Re-introduced after twelve months. Primarily for erasure of reel magnetic recording tapes when tape recorder erasure head function was not always satisfactory. Also for compact cassettes, competer and video tapes. Works by application of strong magnetic field across material for erasure. Operated by spring loaded push button. Will erase a 7in tape in 20 seconds. Price: £25.50 (plus VAT).

It's the cat's whiskers!

A fascinating excursion into the past. The author has unearthed some 400 trade names from the crystal set days, along with nearly 200 manufacturers—giving the name of the set, technical description and original price. He also reviews the first days of broadcasting and looks at the difficulties experienced by crystal set users. Concise information and over 40 illustrations make this book a valuable work of reference as well as a rare piece of nostalgia for collectors.

VINTAGE CRYSTAL SETS 1922-1927

£2.50 from bookshops or £2.80 inclusive direct from Wireless World, Room 11, General Sales Dept., IPC Business Press Ltd., Dorset House, Stamford Street, London SE1 9LU.



A
book
from
wireless
world

Tape Amplifiers and Mixer Units

★ Indicates entry is illustrated

Abbreviations used in this section are given on page 27.

■ AUDIO DEVELOPMENTS

Hall Lane, Walsall Wood, Walsall, Staffs WS9 9AU.
Tel: Brownhills 5351.

AD007

Eight inputs into four outputs. Battery powered. 80dB overall gain. Transformer balanced inputs and outputs. Three-band equaliser. Size: 54 × 48 × 22.5cm. Weight: 22.7kg. Price: on application.

AD031

Eight inputs into two outputs. Lightweight. Battery powered. Outputs electronically balanced. +24dB output capability. Size: 42 × 33.5 × 12.7cm. Weight: 10kg. Price: on application.

Both models capable of being extended to increase number of inputs. Metering VU or PPM.

■ BRENELL

Brenell Engineering Ltd, 231-235 Liverpool Road, London N1 1LY.
Tel: 01-607 8271.

Hi-Fi Tape Link ★

Stereo tape preamplifier and oscillator unit. Connects between tape deck and hi-fi system. Twin transistorised recording amplifiers, bias/erase oscillator, twin transistorised playback amplifier. Designed for use with three-headed stereo tape deck (i.e. separate erase, record and playback heads), ¼-track or ½-track. Mono and stereo recording facilities provided. Monitoring. Immediate comparison of recorded and original signal. Individual gain controls for each amplifier. Frequency correction for four tape speeds. Inputs: mic 220μV 200 ohms, aux 8mV 50K, aux 8mV 50K Cross-

fade mixing between inputs. Two illuminated level meters. Outputs: 1.4V (2V at 2% distortion level). FR: (when used with specified heads) 7½i/s 40Hz-20kHz ±3dB, 3¾i/s 50Hz-14kHz ±3dB, 1¾i/s 60Hz-7kHz (±3dB), 15i/s 40Hz-22kHz ±3dB. S/N: 56dB. Size: (tape link) 15 × 7 × 4½in; (power unit) 5½ × 5¾ × 4¾in. Weight: (tape link) 9lb; (power unit) 5lb. Price: (complete with PU) £162.00 (plus VAT).

■ EAGLE

Eagle International, Precision Centre, Heather Park Drive, Wembley HA0 1SU.
Tel: 01-902 8832.

MP12 ★

Six-channel stereo/mono mixer and pre-amplifier. Studio type slider controls. Mic inputs can be individually switched between high and low impedance. Inputs: four microphone 1mV 600 ohms or 2mV 50K, two pickup 3.5mV at 47K RIAA. S/N: better than 50dB. Output: (switched stereo/mono) two 250mV. Low profile desk console. Size: 10 × 7 × 1¾in. Price: £34.00 (plus VAT).

FF1

Transistorised five-channel mono mixer. Slider type controls. Microphone inputs: 0.5mV at 600 ohms, switchable for 4mV 50K. Aux input: 180mV 100K. Two outputs: (low) 200mV 50K-500K, (high) 2V 50K-500K. Controls: on/off switch, slider control for each input, overall master gain control. Power: two PP3 batteries. Size: 10 × 7 × 1¾in. Monitoring facilities included. Price: £28.00 (plus VAT).

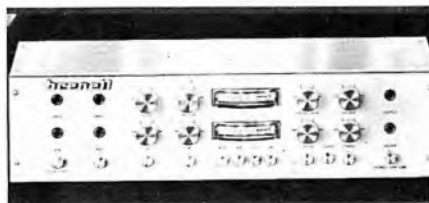

Brenell Tape Link



Eagle MP12

★ indicates entry is illustrated



Eagle FF10

FF10 ★

Stereo seven-channel mixer/preamplifier. Inputs: mic 3mV 50K, stereo PU (1)3mV 47K, stereo PU (2) 3mV 47K, stereo tape 100mV 100K. Output: two 250mV 50K (switchable stereo/mono). Controls: master gain, mic gain, PU (1) gain, PU (2) gain, tape gain, on/off, stereo/mono mode switch. Power supply: internal 9V battery. Size: 9 7/8 × 7 × 1 7/8 in (sloping down to 1 1/8 in). Finish: black and silver trim. Price: £34.00 (plus VAT).

FF32

Tape mixer unit. Inputs: phono, stereo 3mV

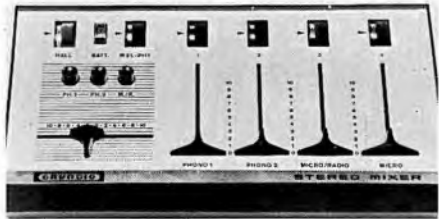

Grundig 422 Mixer

47K (× 2), mic 3mV 50K, stereo tape 100mV 100K. Outputs: 2 stereo outputs 250mV 50K. Pre-fade headphone monitor. Controls: master volume, tape level, phono 1 level, phono 2 level, mic level, prefade monitor switch, stereo/mono switch, on/off switch. Power: 9V DC (2 × PP3). Size: 9 7/8 × 7 1/8 × 1 7/8 (sloping to 1 1/8 in). Price: £36.00 (plus VAT).

PRE 38

Tape or microphone booster pre-amplifier for increasing record/playback signals from/to amplifier. Inputs and outputs are phono sockets. Variable output. Price: £6.90 (plus VAT).

■ **GRUNDIG**

Grundig International Ltd,
Newlands Park,
London SE26 5NQ.
Tel: 01-659 2468.

Mixer 422 ★

Transistorized stereo mixer for four inputs. Three coarse level controls. Directional control and control for reverberation unit. Four microphone preamplifiers fitted. Channel separation: mic 50dB, PU 35dB. Response: 40Hz-20kHz ±2dB. Powered by two 9V batteries. Dimensions: 34 × 9 × 9.5cm. Price: £63.20 (plus VAT).

■ **SENNHEISER ELECTRONIC**

Distributors: Hayden Laboratories Ltd,
Hayden House, Churchfield Road,
Chalfont St. Peter, SL9 9EW.
Tel: Gerrards Cross 88447.

Audio equipment showroom service department and despatch department:
6 Bendall Mews, Bell Street, London, NW1.

M101 ★

Battery operated portable mixer. Inputs: four microphone inputs switchable for 200 ohm dynamic and 12V powered capacitor (MKH series of Sennheiser mics). Output: unbalanced +6dB at 60 ohms. Pre-fade listening using ML101 mixer monitoring unit. PPM. Slider-type faders. Separate bass and treble

It's good to see the
SOUNDEX
Mixers back



Floating transformer inputs	Each with 5 modes	RSA & pan-pot.	PPM to BS 4297	All-metal case
-----------------------------	-------------------	----------------	----------------	----------------

Plus: Pre-fade listen, break jacks on four channels, A-B tape monitoring, Built-in 1KHz line-up osc., XLR-type connectors, 24-volt power input. For broadcasting and recording.
less than £400 plus VAT

SOUNDEX LIMITED

728 High Road, Leytonstone, London. 539-4347

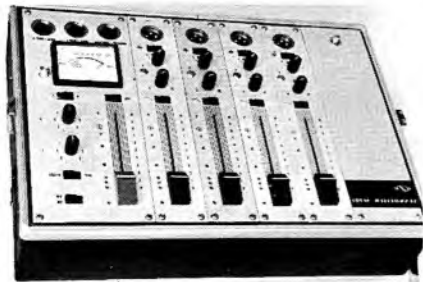

Sennheiser M101

controls switchable to one channel or to mixed output. Treble control: ± 12 dB at 15kHz, bass control +10dB - 14dB at 40 Hz. Power supply: two 9V Ever-Ready cells type 276 or equivalent, or 18V from other equipment. Price: on application.

■ SHURE ELECTRONICS LTD

Eccleston Road, Maidstone
Kent ME15 6AU.
Tel: Maidstone 59881

M64-2E

Stereo Pre-amplifier to provide $7\frac{1}{2}$ IPS NAB equalization for tape decks containing no electronics. Full specification and price in Amplifier Section.

M68FCE

Five-channel mono mixer/pre-amplifier to accept dynamic, ribbon or condenser type microphones. Inputs: four microphone low impedance balanced or high impedance unbalanced plus one auxiliary high level input. Controls: five input volume controls plus master volume control which adjusts level of all inputs. Outputs: high or low impedance microphone level and high level auxiliary output. Mains or external battery powered: $2\frac{3}{4} \times 11\frac{3}{8} \times 5\frac{1}{2}$ in. Price: £60.80.

M688E

Five-channel stereo mixer/pre-amplifier to accept dynamic, ribbon or condenser type microphones. Inputs: four microphone low impedance balanced or high impedance unbalanced. Three inputs switchable left/right and one input with pan control plus auxiliary high level stereo input. Controls: five input volume controls plus master stereo volume which adjusts level of all inputs. Outputs: high or low impedance mono microphone level and

high level stereo auxiliary output. Mains or external battery powered $2\frac{3}{4} \times 11\frac{3}{8} \times 7$ in. Price: £77.60.

■ SONY (UK) LTD

London Showroom, Consumer Information Service,
134 Regent Street, London W1R 6DJ.
Tel: 01-439 3874

MX8 ★

Passive six-channel stereo mixer for microphone or line inputs. Inputs: six-channel inputs (passive type). Impedance: Mic low. Sensitivity: -50dB (2.1mV). Impedance: Line 82K ohm. Sensitivity: -5dB (435mV). Output Impedance: Line 280 ohm. Output level: -60dB (0.775mV). General: Dimensions (approx.): $9\frac{3}{8}(W) \times 3(H) \times 5\frac{7}{8}(D)$ in. (238 x 76 x 148mm) including projecting parts. Weight (approx.): 3lb 2oz (1.4kg). Supplied accessories: 2 x PC1 plug adaptor.

MX510 ★

Battery operated five-channel stereo mixer with mic, line and phono inputs; one pan-pot and twin VU meters. Inputs: five-channel inputs. Impedance: Mic low. Sensitivity: -72dB

It's good to see the back of a
SOUNDEX
Mixer



If you're recording on location, rigging sound reinforcement or trying to cope with odd feeds you'll be glad to see the back of your stereo SOUNDEX STUDIO SERIES SIX MIXER. On its rear you'll find a five-way switch on each of the 6 channels to handle whatever* comes, from magnetic pick-up to capacitor mic needing phantom power. Soundex cares. ★Choose five options from our list.

Less than £400 plus VAT

SOUNDEX LIMITED
728 High Road, Leytonstone, London E11.

★ indicates entry is illustrated

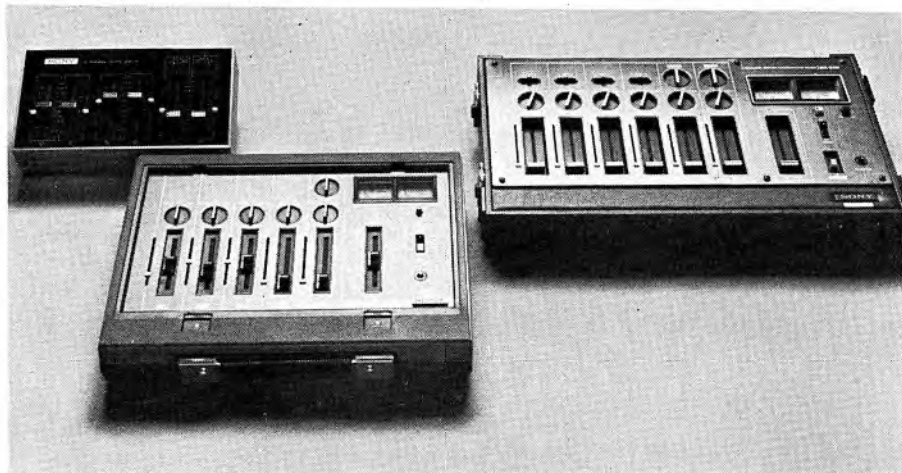

Sony MX8/MX510/MX650

(0.2mV). Impedance: Line 100k ohm. Sensitivity: -22dB (60mV). Impedance: Phono 50k ohm. Sensitivity: -51dB (2.2mV). Outputs: two-channel outputs. Impedance: Line 10k ohm. Output level: -5dB (435mV). Impedance: Headphone 8 ohm. Output level: -24dB (47mV). Frequency response: 30-25,000Hz. S/N ratio: 60dB. General. Power requirements: DC12V, 8 × HP11 batteries. Dimensions (approx.): 13 $\frac{3}{4}$ (W) × 3(H) × 9 $\frac{1}{2}$ (D) in, 348 × 75 × 240mm including projecting parts. Weight (approx.): 6lb 10oz (3kg). Semi-conductors: 20 transistors, 5 diodes. Supplied accessories: RK74 connecting cord.

MX650 ★

Battery operated six-channel stereo mixer, with mic, line and phono inputs; 2 pan-pots, twin VU's and line-up oscillator. Inputs: six-channel inputs. Impedance: Mic low. Sensitivity: -72dB (0.2mV). Impedance: Line 100k ohm. Sensitivity: -22dB (60mV). Impedance: Phono 50k ohm. Sensitivity: -51dB (2.2mV). Impedance: Cascade 50k ohm. Sensitivity: -5dB (435mV). Outputs: two-channel outputs. Impedance: Line 10k ohm. Output level:

-5dB (435mV). Impedance: 600 ohm. Output level: -60dB (0.775mV). Impedance: Headphone 8 ohm. Output level: -24dB (49mV). Frequency response: 30-25,000Hz. S/N ratio: 60dB. General: Power requirements: DC12V, 8 × HP11 batteries. Dimensions (approx.): 17 $\frac{7}{8}$ (W) × 3 $\frac{3}{8}$ (H) × 10(D) in., (452 × 83 × 252mm) including projecting parts. Weight (approx.): 9lb 8oz (4.3kg). Semi-conductors: 27 transistors, 7 diodes. Supplied accessories: RK74 connecting cord. Prices: on application.

■ UHER

Uher (UK) Ltd, P.O. Box 53, York.
Tel: York 30421.

A124 ★

Portable mixer unit for five channels: two stereo plus one mono or five mono channels. Inputs available for 200 ohms microphone, radio or pickup. Outputs: one 40mV nominal, one 500mV nominal. FR: 20Hz-20kHz. Slider faders with directional control, muting switches and 1kHz generator. Powered by PP3 battery or Z131 mains unit. Price: £103.00 (plus VAT).

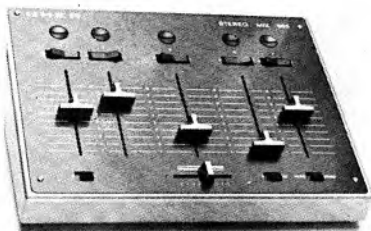

Uher A124

Tape Decks and Recorders

<0.12% at 7½, <0.15Hz at 3¾. FR: 23-23,000Hz at 7½, 30-16,000Hz at 3¾. Distortion: <1%. Output power: 0.775 V (line 2). S/N: better than 56dB. Crosstalk: better than 50dB (stereo). Bias frequency: 100kHz. 4-pole induction motor. Playback, record and erase heads. Max tape capacity: 1,800 ft. Dimensions: 41 × 20 × 31cm. Price: £138.00 (plus VAT).

★ Indicates entry is illustrated.

Abbreviations used in this section are given on page 27.

■ AKAI

Rank Audio Visual, Rank Hi-Fi,
PO Box 596, Power Road, Chiswick,
London W4 5PW.
Tel: 01-994 6491.

1722L

Stereo tape recorder. Tape speed: 7½ and 3¾/i/s. W and F: 7½/i/s less than 0.14% RMS, 3¾/i/s less than 0.18% RMS. FR: 30Hz-21kHz ±3dB at 7½/i/s, 40Hz-15kHz ±3dB at 3¾/i/s. Distortion: less than 2.0%. Output power: 10W total music power at 8 ohms. S/N ratio: better than 50dB. Erase ratio: better than 70dB. Crosstalk: better than 45dB (stereo). Bias frequency: 63kHz. Heads: erase, record/playback. Motor: 2-speed induction motor. Mains: 100-240V AC 50/60Hz. Size: 359 × 366 × 249mm. Weight: 14kg. Price: on application.

4000DB

Stereo tape deck. Tape speeds: 7½ and 3¾/i/s. W and F: less than 0.15% at 7½/i/s, less than 0.2% at 3¾/i/s. FR: 30Hz-23kHz ±3dB at 7½/i/s, 30Hz-16kHz at 3¾/i/s. Distortion: less than 1.0%. S/N ratio: better than 55dB (with Dolby process 60dB at 5kHz). Erase ratio: better than 70dB. Crosstalk: better than 40dB (stereo). Bias frequency: 105kHz. Heads: one micron gap recording head, one micron gap playback head, erase head. Motor: 4-pole induction motor. Fast forward/rewind time: 120/150 sec using a 1200ft tape at 60/50Hz. Mains: 100-240V AC 50/60Hz. Size: 406 × 325 × 196mm. Weight: 12.0kg. Price: on application.

4000 DS Mk 11

Four track, 2 channel stereo/monaural with one micron gap head. Featuring 2-lever control system. Tape speed: 7½, 3¾ ips. W and F:

GXC 205 D

Four track 2 channel stereo/monaural. Tape speed: 7½, 3¾ ips. W and F: <0.06% at 7½, <0.09% at 3¾. FR: 30-25,000Hz at 7½, 30-19,000 at 3¾. Distortion: <0.5%. Output power: line(2); 0.775 V, (phono 1) 30 mV. S/N: better than 56dB. Crosstalk: better than 40dB (stereo). Bias frequency: 100kHz. Motors; one AC servo motor for capstan drive and two eddy current motors for reel drive. No. of Heads: 6 forward and reverse playback record and erase. Max tape capacity: 1,800 feet. Dimensions: 44 × 21 × 40cm. Price: £318.00 (plus VAT).

GX 630 DB

Four track 2 channel stereo/monaural system. Tape speeds: 7½, 3¾ ips. W and F: <0.06Hz at 7½, <0.09% at 3¾ ips. FR: 30-25,000Hz at 7½, 30-19,000Hz at 3¾. Distortion: <0.5%. Output power: 0.775 Volts (line 2), 30 mV (phone 1). S/N: better than 50dB. Crosstalk: better than 45dB (stereo). Bias Frequency: 100kHz. Motors: 2-speed AC servo control auto motor and 6-pole eddy current for reel drive. No. of Heads: 6. Forward and reverse, playback, record and erase. Max tape capacity: 4,200 feet. Dimensions: 44 × 24 × 47cm. Price: £439.60 (plus VAT).

GX 630 DSS

Four track 4/2 channel compatible stereo system. Tape speeds: 7½, 3¾ ips. W and F: <0.06 at 7½, <0.1% at 3¾. FR: 30-21,000Hz at 7½, 30-15,000 at 3¾. Distortion: less than 0.5%. Output power: 0.775 V (line 2), 30 mV (phono 1). S/N: better than 54dB. Crosstalk: better than 40dB. Bias frequency: 100 kHz. Motors: one AC servo for capacity drive, 2 eddy current for reel drive. Max. spool capacity: 4,200 ft. Dimensions: 44 × 24 × 53cm. Price: £540.00 (plus VAT).

■ AMCRON

Macinnes Laboratories Ltd, Macinnes House, Carlton Park Industrial Estate, Saxmundham, Suffolk IP17 2NL.
Tel: Saxmundham 2262/2615.

★ Indicates entry is illustrated.

800 Series ★

Stereo tape deck, 1/4- or 1/2-track. Three-speed 15i/s or 17 1/2i/s optional. Max reel 10 1/2 in. W and F: 15i/s 0.06%; 7 1/2i/s 0.09%; 3 3/4i/s 0.18% (RMS). H and N: 15i/s -60dB; 7 1/2i/s -60dB; 3 3/4i/s -55dB (below peak level). FR (± 2 dB): 15i/s 30Hz-30kHz; 7 1/2i/s 30Hz-25kHz; 3 3/4i/s 30Hz-15kHz. Replay char: CCIR. VU meter. Rewind time: 58 seconds for 2400ft. 38 seconds for 1200ft. Inputs: 2 mixable inputs per channel, mic or line. Sensitivity: 45mV for 0 level line), 0.4mV for 0Vu level (mic); impedance 100K, balanced or unbalanced 600 ohms, or 50/200 ohms. Output: 600 ohms. Three motors, magnetic brakes, logic circuitry for tape handling, all tape commands can be remote. A-B monitoring, source and tape mixing, echo, individual bias adjustment and metering. Size: 17 1/2 x 19 x 8 in. Weight: 50lb. Price: £700 to £2,300.



Amcron 800 series

■ AMPEX

Amplex GB Ltd, Acre Road, Reading, Berks RG2 0QR. Tel: Reading 85200.

MM-1200

Full specifications and prices on request.

AG-440C

Full specifications and prices on request.



Bias BE 1000S/RR/C

■ BIAS.

319 Trinity Road, Wandsworth, London. SW18 3SL.
Tel: 01-874 9054.

BE1000M/RR/C

Professional tape deck with pre-amplifiers. Mains operated. Console mounted or available in unit form for rack mounting. Mono full track 1/4 in tape recording and play-back. Speeds (two) (9.5/19cm/sec) 3 3/4/7 1/2ips or (19/38cm/sec) 7 1/2/15ips Max. spool size 11 1/4 in. W and F: (3 3/4i/s) <0.10% RMS. (7 1/2i/s) <0.08% RMS. (15i/s) <0.06% RMS. Equalisation switchable NAB/IEC standards. Variable speed spooling. Rewind time: <100 seconds, (driven by tape) calibrated in minutes and tenths. Inputs: Line-20dB-0dB 10K floating (bridging). Output: 0dB 600 ohms (max + 20dB) Motors: Two Papst ROT one Papst HSKZ Size 915 x 608 x 588mm. Price: on application.

BE1000S/RR/C ★

Professional tape deck with pre-amplifiers. Mains operated. Console mounted or available in unit form for rack mounting. Stereo 1/2 track 1/4 in tape, recording and play-back. Speeds (two) (9.5/19cm/sec) 3 3/4/7 1/2ips or (19/38cm/sec) 7 1/2/15ips Max. spool 11 1/4 in. W and F: (3 3/4i/s) <0.10% RMS (7 1/2i/s) <0.08% RMS. (15i/s) <0.06% RMS. Equalisation switchable NAB/IEC standards. Variable speed spooling. Rewind time: <100 seconds for 2400ft. VU or Peak Programme meter extra. Tape position clock indicator, (driven by tape) calibrated in minutes and tenths. Input: Line -20dB -0dB 10K floating (bridging). Output: 0dB 600 ohms (max + 20dB) Motors:

Two Papst ROT one Papst HSKZ. Size 915 × 608 × 588mm. Price: on application.

BE1000 Mk II T.P. ★

Transportable professional tape deck with pre-amplifiers. Mains operated. Mono or Stereo versions available. Speeds (two): 9.5/19cm/sec $3\frac{3}{4}/7\frac{1}{2}$ ips (19/38cm/sec) $7\frac{1}{2}/15$ ips. Max spool $11\frac{1}{4}$ in. W and F: ($3\frac{3}{4}$ ips) 0.1% RMS. ($7\frac{1}{2}$ ips) <0.08% RMS (15ips) <0.06% RMS. Signal/noise ratio overall. Mono full track 15ips -60dB Stereo -60dB FR: ($3\frac{3}{4}$ ips) 40Hz-10kHz ± 2 dB. ($7\frac{1}{2}$ ips) 40Hz-16kHz ± 2 dB. (15ips) 40Hz-18kHz ± 2 dB. Equalisation switchable NAB/IEC standards. Variable speed spooling. Rewind time: <100 seconds for 2400ft. VU or Peak Programme meter extra. Tape position clock indicator, (driven by tape) calibrated in minutes and tenths. Inputs: Line -20dB -0dB 10K floating (bridging) Output: 0dB 600 ohms (max +20dB) Motors: two Papst ROT one Papst HSKZ. Recorder operates in vertical or horizontal position. Dimensions approx. 24 × 20 × 9 $\frac{1}{2}$ in.

■ BRENELL ENGINEERING CO LTD

231-235 Liverpool Road, London N1 1LY.
Tel: 01-607 8271.

Mk 6 Stereo Unit

Stereo tape deck with preamplifiers. Twin 2/2 or quarter 2/4 track system. Speeds: 15, $7\frac{1}{2}$, $3\frac{3}{4}$, $1\frac{7}{8}$ ips. Max spool: $8\frac{1}{4}$ in. ($10\frac{1}{2}$ in NAB reel version available). W and F: 15ips 0.05%, $7\frac{1}{2}$ ips 0.08%, $3\frac{3}{4}$ ips 0.1%, $1\frac{7}{8}$ ips 0.12%. S/N: 56dB below 2% distortion levels of recording. FR: 15ips 40Hz-22kHz ± 3 dB, $7\frac{1}{2}$ ips 40Hz-20kHz ± 3 dB, $3\frac{3}{4}$ ips 50Hz-14kHz ± 3 dB, $1\frac{7}{8}$ ips 60Hz-7kHz ± 3 dB. Two illuminated edge-scale meters. Rewind time: less than 60 seconds for 1200ft. Inputs: mic 200 μ V 200-600 ohms, aux (1) 8mV 50K, aux (2) 8mV 50K. Output: two at 1.4V from tape recorded to 0dB meter level. Two output jack sockets on front panel, two phono sockets on rear. Horizontal or vertical operation. Three motors (all outer rotor). Four-digit tape indicator. Auto-stop. A/B switching A/B balance. Mains: 115, 210, 240V AC 50Hz. Size: $17\frac{1}{2} \times 16\frac{3}{4} \times 8$ in. Weight 33lb. Price: £185.00 (plus VAT). Industrial version with $10\frac{1}{2}$ in. NAB reels available. Prices: on application.

Mk 6 Type M

Mains mono recorder. $\frac{1}{2}$ -track (full-track version available). Speeds: 15, $7\frac{1}{2}$, $3\frac{3}{4}$, $1\frac{7}{8}$ ips. Max spool: $8\frac{1}{4}$ in ($10\frac{1}{2}$ in NAB version avail-



Bias BE 1000 Transportable

able). W and F: $1\frac{7}{8}$ ips 0.12%, $3\frac{3}{4}$ ips 0.1%, $7\frac{1}{2}$ ips 0.08%, 15ips 0.05%. H and N: $1\frac{7}{8}$ ips 50dB, $3\frac{3}{4}$ ips 54dB, $7\frac{1}{2}$ ips 56dB, 15ips 56dB. FR: $1\frac{7}{8}$ ips 60Hz-8kHz, $3\frac{3}{4}$ ips 50Hz-15kHz, $7\frac{1}{2}$ ips 40Hz-20kHz, 15ips 40Hz-22kHz, all ± 3 dB. Replay char: CCIR. Rewind time: under 60 sec for 1200ft. Illuminated edge-scale VU meter. Inputs: mic 0.1mV 200-250 ohms, aux 5mV 250K; PU mag 4mV 47K, PU ceramic 160mV 1.5 megohms. Outlets: external amplifier 200mV into 10K, external speaker 15W into 8 ohms or 8W into 15 ohms. Speaker: 7 × 5in. Output: 15W RMS into 8 ohms, 8W into 15 ohms. Transistorised. Own deck. Horizontal or vertical operation. Three motors (Papst outer rotor). Pause control. Straight-through amplifier. Monitoring. Input mixing. Accepts pickups direct. A/B switching. Size: $16\frac{1}{2} \times 7 \times 18$ in. Weight: 35lb. Mains: 110, 210, 240V AC. Price: £150 (plus VAT).

Multi-channel recorders

A new range of master recorders for sound recording studios and industrial and scientific applications. Series A, full-track on $\frac{1}{4}$ in tape; Series B, half-track on $\frac{1}{4}$ in tape; Series C, four-track on $\frac{1}{2}$ in tape; Series D, four-track on 1in tape; Series E, eight-track on 1in tape; Series F, 16- and 24-track on 2in tape. Each series comprises four basic self-contained units; (1) tape transport, (2) record/play amplifier (one per channel), (3) master oscillator unit, (4) power supply unit, (5) optional remote control unit for all deck functions. Suitable for 19in rack mounting. Consoles available. Full specifications and prices on request.

★ Indicates entry is illustrated.

■ FERROGRAPH

The Ferrograph Company Ltd, Auriema House, 442 Bath Road, Cippenham, Slough SL1 6BB. Tel: Burnham 62511.

Series 75 ★

Series 75 is a full new range of stereo tape recorders. Other versions available: 7502, 7502H, 7522, 7522M, 7504, 7504H, 7524, 7524H. High speed models (suffix H). Prices range from £360-465 (excluding VAT).

7502

1/2-track stereo tape unit with preamps only. Speeds (cm/sec): 19, 9½, 4¾. Max spool size: 10½in. W and F: 0.08% (19), 0.15% (9½), 0.20% (4¾). S/N ratio: better than 60dB (CCIF weighted). FR: 30Hz-17kHz ±2dB (19), 40Hz-14kHz ±3dB (9½), 40Hz-14kHz ±3dB (4¾). Replay char: DIN. Rewind time: variable up to 1¼min for 360m tape. Level indicator: VU. Inputs: mic 300µ V-15mV 10K, line 50µ V-10V/2M ohms. Outputs: line 2V/600 ohms, low level 300m V 10K, low level adjustable up to 300mV 10K. Motors: one synchronous and two constant torque. Three heads, PB multiplex, AB comparison, adjustable tape tensioning. Mains: 200-250V or 117V (suffix A). Size: 20¼ × 17½ × 10in. Weight: 55lb. Price: £450.00 (inclusive of VAT).

7502D

Same specifications as 7502 but includes Dolby 'B'. Price: £531.25 (inclusive of VAT).

7522

Same specifications as 7502 but with power amps. Speaker output up to 10W per channel into 8-16 ohms. Speaker size: 7 × 4in. Price: £500.00 (inclusive of VAT).



Ferrograph Super Seven Series 75

7522D

Same specification as 7502 but includes Dolby 'B' and power amps. Speaker output up to 10W per channel into 8-16 ohms. Speaker size: 7 × 4in. Price: £581.25 (inclusive of VAT).

7504

¼-track-stereo tape unit with preamps only. Specification same as 7502. Price: £450.00 (inclusive of VAT).

7504D

¼-track stereo tape unit with preamps only. Specification same as 7502 but with Dolby 'B'. Price: £531.25 (inclusive of VAT).

7524

¼-track stereo tape unit with power amps. Same specification as 7502. Output up to 10W per channel into 8-12 ohms. Speaker size: 7 × 4in. Price: £500.00 (inclusive of VAT).

7524D

¼-track stereo tape unit with Dolby 'B' and power amps. Same specification as 7502. Speaker output up to 10W per channel into 8-16 ohms. Speaker size: 7 × 4in. Price: £581.25 (inclusive of VAT).

7502H

1/2-track, high speed stereo tape unit, with preamp only. Speeds (cm/sec): 38, 19, 9½. Max spool size: 10½in. W and F: 0.08% (38), 0.10% (19), 0.15% (9½). S/N ratio: better than 60dB (CCIF weighted). FR: 30Hz-20Hz ±2dB (38), 30Hz-17kHz ±2dB (19), 40Hz-14kHz ±3dB (9½). Replay char: DIN. Rewind time: Variable up to 1¼ min for 360m tape. Level indicator: VU. Inputs: mic 300µV-15mV 10K, line 50µV-10V/2M ohms. Outputs: line 2V/600 ohms, low level 300mV 10K, low level adjustable up to 300mV 10K. Motors: one synchronous and two constant torque. Mains: 200-250V AC or 117 (suffix A). Three heads, PB multiplex, AB comparison, adjustable tape tensioning. Size: 20¼ × 17½ × 10in. Weight: 55lb. Price: £450.00 (inclusive of VAT).

7502DH

Same specification as 7502H, but includes Dolby 'B'. Price: £531.25 (inclusive of VAT).

7522H

Same specifications as 7502H but with power amps. Speaker output up to 10W per channel into 8-16 ohms. Speaker size: 7 × 4in. Price: £500.00 (inclusive of VAT).

7522DH

Same specifications as 7502H but with power amps and Dolby 'B'. Speaker output up to 10W per channel into 8-16 ohms. Speaker size: 7 x 4in. Price: £581.25 (inclusive of VAT).

7504H

1/4-track, high speed stereo tape unit with preamps only. Same specifications as 7502H. Price: £450.00 (inclusive of VAT).

7504DH

1/4-track, high speed stereo tape unit with Dolby 'B' and preamps. Same specifications as 7502H. Price: £531.25 (inclusive of VAT).

7524H

1/4-track, high speed stereo tape unit with power amps. Same specification as 7502H. Speaker output up to 10W per channel into 8-16 ohms. Speaker size: 7 x 4in. Price: £500.00 (inclusive of VAT).

7524DH

1/4-track, high speed stereo tape unit with Dolby 'B' and power amps. Same specification as 7502H. Speaker output up to 10W per channel into 8-16 ohms. Speaker size: 7 x 4in. Price: £581.00 (inclusive of VAT).

■ **GRUNDIG**

Grundig International Ltd, Newlands Park, London SE26 5NQ.
Tel: 01-659 2468.

TK745 ★

1/4-track stereo tape recorder. Speeds (cm/sec): 19, 9½, 4¾. Max spool size: 7in. W and F: 0.07% (19), 0.12% (9½), 0.2% (4¾), S/N ratio: <54dB (19), <52dB (9½), <45dB (4¾). FR: 40Hz-18kHz (19), 40Hz-15Hz (9½), 40Hz-8kHz (4¾). Level indication: VU. Inputs: mic 1mV 100K, radio diode 3mV 30K, phono 100mV/1M ohms. Outputs: line 800mV 20K, speakers 7W/4 ohms, phones 2V/100 ohms. Facilities for synchronous, multiplay and echo recordings. Automatic or manual recording level control. Mains: 110-240V. Size: 49.7 x 30.7 x 15.2cm. Weight: 27½lb. Price: £212.00 (inclusive of VAT).

TK545 ★

Stereo tape recorder. W and F: 0.07% (19), 0.12% (9½). S/N Ratio: <54dB (19), <52dB (9½). FR: 40Hz-18kHz (19), 40Hz-15kHz (9½). VU meter. Inputs: mic 1mV 100K, radio diode 5mV 50K, phono 100mV 1M. Outputs: line 1V/10K, speakers 7W/4 ohms. One motor. Mains: 110-240V. Dimensions: 41.8 x 30 x 15.4cm. Price: £175.00 (inclusive of VAT).



Grundig TK745

■ **KLARK-TEKNIK**

Klark-Teknik Research Ltd, Summerfield, Kidderminster.
Tel: Kidderminster 64027/63467

SM2

Full servo controlled professional stereo recording console. All professional track configurations used at this time are available. Features dual variable speed capstans independent from mains frequency. Specifications: S/N Ratio 65dB. Two fixed speeds: 19cm/sec and 38cm/sec or 38 and 76cm/sec. Varispeed covers 12cm/sec-90cm/sec. W and F: <0.05%. Start time: 0.3sec. NAB and DIN equalisation. FR: 30-18KHz ± 1.5dB both speeds. 4 D.C. servo controlled motors. Mains: 110/120-220/240 AC. Price and further details on request.



Grundig TK 545

★ Indicates entry is illustrated.

■ LEEVERS-RICH

Leevers-Rich Equipment Ltd,
319 Trinity Road, Wandsworth,
London SW18 3SL. Tel: 01-874 9054.

Model E200

Speeds: 15i/s, 3 $\frac{3}{4}$, 7 $\frac{1}{2}$ i/s or 15/30i/s to special order. Max spool 11 $\frac{1}{4}$ in. Three motors. Full-track, twin-track or stereo. FR: 40Hz-18kHz. Noise: full track -62dB, twin track -58dB. W and F: better than 0.1% at all speeds. VU level meter. PPM to special order. Fully transistorised amplifiers. Modular construction throughout. Price: from £1,080.00 (plus VAT).

E200F/M

Heavy duty professional recorder/reproducer system. Mono full track $\frac{1}{4}$ in tape. Max. spool 11 $\frac{1}{4}$ in. Speeds (two) 3 $\frac{3}{4}$ /7 $\frac{1}{2}$ ips (9.5&19cm/sec) to order or 7 $\frac{1}{2}$ /15ips (19/38cm/sec). Equalisation: IEC or NAB standard. W and F: (3 $\frac{3}{4}$ ips) <0.1% RMS (7 $\frac{1}{2}$ ips) <0.08% RMS (15ips) <0.06% RMS. Signal/noise at 15ips -62dB. FR: Overall (3 $\frac{3}{4}$ ips) 40Hz-10kHz \pm 2dB (7 $\frac{1}{2}$ ips) 40Hz-14kHz \pm 2dB (15ips) 40Hz-18kHz \pm 2dB. Input: 10K bridging -14dBm for peak recording level. Output: Max output before clipping \pm 22dBm into 600 ohms. Terminations Cannon XLR3. Console mounted or in unit form for rack mounting. Dimensions: Console form 24 x 24 x 38in. Weight 215lb. Optional extras: peak programme meters (self contained) Speaker/Monitor Amplifiers Remote Control. Price: available on request.

E200 LowLine ★

Heavy duty professional audio recorder/reproducer system. Mono or Stereo versions available. Specifications as E200. Various optional extras include peak programme meters, self contained monitor speaker/amplifiers, remote control and edit panel. (containing splicing block and leader tape cartridge) Price: available on request.

E200S/M

Heavy duty professional recorder/reproducer system, stereo $\frac{1}{4}$ in tape. Max spools 11 $\frac{1}{4}$ in. Speed (two) 3 $\frac{3}{4}$ /7 $\frac{1}{2}$ ips (9.5/19cm/sec) to order or 7 $\frac{1}{2}$ /15ips (19/38cm/sec) Equalisation IEC or NAB standards. W and F: (3 $\frac{3}{4}$ ips) <0.1% RMS (7 $\frac{1}{2}$ ips) <0.08% RMS (15ips) <0.06% RMS. S/N: at 15ips -dB. FR: Overall (3 $\frac{3}{4}$ ips) 40Hz-10kHz \pm 2dB (7 $\frac{1}{2}$ ips) 40Hz-14kHz \pm 2dB (15ips) 40Hz-18kHz \pm 2dB. Input: 10K bridging -14dBm for peak recording level. Output: Max output before clipping +22dBm into 600 ohms. Terminations cannon XLR3. Console mounted or in unit form for rack mounting. Dimensions: Console form 24 x 24 x 38in.



Leevers-Rich E200 Lowline console



Nagra Model 4.2

Weight 215lb. Optional extras: peak programme meters (self contained) Speaker/Monitor amplifiers remote control. Price: AVAILABLE ON REQUEST.

■ NAGRA

Distributed by: Hayden Laboratories Ltd,
Hayden House, Churchfield Road,
Chalfont St. Peter, Bucks SL9 9EW
Tel: Gerrards Cross 5511.

Audio equipment showroom, service department and despatch department: 6 Bendall Mews, London, NW1.

Model 4.2 ★

Professional battery-operated portable tape recorder. Speeds: 15i/s, 7 $\frac{1}{2}$ i/s, 3 $\frac{3}{4}$ i/s. Size: 12 $\frac{1}{2}$ x 8 $\frac{3}{4}$ x 4 $\frac{1}{4}$ in. Weight: (excluding batteries) 11 $\frac{1}{2}$ lb. Max spool: (lid closed) 5in. (lid open) 7in. Power supply; 12 type SP2 batteries fitted internally, or external mains unit. Switchable auto-level control. Switchable input filters. Two-stage over-load filter. Modu-

lar construction. Preamplifiers to suit all types of microphones. Built-in monitoring speaker. Single DC servo-controlled motor. Monitoring headphones switchable to tape or direct. Reference tone generator. Separate record and playback amplifiers. Electromagnetic indication of speed stability, battery level and tape jamming. W and F: 15i/s 0.05%, 7½i/s 0.07%, 3¾i/s 0.15%. Overall speed stability: better than 0.05%. Temperature range -55deg C to +77deg C. FR: 15i/s 30Hz-20kHz ±2dB, 7½i/s 30Hz-15kHz ±2dB, 3¾i/s 30Hz-10kHz ±2dB. Rewind time: 600ft/min. Details and prices of various models as follows.

Model 4.2L

Full-track mono version with pilotone. Inputs from two mics and line. Line output: 4.4V, 600 ohms. S/N ratio: -67 to -70dB depending on speed and tape. Visual pilotone indicator. Pilotone input level 0.5-25V. Price: £1,452.00 (plus VAT).

Model 4.2LSP

As Model 4.2L but excluding pilotone facility. Price: £1,386.00 (plus VAT).

Model IV-SL

½-track model with pilotone. Preamplifiers switchable to suit all types of microphone. Output: 1V 600 ohms. Special Nagra master recording position. Coaxial PPM with two needles to indicate record level and groove cutting depth. S/N ratio: -65dB to -72dB depending on speed and tape. Frequency modulated pilotone channel to permit pilotone and cue speech recording. Pilotone level 2V. Price: £1,809.50 (plus VAT).

Model IV-S

As Model IV-SL but excluding pilotone facility. Price: £1,603.00 (plus VAT).

Special models for industrial sound level recording available.

Miniature Nagra SN ★

Full-track battery-operated professional stereo recorder. Speeds: (model SNN-2) 3¾, 17/8i/s; (model SNS-2) 17/8, 15/8i/s. Spool capacity: 154m standard tape, 308m 12.5 micron tape. W and F: 3¾i/s ±0.1%, 17/8i/s ±0.15% (both to DIN 45 507). S/N ratio: 3¾i/s 60dB (ASA 'A' with tape); 17/8i/s 55dB (ASA 'A' with tape); 15/8i/s 55dB (ASA 'A' with tape). FR: 80Hz-15kHz ±2dB. Replay char: CCIR. Rewind time: (hand winding) 60 sec. Meter level indicator. Inputs: microphone, current input from 200 ohms or greater (3µA RMS, max level 100µA RMS). Alternative line input for normal

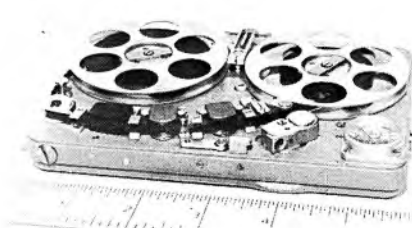

Nagra Miniature SN

modulation level from 100 ohms source -160mV RMS. Outlets: line 600mV across 1K, headphones. One DC series commutator motor. Own deck. Compression indicator and battery check meter. Remote control start/stop. Pilotone version available. Size: 5¼ × 4 × 1½in, approximately. Weight: 1.3lb. (including batteries and tape). Supply: two manganese cells (Mallory Mn1500 or equivalent) Price: £821.70 (plus VAT).

IS

Compact, battery operated mono portable tape recorder of modular construction equipped with two microphone inputs and switchable input filters. DC servo-controlled motor. monitoring headphones switchable to either tape or direct. Tape speed: 7½ips. W and F: 0.15%. FR: 50-15,000. Output power: 4.4 V into 600 ohms. SN: 68dB ASA weighted ref 320nWb/mm. Bias frequency: 120kHz. DC brush type motor. Three heads. Maximum spool capacity: 5in. Dimensions: 10¾ × 8 × 3½in. Price: £1,129.70 (plus VAT).

IS-DE

Identical to IS-D version but with universal microphone preamplifier (for dynamic and capacitor microphones), level metering switchable to modulometer, super VU-meter or PV-meter, reference generator supplied as an option.

IS-DT

Identical to IS-DE version, but with two tape speeds, 7½ and 3¾ins. A combined circuit with automatic level control and reference generator is supplied as an option.

IS-L

Same as IS-D but with Pilotone

IS-LE

Same as IS-DE but with Pilotone

IS-LT

Same as IS-DT but with Pilotone.

■ PHILIPS

Philips Electrical Ltd, Century House,
Shaftesbury Avenue, London WC2H 8AS.
Tel: 01-437 7777.

N4511

Mains operated stereo 1/4-track tape deck. Speeds: 7 1/2, 3 3/4, 1 7/8 i/s. Max. spool: 7in. W and F: (DIN 45 500) 7 1/2 i/s 0.15%, 3 3/4 i/s 0.2%, 1 7/8 i/s 0.35%. Noise: 7 1/2 i/s -50dB, 3 3/4 i/s -50dB 1 7/8 i/s -48dB. Hum: 7 1/2 i/s (all speeds) -45dB. FR: 7 1/2 i/s 40Hz-25kHz (DIN) 3 3/4 i/s 20Hz-15kHz \pm 3dB, 1 7/8 i/s 60Hz-8kHz \pm 3dB. Replay char: DIN. Rewind time: 180 seconds for 1800ft. Two level meters. Four-digit tape position indicator with PB reset. Inputs: mic 0.15mV 2K, radio 100mV 100K, line 2mV 20K, PU 1.5V 47K. Outlets: line 1V 50K, headphones 3V 400-600 ohms, monitor 1V 50K. Three DC motors. Fitted with long life heads. Own deck. Size: 20 1/4 \times 15 \times 7 3/4 in. Weight: 24lb. Pause control. Monitoring on record. Input mixing. Parallel track replay. Solenoid controlled operation. Full remote control operation using Philips unit N6719. Price: £249.00 (including VAT)

N4504 ★

Mains operated 1/4-track tape deck. Speed: 7 1/2 3 3/4 1 7/8 ips. Max spool 7in. (DIN 45,500) 7 1/2 0.15% 3 3/4 2% 1 7/8 i/s \leq 2%. Noise 7 1/2 \geq 58dB 3 3/4 \geq 58dB 1 7/8 ips. \geq 56dB weighted. FR: 7 1/2 i/s 35-20,000Hz, 3 3/4 i/s 35Hz-18kHz 1 7/8-35-11,000 Hz. Rewind time \leq 180 sec for 7in LP tape. 3 heads. Long life. A-B monitoring suitable DNL with light, electronically controlled capstan motor. Solenoid operation 2 DC winding motors. Two metres 4 digit counter. Sockets tape in/out monitor output. Mic input left or stereo. Mic input right. Headphones socket. Remote control socket. Size: 58 \times 53.5 \times 34cm. Weight: 10.75Kg. Price: £202.50 (inclusive of VAT).

■ PIONEER

Shriro (UK) Ltd, Shriro House,
The Ridgeway, Iver, Bucks SL0 9JL.
Tel: Iver 652222.

RT 1050

Open reel professional tape deck. Drive system: 3 motor. Tape heads: interchangeable plug-in assemblies. Speeds: 15 and 7 1/2 i/s. Reel size: 10in. Fast wind: 110 secs (10 1/2 in). W and F: less than 0.04% WRMS. S/N ratio: better than 57dB. FR: 30-22,000Hz \pm 3dB. Stereo separation: better than 53dB. Erasing coefficient: better than 60dB. Bias frequency: 125kHz. Inputs: mic 0.25-80mV 20K, line



Philips 4504

50mV-25V 100K, Rec/PB DIN jack 15mV-1.5V 1.5K. Outputs: line 316mV 50K, Rec/PB DIN jack 316mV. Price on application.

RT 1011L

Open reel tape deck. Drive system: 3 motor. Tape heads: 1 \times 4-track, 2-channel erase; 1 \times 4-track, 2-channel record; 1 \times 4-track, 2-channel PB. Reel size: 10 1/2 in. Tape speeds: 7 1/2 and 3 3/4 i/s. W and F: less than 0.08% WRMS. S/N ratio: better than 55dB. FR: 40-20,000Hz. Crosstalk: better than 60dB. Channel separation: better than 50dB. Erase coefficient: better than 60dB. Bias frequency: 125kHz. Equaliser: 2-step NAB standard. Bias selector: 2-step. Line/mic mixing. Inputs: 2 \times line 50mV/25V/100K, 2 \times mic 0.25mV/80mV/20K, 1 \times Rec/PB DIN jack 15mV/1.5V/1.5K. Size: 16 7/8 \times 16 7/8 \times 9in. Price: on application.

■ REVOX

Distributors: C. E. Hammond & Co. Ltd,
Lamb House, Church Street,
London W4 2PB. Tel: 01-995 4551.

Series 77 ★

Stereo tape recorder. Tape speed: 3 3/4 i/s and 7 1/2 i/s max deviation from nominal \pm 0.2%. W and F: total RMS, weighted 0.04% at 7 1/2 i/s and 0.05% at 3 3/4 i/s. Weighted peak to peak flutter as per DIN 0.08% at 7 1/2 i/s and 0.1% at 3 3/4 i/s. Tape slip: not exceeding 0.2%. Max spool size: up to 10 1/2 in (minimum hub diameter 2 3/4 in). Operating position: horizontal, vertical or

inclined. S/N ratio: weighted as per ASA-A, readings via tape; $7\frac{1}{2}$ /s better than 66dB (4 track 59dB). stereo better than 45dB. Inputs (per channel): mic, low impedance 50-600 ohms. 0.15mV, high impedance up to 100K, 2.5mV, radio 2.5mV; aux 35mV. All inputs have an overload margin of 40dB (1:100). Outputs (per channel: amplifier max 2.5V; Internal impedance: 600 ohms: radio max 1.2V; internal impedance 2.5K; headphones, volume adjustable, load impedance 200 ohms or more. Power amplifier: optional plug-in amplifiers, $2 \times 10W$ music power as per IHFM. Power requirements: voltage selector for 110-250V, 50-60Hz operation without need for conversion, consumption 70-100W. Various versions as follows.

Model 1102 or 1104

Chassis in teak surround, no output amplifiers, $\frac{1}{2}$ or $\frac{1}{4}$ -track. Price: £369.00 plus VAT).

Model 1122 or 1124

Chassis in teak surround with output amplifiers, $\frac{1}{2}$ on $\frac{1}{4}$ -track. Price: £409.00 plus VAT).

Model 1302 or 1304

Chassis in metal encasement for rack mounting, no output amplifiers, $\frac{1}{4}$ or $\frac{1}{2}$ -track. Price: £425.00 (plus VAT).

Model 1322 or 1324

As 1302/4, but with 10W output amplifiers; $\frac{1}{2}$ or $\frac{1}{4}$ -track. Price: £474.00 (plus VAT).

Model 1222 or 1224

Complete recorder in suitcase with amplifiers and four speakers, $\frac{1}{2}$ or $\frac{1}{4}$ -track. Price: £369.00 (plus VAT).

Model DL1132 or DL1134

As 1102 and 1104 but with Dolby B noise reduction system. Price: £474.00 (plus VAT).

Model DL1332 or DL1334

As 1302 and 1304 but with Dolby B noise reduction system. Price: £409.00 (plus VAT).

All models available in High Speed series ($7\frac{1}{2}$ /15i/s).

A700 ★

Stereo tape recorder. Tape speed: 15i/s, $7\frac{1}{2}$ i/s and $3\frac{3}{4}$ i/s. Weighted peak flutter: at 15i/s less than 0.08%, at $3\frac{3}{4}$ i/s less than $\pm 0.06\%$, at $7\frac{1}{2}$ i/s less than $\pm 0.1\%$. Timer: read-out in minutes and seconds (4 digits),



Revox Series 77



Revox A700 tape recorder and deck

reel-time indication for $7\frac{1}{2}$ i/s tape speed. Accuracy 0.5%. Tape-reel dimension: up to $10\frac{1}{2}$ in outside diameter with automatic tension change down to a minimum hub diameter of $1\frac{1}{2}$ in. FR (via tape); 15i/s 50Hz-18Hz ± 1.5 dB; $7\frac{1}{2}$ i/s 50Hz-15kHz ± 1.5 dB; $3\frac{3}{4}$ i/s 50Hz-10kHz ± 1.5 dB. Equalisation: NAB. Peak recording level: 514nWb/m (corresponds to +6 VU). Level indication: VU meter. Overload indication (trigger level): +6 VU (514n Wb/m). Response time: approximately 10m/sec. Storage time: approximately 0.2 sec. S/N: (ASA-A) referred to peak recording level (+6 VU), 15i/s better than 65dB, $7\frac{1}{2}$ i/s better than 63dB. Inputs: mic stereo, balanced 50-6000 ohms; position Low: 0.15mV 6K; position High: 1.8V 6K. Phono 2.5mV 50K; radio 3mV 33K, $2 \times 40mV$ 100K. All inputs have an

★ Indicates entry is illustrated.

overload margin of 40dB (1:100). Outputs: output level from a peak-level-recording at +6VU. Line A and B 1.55V 5K. 1 × radio (DIN): 0.775V, 10K; 2 × headphone: max 4.9V 100 ohms; 1 × power amplifier: max 3.1V 100 ohms, including remote mains switching for A722. Power requirements: voltage selector for 110-220V 50-60Hz. Price: (code 1372 2-track, code 1374 4-track). £765.00 (plus VAT).

■ SONY

Consumer Information, Sony Showroom, 134 Regent Street, London W1R 6DS. Tel: 01-439 3874.

TC 280

Stereo tape deck: 1/4-track stereo and 1/4-track mono. Max. spool: 7in. Speeds: 7 1/2, 3 3/4, 1 7/8 i/s. W and F: 7 1/2 i/s 0.1% RMS; 3 3/4 i/s 0.15% RMS; 1 7/8 i/s 0.2% RMS. FR: "normal" tape, 7 1/2 i/s 40Hz-18kHz ±3dB, 30Hz-18kHz DIN; 3 3/4 i/s 40Hz-12.5kHz DIN. "SLH" tape, 7 1/2 i/s 40Hz-21kHz ±3dB, 30Hz-20kHz DIN; 3 3/4 i/s 40Hz-14kHz DIN. S/N: "normal" tape 52dB, "SLH" tape 55dB. Bias frequency: 160kHz. Heads: F & F rec/PB, erase head. Input: mic low 0.2mV; line 0.06V 100K; rec/PB 3.8K. Output: line 0.775V 100K; phono 8 ohms, rec/PB 3.3K. Mains: 110, 127, 220 and 240V AC 50-60Hz (factory set 240V, 50Hz). Size: 394 × 184 × 353mm. Weight: 9.6kg. Supplied accessories: one reel R7ES, two connecting leads RK74, one head cleaning tip, one mains lead. Price: £106.43 (plus VAT).

TC 458

Stereo tape deck: 1/4-track stereo and 1/4-track mono. Continuous playback, forward and reverse recording. Max spool 7in. Speeds: 7 1/2, 3 3/4 i/s. W and F: 7 1/2 i/s 0.06% RMS; 3 3/4 i/s 0.1% RMS. FR: "normal" tape, 7 1/2 i/s 30Hz-20kHz ±3dB, 30Hz-20kHz DIN; 3 3/4 i/s 20Hz-17kHz -15dB; 40Hz-13kHz DIN. "SLH" tape, 7 1/2 i/s 30Hz-25kHz ±3dB, 30Hz-24kHz DIN; 3 3/4 i/s 20Hz-20kHz -15dB, 40Hz-16kHz DIN. S/N: "Normal" tape 53dB, "SLH" tape 56dB. THD: <1.2%. Heads: F & F, one record, one playback, two erase. Input: mic low 0.2V; line 0.06V 100K DIN 10K. Output: line 0.775V 10K, phones 8 ohms DIN 50K. Mains: 240V AC 50Hz. Size: 403 × 413 × 203mm. Weight: 15kg. Supplied accessories: two RK74 connecting leads, head cleaning tips; 7in plastic reel. Price: £222.18 (plus VAT).

TC 755

Stereo tape deck: 1/4-track stereo and 1/4-track mono. Max spool 10 1/2 in. Speeds: 7 1/2, 3 3/4 i/s. W and F: 7 1/2 i/s 0.05% RMS; 3 3/4 i/s 0.08% RMS.

FR: "normal" tape, 7 1/2 i/s 30Hz-20kHz ±3dB, 30Hz-20kHz DIN; 3 3/4 i/s 20Hz-17kHz -15dB, 40Hz-13kHz DIN. "SLH/CrO₂" tape, 7 1/2 i/s 30Hz-25kHz ±3dB, 30Hz-24kHz DIN; 3 3/4 i/s 20Hz-20kHz -15dB, 40Hz-16kHz DIN. S/N: "normal" tape" 53dB, "SLH/CrO₂" tape 56dB. THD: <1.2%. Heads: F & F, one record, one playback, one erase. Three motors. Inputs: mic low 0.2mV; line 0.06V 100K DIN 3.9K. Output: line 0.43V 10K; phones 8 ohms, DIN 0.43V 2K. Mains: 110, 127, 220 and 240V AC 50Hz (factory set 240V, 50Hz). Size: 435 × 451 × 221mm. Weight: 24kg. Supplied accessories: two RK74 connecting leads, head cleaning tips, 10 1/2 in plastic reel. Price: £305.51 (plus VAT).

TC 756-2

Stereo tape deck: 1/2-track stereo and 1/2-track mono. Max spool 10 1/2 in. Speeds: 15, 7 1/2 i/s. W and F: 15 i/s 0.04% RMS; 7 1/2 i/s 0.06% RMS. FR: "normal" tape 15 i/s 30Hz-22kHz ±3dB, 30Hz-30kHz DIN; 7 1/2 i/s 30Hz-15kHz ±3dB, 30Hz-20kHz DIN. "SLH" tape, 15 i/s 30Hz-30kHz ±3dB, 30Hz-35kHz DIN; 7 1/2 i/s 30Hz-25kHz ±3dB, 30Hz-25kHz DIN. S/N: "normal" tape 56dB, "SLH" tape 59dB. THD: 1.2%. Heads: F & F, one record, one playback, one erase. Three motors. Input: mic low 0.2mV; line 0.06V 100K. Output: line 0.435V 100K; phones 8 ohms. Mains: 110, 127, 220, 240V AC 50-60Hz (factory set 240V, 50Hz). Size: 435 × 450 × 221mm. Weight: 24kg. Supplied accessories: 10 1/2 in plastic reel, RK74 connecting lead, head cleaning tips, mains lead. Price: £333.29 (plus VAT).

TC 645

Stereo tape recorder. Recording system. AC bias, 160kHz. Track system: 4-track, 2-channel. Tape speeds, 7 1/2 i/s, 3 3/4 i/s. W and F: DIN ±0.09% at 7 1/2 i/s; ±0.12% at 3 3/4 i/s. S/N ratio: 53dB normal, 56dB special SLH. Heads: F & F record head, PB head, erase head. FR: normal, 7 1/2 i/s 30Hz-20kHz ±3dB, 30Hz-20kHz DIN, SLH tape 30Hz-25kHz ±3dB, 30Hz-24kHz DIN, normal 3 3/4 i/s 20Hz-17kHz -15dB, 40Hz-13kHz DIN, SLH tape 3 3/4 i/s 20Hz-20kHz -15dB, 40Hz-16kHz DIN. THD: 1.2%. Inputs: mic low 0.2mV (-72dB), line 60mV (-22dB) 100K, DIN 10K. Size: 370 × 378 × 224mm. Weight: 18.5kg. Price: £212.92 (plus VAT).

TC 377 ★

Stereo tape recorder. Recording system: 4-track, 2-channel, stereo and 4-track monaural. Speeds: 7 1/2 i/s, 3 3/4 i/s, 1 7/8 i/s. Heads: F & F head, F & F PB head, erase head. Bias

frequency: 160kHz approx. S/N ratio; normal tape 52dB, with SLH tape 55dB. FR: normal 7½i/s 30Hz-20kHz ±3dB, 30Hz-20kHz DIN, with SLH tape 7½i/s 30Hz-25kHz ±3dB. 30Hz-24kHz DIN, normal 3¾i/s 40Hz-13kHz DIN, SLH tape 3¾i/s 40Hz-16kHz DIN. THD: less than 1.2%. W and F: 7½i/s ±0.09% DIN, 3¾i/s ±0.12% DIN. Inputs: mic low -72dB (0.2mV), line -22dB (0.06V) 100K, Rec/PB -33dB 3.8K. Size: 418 × 210 × 392mm. Weight: 11.5kg. Mains: 110, 127, 220 and 240V AC 50/60Hz. Price: £143.00 (plus VAT).

TC 880-2

Stereo tape recorder. Recording system: AC bias, 160kHz. Track system: 2-track, 2-channel, rec/PB, 4-track, 2-channel, PB. Speeds: 7½i/s, 15i/s. W and F: 7½i/s ±0.04% DIN, 15i/s ±0.03 DIN. S/N ratio: 60dB SLH tape. FR: normal 7½i/s 25Hz-20kHz ±2dB. FeCr tape 25Hz-30kHz ±2dB, normal 15i/s 25Hz-30kHz ±2dB, FeCr tape 20Hz-40kHz ±2dB. Inputs: mic low -72dB (0.2mV), line -22dB (60mV) 100K. AC servo-controlled, direct-drive system motor. Mains: 240V AC. Price: £960.00 (plus VAT).



Sonov TC 377 and TC 280

■ **TANDBERG (UK) LTD**

Farnell House, 81 Kirkstall Road, Leeds LS2 1HR. Tel: Leeds 35111.

10 XD ★

Professional stereo deck combining the Crossfield recording technique with Dolby "B" noise reduction system. Features include facilities for echo, sound-on-sound, editing, A and B tape, tests, etc., peak level meter, remote control facility. Tape speeds: 7½, 3¾, 15i/s. W and F: 0.07% using 15i/s tape, 0.09% for 7½, 0.15% for 3¾. FR: 30-30,000Hz at 15i/s, 20-26,000Hz at 7½, 20-20,000Hz at 3¾. Distortion from amplifier at 0dB: 0.2%. Crosstalk at 1,000Hz min: mono 60dB, stereo 50dB. Four heads. Max. spool capacity: 10in. Dimensions: 43.5 × 45 × 18.5cm. Price: £556.00 (plus VAT).



Tandberg 10XD Reel-to-Reel recorder

3400X ★

A stereo tape recorder with stereo power amplifier and featuring sound on sound, echo, two built-in loudspeakers with bass and treble controls. Tape speeds: 7½, 3¾, 1½i/s. FR: 7½ 30-26,000Hz, 3¾ 30-20,000Hz, 1½ 30,11,000Hz. Distortion: 0.3%. Crosstalk: mono 60dB, stereo 50dB. Four heads. Max. spool capacity: 7in. Dimensions: 40 × 18 × 41cm. Price: 2-track £254.00 (plus VAT), 4-track: £229.00 (plus VAT).

3500 X

Middle priced recorder with the Crossfield recording technique and featuring peak level meters, sound on sound, echo, source and tape tests for recording, photo-electric stop and front output for stereo headphones. Tape speeds: 7½, 3¾, 1½i/s. W and F: 7½ 0.1%, 3¾ 0.18%, 1½ 0.35%. FR: 7½ 30-26,000Hz, 3¾ 30-20,000Hz, 1½ 30-11,000Hz. Distortion: 0.3%. S/N: 57dB. Crosstalk: mono 60dB, stereo 50dB. Four heads. Max. spool capacity: 7in. Dimensions: 40 × 18 × 41cm. Price: £180.00 (plus VAT).

★ Indicates entry is illustrated.

3600 XD

Dolby recorder in middle price range with Crossfield recording technique and following features: peak level meters, sound on sound, echo, source and tape tests for recording, photo-electric stop and front output for stereo headphones. Tape speeds: $7\frac{1}{2}$, $3\frac{3}{4}$, $1\frac{7}{8}$ i/s. W and F: $7\frac{1}{2}$ 0.1%, $3\frac{3}{4}$ 0.18%, $1\frac{7}{8}$ 0.35%. FR: $7\frac{1}{2}$ 30-26,000Hz, $3\frac{3}{4}$ 30-20,000Hz, $1\frac{7}{8}$ 30-11,000Hz. Distortion: 0.3%. S/N: 60dB. Crosstalk: mono 60dB, stereo 50dB. No. of heads: four. Max. spool capacity: 7in. Dimensions: 40 × 18 × 41cm. Price: £226.00 (plus VAT).

9100 X

Stereo tape deck available as 2 or 4 track with mixing in stereo, echo, sound on sound, AB tests, peak level meters, logic controls, remote control facility. Tape speeds: $7\frac{1}{2}$ 0.09%, $3\frac{3}{4}$ 0.15%, $1\frac{7}{8}$ 0.30%. FR: $7\frac{1}{2}$ 30-26,000Hz, $3\frac{3}{4}$ 30-20,000Hz, $1\frac{7}{8}$ 30-11,000Hz. Distortion: 0.2%. Crosstalk: mono 60dB, stereo 50dB. Three motors, four heads, 7in spool size. Dimensions: 40 × 18 × 41cm. Price: 2-track £330.00 (plus VAT), 4-track, £322.00 (plus VAT).

■ TEAC

Teledyne Acoustic Research, High Street, Houghton Regis, Dunstable, Beds.
Tel: Dunstable 603151.

A 2300 SD

$\frac{1}{4}$ -track 2 channel stereo with Dolby system. Tape speeds: $7\frac{1}{2}$, $3\frac{3}{4}$ i/s. W and F: 0.08% at $7\frac{1}{2}$, 0.10% at $3\frac{3}{4}$. FR: 40-24,000 at $7\frac{1}{2}$, 40-16,000Hz at $3\frac{3}{4}$. Distortion: 1% at 1kHz. Output power: 0.3V. S/N: 58dB (65dB wtd) at 3% THD, 65dB (74dB wtd) at 3%. THD with Dolby. One dual speed hysteresis synchronous motor, two eddy current induction motors. Three heads, 7in spool. Dimensions: 44 × 39 × 21cm. Price: £344.00 (plus VAT).

A 3300S ★

Stereo tape deck. Tape speeds: $7\frac{1}{2}$, $3\frac{3}{4}$ i/s. W and F: 0.06% $7\frac{1}{2}$, 0.09% $3\frac{3}{4}$ i/s. FR: 30-28,000Hz at $7\frac{1}{2}$, 30-20,000Hz at $3\frac{3}{4}$. Distortion: 1% at normal operating level. S/N: 58dB. Erase, record and playback heads. Maximum spool capacity: 10 $\frac{1}{2}$ in. Dimensions: 44 × 44 × 21cm. Price: £368.00 (plus VAT).

A3340S

Four channel stereo tape deck. Tape speeds: 15, $7\frac{1}{2}$ i/s. W and F: 0.04% at 15, 0.06% at $7\frac{1}{2}$ i/s. FR: 25-24,000 at 15, 25-22,000 at $7\frac{1}{2}$. Distortion: 1% at normal operating level. S/N: 55dB at 3% THD level, weighted overall. Three



Tandberg 3400 X



Teac A 3300S

heads. Max. spool capacity: 10 $\frac{1}{2}$ in. Dimensions: 44 × 52 × 22cm. Price: £598.00 (plus VAT).

A 7300

$\frac{1}{4}$ -track reel-to-reel, 2 channel stereo or mono. Tape speeds: $7\frac{1}{2}$, $3\frac{3}{4}$ i/s. W and F: 0.05% at $7\frac{1}{2}$, 0.08% at $3\frac{3}{4}$ i/s. FR: 25-28,000Hz at $7\frac{1}{2}$, 25-20,000Hz at $3\frac{3}{4}$. Distortion: overall 0.8% at 1000Hz normal operating level. S/N: 58dB. Erase, record, playback. Max. spool capacity: 10 $\frac{1}{2}$ in. Dimensions: 54.8 × 44 × 24.6cm. Price: £693.00 (plus VAT).

A 7300/2T

Reel to reel, 2 track recorder, stereo or mono.

Tape speeds: 15, 7½/i/s. W and F: 0.04% at 15, 0.05% at 7½. FR: 25-30,000 at 15, 25-28,000 at 7½. Distortion: Overall 0.08 at 1,000Hz normal operating level. S/N: 60dB. Erase, record and playback heads. Max. spool capacity: 10½in. Dimensions: 54.8 × 44 × 24.6cm. Price: £714.00 (plus VAT).

A-7300 RX

Professional stereo tape deck with DBX system. Tape speeds: 15, 7½/i/s. W and F: 0.04% at 15, 0.05% at 7½. FR: 25-30,000 at 15, 25-28,000 at 7½. S/N: 60dB, 100dB at DBX in. One direct drive DC servo capstan motor. Erase, record and playback heads. Max. spool capacity: 10½in. Price and further details: on application.

■ TELEFUNKEN

AEG Telefunken (UK) Ltd, Bath Road, Slough, Bucks.
Tel: Slough 33311.

M3002 ★

¼-track stereo tape recorder. Speeds: 178i/s, 3¾i/s, 7½i/s. Max. spool size: 7in. W and F: (measured to DIN 45 405) less than 0.2% (178i/s), less than 0.15% (3¾i/s), less than 0.1% (7½i/s). S/N ratio (measured to DIN 45 405): less than 48dB (178i/s), less than 52dB (3¾i/s), less than 55dB (7½i/s). FR: 30Hz-12½kHz (178i/s), 30Hz-15kHz (3¾i/s), 30Hz-20kHz (7½i/s). Replay char: DIN 45 500. Rewind time: approximately 2½min. with 720m tape. Level indication: VU. Inputs: tuner 4mV 40K, mic 0.15mV 2K, pickup/tape 100mV/1M ohm. Outputs: line 0.7V 12K, monitor 0.7V 3.3K, phones 2½ 400K, speakers 35W per channel into 4 ohms. Motors: Cut out switch for motor when unit is used as amplifier. Size: 21 × 6¼ × 13¾. Weight: 16kg. Mains: 110-240V AC 50Hz. 117 AC 60 Hz. Price: £307.00 (including VAT).

M3000 Hi-Fi Deck

Specification the same as M3002 but without output stages and motor cut-off switch. Price: £260.00 (including VAT).

■ TOSHIBA

Toshiba (UK) Ltd, Toshiba House, Great South West Road, Feltham, Greater London.
Tel: 01-751 1281.

PT862D

Stereo tape deck. 3 heads. Tape speeds: 4.75cm/s, 9.5cm/s and 19cm/s. FR: at 19 cm/s; 20Hz-25kHz. Sound-on sound and echo, bias control and tape selector switch. Price: £119.60 (plus VAT).

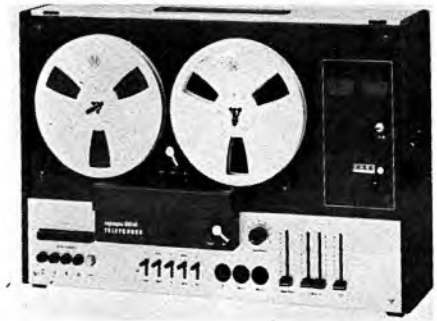

Telefunken 3002 Hi-Fi

■ UHER (UK) LTD

Peas Home House, St. Saviour Place, York.
Tel: York 30421.

Uher 1200 Report Synchro ★

Transistorised professional mains/battery mono recorder. Full track. Speed 7½i/s. Max spool 5in. W and F 0.07%. H and N -52dB. FR: 40Hz-20kHz +0dB -5dB. Replay char: CCIR or NARTB. Meter level indicator. Rewind time: 3 min for 900ft. Inputs: mic (2) 0.2mV 200 ohms balanced, line 40mV-1.55V. Output 1W RMS. 600 ohms balanced line, pilot tone to synchroniser. Brushless DC motor. Pause. Digit tape indicator. Straight-through amplifier. A/B monitoring. NeO-pilot tone input for synchronising sound with film camera. Optional automatic level control, pilot tone indicator, mixing of two mic channels. Supply: internal dry cells, rechargeable accumulator, or from 6V AC mains with additional adaptor units. For supply only to industrial or scientific users. Size: 11 × 3 × 8in. Weight: 7lb. Price: on application.

Accessory

Scene marker module No. Z521. Price £10.30.

4200 Report Stereo IC

Transistor mains/battery stereo tape recorder. ½-track. Speeds: 7½, 3¾, 178, 1516i/s. Max spool 5in. W and F: 7½i/s 0.2%, 3¾ i/ 0.25%, 178i/s 0.35%, 1516i/s 0.56%. H and N 7½i/s -57dB; 3¾i/s -55dB; 178i/s -53dB. FR: 7½i/s 35Hz-20kHz; 3¾i/s 35Hz-16kHz; 178i/s 35Hz-8kHz; 1516i/s 35Hz-5kHz (all to DIN 45-500). Replay char: NARTB. Level indicator: two meters. Rewind time: 3 min for 900ft. Inputs: mic 0.1mV 200 ohms; radio 2mV 47K; PU 30mV 1M. Outputs line 1V 15K, speaker 4 ohms. One motor. Pause. Digital position indicator. Monitoring. Parallel track replay. Size: 11 × 3 × 8in. Weight: (approx.) 7lb (3.8kg).

★ Indicates entry is illustrated.

Supply: internal dry cells, rechargeable accumulator, or from 6V, 12V, 24V car battery; 100-240V AC mains with additional adaptor units. Price: £371.20 (plus VAT).

4400 Report Stereo IC

¼-track version of 4200. Specification almost identical. Price: £371.20 (plus VAT).

Uher 5000 Universal

Mains ½-track mono recorder. Speeds: 3¾, 1⅞, 1⅝/16i/s. FR: 40Hz-15kHz ±3dB at 3¾i/s. Max spool: 5¾in. W and F: 3¾i/s ±0.2%. Inputs: mic 200 ohms, radio 47K, PU IM. Solenoid operation for remote control working. All metal case. Large range of dictation and transcription accessories available. Price: approximately £320.60 (including VAT).

5000 Language Tutor

Specification as for 5000 Universal except double ½-track heads and 3¾i/s speed only. Top track playback only, lower track record and playback. Price: on application.

SG520

Stereo mains operated reel to reel tape recorder with internal speakers and interchangeable head assemblies (½-track and ¼-track). Speeds: 7½, 3¾, 1⅞i/s. Max. spool size: 7in. W and F: 7½i/s 0.05%, 3¾i/s 0.10%. Hum and noise: 7½i/s -57dB/2-tracks (-55dB/4-tracks), 3¾i/s -55dB/2-tracks (-53dB/4-tracks), 1⅞i/s -55dB/2-tracks (-53dB/4-tracks). FR: 7½i/s 30Hz-20kHz, 3¾i/s 30 Hz-15kHz, 1⅞i/s 30Hz-8kHz. All figures to DIN specification 45 500. Inputs: mic 0.16mV-30mV, radio 1.8mV-600mV, phono (1) 80.0mV-7mV, phono (2) 250.0mV-25V. Outputs: line (2 tracks) 2 × 800mV across 15K, line (4 track) 2 × 600mV across 15K. Speaker: 2 × 6W (sine) across 4 ohms. Features: Input mixing, vertical and horizontal operation, interchangeable plug-in head assemblies, add-on automatic level control module (optional accessory), matt black finish and tinted perspex cover. Price: £327.05 ½-track (plus VAT); £327.05 ¼-track (plus VAT).

SG560

Semi-professional mains operated reel to reel tape recorder with Dia-pilot slide synchroniser mono/stereo ¼-track or ½-track (interchangeable assemblies). Speeds: 7½, 3¾, 1⅞, 1⅝/16i/s. Max spool size: 7in. W and F: 7½i/s ±0.04%, 3¾i/s ±0.10%, 1⅞i/s ±0.20%. Hum and noise: 7½i/s -58dB/2-track (-56dB/4-track), 3¾i/s -57dB/2-track (-55dB/4-track), 1⅞i/s



Uher 1200 Report Synchro and Synchroniser W352

-56dB/2-track (-55dB/4-track). FR: 7½i/s 20Hz-20kHz, 3¾i/s 20Hz-15kHz, 1⅞i/s 20Hz-9kHz. All figures to Din specification 45 500. Replay characteristic: NARTB. Level indicators: 2 VU meters. Inputs: mic 0.12mV-70mV 200 ohms, radio 1.2mV-110mV 47K, phono (1) 40.0mV-2.8V, phono (2) 200mV-18V. Outputs: monitor 2 × 0.65V across 15K, line 2 × 600mV across 15K, speaker 2 × 10W (sine) across 4 ohms. Audio output with internal speakers: 6W per channel (sine). Features: pause, inching, straight through amplifier, horizontal or vertical operation, A-B monitoring, input mixing, echo, sound with sound, sound on sound, dia-pilot slide synchronising, separate replay bass and treble controls, matt black finish and tinted perspex cover. Weight: 13.1kg. Price: £517.65 ½-track (plus VAT); £517.65 ¼-track (plus VAT).

4000 Report IC

Transistor mono battery portable tape recorder ½-track. Speeds: 7½, 3¾, 1⅞, 1⅝/16i/s. W and F: 7½i/s 0.20%, 3¾i/s 0.25%, 1⅞i/s 0.35%. Hum and noise: 7½i/s -57dB, 3¾i/s -55dB, 1⅞i/s -53dB. FR: 7½i/s across 35Hz-20kHz, 3¾i/s 35Hz-16kHz, 1⅞i/s 35Hz-8kHz, 1⅝/16i/s 35 Hz-5kHz. All figures to DIN specification 45 500. Inputs: mic 0.12mV-40mV across 200 ohms, radio 2.4mV-700mV across 47K, phono 45mV-20V across 2M ohms. Output: line 1 V across 15K, speaker 0.8W across 4 ohms. Features: die-cast metal case, 5in spool size, operation from dry batteries, rechargeable accumulator, 110-240V AC mains/charger unit, 6V, 12V and 24V car battery, power supply for condenser mic, internal speaker, switchable (speech, music and off) automatic level control. Weight: 3.6kg. Price: £302.95 (plus VAT).

Test Tapes and Discs

Abbreviations used in this section are given on page 27.

■ AGFA-GEVAERT

Agfa-Gevaert Ltd, Great West Road, Brentford, Greater London.
Tel: 01-560 2131.

Calibration Test Tape 38-25

Full-track recording. Speed: 15i/s. NARTB core. Magnetic coating out. 1in tape. Reference frequency: 1kHz. Gap adjustment frequency: 1kHz and 10kHz. Equalisation: 35 μ s. Gliding tone: 31.5Hz-18kHz. Blank sections as per DIN 45 513. Price: on application.

Calibration Test Tape 38-12

Same specification as Tape 38-25 above but on 1/2in tape. Price: on application.

Calibration Test Tape 38

Same specification as Tape 38-25 above but on 1/4in tape wound on AEG core. Price: on application.

Stereo Reference Tape 38

Recordings for both stereo channels and the separation track. Speed: 15i/s. Wound on AEG core. 1/4in tape. Reference frequency: 1kHz. Gap adjustment recording: random noise. Equalisation: 35 μ s. Gliding tone: 63Hz-10kHz. Price: on application.

Reference Tape 19-25

Full-track recording. Speed: 7 1/2i/s. 1in tape. Wound on NARTB core. Reference frequency: 1kHz. Gap adjustment frequency: 1kHz and 10kHz. Equalisation: 70 μ s. Gliding tone: 31.5kHz-18kHz. Price: on application.

DIN Reference Tape 19S (Studio)

Same specification as Reference Tape 19-25 but on 1/4in tape. Price: on application.

DIN Reference Tape 19H (Amateur)

Full-track recording. Speed: 7 1/2i/s. 1/4in tape type PE31. Spool with 3/8in diameter. Magnetic coating in. Reference frequency: 1kHz. Gap adjustment frequency: 1kHz and 10kHz. Equalisation: 50/1590 μ s. Gliding tone: 31.5Hz-18kHz. Price: on application.

DIN Reference Tape 9.5

Similar to Tape 19H above except speed 3 3/4i/s and reference frequency 333Hz. Gliding tone: 31.5Hz-12.5kHz. Price: on application.

■ AMPEX

Ampex Great Britain Ltd,
72 Berkeley Avenue, Reading,
Berks RG1 6HZ.
Tel: Reading 55341.

For all pro audio tapes, including CCIR and NAB test tapes 1/8in to 2in. Prices and details of specifications on request.

■ BASF

BASF United Kingdom Ltd,
Audio/Video Tapes Division, P^O Box 473,
Knightsbridge House, 197 Knightsbridge,
London SW7 1SA.
Tel: 01-584 5080.

DIN Calibration Tape 9

Full-track recorded 1/4in tape. Speed 3 3/4i/s. Equalisation: 90 + 3180 μ s. Tape flux: 250nWb/m. Frequency range: 31.5Hz-16kHz in steps. Also for azimuth alignment. Unrecorded section, reference tape.

DIN Calibration Tape 19H

Full-track recorded 1/4in tape. Speed: 7 1/2i/s. Equalisation: 50 + 3180 μ s. Tape flux: 320nWb/m. Frequency range: 31.5Hz-18kHz in steps. Also for azimuth alignment. Unrecorded section, reference tape.

DIN Calibration Tape 38

Full-track recorded 1/4in tape. Speed: 15i/s. Equalisation: 35 μ s. Tape flux: 320nWb/m. Frequency range: 31.5Hz-18kHz in steps. Also for azimuth alignment. Unrecorded section, reference tape.

DIN Calibration Tape 4.75

Full-track recorded 1/4in tape. Speed: 1 7/8i/s. Equalisation: 120 + 3180 μ s. Tape flux: 250nWb/m. Frequency range: 31.5Hz-16kHz in steps. Also for azimuth alignment. Unrecorded section, reference tape.

Stereo Test Tapes

Available for speeds 7 1/2i/s and 15i/s and is used in conjunction with Calibration Tapes 19 or 38 respectively, for aligning stereo recorders. Recordings are divided into four sections. (1) Reference level 1kHz for 15 sec separate on each channel; (2) Track positioning (head alignment) 1kHz for 90 sec; (3) Azimuth align-

★ Indicates entry is illustrated

ment noise recordings from 5.6kHz-16kHz; (4) Cross-talk test 63Hz, 1kHz and 10kHz for 8 sec separate on each channel.

Head Alignment Tape

Noise recording 5.6kHz-16kHz, track 3 erased. For azimuth alignment on domestic recorders, also suitable for head alignment on 4-track machines.

Azimuth Test Tape

1/4in test tape for speeds 7 1/2, 15 and 30i/s. Used for testing or aligning azimuth of replay heads. Accurate tests can be made without adjusting the head.

DIN Calibration Cassette Tape (Fe)

Full-track recorded cassette tape. Speed: 1 7/8i/s. Equalisation: 120 + 3180µs. Tape flux 250nWb/m; unrecorded section reference tape.

DIN Calibration Cassette Tape (Cr)

Full-track recorded cassette tape. Speed: 1 7/8i/s. Equalisation: 120 + 3180µs. Tape flux 250nWb/m. FR: 31.5Hz-12.5kHz. Also for azimuth alignment. Unrecorded section reference tape.

Speed Test Cassette Tape

Full-track recorded 50Hz. Speed: 1 7/8i/s. For testing speed on cassette recorders.

Wow and Flutter Cassette Test Tapes

Full-track recorded 3150Hz/3000Hz, to check wow and flutter on cassette recorders.

BASF Service Cassette (Fe)

Full-track recorded cassette tape. Speed: 1 7/8i/s. Equalisation: 120 + 3180µs. FR: 50Hz-6300Hz. For speedy tests of wow and flutter, equalisation, tape speed, azimuth alignment on cassette recorders.

Dolby B Test Cassette

Full-track recorded 400Hz Dolby level; to align level of cassette recorders with Dolby B System. Available in cassette only.

Cassette Azimuth Alignment Tape

Full-track recorded 6300Hz; to align azimuth of cassette recorders.

Prices of all BASF Test Tapes and Discs available on request.

■ BIB

Bib Hi-Fi Accessories Ltd, PO Box 78, Hemel Hempstead, Herts Hp2 7EP. Tel: Hemel Hempstead 61291.

Ref: 53

Test cassette. Price: £2.60 (including VAT).

■ DECCA

The Decca Record Co Ltd, Decca House, 9 Albert Embankment, London SE1 7SW. Tel: 01-735 8111.

How to give yourself a stereo check out

Stereo SKL-4861. The record is designed to provide a means for the exacting listener to check the performance of his equipment without the need for expensive and complicated instruments. Side One starts with a short explanation of the purpose of the record and there is a detailed account of each band and how the information should be used on the sleeve. Side One: (1) Introduction, (2) left-right channel identification, speaker balance, channel phasing, (3) mono music, (4) tone controls, (5) sound colouration, (6) stereo music, (7) groove-jumping and distortion, (8) silent grooves. Side Two: (1) live versus recorded sound, (2) wow and flutter, (3) anti-skating band, (4) crosstalk, (5) musical show-piece. Price: approximately £2.99 (including VAT).

■ DEUTSCHE GRAMMOPHON

Polydor Ltd, 17 Stratford Place, London W1N 0BL. Tel: 01-499 8686.

101497

Stereo 7in 45rpm record providing test for balance, phase, music, voice and effects. Price: £1 (plus VAT).

■ EMI RECORDS

EMI Records Ltd, EMI House, 20 Manchester Square, London, W1. Tel: 01-486 4488.

TCS102

12in stereo record at 33 1/3rpm. 30Hz-20kHz gliding tone. Price: £2.99 (including VAT).

TCS101

12in stereo record at 33 1/3rpm. 30Hz-20kHz in bands. Price: £2.99 (including VAT).

TCS104

12in mono record (lateral) at 33 1/3rpm. Price: £2.99 (including VAT).

SEOM 6

12in stereo record at 33 $\frac{1}{3}$ rpm providing tests for channel identification, channel balance, phase checking, stereo spread, volume and tone plus nine musical excerpts. Price: £1.20 (including VAT).

EMI SERVICE DIVISION

EMI Sound and Vision Equipment Ltd,
252 Blyth Road, Hayes UB3 1HW.
Tel: 01-573 3888.

SRT19

Test tape at 3 $\frac{3}{4}$ i/s with 90 + 3180 μ s characteristic. Full-track recording. Spoken announcements followed by 30Hz-14kHz in bands. Section of 3kHz tone for checking wow and flutter, also strobe markings for checking speed.

SRT18

Test tape at 7 $\frac{1}{2}$ i/s with 70 μ s characteristic. Full-track recording. Spoken announcement followed by 30Hz-16kHz in bands. Section of 3kHz tone for checking wow and flutter, also strobe markings for checking speed.

SRT17

Test tape at 15i/s with 35 μ s characteristic. Full-track recording. Spoken announcement followed by 30Hz-20kHz in bands. Section of 3kHz tone for wow and flutter check also strobe markings for checking speed.

SRT18C

Test tape at 7 $\frac{1}{2}$ i/s with 70 μ s characteristic. Full-track recording. Spoken announcement followed by 30Hz-16kHz in bands. Wound into broadcast type cartridge.

Prices and further details of EMI test tapes available on request.

HI-FI SOUND

Distributors: Howland-West Ltd,
3-5 Eden Grove, London N7 8EQ.
Tel: 01-609 0293/6.

Test Record HFS75

Side 1. Test 1, channel recognition and phasing; Band A left and right channel identification; Band B phasing check signals in phase; Band C phasing check signals out of phase. Test 2, lateral modulation for determination of tracking pressure in conjunction with bias correction. Band A 300Hz lateral + 11dB; Band B 300Hz lateral + 14dB; Band C 300Hz lateral + 18dB. Test 3, vertical modulation for

determination of tracking pressure in conjunction with bias correction. Band A 300Hz vertical + 7dB; Band C 300Hz vertical + 11dB. Test 4, pink noise. Test 5, rumble.

Side 2. Test 1, determination of bias correction and tracking ability at outside of disc. Test 2, white noise. Test 3, determination of bias correction and tracking ability at centre of disc. Test 4, channel balance and separation. Band A left channel, Band B right channel. Test 5, wow and flutter. Test 6, determination of bias correction and tracking ability at inside grooves of disc. Price: £2.20 (plus VAT).

LYRICHORDS

N. Miers & Co Ltd, 28 Piercing Hill,
Theydon Bois, near Epping,
Essex CM16 7LE.
Tel: 037-881 2611.

8-track cartridge demonstration and test tape £2.48 (plus VAT).

METROSOUND AUDIO PRODUCTS LTD

Audio Works, Cartersfield Road,
Waltham Abbey, Essex EN9 1JF.
Tel: Lea Valley 712712.

MT63 Cassette Azimuth Alignment Tape

For accurate alignment of cassette deck playback heads. Price: £2.20 (plus VAT).

MT73 Cassette Frequency Response Test Tape

Required for the precise checking of accuracy of tones produced from cassette machines. Price: £9.00 (plus VAT).

MT74 Reel to Reel Azimuth Alignment Test Tape

To allow for correct setting of replay heads on open reel recorders. Price: £3.50 (plus VAT).

MT75 Reel to Reel Dolby Tone Test Tape.

A specially produced tape for correct setting up and calibration of reel to reel recorders incorporating Dolby Noise reduction systems. Price: £3.20 (plus VAT).

MT76 Reel to Reel Frequency Response Test Tape

Essential for the precise checking of accuracy of tones produced from open reel recorders. Price: £9.00 (plus VAT).

MT77 8-Track Cartridge Azimuth Alignment Test Tape

For accurate alignment of 8-track deck playback heads. Price: £2.20 (plus VAT).

★ Indicates entry is illustrated

MT78 8-Track Cartridge Dolby Tone Test Tape

Essential for the correct setting up and calibration of 8-track decks with Dolby facilities. Price: £2.00 (plus VAT).

MT79 8-Track Cartridge Frequency Response Test Tape

To test to a high degree of accuracy that tones obtained from 8-track machines are correct. Price: £9.00 (plus VAT).

■ PHILIPS

Combined Electronic Services Ltd,
604 Purley Way, Waddon,
Croydon CR9 4DR.
Tel: 01-686 0505.

Testcassette 397 37001

Speed: $1\frac{7}{8}$ i/s. Test cassette designed for checking and adjusting tape speed and the azimuth setting of the record/playback head. Range: $6.3\text{kHz} \pm 1$ per cent tone with 800Hz pulses. Equalisation: $120\mu\text{s} + 1,500\mu\text{s}$. Price: £8.48 (plus VAT).

Head Cleaning Cassette 811/CCT

It is inevitable that the slight friction between tape and tape-heads/guides should grind small amounts of material off the tape and certain low quality types are more prone to this problem than others. Particles adhere to heads reducing tape contact degrading both recording and playback. Normally the Head Cleaning Cassette can cope but where build-up becomes excessive, cleaning with alcohol is necessary. Price: 60p (plus VAT).

Testcassette 812/MCT

The azimuth setting of the record/playback head may be adjusted using 812/MCT which has an 8kHz tone recorded on one of its tracks. Only if the record/playback head is accurately set so that it is vertical to the running direction of the tape will high frequencies, which includes the 8kHz tone, be reproduced properly. Price: £2.73 (plus VAT).

Mirror Cassette 814/SMC

Device which enables visual check to be made on state of tape guide and pressure roller as well as providing check on recording/playback and erase heads for wear and/or contamination. Adjustments can then be made as necessary to ensure tape runs in straight path past the heads and capstan with a minimum of twisting and bending. Price: £18.00 (plus VAT).

■ PYE

Pye Business Communications,
Cromwell Road, Cambridge CB1 3HE.
Tel: Cambridge 45191.

7in 45rpm record. Side One: (mono) For the Love of Mike — information on use and installation of microphones. Side Two: (stereo) stereo tests. Sent free on request.

■ REDIFFUSION

Rediffusion Ltd, King's Court,
2-16 Goodge Street, London W1.
Tel: 01-580 9506.

Popular Guide to Stereo PHF 1000

12in demonstration disc created by Popular Hi-Fi and Rediffusion Records narrated by James Burke. It presents contrasts in stereo, large orchestra, small groups, voices, soloists accurately recorded and precisely projected. James Burke uses twelve music tracks to show stereo quality, ambience, balance, projection, channel identification and special effects. Price: £1.65 (including VAT).

■ SHURE ELECTRONICS LTD

Eccleston Road, Maidstone, Kent ME15 6AU
Tel: Maidstone 59881:

These records provide an effective means of cartridge evaluation through a variety of technical measurements. Shure engineers have developed four records for testing trackability, stylus wear, channel balance, phasing and anti-skating. TTR 110 is designed for listening tests at home; the other three for use with professional test equipment.

TTR 102 Phono Cartridge Test Record

Primarily designed for Shure dealers, this 33 $\frac{1}{3}$ rpm test record is ideal for testing low frequency tracking. The record also includes a 400/4,000Hz intermodulation test signal and bands for checking crosstalk at 1kHz and 10kHz. Price: £6.90.

TTR 103 Phono Cartridge Trackability Test Record — Professional Equipment required

This 45rpm 12in laboratory standard test record is designed for use with sophisticated measuring equipment. TTR 103 contains three tests for trackability: (a) 10.8kHz pulsed high-frequency test with 270Hz repetition rate trackability and distortion test; (b) 1,000Hz plus 1,500Hz mid-frequency trackability and distortion test; (c) 400Hz plus 4,000Hz low-frequency trackability and distortion test. Three inspection methods are suggested: dis-

tortion measurements, an oscilloscope examination, and listening. Instructions on usage are included with the record. Price: £6.90.

**TTR 109 Level and Crosstalk Test Record
Professional Equipment required**

This 33 $\frac{1}{3}$ rpm 12in record provides 12 bands of 1kHz Left and Right reference levels at 5cm/sec recorded velocity. May be used as a cross talk test. Designed for professional use. Instructions are included. Price: £4.80.

**TTR 110 "An Audio Obstacle Course —
Era III" — Listening Test Record**

This 33 $\frac{1}{3}$ rpm test record provides the most demanding and definitive audio tests for high fidelity cartridges. The total level range is the same as the TTR 101, but the increments of increased velocity are refined (6dB from first to second level; 2dB for the remaining three levels). The TTR 110 includes recordings of difficult-to-track instruments, with complete orchestral and vocal ensembles from commercial recordings plus level, balance and phasing checks. Complete instructions are included. Price: £3.00.

■ **TUTCHINGS ELECTRONICS LTD**

14 Rook Hill Road, Friars Cliff,
Christchurch, Dorset BH23 4DZ.
Tel: Highcliffe 72019.

Test Tape No. 1

Pure tones 40Hz-10kHz with voice identification of each band. Recorded to NAB 50 plus 3180 microsecond characteristic full track. Track 2 carries continuous 7.5kHz tone for azimuth alignment.

This tape is used to measure the playback frequency response of $\frac{1}{4}$ -track and $\frac{1}{2}$ -track recorders. 3in spool. Price: £2 (including VAT and postage).

Test Tape No. 2

Pure tones 40Hz-7.5kHz with voice identification of each band. Recorded to NAB 90 plus 3180 microsecond characteristic at 3 $\frac{3}{4}$ i/s. Track 2 carries continuous 7.5Hz tone for azimuth alignment.

This tape is used to measure the playback frequency response of $\frac{1}{4}$ -track and $\frac{1}{2}$ -track recorders. 3in spool. Price: £2 (including VAT and postage).

Test Cassette No. 1

Track 1. Frequency run 7500Hz to 40Hz followed by 7500Hz azimuth alignment tone. IEC 120 + 1590 μ s characteristic. Track 2.50Hz speed test. Set recorder speed for zero beat

with 50Hz mains supply. Price: £2 (including VAT and postage).

Test Tape No. 3

One third octave bands of filtered white noise covering range 40Hz-10kHz with voice identification of each band. Recorded to IEC 70 plus 3180 microsecond characteristic at 7 $\frac{1}{2}$ i/s.

This tape is used to measure acoustic responses of recorders, microphones and loudspeakers. On 3in spool. Price: £2 (including VAT and postage).

Test Tape No. 4

One octave bands of filtered white noise with centre frequencies 100Hz-6.4kHz with voice identification of each band. Recorded to IEC 70 plus 3180 microsecond characteristic at 7 $\frac{1}{2}$ i/s. Track 2 carries full range of unfiltered white noise.

This tape is used for reverberation and transmission tests of rooms, studios, etc. It can also be used for subjective testing of room acoustics and listening tests on loudspeakers and enclosures. On 3in spool. Price: £2 (including VAT and postage).

Test Tape No. 5

Azimuth and vertical head alignment tape. Full track white noise with track 3 blank. Allows accurate setting of height and azimuth of $\frac{1}{4}$ -track heads by ear, using no test equipment at all. On 3in spool. Price: £2 (including VAT and postage).

Table of Tape Playing Times

Length of Tape (Feet)		3600	2400	1800	1700	1200	900	850
Size of Spool		8¼ DP	7 DP 8¼ LP	5 TP 7 LP 8¼ S	5¾ DP	5 DP 5¾ LP 7 S	4 TP 7 LP	5¾ S
Maximum Playing Times		H M	H M	H M	H M	H M	H M	H M
1 Track	15 i/s	48	32	24	22	16	12	11
	7½ i/s	1 36	1 4	48	47	32	24	22
	3¾ i/s	3 12	2 8	1 36	1 30	1 4	48	45
	1⅞ i/s	6 24	4 16	3 12	3 1	2 8	1 36	1 30
2 Tracks	15 i/s	1 36	1 4	48	45	32	24	22
	7½ i/s	3 12	2 8	1 36	1 30	1 4	48	45
	3¾ i/s	6 24	4 16	3 12	3 1	2 8	1 36	1 30
	1⅞ i/s	12 48	8 32	6 24	6 2	4 16	3 12	3 1
4 Tracks	15 i/s	3 12	2 8	1 36	1 30	1 4	48	45
	7½ i/s	6 24	4 16	3 12	3 1	2 8	1 36	1 30
	3¾ i/s	12 48	8 32	6 24	6 2	4 16	3 12	3 1
	1⅞ i/s	25 36	17 4	12 48	12 5	8 32	6 24	6 2
Length of Tape (Feet)		600	450	400	300	200	150	
Size of Spool		3¼ TP	4 DP 5 S	3 TP 4 LP	3¼ LP 3¼ DP 4 S	3¼ S	3 S	
Maximum Playing Time		H M	H M	H M	H M	H M	H M	
1 Track	15 i/s	8	6	5	4	2½	2	
	7½ i/s	16	12	10	8	5	4	
	3¾ i/s	32	25	21	16	10	8	
	1⅞ i/s	1 4	48	42	32	21	16	
2 Tracks	15 i/s	16	12	10	8	5	4	
	7½ i/s	32	24	21	16	10	8	
	3¾ i/s	1 4	48	42	32	21	16	
	1⅞ i/s	2 8	1 36	1 25	1 4	42	32	
4 Tracks	15 i/s	32	24	21	16	10	8	
	7½ i/s	1 4	48	42	32	21	16	
	3¾ i/s	2 8	1 36	1 25	1 4	42	32	
	1⅞ i/s	4 16	3 12	2 50	2 8	1 25	1 4	

Note: The 4 tape thicknesses are listed as S (Standard), LP (Long Play), DP (Double Play) and TP (Triple Play).

Unit Audio: Record Systems

(see also Music Centres section)

★ Indicates entry is illustrated

Abbreviations used in this Section are given on page 27.

■ **ALBA (RADIO AND TELEVISION) LTD**,
Bull Lane, Edmonton, London N18 1SD.
Tel: 8070.

Tuner/Amplifier/Record player. Band coverage; 87-104MHz, 1640-520kHz, 270-158kHz. VHF sensitivity: better than 1 micro Volt (IHF). Ceramic IF Filter (AM and FM). FM distortion less than 0.5%. VHF channel separation greater than 40dB. VHF aerial: 75 ohm co-ax. Audio power output: 10W × 10W rms both channels driven. THD: less than 0.2% at all levels up to rated maximum. Range of Tone Controls: ±12dB. BSR: 172 D1 Record Deck. Speeds: 33, 45, 78rpm. W and F: less than 0.2%. Cartridge: Ceramic. Stylus: Sapphire. Loudspeaker drive unit: 16.5cm dia. full range. Impedance: 8 ohms. Centre unit dimensions: 59.8(W) × 36.9(D) × 15.2(H). Loudspeaker dimensions: 26.0(W) × 16.5(D) × 36.0(H). Matching black and teak finished cabinets. Price: on application.

■ **ALPHA**
Highgate Acoustics Ltd,
38 Jamestown Road, London NW1 7EJ.
Tel: 01-267 4937.

GF3500

Stereo combination unit with FM radio 2 × 18W RMS. Power output: 2 × 18W RMS. Harmonic distortion: less than 0.1% at 10W. Frequency response: 20Hz-25kHz. Hi filter: -8dB at 15kHz. Loudness: +8dB at 50kHz, +6dB at 10kHz. Bass: ±12dB at 50Hz. Treble: ±12dB at 10kHz. Tape input: 250mV-3V max. Tape output: 250mV. Headphones: 8 ohms Jack. FM sensitivity: 1.8µV. Aerial (2 socket-s): 75 ohms and 300 ohms. Tuning range: 87.5-108MHz. Stereo crosstalk: better than 35dB. Signal/Noise ratio: better than 60dB. Image rejection: better than 50dB. Mains voltage: 240V A/C. Cabinet: Teak finish. Price: on application.

■ BEOCENTER

Bang & Olufsen (UK) Ltd, Eastbrook Road,
Gloucester GL4 7DE.
Tel: Gloucester 21591.

Beocenter 3500

FM stereo receiver in cabinet with record deck. Motor unit: B & O. Two speeds. 12in grooved aluminium alloy platter. Belt drive. High compliance pickup arm. Cartridge: B & O SP10A, 0.6 thou diamond stylus. Range: FM 87.5-104MHz. Variable tuning plus six presets. AFC. Ratio detector. 'Balanced light' tuning system. Usable sensitivity: 2µV. Aerial input: 75-ohm coaxial. Stereo decoder fitted. Inputs: PU (1) 3mV 47K, PU (2) 200mV-3V 1M, tape 200mV-3V 1M. Output: 40W RMS per channel. Output impedance: 4 ohms. Tone controls: bass ±17dB at 50Hz, treble ±14dB at 10kHz. Rumble filter: 12dB/octave below 80Hz, scratch filter - 12dB/octave above 4kHz. HD: 0.3% at 1kHz at rated output (both channels driven). FR: 40Hz-20kHz ±1.5dB. Mains: 110, 130, 220, 240V AC. Sizes: 22⁷/₈ × 13⁷/₈ × 5³/₄in. Finish: brushed aluminium fascia and deck, teak, rosewood or white side panels, hinged dust cover. Price: on application.

Beocenter 1800 ★

FM stereo receiver with built-in record deck. Tuning range 87.5-108MHz. Variable tuning. Sensitivity: <2.5µV/75 ohms IHF. HD: <0.5% at full output. Output: 40W RMS per channel. Speakers: 4 ohms. Headphones: max. 10V 200ohms. FR: 20Hz-30kHz ±1.5dB. Motor unit: 33¹/₂ and 45rpm. Radial pick-up arm with MMC 3000 cartridge. Fully automatic. Rumble: >±60.12% DIN. Wow and flutter: <±0.12% DIN. A synchronous motor. Idler wheel and belt drive. 12in grooved aluminium alloy platter. Hinged translucent dust cover. Finish: brushed aluminium deck, black anodised fascia. Size: 19³/₄ × 4³/₄ × 14¹/₂in. Price: on application.

■ DANSK

Plustronics Ltd, Hempstalls Lane,
Newcastle, Staffs.
Tel: Newcastle Staffs 615131.

Club 2200

Combination turntable and radio receiver in single compact housing. Turntable: Speeds: 45 and 33 RPM. Rumble: measured according to DIN 45.500. Weighted: better than 55dB. Unweighted: better than 35dB. W and F: less ±0.2%. Cartridges: type ADC K7E. Frequency range: 15-18000Hz ±4dB. Channel separation: better than 20dB/1kHz. Amplifier section. Power output: 2 × 22W sinus /4 ohm.

★ Indicates entry is illustrated

Distortion: less than 0.5% max. output/1kHz. Frequency response: 20-25.000Hz. Signal to noise ratio: better than 70dB/max. output. Channel separation: better than 50dB/1kHz. Inputs: Phono/Tape. FM Section. Tuning range: 87-104MHz. Pre-select stations: Diode tuned. Sensitivity: $1.8\mu\text{V}/26\text{dB S/N} \pm 75\text{kHz}$. Signal to noise ratio: 60dB/1mV/100% mod. Channel separation: better than 40dB 1kHz. Frequency response: 50-15.000Hz $\pm 1.5\text{dB}$. AM Section. Tuning range MW: 510-1660kHz. Sensitivity: $1\mu\text{V}/3\text{dB}$ signal to noise. Signal to noise ratio: 53dB/1mV. Control Range. Tuning: variable AM and FM tuning, 5 pre-select station. Bass: rotary knob $\pm 15\text{dB}$. Treble: rotary knob $\pm 15\text{dB}$. Balance: rotary knob 0-100%. Mono: Push button. AFC: Push button. Connections. FM antenna: 75 ohm. Phono: 2mV/47k ohm. Tape: 200mV/100k ohm. Speakers: 2 \times stereo (4-16 ohm). Price: £227.61.

■ DECCA RADIO AND TELEVISION LTD

Neachells Lane, Willenhall,
West Midlands, WV13 3RW.
Tel: Willenhall 67367.

DS5328 (Audio 12)

Power output: 2 \times 12W RMS. Distortion: 0.2% max. at 1kHz. Frequency response: 20Hz-30kHz. Signal/Noise ratio: 70dB. Turntable: Garrard 6200CP single play with cue facility. Cartridge: Acos GP104 Ceramic Diamond. Tuner. LW: 150-275kHz, MW: 510-1620kHz, FM: 87.5-107.5MHz. Sockets. Input: FM aerial 75 ohm, FM aerial 300 ohm, AM aerial/earth, tape playback, DIN 300mV/100K. Output: Headphones 8 ohms, tape record, DIN 50mV/5K, front and rear speakers 8 ohms. Dimensions. Main unit: 48.4 \times 39.5 \times 19cm. Weight: 9Kg. Speakers: 23.9 \times 14.3 \times 34.3cm. Weight: 3.3Kg. Price: £127.20 (plus VAT).

DS5326 (Compact 3)

Power output: 2 \times 6W RMS. Frequency response: 30Hz-20kHz. Signal/Noise ratio: 60dB. Turntable: BSR C141/R Cue facility, bias compensation, manual override. Cartridge: Acos GP104 ceramic. Tuner. LW: 150-250kHz. MW: 520-1620kHz. FM: 87.5-101MHz. SW: 5.8-15.5MHz. Sockets. Input: FM aerial 75 ohm, AM aerial, tape playback, DIN 50mV/5K. Output: speakers 8 ohms, tape record, DIN 40mV/5K. Dimensions. Main unit: 77.2 \times 37.2 \times 21.3cm. Weight: 14.4Kg. Speakers: 21.5 \times 14 \times 31.5cm. Weight: 3Kg. Price: £141.20 (plus VAT).

DS5350 (Audio 20)

Power output: 2 \times 20W RMS. Distortion:

<0.1% at 20W, 1kHz. Frequency response: 20-30000Hz. Signal/Noise ratio: >60dB. Turntable: Garrard 35SB, belt drive, single play with repeat facility. Cartridge: Shure M75-6S, diamond stylus. Tuner. LW: 150-275kHz. MW: 510-1620kHz. FM: 87.5-107.5MHz. Sockets. Input: FM aerial 75 ohm, FM aerial 300 ohm, AM aerial/earth, tape playback, DIN 300mV/100K. Output: headphones 8 ohms, tape record, DIN 50mV/5K, front and rear, speakers 8 ohms. Dimensions. Main unit: 48.4 \times 39.5 \times 19cm. Price: on application.

DS1503

Amplifier. Power output: 2 \times 15W RMS. Distortion: 0.1% max. at 1kHz. Frequency response: 25Hz-18kHz. Signal/Noise ratio: -70dB. Turntable: BSR C142/R with cue facility and bias compensation. Cartridge: Sonotone V100 or Acos M6 magnetic. Sockets. Input: tuner, DIN 50mV/22K, tape playback, DIN 300mV/40K, microphone 2mV/47K. Output: headphones 8 ohms, speakers 8 ohms, tape record, DIN 100mV/1K. Available with either shelf (AL0410) or floor (AL0400) speakers. Finished in either Teak and White or Walnut. Prices: £125.46 with shelf speakers, £134.72 with floor speakers (plus VAT).

DS1513

Amplifier. Power output: 2 \times 15W RMS. Distortion: 0.1% max. at 1 kHz. Frequency response: 25Hz-18kHz. Signal/Noise ratio: -70dB. Turntable: BSR P128 single play with cue facility and bias compensation. Cartridge: Acos M6 magnetic. Sockets. Input: tuner DIN 50mV/22K, tape playback, DIN 300mV/40K, microphone 2mV/47K. Output: headphones 8 ohms, speakers 8 ohms, tape record, DIN 100mV/1K. Available with floor (AL0401) speakers only. Finished in Teak. Price: £134.72 (plus VAT).

DS633

Amplifier. Power output: 2 \times 6W RMS. Frequency response: 30Hz-20kHz. Signal/Noise ratio: -60dB. Turntable: BSR C141/R with cue facility, bias compensation. Cartridge: Acos GP104 ceramic. Sockets. Input: tuner DIN 200mV/68K, tape playback, DIN 300mV/100K. Output: Headphones 8 ohms, Speaker 8 ohms, tape recorder, DIN 50mV5K. Dimensions. Main unit: 46 \times 42 \times 20cm. Weight: 8Kg. Speakers: 21.5 \times 14 \times 31.5cm. Weight: 3Kg. Price: £75.46 (plus VAT).

DS5329 (Compact 10)

Power output: 2 \times 10W RMS. Distortion: 0.1% max. at 1kHz. Frequency response: 30Hz-

25kHz. Signal/Noise ratio: -70dB. Turntable: BSR C141/R with cue facility. Bias compensation. Manual override. Cartridge: Acos GP104 ceramic. Tuner. LW: 150-275kHz. MW: 510-1620kHz. FM: 87.5-107.5MHz. Sockets. Input: FM aerial 75 ohm. FM aerial 300 ohm, tape playback, DIN 300mV/10K. front and rear. speakers 8 ohms. Dimensions. Main unit: 78.2 x 36.2 x 21cm. Speakers: 24 x 14.4 x 34.3cm. Price: £150.46 (plus VAT).

■ DYNATRON

Dynatron Radio Ltd, Ditton Walk, Cambridge CB5 8QD. Tel: Teversham 2781.

HFC 202 Mazurka

Integrated stereo tuner-amplifier (top presentation) and record player unit in contemporary styled cabinet. Motor unit: Garrard 86SB Cartridge: Shure M75/6S. Power output: 20W RMS per channel. Bands: LW, MW, stereo VHF/FM with 6 pre-sets on FM. Controls: volume, balance, bass, treble, mains, on/off; contour filter, MPX filter, FM mute circuit, AFC, stereo/mono mode, input selectors for: tape, disc, radio bands; quadro sound 4-channel system with selector switch and rear speaker level switch. THD: 0.3% at -0.5dB below rated maximum output. FR: 20Hz-30kHz, linear inputs. Finish: teak veneered/brown lacquer cabinet with bronze tinted acrylic plastics lid. Size: 626 x 400 x 178mm. Price: £226.40.

HFC 203 Buckingham Suite

Integrated stereo tuner-amplifier and record player unit housed in a Queen Anne style period cabinet. Specification as for HFC 202 Mazurka but motor unit Garrard SP 25 Mk IV. Cartridge: Shure M756S. Finish: walnut using selected hurr veneers. Size: 978 x 432 x 640mm. Price: £290.40.

HFC 204 Carlton Suite

As HFC 203 but in Regency style cabinet finished in flame mahogany veneers. Size as HFC 203. Price: £287.20.

HFC 105 '100 Series'

Integrated stereo tuner/amplifier and record player unit housed in contemporary styled cabinet. Motor unit: Goldring Lenco GL 78. Cartridge: Shure M55E. Power output: 50W RMS per channel. Bands: LW, MW, stereo VHF/FM, manual tuning. Controls: volume, bass, treble, balance, mains, on/off, MPX filter, AFC/FM mute circuit, scratch filter, rumble filter, loudness filter, input selectors for: tape, tape monitor, disc, radio, bands,



Dynatron HFC 105 (100 Series)



Dynatron Empress

mono/stereo mode, A/B speaker circuits. Quadro sound 4-channel system with selector switch. Stereo headphone socket. Tuning meter (all bands). THD: 0.3% at -0.5dB max. output. FR: 20Hz-20kHz ± 1.5 dB. Tone controls: Bass ± 10 dB at 100Hz, treble ± 12 dB at 10kHz, -10dB at 10kHz. Filters: rumble -20dB at 20Hz steep slope from 50Hz, scratch -20dB at 20kHz steep slope from 5kHz, loudness +14dB at 30Hz, +4dB at 10kHz (Vol -30dB or below). Input sensitivity: -2dB ref. max. output at 1kHz, tape 165mV (6V max.) 230K, radio: 20% mod. Disc: 2.4mV (100mV max.) 47K. Tape output: socket 1 165mV via 22K (6V max. at 1kHz); socket 2 165mV via 100K (6V max. at 1kHz). Headphones: 8 ohms nominal. Channel separation: 40dB - 10kHz, inputs terminated. Damping factor: 50 into 8 ohms (relative). Bands: AM, MW 525-1630kHz, LW 150-280kHz VHF/FM 87.5-104MHz. Aerials: FM socket for 75 ohms unbalanced. AM internal ferrite rod, socket for external long wire. MPX channel separation: 40dB at 1kHz. S/N ratio: tape -66dB, disc -60dB, main amp (vol min) -80dB, FM 30dB with 1 μ V/m input. AM 20dB with 300 μ V/m

★ Indicates entry is illustrated

input average, VHF/AM rejection: 55dB with 200 μ V input. MPX stereo residual pilot tone output: 40dB rel. 100% mod. Finish: teak veneered cabinet with black anodised control panel and bronze tinted acrylic plastics lid. Size: 542 x 412 x 210mm. Price: £295.20.

HFC 208 Empress ★

Integrated stereo tuner-amplifier and record player unit housed in an attractive cabinet styled as a coin collector's chest. Specification as for HFC 203. Finish: walnut using selected burr veneers. Size: 660 x 457 x 205mm. Price: £256.00 (plus VAT).

■ FERGUSON

Thorn Consumer Electronics Ltd,
Thorn House, Upper St. Martin's Lane,
London WC2H 9ED.
Tel: 01-836 2444.

3495

Audio compact stereo/tuner/amplifier and record deck with two matched speakers. Record deck: BSR C173, 3-speed, ceramic cartridge, automatic. Amplifier. Output: 10W RMS, PC into 8 ohms. THD: <0.5%. Frequency response: 25Hz-30kHz \pm 3dB. Loudness compensation. Tuner. Band coverage: FM, MW, LW, SW. Switchable AFC: FM stereo beacon. FM: 87.5-104MHz. MW: 184-571 metres. LW: 1110-2000 metres. SW: 47-51.2 metres. Speakers (2). Finish: black and silver with teak surround. Price Excluding VAT: on application.

■ FIDELITY RADIO LTD

Victoria Road, London NW10 6ND.
Tel: 01-965 8771.

UA6 ★

Record player/radio unit in black leather grain finish with brushed aluminium. Controls: Piano keys, LW, MW, FM, AFC, Phono, Tape and Mains On/Off. Rotary Tuning, Slider volume left, volume right, bass and treble. Sockets: left hand loudspeaker 2 pin DIN, right hand loudspeaker 2 pin DIN, tape socket 5 pin DIN, FM aerial socket 75 ohm, AM aerial socket, stereo headphone jack socket. Other facilities: internal ferrite rod for LW and MW, automatic FM stereo indicator light. Turntable unit: Garrard SP25 Mk IV single play unit, 3 speed with magnetic cartridge and cueing device. Power supply: 200-250V 50Hz, export model 220-110V 50Hz. Power consumption: 60W. Performance. MW: 525-1620kHz, 572-186 metres. LW: 150-250kHz, 2000-1200 metres. FM: 87.5-108MHz. Power: 10W per channel sine wave (into 8 ohms), 14W per channel speech music (into 8 ohms). Harmonic



Fidelity UA6

distortion: less than 1% at 10W. Frequency response: 40Hz to 15kHz \pm 3dB tone controls flat. Tone controls: Bass +11dB -13dB at 100Hz; Treble +11dB -15dB at 10kHz. Tape: input sensitivity 200mV into 30K ohm, output 100mV into 100K ohm. Speakers: two units each with 165mm (6 $\frac{1}{2}$ in) round drive unit and 85.5mm (3 $\frac{3}{8}$ in) round tweeter, impedance 8 ohms, lead length approx. 3.6 metres (12ft) terminated with 2 pin DIN plug. Dimensions: unit with lid lowered, 155mm high x 378mm deep x 730mm wide (6 $\frac{1}{8}$ x 14 $\frac{7}{8}$ x 24 $\frac{7}{8}$ in); unit with lid raised, 413mm high x 434mm deep x 730mm wide (16 $\frac{1}{4}$ x 17 $\frac{1}{8}$ x 24 $\frac{7}{8}$ in). Price: £115.74 (plus VAT).

■ HACKER RADIO LTD

Norreys Drive, Cox Green,
Maidenhead, Berks. SL6 4BP.
Tel: Maidenhead 22261.

GAR600 ★

Record playback: DIN on front panel. Record, 140mV from 10K ohm source: playback, 150mV into 180K ohm impedance. Loudspeakers: DIN for front (main) speakers and rear (ambiophonic) speakers. 4-16 ohms impedance. Ambiophonic output is fixed at -10dB on main front output. Aerials: standard co-axial for VHF/FM. Co-axial car type for AM. Stereo headphones: (8-200 ohms impedance). Standard 6mm jack. Insertion of headphones plug automatically cuts out the loudspeakers. Radio Section. Wavebands: VHF, long and medium. FM: (VHF). Coverage: 87.5-104.5MHz. Inter-station muting and automatic frequency correction operated by push-button switch. IHF sensitivity: 2 μ V. Input for 50dB signal-to-noise: 10 μ V. Ultimate signal-to-noise: 65dB. Image: 44dB. Repeat spot: 48dB. AM rejection: 45dB. Total harmonic distortion: better than 0.5%. Stereo radio decoder: phase locked loop. Separation: 32dB at 80Hz, 33dB at 1kHz, 30dB at 5kHz. Pilot tone rejection: 50dB. AM: (LW and MW). Coverage. LW: 150-276kHz. MW: 518-1622kHz. Sensitivity (L and MW): 3-7 μ V for 10dB signal-to-noise ratio. Audio Section.



**For people
who use more than
their ears!**

Wireless World

**for people who read
and think as well as listen**

The leading UK journal
on audio Hi-Fi and electronics technology

lecson

AC1

Pre-Amplifier Control Unit

AP3

**Power Amplifier
100 + 100 Watt**

AP1

**Power Amplifier
50 + 50 Watt**

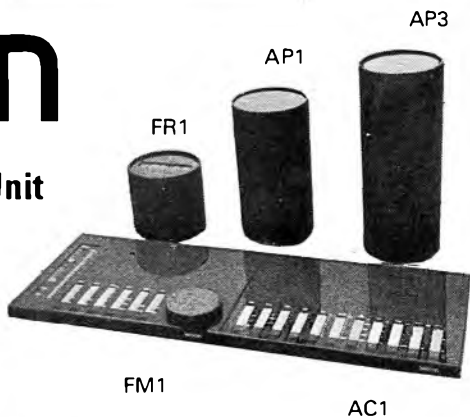

HL1

SP1

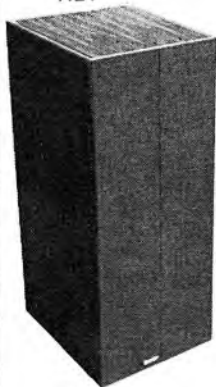

lecson

SP1

**Monitor Reflex Speaker
5 Way 50 Watt DIN**

HL1

**Horn Loaded Speaker
3 Way 50 Watt DIN**

FM1

Stereo FM Tuner

FR1

Frequency Readout



FR1

FM1

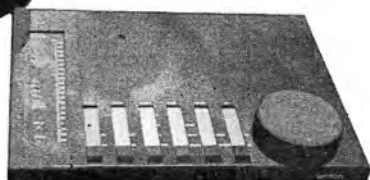

lecson

Lecson Systems Limited

Burrell Road, St. Ives, Huntingdon, Cambridge,
England PE17 4LE Telephone 0480 64124



Hacker GAR 600

Power output: 14W + 14W RMS into 8 ohms; both channels driven. Bandwidth: 25Hz-40kHz. Total harmonic distortion: 0.075% at 1kHz typical for + 15dB on nominal input. 0.15% from 70Hz-10kHz. Tone controls. Bass: ± 12 dB at 100Hz ± 2 dB. Treble: ± 12 dB at 10kHz ± 2 dB. Balance control: complete fade of either channel. Separation: greater than 40dB at 70Hz-10kHz. Overload factor: 28dB (approx. thirty times the recommended input). Scratch filter: sharply rejects frequencies of 7kHz and above. 3dB at 7kHz, 12dB/octave. Rumble filter: sharply rejects frequencies of below 60Hz. 3dB at 60Hz; 12dB/octave ultimate. Contour: equalises frequency response at low acoustic levels. Effective on all modes; disc, radio, tape and playback. At -30dB on full power: +10dB at 100Hz; +5dB at 10kHz. Record playing deck: Garrard 35SB two-speed (33 $\frac{1}{3}$ rpm and 45rpm) single play with Vermitron V100 magnetic pick-up and diamond stylus. Teak Cabinet. Designed to operate with any quality 8 ohm speakers. Price: £196.00 (plus VA1).

HITACHI (UK) LTD

Hitachi House, Station Road,
Hayes, Middlesex.
Tel: 01-848 8787.

STD2680

LW/MW/SW/FM stereo tuner, amplifier, cassette deck, record player and speaker system. Specifications. Radio. Tuning range: FM: 87.5-108MHz with FM stereo. MW: 530-1605kHz. LW: 150-350kHz. SW: 5.9-10MHz. Sensitivity: FM: 3.5 μ V (1HF), MW: 200 μ V (S/N = 20dB), LW: 400 μ V (S/N = 20dB), SW: 100 μ V (external aerial S/N = 20dB). Output

power: 20W + 20W (RMS) (THD < 1% both channels driven into 4 ohm). Aerial MW/LW: ferrite aerial. FM/SW: external DIN aerial jacks. Semi-conductors: 6-IC, 26 transistors, 1-FET, 27 diodes, 4 varistors, 3 varicap. Player. Type: single automatic player, 11 $\frac{1}{4}$ in (300mm) turntable dia., static balance pipe tonearm. Motor: 4-pole synchronous motor. Speed: 33 $\frac{1}{3}$; 45rpm. Cartridge: induced magnetic type. Stylus Hitachi DS-ST101 diamond, pressure 2.5g. Cassette Deck. Track system: 4 track, 2 channel stereo record/playback. Tape speed: 1 $\frac{1}{2}$ ips (47.5mm/sec). Frequency response: 50-10,000Hz ± 6 dB with normal tape. 50-13,000Hz ± 6 dB with CrO₂. Signal-to-noise ratio: 48dB. Crosstalk: 50dB. Speakers: SS6261G (8in bass, 3 $\frac{1}{2}$ in tweeter, 4 ohms). Recording system: AC bias 60kHz. Erasing ratio: 50dB. W and F: 0.28% WRMS. Power source: AC 240V 50Hz. Power consumption: 160W. Dimensions: Main unit - (WHD) 23 $\frac{1}{16}$ \times 16 $\frac{1}{16}$ \times 16 $\frac{1}{16}$ in (589mm \times 196mm \times 415mm) approx. Speakers: (WHD) 9 $\frac{7}{16}$ \times 17 $\frac{1}{16}$ \times 7 $\frac{1}{16}$ in (240mm \times 440mm \times 131mm) approx. Approx. av. weight: 26.4lbs (12kg) Price: £231.20 (plus VAT).

STD2370

LW/MW/FM stereo tuner amplifier, cassette deck, record player and speakers. Specifications. Radio. Tuning range: FM: 83-108MHz with FM stereo, MW: 530-1605kHz, LW: 150-350kHz. Output: 10W \times 10W RMS. 5% THD both channels driven into 8 ohm. Semiconductors: 6 \times IC, 9 transistors, 16 diodes. Player. Type: BSR P 146R. Motor: 4 pole induction motor. Speeds: 33 $\frac{1}{3}$, 45, 78 rpm. Stylus: S1 17 diamond. Cartridge: SC 12M. Cassette deck. Track system: 4 track, 2 channel stereo record/playback. Tape speed: 1 $\frac{1}{2}$ ips (47.5mm/sec). FR: 50-10,000Hz with normal tape, 50-12,000Hz with CrO₂ tape. S/N ratio: 48dB. Crosstalk: 50dB. Recording system: AC bias. Erasing system: AC erase. W and F: 0.28% WRMS. Power source: AC 240V 50Hz. Power consumption: 100W. Speaker system: SS 6275G (bass 8in, tweeter 3 $\frac{1}{2}$ in, 3 ohm). Dimensions: Main unit 23 $\frac{1}{2}$ \times 7 $\frac{1}{2}$ \times 15 $\frac{1}{16}$ in (597 \times 191 \times 403mm) approx. Speakers: SS 6275 8 $\frac{1}{16}$ \times 13 $\frac{1}{16}$ \times 5 $\frac{1}{16}$ in (221 \times 351 \times 149mm) approx. Accessories: Hitachi stereo microphone. Hitachi C60 blank cassette tape. FM indoor aerial. Price: £ 159.20 (plus VA1).

STD2690

LW/MW/SW/FM stereo tuner, amplifier, Dolby cassette deck, record player and speaker system. Specifications. Radio. Tuning range: FM: 87.5-108MHz with FM stereo,

★ Indicates entry is illustrated

MW: 530-1,605kHz, LW: 150-300kHz, SW: 5.9-10MHz. Sensitivity: FM: 2.2µV (IHF), MW: 200µV (S/N 20dB), LW: 400µV (S/N 20dB), SW: 100µV (S/N 20dB external aerial). Output power: 25W plus 25W RMS. THD: less than 1% both channels driven into 4 ohm). Aerial: MW/LW: ferrite core aerial, FM/SW/LW-TR: external DIN jack. Semiconductors: 15-IC, 21 transistors, 3-FET, 42 diodes, 1 varistor, 10 LED, 3 varicap (variable capacitor for FM tuning). Player. Type: single automatic player, 11³/₄in (300mm) turntable dia. Static balance pipe tone arm. Motor: 4 pole synchronous motor. Speed: 33¹/₃, 45 rpm. Cartridge: induced magnetic (interchangeable head shell). Stylus: Hitachi DS-ST101 diamond, pressure 2.5g. Cassette deck. Track system: 4 track, 2 channel stereo record/playback. Tape speed: 17¹/₂in/s (47.5 mm/sec). FR: 40-10,000Hz with normal tape, 40-15,000Hz with CrO₂. S/N ratio: better than 50dB. Cross talk: better than 55dB. Recording system: AC bias 57kHz. Erasing system: AC erase. Erasing ratio: better than 60dB. W and F: less than 0.15% WRMS. Power source: AC 240V 50Hz. Power consumption: 170W. Speaker system: 3 way speaker system SS 8310G (8 bass, 3¹/₂in mid-range, 3¹/₂in tweeter, 4 ohms). Dimensions: Main unit 25¹/₂in × 7¹/₄ × 16³/₄in (650mm × 185mm × 416mm) approx. Speakers: 10¹/₂ × 18¹/₂ × 9⁷/₈in (262mm × 354mm × 251mm) approx. Accessories: Hitachi stereo microphone, Hitachi C60 blank cassette tape, FM indoor aerial. Price: £279.20 (plus VAT).

SD2520

LW/MW/FM stereo tuner amplifier, record player and speaker system. Specification. Radio. Tuning range: FM: 88-104MHz with Multiplex stereo, MW 530-1605kHz, LW 150-300kHz. Output power: 2W plus 2W RMS. THD: less than 5% both channels driven into 8 ohms. Speaker system: SS 6270 G 6¹/₂in bass, 3³/₈ tweeter, 8 ohm. Aerial: MW/LW Ferrite core, FM external aerial jack. Semiconductors: 3-IC, 8 transistors, 10 diodes. Player. Type: Autochange BSR C-123R, 11in (280mm) turntable dia, static balance tonearm. Motor: 2 pole induction. Speed: 33¹/₃, 45, 78 rpm. Cartridge: BSR SC-12M. Stylus: BSR ST-17 diamond, pressure 5g. Power supply: 220/240V AC Mains 50Hz. Power consumption: 70W. Dimensions: main unit 16³/₄ × 8⁷/₈ × 13³/₈ (425mm × 225mm × 339mm) approx. Speakers: 8¹/₂ × 13¹/₂ × 5⁷/₈ (221mm × 351mm × 149mm) approx. Approx. av. weight: 15.4lb (7kg) (Ex. speakers). Accessory: Indoor FM aerial. Price: £100.00 (plus VAT).

■ HMV

Thorn Consumer Electronics Ltd,
Thorn House, Upper St Martins Lane,
London WC2H 9ED. Tel: 01-836 24444.

2488

Hi-fi combined stereo tuner/amplifier and record player. Record deck: Garrard 86SB automatic record deck. Cartridge: Shure M75ED2. Amplifier. Output: 45W RMS per channel into 4 ohms. THD: <0.1% up to 40W. FR: 25Hz-30kHz 0dB-3dB. 4D facility. Tuner: Band coverage: FM, MW. Switchable AFC, FM stereo beacon, tuning indicator. 4 FM presets and variable tuning. Speakers: 2 × 20.5cm bass units, 1 × 2.5cm treble unit. Finish: teak. Price: on application.

2455B

Hi-fi combined stereo tuner/amplifier and record player. Record deck: Garrard SP25 Mk IV. Cartridge: Shure M75 6S automatic. Amplifier. Output 25W RMS per channel into 4 ohms. THD: <0.1 up to 20W. FR: 25Hz-30kHz -0dB +3dB. 4D facility. Tuner. Band coverage: FM, MW. Switchable AFC, FM stereo beacon, tuning indicator. 4FM presets and variable tuning. Speakers: 2 × 12.7cm bass units, 1 × 8.6cm tweeter. Finish: teak. Price: on application.

■ ITT CONSUMER PRODUCTS (UK) LTD

Maidstone Road, Footscray,
Sidcup, Kent DA14 5HT. Tel: 01-300 7733.

KA1026

Combined stereo amp and record player, teak appearance, upward facing control panel. Controls: slides volume, treble, bass tolerance; push-buttons on/off disc, tape/radio. Sockets: 2-pin DIN loudspeakers. 5-pin DIN tape/radio (6.25mm). Stereo jack, headphones, automatic disconnects and speakers. Dimensions: 190 × 463 × 370mm (7¹/₂ × 18¹/₂ × 14³/₄in). Weight: 6.1kg, 13lb 6oz. Power supply: 220V-240V, 50Hz. Power consumption: 26W 35VA. Power output: 5W 1dB (music), 2.5W (mean) in to 8 ohms at 1.0% distortion measured at 1kHz. FR: 3dB at 50Hz and 15kHz. Speaker impedance: 8 ohms minimum. Record player: BSR C123R2. Cartridge: BSR 5C12H ST16 turnover stylus. Complement: 2 ICs (SN76023ND-07). Optional extras: stereo headphones, range of loudspeaker, pedestal stand. Price: £67.60 (plus VAT).

KA2000

Combined radio, stereo amp, record player. Controls: sliders, tolerance, volume, bass, treble, roller tuning. Push-buttons, disc, MW,

LW, FM, on/off. Sockets: FM aerial (co-axial) 5 pin DIN. Stereo jack socket (125mm) 2 pin DIN loudspeakers. Wavebands: FM 87MHz-104MHz, MW 525kHz-1620kHz (185-571m), LW 150kHz-260kHz (1153m-2000m). Dimensions: 270 x 367 x 555mm (8½ x 14½ x 21¼in). Power supply: 220V-240V AC, 50Hz. Power consumption: 26W, 50VA. Power output: 5W ± 1dB (music), 2.5W (mean) per channel into 16 ohms at 1.0% distortion at 1kHz. Input sensitivity: PINS 3 and 5 750mV into 1M. Output: PINS 1 and 2 750mV via 1.5M. Loudspeaker impedance: 8 ohms minimum. FR: 3dB at 100Hz and 12kHz. Record player: BSR 123R. Cartridge: BSC SC12M with ST16 turnover stylus. Component: 3 ICs a transistor, 11 diodes, 1 bridge rectifier. Optional extras: stand, range of loudspeakers, stereo headphones. Price: £110.20 (plus VAT).

■ MARCONIPHONE

Thorn Consumer Electronics Ltd,
Thorn House, Upper St Martin's Lane,
London WC2H 9ED.
Tel: 01-836 24444.

4495

Audio compact stereo tuner/amplifier with record deck and two matched speakers. Record deck: BSR C173, 3 speed, ceramic cartridge. Amplifier. Output: 10W RMS into 8 ohms. THD: <0.5%. FR: 25-30,000Hz. Loudness compensation. Tuner. Band coverage: FM/L/M/S. Switchable AFC. FM stereo beacon. Black and silver finish with teak surround. Price: on application.

■ PHILIPS

City House, 420/430 London Road,
Croydon CR9 3QR. Tel: 01-689 2166.

GF907 ★

Record player/amplifier combination. With stereo 4 surround sound facility. Output: 8.5W RMS per channel ± 1dB. Distortion: ≤ 1%. FR: 30Hz-30kHz ± 2dB. Power bandwidth: 60Hz-20kHz. Tone controls: bass ± 12dB at 100Hz, treble ± 10dB at 10kHz. Presence: (switchable) +7dB at 3kHz. Scratch filter: (switchable) -4dB at 7kHz. W and F: 0.2%. Rumble: ≤ -35dB (DIN A), ≤ -55dB (DIN B). Turntable speeds: 33⅓ and 45 rpm. Motor: low-speed synchronous, belt drive. Cartridge: GP400 magnetic with diamond spherical LP stylus. Loudspeakers: 4 ohms impedance. Mains: 110, 127, 220, 240V AC 50Hz. Size: (main unit) 490 x 405 x 131mm; (speakers) 265 x 265 x 100mm. Price: £159.20 (plus VAT).

RH852

Stereo tuner/amplifier/record player combina-

tion. Range: FM 87.5-104MHz, SW 5.95-9.78MHz, MW 520-1605kHz. LW 150-345kHz. Output: 6W RMS per channel ± 1dB into 4 ohms. HD: ≤ 1%. FR: 20Hz-20kHz + 1dB, -3dB. S/N ratio: better than +50dB at rated output. Tone controls: bass ± 10dB at 50Hz, treble ± 10dB at 10kHz. DIN socket for recorder. Philips GCO27 record player. Speeds: 33⅓ and 45rpm. Pick-up cartridge: GP 400. Mains: 110, 127, 220 and 240V AC. Power consumption: 47W max. Cabinet: polystyrene, silver finished. Size: 545 x 400 x 176mm. Price (complete system): £200 (plus VAT).

RH837 ★

FM tuner/amplifier in cabinet with record deck and two separate speakers. 46 transistors, 23 diodes and one IC. Range: 87.5-104MHz. Four preset stations. Switchable AFC. Stereo decoder fitted. Slider controls for volume, balance, bass, treble, presence, contour/rumble/scratch, silent tuning, speaker selection, input selectors, AFC, headphones, stereo-4.



Philips GF 907

★ Indicates entry is illustrated

Output: 20W RMS per channel \pm 1dB. Output impedance: 4 ohms. FR: 25Hz-25kHz \pm 1.5dB. HD: <1%. Motor unit: Philips GC008. Finish: polystyrene case with tinted transparent plastic cover. Speakers: Philips RH431 enclosures. Price (complete system): £280 (plus VAT).

GF614

Three-speed single play turntable. Arm with adjustable stylus force. GP215 ceramic cartridge. Output: 2 \times 5W music power. Separate bass/treble controls. Loudspeakers: with 6in dia. drive units. Silver and black finish with smoked perspex lid. Price: £52.00 (plus VAT).

GF851

Two-speed autochange turntable with facility for converting to single play. Sliding controls for volume, balance, bass/treble. Headphone socket. Accessory storage drawer. Hinged lid. Output: 2 \times 5W continuous sine wave. Silver and black finish. Price: £84.00 (plus VAT).



Pye SX 6845 Sound Project

■ PYE LTD

PO Box 49, St. Andrews Road,
Cambridge CB4 1DS.
Tel: Cambridge 58985.

ZU9 ★

Tuner/Amplifier/Player. VHF stereo radio with switchable AFC, pre-selection of 5 FM stations; interstation silent tuning. Transcription type Philips GC012 electronic turntable with GP401 magneto-dynamic cartridge and elliptical diamond stylus. Touch sensitive speed controls. Treble, bass and presence controls; 3-position contour switch. Tape, headphone and stereo; 4 speaker sockets. Separate level control for semi-speakers. Main unit finished black/silver; speakers in walnut veneers. Output: 2 \times 35W RMS. THD: <0.1% below 2 \times 30W. Frequency response: 20-30000Hz \pm 1.5dB. Speakers: 1 \times 10in; 1 \times 5in; 1 \times 1in each enclosure. Dimensions. Speakers: 29.8 \times 24.1 \times 54.9cm (W \times D \times H). Unit: 61 \times 40.6 \times 17.1cm. Price: £406.43 (plus VAT).

SX6845 ★

Record Deck. Turntable unit: Philips GC027 with damped pick-up mechanism, light weight resonance-free pick-up arm, direct reading stylus force adjustment and adjustable side thrust compensation. Speeds: 33 $\frac{1}{3}$, 45rpm. W and F: \leq 0.16%. Rumble: \leq -58dB (DIN B). Cartridge: Philips GP400 magneto-dynamic. Diamond stylus. Amplifier. Output: 15W RMS per channel into 4 ohms. THD: <1% for 15W RMS per channel. Power bandwidth: 40Hz-20kHz at -3dB. FR: 30Hz-20kHz linear, \pm 1.5dB. S/N ratio: better than 50dB. Tone

controls: bass +15 to -13dB at 50Hz, treble \pm 11dB at 10kHz. Radio Tuner. Band coverage: MW 520-1605kHz (577-187m), VHF 87.5-104MHz. Tuning system: varicap with four pre-selectors plus free tuning. Aerials: Ferroceptor for MW and wire aerial for FM; sockets for FM dipole aerial and AM aerial/earth. Speakers. Drive units: one 208mm (8in) bass/mid-range and one 24.4mm (1in) dome tweeter in each enclosure. Impedance: 4 ohms. HC: 20W. Dimensions: 37 \times 27.5 \times 19cm. Finish: black Ash. Main Unit. Dimensions: 50.2 \times 37.7 \times 15cm. Features/Facilities. Built-in automatic stereo decoder and beacon indicator. Switchable AFC. Slide controls. Auto contour control. Stereo - 4 speaker sockets. Tape and headphone sockets. Price: £256 (excluding VAT).

1570 ★

Record Deck. Turntable unit: BSR P128R automatic single player. Speeds: 33 $\frac{1}{3}$, 45, 78rpm. W and F: <0.2% and <0.06%. Cartridge: Sonotone 3549, ceramic. Stylus: sapphire turnover type. Amplifier. Output: 10W RMS per channel. THD: <5% at 1kHz. FR: 60Hz-20kHz \pm 3dB. H and N: better than -45dB at 1kHz. Radio Tuner. Band coverage: LW 144-258kHz, MW 526-1635kHz, SW 5.87-22.6MHz, VHF 87.5-108MHz. Tuning system: manual, with push-button wave-change selection. Speakers. Drive units: one 6 $\frac{1}{2}$ in bass unit, one 3 $\frac{1}{2}$ in tweeter. Power rating: 10W. Impedance: 8 ohms. Dimensions (each speaker): 25.4 \times 46.4 \times 21.1cm. Finish: teak

veneer. Main unit. Dimensions: 53.4 × 23 × 35.6cm. Finished in teak veneer. Features/Facilities. Built-in stereo decoder and beacon indicator. Switchable auto frequency control on VHF. Illuminated wide tuning scale with slide-rule type cursor. Mounted on castors and provided with record storage cabinet. Price: £199.20 (excluding VAT).

5003

Record Deck. Turntable unit: BSR PI28R single player with viscous cueing device. Speeds: 33 $\frac{1}{3}$, 45, 78rpm. W and F: <0.2% RMS and <0.06% RMS. Cartridge: Acos GP104 ceramic. Stylus: diamond (LP), sapphire (78rpm). Stylus pressure adjustment and side thrust compensation. Amplifier. Output: 11W (music power). THD: <5% at max. power. FR: 40Hz-20kHz. Power bandwidth: 60Hz-15kHz at 1dB below max. power. Noise level: better than 45dB. Channel separation: better than 40dB. Radio Tuner: Band coverage: LW 146-262kHz, MW 527-1650kHz, VHF



Pye ZU91DX

ZU530 ★

Record Deck. Turntable unit: Philips GC008 2-speed transcription type. Speeds: 33 $\frac{1}{3}$, 45rpm. W and F: 0.2%. Rumble -38dB (DIN A), -58dB (DIN B). Cartridge: Philips GP400 magneto-dynamic. Stylus: 15 micron diamond. Amplifier. Output: 20W RMS per channel into 4 ohms. THD: 0.1% at 15W RMS per channel. FR: 25Hz-25kHz \pm 1.5dB with tone controls flat. Power bandwidth: 30Hz-20kHz at -3dB. S/N ratio: 55dB. Channel separation: 45dB at 1kHz. Tone controls: Bass +15, -12dB at 50Hz, Presence \pm 6dB at 2kHz, Treble +12, -10dB at 10kHz. Radio Tuner. Band coverage FM 87.5-104MHz, AM 520-1605kHz. Tuning system: Varicap with four pre-selectors plus free tuning. Aerial: Ferroceptor for MW and AM aerial/earth. Speakers. Drive units: one 203mm (8in) bass/mid-range unit plus two 25.4mm (1in) dome tweeters. The tweeters are top and front mounted in the enclosures to provide continuously adjustable direct/indirect sound radiation via a rotary control at the rear. Impedance: 4 ohms nominal. Power handling: 20W. Dimensions (each speaker): 29 × 43 × 23cm. Main unit. Dimensions: 61 × 14 × 33cm. Features/Facilities: Built-in stereo decoder and beacon indicator. FET front end eliminates unwanted FM signals. Silent illustration tuning on FM. Switchable AFC. Illuminated mimic display panel shows network selected. Stereo-4 speaker sockets with level control. Switchable scratch and rumble filters. Tape and headphone sockets. Price: £287.60 (excluding VAT).



Pye 1570 Console Unit Audio

87.5-104MHz. Tuning system: variable capacitance tuner with rotary tuning knob. Aerials: AM internal ferrite. Socket for external aerial and earth. FM DIN socket for external aerial (300 ohms). Speakers. Drive units: 6 $\frac{1}{2}$ in, 12,500 lines. Power rating: 8W RMS. Impedance: 8 ohms. Dimensions (each speaker): 16 $\frac{1}{8}$ × 10 $\frac{7}{8}$ × 8 $\frac{1}{8}$ in. Finish: structural foam plastic with simulated teak. Main unit. Dimensions 7 $\frac{3}{4}$ × 21 $\frac{1}{4}$ × 19in. Cabinet moulded in black grained plastic with white trim, simulated teak side pieces. Tinted transparent hinged lid. Features/Facilities: pushbuttons for on/off, waveband, AFC, function selection and speaker muting. Slide controls for volume, balance, bass and treble. Switchable AFC on VHF. Built-in stereo indicator with automatic switching and beacon indicator. Price: £126.85 (excluding VAT). Stand included in price.

ZU9/DX

Tuner/Amplifier/Player. Same specification as Model ZV9 but supplied with multiple speaker

★ Indicates entry is illustrated

system consisting of 10in drive units housed in acoustic chamber mounted on castors and 2 × 5in and 1 × 1in units contained in separate cubes for wall or shelf innovating. Available in choice of white, teak or rosewood finishes. Dimensions. Bass unit: 31.1 × 40 × 45.7cm (W × D × H). Mid Range/Treble Unit: 17.5 × 17.5 × 17.5cm. Price: £502.73 (plus VAT).

■ RADIONETTE

Norse Audio Systems Ltd,
9 Hawksworth Trading Estate,
Swindon, Wilts. SN2 1DZ.
Tel: Swindon 31287.

SM240G ★

2 × 25W into 4 ohms. AM/FM tuner with four pre-sets on FM plus free tuning scale. Physiological volume control switchable to give linear output. Available in teak, rose, or black. Price: £215.00 (plus VAT). Speakers extra.



Radionette SM 240 G.

SM240 EFM

As above but incorporating FM tuner instead of AM section. Price: £207.20 (plus VAT). Speakers extra.

■ RICHMOND

Richmond Audio Ltd, 27 Church Road,
Bishops Cleeve, Cheltenham, Glos.
Tel: Bishops Cleeve 3952.

SA40

Output: 10W RMS per channel. Inputs: mag. PU, ceramic, tuner, tape. FR: 35Hz-20kHz. THD: better than 0.3%. Garrard 63SP deck. Goldring G800 cartridge. Teak plinth. Drive unit: 6½in bass, parasitic tweeter. Price: £99.75 (excluding VAT).

■ SHARP ELECTRONICS (UK) LTD

107 Hulme Hall Lane, Manchester M10 8HL.
Tel: 061-205 7321.

SD-308/CP-130

Stereo tuner-amplifier with record deck plus

two speakers. Details as SG-309H/CP-130 music centre without tape section. Price: £143.96 (plus VAT).

■ SONY (UK) LTD

Consumer Information, Sony Showroom,
134 Regent Street, London W1R 6DJ.
Tel: 01-439 3874.

HMP-40

FM section. Tuning range: 87.5-108MHz. FR: 20-15,000Hz. AM section. Tuning range: 530-1,605kHz, 150-350kHz. Amplifier. Output: 10W RMS per channel both channels operating at 8 ohms load. THD: -1%. Power Bandwidth: 60-12,000Hz. Harmonic Distortion: 1% at 1kHz at rated output. FR: 20-40,000Hz at 1W. Turntable: Diameter 10½in. Speeds: 33½, 45, 78 rpm. W and F: 0.15%. S/N: 53dB. Speaker section. Woofer 6½in dia. Tweeter 2in dia. Impedance: 8 ohms at 1kHz. Price: £161.99 (plus VAT).

HMP 70

FM section. Tuning range: 87.5-108MHz. HD: mono 0.5%, stereo: 1%. AM section. Output power: 20 + 20W. Power bandwidth: 40-12,500Hz. HD: less than 0.9% at continuous RMS power. Player section. Platter: 30cm. Speeds: 33½, 45 rpm. W and F: 0.09%. S/N: better than 63dB. Speaker systems: woofer 8¾in. Mid-range 3½in, tweeter 2in. Price: £231.96 (plus VAT).

■ TELEFUNKEN

Aeg-Telefunken (UK) Ltd,
217 Bath Road, Slough, Berks. SL1 4AW.
Tel: Slough 872101.

HI Fi Centre 4040

Record deck: Telefunken with speeds of 33½ and 45 rpm. Shure M75-D magnetic pick-up with diamond stylus. Amplifier: 2 × 40W. Tuner: FM/L/M/S. FR: 20-20,000Hz. Main unit. Dimensions: 45 × 36 × 20.2cm. Light matt walnut or black and silver finish. Price: £216.00 (plus VAT).

Electronic Centre 6001

Telefunken deck with speeds of 33½ and 45 rpm. Shure 91ED cartridge with diamond stylus. Amplifier: output 2 × 60W. Tuner: FM/L/M/S. Sensor waveband switchover. Main unit: dimensions: 68 × 37.6 × 18.5cm. Plastic, black and silver. Price: £380.00 (plus VAT).

■ TOSHIBA (UK) LTD

Toshiba House, Great South West Road,
Feltham, Middlesex. Tel: 01-751 1281.

SM-2200

4 waveband stereo compact. FM/MW/LW/SW. Audio output: 15 x 2 RMS 1kHz 8 ohms. 1% distortion. Magnetic cartridge. Semi-automatic turntable, 4 pole motor, 30cm platter, S-shaped arm, belt drive. L.E.D. tuning indicator. A/B speakers. Complete with speakers. Dimensions: 51 x 38 x 20cm. Silver/wood finish. Price: on application.

SM 5200

4 waveband stereo compact. FM/MW/LW/SW. Audio output 15W u09 2 RMS 1kHz, 8 ohms. 0.5% distortion. Presets on 5 FM stations. L.E.D. tuning pointer. Slider controls: volume, left and right, bass and treble. Belt drive. Magnetic cartridge. S-shaped arm. 30cm platter. Silver finish. Dimensions: 69 x 36 x 20cm. Price: on application.

SM 2100

3 waveband. Stereo compact. Auto return rim drive record player. Ceramic cartridge. Static balance. Pipe arm. 25cm platter. Audio power 8W x 2 RMS at 1kHz 8 ohms. 1% distortion. L.E.D. for power, tuning, stereo beacon. Complete with 2 way speaker system in wood finish. Price: on application.

■ ULTRA

Thorn Consumer Electronics Ltd,
Thorn House, Upper St Martin's Lane,
London WC2H 9ED.
Tel: 01-836 24444.

6495

Audio compact. Stereo tuner/amplifier and record deck with two matched speakers. Record deck: BSR C173. 3 speed, ceramic cartridge. Amplifier. Output: 10W RMS per channel into 8 ohms. THD: <0.5%. FR: 25Hz-30kHz \pm 3dB. Loudness compensation. Tuner. Band coverage: FM, MW, LW, SW. Switchable AFC. FM stereo beacon. FM 87.5-104MHz. MW 184-571m. LW 1110-2000m. SW: 47-51.2m. Speakers. Price: on application.

6453

Hi-fi combined stereo tuner/amplifier and record player. Record deck: Garrard SP25 Mk IV. Cartridge Shure M75-6S. Automatic. Amplifier. Output: 25W RMS per channel into 4 ohms. THD: <0.1% up to 20W. FR: 25Hz-30kHz +0dB -3dB. 4D facility. Tuner. Band coverage: FM, MW. Switchable AFC. FM stereo beacon. Tuning indicator. Speakers: 2 x 12.7cm bass units. 1 x 8.6cm tweeter. Finish: white. Price: on application.

■ VIDEOTONE

Perdix, 31 Green Lane, Chislehurst, Kent.
Tel: 01-137 0100.

500

Record player plus speakers. Garrard 86SB belt drive turntable. Good quality magnetic cartridge. 18W RMS per channel into 8 ohms. THD: <0.1% 20Hz-20kHz. S/N PU <56dB. FR: 40-25kHz \pm 1.5dB. Inputs sensitivity: PU 4mV into 47K ohms. R and tape 75mV into 220K ohms. Quadrophonic 4 speakers with front/back volume. Bass control \pm 15dB 100Hz. Treble control: \pm 15dB 10kHz. Filters: 12dB per octave. Roll over at 80Hz. Contour control: 6kHz plus hi-fi speakers. Price: £135.50 (plus VAT).

400

Record player and speakers. Record player: SP25 Mk IV. Magnetic cartridge. Slider controls. 6W RMS into 8 ohms. FR: 40Hz-25kHz \pm 1.5dB. S/N: -65dB. THD at 1dB below output: 0.15%. Damping factor: -40. Treble filter: -14dB at 10kHz. Bass control: \pm 15dB at 100Hz. Treble control: \pm 15dB at 10kHz. Hi-fi speakers. Tape outlet: 100mV 10k ohms. Stereo jack socket with speaker muting. Contour (loudness) control. Dimensions: 445 x 445 x 205mm. Weight: 8.5kg. Price: £104.50 (plus VAT).

450

Radio/record player and speakers. Amplifier and deck as 400. Radio: FM, MW, LW. FM frequency range: 87.5-108MHz. 75 ohm input. Capture ratio: 2dB. AM suppression: -60dB. Stereo crosstalk: -40dB. Pilot tone rejection: 19kHz -35dB. 38kHz -45dB. Hi-fi speakers. AM MW: 540-1500kHz. LW: 150-260kHz. Sensitivity: 20 μ V for 20dB S/N. Selectivity: 45dB. Dimensions: 445 x 445 x 204mm. Weight: 11.3kg. Price: £124.50 (plus VAT).

You've asked for it!

Time and again we are asked for reprints of Wireless World constructional projects: tape, disc, radio, amplifiers, speakers, headphones. Demand continues long after copies are out of print. To meet the situation we have collected fifteen of the most sought after designs and put them in one inexpensive book. And we've updated specifications where necessary to include new components which have become available. A complete range of instruments is presented, from the Stuart tape recorder and Nelson-Jones f.m. tuner, through the Bailey, Blomley and Linsley Hood amplifiers, to the Bailey and Baxandall loudspeakers – some of which have been accepted as standard in the industry.

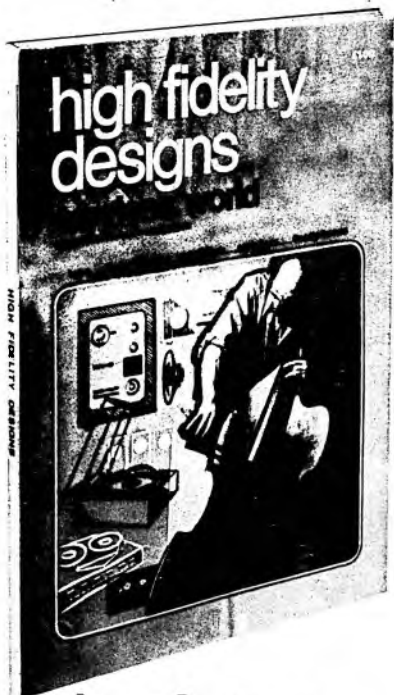

high fidelity designs

£1 from newsagents and bookshops. A book from

WirelessWorld

Unit Audio: Tape Systems

(See also Music Centres section)

★ Indicates entry is illustrated.

Abbreviations used in this section are given on page 27.

■ BANG AND OLUFSEN (UK) LTD.

Eastbrook Road, Gloucester GL4 7DE.

Tel: Gloucester 2159.

Beocenter 1600

Radio Section: Band coverage: 87.5-108MHz plus 4 pre-sets. Sensitivity: $<1.8\mu\text{V}/75\text{ ohms IEC}$ $<2.5\mu\text{V}/75\text{ ohms IHF}$. S/N: $>65\text{dB DIN 45 500}$. Selectivity: $>55\text{dB IHF}$. FR: 20-15,000Hz $\pm 1.5\text{dB DIN 54 500}$ HD: $<0.5\%$ DIN 45 500. Amplifier Section: Power output: $2 \times 22\text{W RMS}$, $2 \times 40\text{W music power}$. HD: $<0.1\%$ at 50mW/1kHz. $<0.5\%$ at full output/1kHz. FR: 20-30,000Hz $\pm 1.5\text{dB DIN 45 500}$. Inputs: Phono: $2.5\text{mV}/47\text{ k Ohms}$, Tape: $140\text{mV}/700\text{ k Ohms}$, FM aerial: 75 and 240 Ohms. Dimensions: $8.5 \times 26 \times 10.2\text{cms}$. Price: on application.

HCD 1000 ★

For recording and playback of cassettes in conjunction with Hi-Fi audio equipment. Fitted with Dolby noise reduction unit. Will accept standard and Chromium Dioxide tape. Tape speed: $1\frac{1}{2}\text{ips}$. Price: £158.40 (plus VAT).

■ DECCA RADIO AND TELEVISION LTD.

Neachells Lane, Willenhall, West Midlands WV13 3RW.

Tel: Willenhall 67367.

DS 8100

Amplifier Section: Power output: $2 \times 4\text{W RMS}$. FR: 40-20kHz. Cassette Tape Deck: W and F: 0.18% RMS. Twin illuminated VU meters. Cr02. Inputs for mic, aux, DIN. Output for headphones, speakers, DIN. Dimensions: $35.2 \times 23.7 \times 11\text{cms}$. Speakers: $21.5 \times 14 \times 31.5\text{cms}$. Price: £90.28 (plus VAT).

■ HACKER RADIO LTD.

Norreys Drive, Cox Green, Maidenhead, Berks SL6 4BP.

Tel: Maidenhead 22261.

CTA 700

Stereo radio/cassette system. Amplifier: Output $14 + 14\text{Watts}$ into 8 ohms both channels driven. FR: 25-40,000Hz. THD: 0.075% at 1kHz typical for + 15dB on nominal input. Radio Tuner: Band coverage FM/L/M. THD: better than 0.5%. Tape Deck Dolby noise reduction circuit. W and F: less than 0.2% wtd peak. S/N: CrO₂ tape with Dolby out 53dB wtd (CCIR) nominal: Dolby in 60dB wtd (CCIR) nominal. FR: CrO₂ tape: 50-13,000Hz. Fe₂O₃ tape: 50-12,000Hz. Speakers handling capacity: 70Watts. DIN. Impedance: 8 ohms. Drive Units: 254mm bass, 127mm mid-range, 25.40mm treble. Dimensions $39 \times 30.5 \times 61.8\text{cm}$. Main Unit Dimensions $59.5 \times 43.2 \times 19.6\text{cms}$. Teak finish. Features built-in facilities for immediate connection of rear speakers for ambiophonic reproduction. Input for magnetic pick-up. Cassette storage space. Facilities for chromium dioxide tape. Can record and play back material from radio and disc, similarly record and play back material from external sources, record on external equipment, mix voice with recording. Price to be advised.

■ HITACHI (UK) LTD.

Hitachi House, Station Road, Hayes, Middlesex.

Tel: 01-848 8787.

SDT 2480

Tuner, Amplifier, Cassette Deck and Speaker



Hacker Stereo Cassette Unit HCD 1000

★ Indicates entry is illustrated

system. Radio Section: Waveband coverage: FM/L/M/S. Output: 15W plus 15Watts less than 1% THD both channels driven into 4 ohms. Cassette Deck: 4-track, 2 channel stereo, record, playback. Speed: 1 $\frac{7}{8}$ ips. FR: 50-10,000Hz \pm 6dB normal tape, 50-13,000Hz \pm 6dB CrO₂ tape. S/N: 48dB. Crosstalk: 50dB. W and F: 0.28% WRMS. Dimensions: 59.7 \times 21 \times 41.3cms. Speakers: 23.3 \times 44.1 \times 17.8cms. Price: £199.20 (plus VAT).

■ PHILIPS ELECTRICAL LTD.

City House, 420-430 London Road, Croydon CR9 3QR.

Tel: 01-689 2166.

RH 851

Tuner, amplifier, cassette recorder complete with speakers. Output: 2 \times 10W RMS. Waveband coverage: FM/L/M/S. CrO₂ or Fe₂O₃ tape facility with automatic switchover. DNL noise reduction system. Loudspeakers each with 6 $\frac{1}{2}$ ins. dia. drive units. Finish: Black and silver. Price: £207.20 (plus VAT).

RH 831

Tuner, amplifier, cassette recorder. Outputs: 2 \times 25W RMS. THD: <1%. FR: 20-20,000Hz \pm 1dB. Waveband coverage: FM/L/M/S. CrO₂ and Fe₂O₃ tape facility with automatic switchover. Dolby noise reduction system. Double stereo or Stereo 4 surround sound facility. Finish: Black and silver. Dimensions: 60.3 \times 33 \times 12.5cms. Weight: 13 $\frac{1}{2}$ kg. Price: £399.20 (plus VAT).

■ PYE

Pye Ltd, PO Box 49,
St Andrews Road, Cambridge CB4 1DS.
Tel: Cambridge 58985.

SW0841 ★

4-waveband tuner/amplifier and cassette recorder with matching full range loudspeaker enclosures. Built-in stereo decoder and beacon indicator. Sockets for connecting external sound source, mic, speakers and headphones.



Pye SX 0841 Tuner/Amplifier/Cassette



Sony HST 139

Pushbutton stereo cassette recorder with ALC, switchable interference filter, auto tape-end stop, pause switch. Output: 5W RMS per channel. THD: \leq 5% at 4W per channel. FR: 45Hz-20kHz. One 203mm drive unit in each enclosure. Dimensions: (speaker enclosures) 24.2 \times 10 \times 26.5cm; (main unit) 51.2 \times 32.7 \times 10.5cm. Finish: black moulded cabinet and speaker enclosure with silver coloured styling trim. Price: £140.00 (plus VAT).

■ SONY (UK) LTD.

Consumer Information, Sony Showroom, 134 Regent Street, London W1R 6DJ.

Tel: 01-439 3874.

CF 620

Amplifier Section: Power output: 2 \times 6Watts into 8 ohms. HD: less than 2.5%. Speaker 6ins. dia, 2 \times 8 ohms. S/N: 50dB. Recorder: 4 track, 2 channel, stereo and 2 track mono. Speed: 1 $\frac{7}{8}$ ips. W and F: 0.22% weighted \pm 0.38% DIN. S/N: 46dB. FR: Normal tape 30-12,000Hz-15dB, 60-10,000Hz DIN or CrO₂ 30-13,000Hz - 15dB, 60-11,000Hz DIN. Dimensions: 42 \times 13.8 \times 31.1cms. Speakers 38.5 \times 29.4 \times 15.9cms. Supplied with microphones, demonstration tape, mains lead, head cleaning tips. Price: £161.99 (plus VAT).

TC 133 CS ★

Amplifier Section: Power output: 2 \times 6 Watts into 8 ohms. HD: less than 2.5%. Speaker 43 $\frac{3}{4}$ ins. diameter, 2 \times 8 ohms. Recorder Section: 4 track, 2 channel, stereo and 2 track mono. Speed: 1 $\frac{7}{8}$ ips. W and F: 0.22% RMS weighted \pm 0.35% DIN. S/N: 50dB with normal tape. FR: with normal tape 30-12,000Hz - 15dB, 60-9,000Hz DIN or CrO₂ tape 30-13,000Hz - 15dB 60-11,000Hz DIN. Dimensions: 39.8 \times 31.1 \times 19.6cms. Supplied with mics, demonstration tape, head cleaning tips. Price: £95.96 (plus VAT).

HST 139 ★

Amplifier Section: Power output: 2 \times 12 Watts into 8 ohms. HD: 5% at rated output power, 0.5% at 1 Watt. FR: 40-40,000Hz 0-3dB at 1

★ Indicates entry is illustrated



Sony TC 133CS

Watt output. S/N: 60dB. Recorder Section: 4 track, 2 channel, stereo and 2 track mono. Speed: 1 $\frac{7}{8}$ ips. S/N: better than 40dB. FR: 40-10,000Hz. Dimensions: 55 × 13.3 × 32.5cms. Supplied with VHF aerial, head cleaning tips, speaker leads, mains lead. Price: £124.95 (plus VAT).

■ SANSUI

Vernitron Ltd, Thornhill,
Southampton SO9 5QF.
Tel: Southampton 444811.

QRX 7500

AM/FM comprehensive 4-channel de-coder tuner/amplifier. Output: 235W all channels driven into 8 ohms. THD: less than 0.3% at rated output. Will synthesize 2 to 4 channel, will decode QS, SQ and CD4 material. 4 VU meters indicate de-coder output. Facilities for phono (2), 1 2-channel tape deck and 2 4-channel tape decks. FM sensitivity: 1.9 μ V. Controls: front bass and treble, rear bass and treble, speaker switch, A.B.A. + B. Balance controls for front main and rear, volume, de-coder function, input selector, CD4 adjustment. Push switches power on/off, front high and low filters, rear low and high filters, loudness, 2-channel tape monitor, 4-channel tape monitor. 1, 4-channel tape monitor 2 and FM muting. Size: 594 × 203 × 370mm. Price: £543.55 (plus VAT).

■ TELEFUNKEN

AEG-Telefunken (UK) Ltd,
217 Bath Road, Slough, SL1 4AW.
Tel: Slough 872101.

Compact Centre 6002

Amplifier: Music output 2 × 60 Watts. FR: 20-22,000Hz. Radio tuner Four wavebands FM/L/M/S. Tape deck Dolby noise reduction system. S/N: >57dB. Main unit dimensions 68 × 36.7 × 11.9cms. Cabinet black and silver finish. Price: £439.20 (plus VAT).

Radford

Radford HiFi Limited
52/54 Gloucester Road
Bristol BS7 8BH
Tel Bristol 422709 and 44593
Telex No 449315

open 6 days a week 9 - 5.30

AIWA
ACOS
ADVENT
ADC
ACOUSTIC RESEARCH
AMPEX
ARISTON
ARMSTRONG
ALTEC
AMCRON
AKG
AGFA
BGW
B & W
BOSE
BRAUN
CAMBRIDGE
CELEF
CELESTION
CHARTWELL
DUAL
DENON
EMPIRE
FONS
FERROGRAPH
GALE
GRACE
GROOVAC
HARMAN KARDON
HARRISON
INFINITY
IMF
JVC
JBL
KEF
KLH
KLIPSCH
LARSON
LUX
LEGSON
LINN SONDECK
LEAK
MONITOR AUDIO
MARANTZ
MAYWARE
MICRO
MICRO ACOUSTICS
MEMOREX
NAKAMICHI
NATIONAL PANASONIC
NEAL
OMAL
ORTOFON
PIONEER
PHASE LINEAR
QUAD
REVOX
ROGERS
ROGERS PROFESSIONAL
ROTEL
SANSUI
SME
SPENDOR
STANTON
STUDIOCRAFT
SUPEX
TANNOY
TANDBERG
TEAC
TECHNICS
TRANSCRIPTORS
TRIO
TDK
UHER
VIDEOTONE
WHARFEDALE
YAMAHA
ZEROSTAT

The greatest selection of the world's hi-fi equipment displayed on three floors.

Professional advice from the experts with unequalled demonstration facilities enable you to comfortably compare and select the equipment best suited to your taste, your budget and your home.

Intelligent purchasing enables us to offer enormous discounts. Part exchange, credit facilities, Access and Barclaycard are welcome.

Mail order delivery in safety by Securicor in the UK and exports throughout the world.

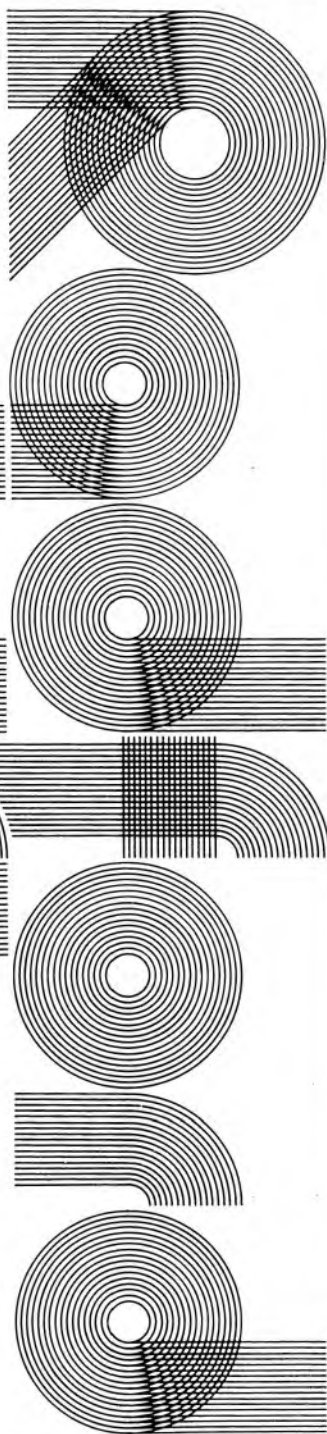

Stop Press

Pyser terminates Marantz contract

As from July 1st, 1976 Pyser Ltd ceased to market Marantz and commenced distribution of its own brand NAD. The bulk of this book had been printed when the news broke, but we understand that the NAD range comprises:

NAD 60 Amplifier ★

Delivers 30W RMS per channel into 8 ohms from 20Hz to 20kHz at no more than 0.3% THD. The unit offers full complementary direct coupled output circuitry, illuminated power meters and a comprehensive range of controls. Price: £137.50 (excluding VAT).

NAD 90 Amplifier ★

NAD 90 delivers 45W RMS per channel into 8 ohms from 20Hz-20kHz at no more than 0.3% THD. The unit offers full complementary direct coupled output circuitry, illuminated power meters, microphone mixing facilities, independent tone controls for each channel and a comprehensive range of controls. Price: £163.50 (excluding VAT).

NAD 200 Amplifier ★

NAD 200 delivers 100W RMS per channel into 8 ohms from 20Hz-20kHz at no more than 0.2% THD. The unit offers full complementary direct coupled output circuitry, a built-in Dolby system, illuminated power meters, independent tone controls for each channel, a subsonic filter and a comprehensive range of controls and inputs/outputs. Price: £298.00 (excluding VAT).

NAD 140 Receiver

Delivers 30W RMS per channel into 8 ohms from 20Hz-20kHz at no more than 0.3% THD, and offers full complementary direct coupled output circuitry and a comprehensive range of controls. The AM/FM tuner section features low distortion FET RF and IF circuitry and the FM sensitivity is 2.0 μ V for 30dB quieting. Price: £192.00 (excluding VAT).

NAD 160A Receiver

NAD 160A delivers 45W RMS per channel into 8 ohms from 20Hz-20kHz at no more than 0.3% THD, and offers full complementary direct coupled output circuitry and a comprehensive

range of controls. The AM/FM tuner section features four FETs, a dual gate MOSFET mixer stage, six ceramic filters, separate oscillator and AM/FM IF amplifiers and a phase lock loop demodulator for maximum separation and minimum distortion. The FM sensitivity is 1.8 μ V for 30dB quieting. Price: £242.00 (excluding VAT).

NAD 300 Receiver

NAD 300 delivers 100W RMS per channel into 8 ohms from 20Hz-20kHz at no more than 0.3% THD, and offers full complementary direct coupled output circuitry, a built-in Dolby system, independent tone controls for each channel, a subsonic filter and a comprehensive range of controls and inputs/outputs. The AM/FM tuner section incorporates the same circuitry as the model 160A including the phase lock loop demodulator, and the FM sensitivity is 1.8 μ V for 30dB quieting. Price: £437.00 (excluding VAT).

NAD 900 Cassette Deck

NAD 900 is a front loading, twin ferrite head, Dolby cassette deck, featuring an electronically controlled dual capstan motor (W and F: 0.06% WRMS). The unit incorporates a ferric/chrome switch, large illuminated VU meters, and LED display of peak recording levels, auto stop at the end of a tape, a memory switch and a tape run indicator. Price: £195.00 (excluding VAT).

NAD M180 Microphone

Dual impedance (50K ohms/600 ohms) omnidirectional microphone, featuring a special



*NAD range of stereo amplifiers.
From top to bottom: NAD60, NAD90, NAD200.*

★ Indicates entry is illustrated

frequency compensation circuit which reduces signal losses when long cable lengths are used. The unit is fitted with a wire mesh screen to reduce pop and wind noise outdoors. Price: £12.80 (excluding VAT).

NAD MX286 Microphone

A highly directional cardioid microphone with an impedance of 600 ohms. The unit features a self-powered high performance FET amplifier circuit and is fitted with a windscreen to reduce pop and wind noise. Price: £17.40 (excluding VAT).

NAD 05 Headphone

NAD 05 stereo headphones are open moving coil headphones having a system diameter of 43mm. The headphones operate from source impedances between 4 ohms and 50 ohms and the load handling capacity is 65mW. Price: £12.70 (excluding VAT).

NAD 10 Headphones

NAD 10 stereo headphones are closed moving coil headphones having a system diameter of 57mm. The headphones operate from source impedances between 4 ohms and 50 ohms and the load handling capacity is 65mW. Price: £18.80 (excluding VAT).

NAD 16 Headphones

NAD 16 stereo headphones are open moving coil headphones having a system diameter of 59mm. The headphones operate from source impedances between 4 ohms and 50 ohms and the load handling capacity is 65mW. Price: £28.00 (excluding VAT).

NAD RP18 Headphones

NAD RP18 stereo headphones are regular phase open magnetic surface diaphragm headphones in which the conductor tracks are fused to the diaphragm to form the voice coil. This gives the headphones similar performance characteristics to electrostatic headphones without the need for a separate energiser. The headphones operate from source impedances between 4 ohms and 50 ohms and the load handling capacity is 200mW. Price: £42.70 (excluding VAT).

NAD 20e Headphones

NAD 20e stereo headphones are open electrostatic headphones having a system diameter of 64mm. A separate energiser operates between 4 ohms and 16 ohms and the maximum input power which can be handled is 5W. Price: £60.50 (excluding VAT).

Combined amplifier/cassette and phase-link speakers from B & O.

Bang and Olufsen has introduced two new products:

Beocenter 1500

Stereo FM/AM (long and medium) radio-amplifier with combined cassette unit. Amplifier output is 20W effective per channel and the tape unit features super Permalloy R/P head and auto stop. Connections for AM and FM aerials, extra tape recorder, pick-up (magnetic or crystal), two pairs of loudspeakers and headphones. Finished in teak, rosewood or oak with brushed aluminium fascia and controls. Price around £217.00.

Beovox S.22

The most recent addition to the range of Phase-Link loudspeakers. Features: compact size suitable for the smaller system, acoustic focusing, rated at 22-30W, impedance 4 ohms. FR: (+4 -8dB) 50-20,000Hz. Finished in teak, rosewood or white. Price around £72 per pair.

Andromeda launches speakers and turntables

A name new to the Hi-Fi Year Book is Andromeda Audio Ltd, of 8 Ofbring Road, Tuffnell Park, London NW5. Products include speakers, amplifiers, and turntables.

Philips deletes five items

Since this booklet went to press Philips announced the deletion of five items: AH 967 TAPC; AS561 amplifier; RH 742 tuner/amplifier; RH 651 tuner; RH 453 loudspeaker.

Fuji tapes

Fuji Film Magnetic Tapes are marketed by Belmont A/V Ltd, a member of the Pyser Group, and were shown for the first time at High Fidelity 76 exhibition.

Rotel RX 7707 receiver ★

A 35W per channel receiver with VHF/M



Rotel RX 7707 Receiver.



**Audiomaster
Image 2**

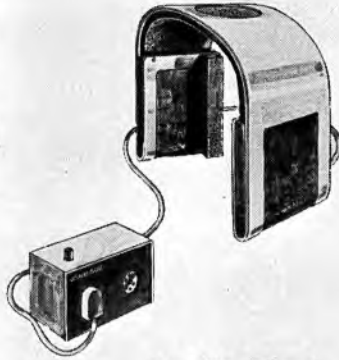

Jecklin Float



**Audiomaster
BBC LS3/5A**

Image 2, Jecklin Float and Audiomaster from Audiomaster Ltd.

wavebands is the latest release from Rank Hi-Fi. There are five touch/selected presets as well as manual tuning. Two sets of speakers can be connected. The receiver is finished in matt black and walnut and retails at approx. £220.

Audiomaster hacks British

Audiomaster Ltd, 33 Bridle Path, Watford, Herts WD2 4BZ, presents a new range of British-made loudspeakers. The firm also distributes the Swiss-made Jecklin Float electrostatic headphone.

Image 2 Loudspeaker ★

To fulfil the steadily growing demand for a high performance loudspeaker of compact dimensions and modest cost. It will be appreciated for its low order of coloration, smooth response and stable stereo image. Built to 'no compromise' standards Image 2 has the backing of the Audiomaster 5 year guarantee. Price: £109.90 per pair (including VAT).

BBC LS3/5A Loudspeaker ★

Designed by the BBC and built under licence from them, LS3/5A is intended primarily for monitoring purposes where space is at a premium. Hand built in small quantities. Guaranteed for 5 years. Price: £139.90 per pair (including VAT).

Jecklin Float Electrostatic headphone ★

Jecklin Float looks different from a normal headphone. It would be more accurate to call

them 'ear speakers' as the capsules deliver sound to the ear in much the same way as a pair of loudspeakers. This means that the 'sound stage' appears to be in front of you as it would normally be when you listen, unlike ordinary headphones where the 'sound stage' appears to be located in the centre of the head. Price: (including power supply box) £125.00 (including VAT).

Soundex Studio Series ★

Mobile/desk models to high standards. Six balanced transformer inputs each switched to five modes and each having treble and bass controls. Robust sliders and panpots into two groups. Pre- and post-fade listening and PPM to BBC specification. Break jacks on four channels, A&B tape monitoring and built-in 1kHz oscillator. Nearly horizontal sliders with

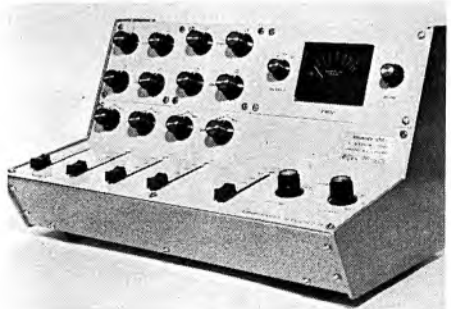

Soundex Studio 4.

★ Indicates entry is illustrated

nearly vertical meter and rotary controls in all-metal case. Power required: +24V. With Canon in/out connectors £380.00 plus VAT, with locking DIN in/out connectors £370.00 plus VAT. Four-channel and other options on application.

Also Unimixer 4SB for one stereo crossed-pair and two spot microphones. Balanced transformer inputs, switched for 25 to 600 ohm microphones, and peak-reading VU meter. Price: £145.00 plus VAT. Other options on application.

Brand new from Hacker ★

Stereo Radio/Cassette/Amplifier System CTA700

Designed for the listener who wants a means of playing and recording at home, tapes he can also enjoy in his car. System features a high sensitivity AM/FM tuner with phase locked loop stereo radio decoder; cassette deck - with Dolby noise reduction circuit - capable of handling all types of tape; built-in facilities for the immediate connection of rear loudspeakers for ambiphonic reproduction; input for magnetic pick-up; cassette storage space; two LS1300 extended-bass 3-way loudspeakers. And a power output of 14W RMS per channel. Finished in teak veneers. Price: approx. £430.00 (inc. VAT)

Teleton MC 600 hi fi music centre

A unit on classical lines giving fine performance levels in all functions which exceed DIN 45 500. Cassette Recorder incorporates ALC which may be switched out enabling

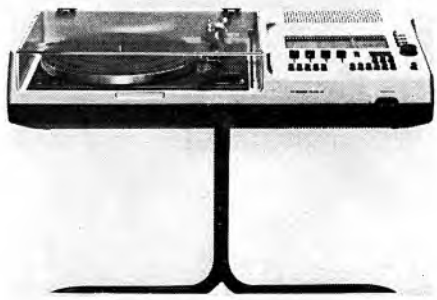

Technics SB-5000 flat-phase speaker system.

metered level to be controlled for more demanding material. Three waveband tuner has tuning/signal strength meter and AFC. Low distortion amplifier has full 10W RMS per channel output which drives twin loudspeakers. Garrard 35 SB belt-drive deck.

And CS 400 Stereo/tuner/amplifier/player.★

This unit includes a four waveband receiver with pre-set selection buttons and individual tuning scales, powerful 20W channel amplifier and belt-driven turntable. Prices: on application.

Automatic budget-priced turntable from Technics.

Model SL-23 is an addition to the budget-priced end of Technic's High-Fidelity range. FG servo control assures rotational accuracy



Hacker CTA 700 stereo radio cassette amplifier system.

of the belt-drive. W and F: 0.05% W RMS. S-shaped arm, electronic speed switching, individual pitch control and a see-it-yourself turntable speed check. Price: £79.95 (inc. VAT).

And addition to flat-phase speaker range.★

Following up the SB-7000 introduced last year, Technics now present SB-6000 and SB-5000. Development of flat-phase response gives an improvement in audio reproduction, says the firm. SB-5000 accepts up to 75W input power, SB-600 up to 100W. Price: SB-5000 £99.95 each, SB-6000 on application. Full details from National Panasonic (UK) Ltd, Whitby Road, Slough, Berks SL1 3DR.

Farnell-KF Ltd.

Details of five loudspeakers came to us too late for inclusion in the main body of the book:

HF6

Infinite baffle enclosure with 6½in. bass unit and 2¼in. tweeter. 5W RMS. 8 ohms. FR: 100Hz - 18kHz. Size: 13½ × 10½ × 4in. Finish: teak or mahogany. Price: £28.20 per pair (plus VAT).

HF8

Infinite baffle enclosure with 8in. bass unit and 2¼in. tweeter. 10W RMS. 8 ohms. FR: 80 - 18kHz. Size: 15 × 10½ × 5¼in. Finish: teak or mahogany. Price: £31.00 per pair (plus VAT).

OPUS 20 ★

Infinite baffle enclosure with 170mm twin cone speaker. 15W DIN. 4 to 8 ohms. FR: 100Hz-20kHz ±4dB. Sensitivity: 1W produces 91dB

at 1 metre. Size: 11 × 8½ × 7in. Finish: teak or walnut. Price: £39.64 per pair (plus VAT).

OPUS 45 ★

Infinite baffle enclosure. 3 way system. Bass 200mm. Mid range 100mm, Tweeter 30mm. 35W DIN. 4-8 ohms. FR: 45Hz-20kHz ±4dB. Sensitivity: 1W produces 87dB at 1 metre. Size: 19 × 10½ × 9½in. Finish: teak or walnut. Price: £71.88 per pair (plus VAT).

OPUS 55

Infinite baffle enclosure. 3 way system. Bass 250mm. Mid range 100mm. Tweeter 30mm. 40W DIN. 4-8 ohms. FR: 43Hz-20kHz ±4dB. Sensitivity: 1W produces 90dB at 1 metre. Size: 24 × 15 × 11½in. Finish: teak or walnut. Price: £103.72 per pair (plus VAT).

Further details from Farnell-KF Ltd, Ashton Road, Bredbury, Stockport SK6 2SP. Tel: 061-494 1441.

New from AKG

K240 ★

The new AKG K240 headphones use a unique multi-diaphragm system incorporating on each channel a main system with six additional diaphragm to stabilize the frequency response and produce an enhanced sound image. These headphones comprise a top quality monitoring unit for Studios and professional users. Price: £30.20.

K140 "Cardan"

The large diaphragms give a natural full tone throughout the entire frequency range, without

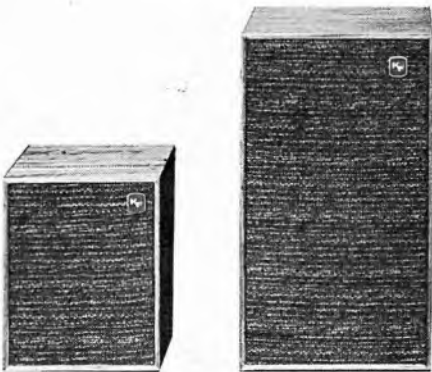

KF Opus Speakers.



★ Indicates entry is illustrated

any sound coloration. They're high in quality and low in weight. The earpieces are self-adjusting – and so is the headband. In short you can wear them without looking like a refugee from a space mission. Impedance: 60 ohms per channel. FR: 20-20,000Hz. Price: £18.70.

D190C

Undirectional recording and PA microphone with 3 pin miniature DIN plug. Supplied with matching socket PC1/2, 5 metre (16.4ft) cable and stand Adaptor SA11/1. Impedance: 60 or 200 ohms. Price: £33.30.

D224C

Highly directional double capsule system dynamic microphone. Similar to D202E1 but of slim design. Diameter 23mm (0.9in.) 3-position bass cut switch giving 0.87, -12dB attenuation to 50Hz. Built-in 3-conductor DIN plug. Supplied with 5m cable, front and rear windshields W2 and W2A and stand adaptor SA18/3. Impedance: 200 ohms. Price: £84.20.

D900C

Narrow angle 'Gun' microphone with Lobar Directional Pattern 3-position bass cut switch. 0, -7, -20dB at 50Hz and built-in 3 pin DIN plug. Supplied with matching socket PC1/2, 5m cable and stand adaptor SA16/1. Price: £66.60.

Lecson systems Ltd.

Burrell Road, St. Ives, Hants, Cambs. Tel: St. Ives 64124.

AC1

Stereo pre-amplifier control unit. Inputs: mag PU 2.5mV 68K, Aux 1 and Aux 2. 125mV 68K. Pickup overload capability: 50dB. S/N Ratio: PU. 70dB; other inputs 80dB (ref. rated output). Rated output Level: 500mV and 1.2V. Controls: Treble ± 10 dB at 10kHz; Bass ± 12 dB at 100Hz; HF Filter -3dB at 5, 8 and 13kHz 18dB/Octave (Bessel Slope); LF Filter -3dB at 35Hz 12dB/Octave (Bessel Slope). Harmonic Distortion: less than 0.05% at 1kHz. Mains: 120-240V AC. Size: $14\frac{3}{8} \times 1\frac{1}{8} \times 10\frac{1}{2}$ in. Finish: black anodised frame with polished top plate. Design Council Award 1974. Price: £168.50 (excluding VAT).

AP1

Stereo power amplifier. Output: 50W RMS per channel into 8 ohms. HD: less than 0.05% at rated output a Typically 0.005% for 35W at 1kHz. Input Sensitivity: 500mV. Size: $5\frac{3}{8}$ in diameter; $11\frac{1}{2}$ in high. Finish: black anodised aluminium. Exclusive circuitry designed to eliminate transient distortion effects. Design Council Award 1974. Price: £122.90 (excluding VAT).

AP3

Stereo power amplifier. Similar specification to AP1 except rated power output: 100W RMS per channel into 8 ohms. Size: $5\frac{3}{8}$ in diameter 14in high. Price: £182.10 (excluding VAT).

FM1

Stereo FM tuner. Range: 88-108 MHz highly stable varicap tuning. Sensitivity: 1, 9V μ for 30dB quieting. Aerial input: 75 ohms coaxial or 300 ohms balanced. S/N ratio: 70dB (mono). Image rejection: 65dB. Capture ratio: 1.3dB at 1kHz. THD: 0.2% mono. IF rejection: 85dB. Output up to 7000mV variable. De-emphasis: 50 μ S (75 μ S American) and 25 μ S Dolby switchable. Variable tuning and four preset stations: AFC: squelch: noise cancelling stereo blend. Solid state visible tuning scale. Light emitting diode scales for signal strength and centre tuning. Advanced circuit design. MOSFET front end; ceramic filters; C-MOS tuning control; discrete multi phase locked loops; FET stereo de-multiplexer. Finish: black anodised frame with polished top plate to match AC1 control unit. Price: to be announced.

FR1

Digital frequency meter for use with the FM1 tuner. Direct reading of station frequency in MHz. Uses green LED readout. Constructed in black anodised case to match the existing Lecson range. Price: to be announced.

HL1

Horn loaded speaker system. Two 13×8 in bass drivers coupled to main folded horn, 5in mid-range unit coupled to polyurethane exponential horn. Horn loaded tweeter. Crossover: 840Hz (12dB/octave) 5kHz (18dB/octave). Power handling: 50W DIN. Nominal impedance: 8 ohms. Size: 15in wide, 37in high, $17\frac{1}{2}$ in deep. Finish: black fabric with teak or rosewood top panel as standard. Price: £126.50 (excluding VAT).

SP1

Five way direct radiator reflex loudspeaker system. A multi-position switch is fitted to modify the frequency response for room acoustics and loudspeaker sitings. Drive units: two 10in bass drivers with heavily doped cones, 8in Bexdrene cone mid-range driver, exclusive to Lecson, HF 1300/11 high frequency driver, HF2000 very high frequency driver. Crossovers: 362Hz; 3.2kHz; 15kHz all at 18dB/octave. Nominal impedance: 8 ohms. Power handling: 50W DIN. Size: 1100mm high, 315mm wide, 430mm deep. Finish: Covered in black sculptured acoustically transparent foam with black glass top. Price: £168.50 (excluding VAT).

Directory of Brand Names

Where the brand is the same as the name of the supplier please refer to the Directory of Manufacturers and Suppliers.

A

Accuphase. Belmont A/V Ltd, Fircroft Way, Edenbridge, Kent TN8 6HA. Tel: Edenbridge 4116.
Adastra. Doram Electronics, P.O. Box T.R8, Leeds LS12 2UF. Tel: Leeds 34222.
ADC Accutrac. BSR Ltd, Powke Lane, Cradley Heath, Warley, West Midlands B64 5QH. Tel: Cradley Heath 69272/8.
Aiwa. Johnsons of Hendon Ltd, 14 Priestley Way, London NW2 7TN. Tel: 01-450 8070.
Akai. Rank Audio Visual, PO Box 70, Great West Road, Brentford TW8 9HR. Tel: 01-568 9222.
Alpha. Highgate Acoustics, 38 Jamestown Road, London NW1 7EJ. Tel: 01-267 4937.
Amcron. Macinnes Laboratories Ltd, Macinnes House, Carlton Park Industrial Estate, Saxmundham, Suffolk IP17 2NL. Tel: Saxmundham 2262/2615.
Amstrad. AMS Trading (Amstrad) Ltd, 89 Ridley Road, London E8. Tel: 01-249 5237.
AR. Teledyne Acoustic Research, High Street, Houghton Regis, Dunstable, Beds LU5 5QL. Tel: 0582 603151.
A/R/D. Audio Research and Development, Navas House, The Maultway, Camberley, Surrey GU15 1QE. Tel: Camberley 24684.
ATC. Acoustic Transducer Co Ltd, Pier House Laundry, Strand-on-the-Green, Chiswick W4. Tel: 01-995 3654.
ATC. Executive Audio Ltd, Unit 5A, Pier House Laundry, Strand-on-the-Green, Chiswick, W4. Tel: 01-995 3654.
Atron. Teledyne Acoustic, High Street, Houghton Regis, Dunstable, Beds. Tel: 0582 603151.
Audio Packs. Tape Recorder Spares Ltd, 206-210 Iderton Road, London SE15 1NS. Tel: 01-639 7844.
Audio Technica. Shriro (UK) Ltd, Shriro House, The Ridgeway, Iver, Bucks SL0 9JL. Tel: Iver 652222.

B

Beocenter. Bang & Olufsen (UK) Ltd, Eastbrook Road, Gloucester GL4 7DE.

Tel: Gloucester 21591.
Beogram. Bang & Olufsen (UK) Ltd, Eastbrook Road, Gloucester GL4 7DE. Tel: Gloucester 21591.
Beolab. Bang & Olufsen (UK) Ltd, Eastbrook Road, Gloucester GL4 7DE. Tel: Gloucester 21591.
Beomaster. Bang & Olufsen (UK) Ltd, Eastbrook Road, Gloucester GL4 7DE. Tel: Gloucester 21591.
Beosystem. Bang & Olufsen (UK) Ltd, Eastbrook Road, Gloucester GL4 7DE. Tel: Gloucester 21591.
Beovox. Bang & Olufsen (UK) Ltd, Eastbrook Road, Gloucester GL4 7DE. Tel: Gloucester 21591.
BIC. Belmont A/V Ltd, Fircroft Way, Edenbridge, Kent TN8 6HA. Tel: Edenbridge 4116.
Bigston. Brown Brothers Ltd, Great Eastern House, Temple Fields, Harlow, Essex. Tel: Harlow 29511.
Binatone. J. Parker & Co (London) Ltd, Parker House, Beresford Avenue, Wembley HA0 1YX. Tel: 01-902 8991.
BSR McDonald. BSR Ltd, Powke Lane, Cradley Heath, Warley, West Midlands B64 5QH. Tel: Cradley Heath 69272.
Bush. Rank Radio International Ltd, PO Box 596, Power Road, Chiswick, London W4 5PW. Tel: 01-994 6491.
Bush-Arena. Rank International Ltd, PO Box 596, Power Road, Chiswick, London W4 5PW. Tel: 01-994 6491.

C

C.A.S. City Audio Services Ltd, 144 Lavender Hill, London SW11 5RA. Tel: 01-233 2496.
Celestion. Rola-Celestion Ltd, Ditton Works, Foxhall Road, Ipswich, Suffolk IP3 8JP. Tel: Ipswich 73131.
Colton. Musonic Ltd, 34-38 Verulam Road, St. Albans, Herts AL3 4DF. Tel: St. Albans 50611.
Connoisseur. A. R. Sugden & Co (Engineers) Ltd, Connoisseur Works, Atlas Mill Road, Brighouse, Yorks HD6 1ES. Tel: Brighouse 2142.
Crown Merton. Hancock, Corfield & Waller Ltd, Station Road, Merton Abbey, London SW19 2NJ. Tel: 01-542 1012.

D

Dansk. Plustronics Ltd, Hempstalls Lane, Newcastle, Staffs. ST5 0SW. Tel: Newcastle 615131.

Dayton Wright. Exposure Electronics, Richardson Road, Hove, Sussex BN3 5RB. Tel: Brighton 777912.
Decca. Decca Radio & Television Ltd, Neachells Lane, Willenhall, Wolverhampton, Staffs. Tel: Wolverhampton 67367.
Decca. Decca Special Products, Ingate Place, Queenstown Road, London SW8 3NT. Tel: 01-622 6677.
Deutsche Grammophon. Polydor Ltd, 17 Stratford Place, London W1N 0BL. Tel: 01-499 8686.
Dokorder. Acoustico Enterprises Ltd, Unit 7, Space Way, North Feltham Trading Estate, Feltham TW14 0TZ. Tel: 01-751 0141.
Dual. A. C. Farnell Ltd, Kenyon Street, Sheffield S1 4BD. Tel: Sheffield 78901.
Dunlap-Clarke. Exposure Electronics, Richardson Road, Hove, Sussex BN3 5RB. Tel: Brighton 777912.

E

Echonica. Ambionic Sound Reproducers Ltd, Omal House, North Circular Road, London NW10 7UF. Tel: 01-965 8787.
Edwards, J. R. Edwards Electronics Ltd, 783 Romford Road, Manor Park, London E12. Tel: 01-553 4349.
Ekeo. Pye Ltd, PO Box 49, St. Andrews Road, Cambridge CB4 1DS. Tel: Cambridge 58985.
Elac. Ambionic Sound Reproducers Ltd, Omal House, North Circular Road, London NW10 7UF. Tel: 01-965 8787.
Electrophonic. J. Parker & Co (London) Ltd, Parker House, Beresford Avenue, Wembley HA0 1YX. Tel: 01-903 5211.
Electro-Voice. Gulton Europe Ltd, Special Products Division, The Hyde, Brighton BN2 4JU. Tel: Brighton 66271.
Emperor. MMG Associates, 19 St. Andrews Road, Malvern, Worcs.
Empire. Hayden Laboratories Ltd, Hayden House, Churchfield Road, Chalfont St. Peter, Bucks SL9 9EW. Tel: Gerrards Cross 88447.
EMT. F. W. O. Bauch Ltd, 49 Theobald Street, Boreham Wood, Herts. Tel: 01-953 0091.
Environmental Sound. J.B. Manufacturing Acoustics & Design Ltd, London House, Mayfield, Sussex. Tel: 04355 3419/2495.
ERA. Wilmex Ltd, Import Division, Crompton House, New Malden, Surrey KT3 4DE. Tel: 01-949 2545.

ESS. Regent Acoustics, Carrington House, 130 Regent Street, London W1R 6BR. Tel: 01-437 1997.

F

Falcon. John Street (Manufacturers) Ltd, Falcon Works, Barneston Road, Catford, London SE6. Tel: 01-698 1177.

Fantavox. Adastra Electronics Ltd, Unit N22, Cricklewood Trading Estate, Claremont Road, London NW2 1TU. Tel: 01-452 6288.

Ferguson. Thorn Consumer Electronics Ltd, Thorn House, Upper St Martin's Lane, London WC2H 9ED. Tel: 01-836 3444.

Fons. Fergus Fons Ltd, Maybole, Ayrshire, Scotland. Tel: Maybole 82424.

G

Galactron. Goodmans Loudspeakers Ltd, Downley Road, Havant, Hants PO9 2NL. Tel: Havant 6344.

Goldring. Doram Electronics, P.O. Box T.R.8. Leeds LS12 2UF. Tel: Leeds 34222.

Grado. Howland-West Ltd, 3-5 Eden Grove, London N7 8EQ. Tel: 01-609 0293.

Groovac. R. I. Audio, Kernick Road, Penryn, Cornwall TR10 9DQ. Tel: Penryn 72753.

H

Harrison-Kardon. Highgate Acoustics, 38 Jamestown Road, London NW1 7EJ. Tel: 01-267 4937.

Harrison. Gimar Ltd, 10 Museum Street, London WC1A 1JS. Tel: 01-836 3222.

Heathkit. Heath (Gloucester) Ltd, Bristol Road, Gloucester GL2 6EE. Tel: Gloucester 29451.

Hi-Ball. Executive Audio Ltd, Unit 5A, Pier House, Strand-on-the-Green, Chiswick, London W4. Tel: 01-995 3654.

Hi-Fi Sound. Howland-West Ltd, 3-5 Eden Grove, London N7 8EQ. Tel: 01-609 0293.

HMV. Thorn Consumer Electronics Ltd, Thorn House, Upper St Martin's Lane, London WC2H 9ED. Tel: 01-836 2444.

I

Isophon-Werke. Hayden Laboratories Ltd, Hayden House, Churchfield Road, Chalfont St Peter SL9 9EW. Tel: Gerrards Cross 88447.

J

JBL. C. E. Hammond & Co Ltd, Chertsey Road, Byfleet, Surrey KT14 7LA. Tel: Byfleet 41131.

Jecklin. Belcaire Trading, 59 Cheriton High Street, Folkestone, Kent. Tel: Folkestone 76834.

Jensen. B. H. Morris & Co (Radio) Ltd, Trio House, The Hyde, London NW9 6JP. Tel: 01-205 6441.

Jordan-Watts. Jordan-Watts Ltd, Benlow Works, Silverdale Road, Hayes UB3 3BW. Tel: 01-573 6928.

K

KLH. Webland International Ltd, Mirabel House, 117-121 Wandsworth Bridge Road, London SW6. Tel: 01-736 0989.

Korting. Europa Electronics Ltd, 9 Howard Place, Shelton, Stoke-on-Trent ST1 4NW. Tel: Stoke-on-Trent 29316.

Koss. Tape Music Distributors Ltd, 114 Ashley Road, St Albans, Herts AL1 5JR. Tel: St Albans 64337.

Kudelski S.A. Hayden Laboratories Ltd, Hayden House, Chalfont St Peter, Bucks SL9 9EW. Tel: Gerrards Cross 88447.

Leak. Rank Audio Visual, PO Box 70, Great West Road, Brentford, Middx. TW8 9HB. Tel: 01-566 9222.

LEM. Douglas A. Lyons and Associates Ltd, 99 Larkhall Lane, London SW4. Tel: 01-622 0287.

Lenco. Goldring Limited, 10 Bayford Street, Hackney, London E8 3SE. Tel: 01-985 1152.

Linn-Sondek. Linn Products Ltd, 235 Drakemire Drive, Castlemilk, Glasgow G45 9SZ. Tel: 041-634 3860.

Linn-Isobarik. Linn Products Ltd, 235 Drakemire Drive, Castlemilk, Glasgow G45 9SZ. Tel: 041-634 3860.

Lux. Howland-West Ltd, 3-5 Eden Grove, London N7 8EQ. Tel: 01-609 0923/6.

Lyrichords. N. Miers & Co Ltd, 28 Piercing Hill, Theydon Bois, near Epping, Essex CM 16 7LE. Tel: 037-881 2611.

M

Marconiphone. Thorn Consumer Electronics Ltd, Thorn House, Upper St Martin's Lane, London WC2H 9ED. Tel: 01-836 24444.

Maxell. Natural Sound Systems Ltd, Strathcona Road, North Wembley HA9 8QL. Tel: 01-904 0141.

McIntosh. Wilmex Ltd, Import Divisions, Crompton House, New Malden, Surrey KT3 4DE. Tel: 01-949 2545.

Melodium. Keith Monks (Audio) Ltd, 26-30 Reading Road, South Fleet, Near Aldershot, Hants. Tel: Fleet 7316 and 3566.

Metrocare. Metrosound Audio Ltd, Audio Works, Cartersfield Road, Waltham Abbey, Essex EN9 1JF. Tel: Lea Valley 712712.

Micro. Howland-West Ltd, 3-5 Eden Grove, London N7 8EQ. Tel: 01-609 0293/6.

Mirsch of Sweden. Tape Music Distributors Ltd, 114 Ashley Road, St. Albans, Herts. AL1 5JR. Tel: St Albans 64337/9.

N

Nagra. Hayden Laboratories Ltd, Hayden House, Churchfield Road, Chalfont St Peter, Bucks SL9 9EW. Tel: Gerrards Cross 88447.

Nakamichi. Natural Sound Systems Ltd, Strathcona Road, North Wembley HA9 8QL. Tel: 01-904 0141.

NEAL. North East Audio Ltd, 5 Charlotte Square, Newcastle-upon-Tyne NE1 4XF. Tel: Newcastle-upon-Tyne 26660.

New Classic. J. W. (W.) Company, 14-16 Walton Street, Walton-on-the-Hill, Surrey. Tel: Tadworth 3778.

Neumann GMBH. F. W. O. Bauch Ltd, 49 Theobald Street, Borehamwood, Herts WD6 4RZ. Tel: 01-953 0091.

Nikko. Howland-West Ltd, 3-5 Eden Grove, London N7 8EQ. Tel: 01-609 0293/6.

Normende. Vessco Vision & Radio Ltd, Unit 4, Blackwater Way, Ash Road, Aldershot, Hants GU12 4DL. Tel: Aldershot 321661.

O

Omni. Ambionic Sound Reproducers Ltd, Omni House, North Circular Road, London NW10 7UF. Tel: 01-965 8787.

Onkyo. J. Parkar & Co (London) Ltd, Parkar House, Beresford Avenue, Wembley HA0 1YX. Tel: 01-903 5211.

Ortofon. Metrosound (Sales) Co Ltd, Cartersfield Road, Waltham Abbey, Essex EN9 1JF. Tel: Lea Valley 712712.

P

Pearl. Allotrope Ltd, 90 Wardour Street, London W1V 3LE. Tel: 01-437 1892.

Peerless. Ross Electronics,
32 Rathbone Place, London W1P 1AD.
Tel: 01-580 7112.

Philips. Philips Electrical Ltd,
Century House, Shaftesbury Avenue,
London WC2H 8AS. Tel: 01-437 7777.

Pickering. Highgate Acoustics,
38 Jamestown Road, London NW1 7EJ.
Tel: 01-267 4937.

Pioneer. Shriro (UK) Ltd,
Shriro House, The Ridgeway, Iver,
Bucks SL0 9JL. Tel: 1ver 652222.

Q

QAS. Quality Audio Supplies,
Wollaton Road, Beeston, Nottingham
NG9 2PB. Tel: Nottingham 256141.

Quad. Acoustical Manufacturing Co
Ltd, St Peter's Road,
Huntingdon, Hunts PE18 7DB.
Tel: Huntingdon 52561.

Quasar. Eagle International. Precision
Centre, Heather Park Drive, Wembley
HA0 1SU. Tel: 01-902 8832.

R

Radionette. Norse Audio Systems Ltd,
9 Hawkesworth Trading Estate,
Swindon, Wilts SN2 1D2. Tel: Swindon
22592.

Revox. C. E. Hammond & Co Ltd,
105-109 Oyster Lane, Byfleet, Surrey
KT14 7LA. Tel: Byfleet 41131.

Rogers. Swistone Electronics Ltd, 4-14
Barmeston Road, SE6 3BN.
Tel: 01-697 8511.

Rotel. Rank Audio Visual Ltd,
Great West Road, Brentford TW8 9HR.
Tel: 01-568 9222.

R. S. Components. Doram Electronics,
P.O. Box T.R.8, Leeds LS12 2UF.
Tel: Leeds 34222.

Rusco Electronics. C. E. Hammond &
Co Ltd, Lamb House, Church Street,
London W4 2PB. Tel: 01-995 4551.

S

Sansui. Vernitron Ltd,
Thornhill, Southampton SO9 5QF.
Tel: Southampton 44811.

Salora. Luxitone, 38 Jamestown Road,
London NW1 7EJ. Tel: 01-267
4939/4930.

Scanonic. Howland-West Ltd,
3-5 Eden Grove, London N7 8EQ.
Tel: 01-609 0293/6.

Scotch. 3M United Kingdom Ltd, 3M
House, Wigmore Street, London W1A
1ET. Tel: 01-486 5522.

Scott. Photax (London)Ltd,
Hamptden Park, Eastbourne, Sussex.
Tel: Eastbourne, Sussex. Tel:
Eastbourne 51197.

Sennheiser Electronic. Hayden
Laboratories Ltd, Hayden House,
Churchfield Road, Chalfont St Peter
SL9 9EW. Tel: Gerrards Cross 88447.
Silver. J. J. Silber Ltd, 11 Northburgh
Street, London EC1.
Tel: 01-253 8031.

SMC. Monitor Distribution Co Ltd, 76
Bedford Road, Kempston, Beds. MK42
8BB. Tel: Bedford 854133.

Soundcraftsmen. Gale Electronics &
Design Ltd, 39 Upper Brook Street,
London W1Y 1PE. Tel: 01-499 9966.

Stanton. Wilmex Ltd, Compton House,
New Malden KT3 4DE. Tel: 01-949
2545.

STAX. Wilmex Ltd, Import Division,
Crompton House, New Malden, Surrey
KT3 4DE. Tel: 01-949 2545.

STC. Coles Engineering (Hoddesdon)
Ltd, Pindar Road, Hoddesdon, Herts.
Tel: Hoddesdon 66685.

Stephen Speakers. Wilmslow Audio,
Swan Works, Bank Square, Wilmslow.
Tel: Wilmslow 29599.

Studiocraft. Bose (UK) Ltd, Milton
Regis, Sittingbourne, Kent. Tel:
Sittingbourne 75341/5.

Synchrotape. Adastra Electronics Ltd,
Unit N22, Cricklewood Trading Estate,
Claremont Road, London NW2 1TU.
Tel: 01-452 6288.

Stolle. Karl Stolle, 29 Church Street,
Ickley, Yorks. Tel: Ickley 2193.

T

Tandberg. Farnell-Tandberg Ltd,
Farnell House, 81 Kirkstall Road, Leeds
LS3 1HR. Tel: Leeds 35111.

TDK. Tape Distributor (UK) Ltd, 341
Brighton Road, South Croydon, Surrey
CR2 6EQ. Tel: 01-688 7372.

Teac. Teledyne Acoustic Research,
High Street, Houghton Regis,
Dunstable, Beds. Tel: 0582 603151.

Teknik. Klark-Teknik Ltd,
Summerfield, Kidderminster DY11
7RE. Tel: Kidderminster 64027.

Telefunken. AEG-Telefunken (UK) Ltd,
Bath Road, Slough, Bucks. Tel: Slough
33311.

Tenorel. Condor Electronics Ltd, 100
Coombe Lane, London SW20 0AY. Tel:
01-946 0033.

Thomas Laney. Audio Electronic
Manufacturing Co (UK) Ltd,
Devonshire House, High Street,
Deritend, Birmingham B12 0LP. Tel:
021-772 3669/7145.

Thorens. Metrosound Audio Products
Ltd, Cartersfield Road, Waltham
Abbey, Essex EN9 1JF. Tel: Lea Valley
712712.

Tidi-Fi. Joyce & Co (P.M.) Ltd, 29
Clerkenwell Green, London EC1R 0DT.
Tel: 01-253 7355.

TMT. Tape Marketing Technology Ltd,
8 Green Street, London W1. Tel: 01-493
4205.

Trio. B. H. Morris & Co (Radio) Ltd,
Trio House, The Hyde, London NW9
5JP. Tel: 01-205 6441.

Tristan. Danil Engineering Co, Old
Teme Bridge, Lower Wick, Worcester
WR2 4BY. Tel: Worcester 425595.

T.T.C. Doram Electronics Ltd, P.O.
Box T.R.8, Leeds LS12 2UF. Tel:
Leeds 34222.

U

Ultimo. Chave Innovations Ltd, The
Granary, Jackass Lane, Keston, Kent
BR2 6AH.

Ultra. Thorn Consumer Electronics Ltd,
Thorn House, Upper St Martin's Lane,
London WC2H 9ED.
Tel: 01-836 2444.

Unisound. Condor Electronics Ltd,
100 Coombe Lane, London
SW20 0AY. Tel: 01-946 0033.

V

Voxson. DCS (Audio Products) Ltd,
Colwyn Bay, North Wales LL28 5HD.
Tel: Colwyn Bay 49275.

W

Waltham. Telerenters (London &
Provincial) Ltd, 155-159 Queens Road,
Watford, Herts. WD1 2QH. Tel:
Watford 24543.

Wharfedale. Rank Audio Visual,
PO Box 70, Great West Road,
Brentford, Middx. TW8 9HB.
Tel: 01-568 9222.

Y

Yamaha. Natural Sounds Systems Ltd,
Strathcona Road, North Wembley
HA0 8QL. Tel: 01-904 0141.



Tomorrow's Choice

New from KLH Research and Development Corporation is their range of loudspeakers which improves still further on our reputation for outstanding quality and performance.

An exciting event for a Company whose earliest models are still rated among the best in the world – the legendary KLH9, for instance, 15 years after its introduction is still rated "the best attainable sound" by the American *Stereophile* magazine.

In bringing out this new range we are taking advantage of a number of recent technological breakthroughs to put the KLH owner yet another 15 years ahead. In many models we have used drive units which are unique to KLH, and the subject of over twenty distinct claims under different United States patents. Our Megaflex Woofer and the DVR Tweeter are just two examples of such technological achievements.

Small wonder, that KLH should remain the choice of the music lover and the professional alike. Be it the bookshelf KLH 331 or the overwhelming KLH SCX3, you are assured of the most accurate musical reproduction.



The Megaflex Woofer is unique and probably the most outstanding magnetic structure available today. It uses many specialised strips of magnetic material which create and focus magnetic energy into the voice coil gap with no external stray field. Since all the energy is directed to a precise area of the voice coil, very large woofer excursions are possible. The magnetic field produced is so uniform that many nonlinear types of distortion found in conventional designs are insignificant in this configuration.



The new DVR Tweeter combines the best attributes of dynamic and electrostatic tweeters. It has an ultra thin membrane with an etched printed circuit voice coil, plus an array of rare-earth "samarium-cobalt" magnets on either side of the membrane to create a push-pull effect. Because the membrane mass is so low and the magnets have such extraordinary force, the inertial qualities are exceptional. The membrane can be accelerated and stopped with extreme accuracy. The result is very extended frequency response with unbelievably low distortion, giving you the transparency and accuracy of living music in the concert hall.

Wet Stand International Miraflores 117/121 Wandsworth Bridge Road, London SW6 2NA
 Telephone 01 738 0931/8/9/0 Telex 25510

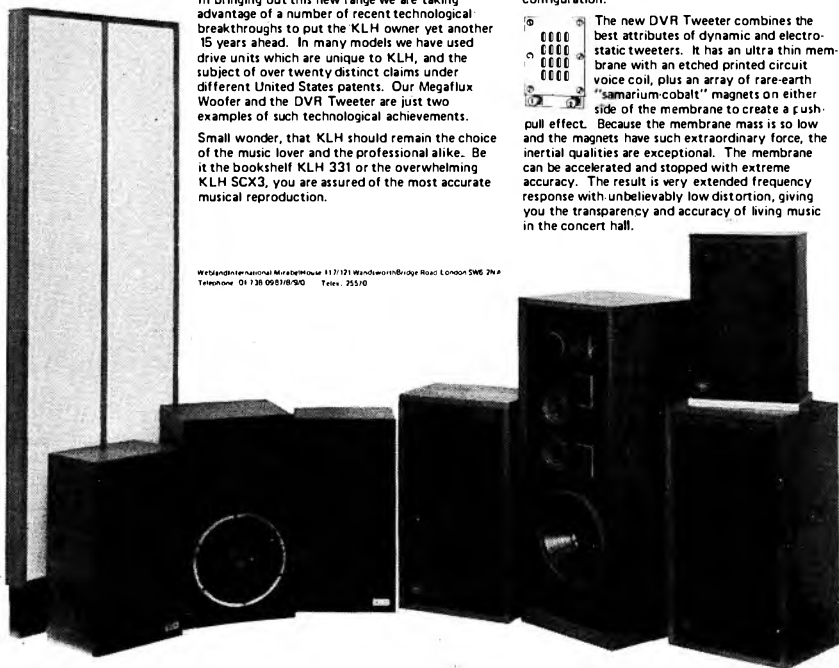

Directory of Makers and Suppliers

A

Abstracta Construction Ltd, Eldonwall Trading Estate, Staples Cnr., Edgware Road, London, NW2. Tel: 01-450 2511.

Ame Electric Co (Finsbury) Ltd, 74 Great Eastern Street, London EC2. Tel: 01-739 6486.

Acoustical Manufacturing Co Ltd, St. Peter's Road, Huntingdon, PE18 7DB. Tel: Huntingdon 52561.

Acoustic Research International, High Street, Houghton Regis, Beds, LL15 5QJ. Tel: Dunstable 603151.

Acoustic Transducer Co Ltd, (Acoustic Engineers), Pier House Laundry, Strand-on-the-Green, Chiswick, London, W4. Tel: 01-995 3654.

Adastra Electronics Ltd, Unit N22, Cricklewood Trading Estate, Claremont Road, London, NW2 1TU. Tel: 01-452 6288.

AEG-Telefunken (UK) Ltd, 217 Bath Road, Slough, SL1 4AW. Tel: Slough 872101.

A.E.L. Electronics Ltd, 91 Ewell Road, Surbiton, Surrey KT6 6AH. Tel: 01-399 0966.

Aerialite Aerials Ltd, Whitegate, Broadway, Chadderton, near Oldham, Greater Manchester, OL9 9QE. Tel: 061-652 1111.

Agfa-Gevaert, Great West Road, Brentford, Greater London. Tel: 01-560 2131.

AKG Equipment Ltd, 182-184 Campden Hill Road, Kensington, London, W8 7AS. Tel: 01-229 3695.

Alba (Radio & Television) Ltd, Bull Lane, Edmonton, London, N18 1SD. Tel: 01-803 4451.

Richard Allan Radio Ltd, Bradford Road, Gomersal, Cleckheaton, West Yorkshire, BD19 4AZ. Tel: Cleckheaton 2442.

Allotrope Ltd, 90 Wardour Street, London, W1V 3LE. Tel: 01-437 1892/3.

Ambionic Sound Reproducers Ltd, 1 Omal House, North Circular Road, London, NW10 7UF. Tel: 01-965 8787.

Amos of Exeter Ltd, Weircliffe Court, Exwick, Exeter, EX4 2AG. Tel: Exeter 72132.

Ampex Great Britain Ltd, Acre Road, Reading, Berks. R92 0QR. Tel: Reading 85200.

AMS Trading (Amstrad) Ltd, 89 Ridley Road, Dalston, London, E8 2NN. Tel: 01-249 5237.

Antiference Ltd, Bicester Road, Aylesbury, Bucks, HP19 3BJ. Tel: Aylesbury 82511.

Ariston Audio Ltd, PO Box 13, Irving, Ayrshire, Scotland, KA12 8JL. Tel: Irvine 75211.

Armstrong Audio Ltd, Warters Road, Holloway, London N7 0RZ. Tel: 01-607 3213.

Arnex Products Ltd, London Road, Daventry, Northants, NN11 4DU. Tel: Daventry 2231.

Arnold Electronics, 40c Queen Street, Hitchin, Herts. Tel: Hitchin 3387.

ASA (UK) Television and Radio Ltd, 31-35 High Street, Shirehampton, Bristol, BS11 0DX. Tel: Avonmouth 5035.

Audio Developments Ltd, Hall Lane, Walsall Wood, WS9 9AU. Tel: Brownhills 5351.

Audio Devices (UK) Ltd, EMI Elstree Studios, Borehamwood, Herts. WD6 1JG. Tel: 01-953 1600.

Audio Magnetics Incorporated (UK) Ltd, 32 Eveline Road, Mitcham, Surrey CR4 3LE.

Audio Research & Development Ltd, Navas House, The Maultway, Camberley, Surrey, GU15 1QE. Tel: Camberley 24684.

R.I. Audio, Kernick Road, Penryn, Cornwall, TR10 9DQ. Tel: Penryn 72753.

Audio Workshops Ltd, 29 High Street, Robertsbridge, Sussex, TN32 5AQ. Tel: Robertsbridge 880580.

B

Baker Loudspeakers Ltd, Bensham Manor Road Passage, Thornton Heath, Surrey. Tel: 01-684 1665.

Bang & Olufsen (UK) Ltd, Eastbrook Road, Gloucester, GL4 7DE. Tel: Gloucester 21591.

BASF United Kingdom Ltd, Audio/Video Tapes Division, PO Box 473, Knightsbridge House, 197 Knightsbridge, London, SW7 1SA. Tel: 01-584 5080.

F.W.O. Bauch Ltd, 49 Theobald Street, Borehamwood, Herts, WD6 4RZ. Tel: 01-953 0091.

Belcaire Trading, 59 Cheriton High Street, Folkestone, Kent, CT19 4EZ. Tel: Folkestone 76834.

Belmont A/V Ltd, Fircroft Way, Edenbridge, Kent, TN8 6HA. Tel: Edenbridge 4111.

Beyer Dynamic (G.B.) Ltd, 1 Clair Road, Haywards Heath, Sussex. Tel: Haywards Heath 51003.

Bias Electronics Ltd, 527 Kingston Road, London, SW20 8DR. Tel: 01-540 8808.

Bib Hi-Fi Accessories Ltd, PO Box 78, Hemel Hempstead, Herts, HP2 4RH. Tel: Hemel Hempstead 61291.

B. + J. Imports, 66 Woodcock Hill, Kenton, Harrow, HA3 0JF. Tel: 01-907 6667.

Black Knight Rumblecure, Bank Top, Currier Lane, Ashton-under-Lyne, Lancs, OL6 6TA. Tel: 061-330 2836.

Bose (UK) Ltd, Gas Road, Milton Regis, Sittingbourne, Kent. Tel: Sittingbourne 75341.

Bradmatic Ltd, 338 Aldridge Road, Streety, Sutton Coldfield, West Midlands, B74 2DT. Tel: 021-353 3171.

Brahms Manufacturing and Development Co, Unit E, Rochester Airport, Maidstone Road, Rochester, Kent, ME1 3QJ. Tel: Medway 48816.

Brenell Engineering Co Ltd, 231-235 Liverpool Road, London, N1 1LY. Tel: 01-607 8271.

Bryan Amplifiers Ltd, 8 Greenacres Road, Oldham, Lancs. OL4 1HA. Tel: 061-624 4074.

BSR Ltd, Powke Lane, Cradley Heath, Warley, Worsc. B64 5QH. Tel: Cradley Heath 69272.

C

Calree Audio Ltd,
Haningroyd Lane, Hebden Bridge,
Yorks. HX7 7DD.
Tel: Hebden Bridge 2159.

Cambridge Audio Ltd,
111 Chertsey Road, Byfleet,
Surrey T14 7UA. Tel: Byfleet 41131.

Canterbury Audio
4 Station Road West, Canterbury,
Kent. Tel: Canterbury 60431.

Capitol Magnetic Products,
Subsidiary of Capital Records,
Elstree Studios, Borehamwood, Herts.

Castle Acoustics Ltd, Park Mill,
Shortbank Road, Skipton, Yorks.
Tel: Skipton 5333/4.

Celef Audio, 130 Thirsk Road,
Borehamwood, Herts.
Tel: 01-953 8933.

Cerwin-Vega UK, 281 Balmoral Drive,
Hayes, Greater London.
Tel: 01-573 1566.

Channel Electronics (Sussex) Ltd,
Cradle Hill Industrial Estate,
Seaford, Sussex, BN25 3JE.
Tel: Seaford 894961.

Chartwell Electro Acoustics Ltd,
Alicric Avenue, London NW10 8RA.
Tel: 01-451 1442/1452.

Chave Innovations Ltd,
The Granary, Jackass Lane, Keston,
Kent, BR2 6AH.
Tel: 0689-66 52051.

City Audio Services Ltd,
Rush Hill Mews, London SW11.
Tel: 01-223 2496.

Clark Speakers, 122 Hull Road, Anlaby,
North Humberside, HU10 6UV.
Tel: Hull 656706.

Clendisc (Mail Order) Ltd,
7 Trinity Court, Gray's Inn Road,
London, WC1X 8JX.
Tel: 01-837 9088.

Cole Electronics Ltd,
Church Road, Croydon, Surrey,
CR0 1SG. Tel: 01-686 7581.

Coles Engineering (Hoddesdon) Co Ltd,
Pindar Road, Hoddesdon, Herts.
Tel: Hoddesdon 66685.

Colne Loudspeaker Research,
51 Lion Road, Twickenham,
Greater London. Tel: 01-891 1837.

Combined Electronic Services,
604 Purley Way, Waddon,
Croydon, CR9 4DR.
Tel: 01-686 0505.

Condor Electronics Ltd,
100 Coombe Lane,
London, SW20 0AY.
Tel: 01-946 0033.

Contek Magnetics Ltd,
32 Eveline Road, Mitcham, Surrey.
Tel: 01-648 5156.

Cosmocord Ltd, Eleanor Cross Road,
Waltham Cross, Herts, EN8 7NX.
Tel: Lea Valley 716666.

Crown Radio Co Ltd, Russell Gardens,
Wickford, Essex, SS1 8RT.
Tel: Wickford 63414.

Cygnat Audio Visual Co. Ltd,
7 Priory Road, High Wycombe, Bucks.

D

Dalesford Speakers Ltd,
Upper Carr Lane, Calverley,
Pudsey, Yorks. LS28 5QE.
Tel: Pudsey 4574.

Danil Engineering CO,
Old Terme Bridge, Lower Wick,
Worcester WRS 4BY.
Tel: Worcester 425595.

Decca Radio & Television,
Neachells Lane, Willenhall,
Wolverhampton, Staffs, WV13 3RW.
Tel: Wolverhampton 67367.

Decca Record Co, Decca House,
9 Albert Embankment, London,
SE1 7SW. Tel: 01-735 8111.

Decca Special Products, Ingate Place,
Queenstown Road, London, SW8 3NT.
Tel: 01-622 6677.

D.E.S. Wholesale Ltd,
10-12 High Street, Colliers Wood,
London SW19. Tel: 01-450 9684.

Diamond Stylus Co Ltd,
Mochdre, Colwyn Bay, Clwyd,
North Wales.

Doray Electronics Ltd,
PO Box TR8, Leeds LS12 2UF.
Tel: Leeds 34222.

DSC (Audio Products) Ltd, Colwyn Bay,
Clwyd, North Wales, LL28 5HD.
Tel: Colwyn Bay 49275.

Dynatron Radio Ltd,
Hansa Road, King's Lynn,
Norfolk, PE30 4JD.
Tel: King's Lynn 61100.

E

Eagle International, Precision
Centre, Heather Park Drive,
Wembley, HA0 1SU. Tel: 01-902 8832.

Eaton Audio Fitments,
Leopold Street, Long Eaton,
Nottingham NG10 4QF.
Tel: Long Eaton 2662/2818.

Edwards Construction Co,
4 Brunswick Drive, Harrogate,
Yorkshire. Tel: Harrogate 60921.

J.R. Edwards Electronics Ltd,
783 Romford Road, Manor Park,
London, E12 5AN.
Tel: 01-553 4349.

Electrocomponents Ltd,
PO Box 427, 13-17 Epworth Street,
London EC2P 2HA.
Tel: 01-253 1222.

Electronic Manufacturing Sales Ltd,
Devonshire House, High Street,
Deritend, Birmingham, B12 0LP.
Tel: 021-772 7145/3669.

EMI Records Ltd, EMI House,
20 Manchester Square, London, W1.
Tel: 01-486 4488.

EMI Sound & Vision,
252 Blythe Road, Hayes, UB3 1HW.
Tel: 01-573 3888.

EMI Tape Ltd, Tape House,
Dawley Road, Hayes, UB3 1BT.
Tel: 01-573 3888.

Europe Electronics Ltd, 9 Howard Place,
Shelton, Stoke-on-Trent, ST1 4NW.
Tel: Stoke-on-Trent 29316.

Europhon (UK) Ltd,
70 Caledonian Road, London,
NL 9DN. Tel: 01-837 3045/6.

Executive Audio Ltd,
Unit 5a, Pier House Laundry,
Strand-on-the-Green, Chiswick,
London W4. Tel: 01-995 3654.

Expert Pickups, PO Box 5, Ashtead,
Surrey, KT21 2QD. Tel: Ashtead 76604.

Exposure Electronics, Richardson Road,
Hove, BN3 5RB, Sussex.
Tel: Brighton 777912.

F

Fane Acoustics Ltd, Hick Lane, Batley,
Yorks. Tel: Batley 6431.

A. C. Farnell Ltd, Kenyon Street,
Sheffield, S1 4BD.
Tel: Sheffield 78901.

Fergus Fans Ltd,
1 Society Street, Maybole,
Ayrshire, KA19 7BH, Scotland.
Tel: Maybole 82424.

The Ferrograph Company Ltd,
Auriema House, 442 Bath Road,
Cippenham, Slough, SL1 6BB.
Tel: Burnham 62511.

Fidelity Radio Ltd,
Victoria Road, Willesden,
London, NW10 6ND.
Tel: 01-965 8771.

Film Industries Ltd,
Station Avenue, Kew Gardens,
Surrey. Tel: 01-940 8078.

C. F. Fraser Ltd,
21 Princes Road, London NW1 8HR.
Tel: 01-772 6633.

G

Gale Electronics and Design Ltd,
273 Bruton Place, London W1X 8AB.
Tel: 01-499 9966.

Gardners Transformers Ltd,
Christchurch, Dorset, BH23 3PN.
Tel: Christchurch 2284.

Garrard Engineering Ltd,
Newcastle Street, Swindon, Wilts,
SN1 1DA. Tel: 0793 5381.

GEC (Radio & Television) Ltd,
Langley Park, Slough, SL3 6DP.
Tel: Slough 22201.

Gimar Ltd, 10 Museum Street,
London, WC1A 1JS.
Tel: 01-836 3222.

Golding Audio Ltd, Marks Tey,
Colchester.
Tel: Colchester 210433.

Goldring Ltd, 10 Bayford Street,
Hackney, London E8 3SE.
Tel: 01-985 1152.

Goodmans Loudspeakers Ltd,
Downley Road, Havant,
Hants, PO9 2NL.
Tel: Havant 6344.

C. C. Goodwin,
7 The Broadway, London N22.
Tel: 01-888 0077.

Grampian Reproducers Ltd,
The Hanworth Trading Estate,
Hampton Road West,
Feltham, TW13 6EJ.
Tel: 01-894 9141.

H. K. Griffin & Co (Electronics),
Sidons Factory Estate, Howard Street,
West Bromwich, Staffs.
Tel: 021-556 0559/0751.

Grundig International Ltd,
Newland Park, London,
SE26 5NQ. Tel: 01-659 2468.

Gulton Europe Ltd,
Special Products Division,
The Hyde, Brighton, BN2 4JU.
Tel: Brighton 66271.

H

Hacker Radio Ltd,
Norrays Drive, Cox Green,
Maidenhead, Berks, SL6 4BP.
Tel: Maidenhead 22261/5.

G. F. C. Hadcock,
Audio Division, The Old Vicarage,
Doveridge, Derby, DE6 5NN.
Tel: Uttoxeter 2452.

Hamilton Wholesale Supplies Ltd,
Chesford Grange, Grange Industrial
Estate, Woolston, Warrington,
Cheshire. Tel: Warrington 54341.

C. E. Hammond & Co Ltd,
105-109 Oyster Lane, Byfleet,
Surrey KT14 7LA. Tel: Byfleet 41131.

Hampstead High Fidelity,
63 High Street, Hampstead,
London, NW3.
Tel: 01-435 0999.

Hancock, Corfield & Waller Ltd,
Station Road, Merton Abbey,
London SW19 2NJ. Tel: 01-542 1012.

Hanimex (UK) Ltd, Hanimex House,
Dorcan, Swindon, Wilts, SN3 5HW.
Tel: Swindon 26211.

Harris Overseas Ltd,
Harvard House, 14 Thames Road,
Barking, Essex. Tel: 01-594 1473.

Hayden Laboratories Ltd,
Churchfield Road, Chalfont St Peter,
Bucks, SL9 9EW.
Tel: Gerrards Cross 88447.

Heath (Gloucester) Ltd, Bristol Road,
Gloucester, GL2 6EE.
Tel: Gloucester 29451.

Helme Audio Products Ltd,
Summerbridge, Harrogate,
Yorks, HG3 4DR.
Tel: Darley 279.

Highgate Acoustics Ltd,
38 Jamestown Road,
London, NW1 7EJ.
Tel: 01-267 4937.

Hisonic Ltd,
Eccleston Road, Tovil,
Maidstone, Kent.
Tel: Maidstone 57258.

Hitachi Sales (UK) Ltd, Hitachi House,
Station Road, Hayes, UB3 4DR.
Tel: 01-848 8787.

Hokushin Audio Visual Ltd,
2 Ambleside Avenue, London, SW16.
Tel: 01-769 0967.

Holder Pearce Ltd, 66 Grove Road,
Eastbourne, Sussex, BN21 4UH.
Tel: Eastbourne 26565.

Howland-West Ltd,
3-5 Eden Grove, London, N7 8EQ.
Tel: 01-609 0293/6.

I

IMF Electronics Ltd, Westbourne
Street, High Wycombe, Bucks.
Tel: High Wycombe 35576.

Imhof-Bedco Ltd,
112-116 New Oxford Street,
London, WC1A 1HJ.
Tel: 01-636 7878.

Interlectric (UK),
Scottish Life House, Kings Road,
Reading, Berks.
Tel: Reading 595222.

ITT Consumer Products (UK) Ltd,
Maidstone Road, Footscray, Sidcup,
Kent, DA14 5HT.
Tel: 01-300 7733.

J

Jaybeam Ltd, Sandfield Close,
Moulton Park Industrial Estate,
Northampton, NN3 1QQ.
Tel: Northampton 46611.

Jamo Audio Ltd, Rock House,
3 Grenfell Road, Maidenhead, Berks.
Tel: Maidenhead 37575/6.

**J.B. Manufacturing Acoustics &
Design Ltd,** London House, Mayfield, Sussex.
Tel: 04355 3419/2495.

Jeffries Hi-Fi, 4 Albert Parade,
Greenstreet, Eastbourne.
Tel: Eastbourne 31336.

Johnson Brody Marketing Company,
Parr Road, Stanmore, Middlesex
HA7 1PZ. Tel: 01-951 0225.

Johnsons of Hendon Ltd,
14 Priestley Way, London, NW2 7TN.
Tel: 01-450 8070.

E. J. Jordan, 22 Hyde Green,
Marlow-on-Thames, Bucks, SL7 1QL.
Tel: Marlow 3787.

Jordan-Watts Ltd., Benbow, Works,
Silverdale Road, Hayes, UB3 3BW.
Tel: 01-573 6928.

Joyce & Co (PM) Ltd,
29 Clerkenwell Green, London
EC1R 0DT. Tel: 01-253 7355.

JVC (UK) Ltd,
Eldonwell Trading Estate,
Staples Corner, 6-8 Priestley Way,
London, NW2. Tel: 01-450 2621.

J. W. (W.) Company,
14-16 Walton Street,
Walton-on-the-Hill,
Surrey. Tel: Tadworth 3778.

K

Keesonic Audio Sales Ltd, Halldore Hill,
Cookham, Maidenhead, Berks.
Tel: Bourne End 22726.

Kef Electronics Ltd, Tovil, Maidstone,
Kent, Maidstone 57258.

KF Products Ltd, Ashton Road,
Bredbury, Stockport,
Cheshire, SK6 2SP.
Tel: 061-494 1441.

Klark-Teknik Ltd, M.O.S. Industrial
Site, Summerfield, Kidderminster,
DY11 7RE, Worcs.
Tel: Kidderminster 64027.

Kuba Radio Sales and Service,
1105 London Road, Thornton Heath,
Surrey, CR4 6JJ.
Tel: 01-764 5255/3702.

L

Lallex & Co Ltd,
PO Box 98, Manchester M60 3BJ.
Tel: 061-236 8186.

Larson Sound Ltd, 31 Ash Close,
Merstham, Redhill RH1 3HJ.
Tel: Merstham 2656.

Lawtronics Ltd, 139 High Street,
Edenbridge, Kent TN8 5AX.
Tel: Edenbridge 5191/2.

Lescon Audio Ltd, Burrel Road,
St Ives, Hunts PE17 4LE.
Tel: St Ives 64124.

Leisure Times Ltd, Crozier Road,
Mutley, Plymouth, Devon.
Tel: Plymouth 61668.

Leavers-Rich Equipment Ltd,
319 Trinity Road, Wandsworth,
London SW18 3SL. Tel: 01-874 9054.

Lennard Developments Ltd,
206 Chase Side, Enfield EN2 0QX.
Tel: 01-363 8238.

Lentek Audio Ltd, 9 Station Road,
St Ives, Huntingdon, Cambs.
PE17 4BH. Tel: St Ives 62225.

L.G. Sound Systems Ltd,
5 Eden Grove, London N7 8EQ.
Tel: 01-609 0293/6.

L. & H. Britimpex Ltd,
8-12 Rickett Street, London SW6.
Tel: 01-385 0883.

Linn Products, 235 Drakemire Drive,
Castlemilk, Glasgow, G45 9SZ,
Scotland. Tel: 041-634 3860.

Lloytron Electronics Ltd,
Audio House, Albert Place,
Bourges Boulevard, Peterborough,
PE1 1DE. Tel: Peterborough 62935.

L.N.B. Audio Ltd,
Duke Street, Loughborough, Leics.
Tel: Loughborough 61229.

Lockwood and Co. (Woodworkers) Ltd,
63 Lowlands Road, Harrow, Greater
London. Tel: 01-422 3704.

London Bridge Audi Sales Ltd,
3 London Bridge Walk, London SE1.
Tel: 01-407 8787.

Loudspeakers Ltd, Brookroyd Mills,
Bradford Road, Batley, Yorks.
Tel: Batley 473646.

Lowther Onlife Developments Ltd,
41 Masons Hill, Bromley,
Kent, BR2 9HQ.
Tel: 01-460 5225.

Luxitone, 38 Jamestown Road,
London, NW1 7 ES.
Tel: 01-267 4937/4930.

Douglas A. Lyons & Associates Ltd,
99 Larkhall Lane, London, SW4.
Tel: 01-622 0287.

M

Macel Electronics Ltd, PO Box 64,
14 High Street, Ipswich, IP1 3LR.
Tel: Ipswich 215465.

Macinnes Laboratories Ltd,
Macinnes House, Carlton Park
Industrial Estate, Saxmundham,
Suffolk, IP17 2NL.
Tel: Saxmundham 2262/2615.

Magnat Sound Systems Ltd, Unit D,
St John's Industrial Estate,
Penn, Bucks. Tel: Penn 4615.

Magnetic Components Ltd,
Penryn, Cornwall, TR10 8AR.
Tel: Penryn 2267.

Magnetic Tapes Ltd, Chilton Works,
Garden Road, Richmond, Surrey.
Tel: 01-876 7957.

Mastertapes Cassettes Ltd,
Blackthorne Road, Poyle Trading
Estate, Colnbrook, Bucks, SL3 0AQ.
Tel: Colnbrook 2431.

Maxview Aerials Ltd,
Seitch, King's Lynn, Norfolk.
Tel: Watlington 376.

Mayware Ltd, 15 Heather Walk,
Edgware, HA8 9TS.
Tel: 01-958 9421.

Memorex (UK) Ltd, Hoechst House,
50 Salisbury Road, Hounslow West,
TW4 6JN. Tel: 01-570 7716.

Mercantile Electronics,
Amelton House, 61 Derby Street,
Manchester, Lancs. M8 8HE.
Tel: 061-832 6525.

Metrosound Audio Products Ltd,
Audio Works, Cartersfield Road,
Waltham Abbey, Essex, EN9 1JF.
Tel: Lea Valley 712712.

J. A. Mitchell Engineering,
2 Theobald Street, Borehamwood,
Herts. Tel: 01-953 0771/2.

N. Miers & Co Ltd,
28 Piercing Hill, Theydon Bois, Epping.
Essex, CM16 7LE.
Tel: 01-849 2611/2.

Millbank Electronics Group,
Bellbrook Estate, Uckfield,
Sussex, TN22 1PS.
Tel: Uckfield 4166.

Milty Products Ltd, New Mansion
House, 173-191 Wellingdon Road South,
Stockport, Cheshire SK1 3UA.
Tel: 061-480 8142/3.

M.M.G. Associates, 19 St Andrews
Road, Malvern, Worcs.
Tel: Malvern 63555.

Modern Engineering & Technology,
4 Station Road West,
Canterbury, Kent.
Tel: Canterbury 604310.

Monitor Audio Ltd,
347 Cherry Hinton Road,
Cambridge, CB1 4DJ.
Tel: Cambridge 42898.

Monitor Distribution Co Ltd,
76 Bedford Road, Kempston,
Beds, MK42 8BB.
Tel: Bedford 854133.

Monitor Sound Equipment Ltd,
PO Box 28, Eastleigh,
Hants, SO5 5XD.
Tel: Chandler's Ford 68492.

Keith Monks (Audio) Ltd,
26-30 Rading Road South, Fleet,
Aldershot, Hants.
Tel: Fleet 7316/3566.

Monogram Professional Audio,
281 Balmoral Drive, Hayes,
Middx. Tel: 01-573 1566.

Mordaunt-Short Ltd,
Durford Mill, Petersfield,
Hampshire GU31 5BB.
Tel: Rogate (073 080) 721/2.

B. H. Morris & Co (Radio) Ltd,
Trio House, The Hyde,
London, NW9 6LP.
Tel: 01-205 6441.

Motion Electronics Ltd,
Addlestead Farm, Tonbridge Road,
East Peckham, Kent.
Tel: East Peckham 871354.

Musonic Ltd, 34-38 Verulam Road,
St Albans, Herts, AL3 4DF.
Tel: St Albans 50611.

Mustang Communications,
Nelson Street, Scarborough,
North Yorks YO12 7SZ.
Tel: Scarborough 63298.

N

National Panasonic (UK) Ltd,
101-109 Whitty Road, Trading Estate,
Slough, SL1 3DR.
Tel: Slough 34522.

Natural Sound Systems Ltd,
Strathcona Road, North Wembley,
London, HA9 8QL.
Tel: 01-904 0141.

Nichols Acoustic Fittings,
Church Street, Bubwith,
Near Selby, Yorks.
Tel: Bubwith 206.

Norse Audio Systems Ltd,
9 Hawkesworth Trading Estate,
Swindon, Wilts, SN2 1DZ.
Tel: Swindon 22592.

North East Audio Ltd,
5 Charlotte Square,
Newcastle-upon-Tyne, NE1 4XF.
Tel: Newcastle-upon-Tyne 26660.

O

Omni Group Ltd, Omal House,
North Circular Road,
London, NW10 7UF.
Tel: 01-965 8787.

Omex Products Ltd,
Hereford House, Wandle Mills,
Beddington, Croydon,
Surrey CR0 4SB.
Tel: 01-686 9022/5.

Osmabet Ltd, 46 Kenilworth Road,
Edgware, HA8 8YG.
Tel: 01-958 9314.

P

Pagantry Radio & TV Co Ltd,
104 Felsham Road, Putney,
London SW15 1DQ.
Tel: 01-788 5588.

J. Parkar & Co (London) Ltd,
Parkar House, Beresford Avenue,
Wembley, HA0 1XY.
Tel: 01-903 5211.

Parry Electronic Developments Ltd,
Assay House, 28 Greville Street,
London EC1N 8SU.
Tel: 01-242 1100.

Perdix Components,
98 Crofton Park Road, Crofton Park,
London SE4. Tel: 01-690 1914/15.

Period High Fidelity Ltd, Clivemont
Road, Cordwallis Trading Estate,
Maidenhead, Berks, SL6 7BO.
Tel: Maidenhead 21221.

Philips Electrical Ltd, Century House,
Shaftesbury Avenue,
London, WC2H 8AS.
Tel: 01-437 7777.
City House, 420-430 London Road,
Croydon, Surrey, CR9 3QR.
Tel: 01-689 2166.

Photax (London) Ltd,
Hampden Park, Eastbourne, Sussex.
Tel: Eastbourne 51197.

Planet Projects Ltd,
Goodman Works, Belvue Road,
Northolt. Tel: 01-845 1775.

Plastic Engineers Ltd, Treforest
Industrial Estate, Pontypridd,
Glamorgan CF37 5TP.

Plontronics Ltd, Hempstalls Lane,
Newcastle, Staffs. ST5 0SW.
Tel: Newcastle 615131.

Polydor Ltd, 17-19 Stratford Place,
London W1N 0BL.
Tel: 01-499 8686.

Precision Tapes Ltd,
Precision House, 11 Denmark Street,
London WC2H 8NR.
Tel: 01-836 3104/2534.

Premier Industries Ltd,
343-345 High Street, Cheltenham Spa,
Gloucester, GL50 3HS.
Tel: Cheltenham 27782.

Pye Ltd, PO Box 49, St Andrews Road,
Cambridge, CB4 1DS.
Tel: Cambridge 58985.

Pye Radio and Television Ltd,
St Andrews Road,
Cambridge, CB4 1DS.
Tel: Cambridge 58985.

Pye Business Communications Ltd,
Cromwell Road, Cambridge, CB1 3HE.
Tel: Cambridge 45191.

Pyral Magnetics Ltd, Airport House,
Purley Way, Croydon,
Surrey, CR0 0XZ.
Tel: 01-681 2833.

Pyser Ltd, Fircroft Way,
Edenbridge, Kent, TN8 6HA.
Tel: Edenbridge 4111.

Q

Quality Audio Supplies, Wollaton Road,
Beeston, Notts, NG9 2PB.
Tel: Nottingham 256141.

R

Radford Audio Ltd,
Ashton Vale Road, Bristol, BS3 2HZ.
Tel: Bristol 662301.

Rank Audio Visual,
PO Box 70, Great West Road,
Brentford, TW8 9HR.
Tel: 01-568 9222.

Rank Radio International Ltd,
PO Box 596, Power Road, Chiswick,
London, W4 5PW.
Tel: 01-994 6491.

Record Housing Ltd,
17a Newnham Road,
London, N22 5SS.
Tel: 01-888 7487/8.

Rediffusion Ltd, King's Court,
2-16 Gooidge Street, London W1.
Tel: 01-580 9506.

Regent Acoustics, Carrington House,
130 Regent Street, London, W1R 6BR.
Tel: 01-437 1997.

Resosound Ltd, Eagle Road,
Rye, Sussex, TN31 7NB.
Tel: Rye 2988.

Richmond Audio Ltd, 27 Church Road,
Bishops Cleeve, Cheltenham. Glos.
Tel: Rye 2988.
Rola-Celestion Ltd,
Ditton Works, Foxhall Road, Ipswich,
Suffolk, IP3 8JP.
Tel: Ipswich 73131.

Ross Electronics Ltd,
32 Rathbone Place, London, W1P 1AD.
Tel: 01-580 7112.

S

Saba Radio & Television Ltd,
6-12 Cornbrook Park Road,
Manchester, M15 4EE.
Tel: 061-872 7661.

Sanyo Marubeni (UK) Ltd,
Sanyo House, Bushey Mill Lane,
Watford, Herts, WD2 4UQ.
Tel: Watford 30421.

Scan Promotions (Glasgow) Ltd,
41 Robertson Street, Glasgow G28 HN,
Scotland. Tel: 041-221 2486.
17 Nottingham Street, London
W1M 3RD. Tel: 01-486 7644.

Scandinavian Audio Systems Ltd,
Sun Alliance Buildings,
65 London Road, Gloucester
GL1 3HF. Tel: Gloucester 32791.

Scopetronics Ltd, Crown Works,
91 Ewell Road, Surbiton,
Surrey, KT6 6BQ.
Tel: 01-390 0184.

Selmer Engineering Industries Ltd,
24 Mulberry Street, Tower Hamlets,
London, E1 1EH.
Tel: 01-247 3344.

Servo-Sound (Cybernetic Hi-Fi),
Lamb House, Church Street,
London, W4 2PB.
Tel: 01-995 4551.

Shaftesbury Furniture Ltd,
Flempton Road, Leyton, E10 7NH.
Tel: 01-539 1041.

Sharp Electronics (UK) Ltd, 107 Hulme
Hall Lane, Manchester, M10 8HL.
Tel: 061-205 7321.

Shriro (UK) Ltd, Shriro House,
The Ridgeway, Iver, Bucks, SL0 9JL.
Tel: Iver 65222/7.

Shure Electronics Ltd, Eccleston Road,
Maidstone, Kent, ME15 6AU.
Tel: Maidstone 59881.

Siemens Ltd, Great West House,
Brentford, Greater London.
Tel: 01-568 8281.

J. J. Silber Ltd, 11 Northburgh Street,
London, EC1. Tel: 01-253 8031.

Sinclair Radionics Ltd, London Road,
St Ives, Hunts. PE17 4HJ.
Tel: St. Ives 64646.

Skantic (UK) Ltd, Station Road,
Edenbridge, Kent, TN8 6EY.
Tel: Edenbridge 5231.

SME Ltd, Mill Road, Steyning,
Sussex, BN4 3GY.
Tel: Steyning 814321.

Sonab Ltd, 214 Harlequin Avenue,
Brentford TW8 9EW.
Tel: 01-568 2952/3.

Sony (UK) Ltd, Consumer
Information, Sony Showroom,
134 Regent Street, W1R 6DJ.
Tel: 01-439 3874.

Soundex Ltd, 18 Blenheim Road,
London, W4 1ES.
Tel: 01-995 1661.

Sound Ideas,
216 Brampton Road, Bexleyheath,
Kent. Tel: 01-303 9272.

Sound Incorporated (Sutton) Ltd,
Compton House, New Malden,
Surrey, KT3 4DE.
Tel: 01-942 9566.

Soundingham Ltd, 171 Uxbridge Road,
London W12.
Tel: 01-749 3662.

The Sound Studio Ltd,
London House, Mayfield, Sussex.
Tel: Mayfield 3419.

Sound Unlimited Ltd,
36 Baker Street, London W1M 1DG.
Tel: 01-935 2238/5920.

South Western Agencies,
Spring Gardens, Bigbury, Kingsbridge,
Devon, TQ7 4AP.
Tel: Bigbury-on-Sea 323.

Spendor Audio Systems Ltd,
Unit 12, Station Road Industrial
Estate, Hailsham, Sussex.
Tel: Hailsham 843474.

Steepleton Products Ltd,
Cinema House, Middle Barton,
Oxford OXS 4D4.
Tel: Steeple Aston 47116.

Stereo Sound Productions,
Capital Works, 12-14 Wakefield Road,
Brighouse, Yorks, HD6 1PQ.
Tel: Brighouse 4355.

Karl Stolle & Co,
29 Church Street, Ilkley, Yorkshire.
Tel: Ilkley 2193.

Strathearn Audio Ltd,
Kennedy Way Industrial Estate,
Belfast, Northern Ireland.

John Street (Manufacturers) Ltd,
Falcon Works, Barmeston Road,
Cafford, London SE6.
Tel: 01-698 11778.

A. R. Sugden & Co (Engineering) Ltd,
Atlas Mill Road, Brighouse,
West Yorkshire, HD6 1ES.
Tel: Brighouse 2142.

J. E. Sugden & Co Ltd,
Carr Street, Cleckheaton,
West Yorks, BD19 5LA.
Tel: Cleckheaton 872501.

Swisstone Electronics Ltd,
4-14 Barmeston Road,
London SE6 3BN.
Tel: 01-697 8511.

T

Tandberg (UK) Ltd,
Farnell House, 81 Kirkstall Road,
Leeds LS3 1HR. Tel: Leeds 35111.

Tannoy Products Ltd, Norwood Road,
West Norwood, London, SE27 9AB.
Tel: 01-670 1131.

Tape Distributors (UK) Ltd,
Brighton Road, South Croydon, CR2
6EQ.
Tel: 01-639 7844.

Tape Marketing Technology Ltd,
8 Green Street, London, W1.
Tel: 01-493 4205.

Tape Music Distributors Ltd,
114 Ashley Road, St Albans,
Herts, AL1 5JR.
Tel: St Albans 64337/9.

Tape Recorder Developments Ltd,
Hall Lane, Walsall Wood, Staffs.
Tel: Brownhills 5351.

Tape Recorders Spares Ltd,
206-210 Ilderton Road,
London, SE15 1NS.
Tel: 01-639 7844.

Technics, Technics Hi-Fi Division,
Building 63, Whitby Road, Trading
Estate, Slough SL1 3DR.
Tel: Slough 34522.

Teledyne Acoustic Research,
1 High Street, Houghton Regis,
Dunstable, Beds LU5 5QJ.
Tel: Dunstable 0582 603151.

Telerenters (London & Provincial) Ltd,
155-159 Queens Road, Watford.
Herts. WO1 2QH.
Tel: Watford 24543.

Teleton Electro (UK) Co Ltd,
Teleton House, Waterhouse Lane,
Chelmsford, Essex, CN1 1BD.
Tel: Chelmsford 62442.

H. O. Thomas Electronics Ltd,
Thames Road, Crayford, Kent.
Tel: Crayford 26671.

Thorn Consumer Electronics Ltd,
Thorn House, Upper St Martin's Lane,
London, WC2H 9ED.
Tel: 01-836 2444.

Thorpe Grenville Manufacturing Ltd,
Audio House, Albert Place,
Bourges Boulevard, Peterborough
PE1 1DB. Tel: Peterborough 62935/
61244/52431/2.

3M United Kingdom Limited,
3M House, Wigmore Street, W1A 1ET.
Tel: 01-486 5522.

Toshiba (UK) Ltd, Toshiba House,
Great South West Road, Feltham,
Greater London. Tel: 01-751 1281.

Tutchings Electronics Ltd,
14 Rook Hill Road, Friars Cliff,
Christchurch, Dorset, BH23 4DZ.
Tel: Highcliffe 72019.

U

Uher (UK) Ltd, PO Box 53,
York. Tel: 0904 30421.

Uni-Com Electronics Ltd,
36 Clarges Street, London W1 7PJ.
Tel: 01-409 1012.

V

Valradio Ltd, Browells Lane,
Feltham, TW13 7EN.
Tel: 01-890 4837/4242.

Van der Molen Ltd, 101 Hainault Road,
Romford, Essex, RM5 3HF.
Tel: Romford 22018/9.

Vernitron Ltd, Thornhill,
Southampton, SO9 5QF.
Tel: Southampton 444811.

Vero Electronics Ltd,
Industrial Estate, Chandler's Ford,
Eastleigh, Hants, SO5 3ZR.
Tel: Chandler's Ford 2952.

Veseco Vision and Radio Ltd,
Unit 4, Blackwater Way, Ash Road,
Aldershot, Hants, GU12 4DL.
Tel: Aldershot 321661.

Videotone Ltd, 31 Green Lane,
Chislehurst, Kent DA4 6AG.
Tel: 01-437 0100.

Vitavox, Westmoreland Road,
London, NW9 9RJ.
Tel: 01-204 4234.

Vor Distributors (Europe),
48D Sandwich Industrial Estate,
Sandwich, Kent.
Tel: Eastry 230.

Vorta Systems (UK),
297-299 High Street, Cheltenham Spa,
Gloucestershire, GL50 3HS.
Tel: Cheltenham 31166.

W

Cecil E. Watts Ltd,
Darby House,
Sunbury-on-Thames.
Tel: Sunbury-on-Thames 83252.

Webland Electronics Ltd,
Mirabel House,
117-121 Wandsworth Bridge Road,
London SW6. Tel: 01-736 0989/9410.

Webland International Ltd,
Mirabel House, 117-121 Wandsworth
Bridge Road, London, SW6.
Tel: 01-736 0989/9410.

Wendaford Ltd, 2 Chipping Hill,
Halstead, Essex. Tel: Halstead 3044.

Western Audio Research Ltd,
Chosen View Road, Cheltenham,
Gloucester GL51 9LT.
Tel: Cheltenham 34749.

Whiteley Electrical Radio Co Ltd,
Radio Works, Victoria Street,
Mansfield, Notts. NG18 5RW.
Tel: Mansfield 24762.

Wilmex Ltd, Import Division,
Crompton House, New Malden,
Surrey, KT3 4DE.
Tel: 01-949 2545.

Wilson Stereo Library Ltd,
104 Norwood High Street,
London, SE27 9AB.
Tel: 01-670 6394.

Witco, 243 Regent Street,
London W1R 8PN.
Tel: 01-439 1653.

Wolsey Electronics, Cymmer Road,
Porth, Rhondda, Glam, CF39 9BT.
Tel: Porth 2711.

Woollett Audiostatics,
Anerley Station Road,
London, SE20 8PY.
Tel: 01-699 5296.

Worden Audio Developments Ltd,
54 Chepstow Road, London, W2 5BE.
Tel: 01-299 4996.

Wye Electronics Ltd,
27 Station Road, Brimington,
Chesterfield, Derbyshire S43 255.
Tel: Chesterfield 70297.

Wyndors Recording Co Ltd,
2 Bellevue Road, London, N11 3ES.
Tel: 01-368 2226.

Z

Zerostat Instruments Ltd,
9 Station Road, Huntingdon, Cambs.
Tel: St. Ives 62225.

This advertisement is unsuitable for those of a mean or heartless disposition

An electrical worker's child needs a kidney machine. A Shift Engineer cannot pay his bills through a prolonged illness. A widow of an Electrical Engineer develops cancer, but her biggest worry is over the future of her child.

These are the sort of cases where EEIBA helps. Every year we deal with around 800 different such cases, filling in the gaps left, inevitably, by the Welfare State.

We exist to help people like you, and we need your help in two ways.

To tell us of any cases you might know where help is required.

And to help us with regular donations.

We're not asking for a fortune, we're simply asking you to appreciate how lucky you are and to send what you can spare.



With your help we can help

The Electrical and Electronics Industries Benevolent Association,
8 Station Parade, Balham High Road, London SW12 9BH.

Telephone: 01-673 0131.

45 branches throughout the country.

LATEST additions to our audio series



ABC of HI-FI *John Earl*

By the successful author of 'Improving your Hi-Fi'. The main objective of this book is to provide information on particular subjects, to define terms, to supply facts about equipment, and to outline essential aspects of the art of hi-fi listening. The wealth of information contained makes this book a must in the home, reference libraries, the laboratory, and service workshop.

176pp 216 × 138mm Casebound
0 85242 409 4 £3.75

Available shortly:

CASSETTE RECORDERS *Gordon King*

A fully up-to-date handbook on the subject essential reading for all who wish to realise the full potential of the cassette recorder. Profusely illustrated. **Approx. £3.50**

IMPROVING YOUR HI-FI *John Earl*

The author details how to connect the units together to obtain top performance and explains the meaning and proper use of the many control knobs and switches found on modern hi-fi gear. There are useful hints on simple performance checks, running repairs and adjustments. Final chapter on surround sound and quadraphony.

176pp 216 × 138mm Casebound
0 85242 335 7 £3.00



other titles in the series

PICKUPS AND LOUDSPEAKERS	JOHN EARL	£3.00
CREATIVE TAPE RECORDING	V CAPEL	£3.50
TUNERS AND AMPLIFIERS	JOHN EARL	£2.50
TAPE RECORDERS	H W HELLYER	£3.75
STEREO SOUND	H W HELLYER	£3.50

Order from your local bookseller or direct from the publishers

Fountain Press

Argus Books Ltd., 14 St. James Road,
Watford, Hertfordshire.

ERT

ELECTRICAL+RADIO TRADING

Registered Office: Dorset House, Stamford Street, London, SE1 9LU, England Registered No. 677128

The *COMPLETE* weekly trade paper. First with the news, expert opinion, technical and business know-how. Plus many free extras—including a free ERT PRICE LIST quarterly. Keeps you right up to date. No wonder it's the weekly paper with the highest paid circulation.

- **NEWS** Week-by-week coverage of news affecting your business, written in concise easy-to-read style by industry experts.
- **PRODUCTS** Specifications, pictures, prices and suppliers of the latest money-spinning products that should be in your showroom.
- **PEOPLE** in the news—men and movements, appointments, promotions, elections.
- **MERCHANDISING** Advance news of manufacturers' special promotions and sales aids that will sell goods to your customers.
- **TECHNICAL** Developments in circuits and components, servicing and repairs techniques explained in articles designed to keep your service staff at optimum efficiency.
- **EXHIBITIONS** Special articles provide you with a preview and planning guide to all the major exhibitions throughout the year, including extended coverage of the all-important Trade Shows.
- **FEATURES** on how to run an efficient business—commercial and professional information and advice about the business of retailing, how to buy and how to sell.

Advertisers Index

A.K.G. Equipment Ltd.	152	Lennard Development Ltd.	209
Acoustical Mfg. Co. Ltd. (Quad)	49	Linn Products Ltd.	310
Aerialite Aerials Ltd.	30	Lowther On-Line Development Ltd.	350
Agfa Gevaert Ltd.	140		
Alba (Radio & Television) Ltd.	47	3M UK Ltd.	145
Antiference Ltd.	28	MacInnes Laboratories Ltd.	48
Ariel Pressings Ltd. (QAS)	4	Magee, E. and W. Ltd.	232
Armstrong Audio Ltd.	3	Markovits, I. Ltd.	74
		Miers, N. & Co. Ltd.	247
BSR Ltd.	300	Milty Products Ltd.	201
Bang & Olufsen (UK) Ltd. <i>Back Cover</i>		Monitor Audio Ltd.	349
Beyer Dynamics (GB) Ltd.	175	Monogram Professional Audio	62
Bib Hi-Fi Accessories Ltd.	414	Morris, B. H. & Co. (Radio) Ltd.	291
CHB Supplies Ltd.	358	Philips Electrical Ltd.	361
Cerwin-Vega (UK)	396		
Chartwell Electro Acoustics Ltd.	352, 393	Radford Hi-Fi	462
Coles Engineering (Hoddesdon) Co.	167	Richard Allan Radio Ltd.	394
Contek Magnetics Ltd.	151	Rola Celestion Ltd.	369, 370, 371, 372
Cosmocord Ltd.	218	Ross Electronics	123
Eagle International <i>Front Cover</i> , 61, 160		SME Ltd.	226
E.E.I.B.A.	480	Sanyo Marubeni Ltd.	188
Electrical & Radio Trading	482	Shriro (UK) Ltd.	227, 299
		Shure Electronics Ltd.	217
Farnell-K.F. Ltd.	384	Sony Ltd.	146
Fidelity Radio Ltd.	187	Soundex Ltd.	422, 423
Fountain Press	481	Spendor Audio Systems Ltd.	395
		Squirrel Holloware Mfg. Co. Ltd.	328
Goldring Ltd.	228, 309	Sugden, A. R. & Co. (Engineers) Ltd.	301
Goodmans Loudspeakers Ltd.	50, 383		
Griffin, H. K. & Co. (Electronics)	362	Toshiba (UK) Ltd.	80, 81
Hampstead High Fidelity Ltd.	234	Vintage Crystal Sets	420
Hi-Fi Designs	248		
Hitachi Sales (UK) Ltd.	292	Webland International Ltd.	472
		Wireless World	449
Imhof's Ltd.	6	Wolsey Electronics	34
Lecson Systems Ltd.	450	Zerostat Ltd.	210

Directory of Hi Fi Dealers

IMPORTANT NOTE

The following list is of shops where stocks of equipment are kept, and where facilities for demonstration exist. It is not necessarily a complete list, and we invite new dealers to submit details for future publications.

AVON

GREEN BROTHERS
19 New Bond Street, Bath.
Tel: 63146.

MILSONS
Northgate.
Tel: 5675.

BEDFORDSHIRE

BEDFORD AUDIO SUPPLIES
76 Bedford Road, Kempston.
Tel: Bedford 854133.

BERKSHIRE

THE LISTENING POST formerly
AUDIO T. BUCKS
105 High Street, Eton.
Tel: Windsor 54531.

B & B HI-FI
16 Gun Street, Reading.
Tel: Reading 583730.

BERKSHIRE HI-FI AND VIDEO
125 Bridge Road, Maidenhead.
Tel: Maidenhead 27760
8 The Meadow Precinct,
Honey End Lane, Reading.
Tel: Reading 582988

L. J. GALE LTD
66-68 King's Road, Reading.
Tel: Reading 51046/51062.

**READING CASSETTE &
HI-FI CENTRE**
6 Harris Arcade, Friar Street, Reading.
Tel: Reading 585463.

SOUND SYSTEMS A.V. LTD
49-51 King Street, Maidenhead.
Tel: Maidenhead 32796.

BIRMINGHAM

**BIRMINGHAM TAPE RECORDER
CENTRE LTD.**
37 Hurst Street, Birmingham, B5 4BJ.
Tel: 021-622 2323.

**NORMAN H. FIELD HI-FIDELITY
CENTRE**
423 Stratford Road, Sparkhill 11.
Tel: 021-772 5160.
35 Hurst Street, B5 4BJ.
Tel: 021-622 2323.
23a Hurst Street, B5 4BT.
Tel: 021-622 3619.

LASKY'S
116 Corporation Street.
Tel: 021-236 1953.

W. J. TAYLOR (D.S.) LTD
126-130 Hawthorn Road,
Kingstanding, Birmingham B44 8QA.
Tel: 021-382 1312.

KEN WHITTLE LTD
788 Stratford Road, Sparkhill, B11 4BP.
Tel: 021-777 5964.

BRISTOL

AUDIO BRISTOL
Park Street Avenue, Bristol 1.
Tel: Bristol 291931.

BRISTOL HI-FI CENTRE
26-27 Broad Street.
Tel: 0272 294183.

HUSBANDS
The Centre, Bristol 1.
Tel: Bristol 293978.

RADFORD HI-FI
52-54 Gloucester Road,
Bristol BS7 8BH.
Tel: Bristol 422709.

**TAPE RECORDER & HI-FI
CENTRES LTD**
82 Stokes Croft, BS1 3RP.
Tel: 49677.

BUCKINGHAMSHIRE

B & B HI-FI
4 Priory Road, High Wycombe.
Tel: High Wycombe 35910.

CHILDERN SOUND
27 Spittal Street, Marlow.
Tel: Marlow 71588.

**HUGHES PHOTOGRAPHIC
HI-FI SPECIALISTS**
7 High Street, High Wycombe.
Tel: High Wycombe 30138.

THE LEISURE CENTRE
1 Packhorse Road, West Compton,
Gerrards Cross.
Tel: Gerrards Cross 84417.

CAMBRIDGESHIRE

A & R
French's Mill, French's Road,
Cambridge, CB4 3NP.
Tel: Cambridge 54507.

HI-FI CONSULTANTS
13A Whitsea Street, Peterborough.
Tel: Peterborough 51007.

REMU AUDIO
4 Mill Road, Cambridge CB1 2AD.
Tel: 0223 69235.

T.A.S.
12 The Broadway, St. Ives,
Huntingdon. Tel: St. Ives 65052.

UNIVERSITY AUDIO
1-2 Peas Hill, Cambridge.
Tel: Cambridge 54237.

CENTRAL (SCOTLAND)

TALISMAN HI-FI
44 Cow Wynd, Falkirk.
Tel: 29011.

CHANNEL ISLANDS

LAKERS LTD
30-34 The Arcade, St. Peter Port,
Guernsey. Tel: Guernsey 23626.

CHESHIRE

CHARLESWORTHS HI-FI
112 Foregate Street, Chester CH1 1HB.
Tel: Chester 25075.

**CHARLESWORTHS OF
CREWE LTD**
14 Highton, Crewe CW1 3BT.
Tel: Crewe 56342.

CHESTER SOUND STUDIOS LTD
23 Mercia Square, Frodsham Street,
Chester. Tel: Chester 315058.

HI-FI SYSTEMS
118 Buttermarket Street, Warrington.
Tel: Warrington 32981.

RELAY VISION LTD
57-59 Bridge Street, Warrington.
Tel: Warrington 30444.

SOUND ADVICE
494 Overpool Road, Whitby, Ellesmere
Port. Tel: 051-355 2833.

SWIFT OF WILMSLOW
5 Swan Street, Wilmslow SK9 1HF.
Tel: Wilmslow 26163.

WILMSLOW AUDIO
Dept. 11FYB, Swan Works,
Bank Square, Wilmslow SK9 1HF.
Tel: Wilmslow 29599.

CLEVELAND

McKENNA & BROWN LTD
135/7 High Street, Redcar.
Tel: Redcar 3829.

**CORNWALL
CAMBORNE AUDIO CENTRE**
63 Trelowarren Street, Camborne.
Tel: Camborne 714286.

HYDROVOLT LTD
2 Church Street, Helston.
Tel: Helston 2545.
91 Market Jew Street, Penzance.
Tel: Penzance 5075.

CUMBRIA

DERHAMS HI-FI
5 Furness House, Barrow-in-Furness,
Tel: Barrow 22973.
Kent Street, Stramongate, Kendal.

MISONS HI-FI SPECIALISTS
11 Warwick Road, Carlisle.
Tel: Carlisle 22620.

DEVBY

VICTOR BUCKLAND LTD
41-49 London Road, Derby.
Tel: Derby 48425.

MICRON AUDIO LTD
135 Sheffield Road (A61),
Chesterfield. Tel: 34923.

DEVON

EXON AUDIO
164-166 Sidwell Street, Exeter.
Tel: Exeter 50802.

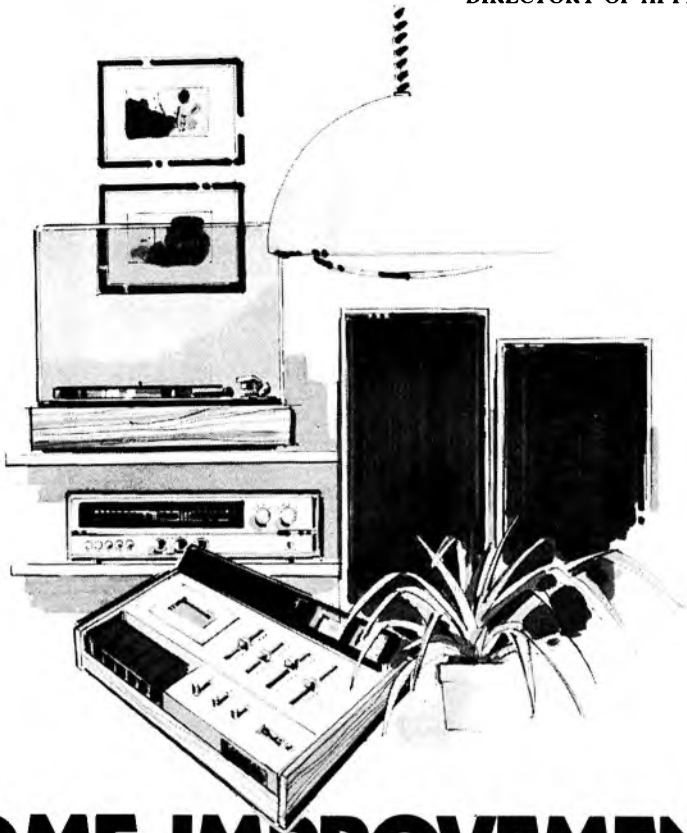

HOME IMPROVEMENT:

You know how important good hi-fi is to modern gracious living and as an investment for years to come. Likewise, we at Laskys know the importance of our huge selection of famous hi-fi names and our friendly, helpful service. As Europe's leading hi-fi retailers, we've had plenty of experience. We can offer extensive financial facilities, Access, Diner's

Club and Barclaycard service, full 12 month guarantees including parts and labour (excluding stylus), Mail Order, export, free demonstrations and Laskys very attractive prices. And of course, our FREE 32-page monthly Catalogue, with details of services, prices – even articles by your favourite personalities. Who could ask for more?

LONDON	
481 Oxford Street, W1	01-493 8641
10 Tottenham Court Rd, W1	01-637 2532
33 Tottenham Court Rd, W1	01-636 2605
42 Tottenham Court Rd, W1	01-636 0845
257 Tottenham Court Rd, W1	01-580 0670
3 Lisie Street, WC2	01-437 8204
118 Edgware Road, W2	01-723 9789
193 Edgware Road, W2	01-723 6211
311 Edgware Road, W2	01-262 0387
346 Edgware Road, W2	01-723 4453
387 Edgware Road, W2	01-723 4134
105 Fleet Street, EC4	01-353 5812
152 Fleet Street, EC4	01-353 2813

LEWISHAM	
29 Riverside, Lewisham Centre	01-318 2297
BRENT CROSS	
Brent Cross Shopping Centre	
Hendon Way, NW4 3FB	01-202 0977
BIRMINGHAM	
116 Corporation Street	236-3503
BRISTOL	
16-18-20 Penn Street	20421
CHATHAM	
8 Pentagon Centre	407104
COLCHESTER	
Lion Walk Shopping Centre	020662636
CROYDON	
1046 Whitgift Centre	01-681 3027
DARTFORD	
39 Arndale Centre	73481
KINGSTON	
38/40 Eden Street	01-546 1271
LEICESTER	
45 Market Place	537678

NORTH HAMPTON	
78 Abington Street	35753
NOTTINGHAM	
5-7 Lower Parliament St.	489587
OXFORD	
16 Westgate Centre	722870
READING	
6 Friars Walk, Friars St.	595459
RICHMOND	
32 Hill Street	01-948 1441
ROWFORD	
86 South Street	20218
SLOUGH	
65 Queensmere Centre	24401
SOUTHEND	
205/206 Churchill West	612241
SWINDON	
12 Brunel Plaza	33750
TUNBRIDGE WELLS	
53/57 Camden Road	23242
WOLVERHAMPTON	
30 Wulfrum Way	23384
All branches open:	
Monday 9.30-6pm Tuesday to Saturday 9.00-6pm	
(Oxford 9-1 Weds. Fleet Street 9-1 Sats)	

LASKYS

The Hi-Fi people

DIRECTORY OF HI FI DEALERS

ALBERT E. FORD LTD
84 Cornwall Street, Plymouth.
Tel: Plymouth 63319.

HOWARDS (EXETER) LTD
90 Sidwell Street, Exeter.
Tel: Exeter 38518/9.

TOM MOLLAND LTD
110 Cornwall Street, Plymouth.
Tel: Plymouth 69285.

RICHLow ELECTRONICS
20 Roundhill Road, Livermead,
Torquay. Tel: Torquay 65028.

PETER RUSSELL LTD
58 New George Street, PL1 1RR.
Tel: Plymouth 69511.

UPTON ELECTRONICS
2 Churchill Court, Bilton Street,
Brixham. Tel: Brixham 51893.

WANSTALL HI-FI LTD
25 The Parade Barbican, Plymouth.
Tel: Plymouth 20750.

DORSET

H.A.T.V.
45 Bargates, Christchurch.
Tel: Christchurch 73901

MANAGEMENT ELECTRONICS
254 Old Christchurch Road,
Bournemouth.
Tel: Bournemouth 291524.

POOLE CAMERA CENTRE
91 Arndaie Centre, Poole.
Tel: Poole 6289.

QUALITY HI-FI
55 North Road, Poole.
Tel: Parkstone 742706.

SUTTONS (HI-FI) CENTRE
10 Gervis Place, Bournemouth.
Tel: 0202 25512.

DURHAM

McKENNA & BROWN
11 Bondgate, Darlington.
Tel: Darlington 65990.
134 Newgate Street, Bishop Auckland.

DYFED

MILFORD AUDIO CENTRE
85 Queen Street, Pembroke Dock.
Tel: Pembroke 3251.
90 Robert Street, Milford Haven.
Tel: Milford Haven 4078.

EAST SUSSEX

C.P. ABRAHAM LTD
192 Queens Road, Hastings.
Tel: Hastings 429231.

AVERYS RADIO & TELEVISION
77 St. James Street, Brighton.
Tel: 63965 & 685381.

THE BEST IN HI-FI
32 Grove Road, Eastbourne.
Tel: 0323 27362.
36 High Street, Rottingdean,
Brighton. Tel: 0273 31082.

COMPLETE AUDIO SYSTEMS LTD
32 Grove Road, Eastbourne
Tel: Eastbourne 27362

36 High Street, Rottingdean,
Brighton. Tel: Brighton 31082

JOHN KING (FILMS) LTD
Film House, 71 East Street,
Brighton BN1 1NZ.
Tel: Brighton 25918/27674.

LANES RADIO LTD
94 Church Road, Hove BN3 2EB.
Tel: Brighton 738517.

THE MUSIC SHOP
80 High Street, Uckfield.
Tel: Uckfield 2316.

SOUNDS SUPREME
136 Portland Road, Hove
Tel: Brighton 723399

EDINBURGH

AUDIO AIDS
20 South Clerk Street,
Tel: 031 5569838
274 Canongate, Royal Mile.
Tel: 031-556 9838
33 Morningside Road
Tel: 031-447 2229

EDINBURGH AUDIO
5-7 Lothian Road,
Edinburgh EH1 2DW
Tel: 031-229 1729

HI-FI CORNER
1 Haddington Place, Edinburgh
Tel: 031-5567901

ESSEX

AUDIO TECHNICS
145 Old Road, Clacton-on-Sea.
Tel: Clacton-on-Sea 28019.

CHEW & OSBORNE LTD
148-156 High Street, Epping.
Tel: Epping 74242.
26 King Street, Saffron Walden.
Tel: Saffron Walden 23728.

KELLEYS RADIO LTD
82 Town Square, Basildon
Tel: Basildon 21638.

Speaker Selection Ltd

611 FOREST RD
WALTHAMSTOW
LONDON E.17
Tel. 01-531 3117

- ALL CALLERS WELCOME FOR SALES, COLLECTIONS OR JUST A CHAT.
- DEMONSTRATIONS AT ALL TIMES.
- MOST MAKES OF HI-FI EQUIPMENT SUPPLIED AT DISCOUNT PRICES.

LONDON W2 Established 1910

H. L. SMITH & CO. LTD.

Comprehensive stocks of
components and equipment
National Panasonic and
Technics

287/289 EDGWARE ROAD,
LONDON W2 1BE
Telephone: 01-723 5891

ASHFORD

PHOTOCRAFT HI-FI

Opposite Top Rank, 40 High Street
Telephone: Ashford 24441

Agents for:

A.R. Armstrong, Bang & Olufsen,
Celestion, Dynatron, KEF, Koss,
Luxman, Micro, Nakamichi, Quad,
Revox, Sonab, Strathearn, Tandberg,
Teac, Trio, Toshiba.

MORE HI·FI HELP FROM HARDMAN'S



You only have to ask

We simply say that if you come to us first, the largest hi-fi retailer in the North West, with superstores in Liverpool, Manchester, Preston and Chester you'll see and hear the biggest choice of hi-fi at really competitive prices, so you'll save yourself time, trouble and money looking elsewhere and you'll have a 2 year free parts and labour guarantee.

The choice is yours, so choose Hardman's.

Major stockists of the following products:-

ACOUSTIC RESEARCH
A. D. C.
AGFA
AIWA
AKAI
A. K. G.
ARMSTRONG AUDIO
AUDIO TECHNICA
BANG & OLUFSEN
B. A. S. F.
BIB
BOWERS & WILKINS
B. S. R. McDONALD
CAMBRIDGE AUDIO
CASTLE ACOUSTICS
CELESTION

DUAL
FERROGRAPH
GALE
GARRARD
GOLDRING
GOODMANS
HITACHI
I.M. F.
KEF
KLH
KOSS
LEAK
LIN-SONDEK
MEMOREX
METRO SOUND

MICRO
NAKAMICHI
NATIONAL PANASONIC
NEW ACOUSTIC DIMENSION
PHILIPS
PIONEER
PIXALL
Q. A. S.
QUAD
REVOX
ROCKWELL
ROTEL
SENNHEISER
SHURE
S. M. E.
SONY

STAX
STANTON
SUGDEN
TANDBERG
T. D. K.
TEAC
TEXAS
THORENS
TRIO
TECHNICS
UHER
WATTS
WHARFEDALE
YAMAHA
ZEROSTAT

All leading records and tapes

HARDMAN'S
A WHOLE WORLD OF HI-FI
AT SOUND PRICES

CHESTER: The Forum, Northgate Street,
Chester CH1 2BZ. Tel. (0244) 317667

LIVERPOOL: 33 Dale Street, Liverpool
L2 2HF. Tel. 051-236 2828.

MANCHESTER: 12 St. Mary's Gate,
Manchester M1 1PX. Tel. 061-832 6087.

PRESTON: Guild Hall Arcade, Preston
PR1 1HR. Tel. (0772) 59264.

DIRECTORY OF HI FI DEALERS

NUSOUND

89-100 Pioneer Market,
Ilford Lane, Ilford.
Tel: 01-478 2291.

RUSH HI-FI CENTRES

6 Cornhill, Chelmsford.
Tel: 0245 57593.
38 North Street, Romford.
Tel: Romford 0708.

SOUND SUPPLIES (LOUGHTON)

CO. LTD
309 High Road, Loughton IG10 1AH.
Tel: 01-508 2715.

SOUNDTRACK (AUDIO/VISUAL CENTRE)

149 Leigh Road, Leigh-on-Sea.
Tel: Southend 74752.

D.T. WICKS

49-51 North Station Road, Colchester.
Tel: Colchester 78807.

GLASGOW

McCORMACKS
33 Bath Street, Glasgow.
Tel: 041-332 6644.

VICTOR MORRIS

340 Argyle Street,
31 Sauchiehall Street,
8-10 Glassford Street,
Glasgow C2.

G. H. STEELE LTD

141-143 St. George's Road,
Glasgow C3 6JB.
Tel: 041-332 7124/5/6.

GLOUCESTERSHIRE

R. LEWIS & Co LTD
The Green, Stonehouse.
Tel: Stonehouse 2176.

T.V. & HI-FI CENTRE

35 Castle Street, Cirencester.
Tel: Cirencester 4756.

GRAMPIAN

HOLBURN HI-FI
445 Holburn Street, Aberdeen.
Tel: Aberdeen 25713.

JOHN MUNRO

26 Seatown, Lossiemouth.
Tel: Lossiemouth 2340.

GREATER MANCHESTER

AUDIO CORNER
117 Portland Street, Southport.
Tel: Southport 599404.

CENTRAL RECORDS

Arndale Centre, Middleton M24 4EL.
Tel: 061-643 0429.

R.N. CLEARSTONE LTD

166 Blackburn Road, Bolton BL1 8DR.
Tel: Bolton 31423.

FAIRBOTHAM & CO LTD

58-62 Lower Hillgate,
Stockport SK1 3AN.
Tel: 061-480 4875.

HARDMAN RADIO

12 St. Mary's Gate,
Manchester M1 1PX.
Tel: 061-832 6087.

HARKER & HOWARTH

(Music) LTD
Goodwin Street, Folds Road, Bolton.
Tel: Bolton 26623/4.

H.D. KIRK STEREOELECTRICS

203 St. Georges Road, Bolton.
Tel: Bolton 23093.

J. KOCZUR

185 Yorkshire Street, Rochdale.
Tel: Rochdale 42107.

LANCS HI-FIDELITY LTD

Home Music Centre,
248 Wilmslow Road, 1.
Tel: 061-236 3051.

LLOYD PATON-McGLYNN LTD

Urmston Shopping Centre,
34 Moorfield Walk, Urmston.
Tel: 061-747 9722.

STEREO ELECTRICS

203 St. Georges Road, Bolton.
Tel: Bolton 23093.

GWENT

HI-FI WESTERN LTD

(HI-FI CENTRE)
49-52 Cambrian Road, Newport.
Tel: Newport 66790/59602.

HAMPSHIRE

AUDIOMATCH LTD
135 West Street, Fareham.
Tel: Fareham 2876.

EXPRESS RADIO

105-107 Fawcett Road, Southsea.
Tel: Portsmouth 22721.

HAMILTON ELECTRONICS LTD

35 London Road, Southampton.
Tel: 286222.

HAMPSHIRE AUDIO LTD

8 Hursley Road, Chandler's Ford,
Eastleigh.
Tel: Chandler's Ford 2827.

KEN ROSE AUDIO LTD

283 Fleet Road, Fleet.
Tel: Fleet 5053.

Rush Hi-Fi Centres

WE DON'T JUST SELL WE SERVE:-

Two Years Guarantee
Parts and Labour * Demonstrations
Free exchange if goods returned
within 7 days
Discount Prices + Free Advice

Technics. Sony. Yamaha. Amstrad.
Quad. J.V.C. KEF. B + W.

Monitor Audio. Aiwa + many more

Chelmsford 6 Corn Hill Phone 57593 Closed ½ day Wed.	Romford 38 North Street Phone 26840 Closed all day Thurs.	Chelmsford 74 Baddow Road Phone 64393 Closed all day Wed.
--	---	---

* does not apply
to sale goods,
cartridges or styl!

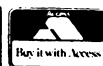

B & O

HI-FI
T/V VIDEO & CCTV
RECORDS & TAPES

Russell's

40 UPPER ST. JAMES'S STREET
NEWPORT I-O-W 3864

TRIO

SONY

TECHNICS

76 Bedford Road · Kempston · Beds MK42 8BB · ☎ Bedford 854133

Bedford Audio

OPEN UNTIL 8PM FRIDAY. CLOSED MONDAY

- PERSONAL ATTENTION
- LEADING MAKES
- COMPETITIVE PRICES
- COMPARATOR DEMONSTRATIONS
- SERVICING BY EXPERTS

INTEREST FREE CREDIT

In this day and age of soaring inflation this remarkable offer is just the sort of thing you are looking for. Simply:-

Choose your repayment schedule with 10% deposit and 8 months to pay or ½ deposit for 12, 18, or even 24 months COMPLETELY INTEREST FREE. All you pay is the price of the equipment.

e.g. A System costing £300

Deposit £100 and 24 payments of £8.33 instead of 24 payments of £11 with interest of £64

e.g. A System costing £800

Deposit £267 and 24 payments of £22.22 instead of £29.32 saving you charges of £170.68.

So take this opportunity to enjoy truly luxurious Hi-Fi quality from a carefully selected range that represents the best in value and the best in Hi-Fi from the many makes available today.

Franchise agents for: Trio, Omal, Gale, Harman-Kardon, Scan-Dyna, Linn Sondek, S.M.E., KEF, J.B.L., Transcriptors, Harrison, Aiwa, Scott, Altec Lansing, Naim, Armstrong, Neal, Monitor Audio, Sugden, Revox, Cambridge Audio, Luxor, Celestion, Stanton, Grace, Zerostat, Pickering, Kos, S.A.E. and many others.

VICKERS^{HI-FI}

and postal enquiries

24 Gillygate,
York.

Tel: 0904 29659

VICKERS^{HI-FI}

43 Princegate,
Waterdale Centre,
Doncaster.

Tel: 0302 63806

YORKSHIRE'S REVOX CENTRES

DIRECTORY OF HI FI DEALERS

SUTTONS

15 Southgate Street, Winchester.
Tel: Winchester 68402.
50 Blue Boar Row, Salisbury.
Tel: Salisbury 27171.
421 Shirley Road, Southampton.
Tel: Southampton 772069.

HEREFORD & WORCESTER

RALPH HALES AUDIO VISION
154 Worcester Road, Malvern Link.
Tel: Malvern 4433.
JOHNSONS SOUND SERVICE
43 Friar Street, Worcester.
Tel: Worcester 25740.

HERTFORDSHIRE

A & M SUPPLIES
123-5 High Street, Stevenage.
Tel: Stevenage 54321.

HAMILTON SOUND LTD
129 Marlbowes, Hemel Hempstead.
Tel: Hemel Hempstead 51718.

K. J. LEISURE SOUND LTD
101 St Albans Road, Watford
WD2 4BZ. Tel: Watford 45250.

PORTOGRAM RADIO LTD
175 High Street, Barnet.
Tel: 01-449 4183.

THE RECORDERIE
333 Watling Street, Radlett.
Tel: Radlett 6060.

RUSSELLS HI FI CENTRE
318A St Albans Road, Watford.
Tel: Watford 32717.

**SOUNDS STEREO (HI-FI
CONSULTANTS)**
3 Haffingbury Close, Little Haffingbury,
Bishop's Stortford.
Tel: Bishop's Stortford 56305.

STUDIO 99 LTD
82 High Street, Harpenden
Tel: 05827 64246.

HUMBERSIDE

A-Z RADIO
758 Spring Bank West,
Hull. Tel: 508021.

G. SANDS & SON
61 Princess Avenue, Hull.
Tel: 0482 42118.

ISLE OF WIGHT

**RUSSELL'S RADIO & T.V.
SERVICE**
40 Upper St. James's Street,
Newport PO30 1LG.
Tel: Newport 3864.

IRELAND

AUDIO SYSTEMS LTD
Northside Shopping Centre,
Cotoicock, Dublin 5.
Tel: Dublin 336286.

CENTRESOUND LTD
2-3 Lincoln Place, Dublin 2.
Tel: Dublin 763466.

J. S. MARTIN
21 Railway Road, Coleraine, Co. Derry.
Tel: Coleraine 52843.

MOORE'S HI FI
58 Francis Street, Newtownards,
Co. Down. Tel: Newtownards 812417.

KENT

TERRY BURKE (AUDIO) LTD
64 Wincheap, Canterbury C11 3RS.
Tel: 0227 69848.

CANTERBURY HI-FI CENTRE
1-2 The Friars, Canterbury.
Tel: Canterbury 65313.

D. E. HADAWAY & SON LTD
95 & 97 Watling Street,
Gillingham, Kent. Tel: Medway 50058.

HERMLYN HI FI LTD
14 Elmfield Road, Brumley.
Tel: 464 2666.

MEDWAY ELECTRONICS
15a Church Street, Chatham.
Tel: Medway 44805.

PHOTOCRAFT HI-FI
40 High Street, Ashford.
Tel: Ashford 24441.

WOODS & PORTER LTD
23 West Hill, Dartford
Tel: Dartford 20002.

LANCASHIRE

F. BENFELL LTD
78 Westfield Road (Ansdell Road),
Blackpool FY1 6NX.
Tel: Blackpool 49625.

ELECTRA CENTRE,
58 Lancaster Road, Preston.
Tel: Preston 58488.

HARDMAN RADIO LTD
1-4 Guildhall Arcade,
Lancaster Road, Preston.
Tel: Preston 59264.



AUDIO T

THE AUDIO CONSULTANTS

190 West End Lane, London NW6 1SQ
Tel: 01-794 7848

Specialists for: ● AMCRON ● B.G.W. ● CELEF ● DUAL
● KEF ● LECSON ● MONITOR AUDIO ● NAKAMICHI
● PHASE LINEAR ● QUAD ● REVOX ● SME ● SPENDOR
● SUGDEN ● TECHNICS ● YAMAHA and many others.

● DIRECT AND PERSONAL EXPORT ● COMPREHENSIVE AFTER SALES SERVICE ● DEMONSTRATIONS BY APPOINTMENT
● FULL TESTING AND SERVICE FACILITIES ● ACCESS - BARCLAYCARD ● CREDIT SALE FACILITIES N.B. CALLERS ONLY

ELECTRONIC SERVICES

33 City Arcade
Coventry CV1 3HX

Your central Hi-Fi supplier

Phone Coventry 24632

High Fidelity & Video
Specialists

Hamilton Electronics **HE**

Hamilton Electronics (Southampton) Ltd
35 London Road, Southampton Phone 28622 3lines

mccormack's

(MUSIC) LTD

33 BATH ST., GLASGOW

Tel. 041-332 6644

Main Stockists of:

A.R., VIDEOTONE, KLH, B & W, IMF, MONITOR AUDIO, AND QUAD LOUDSPEAKERS.
YAMAHA, TRIO, TECHNICS, TOSHIBA, SONY, ATRON, NAKAMICHI, NATIONAL PANASONIC, LINN SONDEK, ARISTON, REVOX, TEAC, TANDBERG, MICROACOUSTICS, SHURE, STANTON AND EMPIRE.

RECOMMENDED SYSTEMS:

SUGGESTED SYSTEM ONE

TRIO KP1022 with cartridge / TRIO KA3300 Amp / VIDEO TONE MINI MAX II Loudspeakers.

SUGGESTED SYSTEM TWO

TECHNICS SL110 / SME / MICROACOUSTIC Cartridge / YAMAHA CA1000 / AR11 Loudspeakers.

FROM STOCK AT McCORMACK'S OF GLASGOW



Complete Audio Systems Ltd

THE BEST IN HI-FI

32 Grove Rd EASTBOURNE. Tel (0323) 27362
36 High St ROTTINGDEAN. Tel (0273) 31082



BRADFORD FOR QUALITY HI-FI

from B & O, Sony, Quad, Uher, Revox, A-R, KEF, B & W, Teac, Tandberg, Dual, Sugden, Bose, Tannoy, Zerostat, Marantz, JBL, Linn, Fons, Richard Allen, Philips and JVC colour videos

★ FREE INSTALLATION ★
★ EXCHANGES ★ CREDIT ★

Always 60 Speakers to hear!

NORTHGATE, BRADFORD 31648
BARCLAYCARD & ACCESS



**BEOVISION
BEOCORD
BEOLAB
BEOGRAM
BEOMASTER
BEOVOX
BEOCENTER
BEOLIT
BEOMIC**

Relay Vision Ltd.

57 Bridge Street Warrington

Telephone (0925) 30444

DIRECTORY OF HI FI DEALERS

HOLDINGS PHOTO AUDIO CENTRE

Photo Audio Centre, 39-41 Mincing Lane, Blackburn BB2 2AF.
Tel: Blackburn 59595/6.

MONITOR SOUND

64 Chapel Street, Chorley PR7 1BS.
Tel: Chorley 71935.

TAPE RECORDER CENTRE (B'POOL)

266 Waterloo Road, Blackpool.
Tel: Blackpool 45049.

WHITELEYS OF DEANSGATE

Deansgate, Blackpool.
Tel: Blackpool 28357.

JOHN F. WIGNEY LTD

Cleveleys Hi-Fi Centre, Orion Buildings, Cleveleys, Blackpool.
Tel: Cleveleys 2627.

LEICESTERSHIRE

REALISTIC SOUND CENTRES LTD
32 High Street.

Tel: Leicester 56420.

THE TAPE SCENE

18 Haymarket LE1 39D.
Tel: Leicester 50572.

S. D. TEBBATT

111 London Road,
Leicester.

LINCOLNSHIRE

ADDYS (BOSTON) LTD
9 Wide Bargate, Boston.
Tel: Boston 62454.

LINCOLN HI-FI CENTRE
271a High Street, Lincoln.
Tel: Lincoln 20265.

STAMFORD HI-FI CENTRE

9 Red Lion Square, Stamford.
Stamford.
Tel: 2128.

LONDON

ACTON CAMERA & HI-FI CENTRE

86 High Street, Acton W3 6QX.
Tel: 01-992 4788.

A.T. LABORATORIES

191 Chase Side, Enfield EN2 0QZ.
Tel: 01-363 7981.

AUDIO T

190 West End Lane, NW6.
Tel: 01-794 7948.

BERRY'S RADIO LTD

319-320 High Holborn, WC IV 6AZ.
Tel: 01-405 6231.

THE CAMERA CENTRE

96 The Whitgift Centre, Croydon.
Tel: 01-686 8393.

COX HI-FI LTD

219 Eltham High Street, SE9.
Tel: 01-850 0384.

E.M.G. HANDMADE

GRAMOPHONES LTD
26 Soho Square W1V 6BB.
Tel: 01-734 4311.

FRANCIS OF STREATHAM

169/173 Streatham Road, SW16.
Tel: 01-769 0466/0192.

C. C. GOODWIN (SALES) LTD

7 The Broadway, High Road,
Wood Green N22 6DU.
Tel: 01-888 0077/8.

GRAHAMS ELECTRICAL LTD

86-88 Pentonville Road NI 9HS.
Tel: 01-837 4412.

GREENE & COOPER LTD

211 Kenton Road, Kenton.
Tel: 01-907 9660.

HAMPSTEAD HIGH-FIDELITY

63 Hampstead High Street NW3 10H.
Tel: 01-435 6377/0999.

HANSPAL'S AUDIONICS

54 St Anns Road, Harrow.
Tel: 01-863 3400.

488 Lady Margaret Road,
Southall. Tel: 01-578 2258.

276 Preston Road, Harrow.
Tel: 01-904 8549.

HAVEN HI-FI (EALING) LTD

8 Sunbury Cross Centre,
Sunbury-on-Thames.
Tel: Sunbury 88963.

THOMAS HEINTZ LTD

35 Moscow Road, Queensway W2 4A4.
Tel: 01-229 2077.

HERMLYN HI-FI LTD

230-232 Eltham High Street, SE9.
Tel: 01-850 9548.

HI-FI COMPONENTS LTD

84 Battersea Rise, SW11 1EH.
Tel: 01-223 1110.

HOUNSOM

23 Watford Way, Hendon NW4 3AD.
Tel: 01-202 8921.

MRS. BEAN SOUND SYSTEMS

★ real hi-fi

TRIO - DUAL - A.R. - SCAN DYNA
MORDAUNT-SHORT - J.B.L. - SUGDEN
SHURE - TANDBERG - SONY - FISHER
MONITOR-AUDIO - CELESTION - MICRO
CAMBRIDGE - REVOX - SENNHEISER etc.

★ real service

DEMONSTRATIONS. FREE HOME TRIAL,
DELIVERY, INSTALLATION, INCLUDING
PLUGS AND LEADS
TWO YEARS FULL GUARANTEE

★ real value

UNBEATABLE SOUNDS AT LOWEST PRICES

station lane precinct

FEATHERSTONE

tel: pontefract 76178

WHERE CHOOSING
IS A PLEASURE

FOR THE RIGHT APPROACH TO
MUSIC—WHETHER CREATING OR
LISTENING—VISIT

HARKER & HOWARTH

(Music) Ltd.,

FOLDS ROAD, BOLTON

Tel: 26623/4

Piano, Organ and Hi-Fi Showrooms
situated on the A676 Bolton to Burnley
road—just near the town centre. Customer
Car Park.

(G. J. & D. Badman)

WATTS RADIO

not just performance —

reliability

All the leading makes, B & W, Celestion, Connoisseur, Quad, Revox, Rogers and Tannoy.

Tel SOMERTON 72440
Somerset

Shannons

25/29 STATION RD URMSTON MANCHESTER 061-748-2339

SONY Technics AIWA
Celestion spendor  **Mordaunt-Short**

BEST PRICES FOR CASH TOP DEMO'S TOP SERVICE

PRESTON

ELECTRA CENTRE

Comparator Demonstrations of most leading makes

B & O, Sony, Trio, Quad, etc.

58 Lancaster Road Tel: 58488
 8 Victoria Buildings, Fishergate Tel: 55603
 72 Hough Lane, Leyland Tel: 24372



... good local people to deal with

The most respected names in hi-fi are here

BOWERS  WILKINS

WORTHING

Littlehampton Road · Tel. Worthing 64141



SWIFT OF WILMSLOW

AIWA, AKAI, ARMSTRONG, DUAL, B & W, TRIO, RADFORD, ROTEL, MONITOR AUDIO, IMF, GOODMAN, KEF, PIONEER, TANNOY, TEAC and CHARTWELL ETC.

5 Swan Street (nr. traffic lights), Wilmslow, Cheshire Wilmslow 26213

For the best in Hi-Fi

LINCOLN HI-FI CENTRE

271a HIGH STREET
 LINCOLN LN2 1JG

Telephone (0522) 20265



audio aids

All Leading Brands of Hi-Fi Equipment
 We have a demonstration studio in all shops and an audio consultancy service to assist you with your choice

AUDIO AIDS
 20 South Clerk St., Edinburgh. 031-567 2877
 Royal Mile (274, Cannongate) 031-556 9838
 133a Morningside Rd. Edinburgh EH10 4DR 031-447 2229



2 HIGH STREET EAST GRINSTEAD SUSSEX. EAST GRINSTEAD 27787

DIRECTORY OF HI FI DEALERS

IMHOF'S

112-116 New Oxford Street,
WC1A 1JH. Tel: 01-636 7878.

LANDAU RADIO LTD

195/9 High Street, Sutton.
Tel: 01-643 6873/6503.

K.J. LEISURESOUND LTD

48 Wigmore Street, W1.
Tel: 01-486 8263.
278 High Street, Uxbridge.
Tel: Uxbridge 33474.
27 Springfield Road, Harrow.
Tel: 01-863 8690.

LEWIS RADIO CO

100 Chase Side, Southgate N14.
Tel: 01-886 3733/9666.

LONDON BRIDGE AUDIO SALES LTD

3 London Bridge Walk, SE1 2SX.

LONDON SOUND

70 West Street, Harrow-on-the-Hill.
Tel: 01-864 6781.

MYERS AUDIO

199 Hoe Street, Walthamstow E17 9PP.
Tel: 01-520 7277.

NUSOUND

191-3 Plashet Road, Upton Park E13.
Tel: 01-472 2185 2110.

36 Lewisham High Street,
Lewisham SE13. Tel: 01-852 2399.

228 Bishopsgate, EC2.
Tel: 01-247 2609.

82 High Holborn WC1.
Tel: 01-242 7401.

242-4 Pentonville Road, N1.
Tel: 01-837 8200.

M. O'BRIEN (HI-FI SPECIALISTS)

95 High Street, Wimbledon Village,
SW19. Tel: 01-946 1528.

PIERCYS (LECTRONICS) LTD

56-62 Lupus Street, SW1.
Tel: 01-821 0333.

PREMIER RADIO

23 & 48 Tottenham Court Road, W1.
Tel: 01-636 3451/01-636 0647.

THE RECORDER CO

186-188 West End Lane, West
Hampstead, NW6. Tel: 01-794 4977.

SHERBOURNE HI-PHONICS LTD

256 Muswell Hill Broadway, N10.
Tel: 01-883 3350.
50 Topsfield Parade,
Crouch End, N8 8PT.
Tel: 01-340 1987.
150 Tollington Park, N4 3AD.
Tel: 01-272 4327.

H. L. SMITH & CO LTD

278-289 Edgware Road, W2.
Tel: 01-723 5891.

SOUND CENTRE

115 Kingsway, WC2.
Tel: 01-10-405 0446.

SOUTHERN AUDIO

43 High Street, Kingston-upon-Thames.
Tel: 01-549 3194.
22/34 Buckingham Palace Road, SW1.
Tel: 01-834 9382/3.

SPALDING ELECTRICAL LTD

352-354 Lower Addiscombe Road,
Croydon. Tel: 01-654 1231.

SPEAKER SELECTION LTD

611 Forest Road, Walthamstow,
E17 4PP. Tel: 01-531 3118.

STAINES HI-FI

122 High Street, Staines.
Tel: Staines 58284.

STUDIO 99

81 Fairfax Road, NW6.
Tel: 01-624 8855.

TELESONIC

92 Tottenham Court Road, W1.
Tel: 01-636 8177.

MERSEYSIDE

ACE AUDIO

66 Renshaw Street, Liverpool.
Tel: 051-709 9258.

BEAVER RADIO (L'vool) LTD

20-22 Whitechapel I.
Tel: 051-709 8958.

W. A. BRADY & SON

401 Smithdown Road, Liverpool 15.
Tel: 051-733 6859.

HARDMAN RADIO

33 Dale Street, Liverpool.
Tel: 051-236 2828.

NEWCASTLE-UPON-TYNE

HI FI OPPORTUNITIES

33 Handyside Arcade, off Percy Street,
Newcastle. Tel: Newcastle 27791.

TURNERS (AUDIO VISUAL) LTD

Pink Lane, Newcastle-Upon-Tyne
NE1 5HT. Tel: Newcastle 25391.

J. G. WINDOWS LTD

1-7 Central Arcade,
Newcastle-Upon-Tyne NE1 5BP.
Tel: Newcastle 21356.

NORFOLK

CLIMAX AUDIO

2 Broad Row, Gt. Yarmouth
NR30 1HT.
Tel: Gt. Yarmouth 50354

SOUTH WEST

BANG & OLUFSEN • SONY • TANDBERG

HUSBANDS OF BRISTOL
HUSBANDS OF WESTON
GRAYS CAMERA SHOP
POOLE CAMERA CENTRE
WINCHESTER CAMERA CENTRE

The Centre Bristol 293978
18 High St. Weston-S-Mare 20295
1 St. James Street Taunton 2986
91 Arndale Centre Poole 6289
75 Parchment St. Winchester 3982

Mansfield

Tel: 26315.

SYD. BOOTH, QUEEN ST.

Comparator Demonstrations of
Leading Makes

Home Demonstrations - Day or
Evenings by Appointment



For the best in Hi-Fi

NOTTINGHAM HI-FI CENTRE

156 ALFRETON ROAD

NOTTINGHAM

Telephone 76019

BLACKPOOL Tel. Blackpool 49625

**BENFELL
OF BLACKPOOL**

F. BENFELL LIMITED
78, WESTFIELD RD.,
(Ansdell Rd.)

*The Specialists in
High Fidelity Sound*

H. D. KIRK
Stereolectrics
LIMITED

Where
Service
Matters



203 Phone 23093
St. Georges Road BOLTON

**Henley-on-Thames
and Reading District**

G. O. MOORHEN
High Fidelity Specialist

190 Reading Road, Henley
Tel. 4163

Appointed Agent for

Bang & Olufsen, Tandberg,
Teac, Sony, AR,
Bose, Jecklin
Float, KEF, Quad, Revox,
Sonab, Spondor, Aiwa.

Closed Saturdays from 1 p.m.

Established
1960



**HI-FI
AT 20%
DISCOUNT**

... including the difficult makes!

We supply everything for the Hi-Fi enthusiast — amplifiers, tuners, loudspeakers, cabinets, turntables, pickups, cartridges, tape recorders and so on.

Our associated Hi-Fi Company has been in this field since 1925 — and we ourselves were established in 1960 as one of Britain's first Mail Order Discount Agencies.

Since then, we have become known for prompt personal service — all enquiries and orders are dealt with on the same day as received — and immaculate after-sales service which is vital when buying at discount.

Only new unused branded equipment with manufacturers' guarantees. No Membership charges. Hire purchase if required. Send for free brochure (including full range of domestic appliances, motor cars, etc.) to:—

THE
DISCOUNT BUYING AGENCY

111 SOUTH FARM ROAD,
WORTHING, SUSSEX

Tel: Worthing 31415 (STD 0903)

**NO GIVEAWAY GIMMICKS!
NO MASSIVE DISCOUNTS!**

We haven't hundreds of units to confuse you, only very selected equipment like Sonab, Sony, Bang & Olufsen, Marantz, AR, Teac, Technics, and one or two other top products, with our unique before and after sales service — Try us! We promise you'll never regret it! — at

DAYTRONICS LTD.

119a High St, Teddington, Middlesex
TW11 8HG Tel: 01-977 1324

Norman H. Field

hi-fi

Main Dealers AIWA, A.R., BOSE, B & W, IMF, KEF, LINN SONDECK, LUX, MONITOR AUDIO, NATIONAL PANASONIC, RAM, SONY, TEAC, TECHNICS, TOSHIBA, YAMAHA

Tel. 021 622 2323

35/37 Hurst Street, Birmingham 5.

DIRECTORY OF HI FI DEALERS

MARTINS HI FI SPECIALISTS

81 Dereham Road, Norwich.
Tei: Norwich 26060.
85-87 Ber Street, Norwich.
Tei: Norwich 27010.
5 High Street, King's Lynn.
Tei: King's Lynn 61683.

NORWICH HI FI

22 St John, Maddermarket.
Tei: 0603 22792.

NORTHAMPTON

AUDIOCRAFT

23-25 Derngate, Northampton.
Tei: Northampton 36291.

SOUND QUALITY

Newland Street, Kettering.
Tei: Kettering 83833.

NORTH HUMBERSIDE

G. SANDS & SON

61 Princes Avenue, Hull.
Tei: 42118.

NORTH YORKSHIRE

J. W. GARNETT

Market Place, Settle.
Tei: Settle 3558.

MULTISOUND HI FI

7 Davygate Arcade, York.
Tei: York 51712.

JOHN SAVILLE & SONS LTD

7 Goodramgate, York.
Tei: 25755-6.

VICKERS HI FI

43 Princegate, Waterdale Centre,
Doncaster. Tei: 0302 63806.

SURREY

AERCO RECORDS LTD

27 Chobham Road, Woking.
Tei: Woking 4667.

DORKING AUDIO SYSTEMS LTD

23 South Street, Dorking.
Tei: Dorking 2897.

EDWIN P. FOX

87 Walton Road, East Molesey, Surrey.
Tei: 01-979 2721.

GUILDFORD HI-FI

270 High Street, Guildford.
Tei: Guildford 65508.

HI-FI AND COMPONENTS LTD

7 Sutton Court Road, Sutton SM1 45Z.
Tei: 01-642 2853.

ALAN LAURENSEN & CO.

9 Beii Street, Reigate.
Tei: Reigate 46494.

LLOYD & KEYWORTH LTD

26-28 Downing Street,
Farnham, GU9 7PE.
Tei: Farnham 5534 or 6275.

MERROW SOUND LTD

21 & 22 Tunsgate, Guildford.
Tei: Guildford 33224-5
207 Epsom Road, Merrow GU1 2RD.
Tei: Guildford 33227.

MUSIC IN MOTION

915 Brighton Road, Purley.
Tei: 660 1028.

RUNNYMEADE HI-FI

42 High Street, Egham.
Tei: Egham 5036.

SURBITON PARK RADIO LTD

48 Surbiton Road,
Kingston-upon-Thames KT12HT.
Tei: 01-546 5549.

TAYSIDE

LARG'S GROUP

24 Whitehall Street, Dundee.
Tei: Dundee 26061.

TALISMAN HI FI

32 Victoria Road, Dundee DD1 2NT.
Tei: Dundee 26276.

WARWICKSHIRE

G.D.S. AUDIO (MIDLANDS) LTD

321-323 Croft Road, Stockingford,
Nuneaton. Tei: Nuneaton 66222.

WEST GLAMORGAN

ELECTROPHONIC

10 Forge Road, Port Talbot.
Tei: Port Talbot 2068.

HOLT HIGH FIDELITY

8 Portland Street, Swansea.
Tei: Swansea 41032.

WEST MIDLANDS

BELMONT RECORDING CO

25 Belmont Road, Bearwood, Warley.
Tei: 021-429 4463

ELECTRONIC SERVICES

33 City Arcade, CV1 3HX.
Tei: Coventry 24632.

GRATISPOOL INTERNATIONAL

LTD
10N Martineau Way, Birmingham B2
4UN.
Tei: 021-236 1024.

AUDIO EQUIPMENT IN THE WEST

BACKED BY OUTSTANDING SERVICE FACILITIES
from

AT

TAUNTON Phone 2638
BRIDGWATER Phone 2142
MINEHEAD Phone 2294
WELLINGTON Phone 2189
CULLOMPTON Phone 2202

P. Taylor
LTD

Stockists of
B & O, DYNATRON, HACKER,
H.M.V., MORDAUNT-SHORT,
TOSHIBA, QUAD, SONY,
GEC, FERGUSON, ULTRA, LEAK
AND OTHERS COMPLEMENTED
BY RECORDED MUSIC ON DISC
AND TAPE

LOUDSPEAKERS



Speakers, kits and
cabinets for D.I.Y., Hi Fi,
P.A., Disco, etc. by KEF,
Fane, Goodmans, Baker,
Elac, Richard Allan, Whar-
fedale, Tannoy, Radford,
Isophon, etc. Send Stamp
for free booklet, "Choosing
a Speaker".

**WILMSLOW
AUDIO**

Dept. HYFB, Swan Works, Bank Square, Wilmslow,
Cheshire SK9 1HF Tel. Wilmslow 29599

Telephone 73862
**NICK
DAKIN** (HI-FI
SPECIALISTS)
LTD

Enthusiastic Demonstrations
with Pleasure

**45 RADFORD ROAD,
NOTTINGHAM**

G. H. **STEELE** LTD.
HI-FI AND AUDIO CENTRE

141-143 ST GEORGE'S ROAD
GLASGOW G3 6JB
041-332 7124/5/6

For the Best in Hi-Fi and Services

**TAPE RECORDER CENTRE
(HALIFAX)**

*For all that is best in Hi-Fi
equipment — Reel and
Cassette Recorders*

30 KING CROSS STREET, HALIFAX
Phone 66832

**SOUND SUPPLIES
(Loughton) CO. LTD.**

Stockists for:
QUAD, HACKER,
GOLDRING, REVOX, TRIO,
THORENS, AIWA TECHNICS.

Speakers:
MORDAUNT-SHORT, JORDAN-WATTS
B. & W. KEF, CASTLE.

BROOKLYN PARADE

309 High Rd., Loughton, Essex. 01-508 2715

WALES

Leading Hi-Fi Specialists Est. 1930

J. GOUGH & CO LTD, CARDIFF

Designers of the "Gough Loudspeaker Cabinet"

Stockists of Quad, Dual, Armstrong, Sony, Trio,
Bang & Olufsen Main Dealer.

★ **Demonstration rooms available** ★

148-154 NORTH ROAD

Telephone 28473



The Bournemouth area
**Specialists for real quality
Hi-Fi equipment.**

**AIWA
TECHNICS
QUAD
KEF
YAMAHA
NAKAMICHI
A.R.
SONY etc. .**

**Competitive prices and
Personal Export facilities
available.**

Management Electronics

254 - 256 Old Christchurch Road, Bournemouth BH1 1PF
Telephone 291524

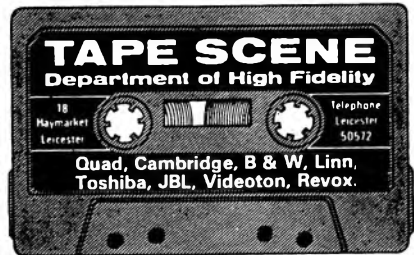

**All the best in Hi-Fi
& Audio at the UK's
keenest prices!**

WICKS

D. T. Wicks & Co., 49/51 North Station Road
Colchester Essex
Tel Colchester (0206) 49842/3/4

DIRECTORY OF HI FI DEALERS

WEST SUSSEX

BARKERS

31/33 Oxford Road, Worthing.
Tel: Worthing 35664.

BOWERS & WILKINS LTD

i Becket Buildings,
Littlehampton Road, Worthing.
Tel: Worthing 64141.

THE DISCOUNT BUYING AGENCY

111 South Farm Road, Worthing.
Tel: Worthing 31415.

JOHN KING (FILMS) LTD

Guildbourne Centre, Worthing.
Tel: Worthing 35416.

KIRKMAN

40 The Broadway, Crawley RH10 1HG.
Tel: Crawley 26670.

JOHN REES Hi Fi

2 High Street, East Grinstead.
Tel: East Grinstead 27787.

SPORTS & RADIO LTD

Bognor's Stereo Centre,
25-29 Aldwick Road, Bognor Regis.
Tel: Bognor Regis 5331.

SUMMIT AUDIO SYSTEMS LTD

10 High Street, Crawley R10 1BJ.
Tel: Crawley 24316.

WEST YORKSHIRE

ALLEN & WALKER

Cowpasture Road, Ickley.
Tel: Ickley 3832.

AUDIO PROJECTS

40 Blenheim Terrace, Leeds LS2 9HX.
Tel: Leeds 31608.

BRIGHOUSE HI FI CENTRE

24 Commercial Street, Brighouse.

ERRICKS' OF BRADFORD

25-27 Northgate, Bradford BD1 3JR.
Tel: Bradford 31648.

THE HI-FI STUDIO

8 Byram Street, Huddersfield.
Tel: Huddersfield 35333.

HUDDERSFIELD HI-FI CENTRE

17 Chapel Hill, Huddersfield.

KEIGHLEY CAMERA & HI-FI CENTRE

38-40 Cavendish Street, Keighley.
Tel: Keighley 2933.

PRATTS

North Parade, Bradford BD1 3JJ.
Tel: Bradford 25894.

J. S. RAMSBOTTON & CO LTD

Coney Lane, Keighley.
Tel: Keighley 605444.

TAPE RECORDER CENTRE

30 Kings Cross Street, Halifax.
Tel: Halifax 66832.

ERIC WILEY

64 Beacroft Road, Castleford.
Tel: Castleford 53066.

J. WOOD & SONS LTD

67 New Street, Huddersfield.
Tel: Huddersfield 27455.
28 Sunbridge Road, Bradford.
Tel: Bradford 20014.

WILTSHIRE

FOX RADIO SERVICE LTD

5 Milford Street, Swindon.
Tel: Swindon 5498.

LOUIS J. RUTTER

Devizes Photo-Audio Centre,
17 The Brittox, Devizes.
Tel: Devizes 2268.

PETER SIMMONS CAMERAS LTD

45 High Street, Melksham SN12 6JY.
Tel: Melksham 702700.

WOLVERHAMPTON

LASKY'S

30 Wulfrum Way,
Tel: 0902 23384.

MILLWARDS LTD

8-11 Salop Street,
Tel: Wolverhampton 23980.

M. R. WARNER & SON LTD

22/26 Chapel Ash,
Tel: Wolverhampton 26581.

KRAKEN ROSE AUDIO

283, FLEET ROAD, FLEET, HANTS. Tel: 5053

Specialists in Sound

***GUILDFORD
HI-FI CENTRE**

have bought you this

Space

for noting all your hi-fi needs.....
and *where to get them

AT THE TOP OF THE HIGH STREET (270)

Surrey's leading hi-fi centre

**jim park
audio**



**5, Bridge Street
Godalming
Tel: 22300**

TOM MOLLAND LTD
 110, CORNWALL STREET,
 PLYMOUTH, S. DEVON
 Telephone: 0752 69285



Technics

MAIN DEALERS FOR:
 SONY, AR, TOSHIBA
 TECHNICS CENTRE
 VTR SPECIALISTS — TANDBERG LANGUAGE LABS

HI-FI IN EDINBURGH



CORNER
 Clearly better Hi-Fi.

1 Haddington Place, Edinburgh EH7 4AE
 Telephone: 031-556 7901.

Bang & Olufsen Centre

**Birmingham's Main Dealer
 for all Bang & Olufsen Hi-Fi**

Main Dealers for: SANYO-HITACHI Stockists of: TECHNICS-TRIO-THORENS REVOX-A.R.-YAMAHA-TOSHIBA-QUAD-NATIONAL PANASONIC-J.B.L.SPEAKERS-JORDAN-WATTS



Tel: **021-382 1312**

W.J. Taylor (D.S.) Ltd.
 126/130 Hawthorn Road.
 Kingstanding, Birmingham B44 8QA.

HI-FI CENTRE
 (The Sound Specialists)

For: Trio, Armstrong, KEF,
 B & W, Harmon-Kardon,
 Quad, Monitor Audio

31 PALL MALL, HANLEY
 STOKE-ON-TRENT
 Phone 25194

SHOP LATE NITE FRIDAY TILL 8 PM

Main Agents for: CELESTION,
 B&W, QUAD, TEAC,
 TASCAM, JVC, SONAB,
 TANNOY, ARMSTRONG, HARMAN-
 KARDON, PIONEER, AIWA

Shop and Home Demonstrations

Libby's 021 554 8557

HI-FI RECORDS

244 Soho Road, Birmingham B21 9LR

Buy from the specialists for qualified advice and professional service:

Armstrong, B&W, Dual, Ferrograph, Goldring, KEF, Koss, Leak, Mirsch, Mordaunt-Short, Quad, Shure, SME, Sonab, Sony, Tandberg, Thorens, Wollensak, and a full range of complementary accessories.

D E Hadaway & Son Ltd

95 & 97 Watling Street, Gillingham,
 Kent. Medway 50058

Managing Director: J. Hadaway,
 T. Eng (CEI), FSERT, MAES.

LISTENING TO MUSIC IN THE HOME

We specialise in acoustic test in the home within a 60-mile radius of Settle at no extra charge for every complete Hi-Fi installation.

J. W. GARNETT

THE HI-FI SPECIALISTS OF
 THE NORTH WEST

Please phone Settle 3558
 for an appointment

BRIGHOUSE HI FI CENTRE
 24 COMMERCIAL ST., BRIGHOUSE
 Tel: 20774

Personal attention, home demonstrations,
 competitive prices.
DEMONSTRATION FACILITIES

We stock:

Aiwa, Armstrong, AR, B & W, Connoisseur, Dual, Goodmans, KEF, KLH, Koss, KMAL, LNB, Monitor Audio, N.E.A.L., Pioneer, Quad, Richard Allan, Senheiser, Sony, Scan-Dyna, Sonab, Stanton, Shure, A. R. Sugden, J. E. Sugden, Tandberg, TDK Tape, Toshiba, Trio, KMAL Record Cleaning Service

EASTBOURNE

MAIN DEALER FOR

SONY

All the latest hi-fi and audio systems

CENTRAL RADIO LTD

15 Langney Road Eastbourne Telephone 21989 / 20139



McKenna & Brown
(PHOTO FILM LTD)
 135/17 High Street, Redcar, Cleveland, Tel. 3829
 or Personal Shoppers from any of our other branches at
 Middlesbrough, Stockton, Darlington and Bishop Auckland

Main dealers for:-
 Technics -
 Bang & Olufsen -
 Sony - Trio -
 Quad etc.

Canterbury Hi Fi Centre

THE KENT CENTRE OF SOUND

TRIO, YAMAHA, JVC, SANSUI,
 PIONEER, KOSS, KEF etc

1-2 The Friars, Canterbury
 Tel Canterbury 65315 Closed all day Thursday

NSE

for real high fidelity

OFFICIAL TECHNICS CENTRE

Also agents for:
 BANG AND OLUFSEN, MORDAUNT SHORT, QUAD,
 REVOX, SONY, LUX, SPENDOR, TRIO, ETC.

Manager: Mike Rogerson Personal service assured

Peeveril Street, Nottingham Tel 75756

Equipment Selected from the
 World's Finest in Stock

CREDIT SALE
 CASH SETTLEMENTS
 PERSONAL LOANS

LLOYD PATON-McGLYNN LIMITED

Urmston Shopping Centre,
 34 Moorfield Walk,
 Urmston, Manchester
 061-747 9722

Car Parking 400 cars We are near M63.
 leave exit B5214

PETER ANSON NOTTINGHAM

A wide range of equipment demonstrated under
 ideal conditions plus full comparator facilities.
 Agents for: B & O, Sony, Roberts, Dual, Toshiba,
 Tandberg, Quad, Revox, Trio, Bowers & Wilkins,
 Koss

2 YEAR LABOUR AND PARTS GUARANTEE

BOBBERS MILL

0602 73312

VICTOR MORRIS

All leading makes including
 AR, Akai, Leak, Wharfedale, Teac,
 Bose, Technics, B & O, B & W, Aiwa,
 Trio, Amstrad, Marantz, National.

*We buy, sell and exchange Hi-Fi
 and recorders*

340 ARGYLE STREET,
 8-10 GLASSFORD STREET,
 GLASGOW G.2.

MILSOMS

FOR

Arena, Armstrong, Band W., Ferrograph,
 Garrard, Goldring, Goodmans, Leak, Quad,
 Record Housing, Rogers, Shure, S.M.E.,
 Tandberg, Thorens, Trio, Wharfedale, etc

NORTHGATE BATH TEL: 5675

The perfect combination of performance, technical refinement, good listening and price.



HIFI YEAR BOOK 1977

Bang & Olufsen
We think differently.

Bang & Olufsen UK Ltd, Eastbrook Road, Gloucester, GL4 7DE Telephone (0452) 21591