

1973

HIFI YEAR BOOK

1973

HIFI YEAR BOOK

Pickups/Motors/Tuners/Amplifiers/Microphones
Recorders/Speakers/Cabinets

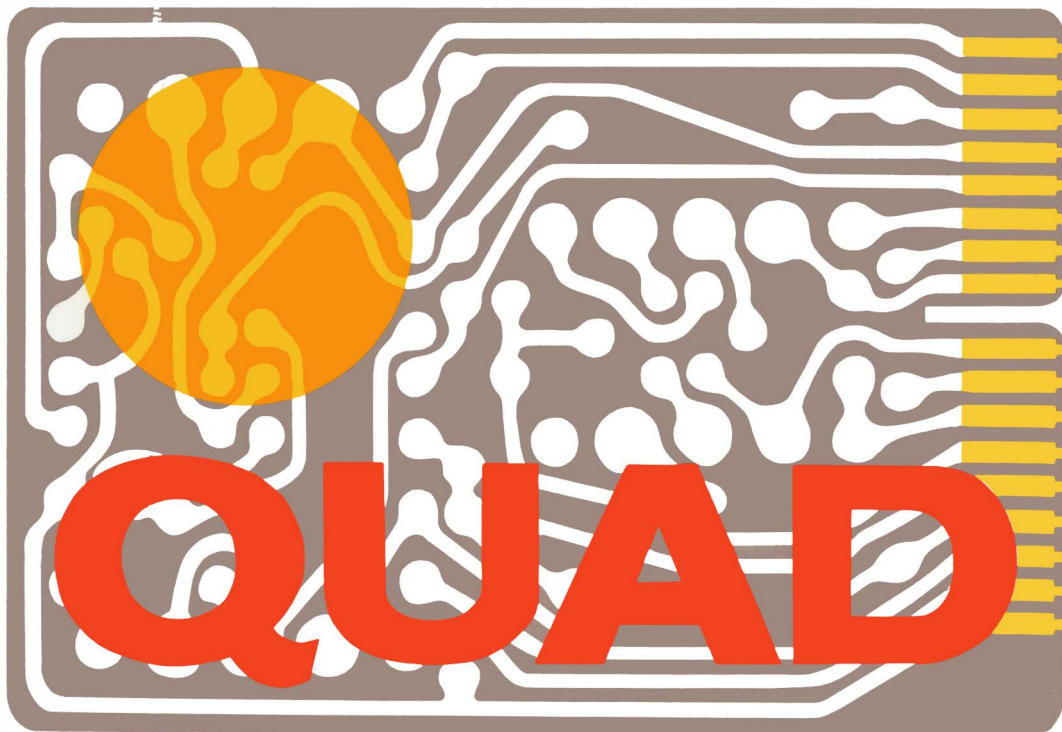

for the closest approach to the original sound

Send postcard for illustrated leaflet to Dept. HYB
Acoustical Manufacturing Co. Ltd., Huntingdon, Tel: (0480) 52561
QUAD is a Registered Trade Mark.

HIFI YEAR BOOK 1973

Editor Colin Sproxton

Technical Editor of Electrical & Radio Trading.

© IPC Electrical-Electronic Press Limited 1972

Published by

IPC Electrical-Electronic Year Books Limited
Dorset House Stamford Street London SE1 9LU 01-261 8000

Printed in Great Britain by

Chapel River Press, Andover, Hants.

Contents

Articles

- 5 Audio Specification Insight
by Gordon J. King
- 15 The Challenge of Cassettes
by A. C. Williams
- 18 Loudspeakers—Past, Present and Future
by Ralph West
- 28 A Brief Survey of Four-Channel
Stereo Techniques
by Donald Aldous

Directory Sections

- 39 Pick-ups and Arms
- 57 Pick-up Accessories
- 71 Motor Units
- 91 Radio Tuners
- 107 Tuner/Amplifiers
- 141 Amplifiers and Control Units
- 177 Quadraphonics
- 183 Tape Playing Times
- 185 Tape Recorders
- 205 Tape Players
- 207 Tape Transport
- 211 Tape Decks
- 227 Tape Amplifiers and Mixer Units
- 235 Tape Accessories/Components
- 246 Magnetic Tapes
- 251 Test Tapes and Discs
- 255 Constructional Kits
- 265 Microphones
- 295 Speaker Drive Units
- 309 Speaker Accessories
- 321 Speaker Enclosures
- 377 VHF Radio Transmitting Stations
- 383 Hi-Fi Cabinets
- 399 Complete Audio Systems
- 421 Hi-Fi Headphones
- 433 FM/VHF Aerials
- 437 Directory of Manufacturers
- 443 Directory of Hi-Fi Dealers
- 464 Advertisers' Index

Introduction

Reflecting the growing interest in high quality audio reproduction this new larger-than-ever edition of the *Hi-Fi Year Book* contains more information than any previous publication.

As usual the basic objective of the book is to present in concise form detailed specifications and prices covering the wide range of domestic high fidelity equipment currently available in the UK. But although the information is centred on domestic hi-fi it is inevitable, due to the lack of accepted standards, that the contents spill over into professional equipment at one end and popular unit audio models at the other. In some instances certain items below hi-fi standard are included solely for the purpose of showing a complete range.

In addition to the audio specifications, which this year cover more than 300 different brand names, there are also the usual feature articles at the front. Articles in this year's book cover the meaning of audio specifications, the evolution of modern loudspeaker systems, the growing impact of pre-recorded cassette tapes and the latest situation regarding four-channel stereo.

Although the pattern is the same there are a number of important changes all designed to make the *Hi-Fi Year Book* even more useful. For example this year three new sections are introduced. These cover furniture-style tape player units, record deck and amplifier (or tuner/amplifier) combination units and four-channel stereo equipment of various kinds.

Another change concerns the titles of two tape recording sections. In order to conform to popular usage the Tape Deck Section now lists tape units that incorporate preamplifiers and oscillators but exclude power output stages. The section that covers mechanical systems only, previously called tape decks, is now renamed the Tape Transport Section.

Prices quoted are the recommended retail prices at the time of going to press. In most instances purchase tax (PT) is shown separately, where it is applicable. But two events occurring during the life of this edition will have some effect on the figures quoted.

The first one is the floating pound and this is likely to cause marginal fluctuations in the price of imported goods from time to time. The second and more important event is the changeover to value-added-tax (VAT) in the spring of 1973. At the time of going to press manufacturers were unwilling to give firm figures but it seems certain that

all prices will be affected to some extent. In general those items at present carrying purchase tax should be a little cheaper and those currently free of PT will be a little dearer.

All prices published are the ones recommended by the manufacturer or distributor, but by shopping around it is often possible to show considerable savings.

It must be emphasised that none of the equipment listed is in fact tested by the publishers of the *Hi-Fi Year Book*. The information given is that provided by the manufacturers or extracted from their current literature. It should also be stated that since these manufacturers come from many different countries the standards adopted for measuring performance parameters may also vary in detail.

A point worth noting is the increasing complexity of high fidelity equipment. The days when an audio system consisted of neat separate boxes, each performing a specific function in the sound reproduction chain, are fast disappearing. Nowadays the modern audiophile is faced with a bewildering array of equipment, making a publication like the *Hi-Fi Year Book* of even greater value to audio retailers and their customers.

Great care is taken in compiling and checking the information contained in the *Hi-Fi Year Book* to ensure its accuracy, but the publishers regret they are unable to accept responsibility for any errors that may have occurred.

Comments on the book, and suggestions for improving or enlarging future editions, are always welcome.

Audio specification insight

by Gordon J. King

A major problem confronting potential purchasers of audio equipment lies in the interpretation of the wide spectrum of specifications. What exactly do they mean? How do they influence performance? Are there differences in the *sound* of the same category of equipment with different specifications? How does an item of equipment based on one specification standard differ from a similar item based on a different standard? Questions like these are made even more difficult to answer accurately owing to the lack of a British hi-fi standard, and this of course encourages the teasing question of what constitutes a hi-fi specification anyway?

With the introduction of mass produced 'unit audio' and 'music compacts' and the like, capable of remarkably good quality of reproduction, it becomes increasingly difficult to draw a line between such equipment and true hi-fi equipment. This is not the same as the situation of a decade ago when almost any reproducing device was given the hi-fi label. Today quite a few manufacturers seemingly have every right to adopt the term, for some domestic record-players and radiograms, equipment that a few years ago would have been singularly debunked by the fraternity, now perform better than some of the hi-fi equipment of that era. There are of course exceptions!

Much of this development stems from the greater control provided by solidstate devices and integrated circuits, and by techniques that have evolved on a common basis, bringing hi-fi workers and those concerned essentially with fundamental domestic-type equipment into a common fold.

No longer is it difficult to design and manufacture an amplifier with less than 0.1 per cent total harmonic distortion. True hi-fi equipment of course has greater detail paid to small points of design and tolerances; but even so it need not be a particularly costly exercise to secure realistic audio power at such level of distortion—witness the Alba AU700 for instance.

Probably the biggest area of difference lies at the transducer end—notably the loudspeaker system. The gramophone pickup, too, is a very important hi-fi contributory, but the influx of American and oriental magnetics is tending towards low cost quality even in this more difficult area. Again there are exceptions and with pickups there are the mechanical aspects to do with record wear, tracking, etc. to take into account, and perfecting these cannot be done cheaply.

The standard appropriate to radio tuners is also improving with the advancement of VHF field effect transistors, IF and stereo decoder integrated circuits, crystal and ceramic filters and so on, and it is obvious that as more of these devices are used so the price will fall and thus present proved components for the mass-market type of equipment. Indeed, this is already happening to some extent.

Design-wise, therefore, much of the mass market type of equipment is getting mighty close to true-hi-fi and I forecast a steadily diminishing margin between the two types of equipment in the next few years. There will always be the really exotic type of audio equipment, of course, and this will probably be geared to the four-channel quadraphonic systems based on discrete channels and/or matrix techniques.

At the present time the only generally accepted parameters qualifying equipment in terms of 'minimum hi-fi quality' are those detailed in DIN 45-500. This is now becoming very dated and it is noteworthy that even those manufacturers referring directly to it are commonly producing equipment in advance of its terms.

However, a new standard is in the course of creation by way of the Audio Specification Coordinating Committee (ASCC), and when the interface parameters have been approved by mutual agreement between the constituent Associations of the ASCC they will be submitted to the British Standards Institution for consideration.

With the flexibility in term, I often wonder

about the degree of consumer protection in audio and hi-fi afforded by the Trade Descriptions Act. It certainly requires a definite ruling, not only to protect the consumer but also the reputable hi-fi manufacturer.

Similar reasoning of course applies to the parameters of a specification, but measuring certain of these is far different from weighing potatoes! And with the various methods of measurement and expressions the Weights and Measures chaps would need to be remarkably well versed in the 'arts'.

Nevertheless, it is essential that a definite specification standard and common methods of measurement and expression eventually be evolved. Each parameter of a spec. should also be within a realistic spread and measurement tolerance.

I am not going specifically to detail methods of measurement since these are contained in the literature issued by the various standards organisations. They are also dealt with in a recent book (see Ref 3). The appropriate organisations include the British Standards Institution (BSI), British Standards House, 2 Park Street, London W1 (BS 3860:1965 and BS 4054:1966 covering audio and radio), the Institute of High Fidelity Inc. (IHF), 516 Fifth Avenue, New York (IHFM-T-100 on tuners and IHF-A-201:1966 on amplifiers) and the International Electrotechnical Commission (IEC), 1, rue de Varembe, Geneva. There are also various DIN standards in addition to DIN 45-500 already mentioned. DIN is the German Deutscher Industrie Normenausschuss organisation.

I do intend, however, to explain the salient features of the main specification parameters of amplifiers and tuners, starting with the former.

AMPLIFIER SPECIFICATION PARAMETERS

Power Output

Power output is generally one of the first parameters to be scrutinised by an intending purchaser. It is commonly based on the measurement of the audio voltage across a resistive output load when the power is set *just* prior to waveform clipping level due to a continuous wave test signal, such that $W = E^2/R$, where W is the steady-state power, E the RMS-voltage across the load and R the load resistance in ohms. Unless stated otherwise the power can be assumed to be at 1kHz.

When both channels of a stereo amplifier are driven to capacity together the per-channel power is often 1dB or so below that when only one channel is driven, and when the parameter refers to two-channel simultaneous drive it might be expressed as 30+30W, implying that the amplifier is capable of sustaining *two times 30W*.

However, when it is given as 30W per channel, this could mean the power with only one channel driven, so while an amplifier with the first specification would give a total of 60W, that with the second specification might give something less than 60W—about 55W on average.

The load across which the power is measured is also very important, for with many transistor amplifiers the power falls with increasing load value. A DIN preferred load value is 4 ohms, and this is increasingly being used for power measurements (by manufacturers). Although DIN-based loudspeaker systems have a like impedance (at around 400Hz), many British and other systems have impedances of 8 and sometimes 15 or 16 ohms, so the power into these will be significantly less than into 4 ohms (**Fig 1**). Remember that -3dB means that the power has been halved.

If you have 8-ohm loudspeaker systems, therefore, make sure the proposed amplifier will provide all the hi-fi-scaled power you will need into that impedance. Sometimes the spec. gives the power into 8 and 16 ohms as well as into 4 ohms.

Music Power

Another power parameter is based on music signal rather than on continuous wave signal. Continuous power, of course, is akin to the power that runs electric heaters, light bulbs, etc., and since the average value of a music waveform, even one with transient peaks reaching full power, is well below that of continuous power, it is contended by some authorities that a music power rating is more realistic.

Accordingly, IHF have devised a special test method, and the appropriate parameter is given in the spec. as 'music power (IHF)'. This commonly takes into account the simultaneous power of both channels, and since music waveforms are less demanding on the amplifier's heat sinks and power supply than continuous wave power, the music power is often about 50 per cent higher than the continuous power (sometimes called steady-state power or, incorrectly, RMS power). Thus, the 30+30W amplifier mentioned earlier might have a music power rating

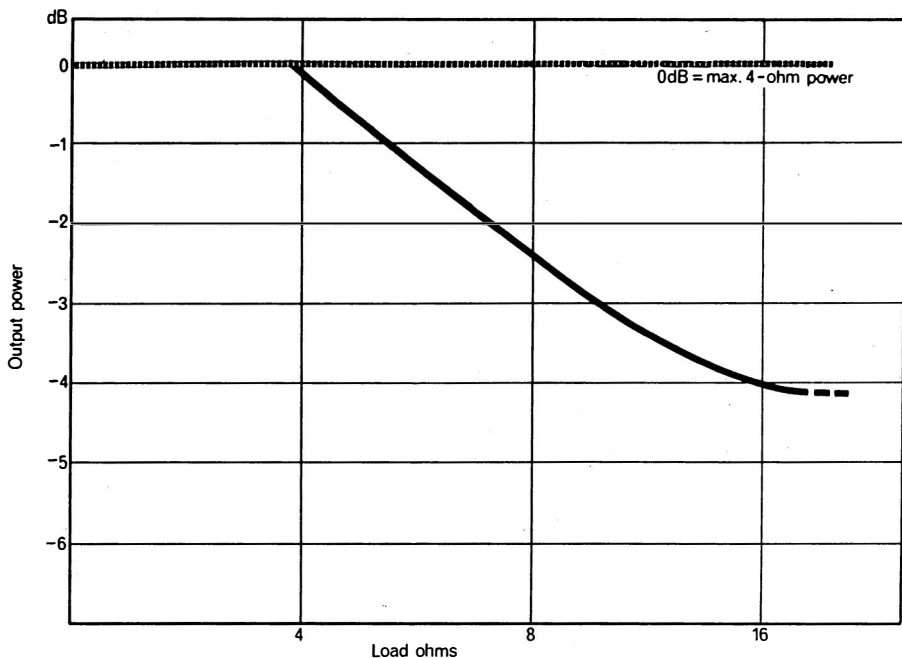

Figure 1 Impression of how the output power falls with increasing load value

of 90W. For the best comparison, however, the continuous wave power rating is to be preferred.

Power Bandwidth

Power bandwidth reveals how the 1kHz power holds or falls at the LF and HF ends of the spectrum. One method of expression relates the terminal frequencies to a power half that at 1kHz when the test signal level input is constant. Thus, a parameter given as 15Hz-30kHz (-3dB) implies that at 15Hz and 30kHz the power has fallen to half that at 1kHz. Other expressions are based on -1dB at the terminal frequencies and on a minimum value of total harmonic distortion at the terminal frequencies.

For musical attack, characteristic of true hi-fi reproduction, the power bandwidth at the treble end should exceed the frequency response of the human ear, going to at least 20kHz, while the ear often rolls-off before 15kHz, depending on age.

Damping Factor

Amplifiers are made to suit a range of load resistances (impedances), often from 4 to 8 or 16 ohms. But the actual terminal resistance as seen by the connected loudspeaker system is com-

monly well below this. The ratio of the loudspeaker impedance to the source resistance is the damping factor. Thus, a source of 0.1 ohm and a loudspeaker of 8 ohms would yield a damping factor of 80, which is very good.

The higher the damping factor, particularly at the bass end, around 40Hz, the better, for it subjects the loudspeaker to electromagnetic damping control, avoiding ringing and overshoot and the consequent overhang and boominess in reproduction. Some loudspeakers are more prone to these defects, when not adequately damped, than others.

Total Harmonic Distortion

The distortion analyser, used for this test, merely deletes the fundamental test frequency, which itself should be very low in distortion content, and sums all the remaining harmonic voltage components. These are then measured as a percentage (or dB ratio) relative to the real signal voltage across the load (often plus the distortion, which should be insignificant in comparison).

Since a wide frequency spectrum is necessary in order to cater for all the higher-order distortion components, the noise of the amplifier, etc. is included in the readout, and this can make the

'distortion' percentage seem greater than it really is. For more accurate results the noise is calculated out, such that the *true THD* = $\sqrt{a^2 - b^2}$, where *a* is the THD readout including the noise and *b* the noise as indicated by the THD readout when the test signal is turned to zero.

The THD parameter is very convenient for comparing quickly the distortion performance of one amplifier against that of another over the dynamic range. However, at low power the noise often predominates and the calculation for true THD is made very difficult if not impossible to process.

To find the distortion at very low power, therefore, a wave analyser is required. This tunes each distortion component within a narrow 'window' bandwidth and thus reduces the noise readout in the ratio of the bandwidth of the amplifier to that of the analyser's 'window'.

One should study the distortion parameter wherever possible not only at maximum power but also at powers down to noise threshold, for some class B amplifiers exhibit rising distortion, due to non-linearity of the transfer function, as the power is diminished at the bottom end of the dynamic range (Fig 2). Since most of our listening is done at the modest nominal power of about 100mW this can give some idea of how an amplifier will sound.

Unfortunately, THD figures often fail to correlate with the 'sounding' of an amplifier. It is possible for an amplifier with a THD readout of, say, 0.3 per cent to sound better than a similar power (frequency response, etc.) one with a readout of, say, 0.1 per cent. This occurs when the latter THD residual comprises a very peaky waveform, due to high-order odd-numbered

harmonics, and the former THD residual is mostly second and third harmonic. The readout device is unable to respond to the peaks and thus records a low average harmonic content. For this reason THD parameters should preferably include an oscillogram of the residual.

It seems possible to apply some 'meaningful' THD weighting, and with a colleague I am currently investigating this possibility so as to secure a better objective/subjective correlation.

A good hi-fi THD parameter should be less than 0.1 per cent from the rated power down to readout threshold. Measurements are usually made at 1kHz, and with weighting this would be adequate, but as things stand at present readouts at 40Hz and 10kHz, in addition to 1kHz with THD oscillogram, are useful and revealing.

Intermodulation distortion

Intermodulation distortion is another linearity test but uses two signals instead of one and detects the modulation components arising from the non-linearity. It has the advantage that the test signal purity is less important than for THD measurement, but again it provides no 'sounding' correlation and can result in confusing comparisons owing to the different test methods available. The IMD is generally a little higher than THD for a given amplifier.

Input Sensitivity

Input sensitivity indicates the RMS input voltage at 1kHz required for the rated output with the volume control at maximum, balance control centred and tone controls and filters set for the least effect. The designer should aim for a sensitivity which makes it possible to obtain room-

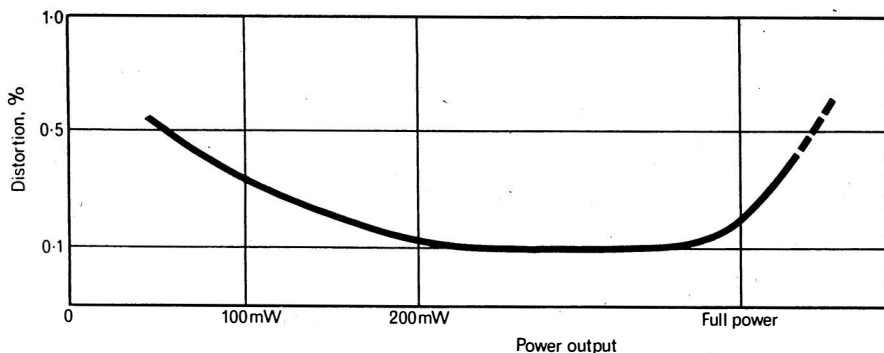
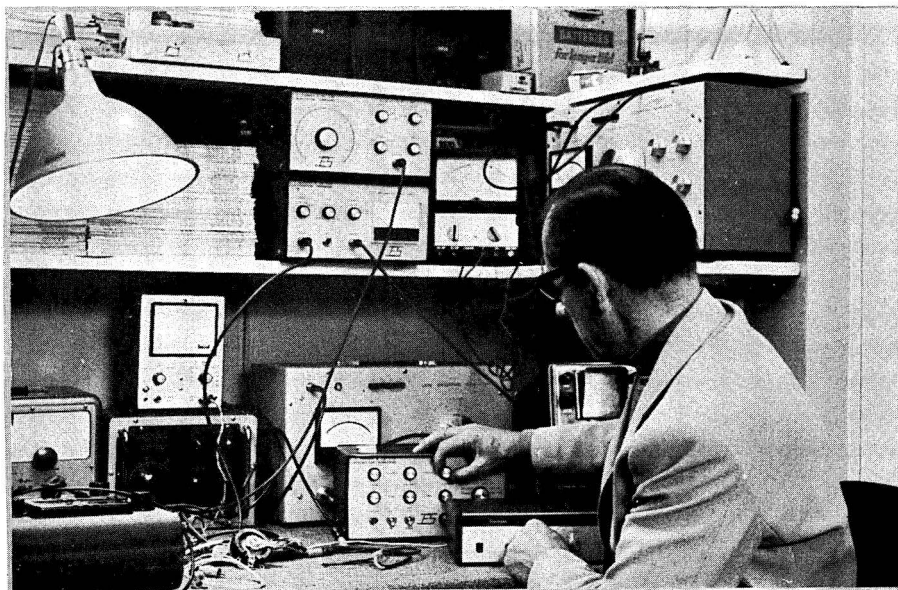

Figure 2 Some class B amplifiers exhibit rising distortion as the power is reduced at the bottom end of the dynamic range



The author specification testing in a corner of his studio

scaled hi-fi loudness (for the full dynamic range of the power amplifier) with the volume control set between 12 o/c and 2 o/c.

Most magnetic pickups give a little over 1mV per 1cm/S of recorded velocity, so a reasonable sensitivity on this input would be between 2 and 3.5mV. However, there is also the RIAA-equalized pickup preamplifier overload to take into account, for on heavily modulated discs the velocity can rise to 25cm/S or more on peaks, and peak overload can produce unpleasant sounds, sometimes like mistracking.

A good overload margin would be 36dB relative to the input sensitivity. Some amplifiers do better than this and others not as good. The magnetic pickup input should cater for at least 50mV before overload.

Many radio tuners provide 0.5V or more at 100 per cent modulation (average modulation about 200mV), so the input for this source should correspond. For auxiliary input a sensitivity between 200 and 500mV is useful. For tape replay (from a recorder with equalized head preamplifier) 150mV can be useful, but for DIN-based equipment a DIN socket is now often provided on the amplifier (sometimes in addition to the higher-level tape replay circuit) to facilitate signal level and impedance matching. Incidentally, this socket also delivers recording signal at a level suitable for a recorder with a DIN socket.

Input Impedance

Input impedance is the impedance (or the DC resistance) seen by the source at the input sockets at 1kHz. Most magnetic pickups are engineered to provide the best response into 47K or near, and as some are load sensitive (the treble falling when the load is too low and rising when too high) the best choice is around 47K. Sadly, I have noticed recently inputs as low as 35K and as high as 100K. There is no need for this.

A ceramic pickup requires a load of 2M or more, and only those amplifiers with bootstrapping or FET input provide this requirement. A lower value rolls off the bass (at 6dB/octave owing to the capacitive nature of the source). Some manufacturers deliberately exploit this effect and then endeavour to correct with the magnetic RIAA equalization. Very few amplifiers, in fact, are correctly equalized for a range of piezo pickups.

Loads at the other inputs are less critical and values of 100K are commonplace.

Hum and Noise

Unless otherwise stated hum and noise refers to the ratio of the full power signal voltage across the load to the voltage of the hum and noise components at full gain and flat response and with the input shorted or loaded. The ratio is generally expressed in decibels, such that 60dB implies

a hum and noise voltage 1000 times below that of the signal (corresponding to a *power* ratio of 1,000,000:1).

Sometimes the hum and noise figure is given merely as a voltage across the output load, particularly when the parameter refers essentially to the power amplifier section. Since this does not involve a ratio it avoids possible error due to the hum and noise voltage as well as the signal voltage constituting the 'signal' part of the ratio. But since the hum and noise level is generally very much below the signal *plus* the hum and noise voltage, the error is insignificant.

The ratio takes account of all the noise in the full spectrum of the amplifier, and because this is not all directly related to the annoyance value (the ear being more sensitive to sounds at middle frequencies than at treble and particularly bass frequencies) a weighting might be applied which rolls off the bass and to a smaller extent the treble components of the hum and noise (Fig 3). The weighted ratio, therefore, is greater than the corresponding unweighted one—a point worth remembering when reading specs.

Responses

The power bandwidth gives a good impression of the frequency response down to half power, but at lower power the response is usually better than the power bandwidth, and tests are often made around the 1W mark, taking into account RIAA equalization, tone controls, filters, loudness control, etc. However, these are not very often given as actual curves in the specs.; instead, they are expressed as deviations over the spectrum relative to 1kHz, the deviations being in decibels.

A frequency response parameter expressed as 20Hz-20kHz ± 1 dB would indicate that the change in gain/output from 20Hz to 20kHz is no greater than +1 and -1dB relative to 0dB at 1kHz. This is quite good and a very sensitive ear is needed to detect a change of 1dB.

Filter responses, too, are referred to 0dB at 1kHz. The filter frequency, more correctly crossover, turnover or critical frequency, means that the response has fallen (or risen) by 3dB. The rate of slope might be given in terms of dB/octave, or one might be expected to work this out from the attenuation (or boost) resulting at a high-frequency for a low-pass filter (e.g. treble filter) and at a low frequency for a high-pass filter (e.g. rumble filter).

Tone control responses are often signified in terms of decibels of cut and lift at appropriate

frequencies. For example, for bass we may read +14dB and -12dB at 50Hz and for treble ± 12 dB at 10kHz. Such parameters fail to reveal the exact nature of the curves or how they shape at intermediate settings of the tone controls. The reviews and test reports in the hi-fi glossies generally go into these in some detail and are thus well worth reading before making a final decision to purchase.

So-called loudness controls introduce bass boost and to a lesser degree treble boost with decreasing setting. This is done as a means of combating the natural laws of hearing, whereby the loudness sensation diminishes at the bass and treble ends of the spectrum with reducing sound intensity. The relative bass and treble boosts with the control set to attenuate a 1kHz signal by 30dB are usually specified.

A parameter of frequency *range* is meaningless, since it fails to relate the response to frequency. It merely indicates that some sort of output (could be many decibels down—or up—compared with the output at 1kHz) occurs over the frequency range stated.

FM TUNER SPECIFICATION PARAMETERS

Sensitivity

Basic sensitivity refers to the VHF signal EMF required at the aerial socket to produce a standard audio output when the modulation is 1kHz and 30 per cent.

However, since modern tuners produce full limited output from a small VHF input, the input EMF required for full limiting may be given as one measure of 'noise-limited' sensitivity.

Most important, though, is *usable sensitivity*, and this refers to the aerial signal EMF required for a given signal-to-noise (S/N) ratio. In this case the noise is referred to the modulation carried by the signal at 400Hz or 1kHz and at 30 per cent or 100 per cent level.

Owing to the different test procedures employed this is one area where significant confusion often arises, and it is sometimes extremely difficult, if not impossible, usefully to compare the sensitivity performance of one tuner with that of another, particularly when the parameter is inadequately detailed.

If the parameter is given as, say, 'usable sensitivity (IHF): 2 μ V', then we are on to something and we can easily make comparisons, for a definite procedure for this has been laid down by

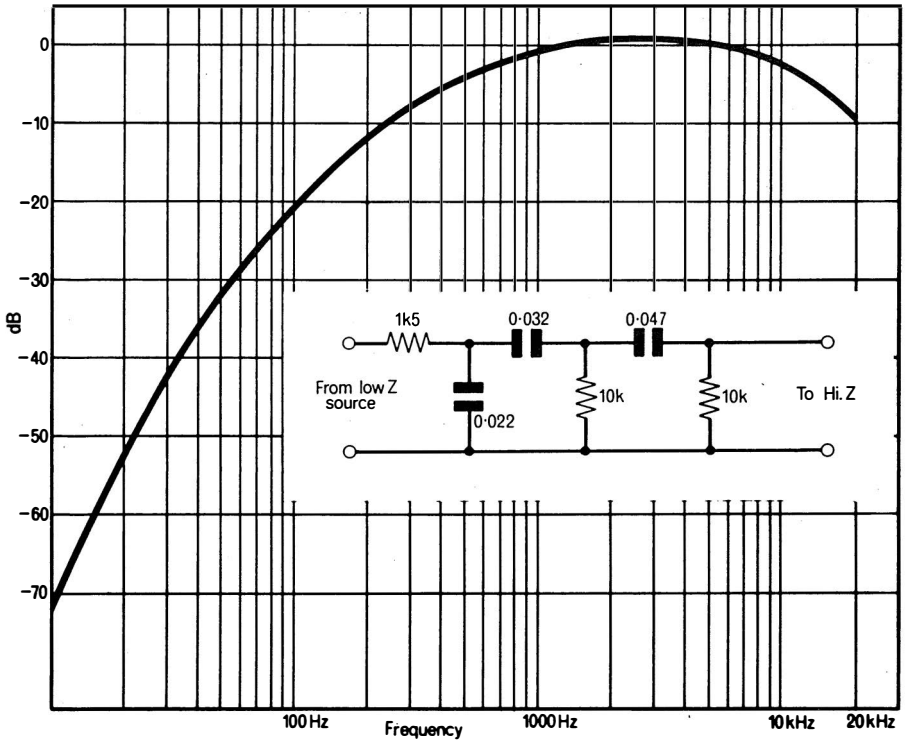
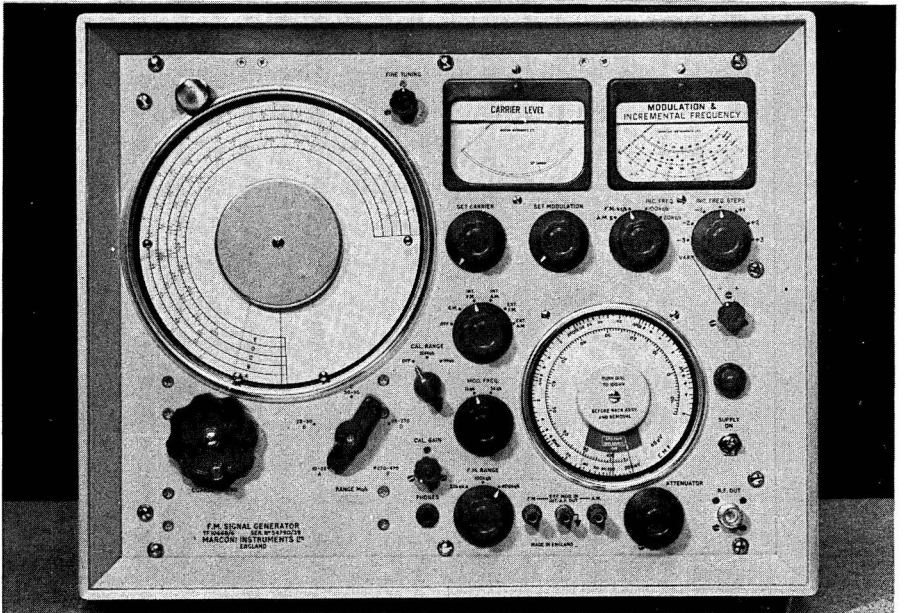

Figure 3 Weighting curve and network



Marconi Instruments TF1066B FM signal generator

IHF. Basically, it means that with an aerial input of $2\mu\text{V}$ the S/N ratio is 30dB referred to 100 per cent modulation at 400Hz.

However, the ratio is measured not by switching the modulation off but by notching it out with a null filter. That remaining, including distortion, is the noise part of the ratio. It is one of the best sensitivity parameters and is more critical of tuner design than some others.

The test modulation stipulated by BSI is 1kHz at 30 per cent, so if this modulation level is adopted (the actual frequency is not very important) the ratio will be about 9dB less than that obtained with 100 per cent modulation.

Specs. which give the sensitivity as, for example, '3 μV for 20dB quieting' are not very meaningful unless the reference modulation level is stated or the method of measurement detailed, it then being possible to convert to a standard comparative expression.

A tuner with a IHF usable sensitivity of $2\mu\text{V}$ or less would be very sensitive, the implication, in fact, being that usable performance is possible when the aerial signal is as low as $2\mu\text{V}$.

Sensitivity parameters normally refer to mono operation, which is sad because considerable impairment in the S/N ratio results when the stereo decoder is active on a stereo input. At the usable sensitivity level the ratio may be reduced by as much as 15dB or more, the margin becoming less with increasing level of input signal,

until at high level it almost reaches that of the mono ratio (Fig 4).

Thus, if the usable sensitivity is, say, 1.5 μV mono (representing a very sensitive tuner), it might only be 5 or 6 μV stereo, depending on the design, and some tuners incorporate an auto switch which activates the decoder only when the signal is of that sort of level (or more). This is why a stronger aerial signal is always required on stereo for a given minimum mono S/N ratio.

Maximum S/N Ratio

As the aerial input is increased the S/N ratio goes on improving until it reaches a maximum, where it usually remains. The curves in Fig 4 illustrate all these points. To conclude, the parameters of limiting and sensitivity in their various guises mention must be made of the importance of generator to aerial matching and of low signal leakage from the generator, both of which can affect the results. Tests are made either at one centre Band II frequency or at several frequencies over the band.

Signal-to-Interference Ratio

There is also the question of signal-to-interference ratio. The S/N ratio refers to the noise actually produced by the active and passive circuits of the tuner and any test equipment and intercouplings. In practice, however, cars and domestically-based electrical equipment radiate

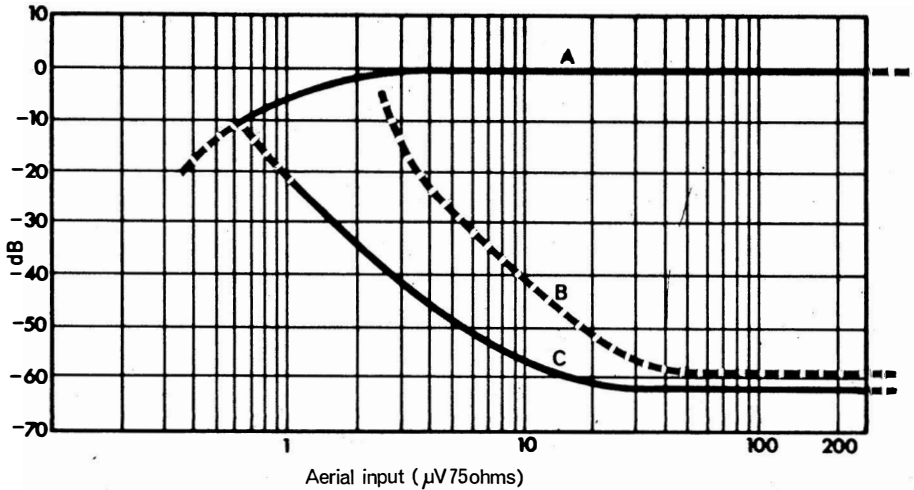

Figure 4 Limiting and mono and stereo S/N ratio curves of a sensitive tuner with the S/N ratio referred to 100 per cent modulation. Maximum mono S/N ratio is about 62dB and maximum stereo about 57dB, both good

interference which appears on the tuned VHF signal as amplitude modulation.

Steady-state AM is ironed-out in the IF channel by the limiting action and any remaining is rejected by the FM detector, and this parameter is sometimes given in the specs. as 'AM rejection ratio'. Unfortunately impulsive AM is not often so neatly dealt with, particularly on stereo which relies on AM in the subchannel.

This means that a signal level significantly in excess of that corresponding to the usable sensitivity will be required in areas where electrical and impulsive interference is strong so that the IF channel is pushed deeply into limiting and the impulsive peaks of interference removed. AM can also encourage 'by-product phase modulation' (see Ref 1) and just how well this is rejected is another factor of design.

While most tuners efficiently limit steady-state AM, a time-constant effect in the IF channel, resulting from the action of the limiter across tuned circuits or bandpass couplings, tends to diminish the efficiency with respect to short-duration high amplitude pulses. One manufacturer (see Ref 2) counteracts this by lumping the IF selectivity at the IF input so that there is no damping on the tuned circuits by the integrated circuit limiter.

The signal-to-interference ratio is not a specified parameter, but it is a very important one so far as the user is concerned.

Capture Ratio

Capture ratio is another IHF parameter which is a measure of the efficiency of the tuner in rejecting an unwanted signal at the same or near frequency as the wanted one. It is a complicated test to make and requires two generators (see Ref 3). Basically, however, the ratio is that of the two generator input voltages—the unwanted signal being the smaller—when the unwanted signal is responsible for 30dB S/N ratio at the output. The smaller the ratio, therefore, the better the capture performance, and good contemporary tuners boast a ratio down to 1dB. The average for this class of equipment lies between about 3 and 1.5dB.

Selectivity

Selectivity is another parameter which can cause confusion. It is important, too, for there is little joy in owning a super-sensitive tuner which is unable adequately to discriminate between adjacent stations.

The IHF selectivity parameter can be mea-

sured with the unwanted signal 200kHz or 400kHz from the wanted one, called adjacent channel selectivity and alternate channel selectivity respectively. Clearly, the farther the unwanted station from the wanted one, the better the selectivity readout. Therefore specifications usually give the alternate channel selectivity, although the term 'alternate channel' may not be mentioned.

The IHF expression is based on something like the following. Assume an unmodulated wanted signal accurately tuned and an unwanted modulated one in the adjacent or alternate channel increased in strength until it interferes with the wanted signal to an extent equivalent to a 30dB S/N ratio. The ratio of the two signal levels in decibels is the selectivity measure. The displaced unwanted signal will generally be stronger than the wanted signal, so the greater the ratio (dB number) the better the selectivity.

Measurements can be made at 30 per cent or 100 per cent modulation of the unwanted signal, but the IHF selectivity *rating* is 100 per cent modulation alternate channel at 100µV wanted signal level.

A similar BSI test is based on 30 per cent modulation over a range of wanted signal levels, expressed by curves. Selectivity can also be expressed by a single simple response curve of signal strength increase required to maintain a given output *versus* plus and minus deviations from the tuned frequency. Only one generator is needed for this less exacting test.

Spurious Responses

The tuner spec. might also contain information on the rejection ratio of spurious responses, such as second channel (image), IF, etc. The dB ratio given refers to how much stronger the input signal needs to be at the spurious frequency for a given output or S/N ratio.

The highest ratios result from tuners with good front-end selectivity (two or more tuned circuits in front of the mixer), while tuners with field effect transistors (FETs) in the RF amplifier(s) and mixer stages are currently less prone to spurious in the form of third-order intermodulation components in areas of high signal field.

Pilot Tone and Sub-channel

To avoid 19kHz pilot tone and stereo sub-channel components passing from the tuner into the audio section or, indeed, into a tape recorder where they could beat with the bias signal and cause recorded whistles, some tuners include

rejectors geared into the de-emphasis network. A good attenuation factor at 19kHz and 38kHz is 40dB or more.

Frequency Response

Tuners destined for the British and European markets should have 50 μ S de-emphasis, and when this is well engineered the response should be up to 15kHz at no more than -2dB when the test signal has corresponding pre-emphasis. If the American 75 μ S de-emphasis is adopted, then the treble response will fall off too rapidly.

Distortion

THD at 1kHz and 30 per cent modulation is usually less than 0.5 per cent, and in top grade tuners it may not rise above that value at 100 per cent.

Aerial Input

Tuners used in the UK are expected to work from 75-ohm coaxial aerial feeder, so a suitable matching input should be available. The DIN standard is 240 ohms balanced feeder and the American standard 300 ohms balanced feeder. When a tuner is equipped only with one of these inputs, a reasonable match to 75-ohm coaxial can often be achieved by connecting the braid to an 'earth' tag or terminal on the tuner and the inner conductor to one of the balanced ter-

minals, leaving the other vacant. If this fails to match the coaxial, then a low-loss balun transformer (see Ref 4) should be used.

Tuner Summary

To summarise, *high sensitivity* is obtained by the use of integrated circuits in the IF channel, these also providing *good limiting performance and capture ratio*, the latter aided by a wideband FM detector. *High selectivity* is provided by crystal or ceramic IF filters and *good rejection of spurious responses and intermodulation spurs* by the use of field effect transistors and two or three tuned circuits prior to the mixer in the front-end, particularly in areas close to a powerful transmitter.

For freedom from FM 'birdies' a low-pass filter should also be included between the FM detector and stereo decoder.

REFERENCES

1. *FM Radio Servicing Handbook 2nd Edition*, p. 31, Gordon J. King, published by Newnes-Butterworths.
2. Scaneltra, UK Distributors Kelgrove Sales Limited.
3. *Audio Technicians Bench Manual*, p. 87, John Earl, published by Fountain Press Limited.
4. Available from Transistor Devices Limited, 6 Orchard Gardens, Teignmouth, Devon.



Distortion measuring equipment type DMS from Radford Audio

The challenge of cassettes

by A. C. Williams

The cassette has now definitely arrived, and with this stereo reproduction may be said to have turned full circle. Stereo sound (originally dubbed stereosonic, not stereophonic) first became available to the public in the form of reel-to-reel tapes playing at $7\frac{1}{2}$ in per second. That they failed to make any serious impact was not because of any deficiency in the quality of sound. This indeed was better than that from the first stereo LPs, and these early tapes still sound remarkably good. It was mainly a matter of relative convenience.

For long it was found impossible to obtain sound of a quality acceptable to sensitive ears from tapes playing at slower speeds than $7\frac{1}{2}$ ips, and early pre-recorded cassettes playing at $1\frac{1}{8}$ ips, and giving the same playing time as an LP record, were suited only for the provision of background music, or the reproduction of speech.

Within the last couple of years or so cassette sound quality has been revolutionised and these minitapes are now beginning to offer a serious challenge to the supremacy of the LP in this country, and an even greater one in America and one or two European countries.

The range of cassette playing equipment is now both wide and versatile. Most models, whether little more than pocket-size or expensive playing decks fitted with the Dolby playback system and designed to be used in conjunction with high-fidelity amplification systems and speakers, are provided with rewind, fast wind, pause and recording facilities.

First a word about the Dolby system, by which more and more minitapes are now being made. Dolbied tapes are subjected to a process designed primarily to eliminate the background noise and hiss which has for so long bedevilled slow-playing tapes. In basic terms the process consists of filtering the signal being recorded onto the tape in a way designed to boost the weaker high frequency sounds.

When played back through a player fitted with

a Dolby compensating device the proper balance is restored, but most, if not all, of the audible hiss is eliminated. In cassette players so fitted the Dolby circuitry can be brought into play or bypassed at will. Dolbied tapes can, of course, be played on any normal tape player but obviously they can only be expected to sound at their best when played back through one in which the special playback circuitry is fitted. Incidentally, sometimes, although by no means always, the Dolby playback system improves the sound from tapes not so made.

Whatever cassette player is used the optimum quality of sound cannot be expected to continue indefinitely without regular maintenance. Tape heads and capstans must be kept clean. The Bib Division of Multicore Solders now makes an admirably effective and cheap device to do just this, in the shape of a Cleaning Tape housed in cassette form. Running this through the player

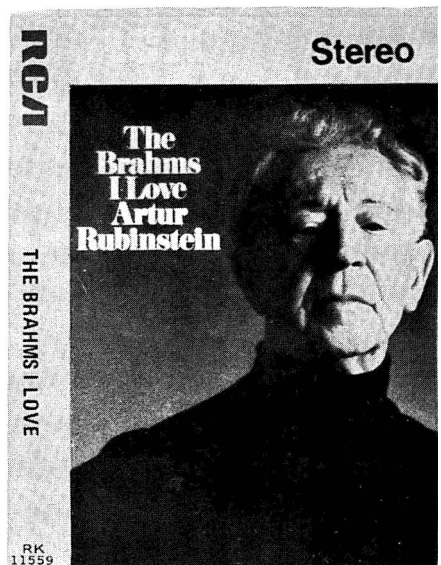

RCA RK11559 (stereo)

after every 30 hours or so of playing time pays handsome dividends in maintaining optimum quality of sound.

Now for a few cassettes of outstanding quality in different fields of music. Where comparisons between their quality of sound and that of corresponding discs are made it is on the basis of both being heard through the same amplification system and pair of speakers. All are stereo, of course, and those made by the Dolby system are indicated.

As a test of capacity to cope with sheer volume a coupling of Tchaikovsky's *1812 Overture* and Beethoven's *Wellington's Victory* played by Eugene Ormandy and the Philadelphia Orchestra, with brass bands, chorus, electronic cannon, bells and 'the lot' is recommended more for the former than the latter. I have been unable to get quite the same undistorted volume from the tape as from the LP, but it is tremendously impressive nevertheless, far different from the attenuated, undernourished sound we got from most mini-tapes no more than a couple of years or so ago, even on top-quality hi-fi equipment (RCA 11574).

Perhaps even more exciting and unexpected to those unfamiliar with what a modern cassette can cope with is the sound from Mahler's *Symphony No. 9* superbly played by the London Symphony Orchestra conducted by George Solti. This is one of the 2LP cassettes, so called because by using ultra-thin tape the contents of two full-length LPs are contained within a single cassette. So much music in such excellent sound in so small a space still fills me with wonder bordering upon awe (Decca CET2 7003—Dolby).

On the other hand a surprising degree of the rich warmth of the London Philharmonic Orchestra conducted by Sir Adrian Boult in some of Elgar's lighter music—the two *Wand of Youth Suites*, *Chanson de Matin*, *Chanson de Nuit* and 3 *Bavarian Dances*—comes through on even modest equipment, and what beautifully affectionate performances they are (HMV TC-ASD2356).

Eminently satisfying orchestral sound and music of immense charm is to be heard in 'Welcome the New Year', the cassette with which Willy Boskovsky and the Vienna Philharmonic Orchestra saluted the birth of 1972. Here is a selection of waltzes, polkas and marches by Johann Strauss and his younger brother Josef, a few of which are familiar but many of which are not often heard, seductively played and beautifully recorded.

I have played the tape and disc versions side by side to several friends and have enjoyed their confusion as to which was which. It is one of the most successful cassettes I have ever heard (Decca SXC6526—Dolby).

Another outstanding cassette from the same orchestra, this time conducted by George Szell, and with Pilar Lorengar as the soprano soloist in the songs, gives us the complete *Egmont* music of Beethoven in a version in which the movements are linked by brief spoken commentaries.

Friedrich Mosengail was the first to conceive the idea of a spoken commentary to make more sense of the music when not played in a theatre to accompany a performance of Goethe's play. This was in Beethoven's own time. Later the poet Franz Grillparzer revised Mosengail's words and it is a shortened version of this revised version that is spoken so sensitively here by Klausjuergen Wussow.

The recording throughout is of quite magnificent quality and combines with the performance to create a fine dramatic effect, which, in its turn, is emphasised and enhanced by realistic stereo effects (Decca SCX6465—Dolby).

Coming to orchestral music of chamber proportions, brightness and integration combine to make splendid listening in a selection of Baroque trumpet music played by the Academy of St Martin-in-the-Fields directed by Neville Mar-



Philips 708028 (stereo)

riners and with Don Smithers as the principal soloist. In the not so far distant past such sound from a cassette would inevitably have tended towards acidity and even harshness (Philips 7300 066).

The piano has long been and still is an excellent test. In 'The Brahms I Love' Artur Rubinstein, the nimbleness of whose fingers has been taken for granted for well over half a century, displays rare musical sensibility in performances which are distinguished by their absolute simplicity. Keen ears may detect just a suspicion of wow occasionally (a very common fault of slow-playing tapes until recently) but it is a fine recording (RCA RK11559).

Even better, soundwise, is a Chopin recital by Maurizio Pollini, who is young enough to be Rubinstein's grandson, but is a very fine pianist and very much on his home ground in this music. The sonority in the Polonaises and delicate tracery in the Nocturnes are equally impressive. Even a year or two ago such rich and pitch-steady tone from a minitape would have been quite unimaginable (HMV TC-ASD2577).

Opera lovers are recommended particularly to a selection of excerpts from *Carmen* with Marilyn Horne as the principal soloist and the Royal Philharmonic Orchestra and Chorus conducted by Henry Lewis. Miss Horne is in lovely voice and has admirable support from her occasional partners, chorus and orchestra alike, and the sound (recorded by the Phase 4 Stereo process) is notable for its immediacy and presence (Decca PFC4204—Dolby).

Not quite so immediate in its sound but very good nevertheless, particularly at the bargain price of 90p, is 'The World of Joan Sutherland' in which Miss Sutherland ranges from Handel, Verdi, Bellini and other composers of opera to lighter music by Johann Strauss and Noel Coward. With her are various orchestras and conductors (Decca CSP100). Someone, I forget who, once aptly described the art of Miss Sutherland as not faultless but always inspired.

At first I was rather disappointed with 'Grand Operetta Gala' by comparison with the LP version. Here is a miniature history of Viennese operetta from Suppé and Johann Strauss to Léhár and Robert Stolz with soloists of the calibre of Anneliese Rothenberger, Rita Streich, Nicolai Gedda and Hermann Prey, and excellent accompanying orchestras.

The initial disappointment was that at full volume the sound tended to be a little muddy, but I soon found that comparatively small



Columbia TC-TW0320 (stereo)

adjustments of the controls got rid of most if not quite all of this (Col TC-TWO320).

By contrast I find no adjustments at all necessary, apart from bringing the Dolby circuitry into play, to get some of the best cassette sound that I have ever heard in selections from *HMS Pinafore*, *Mikado*, *Pirates of Penzance* and *Rudwigore* sung by principals and chorus of the D'Oyly Carte Company and perfectly supported by the Royal Philharmonic Orchestra, the whole under the wise and sensitive guidance of the late Sir Malcolm Sargent. If I were an audio retailer I should always have this handy for demonstrations (Decca PFC4097—Dolby).

'The World of Brass Bands', played by the Mased Fodens, Fairey and Morris Motors Bands directed by Harry Mortimer is impressive alike in the brilliance of such numbers as the Coronation March from Meyerbeer's *Le Prophète* and the sensitivity of the ever-popular *Serenade* by Johnny Heykens and other quieter items (Decca CSP20—Dolby).

Finally Cleo Laine is in magnificent voice in a selection of old and more recent songs labelled 'Portrait'. Outstanding, perhaps, are *Night Owl*, *Ridin' High*, *Aquarius* and *Model Cities*. Apart from the fine singing and excellent recording an outstanding feature of this cassette, as in the corresponding LP with which it compares so favourably, is Miss Laine's absolute involvement in whatever she sings (Philips 7108 082).

Loudspeakers- past, present and future

by Ralph West

The first loudspeakers were little more than modified telephone earpieces. Then a horn was added, flimsy at first, but later larger and gracefully curving. Often these early horns were cunningly made of beautifully polished woods. Unfortunately the sound quality from them was inferior even to the telephone earpiece, mainly because they did not enjoy the acoustic damping that was present when the earpiece was pressed tightly to an ear. They also suffered an extra resonance caused by the too-short horn.

However as the quality of transmitted signals left much to be desired, and since this was the first attempt at loud-speaking radios, listeners were thrilled and satisfied, for a time anyway.

Then came the moving iron cone-type loudspeakers, very mellow and no longer sounding like a little megaphone. These came in all sizes, shapes and materials. Separate driving units with widely advertised specifications (usually the number of poles) were readily available and D.I.Y. was the 'in thing' in radio during the nineteen-twenties and early thirties.

We made our own paper cones, pleated 'cones' and linen diaphragms, some with woofer and tweeter, though at that time those terms were still unknown. I well remember making a magnificent 2-ft-square linen diaphragm speaker from a *Wireless World* design.

There were many cunning designs devised to overcome the inherent distortion of this type of drive unit. Some were slightly successful, but none could produce really loud sounds without atrocious distortion.

The moving coil loudspeaker was 'invented' in several countries within a short period. The discovery is usually attributed to Rice and Kellogg in the USA and they were certainly the first to exploit it. Voigt, in England, had come to the same conclusion independently and discovered he was a month too late, only when he applied for a patent. Now, it is generally conceded that Siemens in Germany was really first,

but Sir Oliver Lodge was using the moving coil mechanism before 1900.

The dramatic reduction in distortion enabled the moving coil to take over rapidly from the moving iron and this was more or less complete by 1939. Though there were quite a few moving coil speakers, including permanent magnet types, by 1934, few would compare with present day designs. One or two engineers had learnt enough and two notable designs come to mind that have hardly been bettered since.

One was the Western Electric (USA) horn loaded cinema speaker with an efficiency of 50 per cent. It could fill a fair-sized cinema with really good sound from a mere two watts. The other was Voigt's design, twin cone, full range, and with a magnet flux density higher than 99.9 per cent of all present day speakers, and it produced a sound quality enthusiasts would not be ashamed of today.

A second method of turning electrical signals into sound, uses electrostatic forces of attraction and repulsion. Several designs appeared in Germany and in this country during the early nineteen-thirties, but they all disappeared, outperformed by the rapidly developing moving coil loudspeaker. Then came the 1939-45 war and a halt in domestic audio activity.

After the war, there was a big backlog of domestic demand to fulfil which kept most manufacturers busy just producing. On a smaller scale there was demand for something very much better, both created and met by enthusiasts who had become experts in some aspect of the art. Many of these people became household names and happily most are still carrying on this good work. Thus was hi-fi born, though Voigt himself, through his work during the nineteen-thirties is really the father of it all.

Post-war development was very rapid indeed, partly due to the release of so much pent-up energy and enterprise, but also because parallel progress in disc and radio, made loudspeaker

improvements very worthwhile. The LP disc with its silent (nearly) background, and later FM radio, with its even quieter background, were two of the largest factors, as they made another whole octave at the top end of the musical scale both usable and desirable.

At the same time many heard real bass for the first time, thanks to the reflex or phase inverter cabinet originally due to Thuras in the USA, or to the quarter-wave bass chamber of Voigt. There must still be a few brick and sand-filled corner reflex systems in existence working just as well today as they did twenty years ago. After all, the laws of nature have not changed during that time.

Our habits have, however, and a rapidly rising population, housed in smaller rooms, produced a demand for smaller loudspeakers. As a fuller understanding of the underlying principles grew, smaller and smaller speakers appeared, still spanning the full frequency range. Nine cubic feet enclosures became four cubic feet, then two, then one, and in 1964 the Goodmans Maxim, a

quarter of a cubic foot, was to hold the record. This was a good loudspeaker by any standard, but few other manufacturers attempted such extremes, and sizes between one or two cubic feet became the most popular.

A further factor that favoured the smaller speaker was the advent of stereo. The FM plus TV stereo broadcasts had whetted our appetites in 1961 and FM multiplex in 1963 confirmed our hopes. From then on, two speakers it had to be, but they must not take up more space than the original one.

One of the first technical books on electroacoustics to appear after the war was by Prof. F. V. Hunt of the USA and everyone devoured it eagerly. Amongst the many interesting and informative chapters was one on electrostatic loudspeakers that contained a veritable gem of information. It pointed out a bit of O-level physics that everyone had overlooked and was the key to the design of a virtually distortionless electrostatic loudspeaker.

This set all the loudspeaker designers working

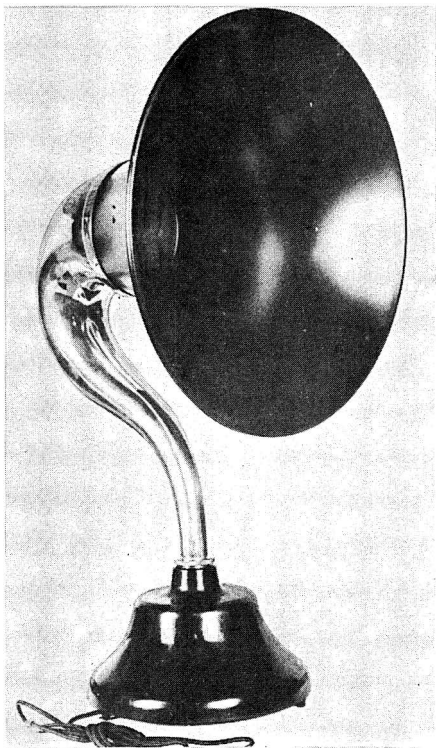

Horn type speaker popular around 1928

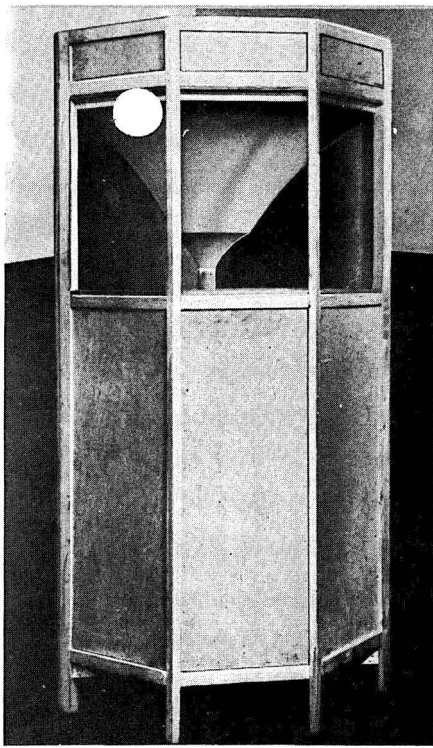

Voigt quarter-wave bass chamber

furiously and the whole hi-fi fraternity waited with mounting excitement as rumours passed around. Eventually three full-range electrostatics were demonstrated at an Audio Fair, but only one, the Quad, by Acoustical Manufacturing, survived. This model has remained in continuous production virtually unaltered since its

inception in 1956 and is still referred to as 'the loudspeaker we judge all others against'.

The Quad is still the only full range electrostatic in the world in full production, though quite a number of successful electrostatic tweeters have appeared in the last five or ten years.

The advent of transistors has not as yet had much influence on loudspeaker design except to make 8-ohm and 4-ohm impedances more popular than the earlier 15 or 16 ohms. Solid state amplifiers are smaller and run cooler, so higher powers are no longer an embarrassment in domestic surroundings. The speaker designer thus has less need to worry about electroacoustic efficiency now signal power is so cheap and convenient.

The latest fashion is the 'Monitor' speaker. Though the word is often used loosely, its dictionary definition as far as we are concerned is 'a high fidelity loudspeaker in the control room of a broadcasting studio for checking the quality of the transmission'. This means in practice the best loudspeaker that can be made (at that time).

It is a fundamental rule in all measurements that the measuring instrument must be more accurate than the desired accuracy of the final product. Whether all the so-called monitor loudspeakers measure up to this criterion is a moot point, but the more reputable manufacturers do take it seriously and our own BBC Research engineers have given a very good lead in this matter.

This more or less brings us to the present, so let us have a look at the inner workings of loudspeakers. Moving coil loudspeakers are always mounted in a box or on a large flat surface. This is because the oscillations of a cone at low frequencies cause little disturbance beyond the edge of the cone. Movement of the cone merely shunts air to and fro round the edge, cancelling any build-up of pressure which could launch sound waves into the distance.

At high frequencies the 'naked' cone works quite well as cancellation no longer takes place. The air shunting to and fro, never gets there in time to do any cancelling, as the cone is so soon moving the other way. If we made the cone large enough, say 3 feet or more in diameter, then we would hear bass at a distance, but apart from its huge weight, its mechanical behaviour at higher frequencies would be hopeless.

The flexibility of this huge cone would allow the outer parts to flap and resonate almost independently of the voice coil movements. It would

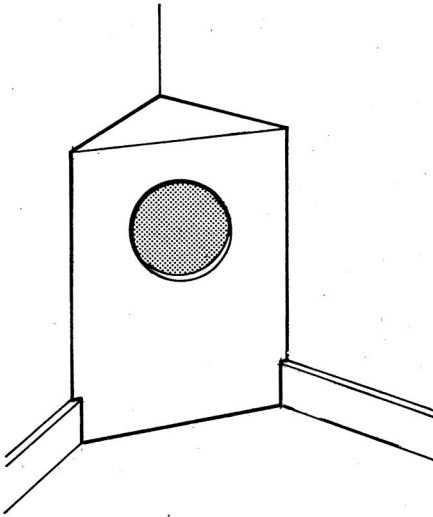

Corner position makes use of walls and floor

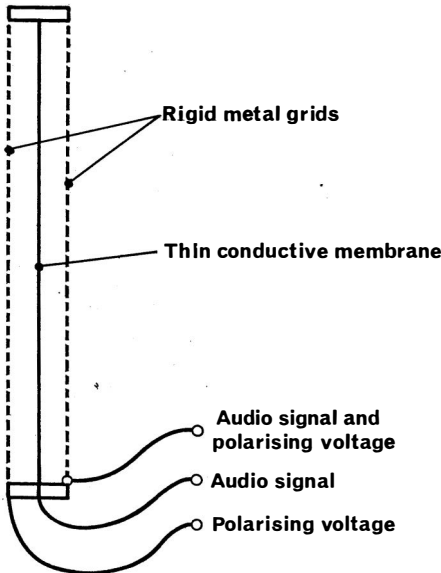

Cross-sectional diagram showing principle of the electrostatic speaker

also take so long for all vibrations to reach the edge areas, that it is obvious the whole surface could never vibrate in phase except at the very lowest frequencies.

An electrostatic speaker on the other hand *will* behave, as every bit of the diaphragm, however large, is driven by the same force at the same time. This is its main attractive feature, and it is indeed the only loudspeaker in which the total behaviour can be predicted with mathematical accuracy.

The moving coil speaker then has to have an acoustic barrier between the front and back of the cone. The first commonly used device was the baffle, closely followed by the open-backed cabinet, really only a folded baffle, but a more convenient shape for the home. Almost complete isolation between front and back can be arranged by mounting the speaker in a hole in a large wall or in a floor which is hollow underneath.

This approximates to an 'infinite baffle' and

will work perfectly down to as low a frequency as the driving unit itself can manage. A closed box with rigid walls, is of course a perfect barrier and is often called (loosely) an infinite baffle or IB. Though it is obviously a very convenient trick, the air trapped in the box behind the cone acts as a spring—an air spring or acoustic spring.

This stiffens up the cone suspension, making large cone movements, necessary for bass notes, more difficult to achieve. In more detail, there is a rise in sound output at the frequency where the mass of the cone resonates with the suspension stiffness controlling it. Below this resonant frequency, output falls very rapidly and is generally inaudible at about half this frequency.

Now this air spring raises the frequency of this resonance, which makes it more noticeable, and also further reduces the lower bass output. The bass resonant frequency then represents the lower useful limit of this type of loudspeaker. To keep this low enough for good performance there are four things that can be done. The first

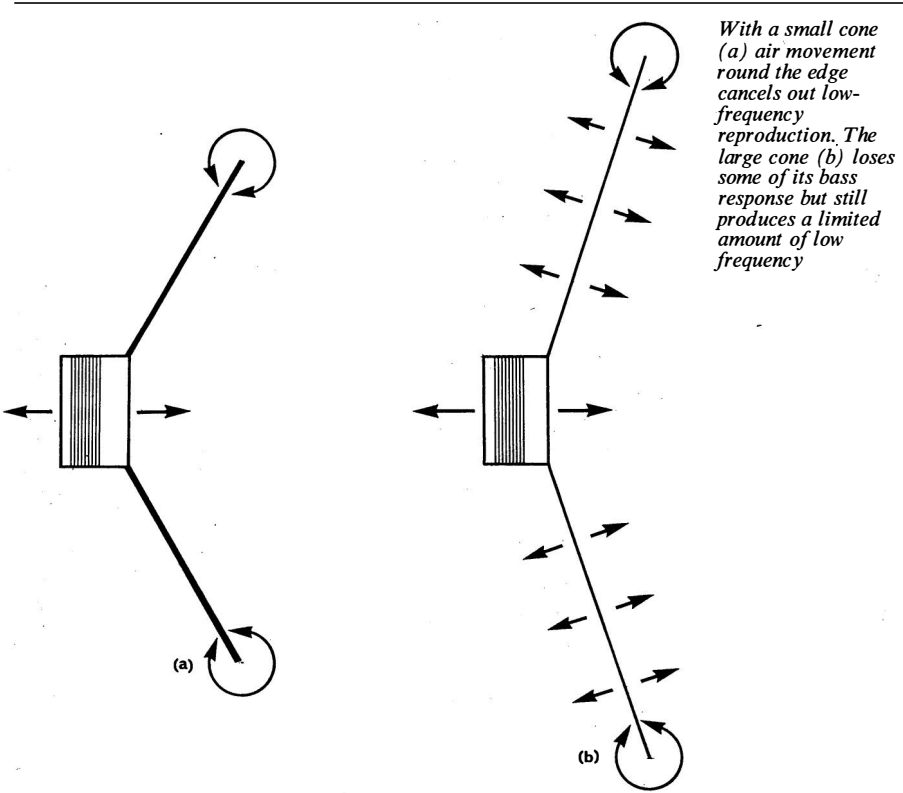

is to use a large volume box so that the 'air spring' is comparatively soft. This is the origin of the 9 cubic feet of, yester-year—perfectly satisfactory if one can spare the room.

The second is to soften up as much as possible the cone suspending members without risking the voice coil scraping the poles of the magnet. This is of limited value, as it still leaves the air spring, but it makes possible a size reduction to 4 or 5 cubic feet.

The third move is to make the cone heavier. This means the cone can be stiffer, which helps, but incurs a penalty—reduced electro-acoustic efficiency. This means we shall need more amplifier output power for the same sound level. A little of the efficiency can be regained by using a longer and more powerful magnet system, but amplifier watts are cheaper!

This ploy halved cabinet volumes yet again, at not too high a price, though it did necessitate the use of a tweeter to handle the high notes as the main cone had become too heavy to move much at these frequencies.

The fourth possibility, not realised for many years, was the use of a very small cone. This makes the air spring effectively softer, enabling an even smaller cabinet to be used. A further penalty here is reduced power handling as the little cone cannot possibly 'pump' the same volume of air for the bass notes as can a larger cone.

However, the Goodmans Maxim, though the smallest ever to reproduce audibly down to the lowest organ pedal note, will still produce enough sound at really high quality for domestic use. In general, speaker enclosures less than about 2 cubic feet in volume have a falling bass response that can with advantage be corrected by judicious use of bass lift using the tone controls.

How very true that history often repeats itself. This is now happening with the reflex or phase-invertor. Thuras first devised a scheme to extend the bass response of moving coil microphones, but it works just as well with loudspeakers.

The cabinet, otherwise closed, has an extra opening or 'port' of calculated size, usually fairly close to the driving unit, but not necessarily so. The slug of air in and around this hole will vibrate to and fro and radiate sound, as well as the main cone. The operative quantity is the mass of this slug of air.

The mass can be increased by *reducing* the area of this hole, probably because the resulting increase in air velocity carries more surrounding

air with it. Its mass can also be increased by fitting a tube or 'tunnel' (much easier to understand). This slug of air provides useful sound radiation over the bottom two octaves. 'Useful' means *not* cancelling the two from the cone itself. In fact over much of this range it is practically in phase with the cone.

Think of it as two masses on opposite ends of a spring. The cone and the port air are the masses, and the air in the cabinet is the spring. It is then easy to visualise the 'phase invertor' action, i.e. both masses moving towards and away from each other at the same time. The practical result is less driving cone movement for a given (bass) sound output and therefore less distortion.

A more compact version, going back at least twenty years (S. Kelly, BK Partners), uses a solid suspended mass rather like a dummy cone. This has recently come back into popularity and is now used as often as the tunnel type port.

The reflex design was very popular twenty years ago and then came under a shadow as it was thought to have a less smooth response than the cabinet IB as it has *three* system resonances, against *one* for the IB. When examined closely, this fear is completely unfounded. The highest bass resonance, the one most likely to be noticed, is much the same as that of the IB. This will be carefully damped, just the right amount, to extend the bass as far as possible without booming on male speech.

The next lower resonance occurs where the bulk of the sound output comes from the port. This is usually damped well enough without any special cone, and anyway is generally so low in frequency it is no worry because musical sounds in that range are always relatively slow starting and slow stopping. So within reason damping here hardly matters. This merely carries the useful frequency response a little lower than otherwise.

The lowest resonance is even lower, hardly audible, rarely excited, and in this mode the outputs from cone and port subtract, and may even cancel out, so it can be forgotten. I think it is the wider realisation of these considerations that is bringing the reflex design back into popularity.

There are other ways of preventing the mutual cancellation of sound from the front and back of the cone. Looking back at the true IB, the speaker built into a hole through a large wall, we find an unlimited volume of free air on the other side and hence nothing to raise its natural frequency of resonance.

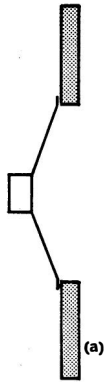

(a)

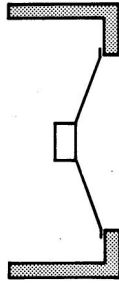

(b)

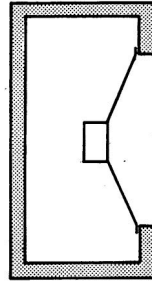

(c)

Some type of acoustic barrier is necessary between the front and rear surfaces of a speaker cone for satisfactory reproduction of lower frequencies. The diagrams show (a) simple baffle, (b) open-back cabinet and (c) enclosed or infinite baffle cabinet

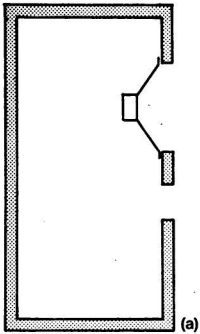

(a)

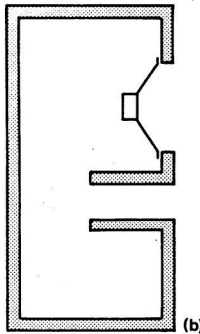

(b)

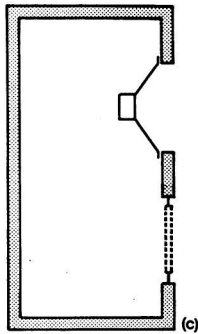

(c)

Increase in bass response is provided by the reflex type enclosure in which an accurately proportioned port or tunnel is introduced (diagrams a and b). An acoustic resistance unit (ARU) fitted in the port (c) is said to give a smoother response

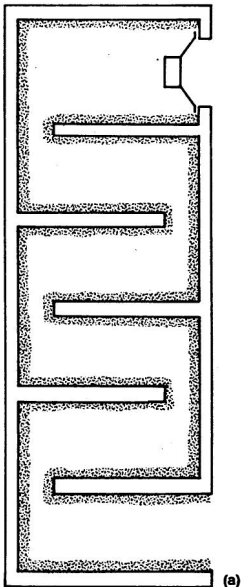

(a)

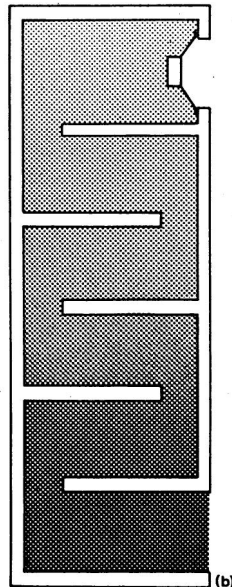

(b)

Two types of tunnel or labyrinth enclosure. In diagram (a) all internal surfaces are lined with sound absorbent material. In (b) the whole inside volume is filled and the material is packed progressively more tightly as it nears the open port

No sound wave ever needs to try and return since it has a real escape route, i.e. we simply 'lose' all the sound from the rear of the cone. If we could *absorb* all the energy from the rear of the cone, we would have a similar desirable state of affairs, and thus avoid the limitations of the closed box IB. This is fine in theory, but very difficult to carry out in practice in any cabinet size suitable for the home.

High frequency sounds are easily absorbed by thin layers of absorbent, possibly helped by a few corners to go round. The laws of nature decree that we will need suitable absorbing materials generally at least a quarter of a wavelength thick to get anywhere near to say 90 per cent absorption. This amounts to 3 inches at 1000Hz, 30 inches for 100Hz and over 6 feet for 30Hz, the lowest frequency we are normally interested in. So it is another case of easier said than done.

Absorption is usually attempted in practice by arranging a long folded tunnel at least 6 feet long behind the cone. This tunnel may have the same cross-sectional area throughout, or may start somewhat wider behind the cone and taper. It will obviously have to be folded, but is the better for that. Some designs line its interior surfaces with absorbent whilst others fill it completely, often less densely packed behind the cone (so that it feels as it were, open air) and more tightly packed towards the far end.

If the tunnel could absorb all the sound it would not matter whether the far end is open or shut. As it will not manage this at the lowest frequencies, it is better left open as an escape route. This type of speaker is often known as a 'labyrinth' speaker, or if one is mathematically inclined, it can be viewed as a 'transmission line' type.

Ideally it has no resonances at all and can even damp out the driving unit resonance by suitable design. In practice, unless it is very large indeed, quite a lot of low frequency sound will come from the escape hole and its behaviour will then be comparable to that of a reflex type of the same size. At best, if one has the room, then it will have a superior bass response, in quantity as well as quality.

Earlier mention was made of the 50 per cent efficiency of the old Weston Electric cinema speaker of the thirties. Most modern high quality speakers manage about or just under 1 per cent. The rest is turned into heat, mainly in the voice coil. This low efficiency is because the cone is so heavy compared with the air it is pushing. It's like using a hammer to try and set air into vibra-

tion. As engineers we say this is a case of very bad mismatch between the source (cone) and the load (air).

An electrical mismatch can be corrected by using a transformer of suitable ratio. The acoustic version of a transformer was well known to the ancients and is the horn. The narrow end handles relatively high alternating air pressures, but only a very small volume of air moves to and fro. The other end enjoys low air pressures, but a much larger volume of moving air due to the gradual expansion along the length of the horn.

Like the labyrinth, it is a most attractive proposition in theory, but unfortunately is even more difficult to carry out in practice. As in the electrical case, it is difficult to design a transformer that will operate equally well over a very wide frequency range.

At the high frequency end, the throat diameter must be not more than a quarter of a wavelength at the highest frequency we wish it to handle. Half-an-inch is really too large, as that is already falling off at 10kHz. The lowest frequency is determined both by its rate of taper (slow for low!) and the final mouth diameter. It will be around 30 feet long and 20-25 feet mouth diameter to handle the 30Hz lower limit, and one cannot fold it if it is to handle high notes as well. It *has* been done once or twice by enthusiasts and results were (and are) indeed magnificent, but we generally have to think smaller than that.

One can easily use a horn with a tweeter as it will only be inches wide. This has been done many times with conspicuous success—Tannoy Dual Concentric, Decca-Kelly Ribbon, Goodman Trebax, to name a few.

Only a few designers of high fidelity loudspeakers have attempted horn loading in the range covering hundreds to thousands of cycles per second—Voigt in the nineteen-thirties and Lowther during the last 25 years. Of course the public address people regularly use horn speakers for outdoor work. The high efficiency and directivity are a great help in the open, where there are no walls or ceiling to contain the sound and very high acoustic outputs are needed.

Quite a number of designers have used horn loading at the bass end, one way or another. A few enthusiasts have done it properly. Being so large it has to be pretty well built into the structure of the house.

One form is a cabinet containing the folded start of a very large horn. This is placed in a

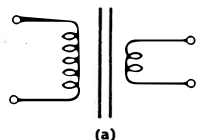

(a)

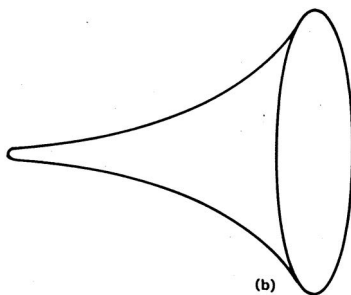

(b)

Electrical impedance matching is provided by a suitable transformer (a) while acoustic matching can be achieved by a horn type structure as shown at (b)

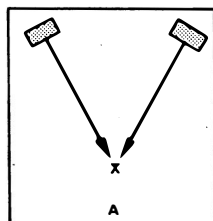

A

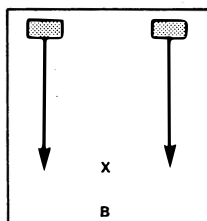

X

B

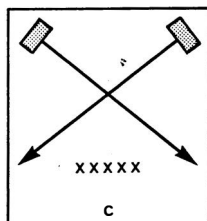

X X X X X

C

Three speaker arrangements for reproduction of stereo. The advantages and drawbacks of each layout are discussed in the text

corner so that the two walls and floor act as a continuation of the horn. Though obviously somewhat of a compromise one can often produce quite impressive bass down to lower than usual frequencies.

Usually the front of the driving unit radiates the higher frequencies, whilst the horn loads the rear of the unit. The large empty volume round the unit is calculated to act as an acoustic crossover, and prevents the horn receiving anything but bass. The horn is of course folded, often quite intricately, to get the correct rate of taper and yet fit into the desired cabinet shape.

As the narrower and more accurate part of the horn is somewhat arbitrarily terminated when it runs out of space, its overall behaviour is not so very different from that of a large reflex design, but it does usually have a higher electro-acoustic efficiency.

A few words about placing loudspeakers for listening in the home. Placed right in a corner, the speaker will produce the maximum bass, but it will excite *all* the room resonances. In smaller rooms this is liable to produce an objectionably boomy sound, so it is always wise to try moving the speaker about 1 to 2 feet in various directions until one finds a better spot.

Even standing the speaker on the floor produces a boost of some bass frequencies (by reflection from the floor) and leads to an un-

naturally heavy sound. One can try raising it 6 inches to a foot or so. It should be on legs, or something with free air under it, not on a box. In fact the latest high quality monitor speakers are only intended to be used raised on legs. While many older loudspeakers may not have such a smooth response as the better modern speakers, it is worth trying the effect of raising them. Even 3 inches makes an audible improvement sometimes, and anyway the tweeter ought to be approximately ear height, seated in the favourite chair.

This matter was dealt with in detail in the *Wireless World* (April 1970) by H. D. Harwood, BSc, of BBC Research.

For stereo, three different speaker arrangements are shown in the diagrams. Position 'A' will give the most dramatically sparkling stereo effect, but it will prove somewhat uncomfortable and tiring after a while. The head only needs to move an inch or so and the stereo image is liable to jump about and spoil the illusion.

The Americans always seem to advocate position 'B', for reasons unknown. It will certainly be less 'touchy' than A, but anyone sitting left or right of the central seat will find a large part of the sound picture has moved over to his side. Like 'A', it has only a very restricted good listening area.

The arrangement in 'C', first described by

Hugh Brittain, gives not only more comfortable listening—i.e. natural movements of the head produce no more change in what is heard than it does in a concert hall, but also a wide seating area with nearly identical results. Sitting, say, left of centre, one is nearer the left speaker and so its sound reaches one's ears first. Our senses tend to lock on to the first sound to arrive for the assessment of direction (the Haas effect).

However, with the speakers angled as in 'C', this left seat puts one nearer to the axis of the *right* speaker where there is usually at least some concentration of the higher frequencies. This tends to offset the other effect, and with the right amount of high note beaming it is possible to experience the same acoustic picture all along the row. With any forward-facing speaker this angling should give best all-round results.

From time to time speakers have appeared with very different radiation patterns. Omni-directional types radiate their high notes in (nearly) all directions, either by virtue of reflectors, or by having lots of tweeters pointing in different directions. Only one woofer is necessary, as low frequency sound spreads in all directions quite naturally, as long as the dimensions of the source are small compared to a wavelength (and this is so).

Other designs deliberately fire all or most of their sound against a wall or into a corner. The claims made for these 'deviations' are various and hotly contested, but there is no doubt many people do genuinely prefer such sound presentation.

There is also little doubt that these types do

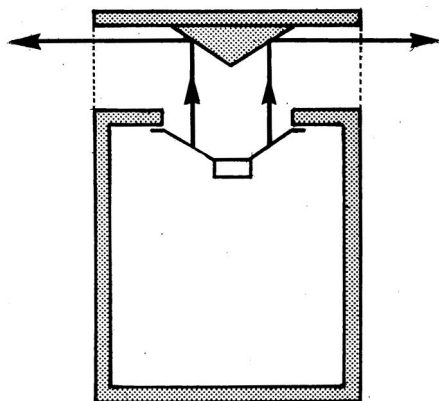

Upward-facing speaker and cone dispersion unit designed to give omni-directional radiation

not produce anywhere near such a clear and precise stereo picture, but they do produce 'comfortable' listening for most folk. This is because they produce a diffused sound field, as the sound in a concert hall is diffused beyond the first few rows of front seats. These two sound fields are of course very different, but they do have one thing in common. Both give our ears sounds coming from a wide variety of directions.

Sounds coming from many directions mean sounds arriving at our ears with a wide variety of differences in time of arrival between the two ears. There is evidence to suggest that our hearing senses are somewhat put out or upset if deprived of this variety. One has only to experience an anechoic room for the first time, or watch the dramatic effect on others experiencing it for the first time.

It may be that when we have real quadraphonic sound all the time, we may lose all interest in 'omnis' and the like. Present two-channel stereo gives the variety of angle only over a range of 60 degrees or perhaps up to 90 degrees. True four-channel sound will cover the whole 360 degrees and our senses should be fully satisfied.

There is more than a little confusion over the sound effects we can expect in our own rooms at home. Some refer to the impossibility of getting a whole symphony orchestra into a suburban living room. Others point to the hopelessness of trying to do justice to a 60-foot-wide orchestra between two speakers only 10 feet apart. A third argument talks about trying to get the same amount of sound out of two loudspeakers as from an orchestra in order to be realistic. All three views are misleading nonsense.

With a good stereo signal, two speakers somewhere near the corners of the room and the right volume control setting, one should get the impression of an acoustically transparent wall between and behind the loudspeakers with the orchestra spread out beyond this gap. Depending on the precise nature of the signal and the volume setting, the front row of the orchestra should seem to be about 10 feet *beyond* the speakers. Solo items, vocal or instrumental, may well have one leg just inside the room.

The angle subtended by the two loudspeakers at the listener's head, will be the kind of angle a real orchestra would subtend in a good seat in the concert hall.

The sound level in the room and around the listener's head should never be more than it would be in real life listening—much less than

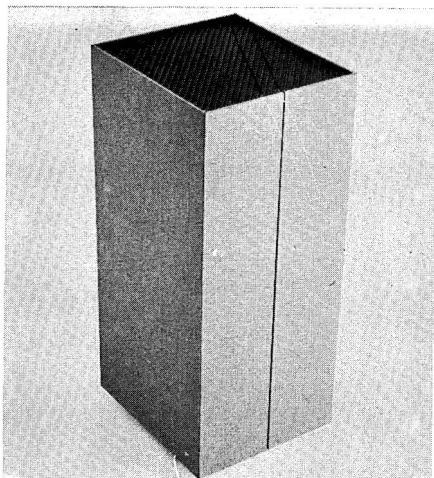

Latest horn type enclosure to be introduced to the hi-fi market is the HLI from Lecson Audio

the level in the middle of an orchestra. Turning the volume down a little, in respect for neighbours or sleeping children, should merely give the impression of sitting in a seat much farther back.

A little beyond our brief, but relevant, is stereo listening via phones. Theoretically, most of the stereo material we have should not suit phones as it is intended for loudspeaker dissemination. With loudspeaker listening both ears hear both speakers, whereas with phones each ear hears only *one* signal.

If we recorded using two omnidirectional microphones fixed on either side of a dummy head, one would get perfect stereo with phones, though the whole concert hall would turn with the head!

However the effect with phones is generally very good and certainly enjoyable. Extreme left or right comes out clearly, but for most people everything else seems to swirl round somewhere in the top of the head—but it is pleasant and does not annoy anyone else.

Attempts have been made to feed the right amount and quality of signal to each phone from the other side. Most of these circuits are based on an original idea of G. Bauer (see *Wireless World*).

Many better quality moving coil phones give sound quality comparable to that from really expensive loudspeakers. Electrostatic earphones are more nearly equivalent to monitor speakers, and cost a lot less too.

Choosing a loudspeaker is a very personal thing in the long run. There are many considerations: size, cost, shape, technical specification etc. But the most important question is 'Do you like it?'. Since all loudspeakers are imperfect, all have faults. The good loudspeaker is the one with fewer than average faults, but more important to the listener, fewer of the faults that worry his senses most.

Our senses do not worry unduly if some notes are a little louder than others, i.e. response not quite flat, but they are worried a lot by sounds and noises that carry on after the signal has stopped—and these shortcomings rarely show up clearly on an ordinary frequency response test.

This last section of the article is headed '... and Future'. This really needs someone who can read a crystal ball, but looking at the *last* five to ten years, one can see some possible future trends, though a breakthrough is always possible. During this period, we have seen a far more widespread understanding of the laws of nature that govern everything to do with loudspeakers.

Many wonderful new plastic materials with highly desirable properties have come along. Better, more convenient and more accurate measuring and testing equipment has become available and with all the other things has led to some very good loudspeakers, especially in the last year or so.

Signals to drive our loudspeakers have improved too; almost distortionless amplifiers, better tape, Dolby A, Dolby B and super precision in cassette machines, pickups that will really track *everything* with under 3 grams playing pressure etc., have given an added spur to loudspeaker progress.

Solid state amplifiers, having now got over most of their teething troubles, are becoming so inexpensive and convenient that we may yet change over to the studio pattern speaker for normal home use. This has its own amplifier built in, and with it, all the correction circuits to compensate for the shortcomings that either the designer could not overcome, or which were too costly to correct mechanically.

Four-channel sound of one sort or another is pretty certain, though it is likely to last only if it is done really well. My lady only just manages to tolerate the second loudspeaker as it is.

One thing is clear, we do not know everything about sound and loudspeakers yet, so there is lots more to come.

A brief survey of four-channel stereo techniques

by Donald Aldous

Audio engineers have for many years undertaken intensive investigations into the possible advantages—technically and commercially—to be gained from multi-channel sound recording and reproduction systems. In the gramophone recording field the major studios of the world have been making multi-track master tapes, containing 12, 16 or more channels, for the last decade or so, and these are mixed down to two- and now four-channel recordings for domestic reproduction.

Four-channel sound techniques have been given such names as quadraphonic, quadra-sonic, surround or environmental sound, ambiphonic stereo and even the impressive 'tetrahedral ambiophony' for a special method of recording and reproducing three-dimensional spatial sound.

The innocent audiophile may well at this moment ask 'Why four-channel sound?', as some record enthusiasts asked in 1958 'Why stereo records?' or, peering further back, 'Why long-playing discs, as my favourite 78s give me all the sound quality I want?'

The only worthwhile answer to all these questions is one and the same, namely, to enhance musical realism, to offer the listener the 'living presence' of performers in the original acoustic environment of the studio or concert hall, and so extend the sheer musical pleasure of reproduced sound entertainment in the home.

Cynical enthusiasts will counter with the comment that a more likely reason is that the record industry thinks the time is ripe for another technical innovation to boost the market (which has sagged a little in the USA, for example).

And of course it is true that audio equipment manufacturers are happy with the prospect of quadraphonic sound, as the new systems (disc or tape) will require more hardware in the shape of amplifiers, decoders, tape players and loudspeakers.

This aspect of quadraphonics has obviously not been overlooked by the industries concerned,

but it is probably unfair to assume that they are regarding the situation solely from a hard commercial viewpoint. Most, if not all, of the reputable hi-fi equipment makers are genuinely interested in advancing the art of sound reproduction, and good four-channel systems can certainly provide a new sonic experience.

After all, stereophony introduced space and motion into reproduced sound. Quadraphony adds depth and can envelope the listener in a sound field. Incidentally, apart from the efforts of Michael Gerzon and Granville Cooper in their 'tetrahedral ambiophonic' technique already mentioned, all the systems to be discussed offer no up-and-down information, and so are really still only two-dimensional. Have we got to envisage 'octaphony', as John Borwick (*The Gramophone*) has suggested?

So in the endless quest for perfect sound, we come to the 'super-stereo' concept, although purist music lovers may remark, as one was heard to say at a hi-fi exhibition after a very inadequate demonstration of a four-channel system—'If that's quadraphony, it sounds more like cacophony to me!'

A funny but unfair comment at this first stage in the development of four-channel sound since the repertoire (particularly classical) is very limited at present. Because of this there is the inevitable interest in gimmicky material to show off the technique, allied to the fact that, at the time of writing no standard has been accepted for four-channel systems by the recording industry or the buying public.

Examining the listening end first, by careful siting of the loudspeakers (not necessarily in the four corners of a room, as often thought), the listener can perceive reverberant sound to simulate the concert hall acoustics or the artists can move around to the left, right, front or back, as the producer or creator of the original recording desires.

The musical value of this 360-degree sound perception is not universally acclaimed, and,

indeed, some critics believe that the law of diminishing returns applies here, providing spatial or directional characteristics at the price of reduced overall fidelity for a given outlay. Again, in my view, these comments are all premature, as the systems and software are still in the early days of development.

Four-channel stereo has been developed to attack the biggest problem inherent in orthodox two-channel stereo, namely, that all sounds, both direct and indirect, and of different phases, are heard emanating from two loudspeakers located in front of the listener.

Four-channel stereo employs four loudspeakers, usually placed two in front and two at the rear of the listener. Some of the various arrays possible for loudspeaker location are shown in the accompanying diagrams.

In following the progress of four-channel sound, it will be understood by most readers of the *Hi-Fi Year Book* that quadrasonic sound presents no special problems for the tape medium, as, of course, methods of recording four or eight tracks on open-reel tape are already fully developed, and cartridge four-channel eight-track systems (like the RCA Q-8 type, supported by the Fisher Radio Corporation in the USA, and by EMI and others here) are already marketed, with the possibility of such configurations in the compact cassette format too.

The really difficult technical problems arise in compressing the four channels on to a familiar LP disc in such a way that they can be replayed on normal two-channel stereo equipment, and on monophonic reproducers, as well as being acceptable for use in conventional radio broadcast transmissions and providing, after decoding, four separate channels for replay on suitable quadrasonic units.

Today there are many competing four-channel systems using the disc medium, including JVC-Nivico, E-V (Electro-Voice and Feldman), Sansui, Scheiber, Toshiba, Dynaco/Gately Utah Studio 4 (Ambience Regenerator) and the CBS-SQ technique.

These various types and forms of circuitry are being strongly promoted to introduce four-channel stereo programme sources but, in general, they can be classified as 'discrete' and 'matrix' or encoder/decoder systems. The former demands four separate signal paths (as on tape) and, in fact, four separate channels throughout. This is obviously expensive and the system is referred to as the 4-4-4 technique.

The matrix technique can be transmitted or preserved in the two-channel format. Four signals are fed through an encoder, converted into two signals, then decoded on playback to recreate the original four-channels of sound. This is known as a 4-2-4 system. A third method converts conventional two-channel stereo into four-channel stereo by special circuitry. This pseudo-quadrasonic is referred to as a 2-2-4 system.

In fact some of the important benefits of four-channel sound can be obtained simply for the cost of an extra loudspeaker driven from a third-channel circuit derived from the existing two stereo channels. It is often not recognized that ordinary stereo LP discs and, indeed, some stereo broadcasts, enshrine information that can be extracted merely by the addition of a loudspeaker (or speakers) to the hi-fi system. This extra information provides the listener with 'hall ambience'. The basic method of obtaining these out-of-phase components is shown in the accompanying diagram.

It is wise, however, to check with the amplifier manufacturer that this additional loading will not upset the output stages. This form of 'surround sound' extraction (using information already present on ordinary stereo records) is primarily due to David Hafner, and the Dynaco Company (USA) markets an inexpensive 'Quadaptor' to facilitate coupling four loudspeakers from a normal stereo unit. Manufacturers have appended such names to these systems as synthesizing, quadrasonic or composing a sound field.

Electro-Voice in America has tackled the four-channel problem by introducing their Stereo-4 compatible system, which encodes four channels into a stereo signal that can be transmitted over FM radio or transferred to a disc. In the home all that is needed is the EVX-4 decoder, plus an extra stereo amplifier and a pair of rear speakers, for satisfactory reproduction of practically any kind of sound signal, even mono, hence their claim to compatibility.

Of course, a broadcast station or recording studio has to install an Electro-Voice 4 to 2 encoder, which has been accepted by the FCC for use by any station.

Yet another approach is seen in the Lafayette LRK-855 AM/FM stereo receiver/eight-track cartridge player which, in addition to its normal radio facilities, has special so-called 'Composer' and 'Adapter' circuits for deriving four-channel sound from conventional two-channel sources, such as, stereo discs, tapes and FM broadcasts.

This model does not require an external amplifier, one just adds two more loudspeakers.

Other models from such well-known American companies as Scott and Fisher have built-in 'surround-sound' circuitry, as has the Japanese Sanyo DCA-1700X unit, fitted with a toggle switch marked 'Quad Effect'—Hall and Surround. Similar systems have also been announced by Toshiba and Onkyo. The latter's console model incorporates a unit able to repro-

duce discrete four-channel or matrix-type two-channel/four-channel material from disc, tape or radio sources, with two big front speakers and a pair of smaller loudspeakers for wall mounting on the rear or side walls. We can expect more hardware from many sources.

For example, Pye Stereo Plus 2 (an amplifier, two loudspeakers and all leads) was marketed in the spring of 1972 for £37.25, and was designed to work in conjunction with an existing stereo

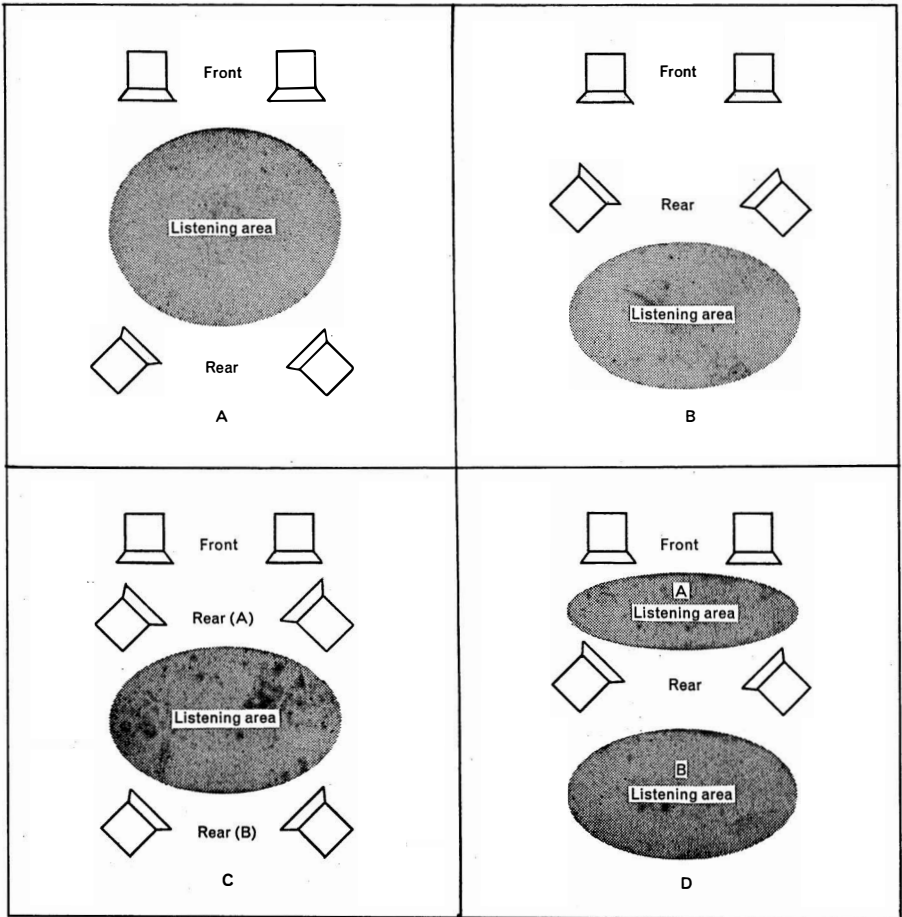

Figure 1 Suggested arrangements of loudspeakers for providing the best quadraphonic sound. (A) Universally accepted four corner position, or with two front speakers facing inwards to listening area. Effective method for mood music, rhythm and blues, vocal numbers and 'live' location sounds. (B) Front-facing speakers with 'rear' units midway along the room. Preferred by some listeners for symphonies, opera, chamber music and big band jazz. (C) Method for affluent audiophiles. Requires suitable room and employs six loudspeakers. Changeover switch on amplifier permits instant choice of system (A) or (B). Method (D) is the so-called compatible positioning. Locating the rear speakers as shown permits the listener to enjoy system (A) or (B) simply by moving the units. See also Figure 2

system. The Pye company, too, has provisionally adopted the Sansui technique for four-channel disc stereo, and the huge EMI concern has announced its allegiance to the CBS Laboratories SQ matrix system, with a release firstly of quadraphonic cartridges, followed by a small batch of classical and popular discs.

The price of these 'quad' discs is expected to be around 50p higher than stereo LPs. (Incidentally, 'quad' unitalicized is bad practice, as QUAD is the familiar trade name assigned to Acoustical Manufacturing Co. Ltd., Huntingdon.)

It must be said that for full comprehension of the various four-channel systems now in conflict for universal acceptance, a grasp of matrix algebra is necessary, allied to delight in juggling logarithms. Space is not available for such a detailed examination here, but for the mathematically gifted the articles by Geoffrey Shorter (*Wireless World*) in the reference list should be consulted.

We can clarify the picture however, by examining the differences between the techniques. For instance, the JVC CD-4 system, backed by National Panasonic (Matsushita Electric), RCA Records and the Victor Company of Japan, is not a matrix system, but is, in fact, a multiplex method using a carrier technique centred on 800Hz, with frequency modulation below and phase modulation above that frequency.

The CD-4 system can be described as 'discrete', offering low distortion with good S/N ratio, but it does demand a first-class cartridge capable of performing up to 45kHz. Problems encountered include tracking difficulties (with cheaper cartridges), playing time per disc side and the destruction or wearing of the HF sub-carrier content by worn styli. But improvements have been promised that, say the designers, will nullify any advantages by way of compatibility that is claimed for two-channel equipment promoted by rival systems.

Matrixing techniques, in contrast, do not demand a wider bandwidth, but do involve a judicious balancing of one benefit or parameter against another, usually cost. This means that matrix systems exchange unrequired degrees of channel separation (crosstalk from right-front to right-rear, left-front to right-front, etc.) for the ability to reproduce not only ambience, but the directional or spatial characteristic of four discrete channels, without making existing replay equipment unusable.

So synthesizers were developed with the

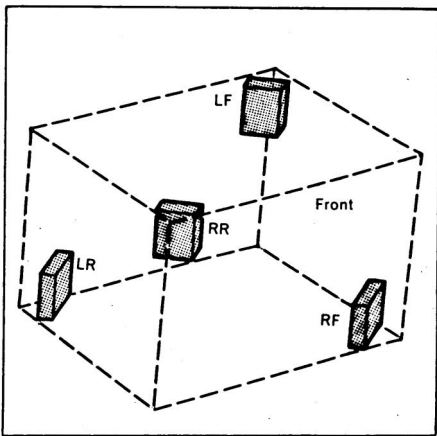

Figure 2 Method of loudspeaker positioning known as the skew tetrahedral system, due to Michael Gerzon. It should be noted that speaker placement for best results is to some extent personal, dependent upon the listener, the room furnishings and the shape of the area. For example Sansui suggests that improved quadraphonic effect is obtained by siting the two front speakers at floor level and slightly in from the left and righthand corners, while the rear are raised about three feet from the floor

object of extracting various in-phase and out-of-phase components to create a form of four-channel sound. Sansui's QS-1 model was launched in June 1970 and sold many thousands in the first months of its release in the USA and Japan.

The latest Sansui QS technique records the four signals on a disc at 67.5 degrees, 22.5 degrees, -22.5 degrees and -67.5 degrees to the horizontal. The system is rather akin to the E-V Stereo-4 arrangement, but there are differences. For instance, channel separation is symmetrical at 3dB, which produces a square sound field, and the back channels are processed in a different way.

Roughly, the rear channel sound components are phase-modulated from 0 to 180 degrees, which means that sounds emanating from the rear speakers have time and frequency differences between the indirect and direct sound components and the non-modulated direct sound signals. These time delays at the listener's ears mean a significant increase in 'presence' of the sounds, Sansui claim, as well as an improved dynamic range of pulsed tones.

Programme material processed by a 22.5-degree encoder can be handled by a decoder with

different vector value without too much degrading of the four-channel effect. This is important as, although in theory recordings made by one system will not replay satisfactorily on another, in practice it seems that useful and even acceptable results are possible.

Obviously technical evaluations—as well as subjective checks—are being undertaken all over the world and, indeed, Electro-Voice in America

reports that they have produced an integrated chip that will decode all existing matrixed programmes without any switching—and that's a good trick, if they can do it!

Audio consumers will await these tests with some interest, perhaps even impatience, so it behoves broadcasting authorities, recording companies and the equipment manufacturers to agree on a common standard quickly, before

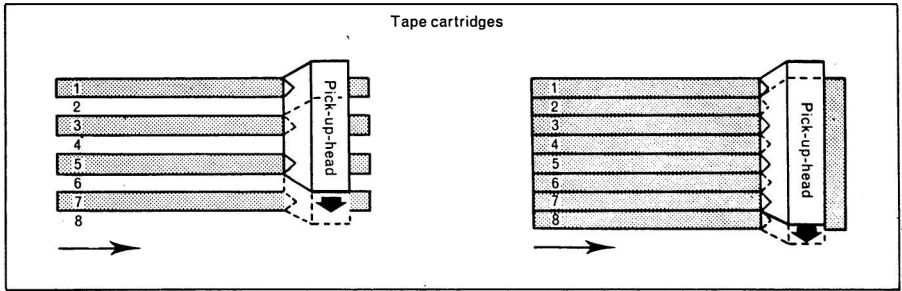

Figure 3 Stereo-8 cartridges accommodate the musical material in the form of four pairs of two-track stereo programmes. In each pair one track provides lefthand channel sound and the other righthand. With Q8 cartridges the music is recorded as two four-channel programmes. In each programme there is an independent track for front left, front right, rear left and rear right speakers respectively. For the same playing time Q8 cartridges require twice the length of tape as the Stereo-8 type. Both cartridges are the same size and use $\frac{1}{4}$ in tape with eight tracks. The Q8 type has a small vertical notch in its top to indicate to the producer that it is four-channel

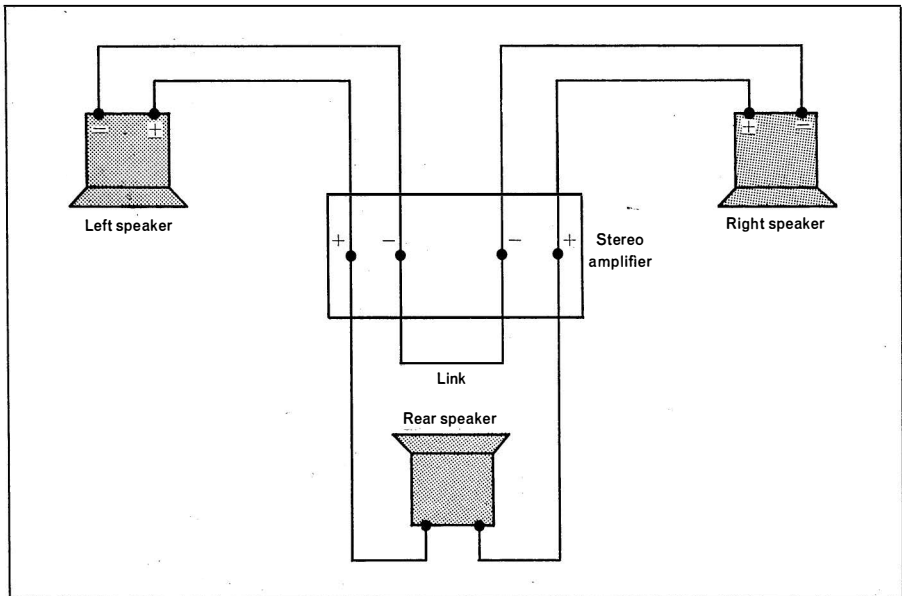

Figure 4 Simple method for obtaining 'surround sound' effect suggested by David Hafler. In this system one extra speaker is added at the rear to handle out-of-phase components. More elaborate four-speaker circuits have also been developed.

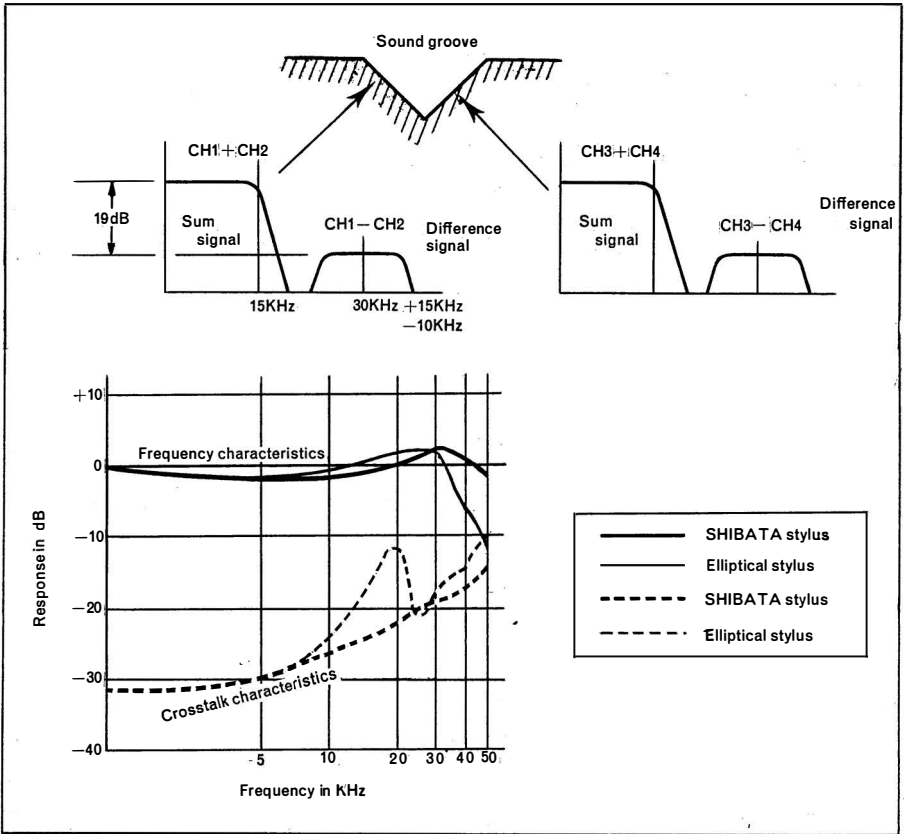

Figure 5 JVC-Nivico CD-4 system (*C* refers to compatibility, *D* to discreteness and 4 to four-channel). Upper diagram illustrates how sum and difference signals for the four channels are accommodated in the two sides of a single record groove. To provide the required response, up to at least 45kHz, a new stylus configuration known as the Shibata is employed. The lower diagram compares the performance of the Shibata stylus with a high grade elliptical. Claimed advantages include better groove contact, lower tracing distortion, reduced disc wear, better signal-to-noise ratio and higher mechanical resonance

potential interest wanes or never gets started.

So we come to the Columbia SQ (Stereo-Quadraphonic) matrix system, most effectively described and demonstrated by one of its inventors Benjamin B. Bauer, Vice President of CBS Labs in a tour of European capitals, including the Berlin Radio Exhibition and AES members in London during the summer of 1971.

The CBS-SQ disc recording system retains the two basic stereo modulations, that is, at ± 45 degrees to the horizontal. The LH modulation becomes the left front 'quad' channel and the RH modulation becomes the right front 'quad' channel. In addition, the SQ system provides two new modes of modulation for the remaining two channels.

To record an SQ master disc all four channels of a master tape are passed through the SQ encoder, which preserves undiluted the signals, of the front two channels enabling them to be recorded exactly like those of normal stereo discs.

It also produces two additional 'circular' modulations, corresponding to the rear channels. As the disc rotates and the groove advances, a clockwise helix (spiral) is produced for the left back channel and a counterclockwise helix is produced for the right back channel. These two spirals carry the rear channel information in the SQ disc. See diagram.

As is customary with matrix methods, to create the quadraphonic material, a special de-

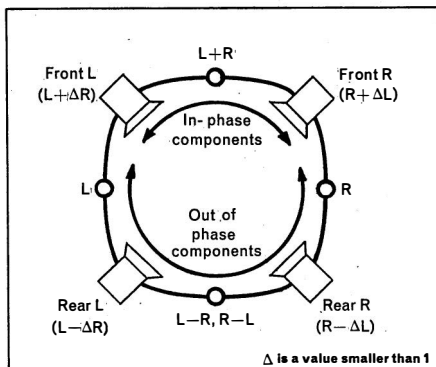

Figure 6 The sound field produced by the Sansui QS system in which crosstalk between adjacent channels is equally 3dB and the four channels are reproduced uniformly. Distinct sound images can be located accurately in any direction inside the square and the presence is said to be greatly enhanced

coder is needed. Sony is manufacturing suitable models for the CBS-SQ system, outside the USA, although non-exclusively. In a more complex form of the SQ decoder, an electronic 'logic' circuit is provided which senses the existence of the predominant signals in the four channels and instantaneously directs the changes in the amplification of these channels, with the aim of adding more realism.

Probably the strongest selling point for the CBS-SQ technique, now taken up by EMI and other organizations, is that their new quadrasonic discs are fully compatible with existing stereo and, indeed, mono disc reproducing equipment.

This means anyone buying the records can play them on his present hi-fi system, or modest record player, and yet be able to start his 'quad' record collection at the same time. This two-way compatibility applies not only to present day records, but also to broadcasting systems in general use. All that is needed is suitable hardware to enjoy the full advantage of four-channel sound.

Put another way, one's present hi-fi system is not rendered obsolete. Some additional items will be required, good loudspeakers will still sound better than inferior types, and a good pick-up is still to be preferred.

Four-channel tape systems are now available for car installations, and experimental radio programmes have been transmitted in four-channel

format over several FM/VHF stations in the USA.

Four-channel simulation is possible by using time delay systems. Most of these devices appear to rely on psychoacoustic phenomena like the Haas precedence effects. The least expensive time delay device generally available is, of course, a spring type reverberation unit (such as the Grampian model) and the designs differ mainly in the length of the spring fitted, and the means of damping to avoid "bonging" noises.

Other methods to achieve time delay for this purpose include a tape deck system, using two displaced heads, with one head supplying signals to the front amplifiers and speakers, and the second head feeding the rear amplifiers and loudspeakers. This ambience system is due to E. R. Madson, of Bang & Olufsen.

Electro-acoustical methods of generating time delays for producing pseudo four-channel stereo involve the use of folded pipe structures, perhaps 60 ft. long, with tiny microphones located at different positions to provide specific time delays of adjustable amplitude. Another similar, but more complex device, has been created by Prof. Duane Cooper, of the University of Illinois. This consists of a copper tube, with pickup and driver transducer elements, plus an equalizer. Delays of about 14 to 16 mS. are obtainable, at low levels of distortion and good S/N ratio.

Probably the most advanced of these time delay devices has been developed by two MIT engineers. Known as the Delta-Tau model 101 digital audio signal delay unit, this solid-state unit accepts analogue signals, converts them into digital signals for storage in a memory core, finally reconverts them to analogue type, with delays available up to 320 mS. in 5-mS. increments.

All these techniques are aimed at providing more spatial realism in domestic sound reproduction, but it seems doubtful that any one will be adopted in place of the competing matrix or discrete systems for "true" quadraphony. The methods would seem to be better adapted as a tool for the recording engineer in the first stage.

As we close for Press, we learn that a joint agreement has been made between Electro-Voice, Gulton Industries and Columbia Records, which enables E-V to introduce a professional encoder that makes compatible the matrix coding system of both companies. The E-V Universal Chip which will now be available to

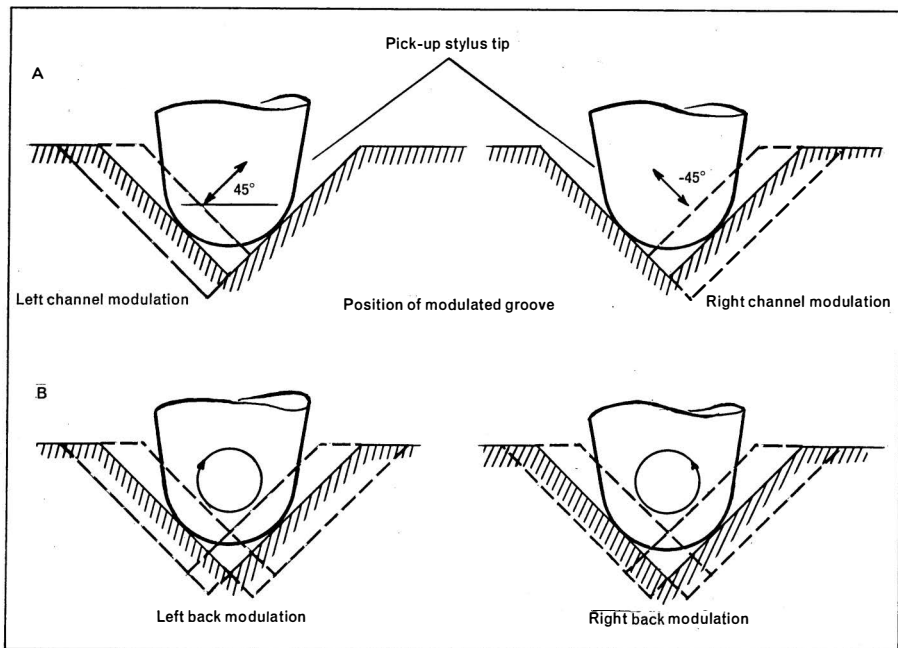

Figure 7 Cross sectional diagrams of stylus tip in record groove. (A) shows conventional 45/45° modulations in stereo recording. (B) illustrates additional helical modulations for rear channel sound, as developed by the CBS Laboratories for their SQ four-channel discs.

original equipment manufacturers, contains the decoding circuitry to process *all* current matrix encodings.

Which of these four-channel techniques will become an accepted world standard remains to be seen, and considerations beyond the immediate cost of the extra equipment may well determine or certainly strongly influence its final acceptability. By this remark is meant the limited space available in many modern homes to site additional loudspeakers, not to mention the problems of persuading the distaff side of the household to allow more boxes in the living room!

The industry will certainly not be happy to let this development remain the province of affluent audiophiles living in large rooms with no womenfolk. All is not lost, however, as JVC—and a few other firms—have designed ingenious high quality dynamic four-channel/two-channel compatible headphones, the JVC model incorporating built-in phase-shifter switches to appreciate 'dynamic presence'.

We seem to have gone full circle, and it is worth recalling that a Parisian engineer, Clément

Ader, patented in Germany in 1881 a system for relaying, over telephone headsets, performances from the Paris Opera, in binaural sound!

SELECTED REFERENCES

1. H. Burrell Hadden, *Practical Stereophony*, Iliffe, 1964.
2. Geoffrey Shorter, Four-Channel Stereo, Parts 1 and 2, *Wireless World*, Jan. and Feb. 1972.
3. Peter Scheiber, Four Channels and Compatibility, *Journal, Audio Engineering Society*, Vol. 19, 1971, pp. 267–279 (April).
4. B. B. Bauer, D. W. Gravereaux, A. J. Gust, *A Compatible Stereo-Quadraphonic (SQ) Record System*, *Journal AES*, Vol. 19, 1971, pp. 638–646 (September).
5. *Quadraphonics*, by various authors, *Audio*, USA. Vol. 55, No. 10, 1971 (October).
6. M. Gerzon, Experimental Tetrahedral Recording, *Studio Sound*, Aug., Sept. and Oct. 1971.
7. Duane Cooper, How Many Channels?, *Audio*, November, 1970.
8. Joe Shane, The Matrix and 4-Channel Stereo, *Radio-Electronics*, June, 1972.

Abbreviations

A	- - ampere	m	- - metres	VHF	- - very high frequency (VHF radio approx 88-108MHz, VHF TV approx 174-216MHz)
A-B	- - comparison test	M	- - megohms (millions of ohms)	V	- - volts or voltage
AC	- - alternating current	mA	- - milliamps (0.001A)	VA	- - volt/ampere
AFC	- - automatic frequency control	mag	- - magnetic	vci	- - voice coil impedance
AGC	- - automatic gain control	ME	- - magic eye	VU	- - volume units
AM	- - amplitude modulation	MC	- - moving coil	W	- - watts
ASA	- - Acoustical Society of America	mg	- - milligram	W and F	- - wow and flutter
aux	- - auxiliary	MHz	- - megahertz (see Hz)	xtl	- - crystal (pickup or microphone)
BAF	- - bonded acetate fibre	mic	- - microphone	Z	- - impedance
CCIR	- - International Radio Consultative Committee	MOS	- - metal oxide semiconductor	Miscellaneous	
char	- - characteristic	mpx	- - multiplex	%	- - per cent
cm	- - centimetre	mV	- - millivolts (0.001V)	>	- - greater than
c/o	- - cut-off frequency	MW	- - medium waves (approx 185-570m)	<	- - less than
coax	- - coaxial *	N	- - newton (SI unit of force).	±	- - plus or minus
dB	- - decibel	NAB	- - National Association of Broadcasters (see also NARTB)	≥	- - equal to or greater than
dBm	- - decibel/milli watt	NARTB	- - National Association of Radio and Television Broadcasters (USA).	≤	- - equal to or less than
DC	- - direct current	NL	- - noise level	μ	- - mu (micro or millionth)
deg	- - degrees	Pat	- - power available for tuner	μA	- - microamp
det	- - detector	pF	- - picofarad (10 ⁻¹² farad)	μV	- - microvolt
DIN	- - Deutscher Industrie Normen (German audio standards)	PPM	- - peak programme meter	μBar	- - microbar (air pressure equal to 1 dyne/cm ²)
disc	- - discriminator	Psn	- - power supply needed		
FET	- - field effect transistor	PT	- - purchase tax (UK only)		
ffss	- - full frequency stereo sound (Decca)	PU	- - pickup cartridge		
fl oz	- - fluid oz	Pw	- - playing weight		
FM	- - frequency modulation	Q	- - Q-factor (quality of tuned circuit)		
FR	- - frequency response	ref	- - recommended crossover frequency		
gm	- - gramme	rec load	- - recommended load		
HC	- - handling capacity	Replay			
HD	- - harmonic distortion	char	- - replay characteristic		
HF	- - high frequency	RIAA	- - Record Industry Association of America		
H & N	- - hum and noise	RMS	- - root mean square (0.707 peak value of AC)		
H z	- - hertz (cycles per second)	rpm	- - revolutions per minute		
IC	- - integrated circuit	sec	- - second (time)		
IEC	- - International Electro-technical Commission	sel	- - selector switch		
IF	- - intermediate frequency	S/N	- - signal-to-noise ratio		
IHFM	Institute of High Fidelity (USA)	SW	- - short waves (approx 10-60m)		
imp	- - impedance	THD	- - total harmonic distortion		
in	- - inches	thou	- - thousandths of an inch (0.001 in)		
ind	- - indicator	tpi	- - turns per inch (screw threads)		
i/s	- - inches per second	UHF	- - ultra high frequency (approx 470-854MHz)		
K	- - kilohms (thousands of ohms)				
kHz	- - kilohertz (see Hz)				
lb	- - pound (weight)				
L/C	- - inductance/capacitance				
LP	- - long play (records or tape)				
LW	- - long waves (approx 1100-2000m)				

Decca's Very Special Products

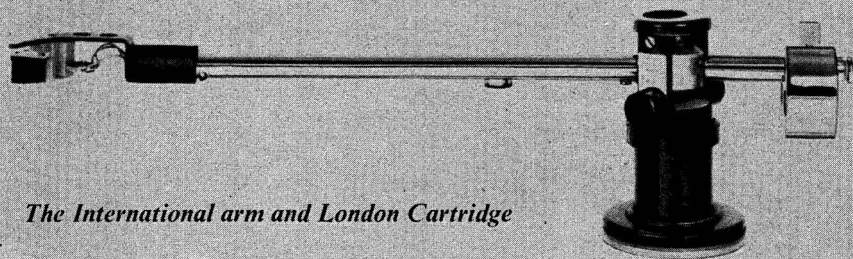

The International arm and London Cartridge

The Decca International Pick-up arm

A superbly engineered pick-up arm for use with the majority of high grade cartridges and incorporating many unique principles:
Magnetic Bias compensation
Inverted Jewelled uni-pivot
Optional lateral and vertical damping
Magnetic floating action
Accurate balance and playing weight adjustment

The London Cartridge

The latest in the renowned *ffss* range and may be used with most top quality arms. Features include;
Positive Scanning
Revolutionary circuit designs
Essentially stable performance and flat response
Mass only 4 grams

The Deram Cartridge

The Deram is instantly recognisable by its unique shape and is now regarded as *the* outstanding ceramic cartridge, giving a freedom from high-frequency distortion comparable to the most expensive pick-ups available. It can be fitted with either a spherical or an elliptical stylus, and is remarkable value for money.



For full details of these and other Decca High Fidelity Products write to:-
Decca Special Products Division, Ingate Place, Queenstown Road, London SW8

3009 Improved

Since their inception our precision pick-up arms have been the subject of continuous detail refinement. Now the almost universal use of lightweight magnetic cartridges enables us to employ a re-designed balance system and non-detachable shell with advantage.

Where the facility is demanded an alternative version, the Model 3009/S2 Improved is similar but has a detachable shell. Its mass is consequently higher than the standard model.

Following our established policy earlier arms can be updated at the factory. Particulars are available from our Service Department.



SME

The best pick-up arm in the world

Write to SME Limited · Steyning · Sussex · England
Telephone Steyning (0903) 814321

LTD/S11

Directory of Pickups and Arms

★ Indicates entry is illustrated

Abbreviations used in this section are given on page 36.

■ ACOS

Cosmocord Ltd, Eleanor Cross Road, Waltham Cross, Herts.
Tel: Waltham Cross 27331. Telex: 24294.

GP91-1 SC ★

Mono/stereo compatible crystal cartridge. Turnover dual stylus. Pw: 3-6gm. Tip mass 2.5 milligram (sapphire), 2.8 milligram (diamond). Dynamic compliance: vertical 2×10^{-6} cm/dyne, lateral 4×10^{-6} cm/dyne. FR: 50Hz-12kHz. Output: 178mV. Min load 1 megohm. Approximate prices: (sapphire/sapphire) £1.70 (including PT); (diamond/sapphire) £2.23 (including PT).

GP92-1 SC

Mono ceramic cartridge. Turnover stylus assembly. Stereo/LP 0.6/0.8 thou diamond or sapphire, 78 2.5 thou sapphire. Pw: 4-10gm. Tip mass 2.5mg dynamic. Compliance: 2.5×10^{-6} . FR: 150Hz-16kHz ± 3 dB, 12dB down at 30Hz relative to 1kHz. Output: 100mV. Load impedance 1 megohm. Low temperature coefficient. Approximate prices: (sapphire/sapphire) £1.86 (including PT); (diamond/sapphire) £2.50 (including PT).

GP93 ★

Stereo crystal cartridge. Turnover dual stylus. Stylus 0.6/0.8 thou diamond or sapphire, 2.5 thou sapphire. Pw: 4-8gm. Tip mass 2.5mg dynamic. Compliance: vertical 2.2×10^{-6} cm/dyne, lateral 2.2×10^{-6} cm/dyne. FR: flat 250Hz-18kHz 3dB down at 100Hz relative to 1kHz. Output: 250mV. Rec load 1 megohm. Low temperature coefficient. Approximate prices: (sapphire/sapphire) £2.50 (including PT); (diamond/sapphire) £3.10 (including PT).

GP94

Stereo ceramic cartridge. Turnover dual stylus. Stylus 0.6/0.8 thou diamond or sapphire, 2.5 thou sapphire. Pw: 2-4gm. Tip mass 2.5mg dynamic. Compliance: lateral 5×10^{-6} cm/dyne, vertical 6×10^{-6} cm/dyne. FR: flat 100Hz-12kHz, 7-8dB at 30Hz relative to 1kHz. Separation 20dB at 1kHz, 8dB at 10kHz, minimum. Output: 80mV average. Load impedance: 1 megohm

each channel. High capacity ceramic elements (1,000pF). Low temperature coefficient. Approximate prices: (sapphire/sapphire) £2.80 (including PT); (diamond/sapphire) £3.40 (inc. PT).

GP95

Specification and price as GP93. Stylus (LP) 0.5-0.6 thou; (stereo/LP) 0.6/0.8 thou.

GP96

Specification and price as GP94. Stylus (LP) 0.5-0.6 thou; (stereo/LP) 0.6/0.8 thou.

104 ★

Stereo ceramic cartridge. Two versions; turnover and single-sided. Stylus: 0.5/0.7 thou and 2.5/3 thou. Sapphire or diamond. Pw: 3-4gm. Tip mass: 2-3mg. Compliance: (static) lateral 20×10^{-6} , vertical 17×10^{-6} ; (dynamic) lateral 6×10^{-6} , vertical 5×10^{-6} . Separation: 20dB at 1kHz, 7dB at 10kHz. FR: 70Hz-15kHz + 5dB. Output: 100mV. Rec. load minimum 1 megohm. Approximate prices: (sapphire/sapphire) £3.90 (including PT); (diamond/sapphire) £4.52 (including PT); (diamond/diamond) £4.93 (including PT).

104 Transcription ★

Stereo ceramic cartridge. Single sided. Diamond stylus 0.5/0.7 thou. Pw: 2-5gm. Tip mass 1.6-2.6mg. Compliance: (static) lateral 20×10^{-6} cm/dyne, vertical 17×10^{-6} cm/dyne; (dynamic) lateral 6×10^{-6} cm/dyne, vertical 5×10^{-6} cm/dyne. FR: 70Hz-12kHz ± 5 dB. Channel separation not less than 20dB at 1kHz. Output: 100mV. Rec. load: 1 megohm minimum. Approximate price: £4.50 (including PT).

■ AUDIO DEVELOPMENTS

UK distributors: B. H. Morris & Co (Radio) Ltd, 84-88 Nelson Street, Tower Hamlets, London, E1 2DY. Tel: 01-790 5011.

AD76K

Moving magnet stereo cartridge for stereo and LP only. FR: 20Hz-20kHz. Sensitivity 5mV at 1kHz. Diamond stylus. Channel balance within 2dB. Separation 20dB. Compliance: 10×10^{-6} cm/dyne. Tracking force 0.5gm. Weight: 5gm. Dimensions: $30 \times 10 \times 16$ mm with standard $\frac{1}{2}$ in centres. Price: £4.30 (including PT). Replacement stylus JS-P1 £1.97 (including PT).

AD76KE

Similar specification to AD76K but fitted with elliptical diamond stylus. Price: £7.40 (including PT); replacement stylus AA25E £5.40 (including PT).

■ AUDIO DYNAMICS CORPORATION

Sole UK agents: Hisonic Ltd, Tovil, Maidstone, Kent. Tel: Maidstone 57258.

ADC 25 ★

Stereo cartridge. Induced magnet. Sensitivity:



Acos GP91-ISC

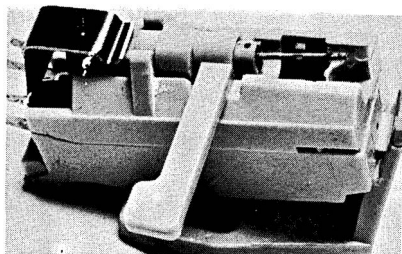

Acos GP93 Crystal Stereo

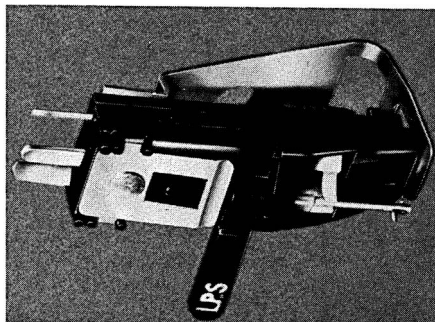

Acos 104

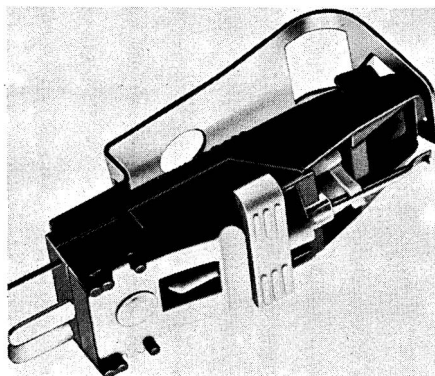

Acos 104 Transcription

4mV at 5.5cm/sec. Separation: 30dB, 50Hz-15kHz. FR: 10Hz-24kHz \pm 2dB. Vertical tracking angle 15°. Pw: $\frac{1}{2}$ -1 $\frac{1}{4}$ gm. Cartridge weight: 8.3gm. Stylus: 0.3 \times 0.7 or 0.3 \times 0.9 or 0.6 thou spherical. Compliance: 50×10^{-6} cm/dyne. Price: £69.95 (plus £11.03 PT).

ADC 26

Stereo cartridge. Induced magnet. Sensitivity: 4mV at 5.5cm/sec. Separation: 30dB, 50Hz-15kHz. FR: 10Hz-24kHz \pm 2dB. Vertical tracking angle 15°. Pw: $\frac{1}{2}$ -1 $\frac{1}{4}$ gm. Cartridge weight: 8.3gm. Stylus: 0.3 \times 0.7 thou. Compliance: 50×10^{-6} cm/dyne. Price: £49.95 (plus £7.91 PT).

ADC 10E Mk IV ★

Stereo cartridge. Induced magnet. Sensitivity: 4mV at 5.5cm/sec. Separation: 30dB from 50Hz-12kHz. FR: 10Hz-20kHz \pm 2dB. Vertical tracking angle 15°. Pw: $\frac{1}{2}$ -1 $\frac{1}{2}$ gm. Stylus: 0.3 \times 0.7 thou. Compliance: 35×10^{-6} cm/dyne. Price: £29.95 (plus £4.74 PT).

ADC 550XE

Stereo cartridge. Induced magnet. Sensitivity: 5mV at 5.5cm/sec. Separation: 25dB, 50Hz-12kHz. FR: 10Hz-20kHz \pm 2dB. Vertical tracking angle 15°. Pw: $\frac{3}{4}$ -2 $\frac{1}{2}$ gm. Cartridge weight: 8.0gm. Stylus: 0.3 \times 0.7 thou. Compliance: 35×10^{-6} cm/dyne. Price: £14.95 (plus £2.37 PT).

ADC 220XE ★

Stereo cartridge. Induced magnet. Sensitivity: 6.0mV at 5.5cm/dyne. Separation: 20dB, 50Hz-10kHz. FR: 10Hz-18kHz \pm 3dB. Vertical tracking angle 15°. Pw: 1 $\frac{1}{2}$ -3gm. Stylus: 0.3 \times 0.7 thou. Compliance: 20×10^{-6} cm/dyne. Price: £8.95 (plus £1.42 PT).

■ AUDIO TECHNICA

Distributors: Shiro (UK) Ltd,
42 Russell Square, London, WC1B 5DF.
Tel: 01-580 6996.

AT21

Stereo magnetic cartridge. Stylus: 0.7 thou (compatible) or 0.5 thou (stereo only). Also available with 0.7 \times 0.3 elliptical stylus. All diamond. Pw: (0.7 and 0.5) 1-2gm, (elliptical) $\frac{1}{2}$ -2gm. Effective tip mass: 0.6mg. Compliance: 30×10^{-6} cm/dyne. FR: 20Hz-25kHz \pm 2dB. Channel separation: 31dB at 1kHz. Output: 1.6mV/cm/sec. Price: (0.7 and 0.5 thou stylus) approximately £11 (including PT). (elliptical) approximately £17 (including PT).

AT66

Stereo magnetic cartridge. Stylus: (diamond) 0.5, 0.7, 2.5 or elliptical. Pw: 1-2.5gm. Effective tip mass: 0.6mg. Compliance: 30×10^{-6} cm/dyne. FR: 20Hz-20kHz \pm 2dB. Channel separation: better than 25dB at 1kHz. Output: 1mV/cm/sec. Price: (0.5, 0.7 and 2.5 thou stylus) approximately £6.50 (including PT). (elliptical) approximately £15.90 (including PT).

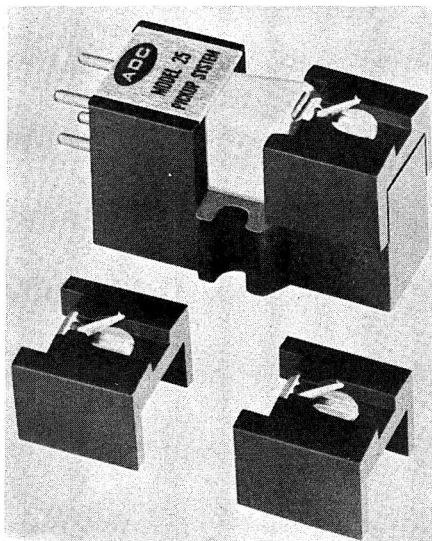

ADC 25

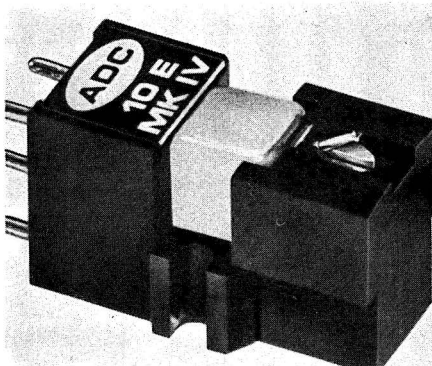

ADC 10E Mk IV

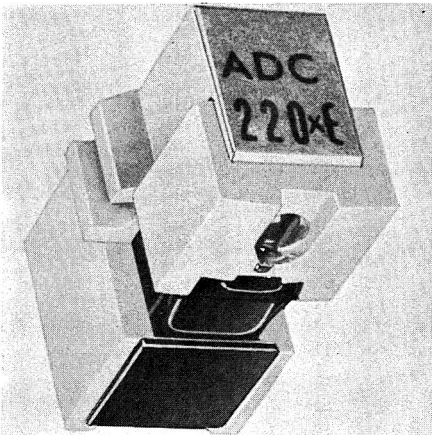

ADC 220XE

AT1005 Mk II

Tubular counter-balanced pickup arm. Length 12 $\frac{3}{4}$ in. Effective length: 9 $\frac{1}{2}$ in. Bias compensation. Calibrated weight adjustment. Hydraulic lift and lowering. Tracking error: <1.5 deg. Price: £16.25 (plus £2.53 PT).

■ **BANG & OLUFSEN UK LTD**

Eastbrook Road, Gloucester, GL4 7DE.

Tel: Gloucester 21591.

SP10, SP12 ★

Stereo cartridges. Standard $\frac{1}{2}$ in centres. Moving iron. Pw: 1-1.5gm. Compliance: 25 \times 10⁻⁶cm/dyne. FR: 15Hz-25kHz \pm 3dB. Separation: >25 dB at 1kHz. Output: 5mV per channel (1mV/cm/sec). Rec. load 47K. Effective tip mass <1 mg. SP10: 0.6 thou diamond. SP12: 0.7 \times 0.2 thou diamond (interchangeable). Price: (SP10) £9.95 (including PT); (SP12) £14.95 (including PT).

SP10A, SP12A

Plug-in versions of the SP10 and SP12, for use with Beogram 1800. Price: (SP10A) £9.95 (including PT); (SP12A) £14.95 (including PT).

SP14, SP14A

Identical to SP10 and SP10A respectively except for compliance which is 15 \times 10⁻⁶cm/dyne. Price: £7.95 (including PT).

ST/L

Pickup arm. Price: (with SP7 cartridge) £16.95 (including PT).

Pickup lift for ST/L arm

Gives hydraulically controlled lowering. Price: £3.95 (including PT).

SP15

Stereo magnetic integrated cartridge. Factory sealed assembly, no replacement stylus available. Stylus: 0.2 \times 0.65 thou diamond. Pw: 1gm. Compliance: 30 \times 10⁻⁶cm/dyne. FR: 50Hz-20kHz \pm 1.5dB. Separation: 24-30dB at 1kHz, 20dB at 500Hz-10kHz. Output: 0.6mV. Rec. load: 47K. Price: to be announced.

■ **COLTON**

Musonic Ltd, 34-38 Verulam Road, St Albans, Herts. Tel: St Albans 50611/2.

MC101

Precision pickup arm. Bias compensator. Hydraulic lift and lowering device. Ultra-lightweight headshell. Laterally balanced. Accepts most modern cartridges. Price: £15 (plus £2.40 PT).

MC-101

Precision pickup arm. Length: (overall) 13in, (effective) 9 $\frac{3}{8}$ in. Overhang: $\frac{5}{8}$ in approximately. Tracking error: +1.5° - 0.5°. Stylus pressure: adjustable 0-4gms. Recommended cartridge weight: 3-18gms. Headshell: light alloy 1mm

★ Indicates entry is illustrated

thick four-pin universal. Anti-skating bias. Lateral balance. Direct reading stylus pressure control. Hydraulic lift device. Precision ground pivot bearings. Price: to be announced.

■ CONNOISSEUR

A. R. Sugden & Co (Engineers) Ltd,
Market Street, Brighouse, Yorkshire.
Tel: Brighouse 2142. Cables: Connoisseur,
Brighouse.

SCU1 ★

Stereo ceramic cartridge with $\frac{1}{2}$ in fixing centres. Stylus diamond 0.5-0.6 thou or 1 thou for mono. Pw: 2-4gm. Tip mass 1mg. Compliance: lateral 12×10^{-6} cm/dyne; vertical 8×10^{-6} cm/dyne. Range: 25Hz-18kHz \pm 3dB. Separation (1kHz) 25-30dB; (10kHz) 18dB. Output with rec. load

of 100K, 50mV per channel, RIAA equalisation required. Output with 2 megohm load, 150mV per channel, no equalisation required. Features: Four-terminal output, easily replaceable diamond stylus. Price: £5 (plus 80p PT).

SAU2

Pickup arm with gimbal mountings on ball bearings set at 45/45. Automatic bias compensator. Hydraulic lowering device. Decoupled counterbalance weight. Additional weight supplied to accommodate different cartridges. Single hole fixing. Height adjustable from 1in to 2in. Lightweight shell with $\frac{1}{2}$ in fixing centres. Five-pin plug connection to base of pickup. Low resistance self-cleaning contacts. New head shell allows backward-forward horizontal adjustment so that minimum tracking error is obtained with

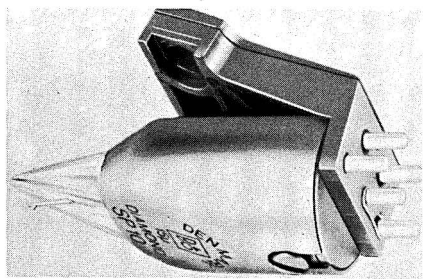

Bang & Olufsen SP10

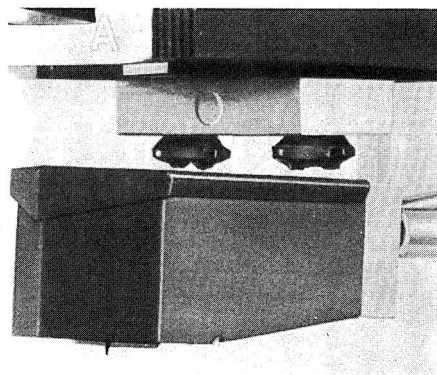

Decca London Cartridge

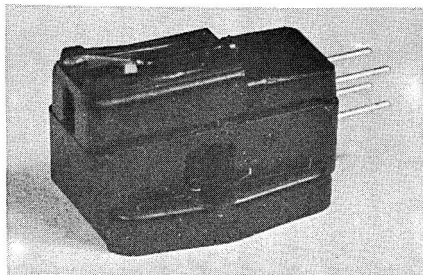

Connoisseur SCU1

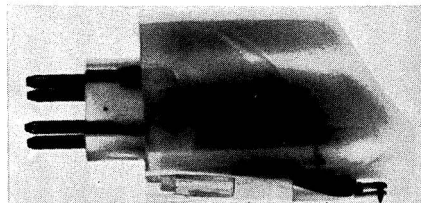

Decca Deram

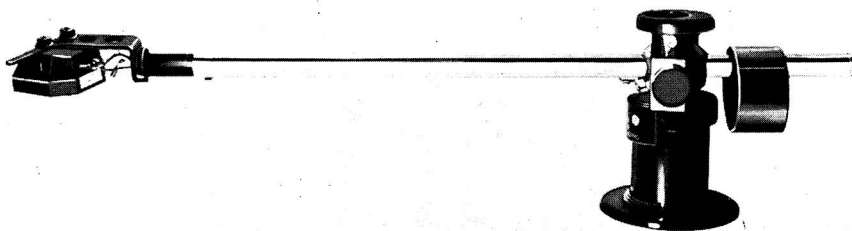

Decca International Arm

all cartridges. Alignment protractor provided. Supplied with set of leads and separate precision balance with range 0-6gm. Price: £12 (plus £1-92 PT). Extension stem for use with high turntables: 35p.

■ COSMOCORD See Acos

■ DECCA

Decca Special Products, Ingate Place, Queenstown Road, London, SW8 3NT. Tel: 01-622 6677.

Deram ceramic (New series)

Stereo/mono cartridge. White shell transcription quality. Pw: 2.5gm. Tip mass 0.6mg. Compliance: 9×10^{-6} lateral, 5×10^{-6} vertical. FR: 18Hz-18kHz \pm 3dB. Separation better than -20 dB at 1kHz. Output: 200mV at 5cm/sec. Rec. load impedance 2 megohms. Stylus: diamond. Price: (spherical stylus) £4.31 (plus 69p PT); (elliptical stylus) £5.17 (plus 83p PT).

NOTE

All Deram cartridges are of transcription quality, the black shell range intended primarily for cheaper auto-changers is discontinued.

Deram ceramic ★

Mono cartridge. Stylus 1 thou diamond. All other details as for stereo/mono cartridge. Price £4.31 (plus 69p PT).

ffss Mk 4 cartridge C4E

Stereo/mono cartridge. FR: 20Hz-20kHz (20Hz-16kHz \pm 2dB). Separation as for Mk II. Output: 5mV at 5cm/sec per channel. Stylus 0.3 \times 0.65 thou elliptical diamond. Pw: 1-2½gm. Compliance 30×10^{-6} lateral, 6×10^{-6} vertical. Rec. load 50K. Output from each channel balanced within 1dB. Price: £18.74 (plus £3.01 PT).

ffss Mk 4 cartridge 4RC

Stereo magnetic head. Diamond stylus 0.5/6 thou. Pw: 3.5gm. Tip mass less than 1 milligram. Compliance: 15×10^{-6} cm/dyne lateral, 4×10^{-6} cm/dyne vertical. FR: 30Hz-20kHz (30Hz-16 kHz \pm 3dB). Separation: better than 20dB. Output: 1.5mV at 1 cm/sec at 1kHz. Rec. load 47K. Price: £14.22 (plus £2.28 PT).

ffss Mono 78

Variable reluctance 78 equivalent of Mk II stereo/mono head. Stylus 2.8 thou diamond. Price: £8.75 (plus £1.40 PT). Available to special order only.

ffss Mk 4 cartridge 78C

Mono magnetic cartridge. Diamond stylus 2.8 thou. Pw: 3.5gm. Tip mass less than 1 milligram. Compliance: 15×10^{-6} cm/dyne lateral. FR: 30 Hz-16kHz \pm 3dB. Output: 1.5mV cm/sec. Rec. load: 47K. Available to special order only. Price: £8.75 (plus £1.40 PT).

London ★

Stereo magnetic cartridge. *ffss* sum-and-difference system. Stylus: 0.6 thou spherical diamond. Pw: 3gm. Effective tip mass: < 1mg. Compliance: (lateral) 12×10^{-6} cm/dyne, (vertical) 5×10^{-6} cm/dyne. FR: 20Hz-20kHz. Channel separation: better than 20dB. Output: 1.5mV. Rec. load: 47K. Price: £23.27 (plus £3.37 PT).

London cartridge adaptors

Type A. Simple slide-on adaptor for use with *ffss* arms (Mk I, Mk I Super and Professional) to accommodate the London cartridge. Automatically adjusts playing weight. Price: to be announced. Type B. Simple slide-on adaptor for use with International arm to accommodate the London cartridge. Collar arrangement to adjust for correct playing weight. Price: to be announced.

ffss 'International' Arm ★

Stereo pickup arm. Jewelled uni-pivot. Pw: ½-3½ gm. Constantly variable magnetic bias compensation. Suspended on magnetic cushion. Provision for damping lateral and vertical resonances. Price: £21.97 (plus £3.53 PT).

Deram heads are suitable for use with amplifiers having a sensitivity of 100mV.

Diamond styli for all Deram pickup heads, including 78 heads, are £1.45 each including PT. Replacement Deram elliptical styli are now available at £2.50 each (including PT).

Decca *ffss* pickup heads can be inspected for a charge of 70p. When the stylus is worn on a Decca *ffss* head it must be returned to the maker for replacement. The service offered is complete replacement of the head with a reconditioned head having a new stylus. Performance is guaranteed to be as new. Prices for this service are as follows: Mk III elliptical styli £7.70; Mk I and Mk II spherical styli £6.20; mono LP and 78 styli £6; Mk 4 H4E and C4E elliptical styli £8.50; Mk 4 SH4E and SC4E elliptical styli £11; Mk 4 78C spherical styli £5.50. All prices include PT.

■ EAGLE INTERNATIONAL

Heather Park Drive, Wembley, HA1 1SU. Tel: 01-903 0144.

LC05

Stereo cartridge. Moving magnet. FR: 30Hz-18 kHz. Compliance: 9×10^{-6} cm/dyne. Separation: 20dB at 1kHz. Output: 6mV per channel. Rec. load: 47K. Price: £4.15 (plus 71p PT).

LC07 ★

Stereo cartridge. Moving magnet. LP and stereo. FR: 20Hz-21kHz. Compliance: 12×10^{-6} cm/dyne. Separation: 28dB at 1kHz. Output: 7mV per channel. Rec. load: 47K. Price: £5.56 (plus 95p PT).

★ Indicates entry is illustrated

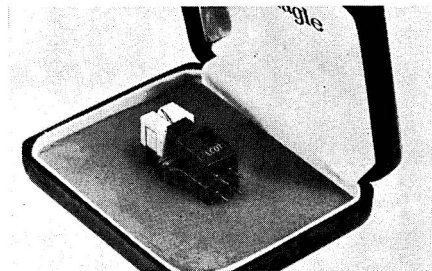

Eagle LC07

■ EMPIRE SCIENTIFIC

Empire Scientific Corporation, U.S.A.
Distributors: Rank Audio Visual Ltd,
PO Box 70, Great West Road,
Brentford, Middlesex, TW8 9HR.
Tel: 01-568 9222. Telex: 24408.

90EE/X

Stereo magnetic cartridge. Elliptical diamond stylus, 0.4×0.7 thou. Compliance: 15×10^{-6} cm/dyne. FR: 15Hz-25kHz. Separation: 30dB. Output: 8mV. Price: £8 (plus £1.30 PT).

909E/X

Stereo magnetic cartridge. Elliptical diamond stylus, 0.4×0.7 thou. Compliance: 15×10^{-6} cm/dyne. FR: 12Hz-25kHz. Separation: 30dB. Output: 8mV. Price: £10.35 (plus £1.68 PT).

999E/X

Stereo magnetic cartridge. Elliptical diamond stylus, 0.3×0.7 thou. Pw: $\frac{3}{4}$ -2gm. Compliance: 25×10^{-6} cm/dyne. FR: 10Hz-30kHz. Separation: 35dB. Output: 8mV. Price: £13.30 (plus £2.16 PT).

999SE/X

Stereo magnetic cartridge. Elliptical diamond stylus, 0.2×0.7 thou. Pw: $\frac{1}{2}$ -1 $\frac{1}{2}$ gm. Compliance: 30×10^{-6} cm/dyne. FR: 8Hz-32kHz. Separation: 35dB. Output: 8mV. Price: £17 (plus £2.76 PT).

999TE/X

Stereo magnetic cartridge. Elliptical diamond stylus, 0.2×0.7 thou. Pw: $\frac{1}{2}$ -1 $\frac{1}{2}$ gm. Compliance: 30×10^{-6} cm/dyne. FR: 6Hz-32kHz. Separation: 35dB. Output: 6mV. Price: £21 (plus £3.41 PT).

999VE ★

Stereo magnetic cartridge. Hand-polished diamond stylus. Tip: 0.2×0.7 thou. Pw: $\frac{1}{2}$ -1 $\frac{1}{2}$ gm. Compliance: 35×10^{-6} cm/dyne. FR: 6Hz-36kHz. Separation: 35dB. Output: 6mV. Price: £36 (plus £5.85 PT).

1000ZE/X

Stereo magnetic cartridge. Hand-polished dia-

mond stylus. Tip: 0.2×0.7 thou. Pw: $\frac{1}{2}$ -1 $\frac{1}{2}$ gm. Compliance: 35×10^{-6} cm/dyne. FR: 4Hz-40kHz. Separation: 35dB at 1kHz, 25dB at 20kHz. Output: 5mV per channel. Price: £50.50 (plus £8.20 PT).

■ EUPHONICS

Distributors: Farnell-Tandberg Ltd,
81 Kirkstall Road, Leeds, LS3 1HR.
Tel: Leeds 35111.

Miniconic

Semiconductor stereo cartridge. Crystalline silicon element treated so that changing pressures produced by stylus vary the resistance. FR: 20Hz-20kHz \pm 2dB. Pw: 0.5gm. Tracks up to 40kHz. Stylus 0.2×0.7 elliptical diamond. Compliance: 25×10^{-6} cm/dyne horizontal and vertical. Output dependent on setting of power supply unit and adjustable between 8mV at 47K to 400mV at 500K. Also supplies 100mV at 600 ohms. Must have external power source which may be from a separate unit or derived from associated equipment. Prices on application.

Miniconic PS-15F Power Supply

Supplies 6mA polarising current to each element at 14V DC. Inverts phase of one element to provide normal in-phase output signals. Matches impedance and levels to suit any type of pre-amplifier input. Price on application.

■ EXCEL SOUND CORPORATION

Mathers Photographic Ltd, 35 John Dalton Street, Manchester 2. Tel: 061-834 6133.

ES-705

Stereo magnetic cartridge. $\frac{1}{2}$ in mounting centres. Stylus: 0.6 thou spherical diamond. Pw: 2gm. Compliance: 10×10^{-6} cm/dyne. FR: 15Hz-25kHz. Separation: $>$ 20dB at 1kHz. Output: 5mV at 1kHz at 5cm/sec. Price: £5 (including PT); (replacement styli) £1.95 (including PT).

ES70E

Stereo magnet cartridge. $\frac{1}{2}$ in mounting centres. Stylus: 0.2×0.8 thou elliptical diamond. Pw: 1.25gm. Compliance: 15×10^{-6} cm/dyne. FR: 10Hz-30kHz. Separation: $>$ 20dB at 1kHz. Output: 5mV at 1kHz at 5cm/sec. Price: £8 (including PT); (replacement styli) £4.25 (including PT).

ES70EX

Stereo magnetic cartridge. $\frac{1}{2}$ in mounting centres. Stylus: 0.2×0.8 thou diamond elliptical. Pw: 0.7-2gm. Compliance: 20×10^{-6} cm/dyne. FR: 10Hz-35kHz. Separation: 30dB at 1kHz. Output: 3mV at 1kHz at 5cm/sec. Effective tip mass: 0.5 milligram. Price: £20 (including PT); (replacement styli) £11. Cartridge supplied in presentation box with cleaning brush, stylus guard and two sets of mounting screws.

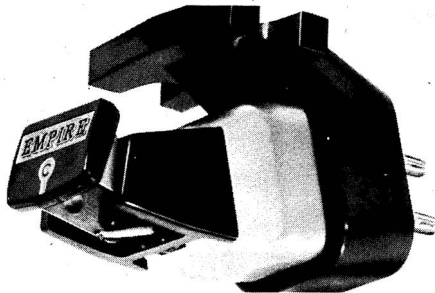

Empire 999VE



Goldring L75 pickup arm

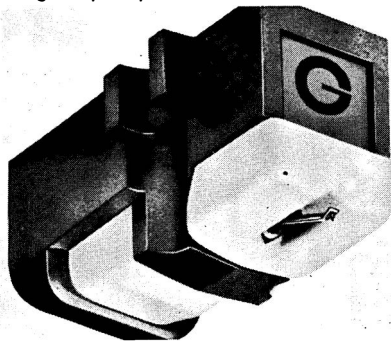

Goldring 800

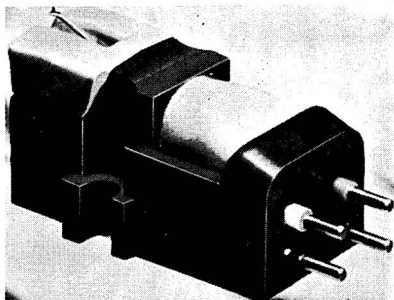

Goldring G800/E Super E

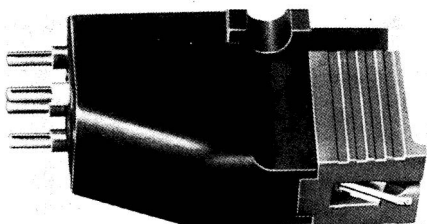

Goldring 850

■ EXPERT PICKUPS LTD

PO Box No. 3, Ashtead, Surrey.

Tel: Ashtead 76604.

See entry in Pickup Accessories Section.

■ GOLDRING MANUFACTURING CO

(Great Britain) LTD

10 Bayford Street, London, E83SE.

Tel: 01-985 1152.

Goldring/Lenco L75 ★

Transcription pickup arm. Calibrated stylus pressure adjustment. Removable plug-in shell with adjustable stylus position. Anti-skating bias compensator. Price: £12 (plus £1.96 PT).

Goldring/Lenco L69

Pickup arm. Stereo. Low mass tubular arm. Removable plug-in shell with stylus position adjustment. Sliding counterweight stylus pressure adjustment, height adjustment. Price: £9 (plus £1.46 PT).

CS90

Stereo ceramic cartridge. Stylus 0.5 or 0.7 thou diamond. Pw: 2gm. Compliance: 8×10^{-6} cm/dyne. FR: 30Hz-20kHz. Separation: 20dB at 1kHz, 10dB at 10kHz. Output: 80mV. Rec. load: 1-2 meohms. Price: £4.20 (plus 68p PT).

CS91E

Stereo/LP ceramic cartridge. Stylus: elliptical diamond. Pw: 1.3gm. Tip mass 1mg. FR: 30Hz-20kHz. Separation: 20dB. Output: 30mV. Rec. load: 1-2 megohms. Price: £6.30 (plus £1.03 PT).

'800' ★

Stereo magnetic cartridge. Stylus 0.5 thou diamond. Pw: $1\frac{1}{2}$ -2 $\frac{1}{2}$ gm. Tip mass less than 1mg. Compliance: 20×10^{-6} cm/dyne. FR: 20Hz-20kHz \pm 3dB. Separation: 20dB at 1kHz, 15dB at 10kHz. Output: 1mV. Rec. load: 47K. Price: £10.50 (plus £1.71 PT).

G800E

Stereo magnetic cartridge. Stylus: 0.3 \times 0.7 diamond. Pw: $\frac{3}{4}$ -1 $\frac{1}{2}$ gm. Tip mass: less than 1mg. Compliance: 30×10^{-6} cm/dyne lateral and vertical. FR: 10Hz-23kHz. Separation: 20dB at 1kHz, 15dB at 10kHz. Output: 1mV. Rec. load: 47K-100K. Price: £15.20 (plus £2.47 PT).

G800E Super E ★

Stereo magnetic cartridge. Single-sided with elliptical diamond, 0.3 \times 0.7 thou replaceable. Pw: $\frac{1}{2}$ -1 $\frac{1}{2}$ gm. Tip mass less than 1mg. Compliance 35×10^{-6} . FR: 10Hz-23kHz. Channel separation: 25dB (1kHz) and better than 15dB (10kHz). Output voltage: 0.8mV. Rec. load: 47K. Price: £21 (plus £3.41 PT).

Goldring G800/H

Magnetic stereo cartridge. Single-sided with 0.7 thou tip radius diamond. Replaceable. Pw: 2 $\frac{1}{2}$ -3 $\frac{1}{2}$ gm. Tip mass 1.2mg. Compliance: 18×10^{-6} .

★ Indicates entry is illustrated

FR: 20Hz-20kHz. Separation: 20dB at 1kHz, 10dB at 10kHz. Output: 1.6mV. Rec load: 47K. Price: £8-60 (plus £1.40 PT).

Goldring 850 ★

Magnetic stereo cartridge. Single-sided, $\frac{1}{2}$ in fixing centres. Stylus: 0.7 thou diamond, replaceable. Pw: 2.4gm. FR: 20Hz-18kHz. Separation: 20dB at 1kHz. Output: 1.6mV. Rec. load: 47K-100K. Price: £5.25 (plus 85p PT).

GRADO

Distributors: Howland-West Ltd, 3-5 Eden Grove, London N78EQ. Tel: 01-609 0293/4/5.

F3E ★

Stereo magnetic cartridge. Stylus: 0.7 × 0.3 thou diamond. Pw: $1\frac{1}{2}$ -3 $\frac{1}{2}$ gms. FR: 10Hz-35kHz. Output: 3mV. Price: £14 (plus £1.99 PT).

F2 ★

Stereo magnetic cartridge. Stylus: 0.6 × 0.3 thou diamond. Pw: 1-2gms. FR: 7Hz-60kHz. Output: 3mV. Price: £25 (plus £3.56 PT).

FTR ★

Stereo magnetic cartridge. Stylus: 0.6 thou spherical diamond. Pw: $1\frac{1}{2}$ -3 $\frac{1}{2}$ gms. FR: 10Hz-35kHz. Output: 3mV. Price: £6.50 (plus 92p PT).

FTE ★

Stereo magnetic cartridge. Stylus: 0.7 × 0.3 thou diamond. Pw: $1\frac{1}{2}$ -3 $\frac{1}{2}$ gms. FR: 10Hz-35kHz. Output: 3mV. Price: £10.50 (plus £1.49 PT).

G. F. C. HADCOCK

Audio Division, The Old Vicarage, Doveridge, Derby, DE65NN. Tel: Uttoxeter 2452.

GH Unipivot ★

Featuring a new bearing assembly offering friction of less than 6mg at the pivot. Finely engineered tubular aluminium arm with slotted headshell. Accepts all lightweight cartridges down to 0.5gm. Standard $\frac{1}{2}$ in fixing centres. Easy operation due to simplicity of unipivot design. Bias compensation assembly included. Easily adjusted calibrated weight 0-3gm. GH Unilift lowering device available separately (see pickup accessories section). Size: Length 12 $\frac{1}{2}$ in, height 2.4in, pivot to stylus tip 9in, pivot to centre of turntable 8 $\frac{3}{8}$ in. Offset angle 23°. Rear overhang 3in. Price: £13-60 (plus £2.18 PT).

KEITH MONKS (Audio) LTD

26-30 Reading Road South, Fleet, Aldershot, Hants. Tel: Fleet 7316.

Laboratory 9 ★

9in pickup arm designed for low-mass ultra-high compliant cartridges tracking at very low stylus pressures. Damped unipivot arm with no lead-out wires. Bias correction and lifting device incorporated. Lathe base all fully adjustable by finger locking levers. Price: £25 (plus £4.16 PT).

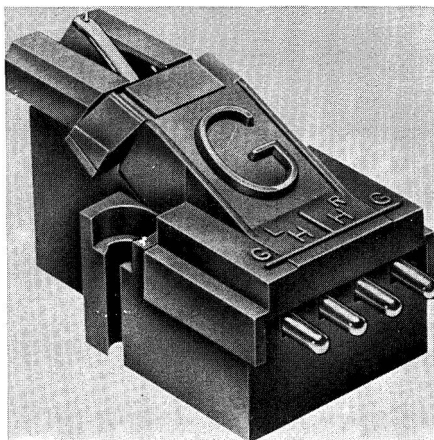

Grado F series

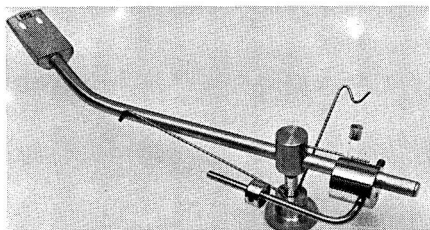

GH Unipivot

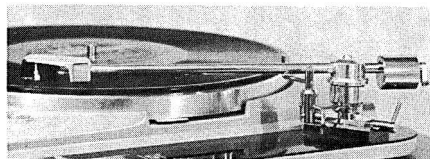

Keith Monks Laboratory 9

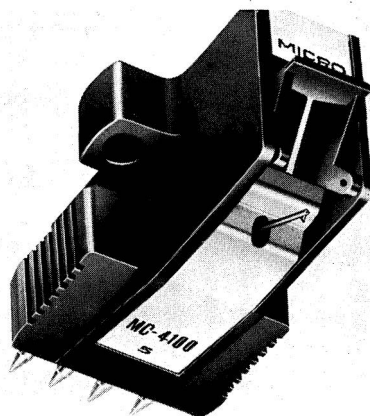

Micro-Seiki MC-4100/5

■ MICRO-SEIKI

Distributors: B. H. Morris & Co (Radio) Ltd,
84-88 Nelson Street, London, E12DY.
Tel: 01-790 5011.

MA-77 Mk-11 (SR)

Static balance S-shape arm. Total length $13\frac{3}{16}$ in, effective length $9\frac{3}{8}$ in. Split revolving counterweight with spare sub-weight for 2-18gm cartridges. Direct-reading scale ring for playing weight adjustment 0-6gm. Spring anti-skate device with adjustable cancel force (0-0.33gm) to eliminate bias. Oil-damped arm lifter. Price: £24.30 (including PT).

MA-101

Static balance S-shape arm. Total length 15in, effective length $10\frac{1}{2}$ in. Split revolving counterweight for 5-24gm cartridges. Direct-reading scale ring. Spring anti-skate device with special cam and variable bias force (0-6gm). Oil-damped arm lifter. De luxe base with Teflon 'stopper', three lateral adjustment screws and temporary rest to protect bearings. Price: £34 (including PT).

MC-4100 ★

Moving-coil stereo cartridge. Suffix/E indicates 0.3 × 0.8 thou stylus; /5 has 0.5 thou round diamond stylus. FR: (-0.5, +2.5dB): 20Hz-20kHz. Separation: 33dB. Compliance: 25×10^{-6} cm/dyne. Tracking force: 1.5gm. Output: 0.1mV (3.45cm/sec). Price: (MC-4100/E) £21 (including PT); (MC-4100/5) £17.50 (including PT).

VF-3100 E11

Variable flux stereo cartridge. /E-11 elliptical, /5-11 round stylus. FR: as above. Sep: 30dB. Compliance: 20×10^{-6} cm/dyne. Tracking force: 2gm. Output: 3mV. Price: £12.95 (including PT).

VF-3100/5

Variable flux stereo cartridge. FR: 5Hz-30kHz. Separation: 30dB. Compliance: 20×10^{-6} cm/dyne. Tracking force: 2gm. Output: 4mV. Price: £9.60 (including PT).

VF-3200/EB

Variable flux stereo cartridge. Pw: $1\frac{1}{2}$ gm. Stylus: 0.3 × 0.8 thou elliptical diamond. Compliance: 30×10^{-6} cm/dyne. FR: 5Hz-35kHz. Separation: 30dB at 1kHz. Output: 3mV at 1kHz (3.54cm/sec). Output balance: less than $\frac{1}{2}$ dB. Rec. load: 47-50K. Cartridge weight: 4.5gms. Price: to be announced.

VF-3200/5

Specification as VF-3200/EB but with 0.5 thou diamond stylus. Price: to be announced.

■ N. MIERS & CO LTD

28 Piercing Hill, Theydon Bois, Epping, Essex.
Tel: Theydon Bois 2611/3.

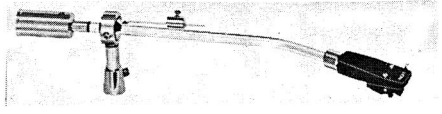

Neat G30

SX6M

Stereo crystal cartridge. LP/78 diamond stylus. Pw: 4-6gms. Output: 280mV. Price: £3.02 (including PT).

SX5H

Stereo crystal cartridge. LP/78 diamond stylus. Pw: 7gms. Output: 700mV. Price: £3.02 (including PT).

SC5M

Stereo ceramic cartridge. LP/78 diamond stylus. Pw: 2-6gms. Output: 110mV. Price: £3.60 (including PT).

SC5H

Stereo ceramic cartridge. LP/78 diamond stylus. Pw: 5-7gms. Output: 190mV. Price: £3.60 (including PT).

SC8M

Stereo ceramic cartridge. LP/78 diamond stylus. Pw: 2-6gms. Output: 110mV. Price: £4.21 (including PT).

■ NEAT CORPORATION

Howland-West Ltd, 3-5 Eden Grove,
London N78EQ. Tel: 01-609 0293/4/5.

G-20/BL

Pickup arm. Raising and lowering device. Bias compensation. Full specification awaited. Price: £15 (plus £2.37 PT).

G30 ★

Transcription arm and shell. Wired for mono or stereo. Easy mounting. Accommodates all standard cartridges. Adjustable tracking weight. Supplied with aluminium head shell, pickup rest, pressure gauge and plug-in leads with phono plugs. Vertical balance by miniature ball bearings, horizontal balance by jewelled pivots. Decoupled balance weight at rear of arm provides coarse adjustment of playing weight, rider weight at side of arm provides fine adjustment. Screw collar permits height adjustment. Pivot to stylus $9\frac{3}{4}$ in. Arm length 13in. Leads 56in. Height (adjustable) $1\frac{3}{4}$ - $3\frac{1}{4}$ in. Mounting hole $\frac{1}{2}$ in dia. Cartridge fixing $\frac{1}{2}$ in centres. Price: £12 (plus £1.90 PT).

Lift

Optional oil lift for G30 arm. Price: £3.70 (including PT).

G30B

Same as G30 but with bias adjuster. Price: £14 (plus £2.21 PT).

★ Indicates entry is illustrated

V60MH

Stereo cartridge. Magnetic. Sensitivity: 3.5mV 1kHz at 5cm/sec. Separation: 30dB 1kHz. FR: 20Hz-20kHz. Rec. load: 30-100K. Rec. playing weight: 1-3gm. Compliance: 15×10^{-6} cm/dyne. Stylus, diamond, spherical. Price: £7 (plus £1.11 PT).

V70

Magnetic stereo cartridge. Stylus 0.5 thou diamond. Pw: $1\frac{1}{2}$ -3gm. Separation: 30dB at 1kHz. Rec. load: 50K. Output: 5mV at 100Hz 5cm/sec. Price: £4.50 (plus 71p PT).

V70E

Stereo magnetic cartridge. Elliptical diamond 0.2 × 0.7 thou. Pw: 1.5-3gm. Compliance: 5×10^{-6} . FR: 18Hz-22kHz. Channel separation: 30dB at 1kHz. Output voltage: 5mV. Load impedance: 50K. Price: £6.75 (plus £1.07 PT).

■ ORBIT

Distributors: Highgate Acoustics, 184-188 Great Portland Street, London, W1. Tel: 01-636 2901.

NM22

Magnetic stereo cartridge with diamond stylus. FR: 20Hz-20kHz. Channel separation: 20dB at 1kHz. Output: 5mV. Load: 50K-100K. Playing weight: 2-3gm. Price: (complete cartridge) £4.75 (including PT); (replacement diamond stylus) £2.75 (including PT).

■ ORTOFON

Distributed in the UK by Metrosound (Sales) Co Ltd, Cartersfield Road, Waltham Abbey, Essex. Tel: Waltham Cross 31933.

SL15/E ★

Moving coil stereo cartridge. Pw: 1-2gm. Tip mass: 0.9mg. Compliance: 25×10^{-6} cm/dyne. FR: 10Hz-40kHz. Separation: 20-30dB. Output: 0.04mV/cm/sec (loaded). Output impedance 2 ohms. Matching transformer required for most amplifiers (see transformer below). Stylus diamond 0.6 × 0.3 thou. Tracking angle: 15°. Price: £25 (plus £4.01 PT).

SL15

Similar specification to SL15/E but with spherical 0.6 thou diamond stylus. Price: £19 (plus £3.05 PT).

Transformer module

Primary impedance: 2 ohms. Secondary impedance: 15K. Load: 10K to 50K without change in frequency response. FR: 20Hz-40kHz. Price: £7.50.

M15E Super

Moving magnet stereo cartridge. Compliance: (horizontal) 50×10^{-6} cm/dyne; (vertical) 30×10^{-6} cm/dyne. Trackability: 80µm. Output: 0.8

mV. FR: 20Hz-20kHz. Pw: $\frac{3}{4}$ -1 $\frac{1}{2}$ gm. Separation: better than 25dB at 1kHz. Price: £28 (plus £4.49 PT).

M15 Super ★

Moving magnet stereo cartridge. Compliance: (horizontal) 50×10^{-6} cm/dyne; (vertical) 30×10^{-6} cm/dyne. Trackability: 80µm. Output: 0.8 mV. FR: 20Hz-20kHz. Pw: $\frac{3}{4}$ -1 $\frac{1}{2}$ gm. Separation: better than 25dB at 1kHz. Price: £24 (plus £3.85 PT).

MF15E

Stereo cartridge. Price: £20 (plus £3.21 PT).

MF15

Stereo cartridge. Price: £16 (plus £2.57 PT).

F15E

Stereo cartridge. Compliance: (horizontal and vertical) 25×10^{-6} cm/dyne. Trackability: 60µm. Output: 1mV. FR: 20Hz-20kHz. Separation: better than 25dB at 1kHz. Pw: 1-2gm. Price: £12.50 (plus £2 PT).

F15

Stereo cartridge. Compliance: (horizontal and vertical) 25×10^{-6} cm/dyne. Trackability: 60µm. Output: 1mV. FR: 20Hz-20kHz. Separation: better than 25dB at 1kHz. Pw: 1-2gm. Price: £10 (plus £1.60 PT).

FF15E

Stereo cartridge. Compliance: (horizontal and vertical) 20×10^{-6} cm/dyne. Trackability: 60µm. Output 1mV. FR: 20Hz-20kHz. Separation: better than 25dB at 1kHz. Pw: 1-3gm. Price: £12.50 (plus £2 PT).

FF15

Stereo cartridge. Compliance: (horizontal and vertical) 20×10^{-6} cm/dyne. Trackability: 60µm. Output: 1mV. FR: 20Hz-20kHz. Separation: better than 25dB at 1kHz. Pw: 1-3gm. Price: £10 (plus £1.60 PT).

Replacement styli

SL15E elliptical diamond. Price: £9.50 (plus £1.52 PT); SL15 0.6 thou spherical diamond. Price: £7 (plus £1.12 PT); M15E elliptical diamond stylus. Price: £14 (plus £2.25 PT); M15 0.6 thou spherical diamond. Price: £10 (plus £1.60 PT); MF15E elliptical diamond. Price: £12 (plus £1.92 PT); MF15 0.6 thou spherical diamond. Price: £8 (plus £1.28 PT); F15. Price: £5 (plus 80p PT); F15E. Price: £6.50 (plus £1.04 PT); FF15. £5 (plus 80p PT); FF15E. Price: £6.50 (plus £1.04 PT).

Note: SL15 Series styli are factory-replaceable only and the charge includes reconditioning the cartridge.

RMG/309

16in pickup arm for stereo and mono cartridges. Playing weight adjustable from 0-12gm. Price: £21 (plus £3.37 PT).

AS212

12in pickup arm for stereo and mono cartridges. Playing weight: adjustable 0-3gm. Magnetic anti-skating device. Hydraulic lifting, lowering and cueing. Easy to mount. Arm base to turntable centre: $8\frac{3}{8}$ in. Height adjustable: $1\frac{1}{4}$ - $2\frac{5}{8}$ in. Effective length: (stylus to pivot) 9in. Optimum overhang: $\frac{3}{8}$ in. Maximum tracking error: 0.16 deg/cm. Price: £27.50 (plus £4.41 PT).

M Shell

Type M metal shells for 15 Series cartridges. Price: £1.50 (plus 24p PT).

■ **PHILIPS ELECTRICAL LTD**

Century House, Shaftesbury Avenue, London, WC2. Tel: 01-437 7777.

GP412 ★

Stereo magneto dynamic cartridge. 45/LP only. Standard $\frac{1}{2}$ in mounting centres. Stylus: 0.3×0.7 thou bi-radial diamond. Pw: 0.75-1.5gm. Effective tip mass <0.75mg. Compliance lateral >20 typical 25; vertical >15 typical. 20. FR: 20 Hz-20kHz ± 2 dB. Channel separation >25dB at 1kHz, >16dB at 10kHz. Output: 0.8mV. Rec. load: 47K. Price: £38.47 (including PT).

GP400

Stereo magneto dynamic cartridge. $\frac{1}{2}$ in fixing centres. Pw: 1.5-3gm. Sensitivity: $1.2\mu\text{V/cm/sec}$. Stylus: 15 micron diamond. Compliance:

20mm/N lateral, 16mm/N vertical. Rec. load: 47K. Separation: >20dB at 1kHz. Dynamic mass: <0.8mg. FR: 20Hz-20kHz ± 3 dB. Net weight. 7gm. Price: £19.23 (including PT).

GP401

Specification as for GP400 but fitted with elliptical stylus 18 micron by 7 micron diamond. Price: £24.16 (including PT).

GP213

Stereo ceramic cartridge. $\frac{1}{2}$ in fixing centres. Stylus: 18 micron diamond LP, 75 micron sapphire 78 (turnover assembly). Pw: 3-7gm. Sensitivity: 65mV/cm/sec at 1kHz. Compliance: >5mm/N. Rec. load: 1M. Separation: >18dB at 1kHz. Net weight: 2.5gm. Price: to be announced.

■ **PICKERING**

Distributors: Highgate Acoustics, 184-188 Great Portland Street, London, W1. Tel: 01-636 2901.

XV-15 DCF Series ★

With Dustomatic. Stereo magnetic cartridges all with 35dB channel separation. Series comprises the following:

750E

Output 4.4mV. FR: 10Hz-25kHz. Pw: $\frac{1}{2}$ -1gm. Stylus 0.2×0.9 thou. Price: £31.44 (plus £6.06 PT).

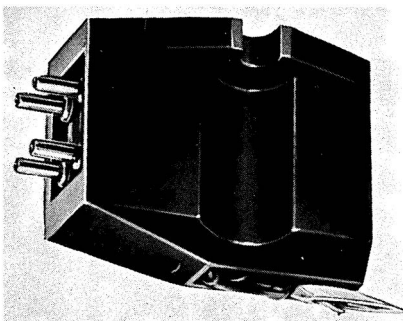

Ortofon SL 15/E

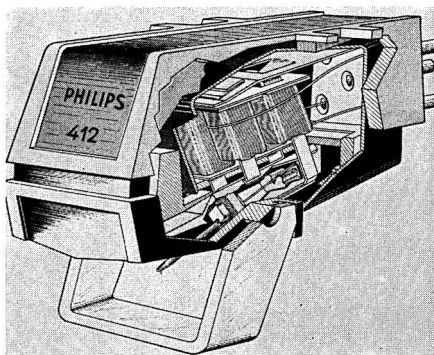

Philips GP412

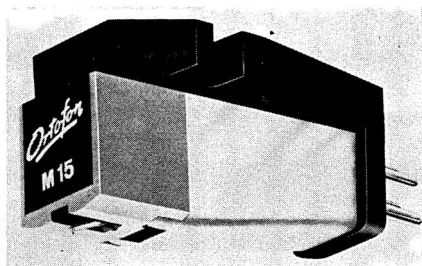

Ortofon M15

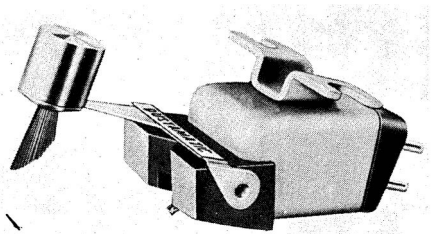

Pickering V-15 Series

★ Indicates entry is illustrated

- 400E**
Output: 4.5mV. FR: 10Hz-25kHz. Pw: $\frac{3}{4}$ -1½gm.
Stylus 0.3 × 0.9 thou. Price: £20.50 (plus £3.96 PT).
- 140E**
Output: 8mV. FR: 10Hz-20kHz. Pw: 3-5gm.
Stylus 0.4 × 0.9 thou. Price: £16.80 (plus £2.70 PT).
- 350**
Output: 6mV. FR: 10Hz-25kHz. Pw: 1-3gm.
Stylus: 0.7 thou spherical. Price: £15.94 (plus £2.56 PT).
- 150**
Output: 8mV. FR: 10Hz-25kHz. Pw: 2-5gm.
Stylus: 0.7 thou. Price: £13.36 (plus £2.14 PT).
- 100**
Output: 8mV. FR: 10Hz-20kHz. Pw: 3-7gm.
Stylus: 0.7 thou. Price: £11.63 (plus £1.87 PT).
- V15 Phase IV AME**
Stereo magnetic cartridge. Stylus: 0.3 × 0.7 thou elliptical diamond. Pw: 1-2gm. FR: 20Hz-20kHz. Channel separation: 30dB. Output: 5.5mV. Rec. load: 47K. Price: £16.80 (plus £2.70 PT).
- V15 Phase IV AM**
Stereo magnetic cartridge. Stylus: 0.7 thou spherical diamond. Pw: 1-3gm. FR: 20Hz-20kHz. Channel separation: 30dB. Output: 6.5mV. Rec. load: 47K. Price: £13.36 (plus £2.14 PT).
- V15 Phase IV AT**
Stereo magnetic cartridge. Stylus: 0.7 thou spherical diamond. Pw: 2-4gm. FR: 20Hz-18kHz. Rec load: 47K. Price: £11.63 (plus £1.87 PT).
- V15 Phase IV ACE**
Stereo magnetic cartridge. Stylus: 0.4 × 0.9 thou elliptical diamond. Pw: 3-5gm. FR: 20Hz-17kHz. Channel separation: 26dB. Output: 7.5mV. Rec. load: 47K. Price: £11.63 (plus £1.87 PT).
- V15 Phase IV AC**
Stereo magnetic cartridge. Stylus: 0.7 thou spherical diamond. Pw: 4-6gm. FR: 20Hz-17kHz. Channel separation: 26dB. Output: 7.5mV. Rec. load: 47K. Price: £10.34 (plus £1.66 PT).
- P Series P/ATE**
Stereo magnetic cartridge. Stylus: 0.5 × 1.0 thou elliptical diamond. Pw: 2-5gm. FR: 20Hz-20kHz. Channel separation: 35dB. Output: 5.5mV. Rec. load: 47K. Price: £10.34 (plus £1.60 PT).
- P Series P/AT**
Stereo magnetic cartridge. Stylus: 0.7 thou spherical diamond. Pw: 2-5gm. FR: 20Hz-20kHz. Channel separation: 35dB. Output: 6.9mV. Rec. load: 47K. Price: £8.19 (plus £1.31 PT).
- P Series P/AC**
Stereo magnetic cartridge. Stylus: 0.7 thou spherical diamond. Pw: 3-7gm. FR: 20Hz-20kHz. Channel separation: 35dB. Output: 7.5mV. Rec. load: 47K. Price: £6.46 (plus £1.04 PT).
- **SHURE ELECTRONICS LTD**
84 Blackfriars Road, London, SE1 8HA.
Tel: 01-928 3424.
- M3D ★**
Stereo Dynetic cartridge. Moving magnet. $\frac{1}{2}$ in fixing centres. Stylus: 0.7 thou diamond. Pw: 3-6 gm. Compliance: 4×10^{-6} cm/dyne. FR: 20Hz-15kHz. Separation: 20dB at 1kHz. Output: 1mV. Load impedance: 47K. Price: £6.10 (including 82p PT).
- M44C**
Stereo Dynetic cartridge. Moving magnet. $\frac{1}{2}$ in fixing centres. Stylus: 0.7 thou diamond (1 thou and 3 thou styli available). Pw: 3-5gm. Compliance: 7.5×10^{-6} cm/dyne. FR: 20Hz-20kHz. Separation: 25dB at 1kHz. Output: 1.8mV. Load impedance: 47K. Price: £7.90 (including £1.06 PT).
- M44E**
Stereo Dynetic cartridge. Moving magnet. $\frac{1}{2}$ in fixing centres. Stylus: 0.7 × 0.4 thou bi-radial diamond (3 thou styli available). Pw: 1½-4gm. Compliance: 15×10^{-6} cm/dyne. FR: 20Hz-20 kHz. Separation: >25dB at 1kHz. Output: 1.8 mV. Rec. load: 47K. Price: £8.60 (including £1.16 PT).
- M44G ★**
Stereo Dynetic cartridge. Moving magnet. $\frac{1}{2}$ in fixing centres. Stylus: 0.6 thou diamond (1 thou and 3 thou styli available). Pw: $\frac{3}{4}$ -1½gm. Compliance: 25×10^{-6} cm/dyne. FR: 20Hz-20kHz. Separation: 25dB at 1kHz. Output: 1.4mV. Load impedance: 47K. Price: £8.30 (including £1.11 PT).
- M44-7**
Stereo Dynetic cartridge. Moving magnet. $\frac{1}{2}$ in fixing centres. Stylus: 0.7 thou diamond (1 thou and 3 thou styli available). Pw: 1½-3gm. Compliance: 20×10^{-6} cm/dyne. FR: 20Hz-20kHz. Separation: 25dB at 1kHz. Output: 2.2mV. Load impedance 47K. Price: £7.90 (including £1.06 PT).
- M55E ★**
Stereo Dynetic cartridge. Moving magnet. $\frac{1}{2}$ in fixing centres. Stylus: 0.7 × 0.2 thou elliptical diamond (3 thou styli available). Pw: $\frac{3}{4}$ -2gm. Compliance: 15×10^{-6} cm/dyne. Output: 1.3mV.

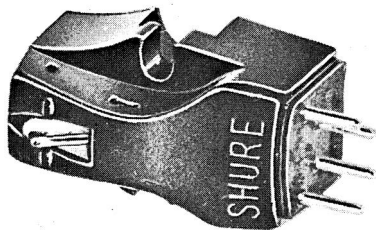

Shure M3D

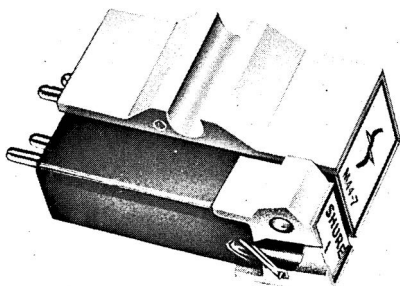

Shure M55E

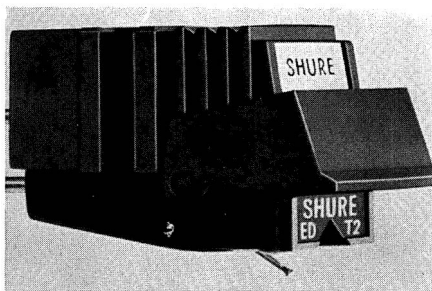

Shure M75ED Type 2

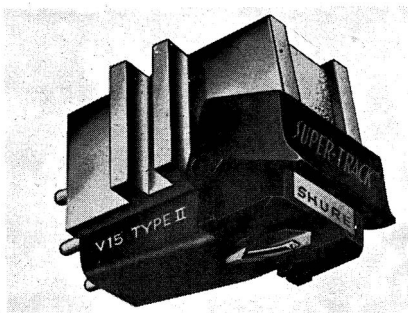

Shure V15-11 (improved)

Load imp: 47K. Price: £9.70 (including £1.30 PT).

M75B Type 2

Stereo Dynetic cartridge. Moving magnet. $\frac{1}{2}$ in fixing centres. Stylus: 0.6 thou conical diamond (3 thou stylus available). Pw: 1 $\frac{1}{2}$ -3gm. Trackability (see note at end) at 2gm in SME 3009 arm: 400Hz 28cm/sec, 1kHz 35cm/sec, 10kHz 20cm/sec. FR: 20Hz-20kHz. Separation: >25dB at 1kHz. Output: 1mV. Rec. load: 47K per channel. Price: £13.60 (including £1.83 PT).

M75ED Type 2 ★

Stereo Dynetic cartridge. Moving magnet. $\frac{1}{2}$ in centres. Stylus: 0.7 × 0.2 thou elliptical diamond (3 thou stylus available). Pw: $\frac{3}{4}$ -1 $\frac{1}{2}$ gm. Trackability (see note at end) at 1gm in SME 3009 arm: 400Hz 22cm/sec, 1kHz 33cm/sec, 5kHz 28cm/sec, 10kHz 19cm/sec. FR: 20Hz-20kHz. Separation at 1kHz: 25dB. Output: 5mV. Rec. load: 47K per channel. Price: £19 (including £2.55 PT).

M75G Type 2

Stereo Dynetic cartridge. Moving magnet. $\frac{1}{2}$ in fixing centres. Stylus: 0.6 thou conical diamond (3 thou stylus available). Pw: $\frac{3}{4}$ -1 $\frac{1}{2}$ gm. Trackability (see note at end) at 1gm in SME 3009 arm: 400Hz 20cm/sec, 1kHz 28cm/sec, 10kHz 18cm/sec. FR: 20Hz-20kHz. Separation: >25dB at 1kHz. Output: 1mV. Rec. load: 47K per channel. Price: £14.70 (including £1.97 PT).

M75EJ Type 2

Stereo Dynetic cartridge. Stylus: 0.7 × 0.4 thou bi-radial diamond. Pw: 1 $\frac{1}{2}$ -3gm. Trackability at 2gm in SME 3009 arm: 400Hz 28cm/sec, 1kHz 35cm/sec, 10kHz 20cm/sec. Price: £15.40 (including £2.07 PT).

V15-11 (improved) ★

Stereo Dynetic cartridge. Moving magnet. $\frac{1}{2}$ in fixing centres. Stylus: 0.7 × 0.2 thou bi-radial diamond (3 thou stylus available). Pw: $\frac{3}{4}$ -1 $\frac{1}{2}$ gm. Trackability (see note at end) at 1gm in SME 3009 arm: 400Hz 28cm/sec, 1kHz 35cm/sec, 5kHz 30cm/sec, 10kHz 22cm/sec. FR: 20Hz-25kHz. Separation: >25dB at 1kHz, >17dB at 500Hz-10kHz. Output: 0.7mV. Rec. load: 47K. Price: £39.40 (including £5.29 PT).

NOTE

Trackability is a term introduced by Shure to give a measure of the total performance of a cartridge. It takes into account the mechanical design parameters of tip mass, inertia, compliances throughout the system, tracking pressure, recorded velocity, etc. Explanatory leaflet available on request.

■ S.M.E. LTD

Steyning, Sussex, BN43LN.
Tel: Steyning (0903) 814321.

★ Indicates entry is illustrated

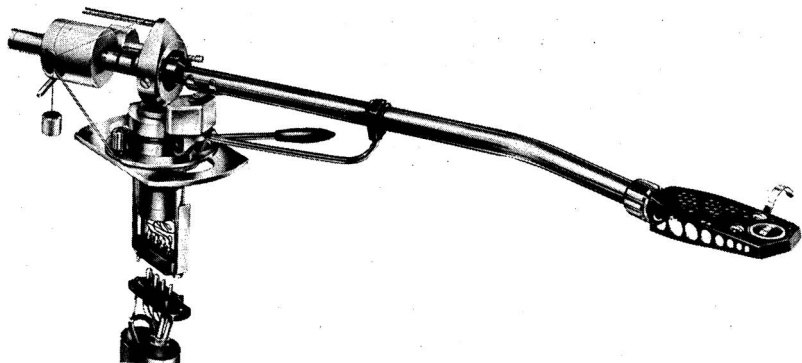

SME Series 2 precision pickup arm and shell

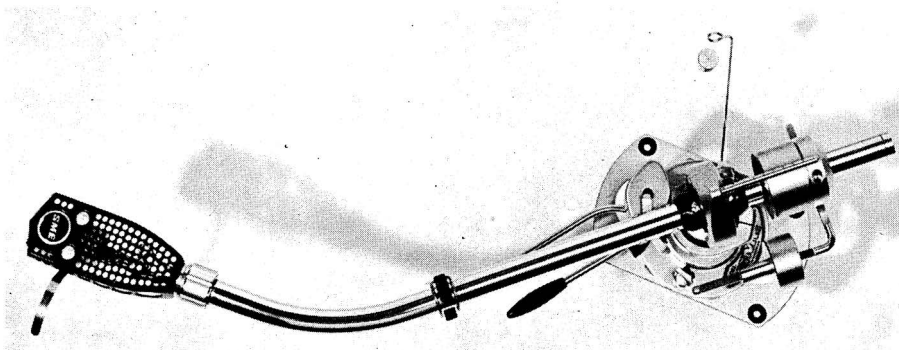

SME Series 2

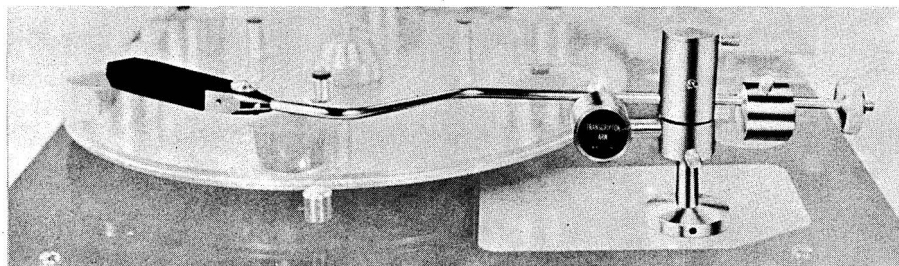
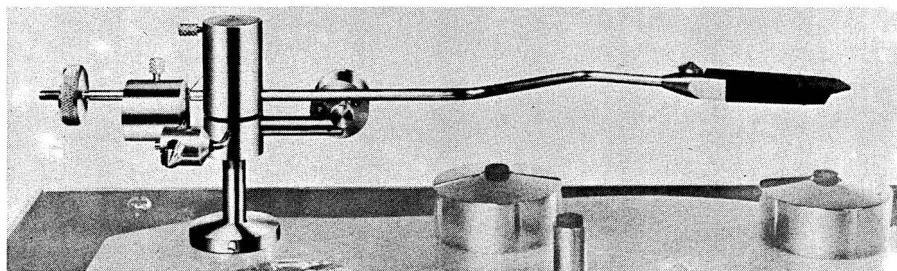

Transcriptors Fluid Arm

Model 3009 ★

(9in). Series II precision pickup arm. Extremely low vertical and lateral friction. Side-thrust compensation. Hydraulically damped lowering control. Tracking force applied precisely, without the need for a gauge. Rapidly adjustable for a wide range of cartridges and heads. Supplied complete with 4-ft connecting lead, mounting template, alignment protractor, fixing screws and instructions for use. Price: (with S2 ultra-lightweight shell) £27.72 (plus £4.62 PT).

Model 3012

(12in). Series II precision pickup arm. Specification and details as for 3009 except 12in arm. Price: (with S2 ultra-lightweight shell) £29.52 (plus £4.92 PT).

Special note

Standard SME arms require $3\frac{1}{2}$ in clearance under the bedplate. An alternative version (Type HE) has horizontal cable entry and requires only $2\frac{1}{2}$ in clearance. Type HE can be supplied to order at an additional charge of £1.17 (plus 20p PT).

Accessories

S2 ultra-lightweight shell, boxed with mounting hardware and finger lift. Price: £2.22 (plus 37p PT). Precision phono plug. Price: 24p.

■ SONOTONE

Vernitron Ltd, Thornhill, Southampton, Hants, S095QF.
Tel: Southampton 44811; Telex: 47138.

2T

Monaural ceramic cartridge with turnover stylus. Stylus sapphire 2.5 thou (78), 0.7 thou (LP). Pw: 8-10gm. Compliance: 1×10^{-6} cm/dyne. Output: 180mV/cm/sec at 1kHz. Capacitance: 650pF. Serviceable under all climatic conditions and compatible for 33 $\frac{1}{3}$, 45 and 78rpm records. Price: £1.54 (including PT).

8TA4

Stereo ceramic cartridge with turnover stylus. Sapphire, 2.5 thou (78), 0.7 thou (LP). Pw: 4-6 gm. Compliance: 1.4×10^{-6} cm/dyne. Separation: 25dB at 1kHz. Output: 90mV/cm/sec at 1kHz. Capacitance: 650pF. Price: £2.16 (including PT).

9TA

Stereo turnover ceramic cartridge. Sapphire stylus. Pw: 2-4gm. Tip mass: 3.5mg. Compliance: 5.3×10^{-6} cm/dyne. FR: 30Hz-15kHz \pm 3dB. Separation: 27dB. Output voltage: 80-120mV. Load imp 2 megohm. Price: £3.09 (including PT).

9TA-G

As 9TA but for single-hole slim fitting head shells.

9TAD

Similar specification to 9TA but with diamond stylus. Price: £4.02 (including PT).

9TAHC

Stereo turnover ceramic cartridge. Choice of both sapphire styli or sapphire 78/diamond stereo LP. FR: 20Hz-20kHz \pm 3dB from 1kHz. Rec. load: 2M. Sensitivity: 55-85mV/cm/sec at 1kHz. Lateral compliance: 8.5×10^{-6} cm/dyne. Separation: 25dB at 1kHz. Pw: 1-3gm. Tip mass: 2.5mg. Capacitance: 800pF. Price: (with sapphire stylus) £3.09 (including PT); (with diamond stylus) £4.02 (including PT).

9TAHC-G

As 9TAHC but for single-hole slim fitting head shells.

2109

Mono Rochelle cartridge. Output at 1kHz 700 mV/cm/sec. Capacitance: 800pF. Compliance: 1.5×10^{-6} cm/dyne. Tracking: +12dB at 5gm. FR: 100Hz-8kHz \pm 3dB. Rec. stylus force: 6-8gm. Price: £1.70 (including PT).

2509

Stereo Rochelle cartridge. Output at 1kHz: 340mV. Capacitance: 1000pF. Channel difference less than 3dB. Separation at 1kHz better than 12dB. Pw: 7gm. FR: 50Hz-8kHz \pm 3dB. Price: £2.43 (including PT).

2539

Stereo Rochelle cartridge. Output at 1kHz 550 mV/cm/sec. Capacitance: 800pF. Channel difference less than 3dB. Separation at 1kHz better than 12dB. Tracking: +9dB at 9gm. FR: 100Hz-8kHz. Rec. stylus force 8-10gm. Price: £2.43 (including PT).

3509

Stereo ceramic cartridge. Output at 1kHz: 140 mV/cm/sec. Channel difference less than 3dB. Separation at 1kHz: better than 15dB, typically 20dB. Capacitance: 600pF. Tracking: +12dB, typically +15 at 5gm. FR: 100Hz-8kHz \pm 3dB. Rec. stylus force: 5-7gm. Price: (with sapphire stylus) £2.80 (including PT); (with diamond stylus) £3.22 (including PT).

3559

Ceramic stereo cartridge with stylus. Pw: 2 $\frac{1}{2}$ -4gm. FR: 20Hz-12kHz. Separation: better than 15dB at 1kHz. Output: 70mV/cm/sec nominal. Rec. load: 2 megohms and 100pF. Price: (sapphire stylus) £2.92 (including PT); (with diamond stylus) £3.34 (including PT).

3549

Ceramic stereo cartridge with stylus. Pw: 3-5gm. FR: 30Hz-10kHz. Separation: better than 15dB at 1kHz. Output: 100mV/cm/sec nominal. Rec. load: 2 megohms and 100pF. Price: (sapphire

★ Indicates entry is illustrated

stylus) £2.92 (including PT); (with diamond stylus) £3.34 (including PT).

■ SONY (UK) LTD

Pyrene House, Sunbury Cross,
Sunbury-on-Thames, Middlesex.

Tel: Sunbury 87644/7.

Sony VC-8E

Stereo moving coil cartridge. Stylus: 0.2 × 0.8 thou diamond. Pw: 0.5-2gm. Lateral and vertical compliance: 10×10^{-6} cm/dyne. FR: 10Hz-25 kHz. Separation: 30dB at 1kHz, 20dB at 10kHz. Output: 4mV ± 2dB. Rec. load: approx 40 ohms at 10Hz-25kHz. Price: £26.86 (including PT).

■ TANNOY PRODUCTS LTD

Norwood Road, West Norwood, London,
SE279AB. Tel: 01-670 1131. Cables: Tannoy,
London.

Varilutance

Turnover cartridge. Output voltages: LP: 10-12mV; 78 18-20mV. Range: 20Hz-16kHz ± 2dB. Pw: 5-6gm (less with professional arms). Load imp: 50K ohms. Price (with 2 diamonds): £12 (plus £3.18 PT); (with 1 diamond and 1 sapphire): £9.50 (plus £2.52 PT); (with 2 sapphires): £7 (plus £1.85 PT). Compatible styli available £3 (plus 80p PT). Lightweight stereo/mono styli assembly. Price: £3 (plus 80p PT).

Single stylus version of Varilutance for LP also available. Price (with diamond): £6.75 (plus £1.52 PT).

■ TRANSCRIPTORS LTD

2 Theobald Street, Boreham Wood, Herts.
Tel: 01-953 0771.

Transcriptors fluid arm ★

Stereo or mono low-mass arm with fluid Uni-pivot mount. Modular counter-weight system with fine balance adjustment. Suitable for all cartridges with compliance of 20×10^{-6} cm/dyne or above, tracking at not more than 2.5gm. Hydraulic lowering device with manual override control. Incorporates precise cueing system. Single hole fixing. Integrated leads. Plug-in head shell. Roller-action adjustable, bias compensation. British made. Price: £22 (plus £3.57 PT).

■ T.T.C.

Joint distributors: Adastra Electronics Ltd,
Unit 22, Cricklewood Trading Estate,
Claremont Road, London, NW2 1TU.
Tel: 01-452 6288. E.R. (Factors) Ltd,
373-378 Harrow Road, Paddington, London,
W9. Tel: 01-286 0361.

J2203

Moving magnet stereo cartridge. Stylus: 0.7 thou diamond. Pw: $1\frac{1}{2}$ -2½gms. Compliance:

12×10^{-6} cm/dyne. FR: 20Hz-20kHz. Separation: 20dB. Balance: within ± 1dB. Output: 5mV. Rec. load: 2 megohms. Price: £4.50 (including PT); (replacement stylus) £2.75 (including PT).

J2203E

Moving magnet stereo cartridge. Stylus: 0.8 × 0.3 thou diamond. All other details as per J2203 above. Price: £9.50 (including PT); (replacement stylus) £6.90 (including PT).

J3000E

Moving magnet stereo cartridge. Stylus: 0.8 × 0.3 thou diamond. Pw: $1\frac{1}{2}$ -2½gms. Compliance: 12×10^{-6} cm/dyne. FR: 20Hz-20kHz. Separation: 20dB. Balance: within ± 1dB. Rec. load: 2 megohms. Output: 5mV. Supplied in presentation case with spare stylus. Price: (including spare elliptical diamond stylus) £15 (including PT).

J1111

Complete pickup arm with moving magnet stereo cartridge. Stylus: 0.7 thou diamond. Pw: $1\frac{1}{2}$ -2½gms. Compliance: 12×10^{-6} cm/dyne. FR: 20Hz-20kHz. Separation: 20dB. Balance: within ± 1dB. Overall length: $11\frac{1}{4}$ in. Effective length: $8\frac{3}{4}$ in. Output: 5mV. Precision turned stainless steel arm. Weight/bias adjustment. Tracking error: 5°. Self-lubricating ball bearings. Supplied with J2203 cartridge but will accept most other makes. Price: £10.75 (including PT).

PU402

Complete pickup arm with moving magnet stereo cartridge. Stylus: 0.7 thou diamond. Pw: $1\frac{1}{2}$ -2½gms. Compliance: 12×10^{-6} cm/dyne. FR: 20Hz-20kHz. Separation: 20dB. Balance: within ± 1dB. Output: 5mV. Overall length: $12\frac{1}{4}$ in. Effective length: $8\frac{3}{4}$ in. Chrome finished transcription arm. Bias compensation. Weight adjustable 0.25-14gms. Adjustable mounting pillar. Tracking error: +4 to -1°. Fitted with J2203 cartridge but will accept most other makes. Price: £18 (including PT).

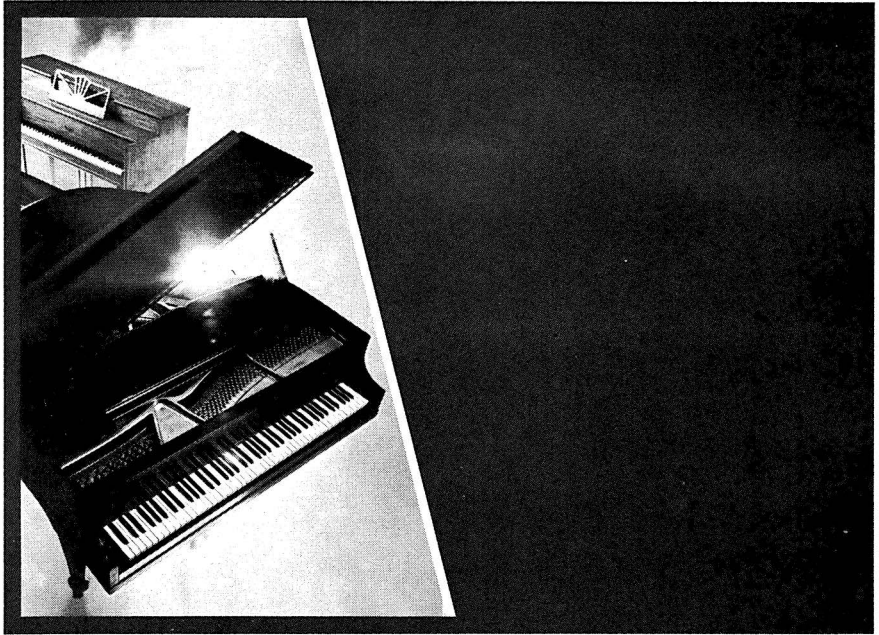

To each his own.

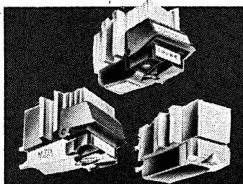

Not everybody needs a concert grand piano, nor does everybody need the Shure V-15 Type II, the most sophisticated cartridge in the world, to enjoy his kind of music in his kind of hi-fi system. For many, the M75 Type 2 Series, widely acclaimed as second only to the V-15, will be more than adequate. Within more circumscribed budgets the M55, M44 Series or M3D, each offering optimum performance in successively lower price ranges, may be an excellent choice. Write to us describing your equipment and we will send you our recommendations on the cartridge that is most closely matched to your equipment.

Shure Electronics Limited
84 Blackfriars Road
London SE1, 8HA, Telephone (01) 928 3424





TAKE CARE OF YOUR RECORDS

*Use the world's best cleaning
and maintenance devices.*

**WATTS EQUIPMENT CARES FOR YOUR
RECORDS IN ALL CONDITIONS OF USE**

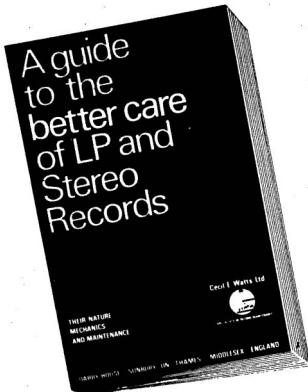

Only the user knows the local conditions in which his records will be played. A study of the Booklet "A GUIDE TO THE BETTER CARE OF YOUR L.P. & STEREO RECORDS" will, it is hoped supply the necessary information to enable him to choose the appropriate device to suit his particular requirements.

SEND IMMEDIATELY 15p POST FREE

**CECIL E. WATTS LIMITED
DARBY HOUSE · SUNBURY ON THAMES · MIDDLESEX**

Pickup Accessories

★ Indicates entry is illustrated

Abbreviations used in this section are given on page 36.

■ ACOS

Cosmocord Ltd, Eleanor Cross Road,
Waltham Cross, Herts.
Tel: Waltham Cross 27331.

DJ Dust Jockey

Record cleaning device comprising brush and plush pad mounted on arm. Mounting base incorporates suction pad for securing to base-board. Can be fitted anywhere round the turntable where it does not impede the pickup arm. Suitable for most single-play record decks (and autochangers when used manually). Brush removes dirt from grooves and plush pad applies anti-static fluid. Anti-static fluid supplied as separate item. Price: £1 (including PT).

■ ADASTRA ELECTRONICS LTD

Unit 22, Cricklewood Trading Estate,
Claremont Road, London, NW2 1TU.
Tel: 01-452 6288 (answering service 01-452 6289)

Imp-Verta ★

Matches low impedance PU cartridges, micro-phones and tape heads into high impedance amplifier inputs. Solid state printed circuit device using silicon transistor. Automatically switched internal 9V battery. Negligible drain. Conversion factor approximately 20 (depending on load). Virtually no hum or signal loss. Metal case, black crackle finish. Size: $5 \times 1\frac{1}{2} \times 1\frac{1}{2}$ in. Price: £3.50.

■ AUDIO PACKS

Audio Packs Ltd, 206-210 Ilderton Road,
London, SE15 1NS. Tel: 01-639 7844.

Audio Packs

Pre-packed spares and audio accessories.

Connecting cords

Cables of various types with plugs, sockets and other terminations covering all equipment in use for domestic radio.

Adaptors

Convert from any type of plug or socket termination to any other type.

Audio spares

Plugs, sockets, chassis mounted components,

fuses and audio accessories. Pre-packed for counter or showroom display.

Mains units ★

Three different 6-12V battery eliminators complete with connecting leads for use with all standard battery-operated tape recorders and radios. Full specifications on request.

■ BIB

Bib Sales, PO Box 78,
Hemel Hempstead, Herts.
Tel: Hemel Hempstead 3636. Ext 100.

Stylus and turntable cleaning kit

Includes: cleaning cloth, non-inflammable anti-static cleaning fluid and small nylon brush applicator. Brush can be fastened to board by small suction pad. Price: 34p.

Anti-static cleaner

Non-inflammable anti-static fluid with cleaning cloth. Does not smear or scratch. Suitable for instrument panels, plastic, chrome, glass and exteriors of electronic equipment. Price: 24p.

Record covers

12in. Shaped containers made from clear plastic sheet. Protects records from dirt and prevents wear. One required for each record. Price: pack of five 12½p.

Record sleeve protectors

Made from strong clear plastic to fit over record sleeve and keep like new. Price: pack of five 44p.

Stylus balance ★

Made from non-magnetic material and fitted with non-scratch base. Measures from $\frac{1}{4}$ to 5gm and calibrated to be accurate to within $\frac{1}{4}$ gm. Simple to use and supplied with full instructions. In presentation case. Price: £1.45.

Groov-Kleen Model 42 ★

Automatic record cleaner in the form of a miniature pickup arm equipped with brush to loosen the dust and a non-revolving roller which sets the height and collects the dirt. Self-adhesive base for fitting to motor board. Finished in anodised aluminium with chromium-plated adjustable pillar. Swivelling armrest provided for use when cleaner is not traversing a record. Designed to fit any make and model of turntable, including the Garrard SP25 Mk III. Packed in transparent plastic box. Price: £1.95. Replacement roller and brush 18p.

Record and stylus cleaning kit

Comprises two record cleaning cloths and special stylus cleaning brush which stands upright to keep clear of dirt. Price: 24p.

Record cue and swinger detector ★

Identifies selected items on records. Comprises graduated scale that swings across record. Moves clear for changing record. Self-adhesive

★ Indicates entry is illustrated



Adastra Imp-Verta

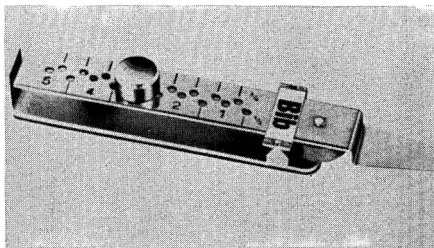

Bib Stylus Balance

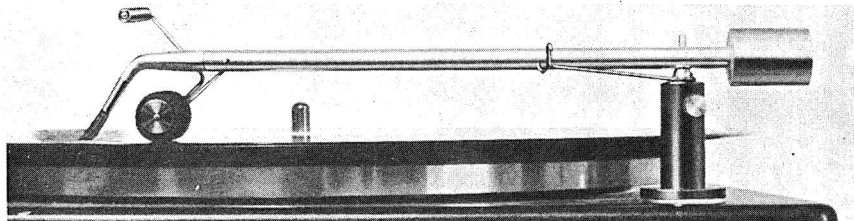

Bib Groov-Kleen

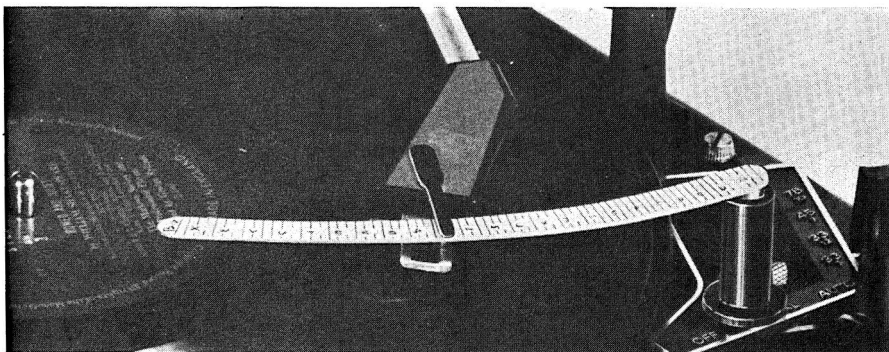

Bib Cue and Swinger Detector



Black Knight Rumblecure Plinth with 401/3009

base to fit all turntables. Detects 'swinger' records. Price: £1.45.

Spirit level

Intended for use with record deck to obtain accurate level for correct tracking and minimum stylus and record wear. Packed in plastic container. Price: 56p.

Record Dust-off Size 48

Record cleaning pad mounted on plastic handle. Size: 3½ in long, 1 in wide. Velvet cleaning pad with foam backing. Is applied to record on turntable while rotating to remove dust and dirt. Price: 20p (including PT).

Hi-fi stereo hints and tips

Book for hi-fi enthusiasts describing how to make the most of audio equipment. Contains 29 illustrations, diagrams and reference tables. 36 pages. Written by John Borwick B.Sc. Price: 25p.

■ BLACK KNIGHT RUMBLECURE

Bank Top, Currier Lane, Ashton-under-Lyne, Lancs. Tel: 061-330 2836 (open 7 days). Demonstration showroom at 15 Irving Street, London, WC2.

Specialists in curing rumble due to acoustic feedback through floors and cabinets.

Kits and items designed to isolate and acoustically damp pickup arms, turntables, motor units, plinth assemblies, tape recorders, speaker enclosures and other audio equipment.

Plinths fitted with Rumblecure equipment available. Details on request. Many standard items now available and more being added all the time. Quotations on receipt of full details of equipment.

■ BSR McDONALD

(McDonald Division) BSR Ltd, Cradley Heath, Warley, Worcs. Tel: Cradley Heath 69272.

Cartridge carrier

Quick-change slide-in carrier. Permits changing or inspecting cartridge easily and quickly without interfering with wiring. Models to suit all BSR McDonald pickup arms (except 20 mini-changer). Price: 40p (plus 8p PT).

■ BURNE-JONES & CO LTD

18 Brunswick Road, Sutton, Surrey.

Alignment protractor ★

For measuring the tracking accuracy of all pickup assemblies. Made in plastic ivory. Price: 60p.

■ B. & W. ELECTRONICS

Bowers & Wilkins Electronics Ltd, Meadow Road, Worthing, Sussex. Tel: Worthing 205611/4.



Black Knight Rumblecure Kit TD 124 Mk II/3009

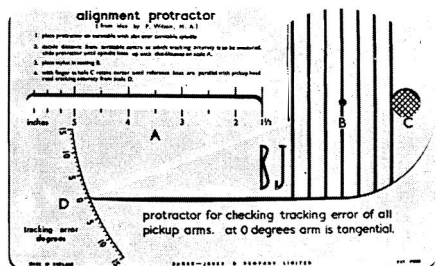

B-J alignment protractor

SE/A

A special equaliser for the Shure V15/11 and similar cartridges designed for use with SME Series II pickup arms.

■ CLENDISC (Mail Order) LTD

7 Trinity Court, Gray's Inn Road, London, WC1. Tel: 01-837 9088.

Clendisc

An anti-static cleaner and preservative for records, photographic and optical lenses, copying machines, tape heads and computers. 4 fl oz bottles. Price: 22½ p.

Clendisc Cleaning Pad

Pad impregnated with Clendisc fluid which assists in the removal of dust and dirt and also neutralises any electrostatic charges present. Price: 16½ p (including PT).

■ COLTON

Musonic Ltd, 34-38 Verulam Road, St Albans, Herts. Tel: St Albans 50611/2.

Varilift Mk III

Fluid damped pickup lifting and lowering device. Price to be announced.

Precision Turntable level

Circular bubble-type spirit level in white plastic

★ Indicates entry is illustrated

case $1\frac{3}{8}$ in diameter, $\frac{1}{2}$ in high. Three fixing holes provided or it may be fixed with adhesive. Ensures accurate levelling in all directions. Price: 34p.

Antistatimat

All-rubber 12in turntable mat. Accurately balanced and moulded with guard edge recess. Introduction of certain materials into the rubber renders it conductive to static charges on micro-groove records. When a record is placed on the mat static charges are dispersed freeing the record from induced noises without use of sprays, etc. Price: 67p (plus 11p PT).

Times-Fifty ★

Miniature pocket microscope with stylus locating slot and adjustable focus. Gives clear picture of stylus tip at X50 magnification. $4\frac{1}{2}$ in long and fitted with pen clip. Price: 88p.

Magnalift Mk II ★

Centre lift-off device. Fixes beside pickup and automatically lifts arm off record at end of playing cycle. Price: £2.77 (plus 44p PT).

Variscale ★

Tracking force indicator. Simple and accurate stylus balance measuring from $\frac{1}{2}$ to 6gm. Finish: black wrinkle and satin chrome. Price: 97p (plus 16p PT).

Precise Lift ★

Manually operated pickup lifting device. Simple precise movement. Single hole mounting. Finish: satin chrome. Price: £2.62 (plus 42p PT).

Gripex

Anti-slip dressing. A spirit suspended solution supplied in 1 fl oz bottles with brush. Applied thinly to drive surfaces of belts or friction wheels, it dries in 10-15 minutes. Price: 25p per bottle.

■ CONNOISSEUR

A. R. Sugden & Co (Engineers) Ltd,
Market Street, Brighouse, Yorkshire.
Tel: Brighouse 2142. Cables: Connoisseur,
Brighouse.

Connoisseur Stylus Balance ★

Precision stylus balance with sliding weight adjustment. Scale calibrated 0-6gm. Simple operation giving accurate stylus pressure settings. Price: 90p (plus 14p PT).

■ DECCA

Decca Special Products, Ingate Place,
Queenstown Road, London, SW83NT.
Tel: 01-622 6677.

Magnetic bias compensator

Neat, simple, unobtrusive device using magnetism precisely to neutralise the forces which draw a pickup towards the centre of the turntable. Type A for Mk I and Mk I 'Super' *ff*ss arms, and for Deram ARI arm. Price: £1.03 (plus 17p PT).

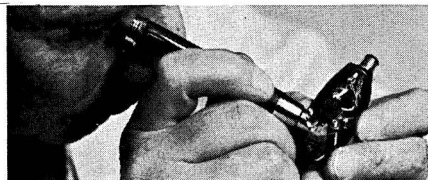

Colton Times-Fifty Stylus Viewer

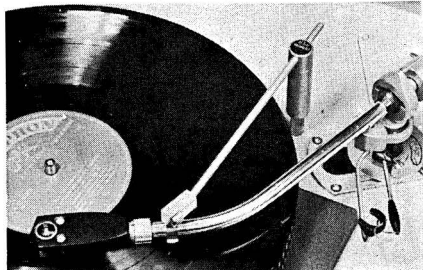

Colton Magnalift



Colton Variscale



Colton Precise lift

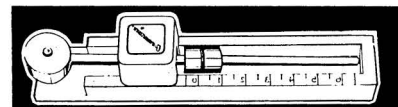

Connoisseur stylus balance

Centre locator

Fits on *ffss* arm like *ffss* head. Pickup arm is correctly positioned when the locator moulding fits the turntable centre spindle. Price: 26p (plus 4p PT).

Decca Microlift ★

A device for raising and lowering a manual pickup arm at any point on the record for minimising risk of damage either to record or stylus through handshake. Easy to fit to most types of back-pivoted pickup. It does not hinder record handling by over-lapping the turntable. Price: £1.47 (plus 23p PT).

Deccalift

Motorised lifting and lowering device which can be controlled at the turntable and/or remotely. Requires 6.3V AC. Transformer optional extra. Price: £7.07 (plus £1.13 PT).

London cartridge adaptors

Type A. Simple slide-on adaptor for use with *ffss* arms (Mk I, Mk I Super and Professional) to accommodate the London cartridge. Automatically adjusts playing weight. Price: to be announced. Type B. Simple slide-on adaptor for use with International arm to accommodate the London cartridge. Collar arrangement to adjust for correct playing weight. Price: to be announced.

■ **EAGLE INTERNATIONAL**

Heather Park Drive, Wembley, HA1 1SU.
Tel: 01-903 0144.

PRE 402 ★

Mains powered stereo pickup preamplifier for magnetic cartridges including Eagle LC 05 and LC 07. Provided with dual phono sockets. Price: £5.30.

■ **EXPERT PICKUPS LTD**

PO Box No. 3, Ashted, Surrey.
Tel: Ashted 76604.

Expert moving coil pickups serviced

Full details on request.

Replacement stylus service

For detachable cantilever systems using client's own stylus assembly. Radius to choice; from 0.5 thou (stereo) to 4 thou (78 oversize). Ellipticals where suitable. Radius checked using X 500 magnification.

Grade A transcription diamond styli

Finest quality, highly polished, giving minimum background noise and optimum results. Spherical or elliptical tip.

Grade B

Commercial standard, 0.5 thou to 2.5 thou only. Oversize sapphires and diamonds (Grade A only) for Pathe and Edison reproducers formed and fitted. Expert Pickup diamonds are manu-



Decca Microlift

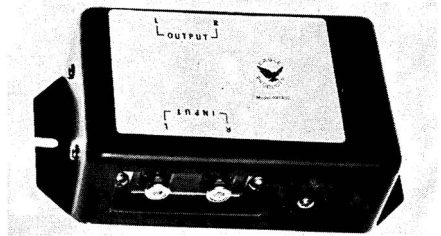

Eagle PRE402 pickup preamp

factured only to customers' specifications. Special quotations and prospectus on request.

To collectors of 78rpm records

Advice available as to the best method of reproducing from old 78rpm records.

Replacement stylii

Complete range of replacement stylii in sapphire and commercial diamond, also professional Grade A diamonds of our own manufacture.

Disc-cutting styli

Cutters to CBS specification. Development to other specifications carried out.

Leak pickup servicing

Sole agents for the servicing of Leak Mk I and Mk II pickups.

■ **GOLDRING MANUFACTURING CO**

(Great Britain) LTD

10 Bayford Street, Hackney, London, E8 3SE.
Tel: 01-985 1152.

Lenco STB.2

Stylus pressure balance. A simple and accurate device, not relying on springs. Price: 90p (plus 15p PT).

Lencoclean

Record cleaning device mounted on turntable. Tracks in front of the pickup, dispensing a narrow band of special fluid. Leaves no deposit on record, cleans the groove and cools the point

★ Indicates entry is illustrated

contact. Keeps stylus point clean. Price: £2.70 (plus 44p PT).

Lencoclean refill £1.05.

Goldring/Lenco VV7

Stereo preamplifier for magnetic cartridges. Input: 1mV 47K. Noise level: -60dB. Output: 100mV RMS. Mains: 200-240V 50Hz. Size: $4\frac{3}{4} \times 2 \times 1\frac{1}{2}$ in. Price: £9.60 (plus £1.56 PT).

■ **G. F. C. HADCOCK**

Audio Division, The Old Vicarage, Doveridge, Derby, DE65NN. Tel: Uttoxeter 2452.

GH Uni-lift ★

Raising and lowering device suitable for use with all pickup arms. Two-hole fixing for stability. Ensures accurate lowering and easy cueing. Allen key provided for height adjustment of horizontal arm. Finish: chromium-plated brass. Price: £2.50 (plus 40p PT).

■ **JOHN HORWITZ (IMPORT)**

305 Kenton Road, Kenton, Harrow, Middlesex. Tel: 01-907 6667.

Stereo stamp

Rubber stamp to enable record collectors to label stereo discs to make them immediately visible. Price: 40p including postage.

■ **HOWLAND-WEST LTD**

3-5 Eden Grove, London, N78EQ. Tel: 01-609 0293/4/5.

Howland-West Alignment Protractor ★

Made in laminated Perspex. Provides facilities for checking: (1) vertical tracking angle, (2) lateral tracking angle and (3) channel balance and separation. Price: 46p.

■ **IMPEX**

McArdle & Brainsby (Import & Export) Ltd, PO Box 2BB, Newcastle upon Tyne, NE99 2BB.

MS7

Stereo magnetic pickup amplifier. Input: 3mV 47K. Output: 100mV 470 ohms at 1kHz. FR: RIAA equalised ± 1.5 dB (bass roll-off from 30dB at 12dB/octave). Distortion: <0.03% at 100mV output at 1kHz. Overload margin: >28dB on rated input. S/N ratio: >60dB (unweighted); >75dB (weighted to CCIF curve). Separation: >80dB at 1kHz, >60dB at 10kHz. Connectors: (input) dual phono sockets; (output) jack plugs on flying leads; (power) DIN connector suitable for Impex power supply unit PS50 or for direct connection to Ferrograph Series Seven tape recorder. Will also operate from any supply of approximately 50V DC at 7mA. British made. Price: £9.

MS24

Similar specification but designed to operate from supply of 22-25V DC at 6-7.5mA.

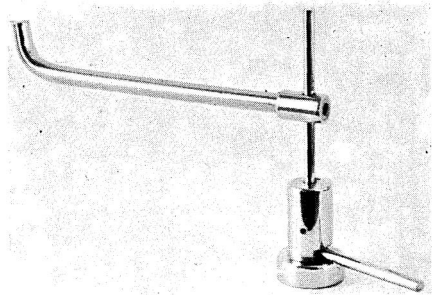

Hadcock GH Uni-lift

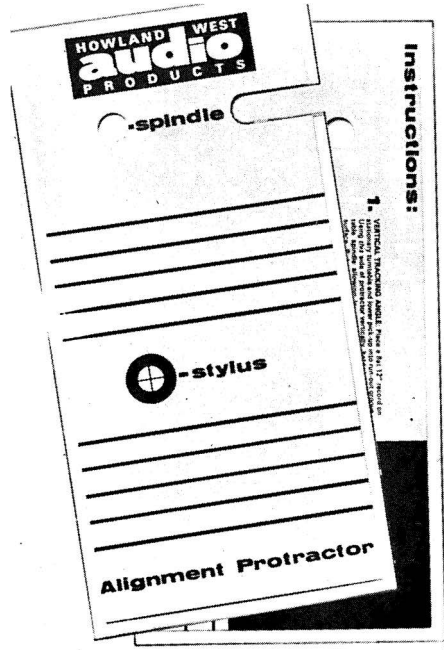

Howland-West Protractor



Keith Monks Professional Record Cleaning Machine

Other models available for earlier Ferrograph recorders, different amplifiers and special supply voltages. Details on request.

■ **LENNARD DEVELOPMENTS LTD**
206 Chase Side, Enfield, Middlesex, EN20QX.
Tel: 01-363 8238.

Play-fair Stylus Timer

Manually operated device which indicates when stylus is due for replacement. Self-adhesive to attach to motor board if desired. Swiss mechanism. Neat plastic case with instructions. Two models: one for sapphires, one for diamonds. Price (either model): 80p (plus 13p PT).

Play-fair Cleaning Pad

Anti-static. Price: 10p.

Play-fair Stylus Cleaner

Cleaning fluid with separate brush. In presentation case. Price: 30p.

Play-fair Antistatic Cleaning Fluid

30cc polythene bottle. Price: 23p.

Play-fair Discoda

Record sleeve indexing device for quick identification of records. Price: 3 for 13p, 12 for 40p. (Bulk prices on application).

Micro-Diamond replacement styli

Comprehensive range. Also retipping service. Price: on application.

Micro-Sapphire replacement styli

Comprehensive range. Also retipping service. Price on application.

Play-fair Discoduster

Record cleaning device. Two models; one for single play record decks, one for autochangers. Price: to be announced.

■ **KEITH MONKS (Audio) LTD**

26-30 Reading Road South, Fleet, near Aldershot, Hants. Tel: Fleet 7316.

Professional Record Cleaning Machine ★

Used by broadcasting companies, sound studios, record retailers and gramophone libraries.

Special washing, scrubbing and suction action leaves record clean and dry. Retail price: (single) £233; (double) £333-38.

The following dealers offer a record-cleaning service to the public using Keith Monk's equipment. The list is not necessarily comprehensive and other shops with the equipment installed are invited to submit details for publication in future issues of the Year Book.

- Central Records, Ashton-under-Lyne.
- Curtiss Records, Sheffield.
- Grahams, Pentonville Road, London, N1.
- Griffin Radio, Birmingham.
- Hi-Fi Corner, Edinburgh.

J. Windows, Newcastle upon Tyne.
Ken Rose, Fleet, Hants.
Marble Arch Cameras, Edgware Road, London.
Sound Incorporated, Wimbledon, London, SW19.
Sound Studios, Crawley, Sussex.

■ **MAC**

Modular Audio Components Ltd, Canterbury Road, Nottingham, NG8 1PQ.

Tel: Nottingham 79797.

Manual Groovy Clean

A record cleaner brush designed for use on discs that do not respond to normal cleaning methods. Micro-fibre brush penetrates to bottoms of the grooves. Stands up to continued use in record cleaning solutions and water. Brush mounted in extruded plastic section. Price: 25p.

AAU-3

Audio adaptor unit for connecting three pickups to a common amplifier input, also suitable for microphones, tuners, tapes, etc. Two phono inputs at rear alternately switched to front DIN sockets for feeding other equipment. Fitted with 24in leads with phono plugs, or with DIN plug (AAU-3Q). Provision for fitting attenuator or load resistors internally. Dimensions: 3 × 3 × 3in. Finish: jaguar silver. Price: £4-40.

All MAC AAU units are available in solid teak case at an additional cost of £1-32. See Tape Accessory, Constructional Kits, Speaker Accessory and Headphone Sections for details of other models.

■ **METROSOUND**

Metrosound Audio Products Ltd, Cartersfield Road, Waltham Abbey, Essex. Tel: Waltham Cross 31933.

M.2 Record Cleaning Sponge

Special soft texture for cleaning of records. Price: 15p (plus 2p PT).

M.3 Record Care Kit

Comprising bottle of Metro-Spray spirit-based anti-static record cleaning fluid; special texture sponge applicator with moulded handle; and soft stylus cleaning brush. Price: 37½p (plus 6p PT).

M.10 Metro Mat ★

Ribbed rubber full transcription size anti-static turntable mat, complete with separate stroboscope. Price: 65p (plus 10p PT).

M.11 Hi-Fi Stylus Cleaning Kit ★

Bottle of specially developed mild solvent fluid. Moulded plastic retaining clip on bottle for soft nylon cleaning brush. Price: 36p (plus 6p PT).

M.21 Metro Scale Stylus Balance

Works on knife edge balance principle. Supplied

★ Indicates entry is illustrated



Metrosound Metro-mat



Metrosound stylus cleaning kit



Micro-Seiki MSB-1

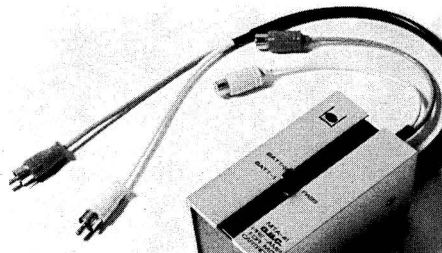

Micro-Seiki MT4-41

with eight plastic weights enabling checking from $\frac{1}{4}$ gm to $4\frac{1}{8}$ gm. Price: 40p (plus 6p PT).

M.23 Spirit level

Plastic spirit level for use on turntables, etc. Price: 40p (no PT).

M.24 Lubricating Kit

Suitable for transcription turntables and mechanical moving parts. Comprises small bottle each of R.O.B. and R.O.G. oil and container of Starfax. Price: 40p (no PT).

M.26 Ioniser

High-fidelity record cleaner. Permanently anti-static, humid soft velvet enclosed in plastic moulding. Price: 37 $\frac{1}{2}$ p.

M.27 Anti-static cleaning cloths

Permanently impregnated anti-static record cleaning cloth. Price: 15p.

M.28 High Fidelity Maintenance Kit

Designed for optimum maintenance of transcription record players and discs. Contents: ioniser, hi-fi cleaning kit, Metro Scale stylus balance, lubricating kit, and spirit level. Price: £2 (plus 14p PT).

■ MICRO-SEIKI

Distributors: B. H. Morris & Co (Radio) Ltd, 84-88 Nelson Street, London, E1 2DY. Tel: 01-790 5011.

MSB-1 ★

Micro shock absorber. Microsorber employs air-damped high efficiency materials to eliminate acoustic feedback to the record playing deck. Adjustable for height to equalise unbalanced weight of turntable. Price: (set of four) £4.95 (including PT).

MTA-41 ★

Solid state stereo preamplifier for use with MC-4100 moving coil or similar cartridges. Bypass switch permits use of higher output cartridges. Operation from two 1.5V batteries. Grounded base transistor circuits. Price: £11.

■ MULTICORE See Bib.

■ MUSONIC LTD

34-38 Verulam Road, St Albans, Herts. Tel: St Albans 50611/2.

DisClens

Soft cloth impregnated with anti-static solution for cleaning records. Price: 13p.

DisCentres

Record centre adaptors designed to convert 7in 45rpm records from large hole to standard spindle size. In boxes of 12. Price: (per box) 16p (plus 3p PT).

DisSleeves

Made from 200 gauge polythene. Protect records

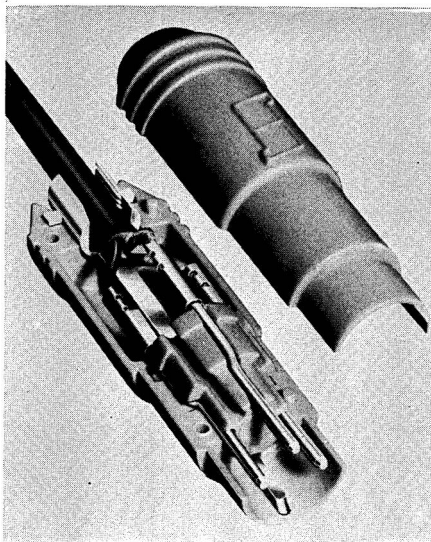

PD Connector

from dust and dirt. Round bottomed. In packets of 12. Price: (7in size) 14p; (12in size) 28p.

DisCovers

Made from 200 gauge polythene. Protect record sleeves against rubbing and scratching. Supplied in packets of 12. Price: (12in size only) 18p.

DisCase

Record case finished in wood and plastic. Three sizes, 60 7in records, 30 12in records, 60 12in records. Padded. Available in black, blue, brown, green and red. Prices: (60 7in size) £1.39 (plus 23p PT); (30 12in size) £1.65 (plus 26p PT); (60 12in size) £2.12 (plus 34p PT).

DiscRack

Heavy gauge steel wire rack welded at all points and with plastic coated or plated finish. Price: from 53p (plus 8p PT).

Stylus Cleaner

A special solution which cleans and renders stylus tip anti-static. Application brush provided. Price: 30p (plus 5p PT).

Superactive

New formula anti-static fluid for cleaning and neutralising static in records and other plastic surfaces. Applied with sponge or cloth. No sticky deposit. Suitable for recharging anti-static devices. Price: (½oz) 13p; (1oz) 23p.

PD CONNECTORS

Parry Electronic Developments Ltd, Assay House, 28 Greville Street, London, EC1. Tel: 01-242 1100.

DIN plugs ★

New design of DIN plug which requires no soldering or screw connections. Pins interchangeable to match any DIN configuration. Space inside housing to accommodate matching or attenuating resistors. Ratchet-type cable clamp adjusts to all sizes of connecting lead. Designed for home constructors and hi-fi enthusiasts. Price: 28p.

■ **PLAYFAIR** See Lennard Developments.

■ **QAS**

Quality Audio Supplies, Wollaton Road, Beeston, Nottingham, NG9 2PB. Tel: 0602 252222 and 256141.

Wide range of individually blister-packed audio accessories including phono plugs, DIN plugs and sockets, 4mm and wander plugs, couplers, screw terminals, slider switches, connecting leads with all types of terminations, audio switching units and remote control stations.

Dusta-Disc

Counterbalanced arm to mount alongside turntable for cleaning records while playing. Comprises base with height adjustment, arm with counterbalance weight, super-fine brush for cleaning grooves, plus a soft fabric roller for applying anti-static fluid. Price: £2 (including PT).

See Speaker Accessories Section for details of other QAS equipment.

■ **SHURE ELECTRONICS LTD**

84 Blackfriars Road, London, SE1 8HA. Tel: 01-928 3424.

SFG2 Stylus gauge ★

Accurate beam balance type gauge designed for measuring tracking force in the range of 0.5gm to 3gms. Measures existing playing weight of arm, or can be used to adjust arm to a desired tracking force. Price: £4.30 (including 58p PT).

M64-2E

Preamplifier for use with magnetic pickup head and amplifier not having sensitive enough input. Full specification and price in Amplifier Section.

■ **TELEFI**

Sound take-off adaptor for feeding hi-fi from TV. See Tape Recorder Accessories Section.

■ **TRANSCRIPTORS LTD**

2 Theobald Street, Boreham Wood, Herts. Tel: 01-953 0771.

Transcriptors Stylus Scale

Precision scales in polished aluminium with jewelled pivot. Sensitive to less than 0.01gm.

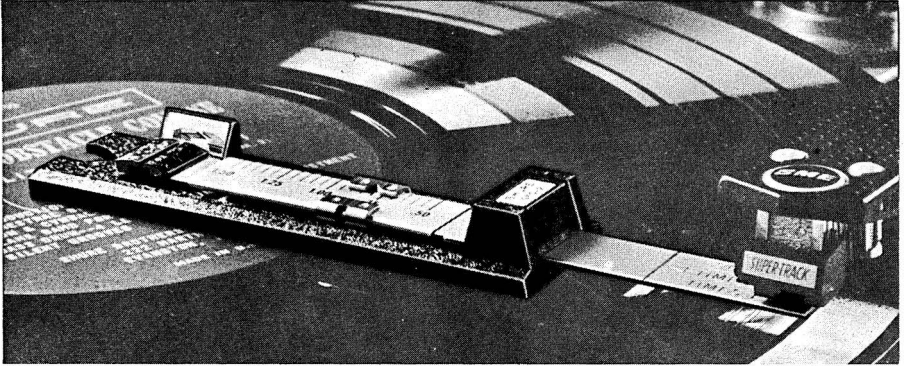

Shure SFG2 Stylus Tracking Force Gauge

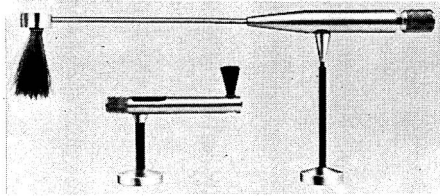

Transcriptors sweep arm and stylus brush



Watts Manual Parastat with Humid Mop

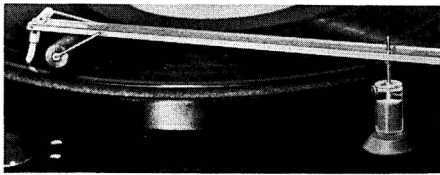

Watts 'Dust Bug'



Watts Humid Mop and new formula fluid



Watts Manual Parastat

Accuracy better than 0.02gm. Measures 0-5gm in increments of 0.05gm. Bubble read-out. Supplied with reference calibration check weights. British made. Price: £3.30 (plus 53p PT).

Transcriptors Sweep Arm ★

Record cleaning device for permanent fixing. Height adjustable over 3½ in. Tracks at ¼-½ gm. Balance cursor. Integrated parking device. Precision unipivot construction. Polished aluminium. British made. Price: £3.40 (plus 55p PT).

Transcriptors Stylus Brush ★

For permanent installation. Comprises squirrel hair brush for cleaning stylus. Adjustable for height. Single hole fixing. Polished aluminium construction. British made. Price: £2 (plus 33p PT).

■ **CECIL E. WATTS LTD**

Darby House, Sunbury-on-Thames, Middx.
Tel: Sunbury 3252.

Watts Dust Bug ★

Claimed to be the most efficient method of removing static and dust from records as they are played. Instantly fitted, suitable for all types of records. Record quality is improved, surface noise and wear reduced. Price: £1 (plus 16p PT).

Watts Disc Preener

For record maintenance where anti-static agents are not desirable (where stylus force is less than 2gm). Price: 35p.

Watts Manual Parastat with Humid Mop ★

Manual model Parastat record cleaning machine. For cleaning and applying anti-static agents to LP records. Complete with humid mop for cleaning bristles and velvet pads. Price: £2.65.

Watts Manual Parastat ★

Available separately (without Humid Mop). Price: £2.40.

Watts Humid Mop ★

Available separately. Price: 25p.

Hi-Fi Parastat Model Mk 4

Gramophone record maintenance and stylus cleaning kit. Designed for use on records in new condition which are played with pickups requiring very low tracking pressures. Price: £2.20 (plus 5p PT).

Watts Stylus Cleaner

As included with Hi-Fi Parastat kit. Price: 25p (plus 5p PT).

Watts Spares and Replacements

Dust bug nylon bristle and plush pad. Price: 10p.

New Formular Dispenser. Price: (½oz) 15p; (1oz) 25p.

Preener Wicks. Price: (packet of four) 10p.

Manual Parastat Brush. Price: 65p.

Parastat Nylon Velvet Pad Covers. Price: 20p a pair.

Parastat White PVC Sponge. Price: 5p.

Humid Mop (sponge and four wicks). Price: 15p.

Hi-Fi Parastat Distilled Water Dispenser. Price: 20p.

Hi-Fi Parastat pad cover and ribbons. Price: 10p.

■ **WILSON STEREO LIBRARY LTD**

104-106 Norwood High Street, London, SE27.
Tel: 01-670 6394.

W.S.L. Blank Disc

Highly polished blank vinyl disc for adjusting side thrust and alignment. Indicates the amount of side thrust to be corrected. Mirror-like surface reflects underside of cartridge and stylus and assists in accurate alignment. Supplied with instructions for correcting side thrust. Price: 75p, postage and packing included.

W.S.L. Side Thrust Corrector

Pulley device which may be fitted to any pickup to correct side thrust. Should be used in conjunction with W.S.L. Blank Disc for precise elimination of side thrust. Price: 45p (including PT), postage and packing included.

PLAY-FAIR

Record Accessories, Stylus Timers, Stylus Cleaners, Antistatic Cleaning Pads, Antistatic Fluid, Discodas, and Discodusters, Tape Cassettes and Cassette cleaners.

MICRO-DIAMOND

MICROSAPHIRE

Replacement Styli. Most comprehensive range, best quality, reliable service, keen prices; also MICRO-DIAMOND retipping service.

**DRY-SPLICE
TAPE ACCESSORIES**

(Plugs and sockets and assemblies)

MINIFLUX - B. Woelke Tape Heads

Manufacturers and Distributors:

LENNARD DEVELOPMENTS LTD

**206, CHASE SIDE,
ENFIELD, MIDDLESEX**

Tel. (01) 363 8238

Even in a range as famous as ours there has to be a best



When a brand new unit is added at the top of a range already famous for its quality, you really have to stop and listen.

It has to be something special.

And in the Lenco GL 85P we have a new unit that will quickly secure itself a place as the ultimate transcription unit of the Hi-fi connoisseur.

It has all the quality features you'd expect in a Lenco unit, combined with some totally new ones.

Like a low-speed 16-pole synchronous motor, of exceptional accuracy, which transfers the drive via a non-stretch flat belt.

An electronically controlled shut-off mechanism. Electronic speed adjustment and an illuminated stroboscope cunningly set in the turntable.

And a pick-up arm that treats a record with

almost obsessive care.

With the whole unit housed in a style to which it has every right to become accustomed.

A fit companion for this fine new turntable is the Goldring 800 Super E cartridge. A cartridge with extraordinarily low mechanical impedance, and a performance aimed to satisfy the perfectionist.

Ask your Goldring dealer. He'll be glad to arrange a hearing at which you can judge for yourself.

For illustrated brochure write to: Goldring Manufacturing Company (Great Britain) Limited, 10 Bayford Street, Hackney E8 3SE.

Goldring

The Lenco GL 85P. Integrated transcription turntable, 33 $\frac{1}{3}$ and 45 rpm with electronic fine speed adjustment of plus or minus 3%. Counter-balanced pick-up arm with removable plug-in shell. Electronic shut-off mechanism switches current off at end of play and raises arm from record surface with no mechanical interference. GL 85P with handsome hand-finished wooden base and clear dust cover: £79.05. Also available in chassis form without base or cover as GL 85: £62.74.

Connoisseur Precision in Sound

THE BIG 4-FOR THE ENTHUSIAST

B.D.2 PRESS BUTTON SPEED CHANGE TURNTABLE

Now, a new development on the well-established Connoisseur B.D.2 belt drive turntable—press button speed change. This new development is exciting news for the enthusiast and comes as part of an integrated turntable and pickup arm assembly which also features a special version of the popular S.A.U. 2 arm. This is now fitted with a new lifting device which gives improved lowering characteristics, the headshell allowing for lateral adjustment of the cartridge. The B.D.2 is supplied as a chassis unit or spring mounted on a wood plinth with dust cover.

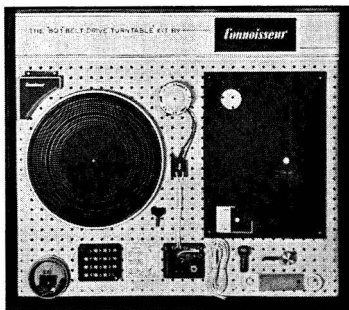

TURNTABLE KIT

Something new from Connoisseur—a Kit of the world famous B.D.1 Turntable. Construction is simplicity itself—the only tools required being a small screwdriver and a pair of pliers apart from the special spanner which is included. No soldering is required.

The B.D.1 Turntable operates at 33 $\frac{1}{3}$ and 45 rpm incorporating a flexible belt drive system, virtually eliminating vibrating and transmission noise and giving a performance that will meet the requirements of the discerning enthusiast.

S.A.U.2 PICK-UP ARM

This is one of today's most advanced pick-up arms and features:

- ★ New head shell—with lateral adjustment.
- ★ Auto-bias compensator
- ★ Precision balance
- ★ Hydraulic lowering device



S.C.U.1 STEREO CARTRIDGE

This is the cartridge for the person who really cares about his equipment.

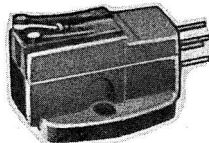

Full details of all Connoisseur Equipment on request to:

A. R. SUGDEN & CO. (ENGINEERS) LTD.

Market Street, Brighouse, HD6 1DX, Yorkshire.

Tel. 2142

Hi-Fi decks to choose with confidence



Garrard SP 25 Mk III



Garrard Zero-100S



Garrard AP 76



Garrard 401

Many years of turntable technology are behind every Garrard deck. For you, many years of precision playing - whichever turntable you use.

SP 25 Mk III

The successor to the SP 25 Mk II, probably the most popular single play unit in the moderate price range. Features include non-magnetic turntable, calibrated fine stylus force adjustment, bias compensator, viscous-damped cue and pause, decoupled weight counterbalanced pick-up arm with slide-in cartridge carrier. Plays automatically when required. Base and rigid plastic cover available.

AP 76

A transcription quality three-speed single record playing unit, which features automatic play of single records when required. The tubular pick-up arm, fitted with a slide-in cartridge carrier is counterbalanced by decoupled weight and incorporates a bias compensator, calibrated for spherical and elliptical styli, and fine stylus force adjustment. Other features include non-magnetic turntable, fluid-damped cue and pause and tab controls. Base and rigid plastic cover available.

Zero-100S

The Zero-100S offers the greatest combination of advanced features available in any turntable available today. It is a two-speed (33 $\frac{1}{3}$ and 45 rpm) single play transcription unit which incorporates an ingenious pick-up arm design that virtually eliminates

tracking error.

Features include magnetic bias compensation, illuminated strobe and fine speed control, stylus force adjustment from 0.3 grammes and automatic play of single records. The Zero-100 is also available as an auto-changer. Base and rigid plastic cover available.

401

With its heavily-shielded 4-pole induction motor, precise speed control, non-magnetic diecast turntable, built-in stroboscopic light and elegant styling, the 401 is the ultimate in transcription turntables. It meets the most exacting requirements of radio, television and recording studios throughout the world and of hi-fi enthusiasts everywhere. Each unit is supplied with its own individual test report. (Garrard bases and covers not available for this unit.)

Choose a Garrard deck - with confidence.

Garrard 
A PLESSEY QUALITY PRODUCT



Garrard, Newcastle Street,
Swindon, Wiltshire.
Telephone: Swindon 5381.

Directory of Motor Units

★ Indicates entry is illustrated

Abbreviations used in this section are given on page 36.

■ ACOUSTIC RESEARCH

Pending new distribution arrangements in the UK all AR products are available direct from Acoustic Research International, Radiumweg 7, Amersfoort, Holland. (POB 209). Tel: (03490) 12556.

AR Universal ★

Two-speed turntable, pickup arm, plug-in cartridge shell, plinth and transparent plastic cover. Speeds: 33½ and 45rpm. W and F: <0.1% (combined wow and flutter measured to NAB standards). Rumble: at least 35dB below 1cm/second (measured to NAB standards). Speed accuracy: ±0.3% of absolute speed. Turntable: 12in non-magnetic. Belt drive. Miniature synchronous motor. Adjustable playing weight. Internal adjustable viscous damping. Decoupled turntable isolated from plinth. Adjustable stylus pressure with built-in gauge. Finish: walnut. Performance guaranteed to exceed NAB broadcast equipment standard for three years after purchase. Price: on application.

■ ALBA (Radio & Television) LTD

Tabernacle Street, London, EC2.
Tel: 01-253 1322.

UA200A

Shelf-mounting cabinet with lift-up lid containing Garrard SP25 Mk III record deck and pickup arm. Stereo magnetic cartridge. Diamond stylus. Cueing device. Teak finished cabinet. Supplied complete with leads and plugs. See Garrard entry for complete specification of motor unit. Price: £31.75 (including PT).

■ ARISTON

Distributors: C. W. & J. Walker, 3 Kirklands, Church Street, Cleckheaton, Yorks, BD193RW. Tel: 097-62 3756.

RD11

Single-speed transcription motor unit available as chassis only, with plinth and cover, and complete with plinth, cover and pickup arm. Speed: 33½rpm. W and F: below meaningful measurement. Rumble: below meaningful measurement. Turntable: 12in diameter, 8½lb, made in non-ferrous alloy with single-point

bearing in PTFE bushes. Belt drive. Stainless steel chassis. Felt and rubber mats supplied. Motor: 24-pole precision synchronous. Pickup arm (when fitted): SME3009/2HE. Price: (chassis only RD11) £44 (plus £7.84 PT); (chassis with plinth and cover RD11PC) £54 (plus £9.62 PT); (chassis with plinth, cover and SME arm RD11PCA) £90 (plus £13.30 PT).

■ BANG AND OLUFSEN UK LTD

Eastbrook Road, Gloucester, GL47DE.
Tel: Gloucester 21591.

Beogram 1000LM

Plinth mounted motor unit with arm and SP14A magnetic cartridge. Speeds: 78, 45 and 33½rpm with 12% vernier adjustment. Wow: ±0.2% peak. Rumble: > 32dB below 10cm/sec PU output. Belt drive. B and O ST/L 15° arm with micro-lift. Anti-static mat with strobe disc. Anti-microphonic suspension. Built-in 45rpm disc insert. Power supply and socket for GF3 preamp. Price (teak): £45.90 (including PT); (rosewood) £46.90 (including PT). GF3 preamplifier to slot into socket under Beogram 1000. Price: £5.75 (no PT).

Beogram 1202

Plinth-mounted motor unit with arm, cartridge and separate dust cover. Speeds: 33½ and 45rpm. W and F: <0.15%. Rumble: better than 55dB (DIN). Turntable: 12in aluminium alloy with conical studs instead of disc mat. Belt drive. Two-pole asynchronous motor. B and O pickup arm with built-in bias compensation and stylus pressure adjustment. Fully automatic operation with single master control. Price: to be announced.

Beogram 3000

Plinth-mounted motor unit with arm, cartridge and hinged-detachable dust cover. Speeds: 33½ and 45rpm with ±6% fine adjustment. W and F: <0.15%. Rumble: better than 60dB (DIN). Turntable: 12in grooved aluminium. Belt drive. Two-pole asynchronous motor, 110-240V AC switchable. B and O pickup arm with built-in bias compensation. Stroboscopic disc. Fully automatic motor/arm/speed/record size action. Price: to be announced.

■ BSR McDONALD

(McDonald Division) BSR Ltd, Cradley Heath, Warley, Wors. Tel: Cradley Heath 69272.

HT70 ★

Four-speed single player. Wow: <0.2% RMS (0.4% peak). Flutter: 0.06%. Rumble: -35dB to DIN 45-500 specification. Speed constant down to 16% reduction in mains voltage. Turntable: 11in diameter diecast alloy weighing 5lb. Pulley drive. Synchronous dynamically balanced four-pole motor. Double ball-race mounted pickup

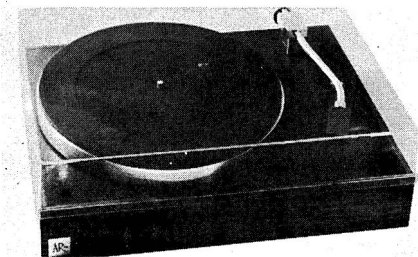

Acoustic Research Turntable



BSR McDonald HT70



BSR-McDonald MP60



BSR-McDonald 610



BSR-McDonald 810

arm. Plug-in head. Counter-balanced arm. Bias compensator. Tracking control. Viscous damped cue control. Anti-skate device. Muting switch. Adjustment for playing weight. Rotating record stub spindle to combat drag. Price: (HT70 chassis) £17.72 (plus £2.91 PT); (mounted in afrormosia plinth with dust cover) £25.62 (plus £4.22 PT).

MP60 ★

Four-speed single player. Wow: <0.2% RMS (0.4% peak). Flutter: 0.06%. Rumble: -35dB to DIN 45-500 spec. Speed constant down to 16% reduction in mains volts. 11in diecast turntable. Pulley drive. Four-pole motor. Double ball-race mounted pickup arm. Plug-in head. Counterbalanced. Bias compensator. Tracking control. Viscous damped cue control. Anti-skate device. Muting switch. Price: (MP60 chassis) £12.69 (plus £2.09 PT); (mounted in black styrene plinth with dust cover) £18.56 (plus £3.05 PT); (mounted in afrormosia plinth with dust cover) £20.58 (plus £3.39 PT).

610 ★

Automatic four-speed changer. Wow: <0.2% RMS (0.4% peak). Flutter: 0.6%. Rumble: -29dB ref 1kHz recorded laterally at 1.2cm/sec. Speed constant down to 16% reduction in mains voltage. 11in diecast turntable. Pulley drive. Synchronous motor. Double ballrace pickup mounting. Anti-skate device. Counter-balanced. Plug-in head. Viscous damped cue control. Muting switch. Price: (610 chassis) £16.10 (plus £2.65 PT); (mounted in black styrene plinth with dust cover) £21.97 (plus £3.62 PT); (mounted in afrormosia plinth with dust cover) £23.99 (plus £3.95 PT).

810 ★

Two-speed transcription motor unit fitted with pickup arm. Manual or automatic changer. Available in chassis form or plinth mounted. Speeds: 33½ and 45rpm. Fine speed control. Wow: better than 0.1%. Flutter: better than 0.05%. Rumble: better than -55dB relative to 1kHz at 10cm/sec (weighting curve has roll-off of 12dB/octave above and below 315Hz). Diecast turntable weighing 6¾lb. Four-pole synchronous motor. Low-mass transcription pickup arm with concentric gimbal mounting. Stroboscopic centre disc to turntable. Rotating centre stub spindle. Dual-range anti-skate device. Stylus position gauge. Stylus brush. Stylus pressure adjustment. Automatic pickup arm lock. Slide-in cartridge carrier. Viscous damped cue and pause. Pushbutton operation. Capacity: up to six 7in, 10in or 12in records. Manual selection of record size and speed. Tracking: down to a minimum of ¼gm with high compliance cartridge. Size: (chassis) 15in wide, 12¼in deep, 5in above lower edge of

baseplate, 2 $\frac{5}{8}$ in below lower edge of baseplate. Mains: 100-125V or 200-250V 50 or 60Hz. Finish: Satin black mainplate, black turntable mat, brushed aluminium trim. Price: (810 chassis) £38 (plus £6.25 PT); (810 plinth) £8.50 (plus £1.40 PT); (810 dust cover) £4 (plus 66p PT).

BSR McDonald plinths

Afrormosia wood plinth with black baseboard. Designed for BSR MP60, HT70 and 610 turntables. Price: £4.03 (plus 66p PT). Smoke tinted dust cover. Price: £2.82 (plus 46p PT).

■ CONNOISSEUR

A. R. Sugden & Co (Engineers) Ltd, Market Street, Brighouse, Yorkshire. Tel: Brighouse 2142. Cables: Connoisseur, Brighouse.

BD1 ★

Two-speed motor unit supplied as motor only or plinth mounted with any Connoisseur arm. Two fixed speeds, 33 $\frac{1}{3}$ and 45 rpm. Wow: <0.1%. Flutter: <0.1%. Rumble: -50dB measured at RIAA characteristics ref 7cm/sec at 1kHz. No change in speed for 20% variation in supply voltage. 10 $\frac{1}{4}$ in non-ferrous lathe-turned turntable. Precision ground belt drive. Unique drive arrangement eliminates transmission noise. Simple manual speed change. Low hum field. Slim line construction. Only 1 $\frac{3}{8}$ in required below mounting platform. Mains: 100-120V and 200-240V, 50 or 60 Hz. Price: £13.40 (plus £2.15 PT). Price of assemblies on application.

BD2 ★

Integrated transcription unit. Includes a BD1 motor unit (mounted on a larger platform and fitted with pressbutton speed change) and a type SAU2 pickup arm. Hydraulic arm lift operated from front. Anti-vibration springs. Supplied either chassis only or plinth mounted. Perspex cover. Size: 12 $\frac{1}{4}$ × 14 × 4 $\frac{3}{8}$ in (2in below and 2 $\frac{3}{8}$ in above the platform). Price: (chassis model) £26.85 (plus £4.31 PT); (assembly mounted on plinth complete with transparent plastic cover) £33.90 (plus £5.44 PT).

■ DECCA

Decca Special Products, Ingate Place, Queenstown Road, London, SW8 3NT. Tel: 01-622 6677.

Studio turntable ★

Combination of Decca Mk 4 *ffs* cartridge and Garrard AP76 three-speed single record playing unit. Speed: 33 $\frac{1}{3}$, 45 and 78rpm. Automatic motor switch off and return of pickup at end of record. Cue and pause facility, calibrated pickup arm bias compensation, calibrated stylus weight adjustment. Price: £33.18 (plus £5.32 PT).



Connoisseur BD1



Connoisseur BD2



Decca Studio

■ DUAL

International Audio Ltd, Clive House, Queens Road, Weybridge, Surrey. Tel: Weybridge 40125/6. Telex: 928153.

1216

Three-speed turntable with pick-up arm and cartridge. Manual, semi-automatic or fully automatic operation. Featherlight controls. Speed control provides variation of approximately one semitone. Clip-in headshell. Damped cueing control. Anti-skating device coupled to tracking weight control. New design lightweight cast alloy pickup arm with decoupled counterweight assembly. Playing weight adjustable 1-8gm. Anti-skating device. Headshell accepts all cartridges with $\frac{1}{2}$ in fixing centres. Speeds: 33 $\frac{1}{3}$, 45,

★ Indicates entry is illustrated

78rpm. Four-pole asynchronous motor with radially elastic suspension. Turntable: 10½in diameter, 4½lb, non-magnetic. Rumble: > -57dB (weighted). Mains: 110/117, 220/240V 50/60Hz. Consumption: 10W. Size: (chassis) 13 × 11in. Price: (chassis only) £31.17 (plus £5 PT); (with Shure M75-D cartridge) £44.50 (including PT).

1218

Three-speed turntable with pickup arm and cartridge. New design pickup based on the 1219 arm. Tubular aluminium arm supported at the rear in four micro-races set in a two-ring gimbal system. Headshell incorporates mechanism, operated by small side knob, which tilts cartridge to compensate tracking angle when playing a stack of discs. Anti-skating adjustment, calibrated for spherical or elliptical stylus. Speed control provides variation of approximately one semitone. Speeds: 33½, 45, 78rpm. Four-pole synchronous motor with ferrite ring rotor and suspension by radially elastic supports. Mains: 110/117, 220/240V 50/60Hz. Consumption: 10W. Turntable: 10½in diameter, 4½lb, non-magnetic. Rumble: (weighted) > -59dB. Size: (chassis) 13 × 11in. Price: (chassis) £43.53 (plus £6.98 PT); (with Shure M91 MG-D cartridge) £53.40 (plus £8.57 PT).

1229

Three-speed turntable with pickup arm and cartridge. 12in diecast turntable. Extra long light-weight tubular aluminium pickup arm. Effective pivot to stylus tip length 8½in. Maximum tracking error over record diameter of 4½-11½in is 1½°. Speed control giving variation of approximately one semitone. Illuminated strobe. Cueing device damped on lowering and raising. Adjustment for playing single records or a stack to keep tracking angle correct. Accepts all standard ½in fixing centre cartridges. Speeds: 33½, 45, 78rpm. Built-in stroboscope. Four-pole synchronous motor with ferrite ring rotor and suspension by radially elastic supports. Mains: 110/117V, 220/240V 50/60Hz. Consumption: 8W. Turntable weight: 7lb approx. Rumble: (weighted) -60dB (DIN). W and F: 0.06% or less (DIN 45507). Price: (chassis) approximately £84.50 (including PT); (with Shure M103 cartridge) approximately £90 (including PT).

■ DYNATRON RADIO LTD

St Peter's Road, Maidenhead, SL6 7QY,
Berks. Tel: Maidenhead 23331.

Dynatron P.100 Teak ★

Plinth unit comprising Goldring-Lenco GL75 mechanism with Goldring G800 cartridge. Four speeds, fully variable. Fitted with mains lead and plug, also audio lead and DIN plug. Price: £49.55 (plus £7.95 PT).

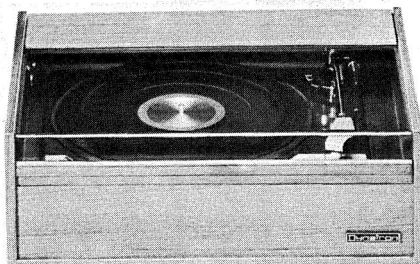

Dynatron P100 teak

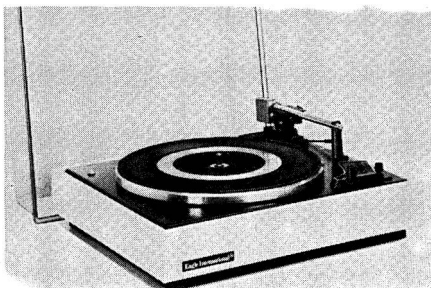

Eagle AA18B & AA18W



EMT 930st

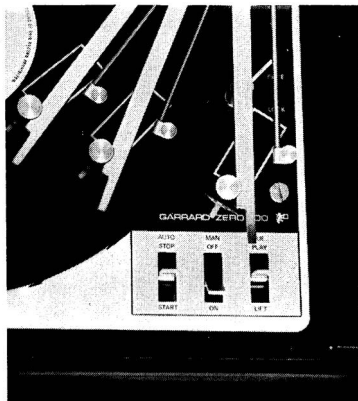

Garrard Zero 100 Pickup arm

■ EAGLE INTERNATIONAL

Heather Park Drive, Wembley, HA1 1SU.
Tel: 01-903 0144.

AA18B and AA18W ★

Three-speed record deck in plinth with cover. Pickup arm wired for mono or stereo. Motor unit Garrard SP25 Mk III. Speeds: 33 $\frac{1}{3}$, 45 and 78rpm. Rim drive. Four-pole screened motor. Counterbalanced tubular aluminium arm. Price: £22-11 (plus £3-66 PT).

■ EMT WILHELM FRANZ KG

Sole UK agents: F. W. O. Bauch Ltd,
49 Theobald Street, Boreham Wood, Herts.
Tel: 01-953 0091.

EMT 930st ★

Professional transcription turntable fitted with pickup arm and equaliser amplifier, chassis construction. Speeds: 33 $\frac{1}{3}$, 45 and 78rpm with fine speed control. W and F max: 0-075%. Rumble: referred to a peak velocity $V=10\text{cm/s}$ at 1kHz 58dB (weighted) (0dB=0-775V). Speed constancy: max $\pm 0-15\%$. Turntable: 13in dia heavy cast non-magnetic with light plastic auxiliary turntable on top. Drive: pulley. Motor: EMT manufacture with artificially aged shaft. Pickup arm: EMT type 929. Features: stroboscope, quick start, remote start, pickup illumination, scratch filter and equalisation control on deck, headphone sockets, pickup lowering device. Price on application.

EMT 928

Professional transcription turntable fitted with pickup arm and equaliser amplifier. Speeds: 33 $\frac{1}{3}$, 45 and 78rpm with $\pm 2\%$ fine speed control. Rumble: better than -65dB weighted (to DIN 45 539). Turntable: 11 $\frac{1}{2}$ in. Belt drive. Three-phase synchronous motor fed by electronic three-phase generator. EMT 929 pickup arm. Statically and dynamically balanced in all directions. Stroboscope. Quick start with muting relay. Pickup illumination. Equaliser amplifier with headphone outlet. Price on application.

■ GARRARD ENGINEERING LTD

Swindon, Wiltshire, England.
Tel: Swindon 5381. Cables: Garrard, Swindon.

Zero 100 ★

Two-speed transcription record unit with tangential pickup arm. Speeds: 33 $\frac{1}{3}$ and 45 rpm. Fine speed adjustment giving $\pm 3\%$. Stroboscopic neon speed indicator. W and F: better than 0-1% RMS. Rumble: better than -51dB relative to 1-4cm/sec at 100Hz. Garrard Synchro-Lab two-section motor. Tangential pickup head incorporating an automatic pivoting device that keeps the cartridge in precisely the correct attitude and so virtually eliminates tracking

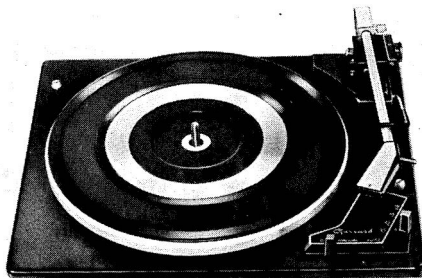

Garrard SP25 Mk III

error. Stylus angle adjustable for single records or for playing a number of discs on automatic. Provided with gauge for exact positioning of cartridge in head. Magnetic bias compensation calibrated for spherical and elliptical stylus. Adjustable playing weight calibrated in $\frac{1}{4}$ gm steps from 0-3gm over 3in. Non-magnetic 11 $\frac{1}{2}$ in turntable. Pulley drive. Three brass tab keys for controls. Functions provide automatic operation, manual operation, cue, pause and stop. Fluid damped lowering device. Price: £49-22 (plus £8-20 PT).

Zero 100S

Single play version of Zero 100. Price: (unmounted) £45-28 (plus £7-55 PT); (mounted) £49-22 (plus £8-20 PT).

Model 401

Transcription motor. Three speeds: 33 $\frac{1}{3}$, 45, 78rpm. Adjustable by eddy current brake. 6lb machined aluminium turntable with gear-cut illuminated strobe markings on rim. Statically balanced. Die-cast aluminium unit plate. Completely screened spring-mounted shaded-pole motor. Styled by Eric Marshall and finished in metallic charcoal with chrome relief. W. and F. less than 0-05% RMS. Rumble almost non-existent. Mains: 110-125V and 220-250V, 50 or 60Hz according to pulley fitted. Size: 13 $\frac{3}{4}$ in wide, 14 $\frac{5}{8}$ in front to rear, 2 $\frac{1}{2}$ in above and 3 $\frac{1}{8}$ in below lower edge of unit plate. Price: £33-46 (plus £5-58 PT).

SP25 Mk III ★

High quality single record playing unit with performance to DIN 45-500. Non-magnetic turntable. Three-speed. Four-pole screened motor. Cueing device to raise or lower pickup arm where required. Counter-balanced tubular aluminium arm. Slide-in cartridge carrier. Integral calibrated stylus pressure adjustment. Bias compensator. Automatic play of single records. Wired for stereo and mono. Mains: 100-125V, 220-250V, 50 or 60Hz according to pulley. Size: 15 $\frac{1}{8}$ in wide, 12 $\frac{1}{2}$ in front to rear, 2 $\frac{7}{8}$ in above, 2 $\frac{1}{8}$ in below lower edge of unit plate. Plus clear-

★ Indicates entry is illustrated



Garrard AP76



Goldring GL75/P

ances. Price: (unmounted) £13.86 (plus £2.31 PT); (mounted) £20.13 (plus £3.36 PT).

SL95B

Transcription turntable with autochange facility and automatic single record play. Combined record size and speed selector. 11½in aluminium turntable. Weight-counterbalanced wood and aluminium pickup arm with gimbal type pivots. Calibrated fine stylus force adjustment. Calibrated bias compensator. Slide-in cartridge carrier accepts most makes and types. Cue and pause facility. Wired for mono and stereo. Synchro-Lab constant speed motor. Size (including rear and side overhang of pickup arm): 15½in wide, 14½in front to rear, 4½in above, 2½in below edge of unit plate. Plus clearances. Price: £42.18 (plus £7.03 PT).

WB4 Mk II

Wood base for SL95B. Price: £4.80 (plus 80p PT).

SPC4 Mk II

Rigid transparent plastic dust cover for SL95B. Price: £3.75 (plus 63p PT).

SL72B

Transcription turntable with autochange facility and automatic single record play. Combined record size and speed selector. Non-magnetic turntable. Aluminium pickup arm is weight counterbalanced, fitted with slide-in cartridge carrier and features gimbal type pivots. Calibrated stylus force adjustment. Calibrated bias compensator. Cue and pause facility. Wired for stereo and mono. Size (including rear and side overhang of pickup arm): 14½in wide, 12½in front to rear, 4½in above and 2½in below lower edge of unit plate, plus clearances. Price: £27.94 (plus £4.66 PT).

WB4 Mk II

Wood base for SL72B. Price: £4.80 (plus 80p PT).

SPC4 Mk II

Rigid plastic cover for SL72B. Price: £3.75 (plus 63p PT).

AP76 ★

Single record playing unit complying with DIN 45-500 standards. Manual or automatic play of single records. Combined record size and speed selector. 11½in diameter aluminium turntable. Aluminium pickup arm. Counter-balanced. Calibrated fine stylus force adjustment. Calibrated bias compensator. Slide-in cartridge carrier accepts most makes and types. Cue and pause facility. Wired for stereo and mono. Four-pole induction motor. Size (including rear and side overhang of pickup arm): 14½in wide, 12½in front to rear, 2½in above, 2½in below edge of unit plate. Plus clearances. Price: (unmounted) £24.38 (plus £4.06 PT); (mounted) £31.88 (plus £5.31 PT).

■ GOLDRING MANUFACTURING CO. (Great Britain) LTD

10 Bayford Street, Hackney, London, E83SE. Tel: 01-985 1152.

Goldring-Lenco GL75 ★

Integrated turntable and pickup arm. Four speeds, infinitely variable. Wow: < 0.2%. Flutter: < 0.2%. Speed change less than 1% for 13% voltage change. 12in diameter diecast zinc turntable, 8lb. Vertical pulley drive. Four-pole 15W induction motor. L75 pickup arm. Counterbalance weight adjustment, knife-edge bearing, plug-in shell. Hydraulic lowering device. Price: £36 (plus £5.86 PT). Available on plinth as GL75/P £44.40 (plus £7.22 PT).

Goldring G99

Transcription motor only. Infinitely variable speeds 30-80rpm. Wow: 0.1%. Speed remains constant with 13% voltage change. Turntable 12in die-cast zinc. Vertical idler wheel with provision for disengagement. Four-pole motor.

Amplifiers
Tuners
Motor units
Compact units

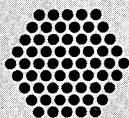
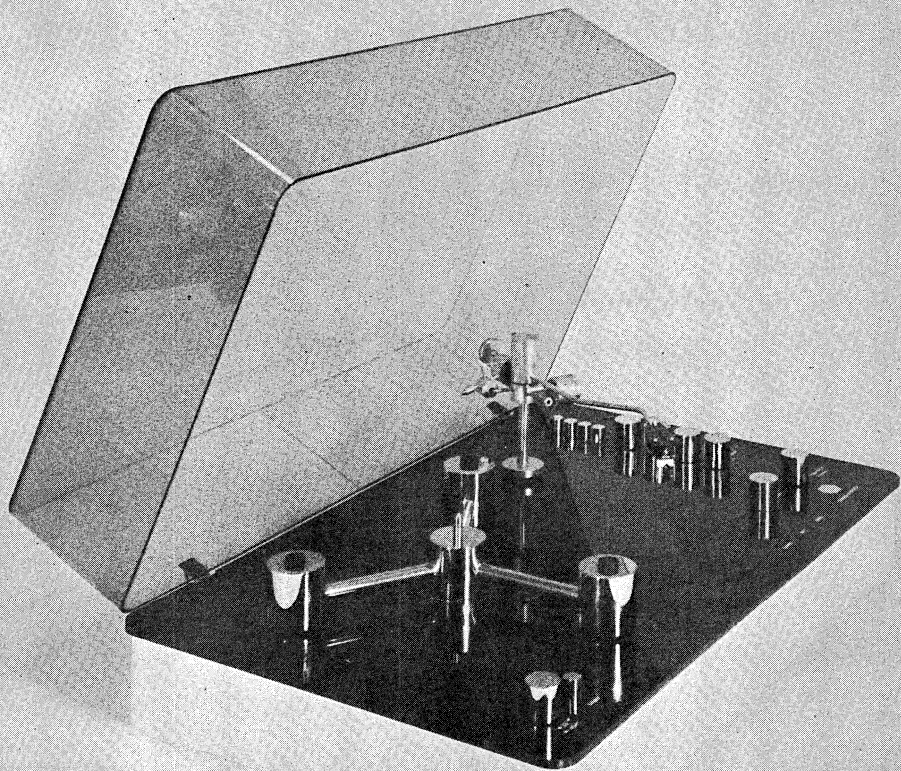

SYKES+HIRSCH

SYKES+HIRSCH LIMITED, 201 Greenwich High Road, London SE10 01-858 0549

Transcriptor

SATURN

turntable

Transcriptors is a wholly British Company with an enviable reputation for making the finest Turntables and accessories marketed today. The Saturn

Turntable has been designed and developed with our reputation for quality in mind, and no expense has been spared in materials and finish to present the British market with a unit of superior design and finish.

The Saturn is aimed at the mid-price Turntable market, and in this market it is true to say that only imported units compete. Thus, the Saturn, without its competitors disadvantages of overseas freight, import duty, and wholesalers charges, is able to offer far greater value for money. The distinctive appearance of the original Transcriptor designs has been

retained, and many of the commendable features incorporated in the more expensive Hydraulic Reference unit have been included. Technically, the unit is in advance of any competitor in its price range, and in appearance, its polished aluminium finish, with its solid black acrylic baseboard, and lavishly gold plated platter weights, it is, once again, far in advance of all comers within this price range.

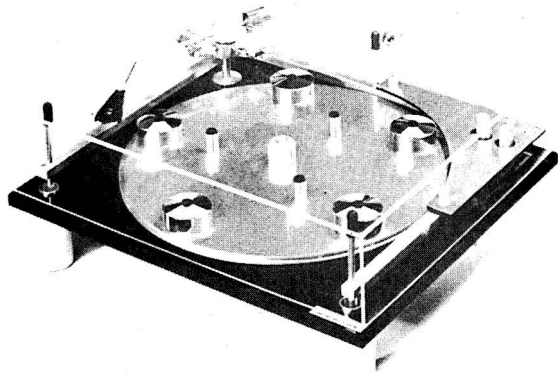

SPECIFICATION

PLATTER. Non-ferrous aluminium disc fitted with five gold plated non-ferrous platter weights, the whole balanced to within 3 grammes.

MAIN BEARING. Slim section ball ended ground and polished steel spindle, running on to hardened steel plate and running in P.T.F.E. bearings.

MOTOR. Low speed synchronous récoil start.

SPEEDS. 33 $\frac{1}{3}$ R.P.M. and 45 R.P.M. flick switch change.

ACOUSTIC FEEDBACK. The baseboard is designed to float separately from the legs and steady bar, the long telescopic oil damped springs give exceptional freedom from acoustic feedback.

DRIVE. Long soft natural rubber belt.

ELECTRICAL. Any mains voltage or frequency, by changing mains selector panel and pulley.

SPEED STABILITY. Typical figure at 33 R.P.M. 0.05%. **RUMBLE.** Not measurable.

LID. The clear acrylic lid is of the fabricated straight line type as opposed to the much cheaper vacuum moulded type. It is mounted on hinge pins and may be removed at will. The lid is retained in its open position by a unique swingleg as used on the professional Reference model.

SATURN TONEARM

The TONEARM designed for the SATURN deck is of jewelled unipivot type, but incorporating a unique ball race stabiliser. The frictional characteristics of this pivot system approach closely to the ideal. The tonearm is of extremely low mass, and this low mass, coupled with the low bearing friction, makes this arm ideal even for the latest cartridges of very high compliance.

TRANSCRIPTORS LIMITED

2 Theobald Street, Boreham Wood, Herts. Telephone 01-953 0771

Built-in illuminated strobe. Pushbutton on/off. Price: £25.50 (plus £4.14 PT).

Goldring G101 P ★

Two-speed motor unit on plinth with pickup arm. Speeds: $33\frac{1}{3}$ and 45rpm. W and F: 0.2% (DIN). Rumble: (weighted) -60dB. Turntable: steel 10in diameter, $2\frac{1}{2}$ lb. Belt drive. 16-pole synchronous motor. Counter-balanced pickup arm. Removable shell. Bias compensation. Viscous damped lowering device. Price: £25.50 (plus £4.14 PT).

Goldring-Lenco GL72 ★

Turntable unit with pickup. Available in chassis form or with plinth and cover. Speeds: 30-86rpm continuously variable with 'click' stops at $16\frac{2}{3}$, $33\frac{1}{3}$, 45 and 78rpm. W and F: 0.12%. Speed variation: 0.3% for 10% change in mains voltage. Pulley drive. Four-pole motor. Viscous damped lowering device. Removable shell. PU arm type L69. Bias compensation. Price: (motor unit) £27 (plus £4.39 PT); (motor unit on plinth) £35.10 (plus £5.71 PT); (dust cover) £4.05 (plus 66p PT).

Lenco GL85/P/C ★

Two-speed motor unit with pickup arm on plinth with cover. Speeds: $33\frac{1}{3}$ and 45rpm. Electronic fine speed adjustment $\pm 3\%$. W and F: (linear) $\pm 0.16\%$, (weighted) $\pm 0.08\%$ (DIN). Rumble: (linear) -45dB, (weighted) -60dB. Turntable: 12.4in alloy, $3\frac{1}{2}$ lb. Belt drive. 16-pole synchronous motor. Viscous damped lowering device. Electronic switch-off and pickup raising at end of record. Counter-balanced arm. Bias compensation. Removable shell. Illuminated stroboscope. Price: £75 (plus £12.19 PT).

■ GOODMANS LOUDSPEAKERS LTD

Downley Road, Havant, Hants, PO92NL.
Tel: Havant 6344. Telex: 86296.

TD100

Record deck in plinth with lid. Goldring GL75 motor unit. Infinitely variable speed adjustment with click stops for $16\frac{2}{3}$, $33\frac{1}{3}$, 45 and 78rpm. W and F: <0.2%. Speed constancy: <1% change for 13% variation in mains voltage. Turntable: 12in diecast zinc platter. Weight: 8lb. Vertical pulley drive. Four-pole motor. Counter-balanced pickup arm. Plug-in head shell. Hydraulic lowering device. Anti-skate device. Price: to be announced.

■ JAPAN PHONO MOTOR CO LTD

Distributors: Howland-West Ltd,
3-5 Eden Grove, London, N78EQ.
Tel: 01-609 0293/4/5.

JP TP-601 ★

Turntable with pickup arm. Plinth and cover available as extras. Speeds: $33\frac{1}{3}$ and 45rpm. Wow: <0.1%. Rumble: <40dB. Turntable:



Goldring G101/P



Goldring-Lenco GL72/P



Lenco GL85/P/C



JP TP-601

★ Indicates entry is illustrated

12in diecast aluminium approximately 3¼lb. Belt drive. Four-pole synchronous motor. Lightweight pickup arm with damped lowering device. Plinth fitted with Bulgin mains plug and socket, colour-coded phono plugs and sockets for PU. Price: (motor and pickup unit) £34.50 (plus £5.46 PT); (plinth) £10 (plus £1.66 PT).

■ LEAK

H. J. Leak & Co. Ltd, Bradford Road, Idle, Bradford, Yorks. Tel: Bradford 612552. Telex: 51407.

Delta Turntable ★

Dynamically balanced turntable. Viscously damped pickup lowering device. Speed adjustment infinitely variable between 30 and 86rpm. Wow and flutter according to DIN specification >60dB. Maximum speed variation when loaded by pickup playing at 6gms 0.03%. Fitted with Shure M75/6 magnetic cartridge. Tracking error: ±0.8%. Size: 18½ × 6½ × 14½in. Price: £57.45 (plus £10.05 PT).

■ MICRO-SEIKI

Distributors: B. H. Morris & Co (Radio) Ltd, 84-88 Nelson Street, London, E1 2DY. Tel: 01-790 5011.

MR-111 ★

Turntable, arm and cartridge. Speeds: 33½, 45rpm. Belt drive from four-pole synchronous motor. Auto stop. Static balance type tubular arm with anti-skate device. Oil-damped lifter. Direct-reading stylus pressure adjuster. Revolving type counterweight. Accepts 4-8gm cartridges. Weight: 10lb. Dimensions: 15¼ × 12½ × 5½in. Price: £32.10 (including PT); (teak plinth and transparent plastic dust cover) £9.50 extra (including PT).

■ N. MIERS & CO LTD

28 Piercing Hill, Theydon Bois, Epping, Essex. Tel: 01-849 2611/3.

C141/SC5MD

Four-speed record deck with pickup arm and cartridge. Speeds: 16⅔, 33½, 45, 78rpm. Stereo ceramic cartridge. Diamond stylus. 11in turntable. Autochanger. Price: £15.77 (including PT).

C142/SC5MD

Four-speed record deck with pickup arm and cartridge. Speeds: 16⅔, 33½, 45, 78rpm. Stereo ceramic cartridge. Diamond stylus. 11in turntable. Autochanger. Price: £18.99 (including PT).

C142/A3/SC5MD

Four-speed record deck with pickup arm and cartridge. Speeds: 16⅔, 33½, 45, 78rpm. Stereo ceramic cartridge. Diamond stylus. 11in turntable. Autochanger. Price: £22.19 (including PT).

Plinth and dust cover

To fit C141, C142 and C142/A3. Price: £7.97 (including PT).

■ NIVICO

Denham & Morley (Overseas) Ltd, Denmore House, 453 Caledonian Road, London, N7. Tel: 01-607 6568.

SRP-473

Record turntable in plinth cabinet with pickup arm. Speeds: 33½ and 45rpm. Belt drive. Four-pole motor. W and F: <0.1%. Turntable: 12¼in diecast aluminium. Auto return of arm. Special acoustic isolation. Size: 18¼ × 7⅞ × 14¼in. Price: (less cartridge) £65.95 (including PT).

5240B

Record turntable in plinth with pickup arm and cartridge. Speeds: 33½ and 45rpm. Belt drive. Four-pole outer rotor motor. W and F: <0.08%. Turntable: 12¼in diecast aluminium. Induced magnet cartridge. Automatic return and switch-off. Oil-damped arm raising and lowering. Price: £84.39 (including PT).

■ PERPETUUM-EBNER

Highgate Acoustics Ltd, 184-188 Great Portland Street, London, W1. Tel: 01-636 2901 (4 lines).

PE 2016

Motor unit with base, dust cover and pickup



Leak Delta



Micro-Seiki MR-111

arm (less cartridge). Speeds: $33\frac{1}{3}$, 45, 78rpm with $\pm 3\%$ fine speed adjustment. Wow: $<0.15\%$, Flutter: $<0.15\%$, Rumble: >-56 dB at 10cm/sec and 1kHz. Turntable: $10\frac{1}{2}$ in. approx. cast aluminium weighing approx. $4\frac{1}{4}$ lb. Pulley drive. Four-pole synchronous motor. Tubular lightweight pickup arm mounted on low-friction ball bearings. Price: £36.61 (plus £5.39 PT).

PE 2018L

Motor unit with pickup arm. Speeds: $33\frac{1}{3}$, 45, 78rpm. $\pm 3\%$ fine speed control. W and F: $\leq 0.17\%$, Rumble: ≥ 56 dB at 10cm/sec at 1kHz. Turntable: $10\frac{1}{2}$ in $4\frac{1}{4}$ lb cast metal. Pulley drive. Four-pole motor. Mains: 110/240V 50/60 Hz. Low friction tubular arm mounted in precision ball bearings. Stroboscopic speed indicator. Anti-static mat. Automatic or manual operation. Centre spindle rotates on manual. Price: £38.78 (plus £6.22 PT).

PE 2020L

Motor unit with pickup arm. Speeds: $33\frac{1}{3}$, 45, 78rpm. $\pm 3\%$ fine speed control. W and F: $\leq 0.1\%$, Rumble: ≥ 58 dB at 10cm/sec at 1kHz. Turntable: $11\frac{1}{2}$ in 7lb cast metal. Pulley drive. Four-pole motor. Mains: 110/240V 50/60Hz. Low friction tubular pickup arm mounted in precision ball bearings. Stroboscope. Anti-static mat. Adjustable vertical tracking angle. Fully automatic or manual operation. Adjustable stylus overhang. Centre spindle rotates on manual. Price: £47.39 (plus £7.61 PT).

■ PHILCO-FORD

Philco International Ltd,
42 Leicester Square, London, WC2H 7LR.
Tel: 01-930 7667.

1660

Garrard single-play deck in white satin finish self-mounting case with tinted plastic dust cover. $10\frac{1}{2}$ in turntable. Counterbalanced pickup arm. Bias compensation. Integral calibrated stylus pressure adjustment. High compliance stereo magnetic cartridge. AC mains 220-240V 50Hz. Size: $16\frac{1}{8} \times 7\frac{1}{8} \times 15\frac{1}{4}$ in. Connecting leads: 7ft mains lead, 5ft audio output with DIN plug. Price: £30.01 (including PT).

■ PHILIPS ELECTRICAL LTD

Century House, Shaftesbury Avenue,
London, WC2. Tel: 01-437 7777.

GA105

Player complete with arm, plinth, ceramic cartridge and with Perspex cover. Speeds: $33\frac{1}{3}$, 45 and 78rpm. W and F: $<0.25\%$, Rumble: <-52 dB (DIN 'B'). Turntable: $8\frac{1}{2}$ in. Drive: via rubber idler wheel. Tubular aluminium arm, direct-reading playing-weight adjustment, damped pickup lowering device and auto switch-off for



Philips GA160



Philips GA308

all sizes of record including 4in. Mains: 110-127V, 220-240V AC. Price: £18.75 (including PT).

GA 160 ★

Single-play record deck with autochange facility. Complete with pickup arm and cartridge on walnut veneered plinth with perspex dust cover. Speeds: $16\frac{2}{3}$, $33\frac{1}{3}$, 45, 78rpm. Maximum loading: 7 records. W and F: $<0.2\%$, Rumble: -55 dB (DIN). Turntable: $9\frac{3}{4}$ in. Size: $14\frac{1}{2} \times 12\frac{1}{4} \times 6$ in. Mains: 110, 120, 220, 240V 50Hz. Short single-play centre spindle supplied. Price: £32.80 (including PT).

GA308 ★

Transcription motor unit with arm and headshell on walnut veneered plinth with hinged cover. Slide-in cartridge carrier. Speeds: $33\frac{1}{3}$, 45rpm. W and F: $<0.2\%$, Rumble: <-58 dB (DIN 'B'). Pickup arm friction: lateral <0.1 gm, vertical <0.15 gm (measured at stylus tip). Tracking error: $<0' 8''$ /cm. Turntable: $10\frac{1}{2}$ in steel. Low speed synchronous motor. Adjustable bias compensation for spherical and elliptical stylus. Calibrated playing weight adjustment.

★ Indicates entry is illustrated

Automatic lift-off and switch-off at end of record. Mains: 110, 120, 220, 240V 50Hz. Consumption: 1.7W. Size: $14\frac{1}{2} \times 12\frac{1}{4} \times 5\frac{1}{2}$ in. Price: (complete with Philips GP400 magnetic cartridge) £47.65 (including PT).

GA212 ★

Integrated turntable, pickup arm and cartridge mounted on walnut veneered plinth with hinged tinted plastic lid. Speeds: $33\frac{1}{3}$, 45rpm. Fine speed adjustment: $\pm 3\%$. W and F: $< 0.1\%$. Rumble: < 62 dB (DIN 'B'). Turntable: $11\frac{1}{4}$ in diameter steel, $2\frac{1}{2}$ lb. Belt drive. Motor: DC type with tachogenerator giving electronic control, obviates the need for a heavy flywheel type platter. Lightweight tubular gimbal-mounted pickup arm. Decoupled counterweight. Bias compensation. Stylus pressure adjustment. Standard $\frac{1}{2}$ in headshell with slide-in cartridge carrier. Electronic touch controls for speed selection, start and stop. Light beam operated autostop. Viscous damped pickup arm raising and lowering device. Supplied complete with Philips GP400 cartridge. Price: to be announced.

■ PIONEER

Distributors: Shiro (UK) Ltd,
42 Russell Square, London, WC1B 5DF.
Tel: 01-580 6996.

PL12AC

Two-speed record deck with pickup arm on plinth with cover. Speeds: $33\frac{1}{3}$ and 45rpm. Wow: $< 0.12\%$. Flutter: $< 0.12\%$. S/N ratio better than 45dB. 12in aluminium turntable. Belt drive. Four-pole synchronous motor. Static balanced pickup arm, incorporating bias compensation and hydraulic lift device. Price: £41.20 (plus £5.95 PT).

PL15

Two-speed record deck with pickup arm on plinth with cover. Speeds: $33\frac{1}{3}$ and 45rpm. W and F: $< 0.1\%$. S/N ratio better than 47dB. 12in diecast aluminium turntable. Belt drive. Four-pole synchronous motor. Static balanced arm incorporating automatic return, bias compensation, hydraulic lift and direct weight calibration. Price: £57.52 (plus £8.30 PT).

PL31

Two-speed record deck with pickup arm and cartridge mounted on plinth with cover. Speeds: $33\frac{1}{3}$ and 45rpm. W and F: $< 0.1\%$. S/N ratio better than 50dB. 12in diecast aluminium turntable. Belt drive. Four-pole synchronous motor. Static balanced tubular pickup arm incorporating calibrated weight adjustment, overhang indicator, hydraulic lift device, magnetic bias compensation and lateral balance. Price: £99.18 (plus £14.31 PT).

PL41D

Two-speed record deck with pickup arm and cartridge mounted on plinth with cover. Speeds: $33\frac{1}{3}$ and 45rpm. W and F: $< 0.08\%$. S/N ratio better than 50dB. 12in diecast aluminium turntable. Belt drive. Four-pole synchronous motor. Static balanced pickup arm incorporating bias compensation, lateral balance, calibrated weight adjustment and hydraulic lift device. Price: £130.95 (plus £18.91 PT).

PL50

Two-speed record deck with pickup arm and cartridge mounted on plinth with cover. Speeds: $33\frac{1}{3}$ and 45rpm. W and F: $< 0.08\%$. S/N ratio better than 50dB. 12in diecast aluminium turntable. Belt drive. Four-pole synchronous motor. Static balanced arm incorporating magnetic bias compensation, lateral balance, automatic return and calibrated weight adjustment. Price: £123.68 (plus £17.86 PT).

PLA35

Two-speed record deck with pickup arm and cartridge mounted in plinth with cover. Speeds: $33\frac{1}{3}$, 45rpm. 12in diecast aluminium turntable. W and F: $< 0.1\%$. Static balance tubular arm. Induced magnet cartridge. 0.5 thou diamond stylus. Output: 3mV. Price: £78.77 (plus £11.37 PT).

■ RADON

Radon Industrial Electronics Co Ltd,
Orme Road, Worthing, Sussex.
Tel: Worthing 34904.

RP60

Record deck in plinth cabinet with lift off lid. Designed for use with Radon System 60 amplifier. Motor unit: Garrard SP25. Contemporary styled cabinet in teak/leather cloth finish. Size: $7 \times 16 \times 14$ in. Price: £27 (plus £4.32 PT).

P100

Lowline cabinet in teak with black inset and transparent plastic cover designed for use with Radon System 500 amplifier. Motor unit: Garrard SP25 Mk III or Garrard SL65B. Lift-off lid. Cartridge: Goldring G800H. Size: (excluding lid) $3 \times 14 \times 15$ in. Price: (P100/SP25 Mk III) £28 (plus £5.05 PT); (P100/SL65) £30 (plus £5.43 PT).

■ SANSUI

Vernitron Ltd, Thornhill, Southampton,
SO95QF. Tel: Southampton 44811.

SR1050C ★

Motor unit and pickup in cabinet with clear plastic lid. Speeds: $33\frac{1}{3}$ and 45rpm. Belt drive. 12in dia. platter. 2.64lb. Mains: 100, 117, 200, 220, 250V AC. Wow: $< 0.07\%$. S/N: better than 40dB. Tubular balanced arm with bias

compensation. Cartridge: induced magnet. Output: 5mV. FR: 20Hz-20kHz. Stylus: 0.5 thou diamond. Compliance: 7×10^{-6} cm/dyne. Finish: walnut with smoked acrylic lid. Size: $17\frac{3}{8} \times 13\frac{1}{4} \times 7\frac{1}{2}$ in. Two years guarantee. Price: £70.98 (plus £11.83 PT).

SR2050C ★

Motor unit and pickup in cabinet with smoked acrylic dust cover. Speeds: 33 $\frac{1}{3}$ and 45rpm. Belt drive: 12in dia. platter. 2.9lb. Mains: 100, 117, 200, 220-240V AC. S/N ratio: better than 40dB. Wow: <0.07%. Balanced tubular arm with bias compensation and pressure adjustment. Max. tracking error: $\pm 1.5\%$. Cartridge: induced magnet. Output: 5mV. FR: 20Hz-20kHz. Stylus: 0.5 thou diamond. Compliance: 7×10^{-6} cm/dyne. Automatic lift-off and stop. Finish: walnut. Size: $17\frac{1}{2} \times 13\frac{7}{8} \times 7\frac{1}{2}$ in. Two year guarantee. Price: £88.20 (plus £14.70 PT).

SR4050C ★

Motor unit and pickup in cabinet with smoked acrylic lid. Speeds: 33 $\frac{1}{3}$ and 45rpm. Belt drive. 12in dia. platter. 3.3lb. Mains: 100, 117, 200, 220, 240V AC. S/N ratio: better than 45dB. Wow: less than 0.06%. Gimbal supported statically balanced arm with bias compensation. Stylus pressure adjustment. Max. tracking error: $\pm 1.5\%$. Cartridge: induced magnet. Output: 5mV. FR: 20Hz-20kHz. Stylus: 0.5 thou diamond. Compliance: 17×10^{-6} cm/dyne. Auto lift-off and stop. Finish: walnut. Size: $19\frac{5}{8} \times 14\frac{1}{2} \times 7\frac{7}{8}$ in. Two years guarantee. Price: £122.61 (plus £20.44 PT).

■ SANYO

Sanyo Marubeni (UK) Ltd, Sanyo House, Bushey Mill Lane, Watford, Herts. Tel: Watford 30421.

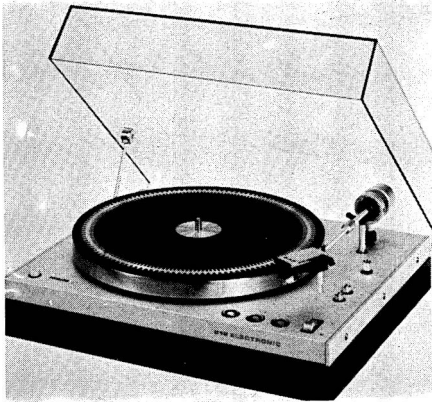

Philips GA212



Sansui SR2050C



Sansui SR4050C



Sansui SR1050C

★ Indicates entry is illustrated

TP-78 ★

Turntable with PU and arm on base with tinted Perspex cover. 2-speed, 4-pole motor. Wow and flutter less than 0.3%. Static balance arm with counterbalance weight and lateral balance. Cueing system. Magnetic cartridge MG15 5mV. FR: 20Hz-20kHz. Tracking: 0.2gm. Price: £55.95 (including PT).

TP80S

Turntable with PU arm in shelf mounting cabinet with tinted lift-up lid. Two speeds (33 $\frac{1}{3}$, 45rpm). Belt drive. Four-pole synchronous motor. 11 $\frac{1}{2}$ in diecast turntable. S-shaped tubular arm. Lateral balance weight. Accepts all standard cartridges. Tracking force adjustable 0.4gm. Pickup arm returns to rest automatically. Lifting and lowering device. Moving magnet stereo cartridge supplied. Finish: walnut with transparent cover. Price: to be announced.

TP91S

Turntable with PU arm in shelf mounting cabinet with lift-up lid. Two speeds (33 $\frac{1}{3}$, 45rpm). Belt drive. Four-pole synchronous motor. Diecast turntable. Statically balanced pickup arm. Maximum tracking error 1.5°. Arm accepts all standard cartridges. Supplied with moving magnet stereo cartridge with 0.5mm diamond stylus. Pickup arm returns automatically at end of record. Price: to be announced.

■ SCAN-DYNA

Scandinavian Audio Systems Ltd,
Sun Alliance Building, 65 London Road,
Gloucester, GL1 3HF.
Tel: Gloucester (0452) 32791/2.

800 ★

Plinth-mounted motor and pickup arm with cartridge. Lift-off plastic dust cover. Speeds: 33 $\frac{1}{3}$ and 45rpm, selected by pushbutton. W and F: 0.12% p-p (0.05% RMS). Rumble: (unweighted) -43dB, (weighted) -65dB. 12in non-magnetic turntable. Flat Neoprene belt drive. 16-pole motor. Mains: 200-240V AC. Tubular lightweight pickup arm. Maximum tracking deviation: 2°. 9 $\frac{3}{8}$ in from stylus to pivot. Stylus pressure adjustable $\frac{1}{2}$ -3gm. Oil-damped lift and lower device, pushbutton operation. Cartridge: AT66. Price: £40.14 (plus £6.76 PT).

1200

Two-speed motor unit fitted with Ortofon arm and cartridge. Speeds: 33 $\frac{1}{3}$ and 45rpm, selected by pushbutton. Flat Neoprene belt drive. Mains: 200-250V AC. Plastic dust cover. Price and full specification to be announced.

■ SIEMENS

Interconti Electronic Ltd, Albany House,
Petty France, London, SW1H9EA.
Tel: 01-222 2523. Telex: 918770.



Sanyo TP78

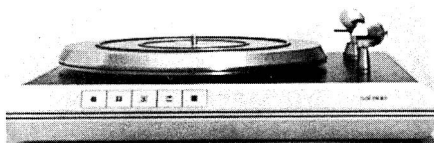

Scan-Dyna 800



Sonab 75-S Mk 1



RW346

Three-speed record deck with pickup arm and cartridge in plinth with dust cover. Shure magnetic cartridge with diamond stylus. Finish: white or light satinwood. Full specification on request. Price: £89.50 (including PT).

SONAB LTD

PO Box 4, Oldfield Road, Hampton, Middlesex, TW122HN. Tel: 01-979 0134.

75-S Mk I ★

Transcription turntable unit with pickup arm and cartridge mounted in plinth with transparent plastic dust cover. Speeds: 33 $\frac{1}{3}$ and 45rpm. Wow: <0.08% (DIN). Flutter: <0.08% (DIN). Rumble: <60dB (weighted). Speed constancy: better than $\pm 1\%$. Turntable: 12in diameter non-magnetic, 2 $\frac{1}{2}$ lb. Belt drive. Four-pole synchronous motor. Lightweight tubular arm balanced statically and dynamically. Adjustable for stylus pressures 0.5-3.5gm. Fitted with Shure M75MG type II cartridge with spherical diamond stylus. Price: £68.50 (including PT).

85-S

Similar to 75-S but with additional refinements and Shure M75E cartridge. Price: to be announced.

SONY (UK) LTD

Pyrene House, Sunbury Cross, Sunbury-on-Thames, Middlesex. Tel: Sunbury 87644/7.

PS230

Two-speed motor turntable unit fitted with pickup arm, cartridge, plinth and dust cover. Speeds: 33 $\frac{1}{3}$ and 45rpm. Turntable: 11in diameter. Belt drive. Four-pole synchronous motor. AC mains 100, 120, 220 or 240V. Induced magnetic cartridge. Price: to be announced.

PS5520 ★

Two-speed auto-manual turntable system in plinth with pickup arm and cartridge. Speeds: 33 $\frac{1}{3}$ and 45rpm. W and F: 0.1%. Turntable: 12in diameter diecast aluminium. Belt drive. Four-pole hysteresis synchronous motor. Statically balanced pickup arm. Pivot to stylus 8 $\frac{1}{2}$ in. Stylus pressure adjustment: 0-3gm. Fitted with induced magnet cartridge. Price: £58.03 (plus £9.77 PT).

TELEFUNKEN

Distributor: AEG (Great Britain) Ltd, AEG House, Chichester Rents, Chancery Lane, London, WC2. Tel: 01-242 9944. Cables: Allgem, London.

W215

Four-speed record deck in shelf-mounting plinth. Speeds: 16 $\frac{2}{3}$, 33 $\frac{1}{3}$, 45, 78rpm. Tubular



Thorens TD150AB Mk II



Thorens TD125 Mk II and plinth

pickup arm with Pickering V15/AC-2 magnetic cartridge. 11in diameter turntable. Tinted dust cover. Size: 14 $\frac{1}{2}$ × 7 $\frac{1}{2}$ × 12in. Price: £62.29 (including PT).

W250

Three-speed record deck in shelf-mounting plinth. Speeds: 33 $\frac{1}{3}$, 45, 78rpm. Speeds adjustment $\pm 3\%$. Tubular counter-balanced arm with Shure M75-6 cartridge. 7 $\frac{1}{2}$ lb turntable. Rotating centre spindle. Anti-skating device. 15° pickup sensing angle. Joystick controls all functions. Record cleaner included. Size: 19 × 5 × 13in. Price: £101.23 (including PT).

THORENS

Metrosound (Sales) Co Ltd, Cartersfield Road, Waltham Abbey, Essex. Tel: Waltham Cross 31933.

TD150A Mk II

Transcription turntable with integrated pickup arm. Two speeds, 33 $\frac{1}{3}$ and 45rpm. New lowering device, controlled from front panel, and anti-skating device. Patented plug-in head shell with adjustable vertical tracking angle. Stylus pressure adjustable $\frac{1}{2}$ -4gm. Rumble: -65dB DIN. Price: £36.50 (plus £6.59 PT).

TD150AB Mk II ★

Details as for TD150A Mk II, but plinth mounted. Price: £39.50 (plus £7.13 PT).

TD150 Mk II

Details as for TD150A Mk II but less pickup arm. Price: £28.50 (plus £5.14 PT).

★ Indicates entry is illustrated

TD125 Mk II ★

Transcription turntable. Three speeds: $33\frac{1}{3}$, 45 and $16\frac{2}{3}$ rpm. With $\pm 2\%$ electronic speed control. Low speed synchronous motor, belt driven. Motor is transistor governed. Neon-lit strobe. 12in non-ferrous turntable. W and F: 0.09%. Plinth and cover available, also mounting frame if cabinet mounted. Price: £62.50 (plus £11.28 PT).

TD125AB Mk II

Details as for TD125 but complete with TP25 pickup arm and plinth. Price: £95 (plus £17.14 PT).

Teak Plinth

Suitable for TD125 unit. Price: £6 (plus £1.08 PT).

Perspex cover

Suitable for TD125 unit. Price: £4.50 (plus 81p PT).

■ TRANSCRIPTORS LTD

2 Theobald Street, Boreham Wood, Herts.
Tel: 01-953 0771.

Hydraulic reference turntable ★

Self-standing unit, on adjustable acoustic feedback legs. Level incorporated. Speeds: $33\frac{1}{3}$ and 45rpm only, $\pm 3\%$ fine speed adjustment by the incorporated hydraulic speed stabiliser. Soft rubber belt, drives 9lb non-ferrous platter via a neon idler stroboscope from a synchronous motor. Strobe geared up 6:1 ratio, resulting in indications more accurate than any measuring instrument. Slipping clutch recoil start motor operated via a vacuum switch. P.T.F.E. main bearing, solid brass gold-plated platter weights. Fabricated Perspex top hinged at rear with swing leg support. Finish: Black and Aluminium. All mains voltages and frequencies available. Rumble not measurable. Speed stability: 0.005% short term, 0.01% long term. Size: $17 \times 17 \times 7$ in. Price: (less pickup arm) £76 (plus £12.35 PT); (with pickup arm) £90 (plus £14.62 PT).

Saturn turntable ★

Self-standing turntable unit with pickup arm, cover and anti-feedback legs. Speeds: $33\frac{1}{3}$ and 45rpm. No fine speed adjustment. Wow: better than 0.03%. Flutter: not measurable. Rumble: not measurable. Speed remains constant with variation of mains voltage. 12in diecast aluminium turntable. Weight: $6\frac{1}{2}$ lb. Belt drive. Mains: 100-110V or 200-240V 50 or 60Hz. Pickup arm has low-friction stabilised unipivot mounting. Hydraulic lowering. Cueing. Full adjustments. Unit fully suspended. Arm and turntable float free at under 5Hz for acoustic feedback damping. Price: £54 (plus £9.21 PT).

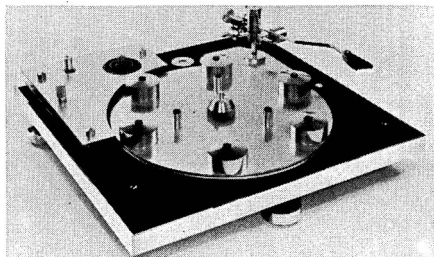

Transcriptors Reference turntable

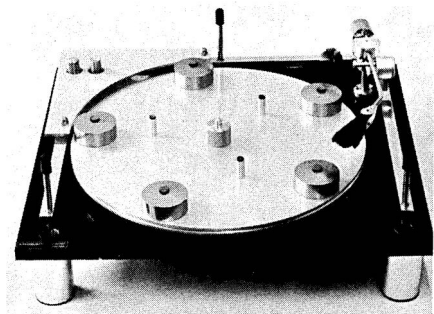

Transcriptors Saturn



Wharfedale Linton

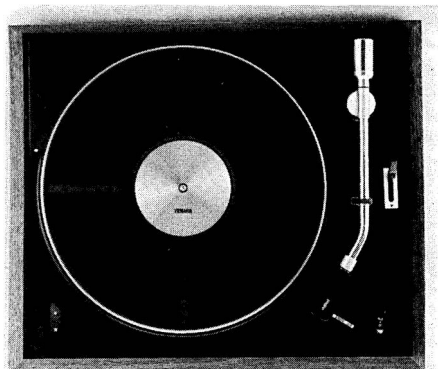

Yamaha YP500X

■ TRIO

B. H. Morris & Co (Radio) Ltd,
84-88 Nelson Street, Tower Hamlets,
London, E1 2DY. Tel: 01-790 5011.

KP2022

Two-speed turntable unit with pickup arm. Mounted in plinth base with dust cover. Cueing device. No further details available as this edition of the year book closed for press. Price: to be announced.

■ VALEK LTD

Lark Street, Darwen, Lancs, BB3 2LT.
Tel: Darwen 71881.

Turntable kits

Kits of parts for home assembly of record turntable units. Full details and prices on request.

■ WHARFEDALE

Rank Wharfedale Ltd, Bradford Road, Idle,
Bradford, Yorks. Tel: Bradford 612552.
Telex: 51407.

Linton Turntable ★

Hydraulic arm lowering device. Adjustable arm balance. Bias compensator. Automatic stop/arm return mechanism. Wow: better than 0.2%. Flutter: better than 0.06%. Rumble: better than 35dB. Fitted with Shure M44.7 cartridge. Price: £29.36 (plus £5.14 PT).

■ YAMAHA

Jonathan Fallowfield Ltd, Strathcona Road,
North Wembley, HA9 8QL. Tel: 01-904 0141.

YP-500X ★

Plinth mounted motor unit with pickup arm, cartridge and tinted hinged dust cover. Speeds: 33 $\frac{1}{3}$, 45rpm. W and F: <0.08%. Rumble: 48dB. Speed constancy: 0.08%. 12in diecast aluminium turntable. Belt drive. Four-pole motor (110 or 240V AC). Pickup arm tracks from 0-5gm. Tracking length: approx 9in. Bias compensation. Auto-return of pickup arm. Silicone damped lowering device. Price: £62 (plus £10.08 PT).

YP-700

Plinth mounted motor unit with pickup arm, cartridge and tinted hinged dust cover. Speeds: 33 $\frac{1}{3}$, 45rpm. W and F: <0.05%. Rumble: 58dB. Speed constancy: 0.05%. 12in diecast aluminium turntable. Belt drive. 16-pole outer rotor motor (110 and 240V AC). 9in pickup arm with tracking weight and bias compensation adjustments. Auto-return of pickup arm. Dual hydraulic cueing device. Built-in stylus protractor. Yamaha CG-7000 cartridge. Price: £99.81 (plus £16.21 PT).

All you need for Hi-fi. An amplifier, two speakers, and a

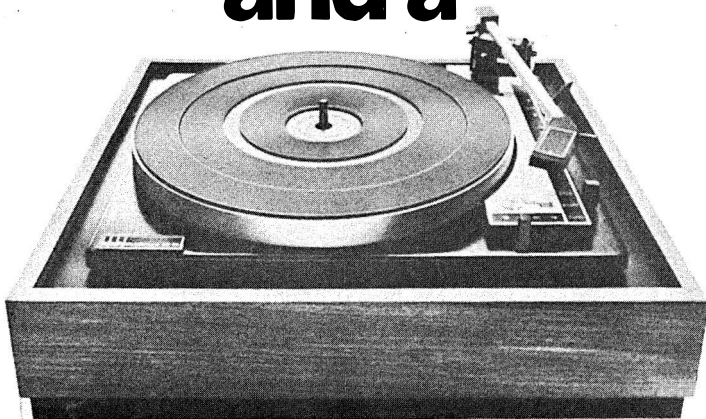

BSR make more turntables than everyone else in the world put together.

Our range includes high-quality sensibly priced models, both single play and automatic.

The MP60 player, already immensely popular, costs only £15.20, complete with low mass, fully counterbalanced square section pick up arm, slide in cartridge holder, bias compensator, viscous cueing, 3½lb die cast turntable, 4-pole motor and immaculate BSR styling.

For a few pounds more, you can buy the HT70, boasting the same super features but with three more refinements. A deep-rim die cast turntable which is one pound heavier than the MP60, a rotating stub spindle to reduce record friction and a dynamically balanced synchronous motor, which compensates for normal fluctuation in mains voltage.

With these models, and our range of automatics, you get the flexibility of price you need to build your whole Hi-fi set up.

You can choose your own speakers and your own amplifier, to suit your pocket, from the many excellent examples on the market.

And if you're not too sure about the ins and outs of Hi-fi, your dealer will be only too pleased to help and advise you. But make sure you ask him to show you the range of BSR turntables. For a preview, just return the coupon below, and we'll send you our illustrated brochures.

BSR Ltd., McDonald Division, Monarch Works, Cradley Heath, Warley, Worcs. Tel: Cradley Heath 69272.

HEAR OVER 5,000 HI-FI SYSTEMS IN ALL LIND-AIR DEMONSTRATION STUDIOS

All Lind-Air Hi-Fi shops include a specially designed Comparator Console in their demonstration studios in which you can hear under ideal conditions over 5,000 computations of amplifiers, turntables, cartridges, loudspeakers or tape recorders. These Comparators will switch from one system to another automatically permutating the various items of equipment thus enabling our experienced Hi-Fi salesmen to explain the different advantages of one system against another whilst actually demonstrating them to you. This ensures that the combination you choose will be the system best suited to your needs with due consideration to both your budget and the layout of your home. Visit your nearest Lind-Air branch—they will have one for you!



LIND-AIR

LONDON BRANCHES

241-242, TOTTENHAM COURT ROAD, LONDON W.1. 01-580 2255
53, TOTTENHAM COURT ROAD, LONDON W.1. 01-637 1601
137, CHARING CROSS ROAD, LONDON W.C.2. 01-437 8718
149, FLEET STREET, LONDON E.C.4. 01-353 1419
301-315, EDGWARE ROAD, LONDON W.2. 01-262 2251/2

NOTTINGHAM BRANCH

94-96, UPPER PARLIAMENT STREET. (STD 0602) 40403

APPOINTED STOCKISTS

Alpha, Armstrong, Cambridge, Ferrograph, B & O, SONY, Leak, SANYO, Akai, Wharfedale, SANSUI, GRUNDIG, Teleton, PHILIPS, ROBERTS, HACKER, PIONEER, Nikko, Rogers, Sinclair, Goodmans, Tandberg, Toshiba, CELESTION, Tannoy, Shure, Neat, Rotel, Thorens, GARRARD and all other leading manufacturers.

HAMPSTEAD HIGH FIDELITY

Present an exciting example of a stereo gramophone system assembled into a compact, well designed unit with tinted perspex lid.

The equipment shown in the photograph is as follows:—

Quad amplifier 33 and 303, Quad FM3 tuner, Thorens TD 125 turntable, SME 3009 PU arm 9", Shure cartridge M75ED.

Our Hampstead Showroom contains a wide selection of quality equipment, together with our range of stock cabinets.

For full particulars call or write to:—



HAMPSTEAD HIGH FIDELITY

91 HEATH ST. LONDON NW3 6SS TEL: 01-435 0999

The professional designers & suppliers of fine high fidelity systems.



Directory of Radio Tuners

★ Indicates entry is illustrated

Abbreviations used in this section are given on page 36.

■ ACOUSTICAL MANUFACTURING

See Quad.

■ A/R/D

Audio Research and Development Ltd,
PO Box 73, Hounslow, Middlesex.
Tel: 01-570 0471.

2000

Stereo FM/VHF tuner with pushbutton station selector. Designed to operate with A/R/D 2000 amplifier system. Price: (grey case) £45 (plus £7.50 PT); (teak veneered case) £47.40 (plus £7.90 PT).

■ ALPHA

Highgate Acoustics Ltd, 184 Great Portland Street, London, W1. Tel: 01-636 2901.

FT150

AM/FM stereo tuner. Range: FM 88-108MHz, MW 176-600m. Variable tuning. AFC. Balanced ratio detector. Meter tuning indicator. Usable sensitivity: AM 25µV, FM 2.5µV. Aerial input: 300 ohms balanced. Stereo decoder fitted. Output: 1V. Adjustable AM aerial. Finish: teak with brushed aluminium. Mains: 110, 240V AC. Size: 14½ × 5 × 13½in. Price: £39.64 (plus £6.36 PT).

■ ARMSTRONG AUDIO LTD

Walters Road, London, N7. Tel: 01-607 3213.

Model 523 ★

AM/FM tuner. Range: VHF 86-109 MHz, MW 185-590 metres, LW 1000-2000 metres. Variable tuning. FM ratio detector. Meter tuning indicator. Sensitivity: FM 1.5µV for 30dB quieting, AM 5µV for 20dB quieting. Aerial input: 75 ohms coaxial and 300 ohms balanced. Output: 0-1V variable. Stereo multiplex decoder optional (see M8 Decoder below). FM quiet-tuning control. Stereo indicator light. Edge connector for plug-in decoder. Mains: 100-125V and 200-250V AC. Size: 11½in wide, 10¾in deep, 4¾in high. Price: £45 (plus £7.68 PT).

Model 524 ★

FM tuner. Range: 86-109MHz. Variable tuning. Ratio detector. Meter tuning indicator. Sensitivity: 1.5µV for 30dB quieting. Aerial input:

75 ohms coaxial and 300 ohms balanced. Output: 0-1V variable. Stereo multiplex decoder optional extra (see M8 Decoder below). Quiet-tuning control. Stereo indicator light. Edge connector for plug-in decoder. Mains: 100-125V and 200-250V AC. Size: 11½in wide, 10¾in deep, 4¾in high. Price: £35 (plus £5.97 PT).

Model M8

Plug-in stereo multiplex decoder for 523 and 524 tuners, 525 and 526 tuner/amplifiers. Price: £9 50.

■ BRYAN AMPLIFIERS LTD

18 Greenacres Road, Oldham, Lancs.
Tel: 061-624 4074.

FET 1500

Stereo FM tuner incorporating FET front end. Range: FM 87.5-108MHz. Usable sensitivity: 2.5µV for 30dB signal/noise ratio. Output: 400mV RMS for 100% modulation at 1kHz. HD: 0.5% at full modulation. FR: 40Hz-14kHz ± 1dB. Price: (chassis) £56 (plus £9.64 PT); (cabinet model) £60 (plus £10.33 PT).

■ CROWN RADIO CO LTD

128-129 Shoreditch High Street,
London, E1 6JE. Tel: 01-739 2382.

FM-500 ★

Solid state stereo tuner. Range: 87-108MHz, 187-570m. AFC. Output: 0.5V 10K. Stereo indicator glows automatically. Finish: oiled walnut. Dimensions: 4½ × 15½ × 10½in. Weight: 8½lb. Price: approximately £52 (including PT).

■ EAGLE INTERNATIONAL

Heather Park Drive, Wembley, HA1 1SU.
Tel: 01-903 0144.

TST152 ★

AM/FM stereo tuner matching the Eagle TSA-149 and TSA151 integrated amplifiers. Range: FM 87-109MHz, MW 182-572 metres. Variable tuning. AFC. Inter-station muting. Sensitivity: FM 2µV for 20dB quieting. AM 300µV. Stereo separation: 28dB at 1kHz. Aerial input: 75 ohms coaxial. Output: 0-500mV adjustable. Size: 13 × 3¾ × 8¾in. Wood shelf-mounting cabinet. Price: £33.03 (plus £5.56 PT).

AA8 ★

Stereo AM/FM tuner. Range: FM 88-108MHz, MW 187-500 metres. Variable tuning. Switchable AFC. Meter tuning indicator. Usable sensitivity: AM 250µV, FM 3µV. Aerial input: 75 ohms coaxial, 300 ohms balanced. Output: 0-1V adjustable. Stereo decoder included. Mains: 240V AC. Size: 13 × 10½ × 3¾. Finish: teak cabinet with metal fascia. Interstation muting switch. Price: £46 (plus £7.75 PT).



Armstrong Audio 523 AM-FM

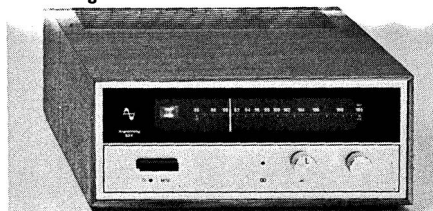

Armstrong Audio 524 FM

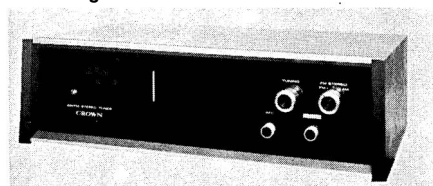

Crown FM-500

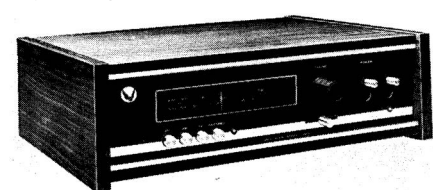

Eagle TST 152



Eagle AAB



Fal ICFM Tuner

■ FAL

Futuristic Aids Ltd, 104 Henconner Lane, Leeds, LS134LQ. Tel: Pudsey 5478.

FAL ICFM ★

FM stereo tuner. Range: FM 87.5-104.5MHz. Variable tuning plus four preset pushbuttons. Electronic varicap tuning. FET front end. Ceramic filters in IF stages. Switchable AFC. Usable sensitivity: $7\mu\text{V}$. Audio output: $>600\text{ mV}$. Aerial input: 75 ohms coaxial or 300 ohms balanced. Separation: 45dB at 1kHz. AM rejection: 53dB. Distortion: 0.35%. Balance: 0.5dB at 100mV. Size: $14\frac{3}{4} \times 10 \times 4\frac{1}{2}$ in. Weight: 10lb. Stabilised power supply. Tuning meter. Auto stereo beacon. Decoder fitted. Price: £49.90 (including PT).

■ GRUNDIG (Great Britain) LTD

Hi-Fi Division, Sydenham, London, SE26. Tel: 01-778 2211.

RT100 ★

AM/FM stereo tuner. Pre-selection of five VHF stations. Range: 87.5-108MHz, MW 185-587m, LW 680-2050m, SW1 34-99m, SW2 13.5-35m. Tuning meter. Stereo indicator beacon. Sensitivity: VHF $1.5\mu\text{V}$ at 15kHz deviation and 26dB quieting, AM $5.12\mu\text{V}$ for 10mV audio. Stereo multiplex decoder fitted. Switched AFC. 45 transistors, 37 diodes. Image rejection: FM 60dB, AM 12.56dB. Distortion factor: $<0.5\%$ for 40kHz deviation. Output: FM 650mV, AM 800mV. Output impedance: 2K, rec. load $>22\text{K}$. Mains: 110, 130, 220, 240 50/60Hz. Finish: matt walnut. Size: $6 \times 20 \times 12$ in. Price: £169 (including PT).

■ KLINGER

Klinger Controls Ltd, Spencer Court, 7 Chalcot Road, London, NW18LU. Tel: 01-586 2922/3.

KC91 ★

Stereo FM tuner. Range: 87.5-108MHz. Five preset stations. Switchable AFC. Ratio detector. Usable sensitivity: $2\mu\text{V}$. Aerial input: balanced and coaxial. Output: 0.2V. Stereo decoder fitted. Mains: 100-120V, 200-240V AC. Ceramic filters in IF strip. IC. Complies with DIN 45 500 spec. Finish: teak with diecast enamelled sides. Size: $13 \times 4\frac{1}{2} \times 8\frac{1}{2}$ in. Price: £41.40 (plus £6.70 PT).

■ KORTING

Distributors: Europa Electronics Ltd, Howard Place, Shelton, Stoke on Trent, ST14NW. Tel: Stoke on Trent 29316.

T500, Type 29813 ★

AM/FM stereo tuner. Range: FM 87.5-104 MHz, SW 40-51 metres, MW 185-587 metres, LW 850-2070 metres. 12 silicon transistors, 11

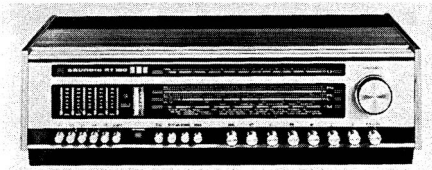

Grundig RT100



Klinger KC91

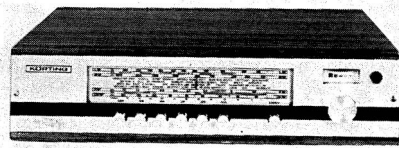

Korting T500

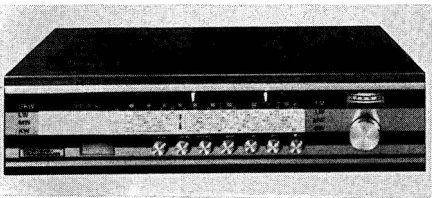

Korting T600



Leak Delta AM/FM



L & H Signalmaster 6087

diodes and one rectifier. Four-stage IF amplifier. Automatic band-width control on AM, dependent on signal strength. Tuning meter. Sensitivity: $3\mu\text{V}$ for 20dB quieting on FM. Internal ferrite aerial for AM bands. Stereo decoder fitted. Automatic stereo beacon. Finish: satin walnut. Size: $14 \times 3\frac{1}{2} \times 9\text{in}$. Price: £49.75 (including PT).

T600, Type 30816 ★

AM/FM stereo tuner. Range: FM 87.5-104 MHz, SW 40-51 metres, MW 185-587 metres, LW 850-2060 metres. 12 transistors, 11 diodes, one rectifier. AFC. Automatic bandwidth control on AM (dependent on signal strength). Meter tuning indicator. Stereo decoder with automatic beacon. Internal ferrite rod for LW and MW. Sockets for FM dipole, AM aerial and earth, diode output. Pushbutton selection for FM, SW, MW, LW, AFC, ON-OFF, STEREO. Mains: 130-230V AC 50Hz. Finish: natural satin walnut. Size: $15 \times 4 \times 8\text{in}$. Price: £49.75 (including PT).

■ **LEAK**

H. J. Leak & Co Ltd, Bradford Road, Idle, Bradford, Yorks. Tel: Bradford 612552. Telex: 51407.

Delta AM/FM ★

AM Tuner Section: Range 182-587 metres. Sensitivity: 25 microvolts for 20dB. signal/noise at 1MHz. FM Tuner section: Range: 87-108MHz. Sensitivity 2.5 microvolts for 30dB signal/noise at 75kHz deviation. AM suppression 50dB. Distortion: less than 0.5% for 75kHz deviation. Dimensions of both tuners: $12\frac{1}{4} \times 4\frac{3}{4} \times 9\frac{1}{2}\text{in}$. Price: Delta AM/FM £74.04 (plus £12.96 PT).

Delta FM

Specifications as for FM section of Delta AM/FM. Price: £62.13 (plus £10.87 PT).

■ **L & H**

Distributors: Britimpex Ltd, 8-12 Rickett Street, London, SW6. Tel: 01-385 0883. Telex: 22758 Brytron, London.

Signalmaster Mk III 6087 ★

Self-contained battery-operated FM/VHF tuner. Will also operate from 32V from L & H Audiomaster amplifier. Plug-in V aerial. Socket for 70 ohm external aerial. Push-button on/off and AFC. Illuminated tuning scale. Transistors. Range: 86-104MHz. PP9 or equivalent battery. Consumption 9mA. Teak case. Size: $11\frac{1}{4} \times 3\frac{1}{2} \times 7\frac{1}{2}\text{in}$. Price: £31.45 (including PT).

Stereo decoder module

Plug-in type suitable for Signalmaster Mk III. Fits inside case. Channel separation better than 32dB at 1kHz. Consumption: 3mA. Automatic

★ Indicates entry is illustrated

stereo beacon. Price: £7-87. Connecting lead with 5-pin plug. Price: 75p.

■ LOWTHER MANUFACTURING CO

Lowther House, St Mark's Road, Bromley, Kent, BR29HQ.

Tel: 01-460 5225. Cables: Lowther, Bromley.

FM Tuner Mk VII ★

Self-powered transistorised VHF/FM tuner. Range: 87.5-108MHz. Variable tuning with switchable AFC. Stereo decoder fitted. Aerial input: 72 ohms coaxial. Output: 0.75V RMS. Stereo beacon. Tuning meter. Finish: teak or walnut with satin chrome panel. Size: $10\frac{3}{8} \times 5\frac{1}{8} \times 5\frac{1}{8}$ in. 200-240V 50Hz. Price: £40 (plus £7-25 PT).

TV Sound Tuner

Self-powered TV tuner. Range: UHF bands IV and V. Push-button tuning, adjustable to all channels. Output: preset gain control 0-500mV RMS. Output socket for tape recorder. Aerial input: 72 ohms coaxial. Size: $10\frac{3}{8} \times 5\frac{1}{8} \times 5\frac{1}{8}$ in. Finish: teak or walnut with satin chrome panel. 200-240V 50Hz. Price: £38 (plus £6-77 PT).

■ LUX

Howland-West Ltd, 3-5 Eden Grove, London, N78EQ. Tel: 01-609 0293/4/5.

WL717 ★

AM/FM stereo tuner. Range: 88-108MHz, 187-572 metres. Variable tuning. Meter tuning indicator. Sensitivity: $3\mu\text{V}$ for 20dB quieting. Output: 700mV. Stereo decoder fitted. FET cascode amplifier in front end. Mains: 240V AC. Size: $15\frac{3}{8} \times 5\frac{1}{8} \times 9\frac{3}{8}$ in. Price: £65 (plus £10-80 PT).

WL515

AM/FM stereo tuner. Range: 88-108MHz, 187-572 metres. Variable tuning. Meter tuning indicator. Sensitivity: $2.5\mu\text{V}$ for 20dB quieting. Aerial input: 75 ohms coaxial or 300 ohms balanced. Output: 1V. Stereo decoder fitted. FET cascode front end. Five IF amplifier stages. Mains: 100, 117, 220, 240V AC. Size: $17\frac{3}{8} \times 5\frac{7}{8} \times 10\frac{1}{8}$ in. Price: £94 (plus £15-62 PT).

WL212

AM/FM stereo tuner. Range: 88-108MHz, 187-572 metres. Variable and preset tuning. Meter tuning indicator. Sensitivity: $1.7\mu\text{V}$ for 20dB quieting. Aerial input: 75 ohm coaxial or 300 ohm balanced. Output: 1V. Stereo decoder fitted. Five preset station stations on FM. Mains: 100, 117, 220, 240V AC. Size: $18\frac{3}{8} \times 6\frac{1}{2} \times 11$ in. Price: £215 (plus £35-65 PT).

WL500

AM/FM stereo tuner. Range: FM 88-108MHz, MW 187-572 metres. Variable tuning. Signal strength meter. Centre-zero tuning meter. Stereo

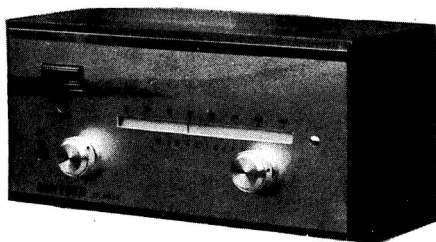

Lowther Stereo tuner Mk VII

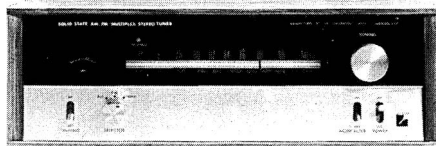

Lux WL717



Marantz 110

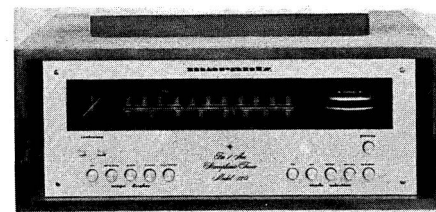

Marantz 120

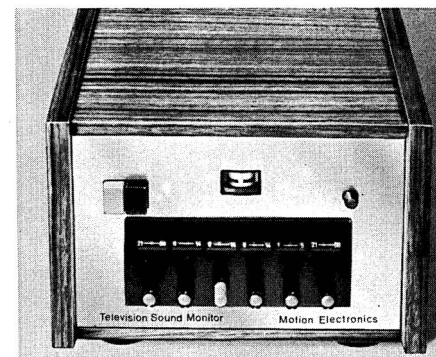

Motion Electronics TV Tuner

decoder included. Auto stereo beacon. Usable sensitivity: FM 1.7 μ V, MW 45 μ V. Dual gate FET front end. Quiet tuning facility. Noise limiter switch. Mains: 240V AC. Size: 17 $\frac{3}{4}$ \times 6 $\frac{3}{8}$ \times 10 $\frac{1}{2}$ in. Finish: rosewood. Price: £130 (plus £21-61 PT).

■ MARANTZ

Pysier-Britex (Swift) Ltd, Fircroft Way, Edenbridge, Kent.
Tel: Edenbridge (0732-71) 2434/6.

Model 20

Stereo FM tuner. Range: 88-108MHz. Variable tuning with gyro control. Oscilloscope tuning indicator. Usable sensitivity: (IHF) 1.8 μ V or better. Aerial input: 300 ohms balanced, 75 ohms unbalanced. Stereo decoder included, with automatic photoelectric switching. Steep quieting slope. Four limiter stages. Aerial attenuator switch. Parametric muting to eliminate AM burst modulation effects. Dual-gate FET RF amplifier. Individually calibrated tuning scale. Quiet tuning facility. Separation: 40dB at 20Hz, 30dB at 15kHz. FR: 20Hz-15kHz \pm 0.5dB. HD: (mono) 0.15%, (stereo) 0.15%. 19kHz and 38kHz rejection: better than 60dB. AM suppression: better than 40dB. H and N: better than -73dB below 100% modulation. Circuit comprises nine FETs, 31 transistors and 44 diodes. AC mains. Size: 15 $\frac{3}{8}$ \times 5 $\frac{1}{4}$ \times 14 $\frac{1}{8}$ in. Weight: 24lb. Price: £445.50 (plus £74.50 PT).

Model 110 ★

Stereo FM/AM tuner. Range: FM 88-108MHz, MW 187-555 metres. Variable tuning with gyro control. Signal strength meter. Aerial input: 300 ohms balanced, 75 ohms coaxial. Stereo decoder included. Pushbutton selector. Quiet tuning facility. Ferrite rod aerial for MW. AC mains outlet socket. Dual stereo outputs to feed tape recorder and amplifier. Output level controls. FET and IC circuitry. Steep quieting slope. Capture ratio: 1.6dB. FR: 20Hz-15kHz \pm 1dB. Separation: 42dB at 1kHz, 26dB at 10kHz. HD: (mono) 0.3%, (stereo) 0.15%. Provision for quadraphonic output. Circuit comprises 37 transistors, 30 diodes and one IC. Mains: 100, 120, 200, 220, 240V AC. Size: 14 $\frac{1}{4}$ \times 4 $\frac{3}{4}$ \times 12in. Weight: 17lb. Finish: walnut cabinet. Price: £107 (plus £18 PT).

Model 120 ★

Stereo AM/FM tuner. Range: FM 88-108MHz, MW 187-555 metres. Variable tuning. Ratio detector. Oscilloscope tuning indicator. Usable sensitivity: AM 20 μ V, FM 1.4 μ V for 30dB quieting. Aerial input: 300 ohms balanced, 75 ohms coaxial. Stereo decoder included and ready for quadraphonic transmissions. Size: 15 $\frac{3}{8}$ \times 5 $\frac{3}{8}$ \times 13in. Gold anodised front panel. Price: £236 (plus £39 PT).

■ MOTION ELECTRONICS

Addlestone Farm, Tonbridge Road, East Peckham, Kent. Tel: East Peckham 354.

Television Sound Monitor ★

Tuner unit designed to receive VHF and UHF television sound broadcasts. Varicap tuning with six preset pushbuttons, all manually adjustable. Ratio detector for FM, diode detector for AM. Centre-zero tuning meter. Sensitivity: 10 microvolts. Aerial input: 75 ohm coaxial or 300 ohm balanced. Output adjustable up to 0.5V. Mains: 110/240V AC. Consumption: 5W. Available in cabinet or chassis form for building-in. Cabinet teak veneered with finely grained silver finished front panel. Suitable for vertical or horizontal mounting. VHF coverage: 41-66.75MHz and 176-215MHz. UHF coverage: 470-846MHz. Prices: (VHF-only model chassis) £36.10 plus £6.52 PT; (VHF-only model in cabinet) £39.56 plus £7.14 PT; (UHF-only model chassis) £35.65 plus £6.44 PT; (UHF-only model in cabinet) £39.15 plus £7.06 PT; (VHF/UHF model chassis) £40 plus £7.22 PT; (VHF/UHF model in cabinet) £43.50 plus £7.85 PT.

■ NIKKO ELECTRIC MFG CO LTD

Distributors: Howland-West Ltd, 3-5 Eden Grove, London, N78EQ.
Tel: 01-609 0293/4/5.

FAM-14

AM/FM tuner. Range: 88-108MHz, 187-567m. Variable tuning with meter indicator. Sensitivity: 1.8 μ V. Output: FM 1.2V; AM 0.5V. Multiplex decoder fitted. AFC. Mains powered. Dimensions: 13 \times 9 $\frac{1}{2}$ \times 3 $\frac{3}{4}$ in. Panel dimmer control. Stereo output 10mV. Price: £81 (plus £13.46 PT).

FAM-300 ★

AM/FM stereo tuner. Range: FM 88-108MHz, MW 187-566 metres. Variable tuning. Meter tuning indicator. Usable sensitivity: FM 1.8 μ V, MW 200 μ V. Aerial input: 75 ohms coaxial, 300 ohms balanced. Stereo decoder included. Output: FM 1V, MW 300mV. Mains: 240V AC. Size: 12 \times 9 $\frac{3}{8}$ \times 3 $\frac{3}{4}$ in. Metal case. Price: £41.50 (plus £6.90 PT).

FAM-400 ★

AM/FM stereo tuner. Range: FM 88-108MHz, MW 187-566 metres. Variable tuning. Meter tuning indicator. Aerial input: 75 ohms coaxial, 300 ohms balanced. Usable sensitivity: FM 1.5 μ V, MW 150 μ V. Output: FM 1V, MW 300mV. Stereo decoder included. Mains: 240V AC. Size: 12 \times 9 $\frac{3}{8}$ \times 3 $\frac{3}{4}$ in. Metal case. Price: £54.50 (plus £9.06 PT).

FAM-1200 ★

AM/FM stereo tuner. Range: FM 88-108MHz, MW 187-566 metres. Variable tuning. AFC. Meter tuning indicator. Usable sensitivity: FM 1.5 μ V, MW 100 μ V. Aerial impedance: 75 ohms



Nikko FAM-300

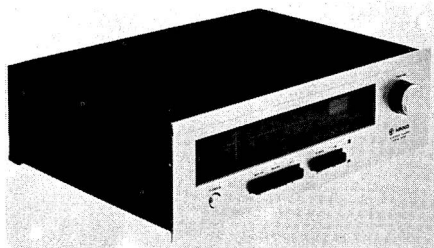

Nikko FAM-400



Nikko FAM-1200



Onkyo 433

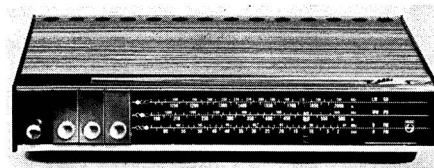

Philips RH690



Philips RH621

coaxial, 300 ohms balanced. Output: FM 1-2V, MW 300mV. Stereo decoder included. Mains: 100, 120, 220, 240V AC. Size: $15\frac{1}{2} \times 4\frac{1}{2} \times 12\frac{3}{4}$ in. Modular construction, Headphone amplifier included. Metal case. Price: £120 (plus £19.95 PT).

■ NIVICO

Denham & Morley (Overseas) Ltd, 453 Caledonian Road, London, N7. Tel: 01-607 6568.

MCT-V5E

AM/FM stereo tuner. Range: FM 88-108MHz, MW 187-560 metres. Usable sensitivity: FM $2\mu\text{V}$ (IHF), MW $20\mu\text{V}$. Mains: 100-240V AC. Four-element ceramic filter IF stage. Signal strength meter. Centre tuning indicator. Stereo decoder fitted. Noise cancelling switch. Aerial input: 75ohms coaxial and 300 ohms balanced. Quiet tuning facility. Detector output for four-channel working. Price: £86.99 (including PT).

■ ONKYO

J. Parkar & Co (London) Ltd, Parkar House, 1 Paul Street, London, EC2A 4JQ. Tel: 01-628 4577.

Integra 433 ★

Stereo AM/FM tuner. FET input, four-gang tuning, four-stage limiter. Range: FM 88-108MHz, MW 187-565 metres. Variable tuning. Sensitivity: FM $1.8\mu\text{V}$, MW $20\mu\text{V}$. S/N ratio: FM 70dB, MW 45dB. FR: 20Hz-15kHz ± 1 dB. Stereo separation: 40dB. Stereo decoder with automatic switching. Stereo beacon. Tuning meter. Quiet tuning facility on FM. Stereo filter. Output: FM 0.75V, MW 2V. Mains: 100/110V or 220/240V 50/60Hz. Size: $12\frac{3}{8} \times 5\frac{3}{8} \times 13\frac{1}{2}$ in. Price: £116.75 (including PT).

■ PHILIPS

Philips Electrical Ltd, Century House, Shaftesbury Avenue, London, WC2. Tel: 01-437 7777.

RH690 ★

Three waveband stereo tuner. 87.5-108MHz, 187-577 metres and 1,154-2,000 metres with variable tuning and ratio FM det. Sensitivity: $7\mu\text{V}$ (VHF) for 26dB quieting; $500\mu\text{V}$ (AM). Aerial 300 ohm balanced and ferrite rod. Switchable decoder with indicator lamp. AFC. Output: 250mV, 10K. Psn: 110, 127, 220, 240V AC. Dimensions: $13\frac{1}{8} \times 2\frac{7}{8} \times 8\frac{1}{2}$ in. Price: £44.15 (including PT).

RH621 ★

AM/FM stereo tuner. Range: FM 87.5-108MHz, MW 187-577 metres, LW 877-2000 metres, SW 16.8-50.4 metres. Variable tuning plus five presets on FM. Switchable AFC. Ratio detector. Moving coil tuning meter. Usable sensitivity:

FM 1 μ V at 75 ohms for 26dB quieting, AM 120 μ V for 26dB S/N. Aerial input: 75 ohms coaxial, 300 ohms balanced. Output: FM 0.6V at 40kHz deviation, AM 350mV at 30% modulation. Stereo decoder fitted. Mains: 110, 127, 220 and 240V AC. Size: 16 $\frac{1}{2}$ \times 11 \times 4 $\frac{1}{2}$ in. Finish: walnut veneer cabinet with brushed aluminium fascia. Silent tuning facility on FM. Price: to be announced.

■ **PIONEER**

Distributors: Shiro (UK) Ltd,
42 Russell Square, London, WC1B5DF.
Tel: 01-580 6996.

TX500A

AM/FM stereo tuner. Range: FM 87-108MHz, MW 187-562 metres. Variable tuning. Meter indicator. Sensitivity: 2.5 μ V for 20dB quieting. Aerial input: 300 ohms balanced. Output: 1V. Stereo decoder fitted. AFC. FET input with three-gang tuning. Multiplex noise filter. Outlet for tape recorder. Mains: 110, 117, 220 and 240V AC. Size: 13 \times 5 \times 13in. Price: £61.98 (plus £8.95 PT).

TX700

FM stereo tuner. Range: FM 87.5-108MHz. Variable and preset tuning. Meter tuning indicator. Sensitivity: 2.2 μ V for 20dB quieting. Aerial input: 300 ohms balanced. Output: 1V. Stereo decoder fitted. FET front end. Variable capacity diode tuning. Up to five preset stations. Mains: 110, 120, 130, 220, 240V AC. Size: 10 $\frac{3}{8}$ \times 4 $\frac{3}{8}$ \times 13 $\frac{1}{4}$ in. Price: £94.40 (plus £13.63 PT).

TX900

AM/FM stereo tuner. Range: FM 87.5-108MHz; MW 187-562 metres. Variable tuning. Two tuning meters. Sensitivity: 1.7 μ V for 20dB quieting. Aerial input: 300 ohms balanced. Output: 1V. Stereo decoder fitted. AFC. Three FETs. Two crystal filters. Four ICs. Muting control. Gain controls for AM and FM outputs. Mains: 110, 117, 130, 220, 240V AC. Size: 16 \times 5 $\frac{1}{2}$ \times 14in. Price: £125.42 (plus £18.11 PT).

TX600

AM/FM stereo tuner. Range: FM 87.5-108MHz, MW 187-562 metres. Variable tuning. 16 transistors, 19 diodes, two ICs, one FET. Sensitivity: FM 2.2 μ V, MW 15 μ V. Two meters (one centre zero). Output: 80mV-2.4V adjustable. Aerial input: 300 ohms balanced and 75 ohms coaxial. AC mains. Quiet tuning facility. Output socket for headphones. Price: £85.55 (plus £12.35 PT).

TX800

AM/FM stereo tuner. Range: FM 87.5-108MHz, MW 187-562 metres. Variable tuning. 29 transistors, 18 diodes, four ICs, two FETs. Sensitivity: FM 1.8 μ V, MW 10 μ V. Two meters (one centre zero). Output: 80mV-2.4V adjustable. Aerial in-



Quad AM3

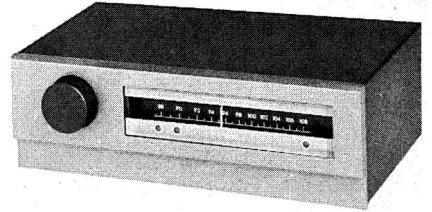

Quad FM3

put: 300 ohms and 75 ohms. AC mains. Price: £104.32 (plus £15.06 PT).

TX1000

AM/FM stereo tuner. Range: FM 87.5-108MHz, MW 187-562 metres. Variable tuning. 30 transistors, 19 diodes, six ICs, four FETs. Sensitivity: FM 1.7 μ V, MW 8 μ V. Two meters (one centre zero). Output: 80mV-2.4V adjustable. Aerial input: 300 ohms balanced, 75 ohms coaxial. AC mains. Separate AM and FM level controls. Outlet for stereo headphones. Price: £146.63 (plus £21.17 PT).

■ **QUAD**

Acoustal Manufacturing Co Ltd,
St Peter's Road, Huntingdon, Hunts.
Tel: Huntingdon 2561/2. Cables: Acoustical.

Quad AM3/European ★

Variable tuning. Range: LW 800-2,070 metres, MW 185-588 metres, SW 16.2-52 metres. Tuning indicator. Aerial/earth sockets. Output: 100mV nominal for 30% modulation. Output impedance: 15K. Switched variable selectivity, 9kHz filter for adjacent channel heterodyne. IF: 470kHz. Mains: 100-130V or 200-250V 50-60Hz. Consumption: 25W. Three valves plus magic eye. Removable metal cover permits mounting through cabinet cut-out. Size: (free standing) 3 $\frac{3}{8}$ in high, 10 $\frac{1}{4}$ in wide, 8in deep; (panel mounting) 3 $\frac{1}{4}$ in high, 10 $\frac{1}{4}$ in wide, 7 $\frac{1}{8}$ in deep. Weight: 8lb. Price: £38 (plus £7.13 PT).

Quad AM3/Overseas ★

Range: MW 185-588 metres, SW1 45-136 metres (2.2-6.6MHz), SW2 16.2-52 metres (5.8-18.5MHz). 10kHz filter for adjacent channel hetero-

★ Indicates entry is illustrated

dyne. All other details as for AM3/European. Price: £38 (plus £7.13 PT).

Quad FM3 ★

Stereo FM tuner. Range: 88-108MHz. Variable tuning. High stability tuned stages maintain accuracy without AFC. Twin neon tuning indicator. Sensitivity: $2\mu\text{V}$ for full limiting. Aerial input: 75 ohm coaxial and 300 ohm balanced. Output: 100mV per channel for 30% modulation. Stereo decoder fitted. Image rejection: 56dB. IF rejection: 80dB. Capture ratio: 3dB. FR: $20\text{Hz}-15\text{kHz}\pm 1\text{dB}$. Separation: 40dB at 1kHz. Distortion: 1kHz at 40kHz deviation, 0.2%. Recommended load: greater than 50K. De-emphasis: 50µSec or 75µSec as required. Mains: 100-125V, 200-250V 50-60Hz. Dual gate MOS FET input stage. Integrated circuits (ICs) in IF and decoder. Ceramic filters in IF chain. Output via 5 pin DIN connector. Size: $10\frac{1}{4}\times 3\frac{1}{4}\times 5\frac{1}{2}$ in. Price: £58 (plus £10.88 PT).

■ RADFORD AUDIO LTD

Ashton Vale Road, Bristol, BS32HZ.
Tel: Bristol 662301.

FMT4

Stereo FM tuner. Range: 87.5-108.5MHz. Variable tuning plus four preset stations. AFC. Differential peak detector. Meter tuning indicator. Usable sensitivity: $1.5\mu\text{V}$. Aerial input: 75 ohms coaxial and 240 ohms balanced. Output: 1V RMS for 75kHz deviation. Stereo decoder fitted. Mains: 110, 120, 130, 220, 230, 240V AC. Finish: designed to match SC24/SPA50. Size: $16\frac{3}{8}\times 4\frac{1}{2}\times 8\frac{3}{4}$ in. Price: £110 (plus £19.59 PT).

■ RADON

Radon Industrial Electronics Co Ltd,
Brooklands Trading Estate, Orne Road,
Worthing, Sussex. Tel: Worthing 34904/5/6.

Series 404 Mk II

Solid state FM tuner. Range: 87-106MHz. Sensitivity: $15\mu\text{V}$ for limiting. AFC. Aerial: 75 ohms coaxial. AGC: 6dB for 60dB input change. Fuse protected power pack. Modular construction. Controls: tuning, on-off, AFC. Cabinet finish: blond oak or teak with satin lacquer. Stereo decoder fitted. AFC. Price: £22.10 (plus £3.61 PT).

■ REVOX

Distributors: C. E. Hammond & Co Ltd,
Lamb House, Church Street, London, W4.
Tel: 01-995 4551. Telex: 934047.

Revox A76 ★

Stereo FM tuner. Range: 87.5-108MHz. Sensitivity: $1\mu\text{V}$ for 30dB S/N. Distortion: 0.2% for 40kHz deviation at 1kHz. S/N (unweighted) 70dB. Stereo separation: 40dB. Output: 0.1V for 75kHz deviation (adjustable). FR: 30Hz-15kHz $\pm 1\text{dB}$. De-emphasis: 50µsecs. 41 silicon transistors, 27 diodes, 6 integrated circuits, 2 dual insulated-gate FET, 2 rectifiers. Mains: 110, 130, 150, 220, 240, 250V 50/60Hz. Consumption: 20W. Size: $6\frac{5}{16}\times 16\frac{3}{8}\times 9\frac{5}{8}$ in. Weight: $17\frac{1}{2}$ lb. Price: £168 (including PT).



Revox A76



Rogers Ravensbrook



Rogers Ravensbourne 2FET

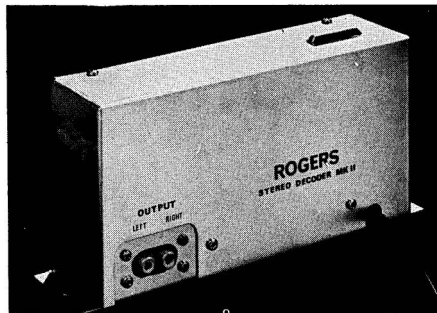

Rogers stereo decoder

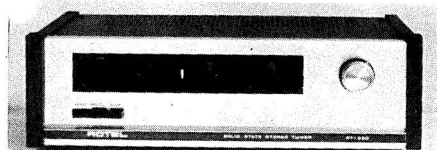

Rotel RT320

■ **ROGERS DEVELOPMENTS (Electronics) LTD**

4-14 Barmeston Road, Catford, London, SE6.
Tel: 01-698 7424/4340. Cables: Rodevco, London, SE6.

■ **Ravensbrook FET FM tuner ★**

Range: 88-108MHz. Variable tuning. Ratio detector. Centre-zero meter. Sensitivity: better than $5\mu\text{V}$ (IHFV). Aerial impedance: 75 ohms coaxial and 300 ohms balanced. Output: 200 mV for 30% modulation. Stereo decoder fitted. Switchable AFC. Three-gang FET front-end. Integrated circuit IF strip. Switchable inter-station noise suppression. Mains: 105/125V, 200/250V, 50-60Hz. Consumption: 7.5W. Size: (chassis) $3\frac{3}{4} \times 10\frac{3}{4} \times 10\text{in}$; (cabinet) $5 \times 11\frac{1}{2} \times 10\text{in}$. Prices: (chassis) £42-14; (in cabinet) £48. Both prices include PT.

■ **Ravensbourne 2 FET tuner, Series II ★**

Range: 88-108MHz. Variable tuning. Wide-band ratio detector. Centre-zero tuning meter. Sensitivity: $2.7\mu\text{V}$ for 30dB quieting. Aerial impedance: 75 ohms coaxial and 300 ohms balanced. Output: 200mV average for 30% modulation. Integrated circuits in IF strip. Multiplex decoder. Switched AFC. FET front end. Inter-station noise suppression. Mains: 200-250V AC. Consumption: 8W. Size: (chassis) $11\frac{1}{2} \times 11 \times 4\text{in}$; (case) $12\frac{1}{2} \times 11\frac{1}{2} \times 5\frac{1}{2}\text{in}$. Prices: (chassis with decoder) £57-95; (in cabinet with decoder) £62-63. Both prices including PT.

■ **Multiplex stereo decoder Mk II ★**

Designed for use with Rogers FM tuners but also suitable for operation with other makes of tuner. Unpowered and self-powered versions. Automatic electronic switching for stereo broadcasts. Mullard Vinkor tuned circuits. Seven silicon planar transistors. Selective anti-noise filter. High degree of filtering permits tuner to be connected to tape recorder without interference (input impedance to recorder must be over 100K). Stabilised 12V supply. Input signal level: 0.5-1V. Input imp 30K approx. Output: 700mV RMS for input of 350mV RMS per channel. Separation: better than 30dB at 1kHz. Total spurious output (including 19/38kHz): better than -50dB. Mains: 105-125V, 200-250V AC. Price: (less power supply unit) £15; (with supply unit) £17.

■ **ROTEL**

Rank Aldis-Audio Products, Rank Audio Visual Ltd, PO Box 70, Great West Road, Brentford, Middlesex.
Tel: 01-568 9222. Telex: 24408.

■ **RT620**

AM/FM stereo tuner. Range: FM 88-108MHz, MW 187-562 metres. Variable tuning. Meter indicator. Sensitivity: $1.7\mu\text{V}$ for 20dB quieting. Aerial input: 300 ohms balanced (can be changed to 75 ohms coaxial). Stereo decoder fitted. FET input. Integrated circuits. Four-gang variable capacitor tuning. Two-stage RF amplifier. Ceramic filters. Variable muting. Adjustable output voltages for AM and FM. Mains: 100-240V AC. Size: $16\frac{1}{4} \times 8\frac{3}{4} \times 4\frac{7}{8}\text{in}$. Price: £73-75 (plus £12-58 PT).

■ **RT320 ★**

AM/FM stereo tuner. Range: FM 88-108MHz, MW 187-562 metres. Variable tuning. Meter indicator. Sensitivity: $8\mu\text{V}$ for 20dB quieting. Aerial impedance: 300 ohms balanced (can be changed to 75 ohms coaxial). Stereo decoder fitted. FET front end. Integrated circuits. FM stereo/mono switching. Illuminated dial pointer. Mains: 117, 240V AC. Size: $13\frac{3}{8} \times 4\frac{3}{8} \times 9\frac{1}{8}\text{in}$. Price: £45-60 (plus £7-78 PT).

■ **SABA**

Distributors: Lampitt Electronics Ltd, 6-12 Cornbrook Park Road, Manchester, M154EE. Tel: 061-872 7661.

■ **TS80 ★**

AM/FM stereo tuner. Range: FM, LW, MW, SW. Variable tuning plus five preset tuning buttons on FM. Tuning meter. Stereo decoder with auto switching. 25 transistors and 21 diodes. Mains: 120-240V AC. Size: $16\frac{3}{8} \times 4\frac{1}{2} \times 1\text{in}$. Finish: light walnut or white. Price: £102-09 (including PT).

■ **SANSUI**

Vernitron Ltd, Thornhill, Southampton, SO95QF. Tel: Southampton 44811.

■ **TU555 ★**

Stereo AM/FM tuner. Range: 88-108MHz. 187-560metres. Variabletuningwithindicator meter.



Saba TS80 and VS80

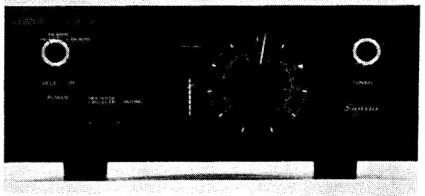

Sansui TU555

★ Indicates entry is illustrated

FM detector: ratio. Sensitivity: FM $2.0\mu\text{V} \pm 3$ dB (20dB quieting). Aerial: coaxial and balanced. Output voltage: greater than 1.5V. Multiplex decoder fitted. Psn: 100-240V AC, 10W. Dimensions: $4\frac{3}{8} \times 11\frac{1}{2} \times 11\frac{1}{2}$ in. FET front end. Noise muting circuit. Price: £74.54 (plus £12.42 PT).

TU666 ★

Stereo AM/FM tuner. Range: FM 88-108MHz, MW 187-572 metres. Stereo decoder fitted. Variable tuning. Ratio detector. Tuning meter. Sensitivity: $2\mu\text{V}$ for 20dB quieting. Aerial input: 300 ohms balanced. Output: 0.7V. Mains: 100-240V AC. Size: $13 \times 5 \times 10$ in. Price: £84.29 (plus £14.05 PT).

TU888 ★

Stereo AM/FM tuner. Range: 88-108MHz, MW 187-560 metres. Variable tuning. AFC. Ratio detector. Two meters. Usable sensitivity: FM $1.4\mu\text{V}$, AM $150\mu\text{V}$. Aerial input: 75 ohms coaxial, 300 ohms balanced. Stereo decoder fitted. Mains: 100, 117, 220, 240V AC. Size: $18\frac{1}{2} \times 12\frac{1}{2} \times 5\frac{3}{8}$ in. Two FETs. Quiet tuning facility. Finish: walnut cabinet with black front panel to match AU888. Price: £114.97 (plus £19.16 PT).

TU999 ★

Stereo AM/FM tuner. Range: 88-108MHz, MW 187-560 metres. Variable tuning. AFC. Ratio detector. Two meters. Usable sensitivity: FM $1.4\mu\text{V}$, MW $150\mu\text{V}$. Aerial input: 75 ohms coaxial, 300 ohms balanced. Stereo decoder fitted. Multiplex filter. Mains: 100, 117, 220, 240V AC. Size: $17\frac{1}{2} \times 12\frac{1}{2} \times 6\frac{1}{8}$ in. Black metal case, black front, silver trim to match AU999. Price: £148.33 (plus £24.72 PT).

■ SANYO

Sanyo Marubeni (UK) Ltd, Sanyo House, Bushey Mill Lane, Watford, Herts. Tel: Watford 30421.

FMT 1400K

AM/FM stereo tuner. Range: MW 187-560 metres, FM 88-108MHz. Variable tuning. Meter tuning indicator. Usable sensitivity: MW $15\mu\text{V}$, FM $1.9\mu\text{V}$. Output voltage: 0.4-0.5V. Decoder included. FR: (FM) 10Hz-15kHz. Signal to noise: FM better than 60dB, AM better than 50dB. Stereo noise filter. Muting switch. Incorporates FET input and IC. Price: to be announced.

■ SERVO-SOUND

Sonosound Ltd, 5 Queen Street, London, EC4N 1SU. Tel: 01-248 9461.

SR3

Stereo FM tuner. Range: 88-108MHz. Variable tuning. Switchable AFC. Squelch circuit FM discriminator. Meter tuning indicator. Usable sensitivity: $0.9\mu\text{V}$ for 30dB signal-to-noise. Aerial input: 240-300 ohms balanced. Output:

1V. Stereo decoder included. Circuit includes two FETs and one IC. Size: $15\frac{1}{2} \times 3 \times 7\frac{1}{2}$ in. Mains: 110-240V AC. Finish: wood and steel cabinet in walnut or white matt. Price: £75 (plus £11 PT).

■ SINCLAIR RADIONICS LTD

London Road, St Ives, Huntingdonshire, PE174HJ. Tel: St Ives (Hunts) 4311.

Project 60

Stereo FM tuner employing phase lock loop principle of detection. Range: 87.5-108MHz. Capture ratio: 1.5dB. Sensitivity: $2\mu\text{V}$ for 30dB

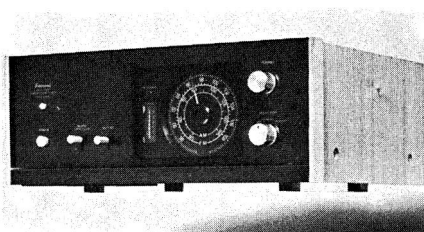

Sansui TU666

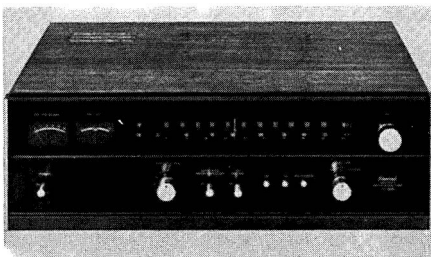

Sansui TU888

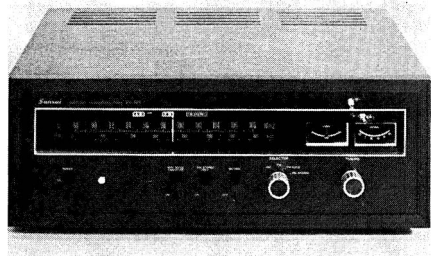

Sansui TU999

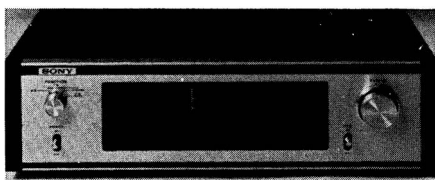

Sony ST-5600

quieting, $7\mu\text{V}$ for full limiting. AFC fitted (range $\pm 200\text{kHz}$). S/N: $>65\text{dB}$. FR: $10\text{Hz}-15\text{kHz}$ $\pm 1\text{dB}$. HD: $0-15\%$ for 30% modulation. Stereo decoder fitted (operating level $2\mu\text{V}$). Pilot tone suppression: 30dB . Crosstalk: 40dB . Output: 150mV per channel RMS. Aerial input impedance: 75ohms . Tuning indicator. Stereo beacon. Mains-on pilot light. Power supply required: $25-30\text{V DC}$. Size: $8\frac{1}{8} \times 1\frac{5}{8} \times 3\frac{5}{8}\text{in}$. Varicap diode tuning. Printed circuit coils. IC decoder. 16 discrete transistors. Inter-station muting. Price: $\pounds 25$ (including PT).

■ SONY (UK) LTD

Pyrene House, Sunbury Cross,
Sunbury-on-Thames, Middlesex.
Tel: Sunbury 87644/7.

ST-80F

AM/FM stereo tuner. Range: FM $87-108\text{MHz}$, MW $187-560$ metres. Variable tuning. Meter tuning indicator. Sensitivity: (FM) $2-4\mu\text{V}$ for 30dB S/N , AM $10\mu\text{V}$ (external aerial). Aerial input: (FM) 300ohms balanced. Output: (high level) 2V at 10K , (low level) 700mV at 10K . Stereo decoder fitted. Two FETs, 18 transistors, 16 diodes. FM image rejection: 50dB . FM FR: $30\text{Hz}-15\text{kHz} + 0\text{dB} - 2\text{dB}$. Stereo separation: better than 36dB at 1kHz . FM HD: (stereo) $0-8\%$ (mono) $0-5\%$. Mains: $100, 117, 220, 240\text{V}$ $50/60\text{Hz}$. Consumption: 13W . Size: 5in wide, $9\frac{1}{2}\text{in}$ high, $7\frac{1}{2}\text{in}$ deep. Finish: walnut with black and satin silver front panel. Price: $\pounds 48-35$ (including PT).

ST-5600 ★

AM/FM stereo tuner. Range: FM $87-108\text{MHz}$, MW $187-560$ metres. Variable tuning. Meter tuning indicator. Sensitivity: $1-4\mu\text{V}$ for 20dB S/N . Aerial input: (FM) 300ohms balanced. Output: (fixed) 750mV 5K , (variable) $0-1-5\text{V}$ $2-5\text{K}$. S/N: (FM) 65dB . Capture ratio: $1-6\text{dB}$. FM FR: $30\text{Hz}-15\text{kHz} \pm 1\text{dB}$. HD: (FM) mono $0-3\%$, stereo $0-7\%$. Separation: better than 38dB at 400Hz . 20 transistors, 18 diodes. Mains: $100, 117, 220, 240\text{V}$ $50/60\text{Hz}$. Consumption: 13W . Size: $16\frac{5}{8} \times 4\frac{7}{8} \times 10\frac{1}{2}\text{in}$. Weight: 9lb . Price: $\pounds 60$ (including PT).

ST-5055L

AM/FM stereo tuner. Range: VHF, LW, MW. Variable tuning. Ratio detector. Meter tuning indicator. Usable sensitivity: FM $2-2\mu\text{V}$ (IHF), $1-7\mu\text{V}$ for 30dB S/N . Aerial input: balanced $240-300\text{ohms}$. Stereo decoder fitted. FET front end. Ceramic filters. IC amplifier stage. Balanced diode limiter. High blend noise cancelling circuit. Auto mono/stereo switching. Two outputs. Pushbutton selection. Finish: walnut cabinet, brushed aluminium panel and black scale. Price: $\pounds 68-25$ (plus $\pounds 11-50$ PT).

ST70

AM/FM stereo tuner. Variable tuning. AFC. Ratio detector. Meter tuning indicator. Usable sensitivity: AM $20\mu\text{V}$, FM $2\mu\text{V}$. Aerial input: 300ohms balanced. Output: (high) 2V , (low) 750mV . Stereo decoder fitted. Mains: $220-240\text{V AC}$. Size: $13 \times 7\frac{1}{2} \times 9\frac{5}{8}\text{in}$. Finish: walnut cabinet and anodised aluminium panel and trim. Price: to be announced.

■ STANDARD

Telerenters (London & Provincial) Ltd,
Standard House, 1-2 Church Way, Edgware,
Middlesex. Tel: 01-952 7488. Telex: 24792.

TU-108EE

Stereo four-band tuner. Range: FM $88-108\text{MHz}$, MW $187-560$ metres, LW $810-2,000$ metres, SW 49-metre band. Variable tuning. Ratio detector for FM. Tuning indicator. Stereo beacon. AFC. Sensitivity: (FM) $5\mu\text{V}$, (AM) $20\mu\text{V}$. Aerial input: (FM) 300ohms balanced, (AM) internal ferrite rod. Output: 120mV at 10K . Stereo decoder fitted. Size: $13\frac{1}{2} \times 3\frac{1}{4} \times 7\frac{1}{4}\text{in}$. Mains: 230V $50/60\text{Hz}$. Price: $\pounds 40-24$ (plus $\pounds 6-07$ PT).

■ STEEPLETONE

Steeple Supplies (Electronics) Ltd,
Cinema House, Middle Barton,
Oxford OX54DA. Tel: Steeple Aston 7116.

STV-1

Stereo FM tuner. Range: $87-5-108\text{MHz}$. Five preset stations. Switchable AFC. Usable sensitivity: (mono) $2\mu\text{V}$, (stereo) $8\mu\text{V}$, both for 26dB quieting. Aerial input: $70-80\text{ohms}$ coaxial, $240-300\text{ohms}$ balanced. Output: variable $0-2\text{V}$ per channel. Stereo decoder included. Mains: $100-125, 200-250\text{V AC}$. Size: $13 \times 8\frac{1}{2} \times 4\frac{1}{2}\text{in}$. Finish: teak cabinet with diecast enamelled sides and brushed aluminium fascia. Price: $\pounds 39-43$ (plus $\pounds 6-65$ PT).

■ STEREOSOUND PRODUCTIONS LTD

Wakefield Road, Brighouse, Yorks.
Tel: Brighouse 4355.

Stereosound T20

AM/FM radio tuner. Range: FM $87-4-104-5\text{MHz}$, MW $185-555$ metres, LW $1,110-1,940$ metres. Variable tuning. AFC. Ratio detector. Aerial input: 75ohms coaxial. Output: 50mV and 750mV . Mains: 240V AC . Size: $18\frac{1}{2} \times 4\frac{3}{4} \times 8\text{in}$. Finish: teak cabinet with clear plastic scale. Price: $\pounds 26-93$ (plus $\pounds 4-32$ PT).

■ J. E. SUGDEN & CO LTD

Carr Street, Cleckheaton, Yorks, BD19 5LA.
Tel: Cleckheaton 2501.

R21 and R51 ★

FM stereo tuner. Range: $88-104\text{MHz}$. Variable and preset tuning. Ratio detector. Centre-zero tuning indicator. Sensitivity: $2\mu\text{V}$ for 20dB quieting. Aerial input: 75ohms coaxial and 300ohms

★ Indicates entry is illustrated

balanced. Output: 0.5V. Stereo decoder fitted. AFC. Mains: 110, 120, 220, 230 and 240V AC. Thermometer type tuning dial. Special decoder filter to prevent spurious oscillations. Switchable decoder filter for low-level transmissions. R21 designed to match J. E. Sugden A21 amplifier. R51 designed to match J. E. Sugden C51 amplifier. Size: (R21) 12×9×5in; (R51) 11×4×7in. Price: (both models) £75 (including PT).

■ TEAC

Acoustico Enterprises Ltd, 6-8 Union Street, Kingston-on-Thames, Surrey.
Tel: 01-549 3471/3.

AT-100 ★

Stereo FM tuner. Range: 88-108MHz. Variable tuning. AFC. Two tuning meters. Usable sensitivity: 2µV (IHF). Aerial input: 75 ohms coaxial and 300 ohms balanced. Output: 1V. Stereo decoder fitted. Mains: 100, 117, 220, 240V AC. Size: 16½×5½×13in. Finish: silver and black, black-out dial. Dual gate FET front end. Six ceramic filters in IF strip. Price: £84.43 (plus £14.60 PT).

AT-200 ★

AM/FM stereo tuner. Range: FM 88-108MHz, MW 182-555 metres. Variable tuning. AFC. Two tuning meters. Usable sensitivity: FM 1.8µV, MW 10µV. Aerial input: 75 ohms coaxial, 300 ohms balanced. Output: 0.3V. Stereo decoder fitted. Mains: 100, 117, 220, 240V AC. Size: 16½×6×13in. Finish: wood trim. FET front end. Ceramic filters. Price: £182.16 (plus £31.88 PT).

■ TELEFI

Sound take-off adaptor for feeding hi-fi system from TV. See Tape Recorder Accessories Section.

■ TELEFUNKEN

Distributor: AEG (Great Britain) Ltd, AEG House, Chichester Rents, Chancery Lane, London, WC2.
Tel: 01-242 9944. Cables: Allgem, London.

T250 ★

Stereo transistorised tuner to DIN 45.500 standards. Ranges: 87.5-104MHz, SW 5.9-18MHz, MW 185-577 metres, 860-2,000 metres. Sensitivity: FM 0.8µV for 26dB signal/noise ratio at 25kHz deviation, AM approx 5µV for 10dB signal/noise. Separate AM and FM tuning and tuning indicators. Audio response: (-1dB) 30Hz-14kHz, less than 0.5% distortion. Sockets for FM and AM aerials, amplifier and tape recorder. Features include five buttons for electronic pre-selection of FM stations, AM bandwidth switching and excellent cross-modulation characteristics. Mains: 110/125, 220/240V 50/60Hz. Price: £178.12 (including PT).



J. E. Sugden R21



Teac AT100

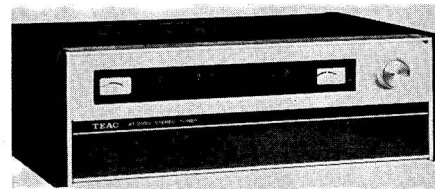

Teac AT200

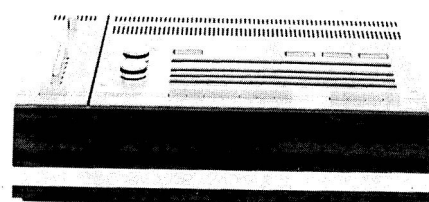

Telefunken T250

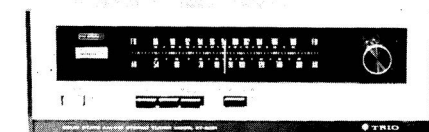

Trio KT2001

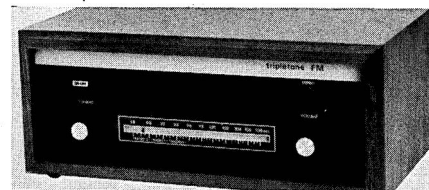

Tripletone FET FM tuner Mk II

■ TELETON

Teleton Electro (Distributors) Co Ltd,
Teleton House, Robjohns Road, Widford,
Chelmsford, Essex.
Tel: Chelmsford 62442. Telex: 99338.

GT.101

Solid state FM/AM stereo tuner matching GA.101 amplifier. Ranges: 88-108MHz, 187-570 metres. Sensitivity: better than $7\mu\text{V}$ (FM), $150\mu\text{V/m}$ (AM). Multiplex separation: more than 25dB, signal/noise more than 50dB. Aerial: built-in plus extension, 300 ohms balanced. Output: 1V 100% modulated. Mains: 110-117, 220-240V 50-60Hz. Dimensions: $12 \times 9\frac{1}{2} \times 4$ in. Price: £38-77 (plus £6-22 PT).

■ TRIO

Distributors: B. H. Morris & Co (Radio) Ltd,
84-88 Nelson Street, London, E1 2DY.
Tel: 01-790 5011.

KT1000A

AM/FM stereo tuner. Range: FM 88-108MHz, MW 187-556 metres. Variable tuning. Meter tuning indicator. Sensitivity: $3\mu\text{V}$ (IHFM standard). Aerial input: 75 ohms coaxial and 300 ohms balanced. Output: 1V FM, 0-4V AM. Stereo decoder fitted. Multiplex noise filter fitted (switchable). Mains: 100-120V and 220-240V 50-60Hz. Price: £49-91 (plus £6-59 PT).

KT2001 ★

AM/FM stereo tuner. Range: FM 88-108MHz, MW 187-556 metres. Variable tuning. Meter tuning indicator. Sensitivity: $2\mu\text{V}$ (IHFM standard). Aerial input: 75 ohms coaxial and 300 ohms balanced. Output: 1V FM, 0-4V AM. Stereo decoder fitted. Circuit incorporates ICs. Multiplex noise filter fitted (switchable). Mains: 110-120V and 220-240V AC 50/60Hz. Size: $13 \times 4\frac{5}{8} \times 9\frac{1}{2}$ in. Price: £56-27 (plus £7-23 PT).

KT5000

FM stereo tuner. Range: FM 88-108MHz. Variable tuning. Two tuning meters. Sensitivity: $1.7\mu\text{V}$ (IHFM standard). Aerial input: 75 ohms coaxial and 300 ohms balanced. Output: $1V \pm 1\text{dB}$. Stereo decoder fitted. Circuit incorporates FET input and ICs. Output level control. Mains: 110-120V and 220-240V 50/60Hz. Size: $16\frac{1}{4} \times 5\frac{1}{4} \times 11$ in. Price: £84-46 (plus £11-04 PT).

KT7001

AM/FM stereo tuner. Range: FM 88-108MHz, MW 187-556 metres. Variable tuning. One signal strength meter, one centre-zero tuning meter. Sensitivity: $1.5\mu\text{V}$ (IHFM standard). Aerial input: 75 ohms coaxial and 300 ohms balanced. Output: 1.5V AM and FM. Stereo decoder fitted. AFC. Circuit incorporates FETs, ICs and crystal filters. Mains: 110-120V and

220-240V 50/60Hz. Size: $16\frac{1}{4} \times 5\frac{1}{8} \times 11\frac{1}{8}$ in. Price: £130-45 (plus £17-05 PT).

KT6005

AM/FM stereo tuner. Range: FM 88-108MHz, MW 187-556 metres. Variable tuning. AFC. Tuning and signal strength meters. Usable sensitivity: FM $1.5\mu\text{V}$, AM (internal aerial) $300\mu\text{V}$, (external aerial) $13\mu\text{V}$. Aerial input: 300 ohms balanced and 75 ohms coaxial. Stereo decoder included. Output: 1.5V at 100% modulation at 400Hz. Three FETs, one IC. Quiet tuning facility on FM. Auto stereo switching. Multiplex filter. Output level control. Finish: wood sides with satin chrome facia. Size: $17\frac{1}{8} \times 6\frac{1}{8} \times 11\frac{1}{8}$ in. Price to be announced.

■ TRIPLETONE MANUFACTURING CO LTD

Kelgrove Sales Ltd, St Marks Rise, Dalston, London, E8.

FM tuner Mk II ★

Transistorised stereo tuner. Range: 88-108MHz. Variable tuning with AFC. Sensitivity: 2-3 μV for 20dB quieting. Aerial input: 70-80 ohms coaxial. Output: 0-1V via emitter follower. Controls: tuning, volume, mains on/off push-button. Crosstalk: better than 30dB at 1kHz. AFC hold: 400kHz. Bandwidth: 210kHz. IF: 10-7MHz. FET tuner. Stereo decoder included. Automatic stereo switching. Stereo beacon. Size: (chassis) $3\frac{3}{4} \times 11 \times 7\frac{1}{2}$ in; (cabinet) $5\frac{1}{4} \times 13 \times 9$ in. Weight: (chassis) 6lb; (cabinet model) 9lb. Prices: (complete with stereo decoder and cabinet) £37-99; (in cabinet but less decoder) £31-45.

■ YAMAHA

Jonathan Fallowfield Ltd, Strathcona Road, North Wembley, London, HA98QL.
Tel: 01-904 0141.

CT-700

AM/FM stereo tuner. Range: FM 88-108MHz, MW 186-560 metres. Variable tuning. AFC. Dual tuning meters. Usable sensitivity: AM $15\mu\text{V}$, FM $1.7\mu\text{V}$. Aerial input: 300 ohms balanced. Output: 100mV. Stereo decoder included. Quiet tuning facility. Noise filters. Auto stereo switching. Mains: 110-240V AC. Finish: American walnut and satin chrome. Size: $16 \times 5\frac{1}{2} \times 12$ in. Price: £95 (plus £15 PT).

FRANCIS OF STREATHAM

invite all
Hi-Fi and Recorder
enthusiasts to their
South London Showrooms

There must be very good reasons why, when there are so many diverting offers of equipment at reduced prices, that the number of our customers gets larger and larger all the time. Essentially, we are tape recorder specialists, but our hi-fi department is now very large too and we try at all times not to advertise items which will not be in stock when our ads. appear. We try too, to study our customers' personal requirements and generally manage to carry out transactions on a friendly and knowledgeable basis. You will find our premises close to St. Leonard's Church in Streatham and there is a free car park nearby in Prentis Road, as well as parking in side turnings.

- London's foremost Tandberg stockists
- No interest or service charges on credit facilities up to 18 months
- Free service during Guarantee period
- Fair Part Exchange allowance on your old recorder
- Reconditioned recorders available to personal shoppers
- Large stocks of Musicassettes

FRANCIS OF STREATHAM

169-173, STREATHAM HIGH ROAD, LONDON, S.W.16

Between Streatham Station and St. Leonard's Church

Phone: 01-769 0466 and 01-769 0192

Free Car Park, Prentis Road, nearby

Closed all day Wednesday

Please note this is our only address

Where can I get
TOP DISCOUNTS
on hi-fi
equipment?

AT
GLOBAL AUDIO DISCOUNT
WAREHOUSES
THEY GIVE **60%**
UP TO **OFF**

They stock all leading makes...
AKAI · LEAK · SINCLAIR
ARMSTRONG · TELETON
THORENS · PHILIPS
ROTEL · GOLDRING · ROGERS
PIONEER ETC.

For the latest discount prices
see their advertisements in the
current hi-fi magazines or
write for list



GLOBAL AUDIO DISCOUNT WAREHOUSES

Dept. YB 174 Pentonville Road, London, N1. Telephone 01-278 1769

Or: 4 High View Parade, Redbridge Lane East, Woodford Avenue, Ilford, Essex. Tel: 01-550 1086.

Tyson's

SOUND Engineers

PROPRIETOR: J.E. BARKLEY

*All leading makers
represented*

'Quad' usually from stock.
No gimmicks, No salesman-
ship, No discounts.

Only

Sound advice
and Sound service

41 RUSSELL STREET
LEAMINGTON SPA

Telephone: (0926) 24935

Hi-Fi Stand

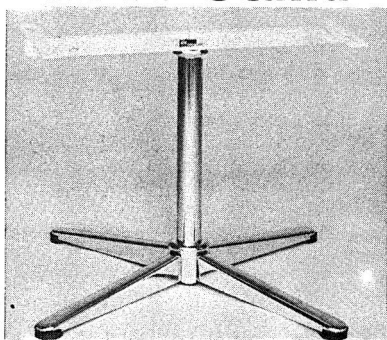

New chrome hi-fi or TV stand with simple thumb screws providing adjustment to accommodate most makes. Rubber vibration mounts. Simple assembly. Fits in 17 in. x 17 in. x 4 in. box. Manufacturers of special purpose tubular stands and swivels.

For further information contact:

MUNDY MILLS LIMITED

Park Works, Cotmanhay Road,
Ilkeston, Derby. Tel: 060 725519

TELEFUNKEN



PRESENT THE CONCERTO Hi-Fi 101



A top-flight Hi-Fi tuner-amplifier. 5 wavebands :

FM, SW, MW₁ = 1415–1610 kHz (European waveband MW₂ = 520–1420 kHz),

LW. 7 FM stations buttons. Electronic frequency indicator with instrument.

2 x 30 watts music power (which corresponds to 2 x 22 watts continuous output power). Built-in equaliser/preamplifier. Separate sockets for pick-up (crystal) pick-up (magnetic), tape recorder. Illuminated indicator for stereo operation.

Noise filter. FM fine tuning (AFC). Floodlit dial.

Frequency response 20–20,000 Hz.

Cabinet: light-matt walnut, pearl-white or rosewood.

Dimensions (W/H/D) : 25" x 4" x 10½". (63 x 10 x 26.5 cm).

ONE OF TELEFUNKENS MANY HIGH-FIDELITY PRODUCTS

For further information please write to:

TELEFUNKEN QUALITY PRODUCTS

AEG (Great Britain) Ltd. AEG House, Chichester Rents,
Chancery Lane, W.C.2. Telephone : 01-242 9944.

Directory of Tuner/ Amplifiers

★ Indicates entry is illustrated

Abbreviations used in this section are given on page 36.

■ ACOUSTIC RESEARCH

Pending new distribution arrangements in the UK all AR products are available direct from Acoustic Research International, Radiumweg 7, Amersfoort, Holland, (POB 209). Tel: (03490) 12556.

AR Tuner Amplifier ★

FM stereo tuner/amplifier. Range: FM 88-108 MHz. Variable tuning. FET front end and multi-section crystal filter IF amplifier. Tuning meter. Sensitivity: $1\mu\text{V}$ for 20dB quieting. Aerial input: 300 ohms balanced. Stereo decoder fitted. Inter-station quiet tuning. S/N 65dB. IC IF amplifier. De-emphasis switchable 50 μSec or 75 μSec . Inputs: magnetic PU 2-5mV (adjustable) 50K, tape 200mV 150K, aux 200mV 150K. Noise level: PU input 57dB, other inputs 75dB. Controls: bass, treble, volume, balance, input selector, tuning, mains on-off, speaker/headphones. Output: 60W RMS. HD: <0.5% at rated output. FR: 20Hz-20kHz \pm 1dB. Output impedance: 4-16 ohms. Mains: 100, 120, 220, 240V 50/60Hz. Finish: wood case with brushed aluminium panel and spun knobs. Size: $17\frac{1}{4} \times 6 \times 11\frac{1}{2}$ in. Price: on application.

■ ADMIRAL

Interconti Electronic Ltd, Albany House, Petty France, London, SW1H9EA. Tel: 01-222 2523. Telex: 918770.

ET500

AM/FM stereo tuner/amplifier. Special 'Crescendo' noise reduction system. Output: 43W RMS per channel. Full specification on request. Price: £160 (including PT).

■ AKAI

UK distributors: Rank Audio Products, PO Box 70, Great West Road, Brentford, Middx. Tel: 01-568 9222. Telex: 24408.

AA6600 ★

Stereo AM/FM. Range: FM 88-108MHz, AM 187-565 metres. Variable tuning. One signal strength meter, one centre zero tuning meter.

Sensitivity: FM $2\mu\text{V}$, AM $20\mu\text{V}$. Aerial input: 300 ohms balanced, 75 ohms coaxial. Stereo decoder fitted. AFC. FET front end. Integrated circuits incorporated. Inputs: mag PU 3mV, aux 200mV, tape monitor 200mV. Output: 35W RMS per channel. HD: 0.8% at rated output. FR: 20Hz-50kHz -3dB. Output impedance: 4-16 ohms. Mains: 100-240V AC. Size: $5\frac{1}{4} \times 17\frac{1}{2} \times 13\frac{3}{8}$ in. Four-way speaker outlets. Price: £124.09 (plus £21.17 PT).

AA6200 ★

AM/FM stereo tuner/amplifier. Range: FM 88-108MHz, MW 187-560 metres. Variable tuning. Meter tuning indicator. Sensitivity: (FM) 2.5 μV for 20dB quieting, (AM) $250\mu\text{V}$. Aerial input: 75 ohms coaxial and 300 ohms balanced. Stereo decoder fitted. FET and IC. Inputs: mag PU 3mV, aux 200mV, tape 200mV. Noise level: (mag PU) -60dB, (other inputs) -65dB. Controls: bass \pm 10dB, treble \pm 10dB, loudness +7dB at 100Hz, +4dB at 10kHz. Output: 15W RMS per channel into 4 ohms, 10W RMS per channel into 8 ohms. HD: 0.2% at 8W RMS into 8 ohms. FR: 20Hz-50kHz -3dB. Output impedance: 8 ohms. Mains: 100-240V AC. Size: $16\frac{3}{8} \times 5 \times 1$ in. Price: £82.94 (plus £14.15 PT).

AA6300

AM/FM stereo tuner/amplifier. Range: FM 88-108MHz, MW 187-560 metres. Variable tuning. Meter tuning indicator. Sensitivity: (FM) $2\mu\text{V}$ for 20dB quieting, (AM) $150\mu\text{V}$. Aerial input: 75 ohms coaxial and 300 ohms balanced. Stereo decoder fitted. FET and IC. Auto stereo switching. Inputs: mag PU 3mV, aux 150mV, tape 200mV. Noise level: (mag PU) -60dB, (other inputs) -70dB. Controls: bass \pm 10dB, treble \pm 10dB, Loudness +6dB at 100Hz, +6dB at 10kHz. Output: 20W RMS per channel. HD: 0.15% at 15W into 8 ohms. FR: 20Hz-40kHz -3dB at 8 ohms. Output impedance: 4, 8, 16 ohms. Speaker switching: A plus B, A or B. Mains: 100-240V AC. Size: $17\frac{1}{2} \times 5\frac{3}{8} \times 13\frac{1}{2}$ in. Price: £107.49 (plus £18.34 PT).

AA8500 ★

AM/FM stereo tuner/amplifier. Range: FM 88-108MHz, MW 187-560 metres. Variable tuning with special graphic scale. Two tuning meters. Sensitivity: (FM) $2\mu\text{V}$ for 20dB quieting, (AM) $100\mu\text{V}$. Aerial input: 75 ohms coaxial, 300 ohms balanced. Stereo decoder fitted. AFC. FET and IC. Inputs: mag PU 3mV 50K, aux 150mV 50K, mic 0.77mV 100K, tape 200mV 50K, tape 200mV 50K. Noise level: (mag PU) -70dB, (other inputs) -80dB. Controls: bass \pm 10dB, treble \pm 10dB, loudness +8dB at 100Hz, +4dB at 10kHz. Scratch filter -5dB at 10kHz. Rumble filter -9dB at 100Hz. Output: 85W RMS per channel into 4 ohms, 65W RMS per channel into 8 ohms. HD: 0.05% at 30W. FR: 20Hz-50kHz.

★ Indicates entry is illustrated

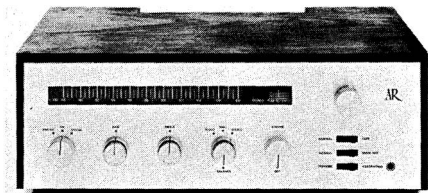

Acoustic Research tuner/amplifier

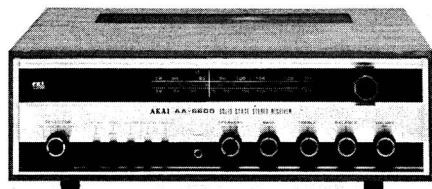

Akai AA6600



Akai AA6200

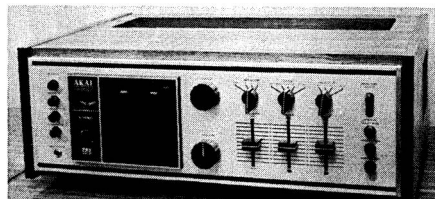

Akai AA8500

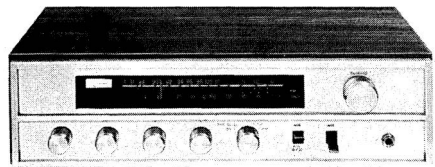

Alpha R150

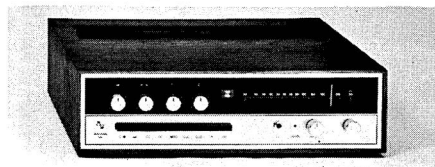

Armstrong Audio 525

Output impedance: 4, 8, 16 ohms. Mains: 100-240V AC. Size: $19\frac{1}{4} \times 7 \times 14\frac{1}{2}$ in. Slider balance and volume. Price: £195.06 (plus £33.28 PT).

■ ALBA (RADIO & TELEVISION) LTD

Tabernacle Street, London, EC2.

Tel: 01-253 1322 (6 lines).

UA100D

AM/FM stereo tuner/amplifier. Range: FM 87-108MHz, LW 1,100-1,900 metres, MW 183-570 metres, SW 5.7-19.2MHz. Variable tuning. Switchable AFC. Stereo decoder fitted. Automatic stereo beacon. Usable sensitivity: FM $2\mu\text{V}$ for 20dB quieting. Aerial input: FM 75 ohms coaxial, internal ferrite rod aerial for AM bands. Inputs: pickup 25mV 47K, tape 700mV 390K. Output: 15W RMS per channel into 8 ohms. Tape outlet: 300mV 330 ohms. Tone controls: bass $\pm 12\text{dB}$ at 70Hz, treble $\pm 12\text{dB}$ at 12kHz. HD: $<0.3\%$ at 15W. FR: 20Hz-20kHz $\pm 2\text{dB}$. Switchable quiet tuning. Finish: teak end panels. Size: $16 \times 6 \times 7$ in. Price: £76.75 (including PT).

■ ALPHA

Highgate Acoustics Ltd,

184-188 Great Portland Street, London, W1.

Tel: 01-636 2901.

R150 ★

Stereo tuner/amplifier. Range: 87-108MHz, 187-572 metres. Variable tuning. FM ratio detector. Meter tuning indicator. Sensitivity: $2\mu\text{V}$ for 20dB quieting. Aerial input: 300 ohm balanced. Stereo decoder fitted. AFC. Inputs: magnetic PU 3mV, crystal PU 250mV, aux 250mV. Output: 8W RMS per channel. HD: 0.5% at rated output. FR: 30Hz-30kHz. Output impedance: 8 ohms. Mains: 117, 220, 240V AC. Size: $15\frac{1}{4} \times 4\frac{1}{4} \times 10\frac{1}{2}$ in. Price: £51.69 (plus £8.29 PT).

R200

Stereo tuner/amplifier. Range: 87-108MHz, 187-572 metres. Variable tuning. FM ratio detector. Meter tuning indicator. Sensitivity: $3\mu\text{V}$ for 20dB quieting. Aerial input: 300 ohms balanced. Stereo decoder fitted. AFC. Inputs: magnetic PU 3mV, crystal PU 250mV, aux 250mV. Output: 10W per channel. HD: 0.5% at 10W. FR: 30Hz-30kHz. Output impedance: 8 ohms. Mains: 117, 220, 240V AC. Slider controls for bass, treble and volume. Size: $15\frac{1}{4} \times 4\frac{1}{4} \times 10\frac{1}{2}$ in. Price: £60.28 (plus £9.67 PT).

FR3000

AM/FM stereo tuner/amplifier. Range: FM 88-108MHz, MW 176-600 metres. Variable tuning. AFC. Balanced ratio detector. Meter tuning indicator. Usable sensitivity: AM $25\mu\text{V}$, FM $3\mu\text{V}$. Aerial input: 300 ohms balanced. Stereo decoder fitted. FET front end. Inputs:

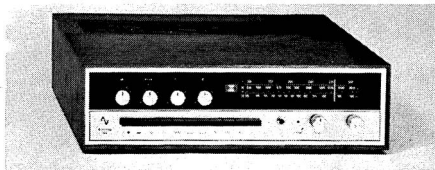

Armstrong Audio 526

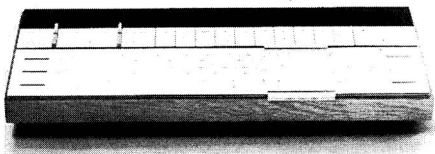

Bang & Olufsen Beomaster 1200

crystal PU 250mV 1M, mag PU 3mV 50K; aux 200mV 100K, tape 200mV 100K. Noise level: (mag PU) 60dB, (other inputs) 70dB. Output: 14W RMS per channel. Tone controls: bass slider ± 10 dB at 50Hz, treble slider ± 12 dB at 10kHz, loudness switch $+ 12$ dB at 50Hz and $+ 4$ dB at 10kHz. HD: 0.5% at 12W output. Output impedance: 8 ohms. FR: 20Hz-25kHz ± 3 dB at 12W. Mains: 110, 240V AC. Finish: teak with brushed aluminium. Size: $17 \times 12 \times 5\frac{1}{2}$ in. Price: £76.69 (plus £12.31 PT).

FR4000

AM/FM stereo tuner/amplifier. Range: FM 88-108MHz, MW 176-600 metres. Variable tuning. AFC. Balanced ratio detector. Meter tuning indicator. Usable sensitivity: AM 25 μ V, FM 2 μ V. Aerial input: 300 ohms balanced. 1C stereo decoder fitted. FET front end. Inputs: mag PU 3mV 50K (noise level 60dB), crystal PU 250mV 1M (noise level 70dB), aux 200mV 100K (noise level 70dB), tape 200mV 100K (noise level 70dB). Output: 18W RMS per channel. Output impedance: 8 ohms. Tone controls: treble ± 12 dB at 10kHz, bass ± 10 dB at 50Hz, loudness $+ 12$ dB at 50Hz and $+ 4$ dB at 10kHz. HD: 0.5% at 15W output. FR: 20Hz-30kHz ± 3 dB. Mains: 110, 240V AC. Finish: teak with brushed aluminium. Size: $17\frac{1}{4} \times 5\frac{1}{2} \times 12$ in. Price: £85.31 (plus £13.69 PT).

ARMSTRONG AUDIO LTD

Warlters Road, London, N7. Tel: 01-607 3213.

Model 525 ★

FM. Range: VHF 86-109 MHz. Variable tuning. Ratio detector. Meter tuning indicator. Sensitivity: 1.5 μ V for 30dB quieting. Aerial imped-

ance: 75 ohms coaxial and 300 ohms balanced. Plug-in stereo multiplex decoder optional extra (see Radio Tuner Section). Quiet-tuning control. Stereo indicator light. Inputs: PU(1) 60mV 100K, PU(2) 3.5mV 50K, tape play 400mV 100K. Noise level: PU - 55dB, tape - 70dB. Controls: balance (maximum to zero each channel), bass ± 10 dB, treble ± 10 dB, loudness (two volume levels with loudness contours at low level), rumble filter - 5dB at 30Hz, treble filter (1) 6.5kHz - 3dB, 10kHz - 25dB, treble filter (2) 4.5kHz - 3dB, 9kHz - 40dB. Output: 25W RMS per channel. Output impedance 4-16 ohms. HD $< 0.5\%$ at rated output. FR: 20Hz-20kHz - 1dB at 25W RMS. Transistorised. Mains: 100-125V and 200-250V AC. Size: $17 \times 10\frac{3}{4} \times 5\frac{1}{2}$ in. Price: £77 (plus £13.14 PT).

Model 526 ★

AM/FM. Range: VHF 86-109MHz, MW 185-590 metres, LW 1,000-2,000 metres. Variable tuning. FM ratio detector. Meter tuning indicator. Sensitivity: 1.5 μ V for 30dB quieting on VHF, 5 μ V for 20dB quieting on AM. Aerial impedance: 75 ohms coaxial and 300 ohms balanced. Plug-in stereo multiplex decoder optional extra (see Radio Tuner Section). FM quiet-tuning control. Stereo indicator light. Inputs: PU(1) 60mV 100K, PU(2) 3.5mV 50K, tape play 400mV 100K. Noise level: PU - 55dB, tape - 70dB. Controls: balance (maximum to zero each channel), bass ± 10 dB, treble ± 10 dB, loudness (two volume levels with loudness contours at low level), rumble filter - 5dB at 30Hz. Treble filter (1) 6.5kHz - 3dB, 10kHz - 25dB, treble filter (2) 4.5kHz - 3dB, 9kHz - 40dB. Output: 25W RMS per channel. Output impedance: 4-16 ohms. HD: $< 0.5\%$ at rated output. FR: 20Hz-20kHz - 1dB at 25W RMS. Transistorised. Mains: 100-125V and 200-250V AC. Size: $17 \times 10\frac{3}{4} \times 4\frac{1}{2}$ in. Price: £85.75 (plus £14.97 PT).

■ BANG & OLUFSEN UK LTD

Eastbrook Road, Gloucester, GL47DE.

Tel: Gloucester 21591.

Beomaster 1200 ★

Stereo, transistorised, 15W per channel. Ranges: 87.5-104MHz, 184-578 metres, 857-2,040 metres. Variable tuning plus 3 FM presets. Lamp indicator. Sensitivity: 1.5 μ V for 26dB S/N on FM. Ratio detector. Decoder fitted. Switched AFC. Aerial: 75 ohms IEC. FR ($\pm 1\frac{1}{2}$ dB): 20Hz-40 kHz. HD: less than 1% at 2×15 W; N level - 65 dB. Inputs: switched PU, magnetic 4mV 47K and crystal 200mV 470K, tape 200mV 470K. Outputs: tape 100mV 100K, headphones 100 ohms nominal, speakers 4 ohms. Controls: wide cursor tuning, slider volume and tone, bass, treble. Features include: use of FETs, speaker's/c proof, built-in tilt bracket. Mains: 110, 130, 220, 240V

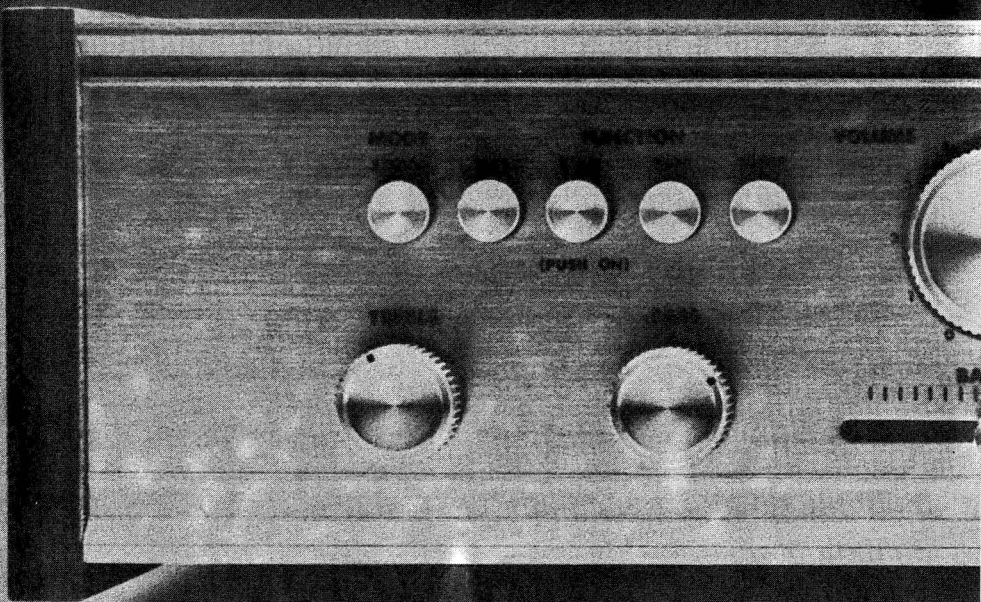

Maybe you can afford a better amplifier than you thought.

There's one big problem with hi-fi.

As your ear becomes educated, run-of-the-mill equipment just won't do anymore.

40-18,000 Hz no longer sounds impressive.

4 or 5 watts per channel becomes 4 or 5 times too little.

Meanwhile, your income doesn't develop as noticeably as your ear.

And unless you've kept an eye open for new developments—like Eagle's AA4 amplifier—you can find yourself stuck.

At £48, the new AA4 turns in a better performance than amps costing £10, £15 or £20 more.

20 watts per channel RMS, with exceptionally low distortion. 20-36,000 Hz \pm 2dB. Scratch and rumble filters. Go on, compare the full specifications.

You don't buy advanced performance at the expense of reliability or looks either.

At maximum output, for instance, the AA4's transistors are running at 50% of their maximum capacity. That way they last longer.

And the teak cabinet and brushed silver fascia look beautiful. With clean, crisp controls that are a pleasure to push, turn and click.



Your Eagle dealer can show you the AA4 right now. (Together with the AA18, our new turntable, and the AA14, our new speakers.)

While you're there, you might also ask to see the AA8, our new AM/FM/MPX stereo tuner.



It has an FET front end, noise filter and interstation muting. And though it can be used with any amplifier, it's specially designed to go with the AA4, for which it's a perfect match in terms of looks, performance and reliability.

Alternatively, please write to us for details of all this equipment.

Maybe you'll find a better amplifier isn't all you can afford.

Eagle International 

Eagle International Precision Centre Heather Park Drive
Wembley HA0 1SU Telephone 01-903.0144

★ Indicates entry is illustrated

50/60 Hz. Dimensions: 21.4×8.1×3.1in. Price: (teak) £99.50; (rosewood or white) £100.50 (including PT).

Beomaster 1600M ★

Stereo, transistorised. 15W per channel. Ranges: 87.5-104MHz, 16-49 metres, 66.6-200 metres, 188-578 metres, 857-2,040 metres. Variable tuning plus 4 FM presets. Meter indicator. Sensitivity: 2µV for 26dB quieting on FM. Decoder fitted. Ratio detector. Switched AFC. Aerial: 75 ohms IEC. FR: (±1dB): 30Hz-25kHz. HD: less than 1% at 2×15W; N level better than 50dB. Inputs: magnetic PU 4mV 47K, tape 200mV 500K. Output impedance: 4 ohms. Controls: sliders for volume, bass and treble; balance, wavebands and presets, mono/stereo mode, speakers, ext aerial and AFC. Features include: FETs and ceramic filters. Mains: 110, 130, 220, 240V 50/60Hz. Dimensions: 16½×9⅝×4⅜in. Price: (teak) £129.50; (rosewood) £130.50 (including PT).

Beomaster 3000

Stereo, transistorised. 40W per channel. Range: 87.5-108MHz. Variable tuning plus 6 presets. Meter indicator and two illuminated panels. Decoder fitted. Ratio detector. Switched AFC. Aerial: IEC sockets for 75 ohms and 240 ohms. FR (±1dB): 40Hz-20kHz. HD: 0.3%; N level -65dB. Inputs: magnetic PU variable 1.5-100 mV 47K, crystal/ceramic variable 200mV-3V 1M, tape variable 200mV-3V 1M. Controls: tuning and presets, volume, balance, mono L, mono R, speakers pair 1, speakers pair 2, low filter (80Hz 12dB octave), high filter (4kHz 12dB per octave), bass ±17dB at 50Hz, treble ±14dB at 10kHz. Features include: FETs, ceramic filters, integrated circuits, special tuning device, variable input sensitivities, slider controls. Mains: 110, 130, 220, 240V 50/60Hz. Dimensions: 22½×10¼×3¾in. Prices: (teak) £149.50; (rosewood) £150.50 (including PT).

■ BRYAN AMPLIFIERS LTD

18 Greenacres Road, Oldham, Lancs.
Tel: 061-624 4074.

6000

Solid state stereo tuner/amplifier. Range: 88.5-108MHz. Variable tuning with meter indication. FM ratio detector. Sensitivity: 2µV. Aerial impedance: 80 ohms coaxial. Output voltage: 150mV at 30% modulation. Multiplex decoder fitted. AFC. Power output: 20W per channel RMS, 4-15 ohms. HD: 0.25%. FR: 35Hz-33kHz at 1W ±1dB. Feedback: -60dB. Inputs: magnetic pickup, 3mV 50K, noise level -60 to 70dB; ceramic pickup, 40mV 100K, noise level -52 to 60dB; radio, tape and aux, 75mV 50K, -60 to 70dB. Controls: volume and on/off; balance; bass; treble; selector; mode; monitor;

rumble filter. Psn mains. Dimensions: 17¼×12×5¾in. Price: £82.36 (plus £13.69 PT).

■ DUAL

International Audio Ltd, Clive House,
Queens Road, Weybridge, Surrey.
Tel: Weybridge 40125/6. Telex: 928153.

CR50

AM/FM stereo tuner/amplifier. Range: LW, MW, SW1, SW2 and VHF. Aerial input: 240 ohms balanced. Sensitivity: (stereo) 8µV, (mono) 1.5µV. Stereo decoder fitted. Stereo beacon. Automatic stereo switching. Five preset tuning buttons plus variable tuning. Tuning meter. Output: 18W RMS per channel into 4 ohms. FR: 20Hz-40kHz ±0.6dB. HD: <0.3% at 1kHz at 18W. Inputs: magnetic PU, ceramic PU, tape. Size: 16½×4½×11¼in. Price: £155 (including PT).

■ DUETTE

Distributors: J. J. Silber Ltd,
11 Northburgh Street, London, EC1.
Tel: 01-253 8031.

SAT260 ★

Stereo tuner/amplifier. Range: 88-108MHz, 187-560 metres. Variable tuning. AFC. Foster-Seeley discriminator. Meter tuning indicator. Sensitivity: FM 3.5µV, AM 10µV. Aerial impedance: 80 ohms. Stereo decoder fitted. Output: 12W RMS per channel. HD: <1% at rated output. FR: 20Hz-25kHz ±0.5dB. Noise level: 55dB. Inputs: mag PU 3mV, crystal PU 50mV, aux 200mV, tape 200mV. Output impedance: 4, 8, 16 ohms. Size: 3⅞×14½×11in. Mains: 240V AC. Price: £76.06 (including PT).

SAT460

Stereo tuner/amplifier. Range: 88-108MHz, 187-560 metres. Variable tuning. AFC. Foster-Seeley discriminator. Meter tuning indicator. Sensitivity: FM 2µV for 20dB quieting, AM 10µV for 10dB quieting. Aerial impedance: 80 ohms. Stereo decoder fitted. Output: 12W RMS per channel. HD: <1% at rated output. FR: 20Hz-25kHz ±0.5dB. Noise level: -55dB. Inputs: mag PU 3mV, tape 200mV, aux 200mV. Output impedance: 4, 8, 16 ohms. Size: 4½×16¼×11½in. Mains: 240V AC. Price: £99.87 (including PT).

■ DYNATRON RADIO LTD

St Peters Road, Maidenhead, Berks, SL67QY.
Tel: Maidenhead 23331.

TVR26 ★

Stereo transistorised AM/FM tuner/amplifier. Ranges: 87-108MHz, MW 185-570 metres, LW 1,100-2,000 metres. Variable tuning. Ratio detector. Meter tuning indicator. Sensitivity: 5µV for 20dB quieting. Aerial input VHF: 75 ohms coaxial. Stereo decoder fitted. AFC. Output: 8W

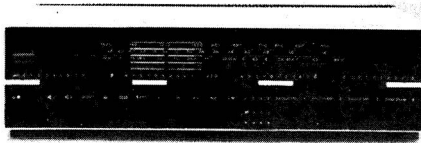

Bang & Olufsen Beomaster 1600



Duette SAT260

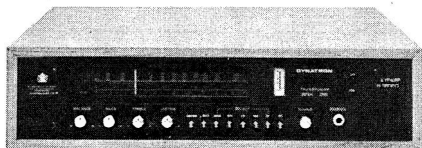

Dynatron TVR26

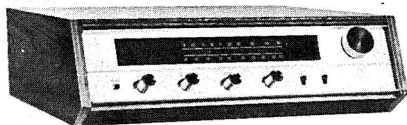

Eagle SMC20



Eagle SMC60

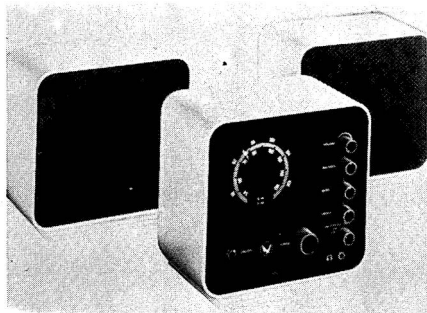

Eagle SC720

per channel at less than 1% distortion. FR: (± 3 dB) 40Hz-16kHz at $\frac{1}{2}$ W. Noise level -90dB. Output impedances: speakers 4 ohms, earphones 8 ohms or greater. Inputs: tape 35mV 20K, noise level -70dB; crystal PU 75mV 100K (special correction), noise level -60dB; magnetic PU 5mV, noise level -60dB. Controls: tuning, balance, input selector, bass, treble, volume, loudness, AFC, filter, on/off. Size: 19 x 14 x 5 $\frac{1}{2}$ in. Mains: 240V AC only. Price: £87 (including PT).

■ EAGLE INTERNATIONAL

Heather Park Drive, Wembley, HAI 1SU.
Tel: 01-903 0144.

SMC10

Stereo tuner/amplifier. Range: FM 88-108MHz, MW 187-560 metres. Stereo decoder fitted. Output: 3.5W per channel. FR: 30Hz-18kHz. S/N better than 50dB. Inputs: PU 250mV, tape 300mV. Size: 6 $\frac{1}{4}$ x 15 x 9 $\frac{3}{8}$ in. Price: £24.85 (plus £4.21 PT).

SMC20 ★

Stereo tuner/amplifier. Range: FM 88-108MHz, MW 187-560 metres. Stereo decoder fitted. Output: 5W RMS per channel. FR: 25Hz-20kHz. S/N better than 55dB. Inputs: PU 250mV, tape 300mV. Designed to accommodate Garrard 20 Series gram unit which drops into optional cut-out in top of cabinet. Size: 5 $\frac{1}{8}$ x 16 $\frac{1}{2}$ x 15 $\frac{3}{8}$ in. Price: £41.02 (plus £6.90 PT).

SMC60 ★

Stereo tuner/amplifier. Range: FM 88-108MHz, MW 187-560 metres. Stereo decoder fitted. Output: 15W RMS per channel. FR: 25Hz-25kHz. S/N better than 55dB. Inputs: mag PU 3mV, tape 300mV. Designed to accommodate Garrard gram unit which drops into optional cut-out in top of cabinet. Size: 5 $\frac{1}{8}$ x 16 $\frac{1}{2}$ x 15 $\frac{3}{8}$ in. Price: £57.98 (plus £9.77 PT).

SC720 ★

AM/FM stereo tuner/amplifier with two separate speakers. Range: FM 88-108MHz, MW 186-578 metres. Variable tuning with AFC. Usable sensitivity: FM 12 μ V, AM 200 μ V. Aerial input: 75 ohm coaxial, or balanced. Stereo decoder included, with automatic beacon. Mains: 240V AC. Size: 9 $\frac{1}{2}$ x 9 $\frac{5}{8}$ x 6 $\frac{3}{8}$ in. Finish: matt white moulded cases, black facia with dial illuminated in green. Price: £53.29 (plus £8.92 PT).

■ FISHER

UK Distributors: REW Audio Visual Ltd, 266-268 Upper Tooting Road, London, SW17. Tel: 01-672 4471/2 and 9175.

Details of new range of Fisher hi-fi equipment not available as this edition of the Year Book closed for press.

★ Indicates entry is illustrated

GOODMANS LOUDSPEAKERS LTD

Downley Road, Havant, Hampshire, PO92NL.
Tel: Havant 6344. Telex: 86296.

Module 80 ★

FM stereo tuner/amplifier. Range: 87-108MHz. Variable tuning with switchable AFC. Tuning indicator. Stereo decoder fitted. Automatic stereo beacon. Aerial input: 240-300 ohms balanced. Inputs: magnetic PU 2mV 50K, aux and crystal PU 60mV 600K, tape play 320mV 50K. Controls: mains on/off and speaker selector, balance, treble +10dB -17dB at 10kHz, bass +13dB at 50Hz, volume, HF filter -11dB at 16kHz, LF filter -11dB at 25Hz, loudness +11dB at 50Hz and +6dB at 10kHz (with volume control retarded 30dB), left/right reverse, stereo/mono, tape play and monitor, tuning, input selector buttons, AFC, on/off. Output: 35W RMS per channel into 4 ohms. HD: <0.1% at 30W per channel. FR: 30Hz-20kHz $\pm 1\frac{1}{2}$ dB. Damping factor: (4 ohm load) 40; (8 ohm load) 80; (15 ohm load) 150. Socket for stereo phones. DIN sockets for two sets of speakers. AC mains outlet socket. H and N: 80dB below 35W on tape/aux input, 66dB below 35W on magnetic PU input. Crosstalk between channels: better than 45dB 40Hz-13kHz. FM radio sensitivity: better than 1.5 μ V for 26dB S/N. Pilot tone rejection: -36dB at 19kHz and 38kHz (ref 0dB at 67kHz deviation). 68 semi-conductors (including two FETs). Size: 22 \times 3 $\frac{3}{4}$ \times 11 $\frac{3}{4}$ in. Mains: 120V, 220V or 240V AC. Consumption: 150W maximum. Price: £89.02 (including PT).

Model One Ten ★

AM/FM stereo tuner/amplifier. Range: FM 87.5-108MHz, MW 187-570 metres, LW 1,130-2,000 metres, SW 48-51 metres. Variable tuning. Switched AFC. Signal strength meter. Aerial input: 75 ohms coaxial, 240 ohms balanced. Usable sensitivity: (FM 75 ohms) 1 μ V; (FM 240ohms) 2 μ V; AM typically 20-40 μ V. Ceramic filters in IF amplifier. Quiet tuning facility on FM. 89 semiconductors. Inputs: mag PU 2-5mV 56K, ceramic PU 200mV 1 megohm, tape play 200mV 100K. Noise level: mag PU -70dB, other inputs -80dB. Overload capability: +30dB. Output: 50W RMS into 4 ohms. Controls: balance, bass, treble, volume, contour, plus 17 tabs for all functions. HD: <0.01% at 30W, <0.1% at any power up to maximum. FR: 15Hz-45kHz ± 3 dB, 20Hz-20kHz ± 1 dB. Mains: 115-125V, 200-250V AC. Size: 23 \times 5 $\frac{3}{8}$ \times 12in. Finish: teak or walnut with brushed aluminium facia, or black and white with white controls and black facia. Electronic protection of output stages. Price: (with tuner) £112.30 (plus £18.92 PT).

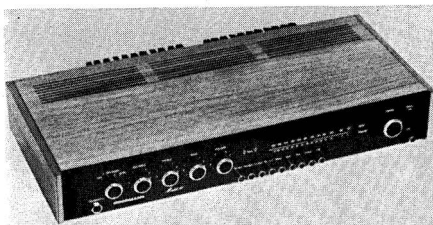

Goodmans Module 80

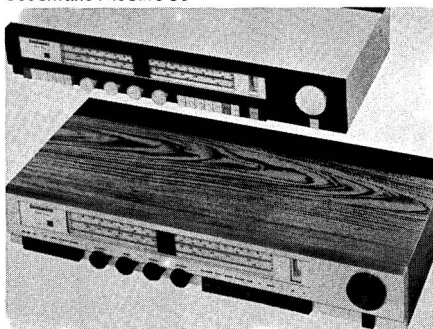

Goodmans Model One Ten

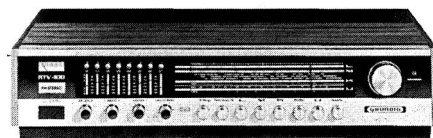

Grundig RTV400

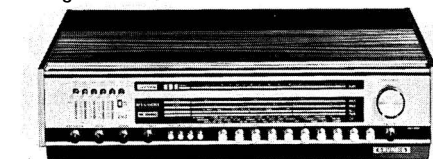

Grundig RT650



Harman-Kardon 330A



Harman-Kardon

GRUNDIG (Great Britain) LTD

Hi-Fi Division, Sydenham, London, SE26.
Tel: 01-778 2211.

RTV400 ★

Transistorised stereo tuner/amplifier. 43 transistors, 37 diodes. Range: VHF 87.5-108MHz, LW 680-2,050 metres, MW 185-587 metres, SW 18.5-55.6 metres. Eight FM station pre-selectors. Output: 20W RMS per channel. Output impedance: 4-16 ohms. HD: 0.5% at rated output. FR: (audio stages) 40Hz-16kHz ± 1.5 dB. Stereo decoder fitted. Automatic stereo switching. Stereo beacon. Aerials: internal ferrite rod for AM, FM dipole 240 ohms. Sensitivity: FM 2 μ V MW 15 μ V, SW 3-5 μ V. IFs: 460kHz and 10.7MHz. AFC. Stereo separation: >35dB at 1kHz. Inputs: mag PU 3mV 47K, crystal PU 200mV, tape 200mV. Noise level: (tape socket) -80dB, (mag PU socket) -55dB. Bass control: -20dB +13dB at 40Hz. Treble control: -15dB +13dB at 16kHz. Balance control: +3dB -10dB. Automatic overload cut-out. Size: 4 $\frac{3}{4}$ x 22 x 11in. Price: £165.30 (including PT).

RTV650 ★

Transistorised stereo. Ranges: VHF 87.5-108MHz, LW 680-2,050 metres, MW 185-587 metres, SW1 34-99 metres, SW2 13.5-35 metres, SW fine tuning ± 60 kHz of SW bands. Sensitivity: FM 1.4 μ V, AM (MW) 6.5 μ V. IFs: 460kHz and 10.7MHz. AFC. Noise level: -73dB at 40kHz deviation. Distortion factor: <0.5%. FR: 40Hz-15kHz ± 2 dB. Stereo decoder with automatic switching and stereo beacon. Separation: better than 40dB at 2kHz. Aerials: internal ferrite rod, FM dipole 240 ohms. 3kHz and 5kHz treble filters. Output: 20W RMS per channel. FR: (audio stages) 20Hz-20kHz ± 1.5 dB. Inputs: mag PU 3mV 47K, tape 200mV 470K. Output impedance: 4-16 ohms. Automatic overload cut-out. Bass control: -20dB +15dB at 20Hz. Treble control: -20dB +15dB at 20kHz. Mains: 110, 130, 220, 240V 50-60Hz. Consumption (no load): 30W. Size: 24 x 6 x 12in. Price: £227.35 (including PT).

HARMAN-KARDON

Highbate Acoustics Ltd,
184 Great Portland Street, London, W1.
Tel: 01-636 2901.

330A ★

AM/FM stereo tuner/amplifier. Range: FM 88-108MHz, MW 175-600 metres. Variable tuning. AFC. Ratio detector. Meter tuning indicator. Usable sensitivity: MW 25 μ V, FM 1.9 μ V. Aerial input: 300 ohms balanced, 75 ohms coaxial. Stereo decoder included. Inputs: mag PU 1.9mV 47K, aux 300mV 20K. S/N ratio: PU 65dB. Overload capability: (PU) 90mV. Output: 22.5W RMS per channel. Tone

controls: (independent bass and treble controls for each channel) bass ± 12 dB, treble ± 12 dB, contour +8dB at 50Hz. HD: 0.2% at 20W. Output impedance: 8 ohms. FR: 7Hz-50kHz ± 1 dB at 20W. Mains: 110, 240V AC. Finish: black cabinet with brushed aluminium trim, walnut sleeve optional extra. Price: £111.16 (plus £17.84 PT).

630EX ★

AM/FM stereo tuner/amplifier. Range: FM 88-108MHz, MW 175-600 metres. Variable tuning. AFC. Ratio detector. Meter tuning indicator. Usable sensitivity: MW 15 μ V, FM 1.9 μ V. Aerial input: 300 ohms balanced, 75 ohms coaxial. Stereo decoder included. Inputs: mag PU 1.5mV 47K, aux 1 300mV 20K, aux 2 300mV 20K. Noise level: PU input 65dB, aux inputs 85dB. Output: 30W RMS per channel. Tone controls: (independent bass and treble controls for left and right channels) bass ± 12 dB, treble ± 12 dB, contour +8dB at 50Hz, high cut filter -8dB at 10kHz (6dB/octave). HD: 0.2% at 30W. Output impedance: 8 ohms. FR: 4Hz-70kHz ± 0.5 dB. Mains: 110, 240V AC. Size: 12 x 4 $\frac{3}{4}$ x 13 $\frac{3}{4}$ in. Finish: black case with brushed aluminium trim, walnut sleeve optional extra. External Dolby B input/output equalisation. Quiet tuning facility on FM. Price: £128.39 (plus £20.61 PT).

930EX

AM/FM stereo tuner/amplifier. Range: FM 88-108MHz, MW 175-600 metres. Variable tuning. AFC. Ratio detector. Tuning indicators: FM centre-zero meter, AM/FM signal strength meter. Usable sensitivity: MW 15 μ V, FM 1.8 μ V. Aerial input: 300 ohms balanced, 75 ohms coaxial. Stereo decoder included. Quiet tuning facility on FM. FET front end. Rotating AM ferrite rod aerial. Inputs: mag PU (1) 1.5mV 47K, mag PU (2) 1.5mV 47K, aux (1) 300mV 20K, aux (2) 300mV 20K. Noise level: PU inputs 65dB, aux inputs 85dB. Overload capability: (PU inputs) 90mV. Output: 45W RMS per channel. Tone controls: (independent bass and treble controls for each channel) bass ± 12 dB, treble ± 12 dB, high cut filter -8dB at 10kHz (6dB/octave), low cut filter -15dB at 25Hz, contour +8dB at 50Hz. HD: 0.2% at 45W. Output impedance: 8 ohms. FR: 3Hz-100kHz. Separate power supply for left and right channels. Size: 17 x 4 $\frac{3}{4}$ x 13 $\frac{3}{4}$ in. Mains: 110, 240V AC. Finish: black case with brushed aluminium trim, walnut sleeve optional extra. Price: £180.10 (plus £28.90 PT).

HECO

Distributors: Acoustico Enterprises Ltd,
6-8 Union Street, Kingston-upon-Thames,
Surrey. Tel: 01-549 3471/3.

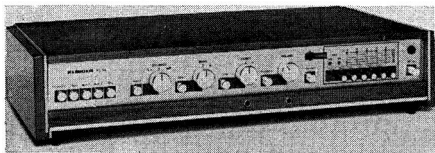

Klinger KC96

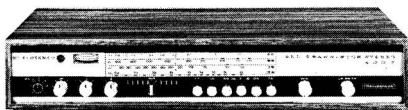

Korting Stereo 400T

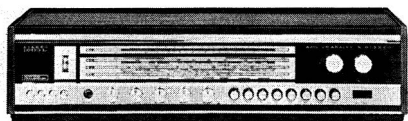

Korting Stereo 1000L

■ Heco 90

Stereo tuner/amplifier. Range: 87.5-108MHz. Three preset tuning buttons. Switchable AFC. Ratio detector. Sensitivity: $5\mu\text{V}$ for 30dB S/N. Aerial input: 240 ohms balanced. Stereo decoder fitted. Inputs: magnetic PU 2.4mV 47K, ceramic PU 200mV, radio 250mV 100K, tape 250mV 100K. Tone controls: bass $\pm 14\text{dB}$ at 30Hz, treble $\pm 16\text{dB}$ at 20kHz. Output: 30W RMS per channel. Mains: 110-220V 50/60Hz. Size: $16\frac{1}{4} \times 4\frac{3}{8} \times 10\frac{3}{8}$ in. Price: on application.

■ KLINGER

Klinger Controls Ltd, Spencer Court, 7 Chalcot Road, London, NW18LU. Tel: 01-586 2922/3.

★ KC96

FM stereo tuner/amplifier. Range: 87.5-108MHz. Five preset stations. Switchable AFC. Usable sensitivity: $2\mu\text{V}$. Aerial input: balanced and coaxial. Stereo decoder fitted. Circuit comprises 37 transistors, 40 diodes and one IC. Inputs: mag PU 2mV 47K, tape 50mV 220K, aux 1 100mV 470K, aux 2 0.15mV 30 ohms. Noise level: (mag PU) 60dB, (other inputs) 70dB. Overload capability: 30dB. Output: 25W RMS per channel. Output impedance: 8 ohms. Tone controls: bass $\pm 15\text{dB}$, treble $\pm 15\text{dB}$, scratch filter 18dB/octave from 8kHz, rumble filter 12dB/octave from 80Hz. Full range balance control. HD: 0.1% at 20W. FR: 35Hz-



Leak Delta 75



Lux FQ990

35kHz $\pm 2\text{dB}$ at 20W. Stabilised power supply. Two pairs of switched speaker sockets. Two outlets for stereo headphones. Direct and switched mains outlets. Finish: teak with die-cast enamelled sides. Size: $21 \times 4\frac{1}{2} \times 8$ in. Price: £82.20 (plus £13.30 PT).

■ KORTING

Distributors: Europa Electronics Ltd, Howard Place, Shelton, Stoke-on-Trent, ST1 4NW. Tel: Stoke-on-Trent 29316.

★ Stereo 400T, Type 30476

Stereo. Natural walnut colour cabinet with satin finish. Ranges: SW, MW, LW, VHF/FM. Tuning indicator. Compensated detector/amplifier. FM sensitivity: $3\mu\text{V}$, band width approximately 140kHz. Ferrite aerial for AM. Multiplex decoder with indicator. AFC. 23 transistors, 11 diodes and one rectifier. Output: 8W per channel. Controls: bass, treble, balance and push-button waveband selection. Sockets for aerials, earth, magnetic pickup, tape recorder (and crystal pickup), speakers. Size: $22 \times 4\frac{1}{2} \times 7$ in. Price: £75 (including PT).

★ Stereo 700, Type 29478

Stereo. Natural walnut, satin finish cabinet. Ranges: SW, MW, LW, VHF/FM. Tuning indicator. Sensitivity: FM $1.5\mu\text{V}$, AM $10\mu\text{V}$. Ferrite aerial for MW and LW. Multiplex decoder with automatic indicator. AFC. 35 tran-

sistors, 15 diodes and one rectifier. Controls: bass, treble, balance, pushbutton waveband selection. Output: 10W per channel. Sockets for aerials, earth, crystal, ceramic and magnetic pickup, tape recorder, speakers and headphones. Dimensions: $6 \times 25 \times 9\frac{1}{2}$ in. Price: £117 (including PT).

Stereo 1000L, Type 29480 ★

Stereo. Natural walnut cabinet with satin finish. Ranges: SW, MW, LW and VHF/FM. Tuning indicator. Sensitivity: FM $1.5\mu\text{V}$, AM $10\mu\text{V}$. Ferrite aerial for MW and LW. Multiplex decoder with automatic indicator. AFC. 39 transistors, 16 diodes and two rectifiers. Output: 25W per channel. Controls: treble, bass, balance, pushbutton wave-change. Sockets for aerials, earth, magnetic, crystal or ceramic pickup; tape recorder, earphone, speakers. Dimensions: $25 \times 6 \times 9\frac{1}{2}$ in. Price: £130 (including PT).

■ KOYO

Distributors: Kingsway Mills Ltd,
5 Worship Street, London, EC2.
Tel: 01-628 6157.

FS-900

AM/FM stereo tuner/amplifier. Range: FM 88-108MHz, MW 187-556 metres. Variable tuning. AFC. Inputs: pickup jack socket, tape recorder socket. Sensitivity: FM $3\mu\text{V}$, AM $100\mu\text{V}$. Output: 10W per channel. Stereo decoder included, with beacon. Slide rule tuning scale. Slider controls for bass, treble, volume and balance. Size: $17\frac{3}{8} \times 4\frac{3}{8} \times 9\frac{3}{8}$ in. Finish: walnut end panels with leather finish top. AC mains. 29 transistors, 1 diodes. Price: to be announced.

■ LEAK

H. J. Leak & Co Ltd, Bradford Road, Idle,
Bradford, Yorks. Tel: Bradford 612552.
Telex: 51407.

Delta 75 ★

AM/FM solid state tuner/amplifier. Range: FM 87.5-108MHz; MW 187-556 metres. Variable tuning. Aux tape (2). Inputs: tape and aux 100mV 50K, mag PU 3.5mV, ceramic PU 20mV 33K. Stereo beacon. Controls: waveband selectors, tuning, volume, on/off, balance, treble, bass, pushbuttons for filter, loudness, tape, aux, disc, radio, mono, quasi stereo, mute and AFC. Output: 35W RMS into 8 ohms, 40W RMS into 4 ohms. HD: (8 ohms) less than 0.07%, (4 ohms) <0.14%, (15 ohms) <0.05%. FM: stereo crosstalk better than 35dB at 1kHz. Headphone socket. Will drive two pairs of speakers. Finish: teak or walnut. Size $16\frac{3}{8} \times 4\frac{3}{8} \times 12\frac{1}{4}$ in. Price: £134.74 (plus £25.26 PT).

■ LUX

Distributors: Howland-West Ltd,
3/5 Eden Grove, London, N78EQ.
Tel: 01-609 0293/4/5.

FQ990 ★

AM/FM stereo tuner/amplifier. Range: FM 87.5-108.5MHz, MW 187-572 metres. Variable tuning plus preset stations on FM. AFC. Centre-zero tuning meter. Usable sensitivity: FM $2\mu\text{V}$, MW $18\mu\text{V}$. Aerial input: 75 ohms coaxial, 300 ohms balanced. Stereo decoder included. Inputs: mag PU 2mV 50K, PU (2) 10mV 50K, aux 100mV 100K, tape 100mV 100K, tape head ($3\frac{3}{4}$ /s) 1.8mV 100K, tape head ($7\frac{1}{2}$ /s) 2mV 100K. Noise level: PU inputs -60dB, tape head inputs -55dB, aux input -75dB. Overload capability: mag PU and tape head 130mV, aux 5V. Controls: mode switch, tape monitor, noise level, volume, loudness, main or remote speakers, slope selector bass, slope selector treble, three FM preset buttons. HD: 0.1%. Output: 70W RMS per channel. Output impedance: 8 ohms. FR: 10Hz-40kHz. Size: $18\frac{1}{2} \times 13\frac{1}{2} \times 6$ in. Price: £238 (plus £39.57 PT).

■ LUXOR (Luxor Industri Aktiebolag)

Highgate Acoustics Ltd,
184 Great Portland Street, London, W1.
Tel: 01-636 2901.

Luxor 3411-FM

FM tuner/amplifier. Range: FM 87-104.5MHz. Five preset stations. AFC. Ratio detector. Meter tuning indicator. Usable sensitivity: $3\mu\text{V}$. Aerial input: 120 ohms coaxial, 240 ohms balanced. Stereo decoder optional extra. 28 transistors. Inputs: mag PU 4mV 47K, crystal PU 150mV 1.8M, tape (high) 70mV 47K, tape (low) 250mV 47K. Output: 15W RMS per channel. Output impedance: 4 ohms. Controls: volume, bass and treble, plus pushbuttons for contour, mono/stereo, headphones, function, AFC. HD: 0.4% at 15W. FR: 30Hz-25kHz ± 1.5 dB. Mains: 120, 220, 240V AC. Size: $20\frac{1}{8} \times 3\frac{1}{8} \times 10\frac{1}{4}$ in. Finish: teak, rosewood or black, with brushed aluminium trim. Price: £76.69 (plus £12.31 PT).

Luxor 3412

FM tuner/amplifier. Range: 87-107MHz. Six preset stations. Ratio detector. Meter tuning indicator. Usable sensitivity: $2\mu\text{V}$. Aerial input: 120 ohms coaxial, 240 ohms balanced. Inputs: mag PU 4mV 47K, crystal PU 130mV 1M, tape (high) 65mV 400K, tape (low) 350mV 400K, microphone 3mV 40K, aux 250mV 100K. H and N: mag PU and tape inputs 56dB, other inputs 60dB. Output: 30W RMS per channel. Output impedance: 4 ohms. 24 transistors in amplifier. Controls: separate right- and left-channel volume control sliders, bass slider

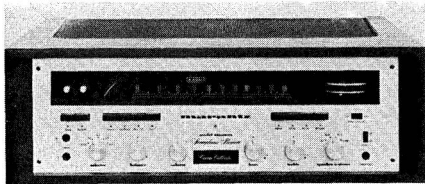

Marantz 19

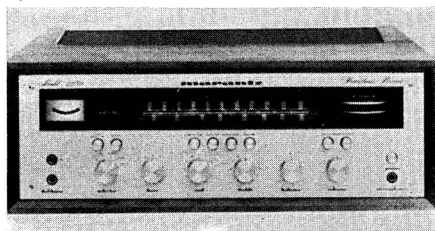

Marantz 2230

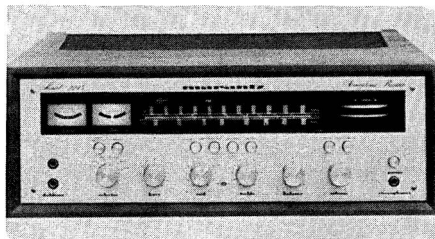

Marantz 2245

±18dB at 50Hz, treble slider ±16dB at 20kHz, rumble filter -12dB at 20Hz, scratch filter -20dB at 20kHz, mid-range cut switch, push-button speaker switches, pushbutton headphone switch. HD: 0.5% at 30W RMS. FR: 20Hz-20kHz ±1.5dB. Two VU meters indicating output level of each channel. Mains: 120, 220, 240V AC. Size: 25×4 $\frac{3}{8}$ ×10 $\frac{5}{8}$ in. Finish: teak, rosewood or black, with chrome trim. Each preset tuning button incorporates window indicating frequency tuned. Price: £124.95 (plus £20.05 PT).

■ MARANTZ

Pysier-Britex (Swift) Ltd,
Fircroft Way, Edenbridge, Kent.
Tel: Edenbridge (0732-71) 2434/6.

Model 19 ★

Stereo FM tuner/amplifier. Range: 88-108MHz. Variable tuning with gyro control. Oscilloscope tuning indicator. Sensitivity: (IHF) 1.8µV or better. Separation: 40dB at 20Hz, 30dB at 15kHz. Capture ratio: 3.5dB. HD: 0.15%. 19kHz and 38kHz suppression: better than 60dB. Aerial impedance: 300 ohms balanced, 75 ohms coaxial. Inputs: PU 1mV 47K, aux

100mV 100K. Output: 50W RMS per channel into 8 ohms, 30W per channel into 16 ohms. HD: <0.15% (typically <0.06%). FR: 20Hz-20kHz±0.5dB. Tone controls: bass ±10dB at 100Hz, treble ±10dB at 10kHz. High filter: 12dB/octave at 7kHz. Low filter: 12dB/octave at 70Hz. Mains: 220V AC. Size: 18 $\frac{1}{4}$ ×5 $\frac{3}{8}$ ×16in. Weight: 46lb. Finish: walnut. Price: £686 (plus £114 PT).

Model 2215

Stereo AM/FM tuner/amplifier. FM 88-108MHz, MW 187-555 metres. Variable tuning. Ratio detector. Tuning meter. Usable sensitivity: AM 26µV, FM 2.0µV for 30dB quieting. Aerial input: 300 ohms balanced, 75 ohms coaxial. Stereo decoder included. 56 transistors and one IC. Inputs: PU 2.1mV 47K, mic 2.1mV, aux 150mV. Output: 15W RMS per channel (both channels driven) into 8 ohms. Tone controls: bass ±12dB at 50Hz, treble ±12dB at 15kHz. HD: 0.3% 20Hz-20kHz. Size: 16 $\frac{7}{8}$ ×5×14in. Gold anodised front panel. Price: £145 (plus £24 PT).

Model 2230 ★

AM/FM stereo tuner/amplifier. Range: FM 88-108MHz, MW 187-555 metres. Variable tuning. Ratio detector. Tuning meter. Usable sensitivity: AM 20µV, FM 2µV for 30dB quieting. Aerial input: 300 ohms balanced, 75 ohms coaxial. Stereo decoder included. 68 transistors plus one IC. Impedance: PU 1.8mV 47K, mic 1.8mV, aux 180mV. Noise level: (PU input) -96dB. Output: 30W RMS per channel, both channels driven. Output impedance: 8 ohms. Tone controls: bass ±15dB at 50Hz, treble ±15dB at 15kHz, middle ±6dB at 700Hz. HD: <0.5% 40Hz-20kHz. FR: 20Hz-20kHz±0.5dB. Size: 16 $\frac{7}{8}$ ×5×14in. Finish: gold anodised front panel. Price: £196.50 (plus £32.50 PT).

Model 2245 ★

AM/FM stereo tuner/amplifier. Range: 88-108MHz, MW 187-555 metres. Variable tuning. Ratio detector. Tuning meter and signal strength meter. Usable sensitivity: AM 20µV, FM 1.7µV for 30dB quieting. Aerial input: 300 ohms balanced, 75 ohms coaxial. Stereo decoder included. 87 transistors plus one IC. Inputs: mag PU 1.8mV 47K, mic 1.8mV, aux 180mV. Noise level: PU input -96dB. Output: 47W per channel RMS into 4 and 8 ohms, both channels driven. Output impedance: 8 ohms. Tone controls: bass ±15dB at 50Hz, treble ±15dB at 15kHz, middle ±6dB at 700Hz. HD: <0.3%. FR: 7Hz-70kHz for 0.3% THD. Size: 16 $\frac{7}{8}$ ×5×14in. Finish: gold anodised front panel. Price: £239 (plus £40 PT).

Model 2270

AM/FM stereo tuner/amplifier. Range: 88-108



Beautiful Bang & Olufsen

Bang & Olufsen equipment may be renowned for its beauty but of course its talents go deeper than that. The outstanding quality of cabinet work and construction is more than equalled by Bang & Olufsen's genius for down-to-earth engineering. The Beosystem 1200 is a fine example of this flair for combining performance with elegance – it has almost every facility you are likely to need and standards you are unlikely to improve on at an equivalent price. Next time you meet the Beosystem 1200, don't just look at it – listen.

Beosystem 1200, available in natural teak, rosewood or white lacquered finish.

Further information from Bang & Olufsen U.K. Limited
Consumer Advisory Service, Mercia Road, Gloucester GL1 2SQ 0452 31491

Sharp make homes sound better.

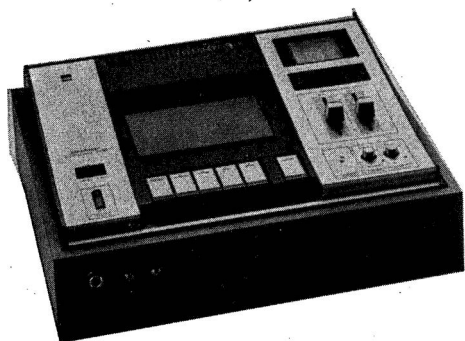

RT 442 solid state 4-track
stereo cassette tape deck.
£59.95 inc. P.T.

RT 811 solid state
8-track stereo cartridge
recorder/player deck.
£73.00 inc. P.T.

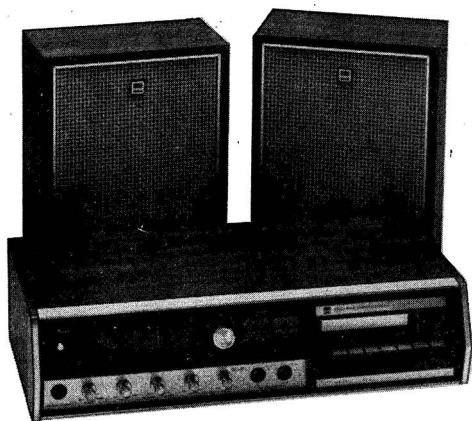

SC 103 Solid state AM/FM
stereo music system with 4-track
tape player.
Without speaker £97.26 inc. P.T.
With speaker £115.80 inc. P.T.

Sharp Electronics (UK) Ltd, 48 Derby Street, Manchester M8 8HN



MHz, MW 187-555 metres. Variable tuning. Ratio detector. Signal strength meter and tuning meter. Usable sensitivity: AM $20\mu\text{V}$, FM $1.7\mu\text{V}$ for 30dB quieting. Aerial input: 300 ohms balanced, 75 ohms coaxial. Stereo decoder included. 87 transistors and one IC. Inputs: mag PU 1.8mV 47K, mic 1.8mV , aux 180mV . Noise level: -96dB . Output: 70W per channel RMS into 8 ohms, both channels driven. Output impedance: 8 ohms. Tone controls: bass $\pm 15\text{dB}$ at 50Hz, treble $\pm 15\text{dB}$ at 15kHz, middle $\pm 6\text{dB}$ at 700Hz. HD: $<0.3\%$. FR: 20Hz-20kHz $\pm 0.25\text{dB}$. Size: $16\frac{7}{8} \times 5 \times 14\text{in}$. Finish: gold anodised front panel. Price: £297 (plus £50 PT).

■ NIKKO ELECTRIC MFG CO LTD

Distributors: Howland-West Ltd,
3-5 Eden Grove, London, N78EQ.
Tel: 01-609 0293/4/5.

Nikko STA-301 ★

Stereo transistorised tuner/amplifier. Range: 88-108MHz, 187-560 metres. Variable tuning. Meter tuning indicator. Sensitivity (for 20dB quieting): $2\mu\text{V}$. Stereo decoder fitted. Output: 12W per channel, less than 0.8% distortion. FR ($\pm 1\text{dB}$): 20Hz-50kHz. Output impedance: 4-16 ohms. Inputs: gram 2.8mV 50K, noise level -60dB , tape 1.8mV 200K, aux 200mV 330K. Controls: tuning, volume, balance, loudness, function, mono/stereo, bass, treble. Size: $14\frac{1}{2} \times 12\frac{3}{4} \times 4\frac{1}{2}\text{in}$. Mains: 110-120/220-240V AC. Price: £83 (plus £13-80 PT).

Nikko STA-1101 ★

Stereo transistorised tuner/amplifier. Range: 88-108MHz and 187-560 metres. Variable tuning. Meter tuning indicator. Sensitivity (for 20dB quieting): $1.5\mu\text{V}$. Stereo decoder fitted. AFC. Output: 37W per channel at 0.3% distortion. FR ($\pm 1\text{dB}$): 10Hz-70kHz. Output impedance: 4-16 ohms. Inputs: gram 2mV 50K, tape 200mV 100K, mic 2mV 100K. Controls: FM tuning, AM tuning, function, volume, loudness, balance, bass, treble, remote speaker selector, remote speaker volume control. Includes six FETs and twelve ICs. Size: $18\frac{1}{2} \times 14\frac{3}{8} \times 6\frac{1}{2}\text{in}$. Mains: 120/220/240V AC. Price: £215 (plus £35-74 PT).

STA-6010 ★

AM/FM stereo tuner/amplifier. Range: FM 88-108MHz, MW 182-556 metres. Variable tuning. Meter tuning indicator. Usable sensitivity: FM $1.8\mu\text{V}$, MW $150\mu\text{V}$. Aerial input: 75 ohms coaxial, 300 ohms balanced. Stereo decoder included. Inputs: mag PU 2.8mV 50K, tape head 1.8mV 200K, aux (1) 150mV 250K, aux (2) 750mV 1 megohm, tape monitor 200mV 100K. Noise level: tape head input 55dB, mag PU 60dB, other inputs $<65\text{dB}$. Output: 18W RMS per channel. Output impedance: 8 ohms. Tone controls: bass $\pm 13\text{dB}$ at 70Hz, treble

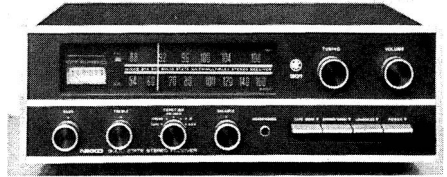

Nikko STA-301

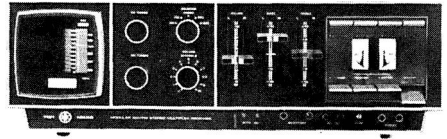

Nikko ST1101



Nikko STA-6010

$\pm 13\text{dB}$ at 10kHz, low filter -5dB at 70Hz, high filter -8dB at 10kHz. HD: 0.8%. FR: 20Hz-30kHz $\pm 1\text{dB}$. Mains: 100, 120, 220, 240V AC. Size: $15\frac{1}{2} \times 12\frac{3}{4} \times 4\frac{1}{2}\text{in}$. Price: £102 (plus £16-95 PT).

STA-8010

AM/FM stereo tuner/amplifier. Range: FM 88-108MHz, MW 182-556 metres. Variable tuning. Meter tuning indicator. Usable sensitivity: FM $1.8\mu\text{V}$, MW $150\mu\text{V}$. Aerial input: 75 ohms coaxial, 300 ohms balanced. Stereo decoder included. Inputs: mag PU 2.8mV 50K, aux (1) 150mV 250K, aux (2) 750mV 100K, tape head 1.8mV 250K, tape monitor 200mV 100K. Output: 26W RMS per channel. Output impedance: 8 ohms. Tone controls: bass $\pm 13\text{dB}$ at 70Hz, treble $\pm 13\text{dB}$ at 10kHz, loudness $+13\text{dB}$ at 70Hz $+9\text{dB}$ at 10kHz. Low and high filters. HD: 0.8%. FR: 20Hz-30kHz $\pm 1\text{dB}$. Size: $15\frac{1}{2} \times 12\frac{3}{4} \times 4\frac{1}{2}\text{in}$. Mains: 100, 120, 220, 240V AC. Price: £117 (plus £19-45 PT).

STA-9010 ★

AM/FM stereo tuner/amplifier. Range: FM 88-108MHz, MW 182-556 metres. Variable tuning. Meter tuning indicator. Usable sen-i-

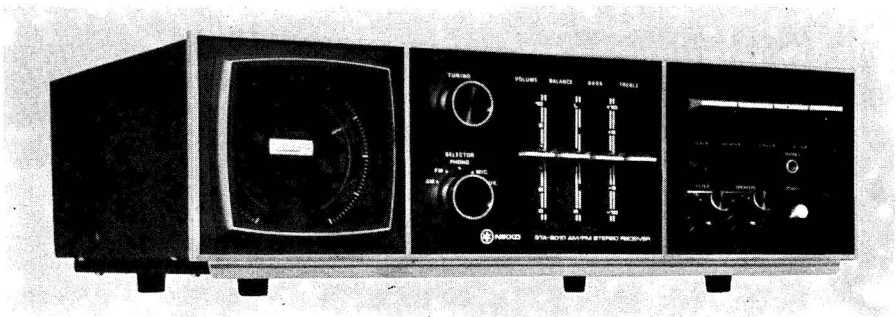

Nikko STA-9010

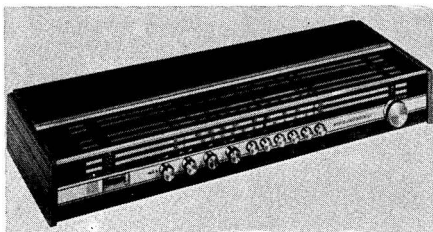

Normende 5003ST



Onkyo Integra 225

tivity: FM 1.5 μ V, MW 150 μ V. Aerial input: 75 ohms coaxial, 300 ohms balanced. Stereo decoder included. Inputs: mag PU 2.5mV 50K, mic input 2.5mV 50K, aux 240mV 200K, tape 240mV 200K. Noise level: mag PU and mic inputs \pm 65dB, other inputs \pm 80dB. Output: 45W per channel RMS, Output impedance: 8 ohms. Controls: sliders for bass, treble, balance and volume. Low and high filters. Mains and remote speaker switch. HD: 0.5% FR: 20Hz-40kHz \pm 1dB. Mains: 100, 120, 220, 240V AC. Size: 16 $\frac{1}{2}$ \times 13 $\frac{1}{2}$ \times 5in. Price: £140 (plus £23-27 PT).

■ NIVICO

Denham & Morley Ltd, Denmore House, 453 Caledonian Road, London, N7.
Tel: 01-607 6568. Telex: 24562.

5010U

AM/FM stereo tuner/amplifier with sound-effect preamplifier. Range: FM 88-108MHz, MW 187-567 metres. Variable tuning. Meter tuning indicator. Sensitivity: (FM) 2.5 μ V, (AM) 30 μ V. Inputs: mag PU 2mV, aux 150mV, tape play 150mV. Output: 20W per channel into 4 ohms, 17W per channel into 8 ohms. Output impedance: 4-16 ohms. THD: 1% at 1kHz at rated power. FR: 30Hz-20kHz +1dB. Sound effect amplifier centre frequencies: 60Hz, 250 Hz, 1kHz, 5kHz, 15kHz (all adjustable \pm 12dB). AC mains 100-240V. Size: 16 $\frac{5}{8}$ \times 4 $\frac{3}{8}$ \times 13in. Weight: 17.2lb. Price: £127-36 (including PT).

5500

AM/FM stereo tuner/amplifier. Range: FM 88-108MHz. Usable sensitivity: 2.5 μ V (IHFM). Stereo decoder fitted. Output: 20W per channel into 4 ohms. Output impedance: 4-16 ohms. FR: 20Hz-40kHz. Slider bass and treble controls. Price: £96-96 (including PT).

5540U

AM/FM stereo tuner/amplifier with sound effect amplifier (SEA) system. Range: 88-108 MHz. Usable sensitivity: 2 μ V (IHF). Stereo decoder fitted. Output: 70W per channel into 4 ohms. Output impedance: 4-16 ohms. HD: <0.5%. FR: 20Hz-40kHz. Two tuning meters. Price: £198 (including PT).

5550

AM/FM stereo tuner/amplifier with sound effect amplifier (SEA) system. Range: 88-108MHz. Usable sensitivity: 1.6 μ V. Output: 110W per channel into 4 ohms. Output impedance: 4-16 ohms. HD: <0.4%. FR: 40Hz-20kHz. Two meters. Price: £198 (including PT).

VR-5521L

AM/FM stereo tuner/amplifier. Full details on request. Price: £165 (including PT).

■ NORDMENDE

Distributors: TAK Continental Importers, 16a High Street, Stone, Staffordshire.
Tel: Stone 3232, 3233.

5003ST ★

Stereo tuner/amplifier only 3in high. Ranges: FM/VHF, LW, MW and 49 metre band. Electronic mono/stereo switching with indicator, ICs, ceramic IF filters, panoramic scale. Output: $2\frac{1}{2}$ W RMS per channel. Finishes: walnut, teak, elm or Rio rosewood. Dimensions: $22 \times 8 \times 5$ in approx. Price: £93.45 (including PT). With two LB31, LB32 or LB33 speakers.

7001

Bands and stereo facilities similar to 5003. Automatic precision tuning on VHF. Inbuilt aerials. Output: 17W RMS per channel. Finishes: as 5003. Dimensions: $24 \times 8 \times 5$ in approx. Price: £103.95 (including PT). With two LB31, LB32 or LB33 speakers.

ONKYO

J. Parkar & Co (London) Ltd,
Parkar House, 1 Paul Street, London,
EC2A 4JQ. Tel: 01-628 4577.

Integra 225 ★

AM/FM stereo tuner/amplifier incorporating IC in decoder stage, four-gang tuning, six-element ceramic IF filter and four-stage limiter. Range: FM 88-108MHz, MW 187-565 metres. Variable tuning. Sensitivity: FM $2\mu\text{V}$, MW $40\mu\text{V}$. S/N ratio: FM 65dB, MW 45dB. Stereo decoder with auto switching. Stereo beacon. Tuning meter. Quiet tuning facility on FM. Inputs: PU 2mV 50K, aux 100mV 100K. Tone controls: bass +14dB -18dB at 20Hz, treble +11dB -14dB at 20kHz, low filter -6dB/octave from 70Hz, high filter -6dB/octave from 7kHz. Output: 22W RMS per channel. Output impedance: 4-16 ohms. Outlets for headphones and AC mains. FR: 15Hz-30kHz ± 1 dB. HD: <0.3% at rated output. H and N: better than 70dB on PU input, better than 85dB on aux input. Mains: 100/110V or 220/240V 50/60Hz. Size: $17\frac{1}{4} \times 5\frac{3}{8} \times 13\frac{1}{2}$ in. Weight: 22 $\frac{1}{2}$ lb. Price: £149.36 (including PT).

PHILIPS ELECTRICAL LTD

Century House, Shaftesbury Avenue,
London, WC2. Tel: 01-437 7777.

RH702

AM/FM stereo tuner/amplifier. Range: FM 87.5-108MHz, MW 211-577 metres, 187-214 metres, LW 882-2,000 metres, SW 30.7-50.4 metres. Variable tuning on AM bands, variable tuning plus five preset buttons (electronic tuning) on FM. Meter tuning indicator. Sensitivity: (FM) $6\mu\text{V}$ for 26dB S/N across 300 ohms, (AM) $80\mu\text{V}$ for 26dB S/N. Stereo decoder fitted. Stereo beacon. Output: 15W RMS per channel into 4 ohms. HD: <1%. FR: 20Hz-20kHz ± 1 dB. S/N: -70dB. Inputs: mag PU 1.1mV 50K, mic 0.5mV 2K, tape 220mV 500K. Switched headphone outlet socket. Controls:

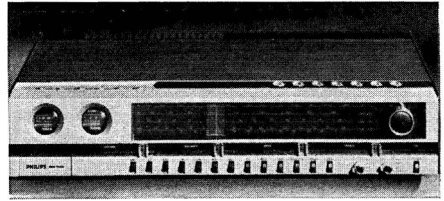

Philips RH720

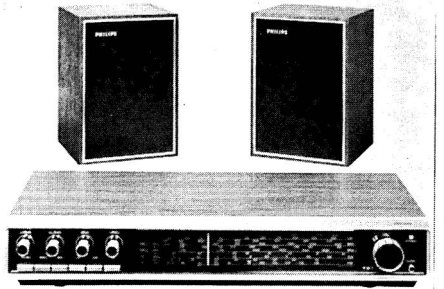

Philips RH 901

volume (adjusted for physiology), bass ± 15 dB at 50Hz, treble ± 14 dB at 10kHz, balance 0 to 20dB per channel (all controls with thermometer type scales). Finish: walnut veneer. Size: $22\frac{1}{4} \times 4\frac{1}{2} \times 8\frac{1}{2}$ in. Mains: 110, 127, 220, 240V AC 50/60Hz. Price: £96 (including PT).

RH720 ★

AM/FM stereo tuner/amplifier. Range: FM 87.5-104MHz, MW 187-577 metres, LW 857-2,000 metres, SW 16.7-50.4 metres. Variable tuning plus six presets. Switchable AFC. Ratio detector. Moving coil tuning meter. Usable sensitivity: FM $2\mu\text{V}$ for 26dB quieting, AM $150\mu\text{V}$ for 26dB S/N ratio. Aerial input: 300 ohms balanced. Stereo decoder fitted. Silent tuning facility on FM. 75 transistors plus two ICs. Inputs: mag PU 2mV 50K, crystal PU 60mV 100K, tape 250mV 100K, mic 1mV 2K. Output: 30W RMS per channel. Output impedance: 4 ohms. Tone controls: bass ± 14 dB at 50Hz, treble ± 15 dB at 10kHz. Two-position loudness control. HD: <0.1% at 20W per channel. FR: 15Hz-40kHz +0.5dB -3dB. Mains: 110, 127, 220, 240V AC. Size: $23\frac{1}{4} \times 4\frac{3}{8} \times 11$ in. Finish: walnut veneer cabinet, brushed aluminium fascia. Socket outlet for headphones. Scratch filter. Price: to be announced.

RH901 ★

AM/FM stereo tuner/amplifier. Range: FM 87.5-108MHz, MW 214-577 metres, MW band-spread 187-214 metres, LW 870-2,000 metres, SW 30.7-50.4 metres. Variable tuning. AFC. Ratio detector. Usable sensitivity: FM $7\mu\text{V}$ for 26dB quieting, AM $70\mu\text{V}$ for 26dB S/N ratio.

★ Indicates entry is illustrated

Aerial input: 300 ohms balanced. Stereo decoder fitted. 25 transistors. Inputs: ceramic PU 210mV 350K, tape 150mV 500K. Noise level: -50dB. Output: 8W RMS per channel. Tone controls: bass ± 9 dB at 100Hz, treble ± 8 dB at 10kHz. HD: <2% at 1kHz at 4.5W output per channel. Output impedance: 4 ohms. FR: 45Hz-20kHz ± 3 dB. Mains: 110, 127, 220, 240V AC. Size: $20 \pm 3\frac{1}{4} \times 8\frac{3}{4}$ in. Finish: simulated walnut veneer. Price: (including two RH411 speakers) £86.50 (including PT).

■ PIONEER

Distributors: Shriro (UK) Ltd,
42 Russell Square, London, WC1.
Tel: 01-580 6996.

SX440

AM/FM stereo tuner/amplifier. Range: FM 87-108MHz, MW 187-562 metres. Variable tuning. Meter indicator. Sensitivity: 2.5 μ V for 20dB quieting. Aerial input: 300 ohms balanced. FET front end. Midnight black front panel with blue light indicators. Inputs: magnetic PU 3mV, tape 130mV, aux 130mV. Noise level: better than 75dB on PU, better than 85dB on other inputs. Controls: bass +13dB -11dB at 50Hz, treble +9.5dB -10dB at 10kHz, loudness +12dB at 50Hz and +6dB at 10kHz. Output: 12W RMS per channel into 8 ohms. HD: <1% at 1kHz. FR: 20Hz-70kHz ± 3 dB. Output impedance: 4-16 ohms. Mains: 110, 117, 130, 220, 240V AC. Size: $16 \times 5\frac{1}{2} \times 15$ in. Price: £88.74 (plus £12.86 PT).

LX440

AM/FM stereo tuner/amplifier. Range: FM 87.5-108MHz, MW 187-562 metres, LW 860-2,000 metres. Variable tuning. Meter indicator. Sensitivity: 2.5 μ V for 20dB quieting. Aerial input: 300 ohms balanced. Output: 1V. Stereo decoder fitted. AFC. FET front end. Inputs: magnetic PU 3-6mV, tape 200mV, aux 160mV. Noise level: PU better than 75dB, other inputs better than 85dB. Controls: bass +13dB -11dB at 50Hz, treble +9.5dB -10dB at 10kHz, loudness +12dB at 50Hz, +6dB at 10kHz. Power output: 12W RMS per channel into 8 ohms. HD: <1% at rated output. FR: 20Hz-70kHz ± 3 dB. Output impedance: 4-16 ohms. Connections and switching for two separate speaker systems. Mains: 110, 117, 130, 220 and 240V AC. Size: $16 \times 5\frac{1}{2} \times 15$ in. Price: £109.43 (plus £15.80 PT).

SX770 ★

AM/FM stereo tuner/amplifier. Range: FM 87.5-108MHz, MW 187-562 metres. Variable tuning. Meter indicator. Sensitivity: 1.8 μ V for 20dB quieting. Aerial input: 300 ohms balanced. Stereo decoder fitted. AFC. FET front end. Two ICs. Inputs: mic, magnetic PU 2.5mV 50K, ceramic PU 58mV 100K, aux 200mV 100K, tape

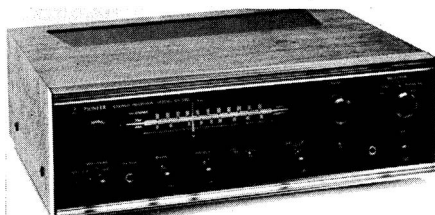

Pioneer SX770



Pioneer SX2500



Pioneer SX9000

200mV 100K. Controls: bass +13dB -14dB at 50Hz, treble +10dB -9dB at 10kHz, loudness +12dB at 50Hz, +7.5dB at 10kHz. Output: 20W RMS into 8 ohms. Output impedance: 4-16 ohms. Two speaker outputs for A+B, or A and B. Stereo headphone jack. FM muting control. Mains: 110, 117, 130, 220, 240V AC. Size: $17 \times 5\frac{1}{2} \times 13\frac{3}{4}$ in. Price: £109.34 (plus £15.76 PT).

SX2500 ★

AM/FM stereo tuner/amplifier. Range: 87.5-108MHz, MW 187-562 metres. Variable and pre-set tuning. Two tuning meters. Sensitivity: 1.6 μ V for 20dB quieting. Aerial input: 300 ohms balanced. Output from preamplifier: 1V. Stereo decoder fitted. AFC. Automatic tuning on AM and FM, also remote control for auto-tuning. Five ICs. Two crystal filters. Multiplex noise filter. Preset stations on FM stereo and local radio. Inputs: magnetic PU 2.7mV 50K, ceramic PU 60mV 100K, aux (2) 200mV 100K, tape (2) 200mV 100K. Noise level (magnetic PU) better than 80dB; (other inputs) 100dB. Controls: bass +12dB -9dB at 100Hz, treble +9dB -12dB at 10kHz, loudness +13dB at 50Hz, +6dB at 10kHz, low filter -8dB at 50Hz, high filter -10dB at 10kHz. Output: 84W RMS per channel into 8 ohms. HD: <0.5%. FR: 20Hz-

70kHz \pm 2dB. Output impedance: 4-16 ohms. Mains: 110, 117, 130, 220, 240V AC. Size: 19 $\frac{1}{8}$ \times 5 $\frac{3}{8}$ \times 15 $\frac{1}{8}$ in. Price: £290.58 (plus £41.95 PT).

SX9000 ★

AM/FM stereo tuner/amplifier. Range: FM 87.5-108MHz, 187-562 metres. Variable tuning. Two tuning meters. Sensitivity: 1.6 μ V for 20dB quieting. Aerial input: 300 ohms balanced. Output of preamplifier: 1V. Stereo decoder fitted. AFC. FET front end. Four ICs in IF amplifier section. Inputs: magnetic PU (2) 2.5mV 50K, tape (2) 160mV 50K, aux (2) 160mV 50K, mic (2) 1.6mV 65K. Noise level: PU inputs better than 80dB, other inputs better than 100dB. Controls: bass +12.5dB -14dB at 100Hz, treble +9dB -11dB at 10kHz, loudness +12dB at 50Hz, +7dB at 10kHz, low filter -6dB at 50Hz, high filter -12dB at 10kHz. Reverberation time: 0.2 seconds. Output: 62W RMS into 8 ohms. HD: <0.5%. FR: 10Hz-35kHz \pm 1dB. Output impedance: 4-16 ohms. Separate reverberation amplifier. Special tone colour selector. Combination of speaker switching. Microphone mixing on mono and stereo. Headphone socket. Mains: 110, 117, 130, 220, 240V AC. Size: 20 $\frac{5}{8}$ \times 7 $\frac{7}{8}$ \times 13 $\frac{3}{8}$ in. Price: £261.30 (plus £37.73 PT).

SX1500TD

AM/FM stereo tuner/amplifier. Range: FM 87.5-108MHz, MW 187-562 metres. Variable tuning. Two tuning meters. Sensitivity: 1.7 μ V for 20dB quieting. Aerial input: 300 ohms balanced. Output from tuner section: 1V. Stereo decoder fitted. AFC. FET front end. Four ICs in IF section. Four-gang FM tuning. Inputs: magnetic PU 3.3mV 50K, ceramic PU 24mV 100K, tape 200mV 100K, aux 200mV 100K, mic 3.2mV 30K. Controls: bass +11dB -16dB, treble +10dB -9dB, loudness +12dB at 50Hz, +9dB at 10kHz. Low filter -8dB at 50Hz, high filter -6dB at 10kHz. Output: 58W RMS per channel into 8 ohms. Output impedance: 4-16 ohms. Facilities for mic mixing. Variety of speaker combinations including centre channel connections. Mains: 110, 117, 130, 220, 240V AC. Size: 18 $\frac{1}{2}$ \times 5 $\frac{3}{8}$ \times 14 $\frac{1}{2}$ in. Price: £196.37 (plus £28.34 PT).

SX525

AM/FM stereo tuner/amplifier. Range: FM 87.5-108MHz, MW 187-562 metres. Variable tuning. Sensitivity: FM 2.2 μ V, MW 15 μ V. Meter tuning indicator. Switchable quiet tuning facility. Output: 21W RMS per channel into 4 ohms. HD: <1% at rated output. FR: 15Hz-30kHz \pm 1dB. Output impedance: 4-16 ohms. Inputs: mag PU 2.7mV 50K, mic 6mV 100K, aux 200mV 70K, tape 1.2-200mV 70K. AC mains. Price: £118.67 (plus £17.13 PT).

SX626

AM/FM stereo tuner/amplifier. Range: 87.5-108MHz, MW 187-562 metres. Variable tuning. Sensitivity: FM 2 μ V, MW 10 μ V. 41 transistors, 22 diodes, four ICs, four FETs. Meter tuning indicator. Switchable quiet tuning facility. Output: 40W RMS per channel into 4 ohms. HD: <1%. FR: 5Hz-80kHz \pm 1dB. Inputs: mag PU (2) 2.5mV 45K, mic 2.2mV 22K, aux 200mV 100K, tape 200mV 70K. AC mains. Price: £158.68 (plus £22.91 PT).

SX727

AM/FM stereo tuner/amplifier. Range: FM 87.5-108MHz, MW 187-562 metres. Variable tuning. Sensitivity: FM 1.8 μ V, MW 10 μ V. 56 transistors, 37 diodes, four ICs, four FETs. Two tuning meters (one centre zero). Switchable quiet tuning facility. Inputs: mag PU (2) 3mV 50K, mic 2.7mV 50K, aux 200mV 100K, tape 200mV 100K. Output: 69W RMS per channel into 4 ohms. HD: <0.5% at rated output. FR: 7Hz-80kHz \pm 1dB. Output impedance: 4-16 ohms. AC mains. Price: £196.27 (plus £28.34 PT).

LX880

AM/FM stereo tuner/amplifier. Range: FM 87-108MHz, MW 187-562 metres, LW 860-2,000 metres. Sensitivity: FM 2 μ V, MW 28 μ V, LW 100 μ V. Inputs: ceramic PU 53mV 100K, mag PU 2.4mV 50K, tape 210mV 100K, aux 210mV 100K, aux 2 5.3mV 1.3K. Output: 17.5W per channel into 4 ohms. HD: <0.5% at rated output. FR: 30Hz-80kHz \pm 3dB. Output impedance: 4-16 ohms. AC mains. Price: £147.63 (plus £21.31 PT).

SX828

AM/FM stereo tuner/amplifier. Range: FM 87.5-108MHz, MW 187-562 metres. Sensitivity: FM 1.7 μ V, MW 10 μ V. Power: 75W RMS per channel into 4 ohms. HD: 0.5%. FR: 5Hz-80kHz \pm 1dB. Inputs: mag PU 2.7mV 50K, mic 2.6mV 50K, tape 200mV 100K, aux 200mV 100K. Tone controls: bass \pm 10dB at 100Hz, treble \pm 10dB at 10kHz, low filter -3dB at 50Hz, high filter -3dB at 10kHz. 57 transistors, 38 diodes, 4 FETs. Price: £246 (plus £35.52 PT).

SX6000

Full details of specification not available at time of going to press. Price: £190.80 (plus £27.55 PT).

■ ROGERS DEVELOPMENTS (Electronics) LTD

4-14 Barmeston Road, Catford, London, SE6.
Tel: 01-698 7424/4340.

Ravensbrook ★

Integrated stereo tuner/amplifier. Range: 88-108MHz. Variable tuning. Ratio detector. Aerial input 75 ohms coaxial and 300 ohms



Rogers Ravensbrook

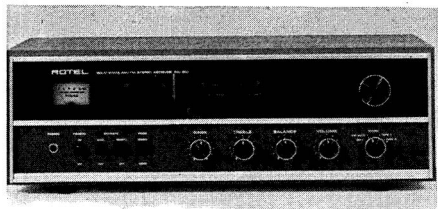

Rotel RX150



Saba Hi-Fi Studio 8035

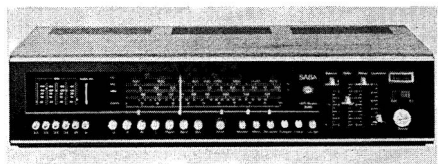

Saba Hi-Fi Studio 8080



Saba Freiburg Telecommander

balanced. Stereo decoder fitted. Three-gang FET front end. Integrated circuit (IC) IF amplifier. Inter-station quiet tuning. Output: 10W RMS per channel into 15 ohms, 15W RMS per channel into 8 ohms. HD: 0.1% at rated output. FR: 20Hz-50kHz -3dB. S/N: PU input -53dB. Push-button input selector. Controls: bass, treble, volume, balance, high filter, low filter. Tuning meter. Price: (chassis) £96.57; (in cabinet) £105.35.

■ ROTEL

Rank Aldis-Audio Products,
Rank Audio Visual Ltd,
PO Box 70, Great West Road, Brentford,
Middlesex. Tel: 01-568 9222. Telex: 24408.

RX150 ★

AM/FM stereo tuner/amplifier. Range: FM 88-108MHz, MW 188-545 metres. Variable tuning. Usable sensitivity: FM $5\mu\text{V}$, MW $30\mu\text{V}$. Meter tuning indicator. Aerial input: 300 ohms. Stereo decoder fitted. Inputs: mag PU 2.8mV 45K, ceramic PU 100mV 190K, aux 250mV 125K. Noise level: PU inputs -60dB, aux inputs -70dB. Output: 11W RMS per channel into 4 ohms. Output impedance: 4-8 ohms. Tone controls: bass +14dB -11.5dB, treble +11dB -14dB. HD: 0.35% at 30W. FR: 30Hz-20kHz at 30W. Mains: 240V AC. Size: $16\frac{3}{8} \times 6\frac{7}{8} \times 5\frac{1}{4}$ in. Weight: 10lb. Finish: wood grain. Price: £58.03 (plus £9.90 PT).

RX200

AM/FM stereo tuner/amplifier. Range: FM-88-108MHz, MW 187-562 metres. Variable tuning. Meter indicator. Sensitivity: $3.5\mu\text{V}$. Aerial input: 300 ohms balanced (can be changed to 75 ohms coaxial). Stereo decoder fitted. Inputs: mag PU 2mV 35K, crystal PU 200mV 150K, tape 250mV 13K, aux 130mV 50K. Noise level: -60dB on PU inputs, -70dB on other inputs. Output: 13W RMS per channel into 4 ohms, 10W RMS per channel into 8 ohms. Controls: bass +12dB -14dB at 50Hz, treble +13dB -12dB at 10kHz, loudness, balance, volume, tape monitor, tuning. HD: 0.2% at rated output. FR: 30Hz-20kHz -1.5dB at 10W. Output impedance: 4, 8, 16 ohms. Mains: 100, 120, 200, 240V 50/60Hz. Size: $14\frac{1}{4} \times 4 \times 8\frac{1}{4}$ in. Price: £72.63 (plus £12.39 PT).

RX400

AM/FM stereo tuner/amplifier. Range: FM 88-108MHz, MW 187-562 metres. Variable tuning. Meter indicator. Sensitivity: (FM) $2.5\mu\text{V}$ for 20dB quieting, (AM) $30\mu\text{V}$. Aerial input: 300 ohms balanced (can be changed to 75 ohms coaxial). Stereo decoder fitted. FET front end. Integrated circuits. A plus B, or A and B speaker switching. Inputs: mag PU 3mV 50K, tape 400mV 15K, aux 200mV 100K. Noise level: PU -60dB, other inputs -70dB. Controls:

bass +14dB -12dB at 50Hz, treble \pm 12dB at 10kHz, loudness, volume, tuning, balance, input selector. Output: 22W RMS per channel into 4 ohms, 20W RMS per channel into 8 ohms. FR: 15Hz-50kHz into 8 ohms. Output impedance: 4, 8, 16 ohms. Mains: 100, 120, 200, 240V 50/60Hz. Size: $17\frac{3}{8} \times 5 \times 12\frac{1}{2}$ in. Price: £82-94 (plus £14-15 PT).

■ SABA

Distributors: Lampitt Electronics Ltd,
6-12 Cornbrook Park Road,
Manchester, M15 4EE. Tel: 061-872 7661.

Hi-Fi Studio 8035 ★

AM/FM stereo tuner/amplifier. Range: FM, LW, MW, SW. Variable tuning. Slider controls. Tuning meter. Output: 18W music power per channel. HD: <0.25% at 12W output. 62 semi-conductors. Output impedance: 4-16 ohms. Output fully protected against short circuits. Headphone socket on front panel. Inputs for mag PU, crystal PU and tape recorder. Size: $23\frac{3}{8} \times 5\frac{3}{8} \times 11\frac{3}{8}$ in. Finish: light walnut or white. Price: £121-53 (including PT).

Hi-Fi Studio 8080 ★

AM/FM stereo tuner/amplifier. Range: FM, LW, MW, SW. Variable tuning plus six preset FM stations. Tuning meter. FET front-end on all bands. Quiet tuning facility on FM. 54 transistors, 30 diodes, one IC. Output: 30W RMS per channel. HD: <0.1%. Socket for reverberation unit. Output protected against short circuits. Mains: 110, 130, 220, 240V AC. Size: $23\frac{7}{8} \times 5\frac{3}{8} \times 12\frac{1}{2}$ in. Finish: walnut or white. Price: £179-87 (including PT).

Freiburg Telecommander ★

AM/FM stereo tuner/amplifier with ultra-sonic cordless remote control. Range: LW, MW, SW, FM/VHF. Variable tuning plus seven preset stations on FM. AFC. Meter tuning indicator. 69 transistors, 36 diodes, 13 rectifiers, 8 thyristors and 5 ICs. Output: 40W RMS per channel. Inputs for mag PU, tape, aux. Connection for reverberation unit. HD: <0.1%. Output circuits protected against short circuit. Silent tuning facility on FM. Size: $29\frac{3}{8} \times 6\frac{3}{8} \times 13$ in. Finish: light walnut and white. Price: £286-85 (including PT).

■ SANSUI

Vernitron Ltd,
Thornhill, Southampton, SO9 5QF.
Tel: Southampton 44811.

Eight

AM/FM stereo tuner/amplifier. Stereo decoder fitted. Output: 60W RMS per channel into 8 ohms. HD: <0.3% at rated output. FR: 5Hz-50kHz. Sensitivity: FM 1.4 μ V. Range: FM 88-108MHz. Pushbutton controls. Provision for

Sanyoscience

(or how to bring studio-quality hi-fi within the reach of every enthusiast!)

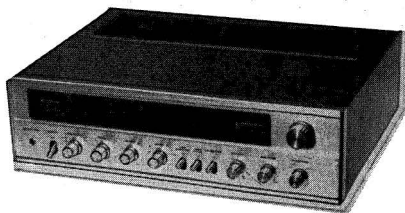

For example the **DCX2500K** - an advanced solid state AM/FM stereo tuner amplifier. Delivers 10 watts per channel. 30 watts total music power.

And again: the **TP92S** - a true studio-quality hi-fi turntable with auto tonearm return. Synchronous 4-pole motor drives heavy diecast turntable platter by belt drive. Complete speed accuracy - motor speed locked to AC line frequency. Excellent signal to noise ratio, with fitted cartridge. Low wow, rumble and flutter. Statically balanced low-mass S-shaped tonearm with lateral balance weight for perfect centre-groove tracking. Accepts all standard cartridges. Cartridge supplied: moving magnet - 0.5 mil diamond stylus. Stereo channel separation better than 25dB/1000Hz. Light weight shell. Controls: auto tonearm return, reject button.



SANYO
a world of difference

For full details and name of your nearest Sanyo stockist, write to:
Sanyo Marubeni (UK) Ltd.
Bushey Mill Lane, Watford WD2 4UQ. Tel: Watford 3042



Sansui 350A

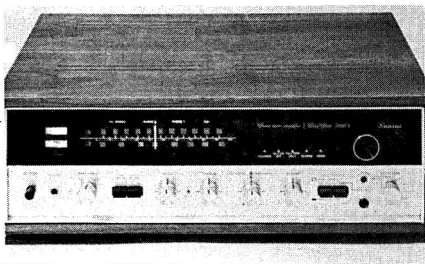

Sansui 5000X

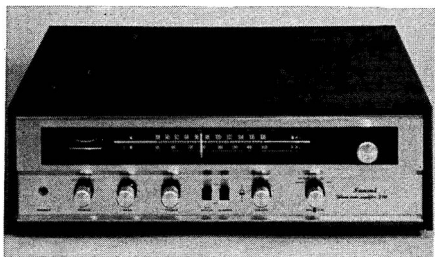

Sansui 210

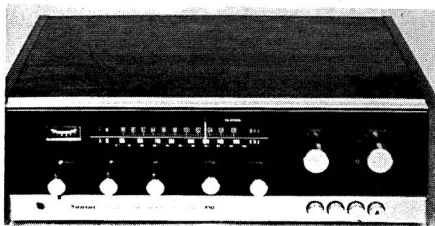

Sansui 310

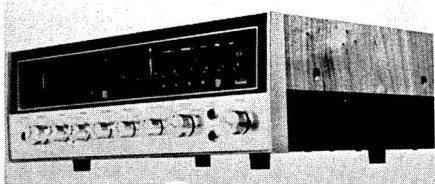

Sansui 7000

three sets of speakers. Controls: bass, treble, mid-range, balance, volume, input selector, tuning. Sockets for headphones, tape record/play. Balance check pushbutton. High-pass and low-pass filters. FM quiet tuning. Price: £265-84 (plus £44-30 PT).

350A ★

AM/FM multiplex stereo. Solid state. Range: 88-108MHz, 187-562 metres. Variable tuning with meter indicator. Sensitivity: $2.5\mu\text{V} \pm 3\text{dB}$ (20dB quieting) FM: $25\mu\text{V} \pm 3\text{dB}$ at 1MHz on AM. Inputs: pickup $2.2\text{mV} \pm 3\text{dB}$; aux $150\text{mV} \pm 3\text{dB}$; tape monitor $150\text{mV} \pm 3\text{dB}$; H and N: pickup 60dB, aux 65dB. Power output: 20W per channel $\pm 1\text{dB}$ at 8 ohms. FR: 30Hz-20kHz. Distortion: 1%. Dual speaker system. Aerial: 75 and 300 ohms. Controls: tuning, bass, treble, volume, balance, selector, switches for speakers, multiplex noise canceller, loudness, mono mode and tape monitor. Psn: 100, 117, 220 and 240V 50 or 60Hz. Size: $4\frac{1}{2} \times 15\frac{1}{8} \times 13\frac{1}{2}$ in. Weight: 19-5lb. Price: £128-47 (plus £21-41 PT).

2000X

AM/FM stereo. Range: VHF 88-108MHz, MW 186-560 metres. Variable tuning. Ratio detector. Meter tuning indicator. Sensitivity: $1.4\mu\text{V}$ for 20dB quieting. Aerial input: 75 ohms coaxial. Multiplex decoder fitted. AFC. FET front end. Inputs: PU 2.2mV 50K, tape head 2mV 100K, aux 150mV 100K, tape monitor 150mV . Noise level: -70dB on PU, -75dB on other inputs. Controls: speakers A or B, bass/treble cut, bass (each channel), treble (each channel), loudness, muting, tape monitor, reverse stereo, mono. Output: 39W RMS per channel. FR: 15Hz-40kHz $\pm 1.5\text{dB}$. Output impedance: 4-16 ohms. Mains: 240V 50Hz. Consumption: 150VA. Size: $16\frac{3}{8} \times 4\frac{7}{8} \times 13\frac{1}{2}$ in. Price: £139-50 (plus £34-1 PT).

5000X ★

AM/FM multiplex stereo. Solid state with FET and IC circuitry. Range: 88-108MHz, 187-561 metres. Sensitivity: $1.4\mu\text{V} \pm 3\text{dB}$ (20dB quieting) on FM; $15\mu\text{V} \pm 3\text{dB}$ at 1MHz on AM. Power output: 60W RMS per channel $\pm 1\text{dB}$ at 4ohms. FR: 15Hz-30kHz at 8 ohms. Distortion: less than 0.8%. Will handle three-speaker systems and four tape recorders at same time- Inputs: pickup $2.5\text{mV} \pm 3\text{dB}$; tape head $2\text{mV} \pm 3\text{dB}$; aux $150\text{mV} \pm 3\text{dB}$; tape monitor $200\text{mV} \pm 3\text{dB}$. H and N (below rated output): volume minimum, better than 80dB. Damping factor: 15 and 50 at 8 ohms. Psn: 100, 117, 220 and 240V, 50 or 60Hz. Dimensions: $4\frac{7}{8} \times 17\frac{1}{2} \times 14\frac{1}{2}$ in. Weight: 29lb. Price: £217-63 (plus £36-27 PT).

210 ★

Stereo AM/FM tuner/amplifier. Range: FM 88-108MHz, MW 187-560 metres. Variable tuning. AFC. Ratio detector. Meter tuning

indicator. Usable sensitivity: FM $3\mu\text{V}$, MW $370\mu\text{V}$. Aerial input: 75 ohms coaxial, 300 ohms balanced. Stereo decoder fitted. Mains: 100, 117, 220, 240V AC. Size: $17\frac{1}{2} \times 11\frac{1}{8} \times 5$ in. Finish: light walnut cabinet. Output: 10W RMS per channel. Inputs for mag PU (3mV), tape, aux. Outputs for tape, headphones. Two AC outlet sockets. Price: £73.06 (plus £12.18 PT).

310 ★

Stereo AM/FM tuner/amplifier. Range: FM 88-108MHz, MW 187-560 metres. Variable tuning. AFC. Ratio detector. Meter tuning indicator. Usable sensitivity: FM $2.3\mu\text{V}$, MW $180\mu\text{V}$. Aerial input: 75 ohms coaxial, 300 ohms balanced. Stereo decoder fitted. Mains: 100, 117, 220, 240V AC. Size $17\frac{1}{2} \times 11\frac{1}{8} \times 5$ in. Finish: light walnut cabinet with black fascia. Output: 15W RMS per channel. Two speaker systems. Multiplex filter. Tape monitor socket. Price: £97.96 (plus £16.33 PT).

1000X ★

Stereo AM/FM tuner/amplifier. Range: FM 88-108MHz, MW 187-560 metres. Variable tuning. AFC. Ratio detector. Meter tuning indicator. Usable sensitivity: FM $2\mu\text{V}$, MW $150\mu\text{V}$. Aerial input: 75 ohms coaxial, 300 ohms balanced. Stereo decoder fitted. Mains: 100, 117, 220, 240V AC. Size: $16\frac{3}{8} \times 11\frac{7}{8} \times 5\frac{3}{4}$ in. Finish: light walnut cabinet, silver control panel. black dial. Output: 28W RMS per channel. Two sets of speaker outlets. Sockets for tape, phones. Quiet tuning facility. Price: £152.70 (plus £25.45 PT).

7000 ★

Stereo AM/FM tuner/amplifier. Range: FM 88-108MHz, MW 187-560 metres. Variable tuning. AFC. Ratio detector. Two tuning meters. Usable sensitivity: FM $1.4\mu\text{V}$, MW $10\mu\text{V}$ external aerial, $200\mu\text{V}$ ferrite rod. Aerial input: 75 ohms coaxial, 300 ohms balanced. Stereo decoder fitted. Mains: 100, 117, 220, 240V AC. Size: $17\frac{1}{2} \times 5\frac{1}{2} \times 12\frac{3}{8}$ in. Finish: light walnut cabinet, silver control panel, black dial. Output: 70W RMS per channel. HD: $<0.1\%$. Quiet tuning facility. Three sets speaker sockets. Mic input. Price: £265.84 (plus £44.30 PT).

■ SANYO

Sanyo Marubeni (UK) Ltd, Sanyo House, Bushey Mill Lane, Watford, Herts.
Tel: Watford 30421.

DCX2500K

Stereo tuner/amplifier. AM/FM. Stereo decoder included. Output: 10W sine per channel, 15W music power. Inputs: PU 2.5mV, aux 100mV, tape play 150mV. FR: 30Hz-40kHz. Controls: volume, bass, treble, input selector, mode selector, tape monitor, high filter and loudness.

Sanyoscience



(or how to bring studio-quality hi-fi within the reach of every enthusiast!)

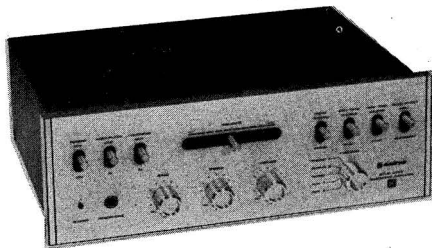

For example: the DCA 1700X — Quadrasonic stereo synthesizer giving 70 watts total music power and 20 watts per channel R.M.S. Connections for two phono and two auxiliary inputs, tuner, tape recorder two speaker systems, stereo headphones. Rotary controls for volume, bass and treble. Slide control for balance. Switches for 2-channel and 4-channel tape recorder, loudness, high filter, mode selector, function selector and quad effect. 120/240 V AC adjustable.

And again: the DCX 2300K — Solid state stereo tuner amplifier, receives AM/FM and FM and FM stereo with fitted multiplex. 45 watts total music power—15 watts continuous power per channel.



SANYO
a world of difference

For full details and name of your nearest Sanyo stockist, write to:
Sanyo Marubeni (UK) Ltd.
Bushey Mill Lane, Watford WD2 4UQ. Tel: Watford 3042

★ Indicates entry is illustrated

Bass control: ± 10 dB at 100Hz. Treble control: ± 10 dB at 10kHz. Loudness control: ± 10 dB at 100Hz. Signal to noise: better than 45dB. Meter tuning indicator. Outlet for stereo headphones, tape recorder, two sets of speakers. Price: £79.95 (including PT).

DCX2300K

Stereo tuner/amplifier. AM/FM. Stereo decoder included. Output: 15W sine per channel, 22.5W music power. Inputs: PU 2.5mV, aux 100mV, tape play 150mV. Signal to noise: PU 60dB, aux 70dB. FR: 15Hz-80kHz. Sockets for stereo headphones, tape recorder, PU, microphone and speakers. Controls: volume, mic volume, bass ± 10 dB at 100Hz, treble ± 10 dB at 10kHz, loudness: +10dB at 100Hz and +5dB at 10kHz, balance, plus switches for speakers, input selector, monitoring high filter and mono/stereo. 32 transistors, one IC, one FET. Mains: 120-240V AC. Usable sensitivity on radio: AM 25 μ V, FM 3 μ V. Price: £96.95 (including PT).

■ SCAN-DYNA

Scandinavian Audio Systems Ltd,
Sun Alliance Buildings, 65 London Road,
Gloucester, GL1 3HF.
Tel: Gloucester (0452) 32791/2.

2000 ★

Stereo tuner-amplifier. Range: FM 87-104MHz, MW 190-600 metres, LW 855-2,000 metres. Variable tuning plus five preset FM stations.



Scan-Dyna 3000



Scan-Dyna 4000

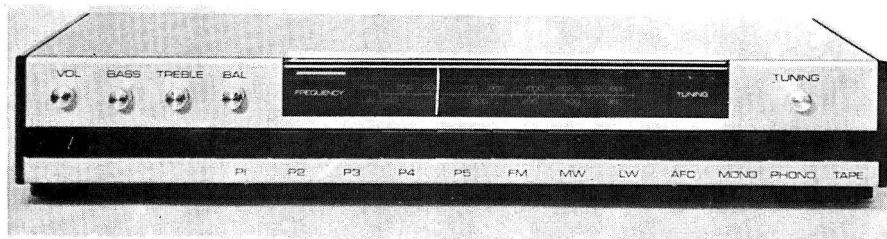

Scan-Dyna 2000

AFC. Meter tuning indicator. Usable sensitivity: (FM) 1.8 μ V, (AM) 1.0 μ V. Aerial input: 300 ohms balanced. Stereo decoder fitted. Output: 25W RMS per channel. Output impedance: 4 ohms. Headphone socket. Two sets of output sockets. Mains: 240V 50Hz. Size: 21 $\frac{3}{8}$ \times 10 \times 3 $\frac{5}{8}$ in. Finish: aluminium and matt black. Price: £72.66 (plus £12.24 PT).

3000 ★

Stereo tuner-amplifier. Range: FM 87-108MHz, MW 190-600 metres. Variable tuning. Switched AFC. Meter tuning indicator. Usable sensitivity: MW 1 μ V, FM (mono) 1.6 μ V, FM (stereo) 10 μ V. Aerial input: 75 ohms coaxial. Stereo decoder fitted. Output: 50W RMS per channel. Output impedance: 4 ohms. Stereo filter. High-pass and low-pass filters: Loudness control. Twin switched outputs. Monitor switch. Headphone socket. Mains: 110, 240V 50-60Hz. Size: 17 $\frac{3}{8}$ \times 9 $\frac{3}{8}$ \times 5in. Finish: teak or rosewood. Price: £102.62 (plus £17.28 PT).

4000 ★

Stereo tuner-amplifier. Range: FM 87-108MHz, MW 190-600 metres, LW 855-2,000 metres. Variable tuning. AFC. Meter tuning indicator. Usable sensitivity. AM 1 μ V, FM 1.2 μ V. Aerial input: 75 ohms coaxial, 300 ohms balanced. Stereo decoder fitted. Output: 60W RMS per channel. Output impedance: 4 ohms. Loudness switch. Headphone socket. Separate illuminated scales for AM and FM. Twin switched speaker sockets. Finish: teak or rosewood. Size: 21 $\frac{3}{8}$ \times



Sharp STA32L

9 $\frac{7}{8}$ × 5 $\frac{3}{8}$ in. Mains: 110, 240V 50-60Hz. Price: £111.17 (plus £18.73 PT).

■ **SHARP**

Sharp Electronics (UK) Ltd,
48 Derby Street, Manchester, M88HN.
Tel: 061-832 6115.

STA32L ★

Stereo AM/FM tuner/amplifier. Range: 88-108 MHz, 187-566 metres. 810-2000 metres. Variable tuning. Ratio detector on FM. Meter tuning indicator. AFC. Sensitivity: 5 μ V. Aerial input: (FM) 300 ohms balanced. Stereo decoder fitted. Inputs: mag PU 3mV, crystal PU 150mV, tape 200mV, aux 200mV. Controls: volume, balance, bass, treble, tuning, selector. Output: 40W RMS per channel into 4 ohms, 30W RMS per channel into 8 ohms. HD: 0.1% at 5W. FR: 30Hz-50kHz. Noise level: 4mV at minimum volume, 50mV at maximum volume. Output impedance: 4 ohms, 8 ohms, 16 ohms. Size: 4 $\frac{7}{8}$ × 18 $\frac{1}{4}$ × 14in. Price: £96.44 (plus £15.47 PT).

SA606

Stereo AM/FM tuner/amplifier. Range: FM 88-108MHz, MW 189-560 metres, LW 1,000-2,000 metres, SW 16-50 metres. Variable tuning plus FM presets. AFC. Ratio detector. Meter tuning indicator. Usable sensitivity: FM 5 μ V, AM 100 μ V. Aerial input: 300 ohms balanced. Decoder included. Output: 4W RMS per channel DIN. Output impedance: 8 ohms. Mains: 110, 220, 240V AC. Finish: Cabinet PVC laminated veneer, front panel aluminium. Size: 18 $\frac{3}{4}$ × 13 $\frac{3}{4}$ × 4 $\frac{1}{2}$ in. Price: £74.98 (plus £12.02 PT).

■ **SIEMENS**

Interconti Electronic Ltd,
Albany House, Petty France,
London, SW1H9EA.
Tel: 01-222 2523. Telex: 918770.

RS202

Five-waveband AM/FM quadrasonic tuner/amplifier. 58 semiconductors and 20 ICs. Slide controls plus pushbuttons. Output: 15W per channel. Finish: white or brown. Full specification on request. Price: £134.50 (including PT).

RS302

Four-waveband AM/FM quadrasonic tuner/amplifier. 66 semiconductors. Slide controls plus pushbuttons. Output: 30W per channel. Finish: white or light satinwood. Full specification on request. Price: £180 (including PT).

RS172

Five-waveband AM/FM quadrasonic tuner/amplifier. 87 semiconductors and 23 ICs. Slider controls plus 24 pushbuttons. Output: 50W per channel. Finish: white or light satin-

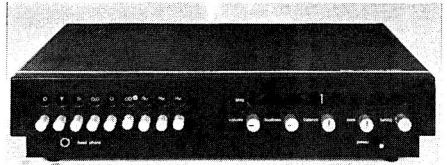

Sonab R7000

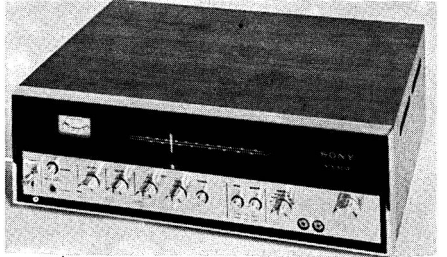

Sony STR6036

wood. Full specification on request. Price: £216 (including PT).

■ **SONAB LTD**

PO Box 4, Oldfield Road, Hampton,
Middlesex, TW122HN. Tel: 01-979 0134.

Sonab R7000 ★

Stereo tuner/amplifier. Range: FM/VHF. Variable tuning. Tuning indicator. Aerial input: coaxial. Stereo decoder fitted. AFC. Transistors. Output: 35W RMS per channel into 8 ohms. HD: 0.02% at 1kHz and 30W into rated load (never more than 0.1% at all levels 25Hz-25kHz). FR: 25Hz-25kHz ±0.5dB. Size: 15 × 3 × 11 in. Mains: 240V AC. Price: £223 (including PT).

■ **SONY (UK) LTD**

Pyrene House, Sunbury Cross,
Sunbury-on-Thames, Middlesex.
Tel: Sunbury 87644/7.

STR-6036 ★

AM/FM stereo tuner/amplifier. Range: FM/VHF, MW. Variable tuning. Ratio detector. Meter tuning indicator. Usable sensitivity: FM 2 μ V, AM 30 μ V. Stereo decoder fitted. FET front end. 39 transistors and one FET. Inputs: mag PU 2.5mV 47K, mic 2mV 47K, aux 250mV 100K, tape 250mV 100K. Noise level: (low level inputs) 60dB, aux 70dB, tape 80dB. Output: 16W RMS per channel into 8 ohms. Tone controls: bass ±10dB at 100Hz, treble ±10dB at 10kHz. HD: 0.1% at 1W. FR: 30Hz-40kHz +0dB -3dB. Mains: 100, 120, 240V AC. Size: 17 $\frac{1}{8}$ × 5 $\frac{3}{8}$ × 3 $\frac{5}{8}$ in. Finish: wood grain cabinet with black and silver facing. PA facility. Loudness control. Price: £99.75 (including PT).

★ Indicates entry is illustrated

STR-6046 ★

AM/FM stereo tuner/amplifier. Range: FM/VHF, MW. Variable tuning. Ratio detector. Meter tuning indicator. Usable sensitivity: MW 30 μ V, FM 1.4 μ V. Aerial input: 300 ohms balanced. Stereo decoder fitted. 44 transistors and one FET. Inputs: mag PU 2.5mV 47K, mic 2mV 47K, aux 250mV 100K, tape 250mV 100K. Noise level: (low level inputs) 60dB, aux 70dB, tape 80dB. HD: <1% at 1W output. Output: 25W RMS per channel into 8 ohms. FR: 30Hz-40kHz +0dB -3dB. Mains: 100, 120, 220, 240V AC. Size: 17 $\frac{1}{8}$ × 5 $\frac{3}{4}$ × 13 $\frac{5}{8}$ in. Finish: wood grain cabinet with black and silver panel. Input mixing facility. Illuminated mode display. Price: £119.75 (including PT).

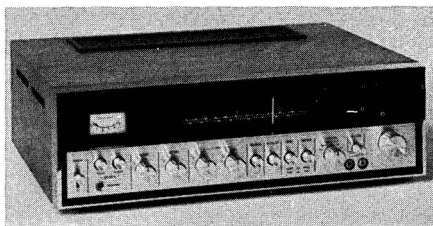

Sony STR6046

STR-6055 ★

AM/FM stereo tuner/amplifier. Range: FM/VHF, MW. Variable tuning. Ratio detector. Meter tuning indicator. FET front end. Usable sensitivity: FM 1.8 μ V, MW 20 μ V. Aerial input: 300 ohms balanced. Stereo decoder fitted. 51 transistors and five FETs. Inputs: mag PU 1.8mV 47K, aux (2) 140mV 100K, tape 140mV 100K. Noise level: mag PU 70dB, other inputs 90dB. Output: 40W RMS per channel into 8 ohms. HD: <1% at 1W. FR: 10Hz-60kHz +0dB -3dB. Mains: 100, 117, 220, 240V AC. Size: 18 × 5 $\frac{7}{8}$ × 13 $\frac{5}{8}$ in. Price: £160.15 (including PT).

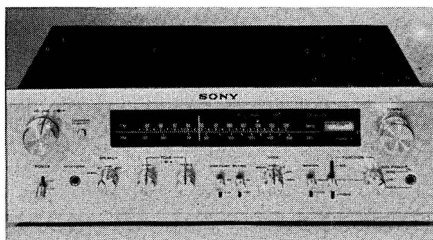

Sony STR6055

STR-6200F ★

FM stereo tuner/amplifier. Range: 87.5-108 MHz. Variable tuning. FET front end. Ratio detector. Twin tuning meters. Usable sensitivity: 1.8 μ V. Aerial input: 75 ohms coaxial, 300 ohms balanced. Stereo decoder fitted. 71 transistors and 5 FETs. Inputs: mag PU 1.4mV 47K, aux (3) 140mV 100K, tape (2) 140mV 100K. Output: 100W RMS per channel into 8 ohms. HD: <2% FR: 10Hz-100kHz +0dB -3dB. Mains: 100, 117, 220, 240V AC. Size: 19 × 5 $\frac{7}{8}$ × 15 $\frac{7}{8}$ in. Finish: wood grain and brushed aluminium. Muting facility. Bass compensator. Price: £303.48 (plus £51.12 PT).

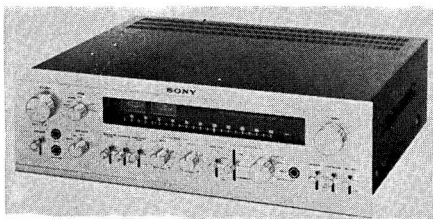

Sony STR6200F

■ TANDBERG

Distributors: Farnell-Tandberg Ltd, Farnell House, 81 Kirkstall Road, Leeds, LS3 1HR. Tel: 35111.

Solvsuper 1171 ★

Stereo tuner/amplifier. Range: FM 87.5-108 MHz, MW 188-580 metres, LW 1,120-2,000 metres, SW 16.3-57 metres. Variable tuning. Meter tuning indicator. Aerial input: 300 ohms balanced and 75 ohms coaxial. Stereo decoder optional extra. AFC. Inputs: magnetic PU 2.5mV 47K, ceramic PU 50mV 1 megohm, tape 250mV 30K. Controls: bass \pm 13dB at 50Hz, treble +10dB -14dB at 10kHz, loudness +6dB

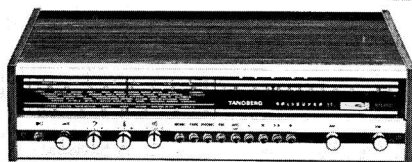

Tandberg Solvsuper 1171



Teac AG3000

at 50Hz, +3.5dB at 10kHz. Output: 15W RMS per channel. HD: 0.5% at rated output. FR: 25Hz-25kHz (DIN). Noise level: tape input 54dB, magnetic PU 53dB, ceramic PU 55dB. Output impedance: 4 ohms. Mains: 115-250V 50/60Hz. Size: $17\frac{1}{4} \times 4\frac{3}{8} \times 9\frac{3}{8}$ in. Price: £79.03 (plus £13.31 PT); stereo decoder £9.50 extra.

TR200

Stereo FM tuner/amplifier. Range: 87.5-108MHz. Variable tuning plus five presets. AFC. Meter tuning indicator. Usable sensitivity: $1\mu\text{V}$. Aerial input: 75 ohms coaxial. Stereo decoder extra. Inputs: tape 250mV 30K, PU 2.3mV 47K, aux 100mV 100K. Noise level: -52dB. Output: 15W per channel into 8 ohms, 20W per channel into 4 ohms. Output impedance: 4 ohms. Tone controls: bass $\pm 16\text{dB}$ at 50Hz, treble $\pm 15\text{dB}$ at 10kHz. Loudness: +11dB at 50Hz. HD: 1% at rated output. FR: 20Hz-40kHz $\pm 3\text{dB}$. Size: $17 \times 3\frac{1}{2} \times 9\frac{1}{2}$ in. Speaker selector switch. Magnetic/crystal PU switch. Tapemonitor switch. Headphonesocket. Finish: teak or rosewood. Price: £73.21 (plus £12.32 PT).

TEAC

Acoustico Enterprises Ltd,
6-8 Union Street, Kingston-on-Thames,
Surrey. Tel: 01-549 3471/3.

AG3000 ★

AM/FM stereo tuner/amplifier. Range: FM 88-108MHz, MW 187-560 metres. Variable tuning. Meter tuning indicator. Usable sensitivity: FM $1.8\mu\text{V}$ (IHF), MW $10\mu\text{V}$. Aerial input: 75 ohms coaxial, 300 ohms balanced. Stereo decoder fitted. Inputs: mag PU 2mV, aux 150mV, tape (2) 150 mV. Output: 40W per channel into 4 ohms. Output impedance: 4-8 ohms. Tone controls: bass $\pm 15\text{dB}$ at 50Hz, treble $\pm 11\text{dB}$ at 10kHz, loudness +10dB at 50Hz, +4dB at 10kHz, low filter -6dB/octave from 100Hz, high filter -12dB/octave from 5kHz. HD: <0.8%. FR: 20Hz-30kHz $\pm 1\text{dB}$. Mains: 100, 117, 220, 240V AC. Size: $16\frac{1}{2} \times 4\frac{3}{4} \times 14$ in. Finish: walnut case. Price: to be announced.

AG6000 ★

AM/FM stereo tuner/amplifier. Range: FM 88-108MHz, MW 187-560 metres. Variable tuning. Meter tuning indicator. Usable sensitivity: FM $1.8\mu\text{V}$ (IHF), MW $10\mu\text{V}$. Aerial input: 75 ohms coaxial, 300 ohms balanced. Stereo decoder fitted. Inputs: mag PU 2mV, aux 150mV, tape (2) 150 mV. Output: 60W per channel into 4 ohms. Output impedance: 4-8 ohms. Tone controls: bass $\pm 15\text{dB}$ at 50Hz, treble $\pm 11\text{dB}$ at 10kHz, loudness $\pm 10\text{dB}$ at 50Hz, +4dB at 10kHz, low filter -6dB/octave from 100Hz, high filter -12dB/octave



Teac AG6000



Teac AG6500



Teac AG7000

from 5kHz. HD: <0.8%. FR: 20Hz-30kHz $\pm 1\text{dB}$. Mains: 100, 117, 220, 240V AC. Finish: walnut trim. Price: £160.73 (plus £28.13 PT).

AG6500 ★

AM/FM stereo tuner/amplifier. Range: FM 88-108MHz, MW 187-560 metres. Variable tuning. AFC. Two tuning meters. Usable sensitivity: FM $1.7\mu\text{V}$, MW $10\mu\text{V}$. Aerial input: 75 ohms coaxial, 300 ohms balanced. Stereo decoder fitted. Output: 45W per channel. Output impedance: 8 ohms. HD: <0.5%. FR: 5Hz-20kHz +0dB -1dB. Mains: 100, 117, 220, 240V AC. Finish: walnut and black with silver trim. Price: approximately £265 (including PT).

AG7000 ★

AM/FM stereo tuner/amplifier. Range: FM 88-108MHz, MW 187-560 metres. Variable tuning. AFC. Two tuning meters. Usable sensitivity: FM $1.2\mu\text{V}$, MW $10\mu\text{V}$. Aerial input: 75 ohms coaxial, 300 ohms balanced. Stereo decoder fitted. Dual gate FET front end. 31 transistors, 4 FETs, 2 ICs. Inputs: mag PU 2mV 47K, tape 150mV, aux 150mV. Noise level: mag PU -65dB. Output: 65W RMS per

★ Indicates entry is illustrated

channel. Output impedance: 8 ohms. Tone controls: bass ± 15 dB at 50Hz; treble ± 11 dB at 10kHz, loudness +10dB at 50Hz, +4dB at 10kHz, low filter -6dB at 100Hz, high filter -12dB/octave from 5kHz. HD: <0.5%. FR: 5Hz-35kHz ± 1 dB. Mains: 100, 117, 220, 240V AC. Size: $16\frac{1}{4} \times 4\frac{3}{4} \times 14$ in. Finish: walnut. Price: £191.91 (plus £33.63 PT).

■ TELEFUNKEN

Distributor: AEG (Great Britain) Ltd,
AEG House, Chichester Rents,
Chancery Lane, London, WC2.
Tel: 01-242 9944. Cables: Allgem, London.

Concertino 301

Four waveband transistorised stereo tuner/amplifier with five FM station buttons. Ranges: FM, SW, MW, LW. Separate flywheel FM and AM tuning. AFC with meter. Separate VU meter for station tuning control. Automatic stereo indicator. Sensitivity: FM $1\mu\text{V}$ for 26dB signal/noise ratio at 40kHz deviation. Output: 15W per channel RMS. HD not greater than 1%. FR: (± 1.5 dB) 20Hz-20kHz. Sockets for 240 ohms FM dipole, local FM dipole (attenuator fitted), AM aerial, PU (high impedance), tape recorder (record and playback), two extension speakers. Controls: volume, balance, bass, treble. Pushbuttons: on/off, stereo, PU/tape, wavebands, 5 FM stations, AFC. Mains: 110/127, 220/240V 50Hz. Price: £125.56 (including PT).

R205 ★

Four waveband radio with stereo amplifier. Ranges: FM, SW, MW, LW, VU meter. AFC. Output: 6W per channel RMS. Output impedance: 4 ohms. Sockets for 240 ohms FM dipole, local FM dipole (attenuator fitted), AM aerial, high-impedance PU, tape recorder (record and playback), two extension speakers. Controls: volume on/off, balance, bass, treble. Pushbuttons for stereo, PU/tape, AFC, four wavebands. Mains: 110/127, 220/240V 50Hz. Price: £74.75 (including PT).

Concerto Hi-Fi 101 ★

Five waveband stereo tuner/amplifier. Range: 87.6-104MHz, 910-2,000 metres, 186-212 metres, 211-578 metres, 19-51 metres. Variable tuning plus seven preset FM stations. Tuning meter. Sensitivity: FM $1\mu\text{V}$ for 26dB S/N; AM $6\mu\text{V}$ for 50 mW output at 30% modulation, $15\mu\text{V}$ for 10dB S/N. Stereo decoder fitted. Stereo beacon. Switchable AFC. Inputs: magnetic PU, crystal PU, tape recorder. Controls: pushbuttons for preset FM stations, AFC, wavebands, mono/stereo, input selector. Rotary controls for tuning volume, balance, treble, bass. Output: 30W music power per channel, 22W RMS per channel. HD: better than 1% at rated output. FR: 20Hz-20kHz ± 1.5 dB. Output impedance: 4

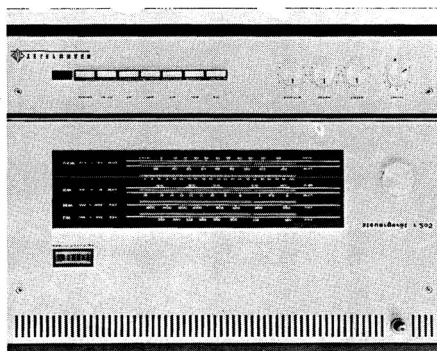

Telefunken R205

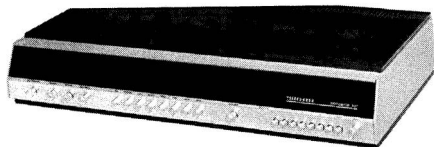

Telefunken Concerto Hi-Fi 101

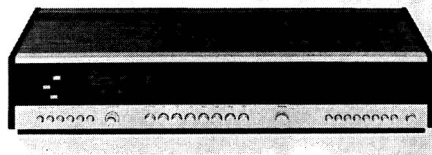

Telefunken Hymnus 101



Trio KR2120

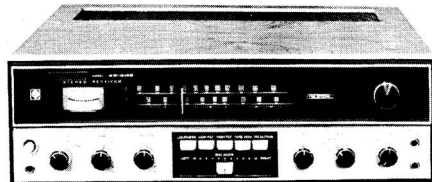

Trio KR4140

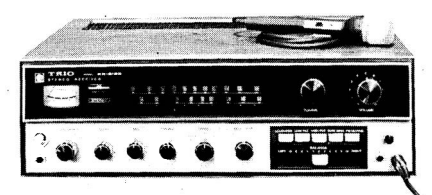

Trio KR6160

ohms. Socket for stereo phones, 43 transistors, 20 diodes, 4 rectifiers. Mains: 110, 127, 220, 240V 50Hz. Two FETs in FM tuner stage. Variable capacity diode tuning. Price: £130.66 (including PT).

Hi-Fi Compact 2000

FM tuner/amplifier. Range: FM 87.6-104MHz. Variable tuning. Stereo decoder fitted. Inputs: magnetic PU, crystal PU, tape. Controls: treble, bass, balance, volume, pushbutton function selectors. Switchable AFC. Output: 15W RMS per channel, 22W music power per channel. HD: <1% at rated output. FR: 20Hz-20kHz ± 1.5 dB. Output impedance: 4 ohms. 43 transistors, 10 diodes, 3 rectifiers. Stereo headphone socket. Mains: 110, 220V 50-60Hz. Consumption: 65W maximum. Sensitivity: 1.3 μ V for 26dB S/N. Price: to be announced.

Hymnus 101 ★

AM/FM stereo tuner/amplifier. Range: FM, MW, LW, SW. Variable and preset tuning. AFC. Meter tuning indicator. Stereo decoder fitted. Output: 30W RMS per channel. Mains: 2,220-240V AC. Size: 25 \times 10 $\frac{1}{2}$ \times 4 $\frac{3}{4}$ in. Finish: light matt walnut. Price: to be announced.

TELETON

Teleton Electro (Distributors) Ltd, Teleton House, Robjohns Road, Widford, Chelmsford, Essex.
Tel: Chelmsford 62442. Telex: 99338.

F.2300

AM/FM stereo solid-state tuner/amplifier. Ranges: 88-108MHz, MW 187-560 metres. Sensitivity: FM 10 μ V, AM 150 μ V/m. IF bandwidth: FM 300kHz, AM 7kHz. Image rejection: FM 45dB, AM 36dB. Signal/noise: AM 30dB. Aerials: FM 300 ohms balanced, AM ferrite rod. Output: 4.5W RMS per channel. FR: 30Hz-15kHz. Signal/noise: 50dB 1kHz. Mains: 220V 50Hz. Dimensions: 16 $\frac{1}{2}$ \times 10 \times 4 $\frac{1}{2}$ in. Price: £44.86 (plus £7.20 PT).

TFS.50 LA

AM/FM stereo solid-state tuner/amplifier. Ranges: 87-108MHz, 187-565 metres. Sensitivity: FM 5 μ V (30dB quieting), AM 200 μ V/m (S/N 20dB). Multiplex separation: 35dB at 1kHz. Image rejection: FM 50dB, AM 60dB. Aerials: ferrite rod and 300 ohms balanced input. Output: 15W RMS per channel at 8 ohms. Controls: six rotary and ten push keys. Mains: 115, 230V AC. Dimensions: 19 $\frac{1}{2}$ \times 12 $\frac{1}{2}$ \times 4in. Price: £80.08 (plus £12.85 PT).

TRIO

Distributors: B. H. Morris & Co (Radio) Ltd, 84-88 Nelson Street, Tower Hamlets, London, E1 2DY. Tel: 01-790 5011.

KR2120 ★

AM/FM stereo tuner/amplifier. Range: FM 88-

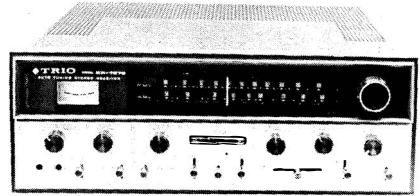

Trio KR7070

108MHz. MW 187-550 metres. Variable tuning. Meter tuning indicator. Sensitivity: 2.3 μ V (IH-FM standard). Aerial impedance: 75 ohms coaxial, 300 ohms balanced. Stereo decoder fitted. Inputs: PU (1) 2.5mV 50K, PU (2) 2.5mV 50K, aux/tape 180mV 30K. Noise level: PU inputs -60dB, aux/tape -70dB. Controls: volume, treble, bass, loudness, balance, input selector. Output: 12W RMS per channel. HD: 0.2% at rated output. FR: 25Hz-20kHz (IHFM standard). Output impedance: 4-16 ohms. Mains: 110-120 and 220-240V 50/60Hz. Size: 16 $\frac{3}{4}$ \times 5 $\frac{1}{4}$ \times 12 $\frac{3}{8}$ in. Circuit incorporates FETs, ICs, step-type tone controls, two sets speaker outlets. Price: £85.28 (plus £11.22 PT).

KR4140 ★

AM/FM stereo tuner/amplifier. Range: FM 88-108MHz, MW 187-556 metres. Variable tuning. Meter tuning indicator. Sensitivity: 1.8 μ V (IH-FM standard). Aerial impedance: 75 ohms coaxial and 300 ohms balanced. Stereo decoder fitted. Inputs: magnetic PU (1) 2.5mV 50K, magnetic PU (2) 2.5mV 50K, aux/tape 150mV 100K, microphone 1.8mV 100K. Noise level: mic input -58dB, mag PU -65dB, aux/tape input -75dB. Controls: volume, bass, treble, balance, mono/stereo, input selector. Output: 24W per channel RMS. HD: 0.1% at rated output. FR: 18Hz-30kHz (IHFM standard). Output impedance 4-16 ohms. Circuit incorporates FETs, ICs and ceramic filters. Two sets of speaker outlets. Price: £131.56 (plus £17.44 PT).

KR6160 ★

AM/FM stereo tuner/amplifier. Range: FM 88-108MHz, MW 187-556 metres. Variable tuning. Two tuning meters. Sensitivity: 1.6 μ V (IHFM standard). Aerial impedance: 75 ohms coaxial and 300 ohms balanced. Stereo decoder fitted. Inputs: magnetic PU (1) 2.5mV 50K, magnetic PU (2) 2.5mV 50K, aux/tape (1) 180mV 100K, aux/tape (2) 180mV 100K, microphone 1.8mV 100K. Noise level: magnetic PU and mic inputs -65dB, other inputs -75dB. Controls: volume, bass, middle, treble, balance, input selector. Output: 70W RMS per channel. HD: 0.1% at rated output. FR: 12Hz-30kHz. Output impedance: 4-16 ohms. Circuit incorporates FETs, ICs, low and high filters and middle-range tone

★ Indicates entry is illustrated

control. Step-type controls. Wood sleeve fitted. Mains: 110-120V and 220-240V 50/60Hz. Size: $16\frac{3}{4} \times 5\frac{1}{2} \times 12\frac{3}{8}$ in. Price: £176.70 (plus £23.25 PT).

KR7070 ★

AM/FM stereo tuner/amplifier. Range: FM 88-108MHz, MW 187-556 metres. Variable and automatic tuning. Meter tuning indicator. Sensitivity: 1.5µV (IHF standard). Aerial impedance: 75 ohms coaxial and 300 ohms balanced. Stereo decoder fitted. Inputs: magnetic PU (1) 0.05mV 200 ohms, magnetic PU (2) 2.5mV 50K, microphone 2.5mV 100K, aux/tape play 200mV 100K. Noise level: PU (1) -45dB, PU (2) -65dB, mic -67dB, aux/tape -75dB. Controls: volume, bass, treble, balance, mono/stereo, input selector, filters, loudness, presence. Output: 90W RMS per channel. HD: <0.05% at rated output. FR: 10Hz-30kHz (IHF standard). Output impedance: 4-16 ohms. Automatic and remote station tuning. Tape dubbing facilities. Full range of filters. Mains: 110-120V and 220-240V 50/60Hz. Size: $17 \times 6\frac{1}{2} \times 15$ in. Price: £280.96 (plus £37.04 PT).

KR2200

AM/FM stereo tuner/amplifier. Range: FM 88-108MHz, MW 187-556 metres. Variable tuning. AFC. Meter tuning indicator. Usable sensitivity: FM 2.5µV, AM 25µV. Aerial input: 300 ohms balanced, 75 ohms coaxial. Stereo decoder included. One FET, 32 transistors, 30 diodes, one zener. Inputs: mag PU 3mV 50K, mic 3mV 50K, aux 120mV 30K. Noise level: (PU and mic inputs) 60dB, (aux input) 70dB. Output: 10W RMS per channel. Output impedance: 4-16 ohms. Tone controls: bass ±8dB at 100Hz, treble ±8dB at 10kHz. Loudness: -30dB +8dB at 100Hz. A-B speaker switching. Mode: mono, stereo, quadrix, discrete. HD: 0.8% at rated output, 0.2% at -3dB. FR: 25Hz-35kHz ±2dB. Mains: 110/120V, 220/240V AC. Size: $17\frac{5}{8} \times 4\frac{3}{4} \times 15\frac{1}{2}$ in. Finish: wood case with satin aluminium fascia. Price: to be announced.

KR5200

AM/FM stereo tuner/amplifier. Range: FM 88-108MHz, MW 187-556 metres. Variable tuning. AFC. Sensitivity: FM 1.8µV, MW 15µV. Aerial input: 300 ohms balanced, 75 ohms coaxial. Stereo decoder included. Two FETs, one IC, 52 transistors, 48 diodes. Inputs: mag PU 2.5mV 50K, mic 3mV 50K, aux (1) 125mV 30K, aux (2) 125mV 30K, tape play (A and B) 125mV 30K. Noise level: mic input 55dB, PU input 65dB, aux and tape inputs 75dB. Tone controls: bass ±10dB at 100Hz, treble ±10dB at 10kHz, high filter -10dB at 10kHz, low filter -7dB at 100Hz. Loudness: -30dB +10dB at 100Hz, +5dB at 10kHz. Switch for speakers A + B + C;

A + B and A + C. Quiet tuning facility on FM. Output: 40W RMS per channel. Output impedance: 4-16 ohms. HD: 0.5% at rated output, 0.1% at -3dB. FR: 20Hz-40kHz ±2dB. Mains: 110-120V, 220-240V AC. Size: $17\frac{5}{8} \times 5\frac{3}{4} \times 14$ in. Finish: wood case with satin aluminium fascia. Price: to be announced.

KR6170 Jumbo

AM/FM stereo tuner/amplifier with electronic rhythm and percussion generators built in. Range: 88-108MHz, MW 187-556 metres. Variable tuning. Tuning meter. Left- and right-channel level meters. Usable sensitivity: FM 1.9µV, MW 25µV. Inputs: mag PU (2) 2.5mV 50K, mic 2mV 10K, guitar 15mV 30K, aux (2) 150mV 100K, tape play (2) 150mV 100K. Output: 55W per channel into 8 ohms. Output impedance: 4-14 ohms. HD: 0.1% at -3dB rated power. Power bandwidth (IHF) 17Hz-30kHz. Electronic rhythm produces 12 different rhythms and five different percussions. Reverberation control 0-2 seconds. Echo sound output for four channel reproduction. Four sets of speaker terminals. Three-step power limiter for speaker protection. Two-hour timer for automatic switch off. Two sets of headphone jack sockets. Mains: 110/120V, 220/240V AC. Size: $21\frac{3}{4} \times 6\frac{3}{4} \times 16\frac{1}{4}$ in. Weight: 35lb. Accessories: (included in price) dynamic microphone, foot switch for rhythm composer. Price: £238.45 (plus £31.05 PT).

■ YAMAHA

Jonathan Fallowfield Ltd, Strathcona Road, North Wembley, London, HA98QL.
Tel: 01-904 0141.

CR-500

AM/FM stereo tuner/amplifier. Range: FM 88-108MHz, MW 186-560 metres. Variable tuning. AFC. Meter tuning indicator. Usable sensitivity: AM 20µV, FM 2µV. Aerial input: 300 ohms balanced, 75 ohms coaxial. Stereo decoder included. Output: 22W RMS per channel. Two mic inputs with separate volume control. Auto stereo beacon. Mains: 110-240V AC. Finish: steel grey cabinet with brushed chrome fascia. Sizes: $17 \times 12 \times 6$ in. Price: £99 (plus £16 PT).

CR-700

AM/FM stereo tuner/amplifier. Range: 88-108MHz, MW 186-560 metres. Variable tuning. Auto-touch AFC switching. Meter tuning indicator. Usable sensitivity: AM 15µV, FM 1.7µV. Aerial input: 300 ohms balanced, 75 ohms coaxial. Auto-touch FM tuning. Two-stage RF circuit. High-pass and low-pass filters. Output: 40W RMS per channel. Finish: walnut cabinet with brushed chrome fascia. Size: $16\frac{1}{2} \times 6 \times 12$ in. Price: £139 (plus £21 PT).

Now calm down



It is perfectly clear to see that all you really want is to own a balanced Stereo Hi-Fi system that will delight your family, will blend with your decor and that won't cost you the earth.

So you have read the "Hi-Fi Year Book" from cover to cover and all the advertisements, your friends have added their advice—which differs strangely from the experts recommendations and advertisers claims. It's not surprising that your head is spinning and that you are feeling utterly confused!

Calm down! Now is the time to stop—look and listen at Lasky's and let us do the worrying. We have specialised in high fidelity since its birth, we have nursed it through infancy and now that it's growing up we know every one of its problems and perhaps most important of all we know 99% of the answers—that's why we don't lose our composure so easily. We stock an incomparable range of equipment which together with expert guidance from our staff enables you, in one place, at one time, to select the system best suited to your requirements at the price you can afford and our comprehensive after sales service and continuing interest assures your lasting pleasure and satisfaction.

If you are unable to pay us a visit and you are still feeling confused please do not hesitate to write to our Hi-Fi planning department, who will give a free quotation on a complete system "custom planned" to your specification and budget.

Be cool, calm and collected at the Home of High Fidelity.

Lasky's

Mail orders. 3-15 Cavell Street, London E1 2BN.

Branches.

42-45 Tottenham Court Road, London W1.

33 Tottenham Court Road, London W1.

207 Edgware Road, London W.2.

109 Fleet Street, London EC4.

Take a good look, then listen...

'Hi-Fi Sound'

For its price the UA 700 is an excellent amplifier and has a performance that compares with that of amplifiers costing more. It is well designed and constructed and its facilities are more than adequate for the usual Hi-Fi signal sources.

'The Gramophone' 'Hi-Fi News'

It has been a pleasure to test this new amplifier and find that, contrary to the impression one sometimes receives with the audio units assembled by radio and TV Companies, the design is quite forward-looking and offers excellent value at its low price.

I found the subjective performance at least equal to that of amplifiers costing almost twice as much—power capacity apart. This is a budget Hi-Fi amplifier that I can thoroughly recommend.

Rec. price £37.93

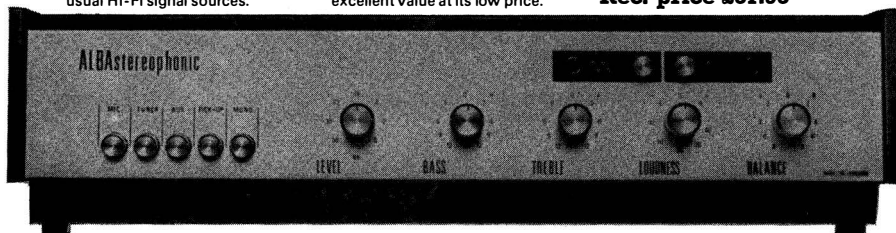

Literature and copy of full report from:

ALBA

Alba (Radio & Television) Ltd.,
Tabernacle Street, London, E.C.2.

Grampian

'SERIES 7 AMPLIFIERS'

Providing continuous rated

sinusoidal power into reactive loads having phase shift up to 35°.

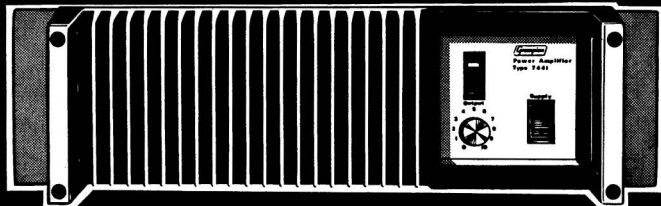

**For other manufactured products including
Ambiophonic, Reverberation Units and
Microphones consult...**

GRAMPIAN REPRODUCERS LIMITED
Hanworth Trading Estate, Feltham, Middlesex.
Telephone: 01-894 9141.

JACW/X/162

KLINGER

HI-FIDELITY
STEREO

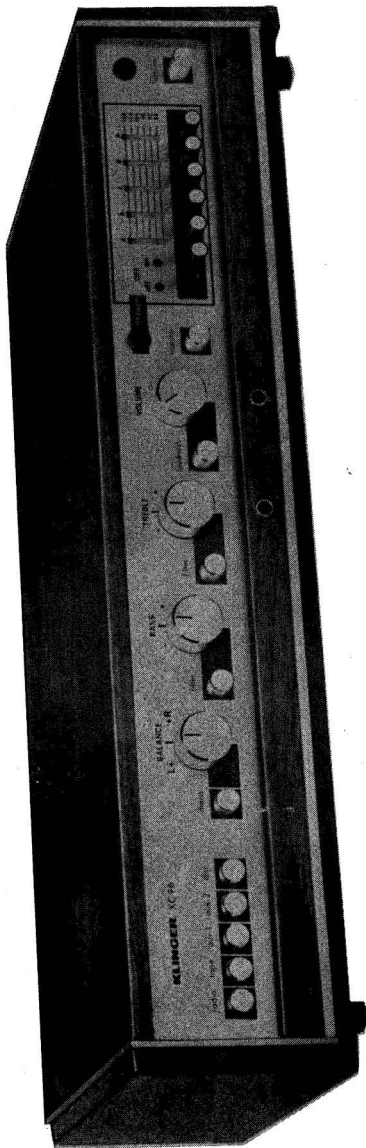

MODEL KC 96 TUNER AMPLIFIER — *One of a matching range of six models*

- * All silicon dual 25 Watt RMS Power Amplifiers.
- * Stabilised power supply.
- * Wide range precision ganged tone controls.
- * Scratch Filter.
- * Rumble Filter.
- * Contour (loudness) control.
- * Comprehensive tape record and replay facilities with A/B (Monitor) switch.
- * Two stereo headphone sockets.
- * Individual switching for two pairs of loudspeakers.
- * Solid state FM stereo tuner of outstanding performance and stability.

WRITE OR TELEPHONE FOR LITERATURE AND FULL SPECIFICATION ON ENTIRE RANGE.

Designed, Engineered and Manufactured in London by

KLINGER CONTROLS LTD. 7 Chalcot Road London NW1 8LU Telephone 01-586 2922/3

TRIO

Stereo Amplifiers

from 16 to 55 watts RMS per channel

AM/FM Stereo Tuners

to match every amplifier, all with integral multiplex decoder

AM/FM Stereo Receivers

from 10 to 90 watts RMS per channel

Stereo Cassette Decks

with and without Dolby noise reduction

Transcription Turntable

fully integrated with pick-up arm, cartridge plinth and cover

All these plus stereo headphones, a quadrophonic adaptor and a noise reduction unit comprises the complete 1973 TRIO range, totalling 22 individual units, each and every one a prime example of TRIO's enviable reputation for quality, performance and value for money. You will find all the current TRIO models featured in the respective sections of the Hi-Fi year book. To see and hear them you must visit your local franchised dealer – there are now over 350 throughout Great Britain, the Republic of Ireland and the Channel Isles.



TRIO

*exclusive United Kingdom distributors B. H. Morris and Co. (radio) Limited
84-88 Nelson Street, London E1 2DY Tel. 01-790 5011*

TRIO equipment is available in the U.S.A. and other parts of the world under the Kenwood brand name.

Directory of Amplifiers and Control Units

★ Indicates entry is illustrated

Abbreviations used in this section are given on page 36.

■ ACOUSTICAL MANUFACTURING See Quad.

■ ACOUSTIC RESEARCH

Pending new distribution arrangements in the UK all AR products are available direct from Acoustic Research International, Radiumweg 7, Amersfoort, Holland (POB 209). Tel: (03490) 12556.

AR Universal Amplifier

Integrated stereo amplifier. Inputs: magnetic PU 2-5mV (adjustable) 50K, tape 200mV 150K, aux 200mV 150K. Noise level: PU input 57dB, other inputs 75dB. Controls: bass, treble, balance, volume, input selector, mono/stereo mode. Output: 60W RMS per channel. HD: <0.5%. FR: 20Hz-20kHz ± 1dB. Output impedance: 4-16 ohms. Mains: 100, 120, 220, 240V 50/60Hz. Size: 15½ × 4½ × 10in. Price: on application.

■ ALBA (RADIO & TELEVISION) LTD Tabernacle Street, London, EC2.

Tel: 01-253 1322.

UA700 ★

Integrated stereo amplifier. Inputs: mic 2.3mV 50K, aux (1) 2V 3 megohms, aux (2) 375 mV at 500K, radio 100mV 150K, magnetic PU 5mV 50K, ceramic PU 60mV. Controls: volume, bass ± 15dB at 60Hz, treble ± 15dB at 14kHz, loudness, balance, input selector pushbuttons. Output: 15W per channel (20W per channel IHF rating). HD: <0.1% up to rated output. FR: 30Hz-18kHz ± 1dB. Noise level: (magnetic PU) -55dB, (aux and radio) -63dB. Crosstalk: better than -38dB. Output impedance: 8-15 ohms. AC mains 240V 50/60Hz. Size: 16½ × 4 × 7½in. Finish: teak end pieces, black leathercloth top and brushed aluminium front panel. Price: £37-93.

■ ALPHA

Highgate Acoustics Ltd,
184-188 Great Portland Street, London, W1.
Tel: 01-636 2901.

F212 ★

Integrated stereo transistor amplifier. Inputs: magnetic PU 5mV 50K, ceramic PU 50mV 1 megohm, tape recorder 150mV 350K, aux 500mV 1 megohm. Tone controls: bass ± 12dB, treble ± 12dB. Output: 12W RMS per channel. HD: <0.1% at 8W output, <0.5% at 10W. FR: 20Hz-20kHz. Output impedance: 8 ohms. Outputs for four speakers. AC mains. Size: 10½ × 3½ × 7½in. Price: £37-75.

FA200 ★

Integrated stereo amplifier. 18 transistors. Inputs: mag PU 3mV 50K, crystal PU 250mV 1M, aux 200mV 22K, radio 200mV 22K, tape 200mV 22K. Noise level: (mag PU) 60dB, (other inputs) 70dB. Output: 10W RMS per channel. Output impedance: 8 ohms. Tone controls: bass slider + 14dB - 12dB at 50Hz, treble slider + 12dB - 14dB at 10kHz. HF filter switch - 8dB at 10kHz. HD: <0.4% at 8W output. FR: 20Hz-25kHz ± 3dB. Finish: teak with brushed aluminium. Size: 13½ × 5 × 9½in. Mains: 110, 240V AC. Price: £32.

FA300 ★

Integrated stereo amplifier. 18 transistors. Inputs: mag PU 3mV 50K, crystal PU 250mV 1M, aux 200mV 22K, radio 200mV 22K, tape 200mV 22K. Noise level: (mag PU) 60dB, (other inputs) 70dB. Output: 14W RMS per channel. Tone controls: bass slider + 14dB - 12dB at 50Hz, treble slider + 12dB - 14dB at 10kHz, loudness switch + 12dB at 50Hz + 3dB at 10kHz. HD: <0.5% at 12W. Output impedance: 8 ohms. FR: 20Hz-25kHz ± 3dB at 12W. Finish: teak and brushed aluminium. Size: 13½ × 5 × 9½in. Mains: 110, 240V AC. Price: £39-95.

FA400 ★

Integrated stereo amplifier incorporating 17 transistors and two ICs. Inputs: mag PU 3mV 50K, crystal PU 250mV 1M, aux 200mV 22K, radio 200mV 22K, tape 200mV 22K. Noise level: (mag PU) 60dB, (other inputs) 70dB. Output: 18W RMS per channel. Output impedance: 8 ohms. Tone controls: bass slider + 14dB - 12dB at 50Hz, treble slider + 12dB - 14dB at 10kHz, loudness switch + 12dB at 50Hz and + 3dB at 10kHz. Low filter - 10dB at 50Hz. High filter - 12dB at 10kHz. HD: 0.5% at 15W. FR: 20Hz-30kHz ± 3dB at 15W. Finish: teak and brushed aluminium. Size: 14½ × 5 × 9½in. Mains: 110, 240V AC. Price: £46-50.

■ AMSTRAD ELECTRONICS LTD

34/35 Great Sutton Street, London, EC1.
Tel: 01-251 0241/2.

8000 Mk II ★

Stereo transistor amplifier. Inputs: magnetic PU 4mV 47K, ceramic PU 80mV, crystal PU 350mV,

★ Indicates entry is illustrated



Alba UA700

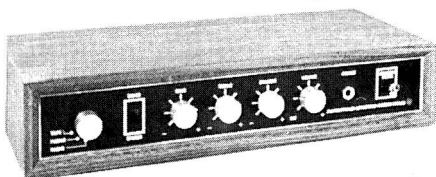

Amstrad 8000 MkII

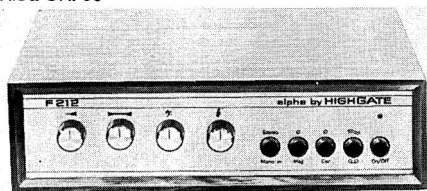

Alpha F212

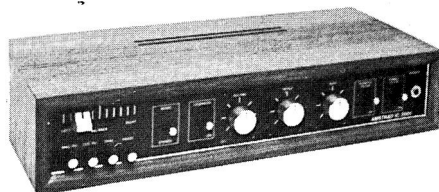

Amstrad IC2000

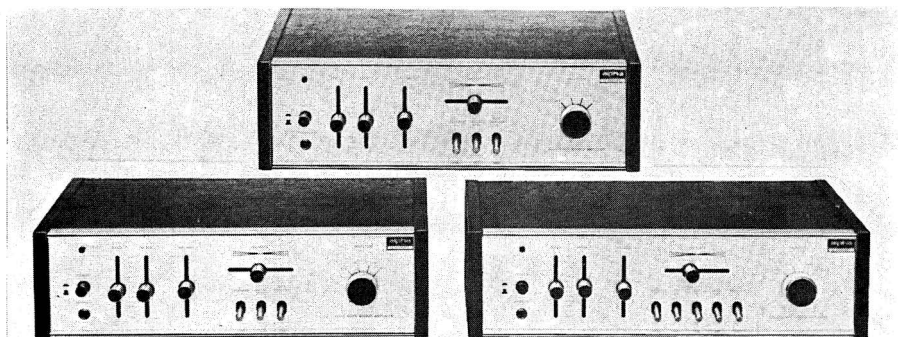

Alpha FA200

Alpha FA300

Alpha FA400

radio 100mV, tape 100mV. Noise level: -55dB on all inputs. Overload capability: 25dB on all inputs. Output: 7W RMS per channel. Controls: bass, treble, balance, volume, scratch filter, mono/stereo. HD: 0.5% at 5W. Output impedance: 8 ohms. FR: 25Hz-20kHz±3dB. Mains: 220-240V 50Hz. Size: 17×3×7in. Finish: teak cabinet with black trim. Price: £27.95.

IC 2000 ★

Stereo amplifier incorporating integrated circuits. Inputs: magnetic PU 3mV 47K, ceramic PU 60mV, tape 100mV, radio 100mV. Noise level: magnetic PU -55dB, other inputs -60dB. Overload capability 33dB on all inputs. Output: 18W RMS per channel. Controls: volume, balance, bass, treble, loudness, scratch filter, rumble filter, mono/stereo. HD: 0.5% at 18W. Output impedance: 8 ohms. FR: 20Hz-25kHz±3dB. Mains: 220-240V 50Hz. Size: 17×3×7in. Finish: teak cabinet with black facia and silver trim. Price: £42.95.

■ A/R/D

Audio Research and Development Ltd, PO Box 73, Hounslow, Middlesex. Tel: 01-570 0471.

2000 Series 2 ★

Solid state stereo amplifier. Power output 15W RMS into 8 ohms. HD: 0.25% at 15W RMS. FR: 20Hz-20kHz±0.5dB. Controls: bass ±12dB at 50Hz; treble ±12dB at 10kHz; volume, balance. Pushbuttons for on/off, radio, tape record. Inputs: PU sockets with DIN duplicates for tape and radio: tape record, tape play, radio tuner, ceramic pickup, magnetic pickup, with RIAA equalisation. Psn: 190/255V 50Hz or 110-120V 60Hz. Dimensions: 7×4½×12in. Price: (grey case) £54; (teak veneered case) £58.

■ ARGON

Hampstead High Fidelity, 91 Heath Street, London, NW3 6SS. Tel: 01-435 0999 and 6377. New stereo amplifier system. No details of specification available as this edition closed for press.

ARMSTRONG AUDIO LTD

Walters Road, London, N7. Tel: 01-607 3213.

Model 521 ★

Integrated stereo transistor amplifier. Inputs: PU (1) 60mV 100K, PU (2) 3.5mV 50K, radio 100mV 100K, tape play 400mV 100K. Noise level: PU -55dB, radio -60dB, tape -70dB. Controls: balance (maximum to zero each channel), bass ± 10 dB, treble ± 10 dB, loudness (two different volume levels with loudness contours at low level), rumble filter -5dB at 30Hz, treble filter (1) 6.5kHz -3dB, 10kHz -25dB; treble filter (2) 4.5kHz -3dB, 9kHz -40dB. Output: 25W RMS per channel. Output impedance: 4-16 ohms. Output transistors: AL102. FR: 20Hz-20kHz -1dB at 25W RMS. Mains: 100-125V and 200-250V. AC. Size: 11½in wide, 10¾in deep, 4¾in high. Price: £56.

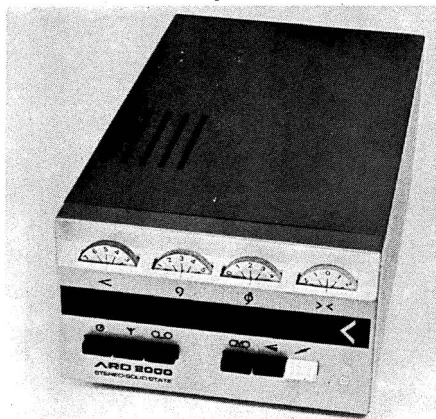

ARM 2000

ASTRONIC

Associated Electronic Engineers Ltd,
Dalston Gardens, Stanmore, Middlesex,
HA7 1BL. Tel: 01-204 2125.

Series 1700

Modular amplifying equipment, enables a special system to be built up from standard units.

Type 1701

Basic 10W amplifier with 8 ohms output. Source impedance: 1 ohm. Inputs: impedance 1,000 ohms; sensitivity: 0.5V. FR: 40Hz-40kHz+1dB, 40Hz-12kHz+2dB. Noise: -75dB. Distortion: 1%. Psn: 200-250V 40-60Hz, 30VA. Dimensions: 5×7×6½in. Weight: 7lb. Input connections by single coax plug/socket. Output connection by terminal block. Various types of pre-amplifier modules available. Full details on request.



Armstrong Audio 521

100K, noise level -60dB; radio, tape and aux, 75mV, 50K, noise level -60 to -70dB. Controls: volume and on/off; balance; bass; treble; selector; mode; monitor; rumble filter. Mains powered. Dimensions: 13¾×5¼×10¾in. Price: (chassis) £61; (cabinet model) £66.

A new Bryan amplifier, in addition to the 9000/50, is being released in October, 1972. Details of price and specification were not available as this edition of the Hi-Fi Year Book closed for press.

BRADMATIC LTD

338 Aldridge Road, Streetly, Sutton Coldfield,
Warwickshire. Tel: 021-353 3171.

Solid state mono and stereo power amplifiers manufactured to order. Enquiries welcomed and full details of service offered provided on request.

BRYAN AMPLIFIERS LTD

18 Greenacres Road, Oldham, Lancs.
Tel: 061-624 4074.

9000/50

Integrated stereo amplifier and control unit. Output: 25W per channel into 15 ohms. HD: better than 0.1%. FR: 35Hz-33kHz±1dB at 1W. Feedback -60dB. Output impedance 4-15 ohms. Inputs: magnetic pickup, 3mV, 50K, noise level -70dB; ceramic pickup, 40mV,

BUSH NELSON LTD

Bush House, 6 Yattendon Road, Horley, Surrey.
Tel: Horley 5983.

Integrated transistor stereo amplifier

Controls: on/off, mono/stereo, volume, balance, bass, treble. Output: 35W music (total). FR: 15Hz-30kHz±1dB at 1W. Size: 12×6×2in. Price: £31.

CAMBRIDGE AUDIO

Cambridge Audio Ltd, The River Mill,
St Ives, Huntingdon, PE17 4EP.
Tel: St Ives (Hunts) 62901.

★ Indicates entry is illustrated

P50 ★

Stereo integrated amplifier. Output: 25W per channel into 8 ohms, 15W into 15 ohms (both at 1kHz). FR: 25Hz-25kHz ± 0.5dB. HD: < 0.05% at all levels up to rated output. Intermodulation distortion: < 0.1% at all levels up to rated output. S/N: > 60dB on pickup input, > 70dB on tuner input (both figures unweighted and unaffected by volume setting). Inputs: PU 3mV 47K, PU 100mV 100K (both RIAA equalised), radio 25mV 180K flat, aux 150mV 100K flat. Tape monitor: 500mV. Tape output: 250mV. Crosstalk: better than 50dB at 1kHz. Size: 16½ × 9⅝ × 2in. Price: £89.95.

P100

Similar specification to the P50 amplifier but power output 50W per channel into 8 ohms, 36W per channel into 5 ohms. Also PU2 3mV 47K. Price: £139.

■ CANTERBURY AUDIO

4 Station Road, West Canterbury, Kent.
Tel: Canterbury 60431.

Stereo 80 Series

Modular construction integrated stereo amplifier. Inputs: pickup, tape and radio with individual preset gain controls. Tone controls:

bass ± 15dB at 100Hz, treble ± 15dB at 10kHz. Scratch filter: -12dB/octave from 5kHz. Rumble filter: -12dB/octave from 100Hz. Output: 35W RMS per channel. Output impedance: 4 ohms (also suitable for 8 and 15 ohm speakers but will supply reduced power). S/N ratio: better than 65dB. FR: 25Hz-25kHz ± 1dB. HD: 0.02% at 1kHz. Mk I with integral input selector module. Mk II with separate input selector module adaptable to different inputs. Price: (Mk I) £31.95; (Mk II) £33.45; (regulated modular power supply) £6.95; (Mk I in cabinet with power supply) £38; (Mk II in cabinet with power supply) £39.75.

■ CROWN INTERNATIONAL

Macinnes Laboratories Ltd,
Stonham, Stowmarket, Suffolk, IP14 5LB.
Tel: Stonham (044 971) 486.

D-40 ★

Stereo power amplifier. Output: 45W RMS into 4 ohms, 30W into 8 ohms, 20W into 16 ohms (per channel); 80W RMS into 8 ohms (mono). HD: < 0.5% at rated output. FR: 5Hz-50kHz ± 1dB at rated output. Damping factor > 200. H and N: 100dB below 30W. Input 0-6V for full output. Psn: 117-240V, 50/60/400Hz. Size: 19 × 1¼ × 7⅝ in. Weight: 8½lb. Fully protected against

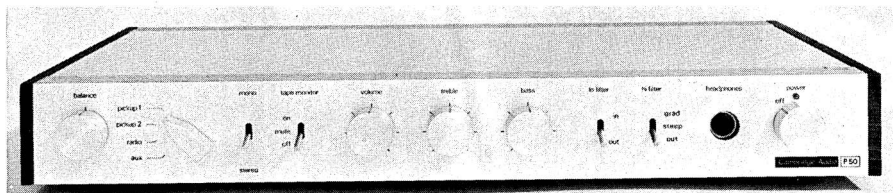

Cambridge Audio P50

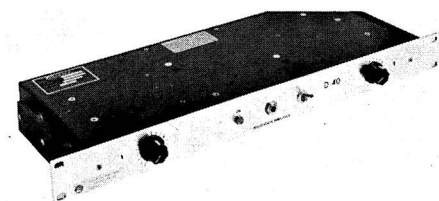

Crown International D-40

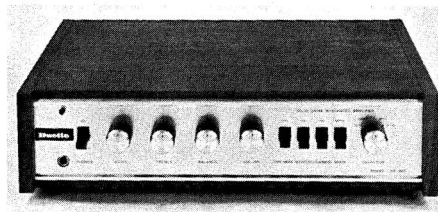

Duetto SA400



Crown International DC300

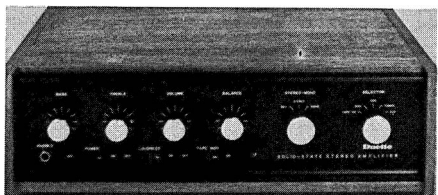

Duetto SA500

short circuit or mismatch. Headphone monitor socket. Price: on request.

DC-300 ★

Stereo power amplifier. Output: 340W RMS into 4 ohms, 190W RMS into 8 ohms. FR: 0-30 kHz. HD: <0.2%. H and N: >100dB below 150W. Size: 19 × 7 × 9 $\frac{3}{4}$ in. Price: on request.

IC-150

Stereo preamplifier and tone control unit incorporating IC circuitry. Comprehensive specification. Full details on request. Price: on request. Details of new range of equipment on request.

■ DUAL

International Audio Ltd,
Clive House, Queens Road, Weybridge, Surrey.
Tel: Weybridge 40125. Telex: 928153.

CV30

Integrated stereo amplifier with 12W per channel output. No other details available at time of going to press. Price: £52.50.

CV60

Integrated stereo amplifier with 30W per channel output. No other details available at time of going to press. Price: £74.50.

CV120

Integrated stereo amplifier with 50W per channel output. No other details available at time of going to press. Price: £115.

■ DUETTE

Distributors: J. J. Silber Ltd,
11 Northburgh Street, London, EC1.
Tel: 01-253 8031.

SA616

Stereo transistor amplifier. Output: 6W RMS per channel. HD: <0.1% at rated output. FR: 30Hz-20kHz ±1dB. Noise level: -55dB. Inputs: pickup 100mV, radio 100mV, aux 100mV. Output impedance: 4, 8, 16 ohms. Mains: 240V AC. Size: 4 $\frac{3}{4}$ × 11 × 8 $\frac{1}{4}$ in. Price: £21.35.

SA400 ★

Stereo transistor amplifier. Output: 6W RMS per channel. FR: 30Hz-20kHz ±1.5dB. Noise level: better than 60dB. Inputs: mag PU 3mV, radio 150mV, crystal PU 150mV. Output impedance: 4, 8, 16 ohms. Mains: 240V AC. Size: 4 × 13 $\frac{1}{2}$ × 10 $\frac{1}{2}$ in. Price: £35.28.

SA500 ★

Stereo transistor amplifier. Output: 10W RMS per channel. FR: 20Hz-20kHz ±1dB. HD: <1% at rated output. Noise level: better than 60dB. Inputs: mag PU 3mV, ceramic PU 30mV, radio 150mV. Output impedance: 4, 8, 16 ohms. Tape outlet. Mains: 240V AC. Size: 4 $\frac{1}{4}$ × 13 $\frac{1}{2}$ × 10 $\frac{3}{4}$ in. Price: £44.91.



Dynaco PAT-4

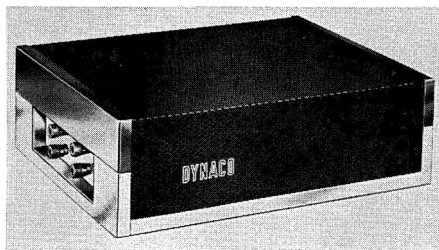

Dynaco ST-120

■ DYNACO

Distributors: Howland-West Ltd,
3-5 Eden Grove, London, N78EQ.
Tel: 01-609 0293/4/5.

PAT.4 ★

Transistorised stereo control unit. Inputs: PU (low level), PU (high level), tape head, tape amplifier, radio, aux (high level), aux (high level) to socket on front panel. Noise level: -70 dB on low level inputs, -85dB on high level inputs. Controls: selector, volume, balance, bass (left and right), treble (left and right), filter, loudness, tape monitor, bass filter, mode, on/off. Mains: 120-240V 50-60Hz. Designed for use with Dynaco Stereo 120 or other similar high quality amplifiers. Size: 13 $\frac{1}{2}$ × 4 $\frac{1}{4}$ × 9in. Price: (assembled) £74; (kit) £56.

STEREO 120 ★

Transistor stereo power amplifier. Output: 35W RMS per channel. HD: less than 0.25% up to 60W 20Hz-20kHz. FR: 5Hz-100kHz ±0.5dB. Noise: 95dB below stated output (unweighted). Input: 1.5V for stated output. Output impedance: 4-16 ohms. Output transistors: selected RCA 2N3055. Mains: 220-240V AC. Size: 13 × 10 $\frac{1}{2}$ × 4in. Designed for use with Dynaco PAT.4 or any other similar high quality stereo control unit. Price: (assembled) £109; (kit) £93.

SCA-80

Solid state stereo amplifier. Power output: 50W per channel RMS, 4-16 ohms. HD: less than 0.5%. FR: 15Hz-50kHz ±1dB. NL: better than -60dB. Inputs: pickup, 3mV, 47K. Controls: tape monitor switch, blend, treble for each channel, rumble filter, bass for each channel, balance,

★ Indicates entry is illustrated

volume, loudness. Mains powered. Size: $13\frac{1}{2} \times 4\frac{1}{4} \times 10$ in. Price: (assembled) £142; (kit) £110.

ST-80

Solid state stereo amplifier. Power output: 50W per channel RMS. 4-16 ohms. HD: better than 0.5%. FR: 15Hz-50kHz ± 1 dB. NL: better than -60dB. Mains powered. Dimensions: $13\frac{1}{2} \times 4\frac{1}{4} \times 9$ in. Control unit: Dynaco PAT.4, or others. Price: (assembled) £92; (kit) £78.

■ EAGLE INTERNATIONAL

Heather Park Drive, Wembley, HAI1SU.
Tel: 01-903 0144.

TSA.149 ★

Integrated stereo amplifier. Output: 7W RMS per channel. FR: 25Hz-18kHz. Inputs: magnetic PU 3.5mV, ceramic PU 100mV, tape 200mV, radio 200mV. S/N: better than 50dB. All silicon transistors. Wood cabinet. Size: $11\frac{1}{4} \times 3\frac{3}{8} \times 8\frac{5}{8}$ in. Price: £28.

TSA.150 ★

Integrated stereo amplifier. Output: 7W RMS per channel. FR: 30Hz-18kHz. Inputs: mag PU 3.5mV, ceramic PU 100mV, radio 100mV, aux 100mV. S/N better than 50dB. Remote speaker outlet and switch. Size: $3\frac{1}{8} \times 13 \times 8\frac{1}{2}$ in. Price: £29-60.

TSA.151 ★

Integrated stereo amplifier. Output: 15W RMS per channel. FR: 20Hz-40kHz. Inputs: magnetic PU 3mV, ceramic PU 100mV, tape 100mV, radio 200mV. S/N: better than 60dB. Silicon transistors. Wood cabinet. Size: $13 \times 4 \times 8\frac{3}{4}$ in. Price: £39.

AA2 ★

Integrated stereo amplifier. Output: 10W RMS per channel. FR: 25Hz-20kHz ± 2 dB. Inputs: magnetic PU 3mV 47K, ceramic PU 80mV 100K, radio 180mV 100K, tape 180mV 100K. Noise level: magnetic PU 64dB, ceramic PU 66dB, other inputs 68dB. Controls: bass, treble, volume, balance, on/off, rumble filter, scratch filter. HD: 0.5%. Output impedance: 8-16 ohms. Mains: 240V AC. Size: $10\frac{7}{8} \times 8\frac{3}{4} \times 3\frac{3}{8}$ in. Finish: teak cabinet with metal fascia. Price: £34.

AA4 ★

Integrated stereo amplifier. Output: 20W RMS per channel. FR: 20Hz-36kHz ± 2 dB. Inputs: magnetic PU 3mV 47K, ceramic PU 80mV 100K, radio 180mV 100K, tape 180mV 100K. Noise level: magnetic PU 66dB, ceramic PU 68dB, other inputs 70dB. Controls: bass, treble, volume, balance, on/off, rumble filter, scratch filter. HD: 0.2%. Output impedance: 8-16 ohms. Mains: 240V AC. Size: $13 \times 10\frac{1}{2} \times 3\frac{3}{8}$ in. Finish: teak cabinet with metal fascia. Price: £48.

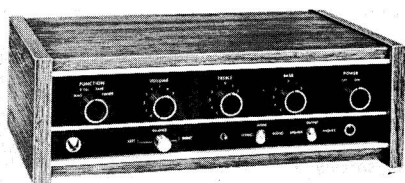

Eagle TSA149

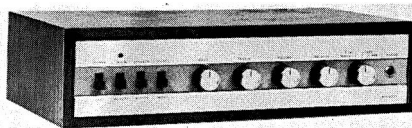

Eagle TSA150

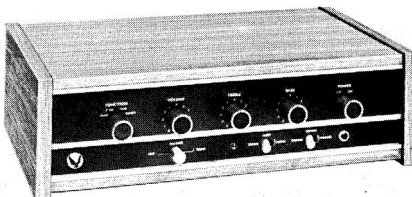

Eagle TSA151

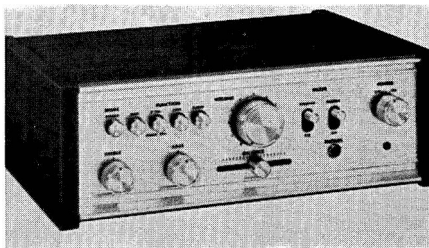

Eagle AA2

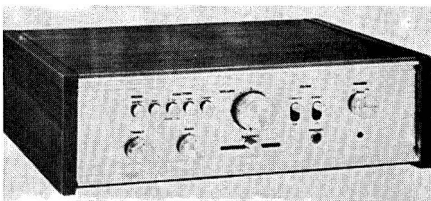

Eagle AA4

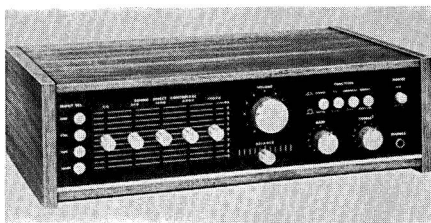

Eagle AA6

AA6 ★

Integrated stereo amplifier. Output: 14W RMS per channel. FR: 20Hz-36kHz \pm 2dB. Inputs: magnetic PU 3mV 47K, ceramic PU 80mV 100K, radio 180mV 100K, tape 180mV 100K. Noise level: magnetic PU 63dB, ceramic PU 65dB, other inputs 70dB. Controls: bass, treble, volume, balance, on/off, pushbutton input selectors, five sound effect controllers giving \pm 5dB over five channels in the audio spectrum. Finish: teak cabinet with metal facia. Price: £64.

AA10

See Quadraphonic Section for details of the Eagle AA10 four-channel quadraphonic synthesiser.

ELGAR

English Audio (1970) Ltd,
North Station Road, Colchester, Essex.
Tel: Colchester (0206) 73467.

Elgar

Integrated stereo amplifier. Inputs: mag PU 3.5mV 56K, ceramic PU 20mV 33K, radio 100mV 100K, tape 100mV 100K. Noise level: -65dB on all inputs. Output: 18W per channel. HD: <0.5% at all levels up to rated output. FR: 20Hz-20kHz \pm 3dB. Overload capacity: 29dB on all inputs. Independent outlet for tape provides 200mV irrespective of volume setting. Controls: (rotary) bass, treble, volume, balance and input selector, (slider switches) mono/stereo, HF filter, loudness, phones/speaker. Indicator light. Output impedance: 8-16 ohms. Connections by DIN plugs. Finish: teak case. Price: £59.

FAL

Futuristic Aids Ltd, Henconner Lane,
Leeds, LS134LQ. Tel: Pudsey 5478.

Phase 44

Stereo transistorised integrated amplifier. Inputs: PU 2.5mV 47K (magnetic), PU 35mV 47K (ceramic), radio 175mV 68K, tape 175mV 68K. Noise level: -65dB all inputs. Outlet for tape 200mV. Controls: treble \pm 15dB at 14kHz, bass \pm 15dB at 40Hz, volume, balance, filter -6dB at 9kHz, 12dB/octave roll-off. Output: 30W per channel into 4 ohms, 20W per channel into 8 ohms, 10W per channel into 15 ohms. HD: 0.05% at 10W RMS 1kHz. FR: 10Hz-70kHz at 3dB points. Output impedance: 8 or 15 ohms. Mains: 230/240V AC. Consumption: 50W. Size: 15 \times 9 $\frac{1}{2}$ \times 4 $\frac{1}{2}$ in. Finish: teak veneered cabinet with satin aluminium panel. Price: £42.50.

Phase 25 'Class A' ★

Stereo transistorised integrated amplifier. Inputs: PU (magnetic) 2.5mV 47K, radio 175mV 68K, tape 175mV 68K. Noise level -70dB all



FAL Phase 25

inputs. Outlets for tape recorder 200mV. Controls: treble \pm 15dB at 14kHz, bass \pm 15dB at 40Hz, volume, balance +1dB - zero, filter 9kHz, 12dB/octave roll-off. Output: 12W per channel into 8 ohms, 10W per channel into 15 ohms. HD: 0.02% at rated output. FR: 15Hz-68Hz at 3dB points at -10dB full power. Output impedance 8 or 15 ohms. Mains: 230/240V AC. Size: 14 $\frac{3}{4}$ \times 11 \times 4 $\frac{3}{4}$ in. Finish: teak veneered cabinet with satin aluminium panel. Price: £56.

FANTAVOX

Joint distributors: Adastra Electronics Ltd,
Unit 22, Cricklewood Trading Estate,
Claremont Road, London, NW2 1TU.
Tel: 01-452 6288. E.R. (Factors) Ltd,
374-378 Harrow Road, Paddington,
London, W9. Tel: 01-286 0361.

A3550

Integrated stereo amplifier. 14 transistors and two diodes. Inputs: mag PU 3mV 50K, ceramic PU 300mV 50K, radio 200mV 50K, aux 200mV 50K. Noise level: mag PU input -50dB, other inputs -60dB. Output: 20W RMS per channel. Tone controls: bass \pm 10dB at 70Hz, treble \pm 10dB at 15kHz. Loudness control. HD: <1% at 1kHz at rated output. Output impedance: 4-16 ohms. Mains: 240V AC. Socket for AC outlet. Size: 12 \times 4 $\frac{1}{2}$ \times 9 $\frac{1}{4}$ in. Finish: Metal case with simulated wood grain finish, brushed gold facia. Price: £40 approximately.

A3525

Integrated stereo amplifier. 12 transistors and two silicon diodes. Inputs: mag PU 3mV 50K, ceramic PU 300mV 50K, radio 250mV, 50K, aux 250mV 50K. Noise level: mag PU input -50dB, other inputs -60dB. Output: 9W RMS per channel. HD: <1% at 1kHz at rated output. Output impedance: 4-16 ohms. FR: 30Hz-30kHz \pm 2dB. Mains: 240V AC. Unswitched socket for AC outlet. Size: 10 \times 4 $\frac{1}{4}$ \times 7 $\frac{3}{4}$ in. Finish: metal case with simulated wood grain finish, brushed gold facia. Price: £30 approximately.

FERROGRAPH CO LTD

Auriema House, 442 Bath Road, Crippenham,
Slough, Bucks, SL1 6BB.
Tel: Burnham 062-86 62511. Telex: 847297.

★ Indicates entry is illustrated

F307 ★

Stereo amplifier styled to match Ferrograph Series 7 recorder. Per channel: 20W into 8 ohms or 15W into 15 ohms. Total HD: less than 0.25% at 1kHz all levels. FR: (± 1 dB) 20Hz-25kHz, ($+1$ dB -3 dB) 15Hz-30kHz. Inputs: ceramic PU, tuner and aux, 100mV-5V at 2 megohms; magnetic PU (RIAA), 3mV at 100K, 68K or 47K; tape, 150mV at 50K. Outputs: speaker 8-16 ohms, phones 8 ohms or greater; tape 50K or greater. H and N: less than -65 dB (except magnetic PU which is less than -60 dB). Bass control ± 17 dB at 50Hz, treble control ± 13 dB at 15kHz. Pushbutton low-pass filters -3 dB at 10, 7 and 5kHz. Mains: 117/220/240V 50/60Hz. Size: $16\frac{1}{2} \times 5 \times 9\frac{5}{8}$ in. Price: (metal case) £60; (wood case) £64.

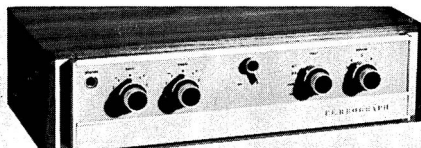

Ferrograph F307



Grundig SVI 40

Type 2001

Modular multi-channel amplifiers. Output: 35W into 4 ohms. FR: 25Hz-25kHz ± 1 dB. S/N ratio: better than 65dB. HD: 0.02% at maximum output at 1kHz. Bass: ± 15 dB at 100Hz. Treble: ± 15 dB at 10kHz. Balance: zero to maximum on each channel. Scratch filter: -12 dB/octave, variable from 5kHz-20kHz. Rumble filter: -12 dB/octave, variable from 25Hz-100Hz. Regulated power supply. Amplifier cabinet can accommodate a wide variety of turntable and pickup. Price: (four channels) £295; (six channels) £325; (eight channels) £357; (12 channels) £475.

GRAMPIAN REPRODUCERS LTD

19 Hanworth Trading Estate, Feltham, Middx. Tel: 01-894 9141.

FISHER

UK Distributors: REW Audio Visual Ltd, 266-268 Upper Tooting Road, London, SW17. Tel: 01-672 4471/2 and 9175.

Details of new range of Fisher hi-fi equipment not available as this edition of the Year Book closed for press.

A. R. FRANKLIN

(Audio engineer), 4 Birch House, Howard Road, Penge, London, SE208HJ. Tel: 01-659 0912.

Control unit/mixer

Six-channel mono, or three-plus-three-channel stereo. All inputs 100mV 47K for 1V output into 47K. HD: $<0.2\%$. FR: 10Hz-68kHz ± 3 dB. Noise: -60 dB. Maximum output: 3V. Inputs infinitely variable. Headphone position with pre-select listening. Mains: 110-250V 50/60Hz. Size: $12\frac{1}{2} \times 9 \times 3\frac{1}{4}$ in. Price: £36.

Stereo control unit/mixer

Four inputs at 800K selected by switching. Microphone mixing independent of selector switch. Controls: treble, bass, balance. Headphone position. HD: $<0.2\%$. FR: 20Hz-30kHz ± 3 dB. Maximum output 3V. Microphone input 20mV, other inputs up to 3V. Mains: 110-250V 50-60Hz. Size: $12\frac{1}{2} \times 9 \times 3\frac{1}{4}$ in. Price: £36.

Plug-in preamplifiers

Stereo modular preamplifiers for use with above control unit/mixers. For low impedance microphones: £6 and £12. For magnetic pickup with RIAA correction: £6. For tape head: £6. Send s.a.e. for lists and prices.

GABRAPHONE

Modern Engineering and Technology Ltd, 4 Station Road, West Canterbury, Kent. Tel: Canterbury 60431.

Grampian 666 Ambiophonic unit

Enables one to four small speakers to be fed with amplified and delayed signal from main amplifier output. Delay device consists of two parallel springs and transducers as used in Grampian reverberation unit. Provides echoes similar to those produced by room 32×42 ft. Volume of delayed signals controllable by listener. Twin high-impedance line-bridging input connections. Output: $2\frac{1}{2}$ W push-pull power amplifier with 5 ohms and twin 600-ohm outputs. Fully transistorised. Mains: 100-125V or 200-250V. Consumption: 8W. Size: $18 \times 4\frac{3}{4} \times 5\frac{1}{4}$ in. Weight: 7lb. Price: £65.

743

Solid-state mono power amplifier. Input: balanced or unbalanced 600 ohms (to match 10K input) at 800mV for rated output. Output: 50W RMS. Output impedance: 4-8 ohms, 100V line. FR: 100Hz-10kHz $+0$ dB, -1 dB; 50Hz-15kHz $+0$ dB, -3 dB. HD: $<1\%$ 100Hz-10kHz at rated output. S/N: greater than 70dB. Controls: on/off switch, single gain control giving zero to rated output. Mains: plug-in voltage selection giving 100-125V in 5V steps, 200-250V in 10V steps. Size: $19 \times 5\frac{1}{4} \times 12\frac{1}{2}$ in. Weight: 32lb. Full specification leaflet on request. Price: £128.

7431

Specification as for the 743 but is fitted with $1\frac{1}{4}$ in peak reading output meter. Price: £134.

744

Specification as for the 743 but with 100W RMS output. Weight: 40lb. Price: £142.

7441

Specification as for the 744 but with cover over output control and no supply on/off switch. Price: £148-50.

■ GRUNDIG (Great Britain) LTD

Hi-Fi Division, Sydenham, London, SE26
Tel: 01-778 2211.

SV85

Transistor integrated stereo amplifier and control unit. 31 transistors, 14 diodes. Inputs: mic 7mV at 100K, PU (mag) 3-5mV 47K. PU (crystal) 220mV-3V 1 megohm, radio/tape 220mV 470K. Controls: volume, stereo balance, bass ± 18 dB at 30Hz, treble ± 18 dB at 15kHz, pushbutton selector, scratch filter, rumble filter, tape monitoring, slope 1, slope 2, presence. Output: 30W RMS per channel. Distortion $< 0.5\%$. Outlets: two speakers 4-16 ohms, two 300-ohm phonesockets, two 1-5V 200-ohm line. Stabilised supply to pre-amplifier stages. Mains: 110, 130, 220, 240V 50-60Hz. Consumption 180W maximum. FR: 20Hz-20kHz ± 1 dB. Size: 20 \times 6 \times 12in. Finish: matt walnut. Price £135-65.

SV140 ★

Transistorised integrated stereo amplifier. Slider controls for balance, volume and five tone ranges. Full overload and mismatch protection. Moving coil meters. 51 silicon transistors, 23 diodes. Inputs: mic 7-5mV 100K, PU (2) 3-7mV 47K for magnetic cartridge, aux 250mV 470K, tuner 250mV 470K, tape 250mV 470K. Tape monitor. Outputs: 1V 600 ohms line, headphones, speakers. Pushbuttons for: tape monitoring, scratch/rumble filters, slope 1, slope 2. Output: 50W RMS per channel. HD: less than 0.5%. Speaker impedance: 4-16 ohms. FR: 20Hz-20kHz ± 1 dB. Mains: 110-240V 50-60Hz. Finish: matt walnut. Size: 6 \times 20 \times 12in. Price: £192-85.

■ HARMAN-KARDON

Hightate Acoustics Ltd,
184 Great Portland Street, London, W1.
Tel: 01-636 2901.

Citation 11

Stereo preamplifier. 13 transistors. Inputs: mag PU (2) 1-5mV 47K, aux (2) 150mV 20K, aux 300mV 20K. Noise level: mag PU input 66dB, other inputs 80dB. Output: 6V RMS per channel at 500 ohms. Tone controls: bass ± 12 dB at

60Hz, ± 12 dB at 320Hz, ± 12 dB at 1kHz, ± 12 dB at 12kHz, high-cut filter -8 dB (6dB/octave) at 10kHz, sub-sonic filter -12 dB (6dB/octave) at 15Hz. Two low impedance headphone outlets. HD: 0-05% at 6V. Output impedance: 500 ohms. FR: 2Hz-250kHz ± 1 dB at 6V output. Mains: 110-240V AC. Audio equaliser control. Size: $16\frac{1}{8} \times 4\frac{3}{4} \times 12$ in. Price: £179.

Citation 12

Stereo power amplifier designed for use with Harman-Kardon Citation 13 speakers or other similar high quality systems. Input: 1-6V 47K. Noise level: 100dB. Output: 60W RMS per channel. HD: 0-06% at 60W. Output impedance: 8 ohms. Separate power supply unit for left and right channels. FR: 1Hz-100kHz ± 1 dB. Mains: 110-240V AC. Size: $12\frac{3}{8} \times 5\frac{1}{2} \times 12\frac{3}{8}$ in. Finish: black case with brushed aluminium panel. Price: £179.

■ HECO

Distributors: Acoustico Enterprises Ltd,
6-8 Union Street, Kingston-upon-Thames,
Surrey. Tel: 01-549 3471/3.

Heco Ampli

Integrated stereo amplifier. Inputs: magnetic PU 2-4mV 47K, ceramic PU 200mV, radio 250mV 100K, tape 250mV 100K. Noise level: mag PU input 59dB, other inputs 85dB. Tone controls: bass ± 14 dB at 30Hz, treble ± 16 dB at 20kHz. Output: 30W RMS per channel into 4 ohms. HD: $< 0.3\%$ at rated output at 1kHz. FR: 10Hz-40kHz -2 dB. Output impedance: 4-16 ohms. Mains: 220V 50/60Hz. Size: $16\frac{1}{4} \times 4\frac{3}{8} \times 10\frac{3}{8}$ in. Price: £80.

■ P. F. & A. R. HELME

Summerbridge, Harrogate, Yorks, HG34DR.
Tel: Darley (0423-72) 279.

Atlantis 100

Integrated stereo amplifier. Inputs: mag PU 2mV, mic 0-5mV, tape play 150mV, radio 150mV, aux 150mV. Overload capability: better than 30dB. Noise level: mic input -45 dB, mag PU input -60 dB, other inputs -70 dB. Output: 55W RMS per channel into 8 ohms, 50W RMS per channel into 4 ohms, 28W per channel into 16 ohms. Tone controls: bass ± 15 dB at 40Hz, treble ± 10 dB at 20kHz. Rumble filter: 6dB/octave at 20Hz. HF filter: 20dB/octave at 7kHz. HD: $< 0.3\%$ at full output (55W). FR: 20Hz-20kHz. Size: $14\frac{3}{4} \times 4 \times 10\frac{3}{8}$ in. Channel balance: ± 1 -6dB. Crosstalk: -45 dB at 1kHz. Nine pushbutton selectors. Outlet for tape recorder: 200mV 1K. Jack socket for stereo headphones. Dynamic matching control (DMC) to match

★ Indicates entry is illustrated

amplifier to characteristics of speakers. Price: £119.

■ H/H ELECTRONIC

Industrial Site, Cambridge Road, Milton, Cambridge. Tel: Cambridge 65945.

IC-100S

Professional power amplifier with two input channels and mono power output. Transistors and ICs. Inputs: (two) 25mV 100K. Noise level: -70dB all inputs. Overload capability: 35dB. Output: 100W RMS into 8 ohms. Bass control: +18dB -9dB at 30Hz. Treble control: +8dB -10dB at 15kHz. Presence control: +10dB at 2kHz. FR: 20Hz-20kHz ± 0.5 dB. HD: <0.2% at 80W 20Hz-20kHz (typically 0.05% at 1kHz). Slave output at 500mV 50 ohms. Mains: 115, 210, 220, 230 and 240V AC. Size: $26\frac{3}{8} \times 4\frac{1}{4} \times 11\frac{1}{2}$ in. Finish: top and bottom ABS plastic with bison grain, bright aluminium front panel. Price: £96.

IC-100

Professional power amplifier with two input channels and mono power output. Designed for use with musical instruments. Input: (two) 25mV 100K. Noise level: (power amplifier) -90dB. Bass control: +18dB -20dB at 20Hz. Treble control +16dB -18dB at 15kHz. Presence control: +12dB at 1kHz. Brilliance control: +10dB at 2kHz. Output: 100W RMS into 7.5 ohms, 120W RMS into 4 ohms. Output impedance: 4-15 ohms. Output protected against short-circuit and open-circuit operation. Mains: 115, 210, 220, 230 and 240V AC. Size: $26\frac{3}{8} \times 4\frac{1}{4} \times 11\frac{1}{2}$ in. Finish: top and bottom ABS plastic with bison grain, bright aluminium front panel. Price: £129.

TPA Series

Professional power amplifiers with outputs from 50W-200W RMS. Modular construction. Bench or rack mounting. Full range of accessories. Full details and specifications on request.

■ IMF PRODUCTS (GB)

Westbourne Street, High Wycombe, Bucks. Tel: High Wycombe 35166.

IMF-Galactron IC Mk 10

Integrated stereo amplifier. 24 transistors, 34 diodes and from four to eight ICs. Output: 70W RMS per channel. HD: <0.1% at rated output at 1kHz, 0.2% at rated output 20Hz-20kHz. FR: (power amplifier) 15Hz-40kHz, (low level inputs) 30Hz-16kHz, (high level inputs) 20Hz-20kHz ± 2 dB. Damping factors: >100 at 8 ohms. Tone controls: bass ± 18 dB at 50Hz, treble ± 12 dB at 10kHz. Inputs: 150mV 100K, 3mV 47K, 2mV 300K, 65mV 47K, 775mV 50K. Outlets: 775mV monitor, 4-16 ohms for speakers. Mains: 230V AC. Weight: approx 40lb. Detailed specification sheet on request. £298.

■ IMPEX

McArdle & Brainsby (Import & Export) Ltd, PO Box 2BB, Newcastle upon Tyne, NE992BB.

'Hi-Fi Sound' 10-20

Integrated stereo amplifier design published by 'Hi-Fi Sound' magazine. See Constructional Kits Section for details of parts and prices.

MS7 and MS24

Stereo pickup amplifiers. See Pickup Accessories Section for full specification and prices.

■ KLINGER

Klinger Controls Ltd, Spencer Court, 7 Chalcot Road, London, NW18LU. Tel: 01-586 2922/3.

KC92

Integrated stereo amplifier. 28 transistor circuit. Inputs: mag PU 2mV 47K, radio 50mV 220K, tape 50mV 220K, ceramic PU 100mV 470K, aux (mic) 0.15mV 30 ohms. Noise level: (mag PU) 66dB, (other inputs) 70dB. Overload capability: 30dB. Tone controls: bass ± 15 dB, treble ± 15 dB, scratch filter 18dB/octave from 8kHz, rumble filter 12dB/octave from 80Hz. Full-range balance control. HD: 0.1% at 20W. Output: 25W RMS per channel. Output impedance: 8 ohms. Tape outlet: 100mV. FR: 25Hz-35kHz ± 2 dB at 20W. Stabilised power supply. Two stereo headphone sockets. Switching for two pairs of speakers. Switched mains outlet socket. Finish: teak with diecast enamelled sides. Size: $17\frac{1}{4} \times 4\frac{1}{4} \times 8\frac{1}{2}$ in. Price: £49-50.

KC93 ★

Integrated stereo amplifier. 18 transistor circuit. Inputs: mag PU 3mV 47K, ceramic PU 40mV 470K, radio 50mV 470K, tape 50mV 470K. Noise level: (mag PU) 60dB, (other inputs) 66dB. Overload capability: 30dB. Output: 10W RMS per channel. Output impedance: 8 ohms. Tape outlet: 100mV. Tone controls: bass ± 15 dB, treble ± 15 dB. HD: better than 0.5% at 10W. FR: 40Hz-18kHz ± 2 dB at 10W. Stereo headphone socket. Switched and direct mains outlet sockets. Finish: teak with enamelled sides. Size: $13 \times 4\frac{1}{4} \times 8\frac{1}{2}$ in. Mains: 120-240V AC. Price: £33.

■ KORTING

Europa Electronics Ltd, Howard Place, Shelton, Stoke-on-Trent, ST1 4NW. Tel: Stoke-on-Trent 29316.

A500, Type 29833 ★

Stereo amplifier. 21 transistors. Push buttons for stereo, scratch, tape, pickup 1 and 2, tuner and on/off. Controls: treble, bass, balance and volume, with indicator lamp. Sockets: diode output for tuner; crystal, ceramic or magnetic pickup; tape recorder; speakers. Output: 10W per channel. Drift power transistors and triple

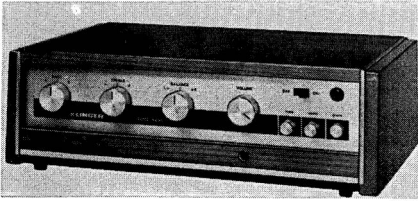

Klinger KC93

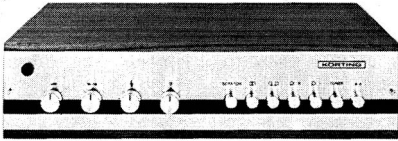

Korting A500

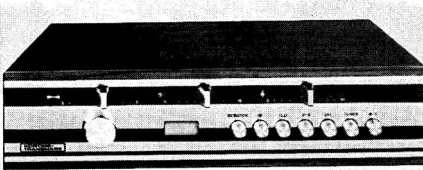

Korting A600

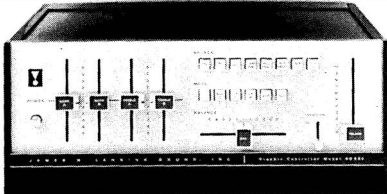
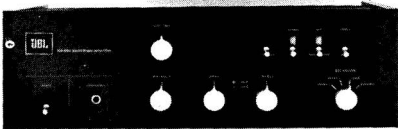
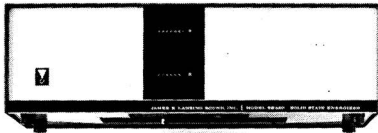

JBL amplifiers and controller

negative feedback. Cabinet in natural walnut colour, satin finish. Size: $3\frac{1}{2} \times 14 \times 9$ in. Price: £42.75.

A600, Type 30836 ★

Stereo amplifier. 21 transistors, one rectifier. Pushbuttons for stereo, scratch filter, tape, pickup 1 and 2, tuner and on/off. Controls: treble, bass, volume and balance (± 15 dB). Inputs for tuner, crystal pickup, ceramic pickup, magnetic pickup, tape recorder. Output: 15W sine wave per channel. Output impedance: 4 ohms. Complies with DIN 45500. Slider controls for bass, treble and volume. On/off switch for speakers. Finish: natural satin walnut. Size: $15 \times 4 \times 8$ in. Price: £49.75.

■ **JAMES B. LANSING**

Distributors: Feldon Recording Ltd, 126 Great Portland Street, London, W1. Tel: 01-580 4314.

JBL Graphic Controller SG250 ★

Stereo control unit. Inputs: (pickup 1) 1-6mV 47K, (pickup 2 or tape head) 1-6mV 47K, mic 50-200mV at high impedance, tape 250mV adjustable, aux (2) 250mV to 3V adjustable at 35K, (radio 1) 200mV 35K, (radio 2) 300mV to 2V adjustable at 35K. Output: line 600mV to 3V adjustable. HD: 0.13% at all frequencies and all power levels. Controls: sliders for treble left and right, sliders for bass left and right, sliders for volume and balance, switches for stereo, stereo reverse, channel A, channel B, A+B test, rumble filter, scratch filter, test tone (1kHz) and tape monitor. Noise level: (low level) -84dB; (high level) -91dB. Designed to operate with JBL SE460 main energiser or any good quality amplifier. Mains: 110-240V AC. Size: (front panel) $15\frac{1}{2} \times 6\frac{3}{8}$ in; (remainder) $14\frac{1}{4} \times 6 \times 11\frac{1}{2}$ in. Price: approximately £245.

JBL SE460 Energiser

Stereo power amplifier. Output: 60W RMS per channel. FR: (tone controls flat) 20Hz-20kHz ± 0.25 dB, 3Hz-175kHz ± 1.5 dB at all powers. Plug-in equaliser boards. HD: 0.13% 20Hz-20kHz. Noise level: -90dB below rated output. Input voltage: 300mV to 3V. Output impedance: 4-16 ohms. Designed for studio monitors but also suitable for use with JBL Graphic Controller or other good-quality stereo control unit. Mains: 110-240V AC. Size: $15\frac{1}{4} \times 4\frac{5}{8} \times 7$ in. Price: approximately £200.

JBL SA660

Integrated stereo amplifier. Inputs: (pickup 1) 4, 8 or 16mV 47K, (pickup 2) 4, 8 or 16mV 47K, aux 250mV 35K, radio 250mV 35K. Noise level: pickup inputs -72dB, -75dB and -78dB respectively, other inputs -85dB. Controls: volume, bass left, bass right, treble left, treble right, balance, loudness, test, tape monitor.

★ Indicates entry is illustrated

Output: 60W RMS per channel into 8 ohms, 80W RMS per channel into 4 ohms. HD: <0.15% at all frequencies and any power. FR: 20Hz-20kHz ± 0.25 dB. Noise level: (main amplifier) -94dB. Output impedance: 4-16 ohms. Mains: 110-240V 50/60Hz. Size: $15\frac{3}{4} \times 4\frac{3}{4} \times 11\frac{7}{8}$ in. Price: approximately £240.

LEAK

H. J. Leak & Co Ltd,
Bradford Road, Idle, Bradford, Yorks.
Tel: Bradford 612552. Telex: 51407.

Delta 30 ★

Transistorised integrated stereo amplifier. Inputs: PU (1) 2mV 47K; PU (2) high sensitivity 10mV 33K, low sensitivity 30mV 100K; tuner/mic 25mV 47K; tuner (2) high sensitivity 60mV 50K; low sensitivity 250mV 50K; replay 400mV 47K. Output: 15W per channel 8 ohms, 20W per channel 4 ohms. Controls: input selector, bass, treble, balance, filter, volume, tape monitor, 6kHz filter. Headphone socket. H and N: -87dB. HD: 0.1% up to 12W at 1kHz into 8 ohms. Mains: 110-250V 40-60Hz. Size: $13\frac{1}{2} \times 4\frac{3}{4} \times 10$ in. Price: £65.

Delta 70 ★

Transistorised integrated stereo amplifier. Inputs: PU (1) 2mV 47K R1AA, PU (2) 10mV 33K R1AA, radio 25mV 47K or 2mV 47K, aux 60mV 50K or 250mV 50K, tape replay 400mV 47K. Controls: bass ± 16 dB at 50Hz, treble ± 16 dB at 14kHz, volume, balance, input selector, pushbuttons for tape monitor, treble filter, speaker on/off. Headphone socket. Output 35W RMS per channel into 8 ohms. HD: 0.1% all powers up to 25W RMS. FR: 30Hz-20kHz ± 1 dB. Will drive two pairs of loudspeakers. Size: $13\frac{1}{2} \times 4\frac{3}{4} \times 10$ in. Price: £79.50.

LEEVERS-RICH EQUIPMENT LTD

319 Trinity Road, Wandsworth,
London, SW18. Tel: 01-874 9054/6.
Cables: Leemag, London, SW18.

7 Band Audio Equaliser Model A501 ★

Wide range equaliser covering spectrum in 7 separately adjustable and overlapping bands, suitable for use in transcription to match widely differing recordings to a common quality standard. Price: £190.

LINEAR PRODUCTS LTD

Electron Works, Armley, Leeds.
Tel: Leeds 630126.

606

Integrated stereo amplifier. Inputs: mag PU 3.5mV 47K, ceramic PU 35mV 100K, tape 100mV 100K, radio 400mV 400K. H and N: -75dB at minimum volume, -65dB at maximum volume. Crosstalk: -53dB. HD: 0.1%

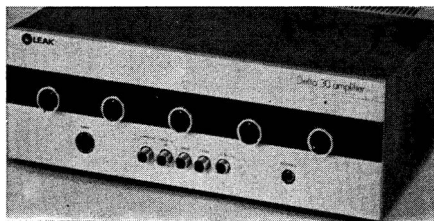

Leak Delta 30

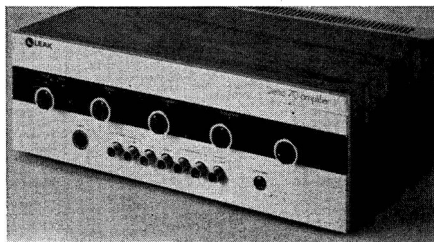

Leak Delta 70

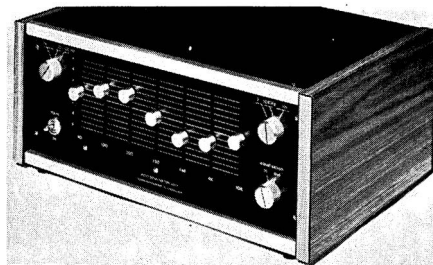

Leavers-Rich A501

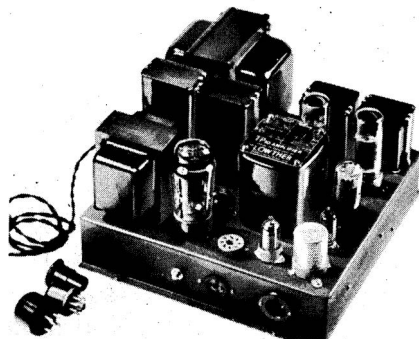

Lowther LL26 amplifier

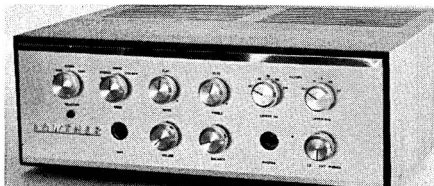

Lowther I.A.20

at 1W. Output: 6.5W per channel (IHF). Output impedance: 3-15 ohms. Tone controls: bass ± 12 dB at 40Hz, treble ± 12 dB at 14kHz. FR: 20Hz-65kHz ± 1.5 dB. Stereo/mono switching. Input selector switch. Mains: 200, 230, 250V AC. Finish: silver colour metal facia with matching control knobs, teak finish case. Price: £22.50.

■ LOWTHER MANUFACTURING CO

Lowther House, St Mark's Road, Bromley, Kent, BR29HQ. Tel: 01-460 5225. Cables: Lowther, Bromley.

L18 amplifier

18W. Distortion $< 0.1\%$. Input for specified output 0.75V. Response 20Hz-40kHz ± 1 dB. Feedback 20dB. Noise level -85dB. Output impedance: 16 ohms with adjustment. Output: EL506 distributed load circuitry. Pat. Size: 12 \times 6 \times 6in. To operate with SCU/T control unit. Price: £27.

LL26 Mk II amplifier ★

26W. Dist $< 0.1\%$. Input for spec output 0.75V. Response 20Hz-70kHz ± 1 dB. Feedback 22dB. NL -90dB. Output imp 16 ohms with adjustment. Output: EL34s. Lowther linear. Size: 11 \times 12 \times 7 $\frac{1}{2}$ in. Weight: 33lb. To operate with SCU/T control unit. Price: £47.

L18S stereo amplifier

18W output on each channel. Distortion 0.1%. Input for specified output 0.75V. Response 20 Hz-40kHz ± 1 dB. Noise level -85dB. Output imp 8.4 or 16 ohms. Output EL506 ultra linear. Size: 11 \times 12 \times 7 $\frac{1}{2}$ in. To operate with SCU/T control unit. Price: £47.

I.A.20 ★

Integrated stereo amplifier with Class A output. Inputs: magnetic PU 1-10mV (switched 47K RIAA); radio 100mV, aux 100mV, tape record and replay. Output: 10W RMS per channel into 15 ohms. HD: 0.1%. H and N: > 65 dB RIAA. Controls: bass ± 16 dB at 50Hz, treble ± 16 dB at 15kHz. Low filters: (switched) 40Hz, 80Hz, 160Hz, 270Hz. High filters: (switched) 3.2kHz, 4.5kHz, 9kHz and 11kHz. Balance control: zero to maximum each channel. Switch for main speaker, auxiliary speaker and phones. DIN correction. AC outlet sockets. Mains: 110, 220, 240V 40-60Hz. Finish: teak or walnut cabinet with satin chrome panel (or black Perspex with rear lighting). Size: 15 \times 5 $\frac{3}{4}$ \times 12 $\frac{5}{8}$ in. Price: £82.

SCU/T

Stereo control unit. Output: 0-750mV RMS per channel at 5K. Specification as I.A.20. Price: £47.

■ LUX

Howland-West Ltd, 3-5 Eden Grove, London, N78EQ. Tel: 01-609 0293/4/5.



Lux SQ707



Lux SQ503

SQ707 ★

Integrated stereo transistor amplifier. Inputs: PU 2mV 50K, radio 120mV 50K, tape recorder 120mV 50K, aux 120mV 50K. Noise level: -60dB on magnetic PU, -65dB all other inputs. Controls: two bass, two treble, mild/intense tone operation, function selector, volume, mono/stereo, balance, A/B speaker switch for two systems. Output: 17W RMS per channel into 8 ohms, 20W RMS per channel into 4 ohms. HD: $< 1\%$ at maximum output. FR: 30Hz-30kHz ± 1 dB. Output impedance: 8 ohms. Mains: 240V AC. Size: 14 $\frac{3}{4}$ \times 5 \times 9in. Polished wood veneered case. Price: £64.

SQ503 ★

Integrated stereo transistor amplifier. Inputs: PU 2mV 50K, radio 120mV 150K, tape play 120mV 150K, aux (1) 1V 1 megohm, aux (2) 120mV 150K. Controls: two bass, two treble, monitor, on/off, main/remote speakers, bass switch 400Hz-200Hz, treble switch 2kHz-4kHz, mono/stereo, volume, balance, function selector. Output: 30W RMS per channel into 8 ohms. FR: 20Hz-50kHz -2dB. Noise level: -60dB on PU, -70dB all other inputs. Output impedance: 8 ohms. Mains: 100, 117, 220, 240V AC. Size: 17 $\frac{3}{4}$ \times 6 $\frac{3}{8}$ \times 10 $\frac{5}{8}$ in. Polished wood veneered case. Price: £88.

SQ202

Integrated stereo transistor amplifier. Inputs: PU (1) 2mV 30-100K, PU (2) 2mV 30-100K, microphone-mixer 2.5mV 50K, aux (1) 110mV 100 ohms, aux (2) > 110 mV 100K, aux (3) 110mV 100K. Noise level: -66dB on PU and mic inputs, -80dB on all other inputs. Comprehensive



Lux 503X

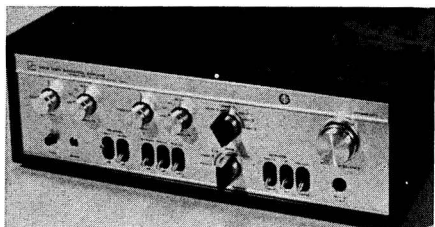

Lux 507X

range of 25 controls. Output: 80W RMS per channel into 8 ohms. HD: <0.05% at 5kHz. FR: 20Hz-70kHz at less than ± 1 dB. Output impedance: 8 ohms. Size: $18\frac{7}{8} \times 6\frac{1}{2} \times 11$ in. Price: £225.

SQ507

Integrated stereo transistor amplifier. Inputs: PU (1) 2mV 30-100K, PU (2) 2mV 50K, tape play 100mV 100K, aux (1) 100mV ad justable at 100K, aux (2) 100mV 200K. Noise level: -60dB PU and aux (1) inputs, -70dB other inputs. Controls: two bass, two treble, turnover frequency selectors (bass 150, 300, 600Hz; treble 1.5, 3, 6kHz), twin speaker systems switch, balance, low boost (80Hz 6dB/octave), high cut (5kHz-6dB/octave). Output: 60W RMS per channel at 8 ohms. FR: 20Hz-50kHz less than 1dB. Output impedance: 8 ohms. Mains: 100, 117, 220, 240V AC. Size: $17\frac{3}{4} \times 6\frac{3}{8} \times 10\frac{5}{8}$ in. Price: £132.

503X ★

Integrated stereo amplifier. 33 transistors. Inputs: PU (1) 2mV 50K, PU (2) 2mV 50K, aux (1) 95mV 50K, aux (2) 95mV 50K. Noise level: PU inputs -60dB, aux inputs -70dB. Output: 20W RMS per channel. Controls: bass each channel, treble each channel, low filter, high filter, balance, main and remote speakers, monitor, volume, input selector. HD: 0.1%. Output impedance: 8 ohms. FR: 10Hz-80kHz -1dB. Size: $17\frac{3}{4} \times 10\frac{5}{8} \times 6\frac{3}{8}$ in. Mains: 110, 117, 220, 240V AC. Finish: rosewood cabinet with white/gold facia. Price: £98.

507X ★

Integrated stereo amplifier. 39 transistors. In-



Marantz 1030

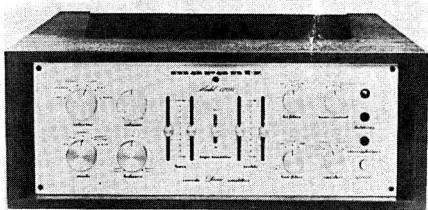

Marantz 1200

puts: PU (1) 2mV 30K/50K/100K switched, PU (2) 2mV 50K, aux (1) 90mV 50K, aux (2) 90mV 200K. Noise level: PU inputs -63dB, aux inputs -80dB. Output: 50W RMS per channel. Output impedance: 8 ohms. Tone controls: bass defeat 150, 300, 600Hz; treble defeat 6kHz, 3kHz, 1.5kHz; bass cut -6dB/octave from 70Hz, treble cut -6dB/octave from 6kHz. HD: 0.04%. FR: 10Hz-60kHz -1dB. Size: $17\frac{3}{4} \times 10\frac{5}{8} \times 6\frac{3}{8}$ in. Finish: rosewood cabinet with white/gold metal facia. Price: £155.

■ MARANTZ

Pysier-Britex (Swift) Ltd, Fircroft Way, Edenbridge, Kent.

Tel: Edenbridge (0732-71) 2434/6.

Model 1030 ★

Integrated stereo amplifier: 22 transistors and 14 diodes. Inputs: mag PU 2.1mV 47K, mic 2.1mV 47K, aux 150mV 100K. Noise level: (PU input) -93dB. Overload capability: (PU input) 100mV. Output: 15W RMS per channel, both channels driven. Output impedance: 8 ohms. Tone controls: bass ± 12 dB at 50Hz, treble ± 12 dB at 15kHz, high filter 16dB/octave from 5kHz, low filter 16dB/octave from 100Hz. HD: 0.5% from 40Hz-20kHz. FR: 20Hz-20kHz ± 1 dB at 1W. Output circuits automatically protected. Mic input on front panel. Main and remote speakers and headphones. Size: $14\frac{1}{2} \times 4\frac{3}{4} \times 12$ in. Finish: gold anodised front panel. Price: £79.

Model 1060

Integrated stereo amplifier. 35 transistors and 14 diodes. Inputs: mag PU 1.8mV 47K, mic

1.8mV 47K, aux 180mV 100K. Noise level: (PU input) -96dB. Overload capability: (PU input) 100mV. Output: 30W RMS per channel, both channels driven. Output impedance: 8 ohms. Tone controls: bass ± 15 dB at 50Hz, treble ± 12 dB at 15kHz, high filter 16dB/octave from 5kHz, low filter 16dB/octave from 100Hz, middle control ± 6 dB at 700Hz. HD: 0.5% 20Hz-20kHz. FR: 20Hz-20kHz ± 0.5 dB at 1W. Automatic protection of output circuits. Three-zone tone controls. Front panel sockets for mic and aux. Size: $14\frac{1}{4} \times 4\frac{3}{4} \times 14$ in. Finish: gold anodised front panel. Price: £110.

Model 1200 ★

Integrated stereo amplifier. 63 transistors and 23 diodes. Inputs: mag PU 1.35mV 47K, aux 134mV 100K. Output: 100W per channel RMS, both channels driven. Output impedance: 8 ohms. High filter: 5kHz, 9kHz. Low filter: 50Hz, 100Hz. HD: 0.15% 20Hz-20kHz. FR: 20Hz-20kHz ± 0.1 dB at 1W. Centre channel output facility. Fully protected output circuits. Slider type graphic tone controls. Tape dubbing jack sockets on front panel. Size: $15\frac{3}{8} \times 5\frac{3}{4} \times 14$ in. Finish: gold anodised front panel. Price: £399.

Model 3300

Stereo preamplifier control unit. 22 transistors and 10 diodes. Inputs: mag PU 1.35mV 47K, mic 1.35mV 47K, aux 135mV 50K. Outputs: (main) 3V into 47K, (tape) 3V into 47K, (centre channel) 3V into 47K, (headphones) 3V into 8 ohms. Tone controls: treble ± 10 dB at 10kHz, bass ± 10 dB at 100Hz, high filter 5kHz and 9kHz switchable, low filter 50Hz and 100Hz switchable. HD: $< 0.02\%$ at 3V 20Hz-20kHz. FR: 6Hz-80kHz ± 0.3 dB, 20Hz-20kHz ± 0.25 dB. Tape dubbing jack sockets on front panel. Centre channel output. Slider type graphic tone controls. Tape monitoring facility for two or three head decks. Size: $15\frac{3}{8} \times 5\frac{3}{4} \times 8\frac{3}{4}$ in. Finish: gold anodised front panel. Price: £255.

Model 250

Stereo power amplifier. 45 transistors and 18 diodes. Input sensitivity: 1.35V for rated power. Input impedance: 100K. Noise level: better than 106dB below rated power into 8 ohms. Output: 125W per channel RMS, both channels driven. HD: $< 0.1\%$ 20Hz-20kHz. Output impedance: 8 ohms. FR: 20Hz-20kHz ± 0.1 dB, 2Hz-100Hz ± 1.5 dB at 1W. VU meters. Relay-operated overload protection. Direct-coupled output circuitry. Size: $15\frac{3}{8} \times 6\frac{1}{8} \times 9\frac{1}{2}$ in. Gold anodised front panel. Price: £329.

■ METROSOUND

Metrosound Manufacturing Co Ltd,
Audio Works, Cartersfield Road,
Waltham Abbey, Essex.
Tel: Waltham Cross 31933.

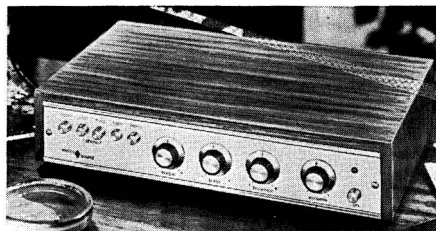

Metrosound ST20E

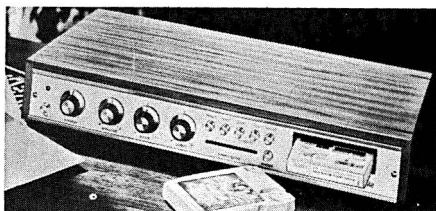

Metrosound SS30E

ST20E ★

Transistorised stereo amplifier. Output: 10W RMS per channel. HD: less than 1% at rated output. FR: 30Hz-30kHz ± 2 dB at rated output. Noise level: -70dB. Inputs: mag PU 2.5mV, ceramic PU 150mV, radio 150mV. Output impedance: 8 ohms. Mains: 200-250V AC. 20 transistors, 2 diodes. Controls: pushbutton controls for mains on/off, mono/stereo, tape, tuner, mag PU, ceramic PU. Rotary controls for treble, bass, balance and volume. Bass control: ± 12 dB at 40Hz. Treble control: ± 12 dB at 14Hz. Tape outlet: 300mV per channel at 5K. Automatically switchable headphone socket, 4-16 ohms. Finish: anodised brushed silver fascia with polished trim and knobs, teak veneer cabinet. Size: $3\frac{1}{2} \times 15\frac{1}{4} \times 10$ in. Price: £39.50.

SS30E ★

Transistorised stereo amplifier with tape cartridge playing facility incorporated. 24 transistors, 5 diodes. Output: 10WRMS per channel. HD: less than 1% at rated output. FR: 30Hz-30kHz ± 2 dB at rated output. Noise level: -70 dB. Inputs: mag PU 2.5mV, ceramic PU 150mV, radio 150mV. Output impedance: 8 ohms. Mains: 200-250V 50/60Hz. Controls: pushbutton controls for mains, on/off, mono/stereo, tape, tape programme selector, tuner, magnetic PU, ceramic PU. Rotary controls for treble, bass, balance and volume. Bass control: ± 12 dB at 40Hz. Treble control: ± 12 dB at 14kHz. Balance control: either channel may be faded to zero without affecting the other. Tape output: 300mV at 5K. Automatically switchable headphone socket, 4-16 ohms. Tape cartridge system.

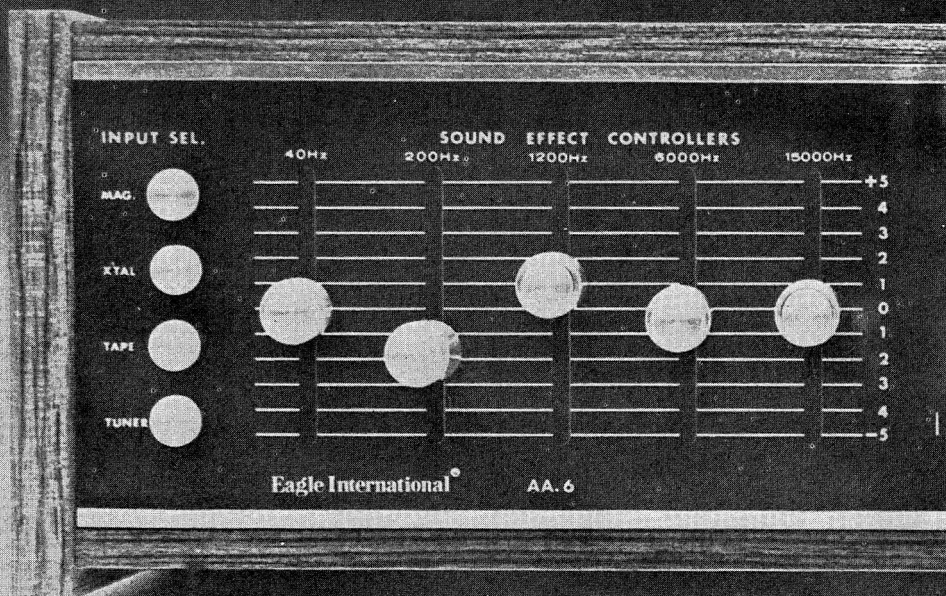

To boost the violins, slide the fourth knob from the left upwards.

To boost the bass trombones, slide the first knob upwards.

To get Gigli or Sinatra to sing out, slide the third knob upwards. It gives the human voice more 'presence'.

We could go on, but by now you'll take the point.

With the new Eagle AA6 amplifier, you have complete control over the sound you hear.

Much more than you ever had with normal Bass and Treble controls.

Why?

Because the five slide controllers allow you to boost or cut five separate sectors across the whole frequency range, around 40, 200, 1,200, 6,000 and 15,000 Hz.

As opposed to ordinary Bass and Treble controls which simply give you 'blanket' cut or boost, generally around 100 and 10,000 Hz.

The difference is amazing.

With the AA6, you can literally pick and choose what you hear.

You can create entirely new balance by 'mixing'.

You can compensate for poor room acoustics.

Or poor recordings.

Or quirks in your other hi-fi components.

And when you're not listening so critically, you

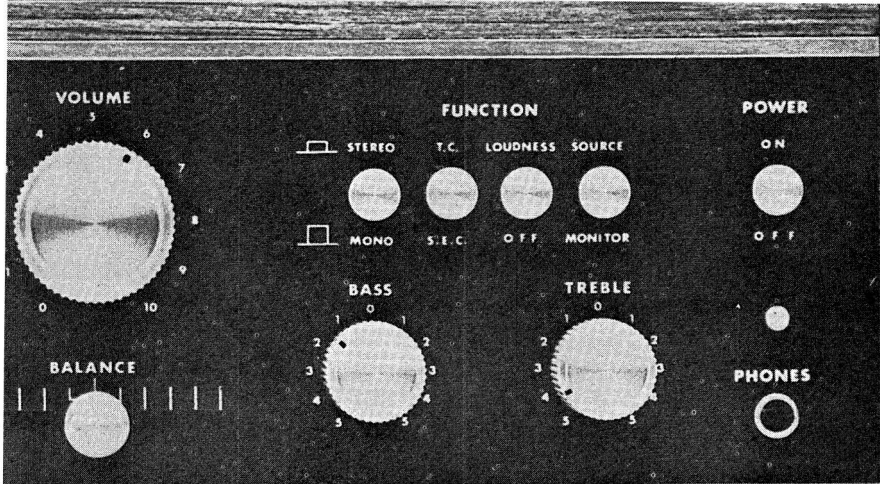

can revert to simple Bass and Treble controls merely by pushing a button.

Now there's something you must do. Visit your Eagle dealer and ask for a demonstration.

More than any other amplifier, you need to have the Eagle AA6 demonstrated.

To hear it. To experiment with the controllers.

To realise what you're missing.

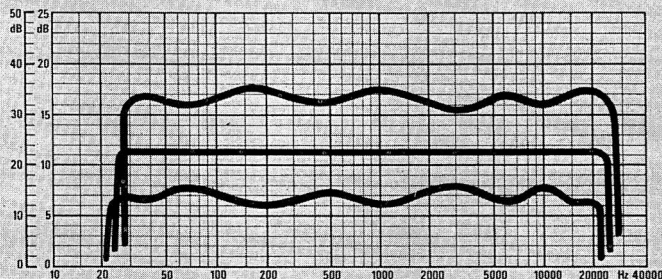

Graph shows degree of control throughout frequency range with Sound Effect Controllers in maximum and minimum positions.

Eagle International

Eagle International Precision Centre Heather Park Drive
Wembley HA0 1SU Telephone 01-903 0144

★ Indicates entry is illustrated

Speed: $3\frac{3}{4}$ i/s. W and F: less than 0.3%. FR: 40Hz-12kHz \pm 3dB. H and N: -45dB. Eight-track stereo tape cartridge. Size: $3\frac{1}{2} \times 20\frac{3}{4} \times 10$ in. Price: £68 (plus £11.45 PT).

ST60

Integrated stereo amplifier. Output: 30W RMS per channel. Output impedance: 4-16 ohms. FR: 20Hz-50kHz \pm 2dB. HD: 0.08%. H and N: (mag PU) 65dB. (other inputs) 70dB. Tone controls: bass \pm 14dB at 40Hz, treble \pm 14dB at 14kHz. Inputs: mag PU 3mV or 10mV at 47K, radio 5mV 120K, tape 5mV 120K, aux 5mV 120K. Filter: switched at 10kHz, 7kHz, 4kHz, variable from 0-20dB per octave. Outlets: two pairs of separately switched speaker sockets. Two switched mains outlet sockets. Tape outlet: 250mV. Size: $20\frac{3}{8} \times 3\frac{3}{8} \times 12\frac{1}{2}$ in. Weight: 20lb. Price: £70.

■ MILBANK ELECTRONICS

Bellbrook Estate, Uckfield, Sussex.
Tel: Uckfield 4166.

MTA301

Transistorised mono power amplifier. Output: 30W RMS. HD: 0.3%. FR: 30Hz-20kHz -3dB. Noise level: -90dB for stated output. Input: 4.5mV. Output impedance: 4, 8, 16 ohms. Mains: 220-250V AC. Size: $19\frac{1}{2} \times 14\frac{1}{8} \times 4\frac{1}{2}$ in. Price: £67-60.

MTA501

Transistorised mono power amplifier. Output: 50W RMS. HD: 0.3%. FR: 30Hz-20kHz -3dB. Noise level: -90dB for stated output. Input: 4.5mV. Output impedance: 4, 8, 16 ohms. Mains: 220-250V AC. Size: $19\frac{1}{2} \times 14\frac{1}{8} \times 4\frac{1}{2}$ in. Price: £84-20.

MTA1001

Transistorised mono power amplifier. Output: 100W RMS. HD: 0.3%. FR: 30Hz-20kHz -3dB. Noise level: -90dB for rated output. Input: 4.5mV. Output impedance: 4, 8, 16 ohms. Mains: 220-250V AC. Size: $19\frac{1}{2} \times 14\frac{1}{8} \times 4\frac{1}{2}$ in. Price: £110.

Module 070

Magnetic cartridge preamplifier. Two inputs: 5mV 47K. Two outlets: 3.5V max. Gain control. Power requirements: 24V 6mA. Size: 4×2 in. Price: £8-50.

Module 071

Tape head preamplifier. Two inputs: 3.5mV 47K. Two outlets: 500mV. Gain control. Power requirements: 24V 6mA. Size: 4×2 in. Price: £8-50.

Various other input preamplifier modules avail-

■ MULLARD LTD

Mullard House, Torrington Place,
London, WC1. Tel: 01-580 6633.

Unilex

See Constructional Kits Section for details of Mullard preamplifier and amplifier modules for the home constructor.

■ NIKKO

Nikko Electric Mfg Co Ltd,
Distributors: Howland-West Ltd,
3-5 Eden Grove, London, N78EQ.
Tel: 01-609 0293/4/5.

TRM-50 ★

Solid state stereo amplifier. Power output: 4-16 ohms, 17W per channel RMS. HD: less than 0.9%. FR: 10Hz-50kHz \pm 1½dB. Noise level -65dB. Mains powered. Dimensions: $8.4 \times 6.5 \times 2.4$ in. Price: £59-50.

TRM-1200 ★

Integrated transistor stereo amplifier. Inputs: mic 2mV 50K, tape 220mV 100K, PU 1.2mV 50K, radio 220mV 100K, aux 220mV 100K. Signal to noise: tape, tuner and aux inputs 85dB; mic and PU 70dB. Controls: function, volume, balance, tone controls in/out, low filter, high filter, speaker switching, mode, tape monitor on/off, bass right, bass left, treble right, treble left, on/off, meter level control, loudness. Output: 40W RMS into 8 ohms. HD: 0.9% at rated output. FR: 13Hz-50kHz \pm 1dB at 30W. Output impedance: 4-16 ohms. Mains: 117-240V 50/60 Hz. Size: $15\frac{1}{4} \times 12\frac{1}{4} \times 4\frac{1}{2}$ in. Price: £110.

TRM-300 ★

Integrated stereo amplifier. 26 transistors. Inputs: mag PU 1.8mV 70K, PU (2) 120mV 50K, radio 200mV 100K, aux 150mV 100K, tape monitor 190mV 50K. Noise level: PU (2) input 60dB, other inputs > -70dB. Output: 12W RMS per channel. Output impedance: 8 ohms. Controls: bass, treble, balance, volume, input selector, loudness, tape monitor, mono/stereo. HD: 1%. FR: 30Hz-20kHz \pm 1dB at rated output. Size: $12 \times 8\frac{1}{2} \times 3\frac{3}{4}$ in. Price: £39-50.

TRM-400 ★

Integrated stereo amplifier. 22 transistors, two ICs. Inputs: mag PU 1.8mV 35K, tape head 1.8mV 200K, PU (2) 120mV 35K, radio 200mV 220K, aux 150mV 220K, tape monitor 190mV. Noise level: tape head and PU inputs -60dB, other inputs -70dB. Output: 16W RMS per channel. Output impedance: 8 ohms. Controls: bass, treble, balance, volume, A+B speakers, low filter, high filter, loudness, tape monitor. HD: 1%. FR: 30Hz-20kHz. Size: $12 \times 8\frac{1}{2} \times$

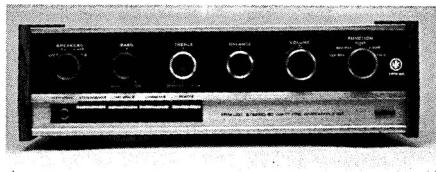

Nikko TRM-50



Nikko TRM1 200



Nikko TRM-300

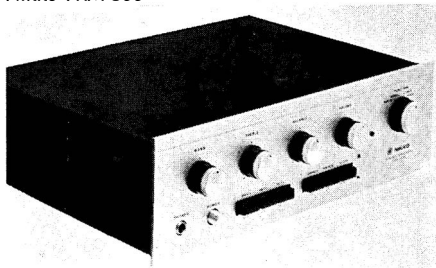

Nikko TRM-400

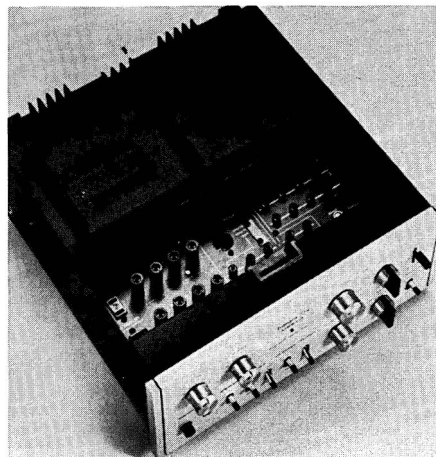

Onkyo Integra 725

■ NIVICO

Denham & Morley Ltd, Denmore House
453 Caledonian Road, London, N7.
Tel: 01-607 6568. Telex: 24562.

SEA-100E

Control unit incorporating sound-effect pre-amplifier. Sound-effect centre frequencies: 60 Hz, 250Hz, 1kHz, 5kHz, 15kHz (all adjustable ± 10 dB). FR: 20Hz-30kHz +0dB -0.5B. Output: 1V. THD: <0.1% at rated output. Input: 500-800mV. S/N: better than 70dB. Input impedance: (normal) 100K, (high) 700K. Output impedance: 1K. Mains: 100-240V 50/60Hz. Size: $10\frac{3}{8} \times 4\frac{7}{8} \times 11\frac{1}{2}$ in. Weight: 6 $\frac{1}{2}$ lb. Controls: Mains on/off, SEA over-ride, impedance selector, five SEA sliders. Price: £46-50.

MCA-105E

Integrated stereo amplifier with sound-effect preamplifier plus built-in pink noise generator. Inputs: PU (2) 1mV 47K, radio 30mV 100K, tape play (2) 30mV 100K, mic 1mV 47K, aux (2) 30mV 100K. Sound-effect preamplifier centre frequencies: 40/60Hz, 150Hz, 400Hz, 1kHz, 2.4kHz, 7kHz, 15kHz (all adjustable ± 10 dB). Output: 60W per channel into 4 ohms, 50W per channel into 8 ohms. Output impedance: 4-16 ohms. THD: <0.5% at 1kHz at rated output. Damping factor: 50 at 8 ohms load. Equalisation: (PU) RIAA. Mains: 100-240V 50/60Hz. Consumption: 145W maximum. Size: $17\frac{3}{8} \times 5\frac{1}{8} \times 15\frac{3}{8}$ in. Weight: 25.3lb. Price: £130-50.

MCA-104Z

Integrated stereo amplifier. Output: 50W per channel into 4 ohms. HD: <0.8% at 1kHz. FR: 20Hz-20kHz ± 0.5 dB. Sound effect amplifier (SEA) system. Mains: 100-240V AC. Price: £79-95.

See Quadraphonics Section for details of Nivico four-channel amplifiers and accessories.

■ ONKYO

J. Parker & Co (London) Ltd, Parkar House,
1 Paul Street, London, EC2A4JQ.
Tel: 01-628 4577.

Integra 725 ★

Integrated stereo amplifier. Inputs: PU (1) 2.4mV 50-100K, PU (2) 2.4mV 50-100K, tuner 100mV 100K. H and N: (PU input) better than 75dB, (tuner input) better than 90dB. Overload capability: PU input 200mV. Tone controls: bass ± 10 dB at 100Hz, treble ± 10 dB at 10kHz, low filter -6dB/octave at 70Hz, high filter -6dB/octave at 8kHz. Output: 22W RMS per channel into 8 ohms. HD: <0.1% at rated output. FR: 15Hz-70kHz at rated output. Output impedance: 4-16 ohms. Loudness control. Headphone and mains outlets. Mains: 100-120V or 220-240V AC 50Hz/60Hz. Size: $12\frac{3}{8} \times 5\frac{3}{8} \times 13\frac{1}{2}$ in. Weight: 17 $\frac{1}{2}$ lb. Price: £97-88.

★ Indicates entry is illustrated

■ PHILCO

Philco International Ltd, 42 Leicester Square, London, WC2H7LR. Tel: 01-930 7667.

M1550

Integrated stereo amplifier. Output: 12W RMS per channel. Inputs: magnetic PU, ceramic PU, tape recorder, radio. Pushbutton input selectors. Controls: bass, treble and balance. Connections to DIN standard. Finish: white satin. Size: $15\frac{3}{8} \times 8 \times 4$ in. Price: £39.95.

■ PHILIPS ELECTRICAL LTD

Century House, Shaftesbury Avenue, London, WC2. Tel: 01-437 7777.

RH-580 ★

Solid state stereo amplifier. Power output: 6W per channel RMS into 8 ohms; provision for 4 ohms (reduced power). HD: $<1.5\%$ at 5W per channel. FR: 50Hz-20kHz 3dB down for 6W. Noise level: 55dB below 6W (overall). Output transistors: two AD161/162. Psn 110, 127, 220, 240V. Inputs: magneto/dynamic pickup 3mV, 47K; crystal pickup 100mV 60K; tuner and tape 100mV 140K; all -55dB overall for 6W. Controls: volume (with bass compensation +8 dB max at 65Hz); bass ± 13 dB at 65Hz; treble +11 to -10dB at 10kHz; balance. Dimensions: $2\frac{7}{8} \times 13\frac{3}{8} \times 8\frac{1}{2}$ in. Price: £29.

RH590 ★

Solid state stereo amplifier. Power output: 10W per channel RMS into 8 ohms (4 ohms at reduced power). HD: $<1\%$. FR: 20Hz-20kHz 3dB down. Distortion: 1%. NL: 80dB below 10W. Output transistors: four AD149. Psn 110, 127, 220, 240V. Inputs: magneto/dynamic pickup 3mV 47K; crystal pickup, tape and tuner 100mV 100K each, -80dB overall for 10W out. Controls: volume (with bass compensation +8dB max at 50Hz); treble ± 14 dB at 10Hz; bass +16 to -14dB at 50Hz; balance; rumble 12dB/octave 3dB down at 100Hz; scratch 12dB/octave 3dB down at 6kHz. Dimensions: $3\frac{7}{8} \times 14\frac{1}{2} \times 10$ in. Price: £52.

RH521 ★

Integrated stereo amplifier. 32 transistors. Inputs: mag PU 2mV 50K, radio 100mV 100K, tape 250mV 100K, aux 100mV 1megohm. Noise level: -90dB. Output: 30W RMS per channel. Controls: volume, balance, bass ± 15 dB, treble ± 15 dB, presence ± 6 dB at 2kHz, loudness (three positions) scratch filter, rumble filter, monitor. Output impedance: 4 ohms. HD: $<0.1\%$ at 20W per channel. FR: 15Hz-40kHz +0.5dB, -3dB at 30W per channel. Mains: 110, 127, 220, 240V AC. $18\frac{1}{2} \times 4\frac{5}{8} \times 11$ in. Microphone input. Two sets of speaker outlets. Headphone socket. Finish: walnut veneer cabinet with brushed aluminium fascia. Price: to be announced.

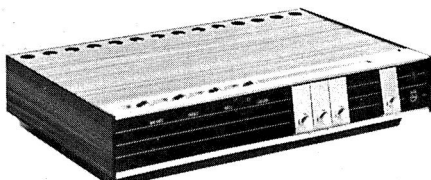

Philips RH580

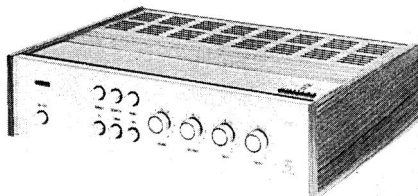

Philips RH590

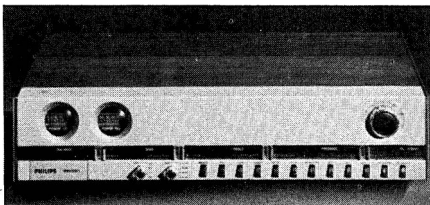

Philips RH521

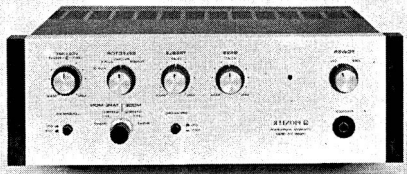

Pioneer SA-500



Quad 50E power amplifier

■ PHOENIX

H. L. Audio Ltd, 5 Shakespeare Road,
Finchley, London, N3. Tel: 01-346 3332.

Phoenix 77

Integrated stereo amplifier. Inputs: mag PU, ceramic PU, radio, tape. Output: 10W RMS per channel. FR: 40Hz-20kHz. Controls: bass, treble, balance, volume, scratch filter. Switched headphone socket. Finish: black and brushed aluminium fascia. Price: £29.

■ PIONEER

Distributors: Shriro (UK) Ltd,
42 Russell Square, London, WC1B5DF.
Tel: 01-580 6996.

SA500A ★

Integrated stereo amplifier. Inputs: magnetic PU 2.5mV 47K, radio 200mV 100K, tape 200mV 100K, aux 200mV 100K. Noise level: PU input 75dB, other inputs 90dB. Controls: bass \pm 13dB at 50Hz, treble +8dB -11dB at 10kHz, loudness +12dB at 50Hz, +5.5dB at 10kHz. Output: 13W RMS into 8 ohms. HD: <0.5% at 1kHz. FR: 20Hz-50kHz \pm 1dB. Output impedance: 4-16 ohms. Mains: 110, 117, 130, 220, 240V AC. Size: $13 \times 4\frac{3}{8} \times 12\frac{3}{8}$ in. Price: £45.50.

SA700

Integrated stereo amplifier. Inputs: magnetic PU (2) 3mV, radio 200mV, tape 200mV, aux 200mV. Controls: bass +12dB -9dB at 100Hz, treble +9dB -12dB at 10kHz, loudness +13dB at 50Hz, +4dB at 10kHz, low filter -8.4dB at 50Hz, high filter -7.8dB at 10kHz, muting -20dB. Output: 34W RMS into 8 ohms. HD: <0.05% at 20W output. FR: 20Hz-40kHz \pm 1dB. Output impedance: 4-16 ohms. Mains: as for SA500. Size: $14\frac{3}{8} \times 4\frac{3}{8} \times 12\frac{3}{8}$ in. Price: £97.97.

SA900

Integrated stereo amplifier. Inputs: magnetic PU (2) 3.1mV 50K, tape (2) 180mV 150K, radio 180mV 200K, aux (2) 180mV 180K. Noise level: PU inputs better than 80dB, other inputs better than 95dB. Controls: bass (2) +12dB -9dB at 100Hz, treble (2) +9dB -12dB at 10kHz, loudness +7dB at 10kHz, +14dB at 50Hz, low filter -6dB (12dB per octave at 50Hz), high filter -6dB (12dB per octave at 10kHz), muting -20dB. Output: 60W RMS per channel into 8 ohms. HD: <0.08% at 45W at 1kHz. FR: 20Hz-50kHz \pm 1dB. Output impedance: 4-16 ohms. Mains: 110, 117, 130, 220, 240V AC. Size: $16 \times 5\frac{1}{2} \times 13\frac{3}{8}$ in. Price: £133.83.

SA600

Integrated stereo amplifier. Inputs: mag PU (2) 2.3mV 50K, mic 3.3mV 20K, radio 200mV 95K, aux (2) 200mV 95K, tape (2) 200mV 95K. 21 transistors, 8 diodes. Output: 31W RMS per channel into 4 ohms. HD: <0.5%. FR: 15Hz-

70kHz \pm 1dB. Output impedance: 4-16 ohms. AC mains. Price: £89.60.

SA1000

Integrated stereo amplifier. Inputs: mag PU 2.9mV 50K, ceramic PU 58mV 100K, mag PU 2.9mV 20-100K switchable, mic 115 μ V 30 ohms, mic 2.2mV 50K, radio 200mV 200K, aux (2) 200mV 200K, tape (2) 200mV 200K. Output: 94W RMS per channel into 4 ohms. HD: <0.3% at rated output. FR: 20Hz-60kHz \pm 1dB. Output impedance: 4-16 ohms. Centre channel output: 500mV. AC mains: 110, 120, 220, 240V. Price: £147.83.

SR-202W

Reverberation amplifier for adding natural depth to stereo tapes and recordings. Employs double-scatter system by blending direct signals from source with reverberation effect. A variety of effects can be achieved. Easily connected to existing amplifier and tape unit. Adjustable reverb time. Full descriptive leaflet on request. Price: £51.05.

SA800

Integrated stereo amplifier. Output: 39W RMS per channel into 4 ohms. HD: 0.5%. FR: 5Hz-80kHz \pm 1dB. Inputs: mag PU 3mV 50K, mic 2.3mV 25K, tape 230mV 200K, aux 230mV 200K, radio 230mV 200K. Tone controls: bass +12dB -9dB at 100Hz, treble +9dB -12dB at 10kHz, low filter -3.5dB at 50Hz, high filter -3dB at 100kHz. 35 transistors, 20 diodes, 2 FETs. Price: £119.85.

SC700

Multi-amplifiers. Full details not available at time of going to press. Price: £58.51.

SF700

Multi-amplifier. Full details not available at time of going to press. Price: £82.12.

■ QUAD

Acoustical Manufacturing Co Ltd,
St Peter's Road, Huntingdon, Hunts.
Tel: Huntingdon 2561/2. Cables: Acoustical.

Quad 33 control unit

Transistorised mono/stereo control unit. Inputs: PU from 2mV, radio(1) 100mV 100K, radio(2) 100mV 100K, tape from 100mV 40K. Signal-to-noise level: -70dB on PU, -85dB on all other inputs. Output: 0.5V. Controls: volume, balance, bass, treble, filter slope, filter frequency. Mains powered. Designed for use with Quad 303 amplifier but suitable for operation with other high quality equipment. Size: $10\frac{1}{2} \times 3\frac{3}{8} \times 6\frac{1}{2}$ in. Price: £48.

Quad 50/E ★

High quality transistor power amplifier primarily intended for professional and industrial use. Input: 500mV RMS into 14 to 50K according to

★ Indicates entry is illustrated

gain control setting for 50W output, or standard 600-ohm line bridging input. Output: 50W. Output transformer secondaries linked by output connector to provide for 4 to 300 ohm loads. Damping factor 10. Total harmonic distortion: 0.1% at 1kHz at any level up to 50W output. Hum better than 80dB. Consumption: 24-150W depending on power output. Mains: 100-127V or 200-250V 50-60Hz. Size: $12\frac{3}{4} \times 6\frac{1}{2} \times 4\frac{3}{4}$ in. Weight: 24lb. Price on application.

Quad 303 power amplifier ★

Transistorised stereo power amplifier. Output: 45W into 8 ohms. HD: 0.03% at 70Hz and 700 Hz, 0.1% at 10kHz. FR: -1dB 30Hz-35kHz into 8 ohms, -1dB 20Hz-35kHz into 16 ohms. Noise level: -100dB. Sensitivity: 0.5V. Output impedance: 4-16 ohms. Output transistors: High voltage 2N3055. Mains. Designed for use with Quad 33 control unit but can be used with other high quality equipment. Size: $4\frac{3}{4} \times 6\frac{1}{4} \times 12\frac{3}{4}$ in. Price: £58.

■ RADFORD AUDIO LTD

Ashton Vale Road, Bristol, BS32HZ.
Tel: Bristol 662301.

SC-24 ★

Stereo control unit. Transistors. Inputs: PU 2mV 50K, aux(1) 2mV 50K, aux(2) 80mV 100K, radio 80mV 100K, tape monitor 80mV 100K. Noise: (2mV inputs) -70dB; (80mV inputs) -75dB. Output: 1V RMS. Controls: balance, bass, middle, treble, input selector, filter 4, 7 and 10kHz at 12dB/octave. Designed for use with Radford SPA-50 amplifier but suitable for any power amplifier. AC mains. Size: $4\frac{1}{2} \times 16\frac{1}{2} \times 9\frac{3}{4}$ in. Price: £80.

SPA-50

Stereo power amplifier. Transistors. Output: 50W RMS per channel. HD: 0.025% at rated output. FR: 10Hz-500kHz -3dB at 50W output. Noise: -95dB. Input: 1V RMS for rated output. Output impedance: 8 ohms. Mains: 110



Quad 303 power amplifier



Revox A78

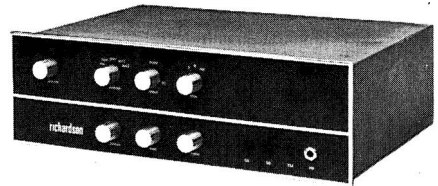

Richardson Electronics SIA100

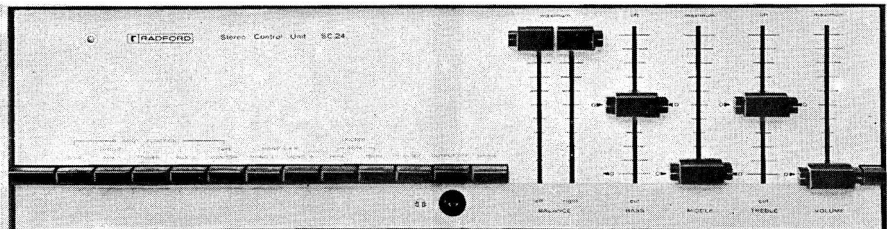

Radford SC24

120, 130, 220, 230, 240V AC. Size: $10\frac{3}{4} \times 4\frac{1}{2} \times 12\frac{1}{2}$ in. Price: £85.

PA-50

Mono power amplifier. Transistors. Output: 50W RMS. HD: 0.025% at rated output. Noise: -95dB. Input: 1V RMS. FR: 10Hz-500kHz -3dB at 50W. Output impedance: 8 ohms. Mains: 110, 120, 130, 220, 230, 240V AC. Size: $4\frac{1}{2} \times 12\frac{1}{2} \times 8$ in. Price: £55.

RADON

Radon Industrial Electronics Co Ltd, Orme Road, Worthing, Sussex. Tel: Worthing 34904.

System 60

Integrated stereo transistor amplifier. Inputs: PU(1) 180mV, PU(2) 45mV, radio 150mV, aux 150mV. Output: 4W RMS per channel. Controls: bass, treble, volume, balance, selector, mode. HD: better than 0.2% at rated output. FR: 40Hz-20kHz. Noise: -60dB. Output impedance: 15 ohms. Mains: 240V AC. Price: £26.

REVOX

Distributors: C. E. Hammond & Co Ltd, Lamb House, Church Street, London, W4. Tel: 01-995 4551. Telex: 934047.

Revox A78 ★

Stereo amplifier. Output: 40W RMS per channel into 4-8 ohms, 25W RMS per channel into 16 ohms. HD: less than 0.1% at 1kHz, 0.3% 40Hz-15kHz. FR: 20Hz-20kHz ± 1 dB. Inputs: mag PU 3mV, ceramic PU 230mV, tape 100mV, aux 100mV, radio 100mV, tape monitor 250mV. Treble control: ± 12 dB at 12kHz. Bass control ± 12 dB at 60Hz. Mains: 110, 130, 150, 220, 240, 250V 50/60Hz. 30 silicon transistors, 3 rectifiers, 14 diodes. Size: $6\frac{1}{2} \times 16\frac{3}{8} \times 9\frac{5}{8}$ in. Weight: 18lb. Price: £124.

RICHARDSON ELECTRONICS LTD

57 Jamestown Road, London, NW1. Tel: 01-267 0723.

SCP.2P

Stereo self-powered control unit. Modular construction with pluggable circuits. FET high Z input. Silicon semi-conductors. Stabilised power supply. Low noise and distortion 0.01% for 1V output. Bass ± 20 dB. Treble ± 16 dB. Rumble filter on disc. Quiet listening tape monitor. Mag pickup 2mV inputs (two); high Z 2Mohms 50mV; aux 250mV (two). Size: $14\frac{3}{8} \times 14\frac{3}{8} \times 10\frac{1}{2}$ in. Psn 200-250V 50 or 60Hz. Price: approximately £55 including teak case.

SIA.100 ★

Stereo integrated amplifier and control unit. Preamp specification as for SCP 2P. Power amplifier incorporates advance design comple-



Rogers Ravensbourne

mentary push-pull output to reduce crossover distortion. Output: 30W RMS per channel into 8 ohms. HD: 0.04%. Output protected against short circuit. Stable at all loads. Mains: 200-250V AC 50/60Hz. Price: approximately £95 including teak case.

STA.200

Stereo transistor amplifier. Output: 100W RMS per channel into 8 ohms. 175W RMS per channel into 4 ohms. Mono version available giving balanced output of 50V into 8 ohms. Price: approximately £160.

STA.100

Stereo transistor amplifier. Output: 50W RMS per channel into 8 ohms. 85W RMS per channel into 4 ohms. Price: approximately £110.

SA170 Mk 2 and MA135 Mk 2

Valve power amplifiers. Full specification and prices on request.

ROGERS DEVELOPMENTS (Electronics) LTD

4-14 Barmeston Road, Catford, London, SE6. Tel: 01-698 7424/4340. Cables: Rodevco, London, SE6.

Ravensbourne ★

Solid state stereo amplifier and control unit. Power output: 4, 8 and 16 ohms; 25W per channel RMS. HD: 0.1% average (0.06% at 15W). FR: 25Hz-25kHz ± 1 dB at 25W. Feedback: 36 dB. N/L: -80dB. Output transistors: 2N3055. Power consumption: quiescent 40W; at 25W + 25W into 15 ohms 110W. Inputs: disc, sensitivity 4/8/100/200mV, impedance 50K, noise level -60/65dB; aux, radio and tape, sensitivity 200mV, impedance 100K, N/L: -75dB. Controls: pushbutton input selector, volume, bass and treble, balance, low pass filter and slope, function, headphone. Dimensions: case $14\frac{3}{4} \times 10\frac{1}{4} \times 5\frac{1}{2}$ in; chassis $13\frac{3}{4} \times 10\frac{1}{8} \times 4$ in. Price: (chassis) £64.50; (in cabinet) £69.50.

Ravensbrook Mk II ★

Solid state stereo amplifier and control unit. Power output: 10W per channel into 15 ohms. 15W per channel into 8 ohms. HD: less than

★ Indicates entry is illustrated

0.1% at 10W into 15 ohms. FR: 20Hz-50kHz -3dB. Noise level: disc -53dB, radio -8dB. Power consumption: quiescent 22W; 10W/15 ohms 50W. Inputs: disc, sensitivity 2/4/25/50 mV, impedance 47K, noise level: -53dB. Controls: pushbutton input selector, function, bass and treble, balance, high pass filter switch, low pass filter/slope. Output facility for headphones. Dimensions: cabinet $14\frac{3}{8} \times 9\frac{3}{4} \times 5\frac{1}{2}$ in; chassis $13 \times 9\frac{3}{4} \times 3\frac{1}{4}$ in. Price: (chassis) £50.50; (in cabinet) £55.50.

■ ROTA

Distributors: Kelgrove (Sales) Ltd,
St Marks Rise, Dalston, London, E8.

OTL-1500

Integrated stereo amplifier. Inputs: crystal or ceramic PU 200mV, magnetic PU 5mV, tape, radio, aux 200mV. Controls: bass, treble, balance, volume, input selector. Output: 5W RMS per channel. Output impedance: 4-16 ohms. FR: 20Hz-20kHz \pm 1dB. Stereo headphone socket. Wood end pieces with simulated wood grain finish and dark control panel. Size: $12 \times 3\frac{1}{2} \times 8$ in. Price: £25.

OTL-2200

Integrated stereo amplifier. Inputs: crystal or ceramic PU 200mV, magnetic PU 4mV, radio, microphone 5.5mV, tape 200mV. Controls: volume, treble, bass, input selector, slider balance adjustment. Output: 10W RMS per channel. Output impedance: 4-16 ohms. FR: 20Hz-40kHz \pm 1dB. Stereo headphone socket. Wood end pieces with simulated wood grain finish and dark control panel. Size: $14 \times 4 \times 9\frac{1}{2}$ in. Price: £34-75.

■ ROTEL

Rank Aldis-Audio Products,
Great West Road, Brentford, Middlesex.
Tel: 01-568 9222. Telex: 24408.

RA310 ★

Integrated stereo amplifier. Inputs: magnetic PU 3mV, crystal PU 100mV, aux 200mV, tape 300mV. Noise level: -60dB on mag PU, -65dB on other inputs. Controls: +14dB -12dB at 50Hz, treble \pm 12dB at 10kHz, balance, volume, input selector with light indicators, pushbuttons for mode, on/off, loudness, speakers. Output: 20W RMS per channel into 4 ohms, 15W RMS per channel into 8 ohms. HD: 0.2% at rated output. FR: 20Hz-30kHz -1.5dB. Output impedance: 4, 8, 16 ohms. Mains: 100, 120, 200, 240V 50/60Hz. Size: $14 \times 4\frac{1}{2} \times 7\frac{1}{2}$ in. Price: £47-50.

RA610 ★

Integrated stereo amplifier. Inputs: magnetic PU(1) 2.5mV 50K, magnetic PU(2) 2.5mV 100K, radio 120mV 25K, aux(1) 120mV 25K, aux(2)



Rogers Ravensbrook



Rotel RA310



Rotel RA610



Rotel RA210



Sansui AU222

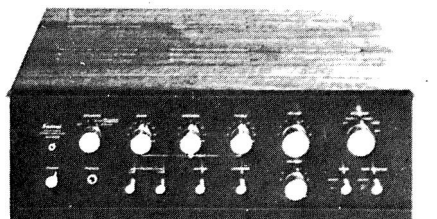

Sansui AU666

120mV 25K, tape 620mV 35K, main amplifier 650mV 35K. Controls: loudness ± 10 dB at 5kHz, high filter -9 dB at 10kHz, low filter -9 dB at 50Hz, muting -20 dB at 1kHz, bass $+15$ dB -13 dB at 50Hz, treble $+14$ dB -16 dB at 10kHz. Output: 32W RMS per channel into 8 ohms. HD: $<0.1\%$ at rated output. FR: (main amplifier) 3Hz-100kHz -3 dB, (aux inputs) 5Hz-90kHz -3 dB. Output impedance: 4, 8, 16 ohms. Mains: 117, 240V AC. Size: $16\frac{1}{4} \times 8\frac{3}{4} \times 4\frac{7}{8}$ in. Price: £74.50.

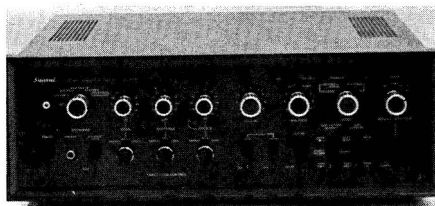

Sansui AU999

RA210 ★

Integrated stereo amplifier. Inputs: mag PU 2.7mV 45K, radio 120mV 150K, tape 120mV 150K, aux 120mV 150K. Noise level: mag PU input -60 dB, other inputs -70 dB. Output: 8W RMS per channel at 8 ohms. Tone controls: bass ± 12 dB at 50Hz, treble ± 12 dB at 10kHz. HD: $<0.5\%$ at rated output. Output impedance: 4, 8 and 16 ohms. FR: 25Hz-75kHz. Mains: 240V AC. Size: $12\frac{7}{8} \times 3\frac{3}{4} \times 6\frac{1}{2}$ in. Wood cabinet. Front headphone socket. Price: £34.90.

■ SABA

Distributors: Lampitt Electronics Ltd, 6-12 Cornbrook Park Road, Manchester, M15 4EE. Tel: 061 872 7661.

VS80

Integrated stereo amplifier. Output: 45W music power per channel. Inputs for mag PU, crystal PU, radio and tape. Full overload protection. Headphone socket on front panel. Slider controls for volume, bass, treble and balance. 29 transistors, 5 diodes. Output impedance: 4-16 ohms. Size: $16\frac{3}{8} \times 4\frac{1}{2} \times 11$ in. Finish: light walnut or white. Price: £85.

■ SANSUI

Vernitron Ltd, Thornhill, Southampton, SO9 5QF. Tel: Southampton 44811.

AU101

Integrated stereo amplifier. Input: PU 3mV 50K, mic 4mV 50K, aux 200mV 50K, tape (2) 200mV 50K. Noise level: PU and mic inputs >65 dB, other inputs >75 dB. Output: 15W RMS per channel. Output impedance: 4-8 ohms. Tone controls: bass ± 13 dB at 50Hz, treble ± 10 dB at 6kHz. Loudness control: $+8$ dB at 50Hz, $+3$ dB at 10kHz. HD: $<0.8\%$ at rated output. FR: 20Hz-60kHz ± 2 dB. Mains: 100, 117, 220, 240V AC. Finish: black front panel with light walnut ends. Size: $16 \times 4\frac{5}{8} \times 11$ in. Two AC outlet sockets. Two year guarantee. Price: £45.24.

Sansui AU222 ★

Solid state stereo amplifier. Power output: 18W per channel ± 1 dB at 8 ohms. HD: less than 0.8%. FR: 20Hz-20kHz at 8 ohms. Damping factor: 20 at 8 ohms. H and N, volume at minimum, -80 dB. Inputs: pickups 2mV (47K and

100K); tape head 1.5mV (200K); aux (two) 150mV (100K); tape monitor 150mV (40K). Psn: 100, 117, 220 and 240V, 50 or 60Hz. Dimensions: $4\frac{3}{8} \times 11\frac{1}{2} \times 10\frac{1}{2}$ in. Weight: 12.8lb. Price: £69.17.

Sansui AU555A

Solid state integrated stereo amplifier. Power output: 25W per channel ± 1 dB at 4 ohms. HD: less than 0.5%. Distortion: less than 0.8%. FR: 20Hz-30kHz. H and N: better than -100 dB. Damping factor: 12 and 45 at 8 ohms. Inputs: pickup 2mV (47K and 100K); tape head 1.5mV 200K; aux 200mV (100K), mic 3.8mV (10K) and 140mV (100K); tape monitor 150mV (100K). Psn: 100, 117, 220 and 240V, 50/60Hz. Dimensions: $4\frac{3}{8} \times 15 \times 10\frac{7}{8}$ in. Weight: 17.4lb. Fitted in light walnut case. Price: £95.07.

Sansui AU666 ★

Stereo integrated amplifier. Output: 35W per channel into 8 ohms. 45W per channel into 4 ohms. Inputs: pickup (2) 2mV 50K, mic 3mV 50K, radio 180mV 180K, aux 180mV 100K, tape monitor 180mV 100K. FR: 10Hz-40kHz ± 1 dB. Separation: better than 60dB. Controls: bass, treble, mid-range, balance, volume, input selector, muting filter, speakers, loudness. Fitted into light walnut cabinet with black panel. Price: £122.71.

AU888

Integrated stereo amplifier. Inputs: mic 2mV 100K, PU (1) 2mV 50K, PU (2) 2mV at 30K/50K/100K, radio 180mV 100K, aux 180mV 100K, tape (2) 180mV 100K. Noise level: low level inputs >80 dB, high level inputs >85 dB. Output: 45W RMS per channel. Output impedance: 4-8 ohms. Tone controls: bass ± 16 dB at 30Hz, treble ± 15 dB at 15kHz, mid range ± 5 dB at 1.5kHz. Low filter: -10 dB at 20Hz. High filter: -10 dB at 20kHz. Loudness: $+8$ dB at 50Hz, $+3$ dB at 10kHz. HD: $<0.4\%$ at rated output. Mains: 100, 117, 220, 240V AC. Size: $18\frac{1}{8} \times 5\frac{7}{8} \times 12\frac{1}{2}$ in. Finish: light walnut with black front panel and silver controls. Provision for separating main and preamplifier. Two year guarantee. Price: £152.73.

AU999 ★

Integrated stereo amplifier. Inputs: mic 3mV 50K, PU (1) 2mV 50K, PU (2) 2mV 30K/50K/

★ Indicates entry is illustrated



Sansui RA500



Shure Solo-phone SA-2E

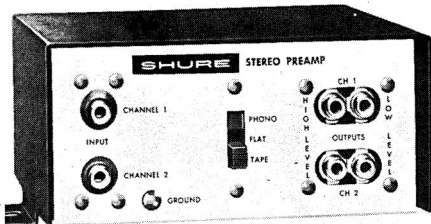

Shure M64-2E

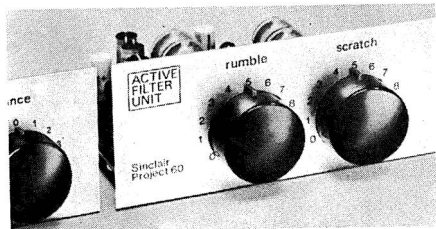

Sinclair Filter

100K, aux 200mV 50K, radio 200mV 50K, tape (2) 200mV 50K. Noise level: low level inputs >80dB, high level inputs >85dB. Output: 50W RMS per channel. Output impedance: 4-8 ohms. HD: <0.4% at rated output. FR: 5Hz-100Hz \pm 1dB at normal listening. Mains: 100, 117, 220, 240V AC. Size: $18\frac{1}{8} \times 6\frac{1}{8} \times 11\frac{3}{4}$ in. Finish: black metal case, black front panel with silver controls. Main amplifier and preamplifier can be separated. Balance check facility. Two year guarantee. Price: £182.82.

RA500 ★

Stereo reverberation amplifier. Controls: mains on/off, reverberation on/off record, tape mode. FR: 20Hz-30kHz. Reverb time: 1.9 to 3.2 seconds. Rainbow reverberation indicator. Mains: 100, 117, 220, 240V AC. Size: $11\frac{7}{8} \times 6\frac{3}{8} \times 10\frac{7}{8}$ in. Finish: light walnut cabinet with black acrylic top panel and silver control panel. Two years guarantee. Price: £58.08.

■ SANYO

Sanyo Marubeni (UK) Ltd, Sanyo House, Bushey Mill Lane, Watford, Herts. Tel: Watford 30421.

DCA 1400

Integrated stereo amplifier. Inputs: PU (1) 2.5mV 50K, PU (2) 2.5mV 50K, aux (1) 100mV 100K, aux (2) 100mV 100K, radio 100mV 100K. H and N: PU inputs -70dB, other inputs -75dB. Output: 20W sine into 8 ohms, 17W sine into 8 ohms (both channels driven). HD: <0.8% at rated output. FR: 10Hz-100kHz

\pm 2dB. Controls: bass \pm 12dB at 100Hz, treble \pm 12dB at 10kHz, loudness +10dB at 100Hz, +3dB at 10kHz. Connections for two speaker systems, stereo headphones. Slider control for balance. Output impedance: 4-8 ohms. Mains: 120-240V AC. Price: to be announced.

■ SERVO-SOUND

Sonosound Ltd, 5 Queen Street, London, EC4N 1SU. Tel: 01-248 9461.

SC100BEE

Stereo preamplifier incorporating 12 silicon transistor circuit. Inputs: mag PU 1-1.5mV 47K, tape 300mV 40K, aux (1) 300mV 40K, aux (2) 300mV 40K. Output: 1.2V per channel into not less than 400 ohms. HD: 0.3% at 1kHz. Output impedance: 400 ohms. FR: 30Hz-30kHz. Special stereo crossing network incorporated. Size: $15\frac{1}{2} \times 3 \times 7\frac{1}{2}$ in. Mains: any AC voltage up to 240V. Finish: wood and steel cabinet finished in walnut or white. Designed specifically for use with Servo-Sound SL20 amplifier/speaker units. Price: £60.

■ SHURE ELECTRONICS LTD

84 Blackfriars Road, London, SE1 8HA. Tel: 01-928 3424.

Solophone SA-2E ★

Provides personal stereo listening for one or two people. Gives sufficient amplification to accept output from any high quality cartridge (for example Shure Stereo Dynetic range), tape deck or FM tuner. There are input selector switch,

separate volume controls for each channel and two headphone jacks mounted on the front panel. Size: $10\frac{1}{2} \times 3\frac{1}{2} \times 3$ in. Weight: 2lb. Mains: 240V 50Hz. Price: £24-60.

M64-2E ★

Stereo preamplifier designed to furnish voltage gain and equalisation to enable amplifiers not equipped with necessary input facilities to be used with magnetic pickup cartridges and tape heads. Can also be used for microphones and as buffer amplifiers. FR: 20Hz-20kHz ± 2 dB. Input Impedance: 50K at 1kHz. Load impedance: (high) 22K minimum; (low) 600 ohms optimum. Separation: 50dB at 1kHz. H and N: 71dB minimum below 10mV input from 20Hz-20kHz. Price: £19-20. Optional battery power unit: Price: £9.

■ SINCLAIR RADIONICS LTD

London Road, St Ives, Huntingdonshire, PE174HJ. Tel: St Ives (Hunts) 4311.

Stereo 60

Stereo preamplifier designed for Sinclair Project 60 range but suitable for other amplifiers. Inputs: mag PU 3mV, radio 3mV, ceramic PU 3mV, aux 3mV. Output: 250mV. SN: better than 70 dB. Channel matching: within 1dB. Treble control: ± 15 dB at 10kHz. Bass control: ± 15 dB at 100Hz. Silicon epitaxial planar transistors. Pushbutton input selection. Consumption: 5 mA. Finish: brushed aluminium panel with black knobs. Size: $1\frac{1}{2} \times 8\frac{1}{4} \times 4$ in. Price: £9-98.

Active Filter Unit ★

Designed for Project 60 Series but suitable for other systems. For connection between a Stereo 60 preamplifier and two Z-30 or Z-50 power amplifiers. Two filter stages, one a rumble (high pass) filter the other a scratch (low pass) filter. Supply required: 15-35V at 3mA. Gain at 1kHz: 0-98 ($-0-2$ dB). HF filter slope: 12dB/octave. LF filter slope: 12dB/octave. FR: 35Hz-20kHz -1 dB. Finish: brushed aluminium panel with black knobs. Price: £5-98.

System 3000

Integrated stereo amplifier. Output: 17W RMS per channel. HD: less than 0-04% at full output at 1kHz, less than 0-1% at all power levels and all audio frequencies. Stabilised power supply. Full overload protection. Inputs: two pickup, radio, tape. Outlets for tape, headphones and AC mains. All silicon transistors. Finish: modern functional design in black anodised aluminium. Features include scratch filter and speaker muting switch. Price: £45.

See Constructional Kits Section for details of Sinclair Radionics Z-30, Z-50, PZ-5, PZ-6 and PZ-8 modules.

■ SONY (UK) LTD

Pyrene House, Sunbury Cross, Sunbury-on-Thames, Middlesex. Tel: Sunbury 87644/7. Telex: 266371.

TA-1010

Transistor stereo integrated amplifier. Inputs: PU (1) and PU (2) 1-2mV 47K (noise level better than 70dB), tuner and aux 1, aux 2, tape and DIN socket 250mV 100K (noise level better than 90dB). Output: 15W per channel into 8 ohms. HD: less than 0-5% at 1kHz. FR (+0, -2 dB): 20Hz-60kHz. Outlets: record out 250mV 10K, DIN socket 36mV 80K. Controls: volume balance, loudness, mode, input selector, tape monitor, bass, treble, high filter (6dB per octave above 5kHz). Mains: 100, 117, 220, 240V 50/60Hz. Dimensions: $16\frac{9}{16} \times 4\frac{7}{8} \times 9\frac{3}{4}$ in. Price: £52-75.

TA-70

Integrated stereo amplifier. Inputs: mag PU 3-5mV 50K, radio 250mV 100K, tape 440mV 100K. Output: 10W RMS per channel. Output impedance: 8 ohms. Mains: 220, 240V AC. Size: $13 \times 3\frac{1}{2} \times 9\frac{5}{8}$ in. Finish: wood cabinet with anodised aluminium panel. High filter. Main/remote filter switch. Price: to be announced.

TA-88

Integrated stereo amplifier. Inputs: mag PU, radio, aux. Output: 10W RMS per channel. Output impedance: 8 ohms. HD: $< 1\%$ at rated output. Mains: 110, 117, 220, 240V AC. Size: $5\frac{1}{8} \times 9\frac{1}{8} \times 6\frac{1}{2}$ in. Finish: walnut cabinet with brushed aluminium front panel. Input source indicator lamps. Front panel headphone jack. Designed to match ST80F tuner. Price: £42-75.

TA-1055

Integrated stereo tuner/amplifier. Inputs: mag PU, mic, radio, aux. Output: 20W RMS per channel. Output impedance: 4, 8 ohms. HD: $< 0-5\%$ at rated output, $< 0-2\%$ at 1W. Mains: 110, 117, 220, 240V AC. Size: $16\frac{1}{8} \times 4\frac{3}{8} \times 11\frac{1}{4}$ in. Finish: walnut cabinet with brushed aluminium front panel. Mic and aux input jacks on front panel. Inputs and outputs for two tape recorders. Price: £62-75.

TA-1130

Integrated stereo amplifier. Inputs: mag PU 1-5mV 47K, radio 130mV 100K, aux 130mV 100K, tape 130mV 100K. Noise level: mag PU 60dB, other inputs 70dB. Output: 75W RMS per channel. Tone filters: (high) 6dB/octave from 7kHz, (low) 6dB/octave from 100Hz. Loudness control: +8dB at 50Hz. HD: $< 0-5\%$ at 1W. Output impedance: 4-16 ohms. FR: 10Hz-200kHz +0dB -2 dB. Mains: 100, 117, 220, 240V AC. Size: $15\frac{3}{4} \times 5\frac{7}{8} \times 12\frac{7}{8}$ in. Finish: anodised front panel, cabinet optional extra. Price: £154-75.

★ Indicates entry is illustrated

TA-1140 ★

Integrated stereo amplifier. Inputs: mag PU 1.2mV 47K, aux (2) 130mV 100K, radio 130mV 100K, tape (2) 130mV 100K. Noise level: mag PU 70dB, other inputs 90dB. Output: 45W RMS per channel. Output impedance: 4-16 ohms. Tone controls: bass ± 10 dB at 50Hz, treble ± 10 dB at 20kHz. High and low filters. HD: $<0.05\%$ at 1W. FR: 10Hz-200kHz +0dB -2dB. Mains: 100, 120, 220, 240V AC. Size: $15\frac{3}{4} \times 5\frac{7}{8} \times 12\frac{1}{2}$ in. Finish: anodised front panel, wood cabinet optional extra. Price: £109.75.

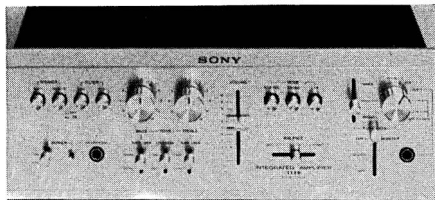

Sony TA1140

TA-3140F ★

Stereo power amplifier. 22 transistors. Inputs: 0.85mV per channel. Output: 45W RMS per channel. Output impedance: 4-16 ohms. HD: 0.05% at 1W. FR: 10Hz-200kHz +0dB -2dB at 1W. Controls: left level, right level, power on/off. Mains: 100, 120, 220, 240V AC. Size: $7\frac{7}{8} \times 5\frac{7}{8} \times 12\frac{5}{8}$ in. Finish: anodised front panel, metal cabinet. Price: £69.75.



Sony TA3140F

TA-3200F

Stereo power amplifier. Inputs: left (2) 140mV 75K, right (2) 140mV 75K. Output: 110W per channel into 8 ohms. Output impedance: 4-16 ohms. HD: $<0.05\%$ at 1W. FR: 5Hz-200kHz +0dB -2dB. Mains: 100, 110, 220, 240V AC. Size: $15\frac{3}{4} \times 5\frac{7}{8} \times 12\frac{3}{4}$ in. Finish: anodised front panel, metal cabinet. Price: £119.75.



■ STANDARD

Telerenters (London and Provincial) Ltd, Standard House, 1-2 Church Way, Edgware, Middlesex. Tel: 01-952 7488/9. Telex: 24792.

PM-158EE

Integrated stereo amplifier. Output: 7.5W RMS per channel. HD: $<0.5\%$ at rated output. FR: 20Hz-30kHz at 8 ohms. S/N: (PU) 60dB, (aux) 70dB. Inputs: magnetic PU 1mV, crystal PU 200mV, radio 100mV, aux 50mV, tape recorder 500mV. Output impedance: 8 ohms. Size: $13\frac{1}{2} \times 3\frac{3}{4} \times 7\frac{1}{4}$ in. Mains: 230V 50/60Hz. Price: £34.69.

J.E. Sugden A21



J.E. Sugden C51

■ STEEPLETONE

Steeple Supplies (Electronics) Ltd, Cinema House, Middle Barton, Oxford, OX54DA. Tel: Steeple Aston 7116.

STA-1

Integrated stereo amplifier. 18 transistors. Inputs: mag PU 3mV 47K, ceramic PU 40mV 470K, radio 50mV 470K, tape 50mV 470K. Output: 10W RMS per channel. Controls: volume, treble, bass, balance, slider switch for on/off, pushbuttons for tape, radio, gram. Changeover switch on back panel for magnetic/ceramic cartridge. HD: $<1\%$ at rated output.



J.E. Sugden A51

Output impedance: 8 ohms. FR: 40Hz-18kHz ± 2 dB. Mains: 210-250V AC. Size: $13 \times 4\frac{1}{2} \times 8\frac{1}{2}$ in. Finish: teak cabinet with stove enamelled sides and brushed aluminium fascia. Headphone socket. Two mains outlet sockets, one controlled by switch. Price: £32.50.

■ J. E. SUGDEN & CO LTD

Carr Street, Cleckheaton, Yorks, BD19 5LA.
Tel: Cleckheaton 2501.

A21 SERIES TWO ★

Transistor stereo integrated amplifier with Class A output stages. Inputs: radio 150mV 200K; tape 150mV 200K; aux 150mV 200K. PU 1, 2.5mV 68K; PU 2, 50mV into special input circuit. Controls: bass ± 14 dB at 40Hz; treble ± 14 dB at 10kHz; treble filter 18dB/octave above 7kHz. Rumble filter: 12dB/octave below 30Hz. Balance: ± 6 dB for 180° rotation. Channel balance maintained ± 1 dB per channel. Push-button selection for input and operating mode. Power output: 12W RMS per channel into 8 ohms, at clipping level. HD: 0.15% at 10W. FR: 20Hz-20kHz ± 1 dB. S/N: 80dB on radio, tape and aux, 70dB on disc. Outlet to recorder: 150mV. Size: $15\frac{1}{2} \times 5 \times 9$ in. Weight: 24lb. Price: £65.

C51 control unit ★

Transistorised stereo control unit designed for use with A51 power amplifier. Inputs: radio, tape and aux, each 150mV into 250K for flat response. PU 1 2.5mV 68K RIAA. PU 2 same as PU 1 or any characteristic to choice with basic sensitivity 0.25mV. Plug-in adaptors available for various cartridges, microphones, etc. Controls: bass ± 16 dB at 40Hz, treble ± 12 dB at 10kHz, volume ± 1 dB per channel, balance ± 6 dB for 180° rotation. Rumble filter: 12dB/octave below 30Hz. Treble filter: 4kHz, 7kHz and 10kHz. Treble filter slope: gradual 6dB/octave, steep 18dB/octave. HD: better than 0.1% at rated output. S/N: better than 85dB on 150mV inputs, better than 75dB on PU 2 input. Pushbutton selection of inputs and operating mode. Power: obtained from A51 amplifier. Size: $10 \times 4 \times 6$ in. Weight: 6lb 3oz. Price: £50.

A51 ★

Power amplifier with Class A output stages designed for use with C51 control unit. Transistors. Output: 25W per channel into 15 ohms. HD at 20W: better than 0.1%. FR: 30Hz-20kHz ± 0.5 dB. S/N: 90dB 10K source. Sensitivity for 25W output: 600mV. Input impedance: 200K. Size: $13\frac{1}{2} \times 8\frac{1}{2} \times 10$ in. Weight: 22lb. Price: £75.

■ SYKES + HIRSCH

201 Greenwich High Road, London, SE10.
Tel: 01-858 0549.



Teac AS-100

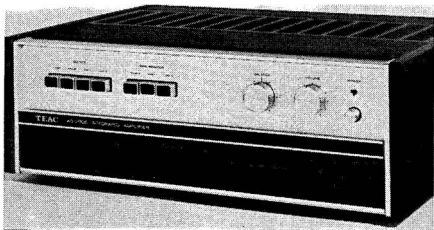

Teac AS-200

Compacta

Integrated stereo amplifier. 35 transistors and four diodes. Inputs: aux 100mV 100K, mag PU 3mV 47K (RIAA), radio 100mV 100K. Noise level: PU input 65dB, other inputs 75dB. Overload capability 34dB. Output: 30W RMS per channel into 8 ohms. Tone controls: bass ± 14 dB at 100Hz, treble ± 14 dB at 10kHz. HD: better than 0.07%. Output impedance: 8 ohms. FR: 16Hz-60kHz ± 1.5 dB at 30W. Mains: 220-240V AC (110V to order). Full overload protection. Size: $15 \times 2\frac{1}{2} \times 8$ in. Finish: polyester and aluminium. Price: £65.

■ TELEFI

Sound take-off adaptor for feeding hi-fi system from TV. See Tape Recorder Accessories Section.

■ TEAC

Acoustico Enterprises Ltd, 6-8 Union Street, Kingston-on-Thames, Surrey.
Tel: 01-549 3471/3.

AS-100 ★

Integrated stereo amplifier. 26 transistors. Inputs: mag PU (2) 2mV 50K, radio 150mV 50K, aux 150mV 50K, tape 150mV 50K. Noise level: mag PU -70dB, other inputs -80dB. Tone controls: bass ± 10 dB at 100Hz, treble ± 10 dB at 10kHz, loudness +7dB at 50Hz, +4dB at 10kHz; low filter -6dB/octave from 100Hz, high filter -6dB/octave from 8kHz. HD: <0.2%. FR: 5Hz-20kHz ± 0 dB -2dB. Mains: 100, 117, 220, 240V AC. Size: $16\frac{1}{2} \times 5\frac{3}{8} \times 13$ in. Finish: matt black. Price: £107.15.

★ Indicates entry is illustrated

AS-200 ★

Integrated stereo amplifier. 40 transistors, two FETs. Inputs: mag PU 2mV 50K, mag PU 2mV 80K, radio 130mV 100K, aux 130mV 100K. Noise level: mag PU input 70dB, other inputs 90dB. Tone controls: bass ± 15 dB at 50Hz, treble ± 15 dB at 100kHz, loudness +5dB at 100Hz, low filter -12dB/octave from 100Hz, high filter -12dB/octave from 9kHz. HD: $< 0.5\%$. Output impedance: 8 ohms. FR: 20Hz-80kHz +0dB -1dB. Mains: 100, 117, 220, 240V AC. Size: $16\frac{1}{2} \times 6 \times 11\frac{3}{4}$ in. Finish: walnut. Price: £170-48.

AE-200 ★

Stereo power amplifier. Inputs: mag PU (1) 2mV 50K, mag PU (2) 2mV 80K, radio 130mV 100K, aux 130mV 100K. Noise level: PU inputs -70dB, other inputs -90dB. HD: $< 0.5\%$. Output impedance: 8 ohms. FR: 20Hz-80kHz +0dB -1dB. Mains: 100, 117, 220, 240V AC. Finish: walnut. Price: to be announced.

AN40

Dolby noise reduction unit. Inputs: mic 0.78V 10K, line 0.1V 30K. Controls: record level R and L, record calibrator switch, mode switch, Dolby switch. HD: $< 0.5\%$. FR: 20Hz-12kHz ± 2 dB. Mains: 100, 117, 220, 240V AC. Size: $5\frac{1}{2} \times 3\frac{1}{2} \times 10\frac{1}{4}$ in. Finish: black metal case. Designed for use with cassette tape units. Price: £37-80.

AN80 ★

Dolby noise reduction unit. Inputs: line 0.03V 35K. Output: 0.58V. HD: $< 0.5\%$. Output impedance: 50K or higher. FR: 20Hz-15kHz ± 2 dB. Mains: 100, 117, 220, 240V AC. Size:

$16\frac{1}{8} \times 3\frac{1}{2} \times 10\frac{3}{4}$ in. Finish: black. Price: £64-28.

AN180 ★

Dolby noise reduction unit. Inputs: mic 0.25mV 50K, line 100mV 100K. Noise level > 65 dB. Controls: mic and line inputs, record cal, Mpx filter, Dolby switch, play cal R and L, monitor, output level. Two VU meters. HD: $< 0.3\%$. Output impedance: 50K or higher. FR: 20Hz-15kHz ± 1.5 dB. AC mains 100-240V. Size: $16\frac{1}{8} \times 5\frac{1}{2} \times 12\frac{3}{4}$ in. Black and chrome finish. Price: £126-44.

TELEFUNKEN

Distributor: A.E.G. (Great Britain) Ltd, A.E.G. House, Chichester Rents, Chancery Lane, London, WC2.
Tel: 01-242 9944. Cables: Allgem, London.

V201

Stereo amplifier. 25W per channel into 4 ohms. HD: less than 0.3% at 1kHz and 2×25 W. FR: (± 1.5 dB) 20Hz-22kHz, (± 3 dB) 17Hz-35kHz. Inputs: magnetic pickup, crystal pickup, tape, mic, radio. Outputs: speakers (4 ohms), ear-phones (100-400 ohms). Controls: volume, balance, bass, treble. Also 11 pushbuttons for flat response, rumble filter, noise filter, mono/stereo, stereo base width (extreme), PU1, PU2, tape, radio, on/off. Price: £93-45.

V250 ★

Stereo amplifier. 35W per channel (music power because of stabilised power supply) at 4 ohms. HD: less than 0.2% at 1kHz and 2×35 W. FR: (± 1.5 dB) 20Hz-18kHz, (± 3 dB) 10Hz-20kHz. Cross-talk better than 52dB at 250Hz-101Hz. Inputs: magnetic pickup, 4.5mV 47K; crystal



Teac AE-200



Teac AN-80

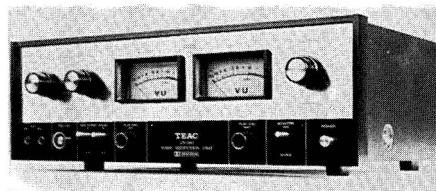

Teac AN-180

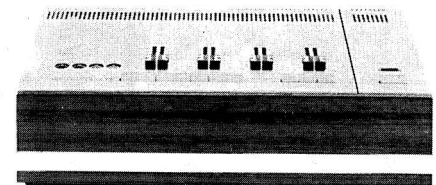

Telefunken Hi-Fi V250

pickup, 300mV 470K; mic I and II, 1.5mV 47K; tuner, 300mV 470K; tape playback, 300mV 470K; tape record, 0.36mV/K. Outputs: speakers, 4 ohms; tape monitoring, 300mV 47K. Controls: slider stereo (both channels), volume, bass, treble, fade-in and fade-out (mixing). 11 pushbuttons for: mic, PU1, PU2, tuner, tape recorder, monitor, mono, rumble filter, noise filter, linear, on/off. Bass control gives $\pm 16\text{dB}$ (50Hz), treble $\pm 12\text{dB}$ (10kHz), rumble filter 25dB (15Hz) and 15dB (20Hz), noise filter 3dB (5.5kHz) and 20dB/octave above. Features include electronic fuses, short-circuit protection, sockets for stereo recording, earphone socket with on/off speaker switching, three mains outlets. Price: £149.

■ TELETON

Teleton Electro (Distributors) Co Ltd,
Teleton House, Robjohns Road, Widford,
Chelmsford, Essex. Tel: 62442. Telex: 99338.

SAQ206B

Solid-state stereo amplifier. Inputs: mag PU 3mV 50K, crystal PU 130mV 600K, aux 200mV 100K, tape 230mV 100K. Controls: loudness 13dB at 50Hz, 3dB at 10kHz; scratch filter -6dB at 10kHz; bass +13dB -18dB at 100Hz; treble $\pm 10\text{dB}$ at 10kHz; volume and balance. Output: 6W RMS per channel. HD: 1% at rated output. Intermodulation distortion: <1% 250Hz-8kHz. FR: 20Hz-20kHz. Output impedance: 8 ohms. Mains: 115, 230V AC. Size: $15\frac{1}{2} \times 9 \times 3\frac{1}{4}$ in. Price: £33.

SAQ307

Integrated stereo amplifier. Inputs: mag PU 3mV, crystal PU 130mV, aux 200mV, tape 235mV. Output: 8W RMS per channel. HD: 1% at rated output. FR: 20Hz-20kHz. Controls: input selector, mains on/off, loudness, mode, balance, scratch filter, volume, bass, treble. Mains: 105-125V, 210-250V AC. 18 transistors, four diodes, four rectifiers. Headphone and tape sockets. Slider controls. Finish: oiled walnut with black and aluminium facia. Sizes: $15\frac{1}{4} \times 8\frac{3}{8} \times 3\frac{1}{8}$ in. Price: £33.

■ TRIO

Distributors: B. H. Morris & Co (Radio) Ltd,
84-88 Nelson Street, London, E1 2DY.
Tel: 01-790 5011.

KA2000A

Integrated stereo amplifier. Inputs: magnetic PU 2mV 50K, aux (1) 130mV 50K, aux (2) 130mV 50K, radio 130mV 50K, tape 130mV 50K. Noise level: mag PU input -60dB, all other inputs -70dB. Controls: volume, bass, treble, input selector, loudness, tape monitor. Output: 16W RMS per channel. HD: <0.8% at rated output. FR: 20Hz-30kHz $\pm 2\text{dB}$. Output impedance: 4-16 ohms. Mains: 110-120V

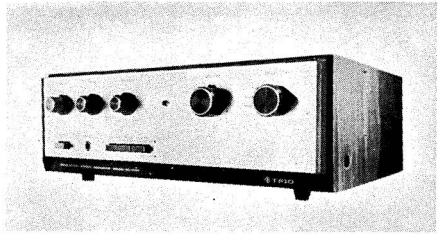

Trio KA2002



Trio KA4000

and 220-240V 50/60Hz. Size: $10\frac{1}{4} \times 4\frac{1}{8} \times 9\frac{3}{8}$ in. Price: £37.50.

KA2002 ★

Integrated stereo amplifier. Inputs: magnetic PU (1) 2mV 50K, magnetic PU (2) 2mV 50K, radio 150mV 50K, aux 150mV 50K, tape 150mV 50K. Noise level: PU and radio inputs -60dB, aux and tape inputs -70dB. Controls: volume, bass, treble, balance, input selector, loudness. Output: 17W per channel RMS. HD: 0.8% at rated output. FR: 20Hz-30kHz $\pm 2\text{dB}$. Output impedance: 4-16 ohms. Mains: 110-120V and 220-240V 50/60Hz. Size: $13 \times 4\frac{5}{8} \times 9\frac{1}{2}$ in. Price: £44.

KA4000 ★

Solid state stereo amplifier. Power output: 41W per channel at 4 ohms, 32W per channel at 8 ohms. HD: less than 0.5%. FR: main amp, 18 Hz-50kHz $\pm 1\text{dB}$; high level input 20Hz-50kHz $\pm 1\text{dB}$. Sensitivity: pickups 1 and 2, 2mV; tape head, 2.3mV; mic, 2mV; aux, tuner, tape play, 200mV each; main amp input, 100mV. S/N ratio: pickups 65dB; tape head 63dB; mic 67dB; aux, tuner, tape play 77dB. Output impedance at speaker terminal: 0.29 ohm at 1kHz, 0.52 ohm at 50Hz, 0.29 ohm at 10kHz. Damping factor: 55 at 16 ohms load; 27.5 at 8 ohms load. Low filter: 80Hz cut-off, 12dB per octave. High filter, 8kHz cut-off, 12dB per octave. Bass Control: $\pm 10\text{dB}$ at 100Hz with 2dB step switch. Treble control: $\pm 10\text{dB}$ at 10kHz with 2dB step switch. Outputs: two pairs speaker outputs (4-16 ohms); pre-amp outputs, headphone jack, low level mono output, tape recording outputs, DIN standard tape rec/play connector, switched and unswitched

★ Indicates entry is illustrated

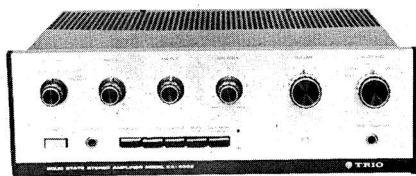

Trio KA4002



Tripletone Stereo 800 Mk II



Tripletone Gemini Mk II

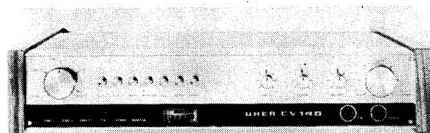

Uher CV140

AC outlets. Controls: input selector switch, mode/tape monitor switch, output selector switch, volume, balance, bass, treble, muting switch (-20dB), loudness contour switch, low and high filter switches. Power consumption: 13W \times 16, 180W at full power. Dimensions: $5\frac{5}{8} \times 16\frac{5}{16} \times 11\frac{1}{2}$ in. Weight: 17.6lb. Price: £82.50.

KA4002 ★

Integrated stereo amplifier. Inputs: magnetic PU (1) 2.5mV 50K, magnetic PU (2) 2.5mV 50K, aux (1) 150mV 100K, aux (2) 150mV 100K, radio 150mV 100K, tape 150mV 100K. Noise level: magnetic PU input -60dB, all other inputs -70dB. Controls: volume, balance, treble, bass, input selector, loudness, filters, output switching. Output: 24W per channel RMS. HD: 0.5% at rated output. FR: 20 Hz-40kHz \pm 1.5dB. Output impedance: 4-16 ohms. Mains: 110-120V and 220-240V 50/60Hz. Size: $13 \times 4\frac{3}{8} \times 9\frac{1}{2}$ in. Price: £57.50.

KA6004

Integrated stereo amplifier. Inputs: mag PU (2) 2.5mV 50K, mic 3mV 50K, radio 200mV 100K, tape play 200mV 100K, aux (2) 200mV 100K. Input to main amplifier: 1V 50K. Output: 55W RMS per channel. Output impedance: 4-16 ohms. Tone controls: bass \pm 10dB at 100Hz in 2dB steps, treble \pm 10dB at 10kHz in 2dB steps, low filter 40Hz cut-off and 80Hz cut-off (both 12dB per octave), high filter 7kHz cut-off (6dB per octave). Loudness: +8dB at 100Hz and +3dB at 10kHz. Speaker switch for A, B, and A+B. HD: <0.5% 20Hz-20kHz (<0.05%

-3dB). FR: 20Hz-50kHz. Mains: 110, 230V AC. Size: $17\frac{1}{8} \times 6\frac{1}{8} \times 11\frac{3}{8}$ in. Finish: wood sides with satin aluminium panel. Price: to be announced.

KF6011

Audio noise reduction unit designed for use with amplifiers, tape recorders, tuner/amplifiers, etc. Noise blocking filter operates from 5-10kHz. Noise-blocking characteristics: input 0dB, noise-blocking 0dB; input -30dB, noise-blocking 0dB; input -40dB, noise-blocking 2dB; input -45dB, noise-blocking 6dB, input 50dB, noise-blocking 10dB. FR: 10Hz-80kHz \pm 0.5dB. Gain: 0dB \pm 1dB at 1kHz. Channel levels: within \pm 1dB. Separation: better than 55dB. Level meter. Input attenuator (-10dB). Tape monitor switch. Mains: 110/120, 220/240V 50/60Hz. Size: $5\frac{1}{2} \times 5\frac{1}{2} \times 12\frac{1}{2}$ in. Weight: 6 $\frac{1}{2}$ lb. Price: £29.

■ TRIPLETONE

Kelgrove Sales Ltd,
St Marks Rise, Dalston, London, E.8.

Solid State FET Gemini Mk II ★

Integrated stereo transistor amplifier. Output: 5W RMS per channel into 3 ohms. HD: <1% at rated output. Output impedance: 3-8 ohms. FR: 30Hz-20kHz \pm 2dB. Sensitivity: 80mV into 2 megohms, FET input (magnetic PU) 3.5mV into 47K, tape and radio inputs 80mV into 100K. H and N: better than -60dB on all inputs. Bass control: \pm 15dB. Treble control: \pm 12dB. Middle control: \pm 15dB. In teak cabinet. Price: £28.50.

Solid State Stereo 800 Mk II ★

Integrated design with controls, preamplifiers and twin power amplifiers in one chassis. Inputs for gram, tape recorder and radio in mono or stereo. Controls for top cut, low-pass filter, treble, middle and bass. Output: 15W RMS per channel. HD: less than 0.2%. FR: 30Hz-20kHz ± 1.5 dB. Inputs: ceramic PU 80mV into 2 megohms, magnetic PU 3.5mV into 47K, tape recorder 80mV into 100K, radio 80mV into 100K. Tape outlet: 200mV into 100K ± 1 dB 15Hz-30kHz. H and N: better than -60dB all inputs. In teak cabinet. Price: £38.50.

■ UHER

Distributors: Bosch Ltd, PO Box 166, Rhodes Way, Radlett Road, Watford, Herts, WD24LB. Tel: Watford 44233.

Uher CV140 ★

Integrated power amplifier. Stereo transistorised. Inputs for radio, tape, PU, mic. Output: 35W RMS per channel into 4 ohms. FR: 20Hz-20kHz ± 1 dB. Bass control: ± 20 dB at 20Hz. Treble control: ± 20 dB at 20kHz. Presence control: ± 20 dB at 7kHz. Scratch filter: 12dB per octave from 6.5kHz. Rumble filter: 6dB per octave from 100Hz. HD: better than 0.2% at 1kHz. Input impedance: all 100K. Main chassis pressure casting with printed boards well supported. Easily accessible. Presets on front panel permit all inputs to be adjusted to a common level (indicated on meter on panel) before being passed to main amplifier. Six DIN input sockets provided, three have facilities for plug-in pre-amplifier modules for low impedance mic, magnetic or ceramic PUs or stereo mixer. Mains: 100/130V or 200/240V, 50 or 60Hz. Consumption: 160W at full output. Price: £144.30. Plug-in pre-amplifier modules available extra. Price: £6.

■ VORTEXION LTD

257/263 The Broadway, Wimbledon, London, SW19. Tel: 01-542 6242/3/4 and 2814. Cables: Vortexion, London, SW19.

CP50 Amplifier

AC mains and 12-volt. The CP50 is an all silicon transistor amplifier for mains and 12-volt battery use, with 8 Ω -15 Ω and 100-volt line output. The amplifier itself has overload or short circuit protection and all inputs have reasonable overload protection. Very large heat sinks are used with good ventilation and it is quite cool running on speech or music peaking 50 watts and even with over 40 watts of continuous sine wave the temperature conditions are not exceeded. The reservoir capacitor has been divided into 4 parts, each fused. The frequency response is within 3dB from 25Hz to 20kHz and bass and treble controls are fitted, of 26dB sweep each. This is

housed in our durable steel case. Size: 18 x 6 x 11½ in. Battery consumption 3 amps. Weight: 35lb. Prices: 1 PU and 2 low Mic inputs £102, 1 PU and 3 low Mic inputs £110, 4 low Mic inputs £115.

All Silicon Mixer Amplifier 20/30 Watt ★

This is a high fidelity 'minimised' distortion transistor amplifier made possible by the latest types of silicon transistors. Since it gives 20 watts at 0.1% harmonic and 0.2% intermodulation distortion and less than 3 times this at 30 watts on 7½ Ω it is suitable for high quality P.A. or High Fidelity use. No output transformer is fitted in this instance, but full overload protection is provided for this cool running amplifier which is suitable for continuous night and day operation and has a quiescent consumption of less than 4 watts from the mains. In the event of overload the output is instantly switched off until it ceases without blowing any fuses, the circuit operates far faster than any fuse. The response is within 1dB from 20Hz-20kHz and feedback bass and treble controls have a total range of 24-26dB each. It can be supplied for balanced line low impedance microphone (or high impedance at reduced prices) and the normal aux or gram at 50mV into 100K. Price: £35.

100 Watt All Silicon Amplifier

This is a high-fidelity amplifier for audio frequencies featuring a new principle protection circuit, which is automatic on output overload, far faster than any fuse, and of course resetting when the signal is reduced. In addition a thermal cut-out is fitted which automatically switches off should it be possible for any reason to take the heat sinks beyond the safe limits. The large heat sinks are funnel cooled to aid efficiency, and when supplying 100 watts power at low to medium frequencies the output transistors only have to dissipate some 18 watts each and they are capable of over 100 watts each. These transistors also have a voltage rating double that required. Large output transistors are not satisfactory above 20kHz, and since it is not required for audio purposes, the overload limits the power capacity to the safe power available at high frequencies. The response is level from 20Hz to 15kHz and 3dB maximum down at 20kHz. Outputs are for 8-15 ohms and 100-volt line. Harmonic distortion does not tell the whole story with transistor amplifiers, so in this case only the intermodulation distortion is given which is less than 0.5%. The input required is less than 0.5 volt on 100K Ω . Price: £80.

200 Watt Amplifier

Can deliver its full audio power at any frequency in the range of 30Hz-20kHz ± 1 dB. Less than 0.2% distortion at 1kHz. Can be used to drive mechanical devices for which power is over 120

★ Indicates entry is illustrated



Wharfedale Linton

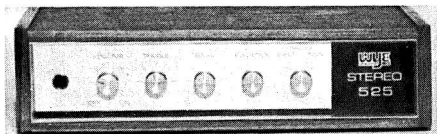

Wye Electronics Stereo 525

watt on continuous sine wave. Input 1mW 600 Ω . Psn: 100-120V or 200-240V. Additional matching transformers for other impedances are available. Price: £135.

4C/FET/100W

Mono mains amplifier with four input channels. Inputs: 30/60 ohms balanced line standard, 200 ohms and 600 ohms to order. Controls: separate gain control for each input, common bass and treble. Tone controls give approximately 12dB lift and 12dB cut. All silicon transistors with FET input stages. Output: 100W RMS. FR: level 30Hz-15kHz, -3dB (maximum) at 20kHz. Output impedance: 100V at 100 ohms (other impedances to order). Stove enamelled case. Size: 18 \times 6 \times 11 $\frac{1}{2}$ in. Weight: 37lb. Price: £115.

See Tape Amplifier and Mixer Units section for details of Vortexion mixer/amplifiers.

■ WHARFEDALE

Rank Wharfedale Ltd,
Bradford Road, Idle, Bradford, Yorks.
Tel: Bradford 612552. Telex: 51407.

Linton ★

Integrated stereo amplifier. Output: 15W RMS per channel into 8 ohms. HD: 0.1% at all power levels up to 10W each channel. FR: 30Hz-20kHz \pm 1dB. Inputs: PU 3.5mV 47K or 20mV 1K, tuner 60mV at 50K or 250mV 50K. Controls: balance, treble, bass, stereo/mono, filter, tape monitor, tape replay, tuner, PU, off/on/volume. Finish: teak or walnut. Price: £60.

■ WYE ELECTRONICS LTD

Queen Street North, Whittington Moor,
Chesterfield, Derbyshire.
Tel: Chesterfield 51116.

Stereo 525 ★

Transistorised integrated stereo amplifier. Inputs: PU 50mV 1 megohm, radio 30mV 1 megohm, tape 30mV 1 megohm. Controls: treble +11dB -16dB at 10kHz, bass +8dB -12dB at 100Hz, volume, balance, function selector. Output: 10W RMS per channel into 4 ohms. HD: 1.5% at 1kHz 10W into 4 ohms. FR: 40Hz-18kHz \pm 3dB. Finish: veneered shelf-mounting cabinet with satin metal panel. Price: £30.

■ YAMAHA

Jonathan Fallowfield Ltd, Strathcona Road,
North Wembley, London, HA98QL.
Tel: 01-904 0141.

CA-500

Integrated stereo amplifier. Inputs: mag PU (2) 4mV 50K (noise level 95dB); aux (2) 100mV 100K (noise level 90dB); radio 100mV 50K (noise level 90dB). Overload capability: PU inputs 90mV. Output: 22W RMS. Output impedance: 8 ohms. Tone controls: bass \pm 10dB, treble \pm 10dB. Loudness control. High-pass and low-pass filters. HD: 0.05% at 20W. FR: 18Hz-46kHz \pm 2dB at 20W. Preamplifier outlet, input to main amplifier and mono output. Finish: steel grey cabinet with satin chrome fascia. Size: 16 \times 6 \times 12in. Price: £75.

CA-700

Integrated stereo amplifier. Inputs: mag PU (1) 4mV 50K, mag PU (2) 0.1mV 100K, radio 100mV 100K, aux (2) 100mV 50K. Noise level: (mag PU) 95dB, (other inputs) 90dB. Overload capability: mag input 90mV. Output: 60W RMS per channel. Output impedance: 8 ohms. Tone controls: bass \pm 10dB, treble \pm 10dB. Tape A and Tape B monitor. Tape A to Tape B dubbing. Loudness control. HD: 0.05%. FR: 10Hz-56kHz +0dB -2dB at 50W RMS. Pre-amplifier outlet, main amplifier input. Will cater for two three-head tape units simultaneously. Volume control for mic input. Mains: 190-240V AC. Finish: walnut cabinet with satin chrome fascia. Size: 16 \times 6 \times 12in. Price: £99.60.

The best is not always the most expensive.

STE-MA. One of Denmark's largest system manufacturers, Ste-Ma have combined traditional Danish craftsmanship with the expertise of one of Scandinavia's largest acoustic laboratories to produce the superb loudspeakers shown here.

STE-MA 195 TWO SPEAKER SYSTEM SPECIFICATION

Power Handling 7 Watts RMS
14 Watts peak Music Power
Finish Teak
Recommended Retail Price £20.90 each.

STE-MA 450 TWO SPEAKER SYSTEM SPECIFICATION

Power Handling 10 watts RMS
20 watts peak Music Power
Finish Teak
Recommended Retail Price £25.00 each.

STE-MA 375 THREE SPEAKER SYSTEM SPECIFICATION

Power Handling 25 watts RMS
50 watts peak Music Power
Finish Teak
Recommended Retail Price £41.75 each.

STE-MA HI-FI 6 FOUR SPEAKER SYSTEM SPECIFICATION

Power Handling 40 watts RMS
80 watts peak Music Power
Recommended Retail Price £59.40 each.

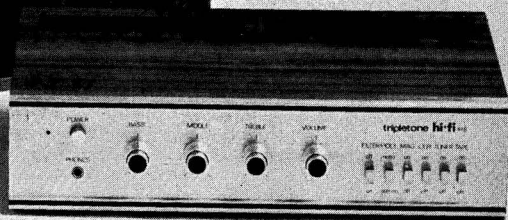

TRIPLETONE. The Hi-Fi 1818 and Hi-Fi 77 amplifiers are the first of a new range combining the best of previous designs with the very latest in circuit technology.

TRIPLETONE HI-FI 1818

Power Output Each Channel - 18 watts RMS 1 KHz, 8 ohms
Both Channels - 15 watts RMS
Tone Controls Bass $\pm 15\text{dB}$ @ 30 Hz Middle $\pm 12\text{dB}$ @ 1 KHz
Treble $\pm 15\text{dB}$ @ 10 KHz
Inputs Magnetic 3mV, -47 K Ω (RIAA) Ceramic 80mV, (2Mohm)
Tuner 100 mV, 100 K Ω Tape 100 mV, 100 K Ω
Outputs Speakers 8-16 ohms Headphones 8-16 ohms
Tape 200 mV (100 K Ω)
Recommended Retail Price £46.50 each.

TRIPLETONE HI-FI 77

Power Output Each Channel - 7 watts RMS 1 KHz, 8
Both Channels - 5 watts RMS
All other specifications are same as the Hi-Fi 1818 model
Recommended Retail Price £36.50 each.

Send today for free illustrated literature on all these models.

KELGROVE SALES LTD.

St. Marks Rise, London, E 8



Crown
INTERNATIONAL



AMPLIFIERS & PRE-AMPLIFIERS

Better than anything you have ever experienced before and yours if you are prepared to pay appreciably more than for almost any other system in the world.

The designers and makers of Crown amplifying equipment have produced the answer to just about every problem of quality, reliability and use that ever was in audio-electronics. Literature and list of approved stockists from the sole agents.

MACINNESS LABORATORIES LIMITED
STONHAM, STOWMARKET 1P14 5LB Tel. Stonham (044 971) 486

Quadraphonics

turntable and pickup. Price: (four channels) £295; (six channels) £325; (eight channels) £357; (12 channels) £475.

★ Indicates entry is illustrated

Abbreviations used in this section are given on page 36.

■ ADMIRAL

Interconti Electronics Ltd, Albany House, Petty France, London, SW1H9EA.
Tel: 01-222 2523.

STC981 ★

Eight-track discrete four-channel tuner/amplifier and tape cartridge player with four speaker systems. FM stereo decoder fitted. Stereo beacon. Slide-rule tuningscale. Switchable AFC. Slider controls. Tape track indicators. Sockets for headphones, PU and tape recorder. Walnut grained vinyl finish. Speakers: 6in bass driver and 3½in HF unit in each cabinet. Price: £120 (including PT).

■ EAGLE INTERNATIONAL

Heather Park Drive, Wembley, HA1 1SU. Tel: 01-903 0144.

AA10 ★

Four-channel quadraphonic synthesiser. The AA10 plus two extra speakers provides two additional information channels from ordinary two-channel stereo. Self-contained matrix system with level controls and speaker check switches. Rating: 35W RMS per channel. Input impedance: 8 ohms. Output impedance: 8 ohms. Size: 8¾ × 2¾ × 5½in. Finish: teak cabinet. Price: £12-80.

■ GABRAPHONE

Modern Engineering and Technology Ltd, 4 Station Road, West Canterbury, Kent.
Tel: Canterbury 60431.

Type 2001

Modular multi-channel amplifiers. Output: 35W into 4 ohms. FR: 25Hz-25kHz ±1dB. S/N ratio: better than 65dB. HD: 0.02% at maximum output at 1kHz. Bass: ±15dB at 100Hz. Treble: ±15dB at 10kHz. Balance: zero to maximum on each channel. Scratch filter: -12dB/octave from 5kHz to 20kHz. Rumble filter: -12dB/octave, variable from 25Hz-100Hz. Regulated power supply. Amplifier cabinet can accommodate a wide variety of

■ GRAMPIAN REPRODUCERS LTD

Hanworth Trading Estate, Feltham, Middlesex. Tel: 01-894 9141.

666 Ambiphonic unit

Enables from one to four speakers to be fed with amplified and delayed signal from main amplifier output. Delay device comprises two transducers and parallel springs as used in Grampian reverberation unit. Volume of delayed signal controlled by listener. Twin high-impedance line-bridging connections. Output: 2½W into 5 ohms and 600 ohms. Mains: 200-250V AC. Size: 18 × 4¼ × 5¼in. Weight: 7lb. Price: £65.

■ KOSS

Tape Music Distributors Ltd, 11 Redvers Road, London, N226EP. Tel: 01-888 0152.

K2+2

Four-channel dynamic headphones. Wired for quadraphonic and stereo. Suitable for amplifiers having output impedance of 3-600 ohms. Normal listening input: 1.4V at 95dB SPL. Maximum input: 29V. FR: 10Hz-20kHz. HD: negligible at 95dB SPL. Weight: 600 gms. Special coiled cord; 3ft coiled, 10ft extended. Two headphone jackplugs. Black finish. Washable fluid-filled earcushions. Switch for two- or four-channel operation. Price: to be announced.

See Headphone Section for full Koss range of headphones and accessories.

■ NATIONAL PANASONIC

Unamec Ltd, United Africa House, Blackfriars Road, London, SE1 9UG.
Tel: 01-928 2070.

RS-845US

Eight-track four-channel stereo tape player. Eight-track cartridges. Speed: 3¾i/s. AC mains. FR: 30Hz-15kHz. Four ICs. Size: 12¾ × 4 × 8¾in. Weight: 9¼lb. Finish: oiled walnut, black panel with bright trim. Mode and channel indicator lights. Price: £61-98 (plus £10-85 PT).

RE-7750B

AM/FM four-channel tuner/amplifier with four separate speakers. Quadraplex system also provides four-channel output from two-channel sources. One IC and 27 transistors. Range: FM, MW. AC mains. Output: 5.5W RMS per channel (four-channel output). AFC on FM. Speakers: One 6½in full-range driver in each enclosure. Loudness control. Separate bass and treble. Slider volume controls. Price: (complete with four speakers) £111-57 (plus £19-53 PT).

★ Indicates entry is illustrated

■ NIVICO

Denham & Morley (Overseas) Ltd,
453 Caledonian Road, London, N7.
Tel: 01-607 6568.

1202

Four-channel tape player unit. Eight-track cartridge. Speed: $3\frac{3}{4}$ i/s. FR: 30Hz-15kHz. S/N ratio: better than 50dB (peak level). W and F: 0.25% RMS. 14 transistors and five diodes. Continuous play. Programme selector. Programme indicator lights. Price: £62.75 (including PT).

4800

Four-channel tape cartridge player. Full details and specification on request. Price: £110 (including PT).

MCA-V5E

Two- and four-channel integrated amplifier. Output: 15W per channel (four channels) into 8 ohms. Output impedance: 8-16 ohms. HD: <0.5%. FR: 20Hz-40kHz -1.5dB. Tone controls: bass ± 10 dB at 100Hz, treble ± 10 dB at 10kHz. Inputs: mag PU 1mV, tape 120mV, radio 120mV, aux 150mV. Mains: 100, 120, 220, 240V AC. Size: $15\frac{1}{2} \times 5\frac{1}{2} \times 12$ in. Weight: 19lb. Price: £85.

MCA-V9E

Two- and four-channel integrated amplifier. Output: 45W per channel (four channels) into 8 ohms. Output impedance: 8-16 ohms. HD: 0.08%. FR: 20Hz-50kHz ± 0.5 dB. Tone controls: bass ± 5 dB at 100Hz, treble ± 7 dB at 10kHz. Inputs: mag PU 2mV, tape 100mV, radio 100mV, aux 100mV. S/N ratio: mag PU input 74dB, other inputs 84dB. Mains: 100-240V AC. Size: $16\frac{1}{2} \times 5\frac{3}{8} \times 14\frac{1}{4}$ in. Weight: 29 $\frac{3}{4}$ lb. Price: £140.

5100 Add-amplifier

Four-channel amplifier for use with two-channel or four-channel systems. Output: 33W RMS per channel into 4 ohms. Output impedance: 4-16 ohms. HD: <0.5%. FR: 20Hz-50kHz. Sound effect amplifier (SEA) tone control section. Mains: 100-240V AC. Price: £89.50.

5444

AM/FM four-channel tuner/amplifier. Output: 33W RMS per channel (four channels) into 4 ohms, 26W RMS per channel (four channels) into 8 ohms. Output impedance: 4-16 ohms. HD: <0.5%. FR: 20Hz-50kHz. Sound effect amplifier (SEA) tone control section. FM tuner section: usable sensitivity 2.5 μ V. Mains: 100-240V AC. Price: £291.55.

■ ONKYO

J. Parkar & Co (London) Ltd,
Parkar House, 1 Paul Street, London,
EC2A 4JQ. Tel: 01-628 4577.

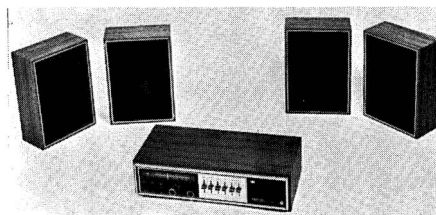

Admiral STC981

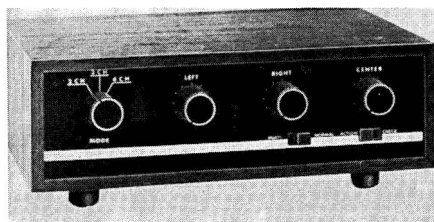

Eagle AA10

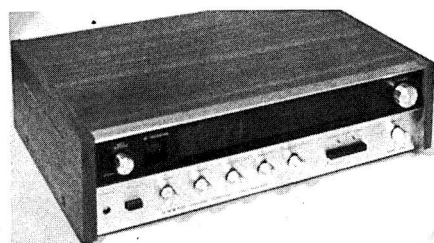

Onkyo Model Y-3A



Onkyo Model Y-2

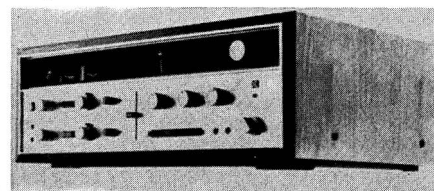

Sansui QR6500

Model X-1

Four-channel sound system comprising console cabinet with AM/FM tuner/amplifier and record deck, two main-channel speaker enclosures and two slim wall-fixing ambience speakers. 49 transistors and 32 diodes. Range: FM 88-108MHz, MW 187-565 metres. Variable tuning. Stereo decoder with auto switching and stereo beacon. Output: 16W per channel (total 64W). Sensitivity: FM 2 μ V, MW 12 μ V. Special "Sound Composer" network permits matrix four-channel operation from two-channel sources in addition to discrete four-channel reproduction. Tuning meter. Headphone jack. Two-speed record deck with auto cut-off and return of pickup arm. 12in diameter belt drive. Moving magnet cartridge with diamond stylus. Pw: 1.5-2.5gm. Front speakers: two-way system incorporating 8in bass driver and 2 $\frac{3}{4}$ in mid/HF unit in each. Rear speakers: one 6 $\frac{1}{2}$ in full-range unit in each. Separate mic input mixing circuit. Price: (complete system) £335.07 (including PT).

Model Y-2 ★

Four-channel sound system comprising AM/FM tuner/amplifier, shelf-mounting record deck, two front-channel speakers and two rear-channel speakers. 47 transistors and 24 diodes. Range: FM 88-108MHz, MW 187-565 metres. Sensitivity: FM 2.5 μ V, MW 15 μ V. Stereo decoder with auto-switching and stereo beacon. Variable tuning. Output: 16W per channel (total 64W). Special "Sound Composer" network permits matrix four-channel operation from two-channel sources in addition to discrete four-channel reproduction. Tuning meter. Headphone jack. Two-speed record deck with auto cut-off and return of pickup arm. 12in diameter belt-drive platter. Moving magnet cartridge with diamond stylus. Pw: 1.5-2.5gm. Front speakers: two-way reflex system with 8in bass driver and horn tweeter in each. Rear speakers: wall-hanging type with single full-range 6 $\frac{1}{2}$ in unit in each. Price: (complete system) £261.52 (including PT).

Model Y-3A ★

Four-channel AM/FM tuner/amplifier. Range: FM 88-108MHz, MW 187-565 metres. Sensitivity: FM 2.5 μ V (IHF), MW 15 μ V (IHF). 47 transistors and 24 diodes. Inputs: four-channel discrete PU, four-channel matrix PU, stereo tape play, four-channel stereo tape play, stereo microphone. Stereo decoder with auto switching and stereo beacon. Output: 16W per channel (total 64W). Outputs for stereo tape recording and four speakers. Controls: bass, treble, mic volume, master volume, tuning, input selector, mode, SCC (composite surround signal control), mains on/off. Finish: wood grained cabinet with aluminium trim. Price: £130.76 (including PT).

■ **PIONEER**

Shriro (UK) Ltd,
42 Russell Square, London, WC1B 5DF.
Tel: 01-580 6996.

QA800

Integrated four-channel amplifier. HD: 0.08%. Inputs: mag PU 2.5mV 50K, radio 200mV 100K, aux 200mV 100K, tape monitor 200mV 100K. Tone controls: bass \pm 10dB at 100Hz, treble \pm 10dB at 10kHz. Output: 34W RMS per channel (4). FR: 8Hz-70kHz. 48 transistors, 9 diodes. Price: £179.05.

QC800

Four-channel preamplifier. HD: 0.05%. Inputs: mag PU 4mV 50K, radio 250mV 180K, aux 250mV 180K. Tone controls: bass +12dB -9dB at 100Hz, treble +9dB -12dB at 10kHz. FR: 10Hz-70kHz. Output: 4V at less than 5 ohms. 32 transistors, 3 diodes, 4 FETs. Price: on request.

QM800

Four channel power amplifier. Output: 42W RMS per channel (4). FR: 5Hz-80kHz. 39 transistors, 37 diodes. Price: £152.88.

QL600

Integrated four-channel amplifier. HD: 0.5%. Inputs: mag PU 200mV 150K, aux 250mV 180K. Tone controls: bass +12dB -11dB at 100Hz, treble +9.5dB -10dB at 10kHz. Output: 12W RMS per channel into 4 ohms. FR: 20Hz-20kHz. Price: £94.43.

QX8000

Four-channel tuner/amplifier. Range: FM 87.5-108MHz, MW 187-562 metres. Sensitivity: FM 2.2 μ V, MW 15 μ V. Two meters (one centre zero). Output: 32W per channel (4) into 4 ohms. FR: 10Hz-40kHz \pm 3dB. Inputs: mag PU (2) 2mV 50K, aux (2) 170mV 110K, tape (2) 180mV 120K. Tone controls: bass +11dB -12dB at 100Hz, treble +10.5dB -8.5dB at 10kHz, low filter -6.5dB/50Hz, high filter -11.5dB/10kHz. 65 transistors, 27 diodes, two ICs, one FET. Price: £236.72.

QT6600

Four-channel tape unit. Open reel type. Speeds: 7 $\frac{1}{2}$, 3 $\frac{3}{4}$ i/s. Max spool: 7in. One four-pole hysteresis synchronous motor. Price: £315.05.

QT2100

Four-channel tape unit. Eight-track cartridge. Speed: 3 $\frac{3}{4}$ i/s. One motor. FR: 30Hz-12kHz. S/N ratio: better than 48dB. W and F: <0.2%. Output: 0.775V 50K (4). Headphone socket 4-16 ohms. A.C mains. Price: £134.42.

■ **PYE**

Pye Ltd, St Andrews Road, Cambridge.
Tel: Cambridge 58985.

★ Indicates entry is illustrated

5551 Stereo Plus Two ★

Converter kit comprising add-on amplifier, decoder and two speakers. For use with existing stereo equipment (players, taperecorders, radio). Output: 10W RMS connected to two speakers in series giving 5W RMS per channel into 4 ohms. Mains: 240V AC. Controls: on/off push-button with indicator light, volume. Size: $10\frac{3}{4} \times 4\frac{1}{2} \times 9$ in. Speakers: 6×4 in high flux speaker unit. Impedance: 4 ohms. HC: 4W. Size: $10 \times 7 \times 7\frac{1}{2}$ in. Finish: teak veneers. Price: £36.84.

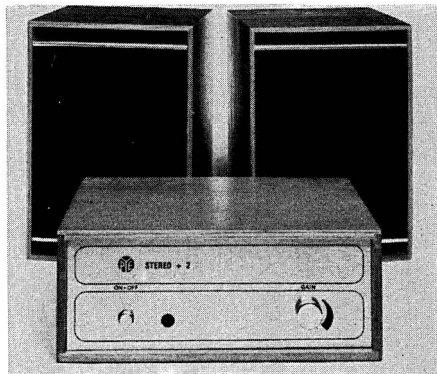

Play Model 5551 Stereo Plus Two

■ SANSUI

Vernitron Ltd,
Thornhill, Southampton, SO95QF.
Tel: Southampton 44811.

QS-1 ★

Four-channel synthesizer decoder. Controls: mains on/off; balance (front, rear and main); tape monitor (two and four-channel); input level; volume; function (concert hall, solo, two-channel, surround, $\frac{1}{4}$ -turn, $\frac{1}{2}$ -turn, etc.). Four large VU meters. Two AC outlet sockets. Mains: 100, 117, 220, 240V AC. Size: $15\frac{5}{8} \times 10\frac{7}{8} \times 5$ in. Add-on unit designed to convert two-channel stereo into four-channel sound. Finish: walnut cabinet with black front panel and silver trim. Two year guarantee. Price: £92.19.

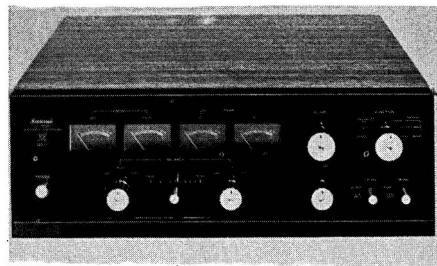

Sansui QS1

QS-100 ★

Four-channel rear amplifier. Inputs: tape monitor (2) 200mV 50K, two-channel input 200mV 50K. Noise level: better than 80dB. Output: 15W RMS per channel. Output impedance: 4-8 ohms. HD: <0.8%. FR: 25Hz-40kHz. Controls: input level, volume, tape monitor, main balance, left/right, rear balance, speakers, synthesizer selector. Four VU meters. Mains: 100, 117, 220, 240V AC. Size: $9\frac{7}{8} \times 5 \times 11$ in. Finish: light walnut cabinet with black front panel. Price: £114.

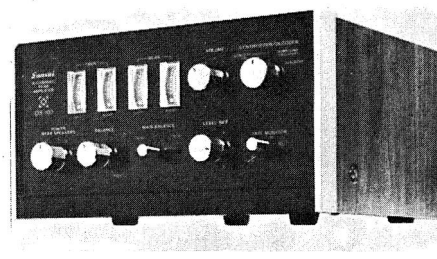

Sansui QS100

QR500 ★

Four-channel AM/FM tuner/amplifier. Range: 88-108MHz, MW 187-560 metres. Variable tuning. AFC. Ratio detector. Meter tuning indicator. Usable sensitivity: FM $2.5\mu\text{V}$, MW $350\mu\text{V}$. Aerial input: 75 ohms coaxial, 300 ohms balanced. Stereo decoder included. Output: 8W RMS per channel (four channels). Controls: mains, on/off, headphones, bass, treble, tape monitor, selector, synthesizer/decoder, volume front, volume rear. Size: $17\frac{5}{8} \times 12\frac{3}{8} \times 5\frac{1}{8}$ in. Finish: walnut cabinet with black acrylic front panel and silver trim. Price: £125.18 (plus £20.86 PT).

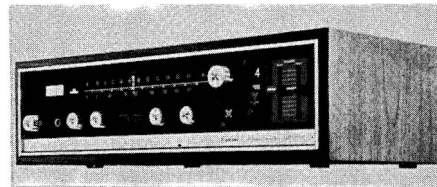

Sansui QR500

QS500 ★

Four-channel rear amplifier. Inputs: (two channel) 150mV 50K, tape monitor (two channel) 150mV 50K, (four channel) 775mV 50K. Noise level: better than 70dB. Output: 33W RMS



Sansui QS500

per channel. Output impedance: 4-8 ohms. Four VU meters. HD: <0.5% at rated output. Controls: volume, synthesizer/decoder, speakers, rear volume, input level, two and four-channel tape monitor, front balance, main balance and rear balance. FR: 20Hz-50kHz \pm 1dB at normal listening level. Designed to convert existing two-channel stereo into four-channel sound. Mains: 100, 117, 220, 240V AC. Size: $15\frac{1}{4} \times 6\frac{1}{2} \times 13\frac{3}{8}$ in. Price: £157.44.

QR1500

Four-channel stereo AM/FM tuner/amplifier. Range: FM 88-108MHz, MW 187-560 metres. Variable tuning. AFC. Ratio detector. Meter tuning indicator. Usable sensitivity: FM 2.5 μ V, MW 350 μ V. Aerial input: 75 ohms coaxial, 300 ohms balanced. Stereo decoder fitted. Output: 15W RMS per channel (four channels). Output impedance: 8 ohms. Mains: 100, 117, 220, 240V AC. Size: $19 \times 12\frac{1}{4} \times 5\frac{1}{4}$ in. Controls: mains on/off, phones, bass, treble, loudness, tape monitor, two- and four-channel mode, front and rear volume, synthesizer/decoder. Finish: walnut cabinet with black acrylic front panel with silver trim. Price: £157.73 (plus £26.29 PT).

QR4500

Four-channel AM/FM tuner/amplifier. Range: FM 88-108MHz, 187-560 metres. Variable tuning. AFC. Ratio detector. Meter tuning indicator. Usable sensitivity: FM 1.6 μ V, MW 200 μ V. Aerial input: 75 ohms coaxial, 300 ohms balanced. Stereo decoder included. Output: 27W RMS per channel (four channels). Protected output circuits. HD: <0.5% at rated output. Controls: mains on/off, speakers, bass, treble, high and low filters, front and rear balance, main balance, volume, mode, input selector, loudness, FM muting, tape monitor, four-channel synthesizer and decoder. Mains: 100, 117, 220, 240V AC. Size: $20\frac{7}{8} \times 12\frac{5}{8} \times 6\frac{3}{4}$ in. Finish: walnut cabinet with black dial and silver/gold control panel. Price: £314.39 (plus £52.40 PT).

QR6500 ★

Four-channel AM/FM tuner/amplifier. Range: FM 88-108MHz, MW 187-560 metres. Variable tuning. AFC. Ratio detector. Two tuning meters. Usable sensitivity: FM 1.4 μ V, MW 50 μ V. Aerial input: 75 ohms coaxial, 300 ohms balanced. Stereo decoder fitted. Output: 37W RMS per channel (four channels). Output impedance: 8 ohms. HD: <0.1% at rated output. Controls: balance, bass, treble, high and low filters, speakers, phones, front and rear balance, main balance, mode, input selector, synthesizer/decoder, loudness (front and rear), FM muting, tape monitor. Finish: walnut cabinet with black dial and gold/silver control panel. Size: $21\frac{1}{4} \times 14\frac{3}{8} \times 7\frac{7}{8}$ in. Mains: 100, 117, 220, 240V AC. Price: £365.60 (plus £60.93 PT).

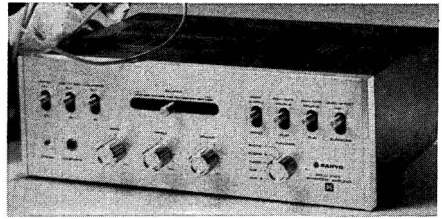

Sanyo DCA 1700X

■ **SANYO**

Sanyo Marubeni (UK) Ltd, Sanyo House, Bushey Mill Lane, Watford, Herts. Tel: Watford 30421.

DCA 1700X ★

Quadrasonic stereo synthesizer. Inputs: PU (1) 2.5mV 150K, PU (2) 2.5mV 150K, aux (1) 100mV 100K, aux (2) 100mV 100K, radio 100mV 100K, tape play 100mV 100K. Output: 20W sine per channel into 8 ohms, 17W sine per channel into 8 ohms (both channels driven). HD: 0.8%. FR: 10Hz-100kHz \pm 2dB. H and N: P U input -70dB, other inputs -75dB. Output impedance: 4-8 ohms. Damping factor: 100 (50Hz at 8 ohms). Bass control: \pm 12dB at 100Hz. Treble control: \pm 12dB at 10kHz. Outputs for two speaker systems, stereo headphones. Slider balance control. Mains: 120-240V AC. Price: £71.95.

■ **SCAN-DYNA**

Scandinavian Audio Systems Ltd, Sun Alliance Building, 65 London Road, Gloucester, GL1 3HF. Tel: Gloucester (0452) 32791/2.

SD4/100

Four-channel sound adaptor for producing rear ambience from two-channel stereo programmes. Suitable for use with most stereo amplifiers. Full details and specification on request. Price: £12.90.

■ **SHARP**

Sharp Electronics (UK) Ltd, 48 Derby Street, Manchester, M8 8HN. Tel: 061-832 6115.

GS1980

Complete quadrasonic system comprising tuner/amplifier, record deck and four speakers. 19 transistors, 14 diodes. Range: FM 88-108 MHz, MW 189-560 metres. AFC. Variable tuning. Ratio detector. Stereo decoder fitted. Output: 2W per channel. Output impedance: 8 ohms. Sharp motor unit with ceramic cartridge. Finish: PVC film on wood. Price: £83.60 (plus £13.40 PT).

GS5730E

Complete quadrasonic system comprising

★ Indicates entry is illustrated

tuner/amplifier, record deck and four speakers. Range: FM 88-108MHz, MW 189-560 metres. Variable tuning. AFC. Ratio detector. Stereo decoder fitted. Controls: mains on/off, volume, mic volume, tuning, bass, treble, function selector, loudness, tape monitor, mode, matrix/discrete four level controls. Output: 10W RMS per channel. Output impedance: 8 ohms. FR: 20Hz-30kHz. Sharp record deck with magnetic cartridge and diamond stylus. Price: £292.15 (plus £46.85 PT).

■ SIEMENS

Interconti Electronic Ltd,
Albany House, Petty France, London,
SW1H9EA. Tel: 01-222 2523. Telex: 918770.

RS202

Five-waveband AM/FM quadrasonic tuner/amplifier. 58 semiconductors and 20 ICs. Slide controls plus pushbuttons. Output: 15W per channel. Finish: white or brown. Full specification on request. Price: £134.50 (including PT).

RS302

Four-waveband AM/FM quadrasonic tuner/amplifier. 66 semiconductors. Slide controls plus pushbuttons. Output: 30W per channel. Finish: white or light satinwood. Full specification on request. Price: £180 (including PT).

RS172

Five-waveband AM/FM quadrasonic tuner/amplifier. 87 semiconductors and 23 ICs. Slider controls plus 24 pushbuttons. Output: 50W per channel. Finish: white or light satinwood. Full specification on request. Price: £216 (including PT).

■ SONY (UK) LTD

Pyrene House, Sunbury Cross, Sunbury-on-Thames, Middlesex. Tel: Sunbury 87644/7.

SQA200

Combined four-channel decoder/amplifier (SQ). Inputs: two channel tape 440mV 180K, four-channel tape 440mV 50K, aux 250mV 100K. Output: 8W RMS per channel (4) into 8 ohms. Controls: mains on/off, volume, balance, bass ± 10 dB at 100Hz, treble ± 10 dB at 10kHz, input selector, monitor. HD: $< 0.2\%$. FR: 30Hz-40kHz $+ 0$ dB $- 2$ dB. Mains: 110, 130, 220, 240V AC. Size: $13 \times 2\frac{7}{8} \times 11\frac{1}{2}$ in. Finish: wood cabinet with anodised front panel. Four-channel sound with right/left and front/back separation. Decodes SQ records and radio signals into quadrasonic sound. Price: £57.75.

■ TRIO

B. H. Morris & Co (Radio) Ltd,
84-88 Nelson Street, London, E1 2DY.
Tel: 01-790 5011.

KSQ20

Four-channel stereo adaptor. 25 transistors, 4 diodes. Provides quadrasonic reproduction from two-channel stereo sources. Full details of specification and price not available as this edition closed for press.

KR6170 Jumbo

AM/FM stereo tuner/amplifier with electronic rhythm and percussion generators built-in. Range: 88-108MHz, MW 187-556 metres. Variable tuning. Meter. Left and right channel level meters. Usable sensitivity: FM 1.9 μ V, MW 25 μ V. Inputs: mag PU (2) 2.5mV 50K, mic 2mV 10K, guitar 15mV 30K, aux (2) 150mV 100K, tape play (2) 150mV 100K. Output: 55W per channel into 8 ohms. Output impedance: 4-14 ohms. HD: 0.1% at -3 dB rated power. Power bandwidth (IHF) 17Hz-30kHz. Electronic rhythm produces 12 different rhythms and five different percussions. Reverberation control 0-2 sec. Echo sound output for four-channel reproduction. Four sets of speaker terminals. Three-step power limiter for speaker protection. Two-hour timer for automatic switch off. Two sets of headphone jack sockets. Mains: 110/120V, 220/240V AC. Size: $21\frac{3}{4} \times 6\frac{3}{4} \times 16\frac{1}{4}$ in. Weight: 35lb. Accessories: (included in price) dynamic microphone, foot switch for rhythm composer. Price: £238.45 (plus £31.05 PT).

■ WILKINSON/FORM

Wilkinson/Form (Electronics)
Low Quay, Blyth, Northumberland.
Tel: Blyth 3574/5.

Quartet 20

Four-channel sound system comprising decoder/amplifier, stereo record deck and four separate speakers. Integrated circuits employed in decoder and output stages. Inputs: ceramic pickup 160mV 2 megohms, tape 160mV 200K, radio 160mV 2 megohms. Noise level: -75 dB on all inputs. Output: 5W RMS per channel. Output impedance: 8 ohms. Tone controls: bass ± 12 dB at 100Hz, treble ± 12 dB at 10kHz. HD: $< 0.1\%$ at all levels up to rated output. FR: 10Hz-35kHz -1 dB. Damping factor: 40. Separate bass and treble controls for rear channels. Rear and front balance control. Master gain control for all channels. Fully protected outputs. Finish: teak veneer with brushed aluminium control panel. Size: (decoder/amplifier unit) $15\frac{3}{4} \times 2\frac{1}{2} \times 11\frac{1}{2}$ in approx. Record unit: Goldring G101 deck with pickup arm and PZT104 transcription cartridge in plinth cabinet with transparent plastic lid. Speakers: infinite baffle enclosures incorporating Peerless $6\frac{1}{2}$ in bass driver and $2\frac{1}{4}$ in HF units. Crossover: L/C 5kHz. FR: 60Hz-18kHz. HC: 12W RMS. Size: $17 \times 10 \times 9$ in. Finish: teak veneer. Price: (complete system) £260 (including PT).

Table of Tape Playing Times

Length of Tape (Feet)		3600	2400	1800	1700	1200	900	850
Size of Spool		8½ DP	7 DP 8½ LP	5 TP 7 LP 8½ S	5¾ DP	5 DP 5¾ LP	4 TP 5 LP	5¾ S
Maximum Playing Times		H M	H M	H M	H M	H M	H M	H M
1 Track	15 i/s	48	32	24	22	16	12	11
	7½ i/s	1 36	1 4	48	47	32	24	22
	3¾ i/s	3 12	2 8	1 36	1 30	1 4	48	45
	1⅞ i/s	6 24	4 16	3 12	3 1	2 8	1 36	1 30
2 Tracks	15 i/s	1 36	1 4	48	45	32	24	22
	7½ i/s	3 12	2 8	1 36	1 30	1 4	48	45
	3¾ i/s	6 24	4 16	3 12	3 1	2 8	1 36	1 30
	1⅞ i/s	12 48	8 32	6 24	6 2	4 16	3 12	3 1
4 Tracks	15 i/s	3 12	2 8	1 36	1 30	1 4	48	45
	7½ i/s	6 24	4 16	3 12	3 1	2 8	1 36	1 30
	3¾ i/s	12 48	8 32	6 24	6 2	4 16	3 12	3 1
	1⅞ i/s	25 36	17 4	12 48	12 5	8 32	6 24	6 2
Length of Tape (Feet)		600	450	400	300	200	150	
Size of Spool		4 DP 5 S	3 TP 4 LP	3½ LP	3¼ LP 4 S	3¼ S	3 S	
Maximum Playing Time		H M	H M	H M	H M	H M	H M	
1 Track	15 i/s	8	6	5	4	2½	2	
	7½ i/s	16	12	10	8	5	4	
	3¾ i/s	32	25	21	16	10	8	
	1⅞ i/s	1 4	48	42	32	21	16	
2 Tracks	15 i/s	16	12	10	8	5	4	
	7½ i/s	32	24	21	16	10	8	
	3¾ i/s	1 4	48	42	32	21	16	
	1⅞ i/s	2 8	1 36	1 25	1 4	42	32	
4 Tracks	15 i/s	32	24	21	16	10	8	
	7½ i/s	1 4	48	42	32	21	16	
	3¾ i/s	2 8	1 36	1 25	1 4	42	32	
	1⅞ i/s	4 16	3 12	2 50	2 8	1 25	1 4	

Note: The 4 tape thicknesses are listed as S (Standard), LP (Long Play), DP (Double Play) and TP (Triple Play).



Up, up, up go Philips specifications

With the immense research facilities of the Philips organisation directed towards producing top Hi-Fi, it could only be a matter of time before outstanding developments like these were announced.

The N4450 Automatic Reverse Tape Recorder is a magnificent machine, with a built-in 2 x 20 Watts RMS Hi-Fi amplifier that you can use with the recorder's three motors switched off. You can therefore build an absolutely superb Hi-Fi stereo system round the N4450 - you don't need a separate amplifier. The features of this highly sophisticated instrument

are far too numerous to list here. Suffice to say, if you want the best, this is it.

Another fine achievement is the RH802 system - two loudspeaker enclosures, plus a unit that combines a 2 x 15 Watts RMS amplifier, 4 waveband AM/FM tuner, and transcription-quality deck with Super M magneto-dynamic cartridge.

Both RH 802 and N4450 make the DIN 45 500 (Hi-Fi) Standard look rather ordinary.

Ask your Philips Audio Dealer for the Philips Audio and Tape Recorder Brochures.



We want you to have the best.

PHILIPS

Directory of Tape Recorders

★ Indicates entry is illustrated

Abbreviations used in this section are given on page 36.

■ AKAI

UK distributors: Rank Audio Products, PO Box 70, Great West Road, Brentford, Middx. Tel: 01-568 9222. Telex: 24408.

X-1800SD ★

Stereo tape recorder. $\frac{1}{4}$ -track. Speeds: $1\frac{7}{8}$, $3\frac{3}{4}$, $7\frac{1}{2}$ and $15\frac{1}{2}$ with adaptor. Max spool capacity: 7in. W and F: $7\frac{1}{2}$ i/s 0-12%; $3\frac{3}{4}$ i/s 0-15%; $1\frac{7}{8}$ i/s 0-2%; cartridge 0-25%. FR: $7\frac{1}{2}$ i/s 30-23kHz ± 3 dB; $3\frac{3}{4}$ i/s 30Hz-18kHz ± 3 dB; $1\frac{7}{8}$ i/s 30Hz-9kHz ± 3 dB; cartridge 50Hz-17kHz ± 3 dB. H and N -50dB. Replay char: NARTB, Level indicator: VU meter. Rewind time: 1,200ft 150 sec. Inputs: microphone 0-5mV, 50K; line, 60mV. Outlets: line and headphones. Audio output: 4W per channel RMS. Speakers: two 4in. Transistorised. Motor: 2-speed induction. Tape deck: own. Dimensions: $15 \times 13\frac{1}{2} \times 9\frac{1}{2}$ in. Weight: 37-4lb. Pause. Position indicator: digit. Straight through amplifier. Monitoring. Input mixing. Record and replay facilities for 8-track cartridges in addition to reel-to-reel. Reel to cartridge transfer. FM multiplex ready. Cross-field head. Walnut cabinet. Psn 100-240V, 50 or 60Hz. Price: £139-06 (plus £23-73 PT).

CR80 ★

Stereo cartridge recorder less speakers. Eight-track. Speeds: $3\frac{3}{4}$ i/s. W and F: 0-25%. H and N: -47dB. FR: 50Hz-16kHz ± 3 dB. Replay char: NARTB. Fast forward wind: 230 sec for 300ft. Two VU meters. Inputs: mic 0-5mV, line 50mV. Outlet sockets for line, headphones, external speakers. Output: 8W RMS per channel. Own tape transport. Headphone monitoring. Size: $13\frac{1}{2} \times 5\frac{1}{2} \times 10$ in. Weight: 19 $\frac{1}{2}$ lb. One micron gap head. Mains: 100-240V 50/60Hz. Price: £90-89 (plus £15-50 PT).

CS50

Stereo cassette recorder less speakers. $\frac{1}{4}$ track. Compact cassette. Speed: $1\frac{7}{8}$ i/s. W and F: 0-2%. H and N: -45dB. FR: 30Hz-16kHz. Replay char: NARTB. Rewind time: 75 sec for C60 cassette. Two VU meters. Inputs: mic 0-2mV 4-7K, DIN 3mV 25K, line 220K. Outlets: line 1-3V 10K, DIN 0-4V, headphones 8 ohms. Out-

put: 6W RMS per channel. Own tape transport. Outer rotor motor. Size: $15 \times 6\frac{1}{4} \times 11\frac{1}{4}$ in. Weight: 16 $\frac{3}{4}$ lb. Pause control. Headphone monitoring. Invert-o-matic automatically withdraws tape cassette, reverses and replaces. Automatic shut-off. Mains: 100-240V 50/60Hz. Price: £107-49 (plus £18-34 PT).

1720L ★

Three-speed $\frac{1}{4}$ track stereo recorder. Speeds: $7\frac{1}{2}$, $3\frac{3}{4}$, $1\frac{7}{8}$ i/s. Max spool: 7in. W and F: $7\frac{1}{2}$ i/s 0-18%, $3\frac{3}{4}$ i/s 0-25%, $1\frac{7}{8}$ i/s 0-35%. H and N: -50dB all speeds. FR: $7\frac{1}{2}$ i/s 40Hz-15kHz ± 3 dB. $3\frac{3}{4}$ i/s 40Hz-12kHz ± 3 dB, $1\frac{7}{8}$ i/s 40Hz-6kHz ± 3 dB. Replay char: NARTB. Rewind time: 2 $\frac{1}{2}$ min for 1,200ft. Meter level indicator. Inputs: mic 3-5mV 20K, line 30mV 150K, DIN 10mV 50K. Outlets: line 1-2V (0 VU) 82K, DIN 2-5V, stereo phones 150mV 8 ohms. Output: 3W RMS per channel. speakers: (2) 7 \times 5in. Own deck. One two-speed motor. Pause. Monitoring. Input mixing. Size: $14\frac{1}{4} \times 14\frac{3}{8} \times 9\frac{5}{8}$ in. Weight: 30lb. Mains: 100-240V AC 50/60Hz. Price: £74-63 (plus £12-73 PT).

GX 365

Three-speed $\frac{1}{4}$ -track stereo tape recorder. Speeds: $7\frac{1}{2}$, $3\frac{3}{4}$, $1\frac{7}{8}$ i/s. Max spool: 7in. W and F: $7\frac{1}{2}$ i/s 0-04%, $3\frac{3}{4}$ i/s 0-07%, $1\frac{7}{8}$ i/s 0-14%. H and N: $7\frac{1}{2}$ i/s -55dB, $3\frac{3}{4}$ and $1\frac{7}{8}$ i/s -50dB. FR: $7\frac{1}{2}$ i/s 30Hz-28kHz ± 3 dB, $3\frac{3}{4}$ i/s 30Hz-23kHz ± 3 dB, $1\frac{7}{8}$ i/s 40Hz-12kHz ± 3 dB. Replay char: NARTB. Rewind time: 1 $\frac{1}{4}$ min for 1,200ft. VU meter. Inputs: mic 0-7mV 10K, line 70mV 150K, DIN (low) 7mV 16K, DIN (high) 70mV 150K. Outlets: line 1-23V (0 VU) 100 ohms, DIN 0-4V, stereo phones 30-40mV 8 ohms. Output: 15W RMS per channel. Speakers: 4 \times 2in monitoring. Three motors (one three-speed 2-4-8 pole, two 6-pole outer rotor). Own deck. Superimpose. Pause. Straight-through amplifier. Monitoring (A-B and headphones). Input mixing. Glass crystal ferrite heads. Auto reverse. Remote control. Magnetic braking. Size: $16\frac{1}{4} \times 18\frac{1}{2} \times 11\frac{1}{8}$ in. Weight: 61lb. Mains: 100-240V 50/60Hz. Price: £331-61 (plus £56-58 PT).

X2000SD

Three-speed stereo recorder with facilities for cassettes, cartridges and reel-to-reel recording and playback. Speeds: $7\frac{1}{2}$, $3\frac{3}{4}$, $1\frac{7}{8}$ i/s. Max spool 7in. W and F: $7\frac{1}{2}$ i/s 0-09%, $3\frac{3}{4}$ i/s 0-14%, $1\frac{7}{8}$ i/s 0-20%. H and N: reel-to-reel all speeds 50dB, cassettes and cartridges 45dB. FR: $7\frac{1}{2}$ i/s 30Hz-23Hz ± 3 dB, $3\frac{3}{4}$ i/s 30Hz-18kHz ± 3 dB, $1\frac{7}{8}$ i/s 30Hz-9kHz ± 3 dB, cassettes 30Hz-16kHz ± 3 dB, cartridges 30Hz-18kHz ± 3 dB. Replay char: NARTB. Rewind time: 2 $\frac{1}{2}$ min for 1,200ft, 80 sec for cassette. VU meters. Inputs: mic 0-15mV, line 25mV. Outlet: line. Output: 8W RMS per channel. Speakers: 4 \times 2in monitoring. Two-speed capacitor motor. Own deck. Cross-field head. Monitoring. Transfer facilities from

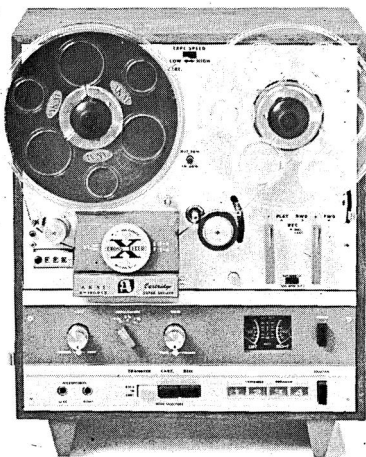

Akai X-1800SD



Akai CR80



Akai 1720L



Akai GXC-40

reel to cassette or cartridge. Size: $10\frac{5}{8} \times 13\frac{3}{4} \times 18\frac{3}{8}$ in. Weight: 49 $\frac{1}{2}$ lb. Mains: 100-240V 50/60Hz. Price: £246.94 (plus £42.13 PT).

GXC-40 ★

Stereo cassette recorder. Speed: $1\frac{7}{8}$ i/s. Compact cassette. W and F: <0.2% RMS. H and N: better than 45dB. FR: (standard tape) 30Hz-16kHz ± 3 dB, (chromium dioxide) 30Hz-18kHz ± 3 dB. Replay char: NARTB. Rewind time: 60 sec for C60 cassette. Twin VU meters. Inputs: mic (2) 0.2mV 4-7K, line (2) 50mV 200K. Outlets: line (2) 1.23V 100 ohms, phones 30mV 8 ohms, speakers 6W 8ohms. Output: 10W RMS per channel. Own deck. One motor. Pause. Straight-through amplifier. Switch position f or chromium dioxide. Size: $16\frac{1}{2} \times 5 \times 8\frac{3}{8}$ in. Weight: 11 $\frac{3}{4}$ lb. Mains: 100-240V AC adjustable. Price: £95.46 (plus £16.29 PT).

■ **AMPEX (GB) LTD**

Acre Road, Reading, Berks, RG20QR.
Tel: Reading 84411.

ABR15, MM1000 ★

Full range of professional and semi-professional tape decks, tape units and complete recorders. Typical specification includes following facilities. Full-, half- or quarter track on $\frac{1}{4}$ in tape. Up to 15in spools. Speeds: selectable pairs from $\frac{1}{6}$, $1\frac{1}{8}$, $3\frac{1}{4}$, $7\frac{1}{2}$, 15. Unidirectional or bi-directional operation. FR: 15i/s 30Hz-18kHz ± 3 dB, $1\frac{7}{8}$ i/s 40Hz-10kHz. Crosstalk rejection: better than 60dB at 1kHz. Bias/erase frequency: 100 kHz. W and F: 15i/s 0.1%, $1\frac{7}{8}$ i/s 0.25%. Start time: operating speed obtained in 0.1 sec or less. Stop time: at 15i/s tape moves 3in. S/N: 15i/s half-track 63dB, $7\frac{1}{2}$ i/s half track 63dB, $3\frac{1}{4}$ i/s half-track 58dB.

Supplied to professional and scientific orders only free of tax. Further details of models and specifications on request.

See Tape Unit Section for further details of Ampex tape recorder, reproducers and copiers.

■ **BANG & OLUFSEN UK LTD**

Eastbrook Road, Gloucester, GL47DE.
Tel: Gloucester 21591.

Beocord 1600

Stereo tape recorder less speakers. $\frac{1}{4}$ -track. Speeds: $3\frac{3}{4}$ and $7\frac{1}{2}$ i/s. Max spool 7in. W and F: $3\frac{3}{4}$ i/s $\pm 0.2\%$, $7\frac{1}{2}$ i/s $\pm 0.15\%$. H and N: $3\frac{3}{4}$ i/s > -50dB, $7\frac{1}{2}$ i/s > -50dB. FR: (DIN 45-500 spec) $3\frac{3}{4}$ i/s 40Hz-16kHz, $7\frac{1}{2}$ i/s 30Hz-20kHz. Replay char. DIN. Rewind time: 3 min 20 sec for 1,800ft. VU meter level indicator. Inputs: mic (2) 80 μ V 50-200 ohms, radio 2.5mV 47K, PU 60mV 470K. Outlets: line 1V 25K, phones 6V max 100 ohms, speakers (2) 4 ohms. Output: 10W RMS per channel. Transistors. Own deck. Papst outer rotor motor. Superimpose. Pause

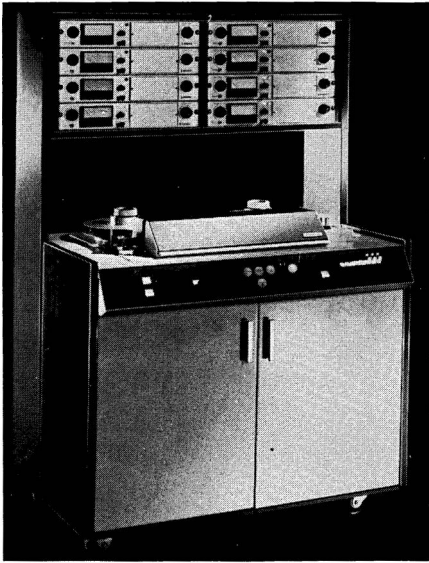

Ampex MM1000

control. Straight-through amplifier. Monitoring (A only). Input mixing (limited). Parallel track replay. Photo-electric stop. Electronic speed change and mode switching. Horizontal or vertical operation. Can be wall-mounted. Size: $17\frac{1}{2} \times 5\frac{3}{4} \times 13$ in. Weight: 26lb. Mains: 110, 130, 220, 240V AC 50Hz. Finish: teak or rosewood. Price: (teak) £149.50; (rosewood) £150.50 (including PT).

■ BASF UNITED KINGDOM LTD

Audio/Video Tapes Division, PO Box 473, Knightsbridge House, 197 Knightsbridge, London, SW7. Tel: 01-584 5080. Telex: 267574/5.

CC9200

$\frac{1}{2}$ -track cassette recorder. Battery/mains operation. Speed: $1\frac{7}{8}$ i/s. Compact cassettes. W and F: $\pm 3\%$. FR: 80Hz-10kHz. Replay char: DIN. Meter level indicator. Output: 1W RMS. Remote control microphone. Mains lead. Automatic cassette rejection. Size: $11\frac{3}{4} \times 8\frac{1}{8} \times 2\frac{3}{8}$ in. Weight: $3\frac{3}{8}$ lb. Mains: 110, 220, 240V AC. Instant review button. Price: £41.46 (plus £7.08 PT).

■ BRENELL ENGINEERING CO LTD

231-5 Liverpool Road, London, N1.
Tel: 01-607 8271 (5 lines).

ST200

Transistorised tape recorder for general-purpose (mains) use. Speeds: $1\frac{7}{8}$, $3\frac{3}{4}$ and $7\frac{1}{2}$ i/s. 2-track. Stereo. W and F: $7\frac{1}{2}$ 0.08%, $3\frac{3}{4}$ 0.1%, $1\frac{7}{8}$ 0.12%. H and N: $7\frac{1}{2}$ -59dB, $3\frac{3}{4}$ -56dB, $1\frac{7}{8}$ -53dB. FR: $7\frac{1}{2}$ 40Hz-14kHz, $3\frac{3}{4}$ 40Hz-11kHz, $1\frac{7}{8}$ 40Hz-5kHz,

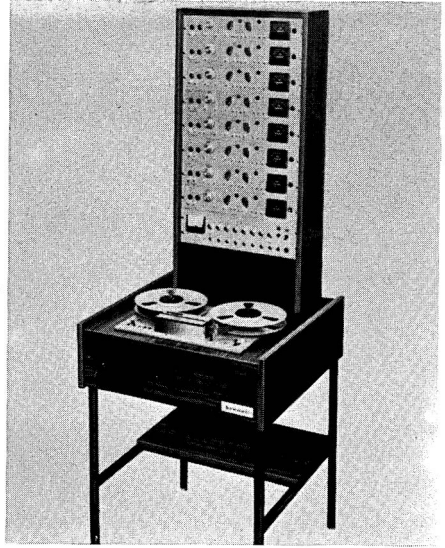

Brenell Master Recorder

each ± 2 dB. CCIR. Two meters. Rewind time: 1,200ft 60 sec. Inputs: microphone, $50\mu\text{V}$, 200 ohms; radio 40mV, 220K. Outputs: hi-fi 200mV into 47K; monitor 2V, 100 ohms; extension speaker 6W RMS, 15 ohms. Output: 6W RMS. Speaker: $3\frac{1}{2}$ in. Three Papst motors. Own tape deck. Dimensions: $15\frac{3}{4} \times 17\frac{3}{4} \times 8\frac{1}{2}$ in. Weight: 33lb. Pause facility. Pressbutton reset revolution counter. Straight-through amplifier on mono. Mono monitoring of input signal. Bass and treble cut and lift on recording and replay. 210V, 240V, 110V, 80W. Price: £128 (plus £21.84 PT).

ST400

4-track version of the previous model. Specification is the same except for: H and N: $7\frac{1}{2}$ -56dB; $3\frac{3}{4}$ -53dB; $1\frac{7}{8}$ -50dB. Price: £128 (plus £21.84 PT).

Mk 6 Type M

Mains mono recorder. $\frac{1}{2}$ -track (full-track version available). Speeds: 15, $7\frac{1}{2}$, $3\frac{3}{4}$, $1\frac{7}{8}$ i/s. Max spool: 8 $\frac{1}{2}$ in (10 $\frac{1}{2}$ in NAB version available). W and F: $1\frac{7}{8}$ i/s 0.12%, $3\frac{3}{4}$ i/s 0.1%, $7\frac{1}{2}$ i/s 0.08%, 15i/s 0.05%. H and N: $1\frac{7}{8}$ i/s 50dB, $3\frac{3}{4}$ i/s 54dB, $7\frac{1}{2}$ i/s 56dB, 15i/s 56dB. FR: $1\frac{7}{8}$ i/s 60Hz-8kHz, $3\frac{3}{4}$ i/s 50Hz-15kHz, $7\frac{1}{2}$ i/s 40Hz-20kHz, 15i/s 40Hz-22kHz, all ± 3 dB. Replay char: CCIR. Rewind time: under 60 sec for 1,200ft. Illuminated edge-scale VU meter. Inputs: mic 0.1mV 200-250 ohms, aux 5mV 250K, PU mag 4mV 47K, PU ceramic 160mV 1.5 megohms. Outputs: external amplifier 200mV into 10K, external speaker 15W into 8 ohms or 8W into 15 ohms. Speaker: 7×5 in. Output: 15W RMS into 8 ohms (8W into 15 ohms. Transistorised. Own deck. Horizontal or vertical operation. Three motors (Papst outer

★ Indicates entry is illustrated

rotor). Pause control. Straight-through amplifier. Monitoring. Input mixing. Accepts pickups direct. A/B switching. Size: $16\frac{1}{2} \times 7 \times 18$ in. Weight: 35lb. Mains: 110, 210, 240V AC. Price: £136.50 (plus £23.29 PT). Industrial version with $10\frac{1}{2}$ in NAB reels free of PT for industrial users only.

Master Recorders ★

A new range of master recorders for sound recording studios and industrial and scientific applications. Series A, full-track on $\frac{1}{4}$ in tape; Series B, half-track on $\frac{1}{4}$ in tape; Series C, four-track on $\frac{1}{2}$ in tape; Series D, four-track on 1 in tape; Series E, eight-track on 1 in tape.

Each series comprises four basic self-contained units; (1) tape transport, (2) record/play amplifier (one per channel), (3) master oscillator unit, (4) power supply unit, (5) optional remote control unit for all deck functions. Suitable for 19 in rack mounting. Full specifications and prices on request.

■ CHILTON

Magnetic Tapes Ltd, Chilton Works, Garden Road, Richmond, Surrey. Tel: 01-876 7957.

Chilton 100S

Transistorised stereo $\frac{1}{4}$ or $\frac{1}{2}$ -track three-speed recorder available as portable with in-built speakers (model 100S/CAP), or chassis in teak surround without power amplifiers (100S/CW), or with power amplifiers (100S/CAW). Speeds: $1\frac{7}{8}$, $3\frac{3}{4}$, $7\frac{1}{2}$ i/s. 7 in reels. Rewind time: 150 sec for 1,800ft. Deck uses hysteresis motor and four DC-operated diode-suppressed solenoids. W and F: 0.1% at $7\frac{1}{2}$ i/s, 0.25% at $1\frac{7}{8}$ i/s. FR: (± 2 dB) via tape 30Hz-18kHz ($7\frac{1}{2}$ i/s), 40Hz-11kHz ($3\frac{3}{4}$ i/s) and (± 3 dB) 50Hz-7kHz ($1\frac{7}{8}$ i/s). Signal/noise, unweighted, 50dB $\frac{1}{4}$ -track and 53dB $\frac{1}{2}$ -track, all speeds. Replay char: IEC (NAB to order). Inputs per channel: mic 600 ohms-50K 0.4mV, radio 100K 40mV (DIN), gram 47K 1mV RIAA DIN. Outlets: line 2K 0.5V DIN, radio 10K 0.25V DIN, speakers (models with power amps) 10W at 8 ohms. LS impedance 4-16 ohms. Two 6×4 in units per channel in model CAP. Stereo headphone jack socket. Size: (portable with lid) $14\frac{1}{2} \times 13\frac{5}{8} \times 6\frac{1}{2}$ in; (chassis) $19 \times 16 \times 8$ in. Various versions offered; 100S/CW tape unit in teak surround for use with external amplifier (output 0.3V at 600 ohms); 100S/CAW with two 10W amplifiers and tone controls for use with external speakers; 100S/CAP as CAW but in leatherette covered case with four in-built speakers; 200S/CAP teak portable with four in-built speakers and transparent plastic lid. Prices on request.

Extras

Two-track version, lockable teak case, cover for

type CW, modifications for vertical operation. Details and prices on request.

■ CINECODER

Distributed by REW Audio Visual Ltd, 266-268 Upper Tooting Road, London, SW17. Tel: 01-672 4471/2 and 9175.

Cinecoder Model A

Mono recorder with BSR deck. $\frac{1}{2}$ -track. Speed: $3\frac{3}{4}$ i/s. W and F: 0.4%. FR: 60Hz-10kHz. Replay char: CCIR. Two channel mixing with two inputs per channel. 4W 15 ohms output. One motor. $5\frac{3}{4}$ in spools. 10 in elliptical speaker housed in detachable lid with 24ft cable. Separate bass and treble controls. Boost and cut. Superimposition. 'Shift-track' tape control for dual recordings. Tapelift/Pause control for cueing, cross-fading. Remote control. Accessories: mic and ext cables, perforated Cinetape, tape sprockets. Size: $16\frac{1}{2} \times 14 \times 8\frac{1}{2}$ in. Weight: 28lb. Price and further details on request.

■ CROWN INTERNATIONAL

Macinnes Laboratories Ltd, Stonham, Stowmarket, Suffolk, IP145LB. Tel: Stonham (044 971) 486.

800 Series ★

$\frac{1}{4}$ -track and $\frac{1}{2}$ -track mono and stereo professional recorders. Three-speeds with 15i/s or $1\frac{7}{8}$ i/s optional. Max spool: $10\frac{1}{2}$ in. W and F: 15 i/s 0.06%, $7\frac{1}{2}$ i/s 0.09%, $3\frac{3}{4}$ i/s 0.18% (RMS). H and N: 15i/s -60dB; $7\frac{1}{2}$ i/s -60dB; $3\frac{3}{4}$ i/s -55dB (below peak level). FR (± 2 dB): 15i/s 30Hz-30kHz; $7\frac{1}{2}$ i/s 30Hz-25kHz; $3\frac{3}{4}$ i/s 30Hz-15kHz. Replay char: CCIR. VU meter. Rewind time: 58 sec 2,400ft, 38 sec 1,200ft. Inputs: 2 mixable inputs per channel, mic or line. Sensitivity: 45mV for 0 level (line), 0.4mV for 0 level (mic); impedance 100K, balanced or unbalanced 600 ohms, or 50/200 ohms. Output: 600 ohms. Three motors, magnetic brakes, logic circuitry for tape handling, all tape commands can be remote. A-B monitoring, source and tape mixing, echo, individual bias adjustment and metering. Size: $17\frac{1}{2} \times 19 \times 8$ in. Weight: 50lb. Price: £700 to £1,500.

■ FERGUSON

British Radio Corporation Ltd, 284 Southbury Road, Enfield, Middlesex. Tel: 01-366 1155.

3248 ★

$\frac{1}{4}$ -track mono recorder. 2-speeds. 7 in reels. At $3\frac{3}{4}$ i/s W $\pm 0.3\%$, F $\pm 0.3\%$, at $1\frac{7}{8}$ i/s W $\pm 0.4\%$, F $\pm 0.4\%$. FR: (6dB); radio input to low-level output: $3\frac{3}{4}$ i/s 40Hz-14kHz, $1\frac{7}{8}$ i/s 40Hz-7kHz. Replay char: DIN. Level meter (illuminated). Rewind time: 2 min 40 sec 1,200ft. Inputs: mic/

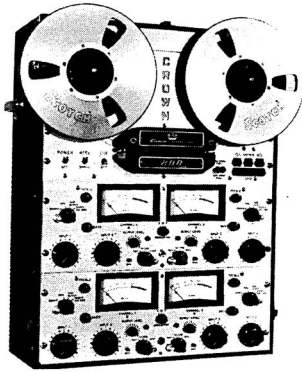

Crown 800

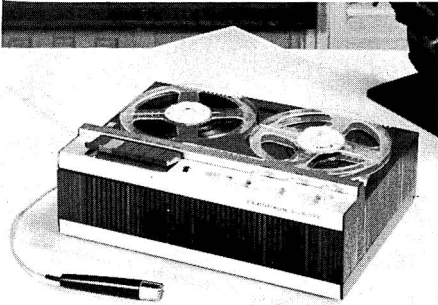

Ferguson 3248



Ferguson 3258

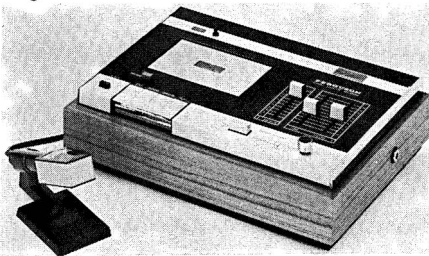

Ferguson 3257

radio 0.2mV 2K, gram 220mV 2.2 meg. Outputs: ext speaker 8 ohms or 30-100 ohm phones, ext amps 500mV 10K, 6-pin accessories socket. 4.5W (5% distortion) to $5\frac{1}{2} \times 2\frac{3}{4}$ in speaker. Deck BRC series F. Inching, pause control, monitoring, parallel track replay, auto recording level control with manual over-ride, auto tape stop, tape position indicator, bass and treble controls. Transistorised. 240V 50Hz mains. Size: $15\frac{1}{4} \times 11 \times 5\frac{1}{4}$ in. MC mic, LP tape, record/playback lead and ext speaker plug included. Price: £45.07 (plus £7.23 PT).

3252

$\frac{1}{4}$ -track stereo recorder. 3-speeds, 7in reels. W and F: $7\frac{1}{2}$ i/s 0.15%, $3\frac{3}{4}$ i/s 0.2%, $1\frac{1}{2}$ i/s 0.25%. H and N: -45dB. FR (6dB): $7\frac{1}{2}$ i/s 40Hz-18kHz. Replay char: CCIR. Level meter. Rewind time: 3 min 20 sec 1,800ft. Inputs: mic, PU (high impedance), PU (low impedance). Outputs: ext speakers 5W 8 ohms, ext amps 500mV 10K. 5W output into 5×3 in speakers. Track transfer switch. Solenoid operated remote pause and auto stop. Mains: 45W. Size: $16\frac{1}{2} \times 14\frac{1}{4} \times 7\frac{1}{2}$ in. Price: £85.45 (plus £13.55 PT).

3258 ★

$\frac{1}{4}$ -track mains stereo recorder. Speed: $3\frac{3}{4}$ i/s. Max spool 7in. W and F: 0.3%, H and N: -42dB. FR: 40Hz-14kHz \pm 6dB. Replay char: CCIR. Rewind time: 2 min 40 sec for 1,200ft. Meter level indicator. Inputs: mic 0.2mV 2K, radio 220mV 10K, line 500mV 10K. Outlets: stereo phones 8 ohms, ext speakers 8 ohms, earphone (monitor) 1-2K. Output: 2.5W RMS per channel. Speakers: $5\frac{3}{8} \times 3\frac{3}{4}$ in. BRC deck. Pause control. Vertical or horizontal operation. Auto recording level with manual over-ride. Slider controls. Size: $18\frac{1}{2} \times 5\frac{3}{4} \times 11$ in. Price: £60.70 (plus £9.75 PT).

3257 ★

Stereo cassette recorder with separate speakers. Four tracks. Speed: $1\frac{7}{8}$ i/s. Compact cassettes. W and F: \leq 0.3%, S/N ratio: 40dB unweighted. FR: 40Hz-10kHz \pm 3dB. Rewind time: 2 min 15 sec for C60 cassette. Moving coil meter level indicator. Three-digit tape position indicator. Inputs: mic 0.2mV 2K, aux 220mV 10K. Outlets: line 500mV 10K, monitoring earphone 1-2K, stereo headphones 8-16 ohms, loudspeakers 6-8 ohms. Output: 2.5W per channel. Own deck. 22 transistors and six diodes. Playing times: (C60) 1 hour, (C90) $1\frac{1}{2}$ hours, (C120) 2 hours. Supplied with stereo dynamic microphone with table stand, C60 cassette, connecting lead for external amplifiers, two DIN speaker plugs. Finish: teak case with black and brushed aluminium top panel and chrome trims. Size: $12\frac{1}{2} \times 9 \times 4$ in. Price: £48.65 (plus £7.80 PT). Speakers: (type 3257-7) £12.58 (plus £2.02) each speaker.

★ Indicates entry is illustrated

■ FERROGRAPH CO LTD

Auriema House, 442 Bath Road,
Cippenham, Slough, Bucks, SL1 6BB.
Tel: Burnham 062-86 62511. Telex: 847297.

Ferrograph 713

Semi-professional mains mono recorder. $\frac{1}{2}$ -track. Speeds: $7\frac{1}{2}$, $3\frac{3}{4}$, $1\frac{7}{8}$ i/s. Max spool $8\frac{1}{4}$ in. W and F: $7\frac{1}{2}$ i/s 0.08%, $3\frac{3}{4}$ i/s 0.15%, $1\frac{7}{8}$ i/s 0.2%. H and N: $7\frac{1}{2}$ i/s better than 55dB. FR: $7\frac{1}{2}$ i/s 30Hz-17kHz ± 2 dB, $3\frac{3}{4}$ i/s 40Hz-14kHz ± 3 dB, $1\frac{7}{8}$ i/s 50Hz-7kHz ± 3 dB. Replay char: DIN. VU meter. Rewind time less than one minute for 1,200ft. Inputs: mic 300 μ V to 15mV at 250-2,000 ohms, line 50mV to 10V at 2 megohms. Outputs: 600 ohms, 300mV 10K, 8-15 ohms 10W. Output: 10W RMS. Two 6 \times 4in speakers. Transistorised. Three motors (synchronous hysteresis capstan motor and shaded pole spool motors). Pause. Four-digit gear driven tape indicator. Straight-through amplifier. Monitoring. Input mixing. Vertical or horizontal operation. Single knob control. Fast wind continuously variable in either direction. Remote start/stop of tape, also time-switch operation. Removable head block. Straight line tape loading. Automatic stop. Reel retainers. Retractable carrying handle. A-B comparison switch. Separate bass and treble controls with cut or lift. Meter indicates signal level on record and playback. Meter switchable to indicate bias. Bias continuously adjustable. Supplied in two styles. Suffix P: portable wood case leathercloth covered; Suffix W: wooden case, natural wood finish; Mains: (Suffix U) 200-250V 50Hz; (Suffix A) 117V 60Hz. Price: £204.45 (including PT).

Ferrograph 713H

Similar specifications to 713 except tape speeds 15, $7\frac{1}{2}$, $3\frac{3}{4}$ i/s. FR at 15i/s: 30Hz-20kHz ± 2 dB. Price: £213.85 (including PT).

Ferrograph 722

Similar specification to 713 except $\frac{1}{2}$ -track stereo version. Track to track transfer switch. Switchable echo. Records mono on upper or lower tracks. Channel separation: stereo approx 50dB, mono better than 65dB. Price: £263.03 (including PT).

Ferrograph 722H

Similar specification to 722 except tape speeds 15, $7\frac{1}{2}$, $3\frac{3}{4}$ i/s. FR at 15i/s: 30Hz-20kHz ± 2 dB. Price: £272.60 (including PT).

Ferrograph 702

Similar specification to 722 except tape unit with preamps only. Additional low level output adjustable 0-300mV. Price: £224.30 (including PT).

Ferrograph 702H

Similar specification to 702 except tape speeds

15, $7\frac{1}{2}$, $3\frac{3}{4}$ i/s. FR at 15i/s: 30Hz-20kHz. Price: £235 (including PT).

Ferrograph 724

Similar specification to 722 except $\frac{1}{4}$ -track version. Price: £262.03 (including PT).

Ferrograph 704

Similar specification to 702 except $\frac{1}{4}$ -track version. Price: £224.43 (including PT).

Series 7D plus Dolby B

The following Ferrograph models are offered with Dolby B noise reduction system incorporated. Model 702/4. Price: £225 (plus £39.38 PT); Model 702/H. Price: £234 (plus £40.95 PT); Model 722/4. Price: £257 (plus £44.98 PT); Model 722/H. Price: £266 (plus £46.55 PT).

Dolby system is said to reduce tape noise by up to 10dB without loss of sound quality. Recordings made at $1\frac{7}{8}$ i/s may have less background noise than ones made at $7\frac{1}{2}$ i/s without Dolby.

■ GRUNDIG (Great Britain) LTD

Newlands Park, Sydenham, London, SE26.
Tel: 01-778 2211.

TK121

Mains operated $\frac{1}{2}$ -track recorder. Transistors. Slider controls for volume, tone and record level. Straight-through amplifier. 10 transistors, 3 diodes. Speed: $3\frac{3}{4}$ i/s. FR: 40Hz-12.5kHz. H and N: -52dB. Max spool 5 $\frac{1}{4}$ in. Four-digit tape position indicator. Record level meter. Inputs: mic 1mV 100K, radio 1-500mV 50K. Outputs: speaker 4W 4ohms, line 500mV 22K. W and F: $\leq 0.2\%$. Mains: 115-230V 50Hz. Size: $15\frac{1}{4} \times 11\frac{1}{4} \times 6\frac{1}{4}$ in. Weight: 17 $\frac{3}{4}$ in. Price: £56.25 (including PT).

TK141

Mains operated $\frac{1}{4}$ -track recorder. Automatic and manual record level. Slider controls for Price: £62.10 (including PT).

TK146 ★

Mains operated $\frac{1}{4}$ -track recorder. Automatic and manual record level. Slider controls for volume, tone and record level. Record level meter. Straight-through amplifier. FR: 40Hz-12.5Hz. H and N: -50dB. Max spool: 5 $\frac{1}{4}$ in. Speed: $3\frac{3}{4}$ i/s. W and F: $\leq 0.2\%$. Four-digit tape position indicator. Inputs: mic 1mV 100K, radio 100mV 50K. Outputs: 4W 4ohms, line 500mV 27K. Size: $6\frac{1}{4} \times 15\frac{1}{4} \times 11\frac{1}{4}$ in. Weight: 17 $\frac{1}{4}$ lb. Price: £66.95 (including PT).

TK248 ★

Mains 2-speed $\frac{1}{4}$ -track full stereo recorder. Stereo record and playback. Multi-synchronous and echo recordings. Straight-through amplifier. Speeds: $3\frac{3}{4}$, $7\frac{1}{2}$ i/s. W and F: $\leq 0.15\%$ at $7\frac{1}{2}$ i/s, $\leq 0.2\%$ at $3\frac{3}{4}$ i/s. Large illuminated VU meters. Max spool: 7in. 22 transistors, 12 diodes. FR: 40Hz-16kHz at $7\frac{1}{2}$ i/s, 40Hz-12.5kHz at $3\frac{3}{4}$ i/s.



Grundig TK146

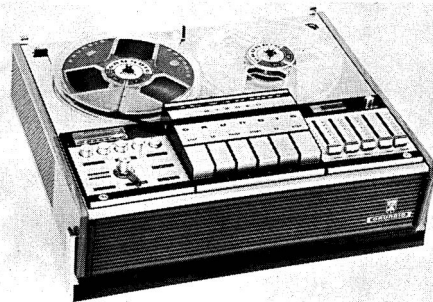

Grundig TK248

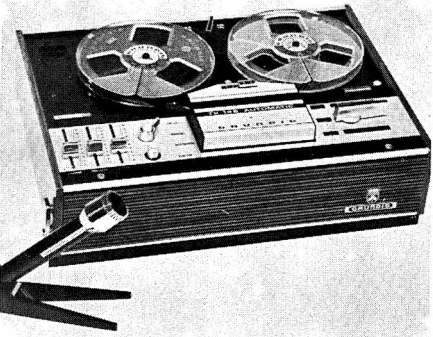

Grundig TK148

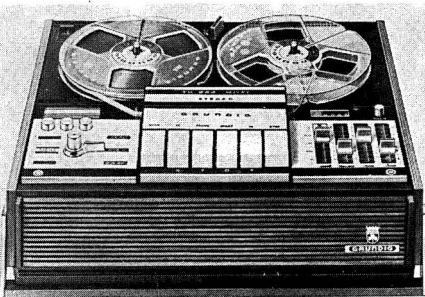

Grundig TK244

H and N: -50dB. Inputs: mic (2) 1mV 100K, radio (2) 1mV 33K, PU (2) 50mV 1.5 megohms. Outputs: line (2) 800mV 20K, speaker (2) 4W 4 ohms. Four speakers. Four-digit tape position indicator. Size: $7\frac{3}{8} \times 17 \times 13\frac{3}{8}$ in. Weight: 30½ lb. Price: £161.15 (including PT).

TK3200 Hi-Fi

Semi-professional portable tape recorder designed to operate from mains or batteries. ½-track. Mono. Speeds: $1\frac{7}{8}$, $3\frac{3}{8}$, $7\frac{1}{2}$ i/s. Automatic or manual record level. Separate controls for record level and replay volume. Independent bass and treble controls. Max spool: $5\frac{3}{4}$ in. Three heads. 31 transistors. Four-digit tape position indicator. FR: 40Hz-16kHz at $7\frac{1}{2}$ i/s, 40Hz-12.5kHz at $3\frac{3}{8}$ i/s, 40Hz-8kHz at $1\frac{7}{8}$ i/s. Dynamic range: 52dB at $7\frac{1}{2}$ i/s, 50dB at $3\frac{3}{8}$ i/s, 48dB at $1\frac{7}{8}$ i/s. W and F: $\leq 0.15\%$ at $7\frac{1}{2}$ i/s, $\leq 0.2\%$ at $3\frac{3}{8}$ i/s, $\leq 0.35\%$ at $1\frac{7}{8}$ i/s. Special mechanical tape tensioner. Remote control microphone switch. Inputs: mic 0.22mV 10K, radio 0.22mV 10K, PU 45mV 2.2 megohms. Output: 800mV to internal speaker, 2W to external speaker. Power supply: six SP2 cells, six rechargeable cells or Grundig mains unit type TN30. Size: $9\frac{1}{2} \times 12\frac{1}{4} \times 3\frac{1}{2}$ in. Weight: 12lb. Price: £141.10 (including PT).

TK147

Mains single-speed ¼-track automatic stereo recorder. Mono playback, stereo playback with external amplifier and speaker. Speed: $3\frac{3}{8}$ i/s. 18 transistors, 10 diodes. W and F: $\leq 0.2\%$. H and N: ≥ 47 dB. FR: 40 Hz-12.5kHz. Four-digit tape position indicator. Max spool: $5\frac{3}{4}$ in. Inputs: mic (2) 1mV 100K, radio (2) 1mV 50K, PU (2) 50mV 2 megohms. Outputs: line (2) 500mV 22K, 4 ohms 4W. Mains: 110-240V AC 50Hz. Size: $15\frac{1}{2} \times 11\frac{1}{4} \times 6\frac{1}{2}$ in. Weight: 17lb approx. Price: £93.05 (including PT).

TK148 ★

Mains operated two-speed ¼-track mono recorder. Speeds: $1\frac{7}{8}$, $3\frac{3}{8}$ i/s. Max spool: $5\frac{3}{4}$ in. W and F: $3\frac{3}{8}$ i/s $\leq 0.2\%$, $1\frac{7}{8}$ i/s $\leq 0.4\%$. H and N: $3\frac{3}{8}$ i/s -50dB, $1\frac{7}{8}$ i/s -48dB. FR: $3\frac{3}{8}$ i/s 40Hz-12.5kHz ± 3 dB, $1\frac{7}{8}$ i/s 40Hz-6.3kHz ± 3 dB. Replay char: DIN. Light strip level indicator. Inputs: mic 1mV 100K, radio (diode) 1mV 33K, PU 50mV 1.5 megohms. Output: 4W RMS. Outlets: high Z 500mV 27K, ext LS 4 ohms. Speaker: $7\frac{1}{4} \times 3\frac{3}{4}$ in. One motor. Own deck. Pause control. Straight-through amplifier. Monitoring. Slider controls. Automatic level control. Auto stop. Size: $15\frac{1}{2} \times 11\frac{1}{4} \times 6\frac{1}{2}$ in. Weight: 17½ lb. AC mains only. Price: (including microphone) £71.30 (including PT).

TK244 ★

Mains operated stereo ¼-track two-speed recorder. Speeds: $3\frac{3}{8}$, $7\frac{1}{2}$ i/s. Max spool: $7\frac{1}{2}$ in. W

★ Indicates entry is illustrated

and F: $3\frac{3}{4}$ i/s $\leq 0.2\%$, $7\frac{1}{2}$ i/s $\leq 0.15\%$. H and N: $3\frac{3}{4}$ i/s -50 dB, $7\frac{1}{2}$ i/s -50 dB. FR: $3\frac{3}{4}$ i/s 40Hz-12.5kHz ± 3 dB, $7\frac{1}{2}$ i/s 40Hz-16kHz ± 3 dB. Replay char: DIN. Rewind time: $5\frac{1}{2}$ min for 2,400ft. Automatic level control. Inputs: mic (2) 1mV 100K, radio (diode) (2) 1mV 33K, PU (2) 50mV 1.5 megohms. Output: 4W RMS per channel. Outlets: high Z (2) 800mV 20K, ext LS (2) 4 ohms. Speakers: two $7\frac{1}{2} \times 3\frac{3}{4}$ in. Own deck. Superimpose. Pause control. Straight-through amplifier. Monitoring. Input mixing. Parallel track replay. Vertical operation. Auto stop. Slider controls. Size: $17 \times 6\frac{3}{4} \times 14\frac{1}{4}$ in. Weight: 25lb. AC mains only. Price: (excluding microphone) £138.70 (including PT).

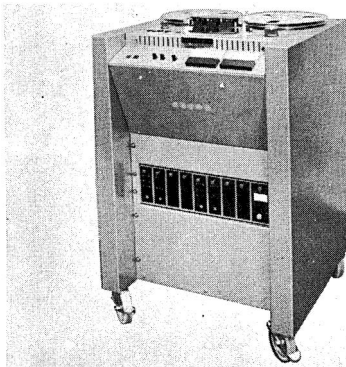

Leavers-Rich E200

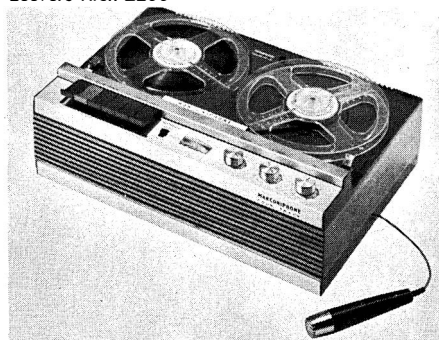

Marconiphone 4248

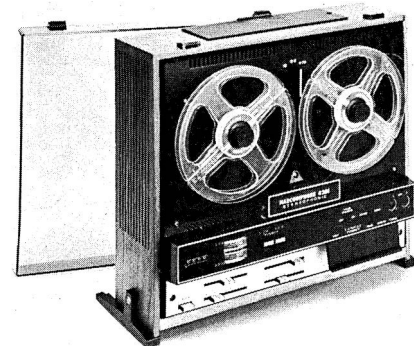

Marconiphone 4261

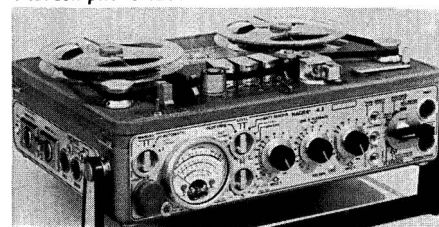

Nagra Model 4.2

■ HITACHI

Hitachi Sales (UK) Ltd, Park House, Coronation Road, Park Royal, London, NW107QS. Tel: 01-965 9861.

TRQ30

Compact cassette tape recorder. Two-track mono. Speed: $1\frac{7}{8}$ i/s. Output: 400mW. Speaker: $2\frac{1}{2}$ in. Built-in capacitor microphone. One IC, six transistors, three diodes. FR: 100Hz-8kHz. Pushbutton controls with pause facility. Three-digit tape position indicator. Sockets for remote microphone, earphone and 6V DC adaptor. Size: $7\frac{7}{8} \times 4\frac{1}{4} \times 1\frac{3}{4}$ in. Weight: $1\frac{1}{2}$ lb. Finish: metal and plastic cabinet with wrist strap. Level control meter. Automatic recording level control. Accessories: carry case, mains adaptor, remote mic, earpiece, demonstration cassette. Price: £49.90 (including PT).

■ KELLAR ELECTRONICS LTD

Lopen Works, Lopen Road, Edmonton, N18. Tel: 01-807 4986.

New range of tape record and playback equipment incorporating Dolby B noise reduction system and Garrard cassette deck. Full details on request.

See Tape Amplifier Section for details of Kellar KDB-1 noise reduction unit.

■ LEEVERS-RICH EQUIPMENT LTD

319 Trinity Road, Wandsworth, London, SW18. Tel: 01-874 9054.

Cables: Leemag, London, SW18.

Series E

Professional $\frac{1}{4}$ in recorders. Available in broadcast type M console, de luxe console, enclosed rack or as units for rack mounting.

Model E200 ★

Speeds: $7\frac{1}{2}/15$ i/s, $3\frac{3}{4}/7\frac{1}{2}$ i/s or 15/30i/s to special order. Max spool $11\frac{1}{4}$ in. Three motors. Full-track, twin-track or stereo. FR: 40Hz-18kHz. Noise: Full track -62 dB, twin track -58 dB.

W and F: better than 0.1% at all speeds. VU level meter. PPM to special order. Fully transistorised amplifiers. Modular construction throughout. Price from £850.

Series G and H

Professional $\frac{1}{2}$ in. and 1in master recorders. Available in studio type S console.

Model G800

Speeds: $7\frac{1}{2}/15$ i/s. Max spool $10\frac{1}{2}$ in NAB. Three motors. Full track preselection facilities. Sync replay and routing. FR: 40Hz-18kHz. Equalisation by plug-in cards. Price: £5,450.

Model H400

Same specification as G800 but four tracks on $\frac{1}{2}$ in-tape. Price: £3,300.

■ LUXOR (Luxor Industri Aktiebolag)

Highgate Acoustics Ltd,
184 Great Portland Street, London, W1.
Tel: 01-636 2901.

MP813

Stereo taperecorder with amplifiers and monitor speakers. Speeds: $1\frac{7}{8}$, $3\frac{3}{4}$, $7\frac{1}{2}$ i/s. Four-track. Max spool 7in. Output: 10W RMS per channel. Inputs: mic, PU, radio. Outputs: speakers, headphones, amplifier. Size: $7\frac{1}{4} \times 20\frac{1}{2} \times 15$ in. Price: £175 (including PT).

MP823

Identical specification to MP813 but without the built-in amplifier. Price: £135 (including PT).

■ MARCONIPHONE

British Radio Corporation Ltd,
284 Southbury Road, Enfield, Middlesex.
Tel: 01-366 1155.

4248 ★

$\frac{1}{4}$ -track mono recorder. 2-speeds. 7in reels. At $3\frac{3}{4}$ i/s W $\pm 0.3\%$ F $\pm 0.3\%$, at $1\frac{7}{8}$ i/s W $\pm 0.4\%$ F $\pm 0.4\%$. H and N: -45dB. FR: $3\frac{3}{4}$ i/s 40Hz-14kHz, $1\frac{7}{8}$ i/s 40Hz-7kHz. Replay char: DIN. Level meter (illuminated). Rewind time: 2 min 40 sec 1,200ft. Inputs: mic/radio 0.2mV 2K, gram 220mV 2.2 meg. Outputs: ext speaker 8 ohms, ext amps 500mV 10K, 3-pin accessories socket. 5W to $7 \times 3\frac{3}{8}$ in speaker. BRC series F deck. Pause control, inching, monitoring, parallel track replay, auto recording level control with manual over-ride. Auto tape stop, tape position indicator, bass and treble controls. Transistorised. 240V 50Hz. Size: $5\frac{1}{4} \times 15\frac{3}{4} \times 11$ in. Price: £45.07 (plus £7.23 PT).

4261 ★

$\frac{1}{4}$ -track mains recorder. Speeds: $7\frac{1}{2}$ i/s, $3\frac{3}{4}$ i/s, $1\frac{7}{8}$ i/s. Max spool 7in. W and F: $7\frac{1}{2}$ i/s 0.15%, $3\frac{3}{4}$ i/s 0.25%, $1\frac{7}{8}$ i/s 0.35%. H and N: -45dB. FR: $7\frac{1}{2}$ i/s 40Hz-18kHz, $3\frac{3}{4}$ i/s 40Hz-14kHz, $1\frac{7}{8}$ i/s 40Hz-7kHz. Replay char: CCIR. Rewind time 2 min 40 sec for 1,200ft. Meter level indicator. Inputs: mic, radio 250mV 4-7K, PU 50mV

1 megohm. Outlets: line 500mV 10K, external speakers 8ohms. Remote pause socket. Output: 5W music power per channel. Speakers: $5\frac{3}{8} \times 2\frac{3}{8}$ in per channel. BRC tape deck. Pause control. Straight-through amplifier. Monitoring. Track transfer. Size: $16\frac{1}{2} \times 6\frac{1}{2} \times 14\frac{1}{2}$ in. Mains: 230-250V AC. Price: £86.05 (plus £13.80 PT).

■ NAGRA

Distributed by: Hayden Laboratories Ltd,
Hayden House, 17 Chesham Road, Amersham,
Bucks. Tel: Amersham 5511.

Audio equipment showroom, service department and despatch department: 12/13 Poland Street, London, W1V3DE. Tel: 01-734 3748/9.

Model 4.2 ★

Professional battery-operated portable tape recorder. Speeds: 15i/s, $7\frac{1}{2}$ i/s, $3\frac{3}{4}$ i/s. Size: $12\frac{1}{2} \times 8\frac{3}{4} \times 4\frac{1}{4}$ in. Weight: (excluding batteries) $11\frac{1}{2}$ lb. Max spool: (lid closed) 5in, (lid open) 7in. Power supply: 12 type SP2 batteries fitted internally, or external mains unit. Switchable auto-level control. Switchable input filters. Two-stage overload filter. Modular construction. Pre-amplifiers to suit all types of microphones. Built-in monitoring speaker. Single DC servo-controlled motor. Monitoring headphones switchable to tape or direct. Reference tone generator. Separate record and playback amplifiers. Electromagnetic indication of speed stability, battery level and tape jamming. W and F: 15i/s 0.05%, $7\frac{1}{2}$ i/s 0.07%, $3\frac{3}{4}$ i/s 0.15%. Overall speed stability: better than 0.05%. Temperature range -55deg C to +77deg C. FR: 15i/s 30Hz-20kHz ± 2 dB, $7\frac{1}{2}$ i/s 30Hz-15kHz ± 2 dB, $3\frac{3}{4}$ i/s 30Hz-10kHz ± 2 dB. Rewind time: 600ft/min. Details and prices of various models as follows.

Model 4.2L

Full-track mono version with pilotton. Inputs from two mics and line. Line output: 4-4V 600 ohms. S/N ratio: -67 to -70dB depending on speed and tape. Visual pilotton indicator. Pilotton input level 0.5-25V. Price: £625.

Model 4.2LSP

As Model 4.2L but excluding pilotton facility. Price: £560.

Model IV SL

$\frac{1}{4}$ -track model with pilotton. Preamplifiers switchable to suit all types of microphone. Output: IV 600 ohms. Special Nagra master recording position. Coaxial PPM with two needles to indicate record level and groove cutting depth. S/N ratio: -65dB to -72dB depending on speed and tape. Frequency modulated pilotton channel to permit pilotton and cue speech recording. Pilotton level 2V. Price: £731.

Model IV-S

As Model IV-SL but excluding pilotton facility. Price: £649.

★ Indicates entry is illustrated

Special models for industrial sound level recording available.

Miniature Nagra SN ★

Full-track battery-operated professional stereo recorder. Speeds: (model SNN) $3\frac{3}{4}$, $1\frac{7}{8}$ i/s; (model SNS) $1\frac{7}{8}$, $1\frac{5}{8}$ i/s. Spool capacity: 154 metres standard tape, 308 metres 12.5 micron tape. W and F: $3\frac{3}{4}$ i/s $\pm 0.1\%$, $1\frac{7}{8}$ i/s $\pm 0.15\%$ (both to DIN 45 507). H and N: $3\frac{3}{4}$ i/s 60dB (ASA 'A' with tape); $1\frac{7}{8}$ i/s 55dB (ASA 'A' with tape). FR: 80Hz-15kHz ± 2 dB. Replay char: CCIR. Rewind time: (hand winding) 60 sec. Meter level indicator. Inputs: microphone, current input from 200 ohms or greater (3μ A RMS, max level 100 μ A RMS). Alternative line input for normal modulation level from 100 ohms source -160mV RMS. Outlets: line 600mV across 1K, headphones. One DC series commutator motor. Own deck. Compression indicator and battery check meter. Remote control start/stop. Piloton version available. Size: $5\frac{3}{4} \times 4 \times 1\frac{1}{8}$ approximately. Weight: 1.3lb (including batteries and tape). Supply: two manganese cells (Mallory Mn1500 or equivalent). Price: £425.

■ NATIONAL PANASONIC

Unamec Ltd, United Africa House,
1-16 Blackfriars Road, London, SE1 9UG.
Tel: 01-928 2070.

RQ-222AS

Two-track cassette recorder with built-in capacitor microphone. Speed: $1\frac{7}{8}$ i/s. Compact cassettes. Auto-stop. Record level and battery check meter. Three-digit tape position indicator. Circuit incorporates five transistors and three ICs. Mains/battery operation. Output: 1W. FR: 70Hz-10kHz. Tone control. Size: $9\frac{1}{4} \times 5\frac{1}{4} \times 1\frac{7}{8}$ in. Weight: 3lb. Price: £48 (plus £8.40 PT).

■ NIVICO

Denham & Morley (Overseas) Ltd,
453 Caledonian Road, London, N7.
Tel: 01-607 6568.

1690U

Cassette recorder. Speed: $1\frac{7}{8}$ i/s. Compact cassettes. Full details and specification on request. Price: £55.64 (including PT).

1260

Eight-track stereo cartridge player/recorder. FR: 30Hz-15kHz. S/N ratio: better than 50dB. W and F: $< 0.22\%$ RMS. 16 transistors and 7 diodes. Fast forward function. Pause. Dual VU meters. Stop indicator. Price: £93.81 (including PT).

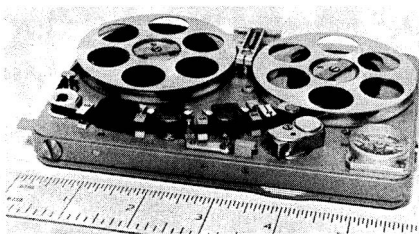

Nagra Miniature SN

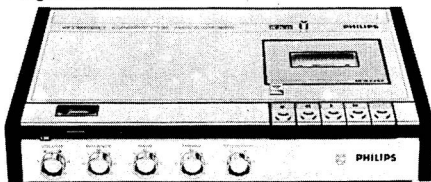

Philips N2400

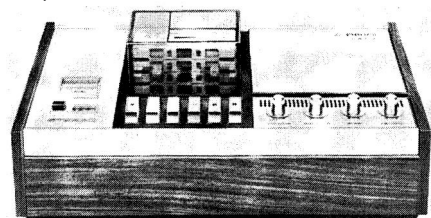

Philips N2401



Philips N4308

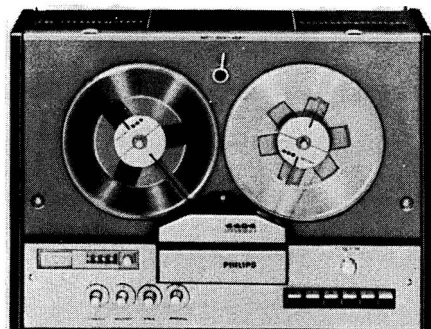

Philips N4404

■ **PHILIPS ELECTRICAL LTD**
 Century House, Shaftesbury Avenue,
 London, WC2.
 Tel: 01-437 7777. Cables: Phillamps, London.

N2400 ★

Mains operated stereo cassette recorder. Speed: $1\frac{7}{8}$ /s. W and F: <0.4%. H and N: >-45dB. FR: 60Hz-10kHz. Replay char: CCIR. Rewind time: <80 sec for C60 cassette. Meter level indicator. Inputs: mic 0.25mV 2K, PU 100mV 1 megohm. Outlets: radio 1V 20K, speakers (2) 4W 8 ohms. Output: 4W RMS per channel. External speakers. Transistors. Own deck. One motor. Pause. Straight-through amplifier. Monitoring. Size: $14 \times 8\frac{3}{8} \times 3\frac{3}{8}$ in. Weight: $6\frac{1}{2}$ lb. Mains: 110/250V 50/60Hz. Price: (less speakers) £56.57 (plus £9.53 PT); (with speakers) £74.89 (plus £12.61 PT).

N2401 ★

Mains operated stereo cassette recorder. Speed: $1\frac{7}{8}$ /s. W and F: <0.3%. H and N: >-43dB. FR: 60Hz-10kHz. Replay char: CCIR. Rewind time: <100 sec for C60 cassette. Meter level indicator. Inputs: mic/radio 0.25mV 2K, PU 100mV 1 megohm. Outlets: diode 1V 20K, speakers (2) 4W 8 ohms. Output: 4W RMS per channel. External speakers. Transistors. Own deck. One motor. Pause. Monitoring. Straight-through amplifier. Automatic cassette changer. Size: $15\frac{1}{4} \times 9\frac{1}{2} \times 6\frac{3}{8}$ in. Weight: 11lb. Mains: 110/250V 50/60Hz. Price: (less speakers) £67.78 (plus £11.42 PT); (with speakers) £86.10 (plus £14.50 PT).

N2506

Mains operated stereo cassette unit to fit in with Audio plan Equipment. Includes dynamic noise limiter (DNL) circuit to improve subjective S/N ratio. Speed $1\frac{7}{8}$ /s. W and F: 0.35%. DIN weighted. H and N: better than 45dB. FR: 60Hz-10kHz. Rewind time: <80sec for C60. Meter level indicator. Input/output sockets for external amplifier. Input/output socket for phono/micro. One motor. Pause. Size: $8\frac{1}{2} \times 8\frac{1}{2} \times 2\frac{3}{8}$ in. Weight: $4\frac{1}{2}$ lb. Mains: 110/240V 50/60Hz. Price: £51.35 (plus £8.65 PT).

N4308 ★

Mains operated $\frac{1}{4}$ -track mono recorder. Speeds: $3\frac{3}{4}$, $1\frac{7}{8}$ /s. Max spool: 7in. W and F: <0.25%. H and N: >-45dB. FR: $3\frac{3}{4}$ /s 60Hz-14kHz, $1\frac{7}{8}$ /s 80Hz-8kHz. Replay char: CCIR. Rewind time: <3 minutes for 1,200ft. Meter level indicator. Inputs: mic 0.25mV 2K, radio 2mV 20K, PU 100mV 1 megohm. Outlets: diode 1V 20K, headphones 0.1-5V 1K, speaker 4W 8 ohms. Output: 4W RMS. Speaker: 6×4 in. Transistors. Own deck. One motor. Pause. Straight-through amplifier. Monitoring. Input mixing. Parallel track replay. Size: $16\frac{1}{2} \times 11\frac{3}{4} \times$



Philips N4450

$5\frac{7}{8}$ in. Weight: $17\frac{3}{4}$ lb. Mains: 200-250V 50Hz. Price: £48.99 (plus £7.86 PT).

N4404 ★

Mains operated stereo $\frac{1}{4}$ -track recorder. Speeds: $7\frac{1}{2}$, $3\frac{3}{4}$ /s. Max spool: 7in. W and F: <0.15%. H and N: >-45dB. FR: $7\frac{1}{2}$ /s 40Hz-18kHz, $3\frac{3}{4}$ /s 40Hz-15kHz. Replay char: CCIR. Rewind time: <200 sec for 1,800ft. Meter level indicator. Inputs: mic 0.25mV 2K, radio 2mV 20K, PU 100mV 1 megohm. Outlets: diode 1V 20K, speaker (2) 2.5W 8 ohms. Output: 2.5W RMS per channel. Speakers: 6×4 in. Transistors. Own deck. One motor. Pause. Straight-through amplifier. Monitoring. Input mixing. Parallel track replay. Size: $19 \times 13\frac{3}{8} \times 7\frac{1}{2}$ in. Weight: 24lb. Vertical or horizontal operation. Mains: 110/250V 50/60Hz. Price: £77.53 (plus £11.72 PT).

N4407

Mains operated stereo $\frac{1}{4}$ -track recorder. Speeds: $7\frac{1}{2}$, $3\frac{3}{4}$, $1\frac{7}{8}$ /s. Max spool: 7in. W and F: <0.15%. H and N: >-45dB. FR: $7\frac{1}{2}$ /s 40Hz-18kHz, $3\frac{3}{4}$ /s 40Hz-15kHz, $1\frac{7}{8}$ /s 60Hz-10kHz. Replay char: CCIR. Rewind time: <200 sec for 1,800ft. Two meter level indicators. Inputs: mic 0.25mV 2K, radio 2mV 20K, PU 100mV 1 megohm. Outlets: diode 0.1V 20K, headphones 0-4V 600 ohms, speakers (2) 4W 8 ohms. Output: 4W RMS per channel. Speakers: 6×4 in. Transistors. Own deck. One motor. Pause. Vertical or horizontal operation. Straight-through amplifier. Monitoring. Input mixing. Parallel track replay. Track transfer. Size: $19 \times 13\frac{3}{8} \times 7\frac{1}{2}$ in. Weight: 24lb. Mains: 110/250V 50/60Hz. Price: £94.25 (plus £14.25 PT).

N4418

Mains operated stereo $\frac{1}{4}$ -track recorder. Speeds: $1\frac{7}{8}$, $3\frac{3}{4}$, $7\frac{1}{2}$ /s. Max spool: 7in. W and F: <0.15%. H and N: >45dB. FR: $7\frac{1}{2}$ /s 40Hz-20kHz,

★ Indicates entry is illustrated

3 $\frac{3}{4}$ i/s 40Hz-15kHz, 1 $\frac{1}{2}$ i/s 60Hz-8kHz. Replay char: CCIR. Rewind time: <180 sec for 1,800ft. Two meter level indicators. Inputs: mic 0.15mV 2K, mag PU 1.5mV 47K, aux 2mV 20K, aux 100mV 1M, diode 2mV 20K, diode 100mV 1 megohm, radio 100mV 1 megohm. Outlets: diode IV 50K, monitor IV 50K, headphones 3V 400-600 ohms. Output: 10W RMS per channel. Output impedance: (speakers) 4-8 ohms. Speakers: (built-in monitor type) 6 x 4in. Three motors. Three heads. A-B monitoring. Slider controls. Track transfer. Illuminated tip-touch buttons for tape transport. Size: 20 $\frac{1}{4}$ x 15 x 7 $\frac{1}{2}$ in. Weight: 26 $\frac{1}{2}$ lb. Mains: 110, 127, 220, 240V AC. Price: £163.52 (plus £26.23 PT).

N4450 ★

Mains operated stereo $\frac{1}{4}$ -track recorder with automatic reverse facility. Speeds: 1 $\frac{1}{2}$, 3 $\frac{3}{4}$, 7 $\frac{1}{2}$ i/s. Max spool: 10 $\frac{1}{2}$ in. W and F: 0.15%. H and N: >48dB. FR: 7 $\frac{1}{2}$ i/s 40Hz-20kHz, 3 $\frac{3}{4}$ i/s 40Hz-15kHz, 1 $\frac{1}{2}$ i/s 60Hz-10kHz. Replay char: CCIR. Rewind time: <150 sec for 1,800ft. Inputs: mic 0.1mV 2K, PU 1.5mV 47K, aux 2mV 20K, aux 100mV 1 megohm, diode 2mV 20K, diode 100mV 1 megohm, radio 100mV 100K. Outlets: diode IV 50K, monitor IV 50K, headphones 3V 400-600 ohms. Output: 20W per channel. Output impedance: 4-8 ohms. Six heads. Three motors. A-B monitoring. Echo. track transfer. 24-hour timer. Illuminated tip-touch buttons for tape transport. Two VU meters. Winding speed control. Cueing. Size: 21 $\frac{1}{4}$ x 20 x 9 $\frac{1}{4}$ in. Weight: 44lb. Mains: 110, 127, 220, 240V AC. Price: £234.86 (plus £37.64 PT).

■ PYE

Pye Ltd, St Andrews Road, Cambridge.
Tel: Cambridge 58985.

9123

Two-speed four-track mono recorder. Speeds: 3 $\frac{3}{4}$, 1 $\frac{1}{2}$ i/s. Max spool: 7in. S/N ratio: >45dB. W and F: <0.25% at 3 $\frac{3}{4}$ i/s. FR: 3 $\frac{3}{4}$ i/s 60Hz-14kHz, 1 $\frac{1}{2}$ i/s 80Hz-8kHz. Inputs: mic 0.2mV 2K, aux 100mV 1 megohm. Output: 4W. Speaker: 6 x 4in. Mains: 100-127, 220-240V AC. Pause control. Tone control. Record level meter. Rewind time: 180 sec for 1,200ft. Outlets: line 0.75V 20K, external speaker 4-8 ohms, phones 0.1-5V 1-5K. DIN sockets. Size: 16 x 6 $\frac{1}{2}$ x 11 $\frac{1}{2}$ in. Weight: 16lb. Finish: black and silver coloured moulded cabinet with wood grain end cheeks. Price: £56.83 (including PT).

9137

Three-speed four-track stereo tape recorder. Speeds: 1 $\frac{1}{2}$, 3 $\frac{3}{4}$, 7 $\frac{1}{2}$ i/s. S/N ratio: >48dB. W and F: <0.2% at 3 $\frac{3}{4}$ i/s. FR: 1 $\frac{1}{2}$ i/s 60Hz-8kHz, 3 $\frac{3}{4}$ i/s 40Hz-15kHz, 7 $\frac{1}{2}$ i/s 40Hz-18kHz. Inputs: mic (2) 0.2mV 2K, radio (2) 2mV 2K, line (2) 100mV 500K. Output: 4W per channel. Max spool: 7in. Mains: 110-127, 220-240V AC 50Hz

(convertible to 60Hz). Rewind time: 180 sec for 1,200ft. Outlets: line (2) IV 50K, external speakers (2) 4-8 ohms, phones 0-2V 400 ohms. DIN sockets. Auto stop. Horizontal or vertical operation. Input mixing. Parallel track playback. Monitoring. Pause. Duoplay and multi-play. Four-digit tape position indicator. Two illuminated VU meters. Speaker muting switches. Size: 18 $\frac{3}{4}$ x 7 $\frac{1}{4}$ x 13 $\frac{3}{4}$ in. Finish: black and silver coloured moulded cabinet with wood veneer end cheeks. Weight: 24lb. Price: £108.50 (including PT).

9116 ★

Four-track stereo cassette recorder. Speed: 1 $\frac{1}{2}$ i/s. Compact cassette. W and F: 0.35% measured with EMT420. H and N: 45dB (DIN). FR: 60Hz-10kHz (DIN and within 6dB). Replay char: DIN. Meter level indicator. Inputs: microphone 0.2mV 2K, radio/PU 100mV 1 megohm. Outlets: line 0.5V 20K, ext speaker 4-8 ohms 4W per channel. Output: 4W RMS per channel. Separate speaker units. One motor. Philips tape transport. Rewind time: <70 sec (C60 cassette). Pause. Straight-through amplifier. Monitoring. Mono or stereo record and playback. Auto tape stop. Illuminated level meter. Three-digit tape indicator. Anti-erasure device. Size: 14 x 3 x 8 $\frac{1}{2}$ in. Weight: 6 $\frac{1}{2}$ lb. Price: (excluding speakers) £66.10 (including PT). Suggested speaker enclosures 5750 (teak) or 5751 (rosewood). Price: (per pair) £15.02.

■ REPS

Reps (Tape Recorders) Ltd, 11-13 Regina Road, Southall, Middlesex. Tel: 01-574 3645.

HW10 tape recorder no longer in production but spares and service available for all Reps machines from above address.

■ REVOX

Distributors: C. E. Hammond & Co Ltd, Lamb House, Church Street, London, W4. Tel: 01-995 4551. Telex: 934047.

Series 77 ★

Silicon transistor stereo tape recorder available in various versions. $\frac{1}{2}$ -track or $\frac{1}{4}$ -track. Speeds: 7 $\frac{1}{2}$, 3 $\frac{3}{4}$ i/s. Max spool: 10 $\frac{1}{2}$ in. W and F: 7 $\frac{1}{2}$ i/s 0.08%, 3 $\frac{3}{4}$ i/s 0.1%. FR: 7 $\frac{1}{2}$ i/s 30Hz-20kHz + 2 - 3dB, 3 $\frac{3}{4}$ i/s 30Hz-16kHz + 2 - 3dB. Record char NAB, playback char NAB and IEC (switchable). Two VU meters. Inputs: mic 0.15mV 50-600 ohms or 2mV up to 100K (switchable), radio 2mV 33K, aux 40mV 1 megohm. Outlets: line 2.5V 600 ohms, 1.2V 2.5K. Output: 8W RMS per channel. HD: better than 1%. Three-motor deck electronically governed. Electronic speed change. Vertical or horizontal operation. Plug-in printed circuit modules. Oscillator frequency 120kHz. Remote control for all functions. Output impedance (power amplifiers) 4-16 ohms. 54



Pye 9116 and LSE4 speakers



Revox Series 77



Saba 544G

transistors, 32 diodes, 4 silicon rectifiers. Mains: 110, 130, 150, 220, 240, 250V 50/60Hz. Weight: approximately 34lb. Prices and variations follow.

Model 1302 or 1304

Chassis in metal encasement for rack mounting, no output amplifiers. $\frac{1}{4}$ or $\frac{1}{2}$ -track. Price: £219 (including PT).

Model 1332 or 1334

As 1302 and 1304 but with Dolby B noise reduction system. £65 extra.

Model 1322 or 1324

As 1302/4, but with 10W output amplifiers, $\frac{1}{2}$ or $\frac{1}{4}$ -track. Price: £253 (including PT).

Model 1102 or 1104

Chassis in teak surround, no output amplifiers. $\frac{1}{2}$ or $\frac{1}{4}$ -track. Price: £219 (including PT).

Model 1132 or 1134

As 1102 and 1104 but with Dolby B noise reduction system. £65 extra.

Model 1122 or 1124

Chassis in teak surround with output amplifiers. $\frac{1}{2}$ or $\frac{1}{4}$ -track. Price: £253 (including PT).

Model 1222 or 1224

Complete recorder in suitcase with amplifiers and four speakers. $\frac{1}{2}$ or $\frac{1}{4}$ -track. Price: £263 (including PT).

Specially modified versions incorporating NAB hubs from £170. Tax-free for industrial and scientific users only.

■ **SABA**

Distributors: Lampit Electronics Ltd, 6-12 Cornbrook Park Road, Manchester, M154EE. Tel: 061 872 7661.

544G ★

Two-speed four-track stereo tape recorder. Speeds: $3\frac{3}{4}$ and $7\frac{1}{2}$ i/s. Output: 10W music power per channel. Automatic or manual level control. Four internal speakers. Multiplay. 31 transistors. 11 diodes. Inputs: mic (2), radio, stereo PU, aux. Outputs: aux, speakers or headphones. FR: $7\frac{1}{2}$ i/s 40Hz-18kHz. Size: $19\frac{1}{2} \times 6\frac{1}{2} \times 13$ in. Finish: light walnut with tinted plastic cover. Horizontal or vertical operation. Four-digit tape position indicator with PB-reset. Slider controls. Twin level meters. Price: £115-68.

325H

Cassette tape recorder. Automatic or manual level control. Separate tone control. Three-digit tape position indicator. Slider and pushbutton controls. Full technical specification on request. Price: to be announced.

■ **SCOPETRONICS LTD**

Crown Works, Church Road, Kingston-upon-Thames, Surrey. Tel: 01-546 1275 and 4135.

★ Indicates entry is illustrated

1151

Stereo tape recorder. Speeds: $7\frac{1}{2}$, 15i/s. Max spool capacity: 11 $\frac{1}{2}$ in. W and F: <0.08% both speeds. H and N: -57dB. FR: 40Hz-15kHz $\pm\frac{1}{2}$ dB (either speed). Replay char: CCIR. Level indicator: meter. Rewind time: 2,400ft in 1 min 45 sec. Inputs: microphone, -75dB 600 ohms. Line bridging, -14dB 50K. Outlets: line, up to 18dBm, 50 ohms or 600 ohms line. Monitor amp, 2W at 15 ohms. Transistorised. 3 Papst motors with ext rotor. Tape deck: own. Superimpose, pause and inching facilities. Straight-through amplifier. Optical stop. Psn: 250V 50Hz. Price: from approximately £475.

SKANDIA ELECTRONICS

Distributors: Golding Audio Ltd,
London Road, Marks Tey, Colchester, Essex.
Tel: Marks Tey (0206 21) 433.

RS82

Eight-track stereo cartridge recorder with output stages but less speakers. Speed: $3\frac{3}{4}$ i/s. Eight-track 400ft cartridge. W and F: <0.3%. FR: 30Hz-12kHz. Fast forward wind at $7\frac{1}{2}$ i/s. Twin VU meters. Inputs: mag PU 2mV, ceramic PU 160mV, aux 80mV, microphone (2). Outlets: speakers at 8 ohms per channel. Output: 7W RMS per channel. Superimpose. Pause control. Inching. Monitoring. Automatic stop at end of pre-selected programme. AC mains. Fully transistorised. One motor in tape transport. Price: £92.40 (plus £16.89 PT).

SHARP

Sharp Electronics (UK) Ltd,
48 Derby Street, Manchester, M88HN.
Tel: 061-832 6115.

RD708V ★

Mains operated stereo $\frac{1}{4}$ -track recorder. Speeds: $7\frac{1}{2}$, $3\frac{3}{4}$, $1\frac{7}{8}$ i/s. Max spool: 7in. W and F: $7\frac{1}{2}$ i/s 0.15%, $3\frac{3}{4}$ i/s 0.2%, $1\frac{7}{8}$ i/s 0.2%. H and N: -45 dB. FR: $7\frac{1}{2}$ i/s 40Hz-16kHz, $3\frac{3}{4}$ i/s 40Hz-8kHz, $1\frac{7}{8}$ i/s 40Hz-4kHz. Replay char: DIN. Rewind time: less than 2 min for 1,200ft. Meter level indicator. Inputs: mic 0.2mV 200 ohms, aux (DIN) 5mV 15K. Outlets: line (DIN) 500mV 2K, speaker 8 ohms. Output: 3.5W RMS per channel. Speakers: $6\frac{1}{4}$ in bass driver, $2\frac{3}{8}$ in tweeter. Transistors. One motor. Sharp deck. Straight-through amplifier. Monitoring. Parallel track replay. Size: $15\frac{3}{8} \times 15\frac{3}{8} \times 10\frac{1}{2}$ in. Weight: 34lb. Mains: 110, 200, 220, 240V 50/60Hz. Price: £82.36 (plus £13.87 PT).

SONY (UK) LTD

Pyrene House, Sunbury Cross, Sunbury-on-Thames, Middlesex. Tel: Sunbury 87644/7.

TC630

Stereo tape recorder, $\frac{1}{4}$ -track. Speeds: $1\frac{7}{8}$, $3\frac{3}{4}$ and

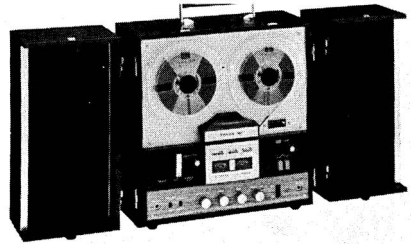

Sharp RD708V

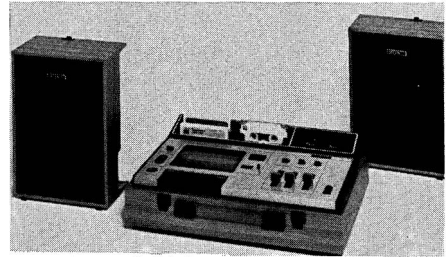

Sony TC133CS

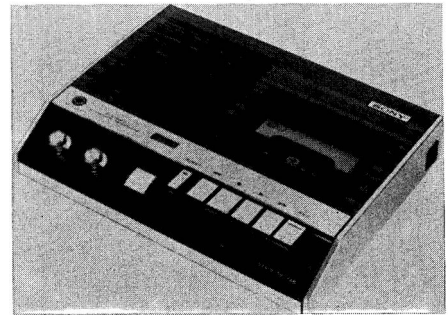

Sony TC146

$7\frac{1}{2}$ i/s. Max spool capacity: 7in. W and F: $7\frac{1}{2}$ i/s 0.09%; $3\frac{3}{4}$ i/s 0.12%; $1\frac{7}{8}$ i/s 0.16%. H and N: $7\frac{1}{2}$ i/s -50dB. FR: $7\frac{1}{2}$ i/s 30Hz-22kHz; $3\frac{3}{4}$ i/s 30Hz-13kHz; $1\frac{7}{8}$ i/s 30Hz-10kHz. Replay char: NARTB. Level indicator: twin VU meters. Rewind time: 1,200ft 2 $\frac{1}{2}$ min. Inputs: microphone, -72dB (0.2mV), 250 ohms; mag PU 2mV (-52dB); tuner, -22dB (0.06V), 100K; aux, -22dB (0.06V), 560K. Outlets: line output 0dB (0.775V), 100K ohms; headphone, -28dB (30mV), 8 ohms; extension speakers, 16 ohms. Audio output: 15W per channel. Transistorised. Dimensions: $20 \times 17\frac{7}{8} \times 11\frac{1}{8}$ in. Motor: capstan drive. Tape deck: own. Weight: 41lb. Superimposition. Pause. Position indicator: digital. Straight-through amplifier. Monitoring. Sound-on-sound. Echo. Three heads. Psn 100, 110, 117, 125, 220 or 240V, 50 or 60Hz. 40W. Price: £189.35 (including PT).

TC124CS

Compact cassette mono/stereo recorder. $\frac{1}{2}$ -track. $1\frac{1}{2}$ i/s. W and F: better than 0.28%. H and N: better than 45dB. FR: 50Hz-10kHz. Replay char: NARTB. Level indicator: meter. Inputs: 2 microphone 0.25mV 400 ohms, 2 aux 78mV 100K. Output: 1W per channel to internal $4 \times 2\frac{3}{4}$ in speaker and two ext speakers. Outlets: two ext speakers 775mV 8 ohms, headphone 24.5mV 8 ohms. Features: AGC recording system, monitoring through ext speakers or line outlets or 8 ohm headphones. Supplied with stereo mic fitted with stop/start switch and complete with int speaker and ext speakers. Power: four HP11 batteries, 100, 110, 120, 220, 240V 50/60Hz. Weight: 4lb 13oz. Dimensions: $6\frac{3}{4} \times 9\frac{3}{4} \times 2\frac{3}{4}$ in. Price: £73-82 (plus £13-28 PT).

TC800B

Mono recorder, $\frac{1}{2}$ -track, $\frac{1}{8}$, $1\frac{1}{8}$, $3\frac{3}{8}$ and $7\frac{1}{2}$ i/s. Max spool capacity: 5in. W and F: better than 0.1% $7\frac{1}{2}$ i/s. H and N: 48dB at $7\frac{1}{2}$ i/s. FR: 30Hz-18kHz $7\frac{1}{2}$ i/s and 30Hz-4kHz $\frac{1}{8}$ i/s. Replay char: NARTB. Level indicator: meter. Inputs: microphone 0.195mV 600 ohms, aux 62mV 100K. Output: 1W into $3\frac{1}{2} \times 6\frac{1}{4}$ in speaker. Outlet: monitor 775mV 10K. Features: built-in Electret condenser microphone can be used same time as external microphone fitted with stop/start switch; 16 transistors, one IC; AGC or manual recording with speech/music switch. Weight: 11lb 13oz. Power: eight HP2 batteries, 110, 120, 220, 240V 50/60Hz. Dimensions: $12\frac{1}{4} \times 10\frac{1}{4} \times 4\frac{3}{8}$ in. Price: approximately £82 (including PT).

TC133CS ★

Stereo cassette tape recorder. Compact cassettes. Speed: $1\frac{1}{2}$ i/s. W and F: $\pm 0.38\%$. H and N: -50dB. FR: (standard tape) 30Hz-12kHz, (Cr02 tape) 30Hz-13kHz. Rewind time: 90 sec for C60 cassette. Twin VU meters. Inputs: mic 0.2mV low Z, PU 1.1mV 40K, line 0.035V 560K. Outlets: line -5dB 10K, phones 8 ohms or 10K, speakers 8 ohms. Output: 6W RMS per channel. Speakers (2) 5in. One motor. Size: $15\frac{3}{4} \times 7\frac{3}{4} \times 12\frac{1}{4}$ in. Weight: 19 $\frac{3}{4}$ lb. Pause. Straight-through amplifier. Input mixing. Parallel track replay. Slider tone control. Separate level controls for each channel. Selector switch for standard or Cr02 tape. Mains: 110, 127, 220, 240V AC. Price: £76-81 (plus £12-94 PT).

TC146 ★

Cassette tape recorder. Mono recording, stereo playback. Speed: $1\frac{1}{2}$ i/s. W and F: 0.22%. H and N: 45dB. FR: 40Hz-10kHz. Rewind time: 90 sec for C60 cassette. Auto level control. Inputs: mic 0.2mV 600 ohms, aux 60mV 560K. Outlets: line 10K, phones 8 ohms. One motor. Size: $11\frac{1}{4} \times 2\frac{5}{8} \times 8\frac{5}{8}$ in. Weight: 6lb 3oz. Straight-through amplifier. Parallel track replay. Built-in

electret mic. Tape end alarm. Mains: 127, 220, 240V AC. 6V DC from batteries (four 1.5V) or BP16 battery pack. Price: £58-03 (plus £9-77 PT).

TC270

Three-speed stereo mains recorder. Max spool 7in. Speeds: $7\frac{1}{2}$, $3\frac{3}{4}$, $1\frac{1}{8}$ i/s. W and F: $7\frac{1}{2}$ i/s 0.16%, $3\frac{3}{4}$ i/s 0.22%, $1\frac{1}{8}$ i/s 0.3%. H and N: $7\frac{1}{2}$ i/s 50dB. FR: $7\frac{1}{2}$ i/s 30Hz-18kHz, $3\frac{3}{4}$ i/s 30Hz-13kHz, $1\frac{1}{8}$ i/s 30Hz-7kHz. Replay char: NAB. Rewind time: 2 $\frac{1}{2}$ minutes for 1,200ft. Twin VU meters. Inputs: mic 0.2mV low Z, line 60mV 160K. Outlets: line 0.43V <10K, ext LS 8 ohms. Output: 5W RMS per channel. Speaker: 5in. One motor. Size: $20\frac{1}{4} \times 10\frac{1}{4} \times 15\frac{1}{2}$ in. Weight: 36 $\frac{1}{2}$ lb. Superimpose. Pause. Inching. Straight-through amplifier. Monitoring through speaker. Input mixing. Parallel track replay. Scratch filter. Auto filter. Built-in reel locks. Digital tape counter. Slider level controls. Mains: 110, 127, 220, 240V AC. Price: £93-93 (plus £15-82 PT).

TC330

Combined open reel and compact cassette stereo mains recorder. Speeds: $7\frac{1}{2}$, $3\frac{3}{4}$, $1\frac{1}{8}$ i/s. Max spool: 7in. W and F: $7\frac{1}{2}$ i/s 0.12%, $3\frac{3}{4}$ i/s 0.15%, $1\frac{1}{8}$ i/s 0.2%. H and N: (open reel) better than 50dB, (cassette) better than 45dB. FR: $7\frac{1}{2}$ i/s 30Hz-18kHz, $3\frac{3}{4}$ i/s 30Hz-13kHz, $1\frac{1}{8}$ i/s 50Hz-10kHz. Replay char: NARTB. Rewind time: (reel) 2 min 30 sec, (cassette) 1 min 30 sec. Twin VU meters. Inputs: mic 0.19mV 600 ohms, aux 60mV 100K, pickup 1.1mV 65K. Outlets: line 0.44V 100K, ext LS 8 ohms, headphones 8 ohms. Output: 5W RMS per channel. Speakers: (2) 5in. Two motors. Size: $21\frac{1}{4} \times 11\frac{7}{8} \times 13\frac{5}{8}$ in. Weight: 43lb. Pause. Straight-through amplifier. Input mixing. Parallel track replay. Independent open reel and cassette function. Mains: 100, 117, 125, 220, 240V AC. Price: £141-21 (plus £23-79 PT).

TANDBERG

Farnell-Tandberg Ltd, 81 Kirkstall Road, Leeds, LS3 1HR. Tel: Leeds 35111.

1521

Mono tape recorder. $\frac{1}{2}$ -track. Speeds: $1\frac{1}{8}$, $3\frac{3}{8}$ and $7\frac{1}{2}$ i/s. Max spool capacity: 7in. W and F: 0.1% $7\frac{1}{2}$ i/s, 0.4% $1\frac{1}{8}$ i/s. H and N: 52dB at $3\frac{3}{8}$ and $7\frac{1}{2}$ i/s. FR: (± 2 dB) 40Hz-18kHz $7\frac{1}{2}$ i/s, 50Hz-12kHz $3\frac{3}{8}$ i/s, 60Hz-6.5kHz $1\frac{1}{8}$ i/s. Rewind time: 2 min 1,200ft. Meter level indicator. Inputs: mic 0.1 mV 200 ohms, radio 10mV 100K, PU 100mV 1 megohm. Output: 10W into 8 ohms 4×7 in speaker. Outlets: preamp 0.9V 20K, ext speaker 10W 4 ohms, free head 2mV 20K. Features: pause, inching, straight-through amp, monitoring, input mixing, auto end stop, bass and treble controls. Weight: 19lb. Dimensions: $15\frac{3}{8} \times 11\frac{3}{4} \times 6\frac{3}{8}$ in. Price: £81-65 (including PT).

★ Indicates entry is illustrated

1522

Portable-case version of above. Price: £92.34 (including PT).

1541

$\frac{1}{4}$ -track version of 1521. Extra feature: parallel track replay. Price: £87.96 (including PT).

1542

Portable-case version of 1541. Price: £99.14 (including PT).

1521F

As 1521 but remote stop/start and rewind control. Price: £108.87 (including PT).

1541F

As 1521F but $\frac{1}{4}$ -track. Price: £116.15 (including PT).

1521SL

Special version for language studies with safety feature to prevent erasure of master track. Price: £113.72 (including PT).

1522SL

Portable version of 1521SL. Price: £125.38 (including PT).

11-I

Similar to above but full track and available with or without new pilot tone facility. Price: £154 (professional users only).

11-2M ★

Battery-operated mono recorder. $\frac{1}{2}$ -track. Speeds: $1\frac{1}{8}$, $3\frac{3}{4}$ and $7\frac{1}{2}$ i/s. Max spool capacity: 7in. W and F: 0.1% $7\frac{1}{2}$ i/s, 0.2% $3\frac{3}{4}$ i/s, 0.3% $1\frac{1}{8}$ i/s. H and N: 58-52dB. FR (± 2 dB): 40Hz-16kHz $7\frac{1}{2}$ i/s, 50Hz-10kHz $3\frac{3}{4}$ i/s, 50Hz-5.2kHz $1\frac{1}{8}$ i/s. Meter indicator. Rewind time: 2 min 1,200ft. Inputs: mic 100mV 200 ohms, music (1) 5mV 10K, music (2) 125mV 200K. Output: $\frac{1}{4}$ W into 2×3 in speaker. Outlets: line 1.55V 200 ohms, speaker 20 ohms. Own pulse-excited motor. Features: off-tape monitoring, cueing in fast forward rewind, pause, inching, straight-through amp, monitoring, input mixing. Weight: 11.3lb. Dimensions: $13 \times 10 \times 4$ in. Mains unit available. Lip synchronisation with Super 8mm cameras. Accessories include variable speed unit, pulse generator and projector synchronizer. Price: £187.59 (including PT).

1741 ★

Mono $\frac{1}{4}$ -track tape recorder. Speed: $3\frac{3}{4}$ i/s. Max spool $5\frac{1}{2}$ in. Meter level indicator. Output: 9W RMS. Speaker: 7×4 in 8 ohms. 17-transistor circuit. Pause control. Straight-through amplifier. Monitoring. Four-digit tape position indicator. Separate bass and treble controls. AC mains. Finish: teak. Size: $13\frac{3}{8} \times 6\frac{3}{8} \times 11$ in. Weight: $14\frac{1}{2}$ lb. Price: £69.50 (including PT); type TM4 microphone £8 extra.

1721

Similar specification to 1741 but $\frac{1}{2}$ -track. Also

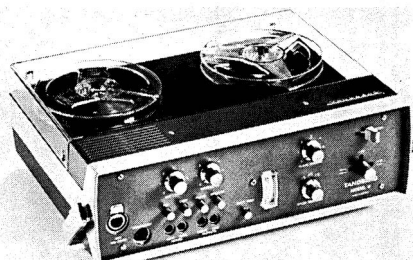

Tandberg 11-2M

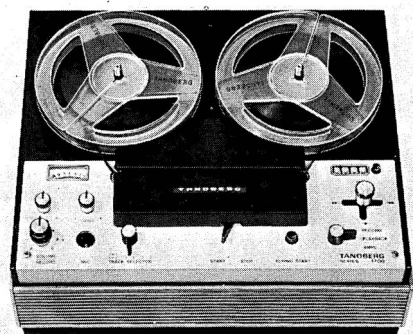

Tandberg 1741



Teac A-2060

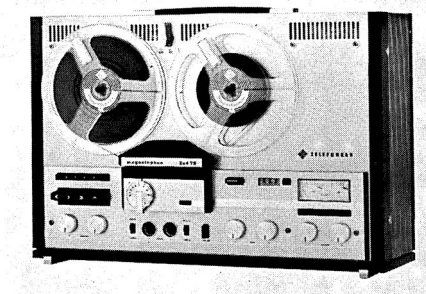

Telefunken M204TS

includes automatic stop at end of tape. Price: £65.12.

4021X

Stereo $\frac{1}{2}$ -track tape recorder. Speeds: $7\frac{1}{2}$, $3\frac{3}{4}$, $1\frac{7}{8}$ i/s. Max spool 7in. W and F: $7\frac{1}{2}$ i/s 0.07%, $3\frac{3}{4}$ i/s 0.14%, $1\frac{7}{8}$ i/s 0.28%. FR: $7\frac{1}{2}$ i/s 40Hz-20kHz, $3\frac{3}{4}$ i/s 50Hz-16kHz, $1\frac{7}{8}$ i/s 50Hz-9kHz, all +2dB. Rewind time: $1\frac{3}{4}$ min for 1,200ft, $2\frac{1}{2}$ min for 1,800ft. Meter level indicator. Inputs: mic 70 μ V (maximum input 70mV) 200 ohms, line 5mV (maximum input 15V) 50K, PU 1.5mV (maximum input 3V) 33K. Push-button equalisation to RIAA for ceramic, crystal or magnetic cartridge. Outlets: speaker 4-8 ohms, line 0.75V 5K minimum load, headphones 200 ohms minimum per channel. Output: 10W RMS per channel. Speakers: 7 \times 4in. One motor. Own deck. Pause control. Straight-through amplifier. Monitoring. Input mixing. Parallel track replay. AC mains. Size: $15\frac{1}{2} \times 6\frac{1}{2} \times 12\frac{3}{8}$ in. Weight: 20lb. Price: £169.12 (including PT).

4041X

Similar specification to 4021X but $\frac{1}{4}$ -track. Price: £169.12 (including PT).

TEAC

Acoustico Enterprises Ltd,
6-8 Union Street, Kingston-on-Thames, Surrey.
Tel: 01-549 3471/3.

A-2060 ★

Three-speed stereo $\frac{1}{4}$ -track recorder. Speeds: $1\frac{7}{8}$, $3\frac{3}{4}$, $7\frac{1}{2}$ i/s. Max spool 7in. FR: $1\frac{7}{8}$ i/s 40Hz-7kHz, $3\frac{3}{4}$ i/s 30Hz-15kHz, $7\frac{1}{2}$ i/s 30Hz-20kHz (\pm 3dB 50Hz-15kHz). Output: 20W music per channel. Speakers: 8in elliptical. Size: $16\frac{1}{8} \times 17\frac{3}{8} \times 8\frac{1}{2}$ in. Four-track bi-directional recording. Mains: 100, 117, 220, 240V AC. Wood case with carry handle. Price: £134.30 (plus £23.50 PT).

Details of new range of Teac recorders received too late for inclusion in this edition. Full details on request.

TELEFUNKEN

Distributor: AEG (Great Britain) Ltd,
AEG House, Chichester Rents, Chancery Lane,
London, WC2. Tel: 01-242 9944.

M204TS ★

$\frac{1}{4}$ -track stereo recorder. 3-speed. Max reel 7in. W and F: $7\frac{1}{2}$ i/s 0.15%; $3\frac{3}{4}$ i/s 0.25%; $1\frac{7}{8}$ i/s 0.4%. H and N: $7\frac{1}{2}$ i/s -50dB; $3\frac{3}{4}$ i/s -48dB. FR (to DIN 45-511) $7\frac{1}{2}$ i/s 40Hz-18kHz; $3\frac{3}{4}$ i/s 40Hz-15kHz; $1\frac{7}{8}$ i/s 40Hz-8kHz. Replay char: DIN. Level meters (two). Inputs: mic 0.15mV 5K. Tuner 0.15mV 5K. PU/tape 70mV 2.2 megohms. Outputs: amplifier 1.5V 8K; phones 0.5V 5K; speaker 6W 4 ohm. Speaker 7 \times $4\frac{1}{4}$ in. Sound on sound. Pause. 4 digit counter. Straight-through amplifier. Monitor. Parallel track replay. Verti-

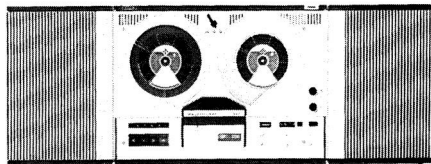

Telefunken M207

cal or horizontal operation. Separate controls for each channel. Track selection switch. Warning light below each meter. Transcribe track-to-track. Psn 110-240V. Price: £117.15 (including PT).

M207 ★

Three-speed $\frac{1}{4}$ -track recorder. Max spool: 7in. Speeds: $1\frac{7}{8}$, $3\frac{3}{4}$, $7\frac{1}{2}$ i/s. W and F: $7\frac{1}{2}$ i/s <0.15%, $3\frac{3}{4}$ i/s <0.25%, $1\frac{7}{8}$ i/s <0.4%. FR: $7\frac{1}{2}$ i/s 40Hz-18kHz, $3\frac{3}{4}$ i/s 40Hz-15kHz, $1\frac{7}{8}$ i/s 40Hz-8kHz. Replay char: DIN. Two level meters. H and N: $7\frac{1}{2}$ i/s -50dB, $3\frac{3}{4}$ i/s -45dB. Inputs: mic, radio, pickup. Outlets: headphones, speakers (2). Output: 2.5W per channel. Pause control. Four-digit tape position indicator. Straight-through amplifier. One channel monitor. Parallel track replay. Vertical or horizontal operation. Selector switch. Clear plastic cover. Separate speakers fit on back of recorder to make one unit for carrying. Mains: 110-240V AC. Price: £96.25 (including PT).

TOSHIBA

Hanimex (UK) Ltd, 15-24 Great Dover Street,
London, SE1. Tel: 01-407 8161.

KT41

Stereo cassette recorder with separate speakers. $\frac{1}{4}$ -track compact cassettes. Speed: $1\frac{7}{8}$ i/s. W and F: 0.35% RMS. FR: 50Hz-10kHz. Two moving coil meters. Inputs: mic 0.3mV 10K, line 100mV 2 megohms. Outlets: line 0.775V 100K, 8 ohms speakers. Output: 10W per channel. Speakers: 6in full range units in separate enclosures. Own deck. Pause control. Straight-through amplifier. Monitoring. Mains. Size: $9\frac{1}{4} \times 4\frac{3}{4} \times 8$ in. Weight: $11\frac{1}{4}$ lb. Price: £138 (including PT).

KT270

Mains/battery cassette recorder. Speed: $1\frac{7}{8}$ i/s. Compact cassette. W and F: 0.5% RMS. H and N: -35dB. FR: 80Hz-9kHz. Rewind time: 140 sec for C60 cassette. Meter level indicator. Inputs: mic 4.7K, line 2.2 megohms. Output: 500mW. Speaker: $2\frac{1}{2}$ in. Own deck. DC motor. Size: $8\frac{1}{2} \times 4\frac{1}{2} \times 2\frac{1}{8}$ in. Price: £49.50 (including PT).

★ Indicates entry is illustrated

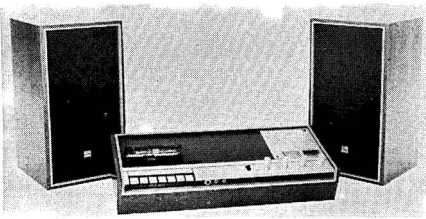

Toshiba KT242D



Uher 4200 Stereo

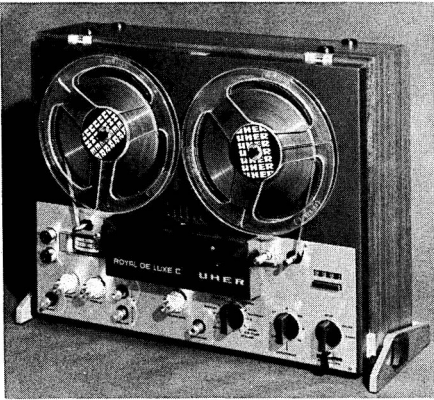

Uher Royal de Luxe

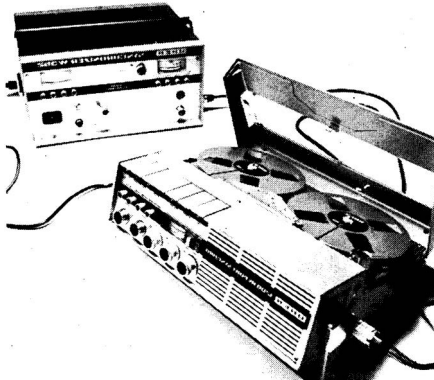

Uher 1200 Report Synchro

KT242D ★

Mains/battery cassette recorder. $\frac{1}{2}$ -track. Compact cassette. Speed: $1\frac{1}{8}$ i/s. W and F: 0.4% RMS. H and N: 40dB. FR: 150-8kHz. Replay char: DIN. Rewind time: 120 sec for C60 cassette. Automatic record level. Inputs: mic 500 ohms, line 500K. Output: 1W. Speaker: $3\frac{1}{2}$ in. Own deck. DC motor. Monitoring facility. Size: $10\frac{3}{8} \times 3\frac{3}{8} \times 9\frac{1}{8}$ in. Weight: 5lb. Price: £47.50 (including PT).

■ UHER

Distributors: Bosch Ltd, PO Box 166, Rhodes Way, Radlett Road, Watford, Herts, WD24LB. Tel: Watford 44233.

Uher 4200 ★

Transistorised mains/battery stereo tape recorder. $\frac{1}{2}$ -track. Speeds: $7\frac{1}{2}$, $3\frac{3}{4}$, $1\frac{7}{8}$, $1\frac{5}{8}$ i/s. Max spool 5in. W and F: $7\frac{1}{2}$ i/s 0.2%, $3\frac{3}{4}$ i/s 0.25%, $1\frac{7}{8}$ i/s 0.35%, $1\frac{5}{8}$ i/s 0.5%. H and N: $7\frac{1}{2}$ i/s -53dB, $3\frac{3}{4}$ i/s -51dB, $1\frac{7}{8}$ i/s -47dB, $1\frac{5}{8}$ i/s -43dB. FR: $7\frac{1}{2}$ i/s 40Hz-20kHz \pm 3dB, $3\frac{3}{4}$ i/s 40Hz-16kHz \pm 3dB, $1\frac{7}{8}$ i/s 40Hz-10kHz \pm 3dB, $1\frac{5}{8}$ i/s 40Hz-4.5kHz \pm 3dB. Replay char: NARTB. Level indicator: two meters. Rewind time: 3 min for 900ft. Inputs: mic 0.1mV 200 ohms, radio 2mV 47K, PU 30mV 1 megohm. Outputs: line 1V 15K, speaker 4 ohms. One motor. Pause. Digital position indicator. Monitoring. Parallel track replay. Size: $11 \times 3 \times 8$ in. Weight: approx 7lb. Supply: internal dry cells, rechargeable accumulator, or from 6V, 12V, 24V car battery, 110-240V AC mains with additional adaptor units. Price: £177.10 (including PT).

Uher 4400

$\frac{1}{4}$ -track version of 4200. Specification almost identical. Price: £177.10 (including PT).

Uher Royal de Luxe ★

Transistorised semi-professional mains recorder. Mono/stereo. $\frac{1}{4}$ -track or $\frac{1}{2}$ -track. Speeds: $7\frac{1}{2}$, $3\frac{3}{4}$, $1\frac{7}{8}$, $1\frac{5}{8}$ i/s. Max. spool: 7in. W and F: $7\frac{1}{2}$ i/s 0.05%, $3\frac{3}{4}$ i/s 0.1%, $1\frac{7}{8}$ i/s 0.25%, $1\frac{5}{8}$ i/s 0.35%. H and N: $7\frac{1}{2}$ i/s -54dB, $3\frac{3}{4}$ i/s -54dB, $1\frac{7}{8}$ i/s -54dB. FR: $7\frac{1}{2}$ i/s 20Hz-20kHz, $3\frac{3}{4}$ i/s 20Hz-15kHz, $1\frac{7}{8}$ i/s 20Hz-9kHz, $1\frac{5}{8}$ i/s 20Hz-5kHz. Replay char: NARTB. Level indicators: two meters. Inputs: mic 0.2mV-100mV 200 ohms, radio 2mV-1V 47K, PU (1) 50mV 1 megohm, PU (2) 200mV 50K. Outputs: line 775mV 15K, speakers 4 ohms. Output: 10W RMS per channel. One Papst motor. Pause. Inching. Straight-through amplifier. Horizontal or vertical operation. Monitoring. Input mixing. Parallel track replay. Interchangeable head assemblies available as optional extras. Dia-pilot. Multiplay. Echo. Weight: 29 $\frac{1}{2}$ lb. Price: £277.80 (including PT).

Uher Royal de Luxe (C)

Stereo unit without power amplifiers or speakers.

Specification as for Royal de luxe. Price: £248.86 (including PT).

Uher 1200 Report Synchro ★

Transistorised professional mains/battery mono recorder. Full track. Speed: $7\frac{1}{2}$ /s. Max spool 5in. W and F: 0.07%. H and N: -52dB. FR: 40Hz-20kHz +0dB -5dB. Replay char: CCIR or NARTB. Meter level indicator. Rewind time 3 min 900ft. Inputs: mic (2) 0.2mV 200 ohms balanced, line 40mV-1.55V. Output 1W RMS. 600ohm balanced line, pilot tone to synchroniser. Brushless DC motor. Pause. Digit tape indicator. Straight-through amplifier. A/B monitoring. Neo-pilot tone input for synchronising sound

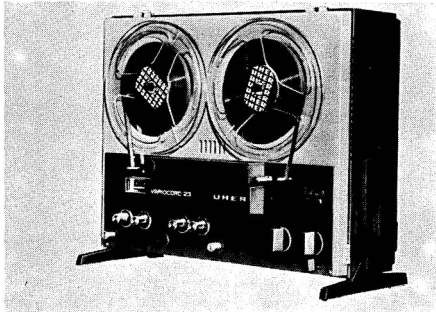

Uher Variocord 23

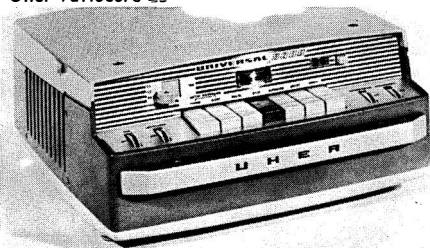

Uher Universal 5000



Uher Compact Report Stereo

with film camera. Optional automatic level control, pilot tone indicator, mixing of two mic channels. Supply: internal dry cells, rechargeable accumulator, or from 6V, 12V, 24V car battery, 110-240V AC mains with additional adaptor units. For supply only to industrial or scientific users. Size: $11 \times 3 \times 8$ in. Weight: 7lb. Price: £271.50.

Accessory

Scene marker module No. Z521. Price: £3.80.

4000 Report L

Transistorised mono battery portable recorder. $\frac{1}{2}$ -track. Speeds: $7\frac{1}{2}$, $3\frac{3}{4}$, $1\frac{7}{8}$, $\frac{1}{2}$ /s. W and F: $7\frac{1}{2}$ /s, $\pm 0.2\%$. H and N: -55dB. FR: $7\frac{1}{2}$ /s 40Hz-20 kHz, $3\frac{3}{4}$ /s 40Hz-16kHz, $1\frac{7}{8}$ /s 40Hz-10kHz, $\frac{1}{2}$ /s 40Hz-4.5kHz. All ± 3 dB. Replay char: NARTB. Inputs: mic 0.1mV 200 ohms, radio 2mV, 47K; gram 30mV, 1 megohm. Outlet direct from pre-amp. One motor. 5in spool. Supply: internal batteries, rechargeable accumulator, or from 6V, 12V, 24V car battery or 110/240V AC mains with additional adaptor units. Size: $11 \times 3 \times 8$ in. Weight: approx 7lb. Price: £145.27 (including PT). Combined mains unit and battery charger type Z124. Price: £18.06 (including PT).

Variocord ★

Transistorised mains mono recorder. Available as $\frac{1}{2}$ -track or $\frac{1}{4}$ -track. Speeds: $1\frac{7}{8}$, $3\frac{3}{4}$ and $7\frac{1}{2}$ /s. W and F at $7\frac{1}{2}$ /s 0.05%. FR: $7\frac{1}{2}$ /s 30Hz-20kHz; $3\frac{3}{4}$ /s 30Hz-15kHz; $1\frac{7}{8}$ /s 30Hz-8kHz. Inputs: mic 0.12mV (200 ohms); radio 1.2mV; gram 45mV. Outputs: line 1.4V; speaker 2W or 6W (depending on type) into 4 ohms. Level indicator meter. Interchangeable head assemblies. Input mixing. Horizontal or vertical operation. Optional 2W or 6W output stages. Optional add-on automatic volume control module. Prices from £109.96 (including PT).

Variocord Stereo

Same specification as Variocord but with twin 6W amplifiers. $\frac{1}{4}$ -track or $\frac{1}{2}$ -track. Price: £150.48 (including PT).

Uher 714L

Mains mono $\frac{1}{4}$ -track recorder. Max spool 7in. Speed: $3\frac{3}{4}$ /s. W and F: 0.3%. S/N: >48dB. Inputs: mic 200 ohms, radio 47K, PU 1 megohm. Output: 2W. Meter level indicator. Monitor facility. Auto shut-off at end of tape. Vertical or horizontal operation. Price: £68.29 (including PT).

Uher 5000 Universal ★

Mains $\frac{1}{2}$ -track mono recorder. Speeds: $3\frac{3}{4}$, $1\frac{7}{8}$, $\frac{1}{2}$ /s. FR: 40Hz-15kHz ± 3 dB at $3\frac{3}{4}$ /s. Max. spool: 5 $\frac{3}{4}$ in. W and F: $3\frac{3}{4}$ /s $\pm 0.2\%$. Inputs: mic 200 ohms, radio 47K, PU 1 megohm. Solenoid operation for remote control working. All metal case. Large range of dictation and

★ Indicates entry is illustrated

transcription accessories available. Price: £143.53 (including PT).

5000 Language Tutor

Specification as for 5000 Universal except double $\frac{1}{2}$ -track heads and $3\frac{3}{4}$ i/s speed only. Top track playback only, lower track record and playback. Price: £137.

Uher 724 Stereo

Transistorised stereo mains recorder. $\frac{1}{2}$ -track. Speeds: $3\frac{3}{4}$, $7\frac{1}{2}$ i/s. W and F: $7\frac{1}{2}$ i/s 0.2%, $3\frac{3}{4}$ i/s 0.25%. FR: $7\frac{1}{2}$ i/s 50Hz-20kHz, $3\frac{3}{4}$ i/s 50Hz-15kHz. Inputs: mic 0.25mV 200 ohms, radio 4.7mV 47K, PU 130mV 1 megohm. Outputs: line 0.7V 4.7K, speaker (2) 4W each into 4 ohms. Level indicator meter. Monitoring via phones or speaker. Vertical or horizontal operation. Price: £120.38 (including PT).

Uher Compact Report Stereo ★

(Advance information.) Transistorised battery cassette stereo recorder. Speed: $1\frac{7}{8}$ i/s. Compact cassette. W and F: approx 0.2%. FR: 30Hz-12.5kHz. Inputs: mic 200 ohms, radio or PU. Outputs: two line, two ext speakers (1W into 4 ohms). Meter for battery check and record level. Manual or automatic record level. Built to DIN standard. Continuous replay with automatic reversal of drive and track-change at end

of tape. Twin capstan drive. Switchable built-in capacitor mic for reporting, etc. Twin-stacked stereo head assembly. Remote control for tape transport. Three-digit tape counter. Monitoring via built-in or external speaker or phones. Supply: internal batteries, rechargeable accumulator, or from 6V, 12V, 24V car battery. 110-240V AC mains via adaptors. Price: £177.10 (including PT); mains unit Z131 £10.76.

■ VAN DER MOLEN LTD

1 Mildmay Road, Romford, Essex, RM7 7DA.
Tel: Romford 41904 and 46911.

VR47

Recorder. Three-speed $\frac{1}{2}$ -track. Max spool: 7in. Speeds: $1\frac{7}{8}$, $3\frac{3}{4}$, $7\frac{1}{2}$ i/s. W and F: $7\frac{1}{2}$ i/s 0.15%, $3\frac{3}{4}$ i/s 0.25%, $1\frac{7}{8}$ i/s 0.35%. H and N: better than 40dB all speeds. FR: $7\frac{1}{2}$ i/s 60Hz-15kHz, $3\frac{3}{4}$ i/s 60Hz-10kHz, $1\frac{7}{8}$ i/s 60Hz-4kHz. Replay char: CCIR. VU meter. Rewind time: 3 min for 1,200ft. Inputs: mic 2mV into 1 megohm, radio 200mV into 1 megohm. Outlets: 1-3V 200K, ext speaker 10W 4 ohms. Speaker: rear-facing 8in. Pause control. Tape position indicator. Straight-through amplifier. Monitoring. Mixing. Vertical operation. Mains: 200-250V AC. Size: $18\frac{3}{4} \times 11\frac{1}{2} \times 7$ in. Weight: 21lb. Price: £53.90 (plus £9.07 PT).

8 TRACK Tape Players



GOLDING AUDIO LTD

MARKS TEY · COLCHESTER

Tel: COL. 210433

Tape Players

★ Indicates entry is illustrated

Abbreviations used in this section are given on page 36.

■ ADMIRAL

Interconti Electronics Ltd, Albany House, Petty France, London, SW1H9EA.
Tel: 01-222 2523. Telex: 918770.

STP991 ★

Eight-track stereo cartridge player unit. Push-button channel selector. Lighted track indicators. Finish: walnut grained vinyl. Size: $7\frac{1}{2} \times 4\frac{3}{8} \times 8\frac{3}{8}$ in. Full specification on request. Price: £24.50 (including PT).

■ BSR McDONALD

(McDonald Division) BSR Ltd, Cradley Heath, Warley, Worcs.
Tel: Cradley Heath 69272.

TD8S ★

Eight-track stereo tape cartridge player. Tracks: eight (four stereo programmes). Speed: $3\frac{3}{4}$ i/s. FR: better than 50Hz-10kHz. Output: two-stage preamplifier giving nominal 125mV from 1kHz standard reference level tape. Playing time: up to 1 hour and 20 min and then repeats indefinitely. Automatic or manually selected track change. Indicator lights show tracks being played. Four-pole motor. Forced ventilation system. Tape head: Nortronics four-track with hyperbolic face. Track playback sequence: 1 and 5, 2 and 6, 3 and 7, 4 and 8. Wow: better than 0.3% total. Mains: 210-250V 50Hz. Size: $10\frac{3}{8} \times 8\frac{1}{2} \times 3\frac{7}{8}$ in. Weight: $5\frac{1}{4}$ lb. Price: £20.25 (plus £3.33 PT).

■ CROWN RADIO

128-129 Shoreditch High Street, London, E1 6JE. Tel: 01-739 2382.

SHC-52

Eight-track stereo tape player with integrated amplifier. Cartridge. Speed: $3\frac{3}{4}$ i/s. S/N ratio: >40dB. W and F: <0.35%. FR: 80Hz-12kHz. Output: 5W per channel. Four ICs, four tran-

sistors, five diodes. Automatic head cleaning device. Slider controls. Headphone jack socket. Size: $12\frac{3}{8} \times 4 \times 8\frac{3}{8}$ in. Finish: walnut. Weight: $9\frac{1}{4}$ lb. Price: £65 (including PT).

SHC-53

Similar specification to the SHC-52 but with the addition of AM/FM radio. Switchable AFC. 21 transistors, four ICs, 21 diodes. Radio range: FM 88-108MHz, MW 182-560m. Finish: walnut with black dial and bright trim. Size: $14\frac{5}{8} \times 4 \times 10\frac{5}{8}$ in. Weight: $11\frac{1}{2}$ lb. Price: £98 (including PT).

■ ELIZABETHAN

Lee Products (Great Britain) Ltd, Dallas House, 10-18 Clifton Street, London, EC2P2JR. Tel: 01-247 6711.

8/LZ-1

Eight-track cartridge tape player. Capstan drive. Speed: $3\frac{3}{4}$ i/s. W and F: better than 0.3%. Output impedance: >10K, FR: 50Hz-10kHz. HD: better than 3%. Separation: better than 45dB. S/N ratio: better than 45dB. Power source: 240V 50Hz. Automatic start and track selection. All silicon transistors. Teak veneer finish. Illuminated channel indicators. Price: £19.95.

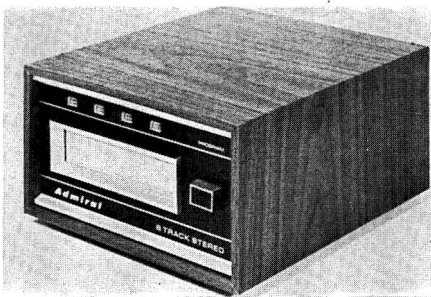

Admiral STP991



BSR-McDonald TD8S

★ Indicates entry is illustrated



Toshiba KT87

■ GOLDING AUDIO LTD

Marks Tey, Colchester, Essex.

Tel: Colchester 210433.

ST856

Eight-track stereo tape player unit. 400ft stereo cartridge. Speed: $3\frac{3}{4}$ i/s. W and F: $<0.3\%$. Output: 5W RMS per channel. Size: $13\frac{3}{4} \times 9\frac{3}{4} \times 4\frac{5}{8}$ in. Weight: 9.9lb. AC mains. Price: approximately £55 (including PT).

HW800 System 8

Eight-track stereo tape player unit. 400ft stereo cartridge. Speed: $3\frac{3}{4}$ i/s. W and F: $<0.2\%$. FR: 30Hz-14kHz. Inputs: mag PU 2mV, radio 250 mV, aux 250mV. Output: 10W RMS per channel. Output impedance: 8 ohms. One four-pole synchronous motor. Pushbutton programme selector. Size: $14\frac{1}{2} \times 4\frac{1}{2} \times 8\frac{3}{4}$ in. Weight: 15.4lb. Price: approximately £88 (including PT).

■ KINGSTEREO

Distributors: Lionel Murray Ltd,
7 West Halkin Street, Belgrave Square,
London, SW1. Tel: 01-235 6424-5-6.

XAR500

4-track record/playback tape player. Price: approximately £140 (including PT).

HW12

4- and 8-track stereo cartridge tape player. FR: 50Hz-10kHz. W and F: $<0.3\%$. Power output: 4W (music) into speakers supplied. Finish: mahogany. Dimensions: $13\frac{1}{4} \times 8\frac{1}{4} \times 3\frac{3}{4}$ in. Price: approximately £90 (including PT).

Wide range of 4-track stereo pre-recorded tape cartridges is available for this equipment.

■ NIVICO

Denham & Morley (Overseas) Ltd,
Denmore House, 453 Caledonian Road,
London, N7. Tel: 01-607 6568.

CHR-100

Eight-track cartridge player. FR: 40Hz-12kHz. S/N ratio: better than 40dB. W and F: less than 0.2% RMS. Six transistors and three diodes.

Channel indicator lights. Selector switch. Walnut cabinet. Price: £37.43 (including PT).

1202

Eight-track cartridge player. FR: 30Hz-15kHz. S/N ratio: better than 50dB. W and F: 0.25% RMS. 14 transistors and five diodes. Channel indicator lights. Selector switch. Price: £62.75.

9850F

Eight-track cartridge player. Full details and specification on request. Price: £45.75 (including PT).

■ TOSHIBA

Hanimex (UK) Ltd,

15-24 Great Dover Street, London, SE1.

Tel: 01-407 8161.

KT87 ★

Eight-track stereo tape player. Speed: $3\frac{3}{4}$ i/s. Eight-track cartridges. W and F: 0.3% RMS. H and N: 40dB. FR: 50Hz-10kHz. Output: 10W RMS per channel. Output impedance: 8 ohms. Own tape transport. Four-pole motor. Slider controls for balance, tone and volume. Size: $15\frac{3}{8} \times 8\frac{3}{8} \times 5\frac{1}{8}$ in. Weight: 12lb. AC mains. Price: £80.60 (including PT).

■ METROSOUND

Metrosound Audio Products Ltd,
Cartersfield Road, Waltham Abbey, Essex.

Tel: Waltham Cross 31933.

SS30E

Stereo amplifier incorporating tape cartridge player. 24 transistors, 5 diodes. Output: 10W RMS per channel. HD: less than 1% at rated output. FR: 30Hz-30kHz ± 2 dB at rated output. Noise level: -70dB. Inputs: mag PU 2.5 mV, ceramic PU 150mV, radio 150mV. Output impedance: 8 ohms. Mains: 200-250V 50-60Hz. Controls: push button controls for mains on/off, mono/stereo, tape, tape programme selector, tuner, magnetic PU, ceramic PU. Rotary controls for treble, bass, balance and volume. Bass control: ± 12 dB at 40Hz. Treble control: ± 12 dB at 14kHz. Balance control: either channel may be faded to zero without affecting the other. Tape output: 300mV at 5K. Automatically switchable headphone socket, 4-16 ohms. Tape cartridge system. Speed $3\frac{3}{4}$ i/s. W and F: less than 0.3%. FR: 40Hz-12kHz ± 3 dB. H and N: -45dB. Eight-track stereo tape cartridge. Size: $3\frac{1}{2} \times 20\frac{3}{4} \times 10$ in. Price: £68 (plus £11.45 PT).

448

Stereo tape cartridge player. Tape transport system as SS30E. Output: 4W RMS per channel. Output impedance: 4-8 ohms. FR: 40Hz-20

kHz. H and N: -50dB. Compound contour tone control. Finish: teak veneer with brushed aluminium and silver trim. Size: $12\frac{1}{4} \times 4 \times 10$ in. Price: £48 (plus £8.09 PT).

SA1 Satellite

Stereo tape cartridge player. Similar to Model 448 but less power output stages. Designed for use with Metrosound ST20E or ST60 amplifiers or other makes of amplifier. Output: 500mV 5K adjustable. Finish: teak veneer with brushed aluminium and silver trim. Price: £37 (plus £6.23 PT).

■ NATIONAL PANASONIC

Unamec Ltd, United Africa House, 1-16 Blackfriars Road, London, SE1 9UG. Tel: 01-928 2070.

RS-802US

Eight-track stereo tape player. Eight-track cartridges. Speed: $3\frac{3}{4}$ i/s. AC mains. FR: 50Hz-15kHz. Two ICs. Size: $6\frac{3}{8} \times 8\frac{1}{4} \times 9\frac{7}{8}$ in. Weight: 6½lb. Pushbutton channel change. Illuminated indicators. Price: £33.67 (plus £5.89 PT).

RS-845US

Eight-track four-channel stereo tape player. See Quadraphonic Section for further details.

■ PIONEER

Shiro (UK) Ltd, 42 Russell Square, London, WC1B 5DF. Tel: 01-580 6996.

H82

Eight-track stereo tape cartridge player. 8 transistors, 5 diodes. Speed: $3\frac{3}{4}$ i/s. W and F: <0.3%. Automatic and manual selection of programmes. FR: 100Hz-8kHz. S/N ratio: >35dB. Output: 775mV 1K. Size: $4\frac{3}{4} \times 8\frac{7}{8} \times 10\frac{7}{8}$ in. Weight: 10½lb. Price: £45.75 (plus £6.36 PT).

■ TELETON

Teleton Electro (UK) Ltd, Teleton House, Robjohns Road, Widford, Chelmsford, Essex. Tel: Chelmsford 62442.

STP801

Eight-track cartridge stereo player. Speed: $3\frac{3}{4}$ i/s. 12 transistors, 6 diodes. Mains: 220-240V AC. Output: $2\frac{1}{2}$ W RMS per channel. S/N ratio: 40dB. W and F: 0.35%. Crosstalk: 40dB. FR: 40Hz-10kHz. DC motor. Controls: volume, bass, treble, balance, tape/pickup switch, push-button track selection. Slider type controls for variables. Straight-through amplifier facility. Size: $14\frac{1}{4} \times 10\frac{1}{4} \times 4$ in. Price: £48.21 (plus £7.73 PT).

Tape Transport

★ Indicates entry is illustrated

Abbreviations used in this section are given on page 36.

■ BRENNEL ENGINEERING CO LTD

231/5 Liverpool Road, London, N1. Tel: 01-607 8251 (5 lines).

Mark 6 Tape Transport ★

Four-speed three-motor with provision for up to four heads. Speeds: 15, $7\frac{1}{2}$, $3\frac{3}{4}$, $1\frac{7}{8}$ i/s. W and F: 15i/s <0.05%, $7\frac{1}{2}$ i/s <0.1%, $3\frac{3}{4}$ i/s <0.15%, $1\frac{7}{8}$ i/s <0.25%. All motors outer rotor type (hysteresis synchronous for capstan drive). Max spool $8\frac{1}{4}$ in. Rewind time: 60 sec for 1,200ft. Four-digit tape indicator. Erase head low impedance, record/playback heads high impedance. Horizontal or vertical mounting. Record/playback switches fitted with extended spindles to accommodate extra wafers. Finish: blue/grey. Size: (deck) $15 \times 11\frac{1}{2}$ in; (depth below) 5in approx; (overlap with $8\frac{1}{4}$ in spools) $1\frac{1}{2}$ in at rear and lin at each side. Mains: 200-250V 50Hz (110-120V 60Hz to order). Weight: 18lb. Price: (less heads) from £53 (plus £9.04 PT).

Mark 610

Modified Mark 6 deck designed to take $10\frac{1}{2}$ in NAB spools. Full details and prices on request.

Mark 610 IND

Industrial and scientific version of Mark 610. Supplied free of PT to industrial users only. Prices on request.

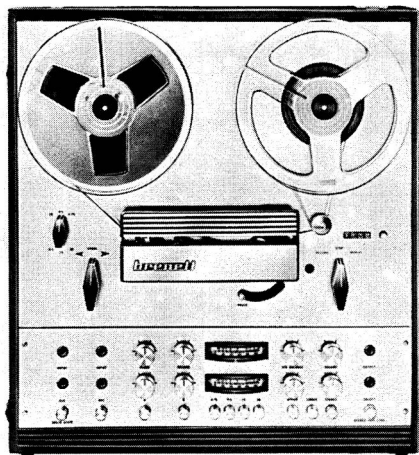

Brennell Mk 6

★ Indicates entry is illustrated

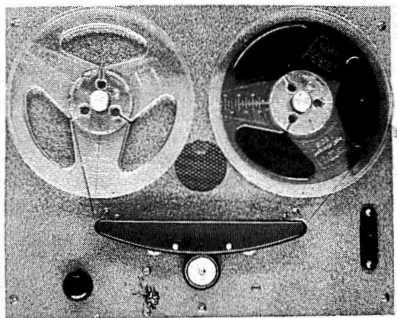

Planet CD2

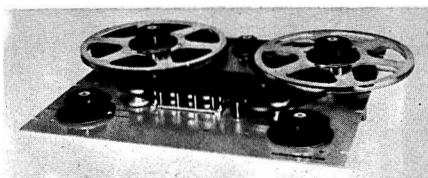

Scopetronics 1150

Type 19

Heavy-duty tape transport. Solenoid operated. Two- and four-speed versions. Speeds: $\frac{1}{8}$ to 60i/s. Tape widths: $\frac{1}{4}$ in, $\frac{1}{2}$ in and 1in. Remote control facility. Provision for up to four heads on removable headplate. Papst hysteresis synchronous capstan motor and two Papst outer-rotor spooling motors. W and F: 30i/s 0.04%, 15i/s 0.05%, 7 $\frac{1}{2}$ i/s 0.08%, 3 $\frac{3}{4}$ i/s 0.1%. Low-voltage pushbutton operation of deck functions including cue. Four-digit tape position indicator. Spools: 11 $\frac{1}{2}$ in, NAB or Cine. Standard 19in rack mounting. Horizontal or vertical operation. Complementary record/replay preamplifiers available for up to eight channels. Price: (tape transport) from £150.

■ FERROGRAPH CO LTD

Auriema House, 442 Bath Road, Cippenham, Slough, Bucks, SL1 6BB.

Tel: Burnham 062-86 62511. Telex: 847297.

Series 7

Semi-professional tape deck. Speeds: 15, 7 $\frac{1}{2}$, 3 $\frac{3}{4}$ i/s or 7 $\frac{1}{2}$, 3 $\frac{3}{4}$, 1 $\frac{7}{8}$ i/s. Mono or stereo. $\frac{1}{4}$ -track or $\frac{1}{2}$ -track. Max spool: 8 $\frac{1}{4}$ in. W and F: 0.08% at 15 i/s, 0.08% at 7 $\frac{1}{2}$ i/s, 0.15% at 3 $\frac{3}{4}$ i/s, 0.2% at 1 $\frac{7}{8}$ i/s. Rewind time: less than 1 min for 1,200ft. Three motors, synchronous hysteresis capstan motor, shaded pole reel motors. Pause facility. Single knob control. Vertical or horizontal operation. Fast wind continuously variable in either direction. Remote start/stop facility. Removable head block. Automatic stop at end of reel. Reel retainers fitted to spindles. Various head arrangements. Full specification and prices on application.

■ PLANET PROJECTS LTD

Goodman Works, Belvue Road, Northolt, Middlesex. Tel: 01-845 1775.

C.D.2 ★

Tape deck. Speed: 3 $\frac{3}{4}$ i/s (1 $\frac{7}{8}$ i/s to special order). W and F: less than 0.2% at both speeds. Mini-flux heads. $\frac{1}{2}$ -track mono or $\frac{1}{4}$ -track stereo. Two heads, one for each track. FR: dependent on speed and heads. Papst hysteresis motor. Spool size 7in. Automatic track change and reversal of tape direction at end of spool, no fast rewind required. Uses standard $\frac{1}{4}$ in tape. Single knob control. Provides over 8 $\frac{1}{2}$ hours uninterrupted playing at 1 $\frac{7}{8}$ i/s. Mains: 220-230V 50Hz. Size: 14 $\frac{3}{4}$ × 11 $\frac{3}{4}$ × 6in. Weight approximately: 10lb. Price on application.

■ SCOPETRONICS LTD

Crown Works, Church Road, Kingston-upon-Thames, Surrey. Tel: 01-546 1275 and 4135.

1150 ★

G. P. tape deck 15, 7 $\frac{1}{2}$ i/s. Three Papst motors with ext rotors. Three heads. W and F: 0.14% at 7 $\frac{1}{2}$ i/s, 0.08% at 15i/s. Spool capacity: 11 $\frac{1}{2}$ in. Pause control and inching facility. Rewind: < 1 min 45 sec for 2,400ft. Weight: 26lb. Price: from approximately £175.

■ TAPE RECORDER DEVELOPMENTS LTD

Hall Lane, Walsall Wood, Staffs.

Tel: Brownhills 5351.

TRD.1 Series 600

Four-speed mono or stereo tape decks. W and F: 15i/s 0.05%, 7 $\frac{1}{2}$ i/s 0.08%, 3 $\frac{3}{4}$ i/s 0.13%, 1 $\frac{7}{8}$ i/s 0.2%, 1 $\frac{5}{8}$ i/s 0.35%. Mains operated. $\frac{1}{4}$ - or $\frac{1}{2}$ -track. Accommodation for four Bogen heads. Drive motors: Papst hysteresis synchronous. Rewind motors: Papst R.O.T. Spool capacity: 3in cine to 10 $\frac{1}{2}$ in NAB. Four-digit tape position indicator. Silicon transistor tape preamplifier/oscillator unit available (see Tape Deck section).

TRD.1/S

Specification as above. Speeds: 7 $\frac{1}{2}$, 3 $\frac{3}{4}$, 1 $\frac{7}{8}$, 1 $\frac{5}{8}$ i/s. Solenoid operation.

TRD.1/S/15

Specification as above. Speeds: 15, 7 $\frac{1}{2}$, 3 $\frac{3}{4}$, 1 $\frac{7}{8}$ i/s. Solenoid operation.

TRD.1/S/30

Specification as above. Speeds: 30, 15, 7 $\frac{1}{2}$, 3 $\frac{3}{4}$ i/s. Solenoid operation.

TRD.1/S/60

Specification as above. Speeds: 60, 30, 15, 7 $\frac{1}{2}$ i/s. Solenoid operation. Prices: (without heads) from about £145; (heads) from about £27.50 each. Supplied to professional and scientific users only free of tax.

BOGEN HEADS

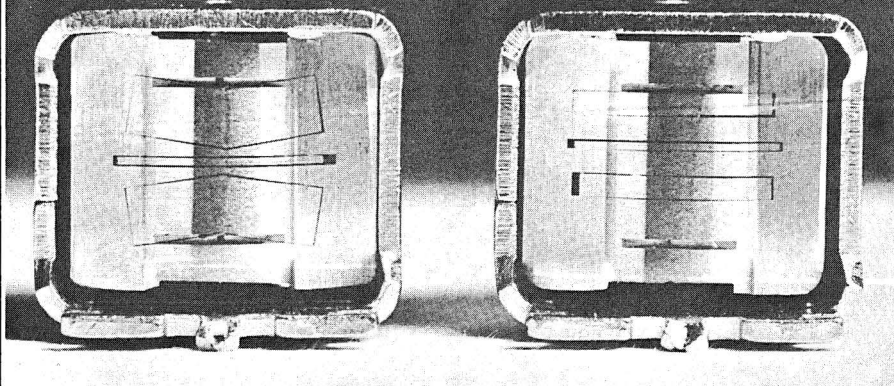

- 1** A ruby pulse laser is used for stress free welding together of the case halves and, in conjunction with the technology of producing the case by casting, this results in an exceptional stability of the gap with complete control of manufacture down to around $1.5 \mu\text{m}$.
- 2** The case halves are die cast and the metallic infrastructure is therefore not affected by slots milled for cores or screens. This makes for exceptionally high stability and linearity of the gap and multiple track phase errors and ageing effects are largely eliminated.
- 3** The tolerance of grinding for the optically flat gap-depth determining faces is well below one wave-length of light which practically eliminates any damage to the soft magnetic structure. The magnetic gap-width is consequently almost identical to the mechanical gap-width and gap losses at the shorter wave-lengths of recording are exceptionally low.
- 4** The head contour is hyperbolically ground to compensate for interference effects during playback and low frequency fluctuations stay below 1 dB even at 38 cm/s (15"/sec) tape velocity.
- 5** The magnetic core is fitted to case halves made of nickel alloy with the same coefficient of expansion, wear properties and chemical resistance as mu-metal and no resin seams are apparent. Consequently these heads have a high stability to temperature changes and the uniform wear properties and hardness of the cores result in a long life.

The chemical resistance adequately prevents oxidation and corrosion of the tape head face which might also result from chemically active dust deposits from the tape. The all-metal appearance of the face is always bright and tape dust will not easily adhere to it.

SOLE UK AGENTS

cole

Cole Electronics Limited
7-15 Lansdowne Road
Croydon CR9 2HB Tel: 01 686 7581

TEAC®

Superior sound/low noise HD Ferrite Head
Tape Deck

TEAC®

Dolby noise reduction units

TEAC®

Cassette tape Deck



A-7010 GSL

AN80

AN 60

A 220

AN 180

Want to know more?

Write or Phone **Sole U.K. Distributor**

ACOUSTICO ENTERPRISES LTD.

6-8 UNION STREET · KINGSTON UPON THAMES · SURREY

TELEPHONE : 01-549 3471

Tape Decks

★ Indicates entry is illustrated

Tape decks are now defined as tape systems including heads, erase/bias oscillators and record/playback preamplifiers, but excluding output stages.

■ AKAI

UK Distributors: Rank Audio Products, PO Box 70, Great West Road, Brentford, Middlesex. Tel: 01-568 9222. Telex: 24408.

4000D ★

Stereo tape unit with preamplifiers, $\frac{1}{4}$ -track. Speeds: $3\frac{3}{4}$ and $7\frac{1}{2}$ i/s. Max spool capacity: 7in. W and F: $7\frac{1}{2}$ i/s 0-15%, $3\frac{3}{4}$ i/s 0-2%. H and N: 50dB. FR: $7\frac{1}{2}$ i/s 30Hz-22kHz ± 3 dB; $3\frac{3}{4}$ i/s 30Hz-16kHz ± 3 dB. Replay char: NARTB. Level indicator: Meter. Rewind time: 1,200ft 150 sec. Inputs: microphone, 0-5mV, 50K; line, 50mV; DIN, 50mV. Outlets: line, DIN, headphone. Transistorised. Induction motor. Tape deck: own. Dimensions: $12\frac{3}{8} \times 15\frac{7}{8} \times 7\frac{1}{2}$ in. Weight: 25-3lb. Pause. Position indicator: digit. Monitoring: A-B. Parallel track replay. One micron gap recording head. Sound on sound. Auto stop. Auto shut off. Tape cleaner. Vertical or horizontal operation. Psn 100-240V. Price: £80 (plus £13-65 PT).

CR80D

Stereo cartridge tape unit with preamplifiers. Eight-track. Speed: $3\frac{3}{4}$ i/s. W and F: 0-25%. H and N: -47dB. FR: 50Hz-16kHz ± 3 dB. Replay char: NARTB. Fast forward: 230 sec for 300ft. VU meters (2). Inputs: mic 0-5mV, line 50mV. Outlets: line, DIN. Recording indicator lamp. Own tape transport. Headphone socket. One micron gap head. Size: $13\frac{1}{2} \times 5\frac{1}{2} \times 10$ in. Weight: 17lb. Mains: 100-240V 50-60Hz. Price: £72-63 (plus £12-39 PT).

CS50D

Stereo cassette tape unit with preamplifiers. $\frac{1}{4}$ -track compact cassette. Speed: $1\frac{7}{8}$ i/s. W and F: 0-2%. H and N: -45dB. FR: 30Hz-16kHz. Replay char: NARTB. Rewind time: 75 sec for C60. Two VU meters. Inputs: mic 0-2mV 4-7K, DIN 3mV 25K, line 220K. Outlets: 1-3V 10K, DIN 0-4V, headphones 8 ohms. Own tape transport. Outer rotor synchronous motor.

Monitoring by headphones. One micron gap head. Size: $15 \times 6\frac{1}{4} \times 11\frac{1}{4}$ in. Weight: 15 $\frac{3}{4}$ lb. Pause control. Mains: 100-240V 50-60Hz. Price: £89-23 (plus £15-23 PT).

X200D

Three-speed stereo tape unit. $\frac{1}{4}$ -track. Speeds: $7\frac{1}{2}$, $3\frac{3}{4}$, $1\frac{7}{8}$ i/s. 15i/s optional. W and F: $7\frac{1}{2}$ i/s 0-08%, $3\frac{3}{4}$ i/s 0-12%, $1\frac{7}{8}$ i/s 0-20%. H and N: -50dB at all speeds. Max spool 7in. FR: $7\frac{1}{2}$ i/s 30Hz-26kHz ± 3 dB, $3\frac{3}{4}$ i/s 30Hz-19kHz ± 3 dB, $1\frac{7}{8}$ i/s 30Hz-9kHz ± 3 dB. Replay char: NARTB. Rewind time: $1\frac{1}{4}$ min for 1,200ft. VU meter. Inputs: mic 0-5mV, line 50mV, DIN (low) 5mV, DIN (high) 50mV. Outlets: line 1-23V (0 VU), DIN 0-4V, stereo phones. Three motors (one three-speed synchronous, two outer rotor). Own deck. Pause, Headphone monitoring. Input mixing. Crossfield head. Auto reverse. Size: $14 \times 14 \times 8\frac{7}{8}$ in. Weight: 37 $\frac{1}{2}$ lb. Mains: 100-240V 50-60Hz. Price: £134-91 (plus £23-02 PT).

GXC-40D ★

Stereo cassette tape unit. Speed: $1\frac{7}{8}$ i/s. Compact cassette. W and F: <0-2% RMS. H and N: better than 45dB. FR: (standard tape) 30Hz-16kHz, (chromium dioxide tape) 30Hz-18kHz ± 3 dB. Replay char: NARTB. Rewind time: 60 sec for C60 cassette. Twin VU meters. Inputs: mic (2) 0-2mV 4-7K, line (2) 50mV 200K. Outlets: line (2) 1-23V 100 ohms. Own deck. One motor. Pause. Straight-through amplifier. Switched bias for chromium dioxide tape. Size: $16\frac{1}{2} \times 5 \times 8\frac{7}{8}$ in. Weight: 11 $\frac{3}{4}$ lb. Mains: 100-240V AC. Price: £78-81 (plus £13-45 PT).

GX-280D ★

Stereo two-speed tape unit. Speeds: $3\frac{3}{4}$, $7\frac{1}{2}$ i/s. Max spool 7in. W and F: $3\frac{3}{4}$ i/s <0-12% RMS, $7\frac{1}{2}$ i/s <0-08% RMS. H and N: better than 50dB. FR: $3\frac{3}{4}$ i/s 30Hz-19kHz ± 3 dB, $7\frac{1}{2}$ i/s 30Hz-24kHz ± 3 dB. Replay char: NARTB. Rewind time: 75 sec for 1,200ft. Twin VU meters. Inputs: mic (2) 0-8mV 10K, line (2) 150mV 150K. Outlets: line (2) 1-23mV into 20K load. Own deck. Three motors. Servo-control. Superimpose. Pause. Inching. Input mixing. Monitoring. Parallel track replay. Three glass crystal ferrite heads. Size: $17 \times 18 \times 10$ in. Weight: 44lb. Mains: 100-240V AC adjustable. Price: £269-77 (plus £46-03 PT).

GX-220D ★

Stereo three-speed tape unit. Speeds: $1\frac{7}{8}$, $3\frac{3}{4}$, $7\frac{1}{2}$ i/s. Max spool 7in. W and F: $1\frac{7}{8}$ i/s <0-2%, $3\frac{3}{4}$ i/s <0-12%, $7\frac{1}{2}$ i/s <0-08%. H and N: better than 50dB. FR: $1\frac{7}{8}$ i/s 30Hz-9kHz ± 3 dB, $3\frac{3}{4}$ i/s 30Hz-19kHz ± 3 dB, $7\frac{1}{2}$ i/s 30Hz-24kHz ± 3 dB. Replay char: NARTB. Rewind time: 75 sec for 1,200ft. Twin VU meters. Inputs: mic (2) 0-2mV 10K, line (2) 50mV 10K. Outlets: line (2) 1-23V into 20K load. Three motors. Own deck. Super-

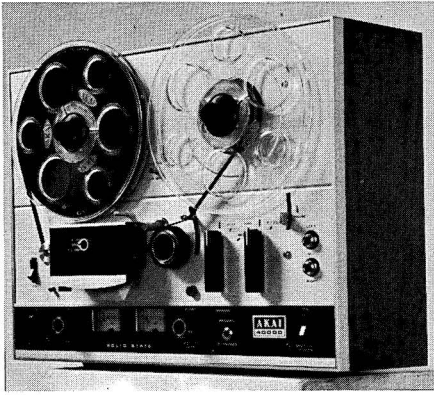

Akai 4000D



Akai GX-220D



Akai GX-280D

impose. Pause. Inching. Monitoring. Input mixing. Three glass and crystal ferrite heads. Auto stop. Auto and manual reverse. Tape speed equaliser. Size: $17\frac{1}{4} \times 17 \times 9\frac{1}{4}$ in. Weight: $41\frac{3}{4}$ lb. Mains: 100-240V AC adjustable. Price: £190-50 (plus £32-50 PT).

■ **AMPEX (GB) LTD**

Acre Road, Reading, Berks RG20QR.

Tel: Reading 84411.

AG-440B ★

Full range of professional and semi-professional tape decks, tape units and complete recorders. Typical specification includes following facilities. Full-, half- or quarter track on $\frac{1}{4}$ in. tape. Up to 15in spools. Speeds: selectable pairs from $\frac{1}{6}$, $1\frac{1}{8}$, $3\frac{3}{8}$, $7\frac{1}{2}$, 15. Unidirectional or bi-directional operation. FR: 15i/s 30Hz-18kHz ± 3 dB, $1\frac{7}{8}$ i/s 40Hz-10kHz. Crosstalk rejection: better than 60dB at 1kHz. Bias/erase frequency: 100 kHz. W and F: 15i/s 0.1%, $1\frac{7}{8}$ i/s 0.25%. Start time: operating speed obtained in 0.1 sec or less. Stop time: at 15i/s tape moves 3in. S/N: 15i/s half-track 63dB, $7\frac{1}{2}$ i/s half-track 63dB, $3\frac{3}{8}$ i/s half-track 58dB.

Full specification and prices on request.

ABR10/ABR15

Studio quality tape recorder/reproducer. Full-, half- or quarter-track on $\frac{1}{4}$ in. tape. Speeds: any pair from $\frac{1}{6}$, $1\frac{1}{8}$, $3\frac{3}{8}$, $7\frac{1}{2}$ or 15i/s. Max spool: (ABR10) 5-10 $\frac{1}{2}$ in, (ABR15) 5-15in. W and F: $7\frac{1}{2}$ i/s 0.15%. H and N: $7\frac{1}{2}$ i/s half-track 63dB. FR: $7\frac{1}{2}$ i/s 40Hz-15kHz ± 2 dB. Input: -17dBm 100K unbalanced. Output: +4dBm balanced. Bias oscillator: 100kHz. Replay char: NAB for $7\frac{1}{2}$ and 15i/s. Rewind time: 90 sec for 2,400ft. Tape speed accuracy: $\pm 0.08\%$. Servo-controlled capstan motors. Bidirectional with automatic reversing. Mini two-way mixer and remote control optional extras.

Full specification and prices on request.

MM-1000

Studio quality tape recorder/reproducer. Tape transport handles 2in tape with provision for 8, 16 or 24 channels. Speeds: $7\frac{1}{2}$ and 15i/s (15 and 30i/s to order). FR: 15i/s 30Hz-18kHz ± 2 dB. W and F: 15i/s $\pm 0.08\%$. Full specification and prices on request.

CD200

High-speed automatic cassette tape copier. Speed: 75i/s throughout length of C60 cassette. Overall cycle time: C30 cassettes approx 40 sec (75 per hour including load time); C60 cassettes approx 75 sec (45 per hour including load time). FR: (system) 30Hz-12kHz ± 2 dB, (typical copy) 50Hz-8kHz ± 2 dB. W and F: $< 0.05\%$ RMS NAB weighted. Four-track stereo or two-track mono. Capacity: 100 cassettes. Load time: 7 sec. Full specification and prices on request.

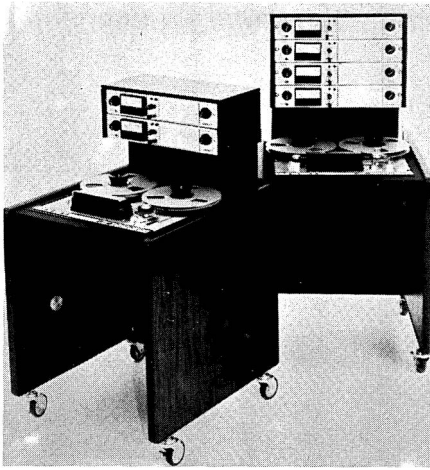

Ampex AG440B

■ BELL & HOWELL LTD

Alpertown House, Bridgewater Road, Alpertown,
Middlesex, HA0 1EG. Tel: 01-902 8812.
Telex: 261378.

Design 1700 ★

Mains operated $\frac{1}{4}$ -track stereo tape unit incorporating Dolby B noise reduction system. Compact cassettes. Speed: $1\frac{1}{2}$ i/s. W and F: 0.2% total. H and N: better than 50dB. FR: 20Hz-12kHz \pm 3dB. Rewind time: <120 sec for C120 cassette. Twin VU meters. Inputs: microphone 0.2mV 200 ohms, aux 100mV 100K. Outlet: variable 0-1V at 5K. One DC motor. Pause control. Selector for standard magnetic tape or chromium dioxide. Automatic stop at end of tape. Size: $14\frac{1}{4} \times 4\frac{3}{8} \times 9$ in. Weight: 8lb. Mains: 220-240V AC. Price: approximately £1106 (including PT).

■ BRENNELL ENGINEERING CO LTD

231/5 Liverpool Road, London, N1.
Tel: 01-607 8271 (5 lines).

Mk 6 Stereo Unit

Stereo tape unit with preamplifiers. Twin 2/2 or quarter 2/4 track system. Speeds: 15, $7\frac{1}{2}$, $3\frac{3}{4}$, $1\frac{1}{2}$ i/s. Max spool: $8\frac{1}{2}$ in ($10\frac{1}{2}$ in NAB reel version available). W and F: 15i/s 0.05%, $7\frac{1}{2}$ i/s 0.08%, $3\frac{3}{4}$ i/s 0.1%, $1\frac{1}{2}$ i/s 0.12%. S/N: 56dB below 2% distortion levels of recording. FR: 15i/s 40Hz-22kHz \pm 3dB, $7\frac{1}{2}$ i/s 40Hz-20kHz \pm 3dB, $3\frac{3}{4}$ i/s 50Hz-14kHz \pm 3dB, $1\frac{1}{2}$ i/s 60Hz-7kHz \pm 3dB. Two illuminated edge-scale meters. Rewind time: less than 60 sec for 1,200ft. Inputs: mic 200 μ V 200-600 ohms, aux (1) 8mV 50K, aux (2) 8mV 50K. Output: two at 1.4V from tape recorded to 0dB meter level. Two output jack sockets on front panel, two phono sockets on rear. Horizontal or vertical operation. Three motors (all outer rotor). Three heads. Pause control (lockable). Four-digit tape indicator. Auto-stop. A/B switching. A/B balance. Mains: 115, 210, 240V AC 50Hz. Size: $17\frac{1}{2} \times 16\frac{3}{4} \times 8$ in. Weight: 33lb. Price: £168 (plus £28.66 PT). Industrial version with $10\frac{1}{2}$ in NAB reels available free of PT to commercial and scientific users only.

■ BUSH-ARENA

Rank Bush Murphy Ltd,
Power Road, Chiswick, London, W4.
Tel: 01-994 6491.

C430 ★

$\frac{1}{4}$ -track stereo cassette unit. Speed: $1\frac{1}{2}$ i/s. Compact cassette. W and F: 0.35% RMS. FR: (overall using standard tape) 60Hz-7.5kHz \pm 3dB. H and N: -45dB. Two record level meters. Three-digit tape position indicator. Inputs: mic (2), line. Output: line, stereo headphones. Seven piano-key controls, including

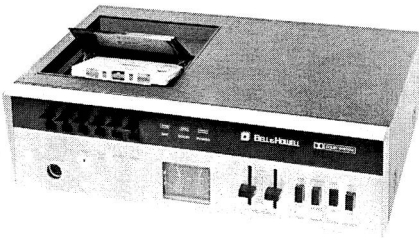

Bell & Howell 1700

■ BANG & OLUFSEN UK LTD

Eastbrook Road, Gloucester, GL4 7DE.
Tel: Gloucester 21591.

Beocord 1200

Stereo tape unit with preamplifiers and mixer. $\frac{1}{4}$ -track. Speeds: $3\frac{3}{4}$ and $7\frac{1}{2}$ i/s. Max spool: 7in. W and F: $3\frac{3}{4}$ i/s <0.2%; $7\frac{1}{2}$ i/s <0.15%. H and N: $3\frac{3}{4}$ i/s > -50dB; $7\frac{1}{2}$ i/s > -50dB. FR: (DIN 45-500 spec) $3\frac{3}{4}$ i/s 40Hz-16kHz; $7\frac{1}{2}$ i/s 30Hz-20kHz. Replay char: DIN. Rewind time: 3 min 20 sec for 1,800ft. VU meter level indicator. Inputs: mic (2) 80 μ V 50-200 ohms, radio 2.5mV 47K, PU 60mV 470K. Outlets: line 1V 25K, phones up to 6V 100 ohms. All transistor. Own deck. Papst outer rotor motor. Superimpose. Pause control. Straight-through amplifier. Monitoring (A only). Input mixing (limited). Parallel track replay. Photo-electric automatic stop. Electronic speed change. Horizontal or vertical operation. Can be wall mounted. Mains: 110, 130, 220, 240V AC 50Hz. Finish: teak, rosewood or white. Price: (teak) £118.50; (rosewood or white) £119.50 (including PT).

★ Indicates entry is illustrated

pause. Slider type level controls. Power and motor indicator lights. Supplied with two microphones (with desk stands), blank cassette and record/play connecting lead. Mains: 220-240V AC. Finish: teak veneer. Size: $12\frac{3}{8} \times 3\frac{3}{8} \times 8\frac{3}{8}$ in. Price: £52.50 (including PT).

C440 ★

$\frac{1}{4}$ -track stereo cassette unit with provision for chromium dioxide (CrO₂) tape. Speed: $1\frac{7}{8}$ i/s. Compact cassette. W and F: 0.3% RMS. FR: (overall using standard tape) 60Hz-8kHz ± 3 dB; (chromium dioxide tape) 50Hz-9kHz ± 3 dB. H and N: (standard tape) 45dB, (chromium dioxide tape) 50dB. Two record level meters. Three-digit tape position indicator. Inputs: mic (2), line. Output: line, stereo headphones. Seven piano-key controls, including pause. Tape bias selector switch. High filter switch for chromium dioxide tape. Power and motor indicator lights. Supplied with two microphones (with desk stands), blank chromium dioxide tape and record/play connecting lead. Mains: 220-240V 50Hz. Finish: teak veneer. Size: $13\frac{1}{4} \times 3\frac{1}{8} \times 9\frac{3}{8}$ in. Price: £63.50 (including PT).

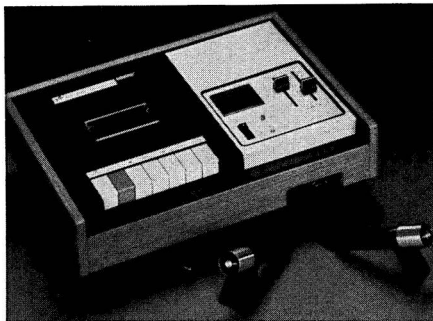

Bush-Arena C430



Bush-Arena C440

■ CHILTON

Magnetic Tapes Ltd, Chilton Works,
Garden Road, Richmond, Surrey.
Tel: 01-876 7957.

Chilton 100S

Transistorised stereo $\frac{1}{4}$ or $\frac{1}{2}$ -track three-speed recorder available as portable with in-built speakers (model 100S/CAP), or chassis in teak surround without power amplifiers (100S/CW), or with power amplifiers (100S/CAW). Speeds: $1\frac{7}{8}$, $3\frac{3}{4}$, $7\frac{1}{2}$ i/s. 7in reels. Rewind time: 150 sec for 1,800ft. Deck uses hysteresis motor and four DC-operated diode-suppressed solenoids. W and F: 0.1% at $7\frac{1}{2}$ i/s, 0.25% at $1\frac{7}{8}$ i/s. FR: (± 2 dB) via tape 30Hz-18kHz ($7\frac{1}{2}$ i/s), 40Hz-11kHz ($3\frac{3}{4}$ i/s) and (± 3 dB) 50Hz-7kHz ($1\frac{7}{8}$ i/s). Signal/noise, unweighted, 50dB $\frac{1}{4}$ -track and 53dB $\frac{1}{2}$ -track, all speeds. Replay char: IEC (NAB to order). Inputs per channel: mic 600 ohms-50K 0.4mV, radio 100K 40mV (DIN), gram 47K 1mV RIAA DIN. Outlets: line 2K 0.5V DIN, radio 10K 0.25V DIN, speakers (models with power amps) 10W at 8 ohms. LS impedance 4-16 ohms. Two 6×4 in units per channel in model. CAP. Stereo headphone jack socket. Size: (portable with lid) $14\frac{1}{2} \times 13\frac{5}{8} \times 6\frac{1}{2}$ in; (chassis) $19 \times 16 \times 8$ in. Various versions available: (100S/CW—tape unit in teak surround for use with external amplifier. Output 0.3V at 600 ohms); (100S/CAW—with two 10W amplifiers and tone controls for use with external speakers); (100S/CAP—as CAW but in leatherette covered case with four inbuilt speakers); (200S/CAP—teak portable with four inbuilt speakers and transparent plastic lid). Prices on request.

Extras

Two-track version; lockable teak case and cover for type CW; modifications for vertical operation. Prices on request.

■ CROWN INTERNATIONAL

Macinnes Laboratories Ltd,
Stonham, Stowmarket, Suffolk, IP145LB.
Tel: Stonham (044 971) 486.

800 Series

Stereo unit. $\frac{1}{4}$ - or $\frac{1}{2}$ -track. Three-speed 15i/s or $1\frac{7}{8}$ i/s optional. Max reel $10\frac{1}{2}$ in. W and F: 15i/s 0.06%; $7\frac{1}{2}$ i/s 0.09%; $3\frac{3}{4}$ i/s 0.18% (RMS). H and N: 15i/s -60dB; $7\frac{1}{2}$ i/s -60dB; $3\frac{3}{4}$ i/s -55dB (below peak level). FR (± 2 dB): 15i/s 30Hz-30kHz; $7\frac{1}{2}$ i/s 30Hz-25kHz; $3\frac{3}{4}$ i/s 30Hz-15kHz. Replay char: CCIR. VU meter. Rewind time: 58 sec 2,400ft, 38 sec 1,200ft. Inputs: 2 mixable inputs per channel, mic or line. Sensitivity: 45mV for 0 level (line), 0.4mV for 0 level (mic); impedance 100K, balanced or unbalanced 600 ohms, or 50/200 ohms. Output: 600 ohms. Three motors, magnetic brakes, logic circuitry for tape handling, all tape commands can be remote. A-B monitoring, source and tape mixing, echo, individual bias adjustment and metering. Size: $17\frac{1}{2} \times 19 \times 8$ in. Weight: 50lb. Price: £700 to £1,500.

■ DUAL

International Audio Ltd,
Clive House, Queens Road, Weybridge, Surrey.
Tel: Weybridge 40125/6. Telex: 928153.

CTG29

Two-speed $\frac{1}{4}$ -track stereo tape unit. Speeds: $3\frac{3}{4}$, $7\frac{1}{2}$ i/s. W and F: $7\frac{1}{2}$ i/s $\pm 0.1\%$, $3\frac{3}{4}$ i/s $\pm 0.15\%$. FR: $7\frac{1}{2}$ i/s 30Hz-20kHz, $3\frac{3}{4}$ i/s 30Hz-14kHz (DIN 45 507). Max spool: 7in. Rewind time: $3\frac{1}{2}$ min 1,750ft. Two illuminated VU meters. Pause control. Emergency stop (not dependent on stop foil). Finish: walnut base with smoked plexiglass cover. Horizontal or vertical operation. Mains: 110, 130, 220, 250V AC. Size: $16\frac{1}{2} \times 7\frac{1}{2} \times 14\frac{3}{4}$ in. Price: to be announced.

■ ELIZABETHAN

Lee Products (Great Britain) Ltd,
Dallas House, 10-18 Clifton Street, London,
EC2P2JR. Tel: 01-247 6711.

C/LZ-1

Stereo cassette tape unit. Stereo or mono. Compact cassettes. Speed: $1\frac{7}{8}$ i/s. Four-track two-channel. 9 transistors, 6 diodes and 2 ICs. W and F: 0.3%. S/N ratio: better than 45dB (playback). Inputs: mic 0.2mV 50K, aux 100mV 220K. Output: 0.775V. Separation: 30dB at 1kHz. Fast forward and rewind: 90-100 sec for C60 cassette. FR: 40Hz-12kHz. Three-digit tape position indicator with PB reset. Slider and pushbutton controls. Illuminated recording level controls. Wood cabinet. Price: £47.95.

■ GRUNDIG (Great Britain) LTD

Newlands Park, Sydenham, London, SE26.
Tel: 01-778 2211.

CN224 ★

Mains operated $\frac{1}{4}$ -track stereo tape unit. Compact cassette. Speeds: $1\frac{7}{8}$ i/s. W and F: $1\frac{7}{8}$ i/s $\leq 0.4\%$. H and N: $1\frac{7}{8}$ i/s -40dB. FR: 60Hz-10kHz ± 3 dB. Replay char: DIN. Automatic level control. Inputs: mic (2) 1mV 100K, radio diode (2) 1mV 25K, PU (2) 40mV 1M. Outlet: 150mV (2) 30K. DC-controlled motor. Own deck. Pause control. Parallel track replay. Auto stop. Digital tape position indicator. Size: $10\frac{1}{2} \times 3\frac{1}{2} \times 9\frac{1}{2}$ in. Weight: 5 $\frac{1}{4}$ lb. Price: £53.15 (plus £8.95 PT).

■ HARMAN-KARDON

Distributors: Highgate Acoustics Ltd,
184-188 Great Portland Street, London, W1.
Tel: 01-636 2901.

CAD5

Stereo cassette tape unit incorporating the Dolby B noise reduction system. $\frac{1}{4}$ -track compact cassettes. Speed: $1\frac{7}{8}$ i/s. W and F: 0.15%. S/N: better than 50dB at zero VU. FR: 30Hz-12.5kHz ± 2 dB. Twin VU meters. Inputs: 200mV



Grundig CN224

± 2 dB for zero VU. input impedance: 200K. HD: $< 1.5\%$. Tape speed variation: within 1%. Bias oscillator frequency: 105kHz. Crosstalk: 40dB. Erasure: better than 55dB. Output: 1.0V. Size: $12\frac{1}{2} \times 9 \times 3\frac{1}{4}$ in. Weight: 10lb. Tape position indicator with pushbutton reset. Pushbutton function switches. Slider type level controls (one for each channel). Mains on/off switch. Dolby in-out switch. Indicator light to show Dolby in. Indicator light to show modulation level overload. Indicator light to show motor on. Indicator light for record. Stereo/mono microphone switch. Special equalisation/bias switch adjusts record and playback characteristics for standard or chromium dioxide tapes. Automatic motor shut-off at end of tape. AC mains. Price: £145 (including PT).

■ HITACHI

Hitachi Sales (UK) Ltd, Park House,
Coronation Road, Park Royal, London,
NW107QS. Tel: 01-965 9861.

TRQ134D

Eight-track cartridge stereo tape deck. Stereo record and play-back. Four stereo programmes per cartridge. Speed: $3\frac{3}{4}$ i/s. FR: 40Hz-12kHz. AC bias. S/N ratio: better than 53dB. Crosstalk: better than 55dB. W and F: less than 0.15% RMS. Inputs: mic 330 ohms, line 47K. Outlets: line 2K, headphones 8 ohms. Four ICs, 13 diodes. Auto stop. Fast forward. Monitoring. Size: $15\frac{3}{4} \times 4\frac{3}{8} \times 11$ in. Weight: 12 $\frac{1}{4}$ lb. Finish: wood cabinet with metal trims. Price: £65 (including PT).

■ KELLAR ELECTRONICS LTD

Lopen Works, Lopen Road, Edmonton,
London, N18. Tel: 01-807 4986.

New range of tape recording and playback equipment incorporating Dolby B noise reduction system and Garrard cassette deck. Full details on request.

See Tape Amplifiers Section for details of Kellar KDB-1 noise reduction unit for use between tape unit and main amplifier.

★ Indicates entry is illustrated

■ **LUXOR (Luxor Industri Aktiebolag)**

Highgate Acoustics Ltd,
184 Great Portland Street, London, W1.
Tel: 01-636 2901.

MP813 ★

Stereo tape unit with amplifiers. Speeds: $1\frac{7}{8}$, $3\frac{3}{4}$, $7\frac{1}{2}$ i/s. Four track. Max spool 7in. Output: 10W RMS per channel. Built-in monitor speakers. Inputs: mic, record player, radio. Outputs: speakers, headphones, amplifier. Size: $7\frac{1}{4} \times 20\frac{1}{2} \times 15$ in. Price: £175 (including PT).

MP823

Identical specification to MP813 but without built-in amplifier. Price: £135 (including PT).

■ **NATIONAL PANASONIC**

Distributed by: Unamec Ltd,
United Africa House, Blackfriars Road,
London, SE19UG. Tel: 01-928 2070.

Panasonic RS-768U/S

$\frac{1}{4}$ -track 3-head 3-speed stereo tape unit. Transistorised with built-in pre-amps. Two VU meters, 4-pole hysteresis synchronous motor. Integrated circuits employed in pre-amp stages. National noise filter eliminates disturbance from non-recorded portions on tape. Auto stop, 40151T counter, sound on sound, sound with sound recording. Price: £87.32 (plus £15.28 PT).

Panasonic RS-735U/S

$\frac{1}{4}$ -track three-speed stereo tape unit. Speeds: $7\frac{1}{2}$, $3\frac{3}{4}$, $1\frac{7}{8}$ i/s. Max spool 7in. W and F: 0.09% at $7\frac{1}{2}$ i/s. FR: 20Hz-28kHz. Replay char: DIN. Meter level indicator. Inputs: mic (2) 0.56mV 20K, aux (2) 0.1mV 100K, DIN input. Outlets: line (2) 0.1mV 3K. Fully transistorised circuit. Own deck. One four-pole hysteresis synchronous motor. Superimpose. Pause control. Monitoring. Input mixing. Parallel track replay. ICs incorporated. Hot pressed ferrite heads. Size: $20 \times 14 \times 8$ in. Weight: 25lb. Mains operation (AC). Price: £122.08 (plus £21.37 PT).

RS-256US

Stereo cassette tape unit. Compact cassettes. Speed: $1\frac{7}{8}$ i/s. AC mains. FR: 30Hz-12kHz. 16 transistors. Auto-stop. Tape position indicator. Two level meter. $10\frac{1}{4} \times 3\frac{3}{8} \times 10$ in. Weight: $7\frac{1}{2}$ lb. Headphone outlet. Price: £54.72 (plus £9.58 PT).

RS-803US

Eight-track stereo tape unit. Eight-track cartridge. Speed: $3\frac{3}{4}$ i/s. AC mains. FR: 50Hz-15kHz. 12 semiconductors. Auto-stop. Level meter. Size: $16\frac{1}{4} \times 4\frac{5}{8} \times 9\frac{1}{4}$ in. Weight: 12lb. Fast forward. Four programme indicators. Stereo headphone outlet. Price: £67.36 (plus £11.79 PT).

RS-262US

Stereo cassette tape unit. Compact cassettes. Speed: $1\frac{7}{8}$ i/s. AC mains. FR: 30Hz-12kHz. 14

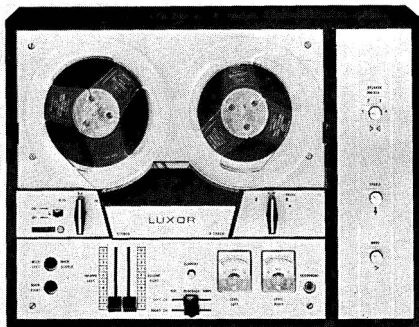

Luxor MP813

semiconductors. Auto-stop. Tape position indicator. Level meters. Size: $13\frac{1}{2} \times 4 \times 9\frac{1}{4}$ in. Weight: $7\frac{1}{2}$ lb. Slider level controls. Switch position for normal or chromium dioxide tape. Headphone outlet. Price: £57.45 (plus £10.05 PT).

■ **NIVICO**

Denham & Morley (Overseas) Ltd,
Denmore House, 453 Caledonian Road,
London, N7. Tel: 01-607 6568.

1450

Stereo two-speed tape unit. FR: 30Hz-20kHz ± 3 dB. S/N ratio: better than 52dB. W and F: 0.1% RMS. 11 transistors and four ICs. Speeds: $3\frac{3}{4}$ and $7\frac{1}{2}$ i/s. Triple head design. Tape selector switch. Mechanical auto-stop. Price: £98.75 (including PT).

1400

Stereo four-track tape unit. FR: 20Hz-25kHz (30Hz-20kHz ± 3 dB). S/N ratio: better than 53dB. W and F: 0.1% RMS. 20 transistors and eight ICs. Mechanical auto stop. Tape selector switch. Four VU meters. Price: £295 (including PT).

MTR-15E

Stereo four-track tape unit. Speeds: $3\frac{3}{4}$, $7\frac{1}{2}$ i/s. FR: $3\frac{3}{4}$ i/s 30Hz-13kHz, $7\frac{1}{2}$ i/s 30Hz-20kHz. W and F: $< 0.15\%$ RMS. S/N ratio: better than 52dB. 30 transistors and six diodes. All-in-one control switch. Sound-on-sound and sound-with-sound recording. Price: £192.94 (including PT).

1661

Stereo cassette tape unit. Speed: $1\frac{7}{8}$ i/s. Compact cassettes. $\frac{1}{4}$ -track. FR: 30Hz-18kHz. S/N ratio: better than 45dB. W and F: 0.15% RMS. 14 transistors and eight diodes. Noise suppressor. Dual VU meters. Slider controls. Three-digit tape position indicator. Price: £71.93 (including PT).

1667 ANRS

Cassette stereo tape unit. Speed: $1\frac{7}{8}$ i/s. Compact

cassettes. Full details and specification on request. Price: £121 (including PT).

1260

Eight-track stereo cartridge player/recorder unit. FR: 30Hz-15kHz. S/N ratio: better than 50dB. W and F: <0.22% RMS. 16 transistors and seven diodes. Fast forward function. Pause. Dual VU meters. Stop indicator. Price: £93.81 (including PT).

■ PHILIPS ELECTRICAL LTD

Century House, Shaftesbury Avenue, London, WC2. Tel: 01-437 7777.

N4500 ★

Mains operated $\frac{1}{4}$ -track stereo tape unit. Speeds: $7\frac{1}{2}$, $3\frac{3}{4}$, $1\frac{7}{8}$ i/s. Max spool: 7in. W and F: <0.15%. H and N: > -50dB. FR: $7\frac{1}{2}$ i/s 40Hz-18kHz, $3\frac{3}{4}$ i/s 40Hz-15kHz, $1\frac{7}{8}$ i/s 60Hz-10kHz. Replay char: CCIR. Rewind time: <3 min for 1,800ft. Two meter level indicators. Inputs: mic 0.2mV 2K, radio 2mV 20K, PU 100-150mV 1 megohm. Outlets: line 0.5-1V 20K, monitor 0.5-1V 50K, headphones 0.3V 600 ohms. Transistors. Own deck. One motor. Pause. Straight-through amplifier. Monitoring. Input mixing. Parallel track replay. Echo. Track to track transfer. Sliding fader-type controls. Size: $19\frac{1}{2} \times 13\frac{3}{8} \times 7\frac{1}{2}$ in. Vertical or horizontal operation. Weight: 22lb. Mains: 110/250V 50/60Hz. Price: £107.12 (plus £17.18 PT).

N2506 ★

Mains operated stereo cassette unit to fit in with Audio plan Equipment. Built-in dynamic noise limiter circuit (DNL) to reduce subjective S/N ratio. Speed: $1\frac{7}{8}$ i/s. W and F: 0.35% DIN weighted. H and N: better than 45dB. FR: 60Hz-10kHz. Rewind time: <80 sec for C60. Meter level indicator. Input/output sockets for external amplifier. Input/output socket for phono/micro. One motor. Pause. Size: $8\frac{1}{2} \times 8\frac{1}{2} \times 2\frac{7}{8}$ in. Weight: 4 $\frac{1}{2}$ lb. Mains: 110/240V 50/60Hz. Price: £51.35 (plus £8.65 PT).

■ PIONEER

Distributors: Shriro (UK) Ltd, 42 Russell Square, London, WC1B 5DF. Tel: 01-580 6996.

T3300 ★

Cassette tape unit with preamplifiers. Stereo $\frac{1}{4}$ -track. Speed: $1\frac{7}{8}$ i/s. Compact cassette. W and F: <0.2%. H and N: better than 45dB. FR: 40Hz-12kHz. Replay char: DIN. Rewind time: 70 sec. Meter level indicator. Inputs: mic (2) 0.35mV 50K, line 35mV 100K. Outlets: line 0.775V 50K, headphones 0.15mW 8 ohms. One motor. Own deck. Pause control. Automatic eject mechanism at end of tape. Left and right slider controls for record and playback. Size: $13 \times 4\frac{1}{4} \times 8\frac{3}{8}$ in. Weight: 10lb. Mains operation. Price: £87.38 (plus £12.62 PT).



Philips N4500

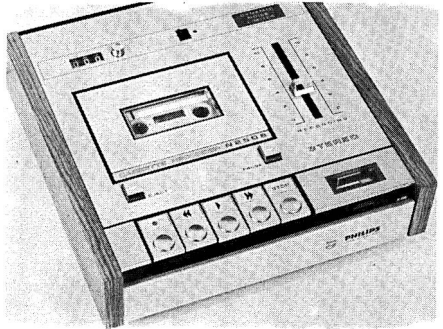

Philips N2506

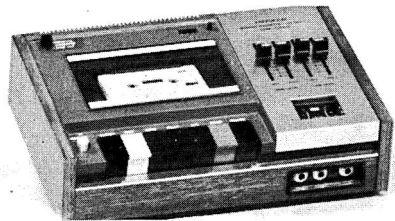

Pioneer T3300



Pioneer T6600

★ Indicates entry is illustrated

T6600 ★

Stereo tape unit with preamplifiers. $\frac{1}{4}$ -track. Speeds: $7\frac{1}{2}$, $3\frac{3}{4}$ i/s. Max spool: 7in. W and F: $7\frac{1}{2}$ i/s <0.12%, $3\frac{3}{4}$ i/s <0.2%. H and N: better than 55dB. FR: $7\frac{1}{2}$ i/s 30Hz-20kHz, $3\frac{3}{4}$ i/s 30Hz-13kHz. Replay char: DIN. Rewind time: 110 sec for 1,200ft. Meter level indicator. Inputs: mic (2) 0.3mV 50K, line (2) 30mV 330K. Outlets: line (2) 0.775V 50K, headphones 0.2mW 8 ohms. One motor, centre capstan drive. Own deck. Size: $17\frac{1}{4} \times 17\frac{1}{4} \times 7\frac{1}{8}$ in. Weight: 28 $\frac{1}{2}$ lb. Pause control. Straight-through amplifier. Automatic reverse on record and playback. AC mains operation. Price: £159.05 (plus £22.96 PT).

T8800

Stereo tape unit with preamplifiers. $\frac{1}{4}$ -track. Speeds: $7\frac{1}{2}$, $3\frac{3}{4}$ i/s. Max spool: 7in. W and F: $7\frac{1}{2}$ i/s <0.08%, $3\frac{3}{4}$ i/s <0.15%. H and N: better than 55dB. FR: $7\frac{1}{2}$ i/s 30Hz-20kHz, $3\frac{3}{4}$ i/s 30Hz-15kHz. Replay char: DIN. Rewind time: 110 sec for 1,200ft. Two level meters. Inputs: mic (2) 0.5mV 50K, line (2) 55mV 100K. Outlets: line 0.775V 50K, line 0.1V, headphones 0.4mW 8 ohms. Two motors (eight-pole/four-pole). Own deck. Size: $21\frac{1}{8} \times 9\frac{1}{2} \times 17$ in. Weight: 50lb. Superimpose. Pause control. Monitoring. Input mixing. Parallel track replay. Automatic reverse on record and replay. Three plus three heads. Recording bias selector switch. Adjustable reel height. Optional remote control. AC mains operation. Price: £320.98 (plus £46.34 PT).

T6100

Stereo tape unit. Open reel. $\frac{1}{4}$ -track, two channel. Speeds: $7\frac{1}{2}$, $3\frac{3}{4}$ i/s. Max spool: 7in. One motor, hysteresis synchronous. Four heads. Price: £142.25 (plus £20.54 PT).

PLANET PROJECTS LTD

Goodman Works, Belvue Road, Northolt, Middlesex. Tel: 01-845 1775.

C.D.2.P.A.

This comprises model C.D.2 tape deck (see Tape Transport section) with built-in preamplifier and power supply. Power supply provides correct voltages for operating both relays and also a stabilised supply for the preamplifier. Preamplifier is three-stage direct coupled block using high frequency silicon planar transistors. Equalisation and stability is achieved with multiple feedback loops operating down to DC. Average output: 250mV. Output impedance: 200 ohms to be fed into a load not less than 2.5K. FR: 30Hz-12kHz+3dB. HD: not greater than 3dB. S/N: 50dB. Price on application.

SANSUI

Vernitron Ltd, Thornhill, Southampton, SO9 5QF. Tel: Southampton 44811.

SC700 (Dolby) ★

Stereo cassette tape unit. Speed: $1\frac{7}{8}$ i/s. Inputs:



Sansui SC-700

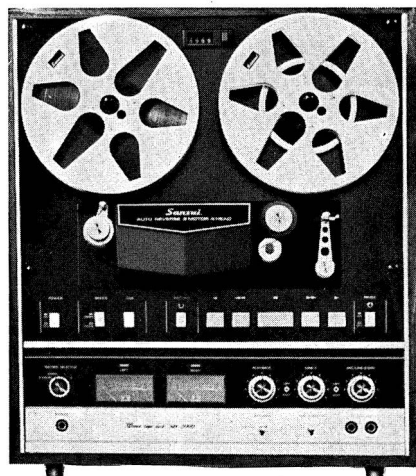

Sansui SD-5000 Heads



Sanyo MR801

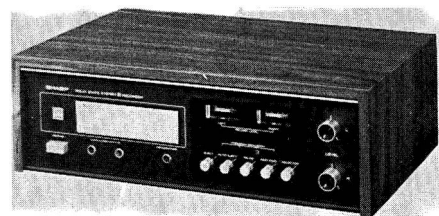

Sharp RT811

mic (L & R) 0.5mV 10K, mic (centre) 0.5mV 10K, line 70mV 100K, DIN 14mV 100K. Output: line (1) 1.2mV, line (2) 0.35mV, DIN 1.2mV, headphones 6mW at 8 ohms. W and F: 0.12%. Tape speed accuracy: within 1%. Fast rewind: 85 sec for C60 cassette. FR: 40Hz-13kHz (standard tape with Dolby); 40Hz-16kHz (Chrome tape with Dolby). S/N ratio: better than 50dB without Dolby, better than 56dB with Dolby. Mains: 100, 117, 220, 240V AC. Size: $15\frac{1}{4} \times 10\frac{1}{8} \times 4\frac{1}{2}$ in. Price: £138.75 (plus £23.12 PT).

SD5000 ★

Stereo reel-to-reel tape unit. Speeds: $3\frac{3}{4}$, $7\frac{1}{2}$ /s. Max spool: 7in. Forward-play head and reverse-play head. Tape speed accuracy: within 0.5%. Two eight-pole motors, one six-pole motor. Capstan drive: belt. W and F: $3\frac{3}{4}$ /s < 0.12%, $7\frac{1}{2}$ /s < 0.08%. Rewind time: 120 sec for 1,800ft. FR: $3\frac{3}{4}$ /s 15Hz-15kHz ± 3 dB, $7\frac{1}{2}$ /s 15Hz-25kHz ± 3 dB. S/N ratio: better than 60dB. Distortion: (amplifier) < 0.15%, (tape) < 1.2%. Inputs: mic 0.5mV 50K, line 70mV 100K, DIN 14mV 100K. Two VU meters. Size: $16\frac{1}{2} \times 10 \times 19\frac{1}{2}$ in. Finish: walnut cabinet. Two year guarantee. Price: £281.11 (plus £46.85 PT).

■ SANYO

Sanyo Marubeni (UK) Ltd, Sanyo House, Bushey Mill Lane, Watford, Herts.
Tel: Watford 30421.

MR801 ★

$\frac{1}{4}$ -track three-speed tape unit. 7in reels. W and F: $7\frac{1}{2}$ /s 0.15%, $3\frac{3}{4}$ /s 0.2%, $1\frac{7}{8}$ /s 0.3%. H and N: $7\frac{1}{2}$ /s -45dB unweighted -50dB weighted. FR: $7\frac{1}{2}$ /s 20Hz-20kHz ± 3 dB. Other speeds: $3\frac{3}{4}$ i/s 30Hz-13kHz; $1\frac{7}{8}$ i/s 30Hz-8kHz. Replay char: NAB ($7\frac{1}{2}$ /s). 2 VU meters. Rewind 2 min 1,200ft. Inputs: mic 0.3mV 50K, line 100mV 300K, tuner 4mV 10K. Outputs: line 800mV, 2K; amp 800mV, 2K; headphones 8 ohms or 10K. Digital position indicator. Monitor. Sound-with-sound. Auto stop. Pause. Psn: 100V, 117V, 125V, 220V, 240V, 50Hz, 35W. Size: $15\frac{3}{8} \times 12\frac{7}{8} \times 6\frac{3}{4}$ in. Weight: 18lb. Price: to be announced.

MR801D

$\frac{1}{4}$ -track three-speed tape unit. Max spool: 7in. Speeds: $1\frac{7}{8}$, $3\frac{3}{4}$, $7\frac{1}{2}$ /s. W and F: $1\frac{7}{8}$ i/s 0.3%, $3\frac{3}{4}$ i/s 0.2%, $7\frac{1}{2}$ i/s 0.15%. FR: $1\frac{7}{8}$ i/s 30Hz-8kHz, $3\frac{3}{4}$ i/s 30Hz-12kHz, $7\frac{1}{2}$ i/s 20Hz-20kHz (30Hz-15kHz ± 3 dB). Twin VU meters. Preset recording level. Automatic shut-off. Single lever control for start, stop, record, play, pause, rewind and fast forward. Sound-with-sound. Monitoring. Sockets for stereo headphones. DIN connectors. Mains: 120-240V AC. 12 transistors. Size: $15\frac{3}{8} \times 12\frac{7}{8} \times 6\frac{3}{4}$ in. Weight: $26\frac{1}{2}$ lb. Supplied with connecting leads, splicing tape empty spool and reel retainers. Price: to be announced.

MR805

$\frac{1}{4}$ -track three-speed stereo tape unit. Max spool 7in. Speeds: $1\frac{7}{8}$, $3\frac{3}{4}$, $7\frac{1}{2}$ /s. W and F: $1\frac{7}{8}$ i/s 0.25%, $3\frac{3}{4}$ i/s 0.18%, $7\frac{1}{2}$ i/s 0.08%. FR: $1\frac{7}{8}$ i/s 30Hz-8kHz, $3\frac{3}{4}$ i/s 30Hz-13kHz, $7\frac{1}{2}$ i/s 30Hz-20kHz. Inputs: fmic (2), aux (2). Outputs: line 0.775V (2). Monitoring. Echo. Sound-on-sound. Sound-with-sound. Built-in tape cleaner. Four-digit tape position indicator with PB reset. Operates in horizontal or vertical position. Mains: 120-240V AC. 21 transistors. Supplied with two connecting leads, empty spool, splicing tape, reel retainers. Size: $15\frac{1}{2} \times 13\frac{3}{4} \times 7\frac{1}{4}$ in. Weight: $23\frac{1}{4}$ lb. Price: to be announced.

■ SCOPETRONICS

Crown Works, Church Road, Kingston-upon-Thames, Surrey. Tel: 01-546 1275 and 4135.

1150

Stereo tape unit. Speeds: $7\frac{1}{2}$, 15i/s. Max spool capacity: $11\frac{1}{2}$ in. W and F: 0.08% (both speeds). H and N: -57dB. FR: $7\frac{1}{2}$ i/s 40Hz-15kHz $\pm \frac{1}{2}$ dB; 15i/s 40Hz-15kHz $\pm \frac{1}{2}$ dB. Replay char: NARTB, CCIR. Level indicator: meter. Rewind time: 2,400ft in < 1 min 45 sec. Inputs: line in, 2V 100K. Line out, 1mW 600 ohms. Valves. Motors: 3 Papst Ext. Rotor. Tape deck: own. Superimpose, pause and inching facilities. Straight-through amplifier. Variable spooling. Removable plug-in head block. Psn: 250V 50Hz. Price: (mono) from approximately £375; (stereo) from approximately £550; (console versions) approximately £85 extra.

■ SHARP

Sharp Electronics (UK) Ltd, 48 Derby Street, Manchester, M8 8HN. Tel: 061-832 6115.

RD712D

Mains operated stereo $\frac{1}{4}$ -track tape unit. Speeds: $7\frac{1}{2}$, $3\frac{3}{4}$, $1\frac{7}{8}$ i/s. W and F: $7\frac{1}{2}$ i/s 0.15%, $3\frac{3}{4}$ i/s 0.2%, $1\frac{7}{8}$ i/s 0.2%. FR: $7\frac{1}{2}$ i/s 40Hz-16kHz ± 6 dB, $3\frac{3}{4}$ i/s 50Hz-9kHz, $1\frac{7}{8}$ i/s 50Hz-3.5kHz. Max spool: 7in. Three digit tape indicator. Rewind time: less than 2 min for 1,200ft. Replay char: DIN. Meter level indicator. Inputs: mic 0.1mV 200 ohms, aux 5mV 15K. Output: line 3K. One motor. Parallel track replay. Mains: 110, 200, 220, 240V 50-60Hz. Size: $11\frac{3}{4} \times 15\frac{3}{4} \times 6\frac{7}{8}$ in. Weight: 22lb. Price: £60.15 (plus £10.13 PT).

RD423E

Mains operated $\frac{1}{4}$ -track stereo tape unit. Speed: $1\frac{7}{8}$ i/s. W and F: 0.18% max. FR: 40Hz-13kHz. Compact cassette. Three digit tape indicator. Dual VU meters. Weight: $5\frac{1}{2}$ lb. Price: £47.83 (plus £8.05 PT).

RT811 ★

Mains operated eight-track stereo cartridge recorder and playback unit. Speed: $3\frac{3}{4}$ i/s. Eight-

★ Indicates entry is illustrated

track endless tape cartridge. Two record level meters. Channel indicator. Record indicator. Inputs: mic (2), line (2). Outlets: line (2), headphones (1). Controls: (pushbuttons) programme selector, record, pause, fast forward, eject, auto eject, (rotary) record level. Motor: 21V two-speed with mechanical governor. AC bias. AC erase. Supplied with four connecting leads. Finish: wood veneered cabinet with black steel panel. Size: $14 \times 4\frac{3}{4} \times 8\frac{5}{8}$ in. Weight: 13lb. Mains: 240V 50Hz. Price: £62.48 (plus £10.52 PT).

■ SONY (UK) LTD

Pyrene House, Sunbury Cross, Sunbury-on-Thames, Middlesex. Tel: Sunbury 87644/7.

TC366

Stereo tape unit with preamps, $\frac{1}{4}$ -track. Speeds: $7\frac{1}{2}$, $3\frac{3}{4}$, $1\frac{7}{8}$ i/s. Max spool 7in. W and F: $7\frac{1}{2}$ i/s <0.09%, $3\frac{3}{4}$ i/s <0.17%. FR: $7\frac{1}{2}$ i/s 20Hz-25kHz, $3\frac{3}{4}$ i/s 30Hz-17kHz, $1\frac{7}{8}$ i/s 30Hz-9kHz. Rewind time: 100 sec for 1,200ft. Two VU meters. Inputs: mic 0.19mV (-72dB) 600 ohms, aux 0.06V (-22dB) 100K. Outputs: line 0.775V 100K, headphones 8 ohms. Stereo recording and playback. S/N: better than 52dB (normal),

55dB (SLH). Three heads. Input mixing. Servo-controlled tape tension. Auto stop. Size: $16\frac{1}{2} \times 8\frac{3}{8} \times 14\frac{7}{8}$ in. Finish: walnut grained wood. Price: £99.65 (plus £15.10 PT).

TC127

Stereo cassette tape unit. $\frac{1}{4}$ -track. Compact cassette. Speed: $1\frac{7}{8}$ i/s. W and F: 0.2%. FR: 30Hz-12kHz. S/N: 48dB. Two VU meters. Inputs: mic 0.2mV (-72dB) low impedance, aux 60mV (-22dB), 560K, record/playback connector -40dB 3.9K. Outputs: line 0.775V (0dB) 100K, headphones 8 ohms, record/playback connector 0dB 8-2K. Slider level controls. Size: $15\frac{3}{4} \times 3\frac{3}{8} \times 8\frac{5}{8}$ in. Weight: 10lb 9oz. Mains: 100, 110, 117, 125, 220 or 240V. Price: £60.50 (plus £10.20 PT).

TC160

Stereo cassette tape unit. $\frac{1}{4}$ -track. Speed: $1\frac{7}{8}$ i/s. W and F: 0.1%. H and N: 49dB. FR: 20Hz-18kHz. Replay char: NARTB. Rewind time: 1 min 20 sec for C60 cassette. Twin VU meters. Inputs: mic (2) 0.2mV 600 ohms, aux (2) 60mV 100K. Outlets: line (2) 0.775V 10K, phones 30mV 8 ohms. One motor. Size: $15\frac{3}{4} \times 5 \times 10\frac{7}{8}$ in. Weight: 13 $\frac{1}{4}$ lb. Pause. Monitoring. Parallel



Sony TC640



Sony TC440

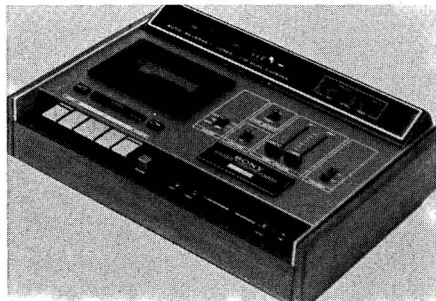

Sony TC165

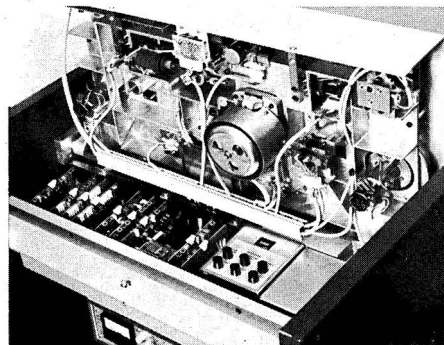

Studer A80 (Underside)

track replay. Dual loop capstan drive. Cr0, tape facility. Slider controls. Tape counter. Mains: 100, 110, 120, 127, 220, 240V AC. Price: £83-02 (plus £13-98 PT).

TC165 ★

Stereo cassette tape unit. $\frac{1}{4}$ -track. Compact cassettes. Speed: $1\frac{7}{8}$ i/s. W and F: 0.1%. H and N: 49dB. FR: 30Hz-17kHz. Rewind time: 1 min 20 sec for C60 cassette. Twin VU meters. Inputs: mic (2) 0.19mV low Z, aux 62mV 100K. Outlets: line (2) 0.775V 10K, phones 8 ohms. One motor. Size: $15\frac{3}{4} \times 5 \times 10\frac{7}{8}$ in. Weight: 15 $\frac{1}{2}$ lb. Pause. Inching. Monitoring. Parallel track replay. Auto reverse. Auto shut-off. Cr₂ tape facility. Slider controls. Tape position indicator. Mains: 100, 110, 120, 127, 220, 240V AC. Price: £117-97 (plus £18-18 PT).

TC440 ★

Three-speed stereo tape unit. $\frac{1}{4}$ -track. Speeds: $7\frac{1}{2}$, $3\frac{3}{4}$, $1\frac{7}{8}$ i/s. Max spool 7in. W and F: $7\frac{1}{2}$ i/s < 0.6%, $3\frac{3}{4}$ i/s < 0.1%, $1\frac{7}{8}$ i/s < 0.2%. H and N: $7\frac{1}{2}$ i/s (normal tape) better than 53dB, (SLH tape) better than 56dB. FR: $7\frac{1}{2}$ i/s 30Hz-20kHz ± 3 dB, $3\frac{3}{4}$ i/s 30Hz-17kHz. Rewind time: 2 min 50 sec for 1,800ft. Twin VU meters. Inputs: mic 0.2mV low Z, aux 60mV 100K. Outlets: line 0.775V 3-3K, phones 8 ohms. One motor, servo-controlled. Size: $16\frac{5}{8} \times 8\frac{1}{2} \times 16\frac{1}{4}$ in. Weight: 27lb. Superimpose. Pause. Inching. Monitoring. Input mixing. Parallel track replay. Auto reverse. Bi-directional recording. Rotating record and playback heads. Selector for standard or high output tapes. Mains: 100, 110, 120, 127, 220, 240V AC. Price: £147-89 (plus £24-91 PT).

TC640 ★

Two-speed stereo tape unit. $\frac{1}{4}$ -track. Speeds: $7\frac{1}{2}$, $3\frac{3}{4}$ i/s. Max spool 7in. W and F: $7\frac{1}{2}$ i/s 0.07%, $3\frac{3}{4}$ i/s 0.11%. H and N: 55dB. FR: $7\frac{1}{2}$ i/s 30Hz-20kHz ± 3 dB. Rewind time: 90 sec for 1,200ft. Twin VU meters. Inputs: mic 0.2mV 600 ohms, line 60mV 100K. Outlets: line 0.775V 100K, phones 8 ohms. Three motors. Size: $14\frac{1}{2} \times 15\frac{1}{2} \times 9\frac{1}{2}$ in. Weight: 33lb. Superimpose. Monitoring. Input mixing. Parallel track replay. Three heads. Tape position indicator. Built-in reel locks. Scratch filter. Separate level controls for each channel. Mains: 100, 110, 120, 127, 220, 240V AC. Price: £86-14 (plus £27-29 PT).

TC-850-2

Three-speed stereo tape unit. $\frac{1}{4}$ - and $\frac{1}{2}$ -track. Speeds: 15, $7\frac{1}{2}$, $3\frac{3}{4}$ i/s. Max Spool 10 $\frac{1}{2}$ in. W and F: 15i/s 0.03%, $7\frac{1}{2}$ i/s 0.04%, $3\frac{3}{4}$ i/s 0.08%. H and N: 59dB. FR: 15i/s 30Hz-20kHz ± 2 dB, $7\frac{1}{2}$ i/s 30Hz-22kHz ± 2 dB, $3\frac{3}{4}$ i/s 40Hz-15kHz ± 2 dB. Rewind time: 170 sec for 2,400ft. Twin VU meters. Inputs: mic (2) 0.2mV 100K, line (2) 0.07mV 100K. Outlets: line (2) 0.775V 2-2K, phones 8 ohms. Three motors, servo-controlled

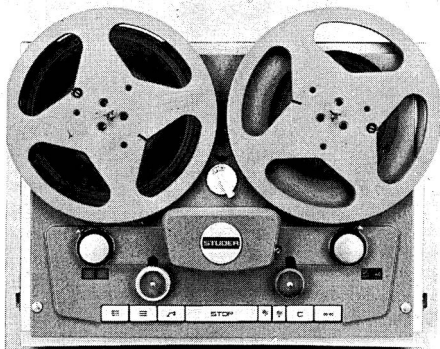

Studer B62

capstan drive. Size: $17\frac{1}{2} \times 19\frac{3}{4} \times 10$ in. Weight: 57 $\frac{1}{2}$ lb. Superimpose. Pause. Inching. Monitoring. Input mixing. Parallel track replay. Remote control facility. Auto shut off. Mains: 100, 110, 127, 220, 240V AC. Price: £178-89 (plus £63-03 PT).

■ STUDER

Studer-Franz AG, Switzerland.
Distributors: F. W. O. Bauch Ltd.,
49 Theobald Street, Boreham Wood, Herts.
Tel: 01-953 0091. Telex: 27502.

Studer A80 ★

Professional tape unit with preamplifiers. Mono or stereo on $\frac{1}{4}$ in tape, four-track on $\frac{1}{2}$ in tape, four-track or eight-track on line tape, 16-track on 2in tape. Speeds: $7\frac{1}{2}$ and 15i/s. Max spool: 12in. W and F: 15i/s $\pm 0.04\%$, $7\frac{1}{2}$ i/s $\pm 0.06\%$. H and N: 15i/s 62dB; $7\frac{1}{2}$ i/s 60dB. FR: 15i/s 30Hz-18kHz ± 1 dB; $7\frac{1}{2}$ i/s 60Hz-12kHz ± 0.75 dB. Replay char: switchable NAB/CCIR. Rewind time: 2 min for 1,000 metres. Separate VU meter for each channel. Inputs: 0.3V to 10V (-8dBm to +22dBm) adjustable. Balanced input with impedance higher than 8K between 30Hz-18kHz. Outputs: -8dBm to +24dBm adjustable. Output balanced with impedance less than 30 ohms between 30Hz-18kHz. Servo-controlled capstan motor, two high-torque asynchronous spooling motors. Tape deck control by eight printed circuit cards equipped with logic circuits, giving constant tape tension throughout all operating modes. Five-digit counter indicating hours, min and sec (accuracy 0.2%). Mains: 240V AC. Prices and further details to professional users on request.

Studer B62 ★

Professional tape unit with preamplifiers. Mono, stereo or twin-track on $\frac{1}{4}$ in tape. Speeds: $7\frac{1}{2}$ and 15i/s. Max spool: 10 $\frac{1}{2}$ in. W and F: 15i/s 0.05%, $7\frac{1}{2}$ i/s 0.08%. H and N: 15i/s 61dB, $7\frac{1}{2}$ i/s 58dB.

★ Indicates entry is illustrated

FR: 15i/s and $7\frac{1}{2}$ i/s 30Hz-18kHz ± 2 dB. Replay char: CCIR or NAB by quick-change equaliser printed circuit cards. Rewind time: 100 sec for 700 metres. Servo-controlled capstan motor, two high-torque asynchronous spooling motors. Size: $19 \times 14 \times 8\frac{5}{8}$ in. Accurate tapetimer indicating min and sec. Mains: 240V AC. Prices and further details to professional users on request.

■ TANDBERG

Farnell-Tandberg Ltd, 81 Kirkstall Road, Leeds, LS3 1HR. Tel: Leeds 35111.

3041X ★

Tape unit with preamps. Stereo. $\frac{1}{4}$ -track. Speeds: $1\frac{1}{8}$, $3\frac{3}{4}$ and $7\frac{1}{2}$ i/s. Max spool capacity: 7in. W and F: 0.1% $7\frac{1}{2}$ i/s, 0.2% $3\frac{3}{4}$ i/s, 0.4% $1\frac{1}{8}$ i/s. H and N: 57-51dB. FR (± 2 dB): 40Hz-20kHz $7\frac{1}{2}$ i/s, 50Hz-16kHz $3\frac{3}{4}$ i/s, 50Hz-9kHz $1\frac{1}{8}$ i/s. Meter indicators. Rewind time: 2 min 1,200ft. Inputs: mic 100mV 200 ohms, line 100mV 1M, radio 5mV 57K. Outlets: emitter follower 0.75V 100 ohms, headphones 0.75V 100 ohms. Features: pause, inching, straight-through amp, input mixing, parallel track replay, off tape monitoring. Weight: 20lb. Dimensions: $15\frac{1}{2} \times 12\frac{3}{8} \times 6\frac{1}{2}$ in. Price: (teak) £104 (including PT); (rosewood) £106.92 (including PT).

6041X

Stereo tape unit with deck details as above. Inputs: mic 70mV 200 ohms, radio 5mV 100K, PU 1mV 33K. Outlets: left, right and centre channels, and headphones, each 1.5V 200 ohms. Features as 3000X plus built-in mixing preamp and A-B test. Weight: 23.3lb. Dimensions: $15\frac{1}{2} \times 11\frac{1}{8} \times 6\frac{3}{8}$ in. Price: (teak) £182.73 (including PT); (rosewood) £185.65 (including PT).

6021X

Similar specification to 6041X but $\frac{1}{2}$ -track. Price: (teak) £182.73 (including PT); (rosewood) £185.65 (including PT).

3021X

Similar specification to 3041X but $\frac{1}{2}$ -track. Price: £104 (including PT).

1841X ★

Stereo $\frac{1}{4}$ -track tape unit with preamplifiers. Speed: $3\frac{3}{4}$ i/s. Max spool: $5\frac{3}{4}$ in. Meter level indicator. 23 transistor circuit. Four-digit tape indicator. Straight-through amplifier. Monitoring. AC mains. Output: 0.75V. Finish: teak or rosewood. Size: $13\frac{1}{4} \times 6\frac{1}{4} \times 11$ in. Weight: 14lb. Price: £66.09 (including PT); microphone £7.50 extra.

■ TAPE RECORDER DEVELOPMENTS

Hall Lane, Walsall Wood, Staffs.
Tel: Brownhills 5351.

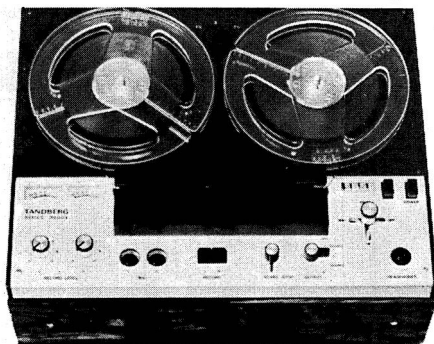

Tandberg 3041X



Tandberg 1841X

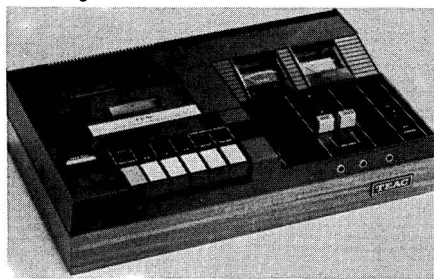

Teac A-110



Teac A-1230

600 Series

4 speed tape units. Independent gain controls for microphones, line inputs, and line outputs. Speeds: (top) $7\frac{1}{2}$, 15 or 30i/s. Upper and lower track function controls. Meter reads 1 or 2 channel or peak of either. Adjustable bias read on meter. Four speed equalisation to DIN 45-513 or NAB. Locking DIN sockets. Input mixing. See TRD1 deck information in Tape Deck section. Inputs: mic 30 to 600 ohms, 70dBm for 600 ohms; line 600 ohms/10K bridging -20dBm +10dBm max into 600 ohms. Output: +10dB max into 600 ohms. FR: 15i/s 40Hz-20kHz; $7\frac{1}{2}$ i/s 40Hz-18kHz; $3\frac{3}{4}$ i/s 40Hz-14kHz; $1\frac{7}{8}$ i/s 40Hz-8kHz (all ± 2 dB). Prices: (replay only machines) £192 to £205; (record/playback machines) £271 to £285. Extras: (remote control) £25; (fourth head and switch) £18; ($\frac{1}{2}$ in tape width) £25; ($\frac{1}{2}$ in heads) £220. Supplied to professional and scientific users only free of tax.

TEAC

Acoustico Enterprises Ltd, 6-8 Union Street, Kingston-on-Thames, Surrey.
Tel: 01-549 3471/3.

A-110 ★

Cassette tape unit. $\frac{1}{4}$ -track stereo. Speed: $1\frac{7}{8}$ i/s. Compact cassettes. W and F: 0-15%. H and N: -50dB. FR: 30Hz-12-5kHz. Replay char: NAB. Rewind time: 70 sec for C60 cassette. Two VU meters. Inputs: mic 72dB 600 ohms, line 0-1V 100K. Outlets: line 0-3V 10K, headphones 8 ohms. Outer rotor motor. Pause. Monitoring. Size: $15\frac{7}{8} \times 4 \times 9\frac{3}{4}$ in. Weight: $8\frac{7}{8}$ lb. Mains: 100, 117, 200, 220, 240V AC. Price: £66-73 (plus £11-68 PT).

A-350

Cassette tape unit. $\frac{1}{4}$ -track stereo. Speed: $1\frac{7}{8}$ i/s. Compact cassettes. W and F: 0-13%. H and N: -50dB, (with Dolby switched-in) -58dB. FR: 30Hz-13kHz, (chromium dioxide) 30Hz-16kHz. Replay char: NAB. Rewind time: 80 sec for C60 cassette. Two VU meters. Inputs: mic 72dB 600 ohms, line 18dB 50K. Outlets: line 0-3V 10K, headphones 8 ohms. Outer rotor motor. Pause. Monitoring. Dolby noise reduction system built-in. Auto-stop. Two heads. Mains: 100, 117, 200, 220, 240V AC. Size: $17 \times 4\frac{3}{8} \times 9\frac{7}{8}$ in. Weight: $11\frac{1}{4}$ lb. Price: £124-71 (plus £21-82 PT).

A1230 ★

Two-speed $\frac{1}{4}$ -track reel-to-reel tape unit. Speeds: $3\frac{3}{4}$, $7\frac{1}{2}$ i/s. W and F: $3\frac{3}{4}$ i/s 0-1%, $7\frac{1}{2}$ i/s 0-08%. FR: $3\frac{3}{4}$ i/s 40Hz-12kHz ± 3 dB, $7\frac{1}{2}$ i/s 40Hz-18kHz ± 3 dB. Replay char: NAB. Rewind time: 90 sec for 1,200ft. VU meter. Inputs: mic 0-3mV 600 ohms, line 0-1V 100K. Outlets: 0-3V 10K, headphones 8 ohms. Three motors; two



Teac A-2520



Teac A-3300

eddy current, one dual-speed. Superimpose. Pause. Monitoring. Input mixing. Parallel-track replay. Size: $17\frac{7}{8} \times 8 \times 15\frac{1}{2}$ in. Weight: Mains: 110, 117, 200, 220, 240V AC. Price: £147-80 (plus £25-87 PT).

A-2520 ★

Two-speed $\frac{1}{4}$ -track stereo reel-to-reel tape unit. Max spool 7in. Speeds: $3\frac{3}{4}$, $7\frac{1}{2}$ i/s. W and F: $3\frac{3}{4}$ i/s 0-1%, $7\frac{1}{2}$ i/s 0-08%. H and N: $3\frac{3}{4}$ i/s -45dB, $7\frac{1}{2}$ i/s -48dB. FR: $3\frac{3}{4}$ i/s 40Hz-10kHz ± 3 dB, $7\frac{1}{2}$ i/s 40Hz-18kHz ± 3 dB. Replay char: NAB. Rewind time: 90 sec for 1,200ft. Two VU meters. Inputs: mic 0-3mV 10K, line 0-1V 100K. Outlets: line 0-3V 10K, headphones 0-3mW 8 ohms. Three motors: one dual-speed, two eddy current. Superimpose. Pause. Input mixing. Monitoring. Parallel track replay. Two-channel recording, four channel playback. Size: $17\frac{7}{8} \times 15\frac{3}{8} \times 8\frac{3}{8}$ in. Weight: $37\frac{1}{2}$ lb. Mains: 100, 117, 200, 220, 240V AC. Price: £237-59 (plus £46-03 PT).



Teac A-7030-SL



Teac R-310

A3300 ★

Two-speed $\frac{1}{4}$ -track stereo reel-to-reel tape unit. Max spool: $10\frac{1}{2}$ in. Speeds: $3\frac{3}{8}$, $7\frac{1}{2}$ i/s. W and F: $3\frac{3}{8}$ i/s 0.09%, $7\frac{1}{2}$ i/s 0.06%. H and N: $3\frac{3}{8}$ i/s -45dB, $7\frac{1}{2}$ i/s -48dB. FR: $3\frac{3}{8}$ i/s 50Hz-10kHz ± 3 dB, $7\frac{1}{2}$ i/s 40Hz-18kHz ± 3 dB. Replay char: NAB. Rewind time: 120 sec for 2,400ft. Two VU meters. Inputs: mic 0.3mV 10K, line 0.1V 100K. Outputs: line 0.3V 10K, headphones 0.3mV 8 ohms. Three motors; one dual speed, two eddycurrent. Superimpose. Pause. Monitoring. Input mixing. Parallel track replay. Bias level switch. 100, 117, 200, 220, 240V AC. Size: $15\frac{3}{8} \times 15\frac{3}{8} \times 9\frac{1}{4}$ in. Weight: 40 $\frac{1}{2}$ lb. Price: £214.35 (plus £37.50 PT).

A7010-SL

Two-speed $\frac{1}{4}$ -track stereo tape unit. Speeds: $3\frac{3}{8}$, $7\frac{1}{2}$ i/s. Max spool: $10\frac{1}{2}$ in. W and F: $3\frac{3}{8}$ i/s 0.09%, $7\frac{1}{2}$ i/s 0.06%. H and N: $3\frac{3}{8}$ i/s -46dB, $7\frac{1}{2}$ i/s -48dB. FR: $3\frac{3}{8}$ i/s 40Hz-7.5kHz ± 2 dB, $7\frac{1}{2}$ i/s 30Hz-20kHz ± 2 dB. Replay char: NAB. Rewind time: 200 sec for 3,600ft. VU meter. Inputs: mic -7dB (0.25mV) 600 ohms, line 0.1V 50K. Outputs: line 0.3V 10K, headphones 8 ohms. Three motors. Superimpose. Pause. Input mixing. Monitoring. Parallel track replay. Auto reverse. Bias level switch. Size: $20\frac{7}{8} \times 17\frac{1}{2} \times 8\frac{1}{4}$ in. Weight: 62lb. Mains: 100, 117, 200, 220, 240V AC. Price: £413.21 (plus £86.77 PT).

A7030-SL ★

Two-speed $\frac{1}{2}$ -track stereo tape unit. Speeds:

$7\frac{1}{2}$, 15i/s. Max spool: $10\frac{1}{2}$ in. W and F: $7\frac{1}{2}$ i/s 0.06%, 15i/s 0.04%. FR: $7\frac{1}{2}$ i/s 30Hz-20kHz ± 3 dB, 15i/s 30Hz-22kHz ± 3 dB. Replay char: NARB. Rewind time: 90 sec for 1,200ft. Two VU meters. Inputs: mic 0.25mV 600 ohms to 10K, line 0.1V 50K. Outputs: line 0.3V 10K, headphones 8 ohms. Three motors. Superimpose. Pause. Input mixing. Monitoring. Parallel track replay. Size: $17\frac{3}{8} \times 21\frac{1}{8} \times 9\frac{1}{2}$ in. Weight: 62lb. Mains: 100, 117, 200, 220, 240V AC. Price: £413.21 (plus £72.30 PT).

R720

Three-speed $\frac{1}{4}$ or $\frac{1}{2}$ -track stereo tape unit. Speeds: $3\frac{3}{8}$, $7\frac{1}{2}$, 15i/s. Max spool: $10\frac{1}{2}$ in. W and F: $3\frac{3}{8}$ i/s 0.06%, $7\frac{1}{2}$ i/s 0.03%, 15i/s 0.02%. FR: $3\frac{3}{8}$ i/s 25Hz-10kHz ± 3 dB, $7\frac{1}{2}$ i/s 25Hz-20kHz ± 3 dB, 15i/s 25Hz-22kHz ± 3 dB. Replay char: NAB. Rewind time: 120 sec for 2,400ft. Two VU meters. Inputs: mic 600 ohms, line 50K. Outputs: line 10K, headphones 8 ohms. Three motors. Full specification and prices on request.

R310 ★

Three-speed $\frac{1}{4}$ or $\frac{1}{2}$ -track stereo tape unit. Speeds: $3\frac{3}{8}$, $7\frac{1}{2}$, 15i/s. W and F: $3\frac{3}{8}$ i/s 0.1%, $7\frac{1}{2}$ i/s 0.06%, 15i/s 0.04%. S/N ratio: (full track) 55dB, (half track) 50dB. FR: $3\frac{3}{8}$ i/s 50Hz-10kHz, $7\frac{1}{2}$ i/s 50Hz-15kHz, 15i/s 30Hz-20kHz. Replay char to order. Rewind time: 90 sec for 2,400ft $10\frac{1}{2}$ in NAB spool. Two VU meters. Size: (tape transport) $19 \times 15\frac{3}{8} \times 8$ in; (amplifier) $19 \times 5\frac{1}{4} \times 8\frac{1}{4}$ in. Full specification and prices on request.

TELEFUNKEN

Distributor: AEG (Great Britain) Ltd, AEG House, Chichester Rents, Chancery Lane, London, WC2. Tel: 01-242 9944.

M250 ★

Two speed $\frac{1}{2}$ -track stereo tape unit. 7in reels. W and F: $3\frac{3}{4}$ i/s $\pm 0.25\%$, $7\frac{1}{2}$ i/s $\pm 0.2\%$. H and N: $3\frac{3}{4}$ i/s -54dB, $7\frac{1}{2}$ i/s -54dB. FR: $3\frac{3}{4}$ i/s 40Hz-15kHz, $7\frac{1}{2}$ i/s 40Hz-18kHz. Replay char: DIN Standard 45-500. Level meters. Inputs: tuner 0.15mV 2K; mic 0.15mV 2K; PU/tape 150mV 2.2M. Outputs: amplifiers 1.5V 10K; earphones 1V into 400 ohms load. Echo at $3\frac{3}{4}$ i/s. Reverberation at $7\frac{1}{2}$ i/s. Monitor combined with instruments. Parallel recording and playback. Track-to-track transcription. Function selector. Record light. Volume control for headphones. Slide control for record level. Preset level controls. Sound-on-sound. Pause: Psn: 110/240V AC. Size: $18\frac{1}{4} \times 12\frac{1}{4} \times 4\frac{1}{4}$. Weight: 26lb. Price: £134.17 (including PT).

M205 ★

Three-speed $\frac{1}{4}$ -track stereo tape unit. Max spool: 7in. Speeds: $1\frac{1}{8}$, $3\frac{3}{4}$, $7\frac{1}{2}$ i/s. W and F: $1\frac{1}{8}$ i/s 0.4%, $3\frac{3}{4}$ i/s 0.25%, $7\frac{1}{2}$ i/s 0.15%. H and N: $3\frac{3}{4}$ i/s -45dB, $7\frac{1}{2}$ i/s -50dB. FR: $1\frac{1}{8}$ i/s 40Hz-8kHz, $3\frac{3}{4}$ i/s 40Hz-15kHz, $7\frac{1}{2}$ i/s 40Hz-18kHz. Inputs: mic, radio, pickup. Outlets: phones, line. Vertical or horizontal operation. Pause control. Multi-function switch. Four-digit tape position indicator. Separate record level controls for left and right channels. Clear plastic lid. Mains: 110-240V AC. Price: £70.97 (including PT).

TOSHIBA

Hanimex (UK) Ltd, 15-24 Great Dover Street, London, SE1. Tel: 01-407 8161.

KT403D ★

Stereo $\frac{1}{4}$ -track cassette tape unit. Speed: $1\frac{1}{8}$ i/s. Compact cassettes. H and N: -40dB. Rewind time: 90 sec for C60 cassette. Twin VU meters. Inputs: mic 0.56mV 10K, line 100mV 1 megohm. Output: 0.5V 10K. W and F: $<0.3\%$. Size: $11\frac{7}{8} \times 4\frac{1}{4} \times 7\frac{3}{8}$ in. Weight: $5\frac{1}{2}$ lb. AC mains. Price: to be announced.

TELETON

Teleton Electro (UK) Ltd, Teleton House, Robjohns Road, Widford, Chelmsford, Essex. Tel: 62442.

STC106

Four-track stereo cassette unit. Speed: $1\frac{1}{8}$ i/s. Compact cassette. W and F: 0.25%. S/N ratio: 32dB. FR: 100Hz-10kHz. Motor speed transistor controlled. AC bias and erasure. Inputs: mic (2) 10K, aux (2) 100K. Output: 0.775V. Mains: 115 or 230V AC. Master level control.

Peak metering, switchable left or right. Finish: oiled walnut. Size: $9\frac{3}{4} \times 9\frac{3}{8} \times 3\frac{1}{8}$ in. Weight: $6\frac{1}{4}$ lb. Price: £40.03 (plus £6.42 PT).

TRIO

Distributors: B. H. Morris & Co (Radio) Ltd, 84-88 Nelson Street, Tower Hamlets, London, E12DY. Tel: 01-790 5011.

KX7010

Stereo cassette tape unit. $\frac{1}{4}$ -track. Speed: $1\frac{1}{8}$ i/s. Compact cassettes. W and F: $<0.2\%$. H and N: better than 45dB. FR: 40Hz-10kHz. Rewind



Telefunken 250 Hi-Fi



Telefunken M-205

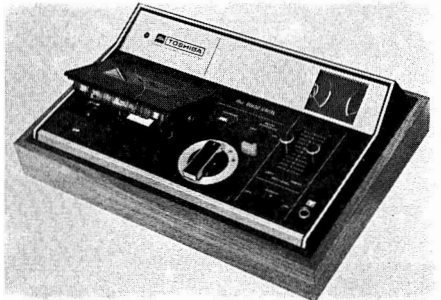

Toshiba KT403D

★ Indicates entry is illustrated



Wharfedale DC9

time: < 70 sec with C60 cassette. Two VU meters. Inputs: microphone (left and right) 0.25mV (69dB) at 50K, line (left and right) 100mV (18dB) at 470K. Outlets: line (left and right) 0.775V (0dB) at greater than 50K, headphones at 8 ohms or over. One motor. Own deck. Pause control. HF filter. Three-digit tape position indicator. Automatic eject cassette system. Record/play indicator light. Size: $10\frac{1}{2} \times 9 \times 4$ in. Weight: 7lb. Mains: 100, 110, 117, 125, 220 and 240V 50/60Hz. Price: £73.77 (plus £11.23 PT).

KX700

Stereo cassette unit with Dolby B noise reduction system. $\frac{1}{4}$ -track. Speed: $1\frac{7}{8}$ i/s. W and F: < 0.15%. FR: CrO₂ 25Hz-16kHz, (standard tape) 25Hz-13kHz. HD: < 2%. Inputs: mic 0.11mV 600 ohms, line 24mV 680K. Output: 0dB (0.775V). Outlet for headphones: 8-16 ohms. Two FETs, 31 transistors, 17 diodes. Rewind time: 75 sec for C60 cassette. H and N: (Dolby in and CrO₂ tape) 88dB, (Dolby in and standard tape) 66dB, (Dolby out and CrO₂ tape) 48dB, (Dolby out and standard tape) 45dB. Automatic shut-off. Dolby indicator. Record level indicator. Three-digit tape position indicator with PB reset. Headphone jack. Mains: 110/120V, 220/240V AC. Size: $11\frac{3}{4} \times 4\frac{3}{8} \times 10\frac{3}{8}$ in. Weight: 7lb. Price: £122 (including PT).

UHER

Distributors: Bosch Ltd, PO Box 166, Rhodes Way, Radlett Road, Watford, Herts, WD24LB. Tel: Watford 44233.

Uher Royal de luxe (C)

Unsterilised semi-professional mains tape unit. Mono/stereo. $\frac{1}{4}$ -track or $\frac{1}{2}$ -track. Speeds: $7\frac{1}{2}$, $3\frac{3}{4}$, $1\frac{7}{8}$, $\frac{1}{2}$ i/s. Max spool 7in. W and F: $7\frac{1}{2}$ i/s 0.05%, $3\frac{3}{4}$ i/s 0.1%, $1\frac{7}{8}$ i/s 0.25%, $\frac{1}{2}$ i/s 0.35%. H and N: $7\frac{1}{2}$ i/s -54dB, $3\frac{3}{4}$ i/s -54dB, $1\frac{7}{8}$ i/s -54dB. FR: $7\frac{1}{2}$ i/s 20Hz-20kHz, $3\frac{3}{4}$ i/s 20Hz-15kHz, $1\frac{7}{8}$ i/s 20Hz-9kHz, $\frac{1}{2}$ i/s 20Hz-5kHz. Replay char: NARTB. Level indicators: two

meters. Inputs: mic 0.2mV-100mV 200 ohms, radio 2mV-1V 47K, PU (1) 50mV 1 megohm. PU (2) 200mV 50K. Outlets: line 775mV 15K. One Papst motor. Pause. Inching. Horizontal or vertical operation. Input mixing. Parallel track replay. Interchangeable head assemblies available as optional extras. Dia-pilot. Multiplay. Echo. Price: £248.86 (including PT).

WHARFEDALE

Rank Wharfedale Ltd, Bradford Road, Idle, Bradford, Yorks.

Tel: Bradford 612552. Telex: 51407.

DC9 ★

Cassette tape unit incorporating Dolby 'B' noise reduction system. Stereo. Speed: $1\frac{7}{8}$ i/s. Compact cassette. W and F: < 0.18%. FR: 50Hz-12kHz \pm 2dB. Rewind time: < 120 sec for C90 cassette. Level indicators: twin VU meters. Inputs: mic 0.2mV \pm 2dB for zero VU, 100mV \pm 2dB for zero VU. Solid state speed controlled DC motor. Pause control. Mains 240V 50Hz. For use with chromium dioxide or standard tape. Price: £91.49 (plus £16.01 PT).

YAMAHA

Jonathan Fallowfield Ltd, Strathcona Road, North Wembley, London, HA98QL.

Tel: 01-904 0141.

TB-500

Stereo $\frac{1}{4}$ -track cassette tape unit. Speeds: $1\frac{7}{8}$ i/s. Compact cassettes. W and F: 0.12%. H and N: 59dB with CrO₂ tape, 50dB with standard tape. Adjustable replay characteristics. FR: (CrO₂) 30Hz-18kHz, (standard tape) 30Hz-16kHz. Rewind time: 90 sec for C90 cassette. VU meter. Adjustable output. DC servo-controlled motor. Pause. Monitoring. Input mixing. Size: $17\frac{1}{4} \times 4\frac{3}{8} \times 12$ in. Weight: $17\frac{1}{2}$ lb. Price: £75 (plus £12.50 PT).

TB-700 (Dolby)

Stereo $\frac{1}{4}$ -track cassette tape unit incorporating Dolby noise reduction system. Speed: $1\frac{7}{8}$ i/s. Compact cassette. W and F: 0.12%. H and N: (without Dolby) 50dB; (with Dolby) 59dB. FR: (standard tape) 30Hz-16kHz \pm 3dB, (CrO₂) 30Hz-18kHz \pm 3dB. Adjustable replay characteristics. Rewind time: 90 sec for C90 cassette. Two VU meters. Adjustable output. DC servo-controlled motor. Pause. Monitoring. Input mixing. Tape speed control gives \pm 3% variation. Three-position bias switch for standard, high-energy and chromium-dioxide (CrO₂) tapes. Size: $17\frac{1}{4} \times 4\frac{3}{8} \times 11\frac{7}{8}$ in. Weight: $18\frac{1}{2}$ lb. Price: £139 (plus £21 PT).

Tape Amplifiers and Mixer Units

★ Indicates entry is illustrated

Abbreviations used in this section are given on page 36.

■ ALPHA

Distributors: Highgate Acoustics Ltd,
184-188 Great Portland Street, London, W1.
Tel: 01-636 2901.

DB6

Noise reducing unit for use between any tape recorder or tape unit and main hi-fi amplifier. Phono and DIN sockets for inputs and outputs. Inputs: two line inputs (>20K) with level control. Input sensitivity: 30mV for Dolby level (0 VU). Slider type level controls. Two VU meters. Outputs: 580mV for 0 VU at 1K impedance. HD: <0.5% at Dolby level at any frequency 20Hz-20kHz. Noise reduction: 8dB at 2kHz, 10dB at 5kHz. With noise reduction switched out the unit becomes a unity gain amplifier. MPX 19kHz filter, response <1dB down at 15kHz, >30dB down at 19kHz and >20dB down at 38kHz. Mains: 117, 220, 230, 250V AC. Price: £59.

■ BRENNELL ENGINEERING CO LTD

231/5 Liverpool Road, London, N1.
Tel: 01-607 8271 (5 lines).

Hi-Fi Tape Link ★

Stereo tape preamplifier and oscillator unit. Connects between tape deck and hi-fi system. Twin transistorised recording amplifiers, bias/erase oscillator, twin transistorised playback amplifiers. Designed for use with three-headed stereo tape deck (i.e. separate erase, record and playback heads). $\frac{1}{4}$ -track or $\frac{1}{2}$ -track. Mono and stereo recording facilities provided. Monitoring. Immediate comparison of recorded and original signal. Individual gain controls for each amplifier. Frequency correction for four tape speeds. Inputs: mic 200 μ V 200 ohms, aux 8mV 50K, aux 8mV 50K. Cross-fade mixing between inputs. Two illuminated level meters. Output: 1.4V (2V at 2% distortion level). FR: (when used with specified heads) 7 $\frac{1}{2}$ i/s 40Hz-20kHz \pm 3dB, 3 $\frac{3}{4}$ i/s 50Hz-14kHz \pm 3dB, 1 $\frac{7}{8}$ i/s 60Hz-7kHz

(\pm 3dB), 15i/s 40Hz-22kHz \pm 3dB. S/N: 56dB. Size: (tape link) 15 \times 7 \times 4 $\frac{1}{4}$ in; (power unit) 5 $\frac{1}{2}$ \times 5 $\frac{3}{4}$ \times 4 $\frac{3}{4}$ in. Weight: (tape link) 9lb; (power unit) 5lb. Price: (complete with PU) £80-50.

■ DEIMOS LTD

Simmonds Road, Wincheap Industrial Estate, Canterbury, Kent. Tel: Canterbury 68597.

Deimos Tape Amplifier

Miniature stereo/mono system with plug-in all-silicon transistor modules. Separate record and playback amplifiers. Sensitivity: 30mV. Output: 6V RMS. Meter level indicator. Separate power supply. Size: panel 13 $\frac{1}{2}$ \times 2 $\frac{1}{2}$ in; depth 4 $\frac{1}{2}$ in. Prices on application. Kit may be available.

■ EAGLE INTERNATIONAL

Heather Park Drive, Wembley,
HA1 1SU. Tel: 01-903 0144.

MP12 ★

Six-channel stereo/mono mixer and preamplifier. Studio type slider controls. Mic inputs can be individually switched between high and low impedance. Inputs: four microphone 1mV 600 ohms or 2mV 50K, two pickup 3.5mV at 47K RIAA. S/N: better than 50dB. Output: (switched stereo/mono) two 250mV. Low profile desk console. Price: £26.40.

FFI

Transistorised five-channel mono mixer. Slider type controls. Microphone inputs: 500mV at 600 ohms, switchable for 4mV 50K. Aux input: 180mV 100K. Two outputs: (low) 200mV 50K-500K, (high) 2V 50K-500K. Controls: on/off switch, slider control for each input, overall master gain control. Power: two PP3 batteries. Size: 10 \times 7 \times 1 $\frac{3}{4}$ in. Monitoring facilities included. Price: £20.

■ A. R. FRANKLIN

(Audio engineer), 4 Birch House, Howard Road, Penge, London, SE20 8HJ. Tel: 01-659 0912.

Control unit/mixer

Six-channel mono, or three plus three channel stereo. All inputs 100mV 47K for IV output into 47K. HD: <0.2%. FR: 10Hz-68kHz \pm 3dB. Noise: -60dB. Maximum output: 3V. Inputs infinitely variable. Headphone position with pre-select listening. Mains: 110-250V 50/60Hz. Size: 12 $\frac{1}{2}$ \times 9 \times 3 $\frac{1}{4}$ in. Price: £36.

Stereo control unit/mixer

Four inputs at 800K selected by switching. Microphone mixing independent of selector switch. Controls: treble, bass, balance. Headphone position. HD: <0.2%. FR: 20Hz-30kHz \pm 3dB. Maximum output: 3V. Microphone input: 20mV, other inputs up to 3V. Mains: 110-250V 50/60Hz. Size: 12 $\frac{1}{2}$ \times 9 \times 3 $\frac{1}{4}$ in. Price: £36.

★ Indicates entry is illustrated

Plug-in preamplifiers

Stereo modular preamplifiers for use with above control unit/mixers. For low impedance microphones: £6 and £12. For magnetic pickup with RIAA correction: £6. For tape head: £6.

Send s.a.e. for lists and prices.

GRAMPIAN REPRODUCERS LTD

19 Hanworth Trading Estate, Feltham, Middx.
Tel: 01-894 9141/3. Cables: Reamp, Feltham.

Grampian 18/4

Four channel preamplifier mixer. Transistors. Inputs: 0.2mV 25 ohms, 0.8mV 600 ohms, 10 mV high impedance, 100mV high impedance. Output: 0.775V. Output impedance: 600 ohms floating. Distortion: <1.5%. Bass control: -8 dB at 100Hz on mic, ±8dB at 100Hz on aux. Treble control: ±8dB at 10kHz. FR: 100Hz-10kHz ±3dB (tone controls level). Noise: -60dB. Supply: PP9 (or equivalent) 9V battery. Consumption: average 18mA. Jack socket outlet at rear. Size: 11 $\frac{3}{8}$ × 7 × 2 $\frac{3}{8}$ in. Weight: 4 $\frac{1}{2}$ lb. Price: £39.75.

Grampian 16/6

Six-channel preamplifier mixer for professional sound engineers. Six independently controlled microphone inputs. On/off key switch for each input permits gain control to be preset if desired. Master gain control normally controls all channels but there is provision for some inputs to operate independently. Sensitivity: 0.2mV input for 0.775V output. Output meter scaled for 1V with overload warning on scale, 1mW indicated by red marker at 0.775V. Specially damped movement. Output impedance: 600 ohms floating. Distortion: <0.1% for 0.775V output. FR: 100Hz-15kHz +2dB with tone controls level. Bass cut: -10dB at 100Hz. Treble cut: -12dB at 10kHz. Treble lift: +6dB at 10kHz. H and N: better than -65dB. Input sensitivity from 200 μV at 25 ohms to 100mV at high impedance to order. Mains: 200-250V AC. Size: 19 $\frac{1}{4}$ × 7 $\frac{3}{8}$ × 6 $\frac{3}{8}$ in. Weight: 12 $\frac{1}{4}$ lb. Price and full specification on request.

GRUNDIG (Great Britain) LTD

Newlands Park, Sydenham, London, SE26.
Tel: 01-778 2211.

422 ★

Transistorised stereo mixer for four inputs. Three coarse level controls, directional control and control for reverberation unit. Four microphone preamplifiers fitted. Channel separation: 50dB (mic), 35dB (PU). Response: 40Hz-20kHz ±2dB. Powered by two 9V batteries. Size: 13 $\frac{1}{4}$ × 2 $\frac{1}{4}$ × 7 $\frac{1}{2}$ in. Price: £35.

420

Mono version of 422 mixer above. Price: £24. Note: Grundig prices include purchase tax where applicable.

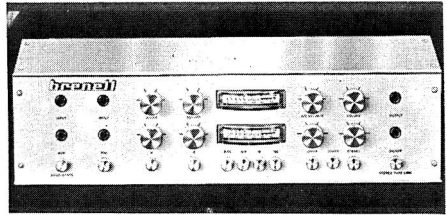

Brenell Tape Link

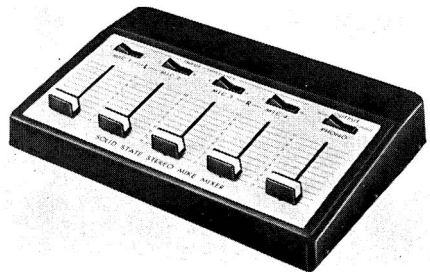

Eagle MP12

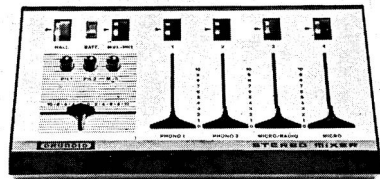

Grundig 422 stereo mixer



Harwell Mixer Unit in discotheque console



Kellar Electronics KDB-1

■ HARWELL INSTRUMENTS

5, 7, 9 Anerley Station Road, London, SE20.
Tel: 01-778 9456.

Harwell mixer ★

Mono or stereo to order. Silicon semiconductors throughout. Three to seven inputs in standard range, mono or stereo. Gram inputs sensitive enough for any make of magnetic cartridge, equalisation as required. Output: 0-3V RMS adjustable to drive main amplifier. Outlets for tape recorder and for headphones to provide pre-fade listening. Controls: independent gain on each channel, master volume, treble, bass, scratch and rumble filters, separate tone controls on microphone channels, optional mute level switch, pre-fade listen selector switch. Monitoring on any channel or programme with headphones with independent volume control. Mono/stereo switch where applicable. AC mains. Indicator light and fuses on front panel. Size: from 24 × 4½ × 6in (depending on number of channels). Price: from £88 (according to required specification).

■ KELLAR ELECTRONICS LTD

Lopen Works, Lopen Road, Edmonton, London, N18. Tel: 01-807 4986.

KDB-1 ★

Noise reduction unit employing Dolby 'B' system. Designed for use with domestic recorders for recording and playback. Can be used for replay of commercially recorded tapes and cassettes now available under Dolby B format.

KDB1 connects in circuit between tape unit or recorder and main amplifier. Improvement in signal/noise ratio is 3dB at 600Hz, 6dB at 1200Hz and 10dB for all frequencies above 3kHz. Only low-level signals are treated, being boosted by a preset amount during record and reduced in replay mode by an exactly complementary manner. Separate circuits for each channel.

Separate level controls for each channel, plus master overall gain control. MPX filter switch prevents interference from inadequately suppressed stereo carrier and pilot tone frequencies.

Two calibration meters, internal test tone oscillator and special Dolby set-level tape included.

Output: (record) 580mV 50 ohms (5K load); (replay) 580mV 5K (50K load). Levels refer to 'Dolby level' which is 18.5mM/mm for open reel recorders and 20mM/mm for cassette recorders.

Input: (record) 25mV for 580mV output, input impedance 20K. (replay) 25mV for 580mV output, input impedance 30K. HD: < 0.1%. FR: (MPX filter out) 20Hz-15kHz ± 1dB; 15kHz-20kHz ± 2dB. MPX filter: -36dB at 19kHz. Separation: better than 50dB at 1kHz. S/N:

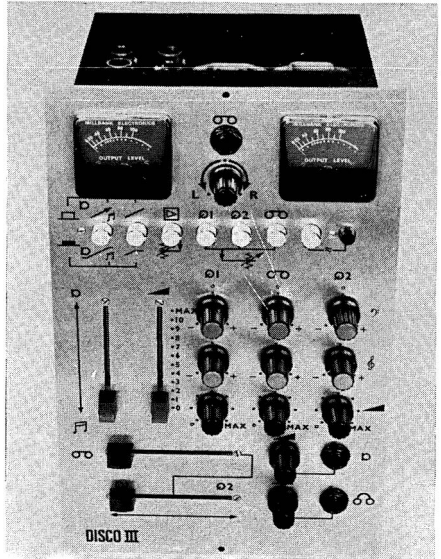

Millbank Electronics Disco III

better than 70dB reference to 580mV un-weighted. Mains: 200-250V 40/60Hz. Regulated power supply. Size: 17 × 3¼ × 9in. Weight: 9¼lb. Finish: simulated black leather finish steel cabinet with brushed aluminium panel and control knobs. Price: approximately £50.

■ LOWTHER MANUFACTURING CO

Lowther House, St Mark's Road, Bromley, Kent, BR29HQ.
Tel: 01-460 5225. Cables: Lowther, Bromley.

Companion Supply Unit No 2

HT and LT power supply suitable to power radio tuners. Pre-amp and tape bias amplifier. Output: 250V at 40mA, 6.3V at 3 amps. Price: £8-75.

Companion Supply Unit No 3

HT and LT power supply suitable to power radio tuners. Pre-amp and tape bias amplifier. Output: 350V at 35mA, 6.3V at 3 amps. Price: £8-75.

■ MILLBANK ELECTRONICS

Bellbrook Estate, Uckfield, Sussex.
Tel: Uckfield 4166.

Disco Three ★

Transistorised mixer unit with wide range of facilities. Inputs: two stereo pickup (ceramic or magnetic), one stereo tape (unequalised), one stereo "jingle" (over-rides other tape input), one mono microphone (low or high impedance). Sensitivity: magnetic PU 5mV 68K, ceramic PU 90mV 1 megohm, tape 55mV 47K, micro-

★ Indicates entry is illustrated

phone (low Z) 0.1mV 200 ohms, (high Z) 3mV 30K. Signal to noise: PU (mag) 68dB, PU (cer) 60dB, tape 70dB, mic 52dB. Channel gains: (minimum) better than 70dB. Separation: better than 40dB. FR: 20Hz-20kHz -3dB. Tone controls: ± 12 dB at 80Hz and 12kHz. Stereo headphone jack. Twin peak reading VU meters. Output: 0dBm (0.775V) maximum 5V, -15dBm (150mV). Full audio/visual monitoring, switchable compression facility, automatic or manual fade to preset level, stereo or mono operation, fully floating earth-free outputs, DIN terminations, printed circuit construction, stabilised power supply. Size: 13in high, 8in wide, 6 $\frac{1}{2}$ in deep. Further details and price on application.

MCC Mk III ★

Transistorised mixer with 10 input channels. Inputs: magnetic PU, tape head, unbalanced line, balanced line, balanced microphone. Signal to noise: microphone better than 66dB. Output: 0dBm calibration, (maximum output level +22dBm). Distortion: better than 0.1% referred to +8dBm at 1kHz. Linear faders. Mixer operates as five-channel stereo or 10-

channel mono. Stabilised 24VDC power supply with negative earth. Normally mains operated but can be supplied for external battery supply. Comprehensive monitoring facilities provided. Metering circuit can be switched into either or both group output channels, or the pre-fade listen circuit. Rear panel monitor output socket. Visual monitoring by broadcast type PPM, standard VU, peak reading VU. Twin output amplifiers designed to deliver +22dBm into 600 ohms balanced line (floating). DIN standard or XLR Cannon connectors. Price: (basic unit with VU meter and DIN standard connectors) £180.55.

■ RADON

Radon Industrial Electronics Co Ltd,
Orme Road, Worthing, Sussex.
Tel: Worthing 34904.

DL6/CM ★

Mains operated mono six-channel mixer. Transistors. Six inputs: 1mV 35-100 ohms (high impedance to order). Output: 1V p-p at 6K, 0.25V p-p at 68 ohms. Independent gain control for

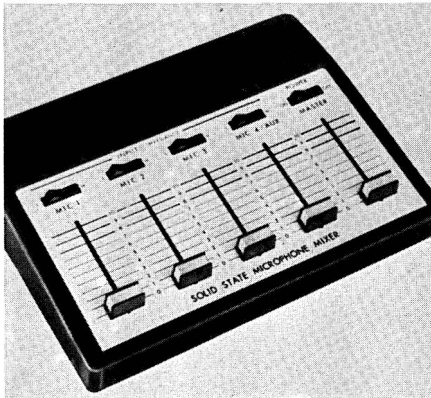

Millbank Electronics MCC Mk III

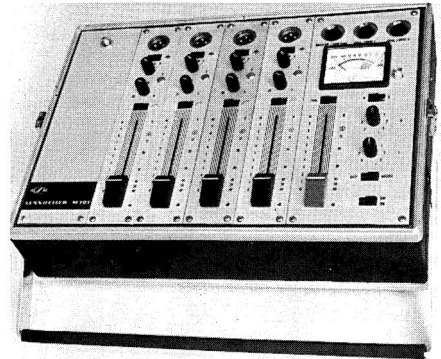

Sennheiser M101

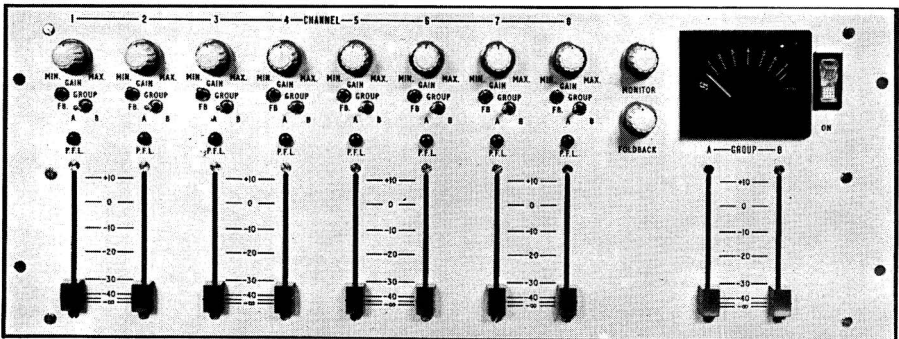

Richardson Electronics Eight-way Mixer

each input. Mains on/off switch with indicator light. H and N: better than 40dB down. FR: 10Hz-35kHz (level 30Hz-25kHz). Mains: 110-120V 50/60Hz or 220-240V 50Hz. Size: 3½ × 13 × 7in. Weight: 6½lb. Finish: satin polished wood cabinet with grey laminate front panel. Price: £35.

■ **J. RICHARDSON ELECTRONICS LTD**
57 Jamestown Road, London, NW1.
Tel: 01-267 0723.

Modular tape amplifiers

System of pluggable tape record/playback modules. Each module is 7in high and designed to fit into 19in rack. Silicon transistors. Remote electronic switching for four separate equalisations. Modules include: record preamplifier, playback preamplifier, PPM, oscillator, self-sync switching unit, power supply. Full specifications on request. Prices from £35.

Mixer units ★

Full range of plug-in mixer modules available separately or in banks of units. Full specifications and prices on request.

■ **SENNHEISER ELECTRONIC**

Distributors: Hayden Laboratories Ltd, Hayden House, 17 Chesham Road, Amersham, Bucks. Tel: Amersham 5511.

Audio equipment showroom, service department and despatch department: 12/13 Poland Street, London, W1V 3DE. Tel: 01-734 3748.

M101 ★

Battery operated portable mixer. Inputs: four microphone inputs switchable for 200 ohm dynamic and 12V powered capacitor (MKH series of Sennheiser mics). Output: unbalanced +6dB at 60 ohms. Pre-fade listening using ML101 mixer monitoring unit. PPM. Slider-type faders. Separate bass and treble controls switchable to one channel or to mixed output. Treble control: ±12dB at 15kHz, bass control +10dB -14dB at 40Hz. Power supply: two 9V Ever-Ready cells type 276 or equivalent, or 18V from other equipment. Price: on application.

■ **SONY (UK) LTD**

Pyrene House, Sunbury Cross, Sunbury-on-Thames, Middlesex. Tel: Sunbury 87644/7.

MX10K/MX600M

Three-input mono mixer. Inputs: mic (3) 10K or 600 ohms. One outlet. Output impedance: (MX10K) 13-5K, (MX600M) 300 ohms. Three level controls. Passive system. Size: 9½ × 2½ × 4in. Price: £7-50.



Richardson Electronics Five-way Mixer

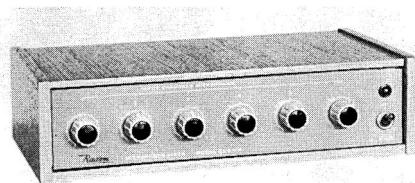

Radon DL6/CM

MX12M

Mono/stereo mixer with six inputs. Inputs: mics (3) 0-195mV 600 ohms, aux (3) 61-5mV 100K. DIN connector 0-775V 10K. Two outlets plus headphone socket. Outlets: (high) 245mV 100K, (low) 0-775mV 10K. Controls: power on/off, battery check, six level controls, selector, attenuate on/off. Twin VU meters. Power: six HP11 batteries or 12V DC source. Size: 15¼ × 7¾ × 7in. Monitoring facilities by 8 ohm phones. Price: £45.

MX6S

Six-input stereo mixer. Inputs: mic (3) 0-775mV low Z, aux 0-245mV high Z. Two outlets. Outlets: 0-245mV low Z. Six level controls plus channel selector. Passive system. Size: 13¾ × 2¾ × 4½in. Price: £11.

■ **T.T.C.**

Joint distributors: Adastra Electronics Ltd, Unit 22, Cricklewood Trading Estate, Claremont Road, London, NW21 1TU. Tel: 01-452 6288.

E.R. (Factors) Ltd, 374-378 Harrow Road, Paddington, London, W9. Tel: 01-286 0361.

B2005

Transistorised mono microphone mixer. Power supply: 9V. Four channels with individual gain controls. Input jack sockets, output phono sockets. Input impedance: 100K. Max input signal: 1V. Gain: 3dB. Free-standing case. Price: £3-90.

★ Indicates entry is illustrated

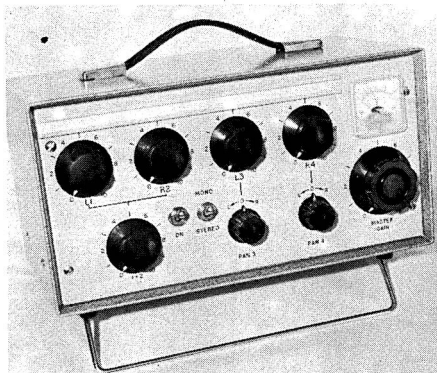

Unimixer 4S

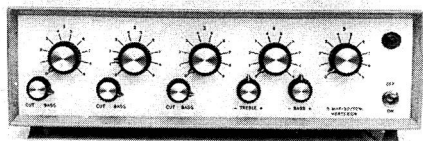

Vortexion 50/70

B2004

Transistorised stereo/mono microphone mixer. Power supply: 9V. Two stereo channels (with independent gain controls) or four mono channels. Input jack sockets, output phono sockets. Mono/stereo mode switch. On/off switch. Input impedance: 100K. Max input signal: 1V. Gain: 3dB. Free-standing case. Price: £5-50.

■ UHER

Distributors: Bosch Ltd, PO Box 166, Rhodes Way, Radlett Road, Watford, Herts, WD24LB. Tel: Watford 44233.

A122

Mixer unit for five channels: two stereo plus one mono or five mono channels. Inputs available for 200 ohm microphone, radio or pickup. Outputs: one 40mV nominal, one 500mV nominal. FR: 20Hz-20kHz. Slider faders with directional control, muting switches and 1kHz generator. Powered by PP3 battery. Price: £49-90.

■ UNIMIXER

Soundex Ltd, 18 Blenheim Road, Woodstock Road, London, W4 1ES. Tel: 01-995 1661.

Unimixer 4S ★

High quality mixing unit for studios and on location. One stereo pair and two pan controlled mics. Input impedance: 25-600 ohms. S/N ratio:

greater than 55dB with input signal of 0.18mV at 200 ohms, or 0.07mV at 30 ohms. Individual test certificate. Price: £52.

Unimixer Studio 4 and Studio 6

Four and six-channel mixers for studio and location work. Each channel switchable for five different inputs. One input with 48V phantom circuit for capacitor microphones. Input connections: jack socket, DIN or Cannon. Slider faders. Mono and stereo. Tone controls and plug-in PPM optional extras. Noise level: better than -127dBV with 200 ohms source. FR: 20Hz-20kHz +2dB -3dB. Overload capability: >55dB. Full monitoring with pre- and post-fade listening. Mains: 110-120, 220-240V AC, or batteries. Test and line-up oscillator provided. Mild steel cases. Price: (four channel) from £87; (six channel) from £108.

■ VORTEXION

257-263 The Broadway, Wimbledon, London, SW19. Tel: 01-542 2814 and 6242/4.

50/70 ★

All-silicon transistor amplifier with built-in four channel mixer. Amplifier circuit similar to 100W model described in Amplifier Section. Mixer portion arranged for three 30-60 ohms balanced line inputs and one high impedance input. Separate bass and treble controls. Balanced line 100V output. Sensitivity: 100µV on low impedance inputs, 100mV 100K on high impedance input. 15 ohm output model available. Size: 14 × 11½ × 4½ in. Weight: 22lb. Price: £75.

50/70 plus 5-way mixer

Similar specification to 50/70 with four channel mixer, but with additional bass-cut controls on three low impedance inputs. Inputs: three 100µV 30-60 ohms balanced, 100mV 10 meg-ohms, 100mV 100K. Size: 14 × 11½ × 2½ in. Weight: 22lb. Price: £84.

FET mixers and PPMs

Various types of mixers available. Three-, four-, six- and eight-channel with peak programme meter. Four-, six-, eight- and ten-way mixers. Twin three-, four- and five-channel stereo. Twin four- and five-channel stereo with two PPMs.

Bib®

HI-FI ACCESSORIES

RECOMMENDED BY LEADING EQUIPMENT MANUFACTURERS AND AUDIO SPECIALISTS

GROOV-KLEEN Modern automatic record cleaner.

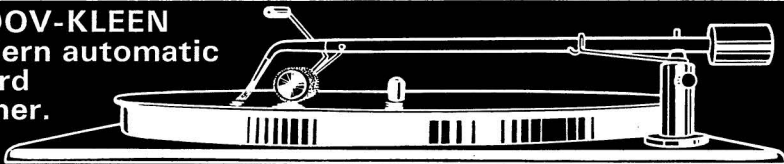

- Removes and collects dust without using liquid.
- Reduces record and stylus wear. Counter weight ensures lightweight tracking.
- Beautifully finished in Chrome, bright anodised Aluminium and shiny black.

- Improves reproduction.
- Operates silently.
- Armrest incorporated.

Model 42 £1.95



The popular priced Model 50 GROOV-KLEEN

has all the features of the Model 42 but is made in high quality plastic. The base is finished in matt black and the cranked arm is white.

Model 50
£1.26

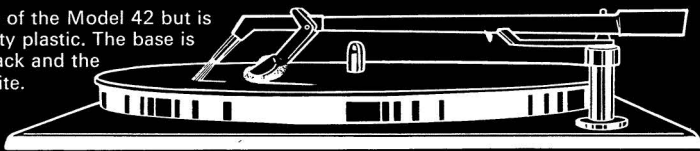

Record Cue & Swinger Detector

Identifies selected items on records. Fitted easily to all turntable decks. Scale moves clear of records, cannot touch pick-up cartridge. Detects swingers for improved reproduction when rectified.

Patent No. 2460/72 Ref 47 £1.45

Cassette Head Cleaning Tape

For all cassette machines. Removes oxide and dirt from heads. Packed in plastic "library" case.



Ref 31 56p

Hi-Fi Stereo Hints and Tips



2nd Edition completely revised. How to make the most of your equipment, by John Borwick, BSc., Technical Editor of "The Gramophone". 48 pages of useful information with 54 invaluable reference charts and illustrations for Hi-Fi enthusiasts. Ref 56 32p

Stylus Balance

Precision built. Calibrated.

Measures stylus pressure within $\frac{1}{4}$ gramme. In plastic container.

Ref 32A £1.45



Tape Editing Kits — in Wallets Tape splicer, cutter, marker, splicing tape. Reel or cassette labels. Instructions. For $\frac{1}{4}$ " tape. Ref 23 £1.36

Ref 24 £1.50 (for cassettes)

8 Track Cartridge Tape Head Cleaner

Maintains tape heads in clean condition. Recommended use after every five hours playing. Complete with dust cover.

Ref 41 96p



Cassette Salvage Kit Ref 29 44p

Cassette Title Labels Ref T4 18p

Cassette Re-record Kit Ref 54 44p

Record Dust Off Ref 48 56p

Spirit Level Ref 46 56p

Hi-Fi Cable and Flex Ties Ref D/2 16p

Bib Sales, PO Box No. 78, Hemel Hempstead, Herts. Tel: Hemel Hempstead 3636

**For those who like to
hear the sound
of their own voice-**

Agfa Magneton Tape

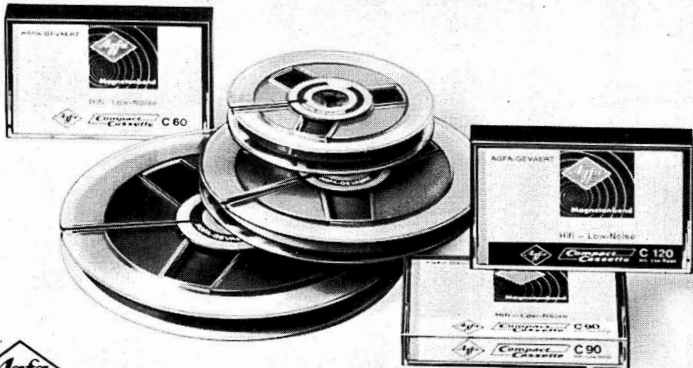

AGFA-GEVAERT

Tape Accessories/ Components

★ Indicates entry is illustrated

Abbreviations used in this section are given on page 36.

■ ADASTRA ELECTRONICS LTD

Unit 22, Cricklewood Trading Estate,
Claremont Road, London, NW21TU.
Tel: 01-452 6288 (answering service 01-425 6289).

Imp-Verta

Matches low impedance tape heads, PU cartridges and microphones into high impedance amplifier inputs. Solid state printed circuit device using silicon transistor. Automatically switched 9V internal battery. Negligible drain. Conversion factor approximately 20 (depending on load). Virtually no hum or signal loss. Metal case, finished black crackle. Size: $5 \times 1\frac{1}{2} \times 1\frac{1}{2}$ in. Price: £3.50.

Tape Editing Kit

See entry under Synchrotape.

Cassette Carrying Case

Designed to hold 15 compact cassettes in rigid drop-front case. Finished in padded simulated leathercloth. Snap-fast closing. Carry handle. Finish: red, tan or black. Size: $11\frac{1}{4} \times 3\frac{1}{2} \times 4\frac{3}{8}$ in. Price: £1.50 (including PT).

■ AGFA GEVAERT

Agfa-Gevaert Ltd,
Great West Road, Brentford. Middlesex.
Tel: 01-560 2131 (20 lines). Telex: 28154.

Editing accessory kit ★

Price: £1.88.

Splicing Tape Dispenser

Price: 37p.

Novodur Plastic Library Boxes

Prices: 4 $\frac{1}{4}$ in and 5 in 34p; 5 $\frac{3}{8}$ in 43 $\frac{1}{2}$ p; 7 in 54 $\frac{1}{2}$ p.

Plastic Spools

Prices: 3 in 17 $\frac{1}{2}$ p; 4 in and 4 $\frac{1}{4}$ in 18 $\frac{1}{2}$ p; 5 in 24 $\frac{1}{2}$ p; 5 $\frac{3}{8}$ in 24 $\frac{1}{2}$ p; 7 in 26 $\frac{1}{2}$ p; 8 $\frac{3}{8}$ in 63p; 10 in 71p; 10 $\frac{1}{2}$ in £1.48.

Splicing tape

33ft of $\frac{1}{4}$ in, 22p

Leadertape

80ft of $\frac{1}{4}$ in, red, green, white, yellow 22p.

Silver Stop Foil

33ft of $\frac{1}{4}$ in, 37p.

Cassette Album ★

Presentation album and storage device. Holds six compact cassettes. Supplied free to purchasers of three C60 and three C90 cassettes. Dustproof and fully indexed. Finished in blue PVC. Price: (retail price of tape only) £5.33 $\frac{1}{2}$.

■ AMOS OF EXETER LTD

Weircliffe Court, Exwick, Exeter.

Tel: Exeter 72132. Cables: Amos, Exeter.

Weircliffe Bulk Erasers

Models 6, 7, and 8. Model 6 accepts reels up to 8 $\frac{1}{2}$ in diameter of $\frac{1}{4}$ -1 in tape. Capacity 180-400 reels per hour. Model 7 accepts 8×8 in cassettes of $\frac{1}{4}$ in tape. Model 8 accepts reels of up to 14 $\frac{1}{2}$ in diameter containing tape from $\frac{1}{4}$ in audio up to 2 in video including $\frac{1}{2}$ in and 1 in instrument tape and 16 and 35mm film. Capacity 100-400 reels per hour (NATO catalogue No. 5835-99-972-5371). Model 9 now takes reels of 2 in wide video tape on 16 in reels as against 35mm only. Sizes: (Models 6 and 7) $11\frac{1}{2} \times 12\frac{1}{4} \times 7\frac{1}{2}$ in. Weight: 43lb. Size: (Model 8) $20\frac{1}{2} \times 20\frac{1}{2} \times 10\frac{1}{2}$ in. Weight: 92lb. Prices: (Models 6 and 7) £51.75; (Model 8) £155.25; (Model 9) £271.50; (Model 14) £1883.70 ex works. Models available for 115V 60Hz.

■ AUDIO PACKS

Audio Packs Ltd,

206-210 Ilderton Road, London, SE151NS.

Tel: 01-639 7844.

Audio Packs

Pre-packed spares and audio accessories.

Connecting Cords

Cables of various types with plugs, sockets and other terminations covering all equipment in use for domestic audio.

Adaptors

Convert from any type of plug or socket termination to any other type.

Audio Spares

Plugs, sockets, chassis-mounted components, fuses and audio accessories. Pre-packed for counter or showroom display.

Mains Units

Three different 6-12V battery eliminators complete with connecting leads for use with all standard battery-operated tape recorders and radios. Full specifications on request.

■ BANG & OLUFSEN UK LTD

Eastbrook Road, Gloucester, GL4 7DE.

Tel: Gloucester 21591.

4001 Synchro Box ★

For synchronising slide projector to tape recorder. Records projector control pulses on one

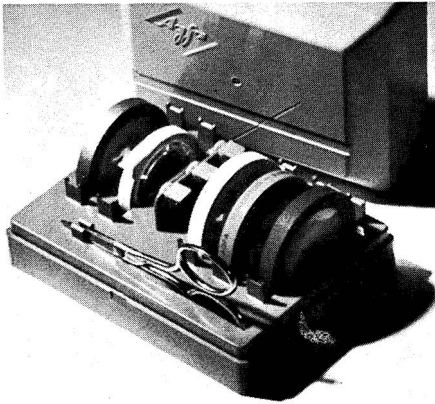

Agfa Tape Editing Kit

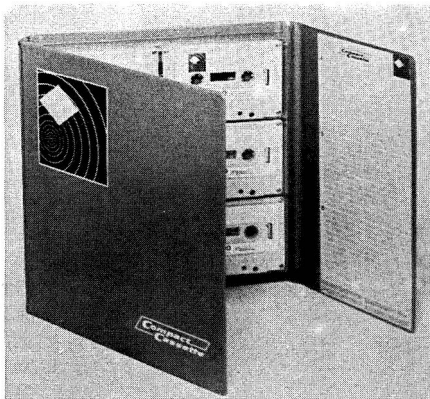

AGFA Gevaert Cassette Album

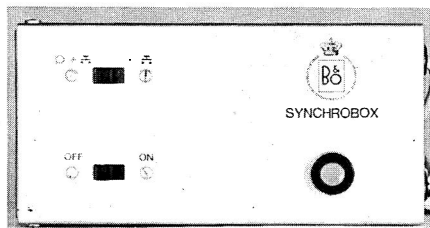

Bang & Olufsen 4001 Synchronbox



Bib splicer

track while commentary is recorded on second track. On playback the control pulse is read and shaped to length required by the projector. Price: £30.95 (including PT).

■ **BASF UNITED KINGDOM LTD**

Audio/Video Tapes Division, PO Box 473, Knightsbridge House, 197 Knightsbridge, London, SW7. Tel: 01-584 5080.

Telex: 267574/5.

Special requirement tapes

SP 52 8¼in 1,800ft £3; LP 35 8¼in 2,400ft £3.80; 10in 3,600ft £5.60; 10½in 4,200ft £6.25. LP 35 LH 8¾in 2,400ft £4.10; 10in 3,280ft £5.60; 10½in 4,200ft £6.95.

Technical-look spools

Standard sizes: 2¼in 19p; 3in 17p; 3½in 19p; 4in 19p; 4½in 19p; 5in 22p; 5¾in 24p; 7in 25p; 8¼in 57p; 8¾in 57p; 10in 70p; 10½in £1.18.

Leader Tape

Green, red or white. Plastic centre spool. 984ft £1.50; 80ft 25p.

Splicing Tape

80ft of ¼in white splicing tape, type AW. Price: 70p; 80ft ½in splicing tape, type PW. Price: 80p.

Splicing Set

Plastic box with bonding groove and 33ft of splicing tape. Price: 36p.

Metallized foil

82ft ¼in sputtered silver tape. Price: £1.02.

Leader Tape Set

Containing red and green leader tapes, 25 strips of metallized foil and spare spool labels. Price: 64p.

Adhesive LG

Contains fluid for PVC base tapes. 1oz bottle. Price: 37p.

Plastic Tape Clips

Box of 10. Price: 16p.

Head Alignment Tape

Price: 92p.

Hobby Box

Contains splicer, marking pencil, 33ft splicing tape, 80ft each of red, white and green leader tapes, 50 pieces of metallized foil, 25 spool labels, 3 tape clips. Price: £1.86.

■ **BIB**

Bib Sales Division, Multicore Works, Maylands Avenue, Hemel Hempstead, Herts. Tel: Hemel Hempstead 3636. Ext 100.

Tape Head Cleaning Kit

Comprises: bottle of Bib non-inflammable tape head cleaner, two tape head applicator tools (blue), two tape head polisher tools (white), 10



Bib Cassette Tape Editing Kit

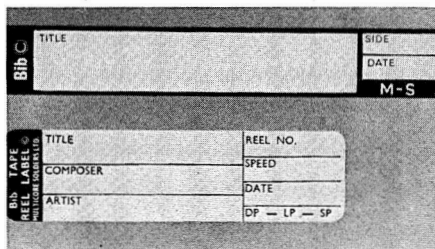

Bib Title Labels



Bib Cassette Cleaning Tape

applicator and polisher sticks, cleaning cloth and plastic wallet. Price: 49p.

Recording Tape Splicer ★

Model 20. For use with $\frac{1}{4}$ in or 6.3mm tape of any thickness. Chrome finished clamps for holding tape. Makes diagonal or butt splices. Non-slip base. Complete with razor cutter and instructions. Price: 99p.

Model 21

Special larger version of Model 20. Designed for editing and splicing $\frac{1}{2}$ in video tape. Four razor cutters and cleaning kit included. Price: £9.50.

Tape Editing Kit

Model 23. Kit contains tape splicer for $\frac{1}{4}$ in or 6.3mm tape, 12 tape reel labels, razor cutter,

splicing tape, tape marker, instruction leaflet and plastic wallet. Price: £1.36.

Cassette tape editing kit ★

Model 24. Enables cassette tapes to be edited quickly and easily. Kit contains cassette tape splicer ($\frac{1}{8}$ in or 3.2mm), two precision tape cutters, tape piercer, 10 self-adhesive cassette and container labels, reel splicing tape, three tape winders and removers (two spares), instruction leaflet and plastic wallet. Price: £1.50.

Precision tape cutters

Model M. Set of four stainless steel cutters with special plastic grips for all types of magnetic recording tape. Price: 23p.

Tape reel labels ★

Self-adhesive labels printed with spaces for title, composer, date, type of tape and number. On backing paper in sheet form so that details can be easily filled in by typewriter or pen. Prices: size T/1 (reel labels) 20 for 12p; size T/4 (cassette and container labels) 27 for 18p.

Anti-static Cleaner

Non-inflammable anti-static fluid with cleaning cloth. Does not smear or scratch. Suitable for instrument panels, plastic, chrome, glass and exteriors of electronic equipment. Price: 24p.

Cassette head cleaning tape ★

Special tape incorporated in Compact cassette for cleaning heads, capstan and pinch wheel in one operation. Suitable for all cassette recorders and players. Price: 56p.

Splicing tape

On handy plastic dispenser. Suitable for $\frac{1}{8}$ in and $\frac{1}{4}$ in tapes. Price: 23p.

Cassette recorder care kit

Kit contained in plastic box comprising $\frac{1}{4}$ in splicer, splicing tape, tape piercer, 10 cassette labels, three tape winders, two tape cutters, polishing cloth and cassette cleaning tape. Price: £2.10.

Cassette salvage kit

Enables welded cassette cases to be opened and tape joined using Model 24 kit. Comprises instructions, razor cutter, two tape winders and new cassette. Price: 44p.

Luxury cassette case

Padded cassette case to hold 12. Designed for easy withdrawal and replacement. Easy opening lid and fitted with carry handle. Price: £1.34.

Cassette wallet

Holds six cassettes in their containers for quick and easy selection. Suitable for car or home. Folds to $9\frac{3}{4} \times 4\frac{1}{2}$ in and is held closed by stud. Finished in brown grain PVC. Price: 58p.

Eight-track cartridge tape head cleaner

Fitted in standard eight-track cartridge case. Removes dust and dirt from tape heads. Normal

★ Indicates entry is illustrated

use is one minute for every five hours playing. Complete with dust cover. Price: 96p.

Hi-fi stereo hints and tips

Book for hi-fi enthusiasts describing how to make the most of audio equipment. Contains 29 illustrations, diagrams and reference tables. 36 pages. Written by John Borwick, B.Sc. Price: 25p.

BLACK KNIGHT RUMBLECURE

Bank Top, Currier Lane, Ashton-under-Lyne, Lancs. Tel: 061-330 2836 (open 7 days). Demonstration showroom at 15 Irving Street, London, WC2.

Specialists in curing rumble due to acoustic feedback through floors and cabinets.

Kits and items designed to isolate and acoustically damp pickup arms, turntables, motor units, plinth assemblies, tape recorders, speaker enclosures and other audio equipment.

Plinths fitted with Rumblecure equipment available. Details on request. Many standard items now available and more being added all the time. Quotations on receipt of full details of equipment.

BOGEN

Cole Electronics Ltd, 7-15 Lansdowne Road, Croydon, CR92HB. Tel: 01-686 7581.

Bogen tape heads

Comprehensive range of magnetic tape heads including record-only, replay-only, combined record/replay and erase. Models and types available for most domestic and professional applications, such as data storage, films, cassettes, audio, video, etc. Details and prices available on request.

BRADMATIC LTD

338 Aldridge Road, Streetly, Sutton Coldfield, Warwickshire. Tel: 021-353 3171.

Magnetic recording heads manufactured to order. Enquiries welcomed and full details of service offered provided on request.

BRITISH RADIO CORPORATION LTD

Thorn House, Upper St Martin's Lane, London, WC2. Tel: 01-836 2444.

Synchro-amp adaptor TA/01

Preamplifier unit for second channel stereo playback. Monitoring one track whilst recording on another. Automatic slide projector synchronisation. For models using D842 and DC43 decks only. Price: £11.84.

Foot switch TA/19

Facilitates use of recorder as dictating machine. Recorder runs when switch is depressed. For models with remote pause facility. Price: £2.92.

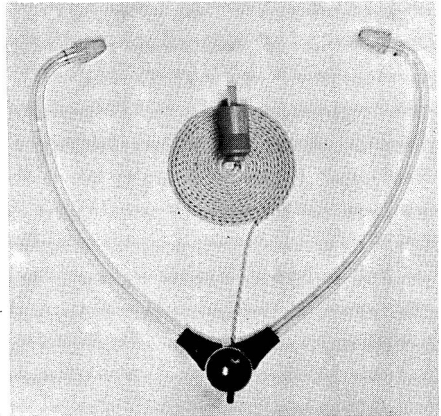

British Radio Corporation Stethoset TA/15



Colton Griplex

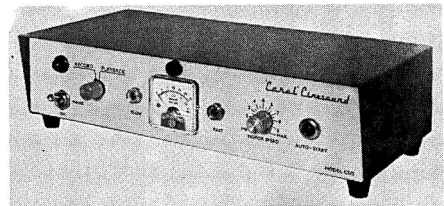

Carol Cinesound (Contronics)

Monitoring Stethoset TA/15 ★

Stethoscope type earpiece to monitor programme during recording. Fitted with Continental speaker plug. Price: £1.35.

Preamplifier TA/27

For providing stereo playback and second channel monitoring with four-track recorders. Price: £8.70.

Slide Projector Synchroniser TA/28

For operating slide change on projectors having a remote control. Used with $\frac{1}{4}$ -track recorders. Price: £9.33.

Stereo headphones TA/39

General purpose stereo headphones. Fitted with $\frac{3}{4}$ in standard jackplug. Price: £7.50.

The tape recorder accessories listed above are primarily for use with machines marketed under the Thorn brand names Ferguson and Marconi-phoné.

■ COLTON

Musonic Ltd, 34-38 Verulam Road, St Albans, Herts. Tel: St Albans 50611/2.

Gripex ★

Anti-slip dressing. A spirit suspended solution supplied in 1fl oz bottles with brush. Applied thinly to drive surface of belts or friction wheels, it dries in 10-15 minutes. Price: 25p per bottle.

■ CONTRONICS LTD

Garth Works, Deepcut Bridge Road, Blackdown, Camberley, Surrey. Tel: Deepcut 5936.

Carol Cinesound ★

Tape/film, tape/slide synchronisers enable home movies to be made with sound. The Carol Cinesound completes a sound system between the projector and tape recorder. There are three models.

Model R.1

Record only unit for projectors or cameras. In a cream-plastic case, size: $4 \times 2 \times 1\frac{5}{8}$ in, it uses a 22-5V Ever Ready B122 battery and weighs $5\frac{1}{2}$ oz complete. Pulse input: miniature jack socket. Output to tape recorder: DIN 3-way socket. Accessories included. Price on request.

Model P.1

Playback only unit for projectors. Mains operated in a steel case, size: $5\frac{1}{4} \times 3 \times 3$ in, weighing 2lb 2oz. Projector control in/out switch. Tape input: DIN 3-way socket. Pulse input: miniature jack socket. Mains input: 3-pin fixed plug. Projector socket: 8-pin octal socket. Accessories included. Price on request.

Model CS/2

Record/playback unit. Mains operated (240V AC). Steel housing finished in grey and off-white stove enamel measuring: $12 \times 7 \times 3\frac{1}{2}$ in. 23 silicon transistors and 15 silicon diodes. Control circuit operated via isolating transformer driving a silicon controlled rectifier in the motor control circuit. Price on request.

■ EAGLE INTERNATIONAL

Heather Park Drive, Wembley, HA11SU. Tel: 01-903 0144.

TD.79 Tape Head Demagnetiser

250V mains operation. Price: £1-60 (plus 26p PT).

T.635 Tape Splicer

Complete with cutting and trimming blades. Price: £1-25 (plus 15p PT).

■ EMI TAPE LTD

Blyth Road, Hayes, Middlesex. Tel: 01-573 3888. Telex: 22417.

API23 Jointing Block

Professional non-magnetic jointing block for precision splicing at 45° or 90°. Price: 52½p.

AP38 Coloured Leader Tape

Approximately 150ft in plastic dispenser. Range of seven colours as follows: white, red, yellow, blue, orange, green, grey. Price: (per reel) 22½p.

Jointing Tape

Adhesive polyester tape specially prepared for splicing. Approximately 30ft in plastic dispenser. Type API02 ($\frac{3}{32}$ in wide) 24p; type API03 ($\frac{1}{2}$ in wide) 37½p.

API25 Stop Foil

Metallic stop foil on 50ft reels in plastic dispenser. Sufficient for 50 tapes. Price: 32½p.

API24 Accessory Kit

Kit for splicing and editing. Contains three dispensers of leader tape, one of stop foil, one of joining tape, jointing block and two cutters. In plastic tray with two spare compartments for additions. Price: £1-87½.

Plastic spools

In cartons; 4in 16½p; 5in 18p; 5¼in 19½p; 7in 35p. In self-standing dust-proof plastic library cases with index: 3in 14½p; 4in 23½p; 5in 29½p; 5¼in 29½p; 7in 35½p.

■ FERROGRAPH CO LTD

Auriema House, 442 Bath Road, Cippenham, Slough, SL1 6BB. Tel: Burnham 062-86 62511. Telex: 847297.

Defluxer

For depolarising heads, capstans and guides. Ensures maximum signal/noise ratio. Prevents hiss and protects tapes from cumulative background noise. Price: £4-68 (including PT).

Carrying case for Series 7 recorders

Waterproof canvas case with zip fastener. Price: £7-05 (including PT).

Plugs

JPS-401 screened plug with aluminium body and cable clamp. Price: 40p.

Endless loop cassette

Permits Ferrograph to be operated continuously on an endless loop of 8 min duration at 7½i/s. Price: £9-40 (including PT).

Ferrotape spools

Aluminium, anodised grey. Prices: 7in £1-09 (including PT); 8¼in £1-22 (including PT).

■ GRAMPIAN REPRODUCERS LTD

Hanworth Trading Estate, Feltham, Middx. Tel: 01-894 9141. Cables: Reamp, Feltham.

★ Indicates entry is illustrated

Grampian G.7 ★

Matching units, consisting of double-wound transformer in a Mu-metal case with jack socket on the primary and a screened lead on the secondary. Dimensions: $3\frac{3}{8} \times 1\frac{1}{4}$ in diameter. Versions available for matching 15/30 ohms, 600 ohms and 50,000 ohms or greater. Price: £5-20.

Grampian Parabolic Reflector

Diameter 24in, depth 5in. Gain: 14dB over range of 500Hz-5kHz. To take Grampian DP4 and DP6 mics. Weight: $4\frac{3}{4}$ lb. Price: £9-80.

Grampian Reverberation Unit

Self-contained portable unit, transistorised and operated from internal dry batteries. Independent input channels, low level and high level. Output: 1V, 600 ohms. Size (including detachable lid): $17\frac{1}{2} \times 5\frac{1}{4} \times 6\frac{1}{4}$ in. Weight: 12lb. Price: £67 (batteries extra). Mains unit available.

■ GRUNDIG (Great Britain) LTD

Newlands Park, Sydenham, London, SE26.
Tel: 01-778 2211.

Sona Dia ★

Designed to synchronise a tape recorder with automatic slide change projector. Records and reads control pulse on lower $\frac{1}{4}$ -track. Pulse frequency: 100Hz. Power consumption: 3W. Price: £17-15 (including PT).

■ JOHN HORWITZ (IMPORT)

305 Kenton Road, Kenton, Harrow,
Middlesex. Tel: 01-907 6667.

Stereo stamp

Small rubber stamp to enable tape enthusiasts who record in stereo to label their tapes, making them instantly visible. Price: 40p including postage.

■ IMPEX

McArdle & Brainsby (Import & Export) Ltd,
PO Box 2BB,
Newcastle-upon-Tyne, NE99 2BB.

MS7

Stereo magnetic pickup preamplifier designed specifically for use with Ferrograph Series Seven tape recorders. Other versions available for earlier Ferrographs and other makes of amplifier. Input: 3mV 47K. Output: 100mV 470 at 1kHz. HD: < 0.03% at 100mV output. Overload margin: > 28dB. S/N ratio: > 60dB. Power supply: from Ferrograph, or 50V DC at 7mA. Price: £9. Also available in kit form, see Constructional Kits Section.

■ LEEVERS-RICH EQUIPMENT LTD

319 Trinity Road, Wandsworth, London, SW18.
Tel: 01-874 9054/6.
Cables: Leemag, London, SW18.



Grampian G7 matching unit

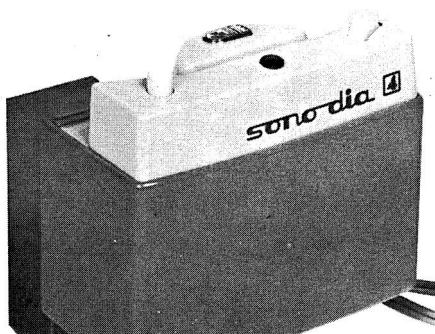

Grundig Sona Dia

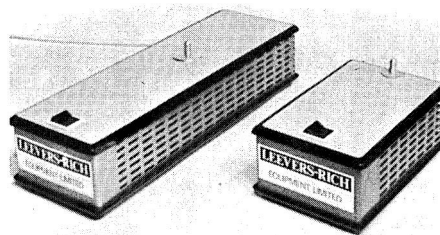

Leevers-Rich LR71

Leevers-Rich LR70

Leeraser LR70, LR71 ★

Bulk tape demagnetisers. Model LR70 for tapes up to $8\frac{1}{4}$ in diameter. Price: £18. Model LR71 for tapes up to $11\frac{1}{4}$ in diameter. Price: £28.

■ LENNARD DEVELOPMENTS LTD

206 Chase Side, Enfield, Middlesex, EN20QX.
Tel: 01-363 8238.

Dry-Splice

Precut adhesive tape for splicing and mending without the aid of a splicing block. Envelopes of 24. Price: 19p.

Playfair Antistatic Cleaning Fluid

30cc polythene bottle. Price: 23p.

Playfair Cassette Cleaners

Further details and price to be announced.

■ MAC

Modular Audio Components Ltd,
Canterbury Road, Nottingham, NG8 1PQ.
Tel: Nottingham 79797.

AAU-1

Audio Adaptor unit providing connections for tape recorders. Provision for fitting attenuator resistors internally. 24in connecting leads fitted with either phono or DIN plugs (AAU-1Q). Panel fitted with two DIN sockets for record/Play. One stereo or two mono recorders can be connected to cabinet mounted Hi-Fi system. Size: 3×3×3in. Finish: jaguar silver. Price: £3-80.

AAU-4

As previous model, but with provision for connecting two stereo recorders to one amplifier for record/replay, one via rear phono sockets, the other via front DIN socket. 3-way switching gives various combination for copying, etc. Price: £5.

AAU-4M

As AAU-4, but fitted with additional replay leads and extra switching for use with amplifiers incorporating special tape monitor circuits. Price: £7-36.

AAU-TV

Audio adaptor unit provides a ready means of connecting various hi-fi equipments to a TV receiver. Built-in isolating transformer tapped 3-8-15 ohms for matching external speakers. Switchable output attenuator for matching input of tape recorder or amplifier. 3-way switching enables TV speaker to be switched on or off. (Remote control switch available with 10ft lead to switch speakers off/on from chair.) Size: 3¼×3¼×3½in. Solid teak case. Finish: jaguar silver. Price: £8-40.

AAU-BOX

Connector box with facilities for various combinations of audio leads fitted with the plugs in common use. Two independent channels of: 4 mm sockets, co-ax, ¼in jack, miniature jack, 3-pole jack, 5-pin DIN, two pairs of phono. DIN pins selected by slide switch. Screw terminals underneath for fitting attenuator and load resistors, which can be switched in or out. Size: 4¾×3¾×1¼in. Finish: jaguar silver. Price: £5-70.

All MAC AAU units are available in solid teak case at an additional cost of £1-32.

■ MASTERTAPE (MAGNETIC) LTD

Blackthorne Road, Poyle Trading Estate,
Colnbrook, Bucks, SL30AQ.
Tel: 01-964 2431.



Metro-sound cleaning brush

Leader Tapes

45ft; colours, red, white, blue, green. Price: (per reel) 15p.

Plastic Tape Clips

25 per packet. Price: 19p.

Metallic foil

20ft reel. Price: 30p.

Adhesive tape

18ft reel. Price: 23p.

Empty Spools (boxed)

3in 11p; 4in 13p; 5in 17p; 5½in 19p; 7in 21p; 8¼in 37p.

Plastic Storage Boxes (empty)

5in 15p; 5½in 21p; 7in 36p.

■ MEMOREX INC

Freight House, Long Lane, Stanwell,
Middlesex. Tel: Ashford (Middlesex) 42177.

Cassette Library Holder

Cat. No. 710-00012. Accommodates six compact cassettes. Price: 75p.

■ METROSOUND

Metro-sound Manufacturing Co Ltd,
Cartersfield Road, Waltham Abbey, Essex.
Tel: Waltham Cross 31933.

M.1 Metro-Splicer

Nylon block impervious to joining compounds, interchangeable guides and channels or use with 8mm films. Supplied with spare cutter blades and emulsion scraper. Price: £1 (plus 16p PT).

M.4 Klentazape kit

Patented head cleaner. Kit comprises ribbed cleaning tape, two special spools and bottle of Klentazape fluid. Price: 75p (plus 12p PT).

M.7 Tape accessory kit

Comprising Metro-Splicer, Klentazape kit, Metro-brush on display card. Price: £1-75 (plus 28p PT).

M.9 Metro-Brush ★

Designed for use with tape recorders for cleaning all surfaces except tape head. Soft nylon with plastic handle. Price: 17p (plus 3p PT).

★ Indicates entry is illustrated

M.12 Metro-Strobe

Stroboscope for checking accuracy of tape recorders on all speeds at 50Hz and 60Hz. Price: 65p (plus 10p PT).

M.16 Tape Recorder Mechanical Maintenance Kit

Presentation pack with Metro-Strobe, lubricating kit, Klenzatape kit, supply of cleaning pads, Metro-Brush. Price: £2.25 (plus 36p PT).

M.17 Metro-Splicing Block

Professional precision metal splicing block for $\frac{1}{4}$ in tape, supplied with non-magnetic cutter blade. Price: 60p (no PT).

M.18 Leader tapes

Choice of six colours, approximately 40ft of leader tape, wound on to plastic mini-spool. Price: 25p (no PT).

M.19 Stop foil

Metallic tape for actuating electronic auto stop mechanisms for tape recorders. Approximately 15ft on mini-spool. Price: 25p (no PT).

M.20 Jointing tape

$\frac{1}{4}$ in wide, approximately 12ft on mini-spool. Price: 25p (no PT).

M.23 Spirit level

Plastic spirit level for tape recorders and turntables, etc. Price: 40p (no PT).

M.24 Lubricating Kit

Suitable for tape recorders and mechanical moving parts. Comprises small bottle of each of R.O.B. and R.O.G. oil and container of Starfax. Price: 40p (no PT).

M.25 Tape Editing Kit ★

Comprises splicing block and cutter, one reel stop foil, one reel jointing tape; three assorted coloured leaders in cassettes with transparent dust cover, mounted on plastic base with soft plastic feet and supplied with fixing screws for bench use. Price: £1.75 (no PT).

M.32 Cassette Head Cleaner

Same size as Philips Compact Cassette. Non-abrasive. Cleans and polishes record and erase heads. For all recorders and tape players using Philips type cassettes. Price: 50p (plus 8p PT).

M.30 Accessory Rack

For radio and audio retailers. Wire display rack with assortment of Metrosound accessories in packs. Full details and prices on request.

M.33 C60 Blank Cassette

Price: 60p (plus 1p PT).

M.34 Ioniser fluid

Price: 25p.

M.39 Cartridge Head Cleaner

Designed for cleaning heads on eight-track cartridge tape players and recorders. Price: £1 (plus 16p PT).

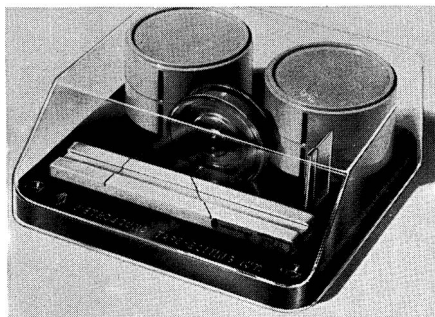

Metrosound M25 editing kit

■ MULTICORE. See Bib.

■ MUSONIC LTD

34-38 Verulam Road, St Albans, Herts.
Tel: St Albans 50611/2.

CaseSet

Carry case for compact cassettes. Made in wood and plastic. Price: £1.05 (plus 17p PT).

Cartabout

Carry case for eight-track cartridges. Made in wood and plastic. Price: £1.80 (plus 29p PT).

Cassette Head Cleaner

Compact cassette containing cleaning tape. Cleans and polishes the tape heads. Price: 42p (plus 7p PT).

Cartridge Head Cleaner

With "beep" tone. Inserted into recorder or player until three "beeps" are heard, after which the heads are clean. Price: 72p (plus 12p PT).

Cartridge Head and Drive Cleaner

Reversible cartridge that cleans the tape heads and the drive wheel. Price: £1.05 (plus 17p PT).

Tape Rack

Heavy gauge welded wire. Plastic coated in black. Suitable all sizes of tape spools and eight-track cartridges. Price: to be announced.

■ OSMABET LTD

46 Kenilworth Road, Edgware, Middlesex.
Tel: 01-958 9314.

'Instant' Bulk Tape Eraser and Recording Head Demagnetizer

Operates from AC mains to provide rapid and complete erase of tapes and cassettes prior to making quality recordings. Weight: 18oz. Price: £2.40.

■ PD CONNECTORS

Parry Electronic Developments Ltd,
Assay House, 28 Greville Street, London, EC1.
Tel: 01-242 1100.

DIN plugs

New design of DIN plug which requires no soldering or screw connections. Pins interchangeable to match any DIN configuration. Space inside housing to accommodate matching or attenuating resistors. Ratchet-type cable clamp adjusts to all sizes of connecting lead. Designed for home constructors and hi-fi enthusiasts. Price: 28p.

PHILIPS ELECTRICAL LTD

Century House, Shaftesbury Avenue, London, WC2.
Tel: 01-437 7777. Cables: Philamps, London.

EL3787A Pre-Amplifier

Designed for use with Philips $\frac{1}{4}$ -track mono mains-operated recorders which have stereo socket and first-stage input transistor circuit. EL3787A with additional equipment offers play-back of pre-recorded stereo tapes, duo-play (playback of one track while recording on parallel track) and multi-play (copying from one track to another and simultaneously adding an accompaniment). Price: £7.38 (plus £1.32 PT).

EL1995/N6400 Slide Synchroniser

For use with most tape recorders and automatic slide projectors (max voltage 30V, max current 1A). Supply: 9V battery. Price: £14.69 (plus £2.36 PT).

N6502

Mains supply unit. Inputs: 110-245V (switchable). Outputs: 6V, 7.5V and 9V (switchable). For use with Philips battery tape recorders and radios fitted with appropriate socket. Price: £5.25.

SK10 Splicing Kit

Contains white, green, red and blue leader tape, switching foil, adhesive tape, adhesive labels, cutting blade, splicing jig and instructions. Contained in plastic case. Price: £1.38.

Stereo headphones

Various models for use with Philips recorders. Price: (mono EL3775/85) £3.60; (stereo EL3775/38) £5.75.

Empty spools in cardboard boxes

5in 21p; 5 $\frac{1}{2}$ in 23p; 7in 26p; 10 $\frac{1}{2}$ in cine centre spool £1.18.

Library cases

5in 18p; 5 $\frac{1}{2}$ in 21p; 7in 25p.

ET 4743/00

Compact cassette box. Price: 4p.

ET 4744/00

Library rack. Price: 7p.

Cassette Cleaning Tape

Price: 82p.

N6705

Car mounting unit for models EL3300, 3301,

3301T, 3302, N2202 tape recorders. 6V or 12V, positive or negative earth (negative earth only with N2202). Price: £15.70.

EL/1900 Leader Tape

LT10 (white), LT20 (green), LT30 (red). Price: 13p per reel.

EL3880/50 Switch foil

Price: 15p.

EL3916/10 Jointing tape

Price: 30p.

■ **PLAYFAIR.** See Lennard Developments.

Q A S

Quality Audio Supplies,
Wollaton Road, Beeston, Nottingham,
NG92PB. Tel: 0602 252222 and 256141.

Wide range of audio accessories including phono plug, DIN plugs and sockets, 4mm and wander plugs, couplers, screw terminals, slider switches, connecting leads with all types of terminations, audio switching units and remote control stations. All items individually blister-packed for over the counter or self-service sales.

See Pickup Accessories and Speaker Accessories Sections for details of other QAS equipment.

SCOTCH

3M (UK) Ltd, 3M House, Wigmore Street, London, W1. Tel: 01-486 5522.

No. 41 Splicing Tape

A white pressure sensitive adhesive tape specifically designed for splicing magnetic tape. $\frac{1}{2}$ in \times 50in 18p; $\frac{1}{2}$ in \times 66ft 33p; $\frac{3}{4}$ in \times 66ft 23p.

Tape a Letter

Send a letter on tape. You can talk for up to thirty minutes on a SCOTCH Tape a Letter. The 3in reel fits all spool type tape recorders. Handy pack is specially designed for easy posting. Price: 38p.

No. 51 Sensing Tape

For recorders with electric sensing controls. A flexible and strong conductive foil tape with a pressure sensitive adhesive that sticks tight and stays clean. The sensing tape adheres to the dull side of the recording tape so that it falls inwards when wound on the spool. Price: 70p.

Accessory Kit

A slim pocket-size kit for outside work or 'on-the-spot' editing. The accessory kit contains: splicer, No. 41 splicing tape on a dispenser, No. 24 white leader tape, in handy pack with cutter, ten tape clips. Price: £1.73.

Tape Clips

For holding tape secure on a spool and preventing spilling or tangling in storage, handling and

★ Indicates entry is illustrated

shipment. Available in packets of ten. Price: (per packet) 13p.

Empty Spools

Made of strong, high-quality plastic. Available in all popular reel sizes each individually boxed and with a slot to allow easy tape threading. In larger sizes the slot is calibrated. Price: 3in 15p; 4in 18p; 5in 20p; 5½in 22p; 7in 23p; 10½in £1.00.

No. 24 Leader Tape

Used to identify ends of tape and sections within a reel. Supplied in red, yellow, white, green and blue. ¼in × 50ft. Price: 10p.

■ **SONY (UK) LTD**

Pyrene House, Sunbury Cross,
Sunbury-on-Thames, Middlesex.
Tel: Sunbury 87644/7.

EAD-1

Equalisation adaptor for adjusting recorder when Sony SLH (super low-noise/high output) tape is employed and the machine has no standard/special tape switching facility. Price: to be announced.

HE-2

Tape head demagnetizer. Size: 2½ × 1½ × 5in. Weight: 13oz. Price: £4.18 (plus 71p PT).

CSS-4

Sound-on-sound adaptor for recorders and tape decks without suitable facilities. Inputs for microphone and line, outlets for feeding into low impedance mic sockets. Price: £4.73 (no PT).

BE-7

Bulk eraser for compact cassettes. Permanent magnet. Size: 4½ × 4⅝ × 1¾in. Weight: 2½lb. Price: £7.69 (plus £1.29 PT).

■ **SYNCHROTAPE**

Sole Distributors. Adastra Electronics Ltd,
Unit 22, Cricklewood Trading Estate,
Claremont Road, London, NW2 1TU.
Tel: 01-452 6288 (answering service 01-452 6289).

Synchrotape Editing Kit

Instant cut and trim splicer, four reels coloured leader tape, one reel metallic stop foil, one reel adhesive tape, six coloured tape-securing clips and 28 self-adhesive titling labels. Presented in see-through crush-proof carton. Complete with 12-page instruction and information booklet. Price: £1.50 (plus 36p PT).

■ **TAPE RECORDER SPARES LTD**

Harmsworth House, 9 Harmsworth Street,
London, SE17. Tel: 01-735 9683.

Audio Packs

Pre-packed spares and audio accessories.

Connecting cords

Cables of various types with plugs, sockets and



TRS Mains Unit Audio Pack 442

other terminations covering all equipment in use for domestic audio.

Adaptors

Convert from any type of plug or socket termination to any other type.

Audio Spares

Plugs, sockets, chassis mounted components, fuses and audio accessories. Pre-packed for counter or showroom display.

Mains units ★

Three-different 6-12V battery eliminators complete with connecting leads for use with all standard-battery-operated tape recorders and radios. Full specifications on request.

■ **TELEFI**

Rola-Celestion Ltd, Ditton Works,
Foxhall Road, Ipswich, Suffolk, IP3 8JP.
Tel: Ipswich (0473) 73131.

Telefi

Special adaptor to permit sound channel output to be taken from most UHF 625-line television receivers. Easy fitting. No connections or modifications to TV. Usually operates without even removing cabinet back. Special probe picks up stray 6MHz inter-carrier sound signal, prior to TV sound detector, and processes the signal to provide a high quality audio output for feeding hi-fi system. Finish: teak. AC mains. Output: typically 100mV-1V adjustable. Output impedance: 2K. Distortion: <1%. FR: 30Hz-20kHz. Two screened leads 6ft long. Price: £29.50.

■ **TELEFUNKEN**

Distributor: AEG (Great Britain) Ltd,
AEG House, Chichester Rents, Chancery Lane,
London, WC2. Tel: 01-242 9944.

Telefunken Endless Tape Cassette

Price: £3.36 (plus 83p PT).

■ T.T.C.

Joint distributors: Adastra Electronics Ltd, Unit 22, Cricklewood Trading Estate, Claremont Road, London, NW2 1TU. Tel: 01-452 6288. E.R. (Factors) Ltd, 374-378 Harrow Road, Paddington, London, W9. Tel: 01-286 0361.

I.1001

Tapesplicer. Self-contained with instant cut and trim action. Spring-loaded arms secure tape to padded cutting block. Price: £1.15 (including PT).

I.1003

Tape head defluxer. AC mains. For removing residual magnetism from tape heads, capstan, guides and other parts of recorders. Hand-shaped moulded body with $1\frac{1}{4}$ in probe. 3ft mains lead. 200-250V. Price: £1.95 (including PT).

I.1004

Bulk tape eraser. Heavy duty. For reels up to 10in diameter. Non-magnetic moulded top. Free-standing metal case with non-scratch feet. On/off switch. Indicator light. Price: £8 (including PT).

■ TUTCHINGS ELECTRONICS LTD

14 Rook Hill Road, Friars Cliff, Christchurch, Hants. Tel: Highcliffe 2019.

Tapesponder's kit

Magnetic rubber for completely erasing tape; and 40ft of white noise azimuth tape. Price: 25p including postage.

■ UHER

Distributors: Bosch Ltd, PO Box 166, Rhodes Way, Radlett Road, Watford, Herts, WD24LB. Tel: Watford 44233.

W212 Stethoset

Stethoscope earphones. Price: £3.60.

Uher A401 Timer

Self-starting synchronous clock mechanism with hour and minute hands. A third hand indicates time over a 24-hour period (i.e. operates at half speed of normal hour hand). This third hand operates switch striker.

72 selectors round perimeter of clock, spaced at 20-minute intervals, permit on/off/on/off switching in sequence, i.e. up to 36 on and 36 off operations within every 24-hour period. Accuracy is \pm two minutes of the set time. Price: £16.80.

Z124

Mains unit/charger designed to operate models 1200 Report Stereo, 4000L, 4200/4400 from 110/240V AC mains, or to recharge Dryfit battery (Z212) or nickel cadmium battery (Z214). Price: £18.06 (including PT).

Z212, Z214

Lead acid accumulator (Z212) and nickel cadmium battery (Z214). Designed to fit into models 1200 Report Stereo, Pilot, 4000L, 4200/4400. Capacity: approx 2.5 AH. Running time per charge: approx 4-5 hours. Prices: (Z212) £7.70; (Z214) £15.40.

Z213, Z215

Lead Acid accumulator (Z213) and nickel cadmium battery (Z215) for Uher Compact Report Stereo. Capacity 1.5AH. Running time per charge approximately 5 hours. Price: (Z213) £7.30; (Z215) £16.40.

■ VALRADIO LTD

Browells Lane, Feltham, Middlesex.

Tel: 01-890 4837/4242.

Service agents: Vibro Supply, 57 Fortess Road, London, NW5. Tel: 01-485 5165.

DC converters

Designed for operating tape recorders and similar mains equipment from ship's supply of 220V DC. Prices from about £22.

Transverter B12/30S

Input 12V DC. Output 50Hz $\pm\frac{1}{4}$ Hz sine wave at 30W. Suitable for positive or negative earthed input. Built-in switch and socket. Supplied complete with input lead. Size: $8 \times 6 \times 6$ in. Weight: 8lb. Price: approximately £32.

Transverter B12/120S

Input 12V DC. Output: 115-230V 50Hz $\pm\frac{1}{4}$ Hz sine wave at 120W. Price: approximately £57.

Transverter B12/200 ★

Input 12V DC. Output: 115-230V 50Hz $\pm\frac{1}{4}$ Hz sine wave at 200W. Price: approximately £80.

Frequency changer

AC-DC. Suitable for records, films, television programme special effects. Prices: (100W) from about £38; (200W) from about £62.

■ WAL

Sole distributor: A. C. Farnell Ltd, Consumer Division, Farnell House, 81 Kirkstall Road, Leeds, LS3 1HR. Tel: Leeds 35111.

WAL D-Mag

Pinpoint eraser for striped film, tapes and tape heads. Nylon-cushioned probes. Weight: $9\frac{1}{2}$ oz. Size: $2\frac{1}{2} \times 4\frac{3}{4} \times 3\frac{3}{4}$ in. Psn 200-250V 50-100Hz. Consumption: 110mA at 240V. Price: £3 (plus 54p PT).

WAL professional tape eraser

Will erase both sides of a 7in tape reel in 30 sec and sound from 16mm 10in aluminium reels. Weight: 7lb. Size: $6\frac{1}{2} \times 4\frac{3}{4} \times 3\frac{3}{4}$ in. Psn 200-250V 50Hz, or 110-125V 60Hz. Finish: oyster hammer grey. Price: £8.93 (plus £1.62 PT).

Directory of Magnetic Tape

★ Indicates entry is illustrated

■ AGFA-GEVAERT LTD

Great West Road, Brentford, Middlesex.
Tel: 01-560 2131 (20 lines). Telex: 28154.

PE36K ★

Long-play tape supplied in plastic library box. 3in 210ft (in universal mailing box) 45½p; 4¼in 600ft £1-29½; 5in 900ft £1-59½; 5½in 1,200ft £1-97; 7in 1,800ft £2-88.

PE36

Long-play tape supplied in cardboard box. 8¾in 2,400ft £3-62; 10in 3,280ft £4-89; 10½in 4,200ft £6-14½.

PE46K ★

Double-play tape supplied in plastic library box. 3in 300ft (in universal mailing box) 67½p; 4¼in 900ft £1-59½; 5in 1,200ft £1-97½; 5¾in 1,800ft £2-88½; 7in 2,400ft £3-65½.

PE46

Double-play tape supplied in cardboard box. 8¾in, 3,280ft £4-89½.

PE66K ★

Triple-play tape supplied in plastic library box. 3in 450ft (in universal mailing box) 90½p; 4in 900ft £1-59½; 4¼in 1,200ft £1-97½; 5in 1,800ft £2-88½; 5¾in 2,400ft £3-63½; 7in 3,600ft £5-28½.

Compact Cassettes

C60 (2 × 30 min) 75½p; C90 (2 × 45 min) £1-00½; C120 (2 × 60 min) £1-50½.

Chromium Dioxide

Chromium dioxide tape in compact cassettes. Especially suitable for Dolby equipment and machines with provision for switching bias for optimum performance. Price: (C60 size) £1-35; (C90 size) £1-75. Supplied to retailers in counter dispensers containing 15 cassettes.

■ AUDIO MAGNETICS (UK) LTD

12 Fife Road, Kingston-on-Thames, KT1 1SZ.
Tel: 01-549 3271/2.

Compact Cassettes

C-60. In library case. Low noise tape giving 60 min recording time. Price: 40p.

C-90. In library case. Low-noise tape giving 90 min recording time. Price: 60p.

C-120. In library case. Low-noise tape giving 120 min recording time. Price: 80p.

Also available in budget-priced economy packs of three cassettes (without library case), and in the well-known Twinpack presentation.

■ BASF UNITED KINGDOM LIMITED

Audio/Video Tapes Division, PO Box 473, Knightsbridge House, 197 Knightsbridge, London, SW7.

Tel: 01-584 5080. Telex: 267574/5.

SP 52

Standard play. Round pack: 5in 600ft £1-13; 5¾in 900ft £1-53; 7in 1,200ft £1-77. In plastic swivel box: 5in 600ft £1-31; 5¾in 900ft £1-72; 7in 1,200ft £1-98.

LP 35

Long play. Round pack: 3in 210ft 45p; 4in 450ft 95p; 4¼in 600ft £1-13; 5in 900ft £1-53; 5¾in 1,200ft £1-77; 7in 1,800ft £2-63. In plastic swivel box: 3in 210ft 57p; 4in 450ft £1-13; 4¼in 600ft £1-30; 5in 900ft £1-71; 5¾in 1,200ft £1-97; 7in 1,800ft £2-83.

LP 35 LH

Long-play. Low noise, high output. In plastic swivel box: 5in 900ft £1-89; 5¾in 1,200ft £2-17; 7in 1,800ft £3-11.

DP 26

Double-play. Round pack: 3in 300ft 60p; 4in 600ft £1-13; 4¼in 900ft £1-53; 5in 1,200ft £1-77; 5¾in 1,800ft £2-63; 7in 2,400 £3-27. In plastic swivel box: 3in 300ft 72p; 4in 600ft £1-30; 4¼in 900ft £1-70; 5in 1,200ft £1-96; 5¾in 1,800ft £2-82; 7in 2,400ft £3-48.

DP 26 LH

Double-play. Low noise, high output. In plastic swivel box: 5in 1,200ft £2-16; 5¾in 1,800ft £3-10; 7in 2,300ft £3-83.

TP 18

Triple-play. Round pack: 3in 450ft 95p; 3½in 600ft £1-13; 4in 900ft £1-53; 4¼in 1,200ft £1-77; 5in 1,800ft £2-63; 5¾in 2,400ft £3-27; 7in 3,600ft £4-13. In plastic swivel box: 3in 450ft £1-09; 3½in 600ft £1-30; 4in 900ft £1-70; 4¼in 1,200ft £1-95; 5in 1,800ft £2-81; 5¾in 2,400ft £3-47; 7in 3,600ft £4-33.

TP 18 LH

Triple-play. Low noise, high output. In plastic

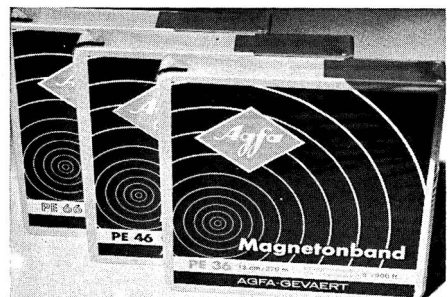

Agfa Low Noise Tapes

swivel box: 5in 1,800ft £3-09; 5½in 2,400ft £3-82; 7in 3,600ft £4-75.

Compact Cassettes

BASF low noise tape in KK8 swivel box for posting or use stacked as book: C60 79p; C90 £1-07; C120 £1-57. In normal pack: C30 59p; C60 71p; C90 99p; C120 £1-49.

SM Chrome dioxide

Chrome dioxide 'Special Mechanics' tape in KK8 swivel box. SM system designed to ensure constant free-running thus reducing wow and flutter caused by variable tape tension. Chrome dioxide tape is said to provide increased dynamic range, lower background noise, less headwear and longer tape life. Price: (C60) £1-34; (C90) £1-74; (C120) £2-24.

Special requirements tapes

See details in Tape Accessories Section.

■ EMI TAPE LTD

Blyth Road, Hayes, Middlesex.
Tel: 01-573 3888. Telex: 22417.

88 Standard Play (red band)

Prestretched polyester base. 3in 175ft 44p; 4in 300ft 58½p; 5in 600ft £1-17; 5½in 900ft £1-55; 7in 1,200ft £1-95½.

99 Long Play (green band)

Prestretched polyester base. 3in 210ft 50½p; 4in 450ft 81p; 5in 900ft £1-56; 5½in 1,200ft £1-95; 7in 1,800ft £2-77½.

100 Double Play (blue band)

Superflex polyester base. 3in 300ft 78p; 4in 600ft £1-38; 5in 1,200ft £2-32; 5½in 1,800ft £3-06½; 7in 2,400ft £4-29.

300 Triple Play (grey band)

Extra tensile polyester base. 3in 450ft £1-21; 4in 900ft £2-10; 5in 1,800ft £3-63½.

All Emitape is supplied in transparent hinged library case. A prefolded index card is included. Card is designed to provide maximum space for titling with easy visible reference without opening the box.

Compact Cassettes

C60 (one hour playing time) 71p; C90 (1½ hours playing time) 98½p; C120 (2 hours playing time) £1-48½.

EMI cassettes are supplied in library case with index sheet.

HMV Voice Letter

Supplied in mailing pack. 3in spool. Price: 30p.

Plastic Spools

In cartons: 4in 16½p; 5in 18p; 5½in 19½p; 7in 35p. In self-standing dust-proof plastic library cases with index: 3in 14½p; 4in 23½p; 5in 29½p; 5½in 29½p; 7in 35½p.

■ GRUNDIG (Great Britain) LTD

Newlands Park, London, SE26.
Tel: 01-778 2211.

GT11

Triple-play: 4½in 1,200ft £2-47.

GL15 Hi-Fi

Long-play: 5½in 1,200ft £1-97.

GD15 Hi-Fi

Double-play: 5½in 1,800ft £2-75.

GL18 Hi-Fi

Long-play: 7in 1,800ft £2-80.

GD18 Hi-Fi

Double-play: 7in 2,400ft £3-75.

C60 Hi-Fi

Compact cassette. 60 minutes playing time at 1⅞i/s. Price: 87p.

C90 Hi-Fi

Compact cassette. 90 minutes playing time at 1⅞i/s. Price: £1-25.

DC90

Cassette. 90 minutes playing time. Price: £1-50.

DC120

Cassette. 120 minutes playing time. Price: £1-77.

Note: Grundig prices include purchase tax where applicable.

■ LENNARD DEVELOPMENTS LTD

206 Chase Side, Enfield, Middlesex, EN20QX.
Tel: 01-363 8238.

Playfair Compact Cassettes

Available in C60, C90 and C120 sizes. Prices to be announced.

■ MASTERTAPE (MAGNETIC) LTD

Blackthorne Road, Poyle Trading Estate, Colnbrook, Bucks, SL30AQ.
Tel: 01-964 2431.

Standard (red)

3in 150ft 30p; 4in 300ft 54p; 5in 600ft £1-07; 5½in 900ft £1-32; 7in 1,200ft £1-69.

Long Play (green)

3in 225ft 39p; 4in 450ft 75p; 5in 900ft £1-31; 5½in 1,200ft £1-65; 7in 1,800ft £2-39; 8½in 2,400ft £2-94.

Double Play (blue)

3in 300ft 54p; 4in 600ft 99p; 5in 1,200ft £1-64; 5½in 1,800ft £2-37; 7in 2,400ft £3-05.

Triple Play (grey)

3in 600ft 99p; 4in 900ft £1-26; 5in 1,800ft £2-36; 5½in 2,400ft £3-03; 7in 3,600ft £4-55.

Mini Voice Letter (mailing carton)

3in 100ft 25p.

Senda Message (mailing envelope) ★

1⅞in 100ft 25p.

★ Indicates entry is illustrated

Compact Cassettes ★

C60 67p; C90 91p; C120 £1-21.

■ MAXELL

Distributors: Harris and Russell Ltd,
124-130 East Road, London, N1.
Tel: 01-253 7551.

Compact Cassettes

Low-noise tape with anti-static arrangement and freedom from print-through. C60 (red label) 60 minutes playing time. Price: 49½p. C90 (blue label) 90 minutes playing time. Price: 74½p. C120 (green label) 120 minutes playing time. Price: 99½p.

All Maxell compact cassettes are supplied in individual library type hinged plastic storage cases.

■ MEMOREX INC

Freight House, Long Lane, Stanwell,
Middlesex. Tel: Ashford (Middlesex) 42177.

Compact Cassettes (702)

C30 56½p; C60 76½p; C90 £1-01½; C120 £1-51½.

Eight-track Cartridges (703)

8T-40 £1-55; 8T-64 £1-70; 8T-80 £1-85.

Compact Cassettes (Chromium dioxide)

CC60 £1-36½; CC90 £1-76½.

Standard Play

5in 600ft £1-37; 7in 1,200ft £2-29.

Long Play

5in 900ft £1-92; 7in 1,800ft £3-24.

Double Play

5in 1,200ft £2-29; 7in 2,400ft £4-04.

Special Tapes

Wound on metal NARTB reels. Standard Play: 10½ in 2,500ft £5; Long Play: 10½ in 3,600ft £6.

Cassette Library Holder

Accommodates six compact cassettes. Price: 75p.

■ MUSONIC LTD

34-38 Verulam Road, St Albans, Herts.
Tel: St Albans 50611/2.

Musonic cassettes

Low-noise professional tape. Price: (C60) 60p; (C90) 80p; (C120) £1.

■ PHILIPS ELECTRICAL LTD

Century House, Shaftesbury Avenue,
London, WC2. Tel: 01-437 7777.
Cables: Philamps, London.

Standard Play (Green) in library case

Coercivity 290 OE, retentivity 950G, tensilised polyester base, S/N at 3¾i/s better than 50dB, print through about 55dB, relative frequency



Mastertape Cassette



Mastertape Senda Message



Mastertape Cassettes

response 333Hz-12.5kHz + 1dB. Price: 5in 600ft £1.27; 5½in 900ft £1.69; 7in 1,200ft £1.95.

Long Play (Red) in library case

Coercivity 290OE, retentivity 950G, tensilised polyester base, S/N at 3¾i/s better than 50dB, print through about 55dB, relative frequency response 333Hz-12.5kHz + 1dB. Price: 5in 900ft £1.42; 5½in 1,200ft £1.79; 7in 1,800ft £2.55.

Double Play (Blue) in library case

Coercivity 290OE, retentivity 950G, tensilised polyester base, S/N at 3¾i/s better than 50dB, print through about 55dB, relative frequency response 333Hz-12.5kHz ± 1dB. Price: 5in 1,200ft £1.92; 5½in 1,800ft £2.82; 7in 2,400ft £3.95.

Triple Play (Olive)

Price: 5in 1,800ft £3.32.

10½in cine centre

Red LP26 3,600ft £5.50.

C30 postal pack compact cassette

Playing time 30 minutes. Price: 53p.

Compact Cassettes

Polyester base, S/N 50dB, bias adjustment 0dB, maximum output level (MOL) at 333Hz 0dB, maximum output level (MOL) at 8kHz - 10dB, relative frequency response (RFR) at 10kHz 0dB, relative tape sensitivity (RTS) at 333Hz 0dB (tape speed 1¾i/s). C60 (one hour playing time) 71p; C90 (1½ hours playing time) 99p; C120 (two hours playing time) £1.49.

EL1907/52 Endless loop cassette CE.10

Approx playing time: 40 minutes at 1½i/s. Approximately 195ft. Price: £3.52.

■ SCOTCH

3M (UK) Ltd, 3M House, Wigmore Street, London, W1. Tel: 01-486 5522.

175

Standard play; polyester base. 5in 600ft £1.06; 5½in 900ft £1.41; 7in 1,200ft £1.77.

215

Long play; polyester base. 3in 300ft 47p; 4in 500ft 74p; 5in 900ft £1.41; 5½in 1,200ft £1.76; 7in 1,800ft £2.52; 8½in 2,400ft £3.66; 10½in 3,600ft £5.55.

220

Double play; tensilised polyester base. 3in 400ft 83p; 4in 600ft £1.26; 5in 1,200ft £2.11; 5½in 1,800ft £2.78; 7in 2,400ft £3.89.

290

Triple play; tensilised polyester base. 3in 600ft £1.24; 4in 900ft £1.96.

Scotch Dynarange Specification

Coercivity 315 oersteds, retentivity 790 gauss, remanence 0.64 lines/quar. in, erasing field required 1,000 oersteds, standard bias 100%,

peak bias 117% compared with standard tape. Full technical data on Scotch Dynarange magnetic tape available on sheet 202-203 which includes notes on testing.

Dynarange 202

Polyester base. Standard play in library cases. 5in 600ft £1.27; 5½in 900ft £1.70; 7in 1,200ft £2.16.

Dynarange 203

Polyester base. Long play in library cases. 5in 900ft £1.68; 5½in 1,200ft £2.11; 7in 1,800ft £2.99; Long play in cardboard box: 8½in 2,400ft £4.20; 10½in 3,600ft £6.30.

Dynarange 204

Double play in cardboard box: 3in 400ft 96p; 4in 600ft £1.46. Double play in library case: 5in 1,200ft £2.38; 5½in 1,800ft £3.10; 7in 2,400ft £4.43.

Scotch Low-Noise Cassettes

Using Dynarange low-noise tape. C60 71p; C90 99p; C120 £1.49.

Scotch High Energy Cassettes

High output cobalt energised tape for use with new generation cassette machines. C60 £1.45; C90 £1.90.

Eight-track low-noise cartridges

40 minutes £1.50; 80 minutes £1.80.

■ SONY (UK) LTD

Pyrene House, Sunbury Cross, Sunbury-on-Thames, Middlesex. Tel: Sunbury 87644/7.

PR150/PR200 series specification

Polyester base. Bias current: 100%. Sensitivity: ±2dB. Uniformity: (333Hz) ±0.5dB, (10kHz) ±0.5dB. FR: 10kHz ±2dB. HD: 6% max at 333Hz. S/N: 58dB minimum. Print-through ratio: 50dB minimum. Erasure: 70dB minimum. Test conditions: 7½i/s, NAB reference tape.

PR150

3in spool 300ft 35p; 5in spool 900ft £1; 6in spool 1,200ft £1.37; 7in spool 1,800ft £1.87.

PR200

3in spool 400ft 63p; 5in spool 1,200ft £1.63; 6in spool 1,800ft £2; 7in spool 2,400ft £2.63.

SLH (low-noise/high-output) specification

Polyester base. Bias current: 108%. FR: 10kHz +4.5dB, 16kHz +7dB. HD: 3%. Linearity: (16kHz) +10dB. Dynamic range: +6.5dB. S/N ratio: 62dB. Erasure: 68dB. Retentivity: 1,100 gauss. Intrinsic coercivity: 300 oersted. Test conditions: NAB reference tape.

SLH

370 7in spool 1,200ft £2; 550 7in spool 1,800ft £2.63; 11-740B 10½in spool 2,400ft £6.

★ Indicates entry is illustrated



Synchronotape



Synchronotape

HF series specification

Sensitivity: at 333Hz: (C60HF) +1.5dB, (C90HF) +1.0dB, (C120HF) -1.0dB. S/N ratio: 58.5dB. Bias current: (C60HF) 100%, (C90HF and C120HF) 95%.

Cassettes

C60 63p; C60HF 87p; C90 87p; C90HF £1.25; C120 £1.25; C120HF £1.44.

■ SYNCHROTAPE

Sole distributors: Adastra Electronics Ltd, Unit 22, Cricklewood Trading Estate, Clarendon Road, London, NW21 1TU. Tel: 01-452 6288 (answering service 01-452 6289).

Specification of Synchronotape includes the following: Coercivity 270 Oersted, remanent induction 0.75 maxwell per 6.25 mm width. At $7\frac{1}{2}$ i/s $\frac{1}{2}$ -track, biased to give max output at 1kHz, with DIN 70µ Sec playback equalisation, main characteristics are: recorded flux for 2% third harmonic distortion 0.2 maxwell, unweighted RMS noise referred to 0.2 maxwell -65dB, print-through after 72 hours at 20°C -58dB.

Standard Play

PVC base: 3in 150ft 22½p; 5in 600ft 82½p; 5¾in 900ft 97½p; 7in 1,200ft £1.27½.

Long Play ★

PVC base: 2¾in 200ft 30p; 3in 200ft 30p; 4in 450ft 67½p; 5in 900ft 93p; 5¾in 1,200ft £1.12½; 7in 1,800ft £1.56.

Double Play

Tensilised polyester base: 2¾in 300ft 37½p; 3in 300ft 37½p; 4in 600ft 97½p; 5in 1,200ft £1.56; 5¾in 1,800ft £1.95; 7in 2,400ft £2.50.

Triple Play

Tensilised polyester: 3in 450ft 75p; 4in 900ft £1.20p; 5in 1,800ft £2.10; 5¾in 2,400ft £2.77½; 7in 3,600ft £3.75.

Except for 2¾in and 3in spools, all Synchronotape tapes have leader, trailer and double metallic stop-foils.

Synccassettes

Synccassette C60 (60 minutes playing time) 57p. Synccassette C90 (90 minutes playing time) 72p. Synccassette C120 (120 minutes playing time) £1.08.

■ TELEFUNKEN

Distributors: A.E.G. (Great Britain) Ltd, AEG House, Chichester Rents, Chancery Lane, London, WC2. Tel: 01-242 9944.

Endless Tape Cassette

Price: £3.36 (plus 83p PT).

■ TUDOR TAPE

A. C. Farnell (Leeds) Ltd, Farnell House, 81 Kirkstall Road, Leeds, LS3 1HR. Tel: Leeds 35111.

Standard Play (green)

3in 150ft; 5in 600ft.

Long Play (red)

3in 250ft; 5in 900ft; 5¾in 1,200ft; 7in 1,800ft.

Double Play (blue)

5¾in 1,800ft; 7in 2,400 ft.

Cassettes

C60, C90 and C120.

Empty spools in boxes

3in, 4in, 5in, 5¾in and 7in.

No retail prices are quoted for Tudor Tape.

Directory of Test Tapes and Discs

Abbreviations used in this section are given on page 36.

■ AMPEX GREAT BRITAIN LTD

Acre Road, Reading, Berks.
Tel: Reading 84411.

A complete range of $\frac{1}{4}$ in, $\frac{1}{2}$ in, 1 in and 2 in NAB/CCIR test tapes. Prices and details of specifications on request.

■ A.P.A.E.

Association of Public Address Engineers Ltd,
6 Conduit Street, London, W1R 9TG.
Tel: 01-493 5256.

A.P.A.E. Test Disc

7in 45rpm double-sided mono disc for testing sound systems, particularly public address and sound reinforcement installations.

Side One consists of three minutes of male speech followed by three minutes of female speech. At end of male speech there is a period of 30 seconds of 'off-mic' speech to illustrate correct microphone technique.

Side Two starts with 60 test phrases selected for phonetic balance. The next two bands are 1,000 Hz tone and warble tone, for equipment line-up and measurement with sound level meters. Final two bands are white noise and pink noise. Produced primarily for A.P.A.E. members the record is now available generally. Price: 70p (plus 12p postage).

■ BASF (UK) LTD

Knightsbridge House, 197 Knightsbridge,
London, SW7. Tel: 01-584 5080.

Calibration Tape 9

$3\frac{3}{4}$ i/s (9cm per second) full-track tape recorded to 90 μ Sec characteristic. Range: 30Hz-16kHz in bands, also for azimuth alignment.

Calibration Tape 19H

$7\frac{1}{2}$ i/s (19cm per second) full-track tape recorded to 50 μ Sec characteristic. Range: 30Hz-18kHz in bands, also section for azimuth alignment.

Calibration Tape 19S

$7\frac{1}{2}$ i/s (19 cm per second) full-track tape recorded to 70 μ Sec characteristic. Range: 30Hz-18kHz in bands, also section for azimuth alignment.

Calibration Tape 38

15i/s (38cm per second) full-track tape recorded to 35 μ Sec characteristic. Range: 30Hz-18kHz in bands, also gliding tone from 30Hz-16kHz and section for azimuth alignment.

Calibration Tape 4-75

$1\frac{1}{4}$ i/s (4.75cm per second) full-track tape recorded to 120 μ Sec characteristic. Range: 30Hz-10kHz in bands, also section for azimuth alignment.

Stereo Test Tape 38

15i/s (38cm per second) test tape used in conjunction with Calibration Tape 38 for aligning stereorecorders. Contains: (1) Tone level section of 1kHz for 15 seconds on each channel, (2) Track position section of 1kHz, (3) Azimuth alignment section of noise containing frequencies from 5.6kHz to 16kHz across the full tape width, (4) Cross-talk section of 63Hz for 8 seconds on each channel, 1kHz for 8 seconds on each channel and 10kHz for 8 seconds on each channel.

Alignment Tape

$3\frac{3}{4}$ i/s (9cm per second) tape used for adjusting replay heads. Noise is recorded to four-track standard, with track 3 erased. Frequencies 5.6 kHz to 16kHz. When replayed at $7\frac{1}{2}$ i/s, frequencies become 11.2kHz to upper limit of recorder, and at $1\frac{1}{8}$ i/s frequencies become 2.8kHz to 8kHz.

Azimuth Test Tape

Used for aligning replay heads at tape speeds of $7\frac{1}{2}$ i/s, 15i/s, and 30i/s. A high frequency is recorded on two 2.75mm edge tracks, and their phase relationship is switched alternately from +45° -45° every second at 15i/s. The replay head is correctly adjusted when there is maximum output without level variations. In stereo both replay channels must be phase-correct.

(Note: Calibration tapes for $\frac{1}{2}$ in (12.5mm) and 1 in (25mm) tape widths are also available, recorded to the standard 35 μ Sec characteristic.)

Prices of calibration and test tapes available on request.

■ THE DECCA RECORD CO LTD

Decca House, 9 Albert Embankment,
London, SE1. Tel: 01-735 8111.

How to give yourself a stereo check-out

Stereo SKL-4861. The record is designed to provide a means for the exacting listener to check the performance of his equipment without the need for expensive and complicated instruments. Side One starts with a short explanation of the purpose of the record and there is a detailed account of each band and how the information should be used on the sleeve. Side One: (1) Introduction, (2) left-right channel identification, speaker balance, channel phasing, (3) mono music, (4) tone controls, (5) sound

★ Indicates entry is illustrated

colouration, (6) stereo music, (7) groove-jumping and distortion, (8) silent grooves. Side Two: (1) live versus recorded sound, (2) wow and flutter, (3) anti-skating band, (4) crosstalk, (5) musical show-piece. Price: approximately £2.

■ DEUTSCHE GRAMMOPHON

Polydor Ltd,
17-19 Stratford Place, London, W1N0BL.
Tel: 01-499 8686.

101497

Stereo 7in 45rpm record providing tests for balance, phase, music, voice and effects. Price: on application.

■ EMI ELECTRONICS LTD

Installation and Maintenance Division,
Blyth Road, Hayes, Middlesex.
Tel: 01-573 3888.

SRT14A

Test tape at $3\frac{3}{4}$ i/s with 120 μ Sec characteristic. Full-track recording. Spoken announcement followed by 40Hz-10kHz in bands. Section of 3kHz tone for wow and flutter check, also strobe markings for checking speed.

SRT15A

Test tape at $3\frac{3}{4}$ i/s with 200 μ Sec characteristic. Full-track recording. Spoken announcement followed by 40Hz-8kHz in bands. Section of 3kHz tone for wow and flutter check, also strobe markings for checking speed.

SRT18

Test tape at $7\frac{1}{2}$ i/s with 70 μ Sec characteristic. Full-track recording. Spoken announcement followed by 30Hz-16kHz in bands. Section of 3kHz tone for checking wow and flutter, also strobe markings for checking speed.

SRT17

Test tape at 15i/s with 35 μ Sec characteristic. Full-track recording. Spoken announcement followed by 30Hz-20kHz in bands. Section of 3kHz tone for wow and flutter check also strobe markings for checking speed.

TBT.1A

Test tape at $7\frac{1}{2}$ i/s with 100 μ Sec characteristic for domestic recorders. Full-track recording. 8kHz section for azimuth adjustment, followed by 40Hz-12kHz.

TBT.2A

Test tape at $3\frac{3}{4}$ i/s with 120 μ Sec characteristic for domestic recorders. Full-track recording. 6kHz section for azimuth adjustment, followed by 40Hz-8kHz.

Prices and further details of EMI test tapes available on request.

■ EMI RECORDS

Gramophone Co Ltd, EMI House,
20 Manchester Square, London, W1.
Tel: 01-486 4488.

TCS101

12in stereo record at $33\frac{1}{3}$ rpm. 30Hz-20kHz in bands.

TCS102

12in stereo record at $33\frac{1}{3}$ rpm. 30Hz-20kHz gliding tone.

TCS104

12in mono record (lateral) at $33\frac{1}{3}$ rpm.

TCS105

12in mono record (vertical) at $33\frac{1}{3}$ rpm.

Prices and further details of EMI test records available on request.

■ HI-FI SOUND

Distributors: Howland-West Ltd,
3-5 Eden Grove, London, N7 8EQ.
Tel: 01-609 0293/4/5.

Test record HFS69

Side 1. Test 1, channel recognition, phasing and balance using transient random noise bursts with spoken announcements recorded in free-air conditions; test 2, white noise (monophonic) for subjective evaluation of pickups and speakers and for setting up tape recorder bias and heads; test 3, determination of side-thrust adjustment and minimum tracking weight of pickup by means of lateral and vertical modulations in four different bands; test 4, applause—for identifying greatest possible number of individual sounds; test 5, music.

Side 2. Test 1, reference level and channel separation at 1kHz 5cm/sec 45 degrees; test 2, pink noise producing constant energy per octave; test 3, tone bursts—eight bands of 1kHz tone in bursts on separate channels at 7 or 10 cm/sec; test 4, wow and flutter, lateral cut 5cm/sec 3kHz for use with wow and flutter meters, also concentricity check; test 5, rumble, lateral cut 10cm/sec 1kHz tone followed by unmodulated grooves. Price: £1.28 (including PT).

■ POLYDOR LTD

17-19 Stratford Place, London, W1.
Tel: 01-499 8686.

220497

7in stereo 45rpm record. Tests for checking and adjusting balance, tone and phasing. Bands of music and effects. Price on request.

■ PYE BUSINESS COMMUNICATIONS

Cromwell Road, Cambridge, CB1 3EL.
Tel: Cambridge 45191.

7in 45rpm record. Side One: (mono) For the Love of Mike—information on use and installation of microphones. Side Two: (stereo) stereo tests. Sent free on request.

■ SHURE ELECTRONICS LTD

84 Blackfriars Road, London, SE1.

Tel: 01-928 3424.

TTR-101 'An audio obstacle course'

Designed to demonstrate the ability of a pickup stylus to remain in contact with groove modulations over a wide range of frequencies and intensities.

The record explores tracking demands by reproducing a number of musical sounds at levels which start very low and progress to highest possible modulation. Each level is 4dB (or 58%) higher than the preceding one. Four steps cover 400%. Side One is designed to test tracking ability at very high and very low frequencies and is recorded in both channels. Side Two has single channel stereo tests for 1kHz level, channel balance, phasing and tracking ability using several instruments.

Side One: band 1—introduction; band 2—orchestral bells; band 3—drum and cymbal; band 4—anti-skating band; band 5—bass drum; band 6—silent grooves.

Side Two: band 1—channel balancing and phasing; band 2—electric organ in left channel only; band 3—piano in left channel only; band 4—accordion in left channel only; band 5—harpisichord in left channel only; band 6—electric organ in right channel only; band 7—piano in right channel only; band 8—accordion in right channel only; band 9—harpisichord in right channel only. Price: £1.40 including packing and postage (special reduced price to purchasers of Shure V-15 Type II cartridge. See leaflet enclosed with cartridge).

■ TUTCHINGS ELECTRONICS LTD

14 Rook Hill Road, Friars Cliff, Christchurch, Hants. Tel: Highcliffe 2019.

Test Tape No. 1

Pure tones 40Hz-10kHz with voice identification of each band. Recorded to IEC 70 plus 3180 microsecond characteristic at $7\frac{1}{2}$ i/s. Track 2 carries continuous 7.5kHz tone for azimuth alignment.

This tape is used to measure the playback frequency response of $\frac{1}{4}$ -track and $\frac{1}{2}$ -track recorders. 3in spool. Price: £1.50 (plus 5p packing and postage).

Test Tape No. 2

Pure tones 40Hz-7.5kHz with voice identification of each band. Recorded to NAB 90 plus 3180 microsecond characteristic at $3\frac{3}{4}$ i/s. Track

2 carries continuous 5kHz tone for azimuth alignment.

This tape is used to measure the playback frequency response of $\frac{1}{4}$ -track and $\frac{1}{2}$ -track recorders. 3in spool. Price: £1.50 (plus 5p packing and postage).

Test Tape No. 3

One third octave bands of filtered white noise covering range 40Hz-10kHz with voice identification of each band. Recorded to IEC 70 plus 3180 microsecond characteristic at $7\frac{1}{2}$ i/s.

This tape is used to measure acoustic responses of recorders, microphones and loudspeakers. On 3in spool. Price: £1.50 (plus 5p packing and postage).

Test Tape No. 4

One octave bands of filtered white noise with centre frequencies 100Hz-6.4kHz with voice identification of each band. Recorded to IEC 70 plus 3180 microsecond characteristic at $7\frac{1}{2}$ i/s. Track 2 carries full range of unfiltered white noise.

This tape is used for reverberation and transmission tests of rooms, studios, etc. It can also be used for subjective testing of room acoustics and listening tests on loudspeakers and enclosures. On 3in spool. Price: £1.50 (plus 5p packing and postage).

Test Tape No. 5

Azimuth and vertical head alignment tape. Full track white noise with track 3 blank. Allows accurate setting of height and azimuth of $\frac{1}{4}$ -track heads by ear, using no test equipment at all. On 3in spool. Price: £1.50 (plus 5p packing and postage).

Test Tape No. 6

Azimuth and vertical head alignment tape. Full track 1.25kHz with track 3 erased and recorded at 7.5kHz. This is a factory or service depot test tape and must be used with oscilloscope or output meter and filters. On 3in spool. Price: £1.50 (plus 5p packing and postage).

Test tapes for any speed and recording characteristics produced to special order.

FREE

*Information on our sophisticated, but low-cost Kits . . .

* New 1214 Audio Range. Build your system in a few evenings.

*New Loudspeaker Range.

*Unbeatable quality and specifications.

*Incredibly good value for your money.

*New continuous credit and no-deposit terms. Even includes instruments.

*Over 30 new models.

*Over 130 models in range.

*Packed full of invaluable information about the world's finest electronics . . .



It's new. It's the biggest Audio/Instrument kit catalogue in the U.K. And it's absolutely FREE.

Our new jumbo size Heathkit catalogue is full of good things: Stereo Amplifiers, Tuner/Amplifiers, Tuners and Loudspeakers, low-cost Testers and Instruments, Electronic Calculator, Metal Detectors, Intercoms - there's even a Battery Charger.

You name it, Heathkit can supply. And what is more, you can build everything yourself. Heathkit help you each step of the way. Simply follow the Heathkit step-by-step construction manual. It's just like painting by numbers with something unique at the end of it . . . Fantastically satisfying, and less expensive than buying readymade. Our products are advanced in specification and performance. They are regularly reviewed by leading journals and you have to be good to merit that sort of treatment.

We guarantee that using the Heathkit step-by-step construction method you can build a piece of electronic equipment without needing to know the first thing about electronics.

Write today to secure your free copy of the Heathkit catalogue. And we promise that whichever kit you choose it'll be more rewarding than washing the car or watching television.

Want to know more? Send for your FREE catalogue today!



Why not visit your Heathkit Electronics Centres . . . and listen to Superb Stereo Hi-Fi

London 233 Tottenham Court Road. Tel: 01-636 7349

Open hours: Monday - Saturday 9-6.00 p.m.

Birmingham 17-18 St. Martin's House, Bull Ring.

Tel: 021-643 4386 Open hours: Friday - Saturday 10-5.30 p.m.

Gloucester Cole Avenue Rounabout, Bristol Road.

Tel: 0452 29451 Open hours: Monday - Friday 9-5.00 p.m. Saturday 9-12.30 p.m.

Please address your enquiries to: Heath (Gloucester) Ltd., Dept. HFY Bristol Road, Gloucester. GL2-6EE

HEATHKIT
Schlumberger

Latest free catalogue will be sent to you.

Directory of Constructional Kits

★ Indicates entry is illustrated

Abbreviations used in this section are given on page 36.

■ **RICHARD ALLAN RADIO LTD**
Bradford Road, Gomersal, Cleckheaton,
Yorkshire. Tel: Cleckheaton 2442/3.
Cables: Acoustics, Bradford.

Twin Assembly ★

Speaker kit comprising CC8 bass/mid-range driver and 460TC treble unit, CN54 crossover, BAF wadding, Vynair fret material (with choice of three patterns), foam backing sheet, detailed assembly instructions, fixing screws, terminals, etc. FR: 40Hz-17kHz. HC: 10W RMS. Impedance: 8 or 15 ohms. Recommended cabinet size: 20 × 12 × 9in. Price: £8.95 (plus £1.38 PT).

Triple-8 Assembly

Speaker kit comprising CF8 bass driver, CP5 mid-range unit, CB4 tweeter, ¼-section printed circuit crossover, BAF wadding, Vynair grille material (with choice of three patterns), foam backing sheet, detailed assembly instructions, fixing screws, terminals, etc. FR: 40Hz-17kHz. HC: 15W RMS. Impedance: 8 or 15 ohms. Recommended cabinet size: 20½ × 13 × 8½in. Design based on Richard Allan Flamenco enclosure. Price: £13.50 (plus £2.08 PT).

Triple Assembly

Speaker kit comprising CG12 bass driver, CP8 mid-range unit, CB4 treble unit, ¼-section printed circuit crossover, BAF wadding, Vynair fret material (with choice of three patterns), foam backing sheet, detailed assembly instructions, fixing screws, terminals, etc. FR: 30Hz-17kHz. HC: 15W RMS. Impedance: 8 or 15 ohms. Recommended cabinet size: 25 × 15½ × 12½in. Design based on Richard Allan Pavane enclosure. Price: £20.35 (no PT).

Super Assembly

Speaker kit comprising CG12 Super bass driver, CB8 mid-range unit, CB4 treble unit. ½-section crossover network. FR: 30Hz-17kHz. HC: 20W RMS. Impedance: 8 or 15 ohms. Recommended cabinet size: 25 × 15½ × 12½in. Design based on Richard Allan Pavane enclosure. Price: £24 (no PT).

■ CONNOISSEUR

A. R. Sugden & Co (Engineers) Ltd,
Market Street, Brighouse, Yorkshire.
Tel: Brighouse 2142. Cables: Connoisseur,
Yorkshire.

BD1 Turntable kit

Description and specification as for BD1 motor unit. (See Motor Unit section.) Easy one-hour assembly. No soldering. Price: £10.75 (plus £1.73 PT).

■ EAGLE INTERNATIONAL

Heather Park Drive, Wembley, HA1 1SU.
Tel: 01-903 0144.

KT3

Three-way speaker kit with crossover. One 8¼in bass driver, 2¾in concentric mid-range radiator. 2¾in tweeter. FR: 30Hz-16kHz. Crossover: 3kHz. Impedance: 8 ohms. L/C crossover mounted on panel with colour coded terminals. Full cabinet making plans included. Price: £12.24 (plus £1.76 PT).

■ EATON AUDIO FITMENTS

Leopold Street, Long Eaton, Nottingham,
NG10 4QF. Tel: Long Eaton 2662/2818.

Wharfedale Unit 3 cabinet kit

Made to Wharfedale specification from ¼in material accurately machined for simplicity of assembly, with the main parts veneered (unpolished) in teak, mahogany and walnut. All kits are complete with screws for fixing the back,



Richard Allan Twin Assembly

★ Indicates entry is illustrated

bolts for fixing fret panel, and fret material. Baffle holes are cut and cabinets veneered all four sides. Prices: small cabinet $14 \times 9\frac{3}{4} \times 8\frac{3}{4}$ in £5.15. Large cabinet $11\frac{1}{2} \times 21 \times 9\frac{1}{2}$ in. £5.90.

Wharfedale Unit 4 cabinet kit

Made to Wharfedale specification from 17mm material accurately machined for ease of assembly. Main parts veneered (unpolished). All kits complete with screws, bolts and fret material. Finish: teak veneer. Largest size recommended: $24 \times 14 \times 12$ in. Price: £8.25.

Wharfedale Unit 5 cabinet kit

Details as Unit 4 cabinet kit except size $29 \times 17 \times 11\frac{3}{4}$ in. Price: £10 (teak).

Wharfedale Pipe kits

Column cabinets using specially designed filter and absorbent pads of bonded acetate fibre. Designed for a single full range 8in speaker (rec. Super 8/RS/DD). FR: 40Hz-20kHz. Suitable for 8 or 15 ohm amplifiers; other impedances by matching transformer WMT1. Dimensions: 3ft high by 1in diameter. Power handling capacity: 6W RMS. Also kit for 10in drive unit (Super 10/RS/DD). FR: 30Hz-20kHz. Prices on request.

Eaton Economy kits

Designed for enthusiasts working on low budgets. Up to one cubic foot made from 12mm high-density chipboard, all other sizes made

from 18mm high-density chipboard. Main joints fit together to form airtight joints without use of screws or nails. Building time under one hour. All kits based on designs by leading speaker manufacturers. Each kit comprises: top, bottom, two sides, baffle (with holes cut to suit speaker), back, battens for fixing back, screws/nails as necessary. No internal damping or fret material is provided. **K1/E** small enclosure for Wharfedale Unit 3 ($14 \times 9\frac{3}{4} \times 8\frac{3}{4}$ in) £3.85; **K2/E** large enclosure for Wharfedale Unit 3 ($21 \times 11\frac{3}{4} \times 9\frac{1}{2}$ in) £4.35; **U4/F2/E** large enclosure for Wharfedale Unit 4 ($24\frac{1}{4} \times 14\frac{1}{2} \times 11\frac{1}{2}$ in) £5.45; **U5/J2/E** large enclosure for Wharfedale Unit 5 ($29 \times 17 \times 11\frac{3}{4}$ in) £6.90; **AXM/8/ES** small enclosure for Goodmans Twinaxiom 8 ($19\frac{1}{2} \times 10\frac{1}{4} \times 9\frac{1}{4}$ in) £4.35; **AXM/8/EL** large enclosure for Goodmans Twinaxiom 8 ($24\frac{1}{2} \times 13\frac{1}{2} \times 12\frac{1}{2}$ in) £5.60; **AXM/10/ES** small enclosure for Goodmans Twinaxiom 10 ($19\frac{3}{4} \times 12\frac{1}{4} \times 9\frac{1}{4}$ in) £4.95; **AXM/10/EL** large enclosure for Goodmans Twinaxiom 10 ($24 \times 17 \times 13$ in) £6.90; **350/E** enclosure for EMI 13×8in unit ($21\frac{1}{2} \times 15 \times 9\frac{3}{4}$ in) £4.95; **1/C/E** one cubic foot reflex enclosure for Wharfedale 8in ($24 \times 11 \times 9$ in) £4.70. All the enclosures (except 1/C/E) are infinite baffle. Material is plain unveneered chipboard as specified. Prices are all ex-works, tax paid. Add 75p carriage for one kit, £1.15 for two kits.

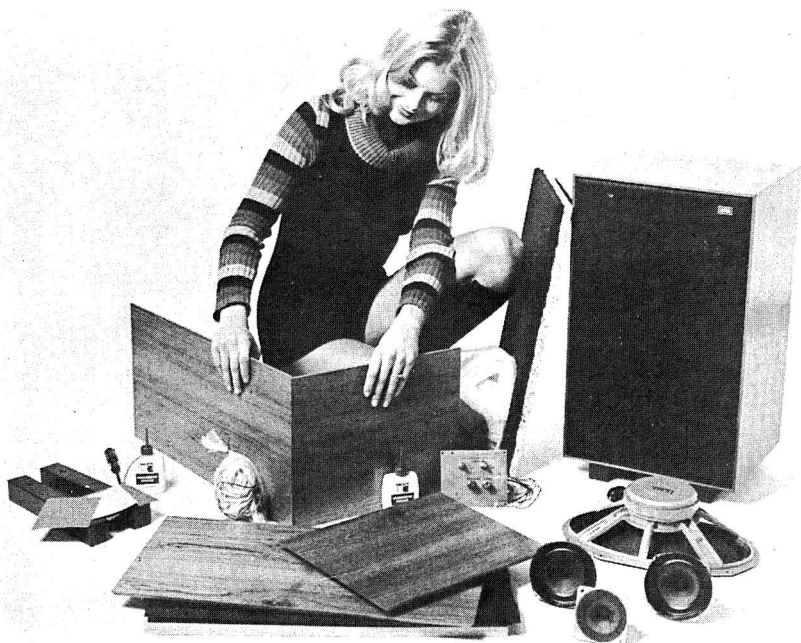

EMI LEK215 Kit

■ EDWARD MICHELSEN CUSTOM CABINETS

The Gramophone Shop, 41 Mason's Hill, Bromley, Kent. Tel: 01-460 5226. Also 216 Brampton Road, Bexleyheath, Kent. Tel: 01-303 9272.

Speaker enclosure kits

Kits of parts to assemble speaker cabinet. Complete with pre-cut timber, battens (when required) pre-cut holes for speakers and supply of veneer. Full instructions included for finishing to professional standard. For full details of sizes and specifications see Speaker Enclosure Section.

Paraline Kit

Price: (kit) £8; (grille) £1.50; (set of legs) £1.50.

Paramid Kit

Price: (kit) £8; (grille) £1.

Bookshelf Horn

Price: (pre-assembled) £8.

ACE Kit

Price: (kit) £8.50; (top cover) £1.50.

Packing and carriage on any of the above kits £1 extra.

■ EMI

EMI Sound Products Ltd, Hayes, Middlesex. Tel: 01-573 3888.

LEK150

Speaker unit and enclosure kit. Infinite baffle system. One $13\frac{1}{2} \times 8\frac{1}{2}$ in full-range driver. FR: 50Hz-11kHz. HC: 8W RMS. Impedance: 4, 8 or 16 ohms. Size: $17\frac{1}{2} \times 10\frac{1}{2} \times 7\frac{1}{4}$ in. Finish: teak veneer. Price: £22.50 per pair. Enclosure kit available separately.

LEK215 ★

Speaker units and enclosure kit. Infinite baffle system. One 14 × 9in bass driver, one 5in mid-range unit, one $3\frac{1}{4}$ in tweeter. Crossover: 1kHz and 5kHz. FR: 20Hz-20kHz. HC: 25W RMS. Impedance: 8 ohms. Size: 31 × 13 × 13in. Finish: teak veneer. Price: £48. Enclosure kit available separately.

LEK250

Speaker units and enclosure kit. Infinite baffle system. One 5in bass driver, one $3\frac{1}{4}$ in HF unit. Crossover: 6.5kHz. FR: 80Hz-20kHz. HC: 6W RMS. Impedance: 8 ohms. Size: $12\frac{1}{2} \times 6\frac{1}{2} \times 8\frac{1}{2}$ in. Finish: teak veneer. Price: (per pair) £19.44 (plus £3.45 PT). Enclosure kit available separately.

LEK315

Speaker units and enclosure kit. Infinite baffle system. One 15in bass driver, two 5in mid-range units, two $3\frac{1}{4}$ in tweeters. Crossover: 1.1kHz, 5kHz. FR: 20Hz-20kHz. HC: 35W RMS. Impedance: 8 ohms. Size: 37 × 25 × 13in. Finish:

teak veneer. Price: £72.50. Enclosure kit available separately.

LEK350

Speaker units and enclosure kit. Infinite baffle system. One $13\frac{1}{2} \times 8\frac{1}{2}$ in bass driver, one $3\frac{1}{4}$ in HF unit. Crossover: 5kHz. FR: 20Hz-20kHz. HC: 15W RMS. Impedance: 8 or 15 ohms. Size: $23\frac{1}{2} \times 12\frac{1}{2} \times 11\frac{1}{2}$ in. Finish: teak veneer. Price: £22.75. Enclosure kit available separately.

LEK450

Speaker units and enclosure kit. Infinite baffle system. One $13\frac{1}{2} \times 8\frac{1}{2}$ in bass driver, two $2\frac{1}{4}$ in HF units. Crossover: 5kHz. HC: 8W RMS. FR: 55Hz-13kHz. Impedance: 4, 8 or 16 ohms. Size: $17\frac{1}{2} \times 10\frac{1}{2} \times 8$ in. Finish: teak veneer. Price: (per pair) £25.50. Enclosure kit available separately.

LEK650

Speaker units and enclosure kit. Infinite baffle system. One $10\frac{3}{4} \times 6\frac{1}{2}$ in bass driver, one $3\frac{1}{4}$ in HF unit. Crossover: 5kHz. FR: 35Hz-20kHz. Impedance: 8 ohms. HC: 8W RMS. Size: $17\frac{1}{2} \times 10 \times 9\frac{1}{2}$ in. Finish: teak veneer. Price: £30 (plus £5.28 PT). Enclosure kit available separately.

LEK850

Speaker units and enclosure kit. Infinite baffle system. One 6 $\frac{1}{2}$ in bass driver, one $3\frac{1}{4}$ in HF unit. Crossover: 6.5kHz. FR: 75Hz-20kHz. HC: 10W RMS. Impedance: 8 ohms. Size: $12\frac{1}{2} \times 8\frac{1}{2} \times 7\frac{1}{2}$ in. Finish: teak veneer. Price: (per pair) £23.44 (plus £4.14 PT). Enclosure kit available separately.

■ FALCON ELECTRONICS

Components Division,
33 Station Road, Bexhill-on-Sea, Sussex.
Tel: Bexhill 1908.

Speaker crossover components, BAF wadding, acoustically transparent micro-porous foam, constant impedance 'L' pads, grill fabrics, etc. See Speaker Accessories Section for further details.

■ GOODMAN'S LOUDSPEAKERS LTD

Downley Road, Havant, Hampshire, PO9 2NL.
Tel: Havant 6344. Telex: 86296.

DIN 20 Kit ★

A complete kit of parts (except timber) for building a two-unit reflex speaker system. Comprehensive instructions including exploded diagrams. No soldering necessary. One 8in bass driver, one 1in dome tweeter. Crossover: 4kHz. Interior volume: 22 litres. FR: 45Hz-22kHz (DIN 45:500). HC: 20W (DIN). Minimum amplifier power: 10W. Impedance: 4 ohms. Connection: DIN plug and cable. Size: $19 \times 10\frac{1}{2} \times 9\frac{1}{4}$ in. Price: £12.19 (including PT).

★ Indicates entry is illustrated

■ HEATHKIT

Manufactured by Heath (Gloucester) Ltd,
Bristol Road, Gloucester, GL26EE.
Tel: Gloucester 29451.

AFM-2 ★

Transistor AM/FM stereo/mono tuner. Range: VHF 88-108MHz, MW 192-555 metres, LW 1,000-1,800 metres. Variable tuning. Ratio detector. AFC. AGC. 18 transistors, 7 diodes. Sensitivity: $2\mu\text{V}$ for 20dB quieting. Aerial input (VHF): 75 ohms coaxial. Output: 300mV with 30% modulation. Stereo multiplex decoder fitted. Automatic stereo indicator light. Edge-lit slide rule scale and flywheel tuning. Internal AM ferrite rod aerial. Pre-assembled and aligned front-end. Separate AM and FM printed boards. Walnut or teak veneered cabinet optional extra. Mains: 105-125V, 210-250V 50-60Hz. Consumption: 10W. Size: $15\frac{1}{2} \times 10\frac{1}{4} \times 3\frac{7}{8}$ in. Weight (less cabinet): 8lb. Price (kit): £25-71; (cabinet) £3-50.

AJ-14

FM stereo tuner. 88-108MHz. Variable tuning. Ratio detector. Four-stage IF amplifier. Sensitivity: $5\mu\text{V}$. Aerial impedance: 300 ohms balanced, 75 ohms coaxial. Output: 700mV. Decoder included. Mains: 105-125, 230-250V AC. Size: $11\frac{3}{4} \times 9\frac{3}{4} \times 2\frac{3}{8}$ in. Weight: 4 $\frac{1}{4}$ lb. Finish: walnut or teak. Prices: AJ-14 in kit form £23-87; cabinet in either finish £3-90 extra.

AR-27 ★

FM mono tuner/amplifier. 88-108MHz. Variable tuning. Ratio detector. Sensitivity: $5\mu\text{V}$. Aerial impedance: 300 ohms balanced. Output: 7W (music). Output impedance: 4-16 ohms. FR: 25Hz-70kHz $\pm 1\text{dB}$ (at 1W). PU input: 5mV. HD: $< 1\%$. 13 transistors, 6 diodes. Mains: 105-125V, 210-240V AC. Horizontal or vertical mounting. Size: $3 \times 12 \times 10\frac{3}{8}$ in. Finish: walnut or teak veneer. Prices: AR-27 in kit form £24-87, cabinet £3-90 extra.

AR-29

AM/FM stereo tuner/amplifier. Range: FM 88-108MHz, MW 185-560 metres. Variable tuning. Centre-zero meter tuning indicator. Signal strength meter. Aerial input: 300 ohms balanced, 75 ohms coaxial. Sensitivity: (FM) $1.8\mu\text{V}$ ($1.5\mu\text{V}$ typical) for 20dB quieting; (AM) external aerial $30\mu\text{V}$ at 500 metres, $20\mu\text{V}$ at 212 metres. Stereo decoder fitted. Stereo beacon. Inputs: magnetic PU 2.2mV, tape 180mV, aux 180mV, tape monitor 180mV. Output: 35W per channel into 8 ohm load (25W into 16 ohms). Controls: pushbutton input selectors; linear slider controls for volume, bass, treble and balance; tuning; pushbuttons for mains on/off, speaker switching, tone, loudness, mute and blend. HD: $< 0.1\%$ at 1kHz with 1W output, $< 0.25\%$ from 20Hz-



Goodmans DIN 20 Kit



Heathkit AFM-2

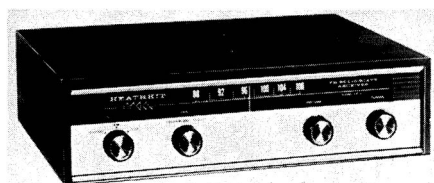

Heathkit AR-27



Heathkit TSA-12

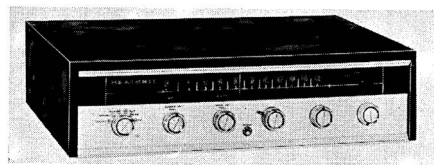

Heathkit AR-14

20kHz at 35W output. H and N: (PU) —65dB, (tape and aux) —75dB. Output impedance: 4-16 ohms each channel. Regulated power supply. All inputs fitted preset gain controls. FET FM tuner. Integrated circuit (IC) stereo decoder. Black glass dial, all markings disappear when set switched off. AC outlet sockets on rear. Mains: 105-125 or 210-250V AC 50/60Hz. Consumption: 55W to 240W. Size: $16\frac{3}{4} \times 5\frac{3}{8} \times 14\frac{1}{2}$ in. Finish: teak or walnut veneer. Price: (kit) £159-67; (cabinet) £10-90 extra.

AA-29

Integrated stereo amplifier. Specification the same as the amplifier section of AR-29 tuner/amplifier. Price: (kit) £75-90; (cabinet) £10-90 extra.

AJ-29

AM/FM stereo tuner. Specification the same as the tuner section of AR-29 tuner/amplifier. Price: (kit) £99-67; (cabinet) £10-90 extra.

TSA-12 ★

Integrated stereo transistor amplifier. Inputs: PU 5mV 47K, radio 300mV 180K, aux 300mV 180K. Controls: selector, balance, volume, bass —15dB +14dB at 20Hz, treble —12dB and +14dB at 20kHz. Output: 12W RMS per channel (8 ohm load). 8W RMS per channel (15 ohm load). HD: 1% or less, 20Hz-20kHz at rated output. Noise level: —50dB (PU), —60 dB (radio and aux). Mains: 100-125, 200-250V 50/60Hz. Size: $15\frac{1}{2} \times 10 \times 3\frac{7}{8}$ in. Weight: 11lb. Price (kit): £26; cabinet £3-50 extra.

AR-14 ★

FM stereo, with multiplex decoder. Range: 87-5-108MHz. Tuning: variable. Ratio detector. Sensitivity: 2µV. Aerial impedance: 75 ohms coaxial, 300 ohms balanced. Output voltage: 300mV. AFC. Power output: 10W RMS per channel. HD: better than 1% 20Hz-20kHz. FR: 15Hz-50kHz at 10W. Feedback: 38dB. Noise level: 80dB (power amp). Output impedance: 4-16 ohms. Output transistors: 2N2148/40465. Psn: 120 or 240V 50 or 60Hz. Inputs: gram, 4-5mV, 50K, 60dB noise level; aux, 300mV, 100K, 65dB noise level. Controls: source, treble, bass, volume, phase, tuning. Dimensions: $3\frac{3}{8} \times 15\frac{1}{2} \times 12$ in. Price: in kit form £52-87 (including PT); (cabinet) £5-50 extra. Carriage extra.

AR-17

FM stereo tuner/amplifier with multiplex decoder. Range: 87-108MHz. Ratio detector. Sensitivity: 2-5µV. Aerial: 75 ohms coaxial or 300 ohms balanced. AFC. Power output: 5W RMS per channel. HD: better than 1% 20Hz-30kHz. FR: 25Hz-35kHz ±1dB. Feedback: 32dB. N/L: 80dB (power amp). Output impedance 4-16 ohms. Output transistors: BD131,

BD132. Psn: 120-240V 50 or 60Hz. Inputs: gram, 5mV, 50K, —45dB noise level; aux, 300mV, 150K, —55dB noise level. Controls: function, tuning, volume, tone. Dimensions: $3 \times 12 \times 10\frac{3}{8}$ in. Price: in kit form £36-37 (including PT); (cabinet) £3-90 extra. Carriage extra.

AA-14

Stereo amplifier. Power output: 10W per channel, 4-16 ohms. HD: 0-5% or less at 1kHz. FR: 15Hz-50kHz ±1dB. Feedback: 38dB. N/L: 80dB power amp. Output transistors: 2N2148/40465. Psn: 120-240V 50 or 60Hz. Dimensions: $3\frac{1}{2} \times 12\frac{1}{2} \times 9\frac{3}{8}$ in. Inputs: aux, 300mV, 180K, —65dB N/L; tuner, 300mV, 18K, —63dB N/L; gram, 4-5mV, 47K, —60dB N/L. Controls: bass, treble, source, volume. Psn: 120-240V 50 or 60Hz. Price: in kit form £30; (cabinet) £3-90 extra. Carriage extra.

AD-27

FM stereo compact system. Transistorised. Range: 87-5-108MHz. Variable tuning. AFC. Multiplex decoder fitted. Controls: FM tune, source, volume, balance, bass, treble, phase, power on/off, speakers on/off, stereo/mono. Power output: 10W RMS per channel. FR: 6Hz-100kHz ±3dB. Output impedance: 4-16 ohms. Distortion: less than 1% from 12Hz-60 kHz. Motor unit: BSR MA70. Pickup cartridge: Shure M44MB. Overall dimensions: $7\frac{1}{2} \times 21\frac{1}{4} \times 14\frac{1}{8}$ in. Speakers: Berkeley, Avon, Ambassador. Finish: teak or walnut. Price: in kit form £85-11. Carriage extra.

AA-22U

Transistorised stereo integrated amplifier. Inputs: PU 6mV, radio 250mV, tape 250mV, aux 1 250mV, aux 2 250mV. Controls: balance, selector switch, mode switch, volume, bass, treble, filter, filter (3-position; flat, 4kHz, 8 kHz, 12dB/octave). Noise —50dB on PU, —65dB all other inputs. Output: 20W per channel RMS. Distortion 0-3% at 20W. FR: 15Hz-30kHz 1dB. Feedback 35dB. Output imp: 4, 8 or 16 ohms. Pre-set gain controls accessible from the front. Mains 110, 200-250V 50-60Hz. Size: $15\frac{1}{2} \times 3\frac{3}{8} \times 12\frac{1}{8}$ in. Price (kit): less cabinet £29; (cabinet) £3-50 extra.

Trent

Infinite baffle enclosure with units and crossover. One 8in bass driver, one totally enclosed 4in tweeter. Crossover: 5kHz. FR: 40Hz-16kHz. HC: 10W RMS. Impedance: 8 ohms nominal. Size: $19 \times 10 \times 8\frac{1}{2}$ in. Vertical or horizontal operation. Finish: teak or walnut veneer melamine. Weight: 13lb. Cabinet material: 12mm pressed wood. Price: (kit) £17-54 (carriage extra).

Berkeley

Infinite baffle hi-fi enclosure with speakers and crossovers. One 12in low-resonance bass unit,

★ Indicates entry is illustrated

one 4in middle and top unit. Inductance/capacitance cross-over at 900Hz. Handling capacity 15W RMS. Kit includes ready finished cabinet shell. Finish: oiled walnut or teak veneer. Size: 26in high, 17in wide, 7 $\frac{3}{4}$ in deep. Price (kit): £22.50. Carriage extra.

Avon

Infinite baffle bookcase enclosure with two units. One 6in high compliance bass driver, one 3in tweeter. Fully finished walnut or teak veneered cabinet. Size: 7 $\frac{3}{4}$ × 13 $\frac{1}{4}$ × 8 $\frac{3}{4}$ in. Price (kit): £15.59. Carriage extra.

Ambassador

Enclosure with three units and crossovers. Infinite baffle. 12in bass driver. 5in enclosed chassis mid-range unit, 1in pressure tweeter. Crossover frequencies: 1kHz and 6kHz. FR: 30Hz-20kHz. HC 20W RMS. Impedance 8 ohms. Size: 28 × 18 × 11 $\frac{1}{2}$ in. Weight: 45lb. Finish: teak or walnut veneers. Lined 12mm Celotex. Ceramic magnet units. Price (kit): £35. Carriage extra.

AV-3U

Audio valve millivoltmeter. Measures voltages as low as 1mV to a maximum of 300V at high impedances in 10 ranges. Frequency range 10-400,000Hz. Uses a 4 $\frac{1}{2}$ in meter. Cathode follower output. Price (kit): £21. Carriage extra.

AW-1U

Audio wattmeter. Uses external loads or the following internal loads: 3, 8, 15 and 600 ohms. 5 power ranges from 0.5mW to 50 watts. 4 $\frac{1}{2}$ in meter calibrated in watts and dB. Price (kit): £25. Carriage extra.

AO-1U ★

Inexpensive audio generator covering 20Hz-150kHz sine wave, 20Hz-25kHz square wave. Output up to 10V RMS sine wave or 80V peak-to-peak square wave. Size: 9 $\frac{1}{2}$ × 6 $\frac{1}{2}$ × 5in. Price (kit): £16.50. Carriage extra.

IM-58U

Low-priced audio distortion meter. Simple to use. Measures distortion at frequencies between 20Hz and 20kHz. Size: 13 × 7 × 8 $\frac{1}{2}$ in. Price (kit): £35.50. Carriage extra.

IG-82U

Audio generator covering 20Hz-1MHz. Sine and square wave available simultaneously. Sine wave output up to 10V RMS, square wave output up to 10V peak-to-peak. Rise time 0.15 μ Sec. Size: 13 × 8 $\frac{1}{2}$ × 7in. Price (kit): £27. Carriage extra.

AG-9U ★

Audio signal generator. Range: 10Hz-100kHz. Distortion less than 0.1% from 20Hz-20kHz. Decade switching over 8 voltage ranges from 3mV-10V monitored. Uses 4 $\frac{1}{2}$ in meter. Price (kit): £31. Carriage extra.

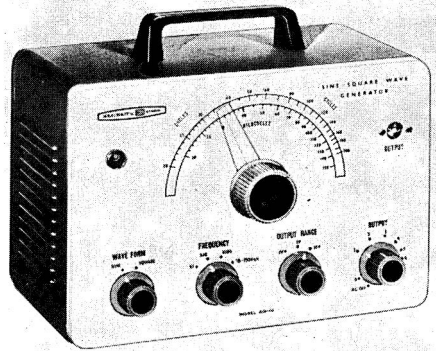

Heathkit AO-1U audio generator

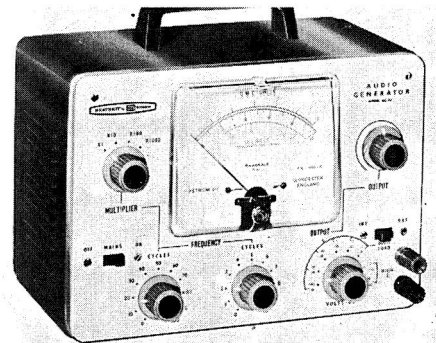

Heathkit AG-9U audio generator

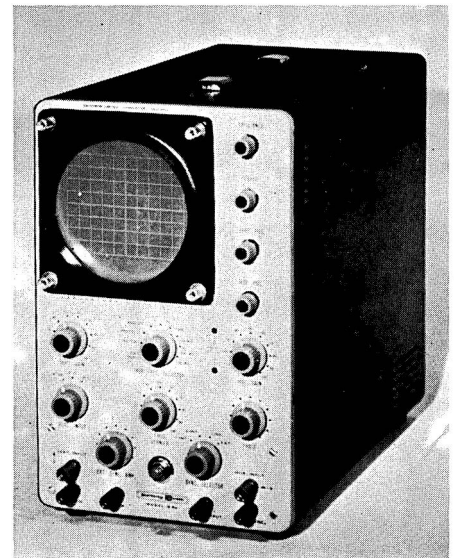

Heathkit 10-18U oscilloscope

IM-18D

Valve voltmeter kit. Printed circuit. Measures AC volts (0-1.5, 5, 15, 50, 150, 500, 1,500) RMS. AC volts (0-4, 14, 40, 140, 400, 1,400, 4,000) peak-to-peak, DC volts (0-1.5, 5, 15, 50, 150, 500, 1,500). Ohms (with 10 ohms centre) \times 1, 10, 100, 1,000, 10K, 100K, 1 megohm, 0.1 ohms to 1,000 megohms with internal battery. Input resistance: 11 megohms. 200 μ A meter movement. Price (kit): £17-50. Carriage extra.

IM-28U

Laboratory valve-voltmeter kit. Printed circuit. Gimbal mounting, for viewing from any angle. Measures AC volts (0-1.5, 5, 15, 50, 150, 500, 1,500 RMS); AC volts (0.4, 14, 140, 400, 1,400, 4,000 peak-to-peak). DC volts (0-1.5, 5, 15, 50, 150, 500, 1,500). Ohms (with 10 ohms centre) \times 1, \times 10, \times 100, \times 1,000, 10K, 100K, 1 megohm. 0.1 ohms to 1,000 megohms with internal battery. Input resistance: 11 megohms. 200 μ A meter movement. Price (kit): £27. Carriage extra.

OS-2

Service oscilloscope. 2 $\frac{3}{4}$ in tube. Vertical bandwidth 2Hz-3MHz. Automatic lock-in sync. Mu-metal CRT shield. Printed circuit. Switched ext/int Y plate connections. Vertical amplifier: sensitivity 100mV/cm, input impedance: 3-3 megohms shunted by 20pF, response 2Hz-3MHz \pm dB. Horizontal amplifier: sensitivity 100mV/cm, input impedance: 10 megohms shunted by 20pF, response 2Hz-3MHz. Time base: 20Hz-200kHz in four steps. Size: 5 \times 7 $\frac{3}{8}$ \times 12in. Weight: 9 $\frac{3}{4}$ lb. Price (kit): £35. Carriage extra.

IO-18U ★

General purpose oscilloscope kit. 5in flat face CR tube. Printed circuits. Vertical band-width 3Hz-4.5MHz. Built-in IV calibrator. Y-sensitivity 10mV RMS per cm at 1kHz. X-sensitivity 50mV RMS per cm at 1kHz. Price (kit): £46. Carriage extra.

S-3U

Electronic switch (oscilloscope trace doubler). Converts a single beam oscilloscope to double beam. Switching rates 150, 500, 1,500, 5,000 and 15,000Hz. Signal frequency response 0-100kHz \pm 1dB. Signal input range 0-1-1-8V RMS. Price (kit): £15-50. Carriage extra.

■ HELME

P. F. and A. R. Helme Ltd, Summerbridge, Harrogate, HG34DR, Yorks. Tel: Darley 279.

Range of easy-to-assemble speaker enclosures for the home constructor ★

Each kit comprises fully finished and polished outer shell (veneered natural teak), set of terminals, wire, uncut baffle, brown Vynair

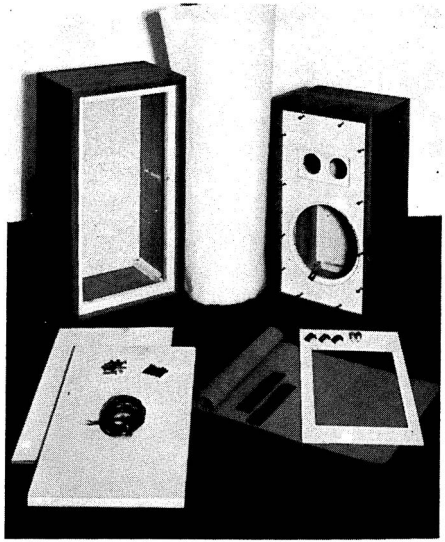

Helme Cabinet Kit (speakers)

covering. All nuts, bolts and screws are included, also BAF wadding for inside cabinet.

All cabinets are infinite baffle type. Speaker units are not specified but internal volume of cabinet will provide guide together with speaker unit literature and data.

Helme cabinet kits include:

RV10

Size: 14 \times 9 \times 7in. Volume: 10 litres. Price: from £7-90.

RV16

Size: 18 \times 10 \times 9in. Volume: 16 litres. Price: from £9-50.

RV20

Size: 20 \times 11 \times 9in. Volume: 20 litres. Price: from £11-80.

RV30

Size: 22 $\frac{1}{2}$ \times 12 $\frac{1}{2}$ \times 10in. Volume: 30 litres. Price: from £13-40.

RV50

Size: 26 $\frac{3}{8}$ \times 15 \times 10 $\frac{3}{4}$ in. Volume: 50 litres. Price: from £21-50.

■ HENELEC ELECTRONIC PRODUCTS

Henry's Radio Ltd, 303, 309, 354, 356, Edgware Road, London, W2. Tel: 01-723 1008.

PA25 Power Module

Output: 25W RMS into 8 ohms. Input: 600mV 15K. Power response: -1dB 11Hz-40kHz. FR: 11Hz-100kHz -1dB. Rise time 10kHz: 2 $\frac{1}{2}$ μ /secs. HD: 0.3% at 25W RMS at 1kHz. Edge connector. Size: 5 \times 3 \times 2in. Price: £7-50.

★ Indicates entry is illustrated

PA50 Power Module

Output: 50W RMS into 4 ohms. Inputs: 700mV 15K. Size: 5×3×4in. All other details as for PA25. Price: £9.50.

MU422 Mains Unit

Output sufficient to power two PA25 modules or one PA50 module. Edge connector for direct connection to power amplifiers. Size: 6½×3¾×5½in. Price: £6.

FET154 Stereo Preamplifier

Self-powered. Inputs: mag PU, ceramic PU, aux, radio. Output: Adjustable 0-1V. Push-button input selector. Stabilised power supply. Price: £16.50.

FET9/4 Mono Preamplifier

Self-powered. Inputs: ceramic PU, aux, radio, mic (50K dynamic). Mic input has mixing facility. Pushbutton input selector. Stabilised power supply. Output: 0-1V. Price: £12.50.

MPA12/3 and MPA12/15

Power modules. Output: 12W RMS. Input: 100mV 33K. FR: 20Hz-18kHz 3dB. Output impedance: (MPA12/3) 3-4 ohms, (MPA12/15) 12-16 ohms. Power supply: (MPA12/3) 18V 0.8A peak, (MPA12/15) 36V 0.4A peak. Prices: (MPA12/3) £4.50; (MPA12/15) £5.25.

MU24/40 Power Supply

Mains supply unit for powering one or two MPA12 amplifier modules. Price: £4.88.

Other products available in kit or ready built form include electronic organs. Full details on request.

■ IMPEX

McArdle & Brainsby (Import & Export) Ltd, PO Box 2BB, Newcastle-upon-Tyne, NE99 2BB.

MS7

Stereo magnetic pickup preamplifier. Input: 3mV 47K. Output: 100mV 470 ohms at 1kHz. HD: <0.03% at 100mV output. Overload margin: >28dB. S/N ratio: >60dB. Power supply needed: 50V DC at 7mA. Price: (printed circuit boards) 43p; (complete set of transistors, resistors, capacitors and printed board—Part A) £2.85; (Case including spacers, screws, etc—Part B) £1.35; (phono sockets, DIN plugs and jack plugs with cable—Part C) £1.15. Posting and packing (UK): 13p per order.

'Hi-Fi Sound' 10-20 amplifier

Integrated stereo amplifier design published by 'Hi-Fi Sound' magazine. Kit 1—printed circuit board £1.90; Kit 2—32 transistors and four zener diodes £11.10; Kit 3—52 capacitors (excluding main reservoirs) £5.95; Kit 4—87 fixed resistors and two RV6 £1.90; Kit 5—potentiometers for balance, tone, volume, tape, plus slide switches and input selector switch £3.75. Kit 6—Power supply components including mains trans-

former, rectifier, neon, main electrolytics, etc. £7.45; Kit 7—five control knobs £1.30; Kit 8—connectors £1.10; Kit 9—ready drilled case and panels £5.20. Post and packing 15p on every order.

■ KEF ELECTRONICS LTD

Tovil, Maidstone, Kent.

Tel: Maidstone 57258. Cables: KEF, Maidstone.

Kefkit 2

B139 and T15 drive units supplied mounted on 22½×13½×4in baffle. Complete with grille fabric, mounting bolts, BAF padding, speaker terminals and full mounting instructions. HC: 25W. FR: 35Hz-35kHz. Impedance: 8 ohms. Price: £25.

Kefkit 3

B139, B110 and T27 units supplied mounted on 28×14×10½in baffle. Complete with grille fabric, mounting bolts, BAF padding, speaker terminals and full mounting instructions. HC: 30W. FR: 30Hz-30kHz. Impedance: 8 ohms. Price: £36.

KEF Components

BAF wadding (5yds 12×1in) £1.20; terminal panels (pair) 17p; 0.25mH inductor (per pair) 58p; 0.6mH inductor (per pair) 70p; 1mH inductor (per pair) 76p; 2mH inductor (per pair) 80p; 5mH inductor (per pair) £1.05; 4mfd 50V capacitor (per pair) 38p; 6mfd 50V capacitor (per pair) 38p; 8mfd 50V capacitor (per pair) 48p; 60mfd 50V capacitor (per pair) 68p; 80mfd 50V capacitor (per pair) 78p.

See Speaker Accessories Section for details of KEF crossover networks.

■ MAC

Modular Audio Components Ltd, Canterbury Road, Nottingham, NG8 1PQ.

Tel: Nottingham 79797.

AAU-K

Audio adaptor unit kit enables dealers and enthusiasts to build their own particular switching circuits. Complete chassis includes sub-panel with 20 wiring pins, rear panel with 4 phono sockets, or with 5-pin DIN socket (AAU-KD). 3-way switch positions engraved on facia. Price: £2.88.

■ MULLARD LTD

Mullard House, Torrington Place, London, WC1. Tel: 01-580 6633.

Unilex

Four modules—preamplifier, two power amplifiers and one power supply unit—expressly designed for do-it-yourself enthusiasts. Available from radio component shops and audio dealers throughout the UK.

The modules can be interconnected without soldering. No electronic knowledge is required to build up a low-cost stereo amplifier.

An illustrated booklet, *Do-it-yourself stereo*, is also available from audio dealers, price 25p. This booklet provides all the information the do-it-yourself man (or woman) needs to build a stereo system, complete with cabinets, incorporating Mullard modules.

Preamplifier module EP9001

Stereo transistorised preamplifier without controls. Inputs: ceramic PU 320mV 2·2M, radio 140mV 1M. Supply needed: 24V DC. Size: 4½ × 5 × 1in. Designed for use with Amplifier module EP9000. Price: £3·10.

Amplifier module EP9000

Transistorised mono amplifier (two required for stereo). Output: 4W. HD: <2%. FR: 50Hz-15kHz ±3dB. Output impedance: 12-15 ohms. Supply needed: 24V DC. Size: 4 × 3¾ × 1in. Designed to operate with preamplifier module EP9001. Price: £2·90.

ED9002

Power Supply Module £4·60.

■ PEERLESS

Distributor: P. F. & A. R. Helme Ltd, Summerbridge, Harrogate, HG34DR, Yorks. Tel: Darley 279.

Peerless speaker kits are of 8 ohms impedance (4 ohms to special order on most kits). A range of crossover networks is available ready wired and assembled on printed circuit boards.

All kits are complete with crossover network or components.

2-8 kit

6½in bass and 2½in HF units. HC: 10W. FR: 50Hz-18kHz. Crossover: 4kHz. Price: £5·95 (plus 80p PT).

2-10 kit

6½in bass driver with rubber roll surround, 2½in tweeter. Crossover: 2·5kHz. HC: 15W RMS. FR: 45Hz-18kHz. Price: £8·80 (plus £1·02 PT).

3-15 kit

8in bass, 5in mid-range and 2in tweeter. HC: 15W. FR: 45Hz-18kHz. Crossover: 750Hz and 4kHz. Price: £11·10 (plus £1·60 PT).

3-25 kit

12in bass, 5in mid-range and 2in tweeter. HC: 25W. FR: 40Hz-18kHz. Crossover: 750Hz and 4kHz. Price: £17·65 (plus 84p PT).

4-30/12 kit (8 ohms only)

12in bass, 7 × 5in mid-range and two 2½in tweeters. HC: 40W. FR: 30Hz-18kHz. Crossover: 500Hz and 3·5kHz. Price: £27·95 (no PT).

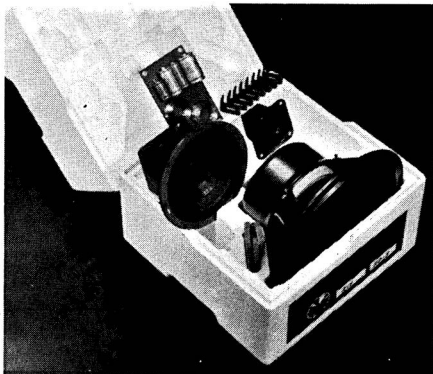

Peerless PR 20-3

20-2 kit

8in bass driver, 2½in HF unit. HC: 40W. FR: 40Hz-20kHz. Crossover: 2·5kHz. Price: £11 (plus £1·32 PT).

20-3 kit ★

8in bass driver, 5in mid-range unit, 2½in tweeter. HC: 40W. FR: 40Hz-20kHz. Crossover: 1·5kHz, 6kHz. Price: £16·60 (plus £1·89 PT).

50-2

12in bass driver, 4in tweeter. HC: 15W RMS. FR: 45Hz-18kHz. Crossover: 4kHz. Price: £9·70 (plus 30p PT).

50-4

12in bass driver, 7 × 5in mid-range unit, two 2½in tweeters. HC: 40W. FR: 30Hz-18kHz. Crossover: 500Hz and 3·5kHz. Price: £24·60 (plus £2·76 PT).

■ SINCLAIR RADIONICS LTD

London Road, St Ives, Huntingdonshire, PE174HJ. Tel: St Ives (Hunts) 4311.

Sinclair Z-30

Transistorised mono amplifier module. Nine silicon transistors. Output: 15W RMS into 8 ohms (35V supply), 20W into 3 ohms (30V supply). FR: 30Hz-300kHz ±1dB. HD: 0·02% at full output into 8 ohms and at all lower power levels. SN: better than 70dB. Input: 250mV into 100K. Output impedance: 3-15 ohms. Full instruction manual and circuit diagram supplied with each module. Price: £4·48, (ready built and tested).

Sinclair Z-50

Transistorised mono amplifier module. Similar specification to the Z-30 but uses higher power transistors. Output: 40W RMS into 3-4 ohms, 30W RMS into 8 ohms. Price: £5·48.

Power supply units

(PZ-5) 30V un stabilised. Suitable for two Z30 and Stereo 60. Price: £4·98. (PZ-6) 35V stabilised. Suitable for two Z-30 and Stereo 60 when low

★ Indicates entry is illustrated

efficiency speakers used. Price: £7-98. (PZ-8) 45V for use with Z-50 amplifiers. Price: (less mains transformer) £7-98; (PZ-8 mains transformer) £5-98.

■ SME LTD

Steinyng, Sussex, BN43LN.
Tel: Steyning (0903) 814321.

Model 2000

Plinth system parts available separately, as follows:

Components

Base in teak, rosewood or walnut. Price: £15-66 (plus £6-60 PT); Motor board in teak, rosewood or walnut. Price: £5-01 (plus 84p PT); Acrylic lid. Price: £9-99 (plus £1-67 PT); spring mounts complete with foam damping blocks (set of four). Price: £4-02 (no PT); Hinges (lefthand or righthand). Price: £2-55.

Accessories

P1 spacer to adjust height when arm is used with deep turntable. Price: 84p (plus 14p PT). Mounting brackets for fitting Thorens TD125 to motor board (PS2000/TD125). Price: £1-26 (no PT).

Mounting boards

For model 3009 on Thorens TD124. Price: £2-88 (plus 48p PT); For model 3012 on Thorens TD124. Price: £3-51 (plus 59p PT); For model 3009 on Thorens TD125. Price: £2-88 (plus 48p PT); For model 3012 on Thorens TD125. Price: £3-51 (plus 59p PT); For model 3009 on Thorens TD150. Price: £2-88 (plus 48p PT); For model 3012 on Thorens TD150. Price: £3-51 (plus 59p PT).

■ VALEK LTD

Lark Street, Darwen, Lancs, BB32LT.
Tel: Darwen 71881.



Wharfedale Unit 4

Turntable kits

Kits of parts for home assembly of record turntable units. Full details and prices on request.

■ VERO

Vero Electronics Ltd, Industrial Estate, Chandler's Ford, Eastleigh, Hants, SO5 3ZR.
Tel: Chandler's Ford 2952. Telex: 47551.

Wide range of equipment cases suitable for hi-fi units, tuners, power supplies and test gear. Available in various panel heights and with or without anodised aluminium front handles. Made in light gauge steel finished in RAF blue/grey vinyl paint. Integral aluminium trim. Neat slim-line appearance. Ventilation slots incorporated. Full list of sizes, accessories and prices, available on request. Ask for Vero 'D' series cases.

Vero circuit boards comprise resin-bonded paper laminate clad on one side with 1oz copper foil of nominal thickness 0-062in (1-5mm). Base material cut to width and punched with a matrix of holes. Copper foil is in parallel strips along the lines of holes. Enables small electronic assemblies to be built easily and quickly. Vero boards are produced in various sizes, also double-sided, in strips, with plug-in terminations, edge-connectors, breadboards and in plain non-coppered versions. Accessories include connector contacts, D-I-P sockets, terminal pins, pin insertion tool, spot face cutter and numerous design-aid sheets. Catalogue on request.

■ WHARFEDALE

Rank Wharfedale Ltd, Bradford Road, Idle, Bradford, Yorks.
Tel: Bradford 612552. Telex: 51407.

Unit 3 Kit

Do-it-yourself hi-fi two-speaker kit comprising 3in tweeter and 8in bass unit. Suitable for output impedance: 4-8 ohms. HC: 15W RMS. Cross-over operates at 1,750Hz. Tweeter has Acoustiprene dome diaphragm. Acoustic wadding, mounting bolts and connecting wire, etc, included. Price: £10-21 (plus £1-79 PT).

Unit 4 Kit ★

Two-speaker kit for floor-standing enclosure. Incorporates 12in bass driver and 3in treble unit. Four element crossover. When assembled into suitable enclosure is equivalent to Wharfedale Melton. Price: £18-00.

Unit 5 Kit

Three-speaker kit for floor-standing enclosure. Incorporates 12in bass driver, 5in mid-range unit and 1in tweeter. Six element crossover network. FR: 40-20kHz. HC: 35W RMS. Price: £26-00.

Directory of Microphones

★ Indicates entry is illustrated

Abbreviations used in this section are given on page 36.

■ ACOS

Cosmocord Ltd, Eleanor Cross Road,
Waltham Cross, Herts.
Tel: Waltham Cross 27331.

Mic 70/12

Omni-directional moving coil. FR: 80Hz-12 kHz (10dB down at 50Hz and 15kHz). Impedance: 200 ohms. Rec. load: 200 ohms-10K. Sensitivity: -80dB re 1V/ μ b. Price: £7-50.

Mic 70/11

Omni-directional moving coil. FR: as for Mic 70/12. Impedance: 50K nominal. Sensitivity: -57dB re 1V/ μ b. Price: £8-40.

■ ADASTRA ELECTRONICS LTD

Unit 22, Cricklewood Trading Estate,
Claremont Road, London, NW21TU
Tel: 01-452 6288 (answering service 01-452 6289).

Imp-Verta ★

Matches low impedance microphones, PU cartridges and tape heads into high impedance amplifier inputs. Solid state printed circuit device using silicon transistor. Automatically switched internal 9V battery. Negligible drain. Conversion factor approximately 20 (depending on load). Virtually no hum or signal loss. Metal case, black crackle finish. Size: $5 \times 1\frac{1}{2} \times 1\frac{1}{2}$ in. Price: £3-50.

■ AKAI

Rank Audio Products, PO Box 70,
Great West Road, Brentford, Middlesex.
Tel: 01-568 9222. Telex: 24408.

UM101 ★

Mono ceramic microphone. Uni-directional response. FR: 100Hz-10kHz +5dB -8dB. Sensitivity: -60dB \pm 3dB. Impedance: 5K at 1kHz. Stand microphone, complete with desk stand. Finish: chrome. Price: £12-65.

■ A.K.G.

Distributors: A.K.G. Equipment Ltd,
182/184 Campden Hill Road, Kensington,
London, W8. Tel: 01-229 3695.

C12A

Professional condenser microphone. Variable polar diagram covering cardioid, omni, figure-of-eight and six intermediate positions. FR: 10 Hz-20kHz. Sensitivity: -68dB. Impedance 50 and 200 ohms. Rec load >150 and 500 ohms. Fitting: $\frac{3}{8}$ in whit, $\frac{1}{2}$ in 26tpi, $\frac{5}{8}$ in 27tpi. Metal case finished matt silver. Price: £165.

C24

Stereo condenser. Sensitivity 1mV/ μ bar. Imp 200 or 500 ohms. Response 30Hz-20kHz. Omni-directional cardioid; bi-directional, hyper-cardioid. Plus 5 intermediate patterns. Sensitivity approx 1mV per microbar (at 200 ohms output terminals) -33dB re 1 milliwatt at a sound pressure of 10 dynes/cm². Crosstalk between channels <40dB throughout entire range. Imp <200 ohms when delivered. 50 ohms by changing solder connections. N.24 power supply unit. Remote control unit. Twin remote control cable. Price: £319.

C451

FET condenser microphone with cardioid, sharp cardioid or omni-directional capsule. FR: 20Hz-20kHz. Prices: microphone, preamplifier and one capsule £50-50; mains power unit with outputs for four microphones £59 nett; battery power unit £18.

D11D-HL ★

Moving coil cardioid microphone. Incorporates adaptor to change polar response from cardioid to super- and hyper-cardioid. FR: 80Hz-15kHz. Front-to-back ratio: 16dB. Impedance: 500 ohms or 50K. Sensitivity: 72-5dB at 500 ohms, 54dB at 50K. Price: £11.

D12

Moving coil with cardioid directional pattern. Response 40Hz-12kHz \pm 4dB. Front to back ratio 15dB. Sensitivity: -77dB. Imp 60 ohms, or to order. Price: £36.

D14

Dynamic cardioid microphone. Imp 60-40,000 ohms. Response 50Hz-15kHz. On/off switch. Swivel joint fits all stand threads. Supplied with $5\frac{1}{2}$ yds two-core screened lead. Weight: 8oz. Price: £14.

D58

Moving coil, close-talk microphone. Response 50Hz-12kHz. Sensitivity: 0.1mV/ μ bar. Imp 60 or 200 ohms. Price: £14-90.

D109 ★

Omni-directional moving coil. FR: 50Hz-15kHz \pm 3-5dB. Sensitivity: -98dB. Impedance: 60 and 200 ohms. Rec load \geq 400 ohms. Hand and lavalier type. Supplied with lavalier cord. Higher frequencies boosted when lavalier attached. Metal case nickel plated. Price: £14-50.



Adastra IMP-VERTA

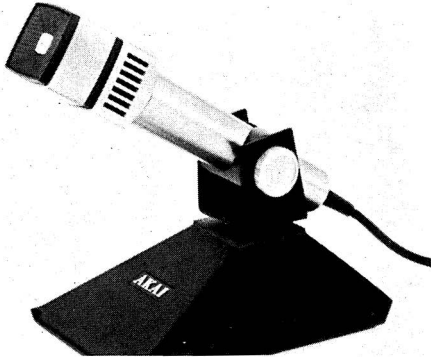

Akai UM101

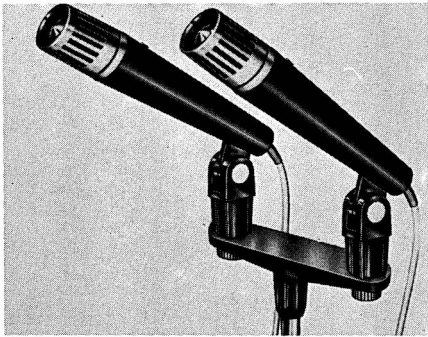

AKG D11D

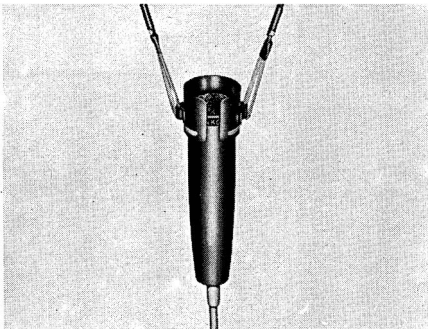

AKG D109

D190

Uni-directional moving coil microphone. Robust construction. FR: 30Hz-16kHz. Ideal for sound recording and public address systems. Complete with Cannon XLR 3-11C connector. Prices: low impedance (60 or 200 ohms) £22·80; high impedance £23·80.

D200C

Two-system cardioid microphone. Incorporates two moving coils, one covering the low and the other the high frequencies. FR: 40Hz-16kHz. Sensitivity: 0·16mV/microbar. Imp 200 ohms. Price: £33.

D.202E1

Similar specification to D-202ES except it is supplied without on/off switch and has three-position bass attenuation step switch (0, -7dB and -20dB) instead of potentiometer. Individually calibrated frequency response curve supplied with each microphone. Price: £44.

D202ES

Moving coil microphone with marked cardioid response (-20dB minimum). FR: 30Hz-15kHz \pm 2dB. Sensitivity: -53dB. Impedance 200 ohms. Rec load \geq 400 ohms. Stand fitting swivel adaptor. $\frac{3}{8}$ in Whit, $\frac{1}{2}$ in 26tpi, $\frac{5}{8}$ in 27tpi. On/off switch and variable bass control providing 0 to -20dB at 50Hz. Strong black metal case with sintered bronze grille. Price: £41.

D224

Mono moving coil. Sensitivity: -78dB re 1V/ μ b. Cardioid response. FR: 20Hz-20kHz \pm 2dB. Impedance: 200 ohms. Rec load: 500 ohms or more. Fitting: $\frac{3}{8}$ in Whit, $\frac{1}{2}$ in 26tpi, $\frac{5}{8}$ in 27tpi. Features bass cut switch. Finish: metal satin silver. Price: £59·50 (DIN connector); £59·50 (Cannon).

D501

Moving coil cardioid and omni-directional model. FR: 50Hz-15kHz \pm 3·5dB. Sensitivity: -73dB. Impedance 60 or 200 ohms. Rec load: \geq 400 ohms. Hand or stand type. Fitting: $\frac{3}{8}$ in Whit, $\frac{1}{2}$ in 26tpi, $\frac{5}{8}$ in 27tpi. Omni/cardioid switch. Remote control switch. Built-in windshield. Quick release adaptor. Leatherette carrying bag. Moulded case with metal grille. Price: £17.

D707

Mono moving coil. Sensitivity: -74dB re 1V/ μ b. Cardioid response. FR: 80Hz-16kHz \pm 3·5 dB. Impedance: 200 ohms. Rec load: 400 ohms or more. Fitting: $\frac{3}{8}$ in Whit, $\frac{1}{2}$ in 26tpi, $\frac{5}{8}$ in 27tpi. Finish: metal satin silver. Price: £15·50 (DIN connector); £19 (Cannon).

D.1000

Moving coil cardioid microphone with three-position switch giving three different sounds. Developed especially for electronic musicians where feedback is important. Impedance: 60 or

TAPE RECORDING ENTHUSIASTS.
 CHURCHES.
 SPEAKERS.
 FILM STUDIOS.
 THEATRES.
 REPORTERS.
 CLUBS AND CABARET ARTISTS.
 RECORDING STUDIOS.
 P.A. ENGINEERS.
 SINGERS.
 DANCE BANDS.
 ORCHESTRAS.
 RADIO AND TV COMPANIES.



Which is YOUR line?

Beyer Dynamic have a microphone to fully satisfy most customer requirements. Their vast range has been built up over the years, from the days when the company catered for the needs of a few specialised customers, to a great enterprise now serving a world market with products of quality that are universally recognised.



Beyer Dynamic also manufacture headsets. Ideal for Industrial Teaching, Schools, Film Studios, Broadcast Studios, and home use.

For further information and illustrated brochure of BEYER DYNAMIC microphones, headsets and full range of accessories, please write to:

**BEYER
 DYNAMIC**
 [GB] LIMITED
 1, CLAIR ROAD, HAYWARDS HEATH, SUSSEX.
 TELEPHONE: HAYWARDS HEATH 51003.

Who wants to be tied down by a microphone?

Have you ever been tied down by the length of your microphone lead? Have you ever felt that you are restricted in what you can do?

Reslosound Ltd. of Romford have solved that kind of problem. How? Simply by manufacturing a microphone that doesn't need a lead. It's a complete microphone with an integrated transmitter which can be picked up on the Reslo receiver. And that can be up to 1,000 feet away. Just think of the freedom you'll have.

Here are the facts

Reslo Cabaret

A microphone and receiver unit contained in an executive-type briefcase with perfect on-the-spot sound reproduction, when you want it, where you want it.

Resloball

This is the microphone as used in the Cabaret unit. No dragging wires to hinder movement.

Reslopel

A microphone that can be clipped to your lapel discreetly. Just plug it in to the Reslopak.

Reslopak

The transmitter unit for the Reslopel unit. Just clip it to your belt and it's out of sight. Need we say more!

Receiver Unit Type RX/A

The same circuitry as the Cabaret receiver. Perfect for use with the Resloball or Reslopel. Just think what you can do, where you can operate. The receiver unit allows you to wander away from the amplifier without the worry of dragging wires.

If you want to know more, ring or write to us and we'll send you literature on whatever you want to know.

RESLO

Reslosound Ltd.
Dept. HF, Spring Gardens
London Road, Romford RM79LS
Tel: Romford 61926

200 ohms. FR: position 1, 40Hz-16kHz; position 2, 70Hz-16kHz; position 3, 100Hz-16kHz. Front-to-back ratio: 20dB. Sensitivity: -78dB at 60 ohms, -72dB at 200 ohms. Various finishes offered including studio grey and 24 carat gold. For high impedance inputs a lead with line transformer is available. Sensitivity at high impedance: -50dB. Price: from £37 according to requirements.

ST200

Microphone floor stand. Telescopic. Height: 42 to 77in. Three collapsible feet with main support locking device. Anti-vibration characteristics. Microphone may be clamped to face any direction. Price: £22.

■ ALTEC LANSING

Distributors: Ling Dynamic Systems Ltd, Baldock Road, Royston, Herts. SG8 5BQ. Tel: Royston 42424. Telex: 81174.

B650 ★

Hand or stand moving coil microphone. Cardioid response. FR: 50Hz-15kHz. Impedance: 150/250 ohms. Sensitivity: -56dBm/10 dynes/cm². 20dB front-to-back discrimination. Mylar diaphragm. Two-position locking type on/off switch. Two-position slide switch provides bass roll-off from 400Hz down. Size: 7¼in long, 1¾in diameter. Finish: satin chrome. Various accessories and mounting attachments available. Model 650BH includes 25ft screened lead with XLR connector and transformer giving output impedance of 20K. Model 650BL includes 25ft screened lead and XLR connector only. Prices: 650BH £34; 650BL £33.

■ BANG & OLUFSEN LTD

Eastbrook Road, Gloucester, GL47DE. Tel: Gloucester 21591.

BM5

Stereo microphone comprising BM6 and BM7. FR: 30Hz-13kHz ±2dB. Imp: 180 ohms per channel. Price: £31.75 in presentation case with desk stand and lead.

Beomic 2000

Moving coil cardioid. FR: 50Hz-15kHz. Sensitivity: -80dB. Impedance: 200 ohms. Rec load: 200 ohms. Hand microphone with foldaway legs and threaded socket for stand. Continental thread. Price: £14.95.

Floor Stand ★

Stable floor stand for B and O microphones. Black and chrome. Price: £9.75.

Boom Arm ★

Adjustable boom arm to match floor stand above. Price: £6.50.

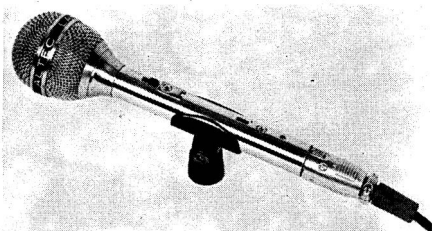

Altec Lansing B 650

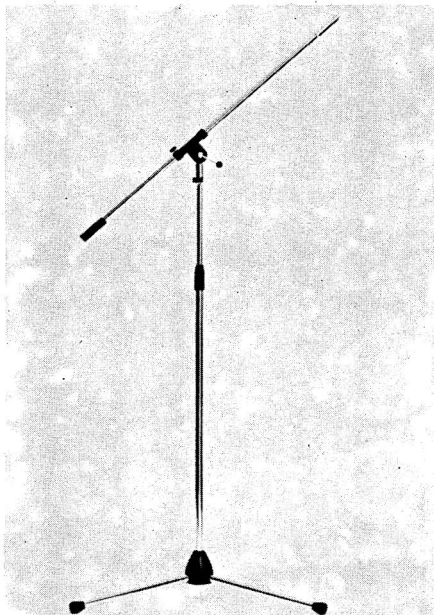

Band & Olufsen floor stand and boom arm

■ BEYER

Beyer Dynamic (GB) Ltd, 1 Clair Road, Haywards Heath, Sussex. Tel: Haywards Heath 51003.

M55HL

Mono moving coil omnidirectional. FR: 70Hz-16kHz ±4dB. Sensitivity: (low Z) 0.17mV; (high Z) 1.5mV. Impedance: (low Z) 500 ohms; (high Z) 50K. Rec. load: (low Z) 2K; (high Z) 200K. Hand mic with plastic table stand and clamp. Polished metal finish. Price: £10.35.

M57

Mono moving coil omni-directional. FR: 300 Hz-14kHz ±3dB. Sensitivity: 0.2mV/μbar. Impedance: 200 ohms. Rec load: 1K. Hand mic with cable. Steel case. Price: £13.65.

M64

Mono moving coil cardioid. FR: 100Hz-10kHz

★ Indicates entry is illustrated

± 3 dB. Sensitivity: $0.2\text{mV}/\mu\text{bar}$. Impedance: 200 or 37.5 ohms. Rec load: 1K. Stand mic with gooseneck and baseplate. Grey plastic case. Price: £11.60.

M64SH

As M64 but with gooseneck and base plate. Price: £16.

M67N

Mono moving coil cardioid. FR: 40Hz-18kHz ± 2.5 dB. Sensitivity: $0.25\text{mV}/\mu\text{bar}$. Impedance: 37.5 or 500 ohms. Rec load: 1K. Rubber suspended hand mic. Brushed aluminium finish. Suitable for any climatic conditions. Built-in speech/music switch. Price: (M67N) £32.65; (M67N-C) £34.05.

M68

Mono moving coil cardioid. FR: 100Hz-10kHz ± 3 dB. Sensitivity: $0.2\text{mV}/\mu\text{bar}$. Impedance: 37.5 or 200 ohms. Rec load: 1K. Fitted with gooseneck and built-in switch. Grey plastic finish. Price: £17.80.

M69 ★

Mono moving coil uni-directional cardioid. FR: 50Hz-16kHz ± 3 dB. Sensitivity: $0.24\text{mV}/\mu\text{bar}$. Impedance: 37.5 or 200 ohms. Rec load: 1K. Hand mic with optional speech-off-music switch. Steel case finished blue stove enamel. Price: (M69) £26.35; (M69SM) £29.30.

M81HL ★

Mono moving coil cardioid. FR: 50Hz-16kHz ± 3 dB. Sensitivity: (low Z) $0.23\text{mV}/\mu\text{bar}$; (high Z) $1.7\text{mV}/\mu\text{bar}$. Impedance: (low Z) 500 ohms; (high Z) 25K. Rec load: (low Z) 2K; (high Z) 100K. Hand mic supplied complete with plated table stand and clamp. Polished metal finish. Price: £13.35.

M88

Mono moving coil hypercardioid. FR: 30Hz-20kHz ± 2.5 dB. Sensitivity: $0.25\text{mV}/\mu\text{bar}$. Impedance: 200 ohms. Rec load: 1K. Hand mic available with cannon plug. Satin chrome case. Price: (M88) £63.95; (M88-C) £65.70.

M101

Mono moving coil omni-directional. FR: 40Hz-20kHz ± 2.5 dB. Sensitivity: $0.13\text{mV}/\mu\text{bar}$. Impedance: 200 ohms. Rec load: 1K. Hand mic with windshield. Anodised aluminium case. Price: (M101) £31.65; (M101-C) £32.50.

M111N

Mono moving coil omni-directional. FR: 60Hz-15kHz. Sensitivity: $0.08\text{mV}/\mu\text{bar}$. Impedance: 200 ohms. Rec load: 1K. Lavalier mic. Anodised aluminium case. Price: £41.15.

M160

Mono double-ribbon super cardioid. FR: 40Hz-18kHz ± 2.5 dB. Sensitivity: $0.1\text{mV}/\mu\text{bar}$. Impedance: 37.5 or 200 ohms. Rec load: 1K. Hand

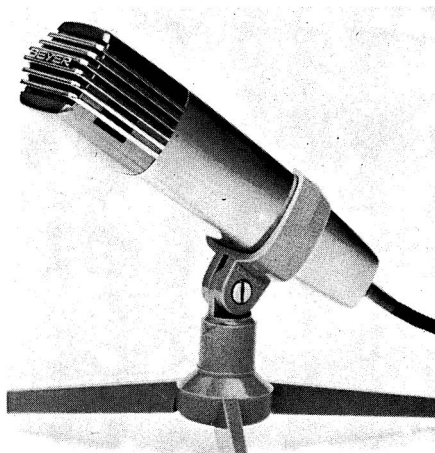

Beyer M81HL

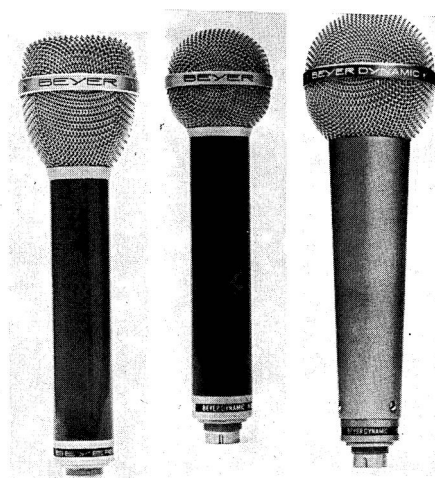

Beyer M69

Beyer M260 Beyer M500

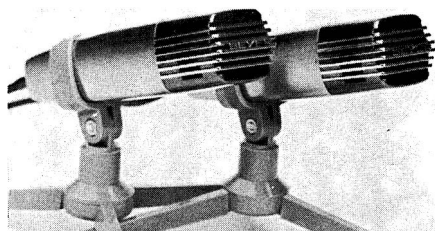

Beyer M818HL

mic. Satin chrome steel case. Price: £69.95.

M260 ★

Mono ribbon super cardioid. FR: 50Hz-18kHz ± 3 dB. Sensitivity: 0.09mV/ μ bar. Impedance: 37.5 or 200 ohms. Hand mic. Steel case stove enamelled blue. Price: £27.95.

M320

Mono ribbon super cardioid. FR: 3Hz-18kHz ± 3 dB. Sensitivity: 0.1mV/ μ bar. Impedance: 200 ohms. Rec load: 1K. Stand mic with three-position music-off-speech switch. Grey plastic case. Price: £33.45.

M360

Mono ribbon cardioid. FR: 30Hz-20kHz ± 2.5 dB. Sensitivity: 0.14mV/ μ bar. Impedance: 200 ohms switchable to 50 ohms. Rec load: 1K. Stand microphone for studio use. Completely hand made. Supplied with lead. Metal case stove enamelled grey. Price: £91.45.

M410

Mono moving coil cardioid. FR: 300Hz-12kHz ± 3 dB. Sensitivity: 0.25mV/ μ bar. Impedance: 200 ohms. Rec load: 1K. Hand mic designed for heavy duty use. Black plasticised steel case. Price: £20.95.

M411N

Mono moving coil uni-directional cardioid. FR: 200Hz-12kHz. Sensitivity: 0.14mV/ μ bar. Impedance: 200 ohms. Rec load: 1K. Hand mic with built-in switch. Designed for close-talking applications. Anodised aluminium finish. Price: (M411) £22.60; (M411N-T) £26.65; (M411N-C) £23.50.

M500 ★

Mono ribbon hypercardioid. FR: 40Hz-18kHz. Sensitivity: 0.13mV/ μ bar. Impedance: 500 ohms. Rec load: 1K. Hand mic. Anodised aluminium finish. Price: (M500) £37.75; (M500N-T) and (M500N-C) £38.75.

M610

Mono moving coil uni-directional. FR: 50Hz-16kHz ± 3 dB. Sensitivity: 0.2mV/ μ bar. Impedance: 37.5 or 200 ohms. Rec load: 1K. Hand mic with optional speech-off-music switch (SM version). Steel case blue stove-enamelled. Price: (M610N) £23.25; (M610SM) £25.60.

M818HL ★

Stereo moving coil cardioid. Comprises pair of matched M81HL. FR: 50Hz-16kHz ± 3 dB. Sensitivity: (low Z) 0.17mV/ μ bar; (high Z) 1.5mV/ μ bar. Impedance: (low Z) 500 ohms; (high Z) 25K. Rec load: (low Z) 2K; (high Z) 25K. Polished metal case. Price: £28.85.

Soundstar XI ★

Mono moving coil cardioid. FR: 30Hz-18kHz ± 2.5 dB. Sensitivity: 0.2mV/ μ bar. Impedance: (X1N) 200 ohms; (XIHLM) 200, 500 or 25K



Beyer Soundstar XI



Bouyer 709 cardioid moving coil

switchable. Rec load: (X1N) 1K; (XIHLM) 1K, 2K, 100K. Stand mic with built-in pop filter and hum compensation. Cannon plug. Moulded case. Price: (X1N-T) £23.65; (X1N-C) £23.65; (XIHLM) £27.30; (XIHLM-C) £27.85; (X1N) £22.80.

M550LM

Omni-directional moving coil. FR: 70Hz-18 kHz. Sensitivity: 0.17mV/ μ bar (-75 dB). Impedance: 500 ohms. Price: £9.85.

M810N

Cardioid moving coil. FR: 50Hz-16kHz. Sensitivity: 0.23mV/ μ bar (-73 dB). Impedance: 500 ohms. Price: £19.20.

BOUYER

Distributors: Douglas A. Lyons and Associates Ltd, 8 Ryecotes Mead, Dulwich, London, SE21. Tel: 01-693 2855.

★ Indicates entry is illustrated

709 ★

Moving coil microphone with marked cardioid response. Rear to front attenuation 20dB. FR: 150Hz-14kHz \pm 3dB. Sensitivity: -63dB reference 1V/dyne/cm². Impedance 20 ohms. Rec load: 20-150 ohms. Robust construction. Stand fitting with flexible stem. Hand grip available. Price: (cardioid head) £12.50. Fittings extra as required.

710

Similar to 709 but with extended bass response and super cardioid response pattern. Suitable for close-talking applications. Impedance 200 ohms. Price: (cardioid head) £25.50. Fittings extra as required.

■ **BRITISH RADIO CORPORATION LTD**

Thorn House, Upper St Martin's Lane, London, WC2. Tel: 01-836 2444.

TA20/TA24 Cardioid microphone ★

Dynamic microphones with variable cardioid characteristics. Switch positions for optimum results on speech and music. Supplied complete with desk stand and tripod adaptor. Low impedance version TA/24. High impedance version TA/20. Price: £9.

■ **CALREC**

Calder Recordings Ltd, Regent Street, Hebden Bridge, Yorkshire.
Tel: Hebden Bridge 2159.

Distributors for South of England, Scotland and overseas: Beyer Dynamic (GB) Ltd, 1 Clair Road, Haywards Heath, Sussex.

CM600 ★

General purpose condenser microphone. Omni-directional. FR: 20Hz-20kHz \pm 2dB. Output: 1.5mV/microbar. Impedance: 50 ohms (unbalanced). Rec load: 30-50K ohms (adjustment on mic). Slim hand or stand mic. Robust encapsulated FET amplifier. Optional windshield. Three-pin DIN lock-ring connectors. Two-year guarantee. Price: approximately £30.

CM652

Mono condenser microphone. Cardioid response. FR: 40Hz-20kHz \pm 2dB (related to standard curve). Sensitivity: -56.5dB. Source impedance: 100 ohms. Rec load: adjustable 30 ohms to 50K. Hand type. $\frac{3}{8}$ " in whit clip supplied. Satin chrome finish. Price: approximately £35.

CM654

Condenser microphone with cardioid pattern and reduced bass response for close-talking applications. Other details as for CM600. Price: approximately £35.

CM1001

Studio condenser microphone. Omni-directional. FR: 20Hz-20kHz \pm 2dB. Output: 0.3

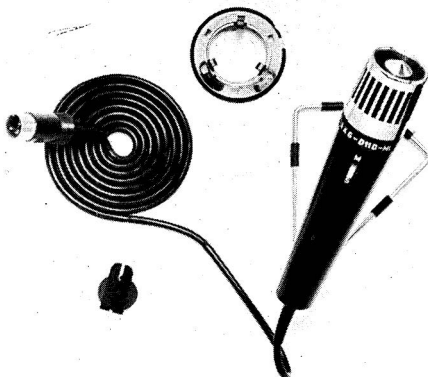

British Radio Corporation TA24

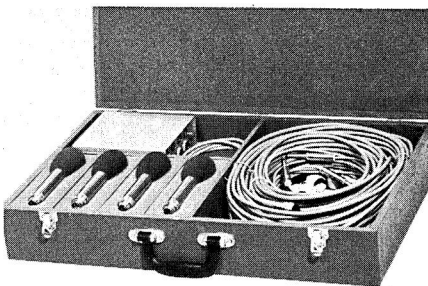

Calrec 600 Series capacitor microphones

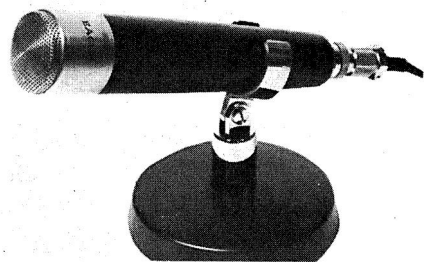

Eagle DM18HL

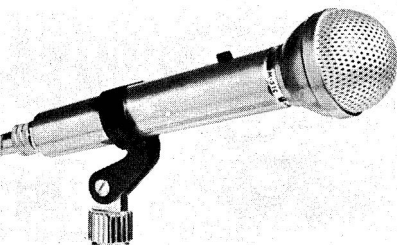

Eagle DM31C

mV/microbar. Impedance: 50 ohms. Rec load: 200 ohms (30 ohms when used with lead CL1081). Slim hand or stand mic. Cannon XLR connectors. Robust encapsulated FET amplifier. Two year guarantee. Windshield enclosed in body tube. Price: approximately £60.

CM1050

Studio cardioid microphone with accurate directional pattern. Other details as for CM1001, except needs external windshield. Price: £58-45.

Wide range of accessories including battery power units, mains power units, connecting leads, windshields, jacks, plugs, adaptors, presentation boxes, twin screened cables, etc. Full details and price list on request.

■ **COSMOCORD.** See Acos.

■ EAGLE INTERNATIONAL

Heather Park Drive, Wembley, HA11SU.
Tel: 01-903 0144.

DM18HL ★

Mono moving coil. Omni-directional. FR: 60 Hz-12kHz \pm 3dB. Sensitivity: -57dB. Impedance: 600 ohms and 50K. Built-in impedance switch. Rec load: 600 ohms and 50K. Stick mic for hand or stand. Fitting: 15.5 \times 1mm thread. Complete with desk stand. Finish: black anodised aluminium. Price: £8-40.

DM31C ★

Mono moving coil. Cardioid. FR: 40Hz-13kHz. Sensitivity: -52dB. Impedance: 50K. Rec load: 50K. Stick mic for hand or stand. Fitting: 15.5 \times 1mm thread. Built-in on/off switch. Finish: satinised stainless steel. Price: £7-90.

UD50HL

Mono moving coil. Cardioid. FR: 40Hz-14kHz \pm 3dB. Sensitivity: -62dB. Impedance: 600 ohms and 50K. Hand and stand mic. Fitting: 15.5 \times 1mm thread. Built-in on/off switch. Finish: satinised stainless steel. Price: £8-90.

CO92 ★

Mono omni-directional condenser. FR: 30Hz-16kHz. Impedance: 600 ohms. Sensitivity: 75dB. Powered by single cell and incorporating built-in low-noise preamplifier. Supplied with 6 metres of screened cable and detachable windshield. Price: £12.

CO96

Mono condenser. Similar specification to CO92 but with better than 20dB cardioid response. Impedance: 600 ohms. FR: 30Hz-16kHz. Sensitivity: 70dB. Price: £15.

UD52S ★

Stereo microphone system using two matched uni-directional units. FR: 100Hz-12kHz. Impedance: 10K (matching into 10K to 50K). Average output: 2.8mV. Each microphone sup-

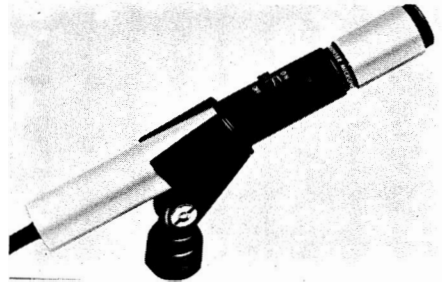

Eagle CO92



Film industries M8S ribbon on S.6 desk stand



Film industries M8 ribbon on S.6 desk stand

plied with heavy desk stand, on/off switch, clamps and 3 metres of cable. Price: £12-50.

UD76HL

Dual impedance dynamic microphone. Cardioid response. FR: 25Hz-20kHz. Impedance: 600 ohms and 50K. Sensitivity: 56dB at 50K, 76dB at 600 ohms. Fitted with music/speech contour control and switched transformer. Cord length: 9 metres. Supplied with carrying case. Price: £21.

■ FILM INDUSTRIES LTD

Station Avenue, Kew Gardens, Surrey.
Tel: 01-940 8078.

M8 ★

Ribbon. FR: 50Hz-13kHz. Figure-of-eight polar diagram. Available matched to all impedances up to 57K. Plug and socket joint between microphone head and flexible. Fitted with 12ft screened cable, other lengths to order. Table, desk and floor stands available. With or without on/off switch. Prices on request.

M8A

Ribbon. Similar unit to M8 but without plug

★ Indicates entry is illustrated

and socket connection between head and flexible. Small detachable desk stand provided. Other stands available. Available in all impedances up to 57K. With or without on/off switch. Prices on request.

M8S ★

Ribbon. Similar unit to M8 but with angled base in place of flexible. Small detachable desk stand provided. Other stands are available. Available in all impedances up to 57K. With or without on/off switch. Prices on request.

Microphone stands

Desk, table and floor stands. Grey hammer finish with cast iron bases. Stems in satin chrome. Prices from £1.50.

Matching transformer

In mu-metal screened case for fitting into microphone lead. Impedance ratio: 30 ohms to 60K. Price on request.

Microphone switch assembly

Suitable for use with all microphones. Prices on request.

FOSTER

Joint distributors: Aadastra Electronics Ltd,
Unit 22, Cricklewood Trading Estate,
Claremont Road, London, NW21 1TU.
Tel: 01-452 6288.

E.R. (Factors) Ltd, 374-378 Harrow Road,
Paddington, London, W9. Tel: 01-286 0361.

DF72BC

Mono moving coil omni-directional stick microphone. FR: 80Hz-12kHz ± 8 dB. Sensitivity: -76 dB ± 3 dB (600 ohms), -59 dB ± 3 dB (50kHz). Impedance: 600 ohms and 50K. Adjustable cradle fitting. Built-in switch. Removable windshield. Metal case with matt black and silver finish. Price: £6.90.

MDF623C

Mono moving coil cardioid stick microphone. FR: 200Hz-10kHz. Impedance: 600 ohms and 50K. Sensitivity: (600 ohms) -82 dB, (50K) -63 dB. Adjustable cradle fitting. Microphone holder and neck cord. Satin metal case. Price: £11.

MDF619BC

Mono moving coil cardioid stick microphone. FR: 200Hz-10kHz ± 6 dB. Impedance: 600 ohms and 50K. Sensitivity: (600 ohms) -76 dB ± 3 dB, (50K) -58 dB ± 3 dB. Adjustable cradle fitting. Built-in switch. Windshield. 16ft cord. Satin gold finish with chrome trim. Price: £12.25.

MDF611BC

Mono moving coil cardioid stand microphone. FR: 100Hz-10kHz ± 6 dB. Impedance: 600 ohms and 50K. Sensitivity: (600 ohms) -76 dB ± 3 dB, (50K) -58 dB ± 3 dB. Adjustable fitting. Built-in

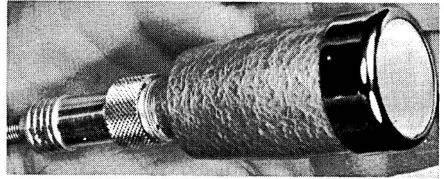

Gramplan DP6

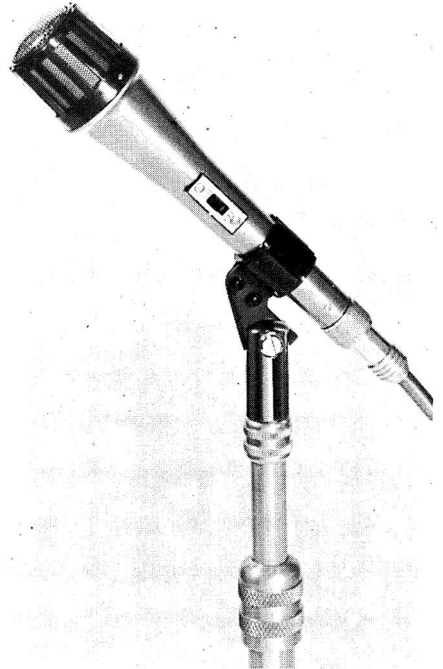

Gramplan GC2

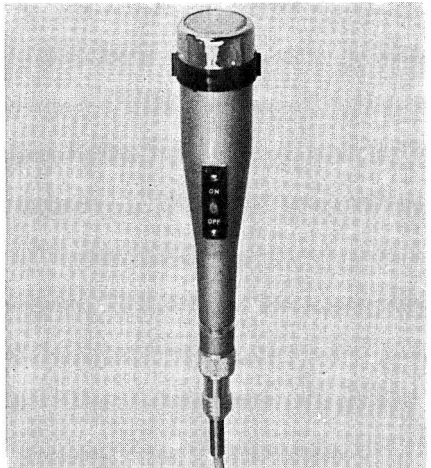

Gramplan DP8

switch. 16ft lead. Moulded housing wiremesh surround. Price: £15.50.

DF104BC

Mono moving coil omni-directional stick microphone. FR: 80Hz-12kHz. Impedance: 600 ohms and 50K. Sensitivity: (600 ohms) $-76\text{dB} \pm 3\text{dB}$. (50K) $-58\text{dB} \pm 3\text{dB}$. Adjustable cradle fitting. Built-in switch. Removable windshield. 9ft lead. Satin finish sprayed case. Price: £16.

DF106BC

Mono moving coil omni-directional stick microphone. FR: 60Hz-13kHz $+2\text{dB} -6\text{dB}$. Impedance: 600 ohms. Sensitivity: $-74\text{dB} \pm 3\text{dB}$. Adjustable cradle fitting. Slip-on windshield. Wood presentation cabinet. 16ft heavy duty lead. Heavy duty satin finished turned metal case. Price: £47.

GRAMPIAN REPRODUCERS LTD

Hanworth Trading Estate, Feltham, Middx.
Tel: 01-894 9141. Cables: Reamp, Feltham.

DP4/H

Moving coil. FR: 50-15,000Hz. Sensitivity: -52dB , -70dB , -86dB , for high, medium and low impedance. 50,000, 600 and 25 ohms. Tubular case. Price including lead: high or medium impedance: £12-15; low impedance: £10-25.

DP6 ★

Moving coil. Omni-directional. FR: 200Hz-15kHz. Sensitivity: -87dB (25 ohms), -75dB (200 ohms), -50dB (600 ohms), -52dB (50K). Built-in transformer fitted to all but low impedance model. Price: (low impedance) £10-25; (other three models) £12-15.

GC2 and GC3 ★

Mono moving coil microphone for hand (GC2) or desk mounting (GC3). Uni-directional response. FR: 70Hz-14kHz. Impedance: (L) 25 ohms; (X) 200 ohms; (M) 600 ohms; (H) 50K. Sensitivity: (L) -86dB $50\mu\text{V}$, (X) -75dB $180\mu\text{V}$, (M) -70dB $300\mu\text{V}$, (H) -52dB 2.5mV . All sensitivity figures per microbar. Easily replaceable diaphragm and coil assembly. GC2 has on/off switch and is supplied with swivel holder for fitting to floor or table stand. Prices: (GC2/L) £18-50; (GC2/X, GC2/M, GC2/H) £20-40; (GC3/L) £15-75; (GC3/X, GC3/M, GC3/H) £17-65.

GR1

Ribbon. Unequal figure-of-eight. Response: 40Hz-15kHz. Sensitivity: -90dB (25 ohms), -81dB (200 ohms), -76dB (600 ohms), -58dB (50K). Imp: 25, 200, 600 ohms, 50K. Built-in transformer. Easily replaceable ribbon. Price: £13-25; (in padded instrument case) £15-75.

GR2

Details as for GR1, but equal figure-of-eight response.

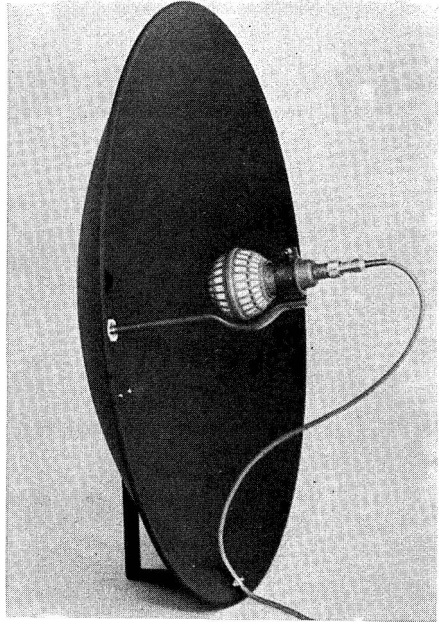

Grampian Parabolic Reflector

DP8 series ★

Moving coil omni-directional microphones. FR: 50Hz-15kHz $\pm 5\text{dB}$. Built-in on/off switch. Interchangeable leads. Hand type with swivel holder for stand use. Sensitivities, impedances and rec loads as for DP4 series. Prices: DP8/L £12-15; DP8/X, DP8/M, DP8/H £15-05.

Boom arm

Suitable for use with various types of mics and stands. The clamp, locked by a single lever, allows the reach and angle to be readily adjusted as required. Length: 34in. Weight: $1\frac{3}{4}\text{lb}$. Thread termination for mic $\frac{5}{16}\text{in}$ BSF male, thread termination for stand $\frac{3}{8}\text{in} \times 27\text{tpi}$ female. Supplied with adaptor to $\frac{1}{8}\text{in}$ BSF female. Adaptors for other sizes available. Price: £6-75.

Windshields

For use with DP4, DP6 and DP8 mics. Pressure moulded cage with an inner lining and acoustic resistance network to reduce air turbulence to a low value. Size: $2\frac{3}{8}\text{in}$ diameter. Weight: $\frac{3}{4}\text{oz}$. Price: £1-05.

Grampian Parabolic Reflector ★

Diameter 24in, depth 5in. Gain 14dB 500Hz-5kHz. Takes Grampian DP4 and DP6 microphones. Weight: $4\frac{3}{4}\text{lb}$. Prices: £9-80.

GRUNDIG (Great Britain) LTD

Newlands Park, Sydenham, London, SE26.
Tel: 01-778 2211.

★ Indicates entry is illustrated

GDM317 ★

High quality directional moving coil microphone with cardioid response. Recommended for acoustically unfavourable conditions. Output impedance: 200 ohms and 22K (dual). FR: 50Hz-12.5kHz. Supplied with tripod table stand. Price: £10-50.

GDM321 ★

Moving coil stick microphone. Dual low/high impedance, 200 ohms/100K. FR: 40Hz-20kHz. Supplied with adjustable table stand. Price: £17-85.

S15 stand

General-purpose folding stand. Opens to 5ft. Folded size: 16 × 2¼in. Price: £5-10.

■ ITT-STC

ITT Components Group Europe,
Standard Telephones & Cables Ltd,
Electro-Mechanical Product Division,
West Road, Harlow, Essex.

Distributors: Hampstead High Fidelity,
91 Heath Street, Hampstead, London, NW3
(01-435 0999); Horns Ltd, 6 South Parade,
Oxford (Oxford 55360).

4037

Omni-directional moving coil stick microphone for field work and P.A. Extremely rugged in construction. FR: 80Hz-10kHz. Impedance 30 ohms or 300 ohms. Sensitivity -76dB. Long (A) or short (C) models available. Available in colours for use in discos and on colour television. Price: approximately £39 retail.

4038

Studio ribbon microphone. Accurate figure-of-eight response. Flat frequency response 30Hz-15kHz. Impedance 30 ohms or 300 ohms. Sensitivity -85dB. Non-linear distortion 0.1%. Controlled transient response. Price: approximately £92 retail.

4104

Broadcast quality commentator's noise-cancelling ribbon lip microphone. Output -82dB. Impedance 30 or 300 ohms. Price: approximately £64 retail.

4105A

Cardioid moving coil microphone specially designed for speech. Flat response 60-10,000Hz. Impedance 30 ohms. Sensitivity -82dB. Front to back ratio 15-20dB. Price: approximately £39 retail.

4136 ★

Condenser cardioid microphone, uniform polar frequency response. Front/back ratio better than 20dB. FR: 40Hz-18kHz. Impedance 30 or 300 ohms. Sensitivity -50dB at 300 ohms. FET head amplifier. Phantom power supply for com-

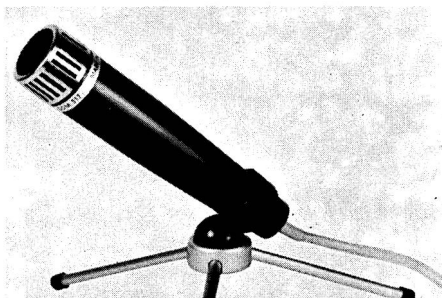

Grundig GDM317

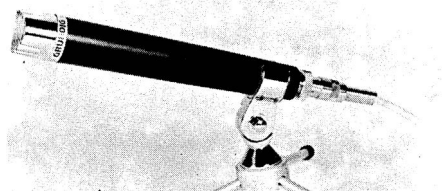

Grundig GDM321

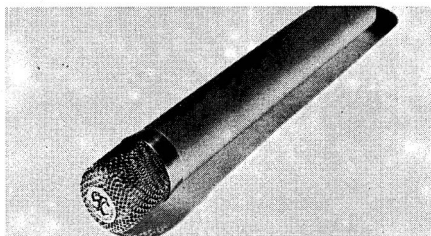

ITT 4136

bined mains and battery supply unit. Complete system with windshield and connecting cable. Price: approximately £140 retail.

■ KEITH MONKS (Audio) LTD

26-30 Reading Road South, Fleet,
Near Aldershot, Hants.
Tel: Fleet 7316.

Microphone stands

High quality chrome finish. Detachable legs with rubber feet. Nylon bushes. Model MS/S floor stand with three screw-in legs. Price: £7-30. Model MS/M floor stand with three screw-in legs. Price: £9-80. Model MS/P floor stand with four screw-in legs and toggle. Price: £10-50. Model MS/PA floor stand with four screw-in legs and toggle. Aluminium stem and anti-shine legs. Price: £11-50. Model MS/PA/B floor stand with four screw-in legs and toggle. Black anti-shine finish. Price: £12-50. Model MS/C floor stand with cast round base and aluminium stem. Price: £6-75. Model MS/F floor stand with

three screw-in legs and aluminium stem. Price: £7. Model MS/L studio floor stand with four screw-in legs. Price: £14-80. MS/CT/1 floor stand with 9lb cast base. Price: £9. Model MS/CT/2 floor stand with 11lb cast base. Price: £10. Model BS/1 banqueting stand with two-angle operation and cast base, aluminium stem. Price: £5-50. Model BS/1/B banqueting stand with two-angle operation and cast base. Finished in black. Price: £6. Model BS/2 banqueting stand with two-angle operation and cast base. Price: £7. Model BS/2/B banqueting stand with two-angle operation and cast base. Finished in black. Price: £7-75. Model BS/2/S banqueting stand with slope stem and on/off switch. Price: £9-50.

Boom arms and accessories

Model BA/S boom arm with single action. Price: £5-50. Model BA/M boom arm with two actions. Price: £5-90. Model BA/A boom arm with two actions. Price: £5-90. Model BA/L studio boom arm, suitable for MS/L. Price: £9-80. Model BA/C boom arm with two actions. In aluminium or non-shine finish. Price: £5-80. Model SB/1 stereo bar for fitting two microphones to one stand. Price: £2. Model SC/1 adjustable bar for fitting microphone to side of stand. Price: £2. Model CC1 plastic clips (three pairs of different sizes) Price: 20p. Model HT1 speaker tripod for outside use. Price: £12 (net). Comprehensive range of thread adaptors to suit most Whitworth, continental and British threads, internal and external. Full details on request. Prices: (STA range) from 25-50p.

LEM

Distributors: Douglas A. Lyons and Associates Ltd, 8 Rycotes Mead, Dulwich, London, SE21. Tel: 01-693 2855. Cables: Daliona London, SE21.

DH80

Miniature moving coil. Omni-directional. FR: 70Hz-14kHz ± 4 dB. Imp 50 ohms or 80K. Sensitivity: (low imp) -82dB, (high imp) -52dB. May be used as hand microphone, desk stand, or attached to floor stand. Price: from about £7.

DO35

Miniature lavalier moving coil microphone. Omni-directional. FR: 80Hz-12kHz. ± 3 dB. Sensitivity: -80dB. Imp 200 ohms. Can also be used as hand or stand microphone. Size: $2\frac{1}{2}$ in long, $\frac{7}{8}$ in diameter. Weight: $1\frac{3}{4}$ oz. Price: approximately £20.

DO21B

Studio-quality omni-directional moving coil microphone. FR: 30Hz-16kHz. ± 3 dB. Imp 50 ohms or 200 ohms. Sensitivity (200 ohms) -77dB. Individually calibrated response curves. Suitable for hand or stand use. Price: approximately £20.



Melodium 76A

DO20

Hand or stand type moving coil microphone. Omni-directional. FR: 40Hz-15kHz. Impedance: 50 ohms, 200 ohms or 80K. Sensitivity: 50 ohms -82dB, 200 ohms -76dB, 80K -50dB. Internal element resiliently mounted to avoid mechanical shock. Price: approximately £14.

DO42

Miniature lavalier. Similar specification to type DO35 but incorporates special features to avoid rubbing noises. Price: approximately £22.

LUSTRAPHONE LTD

St George's Works, Regent's Park Road, London, NW1. Tel: 01-722 8844.

4-20

Mono, moving coil, omni-directional stick type with clip for stand mounting. FR: 50Hz-15kHz ± 5 dB. Sensitivity: -80dB ref 1V/ μ b. Impedance: multiple, 30 ohms, 200 ohms, 600 ohms or higher. Built-in windshield and anti-noise protection. Finish: black and silver anodised aluminium. Price: £15-75.

4-30

Mono, moving coil cardioid stick type with clip for stand mounting. Sensitivity: -78dB ref 1V/ μ b. Impedance: multiple, 30 ohms, 200 ohms, 600 ohms or higher. FR: 50Hz-15kHz ± 3 dB. Built-in windshield and anti-noise protection. Finish: black and silver anodised aluminium. Price: £20-25.

MELODIUM

Distributor: Keith Monks (Audio) Ltd, 26-30 Reading Road South, Fleet, near Aldershot, Hants. Tel: Fleet 7316. (24-hour answering service Fleet 3566.)

76A ★

Moving coil, cardioid. FR: 100Hz-15kHz (3dB).

★ Indicates entry is illustrated

Sensitivity: -63dB ($0\text{dB}=1\text{mW}/10$ microbars)
30 ohms or 200 ohms impedance. Windshields
available. Price: (head) £14.70.

77A ★

Moving coil omni-directional. FR: 40Hz-17kHz
 $\pm 3\text{dB}$. Sensitivity: $-72\text{dB}=0.25\text{mV}$. 200 ohms
impedance. Hand stick. Clamp fitting with $\frac{1}{2}$ in
Whit. Windshields available. Black plastic.
Price: £35.50.

78A or 78A/108

Moving coil cardioid. FR: 50Hz-15kHz $\pm 3\text{dB}$.
Sensitivity: -67dB ($0\text{dB}=1\text{mW}/10$ microbars,
0.042mV/microbar). 30 ohms or 600 ohms im-
pedance. Stick, head removable for fitting to
swan neck. Clamp or swan neck fitting. $\frac{1}{2}$ in Whit.
Switch available on microphone or swan neck.
Windshields available. Steel. Price: (head)
£16.60; (in presentation box) £30.

RM6 ★

Ribbon bi-directional. FR: 30Hz-18kHz $\pm 2\text{dB}$.
Sensitivity: (200 ohms) -56dB 0.16mV/micro-
bar, (50 ohms) -61dB 0.09mV/microbar ($0\text{dB}=1\text{mW}/10$
microbar), 50 ohms or 200 ohms impe-
dance. Stick. Clamp fitting. Four position sensi-
tivity and on/off switch. Steel. Price: £47.50.

C121

Moving coil. Cardioid. Noise-cancelling minia-
ture. FR: 150Hz-14kHz $\pm 3\text{dB}$. Sensitivity:
 -89dB (0.036mV). Removable head for fitting
to swan neck or for use as stick mic. Price:
£13.40.

C133 ★

Moving coil. Cardioid. Stick type mic. FR: 50
Hz-15kHz $\pm 3\text{dB}$. Sensitivity: -83dB (0.072
mV) at 30 ohms, -71dB (0.28mV) at 600ohms.
Built-in pop shield. With or without on/off
switch. Melodium or three-pin DIN screened
plug. Price: (less on/off switch) £18.25; (with
on/off switch) £19.90. Lead, plug and clamp
extra.

Optional accessories

Wide range of plugs, sockets, adaptors, clamps,
goosenecks, stands, stereo bars, mounting
blocks, windshields, lavalier cords, transformers
and adaptors. Full details and prices on request.

■ **NEUMANN GMBH**

Sole UK Agents: F. W. O. Bauch Ltd,
49 Theobald Street, Boreham Wood, Herts.
Tel: 01-953 0091.

U67

Condenser. Switchable: omni-directional, car-
dioid, figure-of-eight. FR: 30Hz-16kHz $\pm 2\text{dB}$.
Sensitivity across 1K: 2mV/dyne/cm² in car-
dioid, 1.1mV/dyne/cm² in omni-directional, 1.4
mV/dyne/cm² in figure-of-eight. Impedance 50
or 200 ohms. Built-in transformer. Special



Melodium 77A

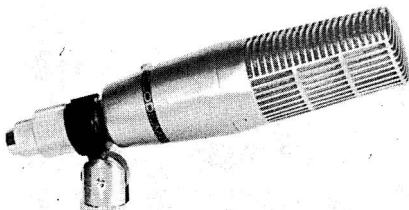

Melodium RM6

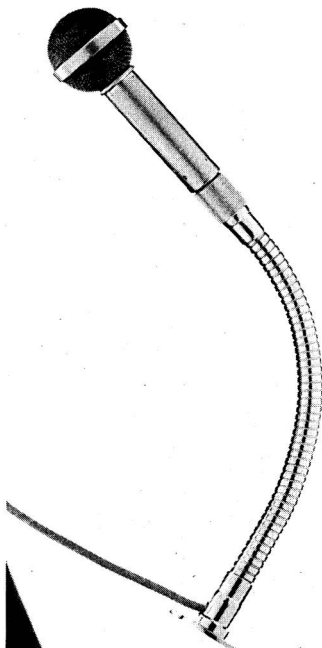

Melodium C133 with 326 gooseneck

sensitivity and bass cut switches. Printed circuit. Pressure gradient mic. Price on application.

M269c

Condenser. Remote controlled: omni-directional, cardioid, figure-of-eight (continuously variable). FR: 30Hz-16kHz ± 2 dB. Sensitivity across 1K: 0.9mV/dyne/cm² in omni-directional, 1.0 (1.55) mV/dyne/cm² in cardioid, 1.1 mV/dyne/cm² in figure-of-eight. Impedance 50 or 200 ohms. Built-in transformer. Special sensitivity and bass cut switches. Printed circuit. Remote controlled pressure-gradient mic. Price on application.

M49c

Condenser. Remote controlled: omni-directional, cardioid, figure-of-eight (continuously variable). FR: 35Hz-15kHz ± 2 dB. Sensitivity across 1K: 0.7mV/dyne/cm². Imp 50 or 200 ohms. Built-in transformer. Remote controlled pressure-gradient mic. Price on application.

M50c

Condenser. Omni-directional. FR: 40Hz-16kHz ± 2 dB. Sensitivity across 1K: 1.5mV/dyne/cm². Imp 50 or 200 ohms. Built-in transformer. Pressure mic. Price on application.

KM53c ★

Condenser. Omni-directional. FR: 40Hz-15kHz ± 2 dB. Sensitivity across 1K: 1.5mV/dyne/cm². Impedance 50 or 200 ohms. Built-in transformer. Printed circuit. Miniature pressure mic. Prices on application.

KM54c ★

Condenser. Cardioid. FR: 40Hz-15kHz ± 2 dB. Sensitivity across 1K: 1.2mV/dyne/cm². Impedance 50 or 200 ohms. Built-in transformer. Printed circuit. Miniature pressure-gradient type mic. Price on application.

KM56c ★

Condenser. Switchable: omni-directional, cardioid, figure-of-eight. FR: 40Hz-15kHz ± 2 dB. Sensitivity across 1K: 0.8mV/dyne/cm². Imp 50 or 200 ohms. Built-in transformer. Printed circuit. Miniature pressure-gradient mic. Price on application.

KM253, KM254, KM256

Condenser mics. RF-proof miniature microphones, otherwise specification as for KM53, KM54, KM56c.

KM63

Condenser. Omni-directional. FR: 40Hz-18kHz ± 2 dB. Sensitivity across 1K: 0.9mV/dyne/cm². Impedance 50 or 200 ohms. Built-in transformer. Special sensitivity switch (-10dB). Printed circuit. Miniature pressure mic. Price on application.

KM64

Condenser. Cardioid. FR: 40Hz-18kHz ± 2 dB.

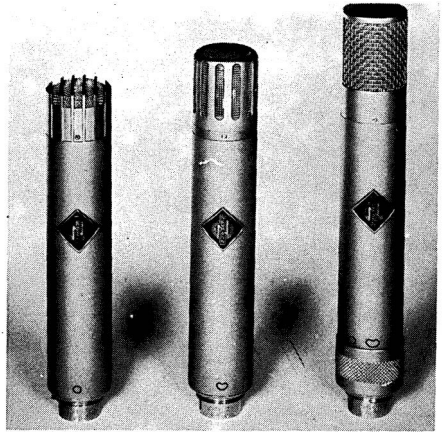

Neumann KM53C, KM54C, KM56C

Sensitivity across 1K: 0.9mV/dyne/cm². Imp 50 or 200 ohms. Built-in transformer. Special sensitivity switch (-10dB). Printed circuit. Miniature pressure-gradient mic. Price on application.

KM64P ★

Announcer desk condenser microphone. Cardioid. Response up to 18kHz with bass cut for better intelligibility. Sensitivity across 1K: 0.9 mV/dyne/cm². Impedance: 50 or 200 ohms. Built-in transformer. Special sensitivity switch (-10dB). Printed circuit. Pressure-gradient mic. Price on application.

SRM64

Condenser. Cardioid. FR: 40Hz-18kHz ± 2 dB. Sensitivity across 1K: 0.8mV/dyne/cm². Impedance 50 or 200 ohms. Built-in transformer. Special sensitivity switch (-10dB). Printed circuit. Miniature pressure-gradient mic. Adjustable-height stand. Price on application.

KM66

Condenser. Switchable: omni-directional, cardioid, figure-of-eight. FR: 40Hz-16kHz ± 2 dB. Sensitivity across 1K: 2.6mV/dyne/cm². Impedance 50 or 200 ohms. Built-in transformer. Printed circuit. Miniature pressure-gradient mic. Price on application.

U64

Condenser. Cardioid. FR: 40Hz-18kHz ± 2 dB. Sensitivity across 1K: 1.1mV/dyne/cm². Imp 50 or 200 ohms. Built-in transformer. Special sensitivity switch (-10dB). Printed circuit. Miniature pressure-gradient mic. Available with combined power units for two or six microphones. Price on application.

SM69 ★

Double or stereo condenser. Both systems separately remote controlled: omni-directional, cardioid, figure-of-eight. FR: 30Hz-16kHz ± 2

★ Indicates entry is illustrated

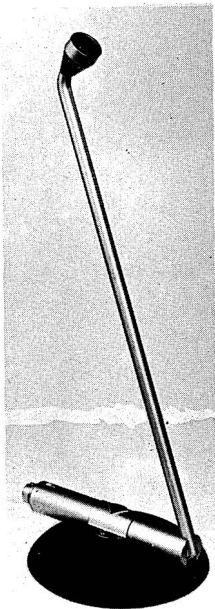

Neumann KM64P



Neumann SM69

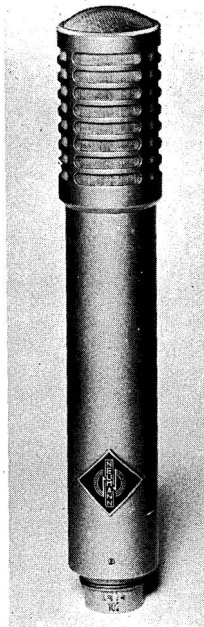

Neumann KM74

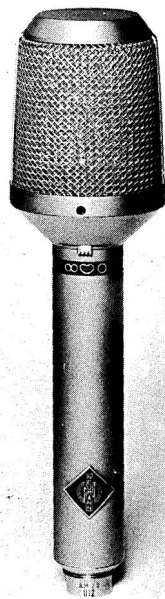

Neumann KM76

dB. Sensitivity across 1K: $1.5\text{mV}/\text{dyne}/\text{cm}^2$. Imp: 50 or 200 ohms. Built-in transformers. Printed circuit. Pressure-gradient mics. Price on application.

KM73

Transistor (FET) condenser. Omni-directional. FR: 40Hz-16kHz $\pm 2\text{dB}$. Sensitivity across 1K: $2.5\text{mV}/\text{dyne}/\text{cm}^2$. Impedance: 200 ohms without transformer. Printed circuit. Miniature pressure mic. Price on application.

KM74 ★

Transistor (FET) condenser. Cardioid. FR: 40Hz-16kHz $\pm 2\text{dB}$. Sensitivity across 1K: $2.5\text{mV}/\text{dyne}/\text{cm}^2$. Impedance: 200 ohms without transformer. Printed circuit. Miniature pressure-gradient mic. Price on application.

KM76 ★

Transistor (FET) condenser. Switchable: omni-directional, cardioid, figure-of-eight. FR: 40Hz-16kHz $\pm 2\text{dB}$. Sensitivity across 1K, $2.6\text{mV}/\text{dyne}/\text{cm}^2$. Impedance: 200 ohms without transformer. Printed circuit. Miniature pressure-gradient mic. Price on application.

KML

Lavalier transistor (FET) condenser. Cardioid. FR: 40Hz-16kHz $\pm 2\text{dB}$. Sensitivity across 1K: 0.5mV (18V) or 1.8mV (45V) per dyne/cm^2 . Impedance: 50 or 200 ohms. Built-in trans-

former. Printed circuit. Battery driven (18V or 45V). Miniature pressure-gradient mic. Price on application.

U77

Condenser FET. Switchable omni-directional or cardioid or figure-of-eight. FR: 40Hz-16kHz. Sensitivity across 1K: $2.6\text{mV}/\text{microbar}$ (omni), $5\text{mV}/\text{microbar}$ (figure-of-eight), $3\text{mV}/\text{microbar}$ (cardioid). Impedance: 200 ohms. Pressure-gradient mic. Bass cut and sensitivity switch of -10dB . Price on application.

KM83

FET condenser. Omni-directional. FR: 40Hz-16kHz. Sensitivity: $0.5\text{mV}/\text{microbar}$. Impedance: 50 or 200 ohms. Built-in transformer. Sensitivity switch: -10dB . Price on application.

KM84

FET condenser. Cardioid. FR: 40Hz-16kHz. Sensitivity: $0.5\text{mV}/\text{microbar}$. Impedance: 50 or 200 ohms. Built-in transformer. Sensitivity switch: -10dB . Price on application.

KM86

FET condenser. Cardioid. FR: 40Hz-16kHz. Sensitivity: $0.5\text{mV}/\text{microbar}$. Impedance: 50 or 200 ohms. Built-in transformer. Sensitivity switch: -10dB . Price on application.

U87

FET condenser. Switchable to omni-directional,

cardioid or figure-of-eight. FR: 40Hz-16kHz. Impedance: 50 or 200 ohms. Built-in transformer. Basscut and sensitivity switch of -10dB . Price on application.

KM88

FET condenser. Switchable to omni-directional or cardioid. FR: 40Hz-16kHz. Impedance: 50 or 200 ohms. Sensitivity across 1K: approx 0.7 mV/microbar. Built-in transformer. Sensitivity switch -10dB . Price on application.

SM69 FET

Stereo transistor condenser. Both systems separately remote controlled: omni-directional, cardioid or figure-of-eight. FR: 40Hz-16kHz. Sensitivity across 1K: 2mV/microbar. Impedance: 50 or 200 ohms. Built-in transformers. Pressure-gradient. Price on application.

U47 FET ★

Mono condenser. Cardioid. FR: 40Hz-16kHz. Sensitivity: 0.8mV/ μbar . Impedance: 150 ohms balanced. Recommended load: ≥ 750 ohms. Stand swivel with thread adaptor. Continues the tradition of the U47 produced from 1947-1960. Elastically mounted capsule and various switches. Finish: matt nickel plated. Price on application.

KMS 85 ★

Mono condenser. Cardioid. FR: 40Hz-16kHz. Sensitivity: 0.6mV/ μbar . Impedance: 150 ohms balanced. Recommended load: ≥ 750 ohms. Hand type. Multistage mechanical filter in front

of condenser capsule provides protection against close-talking popping noises and other explosive sounds. Finish: matt nickel plated. Price on application.

KMA

Mono condenser. Cardioid. FR: 40Hz-16kHz. Sensitivity: 0.5mV open circuit voltage. Impedance: 800 ohms balanced. Recommended load: $\geq 2.7\text{K}$. Lavalier type. Tie-clip fitting. Low sensitivity to noise of clothing etc. Finish: dark satin nickel plate. Price: on application.

PEARL

Feldon Audio Ltd, 126 Great Portland Street, London, W1. Tel: 01-580 4314. Telex: 28668.

Audio Workshops Ltd, 29 High Street, Robertsbridge, Sussex. Tel: Robertsbridge 580.

DC20

Mono condenser microphone. Omni-directional. FR: 30Hz-20kHz. Sensitivity: -50dB at 200 ohms. Impedance: 200 ohms. Rec load: not less than 200 ohms. Miniature model with stand adaptor. $\frac{5}{8} \times 27\text{in}$ tpi. FET preamp. Shockproof boom mount. Lavalier adaptor. Mains or battery. Mono or stereo power supplies available. Size: $2\frac{7}{8} \times \frac{3}{4}\text{in}$ dia. Finish: silver grey anodised alloy with satin chrome grille. Price: £46.25.

DC21

Mono condenser microphone. Cardioid. FR:

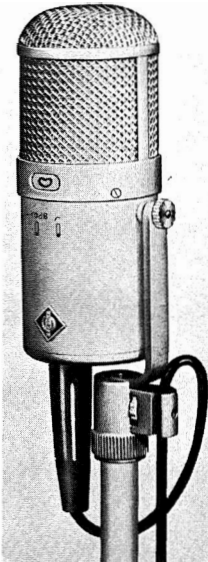

Neumann U47 FET

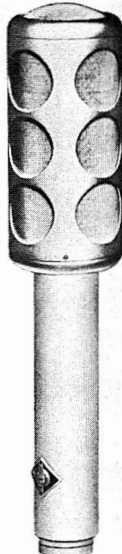

Neumann KMS85

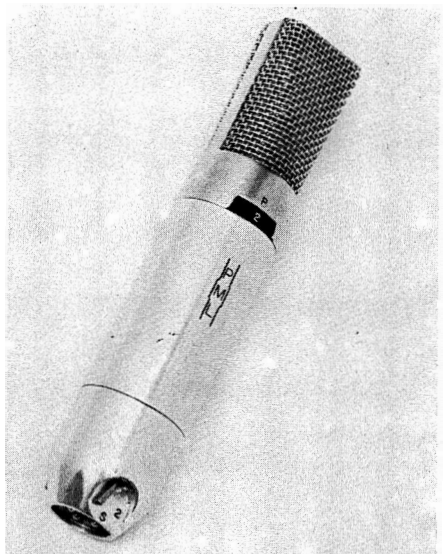

Pearl DC63

★ Indicates entry is illustrated

30Hz-20kHz. Sensitivity: -50dB at 200 ohms. Impedance: 200 ohms. Rec load: not less than 200 ohms. Miniature model with stand adaptor. $\frac{5}{8}$ in \times 27 tpi. FET preamp. Shockproof boom mount. Lavalier adaptor. Mains or battery. Mono or stereo power supplies available. Intended for use in pairs for stereo. Size: $2\frac{3}{8}$ \times $\frac{3}{4}$ in dia. Finish: silver grey anodised alloy with satin chrome grille. Price: £50.

DC63 ★

Mono condenser microphone. Continuously variable response pattern. FR: 30Hz-20kHz \pm 2dB. Sensitivity: -56dB. Impedance: 200 ohms. Rec. load: 1K. Miniature stick microphone. Shockproof boom mount with ball joint. $\frac{5}{8}$ in \times 27tpi fitting. Switchable 60Hz roll-off, switchable 5kHz boost. Finish: satin chrome case. Price: on request.

DC73 ★

Mono condenser microphone. Cardioid. FR: 30Hz-18kHz. Sensitivity: -52dB at 200 ohms. Impedance: 200 ohms. Rec load: not less than 200 ohms. Hand microphone, stand adaptor supplied. $\frac{5}{8}$ in \times 27tpi. FET preamp. Gooseneck and shockproof boom mount available. Electronic windshield. XLR connector to mic. Intended for use in pairs for stereo: Size: $2\frac{7}{8}$ \times $\frac{3}{4}$ \times $\frac{3}{4}$ in dia. Finish: silver grey anodised alloy with satin chrome grille. Price: £50.

EC71

Mono condenser microphone. Cardioid. FR: 40Hz-18kHz. Sensitivity: -58dB at 200 ohms. Impedance: 50, 200, 600 ohms balanced or high impedance unbalanced according to power supply. Rec load: not less than 200 ohms at that output. Miniature stand microphone, adaptor supplied. $\frac{5}{8}$ in \times 27tpi. Mono or stereo. Mains or battery. Shockproof boom mount available. Lavalier adaptor and windshield available. Intended for stereo use in pairs. Finish: silver grey alloy with satin chrome grille. Price: £38.75.

EK71

Mono condenser microphone. Omni-directional. FR: 40Hz-18kHz. Sensitivity: -58dB at 200 ohms. Impedance: 50, 200, 600 ohms balanced or high impedance unbalanced, according to power supply. Rec load: not less than 200 ohms at that output. Miniature stand mic with adaptor. $\frac{5}{8}$ in \times 27tpi. FET preamplifier. Mono or stereo. Mains or battery power supplies available. Shockproof boom mount. Lavalier adaptor and windshield available. Finish: silver grey anodised alloy with satin chrome grille. Price: £36.25.

F69

Mono moving coil microphone. Cardioid. FR: 50Hz-12kHz. Sensitivity: -70dB at 200 ohms. Impedance: 200 ohms. Rec load: not less than



Pearl DC73

200 ohms. Hand microphone with stand adaptor $\frac{5}{8}$ in \times 27tpi. Gooseneck with or without switch. Shockproof boom mount. Windshield. XLR connector. Finish: silver grey anodised alloy with satin chrome grille. Price: £40.

RD16

Mono moving coil microphone. Cardioid. FR: 40Hz-16kHz. Sensitivity: -70dB. Impedance: 200 ohms. Rec load: not less than 200 ohms. Small hand microphone, stand adaptor supplied. $\frac{5}{8}$ \times 27tpi. Gooseneck with or without switch available. XLR connector. Diaphragm of special polyester film. Windshield available. Finish: black and silver grey. Price: £21.37 $\frac{1}{2}$.

RD34

Mono moving coil. Cardioid. FR: 40Hz-16kHz. Sensitivity: -74dB at 200 ohms. Impedance: 200 ohms. Rec load: not less than 200 ohms. Stand or gooseneck mounting. $\frac{5}{8}$ in \times 27tpi. Gooseneck type with or without switch. XLR connector. Finish: black and silver grey. Price: £22.5.

RD36

Mono moving coil microphone. Cardioid. FR: 40Hz-16kHz. Impedance: 200 ohms balanced or high impedance unbalanced. Sensitivity: -54dB at high impedance, -74dB at 200 ohms. Recommended load: not less than 200 ohms, or high impedance according to connections. Stand or gooseneck type. $\frac{5}{8}$ \times 27tpi. Gooseneck available. Lavalier adaptor available. Windshield available. XLR connector. Finish: black and silver grey. Price: £22.50.

TC4

Mono condenser microphone. Cardioid. FR: 30Hz-20kHz. Sensitivity: -52dB at 200 ohms. Impedance: 50 or 200 ohms. Rec load: not less than 200 ohms for that output. Stick microphone

with stand adaptor. $\frac{3}{8} \times 27$ tpi. Double FET preamp. Shockproof boom mount with ball joint. Locking connector for mic. High vacuum condensed diaphragm. Intended for use in pairs for stereo. Finish: black anodised alloy with satin chrome grille. Price: £101.

TC4B

Mono condenser microphone. Figure-of-eight. FR: 30Hz-20kHz. Sensitivity: -56dB at 200 ohms. Impedance: 50 or 200 ohms. Rec load: not less than 200 ohms at that output. Stick microphone with stand adaptor. $\frac{3}{8} \text{in} \times 27$ tpi. Double FET preamp. Shockproof boom mount with ball joint. Locking connector for mic. High vacuum condensed diaphragm. Intended for use in pairs for stereo. Finish: black anodised alloy with satin chrome grille. Price: £106.

TC4K

Mono condenser microphone. Omni-directional. FR: 30Hz-20kHz. Sensitivity: -56dB at 200 ohms. Rec load: not less than 200 ohms at that output. Stick microphone with stand adaptor. $\frac{3}{8} \text{in} \times 27$ tpi. Double FET preamp. Shockproof boom mount with ball joint. Locking connector for mic. High vacuum condensed diaphragm. Finish: black anodised alloy with satin chrome grille. Price: £106.

■ PYE BUSINESS COMMUNICATIONS LTD

Cromwell Road, Cambridge, CB13EL.
Tel: Cambridge 45191.

Philips LBB9005/05

Moving coil cardioid microphone. FR: 40Hz-18kHz. Impedance: 500 ohms. Sensitivity: -71dB. On/off switch. Quick-release holder for stands with $\frac{3}{8}$, $\frac{1}{2}$ or $\frac{5}{8}$ in Whit threads. 10ft twin screened lead. Price: £16.50.

Philips LBB9006/05

Moving coil omni-directional microphone. FR: 35Hz-18kHz. Impedance: 500 ohms. Sensitivity: -71dB. On/off switch. Quick-release holder for stands with $\frac{3}{8}$, $\frac{1}{2}$ or $\frac{5}{8}$ in Whit threads. 10ft twin screened lead. Price: £14.

Philips LBB9007/05

Moving coil cardioid microphone. FR: 40Hz-18kHz. Impedance: 500 ohms and 25K. Sensitivity: 500 ohms -71dB, 25K -54dB. Combined on/off and impedance selector switch. Fitted flexible shaft and 10ft twin screened lead. Finish: brushed satin stainless steel head and chromium plated shaft. Fits stand with $\frac{3}{8}$, $\frac{1}{2}$ or $\frac{5}{8}$ in Whit threads. Price: £21.50.

Philips LBB9008/05

Moving coil cardioid microphone. Similar specification to EL.6025/01 except for panel mounting (or stand mounting with LBC.1201 adaptor) and single impedance (200 ohms). No

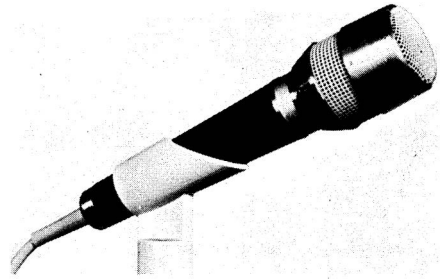

Philips EL6037

on/off switch. Capsule with hum-compensating coil. Price: £17.50.

Philips EL.6033/10

Moving coil. Studio quality. Switchable cardioid or omni-directional. FR: 40Hz-18kHz. Sensitivity: -72dB. Source impedance: 500 ohms (EL.6033/00 50 ohms). Special vibration damper optional extra. Supplied with cable and stand adaptor. Price: £29.50; EL.6207 vibration damper £3.70.

Philips EL.6035/11

High quality moving coil cardioid microphone. FR: 60Hz-17kHz. Impedance: 500 ohms. Sensitivity: -71dB. On/off switch. Quick-release holder for stands $\frac{3}{8}$, $\frac{1}{2}$ or $\frac{5}{8}$ in Whit threads. Three-pole plug (Tuchel T3261/1) for detachable cable. Price: £18.

Philips EL.6042/05

Professional quality omni-directional moving coil. FR: 30Hz-20kHz. Impedance: 200 ohms. Sensitivity: -79dB at 1kHz reference 1V/ μ bar. Size: $5\frac{3}{8} \times \frac{3}{4}$ in. Finish: matt chrome plate. Quick-release holder-clamp for stands with $\frac{3}{8}$, $\frac{1}{2}$ or $\frac{5}{8}$ in Whit threads. Three-pole plug for twin screened cable. Individually calibrated frequency response. Price: £34.

Philips EL.6061/02

Moving coil, noise cancelling. On/off and control switch. FR: 150Hz-15kHz. Source impedance: 500 ohms. Mounting bracket. Price: £14.50.

Philips LBB9003/05

Moving coil omni-directional lavalier microphone. FR: 50Hz-15kHz. Impedance: 200 ohms. Sensitivity: -78dB. Suitable also for hand use. Complete with neck cord and 33ft cable. Price: £14.75.

Philips EL.6037 ★

High quality moving coil. Cardioid. FR: 40Hz-18kHz. Impedance: 500 ohms and 25K. Sensitivity: -71dB (500 ohms); -54dB (25K). Rosewood body. Supplied with 10ft cable. Quick release adaptor. Price: £30.

★ Indicates entry is illustrated

Philips EL.6204

Universal microphone table stand. Provided with $\frac{3}{8}$ in Whit thread and possibility of mounting signal lamps or switches, etc. Price: £3.70.

Philips LBB9050/05 ★

Studio quality dual capsule microphone with crossover filters. Moving coil. Cardioid. FR: 25Hz-20kHz. Impedance: 200 ohms. Sensitivity: -77dB. Quick release holder for all stands. Price: £38.

Philips LBB9500

Moving coil cardioid microphone. FR: 40Hz-18kHz. Impedance: 500 ohms. Sensitivity: -71 dB. Quick release holder. Supplied with tripod table stand and 10ft twin screened lead. Price: £12.

Philips LBB9100/05

Moving coil microphone with all-metal housing. Speech/music switch. Built-in DIN connector. Impedance: 200 ohms. Low hand sensitivity. Price: £30.

Philips LBB9102/05

Moving coil microphone with wood shaft, 3 metres of cable and lockable DIN connector. Impedance: 200 ohms. Low hand sensitivity. Price on request.

Philips LBB9101/05

Moving coil microphone with an all metal housing. Speech/music switch. Built-in DIN connector. Impedance: 200 ohms. Price: £30.

ET907

Telescopic floor stand with heavy base. 42in closed, 72in extended. Price: £11.60.

LBC1203/00

Table stand. Tripod type. Price: £2.10.

LBC1207/00

Windshield for LBB9005, LBB9006, LBB9007, LBB9008, LBB9500. Price: £1.35.

LBC1209/00

Windshield for LBB9050. Price: £1.60.

EL6207

Vibration damper for use with EL6033 on floor or table stands. Price: £3.70.

LBC1200

Short flexible shaft fitted with socket to accept microphones EL6033, EL6035, EL6042, EL6036. Length 8in. Complete with 5 yards cable. Price: £6.90.

LBC1205/01

Cable with switched plug for use with LBB9050, EL6042 and EL6033. Price: £5.80.

LBC1210/00

Three-pole DIN microphone plug for use with LBB9050, EL6042, EL6033. Price: £1.10.



Philips LBB9050



Reslo SRI

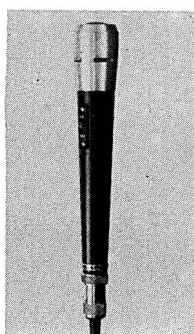

Reslo CPD/2



Reslo MPD/D

For just a little more — we give a lot more.

Vitavox equipment is good—
in fact it's very good.

It has to be to meet the
exacting acoustic demands of
H.M. Polaris submarines.

A situation where immediate
response to a command can
mean life or death!

In theatres, cinemas, auditoria
and homes throughout the world,
the wide range of Vitavox
equipment is used to meet
equally exacting demands.

Yes - for just a little more we give a lot more.

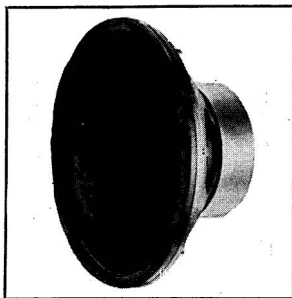

Type AK 124 Loudspeaker

A highly efficient bass
loudspeaker. When coupled
with the 6.PZ pressure
unit makes one of the
finest dual channel
systems available.

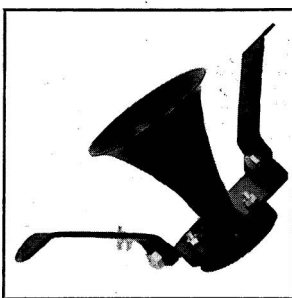

1000 Hz Horn, CN 350

This horn is a light,
compact and inexpensive
unit for use in small dual
channel speaker systems
to supplement the output
at frequencies above
1000 Hz.



GP2 Pressure Unit

A highly efficient pressure
unit. A superb high
frequency complement to
the AK 124 loudspeaker.
Response 300-14Khz.
Impedance 15 ohms.



VITAVOX
Limited

Westmoreland Road, London NW9 9RJ.

Telephone: 01-204 4234



The new KEF badge

Crisp, clean, modern—the new KEF product badge is as distinctive as the appearance of the new generation of KEF loudspeakers. The badge is being used on two new bookshelf models—the Coda and the Cantor.

KEF—the name on the badge—stands for precision sound quality, and engineering. Ask for a demonstration.

KEF Coda and KEF Cantor specifications are included in this book.



KEF Electronics Ltd Maidstone Tovil Kent

Directory of Speaker Drive Units

★ Indicates entry is illustrated

Abbreviations used in this section are given on page 36.

■ ADASTRA ELECTRONICS LTD

Unit 22, Cricklewood Trading Estate
Claremont Road, London, NW21TU.
Tel: 01-452 6288 (answering service 01-452 6289).

Top 20

Bass speaker. 12in. Fibre cone. Voice coil dia: 1½in. Voice coil material: aluminium. Impedance: 8 ohms and 15 ohms. Gap flux: 12,000 lines. Total flux: 80,000 maxwells. HC: 25W RMS. FR: 25Hz-13kHz. Price: £7.

Hi-Ten ★

Full range speaker. 10in. Fibre cone. vci: 8 ohms or 15 ohms. Voice coil dia: 1in. Voice coil material: copper. Gap flux: 10,000 lines. Total flux: 38,000 maxwells. HC: 10W RMS. FR: 40Hz-10kHz. Price: £3.25 (including PT).

■ RICHARD ALLAN RADIO LTD

Bradford Road, Gomersal, Cleckheaton,
Yorkshire. Tel: Cleckheaton 2442/3.
Cables: Acoustics, Bradford.

460TC

4in tweeter. Paper cone. Doped cambric surround. Alcomax II magnet. Voice coil 1⅞in. Gap flux 6,000 gauss. Total flux: 9,000 maxwells. HC: 3W. vci: 8 or 15 ohms. FR: 2kHz-17kHz. ref 5kHz. Price: £1.50 (Plus 23p PT).

CP5

5in mid-range unit. Paper cone with PVC surround. Ceramic magnet. Voice coil lin. Gap flux: 10,000 gauss. Total flux: 40,000 maxwells. HC: 5W. FR: 100Hz-12kHz. vci: 8 or 15 ohms. Price: £3.30 (plus 51p PT).

CB5

5in mid-range unit. Paper cone with PVC surround. Ceramic magnet. Voice coil lin. Gap flux: 12,000 gauss. Total flux: 48,000 maxwells. HC: 5W. vci: 8 or 15 ohms. FR: 100Hz-12kHz. Price: £4 (plus 61p PT).

CB8

8in mid-range. Paper cone, doped cambric surround, voice coil lin. Ceramic magnet. Gap flux 12,000 gauss. Total flux: 48,000 maxwells. HC: 5W. vci: 8 or 15 ohms. FR: 45Hz-10kHz. Price: £4 (plus 61p PT).

CB8T

8in paper cone plus tweeter inner. Doped cambric surround. Voice coil lin. Ceramic magnet. Gap flux 12,000 gauss. Total flux 48,000 maxwells. HC 5W. vci: 8 or 15 ohms. FR: 45Hz-15kHz. Price: £4.15 (plus 64p PT).

CB4

4in tweeter. Paper cone. Doped cambric surround. Ceramic magnet. Voice coil ⅞in. Gap flux 10,000 gauss. Total flux 15,000 maxwells. HC: 3W. vci: 8 or 15 ohms. FR: 2kHz-17kHz. ref 5kHz. Price: £1.95 (plus 30p PT).

CC8

8in bass/mid-range unit. Paper cone. Doped cambric surround. Ceramic magnet. Voice coil 1in. Gap flux: 12,000 gauss. Total flux: 48,000 maxwells. HC: 5W. vci: 8 or 15 ohms. FR: 35Hz-10kHz. Price: £4 (plus 61p PT).

CF8

8in unit. Paper cone. Moulded polyurethane surround. Ceramic magnet. Resonance 25Hz. Voice coil 1in. Gap flux: 14,000 gauss. Total flux: 56,000 maxwells. HC: 6W. vci: 8 or 15 ohms. FR: 25Hz-8kHz. Price: £5.75 (plus 88p PT).

CG8T

8in paper cone, doped cambric surround plus tweeter inner. Voice coil 1in. Ceramic magnet. Gap flux 14,000 gauss. Total flux 56,000 maxwells. HC: 6W. vci: 8 or 15 ohms. FR: 45Hz-15kHz. Price: £6 (plus 92p PT).

CG8

8in paper cone, doped cambric surround. Voice coil 1in. Gap flux 14,000 gauss. Total flux 56,000 maxwells. HC: 6W. vci: 8 or 15 ohms. Ceramic magnet. FR: 45Hz-10kHz. Price: £5.75 (plus 88p PT).

CG10

10in paper cone, doped cambric surround. Ceramic magnet. Voice coil 1½in. Gap flux:

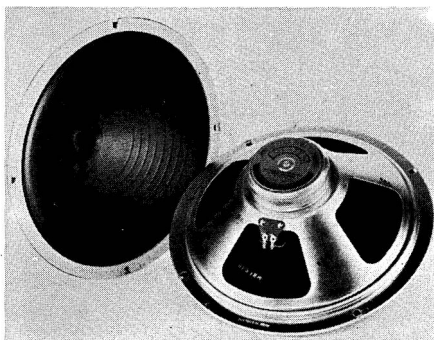

Adastra Hi-Ten

★ Indicates entry is illustrated

14,000 gauss. Total flux 105,000 maxwells. HC: 10W. vci: 8 or 15 ohms. FR: 40Hz-10kHz. Price: £8-50 (plus £1-31 PT).

CG10T

10in paper cone, doped cambric surround plus tweeter inner. Voice coil: 1½in. Ceramic magnet. Gap flux: 14,000 gauss. Total flux: 105,000 maxwells. HC: 10W. vci: 8 or 15 ohms. FR: 40Hz-15kHz. Price: £9 (plus £1-35 PT).

CG12

12in paper cone. Doped cambric surround. Ceramic magnet. Voice coil 1½in. vci: 8 or 15 ohms. Gap flux 14,000 gauss. Total flux 105,000 maxwells. HC: 10W. FR: 25Hz-9kHz. rcf 1kHz. Price: £10. (No PT).

CG12T

12in paper cone plus tweeter inner. Ceramic magnet. Doped cambric surround. Voice coil 1½in. vci: 8 or 15 ohms. Gap flux: 14,000 gauss. Total flux: 105,000 maxwells. HC: 10W. FR: 25Hz-15kHz. Price: £10-25 (no PT).

CG12 Super

12in paper cone, doped cambric surround. Ceramic magnet. Voice coil 2in. Gap flux 14,000 gauss. Total flux 186,000 maxwells. HC: 15W. vci: 8 or 15 ohms. FR: 25Hz-5kHz. Price: £13 (no PT).

CG15

15in paper cone, doped cambric surround. Ceramic magnet. Voice coil 2in. Gap flux 17,000 gauss. Total flux 220,000 maxwells. HC: 20W. vci: 8 or 15 ohms. FR: 20Hz-5kHz. Price: £21-50 (no PT).

CM8

8in mid-range unit. Paper cone. Doped cambric surround. Ceramic magnet. Voice coil 1in. Gap flux: 12,000 gauss. Total flux: 48,000 maxwells. HC: 5W. vci: 8 or 15 ohms. FR: 75Hz-10kHz. Price: £4 (plus 61p PT).

CP8

8in mid-range unit. Paper cone. Doped cambric surround. Ceramic magnet. vci: 8 or 15 ohms. Voice coil: 1in. Gap flux: 10,000 gauss. Total flux: 40,000 maxwells. HC: 5W. FR: 75Hz-10kHz. Price: £3-30 (plus 51p PT).

CR5

5in paper cone. PVC surround. Ceramic magnet. Voice coil 1in. Gap flux 14,000 gauss. Total flux 56,000 maxwells. HC: 10W. vci: 8 or 15 ohms. FR: 30Hz-8kHz. Specially designed for use in small volume infinite baffle enclosure. Price: £5 (plus 77p PT).

Richard Allan full-range speaker modules are included in Speaker Enclosure section. Twin Assembly, Triple Assembly and Super Assembly speaker kits are in the Constructional Kits section.

ALTEC LANSING

Ling Dynamic Systems Ltd,
Baldock Road, Royston, Herts, SG85BQ.
Tel: Royston 42424. Telex: 81174.

604E ★

Duplex speaker unit with crossover. 1½in nominal diameter. Separate LF and HF cone and speech coil assemblies. Damped high compliance edge suspension. LF voice coil 3in diameter, HF voice coil 1½in diameter. Impedance: designed to operate from 8 ohms or 16 ohms. Alnico V magnets: (LF) 4-4lb, (HF) 1-2lb. HC: 35W RMS (50W peak). FR: 20Hz-22kHz. Crossover (included in speaker) 1-5kHz. LF cone resonance: 25Hz. Horizontal distribution 90°, vertical distribution 40°. Flux: LF 13,000 gauss, HF 15,500 gauss. Weight: 34lb. Finish: white and grey. Recommended enclosures: 859A, 860A, 612A, 614A (enclosures not available in UK at present). Price: £117.

ASTEC

A. S. Techniques, 35 Waterloo Street,
Leicester. Tel: Leicester 26319.

Sound motor

Full range 7½in driver unit. FR: 30Hz-22kHz. HC: 15W RMS. Impedance: 8 ohms (4 ohms and 15 ohms available to order). Weight: 7½lb. Specially developed cone and termination. Recommended cabinet plans available from the makers. Price: £15-75.

BAKER REPRODUCERS LTD

Bensham Manor Road Passage, Thornton
Heath, Surrey. Tel: 01-684 1665.

Regent

Full range 12in cone speaker. Paper cone with roll surround. Voice coil: 1½in. Copper voice coil. vci: 3, 8 or 15 ohms. Gap flux: 12,000 gauss. HC: 15W RMS. FR: 45Hz-13kHz. Price: £7.

Major ★

Full range 12in speaker with built-in tweeter cone. 14,000 gauss magnetic gap. FR: 40Hz-14-5kHz. HC: 20W RMS. vci: 3, 8 or 15 ohms. Cast aluminium chassis. Weight: 6lb. Price: £9.

Deluxe Mk II

Full range 12in cone speaker. 15W RMS. Bass resonance: 30Hz. Gap flux: 14,000 gauss. Copper voice coil: 1½in diameter. vci: 8 or 15 ohms. Paper cone with foam plastic surround. Built-in tweeter cone. FR: 25Hz-16kHz. Cast aluminium chassis. Depth: 6in. Weight: 6lb. Price: £10.

Superb Twelve ★

Full range 12in speaker with built-in tweeter cone. Foam plastic surround. Coil diameter: 1½in. vci: 8 or 15 ohms. Gap flux: 16,500 gauss. HC: 20W RMS. FR: 20Hz-17kHz. Bass resonance: 25Hz. Copper speech coil. Diecast aluminium chassis. Weight: 10lb. Price: £15.

LBC1208/10

Ten-metre extension cable complete with plugs. For use with LBB9050, EL6042, EL6033. Price: £4.25.

RESLOSOUND LTD

Spring Gardens, London Road,
Romford, Essex.

Tel: Romford 61926 (3 lines). Telex: 897311.

New Reslosound models being introduced but details not available as this edition closed for press.

RBT Series

High quality miniature ribbon. FR: 40Hz-14 kHz \pm 3dB. Figure-of-eight, modified as required by filter pads. Sensitivity: 58dB below at 40K. Imp RBT/L 30-50 ohms; RBT/M 250 or 600 ohms; RBT/H 30-50 ohms or 40K. A switched model also available with the switch included in a slightly longer body (RBTS/L, RBTS/M, RBTS/H). Finish: satin chrome. Acoustic filter pad for close-talking use. Prices: on request.

CR2 Series

High quality miniature ribbon. FR: 40Hz-16 kHz ($-$ 2dB at 60Hz, \pm 10dB at 16kHz). Cardioid, figure-of-eight partially suppressed at the rear. Sensitivity: 58dB below for high-Z model. Imp: L, M and H as for RBT Series. Flexible swan neck stem. Finish: satin chrome perforated front, diecast case, silver grey hammertone enamel. Prices: on request.

SR1 Series ★

Professional studio ribbon. FR: 30Hz-20kHz $+2$ dB. Nominal figure-of-eight. Damping pads available. Sensitivity: -73 dB at 300 ohms. Imp: SR1/L 30-50 ohms, SR1/M 250 or 300 ohms.

VRT Series

Special miniature ribbon. FR: 30Hz-16kHz ($-$ 2dB at 40Hz, $+2$ dB at 16kHz). Nominal figure-of-eight. Damping pads available. Sensitivity: 81dB below at 300 ohms. Impedance: VRT/L 30/50 ohms, VRT/M 300 ohms. Developed for broadcast and recording studios. Satin chrome finish. Price: on request.

MD3

A special hand held version of MPD Series with direct feed cable. Price: from £9.

CPD Series ★

Cardioid pencil dynamic microphone. FR: 15 Hz-17kHz. Uni-directional partly suppressed at rear. Rear pickup -10 - 20 dB over range 200Hz-15kHz. Sensitivity: -88 dB at 30-50 ohms. Size: $8\frac{1}{2}$ in overall length, $1\frac{1}{2}$ in maximum diameter (head). Impedances (switched model): L = 30-50 ohms, M = dual 250 or 600 ohms, H = dual 30-50 ohms or 40K. Unswitched model in low im-

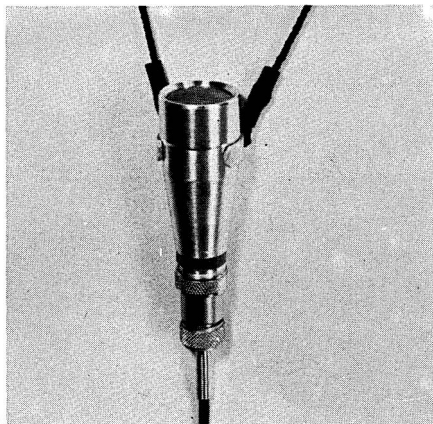

Reslo MPD/L

pedance only. Finish: main case black anodised, top case natural satin anodised. Supplied with cable set and plastic stand holder. Prices: on request.

UD.1

Uni-directional hand or stand microphone. FR: 50Hz-17kHz ($-$ 4dB at 100Hz, $+8$ dB at 16kHz). Rear pickup -10 to -20 dB between 200 Hz-15kHz. Sensitivity: -88 dB at 30-50 ohms. Output: average voice 6in from front of mic 150μ V (low imp), 250 - 450μ V (medium imp), 2 - 4 mV (high imp). Output increases approximately 10 times at one inch from microphone. Impedances: UD.1/L 30-50 ohms or 600 ohms; UD.1/M medium impedance, 200-300 ohms; UD.1/MT. 600-1,000 ohms; UD.1/H, high impedance. Finish: main case beige nylon, top case satin silver. Price: £240.

MPD/L ★

Dynamic, omni-directional, lavalier. FR: 50 Hz-15kHz -12 dB at 100Hz, $+4$ dB at 14kHz. Sensitivity: 88dB below. Impedance: low. Finish: satin anodised. Price: £13.

MPD/D ★

Dynamic, omni-directional, desk base fitted with 8in flexible stem. FR: 50Hz-10kHz. Sensitivity: 88dB below. Impedance: low. Finish: satin anodised microphone, chrome stem, grey enamel base. Price: £17.

SL2 Slimline

Dynamic, omni-directional, hand-type on stand. FR: 200Hz-16kHz. Sensitivity: 84dB below. Impedance: low. Fitting thread: 27 tpi $\frac{3}{8}$ in; 26 tpi $\frac{1}{2}$ in. Finish: all brass finished satin chrome. Price: £29.

Coupler unit GE1

Suitable for use with any impedance micro-

★ Indicates entry is illustrated

phone. Designed for external use adjacent to the tape recorder or amplifier. Gain: 45-40dB. FR: 50Hz-20kHz \pm 1dB. Fitted 36in screened lead and jack plug. Self-contained PP4 battery with average life of 1,500 hours. Price: £11.

Microphone transformers MT101, MT102

Designed for internal mounting in equipment having only high impedance inputs. Input imp: MT101 15-50 ohms, MT102 300-600 ohms. Nominal output imp: 100K. Response: 50Hz-15kHz \pm 2dB. Price: £3-50.

MS.110B

Adjustable floor stand. Minimum height: 40in, maximum height: 62in. Grey hammertone base, chrome outer and inner stem. Price: £11-50.

MS.175 and MS.180

Boom arm fitting available for use with Reslo floor stands. Price: £15.

MS.200

Adjustable table stand. Minimum height: 1ft 4in, maximum height: 2ft 2in. Grey hammertone base with chrome stem and extension piece. Price: £8-50.

MS.300

Circular desk stand. Grey hammertone base fitted with 3in chrome stem. Price: £4-50.

MS.500

Rectangular desk base. Fitted with rubber feet. Finished in silver grey hammertone. Muting switch optional extra. Price: £3-50.

Reslo-Audac

Range of radio microphones for all purposes. Full details on request.

■ SENNHEISER ELECTRONIC

Distributors: Hayden Laboratories Ltd, Hayden House, 17 Chesham Road, Amersham, Bucks. Tel: Amersham 5511.

Audio equipment showroom, service department and despatch department: 12-13 Poland Street, London, W1V 3DE. Tel: 01-734 3748/9.

MD21N ★

Omni-directional moving coil hand or stand microphone. FR: 50Hz-15kHz \pm 3dB. Sensitivity: 0.2mV/ μ bar \pm 3dB. Impedance: 200 ohms. Rec load: 1K. Light alloy case finished hammer stove enamel. Windshield MZW22 optional extra. Price: (microphone) £26-50; (windshield MZW22) £5-05; (desk stand MZT21) £2-85.

MD21HL

Dual-impedance version of MD21. Price: £27-50.

MD.211N

Omni-directional moving coil miniature studio microphone. Hand or stand use. FR: 40Hz-20 kHz \pm 2.5dB. Sensitivity: 0.13mV/ μ bar \pm 2.5dB.



Sennheiser MD21



Sennheiser MD214N

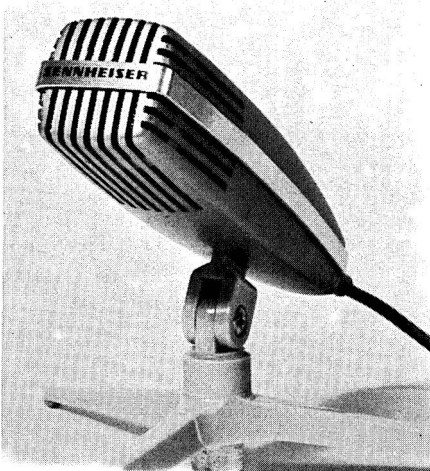

Sennheiser MD41I

Impedance: 200 ohms. Rec load: 1K. Metal case with satin chrome finish. Windsheild MZW211 optional extra. Price: (microphone) £44; (windsheild MZW201) £2-50; (small tripod desk stand MZT104) £2-50.

MD.214N ★

Omni-directional moving coil lavalier microphone. Built-in 'natural voice' equaliser to studio standards. FR: specially designed for lavalier operation. Sensitivity: $0.10\text{mV}/\mu\text{bar} \pm 2.5\text{dB}$. Impedance: 200 ohms. Rec load: 1K. Metal case finished special 'non-glare' enamel. Price: £44.

MD.408N

Super cardioid moving coil microphone with flexible shaft. Specially suitable for PA applications. FR: 100Hz-14kHz $\pm 3\text{dB}$. Impedance: 200 ohms. Sensitivity: -55dB . Case of light gauze woven wire cloth. Price: £23.

MD.411HLM ★

Super-cardioid moving coil mono microphone. FR: 50Hz-12kHz. Impedance: (low) 200 ohms, (medium) 800 ohms, (high) 25K. Sensitivity: $0.12\text{mV}/\mu\text{bar}$, $0.25\text{mV}/\mu\text{bar}$, $1.25\text{mV}/\mu\text{bar}$. Rec load: (low) 50-200 ohms, (medium) 1-2K, (high) 80K. Hand and stand microphone with base fitting clip. Sound from sides and rear heavily attenuated. Case of hardened plastic round metal sleeve. Finish: matt silver. Price: £15-75.

MD420-2 ★

Super-cardioid noise cancelling moving coil mono microphone. FR: 200Hz-10kHz (special response curve for noise cancellation). Impedance: 200 ohms. Rec load: 1K. Sensitivity: $0.18\text{mV}/\mu\text{bar}$. Hand or stand microphone with large Tuchel plug. Metal case with silver finish. Price: (MD420-2) £18-90; (MD420-2T with switch) £21.

MD420-9

Shorter version of MD420 for gooseneck mounting. Price: £18-90.

MD211N

Mono moving coil omni-directional microphone. FR: 40Hz-20kHz. Sensitivity: $0.13\text{mV}/\mu\text{Bar}$ at 1kHz. Impedance: 200 ohms. Rec. load: 200 ohms or greater. Hand/stand mic with optional clip available. Available with Cannon connector. Finish: satin chrome. Price: £44.

MD214N

Mono moving coil omni-directional microphone. FR: 60Hz-15kHz. Sensitivity: $0.1\text{mV}/\mu\text{Bar}$. Impedance: 200 ohms. Rec. load: 200 ohms or greater. Lavalier microphone with lanyard. Frequency response adjusted to compensate for chest resonance. Double suspension system to eliminate handling noise. Finish: matt grey. Price: £44.

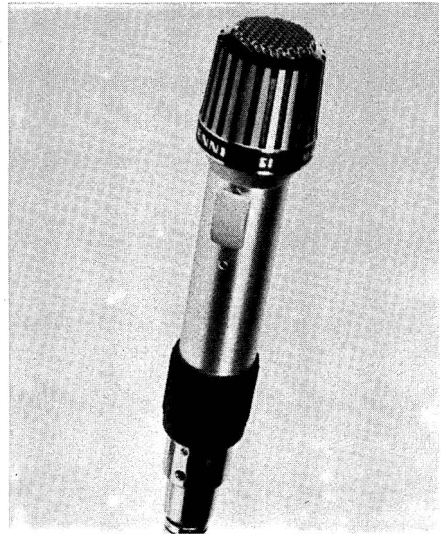

Sennheiser MD420-2T

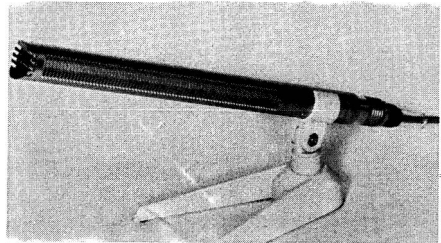

Sennheiser MKH415T

MD402LM

Mono moving coil super cardioid microphone. FR: 80Hz-12.5kHz. Sensitivity: $2.3\text{mV}/\mu\text{Bar}$. Impedance: 750 ohms. Rec. load: 4K. Hand mic with stand and clip. Rugged construction. Frequency response tailored for domestic applications. Finish: satin chrome. Price: £10.

MD408N

Mono moving coil super cardioid microphone. FR: 60Hz-14kHz. Sensitivity: $0.13\text{mV}/\mu\text{Bar}$. Impedance: 200 ohms. Rec. load: 1K. Specially designed for close-talking applications; Gooseneck with $\frac{3}{8}$ in fitting. Finish: polished chrome grille. Price: £23.

MD409N

Mono moving coil super cardioid. FR: 50Hz-15kHz. Sensitivity: $0.18\text{mV}/\mu\text{Bar}$. Impedance: 200 ohms. Rec. load: 200 ohms or greater. Stand mounted musicians' microphone. Finish: black and gold. Price: £31-50.

MD415N

Mono moving coil super cardioid. FR: 60-Hz-15kHz. Sensitivity: $0.12\text{mV}/\mu\text{Bar}$. Impedance:

★ Indicates entry is illustrated

300 ohms. Rec. load: 200 ohms or greater. Hand/stand microphone. Rugged construction. Built-in anti-popping shield. Good feedback immunity. Finish: solid brass, gold plated. Price: £41.

MD421 ★

Mono moving coil cardioid microphone. FR: 30Hz-17kHz. Sensitivity: 0.2mV/μBar at 1kHz. Impedance: (HL series) 200 ohms and 24K; (N, U and 2 series) 200 ohms. Rec. load: (high Z version of HL series) 50K, (all others) 1K. Hand/stick microphone. $\frac{3}{8}$ in thread fitting. Built-in bass cut switch. Low handling noise. Finish: (standard versions) grey plastic body with chrome grille; (de luxe versions) black plastic body with gold grille. Price: (MD421N) £37; (MD421HL de luxe) £47.50.

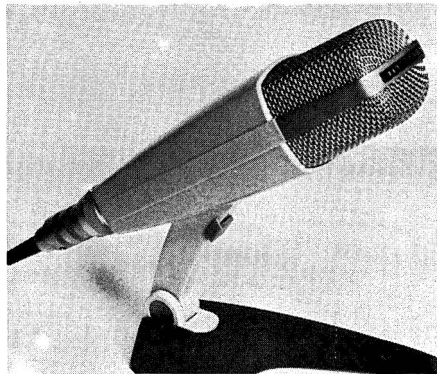

Sennheiser MD421

MD441

Mono moving coil super cardioid microphone. FR: 40Hz-20kHz. Sensitivity: 0.2mV/μBar. Impedance: 200 ohms. Rec. load: 1K. Hand microphone, with optional mounting clip available. Choice of ten switchable frequency responses. Low handling noise. Polar diagram constant over frequency range. Finish: shock resistant metal case. Silver-plated metal grille on matt black body. Price: (MD441N, MD441-2, MD441-U) £57.

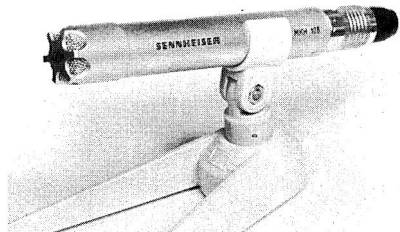

Sennheiser MKH105

MKH105 ★

Mono capacitor omni-directional microphone. FR: 20Hz-20kHz. Sensitivity: 2mV/μBar. Impedance: 10 ohms. Rec. load: 200 ohms or greater. Hand/stand microphone. Table stands MZT104 and 105 available. Low self noise. Windshield. Finish: satin chrome on brass. Price: £91.

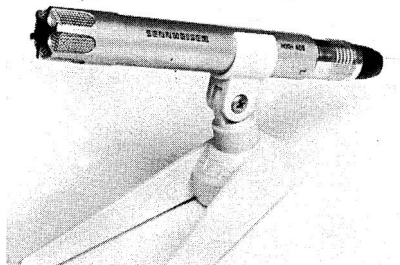

Sennheiser MKH405

MKH124

Mono capacitor omni-directional. FR: 20Hz-20kHz. Sensitivity: 0.32μV/Bar. Impedance: 150 ohms. Rec. load: 200 ohms or greater. Lapel or lavalier microphone with clip or lanyard. Small size: flat frequency response. Presence lift. Finish: matt grey enamel. Price: £124.

MKH125

Mono capacitor omni-directional microphone. FR: 20Hz-20kHz. Sensitivity: 2mV/μBar. Impedance: 10' ohms. Rec. load: 200 ohms. Lapel/lavalier microphone with lanyard or clip. Small size. Flat frequency response. Presence lift. Finish: matt grey enamel. Price: £132.

MKH405 ★

Mono capacitor cardioid microphone. FR: 40 Hz-20kHz. Sensitivity: 2mV/μBar. Impedance: 10 ohms. Rec. load: 200 ohms. Hand/stand microphone. MZT104, 105 and 415 stands available. Low self noise. Windshield MZW30. Suitable for use in pairs for stereo. Finish: satin chrome on brass. Price: £102.



Sennheiser MD409/MD415

MKH415 ★

Mono capacitor super cardioid microphone. FR: 40Hz-20kHz. Sensitivity: 2mV/ μ Bar. Impedance: 20 ohms. Rec. load: 200 ohms. Hand/stand microphone. Table stand MZT415 available. Low self noise. Good wind noise rejection. Windshield MZW415. Finish: satin chrome on brass. Price: £114.

MKH815

Mono capacitor uni-directional (narrow beam) microphone. FR: 50Hz-20kHz. Sensitivity: 4mV/ μ Bar. Impedance: 20 ohms. Rec. load: 200 ohms. Gun microphone. Fittings: boom MZS805 or pistol grip MZP805. Low self noise. Very narrow beam. Windshield: MZW804 and MZW815. Finish: satin chrome on brass. Price: £141.

■ SHURE ELECTRONICS LTD

84 Blackfriars Road, London, SE1 8HA.
Tel: 01-928 3424.

545 Unidyne III ★

Cardioid moving coil. FR: 50Hz-15kHz. Sensitivity: -55dB. Source impedance 25-250 ohms and high. Built-in transformer. Price: £33.

565 Unisphere I ★

Moving coil. Cardioid (with polar diagram uniform with frequency, symmetrical about axis). FR: 50Hz-15kHz. Dual impedance (50-250 ohms and high). Sensitivity: (low Z) -78dB. (high Z) -55dB. Hand or stand. Built-in wind/breath filter. Available with or without switch. Detachable 15ft three-core screened lead. Finish: satin chrome body with plated steel grille. Size: 6 $\frac{1}{2}$ in long, 2in diameter over head. Price: (565 less switch) £37-80; (565S with switch) £39.

588SA Unisphere B ★

Moving coil. Cardioid. FR: 50Hz-13kHz. Impedance: high Z (low version 25-200 ohms available). Sensitivity: (high Z) -59dB, (low Z) -81-5dB. Hand or stand microphone supplied with swivel stand adaptor. Built-in switch with provision for locking on. Wind/breath filter. Detachable 15ft cable. Finish: satin chrome with steel mesh grille. Size: 6 $\frac{1}{2}$ in long, 2 $\frac{1}{2}$ in diameter. Price: (588SA high Z) £24; (588SB low Z) £22-80.

515SA Unidyne B

Moving coil. Cardioid. FR: 80Hz-13kHz. Sensitivity: -58dB. High impedance (low impedance version available). Hand or stand. On/off switch with lock. Size: 6 $\frac{1}{2}$ in long, 1 $\frac{1}{2}$ in diameter. Satin chrome body with black grille and stainless steel screens. Price: 515SA (high impedance) £16-80; 515SB (low impedance) £16-20.

■ SONY (UK) LTD

Pyrene House, Sunbury Cross, Sunbury-on-Thames, Middlesex. Tel: Sunbury 87644/7.

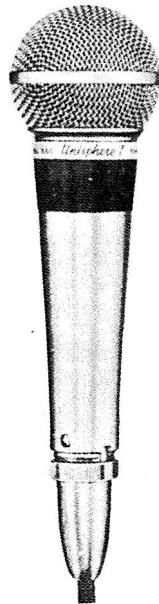
*Shure 545 Unidyne III**Shure 565 Unisphere I**Shure 588SA Unisphere B*

★ Indicates entry is illustrated

ECM95S

Mono capacitor microphone. Cardioid response. FR: 40Hz-18kHz. Sensitivity: -50dB (ref 1V/10 μ bars). Impedance: 1.5K. Hand type. Remote control switch, with twin jack plugs. Anodised aluminium finish. Price: £6.36.

F99B

Stereo hand microphone. Cardioid response each channel. FR: 18Hz-20kHz. Sensitivity: -62dB (ref 1V/10 μ bars). Impedance: 200 ohms per channel. Finish: anodised aluminium. Price: £7.50.

ECM19B

Mono capacitor hand microphone. Cardioid response. FR: 50Hz-12kHz. Sensitivity: -54.8dB (ref 1V/10 μ bars). Impedance: 250 ohms. Electret capacitor system. Finish: anodised aluminium. Price: £13.

ECM21

Mono capacitor hand microphone. Cardioid response. FR: 50Hz-12kHz. Impedance: 50 ohms, 250 ohms, 600 ohms. Sensitivity: -60.8 dB, -53.8dB, -50dB (ref 1V/10 μ bars). Windshield and desk stand included. Finish: anodised aluminium. Price: £20.25.

ECM22P

Mono capacitor hand microphone. Cardioid response. FR: 40Hz-15kHz. Impedance: 250 ohms, 600 ohms. Sensitivity: -54.8dB, -51dB (ref 1V/10 μ bars). Voice/music switch. Finish: anodised aluminium. Price: £64.50.

■ T.T.C.

Joint distributors: Adastra Electronics Ltd, Unit 22, Cricklewood Trading Estate, Clarendon Road, London, NW2 1TU. Tel: 01-452 6288/9.

E.R. (Factors) Ltd, 374-378 Harrow Road, Paddington, London, W9. Tel: 01-286 0361.

B1078

Moving coil cardioid microphone. FR: 50Hz-15kHz. Sensitivity: (600 ohms) -72dB, (50K) -54dB. Impedance: 600 ohms and 50K. Stick type with adjustable cradle fitting. $\frac{5}{8}$ in 27tpi thread. Built-in switch. Wire mesh windshield. 20ft cable. Satin chrome finish. Price: £7.

B7105

Capacitor cardioid microphone. Power supply: 1.5mA 1.5V. FR: 30Hz-16kHz. Sensitivity: -70dB \pm 2.5dB at 1kHz. Impedance: 600 ohms. Stick type mic with adjustable cradle. Built-in battery compartment. Slip-on windshield. 20ft cable. Finish: textured aluminium and black. Price: £16.

Piezo EX220

Capacitor cardioid microphone. Stick type with adjustable cradle. Power supply: 1.5V at 0.8mA. FR: 50Hz-15kHz. Sensitivity: -70dB at 1kHz.



Turner 602

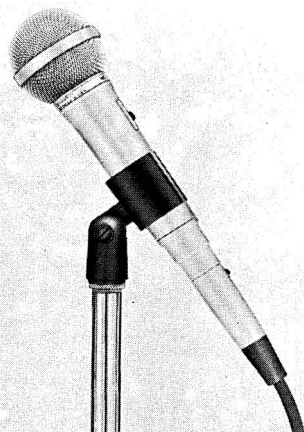

Turner 700

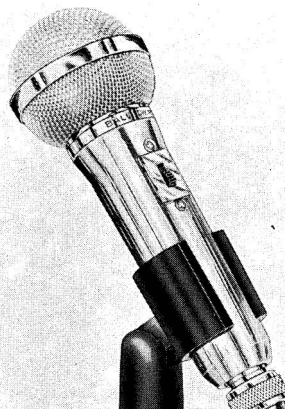

Turner 766

Impedance: 600 ohms. Built-in switch. Internal 1.5V battery. Slip-on windshield. 19ft lead. Price: £13.

■ TURNER

Distributors: Millbank Electronics, Bellbrook Estate, Uckfield, Sussex. Tel: Uckfield 4166.

602 ★

Mono moving coil microphone. Cardioid response. FR: 80Hz-15kHz \pm 4dB. Sensitivity: -79dB. Impedance: 150 ohms. Stick microphone for hand or stand. Fitting: $\frac{5}{8}$ in thread 27tpi. On/off switch. Clamp and cable supplied. Finish: satin chrome zinc alloy with cyclomac grille. Price: £28.55.

700 ★

Mono moving coil microphone. Cardioid response. FR: 40Hz-15kHz \pm 4dB. Sensitivity: (150 ohms) -79dB, (40K) -55dB. Impedance: 150 ohms, 40K. Stick microphone for hand or stand. Fitting: $\frac{5}{8}$ in thread 27tpi. On/off switch. Cannon connector. Dual impedance. Built-in 'pop' filter. Cable and clamp supplied. Finish: satin chrome diecast zinc alloy. Price: £41.70.

766 ★

Mono moving coil microphone. Cardioid response. FR: 50Hz-15kHz \pm 5dB. Sensitivity: -55dB. Impedance: 50K. Recload: 100K. Stick microphone for hand or stand. Fitting: $\frac{5}{8}$ in thread 27tpi. On/off switch. Blast filter. Lead and clamp. Presentation box. Finish: satin chrome steel. Price: £30.75.

866

Mono moving coil microphone. Cardioid response. FR: 100Hz-13kHz \pm 4dB. Sensitivity: -58dB. Impedance: 50K. Stick microphone for hand or stand. Fitting: $\frac{5}{8}$ in thread 27tpi. Blast filter. Clamp and cable supplied. Presentation case. Finish: satin chrome steel. Price: £17.55.

2203 ★

Mono moving coil microphone. Cardioid response. FR: 50Hz-15kHz. Sensitivity: -79dB. Impedance: 150 ohms. Stick microphone for hand or stand. Fitting: $\frac{5}{8}$ in thread 27tpi. On/off switch. Blast filter. Cannon connector. Cable and clamp supplied. Finish: satin chrome steel. Price: £39.65.

2266

Mono moving coil microphone. Cardioid response. FR: 50Hz-15kHz \pm 5dB. Sensitivity: -58dB. Impedance: 50K. Stick microphone for hand or stand. Fitting: $\frac{5}{8}$ in thread 27tpi. On/off switch. Supplied with Cannon connector, lead and presentation box. Finish: steel satin chrome. Price: £39.66.

2850

Mono moving coil microphone. Cardioid re-

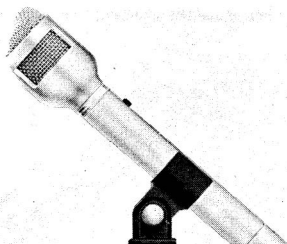

Turner 2203



Uher M154

sponse. FR: 70Hz-10kHz \pm 4dB. Sensitivity: -84dB. Impedance: 150 ohms, 50K. Stick microphone for hand or stand. Fitting: $\frac{5}{8}$ in thread 27tpi. Lightweight. On/off switch. Cable and clamp supplied. Finish: black cyclolac. Price: £19.30.

35A

Mono moving coil lavalier microphone. Omni-directional. FR: 80Hz-12kHz \pm 4dB. Sensitivity: -82dB. Impedance: 150 ohms. Hand or lavalier. Finish: high tensile aluminium with gold finish. Price: £35.15.

2302

Mono moving coil microphone. Omni-directional. FR: 50Hz-15kHz \pm 5dB. Sensitivity: -79dB. Impedance: 150 ohms. Stick microphone for hand or stand. Fitting: $\frac{5}{8}$ in thread 27tpi. On/off switch. Cannon connector. Cable and clamp supplied. Finish: steel satin chrome. Price: £32.90.

2804

Stereo moving coil. Omni-directional. FR: 80 Hz-12kHz \pm 5dB. Sensitivity: -63dB. Impedance: 50K. Stick microphone. Stereo pair in presentation box. Table stands provided. Fitted jack plugs. Price: £17.60.

■ UHER

Distributors: Bosch Ltd, Rhodes Way, Radlett Road, Watford, Herts, WD24LB. Tel: Watford 44233.

M154 ★

Dynamic microphone with remote control switch providing: record, stop, start, rewind.



Uher M537

M537 ★

Dynamic cardioid microphone with speech/music switch. Sensitivity: 0.23mV/μbar. FR: 40Hz-18kHz. Impedance: 500 ohms. Flexibly supported microphone system. Includes stand connecting piece (M937) and table stand (M923). Supplied without connecting lead. Plug wiring: balanced 1-2/3. Price: £28.70.

M538

Dynamic cardioid studio microphone. Sensitivity: 0.14mV/μbar. FR: 30Hz-18kHz. Impedance: low Z. Sintered bronze head. Separate bass and treble systems incorporated. Includes stand connecting piece (M937) and table stand (M923). Supplied without connecting lead. Plug wiring: 1-2/3. Price: £47.70.

M539

Dynamic omni-directional studio microphone. Sensitivity: 0.18mV/μbar. FR: 40Hz-17kHz. Low impedance. Flexibly supported microphone system. Includes stand connecting piece (M937) and table stand (M923). Supplied without connecting lead and windshield. Plug wiring: balanced 1-2/3. Price: £28.60.

M634 (stereo) ★

Dynamic cardioid stereo microphone system. Sensitivity: 0.23mV/μbar. FR: 50Hz-16kHz. Impedance: 500 ohms. Comprises two M534 microphones, one M925 stereo bar and one M923 table stand. Speech/music switch. Price: £24.



Uher M634 Stereo System

■ **VITAVOX**

Westmoreland Road, London, NW99RJ.
Tel: 01-204 4234. Cables: Vitavox, London.

M100

Moving coil microphone. Output level at 1kHz: 1 volt/dyne/cm². Optimum load impedance: 25 ohms. FR: 50Hz-15kHz ± 3dB. 9ft cable and flexible support. Table, desk and floor stands available. Price: (CN500) £24.40; (CN501) switched £35.15.

FR: 50Hz-10kHz. Impedance: 200 ohms. For use with model 5000 tape recorder. Price: £16.67 including PT.

M517

Dynamic cardioid microphone for use with battery portable series. Remote stop/start switch. Speech/music switch. FR: 70Hz-14kHz. Windshield fitted. Impedance: 500 ohms. Price: £14.80.

M534

Dynamic cardioid microphone with speech/music switch. Sensitivity: 0.23mV/μbar. FR: 50Hz-16kHz. Impedance: 500 ohms. For recording under adverse acoustic conditions. Pressure diecast case. Includes table stand (M923). Plug wiring: unbalanced 3/2. Price: £13.

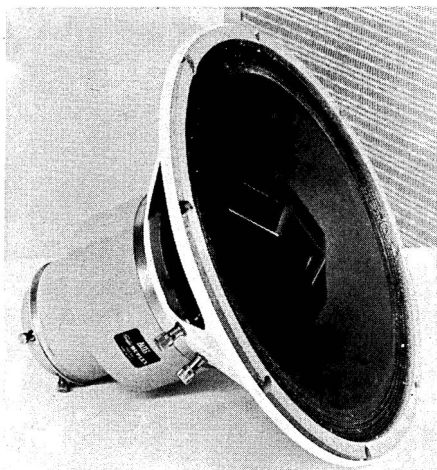

Altec-Lansing 604E

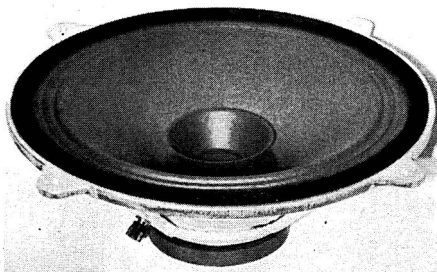

Baker 12in Major

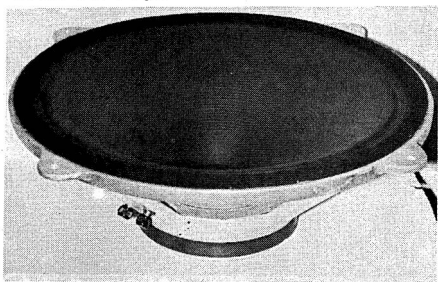

Baker 15in Auditorium

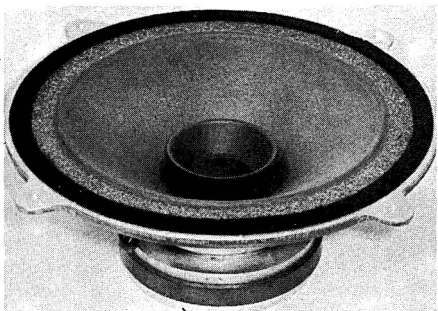

Baker 12in Superb

Auditorium 12

Full range 12in cone speaker suitable for bass unit in multi-speaker system. HC: 25W RMS. Bass resonance: 35Hz. Gap flux: 15,000 gauss. Copper voice coil: 1½in diameter. vci: 8 or 15 ohms. FR: 25Hz-16kHz. Paper cone with roll surround. Cast aluminium chassis. Depth: 7in. Weight: 10lb. Price: £14.

Auditorium 15 ★

High power 15in speaker suitable for bass unit in multi-speaker system. HC: 35W RMS. Bass resonance: 35Hz. Gap flux: 15,000 gauss. vci: 8 or 15 ohms. FR: 20Hz-14kHz. 2in diameter voice coil. 35W RMS. Depth: 8in. Weight: 15lb. Price: £19.

Laboratory Standard 12

Full range 12in speaker employing patented differential wave impedance cone. Resin-impregnated paper cone with double central metallic ellipse. 1½in diameter copper voice coil. Rubberroll surround. Impedance: 8 or 15 ohms. Gap flux: 15,000 gauss. HC: 15W RMS. FR: 20 Hz-20kHz. Bass resonance: 22-27Hz. Price: £22.

Laboratory Standard 15

Medium range 15in speaker employing patented differential wave impedance cone. Resin-impregnated paper cone with central metallic ellipse. Foam plastic surround. 2in diameter copper voice coil. vci: 15 ohms. Cast aluminium chassis. Gap flux: 15,000 gauss. HC: 20W RMS. FR: 20Hz-12kHz. Bass resonance: 18-25Hz. Price: £28.

Group 25

12in cone speaker with heavy duty suspension for electronic music, guitars, etc. HC: 25W RMS. vci: 3, 8 or 15 ohms. Bass resonance: 55Hz. FR: 30Hz-13kHz. Gap flux: 12,000 gauss. Voice coil: 1½in. Depth: 6in. Weight: 5lb. Price: £7.

Group 35

12in cone speaker with heavy duty suspension for electronic music, guitars, etc. HC: 35W RMS. vci: 3, 8 or 15 ohms. Bass resonance: 55Hz. FR: 55Hz-13kHz. Gap flux: 14,000 gauss. Voice coil: 1½in. Depth: 6½in. Weight: 6lb. Price: £9.

Group 50

15in cone speaker with heavy duty suspension for electronic music, guitars, etc. HC: 50W RMS. vci: 8 or 15 ohms. Bass resonance: 45Hz. FR: 30 Hz-13kHz. Gap flux: 17,000 gauss. Voice coil: 2in. Depth: 8in. Weight: 15lb. Price: £19.

■ CELESTION

Rola-Celestion Ltd, Ditton Works, Foxhall Road, Ipswich, Suffolk, IP38JP. Tel: Ipswich 73131.

Studio Series CX1512

12in coaxial unit comprising paper cone bass speaker and pressure driven tweeter. Plastaflex



Celestion Studio 12

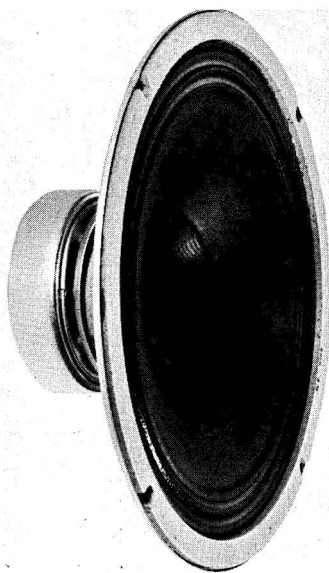

Celestion PS8TC

surround. Bass voice coil: $1\frac{1}{2}$ in diameter, treble voice coil: $\frac{3}{4}$ in diameter, both copper wound. vci: 15 ohms. Gap flux: 13,000 gauss. Total flux: 88,000 maxwells. HC: 15W. FR: 30Hz-15kHz. Price: no price quoted by makers.

Studio Series CX2012

12in coaxial unit comprising paper cone bass speaker and pressure driven tweeter. Hi-flex free surround. Bass voice coil: $1\frac{1}{2}$ in diameter copper wound, treble voice coil: 1in diameter aluminium wound. vci: 15 ohms. Gap flux: 17,000 gauss. Total flux: 180,000 maxwells. HC: 20W. FR: 30Hz-18kHz. Price: no price quoted by makers.

Studio 12 ★

12in bass unit designed specially for use with HF: 1300Mk 2 and CO3K crossover. Paper cone

with ultra compliant rubber surround. Voice coil diameter: $1\frac{3}{4}$ in. vci: 15 ohms. Total flux: 88,000 maxwells. HC: 15W RMS. FR: 30Hz-5kHz. Rec crossover: 3kHz. Rigid die-cast chassis. Enclosure details on request. Price: no price quoted by makers.

HF1300 Mk 2

High frequency 3in tweeter. vci: 15 ohms at 10kHz. HC: 5W RMS. Suitable for use with systems up to 20W. FR: 2kHz-15kHz. Rec crossover: 3kHz. Styled with flange to give easy and accurate mounting. Phase correction plate for improved polar response. Self-aligning diaphragm. Contoured pole piece. Damped acoustic cavity to reduce fundamental diaphragm resonance. High flux magnet. Price: £7-14.

PS8TC ★

8in twin-cone unit. Designed for the home constructor and recommended by Mullard for use with Unilex audio modules. Impedance: 15 ohms. Resonance: 75Hz. 1in voice coil. Paper cone. Copper voice coil. Gap flux: 10,000 gauss. Total flux: 38,500 maxwells. HC: 6W. FR: 50 Hz-12.5kHz. Price: £2-35 (plus 38p PT).

PS12TC

Full-range twin cone unit. 12in diameter. $1\frac{1}{2}$ in voice coil. Impedance: 4-8 ohms or 15 ohms. Gap flux: 11,500 gauss. Total flux: 128,000 maxwells. HC: 20W RMS. FR: 30Hz-12kHz. Designed for use with the Mullard Unilex stereo system and other similar equipment. Price: £10.

912M

Heavy duty 12in unit for electronic musical instruments. HC: 25W RMS. FR: 40Hz-8kHz. Impedance: 8 or 15 ohms. Price: £12-95.

912H

Heavy duty 12in unit for electronic musical instruments. HC: 30W RMS. FR: 40Hz-8kHz. Impedance: 8 or 15 ohms. Price: £15-75.

915C

Heavy duty 15in unit for electronic musical instruments. HC: 50W RMS. FR: 30Hz-8kHz. Impedance: 8 or 15 ohms. Price: £26.

918C

Heavy duty 18in unit for electronic musical instruments. HC: 100W RMS. FR: 25Hz-5kHz. Impedance: 8 or 15 ohms. Price: £34.

■ DECCA

Decca Special Products,
Ingate Place, Queenstown Road, London,
SW8 3NT. Tel: 01-622 6677.

DK30 Ribbon ★

Horn-loaded high frequency ribbon speaker. Size: $6\frac{1}{2} \times 3\frac{1}{2} \times 2$ in. Aluminium ribbon element. Impedance: 8 ohms constant. HC: 30W maxi-

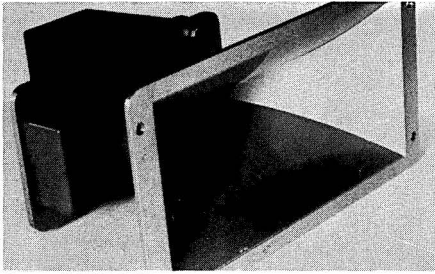

Decca DK30 Ribbon

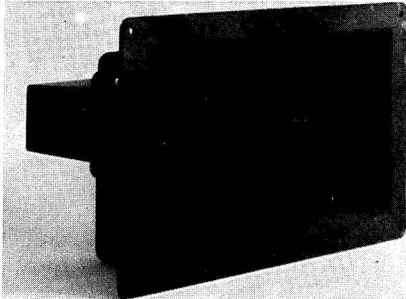

Decca London Ribbon Speaker



Eagle CT10 horn tweeter

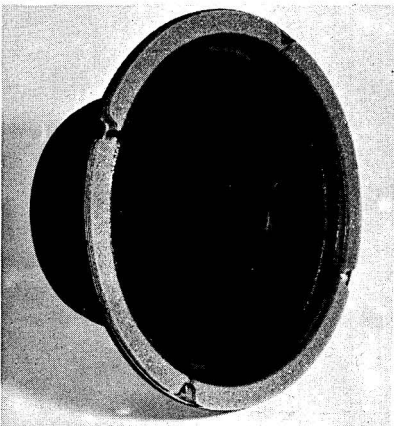

Eagle FR8

mum. FR: 2.5kHz-25kHz. rcf 2.5kHz. Price: £15.75.

London Ribbon ★

Horn-loaded high frequency ribbon speaker. Size: $9\frac{1}{2} \times 4\frac{1}{2} \times 7\frac{1}{2}$ in. Aluminium ribbon element. Impedance: 8 ohms constant. HC: 30W RMS maximum. FR: 1kHz-25kHz. Rec. crossover: 1kHz. Price: £25.

D1/8 Bass Unit

Cone speaker designed for bass use. Size: $12\frac{3}{4} \times 6$ in. Impregnated paper cone. Impregnated fibre surround. 2in voice coil. Copper voice coil. Impedance: 8 ohms at 400Hz. Gap flux: 14,000 gauss. Total flux 250,000 maxwells. HC: 30W. FR: 30Hz-5kHz. rcf 2.5kHz. Price: £14.50.

Decca Acoustic lens

Device for obtaining optimum dispersion of higher audio frequencies produced by Decca Mk II ribbon speaker or the Decca DK30 ribbon speaker. Price: £3 (no PT).

■ EAGLE INTERNATIONAL

Heather Park Drive, Wembley, HAI 1SU.
Tel: 01-903 0144.

CT5 Cone Tweeter

Diameter 3in approximately. HC: 5W. Rec crossover 3kHz. Price: £1.10.

CT10 Horn Tweeter ★

$3\frac{1}{2}$ in aluminium cone and surround. Voice coil: 1in (aluminium), vci: 8 ohms. HC: 10W. FR: 1.5-18kHz. rcf 3kHz. Price: £1.90.

FR4

High-compliance full-range 4in unit. FR: 40 Hz-16kHz. Bass resonance 60-70Hz. HC: 5W RMS. Flux density: over 10,000 gauss. vci: 8 ohms. Baffle opening: $3\frac{1}{2}$ in. Depth: 2in. Price: £3.58 (plus 60p PT).

FR65

High-compliance full-range $6\frac{1}{2}$ in unit. FR: 30Hz-18kHz. HC: 10W. Flux density: over 11,000 gauss. vci: 8 ohms. Baffle opening: $5\frac{3}{8}$ in. Depth $2\frac{3}{8}$ in. Price: £5.20 (plus 87p PT).

FR8 ★

High-compliance full-range 8in unit. FR: 30 Hz-20kHz. Bass resonance 30-50Hz. HC: 15W RMS. Flux density: over 12,000 gauss. vci: 8 ohms. Baffle opening: $6\frac{3}{8}$ in. Depth: $3\frac{3}{8}$ in. Price: £6.49 (plus £1.09 PT).

HT15

High frequency horn unit. FR: 2kHz-18kHz. vci: 16 ohms. HC: 15W music. rcf 3kHz. Flux density: 13,000 gauss. Baffle hole required $2\frac{1}{2}$ in. Price: £3.15.

HT21

Horn tweeter using centre stabiliser to improve efficiency and loading. FR: 2-20kHz. Crossover:

★ Indicates entry is illustrated

3kHz. Impedance: 8 ohms. Flux density: 14,000 gauss. HC: 20W. Price: £3-80.

DT33

Heavy duty horn tweeter. FR: 2-18kHz. Crossover: 3kHz. Impedance: 8 ohms. Flux density: 14,000 gauss. HC: 30W. Front mounted dome to give wide listening angle. Price: £4-80.

KT3

Three-way speaker kit. See Constructional Kits Section for details.

■ ELAC

Electro Acoustic Industries Ltd,
Stamford Works, Broad Lane, Tottenham,
London, N15.

Tel: 01-808 0505. Cables: Elac, London, N15.

Elac 8N/148 Mk II (8N/185)

8in. Exponential paper cone. Paper surround, integral with cone. Voice coil: 1in copper. vci: 15 ohms. Gap flux 12,000 gauss. Total flux 48,300 maxwells. HC: 5 watts. FR: 40Hz-12kHz (loaded conditions), rcf (high frequency) 8kHz. Price: £3-95 (plus 64p PT).

■ EMI

EMI Sound Products Ltd,
Blyth Road, Hayes, Middlesex.

Tel: 01-573 3888.

EMI Chassis

A wide range of speaker chassis covering bass, mid-range, high-frequency and full-range units based on the following nominal sizes: 2½in, 3½in, 5in, 6in, 8in, 12in, 15in, 7×4in, 8×5in, 10×6in, 13×8in, 14×9in, 19×14in. Detailed specifications and prices on request.

LK150

Wide-range elliptical driver. 13½×8½in. Paper cone. 1in diameter voice coil. Impedance: 4, 8 or 16 ohms. Total flux: 30,000 maxwells. HC: 8W RMS. FR: 50Hz-11kHz. Price: £3-25.

LK215

Matched speaker set. One 14×9in bass driver, one 5in mid-range unit, one 3½in tweeter. Cardboard cones, PVC surrounds. Impedance: 8 ohms. HC: 25W RMS. FR: 20Hz-20kHz. Crossover network included. Price: £28 (plus £1-04 PT).

LK250

Matched speaker system. One 5in bass driver, one 3½in HF unit. Paper cones, PVC surrounds. Impedance: 8 ohms. HC: 6W RMS. FR: 80Hz-20kHz. Crossover network included. Price: £3-92 (plus 65p PT).

LK315

Matched five-speaker system. One 15in. bass driver, two 5in mid-range units, two 3½in tweeters. Cardboard cones. Cloth and PVC

surrounds. Impedance: 8 ohms. HC: 35W RMS. FR: 20Hz-20kHz. Crossover network included. Price: £43 (plus £1-27 PT).

LK350

Matched speaker system. One 13½×8½in. bass driver, one 3½in HF unit. Paper cones with PVC surrounds. Impedance: 8 or 15 ohms. HC: 15W RMS. FR: 20Hz-20kHz. Crossover network included. Price: £8-75.

LK450

Matched speaker system. One 13½×8½in. bass driver, two 2½in HF units. Paper cones. Impedance: 4, 8 or 16 ohms. HC: 8W RMS. FR: 55Hz-13kHz. Crossover network included. Price: £4-25.

LK650

Matched speaker system. One 10½×6½in bass driver, one 3½in HF unit. Paper cones, PVC surround. Impedance: 8 ohms. HC: 6W RMS. FR: 35Hz-20kHz. Crossover network included. Price: £7 (plus £1-16 PT).

LK850

Matched speaker system. One 6½in bass driver, one 3½in HF unit. Paper cones, PVC surround. Impedance: 8 ohms. HC: 10W RMS. FR: 75Hz-20kHz. Crossover network included. Price: £4-72 (plus 79p PT).

■ FANE ACOUSTICS LTD

Hick Lane, Batley, Yorks.

Tel: Batley 6431. Cables: Fane, Batley.

101/10

10in ceramic magnet unit with 2in voice coil. HC: 15W RMS. vci: 15 ohms. Main resonance: 60Hz. Gap flux 10,000 gauss. Total flux 100,000 maxwells. Single cone, copper voice coil. FR: 40Hz-10kHz. Price: approximately £7-50 (including PT).

101/10a

Similar to 101/10 but with twin cone, aluminium voice coil and FR: 40Hz-15kHz. Price: approximately £11-25 (including PT).

101/12

Similar to 101/10 but with 12,000 gauss magnet. Price: approximately £8-75 (including PT).

101/12a

Similar to 101/12 but with twin cone, aluminium voice coil and FR: 40Hz-15kHz. Price: approximately £12-50 (including PT).

101/14

Similar to 101/10 but with 14,000 gauss magnet. Price: approximately £11-75 (including PT).

101/14a

Similar to 101/14 but with twin cone, aluminium voice coil and FR: 40Hz-15kHz. Price: approximately £15-50 (including PT).

122/10

12in ceramic magnet unit with 2in diameter voice coil. HC: 20W RMS. vci: 15 ohms. Main resonance 40Hz or 70Hz as required. FR: 30Hz-5kHz. Gap flux 10,000 gauss. Total flux 100,000 maxwells. Copper voice coil. Single cone. Price: approximately £8.

122/10a

Similar to 122/10 but with twin cone, aluminium voice coil and FR: 30Hz-15kHz. Price: approximately £11.50.

122/12

Similar to 122/10 but with 12,000 gauss magnet. Price: approximately £10.50.

122/12a

Similar to 122/12 but with twin cone, aluminium voice coil and FR: 30Hz-15kHz. Price: approximately £14.

122/14

Similar to 122/10 but with 14,000 gauss magnet and HC: 22W. Price: approximately £13.25.

122/14a

Similar to 122/14 but with twin cone, aluminium voice coil and FR: 30Hz-15kHz. Price: approximately £16.75.

122/17

Similar to 122/10 but with 17,000 gauss magnet, 25W handling capacity and FR: 25Hz-6kHz. Price: approximately £16.

122/17a

Similar to 122/17 but with twin cone, aluminium voice coil and FR: 30Hz-17kHz. Price: approximately £19.50.

152/12

15in ceramic magnet unit with 2in diameter voice coil. HC: 25W RMS. vci: 15 ohms. Main resonance 32Hz. Gap flux 12,000 gauss. Total flux 160,000 maxwells. Copper voice coil. Single cone. FR: 25Hz-2.5kHz. Price: approximately £17.

152/12a

Similar to 152/12 but with twin cone, aluminium voice coil and FR: 30Hz-15kHz. Price: approximately £20.25.

152/14

Similar to 152/12 but with 14,000 gauss magnet. HC: 27W and FR: 25Hz-3.5kHz. Price: approximately £19.50.

152/17 ★

Similar to 152/12 but with 17,000 gauss magnet. HC: 30W RMS and FR: 25Hz-4kHz. Price: approximately £23.40.

152/17a

Similar to 152/17 but with aluminium voice coil, twin cone and FR: 30Hz-17kHz. Price: approximately £26.75.

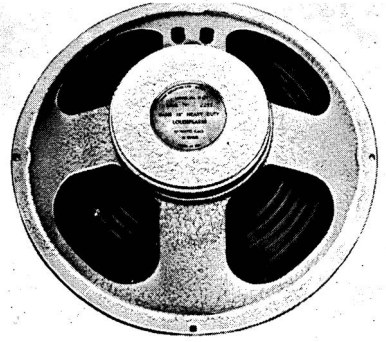

Fane model 152/17

153

15in extra heavy duty unit with ceramic magnet and 3in diameter voice coil. Gap flux 14,500 gauss. Total flux 375,000 maxwells. HC: 40W RMS. Copper voice coil. Single cone. FR: 30Hz-3.5kHz. vci: 15 ohms. Main resonance 40Hz. Weight: 20lb. Price: approximately £25.75.

183

18in extra heavy duty unit with ceramic magnet and 3in diameter voice coil. Gap flux 14,500 gauss. Total flux 375,000 maxwells. HC: 60W. Copper voice coil. Single cone. FR: 20Hz-3kHz. vci: 15 ohms. Main resonance 30Hz. Weight: 22lb. Price: approximately £30.75.

303

3in tweeter unit. $\frac{3}{4}$ in pole. Price: approximately £2.75.

501

5in mid-range unit. Gap flux 15,000 gauss. Total flux 60,000 maxwells. HC: 20W. 1in diameter aluminium voice coil. vci: 15 ohms. Rigid cone with neoprene surround. FR: 400Hz-5kHz. rcf 800Hz and 3.5kHz. Price: approximately £7.25 (including PT).

505

Similar to 501 but with 11,000 gauss magnet and HC: 15W. Price: approximately £5.25 (including PT).

502

5in full-range unit for small enclosures. Gap flux 15,000 gauss. Total flux 60,000 maxwells. HC: 8W. 1in copper voice coil. Price: approximately £7.25 (including PT).

506

Similar to 502 but with 11,000 gauss magnet and HC: 7W. Price: approximately £5.25 (including PT).

801

8in full-range unit. 1in pole piece with 15,000 gauss magnet. Twin cone. Aluminium voice coil.

★ Indicates entry is illustrated



Goodmans Twin Axiom 8

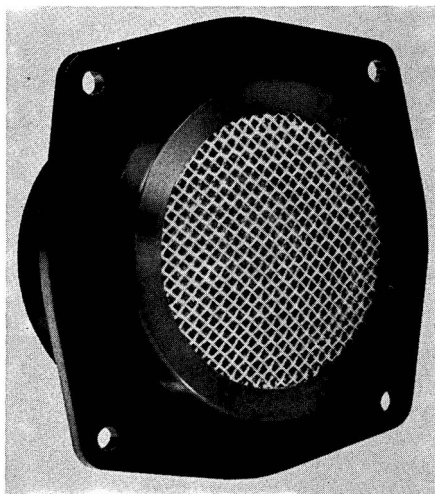

Goodmans Axent 100

Resonance 25Hz. Response up to 15kHz. Price: approximately £7.25 (including PT).

802

8in unit similar to 801 but with single cone and copper voice coil. Resonance 70Hz. Response up to 10Hz. Price: approximately £7.10 (including PT).

805

8in unit similar to 801 but with 11,000 gauss magnet. Price: approximately £6.25 (including PT).

806

8in unit similar to 802 but with 11,000 gauss magnet. Price: approximately £6.75 (including PT).

1001

10in full-range unit. 1in dia pole piece with 15,000 gauss magnet. Twin cone. Aluminium voice coil. Resonance 22Hz. Response up to 15

kHz. HC: 10W. Price: approximately £8.75 (including PT).

1002

10in unit similar to 1001 but with single cone and copper voice coil. Resonance 60Hz. Response up to 10kHz. Price: approximately £8 (including PT).

1005

10in unit similar to 1001 but with 11,000 gauss magnet. Price: approximately £7.50 (including PT).

1006

10in unit similar to 1002 but with 11,000 gauss magnet. Price: approximately £6.75 (including PT).

138/11

13 × 8in elliptical. 11,000 gauss ceramic magnet. 1in voice coil. Impedance: 15 ohms. HC: 15W. FR: 30Hz-15kHz. Price: approximately £6.

138/15

13 × 8in elliptical. Similar specification to 138/11 but with 15,000 gauss magnet. FR: 30Hz-16kHz. Price: approximately £7.75.

Special low resonance versions of 10in, 12in, 15in and 18in speakers are available at slightly higher prices. These are intended for use as bass units in hi-fi multiple systems. They have rigid moulded fibre cones with rubber surround allowing free axial movement. Must be used in suitable reflex or infinite baffle cabinets. Not recommended for use with electric guitars or with small open baffles.

Also available are special 'Pop' versions of 10in, 12in, 15in, 18in speakers. Designed for vocal and instrumental reproduction, and public address systems. Details on application.

■ **GOODMANS LOUDSPEAKERS LTD**

Downley Road, Havant,
Hampshire, PO9 2NL.
Tel: Havant 6344. Telex: 86296.

Twin Axiom 8 ★

8in full-range twin-cone driver. Paper cone. Rubber surround. Voice coil: 1in diameter copper wound. Impedance: 8 or 15 ohms. Gap flux: 13,500 gauss. Total flux: 53,000 maxwells. HC: 15W (DIN). FR: 40Hz-18kHz. Price: £7.80 (plus £1.32 PT).

Twin Axiom 10

Full-range 10in unit. Paper cone. Latex coated paper surround. Voice coil: 1in diameter (copper). Impedance: 8 or 15 ohms. Gap flux: 13,500 gauss. Total flux: 53,000 maxwells. HC: 10W RMS. FR: 40Hz-18kHz. Price: £8.61 (plus £1.45 PT).

Axent 100 ★

Domed diaphragm high-frequency direct radia-

tor. 1in diameter cone. Plastic cone. Voice coil: 1in diameter copper wound. Impedance: 8 ohms. HC: for use in systems rated at not more than 30W. FR: typically 2kHz-22kHz. Crossover: cut-off of 12dB/octave from 3kHz down. Price: £12 (no PT).

Midax 650

Horn loaded pressure unit. Resin impregnated linen diaphragm. Diecast horn. Voice coil: 1½in. HC: suitable for systems up to 25W. vci: 15 ohms. FR: 650Hz-8kHz. rcf, 5kHz. Price: £13-59.

Axiom 401

12in full-range twin-cone driver. Paper cone. Plastic surround. Voice coil: 1¾in diameter copper wound. Impedance: 8 or 15 ohms. Gap flux: 15,500 gauss. Total flux: 179,000 maxwells. FR: 30Hz-11kHz. HC: 40W (DIN). Price: £17-68 (no PT).

Audiom 100

12in bass driver. Paper cone. Plastic surround. Voice coil: 1¾in diameter, copper wound. Impedance: 8 or 15 ohms. Gap flux: 10,000 gauss. Total flux: 860,000 maxwells. HC: 30W (DIN). FR: 35Hz-3kHz. Crossover: 3000Hz, recommended for use with Axent 100. Price: £12 (no PT).

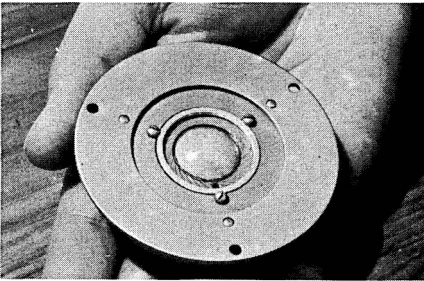

ITT 4001 HF unit

Audiom 8P

8in heavy duty. HC: 15W. Impedance: 8 or 15 ohms. Price: £4-70 (plus 79p PT).

Audiom 10P

10in heavy duty. HC: 15W. Impedance: 8 or 15 ohms. Price: £5-11 (plus 86p PT).

Audiom 12P

12in heavy duty. HC: 50W. Impedance: 8 or 15 ohms. Price: £13 (no PT).

Audiom 15P

15in heavy duty. HC: 50W. Impedance: 8 or 15 ohms. Price: £21 (no PT).

Audiom 18P

18in. Voice coil diameter: 3in. vci: 8 or 15 ohms. HC: 100W. Fundamental resonance: 45Hz. Flux density: 13,500 gauss. Baffle hole diameter: 16¼in. Depth: 8¾in. Weight: 26lb. Recommended sealed enclosure (per speaker): 7,000 cu in. Price: £35-70 (no PT).

■ **ITT-STC**

ITT Component Group Europe, Standard Telephones & Cables Ltd, Electro-Mechanical Product Division, West Road, Harlow, Essex. Tel: Harlow 26811.

Type 4001G, High Frequency Unit ★

High frequency pressure unit. FR: 6kHz-20kHz. Substantially omni-directional. vci: 15 ohms. Flux density: 14,000 gauss. Size: approximately 2⅝ × 1in. Price on request.

■ **JORDAN-WATTS LTD**

Benlow Works, Silverdale Road, Hayes, Middlesex. Tel: 01-573 6928.

Jordan-Watts Module Mk 11 ★

6in square frame. Aluminium diaphragm with plastic surround. Voice coil: 1½in. Ceramic magnet. vci: 4, 8 or 16 ohms. HC: 12W. FR: 25Hz-20kHz. Price: £13.

■ **KEF ELECTRONICS LTD**

Tovil, Maidstone, Kent. Tel: Maidstone 57258. Cables: KEF, Maidstone.

B139 ★

13 × 9½ × 3in. 10lb. HC: 30W. Resonance: 20Hz. Impedance: 8 ohms. FR: 20-1,000Hz. Price: £12-50.

B200

8¾dia × 4in. 3¾lb. HC: 25W. Resonance: 25Hz. Impedance: 8 ohms. FR: 25-3,500Hz. Price: £7-50 (plus £1-25 PT).

B110

5½in dia × 3¼in. 3-6lb. HC: 15W. Resonance: 30Hz. Impedance: 8 ohms. FR: 30-5,000Hz. Price: £6-50 (plus £1-08 PT).

T15

3¾in dia × 1⅞in. 2lb. HC: 6W. Resonance:

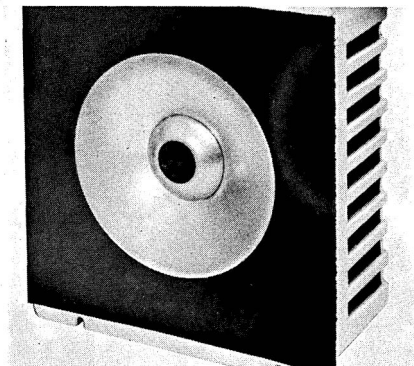

Jordan-Watts speaker drive module

★ Indicates entry is illustrated

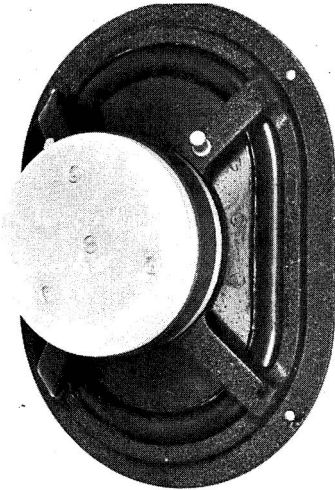

KEF B139

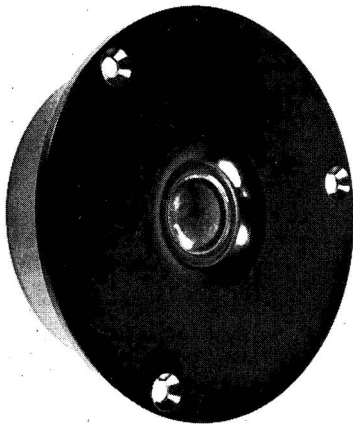

KEF T27



Keith Monks Hypertone

550Hz. Impedance: 8 ohms. FR: 800Hz-20kHz. Price: £6.

T27 ★

4½ in dia × 1½ in., 1-4lb. HC: 6W. Resonance: 900 Hz. Impedance: 8 ohms. FR: 3-30kHz. Price: £5.

See also entry in Constructional Kits section and Speaker Accessories section.

■ **KEITH MONKS (AUDIO) LTD**

26-30 Reading Road South, Fleet, near Aldershot, Hants. Tel: Fleet 7316.

Hypertone ★

Titanium cone speaker module. 6in titanium piston with cantilever suspension. 1½ in dia voice coil. Total flux: 160,000 maxwells. Mean hemispherical power response substantially level to 15kHz. vci: 8 or 15 ohms at 400Hz. HC: 15W RMS at and above the lower system limit (dependent upon loading conditions), 30W music rating, i.e. under normal use. Price: £19.50.

LOWTHER MANUFACTURING CO

Lowther House, St Mark's Road, Bromley, Kent, BR29HQ.

Tel: 01-460 5225. Cables: Lowther, Bromley.

P.M.2 Mk I ★

6in. Selected paper cone. Roll foam rubber surround. Voice coil: 39mm. Gap flux: 21,000 lines per sq cm. Total flux: 281,000 maxwells. HC: 6W; 20W programme material. vci: 15 ohms. FR: 30Hz-20kHz. Price: £40.

P.M.2 Mk II

6in. Selected paper cone. Roll foam rubber surround. Voice coil: 39mm. Gap flux: 23,000 gauss. Total flux: 350,000 maxwells. HC: 6W; 20W programme material. vci: 15 ohms. FR: 25Hz-22kHz. Price: £55.

P.M.4

6in. Selected paper cone. Roll foam rubber surround. Voice coil: 37mm. Gap flux: 24,000 gauss. Total flux: 385,000 maxwells. HC: 6W; 20W programme material. vci: 16 ohms. FR: 25Hz-24kHz. Price: £65.

P.M.6

6in. Selected paper cone. Roll foam rubber surround. Voice coil: 39mm. Gap flux: 17,500 gauss. Total flux: 196,000 maxwells. HC: 6W; 20W programme material. vci: 16 ohms. FR: 30Hz-20kHz. Price: £24.

P.M.6 Mk I

P.M.6 magnet assembly with a new diaphragm assembly: Lowther Special Silver speech coil, roll surround and back centring providing an improved performance. P.M.6 will still be available as a replacement unit. Price: £26.

P.M.7 ★

6in. Selected paper cone. Roll foam rubber

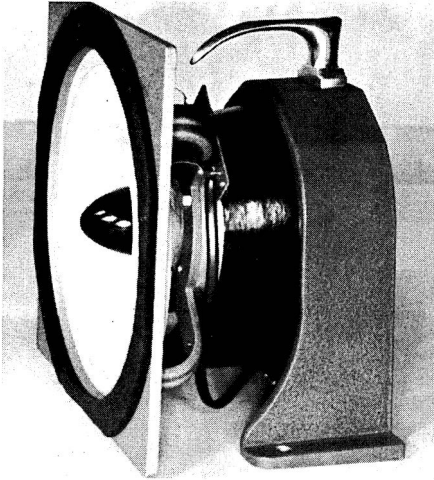

Lowther PM2 Mk I

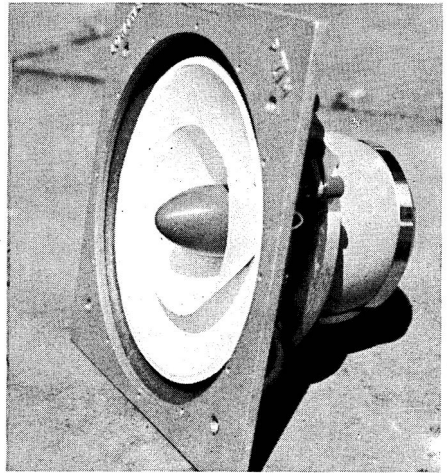

Lowther PM7 Drive Unit

surround. Voice coil: 39mm. Gap flux: 19,650 gauss. Total flux: 250,000 maxwells. HC: 6W; 20W programme material. vci: 16 ohms. FR: 30Hz-20kHz. Price: £36.

Full stabiliser for any of Lowther drive units. Price: £2.50.

■ PEERLESS

Distributor: P. F. & A. R. Helme Ltd, Summerbridge, Harrogate, HG34DR, Yorks. Tel: Darley 279.

All units are 8 ohms impedance, but some tweeters have 16 ohm alternatives.

MT 20 HFC

Tweeter, 2 × 2in. HC: 5W. FR: 2.5-18kHz. Price: £1.60 (plus 27p PT).

MT 225 HFC

Tweeter, 2¼ × 2¼in. vci: 16 ohms. HC: 5W. FR: 1.5-20kHz. Price: £1.65 (plus 27p PT).

MT 25 HFC

Tweeter, 2½ × 2½in. vci: 16 ohms. HC: 5W. FR: 1.5-18kHz. Price: £1.65 (plus 27p PT).

B 65 WG

Woofer, 6½in. HC: 10W. Maxwells: 54,000. Resonant frequency: 50Hz. Price: £4.50 (plus 75p PT).

610 W

Woofer, 10 × 6in. HC: 10W. Maxwells: 54,000. Resonant frequency: 40Hz. Price: £3.40 (plus 57p PT).

P 825 W

Woofer, 8in. HC: 12W. Maxwells: 90,000. Resonant frequency: 45Hz. Price: £5.70 (plus 95p PT).

L 825 WG

Woofer, 8in. HC: 50W. Maxwells: 64,000. Resonant frequency: 25Hz. Price: £6.30 (plus £1.05 PT).

L 100 WG

Woofer, 10in. HC: 50W. Maxwells: 64,000. Resonant frequency: 20Hz. Price: £7.35 (plus £1.22 PT).

CM 120 W

Woofer, 12in. HC: 12W. Maxwells: 90,000. Resonant frequency: 35Hz. Price: £6.90 (no PT).

D 120 WL(Sp)

Woofer, 12in. HC: 40W. Maxwells: 115,000. Resonant frequency: 25Hz. Price: £11.50 (no PT).

D 150 WL(Sp)

Woofer, 15in. HC: 50W. Maxwells: 115,000. Resonant frequency: 20Hz. Price: £22.65 (no PT).

GT 50 MRC

Mid-range unit. 5in dia. HC: 6W. FR: 800Hz-7kHz. Maxwells: 21,500. Price: £2.30 (plus 38p PT).

G 50 MRC

Mid-range unit. 5in dia. HC: 10W. FR: 750Hz-6kHz. Maxwells: 42,000. Price: £3.40 (plus 57p PT).

0570 MRC (4 ohms only)

Mid-range unit. 5 × 7in. HC: 20W. FR: 250Hz-4.5kHz. Maxwells: 54,000. Price: £6 (plus £1 PT).

E.396 M

Full-range 6 × 4in unit. Price: £4 (plus 67p PT).

★ Indicates entry is illustrated

B 65 FM

Full-range. 6½in. HC: 6W. FR: 35Hz-15kHz. Maxwells: 57,000. Price: £3.70 (plus 62p PT).

P 825 FM

Full-range. 8¼in. HC: 10W. FR: 30Hz-16kHz. Maxwells: 90,000. Price: £6.50 (plus £1.08 PT).

CM 120 FM

Full-range. 12in. HC: 12W. FR: 30Hz-14kHz. Maxwells: 57,000. Price: £5.30 (no PT).

D 120 FM

Full range. 12in. HC: 12W. FR: 30Hz-14kHz. Maxwells: 115,000. Price: £10.30 (no PT).

Coax 825-20

Full-range. 8¼in. HC: 12W. FR: 30Hz-18kHz. Maxwells: woofer 90,000; tweeter 12,000. Price: £11.30 (plus £1.88 PT).

Coax 120-20-20

Full-range 12in unit. HC: 12W RMS. FR: 25Hz-18kHz. Maxwells: (bass unit) 90,000; (two tweeters) 120,000 each. Price: £15.50 (no PT).

■ PHILIPS ELECTRICAL LTD

Century House, Shaftesbury Avenue, London, WC2.

Tel: 01-437 7777. Cables: Phillamps, London.

9710M ★

8in. Dual cone. Paper corrugated surround. Voice coil: 1in. Gap flux: 8,000 gauss. Total flux: 97,600 maxwells. HC: 10W RMS. vci: 7 ohms. FR: 40Hz-19kHz. Price: £7.70 (including PT).

■ ROLA-CELESTION See Celestion.

■ STENTORIAN

Whiteley Electrical Radio Co Ltd, Victoria Street, Mansfield, Notts.

Tel: Mansfield (0623) 24762.

Stentorian HF.812

8in. Composite (paper and cambric) cone. Cambric surround. Voice coil: 1in. Gap flux: 12,000 gauss. Total flux: 47,400 maxwells. HC: 5W. vci: universal 3, 7.5 and 15 ohms. FR: 50Hz-12kHz. Price: £5.57 (plus 94p PT).

H.F.816

8in. Composite (paper and cambric) cone. Cambric surround. Voice coil: 1in. Gap flux: 16,000 gauss. Total flux: 63,000 maxwells. HC: 6W. vci: universal 3, 7.5 and 15 ohms. FR: 50Hz-14kHz. Price: £9.16 (plus £1.54 PT).

H.F.912/67

9in die cast. Speech coil: aluminium. Pole dia: 1in. Magnet system: 1.2 Webers/m². vci: 15 ohms. HC: 10W. Price: £6.94 (plus £1.17 PT).

H.F. 1012

10in. Composite (paper and cambric) cone. Cambric surround. Voice coil: 1in. Gap flux:

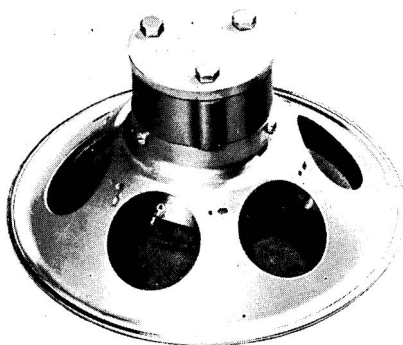

Philips 9710M

12,000 gauss. Total flux: 47,400 maxwells. HC: 10W. vci: universal 3, 7.5 and 15 ohms. FR: 30Hz-14kHz. Price: £6.69 (plus £1.13 PT).

H.F. 1016

10in. Composite (paper and cambric) cone. Cambric surround. Voice coil: 1in. Gap flux 16,000 gauss. Total flux 63,000 maxwells. HC: 10W. vci: universal 3, 7.5 and 15 ohms. FR: 30Hz-15kHz. Price: £10.68 (plus £1.80 PT).

H.F. 1214

12in. Composite (paper and cambric) cone. Cambric surround. Voice coil: 1.5in. Gap flux 14,000 gauss. Total flux 106,000 maxwells. HC: 15W. vci: 15 ohms. FR: 25Hz-14kHz. Price: £18.30.

H.F. 1214/67

12in bass loudspeaker. Speech coil: copper. Pole dia: 1½in. Magnet system: 1.4 Weber/m². vci: 15 ohms. Price: £20.25.

H.F. 1216

Composite (paper and cambric) cone. Cambric surround. Voice coil 1½in. Gap flux 16,000 gauss. HC: 15W. FR: 20Hz-16kHz. Price: £28.06.

T.359

3½in. Paper cone and surround. Voice coil 0.635 in. Gap flux 9,000 gauss. Total flux 14,900 maxwells. HC: 15W with crossover. vci: 5 or 15 ohms. FR: 3-17kHz. rcf 3kHz. Price: £2.34 (plus 40p PT).

T812/67

8in middle and high frequency loudspeaker. Speech coil: aluminium. Pole dia: 1in. Magnet system: 1.2 Webers/m². vci: 15 ohms. ¼ section crossover unit 1kHz. Price: £6.64 (plus £1.12 PT).

■ TANNOY PRODUCTS LTD

Norwood Road, West Norwood, London, SE279AB. Tel: 01-670 1131.

Cables: Tannoy, London.

Direct radiator

12in. Moulded fibre cone. Plastic treated surround. Voice coil: 2in. Gap flux 14,000 gauss. HC: 15W. vci: 8 ohms. FR: 40Hz-16kHz. Price: £22 (to special order).

Monitor Gold III LZ ★

12in dual concentric. Moulded fibre cone. Plastic impregnated surround. Gap flux (LF) 10,000, (HF) 15,000 gauss. HC: 25W. FR: 23Hz-20kHz, recommended crossover (supplied) 1kHz. vci: 8 ohms. Price: £31.

Monitor Gold 'Twelve' ★

12in. Moulded fibre cone. Plastic treated surround. Voice coils (HF and LF) 2in. Gap flux (LF) 11,500, (HF) 15,000 gauss. HC: 35W. FR: 25Hz-20kHz, recommended crossover (supplied) 1kHz. Price: £36-50.

Monitor Gold 'Fifteen'

15in. Moulded fibre cone. Plastic treated surround. Voice coils (HF and LF) 2in. Gap flux (LF) 13,500, (HF) 18,000 gauss. HC: 50W. FR: 23Hz-20kHz, recommended crossover (supplied) 1kHz. Price: £43-25.

■ VITAVOX LTD

Westmoreland Road, London, NW99RJ.
Tel: 01-204 4234. Cables: Vitavox, London.

Duplex coaxial DU121

12in paper cone. Plastic treated paper surround. 3in polyester film cone and surround. Voice coil (LF) 1.78in (HF) 0.65in. Gap flux (LF) 16,000 gauss. (HF) 12,000 gauss. Total flux (LF) 180,000 maxwells, (HF) 15,000 maxwells. vci: 15 ohms. FR: 30Hz-15kHz. Replaceable cone. Price: £56-50.

AK123 Heavy Duty

12in paper cone. Paper surround. Voice coil 1.78in. Gap flux 16,000 gauss. Total flux 180,000 maxwells. vci: 15 ohms. FR: 50Hz-8kHz. Replaceable cone. Price: £39-35.

AK124

12in paper cone. Paper surround. Voice coil 1.78in. Gap flux 16,000 gauss. Total flux 180,000 maxwells. vci: 15 ohms. FR: 30Hz-13kHz. Replaceable cone. Price: £39-35.

Cone Kit

Spare cone kit AK123, DU121, AK124. Price: £8.

AK154 ★

15in paper cone. Treated paper surround. Bass resonance 30-35Hz. Voice coil 2.25in. Gap flux 14,000 gauss. Total flux 260,000 maxwells. HC: 25W nominal. FR: 30Hz-5kHz nominal. (HC and FR determined by enclosure.) vci: 15 ohms. Replaceable cone. Price: £61-85.

AK155

Driver for bass horn of dual channel system.

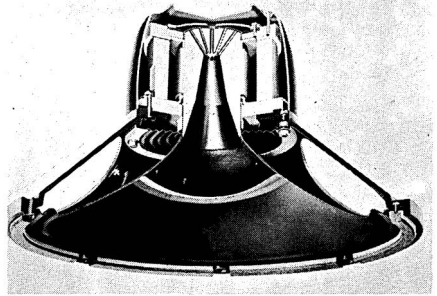

Tannoy Monitor Gold III LZ

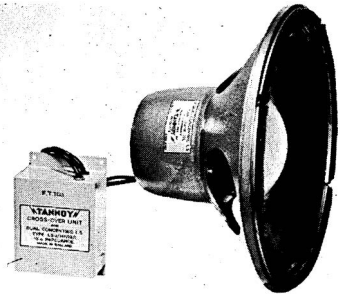

Tannoy Monitor Gold "Twelve"

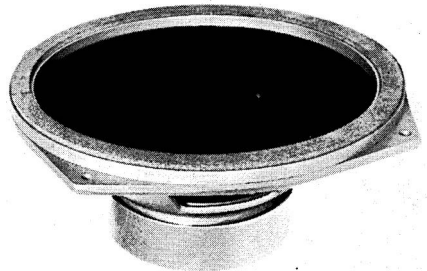

Vitavox AK154

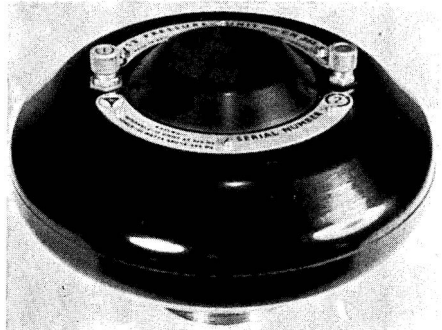

Vitavox S3 Pressure Unit

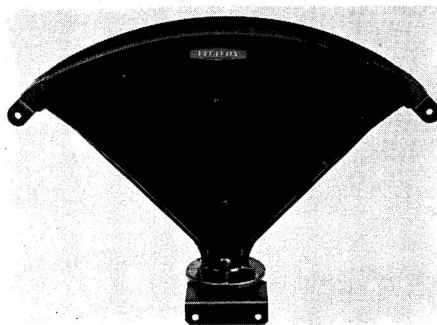

Vitavox High Frequency Horn

15in paper cone, paper surround. Bass resonance 40-50Hz. Voice coil 2½in. Gap flux 14,000 gauss. Total flux 260,000 maxwells. DC resistance of voice coil 5.5-6.5 ohms. HC and FR determined by associated horn characteristics. Replaceable cone. Price: £61-85.

Cone Kit

Spare cone kit for AK154 and AK155. Price: £11-85.

S2 HF pressure unit

Diaphragm pressure-formed from lightweight aluminium alloy. Voice coil 3in diameter. vci: 15 ohms. Gap flux 16,000 gauss. Total flux 150,000 maxwells. HC: above 200Hz 20W peak. Nominal FR: 200Hz-16kHz. Rec crossover 500 Hz. Price: £78-10.

S3 HF pressure unit ★

High frequency pressure unit. 3in voice coil. Copper wound voice coil. Impedance: 15 ohms. Gap flux 18,000 gauss. Total flux 250,000 maxwells. HC: 60W RMS above 500Hz. FR: 200Hz-16kHz. Recommended crossover: 500-1000Hz. Price: £78-10.

High frequency horn ★

Designed for use with S2, S3 and GP1 pressure units. Cast in aluminium alloy. Non-resonant. Cut-off frequency 300Hz. Price: £33-70.

GP1 pressure unit

Diaphragm pressure formed from lightweight aluminium alloy. Voice coil 1.96in diameter. Gap flux 15,000 gauss. Total flux 80,000 maxwells. HC: above 200Hz 20W. Nominal FR: 200Hz-14kHz. vci: 15 ohms. Price: £28-30.

GP2 pressure unit

Diaphragm pressure formed from lightweight aluminium alloy. Voice coil 1.5in diameter. Gap flux 14,000 gauss. Total flux 40,000 maxwells. HC: above 200Hz 15W. Nominal FR: 300Hz-10kHz. vci: 15 ohms. Price: £19-35.

GP2T pressure unit

Diaphragm pressure formed from lightweight aluminium alloy. Voice coil 1.5in diameter. Gap flux 14,000 gauss. Total flux 40,000 maxwells. HC: above 200Hz up to 12W from built-in 100V line transformer. Nominal FR: 300Hz-10kHz. Price: £29-85.

1kHz horn

High frequency horn designed for use with the GP2 Series and GP1 pressure units. With directional swivel and simple two-point mounting. Price: £7-25.

WHARFEDALE

Rank Wharfedale Ltd,
Bradford Road, Idle, Bradford, Yorkshire.
Tel: Bradford 612552. Telex: 51407.

Bronze 8/RS/DD

Full range 8in unit. Paper cone with double diaphragm. Fabric roll surround. Voice coil: 1in (aluminium). vci: 8-15 ohms. Gap flux 10,500 gauss. Total flux 41,000 maxwells. HC: 4W RMS. FR: 50Hz-20kHz. Price: £3-87 (plus 67p PT).

Super 8 RS/DD

Full range 8in unit. Paper cone with double diaphragm. Fabric roll surround. Voice coil: 1in (aluminium). vci: 8-15 ohms. Gap flux 14,500 gauss. Total flux 60,000 maxwells. HC: 6W RMS, 12W peak. FR: 40Hz-20kHz. Price: £6-81 (plus £1-19 PT).

Super 10/RS/DD

Full range 10in unit. Paper cone with double diaphragm. Fabric roll surround. Voice coil: 1in. Gap flux 16,000 gauss. Total flux 85,000 maxwells. HC: 10W RMS. vci: 8-15 ohms. FR: 30Hz-20kHz. Price: £11-06 (plus £1-94 PT).

WHITELEY ELECTRICAL RADIO CO LTD. See Stentorian.

WOOLLETT AUDIOSTATICS

21 Anerley Station Road, London, SE208PY.
Tel: 01-778 9003.

12in Type 1

Low resonance 12in dynamic unit. Paper cone with foam surround. HC: 16W RMS. FR: 20 Hz-5kHz. Special unit for use with Woollett electrostatic treble speakers. Price: £12-75.

Type C

Constant charge push-pull electrostatic. Impedance 16 ohms. HC: 20W RMS. FR: 1-6kHz-20kHz. Integral crossover. Attenuator, mains polariser. Rear sealed for mounting in bass cabinet behind horizontal 9×6½in aperture. Price: £22.

Directory of Speaker Accessories

★ Indicates entry is illustrated

Abbreviations used in this section are given on page 36.

■ **RICHARD ALLAN RADIO LTD**
Bradford Road, Gomersal, Cleckheaton,
Yorkshire. Tel: Cleckheaton 2442/3.
Cables: Acoustics, Bradford.

CN.54 Crossover Unit

Two-way quarter section. Recommended for use with CR5 bass unit and 460TC tweeter. Crossover frequency 5kHz. Impedance: 8 or 15 ohms. Price: £2-20.

CN.104 Crossover Unit

A two-way half-section parallel network. Crossover frequency 5kHz. Impedance: 8 or 15 ohms. Price: £3-30.

CN.1284 Crossover Unit

A three-way crossover with main crossover operating from half wave parallel network and subsidiary crossover capacity fed. Crossover frequencies 1,100Hz and 5kHz. Impedance: 8 or 15 ohms. Price: £5.

CN.1584

Three-way half-section crossover network. Crossover frequencies: 350Hz and 8kHz. Impedance: 8 or 15 ohms. Price: £6-35.

■ **BANG AND OLUFSEN UK LTD**
Eastbrook Road, Gloucester, GL47DE.
Tel: Gloucester 21591.

Beolab 6006 Spread Unit

Provides connection for a centre speaker from stereo amplifier. Connects between amplifier and speakers. Single control to vary the width of stereo effect. Can also be used as headphone output. Price: £7-75.

■ **BLACK KNIGHT RUMBLECURE**
Bank Top, Currier Lane, Ashton-under-Lyne,
Lancs. Tel: 061-330 2836 (open 7 days).

Demonstration room at 15, Irving Street,
London, WC2.

Specialists in curing rumble due to acoustic feedback through floors and cabinets.

Kits and items designed to isolate and acoustically damp pickup arms, turntables, motor units,

plinth assemblies, tape recorders, speaker enclosures and other audio equipment.

Plinths fitted with Rumblecure equipment available. Details on request. Many standard items now available and more being added all the time. Quotations on receipt of full details of equipment.

■ **CELESTION**

Rola-Celestion Ltd, Ditton Works,
Foxhall Road, Ipswich, Suffolk, IP38JP.
Tel: Ipswich 73131.

CO3K crossover

Designed specially for use with Studio 12 and HF1300 Mk 2 units but equally suitable for use with any efficient bass and treble combination. Air-tight terminal assembly with flange mounting. Full half-section filter network. 12dB per octave cut-off at 3kHz. Size: 3 $\frac{3}{8}$ in long, 2 $\frac{7}{8}$ in diameter of body, 3 $\frac{3}{8}$ in diameter of flange. Price: approximately £4-75.

■ **DECCA**

Decca Special Products,
Ingate Place, Queenstown Road, London,
SW83NT. Tel: 01-622 6677.

Acoustic Lens

Device for obtaining optimum dispersion of the higher audio frequencies produced by the Decca Mk II ribbon speaker or the Decca DK30 ribbon speaker. Price: £3 (no PT).

CO/1/8 Crossover

Crossover network specially designed for use with the DK30 ribbon speaker. Ferrite cored inductors and close tolerance capacitors. Low-pass section is constant 12dB/octave, high-pass section is variable slope multi-stage network of novel design. Price: £4-40.

CO/1000/8

Crossover network designed for use with London ribbon speaker. Mounted on printed circuit board. Close tolerance carbon polyester capacitors and inductors. Low-pass section is standard constant-impedance 6dB/octave filter, high-pass section attenuates at 12dB/octave. Crossover frequency: 1kHz. Negligible intermodulation distortion. Price: £6-30.

■ **EAGLE INTERNATIONAL**

Heather Park Drive, Wembley, HA11SU.
Tel: 01-903 0144.

CN.23 and CN.216

Two-way speaker cross-over networks. Crossover frequency 3kHz. CN.23, 3 ohms; CN.28, 8 ohms; CN.216, 16 ohms. Price: 98p.

LS.2W

Stereo headphone control unit with provision for two sets of phones. A and B channel switching. Price: £3-80.

★ Indicates entry is illustrated

JB3 ★

Stereo headphone and speaker switching and attenuation unit. Jack socket for phones. Switch permits phones only, speakers only, or both together. Moulded case with provision for screwing down. Price: £1-60.

■ FALCON ELECTRONICS

Components Division,
33 Station Road, Bexhill-on-Sea, Sussex.
Tel: Bexhill 1908.

Inductors and capacitors for crossover networks, BAF wadding for inside enclosures, acoustically transparent micro-porous foam and 'L' pad attenuators.

Inductors

Wound with self-fluxing wire on high permeability ferrite cores. Low values 1in long, large values 2in long. Epoxy coated. 25 standard values from 0.2mH to 10mH. Special sizes to order. Average DC resistance: 0.25mH 0.25 ohms, 1.8mH 0.8 ohms, 10mH 1.6 ohms. Price list on request.

Capacitors

Plastic cased, fully sealed, non-polarised electrolytics. 15 values from 2 μ F to 100 μ F. Size range: 2 μ F $\frac{5}{8} \times \frac{1}{4}$ in, 100 μ F $1\frac{1}{2} \times \frac{5}{8}$ in. Price list on request.

BAF Wadding

In rolls 24in wide and 1in nominal thickness. Cut in multiples of one foot. Price: 40p per linear yard. Enclosures should be lined so that one quarter of the distance between two opposite faces is filled with wadding.

Acoustic foam

Dark grey and $\frac{1}{8}$ in nominal thickness. Price: 23p per square foot. Negligible attenuation. Any size cut (charged to nearest $\frac{1}{2}$ sq ft above). Sheet size approximately 7 \times 4ft.

Attenuators

'L' pad 8 ohm constant impedance attenuators. Gives change in level without affecting response shape. For use with mid-range and HF units. Supplied complete with knob and recessed flange. Price: £1.

■ FANE ACOUSTICS LTD

Hick Lane, Batley, Yorks.
Tel: Batley 6431. Cables: Fane, Batley.

Model 2X1

Crossover unit for two-speaker system. Crossover frequency 2kHz. 15 ohms. Cut-off 6dB/octave. Size: $5\frac{3}{8} \times 3\frac{1}{4} \times 1\frac{1}{2}$ in. Price: approximately £4-75.

Model 3X1

Crossover unit for three-speaker system. Crossover frequencies 800Hz and 5kHz. Impedance: 15 ohms. Cut-off 6dB/octave. Size: $5\frac{3}{8} \times 3\frac{1}{4} \times 2\frac{1}{2}$ in. Price: approximately £6.

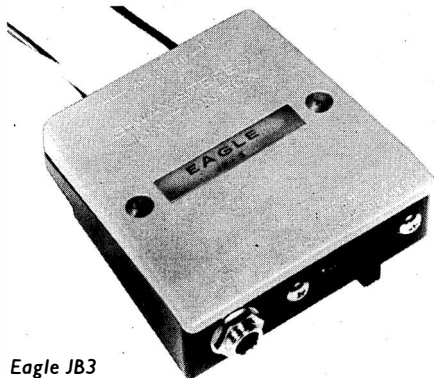

Eagle JB3

Model 3X2

Crossover for three-speaker system. Similar to one used in Ionofane 602 and 603. Crossover frequencies 800Hz and 3.5kHz. Matching impedance: 15 ohms. Cut-off 12dB/octave. Size: $6 \times 5\frac{1}{4} \times 2\frac{3}{4}$ in. Price: approximately £7-35.

■ GOODMAN'S LOUDSPEAKERS LTD

Downley Road, Havant, Hampshire,
PO9 2NL. Tel: Havant 6344. Telex: 86296.

XO/950 Crossover Unit

A two-way half-section, crossover network, operating at 950Hz. All terminations 15 ohms. Price: £7-77.

Attenuator

12dB, eight steps. Price: £3-73.

ARU.172

For use with 12in range. Price: £4-50.

■ HOWLAND-WEST LTD

3-5 Eden Grove, London, N78EQ.
Tel: 01-609 0293/4/5.

De Luxe Audio Switch

For installations with two sets of speakers, or where a headphone socket is not available. Facilities provide for both pairs of speakers to be operated at the same time or separately, or when the unit is switched to phones both sets of speakers are disconnected. With the additional feature of individual volume controls on both speakers of system B. This allows system A speakers to be controlled from the amplifier and system B from the unit. Teak finish. Size: $6 \times 2\frac{3}{4} \times 3\frac{3}{8}$ in. Weight: 17oz. Price: £7-50.

Headphone control Mk II ★

For operating two sets of stereo headphones simultaneously from the same source. Independent volume controls for each earpiece (four in all). On/off switch and jack sockets on front panel. Amplifier and speaker connections to colour coded terminals at rear. Teak finish. Size: $6 \times 2\frac{3}{4} \times 3\frac{3}{8}$ in. Weight: 18oz. Price: £6-98.

Tri-channel control

For use with three sets of speakers. Switch allows each pair of speakers to be selected independently, or all together. In the position where all three sets of speakers are on, the Tri-channel control permits the volume of each speaker to be adjusted independently. Finish: teak. Size: $12 \times 3\frac{1}{4} \times 3\frac{1}{4}$ in. Weight: 34oz. Price: £10.75.

Multi-control Mk II ★

Versatile control unit which caters for almost all domestic listening requirements. Two pairs of stereo speakers may be connected, or one stereo pair and two independent single speakers. Independent volume controls on all four speakers. Two stereo phone sockets are fitted and when switched into circuit speakers are muted. Finish: teak. Size: $12 \times 3\frac{1}{4} \times 3\frac{1}{8}$ in. Weight: 34oz. Price: £9.75.

Remote Control ★

Supplied with 5 metres of cable. Enables volume of speakers to be controlled individually at this distance from the amplifier. Will also accept headphones which are also individually controlled. Ideal for balancing speakers from central position between speakers. Price: (provisional) £6.75.

KEF ELECTRONICS LTD

Tovil, Maidstone, Kent.

Tel: Maidstone 57258. Cables: KEF, Maidstone.

Crossover networks

DN8 (NO6305) combines B139 and T15. Price: £1.75. DN12 (SP1004) combines B139, B110 and T27. Price: £4.50. DN13 (SP1017) combines B110 and T27. Price: £2.25. DN13 (SP1015) combines B200 and T27. Price: £2.80.

See Constructional Kits section for details of KEF crossover inductors, capacitors, terminals and BAF wadding.

KOSS

Tape Music Distributors Ltd, 11 Redvers Road, London, N226EP. Tel: 01-888 0152.

T10A ★

Chairside listening station. Comprises control box with separate volume controls for two sets of stereo headphones, plus on/off switch for speakers. Wires directly into amplifier. Seven-core flat connecting cable suitable for under-carpet installation. Tinted plastic cover. Price: £9.50.

T3

Speaker/headphone switchbox. Incorporates jack socket for stereo headphones, connections for speakers and terminals for connection to stereo amplifier. Switch selects speakers on or off. Price: £3.50.

See Headphone Section for details of full range of Koss headphones and accessories.

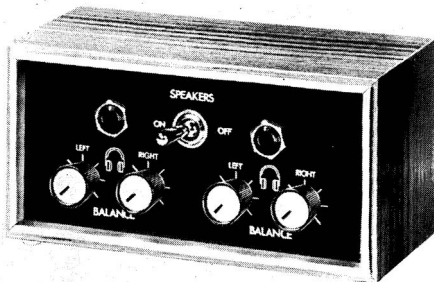

Howland-West Headphone control Mk II

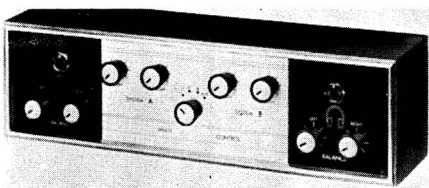

Howland-West Multi-control Mk II



Howland-West Remote control

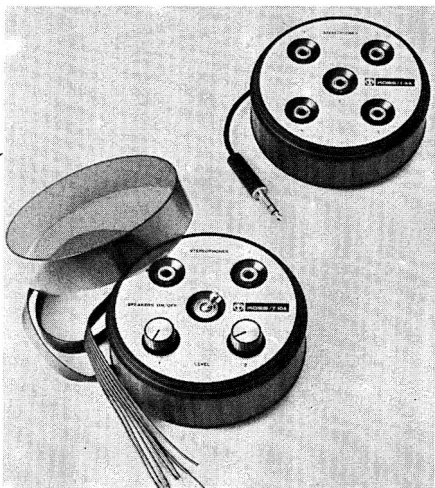

Koss Accessories T10A and T4A

★ Indicates entry is illustrated

■ MAC

Modular Audio Components Ltd,
Canterbury Road, Nottingham, NG8 1PQ.
Tel: 79797.

AAU-2

Audio adaptor unit for connecting stereo headphones, plus two pairs of speakers. 3-way switching provides various combinations. Provision for fitting attenuator resistors internally. 4-ft connecting cable to amplifier. Size: $3 \times 3 \times 3$ in. Finish: jaguar silver. Price: £4.40.

AAU-2S

Audio adaptor unit. Connects two pairs of speakers to either of two amplifiers selected by toggle switch. 3-way switching gives combination of speakers. Two 4-ft connecting cables. Size: $3 \times 3 \times 3$ in. Jaguarsilverfinish. Price: £5.52.

AAU-2X

De-luxe version of AAU-2 housed in solid teak case with pre-set gain controls for earpiece, plus resistive matching networks. Price: £6.88.

AAU-VC

Audio adaptor unit for attenuating extension speakers. Attenuation: Total -20dB in 2dB steps. Off position. Headphone jack. 20W per channel. FR: 20Hz-20kHz ± 2 dB. Channel neglect within 0.1dB. Separation: -85dB. Negligible damping loss. Teak case. Size: $3\frac{1}{4} \times 3\frac{1}{4} \times 3\frac{1}{4}$ in. Mono and stereo versions available. Prices on application.

Various other combinations of audio adaptor units are offered covering connecting and switching TV sound, headphones, etc. Full details on request.

All MAC AAU units are available in solid teak case at an additional cost of £1.32.

■ MICRO-SEIKI

Distributors: B. H. Morris & Co (Radio) Ltd,
84-88 Nelson Street, London, E1 2DY.
Tel: 01-790 5011.

MSB-1

Micro shock absorber. Microsorber employs air damped high efficiency materials to eliminate acoustic feedback from speaker enclosures to record playing deck (fitted under record deck). Adjustable for height to equalise for unbalanced weight of turntable. Price: (set of four) £4.95 (including PT).

■ ROLA-CELESTION See Celestion.

■ QAS

Quality Audio Supplies, Wollaton Road,
Beeston, Nottingham, NG9 2PB.
Tel: 0602 252222 and 265141.

Wide range of audio accessories including phono

plugs, DIN plugs and sockets, 4mm and wander plugs, couplers, screw terminals, slider switches, connecting leads with all types of terminations, audio switching units, record cleaner and remote control stations. All items individually blister-packed for over-the-counter or self-service sales.

Audio Switch

For use with two sets of stereo speakers and two sets of headphones. Pushbuttons provide any combination of speakers and phones. Headphones attenuated by 100 ohms. Connections by DIN and jack sockets. Size: $5\frac{1}{2} \times 1\frac{1}{4} \times 2\frac{3}{4}$ in. Finish: brushed aluminium. Price: £4.75.

De Luxe Audio Switch

Provides for two sets of headphones and two sets of stereo speakers. Pushbutton switches permit any combination to be used. Monitor socket for adjusting level of remote speakers. Level controls for left and right channels. Headphones attenuated at 100 ohms. Wirewound potentiometers handle up to 35W. Size: $7\frac{1}{2} \times 1\frac{1}{2} \times 2\frac{3}{4}$ in. Finish: brushed aluminium. Fixing brackets provided. Price: £8.75.

Phone Switch

Designed to cater for two sets of stereo headphones and one set of speakers. Pushbutton switches provide any combination. Headphones attenuated by 100 ohms. Connections by DIN and jack sockets. Size: $5\frac{1}{2} \times 1\frac{1}{4} \times 2\frac{3}{4}$ in. Finish: brushed aluminium. Fixing brackets included. Price: £4.75.

Input Selector

Designed to permit hi-fi enthusiasts to switch instantly between three different inputs and three different amplifiers. Also suitable for retailers carrying out demonstrations. Units can be stacked or lined up. DIN connections and pushbutton switches. Size: $5\frac{1}{2} \times 1\frac{1}{4} \times 2\frac{3}{4}$ in. Finish: brushed aluminium. Fixing brackets included. Price: £6.75.

Output Selector

For connecting three sets of stereo speakers from one source. Suitable for retailers showrooms for comparison of speakers. Also for supplying three sets of speakers in different rooms in the home. Units can be stacked to provide additional facilities. Pushbutton switches. Size: $5\frac{1}{2} \times 1\frac{1}{4} \times 2\frac{3}{4}$ in. Finish: brushed aluminium. Fixing brackets included. Price: £6.75.

Remote control

Permits listener to balance stereo speakers from listening position. Also provides facilities for stereo headphones. Approximately 16ft cable provided. Colour-coded connection box. Padded cabinet. Two wirewound potentiometers. HC: 35W. Price: £6.75.

SONY (UK) LTD

Pyrene House, Sunbury Cross, Sunbury-on-Thames, Middlesex. Tel: Sunbury 87644/7.

Mode Switch

Permits different channel selections at the flick of a switch. Switch positions permit: mono left, mono right, mono left and right, stereo, reverse stereo. Price: £3-50.

STENTORIAN

Whiteley Electrical Radio Co Ltd, Victoria Street, Mansfield, Notts. Tel: Mansfield (0623) 24762.

CX500 Crossover unit

A two-way half-section crossover network operating at 500Hz. All terminations 15 ohms. Price: £2-46.

CX1000 Crossover unit

As CX500, but operating at 1kHz. Price: £3-57.

CX1500 Crossover unit

As CX500, but operating at 1.5kHz. Price: £3-57.

CX3000 Crossover unit

As CX1500, but operating at 3kHz. Price: £2-82.

Constant impedance volume control

T-pad type attenuator having 10 steps of attenuation. Impedance presented by the load remains constant while the volume level is varied. In three versions for 3, 8 or 15 ohms. Price: £1-96.

TELEFI

Sound take-off adaptor for feeding hi-fi from TV. See Tape Recorder Accessories section.

T.T.C.

Joint distributors: Adastra Electronics Ltd, Unit 22, Cricklewood Trading Estate, Claremont Road, London, NW21TU. Tel: 01-452 6288/9.

E.R. (Factors) Ltd, 374-378 Harrow Road, Paddington, London, W9. Tel: 01-286 0361.

H.1012

Headphone/speaker junction box. Provides instant stereo headphone and speaker switching, either one or both together. Coded leads. Jack socket for phones. Free-standing or screw fixing. Two-tone moulded case. Price: £1-60.

G.1301

Remote control listening station. Stereo control unit providing instant selection of speaker and headphones. Individual volume control on each channel. Jack socket for headphone inputs. Suitable for output impedances of 4-16 ohms. Free-standing unit. Price: £2-85.

VITAVOX LTD

Westmoreland Road, London, NW99RJ. Tel: 01-204 4234. Cables: Vitavox, London.

CN370 Crossover

Half section. Crossover: 500Hz. Attenuation

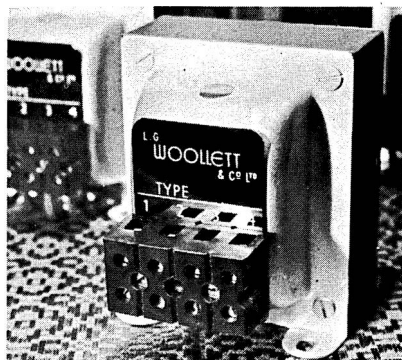

Woollett XS1 and XS2

12dB/octave. All terminations 15 ohms. Balance control giving 0-8dB HF attenuation incorporated. Price: £20-20.

CN371 Crossover

Half-section. Crossover: 1kHz. Attenuation: 12dB/octave. All terminations 15 ohms. Balance control giving 0-8dB HF attenuation incorporated. Price: £15-60.

WHITELEY ELECTRICAL RADIO CO LTD See Stentorian.**WOOLLETT AUDIOSTATIC**

21 Anerley Station Road, London, SE208PY. Tel: 01-778 9003.

XS1 ★

Speaker matching transformer. Converts 16 ohms to 8 ohms, and 8 ohms to 4 ohms. Bifilar wound. Grain orientated laminations. Ratio 1:0.707 auto. FR: 16Hz-30kHz ± 0.6 dB. Price: £3-87.

XS2 ★

Speaker isolating and matching transformer. Converts 16 ohms to 4 ohms. Bifilar wound. Grain orientated laminations. Ratio 1:1 double wound. FR: 16Hz-100kHz ± 0.6 dB. May be used to attenuate -6dB and -12dB while maintaining heavy damping on speaker and offering correct load to amplifier. Suitable for operating stereo system comprising two electrostatic high-frequency units with common bass speaker. *Note:* Not suitable for mains isolation in live chassis equipment. Price: £3-87.

Headphone Equaliser blender

Stereo. Provides variable attenuation and adjustable treble lift. Switch positions for: headphones only, headphones and speakers, or speakers only. Variable negative blend cancels out crosstalk and permits compatible stereo records to be played as full stereo. Two input and two output blocks for easy connection into speaker feeds. Fitted with two yards cable for inputs and speaker feeds: Size: $6 \times 5\frac{1}{2} \times 2\frac{1}{2}$ in. Price: £12-80.



TECHNIQUES

Ask to hear our new
Astec Sound Motor Speaker
Systems 10 & 15



TECHNIQUES

101 LONDON ROAD · LEICESTER Telephone 26319

Manufacturers of High Quality Sound Motor Systems

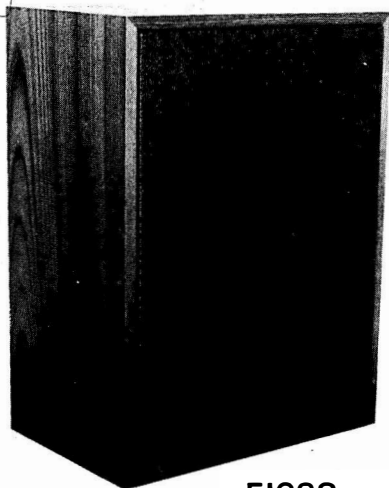

EI38S

13" × 8" TWIN CONE SPEAKER.

IMPEDANCE 15 ohms H. W. D.
POWER HANDLING 18" × 13½" × 9"
20 WATTS PEAK 258 × 342 × 228mm
FITTED ACOUSTIC WADDING.

PERFORMANCE AT ITS HIGHEST

That's the promise K.F. make on their range of Hi-Fi equipment designed to ensure the highest possible standard of reproduction when used within the designed power outputs as stated.

- High standard Teak Veneer.
- MELAMINE Finish.
- Guaranteed in finish & performance.
- £13·40

SEND FOR OUR LATEST BROCHURE
AND PRICE LIST CONTAINING DETAILS
OF OUR EXTENSIVE RANGE OF
EXTENSION SPEAKERS, CABINETS AND
PUBLIC ADDRESS EQUIPMENT.

K. F. PRODUCTS LTD
HOPESCARR

STOCKPORT, CHESHIRE. Tel: 061-480 7428.

Richard Allan

HIGH FIDELITY ENCLOSURES

for CONCERT HALL PERFORMANCE

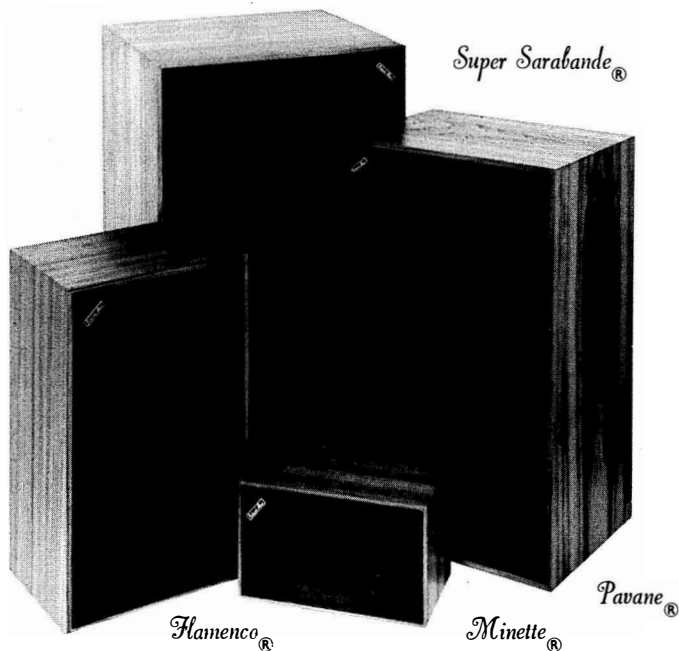

- The enclosures designed with the requirements of the High Fidelity enthusiast in mind.
- This illustration represents a selection from our range of craftsman-built enclosures.
- Richard Allan means Quality and Performance at the right price.

Write now for latest leaflets.

Richard Allan

Richard Allan Radio Limited, Bradford Road, Gomersal,
Cleckheaton, Yorkshire, England.
Telephone Cleckheaton 2442/3



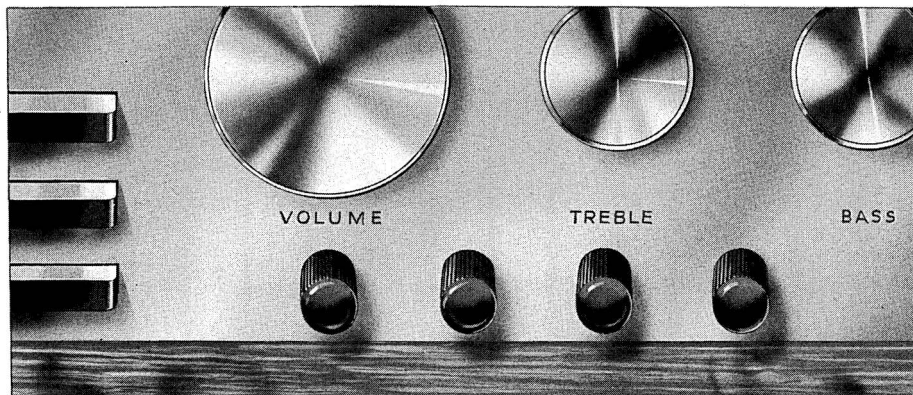

As well as the record shop **E.M.G.** have an exceptionally well appointed equipment department

It contains a most attractive array of products acknowledged to be the best of their kind available, and selected for their excellent performance, quality and reliability. What you will find there covers a usefully wide price range. More important, however, is the extent to which E.M.G. will willingly go to ensure customer satisfaction. Make your requirements known to E.M.G. and you can depend on receiving thorough and impartial advice. This might mean substituting a single item in an existing installation, a conversion and modern-

isation of what you have already, or a complete new installation. When you become a customer of E.M.G., you will find that service can go on long past the time of your purchase and that the Company identifies itself with your interests completely. There is no better way to ensure good listening. For a start, might we suggest, without obligation, a demonstration in our showroom? You will find our approach to high fidelity very much what you have always wanted.

There is also the record shop for records of classical and serious modern works and the E.M.G. Monthly Letter (£1.75 post free for twelve months) to inform and advise on current releases. A well organised records-by-post department serves those unable to call in person.

E.M.G. HANDMADE GRAMOPHONES LIMITED
26, SOHO SQUARE, LONDON, W1V 6BB

Telephone 01-734 4311

Nearest Underground Tottenham Court Road



**The great Hi-Fi debate:
Mr. Speaker intervenes.**

The sustained pursuit of perfection in loudspeaker design over a period of 40 years gives Goodmans the name of 'Mr. Speaker'—to the Public and to the Radio, Television and Hi-Fi industries throughout the world.

Now, after listening to all the pros and cons in the current great hi-fi debate and completing an intensive programme of research, we have produced additional equipment to the same exacting standards. For full information about the current Goodmans range, please write to the address below.

Goodmans
Sound reasoning.



A Member of the Thorn Group

GOODMANS LOUDSPEAKERS LTD., DOWNLEY RD., HAVANT, HAMPSHIRE. TEL: 070-12 6344

*a little
beauty*

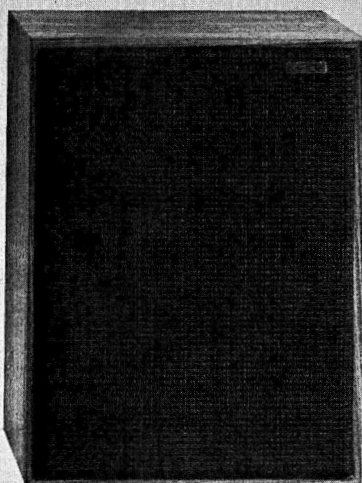

from imhofs

A little beauty, that's the new Imhof IM50 bookshelf speaker. Looks good, sounds good. And what a bargain at only £25 per pair. At this price you could have extension speakers all over the house – and they are ideal for quad sound.

Like all the other Imhof speakers they are in an attractive teak veneer cabinet with a pleasing Forest Green fabric

grille. The technical specifications of all the available models are shown below but if you want to know just how good they really are – pop into Imhofs and judge for yourself. Also, a point to remember is that *any* new equipment bought from us is covered by the Imhofs Sales Charter which includes the first 12 months service completely free of charge.

MODEL	IM50	IM100	IM200	JUNIOR Mk. II
Type	Infinite baffle	Infinite baffle	Infinite baffle	Infinite baffle
Units	6½" long throw twin cone	13"x 8" bass 1½" treble	13"x 9" bass 1½" treble	13"x 8" bass 3" treble
Crossover	—	1 kHz	1 kHz	5 kHz
Frequency Range	55 Hz–16 kHz	50 Hz–20 kHz	40 Hz–20 kHz	50 Hz–16 kHz
Impedance	8 ohms	8 ohms	8 ohms	8 ohms
Power Handling	10 watts r.m.s.	25 watts r.m.s.	25 watts r.m.s.	10 watts r.m.s.
Size	8" w x 10¾" h x 5½" d	11¾" w x 19" h x 7½" d	15¼" w x 24½" h x 10¼" d	12½" w x 24" h x 9¾" d
Price	£25.00 per pair	£25.90 each	£37.80 each	£16.80 each

IMHOFS

Dept HF • 112-116 New Oxford Street
London WC1A 1HJ • tel: 01-636 7878

THE DM LOUDSPEAKERS FROM B&W

Sound

natural, rich, rewarding...

kindling imagination,

capturing the majesty of original creation

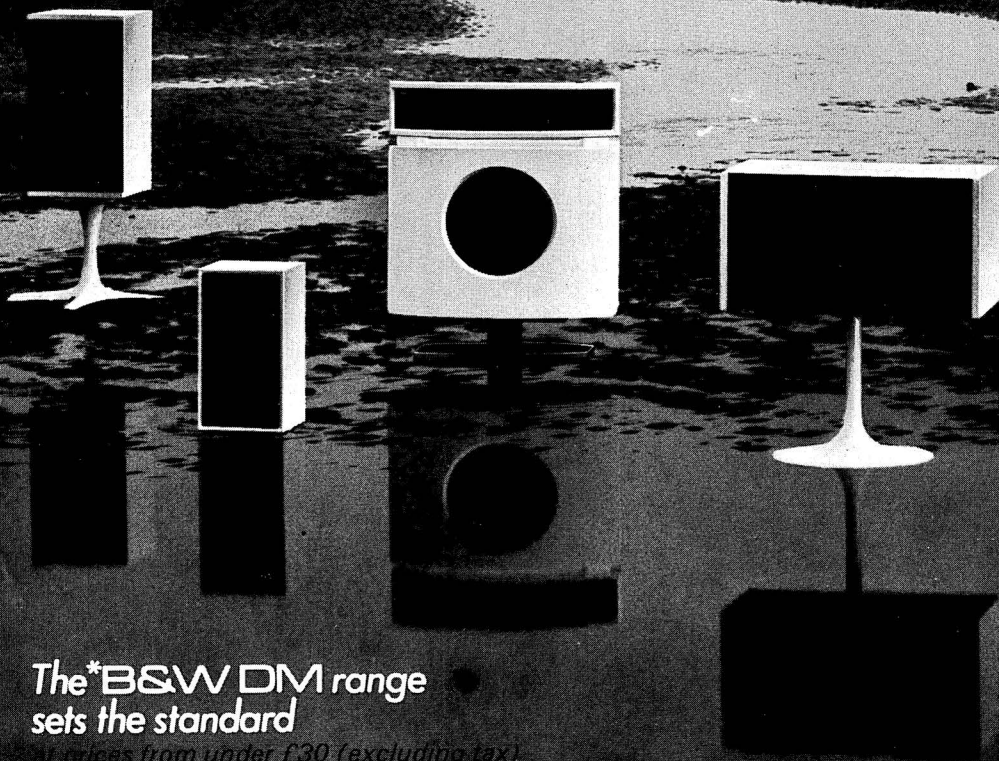

**The* B&W DM range
sets the standard**

at prices from under £30 (excluding tax)

write for brochures

B&W electronics

Meadow Road, Worthing, Sussex Tel. 0903-205611

*B&WDM is the
trade mark of
B&W electronics Ltd

High Fidelity
High Efficiency
High Damping

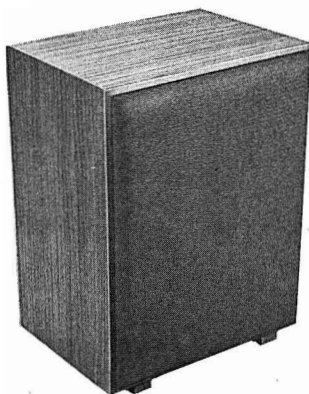
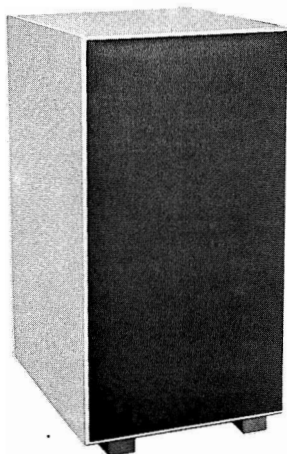
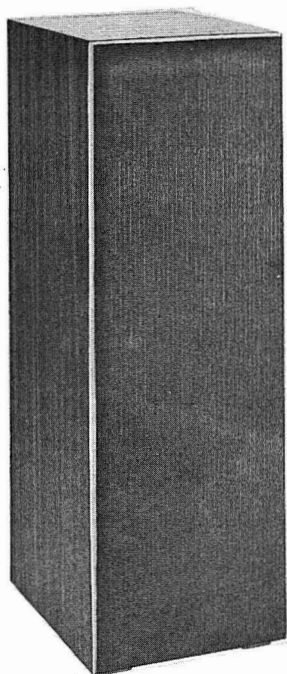
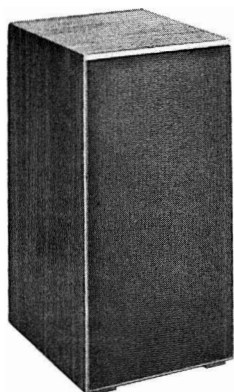

*Canterbury
Audio*

Canterbury Audio
4, Station Road, West, Canterbury, Kent
Phone: Canterbury 60431

Directory of Speaker Enclosures

■ **ACOUSTICAL MANUFACTURING.** See Quad.

■ **ACOUSTIC RESEARCH**

Pending new distribution arrangements in the UK all AR products are available direct from Acoustic Research International, Radiumweg 7, Amersfoort, Holland. (POB 209). Tel: (03490) 12556.

AR-2ax

Infinite baffle enclosure with units and crossover. One 10in bass driver, one 3½in mid-range unit, one ¾in tweeter. Crossovers: 1.5kHz, 5kHz. FR: 30Hz-20kHz (45Hz-20kHz ± 3dB). HC: 20W minimum power, 50W music power. Impedance: 8 ohms. Mid-range and treble attenuators on rear of unit. Size: 13½ × 24 × 11½in. Weight: 36½lb. Finish: (standard) teak, rosewood, pine (other finishes to order). Five-year guarantee. Price: on application.

AR-3a ★

Infinite baffle enclosure with units and crossover. One 12in bass driver, one 1½in mid-range unit, one ¾in tweeter. Crossovers: 600Hz, 5kHz. FR: 20Hz-20kHz. HC: 25W RMS. Impedance: 4 ohms. Size: 14 × 25 × 11¾in. Weight: 53lb. Treble/mid-range adjustment on rear of unit. Finish: (standard) teak, rosewood, pine (other finishes to order). Five year guarantee. Price: on application.

AR-4x

Infinite baffle enclosure with units and crossover. One 8in bass driver, one 2½in cone tweeter. Crossover: 1.25kHz. FR: 30Hz-20kHz (45Hz-20kHz ± 5dB). HC: 15W minimum, 60W music power. Impedance: 8 ohms. Adjustment provided for treble. Size: 10 × 19 × 9in. Weight: 18½lb. Finish: teak or pine. Price: on application.

AR-5

Infinite baffle enclosure with units and crossovers. One 10in bass driver, one 1½in mid-range unit, one ¾in dome tweeter. Crossovers: 600Hz, 5kHz. FR: 30Hz-20kHz (45Hz-20kHz - 3dB). HC: 20W minimum, 60W music power. Im-

pedance: 8 ohms. Separate adjustments on rear of cabinet for treble/mid-range. Size: 13½ × 24 × 11½in. Weight: 39lb. Finish: teak, rosewood, pine (other finishes to order). Five years guarantee. Price: on application.

AR-6 ★

Infinite baffle enclosure with units and crossover. One 8in bass driver with acoustic suspension, one 1½in tweeter. Crossover: 1.5kHz. FR: 25Hz-25kHz (35Hz-20kHz ± 5dB). HC: 20W minimum, 100W music power. Impedance: 8 ohms. Treble adjustment on rear of cabinet. Size: 19½ × 12 × 7in. Finish: teak, pine. Weight: 20lb. Five year guarantee. Price: on application.

■ **ADASTRA ELECTRONICS LTD**

Unit 22, Cricklewood Trading Estate, Clarendon Road, London, NW2 1TU. Tel: 01-452 6288 (answering service 01-452 6289).

Sonata ★

Speaker enclosure without units. Removable sub-baffle suitable for all speakers up to 10 × 6in, plus tweeter. Finish: straight grained teak with contrasting front edges and matching grille material. Size: 16 × 8 × 6in. Price: (per pair) approximately £9-50 (including PT).

La Scala

Speaker enclosure without units. Removable sub-baffle suitable for all speakers up to 13 × 8in, plus tweeter. Finish: polished grained teak with satinwood surround, black/grey flecked Vynair grille. Size: 14 × 21 × 8¼in. Price: (each) approximately £8-25 (including PT).

■ **AKAI**

Rank Audio Products, PO Box 70, Great West Road, Brentford, Middlesex. Tel: 01-568 9222. Telex: 24408.

SW155

Reflex enclosure with units and crossover. One 12in roll-edge bass driver, one 5in cone mid-range unit, one 2in horn tweeter, one 2½in horn super tweeter. Crossover: (6dB/octave and 12dB/octave) 1.2kHz, 5kHz, 15kHz. FR: 25Hz-21kHz. HC: 35W RMS. Impedance: 8 ohms. Size: 25 × 16 × 13¾in. Weight: 40lb. Finish: walnut. Pipe ducted reflex cabinet. Price: £59-50 (no PT).

■ **ALBA (RADIO & TELEVISION) LTD**

Tabernacle Street, London, EC2. Tel: 01-253 1322.

UA300

Infinite baffle enclosure with units and crossover. One 6½in bass driver, one 3in tweeter. Impedance: 8 ohms. Finish: teak with silver trim. Size: 8¾ × 16¾ × 7in. Price: £24-60 (including PT).

★ Indicates entry is illustrated

■ **RICHARD ALLAN RADIO LTD**
Bradford Road, Gomersal, Cleckheaton,
Yorkshire. Tel: Cleckheaton 2442/3.
Cables: Acoustics, Bradford.

Minette

Infinite baffle bookshelf enclosure. 5in bass unit, 4in tweeter. FR: 50Hz-17kHz. HC: 10W. Size: $11\frac{1}{2} \times 7 \times 6\frac{1}{2}$ in. Weight: 11lb. Price: £14.25 (plus £2.20 PT).

Chaconne

Full range two-way system comprising 8in bass driver and 4in tweeter. FR: 40Hz-17kHz. HC: 10W. Size: $20 \times 12 \times 9$ in. Weight: 21lb. Price: £17.25 (plus £2.66 PT).

Flamenco

Full-range three-way system. One 8in bass driver, one 5in mid-range unit, one 4in tweeter. FR: 40Hz-17kHz. HC: 15W. Size: $20 \times 12 \times 8\frac{1}{2}$ in. Weight: 21lb. Finish: teak or walnut. Price: £25 (plus £3.86 PT).

Pavane

Full-range three-way system comprising 12in bass unit, 8in mid-range speaker and 4in tweeter. FR: 30Hz-17kHz. HC: 15W. Size: $25\frac{1}{2} \times 15\frac{1}{2} \times 12$ in. Weight: 38lb. Price: £35.25.

Super Sarabande

Full-range three-way system. One 15in bass

driver, one 8in mid-range unit, one 4in tweeter. FR: 25Hz-17kHz. HC: 20W. Size: $32 \times 18 \times 17$ in. Weight: 75lb. Price: £61 (no PT).

High Fidelity Module

Integrated speaker assembly comprising 5in bass unit, 4in tweeter and crossover network mounted on aluminium alloy baffle for direct mounting into small bookshelf enclosure. Size: $11 \times 6\frac{1}{2}$ in. Weight: 5lb. Price: £9.35 (plus £2.12 PT).

Richard Allan Kits

See Constructional Kits section for details of Twin Assembly, Triple Assembly and Super Assembly speaker kits.

■ ALPHA

Highgate Acoustics Ltd,
184-188 Great Portland Street, London, W1.
Tel: 01-636 2901.

HT7 Mk II ★

Infinite baffle enclosure with units and crossover. One 8in bass driver, one $2\frac{1}{2}$ in tweeter. Crossover: 3.5kHz. FR: 40Hz-18kHz. HC: 20W. Impedance: 8 ohms. Finish: teak or walnut. Size: $17\frac{7}{8} \times 11\frac{1}{4} \times 6\frac{7}{8}$ in. Weight: 15lb. Price: £18.96 (plus £3.04 PT).

HT10 Mk II

Infinite baffle enclosure with units and crossover.

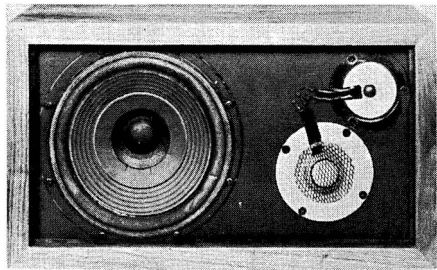

Acoustic Research AR-3a

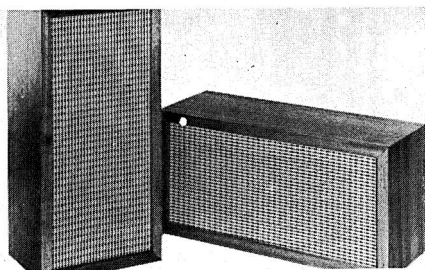

Adastra Sonata

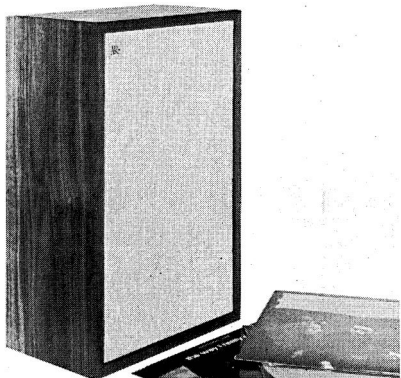

Acoustic Research AR-6

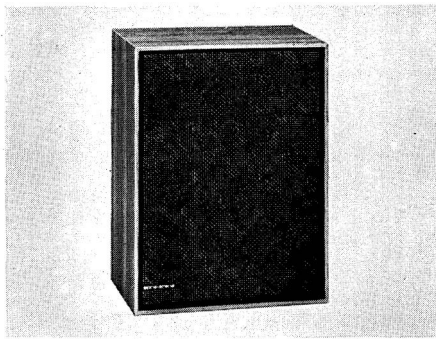

Alpha HT17 Mk II

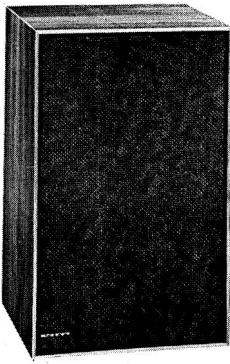

Alpha HT7 Mk II

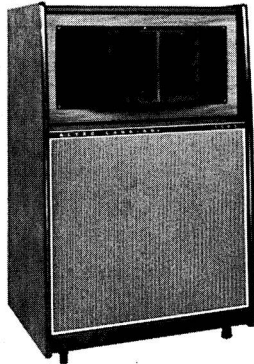

Altec-Lansing 1205

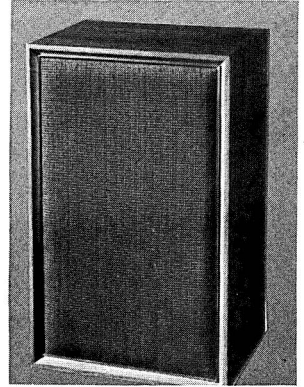

Amstrad Apollo 138

7in bass driver, 4½in dual cone mid-range unit, 4¼in tweeter. Crossover: 3.5kHz. FR: 40Hz-20kHz. HC: 20W RMS. Impedance: 8 ohms. Finish: teak or rosewood. Size: 22⅞ × 15 × 5½in. Weight: 22½lb. Price: £20.68 (plus £3.32 PT).

HT16

Infinite baffle enclosure with unit. 8¼in full-range dual-cone driver. FR: 50Hz-18kHz. HC: 10W RMS. Impedance: 4 or 8 ohms. Finish: teak. Size: 15½ × 11 × 7in. Price: £10.34 (plus £3.04 PT).

HT17 Mk II ★

Infinite baffle enclosure with units and crossover. 7 × 5in bass driver, two 2½in tweeters. Crossover: 3.5kHz. FR: 60Hz-18kHz. HC: 10W RMS. Impedance: 8 ohms. Finish: teak or walnut. Size: 13 × 10 × 4⅝in. Weight: 7lb. Price: £12.93 (plus £2.07 PT).

HT20 Mk II

Infinite baffle enclosure with units. 8¼in bass driver, 5in mid-range unit, 2½in tweeter. Crossovers: 750Hz, 4kHz. FR: 40Hz-20kHz. HC: 20W. Impedance: 8 ohms. Finish: teak or walnut. Size: 17⅝ × 11⅝ × 9⅝in. Weight: 18lb. Price: £24.99 (plus £4 PT).

HT30

Infinite baffle enclosure with units and crossover. One 8in bass driver, one 2½in tweeter. Crossover: 3.5kHz. FR: 50Hz-20kHz. HC: 15W. Impedance: 8 ohms. Finish: teak or walnut. Size: 14¼ × 9⅞ × 5¾in. Price: £14.65 (plus £2.35 PT).

ALTEC LANSING

Ling Dynamic Systems Ltd,
Baldock Road, Royston, Herts, SG8 5BQ.
Tel: Royston 42424. Telex: 81174.

1205AX ★

Reflex enclosure with units and built-in amplifier. 15in bass driver, 808-4Z HF driver, 25in sectoral horn. Crossover: 500Hz. HC: 85W. Input im-

pedance to amplifier: 18K. Speaker system: 4 ohms. FR: 35Hz-20kHz. Size: 45 × 28 × 25in. Weight: 137lb. Finish: black vinyl. Price: £295.

1208A

Altec 23in sectoral horn for middle and high frequencies. 15in bass driver mounted in separate wood horn. Supplied in separate components for assembly as required, i.e. horn on top or inside the cabinet. HC: 50W. Impedance: 8 ohms. Size: 42 × 30 × 24in. Weight: 160lb. Price on request.

AMSTRAD ELECTRONICS LTD

34/35 Great Sutton Street, London, EC1.
Tel: 01-251 0241/2.

Apollo 138 ★

Infinite baffle enclosure with unit. One twin cone 13 × 8in driver. FR: 40Hz-16kHz. HC: 10W RMS. Impedance: 8 ohms. Size: 18 × 11 × 7½in. Weight: 7lb. Finish: teak cabinet with padded front and silver trim. Price: £27 per pair (no PT).

ARISTON

Distributors: C. W. & J. Walker, 3 Kirklands, Church Street, Cleckheaton, BD193RW, Yorks.
Tel: 097-62 3756.

SR90

Infinite baffle enclosure with units and crossover. Enclosure said to have isothermal behaviour. One 13in triple-suspension bass driver, one 7 × 5in elliptical mid-range unit, one modified Decca-Kelly DK30 ribbon tweeter. Crossover: 500Hz, 3kHz. FR: 20Hz-25kHz. Dispersion: over arc of 60° ± 5dB. HC: suitable for amplifiers having outputs of 20-90W RMS. Impedance: 8-10 ohms. Size: 34¼ × 16 × 15in. Weight: 170lb. Finish: teak (left and right-hand versions available). Cabinet walls 1½in thick and comprised of special granite/concrete mix, keyed

★ Indicates entry is illustrated

and bonded to enclosure by special process.
Price: £125.

■ ASTEC

A. S. Techniques, 35 Waterloo Street,
Leicester. Tel: Leicester 26319.

System 10

Hybrid reflex cabinet with unit. Tapered pipe inverter enclosure. One $7\frac{1}{2}$ in Astec full-range unit. FR: 45Hz-20kHz \pm 4dB. HC: 15W RMS. Impedance: 8 ohms. Size: $1\frac{1}{2}$ in high, 11in wide, 9in deep. Finish: teak and white (walnut to order). High power bandwidth at low frequencies. Price: £29-50 (no PT).

System 15

Hybrid reflex cabinet with unit. Tapered pipe inverter enclosure. One $7\frac{1}{2}$ in Astec full-range unit. FR: 30Hz-20kHz \pm 4dB. HC: 15W RMS. Impedance: 8 ohms. Size: $1\frac{1}{2}$ in high, 11in wide, 9in deep. Finish: teak and white (walnut to order). High power bandwidth at low frequencies. Price: £38-75 (no PT).

■ AUDIO SERVICES LTD

82 East Barnet Road, New Barnet, Herts.
Tel: 01-449 6605.

Dynasonic 2T

Reflex enclosure with units and crossover. One 12in bass driver, two tweeters. Crossover: 2-5kHz. FR: 50Hz-20kHz. HC: 15W RMS. Impedance: 8 ohms. Finish: teak. Size: $15 \times 24 \times 11$ in. Price: £31.

Shackman Dynasonic De Luxe

Reflex enclosure with units and crossover. One 12in bass driver, two tweeters. Crossover: 2-5kHz. FR: 40Hz-20kHz. HC: 25W RMS. Finish: teak. Size: $17 \times 27 \times 11$ in. Price: £45.

Shackman Dynastatic ASI

Bass reflex enclosure with units and crossover. One 12in bass driver plus Shackman electrostatic mid-range and high frequency tweeter. Crossover: 800Hz. FR: 35Hz-20kHz. HC: 30W. Impedance: 8 ohms. Finish: teak. Price: £54.

Shackman Dynastatic AS100

Bass reflex enclosure with units and crossover. One 12in bass driver plus Shackman electrostatic unit operating as doublet. Crossover: 500Hz. FR: 30Hz-20kHz. HC: 30W. RMS. Impedance: 8 ohms. Finish: teak or walnut. Price: £100.

■ BANG & OLUFSEN UK LTD

Eastbrook Road, Gloucester, GL47DE.
Tel: Gloucester 21591.

Beovox 1702

Pressure chamber enclosure with units and crossover. One 6in bass driver, one 1in dome tweeter. Crossover: 5kHz. FR: 50Hz-20kHz.

HC: 15W RMS. Impedance: 4 ohms. Spec exceeds DIN 45-500. Size: $13\frac{3}{4} \times 7\frac{1}{8} \times 7\frac{1}{8}$ in. Weight: $8\frac{3}{4}$ lb. Finish: teak or rosewood. Sold in matched pairs. Price: (per pair) in teak £56-90, in rosewood £58-90.

Beovox 1802

Pressure chamber enclosure with units and crossover. One 6in bass driver, one 1in dome tweeter. Crossover: 5kHz. FR: 50Hz-20kHz. HC: 15W RMS. Impedance: 4 ohms. Spec exceeds DIN 45-500. Size: $13 \times 7\frac{3}{8} \times 4$ in. Weight: $13\frac{1}{4}$ lb. Finish: teak or rosewood. Sold in matched pairs. Price: to be announced.

Beovox 2702

Pressure chamber enclosure with units and crossover. One 7in bass driver, one $1\frac{1}{2}$ in mid-range unit, one 1in tweeter. Crossover: 3-5kHz and 10kHz. FR: 45Hz-20kHz. HC: 20W RMS. Impedance: 4 ohms. Spec exceeds DIN 45-500. Size: $16\frac{1}{4} \times 8\frac{1}{8} \times 8\frac{1}{8}$ in. Weight: 12lb 2oz. Finish: teak or rosewood. Sold in matched pairs. Price: (per pair) in teak £67-90, in rosewood £71-90.

Beovox 3702

Pressure chamber enclosure with units and crossover. One 8in bass driver, one $1\frac{1}{2}$ in mid-range unit, one 2in tweeter. Crossover: 3-5kHz and 10kHz. FR: 40Hz-20kHz. HC: 40W RMS. Impedance: 4 ohms. Spec exceeds DIN 45-500. Size: $19\frac{3}{4} \times 9\frac{1}{8} \times 9\frac{1}{8}$ in. Weight: $18\frac{3}{4}$ lb. Finish: teak or rosewood. Sold in matched pairs. Price: (per pair) in teak £82-90, in rosewood £88-90.

Beovox 5702

Enclosure incorporating passive radiator, three driver units and crossover. One 10in bass driver, one $2\frac{1}{4}$ in mid-range unit, one $\frac{3}{4}$ in tweeter, one 10in passive radiator. Crossover: 25Hz and 6kHz. FR: 25Hz-20kHz. HC: 60W RMS. Impedance: 4-8 ohms. Spec exceeds DIN 45-500. Size: $26 \times 14\frac{1}{4} \times 11\frac{3}{4}$ in. Weight: $49\frac{1}{2}$ lb. Sold in matched pairs. Finish: teak or rosewood. Price: to be announced.

■ BLACK KNIGHT RUMBLECURE

Bank Top, Currier Lane, Ashton-under-Lyne, Lancs. Tel: 061-330 2836 (open 7 days).

Demonstration showroom, at 15 Irving Street, London, WC2.

Black Knight ★

Designed to safeguard against amplifier overload and the problems associated with acoustic feedback. High efficiency system enables speaker to be comfortably driven from 6W per channel, but will accept up to 25W RMS per channel. Impedance: 8 ohms. FR: 35Hz-19kHz. Size: 25in high, 15in wide, 12in deep. Fully cushioned to comply with anti-vibration requirements. Supplied direct only. Full specification and price on request.

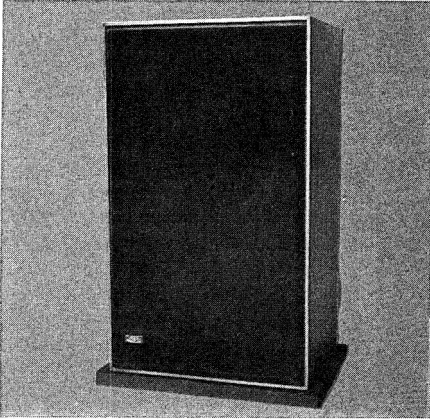

Black Knight Rumblecure Mat with KEF Chorale

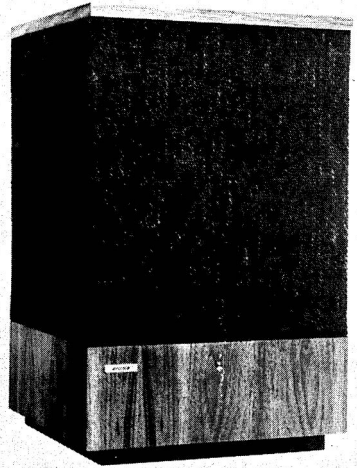

Bose 501

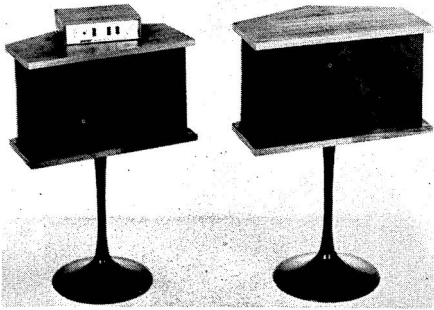

Bose 901

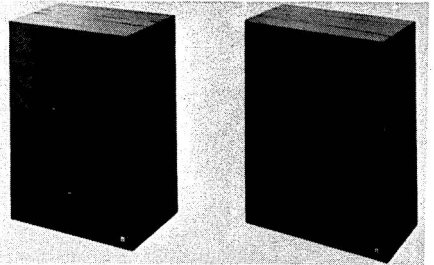

Bush-Arena L530

■ **BOSE CORPORATION**

Distributors: Expotus Ltd, 10 Museum Street, London, WC1. Tel: 01-836 3747.

501 ★

Infinite baffle enclosure with units and crossover. One forward-facing 10in bass driver, two rear-angled 3½in mid-range and HF units. FR: 40Hz-20kHz. HC: 100W RMS. Impedance: 4 ohms. Size: 14½ × 14½ × 24in. Weight: 38lb. Finish: walnut. Sold in matched pairs. Price: (per pair) £150 (no PT).

901 ★

Infinite baffle enclosure with units. Nine 4in high-compliance paper cone speakers (one forward-facing, eight on rear baffles). No crossover network. FR: 25Hz-20kHz. HC: > 100W RMS. Impedance: 8 ohms. Active equaliser corrects response shape and adjusts for room acoustics. Size: 20⅝ × 12¾ × 12⅞in. Weight: 33lb. Finish: walnut. Sold in matched pairs with equaliser. Price: (per pair including equaliser) £250.

■ **BRAHMS MANUFACTURING & DEVELOPMENT CO**

Unit E, Rochester Airport, Maidstone Road, Rochester, Kent. Tel: Medway 48816.

Sandringham

Infinite baffle enclosure with units and crossover. One 12in long-throw bass driver, one 3½in HF unit. Crossover: capacitor at 5kHz. FR: 40Hz-18kHz. HC: 20W (DIN). Impedance: 8 ohms. Size: 20 × 12 × 8½in. Weight: 17lb. Finish: teak, with padded front and picture frame profile. Price: (per pair) £37-60.

Buckingham

Infinite baffle enclosure with units and crossover. One 12in long-throw bass driver, one 3½in HF unit. Crossover: capacitor at 5kHz. FR: 30Hz-18kHz. HC: 20W (DIN). Impedance: 8 ohms. Size: 21 × 15 × 9in. Weight: 20lb. Finish: teak, with padded front and picture frame profile. Price: (per pair) £42-80.

See also entry under Medway in this section.

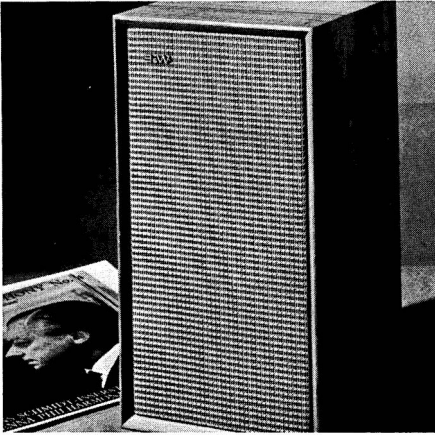

B & W Electronics DM1

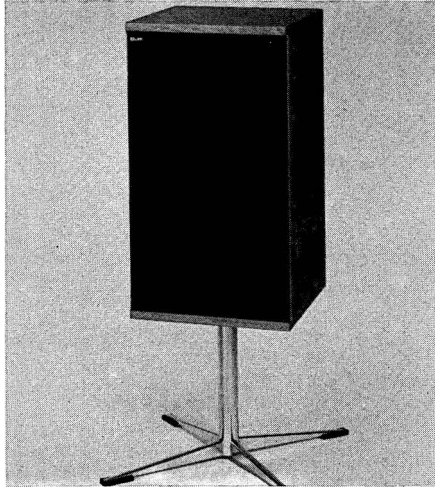

B & W DM2

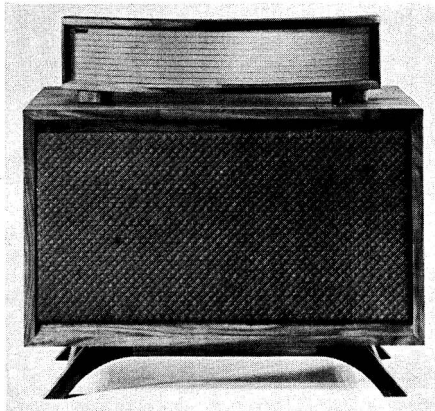

B & W Electronics Model 70 standard

■ BUSH-ARENA

Rank Bush Murphy Ltd, Power Road, Chiswick, London, W4. Tel: 01-994 6491.

L530 ★

Three-unit enclosure for floor or wall mounting. One 10in bass driver, one 5in mid-range unit, one 1in tweeter. FR: 35Hz-20kHz. Impedance: 4 ohms. HC: 25W RMS. Size: $22\frac{3}{4} \times 16\frac{1}{2} \times 9\frac{1}{2}$ in. Finish: teak veneer. Supplied with wall mounting brackets and 20ft connecting leads. Sold in matched pairs. Price: (per pair) £91.14 (no PT).

■ BUSH NELSON LTD

Bush House, 6 Yattendon Road, Horley, Surrey. Tel: Horley 5983.

12/8

Pressure chamber system. One 13×8 in bass unit, one 3in tweeter. Impedance: 8 ohms. FR: 20Hz-20kHz. Power capacity: 20W. Flux density: bass unit 11,000 gauss, HF unit 10,000 gauss. Bass resonance: 20-30Hz. Crossover frequency: 5kHz. Teak. Size: $23 \times 12 \times 11$ in. Price: £65.

■ B. & W. ELECTRONICS

Bowers & Wilkins Electronics Ltd, Meadow Road, Worthing, Sussex. Tel: Worthing 205611/4.

DM1 ★

Bookshelf enclosure measuring $9 \times 8 \times 16\frac{1}{2}$ in, 0.065 cu ft capacity. Units employed: 10×6 in laminated glass cone bass/mid-frequency radiator. Pressure mid-frequency/high frequency unit and single tweeter continuing response into supersonic region. Individually pen-tested and supplied with calibration certificate. Finishes: teak, walnut and rosewood. Price: £32.

DM2 ★

Eighth-wave acoustic line enclosure with units and crossover. One 8in bass driver with Bextrene cone, one $1\frac{1}{2}$ in mid-range unit with high-power coil, one Celestion HF1300 tweeter. Crossover: 3.5kHz, 9kHz. FR: 30Hz-25kHz (± 2 dB 300Hz-6kHz, ± 3 dB 65Hz-20kHz). HC: 50W RMS. Impedance: 8 ohms at 400Hz. Size: $14 \times 25\frac{1}{2} \times 13\frac{3}{4}$ in. Weight: 52lb. Finish: teak, rosewood, walnut or satin white. Every model individually pen tested and calibration certificate supplied. Price: £52 (plus £8.76 PT).

DM3

Floor standing enclosure measuring $15\frac{3}{4} \times 11\frac{1}{2} \times 28\frac{1}{4}$ in with three units. EMI special pen-tested bass radiator. Wide dispersion high frequency transient and wave shaping units. Crossover and filter network individually adjusted for each speaker. Each monitor pen-tested and curve supplied with enclosure. Price: £63 walnut and teak; £69.50 rosewood.

Celestion



Loudspeakers for the Perfectionist

TELEFI

A remarkable Innovation exclusive to Celestion for use in conjunction with Hi Fi and Audio systems for providing high quality television sound reproduction from 625 line television receivers.

*No direct connection to the TV is required, the coupling being effected by an inductive probe.

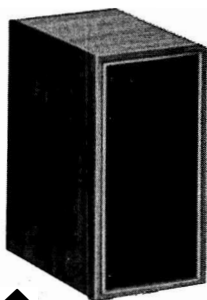

DITTON 10 Mk II

True Hi-Fi Sound from a tiny precision speaker 20 watts, 4-8 ohms.

UNITS: HF 1300 MK II and heavy duty 6" long throw bass speaker. Substantially level response from 45 Hz to 15 kHz.

SIZE $12\frac{1}{2} \times 6\frac{1}{2} \times 8\frac{1}{2}$

Matched pairs

Natural Teak or Walnut Cabinet



DITTON 120

Hi-Fi 'Bookshelf' Speaker achieving a high standard of performance. 20 watts maximum, 4-8 ohms.

UNITS: HF 1300 MK II, heavy duty 6" long throw bass speaker plus A.B.R. (auxiliary bass radiator). Substantially level response from 40 Hz to 15 kHz.

SIZE $17\frac{1}{2} \times 9 \times 7\frac{1}{2}$

Natural Teak or Walnut Cabinet

Packed in matched pairs



'COUNTY'

Designed for budget Hi-Fi systems but without sacrificing quality.

UNITS: HF 1300 MK II and special 8" long throw speaker. Substantially level response from 45 Hz to 15 kHz 25 watts.

SIZE $19 \times 10 \times 9\frac{1}{2}$

Natural Teak or Walnut Cabinet

Matched pairs

ROLA CELESTION LTD., DITTON WORKS, FOXHALL ROAD, IPSWICH IPS 8JP

★ Indicates entry is illustrated

Model 70 Standard ★

Nominal 13in diameter bass radiator. Laminated and reinforced cone. Eleven-module wide dispersion electrostatic HF unit type 701. Power supply unit, high and low pass filter assembly mounted on separate board. Infinite baffle loading on bass unit with multiple bracing and synthetic fibre absorbents. Electrostatic unit free-standing plug-in assembly with removable rear absorbent pad which allows modification to polar distribution. Impedance: nominal 8 ohms, rising to 25 ohms at 1kKz, but not falling below 4 ohms at 20kHz. HC: 25W RMS throughout entire musical range. FR: 50Hz-15kHz better

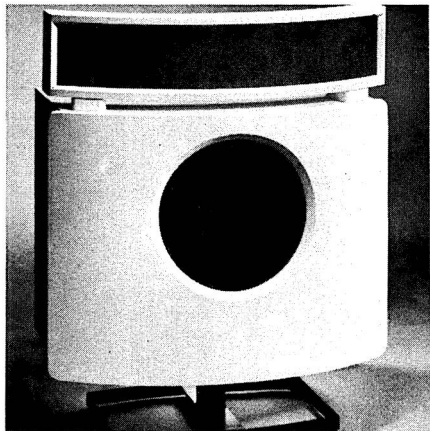

B & W Electronics Continental 70

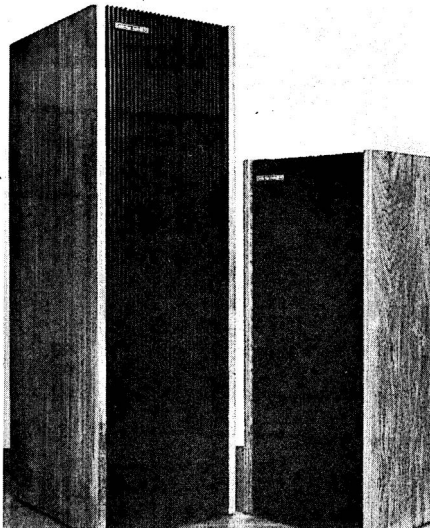

Cambridge Audio R50 (Left) R40 (Right)

than ± 4 dB, 40Hz-20kHz better than ± 5 dB. System resonance: 40Hz $\pm 1\%$. Finish: oiled teak or oiled American walnut. Main cabinet veneered on all surfaces including the back. Size: 31 $\frac{7}{8}$ in high overall, 32in wide, 15in deep. Weight: 107lb. Price: £159.50.

70 Continental ★

Similar technical specification to the DM70 but in modern styling finished in white. Price: £159.50.

■ CAMBRIDGE AUDIO

Cambridge Audio Ltd,
The River Mill, St Ives, Huntingdon.
Tel: St Ives (Hunts) 62901. Telex: 32223.

R50 ★

High quality transmission line enclosure with units and crossover. Bass driver in damped tapered labyrinth, HF driver in damped tapered pipe. Two HF pressure drivers. FR: 25Hz-25kHz. Crossover: 400Hz, 3kHz, 10kHz. HC: 25W RMS, 50W music. Impedance: 8 ohms (nominal). Size: 41 $\frac{1}{2}$ \times 17 $\frac{3}{8}$ \times 13in. Price: £98.

R40 ★

High quality enclosure incorporating three drive units in a damped tapered labyrinth. HC: 25W RMS, 40W music. Impedance: 8 ohms (nominal). Size: 31 $\frac{1}{4}$ \times 13 \times 12 $\frac{3}{4}$ in. Price: £68.50.

■ CANTERBURY AUDIO

4 Station Road, West Canterbury, Kent.
Tel: Canterbury 60431.

CA215

Infinite baffle enclosure with units. HC: 15W. FR: 37Hz-19kHz. Impedance: 6 or 15 ohms. Finish: teak veneered bonded chipboard. Size: 21 \times 13 $\frac{1}{2}$ \times 13 $\frac{1}{4}$ in. Price: £19.60

CA315

Infinite baffle enclosure with units. HC: 35W. FR: 35Hz-22kHz. Impedance: 6 or 15 ohms. Finish: teak veneered bonded chipboard. Size: 31 \times 13 $\frac{1}{2}$ \times 13 $\frac{1}{4}$ in. Price: £39.60.

■ CELESTION

Rola-Celestion Ltd, Ditton Works,
Foxhall Road, Ipswich, Suffolk, IP3 8JP.
Tel: Ipswich 73131.

County ★

Infinite baffle shelf mounting enclosure with units. One 8in bass driver, one HF1300 treble unit. HC: 25W RMS. Impedance: 4-8 ohms. Size: 19 \times 10 \times 9 $\frac{1}{2}$ in. Finish: teak or walnut. Price: £20.97 (plus £3.53 PT).

Ditton 10 Mk II ★

Infinite baffle compact system. Long-throw 5in bass unit, HF1300 Mk 2 HF unit. Built-in half-section crossover 3.5kHz. FR: 35Hz-15kHz. HC: 10W. Size: 12 $\frac{3}{4}$ \times 6 $\frac{1}{4}$ \times 8 $\frac{1}{4}$ in. Weight:

Celestion



Loudspeakers for the Perfectionist

DITTON 25 ▶

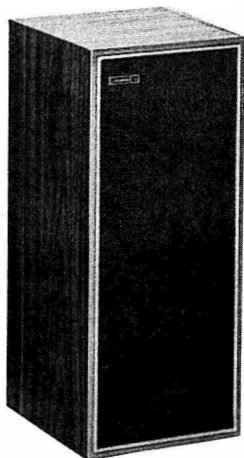

DITTON 15

The world famous high performance 'bookshelf' loudspeaker 30 watts maximum, 4-8 ohms.

UNITS: HF 1300 MK II, heavy duty 8" long throw bass speaker plus A.B.R. (auxiliary bass radiator). Substantially level response 35 Hz to 15 kHz.

SIZE 21 × 9½ × 9½ Matched pairs

This truly remarkable loudspeaker never fails to impress. Natural Teak or Walnut Cabinet

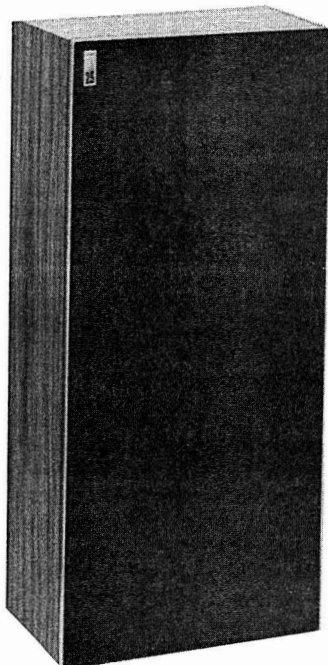

Recommended for luxury Domestic Hi-Fi Installations. A system having extremely low harmonic distortion and high sensitivity. This well established loudspeaker is excellent value and will delight the most fastidious audiophile. Noted by reviewers for complete absence of 'listener fatigue'; smooth and effortless in performance.

UNITS: HF 2000, HF 1300 MK II (two), long throw 12" bass driver plus 12" A.B.R. (auxiliary bass radiator). Substantially level response from 25 Hz to 30 kHz 60 watts maximum 4-8 ohms. Matched pairs.

SIZE 32 × 14 × 11 Natural Teak or Walnut Cabinet

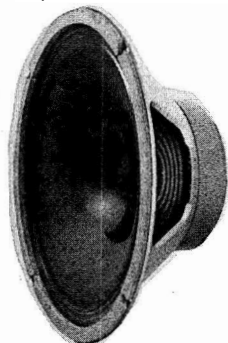

Model: PS12 TC
Type: Dual cone 12in.
Range: 40Hz-12 kHz
Power: 20 watts r.m.s.
Flux: 128,000 maxwells
Impedance: 8 or 15 ohms.



Model: PS8 TC
Type: Dual cone 8in.
Range: 50 Hz—12.5 kHz
Power: 6 watts r.m.s.
Flux: 38,500 maxwells
Impedance: 8 or 15 ohms.

ROLA CELESTION LTD., DITTON WORKS, FOXHALL ROAD, IPSWICH IPS 8JP

★ Indicates entry is illustrated

13lb. Available in teak and walnut. vci: 4-8 ohms. Price: £20.40 (plus £3.43 PT).

Ditton 15 ★

Compact infinite baffle enclosure incorporating auxiliary bass radiator. Units: 8in middle/bass speaker. HF1300 Mk 2 treble radiator. FR: 30Hz-15kHz. HC: 15W RMS. vci: 4-8 ohms. Size: $21 \times 9\frac{1}{2} \times 9\frac{1}{4}$ in. Weight: 20lb. Finish: walnut or teak. Price: £32 (plus £5.38 PT).

Ditton 25 ★

Studio monitoring quality speaker enclosure with five drive units. 12in long-throw bass driver, two pressure type mid-range and HF units, pressure type ultra high frequency unit, 12in auxiliary bass radiator. HC: 25W RMS. vci: 4-8 ohms. Size: $32 \times 14 \times 11$ in. Weight: 48lb. Finish: teak or walnut. Price: £65 (no PT).

Ditton 44

Floor-standing enclosure with units. One 12in

bass driver, one 6in HF unit and HF2000 tweeter. HC: 44W RMS. Impedance: 4-8 ohms. Size: $30 \times 14\frac{1}{2} \times 10$ in. Finish: teak or walnut. Price: £54.

Ditton 66 ★

Floor-standing enclosure with units. One 12in bass driver, one 12in passive radiator (ABR), one dome HF unit, one dome tweeter. HC: 80W RMS. Impedance: 4-8 ohms. Size: $40 \times 15 \times 11\frac{1}{2}$ in. Finish: teak or walnut. Price: £99.

Ditton 120 ★

Infinite baffle enclosure with two active units and one passive radiator. One 5in long-throw bass driver, one pressure type $1\frac{1}{2}$ in tweeter, one 5in auxiliary bass radiator. Crossover: low-loss L/C network. FR: 35Hz-15kHz. HC: 20W (DIN). Impedance: 4-8 ohms. Finish: natural teak or walnut. Size: $17\frac{1}{4} \times 9 \times 7\frac{3}{4}$ in. Price: £24 (plus £4.04 PT).

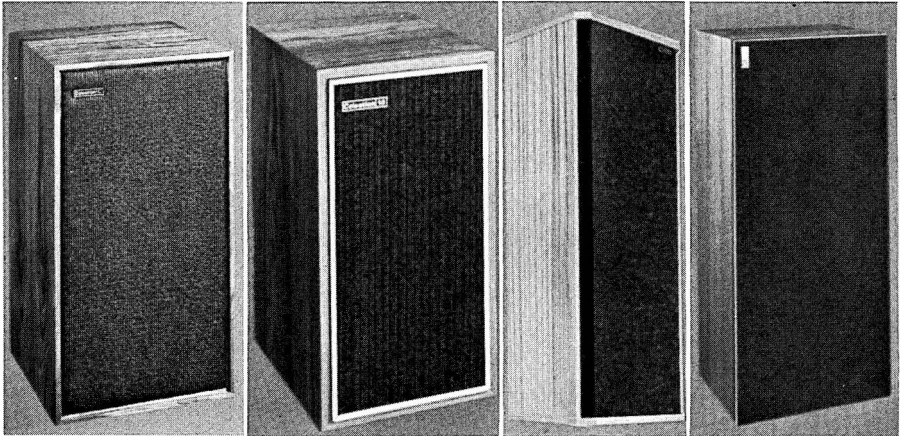

Celestion County

Celestion Ditton 10 11

Celestion Ditton 66 monitor

Celestion Ditton 25

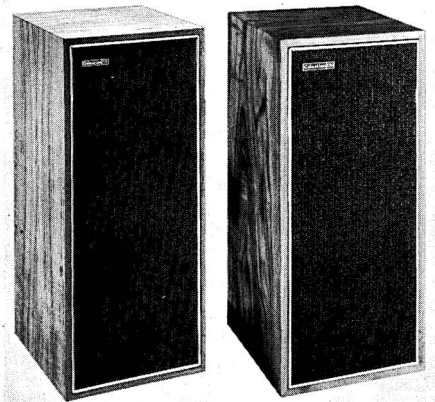

Celestion Ditton 15

Celestion Ditton 120

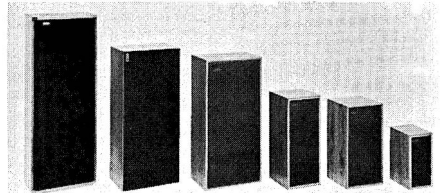

Celestion Dittons 10/County/15/44/25/66

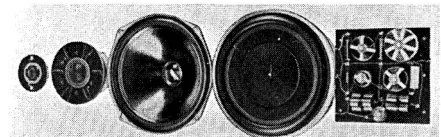

Celestion Ditton 66

Celestion



Loudspeakers for the Perfectionist

DITTON 66 STUDIO MONITOR

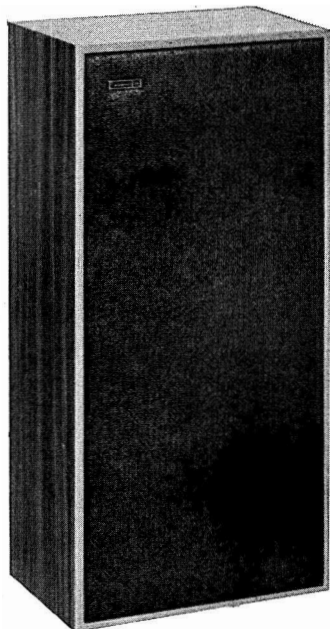
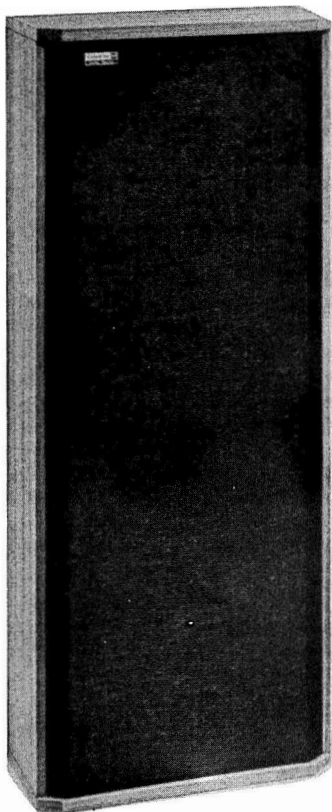

DITTON 44 MONITOR

Designed for the discriminating listener . . . wide, smooth frequency response. Exceptional transient performance, superb controlled bass, accurate mid-range—and smooth extended highs.

UNITS: HF 2000, MF 6 and Ultra linear 12" long throw bass speaker. Crossover system of superior design at 500 Hz and 5000 Hz. Substantially level response from 30 Hz to 30 kHz 44 watts maximum —4-8 ohms.

SIZE 30 × 14½ × 10 Matched pairs
Natural Teak or Walnut Cabinet

A new Loudspeaker of advanced design suitable for studio use and for home installations of the highest quality.

UNITS: HF 2000 (dome 'pressure' type) MF 500 (Mid-range Dome 'pressure' type) Ultra linear 12" bass driver and 12" A.B.R. The crossover has resulted from considerable research and crossover points are at 500 Hz and 5000 Hz 80 Watts Maximum, 4-8 ohm. This monitor loudspeaker system has an exceptionally wide and flat frequency response. Very low order harmonic and inter-modulation distortion. Precise response to transients. Beautifully maintained polar response ensures absence of unwanted directional effects and provides a highly satisfactory stereo image throughout the listening area. Matched pairs.

SIZE 40 × 15 × 11½ Natural Teak or Walnut Cabinet

ROLA CELESTION LTD., DITTON WORKS, FOXHALL ROAD, IPSWICH IPS 8JP

★ Indicates entry is illustrated

■ CITY AUDIO SERVICES LTD

7 Chalcot Road, London, NW1.

Tel: 01-586 3211/2.

CA/11 ★

Sealed speaker enclosure with three units. One 13 × 8in bass and mid-range driver, two 2½in tweeters. Half-section crossover at 8.5kHz. FR: 55Hz-14kHz. HC: 10W. Impedance: 8 ohms. Size: 18½ × 11½ × 8in. Finish: teak. Price: £15.75.

CA/15

Infinite baffle enclosure with units and crossover. One 13 × 8in bass driver, two 2½in mid-range and HF units. Crossover: half-section 8.5kHz. FR: 50Hz-14kHz. HC: 10W RMS. Impedance: 8 ohms. Size: 18½ × 11½ × 8in. Weight: 14lb. Finish: teak. Price: £18.50.

CA/20 Mk 3

Infinite baffle enclosure with units and crossover. One 8in long-throw bass driver with rubber cone suspension, one 3½in mid-range unit, one 2in tweeter. Crossover: L/C at 3.5kHz. FR: 40Hz-19kHz. HC: 12W RMS. Impedance: 8 ohms. Size: 18½ × 11½ × 8in. Weight: 16lb. Finish: teak. Price: £23.30.

■ CROWN RADIO

128-129 Shoreditch High Street,
London, E1 6JE. Tel: 01-739 2382.

CSP-12

Infinite baffle enclosure with unit. One 13¼ × 8¼in bass driver with integral HF unit. Size: 7¼ × 17½ × 9¾in. Finish: walnut cabinet with black grille. Price: (per pair) £29.50 (including PT).

CSP-13

Infinite baffle enclosure with unit. One 13¼ × 8¼in bass driver with two integral HF units. Impedance: 8 ohms. Size: 10½ × 21 × 9in. Finish: walnut cabinet with black grille. Price: (per pair) £39.50 (including PT).

■ A. DAVIES & CO

56 Wellesley Road, London, NW5.

Tel: 01-485 5775.

Sherwood type

Based on Goodmans design for Axiom speakers. Approved for Goodmans Axiom 201, Axiom 301 and Goodmans three-way system. Finish: sapele, oak, walnut, teak. Full polish or satin finish. Size: 23½ × 29½ × 19½in. Price: £22 plus the cost of speaker units and crossovers to customer's choice.

Bass reflex

Suitable for 12in speakers. Cabinets lined with 1in acoustic felt. Finish: sapele, walnut, oak, teak. Full polish or satin finish. Dimensions: 34 × 17½ × 15½in. Price: £16.50 plus the cost of speaker unit to customer's choice.

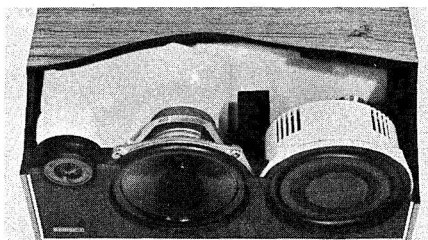

Celestion Ditton 15 (Cut out)

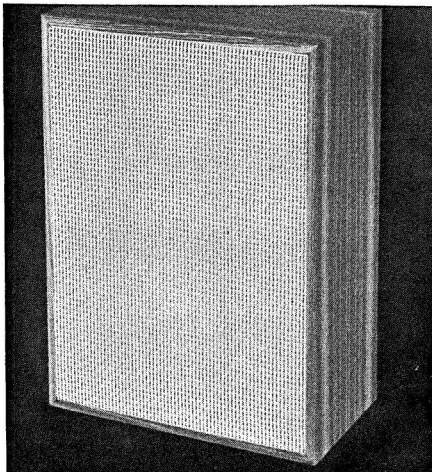

City Audio CA/11

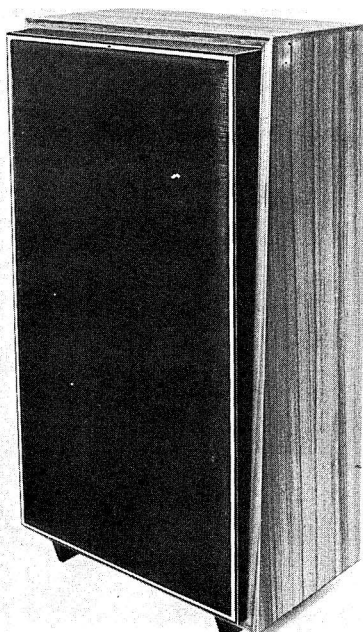

Decca Deram

A.D. Sealed Folded Horn

Designed to house Goodmans three-speaker system; 12in bass, Midax and Trebax. Alternative speaker arrangements are Kelly ribbon tweeter and Goodmans Audiom 51 or Woollett electrostatic treble and Wharfedale W12/RS/PST. Suitable full-range single 12in speakers are Goodmans Triaxiom 1220C, 212C, Axiom 301, Axiom 201, Tannoy Monitor. Rear of cabinet ready cut for attenuators. Size: 31½in high, 18 × 18in. Finish: teak or veneer of colour to choice. Front baffle sealed with black Formica (other colours to order) with neutral colour open-weave Tygan speaker grille. Price: (12in speaker version) £27; (15in speaker version) £32. Plus the cost of speaker units and crossovers to customer's choice.

DECCA

Decca Special Products, Ingate Place, Queenstown Road, London, SW8 3NT.
Tel: 01-622 6677.

Decca Deram Enclosure ★

Two units: 13 × 8in bass driver, 3in tweeter. HC: 8-10W. Size: 25 × 13¼ × 8in. Impedance: 8 ohms. Finish: teak or white. Price: £21.

Apollo

Enclosure incorporating 12in bass driver and DK30 ribbon tweeter. HC: 30W RMS. FR: 30Hz-25kHz. Impedance: 8-15 ohms. Size: 12 × 28 × 17in. Weight: 64lb. Finish: teak. Incorporates Kelly Acoustic lens. Response can be tailored to suit room with Room Acoustic Control (RAC). Price: £58.

DERWENT

Nichols Acoustic Fitments, Church Street, Bubwith, near Selby, Yorkshire.
Tel: Bubwith 206.

Gem

Small bookshelf enclosure only. Designed and approved for use with Richard Allan Hi-Fi module. Size: 13½ × 9 × 6in. Internal volume: 380 cu in. Sealed back panel. Detachable grille fret. Constructed from ¾in hardwoods. Finish: afrormosia, mahogany or teak. Prices from £7 plus units to choice. Carriage extra.

Opal Mk III

Large bookshelf enclosure. Designed for EMI or Fane 13 × 8in unit or KEF 13 × 9in and T.15. Size: 21 × 14½ × 9in. Internal volume: 1,850 cu in. Special baffle support and stiffening battens. Sealed, veneered, back panel. Baffle and grille fret secured from front. Constructed from ¾in solid afrormosia. Prices from £11.50 plus units to choice. Carriage extra.

Minor Mk II

Compact enclosure. Designed for 12in bass and

treble combination or ellipticals as in Opal Mk III. Size: 24 × 15 × 11½in. Internal volume: 1.71 cu ft. Construction identical with Opal Mk III. Prices from £14 plus units to choice. Carriage extra.

Major

Free-standing enclosure. Designed for Celestion Studio series coaxials, Wharfedale Super 12RS/DD. etc. Suitable for most 12in bass and two/three way systems. Size: 31½ × 18¼ × 12in (including 1in plinth). Internal volume: 2.68 cu ft. Sealed back panel. Finish: selected afrormosia veneers. Prices from £18.50 plus units to choice.

DUAL

International Audio Ltd,
Clive House, Queens Road, Weybridge, Surrey.
Tel: Weybridge 40125. Telex: 928153.

New-range of speakers being introduced for the 1972 season. Comprises models CL122, CL124, CL150, CL172, CL180 and CL190. Further details and prices to be announced.

DUETTE

Distributors: J. J. Silber Ltd,
11 Northburgh Street, London, EC1.
Tel: 01-253 8031.

ARS815

Infinite baffle enclosure with units. Two 3½in bass drivers, one 2¾in tweeter. FR: 60Hz-18kHz. HC: 10W. Impedance: 4 ohms. Finish: Canadian nut. Size: 6 × 7 × 10½in. Weight: 7lb. Price: £16.31 (including PT).

ARS740

Infinite baffle enclosure with units. Two 7¼in bass drivers, one 5½in mid-range unit, one 2¾in tweeter. FR: 50Hz-18kHz. HC: 25W. Impedance: 8 ohms. Finish: Canadian nut. Size: 14 × 10 × 24¾in. Weight: 29lb. Price: £28.78 (including PT).

DYNACO

Distributors: Howland-West Ltd,
3-5 Eden Grove, London, N78EQ.
Tel: 01-609 0293/4/5.

Dynaco A25

Speaker enclosure with 10in high compliance unit and two 1½in dome tweeters. Crossover: 1,500Hz. FR: 32Hz-20kHz. HC: 35W RMS. vci: 8 ohms. Dimensions: 20 × 11½ × 10in. Weight: 22lb. Finish: teak, walnut, rosewood. Price: £32 (plus £5.32 PT).

■ **DYNASTIC.** See Audio Services Ltd.

DYNATRON RADIO LTD

St Peters Road, Maidenhead, Berks, SL67QY.
Tel: Maidenhead 23331.

★ Indicates entry is illustrated

LS1034 ★

Shelf mounting infinite baffle enclosure with units. One $6\frac{1}{2}$ in bass driver, two $3\frac{3}{8}$ in tweeters. Impedance: 4 ohms. Size: $13\frac{3}{8} \times 7\frac{1}{2} \times 10\frac{1}{4}$ in. Price: £17-50.

LS1434 ★

Shelf mounting infinite baffle enclosure with units. One 8in bass driver, two $3\frac{3}{8}$ in tweeters. Impedance: 4 ohms. Size: $19\frac{3}{4} \times 11\frac{7}{8} \times 10\frac{1}{4}$ in. Price: £19-50.

LS1638

Infinite baffle enclosure with units. One 8in bass driver, one 3in mid-range unit and one $3\frac{3}{8}$ in tweeter. HC: 15W RMS. FR: 30Hz-18kHz. Impedance: 8 ohms. Finish: teak. Size: $19\frac{3}{4} \times 11 \times 9\frac{1}{2}$ in. Price: £29.

LS1734 ★

Infinite baffle enclosure with units and crossover.

One 8in bass driver, two $3\frac{3}{8}$ in tweeters. Choke/capacitor crossover. FR: 40Hz-16kHz. HC: 10W RMS. Impedance: 4 ohms. Finish: white spray finish. Matches Dynatron HFC36 and fits stand ST21. Size: $19\frac{3}{4} \times 11\frac{7}{8} \times 10\frac{1}{4}$ in. Price: £19-50.

LS2034

Reflex enclosure with units. One 8in bass driver, two $3\frac{3}{8}$ in tweeters. FR: 35Hz-18kHz. HC: 10W RMS. Impedance: 4 ohms. Floor-standing design in teak with padded front. Size: $26\frac{7}{8} \times 10\frac{1}{4} \times 15\frac{1}{2}$ in. Price: £26.

LS3034 ★

Infinite baffle enclosure with units. One 8in bass driver, two $3\frac{3}{8}$ in tweeters. Impedance: 4 ohms. Size: $26\frac{1}{2} \times 14\frac{3}{8} \times 12$ in. Price: £29.

LS4038

Infinite baffle enclosure with units and crossover.

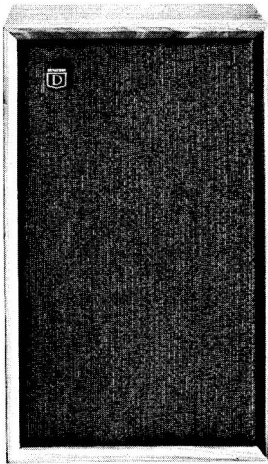

Dynatron LS1034

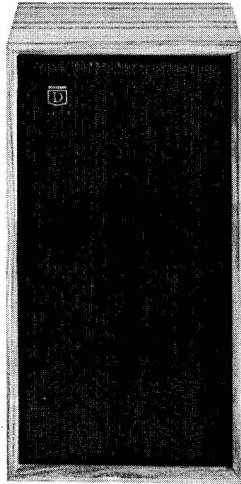

Dynatron LS 1434

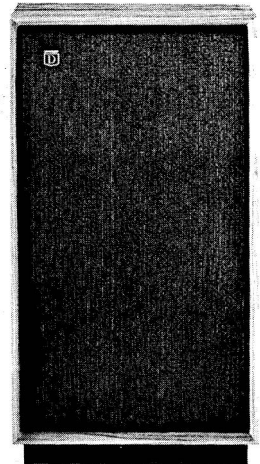

Dynatron LS3034

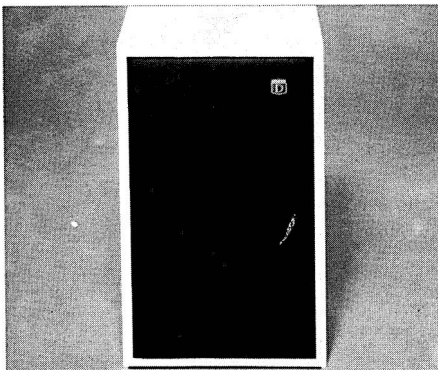

Dynatron LS1734

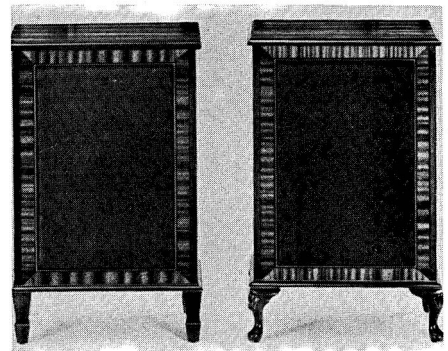

Dynatron LS2638

One 12in bass driver, one 5in mid-range unit, one 1in tweeter. FR: 30Hz-20kHz. HC: 40W RMS. Impedance: 4-8 ohms. Size: $26\frac{1}{2} \times 14\frac{1}{2} \times 12$ in. Finish: teak veneer. Designed to match all units in Dynatron audio separates range. Price: £42.

LS2528

Infinite baffle enclosure with units and crossover. One 8in bass driver, one 3in HF unit. FR: 30Hz-18kHz. HC: 15W RMS. Impedance: 4-8 ohms. Size: $23 \times 15\frac{1}{2} \times 10$ in. Finish: selected walnut veneers. Period style cabinet to match Dynatron HFC46 combination unit. Price: £32-74 (plus £5-26 PT).

LS2638 ★

Infinite baffle enclosure with units and crossover. One 12in bass driver, one 5in mid-range unit, one 1in tweeter. FR: 30Hz-20kHz. Impedance: 4-8 ohms. Size: $27\frac{1}{2} \times 18 \times 12\frac{1}{2}$ in. Finish: selected walnut veneer. Period style cabinet to match Dynatron HFC103 combination unit. Price: £52-50.

LS2828

Infinite baffle enclosure with units and crossover. One 8in bass driver, one 3in HF unit. FR: 30Hz-18kHz. HC: 15W RMS. Impedance: 4-8 ohms. Size: $23 \times 14\frac{1}{2} \times 10$ in. Finish: selected walnut veneer. Period style cabinet to match Dynatron HFC47. Price: £32-74 (plus £5-26 PT).

■ EAGLE INTERNATIONAL

Heather Park Drive, Wembley, HA1 1SU.
Tel: 01-903 0144.

DL.42

Infinite baffle enclosure. FR: 40Hz-20kHz. HC: 5W RMS. One 4in high compliance unit and one horn tweeter. vci: 8 ohms. Size: $10 \times 6 \times 6\frac{1}{2}$ in. Finish: teak and black front. Price: £10-20 (plus £1-71 PT).

DL.67 ★

Infinite baffle enclosure. FR: 35Hz-20kHz. HC: 10W RMS. One $6\frac{1}{2}$ in high compliance unit and one horn tweeter. vci: 8 ohms. Size: $11\frac{3}{4} \times 8 \times 6\frac{3}{4}$ in. Finish: teak and black front. Price: £15-65 (plus £2-79 PT).

AA16

Infinite baffle enclosure. FR: 40Hz-19kHz. HC: 8W RMS, 16W peak. Impedance: 8 ohms. Size: $14\frac{1}{4} \times 8\frac{3}{4} \times 6\frac{1}{4}$ in. Finish: oiled teak with charcoal grey grille. Price: £20-80 (plus £3-50 PT).

AA14

Infinite baffle enclosure with units and crossover. One 12in bass driver, one 6×4 in mid-range unit, two 4in tweeters. LC crossover network. FR: 30Hz-20kHz. HC: 25W RMS. Impedance: 8 ohms. Size: $23 \times 13 \times 11\frac{1}{2}$ in. Finish: oiled teak. Price: £38-60 (no PT).

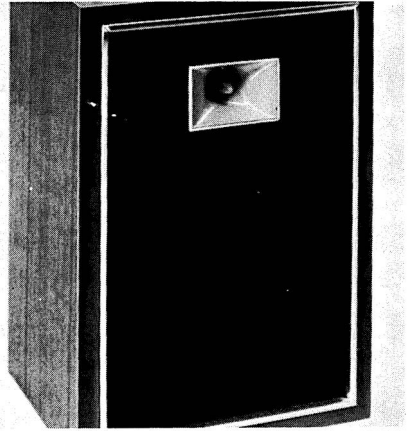
**Eagle DL67****■ EASTMAN**

Cosmocord Ltd,
Eleanor Cross Road, Waltham Cross, Herts.
Tel: Waltham Cross 27331.

Range of speaker systems imported from the USA. Prices vary from £26 to £200 each. No further details available as this edition closed for press.

■ EATON AUDIO FITMENTS

Leopold Street, Long Eaton,
Nottingham, NG104QF.
Tel: Long Eaton 2662/2818.

Trent 8

Corner reflex enclosure based on Goodmans design, suitable for any full-range 8in drive unit. $\frac{3}{4}$ in acoustic chipboard. Veneered in walnut, mahogany, oak or teak. Supplied in kit form. Size: $25\frac{1}{2}$ in high, $21\frac{1}{2}$ in wide, 14in back to front. Price: (teak) £9-95. Legs 45p extra.

Trent 10

Similar to Trent 8 but designed for 10in units. Supplied in kit form. Size: $31\frac{1}{2}$ in high, 25in wide, $15\frac{1}{2}$ in back to front. Also suitable for Celestion CX1512 and CX2012. Price: (teak) £11-20. Legs 45p extra.

Derwent

Bass reflex enclosure based on Wharfedale design. Two cubic feet. Supplied as kit. Suitable for any 8 or 10in full range units and certain 12in dual systems. Size: $28 \times 16 \times 10\frac{1}{2}$ in. Price: (teak) £9-90.

Mullard Unilex system

Cabinets suitable for the Mullard Unilex stereo system available. Full details and prices on request.

Eaton Economy range

See Constructional Kits section for full details

★ Indicates entry is illustrated

of Economy range of loudspeaker enclosure kits. Also details of kits to Wharfedale specifications, including Pipe kits.

Cabinets and enclosures built to customer's own designs and quotations given. Standard models can be modified to suit individual requirements where such alterations are practical.

■ EDWARD MICHELSEN CUSTOM CABINETS

'Sound Ideas', 494 New Cross Road, New Cross, London, SE14. Tel: 01-692 2981.

Also 216 Brampton Road, Bexleyheath, Kent. Tel: 01-303 9272.

Paraline

Designed by Rex Baldock as inexpensive high quality unit for home constructors. Folded horn enclosure driven by 8in unit. FR: better than 50Hz-17.5kHz. HC: 5W normal but with large peak capability. Suitable for amplifiers from 3W-40W. Size: 41in wide, 16in high, 7in deep (plus 12in legs making it 28in from floor). Finish: polished teak veneer. Price: £20.

Paramid

Same specification as the Paraline but a vertical version. Size: 16in wide, 41in high, 7in deep. Price: £20.

Bookshelf Horn

Mini version of Paraline in forward-facing mode. 8in drive unit. FR: better than 60Hz-17.5kHz. HC: 5W. Size: 24 × 16 × 7½in. For shelf-mounting or floor-standing on legs. Price: £18.50; (set of legs) £1.75 extra.

The ACE

An acoustic coupled enclosure designed to give omnidirectional sound dispersion. Utilises Voigt quarter-wave principle with back-loading of the drive unit along two tapered pipes. Drive unit: Lowther PM6, Elac 8N/185, Goodmans Axiette 8, Richard Allan CG8T (enclosure fully described in *Hi-Fi News* October, 1970). Size: 42 × 16 × 9½in. FR: 45Hz-18kHz. HC: 5W, but can be used with amplifiers up to 50W. Finish: teak veneer. Price: (with Elac 8N/185) £18.50; (with Goodmans Axiette 8) £22.50; (with Richard Allan CG8T) £22.50; (with Lowther PM6) £40.

Basset

Large unit designed to encompass the bottom octave only with maximum realism. Designed by Terence Atwell and described in *Hi-Fi News*, April 1970. Extends range of system to below 30Hz. Doubles as occasional seat or other purposes. Size: 66in wide, 17in high, 17in deep. Supplied with electronic filter and two KEF B139 bass drivers. Price: £80.

Unline

Similar to Paramid but designed for low-priced

Celestion 8in unit. Suitable for less expensive low-powered amplifiers. FR: 50Hz-14kHz. HC: 5W. Size: 41 × 14 × 7in. Finish: teak veneer. Price: £17.50.

Special Reflex (8in)

Designed for 8in unit and employing well-proved reflex principle, but with new damping material that extends and smooths the bass response (with Richard Allan CG8T). FR: 45Hz-17.5kHz. HC: 6W (with Wharfedale 8RS/DD). FR: 40Hz-20kHz. HC: 8W. Size: 25 × 12 × 12in (plus 1½in black base). Finish: teak veneer with black Vynair grille. Price: (enclosure only) £12.50; (with Richard Allan or Wharfedale unit) £20.

Special Reflex (10in)

Similar to Special Reflex (8in) but designed for Wharfedale Super 10 RS/DD. FR: better than 35Hz-20kHz. HC: 10W. Size: 28 × 14 × 12in (plus 1½in black base). Finish: teak veneer with dark Vynair grille. Price: (enclosure only) £15; (complete with Wharfedale unit) £27.50.

Small Folded Duct

Based on design by Brian Quilter in *Hi-Fi News*, October, 1968. Employs Elac 9 × 5in unit. FR: 55Hz-12kHz. Size: 18 × 11 × 8in. Finish: teak veneer. Supplied in pairs only. Price: (per pair) £22.

Wharfedale Unit 3

Cabinet only for Wharfedale Unit 3 (larger version). Price: (per pair) £16.

Wharfedale Unit 4

Cabinet only for Wharfedale Unit 4. Price: (per pair) £22.

Wharfedale Unit 5

Cabinet only for Wharfedale Unit 5. Price: (per pair) £30.

See Constructional Kits section for prices of Edward Michelsen speaker kits.

■ ELAC

Electro Acoustic Industries Ltd, Stamford Works, Broad Lane, London, N15. Tel: 01-808 0505/9. Cables: Elac, London, N15.

Elac E6-S

Infinite baffle compact enclosure with unit. Wide-range 6in speaker with long-throw suspension and moulded rubber surround of new design. FR: 55Hz-16kHz. HC: 10W. vci: 8 and 15 ohms. Size: 11 × 8 × 6in. Weight: 7lb. Finish: scratch resistant simulated teak or walnut. Price: £10 (plus £1.62 PT).

Elac E6-S Mk II

New version to be introduced at end of 1972. Details of specification and price being finalised as this edition of the year book closed for press.

■ ELGAR

English Audio (1970) Ltd, North Station Road, Colchester, Essex. Tel: Colchester (0206) 73467.

Elgar

Infinite baffle enclosure with units. One 12in bass driver, one 4in HF unit. HC: 25W RMS. Finish: teak. Size: $14\frac{3}{4} \times 21\frac{1}{4} \times 9\frac{1}{2}$ in. Price: £35.

EMI

EMI Sound Products Ltd, Blyth Road, Hayes, Middlesex. Tel: 01-573 3888.

LE1

Infinite baffle enclosures with units. HC: 5W RMS. Impedance: 8 ohms. Finish: teak. Specification and price on application.

LE2

Infinite baffle enclosure with units. HC: 15W RMS. Impedance: 8 ohms. Finish: teak. Specification and price on request.

LE3.SS

Infinite baffle enclosure with units. HC: 15W RMS. Impedance: 8 ohms. Finish: teak. Specification and price on application.

LE4

Infinite baffle enclosure with units. HC: 25W RMS. Impedance: 8 ohms. Finish: teak. Specification and price on application.

EMPHASIS

50a The Avenue, Kilburn, London, NW6. Tel: 01-451 0517.

DB9

Matched cube-shaped speaker enclosures. Choice of Tannoy Monitor Gold 12in or Altec Lansing 604E driver units. Size: (each cube) $24 \times 24 \times 24$ in on 6in chrome pillar. Finish: teak, rosewood, coloured lacquers or hessian. Prices: according to specification.

FERROGRAPH

The Ferrograph Company Ltd, Auriema House, 442 Bath Road, Cippenham, Slough, Bucks, SL1 6BB. Tel: Burnham (062-86) 62511. Telex: 847297.

Model S1

Reflex system enclosure with units and crossover. One LF driver, one mid-range unit and one tweeter. 18-element steep-cutting crossover network. Impedance: 8 ohms nominal. HC: 25W RMS. FR: 45Hz-20kHz \pm 3dB. Crossover: 400Hz, 3-5kHz. Size: (cabinet) 25in high, 14in wide, $17\frac{1}{2}$ in deep; (stand) $14\frac{1}{2}$ in high. Weight: (cabinet) 56lb, (stand) 6lb. Finish: satin finish dark grey, aluminium trim, white surround and folk weave fabric grille. Connections via recessed press terminals in rear. Price: £95.

FISHER

UK Distributors: REW Audio Visual Ltd, 266-268 Upper Tooting Road, London, SW17. Tel: 01-672 4471/2 and 9175.

Details of new range of Fisher hi-fi equipment

not available as this edition of the Year Book closed for press.

J. J. FRANCIS (Wood Green) LTD

123 Alexandra Road, Hornsey, London, N8. Tel: 01-888 1662.

Countdown

Infinite baffle speaker enclosure. Two units: $3\frac{3}{8}$ in tweeter and $6\frac{1}{2}$ in long-throw low frequency. Crossover: 1kHz half-section. FR: 50Hz-20kHz. HC: 10W RMS. vci: 4-15 ohms. Dimensions: $14 \times 10 \times 6$ in. Weight: 7lb 6oz. Finish: solid teak wood. Internal damping with Dr Bailey's long fibre wool. Price: £12 (including tax).

GABRAPHONE

Modern Engineering & Technology Ltd, 4 Station Road, West Canterbury, Kent. Tel: Canterbury 60431.

Type 11C

Dual-cavity infinite baffle speaker enclosure with units. One 13×8 in bass driver, one 9×5 in dual cone mid-range and HF unit. HC: 25W. FR: 20Hz-22kHz. Impedance: 8 or 16 ohms. Finish: teak or white. Size: $11\frac{1}{4} \times 33\frac{1}{2} \times 12\frac{3}{4}$ in. Price: £99.

Type 111C

Triple-cavity infinite baffle enclosure with units. One 13×8 in bass driver, one 9×5 in mid-range unit, one dual cone 9×5 in HF unit. HC: 35W. FR: 20Hz-20kHz. Impedance: 8 or 16 ohms. Finish: teak or white. Size: $11\frac{1}{4} \times 43\frac{3}{8} \times 15$ in. Price: £199.

GOODMANS LOUDSPEAKERS LTD

Downley Road, Havant, Hampshire, PO92NL. Tel: Havant 6344. Telex: 86296.

Double Maxim

Infinite baffle enclosure with units and crossover. Two 4in bass drivers, one 1in dome HF tweeter. Crossover: 5kHz. FR: 40Hz-22kHz (DIN 45:500). HC: 25W (DIN). Minimum power: 10W. Interior volume: 9 litres. Impedance: 4 ohms. Finish: teak, walnut or white. Size: $17\frac{3}{4} \times 6\frac{3}{4} \times 7\frac{1}{2}$ in. Weight: 11lb. DIN connector with cable. Price: (teak or walnut) £33-70; (white) £36-74.

Havant

Reflex enclosure with units and crossovers. One 8in bass driver, one $3\frac{3}{8}$ in mid-range unit, one $1\frac{1}{8}$ in dome tweeter. Crossovers: 800Hz and 3kHz. Interior volume: 18 litres. FR: 45Hz-22kHz (DIN 45:500). HC: 20W (DIN). Minimum power: 10W. Impedance: 4 ohms. Finish: teak, walnut or white. Size: $19 \times 10\frac{1}{2} \times 10\frac{1}{2}$ in. Weight: $18\frac{1}{2}$ lb. DIN connector with cable. Price: (teak or walnut) £28-56; (white) £31-63.

Mezzo 3

Reflex enclosure with units and crossover. One

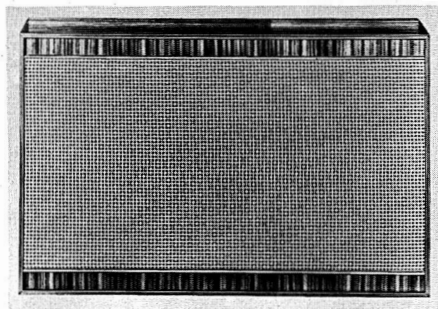

Grundig System 731

12in bass driver, one 1in dome tweeter. Cross-over: 2kHz. FR: 40Hz-22kHz. HC: 30W (DIN). Impedance: 8 ohms. Size: $19\frac{3}{4} \times 12\frac{1}{4} \times 9\frac{1}{2}$ in. Finish: teak or walnut. Price: £35-70.

Magnum K2

Infinite baffle enclosure with units and cross-overs. One 12in bass driver, back-loaded mid-range unit, 1in dome tweeter. Crossover: 800Hz and 5kHz. FR: 30Hz-22kHz. HC: 40W (DIN). Impedance: 4-8 ohms. Air cushion suspension to bass unit. Size: $24 \times 15 \times 11\frac{3}{8}$ in. Finish: teak or walnut. Price: £46-20.

Magister

Infinite baffle enclosure with three units and crossovers. One 15in bass driver, one 4in mid-range unit, one 1in dome tweeter. Crossovers: 800Hz and 5kHz. FR: 26Hz-22kHz. HC: 50W RMS. Impedance: 4-8 ohms. Finish: teak or walnut. Size: $27 \times 20 \times 14\frac{1}{4}$ in. Price: £65-63.

Minister

Floor-standing enclosure with units and cross-over. Bass driver with plastic coated and suspended diaphragm, dome type tweeter. HC: 20W RMS. Impedance: 4-8 ohms. FR: 45Hz-22kHz. Finish: teak or walnut. Size: $19 \times 10\frac{1}{2} \times 10$ in. Supplied in matched pairs. Price: (per pair) £49-20 (including PT).

Dimension-8

Mass-loaded reflex enclosure with units and crossover. One $12\frac{1}{2}$ in bass driver, four $5\frac{1}{4}$ in bass drivers, two $4\frac{1}{2}$ in mid-range units, two 1in dome tweeters. Crossovers: 80Hz, 800Hz, 4kHz. FR: 30Hz-22kHz (DIN 45:500). HC: 60W. Minimum amplifier power: 10W. Interior volume: 40 litres. Impedance: 4 ohms. Finish: teak, walnut or white. Size: $30\frac{1}{2} \times 14 \times 12\frac{1}{2}$ in. Weight: 44lb. Price: (teak or walnut) £72-44; (white) £78-76.

Goodwood

Infinite baffle enclosure with units and cross-over. One 12in bass driver, one 4in mid-range unit, one 1in dome tweeter. Crossover: 800Hz, 4kHz. FR: 40Hz-22kHz. HC: 50W (DIN).

Impedance: 4-8 ohms. Size: $29\frac{1}{2} \times 14\frac{1}{4} \times 10\frac{3}{8}$ in. Finish: teak, white or walnut. Price: to be announced.

GRUNDIG (Great Britain) LTD

Hi-Fi Division, Sydenham, London, SE26.

Tel: 01-778 2211.

System 731 ★

Six-unit enclosure. Two bass drivers, two mid-range units, two HF dome tweeters. HC: 50W RMS. FR: 40Hz-20kHz. vci: 5 ohms. Finish: matt walnut. Size: $24\frac{1}{2} \times 15\frac{3}{4} \times 5\frac{1}{2}$ in. Price: (per pair) £134-90.

Troika 4012

Comprises two separate omni-directional tweeter systems and one bass enclosure. Two drivers in bass enclosure, six tweeters in each treble enclosure. HC: 30W RMS. FR: 40Hz-20kHz. vci: 5 ohms. Finish: matt walnut. Sizes: bass enclosure $24\frac{1}{2} \times 16 \times 5\frac{1}{2}$ in; treble enclosures $5\frac{1}{2} \times 5\frac{1}{2} \times 5\frac{1}{2}$ in. Price: (complete system) £116-60.

Troika 3012

Infinite baffle enclosure with units and cross-over. One "Box 301" bass unit, Sphere 300 mid-range and treble unit. Crossover: 400Hz. FR: 40Hz-20kHz. HC: 25W. Impedance: 4-5 ohms. Size: (bass unit) $21 \times 13\frac{3}{4} \times 5$ in, (HF Sphere) $5\frac{1}{2}$ in diameter. Weight: (bass unit) $25\frac{1}{2}$ lb, (HF Sphere) 3lb. Finish: (bass unit) light matt plus fabric grille, (HF Sphere) black with four circular grilles. Sphere 300 stands on a tripod, total height 10in. Price: £82-73 (plus £13-27 PT).

HACKER RADIO LTD

Norreys Drive, Cox Green, Maidenhead, Berks.

Tel: Maidenhead 22261/5.

LS500B ★

Infinite baffle enclosure with units and cross-over. One 8in long-throw bass driver, one $3\frac{3}{8}$ in HF pressure unit. Impedance: 8 ohms. FR: 75Hz-14kHz. HC: 12W sine wave power. L/C crossover unit. Finish: teak veneer. Input socket: two-pin DIN. Size: $10\frac{3}{4} \times 16\frac{1}{2} \times 8\frac{1}{2}$ in. Price: £21 (including PT).

LS1000C, LS1000D ★

Infinite baffle enclosure with units and cross-over. One 13×8 in long-throw bass driver, one $3\frac{3}{8}$ in HF pressure unit. Impedance: (LS1000C) 15 ohms; (LS1000D) 8 ohms. FR: 60Hz-17kHz. HC: 15W sine wave power. L/C crossover unit. Finish: teak veneer. Input socket: two-pin DIN. Size: $13\frac{3}{4} \times 20\frac{1}{2} \times 11\frac{1}{4}$ in. Price: £27 (no PT); (teak stand to raise speaker 9in from floor) £3-50.

LS1500B ★

Infinite baffle enclosure with units and cross-over. One $13\frac{1}{2} \times 8$ in long-throw bass driver, one

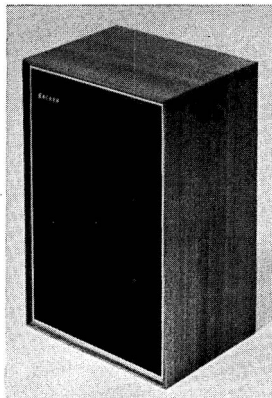

Hacker LS500B

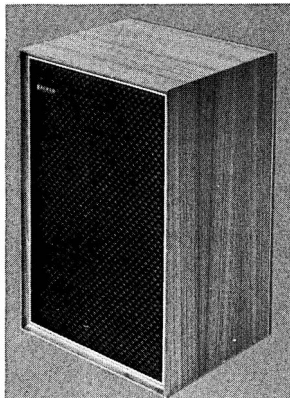

Hacker LS1000C/D

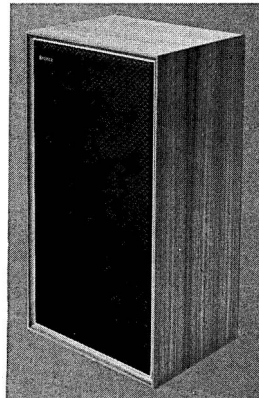

Hacker LS1500B

7 × 5in mid-range unit in isolated chamber, one 1in domed tweeter. Impedance: 8 ohms. FR: 50Hz-20kHz. HC: 20W sine wave power. L/C/R crossover unit. Finish: teak veneer. Input socket: two-pin DIN. Incorporates special mid-range control adjustable from rear of cabinet. Pressing a button increases mid-range response at around 2kHz by approximately 5dB. Size: 15½ × 30 × 12in. Price: £48 (no PT).

Also available for Hacker speakers are extension leads fitted with DIN two-pin plugs and DIN two-pin sockets. LD/DD4 four-metre lead 50p, LD/DD8 eight-metre lead 80p.

■ HARMAN KARDON

Highgate Acoustics Ltd,
184 Great Portland Street, London, W1.
Tel: 01-636 2901.

HK50

Infinite baffle enclosure with units and crossover. One 8in bass driver, one 2¼in tweeter. Crossover: L/C 2kHz. FR: 35Hz-20kHz. HC: 40W RMS. Impedance: 8 ohms. Size: 11¾ × 18¾ × 11¾in. Finish: walnut. High-frequency level control incorporated. Price: £50-84 (plus £8-16 PT).

Citation 13

Enclosure with units and crossover. Dual-chamber triple-port reflex system. Three 7in bass drivers, one 1½in mid-range unit, two 1in dome tweeters. Crossover: 2.5kHz, 7.5kHz. FR: 30Hz-20kHz. HC: 60W RMS. Impedance: 6 ohms. Size: 20¾ × 29½ × 4¾in. Weight: 75lb. Finish: walnut with beige grille cloth. Two level controls for adjusting mid-range and upper-frequency response, mounted on rear panel. Price: £150-80 (plus £24-20 PT).

■ HECO

Distributors: Acoustico Enterprises Ltd,
6-8 Union Street, Kingston-upon-Thames,
Surrey. Tel: 01-549 3471/3.

P2000 ★

Infinite baffle enclosure with units. 7in bass driver, 1in dome tweeter. Crossover: 2kHz. FR: 42Hz-25kHz (DIN). HC: 30W RMS. Impedance: 8 ohms. Size: 13½ × 8¾ × 7in. Weight: 16½lb. Finish: teak, rosewood, oak or white. Price: £48-05.

P3000

Infinite baffle enclosure with units. 7in bass driver, 4in mid-range unit, 1in dome tweeter. Crossover: 800Hz, 2.5kHz. FR: 40Hz-25kHz (DIN). HC: 35W RMS. Impedance: 8 ohms. Size: 15¾ × 8¾ × 7in. Weight: 18½lb. Finish: teak, rosewood, oak or white. Price: £52-88.

P4000

Infinite baffle enclosure with units. 8in bass driver, 1½in mid-range unit, 1in dome tweeter. Crossover: 800Hz, 3kHz. FR: 30Hz-25kHz

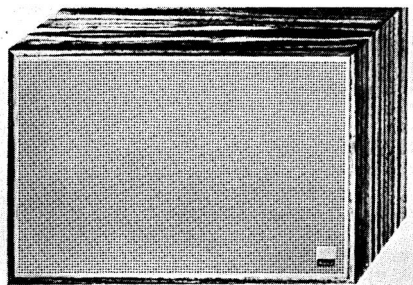

Heco P2000

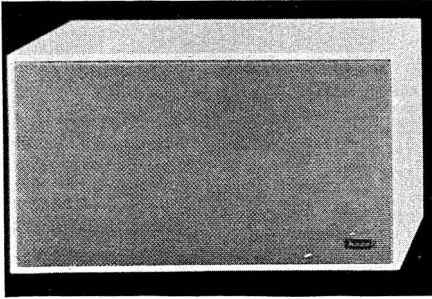

Heco SM525

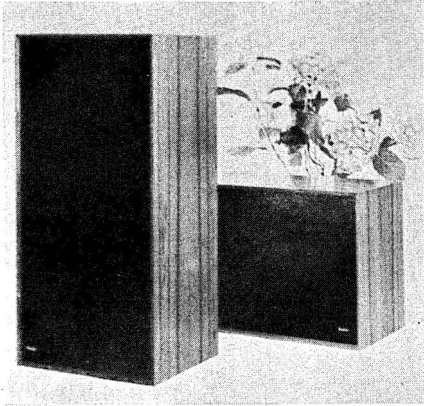

Heco SM540

(DIN). HC: 40W RMS. Impedance: 8 ohms. Size: $18 \times 10 \times 8$ in. Weight: $24\frac{1}{2}$ lb. Finish: teak, rosewood, oak or white. Price: £59.29.

P5000

Infinite baffle enclosure with units. 12in bass driver, 5in mid-range unit, $1\frac{1}{2}$ in tweeter, 1in dome super tweeter. Crossover: 250Hz, 800Hz, 3kHz. FR: 25Hz-25kHz (DIN). HC: 50W RMS. Impedance: 8 ohms. Size: $23\frac{1}{2} \times 12\frac{5}{8} \times 9\frac{7}{8}$ in. Weight: 46lb. Finish: teak, rosewood, oak or white. Price: £84.

P6000

Infinite baffle enclosure with units. 13in bass driver, 5in mid-range unit, $1\frac{1}{2}$ in tweeter, 1in dome super tweeter. Crossover: 250Hz, 800Hz, 3kHz. FR: 20Hz-25kHz (DIN). HC: 60W RMS. Impedance: 8 ohms. Size: $31 \times 14 \times 10\frac{1}{2}$ in. Weight: 57lb. Finish: teak, rosewood, oak or white. Price: £110.

ES1

Infinite baffle enclosure with units and crossover. One 7in bass driver, one 4in tweeter. FR: 50Hz-16kHz (DIN). HC: 12W RMS. Impedance: 4-8 ohms. Size: $17\frac{3}{8} \times 8\frac{3}{4} \times 7\frac{3}{4}$ in. Finish: teak or rosewood. Supplied with cable and DIN plugs. Price: £16.10 (plus £2.80 PT).

ES2

Infinite baffle enclosure with units. FR: 50Hz-14kHz (DIN). HC: 8W RMS. Impedance: 4-8 ohms. Size: $13\frac{3}{4} \times 8\frac{3}{4} \times 7\frac{1}{4}$ in. Finish: teak or rosewood. Cable and DIN plug supplied. Price: £9.08 (plus £1.60 PT).

SM525 ★

Infinite baffle enclosure with units and crossover. One 7in bass/mid-range unit, one 1in dome tweeter. Crossover: 1.7kHz. FR: 45Hz-25kHz (DIN). HC: 25W RMS. Impedance: 4-8 ohms. Size: $15 \times 8\frac{1}{2} \times 6\frac{3}{8}$ in. Weight: $10\frac{1}{4}$ lb. Finish: teak or rosewood. Cable with DIN plug supplied. Price: £19.83 (plus £4.17 PT).

SM535

Infinite baffle enclosure with units and crossover. One 8in bass/mid-range unit, two 1in dome tweeters. Crossover: 1.5kHz. FR: 40Hz-25kHz (DIN). HC: 35W RMS. Impedance: 4-8 ohms. Size: $17\frac{1}{8} \times 9\frac{1}{4} \times 7\frac{7}{8}$ in. Weight: 23lb. Finish: teak or rosewood. Cable with DIN plug supplied. Price: £26.45 (plus £4.63 PT).

SM540 ★

Infinite baffle enclosure with units and crossover. One 10in bass driver, one $5\frac{1}{4}$ in mid-range unit, three 1in dome tweeters. Crossover: 650Hz, 1.6kHz. FR: 30Hz-25kHz (DIN). HC: 40W RMS. Impedance: 4-8 ohms. Size: $22 \times 11 \times 7\frac{7}{8}$ in. Weight: $26\frac{1}{2}$ lb. Price: £35.95 (plus £6.29 PT).

■ THOMAS HEINITZ

35 Moscow Road, Queensway, London, W2. Tel: 01-229 2077.

C.Q. Junior

Controlled Q reflex enclosure. Special Goodmans 10×6 in unit. FR: 45Hz-15kHz, depending on unit. Finishes: teak, walnut, mahogany, all-white (others to order at no extra charge). Size: $16\frac{1}{2} \times 9\frac{1}{2} \times 9\frac{1}{4}$ in. Weight: 7lb. Price: approximately £11.

■ HELME

P. F. and A. R. Helme Ltd, Summerbridge, Harrogate, HG34DR, Yorks. Tel: Darley 279.

Re-styled high fidelity speaker systems finished in teak. All models use drive units by Peerless of Denmark. See separate entry in Speaker Drive Units Section. All systems are infinite baffle and have 4 ohms or 8 ohms impedance.

Linnet ★

Houses one full-range special 6×4 in unit. HC: 15W. FR: 60Hz-20kHz. Dimensions: $12 \times 8 \times 7$ in. Price: £13.53.

Firecrest ★

Houses $6\frac{1}{2}$ in bass driver with two 2in tweeters. Crossover: 2.4kHz. FR: 45Hz-22kHz. HC: 20W RMS. Dimensions: $14 \times 9 \times 7\frac{1}{2}$ in. Price: £24.73.

Swift ★

Houses a 6½in bass unit and two 2in tweeters. Crossover frequency: 2.5kHz. HC: 20W. FR: 40Hz-22kHz. Dimensions: 18 × 10 × 9in. Price: £27.52.

Swallow ★

Houses an 8in bass unit and two 2¼in tweeters. Crossover frequency: 2.5kHz. HC: 30W. FR: 35Hz-22kHz. Dimensions: 20 × 11 × 9in. Price: £32.66.

Oriole ★

Houses a 12in bass unit, 5 × 7in mid-range and two 2½in tweeters. Crossover frequencies: 500 Hz and 3.5kHz. HC: 50W. FR: 25Hz-18kHz. Dimensions: 28 × 16½ × 12in. Price: £59.50.

HI-SOUND

Electronic Manufacturing Co (UK) Ltd, Devonshire House, High Street, Deritend, Birmingham, B12 0LP. Tel: 021-772 7145.

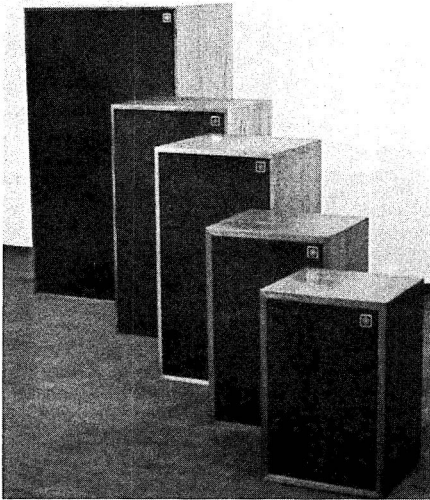

Helme Speaker Systems

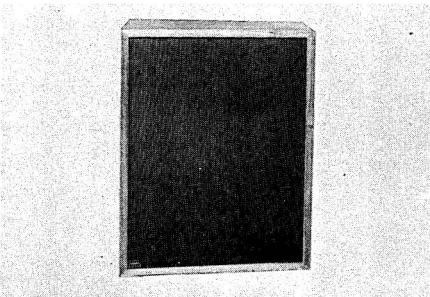

Howland-West Narvik

Isis

Infinite baffle enclosure with units and crossover. One 8in Celestion bass driver, one 3½in Celestion tweeter. HC: 12W RMS. Impedance: 8 ohms. Size: 16 × 10 × 9in. Weight: 5½lb. Finish: teak or walnut. Price: £13.20 (plus £2.14 PT).

Odin

Infinite baffle enclosure with units and crossover. One 12in Goodmans bass driver, one 3½in Goodmans HF unit. HC: 25W RMS. Impedance: 8 ohms. Weight: 12lb. Price: £25 (no PT).

Thor

Infinite baffle enclosure with units and crossover. One 12in Goodmans bass driver, one 3½in Goodmans mid-range unit, one dome tweeter. Impedance: 4 ohms. Size: 26 × 16 × 13in. Weight: 17lb. Finish: teak or walnut. Price: £38 (no PT).

HOWLAND-WEST LTD

3-5 Eden Grove, London, N78EQ.
Tel: 01-609 0293/4/5.

Narvik ★

Infinite baffle enclosure with speakers. 12in bass driver, mid-range unit and tweeter. Crossover network included. FR: 35Hz-22kHz. HC: 25W. Size: 23½ × 17¾ × 12in. Weight: 32½lb. Finish: teak. Price: £29.75.

Bergen

Infinite baffle enclosure with speakers. 6½in high compliance bass driver and tweeter. FR: 50Hz-22kHz. HC: 12W. Size: 13¾ × 9 × 8¾in. Weight: 10¼lb. Finish: teak. Price: £13.50 (plus £2.24 PT).

IMF PRODUCTS (GB)

Westbourne Street, High Wycombe, Bucks.
Tel: High Wycombe 35166.

IMF Compact ★

Compact three-way enclosure with units and crossover designed for bookshelf-mounting or floor-standing on cruciform stand. One 6½in roll-surround bass driver operating under near aperiodic conditions, one 5in mid-range unit in short transmission line, one 3in tweeter with damped surround cone. Crossover: 500Hz, 5kHz. FR: 40Hz-20kHz (substantially flat from 100Hz-15kHz). Recommended driving power: 15-40W. Impedance: 8 ohms. Size: 16½ × 10½ × 10in. Weight: approximately 15lb. Finish: teak, supplied in matched pairs. Price: (per pair) £60 (plus £9.98 PT).

IMF Studio (export)

Transmission line enclosure with four units and crossover. 8in plastic cone bass driver, 5in mid-range unit in separate line, 1¾in tweeter with chemical diaphragm, ¾in super tweeter with chemical dome. Four-way crossover at 375Hz,

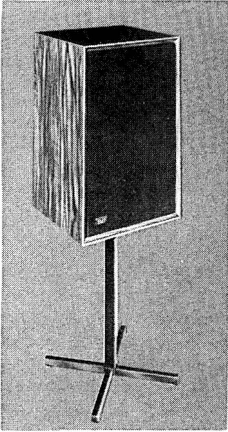

IMF Compact

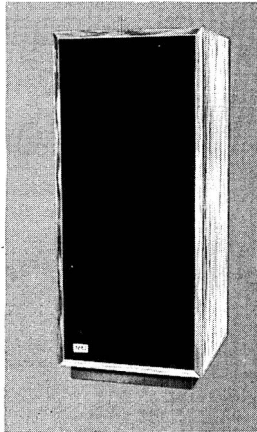

IMF Studio Speaker

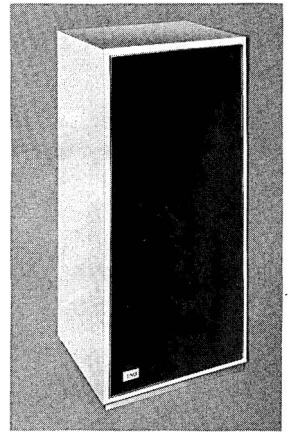

IMF Professional Monitor

3.5Hz and 13kHz. FR: 25Hz to beyond audibility. Driving power: 20-60W RMS. Impedance: 8 ohms. Size: 36×14×15in. Calibrated level controls (±2dB) for mid- and high-frequencies. Finish: supplied in matched 'mirror image' pairs in teak or walnut. Weight: 68lb each. Price: £83-97 (including PT).

IMF Monitor ★

Transmission line enclosure with four units and crossover. 13×9½in flat polystyrene diaphragm bass driver, 6in plastic cone mid-range unit, 1¾in tweeter with chemical diaphragm, ¾in super tweeter with chemical dome. Four-way crossover at 375Hz, 3.5kHz and 13kHz. FR: 20Hz to beyond audibility. Driving power: 25-60W RMS. Impedance: 8 ohms. Size: 40×17½×19¾in. Mounted on castors. Weight: 120lb. Finish: supplied in matched 'mirror image' pairs in teak or walnut (other finishes to order). Price: £116.

IMF Monitor (export)

Same specification as the Monitor but with the addition of a separate mid-range line and separate calibrated level controls providing ±2dB for mid- and high-frequencies. Price: £137-50.

IMF Professional

Similar specification to the Monitor but with high-power crossover allowing use of up to 100W amplifiers. FR: 17Hz to beyond audibility. Made from high density material and finished in plastic laminate. Size: 42×17½×19¾in. Fitted with castors. Handles optional extra. Supplied to order in matched 'mirror image' pairs. Finishes include natural wood laminates, wood facimile laminates and standard plain colours. Weight: approx 140lb. Price: £150-£180.

IMF Professional Studio ★

As Export Studio but with higher power handling crossover and fully laminated finish. Handles and castors optional extras. Weight: 70lb. Price: from £97-50.

Sub Woofer

Designed to extend the low frequency range of high quality bookshelf speakers below 25Hz. Built-in integrated amplifier with electronic filtering. FR: 25-100Hz on variable slope. Impedance: 8 ohms. No further details of specification available at time of going to press. Price: approximately £100.

■ **IMHOFS LTD**

112-116 New Oxford Street, London, WC1.
Tel: 01-636 7878.

Junior Mk II ★

Infinite baffle enclosure with units. 13×8in bass driver, 3in treble unit. Crossover 5kHz. FR: 50Hz-20kHz. HC: 10W RMS. Impedance: 8 ohms. Finish: teak veneer with forest green grille. Size: 12½×24×9¾in. Weight: 15lb. Price: £16-80.

IM.50

Infinite baffle enclosure with unit. One 6½in dual-cone full-range driver. FR: 55Hz-16kHz. HC: 10W RMS. Impedance: 8 ohms. Size: 10¾×8×5½in. Weight: 6½lb. Finish: teak veneer with forest green grille. Price: (per pair) £22-72 (plus £2-28 PT per pair).

IM.100 ★

Infinite baffle enclosure with units. 13×8in bass driver, 1½in treble unit. Crossover 1kHz. FR: 50Hz-20kHz. HC: 25W. Impedance: 8 ohms. Finish: teak veneer with forest green grille. Size: 11¾×19×7½in. Weight: 15lb. Price: £25.90.

IM.200

Infinite baffle enclosure with units. 13×9in bass driver, 1½in treble unit. Crossover 1kHz. FR: 40Hz-20kHz. HC: 25W. Impedance: 8 ohms. Finish: teak with forest green grille. Size: 15¼×24¼×10¼in. Weight: 28lb. Price: £37·80.

■ **ITT-KB**

ITT Consumer Products (UK) Ltd,
Foots Cray, Sidcup, Kent, DA145HT.
Tel: 01-300 7733.

KS653

Bass reflex enclosure with unit. One 8×5in full-range driver. HC: 7W. Finish: teak veneer with slotted front. Impedance: 8 ohms. Size: 15¾×9¾×6in. Weight: 7¼lb. Price: (per pair) £20·50 (including PT).

KS658

Infinite baffle enclosure with units and crossover. One 6½in bass driver, one 3¾in HF unit. Impedance: 8 ohms. HC: 15W music power. Finish: teak appearance with grey front grille. HF control. Size: 18×11½×6¾in. Weight: 12lb approximately. Price: (per pair) £28·50.

KS659

Infinite baffle enclosure with units and crossover. One 6½in bass driver, one 6×4in mid-range unit, one 3¾in tweeter. Impedance: 4 ohms. HC: 18W music power. Finish: teak appearance with grey front grille. FR: 45Hz-18kHz. Size: 27½×11½×9¾in. Weight: 20¾lb. Price: (per pair) £49.

KS660

Infinite baffle enclosure with units and crossover. One 12in bass driver, one 6×4in mid-range unit, one 3¾in tweeter. Impedance: 4 ohms. HC: 20W music power. Finish: teak veneer. Size: 27¾×16×9½in. Weight: 33lb. Price: (per pair) £68.

■ **JORDAN-WATTS LTD**

Benlow Works, Silverdale Road, Hayes,
Middlesex.
Tel: 01-573 6928.

GT

Reflex enclosure. One Jordan-watts module and HF dome tweeter. Treble control fitted. FR: 30Hz-22kHz. HC: 15W. Finish: teak. Price: £34·50 (plus £5·50 PT).

Jodrell

Reflex enclosure. Twin Jordan-Watts module. Treble control fitted. FR: 40Hz-22kHz. HC: 30W. Finish: teak. Weight: 56lb. Price: £51·30 (plus £8·23 PT).

Jumbo

Infinite baffle. Power handling 12W. Forward facing. Shelf or wall mounting. Incorporates one Jordan-Watts modular unit. FR: 70Hz-20kHz. Size: 16½×8×3½in. Weight: 13lb. Finish: teak. Price: £21·60.

Janet

Infinite baffle. One full-range Jordan-Watts module. FR: 70Hz-20kHz. HC: 12W RMS.

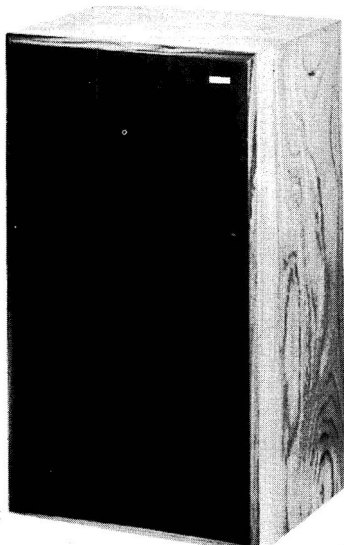

Imhof Junior Mk II

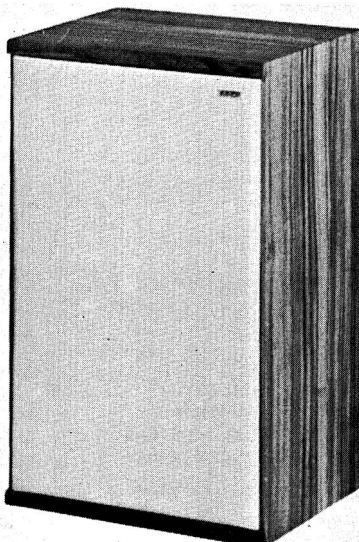

Imhof IM.100

★ Indicates entry is illustrated

Compact shelf-mounting full range speaker system. Finish: teak with green Vynair. Size: $12 \times 8 \times 6\frac{1}{2}$ in. Weight: 13lb. Price: £21.60.

Juno ★

Reflex enclosure. Power handling 12W. Forward facing. Incorporates one Jordan-Watts modular unit. FR: 40Hz-20kHz. Size: $24\frac{1}{2} \times 12\frac{1}{2} \times 6\frac{1}{2}$ in. Weight: 27lb. Price: £28.80.

Juliet ★

Reflex cabinet. One full-range Jordan-Watts module. FR: 40Hz-20kHz. HC: 12W RMS. Compact shelf-mounting full range speaker system. Finish: teak with green Vynair. Size: $16 \times 10 \times 9$ in. Weight: 28lb. Price: £28.20.

Gemini ★

Reflex enclosure. Power handling 25W. Forward facing. Incorporates two Jordan-Watts modular units. FR: 40Hz-20kHz. Size: $30 \times 13\frac{1}{2} \times 7\frac{1}{2}$ in. Weight: 50lb. Price: £44.40.

Jupiter

Reflex enclosure. Power handling 25W. Forward facing. Incorporates two Jordan-Watts modular units. FR: 20Hz-20kHz. Size: $34 \times 5 \times 10\frac{1}{2}$ in. Weight: 70lb. Price: £56.40.

■ **KEF ELECTRONICS LTD**

Tovil, Maidstone, Kent.

Tel: Maidstone 57258. Cables: KEF, Maidstone.

Coda ★

Two-way miniature bookshelf enclosure. One B110 6in bass unit, one T27 1in tweeter. Crossover: 3.5kHz. FR: 45Hz-30kHz. HC: 15W. Impedance: 8 ohms. Size: $13 \times 9 \times 5\frac{1}{2}$ in. Weight: $10\frac{3}{4}$ lb. Finish: teak, walnut or white with brown or grey grille cloth. Price: £18.75 (plus £3.12 PT).

Cantor

Two-way bookshelf or wall-mounting enclosure.

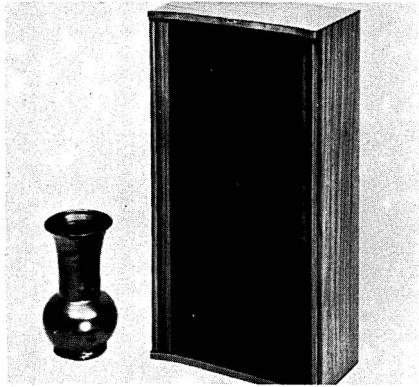

Jordan-Watts Juno

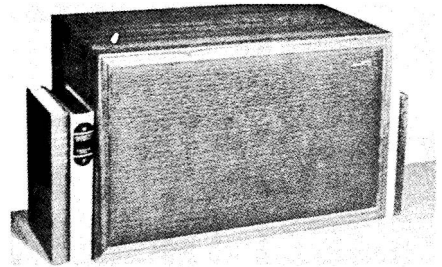

Jordan-Watts Juliet

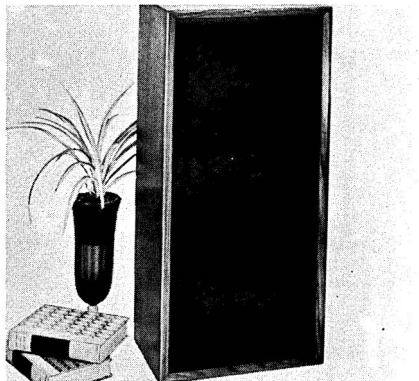

Jordan-Watts Gemini

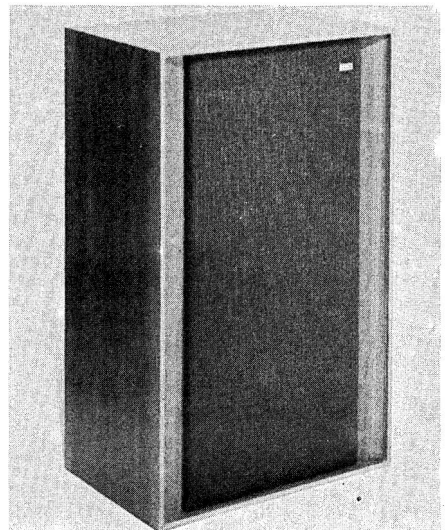

KEF Concerto

One B200 8in bass unit, one T27 1in tweeter. Crossover: 3.5kHz. FR: 40Hz-30kHz. HC: 20W. Impedance: 8 ohms. Size: $18\frac{1}{2} \times 4\frac{3}{4} \times 11$ in. Weight: $13\frac{1}{2}$ lb. Finish: teak, walnut or white with brown or grey grille cloth. Price: £22.25 (plus £3.70 PT).

Cresta II

Compact two-unit enclosure. 6in. bass driver, 1 in tweeter. Integrated electrical crossover at 3.5kHz. HC: 15W. FR: 45Hz-30kHz. Impedance: 8 ohms. Size: $12\frac{1}{2} \times 7\frac{1}{2} \times 8\frac{5}{8}$ in. Finish: teak, walnut or white. Price: £20.84 (plus £3.47 PT).

Chorale

Compact model in choice of walnut, teak or white. Size: $18\frac{1}{2} \times 11 \times 8\frac{5}{8}$ in. B200 and T27 units. HC: 20W. FR: 35Hz-30kHz. Impedance: 8 ohms. Price: £28.50 (plus £4.74 PT).

Celeste

Compact model in choice of walnut or teak with brown or white grille cloth. Size: $18 \times 10\frac{1}{2} \times 6\frac{1}{2}$ in. HC: 20W. FR: 40Hz-20kHz. Impedance: 8 ohms. Price: £30.

Cadenza ★

Reflex design in walnut, teak or white with brown, grey or beige grille cloth. Size: $24 \times 14 \times 12$ in. B200, D300 and T27 units. HC: 35W. FR: 35Hz-30kHz. Impedance: 8 ohms. Price: £42.50.

Concerto ★

Reflex design in walnut, teak or white. Size: $28 \times 17 \times 12$ in. B139, B110 and T27 units. HC: 30W. FR: 30Hz-30kHz. Impedance: 8 ohms. Price: £58.50.

See also Constructional Kits section for Kefkits.

■ KF PRODUCTS LTD

Brookfield House, Hopes Carr, Stockport, Cheshire. Tel: 061-480 7428 and 1761.

PF8-S

Infinite baffle enclosure with single unit. One 8in dual-cone, high-flux full-range unit with ceramic magnet and long-throw bass driver. FR: 80Hz-17kHz. HC: 8W RMS. Impedance: 8 or 15 ohms. Finish: teak veneer with matching Vynair front grille. Size: $15 \times 10\frac{1}{2} \times 5\frac{3}{4}$ in. Price: £8.04 (plus £1.34 PT).

E138S ★

Infinite baffle enclosure with single unit. One EMI 13 × 8in dual-cone driver. FR: 75Hz-13 kHz. HC: 10W RMS. Impedance: 3, 8 or 15 ohms. Finish: teak veneer with matching Vynair front grille. Size: $18 \times 13\frac{1}{2} \times 9$ in. Packed in matching pairs for stereo. Price: (each speaker) £13.40 (no PT).

KR8 ★

Infinite baffle enclosure with units and crossover. One $6\frac{1}{2}$ in dual-cone bass driver, one 4in tweeter.

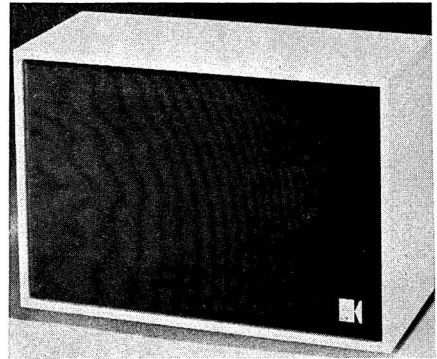

KEF Coda

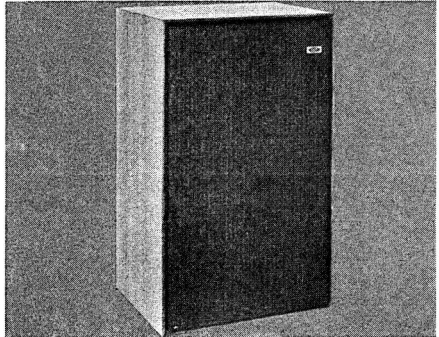

KEF Cadenza

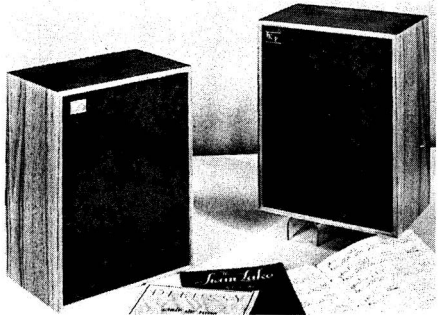

KEF Products E138-S

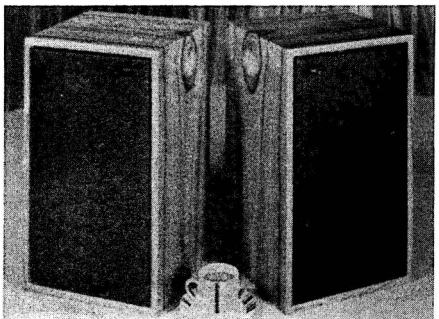

KEF KR8

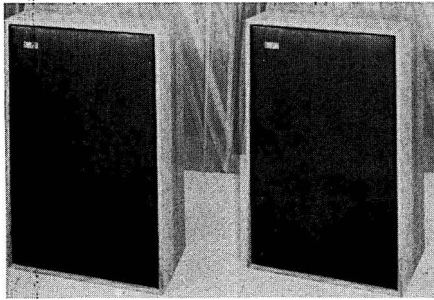

KF KR20

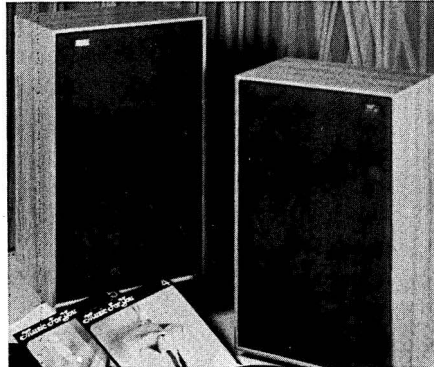

KF KR25

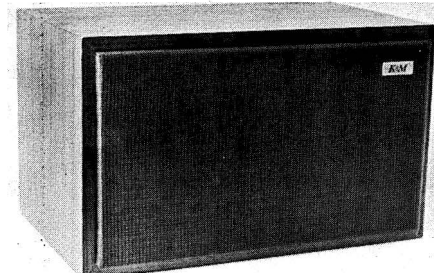

Keith Monks Elf

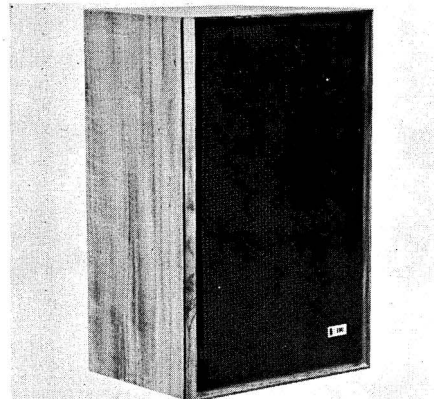

Keith Monks Super Elf

Crossover: 6.5kHz. FR: 65Hz-16kHz. HC: 8W RMS. Impedance: 8 ohms. Size: 17 × 10 × 9in. Finish: teak veneer. Sold in pairs with matched veneer. Price: (per speaker) £15.43 (plus £2.51 PT).

KR10

Infinite baffle enclosure with units and crossover. One 8in bass driver with ceramic magnet, one 4in tweeter. Crossover: 6.5kHz. FR: 55Hz-16kHz. HC: 10W. Impedance: 8 ohms. Size: 21½ × 11½ × 10½in. Finish: teak veneer. Sold in pairs with matched veneer. Price: (per speaker) £18.86 (plus £2.23 PT).

KR20 ★

Infinite baffle enclosure with units and crossover. One 13½ × 8¼in bass driver with ceramic magnet, one 3¼in tweeter. Crossover: 5kHz. FR: 40Hz-20kHz. HC: 20W RMS. Impedance: 8 ohms. Size: 24 × 15 × 11¼in. Finish: teak veneer. Aluminium centre to bass driver and curved cone to tweeter. Price £37.75.

KR25 ★

Infinite baffle enclosure with units and crossover. One 14 × 9in bass driver, two 5in mid-range units, one 3¼in tweeter. HF response switches on crossover panel. FR: 35Hz-20kHz. HC: 30W. Impedance: 8 ohms. Size: 28 × 17 × 11in. Finish: teak veneer. Price: £59.20.

■ **KEITH MONKS (Audio) LTD**

26-30 Reading Road South, Fleet, near Aldershot, Hants. Tel: Fleet 7316.

Elf ★

Bookshelf reflex enclosure with three units. Built-in filter system. 6½in bass driver, two 3in tweeters. HC: 12W RMS. FR: 40Hz-16kHz. Finish: teak, walnut, pine, white, laurel. Price: £20.20 (plus £3.36 PT).

D15/40 Minor

No-compromise bookshelf speaker system. Incorporates one TCL module. Cabinet designed as low friction phase inverter to provide optimum load to driver. HC: 15W RMS over specified range (30W music rating). Finish: teak. Size: 17½ × 11 × 8¼in. FR: 40Hz-22kHz. Weight: 20lb. Price: £30.

Super Elf ★

Bookshelf enclosure with units and crossover. One 8in long-throw bass driver, two 4in-high response tweeters. FR: 40Hz-18kHz. Impedance: 8 ohms. HC: 15W RMS. Size: 17½ × 11 × 8¼in. Finish: hard waxed teak veneer with Vynair grille. Price: £28.50 (plus £4.74 PT).

■ **KELETRON**

Kelgrove Sales Ltd, St Mark's Rise, Dalston, London, E8.

Keletron loudspeakers and amplifiers give you much more sound per pound.



Keletron loudspeakers are already enjoying a well earned reputation for high quality at surprisingly low prices.

The new Keletron 1500 & 700 Stereo Amps. are built to this same high standard.

Amplifier power outputs are 15 and 7 watts

respectively and both the models have input facilities for magnetic and ceramic cartridges, tuner and tape.

They are built from conservatively rated components and solid state circuitry to ensure a long and trouble-free life.

KELETRON KN400 TWO SPEAKER SYSTEM

Power Handling 4 watts RMS

Size 11" x 7" x 6"

Recommended Retail Price £7.72 each.

KELETRON KN600 THREE SPEAKER SYSTEM

Power Handling 6 watts RMS

Size 12½" x 7½" x 6½"

Recommended Retail Price £12.91 each.

KELETRON KN800 THREE SPEAKER SYSTEM

Power Handling 8 watts RMS

Size 18½" x 10½" x 8½"

Recommended Retail Price £15.90 each.

KELETRON KN1100 FOUR SPEAKER SYSTEM

Power Handling 10 watts RMS

Size 21" x 11½" x 9½"

Recommended Retail Price £20.40 each.

KELETRON KN1600 THREE SPEAKER SYSTEM

Power Handling 15 watts RMS

Size 21" x 15" x 8½"

Recommended Retail Price £25.20 each.

KELETRON KN2100 THREE SPEAKER SYSTEM

Power Handling 20 watts RMS

Size 24" x 15" x 11½"

Recommended Retail Price £30.60 each.

KELETRON KSA 1500 STEREO AMPLIFIER

Power Output 15 watts RMS each channel

Half Power Bandwidth 30 Hz - 30 KHz ± 3 dB

Distortion (THD) Better than 0.5% @ 7 watts (1KHz)

Input Sensitivity MAG. 4mV Ceramic 30 mV

Tape/Tuner 250 mV

Output impedance 8-16 ohms

Recommended Retail Price £39.00

KELETRON KSA 700 STEREO AMPLIFIER

Same specifications as Keletron KSA 1500

Power Output 7 watts RMS each channel

Recommended Retail Price £29.00

All Keletron Stereo Amplifiers Incorporate a Press Button Low-Pass Filter Switch

Send today for free illustrated literature on all these models.

KELGROVE SALES LTD.

St. Marks Rise, London, E 8

"York" Height: 3' 6"
 15" Monitor Width: 1' 11½"
 Depth: 1' 2⅝"



Chatsworth R.T. Height: 33½"
 12" Monitor Width: 15½"
 Depth: 10¼"



The best
 speaker
 for the job

**III LZ
 Mk 11** Height: 1' 3"
 Width: 1' 11"
 Depth: 9½"

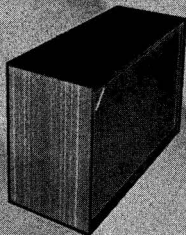

... MADE TO YOUR MEASURE

You CHOOSE THE ENCLOSURE to suit your needs - the difference is only in the power handling capacity and the size to fit your home. Thus you can have the shelf-sized III LZ MARK 11 with 25 watts, the Chatsworth at 35 watts, or the York with 50 watts - whichever you have the sound's the same. All are fitted with unique Monitor Gold "two into one" loudspeakers having a frequency response of 30-20,000 Hz and an impedance of 8Ω nominal, 5Ω minimum.

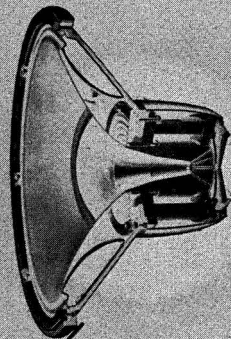

THE *Monitor* **GOLD**
 DUAL CONCENTRIC

... provides the perfect integrated source needed for stereo. The Monitor Gold is two separate transducers in a single assembly fed by a sophisticated cross-over and treble control network.

The majority of Recording and T.V. studios use TANNOY Monitors.

70% of the Monitor Golds produced are exported to:
 U.S.A. · JAPAN · CANADA · SOUTH AFRICA · AUSTRIA
 ITALY · SINGAPORE · HOLLAND · GERMANY
 BELGIUM · SWITZERLAND · NORWAY · SPAIN
 AUSTRALIA · NEW ZEALAND · THAILAND · ZAMBIA
 KENYA · HONG KONG · MALAYSIA · FRANCE



**Norwood Road West Norwood SE27 9AB
 Telephone: 01-670 1131**

KN400

Infinite baffle two-way system with speakers and crossover. 5in bass driver with ferrite magnet, 2in tweeter. Impedance: 8 ohms (15 ohms to order). HC: 8W music power. FR: 80Hz-14kHz. Finish: teak or American walnut. Size: 11 × 7 × 6in. Price: £7-72 (including PT).

KN600

Infinite baffle three-way system with speakers and crossover. 6½in twin-cone bass driver with ferrite magnet, 3in mid-range unit and 2in tweeter. Impedance: 8 ohms (15 ohms to order). HC: 12W music power. FR: 60Hz-19kHz. Finish: teak or American walnut. Size: 12½ × 7¾ × 6¼in. Price: £12-91 (including PT).

KN800

Infinite baffle three-way system with speakers and crossover. 13½ × 8½in twin-cone bass driver with ferrite magnet, 3in mid-range unit and 2in tweeter. Impedance: 8 ohms (15 ohms to order). HC: 16W music power. FR: 40Hz-19kHz. Finish: teak or American walnut. Size: 18½ × 10½ × 8½in. Price: £15-90.

KN1100

Infinite baffle four-way system with speakers and crossover. 13½ × 8½in bass driver with ferrite magnet, 6 × 4in mid-range unit, two 2½in tweeters. Mid-range unit and tweeters housed in separate airtight compartment inside main cabinet. Impedance: 8 ohms (15 ohms to order). HC: 20W music power. FR: 40Hz-19-5kHz. Finish: teak or American walnut. Size: 21 × 11½ × 9¾in. Price: £20-40.

KN1600

Infinite baffle three-way system with speakers and crossover. 12in twin-cone bass driver with ferrite magnet, 8 × 5in mid-range unit, 4in tweeter. Mid-range unit and tweeter housed in separate airtight compartment inside main cabinet. Impedance: 8 ohms (15 ohms to order). HC: 30W music power. FR: 35Hz-19-5kHz. Finish: teak or American walnut. Size: 21 × 15 × 8½in. Price: £25-20.

KN2100

Infinite baffle three-way system with speakers and crossover. 12in twin-cone bass driver with ferrite magnet, 6½in mid-range unit and 4in tweeter. Impedance: 8 ohms (15 ohms to order). FR: 30Hz-19-5kHz. HC: 40W music power. Finish: teak or American walnut. Size: 24 × 15 × 11½in. Price: £30-60.

■ KIRKMAN (Crawley) LTD

40 The Broadway, Crawley, Sussex.
Tel: Crawley 26670.

Home Concert Hall Mk 2 ★

Isothermal tapered reflex enclosure with speakers and crossover. Two Richard Allan

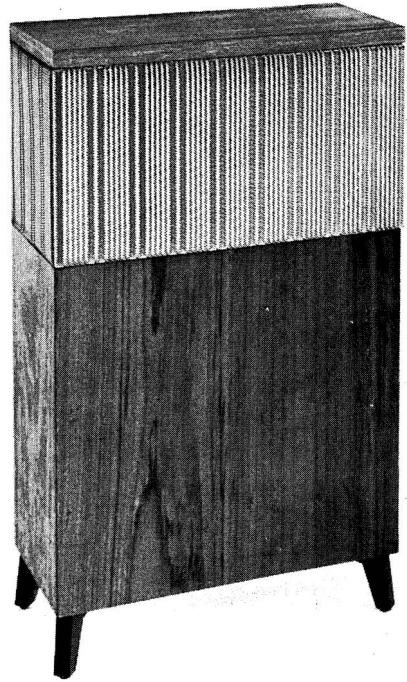

Kirkman Home Concert Hall Mk 2

CR5 bass units and STC 4001E tweeter. Two ¼-section crossovers at 3kHz and 4kHz. FR: 28Hz - 6dB; 20kHz - 3dB. HC: 20W music. Omni-directional throughout frequency range in horizontal plane. Inside and outside of enclosure employed to maintain non-resonant closely controlled acoustic load. Finish: teak with bronze or black grille. Size: 31 × 18 × 8½in. Weight: 44lb. Price: £52.

■ KLEIN & HUMMEL

Sole UK agents: F. W. O. Bauch Ltd,
49 Theobald Street, Boreham Wood, Herts.
Tel: 01-953-0091.

OY ★

Studio monitor speaker enclosure comprising two separate built-in 30W solid state bass and treble amplifiers and 4-unit drive system. Input: 0-775V and 1-55V at 4-7K to 500Hz dividing network filter. Speakers: 9in bass unit, two 5in mid-lift units and a 'top' horn. FR: 30Hz-20kHz. Complete equalisation controls for room and position matching. Dimensions: 19 × 12 × 9in. Weight: 45lb. Finish: grey formica or walnut. Psn: mains. Price on application.

OZ

Full-range studio monitoring speaker system

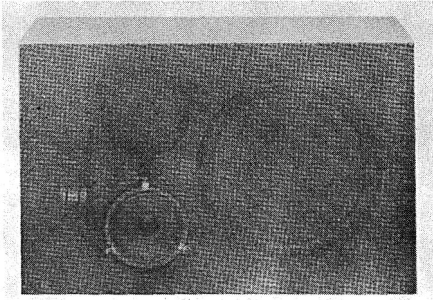

Klein and Hummel OY

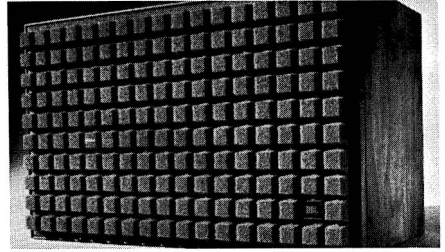

IBL Century LI00

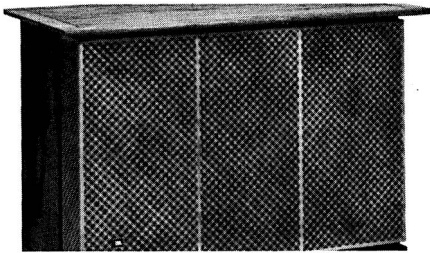

JBL Olympus

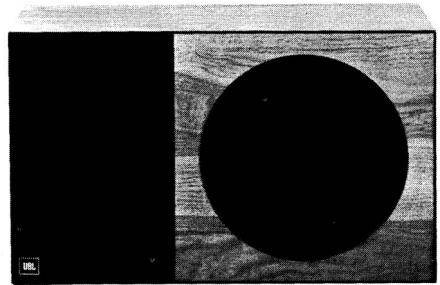

JBL Nova L88

including two built-in 30W amplifiers. Two 12in Altec bass drivers, one Altec mid-range and treble pressure system with horn. Inputs: 0 or +6dB for 110 phon at one metre. Size: $27\frac{3}{4} \times 35\frac{1}{2} \times 16\frac{1}{2}$ in. FR: 30Hz-20kHz (40Hz-16kHz ± 2 dB). Crossover frequency: 800Hz. Price on application.

■ KLINGER

Klinger Controls Ltd,
Spencer Court, 7 Chalcot Road, London,
NW18LU. Tel: 01-586 2922/3.

S34

Infinite baffle enclosure with units and crossover. One 8 \times 5in bass driver, one 2 $\frac{1}{2}$ in tweeter. Crossover: 5kHz (capacitor). FR: 55Hz-12kHz. HC: 6W RMS. Impedance: 8 ohms. Size: 13 \times 7 \times 8in. Weight: 8lb. Finish: teak with slotted wood front. Price: £9 (plus £1.50 PT).

S42

Infinite baffle enclosure with units and crossover. One long-throw 6 $\frac{1}{2}$ in bass driver with rubber surround, one 3 $\frac{1}{2}$ in mid-range unit, one 2 $\frac{1}{2}$ in tweeter. Crossover: 5kHz (L/C). FR: 40Hz-18kHz. HC: 12W RMS. Impedance: 8 ohms. Size: 17 $\frac{1}{2}$ \times 10 \times 8in. Weight: 11lb. Finish: teak cabinet with gold/black woven grille. Price: £16.65 (plus £2.70 PT).

S50 MK II

Infinite baffle enclosure with units and cross-

over. One 8in long-throw bass driver with rubber surround, two 3 $\frac{1}{2}$ in solid-back tweeters. Crossover: 5kHz (L/C). FR: 40Hz-18kHz. HC: 15W. Impedance: 8 ohms. Size: 18 \times 13 \times 7in. Weight: 14lb. Finish: teak cabinet with brown basket weave grille and silver trim. Price: £19.50 (plus £3.15 PT).

■ KORTING

Europa Electronics Ltd, Howard Place,
Shelton, Stoke-on-Trent, ST14NW.
Tel: Stoke-on-Trent 29316.

LSB 15, Type 30 851

Special speaker box, 5in bass and mid-range system, 12,000 gauss; and 4in tweeter system, 9,000 gauss. HC: 15W approx, music power. FR: 45Hz-18kHz. vci: 45 ohms. Natural walnut colour, satin finish. Dimensions: 7 \times 11 $\frac{1}{2}$ \times 9 $\frac{1}{2}$ in. Supplied with 16ft patch cord with flat-pin plug. Price: approximately £17 (inc. PT).

LSB25, Type 29 860

Infinite baffle with bass and treble units. Speakers: 8in bass unit, 5 \times 3in tweeter. FR: 40Hz-16kHz. HC: 15W music power. vci: 4.5 ohms. Size: 22 \times 12 \times 5in. Finish: satin finish natural walnut. Supplied with 10ft lead and plug. Price: approximately £28 (including PT).

LSB 45, Type 30 865

Infinite baffle with bass and treble units. Speakers: 9 $\frac{1}{2}$ in bass unit, 7 \times 5in mid- and

upper-frequency unit. FR: 30Hz-20kHz. HC: 25W music power. vci: 4-5 ohms. Size: 25 × 13 × 7in. Finish: satin finish natural walnut. Supplied with 10ft lead and plug. Price: approximately £40 (including PT).

■ JAMES B. LANSING

Distributors: Feldon Audio Ltd,
126 Great Portland Street, London, W1.
Tel: 01-580 4314.

JBL Aquarius 4

Dual radial horn enclosure with units and crossover. One 8in bass driver, one 2in tweeter. Crossover: 3kHz. FR: 40Hz-20kHz (40Hz-16kHz ±5dB). HC: 25W RMS. Impedance: 8 ohms. Omni-directional system with phase correction devices. Size: 40in high, 10 × 10in square. Weight: 47lb. Finish: walnut or white. Price: approximately £96.

JBL Nova L88 ★

Reflex enclosure with units and crossover. One 12in bass unit with 3in-diameter voice coil, one 2in tweeter. Crossover: 1.2kHz (12dB/octave constant impedance). FR: 20Hz-20kHz (30Hz-18kHz ±4dB). HC: 40W RMS. Impedance: 8 ohms. Bookshelf or free-standing design. Size: 24 × 14 × 12in. Weight: 48lb. Finish: walnut with geometric fabric grille. Price: approximately £100.

JBL Century L100 ★

Reflex enclosure with units and crossover. One 12in bass driver, one 4in mid-range unit, one 2in tweeter. Crossover: 2.5kHz, 7.5kHz (12dB/octave constant impedance). FR: 20Hz-20kHz (40Hz-15kHz ±3dB). HC: 50W RMS. Impedance: 8 ohms. Domestic version of JBL control monitor. Size: 24 × 14 × 13in. Weight: 51lb. Finish: walnut with sculptured grille in blue, orange or brown. Price: approximately £150.

JBL Olympus ★

Reflex enclosure with drive units, passive radiator and crossover. One 15in bass driver, one 15in passive radiator, one 1in horn-loaded aluminium mid- and high-frequency unit with acoustic lens. Crossover: 800Hz (variable crossover, 12dB/octave constant impedance). FR: 20Hz-18kHz ±3dB. HC: 75W RMS. Impedance: 8 ohms. Domestic version of JBL studio monitor. Rated 22% efficient in 10 cu ft enclosure. Size: 40 × 27 × 20in. Weight: 140lb. Finish: walnut with hand-carved walnut grille. Price: approximately £400.

JBL Lancer 101

Reflex enclosure with units and crossover. One 15in bass driver, one 1in horn-loaded mid-high-frequency unit with 90% dispersion acoustic lens. Crossover: 2.5kHz (12dB/octave constant impedance). FR: 20Hz-20kHz (30Hz-20kHz

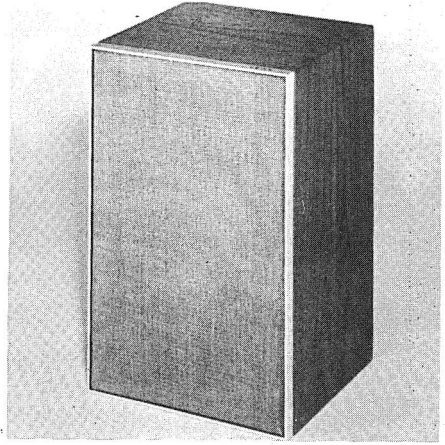

Leak Sandwich 150

±4dB). HC: 50W RMS. Impedance: 8 ohms. High efficiency system with high transient response HF unit. Size: 25 × 18 × 13in. Weight: 60lb. Finish: walnut sides, hand-carved front grille in walnut, marble top. Price: approximately £220.

■ LARSON

Cole Electronics Ltd,
7-15 Lansdowne Road, Croydon, Surrey,
CR92HB. Tel: 01-686 7581.

LP720 Pyramid

Infinite baffle enclosure with units and crossover. One 10in long-throw bass driver with Neoprene suspension, one 1½in dome tweeter. Both drive units to DIN specification. Crossover: 1kHz. FR: 37Hz-20kHz. HC: 40W RMS. Impedance: 4 ohms. Size: (pyramid shape) 25in high, 12½in square at base, 5in square at top. Weight: 20lb. Finish: teak, whitelac or jacaranda. Design claims to provide omni-directional sound dispersion. Price: £49 (plus £9-80 PT).

■ LEAK

H. J. Leak & Co Ltd, Bradford Road,
Idle, Bradford, Yorks, BD108SF.
Tel: Bradford 612552. Telex: 51407.

Sandwich 150 ★

Infinite baffle enclosure with 6½in sandwich bass driver and 2½in cellulose acetate butyrate treble unit. Impedance: 8 ohms nominal. FR: 60Hz-18kHz. HC: 18W DIN. Finish: teak or walnut. Size: 15½ × 10 × 8½in. Price: £20-85 (plus £3-65 PT).

Sandwich 250 ★

Infinite baffle enclosure with units and crossovers. 8in sandwich bass driver with 2½in

★ Indicates entry is illustrated

multi-directional tweeter. Floor-standing or bookshelf system. Impedance: 8 ohms nominal. FR: 50Hz-18kHz. HC: 18W DIN. Finish: teak or walnut. Size: $19\frac{3}{4} \times 11 \times 10$ in. Price: £26-81 (plus £4-69 PT).

Sandwich 600 ★

Infinite baffle freestanding speaker with 12in bass driver, 4in sandwich mid-range unit and 1in multi-directional treble unit. Three-way 10-element crossover at 1kHz and 4kHz. FR: 40Hz-20kHz. Impedance: 8 ohms nominal. HC: 40W DIN. Finish: teak or walnut. Size: $26 \times 15 \times 11\frac{1}{4}$ in. Price: £49-50.

■ **LECSO AUDIO LTD**

Nuffield Road Industrial Estate,
St Ives, Huntingdonshire.
Tel: St Ives (Hunts) 64125 (STD code 0480).

HL1 ★

Horn enclosure with units and crossover. Two 13×8 in bass drivers, one 5in mid-range unit, one pressure tweeter. Crossover: 450Hz (12dB/octave), 5-5kHz (18dB/octave). FR: 30Hz-25kHz. HC: 50W RMS. Impedance: 8 ohms. Size: $14\frac{1}{2}$ in wide, 36in high, 17in deep. Weight: approximately 60lb. Designed to stand against a wall or across a corner for optimum performance. Mid-range horn adjustable for best stereo image. Finish: black/red fabric covering with various top panels. Special fabric finishes to order. Price: £89.

■ **L.N.B. AUDIO LTD**

25 Cambridge Street, Loughborough, Leics.
Tel: 050-93 61229.

Para-Tran 6

Infinite baffle enclosure with speakers and cross-

over. One special 6½in bass driver plus one 3½in tweeter. Crossover: 3kHz. FR: 50Hz-17kHz. HC: 15W music. Impedance: 8 ohms. Special membrane compensator. Long fibre wool damping material. Size: $15\frac{1}{2} \times 11 \times 8$ in. Weight: 15lb. Finish: teak cabinet with complementary grille. Price: £39-25 per pair (including PT).

Para-Lab Super ★

Labyrinth enclosure with speakers and crossover. One special 6½in bass driver plus KEF T27 tweeter. Crossover: ½ section at 3kHz. FR: 40Hz-25kHz. HC: 20W music. Impedance: 8 ohms. Size: $23\frac{1}{2} \times 10\frac{1}{4} \times 9$ in. Weight: 24lb. Finish: teak cabinet with Vynair front and black trim. Labyrinth acoustic line. Price: £59-50 per pair (including PT).

Para-Lab 20

Labyrinth enclosure with speaker and crossover. One KEF B200 bass driver, one KEF T27 mid-range and HF unit, one STC 4001G super HF tweeter. Crossovers: ½ section at 3kHz and 9kHz. FR: 30Hz-25kHz. HC: 30W music. Impedance: 8 ohms. Size: $31 \times 11 \times 11\frac{1}{4}$ in. Weight: 40lb. Finish: teak cabinet with black Vynair front and black trim. Labyrinth acoustic line. Price: £101-50 per pair (including PT).

■ **LOCKWOOD & CO (Woodworkers) LTD**

63 Lowlands Road, Harrow, Middx.
Tel: 01-422 3704/0768.

Mini-slim

Reflex, forward facing, 12in units. Rec. Tannoy 12in dual concentric, Tannoy III LZ dual concentric. Size: $27\frac{1}{2} \times 19 \times 9\frac{3}{8}$ in. Price (with specified units): from approximately £45.

Minor Slim

Reflex, forward facing, 12 or 15in units. Rec.

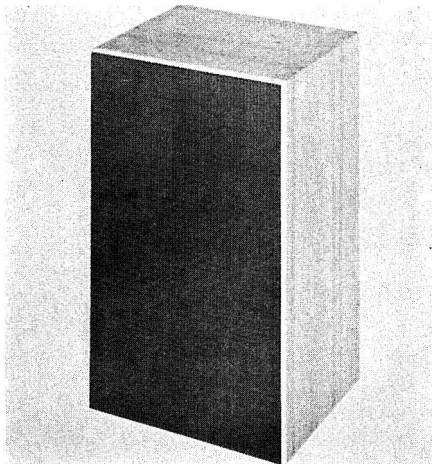

Leak Sandwich 600

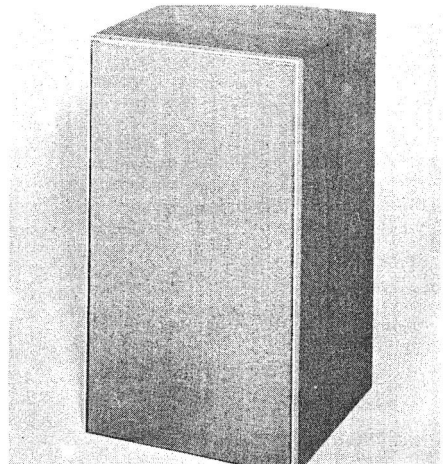

Leak Sandwich 250

Tannoy 12 or 15in dual concentric, and units listed for Mini-slim. Size: $33\frac{1}{8} \times 20 \times 11\frac{1}{4}$ in. Price (with specified units): from approximately £50.

Major Slim

Reflex, forward facing, 12 or 15in units. Rec. Tannoy 12 and 15in dual concentric. Size: $38 \times 24 \times 11\frac{1}{4}$ in. Price: from approximately £64.

■ LOWTHER MANUFACTURING CO

Lowther House, St Mark's Road, Bromley, Kent, BR29HQ.

Tel: 01-460 5225. Cables: Lowther, Bromley.

Corner Reproducer TP1

Folded bass horn/direct HF horn type. One specially designed 6in pressure unit PM3. Acoustical crossover. FR: 40Hz-22kHz. Size: $47 \times 32 \times 31$ in from corner. Weight: 70lb. Price: (Standard Model) £180., (Model B) £200; (Model D) £150.

Acousta Cabinet

Model FH/V. Folded horn type, forward facing, with rear folded horn. Vertical on runners. Designed for use with single 6 or 8in unit. Rec. Lowther PM6. FR: 40Hz-18kHz. Size: $32 \times 18\frac{1}{4} \times 14\frac{1}{2}$ in. Weight: 60lb. Price (without unit): £32 (plus £2-57 PT).

Mini Acousta

Model FH/V (vertical). Folded horn type. Forward facing with rear folded horn. Veneered all round. Designed for use with one 6-8in unit. Rec. Lowther PM6 or PM7. FR: 40Hz-20kHz. Size: $27 \times 15 \times 13$ in. Price (without unit): £32 (plus £2-57 PT).

Audiovector

Compound horn. Upward facing mid- and high-frequency horn with rear folded horn. Designed for use with single 6in unit. Acoustic crossover. FR: 40Hz-22kHz. Rec. PM2, PM2 Mk II or PM4. Size: $26\frac{1}{2} \times 19 \times 34$ in. Weight: 75lb. Price (Model A without unit): £80 (plus £6-41 PT); (Model B without unit) £70 (plus £5-61 PT).

Dual Position Acousta

Folded horn. Rearward facing into corner or along wall at 45°. Bass outlets coupling into corner of room or along wall. Designed for use with single 6in high flux unit. Rec. Lowther PM6 or PM7. FR: 40Hz-18kHz. Size: $32 \times 9\frac{1}{2} \times 18$ in. Price (without unit): £32 (plus £2-57 PT).

L.I.B. Acousta

Lowther Ideal Baffle is a special enclosure in the Lowther range of folded rear and compound horn designs. It has closed back with anti-phase slave membrane to overcome resonance. Membrane is coupled to drive unit by compliance and matched via a short labyrinth. Effect is that drive unit frequency response, say 30Hz-20kHz, such as PM6, becomes 25Hz-30kHz. Veneered teak,

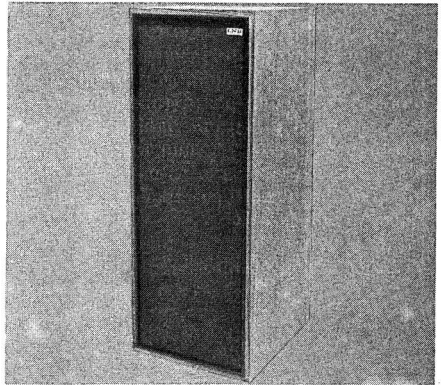

LNB Audio Para-Lab Super

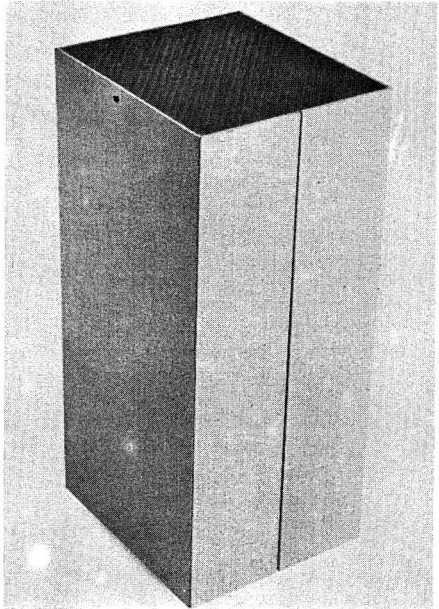

Lecson HLI

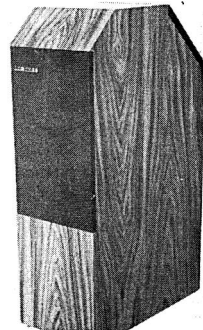

Lowther Auditorium Acousta

★ Indicates entry is illustrated

walnut or sapele finish. Grille cloth: grey. Dimensions: $19 \times 14 \times 7\frac{1}{2}$ in. Price (without unit): £15 (plus £1.20 PT).

Auditorium Acousta ★

Twin channel enclosure. Based on design of Dual Position Acousta with forward-facing drive unit. Variable preset level control. Rear unit only using folded horn. Design for use with two 6-8in units (Lowther PM6, PM6 Mk I and/or PM7). Size: $32 \times 9\frac{1}{2} \times 19$ in. Weight: (less units) $39\frac{1}{2}$ lb. Price (without units): £50 (plus £4.02 PT).

Auditorium Audiovector

Twin channel enclosure. Improved version of Audiovector with forward-facing drive unit (PM2 Mk 1). Variable preset level control. Size: $34 \times 25\frac{1}{2} \times 19$ in. Weight: 108lb. Price: (Model A) £185; (Model B) £175.

■ **LUXOR (Luxor Industri Aktiebolag)**

Highgate Acoustics Ltd,
184 Great Portland Street, London, W1.
Tel: 01-636 2901.

KH520

Incorporates one 5in bass unit and one $2\frac{1}{2}$ in tweeter. FR: 45Hz-18kHz. HC: 15W. vci: 4 ohms. Dimensions: $10 \times 7\frac{1}{2} \times 8\frac{1}{2}$ in. Weight: 7lb. Finish: teak and rosewood. Price: £16.50.

SH104

Infinite baffle enclosure with units. One 10in bass driver, two 2in tweeters. FR: 20Hz-20kHz. HC: 40W RMS. Impedance: 4 ohms. Size: $12\frac{1}{2} \times 10 \times 22$ in. Finish: teak or rosewood. Price: £32.

SH835 ★

Cylindrical type omni-directional speaker enclosure with units. On stand with cruciform base. Four 5in bass drivers, four $2\frac{1}{2}$ in tweeters. Crossover: 1.5kHz. FR: 35Hz-20kHz. HC: 40W RMS. Impedance: 4 ohms. Finish: teak with black grille and chrome stand. Price: £55.

KH501

Infinite baffle enclosure with unit. One long-throw $5\frac{1}{2}$ in driver. FR: 50Hz-16kHz. HC: 10W RMS. Impedance: 4 ohms. Size: $7\frac{1}{2} \times 8\frac{3}{4} \times 4$ in. Finish: teak or rosewood. Price: £9.48 (plus £1.52 PT).

KH821

Infinite baffle enclosure with units and crossover. One 8in bass driver, two 2in mid-range and tweeter units. Crossover: 3kHz. FR: 40Hz-18kHz. HC: 20W RMS. Impedance: 4 ohms. Size: $10\frac{3}{4} \times 15\frac{3}{4} \times 7\frac{1}{2}$ in. Finish: teak or rosewood. Price: £19.39 (plus £3.11 PT).

■ **MARANTZ**

Psyser-Britex (Swift) Ltd,
Fircroft Way, Edenbridge, Kent.
Tel: Edenbridge (0732-71) 2434/6.

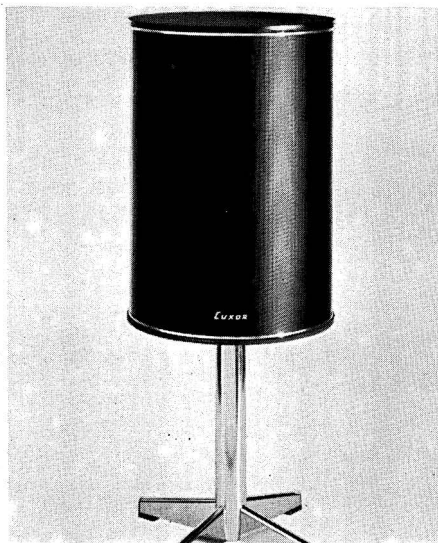

Luxor SH835

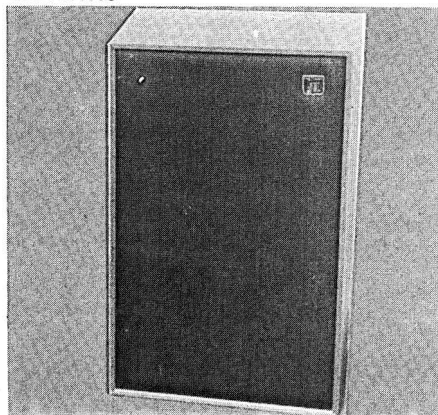

Medway BT15

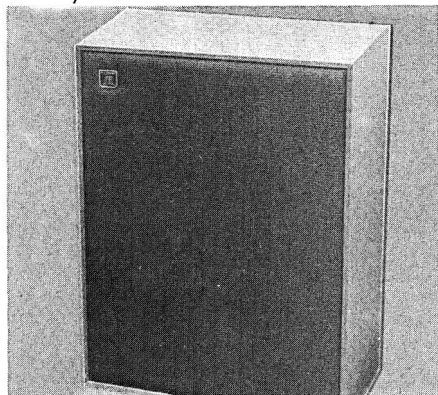

Medway BT20

Imperial 4B

Enclosure with units and crossover. One $8\frac{1}{2}$ in bass driver, one $\frac{3}{4}$ in tweeter. L/C crossover. FR: 60Hz-15kHz ± 5 dB. HC: 40W music. Impedance: 8 ohms. Size: $11\frac{1}{4} \times 19\frac{3}{8} \times 8\frac{1}{2}$ in. Weight: 20lb. Finish: oiled walnut. Price: to be announced.

Imperial 5

Enclosure with units and crossover. One 8in bass driver, one $3\frac{1}{2}$ in tweeter. L/C crossover (12dB/octave from 2kHz). FR: 50Hz-15kHz ± 3 dB. Impedance: 8 ohms. Three-position high-frequency level selector switch. HC: 40W music. Size: $12 \times 23 \times 9\frac{1}{2}$ in. Finish: oiled walnut. Price: to be announced.

Imperial 6

Enclosure with units and crossover. One 10in bass driver, one 2in dome tweeter. L/C crossover (12dB/octave from 3kHz). FR: 40Hz-18kHz ± 5 dB. HC: 100W music. Impedance: 8 ohms. Size: $14\frac{1}{4} \times 25\frac{1}{2} \times 11\frac{1}{2}$ in. Three-position high-frequency level selector switch. Finish: oiled walnut. Price: to be announced.

Imperial 7

Enclosure with units and crossover. One 12in bass driver, one $3\frac{1}{2}$ in mid-range unit, one $1\frac{3}{4}$ in tweeter. L/C three-way crossover. FR: 40Hz-20kHz ± 5 dB. HC: 100W RMS music. Impedance: 8 ohms. Controls: three-position high-frequency level selector switch, three-position mid-range level selector switch. Foam grille. Size: $14\frac{1}{4} \times 25\frac{1}{2} \times 11\frac{1}{2}$ in. Weight: 45lb. Finish: oiled walnut. Price: to be announced.

MEDWAY

Brahms Manufacturing & Development Co, Unit E, Rochester Airport, Maidstone Road, Rochester, Kent. Tel: Medway 48816.

T138

Infinite baffle enclosure with unit and crossover. One 13×8 in bass driver, one $2\frac{1}{2}$ in tweeter. Crossover: L/C 5kHz. FR: 50Hz-15kHz. HC: 10W. Impedance: 8 ohms. Size: $18 \times 11 \times 8$ in. Weight: 14lb. Finish: teak, walnut or white with fabric or $\frac{1}{4}$ in slatted front grille. Price: £13 (no PT).

BT15 ★

Infinite baffle enclosure with unit and crossover. One 13×8 in bass driver, one 3in tweeter. Crossover: L/C 4-5kHz. FR: 25Hz-18kHz. HC: 15W RMS. Impedance: 8 ohms. Size: $20 \times 12 \times 8\frac{1}{2}$ in. Weight: 16lb. Finish: teak, walnut or white with fabric or $\frac{1}{4}$ in slatted front grille. Price: £16 (no PT).

BT20 ★

Infinite baffle enclosure with unit and crossover. One 13×8 in bass driver with roll surround, one 3in tweeter. Crossover: L/C 4kHz. FR:

20Hz-20kHz. HC: 20W RMS. Impedance: 8 ohms. Size: $21 \times 15 \times 9$ in. Weight: 20lb. Finish: teak, walnut or white with fabric or $\frac{1}{4}$ in slatted grille. Price: £19 (no PT).

METROSOUND

Metrosound Manufacturing Co Ltd, Audio Works, Cartersfield Road, Waltham Abbey, Essex. Tel: Waltham Cross 31933.

HFS103

Infinite baffle enclosure with units and crossover. One $10\frac{3}{4} \times 6\frac{1}{2}$ in bass driver, two $2\frac{1}{2}$ in tweeters. Crossover: 5kHz. FR: 50Hz-15kHz. HC: 10W RMS. Impedance: 8 ohms. Size: $14 \times 9 \times 7$ in. Weight: 9lb. Finish: teak veneer cabinet and slatted grille, silver trim. Price: £25 (plus £4-21 PT) per pair.

HFS202

Infinite baffle enclosure with units and crossover. One $13\frac{1}{2} \times 8\frac{1}{4}$ in bass driver, one $3\frac{1}{4}$ in tweeter. Crossover: 5kHz. FR: 40Hz-18kHz. HC: 20W RMS. Impedance: 8 ohms. Size: $23 \times 11\frac{1}{2} \times 11$ in. Weight: $22\frac{3}{4}$ lb. Finish: teak veneer cabinet ($\frac{3}{4}$ in thick) with slatted grille and silver trim. Price: £21-50 each.

Duplex 15

Duplex electrostatic speaker. HC: 15W. Impedance: 8 ohms. FR: 45Hz-17kHz. Crossover: 2-5kHz. Size: $18\frac{1}{4} \times 18\frac{1}{4} \times 8\frac{1}{2}$ in. Weight: 20lb. Finish: crown grain teak. Electrostatic unit energised by mains supply 190-250V 50-60Hz. Price: £32.

Duplex 25

Duplex electrostatic speaker. HC: 25W. Impedance: 8 ohms. FR: 40Hz-18kHz. Crossover: 2-5kHz. Size: $16\frac{1}{2} \times 27\frac{1}{2} \times 12$ in. Weight: 40lb. Finish: crown grain teak. Electrostatic unit energised by mains supply 190-250V 50-60Hz. Price: £52.

MMG ASSOCIATES

19 Southfield Road, Flackell Heath, Near High Wycombe, Bucks. Tel: Bourne End 21048.

Emperor 101 ★

Infinite baffle type enclosure. 13×8 in elliptical driver with coaxially mounted high frequency unit. Crossover: 5kHz choke-capacitor network. FR: 50Hz-16kHz. HC: 20W. vci: 8 ohms. Adjustable high frequency balance. Finish: teak effect in Melamine plastic, with other finishes to order. Size: $31 \times 17 \times 9$ in. Weight: $39\frac{1}{2}$ lb. Price: £33.

Emperor 102 ★

As Emperor 101 but vci is 16 ohms. Price: £33.

Emperor Mk III

FR: 50Hz-18kHz. HC: 25W. vci 8 or 16 ohms.

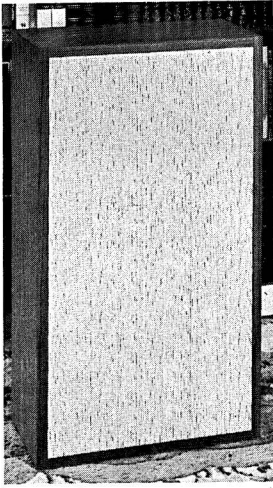

MMG Emperor 101, 102

Finish: teak, mahogany or to order. Size: 35 × 17 × 19in. Weight: 42lb. Price: £60.

Emperor Studio Monitor

Full specification and prices of the Emperor Studio Monitor systems available on request.

Emperor Custom Series

Speaker systems manufactured to customer's own design and specifications. Full details of service on request.

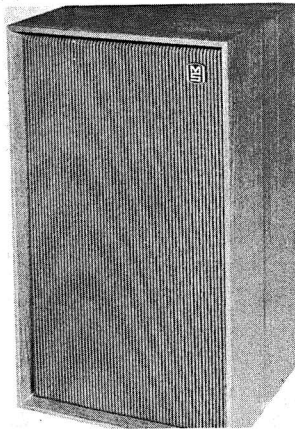

Mordaunt-Short MS077

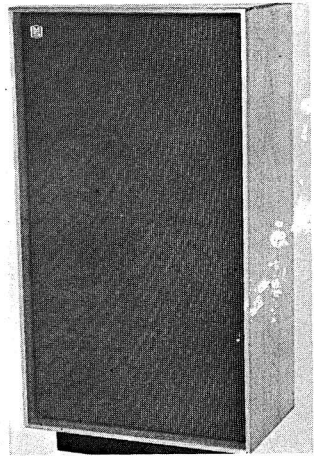

Mordaunt-Short MS400

■ **MORDAUNT-SHORT LTD**

The Courtyard, Heath Road, Petersfield, Hampshire. Tel: Petersfield 4761/2.

MS 077 ★

Infinite baffle compact bookshelf enclosure with three units. 6½in bass driver, 3in mid-range unit, 2in tweeter. Crossover: 1kHz and 5kHz. FR: 40Hz-20kHz. HC: 20W music rating. Impedance: 8 ohms. Size: 15¾ × 9½ × 8in. Weight: 14½lb. Finish: teak or walnut veneer, including rear of cabinet. Other finishes to special order. Price: £27.50 (plus £4.63 PT).

MS 400 ★

Infinite baffle enclosure with one 13 × 8in bass driver, one 3in melinex diaphragm mid-range unit and one STC high frequency tweeter. Crossover: 2.25kHz and 11kHz. Printed circuit network. FR: 35Hz-25kHz. HC: 25W. vci-8 ohms. Dimensions: 27 × 15 × 9in, on 1¾in plinth. Weight: 43lb approximately. Finish: teak or walnut veneer (including rear of cabinet). Other finishes to special order. Price: £56.

MS 700

Infinite baffle enclosure with 12in bass driver,

5in mid-range unit and Decca-Kelly 30W ribbon tweeter. Crossover: 750Hz and 4.5kHz. Multi-stage crossover network. FR: 25Hz-25kHz. HC: 30W. vci: 8 ohms. Dimensions: 33 × 17 × 12in on 1¾in plinth. Weight: 52lb approximately. Finish: teak or walnut veneer, including rear of cabinet. Other finishes to special order. Price: £82.50.

■ **NICHOLS ACOUSTIC.** See Derwent.

■ **NIVICO**

Denham & Morley Ltd, Denmore House, 453 Caladonian Road, London, N7. Tel: 01-607 6568.

GB-1E

Omni-directional speaker system suitable for suspension from a ceiling or fitted to a floor stand. Infinite baffle enclosure. Four 5in free-edge bass drivers, four horn tweeters. Crossover: 5kHz. FR: 20Hz-20kHz. HC: 40W RMS. Impedance: 8 ohms. Dimensions: 13½in diameter approximately. Weight: 26½lb. Finish: perforated black metal case. Price: £100.38 (including PT).

5390U ★

Speaker enclosure with units. One 6½in free rolled-edge bass driver, one 2in cone tweeter. FR: 40Hz-20kHz. Impedance: 8 ohms. HC: 15W RMS. Size: 16 × 19¼ × 7½in. Weight: 7¾lb. Sold in matched pairs. Price: (per pair) £42.50 (including PT).

5335

Speaker enclosure with units. One 12in bass driver, one 5in mid-range unit, one horn tweeter.

Crossover: 800Hz, 5kHz. FR: 20Hz-20kHz. HC: 40W RMS. Impedance: 8 ohms. Price: £89.50.

5395

Speaker enclosure with units. One 8in bass driver, one 2in tweeter. FR: 40Hz-20kHz. HC: 20W RMS. Impedance: 8 ohms. Price (per pair): £42.50.

5325

Speaker enclosure with units. Infinite baffle. One 10in bass driver, one 5in mid-range unit, one horn tweeter. Crossover: 800Hz, 5kHz. HC: 30W RMS. Impedance: 8 ohms. FR: 30Hz-20kHz. Size: $21\frac{3}{4} \times 12\frac{1}{2} \times 11\frac{5}{8}$ in. Weight: 26.4lb. Price: £68.75.

■ NORDMENDE

Distributors: TAK Continental Importers, 16a High Street, Stone, Staffordshire. Tel: Stone 3232, 3233.

LB31

Bookshelf type in natural walnut or white. HC: 15W RMS. FR: 45Hz-20kHz. vci: 5 ohms. Dimensions: $6\frac{1}{4} \times 7 \times 10\frac{1}{2}$ in approx. Price: £18.90 (including PT).

LB32

White/eggshell paint with offset front panel in red or walnut or Rio rosewood with offset front panel in radiant black. HC: 7WRMS. FR: 70Hz-18kHz. vci: $4\frac{1}{2}$ ohms. Dimensions: $9 \times 8 \times 5\frac{1}{2}$ in approx. Price: £18.90 (including PT).

LB33

Natural walnut, teak, Rio rosewood or elm. HC:

10W RMS. FR: 48Hz-20kHz. vci: 5 ohms. Dimensions: $7 \times 8 \times 10\frac{1}{2}$ in approx. Price: £18.90 (including PT).

LB41

Walnut with white front or matt black. HC: 7W RMS. FR: 70Hz-18kHz. vci: $4\frac{1}{2}$ ohms. Dimensions: $7 \times 7 \times 8$ in approx. Price: £18.90 (including PT).

LB60

Finished in red, white, radiant black, green, walnut, teak or Rio rosewood and available with elegant chromium-plated stand for tilting. HC: 20W RMS. FR: 35Hz-20kHz. vci: 8 ohms. Dimensions: $30 \times 15 \times 7$ in approx. Price: £40.95 plus £3.15 for stand (including PT).

■ PEERLESS

Distributor: P. F. & A. R. Helme Ltd, Summerbridge, Harrogate, HG34DR, Yorks. Tel: Darley 279.

PR20-2

Ready-built version of Peerless 20-2 speaker system kit. One 8in bass driver, one $2\frac{1}{4}$ in HF unit. HC: 40W. FR: 40Hz-20kHz. Crossover: 2.5kHz. Impedance: 4 ohms or 8 ohms. Price: £29 (plus £4.82 PT).

PR20-3

Ready-built version of Peerless 20-3 speaker system kit. One 8in bass driver, one 5in mid-range unit, one $2\frac{1}{4}$ in tweeter. HC: 40W. FR: 40Hz-20kHz. Impedance: 4, 8 or 16 ohms. Crossover: 1.5kHz, 6kHz. Price: £35.60 (plus £5.92 PT).

See Constructional Kits Section for further details of Peerless speaker enclosures.

■ PHILCO

Philco-International Ltd, 42 Leicester Square, London, WC27LR. Tel: 01-930 7667.

1600

Infinite baffle enclosure with units and crossover. One $13\frac{1}{2} \times 8\frac{1}{4}$ in bass and mid-range driver, one $2\frac{1}{2}$ in tweeter. Crossover: 8.5kHz. FR: 55Hz-13kHz. HC: 12W RMS. Impedance: (at 1kHz) 8 ohms. Finish: white satin with black grille cloth and brushed aluminium trim. Size: $16 \times 10 \times 8$ in. 10ft connecting lead with DIN plug. Price: £16.

■ PHILIPS ELECTRICAL LTD

Century House, Shaftesbury Avenue, London, WC2. Tel: 01-437 7777. Cables: Phillamps, London.

RH402

Infinite baffle enclosure with units and crossover. One 7in bass driver, one 1in tweeter. Crossover: 1.2kHz. FR: 50Hz-20kHz. HC: 20W RMS. Resonant frequency: 90Hz. Imped-

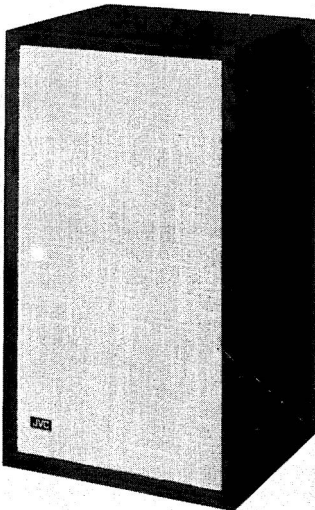

Nivico 5390U

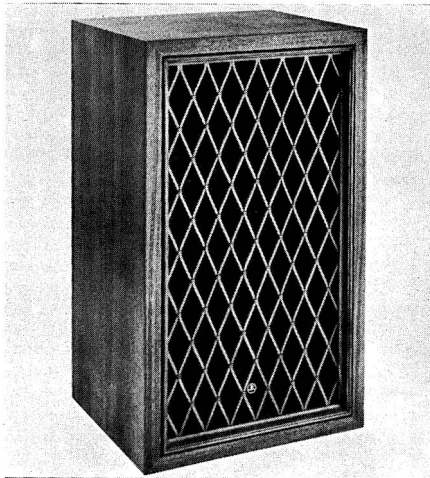

Pioneer CS66

ance: 4 or 8 ohms. Finish: walnut veneer. Size: $10\frac{1}{2} \times 10\frac{1}{2} \times 4$ in. Price: £22.35 (including PT).

RH405

Infinite baffle enclosure with units and crossovers. One 8in bass driver, one 5in mid-range unit and one 1in tweeter. Crossover: 700Hz and 3kHz. FR: 35Hz-20kHz. HC: 30W RMS. Impedance: 4 ohms. Finish: teak veneer. Size: $13\frac{1}{2} \times 18\frac{1}{8} \times 8\frac{3}{8}$ in. Price: to be announced.

RH407

Infinite baffle enclosure with units and crossovers. One 10in bass driver, one 5in mid-range unit and one 1in tweeter. Crossover: 800Hz and 4kHz. FR: 40Hz-20kHz. HC: 40W RMS. Impedance: 4 ohms. Finish: walnut veneer. Size: $21\frac{1}{2} \times 16\frac{1}{4} \times 8\frac{7}{8}$ in. Price: £47.65 (including PT).

RH411

Enclosure with drive unit. One dual-cone 5in driver. HC: 10W. FR: 60Hz-16kHz. Impedance: 8 ohms. Finish: walnut veneer. Size: $10\frac{1}{2} \times 7\frac{1}{4} \times 7\frac{1}{4}$ in. Price: £10.30 (including PT).

RH412

Enclosure with drive unit. One 7in dual-cone driver. HC: 10W. FR: 50Hz-18kHz. Impedance: 8 ohms. Finish: teak veneer. Size: $13\frac{3}{4} \times 10 \times 7\frac{1}{4}$ in. Price: £16.50 (including PT).

■ PIONEER

Distributors: Shriro (UK) Ltd,
42 Russell Square, London, WC1B5DF.
Tel: 01-580 6996.

CS53

Reflex enclosure with two units. One 12in bass driver, one $3\frac{1}{2}$ in tweeter. FR: 45Hz-20kHz. HC:

40W. Impedance: 8 ohms. Size: $22\frac{1}{2} \times 16\frac{1}{2} \times 11\frac{7}{8}$ in. Weight: 28lb. Finish: walnut. Price: £44.25.

CS66 ★

Infinite baffle enclosure with three units. One 10in bass driver, one $6\frac{1}{2}$ in mid-range unit, one $3\frac{1}{2}$ in cone tweeter. Crossover: 1.85kHz, 6.85kHz. FR: 35Hz-20kHz. HC: 40W RMS. Impedance: 8 ohms. Size: $12\frac{3}{4} \times 22 \times 11\frac{1}{2}$ in. Weight: 29lb. Finish: walnut. Price: £55.67.

CSE500

Infinite baffle enclosure with three units. One 10in bass driver, one 5in mid-range unit, one 3in cone tweeter. Crossover: 650Hz, 5kHz. FR: 37Hz-20kHz. HC: 50W RMS. Impedance: 8 ohms. Size: $13 \times 22\frac{1}{2} \times 11\frac{7}{8}$ in. Designed for two-channel or three-channel stereo system. Finish: walnut with fabric grille. Price: £61.35.

CSE700

Infinite baffle enclosure with three units. One 12in bass driver, one 5in mid-range unit, one multi-cellular horn tweeter. Crossover: 500Hz, 4.5Hz. FR: 35Hz-20kHz. HC: 60W RMS. Impedance: 8 ohms. Size: $15 \times 26 \times 11\frac{7}{8}$ in. Weight: 35lb. Designed for use with two or three power amplifiers direct and with electronic crossover independent of crossover in cabinet. Finish: walnut with fabric grille. Price: £84.40.

CSE900

Infinite baffle enclosure with three units. One 12in bass driver, one 5in mid-range unit, one horn type tweeter. Impedance: 8 ohms. FR: 30Hz-28kHz. HC: 75W music. Crossover: 400Hz, 4kHz. Size: $16 \times 27\frac{3}{4} \times 11\frac{7}{8}$ in. Weight: 55lb. Price: £127.28.

CS05

Omni-directional bass reflex enclosure with units. One 8in bass driver, three cone tweeters. Crossover: 3kHz. FR: 60Hz-20kHz. HC: 40W. Impedance: 8 ohms. Price: £65.63 (plus £9.48 PT).

CSE400

Air-suspension enclosure with units. One 8in bass driver, one dome tweeter. Crossover: 2.8kHz. FR: 35Hz-20kHz. HC: 40W. Impedance: 8 ohms. Price: £47.97 (plus £6.93 PT).

CSE300

Air-suspension enclosure with units. One 8in bass driver, one cone tweeter. Crossover: 2kHz. FR: 40Hz-20kHz. HC: 30W. Impedance: 4 ohms. Price: £31.54 (plus £4.55 PT).

CSE301

Air-suspension enclosure with units. One 8in bass driver, one cone tweeter. Crossover: 2kHz. FR: 40Hz-20kHz. HC: 30W. Impedance: 4 ohms. Price: £30.31 (plus £4.38 PT).

CSE200

Air-suspension enclosure with units. One $6\frac{3}{8}$ in

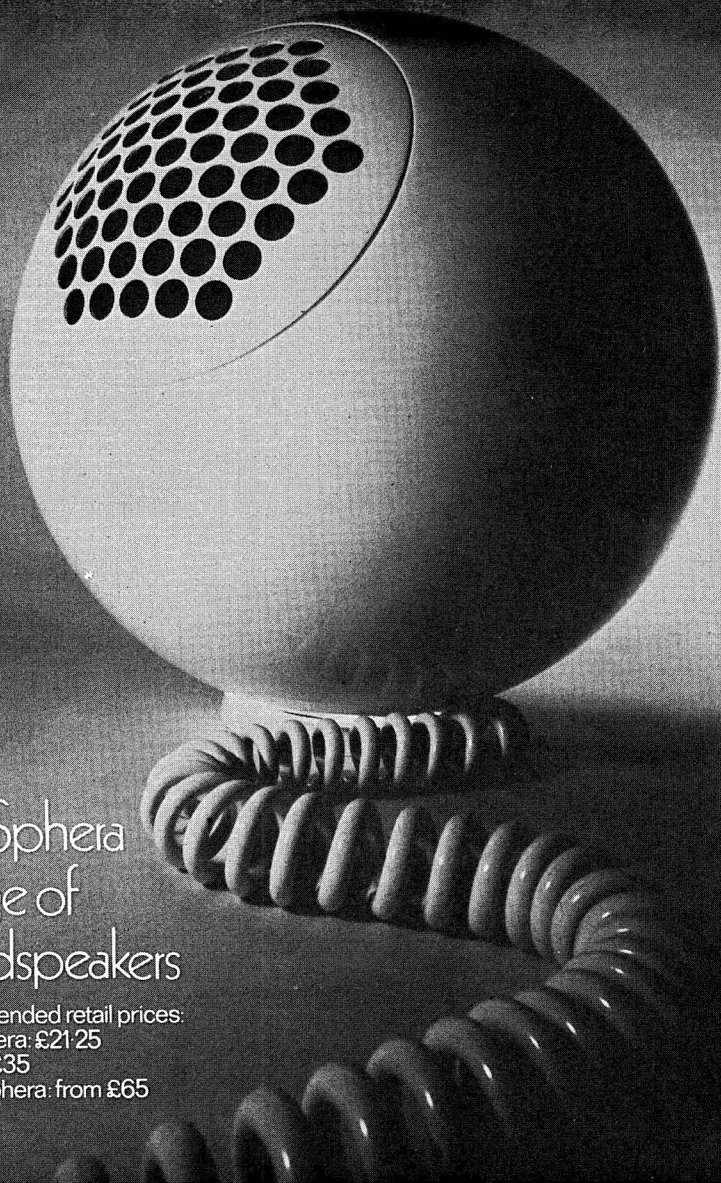

The Sphera Range of Loudspeakers

Recommended retail prices:

Mini Sphera: £21.25

Sphera: £35

Super Sphera: from £65

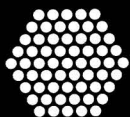

SYKES+HIRSCH

SYKES+HIRSCH LIMITED, 201 Greenwich High Road, London SE10 01-850 4127

Thank you fans, thank you.

The first Sonab speaker was sold back in June 1966.

The first practical, functioning omnidirectional speaker ever marketed, it was the product of twelve years work by Stig Carlsson at the University of Stockholm.

It was covered by world patents.

There was nothing else like it anywhere.

How things have changed.

In the last five years at least six major audio manufacturers have started producing speakers that look uncommonly like ours.

Sadly it's with looks that the resemblance ends.

They sound very different.

Those Carlsson patents keep getting in the way.

Imitation, we're told is the sincerest form of appreciation.

And for that appreciation we would like to say - thank you, fans, thank you.

And a word of encouragement.

Be patient, those patents have only ten years to go.

Sonab
of Sweden,

Sonab Ltd., P.O. Box No. 4
Oldfield Road, Hampton, Middlesex. TW12 2HN
Tel. 01-979 0134 Telex 928384

bass driver, one cone tweeter. Crossover: 2kHz. FR: 50Hz-20kHz. HC: 20W. Impedance: 4 ohms. Price: £19.30 (plus £2.79 PT).

CSE201

Air-suspension enclosure with units. One 6 $\frac{3}{8}$ in bass driver, one cone tweeter. Crossover: 2kHz. FR: 50Hz-20kHz. HC: 20W. Impedance: 4 ohms. Price: £25.04 (plus £3.61 PT).

■ QUAD

Acoustical Manufacturing Co Ltd,
St Peter's Road, Huntingdon, Hunts.
Tel: Huntingdon 2561/2. Cables: Acoustical.

Quad Electrostatic ★

Full range doublet covering 45Hz-18kHz. Attenuation outside band asymptotic to 18dB/8ve. Total integrated radiation at max output equivalent to 95 phons in rooms of up to 5,000 cu ft with average reverberation. Dispersion approx 70° horizontal; 15° vertical. Imp 30-15 ohms, 40Hz to 8kHz, falling above 8kHz. Designed for use with standard Quad 303 Amplifier Suitable for AC supplies 100-120 or 200-250V 50-60Hz. Free-standing unit requires no enclosure or cabinet. Weight: 35lb. Price: £72 complete.

■ RADFORD AUDIO LTD

Ashton Vale Road, Bristol, BS3 2HZ.
Tel: Bristol 662301.

Tri-Star 90/50

Infinite baffle enclosure with units and crossover. One 12in bass driver, one 4in mid-range unit, one 1in tweeter. Crossover: 400Hz, 4kHz (L/C circuit). FR: 55Hz-25kHz. HC: 50W RMS. Impedance: 8-16 ohms. Size: 21 × 12 × 9in. Weight: 30lb. Finish: teak, walnut or white. Price: £45 (no PT).

Monitor 180/50 ★

Infinite baffle enclosure with units and crossover: One 12in bass driver, two 4in mid-range units, two 1in tweeters. Crossover: 400Hz, 4kHz (L/C circuit). FR: 50Hz-25kHz. HC: 50W RMS. Impedance: 8-16 ohms. Size: 30 × 13 $\frac{1}{2}$ × 10 $\frac{1}{2}$ in. Weight: 44lb. Finish: teak, walnut or white. Sound radiates over 180°. Price: £72.50 (no PT).

Studio 270/100 ★

Infinite baffle enclosure with units and crossover. One 15in bass driver, three 4in mid-range units, three 1in tweeters. Crossover: 400Hz, 4kHz (L/C circuit). FR: 35Hz-25kHz. HC: 100W RMS. Impedance: 8-16 ohms. Size: 38 × 17 $\frac{1}{2}$ × 12 $\frac{1}{2}$ in. Weight: 76lb. Finish: teak, walnut or white. Sound radiates over 270°. Price: £100 (no PT).

Studio 360/100 ★

Transmission line enclosure with units and

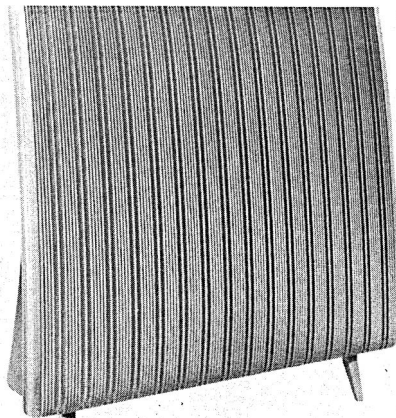

Quad Electrostatic

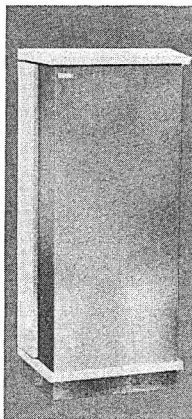

Radford Audio
Monitor 180/50

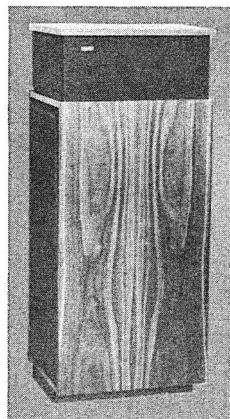

Radford Audio Studio
360/100

crossover. Two 12in bass drivers, four 4in mid-range units, four 1in tweeters. Crossover: 400Hz, 4kHz (L/C circuit). FR: 30Hz-25kHz. HC: 100W RMS. Impedance: 8-16 ohms. Size: 45 × 18 $\frac{3}{4}$ × 15in. Weight: 110lb. Finish: teak, walnut or white. Sound radiates over 360°. Price: £147.50 (no PT).

■ RADON INDUSTRIAL ELECTRONICS CO LTD

Brooklands Trading Estate, Orme Road,
Worthing, Sussex. Tel: Worthing 34904.

Jewel Range

Range of six speakers in hand-built teak enclosures. Finished in satin lacquers and charcoal-coloured fronts. Brass key plates for wall mounting. Impedances: 8 or 15 ohms.

Amethyst SC/1

Infinite baffle. HC: 10W maximum. FR: 60Hz-17kHz ±6dB. System comprises 6 $\frac{1}{2}$ in woofer

★ Indicates entry is illustrated

with ceramic magnet of 10,000 gauss and 1in voice coil; and 4in tweeter with crossover. Size: 19 × 10 × 6in. Price: £13.88 (including PT).

Emerald SC/2

Infinite baffle. HC: 12W maximum. FR: 50Hz-10kHz ±5dB. 10 × 6in woofer with aluminium centre cone and high compliance PVC suspension; tweeter and crossover. Price: £18.88 (including PT).

Opal SC/3

Infinite baffle. HC: 15W maximum. FR: 20Hz-20kHz ±8dB. Speakers: 13 × 8in woofer using ceramic magnet of 11,000 gauss, high compli-

ance PVC surround, aluminium centre cone; tweeter with 10,000 gauss ceramic magnet, driven from crossover network at 5kHz. Dimensions: 23 × 12 × 11in. Price: £24.

Sapphire SC/4 ★

Enclosure with 12in woofer using ceramic magnet of 15,500 lines and 1½in speech coil. 4 × 4in tweeter assembly on heavy diecast alloy frame for non-directional sound. HC: 25W maximum. FR: 20Hz-18kHz ±2dB. Cabinet size: 30 × 16 × 9in. Price: £34.

Topaz SC/5 ★

Infinite baffle enclosure with units. 14 × 9in bass

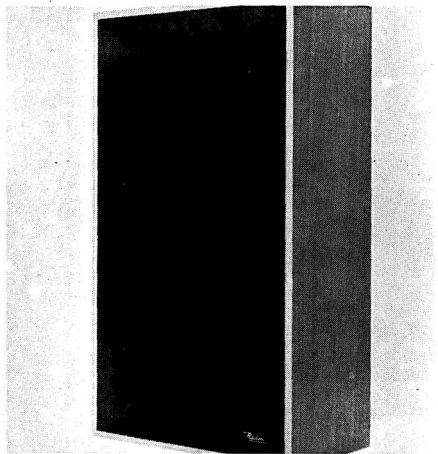

Radon Sapphire

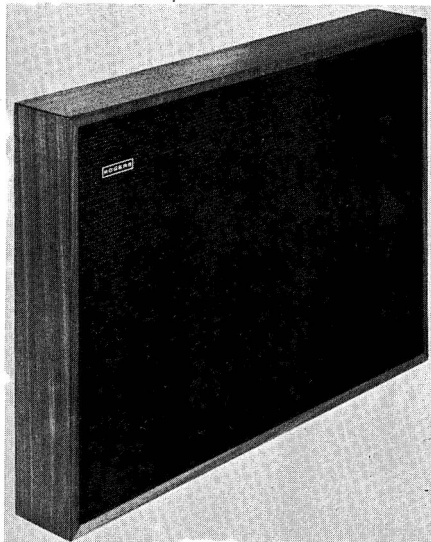

Rogers Wafer

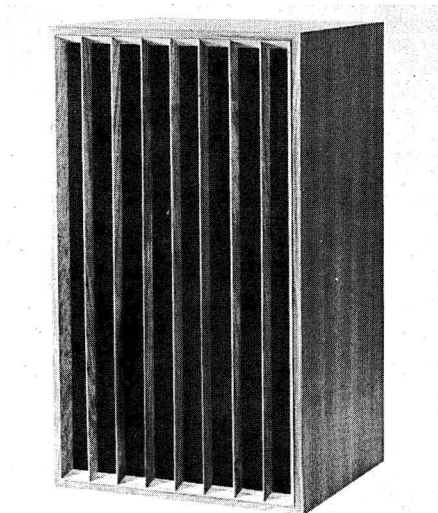

Radon Topaz

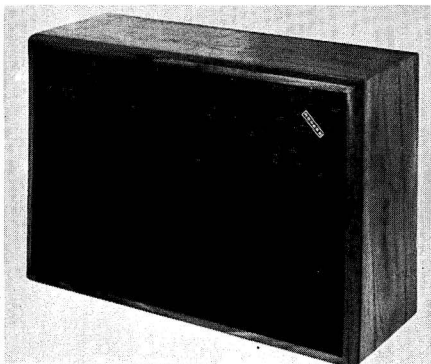

Rogers 3-Speaker System

driver, 5in mid-range unit, 3 $\frac{3}{8}$ in tweeter. FR: 50Hz-20kHz. HC: 20W RMS. Impedance: 8 ohms. Size: 28 × 16 × 13in. Weight: 32lb. Finish: natural teak satin lacquer. Special cross-over provides control to mid-range and HF frequencies. Bass unit fitted with laminated glass fibre cone and diecast chassis. Price: £60.

Pearl SC/6

Labyrinth enclosure with units. 10in Goodmans Axiom bass driver, two 3 $\frac{3}{8}$ in tweeters. Cross-over: LC network. FR: 40Hz-18kHz. HC: 10W RMS. Impedance: 8 or 15 ohms. Size: 25 × 16 $\frac{3}{4}$ × 15 $\frac{5}{8}$ in. Weight: 28 $\frac{1}{2}$ lb. Finish: teak. Cabinet fitted with acoustic resistance and special baffle system for level response. Price: £40.

■ ROGERS DEVELOPMENTS

(Electronics) LTD

4/14 Barmeston Road, Catford, London, SE6.

Tel: 01-698 7424/4340.

Cables: Rodevco, London, SE6.

Wafer System Mk III ★

Infinite baffle enclosure with two units. One 5in bass driver plus tweeter. FR: 40Hz-16kHz. HC: 12W. Impedance: 15 ohms. Finish: solid afrormosia frame with black fret material. Includes volume control for third or fourth channel use. Size: 13 $\frac{1}{8}$ × 16 $\frac{5}{8}$ × 2 $\frac{1}{2}$ in. Price: (afrormosia) £23.41; (white lacquer) £24.58.

Ravensbrook 3-Speaker System ★

Infinite baffle enclosure with three units. One high-flux 8in bass driver, two 3in tweeters. Cross-over: 2kHz (12dB per octave). FR: 40Hz-20kHz. HC: 15W (20W speech and music). Impedance: 8 ohms. Size: 19 × 13 × 7 $\frac{3}{8}$ in. Weight: 18 $\frac{1}{2}$ lb. Finish: teak with black/gold acoustically transparent grille cloth. Supplied in matched pairs. Price: (per pair) £55.60 (including PT).

BBC Studio Monitor

Three-way system based on a design by the BBC research department and produced under license. Conforms to BBC specification LS3/6, but with the addition of a third unit. Three drive units comprise bass driver, mid-range unit and tweeter. Bass and tweeter unit efficiencies are matched by low-loss auto transformer with 1dB tapings. Sophisticated crossover using 5 per cent tolerance inductors and low loss capacitors. FR: 40Hz-25kHz ±3dB. HC: 25W (makers recommend amplifier having output of at least 20W, but caution is necessary with equipment over 40W output as overheating of the speech coil may occur). Impedance: 15 ohms standard, 8 ohms and 25 ohms made to order. Size: 12 × 25 × 12in deep. Height with stand: 37in. Finish: teak. Price: (Monitor speaker, less stand) £77 (plus £12.35 PT); (Monitor speaker, complete with stand) £83.50 (plus £12.81 PT); (stand only) £6.50 (plus 46p PT).



Sansui SP1700

NOTE: Distribution of the Rogers BBC Monitor speaker system is through a very limited number of selected audio retailers. Full list of appointed retailers available from the manufacturers.

■ ROLA-CELESTION. See Celestion.

■ SABA

Distributors: Lampitt Electronics Ltd, 6-12 Cornbrook Park Road, Manchester, M15 4EE. Tel: 061-872 7661.

FL15G

Speaker enclosure with units. One bass driver, one HF unit. FR: 50Hz-20kHz. Size: 15 $\frac{3}{8}$ × 9 $\frac{7}{8}$ × 3 $\frac{1}{2}$ in. Finish: light walnut or white. Price: £29.12.

15G

Speaker enclosure with units. One bass driver, one HF unit. FR: 45Hz-20kHz. Size: 15 $\frac{3}{8}$ × 8 $\frac{5}{8}$ × 8 $\frac{1}{8}$ in. Finish: fabric with wood grille. Price: £29.12.

FL40G

Speaker enclosure with units. Two bass drivers, one HF unit. FR: 40Hz-20kHz. Size: 20 $\frac{1}{2}$ × 12 $\frac{7}{8}$ × 4 $\frac{1}{8}$ in. Price: £48.17.

40G

Speaker enclosure with units. Two bass drivers, one tweeter. FR: 35Hz-22.5kHz. Size: 19 $\frac{1}{2}$ × 11 × 9 $\frac{7}{8}$ in. Price: £48.17.

■ SANSUI

Vernitron Ltd, Thornhill, Southampton, SO9 5QF. Tel: Southampton 44811.

SP1700 ★

Enclosure with units and crossover. One 12in bass driver, two 4in mid-range units, two 2in tweeters. HC: 70W music power. Impedance: 8 ohms. FR: 50Hz-20kHz. Crossover: 700Hz, 6.5kHz. Size: 16 $\frac{3}{4}$ × 25 $\frac{1}{4}$ × 10 $\frac{7}{8}$ in. Weight: 46 $\frac{3}{8}$ lb.

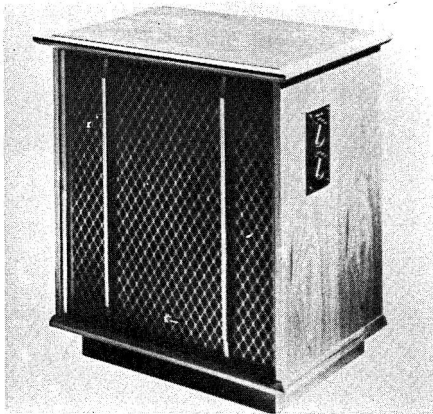

Sansui SP3005

Finish: walnut cabinet with convex Kumiko fretwork grille. Price: £89-03.

SP2500

Enclosure with units and crossover. One 12in bass driver, two 5in mid-range units, two 2in horn tweeters. HC: 80W music power. Impedance: 8 ohms. FR: 30Hz-20kHz. Crossover: 700Hz, 6-5kHz. Size: $16\frac{3}{4} \times 10\frac{7}{8} \times 25\frac{1}{4}$ in. Weight: 56 $\frac{1}{2}$ lb. Finish: walnut cabinet with convex Kumiko fretwork grille. Price: £93-68.

SP3005 ★

Enclosure with units and crossover. One 12in bass driver, one 6 $\frac{1}{2}$ in and two 4in mid-range units, two 2in horn tweeters. HC: 60W music power. Impedance: 8 ohms. FR: 25Hz-20kHz. Crossover: 600Hz, 6.5kHz. Weight: 83 $\frac{1}{2}$ lb. Size: $25 \times 17\frac{1}{8} \times 27\frac{3}{4}$ in. Finish: walnut cabinet with fretwork grille. Price: £156-21.

SP3500

Enclosure with units and crossover. One 14in bass driver, two 4in mid-range units, one 4 $\frac{1}{2}$ × 2in HF unit, two 2in horn tweeters. HC: 100W music power. Impedance: 8 ohms. FR: 25Hz-20kHz. Crossover: 700Hz, 2kHz, 6-5kHz. Size: $17\frac{3}{4} \times 11\frac{1}{2} \times 25\frac{1}{4}$ in. Weight: 58lb. Finish: walnut cabinet with convex fretwork grille. Price: £113-57.

■ SANYO

Sanyo Marubeni (UK) Ltd,
Sanyo House, Bushey Mill Lane,
Watford, Herts. Tel: Watford 30421.

■ SX-X

Speaker enclosure with units and crossover. 8in bass driver, 2 $\frac{1}{2}$ in tweeter. Crossover frequency: 4kHz. Impedance: 8 ohms. HC: 15W. FR: 40Hz-20kHz. Size: $14\frac{3}{8} \times 8\frac{1}{2} \times 11\frac{3}{4}$ in. Price: to be announced.

■ SCAN-DYNA

Scandinavian Audio Systems Ltd,
Sun Alliance Building, 65 London Road,
Gloucester, GL1 3HF.
Tel: Gloucester (0452) 32791/2.

M2

Infinite baffle enclosure with unit. One 5 $\frac{1}{2}$ × 3 $\frac{1}{4}$ in elliptical with additional HF cone. FR: 65Hz-18kHz. HC: 7W RMS. Impedance: 4 ohms. Finish: teak or rosewood. Size: $9\frac{3}{8} \times 8\frac{1}{4} \times 4\frac{3}{8}$ in. Weight: 4 $\frac{3}{4}$ lb. Price: £10-18 (plus £1-72 PT).

M10

Infinite baffle enclosure with units and crossover. One 6 $\frac{1}{2}$ in bass driver, one 1in dome tweeter. FR: 45Hz-20kHz. HC: 15W RMS. Impedance: 4 ohms. Finish: teak or rosewood. Size: $14 \times 8\frac{3}{4} \times 8\frac{3}{8}$ in. Weight: 11lb. Price: £17-03 (plus £2-87 PT).

A20

Twin chamber enclosure with units and crossover. One 8in bass driver, one 1 $\frac{1}{2}$ in dome tweeter. FR: 32Hz-20kHz. HC: 35W RMS. Impedance: 4 ohms. Finish: teak or rosewood. Size: $17 \times 9\frac{3}{4} \times 9\frac{3}{4}$ in. Weight: 18lb. Price: £24-73 (plus £4-17 PT).

A25

Aperiodic enclosure with units and crossover. One 10in bass driver, one 1 $\frac{1}{2}$ in tweeter. FR: 40Hz-20kHz. HC: 35W RMS. Impedance: 4 ohms. Finish: teak, rosewood or black. Size: $19\frac{3}{8} \times 11\frac{1}{2} \times 9\frac{3}{4}$ in. Price: £29-01 (plus £4-89 PT).

A30

Twin chamber enclosure with units and crossover. One 10in bass driver, one 1 $\frac{1}{2}$ in dome tweeter. FR: 30Hz-20kHz. HC: 45W RMS. Impedance: 4 ohms. Finish: teak or rosewood. Size: $22\frac{1}{2} \times 12\frac{1}{2} \times 9\frac{3}{4}$ in. Price: £38-43 (plus £6-47 PT).

A45

Aperiodic enclosure with units and crossover. Two 8in bass drivers, one 1 $\frac{1}{2}$ in dome tweeter. FR: 25Hz-20kHz. HC: 60W RMS. Impedance: 4 ohms. Finish: teak or rosewood. Size: $23\frac{3}{8} \times 13\frac{7}{8} \times 11\frac{3}{8}$ in. Price: £51-26 (plus £8-64 PT).

A50

Twin chamber enclosure with units and crossover. Two 10in bass drivers, one 1 $\frac{1}{2}$ in dome tweeter. FR: 22Hz-20kHz. HC: 70W RMS. Impedance: 4 ohms. Finish: teak or rosewood. Size: $27\frac{1}{2} \times 21\frac{1}{2} \times 9\frac{3}{4}$ in. Price: £55-54 (plus £9-36 PT).

■ S.D.L.

Distributors: Adastra Electronics Ltd, Unit 22,
Cricklewood Trading Estate, Claremont Road,
London, NW21 1TU. Tel: 01-452 6288.
Answering service: 01-452 6289.

Courier

Infinite baffle enclosure with unit. One 13×8in driver with centre tweeter. FR: 40Hz-15kHz. HC: 15W RMS. Impedance: 8 ohms. Size: 15×10½×7½in. Weight: 9¾lb. Finish: teak veneer with matching Vynair front. Price: £31.50 per matched pair.

Envoy

Infinite baffle enclosure with units. One 13×8in dual-cone bass driver, one 2in HF unit. Crossover: 3kHz L/C unit. FR: 40Hz-20kHz. HC: 15W RMS. Impedance: 8 ohms. Size: 18×10½×7½in. Weight: 10½lb. Finish: teak veneer with matching Vynair front. Price: £40 per matched pair.

Consul

Infinite baffle enclosure with units. One 12in dual-cone bass driver, two 2in tweeters. Crossover: 3kHz L/C unit. FR: 20Hz-20kHz. HC: 20W RMS. Impedance: 8 ohms. Size: 21×15×10½in. Weight: 25lb. Finish: teak veneer with matching Vynair front. Price: £32 each.

Diplomat

Infinite baffle enclosure with units. One 12in bass driver, one 5in mid-range unit, two 2in tweeters. Crossover: 800Hz and 3kHz. FR: 26Hz-22kHz. HC: 50W RMS. Impedance: 8 ohms. Size: 27×18×14in. Weight: 35 lb. Finish: teak veneer with matching Vynair front. Price: £64 each.

Ambassador

Infinite baffle enclosure with units. Two 13×8in bass drivers, one 5in mid-range units, two 2in tweeters. Crossover: 800Hz and 3kHz. FR:

22Hz-22kHz. HC: 50W. Impedance: 8 ohms. Size: 36×19¼×12in. Weight: 45lb. Finish: teak veneer with matching Vynair front. Price: £85.

■ SERVO-SOUND

Sonosound Ltd,
5 Queen Street, London, EC4N 1SU.

SL20 ★

Infinite baffle enclosure incorporating drive unit and power amplifier. One 9½×6½ elliptical full-range drive unit. FR: (power amplifier and speaker system) 35Kz-20kHz. HC: 20W RMS. Impedance: 4 ohms. Includes built-in 15W RMS power amplifier incorporating patented 'Cybernetic' circuit to provide servo control of speaker cone. Circuit is designed to monitor speaker cone movement, compare with input to amplifier and apply correction signal to amplifier. Size: 7×10×11in. Weight: 12½lb. Finish: wood cabinet finished in walnut or white, chrome grille. Designed for use with Servo-Sound SC100BEE preamplifier (see Amplifier Section). Price: (speaker and amplifier) £55.

■ SHEPPARD AUDIO LTD

275 Watling Street (A5), Radlett, Herts.
Tel: Radlett 5440.

Chesham Mini

Infinite baffle enclosure with units and crossover. One 5in bass driver, one 3in tweeter. FR: 45Hz-20kHz. HC: 12W RMS. Impedance: 8 ohms. Size: 13×7×8in. Finish: teak. Price: £29.50 per pair (including PT).

Chesham

Infinite baffle three-way system with units and crossover. One 13×8in bass driver, two tweeters. HC: 15W RMS. FR: 40Hz-20kHz. Impedance: 8 ohms. Finish: teak. Size: 18×11×7in. Price: £24.50 (no PT).

Chesham Super

Infinite baffle enclosure with heavy duty units and crossover. One 13×8in bass driver, one 3in HF unit. Two-way system. HC: 20W RMS. FR: 40Hz-20kHz. Impedance: 8 ohms. Finish: teak, walnut or mahogany. Size: 18×11×10in. Price: £30 (no PT).

SA4-X

Infinite baffle enclosure with units and crossover. Two-way system. One 13×8in heavy duty magnet bass driver, one 3in HF unit. FR: 35Hz-20kHz. HC: 20W RMS. Impedance: 8 ohms. Finish: teak. Size: 23¼×14×12in. Price: £42.50 (no PT).

Aldenhams De Luxe

Infinite baffle enclosure with units and crossover. Three-way system. One 13½×9in bass

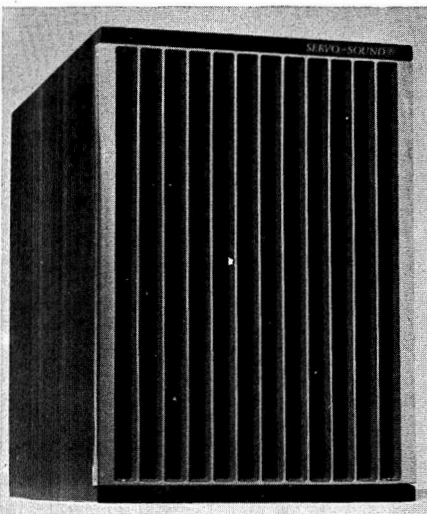

Servo-Sound SL20

★ Indicates entry is illustrated

driver, 6½in mid-range unit and HF tweeter. HC: 25W RMS. FR: 35Hz-30kHz. Impedance: 8 ohms nominal. Size: 23¼ × 15 × 10in. Weight: 42lb. Finish: teak or walnut. Price: £55 (no PT).

Aldenhams Super De Luxe

Infinite baffle enclosure with units and crossover. Four-way system. One 13½ × 9in bass driver, 6½in mid-range unit, 3in mid-upper frequency speaker and HF tweeter. HC: 25W RMS. FR: 35Hz-30kHz. Impedance: 8 ohms nominal. Size: 23¼ × 15 × 10in. Weight: 42lb. Finish: teak or walnut. Price: £65.

Waltham Monitor Elite

Infinite baffle cabinet with speakers and crossover. 13 × 9in bass driver, 5in mid-range unit, 3in mid-upper frequency speaker and T27 tweeter. Crossover: 800Hz, 3.5kHz, 6.5kHz. FR: 20Hz-25kHz. HC: 30W RMS. Impedance: 8 ohms. Size: 29½ × 17½ × 12½in. Weight: 57lb. Finish: teak or walnut (mahogany to order). Controls on mid-range and upper frequency units. Special BAF loading and rigid construction. Price: £80.

Waltham Super Elite

Infinite baffle enclosure with speakers and crossover. 14 × 9in bass driver, two mid-upper frequency units. Specification similar to Waltham Elite but smoother response. Price: £85.

NOTE: All Sheppard Audio speaker systems now have plain black grilles and not the wood strip at side or bottom which was a feature of some earlier models.

SIEMENS

Interconti Electronics Ltd,
Albany House, Petty France,
London, SW1H 9EA.
Tel: 01-222 2523. Telex: 918770.

RL121

Speaker enclosure with unit. One 6½in full-range driver. Impedance: 4 ohms. HC: 10W. Finish: white or brown. Designed for use in pairs with pairs of RL131 in quadraphonic systems. Full specification on request. Price: £26-50 (including PT).

RL131

Speaker enclosure with unit. One 6½in full-range driver. HC: 10W. Impedance: 4 ohms. Finish: white only. Spherical cabinet with swivel base. Designed for use in pairs with pairs of RL121 in quadraphonic systems. Full specification on request. Price: £25 (including PT).

RL203

Three-way speaker system. Volume: 9 litres. HC: 25W. Impedance: 4-5 ohms. Finish: white or brown. Full specification on request. Price: £33-50.

RL164

Three-way speaker system comprising bass driver, mid-range unit and tweeter in 25-litre enclosure. HC: 55W. Impedance: 4-5 ohms. Full specification of on request. Finish: white or brown. Price: £42-50.

RL171

Four-way speaker system comprising two bass drivers, one mid-range unit and one tweeter in 45-litre enclosure. Impedance: 4-5 ohms. HC: 60W. Finish: white. Price: £59-50.

SINCLAIR RADIONICS LTD

London Road, St Ives,
Huntingdonshire, PE174HJ.
Tel: St Ives (Hunts) 4311.

Q16

Slim shelf-mounting enclosure with unit. High compliance full-range driver with aluminium speech coil and ceramic magnet. 11,000 gauss. HC: 14W RMS. Impedance: 8 ohms. FR: 60 Hz-16kHz. Infinite baffle construction. Size: 9¾ × 9¾ × 4¾in. Finish: natural solid teak surround with black cellular foam front. Price: £8-98.

SONAB LTD

PO Box 4, Oldfield Road, Hampton, Middlesex,
TW122HN. Tel: 01-979 0134.

Sonab V-1 ★

Enclosure with one upward-facing 8½in unit. FR: 49Hz-17kHz (DIN). HC: 35W (DIN). Impedance: 8 ohms. Size: 12 × 12 × 12¼in. Weight: 10lb. Finish: rosewood, teak, white, red, yellow or blue. Price: £39-50 (including PT).

Sonab OA-4 ★

Enclosure with upward-facing 8½in bass/middle driver and three 2in tweeters. Crossover: 3-5 kHz. FR: 44Hz-18kHz (DIN). HC: 35W (DIN). Impedance: about 7 ohms. Size: 11½ × 17 × 17½in. Weight: 20lb. Finish: rosewood, teak, walnut, oak or white. Price: £55-50 (including PT).

Sonab OA-5 ★

Enclosure with 8½in upward-facing bass/middle driver and four 2in tweeters. Crossover: 2-7 kHz. HC: 40W (DIN). FR: 37Hz-18kHz (DIN). Impedance: about 7 ohms. Size: 9½ × 17 × 24in. Weight: 22lb. Finish: rosewood, teak, walnut, oak, pine, white, red, blue or green. Price: £67-50 (including PT).

Sonab OA-6 ★

Enclosure with six units and built-in bass amplifier. Units: 8½in bass driver, 8½in mid-range unit, four 2in tweeters. Bass speaker driven by 26W RMS built-in amplifier. Distortion 0.1%. Crossover: 200Hz and 2.7kHz. FR: 26

Hz-18kHz (DIN). HC: 50W (DIN). Impedance: about 7 ohms. Size: $9\frac{1}{2} \times 17 \times 27$ in. Weight: 44lb. Finish: rosewood, walnut, teak, oak, deal or white. Price: £153.50 (including PT).

■ SONICS CORPORATION

UK distributor: B. H. Morris & Co (Radio) Ltd, 84-88 Nelson Street, Tower Hamlets, London, E12DY. Tel: 01-790 4824.

AS-57 ★

Bookshelf speaker system with 7×5 in unit. HC: 10W (music power). vci: 8 ohms. FR: 70Hz-18kHz. Finish: walnut. Dimensions: $15\frac{3}{4} \times 5\frac{3}{8} \times 8\frac{1}{2}$ in. Weight: 5.06lb. Price: £17 per pair (including PT).

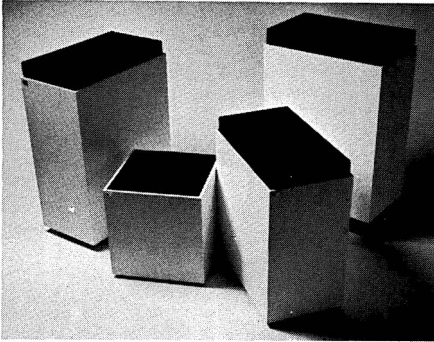

Sonab Enclosures

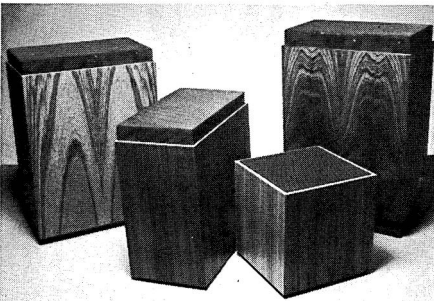

Sonab Enclosures

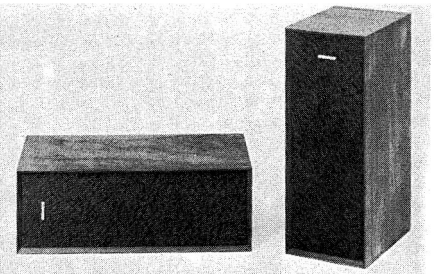

Sonics AS-57

■ SONY (UK) LTD

Pyrene House, Sunbury Cross, Sunbury-on-Thames. Tel: Sunbury-on-Thames 87644/7.

SS-3000 Monitor

Infinite baffle type with three units: $13\frac{1}{2} \times 8\frac{1}{2}$ in bass radiator and pressure HF unit and ultra HF unit. HC: 15W. FR: better than 60Hz-14kHz (± 3 dB) and 40Hz-25kHz (± 5 dB). vci: 8 ohms. Weight: 53lb. Finish: walnut. Dimensions: $28\frac{1}{2} \times 15\frac{3}{8} \times 11\frac{1}{2}$ in. Designed and made in Gt Britain by B & W Electronics to Sony specifications. Price (each): £63.

SS510

Two-unit speaker system. One 8in bass driver, one 2in tweeter. FR: 70Hz-15kHz. HC: 10W RMS. Size: $10\frac{5}{8} \times 17\frac{3}{8} \times 9\frac{1}{2}$ in. Weight: $11\frac{3}{4}$ lb. Finish: oiled walnut. Price: £13.72 (plus £2.32 PT).

SS1005

Infinite baffle enclosure with units and crossover. One $5\frac{1}{2}$ in bass driver, one $2\frac{3}{4}$ in tweeter. FR: 75Hz-18kHz. HC: 15W RMS. Impedance: 8 ohms. Size: $18\frac{3}{8} \times 9\frac{1}{4} \times 7\frac{1}{8}$ in. Weight: 16lb. Finish: walnut grain. Price: £34.75.

SS3300

Reflex enclosure with units and crossover. One 12in bass driver, one 5in mid-range unit, one 2in horn tweeter. Crossover: 500Hz, 3kHz. FR: 30Hz-20kHz. HC: 25W RMS. Impedance: 16 ohms. Size: $22\frac{7}{8} \times 31\frac{1}{2} \times 14\frac{5}{8}$ in. Weight: 90lb. Finish: Eurasian teak with cloth front. Three-channel switch and three-step tone control. Price: £123.50.

SS4200

Reflex enclosure with units and crossover: One 8in bass driver, one 8in mid-range unit, two 3in tweeters. Crossover: 800Hz, 6kHz. FR: 50Hz-20kHz. HC: 20W RMS. Impedance: 6 ohms. Size: $13\frac{3}{4} \times 23\frac{1}{4} \times 11\frac{5}{8}$ in. Weight: 31lb. Finish: walnut with net cloth front. Level control to adjust response to suit room acoustics. Price: £39.15 (plus £6.60 PT).

SS7000

Infinite baffle enclosure with units and crossover. One 12in bass piston driver, 11 electrostatic HF units. Crossover: 400Hz. FR: 40Hz-20kHz ± 4 dB. HC: 25W RMS. Impedance: 8 ohms nominal (rising to 25 ohms at 1kHz). Size: $32\frac{1}{4} \times 26\frac{3}{4} \times 19\frac{1}{2}$ in. Weight: 80lb. Finish: white or walnut. Price: £159.50.

■ SOUND STUDIO LTD

33-35 Camden Road, Tunbridge Wells, Kent. Tel: Tunbridge Wells 32153/30314.

Opus 50

Infinite baffle enclosure with units. Top mounted twin-cone 8in driver giving omnidirectional

★ Indicates entry is illustrated

dispersion. FR: 50Hz-14kHz. HC: 7W RMS. Finish: teak. Size: 12×12×15in high. Price: £12-50 (including PT).

Opus 70

Infinite baffle enclosure with units. One 13×8in bass driver, one 3in tweeter. FR: 20Hz-20kHz. HC: 15W RMS. Finish: teak. Size: 11½×11½×32½in. Price: £25 (including PT).

Figaro

Infinite baffle bookshelf system with unit. One 8in twin-cone driver. FR: 50Hz-14kHz. HC: 7W RMS. Finish: teak. Size: 10×10½×19in. Price: £12-50 (including PT).

Opus 10

Infinite baffle small bookshelf system with unit. One 6½in twin-cone driver. Roll surround. HC: 6W RMS. FR: 75Hz-15kHz. Finish: teak. Size: 9×9×9in. Price: £13-50 (including PT).

Focus-Magna (variant)

Infinite baffle enclosure with unit. Special design permits system to be pivoted to produce the best treble dispersion. Floor or bookshelf mounting. Also corner positioning (without stands). HC: 15W RMS. FR: 50Hz-17kHz. One 8in twin-cone unit with high-flux magnet. Finish: teak. Size: 19×13×13in (plus stand). Price: £23 (including PT).

■ SPENDOR

Spendor Audio Systems Ltd,
3 Station Approach, Redhill, Surrey, RH1 1NX.
Tel: Redhill 63428.

Studio range BCI ★

Reflex enclosure with units and crossover. One 8in plastic cone bass driver, one Celestion HF1300 mid-range unit, one STC 4001G tweeter. Crossover: 3kHz and 13kHz. FR: 45Hz-25kHz (±3dB 60Hz-14kHz). HC: 20W RMS. Impedance: 8 ohms. Main driver based on BBC design with resin-bonded voice coil. Size: 25×11¾×12in. Weight: 31lb. Finish: teak standard (rosewood, walnut or white to order). Price: £61-98 (plus £10-33 PT).

Studio range BCI

Reflex enclosure with units and crossover. One 8in plastic cone bass driver, one Celestion HF1300 mid-range unit, one STC 4001G tweeter. Crossover: 3kHz, 13kHz. FR: 45Hz-25kHz (60Hz-14kHz ±3dB). HC: 25W RMS. Impedance: 8 ohms. Bass driver developed by Spendor with 1½in diameter resin-bonded voice coil. Size: 25×11¾×12in. Weight: 33lb. Finish: teak standard (rosewood, walnut or white to order). Price: £69 (plus £11-50 PT).

Spendor speakers also supplied with 20W or 50W power amplifier built-in (Models BCIA and BCIIA). Amplifier inputs balanced or un-

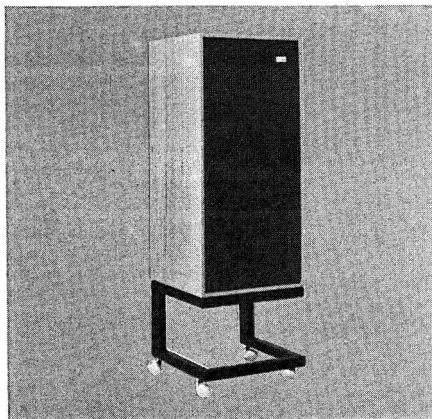

Spendor Studio range BCI

balanced. Designed for professional market. Prices and specifications on request.

■ STE-MA

Distributors: Kelgrove (Sales) Ltd,
St Mark's Rise, Dalston, London, E8.

Type 300

Infinite baffle enclosure with units and crossovers. One 10in bass driver, one 5in mid-range unit, one 2½in tweeter. Crossovers: 750Hz, 4kHz. FR: 40Hz-20kHz. HC: 18W RMS. Impedance: 8 ohms. Wall mounting brackets supplied. Size: 25×15¼×10in. Finish: teak. Price: £33-60.

Type 400

Infinite baffle enclosure with units and crossovers. One 8in twin cone bass and mid-range driver, one 2½in tweeter. Crossover: 4kHz. FR: 50Hz-18kHz. HC: 12W RMS. Impedance: 8 ohms. Wall mounting brackets supplied. Size: 19½×11½×9½in. Finish: teak. Price: £24.

Hi-Fi 3

Infinite baffle enclosure with units and crossovers. One 8in bass driver, one 5in mid-range unit, one 2½in tweeter. Crossovers: 1-5kHz, 6kHz. FR: 35Hz-20kHz. HC: 30W RMS. Impedance: 8 ohms. Wall brackets supplied. Conforms to DIN 45 500. Size: 19½×11½×9½in. Finish: teak or rosewood. Price: £44-10.

Hi-Fi 4

Infinite baffle enclosure with units and crossovers. One 10in bass driver, one 8×5in mid-range unit, two 2½in tweeters. Crossovers: 1-5kHz, 6kHz. FR: 30Hz-20kHz. HC: 35W RMS. Impedance: 8 ohms. Teak wall brackets supplied. Size: 25×15¼×10in. Finish: teak or rosewood with aluminium surround. Price: £50-40.

STENTORIAN

Whiteley Electrical (Radio) Co Ltd,
Victoria Street, Mansfield, Notts.
Tel: Mansfield (0623) 24762.

C14 Thoresby Bass Reflex Corner Console

Designed to utilise acoustic properties of walls. Takes 8in or 10in units with provision for tweeter. Size: $31 \times 19\frac{3}{8} \times 17$ in. Choice of mahogany (C14) or walnut (C14A) finish. Price: (C14 mahogany) £23.50 (plus £1.91 PT); (C14A walnut) £23.99 (plus £1.95 PT). Cabinet only without speaker units.

C15 Thoresby Bass Reflex Console

Designed for 8in or 10in units with provision for tweeter. Size: $31 \times 19\frac{3}{8} \times 18$ in. Choice of mahogany (C15) or walnut (C15A) finish: Prices: (C15 mahogany) £25.46 (plus £2.07 PT); (C15A walnut) £26.23 (plus £2.13 PT). Cabinet only without speaker units.

LC93

Infinite baffle enclosure with unit. One 9in HF912-67 speaker unit. FR: 60Hz-20kHz. HC: 10W RMS. Impedance: 15 ohms. Acoustically loaded cabinet. Speaker has graded melaminated cone with silicon rubber-over-cambic suspension. Size: $19 \times 12\frac{1}{2} \times 8\frac{1}{2}$ in. Weight: 20lb. Finish: teak or rosewood veneer. Price: (teak) £17.67 (plus £2.98 PT); (rosewood) £19.04 (plus £3.21 PT).

LC94

Labyrinth enclosure with unit. One 9in HF912-67 speaker unit. FR: 45Hz-20kHz. HC: 10W RMS. Impedance: 15 ohms. Acoustic labyrinth with acoustic resistance incorporated in pipe. Special 9in speaker as fitted in LC93. Size: $29\frac{1}{2} \times 23\frac{3}{4} \times 6\frac{1}{2}$ in. Weight: 39lb. Finish: oiled teak or rosewood veneer. Price: (teak) £27.20 (plus £4.58 PT); (rosewood) £28.98 (plus £4.88 PT).

LC95

Reflex enclosure with units. One 12in HF1214-67 bass driver, one 8in T812-67 mid- and upper-frequency speaker. Crossover: $\frac{1}{4}$ -section L/C 1kHz. FR: 27Hz-20kHz. HC: 15W RMS. Impedance: 15 ohms. Acoustically loaded bass reflex cabinet. 12in unit melamine treated paper cone with cambic surround, 8in unit melamine treated paper ribbed cone and surround. Size: $31\frac{1}{2} \times 20\frac{3}{4} \times 13\frac{1}{2}$ in. Weight: 62lb. Finish: oiled teak or rosewood veneer. Price: (teak) £61.52; (rosewood) £64.10.

STEREOSTAGE

Nucleus, 22 Hyde Green, Marlow, Bucks.
Tel: Marlow 3787.

Stereostage

Labyrinth enclosure fitted with drive units. Ten Astec speaker motor units. FR: 30Hz-20kHz. HC: 60W per channel. Impedance: 8 ohms.

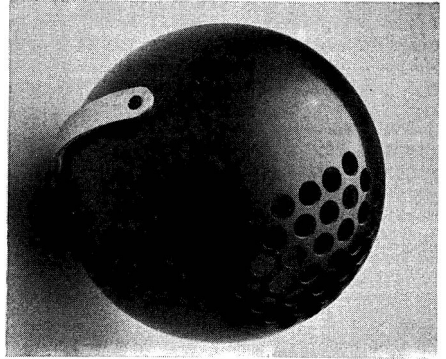

Sykes & Hirsch Mini Sphera

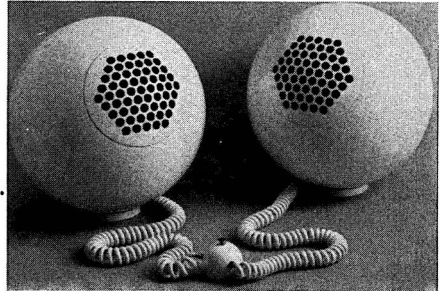

Sykes & Hirsch Super Sphera

Comprises phase delay stereo system integrated in long-line enclosure. Size: 9ft long, 31in high, 10in deep. Finish: to order. Weight: 200lb. Price: £295.

SYKES+HIRSCH LTD

201 Greenwich High Road, London, SE10.
Tel: 01-858 0549.

Mini-Sphera ★

Spherical speaker enclosure with unit. Infinite baffle. One $6\frac{1}{2}$ in full range unit. FR: 35Hz-15kHz. HC: 15W RMS. Impedance: 8 ohms. Size: 10in diameter. Weight: 4 $\frac{1}{2}$ lb. Finish: high gloss white or black. Any British standard colour available at small extra charge, hanging bracket extra. Price: £21.25.

Sphera

Spherical speaker enclosure with units and crossover. Infinite baffle. Two $8\frac{1}{2}$ in bass drivers, one $2\frac{1}{2}$ in tweeter. Crossover: 3.5kHz. FR: 35Hz-20kHz. HC: 50W RMS. Impedance: 8 ohms. Size: 16 $\frac{1}{2}$ in diameter. Finish: high gloss white or black. Any British standard colour available at small extra charge. Price: £37.50.

Super Sphera ★

Spherical speaker enclosure with units and crossover. Infinite baffle. One 12in bass driver,

★ Indicates entry is illustrated

one 2½in tweeter. Crossover: 5kHz. FR: 25Hz-25kHz. HC: 25W RMS. Impedance: 8 ohms. Size: 24in diameter. Finish: high gloss white. Illuminated base with dimmer switch. Any standard colour at small extra charge. Price: £65.

■ SYMPHONY

J. W. (Wholesale) Co. 26 Rosoman Street, London, EC1. Tel: 01-837 5920.

Symphony Monitor

Reflex enclosure with units and crossover. One KEF B139 13 × 9½in bass driver, one KEF B110 5½in mid-range unit, one KEF T27 1in tweeter. Crossover: DN12 (400Hz, 3-5kHz). FR: 30Hz-20kHz. HC: 30W. Impedance: 8 ohms. Size: 30 × 15¾ × 12½in. Weight: 60lb. Supplied direct to user. Price: £39.60.

■ TANDBERG

Farnell-Tandberg Ltd, 81 Kirkstall Road, Leeds, LS3 1HR. Tel: Leeds 35111.

Tan 7 ★

Infinite baffle in teak or rosewood with 6 × 10in and 2in units. HC: 20W music power. FR: 60Hz-16kHz. vci: 32 ohms. Dimensions: 20½ × 10 × 10½in. Prices: (teak) £23.29 (plus £3.93 PT); (rosewood) £24.96 (plus £4.20 PT).

Tan 11

Infinite baffle speaker in teak with 6½in and 2in units. HC: 20W music. FR: 60Hz-16kHz. vci: 4 ohms. Dimensions: Tan 11, 12⅝ × 6 × 8½in. Price: (teak) £15.81 (plus £2.66 PT); (rosewood) £17.47 (plus £2.94 PT).

Tan 12 ★

Infinite baffle with 6½in and 2in units. HC: 20W music. FR: 50Hz-16kHz. vci: 4 ohms. Dimensions: 17¼ × 7¼ × 8½in. Price: (teak) £17.47 (plus £2.94 PT); (rosewood) £19.13 (plus £3.22 PT).

Tan 18

Price: (teak) £17.47 (plus £2.94 PT); (rosewood) £18.72 (plus £3.15 PT).

TL 1210

Infinite baffle enclosure with units and crossover. One 6½in bass driver, one 1in dome tweeter. FR: 30Hz-25kHz. HC: 25W. Impedance: 4-8 ohms. Size: 16½ × 9¼ × 7½in. Finish: teak or rosewood. Price: £21.63 (plus £3.64 PT).

TL 2510

Infinite baffle enclosure with units and crossover. One 8in bass driver, one 1in dome tweeter. FR: 40Hz-22kHz (DIN). HC: 35W. Impedance: 4-8 ohms. Size: 20¾ × 11⅝ × 8¾in. Finish: teak or rosewood. Price: £28.28 (plus £4.76 PT).

TL 5010

Infinite baffle enclosure with units and crossover.

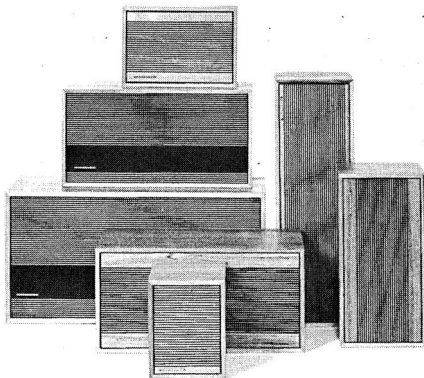

Tandberg speaker enclosures

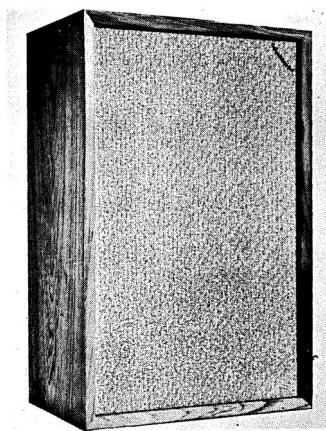

Tannoy Monitor III.LZ Mk II

One 12in bass driver, one 5in mid-range unit, one 1in dome tweeter. FR: 35Hz-22kHz (DIN) HC: 45W RMS. Impedance: 4-8 ohms. Size: 25⅝ × 14¼ × 11in. Finish: teak or rosewood. Price: £65 (no PT).

■ TANNOY

Tannoy Products Ltd, Norwood Road, West Norwood, London, SE27 9AB. Tel: 01-670 1131. Cables: Tannoy, London.

III.LZ Mk II ★

Infinite baffle forward facing. Monitor Gold III LZ dual concentric unit with crossover network. FR: 30Hz-20kHz. Size: 14 × 10¾ × 23¾in. Price: £41.

Lancaster

Reflex (single port) forward facing. Free-standing. One Monitor Gold 12in with crossover network. Size: 33½ × 21½ × 12½in (including 2in plinth). Price: £63.

Lancaster

Reflex (single port) forward facing. Corner placing. One Monitor Gold 12in with crossover network. Size: $33 \times 25 \times 16\frac{3}{4}$ in (including 2in plinth). Price: £63.

Lancaster

Aperiodic free-standing enclosure. One Monitor Gold 15in with crossover network. Size: $33\frac{1}{2} \times 21\frac{1}{2} \times 12\frac{1}{2}$ in (including 2in plinth). Price: £69.

Lancaster

Aperiodic corner-standing enclosure. One Monitor Gold 15in unit with crossover. Size: $33 \times 25 \times 16\frac{3}{4}$ in (including 2in plinth). Price: £69.

Rectangular York

Reflex (single port) enclosure. Forward facing. Complete with Monitor Gold 15in dual concentric unit with crossover. Crossover: 1kHz. FR: 23Hz-20kHz. Size: $15 \times 23\frac{1}{2} \times 42$ in. Price: £86.

York

Reflex enclosure. Forward facing unit. Dual throated ports. Corner placing. One Monitor Gold 15in dual concentric unit with crossover. FR: 35Hz-20kHz. Size: $45\frac{1}{2} \times 32 \times 22\frac{1}{2}$ in. Price: £86.

Rectangular GRF

Single folded horn. Forward facing with front exits. Complete with one Monitor Gold 15in dual concentric unit. Crossover: 1kHz. FR: 23Hz-20kHz. Size: $17\frac{1}{4} \times 23\frac{1}{2} \times 42$ in. Price: £123.

Corner GRF ★

Folded horn. Rear loaded horn, forward facing unit. Corner placing. One Monitor Gold 15in dual concentric unit. FR: 20Hz-20kHz. Size: $48 \times 38 \times 29$ in. Price: £140.

Guy R. Fountain Autograph

Folded horn. Front and rear horn loaded unit. Corner placing. One Monitor Gold 15in unit with crossover. FR: 20Hz-20kHz. Size: $58\frac{1}{2} \times 43 \times 26\frac{1}{2}$ in. Price: £195.

Chatsworth R.T.

Infinite baffle enclosure with dual-concentric unit. One 12in Monitor Gold dual-concentric full-range driver with Tanoplas surround. Eight-section filter with controls for roll-off and level. FR: 30Hz-20kHz. HC: 35W RMS. Impedance: 8 ohms. Designed for domestic high quality where space is limited. Finish: selected teak veneers with melamine finish. Size: $15\frac{1}{2}$ in wide, $33\frac{1}{2}$ in high, $10\frac{1}{2}$ in deep. Weight: 50lb. Price: £57.

Tannoy III LZ Mk II and Lancaster speakers are also available in teak and mahogany. York, GRF and Autograph available in teak, mahogany and walnut.

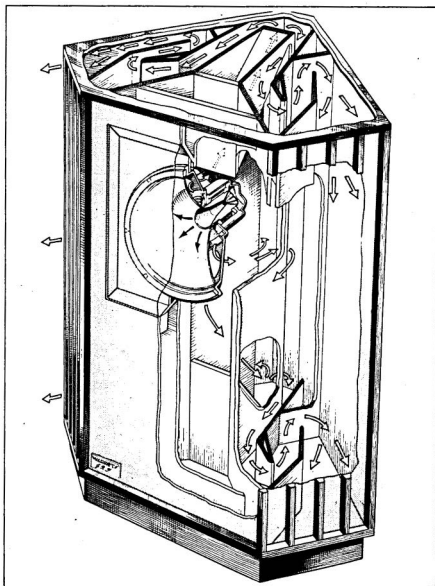

Tannoy Corner G.R.F.

TEAC

Acoustico Enterprises Ltd, 6-8 Union Street, Kingston-on-Thames, Surrey.
Tel: 01-549 3471/3.

LS80

Infinite baffle enclosure with units and crossover. One 12in bass driver, one 5in mid-range unit, one horn tweeter. Crossover: 600Hz, 5kHz. FR: 30Hz-20kHz. HC: 30W RMS. Impedance: 8 ohms. Size: $26\frac{3}{8} \times 16 \times 11\frac{3}{8}$ in. Weight: 42lb. Finish: walnut, fretwork front. Price: £69-73.

LS80M

Infinite baffle enclosure with units and crossover. One 12in bass driver, one 5in mid-range unit, one horn tweeter. Crossover: 600Hz, 5kHz. FR: 30Hz-20kHz. Impedance: 8 ohms. Size: $26\frac{3}{8} \times 16 \times 11\frac{3}{8}$ in. HC: 30W. Finish: walnut. Weight: 48lb. Multi-channel system. Price: £80.

LS400

Infinite baffle enclosure with units and crossover. One 12in bass driver, two 4in mid-range units, two horn tweeters. Crossover: 500Hz, 5kHz. FR: 30Hz-20kHz. HC: 25W. Impedance: 8 ohms. Size: $27\frac{5}{8} \times 17\frac{3}{8} \times 14\frac{1}{4}$ in. Weight: $48\frac{1}{2}$ lb. Finish: walnut. Price: £74-90.

TELEFUNKEN

Distributors: AEG (Great Britain) Ltd, AEG House, Chichester Rents, Chancery Lane, London, WC2. Tel: 01-242 9944.

★ Indicates entry is illustrated

WB60/61

Enclosure comprising two units: 5 $\frac{3}{8}$ in bass driver and 5 × 3in mid/treble unit. HC: 15W. FR: 45Hz-18kHz. Finish: teak. Dimensions: 18 $\frac{1}{2}$ × 6 $\frac{1}{2}$ × 10in. Price: £20.21 (including PT).

RB70

Enclosure comprising two units: 8in bass driver and 7 × 5in mid/treble. vci: 4 ohms. HC: 25W. FR: 40Hz-18kHz. Finish: teak. Dimensions: 21 × 10 $\frac{1}{4}$ × 9 $\frac{1}{4}$ in. Price: £27.15 (including PT).

L250

Enclosure comprising three units: 8in bass driver and two 5 × 3in mid/treble units. vci: 4 ohms. HC: 35W. FR: 35Hz-20kHz. Finish: walnut. Dimensions: 18 × 7 $\frac{1}{8}$ × 12 $\frac{3}{4}$ in. Price: £42.82 (including PT).

TL41

Two-way system with units and crossover. One 5in bass driver, one 5 × 3in mid-range and HF unit. FR: 44Hz-22kHz. HC: 15W RMS. Size: 10 $\frac{1}{2}$ × 6 $\frac{1}{2}$ × 8in. Finish: light matt walnut or pearl white. Price: £18.49 (including PT).

L55

Spherical enclosure with unit. One full-range 5in driver. FR: 50Hz-15kHz. HC: 15W RMS. Impedance: 4 ohms. Size: 8 $\frac{1}{2}$ in diameter. Finish: brushed aluminium. Fitted with special acoustic damping. Stands on plexiglass base or can be suspended. Price: £16.55 (including PT).

TL70

Three-way enclosure with units and crossover. One 8in bass driver, one 5in mid-range unit, one 1 $\frac{1}{4}$ in tweeter. FR: 25Hz-20kHz. HC: 50W RMS. Impedance: 4 ohms. Size: 21 $\frac{1}{4}$ × 11 $\frac{1}{2}$ × 9 $\frac{1}{2}$ in. Finish: light matt walnut. Price to be announced.

TL90

Three-way enclosure with units and crossover. One 12in bass driver, one 5in mid-range unit, one 1in tweeter. FR: 25Hz-20kHz. HC: 50W RMS. Impedance: 4 ohms. Size: 13 $\frac{3}{4}$ × 27 $\frac{1}{2}$ × 12in. Finish: light matt walnut. Price to be announced.

■ VAN DER MOLEN LTD

1 Mildmay Road, Romford, Essex, RM77DA. Tel: Romford 41904.

S10

Shell-mounting enclosure with unit. One full-range dual cone driver. FR: 80Hz-18kHz. Size: 16 × 10 × 4 $\frac{1}{2}$ in. Impedance: 4 or 8 ohms. Price: (per pair) £14.

S20

Picture frame enclosure with unit. One full-range drive unit. Impedance: 4 ohms. HC: 10W. FR: 70Hz-18kHz. Size: 11 $\frac{1}{2}$ × 11 $\frac{1}{2}$ × 3 $\frac{3}{4}$ in deep. Price: (per pair) £18.50.

S40

Floor or shelf enclosure with units. One bass driver, one HF unit. Impedance: 4 ohms. HC: 10W. FR: 60Hz-18kHz. Price: £31.89.

S50

Floor-standing enclosure with units. One 6 $\frac{1}{2}$ in bass driver, one 2 $\frac{1}{2}$ in tweeter. Four-element crossover. FR: 50Hz-18kHz. Impedance: 8 ohms. Size: 16 × 10 × 7 $\frac{1}{2}$ in. Price: (per pair) £45.

■ VIDEOTON

Distributors: Radio and Electronic Distribution Co, 55-63 Goswell Road, London, EC1. Tel: 01-253 1802.

D131E Minimax 1

Bookshelf enclosure with unit. One 5in full-range driver. HC: 20W RMS. FR: 50Hz-12.5kHz. Impedance: 8 ohms. Finish: teak, walnut or coloured. Size: 10 $\frac{1}{4}$ × 8 $\frac{3}{4}$ × 6in. Weight: 8 $\frac{1}{2}$ lb. Price: £15.10 (including PT).

D132E Minimax 2

Bookshelf enclosure with units. One 5 $\frac{1}{2}$ in bass driver, one 4in tweeter. HC: 15W RMS. FR: 45Hz-20kHz. Impedance: 8 ohms. Finish: teak, walnut or coloured. Size: 10 $\frac{1}{4}$ × 8 $\frac{3}{4}$ × 6in. Weight: 9lb. Price: £19.45 (including PT).

DP202E Saphir 1

Bookshelf enclosure with units. One 8in bass driver, one 4in tweeter. HC: 20W RMS. FR: 40Hz-20kHz. Impedance: 8 ohms. Finish: teak, walnut or coloured. Size: 14 × 9 $\frac{1}{2}$ × 8 $\frac{3}{4}$ in. Weight: 17lb. Price: £24.65 (including PT).

DF202E Saphir 2

Wall mounting enclosure with units. One 8in bass driver, one 4in tweeter. HC: 20W RMS. FR: 45Hz-20kHz. Impedance: 8 ohms. Finish: teak, walnut or coloured. Size: 21 × 13 × 4 $\frac{3}{4}$ in. Weight: 17lb. Price: £25.80 (including PT).

D252E Brilliant

Floor-standing enclosure with units. Screw-on legs. One 10in bass driver, one 4in tweeter. HC: 20W RMS. FR: 35Hz-20kHz. Impedance: 8 ohms. Finish: teak, walnut or coloured. Size: 23 $\frac{1}{2}$ × 13 $\frac{3}{4}$ × 12 $\frac{3}{4}$ in. Weight: 35lb. Price: £44.90 (including PT).

D253E Diadem

Floor-standing enclosure with units. Screw-on legs. One 10in bass driver, two 4in tweeters. HC: 25W RMS. FR: 35Hz-20kHz. Impedance: 8 ohms. Finish: teak, walnut or coloured. Size: 23 $\frac{1}{2}$ × 13 $\frac{3}{4}$ × 12 $\frac{3}{4}$ in. Weight: 35lb. Price: £51.30 (including PT).

■ VITAVOX LTD

Westmoreland Road, London, NW99RJ. Tel: 01-204 4234. Cables: Vitavox, London.

System 191 Corner Horn

Double channel horn system. Folded LF horn

with AK155 drive unit. Forward-facing HF horn with S2 pressure unit. Filter network incorporated. Crossover: 500Hz. FR: 30Hz-15 kHz. High translational efficiency. Size: 51 × 30 × 27in. Price: £525.

Bitone Series 3200

Double channel sound system comprising three-cell horn (distribution 60° wide × 20° high) with 12in LF driver in vented enclosure. Filter network: 1kHz crossover, attenuation 12dB per octave. HF balance control 0-8dB attenuation. HC: 20W. FR: 50Hz-15kHz. Size: 24 × 20 × 19in. Price: £261.15.

Bitone Series 6200

Similar specification to 3200 but with six-cell horn giving distribution 60° wide × 40° high. Size: 29 × 20 × 20in. Price: £269.50.

Bitone Major

Double channel sound system comprising HF dispersive horn and S.2 HF pressure unit (distribution 90° wide × 20° high) with 15in LF driver in special reflex enclosure. Filter network 500 kHz. Crossover attenuation 12dB/octave. HF balance control 0-8dB attenuation. HC: 30W. FR: 35Hz-16kHz. Size: 42 × 30 × 24in. Price: (whitewood) £331.15; (studio) £357.45.

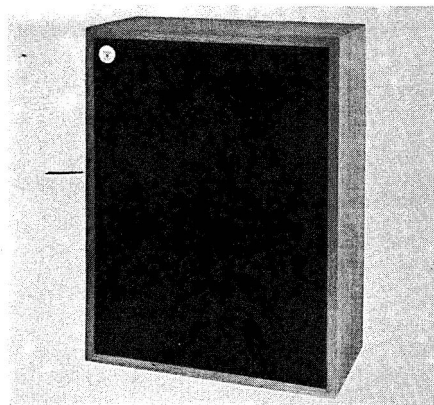

Vitavox Mini Bitone

Mini Bitone ★

Double channel sound system comprising horn and infinite baffle enclosure. 12in AK124 cone type bass driver, GP2 high frequency pressure unit. Crossover: 1kHz. FR: 50Hz-15kHz. HC: 20W RMS. Finish: teak. Size: 24 × 18 × 9in. Price: £144.40.

Where can I get
TOP DISCOUNTS
on hi-fi
equipment?

AT
GLOBAL AUDIO DISCOUNT
WAREHOUSES
THEY GIVE
UP TO **60% OFF**

They stock all leading makes...
AKAI · LEAK · SINCLAIR
ARMSTRONG · TELETON
THORENS · PHILIPS
ROTEL · GOLDRING · ROGERS
PIONEER ETC.

For the latest discount prices
see their advertisements in the
current hi-fi magazines or
write for list



GLOBAL AUDIO DISCOUNT WAREHOUSES

Dept. YB 174 Pentonville Road, London, N1. Telephone 01-278 1769

Or: 4 High View Parade, Redbridge Lane East, Woodford Avenue, Ilford, Essex. Tel: 01-550 1086.

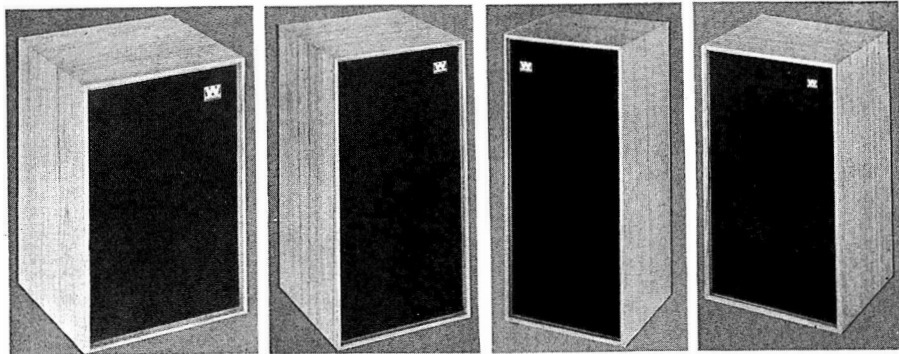

Wharfedale Denton 2

Wharfedale Linton 2

Wharfedale Triton 3

Wharfedale Dovedale 3

■ WHARFEDALE

Rank Wharfedale Ltd, Bradford Road, Idle, Bradford, Yorks, BD108SF.

Tel: Bradford 612552. Telex No. 51407.

Denton 2 ★

Two-unit enclosure, 8in bass driver, 2in tweeter. Crossover: 1400Hz. FR: 60Hz-16kHz \pm 3dB. vci: 4-8 ohms. HC: 18W DIN. Finish: oiled teak or polished walnut. Size: 14 \times 9 $\frac{3}{4}$ \times 8 $\frac{3}{4}$ in. Price: (sold in pairs only) £33.19 (plus £5.81 PT) per pair.

Linton 2 ★

Two-unit enclosure. 8in bass driver, 2in tweeter. Crossover: 1200Hz. FR: 55Hz-18kHz \pm 3dB. vci: 4-8 ohms. HC: 20W DIN. Finish: oiled teak or polished walnut. Size: 19 \times 10 \times 9 $\frac{1}{2}$ in. Price: (sold in pairs only) £41.70 (plus £7.30 PT) per pair.

Triton 3 ★

Infinite baffle enclosure with units and crossover. One 8in bass driver, one 5in mid-range unit, one 1in CAB dome multi-directional tweeter. All units forward facing. Crossover: Seven-element three-way. FR: 55Hz-20kHz \pm 3dB. HC: 25W DIN. Impedance: 4-8 ohms. Finish: teak or walnut. Floorstanding or bookshelf system. Size: 21 $\frac{3}{4}$ \times 9 $\frac{3}{4}$ \times 9 in (sold in pairs only). Price: £53.62 (plus £9.38 PT) per pair.

Melton 2

Infinite baffle enclosure. 2in tweeter and 12in bass driver. Crossover: 1500Hz. FR: 45Hz-17kHz \pm 3dB. HC: 30W DIN. vci: 4-8 ohms. Size: 21 \times 14 $\frac{1}{2}$ \times 10 in. Finish: teak or walnut. Price: £35.

Dovedale 3 ★

Infinite baffle enclosure. 1in tweeter, 5in mid-range unit and 12in bass driver. Crossover: 1500Hz. FR: 45Hz-17kHz \pm 3dB. HC: 30W DIN. vci: 4-8 ohms. Fitted with attenuator

panel to increase or decrease mid-range or treble. Size: 24 \times 14 \times 12 in. Finish: teak or walnut. Electro-mechanical crossover system. Price £45.

Rosedale

Infinite baffle enclosure. 1in tweeter, 5in mid-range unit and 15in bass driver. Crossover: 700Hz and 3kHz. FR: 35Hz-20kHz \pm 3dB. HC: 45W DIN. vci: 4-8 ohms. Size: 23 $\frac{1}{2}$ \times 23 \times 13 $\frac{1}{2}$ in. Finish: teak or walnut. Period style cabinet. Price: £65.

■ WHITELEY ELECTRICAL RADIO CO LTD. See Stentorian.

■ WILKINSON/FORM

Wilkinson/Form (Electronics), Everest Mile Road, Widdrington, Northumberland. Tel: Ulgham 200.

WF25

Infinite baffle shelf-mounting enclosure with units and crossover. One 6 $\frac{1}{2}$ in Peerless bass driver, one 2 $\frac{1}{2}$ in HF unit. Crossover: L/C 5kHz. HC: 25W (DIN), 12W (RMS). FR: 60Hz-18kHz. Size: 17 \times 10 \times 9 in. Finish: teak veneer with aluminium trim. Price: £22 (including PT).

New models of Wilkinson/Form speaker systems being added to range, including monitor type, but details not available as this issue of the Year-Book closed for press.

■ WOOLLETT AUDIOSTATICS

21 Anerley Station Road, London, SE208PY. Tel: 01-778 9003.

Claremont ★

Electrostatic mid-range and HF system. Constant charge push-pull electrostatic unit. Crossover 1.6Hz, -6dB/octave. FR: 1.6kHz-20kHz. HC: 20W RMS. Impedance: 16 ohms. Cabinet contains mains polarising unit, crossover, phase

corrector for transistor amplifiers, depolarising circuit, pre-set treble attenuator (12dB range). Mains 200-250V (100-125V to order). Finish: veneered wood, with Vynair. Size: $11\frac{1}{2} \times 8\frac{3}{4} \times 8\frac{1}{4}$ in. Weight: 4lb 12oz. Price: £24.90.

Kelsey Bass

Infinite baffle frontal-loaded enclosure intended for use as a bass speaker. Small/large room middle switching. Unit 12in foam surround. FR: 20Hz-5kHz. HC: 20W. vci: 16 ohms. Finish: veneered wood. Size: $33\frac{3}{4} \times 18 \times 14$ in. Weight: 52lb. Price: £46.

Frensham Bass

Similar specification to Kelsey Bass but in horizontal cabinet on 6in legs. Small/large room middle switching. Cabinet size: $31 \times 14\frac{3}{4} \times 16$ in. Price: £46.

Leven

Similar specification to Claremont but in bow-fronted cabinet $10 \times 8\frac{1}{2} \times 8\frac{1}{2}$ in. Price: £24.90.

Grasmere Moderna ★

Infinite baffle enclosure with frontal-loading. 12in bass driver plus push-pull constant charge electrostatic. Crossover: 1.6kHz ($\frac{1}{4}$ -section). FR: 20Hz-20kHz. HC: 20W RMS. Impedance: 16 ohms (8-ohm transformer available). Variable treble and middle range. Size: $34 \times 18 \times 14$ in. Weight: 52lb. Finish: matt white, wood veneer and black fabric. Price: £61.75.

Grasmere Futura ★

Similar size and specification to the Moderna but with white front, teak and black fabric. Price: £63.75.

Como Moderna

Enclosure with units, 12in low-resonance bass driver, 2in treble, short horn loaded. FR: 60Hz-16kHz. HC: 16W. Finish: wood veneer and black. Size: $19\frac{1}{2} \times 14\frac{1}{2} \times 12$ in. Weight: 24lb. Suitable for rear speakers in quadrasonic systems. Equalised duo-dynamic system. Price: £32.75.

Como Futura

As Como Moderna but finished in wood veneer with white front and black fabric. Price: £34.75.

Como Futura, Bass

Standard Como but without treble system. Primarily for use as central bass speaker in common bass system, or as rear ambience speaker in derived quadrasonics. Price: £29.90.

Como Moderna, Bass

As Como Futura Bass but with wood veneer front. Price: £27.90.

Addabass

Add-on bass chamber for use with Como system. Gives large-speaker bass and serves as floor stand. Price: £12.80.

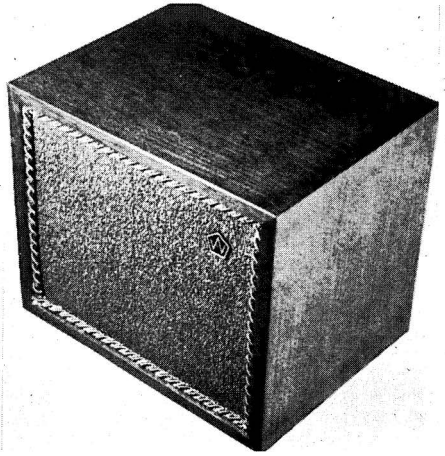

Woollett Claremont

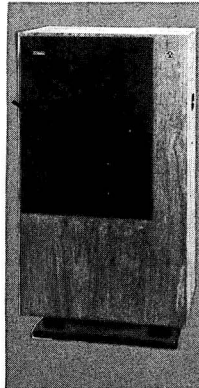

Woollett Grasmere Moderna

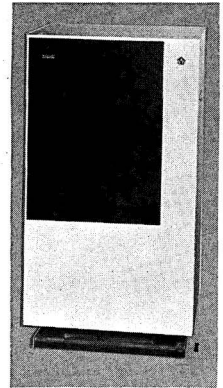

Woollett Grasmere Futura

Esdiyn

A 'do-it-yourself' constant-charge electrostatic and 12in low-resonance dynamic driver supplied in-the-white for customer to finish to own requirements. FR: 40Hz-20kHz. HC: 20W RMS. Size: $31 \times 18 \times 14\frac{3}{4}$ in. Weight: 48lb. Impedance: 16 ohms (transformer available for other impedances). Price: £48.

WORDEN AUDIO DEVELOPMENTS LTD

54 Chepstow Road, London, W2.
Tel: 01-229 4996.

Panosona Reproducer

Double horn with diffusing chamber. Corner reproducer, designed for near plane-wave distribution from single speaker unit. Available in three versions: (Model A) Size: 54in high, 24in wide, $14\frac{1}{2}$ in to corner. FR: (with Lowther PM6

★ Indicates entry is illustrated

or PM7) 20Hz to over 18kHz. (Model B) Size: 48in high, 21½in wide, 12½in to corner. FR: (with Richard Allan CG8T) 30Hz-17kHz: (Model C) Size: 27in high, 24in wide, 13in to corner. FR: (with Richard Allan CG8T) 30Hz-17kHz. Prices: Model A (speaker enclosure only) £60; Model B (enclosure only) £50; Model C (enclosure only) £40. Lowther PM6 £22.50; PM6 Mk I £25; PM7 £35; Richard Allan CG8T £7.11. All prices include PT where applicable.

Panosona Bookshelf Speaker

Designed in accordance with the principles of the Panosona Corner Reproducers. Size: 16 ×

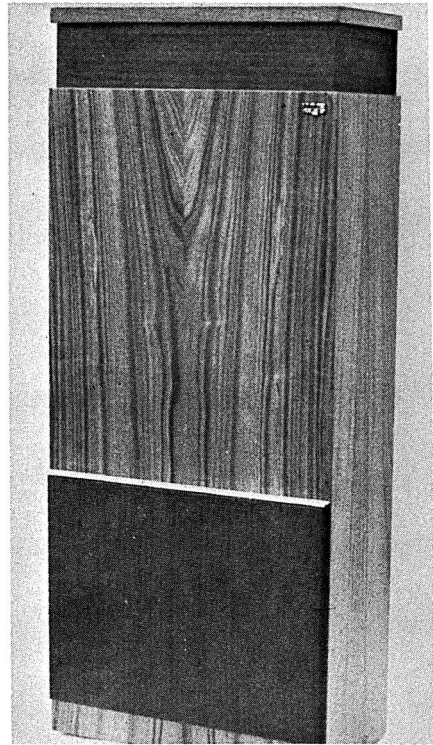

Wye Electronics 1300 column

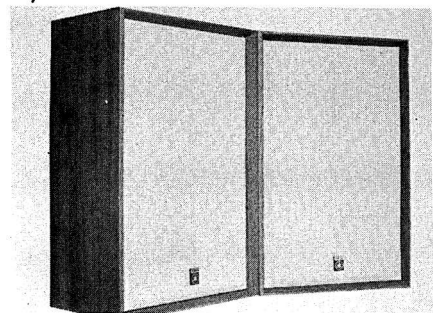

Yamaha NS-410

9 × 9½in. Recommended drive units: Richard Allan CG8T £7.11 (including PT). Standard finish: teak. Other finishes to order. Contrasting Tygan or Vynair front covering. Price: (enclosure only) £21 including purchase tax.

WYE ELECTRONICS LTD

Queen Street North, Whittington Moor, Chesterfield, Derbyshire.

Tel: Chesterfield 51116.

Stereo 525

Two-unit enclosure. 13 × 8in bass with aluminium centre cone and 3¾in HF tweeter. FR: 25Hz-18kHz. HC: 10W RMS. vci: 4 ohms. Crossover: 5kHz. Size: 19¾ × 12 × 8½in. Price: £19.95.

1300 Hi-Fi ★

Two-unit column enclosure speaker with 12in bass unit and HF1300 3in tweeter. FR: 25Hz-15kHz. vci: 4, 8, 16 ohms. Crossover: 3kHz. Size: 36 × 15 × 7½in. Price: £37.80.

YAMAHA

Jonathan Fallowfield Ltd, Strathcona Road, North Wembley, London, HA9 8QL.

Tel: 01-904 0141.

NS-18

Two-way speaker system. One 32 × 18in bass/mid-range driver, one 2½in tweeter, Plastic an aluminium cone. Impedance: 8 ohms. HC: 18W. FR: 35Hz-18kHz. Price: (per pair) £143.02.

NS-230

Two-way speaker system. One 18 × 12½in bass/mid-range driver, one 2½in tweeter, Plastic and aluminium cone. Impedance: 8 ohms. HC: 10W. FR: 45Hz-18kHz. Price: (per pair) £70.08.

NS-250

Two-way speaker system. One 20 × 15in bass/mid-range driver, one 2¼in horn tweeter. Plastic and aluminium cone. Impedance: 8 ohms. HC: 15W. FR: 40Hz-18kHz. Price: (per pair) £99.90.

NS-330

Three-way speaker system. One 27 × 20in bass driver, one 8in mid-range unit, one 2in tweeter. Plastic and aluminium cone. Impedance: 8 ohms. HC: 50W. FR: 50Hz-18kHz. Price: (per pair) £240.

NS-370

Three-way speaker system. One 35 × 25in bass driver, one 12in mid-range unit, one 2½in tweeter. Plastic and aluminium cone. Impedance: 8 ohms. HC: 80W. FR: 45Hz-20kHz. Price: £360.

NS-410 ★

Two-way speaker system. One 8in bass/mid-range driver, one 2in horn tweeter. Paper cone. Impedance: 8 ohms. HC: 10W. FR: 45Hz-18kHz. Price: £42 (plus £6.80 PT).

VHF RADIO TRANSMITTING STATIONS

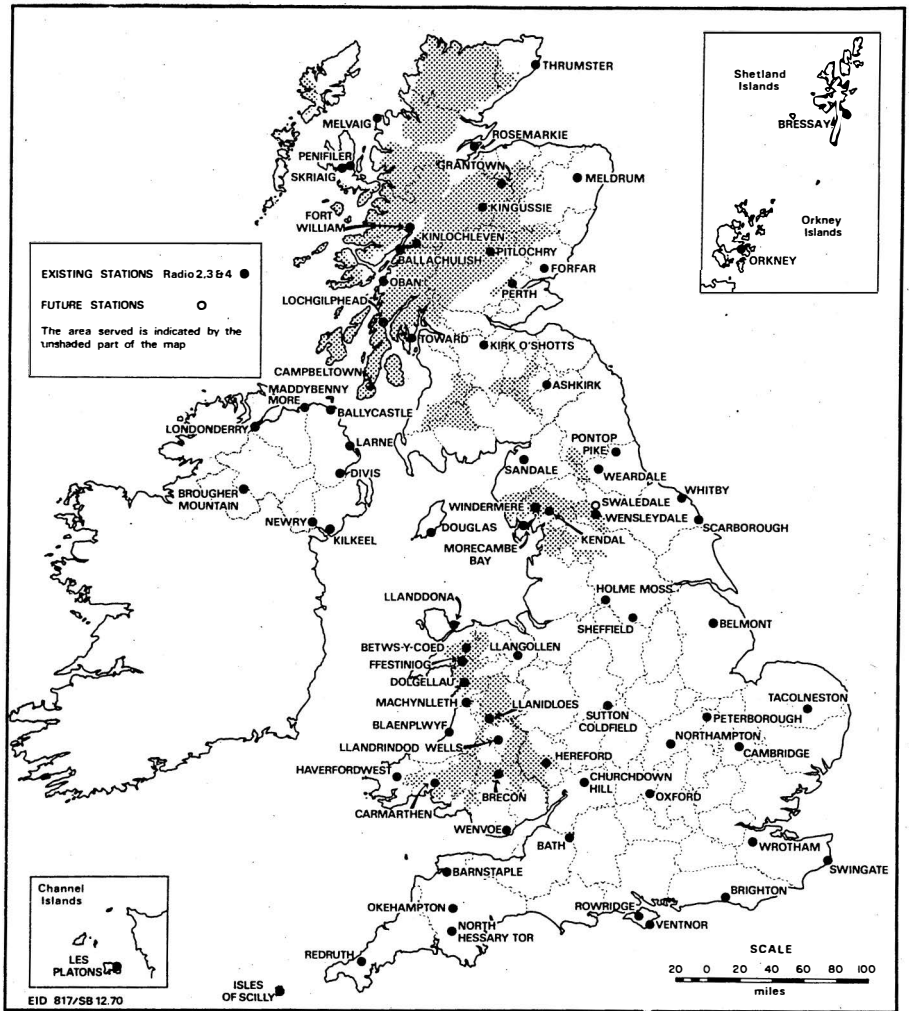

B.B.C. Local Radio Stations

Station	Frequency (MHz)	Maximum E.R.P.	Station	Frequency (MHz)	Maximum E.R.P.
Birmingham	95.6	5.5kW	Medway	97.0	5.5kW
Blackburn	96.4*	1.5kW	Merseyside	95.85	2.5kW
Brighton	95.8	500W	Newcastle	95.4	3.5kW
Bristol	95.1	5kW	Nottingham	94.8*	200W
Derby	96.5*	5.5kW	Oxford	95.0	4.5kW
Durham	94.5	2.6kW	Sheffield	88.6	30W
Humberside	95.3	4.5kW	Rotherham†	95.05	9W
Leeds	94.6	140W	Solent	96.1	5kW
Leicester	95.2	140W	Stoke-on-Trent	94.6	2.5kW
London	95.3	16.5kW	Teesside	96.6	5kW
Manchester					

*Slant polarization; all other transmissions use horizontal polarization

†Relay.



MODEL 2000 PLINTH SYSTEM

The SME model 2000 plinth system is more than a handsome and convenient housing for your turntable and SME precision pick-up arm. It meets the mechanical requirements under which the best performance will be obtained. High-quality workmanship is combined with ease of assembly. The basic unit is finished in selected veneers of teak, straight-grained walnut, or rosewood. A one-piece hinged lid in heavy acrylic is reinforced with a polished stainless-steel trim.

SME

Write to SME Limited · Steyning · Sussex · England
Telephone Steyning (0903) 814321

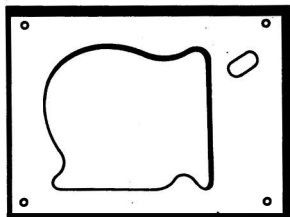

Motor boards in matching veneers are ready cut and drilled for screw-driver assembly with the appropriate pick-up arm and turntable. An uncut board is also available.

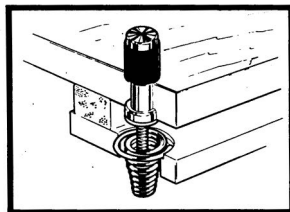

Adjustable four-point spring suspension protects the motor board from acoustic feedback and external vibration.

LTD/S12

Hi Fi Cabinets

★ Indicates entry is illustrated

Abbreviations used in this section are given on page 36.

■ ABSTRACTA

Abstracta Construction Ltd, Netil House,
1-7 Westgate Street, London, E8 3RB.
Tel: 01-986 3131.

Home Frames

A range of slim-line chromium-plated steel tubular frameworks with white melamine faced shelves to accommodate hi-fi equipment. Twelve suggested layouts for audio storage, including space for records, tapes and books. Can be adapted for most types and makes of equipment. Sizes range from 33in to 71in and system can be extended as required. Supplied in flat packs for easy assembly. Additional shelves can be added if needed. Home Frames hi-fi leaflet available on request from makers. Prices: from about £8-10 to £49-60 for complete systems, additional shelves extra.

■ ARNEX PRODUCTS LTD

London Road, Daventry, Northants.
Tel: Daventry (03272) 2231.

Hi-Fi Table

Modern style table designed to accommodate hi-fi system or unit audio. Teak finish top, rack beneath to take bookshelf speakers or records, shaped metal legs with silent castors. Comes packed flat in carton for easy home assembly using just a screwdriver. Full details and leaflet on request.

■ BIB

Bib Sales Division, PO Box 78,
Maylands Avenue, Hemel Hempstead, Herts.
Tel: Hemel Hempstead (0442) 3636. Ext. 100.

Indexa Record

A system of cataloguing and locating gramophone records. Suitable for one to 100 records, and capable of expansion up to 999 records. The system comprises luxury padded index book with 12 clear slip-in filing pockets, 100 pairs of self-adhesive labels, pad of pre-printed and colour coded index pages, 40 general purpose self-adhesive labels. Can also be used for indexing tapes. Price: £1-58½.

■ BSR McDONALD

(McDonald Division) BSR Ltd, Cradley Heath,
Warley, Worcs. Tel: Cradley Heath 69272.

Plinths and covers

Teak veneered wood plinth with aluminium trim. Opaque black brushed satin insert. Designed for BSR 810 deck. Price: £8-50 (plus £1-40 PT). Afrormosia wood plinth with black baseboard. Designed for BSR MP60, HT70 and 610 turntables. Price: £4-03 (plus 66p PT). Smoke-tinted low-line Perspex dust cover for BSR 810 deck. Price: £4 (plus 66p PT). Smoke coloured styrene dust cover for BSR MP60, HT70 and 610. Price: £2-82 (plus 46p PT).

■ A. DAVIES & CO

56 Wellesley Road, London, NW5.
Tel: 01-485 5775.

Handmade cabinets

Cabinets for most makes of equipment and speaker units. Standard range of cabinets or individually designed units. made to order. Standard finishes: sapele, oak, walnut, teak or veneer to choice. Polished or satin finish.

■ DYNATRON RADIO LTD

St Peters Road, Maidenhead, Berks, SL6 7QY.
Tel: Maidenhead 23331.

RSU3

Walnut-finish Queen Anne period cabinet with shelf for TVR26 tuner/amplifier and space for about 150 LPs. Mounted on castors. Size: 23½ × 21¼ × 14¾in. Price: £39-50 (including PT).

RSU2

Modern-style teak-veneered cabinet with drop-down front for sorting records. Top will accommodate audio units. Space for about 250 LPs. Price: £33-50 (including PT).

RSU4 ★

Upright contemporary style record storage unit

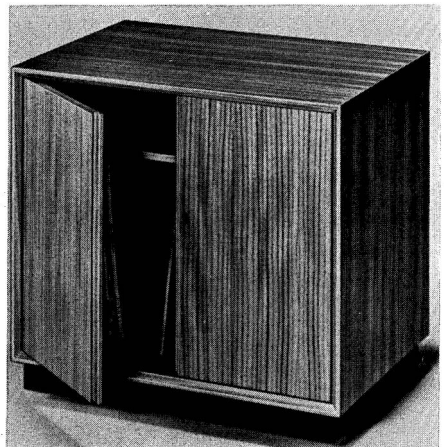

Dynatron RSU 4

★ Indicates entry is illustrated

with doors. Mounted on ball type castors. Two hinged front doors with lock and key. Space for approximately 150 records. Size: $21\frac{3}{4} \times 23\frac{1}{4} \times 16\frac{1}{4}$ in. Finish: teak veneer. Designed to accommodate on top a range of Dynatron Audio Separate units. Price: £24.95 (plus £1.80 PT).

ST16 ★

Metal pedestal stand for use with Dynatron Audio Separates. Black finished pillar with chrome feet and adjustable studs. Price: £5.27 (plus 38p PT).

ST21 ★

Metal framed two-tier trolley stand on easy running ball castors. Shelves finished in plastic laminate, white one side and teak the other. Can be fitted to suit the equipment. Top shelf designed to take Dynatron Audio Separates units, lower shelf accommodates speakers. Space for record rack. Price: £12.82 (plus 93p PT).

ST22 ★

Teak veneered table stand for Audio Separates. Shelf below. Price: £9.23 (plus 67p PT).



Dynatron Stand ST16



Dynatron ST 21

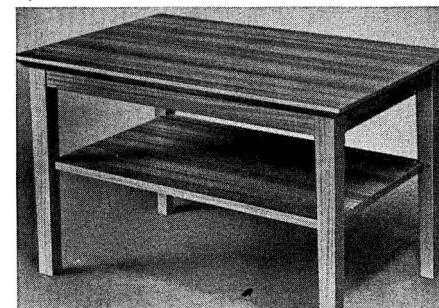

Dynatron ST 22

■ EATON AUDIO FITMENTS

Leopold Street, Long Eaton, Nottingham, NG104QF. Tel: Long Eaton 2662/2818.

Speaker, amplifier, tuner and record cabinets made to customer's requirements. Submit full details for quotation. See also Speaker Enclosure and Construction Kits Sections.

Mullard Unilex system

Cabinets suitable for the Mullard Unilex stereo system available. Full details and prices on request.

■ EDWARD MICHELSEN CUSTOM CABINETS

'Sound Ideas', 494 New Cross Road, New Cross, London, SE14. Tel: 01-692 2981.

Also at 216 Brampton Road, Bexleyheath, Kent. Tel: 01-303 9272.

Unilex Cabinet

Designed to accommodate the Mullard Unilex stereo system. Turntable and amplifier housed under clear plastic lid. Complete with all sockets and ready wired for Unilex. Pre-drilled for control unit. Size: $27 \times 15 \times 8$ in. Finish: teak. Price: £18.50.

Standard Plinths

Models to suit most turntables and arms. Slim style in teak veneer with black base. Lift-off acrylic cover. Motor board ready cut or left plain. SP1 (Garrard 1025, 2025, 3025) £5.50; SP2 (Garrard SP25, BSR MP60, etc) £5.75; SP3 (Garrard AP76, Thorens TD150) £6.50; SP4 (Garrard 401/SME 3009) £8.50; SP5 (Thorens TD150/SME 3009) £8.50.

Super Plinths

Incorporate hinged clear plastic lid to allow records to be played with lid closed. HPL1 (Garrard 2025, 3025) £8.50; HPL2 (Garrard SP25, BSR MP60 series) £8.75; HPL3 (Garrard AP76, Thorens TD150, Goldring GL75) £10.50; HPL4 (Garrard 401/3009, Thorens TD125/3009, Thorens TD500/3009) £12.50.

Small Lowline

A range of small slimline cabinets to accommodate turntable and amplifier, or turntable, tuner and amplifier. For shelf-mounting or floor-standing. Supplied with clear plastic lid.

LEC.1 (for amplifier and turntable). Size: 30 × 7 × 15in. Teak veneer. Price: £17.50.

LEC.2 (for tuner, amplifier and turntable). Size: 36 × 7 × 15in. Teak veneer. Price: £19.50.

LEC.3 (for larger turntables and equipment). Size: 32 × 7 × 16in. Teak veneer. Price: £19.50.

LEC.4 (as LEC.3 but with space for tuner). Size: 40 × 7 × 16in. Teak veneer. Price: £22.50.

Sets of 12in legs for the above cabinets. Price: £1.75. Special versions made to customers' requirements. Packing and carriage on LEC cabinets £1.50.

LEC.1X (as LEC.1 but with space for record storage). Size: 30 × 23 × 15in. Price: £24.50.

LEC.2X (as LEC.2 but with space for record storage). Size: 36 × 23 × 15in. Price: £26.50.

LEC.3X (as LEC.3 but with space for record storage). Size: 32 × 23 × 16in. Price: £25.50.

LEC.4X (as LEC.4 but with space for record storage). Size: 40 × 23 × 16in. Price: £29.

All 'X' series cabinets are in teak veneer and fitted with easy-moving castors.

Record storage cabinets

Standard version. Sliding doors. Teak veneer, on black base. Size: 30 × 15 × 15in. Price: £17.50. Larger version. Similar but measuring 36 × 15 × 15in. Price: £20.50.

Sinclair plinth

Designed to accommodate Sinclair Project 60 tuner, amplifier and most makes of turntable. Finished in teak veneer with black base. Size: 27 × 8 × 16in. Price: £19.50.

■ **EMPHASIS**

50a The Avenue, Kilburn, London, NW6.
Tel: 01-451 0517.

Hi-Fi Equipment Cabinets

Handbuilt custom cabinets to accommodate most hi-fi equipment including record and tape decks, amplifiers and tuner/amplifiers. Space for record and tape storage. Also custom made speaker enclosures.

DB4

Modern style cabinet with space for tuner/

amplifier and record deck recessed into upper surface under smoke tinted plastic cover. Access doors to tape and record storage open out, down, or gull-wing to order. Finish: teak, rosewood or any combination of colours. Also available in black, white or hessian. Size: (standard version) 72 × 24 × 24in; (special version with space for tape deck also) 90 × 24 × 24in. Prices according to specification.

DB6

Similar accommodation to the DB4 but available with flat or curved upper surface. Finish: teak, rosewood or colours, also laquer and hessian. Drawers or door to order. Prices according to specification.

DB5-9

Matched cube-shaped cabinets on chrome pillars. One contains tuner, amplifier and record deck with storage below. Two similar cabinets comprise speaker enclosures employing Tannoy Monitor Gold 12 or Altec Lansing 604E driver units. Size: (each cube) 24 × 24 × 24in on 6in pillar. Finish: teak, rosewood, coloured lacquers or hessian. Prices according to specification.

■ **A. R. FRANKLIN**

(Audio Engineer), 4 Birch House,
Howard Road, Penge, London, SE208HJ.
Tel: 01-659 0912.

Custom Built cabinets

Equipment housings in teak veneer or white laminated plastic. Suitable for most transcription units, tape decks and amplifier units. Screw-on legs. Standard size: 20 × 16 × 10in. Price: (standard size) £18; (special sizes) from £20.

Period cabinets

Variations on the Queen Anne style. Chest includes front flaps, half lids, carved legs and shaped lid mouldings. Individually styled to suit customer. Prices from £60 according to specification.

Send s.a.e. for lists and prices.

■ **GUSDORF**

C. E. Hammond & Co Ltd,
Lamb House, Church Street, London, W4.
Tel: 01-995 4551.

A range of 48 different models of hi-fi and TV furniture made by Gusdorf of America. Trolleys in various designs a speciality. Details and prices on request.

■ **HACKER RADIO LTD**

Norreys Drive, Cox Green, Maidenhead, Berks.
Tel: Maidenhead 22261/5.

T45

Teak table with inset top covered in black leathercloth. Designed specifically for the Hacker Centurion equipment but suitable for

★ Indicates entry is illustrated

other makes. Size: 19¼in wide, 17¼in deep, 16¼in high. Price: £5-50.

T1000

Teak table with inset top covered in black leather cloth. Designed specifically for the Hacker Tribune equipment but suitable for other makes. Size: 32½in wide, 16in deep, 15in high. Price: £14-70.

RST1000A

Teak finished record and tape recorder storage cabinet. Front opening doors. Record storage on right, shelf or recorder on left with storage space below. Shelf for recorder slides out on ball-bearing slides for ease of access. Size: 32in wide, 17¾in deep, 27½in high. Price: £39.



Hampstead High Fidelity Hampstead



Hampstead HQ1

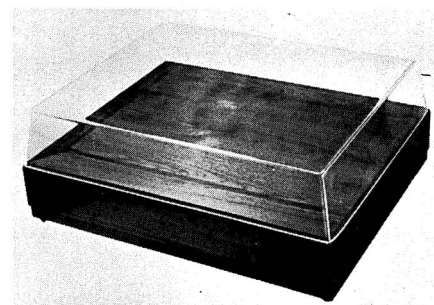

Howland-West HW12

■ HAMPSTEAD HIGH FIDELITY

91 Heath Street, Hampstead, London, NW3.

Tel: 01-435 6377 and 0999.

Hampstead ★

Low upright cabinet with split lift-up lids. Takes gram unit and tape deck. Pull-out front hopper for tuner and control unit or integrated amplifier. Accommodates any control unit or integrated amplifier not exceeding 14in in depth. Available with well to hold complete tape recorder not exceeding 9in high. Space to take Ferrograph or Revox with professional spools. Size: (standard model) 40×26×21in. Finish: teak or mahogany, other finishes to order. Price: (teak or mahogany) £63; quotations given for special finishes.

Heath

Equipment cabinet specially designed to accommodate Quad/Leak units mounted horizontally in top section, together with record deck. Base of cabinet will house 250 records or tape recorder and smaller number of records. Split lids with flap-back to expose amplifier control panel only. Size: 34×26×20in. Finish: teak, larch, mahogany, walnut or other special finishes to order. Price: (teak) £51. Doors (optional extra) £10; dividers (optional extra) £4.

HQ1 Housing Unit ★

Designed specifically to house Quad equipment neatly and efficiently. Accommodation for Quad 30, 33, 303 also Quad AM/FM tuner and choice of turntable. Supplied with cut-outs for Quad and Thorens equipment unless specified otherwise. Size: 24in wide, 20½in high, 23in deep. Made from high quality birch ply with tinted plastic lid. Desk top permits easy access to controls. Undertray protects equipment and contains all interconnecting wires. Shelf provides space for power unit and accessories. Finish: White or Mexican brown. When ordering state if cut-outs required or not. Price: £50 approximately.

Special cabinets and fitments made to order. Designs and drawings prepared for complete room or house hi-fi schemes.

■ HOLDER PEARCE LTD

66 Grove Road, Eastbourne, Sussex.
Tel: Eastbourne 26565.

Built-in or free-standing equipment cabinets designed and built to meet customers' exact requirements. Lift-up or drop-down lids, accommodation to suit any equipment, all standard finishes and also special finishes to blend with furnishing. Details and prices on application.

■ HOWLAND-WEST LTD

3-5 Eden Grove, London, N78EQ.
Tel: 01-609 0293/4/5.

Clearview HW1

Cabinet in teak, walnut or rosewood. Takes gram unit or tape deck. Lift-off Perspex lid. Overall size: $18\frac{1}{2} \times 16\frac{1}{2} \times 8\frac{1}{2}$ in. Clearance above board $3\frac{3}{4}$ in, below board $4\frac{1}{2}$ in. Price: £12.50 (plus 93p PT).

Clearview HW12 ★

Cabinet in teak. Takes gram unit or tape deck. Lift-off perspex lid. Overall size $23\frac{1}{2} \times 19 \times 8\frac{1}{2}$ in. Clearance above board $3\frac{3}{4}$ in, below board $4\frac{1}{2}$ in. Price: £15.50 (plus £1.16 PT).

Clearview HW14

De luxe turntable or tape deck cabinet with Perspex cover. Teak or rosewood with black base. Size: $18\frac{3}{4} \times 19\frac{1}{4} \times 9\frac{1}{2}$ in. Space above board 4in, below top of board $4\frac{1}{2}$ in. Fully-sprung anti-feedback base, adjustable feet for levelling, fitted with Bulgin mains socket and colour-coded phono sockets; supplied with Clearview lid stay and spirit level for fitting by user. Price: £22.50 (plus £1.68 PT).

Clearview HW15LT

Teak/black turntable cabinet with Perspex cover. Size: $17\frac{1}{2} \times 16\frac{1}{4} \times 7\frac{1}{4}$ in. Space above board $3\frac{1}{2}$ in, below top of board $3\frac{1}{4}$ in. LT version board uncut. 1LT version board cut for Garrard SP25, AT60, 3000 etc., 4LT version cut for Garrard AP75, SL75, SL95 etc. Price: £8.50 (plus 64p PT on LT or £1.41 on 1LT and 4LT).

Clearview HW15HT

Teak/black turntable cabinet with Perspex cover. Size: $17\frac{1}{2} \times 16\frac{1}{4} \times 9$ in. Space above board 5in, below top of board $3\frac{1}{4}$ in. Cut-board versions. 1HT and 4HT, as above. Price: £9 (plus 67p PT on HT or £1.49 on 1HT and 4HT).

■ MUSONIC LTD

34-38 Verulam Road, St Albans, Herts.
Tel: St Albans 50611/2.

Disc Case

Record storage case finished in wood and plastic.

Three sizes; for 60 7in records, for 30 12in records, for 60 12in records. Padded. Available in black, blue, brown, green and red. Prices: (60 7in size) £1.39 (plus 23p PT); (30 12in size) £1.65 (plus 26p PT); (60 12in size) £2.12 (plus 34p PT).

DiscRack

Heavy gauge steel wire rack, welded at all points and with plastic-coated or plated finish. Price: from 53p (plus 8p PT).

■ NEW CLASSIC

J. W. (Wholesale) Co, 26 Rosoman Street, London, EC1. Tel: 01-837 5920.

Anti-warp record storage

Features of the New Classic record storage system include spring-loaded panels that keep records flat, upright and easy to withdraw and replace. Also all models have built-in press for dealing with badly warped records.

Compact 100

Contemporary style storage unit with accommodation for 100 LP records. Incorporates anti-warp storage equipment as listed above. Size: $16\frac{1}{2}$ in wide, $13\frac{3}{8}$ in high, $13\frac{3}{4}$ in deep. Finish: matt brown mahogany. Price: £5.05 (plus 52p PT).

Compact 200

Contemporary style on legs. Accommodation for 200 LP records. Incorporates anti-warp storage equipment as listed above. Size: 32in wide, 23in high, $13\frac{3}{4}$ in deep. Finish: oiled matt finish in brown mahogany. Price: £10.85 (plus £1.11 PT).

Major

Incorporates the Compact 100 record storage system detailed above. Storage unit slides out on hidden ball-race runners for easy access. Automatic internal lighting. Solidly built cabinet on legs with two front-opening doors. Finish: storage unit and interior in mahogany, exterior in matt teak or sapele veneer. Smooth flat top for equipment, raised lips at sides for safety. Size: 29in high (including 9in legs), 19in wide, 15in deep. Price: £20.50 (plus £4.48 PT).

Classic De Luxe

Combines the features of the Compact and Major units but with additional facilities. Includes top compartment to accommodate free standing hi-fi unit. Top section slides out for easy access and operation of equipment. Fully ventilated back. Finish: matt teak or sapele veneer. Size: $34\frac{1}{2}$ in high (including 6in legs), $19\frac{1}{2}$ in wide, 15in deep. Price: £26.10 (plus £5.58 PT).

Major 200

Similar facilities to the Major but with accom-

★ Indicates entry is illustrated

modation for 200 LP records. Price: £27 (plus £5-85 PT).

Two-gang plinth

To accommodate two Compact Conversion units. Price: £1-85.

Three-gang plinth

To accommodate three Compact Conversion units. Price: £2-86.

■ PAGEENTRY RADIO & TV CO LTD

104 Felsham Road, Putney, SW15.

Tel: 01-788 5588.

Hand-made cabinets to house hi-fi systems. Two standard designs. Typical is antique reproduction model in selected walnut veneers hand-finished with traditional French polish. Features include intricate hand-carved mouldings on front side panels. Size: 54in wide, 21in deep, 32in high. Lower centre front houses record storage drawer running on precision runners. Size of drawer: 17in wide, 15½in deep, 13in high. Full details of hi-fi cabinets including prices and delivery available on request.

■ RECORD HOUSING

Brook Road, Wood Green, London, N22.

Tel: 01-888 7487.

Lowflex

Lowline cabinet in teak. Takes gram unit, tape deck, tuner, amplifier, etc. Lift-up lids, one with pneumatic stay. Overall size: 59 × 21 × 14in (plus 9in for legs). Record storage on left. Partition removable if not required. Price: £59.

Playview Senior

Shelf unit to accommodate large turntables such as Garrard 301, 401, Goldring/Lenco, etc. Mounting board 17½in wide, 17½in deep. Finish: teak. Clear plastic lid which will hinge back or can be lifted off. Size: 8in high, 18½in wide, 18½in deep. Price: £12-95.

Recaudio record/equipment cabinet

Adjustable cabinet and shelf system that will accommodate player unit, tape recorder, tuner and amplifier, plus 100 records. Cabinet mounted on castors. Two centre-opening full-length doors. Complete with two internal shelves and six removable record partitions. Keeps equipment free from dust (and safe from busy little fingers). Finish: medium walnut or natural afrormosia. Size: 18in wide, 17in deep, 32in high (including castors). Price: £26-95.

Audio Trolley ★

Provides neat housing for tuner, amplifier, record deck and tape recorder, plus storage space for 150 records. Open front and back. Mounted on easy-run castors. Centre compartment measures 14in wide, 14in high and 17in deep. Overall size: 36in wide, 22in high and 17in deep.



Record Housing Audio Trolley



Record Housing Soundmaster Trolley



Record Housing Highmaster Trolley

Finish: medium walnut or natural afrormosia. Trolley is polished all round. Price: £25.

Soundmaster Trolley ★

Lowline equipment cabinet on wheels. Accommodation for turntable, tuner, amplifier, plus 50 records. Adjustable partitions provide facilities for housing a variety of equipment, including Soundmaster 1266 audio system. Size: 25in wide, 23in high, 17in deep. Finish: afrormosia. Price: £20-45 (plus £1-50 PT).

Stereo Trolley ★

Upright style equipment cabinet on wheels. General purpose equipment/record cabinet. Accommodation for turntable, amplifier (or tuner-amplifier) plus 125 records. Size: (amplifier section) 19in wide, 6in high, 18in deep; (overall) 20in wide, 18in deep, 24in high. Finish: walnut or afrormosia. Price: £20-45 (plus £1-50 PT).

Capri ★

Contemporary equipment cabinet on legs. Accommodation for turntable, tuner, amplifier (or records). Front-opening doors: Vertical record partitions slide out and can be replaced in horizontal position as shelves, providing flexible arrangement for housing records and equipment. Size: 32in wide, 16½in deep, 16in high (plus 12in legs). Finish: walnut or afrormosia. Price: £23-32 (plus £1-68 PT).

Highmaster Trolley ★

Lowline equipment and record cabinet on wheels. Two sliding type front-opening doors in lower section holding records. Accommodation for turntable, tape deck, tuner, amplifier and 250 records. Size: (equipment shelf) 35in wide, 6in high, 16in deep; (overall) 36in wide, 24in high, 16½in deep. Finish: medium walnut or natural afrormosia. Price: £30-75 (plus £2-25 PT).

Scan record unit

Contemporary style record storage cabinet. Accommodation for 125 records in each cabinet. Designed as add-on units permitting users to build up a library. Size: 20in long, 15in high, 16½in deep. Finish: walnut or afrormosia. Price: £11-14 (plus 81p PT).

■ SME LTD

Steyning, Sussex, BN43LN.
Tel: Steyning (0903) 814321.

Model 2000 ★

Plinth system with one motor-board ready cut for SME pickup arm and turntable. The one-piece acrylic lid has a stainless steel reinforcing trim. Counter-spring hinges retain the lid open when required. Dimensions: 9 × 24 × 20in. Price: £39-60 (plus £6-60 PT) in teak, walnut or rosewood.

All parts of Model 2000 are available separately.



Record Housing Stereo Trolley

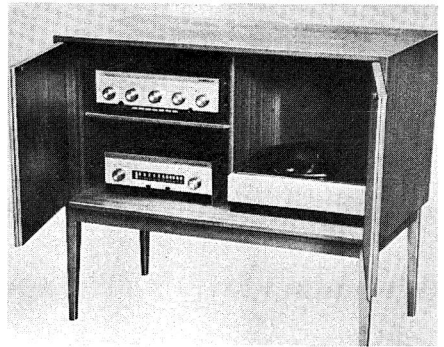

Record Housing Capri



S.M.E. 2000 Plinth

★ Indicates entry is illustrated



Staples Ladderax Hi-Fi

These comprise the base, motorboard, acrylic lid, spring mounts (set of four), and left- or right-hand hinge (see constructional kits section).

■ SONY (UK) LTD

Pyrene House, Sunbury Cross,
Sunbury-on-Thames, Middlesex.
Tel: Sunbury 87644/7.

TAC-1

Walnut finished wood case for the following Sony models: TA3200F, ST5000, STR6045, TA1130, TA1140, TA2000F, TA1120. Price: £9-50.

TAC-5

Walnut finished wood case for the following Sony models: STR6055, STR6060FW, STR5050. Price: £9-50.

TAC-6

Walnut finished wood case for the following Sony models: STR6200F, STR6120. Price: £14-36.

TAC-9

Walnut finished wood case for the following Sony models: TA1144, ST5100. Price: £9-50.

■ STAPLES & CO LTD

Staples Corner, Junction Edgware Road and
North Circular Road, London, NW2.
Tel: 01-452 1144/7.

Ladderax ★

Unit system hi-fi cabinet designed to fit Staples Ladderax assembly. Lift-up main lid giving access to space for tuner, control unit and record or tape deck. Front panel removable to facilitate installation. Will accept most modern equipment. Size: 35in wide, 17in deep, 18 $\frac{3}{4}$ in high. Motorboard: 33 $\frac{3}{4}$ × 16 × $\frac{1}{2}$ in, height above 5 $\frac{3}{4}$ in.

Finish: teak or rosewood veneer. Full details of other matching units on request. Prices from about £41.

■ STENTORIAN

Whiteley Electrical Radio Co. Ltd, Victoria
Street, Mansfield, Notts.
Tel: Mansfield (0623) 24762.

C16 Thoresby Equipment Console

Upright style equipment cabinet with lift-up lid. Takes most makes of gram unit or tape deck, amplifier, control unit and tuner. Available in mahogany or walnut. Supplied packed flat and easily assembled in a few minutes with a screwdriver only. Size: 19 $\frac{3}{8}$ × 18 × 31in. Price: (C16 mahogany) £29-67 (plus £2-41 PT); (C16A walnut) £30-66 (plus £2-49 PT).

■ TYSONS SOUND ENGINEERS

(Prop. John E. Barkley), 41 Russell Street,
Leamington Spa. Tel: Leamington Spa 24935.

Hand-made Dower Chests

Reproduction style in oak. Suitable for gram unit, tape deck, tuner, amplifier. Lift-up lid. Generally 36in to 48 in long. Price: £55 to £75.

Equipment installed in antique or reproduction furniture to customers' requirements. Dower chests a speciality. Agents for all leading manufacturers of hi-fi equipment.

■ VERO

Vero Electronics Ltd, Industrial Estate,
Chandler's Ford, Eastleigh, Hants, SO5 3ZR.
Tel: Chandler's Ford 2952. Telex: 47551.

Wide range of equipment cases suitable for hi-fi units, tuners, power supplies and test gear. Available in various panel heights and with or without anodised aluminium front handles. Made in light gauge steel finished in RAF blue/grey vinyl paint. Integral aluminium trim. Neat slim-line appearance. Ventilation slots incorporated. Full list of sizes, accessories and prices available on request. Ask for catalogue of Vero 'D' series cases.

■ WHITELEY ELECTRICAL RADIO CO LTD See Stentorian.

Combination Units

★ Indicates entry is illustrated

Abbreviations used in this section are given on page 36.

■ ALPHA

Highgate Acoustics Ltd.,
184 Great Portland Street, London, W1.
Tel: 01-636 2901.

GF2500 ★

Stereo amplifier and record deck in shelf cabinet with lift-up tinted plastic lid. Motor unit: Garrard SP25 Mk III. Speeds: 33 $\frac{1}{3}$, 45, 78rpm. Idler wheel drive. Cartridge: Pickering P/AT. Diamond stylus. Inputs: mag PU 6mV, radio 80mV-IV, tape 250mV-3V. Noise level: (tape and radio inputs) better than 60dB, (PU input) 48dB. Overload capability: 23dB on all inputs. Output: 15W RMS per channel. HD: <0.5% at 15W. Output impedance: 8 ohms. FR: FR: 20Hz-25kHz (40Hz-14kHz \pm 2dB). Head-phone socket. Slider volume control. Finish: teak with anodised black and silver control panel. Size: 17 $\frac{1}{2}$ \times 7 \times 13in. Mains: 240V AC. Price: £79.

■ ASA

Maggs (Bristol) Television Ltd,
The Station, Sea Mills Lane, Bristol, BS9 1DX.
Tel: Bristol 684801.

3704

FM stereo tuner-amplifier in plinth with four-speed record deck. Motor unit: BSR P128. Speeds: 16 $\frac{2}{3}$, 33 $\frac{1}{3}$, 45 and 78rpm. Four-pole motor. 10 $\frac{3}{4}$ in diecast turntable. Wow: less than 0.2%. Flutter: less than 0.06%. Automatic or manual operation of pickup arm. Hydraulic lifting and lowering. Playing weight adjustable 0-6gms. Cartridge: Shure M75-6. Range: 87.5-104MHz. Sensitivity: better than 2 μ V for 26dB quieting. Aerial input: 240 ohms balanced. AFC. Variable tuning plus three presets. Quiet tuning facility. IC stereo decoder with auto switching and beacon. Output: 20W RMS per channel. FR: 30Hz-30kHz \pm 1.5dB. HD: <1%. Tone controls: bass +18dB -15dB at 40Hz, treble +14dB -15dB at 10kHz. Rumble and scratch filters. Inputs: mag PU 4mV 47K, crystal PU 70mV 500K, tape play 260mV 500K. Front

jack sockets for headphones (automatically mute speaker outlets). 37 transistors, 15 diodes, one IC, three varicap diodes. Mains: 220-240V 50Hz. Finish: anodised metal front with teak or rosewood cabinet. Size: 20 $\frac{3}{8}$ \times 7 $\frac{1}{8}$ \times 13 $\frac{3}{8}$ in. Price: £129.85 (including PT).

■ BANG & OLUFSEN UK LTD

Eastbrook Road, Gloucester, GL4 7DE.
Tel: Gloucester 21591.

Beocenter 3500

FM stereo tuner-amplifier in cabinet with record deck. Motor unit: B & O. Two-speeds. 12in grooved aluminium alloy platter. Belt drive. High compliance pickup arm. Cartridge: B & O SP10A. 0.6 thou diamond stylus. Range: FM 87.5-10MHz. Variable tuning plus six presets. AFC. Ratio detector. Balanced light tuning system. Usable sensitivity: 2 μ V. Aerial input: 75 ohm coaxial. Stereo decoder fitted. Inputs: PU(1) 3mV 47K, PU(2) 200mV-3V 1M, tape 200mV-3V 1M. Output: 40W RMS per channel. Output impedance: 4 ohms. Tone controls: bass \pm 17dB at 50Hz, treble \pm 14dB at 10kHz, rumble filter -12dB/octave below 80Hz, scratch filter -12dB/octave above 4kHz. HD: 0-3% at 1kHz at rated output (both channels driven). FR: 40Hz-20kHz \pm 1.5dB. Mains: 110, 130, 220, 240V AC. Size: 22 $\frac{3}{8}$ \times 13 $\frac{7}{8}$ \times 5 $\frac{3}{4}$ in. Finish: brushed aluminium fascia and deck, rosewood or white side panels, matt black hinged dust cover. Price: (teak) £219.50; (rosewood or white) £220.50.

■ DUETTE

J. J. Silber Ltd, 11 Northburgh Street,
London, EC1. Tel: 01-253 8031.

SS2005W

AM/FM stereo tuner/amplifier in cabinet with cassette recorder and record deck. Range: FM 88-108MHz, MW 185-565 metres. Aerial input: 300 ohms balanced. Ferrite rod AM aerial. Stereo decoder fitted. Separation: 30dB at 1kHz. Compact cassettes. Speed: 1 $\frac{7}{8}$ 1/s. W and F: 0.25%. H and N: 45dB. Automatic or manual level control. Multiplex filter. Four-speed record deck. Ceramic cartridge with diamond stereo stylus. 11in platter. Four-pole



Alpha GF2500

★ Indicates entry is illustrated

motor with outer rotor. Audio output: 10W per channel. Output impedance: 8 ohms. FR: 35Hz-30kHz. Tone controls: bass+10dB-12dB at 100Hz, treble+9dB-17dB at 10kHz. Mains: 110, 117, 220, 240V 50/60Hz. Size: 22½ × 9 × 17in. Weight: 35lb. This is a provisional specification as full details were not available as this issue of the Year Book closed for press. Price: £171.99 (including PT).

■ DYNATRON RADIO LTD

St Peter's Road, Maidenhead, Berks, SL6 7QY.
Tel: Maidenhead 23331.

HFC30A

Integrated stereo amplifier with record deck incorporated in same cabinet. Controls: mains on/off, volume, bass, treble, input selector, balance. Output: 8W RMS per channel into 3 ohms load. FR: 20Hz-20kHz -3dB at 20Hz and 20kHz. Output impedance: 3-16 ohms. HD: <0.35% -2dB at rated output. Motor unit: Garrard 40B. Cartridge: Goldring G850. Size: 19 × 15 × 7½in. Finish: teak veneer cabinet with black control panel and transparent plastic lid. Price: £63.76 (plus £10.24 PT).

HFC30M

Integrated stereo amplifier with record deck incorporated in same cabinet. Similar specification to HFC30A but manual record deck instead of automatic. Record Unit: Garrard SP25S Mk III. Cartridge: Goldring G850. Price: £64.63 (plus £10.37 PT).

Carnival HFC36/HFC37

Integrated stereo amplifier with record deck in cabinet. Motor unit: Garrard SP25 Mk III. Cartridge: Goldring G850. Stylus: spherical diamond. 17 transistors. Inputs: radio 26mV 12K, tape 26mV 12K. Noise level: ≥ -65dB. Overload capability: 650mV. Controls: volume, bass, treble, input selector, balance, mains on/off, rumble filter, scratch filter, loudness. Output: 8W RMS per channel. Output impedance: 4 ohms. HD: 1% at 8W. FR: 23Hz-20kHz -3dB. Mains: 240V AC. Size: 20 × 13½ × 7½in. Finish: (HFC36) sprayed white, (HFC37) teak veneer. Price: £62.90 (plus £10.10 PT).

Cavalcade Cassette HFC38

AM/FM tuner/amplifier in cabinet with record deck and cassette tape recorder. Motor unit: Garrard SP25 Mk III. Cartridge: Goldring G850. Stylus: spherical diamond. Tape unit: Philips N2505/10, four-track stereo cassette. Speed: 1½i/s. Range: FM 87.5-108MHz, MW 185-570 metres, LW 1,100-2,000 metres. Variable tuning. AFC. Ratio detector. Stereo decoder. Meter tuning indicator. Usable sensitivity: FM 3µV, MW 10µV, LW 15µV. Aerial input: balanced and 75 ohm coaxial. 32 transistors plus tape unit. Input: tape 26mV 12K.

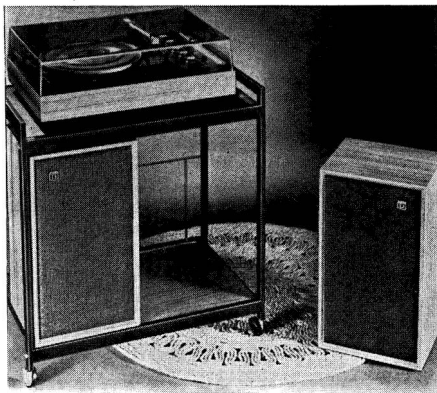

Dynatron HFC 37, ST21 & LS 1434



Dynatron HFC 44



Dynatron HFC 46

Noise level: -65dB . Overload capability: 650mV . Output: 8W per channel. Output impedance: 4 ohms . Controls: tuning, bass, treble, input selector (pushbutton), balance, volume, rumble filter, scratch filter, loudness, HD: 1% at 8W . FR: $23\text{Hz}-20\text{kHz}$ -3dB . Mains: 240V AC . Size: $23\frac{1}{4} \times 16\frac{1}{4} \times 8\frac{1}{2}\text{in}$. Finish: teak veneer. Price: $\pounds 141\cdot 61$ (plus $\pounds 22\cdot 89\text{ PT}$).

VHF Carnival HFC39/HFC40

FM tuner/amplifier in cabinet with record deck. Range: $87\text{-}104\text{MHz}$. Sensitivity: $3\mu\text{V}$. Stereo decoder fitted. Four preset tuning buttons. AFC. Balanced and 75 ohms coaxial input. Audio specification and size as HFC36. Finish: (HFC39) sprayed white, (HFC40) teak veneer. Price: $\pounds 90\cdot 91$ (plus $\pounds 14\cdot 59\text{ PT}$).

Carnival Major HFC41

Integrated stereo amplifier with record deck in cabinet. Motor unit: Goldring-Lenco GL75. Speeds: fully variable $16\text{-}78\text{rpm}$ with click stops. Cartridge: Goldring G800. Stylus: spherical diamond. Audio section as HFC36. Size: $24 \times 16 \times 7\text{in}$. Finish: (HFC41) sprayed white, (HFC42) teak veneers. Price: $\pounds 88\cdot 32$ (plus $\pounds 14\cdot 18\text{ PT}$).

VHF Carnival Major HFC43/HFC44 ★

FM tuner-amplifier in cabinet with record deck. Same specification as HFC41 but with the addition of VHF radio. Range: $87\text{-}104\text{MHz}$. Four preset tuning buttons. Sensitivity: $3\mu\text{V}$. Stereo decoder fitted. AFC. Ratio detector. Aerial input: balanced and 75 ohm coaxial. Size: $24 \times 16 \times 7\text{in}$. Finish: (HFC43) sprayed white, (HFC44) teak veneer. Price: $\pounds 113\cdot 31$ (plus $\pounds 18\cdot 19\text{ PT}$).

Richmond HFC45 ★

AM/FM stereo tuner/amplifier in console cabinet with record storage. Motor unit: Goldring-Lenco GL72. Speeds: fully variable $16\text{-}78\text{rpm}$ with click stops. Cartridge: Goldring G850. Stylus: spherical diamond. Range: FM $87\cdot 5\text{-}108\text{MHz}$, MW $187\text{-}570$ metres, LW $1,100\text{-}2,000$ metres. Variable tuning. AFC. Ratio detector. Meter tuning indicator. Usable sensitivity: FM $3\mu\text{V}$, MW $10\mu\text{V}$, LW $15\mu\text{V}$. Aerial input: balanced and 75 ohm coaxial. Stereo decoder fitted. 32 transistors. Input: tape 26mV 12K . Noise level: $\geq -65\text{dB}$. Overload capability: 650mV . Output: 8W RMS per channel into 8 ohms . Output impedance: 4 ohms . Controls: tuning, bass, treble, input selector, balance, volume, rumble filter, scratch filter, loudness. HD: 1% at 8W . FR: $23\text{Hz}-20\text{kHz}$ -3dB . Mains: 240V AC . Size: $21\frac{3}{4} \times 15\frac{1}{2} \times 31\text{in}$. Finish: teak veneer. Price: $\pounds 125\cdot 38$ (plus $\pounds 20\cdot 12\text{ PT}$).

Hambleton HFC46 ★

Same specification as HFC45 but in Queen Anne period style cabinet finished in walnut veneers.

Size: $23\frac{1}{4} \times 16\frac{1}{4} \times 8\frac{1}{2}\text{in}$. Price: $\pounds 142\cdot 18$ (plus $\pounds 22\cdot 82\text{ PT}$).

Savoy HFC47

Same specification as HFC45 but in Regency period style cabinet finished in mahogany veneers. Size: $23\frac{1}{4} \times 16\frac{1}{4} \times 8\frac{1}{2}\text{in}$. Price: $\pounds 142\cdot 18$ (plus $\pounds 22\cdot 82\text{ PT}$).

HFC100 ★

Integrated stereo amplifier in cabinet with record deck. Motor unit: Goldring-Lenco GL75. Cartridge: Goldring G800. Stylus: spherical diamond. 34 transistors. Inputs: radio 165mV 230K , tape 165mV 230K , mag pickup $2\cdot 4\text{mV}$ 47K . Noise level: (PU input) $\geq -60\text{dB}$, (other inputs) $\geq -66\text{dB}$. Overload capability: (PU input) 100mV , (other inputs) 6V . Output: 45W



Dynatron HFC 45



Dynatron HFC 100



Dynatron HFC 103

per channel at 8 ohms. Output impedance: 4-16 ohms. Controls: bass, treble, volume scratch filter, rumble filter, loudness, input selector, balance, A-B speakers. HD: 0.3% $- \frac{1}{2}$ dB. FR: 16Hz-28kHz $- 3$ dB. Size: $21 \times 16\frac{1}{4} \times 8\frac{1}{2}$ in. Finish: teak veneer. £113.31 (plus £18.19 PT).

HFC101

Similar specification to HFC100 but with the addition of AM/FM radio. Also second tape input instead of mag PU. 59 transistors. Range: FM 87.5-108MHz, MW 185-570 metres, LW 1,100-2,000 metres. Variable tuning. AFC. Ratio detector. Meter tuning indicator. Usable sensitivity: FM 3μ V, MW 10μ V, LW 15μ V. Aerial input: balanced or 75 ohm coaxial. Stereo decoder fitted. Finish: teak veneer. Price: £141.75 (plus £22.75 PT).

HFC102

Similar specification to HFC100 but with addition of FM/VHF radio and second tape input (300mV 450K) instead of mag PU. Range: 87-104MHz. Five preset tuning buttons. AFC. Ratio detector. Usable sensitivity: 3μ V. Aerial input: balanced or 75 ohm coaxial. Stereo decoder fitted. Finish: teak veneer. Price: £133.56 (plus £21.44 PT).

HFC103 ★

FM stereo tuner-amplifier with record deck and cassette recorder in period style cabinet with record and cassette storage space. Drawer for accessories. Motor unit: Goldring-Lenco GL75. Cartridge: Goldring G800. Stylus: spherical diamond. Tape unit: Philips N2505/10. Four-

track stereo. Speed: $1\frac{1}{2}$ i/s. Compact cassettes. Range: 87-104MHz. Five preset tuning buttons. AFC. Ratio detector. Usable sensitivity: 3μ V. Aerial input: balanced or 75 ohm coaxial. Stereo decoder fitted. 58 transistors. Inputs: radio 165mV 230K, tape (1) 165mV 230K, tape (2) 300mV 450K. Noise level: tape (2) ≥ -60 dB, (other inputs) ≥ -66 dB. Overload capability: 6V. Output: 45W RMS per channel into 8 ohms. Controls: bass, treble, balance, volume, tuning pushbuttons, rumble filter, scratch filter, loudness, input selector pushbuttons. HD: 0.3% $- \frac{1}{2}$ dB. Output impedance: 4-16 ohms. FR: 16Hz-28kHz $- 3$ dB. Mains: 240V AC. Size: $31\frac{1}{2} \times 21\frac{3}{4} \times 39\frac{1}{2}$ in. Finish: period style cabinet in selected walnut veneers. Price: £260.22 (plus £41.77 PT).

■ EDWARD MICHELSEN CUSTOM CABINETS

'Sound Ideas', 494 New Cross Road, New Cross, London, SE14. Tel: 01-692 2981.

Also at 216 Brampton Road, Bexleyheath, Kent. Tel: 01-303 9272.

Project 60 System

Comprises integrated stereo amplifier, stereo FM tuner and record deck in shelf-mounting cabinet. System based on the Sinclair Project 60 amplifier and tuner. Range: FM 87.5-108MHz. Variable tuning. AFC. Decoder fitted. Stereo tuning indicator. Controls: pushbutton input selectors, bass ± 15 dB at 100Hz, treble ± 15 dB at 10kHz, volume, balance, rumble filter 12dB/octave 25-100Hz, scratch filter 12dB/octave 5-28kHz, tuning. Output: 30W RMS per channel into 8 ohms. FR: 30Hz-300kHz ± 1 dB. HD: 0.02% into 8 ohms. Output impedance: 3-8 ohms. Motor unit: Thorens TD150 Mk II. Cartridge: Shure M55E. Price: (with Thorens TD150 Mk II) from about £140. Can be supplied with Garrard or Goldring record decks at lower cost.

■ ELGAR

English Audio (1970) Ltd, North Station Road, Colchester, Essex. Tel: Colchester (0206) 73467.

Elgar

Integrated stereo amplifier in plinth cabinet with record deck and pickup. Clear plastic lid. Record unit: Thorens TD150 Mk II two-speed motor with lightweight arm. Cartridge: Shure M75EJ. Elliptical diamond stylus. Finish: teak. Built-in integrated stereo amplifier. Inputs: mag PU 3.5mV 56K, Ceramic PU 20mV 33K, radio 100mV 100K, tape 100mV 100K. Noise level: -65 dB on all inputs. Output: 18W per channel. HD: $< 0.5\%$ at all levels up to rated output. FR: 20Hz-20kHz ± 3 dB. Overload capacity: 29dB on all inputs. Independent outlet

for tape provides 200mV irrespective of volume setting. Controls: (rotary) bass, treble, volume, balance and input selector, (slider switches) mono/stereo, HF filter, loudness, phones/speaker. Indicator light. Output impedance: 8-16 ohms. Connections by DIN plugs. Finish: teak case. Price: £133.20 (including PT).

■ GOODMAN'S LOUDSPEAKERS LTD

Downley Road, Havant, Hampshire, PO92NL.
Tel: Havant 6344. Telex: 86296.

Module 80 Compact ★

FM stereo tuner/amplifier in cabinet with record deck. Motor unit: Goldring-Lenco GL75. Four speeds, infinitely variable. 12in diameter 8lb diecast turntable. Vertical pulley drive. L75 pickup arm with weight adjustment. Cartridge: Goldring G800E. Stylus: elliptical diamond. Range: FM 87.5-108MHz. Variable tuning. Switched AFC. Dual-light tuning indicator. Usable sensitivity: $<1.5\mu\text{V}$ for 26dB S/N. Aerial input: 240-300 ohms balanced. Stereo decoder included. Stereo beacon. 68 transistors, including two FETs. Inputs: aux 60mV 600K, tape play 320mV 50K, mag PU 2mV 50K. Noise level: mag PU -66dB, other inputs: -80dB. Overload capability: +23dB. Output: 35W RMS per channel. Output impedance: 4 ohms. Controls: bass, treble, balance, loudness, volume, on/off, speakers, high pass and low pass filters, input selectors. HD: $<0.1\%$ at rated output into 4 ohms, both channels driven. FR: 30Hz-20kHz $\pm 1.5\text{dB}$ at rated output. Mains: 120, 220, 245V AC. Size: $22 \times 6\frac{1}{2} \times 17\frac{3}{4}$ in; (height with lid raised) 21in. Finish: teak, walnut or white with matt black fascia. Price: (teak of walnut) £160.38 (including PT); (white) £164.26 (including PT). Optional matching stand.

One-Ten Compact

AM/FM stereo tuner/amplifier in case with record deck. Motor unit: Goldring GL85. Cartridge: Goldring G800E. Stylus: 0.3×0.8 thou diamond Range: FM 87.5-108MHz, MW 187-572 metres, LW 1,130-2,000 metres, SW 48-51 metres. Variable tuning. Switched AFC. Signal strength meter. Usable sensitivity: FM $1\mu\text{V}$ into 75 ohms, $2\mu\text{V}$ into 240 ohms, AM $20\mu\text{V}$ MW and SW, $40\mu\text{V}$ LW. Aerial input: 75 ohms coaxial, 240 ohms balanced. Stereo decoder included. Stereo beacon. 89 semiconductors. Inputs: mag PU, ceramic PU 200mV 1 megohm, tape play 200mV 100K, radio to suit inbuilt tuner. Noise level: mag PU input -70dB, other inputs -80dB. Overload capability: 30dB. Output: 50W RMS per channel into 4 ohms. Controls: bass, treble, volume, rumble filter, contour, plus 17 tab controls. HD: $<0.01\%$ at 30W output, $<0.1\%$ at any power up to rated maximum. FR: 20Hz-20kHz $\pm 1\text{dB}$ at



Goodmans Module 80 Compact



Hacker GAR500 Centurion

rated power. Mains: 115-125V, 200-250V, 50/60Hz. Price: to be announced.

■ HACKER RADIO LTD

Norreys Drive, Cox Green, Maidenhead, Berks.
Tel: Maidenhead 22261/5.

GAN500 Centurion

Stereo amplifier in cabinet with record unit. Garrard SP25 Mk III fitted with Goldring G850 magnetic pickup and diamond stylus. Inputs: PU 3mV equalised, 30dB overload capability; radio 50mV 47K, infinite overload capability; aux/tape 50mV 47K, infinite overload capability. Output: 10W RMS per channel into 8 ohms, 7W RMS per channel into 15 ohms. Controls: bass +18dB -14dB at 40Hz, treble +18dB -20dB at 15kHz, low-pass filter -3dB at 7kHz, on/off, balance, volume, pushbutton selection for scratch filter, gram, aux/tape, radio and mono/stereo. HD: better than 0.4% at 8 ohms, better than 0.2% at 15 ohms. FR: 25Hz-30kHz $\pm 3\text{dB}$. Inbuilt rumble filter operates at below 25Hz. Hum and noise level better than 60dB down on all inputs. Outlet for tape recorder of 15mV at 25K. Headphone socket with automatic muting of speakers. Finish: teak. Hinged lid and brushed aluminium front panel. Mains: 200-245V 50Hz. Size: 18in wide, $8\frac{1}{4}$ in high, 16in deep. Price: £75.50 (including PT).

GAR500 Centurion ★

Similar specification to the GAN500 but with

★ Indicates entry is illustrated

the addition of FM/VHF radio. Range: 87.5-101MHz. Usable sensitivity: $2\mu\text{V}$ for 10dB signal-to-noise ratio, $5\mu\text{V}$ for full limiting. Station markers. AFC. Price: £92.50 (including PT).

GAR500/SRD Centurion

Similar specification to the GAR500 but with the addition of a stereo radio decoder. Operated by pushbutton switch. Separation: 35dB at 1kHz, 26dB at 5kHz. Price: £102.20 (including PT).

T45 Table

Teak table with inset top covered with black leathercloth. Designed to accommodate the Hacker Centurion series. Price: £5.50.

GAR1000A Tribune

Stereo tuner-amplifier in cabinet with record unit. Lenco GL75 record deck with Goldring 800H magnetic cartridge and diamond stylus. Separate AM and FM tuners. Range: MW 185-575 metres, LW 1,070-1,940 metres, FM/VHF 87.5-101MHz. Variable tuning with AFC. Quiet tuning control. Adjustable station markers. Centre-zero tuning meter. Usable sensitivity: AM (200m) $2\mu\text{V}$, AM (500m) $6\mu\text{V}$, FM better than $1\mu\text{V}$ for 10dB S/N ratio, $5\mu\text{V}$ for full limiting. Inputs: magnetic PU 3mV 47K, ceramic PU 5mV 500-800pF, radio 22mV 80K, aux 70mV 250K. Overload capability: 30dB all inputs. H and N: 50dB on magnetic PU, 60dB on all other inputs. Tone controls: bass $\pm 16\text{dB}$ at 50Hz, treble $\pm 16\text{dB}$ at 10kHz. Filters: low pass -3dB at 6kHz sloping down to -20dB at 10kHz, high pass -3dB at 50Hz sloping down to -26dB at 10Hz. HD: 0.06% at 15 ohms, 0.08% at 8 ohms, 0.15% at 4 ohms. Speaker damping factor at full power: (15 ohms) 200, (8 ohms) 120, (4 ohms) 70. FR: 20Hz-20kHz $\pm 2\text{dB}$. Mains: 200-245V 50Hz. Finish: teak veneer. Size: $31\frac{1}{2}$ in wide, $8\frac{1}{2}$ in high, $15\frac{1}{2}$ in deep. Price: £178 (including PT); (with Goldring 800E cartridge and elliptical stylus) £185.50 (including PT).

GAR1000A/SRD Tribune

Similar specification to the GAR1000A but with the addition of a stereo radio decoder. Price: £188 (including PT); (with Goldring 800E cartridge and elliptical stylus) £195.50 (including PT).

T1000

Matching low table in teak veneers with inset top in black leathercloth to fit the Hacker Tribune. Price: £14.70.

HI-SOUND

Electronic Manufacturing (UK) Ltd, Devonshire House, High Street, Deritend, Birmingham B12 0LP. Tel: 021-772 7145.

12+ 12 Compact

Combination unit comprising record deck in cabinet with stereo amplifier. Record unit: Garrard SP25 Mk III or BSR P128. Cartridge: Audio Technica AT66. Stylus: spherical diamond. 11 transistors. Inputs: magnetic PU 4mV 47K, aux 150mV 500K, crystal PU 300mV 1M. Output: 13W RMS per channel. Output impedance: 4 ohms. Tone controls: bass $\pm 10\text{dB}$ at 100Hz, treble $\pm 12\text{dB}$ at 10kHz. HD: 0.2% at rated output. FR: 20Hz-25kHz $\pm 1\text{dB}$. Mains: 110, 240V AC. Size: $16 \times 8 \times 13\text{in}$. Finish: teak or walnut cabinet with brushed aluminium front panel. Price: £49 (plus £7.94 PT).

25+ 25 Compact

Combination unit comprising record deck in cabinet with stereo amplifier. Record unit: Garrard SP25 Mk III or BSR P128. Cartridge: Audio Technica AT66. Stylus: spherical diamond. 12 transistors. Inputs: magnetic PU 4mV 47K, crystal PU 300mV 1M, radio 150mV 500K, tape 300mV 500K. Output: 34W RMS. Output impedance: 4 ohms. Tone controls: treble $\pm 12\text{dB}$ at 10kHz, bass $\pm 10\text{dB}$ at 100Hz. HD: 0.2% at rated output. FR: 20Hz-25kHz $\pm 1\text{dB}$. Mains: 110, 240V AC. Size: $18 \times 8\frac{1}{2} \times 14\text{in}$. Finish: teak or walnut. Price: £60 (plus £9.72 PT).

ITT-KB

ITT Consumer Products (UK) Ltd, Foots Cray, Sidcup, Kent, DA14 5HT. Tel: 01-300 7733.

KA2250

FM stereo tuner/amplifier in cabinet with record deck. Range: 87-104MHz. Five preset tuning buttons. Switchable AFC. Stereo decoder included. Controls: pushbuttons for on/off, headphones, records, tape and radio inputs. Slider controls for bass, treble, balance, volume. Five tuning buttons. Output: 15W per channel into 4 ohms. HD: $<0.5\%$ at 1kHz at rated output. FR: 40Hz-50kHz -3dB. Output impedance: 4 ohms minimum. Motor unit: BSR P128. Cartridge: SC5M with single diamond stylus. 27 transistors, 13 diodes, two ICs. Finish: teak veneer. Price: £95.50.

KLINGER

Klinger Controls Ltd, Spencer Court, 7 Chalcot Road, London, NW1 8LU. Tel: 01-586 2922/3.

KC67

Integrated stereo amplifier with record deck. 21 transistors and seven diodes. Motor unit: Garrard SP25 Mk III. Cartridge: Goldring G800H. Diamond Stylus. Inputs: radio 100mV 10K, tape 100mV 10K. Noise level: 66dB.

**Klinger KC95**

Overload capability: 30dB. Output 10W RMS per channel. Tone controls: bass ± 15 dB, treble ± 15 dB. Full-range balance control. HD: 0.15% 1W. FR: 30Hz-50kHz ± 2 dB. Stereo headphone socket. Stabilised power supply. Size: $16\frac{1}{2} \times 8\frac{1}{4} \times 14$ in. Price: £61.50 (plus £10 PT).

KC330TC/H

Integrated stereo amplifier with record deck. Motor unit: Garrard 2025TC. Cartridge: Garrard KS40A or Sonotone 3509. Diamond stylus. 14 transistor circuit. Inputs: radio 250mV 220K, tape 250mV 220K. Noise level: 65dB. Overload capability: 26dB. Output: 6W RMS per channel. Tone controls: bass +15dB-10dB, treble +15dB-10dB. HD: <1% at 5W. Output impedance: 8 ohms. FR: 40Hz-20kHz ± 1.5 dB at 1.5W. Stereo headphone socket. Mains: 240V AC (other voltages to order). Size: $16\frac{1}{2} \times 4 \times 8$ in. Finish: teak with black and silver trim, transparent dust cover. Price: £40.20 (plus £6.70 PT).

KC94

FM stereo tuner/amplifier in cabinet with record deck. Motor unit: Garrard SP25 Mk III. Four speeds. Idler wheel drive. Cartridge: Goldring G800H. Diamond stylus. Range: 87.5-108MHz. Five preset stations. Switchable AFC. Usable sensitivity: 2uV. Aerial input: coaxial and balanced. Outlet for tape: 100mV. Stereo decoder included. Inputs: tape 50mV 220K, aux. 1 100mV 470K, aux. 2 0.15mV 30 ohms. Noise level: 70dB. Overload capability: 30dB. Output: 25W RMS per channel. Output impedance: 8 ohms. Tone controls: bass ± 15 dB, treble ± 15 dB, scratch filter 18dB/octave from 8kHz, rumble 12dB/octave from 80Hz. Loudness control. A/B monitor switch. HD: 0.1% at 20W. FR: 25Hz-35kHz 2dB at 20W. Switching for two pairs of speakers. Two stereo headphone sockets. Stabilised power supply. Size: $21 \times 8 \times 15\frac{1}{2}$ in. Mains: 110-120V, 220-240V AC. Finish: teak cabinet with folding lid. Price: £112.10 (plus £18.40 PT).

KC95 ★

Integrated stereo amplifier with record deck. Motor unit: BSR P144. Cartridge: Goldring G800H. Diamond stylus. 28 transistor circuit. Inputs: radio 50mV 220K, tape 50mV 220K, aux 100mV 470K, mic 0.15mV 30 ohms. Noise level: 70dB. Overload capability: 30dB. Output: 25W RMS per channel. Tape outlet: 100mV. Tone controls: bass ± 15 dB, treble ± 15 dB, scratch filter 18dB/octave from 8Hz, rumble filter 12dB/octave from 80Hz. Loudness control. A/B monitor switch. HD: 0.1% up to 20W. Output impedance: 8 ohms. FR: 35Hz-35kHz ± 2 dB at 20W. Two stereo headphone sockets. Sockets and switches for two sets of speakers. Stabilised power supply. Mains: 110-120V, 220-240V AC. Size: $21 \times 8 \times 15\frac{1}{2}$ in. Finish: teak with transparent folding lid. Price: £79.50 (plus £12.90 PT).

KC58

Integrated stereo amplifier with record deck. Motor unit: Garrard 2025TC. Cartridge: Garrard KS40A or Sonotone 3509. Diamond stylus. 14 transistor circuit. Inputs: radio 250mV 220K, tape 250mV 220K. Noise level: 65dB. Overload capability: 26dB. Output: 8W RMS per channel. Tape outlet: 200mV. Tone controls: bass +15dB -10dB, treble +15dB -10dB. Full-range balance control. HD: <1% at 6W. Output impedance: 8 ohms. FR: 40Hz-20kHz ± 1.5 dB at 1W. Stereo headphone socket. Mains: 240V AC (other voltages to order). Size: $16\frac{1}{2} \times 8 \times 14$ in. Finish: teak cabinet with silver trim and transparent dust cover. Price: £42.60 (plus £7.10 PT).

■ KOYO

Distributors: Kingsway Mills Ltd,
5 Worship Street, London, EC2.
Tel: 01-628 6157.

CFS-600

AM/FM stereo tuner/amplifier with eight-track tape player. Range: FM 88-108MHz, MW 188-556 metres. 27 transistors, 15 diodes. Sensitivity: FM 3uV, MW 100uV. Output: 6.5W RMS per channel. Variable tuning. Stereo decoder with auto switching. Eight-track cartridge player. Speed: $3\frac{3}{4}$ 1/s. W and F: better than 0.3%. Separation: better than 20dB at 1kHz. Indicator lights to show channel playing. Size: $22\frac{3}{4} \times 4\frac{1}{2} \times 9\frac{1}{2}$ in. Price: to be announced.

■ LUXOR (Luxor Industri Atiebolag)

Highgate Acoustics Ltd,
184 Great Portland Street, London, W1.
Tel: 01-636 2901.

Luxor 900

Stereo FM combination unit. Motor unit: Luxor LG-900. Speeds: $33\frac{1}{3}$, 45, 78rpm. Idler wheel drive. Hydraulic arm lift. Anti-skating device.

★ Indicates entry is illustrated

Cartridge: BSR SC5M with diamond/sapphire stylus. Range: 86.7-101.5MHz. Five preset stations. AFC. Ratio detector. Usable sensitivity: 5µV. Aerial input: 300 ohms balanced. Inputs: tape 250mV 470K. S/N: 60dB. Output: 7W RMS per channel. Controls: balance, bass +16dB -8dB at 100Hz, treble +11dB -13dB at 10kHz. HD: 1% at 6W. Output impedance: 4 ohms. FR: 35Hz-18kHz ±2dB. Mains: 240V AC. Size: 19×12×5 $\frac{3}{8}$ in. Finish: teak or rosewood with chrome and black trim. Price: £104.79 (plus £15.21 PT).

Luxor LG910

Stereo FM combination unit. Motor unit: Luxor LG910. Speeds: 33 $\frac{1}{3}$, 45, 78rpm. Turntable: 8 $\frac{1}{2}$ in, weight 2lb 14oz. Idler wheel drive. Hydraulic lowering device. Cartridge: Pickering V15/AT2 magnetic. Diamond spherical stylus. Range: 87-104.5MHz. Five preset stations. AFC. Ratio detector. Usable sensitivity: 3µV. Meter tuning indicator. Aerial input: 300 ohms balanced. Inputs: mag PU 4mV 47K, tape (high) 70mV 47K, tape (low) 250mV 47K, crystal PU 150mV 1.8M. Output: 15W RMS per channel. Output impedance: 4 ohms. H and N: PU inputs 58dB, tape inputs 60dB. Tone controls: bass ±15dB at 50Hz, treble ±16dB at 10kHz. HD: 0.4% at maximum output. FR: 30Hz-25kHz ±1.5dB. Size: 21×7 $\frac{1}{2}$ ×13in. Mains: 240V AC. Finish: teak or rosewood with brushed aluminium trim. Price: £159.42 (plus £25.58 PT).

■ MUSICRAFT

Musicraft Audio Products Ltd,
63 High Street, Hounslow, Middlesex.
Tel: 01-570 4640.

Musicraft 10-10

Transistorised stereo tuner/amplifier with gram unit. Range: FM 88-108MHz. Variable tuning. AFC. No radio decoder. Controls: selector, treble, bass, volume on/off, balance. Output: 10W RMS per channel. FR: 30Hz-20kHz ±2dB. Output impedance: 8-15 ohms. HD: 0.4% at rated output. Motor unit: Garrard SP25. Cartridge: Shure M3D. Size: 24 $\frac{3}{4}$ in high, 27in wide, 17 $\frac{3}{4}$ in deep. Finish: teak veneer. Price: £90 (including PT).

See also Complete System Section.

■ PHILIPS ELECTRICAL LTD

Century House, Shaftesbury Avenue, London, WC2. Tel: 01-437 7777.

RH802 ★

AM/FM stereo tuner/amplifier in cabinet with record deck. Motor unit: Philips GC008. Speeds: 33 $\frac{1}{3}$, 45rpm. Turntable: 10 $\frac{1}{2}$ in diameter. Belt drive. Tubular pickup arm with slide-in cartridge carrier. Antistatic mat. Cartridge: Philips GP400 Super M. Stylus: diamond spherical.



Phillips RH802

Range: FM 87.5-108MHz, MW 211-577 metres, MW bandsread 187-214 metres, LW 870-2,000 metres, SW 30.7-50.4 metres. Variable tuning plus five preset buttons on FM. Switchable AFC. Ratio detector. Moving coil tuning meter. Usable sensitivity: FM 6µV for 26dB quieting, AM 80µV for 26dB S/N ratio. Aerial input: 300 ohms balanced. Stereo decoder fitted. 46 transistors. Inputs: tape 270mV 500K, mic 0.5mV 2K. Noise level: -50dB. Output: 15W RMS per channel. Output impedance: 4 ohms. Tone controls: bass ±15dB at 50Hz, treble ±14dB at 10kHz. HD: <0.15% at 15W per channel. FR: 10Hz-50kHz ±3dB. Mains: 110, 127, 220, 240V AC. Size: 23×6 $\frac{3}{4}$ ×14 $\frac{1}{4}$ in. Finish: walnut veneer cabinet with brushed aluminium fascia. Price: £155 (including PT).

■ SERVO-SOUND

Sonosound Ltd,
5 Queen Street, London, EC4N 1SU.
Tel: 01-248 9461.

SC75BTE

Stereo preamplifier in cabinet with record deck. Designed for operation with Servo-Sound SL20 speaker/power amplifier units and SR2 FM tuner (see appropriate sections). Lenco L75 record deck with tubular pickup arm, lightweight headshell and Stanton 500A magnetic cartridge. Inputs: PU 1.5mV 47K, tape 300mV 40K, aux (1) 300mV 40K, aux (2) 300mV 40K. Output: 1.2V per channel into not less than 400 ohms. HD: 0.3% at 1kHz. Output impedance: 400 ohms. FR: 30Hz-30kHz. 12 silicon transistors. Size: 15 $\frac{3}{8}$ ×5 $\frac{3}{8}$ ×14 $\frac{1}{8}$ in. Finish: wood and steel cabinet finished in walnut or white, black panel and clear plastic dust cover for record deck. Price: £116.50 (including PT).

■ SKANDIA ELECTRONICS

Distributors: Golding Audio Ltd,
London Road, Marks Tey, Colchester, Essex.
Tel: Marks Tey (0206 21) 433.

SK120

Stereo tuner/amplifier incorporating eight-track cartridge tape recorder. Range: FM 88-108 MHz, MW 187-567 metres. Variable tuning. AFC. Stereo decoder fitted. Controls: volume, tuning, record level (right channel), record level (left channel), balance, AM/FM radio, low filter, high filter, treble, input selector, mono/stereo. Output: 45W RMS per channel. FR: 20Hz-20kHz. Output impedance: 8 ohms. HD <3%. Size: $29\frac{1}{2} \times 6\frac{1}{8} \times 13\frac{1}{2}$ in. Finish: walnut. Price: £176 (plus £32.17 PT).

See also the Complete System Section.

SONY (UK) LTD

Pyrene House, Sunbury Cross,
Sunbury-on-Thames, Middlesex.
Tel: Sunbury 87644/7.

HST-139

AM/FM stereo tuner/amplifier with cassette tape deck. Range: FM/VHF, MW. Variable tuning. AFC. FET front end. Ratio detector. Meter tuning indicator. Usable sensitivity: AM $20\mu\text{V}$, FM $2.2\mu\text{V}$. Aerial input: 300 ohms balanced. Stereo decoder fitted. 41 transistors and 20 diodes. Inputs: mag PU 3.5mV 47K, ceramic PU 300mV 3.6 megohms, mic 0.775mV 600 ohms, tape 400mV 100K, record/playback 400mV 100K. Output: 12W RMS per channel. Output impedance: 8 ohms. FR: 40Hz-40kHz, (tape) 30Hz-12kHz. Mains: 110, 127, 222, 240V AC. Size: $21\frac{3}{8} \times 5\frac{1}{4} \times 12\frac{1}{2}$ in. Finish: walnut cabinet with brushed aluminium panel and black tuning scale. Automatic recording level. Cassette tape deck. Price: to be announced.

SYKES+HIRSCH LTD

201 Greenwich High Road, London, SE10.
Tel: 01-858 0549.

Compacta ★

FM stereo tuner/amplifier in cabinet with record deck. Motor unit: S+H $33\frac{1}{3}$ rpm deck with infinitely variable adjustment. 12in diameter chromed brass turntable. Weight: 6lb. Synchrony drive. 10in pickup arm with torsional suspension pivot incorporating bias compensation. Hydraulic damped lowering device. Tracking pressure adjustable $\frac{1}{2}$ -3gms. Automatic stop optional extra. Range: 87-108MHz. Variable tuning. Switchable AFC. Differential peak detector. Neon tuning indicator. Usable sensitivity: $2\mu\text{V}$ for 20dB quieting, $8\mu\text{V}$ for 40dB quieting. Output to amplifier section: 200mV at 100% modulation. Stereo decoder included. 35 transistors and four diodes. Inputs: aux 100mV 100K, mag PU 3mV 47K (RIAA), radio 100mV 100K. Noise level: PU input 65dB, other inputs 75dB. Overload capability: 34dB. Output: 30W RMS per channel into 8 ohms. Tone controls:

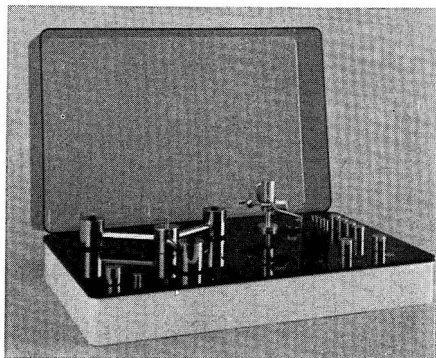

Sykes & Hirsch Compacta

bass $\pm 14\text{dB}$ at 100Hz, treble $\pm 14\text{dB}$ at 10kHz. HD: better than 0.07%. Output impedance: 8 ohms. FR: 16Hz-60kHz $\pm 1.5\text{dB}$ at 30W. Mains: 220-240V AC (110V to order). Full overload protection. Finish: moulded plastic case with chrome trim. Price: £200 (including PT).

TELETON

Teleton Electro (UK) Ltd, Teleton House,
Robjohns Road, Widford, Chelmsford, Essex.
Tel: Chelmsford 62442.

SCX1510

Tuner/amplifier with cassette tape deck in one cabinet. Compact cassettes. Speed: $1\frac{7}{8}$ i/s. Four track. Pause. Stereo record facility. Twin level meters. W and F: 0.2%. FR: (tape recorder) 70Hz-10kHz. AC bias. Vertical operating position. Range: FM 88-108MHz, MW 187-560 metres. Aerial input: 75 ohms coaxial or 300 ohms balanced. Stereo decoder fitted. Output: 10W RMS per channel. HD: 0.5%. FR: (amplifier) 40Hz-20kHz. Input: mag PU 5mV . Output impedance: 8 ohms. Outputs for LS and headphones. 17 transistors, 22 diodes and three ICs. Controls: bass, treble, volume (left and right), mode, mains on/off, record level (left and right). Slider controls. Finish: oiled walnut cabinet with matt black and satin aluminium trim. Mains: 220-240V AC. Size: $11\frac{3}{4} \times 13\frac{3}{4} \times 6\frac{1}{2}$ in. Price: to be announced.

VAN DER MOLEN LTD

1 Mildmay Road, Romford, Essex, RM7 7DA.
Tel: Romford 41904 and 46911.

Sonic 89

Integrated stereo amplifier with record deck. Output: 8W RMS per channel. Output impedance: 4 ohms. FR: 40Hz-18kHz. Tone controls: bass $\pm 12\text{dB}$ at 50Hz, treble $\pm 12\text{dB}$ at 10kHz. Inputs for radio or tape. Motor unit: BSR C141 autochanger. Cartridge: Acos GP104.



Yamaha MC-40



Yamaha MS-3

Stylus: diamond LP/78. Outlet for stereo headphones (4-15 ohms). Size: $25\frac{1}{4} \times 13\frac{5}{8} \times 7\frac{3}{8}$ in. HD: <1%. Scratch filter. Price: £57.88 (including PT).

Sonic 89M

Similar specification to the Sonic 89 but fitted with BSR B144 record deck and Shure M75/6 magnetic cartridge. Price: £75.16 (including PT).

Sonic 99

Similar specification to the Sonic 89 but fitted with stereo AM/FM tuner. Range: VHF 88-104MHz, LW 1,100-1,900 metres, MW 185-570 metres. Automatic stereo decoder. Price: £85.39 (including PT).

Sonic 99M

Similar specification to the Sonic 99 but fitted with BSR B144 record deck and Shure M75/6 magnetic cartridge. Price: £102.77 (including PT).

■ YAMAHA

Jonathan Fallowfield Ltd, Strathcona Road, North Wembley, London, HA9 8QL.
Tel: 01-904 0141.

MC-40 ★

AM/FM stereo tuner/amplifier in cabinet with record deck. Range: FM 88-108MHz, MW 186-560 metres. Variable tuning. AFC. Stereo decoder fitted. Controls: volume, loudness, mono/stereo, treble, tuning, bass, input selector, balance, mains on/off. Output: 10W RMS per channel. Output impedance: 8 ohms. FR: 20Hz-30kHz ± 2 dB. HD: 0.15%. Two-speed belt drive Yamaha turntable. CG-3500 magnetic cartridge. Finish: straight grain American walnut. Price: £98.60 (plus £16.02 PT).

MS-3 ★

AM/FM stereo tuner/amplifier in cabinet with record deck. Range: FM 88-108MHz, MW 186-565 metres. Variable tuning. AFC. Stereo decoder fitted. Controls: volume, treble, bass, balance, acoustic equaliser, loudness, tape monitor, mono/stereo, mains on/off, speaker selector, input selector, tuning. Output: 22W RMS. Output impedance: 8 ohms. FR: 10Hz-30kHz +0dB -2dB. HD: 0.05%. Yamaha two-speed belt drive turntable. Yamaha CG5500 magnetic cartridge. Finish: American walnut. Price: £180.40 (plus £29.31 PT).

MS-5AR

AM/FM stereo tuner/amplifier in cabinet with record deck and cartridge recorder. Range: FM 88-108MHz, MW 186-565 metres. Variable tuning. AFC. Stereo decoder fitted. Controls: eight-track cartridge record/playback, record level, volume, treble, bass, balance, mic volume, loudness, high filter, auto-stop, tuning, function selector. Output: 22W RMS per channel. Output impedance: 8 ohms. FR: 10Hz-30kHz -0dB +2dB. HD: 0.05%. Yamaha two-speed belt drive turntable. Yamaha CG-5500 magnetic cartridge. Finish: American walnut. Price: £224.74 (plus £36.52 PT).

MS-5B

AM/FM stereo tuner/amplifier in cabinet with record deck and cassette recorder. Range: FM 88-108MHz, MW 186-565 metres. Variable tuning. AFC. Controls: cassette tape record/playback, volume, treble, bass, balance, acoustic equaliser, function, loudness, high filter, mic volume, tuning, record level. Stereo decoder fitted. Output: 22W RMS per channel. Output impedance: 8 ohms. FR: 10Hz-30kHz -0dB +2dB. HD: 0.05%. Yamaha two-speed belt drive turntable. Yamaha CG-5500 magnetic cartridge. Finish: American walnut. Price: £224.74 (plus £36.52 PT).



Now look what HMV are up to!

A new peak in high fidelity systems:

Model 2455 stereo amplifier/VHF stereo and MW radio with record playing unit, separate speakers—and provision for 4D sound.

This superb new high performance system now takes its place at the very top of the HMV list. (And at the top of yours—as soon as you've heard it!)

Additional Special Features include:

*Press-button or manually tuned VHF radio complete with stereo decoder *80 watts total music power with both channels working 28+28 watts—sine waving rating, less than 1% distortion—less than 0.2% at any power up to 20 watts per channel. *Each enclosure houses two 5" high compliance bass units and a 3½ tweeter.

HMV



put quality first

His Masters Voice is the registered trademark
of the Gramophone Company Ltd



British Radio Corporation is a member of the Thorn Group.

100 series

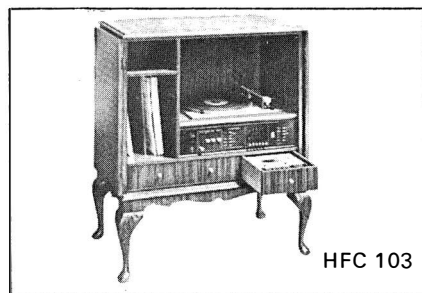

Dynatron's new 45+45 watts output

That's power. Sheer power. Stereo amplifiers delivering a genuine 45 watts RMS per channel into 8 ohms with a maximum harmonic distortion of 0.3% at minus 0.5 dB. Only available from the new Dynatron 100 Series – a four-model range of hi-fidelity audio equipment for the connoisseur. And probably the finest equipment your money can buy.

Really comprehensive facilities include "slide" controls for volume, bass, treble and balance and press buttons for scratch, high-pass, low-pass and loudness filters, mono radio, tape, disc and 'A' and 'B' speakers.

Sockets are provided for two pairs of loudspeaker enclosures, tape in-out, radio in, stereo headphones and of course a mains outlet.

Three models – HFC 100, HFC 101 AM-FM and HFC 102 VHF-FM are contained in high quality natural teak veneered cabinets fitted with hinged, but removable, acrylic plastic lids. The fourth model – the HFC 103 VHF-FM Dorchester – is housed in a traditional "Queen Anne" style craftsman built cabinet and has in addition a stereo cassette tape recorder-player.

Full details of the 100 Series and all other Dynatron equipment are contained in Dynatron Audio and Colour Television News. Free on request.

DYNATRON RADIO LTD.,
St. Peters Road,
Maidenhead, Berks. SL6 7QY.
Tel: Maidenhead 23331



DYNATRON
Audio and colour Television

Complete Audio Systems

★ Indicates entry is illustrated

Abbreviations used in this section are given on page 36.

In this section manufacturers give details of audio systems marketed as complete packages or made up from individual units. Brief specifications only are quoted since many of the units listed are fully covered in the earlier sections of the book.

This list is not comprehensive and other makers who offer similar equipment are invited to submit details for inclusion in future editions of the book.

In order that a wide choice of systems can be shown the equipment in this special section ranges from medium priced unit audio up to top quality high fidelity. But in every case the following minimum requirements are met:

- 1 Fully stereophonic record reproduction and/or tape playback.
- 2 FM or AM/FM radio tuner.
- 3 Record turntable or tape deck (or both).
- 4 Matched units (electronically and aesthetically).
- 5 Marketed as a complete system by one manufacturer.
- 6 Ready for use by purchaser without fitting parts or wiring up (apart from plugging in mains supply and connecting speakers).
- 7 Speakers in separate acoustic enclosures.

■ ALBA (RADIO & TELEVISION) LTD

Tabernacle Street, London, EC2.
Tel: 01-253 1322.

UA100D, UA200 and UA300

Four-unit system comprising UA100D stereo tuner/amplifier, UA200 record deck and two UA300 speaker enclosures. Range: FM 87-108 MHz, MW 183-570 metres, LW 1,100-1,900 metres, SW 16-53 metres. Variable tuning. Switchable AFC. Switchable quiet tuning. Multiplex decoder fitted. Pushbutton controls for: wavebands, AFC, quiet tuning, gram, tape.

Rotary controls for: treble ± 12 dB at 12kHz, bass ± 12 dB at 70Hz, volume, tuning (flywheel). Output: 15W RMS per channel. Output impedance: 8 ohms. HD: $< 0.3\%$ at 15W. Motor unit: Garrard SP25 Mk III. Magnetic cartridge with diamond stylus. Finish: teak cabinets with brushed aluminium trim. Speakers: two UA300 each containing $6\frac{1}{2}$ " in bass driver and 3" in tweeter. Size: (UA100D) $16 \times 6 \times 7$ in; (UA200) $15\frac{3}{8} \times 6\frac{1}{2} \times 13$ in; (UA300) $8\frac{3}{8} \times 16\frac{3}{8} \times 7$ in. Price: (complete system) £157.70 (including PT).

UA7070

AM/FM stereo tuner/amplifier in shelf mounting cabinet with two separate speakers. Range: VHF, LW, MW. Switched AFC on FM. Variable tuning. Ratio detector. BSR four-speed player with cueing device. Slider controls for bass, treble, volume and balance. Pushbutton input selection and rotary tuning control. Outlet sockets for tape recorder and headphones. Finish: teak. Stereo decoder optional extra. Price: (complete system less decoder) £79.80; (complete system with decoder) £86.55.

■ ALPHA

Highgate Acoustics Ltd,
184-188 Great Portland Street, London, W1.
Tel: 01-636 2901.

Alpha MR15

Stereo tuner/amplifier in cabinet with record deck. Range: 88-108MHz, 187-572 metres. Variable tuning. AFC. Stereo decoder fitted. Controls: (slider) bass, (slider) treble, speaker selector, volume, balance, tuning, input selector, on/off, AFC, high pass filter, loudness, stereo/mono, tape monitor. Output: 18W RMS per channel. FR: 20Hz-35kHz. Output impedance: 8 ohms. HD: 0.5% at 15W. Motor unit: Lenco 75. Magnetic cartridge. Size: $18\frac{1}{2} \times 18 \times 5\frac{1}{8}$ in. Speakers: Alpha HT20 Mk II with three units in each. Finish: walnut. Price: (complete system with two speakers) £176.65 (plus £28.35 PT).

■ ASA

Maggs (Bristol) Television Ltd, The Station,
Sea Mills Lane, Bristol, BS9 1DX.
Tel: Bristol 684801.

3199

FM stereo tuner/amplifier. Range: 87.5-104 MHz. Sensitivity: better than $2\mu\text{V}$ for 26dB quieting. Three preset tuning buttons. AFC. Aerial input: 240 ohms balanced. Stereo decoder with auto switching and beacon. Output: 8W RMS per channel. FR: 40Hz-20kHz ± 1.5 dB. HD: $< 1\%$. Tone controls: bass +18dB -15dB at 40Hz, treble +14dB -15dB at 10kHz. Rumble and scratch filters. Inputs: mag PU 5-70mV 47K, crystal PU 80-1,200mV 500K, tape play 260-3,800mV 500K. 30 transistors,

★ Indicates entry is illustrated

one IC, 13 diodes. Mains: 220-240V AC. Finish: anodised metal front, teak or rosewood cabinet. Size: $17\frac{3}{8} \times 3\frac{1}{8} \times 9\frac{1}{4}$ in. Price: £84 (plus £11 PT).

3703

FM stereo tuner/amplifier. Range: 87.5-104 MHz. Sensitivity: better than $2\mu\text{V}$ for 26dB quieting. Aerial input: 240 ohms balanced. AFC. Variable tuning plus three presets. Quiet tuning facility. IC stereo decoder with auto switching and beacon. Output: 20W RMS per channel. FR: 30Hz-30kHz $\pm 1.5\text{dB}$. HD: $< 1\%$. Tone controls: bass $+18\text{dB}$ -15dB at 40Hz, treble $+14\text{dB}$ -15dB at 10kHz. Rumble and scratch filters. Inputs: mag PU 4mV 47K, crystal PU 70mV 500K, tape play 260mV 500K. Front jack sockets for headphones (automatically mute speaker outlets). 37 transistors, 15 diodes, one IC, three varicap diodes. Mains: 220-240V 50Hz. Finish: anodised metal front with teak or rosewood cabinet. Size: $20\frac{1}{2} \times 3\frac{3}{8} \times 9\frac{1}{4}$ in. Price: £92.25 (plus £12.25 PT).

■ BIGSTON

J. Parker & Co (London) Ltd, Parker House, 1 Paul Street, London, EC2A 4JQ. Tel: 01-628 4577.

BHS-100 ★

Stereo tuner/amplifier with cassette record deck and two separate speakers. Range: FM 88-108MHz, MW 187-750 metres. Variable tuning with AFC. Stereo decoder fitted. Controls: tuning, input selector, tone, right-channel volume, left-channel volume, mains on/off, monitor on/off, pushbutton tape recorder controls. Output: 3W RMS per channel. FR: 80Hz-10kHz. Output impedance: 8 ohms. Electronically controlled tape transport motor. 26 transistors, 14 diodes. $\frac{1}{4}$ -track compact cassette deck. 5in high compliance speakers in infinite baffle cabinets. Jack sockets for two microphones (left and right channel). Outlet for stereo phones. Size: (main unit) $10\frac{5}{8} \times 7\frac{1}{8} \times 5\frac{3}{8}$ in. Wood veneered cabinets. Price: £99 (including PT).

Bush-Arena System 3 ★

Stereo tuner/amplifier with record unit and speakers. Range: FM 87-108MHz. 36-transistor circuit. Variable and preset switched tuning. AFC. Stereo decoder fitted. Controls: volume on/off, treble, bass, balance, loudness, rumble filter, mono/stereo switch, input selector, speaker selector, tuning buttons. Output: 15W RMS per channel. FR: 25Hz-20kHz -3dB . Output impedance: 3.2 ohms. HD: $< 0.6\%$. Motor unit: Garrard AP76. Cartridge: Goldring G800E magnetic. Speakers: three units (8in bass driver, $2\frac{1}{2}$ in mid-range unit, $2\frac{1}{2}$ in tweeter). Crossover: 3kHz, 5kHz. Finish: teak or rosewood veneer, or white. Size: (tuner/

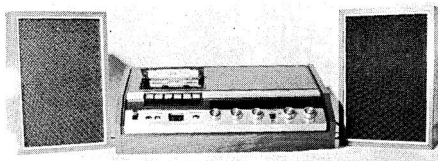

Bigston BHS-100

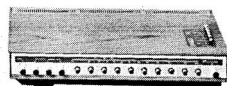
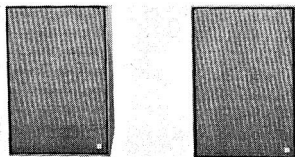

Bush-Arena System 3

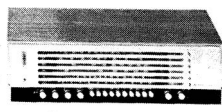
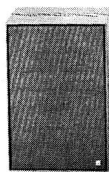

Bush-Arena System 5

amplifier) $19\frac{1}{2} \times 3\frac{1}{4} \times 9\frac{3}{4}$ in; (record deck) $15\frac{1}{4} \times 15\frac{1}{8} \times 6\frac{1}{4}$ in; (speakers) $17 \times 11 \times 9\frac{1}{2}$ in. Price: (complete system) £157.47 (plus £26.53 PT).

Bush-Arena System 4

Stereo tuner/amplifier in cabinet with record deck plus two separate speakers. Range: FM 87-108MHz. 40-transistor circuit. Switched preset tuning. AFC. Stereo decoder fitted. Controls: volume on/off, treble, bass, balance, loudness, input selector, mono/stereo switch, tuning buttons. Output: 15W per channel RMS. FR: 25Hz-20kHz -3dB . HD: $< 0.6\%$. Motor unit: Lenco B55. Cartridge: Goldring G800E magnetic. Speakers: three units (8in bass driver, $2\frac{1}{2}$ in mid-range unit, $2\frac{1}{2}$ in tweeter). Crossover: 3kHz, 5kHz. Finish: teak veneer. Size: (main unit) $22\frac{3}{4} \times 12\frac{3}{4} \times 6\frac{3}{4}$ in; (speakers) $17 \times 11 \times 9\frac{1}{2}$ in. Price: (complete system) £157.47 (plus £26.53 PT).

Bush-Arena System 5 ★

Five-waveband stereo tuner/amplifier with record deck and speakers. 38-transistor circuit. Range: FM 87-108MHz, MW 182-583 metres, LW 833-2,000 metres, SW1 49 metre band, SW2 68.2-187 metres. Variable and preset switched tuning. AFC. Stereo decoder fitted. Controls: volume on/off, treble, bass, balance, loudness, speaker selector, input selector, tuning. Output: 15W RMS per channel. FR: 25Hz-20kHz - 3dB. HD: <0.6%. Motor unit: Garrard AP76. Cartridge: Goldring G800E magnetic. Speakers: three units (8in bass driver, 2½in mid-range unit, 2½in tweeter). Crossover: 3kHz, 5kHz. Finish: teak veneer. Size: (tuner/amplifier) 19½ × 5½ × 9in; (record deck) 6¾ × 15¼ × 15¾in; (speaker units) 16¾ × 11 × 9½in. Price: (complete system) £163.08 plus £27.47 PT).

■ CROWN RADIO LTD

128-129 Shoreditch High Street, London, E1 6JE. Tel: 01-739 2382.

SHC-53, CSP-13 (2)

AM/FM stereo radio in cabinet with eight-track cartridge tape player plus two separate speakers. Range: FM 88-108MHz, MW 182-560 metres. Switchable AFC. Variable tuning. 21 transistors, four ICs, 21 diodes. Cartridge deck. Speed: 3¾i/s. S/N ratio: >40dB. W and F: <0.35%. FR: 80Hz-12kHz. Output: 5W per channel. Automatic head cleaning device. Slider controls. Headphone jack socket. Speakers: infinite baffle enclosures with unit. One 13¼ × 8¼in bass driver with two integral HF units. Impedance: 8 ohms. Finish: walnut cabinets. Amplifier/tape unit has black dial and bright trim, speaker enclosures have black grilles. Price: (complete system) £137.50 (including PT).

■ DUAL

International Audio Ltd,
Clive House, Queens Road, Weybridge, Surrey.
Tel: Weybridge 40125/6. Telex: 928153.

KA50 Music Centre

Comprises CR50 tuner/amplifier, 1218 turntable, Shure M75 cartridge and two separate CL170 speaker enclosures. Equipment is housed in special base with dust cover for record deck. Range: LW, MW, SW1, SW2, VHF. Stereo decoder fitted. Stereo beacon, with auto switching. Variable tuning plus five preset FM stations. Output: 18W RMS per channel into 4 ohms. Inputs: magnetic PU, ceramic PU, tape. FR: 20Hz-40kHz ± 0.6dB. HD: <0.3% at 1kHz at 18W. Three-speed record deck with lightweight tubular pickup arm. Fine speed adjustment. 10½in 4¼lb turntable. Two matching speaker enclosures each fitted with three units. Price: £225 (including PT).

KA30 Music Centre

Similar specification as the KA50 Music Centre but fitted with Dual 1214 motor unit and Shure M75-D cartridge. Price: £155.50 (including PT).

■ DUETTE

J. J. Silber Ltd,
11 Northburgh Street, London, EC1.
Tel: 01-253 8031.

SS2005W

AM/FM stereo tuner/amplifier in cabinet with cassette recorder and record deck. Range: FM 88-108MHz, MW 185-565 metres. Aerial input: 300 ohms balanced. Ferrite rod AM aerial. Stereo decoder fitted. Separation: 30dB at 1kHz. Compact cassettes. Speed: 1¾i/s. W and F: 0.25%. H and N: 45dB. Automatic or manual level control. Multiplex filter. Four-speed record deck. Ceramic cartridge with diamond stereo stylus. 11in platter. Four-pole motor with outer rotor. Audio output: 10W per channel. Output impedance: 8 ohms. FR: 35Hz-30kHz. Tone controls: bass +10dB -12dB at 100Hz, treble +9dB -17dB at 10kHz. Mains: 110, 117, 220, 240V 50/60Hz. Size: 22½ × 9 × 17in. Weight: 35lb. This is a provisional specification as full details were not available as this issue of the Year Book closed for press. Designed for use with Duette speakers type 44SX, 66SX or 88SX. No details of speakers available. Price: (main unit with two speakers) from approximately £220.

■ DYNATRON RADIO LTD

St Peters Road, Maidenhead, Berks, SL67QY.
Tel: Maidenhead 23331.

Cavalcade HFC31A system

Integrated stereo tuner/amplifier with record deck in cabinet plus matching speakers. Range: FM 87-108MHz, MW 185-570 metres, LW 1,100-2,000 metres. Variable tuning. AFC incorporated. Stereo decoder fitted. Output: 8W RMS per channel. HD: <1% at rated output. FR: 40Hz-16kHz ± 3dB. Output impedance: 4 ohms for speakers, 8 ohms or greater for phones. Controls: bass, treble, balance, volume, loudness, input selector, tuning, filter, AFC on/off. Motor unit: Garrard 2025TC. Cartridge: Sonotone 9TAHC. Size: 19 × 16½ × 9¾in. Finish: teak. Suggested speakers: LS1434 (other types available). Price: (complete system including two speakers) £146.50 (including PT).

HFC31MT

Integrated stereo tuner/amplifier with record deck in cabinet plus matching speakers. Similar specification to HFC31A but with Garrard SP25S Mk III record deck and Goldring G850 cartridge. Suggested speakers: LS2034 (other types available). Size: (main unit) 19 × 16¼ ×

★ Indicates entry is illustrated

9 $\frac{7}{8}$ in. Price: (complete system with two suggested speakers) £163 (including PT).

Cavalcade HFC32 system

Integrated stereo tuner/amplifier with record deck in cabinet plus matching speakers. Similar specification to HFC31A but with single-play transcription record unit. Record deck: Goldring-Lenco GL75. Cartridge: Goldring G800. Suggested speakers: LS2034 (other types available). Price: (complete system inc. two speakers) £188.50 (including PT).

■ EDWARD MICHELSEN CUSTOM CABINETS

'Sound Ideas'

494 New Cross Road, New Cross, London, SE14. Tel: 01-692 2981.

Also at 216 Brampton Road, Bexleyheath, Kent. Tel: 01-303 9272.

Project 60 System

Comprises integrated stereo amplifier, stereo FM tuner and record deck in shelf-mounting cabinet with two separate speaker enclosures. System based on the Sinclair Project 60 amplifier and tuner. Range: FM 87.5-108MHz. Variable tuning. AFC. Decoder fitted. Stereo tuning indicator. Controls: pushbutton input selectors, bass ± 15 dB at 100Hz, treble ± 15 dB at 10kHz, volume, balance, rumble filter 12dB/octave 25-100Hz, scratch filter 12dB/octave 5-28kHz, tuning. Output: 30W RMS per channel into 8 ohms. FR: 30Hz-300kHz ± 1 dB. HD: 0.02% into 8 ohms. Output impedance: 3-8 ohms. Motor unit: Thorens TD150 Mk II. Cartridge: Shure M55E. Speakers: Thurston RS-10 column speakers. Price: (with Thorens TD150 Mk II) from about £180. Can be supplied with Garrard or Goldring record decks at lower cost. Also various speakers available.

■ EKCO

Pye Ltd, PO Box 49, St Andrews Road, Cambridge. Tel: Cambridge 58985.

ZU3 ★

FM stereo tuner/amplifier in plinth cabinet with record deck, plus two separate speakers. Stereo decoder included. Pushbutton tuning. Philips three-speed single-play automatic player. GP200 ceramic cartridge. 7in full-range 10W speakers. Price: (complete system) £108.50.

ZU4

FM stereo tuner/amplifier in plinth cabinet with record deck and cassette recorder, plus two separate speaker systems. Range: 87.5-104MHz. Four preset tuning buttons. Varicap tuning. Sensitivity: $< 3\mu V$ for 26dB S/N ratio. Stereo decoder included. Output: 7W per channel into 4 ohms. FR: 30Hz-18kHz ± 1.5 dB. HD: $< 1\%$ at 7W per channel. Record unit: Philips GC005 three-speed deck with GP200

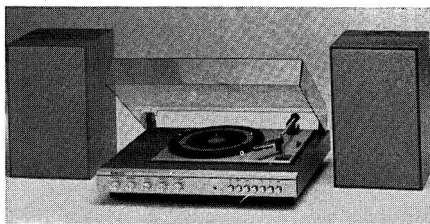

Ekco ZU3

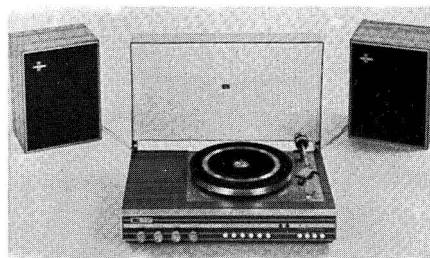

Ekco ZU5

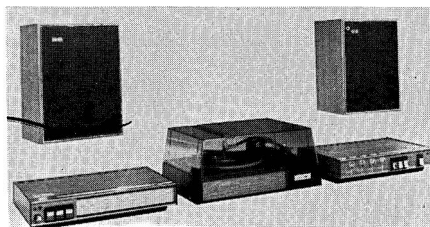

Ekco Network 800

cartridge. Four-track compact cassette tape deck. Speakers: 7 \times 5in full-range drivers. Finish: teak veneer with matt black control panel. Price: £152 (including PT).

ZU5F ★

FM stereo tuner/amplifier in plinth cabinet with record deck, plus two separate speakers. 30 transistors and seven diodes. Range: FM: 87.5-100MHz. Pushbutton tuning with AFC. Stereo decoder included. Output: 15W RMS per channel into 4 ohms. FR: 30Hz-25kHz ± 1.5 dB. HD: 0.2% at 17W output. Motor unit: Philips GC008. Cartridge: GP400 magnetic cartridge with diamond stylus. Speakers: 7in bass driver and 1in tweeter in each enclosure. Finish: teak veneer with silver-coloured trims. Price: (complete system) £155 (including PT).

ZU8

FM stereo tuner/amplifier with record deck in plinth cabinet plus two separate speaker systems. 49 silicon transistors. Variable and pushbutton tuning. AFC. Stereo decoder included. Output: 30W RMS per channel. Output impedance: 4 ohms. FR: 20Hz-30kHz ± 1.5 dB. Tone

controls: treble ± 14 dB at 10kHz, bass +14dB to -11dB at 100Hz. Record deck: Philips GC002 three-speed single-play deck with electronically controlled motor. Cartridge: Philips GP400 magnetic cartridge with diamond stylus. Speakers: 8in bass driver, 5in mid-range unit and 1in tweeter in each enclosure. Finish: teak veneer. Price: (complete system) £244-98 (including PT).

Network 800 ★

AM/FM stereo tuner, stereo amplifier, record deck in plinth and two separate speakers. Range: LW, MW and FM/VHF. Variable tuning. AFC. Stereo decoder included. Auto beacon. Tone controls: bass ± 13 dB at 65Hz, treble ± 10 dB at 10kHz. Output: 7W RMS per channel into 8 ohms. FR: 65Hz-20kHz ± 3 dB. HD: $< 2\%$ at 5-5W. Record deck: four-speed automatic or manual play. Speakers: infinite baffle enclosures with one 7in dual-cone unit in each. Price: (complete system) £103-15 (including PT).

■ FALCON

John Street (Manufacturers) Ltd,
Falcon Works, Barmeston Road, Catford,
London, SE6. Tel: 01-698 1177.

JS-TR8S

Stereo tuner/amplifier with record deck and two separate speaker enclosures. Range: FM, MW, SW and LW. Variable tuning. Sensitivity: FM better than 5 μ V. Controls: bass ± 12 dB at 40Hz, treble ± 10 dB at 15kHz, volume, tuning, balance, input selector, mains on/off. Output: 6W RMS per channel. FR: 30Hz-20kHz ± 3 dB. HD: $< 1\%$ at all outputs. BSR four-speed record deck. 15 transistors, five diodes. Speaker units: 6 $\frac{1}{2}$ in 8 ohms. PU input: 100mV. DIN input and output sockets. Provision for tape record and playback. Headphone socket. Price: £78-77 (including PT).

■ FERGUSON

British Radio Corporation Ltd,
284 Southbury Road, Enfield, Middlesex.
Tel: 01-366 1155.

342S

FM stereo tuner/amplifier in cabinet with record deck, separate speakers. Range: 88-108MHz. Five preset tuning buttons. AFC. Ratio detector. Stereo decoder fitted. Controls: mains on/off, volume, bass, treble, balance, tuning buttons. Output: 6W music per channel. Output impedance: 8 ohms. FR: 30Hz-20kHz ± 1 dB. HD: $< 1\%$. Motor unit: BSR P128. Cartridge: Goldring 850 magnetic with diamond stylus. Finish: teak. Speakers: two 6 $\frac{1}{2}$ in and one 3 $\frac{3}{4}$ in drivers in each enclosure. Price: (complete system) £117-51 (plus £18-84 PT).



Fidelity UA1

■ FIDELITY RADIO LTD

6 Olaf Street, London, W11. Tel: 01-727 0131.

Unit Audio One ★

Stereo tuner/amplifier and record deck with two matched speakers. 20 transistors, one integrated circuit, 7 diodes. Range: FM 87-5-108-2MHz. MW 185-555 metres, LW 1,200-2,000 metres. Variable tuning, separate scales and pointers for AM and FM. Multiplex decoder fitted. Stereo beacon. Switchable AFC. Controls: (pushbuttons) gram, LW, MW, FM, auxiliary, AFC; (rotary controls) bass +16dB -13dB at 70Hz, treble +12dB -14dB at 14kHz, volume +8dB at 100Hz at 30dB down from maximum volume. Output: 6W RMS per channel into 8 ohms. HD: $< 1.5\%$ at rated output. FR: 55Hz-23kHz ± 1.5 dB at 1W with tone controls flat. Motor unit: Garrard SP25 Mk III. Cartridge: Acos GP104 ceramic. Speakers: 10in bass driver and 4in treble unit in each enclosure. Finish: teak. Size: (tuner/amplifier and record deck) 7in high, 17in wide, 15 $\frac{1}{2}$ in deep; (speakers) 13 $\frac{1}{2}$ in wide, 18 $\frac{1}{2}$ in high, 7 $\frac{1}{2}$ in deep. Price: (complete system) £100 (including PT).

Unit Audio Three

AM/FM stereo tuner/amplifier and record deck in plinth with two separate speakers. Range: FM 87-5-108MHz, MW 186-555 metres, LW 1,200-2,000 metres. 11 transistors, three ICs, four diodes. Variable tuning. Switchable AFC. Stereo decoder included with beacon. Tone controls: bass +12-5dB -17dB at 100Hz, treble +13-5dB -13dB at 10kHz. Output: 4W RMS per channel into 8 ohms. FR: 40Hz-15kHz -3dB at 1W. HD: $< 1\%$ (typically 0-1%). Motor unit: BSR changer (four speeds). Crystal cartridge. Speakers: 8 \times 5in full range elliptical. Finish: teak. Price: (complete system) £63 (including PT).

■ J. J. FRANCIS (WOOD GREEN) LTD

123 Alexandra Road, Hornsey, London, N8.
Tel: 01-888 1662.



GEC 2805



GEC 2810

Countdown

Stereo tuner and stereo amplifier with gram unit and matching speakers. Range: 87-108MHz. Switched tuning. AFC. Multiplex decoder fitted. Controls: (tuner) on/off, mono/stereo, AFC on/off, preset tuning buttons; (amplifier) balance, volume on/off, bass, treble, mode, input selector buttons. Output: 10W RMS per channel. Output impedance: 4 ohms. Motor unit: Garrard SP25 MkIII. Pickup cartridge: Orbit NM22 with diamond styli. Speakers: two Francis Countdown enclosures. Size: (radio tuner) $2\frac{3}{4} \times 10 \times 8$ in; (amplifier) $2\frac{3}{4} \times 10 \times 8$ in; (record deck) $7 \times 12\frac{1}{2} \times 14$ in. Finish: (plinth and speakers) solid teak. Price: (complete system) £105.40 (inc. PT).

■ GEC (RADIO & TELEVISION) LTD

Langley Park, Slough, Bucks. Tel: 22201.

2805 ★

AM/FM stereo tuner/amplifier with record deck in cabinet plus separate speakers. Range: FM 87-108.5MHz, MW 186-572 metres, LW 1,090-1,950 metres, SW 18.2-52.2 metres. Variable tuning. Switched AFC. Stereo decoder optional extra. Controls: mains on-off/volume, treble, bass, tuning, balance. Pushbuttons for PU, LW, MW, SW, VHF, AFC. Output: 5W RMS per channel. FR: 30Hz-20kHz. Output impedance: 8 ohms. THD: 5% at rated output. Motor unit: BSR C141. Cartridge: Acos GP104. Size: (main unit) $15\frac{3}{4} \times 10\frac{3}{8} \times 16\frac{1}{8}$ in; (speakers) $15\frac{3}{4} \times 8 \times 7\frac{3}{8}$ in. Finish: teak veneer. Price: (complete system) £66.37 (plus £10.63 PT).

2810 ★

Four-band AM/FM stereo tuner/amplifier in plinth cabinet with record deck. Range: VHF, LW, MW, SW. AFC on FM. BSR C141 four-speed record deck. Sonotone 3549 cartridge. Diamond LP stylus. Finish: teak veneer, black control panel and bright trim. Output: 7W music power per channel. Speakers: infinite baffle enclosures with Goodmans 8×5 in full-range-units. Price: £79 (including PT).

2811

Four-band AM/FM stereo tuner/amplifier in plinth cabinet with record deck. Range: VHF, LW, MW, SW. AFC on FM. BSR C141 four-speed record deck. Sonotone 3549 cartridge. Diamond LP stylus. Slider controls for bass, treble, volume and balance. Finish: teak veneer with black control panel and bright trim. Output: 7W music power per channel. Stereo decoder included with auto switching. Infinite baffle enclosures with $6\frac{1}{2}$ in units. Price: £95 (including PT).

■ HACKER RADIO LTD

Norreys Drive, Cox Green, Maidenhead, Berks.
Tel: Maidenhead 22261/5.

GAR500 Centurian plus speakers

Tuner/amplifier in cabinet with record deck. FM/VHF radio covering 87.5-101MHz. Usable sensitivity: 2uV for 10dB signal-to-noise ratio, 5uV for full limiting. Station markers. AFC. Garrard SP25 MkIII fitted with Goldring G850 magnetic pickup and diamond stylus. Inputs: PU 3mV equalised, 30dB overload capability; radio 50mV 47K, infinite overload capability; aux/tape 50mV 47K, infinite overload capability. Output: 10W RMS per channel into 8 ohms, 7W RMS per channel into 15 ohms. Controls: bass+18dB-14dB at 40Hz, treble+18dB-20dB at 15kHz, low-pass filter-3dB at 7kHz, on/off, balance, volume, pushbutton selection for scratch filter, gram, aux/tape, radio and mono/stereo. HD: better than 0.4% at 8 ohms, better than 0.2% at 15 ohms. FR: 25Hz-30kHz ± 3 dB. Inbuilt rumble filter operates at below 25Hz. Hum and noise level better than 60dB down on all inputs. Outlet for tape recorder of 15mV at 25K. Headphone socket with automatic muting of speakers. Finish: teak. Hinged lid and brushed aluminium front panel. Mains: 200-245V 50Hz. Size: 18in wide, $8\frac{1}{2}$ in high, 16in deep. Suggested speakers: Hacker LS1000D. Two-way system with response 60Hz-17kHz. Size: $13\frac{1}{4} \times 20\frac{1}{4} \times 11\frac{1}{4}$ in. Price: (GAR500 plus two LS1000D speakers) £146.50; (with stereo radio decoder) £156.20.

GARI000A Tribune plus speakers

Stereo tuner/amplifier in cabinet with record unit. Lenco GL75 record deck with Goldring

SABA

the superb sound

SABA HiFi systems are in the international class. Unsurpassed technical excellence is matched by sophisticated elegance in design. Like the SABA Freiburg Telecommander—the world's outstanding cordless remote controlled HiFi stereo tuner/amplifier combination—the ultimate in listening pleasure, completely controlled from the listener's armchair. Just one model from the SABA range of hiFi stereo equipment, which includes tuners, amplifiers, tape recorders and speaker systems.

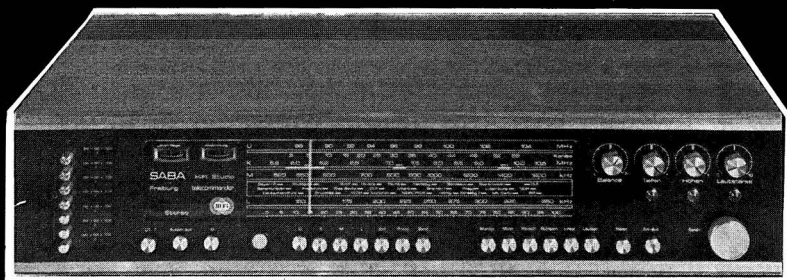

For fuller details and information on becoming an accredited SABA dealer, send in the coupon.

SABA
a new world of living sound
at your fingertips

To: J. W. Cowley, Managing Director, Lamphire Electronics Ltd.,
6-12 Cornbrook Park Road, Manchester M15 4EE
I am interested in selling SABA. Please tell me more

Name.....
Company.....
Address.....

QAS 1,000 NOT OUT!

Q.A.S. started manufacturing and distributing direct to the retail trade their own range only a year ago.

Already over 1,000 retailers throughout the U.K. are stocking Quality Audio Supplies high quality audio connectors and connecting leads. This is proof of the high level of demand by both retailers and their customers.

The wide range of items is all in neat green and black blister packs for easy identification, and to keep them free from dust and damage.

Recent additions to the range include the Q.A.S. Dusta-Disc automatic record cleaner, audio switching units, a headphone switch and small comparitors. More new products are on the way.

For further information to become a stockist, please write to:

Mr. Richard Thornley,
Sales Manager, QAS, Wollaton Road,
Beeston, Nottingham, NG9 2PB.

800H magnetic cartridge and diamond stylus. Separate AM and FM tuners. Range: MW 185-575 metres, LW 1,070-1,940 metres, FM/VHF 87.5-101MHz. Variable tuning with AFC. Quiet tuning control. Adjustable station markers. Centre-zero tuning meter. Usable sensitivity: AM (200 metres) $2\mu\text{V}$, AM (500 metres) $6\mu\text{V}$, FM better than $1\mu\text{V}$ for 10dB S/N ratio, $5\mu\text{V}$ for full limiting. Inputs: magnetic PU 3mV 47K, ceramic PU 5mV 500-800pF, radio 22mV 80K, aux 70mV 250K. Overload capability: 30dB all inputs. H and N: 50dB on magnetic PU, 60dB on all other inputs. Tone controls: bass $\pm 16\text{dB}$ at 50Hz, treble $\pm 16\text{dB}$ at 10kHz. Filters: low pass -3dB at 6kHz sloping down to -20dB at 10kHz, high pass -3dB at 50Hz sloping down to -26dB at 10Hz. HD: 0.06% at 15 ohms, 0.08% at 8 ohms, 0.15% at 4 ohms. Speaker damping factor at full power: (15 ohms) 200, (8 ohms) 120, (4 ohms) 70. FR: 20Hz-20kHz $\pm 2\text{dB}$. Mains: 200-245V 50Hz. Finish: teak veneer. Size: $31\frac{1}{2}$ in wide, $8\frac{1}{2}$ in high, $15\frac{1}{2}$ in deep. Suggested speakers: Hacker LS1500B. Three-way system with response 50Hz-20kHz. Size: $15\frac{1}{2} \times 30 \times 12$ in. Price: (GAR1000A plus two LS1500B speakers) £274; (with stereo radio decoder) £284; (with Goldring 800E cartridge and elliptical stylus, and stereo decoder) £291.

HEATHKIT

Manufactured by Heath (Gloucester) Ltd, Bristol Road, Gloucester. Tel: Gloucester 29451.

Heathkit Stereo Compact ★

AD27 tuner/amplifier and record deck, Ambassador speakers (2). Transistorised. Range: FM 88-108MHz. Variable tuning. AFC. Multiplex decoder fitted. Controls: tuning, selector, volume, balance, bass, treble, phase (stereo radio), on/off, speakers on/off, stereo/mono. Output: 10W RMS per channel. FR: 12Hz-60kHz $\pm 1\text{dB}$. Output impedance: 4-16 ohms. HD: $< 1\%$. Gram motor: BSR MA-70. Pickup cartridge: Shure M44-MB. Finish: teak or walnut. Size: $7\frac{7}{8} \times 21\frac{7}{8} \times 14\frac{1}{2}$ in. Price: (in kit form) AD-27 £85-11, two Ambassador speakers £35 each. Total: £155-11.

HIS MASTERS VOICE

British Radio Corporation Ltd, 284 Southbury Road, Enfield, Middlesex. Tel: 01-366 1155.

HMV 2450 ★

FM stereo tuner/amplifier with record deck and two separate speaker enclosures. Five preset FM stations with pushbutton selection. AFC. Stereo decoder fitted. Controls: mains on/off, bass, treble, balance, volume, pushbutton input selector, pushbutton station selector. Output: 15W RMS per channel. FR: 40Hz-16kHz $\pm 1\text{dB}$ (30Hz-20kHz $\pm 3\text{dB}$). Output impedance: 4 ohms. HD: $< 0.5\%$ at rated output. Motor unit:



Heathkit AD-27 Compact



HMV 2450

BSR P128. Cartridge: Goldring G800M magnetic. Size: (main unit) $21\frac{1}{4} \times 7\frac{1}{2} \times 15\frac{1}{4}$ in. Finish: teak veneers. Speaker enclosures: two 5in high-compliance bass drivers and one $3\frac{3}{8}$ in tweeter in each cabinet. Crossover: L/C network at 1.5kHz. Size: (speakers) $18\frac{1}{2} \times 9\frac{3}{4} \times 8$ in. Price: (complete system) £112-55 (plus £18-05 PT).

HMV 2451

AM/FM stereo tuner/amplifier in cabinet with record deck, separate speakers. Range: FM 88-108MHz, MW 195-550 metres, LW 1,200-2,000 metres. AFC. Variable tuning. Ratio detector. Stereo decoder fitted. Output: 10W RMS per channel. Output impedance: 8 ohms. FR: 30Hz-20kHz $\pm 1\text{dB}$. HD: $< 1\%$. Motor unit: Garrard 5-300. Cartridge: Goldring 850. Finish: teak. Speakers: 15 litre with $6\frac{1}{2}$ in bass driver and $3\frac{3}{8}$ in tweeter. Price: (complete system) £99-92 (plus £16-03 PT).

HMV 2455

AM/FM stereo tuner/amplifier in cabinet with record deck, separate speakers. Range: FM 88-108MHz, MW 200-550 metres. Variable tuning plus four presets. Stereo decoder fitted. Integrated quadrature FM decoder. Slider controls for volume, treble, bass, balance. Pushbuttons for AFC, shape, tape monitor, input selector, wavebands, mode. Output: 20W RMS per channel. Output impedance: 4 ohms.

★ Indicates entry is illustrated

FR: 40Hz-16kHz ± 1 dB. HD: $< 0.1\%$ at all powers up to 20W. Motor unit: BSR P128. Cartridge: Goldring 800 magnetic. Finish: teak. Speakers: two 5in and one 3 $\frac{3}{8}$ in drivers in each speaker enclosure. Price: (complete system) approximately £165 (including PT).

■ HITACHI

Hitachi Sales (UK) Ltd, Park House, Coronation Road, Park Royal, London, NW10 7QS. Tel: 01-965 9861.

DPK311

Four-waveband AM/FM stereo tuner/amplifier with record deck in shelf cabinet, plus two speaker systems. Range: FM 87.5-108MHz, LW 860-2,000 metres, MW 187-566 metres, SW 30-85 metres. Variable tuning. Output: 8W RMS per channel. FR: 20Hz-20kHz. 28 transistors, 23 diodes, one FET. Motor unit: Hitachi two-speed (33 $\frac{1}{3}$, 45 rpm). Cartridge: crystal XFS-182. Sapphire stylus. Stereo decoder fitted. Separate wide-range bass and treble controls. Mains: 220-240V AC 50Hz. Speakers: One 6in bass driver, one 2in tweeter in each enclosure. Size: (amplifier/deck unit) 16 $\frac{1}{2}$ \times 8 $\frac{3}{8}$ \times 16 $\frac{1}{8}$ in, (speaker enclosures) 9 $\frac{7}{8}$ \times 17 \times 7 $\frac{1}{2}$ in. Price: (complete system) £119.

■ ITT-KB

ITT Consumer Products (UK) Ltd, Foots Cray, Sidcup, Kent, DA14 5HT. Tel: 01-300 7733.

KA2010

AM/FM tuner/amplifier with record deck and choice of two speaker systems. Range: FM, LW, MW, SW. Slider type controls for bass, treble, volume and balance. Output: 10W per channel. Finish: teak with detachable hinged lid. Sockets for tape record and playback. Outputs for speaker (8 ohms) and stereo phones. BSR C116 four-speed changer. Ceramic cartridge with single-tip diamond stylus. Speakers: (KS653) 8 \times 5in driver in bass reflex enclosure. Teak finish with slatted front. Size: 15 $\frac{3}{4}$ \times 9 $\frac{7}{8}$ \times 6in; (KS651) 6 $\frac{1}{2}$ in upward-facing unit in omnidirectional cylindrical cabinet. Size: 13 $\frac{1}{2}$ in high, 10 $\frac{1}{2}$ in diameter. Price: (KA2010 with two KS653) £93.50; (KA2010 with two KS658) £101.50.

KA 2250 FM ★

FM stereo tuner/amplifier in cabinet with record deck, plus two separate speakers. Range: 87-104MHz. Five preset tuning buttons. Switchable AFC. Stereo decoder included. Controls: push-buttons for on/off, headphones, records, tape and radio inputs. Slider controls for bass, treble, balance, volume. Five tuning buttons. Output: 15W per channel into 4 ohms. HD: $< 0.5\%$ at 1kHz at rated output. FR: 40Hz-50kHz -3 dB. Output impedance: 4 ohms minimum. Motor

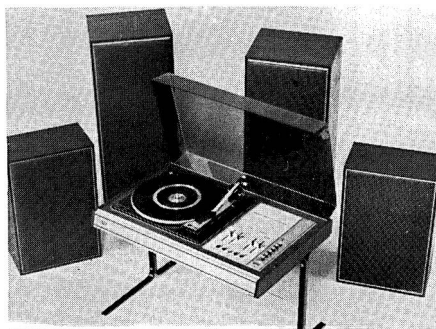

ITT-KB KA2250FM



Klinger KC94 Plus Two S50 Mk II

unit: BSR P128. Cartridge: SC5M with single diamond stylus. 27 transistors, 13 diodes, two ICs. Speakers: KS660 comprising 12in bass driver, 6 \times 4in mid-range unit and 3 $\frac{3}{8}$ in tweeter. Finish: teak veneer. Price: (KA2250 plus two KS660 speakers) £163.50 (including PT).

■ KLINGER

Klinger Controls Ltd, Spencer Court, 7 Chalcot Road, London, NW1 8LU. Tel: 01-586 2922/3.

KC94 plus two S50 Mk II speakers ★

FM stereo tuner/amplifier in cabinet with record deck plus two S50 Mk II speaker enclosures. Motor unit: Garrard SP25 Mk III. Four speeds. Idler wheel drive. Cartridge: Goldring G800H. Diamond stylus. Range: 87.5-108MHz. Five preset stations. Switchable AFC. Usable sensitivity: 2 μ V. Aerial input: coaxial and balanced. Outlet for tape: 100mV. Stereo decoder included. Inputs: tape 50mV 220K, aux (1) 100mV 470K, aux (2) 0.15mV 30 ohms. Noise level: 70dB. Overload capability: 30dB. Output: 25W RMS per channel. Output impedance: 8 ohms. Tone controls: bass ± 15 dB, treble ± 15 dB, scratch filter 18dB/octave from 8kHz, rumble 12dB/octave from 80Hz. Loudness control. A/B monitor switch. HD: 0.1% at 20W. FR: 25Hz-

35kHz \pm 2dB at 20W. Switching for two pairs of speakers. Two stereo headphone sockets. Stabilised power supply. Size: 21 \times 8 \times 15 $\frac{1}{2}$ in. Mains: 110-120V, 220-240V AC. Finish: teak cabinet with folding lid. Price: (KC94 unit, plus two S50 Mk II speakers) £152.10 (plus £24.70 PT).

■ MUSICRAFT

Musicraft Audio Products Ltd, 63 High Street, Hounslow, Middlesex. Tel: 01-570 4640.

Musicraft 10-10

Transistorised stereo tuner/amplifier with gram unit. Range: FM 88-108MHz. Variable tuning. AFC. No radio decoder. Controls: selector, treble, bass, volume on/off, balance. Output: 10W RMS per channel. FR: 30Hz-20kHz \pm 2 dB. Output impedance: 8-15 ohms. HD: 0.4% at rated output. Motor unit: Garrard SP25. Cartridge: Shure M3D. Size: 24 $\frac{3}{4}$ in high, 27in wide, 17 $\frac{3}{4}$ in deep. Speakers: 5in bass driver plus 3in tweeter with crossover in matching cabinets. Finish: teak veneer. Prices: (system less speakers) £90 (including PT); (two speaker enclosures) £40 pair (including PT); (system with speakers) £130.

■ NATIONAL PANASONIC

Distributors: Unamec Ltd, United Africa House, Blackfriars Road, London, SE19 5UG. Tel: 01-928 2070.

Panasonic SG-999A

Stereo tuner/amplifier with 'hide-away' record deck and twin speaker enclosures. Range: FM 87.5-108MHz, MW 187-571 metres. Stereo decoder fitted. 21 transistors, 15 diodes. Controls: treble, bass, volume, mains on/off, balance, FM radio selector, AFC switch, tuning. Visual indicators on bass, treble and volume controls. FET input stage. Output: 10W per channel. Speaker enclosures with two units in each. One 7in long-throw bass driver, one 2 $\frac{1}{2}$ in tweeter. Four-speed automatic changer with lightweight tubular arm. Stereo ceramic cartridge. Auxiliary inputs. Finish: oiled walnut or teak. Size: (main unit) 6 \times 18 \times 16in; (speaker boxes) 10 $\frac{1}{2}$ \times 14 \times 6in. Weight: (main unit) 30 $\frac{7}{8}$ lb; (speaker boxes) 5 $\frac{1}{2}$ lb each. Price: £119.62 (plus £20.93 PT).

SS-7020L

Stereo AM/FM tuner/amplifier in shelf cabinet, plinth-mounted record deck and two omnidirectional speakers. Range: FM 87.5-108MHz, MW 187-580 metres, LW 1,050-2,030 metres. Sensitivity: FM 4 μ V, MW, 300 μ V. S/N ratio: 55dB. Separation: 35dB. Output: 7W RMS per channel. FR: 20Hz-30kHz. Turntable: two-speed (33 $\frac{1}{3}$, 45rpm). 12in platter. Diamond stylus. Speakers: 6 $\frac{1}{2}$ in full-range units in omnidirectional enclosures. Impedance: 4 ohms. AC

Mains 110-240V. Price: (complete system) £147.35 (plus £25.79 PT).

SS-8010

AM/FM stereo tuner-amplifier in plinth cabinet with record deck, plus two separate speakers. Range: FM 87.5-108MHz, MW 187-570 metres. Sensitivity: FM 4 μ V, MW 10 μ V. Output: 5W per channel. S/N ratio: 60dB. Stereo separation: 35dB. Record deck: two speed (33 $\frac{1}{3}$, 45rpm). 9in platter. Speakers: 6 $\frac{3}{8}$ in full-range drivers. AC mains: 110-240V. Stereo decoder included. Finish: teak. Price: £65.96 (plus £11.54 PT).

SS8010 (white)

Same specification as the SS8010 but finished in white. Price: £67.77 (plus £11.86 PT).

RS-253S

AM/FM stereo tuner/amplifier in cabinet with cassette tape recorder, plus two separate speakers. AC mains. Output: 6W per channel. FR: 40Hz-10kHz. Range: FM, MW. AFC on FM. Stereo decoder included. 13 semi-conductors plus two ICs. Auto stop. Tape position indicator. Level meter. Size: 10 \times 17 $\frac{1}{2}$ \times 5 $\frac{3}{8}$ in. Weight: 13 $\frac{1}{4}$ lb. Finish: oiled walnut. Push-button selectors. FET front end. Roller tuning. Price: £98.76 (plus £17.28 PT).

■ NIVICO

Denham & Morley Ltd, Denmore House, 453 Chaldonian Road, London, N7. Tel: 01-607 6568. Telex: 24562.

MSL-201E

Stereo tuner/amplifier with record deck in cabinet with transparent lid plus two speakers. Range: FM 88-108MHz, MW 187-567 metres. Variable tuning. Stereo decoder fitted. Output: 5W per channel (music power). Two-speed motor. Lightweight PU arm with high-compliance ceramic cartridge and diamond stylus. Speakers: 6 $\frac{1}{2}$ in full-range drivers. Impedance: 8 ohms. Size: (main unit) 19 \times 6 $\frac{3}{4}$ \times 14 $\frac{1}{2}$ in; (speakers) 15 $\frac{3}{4}$ \times 10 \times 7 $\frac{1}{4}$ in. Price: £95.99 (including PT).

MSL-501E

Stereo tuner/amplifier with record deck in cabinet with transparent lid plus two speaker enclosures. Amplifier incorporates sound effect preamplifier. Range: FM 88-108MHz, MW 187-567 metres. Variable tuning. Stereo decoder fitted. Sound effect amplifier controls: 60Hz, 250Hz, 5kHz, 15kHz centre frequencies adjustable \pm 10dB. Output: 17W per channel (music power). Output impedance: 8 ohms. Two-speed turntable (33 $\frac{1}{3}$, 45rpm). Tubular arm with high-compliance ceramic cartridge and diamond stylus. Speaker enclosures with 6 $\frac{1}{2}$ in bass drivers and 2in tweeters. Size: (main unit) 19 $\frac{3}{4}$ \times 6 $\frac{3}{4}$ \times 14 $\frac{1}{2}$ in; (speakers) 14 \times 11 $\frac{1}{2}$ \times 7 $\frac{1}{2}$ in. Price: £139.50.

★ Indicates entry is illustrated

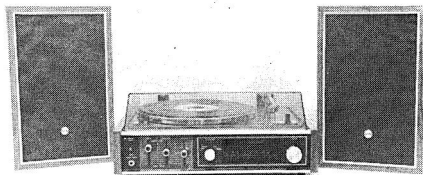

Onkyo SM-10



Onkyo Dynamic Four 800

4344U

AM/FM stereo tuner/amplifier with record deck, tape cassette recorder and two matching speakers. Range: FM 88-108MHz, MW 187-567 metres. Variable tuning. Stereo decoder. Output: 22.5W music power per channel. Output impedance: 8 ohms. Aerial input: 75 ohms coaxial. Switchable AFC. $\frac{1}{4}$ -track cassette recorder. Speed: $1\frac{2}{3}$ i/s. DC motor. Four-speed automatic record deck. Ceramic cartridge with diamond stylus. Speakers: $6\frac{1}{2}$ in bass driver and 2in tweeter in each enclosure. FET front-end. 34 transistors and 23 diodes. Size: (main unit) $21\frac{1}{8} \times 7\frac{7}{8} \times 16$ in; (speakers) $16 \times 9\frac{1}{4} \times 7\frac{1}{2}$ in. Price: £218-70.

STF-600E

Eight-track stereo cartridge player in cabinet with AM/FM tuner/amplifier, plus two separate speakers. 17 transistors and 19 diodes. Range: FM 88-108MHz, MW 188-555 metres. Output: 6W RMS. Tape speed: $3\frac{2}{3}$ i/s. Mains: 110, 220V AC. Size: $18\frac{3}{8} \times 5\frac{5}{8} \times 9\frac{3}{8}$ in. Speaker units: $6\frac{1}{2}$ in full range drivers (8 ohms). Price: £108-86.

■ NORDMENDE

Distributors: TAK Continental Importers, 16a High Street, Stone, Staffordshire. Tel: Stone 3232, 3233.

Nordmende system

Comprises 7504ST tuner/amplifier and PE 7500

record deck (all to DIN 45 500 specification), plus two LB66 speakers. Four-speed motor unit fitted with Shure cartridge. Four-waveband radio AM/FM. Six preset stations on FM. Output: 30W per channel. Price: (7405ST tuner/amplifier) £220 (including PT); (PE record unit) £99 (including PT); (LB66 speakers) £69 each; (remote control unit) £22.

Centrum 427

Comprises tuner/amplifier with preset FM programmes. Built-in Dual 1214 record deck with AT66 cartridge. Output: 15W per channel. Conforms to DIN 45 500 specification. Complete with two 1309 speaker enclosures. Price: (complete system) £179 (including PT).

■ ONKYO

J. Parkar & Company (London) Ltd, Parkar House, 1 Paul Street, London, EC2. Tel: 01-628 4577.

SM-10 ★

Stereo tuner/amplifier in cabinet with record deck, plus matching speaker enclosures. 23-transistor circuit. Range: FM 88-108MHz, MW 187-562 metres. Variable tuning. AFC. Stereo decoder and beacon fitted. Controls: (slider type) balance, volume and treble/bass; (rotary type) tuning, input selector. Output: 6W RMS per channel. Output impedance: 8 ohms. Own two-speed record deck with lightweight tubular arm and high-compliance ceramic pickup. Automatic return of pickup arm and switch-off. Reflex speaker enclosures with 8in full-range units. Finish: matt wood grain cabinets with black control panel and brushed aluminium trim. Size: (tuner/amplifier/player unit) $18\frac{1}{8} \times 7\frac{7}{8} \times 15\frac{1}{2}$ in; (speaker enclosures) $15\frac{3}{4} \times 9\frac{3}{8} \times 7$ in. Price: (complete system) £120-25 (including PT).

Dynamic Four 700

Separate stereo tuner/amplifier, record unit and two speaker enclosures. 23-transistor circuit. Range: FM 88-108MHz, MW 187-562 metres. Variable tuning with AFC. Stereo decoder and stereo beacon. Controls: volume, bass, treble, balance, input selector, mono/stereo, loudness, mains on/off. Output: 14W RMS per channel. Output impedance: 8 ohms. Own two-speed deck with lightweight tubular arm and high compliance ceramic cartridge. Pickup arm automatically returned at end of record. Speaker enclosures with $6\frac{1}{2}$ in bass driver and 5in mid-range and HF unit in each. Sizes: (tuner/amplifier) $16\frac{1}{2} \times 4\frac{1}{2} \times 12\frac{1}{8}$ in; (record deck) $16\frac{1}{2} \times 6\frac{1}{4} \times 12\frac{1}{8}$ in. Price: (complete system) £129-11 (including PT).

Multiac 50D

Separate stereo tuner/amplifier, record unit and two speaker enclosures. 48-transistor circuit.

Somebody's got to be first

Sony first with...

1957

First pocket-size transistor radio.
First two band transistor.

1958

First transistor FM radio.

1959

Esaki tunnel diode.
First all-transistor TV.

1960

Transistor video-tape recorder.

1963

Chromatron colour TV.
Pocket-size FM radio.

1964

Home use video-tape recorder.
Line-sequential colour tape-recording system.

1965

Transistor microphones.

1966

Home use colour video-tape recorder.
Integrated circuits-radio.

1968

The SONY MAGNETODIODE (SMD).
New colour TV picture tube (TRINITRON).

1969

SONY Colour VIDEOCASSETTE System.

1970

SONY Matrix Sound Stereo—
single enclosure stereo system.

SONY®

Sony first in

Hi-fi, Tape Recorders, Trinitron Colour TV, Portable TV, Cassette Radio,
Audio Systems, Digital Clock Radio, Global Radio, Car Radio.

YAMAHA

NS
NATURAL SOUND

AMPLIFIERS

The Performance Power Series

CR-500 Tuner Amplifier

Direct coupled Fet-Type differential Amp. 22/22W RMS. Harmonic distortion 0.05%. AM/FM stereo. FM sensitivity $2.0\mu\text{V}$. FM. S/N Ratio 70 dB. Ceramic filters, Mic-Input Dubbing. Loudness control.



CA-700 Amplifier

Direct coupled Fet-Type differential Amp. with dual output stage. 60/60W RMS, 0.05% Harmonic distortion. Pre-Out/Main-In, High/Low filter, dual tape facility, 4 Spkr. switching, Microphone Inputs with independent volume control.

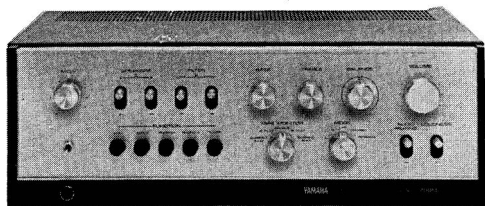

CA-500 Amplifier

22/22W RMS, Dual Phono Inputs, dual Aux Input, 4-Speaker switchable. High/Low filters, top performance from directly coupled output stages.

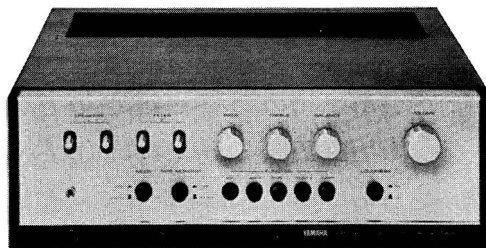

NATURAL SOUND SPEAKERS

NS-250 Speakers

Unique natural sound Speaker units for the best results from your Yamaha music Centre or component system.

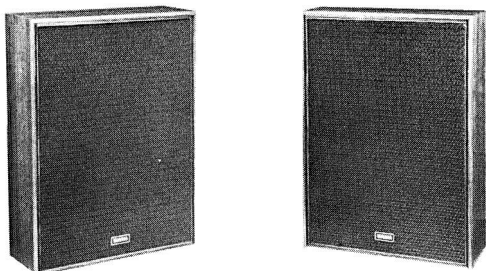

SEE THE WHOLE YAMAHA

SYSTEMS



MUSIC CENTRES

MS-5B Music Centre

A Beautiful balance of styling and technology. 22/22W RMS OCL Power Amplifiers. 2 speed belt drive turntable, ultra-sensitive AM/FM stereo tuner section, top quality cassette deck with mixing facilities.



MC-40 Music Centre

2 speed belt drive turntable, 15/15W RMS stereo amp. AM/FM stereo tuner, head-phone socket, loudness control, built-in AFC. The Economy approach to top performance.



YP-700 Turntable

2 speed belt drive unit, professional S-Type tonearm, synchronous outer-rotor motor, Wow and Flutter: less than 0.05%, S/N ratio: 50dB, fitted with Yamaha CG7000 cartridge.



YAMAHA

NIPPON GAKKI CO. LTD., HAMAMATSU
JAPAN

Fallowfields Sole UK
Distributors

Stathcona Road, North Wembley,
Middlesex HA9 8QL

RANGE

AT YOUR LOCAL
STOCKIST

Range: FM 88-108MHz, MW 187-562 metres. Variable tuning with AFC. Stereo decoder and beacon fitted. Controls: bass, treble, volume, balance, mono/stereo, input selector, loudness, speaker switching, muting, AFC switch, high filter, tape monitor control, automatic gain presets. Output: (four channels) 9W RMS per channel. Four amplifiers; two bass and two HF. FR: 40Hz-20kHz. Distortion: <0.1% at rated output. Own two-speed belt drive motor unit. 12in aluminium turntable. Lightweight balanced tubular arm. Induced magnet cartridge. Bias compensator. Reflex type enclosures with 12in bass driver, 4 $\frac{3}{4}$ in mid-range unit, horn tweeter in each. Crossover: 500Hz, 9kHz. Impedance: 8 ohms. Finish: matt wood grain with black and brushed aluminium trim. Size: (tuner/amplifier) 17 $\frac{3}{4}$ × 5 $\frac{1}{2}$ × 11 $\frac{3}{4}$ in; (record deck) 17 $\frac{3}{4}$ × 7 $\frac{1}{2}$ × 14 $\frac{1}{4}$ in; (speaker enclosures) 15 $\frac{1}{4}$ × 24 $\frac{3}{4}$ × 11 $\frac{3}{4}$ in. Price: £274.61 (including PT).

Dynamic Four 800 ★

AM/FM stereo tuner/amplifier with separate record deck and speakers. 27 transistors and 21 diodes. Range: FM 88-108MHz, MW 187-565 metres. Variable tuning. Stereo decoder with auto switching. Stereo beacon. Tuning meter. Switchable AFC. Controls: bass, treble, loudness, balance, high filter, mode, tuning. Output: 25W per channel. Two-speed motor unit with auto-stop and auto return of arm. 12in belt-driven platter. Balanced tubular arm with moving magnet cartridge. Diamond stylus. Pw: 3gm. Two-way reflex speaker enclosures, each containing 8in bass driver and 5in mid/HF unit. Finish: teak veneer with brushed aluminium fascia and tinted plastic dust cover. Price: (complete system) £190.45.

SM-710

AM/FM stereo tuner/amplifier in cabinet with record deck plus two separate speakers. 23 transistors, 22 diodes. Range: FM 88-108MHz, MW 187-565 metres. Variable tuning. Sensitivity: FM 3 μ V, MW 15 μ V. Stereo decoder fitted with auto switching. Stereo beacon. Tuning meter. Controls: bass, treble, loudness, balance, mode, tuning. Output: 14W per channel. Output impedance: 8 ohms. Outlets for headphones and tape. Inputs for tape, mic and line. Four-speed auto/manual record deck. 11in platter. Ceramic cartridge. Stylus pressure adjustment. Bias compensation. Two-way reflex speaker system incorporating 6 $\frac{1}{2}$ in bass driver and 5in mid/HF unit. Price: (complete system) £149.60.

SM-100

AM/FM stereo tuner/amplifier in cabinet with record deck plus two separate speakers. 25 transistors, 19 diodes. Range: FM 88-108MHz,

MW 187-565 metres. Variable tuning. Stereo decoder with beacon. Tuning meter. Controls: flywheel tuning, bass, treble, balance, volume, input selector, mains on/off. Output: 14W per channel. Sensitivity: FM 3 μ V, MW 15 μ V. Two-speed motor unit with auto cut-off and auto arm return. 12in platter. Balanced tubular arm with high compliance cartridge. Microphone input. Speaker system comprising 8in bass driver and 3in tweeter in bass reflex cabinet. Mains: 100, 110, 220, 240V 50/60Hz. Price: (complete system) £141.31.

For Onkyo four-channel audio systems see Quadraphonic Equipment Section.

PHILCO

Philco International Ltd,
42 Leicester Square, London, WC2H 7LR.
Tel: 01-930 7667.

M4710

AM/FM tuner/amplifier in cabinet with record deck. Separate speaker enclosures. Switchable AFC. Stereo decoder fitted. Output: 3W RMS per channel. Sockets for stereo headphones and tape recorder. Inputs for aerials. Four-speed BSR autochanger. Clear plastic cover to record deck. Size: (main unit) 18 $\frac{3}{4}$ × 12 × 8 $\frac{3}{4}$ in including cover; (speaker enclosures) 10 $\frac{1}{2}$ × 5 $\frac{1}{4}$ × 8 $\frac{3}{4}$ in. Speaker drive units: 6in long throw air-suspension units. Price: £80.74 (including PT).

PHILIPS ELECTRICAL LTD

Century House, Shaftesbury Avenue,
London, WC2.
Tel: 01-437 7777.

RF836

AM/FM stereo-tuner amplifier in cabinet with record deck plus two speakers. 18 transistor plus six diodes. Range: FM 87.5-104MHz, MW 187-560 metres, LW 1,180-2,090 metres. Variable tuning. Switchable AFC. Ratio detector. Stereo decoder optional extra. Tone controls: bass \pm 8dB at 100Hz, treble \pm 8dB at 10kHz. Output: 8W RMS per channel. Output impedance: 8 ohms. FR: 40Hz-20kHz -3dB. HD: 1% at 8W. Motor unit: Philips GC047. Cartridge: Philips GP204. Finish: afrormosia veneer. Speakers: supplied. Price: £95 (including PT).

RH 811 ★

AM/FM stereo tuner/amplifier in cabinet with cassette recorder plus two separate speakers. 43 transistors, 18 diodes. Range: FM 87.5-104MHz, MW 214-577 metres, MW bandspread 187-214 metres, LW 870-2,000 metres. AFC. Variable tuning. Ratio detector. Stereo decoder fitted. Tone controls: bass \pm 9dB at 100Hz, treble \pm 8dB at 10kHz. Output: 8W RMS per channel. Output impedance: 4 ohms.

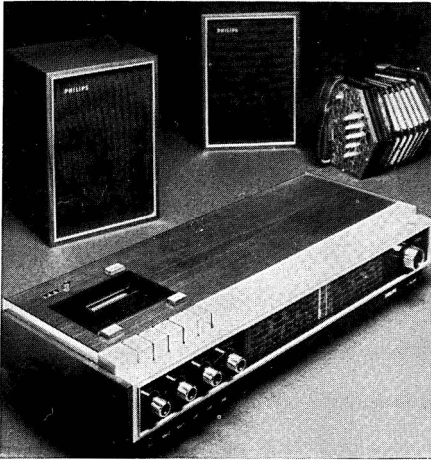

Philips RH811 plus RH411 Speakers



Pye I550

FR: 45Hz-20kHz ± 3 dB. HD: $< 2\%$ at 4.5W per channel. Built-in compact cassette tape unit. Fitted dynamic noise limiter circuit. Finish: simulated walnut veneer. Speakers: Philips RH411. Price: (complete with two RH411 speakers) £117 (including PT).

RH814

AM/FM stereo tuner/amplifier in cabinet with record deck plus two separate speakers. 25 transistors, 13 diodes. Range: FM 87.5-104 MHz, MW 214-577 metres, MW bandspread 187-214 metres, LW 870-2,000 metres. AFC. Variable tuning. Ratio detector. Stereo decoder fitted. Tone controls: bass ± 9 dB at 100Hz, treble ± 8 dB at 10kHz. Output: 8W RMS per channel. Output impedance: 4 ohms. FR: 45Hz-20kHz ± 3 dB. HD: $< 2\%$ at 4.5W per channel. Motor unit: Philips GC060. Pickup cartridge: Philips GP200. Finish: simulated walnut veneer. Speakers: Philips RH411. Price: (including two RH411 speakers) £129 (including PT).

RH813

AM/FM stereo tuner/amplifier in cabinet with record deck and compact cassette tape unit plus two separate speakers. Range: FM 87.5-104 MHz, MW 214-577 metres, MW bandspread 187-214 metres, LW 870-2,000 metres, SW 30.7-50.4 metres. Variable tuning. AFC. Ratio detector. Stereo decoder fitted. 51 transistors, 30 diodes. Tone controls: bass ± 9 dB at 100Hz, treble ± 8 dB at 10kHz. Output: 8W RMS per channel. Output impedance: 4 ohms. FR: 45Hz-20kHz ± 3 dB. HD: $< 2\%$ at 4.5W per channel. Motor unit: Philips GC005. Pickup cartridge: Philips GP200. Fitted with dynamic noise limiter circuit. Speakers: Philips RH411. Compact cassette tape unit. Finish: simulated walnut cabinet. Price: (including two RH411 speakers) to be announced.

PIIONEER

Shriro (UK) Ltd, 42 Russell Square, London, WC1B 5DF. Tel: 01-580 6996.

C5600D

AM/FM stereo tuner/amplifier in plinth with record deck, plus two separate speakers. Range: FM 87.5-108MHz, MW 187-562 metres. Sensitivity: FM 2.5 μ V, MW 10 μ V. Stereo decoder fitted. Channel separation: 35dB at 1kHz. Variable tuning. Two speed motor unit. Speeds: 33 $\frac{1}{3}$, 45rpm. Turntable: 12in aluminium. Wow: 0.1%. Cartridge: PC35 induced magnet. Stylus: PN35 0.5 thou diamond. Output: 30W per channel. HD: less than 1%. Infinite baffle enclosures. One 8in bass driver and one 2 $\frac{1}{2}$ in tweeter in each. Mains: 110, 120, 130, 220, 240V AC. Price: £317.70 (plus £45.87 PT).

PYE LTD

PO Box 49, St Andrews Road, Cambridge. Tel: Cambridge 58985.

1550 ★

Console audio system. Radio coverage: VHF 87.5-104MHz, MW 185-215 and 220-580 metres. LW 800-2,000 metres, SW 31-50 metres. Variable tuning. AFC. Stereo decoder fitted. Controls: pushbuttons for waveband and function selection; rotary treble, bass, volume and balance; three preset programmes. Output: 6.5 RMS per channel. FR: 50Hz-20kHz. Output impedance: 4 ohms. Distortion: $< 2\%$ at 1kHz at 4.5W. Motor unit: BSR P128. Cartridge: SC5M. Size: (excluding speakers) 20 $\frac{1}{2}$ in wide, 29 $\frac{3}{8}$ in high, 14in deep. Speakers: LSE.10/4 enclosures, each having 8in driver and 3in tweeter. Built-in crossover. Finish: teak. Price: £140.72 (including PT).

RADON

Radon Industrial Electronics Co Ltd, Brooklands Trading Estate, Orme Road, Worthing, Sussex. Tel: Worthing 34904.

★ Indicates entry is illustrated

Arundel AP200 ★

Transistorised stereo tuner/amplifier and gram unit in compact table style cabinet. Range: 87-106MHz. Variable tuning. AFC. Stereo decoder fitted. Controls: input selector, AFC on/off, volume, balance, bass, treble, scratch filter, rumble filter, tuning, mains on/off. Output: 10W RMS per channel. FR: 35Hz-18kHz. Output impedance: 8-15 ohms. HD: 0.1% at rated output. Motor unit: Garrard SP25 Mk II or Garrard SL65B. Pickup cartridge: Goldring G800H. Size: 8½ × 22 × 16in. Finish: teak with transparent cover, teak surround.

Complete systems available with Radon Pearl, Emerald, Opal or Topaz speakers. Prices from approximately £160 to £250 for complete system.

Arundel prices (less speakers): Standard model with SP25 deck (AP200/A) £71.39 including PT; De luxe model with tuner and SP25 deck (AP200/B) £92.25 including PT; Super model with SL65B deck (AP200/C) £76.59 including PT; Super de luxe model with tuner and SL65B deck (AP200/D) £97.47 including PT.

AP200 stand

Wooden stand to suit all Arundel models. Price: £6.

■ SANYO

Sanyo Marubeni (UK) Ltd, Sanyo House, Bushey Mill Lane, Watford, Herts. Tel: Watford 30421.

DS93E

AM/FM tuner/amplifier with record unit in walnut veneered cabinet. Range: FM/VHF and medium wavebands. Motor unit: 33½ and 45 rpm. Semi-automatic operation, tone arm returns at end of record. Stereo decoder fitted. Output: 15W music power per channel. Sockets for tape recorder and stereo headphones. Output for two sets of stereo speakers. Price: to be announced.

G2601K

AM/FM tuner/amplifier with three-speed record deck and cassette recorder in one cabinet plus two separate speaker enclosures. Range: FM, MW, SW. Motor unit: Sanyo. Speeds: 33½, 45, 78rpm. 10in platter. Ceramic cartridge. Push-button controls. Mains: 240V AC. Price: £164 (including PT).

■ SERVO-SOUND

Sonosound Ltd, 5 Queen Street, London, EC4N 1SU. Tel: 01-248 9461.

Servo-Sound system

Comprises separate FM tuner, record deck in cabinet with preamplifier and two speaker systems incorporating power amplifiers. 26

transistors and 14 diodes. Range: 88-108MHz. Variable tuning. Switchable AFC. Squelch discriminator. Meter tuning indicator. Stereo decoder fitted. Controls: mains on/off, filter, mono/stereo, tape, aux, PU, bass, treble, balance, volume, tuning, headphones. Output: 15W RMS per channel. FR: 35Hz-20kHz. HD: 1.5% at 1kHz. Motor unit: Lenco L75. Cartridge: Stanton 500A. Speakers: one 9½ × 6½in unit with 15W amplifier in each infinite baffle en-



Radon AP 200 Arundel

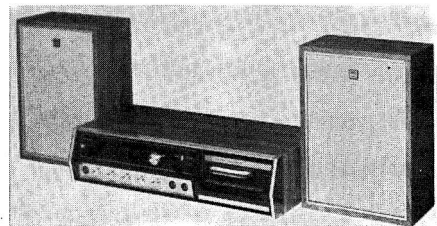

Sharp SCI03/CP108M



Sharp SD305H



Sony HPS11

closure. Price: (SR3 FM tuner, SC75BTE pre-amplifier and record deck, two SL20 speaker/amplifier units) £312.50.

■ SKANDIA ELECTRONICS

Distributor: Golding Audio Ltd, London Road, Marks Tey, Colchester, Essex.
Tel: Marks Tey (0206 21) 433.

SK120

System comprises tuner/amplifier incorporating stereo eight-track cartridge tape recorder. Range: FM 88-108MHz, MW 187-567 metres. Variable tuning. AFC. Stereo decoder fitted. Controls: volume, tuning, record level (right channel), record level (left channel), balance, AM/FM radio, low filter, high filter, treble, input selector, mono/stereo. Output: 45W RMS per channel. FR: 20Hz-20kHz. Output impedance: 8 ohms. HD: <3%. Size: 29½ × 6½ × 13½ in. Recommended speakers: Golding X100. Finish: walnut. Price: (main unit less speakers) £176 (plus £32.17 PT).

SK308

System comprises tuner/amplifier incorporating stereoeight-trackcartridge taperecorder. Range: FM 88-108MHz, MW 187-567 metres. Variable tuning. AFC. Stereo decoder fitted. Controls: volume on/off, record level (right, channel), record level (left channel), balance, treble, bass, selector 1, selector 2, record on, play tape, stop tape. Output: 10W RMS per channel. FR: 30Hz-35kHz. Output impedance: 8 ohms. HD: <3%. Matching three-unit speakers. Finish: walnut. Price: (complete system) £150 (plus £27.42 PT).

■ SHARP

Sharp Electronics (UK) Ltd, 48 Derby Street, Manchester M88HN. Tel: 061-832 6115.

SR102E

Tuner/amplifier with eight-track tape player and two separate speakers. 26 transistors and 15 diodes. Range: FM 88-108MHz, MW 189-560 metres. Variable tuning. AFC. Ratio detector. Stereo decoder fitted. Controls: tuning, mains on/off, volume, balance, bass, treble, function switch, tape programme selector. Output: 1.5W RMS per channel. Output impedance: 8 ohms. FR: 20Hz-30kHz. HD: 1.5%. Sharp tape transport. Finish: wood veneered cabinet with dark matt metal fascia. Speakers in separate enclosures supplied. Price: £79.63 (plus £12.77 PT).

SC103 (CP108H) ★

Tuner/amplifier with built-in cassette recorder and two separate speakers. 31 transistors (including one FET), 14 diodes, one IC. Range: FM 88-108MHz, MW 189-560 metres. Variable tuning. AFC. Ratio detector. Stereo decoder fitted. Controls: tuning, mains on/off, function

selector, bass, treble, monitor volume control (record), left-channel volume, right-channel volume, pause button, fast forward, tape play, rewind, record interlock, reject cassette. Output: 3W RMS per channel. Output impedance: 8 ohms. FR: 40Hz-22kHz. Sharp tape deck. Finish: wood veneered cabinet with dark matt metal fascia. Speakers in separate enclosures supplied. Price: £99.79 (plus £16.01 PT).

SD305H ★

Tuner/amplifier with built-in record deck and separate speakers. Range: FM 88-108MHz, MW 189-560 metres, LW 900-2,000 metres, SW 16.5-50 metres. Variable tuning plus preset programmes on FM. AFC. Ratio detector. Stereo decoder fitted. Controls: volume, balance, bass, treble, tuning, mains on/off, function selector, mode. Output impedance: 8 ohms. Sharp motor unit. Magnetic cartridge. Finish: PVC film on wood with aluminium front panel. Separate speakers supplied. Price: £150.81 (plus £24.19 PT).

■ SONY (UK) LTD

Pyrene House, Sunbury Cross, Sunbury-on-Thames, Middlesex.
Tel: Sunbury 87644/7.

HP511 ★

AM/FM stereo tuner/amplifier with record deck and separate speakers. Range: FM/VHF, MW. Variable tuning. Stereo decoder fitted. Output: 15W RMS per channel. Output impedance: 8 ohms. FR: 40Hz-50kHz ±3dB. Record deck: Sony TTS400. Cartridge: VM22GA induced magnet. Finish: wood grain and silver trim. Price: £145.41 (plus £24.49 PT).

CF610

AM/FM stereo tuner/amplifier with cassette tape deck and separate speakers. Range: FM 87.5-108MHz, MW 187-566 metres. 43 transistors, 29 diodes. Variable tuning. AFC. Ratio detector. Stereo decoder fitted. Output: 6W RMS per channel. Output impedance: 8 ohms. FR: (tape) 30Hz-13kHz. HD: 2.5%. Sony cassette tape deck. Black leatherette finish. Price: £120.42 (plus £20.28 PT).

CF620

AM/FM stereo tuner/amplifier with cassette tape deck and separate speakers. 43 transistors, 29 diodes. Range: FM 87.5-108MHz, MW 187-566 metres. Variable tuning. AFC. Ratio detector. Stereo decoder fitted. Output: 6W RMS per channel. Output impedance: 8 ohms. FR: (tape) 30Hz-13kHz. HD: 2.5%. Sony cassette tape deck. Finish: wood grain. Price: £128.76 (plus £21.69 PT).

HP239

AM/FM stereo tuner/amplifier with cassette tape deck and record unit, plus separate speakers.

★ Indicates entry is illustrated

Range: FM 87.5-108MHz, MW. Variable tuning. Ratio detector. Output: 10W RMS per channel. Output impedance: 8 ohms. FR: 40Hz-40kHz \pm 3dB. Sony cassette tape deck. Sony TTS310 record deck. Sony VM10P induced magnet cartridge. Finish: wood grain with black and silver trim. Price: £157.86 (plus £26.59 PT).

HP211

AM/FM stereo tuner/amplifier with record deck and separate speakers. 28 transistors and 18 diodes. Range: FM/VHF, MW. Variable tuning. Stereo decoder fitted. Output: 10W RMS. Output impedance: 8 ohms. FR: 40Hz-40kHz \pm 3dB. Record unit: Sony TTS310. Cartridge: Sony VX23P ceramic. Finish: wood grain and black and gold panel. Price: £112.22 (plus £18.88 PT).

STEEPLETONE

Steeple Supplies (Electronics) Ltd.,
Cinema House, Middle Barton,
Oxford OX54DA. Tel: Steeple Aston 7116.

300

Complete system comprising AM/FM stereo tuner/amplifier with record deck in cabinet plus two separate speaker enclosures. Motor unit: Garrard 2025TC. Four-speed. 10½ in pressed steel turntable. Idler wheel drive. Tubular aluminium arm with cue and pause lever. Cartridge: Garrard KS40A, with sapphire stylus. Range: FM 88-104MHz, MW 187-560 metres, LW 1,200-2,000 metres. Variable tuning. Switchable AFC. Aerial input: 75 ohms coaxial. Stereo decoder optional extra. Mains: 225-240V AC. 16 transistors. Input: tape 100mV. Output: 4W RMS per channel. Controls: volume, bass, treble, balance, tuning, AFC on/off, push-buttons for band selection and function. Output impedance: 12 ohms. Speaker enclosures each contain one 8×5in bass driver and two 2½ in tweeters. Finish: afrormosia veneer. Size: (main unit) 16⅜×8⅞×14⅞in; (speakers) 7⅞×6¼×8⅞in. Price: £66.15 (plus £11.14 PT).

STEREOSOUND PRODUCTIONS LTD

Capital Works, Wakefield Road,
Brighouse, Yorks. Tel: Brighouse 4355.

Stereosound Star

AM/FM tuner/amplifier with record deck and speakers. Range: FM 87-104MHz, MW 185-555 metres, LW 1,110-1,940 metres. AFC. Ratio detector. Controls: tuning, treble, bass, volume, balance. Pushbuttons for: gram, LW, MW, FM. Output: 3W RMS per channel. Output impedance: 15 ohms. FR: 60Hz-17kHz. motor unit: BSR C129. Cartridge: Sonotone 2509. Finish: teak veneer. Complete with two separate speaker enclosures. Price: £60.27 (plus £9.68).

TELENG LTD

Arisdale Avenue, South Ockenden,
Essex, RM155TR. Tel: South Ockenden 3477.

Studio 353

AM/FM stereo tuner/amplifier in cabinet with record deck, plus two matching speaker enclosures. Motor unit: BSR Professional Series four-speed manual player. Record storage space. Tinted plastic dust cover. Front-facing black and silver control panel and dial. Finish: afrormosia. Matching stand available as optional extra. Speakers: one 8in bass driver plus 3in HF unit in each enclosure. Price: (complete system) approximately £123.67 (including PT).

System 343

Comprises AM/FM stereo tuner/amplifier, four-speed record deck in separate plinth with tinted plastic dust cover and two matching speaker enclosures with 8×5in full-range units. Finish: afrormosia veneer, black leathercloth and silver trim. Price: (complete system) approximately £87.56 (including PT).

TELLUX

Tellux (Sound Productions) Ltd, Tallon Road,
Hutton Industrial Estate, Brentwood, Essex.
Tel: Brentwood 214708/9.

Audic 20

AM/FM stereo tuner/amplifier in shelf-mounting cabinet with record deck, plus two floor-standing speakers. Variable tuning. Plug-in stereo decoder. Output: 8W per channel. Output for tape recorder. Price: to be announced.

TOSHIBA

Hanimex (UK) Ltd, 15-24 Great Dover Street,
London, SE1. Tel: 01-407 8161.

SM290

AM/FM stereo tuner/amplifier in cabinet with record deck. 25 transistors, 17 diodes. Range: FM 88-108MHz, MW 187-562 metres. Variable tuning. AFC. Multiplex decoder fitted. Output: 10W RMS per channel. Output impedance: 8 ohms. FR: 45Hz-20kHz. Toshiba record deck. 16-pole synchronous motor. Cartridge: C22C stereo ceramic. Finish: wood veneer. Price: (complete with two speaker systems) £118.12 (plus £24.13 PT).

SM130

AM/FM tuner-amplifier in cabinet with record deck. 17 transistors, 9 diodes. Range: 88-108 MHz, MW 187-562 metres. Variable tuning. AFC. Output: 3.5W RMS per channel. FR: 100Hz-10kHz. Toshiba record deck. Cartridge: C18C stereo ceramic. Finish: wood veneer. Price: (complete with two speaker systems) £74.15 (plus £12.15 PT).

HRC5010

AM/FM stereo tuner/amplifier in cabinet with

cartridge tape player. Range: FM 88-108MHz, MW 187-562 metres. Variable tuning AFC. Slider controls. Stereo decoder included. AC outlet socket. Eight-track cartridges. Finish: walnut with satin chrome trim. Two-way matched speakers. Price: to be announced.

SP790Y

AM/FM stereo tuner/amplifier in cabinet with record deck. 29 transistors, 20 diodes. Range: FM 88-108MHz, MW 187-562 metres. Variable tuning. AFC. Stereo decoder fitted. Output: 15W RMS per channel. Output impedance: 8 ohms. FR: 30Hz-20kHz. Toshiba record deck. 16-pole synchronous motor. Toshiba IC cartridge type C300FA. Finish: wood veneer. Price: (complete with two speakers systems) £267.14 (plus £52.36 PT).

840

AM/FM stereo tuner/amplifier in cabinet with record deck. 81 transistors (5 FETs). Range: FM 88-108MHz, MW 187-562 metres. Variable tuning. AFC. Stereo decoder fitted. Output: 25W per channel. Output impedance: 8 ohms. FR: 30Hz-20kHz. Toshiba motor unit. 16-pole motor. Toshiba IC cartridge type C300FA. Finish: wood veneer. Price: (complete with two speakers) £367.89 (plus £72.11 PT).

■ VAN DE MOLEN

1 Mildmay Road, Romford, Essex, RM7 7DA. Tel: Romford 41904 and 46911.

Sonic 99/S40

AM/FM stereo tuner/amplifier with record deck in cabinet with two separate speakers. Output: 8W RMS per channel. Output impedance: 4 ohms. FR: 40Hz-18kHz. Tone controls: bass ± 12 dB at 50Hz, treble ± 12 dB at 10kHz. Inputs for tape and aux. HD: $< 1\%$ Scratch filter. Motor unit: BSR C141 auto-changer. Cartridge: Acos GPI04. Stylus: diamond LP/78. Outlet for stereo headphones (4-15 ohms). Range: FM 88-104MHz, LW 1,100-1,900 metres, MW 185-570 metres. Automatic stereo decoder. Two-way speaker enclosures. HC: 10W RMS. FR: 60Hz-18kHz. Size: (main unit) $25\frac{1}{4} \times 13\frac{3}{8} \times 7\frac{1}{4}$ in; (speakers) $16 \times 10 \times 7\frac{1}{2}$ in. Price: (complete system) £117.28 (including PT).

Sonic 99M/S50

Similar specification to the Sonic 99/S40 but fitted with BSR B144 record deck and Shure M75/6 cartridge. Also speaker enclosures fitted with $6\frac{1}{2}$ in bass driver and $2\frac{1}{2}$ in HF unit with four-element crossover. Price: (complete system) £147.77 (including PT).

■ YAMAHA

Jonathan Fallowfield Ltd, Strathcona Road, North Wembley, London, HA9 8QL. Tel: 01-904 0141.

MC-40

AM/FM stereo tuner/amplifier in cabinet with record deck. Range: FM 88-108MHz, MW 186-560 metres. Variable tuning. AFC. Stereo decoder fitted. Controls: volume, loudness, mono/stereo, treble, tuning, bass, input selector, balance, mains on/off. Output: 10W RMS per channel. Output impedance: 8 ohms. FR: 20Hz-30kHz ± 2 dB. HD: 0-15%. Two-speed belt drive Yamaha turntable. CG-3500 magnetic cartridge. Finish: American walnut. Recommended speakers: NS-410, NS-230, NS-250. Price: (including two speakers) from £184.70 (inc. PT).

MS-3

AM/FM stereo tuner/amplifier in cabinet with record deck. Range: FM 88-108MHz, MW 186-565 metres. Variable tuning. AFC. Stereo decoder fitted. Controls: volume, treble, bass, balance, acoustic equaliser, loudness, tape monitor, mono/stereo, mains on/off, speaker selector, input selector, tuning. Output: 22W RMS. Output impedance: 8 ohms. FR: 10Hz-30kHz $+0 -2$ dB. HD: 0-05%. Yamaha two-speed belt drive turntable. Yamaha CG5500 magnetic cartridge. Finish: American walnut. Recommended speakers: NS-250, NS-18, NS-550, NS-330. Price: (complete including two speakers) from £309.61 (including PT).

MS-5AR

AM/FM stereo tuner/amplifier in cabinet with record deck and cartridge recorder. Range: FM 88-108MHz, MW 186-565 metres. Variable tuning. AFC. Stereo decoder fitted. Controls: eight-track cartridge record/playback, record level, volume, treble, bass, balance, mic volume, loudness, high filter, auto-stop, tuning, function selector. Output: 22W RMS per channel. Output impedance: 8 ohms. FR: 10Hz-30kHz -0 dB $+2$ dB. HD: 0-05%. Yamaha two-speed belt drive turntable and CG-5500 magnetic cartridge. Finish: American walnut. Recommended speakers: NS-250, NS-18, NS-550. Price: (including two speakers) from £361.16 (inc. PT).

MS-5B

AM/FM stereo tuner/amplifier in cabinet with record deck and cassette recorder. Range: FM 88-108MHz, MW 186-565 metres. Variable tuning. AFC. Stereo decoder fitted. Controls: cassette tape record/playback, volume, treble, bass, balance, acoustic equaliser, function, loudness, high filter, mic volume, tuning, record level. Output: 22W RMS per channel. Output impedance: 8 ohms. FR: 10Hz-30kHz -0 , $+2$ dB. HD: 0-05%. Yamaha two-speed belt drive turntable. Yamaha CG5500 magnetic cartridge. Finish: American walnut. Recommended speakers: NS-250, NS-18, NS-550. Price: (complete system including two speakers) from £361.16 (including PT).



The finest range of
Stereo Headphones
in the world.

from £10 to £69.



KOSS *hearing is believing*

Koss-TMD Ltd 11 Redvers Road London N 22 6EP TEL 01-888 0152

Hi Fi Headphones

★ Indicates entry is illustrated

Abbreviations used in this section are given on page 36.

■ AKAI

Rank Audio Products, PO Box 70,
Great West Road, Brentford, Middlesex.
Tel: 01-568 9222. Telex: 24408.

ASE-9S

Stereo headphones with acoustic control. Impedance: 8 ohms. Maximum input: 500mW. FR: 25Hz-15kHz. Weight: 18oz approx. Length of cord: 6ft. Price: £6-90.

ASE20

Stereo headphones with acoustic loudness control. Impedance: 8 ohms. Maximum input: 500mW. FR: 25Hz-18kHz. Weight: 17oz approx. Length of cord: 6ft. Price: £9-50.

ASE22

Stereo headphones. Built-in mechanical two-way system. Mylar film diaphragms. Impedance: 8 ohms. FR: 20Hz-10kHz. Normal input: 1mW. Maximum input: 500mW. Sensitivity: 110dB. Weight: 18oz approx. Price: £11-50.

A.K.G.

Distributors: A.K.G. Equipment Ltd,
182/184 Campden Hill Road, Kensington,
London, W8. Tel: 01-229 3695.

K60 ★

Dynamic stereo headphones. FR: 16Hz-20kHz. Impedance: 75 ohms $\pm 20\%$ per channel over entire range, or 600 ohms $\pm 20\%$. Distortion: $< 1\%$ max output. Weight: 7oz. Ear cushions removable for washing. Price: £15.

K120

Mono-stereo 600 ohms built on large ear pads, black. Price: £10.

K150

Mono-stereo 600 ohms, ultra lightweight. Complete with Z50A ear muffs, grey/silver. Price: £11-50.

K180

Mono-stereo 600 ohms. Incorporates control for moving distance of transducer from ear. Large comfortable design. Price: £32.

Accessories

Z50A (ear cushions for K50, K150). Price: 55p pair; Z60 (adaptor for mounting Z60 on K50

and K150). Price: £1-65; Z61 (ear cushions for K60, K50 and K150). Price £2-35.

■ ALPHA

Highgate Acoustics Ltd,
184 Great Portland Street, London, W1.
Tel: 01-636 2901.

Alpha

Stereo headphones. Impedance: 4-16 ohms. Maximum input: 0-5W. FR: 25Hz-17kHz. Weight: 12oz. 6ft cord. Three-pole jack plug. Finish: grey and black headbands and ear cushions. Adjustable headband. Price: £3-75.

■ AMPLIVOX

Amplivox Communications Ltd, Beresford
Avenue, Wembley, HA01RU, Middlesex.
Tel: 01-902 8991.

Astrolite

High quality moving coil headphones. FR: 50 Hz-15kHz. Impedance: 200 ohms. Wired for mono or stereo. Price on application.

Astrolite LS33 ★

Lightweight moving coil headphones. FR: 20 Hz-20kHz. Sensitivity: 0-5mW produces comfortable listening level. Power input: 700mW for 2% total distortion (3W momentary overload). Impedance: 200 ohms per earphone, may be connected in series, parallel or wired independently for stereo. Contoured earshells with detachable foam cushions. Fully adjustable headband. A special version with boom microphone available (LS336). Prices on application.

■ AMSTRAD ELECTRONICS LTD

34/35 Great Sutton Street, London, EC1.
Tel: 01-251 0241/2.

HPS 5A ★

Stereo headphones wired for mono and stereo. Impedance: 4-16 ohms. FR: 20Hz-20kHz. HD: 0-5%. Weight: 12oz. 10ft coiled cord. Supplied with jack plug. Finish: black. Fitted with two volume controls and mono/stereo switch. Price: £6-95.

HPS 7A

Stereo headphones. Wired for stereo. Impedance: 4-16 ohms. FR: 20Hz-25kHz. HD: 0-2%. 13ft coiled cord. Weight: 16oz. Fitted with standard jack plug. Finish: brown and silver. Each earpiece contains LF and HF units. Four slider controls for adjusting levels in each unit. Price: £12-95.

■ BUSH-ARENA

Rank Bush Murphy Ltd, Power Road,
Chiswick, London, W4. Tel: 01-994 6491.

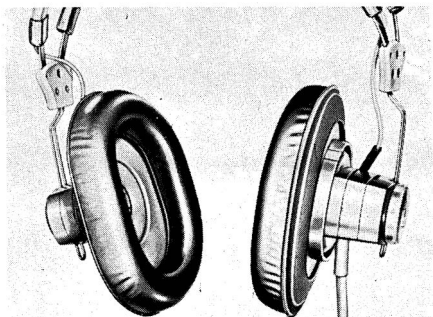

A.K.G. K60

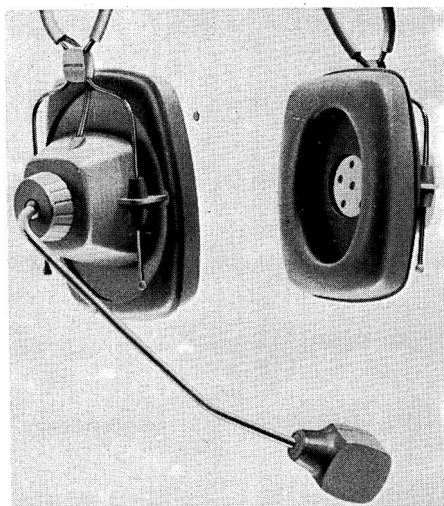

Amplivox Astrolite LS33



Amstrad HP55A

K600 ★

Stereo headphones. FR: 10Hz-16kHz. HD: <1% at maximum output. Impedance: 4-16 ohms. 3½ in driver units. Removable foam-filled ear cushions. 10ft coiled connection lead with jack plug. Price: £11-90.

■ CITY AUDIO SERVICES LTD

7 Chalcot Road, London, NW1.

Tel: 01-586 3211/2.

SE.28

Stereo headphones with extended response due to domed acoustic chambers and special tweeters. Individual adjustment of each dome. FR: 20Hz-20kHz. Price: £11-60.

SE.40

Stereo headphones. Comfortable cushioned earpads exclude extraneous noises. High sensitivity units in acoustic chambers. FR: 25Hz-16kHz. Price: £6-37.

■ CLARK

PO Box 4, Oldfield Road, Hampton, Middlesex, TW122HN. Tel: 01-979 0134.

Clark 100

Stereo headphones. FR: 10Hz-20kHz. Distortion: <0.2% at 100 phon. Maximum power input: 1W per earpiece. Sensitivity: 1mW produces 100 phon at 1kHz. Weight: 16oz. Washable earseal covers. 10ft extended coil cord with moulded plug. Impedance: 8 ohms (also available in 300, 600 and 1,200 ohms). Price: £21-50.

■ DUETTE

Distributors: J. J. Silber Ltd, 11 Northburgh Street, London, EC1.

Tel: 01-253 8031.

ES350 ★

Stereo headphones. Impedance: 8-16 ohms. FR: 25Hz-13kHz. Max input: 0.5W. Price: £6-72.

ES300

Stereo headphones. Impedance: 8-16 ohms. FR: 25Hz-13kHz. Max input: 0.5W. Price: £5-97.

■ DYNATRON RADIO LTD

St Peters Road, Maidenhead, SL6 7QY, Berks. Tel: Maidenhead 23331.

SP.2 ★

Stereo moving-coil headphones. Light weight. Padded earpieces. Impedance: 8 ohms. Price: £7-50.

SP.3

Stereo moving coil headphones with separate bass and treble units. FR: 16Hz-22kHz. Sensitivity: 100dB at 600Hz at 1mV input. Maximum input: 0.5W. Impedance: 8-16 ohms each channel. Price: £13.

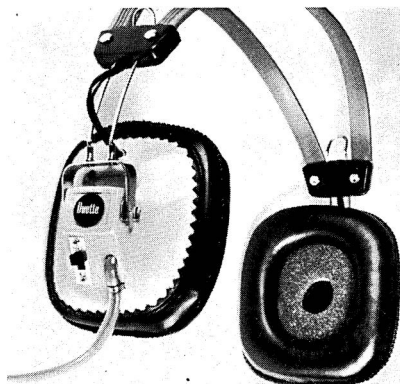
**Bush-Arena K600****Duelle ES350****Dynatron SP2****Eagle SE5**

■ EAGLE INTERNATIONAL

Heather Park Drive, Wembley, HA1 1SU.

Tel: 01-903 0144.

S.E.1

Professional stereo headphones. FR: 25Hz-14kHz. 3in dynamic speakers. Isolated right and left channels. 'Flexifoam' seals. Dual impedance: 15 ohms. Price: £4.95.

S.E.21

Professional two-way stereo headphones. FR: 25Hz-18kHz. Each headphone contains 2½in LF unit and ¾in treble unit. Level controls and built-in attenuator to protect ears. Impedance: 16 ohms. Stereo cable and plug. Adjustable headband. Foam rubber earpads. Price: £10.80.

S.E.5 ★

Budget stereo headphones. FR: 30Hz-15kHz. Lightweight single headband. Impedance: 8 ohms. Price: £3.15.

S.E.28

Studio stereo headphones. FR: 20Hz-20kHz. Dome chambers. Separate LF and tweeter units. Impedance: 8 ohms. Adjustable attenuators. Price: £11.60.

S.E.30

Studio stereo/mono headphones. FR: 30Hz-16kHz. Built-in stereo/mono switch. Impedance: 8 ohms. Leather ear cushions. Price: £7.60.

S.E.60

Studio stereo headphones. FR: 25Hz-18kHz. Impedance: 8 ohms. Lightweight with punched ventilated headband. Price: £9.

S.E.80 ★

Studio stereo headphones. FR: 20Hz-20kHz. Impedance: 8 ohms. Individual slider tone controls. Based on open baffle concept. Price: £16.

S.E.100

Professional stereo headphones. FR: 20Hz-21kHz. Impedance: 8 ohms. Independent volume controls, dual-cone earpieces. Price: £16.

JB3

Stereo headphone and speaker switching and attenuation unit. Jack socket for phones. Switch permits phones only, speakers only, or both together. Moulded case. Price: £1.60.

■ ECHO

Sole Distributors: Adastra Electronics Ltd, Unit 22, Cricklewood Trading Estate, Claremont Road, London, NW2 1TU. Tel: 01-452 6288.

HS.606D

Dual impedance mono headphones. Specially designed for monitoring, electronic musical instruments, language laboratories, etc. Instant switching from 8-16 ohms to 4K. Adjustable earpieces. Soft padded ear cushions. FR: 25Hz-

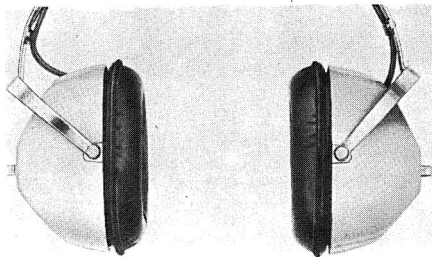

Eagle SE80



Howland-West CIS.500



I.T.T. Components 65/1B

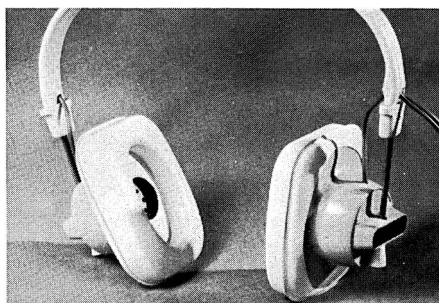

Kirkman Clean

17kHz. Power handling capacity: 0.5W. Supplied with 5ft lead fitted with jack plug. Price: £5.25.

■ **GRUNDIG (Great Britain) LTD**

Newlands Park, London, SE26.

Tel: 01-778 2211.

211/ADR

High-quality stereo headphones. Fitted with J29 plug. FR: 30Hz-20kHz. Distortion factor 1% at 1mW, 3% at 90mW. Impedance: 400 ohms per system. Supplied with 5½ft cable and adaptor to J21 plugs. Price: £7.95.

220

High-quality stereo headphones. Fitted with 5½ft of cable and J29 plugs. FR: 16Hz-20kHz. Distortion factor: less than 0.3% at intensities of 120 phn. Fluid-filled ear covers. Padded headband. Impedance: 400 ohms per system. Adaptor (279) to J21 plugs available. Price: £24.

■ **HOWLAND-WEST LTD**

3-5 Eden Grove, London, N78EQ.

Tel: 01-609 0293/4/5.

CIS.300

Stereo headphones. Supplied complete with standard 'stretch' cable and alternative remote control cable featuring left- and right-channel volume controls and mono/stereo switch. FR: 18Hz-21kHz. Impedance: 8 ohms. Price: £9

CIS.250

Stereo headphones. Impedance: 8 ohms. Maximum input: 500mW. FR: 20Hz-20kHz. Weight: 14oz. Special stretch cord. Standard jack. Finish: black. Price: £6.90.

CIS.500 ★

Stereo headphones. Impedance: 8 ohms. Maximum input: 500mW. FR: 20Hz-20kHz. Weight: 23oz. Stretch cord. Standard jack. Finish: white/black in luxury lined carry case. Dual concentric driver units in each earpiece (1¾in and 3½in). Wirewound volume controls for each channel. Price: £14.97.

■ **ITT-STC**

Standard Telephones & Cables Ltd,
Electro-Mechanical Product Division,

West Road, Harlow, Essex. Tel: Harlow 26811.

65/1B ★

Broadcast quality headset. FR: 30Hz-15kHz. Impedance: 300 ohms. Foam rubber earpads. Supplied complete with 54in tinsel cable. Price: on request.

■ **KALIMAR**

Highgate Acoustics Ltd,

184 Great Portland Street, London, W1.

Tel: 01-636 2901.

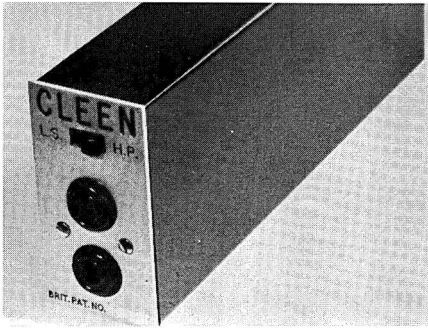

Kirkman Cleen Stereo Headphone Unit

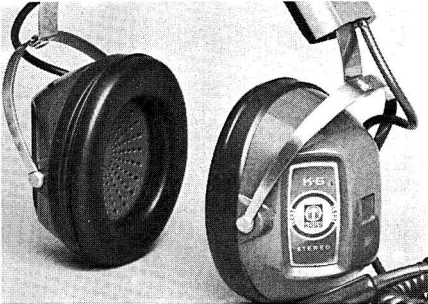

Koss K6

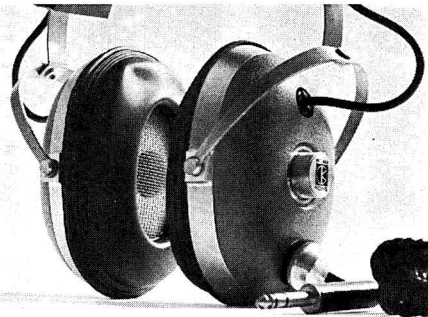

Koss PRO4AA



Koss ESP9

T855

Stereo headphones. Impedance: 8-16 ohms and 400 ohms (switched). Maximum input: 0.5W. FR: 30Hz-20kHz. Weight: 15oz with cord. Three-pole jack plug. 6ft lead. Adjustable headband. Finish: cream with grey band and ear cushions. Price: £5.75.

T862

Stereo/mono headphones. Impedance: 8-16 ohms and 20K (switched). Maximum input: 0.5W. FR: 15Hz-20kHz. Weight: 12oz with cord. 7ft coiled cord. Three-pole jack plug. Finish: rosewood colour with black cord and padding. Individual volume adjustment. Adjustable headband. Price: £11.50.

T865

Stereo headphones. Impedance: 8 and 16 ohms. Maximum input: 0.5W. FR: 15Hz-20kHz. Weight: 14oz with cord. 13ft coiled lead. Three-pole jack plug. Individual slider volume controls for each earpiece. Adjustable headband. Finish: black and white. Price: £13.50.

■ KIRKMAN (Crawley) LTD

40 The Broadway, Crawley, Sussex.

Tel: Crawley 26670.

Cleen Stereo Headphone Unit ★

Supplied in chassis form for mounting on panel or shelf (teak case will be available later). Signal from each channel is delayed and fed to opposite channel to simulate natural stereo. Three-position switch; loudspeakers, headphones, attenuated headphones. Jack socket for two pairs of phones. Impedance to amplifier: 8 ohms resistive. Suitable for headphones: 8-600 ohms. Size: $3\frac{1}{8} \times 1\frac{3}{4} \times 8$ in. Price: £15.

Cleen Stereo Headphones ★

Monitoring quality with good transient response. Recommended for use with Cleen stereo headphone unit. Impedance: 40 ohms. Sensitivity: 104dB for 1mW at 1kHz. Weight: 16 oz. Supplied with 10ft lead and jack plug ($\frac{1}{4}$ in stereo). Sound exclusion approximately 40dB. Price: £10.50.

■ KOSS

Tape Music Distributors Ltd,
11 Redvers Road, London, N226EP.

Tel: 01-888 0152.

K6 ★

Stereo headphones. Suitable for outputs of 4-16 ohms. Normal listening input: 95dB SPL - 18mV. Maximum input: 3.7V. FR: 10Hz-16kHz. HD: unmeasurable at 95dB SPL. Weight: 450gms. Special coiled cord, 3ft coiled 10ft extended. Standard stereo jackplug. Bronze finish. Washable earcushions. Adjustable headband. Price: £12.50.

★ Indicates entry is illustrated

K6LC

Stereo headphones. Suitable for outputs of 4-16 ohms. Normal listening input: 95dB SPL -73mV. Maximum input: 1.25V. FR: 10Hz-16kHz. HD: unmeasurable at 95dB SPL. Weight: 450gms. Special coiled cord; 3ft coiled, 10ft extended. Standard stereo jack plug. Bronze finish. Washable earcushions. Individual volume adjustment for each ear. Adjustable headband. Price: £14.

K711 and KR711

Stereo headphones. Suitable for outputs of 4-600 ohms. Normal listening input: 95dB SPL -1.4V. Maximum input: 29V. FR: 10Hz-17kHz. HD: <0.5% at 110dB SPL. Weight: 320gms. Special coiled cord; 3ft coiled, 10ft extended. Standard stereo jack plug. Finish: (K711) black moulding; (KR711) red moulding. Adjustable headband. Price: £10.

K727B

Stereo headphones. Suitable for outputs of 4-16 ohms. Normal listening input: 95dB SPL -12mV. Maximum input: 2.6V. FR: 10Hz-18kHz. HD: unmeasurable at 95dB SPL. Weight: 450gms. Special coiled cord; 3ft coiled, 10ft extended. Standard stereo jack plug. Black finish. Washable earcushions. Adjustable headband. Price: £16-50.

K0747

Stereo headphones. Suitable for outputs of 4-16 ohms. Wired for mono and stereo with changeover switch. Weight: 500gms. Special coiled cord; 3ft coiled, 10ft extended. Standard stereo jackplug. Finish: two-tone brown. Washable earcushions. Individual volume adjustment. Adjustable headband. Fluid-filled earcushions. Full electrical specification awaited. Price: £20.

PR04AA ★

Stereo headphones. Suitable for outputs of 4-16 ohms. Normal listening input: 95dB SPL -260mV. Maximum input: 4.1V. FR: 10Hz-20kHz. HD: negligible at 95dB SPL. Weight: 650gms. Special coiled cord; 3ft coiled, 10ft extended. Standard stereo jack plug. Finish: beige with black cushions. Washable earcushions. Adjustable headband. Fluid-filled cushions. Price: £28.

PR0600AA

Stereo headphones. Suitable for outputs of 600 ohms. Normal listening input: 95dB SPL -780mV. Maximum input: 15W. FR: 10Hz-20kHz. HD: negligible at 95dB SPL. Weight: 650gms. Special coiled cord; 3ft coiled, 10ft extended. Standard stereo jackplug. Finish: beige with black earcushions. Fluid-filled washable earcushions. Adjustable headband. Price: £30.

ESP6

Electrostatic stereo headphones. Suitable for

outputs of 4-16 ohms. Normal listening input: 1V at 80dB SPL. Maximum input: 20V. FR: 30Hz-19kHz \pm 5dB. HD: <0.2% at 110dB SPL. Weight: 850gms. Special coiled cord; 3ft coiled, 10ft extended. Standard stereo jack plug plus connector box. Finish: black. Washable fluid-filled earcushions. Neon level indicators. Adjustable headband. Carry case included in price. Price: £45.

ESP9 ★

Electrostatic studio monitor stereo headphones. Suitable for outputs of 4-16 ohms. Normal listening input: 1V at 80dB SPL. Maximum input: 20V. FR: 15Hz-15kHz \pm 2dB (10Hz-19kHz \pm 5dB). Weight: 590gms. 6ft cord. Supplied with speaker output terminals. Finish: black. Fluid-filled earcushions. AC or self-energised selector switch. Price: £69.

K2+2

Four-channel dynamic headphones. Wired for stereo and quadraphonic. Suitable for outputs of 3-600 ohms. Normal listening input: 1.4V at 95dB SPL. Maximum input: 29V. FR: 10Hz-20kHz. HD: negligible at 95dB SPL. Weight: 600gms. Special coiled cord; 3ft coiled, 10ft extended. Two headphone jackplugs. Black finish. Washable fluid-filled earcushions. Adjustable headbands. Switch for two- or four-channel operation. Price: to be announced.

Two-way adaptor TPA

For connecting two pairs of headphones to single output. Extends length by 3ft. Price: £2-50.

Extension cable EC25KK

25ft coiled cord terminated with stereo jackplug and socket. Price: £3-50.

T3 Switchbox

Speaker/headphone switchbox. Jack socket for phones, terminals for speaker and connection to amplifier output. Switch selects speakers on or off. Price: £3-50.

T4A Connector box

Accepts up to five pairs of stereo headphones. 14ft extension lead with jackplug for amplifier. Simulated rosewood base with black trim, spun aluminium panel. Price: £4-50.

T10A

Chairside listening station. Provides separate volume controls for two pairs of stereo headphones, also speaker on/off switch. Wires directly to amplifier output. Seven-core flat cable suitable for under carpet installation. Tinted plastic cover. Price: £9-50.

Continental adaptor leads

For use with amplifiers having DIN output sockets instead of jack sockets. Comprises: two DIN speaker plugs with lead and stereo jack socket. Two 100 ohms resistors inserted for attenuation. Price: £1-50.



Nikko 775

■ MAC

Modular Audio Components Ltd,
Canterbury Road, Nottingham, NG8 1PQ.
Tel: Nottingham 79797.

AAU-TV

Provides a ready means of connecting various items of Hi-Fi equipment to a Television Receiver with complete safety. Built-in Isolating Transformer, tapped 3-8-15 ohms, for matching external speaker. Switchable output attenuator for matching input of amplifier or tape recorder. Switching circuit enables TV speaker to be switched on or off as required. Phone jack fitted to suit low impedance headphones. Price: £8-40. impedance headphones. Price: £8-40.

AAU-2

Audio adaptor unit with three-way switch and socket for headphones. Screw connections for a stereo pair of main speakers and a stereo pair of extension speakers. Switch positions give: main speakers only, extension speakers and phones, main and extension speakers. Colour-coded four-way connecting cable. Finish: panel and knob jaguar silver. Price: £4-40.

AAU-HP

Audio adaptor unit for connecting up to four stereo headphones to a stereo amplifier. Individual gain controls with balancing resistive networks incorporated. Fitted with 3ft connecting cable with 3-pole jack plug. Size: $3\frac{1}{4} \times 3\frac{1}{4} \times 3\frac{1}{2}$ in. Finish: jaguar silver. Price: £8.

All MAC AAU units are available in solid teak case at an additional cost of £1-32.

■ NATIONAL PANASONIC

Unamec Ltd, United Africa House,
1-16 Blackfriars Road, London, SE1 9UG.
Tel: 01-928 2070.

EAH-60

Stereo headphones. Price: £9-95.

EAH-65

Stereo headphones. Price: £8-95.

■ NIKKO

Nikko Electric Mfg. Co Ltd,
Distributors: Howland-West Ltd,
3-5 Eden Grove, London, N78EQ.
Tel: 01-609 0293/4/5.

HW3S

Stereo headphones. Single speaker. Impedance: 8 ohms. FR: 20Hz-18kHz. Max. input: 0-3W. Price: £5.

77S ★

Stereo headphones. High response lightweight phones with silicon varistor overload protection. FR: 18Hz-21kHz. Sensitivity: 105dB/mV. Max input: 0-3W. Price: £15.

■ NIVICO

Denham & Morley (Overseas) Ltd,
453 Caledonian Road, London, N7.
Tel: 01-607 6568.

STH-10E

Moving coil stereo headphones. FR: 20Hz-20kHz. Impedance: 8 ohms. Nominal input: 1mW. Maximum input: 500mW per channel. Distortion: <1% at 1mW. 9½ft coiled cord. Padded headband and ear cushions. Price: £13.

5944

Moving coil stereo and four-channel headphones. FR: 20Hz-20kHz. Impedance: (each channel) 8 ohms, (each terminal) 11 ohms. Nominal input: 1mW. Maximum input: 100mW. Distortion: <0.5% at 1mW. 6½ft coiled cord. Built-in phase shifter switches. Soft ear cushions, adjustable padded headband. Two units per earpiece. Price: £19-95.

■ PHILIPS ELECTRICAL LTD

Century House, Shaftesbury Avenue,
London, WC2. Tel: 01-437 7777.

LBB9901

Stereo headphones. Impedance: 600 ohms each channel. FR: 40Hz-18kHz. Price: £5-25.

LBB9902

Stereo headphones. Impedance: 600 ohms each channel. FR: 20Hz-20kHz. Price: £9-50.

Philips stethoscope headphones for use with tape recorders listed in Tape Recorder Accessory Section.

■ PIONEER

Shriro (UK) Ltd,
42 Russell Square, London, WC1B 5DF.
Tel: 01-580 6996.

★ Indicates entry is illustrated

SE100

Stereo headphones. Impedance: 4-16 ohms. FR: 20Hz-35kHz. Sensitivity: 95dB. Electret push/pull static type. Price: £25.06.

JB100

Adaptor for use with SE100 electret headphones. Price: £14.12.

SE50

Stereo headphones. Impedance: 4-16 ohms. Power input: 0.5W. FR: 20Hz-20kHz. Two units: one 3in and one 1½in per earpiece. Two-way volume and tone control. Price: £20.75.

SE30A

Stereo headphones. Impedance: 4-16 ohms. Power input: 0.5W. FR: 20Hz-20kHz. Sensitivity: 115dB. One 2¾in unit per earpiece. Price: £12.60.

SE20A

Stereo headphones. Impedance: 4-16 ohms. Power input: 0.5W. FR: 20Hz-18kHz. One 2¾in unit per earpiece. Price: £7.50.

SEL40

Stereo headphones. Impedance: 4-16 ohms. Power input: 0.5W. FR: 20Hz-20kHz. Sensitivity: 96dB. One 1½in unit per earpiece. Open air type. Price: £16.80.

SEL25

Stereo headphones. Impedance: 4-16 ohms. Power input: 0.5W. FR: 30Hz-20kHz. Sensitivity: 97dB. One 1½in unit per earpiece. 9.8ft cable. Price: £14.08.

SEL20

Stereo headphones. Impedance: 4-16 ohms. Power input: 0.5W. FR: 20Hz-20kHz. Sensitivity: 97dB. One 1½in unit per earpiece. Open air type. Price: £9.98.

■ ROGERS DEVELOPMENTS (Electronics) LTD

4/14 Barmeston Road, Catford, London, SE6.
Tel: 01-698 7424/4340.

Cables: Rodevco, London, SE6.

Ravensbrook ★

Semi-professional stereo headphones. Twin moving-coil system. Separate volume control integral with each earpiece. Lightweight (22oz). Adjustable, lockable headband. Sensitivity: 105dB at 200Hz. FR: 20Hz-20kHz. Impedance: 8 ohms. Nominal input: 1mW. Length of cord: 18-72in. Standard ¼in tip, ring and sleeve jack-plug. Price: £18.50.

■ ROTEL

Rank-Aldis Audio Products,
Rank Audio Visual Ltd, PO Box 70,
Great West Road, Brentford, Middlesex.
Tel: 01-568 9222.

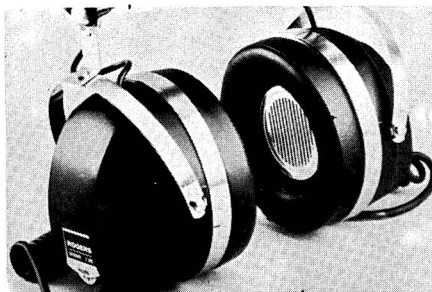

Rogers Ravensbrook

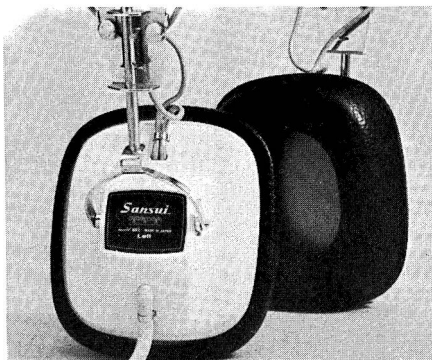

Sansui SS2



Sansui SS10

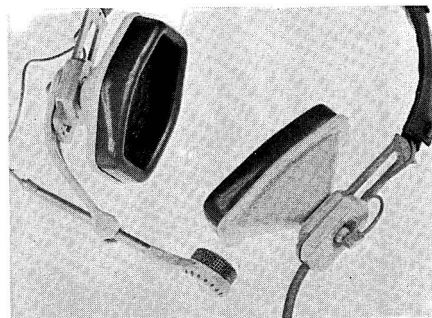

Sennheiser HMD110

RH630

Stereo headphones. Impedance: 8 ohms. Price: £6-50.

RH700

Stereo headphones. Impedance: 8-16 ohms. Maximum input: 500mW. FR: 20Hz-20kHz. 10ft coiled cord. Black headband and ear cushions. Adjustable headband. Price: £9-95.

■ **SANSUI**

Vernitron Ltd,
Thornhill, Southampton, SO95QF.
Tel: Southampton 44811.

SS2 ★

Stereo headphones. Impedance: 8 ohms. Normal listening input: 1mW. Maximum input: 500mW. FR: 20Hz-18kHz. HD: <1%. Weight: 12½oz. Cord: 6ft. Three-pole jackplug. Black headband and ear cushions, white earpieces. Adjustable headband, washable ear cushions. Price: £8-51.

SS10 ★

Stereo headphones. Impedance: 8 ohms. Normal listening input: 1mW. Maximum input: 500mW. FR: 20Hz-20kHz. HD: <0.8%. Sensitivity: better than 110dB. Weight: 22oz. 9-8ft coiled cord. Three-pole jack plug. Washable ear cushions. Individual volume adjustment. 6½ft dual extension lead. Black headband, white earpieces. Price: £14-72.

SS20

Stereo headphones. Impedance: 8 ohms. Normal listening input: 1mW. Maximum input: 500mW. FR: 20Hz-20kHz. HD: <0.8%. Sensitivity: 105dB at 200Hz. Weight: 27½oz. 8ft coiled cord. Individual volume adjustment. Individual tone adjustment. Adjustable headband. 6½ft dual extension lead. Two drive units in each earpiece. Black headband and ear-cushions, white earpieces. Price: £19-52.

■ **SCAN-DYNA**

Scandinavian Audio Systems Ltd,
Sun Alliance Building, 65 London Road,
Gloucester, GL13HF.
Tel: Gloucester (0452) 32791/2.

K72

Stereo headphones. FR: 20Hz-20kHz. HD: 2% at maximum rating. Impedance: 4-16 ohms. Three-position tone control in lead. Independent volume control for each earpiece. Coiled lead; 5ft coiled up, 11½ft extended. Weight: 12oz. Removable foam-filled ear cushions. Adjustable padded headband. Price: £12-90.

■ **SENNHEISER ELECTRONIC**

Distributors: Hayden Laboratories Ltd,
Hayden House, 17 Chesham Road, Amersham,
Bucks. Tel: Amersham 5511.

Audio showroom, service department and
despatch department: 12/13 Poland Street,
London, W1V 3DE. Tel: 01-734 3748.

HD.110

Stereo headphones wired for mono and stereo. Robust design. Removable washable ear cushions. Easily replaceable cable. FR: 20Hz-20kHz. Impedance: 200 ohms \pm 15% per earpiece. Output: 1mW per capsule produces 98dB (16µbar) at 1kHz. Maximum output: 120dB (200µbar) for 1% distortion. Weight: 10oz. Price: £24.

HD.414

Stereo headphones. Wired for mono or stereo. Lightweight robust design. Removable washable sponge ear pads. FR: 20Hz-20kHz. Impedance: 2,000 ohms per capsule. Weight: 5oz. Price: £10-45.

HMD.110 ★

Stereo headset type HD.110 with close-talking boom microphone. FR: 50Hz-14kHz. Response tailored for close speaking. Sensitivity: 0.07mV/µbar. Impedance: 200 ohms. Price: £28-50.

HMD.414

Stereo headset HD.414 with close-talking boom microphone located near corner of mouth. Especially high ratio of desired sound to background noise. Sensitivity: 0.1mV/µbar. Impedance: 200 ohms. Price: £25.

■ **SHARP**

Sharp Electronics (UK) Ltd, 48 Derby Street,
Manchester, M88HN. Tel: 061-832 6115.

HP100

Stereo headphones. Fully adjustable slide fittings. Double headband. Padded comfortable earpieces. FR: 30Hz-18kHz. Complete with lead and jack plug. Price: £5-87.

HP200

Stereo headphones. Fully adjustable slide fittings. Single headband. Padded comfortable earpieces. FR: 30Hz-17kHz. Complete with lead and jackplug. Price: £4-25.

■ **SONY (UK) LTD**

Pyrene House, Sunbury Cross,
Sunbury-on-Thames, Middlesex.
Tel: Sunbury 87644/7.

DR4A, DR4C

Stereo headphones. Impedance: (DR4A) 8 ohms, (DR4C) 10K. Normal listening input: 1mW. Max input: 100mW. FR: 50Hz-17kHz. Cord: two metres. Standard ¼ in jackplug. Lightweight. Black vinyl earpads with aluminium fittings. Adjustable headband. Price: (DR4A) £8-50; (DR4C) £9-50.

DR5A

Stereo headphones. Impedance: 8 ohms. Nor-

★ Indicates entry is illustrated

mal listening input: 1mW. Max input: 100mW. FR: 50Hz-17kHz. Cord: two metres. $\frac{1}{4}$ in standard jackplug. Doubleadjustable headband. Larger earpads than DR4A. Price: £6-75.

■ STAX

Distributor: Wilmex Ltd, Stax Division, 24/26 Ensign Street, London, E1. Tel: 01-949 2545.

Stax SR-3

Lightweight electrostatic headphones. Push-pull operation. FR: 30Hz-25kHz. Impedance: 130K at 10kHz. Sound pressure level: 95dB at input 100V RMS. Polarising voltage: 200V DC. Adjustable headband. All metal parts stainless steel. Ear cushions of soft vinyl leather, replaceable. Total weight approximately 1lb, including cord. Price: see SRD-5 adaptor below.

Stax SRD-5

Adaptor for use with SR-3 phones. Connects to amplifier output and provides switching between speakers and headphones, also supplies polarising voltage to phones. Mains: 110-120V AC, 200-240V AC. Price: (complete system comprising SR-3 phones and SRD-5 adaptor) £47.

■ TOSHIBA

Distributors: Hanimex (UK) Ltd, Hanimex House, 15-24 Great Dover Street, London, SE1. Tel: 01-407 8161.

HR80

Stereo headphones. Incorporates Toshiba cross-field network. FR: 20Hz-20kHz. Impedance: 4-50 ohms (matching). Input power: 15mW. Weight: 12.8oz. Cord: 6 $\frac{1}{2}$ ft. Detachable washable ear covers. Finish: black, grey and chrome. Price: £8-50.

HR50

Stereo headphones. Incorporate Toshiba cross-field network at the turn of a switch. Lightweight with detachable padded ear covers for easy cleaning. Specification similar to HR80. Price: £14-25.

■ TRIO

B. H. Morris & Co (Radio) Ltd, 84-88 Nelson Street, Tower Hamlets, London, E12DY. Tel: 01-790 5011.

KH71

Stereo headphones. Impedance: 8 ohms. Maximum input: 500mW. FR: 20Hz-20kHz. Weight: 1lb. 10ft cloth-covered cord. Brown—real leather finish. Padded headband and ear cushions. Uni-pivot device makes headphones particularly suitable for spectacle wearers. Open-back system. Price: £15.

KH51

Stereo headphones. Impedance: 8 ohms. Maxi-

mum input: 500mW. FR: 20Hz-20kHz. Weight: 15oz. 6 $\frac{1}{2}$ ft vinyl-covered cord. Brown—simulated leather finish. Padded headband and ear cushions. Uni-pivot device makes headphones particularly suitable for spectacle wearers. Open-back system. Price: £10.

■ T.T.C.

Joint Distributors: Adastra Electronics Ltd, Unit 22, Cricklewood Trading Estate, Claremont Road, London, NW2 1TU. Tel: 01-453 6288/9. E.R. (Factors) Ltd, 374-378 Harrow Road, Paddington, London, W9. Tel: 01-286 0361.

G1120

Mono headphones. Impedance: 16ohms. Maximum input: 250mW. FR: 20Hz-10kHz. Weight 15oz. 5ft lead. Fitted with dynamic boom mic. Two-tone grey. Adjustable headband. Washable ear cushions. Price: £6-90.

G2222D

Stereo headphones. Impedance: 8-16 ohms. Maximum input: 650mW. FR: 25Hz-18kHz. Weight: 13oz. 9ft coiled lead. Moulded stereo jack plug. Simulated wood grain finish with black trim. Individual volume controls. Adjustable headband. Washable ear cushions. Mono/stereo slide switch. Price: £6-50.

G3333

Stereo headphones. Impedance: 4-32 ohms. Maximum input: 500mW. FR: 20Hz-20kHz. Weight: 17oz. 5 $\frac{1}{2}$ ft coiled lead. Stereo jack plug. Grey moulded earpieces. Separate 3in and 1 $\frac{1}{2}$ in units in each earpiece. Individual treble control for each earpiece. Soft ear cushions and adjustable headband. Price: £8.

G300B

Stereo headphones. Impedance: 8 ohms. Maximum input: 650mW. FR: 50Hz-19kHz. Weight: 19oz. 10ft coiled lead. White moulded earpieces with black and silver fittings. Control box in lead with volume controls and mono/stereo switch. Adjustable leather padded headband. Washable ear cushions. Price: £9-25.

G1030

Stereo headphones. Impedance: 4-32 ohms. Maximum input: 300mW. FR: 20Hz-20kHz. Weight: 16 $\frac{1}{2}$ oz. 9ft coiled lead. Moulded earpieces with tan finish. Open back housing for 3in unit. Adjustable headband and washable ear cushions. Price: £8-75.

G6000

Stereo headphones. Impedance: 4-16 ohms. Maximum input: 500mW. FR: 15Hz-25kHz. Weight: 21oz. 15ft coiled cord. Stereo plug. Satin white earpieces with black trim. Open back housings with 3 $\frac{1}{2}$ in units. Slide volume controls. Adjustable headband. Washable ear cushions.

**Wharfedale DD1**

Stereo/mono switch. Price: £9-60.

G5555

Stereo headphones. Impedance: 4-16 ohms. Maximum input: 600mW. FR: 20Hz-20kHz. Weight: 17oz. 10ft coiled lead. Stereo jack plug. All-black moulding with chrome trim. 2½in units. Adjustable headband. Washable ear cushions. Price: £11-50.

G3500

Stereo headphones. Impedance: 4-16 ohms. Maximum input: 900mW. FR: 15Hz-25kHz. Weight: 24oz. 8ft coiled lead. Moulded stereo jack plug. Black moulding with chrome trim. 3½in and 1½in units in each earpiece. Wire-wound volume controls. Adjustable headband and washable ear cushions. Price: £15-75.

G8030

Stereo electrostatic headphones. Impedance: 4-16 ohms. Normal listening input: 8W. Maximum input: 10W. FR: 20Hz-19kHz. Weight: (headphones only) 19oz; (headphones and energiser unit) 5½lb. 8ft coiled lead. Black moulding with black leather headband. Adjustable padded headband. Price: £30-75.

G1305

Headphone remote control unit. Slider volume controls for individual channel gain. Stereo/mono mode switch. Stereo jack socket. Moulded case. 10ft self-coiling lead with jack plug. Price: £2-75.

UHER

Distributors: Bosch Ltd, PO Box 166, Rhodes Way, Radlett Road, Watford, Herts, WD24LB. Tel: Watford 44233.

W671

Stereo moving-coil headphones. Price: £13-30.

W673

Stereo moving-coil headphones for use with Uher Compact Report Stereo. Price: £13-30.

W762

Monophonic moving-coil headphones. Price: £13-30.

UNISOUND

Distributors: Mathers Photographics Ltd, 35 John Dalton Street, Manchester, 2. Tel: 061-BLA 6133.

S-444

Stereo and mono headphones. Impedance: 8 ohms. Maximum input: 500mW. FR: 20Hz-18kHz. Sensitivity: 105dB at 1kHz. Weight: 17½oz. 10ft coiled cord. Individual volume adjustment. Adjustable padded headband. All-black finish. Price: £7.

S-888

Stereo headphones. Impedance: 8 ohms. Maximum input: 500mW. FR: 20Hz-20kHz. Sensitivity: 105dB at 1kHz. Weight: 17½oz. 15ft coiled cord. Adjustable padded headband. Leatherette finish. Price: £9-95.

WHARFEDALE

Rank Wharfedale Ltd, Bradford Road, Idle, Bradford, Yorks. Tel: Bradford 612552. Telex: 51407.

D.D.1 ★

Dynamic moving-coil stereo headphones. Two-way system (i.e. separate bass and treble units) with electrical crossover network. Impedance: 8-16 ohms. FR: 16Hz-22kHz ±3dB. Distortion: less than 1%. Supplied with 4½ metres (15ft) non-tangle coiled cable. Cushions readily removable for easy cleaning. Price: £11-00.

Isodynamic Headphones

High quality headphones using an electromagnetic technique which distributes the drive over the whole of the diaphragm in the manner of an electrostatic system. Impedance 40 ohms per capsule but suitable for connection to the output terminals of amplifiers with impedance of 8 ohms. Response down to 35Hz without need for strong side force to seal the cups to the head. Light weight. Adjustable padded headband. Coiled lead. Soft ear pads. Modern white plastic appearance. Price: expected to be in the region of £20 but not confirmed at the time this edition closed for press.

WOOLLETT AUDIOSTATICS

21 Anerley Station Road, London, SE208PY. Tel: 01-778 9003.

Headphone Equaliser Blender

Stereo. Provides variable attenuation and adjustable treble lift. Switch positions for: headphones only, headphones and speakers, or speakers only. Variable negative blend cancels out crosstalk and permits compatible stereo records to be played as full stereo. Two input and two output blocks for easy connection into speaker feeds. Fitted two yards cable for inputs and speaker feeds. Size: 6 × 5½ × 2½in. Price: £12-80.



Get through to the *pure* FM stereo sound

You've bought first-class audio equipment, with an FM stereo tuner capable of giving you sound quality *superior* to anything you've ever heard - on tapes or record. But its performance can only match the quality of signal you feed into it. Did you know, FM stereo needs at least *ten times the signal strength* to give you the results you expect from VHF radio? If you're not feeding it right, you'll get mush, interference, stereo whistle.

Give your tuner a chance to show you just how good it really is. Plug in one of the new Antiference FM Stereo Aerials. They're designed to give the powerful signal, directional discrimination, wide bandwidth and coverage of all present and future stereo broadcasts you need. Antiference have unrivalled experience in solving TV reception problems, and they're also experts in FM stereo and Mono radio.

Send for a leaflet or call in on your local dealer.

The *mush* killers

Antiference Limited Aylesbury Bucks Tel 82511

Antiference FM Stereo Aerials



Directory of FM/VHF Aerials

★ Indicates entry is illustrated

Abbreviations used in this section are given on page 36.

■ AERIALITE

Aerialite Aerials Ltd,
Radnor Park Trading Estate, West Heath,
Congleton, CW124PX.
Tel: Congleton 3892/9.

900

Band II outdoor dipole with stand-off arm and universal bracket to fit up to 2in diameter masts. Price: £2-10.

901

Band II wide-spaced H array with attachment to fit masts up to 2in diameter. Price: £2-60.

902

Band II three-element array comprising director, folded dipole and reflector. Bracket for mast attachment up to 2in diameter. Price: £3-75.

903

Band II four-element array comprising folded dipole, two directors and a reflector. Bracket for attachment to mast up to 2in diameter. Price: £4-25.

Aerialite also manufactures a range of vertical rod-type aerials and anti-static systems.

■ ANTIFERRENCE LTD

Bicester Road, Aylesbury, Bucks.
Tel: Aylesbury 2511.

Loft 233

Band II three-element loft aerial with folded dipole. Universal mounting clamp with stand-off arm. Fully adjustable for angle and direction. Price: £2-50.

214

Band II single dipole (array only) with one-hole fitting for 1in dia masts. Price: £1-60.

224 ★

Band II dipole and reflector array with universal clamp to fit masts up to 2in diameter. Price: £2-75.

234

Band II three-element array comprising folded dipole, director and reflector with universal clamp for masts up to 2in diameter. Price: £3-95.

244 ★

Band II four-element array with universal clamp for masts up to 2in dia (recommended by makers for stereo). Price: £4-35.

■ AUDIO WORKSHOPS

See Exator and Fuba.

■ BANG AND OLUFSEN UK LTD

Eastbrook Road, Gloucester, GL47DE.
Tel: Gloucester 21591.

2010 ★

Band II telescopic V aerial for B & O tuners and tuner/amplifiers. Fits into block in back of tuner and is supplied complete with connecting lead and plug. Price: £2-50.

■ BEN NEVIS AERIALS

Belmont Works, Belmont Site, Lewis Street,
Stranraer, Scotland. Tel: Stranraer 2677/8.

Ben Nevis TM902-1

Band II single dipole with stand-off arm and universal mast clamp for 1-2in masts. Price: £2-10.

Ben Nevis TM902-2

Band II dipole and reflector with boom and stand-off arm and universal mast clamp. Price: £2-60.

Ben Nevis TM902-3

Band II three-element array comprising director, folded dipole and reflector, with stand-off arm and universal mast clamp. Price: £3-75.

Ben Nevis TM902-4

Band II four-element array comprising two directors, folded dipole and reflector, with stand-off arm and universal mast clamp. Price: £4-25.

VHF aerials custom-built to individual customer's specification.

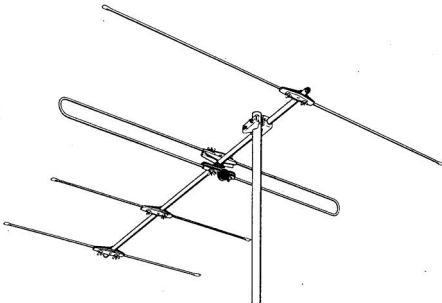

Antiferrence 244

HIGH QUALITY AERIALS FOR HIGH QUALITY STEREO RECEPTION



Band 2 FM Stereo FM4S

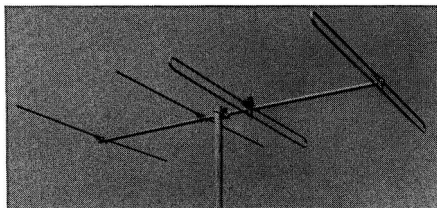

FM4S

With stereo transmissions on V.H.F. radio, the receiving aerial has assumed an increased importance. Firstly due to the Multiplex stereo system used, there is a serious drop in signal to noise ratio. Hence a larger input signal is required by the receiver to give equivalent performance to Mono reception. Secondly, multi-path reception (i.e. reception of one or more reflected signals in addition to the main signal) has not been too troublesome on Mono but will have serious effects on stereo reception. The FM4S overcomes this and is specially designed to give the minimum response to unwanted signals with an overall gain of 7dB reference to a halfwave dipole. The FM4S is a new wide band aerial covering 88-98 mhz. Supplied complete with clamp to fit up to a 2" mast.

Frequency	Any 5 MHz band between 88 and 100 MHz
V.S.W.R. better than	1.8/1
Gain	7.0dB
Half Power Beamwidth	54°
Front to Back Ratio	16dB
Length	74" 188 cm.
Wind Loading @ 100 m.p.h.	33 lb.

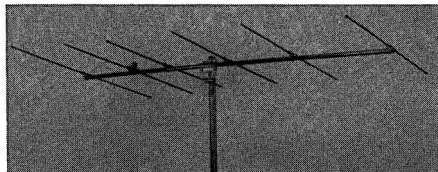

FM6S

The FM6S is specially designed to give superior performance over the band 88-100 mhz and reception of Continental stereo is possible in favourable locations. As this aerial is wide band and employs four directors with less loading at any one frequency, it has proved advantageous to use a centre fed dipole without the need for folding. Aerial is supplied complete with clamp to fit up to a 2" mast.

Band 2 FM Stereo FM6S



Band II FM for Mono

FMG1 The FMG1 is a simple dipole with a 7" stand-off mast enabling it to be clamped to an existing T.V. aerial system. Suitable for local service areas.

FM2 The FM2 has sufficient front to back ratio to reduce interference from the rear. Gain 3dB over a dipole. Comprising single dipole with reflector element and supplied complete with clamp to fit up to a 2" mast.

FM3L The FM3L gives protection against signals of more than 35° off bearing. Gain 5dB over a dipole. Comprising single dipole, director element and reflector and supplied complete with a special loft mounting mast.

These aerials are specially tuned to cover the whole of the FM band. The FM2 and FM3L have excellent polar diagrams to provide maximum rejection of unwanted signals.

NORTHAMPTON · Tel: (STD 0604) 63531 (10 lines) Telex: 311101

Member of the J-Beam Group of Companies

■ EXATOR

Audio Workshops Ltd, 29 High Street,
Robertsbridge, Sussex.
Tel: Robertsbridge (058 088) 580.

Exa Stereo

Five-element Band II array comprising three directors, folded dipole and reflector. Balun unit incorporated to provide optimum matching between dipole and coaxial feeder. Dipole impedance 240 ohms, recommended downlead 60-75 ohm coaxial. Range: 87.5-106MHz. Gain: 7dB average. Front-to-back ratio: 22.5dB average. Price: (array only) £6.85.

Exa Ringdipol

Combined Band II folded dipole with vertical rod AM aerial. Supplied with FM feeder cable, stand-off arm, fixing screws, plugs and insulators. Suitable for wall, window frame or loft mounting. Price: £4.55.

■ FUBA

Audio Workshops Ltd,
29 High Street, Robertsbridge, Sussex.
Tel: Robertsbridge (058 088) 580.

Uka Stereo 2

Band II array. Price: £4.75.

Uka Stereo 5

Band II array. Price: £10.25.

Uka Stereo 8

Band II array. Price: £15.

Fuba RFA 013

Aerial amplifier unit. Price: £4.90.

Fuba USW 100

Aerial combining unit. Price: £4.95.

■ J BEAM

J Beam Aerials Ltd, Rothersthorpe Crescent,
Northampton, NN49JD.
Tel: Northampton 63531 (STD 0604).

FMG1

Band II dipole with 7in stand-off arm enabling it to be clamped to existing TV aerial mast. Suitable local service areas. Price: £2.10.

FM2

Band II dipole with reflector. Supplied with clamp to fit mast up to 2in diameter. Provides 3dB gain over single dipole. Price: £2.80.

FM3L

Band II array comprising dipole, director and reflector. Fitted with special loft mounting mast. Price: £2.90.

FM3

Band II array comprising dipole, director and reflector. Gives protection against unwanted signals 35° off bearing. Provides 5dB gain

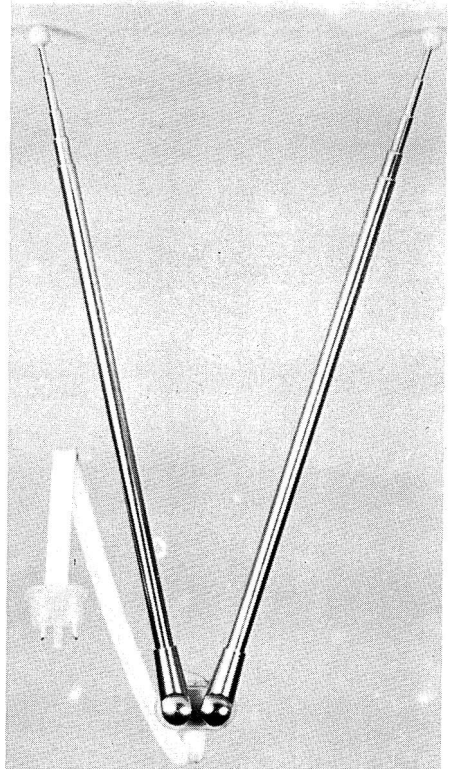

Bang & Olufsen 2010

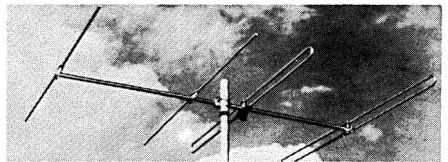

J-Beam FM45

over single dipole. Supplied with clamp to fit masts up to 2in diameter. Price: £4.35.

FM45 ★

Band II array comprising two directors, folded dipole and folded reflector. Latest version now wideband to cover whole of FM/VHF band 88-98MHz. Overall gain 7dB over single dipole. Minimum response to unwanted signals. Supplied with clamp to fit masts up to 2in diameter.

★ Indicates entry is illustrated

Recommended for high quality stereo radio reception. Price: £5-55.

FM6S

Band II array comprising four directors, one dipole and one reflector. Covers FM/VHF band 88-100MHz. Suitable for long distance reception, including continental stations. Supplied with clamp to fit masts up to 2in diameter. Price: £7-80.

■ K.V.A. ELECTRONICS

40 Monarch Parade, London Road, Mitcham, Surrey. Tel: 01-648 4884.

FML

Band II loft dipole. Two-screw fixing bracket, rotatable base, arms of dipole adjustable to V for optimum results or to clear obstructions. Price: £1.

FM.SD/W

Band II wall-mounting single dipole with fixing bracket, stand-off arm and provision for swivelling aerial for optimum results. Price: £2.

FML/H

Band II loft-type H aerial comprising dipole, reflector, mounting boom and stand-off arm. Fixing bracket permits aerial to be orientated for best results. Price: £2.

From the oldest established Aerial Company in B'ham, we offer:—

- 24-HOUR SIX DAY WEEK SERVICE
- DOMESTIC AND COMMUNAL INSTALLATIONS
- ALL INSTALLATIONS GUARANTEED 12 MONTHS
- SUBSTANTIAL PUBLIC LIABILITY
- ESTIMATES FREE
- AERIALS AND KITS SUPPLIED, SEND FOR DETAILS

MEMBERS OF N.F.A.C.

WEST MIDLAND AERIALS

2329 Coventry Road, Sheldon, Birmingham 26
Telephone: 021-743 2395/0899

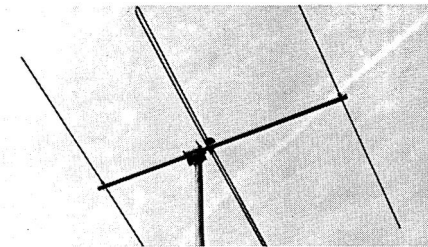

Maxview D/FD3

FML/Y3

Band II three-element loft array comprising director, folded dipole and reflector with stand-off arm and fixing bracket. Particularly suitable in areas where signal strength is poor or where 'ghosting' causes distortion. Price: £3-25.

FML/Y4

Similar to FML/Y3 but with two directors. Price: £3-50.

■ MAXVIEW AERIALS LTD

Maxview Works, Setch, King's Lynn, Norfolk. Tel: Watlington (Norfolk) 376.

Maxview D/DW

Band II wall-mounting dipole with stand-off arm and adjustable swivel fitting. Price: £2-05.

Maxview D/DM

Band II dipole array with bracket for mast fitting. Price: £1-75.

Maxview D/HM

Band II array comprising dipole and reflector on boom. Bracket for mast mounting. Price: £2-42.

Maxview D/S3

Band II three-element array comprising director, dipole and reflector. Bracket for mast mounting. Price: £2-80.

Maxview D/FD3 ★

Band II three-element array comprising director, folded dipole and reflector. Bracket for mast mounting. Price: £3-50.

Maxview D/STB

Band II Twig stub add-on units for TV aerials to boost Band II reception. Price: 64p.

■ VISTA GAIN

Vista Gain Sales Co,
123/124 Newgate Street, London, EC1A 7AA.
Tel: 01-600 3030.

K.2

Band II indoor dipole. Heavily-plated three-step telescopic dipole adjustable for optimum results. Capacity coupled elements for complete safety. Heavy base. Supplied with three yards low-loss coaxial cable. Price: £2-55.

Directory of Manufacturers

Abstracta Equipment Ltd, Netil House,
1-7 Westgate Street, London, E8 3RB.
Tel: 01-986 3131.

Acos See Cosmocord

Acoustical Manufacturing Co Ltd,
St Peter's Road, Huntingdon Hunts.
Tel: Huntingdon 2561/2.

Acoustic Enterprises Ltd, 6-8 Union
Street, Kingston-on-Thames, Surrey.
Tel: 01-549 3471/3.

Acoustic Research Interational,
PO Box 209, Radiumweg 7,
Amersfoort Holland, Tel: (03490) 12556.

ADC See Hisonic

Adastra Electronics Ltd, Unit 22,
Cricklewood Trading Estate,
Claremont Road, London, NW2 1TU.
Tel: 01-452 6288.

Admiral See Interconti Electronics Ltd

AEG (Great Britain) Ltd, AEG House,
Chichester Rents, Chancery Lane,
London, WC2. Tel: 01-242 9944.

Aerialite Aerials Ltd, Radnor Park
Trading Estate, West Heath,
Congleton, CW12 4PX.
Tel: Congleton 3892.

Agfa-Gevaert Ltd, Unity House,
Great West Road, Brentford, Middlesex.
Tel: 01-560 2121.

Akai See Rank Audio Products

AKG Equipment Ltd, 182-184 Campden
Hill Road, Kensington, London, W8.
Tel: 01-229 3695/6.

Alba (Radio & Television) Ltd,
Tabernaec Street, London, EC2.
Tel: 01-253 1322.

Richard Allan Radio Ltd, Bradford Road,
Gomersal, Cleckheaton, Yorkshire.
Tel: Cleckheaton 2442/3.

Alpha See Highgate Acoustics

Altec Lansing See Ling Dynamic
Systems Ltd.

Amos of Exeter Ltd, Weircliffe Court,
Exwick, Exeter, Devon.
Tel: Exeter 72132.

Ampex GB Ltd, Acre Road, Reading,
RG2 0QR. Tel: Reading 84411.

Amplivox Ltd, Beresford Avenue,
Wembley, Middlesex. Tel: 01-902 8991.

Amstrad Electronics Ltd, 34 Great
Sutton Street, London, EC1.
Tel: 01-251 0241/2.

Antiference Ltd, Bicester Road,
Aylesbury, Bucks. Tel: Aylesbury 2511.

APAE See Association of Public
Address Engineers

ARD See Audio Research and
Development

Argon See Hampstead High Fidelity

Ariston See C. W. & J. Walker

Armstrong Audio Ltd, Warlters Road,
Holloway, London, N7. Tel: 01-607 3213.

Arnex Products Ltd, London Road,
Daventry, Northants.
Tel: Daventry 2231.

ASA See Maggs (Bristol) Television Ltd

Associated Electronic Engineers Ltd,
Dalston Gardens, Stanmore, Middlesex.
HA7 1BL. Tel: 01-204 2125.

Association of Public Address Engineers,
6 Conduit Street, London, W1R 9TG.
Tel: 01-493 5256.

A.S. Techniques, 35 Waterloo Street,
Leicester. Tel: Leicester 26319.

Astec See A. S. Techniques

Astronic See Associated Electronic
Engineers

Audio Developments See B. H. Morris &
Co.

Audio Magnetics (UK) Ltd, 12 Fife Road,
Kingston-on-Thames, Surrey, KT1 1SZ.
Tel: 01-549 3271/2.

Audio Packs Ltd, 206-210 Ilberton Road,
London, SE15 1NS.
Tel: 01-639 7844.

Audio Research & Development Ltd,
PO Box 73, Hounslow, Middlesex.
Tel: 01-570 0471.

Audio Services Ltd, 82 East Barnet Road,
New Barnet, Herts. Tel: 01-449 6605.

Audio Technica See Shriro

Audio Workshops Ltd, 29 High Street,
Robertsbridge, Sussex.
Tel: Robertsbridge 580.

Baker Reproducers Ltd, Bensham Manor
Road Passage, Thornton Heath, Surrey.
Tel: 01-684 1665.

Bang & Olufsen UK Division,
Eastbrook Road, Gloucester, GL4 7DE.
Tel: Gloucester 21591.

BASF United Kingdom Ltd,
Knightsbridge House, 197 Knightsbridge,
London, SW7. Tel: 01-584 5080.

F.W.O. Bauch Ltd, 49 Theobald Street,
Boreham Wood, Herts. Tel: 01-953 0091.

Bell & Howell Ltd, Audio Products
Division, Alpernton House, Bridgewater
Road, Alpernton, Middlesex, HA0 1EG.
Tel: 01-902 8812.

Ben Nevis Aerials Ltd, Belmont Works,
Belmont Site, Lewis Street, Stranraer,
Scotland. Tel: Stranraer 2677/8.

Beyer Dynamic (GB) Ltd, 1 Clair Road,
Haywards Heath, Sussex.
Tel: Haywards Heath 51003.

Bib Sales, PO Box 78,
Maylands Avenue, Hemel Hempstead,
Herts. Tel: 0442 3636 ext. 100.

Bigson See J. Parkar & Co (Radio) Ltd

Black Knight Rumblecure, Bank Top,
Currier Lane, Ashton-under-Lyne,
Lancs. Tel: 061-2836 and 330 3991.

Bogen See Cole Electronics Ltd

Bosch Ltd, Rhodes Way, Radlett Road,
Watford, Herts. WD24LB.
Tel: Watford 44233.

Bose See Expotus

Bouyer See Douglas A. Lyons and
Associates

Bradmatic Ltd, 338 Aldridge Road,
Streely, Sutton Coldfield, Warwickshire.
Tel: 021-353 3171.

**Brahms Manufacturing and
Development Co**, Unit E,
Rochester Airport, Maidstone Road,
Rochester Kent.
Tel: Medway 48816.

Brenell Engineering Co Ltd,
231-5 Liverpool Road, London, N1.
Tel: 01-607 8271.

Britimpex Ltd, 8-12 Rickett Street,
London, SW6. Tel: 01-385 0883.

British Radio Corporation Ltd,
284 Southbury Road, Enfield, Middlesex.
Tel: 01-366 1155.

British Radio Corporation Ltd,
Thorn House, Upper St Martins Lane,
London, WC2. Tel: 01-836 2444.

Bryan Amplifiers Ltd,
18 Greenacres Road, Oldham, Lancs.
Tel: 061-624 4074.

BSR McDonald See BSR Ltd

BSR Ltd, Monarch Works,
Cradley Heath, Warley, Worcs.
Tel: Cradley Heath 69272.

Burne-Jones & Co Ltd,
18 Brunswick Road, Sutton, Surrey.

Bush-Arena See Rank Bush Murphy Ltd

Bush Nelson Ltd, Bush House,
6 Yattendon Road, Horley, Surrey.
Tel: Horley 5983.

B & W Electronics Ltd,
Meadow Road, Worthing, Sussex.
Tel: Worthing 20561 1/4.

Calder Recordings Ltd, Regent Street,
Hebden Bridge, Yorkshire.
Tel: Hebden Bridge 2159.

Calrec See Calder Recordings

Cambridge Audio Ltd, The River Mill,
St Ives, Huntingdon.
Tel: St Ives (Hunts) 62901.

Canterbury Audio, 4 Station Road,
West Canterbury, Kent.
Tel: Canterbury 60431.

Celestion See Rola-Celestion

Chilton See Magnetic Tapes

Cinecorder See REW Audio Visual Ltd

City Audio Services Ltd, 7 Chalcot Road,
London, NW1. Tel: 01-586 3211/2.

Clark See Sonab

Cleen See Kirkman (Crawley) Ltd.

Clendisc (Mail Order) Ltd,
7 Trinity Court, Gray's Inn Road,
London, WC1. Tel: 01-837 9088.

- Cole Electronics**, 7-15 Lansdowne Road, Croydon, CR92HB. Tel: 01-686 7581.
- Colton** See Musonic
- Connoisseur** See A. R. Sugden & Co.
- Contronics Ltd**, Garth Works, Deepcut Bridge Road, Blackdown, Camberley, Surrey. Tel: Deepcut 5936.
- Cosmocord Ltd**, Eleanor Cross Road, Waltham Cross, Herts. Tel: Waltham Cross 27331.
- Crown International** See Macinnes Laboratories Ltd.
- Crown Radio Ltd**, 128/9 Shoreditch High Street, London, E1 6JE. Tel: 01-739 2382.
- A. Davies & Co.**, 56 Wellesley Road, London, NW5. Tel: 01-485 5775.
- Decca Record Co**, Decca House, 9 Albert Embankment, London, SE1. Tel: 01-735 8111.
- Decca Special Products**, Ingate Place, Queenstown Road, London, SW8 3NT. Tel: 01-622 6677.
- Deimos Ltd**, 8 Corwell Lane, Hillingdon, Middlesex. Tel: 01-573 3561.
- Denham & Morley (Overseas) Ltd**, 453 Caledonian Road, London, N7. Tel: 01-607 6568.
- Derwent** See Nichols Acoustic Fitments
- Deutsche Grammophon** See Polydor Ltd
- Dual** See International Audio Ltd
- Duette** See J. J. Silber
- Dynaco** See Howland-West
- Dynastatic** See Audio Services
- Dynatron Radio Ltd**, St Peter's Road, Maidenhead, Berks, SL6 7QY. Tel: Maidenhead 23331.
- Eagle International**, Heather Park Drive, Wembley HA01SU. Tel: 01-903 0144.
- Eastman** See Cosmocord
- Eaton Audio Fitments**, Leopold Street, Long Eaton, Nottingham, NG10 4QF. Tel: Long Eaton 2662 and 2818.
- Echo** See Adastra Electronics
- Edward Michelsen Custom Cabinets**, 'Sound Ideas', 494 New Cross Road, New Cross, London, SE14. Tel: 01-692 2981. Also at 216 Brampton Road, Bexleyheath, Kent. Tel: 01-303 9272.
- Ekco** See Pye
- Elac** See Electro Acoustic Industries
- Electro Acoustic Industries Ltd**, Stamford Works, Broad Lane, Tottenham, London, N15. Tel: 01-808 0505.
- Electronic Manufacturing Co (UK) Ltd**, Devonshire House, High Street, Deritend, Birmingham, B12 0LP. Tel: 021-772 7145.
- Elgar** See English Audio (1970) Ltd
- Elizabethan** See Lee Products
- EMI Electronics Ltd**, Installation and Maintenance Division, Blyth Road, Hayes, Middlesex. Tel: 01-573 3888.
- EMI Records Ltd**, EMI House, 20 Manchester Square, London, W1. Tel: 01-486 4488.
- EMI Sound Products Ltd**, Component Division, Blyth Road, Hayes, Middlesex. Tel: 01-573 3888.
- EMI Tape Ltd**, Blyth Road, Hayes, Middlesex. Tel: 01-573 3888.
- Emphasis**, 50a The Avenue, Kilburn, London, NW6. Tel: 01-451 0517.
- Empire Scientific Corporation** See Rank Aldis Audio Products
- EMT Wilhelm Franz** See F. W. O. Bauch
- English Audio (1970) Ltd**, North Station Road, Colchester, Essex. Tel: Colchester 73467.
- E. R. Factors Ltd**, 374-378 Harrow Road, Paddington, London, W9. Tel: 01-286 0361.
- Euphonics** See A. C. Farnell
- Europa Electronics Ltd**, Howard Place, Shelton, Stoke-on-Trent, ST14NW. Tel: Stoke-on-Trent 29316.
- Exator** See Audio Workshops Ltd
- Excel Sound Corporation** See Mathers Photographics Ltd
- Expert Pickups Ltd**, PO Box No. 3, Ashstead, Surrey. Tel: Ashstead 76604
- Expotus Ltd**, 10 Museum Street, London, WC1. Tel: 01-836 3747.
- FAL** See Futuristic Aids
- Falcon** See John Street
- Falcon Electronics**, 33 Station Road, Bexhill-on-Sea, Sussex. Tel: Bexhill 1908.
- Jonathan Fallowfield Ltd**, Strathcona Road, North Wembley, London, HA9 8QL. Tel: 01-904 0141.
- Fane Acoustics Ltd**, Hick Lane, Batley, Yorks. Tel: Batley 6431.
- Fantavox** See Adastra Electronics Ltd and E. R. (Factors) Ltd
- A.C. Farnell Ltd**, Consumer Division, Farnell House, 81 Kirkstall Road, Leeds, LS31HR. Tel: Leeds 35111.
- Feldon Audio Ltd**, 126 Great Portland Street, London, WIN 5PH. Tel: 01-580 4314.
- Ferguson** See British Radio Corporation
- Ferrograph Co Ltd**, Auriema House, 442 Bath Road, Cippenham, Slough, Bucks, SL1 6BB. Tel: Burnham 62511.
- Fidelity Radio Ltd**, 6 Olaf Street, London, W11. Tel: 01-727 0131.
- Film Industries Ltd**, Station Avenue, Kew Gardens, Surrey. Tel: 01-940 8078.
- Fisher** See REW Audio Visual Ltd
- Foster** See E. R. Factors Ltd and Adastra Electronics Ltd
- J.J. Francis (Wood Green) Ltd**, 123 Alexandra Road, Hornsey, London, N8. Tel: 01-888 1662.
- A. R. Franklin (Audio Engineer)**, 4 Birch House, Howard Road, Penge, London, SE20. Tel: 01-659 0912.
- Fuba** See Audio Workshops Ltd
- Futuristic Aids Ltd**, 104 Henconner Lane, Leeds, 13. Tel: Pudsey 5478.
- Gabraphone** See Modern Engineering & Technology
- Garrard Engineering Ltd**, Swindon, Wilts. Tel: Swindon 5381.
- GEC (Radio & Television) Ltd**, Langley Park, Slough, Bucks. Tel: Slough 22201.
- Golding Audio Ltd**, Marks Tey, Colchester, Essex. Tel: Colchester 210433.
- Golding Manufacturing Co (Great Britain) Ltd**, 10 Bayford Street, Hackney, London, E8 3SE. Tel: 01-985 1152.
- Goodmans Loudspeakers Ltd**, Downley Road, Havant, Hampshire, P09 2NL. Tel: Havant 6344.
- Grado** See Howland-West Ltd
- Grampan Reproducers Ltd**, 19 Hanworth Trading Estate, Feltham, Middlesex. Tel: 01-894 9141.
- Grundig (Great Britain) Ltd**, Hi-Fi Division, Sydenham, London, SE26. Tel: 01-778 2211.
- Gusdorf** See C. E. Hammond
- Hacker Radio Ltd**, Norreys Drive, Cox Green, Maidenhead, Berks. Tel: Maidenhead 22261.
- G.F.C. Haddock**, Audio Division, The Old Vicarage, Doveridge, Derby. DE65NN. Tel: Uttoxeter 2452.
- C.E. Hammond & Co Ltd**, Lamb House, Church Street, London, W4. Tel: 01-995 4551.
- Hampstead High Fidelity**, 91 Heath Street, Hampstead, London, NW3. Tel: 01-435 6377 and 0999.
- Hanimex (U.K.) Ltd**, Hanimex House, 15-24 Chesham Street, London, SE1. Tel: 01-407 8161.
- Harman-Kardon** See Highgate Acoustics
- Harris & Russell Ltd**, 124-130 East Road, London, N1. Tel: 01-253 7551.
- Harwell Instruments**, 5-9 Anerley Station Road, London, SE20. Tel: 01-778 9456.
- Hayden Laboratories Ltd**, Hayden House, 17 Chesham Road, Amersham, Bucks. Tel: Amersham 5511.
- Heath (Gloucester) Ltd**, Bristol Road, Gloucester, GL2 6EE. Tel: Gloucester 29451.
- Heathkit** See Heath (Gloucester)
- Hecco** See Acoustico Enterprises
- Thomas Heinitz**, 35 Moscow Road, Queensway, London, W2. Tel: 01-229 2077.
- P.F. and A.R. Helme Ltd**, Summerbridge, Harrogate HG34DR. Tel: Darley 279.
- Henry's Radio Ltd**, 303 Edgware Road, London, W2. Tel: 01-723 1008/9.
- H/H Electronic**, Industrial Site, Cambridge Road, Milton, Cambridge, CB44AZ. Tel: Cambridge 65945/6.

Hi-Fi Sound See Howland-West Ltd

Hightate Acoustics Ltd, 184-188 Great Portland Street, London, W1.
Tel: 01-636 2901.

Hisonic Ltd, Tovil, Maidstone, Kent.
Tel: Maidstone 57258.

Hi-Sound See Electronic Manufacturing Co (UK) Ltd

Hitachi Sales (UK) Ltd, Park House, Coronation Road, Park Royal, London, NW107QS. Tel: 01-965 9861.

H. L. Audio Ltd, 5 Shakespeare Road, Finchley, London, N3. Tel: 01-346 3332.

HMV See British Radio Corporation

Holder Pearce Ltd, 66 Grove Road, Eastbourne, Sussex.
Tel: Eastbourne 26565.

John Horwitz, 305 Kenton Road, Kenton, Harrow, Middlesex.
Tel: 01-907 6667.

Howland-West Ltd, 3-5 Eden Grove, London, N78EQ.
Tel: 01-609 0293.

IMF Products (GB), Westbourne Street, High Wycombe, Bucks.
Tel: High Wycombe 35166.

Imhofs Ltd, 112-116, New Oxford Street, London, WC1. Tel: 01-636 7878.

Impex See McArdle & Brainsby (Import & Export) Ltd

Interconti Electronics Ltd, Albany House, Petty France, London, SW1H9EA.
Tel: 01-222 2523.

International Audio Ltd, Clive House, Queens Road, Weybridge, Surrey.
Tel: Weybridge 40125/6.

ITT-KB Consumer Products Division, Foots Cray, Sidcup, Kent, DA145HT.
Tel: 01-300 7733.

ITT Components Group Europe, Standard Telephones & Cables Ltd, Electro-Mechanical Product Division, West Road, Harlow, Essex.
Tel: Harlow 26811.

Japan Phono Motor See Howland-West

J Beam Aerials Ltd, Rothersthorpe Crescent, Northampton, NN49JD.
Tel: Northampton 63531/6.

Jordan Watts Ltd, Benlow Works, Silverdale Road, Hayes, Middlesex.
Tel: 01-573 6928.

J. W. (Wholesale) Ltd, 26 Rosoman Street, London, EC1.
Tel: 01-837 5920.

Kalimar See Hightate Acoustics Ltd

KEF Electronics Ltd, Tovil, Maidstone Kent. Tel: Maidstone 57258.

Keith Monks (Audio) Ltd, 26-30 Reading Road South, Fleet, Nr. Aldershot.
Tel: Fleet 7316.

Keletron See Kelgrove (Sales)

Kelgrove Sales Ltd, St Marks Rise, Dalston, London, E8.

Kellar Electronics Ltd, Lopen Works, Lopen Road, Edmonton, London, N18.
Tel: 01-807 4986.

K.F. Products Ltd, Brookfield House, Hopes Carr, Stockport, Cheshire.
Tel: 061-480 7428.

Kingstereo See Lionel Murray

Kingsway Mills Ltd, 5 Worship Street, London, EC2. Tel: 01-628 6157.

Kirkman (Crawley) Ltd, 40 The Broadway, Crawley, Sussex.
Tel: Crawley 26670.

Klein and Hummel See F.W.O. Bauch

Klinger Controls, Spencer Court, 7 Chalcot Road, London, NW18LU.
Tel: 01-586 2922/3.

Korting See Europa Electronics

Koss See Tape Music Distributors

Koyo See Kingsway Mills Ltd

KVA Electronics Ltd, 40 Monarch Parade, London Road, Mitcham, Surrey. Tel: 01-648 4884.

Lampitt Electronics Ltd, 6-12 Cornbrook Park Road, Manchester M154EE.
Tel: 061-872 7661.

James B. Lansing See Feldon Audio

Larson See Cole Electronics Ltd

H. J. Leak & Co Ltd, Bradford Road, Idle, Bradford, BD108SQ.
Tel: Bradford 612552.

Lescon Audio Ltd, Nuffield Road, Industrial Estate, St Ives, Hunts.
Tel: St Ives (Hunts) 64125.

Lee Products (Great Britain) Ltd, 10-18 Clifton Street, London, EC2.
Tel: 01-247 6711.

Leavers-Rich Equipment Ltd, 319 Trinity Road, Wandsworth, London, SW18. Tel: 01-874 9054/6.

Lem See Douglas A. Lyons and Associates

Lennard Development Ltd, 206 Chase Side, Enfield, Middlesex, EN20QX. Tel: 01-363 8238.

L & H See Britimpex

Linear Products Ltd, Electron Works, Armlay, Leeds, Yorks.
Tel: Leeds 630126.

Ling Dynamic Systems Ltd, Baldock Road, Royston, SG85BQ, Herts. Tel: Royston 42424.

LNB Audio Ltd, 25 Cambridge Street, Loughborough, Leicester.
Tel: Loughborough 61229.

Lockwood & Co (Woodworkers) Ltd, 63 Lowlands Road, Harrow, Middlesex.
Tel: 01-422 3704/0768.

Lowther Manufacturing Co Ltd, Lowther House, St Mark's Road, Bromley, Kent, BR29HQ.
Tel: 01-460 5225.

Lustraphone Ltd, St George's Works, Regents Park Road, London, NW1.
Tel: 01-722 8844.

Lux See Howland-West

Luxor See Hightate Acoustics

Douglas A. Lyons & Associates Ltd, 8 Rycotes Mead, Dulwich, London, SE21. Tel: 01-693 2855.

3M (UK) Ltd See Scotch

MAC See Modular Audio Components Ltd

Macinnes Laboratories Ltd, Stonham, Stowmarket, Suffolk IP145LB.
Tel: Stonham 486.

Mags (Bristol) Television Ltd, The Station, Sea Mills Lane, Bristol, BS9 1DX. Tel: Bristol 684801.

Magnetic Tapes Ltd, Chilton Works, Garden Road, Richmond, Surrey.
Tel: 01-876 7957.

Marantz See Pyser-Britex (Swift) Ltd
Marconiphone See British Radio Corporation

Martin See Cosmocord

Mastertape (Magnetic) Ltd, Blackthorne Road, Poyle Trading Estate, Colnbrook, Near Slough, Bucks, SL30AQ. Tel: Colnbrook 2431.

Mathers Photographics Ltd, 35 John Dalton Street, Manchester, 2.
Tel: 061 834 6133.

Maxell See Harris and Russell

Maxview Aerials Ltd, Maxview Works, Setch, King's Lynn, Norfolk.
Tel: Watlington (Norfolk) 376.

McArdle & Brainsby (Import & Export) Ltd, PO Box 2BB, Newcastle upon Tyne, NE99 2BB. Tel:

Medway See Brahms Manufacturing & Development Co

Melodium See Keith Monks (Audio)

Memorex Inc, Freight House, Long Lane, Stanwell, Middlesex.
Tel: Ashford (Middlesex) 42177.

Metrosound Audio Products Ltd, Cartersfield Road, Waltham Abbey, Essex. Tel: Waltham Cross 31933.

Micro-Seiki See B. H. Morris (Radio)

N. Miers & Co Ltd, 28 Piercing Hill, Theydon Bois, Epping, Essex.
Tel: Theydon Bois 2611/3.

Millbank Electronics Group, Bellbrook Estate, Uckfield, Sussex.
Tel: Uckfield 4166.

MMG Associates Ltd, 19 Southfield Road, Flackell Heath, Near High Wycombe, Buckinghamshire.
Tel: Bourne End 21048.

Modern Engineering & Technology, 4 Station Road, West Canterbury, Kent.
Tel: Canterbury 60431.

Modular Audio Components Ltd, Canterbury Road, Nottingham, NG8 1PQ. Tel: 79797 or 73075.

Keith Monks (Audio) Ltd, 26-30 Reading Road South, Fleet, Aldershot, Hants. Tel: Fleet 7316.

Mordaunt-Short Ltd, The Courtyard, Heath Road, Petersfield, Hampshire.
Tel: Petersfield 4761.

B.H. Morris & Co (Radio) Ltd, 84-88 Nelson Street, Tower Hamlets, London, E1. Tel: 01-790 5011.

Motion Electronics Ltd, Addlestone Farm, Tonbridge Road, East Peckham, Kent.
Tel: East Peckham 354.

Mullard Ltd, Mullard House, Torrington Place, London, WC1.
Tel: 01-580 6633.

- Multicore Solders Ltd**, Bib Sales Division, Maylands Avenue, Hemel Hempstead, Herts. Tel: HemelHempstead3636 ext. 100.
- Lionel Murray Ltd**, 7 West Halkin Street, Belgrave Square, London, SW1. Tel: 01-235 6424/6.
- Musica Craft Audio Products Ltd**, 63 High Street, Hounslow, Middlesex. Tel: 01-570 4640.
- Musonic Ltd**, 34-38 Verulam Road, St Albans, Herts. Tel: St Albans 50611/2.
- Nagra** See Hayden Laboratories
- National Panasonic** See Unamec
- Neat Corporation** See Howland-West
- Neumann GMBH** See F. W. O. Bauch
- New Classic** See J. W. (Wholesale) Ltd
- Nichols Acoustic Fittings**, Church Street, Bubwith, Near Selby, Yorkshire. Tel: Bubwith 206.
- Nikko** See Howland-West
- Nivico** See Denham and Morley (Overseas)
- Nordmende** See TAK Continental Importers
- Nucleus**, 22 Hyde Green, Marlow, Bucks. Tel: Marlow 3787.
- Onkyo** See J. Parker & Co (London)
- Orbit** See Highgate Acoustics
- Ortofon** See Metrosound (Sales)
- Osmabet Ltd**, 46 Kenilworth Road, Edgware, Middlesex. Tel: 01-958 9314.
- Pageantry Radio & TV Co Ltd**, 104 Felsham Road, Putney, SW15. Tel: 01-788 5588.
- J. Parker & Co (London) Ltd**, Parker House, 1 Paul Street, London, EC2A 4JQ. Tel: 01-628 4577.
- PD Connectors**, See Parry Electronic Developments Ltd
- Parry Electronic Developments Ltd**, Assay House, 28, Greville Street, London, EC1N 8SU. Tel: 01-242 1100.
- Pearl** See Audio Workshops—also Feldon Recording Ltd
- Peerless** See P. F. and A. R. Helme
- Perpetuum-Ebner** See Highgate Acoustics
- Philco-International Ltd**, 42 Leicester Square, London, WC2H 7LR. Tel: 01-930 7667.
- Philips Electrical Ltd**, Century House, Shaftesbury Avenue, London, WC2. Tel: 01-437 7777.
- Phoenix** See H. L. Audio Ltd
- Pickering** See Highgate Acoustics
- Pioneer** See Shiro
- Planet Projects Ltd**, Goodmans Works, Belvue Road, Northolt, Middlesex. Tel: 01-845 1775.
- Playfair** See Lennard Developments
- Polydor Records Ltd**, 17-19 Stratford Place, London, W1. Tel: 01-499 8866.
- Pye Business Communications Ltd**, Cromwell Road, Cambridge, CB1 3EL. Tel: Cambridge 45191.
- Pye Ltd**, PO Box 49, St Andrews Road, Cambridge. Tel: Cambridge 58985.
- Pyser-Britex (Swifts) Ltd**, Fircroft Way, Edenbridge, Kent. Tel: 0732-71 2434/6.
- Quad** See Acoustical Manufacturing
- Quality Audio Supplies**, Wollaton Road, Beeston, Nottingham, NG9 2PB. Tel: 0602 252222 & 256141.
- QAS** See Quality Audio Supplier
- Radford Audio Ltd**, Ashton Vale Road, Bristol BS3 2HZ. Tel: Bristol 662301.
- Radio & Electronic Distribution Co**, 55-63 Goswell Road, London, EC1. Tel: 01-253 1802.
- Radon Industrial Electronics Co Ltd**, Brooklands Trading Estate, Orme Road, Worthing, Sussex. Tel: Worthing 34904.
- Rank Aldis-Audio Products**, Rank Audio Visual Ltd, PO Box 70, Great West Road, Brentford, Middlesex. Tel: 01-568 9222.
- Rank Bush Murphy Ltd**, Power Road, Chiswick, London, W4. Tel: 01-994 6491.
- Rank Wharfedale Ltd**, Bradford Road, Idle, Bradford BD10 8SQ. Tel: Bradford 612552.
- Record Housing Ltd**, Brook Road, London, N22. Tel: 01-888 7487.
- Reps (Tape Recorders) Ltd**, 11-13 Regina Road, Southall, Middlesex. Tel: 01-574 3645.
- Resolound Ltd**, Spring Gardens, London Road, Romford, Essex. Tel: Romford 61926.
- Revox** See C. E. Hammond
- REW Audio Visual Ltd**, 266-268 Upper Tooting Road, Tooting, London, SW17. Tel: 01-672 4471/2 and 9175.
- RGD** See ITT-KB
- Richardson Electronics Ltd**, 57 Jamestown Road, London, NW1. Tel: 01-267 0723.
- Rogers Developments (Electronics) Ltd**, 4-14, Barmstone Road, Catford, London, SE6. Tel: 01-698 7424 and 4340.
- Rola-Celestion Ltd**, Ditton Works, Foxhall Road, Ipswich, Suffolk, IP3 8JP. Tel: Ipswich 73131.
- Rota** See Kelgrove (Sales)
- Rotel** See Rank Aldis-Audio Products
- Saba** See Lampitt Electronics Ltd.
- Sansui** See Vernitron
- Sanyo Marubeni**, Sanyo House, Bushey Mill Lane, Watford, Herts. Tel: Watford 30421.
- Scandinavian Audio Systems Ltd**, Sun Alliance Buildings, 65 London Road, Gloucester, GL1 3HF. Tel: Gloucester 32791/2.
- Scan-Dyna** See Scandinavian Audio Systems Ltd
- Scopetronics Ltd**, Crown Works, Church Road, Kingston-upon-Thames, Surrey. Tel: 01-546 1275 and 4135.
- Scotch, 3M (UK) Ltd**, 3M House, Wigmore Street, London, W1. Tel: 01-486 5222.
- S.D.L.** See Adastra Electronics Ltd.
- Sennheiser Electronics** See Hayden Laboratories
- Servo-Sound** See Sonosound Ltd
- Sharp Electronics (U.K.) Ltd**, 48 Derby Street, Manchester, M8 8HN. Tel: 061-832 6115.
- Sheppard Audio Ltd**, 275 Watling Street (A5) Radlett, Herts. Tel: Radlett 5440.
- Shriro (UK) Ltd**, 42 Russell Sq., London, WC1B 5DF. Tel: 01-580 6996.
- Shure Electronics Ltd**, 84 Blackfriars Road, London, SE1 8HA. Tel: 01-928 3424.
- Siemens** See Interconti Electronics Ltd
- J.J. Silber Ltd**, 11 Northburgh Street, London, EC1. Tel: 01-253 8031.
- Sinclair Radionics**, London Road, St Ives, Huntingdonshire, PE17 4HJ. Tel: St Ives (Hunts) 4311.
- Skandia Electronics** See Golding Audio
- S.M.E. Ltd**, Steyning, Sussex BN43 1LN. Tel: Steyning 814321.
- Sonab Ltd**, PO Box 4, Oldfield Road, Hampton, Middlesex, TW12 2HN. Tel: 01-979 0134.
- Sonics** See B. H. Morris & Co.
- Sonosound Ltd**, 5 Queen Street, London, EC4N 1SU. Tel: 01-248 9461.
- Sonotone** See Vernitron
- Sony (UK) Ltd**, Pyrene House, Sunbury Cross, Sunbury-on-Thames. Tel: Sunbury-on-Thames 87644/7.
- Soundex Ltd**, 18 Blenheim Road, London, W4. Tel: 01-995 1661.
- The Sound Studio Ltd**, 33-35 Camden Road, Tunbridge Wells, Kent. Tel: 32153/30314.
- Spendor Audio Systems Ltd**, 3 Station Approach, Redhill, Surrey. RH1 1NX. Tel: Redhill 63428.
- Standard** See Telenters (London & Provincial)
- Staples & Co Ltd**, Staples Corner, Junction Edgware Road and North Circular Road, London, NW2. Tel: 01-452 1144/8.
- Stax** See Wilmex
- Steeple Supplies (Electronics) Ltd**, Cinema House, Middle Barton, Oxford OX5 4DA. Tel: Steeple Aston 7116.
- Steepletone** See Steeple Supplies (Electronics) Ltd
- Ste-Ma** See Kelgrove (Sales)
- Stentorian** See Whiteley Electrical Radio
- Stereosound Productions Ltd**, Capital Works, Wakefield Road, Brighouse, Yorks. Tel: 4355.
- Stereostage** See Nucleus.

John Street (Manufacturers) Ltd,
Falcon Works, Barmeston Road,
Catford SE6. Tel: 01-698 1177.

Studer See F. W. O. Bauch Ltd

A.R. Sugden & Co (Engineering) Ltd,
Market Street, Brighouse, Yorkshire.
Tel: Brighouse 2142.

J.E. Sugden & Co Ltd, Carr Street,
Cleckheaton, Yorks. BD19 5LA.
Tel: Cleckheaton 2501

Sykes + Hirsch,
201 Greenwich High Road,
London, SE10. Tel: 01-858 0549.

Symphony See J. W. (Wholesale) Ltd

Synchrotape See Adastra Electronics

TAK Continental Importers,
16a High Street, Stone, Staffordshire.
Tel: Stone 3232/3.

Tandberg See Farnell-Tandberg

Tannoy Products Ltd, Norwood Road,
West Norwood, London, SE279AB.
Tel: 01-670 1131.

Tape Music Distributors Ltd,
11 Redvers Road, London, N226EP.
Tel: 01-888 0152.

Tape Recorder Developments Ltd,
Hall Lane, Walsall Wood, Staffs.
Tel: Brownhills 5351.

Tape Recorder Spares Ltd,
Harmsworth House,
9 Harmsworth Street, London, SE17.
Tel: 01-735 9683.

Teac See Acoustico Enterprises Ltd

Telefi See Rola-Celestion Ltd

Telefunken See AEG (Great Britain)

Teleng Ltd, Arisdale Avenue,
South Ockenden, Essex RM155TR.
Tel: South Ockenden 3477.

Telerenters (London & Provincial) Ltd,
Standard House, 1-2 Church Way,
Edgware, Middlesex. Tel: 01-952 7488.

Teleton Electro (Distributors) Ltd,
Teleton House, Robjohns Road,
Widford, Chelmsford, Essex.
Tel: Chelmsford 62442.

Tellux (Sound Productions) Ltd,
Tallon Road, Hutton Industrial Estate,
Brentwood, Essex.
Tel: Brentwood 214708/9.

Thorens See Metrosound Audio Products

Toshiba See Hanimex (UK)

Transcriptors Ltd, 2 Theobald Street,
Boreham Wood, Herts. Tel: 01-953 0771.

Trio See B. H. Morris & Co (Radio)

Tripletone Manufacturing Co,
See Kelgrove Sales

T.T.C. See Adastra Electronics Ltd and
E.R. (Factors) Ltd

Tudor Tape See A.C. Farnell (Leeds) Ltd

Turner See Millbank Electronics

Tutchings Electronics Ltd,
14 Rook Hill Road, Friars Cliff,
Christchurch, Hants.
Tel: Highcliffe 2019.

Tysons, 41 Russell Street,
Leamington Spa.
Tel: Leamington Spa 24935.

Uher See Bosch

Unamec Ltd, PO Box 1,
United Africa House, Blackfriars Road,
London, SE1. Tel: 01-928 2070.

Unimixer See Soundex

Unisound See Mathers Photographics Ltd

Valek Ltd, Lark Street, Darwin,
Lancs, BB32LT.
Tel: Darwin 71881.

Valradio Ltd, Browells Lane, Feltham,
Middlesex. Tel: 01-890 4837 and 4242.

Van der Molen Ltd, 1 Mildmay Road,
Romford, Essex. RM77DA.
Tel: Romford 41904 & 46911.

Vernitron Ltd, Thornhill,
Southampton, SO95QF.
Tel: Southampton 44811.

Vero Electronics Ltd, Industrial Estate,
Chandler's Ford, Eastleigh,
Hants, SO53ZR.
Tel: Chandlers Ford 2952.

Videoton See Radio & Electronic
Distribution Co.

Vista Gain Sales Ltd,
123-4 Newgate Street, London,
EC1A 7AA. Tel: 01-600 3030.

Vitavox Ltd, Westmoreland Road,
London, NW99RJ. Tel: 01-204 4234.

Vortexion Ltd, 257-263 The Broadway,
Wimbledon, London, SW19 1SF.
Tel: 01-542 6242/4.

Wal See A. C. Farnell

C. W. & J. Walker, 3 Kirklands,
Church Street, Cleckheaton, Yorks,
BD193RW. Tel: 097-62 3756.

Cecil E. Watts Ltd, Darby House,
Sunbury-on-Thames, Middlesex.
Tel: Sunbury-on-Thames 3252.

Wharfedale See Rank Wharfedale

Whiteley Electrical Radio Co Ltd,
Radio Works, Victoria Street,
Mansfield, Notts. Tel: Mansfield 24762.

Wilkinson/Form (Electronics) Everest
Mile Road, Widdrington,
Northumberland. Tel: Ulgham 200.

Wilmex Ltd, Stax Division,
24-26 Ensign Street, London, E1.
Tel: 01-949 2545.

Wilson Stereo Library Ltd,
104-106 Norwood High Street, London,
SE27. Tel: 01-670 6394.

L.G. Woollett & Co Ltd,
21 Anerley Station Road, London,
SE208PY. Tel: 01-778 9003.

Worden Audio Developments Ltd,
54 Chepstow Road, London, W2.
Tel: 01-229 4996.

Wye Electronics Ltd, Queen Street North,
Chesterfield, Derbyshire.
Tel: Chesterfield 51116.

Yamaha See Jonathan Fallowfield

Buy your Hi-Fi where you see this sign



-it's your guarantee of a good deal -and a good deal more!

The HFDA symbol, in a showroom or on printed matter, signifies membership of the HIGH FIDELITY DEALERS ASSOCIATION—formed by leading Hi-Fi retailers to provide customers with a rigid guarantee of value for money.

Every purchaser from an HFDA member will receive a printed guarantee and undertaking on the part of the Dealer which, subject to the conditions set out in it, will incorporate the following benefits:—

- 1** *A free replacement for any stock equipment found to be faulty immediately after purchase.*
- 2** *A right for the buyer to receive a full credit for the price paid by him against any other stock equipment if the buyer wishes to change the unit originally supplied, within seven days of a delivery.*
- 3** *A minimum of twelve months service guarantee providing for free labour in addition to the manufacturers component guarantee. This will also be available to the purchaser if he moves house and takes the equipment into the service area of another member who is an agent for the make concerned.*

Member dealers are also pledged to:—

- 4** *Maintain facilities for the demonstration and comparison of all Hi-Fi equipment stocked, and fully qualified staff who will offer sound and honest advice.*
- 5** *Provide a consultancy service which will be free to you at all times once you have purchased your equipment through that HFDA member.*

There is no extra charge whatever for the valuable facilities that are yours when you buy Hi-Fi equipment – whatever its make, whatever its price – from a member of the High Fidelity Dealers Association.

MEMBERS ARE DEALERS WITH STANDARDS THEY TAKE PRIDE IN—AND THEIR PRIDE IN THOSE STANDARDS IS YOUR GUARANTEE OF VALUE FOR MONEY.

H.F.D.A., 100 St. Martin's Lane, London, WC2 4BD

Directory of Hi Fi Dealers

IMPORTANT NOTE

The following list is of shops where stocks of equipment are kept, and where facilities for demonstration exist. It is not necessarily a complete list, and we invite new dealers to submit details for future publications.

LONDON AREA

AUDIO SUPPLIES LTD

(The Big Discount House)
50 Stanford Hill, N16

AUDIO T

9 Dryden Chambers, 119 Oxford Street, W1A 3DA

AUDIO HOUSE LTD

5 Ashbourne Parade, Finchley Road, Temple Fortune, NW11

BERRY'S RADIO LTD

319 High Holborn, WC1V 7PB

BLACK KNIGHT RUMBLECURE

15 Irving Street, WC2

BRAKEFIELDS SALES LTD

286/288 Sangley Road, SE6

F. CAVE

21 Old Compton Street, W1

CHAPPELL MUSIC CENTRES LTD

50 New Bond Street, W1

DAVIS & KAYS LTD

8 Turnpike Parade, N15
4 High Street, Walthamstow, E17
169 Fore Street, Edmonton, N18
61 Seven Sisters Road, N7

DEPTFORD CAMERAS & HI-FI

DESIGN CENTRE LTD
494 New Cross Road, SE14

E.M.G. HANDMADE

GRAMOPHONES LTD
26 Soho Square, W1V 6BB

J. J. FRANCIS (WOOD GREEN) LTD

123 Alexandra Road, Hornsey, N8

FRANCIS OF STREATHAM

169-173 Streatham High Road, SW16

C. C. GOODWIN (SALES) LTD

7 The Broadway, Wood Green, N22 6DU

GRAHAMS ELECTRICAL LTD

14 Exmouth Market, EC1R 4QH
86-88 Pentonville Road, N1 9HS
172 Caledonian Road, N1 0SQ

HAMPSTEAD HIGH FIDELITY

91 Heath Street, Hampstead, NW3

H. C. HARRIDGE LTD

8 Moore Street, Cambridge Circus, W1V 5LJ

HAVEN HI-FI (EALING) LTD

196-198 South Ealing Road, W5

WALLACE HEATON (CITY SALE)

LTD
93 Fleet Street, EC4Y 1DJ

THOMAS HEINITZ

MUSIC IN THE HOME
35 Moscow Road, W2 4AH

HENRY'S RADIO LTD

303-309 Edgware Road, W2
354-356 Edgware Road, W2

HI-FI AND COMPONENTS LTD

84 Battersea Rise, Clapham Junction, SW11 1EH

ALFRED IMHOF LTD

112-116 New Oxford Street, WC1A 1HJ

KINGSONS LTD

2 Brownhill Road, SE6

LASKY'S RADIO LTD

42-45 Tottenham Court Road, W1
33 Tottenham Court Road, W1
207 Edgware Road, W2
152-153 Fleet Street, EC4Y 1DJ
109 Fleet Street, EC4Y 1DJ

LEE ELECTRONICS

400 Edgware Road, W2

LEWIS RADIO COMPANY

100 Chaseside, Southgate, N14 5PL

LIND-AIR OPTRONICS LTD

241-242 Tottenham Court Road, W1

MAC'S CAMERA SHOPS LTD

250-252 King Street, Hammersmith, W6

MASTERSOUND ELECTRONIC

SERVICES LTD
152 Fortis Green Road, N10

EDWARD MICHELSEN CUSTOM

CABINETS
"SOUND IDEAS" 494 New Cross Road, New Cross, SE14

MODERN ELECTRICS (RETAIL)

LTD
120 Shaftesbury Avenue, W1V 7DJ

THE MUSIC ROOM

56 Crystal Palace Park Road, Sydenham, SE26

MYERS AUDIO

199 Hoe Street, E17

NATIONAL RADIO SERVICE

& TELEVISION CO
82 St John's Wood High Street, NW8 7SH

NEWBURY RADIO (FOREST GATE)

LTD
272-274 and 305 Romford Road, Forest Gate, E7

NICHOLLS HI-FI

432 Lee High Road, Lee Green

NUSOUND HI-FI & TAPE

RECORDER CENTRES
82 High Holborn, WC1
228 Bishopsgate, EC2
36 Lewisham High Street, SE13

M. O'BRIEN (HIGH FIDELITY

SPECIALIST)

95 High Street, SW19

PIERCY'S ELECTRONICS LTD

58-62 Lupus Street, Pimlico, SW1

PREMIER RADIO (CANONDELL)

LTD
23 Tottenham Court Road, W1

THE RECORDER CO

186-188 West End Lane, West Hampstead, NW6
R. E. W. AUDIO VISUAL CO
266-268 Upper Tooting Road, SW17 0DR
146 Charing Cross Road, WC2

ROUNDOABOUT RECORDS

8 Parsons Street, NW4

R. O. C. ELECTRONICS LTD

193 Edgware Road, W2 1ET

JAMES RUSSELL & SONS (AUDIO)

LTD
9-11 Winbledon Bridge, SW19

JAMES RUSSELL & SONS

(CAMERAS) LTD
5 Wembleton Bridge, SW19

R.S.C. HI-FI CENTRES

238 Edgware Road, W2

SANDS HUNTER & CO LTD

45 Hare Street, SE18
37 Bedford Street, Strand, WC2
19 Ludgate Hill, EC4

SHERBOURNE'S

150 Tollington Park, N4
50 Topsisfield Parade, N8

G. W. SMITH & CO (RADIO) LTD

311 Edgware Road, W2
3 Lisle Street, WC2
34 Lisle Street, WC2
10 Tottenham Court Road, W1
277 Tottenham Court Road, W1

H. L. SMITH & CO LTD

287-289 Edgware Road, W2 1BE

SOUND CENTRE

(HI-FI EQUIPMENT) LTD
38 Edgware Road, Marble Arch, W2 2EH
48 London Wall, EC2
115 Kingsway, Holborn, WC2
857 High Road, Finchley, N12
152 Rye Lane, Peckham, SE15

SOUND INCORPORATED LTD

114 Broadway, Wimbledon, SW19

SPEAKER SELECTION

61 1, Forest Road, Walthamstow, E17 4QP

STUDIO 99 LTD

81 Fairfax Road, Swiss Cottage, NW6

TAPE RECORDER HI-FI CENTRE

(SHEEN) LTD
3-4 Station Parade, Sheen Lane, Sheen, SW14

TELESONIC LTD

92 Tottenham Court Road, W1

TELETAPE LTD

33 Edgware Road, W2 1BE
84-88 Shaftesbury Avenue, W1

THE THERADIO CO (EDMONTON)

LTD

325 Fore Street, N9

WIRECOMP ELECTRONICS

118 Edgware Road, W2 1BE

ACCINGTON

RELAY VISION LTD

19 Union Street

AIRDRIE (LANARKSHIRE)

TREND HOUSE FURNISHERS LTD

15-17 Graham Street

ASHFORD

PHOTOCRAFT HI-FI

40 High Street

ASHTON-UNDER-LYNE (LANCS)

BLACK KNIGHT RUMBLECURE

Bank Top, Currier Lane

AXMINSTER

GRAHAM NEWBURY

George Street

BANSTEAD (SURREY)

RAYLEC LTD

43 High Street

BARKING (ESSEX)

DAVIS & KAYS, SOUND CENTRE

HI-FI (EQUIPMENT) LTD

21 London Road

BARNET (HERTS)
PORTOGRAM RADIO ELEC. IND.
LTD
175 High Street

BARNSELY
GEOFFREY BARNARD
G. B. Studio, 3 Pitt Street

BARROW-IN-FURNESS
DERHAMS
Furness House

BASILDON
KELLEYS RADIO LTD
82 Town Square

BASINGSTOKE
BASINGSTOKE CAMERA & HI-FI
CENTRE
2 New Market Square

BATH (SOMERSET)
C. MILSOM & SON LTD
North Gate

BEDFORD
CARLOW RADIO LTD
6 St Loyes Street

BELFAST (N. IRELAND)
LLOYD SOUND LTD
11 Havelock Street, BTF 1EA

BIRMINGHAM
BIRMINGHAM TAPE RECORDER
CENTRE LTD
Vehicle & General House, Hurst Street,
B5 4BJ

C. H. (HIGH FIDELITY) LTD
14-15 Suffolk Street, Ringway, B1 1LT
NORMAN H. FIELD HI-FIDELITY
CENTRE
Vehicle & General House, Hurst Street,
B5 4BJ

R. S. C. HI-FI CENTRES LTD
30-31 Great Western Arcade
W. J. TAYLOR (DOMESTIC
SUPPLIES) LTD
128 Hawthorn Road, Kingstanding,
B44 8QA

HI-FIDELITY & PHOTOGRAPHIC
37-39 York Road, Kings Heath, 14
KEN WHITTLE LTD
788 Stratford Road, Sparkhill, B11 4BP

BISHOP AUCKLAND (DURHAM)
McKENNA & BROWN LTD
134 Newgate Street

BLACKBURN (LANCS)
HOLDINGS OF BLACKBURN LTD
Photo-Audio Centre, 39-41 Mincing
Lane, Darwen Street

BLACKPOOL
F. BENFELL LTD
17 Cheapside, FY1 1DW
O & C ELECTRONICS
227 Church Street

THE TAPE RECORDER CENTRE
(C. BRADDOCK LTD), BLACKPOOL
266 Waterloo Road, FY4 3AF

NORMAN WHITELEY LTD
4 Deansgate

JOHN F. WIGNEY LTD
Cleveys Photocentre, 2-3 Orion
Buildings, Cleveleys

BOGNOR REGIS
TANSLEY & COOKE LTD
Television House, Sandymount Avenue
43 London Road
SPORTS and RADIO LTD,
BOGNOR STEREO CENTRE
25-29 Aldwick Road

BOLTON (LANCS)
CLEAR TONE HI-FI LTD
166 Blackburn Road
HARKER & HOWARTH (MUSIC)
LTD
Goodwin Street, Folds Road
28 & 32 Churchgate
H. D. KIRK (STEREOELECTRICS)
LTD
203 St Georges Road

BOSTON (LINCOLNSHIRE)
ADDYS (BOSTON) LTD
9, Wide Bargate

BOURNEMOUTH
DAWSONS RADIO LTD
Seamoor Road, Westbourne

* B & O * LEAK * QUAD * ROGERS * SONY * S.M.E. *
G
A
R
R
A
R
D
*
T
H
O
R
E
N
S
* FERROGRAPH * TANDBERG * REVOX * ARMSTRONG * TANNOY *
HI-FI EQUIPMENT BY THE LEADING MANUFACTURERS
EXPERT ADVICE — COMPARATIVE DEMONSTRATIONS
PART EXCHANGES — CREDIT FACILITIES
FREE DELIVERY AND INSTALLATION OF SYSTEMS UP TO 50 MILES
ALL AVAILABLE FROM
LLOYD & KEYWORTH'S HI-FI CENTRES
2 NEW MARKET SQUARE BASINGSTOKE TEL 22157
36 HIGH STREET CAMBERLEY TEL 5848
26 DOWNING STREET FARNHAM TEL 5534

BLACKPOOL *Tel. Blackpool 28756*

BENFELL
OF BLACKPOOL

F. BENFELL LIMITED
17 Cheapside (Off Abingdon Street)

WALES
Leading Hi-Fi Specialists Est. 1930

J. GOUGH & CO LTD, CARDIFF

Designers of the "Gough Loudspeaker Cabinet"
Stockists of Quad, Leak, Armstrong, Sony, Trio,
Bang & Olufsen Main Dealer.

★ **Demonstration rooms available** ★

148-154 NORTH ROAD Telephone 28473

R.E.W. AUDIO VISUAL CO

The largest range of quality Hi-Fi equipment in London!

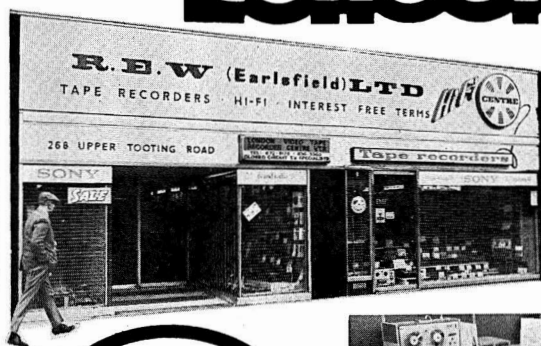

Our South London
Showrooms at 266-8
Upper Tooting Road

A corner of our
demonstration studio at
146 Charing Cross Road
showing our unique
range of high quality
loudspeakers.

ALL THE
TOP NAMES
IN AUDIO
IN MOST CASES ON
**INTEREST FREE
TERMS!**



South London Showrooms
266-8 Upper Tooting Road,
London SW17
Tel: 01-672 4471/2 and 9175

West End Showrooms
146 Charing Cross Road,
London WC2
Tel: 01-836 3365

FORRESTER'S NATIONAL RADIO
SUPPLIES LTD
70-72 Holdenhurst Road

BRADFORD

CHRISTOPHER PRATT & SONS LTD
33 North Parade, BD1 3JJ

R. S. C. HI-FI CENTRES LTD
10 North Parade

VALLANCE & DAVISON LTD
Ardale House, Market Street, BD1 1HS

BROADSTAIRS

THANET MOBILE VISION & AUDIO
CENTRE LTD
78 High Street

BRENTWOOD

KELLEYS RADIO LTD
8, High Street

BRIGHTON

JOHN KING (FILMS) LTD
Film House, 71 East Street

SOUND UNLIMITED
149 North Street

BRISTOL

HUSBANDS & SONS LTD
The Centre, 8 St Augustine's Parade,
BS1 4UU

HOUSE OF SOUND LTD
5 Marsh Street, 1

STEREO CENTRE LTD
309 Gloucester Road, BS7 8PE

TAPE RECORDER AND HI-FI
CENTRE LTD
82 Stokes Croft

BURY (LANCS)

THE STEREO CENTRE, J. SMITH
& SON (THE ROCK) LTD
184 The Rock

VICTOR WRIGHT
36-38 Moorgate

BURY ST EDMUNDS (SUFFOLK)

B.G. RADIO SERVICE
10 Hatter Street

BYFLEET (SURREY)

WEST ELECTRICS
150 High Road

CAMBERLEY

CAMBERLEY CAMERA & HI-FI
CENTRE
36 High Street

CAMBORNE (CORNWALL)

S.R. GEAR LTD
Cross Street

CAMBRIDGE

UNIVERSITY AUDIO
1 & 2 Peas Hill

CANTERBURY

HI-FI CENTRE
26 St Dunstan's Street

TERRY BURKE AUDIO LTD
64 Wincheap

CARLISLE

MISONS
3 & 4 Citadel Row

TURNERS (NEWCASTLE-UPON-
TYNE) LTD
1 Lowther Street

CARDIFF

CITY RADIO (CARDIFF) LTD
Oxford House, Hills Street

J. GOUGH & CO LTD
148-154 North Road

CARDIFF HI-FI CENTRE
Oxford Arcade, The Hayes

CHANDLER'S FORD (HANTS)

HAMPSHIRE AUDIO LTD
8 Hursley Road

CHATHAM

MEDWAY ELECTRONICS
276 High Street

WOODS & PORTER LTD
349 High Street

CHELMSFORD

HI-FI CENTRE (CHELMSFORD) LTD
6 Cornhill New Shopping Precinct

CHELTENHAM

RAY ELECTRICAL (CHELTENHAM)
LTD
287 High Street

KRAKEN ROSE AUDIO
283, FLEET ROAD, FLEET, HANTS. Tel: 5053

Specialists in Sound

**High Fidelity & Video
Specialists**

Hamilton Electronics **HE**

Hamilton Electronics (Southampton) Ltd.
35 London Road, Southampton. Phone: 28622 3Lines

*The Specialists in
High Fidelity Sound*

H. D. KIRK *Stereolectrics*

Where
Service
Matters

hfd
member

203
St. Georges Rd. **Phone 23093
BOLTON**

HENRY'S

AUDIO HI FIDELITY ELECTRONICS

**LARGEST SELECTIONS-BIGGEST DISCOUNTS
DEMONSTRATIONS-12 MONTHS GUARANTEE**

SAVE UP TO 40%

on recommended prices

**QUOTATIONS FOR YOUR SYSTEM
ON REQUEST WITHOUT OBLIGATION
OR CALL IN AND SEE FOR YOURSELF**

- FULL AFTER SALES GUARANTEE
- FREE EXPERT ADVICE
- ALL THE LATEST EQUIPMENT FROM STOCK AT SPECIAL PRICES
- EASY LOADING & PARKING

FREE 100 STEREO SYSTEMS & EQUIPMENT BROCHURE

12 page stock brochure ref. no: 16/17 available on request (Revised every 2-3 months) Hi-Fidelity, Tape Equipment, Lighting Public Address, Kits and Electronics. Save £££'s - everything at Special Prices! Get your copy now! Write, Call or Phone.



FREE

WITH EVERY STEREO SYSTEM PURCHASED FROM HENRY'S

- ALL LEADS, CABLES ETC.
- WATTS "DUST-BUG" (Value £1.16) Keeps your records clean
- 12 MONTHS GUARANTEE

Buy it with your

BARCLAYCARD

You can call or phone in your order and pay with your Barclaycard. Also credit facilities available to callers. (Applicable to "309" and "354/356" stores only)

HENRY'S RADIO LTD.

Hi Fi Dept. : 354/356, Edgware Rd., W.2. 01-402 4736 and 5854

Electronics : 404/406, Edgware Rd., W.2. 01-402 8381 and 8382

PA - Disco - Lighting : 309, Edgware Rd., W.2. 01-723 6963

"309|354|356|404|406"

**Open 6 days a week
9 to 6. Mon. to Sat.**

All Mail to : 303, Edgware Rd., London, W.2.

CHESTER

CHARLESWORTHS HI-FI
112 Foregate Street

LLOYD & WYLIE
42 Bridge Street

PETERS HI-FI AUDIO
24 St Michaels Square, Shopping Precinct

CHICHESTER

CHICHESTER TELE-RADIO
SERVICES LTD
83 East Street

TANSLEY & COOKE LTD
Storrys House, 83 North Street

COLWYN BAY

TURNERS (RHOS-ON-SEA) LTD
30 Rhos Road, Rhos-on-Sea

COVENTRY

COVENTRY TAPE RECORDER
SERVICE

172 Spon Street

ELECTRONIC SERVICES
33 City Arcade

CRAWLEY

KIRKMAN (CRAWLEY) LTD
40 The Broadway

THE SOUND STUDIO LTD
4 Grand Parade, High Street

CREWE

CHARLESWORTHS HI-FI
14-28 Hightown

CROYDON

SPALDING ELECTRICAL LTD
352-354 Lower Addiscombe Road

DARLINGTON

McKENNA & BROWN
(PHOTOGRAPHIC) LTD
PHOTOGRAPHIC & HI-FIDELITY
SOUND

11 Bondgate

R. S. C. HI-FI CENTRES
18 Priestgate

TURNERS (NEWCASTLE-UPON-
TYNE) LTD
3 Queen Street

DARTFORD

WOODS & PORTER LTD
23 West Hill

DERBY

VICTOR BUCKLAND LTD
41-49 London Road

R. S. C. HI-FI CENTRES LTD
26 Osmaston Road

DEVIZES (WILTS)

DEVIZES PHOTO-AUDIO CENTRE,
LOUIS J. RUTTER

17 The Britton

DONCASTER

FIELDS RADIO LTD
52 Hallgate

DORCHESTER

SUTTONS
2 Hardye Arcade

DORKING (SURREY)

AUDIO SYSTEMS
PDSA House, 23 South Street

DUBLIN (EIRE)

CENTRESOUND LTD
2-3 Lincoln Place, 2

DUNDEE

LARG'S WATTS
16-24 Whitehall Street

DURHAM CITY

THE HOUSE OF ANDREWS
73-75 Sadler Street

EASTBOURNE

CENTRAL RADIO (EASTBOURNE)
LTD

15 Langney Road

COMPLETE AUDIO SYSTEMS LTD
32 Grove Road

HOLDER-PEARCE LTD
66 Grove Road

EAST MOLESEY (SURREY)

MOLESEY SOUND REPRODUCERS
LTD

87 Walton Road

EDGWARE

PLANET HIGH FIDELITY CENTRE
88 High Street

COVENTRY RADIO LTD.

ESTABLISHED 48 YEARS (1925)

See and hear the best and latest in Hi-Fi equipment at our
Luton Showrooms and demonstration room

Send for information on your requirements

189/191 Dunstable Road, Luton

Telephone: LUTON 28201

CHESTER

Est. 40 years

TAPE RECORDER AND HI-FI SPECIALISTS

Agents for: Ferrograph, Tandberg, Trio,
Grundig, Philips, Hacker, Armstrong,
Leak, Quad, Goodmans, B & O, Wharfe-
dale, Sony, Bryan, Sanyo, Thorens, S.M.E.,
Telefunken, Rogers, Eddystone, Shure.

LLOYD & WYLIE

42 BRIDGE ST., CHESTER Tel: 26704

REIGATE & DISTRICT Hi-Fi

Stockist of Quad, Tannoy, K.E.F., B & O
and other leading brand names. Demon-
stration showroom above the camera
shop. Service engineers for the after care
of equipment sold by us.

Alan Laurenson & Co.

9 BELL STREET, REIGATE

Ring Reigate 46494 for home demon-
stration.

HI-FI EQUIPMENT • AUDIO • RADIO • TV • TAPE AND CASSETTE RECORDERS

TOP CASH DISCOUNTS PLUS...

DEMONSTRATIONS

Listen before you buy. At any of our stores it is possible to hear a very wide range of Amplifiers, Tuners and Tuner Amplifiers, with Turntables and Tape Recorders as well as a large selection of Speakers to compare the performance of all from budget priced to highly sophisticated Hi-Fi and Audio systems.

PAYBONDS

Highly convenient No Deposit Credit Scheme. Paybonds customers are always welcome.

BARCLAYCARD & DINER'S CLUB CARDS

We are pleased to offer the above Credit Facilities to our customers. Ask for details of special terms.

PERSONAL LOANS & LOW DEPOSIT CREDIT

Ask for details of our special Low Deposit Credit Plan and latest Purchase out of Income scheme.

PERSONAL EXPORT

Personal export, free of UK Purchase Tax can be arranged for overseas visitors on most items of equipment.

HUGE STOCKS WORLD FAMOUS MAKES

AKAI	LOWTHER
AUDIO	METRO SOUND
TECHNICA	PIONEER
ARMSTRONG	PHILIPS
BUSH-ARENA	QUAD
B&W	REVOX
BEYER	ROGERS
BSR	ROTEL
CAMBRIDGE	SONY
CELESTION	SANSUI
CONNOISSEUR	SINCLAIR
DUETTE	SUGDEN
EMPIRE	SHURE
FERROGRAPH	SHARP
GOODMANS	SENNHEISER
GARRARD	TELETON
GOLDRING	TANBERG
GRUNDIG	TANNOY
KEF	TRANSCRIPTOR
KOSS	UHER
LEAK	WHARFEDALE

and many more!

SEND S.A.E. FOR LATEST
LISTS AND.....

ORDER BY MAIL

MAIL ORDERS AND
PRICE LIST ENQUIRIES TO
32 HILL ST. RICHMOND, SY.

sound thinking Caves hi-fi

F.CAVE
Top Discounts

KINGSTON Surrey
27 & 21 EDEN ST.
Tel. 01-546 7845

100yds. big Municipal car park.
Three minutes British Rail
station.

RICHMOND Surrey
32 HILL ST.
Tel. 01-948 1441

Easy parking nearby and 5 mins
British Rail and London
Transport stations.

RICHMOND Surrey
5 BRIDGE ST.
Tel. 01-948 1441

Easy parking nearby and 5 mins
British Rail and London
Transport stations.

LONDON West End
21 OLD COMPTON ST. W.1.
Tel. 01-437 9369

Easy parking in streets and NCP.
5 mins. Leicester Sq. Piccadilly C.
& Tottenham Ct. Rd. stations.

ROMFORD Essex
86 SOUTH ST.
Tel. Romford 20218

Big Municipal car park behind
store, 3 mins British Rail
station.

EDINBURGH

AUDIO AIDS
20 South Clerk Street, EH8 9PR
274 Canongate, The Royal Mile,
EH8 8AA
R. S. C. HI-FI CENTRES LTD
133 Leith Street

ENFIELD (MIDDLESEX)

A.T. LABORATORIES
191 Chase Side

EPPING

CHEW & OSBORNE LTD
148 High Street

EXETER

EXON AUDIO
164 Sidwell Street
HOWARDS (EXETER) LTD
90 Sidwell Street

FALMOUTH (CORNWALL)

S.R. GEAR LTD
FALMOUTH AUDIO CENTRE
The Moor

FARNHAM (SURREY)

LLOYD & KEYWORTH LTD
26-28 Downing Street

FLEET (HANTS)

KEN ROSE AUDIO LTD
283 Fleet Road

FOLKESTONE

GUILDHALL TAPE RECORDERS
33 Guildhall Street

GARSTANG (Nr PRESTON)

GERALD CARTER
Thomas Wicnd

GILLINGHAM (KENT)

D. E. HADAWAY & SON LTD
95-97 Watling Street

GLASGOW

ALEXANDER BIGGAR LTD
271-275 Sauchiehall Street, C2
J. D. CUTHBERTSON & CO
21 Cambridge Street, C2
CHARLES FRANK LTD
145 Queen Street, G1 3BL
GORDON HOUSE AUDIO CENTRE
111 Stockwell Street
GRATISPOOL INTERNATIONAL
LTD
66 Queen Street, G1 3DH
JAMES KERR & CO LTD
98-110 Woodlands Road, C3
McCORMACKS MUSIC LTD
33 Bath Street, C2
McDONALD WYLIE & LOCHHEAD
45 Buchanan Street
M & M ELECTRONICS LTD
551 Sauchiehall Street, C3
VICTOR MORRIS
340 Argyle Street, C2
88 St Vincent Street, C2

R. S. C. HI-FI CENTRES LTD

326 Argyle Street
G. H. STEELE LTD
141 St Georges Road, C3

GOODMAYES (ESSEX)

UNIQUE RADIO LTD
5 The Facade, High Road

GRAVESEND

BENNETT & BROWN
2 Milton Road

GREAT YARMOUTH

NORFOLK RADIO
15 Broad Row

GRIMSBY

LINCOLNSHIRE INSTRUMENT
COMPANY
Hi-Fi House, 69-71 Cartergate

GUILDFORD

MERROW SOUND LTD
205 Epsom Road, Merrow
MERROW SOUND (GUILDFORD)
LTD
Tunsgate
GUILDFORD HI-FI CENTRE
270 High Street

HADLEIGH (ESSEX)

ESSEX HI-FI CENTRE
210 London Road

TAPE, AUDIO & HIGH FIDELITY EQUIPMENT

YOU'LL GET IT FROM

MODERN ELECTRICS

(RETAIL) LTD.



120 Shaftesbury Avenue,
London, W1V 7DJ

01-437 9692/3

SONY ● HACKER ● GRUNDIG
SANYO ● PYE ● PHILIPS
QUAD ● NATIONAL ● PYE
TANDBERG ● WHARFEDALE
LEAK ● THORENS ● GOLD-
RING ● KEF ● GARRARD
SHURE ● AKG ● KOSS ● AKAI
SANSUI ● ARMSTRONG ●
HITACHI etc.

Personal attention. Satisfaction
guaranteed.



SWIFT OF WILMSLOW

HI-FI AND UNIT AUDIO

Quad, Grundig, Leak, Rogers, Korting, Dual
Goodmans, Wharfedale, Thorens, Goldring,
Garrard, Philips, Shure, Trio, Dynatron,
Toshiba, SME, Tandberg etc.

5 Swan Street (nr. traffic lights),
Wilmslow, Cheshire Wilmslow 26213



ST. ALBANS

The Leading Hi-Fi Specialists are:

LONDON AUDIO

32, London Rd., St. Albans, Tel: 59996

STOCKISTS OF ALL LEADING MAKES

FULL SERVICE
FACILITIES

DEMONSTRATION
& CONSULTANCY
SERVICE

PIERCYS (ELECTRONICS) LTD.

OFFER HIGH FIDELITY WITH ALL THE ADVANTAGES

- * An Advisory Service
- * A Unique Hi Fi Demonstration Studio with Comparator
- * All Equipment Demonstrated
- * Our Own Engineers Available
- * Guarantees for 12 months *Including Labour*
- * Installations carried out with pleasure
- * Custom Built Furniture to your Pleasure
- * Modifications to Existing Furniture

PIERCYS 58, 60, 62 LUPUS ST., S.W.1. Tel: 834 5759

SHEFFIELD'S
MAIN DEALERS FOR
SONY[®]
Plus all the latest hi-fi & video equipment
Hodgsons 33 & 35, Charles St.
Tel: 29218/9

EASTBOURNE SUSSEX

COMPLETE **A**UDIO **S**YSTEMS **L**T**D**

*The acknowledged area specialists
stocking all leading makes and providing
expert service and installation facilities*

Large first floor music lounge

32 GROVE ROAD TEL. 27362

CANTERBURY HI-FI CENTRE

Agents for Trio - Sony - Dynatron -
Hacker - Bang & Olufsen - Sansui - etc.
Large Stocks

Comparator operated Demonstration
Room

**26 ST. DUNSTANS STREET,
CANTERBURY**

Tel: Canterbury 65315

AUDIO CENTRE

**FAIRBOTHAM & CO. LTD.
STOCKPORT**

58/62 LOWER HILLGATE · 061-480-4872

**COMPREHENSIVE STOCKS OF
RADIO, TAPE AND DISC EQUIPMENT**

Advisory Service and Satisfaction assured

FULL AFTER SALES SERVICE
EVENING DEMONSTRATIONS ARRANGED

HALIFAX

TAPE RECORDER CENTRE
(HALIFAX)
30 King Cross Street

HARROGATE

CAMERA 65 LTD
15 Station Bridge

HARROW

HANSPALS AUDIONICS AND
ELECTRONICS
54 St Annes Road

HASTINGS

C. P. ABRAHAM LTD
192 Queens Road
484 Old London Road

HAYWARDS HEATH

MASTERSOUND
109 South Road

TANSLEY & COOKE LTD
26 South Road

HAZEL GROVE (CHESHIRE)

CHESTERGATE STUDIOS LTD
92 London Road

HELSTON (CORNWALL)

HYDROVOLT LTD
2 Church Street

HEMEL HEMPSTEAD

HAMILTON SOUND LTD
129 Marlowes

HENLEY ON THAMES

G. O. MOORHEN
190 Reading Road

HEREFORD

WYVEAL LTD
Wyeval House, Bridge Street

HIGH BARNET (HERTS)

DAVIS & KAYS
SOUNDSCENTRE HI-FI (EQUIPMENT)
LTD
4 Hadley Parade

HIGH WYCOMBE

HUGHES HI-FI
7 High Street
M. W. KEEN LTD
THE CHANTRY STUDIOS
Pauls Row

HITCHIN (HERTS)

A & M SUPPLIES
37 Hermitage Road
THE RECORD SHOP
30-31 Hermitage Road

HORSHAM (SUSSEX)

TANSLEY & COOKE LTD
37 West Street
AUDIO SYSTEMS
28 Queen's Parade, Queen Street

HOUNSLOW (MIDDLESEX)

MUSICRAFT HI-FI CENTRE
63 High Street

HOVE (SUSSEX)

LANES RADIO LTD
94 Church Road BN3 2EB

HUDDERSFIELD

SWIRES CAMERAS LTD
Imperial Arcade

J. WOOD & SONS LTD
67 New Street

HULL

A-Z RADIO
758 Spring Bank West

A. BROWN & SONS LTD
24-28 George Street

SANDS AUDIO CENTRE
61 Princes Avenue

R. S. C. HI-FI CENTRES LTD
91 Paragon Street

HUNTINGDON

J. V. ROBINSON LTD
89-91 High Street

ILFORD

DAVIS & KAYS
SOUND CENTRE HI-FI (EQUIPMENT)
LTD
7 Station Road

ILFORD AUDIO CENTRE
335 Green Lane, Seven Kings

NUSOUND
88/100 Pioneer Market, Ilford Lane

ILKLEY

ALLEN & WALKER
Sedburgh Buildings, 4 Cowpasture Road

IPSWICH

R. C. S.
61 Fore Street, IP4 1JL

TURNERS PHOTOGRAPHICS
9 The Walk, IP1 1ED

IRVINE (AYRSHIRE)

IAN STRACHAN
7 Bridgegate

Kingsons

of Catford and Beckenham
Appointed Agents
for

Bang & Olufsen

TRIO

SONY®

Sonab



Barclaycard facilities. No deposit purchase terms.

KINGSONS

2 Brownhill Rd. S.E.6. Tel: 01-698 4842

224 High St. Beckenham. Tel: 01-650 8027

ELECTRONIC SERVICES

33 City Arcade
Coventry CV1 3HX

Your central Hi-Fi supplier

Phone Coventry 24632

HORNS

SIX SOUTH PARADE

Telephone OXFORD 55360

HI-FI EQUIPMENT

SAVE UP TO 33 1/3% OR MORE

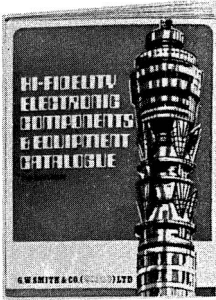
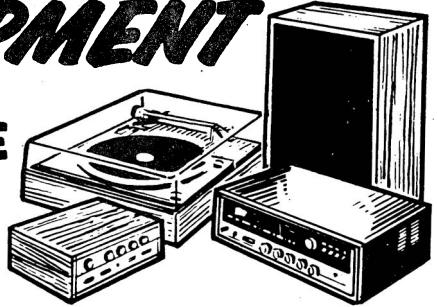

BIG CASH DISCOUNTS

Shop personally at any of our six Central West End Shops or send S.A.E. for discount price list and catalogue of Hi-Fi Equipment, Components, Test Equipment and Communication Equipment. Now over 320 pages, fully illustrated, and detailing 1000's of items at bargain prices.

FREE DISCOUNT COUPONS VALUE 50p.

G.W.SMITH & CO. (RADIO) LTD

10 TOTTENHAM CT. RD. LONDON, W.1
27 TOTTENHAM CT. RD. LONDON, W.1
257/258 TOTTENHAM CT. RD. LONDON, W.1
3 LISLE STREET, LONDON, W.C.2
34 LISLE STREET, LONDON, W.C.2
311 EDGWARE ROAD, LONDON, W.2

Tel: 01-637 2232
Tel: 01-636 3715
Tel: 01-580 0670
Tel: 01-437 8204
Tel: 01-437 9155
Tel: 01-262 0387

CALLERS
WELCOME
MONDAY TO
SATURDAY
9AM-6PM

All Mail Orders to—
11-12, Paddington Green,
London, W.2
Tel: 01-262 6562

HI-FI

Stereo Systems and Tape Recorders, Stereo Radio. Quality Equipment for the connoisseur by Bang and Olufsen, Sony, Tandberg, Ferrograph, Leak, Quad, Trio, etc.

Demonstrations any time. Personal Service. Part exchanges. Full Service and Repair facilities with 90-day guarantee.

COVENTRY TAPE RECORDER SERVICES

172 Spon Street, Coventry
Telephone: Coventry 29668
and C.T.S. HIGH FIDELITY
3 Regent Grove, Leamington Spa
Telephone: 29265/6

LEICESTERSHIRE



audio sound

for sound advice

101 London Road Leicester
Telephone 26319

HI-FI IN LIVERPOOL



For the largest display of Hi-fi equipment & the finest selection at competitive prices. Visit the showroom Liverpool is talking about.

LATE
NIGHT
OPENING
8 P.M.
THURS & FRI



Hardman Radio

33 DALE STREET LIVERPOOL L2 2HF
TEL.051 236 2828/9.

KEIGHLEY (YORKS)

KEIGHLEY CAMERA CENTRE LTD
38-40 Cavendish Street

J. S. RAMSBOTTOM & CO LTD
Coney Lane

KENDAL

DERHAM'S OF KENDAL
Kent Street & Stramontgate

KENTON (MIDDLESEX)

211 Kenton Road

KETTERING (NORTHANTS)

SOUND QUALITY
2 The Arcade

KINGSTON UPON THAMES

ACOUSTICO ENTERPRISES LTD
6-8 Union Street

F. CAVE
27 Eden Street

SOUTHERN AUDIO SERVICES LTD
43 High Street

SURBITON PARK RADIO LTD
48-50 Surbiton Road

KNARESBOROUGH (YORKS)

YORKSHIRE HI-FI CENTRE
82 High Street

LEAMINGTON SPA

COVENTRY TAPE RECORDER
SERVICE
3 Regent Grove

TYSONS SOUND ENGINEERS
41 Russell Street

LEEDS

AUDIO PROJECTS
10 Blenheim Terrace, LS2 9HX

TED GLENN LTD
111 Otley Road, Headingley 6

R. S. C. HI-FI CENTRES LTD
5-7 County (Mecca) Arcade, Briggate

VALLANCE & DAVISON LTD
Headrow House, The Headrow, LS1 8EP

LEICESTER

AUDIO SOUND
101 London Road

HI-FI STEREO LTD
206 St Nicholas Circle

R. S. C. HI-FI CENTRES LTD
32 High Street

LEIGH-ON-SEA

SOUNDTRACK
149 Leigh Road

LEWES

TANSLEY & COOKE LTD
170 High Street

LINCOLN

LINCOLN HI-FI CENTRE
271A High Street

LITTLEHAMPTON

TANSLEY & COOKE LTD
61 High Street

LIVERPOOL

ACE AUDIO LTD
66 Renshaw Street

ALLERTON RADIO
21 Allerton Road, L18 1LG

BEAVER RADIO (L'POOL) LTD
20-22 Whitechapel, 1

HARDMAN RADIO
31-33 Dale Street, L2 2HF

R. S. C. HI-FI CENTRES LTD
73 Dale Street, 2

LLANDUDNO

VALLEY RADIO
Craig-Y-Don

LONG EATON

C. GILBERT LTD
85-89 High Street

LOSSIEMOUTH (MORAYSHIRE)

JOHN MUNRO
26 Seatown

LOUGHBOROUGH (LEICS)

RADIO MAINTENANCE (LEICS)
LTD
Wards End

LOUGHTON (ESSEX)

SOUND SUPPLIES (LOUGHTON)
CO LTD
309 High Road

LOWESTOFT

JOHN WELLS
44 London Road North

SOUTH WEST

BANG & OLUFSEN • SONY • TANDBERG

HUSBANDS OF BRISTOL—The Centre Bristol 293978

HUSBANDS OF WESTON—18 High St. Weston-S-Mare

GRAYS CAMERA—1 St. James Street Taunton 2986

POOLE CAMERA—91 Arndale Centre Poole 6289

WINCHESTER CAMERA—75 Parchment St. Winchester

Mansfield**Tel: 26315**

SYD. BOOTH, QUEEN ST.

Comparator Demonstrations of
Leading Makes

Home Demonstrations - Day or
Evenings by Appointment

*Service Always***PRESTON**

ELECTRA CENTRE

Comparator Demonstrations of
most leading makes
B. & O., Sony, Leak, Quad, etc.

8 Victoria Buildings, Fishergate
Preston Telephone 55603



HI FI STUDIO

W. J. TAYLOR

(Domestic Suppliers) LTD,

128, Hawthorn Road, Kingstanding,
Birmingham 22c

Tel: 021-373 2645/6

BANG AND OLUFSEN

Main Dealer and
all leading makes



STUART BARKER invites you to
His HI-FI CENTRE at

772, High Road,
Goodmayes, Essex

UNIQUE RADIO LTD.

01-590 8277

Sound Specialist in Hi-Fi or P.A.
M.A.P.A.E.



3+9

the **STEREO CENTRE**

MAIN AGENTS FOR

BANG & OLUFSEN · TANDBERG · DYNATRON
SANYO · TRIO · SANSUI · RADFORD · GRUNDIG
THORENS · GOLDRING · REVOX
SCANDINAVIAN COLOUR T.V. CENTRE

the **STEREO CENTRE**

309 GLOUCESTER ROAD, BRISTOL BS7 8PE
TELEPHONE:- 421395

GRIFFIN RADIO LTD

(the high fidelity people)

Fully comprehensive stocks and
advisory service for

Stereophonic and Quadraphonic High
Fidelity, Radio, Tape and Disc
equipment.

94 BRISTOL STREET BIRMINGHAM 5

Tel. 021-692 1359 For Servicing 021-622 4339

STOKE-ON-TRENT, STAFFS.

See and Hear the Best in
the Latest Equipment at

The **HI-FI CENTRE**

31, PALL MALL, HANLEY
(Opp. Theatre Royal) Phone: 25194

The Most Up-to-Date and
Best Demonstration Studio
In the Area.

HAVEN

196-198 South Ealing Road,
London W.5 · 01-560 0194.

AND

8 Sunbury Cross Centre,
Sunbury-on-Thames
Middx. · Sunbury 88963

hi-Fi Ltd.

For all your Hi-Fi Requirements

consult

ROMFORD

SOUND & VISION SERVICES LTD.

78, Brentwood Road, Romford, Essex
Romford 41644

Hi-Fi Specialists—All leading makes stocked
Sales & Service—Cash or Terms

MILSOMS

FOR

Arena, Armstrong, Band W., Ferrograph,
Garrard, Goldring, Goodmans, Leak, Quad,
Record Housing, Rogers, Shure, S.M.E.,
Tandberg, Thorens, Trio, Wharfedale, etc

NORTHGATE BATH

TEL:
5675

LUTON (BEDS)

AUDIO VISION
38 New Bedford Road

COVENTRY RADIO LTD
189-191 Dunstable Road

D. P. HOBBS LTD
11 King Street

MAIDSTONE

SLOMAN & PETTITT
Pudding Lane

MANCHESTER

AVGARDE GALLERY LTD
Lloyd Street, 2

BLACK KNIGHT RUMBLECURE
Bank Top, Currier Lane,
Ashton-under-Lyne

CLEAR TONE HI-FI LTD
Irlam Shopping Centre, Irlam

GODLEY SPEARS LTD
2-10 Shudehill, MA 2AL

LANCS HI-FIDELITY LTD
248 Wilmslow Road, 14

LLOYD PATON McGLYNN LTD
Ralli Buildings, Stanley Street
Salford, 3

MATHERS PHOTOGRAPHICS LTD
35 John Dalton Street, 2

R. S. C. HI-FI CENTRES LTD
60A Oldham Street

XLENT ELECTRICS LTD
537-539 Wilbraham Road,
Chorlton-cum-Hardy

MANSFIELD

SYD BOOTH
9-11 Queen Street

VALLANCE & DAVISON LTD
16 Leeming Street

MARLOW

CHILTERN SOUND
27 Spittal Street

MIDDLESBROUGH (YORKS)

McKENNA & BROWN LTD
190 Linthorpe Road

R. S. C. HI-FI CENTRES LTD
106 Newport Road, TS1 5JF

TURNERS(NEWCASTLE-UPON-TYNE)
LTD
140 Linthorpe Road

NEATH

ELECTROPHONIC
45A Neath Road, Briton Ferry

NEW BARNET (HERTS)

AUDIO SERVICES
82 East Barnet Road

NEWCASTLE UPON TYNE

J. G. WINDOWS LTD
1-7 Central Arcade, NE1 5BP

R. S. C. HI-FI CENTRES LTD
YMCA Building,
41 Blakett Street

RICHLEY & FREEMAN LTD
100 Percy Street, NE1 7RZ

TURNERS (NEWCASTLE UPON TYNE)
LTD
Camera House, Pink Lane, NE1 5HT
Emerson Chambers, Blakett Street

NEW MALDEN (SURREY)

UNILET PRODUCTS LTD
Compton House, 35 High Street

NEWPORT (I.O.W)

RUSSELLS
40 Upper St James Street

NEWTON ABBOT (DEVON)

WESTRONICS
28 Newton Road, Kingskerwell

NORTHAMPTON

AUDIOCRAFT
23-25 Dergate

NORTHWOOD (MIDDLESEX)

THE RECORDERIE
3 Rowland Place, Green Lane

NORWICH

YAXLEY ELECTRONICS LTD
Sound Centre, Earham House, Earham
Road, NOR 91H
Swan Lane, NOR 57G

NOTTINGHAM

PETER ANSON ELECTRONICS
165 Arkwright Street

NOTTINGHAM HI-FI CENTRE
156 Alfreton Road

N.S.E.
64 Peveril Street

R. S. C. HI-FI CENTRES
19 Market Street

BOLTON & IRLAM
CLEARTONE HI-FI LTD

UP TO 30% OFF LIST PRICES
CREDIT AT DISCOUNT PRICES
**DEMONSTRATIONS—SERVICE
GUARANTEES**

166 BLACKBURN ROAD, BOLTON
Tel: 22636. CLOSED MONDAY.

4 IRLAM SHOPPING CENTRE
IRLAM, MANCHESTER.

CLOSED MONDAY. 061-775-5822

MANCHESTER

STEREO EQUIPMENT and RECORDS

Tape Recorders

LANCASHIRE HI-FI

The Specialists
248 WILMSLOW ROAD

MANCHESTER 14

**HI-FI
AT 20%
DISCOUNT**

We supply *everything* for the HI-FI enthusiast—amplifiers, tuners, loudspeakers, cabinets, turntables, pickups, cartridges, tape recorders and so on.

Our associated Hi-Fi Company has been in this field since 1925—and we ourselves were established in 1960 as one of Britain's first Mail Order Discount Agencies.

Since then, we have become known for prompt *personal* service—all enquiries and orders are dealt with on the same day as received—and *immaculate after-sales attention* which is vital when buying at discount.

Only new *unused* branded equipment with manufacturers' guarantees. No Membership charges. Hire purchase if required. Send for free brochure (including full range of domestic appliances, motor cars etc.) to:—

The DISCOUNT BUYING AGENCY

111, South Farm Road, Worthing, Sussex
Tel: (0903)-31415 Est. 1960

Equipment selected from the World's finest in stock.

VISIT OUR NEW STUDIO
CREDIT SALE — CASH SETTLEMENTS
LLOYD PATON — McGLYNN
LIMITED

RALLI BUILDINGS,
STANLEY STREET,
(Off Bridge Street),
MANCHESTER M3 5FH
061-834 4510

NO GIVEAWAY GIMMICKS!
NO MASSIVE DISCOUNTS!

We haven't hundreds of units to confuse you, only very selected equipment like — Sonab, Sony, Bang & Olufsen, Trio and one or two other top products with our unique before and after sales service — Try us! We promise you'll never regret it! at

DAYTRONICS LTD.,
119a High Street, Teddington, Middlesex.
TW11 8HG Tel: 01-977 1324

MAIN DEALERS
B & O
SONY
DYNATRON
myers
audio SOUND CENTRE
199 HOE STREET, E.17 01-520 7277
WALTHAMSTOW

FOR QUALITY HI-FI EQUIPMENT AND RECORDS
visit
HANSPAL'S AUDIONICS & ELECTRONICS
SUPPLIES

488 Lady Margaret Road, Southall
54 St. Anns Road, Harrow

PIONEER, SANSUI, AKAI, NIKKO, LUX,
TELETON, HITACHI, METROSOUND,
GOODMAN'S, TELEFUNKEN, GARRARD,
GOLDRING, etc., etc.

Late evening every Thursday till 8 p.m.
Free demo and car parking facilities. Tel.: 01-578 2258
24 hour telephone answering service.

Hi-Fi Centre

CHELMSFORD

Every main agency held in stock and on demonstration in 2,400 way comparator room. HFDA MEMBER. Generous Discounts even if H.P. required.

6 CORNHILL, CHELMSFORD, ESSEX
Opp. Multi-Storey Car Park
Telephone: Chelmsford 57593

THE RECORDERIE

10 BUCKINGHAM
PARADE,
STANMORE, MIDDX.
Phone: 01-954 2940

3 ROWLAND PLACE
GREEN LANE,
NORTHWOOD, MIDDX
Phone: Northwood 24882

THELMA and ALAN HILL established THE RECORDERIE in 1961, they continue to offer in both their shops:—
A comprehensive range of Classical and Popular Records. An extensive selection of Quality Hi-Fi equipment always on demonstration in the Hi-Fi Showroom.
Fully qualified staff offer friendly and courteous service.

BOTH SHOPS OPEN TUESDAY — SATURDAY 9 am — 6 pm
EVERY RECORD and PIECE OF HI-FI EQUIPMENT
'RECORDERIE' CHECKED and GUARANTEED.



B & O

HI-FI

SONY

T/V VIDEO & CCTV
RECORDS & TAPES

Russell's

40 UPPER ST. JAMES'S STREET
NEWPORT I-O-W 3864

MANUFACTURERS OF
LANGUAGE
LABORATORIES

TRIO

QUAD

PETER ANSON

NOTTINGHAM

A wide range of equipment demonstrated under ideal conditions plus full comparator facilities, Agents for: B & O, Thorens, Shure, Sony, Roberts, Hacker, Tandberg, Leak, Quad, Revox, Lowther, Bowers & Wilkins, Koss, Cairec.

COMPLETE AFTER SALES SERVICE
165 ARKWRIGHT STREET,
Telephone: 0602 869374

OXFORD**HORNS**

6 South Parade, Summertown

WESTWOODS OF OXFORD

46 George Street

WILL R. ROSE LTD

119 Pound Way, Cowley Centre

PAIGNTON**PAUL PINCH LTD**

7 Dartmouth Road

PLYMOUTH**ALBERT E. FORD LTD**

84 Cornwall Street, PL1 1NE

TOM MOLLAND LTD

110 Cornwall Street

PETER RUSSELL'S HOT RECORD**STORE LTD**

58 New George Street

POOLE**HUSBANDS & SONS LTD, POOLE****CAMERA CENTRE**

91 Arndale

HYSLOP & CLAPHAM

120A High Street

PORTSMOUTH**EXPRESS RADIO**

105-107 Fawcett Road, Southsea

PRESTON (LANCS)**ELECTRA CENTRE**

8 Victoria Buildings, Fishergate

PURLEY (SURREY)**SURREY SOUND EQUIPMENT LTD**

3-4 Royal Oak Centre, Brighton Road,

CR2 2BG

READING**EDWARDS TELECOLOUR LTD**

495-499 Oxford Road

L. J. GALE LTD

66-68 Kings Road

RADLETT (HERTS)**SHEPPARD SOUND EQUIPMENT****LTD**

275 Watling Street

RAMSGATE**TOM JOYCE**

147 Boundary Road

REDCAR (YORKS)**McKENNA & BROWN LTD**

135 High Street

REDHILL (SURREY)**MARTYN ELECTRICS**

36 High Street

RHYTHM AGENCIES LTD

30 Station Road

REIGATE**ALAN LAURENSEN & CO**

9 Bell Street

RICHMOND (SURREY)**F. CAVE LTD**

5 Bridge Street

ROMFORD (ESSEX)**F. CAVE**

84-86 South Street

LE CONNOISSEUR SOUND

160 Heath Park Road, RM2 5XL

NEWBURY RADIO (FOREST GATE)**LTD**

120 North Street

ROMFORD SOUND & VISION**SPEAKERS LTD**

78a Buntingford Road

RUSTINGTON (SUSSEX)**TANSLEY & COOKE LTD**

1 Sterling Parade

SALE (CHESHIRE)**HI-FI STEREO**

47 Washway Road

SALISBURY**SUTTONS MUSIC CENTRE**

50 Blue Boar Row

SETTLE (YORKSHIRE)**J. W. GARNETT**

The Market Place

SHEFFIELD**HI-FI SERVICING**

496 Glossop Road, Broomhill

HODGSONS CAMERA SHOP LTD

33-35 Charles Street

PHILIP CANN LTD

Chapel Walk, Fargate, S1 1GJ

OMICRON ELECTRONICS

172 Baslow Road, Totley

R. S. C. HI-FI CENTRES

13 Exchange Street

SHEFFIELD SOUND CENTRE

101A Ecclesall Road, 11

THE SOUTH WEST**Tom Molland Ltd**

Invite you to visit their well-equipped
Demonstration Theatre and compare all
the leading makes of Hi-Fi and Tape
Equipment at

110 CORNWALL STREET, PLYMOUTHTelephone **69285***Immediate delivery to ALL Areas***LISTENING TO MUSIC****IN THE HOME**

We specialise in the final Musical and
Acoustic answer in the Home.

J. W. GARNETT

THE HI-FI SPECIALISTS OF
THE NORTH WEST

The Market Place, Settle, Yorkshire

Phone Settle 3558

SOUND SUPPLIES**(Loughton) CO. LTD.****Stockists for:**

B & O, SONY, SANSUI, QUAD,
GOLDRING, REVOX, TRIO,
BRYAN, THORENS.

Speakers:

MORDAUNT-SHORT, JORDAN-WATTS

8 TRACK STEREO.**BROOKLYN PARADE**

309 High Road, Loughton, Essex. 01-508 2715

HENLEY-ON-THAMES AND READING DISTRICT**G. O. MOORHEN****HIGH FIDELITY SPECIALIST****190 READING ROAD, HENLEY. Tel. 4163**

Appointed Agent for

Tandberg - Revox

Bang & Olufsen - Sony

Leak, Quad, Lowther,
Rogers, K.E.F., Wharfedale, etc.
Closed Saturdays from 1 p.m.

HI-FI STEREO

47 WASHWAY ROAD, SALE, CHESHIRE

(Tel: 061-973 5577) (opposite Sale Locarno)

Complete specialists in Hi-Fi equipment. All reputable Hi-Fi equipment at the right prices—with a two year free service guarantee.

Probably the best selection of classical gramophone records in Cheshire.

Free Hi-Fi brochure sent on request to residents within 30 mile radius of Sale.

If it's Hi-Fi — then it must be

BOWERS & WILKINS

STOCKISTS INSTALLATIONS SERVICE

Littlehampton Road Worthing Tel. 64141

TAPE RECORDER HI-FI CENTRE (SHEEN) LTD.

SPECIALISTS IN TAPE RECORDERS,
ACCESSORIES, HI-FI EQUIPMENT
MUSIC CASSETTES AND 8-TRACK
CARTRIDGES ALWAYS IN STOCK

Open 9 a.m.—6 p.m.—Closed Wednesdays
Plenty of Car Parking Space

3 & 4 STATION PARADE, Telephone: 01-876 0985
SHEEN LANE, LONDON, S.W.14. Opposite Mortlake Station (S.R.)

- Best Hi-Fi show outside London
- Stockist of every lead make
- Expert staff
- Comparator demonstrations
- New Hi-Fi studios
- New 4 channel room
- Part exchange
- Home demonstrations
- Evening demonstrations by appointment
- After sales service

the hi-fi centre



Green Lane · Wilmslow · Cheshire SK9 1LW

- Car park
- Closed Wednesday
- For personal attention phone Wilmslow 24766 or 22112 and ask for Mr. Bird. (No phone calls on Saturdays please)

LONDON AREA *Established 1910*

H. L. SMITH & CO. LTD.

Comprehensive stock of equipment
by all leading makers.

287-9 EDGWARE ROAD
LONDON W2 1BE Tel: 01-723 5891

NSE

Amplifiers by Bang & Olufsen, Marantz, Quad, Revox, Sony, Trio, Yamaha.
Turntables etc. by Bang & Olufsen, Shure, S.M.E., Sony, Thorens, Trio, Yamaha.
Speakers by Bang & Olufsen, Bowers and Wilkins, Celestion, Marantz, Mordaunt Short, Sony, Yamaha.
Tape Recorders by Bang & Olufsen, Revox, Sony, Trio.
T.Vs B & W and Colour by Hitachi, National, Sony.
Manager—Doug. Lane. Personal Service Assured—
Part Exchanges

NOTTINGHAM SCIENTIFIC EXCHANGE,
Pevelil Street. Tel: 75756

LOOK WHAT'S IN
STORE FOR YOU
AT **IMHOFS**

five new showrooms each devoted to one
of the world's leading manufacturers.

PHILIPS • B & O • SONY
EDDYSTONE • HACKER

Imhofs, 112-116, New Oxford
Street, London WC1A 1HJ
Tele: 01-636 7878

FORRESTER'S NATIONAL RADIO SUPPLIES LTD.

70-72 HOLDENHURST ROAD
BOURNEMOUTH HANTS

Largest hi-fi and radio component
store in the south Tel 25232

SHREWSBURY

AVON HI-FI LTD
13 Wyle Cop

SIDMOUTH (DEVON)

SIDMOUTH ELECTRICS
68 High Street

SLEAFORD

JAMES HUGHES
10 Westgate

SOLIHULL

C. H. (HIGH FIDELITY) LTD
12 Drury Lane

SOUTHEND

KELLEYS RADIO LTD
92 High Street

SOUTHALL

HANSFALS AUDIONICS AND
ELECTRONICS
488 Lady Margaret Road

SOUTHAMPTON

HAMILTON ELECTRONICS
(SOUTHAMPTON) LTD
35 London Road, SO9 2TW

MULTI TRACKS LTD
37 Bedford Place, SO1 2DG

J. F. SUTTONS
421 Shirley Road

SOUTHPORT

AUDIO CORNER
W. H. & D. M. Yates
117 Portland Street, PR8 6QZ

BOSUN'S LOCKER
14-18 Ashley Road

GARTH HARRISON

84 Station Road, Ainsdale
WAYFARERS RADIO & TELEVISION
18-20, 29 Burton Arcade, Lord Street,
PR8 1NU

SOUTHSEA

TANSLEY & COOKE LTD
161-163 Albert Road

SOUTH SHIELDS

TURNERS (NEWCASTLE UPON TYNE)
LTD
124-126 Fowler Street

STAFFORD

TOM REEKIE LTD
Tudor House, 10 Bridge Street

LUTON**BEDS.**

D. P. HOBBS Ltd.

11, KING STREET

Tel: LUTON 20907

All leading makes of Hi-Fi equipment stocked including Armstrong, Leak, Quad, Rogers, Ferrograph, Trio, etc. We specialise in the repair of all makes of HI-FI equipment.

MEDWAY ELECTRONICS

Specialists in Hi-Fi and Stereo Radio

Agents for :

Quad, Bryan, Mordaunt Short, Jordan Watts, Cambridge, Nivico, Pioneer, Chilton, Connoisseur, Revox, D.B. Audio.

15A Church Street, Chatham
276 High Street, Chatham
Medway 44805/46430

KENT

Terry Burke (Audio) Ltd.

64 WINCHEAP, CANTERBURY Tel: 69848
SPECIALISTS IN HIGH FIDELITY

Quad, Rogers, Mordaunt-short, Scan-Dyna, KMAIL, Cambridge, Revox, Tannoy, Servo-Sound, Nikko, Nivico, Thorens, Toshiba etc.

Workshop on the premises. We service all makes of Hi Fi Equipment. Comparative demonstrations in Hi Fi Lounge

The Sound Studio Ltd.

HEAD OFFICE:

33-35 Camden Road,
Tunbridge Wells, Kent.
Tel: Tunbridge Wells 32153

4 Grand Parade,
Crawley, Sussex.
Tel: Crawley 33566

29 Lower Stone St.,
Maidstone.
Tel: Maidstone 65097

hifi Half day Mondays
Late night Fridays until 8 p.m.

Specialists in Hi Fi Stereo for
Tunbridge Wells, Crawley & Maidstone



P. Taylor

(TAUNTON LTD)

Telephone 2638-9

THE COMPANY THAT'S KNOWN
BY THE PEOPLE IT KEEPS

2 ST. JAMES ST. TAUNTON

AVGARDE Gallery Ltd.

RECORDS AND FINE SOUND EQUIPMENT

Now in five-times-bigger premises

at

42, KING ST. WEST
MANCHESTER 3

061-834 2178

GLASGOW'S MAIN DEALER

Trio, Leak, Akai, Garrard, Sony,
Tandberg, B. & O., Teleton,
Sansui, Wharfedale, etc.

VICTOR MORRIS

*We buy, sell and exchange cameras,
projectors, hi-fi and recorders.*

340 ARGYLE ST. 88 St. VINCENT ST.
041-221 8958 041-248 7974
GLASGOW C2.

For
Hi-Fi in
Scotland

JAMES
KERR
& CO. LTD.

The best Hi-Fi and Stereo equipment. A comprehensive range of Gramophone Records, Public Address and Background music systems installed. Come in and see the range in our spacious new showroom at:-

98-110 Woodlands Road,
Glasgow C.3.
Tel. 041-332 0988

G.H. STEELE, LTD.

141 ST. GEORGE'S ROAD

Glasgow's

hi-fi
experts

041-332 7124



TEESSIDE & DURHAM

See, Hear, and Choose your equipment from the North's finest Hi-Fidelity and Tape Centres. Specialised agencies include:—Bang & Olufsen - Koss - Hacker - Richard Allan - Mordaunt Short - Sansui Sanyo - Sonab - Sony - Quad - Dynatron - Trio etc. Special discounts available on selected equipment. Shop and Home Demonstrations always with pleasure. H.P. terms up to 24 months. Credit free for settlement within 6 months. Part exchange (Photo and Audio).

McKENNA & BROWN LTD.

190 Linthorpe Road, Middlesbrough. Tel: 48345
135 High Street, Redcar. Tel: 3829
11 Bondgate, Darlington. Tel: 65990
134 Newgate Street, Bishop Auckland. Tel: 2266

mccormack's

(MUSIC) LTD

SCOTLAND'S PREMIER HI-FI STOCKISTS

WIDE RANGE OF—

TUNERS - AMPLIFIERS
SPEAKERS - CASSETTE,
CARTRIDGE & REEL
TO REEL TAPE DECKS
& RECORDERS

SERVICE WORKSHOP ON THE PREMISES

mccormack's
(MUSIC) LTD

29-33 BATH STREET,
GLASGOW G2-1HT
Phone: 041-332 6644

audio
aids

All Leading Brands of Hi-Fi Equipment
We have a demonstration studio in both shops and
an audio consultancy service to assist you
with your choice.
Suppliers to Universities and Schools.
AUDIO AIDS
20 SOUTH CLERK ST., EDINBURGH
031-667 2877
Royal Mile (274 Cannongate)
031-556 9838

EDINBURGH'S HI-FI SPECIALIST

HI-FI

CORNER

HI-FI CORNER EDINBURGH LTD

1 Haddington Place Edinburgh EH7 4AE
Telephone 031-556 7901

VICKERS · HI-FI ·

15-24 GILLYGATE · YORK 29659

The High-Fidelity Specialists

Appointed main agents:

- **harman kardon**
- Luxor of Sweden
- Transcriptors
- Alpha/Arena
- Jordan Watts
- Sansui, etc., etc.

A Hi-Fi complex to make Hi-Fi less complicated with:

- Expert Staff
- 2 Year Guarantee
- Keenest Prices
- Package Deals
- Credit Facilities
- Part Exchange
- Easy Parking
- Home Demos. etc., etc.

HI FI & COMPONENTS SUTTON

Agents for: **QUAD, TRIO, YAMAHA**
and other leading makes

7 Sutton Court Road, Sutton
01-642 2853
and

84 Battersea Rise, Clapham Junction, SW11
01-223 1110

LONDON N.

C. C. GOODWIN (SALES) LTD HI-FI ON EASY TERMS

Equipment from £35 up to £1,000 supplied on Personal Credit Plan (GB only). Deposit up in £1 upwards and up to 36 months to pay.

**Goods Despatched Promptly
Carriage and Insurance Free (UK)**

Call, phone or send S.A.E. for quotation:
7 The Broadway, High Road, Wood Green,
London, N22 6DU. Tel: 01-888 0077/8
WORLD WIDE EXPORTERS

*GUILDFORD HI-FI CENTRE

have bought you this

Space

for noting all your hi-fi needs....
and *where to get them
AT THE TOP OF THE HIGH STREET (270)

The
Specialists
in HI-FI
and
AUDIO



87, WALTON ROAD, EAST MOLESEY
01-979 2721

STANMORE (MIDDLESEX)

THE RECORDERIE
10 Buckingham Parade

STEVENAGE

A. & M. SUPPLIES
123-125 High Street

STIRLING

GRAHAM & MORTON LTD
51 King Street

STOCKPORT (CHESHIRE)

AUDIO CENTRE, FAIRBOTHAM &
CO LTD
58-62 Lower Hillgate
NIELD & HARDY LTD
Merseyway, SK1 1LU

STOCKTON-ON-TEES

TURNERS (NEWCASTLE UPON TYNE)
LTD
Camera Corner, Bishop Street

STOKE-ON-TRENT

BRADBURY'S (PHOTOGRAPHIC
PROCESSING) LTD
20-22 Lonsdale Street, S14 4DP
HIGH FIDELITY (S.O.T.) LTD
HI-FI CENTRE
31 Pall Mall, Hanley

STONEHOUSE (GLOS)

R. LEWIS & CO LTD
The Green

STROUD (GLOS)

MIKE CARWITHEN CAMERAS LTD
5 London Road
COTSWOLD AUDIO CENTRE LTD
5 London Road

ST ALBANS

LONDON AUDIO LTD
32 London Road
NORMAN BUTLER AUDIO
3 St Davids Road South

ST HELENS

HAROLD STOTT LTD
18 Westfield Street

ST PETER PORT (GUERNSEY)

LAKERS LTD
30-34 The Arcade

SUNBURY-ON-THAMES

HAVEN HI-FI
8 Sunbury Cross Centre

SUNDERLAND

TURNERS (NEWCASTLE UPON TYNE)
LTD
Phoenix House, Union Street

SURBITON

SOUND INCORPORATED LTD
4 Winthrop House
St Marks Hill

SUTTON

HI-FI AND COMPONENTS LTD
7 Sutton Court Road

SWANSEA

HOLT HIGH FIDELITY
8 Portland Street

SWINDON (WILTS)

SIGHT & SOUND
52 Fleet Street
FOX RADIO SERVICE LTD
5 Milford Street

TAUNTON

GRAYS CAMERA SHOP
1 St James Street

TEDDINGTON (MIDDLESEX)

DAYTRONICS LTD
119a High Street

TENTERDEN (KENT)

POTTER BROS (KENT) LTD
49 High Street

TUNBRIDGE WELLS

GOULDEN & CURRY LTD
59-63 High Street
SOUND STUDIO LTD
33-35 Camden Road

UXBRIDGE (MIDDLESEX)

BUCKELDEE & TAYLER LTD
50 Vine Street

WALLASEY (CHESHIRE)

W. H. DOLBY LTD
266-291 Wallasey Village

WALSALL

M. R. WARNER & SON LTD
68 Upper Bridge Street, WSI 1JG

WARLEY (WORCS)

BELMONT RECORDING CO
25 Belmont Road, Bearwood

WARRINGTON

GEORGE ARNOLD (ELECTRICAL
CONTRACTORS) LTD
78 Halfpenny Road, Orford Green,
WA2 8DN
JOHN STOCKTON HI-FI SYSTEMS
34 Kildonan Road,
Grappenhall, WA4 2LJ.

WARRINGTON ELECTRICAL
CO LTD
57-59 Bridge Street

WATFORD

K. J. LEISURESOUND
101 St Albans Road
SOUND CENTRE (HI-FI EQUIPMENT)
LTD
22 Woodlands Parade, High Street
RADIOLUX LTD
WATFORD HI-FI CENTRE
36 Woodlands Parade, High Street

WEMBLEY

DAVIS & KAYS LTD
3 Wembley Hill Road

WESTHOUGHTON (LANCS)

MAXTONE HIGH FIDELITY
31 Lee Bank, Platt Lane

WESTON-SUPER-MARE

HUSBANDS
18 High Street

WEYBRIDGE

WEST ELECTRICS
15 The Broadway, New Haw

WHITLEY BAY

TOM S. FORD LTD
242 Park View
TURNERS (NEWCASTLE UPON TYNE)
LTD
2 Park View

WIGAN

H. PLUMB & SON
1A Dicconson Street

WILMSLOW

HI-FI CENTRE
Green Lane
SWIFT OF WILMSLOW
5 Swan Street

WINCHESTER

SUTTONS
15 Southgate Street
WHITHAMS
70 High Street
WINCHESTER CAMERA CENTRE
75 Parchmont Street

WINDSOR

AUDIOCRAFT (AUDIO
INVESTMENTS LTD)
89-90 High Street, Eton

WITNEY (OXFORDSHIRE)

WITNEY AUDIO CENTRE
29 Corn Street

WOKING (SURREY)

AERCO RECORDS LTD
27 Chobhan Road

WOLVERHAMPTON

THE HOUSE OF HI-FI, MILLWARDS
(WOLVERHAMPTON) LTD
8-11 Salop Street
M. R. WARNER & SON LTD
22-26 Chapel Ash, WV3 0TS

WORCESTER

JOHNSONS SOUND SERVICE
43 Friar Street

WORTHING

TANSLEY & COOKE LTD
187 Montague Street
TANSLEY & COOKE LTD &
MANSFIELD
Liverpool Road
BOWERS & WILKINS LTD
Becket Buildings, Littlehampton Road

WREXHAM

THE CAMERA SHOP & HI-FI CENTRE
Central Arcade, Hope Street

YEovil

YEovil CAMERA CENTRE
57 Middle Street

YORK

JOHN SAVILLE & SONS LTD
7 Goodramgate
VICKERS HI-FI
15-24 Gillygate

Advertisers Index

A.E.G. (Great Britain) Ltd	106	J. Beam Aerials Ltd	434
Acoustic Ltd, Enterprises	210		
Acoustical Mfg. Co Ltd	<i>Front cover</i>	KEF Electronics Ltd	294
Agfa-Gevaert	234	Kelgrove (Sales) Ltd	175, 347
Alba Radio & Television Ltd	138	K.F. Products Ltd	314
Antiference Ltd	432	Klinger Controls Ltd	139
A.S. Techniques Ltd	314	Koss (Tape Music Distributors) Ltd	420
Bang & Olufsen (UK) Ltd	119	Lampitt Electronics Ltd	405
Beyer Dynamic (GB) Ltd	267	Lasky's Radio Ltd	137
Bib Sales	233	Lennard Developments Ltd	67
B.S.R. Ltd	188	Lind-Air	89
British Radio Corporation Ltd	397		
B. & W. Electronics Ltd	319	MacInnes Laboratories Ltd	176
		Mundy Mills Ltd	105
Canterbury Audio Ltd	<i>Back Cover, 320</i>	Morris, B. H. & Co (Radio) Ltd	140
Cecil E. Watts Ltd	56		
Cole Electronics Ltd	209	Philips Electrical Ltd	184
Decca Special Products Ltd	37	Quality Audio Supplies	406
Dynatron Radio Ltd	398		
		Rfslosound Ltd	268
Eagle International	110-111, 156-157	Richard Allan Radio Ltd	315
E.M.G. Handmade Gramophones Ltd	316	Rola Celestion Ltd	327, 329, 331
Fallowfield, Jonathan Ltd	412-413	S.M.E. Ltd	38, 378
Francis of Streatham	104	Sanyo Marubeni (UK) Ltd	127, 129
		Sharp Electronics (UK) Ltd	120
Garrard Engineering Ltd	70	Shure Electronics Ltd	55
Global Ltd	105, 373	Sonab (of Sweden)	360
Golding Audio Ltd	204	Sony (UK) Ltd	411
Goldring Mfg. Co (Great Britain) Ltd	68	Sugden, A. R. & Co (Engineers) Ltd	69
Goodmans Loudspeakers Ltd	317	Sykes & Hirsch Ltd	77, 359
Grampian Reproducers Ltd	138		
		Tannoy Products Ltd	348
Hampstead Hi-Fidelity Ltd	90	Transcriptors Ltd	78
Heath (Gloucester) Ltd	254	Tysons Sound Engineers Ltd	105
Hi-Fi Dealers Association	442		
		Vitavox Ltd	293
Imhof-Bedac Ltd	318		
		West Midland Aerials Ltd	436

G

GABRAPHONE

for the Original Sound



1973

HIFI YEAR BOOK

MET

Modern Engineering & Technology Limited
4, Station Road, West, Canterbury, Kent
Phone: Canterbury 60431

IPC Electrical-Electronic Year Books Ltd