



Faithful to your music



Music as it was meant to be heard • Systems start from £3000

For your nearest stockist call +44 (0)1722 332266. Or visit www.naim-audio.com

World Radio History





Simple Perfect Sound

tel: +44 (0) 1480 423700

www.mission.co.uk

pilastro
by
MISSION

The Bristol Sound and Vision show is an enjoyable annual foray into all aspects of the audio/visual market. It gathers a varied and eclectic crowd who are friendly and appreciative. The show also attracts a younger crowd too, which is particularly pleasing.

However, the Show also highlights some of the downsides of the business. These can be summarised in a selection of conditions unique to the industry that many readers may be unaware of, and ones that we all suffer in silence. I therefore feel they need bringing to light.

The first condition is known as Power Amp Back. This condition rears its ugly head after about three years of lugging around ridiculously overweight equipment. It slowly creeps up on you with the odd twinge or two followed by the hammerblow strike. This invariably happens when unloading the van the evening before a show - resulting in having to stand around for three days with the posture of Quasimodo. This is incidentally a good way of discerning how long someone's been in the industry - the more ungainly the gait, the more experienced the individual. Show me one long serving member of the business that hasn't at one stage suffered from this most unpleasant of conditions and I'll show you a flying pig.

Next on my list is the condition known as Brubeck Ear, in my mind one of the nastiest afflictions of all. This strikes the general public as well as the professional. It is caused by over exposure to bland jazz that many hi-fi exhibitors mistake for emotionally communicating, enjoyable music. However, it can make hi-fi sound quite good, hence the profusion of this type of musical tat on many audiophile labels. But after five minutes of such fare watch listeners' eyes start to wander as the Van Gogh reproductions in the hotel room turn into the Sistine Chapel, or the show guide miraculously transforms into the latest Jack Higgins thriller. Some have been known to start living exclusively on roast turkey and tofu as the condition leads the sufferer to crave

more extreme forms of blandness.

Finally we have a very common affliction known as Exhibitor's Thirst. This starts to raise its ugly head about four hours into the first day of exhibiting, or if it's valve amps you're showing off, about thirty minutes. With all that heat flying around in what is usually an already stuffy room the climate moves toward that of a Finnish sauna.

Add to this the fact that most of the time is spent answering questions and chatting to the general throng and you soon have a throat as dry as a Crocodile's undercarriage. No matter how much water is sipped throughout the day, the only effective cure for this complaint seems to be found in a post-show mini-tour of the very fine taverns and wine bars of Bristol, where one will invariably bump into 90% of fellow exhibitors, all in jubilant mood. This condition seems to be the most widespread.

If you think from this tirade that I can't abide shows and all that goes with them, you'd actually be wrong. We often forget how important they are for the industry - for example, it's a chance for the public to judge whether journalists are actually accurate in their descriptions of sound quality, if nothing else!

I have a whale of a time and actually enjoy attempting to answer questions and generally nattering to the hi-fi adoring public. As long as they buy me a throat soother afterwards that, is... ■ ▲



Simon Pope

how we test the products

- Hi-Fi World has its own advanced test laboratory and acoustically treated listening room.
- Hi-Fi World has a dedicated in-house team of experienced listeners. We review thoroughly by extensive auditioning, rather than by quick-fire group listening tests.
- Hi-Fi World's engineering team designs a wide range of products in-house. No other hi-fi magazine is so expert and dedicated.

- £ ——— NICE PRICE - Represents excellent value for money.
- EXCELLENT - Superb sound, among the best available.
- ——— VERY GOOD - Well worth a listen.
- ——— ADEQUATE - Room for improvement.
- ——— POOR - Seriously flawed. Forget it!
- ——— Half globes are added for those products that we feel are between categories

HI-FI WORLD

SUITE G4, IMEX HOUSE
KILBURN PARK ROAD
LONDON, NW6 5LF

www.hi-fiworld.co.uk

Contact Numbers

Mon-Fri 9am-5pm

Editor

Simon Pope
tel/fax +44 (020) 8786 8141
e-mail: editorial@hi-fiworld.co.uk

Computer Audio World Editor

David Price
email: editorial@computeraudio.co.uk

Design & Layout Editor

Faiza Chunara
tel: +44 (020) 7625 3129
fax: +44 (020) 7328 1844
e-mail: adproduction@hi-fiworld.co.uk

Production/Photography Editor

David Noble
tel: +44 (020) 7625 3134
fax: +44 (020) 7328 1844
e-mail: classifieds@hi-fiworld.co.uk

Advertising

Amanda Sweeney
tel/fax +44 (020) 8864 4760
e-mail: advertising@hi-fiworld.co.uk

Accounts

tel: +44 (020) 7625 8032
fax: +44 (020) 7328 1844

Credit Control

Louise Palfrey
tel: +44 (0) 1923 270833
fax: +44 (0) 1923 260588
e-mail: subscriptions@hi-fiworld.co.uk

WORLD AUDIO DESIGN

Technical Manager - Nick Lucas

www.worldaudiodesign.co.uk

tel/fax: +44 (0) 1908 218836
e-mail: nick@worldaudiodesign.co.uk

Publisher

Noel Keywood
e-mail: publisher@hi-fiworld.co.uk

Private & Trade Classified Ads

tel: +44 (020) 7625 3134
fax: +44 (020) 7328 1844
e-mail: classifieds@hi-fiworld.co.uk

Subscriptions & Back Issues

9:30am - 12:00 noon
tel: +44 (0) 1923 270833
fax: +44 (0) 1923 260588
e-mail: subscriptions@hi-fiworld.co.uk

Distributed by

Comag Magazine Marketing,
Tavisstock Road, West Drayton,
Middlesex UB7 7QE
Tel: +44 (0) 1895 444 055

Printed by

Southern Print, Dorset
Tel: +44 (0) 1202 622 226

Our Agents in Malaysia

Millennium Hi-Fi & AV
Simon Chang
Showroom & office, 500-1-3 First Floor
Wisma Indah (Shen Court), Jalan Tun Razak
50400 Kuala Lumpur, Malaysia
Tel: 603 9283 8171 Fax: 603 9281 3762
e-mail: info@millennium-audio.com

All unsolicited submissions and goods are at the owner's risk. We accept no responsibility for such submissions, nor do we undertake to return them.

No material may be reproduced from this magazine without the publisher's written permission.
© Audio Publishing Ltd



contents

reviews

digital source players

PIONEER DV-747A
DVD-A/SACD PLAYER 9



Double first - David Price listens to the world's first multichannel DVD-A/SACD player. Will it be the answer to all our prayers? David Price investigates. . .

AUDIO ANALOGUE
MAESTRO CD PLAYER 22



This stylish heavyweight is the new top of the range player from the Italian company. Featuring high quality components and 24bit/96kHz 'upsampling', will Simon Pope be suitably impressed?

digital recorders

PHILIPS CDR802 42



The new twin deck CDR802 features a disc changer player section in partnership with a recording mechanism. David Price sets the record straight.

amplifiers

ARCAM FMJ A32 12



Going back to their roots, Arcam's newest FMJ offering is a £1,000-plus top of the range integrated amp. Will their new baby impress?

CROFT CAMELEON
INTEGRATED AMPLIFIER 24



Croft's valve amps have a reputation for hi-end sound at a sensible price. The new £875 Cameleon is the latest product to claim this - how will it fare?

MARANTZ PM8200 52



This is a neat looking new midrange amp from the re-vitalised Marantz. Stuffed full of facilities, will the sound match the specifications? Dominic Todd does the honours.

loudspeakers

RED ROSE ROSEBUD 15



With Mark Levinson at the helm, Red Rose's latest range includes this baby sized but full range standmount that features a ribbon tweeter. Simon Pope listens in.

INFINITY KAPPA 600 34



At £1,500 the Kappa 600s are large floorstanders with side firing woofers. Is big necessarily better, asks Mani Sandher?

VELODYNE HGS-12
SUBWOOFER 38



David Price tries out the mightily powerful HGS-12 subwoofer from Velodyne. Hold the furniture down!

JPW 120 50
Dominic Todd encounters these minuscule budget standmounts from JPW.

ELAC 510 55
These standmounts from Germany are the baby brothers of the 512 that impressed us recently. Will David Price find similar results here?

vinyl

REGA P9 TURNTABLE 20
The Planar P9 is the latest top of the range vinyl spinner from the Essex specialist. David Price revels in the black stuff.

accessories

CACTUS DAMPING 19
In a world snake oil and charlatans, David Price discovers an effective upgrade that will convince even the hardest of cynics.

CABLES 26
Two new entry level interconnects from van den Hul and Chord Company are this month's cable candidates

features

REGA FEATURE 59
David Price pays a visit to the notoriously reclusive hi-fi specialists' Essex HQ and interviews their vintage valve-loving designer.

regulars

WORLD NEWS 6

NEXT ISSUE 7

COMPETITION 37
This month we're giving away a superb £2,500 all-valve system from Audio Note.

READERS LETTERS 44
Hi-Fi World's team reply to your letters and e-mails.

SUBSCRIPTIONS 27
Hi-Fi World is second to none for news and reviews. Subscribe today!

HI-FI WORLD KITS 64

HI-FI WORLD LIBRARY 68
A comprehensive selection of titles covering audio, valve amplifiers, loudspeakers, solid state electronics and more.

COLUMNS 71,73,75
The World team get to grips with issues facing both the industry and hi-fi alike.

SPECIALIST HI-FI DEALERS 76
Got a problem? - see a specialist.

OLDEWORLD 41
This month's choice is a 24 carat classic: Musical Fidelity's A1 amplifier.

CLASSIC CUTS 77
Andy Giles highlights Neil Young's early solo effort, 'After The Gold Rush'.

DIAL-A-DEALER 78
Who sells what, and where to find them.

MEET YOUR MAKER 80
Who makes what, and how to get in touch.

WORLD FAVOURITES 87
Components which we know to be truly worthy of audition.

WORLD CLASSICS 92
Our list of products that have stood the test of time.

SUPPLEMENT NO.64 95

DIY NEWS 97

DUTCH BULBS 98
Neville Roberts builds the interestingly named Njoe Tjoeb 4000 Valve output CD Player from the Netherlands.

HEAD CASE 102
Neville Roberts designs a Moving Coil cartridge head amplifier for those who crave vinyl but not wallet ache!

DIY LETTERS 105

MARKETPLACE 107

READERS CLASSIFIED 123
The definitive place to find classic audio components.

ADVERTISERS INDEX 130

computer audio world

PRO AUDIO? 81
David Price looks at the latest in a long line of compressed audio file formats - MP3 Pro - and tries its first commercial implementation, in the shape of Steinberg's MyMP3Pro 'jukebox' software.

WELL CONNECTED 83
David Price tries out two interesting new connection options for computers from Xitel, the Analogue and Digital Hi-Fi Links.

MYSTIK MUSIK 85
David Price tries out an eerily familiar audio editing package from Mystik Media, AudioEdit Deluxe 1.2 for Windows.

CHECK THIS OUT! 86
Sony's new NW-MS9 'Network Walkman' is the Japanese giant's latest digital audio portable. David Price listens in.

world news

▶ CELESTION TAKE UP NEW MARKET POSITION

2002 is set to be a benchmark year in Celestion's illustrious history.

The company are "moving forward" into new 'lifestyle' and AV markets with distinctive, ultra modern styling.

Representative of the new line up is their chic £600 AVF302

loudspeaker which features a finish in a choice of either furniture quality beechwood or hand-crafted Italian glass.



Celestion International Consumer Division
Tovil
Maidstone
Kent ME15 6QP
Tel: 01622 687442
www.celestion.com

▶ MF'S TWO IN ONE WONDER

The latest Musical Fidelity high-end product takes on Krell's much admired KPS25S CD player/preamp and better it, they say. The CD Pre24 uses the same DAC filter, control electronics and mechanism as Musical Fidelity's Nu-Vista CD player. It features 24bit, 96kHz "true" upsampling with the latest digital filter design. The analogue preamp stage is closely related to the A3CR preamp and uses completely separate power supplies with innovative grounding for minimal interaction between analogue, digital and CD stages. The CD Pre24 has three analogue and two digital inputs (in addition to the CD stage) as well as a digital tape loop and an analogue/digital convertor so that the selected input will always appear on the digital tape loop.

As for the aesthetics, we'll leave that to Anthony Michaelson, the company's Managing Director: "hunky, masculine, testosterone-loaded, without being over the top."

Musical Fidelity
15-17 Olympic Trading Estate
Fulton Road
Wembley HA9 0TF
Tel: 020 8900 2866

▶ NAD'S CHANGING TIMES



Not content with merely having one of the best sounding DVD players on the market, NAD have now launched a multi player DVD which can accommodate up to five discs (DVD, CD, CD-R/RW). The player can also read discs encoded with HDCD and MP3 information. Inside there are true 24/96 DACs for the analogue output channels, low-noise op amps and associated analogue circuitry. Connections include Component Video, SCART and S-Video and features such as multi-angle, multi-sound, frame and zoom come

as standard. The price of the T571 is £580.

Lenbrook UK Ltd.
Unit 2, Old Wolverton Mill
Milton Keynes
MK12 5NP
Tel: 01908 313360
www.lenbrook.co.uk

► **LINN'S CLASSIK GOES VIDEO**

March sees the launch of the latest version of Linn's much admired one-box Classik system. The new Classik Movie System has - you guessed it - the added attraction of DVD and multichannel playback. This is the first video product from the Scottish company. It integrates a DVD mechanism with an AM/FM tuner possessing 80 presets, multichannel power amplification and multiroom distributed audio. It also has internal Dolby Digital and DTS decoding. One main Classik can be linked with up to four other units to create a multiroom system.

It's available in five colours priced at £1,995.

Linn Products
Floors Road
Waterfoot
Eaglesham
Glasgow G76 OEP
Tel: 0141 307 7777
www.classik.com
www.linn.co.uk



► **KEF'S 7s JOIN THE Q!**

Following the unveiling of the new Q Series of loudspeakers from KEF at the 2002 Las Vegas International Consumer Electronics Show, the range sees its latest addition in the shape of the flagship Q7. It is a three-way bass reflex floorstander featuring the new KEF 19mm metal dome tweeter, a 'racetrack' format low frequency driver and a 160mm

Uni-Q mid/LF unit. The styling features the Uni-Q pod faired into the curved section cabinets. It's available in three finishes priced at £800.

KEF Audio Ltd.
Tovil
Maidstone
Kent ME15 6QP
Tel: 01622 672261
www.kef.com



► **UK SEES GRYPHON AGAIN**



retailer's expressed an interest in the product. In response to this the company is now working directly with selected UK dealers. Their product line up has been revamped with the recent introduction of a second-generation

Gryphon Audio, the high-end Danish manufacturer of monster sized ultra high-end products, have a new presence in the United Kingdom. After sixteen years of success mainly in the Far East market, where the company has a dedicated following, a number of European

upsampling CD player, the Adagio. The products are initially featured in the following retailers: Audio Salon, Glasgow, KJ WestOne, London and Midland Audio X-change, Kidderminster.

www.gryphon-audio.com

next issue

here's a selection of the goodies we hope to have for you in May's issue.

MOON AUDIO INTEGRATED AMPLIFIER

This monster-build integrated amp hails from Canada. Tune in next month to find out what we think of it.

WILSON BENESCH ARC LOUD-SPEAKER

Here's the latest small standmounter from the wizards of carbon-fibre construction. Will the sound match its gorgeous looks? Find out in four weeks.

DENON DVD-1600

Will it be one of the best budget DVD-A players around? And will it be a £500 bargain? We listen carefully next month.



Faithful to your music



Music as it was meant to be heard • Systems start from £3000

For your nearest stockist call +44 (0)1722 332266. Or visit www.naimaudio.com



DOUBLE FIRST



Pioneer's brand new DV-747A is the world's first silver disc spinner to offer both DVD Audio and SACD multichannel functionality. David Price finds out if it's twice as nice?

Who'd have thought it would be Pioneer - DVD Audio's keenest exponent - which came up with the very first dual standard machine that plays SACDs too? Super Audio Compact Disc is, lest we forget, the brainchild of Philips and Sony - a format developed independently of the DVD Forum and a not inconsiderable threat to the rosy future of DVD-A!

The story so far: In the finest tradition of London Transport buses, after waiting in vain for twenty years for something to appear, suddenly two brand new 'high resolution' audio formats arrive at once. Arguments rage about their respective sound quality, but Sony's success in getting vast numbers of SACD discs into Japanese shops (which are also available here, via the internet, Vivante and a few other outlets) speaks volumes about which is the more viable.

By contrast, what have we seen from the rival DVD-A camp until

recently - practically nothing!

What then of the two new formats' respective sonics? To date, the best sounding player I've heard is Marantz's £5,000 SA-1. It has quite comfortably trounced any DVD-A players I've come across, but to be fair, it costs around five times as much, so maybe it should?

Down in the sub-£1,000 sector, it's Sony that rules the roost. Its SCD-555ES isn't the best CD player at the price, but makes very nice noises with SACD. Its main DVD-A rival has been Pioneer's now-defunct DV-939, which coaxes excellent results from 24/192, and even Denon's bargain basement £499 DVD-1600 is little short of a revelation against most CD players.

It's into this context that the new DV-747A slots. It attempts to consolidate on the 939's success, and grab much of the SACD market from Sony. Its killer 'sales proposition' is total format freedom - it plays virtually any round shiny object you

can think of, short of a silver painted beer mat. For the record, this means DVD-A, DVD-Video, Multi-channel SACD, MP3, CD-R, CD-RW, DVD-R and DVD-RW, and there's even full Dolby Digital & DTS Decoders built in for good measure. Phew!

Considering this machine's significance, and hefty £1,000 price tag, you can't help feeling a little underwhelmed in the flesh. Quite small at 420x97.5x278 mm, it comes in a nice bright silver brushed aluminium case which is less substantial than it looks, weighing just 4.5kg. Offering DVD video playback as well as its aforementioned audio capabilities, it boasts a wealth of picture-related facilities (including full Multi Region, 108MHz/12-bit video DAC, Fine Focus digital filter, 540 line horizontal resolution and extensive picture parameter adjustment), but ties this together with some clever audio DSP features.

Legato Pro is Pioneer's latest attempt to give digital a more

◀ analogue feel, using upsampling to boost both DVD video and CD sound from 48kHz (or 44.1kHz for CD) to 192kHz or (or 176.4kHz with CD). Hi-Bit then 'pads out' 16 or 20bit words to 24bits, adding dither. The greatly enhanced digital audio stream is then converted into analogue by its high quality 24bit, 192kHz Burr Brown DAC. Clever stuff, and reminiscent of what many high end digital aficionados have been doing for years - using systems like the dCS Elgar.

Full MP3 compatibility is built-in - with up to 250 folders with 250 files able to be played back - and there's even an on screen Bit-rate Meter! Round the back you get a wealth of connections, including two SCARTs, two S-Video outs, a Component video out, two RGB video outs, two RCA stereo line outputs and full 5.1 audio outputs, plus a single optical & coaxial digital in and out.

So how does it sound? First a word about its CD replay capabilities. Compare it to the likes of Arcam's FMJ CD23T and you won't give the 747 a second look - or listen. It isn't bad - it's quite rich and full sounding, with no nasties and a decently refined and polished sound, but you hardly get pushed to the edge of your seat with excitement. It does the job perfectly well, but don't buy this primarily as a standard 16bit/44.1kHz CD player. As an aside, you can't say the same about its video capabilities, which are excellent.

The real action is, of course, when you feed it a DVD-A or SACD disc. Frankly, the relative paucity of software with both formats prevents direct comparisons, but live with the Pioneer playing different discs for a week or so and you get the general impression that both its DVD-A and SACD abilities are excellent - but different. In a nutshell, DVD-As sound more powerful and dynamic, and a



little brighter, more edgy and 'digital', whereas SACDs are smoother, warmer and slightly more beguiling. To use an analogue analogy, it's like the difference between an SME V (DVD-A) and a Graham unipivot (SACD).

My much played Denon 24/192 DVD-A disc of Beethoven's Piano Concerto No. 5 (Kyoko Tabe on piano, Martin Sieghart conducting the Bruckner Orchestra Linz) was edge-of-the-seat stuff. The DV-747 conjures up a very wide and expansive soundstage, with impressive depth - the music hangs in space in a way that no CD player can achieve at any price can (but vinyl users will know what I'm talking about). Bass is deep and strong, but noticeably less 'lumpy' than 16/44 CD - it's more even and seems to go at least an octave lower.

The midband is a joy - oodles of detail, tremendous low level resolving ability and a refreshing lack of grain. Suddenly all the 'fuzz' and 'muzz' of 16bit disappears, to be replaced by a glass-clear window on the music. Treble is a joy - the total absence of digital tizz is uncanny, and there's a palpable sense of atmosphere which really adds to the experience.

The downside of the Pioneer's DVD-A performance is that it still sounds 'digital' - it's a long way from

the beautifully beguiling, natural and organic performance you get from vinyl.

Switching to SACD somewhat alleviates this sense - although it doesn't go as far as it could. My favourite DSD SACD disc right now is Marvin Gaye's 'Midnight Love'. This is not because it's a seminal hi-fi recording - it isn't - but thanks to the great music which shines through with top players like Marantz's SA-1. The DV-747 proved surprisingly adept at carrying 'Sexual Healing'; the contrast between the gritty early drum machine and Marvin's velveteen voice was striking. Here the Pioneer really 'emoted', and I found myself locked into the music rather than the whizz-bang hi-fi quality of DVD-A. Tonally, the 747 is smoother and duller with SACD than DVD-A, with a richer, fuller bass and wider, less precise soundstage - this seems to reflect the relative differences between the two formats in general.

This machine is neither the world's best DVD-A player or SACD spinner, but it sounds way better than CD all the same. Its impressive fidelity with either format, plus its raft of other abilities, makes it superb value for money. It's very hard to find a reason not to buy Pioneer's new DV-747A. ■ ▲



Pioneer DV-747A £1,000

Pioneer UK Ltd.
Pioneer House
Hollybush Hill
Berks SL2 4PQ
Tel: 01753 789789
www.pioneer.co.uk

TWO TRIBES
David Price compares
DVD-A with SACD

Make no mistake - neither new format is perfect. Aside from watermarking issues, DVD-Audio's main theoretical drawback is the brickwall filtering it needs to eliminate high frequency digital noise. This chops off all HF content above half the sampling frequency (with 24/192 DVD-A it's 96kHz). When CD was invented, it was assumed we couldn't hear anything above 20kHz, but psycho-acousticians now agree we can 'perceive' far higher up the audio band.

SACD circumvents this by using a completely different coding system to DVD-A's Pulse Code Modulation (PCM). Direct Stream Digital gives naturally extended high frequencies up to 100kHz by taking tiny 1bit samples at a dramatically higher sampling rate of 2.8224MHz. However, this too has limitations - Professor Malcolm Hawksford of

Essex University has argued that the system simply doesn't work at a high enough sampling frequency to give decent resolution, particularly in the treble range. Indeed DPA's Rob Watts says that, "most of DSD's 2.8 million pulses per second are needed just to reach 16bit standard, let alone better it".

There are practical as well as theoretical drawbacks for both systems, too. Few high resolution PCM or DSD analogue to digital converters exist in studios, and - at the moment at least - the 24/192 converters in DVD-A players struggle to give anywhere near that resolution. Rob Watts reckons they're not much better than true 18bit performance, currently. LFD's Richard Bews adds that, "without proper power supplies, earthing and parts even the best DAC won't sound right". Railing against what he calls 'specmanship', he argues that sampling frequencies and word size are more useful to marketing men than digital engineers, "you can't have a free lunch with digital".

Lastly, there's the vexed question of software availability. Here, SACD has the clear lead right now. Eighteen months since the first commercial DVD-A disc release, they're still not in High Street stores. There's a sprinkling of titles from the likes of Warner, BMG, EMI and Universal, but it's still early days. By contrast, there are about ten times as many titles available on SACD, from giants like Sony (and its CBS back catalogue) plus a number of small, audiophile labels like Linn, Opus 3 and AudioQuest. A good place to find either discs is Vivante Music Ltd. (www.vivante.co.uk).

Ultimately, the new wave of DVD video players incorporating DVD-A at dramatically lower prices, should assure the format's popularity. SACD will likely become a specialist audiophile format, like vinyl. The beauty of Pioneer's DV-747A - and similar players likely to follow it - is that you can simply buy discs on the grounds of musical content, rather than format politics.

DVD-AUDIO V.10
SPECIFICATIONS

16, 20 or 24 bit PCM at 44.1, 48, 88.2, 96, 176.4 or 192kHz sampling frequency. Up to six channels with a transfer rate of 9.6Mbps maximum. MLP option. Supplemental information storage, including album title, song titles, artist data, artist discography, plus URLs. No regional coding, unlike DVD-Video. Optional audio format facility

(i.e. SACD). Not compatible with conventional CD or DVD video players- optional 'watermarking' (copyright protection) encoded into the musical data. 144dB signal/noise ratio, 2Hz-96kHz frequency response.

to six channels with a transfer rate of 2.8Mbps option of carrying both multichannel and two channel mixes on the same disc. Hybrid disc option offering 16/44 PCM stereo playable on any standard CD player. No 'watermarking' - copyright protection is kept separate from musical data. 120dB signal/noise ratio, 2Hz-100kHz frequency response.

SACD SPECIFICATIONS

1bit DSD at 2.8224 MHz sampling frequency. Up

PERFORMANCE

Pioneer's multi-function player handled audio CDs very well, returning a ruler-flat audio frequency response our analysis shows. An upper limit of 21.87kHz is higher than usual, showing Pioneer use effective filtering. With good downward extension to 4Hz the DV-747A is well designed in this area.

Distortion levels were low throughout the players dynamic range, but especially so below -60dB. Pioneer have used additional Legato Pro processing to reduce low level quantisation noise, since it is impossible to reduce 'distortion' at -90dB from CD much below 28% without it. The DV474A returned a distortion figure of just 6.6% at this level, so it is very different. Experience shows this detectably smooths out and deepens the sound from CD; it is a significant benefit.

All other figures from this player were exceptionally good, suggesting Pioneer have put quite a lot of effort into its development. I'd expect the DV 474A to turn in good results since its measured performance is exceptional.

Frequency response 4Hz 21.75kHz

	left	right
Distortion %		
-6dB	0.007	0.007
-30dB	0.016	0.017
-60dB	0.365	0.366
-90 6.6.	6.6	6.7
Separation dB	left	right
1kHz	136	136
20kHz	100	101
Noise		-122dB
with emphasis		-122dB

Dynamic range 109.5dB
Output 2V

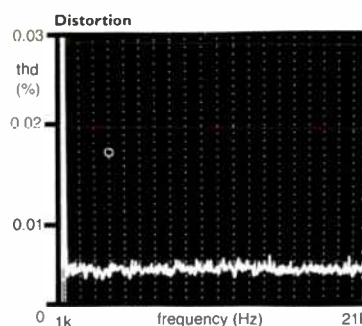
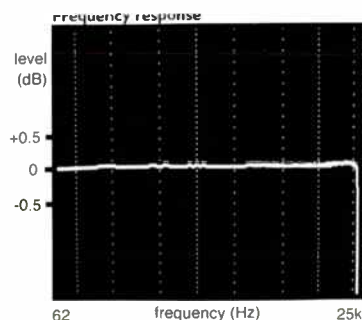

World Verdict



Superb all rounder with a jizzying array of facilities - expensive, but top value nonetheless.

HOMeward



Forget DVD players or CD spinners - Arcam's real 'heartland' is upmarket integrated amplifiers like this. David Price listens to the brand new A32, surely the spiritual successor to the famous A60?

Let us not forget, A&R Cambridge Ltd's launch pad into High Street stardom was the late, lamented A60 integrated amplifier. Back in the tail-end of the seventies, this sold for over £200 - about four times the cost of your average budget separate of the day. As well as having a comparable price point, the £1,100 A32's actual design brief is incredibly similar to its forebear all those years ago. At a time when it was trendy to shave off all excess fat, the A60 proudly sported balance and tone controls. Defiantly offering 'real world' facilities, it went against the 'purist' ethos of the day and duly sold like hot cakes.

It's into this context that Arcam's self-proclaimed "best ever integrated amplifier" fits. Said to "set new standards for its class", this is the Huntingdon company's stab at getting a piece of the upmarket separates sector back. Okay - blah, blah, woof, woof - everyone talks up their products, but Arcam has put its money where its mouth is, in the shape of a purposeful 100W per channel power amp section (8 ohms), claimed to give a straight 150W into 4 ohms. This is in no small part due to a toroidal transformer the size of a tractor tyre. It weighs a ton, and a particularly portly - obese, even - one at that.

True to its roots, the A32 doesn't shirk on the functionality front. To wit, you get five line inputs, plus two tape monitors, plus discrete power amp in

and pre out socketry, plus two pairs of speaker terminals at the back. Up front is a headphone socket, large volume control, push buttons for all the inputs and a bright green multi function display. This normally shows volume, but press the 'Select' button and it goes into an elaborate 'edit' mode. This offers Treble, Bass and Balance controls, plus a 'Customise' [sic] option which gives, variously, type of volume control display, volume control sensitivity, global or localised tone control selection (i.e. individual tone controls on each input, or overall) and input trimming (i.e. individual level controls for each input). Get the picture?

There's more. You can even alter the 'welcome message'. Needless to say, the A32 has various optional extras, from a plug-in MM/MC phono module (which should be good if past history is anything to go by), to a matching P35 100W RMS per side power amplifier, which can be purchased in either 2 channel or 3 channel versions to bi-amp (or tri-amp) your speakers, or provide multi-channel functionality. In three channel guise, you've got 3x90W. Of course, all this stuff is controllable from the supplied remote commander - including the optional power amps!

As I've already suggested, the A32 is a well built piece of kit. Its silver finished 430x370x110mm case is a precision-machined aluminium extrusion with a heavy gauge

aluminium cover and steel chassis. It feels a lot swisher than Arcam's budget fare, and its 13kg weight rather underlines the fact that this is for big boys. To wit, I decided to try it out through my big reference Yamaha NS1000M loudspeakers, with a Michell Orbe turntable and Linn CD12 CD player feeding it. The first twist of the solid metal volume knob suggested this was going to be fun!

Without doubt, the Arcam packs a punch. I rarely hear integrations that can really extend the powers of my Yamaha NS1000M loudspeakers, but this one had a darn good go and got up to flare-flapping levels before showing any undue signs of stress. Kicking off with Roxy Music's 'Take a Chance with Me' from the Avalon LP, the Arcam thumped out the opening drum sequence most purposefully. Attack transients weren't quite as lightening-fast as the Naim NAIT 5 I had to hand, but there was a good degree more 'oomph'. When the guitars, bass, keyboards and vocals kicked in, the A32 exhibited more bass weight, giving it a much fuller, gutsier presentation.

Further up the frequency band the Naim showed greater grip. With a tighter control on the proceedings, the A32 was made to look slightly wrong footed. Still, for its sins it pushed out a wider, more expansive and breathy soundstage than the Naim, giving a noticeably more Phil Spector-like 'wall of sound'. Its

BOUND

Salisbury rival was less concerned with the minutiae of production details, and just cut to the chase, giving a more engaging if less 'hi-fi' sound.

Moving to the simpler strains of Madness's 'The Sun and the Rain', the A32 dived in with aplomb. The opening piano break was rich and full-bodied, with an impressively natural tone, good dynamics and big, bold out-of-the-box image articulation. Unlike the Naim, when the wick was really turned up in anger (to -7.5dB on the display, so it was getting loud), the Arcam kept driving the bass hard, letting those tuneful piano cadences and bouncy bass guitar shine through. Indeed, this kind of rhythmically straightforward pop seemed to suit the Arcam down to the ground.

Moving to the more sinuous drum and bass of Appaloosa's 'Travelling' on CD, this amp again conjured up an expansive acoustic, with sumptuous basslines and a peppy and tuneful midband. Interestingly though, you could hear things go slightly awry as the song built up in intensity. The Nait carried the midband far better,

revelling in the complex twists and turns of the snare drums, and their interplay with the hi-hats. The Arcam lost some of this, preferring simply to bash things out with as much wallop as it could muster. Again, both amps' respective readings of the song were great fun, but quite different!

It was The Crusaders' 'Street Life' on Japanese vinyl that signposted the A32's shortcomings most clearly. Again, it sounded big-hearted and engaging (reminiscent of an old NAD3020 on steroids, methinks!), with big, fat bass that pushed the song along with glee. The problem was Randy Crawford's voice, which seemed a little too grey and uninspiring. It certainly wasn't harsh or fatiguing - far from it - it's just that the big Arcam wasn't really able to capture the grain of her incredibly 'breathy' tones in the way that either the Naim or my Cyrus 7 did. Of course, you don't expect valve levels of tonal accuracy from a product like this, but I still feel it rather steamrollered through the proceedings at the expense of a good

deal of subtlety. Nor did it prove the most delicate reproducer of acoustic cymbals - things sounded just a touch too genetically modified for my liking.

This is the key to the A32. It's not the most transparent or self-effacing performer at the price, preferring to play music with great gusto and a fine sense of fun, regardless of what's actually on the disc. At this price, you can't have your cake and eat it - it's either power or poise - and the Arcam nails its colours to the wall just like a Harley Davidson or Chevrolet Corvette would. You could say it's more early Bruce Springsteen than late Nick Drake! So if you're looking for a go anywhere, do everything amplifier, then this should be at the top of your shortlist. In my experience, products with this kind of flexibility and feature count rarely ever sound this fun. ■ ▲

Arcam FMJ A32 £1099.90

A&R Cambridge Ltd.
Tel: 01223 203200
www.arcam.co.uk

MEASURED PERFORMANCE

Arcam's chunky FMJ A32 amplifier has plenty of punch. It turns out a useful 112W into 8ohms and no less than 200W into 4ohms. Since most loudspeaker bass units are 4ohms nowadays, the Arcam can drive them hard if need be. This amp will certainly go loud.

Arcam have tailored the bandwidth neatly to suit SACD and DVD-A at both ends of the spectrum. The amplifier reaches down to 3Hz, so it will push subsonics, and it extends up to 90kHz, the upper limit of the new disc formats. Distortion levels were fairly low in all areas, but there was a little more high frequency distortion than that for many amplifiers. It comprised mainly second and third harmonics. Subjectively this should not amount to much.

The Moving Magnet disc stage was insensitive but is otherwise well engineered, with accurate equalisation and low noise. The Moving

Coil stage was similarly not too sensitive, being for high output designs. The MM stage gain rolls off below 20Hz and MC below 32Hz, so there is some attenuation of warps around 5Hz but good bass coverage all the same.

The FMJ A32 is a powerhouse with plenty of facilities. It measured well all round, if not quite bettering rivals in any particular area. **NK**

Power	112watts
CD/tuner/aux.	
Frequency response	3Hz-90kHz
Separation	81dB
Noise	-96dB
Distortion	0.007%
Sensitivity	750mV
dc offset	1/4mV

Disc (MM)	
Frequency response	20Hz-78kHz

Separation	72dB
Noise	-70dB
Distortion	0.008%
Sensitivity	6mV
Overload	86mV

Disc (MC)	
Frequency response	32Hz-100kHz
Separation	72dB
Noise	-68dB
Distortion	0.008%
Sensitivity	0.6mV
Overload	8mV

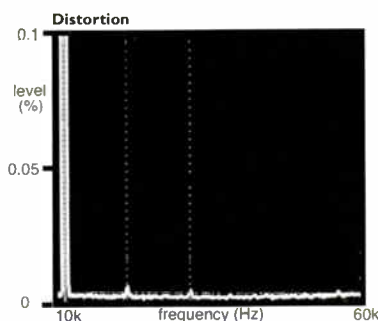

World Verdict

A brilliant package, combining great power, fine sound and superb flexibility, but all-out audiophiles should look elsewhere.

MICHELL GYRODEC SE

A SYMBOL OF PRECISION



WHAT HI-FI?
June 1999

Michell Engineering Ltd, 2 Theobald St, Borehamwood, Herts, WD6 4SE
Tel: 0208 953 0771 Web:www.michell-engineering

THE AFFORDABLE PHONO AMPLIFIER

FROM TRICHORD RESEARCH

only £299.00 inc VAT (COMPLETE WITH TOROIDAL PSU)

DINO

Moving Coil
Moving Magnet
Switchable Gain
Switchable Loading
Super Regulators
Discrete Output Stage
Add a 'Dino+' PSU for true high end performance



WHAT HI-FI?
June 2001



FOR Sweet and revealing sound; fine soundstaging; upgradability
Against Nothing we can think of.

Verdict A great moving magnet/moving coil phono stage that offers a slice of high-end performance at a very competitive price

World Verdict



A real 'hi-fi' sound and all that many will need. Highly recommended.

October 2001

tel: +44(0)1684 573524
fax: +44(0)1684 577380

www.trichordresearch.com

LA VIE EN ROSE

After being impressed by last month's Rosette 1 integrated amplifier, Simon Pope relishes the chance to hear Red Rose's new entry level 'speaker, the Rosebud.



Despite the slightly schmaltzy names of the new range of entry level hi-fi products from Red Rose ('Rosebud', 'Passion', etc.!) I have to admit to being so impressed by the cute little Rosette amplifier that I couldn't wait to get my ears around the new range of 'speakers, which on paper look an even more interesting product than the solid-state amp range.

This has much to do with the inclusion of a ribbon tweeter, much loved by manufacturers and audiophiles alike since the good old days of mono back in the 1930s and championed to great effect by the likes of Celestion, Apogee and Elac. Others have experimented but many fallen prey to simple practical limitations.

The particular ribbon used in the Red Rose range has its own history which requires a little explanation. Those of you who missed last month's review of the Rosette amplifier (shame upon you) or know nothing or little of the company may appreciate this. Those who did read or do know - I'll make it as concise as possible!

Red Rose Music was founded by Mark Levinson and Victor Tiscareno and its first products consisted of a range of valve amplifiers and ribbon tweetered 'speakers available only in full system form. The company are famously adverse to all things PCM and favour DSD/SACD technology (to the extent that they have an SACD recording facility in their New York showroom) and, of course, good old vinyl. The ribbons used in the first

'speaker models were designed by the veteran Swedish ribbon designer Bo Bengstton, and the entry level model standmounter featured two ribbons in close parallel configuration raised above the main cabinet as a sort of attachment. In the new Rosebud the same Bengstton design remains but this time it is a single ribbon incorporated into the main cabinet in a more traditional manner.

There are two new 'speakers in the latest range (the larger Classic is a floorstander) that join the four new amplifiers, and a phono stage. This range differs from later products in that they are part-designed and assembled in China, using drive units made there too.

The Rosebud reviewed here is basically a pretty ordinary looking design for a rather exotic price, apart from the aforementioned ribbon tweeter and the far deeper than usual dimensions of the cabinet (more of which later).

The main design criteria for this 'speaker, as with most standmounts, were to create more bass and a larger sound than you would expect from the dimensions. The crossover is voiced by Mr. Levinson himself in typical labour intensive fashion, one would imagine. Build quality is high; the speakers have a sturdy feel and a nice dead sounding 'thock' from a rap

with the knuckles confirms a solidly built cabinet.

The hand built mid/bass unit is of typical for the breed and around the back we have a single pair of workmanlike binding posts. This feature brings up something which cannot be avoided. The price for this 'speaker isn't cheap - even if it were designed and hand built by the Queen of England herself over a period of three months (and included bi-wiring posts!), £,3000 is still a whole heap of money for this product - period (as our stateside friends would put it).

Now that's over with I can tell you that when it comes to sound quality and nothing more they are one of the best sounding 'speakers that have ever graced my hallowed halls. When you encounter this size of 'speaker - even at the top end - you roughly know what you're going to get: where it will pass and where it will fail. Not so here.

Mr. Levinson has an uncanny and annoying habit of making things sound very good indeed and these were a real surprise, especially at lower frequencies. With an SACD of Frankie Goes To Hollywood's finest pieces ("a blank disc, then" I hear you cry) the classic 'Welcome To The Pleasuredome' with its bells, whistles and general jungle noises was

Walrus Systems

11 New Quebec St, London W1

air tight
 allaerts
 amazon
 apollo furniture
 argento
 audible illusions
 audio note
 audio physic
 audio synthesis
 avantgarde
 breuer dynamic
 brinkmann
 canary audio
 cartridge man
 cat
 cawsey cables
 clearaudio
 coph nia
 decca london
 dnm
 duevel
 dynavector
 ear yoshino
 ergo
 final lab
 graham
 incognito
 lyra



No home cinema, multi-room, or computer audio. No sir, just good old fashioned superb sound from Walrus, the premier Valve and Vinyl specialist!

(clockwise) Michell Gyro SE / RB300 (£975)
 Notts Analogue Spacedeck / Spacearm (£1380)
 SME Model 10 (£2643 - arm extra)
 EAR V20 amplifier (£2699)
 Papworth SE amplifier (£1700)
 EAR 834P MM phono stage (£380)
 Musical Fidelity Nuvista CD (£2999)
 (NB: Check availability - limited edition model)
 Brinkmann amplifier (£2000, or £2500 inc DAC)
 Spondor SP2/3 (£1295)
 Avantgarde Uno (£6809, in midnight blue)



michell engineering
 morch
 musical fidelity
 nordost
 nottingham analogue
 ortofon
 papworth
 phy cables
 pluto
 pro-ject
 reference 3a
 rega turntables
 ringmat
 shun mook
 sme
 spendor
 stax
 sugden
 sumiko
 tci cables
 tom evans
 townshend audio
 transfiguration
 trilogy
 tron
 vaessen
 van den hul
 verdier
 yamamura churchill

Don't delay. Give Les or Pete a call now!

For info on these, and much more, including our numerous second-hand items, please visit our popular website: www.walrus.co.uk

tel: 020 7724 7224

fax: 020 7724 4347

email: mail@walrus.co.uk

web: www.walrus.co.uk

* interest free credit available on most items, subject to status *



MICHELL GYRODEC SE

A SYMBOL OF PRECISION

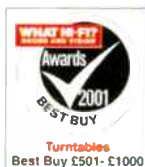

WHAT HI-FI?
 June 1999

Michell Engineering Ltd, 2 Theobald St, Borehamwood, Herts, WD6 4SE
 Tel: 0208 953 0771 Web: www.michell-engineering



orchestral music such as Mahler's seventh symphony, with the spooky woodwind and brass writing of the second movement (the old Castrol GTX advert, for those with a good memory). Flutes and oboes flitted gracefully above the 'speakers and a fine spread of orchestral sound was created at tutti passages that raised the 'speaker to levels found only in similarly priced 'speakers of a much larger physical stature.

Also highlighted was the magical treble that's found with the best ribbon designs - sweet and airy yet smooth and detailed. Playing vinyl LPs of both Thelonius Monk (with the rather modestly and dubiously titled 'Genius Of Modern Music') and Miles Davis's Sketches Of Spain, a fine sense of line and phrase was demonstrated, with very good tonal balance and instrumental colour. This was especially good when used with valve amps - fairly powerful ones, as the Rosebuds take a bit of driving.

The Rosebud is one of the finest standmounters available on the market. They have real hi-fi purist appeal, yet avoid the sterility and forced detail of some designs, which can distract from sheer musical enjoyment.

My one and only gripe rest with the price. If these 'speakers were £1,500 they would be world beaters

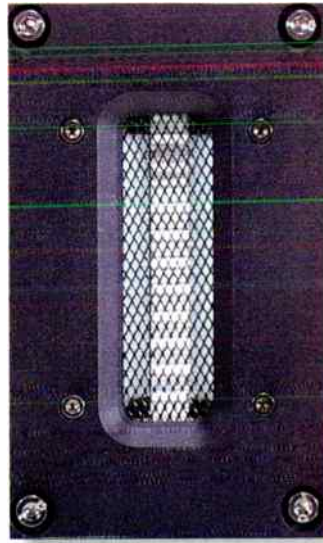

but £3,000 is a lot of money for what at first glance seems a fairly ordinary design - and one that's completely assembled in low cost China. Thus, at £,3000 they have some strong competition - albeit in the larger floorstander and electrostatic markets. As high-end standmounts perhaps only Wilson Benesch's superb £6,000 Discovery comes close performance wise - which is praise indeed. ■ ▲

Red Rose Music Rosebud £2,999

Music Design Company

Tel: 01992 573030

www.redrosemusic.com

◀ wonderfully clear and detailed, with especially impressive imaging. But it was only when the self-indulgent intro stopped and the music kicked in that the Rosebuds showed what they could really do. Here was a good grip with rhythm and quite amazing bass control, which was also impressively deep for the cabinet size. Bass notes vibrated the floorboards in a satisfyingly tight manner. I've not heard such depth and quality from a 'speaker of the size before.

Another trait of the Rosebud is the openness of its midrange. This was best demonstrated with

MEASURED PERFORMANCE

The Rosebud loudspeaker has a long element pleated ribbon tweeter. Conventional ribbon tweeters have problems, not going low enough to match a cone bass/mid-range unit easily and with limited vertical dispersion, a property that makes them beam strongly. The ribbon unit here largely avoids such problems measurement showed. It integrated well with the bass/mid., at a low crossover point around 2.5kHz, and dispersion was relatively good. The designers have tailored a nice, smooth response with treble level being 1dB-2dB lower than the midrange in order to give the 'speaker some body. A good ribbon tweeter can sound sweeter and more open than a normal dome tweeter.

Bass output was limited, the small bass unit cone reaching down

to 80Hz before rolling off slowly. The port was tuned to 63Hz, above the resonant frequency of the bass unit our impedance analysis shows. This loudspeaker may well give fast bass with good, resonant impact. The port gets down fairly low.

Sensitivity was a mediocre 83dB. Although small loudspeakers are always insensitive, this is a little below the norm., the main reason being a very high overall impedance of 12ohms. Together with a smooth impedance characteristic free from sharp changes caused by reactance, the Rosebud is an easy load. It draws little current, tests showed.

This loudspeaker sounded unusually smooth during noise tests. Its tweeter works well and it is an easy load too, although a 60W amplifier is

required just for voltage swing. With light but fast bass it should sound good. **NK**

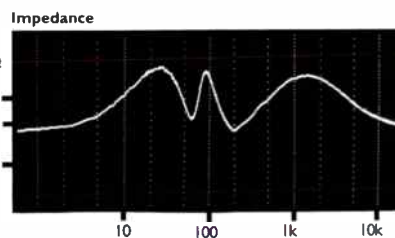
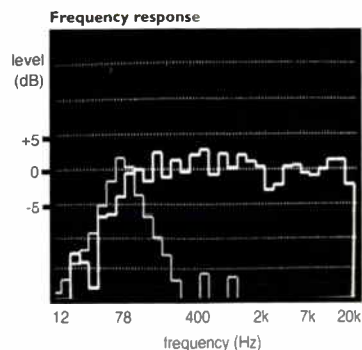

World Verdict



One of the finest standmounts you'll find, with deep bass and a very spacious sound. However, the high price could be a hurdle.

Ortofon



Pro-Ject



The new
**Pro-ject
RPM9**

Exclusively at
Centres of
EXCELLENCE

Town	Dealer	Town	Dealer
Aldridge (West Mids)	Sound Cinergy	Leicester	Leicester Hi-Fi
Ashby De La Zouch	Zouch Audio	Lincoln	Sevenoaks S&V
Bedford	Richards A/V	London (Euston)	Kamla
Birmingham	Music Matters	London (Holburn)	Sevenoaks S&V
Brentwood	Audio T	Maidenhead	Audio Venue
Bristol	Radford HiFi	Manchester	Practical HiFi
Bristol	Audio Excellence	Manchester	Sevenoaks S&V**
Cambridge	The Audiofile	New Malden, Surrey	Unilet
Cardiff	Sevenoaks S&V	Newbury	B&B Hi-Fi**
Chester	Audio Excellence	Newcastle	Lintone Audio
Colchester	Grayston S&V	Norwich	Sevenoaks S&V
Coventry	Frank Harvey	Nottingham	Notts Hi-Fi Centre
Darlington	Hi-Fi Experience	Oxford	Oxford Audio
Doncaster	The Hi-Fi Studios	Peterborough	Sevenoaks S&V
East Grinstead	Audio Designs**	Rainham (Kent)	Progressive Audio
Edinburgh	Hi-Fi Corner	Reading	B&B Hi-Fi**
Edinburgh	Russ Andrews*	Reading	Audio T*
Exeter	Sevenoaks S&V**	Salisbury	Salisbury Hi-Fi**
Glasgow	Glasgow Audio	Sheffield	Moorgate Acoustics
Harrow	Harrow Audio**	Solihull	Music Matters
Helston, Cornwall	Sounds Perfection	Southampton	Phase Three**
Hitchin, Herts	David Orton A/V	Swansea	Sevenoaks S&V
Ipswich	Sevenoaks S&V	Swiss Cottage	Sevenoaks S&V
Ireland (Dingannon)	Kronos Hi-Fi	Tuxford (Notts)	Chantry Audio*
Kidderminster	Midland Audio Ex*	Warrington	Doug Brady*
Leamington	Stratford Hi-Fi	Worthing	Phase Three
Leeds	Sevenoaks S&V	Yeovil	Mike Manning*

* Ortofon only

** Pro-ject only

For a full dealer list and more information contact:
Henley Designs Ltd, Unit 10 Moorbrook, Southmead Industrial Park, Didcot, Oxon, OX11 7HR
Tel: 01235 511166, Fax: 01235 511266, E-mail henley.designs@virgin.net, WWW.henleydesigns.co.uk

TWEAK EASY

David Price rages against those who doubt the fine art of tweaking, and introduces a revolutionary new free product, for just one easy payment.

The fact that 'tweaking' is still regarded by many as a ridiculous activity, practiced by a bunch of hairshirted audiophile extremists with nothing better to spend their money on, is a disgrace. Indeed, it's a sign of the hi-fi community's tragic lack of collective imagination that the very word 'tweak' is used at all. It sounds odd, idiosyncratic and just plain barmy - terms to which this vital 'intricate practice of audio enrichment' (as I prefer to call it) most definitely do not apply.

Such is the paucity of the average audiophile's imagination that anyone who pays more than the slightest attention to the electrical or mechanical well being of their system is dismissed as some kind of snake oil peddling charlatan out to make a fast buck, or a certifiable lunatic who doesn't quite have both oars in the water.

Speaking in my capacity as a world-renown top international audio journalist (of quite some repute), I now intend to nail my cards to the table - so to speak - and declare here and now that all this malicious, misguided and malevolent anti-tweaking 'propaganda' stinks!

The anti-tweaking lobby would have you believe that there's actually something strange about this country's hi-fi journalists exhorting readers to lavish vast sums of their hard earned cash on premium priced squidgy rubber balls, bespoke pointy metal spikes, expertly torn pieces of paper to put in books or electrically polarised hardwoods grown by Buddhist monks in Japan at great personal expense. What could possibly be wrong with that, I ask you?

Worse still, these 'preachers of the church of the poison mind', these 'disciples of the unenlightened',

actually dare to suggest that far from being a sound investment, these bespoke 'audio enrichers' are actually nothing more than a rip-off. Outrageous! Next thing you know, they'll be telling us 'premium' priced interconnects, hewn from rare earth supermetals by Tibetan transcendental meditationists, are a plain waste of cash!

Well, I for one intend to put a stop to all this nonsense. Never let it be said that I sat back impassive when the call came to defend the Holy Tweak. At a stroke, I'll stop the rot written about the alleged dubiousness of audio enrichment by revealing - exclusively - a remedy to transform the sickest of systems into a living, breathing window on the world of music. And to silence the doubters, this one is free!

Yes folks, the solution to the riddle of history, the answer to life's ills and the best way of tightening loose bass and speeding attack transients is - Cactus Damping. Following on from the Japanese audiophile craze for exotic African hardwoods as mass damping, extensive research into the electro-mechanical properties of one secret genus of cacti, indigenous to the Spanish territory of Fuerteventura in the Canary Islands, has born incredible fruit.

Cactus Damping is a long, exhaustive and sometimes dangerous process, involving the rendering of the plant - cutting the prickly bits off - and the application thereof to critical areas of your system components using a special organic glue. Used as a lining for the pressed steel cases of CD, DVD and RDA



players, not to mention the subchassis and plinths of turntables, dramatic results can be obtained. Without wishing to blind you with science, the molecules in this particular type of cactus vibrate in sympathy with the sound - rather like flashing lights in a disco - thus cancelling out all the badness.

Of course, I appreciate that not every reader has access to this bespoke organic damping compound, which is why I've thoughtfully acquired all remaining stocks of this particular type of cactus. If you're interested in acquiring some of this audio elixir (for a nominal handling fee of \$1,000 plus an additional charitable donation to a bank account of my choice), then please e-mail me for your free Cactus Damping Consultation, at: cactus-scram@spacer.net ■ ▲

REVOLUTION



Rega has truly turned the tables on its budget beginnings with the release of the latest P9, says David Price.

In typical Rega style, it took the company an amazing two decades from the launch of its first Planet vinyl spinner to release its high end 'statement' turntable, the Planar 9. Although it's been quietly successful, Rega has been relatively quick off the mark to upgrade it with this, the new revised P9. At £2,250 it's a cost-no-object, no expense spared exercise in analogue excellence. It's really gone to town on the design and build - Rega says that the ceramic platter alone costs more to produce than its P25 turntable!

The fun doesn't stop there, though. As we all now know, to get any kind of decent sound off black discs, you have to design the plinth properly, or (better still, some might say) dispense with it all together. In the P9's case, Rega have designed a complex CNC machined skeletal structure, encased in highly ridged phenolic resin laminates. The inner skeletal structure is also hewn from

ultra lightweight fibre composite. Claimed to be the equivalent to the carbon fibre 'monocoque' chassis found in modern F1 racing cars, it provides an ultra lightweight and rigid foundation for the moving parts.

The theme continues with the aforementioned platter, which is the most exotic material Rega has used to date in a turntable. Made from pure ceramic, it's not only the hardest material known to man apart from diamond, but is also a popular favourite of the aerospace industry - you'll find it on missile nose cones and NASA Space Shuttle insulation tiles. As an aside, it's also a popular accoutrement on ultra high end Japanese esoterica - every self respecting Far Eastern digital disc spinner sporting a telephone number price tag uses ceramic isolation feet, for example. The beauty of this stuff is that it is sonically extremely self effacing - unlike felt damped Mazak (aluminium) found in decks like Linn's

LP12, it adds very little to the closed loop of the vinyl replay system.

Every P9 sports a decorative surround of exotic solid woods, which can be interchanged, should you wish to give your deck a breath of fresh air. Rega says that it's light for superior sonics and uses the same three hollow-rubber feet (tuned to slightly different frequencies) found on all Rega turntables. The single-point main bearing assembly is also said to be engineered to extremely tight tolerances.

As you'd expect, the hard mounted twin-phase AC synchronous motor gets a sophisticated drive circuit courtesy of Rega's chief electronics whizz, Terry Bateman, designed to minimise vibration and keep speed irregularities to the minimum. Its separate quartz crystal referenced power supply has extensive filtering to ensure the lowest motor noise possible - housed in one of the company's full width



No.9

'separates boxes', this is one of the biggest and heaviest off-board turntable PSUs I've ever seen!

As you'd expect, the famous Rega arm also gets the treatment - and unlike the previous RB900, which was little more than a (usefully) 'breathed on' RB300, the 'all new' RB1000 is said to carry more technological changes over previous Rega tonearms than any produced during the last twenty years! Key areas of improvement include the bearing assemblies, wiring and materials used. Mass has been redistributed to areas of the tonearm where it is less critical to performance, as evinced by the new polished aluminium arm tube which has no coatings of any type. The result is a tonearm which takes thirty times longer to produce than an RB300, claimed to have extremely high structural rigidity, ultra low bearing friction and massive stability - oh, and it also looks drop-dead-gorgeous, too.

Setting up the P9 is pretty much the same as with other Rega 'tables, which is refreshingly rapid and fuss-free. Unlike Linn's 'dealer knows best' philosophy or Michell's 'build-it-yourself' creed, with a Planar it's basically a question of getting it out of the box, putting the platter on and plugging in. You have to take care to remove the little cardboard spacer between the plinth and sub platter, and screw the counterweight on, but this aside it's practically plug and play. For this reason - plus the deck's beautiful finish (not quite up with Michell or SME but great all the same) - I found myself rather charmed by the P9 before I even plugged it in.

The review sample came with the £249 Exact moving magnet, which was an obvious starting point. Plugged into my Michell Dino phono stage, Cyrus 7/PSX-R and Mission 782s, I found listening to it a curiously familiar experience. This is because I've owned a Planar 3 since I was 17 years old (it was my first 'proper' deck) and still really rate it. The P9

gives a profoundly bigger and more powerful sound, but still has that trademark even-handedness. It's not 'impressive' (as Michells may sometimes be accused of sounding) or 'charismatic' (Linn LP12), but just gets on with the job of playing music in a characteristically open and unfussy way.

Cueing up a reissue of The Beach Boys' 'Surf's Up', the P9 just cut through the silt covering this rather oddly produced album. The vocals on 'Till I Die' were able to shine through the murky mix, their rich, resonant character carried beautifully. Unlike the Linn LP12 however, the P9 has the characteristic Rega 'dryness' - there's less upper bass/lower mid bloom than the Sondek and slightly less extension and articulation than the Orbe. Rather, the Rega summons up a tight, taut, fast and fluid low frequency performance, which impresses less than its Linn or Michell rivals, but gives nothing away in terms of musicality.

Indeed, this rather 'liberal' bass character lets you focus more on what's happening in the midband than the Michell. The latter attempts to scale and proportion the stereo image over a wider space, showing a better contrast between close and distant images, but the Rega - rather like the LP12 in this respect - pulls things closer together slightly and goes, ferret-like, for the musical centre of attraction. ABC's 'Date Stamp' was a perfect exemplar - rather than sitting at the back of the studio, you feel thrust into the fray. The P9 went straight for the central bass guitar and drum interplay, giving the song an extremely strong and propulsive feel as a result. It retrieved massive amounts of detail - more than a Sondek is capable of - and conjured a wide and tight stereo image, if a little flattened in terms of depth perspective compared to the Orbe.

Treble is another delight - it's very sweet and extended. Here,



substituting the Exact (which is a fine MM - one of the best if you like the more cerebral, Audio Technica style of presentation) for the brilliant Ortofon Kontrapunkt B moving coil brought real rewards. There's a great sense of atmosphere - it really gives an exhaustively detailed recreation of the recorded acoustic. Lee Morgan's 'The Sidewinder' showed a very finely etched and intricate HF performance, more atmospheric than the LP12 and more 'alive' than the Orbe.

Weaknesses? It lacks the crushing power and attack of the Orbe, or the sinuous rhythmic charms of the LP12. Instead, it treads a third way which gets you very close to the recording yet draws absolutely no attention to itself in so doing. Its depth perspective, bass extension and stereo imaging aren't the very best you'll hear, but its beautifully stable, lively yet refined, smooth and even sound is ample compensation. Unlike either the Linn or Michell, there's a sense that you can completely forget that you're listening to a turntable at all, and simply turn the music up! A brilliant product, and a welcome addition to the 'affordable high end' turntable market. ■ ▲

Rega P9 £2,248

Rega Exact £249

Rega Research Ltd.
119 Park Street
Westcliff-On-Sea
Essex
SSO 7PD
Tel: 01702 333071

World Verdict



Beautifully detailed and involving, yet completely self effacing, the P9 is one of the best vinyl spinners around. Superb design and ergonomics complete a fantastic value package.

MASTRO



The superbly constructed Maestro CD player from Audio Analogue is the company's latest top of the range discs spinner. Simon Pope listens with intent. . .

When this very magazine first encountered the PucciniSE integrated amplifier, it could be fair to say that Audio Analogue's presence in the UK was only a fraction of what it is now. We were so impressed by the midpriced integrated's sound quality that we praised from the rafters and the UK audio industry woke up to one of the bargains in of the hi-fi universe. The company's product continued to develop with remote versions of the Puccini range, a monoblock version of the Donizetti power amp and lastly a new version of the Paganini and Maestro CD players. Along the way they also designed and constructed a monster sized integrated amplifier in the high end American mould that was also called the Maestro - the CD player reviewed here is a perfect aesthetic match for this product.

Audio Analogue was formed back in 1995 by a collection of five Italian hi-fi industry professionals and electronic experts. The company's products have a concerted sonic stamp which is one of overall smoothness and ease (in the typical Italian style) as opposed to the 'wham, bam, thank you ma'am' school of audio engineering. This trait is mainly instigated by the 'golden ears' of the gang, a certain Sr. Claudio Bertini who as well as being a hi-fi and music lover, is also a keen tinkler of Ferraris and a wine enthusiast (ever

get the feeling you're in the wrong business?). Bertini apparently has the knack of being able to name components in a blind test - much akin to a wine taster on tasting duties! This results in an experienced and knowledgeable choice of electronic components and in the top end product such as this, a peak inside the lid (if you can lift it off) results in an eye-ful of audiophile goodies. This machine has little in common with its similarly named predecessor except for the name. Here we have a top dog Philips transport replacing the Sony design of old and a completely new DAC and power supply design. We have two 24-bit/96kHz Analog Devices AD1855 DACs used in parallel along with a Crystal CS8420 sample rate converter for every type of digital signal - therefore even CD signals are 'upsampled' and effectively converted at high resolution.

The analogue section features high quality discrete components such as polypropylene and Os-Con capacitors, low noise resistors and high linearity FETs. The analogue devices 24/96 DAC is kept heavily isolated from the transport system making the Maestro a true two-box-in-one player. The Maestro improves on the Paganini's (reviewed as part of a system last month) physical and sonic stature. The build of the player is quite superb - weight wise it's up

there with the Musical Fidelity 3D nu-vista CD player - no mean feat. There's a lot of up to date technology to be found here, which is refreshing, as it retains the status and look of a hard core high end stereo hi-fi product.

A peek at the rear panel results in the discovery of something slightly different from the norm. In addition to the traditional digital outputs we also have the inclusion of a digital input stage. This can be utilised by a DVD player, for example, to make use of the internal high quality 24/96 DAC - handy for those who wish to upgrade their DVD players performance as well as replay CDs to audiophile quality. The digital output can be set from the front panel to work in 44.1 or 96kHz mode and a loop function is also present allowing the internal transport signal to be processed by an external component (if you should wish for such a thing). Also on the rear we have the inclusion of XLR sockets for balanced connection, raising the Maestro further into high end territory.

The sound of the Maestro is at once smooth and relaxed in the traditional Audio Analogue mould but also very clean. Beethoven's seventh symphony conducted by the outstanding Carlos Kleiber and the Vienna Philharmonic on a DG reissue had plenty of life, bounce and attack as well as grace and refinement. Strings

CLASS

sounded tight and visceral and timpani fast yet it still managed to be lyrical and light when necessary, making for a pleasing balance. You may not have the overall transparency and 'brightness' of the Musical Fidelity 3D nu-vista but the sound was certainly heading in this ballpark - at half the price. It's a very user friendly sound, as confirmed with Soundgarden's Superunknown album. This can either sound fantastically alive and full or resemble a tranny radio immersed in oil, luckily it was the former here. Imaging of the mix was highlighted to great effect and there was a constant underlying power in the bass and drums which drove the music on, never becoming too overblown or messy. If I had to pick out a downside, I'd say that with mid eighties rough and ready digital recordings (such as Kleiber's Brahms fourth symphony - a great performance ruined by a rotten recording) it veered to the over lush

with a slightly covered sound, although the CD quality isn't exactly the best around. 'Kind Of Blue' had a nice forward presence that was also light of touch - it can sometimes sound stodgy, strident and ultimately boring with lesser equipment. here, though, there was enough variety of instrumental tone to make the sound realistic and interesting - essential for me with such an old warhorse (no matter how good it is!). Using an external transport in the shape of Meridian's 506.24 and a NAD DVD player the Maestro showed what a fine DAC section it has, exploring every avenue of detail and bringing real presence and life into the NAD especially, and agility to the Meridian.

Recommended then? Definitely. there's strong competition at the price from Arcam's FMJCD23T (good coherence) and Meridian's 506.24 (plenty of insight). Whilst it doesn't have the insight of the latter it also doesn't suffer from the sluggish bass

than can occur with some recordings. It has all the coherence of the Arcam, though, with a little more cleanliness to my ear, too. Although it looks like a monster it doesn't sound like one and is surprisingly smooth and subtle at times. At £1,500 it stands as a fine buy, with a pleasing, all round sound that takes the 'everyday player' appeal one step further. It's not quite up there with the awesome 3D Nu-vista offering when it comes to overall detail but at half its price it's by no means out of the running and competes easily on the build front. ■ ▲

Audio Analogue Maestro
CD player £1500

UKD
23 Richings Way
Iver
Bucks SL0 9DA
Tel: 01753 652669
www.ukd.co.uk

MEASURED PERFORMANCE

Measured frequency response of the Maestro CD was flat to a high figure of 21.4kHz. Our response analysis clearly shows the basic characteristic is flat, with some top end ripple suggesting a slightly different filter design to usual. With the other end of the spectrum reaching down to a low 4Hz this player has wide bandwidth.

Through the dynamic range distortion was low, except down at -60dB, where the figures were a little up on what is possible nowadays. A figure of 0.44% is none too impressive, consisting as it does of random quantisation noise and mush. This brought the EIAJ dynamic range figure down to 108dB - still respectable all the same. I doubt if this minor blemish will affect things too much, although every little improvement is worth having with 16-bit. Our distortion analysis at -30dB, representing typical music

level, shows a low noise floor and an absence of distortion at this level, which is encouraging.

With a normal output of 2V and wide channel separation of 100dB or more the Maestro measures well, even if it doesn't quite match the best players around in terms of measured performance at least. **NK**

Frequency response	4Hz-21.4kHz	
	left	right
Distortion		
-6dB	0.007	0.006
-30dB	0.017	0.018
-60dB	0.44	0.42
-90	29	29
Separation	left	right
1kHz	117	115
20kHz	96	93
Noise		-111dB
with emphasis		-111dB

Dynamic range 108dB
Output 2V

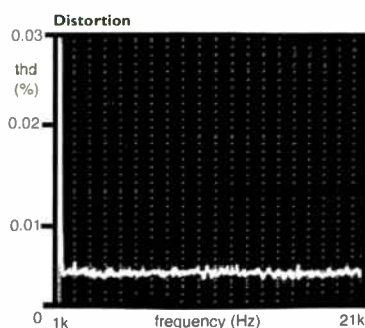
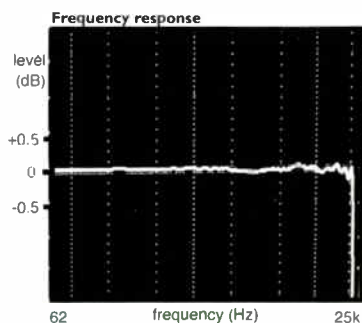

World Verdict
£★★★★

Great value player with awesome build quality and a civilised yet detailed sound. Very fine DAC section.

CROFT HIGHLY



Croft has a reputation for delivering high quality audio at a sensible price. Will their latest integrated amplifier carry on this tradition?

In 'rip off' Britain there are still a few people dedicated to the cause of giving genuine value for money, offering the best possible product at the best possible price. Although it doesn't always seem this way - being perceived by many outsiders as a luxury for show offs - specialist hi-fi has its share of like-minded individuals intended on delivering this service.

Croft is one such company. Specialising in valve amplifiers, the company manufactures a range of products with price tags more akin to the midrange black boxes of the major Japanese companies. Having said this, there's nothing particularly special about the prices themselves, as there are a few valve specialists around who also manage to keep retail prices to a minimum. The crux of the matter here is that Croft manufacture entirely in the UK and the price competitors look to foreign shores (mainly Chinese) to keep prices low. Indeed, many perceived British hi-fi companies manufacture abroad for this reason alone, sometimes with an injection of foreign cash to boot.

To be fair, though, there are still those that manufacture over here, even though their prices often reflect this much. As a rough 'ball park' figure the retail price of a hi-fi product needs to be at least five-to-six times the material and labour cost in order to make some kind of profit, once all cash draining factors have been considered. Croft's Cameleon integrated amplifier reviewed here at £875

would therefore seem a bit of a bargain on paper.

The relatively low price of the Cameleon is reflected in its build quality - although a more stylish aluminium front panel finish is available for those who want more aesthetic appeal and a bit of pizzazz for an extra £300.

The basic finish isn't going to win any innovative design awards. And it also isn't going to win Robot Wars, as the Cameleon is no Ali or George Foreman, weighing in at less than 10kilos! There are no fancy bells or whistles - this is hi-fi at its most basic. Inputs are almost minimal and there's only a single pair of 'speaker terminals.

On the front fascia we have three knobs, one for input selection and one for the volume of each channel. Oh, and forget the remote control. If you therefore want the volume of each channel to exactly equal you've got a tough job on your hands, as there are no markings around the volume controls.

If this is - as I said earlier - hi-fi at its most basic it's also hi-fi at its most purist and let's not forget that this is the goal of many audiophiles attracted to this kind of product. In this respect, internally it's as pure as the driven snow.

The preamp section of the Cameleon, consisting of the two channel potentiometers and input selector, is passive and the power amplifier section is exactly the same as that found in the company's Vista

power amp. This is a circuit discarding as many unnecessary components as the company sees fit - one's that Croft feel inhibit the performance. Croft feels that without this electronic 'dead wood' the amp is free to "express a kaleidoscope of sound".

Another bonus of this, of course, is that a low cost can be maintained. Taking off the lid reveals very little, as there's very little in there! It does, however, reveal four smallish ECL805 triode output pentode valves, not a valve I'm too familiar with, but it does have a warm and sweet characteristics.

There is a noticeable absence of circuit boards in the design, making for very simple circuitry that includes seventeen resistors and four coupling capacitors. The output transformers are designed in-house and the Cameleon works in fixed bias operation. The lack of PCBs means that everything inside is point to point hard wired and the power output is quoted at a modest but adequate 15W.

The overall sound of the Cameleon came as no real surprise as we've encountered the Croft sound previously in their simple yet highly effective Vitale preamp, which excelled when it came to transparency and purity - doing everything a hi-end preamp does but at a fraction of the price. To ensure the best from the Cameleon I used a pair of Diapason's 92dB sensitivity Adamantes III 'speakers (for a 'real

ORIGINAL

world' design I also used Mission's 782s) with Meridian's 506 24 CD player as source. Chord Company Anthem interconnects and Kimber 'speaker cable completed the system.

A CD of the Emerson Quartet playing Shostakovich's fifth and sixth string quartets showed up the Cameleon in its true light. This type of design is well suited to chamber music, which is presented in a natural and highly detailed manner. The strings had a keen sense of life and realism and there was a healthy amount of weight to the sound, which rounded it out nicely. There was little to fault in the sound quality here, as the amp did everything it should have done in relaying an intense, immediate and detailed performance.

One thing I did note about the Shostakovich was the slightly forward nature of the upper midrange and this became further accentuated with Eric Bibb's musically bland but well recorded 'Good Stuff' on Opus3 records. Whilst there was excellent clarity and transparency, plus good detail on acoustic guitars and a nice resonant and fairly deep sound from the upright bass, the vocals I found too forward sounding at times and a little grating when dynamically

pushed. Staging and imaging were very good indeed, however, with a deep, pin-point sound that's rarely found at this price. Miles Davis's 'Sketches Of Spain' called upon the Cameleon to show its sweetness with upper frequencies. Percussion had a nice sheen but violins again had a slight edge in climaxes that was found with Bibb's voice. Again, there was good depth to the sound.

Here is a taste of a real enthusiast product. In many ways it's for die-hards or those wishing to get a first taste of the valve. This amplifier has excellent transparency and a surprisingly full sound for those who expect a lot of midrange and not much else from valve amps. However, the upper midrange can be a tad hard at times, which ultimately mars the natural timbre of voices and instruments somewhat.

What you can't take away from

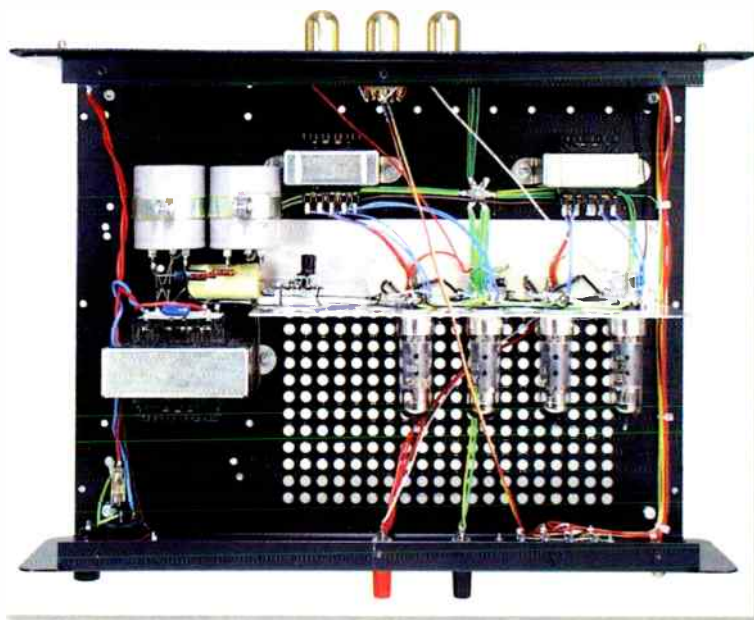

this amp is its ability to perform with most of the traits of high-end valve amps, but at a lower price point and for that Croft can be congratulated. It would make a good starter valve amp for many that want to take the tube but balk at the fares! 

Croft Cameleon £875
Eminent Audio
18 Kidderminster Road
Bridgnorth
Shropshire WV15 6BX
Tel: 01746 769156
www.eminentaudio.co.uk

MEASURED PERFORMANCE

This is a low output valve amplifier best matched with sensitive 8ohm loudspeakers. It produces just 3W for a 3% distortion threshold, but will manage 10W before severe clipping sets in, albeit at greatly increased levels of third harmonic distortion. Used in this region the sound will be sharpened up, as it were. Some people like this sort of incisiveness brightness, so how the amp will be perceived subjectively can be down to taste and expectation.

Power apart, the Croft measured tolerably well, with a useful input sensitivity of 380mV, channel separation of 82dB and frequency

response stretching from 10Hz-53kHz. There was some 100Hz hum though and distortion at low levels never fell below 1%, where with many valve amplifiers it effectively falls to near zero. Second and third harmonics dominated; this is not a second-harmonic only amplifier.

The Croft was a little idiosyncratic, I could say. It does not measure very well, as valve amps go, but it may offer a sound not met elsewhere that some listeners will appreciate. **NK**

Power	3watts
CD/tuner/aux.	
Frequency response	10Hz-53kHz
Separation	82dB
Noise	-74dB
Distortion	1.35%
Sensitivity	380mV

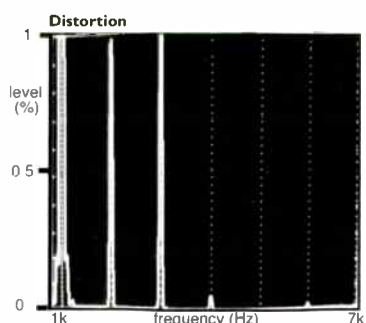

World Verdict

An affordable and effective entry into the valve sound. Transparent and sweet with good bass but the midrange can sometimes jar.

GET CONNECTED

Simon Popes gets connected with cables priced under £50.

► CHORD COMPANY CALYPSO £30/metre

This is the entry level interconnect from the highly regarded Salisbury-based specialist. The Calypso is specifically designed to work with entry level equipment and is available in 1, 2 and 5 metre lengths. It's suitable for both hi-fi and AV systems. The Chord Company make all their products in-house and even at the budget

end of the market, the Calypso is no exception. It uses a coaxial construction, the conductor comprising seventeen strands of oxygen free copper. Use is made of a lapped shield, as opposed to a braided design, to ensure the cable is flexible, and to ensure coverage remains consistent under flexure.

Insulation comes in the form of a gas-foamed polyethylene used for low dielectric constant. The outer protective PVC comes finished in a workmanlike grey colour – actually described as silver by the manufacturer!

This is a fine cable for the money, with a smooth and almost over lyrical stamp as opposed to the bright and fast sound of other budget cables. Unaccompanied choral music had a nice flow to the sound with the voices well blended and never rough



of tone. Whilst not up there with £50-plus cables, the Calypso has a fair amount of detail and depth. The acoustic folk/rock of Turin Brakes's 'Underdog' had a lively and musical sound with the vocal lines strong and full and acoustic guitars warm rather than over-rhythmic.

When all is considered, although this is a very good buy, I found there was a certain lack of focus with choral music and maybe a slight slowing of tempi with percussive detail. All the same, the Calypso offers a giant leap up from your basic 'patch cables' supplied with budget components. This makes the Calypso an affordable and effective upgrade and at this price it is at the top of the tree.

The Chord Company
30a Sarum Business Park
Salisbury
Wilts
Tel: 01722 331674
www.chord.co.uk

VAN DEN HUL THE BAY £38/0.8 metre

Again, like the Calypso, The Bay is the entry level interconnect from the carbon technology cable pioneers. Also like the Chord Company, van den Hul pride themselves on the fact that they research and design every cable in-house. The Bay replaces the Storm Gold as the entry level interconnect in the range and is priced 20% cheaper than its predecessor. It features their unique proprietary carbon technology, championed by van den Hul in their Linear Structured Carbon (LSC) hybrid configuration. Like the Calypso it is a coaxial construction consisting of forty 0.12mm strands with a dense silver coating of LSC carbon insulated

with polyethylene. It has a double screen of stranded braid over a LSC saturated layer to protect against RF noise. The cable comes with a ten-year guarantee – not bad for a £38 product!

Sound wise, it's a top hole product. There's slightly more at the top end here than with the Calypso which makes for slightly more high frequency detail. Choir voices had realistic presence, with precise consonants along with good body. The church acoustic was also well brought out in the recording, creating a rounded and full sound. With Turin Brake's 'Underdog' the acoustic guitars again had good body and rhythms were precise and fast. The lead voice was well catered for and presented forward in the mix with the accompanying instruments doing exactly that and not intruding into the vocal line.

The Bay is a very good cable and a steal at the price. It follows the company's tradition of well-built cable with a very well balanced sound that will fit in well with most budget/midpriced systems. ■ ▲

Van den Hul UK
Tannoy
Coatbridge
North Lanarkshire
Tel: 01236 420199
www.vanden Hul.com



UK SUBSCRIPTION £27

VISIT OUR WEBSITE: www.hi-fiworld.co.uk



Get your issue of hi-fi world straight to your door!

Get to our amazing classified ads first and grab a bargain!!

- > *Run by dedicated hi-fi engineers and enthusiasts.*
- > *Hi-Fi World has become famous for its informative reviews and radical kit designs.*

Credit Card Hotline
+44 01923 270 833
 Monday - Friday 9.30am - 12.00 noon: Fax +44 01923 260 588

MISSED AN ISSUE?

Back issues also available at a cost of £3.50 only (includes P&P), payment by cheque only - overseas please contact subscriptions department for details.
 Send cheque to: Hi-Fi World, Freepost LON3478, London, NW6 6YR.

YES! I want to subscribe to Hi-Fi World for:-

£27.00 for 12 months

Your Details

Title _____ Initial _____ Surname _____

Address _____

Post Code _____

Daytime Tel: _____

Start Issue _____

Delivery Address (if different) _____

I would like to pay by cheque made payable to Audio Publishing Ltd.

Please debit my VISA MASTER SWITCH AMEX

Switch card issue No Expiry Date: ____/____/____

Cardholder Signature: _____



Please choose service:-

Airmail Middle East & South-East Asia **£60**

Airmail Europe **£50**

Airmail USA, Canada, Australia, Japan, Korea & China **£70**

Surface Mail **£40**

Send this form to:

Hi-Fi World, Freepost LON3478, London, NW6 6YR



PRO-JECT Debut II Turntable **£109.95**

"The original Debut turntable romped away with a Product of the Year Award in 1999, and the MKII version continues the extremely good work. It's a simple affair, that's easy to set up, but don't let the price fool you - it sounds a whole lot more expensive than that. This is a fine turntable, and it clearly reveals the benefits of listening to vinyl, with a rich and detailed soundstage, and a good dynamic response.

It's available in six funky colours, so you should find one to suit your decor, and at just a smidge over £100, you can have no excuse not to keep that old vinyl collection in employment for a good few years yet."

★★★★★ What Hi-Fi? Awards 2000

Selected outlets are Project Turntable Centres. Colour Options are available at additional cost

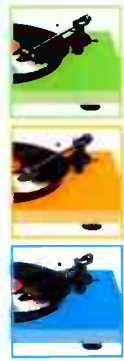

Turtables & Tuners

Arcam DiVA T51 Tuner	£279.95
Denon TU260L MKII Tuner	£119.95
Linn LP12/Basik/Akito Turntable	£1749.95
Marantz ST4000 Tuner	£129.95
Michell Gyro SE RB300 Turntable	£974.95
Project Debut Phono Turntable	£139.95
Sony ST-D777ES FM DAB Tuner	£429.95
Videologic DRX-601E DAB Tuner	£289.95

MUSICAL FIDELITY

A3 CD Player **£799.95** A3 Amplifier **£849.95**

A3 CD Player "OK, so not everyone will be drawn to the styling, but when it comes to turning on the sonic fireworks, few players come even close at this price. A class act and a worthy winner"

A3 Amplifier "The A3 does a wonderful trick of conveying a great romantic sweep of music while at the same time delivering as much internal detail as anyone could possibly want. This is an amplifier capable of performing well beyond its price. We guarantee you won't be disappointed." ★★★★★ What Hi-Fi? Awards 2000



CD Players

Arcam DiVA CD62T.....	£329.95
Arcam DiVA CD92T.....	£849.95
Arcam FMJ CD23T.....	£1149.95
Denon DCD485	£139.95
Linn Genki.....	£994.95
Linn Ikemi.....	£1949.95
Marantz CD4000.....	£109.95
Marantz CD6000Ki Signature	£449.95
Musical Fidelity NuVista 3D	£2999.95
Roksan Caspian MKII	£894.95
Roksan Kandy.....	£494.95
Sony CDPXE570.....	£119.95

Recorder Selection

Marantz DR6000 CD-RW	£349.95
Pioneer PDR609 CD-RW	£199.95
Sony MDS-JE770 MiniDisc	£229.95
Yamaha KX393 Cassette Deck	£119.95
Yamaha KX580SE Cassette Deck	£199.95

Please Note: Some products may not be available at all outlets. Advertisement valid until at least 13th March 2002. E&OE



DM601S3 Speakers **£249.95**

"Ultimately it's the 601 S3s' lack of any weakness that makes them so special. Their talent is so widespread that most of the competition is left reeling. Detail, resolution, dynamics, insight... everything is present and correct, and these speakers rate highly in every area.

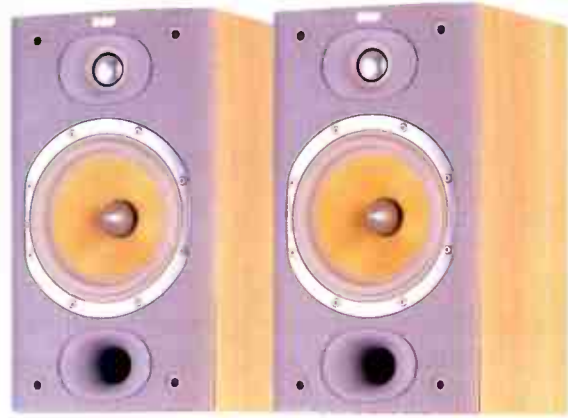

What more can we say? These new B&Ws are a terrific buy. The price rise over their predecessors pits them against tougher rivals, but on this showing B&W has little to worry about. Unlike the competition

★★★★★ What Hi-Fi? January 2002



more entertaining

World Radio History



Amplifier Selection

Arcam DVA A65 Plus Amplifier	£349.95
Arcam DVA A75 Plus Amplifier	£449.95
Arcam FMJ A32 Amplifier	£1099.95
Cyrus ACA7 5 Pre Amplifier	£699.95
Cyrus Smart Power Amplifier	£549.95
Denon PMA355 Amplifier	£229.95
Linn Kolektor Pre Amplifier	£494.95
Linn LK85 Power Amplifier	£494.95
Marantz PM4200 Amplifier	£159.95
Musical Fidelity A300 Amplifier	£1399.95
Musical Fidelity NuVista Amplifier	£2974.95
Roksan Caspian MKII Amplifier	£794.95
Roksan Kandy Amplifier	£494.95



ARCAM

DiVA CD72T CD Player

£399.95

DiVA A85 Integrated Amplifier

£749.95

DIVA CD72 "The CD72 will have you jumping out of your seat from the very first notes. Both powerful and punchy, it delivers every ounce of air and detail present from detailed midrange to smooth, singing treble. Sometimes a product comes along that sets new standards..." ★★★★★ What Hi-Fi? Awards 2001

DIVA A85 "You'll have realised by now that we rather like this amp. It took us completely by surprise, and further strengthens Arcam's already impressive product range... The A85 is superb, and we can't wait to put it up against its peer in a group test." ★★★★★ What Hi-Fi? March 2001



MONITOR AUDIO

Silver 8i Speakers £699.95

"No other speaker in this test can match the Monitor Audios when it comes to delivering seismic basslines with sofa rattling power and weight. That this part of the spectrum also enjoys plenty of speed and control confirms the Silver 8is' position as bass kings... A great speaker needs more than simply great bass, however, and the Silver 8is do far more than merely thump. With the likes of Curtis Mayfield's 'Move On Up', they produce a sound of such verve that it becomes hard to sit still... They produce music with plenty of excitement - but don't forget the subtleties too. Add excellent build and an easy load and these Monitor Audios make a formidable case for themselves." ★★★★★ What Hi-Fi? April 2001

VideoLogic

DRX-601ES Digital Tuner £349.95

"New name, new format, new winner: the VideoLogic story is as simple as that. The £299 DRX-601E digital tuner came out of nowhere to establish the firm as a major player in the digital tuner market. With this upgrade,

VideoLogic goes one step further: it's still a DRX-601E at heart, but quite apart from the sleek silver styling and sexy blue LEDs it now has a better, white-on-blue display, and what the company calls 'Psycho-acoustic Compensation' - a form of signal processing designed to make the tuner sound less digital.

And it works: the DRX-601ES has a presentation that's rich, clean and extremely informative. Bass is big and powerful, while the midband and treble are well controlled. The style alone would justify the slight price rise: the sound quality makes it a Product of the Year." ★★★★★ What Hi-Fi? Awards 2001





CD Players
Best Buy £501-£800



CD7 CD Player £799.95
7 Integrated Amplifier £699.95

Cyrus 7 CD "This player is just as convincing with thundering orchestral strings and brass making a great job of Bernstein's recording of Mahler's Symphony No 5 and it has the definition to unravel the instrumental strands in the Kronos Quartet's disc of Phillip Glass string quartets... It's that that makes it special - and this is a very special player indeed."

★★★★★ What Hi-Fi? November 1999

Cyrus 7 Amplifier "This is a fabulous amplifier. It's fast, punchy and has bags of power on tap but crucially delivers huge sackfuls of subtlety when the music requires. Some of the other amplifiers in this group may be better with particular genres of music but as an all-rounder it takes some beating" ★★★★★ What Hi-Fi? November 1999

MISSION

78 Series

782 bases its performance on a 165mm Nomex bass unit fitted to a reflex enclosure ensuring excellent low frequency extension from a graceful and compact cabinet. The **783** houses a larger 200mm bass unit with massive motor system, capable of floor shaking, yet tightly controlled low frequency extension. Both use Keraform midrange drivers for outstanding clarity and midrange detail coupled to superb dynamic range together with Mission's silk dome tweeter

The **780** and **781** are the pinnacle of Mission's research into creating a three dimensional soundstage, extensive bandwidth and dynamic range from the smallest possible cabinet dimensions. The **780** is massive in its sonic capabilities. Its 130mm Keraform bass unit is carefully matched to a novel reflex enclosure for full bodied bass extension the qualities of Keraform produce a dynamic and ultra detailed midrange. In the **781** a 165mm Keraform driver takes advantage of a larger cabinet to extend bass performance and increase efficiency whilst maintaining that superb midband transparency and finely detailed treble.

780 "Versatile and with a sound that works well with a wide variety of hi-fi kit, these speakers were worthy of this title last year, and this year have achieved the tough task of making it the double."

★★★★★ What Hi-Fi? Awards 2001



Speaker Selection

B&W CDM 1NT.....	£749.95
B&W CDM 7NT.....	£1249.95
B&W DM303	£179.95
B&W DM603 S3	£599.95
Cyrus CLS70 (Black).....	£799.95
KEF Cresta 2	£129.95
Linn Katan (Maple)	£634.95
Linn Nirka (Maple)	£894.95
Mission 780.....	£299.95
Mission M71	£129.95
Monitor Audio Gold Reference 10	£799.95
Monitor Audio Gold Reference 20.....	£1499.95
Ruark Epilogue II	£344.95
Wharfedale Diamond 8 I	£99.95

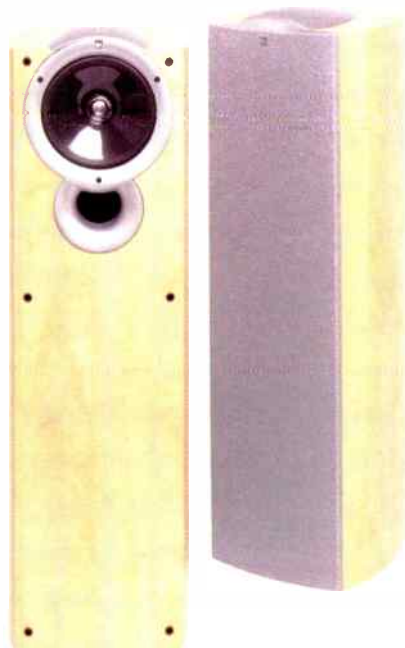

Q3 Speakers £399.95

Like its award-winning predecessor, the floorstanding Q3 offers exceptional value for money. With the new Ferrofluid-cooled metal dome neodymium tweeter derived from the Reference Series unit the coincident source 160 mm (6.5") Uni-Q driver creates a spacious and intricate sound image throughout the room, and bass extension from the large front-firing port is accurately controlled to preserve the clarity of the midrange. KEF's unique bracing system increases cabinet rigidity to minimize distortion, and the sophisticated crossovers are connected directly to the bi-wire terminals for optimum signal integrity



more entertaining

World Radio History



System Selection

Cyrus Quattro Ex Power Amplifier & Speakers	£849.95
Denon 201 Ex Speakers	£649.95
Denon DM50 Ex Speakers	£279.95
Marantz Eclipse 19 Inc Speakers	£599.95
Marantz Eclipse 21 Inc Speakers	£699.95
Marantz Eclipse 22 Inc Speakers	£799.95
Marantz Eclipse 25 Inc Speakers	£899.95
Tag McLaren Aphrodite Ex Speakers	£2994.95
Teac Reference 100 Inc Speakers	£299.95
Teac Reference 500 Ex Speakers	£729.95
Yamaha Pianocraft E150 Inc Speakers	£249.95



LINN Classik K CD Receiver £999.95

The Classik K is an alternative to the sound and looks of mass market compact systems. Designed to be useful throughout the home, the Classik is simple and stylish with all the advanced features needed to satisfy the most demanding hi-fi enthusiast or discriminating music lover.

"Since the Scottish company added a tuner to the amp/CD player, mouths have gaped even wider in appreciation. The addition of colour options panders to the public's taste for kit to match their interior design, but it doesn't just look lovely in the lounge: the Classik sounds simply marvellous. Boasting fine impact and drive, it retains its grip even as it thumps out rock and dance tracks. Ask it to play quiet acoustic music and its smooth, liquid presentation impresses still further. The Classik offers the performance you'd expect from high quality separates in one lovely package - this is a very superior product." ★★★★★ What Hi-Fi? Awards 2001



TEAC Reference 300 System £549.95

"Teac's Reference 300 system is an absolute belter. The company's Reference series has won lots of awards and many admirers in the past, and the 300 range at £200 less than the bigger 500 series, is no disappointment. Your £600 buys you everything but speakers: an amplifier, tuner, CD player and cassette deck... As beautifully built as we've come to expect from Teac, this system delivers the goods with style." ★★★★★ What Hi-Fi? Awards 2001

DENON

D-M30 CD Receiver £229.95 SC-M50 Speakers £69.95

"Denon's gorgeous D-M30 has a fine pedigree - and a record of success. Its forebear the D-M3 kept impressing us with its balance of good looks and great sound, winning two What Hi-Fi? Awards on the trot. Now the latest generation takes home a Product of the Year gong two years in a row. On its own merits, too, as this is much more than a rehash of the D-M3. Upgraded audio circuitry, improved power supply and the Mission-designed speakers all improve the package. The sound is superb, well-balanced and weighty... It's a big system in a very cute box." ★★★★★ What Hi-Fi? Awards 2001

Optional Recorders:

CDR-M30 CD-RW Recorder • DMD-M30 MiniDisc Recorder • DRR-M30 Cassette Deck

Please Note: Some products may not be available at all outlets. Advertisement valid until at least 13th March 2002, E&OE.





J A Michell

Gyro SE Turntable £974.95

Founded in Borehamwood by mechanical engineer John Michell. For over thirty years, Michell Engineering have been at the forefront of quality audio, with world-wide appreciated products like the GyroDec and Orbe Turntables.

In the early eighties, the revolutionary GyroDec Turntable, with its elegant and effective suspension system, was introduced. The Gyro SE is a smaller and cheaper package that retains the classy sound of the GyroDec and can be upgraded to the full GyroDec specification by adding a plinth and dustcover. Price includes Rega RB300 Tone Arm

"The beautifully engineered Gyro SE not only looks the part but has a wonderfully clean and fluid sound." ★★★★★ What Hi-Fi? July 1999



LINN

Genki CD Player £994.95

Majik Line Amplifier £694.95

Genki "Tempting though it is to think of Genki as a Glaswegian word, it's actually Japanese, and the nearest definitions we could find involve vitality, vigour and spirit. And used as adjectives, these words go a long way towards describing the sound of the Genki, which always manages to communicate the music first and foremost, and let the rest of the hi-fi thing look after itself.

It's a very well-thought-out player, too, from its clear and simple control layout to the provision of four sets of analogue outputs, two at fixed level, and two with level control. Completing the package is a 24-bit Burr-Brown DAC and Pacific Microsonics HDCD filter. Few owners will worry about all that stuff, however, as they'll be too busy enjoying the way Genki plays music, its purity of tone and sense of drama on Mozart's Don Giovanni being a fine example of its talent. By any standards this is a superb player, and not just one for the army of Linn enthusiasts." ★★★★★ What Hi-Fi? March 2000

Majik The Linn Majik is a sophisticated control amplifier complete with on-board stereo power amplifiers. A core entry-level product for powerful and flexible control of hi-fi, video or multi-room installations. "Sneaky" add-on modules expand its functions. It can accommodate many source components. The Majik is available in two versions: The 'Phono' version has five line-level inputs and one Moving Magnet phono input and the 'Line-level' version has six line-level inputs.



A limited edition of 500

Musical Fidelity has enough nuvistor tubes to build 500 Nu-Vista 3Ds and also to hold a spare set for every unit. (The limited edition Nu-Vista preamp, power amp and integrated are proving to be remarkably reliable, with a tube failure rate of about 0.1%). Music lovers don't need SACD technology, they just need a better CD player. Now a lucky few will be able to own the Nu-Vista 3D compact disc player. Out of the total production of 500, 265 are allocated for sale in England, and of these, 97 have already been reserved.

Please Note: Some products may not be available at all outlets. Advertisement valid until at least 13th March 2002, E&OE.

MUSICAL FIDELITY

3D CD Player £2999.95

"It's hard to put your finger on exactly why and how the 3D CD Player turns in such a performance and to a certain extent it's a pointless exercise: it just does. OK, so at three grand it's a serious financial commitment, but if you're after a CD player to last 'til you take your final breath it could well fit the bill. Get a move on, though, numbers are limited to just five hundred and they'll sell, believe me. Simply get a listen to one and go back to your reference player - all will be revealed." HI-Fi World October 2001





scotland and north

- Aberdeen** 491 Union Street **01224 587070**
- Edinburgh** 5 The Grassmarket **0131 229 7267**
- Glasgow*** 88 Great Western Road **0141 332 9655**
- Hull** 1 Savile Row, Savile Street **01482 587171**
- Leeds*** 112 Vicar Lane **0113 245 2775**
- Liverpool** 16 Lord Street **0151 707 8417**
- Manchester** 69 High Street, City Centre **0161 831 7969**
- Newcastle** 19 Newgate Street **0191 221 2320**
- Preston*** 40-41 Lune Street **01772 825777**
- Sheffield*** 635 Queens Road, Heeley **0114 255 5861**

midlands and east

- Bedford** 29-31 St Peters Street **01234 272779**
- Cambridge** 17 Burleigh Street **01223 304770**
- Ipswich** 12-14 Dogs Head Street **01473 286977**
- Leicester** 10 Loseby Lane **0116 253 6567**
- Lincoln** 20-22 Corporation Street **01522 527397**
- Norwich** 29/29a St Giles Street **01603 767605**
- Nottingham** 597-599 Mansfield Road **0115 911 2121**
- Oxford** 41 St Clements Street **01865 241773**
- Peterborough** 36-38 Park Road **01733 897697**

midlands and west

- Birmingham** 12 Queensway Arches, Livery Street **0121 233 2977**
- Bristol** 92b White Ladies Road, Clifton **0117 974 3727**
- Cardiff** 104-106 Albany Road **029 2047 2899**
- Cheltenham** 14 Pitville Street **01242 241171**
- Exeter** 28 Cowick Street **01392 218895**
- Plymouth** 107 Cornwall Street **01752 226011**
- Swansea*** 24 Mansel Street **01792 465777**

london and south east

- Brighton** 57 Western Road, Hove **01273 733338**
- Bromley** 39a East Street **020 8290 1988**
- Chelsea** 403 Kings Road **020 7352 9466**
- Crawley** 32 The Boulevard **01293 510777**
- Croydon*** 369-373 London Road **020 8665 1203**
- Epsom*** 12 Upper High Street **01372 720720**
- Guildford** 73b North Street **01483 536666**
- Holborn*** 144-148 Grays Inn Road **020 7837 7540**
- Kingston*** 43 Fife Road **020 8547 0717**
- Maidstone*** 96 Week Street **01622 686366**
- Reading** 3-4 Kings Walk Shopping Centre **0118 959 7768**
- Sevenoaks** 109-113 London Road **01732 459555**
- Southampton** 33 London Road **023 8033 7770**
- Southgate*** 79-81 Chase Side **020 8886 2777**
- Swiss Cottage*** 21 Northways Parade, Finchley Road **020 7722 9777**
- Tunbridge Wells** 28-30 St Johns Road **01892 531543**
- Watford*** 478 St Albans Road **01923 213533**
- Witham (Essex)** 1 The Grove Centre **01376 501733**

*Open Sunday Please call to verify hours of business.
Contact our outlets via **E-Mail** outlet@sevenoakssoundandvision.com

who are sevenoaks?

Founded in 1972, Sevenoaks Sound & Vision are one of the largest, and most successful hi-fi and home cinema retailers in the country.

Each Sevenoaks Sound & Vision outlet stocks a wide range of quality products, covering all categories of specialist home entertainment, from DVD Players to Widescreen Plasma Televisions and Projection Systems, all at highly competitive prices.

Friendly staff are available in all stores to advise, demonstrate and guide you through the home entertainment jungle.



sevenoaks online

The Sevenoaks Sound & Vision website has news and information on the Sevenoaks group and its 44 outlets nationwide. The website is designed to provide you with answers to the questions you may have when buying new equipment.

The site has comprehensive guides to a range of products and technologies from vinyl and compact disc to all the latest formats, including DVD Audio, SACD and widescreen plasma monitors and front projection systems.

There are regularly updated stock clearance lists with hundreds of products on offer and detailed pages to help you locate your nearest outlet.

For impartial advice and information, just click on sevenoakssoundandvision.com

stock clearance

With over forty outlets nationwide, the Sevenoaks Sound & Vision group stock and display a wide range of products. As technology delivers improvements in performance, so individual models and product ranges are changed or superseded. The preceding models are made available at a reduced price, for clearance. Visit our Website for an up-to-date list of the clearance stock, listed by outlet, within the Sevenoaks Sound and Vision group.

0% finance option[†]

Spread the cost of buying. 0% finance option is available on the vast majority of products we stock. [†]Written details on request. Licensed credit brokers. Minimum balance £200. Subject to status.

pricing policy

Whilst we do not claim always to be the cheapest, we try to ensure our prices are highly competitive. Take into account the expert advice, unrivalled product selection, demonstration facilities and excellent pre, during and after sales service and the lower price might not look such good value.

In the event you can find the same products and excellent service at a lower price, please bring it to our store managers' attention. We will always endeavour to offer you the best deal.

TO INFINITY.

The new Infinity range of 'speakers feature some cutting edge design, no more so than the sci-fi styled flagship Kappa 600 floorstander. Mani Sandher prepares for blast-off!



Infinity Systems is one of the brands that make up the new Harman Consumer International group. Since its inception in 1968, historical steps for Infinity include the first system with a separate subwoofer, the 'Servo Static 1', and the use of a polypropylene cone, back in 1978. Nowadays, European operations are located in the heart of the Loire Valley in France, though production of certain models, such as the Kappa 600s that we take a look at here, is undertaken in Denmark.

The 600s are very solidly built, matching the solidity of my more expensive B&W N803s. They stand reasonably tall, a tad below one metre, and are slim and deep, at 220mm and 425mm respectively. That depth is necessary to accommodate the sideward firing 250mm bass driver. Our review sample came in a light maple finish with a small grey plastic front baffle and grey grills. Overall, they look more futuristic than classical and wouldn't look out of place in a modern 'designer' room. Two-way binding posts sit at the back of the cabinets, allowing for bi-wiring or bi-amping.

The 600s are a three-way design, with all drivers incorporating 'Ceramic Metal Matrix Diaphragm' (CMMD) technology. This, claims Infinity, helps to control unwanted in-band resonant modes within the cone, therefore reducing colouration. With a quoted sensitivity of 90dB/2.83V/1m, the 600s should be easily driven by most amplifiers, though their nominal impedance of 6 ohms might be problematic for some very low powered amplifiers.

I connected the 600s to my current reference system: Marantz SA-1, Pass Labs XI/Aleph4, Purenote Epsilon interconnects and speaker cables, Cardas Golden Cross power

cords and Townshend seismic sinks. Placement of the 600s is particularly important, due to their sideward firing bass drivers. These I had firing inwards, towards the centre position with the speakers slightly toed in. The 600s are rear ported and, to me, sounded best over 1.5m from the rear wall and over 1m from the side walls. Bearing in mind their depth, this particular placement may not be practical in many rooms. To ensure proper 'warm-up', the 600s were left playing for a good few days before any serious evaluation.

These 'speakers could not have been more sonically different from the JMLab 906s I reviewed last month. The immediate impression the 600s give is one of good low-end extension. I doubt that the subwoofer brigade would be disappointed. Prince's 'Diamonds & Pearls' CD is full of heavy bass lines and thumping kick drums. The 600s had no problems in getting my window panes to dance in sympathy to this music.

The new Telarc SACD release of Tchaikovsky's '1812 Overture' is a full DSD recording and, for me, redefines the meaning of low-end extension. Through the 600s, the artificially added canons sounded immensely powerful and ominous.

The same was true playing James Horner's 'Titanic' sound track on SACD. Track one starts peacefully enough, until the deep, deep bass notes come into play. All of this sounded great through the 600s!

The 600s are tonally well balanced across the audio band too, though this will be heavily affected by their positioning. 'No Chaser' by the Bill Holman Band (JVC XRCD2) can sound too forward through many speaker systems. Through the 600s, however, the top end was nice and

sweet, if a little reticent. Mid-range purity was generally good, with no boxiness from the cabinets discernible. I did feel that the mid-range sounded slightly edgy though. The saxophones and trumpets on 'No Chaser' had an edge to them that I'm not accustomed to, though this was a very minor distraction.

Vocals on both the Prince CD and Talk Talk's 'Colour of Spring' CD were more revealing, sounding slightly hollow and thin. The Baritone on track four of Carmina Burana (Telarc pure DSD SACD) seemed to have lost his lower octave and, worst of all, Celine Dion's voice on 'Titanic' sounded even more grating than usual.

Unfortunately, the low-end transient and dynamic response of the 600s does not match their low-end extension capabilities. This has implications on overall sound integration and on musicality. The kick drums on the opening track of 'Colour of Spring', though well

AND BEYOND?



extended, sounded smeared and slow. They lacked the bite that I know they have. The exact same effect was apparent playing Prince's 'Willing and Able' track. Here, the kick drums are important to drive the rhythm of the music. The 600s didn't manage to do this music justice. On 'No Chaser', the double bass didn't lead the rhythm of the music, seeming instead to lag behind the horns. This was true

for virtually every CD/SACD I tried. I wanted to be sure that this low-end smearing and timing issue was not due to a lack of power from my beloved single-ended, class A power amp, which will only manage 100W output unconditionally into any load. I had at hand a pair of push-pull monoblocks capable of delivering 900W/ch. into 6 ohms! The situation with these in place was little different.

In conclusion, the 600s have great low-end extension and a laid back sound that is generally sweet and non-fatiguing. However, the former trait is a double-edged sword. 'Real' music, requires good timing, rhythm and pace, which the 600s simply do not deliver low-down. I would imagine the 600s to be perfect for a high-end AV setup, where impressive sound effects are a must. ■ ▲



Infinity Kappa 600 £1499
 Harman Consumer UK
 Unit 2, Borehamwood Ind. Park
 Rowley Lane, Borehamwood
 Herts WD6 5PZ
 Tel: 020 8731 4670

MEASURED PERFORMANCE

The Kappa 600 looks smooth enough in its frequency response, but the measuring mic. was placed quite low - on axis with the midrange unit - for this result. It means the Kappa 600 works best when listened to from a low-ish seating position. Above axis the drivers move out of phase fairly rapidly, causing a crossover suckout to appear. The speaker will sound softer as a result, listened to from above. Whilst this is not uncommon, the Kappa 600 was a little less well integrated than many modern designs.

The side firing bass unit works over the range where our forward response shows falling energy (below 200Hz) and should fill in well enough in a normal living room. The port peaks at 40Hz and extends down to very low frequencies so this loudspeaker will not lack bass.

In all, the Kappa 600 looks smooth enough in response terms. It will sound detailed yet well balanced on-axis and the floor mounted bass units should deliver strong lows.

As a load though the Kappa is a bit wild by today's standards. Large rates of change of impedance right across the band indicate strong reactance and absolute level ranges from 30ohms or so down to 4ohms. The Kappa 600 will challenge any amplifier, delivering energy back to it, likely affecting feedback behaviour. In its favour it is reasonably sensitive, delivering a healthy 87.5dB from one nominal watt of input.

A speaker like this is best auditioned with the amplifier it is to be used with. Reactive loudspeaker highlight amplifier differences. In itself

the Kappa will likely sound fast, clean and dynamic, with firm bass but it must be matched with care. **NK**

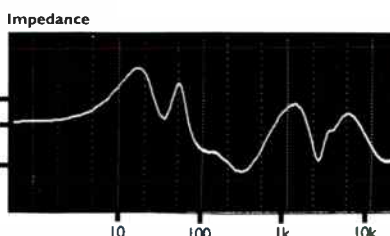
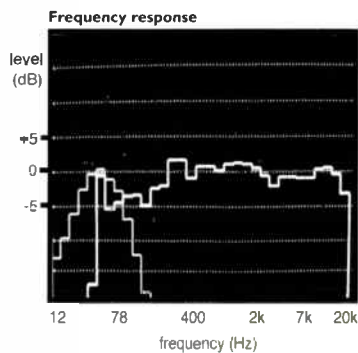

World Verdict



Very deep bass and plenty of power but also a bit loose and laid back. A fine high end AV speaker.

Quality, Power & Looks!



Supplied with beautiful stainless steel & Perspex valve cover (not shown)

icon Audio MC34-A

Beautiful open sound, detailed, smooth & involving, that only valves can provide. 30+30 watts RMS, ample for most speakers 4 & 8 ohm taps. Stunning design supplied with attractive valve guard. Exceptional build quality, using EL34, ECC82, ECC83, in Class Ab, Ultralinear. All hand wired. No printed circuit board. Audiophile components used.

New, optional HT delay timer to protect the valves!

Try it for 30 days. refund if not delighted. Order now by phone or ask now for our free info sheet. Visit our website at:-

www.iconaudio.co.uk Find out what you're missing

Only £599.95* or £649.95* with HT delay timer

Phone 07787 158791. email sales@iconaudio.co.uk

icon Audio 351 Aylestone Road Leicester LE2 8TA

We accept Visa and MasterCard.

CE certified



*Including UK delivery and 12 months guarantee including valves.



definitive audio

Living Voice · Lowther · Vitavox · Electrofluidics · Art Audio · Border Patrol
Canary · DNM · Sugden · Wavac · Lyra · Monarchy · Western Electric · EMT
Wadia · Michell · Stax · Tom Evans · Nott'm Analogue · SME · Van den Hul

Part exchanged and ex-dem clearance.

Sale New

Digital

Sugden Masterclass CD - new - boxed	£1800	£2500
Wadia 860x ex-dem boxed	£5200	£7950

Analogue

Nottingham Analogue 'The Foot' - 12" carbon fibre tonearm - it's new and it's long	£500	£1100
Nottingham Analogue Spacedeck - 'NEW'	£650	£750
Helius Cyalene	£350	£1350

Loudspeakers

Living Voice Auditorium - walnut.	£1150	£1500
Cadence DS - rosewood - giveaway @	£600	£1750
Goya Madonna and Child - immaculate.	priceless	
Klipsh LaScala - black - zippy 105db/watthorn.	£1450	£3500
Living Voice Avatar OBX Dark rosewood - ex-dem/ex-review.	£3200	£4000
Audio Note ANSP speaker cable - various lengths	£POA	

Amplifiers

Border Patrol 300B SE - with new Western Electric valves - light oak - the best SE available - New - excess stock.	£4000	£4500
Art Audio VPS - valve line pre-amp	£450	£1400
Art Audio Diavolo - with 320B valves - chrome + gold - line integrated - juicy. Go on, be a devil.	£2900	£4500
Art Audio Concerto - 40w line integrated - black + chrome	£1250	£2650
Art Audio Concerto - 40w power amp. ▶ giveaways ▶	£1150	£2250
Joule Electra - 2 box phono pre-amp. It's a gem.	£800	£2000
Linn Classic - CD, amp, tuner, thingy	£400	£1000
Cary 2A3 - 7 watt PSE power amp 1992	£850	-
Cary 5500 - line pre-amp 1992	£490	-
Unison Mystery One pre-amp - it's a mystery	£750	£1750
Tube Technology MAC - phono pre-amp - fully refurbished by manufacturer - including Hovland film and foil capacitors.	£900	£1400
Audio Innovations S 500 integrated (+ phono) - 25w Class A	£550	-
Audio Innovations S 700 line integrated - 25w class A	£650	-
Western Electric 300B Valves! New matched pairs in stock		£600

Tel 0115 973 3222 Fax 0115 973 3666
internet: www.definitiveaudio.co.uk email: shout@definitiveaudio.co.uk

at last you can enter a new world



Announcing the new Origin Live Silver 250 tonearm, £599

"this is probably the best tonearm in the world right now"
HI-FI WORLD 2002

If you want to massively improve the quality of your listening experience then this arm will deliver more than you expect..

"the Silver 250 is the very best tonearm I've ever heard...awesomely tight bottom end...the midband - glass clear, incredibly liquid, fantastic image precision, walkaround soundstaging and incredible timbral realism.....the treble is shockingly open and airy up top...the £599 price tag is laughably low....could probably charge 5 times this amount.....words can't express how good this is - one of the designs of the decade" HI-FI WORLD March 2002

"A terrific arm, a terrific bargain, and, obviously, the highest of recommendations" STEREO TIMES

Features of the Silver 250 & Silver Taper tonearms:

- Advanced aircraft alloys and innovative techniques greatly improve performance over conventional tonearms.
- Widely spaced bearings positioned outside the arm tube increase stability (unlike uni-pivots) - resonance is also decreased.

The new Silver Taper tonearm, £970

- The latest "Silver taper arm" is specially profiled from a solid aircraft alloy billet.
- The large diameter provides huge torsional strength which manifests itself in superbly controlled deep bass.
- The performance of this latest arm is absolutely unprecedented.

In terms of their ability to lift your system into new realms of performance these arms are outstanding - expensive cartridge upgrades are unlikely to come even close to the levels of improvement wrought - yes they are that good!

To purchase or arrange an audition contact Origin Live or one of our dealers.

FULL INFORMATION ON WEB SITE OR CONTACT

Origin Live, Unit 5, 362b Spring Road, Sholing, Southampton, SO19 2PB, U.K.

Tel: 02380 578877 Fax: 02380 578877

e mail: originlive@originlive.com web site: <http://www.originlive.com>



HI-FI WORLD'S

GREAT COMPETITION GIVEAWAY

WIN A SUPERB AUDIO NOTE ZERO SYSTEM WORTH £2,500 IN THIS MONTH'S COMPETITION GIVEAWAY.

This month we have a real treat for one lucky winner in the shape of a complete Audio Note Zero hi-fi system consisting of CD transport, DAC, pre and power amps, plus 'speakers, worth a total of £2,500.

Audio Note UK is one of the most individual and respected companies in the world of specialist hi-fi. Its catalogue of designs are resolutely valve influenced and range from the entry level Zero products to the stratospheric, in the shape of the awesome £55,000 Ongaku integrated amplifier.

The system we have up for grabs here is a fine example of the company's art and highlights their philosophy of manufacturing music systems, as opposed to merely hi-fi.

The MD of Audio Note UK is one of the most individual and knowledgeable characters in the business, the Danish born Peter Qvortrup - an avid collector of both rare valves and rare classical vinyl recordings. Qvortrup inherited his love of classical music from his father, who used to listen to recordings on a Philips mono valve system. It was here the audio bug took its initial bite and the young Qvortrup's first student grant (in true student style) was blown on a valve based hi-fi system.

After a stint as a professional marine broker and an amateur audiophile (during which time he discovered he most definitely preferred valves to transistors) he packed in his job in 1977 and started importing classic British hi-fi into Denmark. After setting up a dedicated dealership in his homeland, he sold up and moved to the UK with a view to carrying on his work with classic valve-based hi-fi.

Audio Note UK was started in 1989 as a vehicle for closer collaboration with the Audio Note company

in Japan, headed by the legendary Mr. Kondo. In 1990, under agreement, Audio Note UK started designing and producing products that shared the same name as those made in Japan. Eventually the two companies each went their separate ways.

Audio Note UK now still produces those high-end same-named products such as the 300B Kegon power amps and the aforementioned Ongaku, as well as a wide range of other valve amplifiers, digital sources, filterless DACs, turntables and cartridges.

What perhaps marks Audio Note out from other companies is its total dedication to the art of music reproduction, where the performance is always the main factor, pure and simple.

The Zero system we have to giveaway consists of the CDT Zero CD transport, a DAC Zero convertor, the M Zero Remote preamplifier, a pair of P Zero power amp monoblocks, plus a pair of AZ Two loudspeakers. This system delivers true and faithful reproduction of a recording - something rarely found at this level. There is a wonderful sense of transparency and detail, and the overall impression is one of being there with the performers. Audio Note gear simply makes music. It's a real audiophile product - simply sit back and enjoy the music.

Entering couldn't be easier. Simply answer the questions at right, put them on a postcard and send it to



the address below by March 31st. The first correct answer picked out of our hat wins this cracking prize. ■ ▲

Hi-Fi & Computer Audio World Competition rules and conditions of entry

1. Only one entry per house hold.
2. Multiple entries will be automatically disqualified.
3. Purchase of the magazine is not a pre-condition of entry.
4. No correspondence will be entered into.
5. The Editor's decision is final.
6. No employees of Audio Publishing Limited, or of any companies associated with the production or distribution of the prizes may enter.

Competition Questions

[1] Name the MD of Audio Note UK?

- [a] Peter Qvortrup
- [b] Peter Andersson
- [c] Peter Cook
- [d] Peter Pan

[2] On what did he spend his first student grant?

- [a] Opera tickets
- [b] Books
- [c] Hi-fi
- [d] Beer

[3] On which year was Audio Note UK founded?

- [a] 1988
- [b] 1989
- [c] 1990
- [d] 1889

[4] Name Audio Note's £55,000, top of the range integrated amp?

- [a] Gaku-on
- [b] Ongecko
- [c] Ongaku
- [d] Kendo Nagasaki

April Competition
Hi-Fi World Magazine
Unit G4 IMEX House
The Park Business
Centre
Kilburn Park Rd.
London NW6 5LF

CONGRATULATIONS!

...to Mr. Roger Seaman of Cambridge, the winner of our February competition. A Creek CD 53 CD player is on its way to you!

VELO-



David Price tries out the mightily powerful HGS-12 subwoofer from Velodyne. Is this the best way to reproduce an earthquake?

Subwoofers have been around for many years now. As far back as the mid seventies, JR Loudspeakers made one to partner its LS3/5A-based JR149s, and there was Celestion's superb dipole design for the SL600 at the tail end of the eighties. By the mid nineties however, they'd filtered down from the specialist speaker accessory market to the everyday hi-fi buyer. Tragically, a rash of dire sounding cheapo boom boxes ensued, and the breed rather fell from fashion again.

The problem is that if you don't want bass that's half a second behind the rest of the audio spectrum, you have to pay for a decently designed and built product. Companies such as REL and Velodyne fit into this category - their products are pricey, but work well. The latter is a Californian company, based in San Jose, which has been making subwoofers for decades. In 1983 it patented High Gain Servo technology, an active sig-

nal sensing and control system which sees its modern expression in its Dynamic Driver Control System. This is claimed to ensure linear cone movement via active monitoring of the drive unit's excursions, while also preventing both driver and amplifier from being overdriven.

The HGS-12 is the second model up the company's audiophile range, so called due to its use of the aforementioned servo technology, and a twelve inch forward firing drive unit. Inside it packs a muscular 1250W RMS (3000W peak) Class D amplifier. It has a built-in low pass crossover with 12dB/octave initial, and 48dB/octave ultimate roll-off, plus a subsonic filter working at 20Hz or 35Hz. There's an anti-clipping circuit to prevent the HGS-12 being overdriven, and auto power on and off switching.

The aforementioned 300mm magnetically shielded woofer has 5cm of excursion, and uses the company's proprietary multi-layer laminate cone

with an oversized progressive spider, 75mm Dual Tandem push-pull voice coil, variable thickness EPDM surround and die-cast basket. It's a hefty affair, as you'd expect, its magnet structure weighing in at 8.8kg! The 368x355x355mm enclosure is no less 'industrial' - it's a sealed, infinite baffle design (as opposed to the ported types you find on lesser products) with a strong, durable black finish giving a total mass of 27kg. Round the back, there are controls for the low pass crossover, which ranges from 40-120Hz, along with a phase control (0 or 180 degrees), gain control, RCA line inputs and outputs, and a subwoofer direct for surround sound duties. Gadget fans will doubtless appreciate the option of a remote control.

As I've said, your average cheapo sub is a consummate waste of money - you can never get these things working right. But even serious designs such as this Velodyne are

DYNAMICS



fussier than you'd think. Although the textbooks tell us that low frequencies aren't directional, I still find it's well worth taking some time to position a sub carefully in the room. There's no strict rule here, as every listening environment is different, but suffice to say that they should not be stuck right in the corner, where they'll boom whatever you do.

Suitably set up, the Velodyne sounded superb. Consummately deep and powerful with incredibly fast attack, it's undoubtedly a breed apart from your average budget boombox. The trick is to back off on the gain so much that you can barely detect the sub at all - at this point you don't think you're listening to it, until you

switch it off and your system suddenly sounds bass-light. The HGS-12 brilliantly compensated for the relative lack of low end welly of my valve power amp, making my speakers seem less leaden right the way through the bass range. Things tightened up considerably, my amp losing its slightly breathless quality at high levels, because bass was filtered out, to be handled by the Velodyne alone. Even when extended, the Velodyne showed no signs of distress whatever type of music was playing.

At £2,125 this an extraordinarily expensive way to boost bass, but the qualitative improvements it brings are quite something. It would be pointless to recommend it for any system

costing less than around £10,000 - but if you're fortunate enough to possess such a set-up, you'll find it surprisingly effective at raising its game. Valve users will be particularly impressed by the rewards it brings - while there's no disputing the superior, more liquid midband and treble you get from tubes, gut-churning tracts of low bass aren't exactly a forte of this particular type of amplifier design. A good sub - and this is more than that - really gives you the best of both worlds. All you'd then have to do would be to add a pair of Tannoy Super Tweeters for a fearsome full range system - that would really be saying something! ■ ▲

Velodyne HGS-12 £2,125

Redline
tel: 0131 226 1981
www.redline.co.uk

MEASURED PERFORMANCE

The HGS-12 sits either in an amplifier's tape loop or between pre-amp and power amp. It's useful for valve amps because it actually removes low bass (below 80Hz) from the main amplifying channel. The unit sums both channels to a single drive unit and it can be adjusted to work from 40Hz-120Hz, down to a lower limit of either 20Hz or 35Hz, according to the handbook.

A subsonic sweep test signal from 4Hz to 125Hz showed the unit reaches down to 16Hz (-6dB) and is flat otherwise to 20Hz, as claimed. It reaches up to a maximum of 125Hz measurement confirmed. Our third-octave analysis clearly shows this. The

lower limit has been imposed doubtless to restrict cone excursion. Otherwise, sub-sonic signals from CD will throw the cone against its mechanical end-stops, since the power amplifier used has plenty enough grunt to do this.

Having an input amplifier the subwoofer does not have a varying impedance curve of course, so there is no impedance analysis here.

Velodyne use motional feedback from an accelerometer to control cone motion and reduce distortion. Technically, this is quite a package and measurement shows it performs well. **NK**

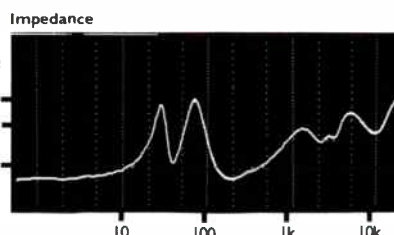
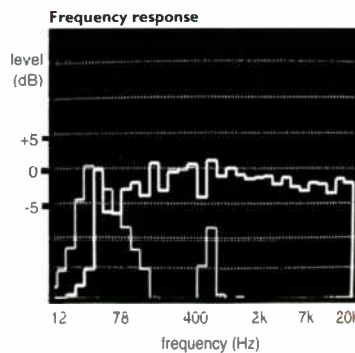

World Verdict

Supertight, well damped and gutsy sound makes it a top performer, but you'll have to pay for the privilege.

marantz®

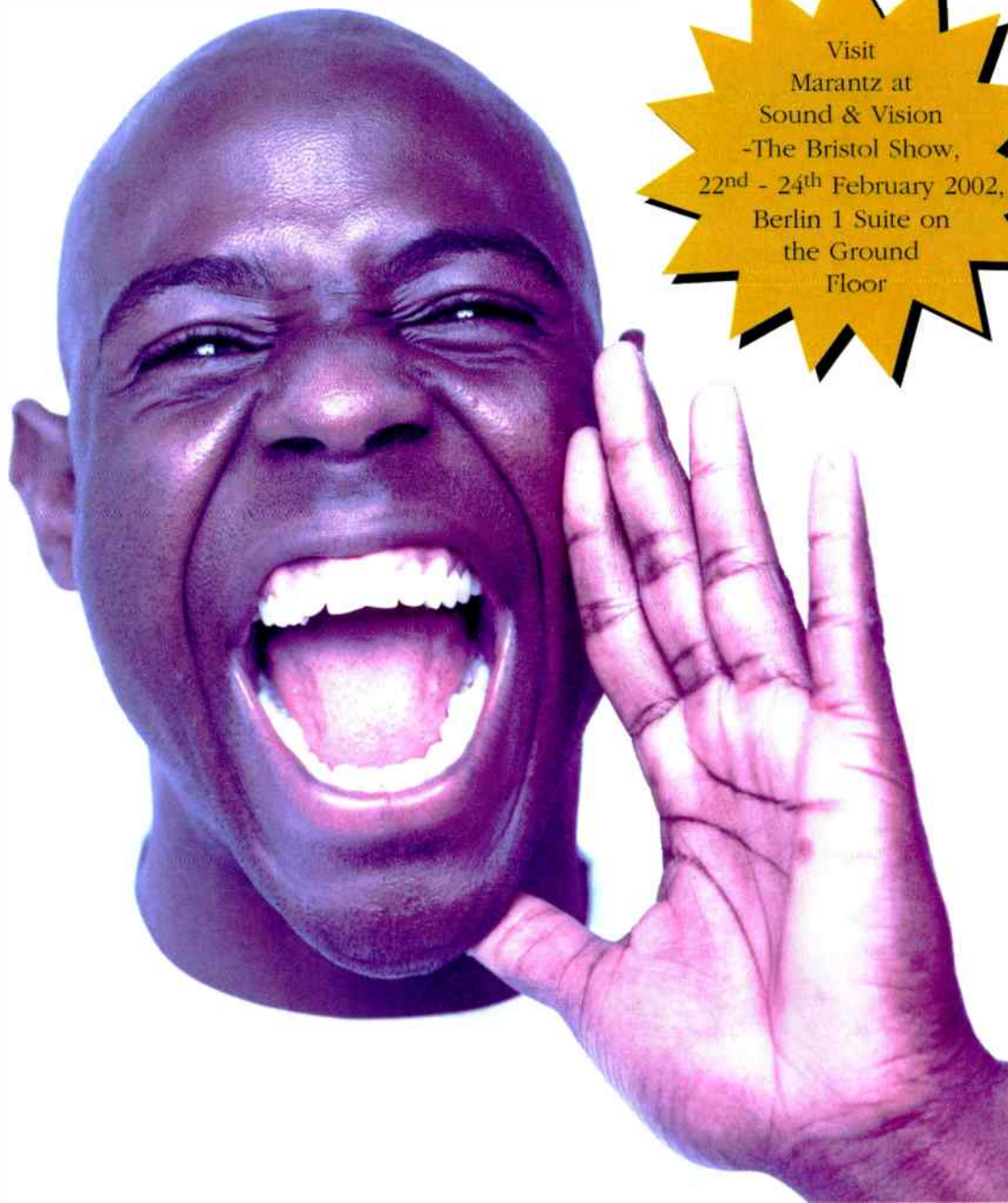

Visit
Marantz at
Sound & Vision
-The Bristol Show,
22nd - 24th February 2002,
Berlin 1 Suite on
the Ground
Floor

Awards worth shouting about

Once again, Marantz has won the most prestigious awards in the industry. WHAT HI-FI? SOUND & VISION – the UK's number one hi-fi and home cinema guide – has given three of its top accolades to Marantz. The DV41000SE is the best DVD-Video player you can buy for the money and wins a Product Of The Year Award. Also honoured is the Marantz SR4200, the Best Buy AV receiver under £400. And Marantz is also the first recipient of the gold Award in recognition of its AV skills. So now Marantz is the best – and that's official.



DVD Players
Marantz DV41000SE



AV Amps/Receivers
Best Buy up to £400



DVD Players
Marantz DV41000SE

The best in home cinema

Tel: 01753 680868 Internet: www.marantz.com

NEVER BETTERED?



Musical Fidelity's A1 integrated amplifier was a 24 carat classic. David Price takes up the story.

Musical Fidelity's A1 is one of those products that just wouldn't be made these days - it's too charismatic. A bizarre combination of incredible 'eighties modernist' styling and distinctly retro full Class A circuit design, it makes today's mass market middleweights seem terminally dull by comparison.

The company's first product, The Preamp, created quite a storm within weeks of its 1982 launch. Reputedly designed on company founder Anthony Michaelson's kitchen table, it created its own merry band of fans who soon came back for more when The Synthesis integrated was launched soon after. Michaelson duly moved out of the kitchen and into a proper factory, whereupon the A1 integrated was born.

Selling for just under £250 in 1985, it was pitched just slightly above Naim's original NAIT and Mission's Cyrus 2 - which were both formidable opponents. It had several aces up its sleeve however.

First it looked incredible - a delicious combination of semi circles and hard, eighties-style straight lines, there was something very 'Bauhaus' about its aesthetics. The (then) stylish black casework allied to rather risqué powder blue silk screened fascia legends made it all the more striking.

Next was its build. That casework was a joy to behold - the perfect combination of form and function, the heavy grooving on the cast aluminium top plate was the unit's only form of heat sinking. Reaching temperatures of between 55-60 degrees Celsius,

some said it could have done with a little more help. Inside, a 160VA toroidal transformer puffed and wheezed through four 10,000uF reservoir caps. An ALPS volume pot hooked up to a line amplifier with unusually high 200mV sensitivity.

Being a little challenged in the output department meant that Musical Fidelity had to sell it to those with particularly sensitive loudspeakers, with relatively benign load characteristics. The problem was that this was 1985, when such speakers were about as fashionable as a mid-seventies supergroup. By this time, most audiophiles aspired to big, butch (heavily Class B biased) transistor amps, and tiny power sapping mini-monitors (Acoustic Energy AE-1s, anyone?) The A1 was not of that ilk, and found itself being marginalised by many reviewers as 'bonkers', 'tweaky' or - to put it mildly - a 'niche product'.

Many potential customers soon found themselves being put off the A1 by a tirade of knocking copy in certain magazines, and a rapidly deteriorating reputation for reliability. In truth, the amp was designed to run flat out with almost no leeway for cooling problems. If it didn't get the careful placement it demanded (with at least 50mm behind it and 250mm above it), things were liable to go bang. It wasn't this simple though, as dealers reported that some batches were far worse than others - with a terrible rate of attrition. The fact that switching the A1 on before you'd connected it to a pair of loudspeakers

could cause the output stage to throw in the towel didn't help, either.

Properly placed and matched to sympathetic loudspeaker loads, a good specimen of an A1 sounds superb. Basically it's very soft and warm, but with oodles of musicality and tactility. It had tonal colour in spades, too - the A1 told you better than all its rivals whether recordings were done on Denon PCM recorders or ye olde Ampex reel-to-reel tape. The fun factor was there in abundance, and you got the sense that you were listening to music rather than hi-fi. Where it failed, it covered its tracks beautifully - although treble was veiled, it was also deliciously sweet, while the bass was hopelessly loose but pleasantly sumptuous too!

For such an unreliable, hard to match, difficult to get the best from, integrated amp (usually such perils are reserved for high end products, after all!) it sold incredibly well. Musical Fidelity say they shifted nearly 200,000 units before it got the chop in the early nineties. To put it another way, if you put all of them end-to-end, the line would stretch for fifty miles!

These days, Darwinian natural selection has taken its course, and the ones still surviving are likely to be as reliable as any other amp of its age. (Of course, a new set of power supply caps wouldn't go amiss). A good one will set you back under £200, which is a bargain for such a rare and charismatic beast - as always, go for boxed, 'one careful owner' specimens. ■ ▲

FOREVER CHANGERS



Philips has been doing its homework about where the CD market is going, and the result you see before you. David Price researches the new CD-R802 CD changer/recorder.

A 'ACDR' is what the industry calls things like this. It stands for Audio CD Recorder, and if you believe what pony-tailed, big suited market research types are telling you, then this is, ermm, the future of CD. How so?

Well, standalone CD separates sales are now in freefall. Right now, the poor old bog standard silver disc player has reached bargain-basement, lowest common denominator status. With the various new DVD-based formats finally reaching the mass market, CD is no longer considered sexy (shock horror!) and simply can't command a premium price anymore. To wit, we have ever-cheaper mid-price software releases and CD players in twenty five quid portables. LP has trotted up market (where some say it always belonged) and ye olde Compact Diske is now the generic bog standard, dirt-cheap music medium.

Fair enough, say I - nothing wrong with that! And this has become all-the-more salient with the advent of recordable CD (CD-R). Thanks to the vast economies of scale derived from the computer industry, the price has fallen dramatically in the space of just

a few years. Lest we forget, Meridian's long lost CD-R cost over £3,000 in the late eighties, Pioneer's first mid-nineties machine cost £1,200 and then came Philips seminal CD-R870 in 1998, which set the cat amongst the pigeons by selling for a whisker under £400. Prices have gone into freefall, to the extent that what you see before you here offers much more for just £300.

Indeed, Philips' own market intelligence suggests this is the place to be if you want to flog any CD-based product these days. In the US, 'ACDR' products outsold all audio products including turntables, cassettes, MiniDisc players and CD players. "According to two-year industry sales figures from several CE manufacturers, more than 2.7 million Audio CD-Recorders have been sold world-wide, making the Audio CD-Recorder the fastest-growing audio product in the history of the consumer electronics industry," quoth Andy Mintz, senior Philips suit, North America. Fair enough, then.

So, is the CD-R802 simply an exercise in printing money from the low lands, or does it have some abiding virtue that might make us

poor, left-out-in-the-cold audiophiles want to buy it? Well, I'll let you into a secret - it's no Linn CD12. Yet how would it work as an audio recorder/general purpose party music machine - a sort of twenty first century double cassette deck?

Eagle-eyed readers will have noticed that it's a digital double decker with a difference - the difference being it has both a 3-CD autochanger and a single CD recorder. As per NAD's C660 it uses a computer CD-R drive to give double speed recording - meaning you can copy your average disc in a little over half an hour. It's also MP3 CD compatible, with the full Fraunhofer Monty of bitrates up to 320kbps, as well as Variable Bit Rate. If you do your sums, then you can continuously play 4 MP3 CDs, each with 12 hours of music (at reasonable 128kbps quality), giving two whole days worth of music, roughly equivalent to half the entire Chicago back catalogue.

The clever stuff doesn't end there - full CD text (read and write) is provided, and a sampling rate converter takes care of digital signals from 12-96kHz (but is bypassed at

44.1kHz, allowing bit-for-bit copying unlike Philips earlier ACDRs - this in turn means even HDCDs can be copied all their glory). There's also a rather handy Automatic Digital Record Level Control, which automatically equalises all CDs up to the same level. This is a boon because even today, not all discs are mastered up to 0dB. As usual there's manual record level adjustment too, but it doesn't just work on the analogue input - you can change the gain on external digital sources too.

The list of features is endless - there's strength in depth here, too. You're recording digitally from one of your MD or DAT tapes, and the CD-R802 comes across the dreaded SCMS copy prohibition, so what does it do? Where lesser decks would go into pause mode and halt your recording, this one simply carries on recording via its analogue ins instead (until it subsequently finds a non-copy protected digital source again). Clever!

There's also all the usual play, repeat and monitor modes, and recording is made easy with Synchro Start and simple one-touch 'Copy CD' and 'Compile CD' buttons.

A great package then, but at this price you're hardly going to get a beautifully built bit of kit. The finish is good enough, and at 6kg for its

435x122x347mm dimensions, it's less flimsy than the likes of LG's ADR-620 tested in February, but it's still nothing special. Philips say that it's hiding its light under a bushel though, thanks to the quality Analog Devices AD1877 and AD1854 digital converters lurking inside - as used in the audiophile CD-R950.

Despite this, the CD-R802 is nothing special when playing back CDs. It's hardly seat of the pants stuff - bland and uninvolved and rather inoffensive. Still, it's smooth and listenable in a quintessentially 'modern Bitstream' way. The frequency extremes are noticeably curtailed, but the midband still fails to grate. I ran through a host of reissues from Blondie's 'Parallel Lines' to Dexys Midnight Runners 'Searching for the Young Soul Rebels' and at no time did the Philips show any undue signs of stress - or emotion for that matter. In a phrase - it's light, bright and fluffy.

Of course, this was never going to be the machine's forte anyway. The point of this deck is the copying (for your own personal purposes only, M'lud) - and this it does reasonably well. Given a decent audio CD-R or CD-RW, you get a clean, open, smooth sound with just a touch of looseness in the bass, hardening of the midband and smudging of the treble. The low frequencies lose some

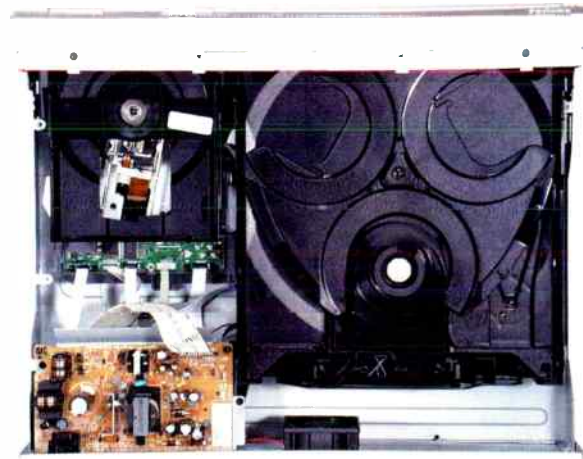

of their energy and articulation - REM's 'Driver 8' lacked the driving force behind the bass guitar. In the midband, all is even and tidy, with a slight flattening of stereo perspective, as Blondie's 'Heart of Glass' showed. Treble lost a little of its sheen, and the track's glorious ride cymbal work sounded a touch too splashy for my liking.

Overall then, this recorder has a decent performance, plus a welter of facilities; a lot of thought gone into its conception. It's a fine package - but if it's brilliant bit-for-bit disc copying you want, then best buy the NAD instead.

Philips CD-R802 £300

Philips Consumer Electronics UK
Tel: 020 8665 6350
www.ce.philips.co.uk

MEASURED PERFORMANCE

Philips CD players and recorders generally measure well and this one was no exception, but for one peculiarity. In record pause its monitor circuits roll off treble strongly, so the signal you hear will sound dull. It is unrepresentative of recording quality, which measurement showed was fine; frequency response reached 20kHz flat. In record pause it reached just 3kHz! Even though this problem does not directly affect sound quality I can't help feeling it should not be there.

Otherwise, the CDR-802 worked fine as a playback machine or a recorder. Our playback response analysis clearly shows a slight roll down in high frequency output, which should give it a smooth sound. Distortion was very low, the 0.015% figure at normal music level of -30dB being as good as it gets. Noise on

recording was unusually low too, measuring -99dB (IEC A weighted). With a dynamic range of 110dB and a normal output of 2V the CDR802 measured well in all respects. **NK**

Frequency response 5Hz- 20.7kHz

	left	right
Distortion		
-6dB	0.005	0.005
-30dB	0.015	0.015
-60dB	0.35	0.36
-90	28	29
Separation		
1kHz	103	102
20kHz	81	80
Noise		-114dB
with emphasis		-114dB
Dynamic range		110dB
Output		2V

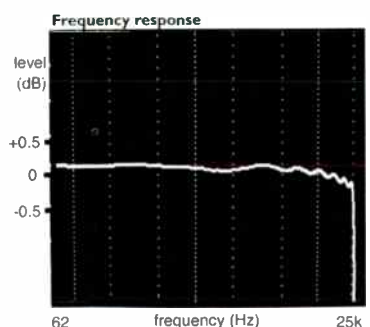
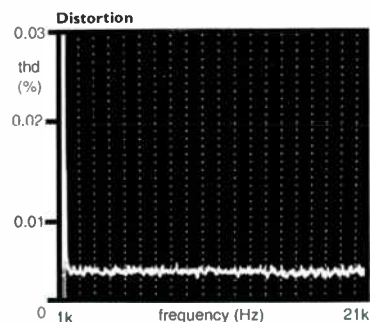

World Verdict



Brimming with facilities, this deck offers great sound per pound, but isn't really the audiophile's choice.

letters & e-mails

Visit our website at www.hi-fiworld.co.uk or send your e-mails to letters@hi-fiworld.co.uk

Every letter we print wins a superb prize including Precious Metals interconnects and a **FREE** subscription to **Hi-Fi World** for the best letter of the month!!

LETTER OF THE MONTH

HEY, BIG SPENDOR!

I have enjoyed my current system for about 10 years now,

but the time is right to update or upgrade it. It comprises an Arcam 170 CD transport plus original Black Box, Naim NAC72 1140 amps and Rega ELA speakers. Room size is 22x14 and my music preferences are classical, jazz and female vocal. My budget is £1,500 at the present time, with additional funds available later. Whilst the Naim is very good I find it dry and uninviting for my taste these days and the ELAs are somewhat compressed. My father in law is also on the upgrade trail with a pair of Epos M15 on order and as a consequence I will be the recipient of a nice pair of Spendor SP2/2s. Should I upgrade the front-end first with a new DAC, or alternatively with a one-box player, upgrading the amplifier later whilst keeping the Spendors? Your guidance would be very much appreciated.

regards

Rod Lamb

Interesting one, this. You've got an impressively well balanced system, with no gaping weak links - credit to you! If anything, I'd say your Rega speakers are holding things back, but the imminent arrival of the Spendors should solve this. They're great speakers, in their way, and to be frank I'm not sure if your father-in-law is making the right move, so best not show him a copy of this mag! You'll find they're a little warm and soft - certainly less 'impressive' sounding than the Eposes - with a very smooth midband that should excel at precisely the sort of music you like, especially jazz and female vocals. Best get them onto good, strong stands as soon as you can.

What then of the rest of your system? The Naims are undoubtedly fine amps, and you might find you get on with them better using your new speakers - the ELAs are also pretty dry and the two together won't exactly let the tonal flavours flood out.

It's tricky to recommend replacements. If you want more

involvement, then upgrading to a better power amp (i.e. NAP250) would certainly do the trick. If you want more grip, then one of Naim's power supply options - or even a new preamp from higher up the range - would help.

For a different sound, try tubes. An easy, one-step solution could be Unison Research's £1,600 S.6. This liquid, velvety sounding parallel single ended integrated would give you a more beguiling, if less powerful, listen.

Another obvious candidate would be a second-hand Michell Argo/Alecto Stereo. This solid state, pure Class A transistor combination would give you much of your Naim combo's power and most of the S.6's tonal colour.

As for your source, do you hang on to what is a very respectable 16bit set up, upgrade it to one of the leading £1,000 machines, or wait until DVD-Audio truly comes on stream later this year? Arcam's new FMJ CD23T would bring greater detail and grip to your traditional silver discs, whilst retaining your old two

ARCAM

Visit www.arcam.co.uk

for Arcam news, product information, technical support and advice on how to get the best from your system

Arcam, Pembroke Avenue, Waterbeach, Cambridge, CB5 9PB, England
Tel: +44 (0) 1223 203203 Fax: +44 (0) 1223 863384
support@arcam.co.uk www.arcam.co.uk

box set-up's beguiling musicality. Meridian's 506.24 would add extra bass weight and depth to the equation, sacrificing just a smidgen of the CD23T's bouncy rhythms. If it were me, I'd go for the Cyrus 7/PSX-R, which isn't quite as warm but offers more punch and attack. Judging by your musical tastes, you'd find that this would partner valve or Class A transistor amplification better, whereas the aforementioned Arcam or Meridian would work better with your Naims. **DP** ■

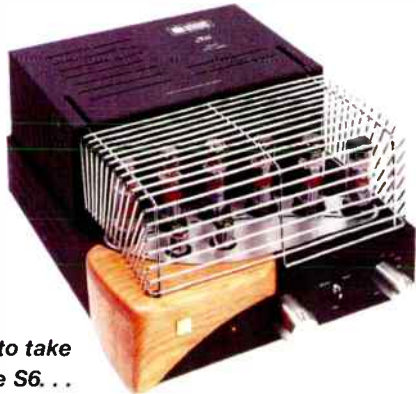

It could be time to take the tube with the S6...

▶ THE VINYL FRONTIER

Please could you give me some advice on the best way to upgrade my turntable? My system comprises a Linn LP12, Lingo, Akito tone arm and Dynavector 20x MC cartridge, Music Fidelity F25 pre-amp and F16 power amp, and Wharfedale E70s (bought in 1977) that I have modified by hard wiring with 1mm solid core cable. I have been thinking of changing the tonearm of the LP12 as I have read that the Akito is not the best tone arm in the world, but buying an Ekos is a bit out of my price range.

Recently I have been reading about the Origin Live RB250 of which there are several versions, the most expensive being the RB250 Silver at £600.00 and the rewired version costing about £300.00. They also supply a DC motor kit which apparently can make a substantial improvement to the sound quality. Should I go for the DC motor upgrade and the £300.00 RB250 or should I just get the RB250 silver and possibly get the DC motor upgrade at a later date when funds allow. Is the £300.00 difference between these two RB250's worth the outlay?

Denis Keating

As Linn's Ivor Tiefenbrun always said, you should always get your source right from the very first link in the

chain. To wit, a DC motor mod will transform your LP12 more than any tonearm - and after hearing the Michell DC upgrade I'm in no doubt about that! So go for this first, and then get a basic RB250 with the counterweight mod. Frankly your E70s aren't the most transparent, and any extra spent on fancy tonearm wiring will be missed on them. Indeed, it's only when you're using modern, £1000-plus loudspeakers that you'll fully hear the difference from this, methinks.

Still, the basic OL RB250 will trounce the Akito, which itself is not a bad arm on an LP12. The OL Silver 250 is a great arm that would make an ideal pick-up in a cost-no-object system, but frankly yours isn't - yet! It's noticeably better than a basic modded OL RB250, but not dramatically so - most of the improvements come in textuality, atmosphere and fine detail, all of which are lost on your E70s, which as you know are hardly the subtlest of loudspeakers! This done, I'd upgrade your DV20 to an Ortofon Kontrapunkt B when funds permit. **DP** ■



The Kontrapunkt B could be the MC for thee!

▶ BREAKING THE MOULD

I've recently dug out some old CDs and noticed what appears to be a mould or crystalline deposit growing on the label side! The CDs most affected are first generation and usually have clear labels. There's a little mould on the playing surfaces of a couple of CDs, but not nearly as much as on the labels. I set to with a little filtered water and a microfibre cloth and everything wiped off quite well. A few of the worst affected still felt a little 'sticky' on the label side and the 'mould' seemed to smear. I also noticed that they seemed to have more pinholes than I remembered - although that could just be pure paranoia! I was wondering if this could be the result of my move from the cold and damp UK to hot and humid Sydney ten years ago or if I'm suffering the first stages of the CD self-destruction that was suggested by the head of Nimbus Records many years ago.

Any thoughts?

Jeff Poole
Sydney

So - in addition to CD's much mentioned 'rusting' problems, along with its penchant for perforations, it looks like there's a serious 'mould' issue now arising for those living in hot climes. Just think - with the number silver discs now in existence, not least all those early pressings with silver label surfaces, and their burgeoning popularity in places with good weather - the world could be sitting on a ticking time bomb of slime. One day, every audiophile in a sub-equatorial region could wake up covered in green fungus, as the little microbe critters crawl off their discs, out of the jewelcases, across the floor and onto the duvet. I'd recommend that you implement the British government's long forgotten plan for saving your life in the event of a Cold War nuclear attack - 'protect and survive'. Paint your CDs white, put a brown paper bag on your head and hide under the table until the fateful day comes.

Seriously Jeff, I would not worry about this. Early CDs had problems but I doubt very much if your whole collection will rot away. Modern discs are quite stable, because accelerated life testing is now used to assess this. **DP** ■



A3 RANGE.

MACHINED, MIL-SPEC ALUMINIUM
FRONT PANEL.

TWENTY-FOUR CARAT GOLD
PLATED FITTINGS.

REMOTE CONTROLLED.

PHONO STAGE.

POWERFUL, ROBUST, BUILT.

MUSICAL FIDELITY

A3 RANGE: INTEGRATED AMPS, PREAMPS, POWER AMPS, TUNER, CD PLAYER AND HOME CINEMA DECODER. FOR DETAILS OF YOUR NEAREST STOCKIST RING 020 8900 2866.

▶▶ NO PICTURE AVAILABLE ▶▶ SYSTEM INTEGRATION

Please help! I am a relative hi fi novice looking at buying a pair of Mordaunt Short MS902 signatures from their Declaration range (approx. £200). They would be wired up to a NAD C350 amp and a Marantz CD6000SE CD player.

I like the look and build but how do they fair overall? I know there is a lot of competition in the budget speaker range so would I be better off going for something else?

Kind regards

Greg

Hi Greg. At £200 for a pair of 'speakers the world is literally your oyster and to be fair the money will get you some better current options than the Mordaunt Shorts. You can first look to Mission's m73s, which have all the traits of a fine budget 'speaker such as bass depth, imaging and speed. Sand loading them will bring even greater audiophile rewards, too. There's also Wharfedale's Diamond 8.3 or KEF's Cresta 3 - these both have a natural fluid nature and a slightly more 'closed in' but musical sound than found with the Missions. Whatever you plump for make sure you get a listen to all that's available and recommended as each contender has its different characteristics. **SP** ■



The Crests 3 is a fluid and musical budget 'speaker

Hello. I am looking to buy a new amplifier with a budget of about £500, to go with a Marantz CD6000K1 Signature and a pair of KEF Concerto 1 loudspeakers.

I like a transparent sound that is kind to vocals. Musical taste is varied so I'm after a jack of all trades. Should I buy new, or look for a second-hand bargain?

Yours in anticipation,

Tim Stevens.

What seems on paper a simple question to answer is in fact a bit of a stinker. Alas, gone are the days of the



The X-A200 could be the answer

saturated integrated amp market. Good all round integrated amps with the audiophile traits that you yearn for, such as transparency are hard to come by new, as many manufacturers of products in this price bracket are

turning to multichannel amps and AV receivers. The obvious choice for transparency is Musical Fidelity. The cheapest integrated from the company is the X-A2 at bang on £500. You won't get any change from your budget but you'll probably get what you're after. There are a couple of other new purchase choices that would fit the bill, such as the Cyrus 5, also at £500 and the Monrio Asty Remote at £550. The former has a good all-round quality and a fine grip on rhythm, whilst the latter has the lyricism of Italian hi-fi but with a bit more drive and clout than usual. **SP** ■

▶▶ A NON-GREY DAY

Hi. My system comprises an Alchemist Kraken Mk2 amp, Eltax Symphony 6.2 speakers and a Marantz CD48 CD player. The CD player isn't as detailed as I would like. I have tried my friend's Arcam CD player (7SE) and it sounds much clearer. The problem is I don't like the look of Arcam kit at all. Could you recommend some CD players in the £300-400 price range which will give me the detail I am looking for. It must be able to perform well with a wide range of music, mainly guitar based, hip-hop, and drum n' bass. Any guidance would be appreciated.

Nicholas Adie

I'm presuming that you're referring to the now defunct Alpha Series when you talk of your aversion to Arcam's aesthetics, as the new DiVA range represents a stylish turn for the company - gone are the workmanlike grey boxes in favour of a range of sleek and smart units available in both black or silver. Fitting your particular bill would be the CD72, a recently re-vamped model which is in a class of its own in the £400 bracket. You'll have all the traits of the

Alpha 7SE sound, such as control and rhythmic attack, along with plenty of detail and insight. If you want something cheaper, the even newer CD62 is available for £100 or so less. It simply lacks the upgrades of the more expensive brother but performance is still fine.

If you don't fancy Arcam at all then there are a few options available. For something completely different and very 'upgradeable' you could have a listen to Sony's SCD-XB670 or 770 multichannel SACD players. These of course will play both two channel SACDs and CDs to a very high standard for the money and a trait of Sony's digital sound is plenty of detail in the upper frequencies. Some find them a bit hard on the ears, though. These are priced around £300 and £400 respectively and whilst not having the sheen, perhaps, of the Arcam styling they are nonetheless smart and modern in a high tech sort of way.

All these will give a better presentation from CD than your Marantz, which while good at the time is not on the pace now. **SP** ■



Arcam's new DiVA range is a long way from the grey boxes of old. . .

►► AND FINALLY. . .

Having spent several thousands of pounds on audio equipment over the years I have had nagging thoughts that maybe the equipment was becoming more important than the music! Two years ago I bought a house in very bad condition so boxed the hi-fi and bought a mini system to use while the building work was being done. Although I found the need to upgrade via a sub woofer my enjoyment of music throughout this period remained, despite the lack of detail of the system. In 2 weeks my

expensive system will be unpacked and back in use and yes I am looking forward to it. But that cheap system taught me a lot about music, and I am relieved that I now know that equipment is less important than the music.

Perhaps readers should try doing the same as an experiment. The outcome may surprise them!

Thanks for a great mag Rob

Although I've always been into the subject, as a trained musician that entered the hi-fi business (as opposed to an electronic engineer) at first I found it incredible how people favoured electronics over music - even though many will ferociously



Kimber
Sole UK Distributor
for Kimber Kable

Cable confusion?



What you need is our new Catalogue...
'Your Guide to buying Hi-Fi & Home Cinema cables and accessories'.
You will find lots of hints and tips, useful information, and a selection of products that we guarantee will make your system sound better - or your money back.



Call NOW for your FREE catalogue:

UK FREEPHONE 0800 373467
quoting ref: AH42

Russ Andrews Accessories Ltd.
Windermere Rd, Staveley, Kendal, Cumbria LA8 9PL.
E-mail: AH42@russandrews.com
www.russandrews.com

FREE UK Delivery • FREE Booklets • 30 Day Home Trial • Cable Upgrade Scheme

deny it. I once knew a highly experienced audio engineer who after listening to many hundreds of thousands of pounds worth of equipment every working day listened to his music on a (beautifully kept) prehistoric mono radiogram! On asking him why, he proceeded to plough through his equally prehistoric 7" vinyl singles and EPs and said "that's how it should be". And I couldn't have agreed more. After many years of listening to the best stuff on the planet I'm looking forward in my retirement to seriously 'downgrading' and letting the notes speak for themselves. **SP**
 P.S. Glad you like the mag, even though it's about hi-fi!

back is the choice of soundcard and audio software. Most of the information available relates to use by musicians for creating music. I am keen to record from vinyl and process to remove noise etc, as well as make timed recording from radio and from CD. I would like to use the computer as a (main?) source for listening, as well as being able to record CDs and MD for use on the move.

It seems sensible to go for a system with 24/96 capability and with analogue in/out as well as optical/electrical digital in/out. I don't need lots of I/O channels and I don't need sound synthesis or MIDI but I am happy with the idea of a breakout box. Do you have any recommendations regarding such soundcards and suitable software? It

not yet really been able to establish the cards that are right for the job.

Alan Haskell
Fleet, Hampshire

Until recently, there were few - if any - realistically priced soundcards that offer full 24/96 functionality. Help is at hand though thanks to the just released TerraTec EWS96M (www.terrateg.net/ttuk). This is an 'affordable' card (price yet to be finalised at the time of writing) that majors on high quality audio processing. It has a 24/96 A-D onboard, offering a quoted 117dB S/N, and a 24/96 DAC with a quoted 120dB S/N. You also get full 24/96 digital ins and outs (also capable of 16/44, etc.) and full MIDI. Look out for a review of this next month. Suffice to say its EWS88T predecessor got a big thumbs up when CAW tested it a couple of years back.

As for software, I'd personally go for Syntrillium's Cool Edit 2000, which is a brilliant value package offering recording quality up to 32bit resolution, along with a very handy dither facility to bolster your plain old 16-bit recordings. The best value version is Cool Edit 2000 v1.1, available for \$69 via a download from the company's website (www.syntrillium.com) - there's even a freeware version to play with for 30 days if you wish. Good luck!

DP



Now that's what I call hi-fi!

COMPUTER WORLD

I have been reading your magazine for about 6 years now and it has slowly but surely influenced my approach to audio. Last year you published a two-part article on building an audio computer. This set me thinking and I am quite keen to do this. In particular, I am interested in going all the way and having an audio computer as a central part of my hi-fi system. Clearly, this means that it has to have good sound quality, be seen and not heard and have full facilities for the 21st century audiophile!

I mostly listen to vinyl on a Garrard 401 with a Goldring 1042 and a DIY Phono amp. This all seems to perform very well through my WAD KLS3 speakers. The thing that is holding me



seems that £200 to £300 would be the right price bracket for a card but I have

Editing made Cool!

I AM THE

JPW's Sonata was one of the kings of the mini loudspeaker brigade back in the late eighties, so they have plenty of experience in the field. Dominic Todd encounters the new 210 baby bookshelf design from the re-launched company.



JPW are no stranger to the art of giant-slaying mini 'speakers. During the late eighties their Sonata won countless awards and sold by the bucket load, no doubt going a fair way to explaining their Queen's Award for export in the early nineties. The JPW Mini Monitor carried on this tradition and can still be found in digs, halls of residence and first time homes up and down the country.

Things all seemed to go a little pear shaped in 1997, though, with the launch of their Millennium Series. It wasn't that the ML310 and ML510 were poor 'speakers, far from it in fact. They simply didn't sell as well as their forebears. Now JPW have returned to steal back some of their lost market. Not that they'll find it at all easy. At £150, the new 210s find themselves priced against some serious opposition. Wharfedale's Diamond 8.1 and Mission's M71 both

undercut the newcomer by at least £20, and at the same price you could have Mordaunt Short's hi-tech 902.

Visually the 'speaker sends mixed messages. It's very compact, smaller than even the baby Missions, suggesting that bass might be limited. Yet the narrow, tapered front panel should be good for imaging. The soft dome tweeter and carbon weave woofer are pretty much de rigueur these days, but the snap on metal grill came as something of a nasty surprise and should really be left off.

Surprisingly, the 210s are not bi-wirable which is unusual when compared with the current competition. This shouldn't be a cause for concern as bi-wiring makes little difference at this level and bi-amping, which makes a considerable difference, would be unlikely at this price point.

On listening to the JPWs, their sound quality very much lived up to

what I'd expected. Claire Martin's 'Some Cats' was mostly an enjoyable listen. The timing was excellent, with detailed percussion and a spacious soundstage all helping to give the illusion of "invisible 'speakers". As expected, bass was rather lightweight. It had fine integrity with the lower mid-range, yet couldn't quite match that of the rival Mission and Wharfedale 'speakers. This also appeared to have a knock on effect in other aspects. Although the piano's timbre was generally good it could, on occasion, lack substance. Likewise, whilst Martin's vocals were well projected, they occasionally sounded slightly 'pinched'.

Steely Dan's 'Janie Runaway' proved surprisingly dynamic for one so small. Although it's a top-notch recording, the 210s did impress with their ability to keep a tight grip on the pace. Anyone used to ponderous floorstanders would be amazed as to

RESURRECTION

just how much slop appears to have been removed from the music. In short, the 210s have musical agility beyond their humble price. Furthermore, there was fine texture present from the vocals. It's a cliché to say, but one could quite easily follow the breaths of the singers throughout. The brass section was suitably vibrant, yet the solo sax again sounded a little thin. The projection into the room couldn't be faulted however.

Perhaps it was unfair of me to play Mission Control's 'The Last Trumpet'. This has a near sub sonic bass line that the 210s, unsurprisingly, merely hinted at. Again, slightly larger rivals are slightly more adept here. That having been said, the rest of the performance was thoroughly enjoyable. Trumpet and vocals were both well separated, and the piece had terrific drive and rhythm. Best of all was that this sense of bounce and enthusiasm was matched by a fine level of refinement. The treble response, in particular, managed to draw the fine line between detail and harshness immaculately.

Such traits were carried through to the portrayal of classical music to

The March (Seventeen Come Sunday) from Vaughan Williams's English Folk Song Suite, provided another enjoyable listen. Although the piece did lack scale, it always sounded eager and involving. Once again, the balance between excitement and refinement was spot on. The timing proved fluid and the instrumental timbre engaging. The only real fly in the ointment here was a slight boxiness that set in during more complex passages, a trait I feel is inherent from such a small cabinet design.

The JPW 210s aren't going to suit everybody. Looked at rationally they can't quite compete with either the Mission M71 or Wharfedale Diamond 8.1s. They just lack a sense of scale with classical music and sheer bass response with pop. At £150 I also can't help but feel that they are also a touch on the expensive side. However, despite these reservations, the 210s really do have much to offer. They have an immediacy, and fleet of foot response that could be just the tonic for a rather tired and dull system. Soundstaging is also first class thanks to the cabinets being so narrow. With

this also comes with an apparently seamless frequency response, fine timbral reproduction and excellent timing. These are all the type of qualities that get your toe tapping. Yet these qualities, perhaps surprisingly, don't come at the expense of refinement. The higher frequencies always remained smooth, and I didn't find myself wincing as volume levels were raised.

The 210s have to be one of the smallest full range 'speakers available. If you have to have to something minuscule, look here first. If not, then you'll probably prefer a few of the rivals, but take a listen anyway. Its range of qualities could just surprise you. ■ ▲

JPW 210 £150

Audio Group International
Holland Road
Language
Science Park
Plymouth
Devon
PL7 5HJ
Tel: 01752 333800

MEASURED PERFORMANCE

Small loudspeakers can measure surprisingly well. Good dispersion around a small cabinet and excellent integration between drivers, because small bass cones deliver high frequencies better than bigger cones, conspire to give a smooth frequency response if all else is engineered well. JPW's 201 is a good enough example of this, having an unusually smooth response curve. It isn't perfect, in this case treble lift meaning the speaker will sound a little bright. And the small bass unit rolls off fairly early too, output falling steadily below 100Hz. The port peaks at 63Hz and produces useful output at 40Hz so

there should be some lower bass too, but small loudspeakers rarely have real bass weight.

Sensitivity measured 85.5dB, quite a reasonable value considering the JPW's small size. To achieve this it uses a 4ohm bass unit, which draws current. Further up the audio band impedance rises smoothly, giving the 'speaker an overall value of 6 ohms. It is a reasonable load by today's standards.

The small 201 is a tidy piece of engineering. It will, however, have a light, bright sound that may be a little too much for some. **NK**

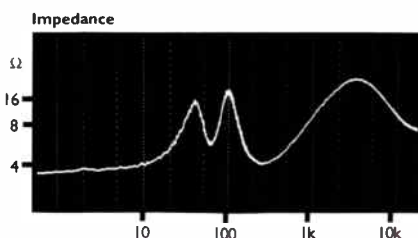
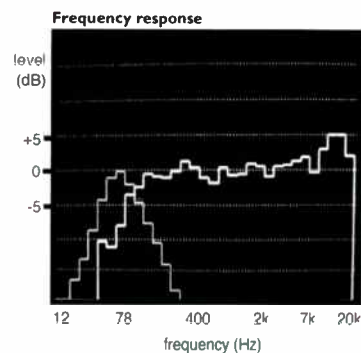

World Verdict



A fine little 'speaker with plenty of bite and rhythm. Not quite as accomplished as the best cheaper competition, however. If size matters, though, they could be for you.

MANLY



Dominic Todd listens to Marantz's latest midprice integrated amplifier, the stylish PM8200. Will it match their reputed CD players for quality?

This is one amp I'd been rather sceptical of. In the past I've always found budget Marantz amps to be, at best, rather average. Their KI range and valve specials are something else, but below £400 the range is somewhat lacklustre. The new PM8200 lies above this category, at £599 putting it up against the likes of Cyrus, Exposure and Audio Analogue.

The new PM8200 seeks to address this aforementioned lack lustre-ness with the promise that "power isn't everything". Even so, at 60W per channel the Marantz is hardly a lightweight, and the copper chassis, toroidal power supply transformer, high current capacitors, shielded binding posts and generally solid build quality make for a decent starting block. The star-framed blue LED has also been a signature of higher grade Marantz products in the past. Yet this is no minimalist design. The remote control, twin tape loops, pre outs and moving magnet phono stage are all well and good, but the loudness control rather undermines the "audiophile" pretensions.

I set the Marantz up using one of their own CD6000OSE CD players and a pair of Mission 773e speakers. The overall impression with Space's 'The Unluckiest Man in the World' was one of a rather bright and aggressive balance. The vocals were very well projected, yet otherwise

the staging I found only average. 'Fran in Japan' from the same group suited the amp far better. There was good detail, even during more complex sections and a strong, powerful bass. In fact, the bass was almost too strident at times, and would require care with partnering speakers. Ponderous floorstanders could find themselves rather overwhelmed.

As with the previous track, although the performance wasn't too bad technically, I found it hard to really engage with the music. It was all rather mechanical, as though fluidity had been sacrificed to dynamic contrasts.

Dido's 'Thankyou' didn't really improve matters. There appeared to be an odd coloration in the upper bass response that led to a rather turgid and boxy bottom end. Vocals sounded a little nasal, and there was something forced about the whole performance. The piano timbre sounded rather strange too. There was a lack of solidity to the timbre that I've heard before from some Marantz CD players. Once again, the song didn't ebb and flow as it should, despite the strong bass response to drive the track along.

Vaughan Williams's *In the Fen Country*, with Sir Adrian Boult conducting the New Philharmonia Orchestra, proved an equally mixed bag. The orchestral soloists lacked a certain body to their individual

performances. The Marantz gave them enough presence, but robbed them of subtle details such as reedy textures, breaths and bow strokes. In short, the instrumental timbre had been de-personalised and sounded somewhat synthetic.

On a brighter note, at least there was decent scale when the double bass entered the fray, and the separation was fine too. It was quite possible, as the old trick goes, to follow individual instruments. Yet, you might not actually be inclined to follow the instruments in the first place, as the sound just didn't really gel.

By now you've probably got a good idea of the Marantz's sonics. Sadly, Jamiroquai's 'Blow Your Mind' did little to alter my impression of the PM8200 as a curiously soulless amp'. Again, there appeared to be a lumpiness to the sound that simply didn't get my foot tapping, even with the funkiest of tunes. At least the brass section had a bit of pizzazz about it, but it simply served to show just how blandly portrayed the rest of the mix was. A quick try out of the phono stage with Bob Marley's 'Exodus' found the Marantz in slightly better shape, with good detail. Some of the inherent smoothness in the recording was overlooked in favour of projection, which was a shame as the bass was decent and, again, the brass had some life.

MARANTZ



I have to say the PM8200 came as something of a disappointment, after a promising start. Build quality was excellent and, loudness control apart, there's a well-chosen and comprehensive selection of features. Yet the sound quality lets it down.

During the listening test I couldn't help but feel that I was listening to a car stereo. There was the sort of power and presence that

you'd expect to drown out all the road noise and impress pedestrians four streets away.

As a party animal, the Marantz performs. No one could argue with its bass clout or powerful dynamic range. Yet, when the party's over and the wick's turned down, it loses its appeal. Although vocals are well projected, the rest of the staging is only average. There's often some

rather odd colorations going on that could effect both vocals and piano. Although brass often sparkled, other instruments suffered from a rather mechanical, "grey" presentation. Finally, and most disappointingly of all, is the timing, which simply fails to get the listener involved, whatever the music genre.

I could see how the PM8200 could fit the bill for some as it has plenty of clout and presence. If it was my money, however, I'd wait for a KI version which, if experience is anything to go by, would be a far more appealing proposition - for me at least. ■ ▲

Marantz PM8200 £599

Marantz Hi-Fi UK Ltd.
Kingsbridge House
Padbury Oaks
575-583 Bath Road
Longford
Middlesex UB7 0EH
Tel: 01753 680868

MEASURED PERFORMANCE

The sturdy Marantz 8200 amplifier felt like a real power house, but in fact delivers a useful but not massive 66W into a normal 8ohm load. In practice most loudspeakers nowadays have 4ohm bass units and into this sort of load it delivered a healthy 100W, showing the power supply has good regulation.

Distortion was minimal right across the audio band, at all power outputs, low or high. Our distortion analysis has just two small blips along the bottom axis, indicating the presence of a little second and third harmonic.

I was not surprised to measure an SACD/DVD-A ready bandwidth that reached up flat to 91kHz, before rolling down gently. At the other end of the audio spectrum this amplifier reaches down to the lower limit of CD, around 5Hz. With good sensitivity and channel separation the

unit measures tidily in all areas.

A phono stage has been included and it offers a conventional set of figures appropriate for Moving Magnet cartridges, namely 3.3mV input sensitivity with a healthy 116mV overload ceiling. There was dead accurate RIAA equalisation, but with no IEC warp filter at 40Hz, so whilst the response goes low and bass from LP will be strong, warped records will cause cone flap. Hiss was satisfactorily low to be about inaudible.

The 8200 measured very well in all areas, as expected. It is a well screwed together sturdy design obviously intended to offer quality.

NK

Power 66watts
CD/tuner/aux.
Frequency response 6Hz-91kHz

Separation	82dB
Noise	-94dB
Distortion	0.005%
Sensitivity	240mV
dc offset	1/1.2mV

Disc	
Frequency response	10Hz-68kHz
Separation	70dB
Noise	-64dB
Distortion	0.006%
Sensitivity	3.3mV
Overload	116mV

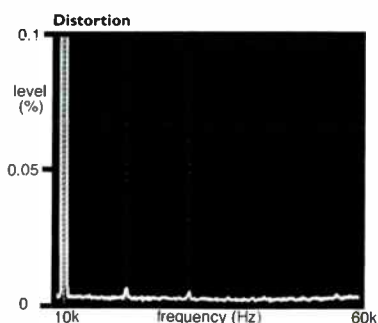

World Verdict



Plenty of clout and projection but has a strangely soulless appeal and some odd coloration.



freedom of choice in Glasgow and Edinburgh

LOUD & CLEAR @ THE MILL NOW OPEN FROM WEDNESDAY – SATURDAY 10.00am – 6.00pm

AVI • Crimson • Chord Co. • Denon • DNM • Epos • JM Lab • Kef • Kef Reference • Krell • Living Voice • Marantz
 Martin Logan • Michell • Monitor Audio • Moon Electronics • Musical Fidelity • NAD • Naim Audio • Nakamichi • Nordost
 Primare • PMC • ProAc • Rega • Rel • Roksan • Ruark • Seleo • Sonus Faber • Tag McLaren • Tannoy • Transparent
 Van den Hul • Velodyne, etc

- Eight dedicated demonstration rooms across three stores
- Home theatre specialists
- Multi room audio and video
- Delivery and installation
- Turntable service and set up
- Full service and repair facilities
- Range of credit terms
- Tuesday – Saturday 10am – 6pm



Loud & Clear

HI-FI AND HOME CINEMA

www.loud-clear.co.uk

520 St Vincent Street, Finnieston, Glasgow G3 8XZ 0141 221 0221 26 Hamilton Place, Stockbridge, Edinburgh EH3 5AU 0131 226 6500
 Loud & Clear @ The Mill, 72 Newhaven Road, Leith, Edinburgh EH6 5QG 0131 555 3963

Second hand and ex-dem items:

Naim SBL loudspeakers piano black (mint)	£1599	Musical Fidelity HTP200 A/V proc.	£999	Meridian 206 CD Player	£395
Naim NAT101 with SNAPS	£500	Musical Fidelity A3 CD	£599	Kef Reference 2.2 rosenut	£1250
Dynaudio Audience 60s black (mint)	£399	Audio Research LS9 pre-amp	£1300	Rel Storm III (black ash)	£450

To view our full range of second hand, ex-dem and trade-in items, please check www.loud-clear.co.uk/offers

EURO STAR

ELAC isn't a familiar name to British audiophiles, but David Price thinks it should be, if its new 510 standmounting loudspeakers are anything to go by.



ELAC Electroacoustic was born on September 1st, 1926. Initially specialising in the research and development of nautical equipment, it wasn't until 1948 that its first turntable was produced. This sold until 1980, with over 4.5 million units made! Elac patented the electromagnetic cartridge in 1957, and has come up with a good deal of clever technology since - some of which is used in these very loudspeakers.

Rather than being a box stuffer, ELAC designs and manufactures all its own drive units in its Kiel factory in Germany. Currently employing 70 people in an 8,000 square metre manufacturing facility, it produces 100,000 loudspeakers a year. Thirty percent of these go abroad - mostly to Taiwan and China, and now - hopefully - to Britain too. I say hopefully, because - at the risk of starting my review with the conclusion - I really rate these speakers. Being a jaded old cynic, many boxes pass through my clutches every year, but few impress like these did.

The build quality speaks for itself

- the cabinets are beautifully veneered, and at 9.9kg a piece, you'd think they were made of gold. Rap one with your knuckles, and you get a dull thud - no flimsy MDF affairs, these. At 385x200x307mm, they're good old fashioned 'bookshelf' designs - to wit, they found themselves perched atop a pair of Atacama SE20s, which they complimented perfectly. A two-way 24.6 litre bass reflex design, round the back you'll find a smallish bass port above a particularly chunky set of four gold plated binding posts (complete with bi-wire jumpers, if you need them).

More interesting though is the sight you see if you pull the front grilles off - there's a sea of space age silver, the like of which I haven't seen since the last episode of Dr Who and The Return of The Cybermen. The 'Jet Tweeter' looks bonkers enough, but ELAC claims real benefits from its novel construction. The membrane area of this tweeter is said to be approximately 10 times larger than that of a conventional 25mm dome tweeter. Along with the special lamella type foil membrane and

strong neodymium rod magnetic system, this is said to give very high efficiency and dynamic range. They're also said to offer excellent extension - to 35kHz no less, which should come in handy with all these new DVD Audio players! The 180mm mid/bass unit is another novel looking affair employing an aluminium sandwich membrane, running from a claimed 32Hz up to 2.8kHz. Thanks to the extended low bass and smallish cabinets, don't expect these babies to go louder than a pair of Tannoy Westminster Royals per Watt. At a published 85dB sensitivity and a nominal impedance of just 4ohms, they don't make obvious partners for tube amps. However, I found my modified World Audio K5881 had little trouble with them, and sounded a lot cleaner than the big transistor integrated I kicked off the listening session with. In fact, their bright balance means you've got to use the best front-end and amp you can find - they don't suffer fools gladly. Oh, and best keep the grilles on, for both sonic and aesthetic reasons!

Essentially, the ELACs sound as bright as their drivers look - they're

EXPERIENCE THE CHORD EFFECT!

The first time you hear your sound system with Chord interconnecting cables will be the first time you've **really heard** it. Be warned - the effect can be shattering. Your eyes and ears will be opened. Your music will never sound the same again. Specify Chord cables - Hear the light!

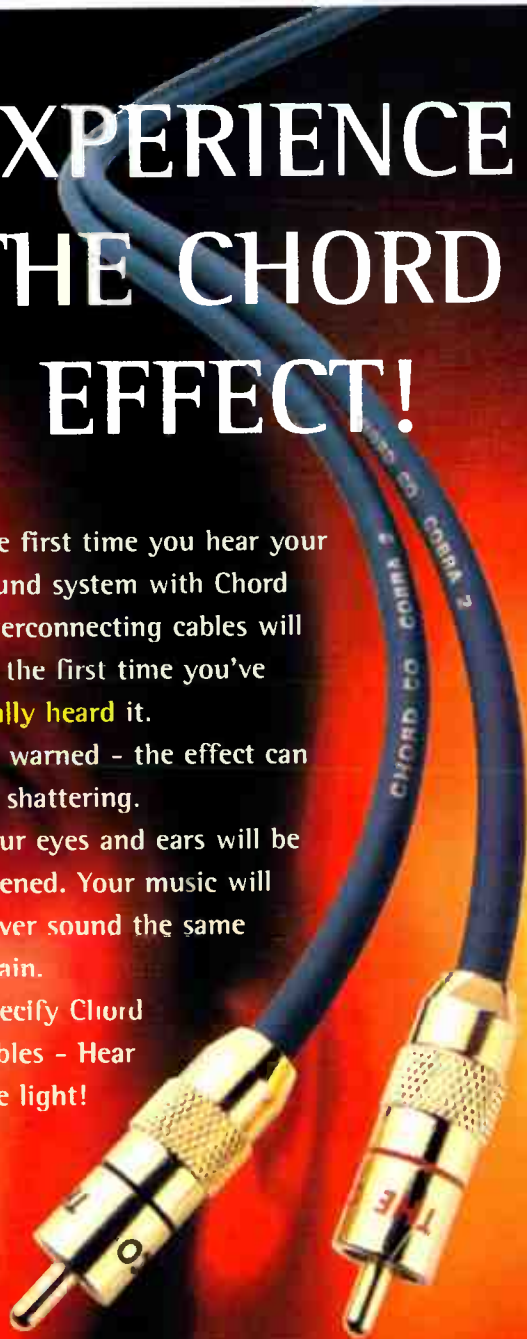

FOR SALES AND INFORMATION
CALL: 01722 331674 FAX: 01722 411388
E-MAIL: CHORD@CHORD.CO.UK
OR VISIT US AT WWW.CHORD.CO.UK

New - two landmark digital players: one playing SACD and CD at the highest level, the other bringing more affordable high quality CD replay.

Stunning

CD Players

When US WADIA and British dCS - world leaders in the fiendishly complex field of digital replay - bring out new models it's time to take a close look.

The WADIA 301 is a new design, using "trickle-down" technologies from their awesome POWER DAC digital amplifier and the top 271x DAC. Wadia shun off-the-shelf chips but use instead their famous UPGRADEABLE Digimaster software to extract the maximum musical information from the CD.

The 301 controls volume in the digital domain and its powerful output will drive amplifiers directly - no preamp - with large gains in DETAIL and AMBIENCE. With the optional 4-Input board the 301 becomes the centre of a DIGITAL SYSTEM, decoding signals up to 96kHz, eg from DAB radio.

The dCS VERDI plays SACD, CD and CD-R, all at the highest level, with a DUAL LASER mechanism which gives fast track access. Great care has been taken to avoid the "digital sound" of JITTER with a high precision clock and a "slave" link to dCS Elgar or Delius DACs.

All dCS products are now simply UPDATED from a dCS CD played in your own transport. These players are MAJOR advances.

Customers say we make some of the BEST SOUNDS they have ever heard, so you know we can do the same in your home. Our advice will take account of your best components and guide you where change is needed, in stages you can afford. You AVOID EXPENSIVE MISTAKES, enjoy music along the way and save money in the long run.

JUST LISTEN AND YOU'LL KNOW

CD: ACCUPHASE, ADVANTAGE, AUDIO SYNTHESIS, BAT, dCS (ELGAR, DELIUS PURCELL, GRIEG, VERDI) MERACUS, PASS, SAT, SUGDEN, WADIA. **VINYL:** BASIS, CLEARAUDIO, CROWN JEWEL, DNM, GRAHAM, THE GROOVE, LEHMANN, MICHELL, SUMIKO BLUE POINT SPECIAL, TRANSGURATION. **AMPLIFIERS:** ACCUPHASE, ADVANTAGE, BALANCED AUDIO TECHNOLOGY, CAT, DNM, GAMUT, HOWLAND, NAGRA, SAT, SONNETTER, SUGDEN. **LOUDSPEAKERS:** AUDIO PHYSIC, AUDIOSTATIC, BKS, ETHOS, LUMLEY, NEAT, TOTEM, VERITY AUDIO. **TUNERS:** ACCUPHASE, MAGNUM DYNALAB. **CABLES:** ARGENTO, CHORD CO., DNM, HOWLAND, NORDOST SILTECH, SPECTRAL, YAMAMURA CHURCHILL ETC. **SUPPORTS:** ARCICI, KINABALU, STANDS UNIQUE

The Right Note

More in the future

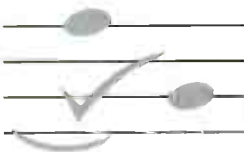

BATH

01225 874728

▶ very upfront and open, but most emphatically not harsh. No, they only sound coarse if you feed them with something rather crass. Properly aspirated - especially using vinyl front ends - they're like a sharp intake of crisp autumn air. Starting with John Lennon's '(Just Like) Starting Over', the 510s caught the recording's crisp balance brilliantly.



They sounded amazingly vivid and dynamic - snare drums were unusually tight for a bass reflex design, while hi-hat cymbals were deliciously sweet and sonorous. You can really hear that extended high end - there's bags of ambience and a real sense of being there.

The midband integrates nicely with the treble - it too is quite 'out there' for all to hear. Certainly not recessed, these speakers image forward and really kick out dynamic accents. Madonna's 'Holiday' is an ideal torture track for any system - her voice is naturally quite hard and cold, and the Sony PCM-F1 digital recorder used in the studio (not to mention those very early digital synths) doesn't make life any easier. The 510s were well able to stay smooth as Ms. Ciccone's voice ran up and down the scale, showing no integration problems and surprising

smoothness. By contrast, the fizzy electronic percussion (probably 8bit samples, but they sound like 4!) sounded suitably crunchy - the point being that these ELACs are incredibly transparent - if the music's hard then so are they, if not then they aren't either. Impressive.

Moving to Lee Morgan's 'The Rajah' - a sweet sixties BlueNote jazz recording - the 510s duly obliged with a deliciously subtle and detailed sound. Again, the cymbals had a fantastically airy, metallic clang, the brass a deep, satisfying rasp and double bass a decent degree of body. Ironically, because these ELACs are so adept at mid and upper frequencies, the lows are a bit of a disappointment - being merely 'good'. Tight, supple, bouncy and rhythmic, the bass units do their job perfectly well - and there's a refreshing lack of

overhang from the cabinets and no obvious signs of the ports puffing either - it's just, well, they're nothing special. Imaging was superb - instruments jump out of the mix with heady abandon, the whole recorded acoustic sounding amazingly spacious and uninhibited, with pinpoint precision within.

I really rate these speakers - they're a genuinely mature and well rounded product, designed for people who appreciate strength in depth rather than just a quick fix of 'boom and tizz'. Fast, punchy, musical, rhythmically engaging, dynamic, transparent, detailed - they get all the essentials so right you almost wonder why it's worth buying anything bigger. The answer is, of course, bass extension. Suitably set up with a decent sub, I imagine these ELACs would be absolute dynamite.

Elac 510 £1000

Sennheiser UK Ltd.
3 Century Point
Halifax Road
High Wycombe, Bucks
HP12 3SL
Tel: 01494 551551

MEASURED PERFORMANCE

Elac loudspeakers always measure well and the 510 was no different. Its ribbon tweeter is superbly integrated, giving the loudspeaker an impressively smooth response with just a slight downward trend toward high frequencies. This will give the 510 a clean sound with good treble but should ensure there's no brightness or glassiness. The absence of a crossover suckout will ensure good delivery of detail. The wide dispersion of this tweeter means quite a lot of treble energy is put into a room.

Bass output rolls down slowly then peaks up at 40Hz. The port works just below this frequency, peaking at 35Hz. This peculiar characteristic suggests the 'speaker

will sound bass light generally, but will deliver occasional deep lows.

Sensitivity measured a healthy 86dB, so the 510 will appear relatively loud for any volume setting. However, to help achieve this it uses a low impedance bass unit that gets down to 3.4ohms - a very low figure. The 510 draws quite a lot of current and although it has a reasonably even impedance characteristic it will benefit from being used with a beefy amplifier.

In every area the 510 has been very well engineered. In some areas it is exceptional. Used with a good amplifier of at least 60W it will likely give superb results. **NK**

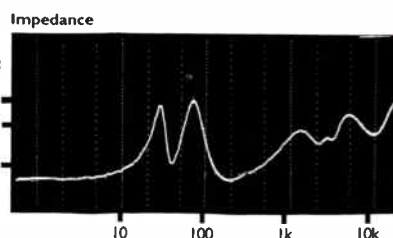
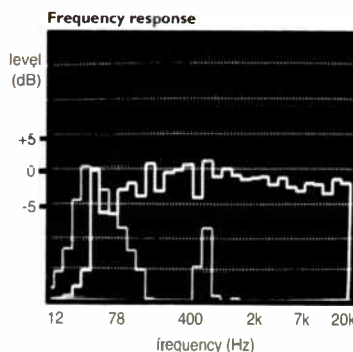

World Verdict



Tremendously capable standmounters with a fantastically musical, open and transparent sound - but high quality ancillaries are a must.



SOUNDS



PERFECTION



**SPECIALIST IN ANALOGUE AND DIGITAL
WE STOCK**

J.M.LABS * LEXICON * PARASOUND PRIMARE * PROJECT * TRIANGLE
REL SUBWOOFERS * VIENNA ACOUSTICS AVID * PROJECT * SME *
ROKSAN STRAIGHT WIRE * MICHELL * ACOUSTIC DESIGN *
AUDIONOTE * MONITOR AUDIO * BOSTON * SUGDEN * AUDIO
ANALOGUE * GRAFF * PHILOSOPHY CABLES

**PLUS MANY OTHER TOP BRANDS
NORDOST VALHALLA CABLES**

AUDIONOTE M3 PHONO EX CON MILITARY SPEC VALVES	£2295
SUGDEN MASTERCLASS POWER AMP BOXED MINT	£1795
AUDIONOTE QUEST MONOBLOCKS EX-DEM	£1895
PARASOUND DAC 2000 (JOHN CURL SPECIAL) ONLY	£995
VIENNA ACOUSTIC MOZART SPKS ROSENUT BOXED	£1095
AUDIONOTE OTO SE PHONO MINT BOXED	£1095
J.M.LABS ELECTRA 90S SPEAKERS BLACK SUPERB AT	£795
AUDIONOTE PI SE POWER AMP BOXED	£695
CHORD SPM 600 POWER AMPLIFIER	£1095
TRIANGLE ZEPHYRS XS BOXED SLIGHT MARK	£425
VIENNA ACOUSTICS HADYNS BOXED MINT	£475
PRIMARE A 20 AMP BOXED MINT	£395
PARASOUND CD-P 1000 CD PLAYER	£295
ARCAYDIS BABY 2 NEW BOXED £400 NOW ONLY	£295
PASS LABS ALPHI 3 POWER AMPLIFIER MINT	£1395
AUDIONOTE ANIJ SPX BLACK EX CON. NOT BOXED HENCE	£795
ELEMENTAL AUDIO REF SPEAKER STANDS BARGIN AT	£795
MERIDIAN M60C ACTIVE CENTRE SPEAKER BOXED	£795
B&W CDM 7 SPEAKERS	£525
PIONEER 50 INCH SDT 5000 REAR SCREEN PROJECTION TV	£975
B&W DS6 THX SURROUND SPEAKERS	£275
REL STRATA III ROSENUT FINISH	£495
PARASOUND HC/A 1200 II POWER AMPLIFIER	£449
MERIDIAN 55S POWER AMPLIFIER	£495
LEXICON MC 1 PROCESSOR MINT BOXED	£2995
LEXICON DC 1 LEVEL 4 SOFTWARE BOXED	£1495
ELECTROCOMPANIE 4.6 PRE-AMP BOXED	£775
BOSTON ACOUSTIC 10X SATS SET OF 4 MINT BOXED	£795
AUDIONOTE CD 3 PLAYER BOXED	£775
AUDIONOTE ZERO PRE & MONOBLOCKS MINT BOX	£795
ALCHEMIST 2 24BIT CD PLAYER BOXED	£595

FOR FRIENDLY SERVICE CALL NIGEL

01326 221372

MOBILE:- 07798 554357

Email :- nigel@soundsp perfection.co.uk

kathryn@soundsp perfection.co.uk

Web :- www.soundsp perfection.co.uk

campaign audio design

Hi-Fi Cables Manufacturer and Supplier

"Love Hertz"



Getting a better, more involving sound often means spending a lot of hard earned money. It's such a waste, because every system can benefit from our cables and accessories, at a fraction of the cost of some new "black box". Here are some of the ways we can help.

We have Linear Crystal Oxygen Free Copper interconnects (£12.48) up to High Purity Silver balanced cables (£99.00) and high definition

loudspeaker cables in Silver Plated Copper or Pure Silver. Our mains cables add weight, power and scale, and with non-inductive RF filtering (£10.00) and over-voltage protection (£3.00) enhance performance still further. Gold plated AV cables, both RF (£19.95) and OFC Scart with PTFE insulation (£30.19), help bring picture quality in line with NICAM sound resolution.

We also have a cure for your noisy fridge or central heating motor (£3.50), enabling you to throw away your big mains noise suppressor, which has been giving you that "sat upon sound" for years. There's lots we can do to bring you closer to the emotion and energy of the performance. So confident are we, that we offer a 21 day money back guarantee.

Ring or write for details:-

CAMPAIGN AUDIO DESIGN

Ty-Mawr Road (HW)

Cardiff CF3 3BS

Tel:- 02920 779401

Website: <http://business.virgin.net/cad.cables/>



Trade and International Enquiries Welcome.



definitive audio

Living Voice * Lowther * Vitavox * Electrofluidics * Art Audio * Border Patrol Canary * DNM * Sugden * Wavac * Lyra * Monarchy * Western Electric * EMT Wadia * Michell * Stax * Tom Evans * Nott'm Analogue * SME * Van den Hul

Part exchanged and ex-dem clearance.

Sale New

Digital

Sugden Masterclass CD - new - boxed	£1800	£2500
Wadia 860x - ex dem - boxed	£5200	£7950

Analogue

Nottingham Analogue 'The Fool' - 12" carbon fibre tonearm - it's new and it's long	£500	£1100
Nottingham Analogue Spacedeck - 'NEW'	£650	£750
Helius Cyalene	£350	£1350

Loudspeakers

Living Voice Auditorium - walnut.	£1150	£1500
Cadence DS - rosewood - giveaway @	£600	£1750
Goya Madonna and Child - immaculate.	priceless	
Klipsh LaScala - black - zippy 105db/walthorn.	£1450	£3500
Living Voice Avatar OBX Dark rosewood - ex-dem/ex-review.	£3200	£4000
Audio Note ANSP speaker cable - various lengths.	£POA	

Amplifiers

Border Patrol 300B SE - with new Western Electric valves - light oak - the best SE available - New - excess stock.	£4000	£4500
Art Audio VPS - valve line pre-amp.	£450	£1400
Art Audio Diavolo - with 320B valves - chrome + gold - line integrated - juicy. Go on, be a devil.	£2900	£4500
Art Audio Concerto - 40w line integrated - black + chrome. ▼	£1250	£2650
Art Audio Concerto - 40w power amp. ▶ giveaways ▶	£1150	£2250
Joule Electra - 2 box phono pre-amp. It's a gem.	£800	£2000
Linn Classic - CD, amp, tuner, thingy.	£400	£1000
Cary '2A3' - 7 watt PSE power amp 1992	£850	-
Cary 5500 - line pre-amp 1992	£490	-
Unison Mystery One pre-amp - it's a mystery	£750	£1750
Tube Technology MAC - phono pre-amp - fully refurbished by manufacturer - including Hovland film and foil capacitors.	£900	£1400
Audio Innovations S 500 integrated (+ phono) - 25w Class A	£550	-
Audio Innovations S. 700 line integrated - 25w class A	£650	-
Western Electric 300B Valves! New matched pairs in stock.	£600	

Tel 0115 973 3222 Fax 0115 973 3666
internet: www.definitiveaudio.co.uk email: shout@definitiveaudio.co.uk



RECALLING REGA

David Price tells the Rega story, and interviews its chief designer Terry Bateman.

Our story starts with a fourteen year old Roy Gandy not getting his way. His mother famously asked him whether he wanted a record player or a TV, and despite begging for the former, got the latter. This - for all we know - could have started the hunger that got him into hi-fi. By his eighteenth year, young Roy had fashioned his first pair of loudspeakers, was listening to LPs and constantly going to concerts.

His first system a-proper was a 'make do and mend affair', based on a Colaro turntable (sourced from a rubbish dump and heavily modded). This soon gave way to the ubiquitous Connoisseur turntable, which formed the base of his system which was to be featured in Hi-Fi Sound magazine's reader's system spot. The reviewer was reportedly surprised at the quality of the sound, and put it down to Roy's vast home made concrete cabineted loudspeakers. At the time, no one realised that it was the source, and not the speakers, in a system which was the primary influence on sound. We pray for them in their darkness!

In time off from his job as a technical editor for the Ford Motor Company, Roy could be found playing with friends' hi-fi systems and building and selling his own loudspeakers. He became a part time retailer, which necessitated him spending an inordinate amount of time repairing turntables (they were, of course, the primary source back then).

With the distinct impression that he could do better, in 1973 he and a partner Tony Relph registered the name Rega (RElphGAndy) and started making the very first Planet turntable.

A brilliantly simple design, it featured the familiar blend of belt drive, solid plinth with decoupled feet and superb build quality that was to make the Planar turntables such a success subsequently. The plinth - consisting of several cast alloy 'podules' for supporting the record - was not quite as timeless a design concept! After a couple of years of manufacturing in his spare time, the decks were becoming increasingly popular in the UK, West Germany, France and Denmark, and so a 'proper' distribution deal was agreed.

Roy left Ford and used his redundancy money on a factory in Rochford. Soon after this, his partnership with Tony ended and Terry Davies joined as Rega's financial administrator.

What followed was critical to the success of the company - the Planar 2 was launched in 1975 and ironed out all the Planet's idiosyncrasies at a stroke. The combination of an excellent medium mass Lustre-derived S-shaped tonearm, nicely implemented Impex motor and a thin glass platter with rubber mat was dynamite. The £95 selling price was also a masterstroke - just a little more than the mass market Japanese direct drives which were selling like hot cakes but couldn't hold a candle to the P2 in sonic terms. Then in June 1977 the Planar 3 was launched, offering more of the same - but better. A selected tonearm, thicker plinth and more substantial glass platter allied to a felt mat made a surprisingly big improvement in sound. The P3 was now a worthwhile rival to more expensive suspended subchassis decks like Thorens' TD160.

It was an instant hit and by 1980

▶▶ Rega employed thirteen staff, exported to twelve countries, had twenty UK dealers. In 1980 Rega moved into a new factory on the site of an old mill, painting it green to affirm Roy's love for this hue. The company was now really going places.

1983 saw the next major moment in the Rega story. After using Japanese and Danish-sourced arms for years, the first batch of RB300-equipped Planar 3s hit the dealers in August. Using a gently tapered, one-piece tube made by an entirely new production method, the new arm soon won a Modern Metals award 'for excellence in the field of Aluminium Die Casting'. This was just the start - the arm was a stunner, totally demolishing all its competition at or anywhere near the price. Selling for £90, it bettered Linn's £253 Ittok LVII in many respects, and blew anything cheaper clean out of the water. That the £188 Planar 3s came with one as standard only made Rega's supply problem even worse! The RB250, and the thus-equipped Planar 2, soon followed.

Not content to rest on its laurels, the Supex-sourced Rega R100 cartridge was replaced by a home-designed RB100, selling for an affordable £36, and then superseded by the Bias and Elys cartridges in March 1988. Soon after in summer 1989 the Ela loudspeaker was introduced. A Rega design originally made in Denmark, production was quickly moved back in house.

In 1991 the electronics arrived, in the shape of the Elex and Elicit amplifiers. This completed the Rega system. Soon after, a new factory was built in 1992 on the Temple Farm Industrial Estate in Southend-on-Sea, under Roy's design. The original Planet CD player then became another legend - although not garnering the critical acclaim of some other rival products, it proved incredibly popular with dealers. For many audiophiles, it was their very first digital disc spinner, bought to complement their high end vinyl sources.

Now, Rega employs fifty-five people and is growing steadily. The Planar 2 and 3 decks have just received a mild makeover, and there's an updated P9 also available, along with the successful P25. The electronics are now all '2000 series' designs, and the Planet is one of the very strongest budget audiophile CD spinners around.

The Terry Bateman-designed Mira amplifier is the company's most sophisticated integrated yet, boasting a slick control system with high quality loss-less switches, relays and specially selected Alps volume controls.

In almost three decades, the company has gone from cottage industry to a successful yet very individual hi-fi manufacturer.



DAVID PRICE INTERVIEWS DESIGNER TERRY BATEMAN

DP - WHAT IS YOUR JOB AT REGA?

TB - I design the electronic products - amplifiers and CD players plus any electronic parts associated with the other Rega products. For example, with the Brio I designed and developed the circuit using CAD and a rats nest hook-up, and I also designed the PCB and performed the EMC testing as well. This gave me complete control over all the electronic aspects of the product. Rega is a team-led company, so I wouldn't be able to do the electronics without the rest of the team members, who do the mechanical design, styling and pre-production.

DP - HOW DID YOU BECOME INVOLVED WITH THE COMPANY?

TB - Through a mutual friend. Rega had the beginnings of the Elex and Elicit amplifiers, but weren't able to

finalise the research and development and pre-production stage, and then take the products on to the final production stage. I was asked to join Rega to perform these tasks. That was twelve years ago - as they say, I only came in to read the electricity meter, but ended up staying!

DP - WHAT DID YOU DO BEFORE REGA, AND WHAT ARE YOU MOST PROUD OF, AND WHY?

TB - I was doing design and R&D tasks in the pro-audio market, working with products like power amps, mixing desks, crossovers, equalisers and many other audio gadgets. My first job on leaving school was building valve guitar amplifiers, and later going on to design and R&D work on the same valve products. To

be honest, back in 1976 there were not too many audio companies using valves, least of all in the hi-fi field! I am most proud of the Jupiter CD player and Brio and Exon amplifiers. They

took several attempts to perfect, but when they were fully developed I was pleased with the final outcome. The Brio come together in a very nice way. To be honest I was very pleased with the sonic quality, technical specification and PCB layout etc. It all fitted together nicely to make a good product.

DP - WHAT MAKES GOOD HI-FI?

TB - Good engineering is working with - and using - a product to achieve the best sonic results, plus product styling. There's a sense of it not being what you put in, but what you leave out, as over engineering can overly complicate a product and swamp any character/potential that the circuit or mechanical parts possess.

There's also a level of synergy between the stages of a circuit and also between the mechanical parts. Using Military specification or state-of-the-art components will not ensure a good sounding product.

In fact there are some overlooked goodies in the run-of-the-mill parts catalogues which give interesting results. Take a look at the level of distortion in some of the better sounding valve amplifiers! Therefore, amazingly low levels of distortion and super specs will not automatically ensure a good sounding product. There's also a knack of knowing what is right - this rule of thumb approach based on sound (no pun intended) experience, which I picked up in my early days working with the "old guys" in the audio industry, is invaluable. I remember one guy Frank working on a 2x12" speaker cabinet, but when it came to the port, he picked up a coffee lid laying on the shelf saying "that's" about the right diameter", and when this speaker was finished it sounded great!

DP - HOW DID YOU GET INTO HI-FI?

TB I've always had a keen interest in radio, electronics and music since I was a young lad. In fact, I had my first radio apart when I was five, so hi-fi was a natural progression! It all started with getting old record players and radiograms from the local rubbish dump and then modifying them in various ways to suit my own needs. The big break came at the age of thirteen when I got a Quad 22 system, which was heading for a jumble sale. Thanks to my mum, it found its way to me.

This complete system comprised two Quad II power amps, a 22 preamplifier, AM & FM tuner, Garrard LAB 80 turntable and a box of spare KT66 valves. It's still my favourite system, because of how it changed my life. I still have it today, along with Leak, Radford and Beam-Echo equipment. Just prior to joining Rega I had Quad 44/405-2 with a pair of custom built KEF loaded speakers (BI39, BI10 & T27) and a Goldring turntable. I have also had various systems in the past comprising of PA power amplifiers both valve and solid state.

DP - WHAT ARE YOUR MOST IMPORTANT HI-FI PRODUCTS EVER?

TB - Difficult. To be honest, as an engineer it would be easier to focus on innovations rather than products.

For example, in the 1930s Blumlein patented binaural or stereophonic sound.

A lot of work was performed during the Second World War and the 1950s gave us Microgroove 33.3RPM records, Williamson, Leak and Quad II amplifiers and FM Radio.

In the 60s it would be Compact Cassettes, FM Stereo radio, efficient multiple speakers (LF, MF, HF) and complementary push-pull transistor circuits.

In the 70s there were good transistor amplifiers and the improvements in semiconductor technology which generally helped hi-fi.

In the 80s it was digital audio and CD, the reappearance of valve amplifiers and MOSFET transistors.

The 1990s had MiniDisc, CD-R, DVD, DAB and MPEG, which wasn't true hi-fi, but still an innovation.

DP - WHERE DO YOU STAND IN THE VINYL-CD & VALVES-SOLID STATE DEBATES?

TB I think that modern CD players with high performance DACs have gone a long way in closing the gap with vinyl, the Planet and Jupiter being included amongst them. But when it gets down to a good two channel system - both valve and solid state - you can't beat the atmosphere and depth that a good turntable and cartridge can get from a piece of vinyl. Someone said recently that, "there must be a planet somewhere in the universe that has all the atmosphere on it (along with all the pens), that was lost when all the master tapes were converted to PCM CD data"!

Being the proud designer of Rega electronics, I can quite easily listen to solid state amps - good ones, that is. However, I also have a collection of valve amps, and tend to use my Leak Stereo 60 and TL25+'s with 25% screen grid UL taps, which have a harder sound, plus a little more grunt (35W) than the Stereo 20 and TL12+'s (12-15W). As I write this, I'm listening to a Triode connected EL34 amplifier. I must add that I feel the old original valve pre-amplifiers are not viable due to the changes in signal sources, so I use solid-state pre-amplifiers with valve power

amplifiers. To conclude the answer, I am at home with all! I need to have an open mind and not exclude certain formats and technology just because they don't fit into my idea of hi-fi, but I do feel that home entertainment cinema systems are not hi-fi, so I do exclude these!



DP - WHAT IS HI-FI'S FUTURE? WILL IT DISSOLVE INTO HOME ENTERTAINMENT?

TB - Hope not! If I want the full-on audio-visual experience I will take the kids to the cinema along with the popcorn, crisps, etc., and if I want to listen to music I will use my two channel 'hi-fi'. I can't see the point in filling my lounge with loads of speakers, to try to emulate the sound you get in a cinema, where they use much large power amplifiers and speakers. You cannot expect one of these cinema systems to reproduce LPs and CDs faithfully. One aspect I especially don't like is the analogue input for the turntable, which is converted to a digital signal usually by a sub-standard ADC.

Another worrying aspect is the general 'dumbing down' of the signal quality. People are getting used to lower quality sources - for example, the BBC was transmitting Radios 1,2 and 4 at 192kb/s True Stereo on DAB (which was acceptable), but dropped it down to 128kb/s Joint Stereo last December (although sometimes it goes up to 160kb/s in the evening but still in Joint stereo). Home entertainment will take-over the mainstream market, but whilst the requirements for a good two channel hi-fi are in conflict with the quality and nature of home entertainment systems, there will always be a small market for two channel hi-fi systems. Imagine 5.1 or 7.1 valve-based systems, or even trying to get the best from your single ended triode amp with a 128kb/s data rate from your DAB or Hard disk using MPEG I Layer 2 and 3! ■ ▲

stock clearance

Sevenoaks stock clearance is a chance to pick up a genuine bargain. Stocks are limited, so be quick! Everything is ex-display and sold with instructions, accessories, packaging and manufacturers warranty. Nothing is Second-Hand. Prices may vary between outlets - this is due to either finish or condition. Please call to confirm product availability before travelling. A regularly updated list is available on our website.

Aberdeen 01224 587070

Arcam A75 Amplifier (Silver)	£319
Celestion AVP1000 5.1 Speaker Package	£149
Keft Q95 2 Centre Speaker	£349
Monitor Audio GR Centre Centre Speaker (Oak)	£499
Musical Fidelity XA100R Amplifier	£499
Rotel RC971 Pre Amplifier	£399
Rotel RSX965RDS AV Receiver	£499
Tag McLaren PA10 Preamp (Black)	£399
Talk Hurricane 2 Pre Amplifier	£379
Tannoy MX Centre Centre Speaker (Maple)	£249
Teac AVH5000 AV Amplifier	£299
Teac DVH500 DVD Player (Region 2)	£299
Toshiba SD200E DVD Player (Region 2)	£249

Bedford 01234 272779

Acoustic Energy Aegis Centre Speaker	£89
Denon AVR1801 AV Receiver (Black)	£349
Denon AVR1801 AV Receiver	£289
Denon AV7800 DVD Player	£299
Marantz DV3100 OSE DVD Player	£199
Musical Fidelity X-Ray CD Player	£399
Naim MKO Active Crossover	£359
Naim Nait 3 Amplifier	£479
Naim SBL Speakers (Black)	£1499
Panasonic DVDRV60 DVD Player (Multi Region)	£399
Rotel RA921 Amplifier	£299
Rotel RC0971 AV Amplifier	£319
Schroers & Schroers AlphaStatic 5 Shelf Rack	£725
Selecso SVD500 CRT Projector	£5999
Sony DVPS336 DVD Player (Multi Region)	£289
Sony DVPS336 DVD Player (Multi Region)	£349
Sony TAFB940 Amplifier	£399
Tag McLaren AlphaWide/Callope System (Black)	£219
Toshiba SD500E DVD Player	£399
Yamaha DSPAX2 AV Amplifier	£899
Yamaha NSE105 Surround Speakers (White)	£69

Birmingham 0121 233 2977

Arcam DVA P75 Power Amp (Silver)	£199
AVI Pro 9 Loudspeakers (Black)	£549
B&W ASW500 Subwoofer (Black)	£299
Keft KH2005 Speaker Package (Silver)	£599
Linn Classic CD Receiver (Black)	£799
Loewe Vitros 32" Widescreen TV (Platinum)	£1399
Loewe Xelos 32" Widescreen TV (Copper/Red/Black)	£1299
Monitor Audio Gold 10 Loudspeakers (Cherry)	£1249
Monitor Audio Studio 2SE Loudspeakers (Cherry)	£299
Monitor Audio Studio 2SE Loudspeakers (Black)	£1899
Naim CDX CD Player (Black)	£2999
Naim NAC 82 Pre Amplifier (Black)	£1999
Philips DVDR1000 DVD Recorder	£1199
Rotel RDV995 and RSX972 DVD and Receiver	£1749
Rotel Vita 50 Speaker Package (Silver)	£749
Sony Lissa System (Silver)	£129

Bristol 0117 974 3727

Arcam DVA A75 AV Amplifier (Black)	£349
B&W LCR6 S2 Centre Speaker (Cherry)	£279
Castle Classic Subwoofer (New)	£299
Denon AVR1801 AV Receiver (Black)	£399
Kef RDM Speakers (Cherry)	£399
Keft Reference 2.2 Speakers (Black)	£299
Meridian 558 S Channel Amplifier	£1399
Rotel RB985 MKII Power Amplifier	£549
Sony DVPS336 DVD Player (Multi Region 2)	£499
Sony DVPS336 DVD Player (Multi Region)	£249
Sony DVPS735 DVD Player (Multi Region)	£399
Sony MDSJE440 Mini Disc Player (Black)	£129

Holborn 020 7837 7540

Acoustic Energy AE1 MkII Loudspeakers (Cherry)	£499
Arcam Alpha 7SE CD Player	£225
Arcam Alpha 9C Pre Amplifier	£149
Arcam DVA AVR100 AV Receiver (Silver)	£499
B&W CM2 Loudspeakers (Maple)	£349
B&W CM4 Loudspeakers (Rosewood)	£499
B&W CMC Centre Speaker (Maple)	£225
Castle Harlech Loudspeakers (Black)	£799
Castle Howard S3 Loudspeakers (Cherry)	£899
Castle Richmond Loudspeakers (Cherry)	£149
Celestion C3 Loudspeakers (Silver)	£499
Celestion C4 Centre Speaker (Silver)	£99
Celestion C5 Surround Speakers (Black)	£199
Denon PMA255 Amplifier	£399
Denon PMA-T10 Power Amp (Black)	£249
Jamo ADO310 Speaker Package (White)	£199
Jamo E8 Centre Speaker (Black)	£75
Jamo E8 Surround Speakers (White)	£99
Jamo E800 Loudspeakers (Black)	£99
Jamo Kiosa Loudspeakers (Black)	£275
Linn Kosoa Loudspeakers (Black)	£1399
Loewe Xelos 32" Widescreen TV (Platinum)	£3999
Loewe Xelos 32" Widescreen TV (Copper)	£75
Marantz CD4000 CD Player	£399
Marantz Eclipse 19 System (Ink Speakers)	£125
Mission 77c1 Centre Speaker (Black)	£149
Mission 772 Loudspeakers (Black)	£249
Mission 773e Loudspeakers (Rosewood)	£99
Mission m72 Loudspeakers (Black)	£199
Monitor Audio Silver 3i Loudspeakers (Black)	£349
Musical Fidelity XA2 Amplifier	£625
Musical Fidelity XA100 Power Amp	£499
Musical Fidelity XP100 Preamp	£149
Pioneer DV340 DVD Player (Multi Region)	£299
Roksan Kandy Amplifier (Silver)	£299
Roksan Kandy CD Player (Silver)	£299
Roksan Kandy Tuner (Silver)	£199
Teac AVH5000 AV Amplifier	£229
Teac DVH500 DVD Player	£199
Yamaha DSPAX2 AV Amplifier	£699
Yamaha DSPAX60 AV Amplifier	£325
Yamaha RXV800 AV Receiver	£449

Cardiff 029 2047 2899

Acoustic Energy AE1 MkII Loudspeakers (Cherry)	£549
Arcam DVA AVR100 AV Receiver (Silver)	£599
Castle Severn 2SE Loudspeakers (Cherry)	£549
Elac CL82 Mk2 Loudspeakers (Maple)	£319
Elac CL102 Loudspeakers (Maple)	£479
Keft Q55.2 Loudspeakers (Aegean Cherry)	£399
Musical Fidelity XA200R Amplifier	£729
Musical Fidelity XA3 Amplifier (Chestnut)	£449
Onkyo D55 System CD Amplifier Tuner Cassette (Silver)	£399
Sennheiser Mucias (Headphone Surround Processor)	£299
Toshiba SD500E DVD Player (Multi Region)	£299

Chelsea 020 7352 9466

Cyrus XPA Power Amplifier (Black)	£199
Denon AVF100 AV System (Black)	£349
Energy Talk 5-1 Speaker Package (Black)	£499
Energy Talk 5-1 Speaker Package (Black)	£1945
Myyrad Cameo Tuner (Silver)	£199
Ruark Epilogue Reference Loudspeakers (Oak)	£249
Yamaha DVD510 DVD Player	£149

Crawley 01293 510777

Arcam DVA A65 Amplifier (Black)	£299
Monitor Audio GR20 Loudspeakers (Cherry)	£999
Musical Fidelity HT600 Pre Amplifier (Rosewood)	£999
Musical Fidelity HTP (Black/Digital/Pre Amplifier)	£999
Musical Fidelity XA200R Amplifier	£399
Onkyo TXDS695 AV Receiver (Silver)	£549
Ruark Dialogue Reference Loudspeakers (Cherry)	£249
Ruark Epilogue Reference Loudspeakers (Black)	£249
Ruark Prologue Reference Loudspeakers (Black)	£699

Epsom 01372 720720

Acoustic Energy Aegis 2 Speakers (Black)	£159
Arcam AVR100 AV Receiver (Silver)	£549
Arcam DVA A65 Amplifier (Silver/Black)	£279
B&W CDMCNT Centre Speaker (Black)	£290
Marantz CD6000 OSELE CD Player (Gold)	£249
Marantz DV31000OSE DVD Player (Black)	£249
Marantz PM6010 Hi Amplifier (Black)	£279
Musical Fidelity XA200R Amplifier	£575
Myyrad MC100 CD Player (Silver)	£669
Myyrad M120 Amplifier (Silver)	£579
NCC 42M2 Plasma Monitor (Black)	£345
Rotel RDV995 DVD Player	£4799
Rotel RSX972 AV Receiver	£799
Ruark CL10 Loudspeakers (Rosewood)	£749
Teac AVH5000 AV Amplifier (Gold)	£1999
Teac DVH500 DVD Player	£349
Yamaha DSP600 AV Processor	£549
Yamaha RXV420 AV Receiver	£259

Exeter 01392 218895

Arcam DVA A22 Amplifier	£799
Arcam DVA A65 Amplifier	£299
Arcam DVA A75 Amplifier	£349
Arcam DVA AVR100 Surround Receiver	£699
Arcam DVA DV88 DVD Player	£849
Arcam DVA P75 Power Amplifier	£249
Castle Howard Loudspeakers (Cherry)	£999
Keft Model 1.2 Loudspeakers (Cherry)	£999
Keft Q95 2 Centre Speaker	£159
Meridian 566-24 DAC (2x Bit)	£189
Naim Credo Loudspeakers (Black)	£1099
Roksan Caspian Amplifier	£599
Ruark CL10 Loudspeakers (Cherry)	£699
Ruark CL20 Loudspeakers (Black)	£1199
Ruark Prologue Reference Loudspeakers	£799
Ruark Solus Loudspeakers & Stands (Rosewood)	£899
Yamaha DSPAX2 Surround Amplifier	£599
Yamaha RXV800 Surround Receiver	£399
Yamaha RXV1000 Surround Receiver	£449

Cambridge 01223 304770

Acoustic Energy Aegis Compact Speaker	£49
Arcam Alpha 7 Tuner Upgrade	£34
Arcam Alpha 9C Pre Amplifier	£329
Arcam Alpha 9CD CD Player	£599
Arcam Alpha 10 DAVE Amplifier	£1249
Arcam Alpha 10P Power Amplifier	£479
B&W D56 Dipole Speakers	£299
Cyrus A0A7 Pre Amplifier	£299
Cyrus AP7 Mono Power Amplifier	£799
Cyrus MR3 Multi-Room Amplifier	£449
Denon DCD835 CD Player	£229
Denon DVD3300 DVD Player	£439
Jamo Concert 8 Speakers	£1099
Keft Ref Model 1.2 Speakers	£1999
Marantz Arch CD/Radio System	£399
Mission 775E Speakers	£499
Musical Fidelity XA1 Amplifier	£379
Musical Fidelity XP100 Pre Amplifier	£399
Project Classic Turntable	£499
Roksan Caspian 5 Channel Amplifier	£799
Roksan Caspian Amplifier	£649
Roksan Caspian CD Player	£699
Roksan Caspian Power Amplifier	£499
Ruark Prologue One Speakers	£749
Sony CPXJE300 CD Player	£119
Sony CMTJ3MD Min Disc System	£399
Sony DVPS325 DVD Player	£279
Sony DVPS536 DVD Player (Multi Region)	£299
Tannoy M2.5 Speakers	£119
Toshiba SD1000 DVD Player	£179
Toshiba SD200E DVD Player (Multi Region)	£199
Toshiba SD3109 DVD Player (Multi Region)	£439
Yamaha DSPA1 AV Amplifier (Gold)	£699
Yamaha DV500 DVD Player	£379
Yamaha MCR5 Mini System	£349
Yamaha TX592 Tuner	£129

Hull 01482 587171

Acoustic Energy AE1 MkII Loudspeakers (Black)	£469
Arcam FMJ A22 DAVE AV Amplifier (Silver)	£1599
Arcam FMJ DT26 DAB Tuner (Silver)	£749
Arcam FMJ P25 2 Ch Power Amp (Silver)	£649
Arcam FMJ P25 3 Ch Power Amp (Silver)	£749
Denon AVR1801 AV Receiver	£299
Denon DVD2500 DVD Player	£199
John Shearn Phase 7 CD Player (Black)	£749
Loewe Planus 32" Widescreen TV (Silver/Black)	£1369
Loewe Spheros 42" Plasma TV (Black/Silver/Black)	£8999
Marantz Eclipse 70 System (Black)	£1319
Musical Fidelity XA2 Amplifier	£429
Musical Fidelity XP100 Preamp	£569
NAC C350 Amplifier	£289
Onkyo DV535 DVD Player (Silver)	£289
Ruark CL10 Loudspeakers (Multi Region)	£699
Ruark CL20 Loudspeakers (Black)	£1199
Ruark CL30 Loudspeakers (Black)	£1699
Ruark Prelude Loudspeakers (Cherry)	£599
Ruark Prelude R Loudspeakers (Black)	£629
Ruark Prologue R Loudspeakers (Black)	£729
Sugden Bjour CD Player (Silver)	£1099
Yamaha DVD796 DVD Player	£179
Yamaha RXV620RDS AV Receiver	£339

Ipswich 01473 286977

Arcam DVA AVR100 Surround Receiver (Black)	£499
Castle Classic Subwoofer (Cherry)	£649
Castle Harlech Loudspeakers (Cherry)	£789
Castle Howard S3 Speakers (Black)	£1249
Castle Severn 2SE Speakers (Black/Gold)	£549
Loewe Xelos 53B12W Television (Black/Silver/Black)	£1149
Marantz SM17 Power Amplifier (Black)	£549
Musical Fidelity A300 Amplifier (Black)	£789
PMC T82 Speakers (Black)	£449

Kingston 020 8547 0717

Jamo E8 Surround Speakers (Black)	£149
Jamo E800 Loudspeakers (Cherry/Black)	£149
Jamo E870 Loudspeakers (Black)	£399
Kef Cresta 2 Loudspeakers (Black)	£99
Kef Cresta 3 Loudspeakers (Cherry)	£179
Meridian M33 Active Speakers	£999
Meridian M33c Active Centre Speaker	£499
Mission 77c1 Centre Speaker (Black)	£149
Mission 771 Loudspeakers (Black)	£175
Mission 773e Loudspeakers (Black)	£299
Monitor Audio Silver 9i Rear Speaker (Black)	£349
Monitor Audio Silver XA200R Amplifier	£599
Rotel RC0971 AV Amplifier	£559
Rotel RSP966/RS985 AV Pre/Power Combination	£899
Ruark Dialogue Reference Centre Speaker (Cherry)	£799
Ruark Dialogue Reference Loudspeakers (Cherry)	£299
Soundstyle SR105 Equipment Rack (Cherry)	£499
Target VV11 Wall Shelf	£99
Teac AVH5000 AV Amplifier	£299
Teac DVH500 DVD Player	£329
Toshiba SD500E DVD Video/Audio Player	£399

Leeds 0113 245 2775

Arcam FMJ A22 Amplifier	£499
B&W CC6 (S2) Centre Speaker (Black)	£199
Boston VRS90 Surround Loudspeakers	£149
Castle Richmond Loudspeakers	£899
Castle Severn II Loudspeakers	£499
Cyrus AP7 (Multi-Region) Mono Power Amp (Black)	£1199
Denon DVD3300 DVD Player	£499
Linn Kosoa Loudspeakers	£299
Mission 771 Speakers	£249
Philips DV957 DVD Player	£349
Pioneer DV535 DVD Player (Multi Region)	£149
Roksan Caspian Tuner	£399
Rotel RDV985 DVD Player	£349
Rotel RDV995 DVD Player	£349
Teac DVH500 DVD Player	£399
Teac DVH500 DVD Player	£299
Yamaha RXV800 AV Receiver	£399

Leicester 0116 253 6567

Acoustic Energy Aegis 2 Speakers (Black)	£149
Acoustic Energy Aegis 3 Speakers	£229
Arcam Alpha 10DR1 Digital Tuner	£699
Denon AVR1801 AV Receiver	£329
Denon DVD1000 DVD Player	£129
Mission 771E Speakers	£229
Mission 772 Speakers	£175
Mission 773e Speakers	£279
Mission 774 Speakers	£299
Musical Fidelity X-Plura Tuner	£449
Panasonic DVDVA360 DVD Player (Black)	£279
Pioneer DV626 DVD Player (Multi Region)	£229
Pioneer DV636 DVD Player (Multi Region)	£279
QED MusQ RFS Systemline	£699
Roksan Caspian DSP Processor	£799
Roksan Caspian Power Amplifier	£479
Roksan Caspian Tuner	£549
Ruark Dialogue One Reference Speakers	£279
Ruark Dialogue Speakers	£299
Ruark Prelude Reference Speakers	£649
Sony SCXD8940 SACD Player	£349
Sony SCXD8940 SACD Player	£279
Toshiba SD200E DVD Player (Multi Region)	£289
Yamaha DV5795 DVD Player (Black)	£289

Lincoln 01522 527397

B&W CM2 Loudspeakers (Rosewood)	£399
B&W CM4 Loudspeakers (Black)	£649
Cyrus aCA7.5 & aPA7 Pre/Mono Power (Black)	£1999
Loewe Videorack 2B Television Stand	£119
Mission 77c1 Centre Speaker (Black)	£179
Mission 772 Loudspeakers (Black)	£299
Mission 773e Loudspeakers (Black)	£349
Mission 774 Loudspeakers (Rosewood)	£399
Onkyo DV5930 DVD Player (Silver)	£649
Onkyo TXDS787 AV Receiver (Black/Silver)	£649
Onkyo TXDS989 AV Receiver (Black/Silver/Black)	£249
Sony SCXD8940 SACD Player (Black)	£249
Teac DVH500 DVD Player (Region 2)	£329
Toshiba SD500E DVD Audio Player (Black)	£399

Liverpool 0151 707 8417

Arcam Alpha 7 Tuner	£225
Arcam DVA A65 Amplifier (Silver)	£299
Arcam DVA A75 Amplifier (Silver)	£399
Arcam DVA AVR100 AV Receiver (Black)	£599
Arcam DVA DV82 DVD Loudspeakers (Black)	£249
Denon AVCA15E AV Amplifier	£2149
Denon AVCA105E AV Amplifier	£1099
Denon AVR1601 AV Receiver (Black)	£299
Denon AVR2801 AV Receiver (Black)	£329
Denon AVF3801 AV Receiver (Black)	£299
Denon DVD1500 Player (Black)	£349
Keft Q35 2 Loudspeakers (Black)	£299
Keft Q55.2 Loudspeakers (Dark Apple)	£429
Keft Q55.2 Loudspeakers (Light Cherry)	£399
Lexicon DC2 AV Processor	£3299
Marantz SR7000 AV Receiver (Black)	£725
Mission 77c1 Centre Speaker (Black)	£149
Mission 7725 Loudspeakers (Black)	£149
Mission 771E Loudspeakers (Black/Silver)	£149
Mission 772 Loudspeakers (Black)	£199
Mission 774 Loudspeakers (Black)	£399
Onkyo DV5930 DVD Player (Multi Region)	£349
Panasonic DVDRV60 DVD Player (Multi Region)	£349
Parasound HCA2205 5 Channel Power Amp	£2149
Parasound HCA2205 Power Amp	£799
Primare A30 5 Amplifier	£1399
Primare P30 Processor	£1649
Primare V20 DVD Player	£375
Rel 10100E Subwoofer	£399
Rogers LS55 Loudspeakers	£149
Ruark Vita 100 5.1 Sub/Sat Package	£1199
Sony CDP/ES30 CD Player	£299
Sony DVPS336 DVD Player (Multi Region/Black)	£369
Sony DVPS336 DVD Player (Black)	£369
Sony SCXD8940 SACD Player (Black)	£225
Teac AVH500 AV Amplifier	£329
Teac DVH500 DVD Player	£369
Teac PDH570 CD Multi Player	£369
Toshiba SD100E DVD Player (Multi Region)	£149
Yamaha MDX596 Mini Disc Player	£199

Manchester 0161 831 7969

Arcam Alpha 7 Tuner	£179
Arcam FMJ DT26 DAB Tuner	£499
B&W CC6 S2 Centre Speaker (Black)	£149
B&W CC6 S2 Centre Speaker (Cherry)	£149
Castle Severn II Loudspeakers	£549
Denon AVCA105E AV Amplifier	£749
Denon DVD3300 DVD Player (Multi Region)	£499
Denon POAT10 Power Amp	£299
Mission 781 Loudspeakers (Black)	£399
Onkyo TXDS787 AV Receiver	£649
Project 6.9s Turntable	£349
Rotel RDV995 DVD Player	£649
Ruark Dialogue One Ref Centre Speaker	£199
Selecso SVD500 CRT Projector	£5999
Sony DVPS7700 DVD Player (Multi Region)	£399
Teac AVH500 AV Receiver	£279
Teac DVH500 DVD Player	£319
Yamaha DPX1 DLP Projector	£4499
Yamaha DSPAX2 AV Processor	£149
Yamaha MDX596 Mini Disc Player	£149

Newcastle 0191 221 2320

Acoustic Energy Aegis 2 Speakers



Maidstone 01622 686366

Monitor Audio GR20 Loudspeakers	£999
Monitor Audio Silver 5i Loudspeakers	£349
Monitor Audio Silver 10i Centre Speaker	£219
Monitor Audio Silver 10i Centre Speaker	£219
Musical Fidelity A3 CD Player	£699

Norwich 01603 767605

Arcam DVA CD92 CD Player	£749
Boston Micro 80 Loudspeakers	£129
Castle Classic Sub Woofer	£699
Castle Severn 2SE Loudspeakers	£595
Kef Cresta 2 Loudspeakers	£99
Marantz AVMM9000 AV Processor Power Amp	£1499
Marantz CD6000i CD Player	£429
Marantz DV3100 DVD Player	£299
Marantz SR8900 Tuner	£159
Monitor Audio Silver 5i Loudspeakers	£339
Myyrad Cameo System	£999
Rotel RSX65 AV Receiver	£749
Standesign Trenza Stand	£239
Yamaha DVD5796 DVD Player	£249

Nottingham 0115 911 2121

Acoustic Energy AE1 MkII Loudspeakers	£599
Acoustic Energy Aegis 2 Loudspeakers	£279
Arcam DVA A65 Amplifier	£369
Arcam DVA A75 Amplifier	£399
Denon AVR2801 AV Receiver	£299
Denon CDRI1000 CD Recorder	£219
Denon DMDD1000 Mini Disc Recorder	£599
Nilesound 771 Sound Speakers	£349
Onkyo TXDS575 AV Receiver	£219
Sony SCDXB930 SACD Player	£299
Sony SCDXB940 SACD Player	£299

Oxford 01865 241773

Acoustic Energy Aegis Centre Centre Speaker	£89
Arcam DVA A65 Amplifier	£279
Arcam DVA AVR100 AV Receiver	£449
Arcam DVA CD92 CD Player	£649
Arcam DVA P75 Power Amplifier	£239
Arcam FMJ A22 Amplifier	£799
Denon DVD3300 DVD Audio Player	£549
Dissolvo 771 Loudspeakers	£159
Mission 772 Loudspeakers	£299
Panasonic DVDVR20 DVD Player	£299
Ruark Dialogue Reference Loudspeakers	£275
Sony DVP3336 DVD Player	£279
Sony DVPS336 DVD Player	£339
Sony DVPS700 DVD Player	£499
Toshiba SD200 DVD Player	£299
Yamaha DSPAX2 AV Receiver	£675
Yamaha DSPAX620 AV Amplifier	£325
Yamaha RXV800 AV Receiver	£449
Yamaha RXV1000 AV Receiver	£549

Peterborough 01733 897697

Acoustic Energy AE11 Loudspeakers	£599
Acoustic Energy AE11 Stands	£89
Acoustic Energy Aegis Centre Speaker	£89
Arcam DVA A65 Amplifier	£299
Arcam DVA CD92 CD Player	£749
Denon AVR1801 AV Receiver	£249
Jamo T8 & DS Surround	£1049
Kef Cresta Centre Speaker	£199
Monitor Audio Silver 3i Loudspeakers	£199
Rotel RCD951 CD Player	£279
Rotel RCD971 CD Player	£349
Ruark Epilogue Loudspeakers	£189
Talk Thunker CD Player	£399
Yamaha DSPAX1 AV Amplifier	£399
Yamaha DSPAX620 AV Amplifier	£399
Yamaha RXV620RDS AV Receiver	£379

Plymouth 01752 226011

Acoustic Energy Aegis 1 Speakers	£119
Arcam DVA AVR100 AV Receiver	£599
B&W D36 Dipole Speakers	£349
Castle Classic Sub Woofer	£719
Castle Harlech 2 Speakers	£899
Castle Howard S3 Speakers	£1199
Castle Keep 2 Centre Speaker	£219
Castle Richmond Speakers	£219
Castle Severn 2SE Speakers	£629
Castle Warwick 3 Speakers	£359
Def Tech Pro 80 Speaker Package	£899
Denon DVD1500 DVD Player	£349
Heybrook HB1 Speakers	£149
Jamo Apollo 3 1 Speaker Package	£349
Kef Model 200 Centre Speaker	£559
Kef O15 2 Speakers	£159
Marantz DVD890 DVD Player	£249
Musical Fidelity XA100R Amplifier	£799
Musical Fidelity X-P100 Amplifier	£649
Onkyo DV5535 DVD Player	£329
Onkyo TXDS35X AV Receiver	£299
Onkyo TXDS787 AV Receiver	£799
Ref 0100E Sub Woofer	£399
Roksan Caspian CD Player	£749
Roksan Caspian Power Amplifier	£499
Roksan Caspian Tuner	£599
Rotel RC971 MkII Pre Amp	£149
Rotel RCD951 CD Player	£219
Rotel RT951 Tuner	£299
Ruark Vita 100 Speaker Package	£1299
Sony CDPX740	£169
Sony DVPS335 DVD Player	£269
Sony DVPS725 DVD Player	£349
Sony STS940 Tuner	£139
Sony STS940 Amplifier	£249
Tag McLaren F3-PA10 Pre Amplifier	£449
Tag McLaren DVJ5700 DVD Player	£299
Yamaha NSP210 Speaker Package	£149
Yamaha YSTS45 Subwoofer	£119

Reading 0118 959 7768

Acoustic Energy Aegis 1 Loudspeakers	£99
Arcam A75 Amplifier	£379
Castle Harlech Loudspeakers	£849
Castle Pembroke Loudspeakers	£479
Castle Severn Loudspeakers	£549
Jamo EBSURR Subwoofer	£249
Jamo EBSURR Surround Speakers	£299
Jamo E800 Loudspeakers	£149
Lexicon DC 2 AV Processor	£149
M&K VX7 Subwoofer	£399
Meridian M33 Loudspeakers	£849
Monitor Audio Silver 4i Loudspeakers	£199
Monitor Audio Studio 60 Loudspeakers	£2599
Musical Fidelity X-Flora Tuner	£499
Musical Fidelity X-Ray CD Player	£549
Musical Fidelity XA200R Amplifier	£449
Nakamichi DR10 Cassette Deck	£449
Pioneer DV525 DVD Player	£149
Rotel RCD951 CD Player	£299
Rotel RG970 Phono Stage	£109
Sony STS5920 Tuner	£399
Tag McLaren Aphrodite & Calliope System	£2999
Toshiba SD500E DVD Audio Player	£399
Yamaha TX492 Tuner	£99

Sheffield 0114 255 5861

Arcam CD72 CD Player	£299
Arcam CD92 CD Player	£649
Castle Severn 2SE Loudspeakers	£449
Lexicon DC 2 AV Processor	£2599
Marantz AV9000 Processor	£749
Mission 773E Loudspeakers	£299
Musical Fidelity HT600 5 Ch Power Amp	£1399
Musical Fidelity X-Ray CD Player	£625
Musical Fidelity XA2 Amplifier	£399
Musical Fidelity XA200R Amplifier	£549
Onkyo DV535 DVD Player	£329
Onkyo TXDS787 AV Receiver	£799
Roksan Caspian Tuner	£549
Roksan Kandy CD Player	£299
Rotel RCD951 CD Player	£275
Teac AVH500 AV Amplifier	£299
Yamaha TX492RDS Tuner	£99

Southampton 023 8033 7770

Acoustic Energy Aego 2 Sub Sat System	£199
Acoustic Energy Aego 2 Sub Sat System	£199
Arcam DVA CD92 CD Player	£649
Arcam DVA D181 DAB Tuner	£499
Lexicon DC 2 AV Processor	£1699
Cyrus AV5 AV Processor	£749
Cyrus PSX-R Power Supply	£249
Cyrus XPA Power Amp	£249
Denon AVF100 AV System	£599
Jamo E8 Centre Speaker	£129
Jamo E800 Loudspeakers	£669
Kef Cresta Centre Speaker	£199
Meridian 588 CD Player	£1499
Musical Fidelity XA200R Amplifier	£499
Onkyo DR90 DVD AV Receiver	£499
Roksan Kandy CD Player	£399
Rotel RS971 MkII Power Amp	£179
Rotel RSX972 AV Receiver	£749
Ruark Vita50 5.1 Speaker Package	£749
Sony DAVS500 DVD System	£499
Sony SCDXB940 SACD Player	£249
Sony STD777ES DAB & Analogue Tuner	£389
Teac DVH500 & AVH500 DVD/AV Receiver	£679
Toshiba SD300 DVD Audio Player	£449
Videologic DRX601ES Digital Tuner	£269
Yamaha DVD510 DVD Player	£169

Southgate 020 8886 2777

Arcam Alpha One Amplifier	£179
Arcam DVA A65 Amplifier	£329
Arcam DVA A65 Amplifier	£329
Arcam DVA A75 Amplifier	£349
Arcam DVA AVR100 AV Receiver	£449
Kef O15 2 Speakers	£139
Kef O85S Surround Speaker	£139
Kef Q95 2 Centre Speaker	£149
Marantz SR5000 AV Receiver	£349
Mission 771E Speakers	£149
Musical Fidelity XA100R Amplifier	£799
Myryad T10 CD Player	£299
Myryad T20 CD Player	£339
Pioneer A300R Precision Amplifier	£249
Pioneer DV717 DVD Player	£399
Rotel RD960BX Cassette Deck	£199
Ruark Prologue One Deluxe Speakers	£749
Yamaha DVD5700 DVD Player	£399

Swiss Cottage 020 7722 9777

Acoustic Energy Aegis 2 Speakers	£169
Arcam Alpha 10 DAVE AV Amplifier	£1749
Arcam Alpha V50 Pro-Logic Amplifier	£349
Castle Severn 2 Speakers	£549
Arcam DVA AVR100 AV Receiver	£499
B&W C6 Centre Speaker	£179
B&W LCR6 (S2) Centre Speaker	£299
Exposure 21RC Pre Amplifier	£599
Linn Koosa Speakers	£459
Monitor Audio Studio 6 Speakers	£599
Monitor Audio Studio 20 SE Speakers	£1099
Pioneer DV636 DVD Player	£329
AVI Bigginton Speakers	£299
Pioneer DV636 DVD Player	£299
Roksan Caspian DSP 5.1 Processor	£999
Roksan Caspian Power 5 Ch Pwr Amp	£749
Rotel RCD991 CD Player	£575
Ruark Crusader 2 Speaker	£999
Ruark Dialogue Reference Speakers	£305
Ruark Epilogue Reference Speakers	£305
Ruark Prelude Speakers	£599
Ruark Prologue Speakers	£795

Swansea 01792 465777

Arcam DVA AVR100 AV Receiver	£399
Arcam FMJ D26 Digital Tuner	£749
Arcam FMJ P25 Power Amplifier	£499
Arcam FMJ T21 Tuner	£319
B&W LMI Speakers	£129
Castle Harlech S2 Speakers	£699
Denon AVF100 System Inc NXT Speakers	£999
Linn AV5120 Centre Speaker	£649
Linn LK140 Power Amp	£699
Linn LP12(Auto)Basic/K5 Turntable	£1549
Linn Ninka Speakers	£749
Linn Pekin Tuner	£449
Linn Wakonda Preamp	£689
Mission FS2AV AV Speaker Package	£499
Monitor Audio GR-Centre Centre Speaker	£449
Monitor Audio Studio-Centre Centre Speaker	£449
Project Perspective Turntable	£1149
Rel Q150 Subwoofer	£449
Rel Strata III Subwoofer	£679
Roksan Caspian DSP & 5 Channel Full	£1399
Roksan Kandy CD Player	£399
Roksan Kandy Amplifier	£399
Rotel RCD951 CD Player	£399
Rotel RCD971 CD Player	£399
Ruark Dialogue R Centre Speaker	£269
Toshiba SD100E DVD Player	£145

Brighton 01273 733338

Bromley 020 8290 1988

Croydon 020 8665 1203

Guildford 01483 536666

Sevenoaks 01732 459555

Tunbridge Wells 01892 531543

Witham 01376 501733

Acoustic Energy AE1 MkII Loudspeakers	£389
Acoustic Energy Aespt 300 Loudspeakers	£229
Acoustic Energy Aespt 301 Rear Speakers	£129
Acoustic Energy Aespt 307 Centre Speaker	£199
Acoustic Energy Aespt 308 Subwoofer	£499
Acoustic Energy Aespt 309 Loudspeakers	£499
Arc Acoustics Sonara 2.1 NXT Loudspeakers	£129
Arc Acoustics Sonara 5.1 NXT Loudspeakers	£279
Arcam DVA A65 Amplifier	£399
Arcam DVA AVR100 AV Receiver	£229
Arcam DVA CD92 CD Player	£299
Arcam DVA A75 Amplifier	£259
Arcam DVA CD72 CD Player	£539
Arcam DVA CD92 CD Player	£539
Arcam FMJ A22 Amplifier	£849
Arcam FMJ A25P Power Amplifier	£849
Arcam FMJ CD23 CD Player	£699
Arcam FMJ P25 Power Amplifier	£479
Arcam FMJ P25 Power Amplifier	£479
Arcam FMJ T21 Tuner	£249
AVI NuMotion 3 Loudspeakers	£339
B&W C622 Centre Speaker	£1119
B&W DM6022 Centre Speaker	£89
Boston CR6 Loudspeakers	£269
Boston TR6000 Speaker Package	£169
Boston VRS Surround Speakers	£89
Castle Clifton 2 Loudspeakers	£999
Castle Invention 100 Loudspeakers	£499
Celestion C2 Loudspeakers	£599
Celestion C3 Loudspeakers	£169
Celestion C4C Centre Speaker	£169
Celestion C5 Surround Speakers	£269
Celestion C6 Subwoofer	£519
Cyrus aCA7 Preamp	£619
Cyrus aPA7 Mono Power Amp	£579
Cyrus aDASQ.24 CD Player	£399
Cyrus MFS	£169
Cyrus Q Module CD Player Upgrade	£189
Cyrus XPA Power Amplifier	£149
Definitive Tech. Pro 80 Sub Woofer	£229
Definitive Tech. Pro Sub 80 Sub Woofer	£229
Denon AVCA105E AV Amplifier	£369
Denon AVR2801 AV Receiver	£369
Denon CDRI1000 CD Recorder	£239
Denon DVD1000 DVD Player	£199
Denon DVD2500 DVD Player	£439
Denon DVD3300 DVD Player	£389
Denon DVD3300 DVD Player	£1299
Denon SCAVF100 5.1 Speaker System	£319
EAR 834 Amplifier	£1169
EAR V20 Amplifier	£199
Energy XLS8 Subwoofer	£139
Epos ES30 Loudspeakers	£999
Final O 3 Speakers	£999
Imerge S102C Soundserver	£2499
Jamo 160 Surround Speakers	£79
Jamo 300 Surround Speakers	£239
Jamo Concert 8 Loudspeakers	£699
Jamo DEPTX 5.1 Speaker System	£249
Jamo D6SURR Surround Speakers	£479
Jamo D8SURR Surround Speakers	£279
Jamo D870 Loudspeakers	£1179
John Shearne Phase 3 Reference Amplifier	£449
John Shearne Phase 6 Amplifier	£619
Kef Q95 2 Loudspeakers	£249
Kef TD22C Centre Speaker	£199
Kef TDM34DS Surround Speakers	£349
Kef TDM45S Subwoofer	£399
M&K VX7 Mk2 Subwoofer	£299
Marantz DR700 CD Recorder	£269
Marantz DV3100 OSE DVD Player	£249
Marantz DV4100 DVD Player	£209
Marantz DVU890 DVD Player	£329
Marantz PM8200 Amplifier	£379
Marantz SR7000 AV Receiver	£449
Meridian 501 2 Pre Amplifier	£499
Meridian 502 Preamp	£999

Meridian 518 Digital Processor	£679
Meridian 541 Preamp	£499
Meridian 551 Amplifier	£619
Meridian 558 Power Amp	£2339
Meridian 566 DAC	£699
Meridian 566 24 DAC	£999
Meridian A500 Loudspeakers	£399
Meridian DSP5000C Centre Speaker	£1299
Meridian DSP5000C 24 Centre Speaker	£1369
Meridian M60 Loudspeakers	£1499
Meridian M60C Centre Speaker	£829
Meridian M1500 Subwoofer	£599
Michell QC Power Supply	£269
Mission 77C1 Centre Speaker	£109
Mission 77C5 Surround Speaker	£109
Mission 77C5 Surround Speaker	£109
Mission 777C Loudspeakers	£99
Mission M60 Loudspeakers	£179
Mission FS2A Loudspeakers	£299
Mission FS2AV Speaker Package	£389
Monitor Audio Silver 9i Loudspeakers	£499
Monitor Audio Silver 12i Centre Speaker	£199
Monitor Audio Studio 20SE Loudspeakers	£799
Musical Fidelity A3 Amplifier	£599
Musical Fidelity DVD1 DVD Player	£919
Musical Fidelity X-Flora Tuner	£369
Musical Fidelity X-Ray CD Player	£489
Musical Fidelity XA200R Amplifier	£429
Myryad T10 CD Player	£199
Myryad T20 CD Player	£299
NAD C520 CD Player	£119
NAD C540 CD Player	£249
Nilesound DVD108 DVD Player	£399
Onkyo DV535S DVD Player	£279
Onkyo DV535S DVD Player	£299
Onkyo TXDS787 AV Receiver	£649
Panasonic DVDV47 DVD Audio Player	£399
Panasonic DVDVR20 DVD Player	£199
Panasonic DVDVR40S DVD Player	£249
Parasound 1500 Power Amp	£669
Philips CDR760 CD Recorder	£169
Philips CDR770 CD Recorder	£299
Philips DVDR70 DVD Player	£199
Philips DVDR978 DVD Player	£899
Philips SACD1000 SACD/DVD Player	£199
Philips VR766 DVD Player	£219
Pioneer DV535 DVD Player	£299
Pioneer DV636 DVD Player	£299
Pioneer F208RDS Tuner	£99
Pioneer NSD1950 DVD System	£499
Pioneer PDF958 Multi CD Player	£179
Roksan Caspian DSP AV Processor	£799
Roksan Caspian Tuner	£399
Roksan Kandy Tuner	£319
Rotel RA931 Mk II Amplifier	£119
Rotel RA972 Amplifier	£259
Rotel RA1060 Amplifier	£379
Rotel RCD300X CD Player	£299
Rotel RCD971 CD Player	£499
Rotel RCD991 CD Player	£499
Rotel RDV985 DVD Player	£399
Rotel RSX965 AV Receiver	£599
Rotel RSX972 AV Receiver	£699
Rotel RT940 Tuner	£119
Rotel RT951 Tuner	£219
Ruark CL10 Loudspeakers	£449
Ruark CL15 Centre Speaker	£449
Ruark CL20 Loudspeakers	£919
Ruark CL30 Loudspeakers	£1529
Ruark Dialogue R Centre Speaker	£189
Ruark Dialogue R Centre Speaker	

PROBABLY THE BEST

NEW DEMONSTRATION ROOM NOW OPEN AT 12A SPRING GARDENS, NEWPORT PAGNELL,

KIT6550 VALVE INTEGRATED AMPLIFIER KIT & KAT6550 VALVE POWER AMPLIFIER KIT

£595



KIT6550
upgrade kit now
available £130

NEW KITS

£580



KaT6550
upgrade kit now
available £120

These are our new 6550 series amplifiers. A pure class A design providing 40 watts into a 8 ohm load. (available in a 4 ohm version if required) A truly high end design by Andy Grove, using Svetlana 6550Cs in push-pull (any 6550 or KT88 tube can be used with this amp). It features valve rectification (5U4) a choke pi filter power supply and is hard wired. Weighs 19kg with dimensions 390mm(w) x 330mm(d) x 190mm(h)

with valves or 220mm(h) with cage. Simon Pope says - "If you favour attack and rhythmic grip, together with a smoothness of sound that's incredibly easy to live with, the KIT6550 could well be the kit amp for you. The 6550 is one for those who like a valve sound married to the attack and clout of a good quality solid state design".

Kel84 VALVE INTEGRATED AMPLIFIER KIT

This is our brand new, low cost, beginner level amplifier kit. It features a pair of EL84 valves per channel in push-pull configuration. They give 15 watts into an 8 ohm load - plenty for medium sensitivity loudspeakers. The output transformers are Ultra Linear, keeping distortion down to a minimum. Up front the ECF80 input/phase splitter valve has an extremely smooth sound.

The Kel84 has very low hum, to solid-state standards. For simplicity the kit is built on a printed circuit board. A strong steel chassis is fronted by a 3mm anodised front panel and attractive chromed custom made knobs. There are five line level inputs, plus one monitor input, with a tape output included, all controlled from the front panel. The phono input sockets and 4mm banana socket speaker terminals are gold plated.

At rear is a mains switch, an IEC power input and an earth post. This kit is aimed at beginners. The instructions include pictures as well as diagrams, making them very easy to follow. At a UK price of £278.00 all inclusive you cannot ignore Kel84. Simon Pope says, "The quality that can be gleaned from this amp is a fine introduction to the joys of the valve sound. The Kel84 will highlight all the intricacies and depth of detail in your favourite recordings whilst retaining a warmth and fullness that is almost exclusive to pure valve amps and is rare at this price point."

Kel84 weighs 10kg. External dimensions with valves are 300mm(w) x 270mm(d) x 150mm(h).

£278

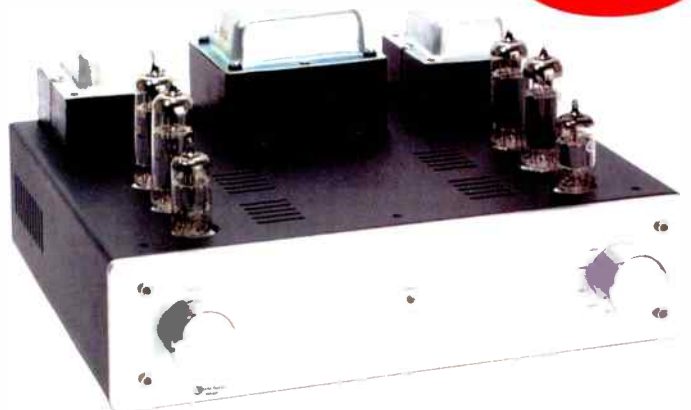

KAT88 VALVE POWER AMPLIFIER KIT

Here is the amazing KaT88. The circuit is similar to that of our popular KEL34 with a few changes to incorporate the Tesla, JJ branded KT88 power tetrode. This is a pure Class A push-pull design providing 36 watts into an 8ohm load. Andy Grove has come up with a gem of an output transformer (E/I). With the KT88 it offers a virtually unmatchable result for a valve amplifier. Frequency response measures 11Hz to 75kHz, separation 71dB, noise 98dB, sensitivity 400mV and distortion 0.03%. "As valve amplifiers go, the KaT88 is one of the best measured performances I have ever come across", said Noel Keywood. Jon Marks said, "The KaT88 pulled a series of surprisingly fast, meaty basslines out of its trickbag when dealing with Suzanne Vega's Nine Objects Of Desire album. As if this wasn't enough, the mid and treble were nice too - cymbals had a deliciously natural, golden shimmer without sounding soft, and vocals were extremely transparent and crisply defined. KaT88 didn't hang around when it came to exploiting the virtues of its four output valves on numbers such as 'Leaves' and 'Suspect Sustain' from Cirrus' Land's End Jazz CD. Saxophone had a wonderfully smooth, realistic character, and acoustic guitar mixed speed with harmonic richness to very impressive effect. Asian Dub Foundation and Moloko showed no sign at all of the sluggish, woolly bottom-end and poorly-delineated bass beats that most valve amps are to blame for. Which makes the KaT88 an all-round, high-end bargain." Weight 16kg, external dimensions with valves are 330mm(w) x 300mm(d) x 190mm (h).

£468



KIT88
upgrade kit now
available £150

KaT88
upgrade kit now
available £140

DIY KITS IN THE WORLD

MILTON KEYNES, BUCKS MK16 0EE - CALL FOR DETAILS ON 01908 218836

ALL NEW SERIES II MODULAR PRE-AMP KIT

The PRE-II is a valve pre-amplifier with six inputs, tape monitor and two sets of output sockets. It utilises a high quality line driver transformer and $\times 5$ gain. The PHONO-II is a dedicated valve phono stage that incorporates a step-up transformer for MC users. Finally, PSU-II is a power supply unit that feeds both the PRE-II and PHONO-II.

Power Supply Unit (PSU-II)	£195.00
Pre-amplifier (PRE-II)	£195.00
Phono Stage (PHONO-II)	£110.00
Moving coil step-up transformer	£77.00
Passive pre-amplifier (PAS-II)	£215.00

NEW!

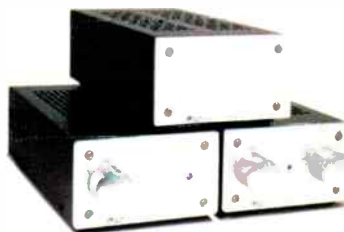

KAT34 VALVE POWER AMPLIFIER KIT & KIT34 VALVE INTEGRATED AMPLIFIER KIT

£480



**KAT34
upgrade kit now
available £120**

NEW KITS

£495



**KIT34
upgrade kit now
available £130**

KIT34 is a 32 watt stereo valve integrated amplifier, featuring a pair of EL34s, in push-pull mode, per channel, plus an ECF80 pentode/triode as input/phase splitter. The power supply is valve rectified (2 x 5U4), using a heavy duty choke to achieve exceptional smoothing. The output transformers are 14% Ultra Linear tapped to keep distortion down to its lowest level and the kit is totally hard wired utilising three tag boards. It has five line level inputs, plus a tape-in and tape out, all controllable from the front.

Simon Pope says, "This integrated bring together the best sonic virtues of our KIT88, kel34 and top of the range 300B PSE in an affordable package. The highlights of the sound are a deep and taut bass response, together with an open and highly detailed mid and high frequency response that only the best valve designs can achieve... a true valve classic" Weight 22kg, External dimensions with valves fitted - 390mm(w) x 360mm(d) x 210mm(h)

300B PSE MONOBLOC KIT

Our Parallel Single Ended amplifiers offer ultimate sound quality Each monobloc has two of the beautifully linear 300B directly heated triode in its output stage, producing 20 watts into an 8 ohm load. At the front we have a 6AU6 pentode and an ECC82 as the driver valve. This design utilises a 5U4 rectifier valve in the power supply, in combination with a 10H choke, giving an extremely quiet supply. Both mains and output transformers we E/I pattern.

For purists, feedback is switchable and the kit is totally hard-wired. For those that require valves we provide the superb Tesla 300Bs, Russian SU4s and European 6AU6s & ECC82. Simon Pope says, "Not to put too fine a point on it, the sound these monoblocs create is among the finest that can be encountered in hi-fi." Our 300B PSE kit bears an affordable price of £875.00 (UK price) excluding valves. Each monobloc weighs 23kgs., external dimensions with valves: 25cm(w) x 38cm(h) x 22cm(d) per monobloc.

**300B PSU
upgrade kit now
available £150**

**£875
A pair**



KEL80 MONOBLOC AMPLIFIER KIT

Following the success of our budget KEL34 40watt kit amplifier, we have come up with a 'big brother' design. The output stage uses two pairs of TESLA EL34 pentodes in parallel-push-pull mode, allowing KEL80 to turn out 80 watts into an 8ohm load. Heading up the input stage we have the wonderfully linear Russian 6AU6 working into an American 5687 phase-splitter. KEL80's output transformers are 4ohm and 8ohm tapped. With an input sensitivity at around 380mV for full output, it will happily partner both passive and active pre-amplifiers. It is easy to assemble. Simon Pope says, "The proof of the pudding is in the eating and the KEL80 is a feast for the ears, with solid bass attack, lightning fast reactions, that emphasises musicality as well as power. At £649.00 a pair, a definite valve winner. Each monobloc weighs 12kgs., external dimensions with valves: 14cm(w) x 8cm(h) x 43.5cm(d).

**£649
A pair**



HD83 VALVE HEADPHONE AMPLIFIER KIT

The HD83 headphone amplifier is a beautifully simple design using Mullard ECL83 valves, a triode and power pentode housed in the same envelope. It works directly from any source, be it CD, tape, tuner etc., or from an amplifier's tape out or pre-amp out sockets. The circuit uses high specification E/I output transformers that will drive any headphone load from 16 ohms to over 300 ohms depending on how the secondaries are wired up. The HD83 is a single-ended design with the power pentode wired up in triode configuration for added sonic purity, and it is as quiet as a mouse. For sound quality Jon Marks says, "The bass is punchy and controlled without becoming artificial, while treble has the crispness of the best

solid-state, with the tonal purity, delicacy and speed associated with valves." External dimensions 18cm(w) x 30cm(l) x 8cm (h) weight 4kg.

£195



World Audio design

PROBABLY THE BEST DIY KITS IN THE WORLD

NEW DEMONSTRATION ROOM NOW OPEN AT 12A SPRING GARDENS, NEWPORT PAGNELL, MILTON KEYNES, BUCKS MK16 0EE- CALL FOR DETAILS ON 01908 218836

KLS10 HIGH TECHNOLOGY COMPACT MONITOR

Our mini-marvel uses an Audax carbon fibre bass/midrange unit, married to the world's most advanced tweeter, the piezo-electric gold dome HD3P from Audax. KLS10 offers high performance from a small package. The main 'speakers are designed to work alone, or with a dedicated subwoofer to extend their bass. Alone, they are suited to near-wall mounting and can be tuned by port adjustment to suit personal taste and location. They are easy to drive and need just 30-60watts. KLS10 is unique. Technically advanced, yet compact and relatively inexpensive, there is little to match it. Sensitivity 89dB 1W/1m, 15mm MDF, internal volume 9Ltrs, external dimensions 19cm(w) x 31cm(h) x 23cm(d).

Drive Unit & Crossover kit **£433.00**
Drive Unit only **£394.00**



£433

KLS10 GOLD SUBWOOFER

Designed to complement KLS10 Gold stand mounters by providing deep and open bass. The subwoofer is inexpensive, easy to build, comprising a simple crossover network with a high quality 8 inch Aerogel dual voice coil unit. A must for all KLS10 Gold customers. Sens. 89dB, volume 25 litres, external dimensions 28cm(w) x 43cm(h) x 34cm(d).

Drive Unit & Crossover kit **£164.00**
Drive Unit only **£78.00**



£164

KLS3 GOLD MK II ADVANCED TECHNOLOGY 3 WAY LOUDSPEAKER

KLS3 Gold uses the latest version of Audax's innovative oval gold dome piezo electric tweeter, giving it the sweetest and most extended treble. Married to a 4in. carbon fibre cone midrange driver for neutral and clear reproduction, and a powerful 8in. bass driver for superb depth, this is our top-of-the-line reference 'speaker. Sensitivity 90dB at 1W/1m, 25mm MDF, internal volume 60Ltrs, external dimensions 26cm(w) x 100cm(h) x 35cm(d).

Drive Unit & Crossover kit **£633.00**
Drive Unit Pack **£495.00**



£633

Upgrade your KLS3s to Gold status. Includes latest oval gold dome piezo tweeter and all components.

for

£363

Mains transformers & Chokes

KIT6550/KAT6550 mains transformers
2 inch stack, 130mm(h)x120mm(w)x135mm(l) drop through fitting with zinc cap. Secondaries 425V-0V-425V, 350mA, 0V-5V, 6A, 3.15V-0V-3.15V, 9A. Suitable for 120V & 240Vac operation

KEL84 mains transformer
1.5 inch stack, 90mm(h)x80mm(w)x95mm(d) drop through fitting with zinc cap. Secondaries: 0V-240V 300mA, 3.15V-0V-3.15V, 5.5A, suitable for 120/240V operation

KIT88/KAT88 mains toroidal transformer
120mm dia. x 60mm(h). Secondaries: 195V-0V-95V, 450mA/0V-27V, 100mA/3.15V-0V-3.15V, 9A, suitable for 120/240V operation

KIT34/KAT34/KIT6550/KAT6550 choke
1.25 inch stack, 65mm(h)x105mm(w) with fitting holes x 60mm(d). clamp fitting, 2.5 H, 350mA

300B PSE mains E/I transformer
130mm(h) x 95mm(w) x 115mm(d). drop through fitting with zinc cap. Secondaries: 380V-0V-380V, 180mA/150-0V-150V, 25mA/0V-5V, 1.2A/0V-5V, 1.2A/0V-5V, 3A/3.15V-0V-3.15V, 0.4A suitable for 120/240V operation

KEL80 mains toroidal transformer (encapsulated)
130mm dia. x 65mm(h). Secondaries: 195V-0V-195V, 390mA/0V-27V, 100mA/3.15V-0V-3.15V, 7.5A, suitable for 120/240V operation

HD83 mains toroidal transformer
80mm dia. x 35mm(h). Secondaries: 0V-165V, 75mA/3.15V-0V-3.15V, 1A, suitable for 120/240V operation

PSU-II mains toroidal transformer
80mm dia. x 35mm(h). Secondaries: 0V-270V, 60mA/0V-10V, 2A, suitable for 120/240V operation

TRANS1 mains toroidal transformer
95mm dia. x 50mm(h). Secondaries: 0V-370V, 150mA/0V-6.3V, 3.5A 300B E/I choke 65mm(h) x 70mm(d) x 80mm(w) open frame fitting, 10H, 180mA.

KEL84 E/I choke
0.5 inch stack, 40mm(h)x35mm(d)x70mm(w) clamp fitting, 1H, 250mA

PSU-II E/I
40mm(h) x 35mm(d) x 70mm(w) clamp fitting, 15H, 20mA

KIT34/KAT34 mains transformer
2.5 inch stack, 120mm(h)x115mm(w)x95mm(d), drop through fitting with zinc cap. Secondaries 365V - 0V - 365V, 300mA/0V - 5V, 6A/3.15V - 0V - 3.15V, 7.5A. Suitable for 120/240V operation.

Output transformers

KIT6550/KAT6550 E/I 16% TAPPED UL push-pull output transformer
2 inch stack, 80mm(w) x 95mm(l) x 100mm(h), drop through fitting with zinc cap. Primary-secondary 4.5K, 16% UL tapped. Secondary 4 Oh 8 ohm, pls specify on order. max output 45 watts, max current 180mA, valves, KT88, 6550 etc

KEL84 E/I Ultra Linear push-pull output transformer
1.25 inch stack, 76mm(h)x63mm(w)x76mm(d) Primary - secondary, 8K with 12.5% UL tap - 8ohms, max o/p-15watts, max current 150mA valves EL84 etc

KIT88/KAT88 E/I push-pull output transformer
80mm(w)x95mm(l)x100mm(h). Primary-secondary 10K - 8ohms, max o/p-40watts, max current-160mA valves-KT88, 6550, EL34

KIT34/KAT34 E/I 14% tapped Ultra Linear push-pull output transformer
2 inch stack, 80mm(w)x95mm(l)x100mm(h), drop through fitting with zinc cap. Primary-secondary 6.4K, 14% UL taps, Secondary 8ohm, max output 34watts, max current 150mA, valves EL34, 6L6, 6CA7

KEL80 E/I parallel-push-pull output transformer
95mm(w)x115mm(l)x133mm(h). Primary-secondary 4.6K - 8 & 4ohms, max o/p-80watts, max current-250mA valves-EL34, 5881, 6L6

HD83 E/I single ended output transformer
40mm(w)x50mm(l) x55mm(h). Primary-secondary 4K - 4 x 64ohms windings, max o/p-1watts, max current-25mA valves-ECL83 etc

Pre-II E/I driver transformer
80mm(w)x60mm(l) x65mm(h), 6:1 step down transformer, max current-10mA valves-6922 etc pre-amp stage

300B PSE E/I parallel single ended output transformer
130mm(h) x 95mm(w) x 115mm(d). drop through fitting with zinc cap. Primary 1K5 Secondary 8R, output .

Printed circuit boards

Kel84 Printed Circuit Board 280mm(w) x 135mm(l) x 1.6mm(d).

KIT88/KAT88 Printed Circuit Board 140mm(w) x 310mm(l) x 1.6mm(d).

Kel34 Printed Circuit Board 140mm(w) x 310mm(l) x 2.4mm(d).

Kel80 Printed Circuit Board (a pair) 120mm(w) x 215mm(l) x 1.6mm(d).

HD83 Printed Circuit Board 140mm(w) x 160mm(l) x 1.6mm(d).

Kit34/KAT34 Printed Circuit Board 105mm(w) x 130mm(l) x 1.6mm(d).

PRE-II Printed Circuit Board 105mm(w) x 130mm(l) x 1.6mm(d).

PHONO-II Printed Circuit Board 105mm(w) x 130mm(l) x 1.6mm(d).

Hi-Fi World in Malaysia at Millennium Hi-Fi & Av. Kuala Lumpur, Malaysia

Hi-Fi World is now distributed through good bookshops and newstands in Malaysia. For back issues, general enquiries and advertising, contact Simon Chang at Millennium Hi-Fi & Av.

Also available are products by World Audio Design, Michell, Trichord, Lowther and ReThm loudspeakers.

Millennium Hi-Fi & Av
500-1-3 First Floor, Wisma Indah (Shen Court),
Jalan Tun Razak 50400 K.L.

tel: 603 9283 8171 fax: 603 9281 3762

137 Jalan Pendekar 2, Taman Skudai Baru, 81300 Skudai, Johor DT
tel: 607 554 5171 fax: 607 554 7645

e-mail: info@millennium-audio.com





order on our website @

www.worldaudiodesign.co.uk

amplifier kits description

KaT6550 valve power amplifier kit (with valves)
KaT6550 valve power amplifier kit (without valves)
KaT 6550 upgrade kit
KIT6550 valve integrated amplifier kit (with valves)
KIT6550 valve integrated amplifier kit (without valves)
KIT 6550 upgrade kit
KAT34 valve power amplifier kit (with valves)
KAT34 valve power amplifier kit (without valves)
KaT34 upgrade kit
KIT34 valve integrated amplifier kit (with valves)
KIT34 valve integrated amplifier kit (without valves)
KIT 34 upgrade kit
Kel84 valve integrated amplifier kit (with valves)
Kel84 valve integrated amplifier kit (without valves)
Kel84 upgrade kit
PSU II power supply unit module
PRE II pre-amplifier module
PHONO - II phono stage module (with valves)
PAS II passive pre-amplifier module with 10K or 50K attenuator (pls specify)
Moving Coil step up transformers
KIT88 upgrade kit
KaT88 Valve integrated amplifier kit (with valves)
KaT88 Valve integrated amplifier kit (without valves)
KaT88 upgrade kit
HD83 Valve Headphone amplifier kit (with valves)
Kel80 Valve Monobloc amplifier kit (with valves) - a pair
Kel80 Valve Monobloc amplifier kit (without valves) - a pair
300B PSE Valve Monobloc amplifier kit (with valves) - a pair
300B PSE Valve Monobloc amplifier kit (without valves) - a pair
300B PSE Upgrade Kit - a pair

order No. qty
KaT6550 (with valves)
KaT6550 (without valves)
KaT 6550 upgrade
KIT6550 (with valves)
KIT6550 (without valves)
KIT 6550 upgrade
KAT34(with valves)
KAT34(without valves)
KaT34 upgrade
KIT34 (with valves)
KIT34 (without valves)
KIT34 upgrade
Kel84 (with valves)
Kel84 (without valves)
Kel84 upgrade
PSU - II
PRE - II
PHONO II
PAS II
MC - step up (pair)
KiT88 upgrade
KaT88(with valves)
KaT88(without valves)
KaT88 upgrade
HD83 (with valves)
Kel80 (with valves)
Kel80 (without valves)
300B PSE (with valves)
300B PSE (no valves)
300B PSE upgrade kit

uk (inc vat & carriage) overseas (exc. vat & carriage)
£495.00 £422.00
£450.00 £380.00
£120.00 £105.00
£120.00 £105.00
£595.00 £510.00
£465.00 £395.00
£130.00 £110.00
£490.00 £410.00
£415.00 £354.00
£120.00 £105.00
£495.00 £420.00
£430.00 £365.00
£130.00 £110.00
£278.00 £237.00
£248.00 £212.00
£100.00 £85.00
£195.00 £167.00
£195.00 £167.00
£110.00 £95.00
£215.00 £185.00
£77.00 £66.00
£150.00 £130.00
£468.00 £399.00
£341.00 £291.00
£140.00 £120.00
£195.00 £167.00
£649.00 £553.00
£572.00 £487.00
£1177.00 £1002.00
£375.00 £345.00
£150.00 £130.00

loudspeaker kits

KLS3 Gold mkII Drive Units
KLS3 Gold mk II Drive Units + Crossover Kit etc
KLS10 Drive Units
KLS10 Drive Units + Crossover Kit etc
KLS10-Subwoofer Drive Units
KLS10 Drive Units + Crossover Kit etc

order No. qty
KLS3G-D
KLS3G-C
KLS10D
KLS10C
KLS10-subD
KLS10-subC

uk (inc vat & carriage) overseas (exc. vat & carriage)
£495.00 £422.00
£633.00 £539.00
£394.00 £336.00
£433.00 £369.00
£78.00 £67.00
£164.00 £140.00

parts description

KIT/KaT6550 mains transformer
KIT34 mains transformer
Kel84 E/I mains transformer
KIT88/KaT88 mains toroidal transformer
Kel80 mains toroidal transformer(encapsulated)
HD83 mains toroidal transformer
PSU-II mains toroidal transformer
300B PSE E/I mains transformer
KIT34 E/I choke
Kel84 E/I choke
KIT6550 choke
300B PSE choke
PSU-II E/I choke
KIT34 E/I UL push pull output transformer
KIT/KaT6550 E/I UL output transformer
Kel84 E/I push-pull output transformer
KIT88/KaT88 E/I push-pull output transformer
Kel80 E/I parallel-push-pull output transformer
HD83 E/I single ended output transformer
Pre-II E/I driver transformer
300B PSE E/I output transformer
Kel84 Printed Circuit Board
KIT88/KaT88 Printed Circuit Board
Kel34 Printed Circuit Board
Kel80 Printed Circuit Board
HD83 Printed Circuit Board
PSU-II Printed Circuit Board
PRE-II Printed Circuit Board
PHONO-II Printed Circuit Board
Tag board 2 x 16 connections (hard wiring)
Alps blue audio grade 50K dual log potentiometer
Alps blue audio grade 100K dual log potentiometer
Stepped attenuator with resistor pack 10K of 50K (pls specify)
LCR 22.5uF 440Vdc polypropylene capacitors
Ansar 22.5uF 630Vdc polypropylene capacitors
Jensen 0.47uF 630Vdc paper in oil capacitor
Jensen 0.22uF 630Vdc paper in oil capacitor
Jensen 0.22uF, 400V paper in oil capacitor
Black Gate 220uF 50Vdc electrolytic
Black Gate 470uF 16Vdc electrolytic
Black Gate 100uF 100Vdc electrolytic
Black Gate 470uF 16Vdc electrolytic
Black Gate 100uF, 16V electrolytic
Black Gate 100uF, 50V electrolytic
KIT88/KaT88 chassis
650V safety gloves (a pair)
6550/34 cage

order No. qty
6550 mains T
KIT34 - mains T
Kel84 - mains T
88 - mains T
Kel80 - mains T
HD83 - mains T
PSU-II - mains T
300B - mains T (each)
KIT34 - choke
Kel84 - choke
KIT6550 choke
300B - choke
PSU-choke
34 - O/P T (pair)
6550 O/P T 40hm??Bohm?(pair)
Kel84 - O/P T (pair)
88 - O/P T(pair)
Kel80 - O/P T(pair)
HD83 - O/P T(pair)
PRE-II - driver T(pair)
300B - O/P T (each)
Kel84 - PCB
88 - PCB
Kel34 - PCB
Kel80 - PCB(pair)
HD83 - PCB
PSU-II - PCB
PRE-II - PCB
PHONO-II - PCB
IAG
ALPS - 50K
ALPS - 100K
Attenuator + resistor pack
LCR - 22.5U
ANSAR - 22.5U
JEN - 0.47U
JEN - 0.22U
JEN - 0.22U, 400V
BG - 220U
BG - 4700U
BG - 100U
BG - 470U
BG - 1000U16V
BG - 100U50V
88-CHAS
SAFETY GLOVES
34/6550 cage

uk (inc vat & carriage) overseas (exc. vat & carriage)
£110.00 £95.00
£100.00 £85.00
£55.00 £47.00
£83.00 £71.00
£83.00 £71.00
£39.00 £34.00
£39.00 £34.00
£130.00 £111.00
£49.00 £39.00
£20.00 £17.00
£45.00 £38.00
£50.00 £43.00
£20.00 £17.00
£130.00 £110.00
£130.00 £110.00
£88.00 £75.00
£143.00 £122.00
£187.00 £160.00
£94.00 £80.00
£77.00 £66.50
£140.00 £119.00
£24.00 £20.90
£41.00 £35.15
£12.00 £11.40
£52.00 £44.65
£20.00 £17.00
£20.00 £17.00
£20.00 £17.00
£3.50 £3.00
£14.00 £12.00
£14.00 £12.00
£75.00 £65.00
£10.00 £8.50
£18.00 £15.20
£20.00 £17.00
£16.00 £14.00
£12.00 £10.20
£12.00 £10.20
£16.00 £13.60
£10.00 £8.50
£8.00 £7.00
£8.00 £7.00
£6.00 £5.20
£100.00 £85.00
£14.00 £12.00
£65.00 £55.00

World Audio Design Amplifiers fully built from Malaysia

Table with 3 columns: Title, Description, Price (exc. VAT + Carriage)

Order from our Far East Distributor: Millenium Hi-Fi & AV
137 Jalan Pendekar 2. Taman Skudai Baru, 81300 Skudai, Johor DT, Malaysia
Tel: 07 554 5171 - Fax: 07 554 7645 - email:mha8@pdjaring.my

order information

NAME:
ADDRESS:
POST CODE:
COUNTRY:
TEL. (DAY):

Tel/Fax: 01908 218 836

I enclose cheque/postal order for £ made payable to World Audio Publishing Ltd. I wish to pay by Mastercard / Visa /Switch/ Solo. Please debit my account no:

Expiry Date: Signature: Issue No. (Switch/Solo only) Valid Date:

Pricing were correct at time of print 01/01/02 they are subject to change
If you wish for a built item, please phone for a quote / Valves included except where otherwise stated If you would like a data sheet on any of the kits, please write a 'D' in the qty box

WARNING - World Audio Publishing Ltd. accept no responsibility for kits, parts or modifications made or supplied by third parties. Order on our website www.worldaudiodesign.co.uk
Please send your completed order form to:



World Audio Design

WE HAVE OVER 30

AUDIO ELECTRONIC THEORY BOOKS



Electronics made Simple
by Ian Sinclair
This book covers the basic theory and principles of electronics. A good read for the beginner.
Code No. 1420
£12.99 + £2.00 P&P (UK)

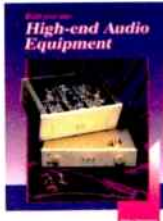

Build your own High-End Audio Equipment
by Elektor
Build your own High-End Audio equipment contains construction projects for solid state preamplifiers and power amplifiers, active cross-over filters, an active subwoofer, a mono/stereo compressor and a headphone amplifier.
Code No. 1390
£14.95 + £2.25 P&P (UK)

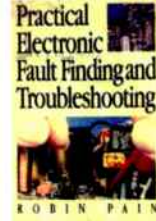

Practical Electronic Fault-Finding and Troubleshooting
by Robin Pain
This book explains the basic techniques needed to be a troubleshooter, using only basic equipment: a digital multimeter and an oscilloscope. Simple circuit examples are used to illustrate principles and concepts fundamental to the process of fault finding.
240pp 235mm x 156mm Paperback
Code No. 1430
£20.99 + £2.25 P&P (UK)



Build your own Electronic Test Instruments
by Elektor
This book contains designs for 17 measuring instruments, seven generators and analysers, ten miscellaneous instruments and a number of test ancillaries and auxiliaries. The designs range from a simple multicore cable designs contain a special printed circuit, drawing of which are given in an appendix.
Code No. 1400
£15.95 + £3.25 P&P (UK)



The LP is back
by Audio Amateurs
Your complete guide to LP care and maintenance designed to offer you everything useful for those who love and enjoy this older music medium. This covers the theory and care of LPs and the electronics and mechanics of its players.
154pp Paperback
Code No. 1620
£8.00 + £1.50 P&P (UK)



The Joy of Audio Electronics
by Charles Hansen
This is a fail-safe guide to the pleasures of hands-on electronic construction. This book covers test and measurement projects, how to build simple kits, safety issues, the workplace, theory and resources. A must for the beginner who plans to build more advanced electronic projects in the future.
124pp Paperback
Code No. 1650
£10.50 + £2.25 P&P (UK)

VALVE BOOKS

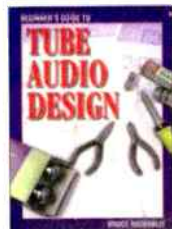

The Beginner's Guide to Tube Design
by Bruce Rozenblitz
This book takes a comprehensive look at tube audio design. It explains how vacuum tubes work and how to design with them. Rozenblitz covers stabilisation and testing, a description of 13 famous and classic amps and preamps and how to work effectively as a designer. A hands-on guide to construction techniques, tools and choosing components and tubes is provided. 1997, 132pp., 8 1/2" x 11" Paperback
Code No. 1340
£15.50 + £2.25 P&P (UK)



Vacuum Tube Amplifiers
by Valley & Walkman
This book is a well known reference valve text book and is assembled from pieces by ten knowledgeable authors. An absolute bible when it comes to valve electronics.
734pp 140mm x 210mm
Paperback
Code 1770
£29.95 + £ 4.00 P&P (UK)



Mullard Tube Circuits for Audio Amplifiers
Includes full designs for eleven power and control amps, including 5-20, using valves. Begins with a four chapter tutorial on getting the best sound from valve amplifiers.
142pp 8" x 10" Paperback
Code 1030
£13.95 + £1.50 P&P (UK)

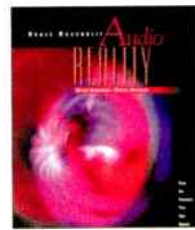

Audio Reality
by Bruce Rozenblitz
A fine read that investigates conductors, skin effect, impedance, interconnects, speaker cables, balanced lines, transmission lines, power cords, isolation transformers, damping systems, tubes, acoustics and much more. Also, includes 6 excellent detailed valve design projects, 80watt OTL/25watt OTL, grounded grid pre-amp, 150watt amp., 6550 SE amp, and a grounded grid cascode phono preamp.
Paperback 128pp
Code No. 1640
Price 21.50 + 2.25 P&P (UK)



An Approach to Audio Electronic Valves in Audio Frequency Amplifiers
by E. Rodenhuis
Originally published in 1954 by Philips, this book encourages amp. builders to experiment with design elements. Discussing the use of valve data, the function of different amplifier stages and includes detailed descriptions of eight designs. A wealth of practical data, measurements and interesting features will be found. A very good read.
Paperback 147pp
Code No. 1520
Price £12.95 + £2.00 P&P (UK)

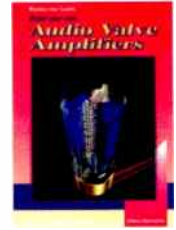

Build your own Audio Valve Amplifiers
by Rainer Zur Linde
This book covers construction projects for preamplifiers, power amplifiers and two amplifiers for musical instruments aimed at the practical audio/hi-fi enthusiasts. It offers much information on the operation of electron tubes, while the first chapter gives a short history of the thermionic valve.
paperback, 251pp, 235mm x 133mm
Code No. 1320 £14.95 + 2.25 P&P (UK)

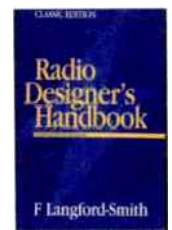

Radio Designers Handbook 4th Edition
by Fritz Langford-Smith
This is a classic reference handbook for all who are interested in the design and application of audio amplifiers and radio receivers, and deals with basic principles and the practical design of all types of classic audio amplifiers, radio receivers and record-producing equipment, up to the invention of the transistor, covering valves, valve testing, general theory and components; audio and radio frequencies; power supplies, design of complete AM and FM receivers, and reference information.
1498pp 216mm x 138mm Hard back
Code No. 1600
£39.99 + £6.00 P&P (UK)

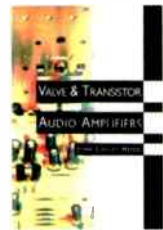

Valve & Transistor Audio Amplifiers
by J L Hood
This is J L Hood's greatest work yet, describing the milestones that have marked the development of audio amplifiers, from the earliest valve amps to the latest solid state design. It is the complete world guide to audio amp design. Other contents: active & passive components, amplifiers, pre-amplifiers and power supplies.
250pp., 156mm x 232mm Paperback
Code No. 1530
£20.99 + £3.50 P&P (UK)

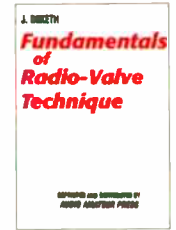

Fundamentals of Radio-Valve Technique
by Luciano Marci
This is part of the Philips technical series written in 1947 it was one of the most authoritative and comprehensive treatment of the nature and function of the vacuum tube.
534pp 6" x 9" Paperback
Code No. 1630
£21.50 + £2.50 P&P (UK)

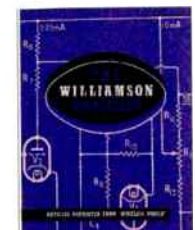

The Williamson Amplifier
by D.T.N. Williamson.
Offers practical advice on how to build and set up the amplifier for best results.
40pp 8 1/2" x 11" Paperback
Code No. 1040
£9.95 + £1.50 P&P (UK)



Valve Amplifiers (second edition)
by Morgan Jones, Audio Engineer
This book allows those with a limited knowledge of the field to understand both the theory and the practice of valve audio amplifier design, such that they can analyse and modify circuits, and rebuild an amplifier. Constructional techniques are also provided so readers can build from scratch designs that actually work.
488pp 6" x 9 1/4" Paperback
Code No. 1330
£25.99 + 3.50 P&P (UK)



The Best of Audion editorial projects
by Luciano Marci
This book contains six excellent audio projects: a high sensitivity speaker, a superb tube pre-amp, a 2A3 amplifier design, a project using the Russian 6C33CB and two projects using 300B as output valves. Overall the book is a fabulous read.
62pp. paper back
book code 1750
£12.00 + £2.00 UK p+p

ORDER 4 BOOKS & OVER & PAY ONLY £7.00 FOR P&P (UK ONLY)

World Audio Library

TITLES ON OFFER!!!

Manuale Hi-Fi a valvole Schematico 2*

An Italian publication with all circuit diagrams in standard conformation, therefore, all circuits are easy to follow. This book is dedicated to self makers and to Hi-Fi tube engineers. With a wealth of circuit diagrams from some of the best valve amplifiers, pre-amplifiers and phono equipment producers in the world. Including, Audio Research, Altec, Conrad Johnson, Art Audio, Luxman, Carver, Dynaco, Electrovoice, Leak, McIntosh, Marantz, Quad, Radford, Quick Silver, numerous OTL designs, Verdier, VTL and Western Electric. Well worth the money.
208pp, 210mm x 300mm Paperback
Code No. 1720
£44.00 + £4.00 P&P (UK)

First in High Fidelity The Products and History of H. J. Leak & Co. Ltd.

by Steven Spicer
 This book is the unique and comprehensive story about one of the world's best high-fidelity audio companies. Contained are 300 pictures, 30 circuit diagrams for classic designs of the day. There are also numerous anecdotes and contributions from ex-employees. A wonderful historical read.
270pp 195mm x 264mm Paperback
Code no. 1740
£19.95 + £3.25 p+p UK

Getting the most out of Vacuum Tubes

by Robert B. Tomer
 From the cover, "Types and causes of tube failures, what to expect from tubes, testing methods and all about tube maintenance programs." This book is intended to offer explanations of why tubes fail and what to do about it. Discussions of catastrophic and degenerative failures; selecting tubes and tube types and testing and predicting tube performance.
160pp 140mm x 216mm
Paperback,
Code No. 1710
£13.95 + £2.00 P&P (UK)

Basic Theory and Application of Electron Tubes

A US Army & Navy Publication
 This book is an excellent introduction into valves. It does just about everything its title suggests. Written in 1957 it was used by the US military as a text book in their electronics department. Superbly written it contains all you need to know.
215pp
200mm x 260mm Paperback
book code 1760
£17.95 + £3.25 P&P (UK)

Modern High-End Valve Amplifiers Based on Toroidal Output Transformers

by Menno van der Ven
 Explains the whys and wherefores of toroidal output transformers at various technical levels. Discussed extensively within this book are designs for amplifiers from 10 to 100 watts. Finally, the author gives some attention to a number of special valve amplifiers, and to the theory and practice of negative feedback.
250pp 170mm x 240mm
Hard back
Code No. 1670
£24.95 + £2.50 P+P (UK)

Sylvania Technical Manual by Sylvania Electric Products Inc.

This 13th edition contains data on more than 3300 electron tubes and semiconductor devices. Reprinted here without the TV picture tube section, this manual contains detailed information on Sylvania's devices including charts and diagrams. A master index is found in the front of the book for reference.
516pp 140mm x 216mm Paper back
Code No. 1700
£16.95 + £3.50 UK p+p

LOUDSPEAKER BOOKS

Testing Loudspeakers+

by Joe D'Appolito
 Joe D'Appolito, loudspeaker designer and consultant, has written the definitive text on testing loudspeakers. Dr. D'Appolito brings his expertise to the subject and provides you with a hands-on discussion of testing drivers and systems. He brings you the theory and physics behind loudspeaker testing in this volume.
Paperback
Code No. 1580
£24.95 + £2.50 P&P (UK)

Bullock On Boxes

by Robert M. Bullock III
 Using Thiele-Small parameters clearly, it offers lots of helpful tables and graphs to get to grips with the sizing of the box and port of a reflex loudspeaker.
72pp 8 1/2" x 11" Paperback
Code No. 1100
£12.95 + £2.00 P&P (UK)

Audio Amateur Loudspeaker Projects

A collection of the 25 best speaker articles published in the Audio Amateur throughout the 1970s, this popular book is proof that great designs are never out of date. This volume is a rich source of theory, practice and design.
135pp 8 1/2" x 11" Paperback
Code No. 1550
£16.95 + £2.50 P&P (UK)

Electrostatic Loudspeaker Design and Construction

by Ronald Wagner
 Step by step guide to the design and construction of a full range electrostatic loudspeaker, including basic operating principles. Strongly recommended for those wanting to either build, repair and/or restore, or who are just interested in electrostatics.
243pp 7" x 9 5/8" Paperback
Code No. 1080
£16.95 + £3.25 P&P (UK)

Theory and Design of Loudspeaker Enclosures

by J. E. Benson
 Covers infinite baffle, reflex, passive radiator etc. in great detail with a highly mathematical approach, making it unsuitable for beginners but highly authoritative for experienced designers.
244pp 6" x 9" Paperback
Code: 1140
£23.95 + £2.50 P&P (UK)

Loudspeakers: The Why and How of Good Reproduction

by G.A. Briggs
 An easy to understand book on building loudspeakers, using empirical techniques that pre-date computer analysis. Strongly recommended for beginners.
88pp 5 1/2" x 8 1/2" Paperback
Code: 1070
£10.95 + £1.50 P&P (UK)

The Loudspeaker Design Cookbook, 6th edition (new) -

by Vance Dickason
 This best seller offers up-to-date design information for the home constructor. It uses modern Thiele-Small theory and parameters.
288pp 8 1/2" x 11 1/2" Paperback
Code No. 1090
£29.50 + £4.00 P&P (UK)

Horn Loudspeaker Design

by Mr J. Dinsdale
 A collection of papers by Mr J. Dinsdale, that discuss the design and theory of this wonderful breed of loudspeaker. The book contains detailed drawings of numerous designs, including some Lowther classics. Also included with the book is a 3.5inch floppy disc with straight forward software to assist in the design process. A serious reference for those with an interest in horn speakers.
112pp paper back & 3.5 floppy disc
210mm x 300mm
Code: 1730
£29.50 + £2.50 P&P (UK)

Acoustics & Psychoacoustics 2nd Edition

by David M. Howard & James Angus
 An introduction to acoustics, covering human perception of sound, notes and harmony, musical dynamics, timbre of musical instruments, acoustic model for musical instruments, hearing music in different environments, deceiving the ear and processing sound electronically.
224pp 244 x 189mm
paperback
Code: 1370
£29.99 + £3.50 P&P (UK)

ORDER FORM

Please send (Code No.) _____ (enter codes clearly)

Pay: World Audio Publishing Ltd. £ _____ or debit my Mastercard/Visa/Switch/Solo (Card No) _____

Expiry date: _____ (Switch/Solo only) Valid Date: _____ Issue No. _____ Name: _____ Signed: _____

Delivery Address: _____

Tel: (Day) _____ Please return to: W.A.P. Ltd. 12A Spring Gardens, Newport Pagnell, Milton Keynes, MK16

SEE ENGLAND TEL/FAX: 01908 218836 **ORDER ON LINE** Website: www.worldaudiodesign.co.uk E-Mail: nick@worldaudiodesign.co.uk

Please contact us for overseas P&P charges. Allow 28 days for delivery. All orders subject to availability. If further space is required please attach separate sheet. **TICK BOX IF YOU HAVE ORDERED BEFORE**

ORDER 4 BOOKS & OVER & PAY ONLY £7.00 FOR P&P (UK ONLY)

improve your listening pleasure

visit our web site for reviews, up-to-date stock lists and much much more

NEW & EX DEMO EQUIPMENT

Wilson Benesch NEW £
We are delighted to announce that we have just been appointed dealers for this superb brand. ACT1 and ARC both on demo. Visit our web site for full specification and links reviews on the whole range.

CHORD

DAC64 (£1900) & CPM 3300 (£5595) on Demo, full range available. Visit our web site for details, prices, specifications & reviews

PS Audio

PS600 with multi wave on demo - Amazing review. See what can be achieved with mains regeneration - £2700

Visit our web site for details, prices, specifications & reviews

Audio Note

Full range available. Many items on demonstration.

Visit our web site for details, prices, specifications & reviews

STAX Headphones

Full range available

Visit our web site for details, prices, specifications & reviews

Perpetual Technologies

If you read the HiFi News review on the amazing PA-1A Digital to Digital processor and the P-3A Up sampling DAC 24/96, you will realize how good they actually are at £1099 & £799 respectively. They will transform your CD playback in a way you could never imagine. Visit our web site for details, prices, specifications & reviews.

P-3a Signature model now also available at £1099. We also have the Manalithic power supply unit at £349

CEC

Full range of these amazing Belt drive CD player transport and DACs available including the incredible TL51Z Belt Drive CD player with 24/356 upsampling for only £1625 - on demo. Visit our web site for details, prices, specifications & reviews

Conrad Johnson

Full range available. Visit our web site for details, prices, specifications & reviews

Magnum Dynalab Tuners

Visit our web site for details, prices, specifications & reviews

EAR

EAR V20 Integrated. Great reviews & a visual masterpiece - on demo 2799
EAR 861 power amp, Great reviews on demo 3799
EAR 864 pre. Balanced inputs/outputs - on demo 1529
EAR 834P deluxe. MM/MC phono stage - on demo 889
MC3 MC step up transformer. Probably the best available - on demo Full range available. Visit our web site for details, prices, specifications & reviews

Veritas

P400 Digital power amp 240W - on demo 2995

Unison Research

NEW Model - DM dual mono power amplifier 150W per channel, can be bridged to form a 500W monoblock. - on demo 850
S2K pure class A using the legendary KT-88 power valve.
Single ended heaven - on demo 1300
S2 single ended ultralinear Class A ex demo 975
SR1 valve & solid state ex demo 1250
S6 single ended pure Class A ex demo 1600
S8 single ended Class A 24W - on demo 2950
Simply Phono - Stunning all valve. New- on Demo 510
PSU for Simply Phono NEW 400
Smart 845 mono blocks - on demo 3450

Kuzma

Stabi S with -Stagi S tone arm - on demo 1245

HEART

CD6000 valve CD player. If you can find a better CD player under £1,000 we would like to know! - new model - on demo 640

Plinius

8100 100W - on demo 1450
1450Jarah phono stage on demo 599
8200 integrated 175W with phono stage 2250

Pathos

Classic One - on demo 995
Twin Towers RR - Hybrid valve & solid state. The best of both worlds. HiFi News loved it - so will you - on demo 3250

NEW £

NEW £

Pink Triangle

We have the all new integral amplifier on demonstration. At £3999 we think it's a bargain. Have a listen & judge for yourself

Audio Analogue

Bellini power amplifier. Superb - on demo 540
Donnizetti 100W monoblocks - on demo - pair 920
Maestro CD player - 24 bit 96 Khz upsampling - on demo 1500
Puccini SE integrated amp - on demo 635 540
Paganini 24 Bit CD player latest model - on demo 795 695
Maestro 150W Integrated amp - on demo 2500

Audio Physic Speakers

Virgo 111. New model - on demo 3999

Avanti 111 £7599, Virgo 111 £3000, Spark 111 £1695

Visit our web site for details, prices, specifications & reviews

Croft

Charisma X pre amp on demo 2050
Vitale pre amp. New - on demo 379
Dakshini S. New model 50W - on demo 3300
2950
Epoch Elite pre amp, reference quality, valve regulated PSU - on demo 1000
Apparition Elite 15W per channel OTL power amp - on demo 1600

Opera speakers, Triangle Loudspeakers, Monitor Audio, Benz Micro, Lyra, Sumiko, Dynavector

Visit our web site for details, prices, specifications & reviews

Final Electrostatics

0.3 ex demo 1495 995
0.4 New - on demo 2500 2195

Loth-X

Othello precision turntable - on demo 1145
Ion 85-1 speakers, 94 db. Great HiFi News review 400
The all new Amaze. 98 db efficient - on demo 750
The all new Aura Floorstander. 98 db efficient - on demo 1600

Lavardin

Full range available. Visit our web site for details, prices, specifications & reviews



EAR 834P SIGNATURE
MM/MC - Boxed
£390



PERPETUAL TECHNOLOGIES
P-1A & P-3A
Stereophile Grade A listed
P-1A On Demo P-3A
£1099 £799



Audio Physic Virgo III
Taking Virgo speakers to a new level
£3999



CHORD DAC 64
On demo - probably the most significant new product available for CD playback
£1900



EAR V20 - Great reviews and a visual masterpiece - on demo
£2799



PS AUDIO
PS600 with multiwave on demo - see what can be achieved with mains regeneration
£2700

CARED FOR USED EQUIPMENT

Turntables/Cartridges/Phono Stages NEW £

Musical Fidelity XLP-2, boxed as new 550 350
EAR 834P Signature MM/MC all valve phono stage 390
Michell Gyrodec SE with acrylic cover + RB300 - NEW 1175 795
Ortofon Jubilee boxed unused 1250 795
SME309, boxed new 629
SME 1V, boxed new 890
Ortofon Rahmann, boxed new 1200 649
Voyd Valdi 2 motor turntable with limited edition Helios Orion 10" silver wired tame arm and Goldring XL (£550) cartridge recently retipped by Vandehel at a cost of £200. All boxed as new 2900 995
Roksan Shiraz MC Cartridge. Boxed. Very low hours 1000 399

Amplifiers - Pre, Power, Integrated

Audion Black Shadow 845 Manos. 2 months old boxed with bal of Audion warranty 5000 3800
MM/MC phono stage. 2 months old 2000 1100
Lavardin II. Boxed as new. Very rare 3250 2600
Primare A30.1, new model with pre-out. Boxed new 1500 1250
EAR 834L, all valve line stage, as new 550 350
Sugden A21a integrated, latest spec, boxed as new 895 495
Trilogy Y1 50W integrated. Stunning looks.
Triade made upgrade. As new 2700 1595
Tube Technology Unisil valve integrated. Bxd as new 2400 1195
Musical Fidelity XP100 pre. Boxed as new 799 499
Naim NAC 92/NAP 90.3 pre/power. As new 1500 495
Capland CSA2B. As new, only 6 months old (see matching CD player) 1500 795
Chord SPM 600. 3 months old 2195 1495
Krell KAV 500i. 250W boxed as new 5495 2950

Amplifiers - Pre, Power, Integrated NEW £

Pathos Classic One, hybrid 50W ex demo 995 795
Unison Feather One remote control pre amp with external PSU. Ex demo 1095 595
Plinius 8100 integrated 100W. Ex demo 1495 995
Lavardin IS. Amazing reviews. 5 mths old. Bxd 1495 1095

Speakers

Living Voice Avatar. 2 months old in cherry 2500 1999
Gershman Acoustics Avantgarde RX-20. Boxed 4900 2990
JM Labs Mezzo Utopia. Bxd new 7400 5600
JM Labs Mini Utopia + matching stands. Bxd 4900 2900
Monitor Audio GR20 (new model) Bxd as new 1595 1095
ATC SCM 50-A SL V. Rare. Bxd as new. Yew finish 7999 3495
Wilson Benesch Actor. Latest spec. Bxd as new 4000 2800
Kef Concerto 2. 3 mths old Bxd as new 799 390
Sonus Faber Minima Amators with Stonewood stands. As new 2700 1090

CD Players, Transports, DACs

DCS Purcell. New Jan 2001. Bal of 5 yr warranty 4000 2795
Marantz SA 1 super audio CD player. Full warranty 5000 3900
Sony SCD-1, 12 months old. Bxd as new 4000 2495
Primare D30.2 24/96 new model. Boxed new 1500 1195
Sony SCD 777 ES(top loading) with Audiacom upgrade - (£550), Bxd as new 2395 1495
Audio Synthesis OAX 11. Bxd as new 2200 895
Roksan ROK OP-1 Transport. Bxd as new 1600 495
Micromega Stage 3 CD player. Top of the range 950 390
Capland CDA 266. 6 months old. As new 1500 795
Krell KAV 300 CD player. Bxd as new 4290 2495
Electrocompaniet EMC-1. Latest spec. NEW 2390 1995
Musical Fidelity X-Ray, CD player. As new 799 495
Cyrus dAD3 CD player 600 350

Croft
Kuzma
Conrad Johnson
Benz Micro
Cardas
Loth-X
Unison Research
Opera
Audio Analogue
Final
Pathos
Graaf
LAT
Monrio
Diapason
Esopower
Ecosse
Veritas
Plinius
Triangle
Michell
Audio Physic
Lavardin
EAR
CHORD
PS Audio
QEC
Perpetual Technologies
Monitor Audio
STAX
Magnum Dynalab Tuners
Wilson Benesch

Open: Mon - Sat 9.30 - 5.30 pm
E Mail: info@connoisseuraudio.co.uk

01592 630652 Connoisseur Audio

www.connoisseuraudio.co.uk

I'm always interested in technology and what new goodies lie just around the corner, seemingly to make life easier, more convenient, cheaper – and all that. We all know that in practice these things usually make life more difficult, as we struggle with arcane complexity – and always more expensive of course. But who cares; the DIY side in me is always alert to new and interesting possibilities. Looked at as toys rather than necessities I'm willing to overlook a certain loss of wonga if in turn it brings me hours of perhaps-perverse fun.

This month seems to be the month of disc drives, new, current and expiring. Let me talk about expiry first – in this particular case "the click of death". This is the repeated clicking, or clunking, that comes from an Iomega Zip drive as it struggles to read a disc. Like so many offices I suspect, at Hi-Fi World we use Zip drives for short term storage and file transfer, or 'sneakernet' as it's sometimes called. Most of them have worked well, but a few have left this mortal coil a little prematurely in my view. Now a relatively new one is starting to click away and I am becoming concerned. Having used 40MB Syquests in the past, like all publishing houses, we moved to their smaller, higher density EZ Flyers. These things would regularly peg out at critical moments, like when trying to assemble all files for the film makers at the very last moment, which always happened to be late Friday night when we were all tired and dreaming of a bit of writer's relaxation down at the local. The EZ Flyer sealed the fate of once great Syquest and left Iomega, their competitors, a free field with the Zip drive. Our Zips have to date worked well enough for us to rely on them, but I wonder whether this will continue.

There's Internet discussion on the subject and a site at - <http://members.aol.com/zipcod1/zip.html> which describes this problem in detail. I wonder whether our Zip drives will end up in a heap in the corner of the office like our Syquests.

It isn't just this problem that has dampened my enthusiasm for building

Zip into our computers to replace the floppy, for fast, hassle free file interchange. It is the upcoming Mount Rainier CD format from Philips. Here's a development that appeals to me especially, because I am convinced about the potential of 8cm mini-CD and MR could well see turn it into the replacement for floppy disc that computers so need.

Mount Rainier is a packet writing format to CD-RW that integrates with operating systems. It will be available for both PCs and Macs. Discs will be UDF formatted and files can be simply

I wonder whether our Zip drives will end up in a heap in the corner of the office like our Syquests.

and quickly dragged and dropped to disc.

At present we write to mini-CDs and fling these around the office, using larger 12cm CDRs for long term storage. It's not ideal though, because old files clutter discs unless stringent housekeeping sees them into the waste bin at the right moment. Zips are more convenient. Trouble is, they are seven times more expensive than CDs and the "click of death" comes from head clogging and surface damage it seems.

I'm reminded by this that one of the enduring strengths of CD is that it's a non-contact medium and it doesn't have a ferromagnetic surface layer either, nor read/write heads. I've never heard of a laser or sensing head crashing onto the surface of a CD.

So all of a sudden the audio CD, launched way back in 1983, looks set to take over from the clanky old floppy disc and the Zip too. One mini-CD can hold 180MB and costs around £1. There's nothing that can compete on price and, with an updateable TOC, on convenience.

But that's not all. Yamaha make some great CD writers and they've been busy improving CD too. Their CRW3200E includes Yamaha's Audio Master Quality Recording technology which widens both pits and lands to lower jitter and improve audio sound quality. Some

playing time is lost, but not much. This drive supports the new CD-MRW Mount Rainier format as well. The audio CD just goes from strength to strength it seems.

It strikes me that MR will allow us to record tracks to CD much as we once did with cassette. If I understand what Philips (www.mt-rainier.org) and Yamaha are saying correctly, this will be possible, but only using players that are Mount Rainier savvy.

In other words, after updating our hi-fi systems/ cars/ computers/ with machines capable of sensing low reflectance CD-RWs, we will shortly be expected to do the same again with MR recorders. How Philips ever made a loss last year I'll never know!

Whilst Philips and Yamaha wrestle to make the CD all-conquering, others dream of replacing it - Constellation 3D for example (www.c-3D.net), with Fluorescent Multi-layer Discs (FMDs). Their "CD sized FMD ROM discs will hold 20-100 GBs. In comparison, a standard DVD disc holds just 4.7 GBs". FMDs are under development and will be with us soon, Constellation tell us. Doubtless just after we have all bought our Audio Master Quality, Mount Rainier CDs and recordable DVDs.

Toys – don't you just love 'em! ●



Noel Keywood



Salon

SCOTLAND'S FIRST AND FOREMOST DEALER

"The List"

All Hi-Fi equipment guaranteed six months from date of purchase, "Supplied and Supported by The Audio Salon Ltd."

All items available next day (UK) by UPS for £9 per box. US and Worldwide Export at cost - details on request.

	List	Sale
ANALOGUE		
Audio Note AN-1S/ANVx Tonearm	£2,450	£1,250
<i>Brand new, boxed, unused. QC reviewer grade!</i>		
Voyd With Zeta arm	£3,225	£ 1,099
<i>Black Ash; ANV silver-wired arm, mint</i>		
Fanfare FT-1 Tuner	£1195	£ 450
<i>Boxed, new, unused, acclaimed</i>		
Nakamichi CR1-E	£ 295	£ 100

DIGITAL

David Manley The RefDac	£5,995	£1,995
<i>A Reference valve DAC, the reviews said it all</i>		
Mark Levinson 31.5 CD Transport	£9,995	£5,895
<i>12 months old, supplied by us, mint, 4-yr warranty</i>		
Mark Levinson No 39 CD player	£5,249	POA
Naim CD 3.5 CD Player	£1,100	£ 600
<i>Mint, perfect, impressive</i>		
Naim CDS-2,XPS, Flash Remote	£6,080	£2,995
Sugden SDT-1	£1,195	£ 495
<i>Classic build + Sonics</i>		
Sugden MasterClass CD	£2,500	£1,895
<i>Ex Dem, Full Warranty</i>		
Timbre DAC TT-1	£2,995	£1,000
<i>Ex-Wadia Heritage</i>		
VAC DAC-2 MkII + Power Supply (230vAC)*		
<i>Legend in the USA, this tube DAC is magnificent anywhere, See photo</i>		
	£4,395	£1,995
WADIA 7 & 9 CD Transport and DAC	£25,000	£9,995
WADIA 20 CD Transport	£4,000	£1,995
WADIA 10 Optical Interface	£2,900	£1,400
<i>Use with Wadia 9</i>		

AMPLIFIERS

ATC SIA2 Integrated	£2,375	£1,495
<i>150 wpc, x/d, r/c, mint, See photo</i>		
Audio Note P4 monoblocks	£5,895	£2,995
<i>6 months use, Black gates, Western Electric 300B's</i>		
Audio Research Line Stage 3	£2,250	£1,350
<i>Balanced ip/op, mint, superbe</i>		

David Manley SE/PP 300B Monoblocks
Switchable Push-pull, highly acclaimed US classic
£4,500 £1,495

David Manley Ref440 £11,995 £3,995
Reference valve monoblocks; review available

Mark Levinson 380 line pre-amp £4,495 POA

Mark Levinson 334 amplifier £5,995 POA
Supplied by us, 4 years warranty remaining

NAIM NAP -500 £10,250 £6,750

NAIM 102 Pre-amp w/ MC phono card £1,200 £ 599

NAIM NAP180 amp 60 wpc £1,150 £ 699
Above Naim items about 30 months old; mint



Sugden MasterClass line Pre-amp
Black, as new, bal, s/e, r/c
Class A, See photo
£2,500 £ 1,450

Managers Special! A Vacuum Amplification Company all-tube system 3 components (may separate)



VAC D/A Converter Mk II w/PSU
£4,395 £1,995
CLA-1 Mk II line pre-amplifier w/PSU
£3,25 £1,495
Renaissance 70/70 Mk II, 300B x 8 amp
£14,000 £4,995

Classic tube amp, priced with existing valves

CINEMA AND 5.1 MUSIC

AMPRO HD1200 7" CRT Projector	£9,995	£3,000
<i>Both ex-dem, little used; first to see will buy</i>		
Faroudja VP400U Line Quadrupler	£27,000	£7,995
<i>PAL/NTSC, prize-winning product, brochure on request</i>		
Perraux 6100 six-channel x 150 wpc	£4,990	£1,200
Pioneer Elite DV-09 DVD Player	\$2,495	£ 695
<i>The ultimate luxury US DVD player; Region 1 DTS/THX, rare 96kHz upsampled audio digital o/p</i>		
Snell & Wilcox G2 Interpolator/shoebbox	£30k	£15,995
<i>As new, photo quality from DVD!</i>		
Stewart 5-ft rear projection screen	£4,995	£1,500
<i>Includes mirror and frame</i>		

LOUDSPEAKERS



ATC SCM-50A SL active Birds Eye Maple, x/d
Contain 3 class A amplifiers per channel
£7,995 £4,995

ATC SCM-10A-2 active	£1,269	£ 995
<i>Active, musical, punchy monitors</i>		
ATC C4 Sub-woofer	£1,900	£ 995
ATC C4 Centre	£2,100	£1,095
<i>Both ex-dem, crated, mint</i>		
Dunlavy SC-IV (Oak)	£8,000	£3,995
Dunlavy SC-V (Rosewood)	£16,900	£7,495
ESP Harp (Cherrywood)	£7,995	£2,495
ESP Concert Grand*	£14,900	£3,995
<i>Amazing reviews on both ESP products</i>		
Genesis Model II.5	£22,000	£9,995
Genesis Model 5 (Rosewood)	£15,000	£5,995
Genesis Model 6 (Rosewood)	£8,500	£3,995
ProAc Response 2.5 (Yew)	£2,970	£1,650
NAIM NBL Speakers	£7,165	£3,500

Von Schweikert VR4/silver (Rosewood) £4,500 £1,750

Von Schweikert VR4.5/silver (Walnut) £5,900 £2,495

Von Schweikert VR3 (Cherry) £1,995 £ 750
Ideal for 5.1 format; centre speakers also available

Zingali Overture .3S
Floorstander, cherry, as new



£3,250 £1,995

AUDIO CABLES

Send for list. New This Month!

JPS The Power a/c cord (UK) 2-metres x/d
(2 pieces only) also one or two x/d interconnects for sale
£ 369 £ 319

JPS The Digital a/c cord £ 279 £ 229
(2 pieces only, x/d)

XLO Signature speaker cables, six-ft pair
£1,590 £ 500

We buy and sell Kondo Labs (Audio Note Japan Ltd) used original audio cables with certificate of authenticity. Phone or send for list.

Spring Clearance List

LINN

Kairn Pro pre-amp (£1,700) for £650; 3 x LK-100 amps for £325 each; Keildh speakers and stands £450; Keildh active cards (£500) for £200; Kaber speakers £595; Kaber active cards x 3 for £200; AV5101 Remote £100.

NAIM

NAIM Frame 6 Level, was	£2,300	£1,300
CDS-2 with XPS and flash remote	£6,080	£2,995
NAC-52, Super Cap	£6,200	£3,200
NAP-135	£1,900	£ 995

Retail is detail. A pithy line that does hold true, yet one that many in manufacturing still have a problem grasping. The factors that make a new format successful can be many and varied, but the design detail can be the greatest stumbling block. Advertising, marketing, and software back up are, of course, crucial to a new format's success. Yet, if I may be bold enough to say, the user friendliness or design detail of a product often counts for more than ultimate sound, picture or even build quality. Take a look at the evidence.

At its time of launch, DCC was generally considered to offer superior sound quality to MiniDisc. You don't need me to tell you the outcome of the two formats, but whilst one died an embarrassing death six years ago, the other still has a strong following. The problem with DCC was not with the marketing, software (which at launch was just as poor as MiniDisc), or the sound quality. Believe it or not, many were turned off DCC simply because of its slow access speed. Not that it was any slower than cassette, but the near instant access afforded by MD meant it appeared cumbersome. Philips realised this by fitting a 'turbo drive' mechanism to their latter models to speed things up, but it was too little too late.

Oddly enough, little seems to have been learned from this mistake with the launch of CDR. Now CDR is far more successful than DCC, and has seriously dented MD, yet it's presence in the recording market could be far greater but for a couple of silly niggles. The first is the fact that, when launched, re-recordable discs (CD-RW) wouldn't play back on the vast majority of conventional CD players. Philips responded by ensuring that all their new players, and supplied transports, would play back CD-RW discs. Yet it's only been as late as last year when we finally saw rival manufacturers catch up. Even now, a sizeable number of brand new CD players won't play the format as well, of course, as the millions of older CD players. Although an inferior product sonically, it's worth

remembering that any recordable MiniDisc will play back on any machine. A blindingly obvious observation and one that has in part led to the continued success of MD.

Another niggle that has hindered sales of both formats, is that a copied disc can't be copied again digitally. This is a copyright issue, but as it stands it is a complete nonsense. Let me cite an example as to why the system makes no sense. A budding DJ buys a hi-fi CD-R to make a disc of his work. This disc then needs to be copied, to be sent to various friends, clubs, music moguls and

” the user friendliness or design detail of a product often counts for more than ultimate sound, picture or even build quality.

whoever. The problem here is that the recording has to be made through the analogue outputs, as the original disc is a copy. There's a loss of sound quality but, more importantly, there's no reliable way of track marking the disc. The auto system doesn't work unless there's silence within the music, and when tracks run into one another this is totally hopeless. The only way of marking the tracks is to sit whilst the recording is taking place, manually pressing a button every time a new track is required. A pain for a one-off recording, but down right unacceptable when one needs 60 or 70 copies. Of course there needs to be copyright protection, yet this is the DJ's own work!

The person concerned brought his CD-R machine back to me and purchased a computer that had no problem in coping with these basic requirements. Either all CD-R systems should have copy protection systems or, far better, original discs should be protected instead. As it stands the system is prejudicial towards the hi-fi industry.

Had this problem been sorted out by the industry as a whole, as it may finally be with the introduction of copy protected discs, and if all discs were rewritable and could be played back on any CD player, then CD-R would be a

more successful format than it is now. As it is, such unnecessary complexity has put potential customers off the format.

One thing the explosion in DVD sales has shown me is that the best selling machines that we sold were the most flexible in what they played. All the top sellers were multi-region and CD-R, CD-RW, VCD and MP3 compatible. Never mind that the picture or sound quality wasn't quite as good as others, it was these players that sold. Most people simply want a machine that they can just chuck any disc into and it will play. They may not even be aware of all the different formats but, in short, they want something that gets on with the job without making a fuss.

With this in mind, imagine my disappointment with recordable DVD. At present there are three systems with a list of compatibility problems that I simply haven't the space to list here. No doubt, in four or five years time there'll be a budget Chinese machine that will play all formats with no sweat. Others will then follow. But is it really worth the intervening years of uncertainty and muddle just to get to this point? The manufacturing industry still has much to learn. ●



Dominic Todd



just compare our prices for the BEST deals.



A selection of our ever changing offers for sale
(all fully guaranteed)

Equivalent
New Price

Sale
Price

A selection of our ever changing offers for sale
(all fully guaranteed)

Equivalent
New Price

Sale
Price

AMPLIFIERS

Tube Technology Seer-L Pre. / (2 x 30 Watts Valve Amplifier) (See Star Product) MINT / As New / Boxed / Manuals	2035.00	1295.00
Thermionic OuTLaw Transformerless Int. Valve - Amp. (2 x 18 Watts / Push-Pull) MINT / As New	1200.00	750.00
A.V.I. S-2000P Pre-Amp. / S2000M Mono-Blocs. (2 x 150 Watts / Remote Control) MINT / Manuals	2350.00	1050.00
Revox B-250 (2 x 150 Watts Int. Amp. With Full Remote-Control) MINT / Boxed / Manuals	1200.00	550.00
Micromega Tempo I Int. (2 x 50 Watts) MINT / Manuals	700.00	349.95
Linn Intek Int. (M.M. / M.C. Phono-Stage) VGC	450.00	199.95
Exposure XII Pre. / XII Power Supply MINT / Boxed	1300.00	550.00
Rotel RB-956 AX (6-Channel Power-Amp.) MINT / Boxed / Manuals	350.00	189.95
Quad 34 Pre. (Buff) / DIN / (Discreet C.D. Input / M.M. Phono-Boards) Good C. / Some Scratches	400.00	179.95
Quad 405 II Power Amp. (Late Black Model) Very Clean	600.00	269.95
Quad 77 Pre / Remote-Station / 77 Power-Amp. (Carbon Finish) MINT / Manuals	1600.00	829.95
Arcam Alpha II Int. Amp. VGC	200.00	99.95

TURNTABLES

Voyd (The Voyd) c/w Helios Orion Silver - Wired Tonearm / Koetsu Black M.C. (Standard PSU) VGC / Manuals	2800.00	995.00
Pink Triangle PT-I / Alphason HR-100SVGC	1500.00 +	449.95
Dual CS-505 I CMV Ortofon M.M. Cartridge G/C	200.00 +	79.95
Monacor SPR (M.M. Phono-Stage) NEW / Excellent Value	N / A	29.95

(Lots of Vinyl in Stock and always WANTED)
(Record-Cleaning Service Available)
Your Records Cleaned to Perfection on Moth Machine
For £1.00 Each Including New Inner-Sleeve.
(Maximum 10 at a time please)

...Turntables / Tonearms / Cartridges (M.M. / M.C.) "Urgently" Required...
...Also any "interesting" Vinyl Accessories. Clamps, Protractors, Stylus Scales, Cleaning Devices etc.

LOUDSPEAKERS

Audionote ANJ / D (Oak) (Includes Stands) MINT / Boxed / Manuals	1230.00	695.00
Monitor Audio Studio 12 (Black-Ash) MINT / Boxed	1000.00	575.00
Monitor Audio R-252 (Walnut) With Linn Index Stands G/C / Boxed	300.00 +	89.95
A.V.I. Position II (Cherry) MINT / Boxed / Manuals	1000.00	595.00
TDL Studio One (Transmission Line Monitors) VGC	650.00	349.95
Acoustic Energy AE-I (Metal L.S.) MINT / Boxed / Manuals	800.00	425.00
Tannoy P-30 Precision (Cherry) MINT	600.00	389.95
Genexox Pro. LX-5 (Linacum Tweeters) VGC / Boxed / Manuals	160.00	99.95
JBL LX-20 (100 Watts) Good C. / Some Marks	200.00	99.95
Celestion Ditton 1S Fair C.	N / A	59.95
Naim SBL Double-De-Coupled L.S. VGC / Boxed I	800.00	750.00
Mission 752 Freedom (Hi-Fi Choice "Best-Buy") MINT / As New Boxed / Manuals	600.00	389.95
Rega Alya Floorstanders (Cherry) MINT	365.00	199.95
Rega Ela Floorstanders VGC	410.00	69.95
Eltax Liberty III (Bi-Wire) MINT	150.00	89.95
Eltax Monitor III (Bi-Wire) VGC / Boxed / (Small Mark On One)	(Cash Sale) 130.00	70.00
Mordaunt Short MS-3.10 Minis / Stands GC / No Grille Cloths	180.00	59.95

MISCELLANEOUS

Yamaha DVD-S700 Remote DVD Player (Region Two) (DVD's In Stock And Always Wanted) MINT / Boxed / Manual	600.00	179.95
Foundation 24" Heavy Stands VGC	80.00 +	49.95
Target HJ-18 "Heavy" Spiked L.S. Stands VGC	100.00	49.95
Target 18" Column Stands VGC	60.00	34.95
Apollo 18" Column Stands VGC	80.00 +	40.00
Monacor SPS-3S Spike Kit (Gold or Anodised Black Finish) Loudspeaker Spikes NEW	9.95 (Per 4)	
Monacor SPS-4S Spike Kit (Small) Loudspeaker Spikes NEW	7.95 (Per 4)	
Monacor SPS-6S Spike Kit (Large) Loudspeaker Spikes NEW	9.95 (Per 4)	
Roni LSS 2 (2-Way Speaker Switch-Box) NEW	18.95	
Vivanco PHC (Optical to Co-Axial Converter) MINT / As New	30.00	10.00
Roni 4 m.m Banana Plugs (Gold Plated) (Screw-Type, Don't Require Soldering) NEW	6.95 Per Four	
Roni Optical Linc Cables (C.D / Minidisc to D.A.C. Etc.) NEW 10.00 Scart to Scart 21-Pin / Gold-Plated		Only 10.95
High-Grade Scart Cables Screened OFC / 1.5 Metres NEW		34.95
Cable Talk Advanced 3 Incon (1.0M) (New) NEW		85.00 49.95
Insert Audio Image S.1 Incon MINT		N/A 8.95
Monacor 75 Ohm. Digital Incon. NEW		N/A 9.95
Nexera Gold S-Pin DIN To 4 Phono NEW		19.95 Set of 4
Monacor SPS-20 Anodised Adjustable Polished Cone Equipment Supports NEW		(Superb Spike System at a very good price) (Black Anodised Or Gold Finish) NEW Only 7.95
Monacor Power Concept Incons (0.8M. / 1.5M / 5.0M) Excellent Value Interconnects		0.8M. 10.95
(Blue And Black)		1.5M. or 14.95 5.0M
affordable-audio Bi-Wire L.S. Cable (In Brown or White) NEW		Only 3.50 Metre
79-Strand L.S. Cable (Black-Round-Section or White-Flat-Section) NEW		Only 1.25 Metre
Allsop Carbonoptic Record Brush VGC		N/A 5.00
Monacor DC-100 Carbon-Fibre Brush NEW		6.95 (Essential)
Various Plugs (RCA / DIN / Cannon Etc.) Various NEW / S/H		P.O.A.

PRODUCT OF THE MONTH

Tube Technology Seer-L Valve Pre-Amp. / Unisys Valve Power-Amp.
(2 x 30 Watts Valve Pre/Power Amplifier) In AS NEW Condition
With Boxes And Manuals.

Last RRP £2,035.00 Affordable-Audio Price @ £1,295.00

RECORDING EQUIPMENT

Revox B-77 Mk. II High-Speed 1/2 Track Reel to Reel (7 1/2 / 15 i.p.s. / Vari-Speed) VGC / NABs / Tape (Recent Service)	2500.00	499.95
JVC XD-250Z D.A.T. Recorder Fair C.	800.00 +	229.95
Nakamichi BX-1 (2-Heads) VGC / Manual	N/A	149.95
Nakamichi BX-150E (2-Heads / Dolby B / C) VGC	N/A	149.95
Nakamichi BX-12SE (2-Heads / Dolby B / C) VGC / Manuals	N/A	149.95
Rotel RD-865 (2-Motor / HX-Pro) MINT / Boxed	230.00	99.95
Denon DRM-500 (2-Motors / HX-Pro Etc.) MINT / Boxed	180.00	89.95
Yamaha KX-300 (Remote / HX-Pro Etc.) VGC / Boxed / Manual	200.00	69.95

DIGITAL

Audio Alchemy Digital-Drive-Engine 1.0/ Power-Station II D.A.C. MINT / As New / Boxed	600.00	289.95
Arcam Black Box 50 D.A.C. (Sync-Lock) MINT / Boxed	500.00	199.95
Arcam Alpha S Remote (Digital-Out Etc) MINT / Boxed / Manuals	350.00	139.95
Marantz CD-63 SE (Digital-Out Etc) Good C. / No Remote	350.00	129.95
Marantz CD-52 SE Remote VGC	450.00	109.95
Mission DAD-S / DAC-S (Two-Box Player) MINT	600.00	199.95
Mission PCM-7000 Remote Etc VGC	600.00	109.95
Sony CDP-C24S (S-Disc Multi-Player) MINT	230.00	109.95

SYSTEMS

affordable-audio will happily "build" Systems to your individual requirements, and if you purchase three or more components, i.e. (C.D. Player, Amplifier, & Loudspeakers), we will give you a *15% Discount on the total price! Please enquire for further details.
***(Does Not Apply To Commission-Based Sales)**

TUNERS

A&R (Arcam) T-21 F.M. Tuner With Pre-Sets VGC	N / A	79.95
Rotel RT-820L 3-Band Tuner VGC	N/A	49.95

PLEASE VISIT OUR WEB-SITE (UPDATED DAILY)
E-MAIL: Sales@affordable-audio.CO.UK
WWW.affordable-audio.CO.UK

***** GOOD HIFI SEPARATES WANTED *****
Phone anytime with your wants, stock changing daily. All equipment is sold with warranties.

Don't forget we can offer mail order.
All major credit cards accepted.

We welcome part-exchange on any of the above.
Affordable Audio is always keen to buy,
(or part-exchange) Good quality Hi-Fi
separates in good condition. Especially top
British manufacturers products!



World Radio History

We can also sell your equipment for you on a commission basis.
(Lowest rates/best return)
(Please phone Paul for details!)

You don't have to be the most astute observer of current affairs to realise that the world is changing - the new European single currency being one of the many reminders. But Britain is - as always - a little less aware of events outside its borders. We are, after all, an island nation and have a natural tendency to look inward, rather than outward.

This is glaringly obvious to anyone, such as myself, who has lived outside Blighty for a considerable length of time. Great as this country is, it's certainly a tad parochial. The cultural implications of this aren't really relevant to this particular column, but the way we treat 'foreign' hi-fi is. Although things have radically improved over the past decade or so, the UK hi-fi press has been traditionally prone to navel gazing. Indeed, on a bad day, you could almost accuse it of xenophobia, such is the way it paints UK based specialist hi-fi companies as 'good', and foreign (invariably Japanese until recently) mass market manufacturers as 'bad'.

Last month I spoke to Pioneer GB's John Bamford and found myself agreeing with much of what he said about the hi-fi equivalent of the 'little Englander' mentality in this country. He pointed out that as a journalist, he'd been privileged to visit Pioneer's Japan-based design and manufacturing facilities. He confesses, "they made a huge impression on me. I'd been led to believe that Japanese companies were blaggards that only manufactured mass-market junk, and didn't care about sound. Yet when I met some of Pioneer's design engineers I discovered that the majority of them were vinyl enthusiasts, I was flabbergasted to see how passionate they were, and by their attention to fine detail - not simply circuit design, but things such as vibration and temperature analysis on components and chassis."

This chimes with my own experience of living in Japan, where I found the most obsessive and exhaustive audiophiles I've ever met - many of whom actually worked for the

very electronics giants that the British press used to decry as 'Jap crap'.

John adds that, "I discovered that these guys were working on a higher level of engineering science entirely. Plus, of course, they had R&D facilities beyond one's wildest dreams. I realised I'd been fed a line for a decade or more that it was only 'specialist' manufacturers who knew what they were doing when it came to sound reproduction, and I could see that these Japanese guys' only crime was that they tried to make many of their products affordable for as many people

“I could see that these Japanese guys' only crime was that they tried to make many of their products affordable for as many people as possible rather than simply for the privileged few.”

as possible, rather than simply for the privileged few."

The upshot is that in the UK at least, many audiophiles have been indoctrinated into the ways of the 'specialist company'. I know many folk who - out of sheer snobbery alone - would never countenance owning something made by Sony, Marantz, Pioneer or Yamaha simply because it doesn't compute. Such has been the hegemony of the UK press that these names are regarded simply as the stuff of Argos catalogues or downmarket High Street stores.

John puts it down to the marketing skills of, "a few entrepreneurs who have been lucky guys in the right place at the right time", certain cowering British hi-fi figures who've managed to charm and seduce this country's opinion formers - and no less importantly - their dealer networks. From this has sprung the cult of the specialist, which you also find in Germany, France, Italy and the US to a lesser extent. It propagates the idea that small is good and, ergo, big is bad. This in turn results in a kind of hi-fi

xenophobia, which as JB puts it, "saddens me immensely".

I think there's something in this - I'm not arguing with the success of Britain's indigenous hi-fi manufacturers for one minute. Audio is a tough business, and to succeed you've got to make the right product and sell it, which is easier said than done. In fact, one of the reasons I'm proud to be British is our nation's excellence in this area. But the obverse is our tendency to poo-poo the big Japanese manufacturers - this is misguided in the extreme, and just plain wrong. May I respectfully suggest that when you buy hi-fi, don't buy into a brand, an image, a lifestyle, and philosophy or a creed - buy the stuff that plays music the way you like it. ●



David Price

LONDON



INSTANT 0% FINANCE AVAILABLE SERVING LONDON FROM BATTERSEA

ORANGES & LEMONS

Juicy fruit from London's newest & freshest hi-fi/home cinema retailer. Telephone demonstrations or just pop in. All the usual, i.e. friendly and efficient service, free home installation + credit cards

THE INNOVATIVE AUDIO/VISUAL HI-FI RETAILER. ARCAM, CABLETALK, CHORD CO, DENON, EPOS, MARANTZ, NAD, NAIM, REGA, ROKSAN, ROTEL, ROYD, RUARK, SOUNDSTYLE, STANDS UNIQUE, YAMAHA

NOW IN OUR SEVENTH SPARKLING YEAR.

020-7924 2040

61/63 WEBBS ROAD, SW11
Visit www.orangesandlemons.co.uk

O'Brien Hi-Fi



ARCAM • ANTHEM • AUDIOGRAM • AUDIO RESEARCH • AUDIO TECHNICA • BEYER • CABLETALK • CHORD • CREEK • DENON • DENON • DENON • JADIS • JEFFREY • MICHELL • MUSICAL FIDELITY • NAD • NAIM • OPERA • PRECIOUS METALS • QED • REGA • ROGERS • ROYD • SENNEHEISER • SILTECH • CABLES • TASC • SONNEMEYER • SOMMIG FABER • TEAC • THORENS • TRANSPARENT CABLES • UNISON • RESEARCH • WILSON

Character • Sound Head • Hi-Fi • Details or request

0% Instant Finance Available

Free Demonstration Room • Free car parking • Major Credit Cards
Personal Export • Mail Order • Installation Service • Repairs •
5 mins walk Rayns Park BR • 20 mins Waterloo
5 mins from A1 (Rayns Park BR) exit • 25 mins M25 exit 10

60 Durham Rd, West Wimbledon, London SW20 0TW
Est 1966
Tel: 020 8946 1528 Fax: 020 8946 0331

We aim to provide a well chosen selection of quality hi-fi and accessories including FMJ, ARCAM, B&W, NAUTILUS, DYNAVECTOR, LINN, LOEWE, MERIDIAN, M&K, NAIM, PIONEER, PROCEED, NEAT, REGA, ROTEL, SHAHINIAN, YAMAHA + more
www.infidelity.co.uk



Infidelity
INDECENTLY GOOD HI-FI

9 High Street, Hampton Wick,
Kingston upon Thames, Surrey KT1 4DA
Tel: 020 8943 3530

Open:
Tues-Fri
10.30am-7pm,
Saturday
10am-6pm

SOUTH

WORTHING AUDIO

20 Treville Gate, W.Sussex BN11 1UA
(01903) 212133

The friendly shop with the best sound system in the South.
Talk Electronics - Friendly Advice - 3 Year Guarantee
Easy Parking - Open Mon-Sat. 10am-6pm.
Late Night Wed 7.30pm.
Appliances include: Dynaudio, Ruark, Gradient, PIONEER, Final, Orelli, Sonneteer, Kora, Cymbol, Talk Electronics, and many more.....

SOUTH WEST

SOUTH WEST ANALOGUE

SME - MICHELL - NOTTINGHAM ANALOGUE - LORICRAFT GARRARD - PROJECT - ORTOFON - TUBE TECHNOLOGY 64bit Valve CD Player, Remote Control Hybrid Integrated Valve Amplifier CROFT VOODOO Isolation platforms/Loudspeakers, Equipment Stands and T/Turntable lift off Perspex Covers. Record cleaning service - Secondhand equipment
01643 851 351
graham@southwestanalogue.fsnet.co.uk

NORTH

Basically Sound

NORWICH • NORFOLK

Audio Analogue, Briston, Cabletalk, Chario, Chord Co., Denon, Epos, Final, Isobue, Naim Audio, PMC, Pro Ac, Rega, Stax, Talk Electronics, Teac, TAD Opera, Audio Note and many others

The Old School
School Road, Bracon Ash
Nr Norwich, Norfolk, NR14 8HG
Tel (01508) 570829

EAST

STOWSOUNDS
audio consultants

These And More Available From:

Creek JM Labs
Epos Living Voice
Exposure Neat Acoustics

For A Demonstration & Expert Advice Call
Stowmarket (01449) 675060
Stone Farm, Borough Lane, Gt. Finborough, Stowmarket

VINYL

THE DIRECT DISC
VINYL VINYL VINYL

Thousands of records always in stock.
+ a full range of sought after compact discs.
Extensive search service for wanted albums.
Comprehensive 96 page full catalogue available at £1.50
Telephone / Fax 01992 447764
Or visit our web site on
www.directdisc.demon.co.uk

CHERISHED RECORD CO

UK SUPPLIERS OF VPI TURNTABLES, RECORD CLEANING MACHINES AND ACCs. HUGE SELECTION OF NEW & USED LPS & CDS
www.cherished-record-company.co.uk
01579 363 603

MAIL ORDER



Russ Andrews Accessories
Mail Order Direct



Q. How do I get the best sound from my system?

A. Order our free booklet! It's essential reading for anyone who wants to hear the best music their system can deliver, and it's full of free tips and advice on how to upgrade your system.

Call and request your free copy quoting ref. AH42 or visit our website where you can download it now.

UK FREEPHONE
0800 373467

Russ Andrews Accessories Ltd.,
FREEPOST NWW881A, Kendal LA8 9ZA
Tel: +44 (0)1539 825500 Fax: +44 (0)1539 825540
E-mail: AH42@russandrews.com
www.russandrews.com

VALVES & TUBES



Chelmer Valve Company
for audio valves

Buy CVC. PREMIUM HI - FI valves direct from us. All valves processed for improved performance. We also have stock of MAJOR BRAND types inc. MULLARD, GEC, BRIMAR, RCA, GE, PHILIPS, etc.

The Stables, Baddow Park, Great Baddow, Chelmsford, Essex CM2 7SY
Tel: 01245 241301 Fax: 01245 241309
Email: sales@chelmervalve.com



£600

Mr. Andrew Everard in Gramophone Magazine
"delivers a sound that's both smooth and refined ... allied to a good degree of clarity and finesse"
Hi-Fi Choice "It's a 'classic valve sound'... warm and cuddly...vocals are generally lifelike and involving"
FREE colour literature. £600 with free delivery
Phone 01634 373410 anytime. 1 month home trial
www.affordablevalvecompany.com 40 watts

SERVICES & CONSULTANTS

Front End Problem?
contact
The Cartridge Man

It doesn't have to cost an arm and a leg to get the best - listen to my Koetsu - and Decca - eater.

Also agents for Croft, Hadcock, E.A.R. Michell & Moth.

plus cartridge re-tipping service
020 8688 6565

Website: www.thecartridgeman.com

SPECIALIST HI-FI DEALERS * SPECIALIST HI-FI DEALERS * SPECIALIST HI-FI DEALERS

CLASSIC CUTS

Almost thirty-two years on and Andy Giles still gets off to Neil Young's early solo effort, 'After The Gold Rush'.

1970 saw the emergence of some damn fine male solo albums. Nick Drake's 'Bryter Later', Van Morrison's 'Moondance' and Neil Young's outstanding 'After The Gold Rush', being just three. And it is the latter which, today, still grabs my attention with the same intensity as it did back in the acid-yellow hazy sun of the early '70s.

In thirty-five years as a recording artist, Neil Young has endured as much near to the ground critical and commercial success as he has enjoyed lofty but, with little argument, he is one of the most significant rock composers and performers North America – Canada to be precise - has produced. His moniker whining voice, piercing guitar work, introspective songs, and flower-child, reclusive-rancher stance have all contributed to his strangely charming, enigmatic reputation. Through his experimentation with every musical facet, from hoedown to techno, Young has fashioned a timbre and sense unique to himself. Born in Toronto on November 12th 1945, the son of a former quiz show panelist on Canadian Television and Scott Young, a leading sportswriter for the Toronto Sun, Young first came into real prominence with Buffalo Springfield, whose eponymous debut album achieved cult-status when released in 1967.

'After The Gold Rush', though Young's third solo album, was his first solo effort after joining Crosby, Stills & Nash. Now, after basking in the benefit of super-group status, the onus was on him to produce the goods on his own, under the scrutiny that comes with being in one of the most talked-about bands of the '70s. Young had contributed with admirable alacrity to 'Déjà vu', the first CSNY studio recording and much was expected. In eventuality

'After The Gold Rush' is uncomplicated, down-to-earth, and delivers raw emotion. Neil Young has never been accused of over-production, and 'After The Gold Rush' is no exception: the songs are usually just comprised of an acoustic guitar, bass, drums, sometimes piano, and Young's plaintive wail. If there is any place where Young can be indulgent, it's with his background vocals and harmonies, where he layers voice upon voice to achieve an effect almost equal to the remarkable harmonies achieved by Crosby, Stills & Nash (indeed, Stephen Stills does lend background vocals on some tracks).

The mood of 'After The Gold Rush' is surprisingly subdued, especially when one looks at Young's later solo efforts that were heavy on the loud guitar and fist-pumping rock anthems. Of the eleven tracks on the album, only two, the brutal 'Southern Man', and 'When You Dance You Can Really Love' even feature the loud bombast that some might associate with Neil Young. The rest of the songs are fairly reflective and quiet, usually featuring a piano instead of a Marshall amp cranked to '11'. The real focus of this album is on Young's song-writing and distinctive voice. With the production laid bare, and nothing to depend on but his guitar and his singing, Young performs estimably.

A screenplay for a movie titled 'After The Gold Rush' which, ironically, was never actually filmed, inspired most of the songs on this album. Although greatly appreciated by many, US soft-rock band Lynyrd Skynyrd (how can you be taken seriously with a name like that?) did not approve of the way Young's songs, in particular 'Southern Man', implied that Americans living in the South dwelt in cabins and regularly lynched African-Americans. The witless Lynyrd



Skynyrd smugly wrote the lamentable 'Sweet Home Alabama' in reply to Young, even referring to him in the song. Missed the point – or what?

Although 'After The Gold Rush' is a seminal album, the first time I listened to it, I thought that 'Southern Man' was the only truly outstanding track on the album. But soon I learned to appreciate the refined lyrics of 'Tell Me Why', and the ingenious melody of 'Don't Let It Bring You Down'. And 'After The Gold Rush' sums up the album, as a title track should. A mostly acoustic recording, it tends to be a bit soft in places, especially Young's drifting cover version of Don Gibson's 'Oh Lonesome Me'. But, on the whole, the arrangements underline what might be Neil Young's finest collection of tender melodies.

Over the years, Young has embodied everything from the angry young songwriter, to the sensitive acoustic cowboy crooner, to the electric madman, to the father of grunge, to the industry-bucking rebel, and back again to the soulful acoustic artist. There is no denying that over his career, he has touched millions with his effortless lyrics and emotional voice. 'After The Gold Rush' is really where it all started. What followed was as unpredictable as the album itself. ■ ▲

After The Gold Rush is available on Reprise 7599-27243-2

DIAL-A-DEALER

This is a comprehensive directory of Hi-Fi Dealers throughout the UK and Ireland.

BEDFORDSHIRE

RICHARD'S AUDIO VISUAL 4 Greyfriars Bedford. Tel: 01234 365165. Stockists of: Arcam, Audioquest, Beyer, B&W, Bose, Cable Talk, Cyrus Denon, Marantz, Mission, Moth, Ortofon, Pioneer, Pro-Ject, Quad, REL, Rotel, Ruark, Sennheiser, Sound Style, Stands Unique, Teac, van den Hul & more! Expert friendly service / Listening room. Pioneer Reference Point. Visa / Access.

BRISTOL & BATH

THE RIGHT NOTE Tel: (01225) 874728. Just think: most audiophiles listen for most of the time to systems that are 'not quite right'. Are you happy with yours? Forget the reviews and trying to put together a system like a patchwork quilt with the 'best' bits around. It's our job to do the assessing, you judge our results. We'll help you to plan a system for the future, even if you spread the purchases. Leave the 'up-grade-itis' behind, save money and enjoy music all the time. Just listen, and you'll know. CD: Acuras, Audio Synthesis, Classe, DCS, Enlightened Audio Design, Meracus, Orelle, Wadia, XTC. Vinyl: Basis, Crown, Jewel, Graham, Michell, Sumiko, Transfiguration. Amps: Acuras, Audio Sculpture & more. Speakers: Audio Artistry, Audio Physics & more. Tuners: Fanfare, Magnum Dynalab & many more. Cables: Chord, DNM, Silver Sounds & more. (Credit Cards Accepted).

VAUDIO HiFi Consultants: 36 Druid Hill, Stoke Bishop, Bristol. B59 1EJ. Tel: 0117 968 6005. ATC, AVI, Alon, Audio Analogue, Audiomeca, Cadence Valve, Chord Amps, Electrocompaniet, Harman Kardon, Heybrook, Jamo, LFD, Lyra, Opera, Ortofon, Pink Triangle, Ruark, Mark Levinson, Michell, REL, SME, Shearman, Sonic Link, Sugden, Townshend, Triangle, Unison Research Valve Amps. Home Cinema demonstrated including A/V Amps, DVD Players, Video Projectors and Screens. Demos by appointment only. Home trial facilities. Free installations. We are not a shop.

BUCKINGHAMSHIRE

NORTHWOOD AUDIO 98 Cambridge St. Aylesbury. Tel: 01296 428790. Established since 1992. Independent specialist retailer. Extensive Hi-Fi, A/V and Multiroom experience catering to your needs. From Vinyl to SACD, Valve to Solid State, from LCD to Plasma. Audiomeca, Audio Note, Cable Talk, Castle, Chord, The Chord Company, Cura, Denon, Elac, Epos, Exposure, Heart, JM Labs, KEF, Linn, Marantz, Michell, Micromega, Monitor Audio, NAD, Nakamichi, PMC, ProAc, Quadraspire, Rega, REL, Revox, Roksan, Rose, Rotel, Ruark, Sony, Sennheiser, Sonus, Talk Electronics, Tannoy, Teac, Tube Technology, Videologic, Vienna Acoustic. Export orders welcome. 2 demo rooms. Credit facilities available. Website: www.northwoodaudio.co.uk Email: info@northwoodaudio.co.uk

TECHNOSOUND 8 Granville Square, Willen, Milton Keynes, MK15 9JL. Tel: (01908) 604949. Fax: (01908) 202166. Audiophile Hi-Fi and Home Cinema specialists. All major brands stocked from Arcam to Yamaha, Meridian Digital Home Theatre dealer. Video projection, Plasma screens. Custom installation. 2 dem rooms and expert advice. Email: hifi@technosound.co.uk www.technosound.co.uk

CAMBRIDGESHIRE

THE AUDIO FILE 41 Victoria Road, Cambridge. Tel: 01223 368305. 'For the best in British Hi-Fi and Home cinema entertainment'. Visit or call to arrange a dem with products from: Arcam, Linn, Naim, Rega, Cyrus, Absolute Sounds, Kef, Sony, Yamaha, Rel, Ruark, Denon.

CHESHIRE

ACOUSTICA 17 Hoole Rd, Chester CH2 3NH. www.acoustica.co.uk. Tel: 01244 344227. All that's best in HiFi & Home Cinema from quality manufacturers including Naim, Rega, Arcam, Musical Fidelity, Rotel, Selec Co Projectors, Kef, Ruark, Densen, Primare, Teac, JM Lab, Nakamichi, Quadraspire, Celestion & Crimson. We offer friendly, helpful advice, interest free credit & trade-in facilities, and deliver & install systems throughout. Cheshire, Merseyside & North Wales. Opening hours are Tuesday to Saturday 10.00 until 5.30, evenings by arrangement

ACTION GATE AUDIO 4 Ruabon Road, Wrexham, North Wales. Tel: 01978 364500. Audio Visual Specialists. Arcam, Audio Analogue, Bose, B&W, Celestion, Castle, Denon, Harmon Kardon, Jamo, Marantz, Michell, Mission, Onkyo, Pro-Ject, Musical Fidelity, NAD, Micromega, Myrad, QUAD,

Radford, Rotel, Ruark, Tannoy, TDL, Teac, Thorens, UKD, Unison Research, Yamaha, DSP Club Member. Demo Room, installation service. Easy Parking and Motorway access. All major credit cards accepted. 9.30 - 5.30 daily. Closed Sunday & Monday.

DOUG BRADY HI-FI Kingsway Studios, Kingsway North, Warrington, WA1 3NU. Tel: 01925 828009 Fax: 01925 825773. Visa, Mastercard, Lombard Tricity. 2 dem rooms, home trial. Agencies include: Arcam, Tag McLaren, AVI, B&W, Castle, Caspian, Chord Electronics, Exposure, Harbeth, Heybrook, Krell, LFD, Michell, Meridian, Musical Fidelity, Monitor Audio, Naim, Nautilus 800 series, Pink Triangle, ProAc, Roksan, SME, Wilson Benesch, XTC and many more.

CORNWALL

SOUNDS PERFECTION Cornwall's most exclusive Audio retailer. Agencies include: Audio Analogue, Audio Design, Audio Note, AudioQuest, Audio Spectrum, AR, Avid, Border Patrol, Boston, Dynavector, Electrocompaniet, Graaf, Henley, JM Labs, Lexicon, Michell, Monitor Audio, Musical Fidelity, Ortofon, Parasound, Primare, Project, NAD, Nakamichi, Nordost, Philoshophy, REL, Roksan, Ruark, Rotel, Totem, Tom Evans, Tsunami, S.M.E., Sugden, Stands Unique, Unison Research, Teac, Vienna Acoustics, Triangle, Trichords, W8T, Sonic Link. Home Demonstrations by Appointment. Tel/Fax: 01326 221372 Mobile 07798 554357 email nigel@soundsperfection.co.uk website www.soundsperfection.co.uk

DORSET

MOVEMENT AUDIO 588 Ashley Road, Poole, Parkstone, Dorset BH14 0AQ. Tel: (01202) 730865/380018. Arcam, B&W, Castle, Chord Electronics, Cyrus, Denon, Marantz, Michell, Mission, Pioneer, Tannoy Dimension, Yamaha, 2 Dem rooms. Listen to the available choice and decide at your leisure - no pressure, no obligation. Our staff enjoy music, with our choice of products, you can too! Service Department. Free installation. Home trial facilities. Access, Visa, Amex, Diners Card. Credit facilities available. Open Tuesday-Saturday 10.5-5.30. www.movement-audio.co.uk

MOVEMENT AUDIO 926 Wimborne Road, Winton, Bournemouth, Dorset. BH9 4DH. Tel: (01202) 529988/520066 Arcam, B&W, Denon, KEF, Marantz, Mission, Musical Fidelity, Opera, Pioneer, Quad, Roksan, Ruark, Yamaha. Full dem facilities available, also home dem. Friendly expert advice. Service Department. Free installation. Home trial facilities. Access, Visa, Amex. Open Tuesday-Saturday 9.30-5.30

DAWSONS OF WESTBOURNE Home Cinema Specialists. Main agents for Bang & Olufsen, Harman Kardon, JBL, REL, Mordaunt Short, Sony, Technics and TDL. Demonstration facilities include our unique Dolby pro-logic system comparator for the ultimate way to choose the perfect system. Also on demonstration large screen televisions from Thomson, sony and Ferguson with video projectors from Sharp and Selec. Dawson's, 23 Seamoore Road, Westbourne, Bournemouth 01202 764965

WEYMOUTH HI-FI 33-35 Maiden Street, Weymouth, Dorset DT4 8BA. Tel: (01305) 785729/766345. Arcam, B&W, Denon, KEF, Marantz, Mission, Musical Fidelity, Panasonic, Pioneer, Quad, Sony, Tannoy, Yamaha. Dem room. Friendly professional advice. Only quality hi-fi dealer in Weymouth area. Service Department. Free installation. Home trial facilities. Access, Visa, Amex, Switch, Delta Mastercard. Interest free credit. Instant credit. Open Mon-Sat 9.30-5.30

ESSEX

GRAYSTON SOUND & VISION 33 Sir Isaac's Walk, Colchester. (01206) 577682. Alchemist, Arcam, B&W, Boston Acoustics, Castle, Denon, Harman Kardon, KEF, Linn, Loewe Opta, Meridian, Michell, Musical Fidelity, Philips, Pioneer, Project, Rotel, Sennheiser. Superb demo rooms, free regional delivery and installation. Regular musical and surround evenings, home demonstrations. Excellent credit facilities.

GLOUCESTERSHIRE

THE RIGHT NOTE - Bath. For specialist advice and home demonstrations. See BRISTOL & BATH.

HEREFORDSHIRE

ENGLISH AUDIO 37 Whitecross Road, Hereford, HR4 0DE. (01432) 355081. Arcam, A.T.C., B&W, Castle, Cura, Cyrus Centre, Elac, Denon, JM Lab, KEF,

Loewe, Marantz, Mission, Musical Fidelity, NAD, Naim, Pink Triangle, Pioneer, Project, QED Systemline, REL, Rotel, Ruark, John Shearman, Stax, System Audio, Teac, Vienna Acoustics, Wadia, and Yamaha. Single speaker dem room, home trial facilities, free installation, service dept, Access/Visa, Credit arranged. Open Mon-Sat, 9.30-5.30pm. BADA members.

HERTFORDSHIRE

AUDIO FILE (THE) 27 Hockerill Street, Bishops Stortford, Herts. Tel: (01279) 506576.

DARBY'S OF ST. ALBANS. 6 Market Place, St Albans, Herts. Tel: (01727) 851596. Fax: (01727 812217) Email: sales@darbystvhifi.co.uk Hertfordshire's premier Hi-Fi/Audio Visual specialists established 1946. Full Home Cinema demonstration suite. Whether your needs are large or small, we stock it all: Arcam, Cyrus, JVC, Yamaha, Quad, Denon, Sony, Bang & Olufsen, Pioneer, REL, KEF, Mission, Ruark, Celestion and many more. Free planning service. Free Delivery and basic installation. Full workshop facilities. Open 9-6 Mon-Sat.

LANCASHIRE

ADVENTURES IN HI-FI S. Bishopgate, off Hallgate, Wigan, WN1 1NL. Tel: 01942 234202. For the best hi-fi and home cinema products from quality manufacturers including Naim, Rega, Cyrus, NAD, KEF, Denon, Dynavector, Rotel, Shahinian, JM Lab, PMC, Project, Quadraspire, Selec and Sanyo projectors. We offer friendly advice, excellent demonstration facilities, 0% finance, free delivery and installation throughout the North West. Opening hours 10.00 - 5.30pm Tuesday to Saturday evenings by appointment.

LEICESTERSHIRE

LEICESTER HI-FI 6 Silver Walk, St Martins Square, Leicester LE1 5EW. Tel: (0116) 2539753. Email: info@leicesterhifi.co.uk www.leicesterhifi.co.uk Arcam, B&W, Chord Electronics, Copland, Cyrus, Denon, Greig Loudspeakers, KEF, Marantz, Michell, Miller & Kreisler, Musical Fidelity, NAD, Nakamichi, Nautilus, Mission, Project, Rotel, Sanyo Projection, Talk Electronics, Teac, Technics, Yamaha, and many more. 4 Listening areas over 3 floors. We can demonstrate, deliver and install. Including A.V. and Multiroom. Credit Facilities. All cards taken, open 6 days 9.30-5.30.

LONDON

BABBER ELECTRONICS SERVICE CENTRE 15B Uxbridge Road, West Ealing, London, W13 85B Tel: 020 8579 6315 Akai, Aiwa, A&R, Celestion, Dual, Goodmans, Harman Kardon, JBL, JVC, Kenwood, Marantz, Panasonic, Sennheiser, Sony, ES range, Tannoy, Technics, Wharfedale, Yamaha and many more. Auth. Service Dept. Credit Facilities, Open 10.30 - 5.30 Mon-Sat.

INFIDELITY 9 High Street, Hampton Wick, Kingston-upon-Thames. Tel: (020) 8943 3530. for full details see entry under SURREY

HIFI EXPERIENCE 227 Tottenham Court Road, London W1. 020 7580 3535. Arcam, Cyrus, Denon Gold, Quad, Kef, Meridian, Yamaha, Marantz, McCormack, Mirage, Nakamichi, Musical Fidelity, PAF and many more. Open 10.00-7.00 Mon-Fri, 9-6 on Sat. Service dept, Credit facilities, delivery and free installation.

THE LISTENING ROOMS 161 Old Brompton Road, London SW5 0LJ. (020) 7244 7750/59. Fax (020) 7370 0192. Linn, Quad, Meridian, Nakamichi, Arcam, Audiolab, Acoustic Energy, SME, Audio Research, Krell, Wadia, Theta, Apogee, Martin Logan, Pioneer, Tannoy, Systemdek, Stax, Pink Triangle, Michell, Monitor Audio, Yamaha, Marantz, KEF, Bose, Celestion, Epos, Mission, Denon, Neat Petite. Mon-Sat 10-6pm.

THOMAS HEINITZ LTD 35 Moscow Road, Bayswater, London, W2 4AH. Tel: 020 7229 2077. Fax: 020 7272 9348. Email: info@thomasheinitz.com. Web site: www.thomasheinitz.com. Established in 1952, Thomas Heinitz has a long history of providing the best music and AV systems available. We continue to offer the highest standard of service in the most relaxed atmosphere. Whatever your needs, from multiroom and home cinema to a high quality stereo system, we offer consultation, design specification, architect liaison and installation in order to ensure your system is tailored to your exact requirements. For quotes contact our manager Johnny Drum.

GREATER MANCHESTER

ADVENTURES IN HI-FI 5, Bishopgate, off Hallgate, Wigan, WNI 1NL. Tel 01942 234202. See our main entry under LANCASHIRE

MANCHESTER

REPLAY AUDIO 64 Flixton Road, Urmston, Manchester, M41 5AB Tel 0161 202 9922. Audio Analogue, Bryston, Creek, DNM, Exposure, LFD, Michell, Myrray, NAD, Onkyo, Ortofon, Pink Triangle, Project, Sonneteer, Sugden, Trichord, Unison Research, Teac, Loudspeakers from Acoustic Energy, A.R.T. Audio Physic, AVI, Blueroom, Epos, Harbeth, Living Voice, Monitor Audio, Neat, PMC, Royd. Lots of cables and accessories available. We are just off Junction 10 of the Manchester Ring Road (M60), five minutes from The Trafford Centre. Our demonstrations are relaxed and informal and help and advice is free! Phone or visit our web site www.replaydial.pipex.com or email replay@dial.pipex.com

MERSEYSIDE

ACOUSTICA 17 Hoole Rd, Chester CH2 3NH. Tel 01244 344227. See our main entry under "Cheshire".

MIDDLESEX

RIVERSIDE HI-FI 422 Richmond Road, East Twickenham, Middlesex, TW1 2EB. Tel: 020 8892 7613 Fax: 020 8892 7749. www.riversidehifi.co.uk Arcam, Bose, B&O, Castle, Copland, Denon, Krell, Marantz, Martin Logan, Michell, Monitor Audio, Musical Fidelity, NAD, Pioneer, Project, Rel, Sonus Faber, Sony, Tag McLaren Audio, Tannoy, Teac, Theta, Wilson. Finance available. Subject to status. Written details available on request. Export orders welcome. UK mail order available. 3 demonstration rooms. All major credit cards. Open 10am-5.30pm Mon-Sat.

NORFOLK

BASICALLY SOUND The Old School, School Road, Bracon Ash (Nr Norwich), Norfolk, NR14 8HG. Tel: (01508) 570 829. Stockists of the following leading Hi-Fi: Audio Analogue, Beyer, Bryston, Denon, Dynavector, Epos, Grado, Naim, PMC, ProAc, Rega, Royd, Sennheiser, Talk Electronics, Teac and more. Bada members, 2 comprehensive demo rooms.

NORTHAMPTON

CLASSIC HI-FI At Classic Hi-Fi we cover the best in quality sounds. Be it a question of taste, a question of balance or a question of price, we're the ones to help. We stock: Marantz, Nad, Pioneer, Roksan, Yamaha, Heybrook, LFD, Sugden, Rotel, Kenwood, B & W, Kef, Rogers, Monitor Audio, Musical Fidelity, Tannoy, Shearpe Audio, Royd, Audio Alchemy, Teac and many more. For more details call: 01536 310855

LISTEN INN 32 Gold Street, Northampton, NN1 1RS. Tel: 01604 637 871. The World's Finest Hi-Fi from Arcam, Audio Analogue, Chord Company, Copland, Denon, FMJ, Fujitsu, KEF, Krell, Linn, Loewe, Martin Logan, Meridian, Miller & Kriesel, Mission, NAD, Naim, Proac, Rega, Rotel, Sennheiser, Sonus Faber, Wilson Benesch, Yamaha. Dedicated Viewing & Listening Rooms, Friendly Staff, Fresh Coffee, 2 Full Years Warranty, Part Exchange Welcome, Free Car Parking, Interest Free Credit, Members of BADA. Open 10am-5.30pm (Closed Thursday).

NOTTINGHAMSHIRE

NOTTINGHAM HI-FI CENTRE 120-122 Alfreton Road, Nottingham. Tel: 0115 9786919. Multi-room specialists. Hi-Fi. Home cinema. All leading brands stocked. Three superb demonstration areas. Two year parts and labour guarantee. Home trials. On site service facility. Full delivery and installation service. Easy free parking. BADA Dealer. Established 1968. Mon-Sat 9.00-5.30

OXFORDSHIRE

OVERTURE HI-FI 3 Church Lane, Banbury, Oxon OX16 8LR. Tel (01295) 271258. Email sales@overture.co.uk Website: www.overture.co.uk Arcam, Bose, Cura, Denon, KEF, Linn Products, Miller & Kriesel, Mission, NAD, Naim Audio, Yamaha. For sensible unbiased advice, call Oxfordshire's audio experts. Superb demo facilities. No appts. necessary. Home Cinema, Plasma TV, Projectors, Lutron Lighting, MultiRoom and Commercial Installations. Access/Visa, instant credit. Mon-Fri 10-6. Sat 9-3. 5.30.

SHROPSHIRE

ADAMS & JARRETT Hi-Fi and Home Cinema Specialist. Phone or visit us at 6-18, Norman Road, St. Leonards-on-Sea, E.Sussex. (01424) 437165/432398. Stockist of quality equipment including: Audio Innovations, Meridian, KEF, Ruark, Marantz, NAD, JBL, Royd, Dali, Jamo, Onkyo, Rel, Traget, Cable Talk, Technics, TDC, Yamaha, Kenwood. Air conditioned listening rooms, on site service and repair facilities

STAFFORDSHIRE

ACOUSTICA 114 Wolverhampton Rd, Stafford ST17 4AH. www.acoustica.co.uk. Tel 01785 258216. All that's best in HiFi & Home Cinema from quality manufacturers including Naim, B&W, Musical Fidelity, Rotel, Seleco Projectors, Kef, Ruark, Teac, JM Lab, Rega, NAD, Yamaha, REL, Sanyo projectors. Fujitsu. We offer friendly, helpful advice, interest free credit & trade-in facilities, and deliver & install systems throughout Staffordshire & the Midlands. Opening hours are Tuesday to Friday 10.30 until 6.00, Saturday 10.30 until 5.00.

SUFFOLK

ANGLIA AUDIO The Street, Hessest, Bury St Edmonds, Suffolk, IP30 9AZ. Tel 01359 270212. "Hi-Fi and speaker centre dedicated to quality hi-fi since 1971. Open 10-6. Closed Weds and Sundays. Evening and Sunday Demos by appointment.

AUDIO IMAGES 128 London Road North, Lowestoft, Suffolk, NR32 1HB. Tel: 01502 582853. Arcam, Acurus, Castle, Rotel, Moth, Triangle, QTA, Sugden, Denon, Yamaha, Mirage, M & K, Definitive, Musical Fidelity, plus the incredible Rothwell range. Refreshingly different selection. Dem Room, Professional AV installer's from budget to high end. Full credit facilities. 9.30 to 5.30 Mon & Sat - 9.30 to 6.00 Tues to Fri.

EASTERN AUDIO 41 Bramford Road, Ipswich, Tel. 01473 217 217. Fax 01473 215705. Quad, Arcam, Audiolab, Meridian, Mission, Denon, Rotel, Marantz, NAD, Sony, Rogers, Nakamichi, Systemdek, Technics, Celestion, B&W, Tannoy, Morel Thorens and Top Tape. Also stock a wide range of accessories, usual credit facilities. A BADA dealer.

SURREY

INFIDELITY 9 High Street, Hampton Wick, Kingston upon Thames, Surrey, KT1 4DA. Tel. 020 943 3330. Email: infidelity@compuserve.com - Web Address: infidelity.co.uk Stockists of: Linn, Naim, Arcam, Meridian, Rega, B&W, Nautilus, Neat, Proceed, Royd, M&K, Rotel, Stax, Shahinian, Dynavector. Open 10.30 - 7.00 Tues - Fri, 10.00 - 6 Sat.

SUSSEX (EAST)

ADAMS & JARRETT For the best Audio Visual Specialist with friendly helpful staff phone or visit us at 6-18 Norman Road St. Leonards-On-Sea, East Sussex. Tel. 01424 437165/432398. Copland, Castle, Denon, Densen, Dynaudio, Jamo, Kef, Kenwood, Marantz, Meridian, Musical Fidelity, NAD, Onkyo, Primare, Rel, Rotel, Ruark, Tannoy, Technics, Yamaha. Interest free credit available subject to status. Visa, Mastercard.

WEST MIDLANDS

ACOUSTICA 114 Wolverhampton Rd, Stafford ST17 4AH. See our main entry under "STAFFORDSHIRE".

MUSIC MATTERS

Birmingham - 363, Hagley Road, Edgbaston, B17 8DL. Tel: 0121 429 2811.
Solihull - 93-95, Hubs Moat Road, B92 8JL. Tel: 0121 342 0254.
Stourbridge - 9, Market Street D48 1AB. Tel: 01384 444184.
Sutton Coldfield - 10, Boldmere Road, B73 5TD. Tel: 0121 354 2311. Arcam, Alchemist, Apollo, Audioquest, Audio Research, B&W, Cable Talk, Castle, Celestion, Chord, Copland, Cyrus, Denon, DPA, JBL, Kef, Krell, Marantz, Martin Logan, Meridian, Musical Fidelity, Panasonic, Pioneer, REL, Rotel, Ruark, SME, Sennheiser, Sonus Faber, Tag McLaren, Teac, Theta, Yamaha etc. Classical CD's available at Birmingham only. Demonstration rooms, service and installation. BADA member. VISA / MASTERCARD / AMEX / SWITCH. Open - 10-5.30 Tuesday to Saturday. Late night Thursday till 7.00 (not Stourbridge).

SOUND ACADEMY For the Midlands. The Parade, Sutton Coldfield, Tel. 0121 321 2445 & High Street, Bloxwich, Nr Walsall, (sharing the ASDA shopping centre) Tel 01922 493499. Hosts 4 private studios plus a Home Theatre Cinema with Tube & LCD Projectors. The best in hi-fi from Naim, Arcam, Audiolab, Chord, Meridian, Monitor Audio and many more. So... if you've taken time to read this, please let us make you welcome. Phone 0121 321 2445 for Sutton or 01922 493499 for Walsall. Call in and to browse our exciting display of hi-fi and home cinema equipment. Mail order available. interest free credit S.T. Status. Open 6 days, 9am to 5.30pm. Please call for late night. Expert Advice, Cable Dressing and Installation.

WILTSHIRE

SALISBURY HI-FI LTD 15 Catherine Street, Salisbury, Wiltshire SP1 2DF. Tel (01722) 322169/330841. Arcam, B&W, Celestion, Denon, KEF, Marantz, Meridian, Mission, Musical Fidelity, NAD, Opera, Pioneer, Ruark, Tannoy, Yamaha. 2 Dem rooms. Friendly, relaxed atmosphere. Professional advice. Home dem available. Service department, Free instal-

lation. Home trial facilities. Access. Visa, Amex. Interest free credit. Instant credit. Open Mon-Sat 9-5.30.

THE RIGHT NOTE - See under BATH & BRISTOL heading.

YORKSHIRE (NORTH)

SOUND ORGANISATION YORK, 2 Gillygate, York YO31 7EQ. Tel (01904) 627108. Carefully chosen Hi-Fi and AV equipment includes Arcam, B&W, Nautilus, Denon, Linn, Naim, Rega, Rotel, Stax etc 3 dem rooms incl. Home Cinema and Linn connect. Service Department. Home installations. Instant Credit and major credit cards. Closed Mondays. Phone for chat and more details. www.soundorg.co.uk

YORKSHIRE (EAST)

ZEN AUDIO 35 George Street, Hull Tel. 01482 587397. "Comfortable listening rooms; Home dems; Personal, friendly service; Free installations. Agencies include: Arcam, Audiolab, Atacama, Audio Innovations, Audio Note, Audion, Alchemist, B&W, Cable Talk, Chord CO, DPA, Densen, Denon, DNM, EAR, Exposure, Fi-Rax, Harbeth, Heybrook, Impulse, KAR, KEF, Michell, Micromega, Monitor Audio, Musical Technology, Myrray, NAD, NAIM, Pioneer, REL, Rehdeko, Rotel, Royd, Ruark, Shearpe Audio, Stands Unique, Sugden, Spendor, Sonic Link, TEAC, TDL, Tube Technology, vivanco and many others.

YORKSHIRE (SOUTH)

THE HI-FI STUDIOS Hi-Fi - Home Cinema - Custom Installation Tel: Doncaster 01302 727274 or 01302 725550. E-Mail: info@thehifistudios.freeserve.co.uk Web Site: www.thehifistudios.co.uk Musical Fidelity, Electrocompaniet, ProAc, PMC, JM Lab, Ruark, Castle, TEAC, Unison Research, Monitor Audio, Impulse, Primare, Harbeth, NAD, Michell Turntables, Nottingham Analogue Studios Audio Analogue, Living Voice, Densen, Celestion, KEF, Opera, Trichord Research, Nordost, Stands Unique, Ortofon, Project, Goldring, REL, Denon, TAG McLaren, Rotel, Yamaha. Proceed - plus many more. Viewing & Demonstration by appointment in a unique setting. Home trials and installation. Card facilities and 0% available. Please phone for more information. BADA. CEDIA.

YORKSHIRE (WEST)

Huddersfield Hi-Fi Centre Hi-Fi • AV • Widescreen Plasma • Installation Service 4 Cross Church St, Huddersfield, 01484 544668. Brands inc. Arcam, B&W, Castle, Cyrus, Denon, KEF, Marantz, Mission, Musical Fidelity, NAD, Project, Sony etc. 3 Dem Rooms, Mon-Sat 9-5.30, Thurs 9-8, Closed Wed.

Huddersfield Hi-Fi Centre Halifax 3-5 King Cross St, Halifax, 01422 366832. Brands inc. Arcam, B&W, Castle, KEF, Marantz, Mission, Musical Fidelity, NAD, PRO-AC, Project, Sugden etc. 2 Dem Rooms, Mon-Sat 9-5.30, Closed Thursday.

WALES

NORTH WALES

ACOUSTICA 17 Hoole Rd, Chester CH2 3NH. Tel 01244 344227. See our main entry under "Cheshire".

ACTON GATE AUDIO 4 Ruabon Road, Wrexham, North Wales, Tel. 01978 364500. See our main ad under Cheshire.

VINYL/RECORD MAIL ORDER

DIVERSE VINYL 10 Charles Street, Newport, NP20 1JU. Tel/Fax: 01633 259661/256261. Email: sales@diverse-music.co.uk Probably the most varied and impressive selection of brand new LPs you'll find anywhere: international new releases, reissues and audiophile products. Also UK distributor of the Disco Anti Stat LP Cleaning Device. Call for a free catalogue, or visit www.diverse-music.co.uk

PRE-OWNED MAIL ORDER

AFFORDABLE AUDIO (NORTHAMPTON) Pre-Owned Hi-Fi Specialists. 168 Wellingborough Road, Northampton, NN1 4DU. Tel/Fax: 01604 231261 or Tel: 01933 273281. Mobile: (0370) 877893. Email: sales@affordable-audio.co.uk Website: www.affordable-audio.co.uk Urgently required: compact disc collections, hi-fi separates, especially Linn products. Naim Audio, Cyrus Electronics, Musical Fidelity, Quad Electronics, almost anything British/American. Cash waiting, part exchange welcome. We also stock lots of audio accessories, compact discs, vinyl, DAT players. All equipment is sold with warranties. All Credit Cards accepted. Please phone anytime for stock update.

MEET-YOUR-MAKER

A reference guide to Britain's manufacturers and distributors

MEET-YOUR-MAKER

AFFORDABLE VALVE COMPANY £600 Valve amplifier. Powerful 40 watts. Powerful bass. See colour photograph in 'Specialist Hi-Fi Dealers' section. Mr Andrew Everard in Gramophone Magazine "delivers a sound that's both smooth and refined... allied to a good degree of clarity and finesse". Free colour literature. Telephone 01634 373 410 anytime. Website: www.affordablevalvecompany.com

AUDIOPHILE FURNITURE LTD The Square, Forest Row, East Sussex RH18 5ES Tel: 01342 826262. Fax: 01342 824845. Manufacturers of the patented BASE Vibration Control Platforms and the Modular Audio Support System. These Products are endorsed by Hi-Fi World. Also newly introduced are the Resonance Controlled Hi-Fi Cabinets which are multi level modular design and available in various sizes and wood finishes. Please telephone for more details and a product portfolio.

AUDIO SYNTHESIS Manufacturers of the outstanding DAX digital to analogue converter, comes DAX-2, a new Hi-End reference converter able to dig deeper into the digital source than ever before! A new addition to the superb PASSION series of all Vishay controllers has just been introduced in the form of PASSION 8, a fully remote controlled uniquely transparent passive preamplifier, the perfect match for DESIRE. By word of mouth our DESIRE power amplifier is rapidly convincing listeners, whether passive or active! New for 1997 is TRANSCEND a state of art CD transport with AES, coaxial, AT&T glass and Toslink outputs. Audio Synthesis, PO BOX 50, Nottingham, NG9 1DZ. Tel: (+44) (0)115 922 4138. Fax: (+44) (0)115 922 9701.

BORDER PATROL 63 Berrisdale Avenue Hove BN3 4JD Tel/Fax 01273 276716. Manufacturers of Power Supply Units for valve amplifiers, Single-Ended Power Amplifiers and high quality Transformers. The Border Patrol PSU: valve-rectified choke input filter power supply units which dramatically improves the sound of valve amplifiers: models available to suit Audionote, Audio Innovations, Audion, Art Audio, Cary, Unison Research, World Audio Designs. The Border Patrol 300B SE single-ended valve amplifier featuring interstage driver transformers and valve rectified choke input filter power supplies. Border Patrol transformers: high quality output (PP and SE), interstage and pre-amp output transformers and high value inductors.

CREEK AUDIO LTD 2 Bellevue Road, Friern Barnet, London N11 3ER Tel: 020 8361 4133. Fax: 020 8361 4136. E-mail: info@creekaudio.co.uk Internet: www.creekaudio.co.uk - Creek Audio build stylish Hi-Fi products in the UK, combining state of the art electronic design, with full bodied, accurate and musically rewarding sound. Our standard size products come in two award-winning ranges, the entry level 43 series and higher priced 53 series. These include: CD43 Mk2 - CD player with 24 bit resolution DAC, T43 AM/FM Tuner, Integrated Amps - 5350, 5350SE and 4330 Mk2 (described by Stereophile Magazine as the best amp under \$1000). Our A43 Mk2 and A53 Power Amps range from 50 to 250 Watts and both P43 and P53 Pre-Amps offer passive and active operation with remote control. In addition we have an award winning OBH range of small products: OBH-8/8SE MM and OBH-9 MC Phono Pre-Amplifiers, OBH-11 and 11 SE Headphone Amplifiers, OBH-10 and 12 Remote Control Passive Pre-Amps and OBH-14 - 24 bit DAC. See our home page for further details or call us for leaflets.

DBS AUDIO. PO BOX 91, Bury St Edmunds, Suffolk, IP32 7JU. Phone: 01284 723933 Fax: 01284 723933. Suppliers of Electro-Acoustic measuring equipment and CAD software to the audio industry. NEW: Clio win and Clio win Lite, the latest Windows versions of the Globally established Clio Electro-Acoustic measuring system, used for loudspeaker design, Quality Control and electronics testing by many major audio companies. Clio win is the full (lab) system and Clio win Lite a lower-cost version for smaller companies and serious hobbyists. Both use the same purpose-built Clio HR200 ISA card, with its in-built mic, pre-amp and phantom powering. The matching Mic 01 (or Mic Lite) plugs straight in to make a complete system. Both versions offer the same high accuracy and ease of use: Clio win Lite simply has fewer functions. Common features include MLS testing (to eliminate sound reflections), sine and third-octave analysis, impedance, Thiele Small Parameters, LC meter, software and manual on CD ROM -- plus much more. Measurements may be exported to our Netscape soft-

ware for accurate and easy crossover design. Also available: Boxcalc and Boxdraw bass optimisation packages and Outline speaker measuring turntable. Write or E mail and we will send fuller information and prices. Also, visit Audiomatica's new Website at: www.audiomatica.com

EMINENT AUDIO Distributor of Croft Valve Amplification. Tel 01902 656517. Fax 0121 681 8772 Mobile 0956 921740 U.K. Stockists are: Classique Sounds (Leicester) GT Audio (London NW) Nottingham Analogue. Purist Audio, The Carriage Man (Len Gregory - Croydon), call for overseas distributors.

EPOS ACOUSTICS 2 Bellevue Road, Friern Barnet, London N11 3ER. Tel: 020 8631 8864. Fax: 020 83614136. Email: info@epos-acoustics.com Website: www.epos-acoustics.com Innovative design and superior sound distinguish EPOS speakers from other brands in a similar price category. Adhering to the EPOS tradition of musicality and communication, the new M12 follows closely the style of the successful ES12, and was awarded five gold stars in the March 2001 edition of *What Hi-Fi?* For more information about the M12 or the new M15 please see our home page or call us for leaflets.

FALCON ACOUSTICS LTD Tabor House, Norwich Road, Mulbarton, Norwich, Norfolk, NR14 8JT. Tel. (01508) 578272. U.K. distributors of FOCAL drive units and SOLENE (Chateauroux) polypropylene capacitors and the largest inductor manufacturer in the U.K. Comprehensive range of DIY Speaker Parts and Kits, Sub-Bass and Electronic Filters. "Everything but the wood" Enquiries should be accompanied by a 44p stamped addressed envelope.

IAN EDWARDS The Old Chapel, 282 Skipton Road, Harrogate, Yorks. Tel. 01423 500442. Somebody Somewhere must make better storage units for CDs, Music, LPs, HiFi, Books, etc. than Ian Edwards. BUT until he appears, why not send for the brochure showing a selection of HAND MADE units. To do this please send 3 x 2nd class stamps.

JEM DISTRIBUTION (FI RAX) Springfield Mills, Spa Street, Ossett, Wakefield, WF5 0HW. Tel: 01924 277626. Fax: 01924 270759. Fi-Rax offers a new dimension in audio visual racking. High quality aluminium construction. Finishes available to your choice. Fully adjustable 6mm glass shelving, sound insulation on shell/feet. Custom created to suit your system. Free delivery throughout the UK. For further information or a free brochure contact JEM Distribution.

LANGREX SUPPLIES LTD 1 Mayo Road, Croydon, Surrey, CR0 2QP. Tel: 020 8684 1166. Fax: 020 8684 3056. One of the largest distributors of electronic valves, tubes and semi-conductors in the UK, and USA manufacturers. stock. We specialise in obsolete types including original UK and USA made audio valves. Telephone or fax for an immediate quotation.

NORTON TECHNOLOGIES LTD Manufacturers of the acclaimed AirPower LPI2 Power Supply. 14 Rothesay Avenue, Chelmsford CM2 9BU. (01245) 283125

NOTTINGHAM ANALOGUE STUDIO Tel: 01773 762947. Design and manufacture of quality analogue audio. We're in the business because we realise how important music is. Our turntable arms and cartridges sell the world over. Our Main UK Dealers: Radlett Audio: Tel: 01727 85577, The Audio Consultants: Tel: 020 7380 0866, Walrus Systems: Tel: 020 7724 7224.

PLATFORM 7 High density marble ISOLATION PLATFORMS for all makes of equipment RACKS/STANDS. An elegant way to UPGRADE. Improves clarity: better BASS control. 3 Abbotts Drive, North Wembley, Middlesex HA0 3SB. Tel: 020 8904 2646. Also NEALGAR DISTRIBUTION Tel/Fax 01296 24756.

PMC/BRYSTON Emmy award winning manufacturers of the highest quality loudspeakers and amplification. Industry standard in Mastering, Film Scoring, Broadcast and Post Productions. (S.I & Stereo) PMC Products: Compacts, Floorstanders, and Large passive & active monitors. Prices range from £500 to £32,000. Finished in a large selection of exquisite real wood veneers, all PMC loudspeakers are available in horizontal mirrored pairs, centre channels and complementary subs for 5.1 surround systems. Bryston's balanced range of products include R/C Preamps, Integrated Amp modules for all the PMC range, Mono, Stereo 150W to 800w per ch, 3 Ch, 4 ch and 5 channel THX amplifiers, Surround processors,

all with distortion figures and build quality to die for. Every product is available in silver or black backed by a 20 year warranty. PMC Ltd 43-45 Crawley Green Road, Luton, LU2 0AA. Tel: 08704 441044 Fax: 08704 441045 Email: sales@promonitor.co.uk Web: www.pmc-speakers.com

REL ACOUSTICS North Road, Bridgend Ind Est, Bridgend, Mid Glamorgan, CF31 3TP. UK. Tel: 01656 768 777, international +44 656 768 777. Fax: 01656 766 093, international. +44 656 766 093. Email: contact@rel.net Web: <http://rel.net> The UK's only specialist sub-bass speaker manufacturer. "The only one that works". Get your dealer to give you a home demo and find out what the fuss is all about.

RDE TANDBERG HI-FI SERVICES Holly Tree House, The Green, Full Sutton, YORK YO4 1HW. Tel: 01759 372795. The service, overhaul and reconditioning of all Tandberg hi-fi products regardless of age.

SONIC LINK The Derwent Business Centre, Clarke Street, Derby, DE1 2BU Tel: 01332 361390. Fax: 01332 200698. "Makes the World's Finest Hi-Fi Cable From the Highest Quality Materials" SonicLink Black Rhodium interconnect uses Rhodium plated wire, Vermilion uses pure Titanium wire. S-Gold mains cable improves the picture quality in TVs, computer monitors and home cinema as well as sound in hi-fi systems. Best selling products include Red, Silver Pink and Violet interconnects. AST75x2 AST200x2 and S130x2 Biwire loudspeakers cables and Green digital 75 ohm interconnect.

SOUND BYTES 72 Novar Drive, Hyndland, Glasgow, G12 9TZ. Tel: 0141 339 7595. Fax: 0141 339 7592. e-mail bytes@colloquium.co.uk. We specialise only in mass loading material. After hours exhaustively testing SOUND BYTES with various types of speakers, we know it works and so do you - we have never had a single complaint. Call us for advice on how much to add to your equipment for the best performance and the location of your nearest dealer.

SOUND IMAGE UK LTD. 52 Milton Road, London SW14 8JR. Tel: 020 -8255-6868. Importers and distributors of the finest audio equipment, featuring the stunning Boulder 2,000 series and the complete range from Norwegian manufacturer Electrocompaniet.

J E SUGDEN & CO LTD Valley Works, Station Lane, Heckmondwike, West Yorkshire, WF16 0NF. Tel: 01924 404088. Email jesugden@compuserve.com. Superb amplifiers and compact disc players from the original class A Company. Our unique wide-bandwidth Masterclass series sets new standards in sound reproduction and can be upgraded to 180 Watt balanced monoblocks. Prices start from £549.00 for the incredible Audition-T and £649 for the legendary A21a. Contact us now for Brochures, reviews and purchase details. British owned - British built.

TALK ELECTRONICS Unit 12, Farnborough Business Centre, Eelmoor Road, Farnborough, Hampshire, GU14 7XA. Tel: 01252 378383. Please ring for details

TAG McCLAREN AUDIO - The Summit, 11 Latham Road, Huntingdon, Cambs, PE18 6ZU. Tel +44 (0) 1480 415600 Fax +44 (0) 1480 52159. Combining science and technology with distinct style, TAG McLaren Audio's complete range of audio and audio-visula products are designed to bring maximum pleasure to the discerning listener. To find out more visit our website at www.tagmclarenaudio.com, email us at HelpDesk@tagmclarenaudio.com or contact our helpdesk on freephone 0800 783 8007.

TECH-LINK distributes some of the best performing hi-fi and a/v accessories currently available in the U.K. These include: Puresonic, best known for its range of high performance interconnects and connectors, and cable adapters for a wide variety of hi-fi and a/v applications in its range; Tech-Link's own brand Switch Boxes are the perfect solution to multiple applications - for example, its highly acclaimed TAS-1 is a very practical and inexpensive way of switching your speakers between hi-fi and home cinema systems; and Shark - a range of very exclusive high quality cables, interconnects and connectors. For more information, contact: Tech-link at Units 1/2, 76a Farnley Road, London, SE25 6NX. Tel: 020 8771 8388, Fax: 020 8771 1840.

To advertise in Meet Your Maker please call Amanda Sweeney on 020 8864 4760

computer audio world

advertising@computeraudio.co.uk
editorial@computeraudio.co.uk
news@computeraudio.co.uk

www.computeraudio.co.uk

PRO AUDIO?

David Price looks at the latest in a long line of compressed audio file formats - MP3 Pro - and tries its first commercial implementation, in the shape of Steinberg's MyMP3Pro 'jukebox' software.

Just what the world was waiting for, another compressed audio file format! Oh go on then; I'm all for as many new file formats as we can possibly get. They can't do any real harm and it's not as if any of the major music labels are going to make any money from them, is it? These days, it's codecs (COderDECoders) that count, and they're in software. If they turn out to be rubbish you can ignore them and move on - gone are the days when you have throw thousands of pounds on the fire by unloading your priceless record collection at the local car boot sale, only to invest in the latest silver frisbees!

The new kid on the block is MP3 Pro. After AAC (Advanced Audio Coding) which Fraunhofer developed in conjunction with AT&T, Dolby, Sony, comes this new update of MP3 which is - lest we forget - largely the brainchild of Fraunhofer, and uses a lot of technology from Philips late but unlamented DCC (Digital Compact Cassette). Confused? Well, don't be! Also in on the MP3 Pro party is French consumer electronics giant Thomson, which obviously reckons there's something in this compressed digital audio lark, thanks to its not inconsiderable financial investment. The idea is to "extend the MP3 music format in a bid to catch

up with the audio quality and level of compression offered by Microsoft's Windows Media Player audio technology".

Now, between you and I, WMA is more impressive for its compression stats than its sound quality. It isn't bad at all, but pitch it against Fraunhofer's MP3 Professional Codec (available for download as part of its MP3 Producer Pro ripper - you'll find it by typing the name into Google at www.google.com) and WMA is suddenly struggling. It's only when you ratchet down MP3's bitrate that does it sound woefully inadequate - at 64 kbps for example, it's forced to choose between a bandwidth of only 10kHz or introducing easily detectable coding artefacts - both of which severely detract from the listening experience. MP3 Pro is about giving '128Kbps quality' at 64Kbps file sizes, if you believe what Thomson said at its launch at the Consumer Electronics Show in Las Vegas late last year. In layman's terms, you get 'CD quality'

audio at a file size that would previously only provide 'FM radio quality'.

MP3 Pro's killer punch is its backwards compatibility with ye olde MP3. This is no bad thing, as MP3 continues to thrive, and thanks in no small part to Napster is THE 'legacy' compressed audio file format. Think of it as a modern day virtual CD - love it or loathe it, everyone's got it.

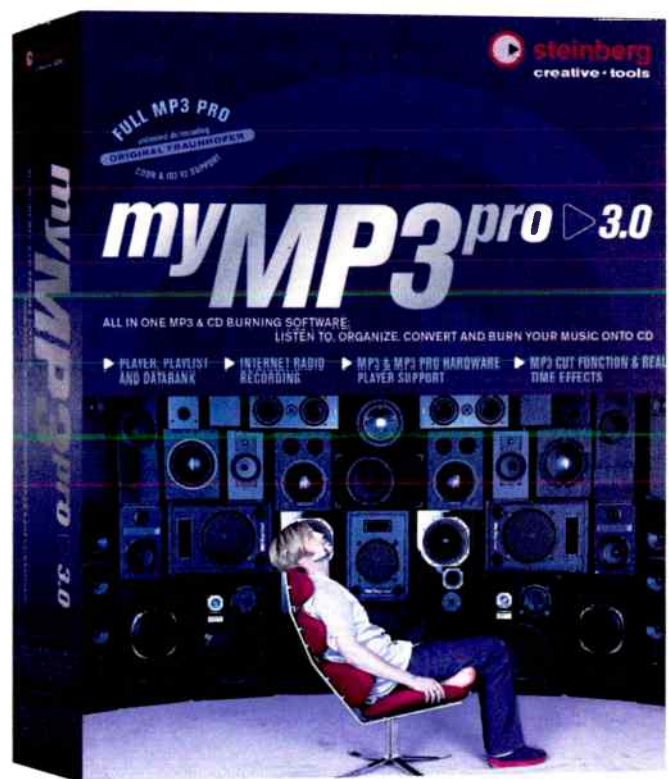

It's claimed to be sufficiently backward compatible with existing MP3s to work with all the software out there now, but you won't get the extra audio/compression benefits. So what's the deal, Neil? The bottom line is that - like the original MP3 (should we call it 'MP3 Classic?'), MP3 Pro is free to writers of non-commercial audio decoders, but producers of encoding software and commercial decoders will have to pay to use it. Commercial MP3 Pro royalties are around 50 per cent higher than their MP3 equivalents. As yet, MP3 Pro has had no official backing from any of the major digital music companies.

Thomson itself will use the technology in its own MP3 players during the second half of 2002, according to Rocky Caldwell, the company's strategic audio business development and product planning manager. Interestingly though, Steinberg has got the scoop - in the shape of MyMP3Pro tested here. MP3 Pro's creators hope it to succeed MP3 as the de facto standard in audio compression, and presumably they will submit the new technology to MPEG for inclusion in the official spec.

It's generally agreed that MP3 isn't half bad at high bit rates. The highest 320kbps offered by Fraunhofer's Advanced codec sounds



excellent, and quite worthy of being termed 'real hi-fi', but it's incredibly 'resource intensive'. For example, your average 64MB digital audio portable will give around 2 hours of playing time with low bit rate MP3s, but cranked up to 320kbps, this falls to just half an hour. The challenge therefore was to develop something that worked better at low bitrates, which is where MP3 Pro comes in. It employs an enhancement technology called "Spectral Band Replication" (SBR) which is said to be a very efficient method of replicating high frequency components of an audio signal.

MP3 Pro uses MP3's coding algorithm to take care of the lower frequencies, along with SBR for the highs. Since this latter 'bolt on' bit needs only a few kbps, it affords backwards compatibility with existing MP3 codecs which simply ignore the SBR part. The problem is that conventional MP3 decoders playing MP3 Pro files won't be able to handle the

SBR aspect, and as a result could sound muffled. The thinking goes that 'reasonable compatibility' with the world's most popular compressed audio format is better than nothing at all - which is precisely what its rival AAC affords! New players supporting MP3Pro technology will of course utilise both parts of the new format to take full advantage of the 'Pro'

enhancement, since this is still an important part of the new format.

There's a freely downloadable demo of MP3 Pro available from Thomson's website. The company reports that the general consensus of opinion is that the quality of 64 kbps MP3 Pro is similar to 96-128 kbps mp3. This then means that you can get nearly twice the amount of music on a portable or MP3 CD player with MP3 Pro. Thomson says that the forthcoming MP3 Pro CD players will be able to cram over 300 songs on a single compressed CD-R. Its creators claim that at lower bit rates the new format is ideal for web casting and Internet radio, while at higher bit rates it's perfect for high quality audio transmission and storage. The first MP3 Pro products will offer 24, 32, 40 and 48 kbps mono bitrates, along with 32, 40, 48, 56, 64, 80, 96 kbps. For more information, click on:-

Steinberg's MyMP3Pro
www.mp3prozone.com/

STEINBERG MY MP3 PRO

First off the MP3 Pro grid is this 'audio jukebox' from the Hamburg-based music software specialist. Along with MP3 support it offers full MP3 Pro functionality in a beautifully integrated piece of software that should give the latest RealJukebox a real run for its money. It combines a player, playlist, equaliser, effects and sophisticated database in combination with internet radio recording, FTP and hardware player support.

Installation is a breeze - as you'd expect from a company like Steinberg - and the software works completely ditchlessly. Upon loading up, it proffers a beautifully styled screen divided into four separate areas. Along with easily discernible 'transport' controls (i.e. play, track skip etc.), there's a sophisticated 'EQ' section which even lets you use optional additional Steinberg VST plugins effects (freely downloadable from the internet), and a Playlist section which takes care of the usual playlist-

ing duties. To the right is the 'Pool' section which shows all the audio tracks on your computer - be it MP3, WAV, AIFF or Ogg Vorbis (there it is again!)

Pressing the SEARCH button will get the program to scan through your system and add all your audio to the 'Pool'. SCAN lets you find a file of a specified name. ADD lets you add a music file from any of your PC's devices (CD-ROM, hard drive, ZIP, etc) and REMOVE will either remove its presence on the list, or physically delete the file itself (depending on what you choose). You can also record CD-ROM music files to your hard drive (via the 'pool') in WAV format (i.e. uncompressed 16/44 PCM) or rip in MP3, MP3 Pro, AIFF or OGG formats - and here's a nice touch - you can even choose your MP3 codec without having to go into the Windows Control Panel. This is the first time I've seen this facility - and big respect due to Steinberg for it!

With the new Track Editor, MP3 files can be easily edited without the need to convert

them beforehand - even real-time fade-in and fade-outs are no problem. Automatic, seamless transitions between tracks are also possible with the Crossfade Function while MetaNormalise ensures a balanced volume level across the various songs on a playlist - another very handy function. There's even an integrated Surround Module which lets you position the listener within a surround sound acoustic - it's a kind of 4-channel balance control. Additional features include the CD Cover and CD Labelling Functions for making your very own covers. A new Visualisation Module enables a breath-taking array of light and colour effects to be triggered directly from the keyboard - Steinberg suggests attaching your PC to a projector for hallucinogenic effects! All in all it's a brilliant package - and one which further advances the art. For £34.99 it's great value too. For more information, check out Steinberg's website or send questions to: info@steinberg.de

World Verdict



Easy to use, fuss-free and with top sound per pound, you can't argue with either of these products!

WELL CONNECTED

David Price tries out two interesting new connection options for computers from Xitel, the Analogue and Digital Hi-Fi Links.

Let's be brutally frank here - if you want to get sound out of your PC, the only reliable way to do it is to buy and fit a decent soundcard. If you've done this a number of times, as I have, it really isn't a problem. It's far less fiddly than - say - installing a cartridge in your tonearm and there's no risk of one slip of the finger taking out hundreds of pounds worth of delicate cantilever and stylus.

However, if you haven't found yourself whipping the cover off your PC every other week, ready to install (yet) another super soundcard, you could be justifiably disinclined to start fiddling around. If you aren't into the nuts and bolts of computer audio, you're left in the invidious position of having to trust to luck and your PC manufacturer's judgement. After all, every bit of audio that comes out of your computer will be going through his choice of soundcard, one which is informed (inevitably) by matters of price and availability, rather than sonics. As a result, don't go expecting anything better than the digital din that issues from your neighbour's micro system.

For many people, the sheer inconvenience of having to sort soundcards out themselves - and/or the hassle of getting their PCs down to the local computer dealer or technician - has meant its audio capabilities have been largely ignored. Until now. In the past couple of months we've witness the arrival of several new 'PC audio interfaces', such as the Edirol MA-3 tested last month. Now, Australian company Xitel has joined the party with its new Digital Hi-Fi Link and Analogue

Hi-Fi Link.

Unlike the Edirol, these aren't semi-pro/musician oriented - quite the reverse. They're very simple, no-nonsense products which are designed for folk who simply don't want to trust to luck and suffer their built in soundcards - but do want decent sound. The two units work in an identical way. Both plug into the USB output found on practically every PC made since the mid-nineties. The Digital Hi-Fi Link offers a standard TOSLINK digital optical output, whereas the Analogue Hi-Fi Link proffers a 3.5mm analogue mini-jack.

First, the Analogue version. Xitel points out that it offers two benefits over conventional soundcards - first is the 20bit DAC and carefully selected audio electronics it uses for high quality sound, and second is the fact that all this resides outside the electrically noisy environment of a PC. By taking all 'audio rendering' outside, it removes any possibility of distortion being introduced through latent electromagnetic radiation.

I tested it by plugging it into my notebook PC (complete with internal TEAC CD-ROM drive), and running a top quality Linn Silver interconnect (via a 3.5mm mini-jack adapter) from it to my reference Cyrus 7/PSX-R where I could hear it through my Mission 782 loudspeakers. Essentially it has a very smooth, even sound with a surprisingly strong and agile bass. Treble is quite sweet, but not as extended as, say, my reference Cyrus CD7/PSX-R, and the mid band is



clean and open with plenty of detail.

Overall, it's an incredible change

from my notebook's

built-in soundcard and not far off a good budget CD player like a Marantz CD6000. Impressive!

Next on was the Digital Hi-Fi Link, claimed to be developed for audiophiles. It's said to employ a custom digital engine with buffered synchronization and clock matching, as well as a high output optical transmitter to ensure stable transmission over extended distances. The result is claimed to be an 'exact replication' of the digital audiostream. I used it to feed the digital input of a Sony MDS-JA555ES MiniDisc player (which acted as a DAC) and the sound was superb - A-B-ing my notebook and the Digital Hi-Fi Link against the transport of the Linn CD12 showed a clear difference. Of course, you'd expect this as the Linn is a £12,000 dedicated hi-fi CD spinner - but still the notebook PC/Xitel combination was no slouch. What a result!

Overall then, these links are highly recommended if quick and easy 'plug and play' computer audio is what you want. ■ ▲

Analogue Hi-Fi Link £64.95

Digital Hi-Fi Link £44.95

Xitel Multimedia Ltd
www.xitel.com

XITEL WHO?

An Australian manufacturer of quality audio components for 25 years, Xitel recently became famous for its MD-Port product which has been bundled by Sony with some of its portable MiniDisc recorders for the last two years.

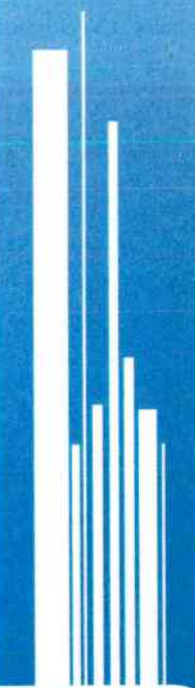

World Verdict
£★★★★

Easy to use, fuss-free and with top sound per pound, you can't argue with either of these products!

Try the competition first. Then make the right choice.

Plinius

Amplifiers and phono stages

The incredible high end amplifiers from New Zealand. Including the extraordinary CD-LAD pre-amplifier, that redefines high end value for money.

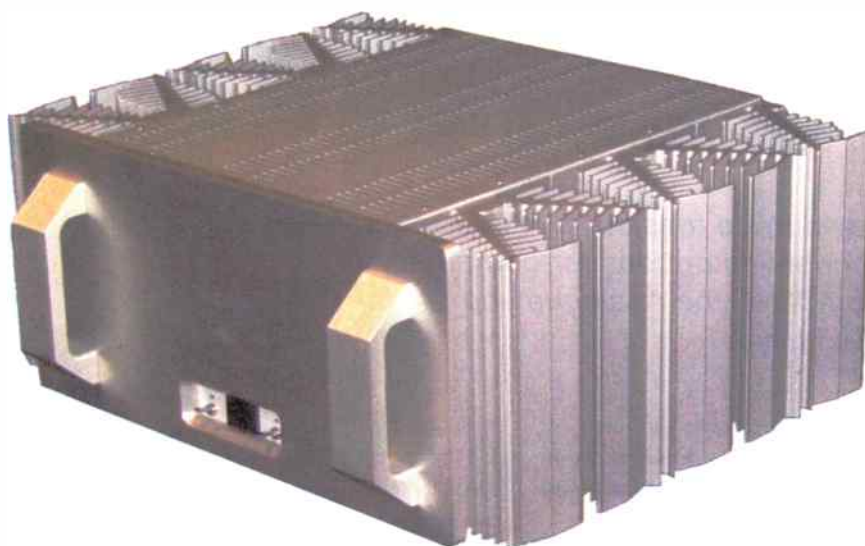

Right, the new SA102 power amplifier, launched at the Las Vegas T.H.E. Show.

Reference 3A

Loudspeakers

The MM Da Capo loudspeaker – described in The Absolute Sound® magazine as "the finest small 2-way monitors I have heard in any home listening room".



Antique Sound Lab

Amplifiers and phono stages

Coming Soon!
Due to arrive in the UK shortly



Distributed in the UK exclusively by **Absolute Analogue™**

Address: PO Box 30429, London, NW6 7GY Tel/Fax: 020 8459 8113 Email: Absolute_Analogue@email.msn.com

MYSTIK MUSIK

David Price tries out an eerily familiar audio editing package from Mystik Media, AudioEdit Deluxe 1.2 for Windows.

This is probably the easiest audio editing software I've ever used. Where Steinberg's WaveLab and Syntrillium's Cool Edit try to reinvent the wheel in their struggle to add functionality, AudioEdit simply asks, 'what do you need?' and obliges. It's simple.

Mystik media is an American company that offers a range of multimedia products for use under the Windows operating system. The company is happy to let anyone try them out for free, for 15 days. After that, if you like AudioEdit, you'll have to pay \$40 for the pleasure of using it again.

AudioEdit Deluxe is an audio editing tool that lets you create, edit, copy, move, select and mix different audio clips into one. The set-up program takes about twenty minutes to load through a standard dial-up modem, after which it installs faultlessly.

AudioEdit Deluxe is soberly divided into FILE, EDIT, COMMAND and HELP menus. Most of these functions are duplicated in toolbars placed below. To wit, the FILE menu has a range of icons for OPEN, SAVE etc, next to most of the EDIT command icons such as CUT and PASTE. Underneath this tool bar is another with all the COMMAND functions, which I'll go into later. To the right of the main waveform display are level sliders for playback and recording (very useful!) and an advanced ZOOM facility which lets you focus on one particular part of the waveform. Under all this is a bar graph type meter display, along with info on the file you're editing (i.e. bitrate, sampling frequency, size, filename, path etc.). All good, straightforward stuff - and it works a treat.

The FILE menu proffers a couple of interesting functions. First is



CONVERT which lets you variously record an audio CD into a WAV file (for editing in AudioEdit Deluxe), convert a WAV file to MP3 or vice versa, convert a WMA to WAV, MP3 or OGG (that's right trainspotters - finally we've found something that reads the long, lost Ogg Vorbis format!) and vice versa.

SELECT CODEC goes straight into your Windows Control Panel and lets you choose an available codec, frequency, bits per sample, channel(s), and other appropriate settings, depending on the codec selected, for use in future save operations.

AUDIO INFORMATION opens a window displaying information on the currently loaded file. You can add or change the information. Any additions or changes you make are saved with the audio file and can be read by audio software when opened in the future.

The EDIT menu offers the usual CUT, PASTE, UNDO, REDO, INSERT SILENCE, INSERT NOISE, SELECT and COPY as well as an interesting MIX FROM FILE facility which automatically overlays one file over another.

The COMMAND menu, in conjunction with its toolbar, offers the following myriad digital signal processing facilities: AMPLIFY, NULL

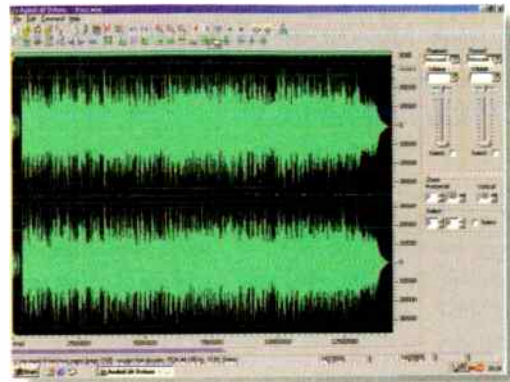

SIGNAL, FADE IN/OUT, INVERT, NORMALIZE, REVERSE, BAND PASS FILTER, DELAY, FFT FILTER, FLANGER, HIGH PASS FILTER, HIGH SHELF FILTER, LOW PASS FILTER, LOW SHELF FILTER, INSET NOISE, INSERT PULSE, INSERT SINE, VIBRATO, NOTCH FILTER, STRETCH and MERGE TO STEREO. Essentially, these are the useful features from Cool Edit - albeit sometimes slightly curtailed - plus a couple of new ones thrown in for good measure.

There are three great things about AudioEdit Deluxe. First are those superb, fuss-free ergonomics that make just about the easiest program of its type to use. Second is its economy - it doesn't need a super-computer to run on (all Mystik Media ask are a Pentium Processor, 128MB RAM, 30MB HD, soundcard and CD-ROM drive) and won't take over your hard drive. Third are its file conversion and encoding capabilities. Installing it adds a host of new audio codecs to your system - including a Fraunhofer Advanced for MP3 playback, and the brilliant sounding, enhanced LAME for MP3 recording.

Recommended wholeheartedly then - the only cloud on the horizon is the fact that the even-more-flexible Cool Edit 2000 costs a mere \$29 more to download. Still, the great thing is that you can try it for yourself first, by downloading a copy from:

ftp://mystikmedia.com/Setup_AED.EX
E.MYSTIK ■ ▲

Media Audioedit Deluxe 1.2 \$40

Email: info@mystikmedia.com

<http://audioedit.mystikmedia.com>

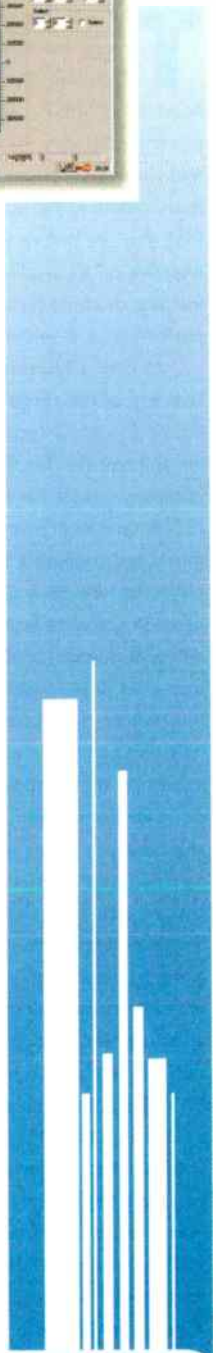

World Verdict



Charismatic little package with the emphasis on ease of use and format conversion flexibility - a bargain, but there are some very capable rivals to consider too.

CHECK THIS OUT!

Sony's new NW-MS9 'Network Walkman' is the Japanese giant's latest digital audio portable. David Price listens in.

The first 'Network Walkman' range, launched in Japan in October 2000, comprised the flagship NW-MS7 (using Sony's proprietary Memory Stick memory card) and the NW-E3 (sporting built-in flash memory). Now, the new NW-MS9 you see before you attempts to improve on its predecessor while keeping the formula - small size, high performance, premium price.

At over £220 this is an expensive, top of the range product. It uses Sony's OpenMG technology for storing and transferring files, which is the company's name for its secure (SDMI-compliant) way of copying music and sending it to and from the player. Its new Sony OpenMG 2.0 Jukebox software lets users create different music compilations everyday, from files downloaded from the Internet or ripped from CD, and usefully, you can also create back catalogues on the jukebox, ready to download onto the Memory Stick at any time.

The user interface is better than that of yore, but still fussy due to Sony's paranoia about piracy. If you're going to use the NW-MS9 everyday (as most commuters would), this is an extremely important point. When the software's been installed, the NW-MS9 thoughtfully appears as a disk drive under 'My Computer' on your desktop. Unfortunately though, you can't then simply drag and drop music files to and from the player as you would, say, a USB digital camera. Rather, you have to go via Sony's 'Check-out/Check-in' copy protection scheme, meaning you first have to load the OpenMG Jukebox and convert your files to Sony's proprietary, encrypted ATRAC3 format. This is a pain because - if you're transferring pre-existing MP3 or WMA files rather than ripping them from CD - it means you have to store your music in both MP3 (or WMA) and ATRAC3 formats, thus

doubling the usage of hard disk space. Then there's the dubious process of compressing already compressed audio (i.e. MP3 to ATRAC3).

Other problems include the limited ATRAC3 compression options - the supplied software at least was limited to just three bitrates of 132, 105 and 66 kbps - and the restriction on the number of copies of CDs you can make. If you choose to rip from CD, which is understandable considering the rigmarole of converting from MP3, OpenMG only lets you 'Check Out' files to the player three times, and no more. After that, you have to 'Check In' a copy to the computer before you can 'Check Out' another - which is a bloody pain. One wonders whether this will really prevent piracy? Ho hum.

It looks that sell 'product' in this particular market though, and in this respect the new NW-MS9 is sublime. Beautifully small and light, and finished in a luxurious matt silver, this digital walkie is pretty much the coolest looking thing around right now. A single two-way rocker button starts or stops playback and lets you skip between tracks, while three small recessed buttons control the dinky LC display, plus built-in bass booster.

The power management functions are a bit fussy. It boasts up to 10 hours of continuous playback via an internal rechargeable 'gum stick' style nickel metal hydride (NiMH) battery, but unfortunately you have to pop it out to recharge it, via the supplied AC adapter/charger. The supplied 64MB MagicGate Memory Stick stores up to 120 minutes of music, although half this is more realistic if you want hi-fi quality.

The unit is a dream to use and carry around. Problems arise when you want to squirt music into it (as mentioned), and when you're wanting



more than just background

music to soothe your passage to the office. Put directly, it doesn't sound too hot. As I found early last year, ATRAC at the permitted bitrates of 132, 105 and 66 kbps just isn't good enough. No matter what Sony says, it doesn't hold a candle to decent Fraunhofer-coded MP3s, and AACs give it an even harder time at a lower bitrate. When you drop the coding density to 66kbps, you get an admittedly bouncy but very ragged sound - mechanical and full of artefacts, it's about as musical as listening to your PC's modem. Ratcheting things up to 132kbps helps no end, but it's still just a touch too phasey and processed sounding for my liking. A-B this against, say, Philips Rush SA-126 MP3 player running 128kbps MP3s and it's night and day.

The Sony is a brilliant product that's been hidebound by politics. First is the silly SDMI compliance, which turns the 'Check In/Check Out' thing into a chore. Second is its manufacturer's desire to go it alone and run with its beloved ATRAC coding technology. If only these two constraints were circumvented, it would beat the living daylights out of the Rio et al., but they aren't. A beautiful bit of kit, but this one isn't for me. ■ ▲

Sony NW-MS9 £229
Sony UK Ltd. 01932 816451

World Verdict



Brilliant ergonomics, but let down by its fiddly SDMI-compliant software and ATRAC.

welcome to

world favourites

Here's a list of products that are a good buy. We've tried to cater for a range of tastes, identifying strong products in every area. We're agnostic so you'll find a wide range of products, from valve pre-amps through to MiniDisc players. Products marked * are recently out of production but make a good second-hand buy.

Prices shown are those at the time of the review



Roksan Caspian CD player
Solid as a ROK

COMPACT DISC

ARCAM FMJ CD23 £1100
This British-built player is extremely versatile. Controlled and detailed with a musical insight that few match. (Jul 2000)

CAMBRIDGE CD4SE* £200
A touch soft in the treble but outstanding in every other respect. (Feb 98)

KENWOOD DP-3080/II* £180
Has great clarity and presence for the price. Not as naturally expressive as the CD4SE though. (Feb 98)

LINN KARIK III* £1775
Under rated and overlooked, the final Karik was a gem. Superb transport gives a brilliantly tight, grippy dynamic sound, albeit tonally rather dry.

MARANTZ CD-17 KI-S £1100
The Marantz excels in all areas. Without doubt this is one of the most involving CD players on the planet. Build quality is also exemplary. (Sep 97)

MARANTZ CD-63 MKII KI-S* £400
Similar to the CD-63SE but more powerful bass and an all-round smoother sound. The famous KI tweaks pay off again. Whether or not it is still pre-eminent against the vastly improved competition is a matter of opinion.

MERIDIAN 506 20-BIT* £1100
Very detailed and revealing player. More cerebral than visceral sounding, however. (May 95)

MUSICAL FIDELITY X-RAY £800
Commonsense sturdy CD player of exceptional ability. Clear and detailed with high quality internal processing system. The X-Ray is inclined to show up poor recordings, but it's only doing its job! (Feb 99)

NAD S500 £1000
This dynamic top of the range Silverline spinner delights with any type of music. Exciting, sophisticated sounding and highly recommended. (Jun 2000)

ROKSAN CASPIAN £895
The Caspian has a smooth, slightly bright sound with some of the clearest treble in the business. Very engaging, dynamic character. (Aug 97)

ROTEL RCD 951 £300
HDCD capability at a midrange price. Plain Jane looks but solid construction. There is some higher than average measured distortion which may take the edge off this otherwise tempting product. (Aug 99)

COMPACT DISC TRANSPORTS

SONIC FRONTIERS TRANSPORT £6999
Cutting-edge design and technology combine to make this one very desirable product. The only problem is the fantasy hi-fi price. (Sep 98)

TEAC P-30 £2500
Cheap it isn't, but then it sounds like a million digital dollars. Nothing short of superb. (Jun 97)

TEAC VRDS-T1 £600
Excellent mid-price silver disc spinner with a powerful, expansive and warm sound. Easily beats most sub-£1000 designs. A good choice for the budget conscious who want the best. (Feb 95)

DACs

CAMBRIDGE AUDIO DACMAGIC 3* £99
Superb value for money with extensive facilities and solid, detailed sonics. Upgrades any sub-£300 player.

DCS ELGAR £8500
Future-proof convertor which will handle 24/96 and 24/192. Extremely open and natural performer. (Nov 97)

DPA LITTLE BIT 3* £299
A taste of the high end on a budget. Rich, clean, punchy sound transforms budget CD players.

MIDIMAN FLYING COW £299
Excellent as a DAC and doubles as an ADC for archiving to CDR. (Jun 98) Great value, as is junior version Flying Calf at £109. (Feb 99)

MUSICAL FIDELITY X-DAC* £300
A bargain for normal CDs and even better with HDCDs (Nov 97)

SONIC FRONTIERS PROCESSOR 3 £6999
Quality never comes cheap! This DAC oozes class and when matched with the Transport 3 is certainly up with the best. (Sep 98)

TURNTABLES

LINN SONDEK LP12 BASIK £1100
Off the pace these days in many respects but still an extremely sweet and engaging listen with a quintessentially analogue sound.

MICHELL GYRODEC SE £775
Exquisitely built, infinitely upgradeable deck that gives true high end sound at mid-fi prices.

MICHELL ORBE £2000
Fantastically capable all rounder with commanding, powerful, detailed sound that gets the best from almost any arm and cartridge. Supreme build, brilliant value. (Apr 95)

ORIGIN LIVE STANDARD (KIT) £145
Good in standard form with AC motor; frighteningly good with a DC motor and battery PSU.

PINK TRIANGLE TARANTELLA £680
Not only does the Tarantella have more style than a catwalk full of models, it also combines PT's usual clarity with real authority. (Oct 97)

PRO-JECT DEBUT £110
Straight out of the box and onto the shelf! Nothing short of a bargain. Vinyl's never had it so good, so cheaply!

REGA PLANAR 2 £214
Brilliant starter deck with extremely polished manner. Better built £274 Planar 3 is a great all-in-one package that eats mid-price CD players for breakfast.

ROKSAN XERXES X £1295
DSU or XPS 3.5 power supply £150/170 extra. Excellent pitch stability from a new Swiss motor and outboard power supply. Very tight bass, fine dynamics and revealing clarity (Jan 97)

SYSTEMDEK IIX900*/RB250 £330
A fine all-rounder and easy to upgrade too. More depth and breadth than Rega Planar 3. (Sep 94)

VESTAX BDT-2000 £225
A stylish looking deck with infinitely variable speed 16-90 rpm, DC belt drive and built-in MM phono stage. Good value, with plenty of chassis room for alternative arms, if required. (Sep 99)

TONEARMS

HADCOCK 242 SE £649
Latest of a long line of unipivot arms. Added mass makes the 242 suitable for both low compliance MCs and straw-in-the-wind high compliance types. Revised geometry and chromium plating completes a first-class job. (Jun 2000)

NAIM ARO* £975
Truly endearing and charismatic performer - wonderfully engaging mid-band makes up for softened frequency extremes

REGA RB300 £180
Some may prefer the simpler RB250 at £130. Detailed, tight, rhythmic sound but tonally rather grey and cold-sounding. Still excellent value, though.

WHICH ONE

The Fabulous new Lumley Lampros loudspeakers and Metropolis amplifiers range are now in stock. Are these the best yet?



All of these products are examples of some of the very best Hi-Fi currently available. If you want to know which is the very best product for you there is only one way to find a total solution.

CALL US FOR THE ANSWER



Sounds Of Music
10-12 Chapel Place
Tunbridge Wells, Kent
TN1 1YQ

Tel: 01892 539245
Fax: 01892 616383

www.sounds-of-music.co.uk

Acoustic Zen, Avontgorde, Argento, Audio Synthesis, Advantage, Audio Physics, Apollo, Aloio, Audio Note, Audio Research, Audio Analogue, Anthem, A.V.I., A.T.C., Acoustic Energy, Atocomo, Bose, Balanced Audio Technologies, Beyerdynamic, Boulder, Bow, Bose, Burmester, Cobosse, Corfrore Horns, Covergent Audio Technology, Chord, Copland, Cable Talk, Celestion, Copulare, Clear Audio, Clearlight Audio, Dunlovy, Echo-Busters, Eggleston Works, Electrocomponient, Gomut, Graham, Goertz, Goldring, Groda, Halcro, Harbeth, Hovland, Jomo, JM Labs, Kharmo, Koetsu, Krell, KEF, Klipsch, Lumley, Lyra, L.A.T., Lavordin, Meadowlark, Magnum Dynolob, Morantz, Martin Logan, Mitchell, Neot, Nordost, Opero, Optimum, Ortofon, Orchid, Parasound, Plinius, Project, Passlobs, Pro-oc, Piega, Pink Triangle, Primore, QED, Quod, Rel, SME, Shure, Sennheiser, Sonic Link, Soundstyle, Sound Organisation, Sumiko, Straight Wire, Sonus-Fober, Stands Unique, Target, Trilogy, Teac, Theto, Tannoy, Totem, Talk Electronics, Townshend, Transporent, Transfiguration, Triangle, Unison Research, Von Den Hull, Wisdom, Wilson, Wodio, XLO, YBA.

Prices shown are those at the time of the review



Musical Fidelity X-Cans2
Warm, sumptuous, sweet sound

SME 3009SII £309

Once state of the art, but no longer. Weak at frequency extremes and detail, but its legendary serviceability makes it a cult in Japan. Can be picked up for peanuts second-hand. (Jan 93)

SME 309 £689

A down-market version of the IV and V with aluminium armtube and detachable headshell. Tight, neutral sound with good tonality, but lacks the IV's pace and precision. Like the older SME 3009 series, this arm is also available in 10" and 12" versions. (Jan 93)

CARTRIDGES

AUDIO TECHNICA

AT-110E £30
Great starter cartridge that's refined, detailed and musical beyond its price. Best value MM under £50

GOLDRING 1012GX £74

An accomplished MM with a solid bass, slightly forward midband and clean transients. Very reasonable price for such an able performer. (Jul 93)

DNM MICA £185

Betters Goldring's 1042 and costs only £135 on trade-in. An assured and transparent MM. (Feb 98)

DYNAVECTOR DV20X-H £299

The best modern budget MC combines deliciously sweet sound with fantastic get-up-and-go. High output version works a treat with valve phono stages too.

MUSIC MAKER £575

When mated with a good quality arm, this hand finished high-output pick-up gives an ear-boggling account of itself. Very high compliance ensures maximum information retrieval. An absolute (grain orientated) gem. (Feb 99)

ORTOFON MC 7500 £2000

Conclusive proof that there's hope for the world. It's a long time ago now but this high-priced favourite still earns its niche - CD lovers would die if they heard it. (May 94)

ORTOFON MC 15 SUPER II £140

Not quite as good as the dearer Supremes but the Super II is a splendid introduction to the joys of moving-coil cartridges.

GOLDRING 1042 £130

One of the best Moving Magnet cartridges going, with beautiful treble and muscular bass. New low price makes it a bargain.

ORTOFON ROHMANN £1000

In a way it's MC 2000 meets MC 7500 with great tonal strengths and a dynamo sound. (Apr 96)

INTEGRATED AMPLIFIERS

AUDIO ANALOGUE

PUCCHINI SE £395
This superbly-built Italian integrated has a lucidity and control which leaves others nowhere. Sound stage a wow. (Dec 97)

AUDIOLAB 8000a * £495

Well rounded integrated with smooth and detailed sound plus a huge feature count. Great build makes later versions a top used buy.

DENON PMA-250SE £160

It might not have bags of grunt but the Denon can sound exceedingly natural and open. (Feb 97)

McINTOSH MA6800* £3735

The MA6800 not so much plays music as takes control of it, with effortless bass drive. (Sep 95)

MISSION CYRUS 2 * £299

Classic eighties minimalism combines arresting styling with clean, open, lively sound. Further upgradable with PSX power supply.

MUSICAL FIDELITY

X-CANS2 £160

Warm, sumptuous, sweet sound h/phone amp. gives startling results with a decent set of headphones.

NAIM NAIT 3 * £575

Superb rhythms and dynamics make for great music making, but tonally monochromatic. Super optional phono stage makes it ideal for vinyl junkies.

ROKSAN CASPIAN £695

Smooth, warm integrated with remote control that works happily into most 'speakers. (Dec 97)

SONNETEER ALABASTER £995

Builds on the strengths of the Campion with ample control, colour and drive. (Oct 97)

PHONO STAGES

CREEK OBH-8 SE £180

Punchy, rhythmic character with oodles of detail makes this a great budget audiophile product.

LFD MISTRAL PHONO STAGE * £300

The Mistral has a warmth and involvement that make many pricier stages sound overpriced.

MICHELL DELPHINI MONOBLOCS £1995

Analogue tour-de-force gives supremely clean, detailed and finely resolved sound with breathtaking dynamics. Great value, even at this price.

MUSICAL FIDELITY X-LP £125

One of the famous MF X series. Full marks throughout for clarity and detail. Switchable between MM and MC. Indestructible build! (May 99)

PRO-JECT PHONO BOX £39

Not the last word in many respects but a thoroughly honest piece of work. Inexpensive introduction to all that vinyl has to offer. MM and MC provision plus choice of two impedances.

ROKSAN ARTAXERXES X £950

With the Attessa PSU the Artaxerxes X MM/MC stage still shines. Great stage depth, neutrality and tonal colour. (Oct 97)

Billy Vee
SOUND • SYSTEMS

248 Lee High Rd, London SE13 5PL (Mon - Sat 10am to 6.30pm Closed Thurs & Sun)

NOT ONLY A CLASSIK BUT MUCH MORE

Call 020 8318 5755 or 8852 1321 now!

Save over £300 on this Linn/Celestion System

This is just one of the fabulous systems available during our Autumn promotion. The offer may be limited in quantity but you can be sure that any product or system we stock is available for audition and backed by experienced staff who work to fulfill the Billy Vee pledge - to give the ultimate in musical satisfaction

- Free delivery (U.K. Mainland) & local installation included
- Five year parts and two year labour warranty on this system
- Deferred & Interest Free Credit available 0% APR - Call for details.
- Arcam, B&W, Linn, Naim, Rega, TAG & more available for audition

Complete with speaker leads - just plug & play only :



£1290

Individually, Linn Classik - any colour £995. Celestion Compact A £599

SONNETEER SEDLEY £399
Combines transparency and fine dynamics with excellent rhythmic ability. (May 98)

PRE-AMPLIFIERS

AMC 1100 £150
Suffers from un-defeatable tone controls but an extremely good value piece of kit. Partners the similarly budget level AMC 2200 power amplifier, also at £150. Comfortable beginners' choice. (Mar 99)

AUDIO ANALOGUE BELLINI £475
Showcases AA's characteristic mix of clarity and musicality and blasts the competition. (Apr 98)

CHORD CPA1800 £1800
Clarity, insight and control are second to none - an addictive mixture. (Mar 98)

CROFT VITALE £350
A modestly priced valve pre-amp with exceptionally transparent performance. MM phono stage plus three line stages are standard. Volume controls are separate for each channel, thus giving balance adjustment. A remarkable item in all respects. (Feb 2000)

XTC PRE-1 * £1000
Almost valve-like in its smoothness, the line-level Pre-1 is warm and seductively clear. (Nov 96)

POWER AMPLIFIERS

ARCAM 9 * £400
With 70W on tap, the 9P will drive most loudspeakers with a spacious and detailed sound. Good bass welly too. (Dec 96)

CHORD SPM400 £1400
There's a sense of effortless power to the Chord that gives music real scale and presence. (Mar 98)

MARANTZ MODEL 9 * £8000
Authentic reproduction monoblocs still more than cut the sonic mustard. Highly expensive and highly sought after. (Mar 97)

MICHELL ALECTO £1989
Crisp, clean and beautifully controlled with gorgeous styling. Partnered with the £1650 Orca this is a superb winning combo. (Oct 98)

MUSICAL FIDELITY X-A200£1000/pair
200W of high-end monobloc power in a grooved tube. (Aug 98)

NAIM NAPI80 £1060
Partnered with a NAC82, this has classic Naim control, and a superbly rhythmic presentation.

TUNERS

CAMBRIDGE T500 £180
An extremely engaging tuner with a performance at odds with its low price. Not exactly a Troughline, but you may not notice... (Feb 99)

CREEK T43 £399
Excellent detail, separation and dynamics. A great little tuner and unbeatable at this price. (May 98)

MARANTZ ST17 £600
A positive dreadnought of a tuner. Sweet and refined but with a heavy punch when needed. A tuner of this quality demands a decent aerial. (Jul 99)

MISSION CYRUS FM7* £300
Clear and lucid sound puts it up with the best. Superb build too. (Apr 94)

NAIM NAT03 £595
The NAT03's warm, atmospheric sound is further proof of Naim's proficiency with tuners. (Sep 93)

SONY ST-SA3ES* £250
Beguiling RDS tuner for the sonically discerning. Good ergonomics and sensitive too. (Apr 97)

CASSETTE DECKS

AIWA AD-S750* £200
Sonically a very decent machine at the price. Comes fitted with Dolby B, C and the dead handy Dolby S. (Apr 96)

AIWA AD-S950* £300
A stable transport, superb head and Dolby S make the AD-S950 an excellent all-rounder. (Feb 95)

KENWOOD KX-3080* £160
A simple deck, but excellent-quality head and transport give top quality sound. (Oct 96)

PIONEER CT-S740S £430
A great piece of engineering from Pioneer, with first-rate sound. (Jun 96)

YAMAHA KX-580SE* £250
The 'SE' tag is more than a marketing gimmick. Sound is solid and clear with Dolby S. (Sep 97)

LOUDSPEAKERS

CASTLE EDEN £469
Impressively vice-free 'speakers that offer great transparency and involvement. One of a select band that simply makes music regardless. (Mar 97)

EPOS ES12 * £495
Strong, punchy bass is allied to finely detailed, articulate midrange and sparkling treble. (Oct 96)



Kef Cresta I loudspeakers
A very musical sound

KEF CRESTA I £100
Delightfully sophisticated presentation for the price. Won't blow the roof off, but will deliver a very musical sound. (April 2000)

KLIPSCH HERESY II £1100
An outstanding high sensitivity loudspeaker with midrange and treble horns coupled with infinite baffle 12" bass driver. Effortless, fast and accurate. (May 99)

MISSION 752 * £495
Cracking mid-price mini towers combined HDA drive units and metal dome tweeters with surprisingly warm results. Benign load characteristics makes them great for valves.

MISSION 771 £170
Characteristically fast, punchy Mission sound from the Aerogel mid/bass and silk-dome tweeter. (Jul 98)

Billy Vee
SOUND SYSTEMS

248 Lee High Rd, London SE13 5PL (Mon - Sat 10am to 6.30pm Closed Thurs & Sun)

You can't touch it but you sure can feel it

You can't see it but you really can hear it

Call 020 8318 5755 & join us for true -

HI-FI PERFORMANCE



What *is* true hi-fi performance?

Here's a simple truth. You *can* believe what you read but you will never really know how good something is until you listen. A demonstration is worth a thousand words and our hi-fi systems all have one thing in common, we guarantee you will get more from your music! When you hear what we mean, you will never look back. Honest!



Rega
The New Brio Amplifier

QUAD ESL 63 * £3450
A reference against which all other loudspeakers are judged, the '63s have superb imaging and genuine transparency.

TANNOY AMS8 * £2700
Bold sounding pro active monitor with solid bass, clear midrange and delicious treble. (Aug 96)

TANNOY MERCURY m2 * £140
A true audiophile bargain which embarrasses many more expensive boxes. Never mind the price, let your ears decide. (May 97)

MINIDISC PLAYERS

KENWOOD DM-9090 £500
One of the best MD players yet. ATRAC 4.5 gives clean and very musical recordings from this Kenwood. (Jan 98)

SONY MDS-JB930Q £250
Great mid-price machine that adds better build and facilities to the '530's already excellent sonics.

SONY MDS-JA50ES * £1300
This Sony can put the wind up Nakamichi cassette decks when used with better blank MDs. (Apr 98)

SONY MDS-JE55ES
MiniDisc recorder £520
The best sounding MD deck made so far, thanks to awesome build and heroic ATRAC-DSP Type R coding.



Alesis Masterdisk
A glimpse of the future

SONY MDS-JE510 £300
An impressive sound and unmatched convenience make this MiniDisc player an excellent buy.

DIGITAL RECORDERS

ALESIS MASTERDISK £1400
A groundbreaking hard disc recorder with a built-in CD drive. An amazing bit of kit, and a glimpse of the future. (July 2000)

KENWOOD DMF-9020 £500
An excellent tool for home recording, combines convenience, superb sound and a fair price. (Aug 99)

MARANTZ DR-17 £1100
Probably the best sounding CD recoder on the market. Built like a brick out house with a true audiophile sound. HDCD compatible. (July 2000)

PHILIPS CDR-765 £360
One of the first twin deck recorders/players that boasts high speed dub facility. Playback could be warmer, but still a bargain. (Oct 99)

PIONEER PDR-555RW £480
Excellent mid-priced CD recorder that both plays and records with equal panache. (Oct 99)

SONY TCD-8 DATMAN * £599
Super clean and detailed sound makes this an amazing portable. Not as robust as it should be though.

DVD PLAYERS

DENON DVD-5000 £1600
Monster build, as you'd expect at this price. Facilities and gadgets galore and drop-dead high end looks. A very smooth and sophisticated sound, although not as good as similarly-priced CD players. (Mar 99)

PIONEER DV-717 £700
Well built and a solid performer, with a 'true' 24/96 digital output. Facilities in abundance and a controlled, exciting way with CD replay. Shame it lacks a Dolby Digital decoder! (Sep 99)

SONY DVP-S725 £490
One of the best buys in the DVD market. Available in a dodgy white case, but the facilities and performance more than make up for this. Excellent with both music and visuals, and a whole host of up to the minute facilities to keep you occupied. (Mar 2000)

HEADPHONES

JECKLIN FLOAT MODEL TWO £99
Wonderful panel-like and open sound from these esoteric-looking headclamps. Do not wear in public unless you like being made a fool of!

SENNHEISER HD-490 £50
Good value cans with an exciting and bassy sound. Everything one should look for in headphones at a sensible price.



Nordost Blue Heaven
A simple and effective upgrade

INTERCONNECTS

CHORD COMPANY CHAMELEON 2 £90/m
One of our favourite favourites, the Chameleons are musical performers with a smooth yet open sound.

DNM RESON £40/m
Neutral and transparent, and a steal at forty quid!

NORDOST BLUE HEAVEN £150/m
Some of the fastest and most transparent cable around. A simple and effective upgrade.

VAN DEN HUL ULTIMATE THE FIRST £260/0.6m
Carbon interconnects that help you forget the electronics and concentrate on the music. Miraculous transparency.

LOUDSPEAKER CABLE

CHORD COMPANY RUMOUR £9.95/m
The Rumour is our reference at the price. Tight and tuneful bass mixed with air and space results in a cracking cable for the money.

DNM RESON £6.95/m
This cable has a transparency of sound that's rarely heard at the price. Excellent value for money.

NORDOST BLUE HEAVEN £375/3m pair
This isn't cheap, but it sounds absolutely fab. An open and spacious sound that simply carries music.

Billy Vee
SOUND SYSTEMS

NEW YEAR DISPLAY CLEARANCE BARGAINS

SOME AS NEW WITH 1 YR WARRANTY. 24HR DEL ONLY £5. CHECK AVAILABILITY BEFORE ORDERING

CALL SALES: (020) 8318 5755 or 8852 1321 - 248 Lee High Road, London, SE13 5PL

0% APR is available on purchases of more than £660. Please call for details. * Prices Correct at 12/06/01 EXOE

Arcam CD72 CD Player NEW! (2Yr G/tee) ..(399.00)	£349.00	Linn Keilidh Blk S/H (1Yr G/tee) ..(775.00)	£395.00
Arcam CD92 CD Player NEW! (2Yr G/tee) ..(849.00)	£499.00	Linn Ninka Speakers (2Yr G/tee) ..(945.00)	£695.00
Arcam A75 Amplifier NEW! (2Yr G/tee) ..(379.00)	£265.00	Linn Kaber Speakers Passive S/H ..(1800.00)	£790.00
Arcam A75 Amplifier NEW! (2Yr G/tee) ..(450.00)	£299.00	Marantz DV4100 DVD Player (1Yr G/tee) ..(399.00)	£249.00
Arcam Alpha10 Amplifier NEW! (2Yr G/tee) ..(799.00)	£399.00	Marantz DV7000 DVD Player (1Yr G/tee) ..(599.00)	£399.00
Arcam Alpha 10DAB Tuner NEW! ..(799.00)	£399.00	Marantz SR5000 AV Receiver (1Yr G/tee) ..(499.00)	£325.00
Arcam Alpha 10/10pDave (AV Amp) S/H ..(2500.00)	£1495.00	Nakamichi Soundspace 3 System ..(449.00)	£295.00
KEF Q35.2 Speakers ..(350.00)	£249.00	Naim NAC72 Preamp (1Yr G/tee) ..(760.00)	£449.00
Linn Karik/2 CD Player S/H ..(1498.00)	£650.00	Naim SBL Passive Speakers S/H (1Yr G/tee)(2500.00)	£1099.00
Linn 5105 Power Amplifier (2Yr G/tee) ..(1200.00)	£600.00	Naim Intro Spkrs - Beech (1Yr /Gtee) ..(790.00)	£590.00
Linn 5150 Subwoofer-Cherry (2Yr G/tee) ..(2999.00)	£1995.00	Rega Jura Speakers (2Yr G/tee) ..(498.00)	£329.00
Linn Kairn Line Preamp (1Yr G/tee) ..(1400.00)	£799.00	Rega Brio Amplifier (2Yr G/tee) ..(298.00)	£229.00
Linn LP12/Lingo/Akito S/H (1YR G/tee) ..(2250.00)	£1250.00	Vision 42" Plasma Screen (1Yr G/tee) ..(5300.00)	£2795.00

welcome to world classics

CASSETTE

NAKAMICHI DR-2

A great machine with Nakamichi's legendary heads. The lowest cost 'true' Nakamichi at the time, retailing for £600.

NAKAMICHI CR-7

The last of the great ones, and definitely the best Nakamichi ever (yes, better than a Dragon)

YAMAHA TC-800G

Early classic in serious cassette. Its ski-slope looks got it a cult following once it had ceased to be simply ugly.

CD PLAYERS

MERIDIAN 207

Beautifully-built two-box with pre-amp stage. Very musical although not as refined as modern Bitstream gear. No digital output.

PIONEER PD-91

Built-to-last player with easy upgrade routes for modifiers. Not knockout as it stands but get one cheap and have a go!

CAMBRIDGE CD1

The first two box player with weighted mechanics and even an optional Dropout/error counter. Radical and effective at the time - a classic.

AMPLIFIERS

LEAK POINT ONE, TL12 & TL10

Ancestors of hi-fi, consequently expensive nowadays. As with all vintage valve stuff, overhauling is de rigueur before use, using original parts if possible.

LEAK PRE-AMPS

Line of 'good for their time' pre-amps. Use of EF86 pentode valve for high gain rules out ultra performance. Not the highest-fi.

LEAK STEREO 20

Excellent workaday classic valve amp. In good order the 20 will not disgrace itself. Various upgrades are available from specialist repairers.

LEAK TL12+

Plentiful monobloc equivalent of Stereo 20. Reasonably inexpensive and a tweakers' dream. Genuine valve hi-fi on a budget.

NAD 3020

You can't argue with success! NAD's budget transistor integrated gave thousands their first taste of hi-fi and remains great value.

QUAD 33/303 PRE/POWER

Great style and construction, also bullet proof. Warm and wooly sound, but easy going. A good introduction to early transistor audio classics.



Garrard 401
A legendary turntable.

QUAD 22/II PRE/POWER

One of the all-time classic valve amplifiers. Unusual circuit but it works beautifully. 22 pre-amp not up to today's standards.

SUGDEN A21

Seventies transistor integrated has an eminently likeable smoothness and musicality. Limited inputs via DIN sockets.

TECHNICS SE-A5 Mk2

Nice transformer and electronics, shame about the casework. With tweaking, this 150watter can sound sweet.

LOUDSPEAKERS

KLIPSCHORN

Not exactly plentiful or cheap but a splendid beast. For efficiency they have seldom been equalled. Space hungry!

AUDIO ILLUSION

23 Langley Broom
Langley, Berkshire SL3 8NB
(2 mins. Junc. 5 off the M4)
TEL: (01753) 542761 FAX: (01753) 772532
www.audioillusion.co.uk
mailto:audioillusion@btinternet.com

Two completely different ways to achieve the ultimate goal –

PERFECT SOUND

Whether it be Home Cinema or Audio – there should be no compromise –



Each System winners of an

PIEGA OF SWITZERLAND

"these speakers blow that 'posh design equals poor sound', concept to pieces"

– Adam Rayner
HCC

AERIAL ACOUSTICS

"this is a Home Theatre experience of the highest order"

– Stuart Robinson
HCC

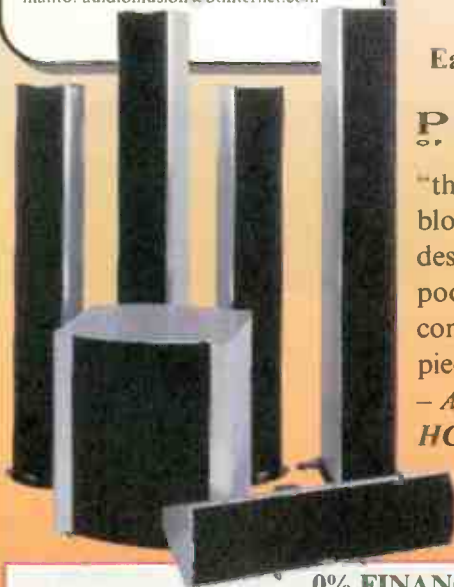

0% FINANCE (subject to status) with up to 3 years to pay.

For further information and your local dealer please contact AUDIO ILLUSION

LEAK SANDWICH

Rather warm sounding big infinite baffle but cheap with it. With a reasonably powerful amp can sound quite satisfying.

LOWTHER PM6A

High quality full-range driver; still manufactured. High sensitivity, as fitted to many classic horn designs.

MAGNEPLANAR SMGa

Touch dry in the bass but a technological loudspeaker with genuinely musical abilities.

MISSION 770

Father of the 77 range which continues to this day. Well mannered with a warm sound and a kind load to amplifiers.

QUAD ESL57

Unrivalled. Properly serviced there is nothing like them. Their natural presentation may make them caviar to the general.

YAMAHA NS1000M

Hi-tech favourites of the Japanese and Americans. Viewed more warily in the UK but can give excellent results.

TANNOY GRF & AUTOGRAPH

Folded horn monsters which certainly sound good if you have the space. For Tannoy vintage see HFW November 1998.

WHARFEDALE SUPER 8 RS DD

ideal experimenters' driver. High sensitivity ~14,000 Gauss magnet and extended frequency range. Inexpensive too!

TANNOY YORK, LANCASTER

Many similar models of infinite baffle or reflex design. Not the last word in tautness but the drivers work well in modern cabinets.

VINYL

ACOS LUSTRE

Very honest piece of kit, well made and easily adjusted. Vinyl beginners could do very much worse.

ALPHASON HRI005

First class arm, up to present-day standards. Buy carefully, though, as there's no service available now.

ARISTON RD11

A one-time king of turntables very similar to the Linn LPI2. Now deposed but worth a look at the right price.

LINN AXIS

Uncomplicated, lower-price version of the famous Sondek. Less expensive than some of its stablemates.

GARRARD 301 & 401

Legendary turntables, once fairly plentiful. Excellent back-up available; many different custom plinths available. High quality.

GOLDRING LENCO 88 & 99

Great deck for the kitchen table enthusiast. Garrard fans won't look at 'em but cheap and capable. Servicing available.

HADCOCK 228

Recently out-classed by Hadcock's updated 228 Special Edition but a proper hi-fi arm for all that. Makers still service.

MICHELL FOCUS ONE

20 years and still going strong. Early runner in the 'modern' turntable cycle with a first class arm. Factory servicing available.

SHURE M75

Recent line-contact improvements have left the M75 behind but the wide range of needles make it a handy tool.

SME 3009 IIS

Everlasting classic tone-arm. Spares permanently available from SME. No longer the last word but peanuts second-hand.

THORENS TD124

Best classic deck ever? Judging by the prices they fetch it's possible - 78rpm too!

THORENS TD150

Mid-price deck with a keen following. No real difficulty with servicing - novices may find the suspension system unnerving.

TRIO L-07D

Knockout heavyweight from 1980 with stainless bearing and 11lb platter! Not a give-away and beware! - spares scarce.

TUNERS

LEAK TROUGHLINE (ORIGINAL)

Interesting ornament but no longer hi-fi. Limited coverage of 88MHz to 100MHz only.

LEAK TROUGHLINE II & III MONO

Arguably the best-sounding tuners ever. Adaptation for stereo easy via phono multiplex socket.

LEAK TROUGHLINE III STEREO

Excellent tuner with indifferent stereo decoding circuit. Best when adapted to use modern outboard decoder.

MARANTZ ST-8

Possibly the ultimate Tardis console, including an oscilloscope for checking the strength of signal. Expensive even now.



Leak Troughline II Mono
Arguably the best sounding tuner ever

Genius, Pure Genius

Distributed by:
Henley Designs
01235 511166
www.henleydesigns.co.uk

MANTRA AUDIO

Specialist Suppliers of Audio Accessories
www.mantra-audio.co.uk

CARTRIDGE SELECTION	STYLUS	REPI ACFMENT STYLI
Goldring 1012 GX £76 £52 GEX £52 1022 GX £95 £67 GEX £67 1042 £124 £86 GEX £86 Eroica LX/H £143 £100 GEX £100 Elite £133 £95 GEX £232 £163 GEX		Swiss Quality Diamond Styli Audi XLM £15.00 Akai AN 5, AN 60 £11.00 AN 2, AN 70 £13.00 Dual DN 145 E, DN 165 E £15.00 Goldring G800 Super E £15.00 JVC DT 55, DT 60 £11.00 National EPS 24 CS, P 30 D, P 33 D £11.00 Ortofon FF 15 E II, VMS 20 E II, OM 20 £15.00 Pioneer PN 210, PN 220, PN 240 £11.00 Shure N 75 C, SC 35 C, £11.00 N 75 ED T2, N 75 EJ T2 £13.00 N 95 ED, N 95 EJ, N 75 3 (78) £15.00 VN 35 E £18.00 N 95 HE, N 97 HE, VN 35 HE £25 Sony ND 142 G, ND 150 G, ND 155 G £11.00 CN234 £13.00
*** Over 500 Styli Types Stocked ***		
HEADPHONE SELECTION		
GRADO Prestige Series SR-60 £77 SR-80 £95 SR-125 £143 SR-225 £190 SR-325 £285 Reference Series RS-1 £626 RS-2 (new) £446		
<p>EX - Exchange price against any Audio Technica, Denon, Goldring or Ortofon moving coil type cartridges</p> <p>All items guaranteed authentic new originals see our website for full selection of accessories order direct from our secure online catalogue</p>		
<p>MAIL ORDER (1-10 DAYS) PRICES (INC P&P); INSURANCE FOR UK DELIVERY -£5 FOR EUROPE DELIVERY & £12 FOR US/WORLDWIDE DELIVERY TO COVER INSURANCE ON ORDERS OVER £50 VALUE</p> <p>Tel/Fax (01757) 288652 e-mail: enquiry@mantra-audio.co.uk</p> <p>MANTRA AUDIO (HFW), 22 GARTH AVENUE, NORTH DUFFIELD, SELBY, NORTH YORKS YO8 5RP</p>		



Choice hi-fi
you choose
Choice hi-fi make it easy for you to fulfill your sonic dreams. Quality hi-fi is not just about expensive brandnames. It's about aspiring to the very best sound, about choosing your ideal system from the widest selection in the country, in a unique no-pressure environment.

your choice

- Acoustic Energy
- Advantage
- ATC
- Audible Illusions
- Audio Physic
- B.A.T
- Boulder
- Bryston
- Cary
- C.A.T.
- Chord
- Clear Audio
- Denon
- DNM
- Egglaston Works
- Electrograph Delphi
- Genelec
- Gryphon
- Graham
- Imerge
- J M Lab
- Krell
- Lexicon
- Linn
- Loewe
- Lutron
- Lyra
- Mark Levinson
- Michell Eng.
- Musical Fidelity
- Naim
- NEC
- Nordost
- Oracle
- Ortofon
- Plinius
- P.M.C.
- Primare
- Project
- Quadraspire
- REL
- Rockport
- Roksan
- Rotel
- Ruark
- Selec
- SME
- Straight Wire
- Sugden
- Tara Labs
- Teac
- Totem
- Transfiguration
- Trichord
- Trilogy
- Van den Hul
- VPI
- Wilson Audio
- Wilson Research
- YBA

H I = F I

HOME CINEMA

MULTIROOM INSTALL

BUY / SELL

Quarterly Sale items

	Our Price	Original Retail Price
Kenwood L1000C pre/ L1000M Power Amp	£795.00	£2,500.00
Pioneer A300 Int	£90.00	£180.00
Exposure VII pre + XII psu	£595.00	£1,200.00
Cyrus Dac Master & Cyrus Disc Master	£695.00	£1,798.00
Harmon Kardon AVPI	£175.00	£ -
Pioneer CLD 2850 Lazerdisc	£175.00	£ -
Cary 572 se Monoblocks	£1,495.00	£2,350.00

New this month

	Our Price	Original Retail Price
POWER AMPLIFIERS		
Meridian 551 + Remote	£595.00	£895.00
Krell KSA 250	£2,995.00	£6,995.00
YBA Passion Integrated Amp new	On Dem	£3350.00
PRE AMPLIFIERS		
Conrad Johnson Prem 7	£3,995.00	£12,000.00
LOUDSPEAKERS		
Audio Physic Virgo III new	On Dem	£4,000.00
Apogee Stage	£795.00	£ -
JM Lab Electra 926 new	On Dem	£2149.00
CD PLAYERS & DACS		
Vadia x32 Dac	£495.00	£2,500.00
Teac P700	£595.00	£1,200.00
Meridian 500 Transport	£595.00	£1,200.00
TURNTABLES, ANALOGUE, VARIOUS		
Conrad Johnson Prem 6 Head Amp	£295.00	£ -
Counterpoint SA2 Head Amp	£690.00	£1,500.00
Stax Lambda Sig SLMT1	£1,395.00	£2,000.00
Krell Kav Processor	£6,500.00	£14,000.00
Transparent Music Link Ultra XL	£995.00	£2,100.00
Cardas Golden Ref 8ft Amp	£995.00	£2,200.00
AV COMPONENTS		
Krell KAV-S processor	£6500.00	£14498.00
SYSTEMS		
Nakamichi PA7/ CA5/ ST5	£1,395.00	£3,300.00

Power amplifiers

Krell 300i Integrated	£1,795.00	£2,550.00
Audio Research M300 Monoblocks	£4,995.00	£12,000.00
Naim Nap 90	£295.00	£650.00
Krell MDA 300	£4,995.00	£12,000.00
Oracle S3000 Integrated new	On Dem	£9,950.00
Bryston 7 BST Monoblocks	£2,750.00	£4,000.00
Cary SLA 70 mk II Silver	£1,295.00	£2,250.00
Linn LK 100	£345.00	£650.00
Boulder 500 AE	£2,850.00	£5,500.00
Acuphase E203 Integrated Amp	£795.00	£ -
Melos 402 Monoblocks	£4,495.00	£9,000.00
Krell FPB 300	£5,995.00	£9,990.00
Krell KAS 2 Monoblocks	£9,995.00	£20,000.00
Linn Klassik	£895.00	£1,030.00
Boulder 1060 Power new	On Dem	£16,500.00
Cary Audio 300 SE Sig VWE300B	£3,495.00	£5,300.00
Primare 30.1 mk II Integrated	£1,350.00	£1,500.00
Copland CTA 402	£1,095	£1,700.00
Plinius SA100 new	On Dem	£3,400.00
Krell 250 A/3 3 Channel amp	£2,995.00	£4,698.00
Audio Note P2 SE	£695.00	£1,500.00
Graff GM200	£4,750.00	£8,000.00
Cary SLA 70 mk II	£995.00	£2,250.00
Audio Refinement Complete Amp	£695.00	£895.00
Audio Research VT200 mk II	£6,995.00	£9,998.00
Audio Research Ref 600 mk II	£29,995.00	£40,000.00
YBA Passion Monoblocks new	On Dem	£8,998.00
YBA Passion Stereo new	On Dem	£5,998.00
Krell FPB 300	£8,500.00	£9,998.00
Sunfire 300 Power Amp	£995.00	£2,400.00
Plinius 250 mk IV	£ -	£6,000.00
Audio Note Kasi	£12,495.00	£30,000.00
Cary 805 C Monoblocks new	On Dem	£8,250.00
Cary 300 se LX20 Monoblocks	£3,750.00	£5,250.00
Krell FPB 600 c	£9,995.00	£14,994.00

AV components

AV COMPONENTS		
Krell HTS (AV Processor)	£4,495.00	£6,498.00
Audio Refinement Pre 5 new	On Dem	£895.00
Audio Refinement Multi 5 (Power) new	On Dem	£2,250.00
Lexicon MC1	£3,500.00	£5,500.00
Lexicon MC12 new	On Dem	£8,100.00

TELEVISIONS & DVD PLAYERS BY LOEWE

Loewe Xemix DVD new	On Dem	£495.00
Loewe Aconda	£POA	
Loewe Planus + Std	£POA	
Loewe Xelos + Std	£POA	
Loewe L2A Active Speakers	£POA	

PLASMAS/LCD/PROJECTORS

From NEC/ Panasonic/Pioneer/Sony
Electograph Delphi/Sony/SIM 2 £ POA

Pre amplifiers

Mark Levinson 380 S	£4,250.00	£6,900.00
Audio Research LS3B (Black/ remote)	£1,395.00	£2,700.00
Naim Nac 72	£395.00	£750.00
Krell KRC 2	£1,995.00	£3,400.00
CAT SL1 Sig Pre Amp	£2,495.00	£5,995.00
Audio Research LS2	£1,795.00	£4,000.00
Hovland HPI100 Line Pre	£POA	£4,950.00
Audio Synthesis Passion 8M bal/ remote	£1,095.00	£1,895.00
Audible Illusions Modulus P3A mm	£1,795.00	£2,565.00
BAT VK50SE	£5,295.00	£6,500.00
Krell KSL 2 Pre	£1,750.00	£3,000.00
Cary SLP98L Remote Pre	£1,495.00	£2,794.00
BAT VK5i + remote	£2,350.00	£3,995.00
Cary SLP 74 pre	£695.00	£1,500.00
Boulder 101Z (pre amp/ 24.96 dac/ Phono) new	On Dem	£13,000.00
Trilogy 901 Pre	£495.00	£995.00

Krell KSL + Phono	£1,295.00	£ -
YBA I Alpha Pre mm/mc + psu new	On Dem	£4,900.00
YBA Passion Pre + mc new	On Dem	£5,595.00
Boulder 2010 Pre	£p.o.a.	£30,000.00
Plinius 16L new	On Dem	£3,200.00
C.A.T. ultimate reference Pre Amp Inc/ Phono new	On Dem	£5,750.00
Audible Illusions P3A Pre MM/MC mk II new	On Dem	£3,140.00
Mark Levinson No 28	£1295.00	£4,000.00
Naim 42.5	£150.00	£450.00

Quality speakers

Audio Physic Virgo 3 new	On Dem	£4,000.00
Quad ESL 63	£1,795.00	£3,000.00
Wilson System 5.1	£7995.00	£18,000.00
Acoustic Research LST	£495.00	£ -
Thiel 7.2	£7,995.00	£14,000.00
Infinity Kappa 9	£1,295.00	£2,100.00
ATC SCM 20 SL (Black)	£1,495.00	£2,051.00
Martin Logan PLUS	£1,995.00	£ -
Soundlab A3 Plus	£2,995.00	£12,000.00
Apogee Mini Grand	£12,495.00	£18,799.00
JM Lab Utopia (Ex Dem)	£1,500.00	£1,500.00
Vienna Acoustics Mozart	£1,095.00	£1,500.00
Audio Physic Avant	On Dem	£1,300.00
Audio Physic Steps and Stands	£799.00	£1,300.00
Audio Plan Contrast 3	£1,395.00	£3,200.00
Proac Studio 3 black	£750.00	£ -
Avalon Ascents	£6,995.00	£12,000.00
JM Lab Micro Utopia + Std	£2,999.00	£4,248.00
JM Lab Mini Utopia + Std	£3,675.00	£5,248.00
JM Lab Mezzo Utopia	£5,499.00	£7,799.00
Audio Physic Tempo III new	On Dem	£2,000.00
Naim SBLs	£1,295.00	£2,225.00
ClaraVox Magnifica	£6,995.00	£14,500.00
Ensemble Speakers PA1	£995.00	£2,000.00
Audio Physic Caldera new	On Dem	£10,000.00
Audio Physic Libra	£1,850.00	£4,799.00
Audio Physic Rhea Sub	On Dem	£3,099.00
Audio Physic Spark new	On Dem	£1,749.00
Audio Physic Steps new	On Dem	£999.00
Audio Physic Virgo II	£2,395.00	£3,000.00
Rogers LS55 (new)	£330.00	£430.00

CD players & DACS

Theta Pro Gen	£595.00	£1,295.00
YBA CD I Delta new	On Dem	£4,000.00
Mark Levinson No. 39	£3,995.00	£5,350.00
Audio Aero new	On Dem	£3,500.00
Audio Note Dac I	£395.00	£700.00
Meridian 508 (24/96)	£1,195.00	£2,250.00
Oracle CD1000 Transport new	On Dem	£3,950.00
Maclaren CD220R	£995.00	£1,500.00
Audio Lab 8000 DAX	£995.00	£1,600.00
Mark Levinson 30.5/ 31	£9,995.00	£24,000.00
Mark Levinson 31/35	£5,995.00	£17,000.00
Bow Wizzard & Wand	£2,295.00	£3,795.00
Oracle CD2000 Transport new	On Dem	£7,500.00
Sony CDPR1/ DAs R1	£2,995.00	£6,000.00
Audiomeca Mephisto CD Transport	£1,200.00	£2,000.00
Audio Research CD2	£2,395.00	£3,400.00
Krell KPS 25s 24/96	£14,995.00	£22,500.00
Audiomeca Kreatura Transport/ Elixir DAC	£1,495.00	£2,800.00
Micromega CD3.1/ Duo B5 DAC	£1,295.00	£2,400.00
Acuphase DP70V	£1,895.00	£ -
Copland CDA 266	£995.00	£1,199.00
Acuphase 90/91	£6,999.00	£16,000.00
YBA CD Speciale	£495.00	£675.00
Audio Refinement CD Complete	£650.00	£875.00
Boulder 2020 dac	p.o.a.	£24,000.00
Krell KPS 25sc	£18,995.00	£23,998.00
Pink Triangle Da Capo (1307) & 24 bit	£850.00	£2,400.00
Theta Data II Transport AT + link	£1,995.00	£4,000.00
YBA CD Integre new	On Dem	£1,195.00

Turtables & analogue

SME 30/2	£7,495.00	£11,500.00
Pierre Lurne J1/ SL5	£1,695.00	£4,000.00
Michel Iso Phono	£250.00	£495.00
Koetsu Red K (Vdh tip)	£895.00	£1,550.00
Lemann Black Qube Phono	£1,195.00	£2,250.00
Goldmund Reference/ T3F	£225.00	£400.00
Ortofon Kontrapunkt new	£9,995.00	£30,000.00
Michell Gyro SE/ RB300 new	On Dem	£500.00
Elemental 4 Tier (Individual)	On Dem	£1,100.00
Elemental 4 Tier (Fixed)	£1,695.00	£2,500.00
Roksan Shiraz	£1,295.00	£2,000.00
Nakamichi Dragon	£450.00	£1,000.00
Michell Orbe/QC	£1,395.00	£2,200.00
Van den Hul Grasshopper	£2,495.00	£3,800.00
Audio Synthesis Phono Eq mm/mc	£POA	£4,000.00
Voyd Valdi/ Orion	£795.00	£ -
Gryphon Phono Pre-Amp (dual mono) Head Amp	£695.00	£ -
Parasound TQ1600 (remote tuner)	£795.00	£1,600.00
SME Series V Arm	£295.00	£400.00
Wilson Benesch Act 2	£POA	£1,650.00
Rotel Michi Phono	£895.00	£1,400.00
Rockport System II c/w Air stand, vac hold and arm	£695.00	£1,200.00
Musical Surroundings Phenomena Phono Stage	£18,000.00	£33,000.00
Pink Triangle PTTo SA/RB300S/VV	£495.00	£ -
Plinius 14 Phono new	£795.00	£ -
Transparent Audio Music Wave Ultra XL Bi-Wire	On Dem	£2,750.00
Cary PH301 MM/MC	£2,100.00	£4,000.00
Nackamichi DR 3	£895.00	£1,695.00
Tom Evans - The Groove new	£225.00	£400.00
Clear Audio Reference Mc phono stage X-demo	On Dem	£1,795.00
Rega Planer 3 + Hi Fi News Out	£1,695.00	£2,065.00
Board Power Supply	£320.00	£423.00
Clear Audio Symphono phono stage	£ -	£ -
X-demo MM/MC	£640.00	£740.00
Lavardin Reference Phono new	On Dem	£2,500.00

Reduced this month

tel: 020 8392 1959 & 020 8392 1963
fax: 020 8392 1994 info@choice-hifi.com

Open from 10am to 6pm Mon-Sat and other times by appointment.

Buy, sell, exchange quality hi-fi equipment.

We accept all World Radio History cards. Finance available subject to status



DIY NEWS

97

DUTCH BULBS

98

Neville Roberts builds the interestingly named Njoe Tjoeb 4000 valve output CD player from the Netherlands

HEAD CASE

102

Neville Roberts designs a Moving Coil cartridge head amplifier for those who crave vinyl but not wallet ache!

DIY LETTERS

105



CHELMER VALVE COMPANY

Chelmer Valve Company, The Stables Baddow Park, Great Baddow, Chelmsford, Essex, CM2 7SU, England.

email: sales@chelmervalue.com ☎ 44 (0)1245 241301 Fax: 44 (0)1245 241309 www.chelmervalue.com

for High Quality Audio Tubes

Everybody in the audio tube business knows that the justly famous brand names of yesteryear like Brimar, GEC, Mullard, RCA, Telefunken etc. etc. are scarce and often quite expensive. Although we supply all major brands as available (and we have many in stock) our policy is to offer a range of tubes, all new and mostly of current manufacture, the best we can find from factories around the world, which we process to suit audio applications. The result - CVC PREMIUM Brand. Our special processing includes selection for low noise, hum & microphony on pre-amp tubes and controlled burn-in on power tubes to improve stability avoid tubes with weaknesses etc.

A selection of CVC PREMIUM Audio Tubes

PRE-AMP TUBES	POWER TUBES	POWER TUBES	RECTIFIER TUBES
ECC81 5.90	EL34G 8.30	(continued)	(continued)
ECC82 5.90	EL34 (JJ) 8.50	6L6WGC 5881 8.90	5Y3GT 4.80
ECC83 5.90	EL34(Large Dia) 11.00	6L6/6681/WXT 9.00	5Z4GT 5.80
ECC85 6.60	EL84 5.50	6V6GT 5.50	
ECC88 5.70	EL509/519 13.00	8080 11.50	
ECF82 5.50	E84L/7189 7.50	6148B 11.00	
ECL82 6.00	KT66 11.00	6336A 48.00	
ECL86 6.30	KT66R 22.50	6550WA/WB 15.00	
EF86 6.00	KT77 13.20	7581A 12.00	
EF80F Gold Pin 11.00	KT88 13.50	807 10.70	
E81CC Gold 8.00	KT88 (Special) 17.00	811A 11.80	
E82CC Gold 9.00	KT88 (GL Type) 30.00	812A 31.00	
E83CC Gold 8.50	PL509/519 9.90	845 (New des) 33.50	
E88CC Gold 8.80	2A3 (4 pin) 15.50		
6EU7 7.00	2A3 (8 Pin) 17.50		
6SL7GT 8.90	211 23.00		
6SN7GT 5.30	300B 45.00		
6922 6.40	6C33C-B 25.00		
7025 7.60	6L6GC 7.60		

***** And a few "Other Brands" (inc. Scarce types). *****

6X4GY Flame GE 8.50	6X4GT STC 13.00	6X4GT STC 10.00	6X4GT Svetlana 18.00
6X4GY Chromium 8.50	6X4GT Brimar 13.00	6X4GT GEC 12.00	6X4GT GEC 18.50
6Y3WGT Sylv 8.50	12AT7WA Mullard 8.00	6X4GT JJ 5.80	6X4GT GEC 15.00
6AS7GT Sylv 12.00	12AU7 Mullard 12.50	300B Svetlana 6.00	6X4GT Mullard 14.00
6AU6WC Sylv 5.10	12AY7 GE + RCA 8.40	300B WE 195.00	6X4GT Mullard 145.00
6B4G Sylv 8.00	12AZ7 Westh 8.00	808 USA 32.00	6X4GT GEC 69.00
6BR8 Brimar 5.80	12BH7A RCA 14.00	1892A GEC 18.00	6X4GT JJ 17.40
6CA1ST GE + RCA 8.00	12BY7A GE 9.90	6080 Telefunken 13.00	6X4GT Svetlana 35.00
6C33C-1 GEC 8.80	12C15 STC 13.10	62221 GEC 31.50	6X4GT JJR 128.00

ALL PRICES IN U. K. POUNDS £
 Please note extras: carriage charge (£3.00 in U.K.) & in EEC VAT (17.50%). When ordering please state if matching required (add £1.00 per tube). Payment by credit card (VISA, AMEX etc.) or TRANSFER or CHEQUE (UK only).
 FAX email or POST your ORDER for immediate attention - We will send PROFORMA INVOICE if required.
 MILLIONS OF OTHER TUBES & SEMICONDUCTORS IN STOCK

** Valve Amplifiers sound better still with CVC PREMIUM Valves! **

PRICE VALIDITY TO END APRIL 2002 - ASK ABOUT ANY TYPES NOT ON THIS LIST

TECHNICAL & GENERAL

SOME NECESSITIES - FROM THE ORIGINAL CLASSIC TURNTABLE SPECIALISTS

CONNOISSEUR		P&P
BD1/2 Drive Belt		£12.60
BD1/2 Motor Suspension kit		£15.50
SAU.2 Headshell		£18.50
SAU.2 Connecting Lead		£16.50
GARRARD STANDARD MODELS		
Wired arm tubes	from	£14.50
Cartridge carriers (sliders)		£12.50
301/401 Transcription models		
Original Thrust pad assembly		£13.50
Original Idler tension spring		£3.65
Original Brake pad		£3.40
Xeroxcopy Owners Manual 301 incl. full size mounting template		£9.30
	401 "	£7.20
Replacement 301 control knobs On-Off/Speed select	pair	£21.50
Replacement 301 suppressor unit		£7.20
Replacement 301 motor pulley (-2%), (-1%), (Std), (+1%)	each	£16.50
Replacement 301 Chrome mounting bolts nuts, washers.	set	£7.85
Recommended Lubrication set - early 301 or 301/401	(specify)	£7.20

GOLDRING/LENCO		
Idler wheel (lock-nut or clip fixing)		£22.50
Tension spring		£3.85
Arm pivot bearings - with fitting instructions		£9.85
Spindle/Main bearing assembly	GL.69/72	£21.00
" "	GL.75/78	£26.50
Chassis suspension springs (set of 4)	set	£21.25
Headshells	from	£23.25
Instruction books	from	£5.20

THORENS		
TD.124 series		
Idler wheel	original	£29.50
Idler wheel	our redesigned replacement	£16.50
Drive belt		£24.65
Suspension rubbers ('mushrooms')		£17.50
TD.150/160		
Drive Belt		£19.35
Suspension springs (-1%), (Std), (+1%) (set of 3)	set	£14.50
Suspension - main bushes (set of 3)	set	£14.50
Armboards TD.150 blank		£12.50
" TD.160 "		£10.20

CECIL WATTS Dustbugs & spares - incl. Preerener wicks
 Cartridges and styli for 78s and Mono LPs in addition to current Stereo LPs

TECHNICAL & GENERAL
 PO BOX 53, CROWBOROUGH, EAST SUSSEX, TN6 2BY
 TELEPHONE: 01892 654 534



Falcon Acoustics Ltd

Falcon Electronics, Basically Sound
<http://www.falcon-acoustics.co.uk>

Full Price List and Focal details on Web Site

DRIVE UNITS: by FOCAL & seas, and a pick of the best from other manufacturers.
 Coming:- ETON HEXACONE Range of units

100+ CROSSOVER NETWORKS:- Active & Passive, Components, Accessories,
 COMPONENTS

SOLENS Polypropylene capacitors, 0.1mFd. to 100mFd.

Polyester and Polycarbonate Film Capacitors, 0.1mFd. to 10mFd.

ALCAP Reversible Electrolytic Capacitors (Non-Polar): 50v, 100v & Low Loss, 2mfd. to 600mFd.

FALCON Custom-wound Inductors.

FERRITE:- Standard, High Power, Super Power, Super-Super Power

AIRCORED 0.56 - 1.25mm wire; IRON DUST, 1mm wire

TAPPED INDUCTORS:- 0-10mH in 1mH steps & 0-1mH in 0.1mH steps

AUDIO AMATEUR PUBLICATIONS

NEW- First in High Fidelity - The story of H. J. Leak & Co. plus lots in P/L.

Back year sets of Speaker Builder, Audio Amateur & Glass Audio, plus the Audio Anthology Set.

Altogether 50+ books and 50+ Audio Amateur's magazine year sets.

2001 year sets available. Feb

FOCAL 'State of the Art' Units & Kit Designs'

Long Awaited 'W' Glass-Sandwich Focal Unit Range

as pioneered in the Utopia range of systems.

Unit Spec Booklet available 30p. OR FREE on Web Site available in pdf format
 Please send A4 SAE with 44p stamp (66p with PL) +30p extra stamps.

SUPPLIERS TO THE TRADE SINCE 1972

Send for our FREE price list PL30: Just send a large S.A.E. (44p stamp) or US\$2 bill overseas.
 Europe US\$1 bill or 3 International Reply Coupons (IRC) to:-(Dept HFW) Tabor House,
 Norwich Road, MULBARTON, Norwich, Norfolk. NR14 8JT Tel (0)1508 578272

AUDIO LABORATORIES (LEEDS)

The U.K.'s Premier Repair & Restoration Centre

Whether your equipment is
 Old, New, in Kit form, Valve, Solid-state, Audio or R.F.,

we will....

Repair, Restore, Re-calibrate, Re-align:-

Tape recorders by Revox, Tascam (up to 1") and Teac
Valve amps., pre-amps., tuners, cinema amps.,
 theatre-organ amps., industrial p.a. amps. from Radford, Quad, Leak,
 Kalee, Clarke & Smith, Compton, Grant, Parmeko, RCA, Altabass etc.

Valve Communications Receivers and Transmitters
 (to 30MHz/2kW/6'3" tall) by KW, Marconi, Labgear, Eddystone,
 Redifon, Ajax, RCA, Tiger... and so on.

We will....

**Build that Kit for you or
 Re-build it if you've had a go but it's gone pear-shaped.**

We will....

Custom-build for you a published Classic design.
 (Fancy a Williamson?? Or a 912+? A 3-3...maybe? No problem)
Design something special and build the prototype.

All this,

as well as being an Authorised Service Centre for such respected
 names of the Digital Era as Denon, Pioneer, Kenwood, Yamaha.

Overall,

some pretty comprehensive facilities...and it will take only
 a few minutes of your life plus a few pence from your pocket to call/fax
 and discuss your requirements: **0113 244 0378.** Or write!

You will find us at:

3 Kildare Terrace Industrial Estate,
 Leeds LS12 1DB, England.

audioXpress... It Just Sounds Better

Your Favorite Audio - One New Magazine!

- PROJECTS
- REVIEWS
- THE NEWEST TECHNOLOGIES
- AUDIO CLASSROOM
- and Much More!



**Only \$59.95 US
 for 12 Issues!**

Subscribe To This
 Great Monthly
 Publication Today!

audioXpress • PO Box 876 • Peterborough, NH
 03458-0876 USA • Phone: 603-924-9464

Fax: 603-924-9467 • E-mail: custserv@audioXpress.com

ORDER ONLINE AT: **www.audioXpress.com**

WHITE NOISE

AUDIO KITS, MODULES, COMPONENTS

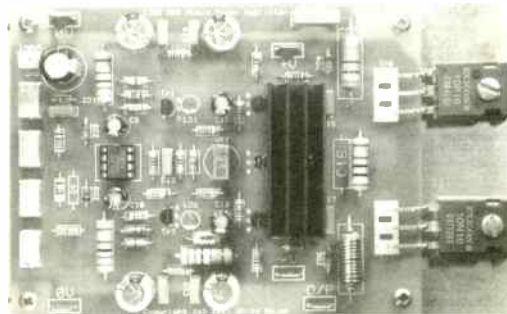

PRODUCTS INCLUDE:- Power Amplifiers 30-250W, Preamplifiers, Phono stages, Active Crossovers, Power Supplies, Buffer Amplifiers, Balanced line drivers / receivers, Stepped attenuators, Gold plated connectors, Cables, Capacitors, Resistors, Semiconductors, Transformers, Subwoofers, Loudspeaker drive units

WHITE NOISE
 11 STATION ROAD
 BEARSDEN
 GLASGOW
 G61-4AW

<http://homepage.ntlworld.com/david.white38>
 Email:- david.white38@ntlworld.com
 Tel:- 0141-942-2460 (until 9pm)
 Fax:- 0141-587-7377

e-mail us with news at - diynews@hi-fiworld.co.uk

KIT & COMPONENT NEWS

WEB TUBES

Prospective valve purchasers with on-line capability can log on to a brand new site dedicated to the supply of vacuum tubes. The company, tube-shop.com, guarantee to be the cheapest supplier of quality valves in the UK and can supply from a stock comprising the largest collection of Svetlana tubes in Europe. Other brands found on the excellent website are Ei, Western Electronic and Golden Dragon. All tubes available can be viewed on the site. In addition there is soon



to be an on-line valve museum at the site featuring the world's rarest valves - promises to be a real treat for all tube addicts!

www.tube-shop.com
info@tube-shop.com

BITS 'N' BOBS 'N' TUBES!

News reached us of a new website (www.tubesandmore.com) dedicated to all things DIY and audio from Antique Audio Supply! Operating out of Arizona the company are a very user friendly and helpful outfit and the site is full of hints and tips, as well as a whole host of varied products for sale such as vacuum tubes, books, transformers, capacitors, resistors and, as the company put it, parts and more parts! The site's Technical Corner, for example, has a list of tasks and DIY related help with titles such as "Replacing an Electrodynamic speaker With A Permanent Magnet Speaker"

(which guide you extremely sensibly through the process with 'plain speak' explanations for the eager amateur) as well as things such as useful conversion factors and an EIA colour code table. The on-line catalogue of products for sale is very extensive and thorough, with something for every audiophile DIYer.

Antique Audio Supply
6221 South Maple Avenue
Tempe
AZ 85283
USA
Tel: 480-820-5411
www.tubesandmore.com

NEW GOLDPOINT GOODIES

There are some interesting new products available from Goldpoint, based in Sunnydale, California. Last month saw the launch of their SA-1 "volume control box" passive preamp kit which they say can be used as a "complete preamp solution for audiophile purists". It's also intended to be used in applications on the audio test bench. Measuring 2.6"x4.2"x5.6", it consists of two line level inputs with a two position C&K brand selector rocker switch and uses a precision Goldpoint 24 position stepped attenuator for apparently low noise and high quality channel to channel signal level tracking. Construction is from cold rolled steel with a semi-gloss, fine pattern black powder coat paint finish, that also claims to be chip resistant. The front and back panel lettering is baked on for high durability. Internal wiring is high grade multi-strand type with Teflon jacketing and the rear panel RCA jacks are gold plated Tiffany style. Due to input impedance of valve power amps, valve users may prefer to employ a 100k stepped attenuator in place of the 50k model

supplied as standard. The price of the SA-1 kit is \$253.

Also from the same company, you can purchase a whole age of mini-sized stepped attenuators for high quality audio and general instrumentation applications. The 24 position Series, Ladder and Shunt designs claim to offer lower noise and better channel to channel signal level than common potentiometers. Mini-V (series type), Mini-L (ladder type), and Mini-H (shunt type) units come fully assembled or as kits. Mini-V stocked values include 1K, 10K, 25K, 50K, 100K, and 250K designs. Blank switches with printed circuit boards attached are also available for user customised controls.



Goldpoints' stepped attenuator



SA-1 passive pre-amp



rear of SA-1

Goldpoint
Sunnydale
California
USA

(408) 737-3920
arn@goldpt.com

http://www.goldpt.com

DUTCH

Neville Roberts builds the interestingly named Njoe Tjoeb 4000 Valve output CD Player from the Netherlands. We provide an English translation.

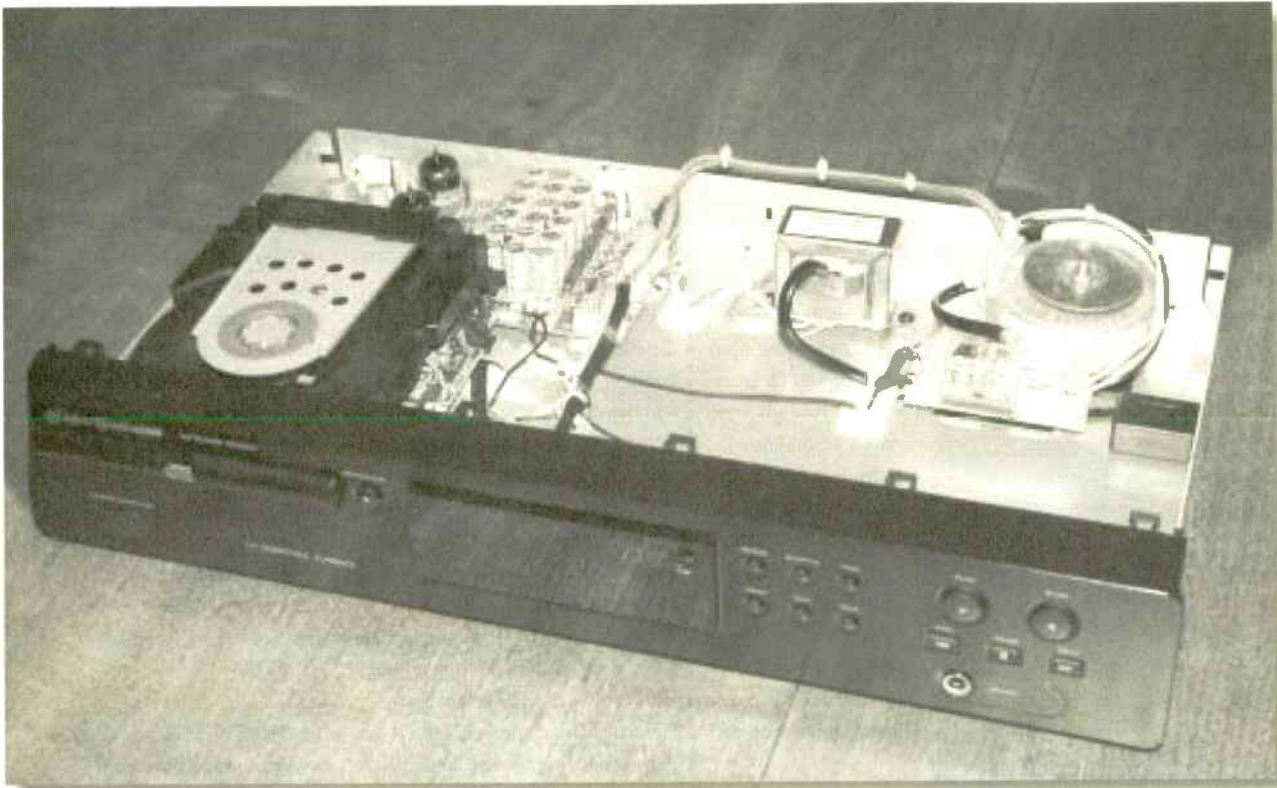

The Njoe Tjoeb 4000 with top removed

Having re-discovered my record collection thanks to the magic of valves, my CD have taken a back seat when it comes to choosing music to listen to. Unfortunately, records are not without their problems. They have become increasingly difficult to obtain and classical recordings have not been released on vinyl for some years. They are susceptible to clicks and pops caused by dust, scratches and static electricity as well as distortions introduced by a combination of RIAA equalisation and tracking errors during playback. It really is amazing that they sound as good as they do. Enter the Compact Disk! Playing the numbers game effectively eliminates all of the above problems, but unfortunately introduces others. Transistors and integrated circuits are, of course, necessary and the elimination of semi-conductors from a CD player would create a machine containing thousands of valves and needing a small warehouse to accommodate it. But it is not all gloom and doom, the trick is realising that digital technology relies on the storage and processing of numbers. In essence, it doesn't matter whether you add

up a column of figures with the aid of a quill pen or use a calculator, the answers will be identical if it is done accurately. Looking at the design of a CD player, you can use semi-conductors to handle the digital data and

equipment to interface satisfactorily with one's bank account has attracted many to the joys of DIY! Wouldn't it be great if someone produced a high quality but affordable valve CD player that would allow the odd tweak or two?



The AH! Njoe Tjoeb 4000 Web Site

logic controls and introduce valve technology only when the signal becomes analogue. A CD player with a valve output stage therefore becomes a very feasible proposition. However, the inability of high quality audio

DUTCH COURAGE

My hunt for such a beast led me to a company called DÉ HIFIWINKEL based in Holland that advertises on the web and is run by Frank van Duijvenvoorde and Herman van den Dungen who have over 25 years of high-end audio experience. They market their products under the appealing name of AH!. Clicking on Error! Reference source not found. takes you to a section in

English and I homed in on their third generation CD player with valve output – the Njoe Tjoeb (pronounced 'new tube') 4000. In order to find out more on the cost of going Dutch, I fired off an email to the company and almost by return I received a friendly and

BULBS



Valves in a modern Philips circuit board!

separately and have to be fitted before use.

The most obvious features are the pair of valve sockets on a circuit board next to a bank of electrolytics. These capacitors are the power supply filter bank and total in excess of 0.03F (yes, Farads!). Some may argue that all this filtering is 'guilddering the lily', but this proved to be just the right amount based on extensive listening tests, according to the manufacturers.

TUBULAR BELLE

I was immediately impressed with the overall quality of the electronics. The valves are seated in heavy-duty sockets, acknowledging that many DIY'ers will want to experiment with different makes of valve. A toroidal mains transformer provides the HT and filament supply and this is switched via a relay that is controlled by the digital electronics. Another nice touch is the bypassing of the transistorised muting circuit. This function is now undertaken with a relay in each channel. All that remains is a barely audible but pleasing "click" from inside the unit when the CD starts playing. All the valve pin connections are clearly marked on the printed circuit board. To the right of each valve base is a group of resistors for changing the output level of the unit. Output is factory-set at 2.5V, but if this proves too high for

your amplifier, you can easily reduce it by following some clear instructions and soldering across adjacent solder pads. The OEM CD4000 includes full remote control facilities and sports the Philips VAM 1201 transport mechanism which allows the unit to play both re-writable and conventional Cds.

Early on in my use of the unit, I noticed that when a CD is removed and the player allowed to detect that there is no CD in place (the display changes from "READING" to "NO DISK" after a few seconds), the mains relay does not deactivate when the player is

informative response from Herman with more details. Purchasing is very simple. You simply send your credit card details to them and they debit your card in the local currency – now, of course, the Euro! After some enquiries I was informed no import duty is payable within the EEC and you only pay VAT once in the country of origin: in this case 19% in Holland. There are currently two versions available – a standard model at about £356 and a 'Super-Tjoeb 4000' at £441 including local VAT. Carriage charges to the UK for either model are an £12 or so. The player is based around a modified OEM CD4000 chassis fitted with a valve output stage. The company obviously recognise that many audiophiles will want to get inside the box and do some tweaking, so they even supply a Torx #10 screwdriver! The standard model now includes items that were extra on previous versions, such as a coax digital output, AC NoiseKiller and SuperCrystal oscillator. The 'Super' version is fitted with a digital output transformer, quality feet (called 'TjoebSjoes'), a quality mains lead, CD mat and 'Tjoeb Ribs' for extra damping. In the end, I decided on the standard version, reviewed here, knowing that I can fit the clogs (sorry, TjoebSjoes) etc. at a later date. My card details were emailed and my Njoe CD player duly arrived within a few days. The first job was, of course, to put the Torx screwdriver to good use and remove the lid to examine my new purchase on the inside! Actually, this is an essential first step as the valves and the CD upper clamp are packaged

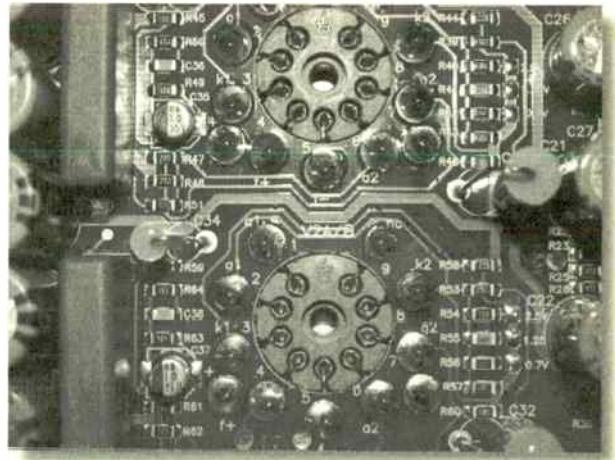

The valve holders beneath the board showing how they integrate with surface mount components.

switched off, leaving the valves powered up. If, however, the CD player is switched off before this time or with the disk tray out (the tray is automatically retracted before the unit powers down) or with a CD in place, the whole unit powers off normally. A short e-mail was sent to Herman who confirmed that this was, in fact, a "feature" of the OEM CD4000 firmware! In reality, this is quite a useful feature as it effectively provides a "standby" facility by leaving the valves powered up ready for use next time and eliminating the warm-up time. However, I decided to fit a small blue LED powered from the 6.3VDC filament supply to show when the valves are on. This is quite easy to do as there are '+-' and '-f-' pads clearly marked on the printed circuit board. I fitted a pair of wires from here to the LED via a 150 ohm resistor to provide the required 20mA current. A small hole was drilled to the left of the 'Power On/Standby' switch to accommodate the LED.

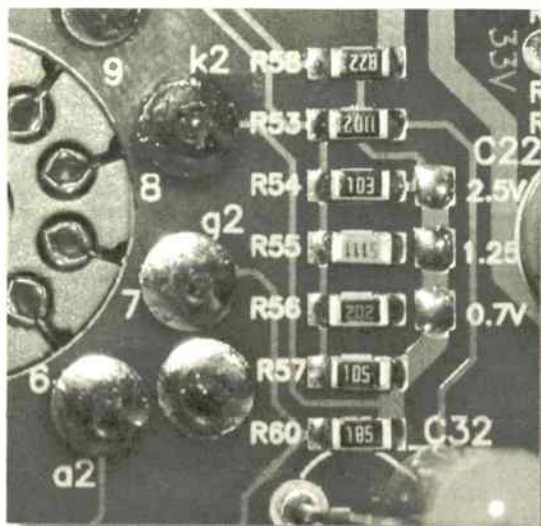

Output level adjustment on the board

Kit & Component Suppliers

CLASSICTURNABLES

Technical & General

P.O. Box 53, Crowborough,

East Sussex TN6 2BY.

Tel: 01892 65 45 34.

The original specialist source of spares, replacements and expertise for the classic turntables. Years of actual experience and comprehensive range of parts (originals and re-manufactures), manuals, ancillaries. No dubious 'improvements' - no harmful 'modifications'. Our specialities: Connoisseur; Garrard; Goldring; Lenco; S.M.E.; Thorens; Watts; Ortofon; Shure; Cartridges and styli for 78s, Mono LPs, Stereo LPs.

COMPONENT SUPPLIERS

AudioCom (UK),

Unit 14 Pier Road

Pembroke Dock

Pembrokeshire, SA72 6TR

Tel: 01646 685601

Fax: 01646 685602

Website: www.audiocom-uk.com

E-Mail: enquiries@audiocom-uk.com

uk.com

Massive range of audio components and accessories available including Black Gate electrolytics, Elna SILMIC (Silk Fibre) electrolytics, Audyn-Cap film and foil capacitors, OFC air core and copper foil inductors, high power resistors, loudspeaker crossovers, high-end cable, Vishay & Holco resistors, 99.9999% pure Silver wire, DACT CT1 & CT2 attenuators, audio connectors, spikes & damping materials, plus over 50 loudspeaker kits. Active products include the SUPERCLOCK master clock plus super-low noise PSU, & Q-power super-low noise discrete regulators. A new, 365 page 2001 handbook is available for £3.50 (UK) and £5.00 (overseas).

White Noise

11, Station Road, Bearsden

Glasgow G61 4AW

Tel: 0141 942 2460

Fax: 0141 587 7377

Email: david.white38@ntlworld.com

Supplier of the widest range of standard and audiophile kits for solid state pre-amplifiers, power amplifiers, headphone amplifiers, power supplies, MM/ MC phono stages, active crossovers, balanced i/o modules, and stepped attenuators; more kits in the pipeline. All kits use the highest quality, glass fibre, solder masked, silkscreened, PCBs. We also supply a wide range of active (esp. Japanese transistors and Exicon mos-fets) and passive components, gold plat-

ed connectors, and silver plated wires.

Write, phone or email for a free catalogue. Mail order only.

LOUDSPEAKER KIT SUPPLIERS

Audio Note (UK Ltd)

Unit C, Peacock Ind. Est.

125-127 Davigdor Road

Hove, East Sussex BN13 1SG

Tel: 01273 220511

Fax: 01273 731298

Suppliers of a large amount of components for the Audiophile Kit builder.

Valve amplification data and vintage circuits also available. See the double page spread in the back section of the main issue for extra & more detailed information.

Falcon DIY Speakers

Falcon Acoustics Ltd.,

Tabor House,

Norwich Road, Mulbarton,

Norfolk NR14 8JT.

Tel: 01508 578272

UK distributors of FOCAL drive units & kits, and ETON loudspeakers, plus SOLEN (SCR-Chateauroux) polypropylene capacitors. We are the largest specialist Audio inductor manufacturer in the UK. We also stock Audio Amateur Publications and Audio Computer Software and a comprehensive range of D.I.Y speaker kits, parts, accessories and books. Please send large SAE (44p) for free price list. "Everything but the wood".

IPL Acoustics, Chelsea Villa, Torr's Park, Ilfracombe, North Devon, EX34 8AY

Tel/Fax: 01271 867 439

Website: www.iplacoustics.co.uk

IPL Acoustics supply a range of 7 transmission line, 3 conventional, speaker kits, and kits for centre speakers and active subwoofers. We also supply a full range of drive units from Audax, SEAS, Morel and Legend Acoustics (Ribbon Tweeters) as well as custom built metal coned drivers. Also included is a range of capacitors, inductors and quality cabinet accessories as well as Silver Plated PTFE insulated cables.

SPECIALIST UPGRADE SERVICES

AudioCom (UK),

Unit 14 Pier Road

Pembroke Dock

Pembrokeshire, SA72 6TR

Tel: 01646 685601

Fax: 01646 685602

Website: www.audiocom-uk.com

E-Mail: enquiries@audiocom-uk.com

Release the full potential of your digital source with CD/DVD upgrades from audiocom. Available is the highly acclaimed SUPERCLOCK master clock oscillator. (Dave Berriman fits the S-Clock to the Teac VRDS-10SE and comments... "there was not one area of music reproduction which didn't improve".) SUPERCLOCK super low noise power supply, & Q-power ultra-low noise discrete regulators. Why not contact us to see how this service can be adapted to suit your requirements?

VALVE AND OUTPUT TRANSFORMER SUPPLIERS

Wilson Valves, 28 Banks Avenue,

Golcar, Huddersfield,

West Yorks HD7 4LZ

Tel: 01484 654650/844554

Fax: 01484 655699

E-mail: wilsonv@zoo.co.uk

We stock over 2,500 different types of valves, N.O.S. and New. Please send a S.A.E. for full list. No charge for matching. Most major credit cards accepted.

Watford Valves

3 Ryall Close, Bricket Wood,

St. Albans, Herts AL2 3TS

Tel: 01923 893270

Fax: 01923 679207

Specialist in new old stock and current production valves. Sole UK distributor of the Harma Diamond range selected for their superior performance. Huge range held, stockists of Mullard, GE, Philips, National, Brimar, Sylvania, Telefunken, RCA, MOV and many more. All valves are new boxed and guaranteed. For free price list and specialist advice call or fax Derek Rocco, Watford Valves.

Chelmer Valve Company Ltd

The Stables, Baddow Park

Great Baddow, Chelmsford, Essex

CM2 7SY

Tel: 01245 241301

Fax: 01245 241309.

Email: sales@chelmervalue.com

Web Site: www.chelmervalue.com

Supplier of premium range of audio valves, other valves and components also available. (Please see our main advertisement in this supplement).

Langrex Supplies Ltd

1 Mayo Road, Croydon,

Surrey CRO 2QP

Tel: 020 86841166

Fax: 020 86843056

One of the largest distributors of elec-

tronic valves, tubes and semi-conductors in the UK by original UK and USA manufacturers. Obsolete types are a speciality. Telephone or fax for an immediate quotation.

Billington Export Ltd.

1E Gillmans Trading Estate,

Billingshurst,

West Sussex

RH14 9EZ

Visitors by appointment only please

Fax: 01403 783519

E-Mail: sales@bel-tubes.co.uk

Website: www.bel-tubes.co.uk

Specialists in guaranteed new/old stock, current production valves & tubes. Also CRT for audio, hi fi (as well as industrial uses). A vast archive of vintage and obsolete types including limited quantities of Mullard, GEC, Sylvania, Philips, Brimar, Telefunken, RCA and others. Large stocks of Chinese, Russian, EI and Tesla etc. A 50-page valve catalogue is available on request. Major stockists of the excellent Billington Gold brand. Contact us for quotations - attractive price on larger orders.

Audio Specialist,

W. Marriott

73 Stonyford Road,

Sutton-in-Ashfield,

Notts,

NG17 2DL

Tel: 01623 461128

Email: wasmarr@talk21.com

Transformers. One of the world's widest range manufactured. Mains choke's, output transformers etc. From the standard I/E M6 to the awesome Hi-B nickle double C-Core's wound with the superb 6N cardas copper cable. All types of transformers manufactured. One off a speciality. A superb range of accessories and components supplied. Steel copper, brass etc cases available for that special project. All types of repairs, modification undertaken. Rebuilds, kits built to both thermionic solid state. Classic vintage equipment always sought, working or not. Catalogue £3.50 redeemed on first order over £30.00

TO ADVERTISE IN THE
KIT & COMPONENT

SUPPLIERS PAGE

PLEASE CALL

020 8864 4760

Email:

diyadvertising@hi-fiworld.co.uk

◀ **SOUND INVESTMENT?**

So much for the technical details – what does it sound like? I started off by listening to a few of my 'old favourites' on my existing CD player and then on the Njoe Tjoeb. I have not named my existing CD player as the difference was so startlingly, I soon realised why I hardly listened to my CDs in recent years! The Njoe Tjoeb is in a totally different league, having an overall cleaner sound, more extended bass and a much clearer and less harsh top end. I could detect more instruments that had been masked by my old CD player. In addition to listening to a range of music CDs, I also included a couple of recordings that were available on both CD and vinyl. Of course, a comparison of the same recording transcribed onto record and CD can only be used as a guide as you are at the mercy of the recording engineer who may use slightly different mixes for each type of media. However, an 'identical' recording of Vivaldi's *The Four Seasons* (The Academy of St. Martin-in-the-Fields conducted by Neville Marriner) on record and CD showed that the Njoe Tjoeb considerably reduced the harshness and 'toppy' sound of my old player and the overall balance of the orchestra was much closer to the sound from the vinyl. Similarly, a friend's copy of Brian Wilson's self-titled album yielded similar results. Repeated switching of the 'Love and Mercy' track between record and CD player showed that the bass of the Njoe Tjoeb was tight,

realism to the sound than it's solid state counterpart. Indeed, listening to 'Why Does my Heart Feel so Bad' from 'Moby Plays Live' on the 4000 provided a far greater sense of being there with the audience. The easiest way to describe the overall effect of the sound is by reference to traditional musical instruments that many readers will be able to compare to 'the real thing'. The strident sounds of trumpets come through without sounding harsh or edgy. Pianos and harpsichords have a realism and presence in the room. Vocals that can sound strained when reproduced on many CD players come thorough clear and effortless as though the artist is actually enjoying the performance. The sharp punch of a bass drum is tight and well controlled and less like the instrument has been filled with treacle! At the other end of the spectrum, the xylophone has a lovely 'milky' musicality with the same presence, detail and clarity as with other instruments.



Mains transformers and power relay

sound with a more controlled bass response compared to the Sovteks. So which sounded better – record or CD? Well, in all honesty I would be lying if I said the CDs sounded better than the records. To my ears, vinyl still

No review of the Njoe Tjoeb would

be complete without a word or two on the choice of valves. The unit is supplied with a pair of Philips Jan 6922 valves. I had to hand a couple of Sovtek 6922s and also a pair of ECC88/6922 Harma valves. Some more listening tests followed, swapping repeatedly between the supplied 'Dutch bulbs' and the other two makes of valves. The differences were subtle but, on balance, I felt both the

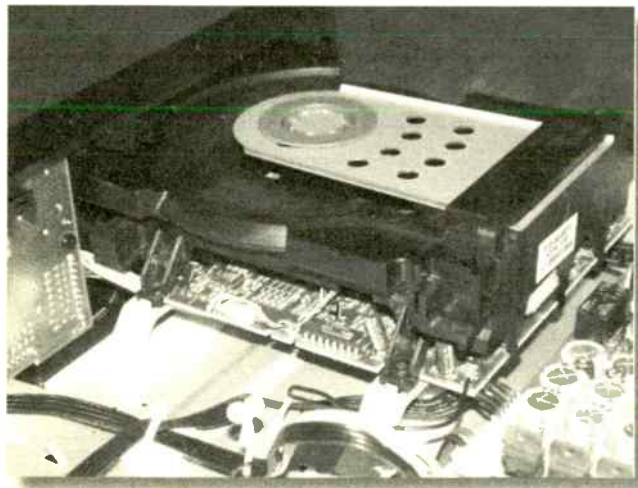

Philips transport finds itself in unusual company

extended and well controlled which had not been the case with my old player.

At this point, I borrowed a Marantz CD-63 Mk2 KI Signature Edition to provide a more realistic CD player reference. It was clear from the outset that this player was far closer to the vinyl sound, but A/B tests between it and the Njoe Tjoeb clearly demonstrated that the valve output of the 4000 offered more presence, clarity and

Sovteks and the Harmas to have a clearer and more 'alive' sound than that the Philips, together with a slightly tighter bass and more overall depth to the image. However, the Sovteks made the strings sound a little too far back and 'grainy' when compared to the Harma valves. For me, the Harmas produce music that is more compelling and conveying more emotion. They combined the clarity of the strings without any tendency to dull the



The additional power LED showing valve stand-by. Very few CD players have this!

has the edge over the CD, but the gap had considerably narrowed to the point where the difference was only quantifiable through the A/B testing process mentioned earlier. I have been fortunate to hear similar comparisons of records against CDs with players costing many thousands of pounds and I came to the same conclusion. However, the Njoe Tjoeb can certainly compete with these expensive units.

My overall verdict? If you like the sound of valves and vinyl and you want your CDs to fight back, then my advice is to grab your credit card and head for your PC! This is truly a Dutch delight with an amazing price/performance ratio.

Ordering direct from Holland is as easy as buying from the UK and with an impressively rapid delivery. In my opinion, this is an excellent player which allows your CD collection to take their rightful place alongside your records and not sound like 'the poor relation'. ■ ▲

HEAD

Neville Roberts designs a Moving Coil cartridge head amplifier for those who crave vinyl but not wallet ache!

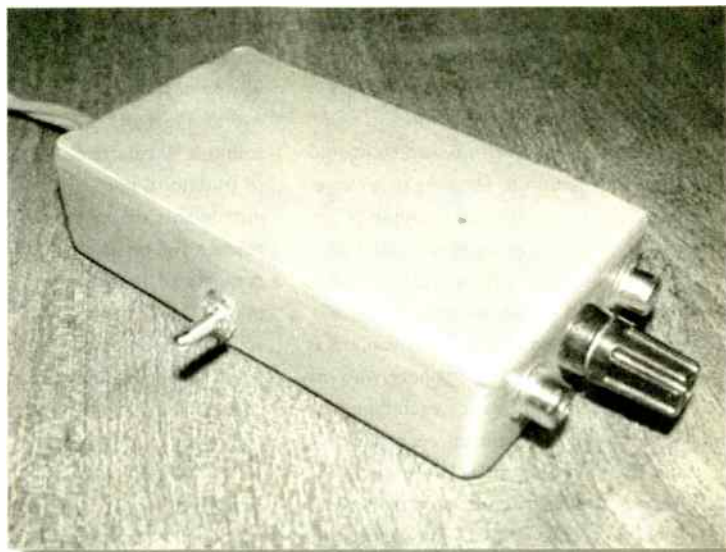

The moving coil cartridge seems to be able to extract those elusive refinements tucked away in the groove of your record that elude most moving magnet designs. Of course, a moving coil cartridge has the disadvantage of not having a replaceable stylus, so it is important for manufacturers to fit a good one in the first place knowing that the customer will be less inclined to buy the cartridge unless it is significantly better than one with a detachable stylus. Whether it is a case of a good stylus "reaching the parts that other styli cannot reach" or that a fully integrated stylus/cantilever/coil assembly is inherently superior, a good moving coil cartridge is certainly a worthwhile upgrade for any vinyl enthusiast.

This brings us onto the other problem associated with most moving coil cartridges: their relatively low output impedance. If your

amplifier already supports this type of cartridge, then there is no problem. However, many amplifiers only support the higher output moving magnet cartridges. There are two solutions to this problem: an impedance-matching transformer or a head amplifier.

I should say at this point that modern moving coil step-up transformers have come a long way since the types being sold when moving coil cartridges first made an appearance. Those available today are, in my opinion, considerably superior to the ones available in the late 1970s. Indeed, you cannot

get away from transformers in the signal path of a valve amplifier. However, judging from some correspondence I have seen on the World Audio Design bulletin board, some people prefer not to have their moving coil cartridges feeding into an impedance-matching transformer and a head amplifier is therefore the only other option.

I must confess to feeling a bit of a traitor to the cause of valve enthusiasts by publishing the design of a transistorised amplifier, being a

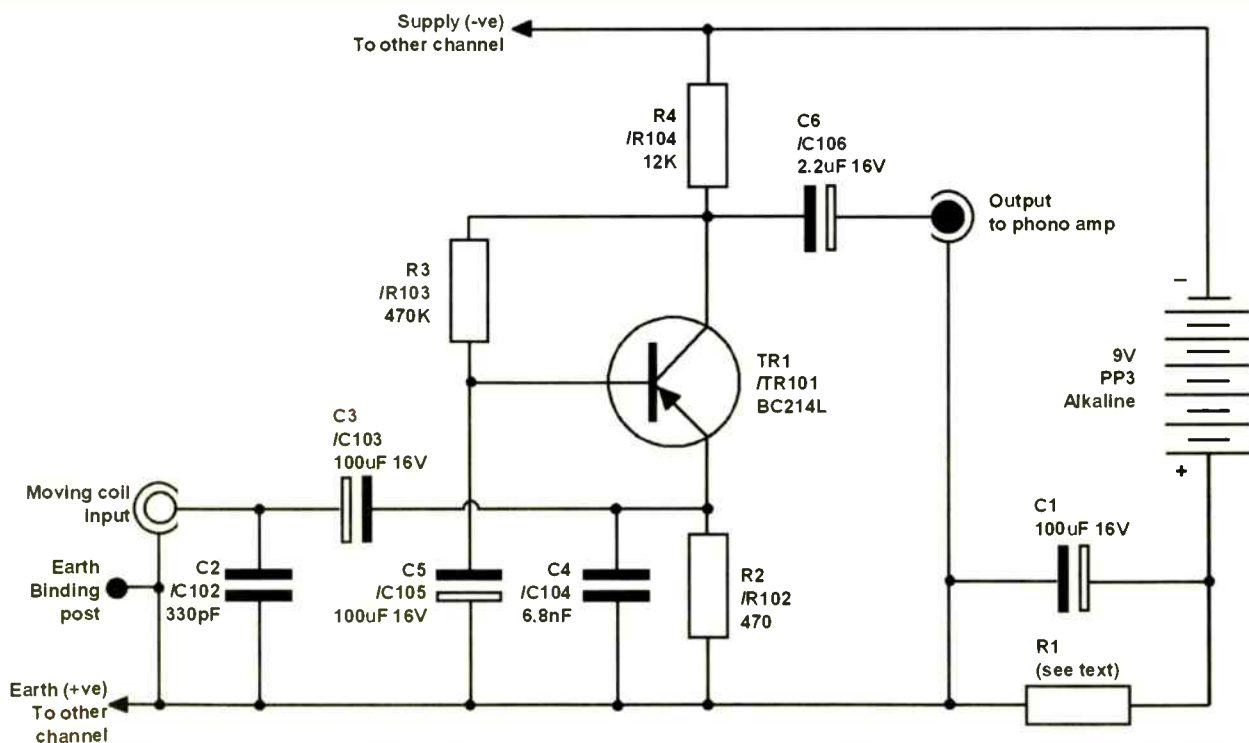

Circuit Diagram

CASE

View from underneath



BC214L

Transistor Leadouts

confirmed valve addict myself! My reasons for doing so are that the design presented here is very simple and will drive any phono stage, be it valve or transistorised. Furthermore, as it is battery powered, it can be situated close to the record deck without fear of induced mains hum and no additional power sockets are needed.

Turning our attention to the circuit, the required characteristics of the head amplifier are a low input impedance, gain, and a higher output impedance in order to match into the moving magnet input of the phono amplifier. A common base configuration is ideally suited to this task as it has all these characteristics. No RIAA equalisation is required as the phono amplifier already provides that.

Note that on the circuit diagram, component numbers starting from 100 refer to the other channel. R1 and C1, being common to both channels, only occur once. The input from the cartridge is delivered to the emitter of the BC214L via a coupling capacitor, C3. C2 ensures no RF finds its way into the system. The input impedance of the amplifier is about 200ohm, with a load capacitance of 6.8nF, which should suit most moving coil cartridges. If a higher load capacitance is required, then an appropriate value can be strapped across C2.

The output comes from the collector through C6 to remove the DC component from signal. It presents an output impedance of about 12kohms and will happily drive a 47kohm phono stage. The frequency response of the amplifier is essentially flat from 10Hz to about 45kHz and the signal to noise ratio is in the region of 60dB, which should keep most audiophiles satisfied!

We also require a circuit that can be easily adapted to suit the wide range of cartridges available. With reference to the

circuit diagram, it can be seen that the power comes in through a single resistor (R1) that is common to both channels. The value chosen for this resistor sets the gain of the amplifier. It also has an effect on the current consumption of the unit and hence the battery life. The table below shows the value of R1 for the required gain and the current drawn from the battery. As a guide, a 9-volt alkaline PP3 size battery will last about a year at a gain of x10. If desired, an on/off switch can be fitted so the unit can be switched off when not in use, thus prolonging the life of the battery. Battery replacement is indicated by an increase in noise and reduction in gain.

220K	x4	12	35
150K	x6	16	50
100K	x10	20	75
62K	x15	24	120
47K	x20	26	180
30K	x30	30	240

Working out the optimum gain for your cartridge is best performed by fitting a 250kohm potentiometer in place of R1 and adjusting it until the required level is achieved. Then remove the potentiometer, measure the value and find the nearest preferred value resistor and solder in permanently.

CONSTRUCTION TIME

The amplifier can be built on a piece of stripboard, or a small PCB can be fabricated if desired. The unit should be housed in a metal die cast box for maximum shielding. The input connections should be high quality chassis-mounted phono sockets, preferably gold plated. Most record decks require a separate earth connection and a suitable binding post can be fitted between the phono sockets to accommodate this connection. It is important to ensure that the metal box is earthed and this can be achieved by ensuring a good metal-to-metal contact of the binding post with the box. On the circuit board, fit metal pins for the input, output and earth connections, as this will facilitate wiring

the external connections in the box later. It is also a good idea to fit pins where R1 will be fitted to make it easy to set this value. The circuit board will need insulating from the metal box, of course. To this end, I cut a piece of clear plastic from an old CD jewel case just larger than the circuit board and glued it in place in the box. The finished circuit board was then fastened to this piece of plastic with a double-sided adhesive fixer, which makes a neat and resilient assembly.

If desired, an on/off switch can be fitted in the side of the box. Now wire the circuit board to the phono sockets, binding post and PP3 battery clip. The output connections can be soldered directly to twin screened flying leads passed through a hole drilled in the box and terminating in a pair of gold plated phono plugs for connecting to the main amplifier. For initial testing, fit a 100kohm resistor across the appropriate pins for R1. All that remains is to connect the unit into your system and attach a battery. Once you have determined that the unit is working satisfactorily, set the gain for your cartridge as previously described.



Interior View

All the components used in the design are readily available. Ceramic capacitors can be used for C2 and C4. The transistors cost less than 15p each from Maplin including VAT. In fact, the most expensive component is the box! Finally, I would recommend the use of Black Gate electrolytic capacitors throughout which are less than £2 each at these values and voltages. ■ ▲

LANGREX SUPPLIES LTD

DISTRIBUTORS OF ELECTRONIC VALVES, TUBES AND SEMI-CONDUCTORS AND I.C.S.

1 MAYO ROAD • CROYDON • SURREY CR0 2QP

PHONE
020 8684 1166

24 HOURS EXPRESS MAIL ORDER SERVICE ON STOCK ITEMS

E MAIL LANGREX@AOL.COM

FAX
020 8684 3056

A selection of our stocks of **New Original Valves/Tubes.**
Many other brands available

STANDARD TYPES			SPECIAL QUALITY TYPES			OTHER TYPES		
ECC83	E.I	3.00	A2900/CV6091	GEC	17.50	12BY7A	GE	7.00
ECC85	RFT	5.00	E82CC	SIEMENS	7.50	5687WB	ECG	6.00
ECC88	BRIMAR	6.00	E83CC	TESLA	7.50	5814A	GE	5.00
ECC88	MULLARD	10.00	E88CC/CV2492	BRIMAR	10.00	6072A	GE	6.00
ECH81	MULLARD	3.00	E88CC GOLD PIN	TESLA	8.50	6146B	GE	15.00
ECL82	MULLARD	5.00	ECC81/CV4024	MULLARD	6.00	6201	GE	6.00
ECL86	PHILIPS	10.00	ECC81/M8162	MULLARD	7.50	6336A	RCA	35.00
EL36	MULLARD	5.00	ECC81/6201	MULLARD	10.00	7027A	GE	25.00
EL37	MULLARD	30.00	ECC82/CV4003	MULLARD	10.00	7308	SYL	5.00
EZ81	MULLARD	7.50	ECC82/M8136	MULLARD	12.50	7581A	SYL	15.00
EZ80	MULLARD	5.00	AMERICAN TYPES			OTHER TYPES		
GZ33/37	MULLARD	20.00						
GZ32	MULLARD	25.00	5R4GY	RCA	7.50	ECC81	RFT	3.00
5Z4G	BRIMAR	6.00	5U4GB	SYLVANIA	10.00	ECC82	RFT	6.00
6V6GT	BRIMAR	7.50	5Y3WGT	SYLVANIA	5.00	ECC83	RFT	8.00
12BH7	BRIMAR	12.00	6BX7GT	GE	7.50	EF86	USSR	5.00
12E1	STC	10.00	6B4G	SYLVANIA	22.00	EL84	USSR	3.00
13E1	STC	85.00	6FQ7	SYLVANIA	7.50	EL34G	SOVTEK	5.00
807	HYTRON	7.50	6L6GC	GE/SYL	20.00	EL34	E.I	5.00
811A	RCA	25.00	6L6WGB	SYL	15.00	6SL7GT	USA	5.00
6080	MULLARD	10.00	12AX7WA	SYLVANIA	6.00	6SN7GT	USA	7.50

THESE ARE A SELECTION FROM OUR STOCK OF OVER 6000 TYPES. PLEASE CALL OR FAX FOR AN IMMEDIATE QUOTATION ON ANY TYPES NOT LISTED. WE ARE ONE OF THE LARGEST DISTRIBUTORS OF VALVES IN THE UK. SAME DAY DESPATCH VISA/ACCESS ACCEPTABLE. OBSOLETE TYPES A SPECIALITY.

CREDIT CARD MIN ORDER £10.00.

OPEN TO CALLERS MON. - FRI. 9AM - 4PM. CLOSED SATURDAY

U.K. P & P 1-3 VALVES £2.00, 4-6 VALVES £3.00 ADD 17.5% VAT TO TOTAL INC P+P O'SEAS P & P PLEASE ENQUIRE

VISA

EUROCARD
MasterCard

13th
5/2/02

Watford Valves

7 DAYS A WEEK 9AM - 9PM The Audiophiles Choice
All output valves multi-tested and digitally matched
Full no quibble guarantee. Expert advice on all valve amps

		£
ECC81	Philips	7.00
ECC82	R.T.	10.00
ECC83	Philips	10.00
ECC83S	JJ Tesla	7.00
ECC84	R.F.T.	7.00
ECC85	R.F.T.	8.00
E88CC/6922	Philips	8.00
ECF80	G.E.	8.00
ECL86	A.E.G	10.00
EF80	Mazda	6.00
EF86	Mullard	20.00
EL34	Svetlana	10.64
EL34	Siemens	45.00
EL84	JJ Tesla	7.00
GZ32	Dario	25.00
GZ34	Sovtek	8.00
KT66	Harma	25.00
KT188	JJ Tesla	25.00
KT88	Svetlana	34.00
300B	JJ Tesla	68.00
5881WXT	Sovtek	7.00
6550C	Svetlana	22.00
6500EH	Sovtek	22.00
6SL7GT	Brimar	6.00
12AX7LPS	Sovtek	8.00
12AX7	Svetlana	7.23

World Audio
design

WORLD AUDIO DESIGN UPGRADE

Many readers have enjoyed the huge improvements made to these fine W.A.D. kits simply by fitting specially selected valves. They are guaranteed to provide tighter bass with improved detail and lower noise with increased dynamics. So take advantage of this special offer and make a great audio upgrade whilst stocks last.

KIT 6550 & KAT 6550 Upgrade



4 x 6550C Svetlana matched
2 x ECF80 GE
2 x 5U4G Russian
£99 the set + vat & carriage



KAT6550

KEL 80 Monobloc Upgrade



8 x EL34 Svetlana matched
2 x 6AU6WC Philips
2 x 5687WB Philips
£90 the set + vat & carriage

KIT 34 & KAT 34 Upgrade



4 x EL34 Svetlana matched
2 x ECF80 GE
2 x 5U4G Russian
£55 the set + vat & carriage



KAT34

300B PSE MONOBLOC Upgrade



4 x JJ Tesla 300B matched
2 x Philips 6AU6WC
2 x Philips ECC82
2 x Harma 5U4G
£284 the set plus vat & carriage

WATFORD VALVES 3 Ryall Close,
Bricket Wood, St Albans, Herts AL2 3TS

Fast mail order/next day delivery/World Wide shipping
1000's more valves stocked. Prices exclude VAT and carriage.

VISA



01923 893270

Fax: 01923 679207

www.watfordvalves.com



e-mail us with letters at - diyletters@hi-fiworld.co.uk

D.I.Y. LETTERS

Can good cables reveal the true abilities of your system? One reader thinks so, especially if you carefully wind your own.

Thanks to Nick and in particular to your contributor Neville Roberts for the feature in the November 2001 DIY Supplement titled Build a Quality Mains Lead.

I purchased supplies and made up one lead terminating in the IEC Socket and another with a 13A Mains Socket so that I could test with equipment having either the IEC input or fixed mains lead. The result was quite amazing.

I looked for better components, including an IEC Plug to attach to mains leads cut off about 6" from the cabinet. Maplins sold a Permaplug 13A Mains Plug which was ideal but they have just substituted it with one less suitable of the same name.

Apart from 13A plugs and earth wire I purchased from Farnell Electronic Components: -

140339 16/0.2 Black Wire 100M
 140341 16/0.2 Red Wire 100M
 964505 IEC Socket (Schurter) These Schurter Plugs and sockets are superb components
 146766 IEC Plug (for cut leads) rated at 10amp and the socket easily accepts the 13 wires
 107445 Heat Shrink 5M

All parts were sent mail order, carriage paid (over £10). They sent me a full catalogue and I have since received a CD - all free. Phone 0113 263 6311 for instant attention and immediate despatch!

From experience I suggest you need an old wooden bobbin and plastic straight sided pen or pencil to wind with. Cut off 5M lengths of cable (about 4M earth), tear off about six 2" strips of PVC tape and locate along path of operation, wind up a pair then move some object such as corner of a table to the bobbin for reference for the next and

ensure a similar number of turns. Tug hard and then let off some pressure at the bobbin to allow unwinding, whilst ensuring it is carefully relaxed to prevent tangling.

When all six are completed wrap with tape to hold all with the earth, as well as hold the six pairs side-by-side and wrap around the earth cable until it is found difficult, then secure with tape.

Untangle the mess behind you then proceed again and repeat. Tidy up the ends and bare wires and solder all 13 to a length of stiff wire, such as 3-core round, to use as a pull-through for the heatshrink. Neatly tape the join.

Cut the heatshrink to suit and feed the pull through and attach to door handle (not inside house). Smear some form of lubricant onto a paper towel and wipe over cable. I used a silicone spray, left in the car after service. The heat shrink can easily be persuaded over the wire - or add more lubricant. Separate each colour and remove about 1/2" of insulation, align and twist together. Then cut off surplus wire.

After fitting to plugs check that each cable is actually secured. I shrunk the sheath, after fitting plugs and sockets which do not require soldering.

I have separate 13A wall sockets for each item and from the top of the rack there is a voltage controlled power supply for SE turntable with DC Motor, Pace Digibox, Naim Power Supply for Pre-Amp, Meridian 508-24 CD Player, Sony 830 Receiver, Naim 180 power amp, and Rel Strata 111. The tape player and VCR will soon be connected by a common cable with twin 13A free sockets.

Over many years I have made up interconnects, which is not easy with the Naim 5 pin DIN Plugs. I have purchased others, but appraisal of these has been confusing and I have even changed equipment, which in hindsight was due to the inconsistent quality and

voltage of the mains!

Similarly, the subwoofer was never right due to the failure of the power amp to supply accurate and consistent information.

Thanks to you I can now fine-tune everything. I have bass detail from Satellite Digital Radio, vinyl, CDs and produce information both previously not known to exist. I can even set up the Sony to produce a front soundstage, which I suppose you would call integrated.

The speakers are Daline kits by Falcon, fitted with Focal Drive Units, but modified with external crossovers and originally MDF varnished, but since laminated, which also improved the sound.

Returning from Tesco with a piece of bubblewrap when I had a spare 12mm MDF shelf to hand. I attached the wrap to the shelf with about six pieces of masking tape and slid this under the turntable. The improvement was astounding. I have repeated this with the power amp, the Sony, and then ran out of spare shelves! I found an offcut of oak about 1/4" thick and 3" wide and cut two pieces to match the shelf depth and taped front and back a piece of bubble wrap which is easy to put under the feet of any unit to assess the result. It worked very well under the Naim Power Supply but looked untidy so I purpose-cut one piece of 15mm MDF to match the size of the Naim Box. Guess what? The result is not the same and has been replaced by two pieces!

My Naim pre-amp now has four 3" x 3" x 1/4" similar 'feet'. The shelves are a mix of MDF and marble mounted on Spurr slotted supports with their deep brackets which mostly I have welded nuts with spikes. The brackets are almost filled with Underseal.

I am amazed that quality products may never achieve their design performance unless tweaked like this.

R. Johnson, York

Kit & Component Suppliers

CLASSIC TURNTABLES

Technical & General

PO. Box 53, Crowborough,
East Sussex TN6 2BY.

Tel: 01892 65 45 34.

The original specialist source of spares, replacements and expertise for the classic turntables. Years of actual experience and comprehensive range of parts (originals and re-manufactures), manuals, ancillaries, No dubious 'improvements' - no harmful 'modifications'. Our specialities: Connoisseur; Garrard; Goldring; Lenco; S.M.E.; Thorens; Watts; Ortofon; Shure. Cartridges and styli for 78s, Mono LPs, Stereo LPs.

COMPONENT SUPPLIERS

AudioCom (UK),
Unit 14 Pier Road
Pembroke Dock
Pembrokeshire, SA72 6TR

Tel: 01646 685601

Fax: 01646 685602

Website: www.audiocom-uk.com

E-Mail: enquiries@audiocom-uk.com

Massive range of audio components and accessories available including Black Gate electrolytics, Elna SILMIC (Silk Fibre) electrolytics, Audyn-Cap film and foil capacitors, OFC air core and copper foil inductors, high power resistors, loudspeaker crossovers, high-end cable, Vishay & Holco resistors, 99.9999% pure Silver wire, DACT CT1 & CT2 attenuators, audio connectors, spikes & damping materials, plus over 50 loudspeaker kits. Active products include the SUPERCLOCK master clock plus super-low noise PSU, & Q-power super-low noise discrete regulators. A new, 365 page 2001 handbook is available for £3.50 (UK) and £5.00 (overseas).

White Noise

11, Station Road, Bearsden
Glasgow G61 4AW

Tel: 0141 942 2460

Fax: 0141 587 7377

Email: david.white38@ntlworld.com

Supplier of the widest range of standard and audiophile kits for solid state pre-amplifiers, power amplifiers, headphone amplifiers, power supplies, MM/MC phono stages, active crossovers, balanced i/o modules, and stepped attenuators; more kits in the pipeline. All kits use the highest quality, glass fibre, solder masked, silkscreened, PCBs. We also supply a wide range of active (esp. Japanese transistors and Exicon mos-fets) and passive components, gold plated

connectors, and silver plated wires. Write, phone or email for a free catalogue. Mail order only.

LOUDSPEAKER KIT SUPPLIERS

Audio Note (UK Ltd)
Unit C, Peacock Ind. Est.
125-127 Davigdor Road
Hove, East Sussex BN13 1SG
Tel: 01273 220511

Fax: 01273 731298

Suppliers of a large amount of components for the Audiophile Kit builder. Valve amplification data and vintage circuits also available. See the double page spread in the back section of the main issue for extra & more detailed information.

Falcon DIY Speakers
Falcon Acoustics Ltd.,
Tabor House,
Norwich Road, Mulbarton,
Norfolk NR14 8JT.
Tel: 01508 578272

UK distributors of FOCAL drive units & kits, and ETON loudspeakers, plus SOLEN (SCR-Chateauroux) polypropylene capacitors. We are the largest specialist Audio inductor manufacturer in the UK. We also stock Audio Amateur Publications and Audio Computer Software and a comprehensive range of D.I.Y speaker kits, parts, accessories and books. Please send large SAE (44p) for free price list. "Everything but the wood".

IPL Acoustics, Chelsea Villa, Torr's
Park, Ilfracombe, North Devon, EX34
8AY

Tel/Fax: 01271 867 439

Website: www.iplacoustics.co.uk

IPL Acoustics supply a range of 7 transmission line, 3 conventional, speaker kits, and kits for centre speakers and active subwoofers. We also supply a full range of drive units from Audax, SEAS, Morel and Legend Acoustics (Ribbon Tweeters) as well as custom built metal coned drivers. Also included is a range of capacitors, inductors and quality cabinet accessories as well as Silver Plated PTFE insulated cables.

SPECIALIST UPGRADE SERVICES

AudioCom (UK),
Unit 14 Pier Road
Pembroke Dock
Pembrokeshire, SA72 6TR
Tel: 01646 685601
Fax: 01646 685602

Website: www.audiocom-uk.com
E-Mail: enquiries@audiocom-uk.com
Release the full potential of your digital source with CD/DVD upgrades from audiocom. Available is the highly acclaimed SUPERCLOCK master clock oscillator. (Dave Berriman fits the S-Clock to the Teac VRDS-105E and comments... "there was not one area of music reproduction which didn't improve".) SUPERCLOCK super low noise power supply, & Q-power ultra-low noise discrete regulators. Why not contact us to see how this service can be adapted to suit your requirements?

VALVE AND OUTPUT TRANSFORMER SUPPLIERS

Wilson Valves, 28 Banks Avenue,
Golcar, Huddersfield,
West Yorks HD7 4LZ.
Tel: 01484 654650/844554
Fax: 01484 655699
E-mail: wilsonv@zoo.co.uk
We stock over 2,500 different types of valves, N.O.S. and New. Please send a S.A.E. for full list. No charge for matching. Most major credit cards accepted.

Watford Valves
3 Ryall Close, Bricket Wood,
St. Albans, Herts AL2 3TS
Tel: 01923 893270
Fax: 01923 679207
Specialist in new old stock and current production valves. Sole UK distributor of the Harma Diamond range selected for their superior performance. Huge range held, stockists of Mullard, GE, Philips, National, Brimar, Sylvania, Telefunken, RCA, MOV and many more. All valves are new boxed and guaranteed. For free price list and specialist advice call or fax Derek Rocco, Watford Valves.

Chelmer Valve Company Ltd
The Stables, Baddow Park
Great Baddow, Chelmsford, Essex
CM2 7SY
Tel: 01245 241301
Fax: 01245 241309.
Email: sales@chelmervalue.com
Web Site: www.chelmervalue.com
Supplier of premium range of audio valves, other valves and components also available. (Please see our main advertisement in this supplement).

Langrex Supplies Ltd
1 Mayo Road, Croydon,
Surrey CRO 2QP
Tel: 020 86841166
Fax: 020 86843056
One of the largest distributors of elec-

tronic valves, tubes and semi-conductors in the UK by original UK and USA manufacturers. Obsolete types are a speciality. Telephone or fax for an immediate quotation.

Billington Export Ltd.
IE Gillmans Trading Estate,
Billingshurst,
West Sussex
RH14 9EZ
Visitors by appointment only please
Fax: 01403 783519
E-Mail: sales@bel-tubes.co.uk
Website: www.bel-tubes.co.uk

Specialists in guaranteed new/old stock, current production valves & tubes. Also CRT for audio, hi fi (as well as industrial uses). A vast archive of vintage and obsolete types including limited quantities of Mullard, GEC, Sylvania, Philips, Brimar, Telefunken, RCA and others. Large stocks of Chinese, Russian, EI and Tesla etc. A 50-page valve catalogue is available on request. Major stockists of the excellent Billington Gold brand. Contact us for quotations - attractive price on larger orders.

Audio Specialist,
W. Marriott
73 Stonyford Road,
Sutton-In-Ashfield,
Notts,
NG17 2DL
Tel: 01623 461128
Email: wasmariott@talk21.com
Transformers. One of the world's widest range manufactured. Mains chokes, output transformers etc. From the standard I/E M6 to the awesome Hi-B nickle double C-Core's wound with the superb 6N cardas copper cable. All types of transformers manufactured. One off a speciality. A superb range of accessories and components supplied. Steel copper, brass etc cases available for that special project. All types of repairs, modification undertaken. Rebuilds, kits built to both thermionic solid state. Classic vintage equipment always sought, working or not. Catalogue £3.50 redeemed on first order over £30.00

TO ADVERTISE IN THE
KIT & COMPONENT
SUPPLIERS PAGE

PLEASE CALL

020 8864 4760

Email:

diyadvertising@hi-fiworld.co.uk



WELCOME TO OUR MARKET PLACE

Here are a wide variety of specialist hi-fi products and services.

Keep an eye open for regular advertisers, who know the market and serve their customers in a friendly and reliable manner.

Audio Classics are back!

Item	Price	Condition	Description
Radford STA25/III	£800	4.9	Classic 25WPC EL34
Leak TL12+ CHROME	£600	5.0	Rebuilt, perfect pair
Leak TL12+ Bronze	£450	3.1	Rebuilt, perfect pair
Decca Kelly DK30	£250	4.9	Pair ribbon tweeters
Leak Troughline III	£100	4.9	Mono FM tuner, perfect
Garrard 301	ASK	4.5	Perfect Garrard TT
Garrard 401	ASK	4.9	Perfect Garrard TT
Tannoy IILZ Monitor Gold	£500	3.9	No badges, nice pair
Lowther TP1	£1200	3.9	No grills, original PM3A
B&W P2H	£1200	4.8	Fully working IONICs
RCA Cinema Monoblocks	£500	3.1	Fully working pair
Gaumont Kalee "Duosonic"	£600	2.9	HUGE monoblocks, pair
B&O Beogram 4000	£400	4.3	Jacobsen classic, new cart
Technics SP-10	£250	1.9	EX-Studio turntable
Technics SL-D1	£80	4.0	Direct Drive parallel track
Nottingham Analog Mentor	£500	3.9	Heavy turntable, no arm
Nottingham Analogue Hyper Space*			
And Space Arm	£2300*		Vinyl perfection
Micro Seiki MA77	£350	5.0	Amazing 1970s arm
Alphason HR100MCS	£350	4.5	My fave arm
EAR MC-3	£600*		High-End MC step up
EAR 834P (MC/V)	£500*		MM/MC phono stage,
EAR CL.EAR	£350*		MM phono & control
Full EAR range available*			(great for Leaks)
Croft Vitale	£360*		Budget BARGAIN!
Full Croft range available*			
B&O Beomaster 8000	£500	4.7	Remote Receiver
Lecson AP1 / CPI	£650	3.9	Design classics
Yamaha T2	£400	5.0	AMAZING FM tuner
EAR V20	£2800*		Simply AMAZING!
KLIPSCHORN	£2000	3.0	Painted white?
KEF LS3/5a L.E.	£1000	5.0	Raymond Cook, pair # 20
JBL L100	£350	3.0	Damage to grill on one
Audio Classics Model "C"	£1500*		

Key * = New item 1 = Poor 2 = Presentable 3 = Average 4 = Good 5 = Mint, like new.
 Part Exchange Welcomed! FREE delivery on all new items, everything else, please enquire.
 Callers welcome by special appointment. New dealers for EAR, Croft, Nottingham Analogue.

Tel:01942 257525 www.audioclassics.co.uk

WANTED

HI-FI & accessories

any make, any age

BUY · SELL · TRADE

OPEN 7 DAYS 10am - 8pm

Please bring official ID with address & signature when selling or exchanging

MUSIC & VIDEO EXCHANGE

56 Notting Hill Gate, London W11
 ☎ 020 7792 3474

480 Fulham Rd (Broadway), London SW6
 ☎ 020 7385 5350

95 Berwick St, Soho, London W1
 ☎ 020 7434 2939

www.buy-sell-trade.co.uk

LARGE SELECTION ON SALE

ALSO BUY, SELL, TRADE MUSICAL & PHOTOGRAPHIC EQUIPMENT

THE WIDEST SELECTION OF CAREFULLY USED & EX-DEMO' EQUIPMENT ALL FULLY GUARANTEED

VINYL REPLAY

DENON DP-2000 (Direct Drive)	£1500	£300
DUAL S503.1		£70
DUNLOP Syntendeck 3 / Basik LVX / K5	£750	£379
GOLDRING GL75	Classic	£74
LINN Axis (Cut for Linn arm)		£350
LINN Axis + Basik Plus	£600	£325
LINN Basik LVX Arm	£125	£44
LUXMAN PD300 Cut for SME		£225
MICHELL ISO/HERA Phono Stage	£895	£448
MICHELL ISO HR/HERA Phono Stage	£895	£480
NAIM Prefix ex demo	£405	£324
PROJECT RPM4 Turntable	£450	£308
REGA Planar 2		£170
ROKSAN Xerxes + RB300	£1750	£550
STD + Linn Basik	£300	£154
THORENS TD125		£150
THORENS TD166		£160
WILSON BENESCH Act2 Arm	£1200	£594

CD • DVD

AUDIO ALCHEMY ACD II	£450	£298
AUDIO ALCHEMY V1 + PSU	£489	£169
AUDIO ALCHEMY V3 DAC + PSU	£900	£549
AUDIO MECCA Kreatura (Trans)	£1250	£648
AURA CD50 CD Plyr		£150
COPLAND CDA 288	£2100	£1498
CYRUS 3q CD	£800	£580
DENSON Beat B400 + Gizmo remote	£1350	£900
DPA PDM 1 DAC	£1000	£438
KRELL 250CD	£2750	£1600
LINN Kank CD	£1850	£1098
MARANTZ CD94 + Assemblage DAC2	£900	£358
MARANTZ CDA-94 DAC	£1000	£295
MERIDIAN 603 DAC		£700
MERIDIAN 606 DAC		£600
MERIDIAN 200 Trans	£700	£358
MERIDIAN 203 DAC	£499	£228
MERIDIAN 206 CD Plyr		£428
MERIDIAN 207 CD/Pre	£1200	£548
MERIDIAN 263 DAC		£398
MERIDIAN 602 Trans		£700
MICROMEGA T-DAC	£1250	£550
MICROMEGA DAC 1		£320
MICROMEGA Stage 2 CD Plyr		£398
MICROMEGA Drive 3 CD Trans & DAC		£528
NAIM CDS *****	£4000	£2298
NAIM CD1	£1600	£858
NAKAMICHI MB-2S (CD)		£POA
NAKAMICHI MB-4S (7 play CD)	£400	£168
ORELLE DA10T Trans	£900	£450
PINK TRIANGLE Literal (CD)	£2650	£1798
PINK TRIANGLE Cardinal (Trans)	£1250	£550
QED Positon + Digit (Trans & DAC)	£500	£170
RADFORD W51 CD Player	£999	£358
ROTEL RSD991 CD Plyr	£900	£550
SONY CDP552 ES + DAS702ES	£2400	£850
SONY CDP-970 CDPlayer	£495	£198
TAG CDT20R (Trans)	£2200	£1100
TEAC P500 (Trans)	£1000	£400
TEAC VRDS 10 (CD Player)		£450
THETA Pro Basic IIIA (DAC)		£1990
TRICHORD Genesis (CD)	£620	£300
WADIA 8 Tran+DDE15 DAC *****	£7500	£4400

AMPLIFIERS • TRANS

A&R A60 Integrated (Black)		£120
ALBARRY AP2 (Pre)		£POA
ALBARRY AP3 (Passive pre)		£POA
ARCAM AVR100 ex demo	£800	£594
AUDIO ANALOGUE Puccini SE	£798	£680
AUDIOLAB 8000C (Pre)	£600	£290
AUDIO INNOVATIONS Alto (Integrated)		£208
AURA APA-200 (Power - Chrome)	£1200	£650
CAMBRIDGE ATAC 3 Integrated	£200	£88
CYRUS One (Integrated)		£100
CYRUS Pre	£700	£358
DENON AVP-A1D Digital Pre-amp	£2500	£1299
DENON POA-6600 Monoblocks		£POA
DEVA 250 Integrated + Matching Power	£1000	£450
DNM PRE2 / PA1 Pre & Power	£2800	£1099
FLAMCO Plentitude Power Amp	£560	£240
GALACTRON MK2121	£1200	£798
HARMON KARDON Citation 17 pre	£699	£199
HARMON KARDON AVR85 AV Rec	£1000	£498
LECSON AC1/AP1	Classic	£294
LFD LS1 Pre-amp	£1900	£500

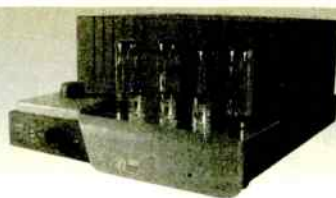

UNISON Simply 4 Integrated
Tireless listening, deliciously informative and with enough 'wallop' to bring most speakers to life. 'Simply' a cut above most integrated amps!
~~£1,595~~ **£1,099**

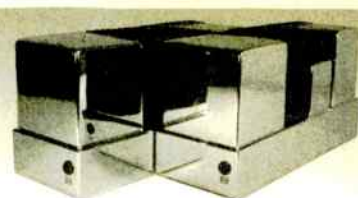

QUAD II Anniversary power Amps
Beautiful in gold plate and absolutely as new. Sounds you could live with forever and so desirably collectable. An audio investment?
~~£6,000~~ **£2,998**

LFD LS2 Pre-amp	£950	£250
LFD PA2 Power-amp	£2100	£750
LINN LK1	(Est)£650	£350
LINN LK2	(Est)£595	£299
LINN Kaim Pre	£1700	£1098
LINN Klout (Power)	£2000	£1350
LINN LK1 Pre	£ 650	£224
LINN Tune Box	£ 519	£394
MARK LEVINSON 27.5 Power	£6000	£3998
MERIDIAN 201 Pre	£760	£329
MERIDIAN 518 Pre	£1095	£648
MERIDIAN 568 ex demo	£3825	£3124
MICHELL Orca + PSU Pre	£999	
MICHELL Argo + Hera		£598
MUSICAL FIDELITY A1 Pre	£250	£120
MUSICAL FIDELITY MVT Pre		£350
MUSICAL FIDELITY The Pre-Amp 3a		£240
MUSICAL FIDELITY F22 Pre	£1250	£898
MYRIAD MA120 (Power)	£600	£280
NAIM NAIT 3R Integrated	£700	£390
NAIM NAC 62 Pre	£250	£104
NAIM NAC 72 Pre	£800	£528
NAIM Hi-Cap	£750	£400
NAIM NAC 32 (Modified)	£ 600	£294
NAIM NAP 140	£ 690	£384
NAIM NAP90 (Power)	£600	£378
NAIM NAP90 (Power)	£600	£400
NAIM NAP250 (Old style)		£748
NVA P90		£POA
NVA AP70	£1100	£598
PERREAUX 350P Power		£398
PERREAUX SM6P Pre *****	£5000	£3558
SONY TA-9000ES	£1100	£398
SONY TA-9000AV	£1000	£398
SUGDEN AU51 Pre	£995	£548
SUGDEN Symetra Monoblocks	£1590	£898
QUAD 33 Pre	£200	£68
QUAD 34 Pre	£400	£228
QUAD 77 Power	£700	£400
QUAD 77 Integrated	£700	£350
ROGERS A-100	£ 600	£184
ROKSAN Caspian (Int)	£900	£698
SONY V88ES ProLogic Amp	£400	£228
SONY Athena III Pre	£900	£350
TALK ELECTRONICS Storm (Intgtd)	£650	£370
TESSERAC Pre	£1500	£798
TOWNSEND Elite 600 Pre	£ 500	£199
YAMAHA DSPE390	£ 300	£ 84

VALVE AMPLIFIERS

ARION Electra Integrated	£1200	£598
AUDION Silver Knight 300B Amp		£650
AUDION Silver Knight 300B Mono's	£2250	£1390
AUDIO INNOVATIONS S 800 (Power)	£1200	£680
AUDIO PRISM Debut	£2940	£1900
AUDIO RESEARCH LS1 Pre	£1500	£650
AUDIO RESEARCH LS2 Pre	£2800	£1798
AUDIO RESEARCH LS7 Pre	£1400	£1100
AUDIO RESEARCH LS12 Pre	£3200	£1500
AUDIO RESEARCH SP15 Pre	£3990	£1900
AUDIO RESEARCH VT-60 Power	£3000	£1298
BAT VR40	£4950	£2600
CONRAD JOHNSON PV10AL Pre	£1098	£848
CONRAD JOHNSON PV11 Pre	£1600	£999
CR DEVELOPMENTS Carmeto (Pre)	£900	£428
EAR 859 (Integrated)		£1648
JADIS Dely 7 (Current Model)	£4790	£3898
LEAK Stereo 20 Power New caps Nice		£350
LUMLEY RelP1 (Passive Pre)		£100
MICHAELSON Odysseus 40w Int	£1150	£699
MICHAELSON + AUSTIN TVA 1	£1000	£594
MUSICAL FIDELITY F22 Pre	£1500	£898
PAPWORTH M100 Mono's *****	£3500	£2498
PAPWORTH M200 Mono's *****	£5000	£3500
PM COMPONENTS Monoblocks	£3000	£1498
UNISON RESEARCH Feather 1 Pre	£800	£558
WORLD AUDIO K5881	£600	£500

TUNERS

ACCUPHASE T108	£1300	£648
BRAUN 301	£269	£99
DENON TU-600L	£200	£94
DENON TU-380 RD tuner	£180	£100
HARMON KARDON TU-915	£300	£120
HARMON KARDON TU-9400	£249	£128
LEAK Delta AM-FM		£75
LECSON FM1 Tuner	Classic	£394
MARANTZ ST-63 (Silver)		£75

MARANTZ ST-17	£650	£350
MERIDIAN 604	£1700	£998
NAIM NAT 01/NAPSC	£1900	£1150
QUAD FM3	£200	£120
QUAD 77 Tuner		£600
SHERWOOD S-2400		£400
TRIO KT9xL (Silver)	£200	£95
YAMAHA CT610	£190	£60

CASSETTE • TAPE

AIWA AF80 3 Head Cassette	£250	£129
DENON DR-M24HX	£220	£120
NAKAMICHI 481 Cassette	£400	£180
NAKAMICHI CR2E Cassette		£600
NAKAMICHI CR5E Cassette		£950
NAKAMICHI 670ZX Cassette		£600
NAKAMICHI 700ZX Cassette		£1500
PIONEER PDR 04 CD Recorder		£700
PIONEER CT-S50S Cassette		£400
REVOX D36 Reel to Reel		£348
REVOX E36 (Reel to reel)		£298
SONY DTC-750 DAT	£500	£230
TANDBERG TCD300 Cassette		£88
TEAC CX650R Cassette		£300
TEAC A 3300-SX 10 1/2" Reel to reel		£1000
YAMAHA CK690 Cassette	£250	£148

LOUDSPEAKERS

ACOUSTAT Model 2's	£1900	£994
ACOUSTIC ENERGY AE 3 (Inc stands)		£1698
ACOUSTIC ENERGY Argo 2 ex demo	£ 300	£204
B&W P4 (Cherry)		£600
B&W Matrix 804		£1400
CASTLE Chester (Blk)		£900
CHORD CEL 301	£3500	£1498
DALI 400		£400
DYNAUDIO Audience 50 (Black)	£577	£350
EPOS ES11 (Walnut)	£499	£298
EPOS ES14 (Black)	£800	£448
GAMMA ACOUSTICS Epoch 5	£3000	£998
HALES Signature System 2	£4000	£1848
HARBETH HLP3		£450
HEYBROOK Heystack (Rosewood)	£500	£297
HEYBROOK Quartet (Walnut + Stands)	£700	£395
IMPULSE H7 (Black)	£1000	£480
JAMO Concert 8 (Piano Black Anniversary)	£1850	£998
JAMO Pro-Ex 400	£800	£500
JAMO Centre 200 (Black)	£1000	£498
KEF Q85S.2	£200	£100
KEF 65DS		£400
LINN Sara 9 with stands (Black)		£900
LINN Kaber (Black)	£2000	£780
LINN Kaber (Rosewood) ACTIVE	£2500	£1350
LINN Nexus (Blk)	£400	£190
MAGNA PLANAR 1a Imp	£1400	£850
MARTIN LOGAN CLS2 II *****	£5000	£2990
MEADOWLARK Shearwater	£2990	£1990
MERIDIAN M3 (Active)	£1000	£348
MERIDIAN DSP 5000 ex demo	£3885	£3194
MERIDIAN DSP 5000 Centre ex demo	£1998	£1594
MISSION 754P (Rosewood)		£698
MISSION 781 (Black) with stands	£250	£130
MISSION Cyrus 781 (Black) with stands		£175
MORDANT SHORT MS 25	£200	£44
MONITOR AUDIO Studio 12 (Black)	£1300	£698
MORREL Bass Master (Oak)	£1600	£728
NOTE PERFECT Virtuoso (Piano laquer)	£2000	£995
PROAC Response 3.6s	£4500	£2500
PROAC Studio 150	£1650	£1100
PROAC Response 1 (Yew)	£1200	£750
PROAC Studio 1 Mk2		£350
QUAD ESL 63	£3500	£1400
REGA ELA (Black)	£400	£200
REGA XEL (Black)	£990	£640
REGA Naos	£ 998	£884
ROGERS LS6 (Black)	£ 399	£185
RUARK Prelude (Mint)	£690	£450
RUARK Broadword (Mahog)	£790	£370
RUARK Crusader (Black)	£1700	£895
RUARK Equinox (Black)	£2200	£1349
RUARK Talisman II		£400
SNELL J3 High Efficiency Monitors	£770	£449
SNELL Type E2		£698
SPENDOR BC1's	£ 650	£224
TRIANGLE Icare	£1500	£748
WHARFEDALE 73 (Blk)	£300	£150
YAMAHA NS1000M		£680



UNISON RESEARCH S8 Integrated
Single ended class A performance from a very stylish single unit. You'll need muscles like it has - just to lift it! Luscious looks and sound!
~~£2950~~ **Ex-dem £2147**

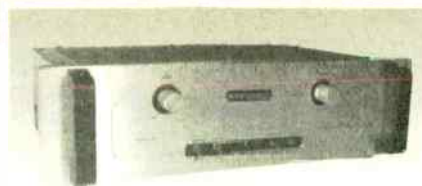

AUDIO RESEARCH LS5 Pre-amp
Amongst the most informative and musical pre-amps in the world. Its influence transforms many aspirational systems into the real thing!
~~£5,095~~ **£2,999**

**NOTHING TO PAY
FOR SIX MONTHS**

then choose either
**Interest Free Settlement
or competitive repayments**

EX-DEMONSTRATION STOCK CLEARANCE

Items as New, Boxed and Fully Guaranteed

APOGEE Centaur Speakers	£2300	£1600	GRAAF 13.5 BII Pre	£3950	£2146	PS AUDIO 4.5 Pre-amp	£998	£548
APOGEE Mini Grand GS Speakers	£7595	£5495	GRAAF GM20 OTL Power	£2950	£2346	PS AUDIO 6.1 Pre-amp	£799	£479
ARCAM Alpha 9 CD Player	£799	£696	KRELL KAV300i	£2790	£2230	PS AUDIO 6.2 Pre-amp	£899	£539
ARCAM FMJ T21 AM/FM Tuner	£399	£294	KRELL KAV300CD	£4289	£3399	QUAD 99 Power	£550	£446
ARCAM Alpha 10 DAB Tuner	£799	£696	KRELL FPB 300C	£9998	£8496	QUAD 99 Pre	£750	£596
ARIEL ACOUSTICS Model 8's (stands)	£5679	£4276	LINN Karik Trans	£1800	£1196	QUAD 99 CD	£650	£496
AUDIO ANALOGUE Paganini	£750	£597	LINN Numeric D-A	£1500	£996	QUAD 99FM	£700	£556
AUDIO ANALOGUE Puccini	£475	£396	LINN Tune Box for active boards	£550	£444	QUAD ESL 988	£3600	£2996
AUDIO ANALOGUE Puccini S/E	£635	£496	MARTIN LOGAN Quest	£5349	£3849	QUAD ESL 989	£4600	£3796
AUDIOGRAM MB1 Integrated Amplifier	£599	£419	MARTIN LOGAN Scenario	£1895	£1596	REGA Brio Mk2	£298	£234
AUDIOGRAM MB2 Integrated Amplifier	£499	£349	MARTIN LOGAN Aenious I	£2298	£1896	REGA Naos	£998	£794
AUDION 300B Integrated	£1125	£976	MARTIN LOGAN CLS (2)	£6998	£4496	ROTEL RT940AX Tuner	£235	£194
AUDIO RESEARCH BL1	£699	£556	McINTOSH MCD751 CD Trans	£1896	£1896	SONUS FABER Musica (Intgrtd)	£2295	£1729
AUDIO RESEARCH LS16 (Black)	£3699	£2796	McINTOSH MDA700 Bal DAC	£2549	£1896	SONUS FABER Electa speakers	£1789	£1349
AUDIO RESEARCH Integrated Amp	£3945	£2955	McINTOSH 700/751	£5100	£3996	SONUS FABER Speaker stands - wood	£595	£445
AUDIO RESEARCH DAC1-20	£3739	£899	MCINTOSH C.15 Pre	£1549	£1246	SONUS FABER Musica	£2295	£1896
AUDIO RESEARCH LS5 Mk2 Pre-amp	£1498	£1298	MCINTOSH C.42 Pre	£4200	£3496	SONUS FABER Guarneri	£5295	£4296
AUDIO RESEARCH LS8 Pre-amp	£5290	£3690	MCINTOSH MC352 Power	£5095	£4196	SONUS FABER Electra Amator II	£2698	£2196
AUDIO RESEARCH PH3 Pre-amp	£2199	£1649	MCINTOSH MC7108 8 Channel	£2549	£1996	TDS Audio Transformer	£349	£266
AUDIO RESEARCH REF 600 Ref Amps	£43,995	£29,995	MCINTOSH CR12 AV Pre	£3349	£2596	THETA ProPrime Converter	£1449	£1099
AUDIO RESEARCH VT50 Power Amp	£3499	£2899	McINTOSH LS320	£1790	£1446	THETA Dreadnaught S	£6899	£5176
AUDIO RESEARCH VT200 Power Amp	£9998	£8248	MERIDIAN 518 Digital Processor	£2150	£1796	THETA Casanova Pre	£4478	£3596
COPLAND CDA289	£1985	£1586	MERIDIAN 556 Power amp	£950	£716	THETA Casanova Pre Chassis	£3998	£2996
COPLAND CDA277 CD/HDCD Player	£1649	£1359	MERIDIAN M1500 (Active sub)	£895	£746	THETA Casanova (Multi)	£5652	£4496
COPLAND CDA288 CD/HDCD Player	£1999	£1649	MERIDIAN 563	£700	£446	THETA Miles SE	£2390	£1896
COPLAND CSA28 Integrated Amp	£1439	£1189	MERIDIAN 518 Digital Processor	£985	£746	UNISON RESEARCH Performance One	£POA	
COPLAND CSA303 Pre-amp	£1349	£1079	M&K VX100 Sub	£795	£634	UNISON RESEARCH Simply 4P	£1595	£1296
COPLAND CTA301 Pre-amp	£1299	£1049	MICHELL ISO HR Phono Stage	£895	£696	UNISON RESEARCH Simply 4	£1595	£1197
COPLAND CTA504 Amp	£1999	£1599	MONRIO ASTI CD Player	£695	£537	UNISON RESEARCH S8	£2950	£2346
DCS Elgar D/A	£9500	£8496	MONRIO Bitmatch Transport	£950	£477	UNISON RESEARCH S8	£2950	£2147
DCS Delius D/A	£5499	£4796	MONRIO 18B.2 DAC	£850	£427	UNISON RESEARCH Feather 1	£795	£597
DCS Purcell Upsampler	£3999	£3496	NAIM NAC 92R Pre	£689	£554	UNISON RESEARCH Feather 1		
DIAPASON Karis (Walnut)	£995	£747	NAIM Prefix phono stage	£405	£324	Remote Control version	£890	£677
DIAPASON Adamantes 3 (Walnut)	£1975	£1497	Opera Super Pavarotti	£1095	£846	WILSON Cub speakers (Black Laminate)	£5495	£4125
DENON AVR-2801 AV Receiver	£549	£POA	PAPWORTH TVA50	£2700	£1548	WILSON Cub speakers (Gloss)	£6890	£4995
DUNTECH PLC500 Speakers	£5250	£3250	PATHOS Classic One	£995	£846	WILSON Maxx	£38998	£24996
EPOS ES22	£1350	£896	PATHOS Twin Towers Integrated	£3250	£2647	WILSON Witt 1	£8887	£4996
FINAL 0.3 (Alum)	£1495	£1297	PIONEER VSA-E08 (AV Amp)	£1599	£1246	Z SYSTEMS Digital Pre-amp	£5449	£3999
GOLDMUND Mimesis 6 Amp	£2900	£2029	PIONEER SD-T5000 (4.3) 50" TV	£3999	£1496			
GOLDMUND Mimesis 6b Pre-amp	£3124	£1796	PRIMARE A30.5	£1699	£1246			
GOLDMUND Mimesis 4 Tuner	£6100	£3900	PRIMARE P30 Processor	£1999	£1596			
GRAAF Venticinque	£1795	£1297	PRIMARE V.20 (Multi)	£1000	£846			
GRAAF Venticinque Power	£1395	£997	PS AUDIO Digilink 1	£995	£595			
GRAAF VT5.35.5 5 Ch Pwr	£2620	£1797	PS AUDIO Digilink 2	£995	£595			
GRAAF 5050	£1995	£1197	PS AUDIO Reference Link	£4549	£3189			
GRAAF GM20	£2950	£2147	PS AUDIO D/A Converter	£2590	£1790			

**NEW WEB SITE
UP-DATED DAILY**
hifitradingstation.com

Let us help you get the
BEST PRICE
for your unwanted hi-fi

Find out about
COMMISSION SALES

**NEXT DAY DELIVERY
ON CREDIT/DEBIT CARD
PURCHASES**

COMPETITIVE FINANCE TERMS*
ARRANGED IN STORE *Subject to status

The Hi-Fi Company's
**Trading
Station**

35 Cowgate
Peterborough PE1 1LZ

World Radio History

PHONE
(01733) 555514

FAX:
(01733) 315079

email:
audiotrader@talk21.com

SHOP HOURS:
**TUES - SAT: 10am - 5.30pm
CLOSED ALL DAY MONDAY**

S/hand and ex-demo clearance items - April 2002

	Was	Now
CD players DACs & Transports		
Accuphase DP75V 24/192 CD Player S/H	7500	6499
Advantage S1 Re-sampling CD Player 3 months old S/H	3750	2500
Dcs Elgar 24/192 DAC S/H	8500	5999
Dcs Purcell 24/192 Upsampler S/H	3500	2299
Roksan DA2 DAC S/H	599	299
Roksan DS5 PSU S/H	579	325
Sony SACD1 S/H	4000	2795
Sony 555ES SACD Ex-Demo	1200	899
Teac P700 Transport S/H	1099	699
Teac VRDS25 CD Player S/H	1200	649

	Was	Now
Turntables Tonearms & Cartridges		
Audio Note IO Kondo Built S/H	2500	749
Audio Note AN-S2 Transformer S/H	450	279
Basis 1400/RB250 (New & Boxed)	1300	899
Basis 2000 Turntable Ex-Demo	1999	1399
Basis 2001 Turntable Ex-Demo	2999	2399
Basis 2004 Turntable Ex-Demo	4500	2999
Conrad Johnson EV-1 Phono Stage Ex-Demo	1499	1349
Kuzma Stogi/Stabi S Turntable (New & Boxed)	1299	1099
Linn LP12 Afrosmosia S/H	N/A	250
Linn Lingo S/H	750	425
Linn Ekos Mk1 Tonearm Boxed S/H	1500	750
Unison Research Simply Phono S/H	495	325
Roksan DS1.5 PSU Ex-Demo	695	499
Roksan Radius/Tabrizi	1150	599

	Was	Now
Preamplifiers		
Audio Note M Zero R Ex Demo	599	449
Audio Note M Zero S/H	449	275
Audio Note M1 Phono Preamplifier S/H	750	449
Conrad Johnson Premier 14 Ex-Demo	1999	1750
Conrad Johnson Premier 17LS Ex-Demo	4500	3999
DNM Primus preamplifier Ex-demo	2100	1799
Krell KAV-S Processor/Preamplifier DTS/AC3/Pro Logic S/H	14989	5499
Mark Levinson No 25S Phono Stage S/H	5999	2999
Roksan L1.5 Reference Line Preamplifier S/H	2250	1395

	Was	Now
Amplifiers		
Accuphase E307v Integrated Amplifier New	3295	2799
Accuphase E211v Integrated Amplifier New	1995	1499
Conrad Johnson MV 55 Valve Power Amplifier S/H	1995	1099
Bow Technologies Wazoo XL Amplifier (New&Boxed)	2495	1950
Conrad Johnson Premier 11 Power Amplifier (New&Boxed)	3695	2799
Densen Beat 300 power Amplifier Ex-demo	795	599
DNM 3C Power amplifier Ex-Demo	1900	1499
Electrocompaniet AW60 (New&Boxed)	999	699
Roksan Rok S1.5 Power Amplifier S/H	1499	995
Unison Simply 4 Valve Integrated Ex-Demo	1600	999

	Was	Now
Loudspeakers		
Audio Note AN-J D Blk S/H	985	499
Audio Note AN- JStands S/H	300	175
Boston Acoustics VR 10 Centre Channel (New&Boxed)	250	175
Audio Physic Virgo 2 Birds eye maple Ex-Demo	3250	2499
Boston Acoustic Lynfield Monitors inc Stands S/H	2000	995
Roksan Ojan 3X Rosewood S/H	1299	699

Midland Audio X-change is looking for good used British & American Hi-Fi
cash paid call John Roberts on 01562 822236

	Was	Now
Loudspeakers (con't)		
Robertson Audio DX7 Cherry Ex-Demo	995	599
Totem Tabu Mahogany Ex-Demo	2300	1599
Totem Arro MKII Cherry New& Boxed	1095	849
VelodyneTX810MK2 Subwoofer S/H	695	349

	Was	Now
Cables & Accessories		
Audio Note AN-V 1m Silver interconnect S/H	420	199
Audiophile Systems BASE Platform S/H	70	25
Bow Technologies Wand Remote (New&Boxed)	349	199
Cardas Quadlink 5C 1mRCA S/H	240	150
Kimber Select 1020 0.5m S/H	1098	499
Goertz MI-2 2x6mCopper Ribbon Speaker S/H	650	399
Naim Audio2x5m Speaker cables white S/H	N/A	45
Roksan HA01 1M Interconnect S/H	99	49
Opera Lux 3 Tier Table Clear/Stainless Ex-Demo	950	499
QED Genesis Silver Spiral 2X 3 M S/HH	395	199
Sound Style 4 Tier in Green S/H	325	159
Tara Labs RSC Air 1m AES/EBU 110 ohm Digital New	450	299
Tara Labs RSC Air 1m RCA 75 ohm Digital New	345	199
Tara Labs "The One" 1m Balanced New	2175	1499
Tara Labs "Floating GroundStation" New	775	499
Transparent The Wave 2X7m S/H	599	299

	Was	Now
Tuners & Tape Decks		
Audiolab 8000T Tuner S/H	850	499
Magnum Dynalab FT-R Remote Switcher for FT101A/Etude (New&Boxed)	450	299
Nakamichi DR8 Cassette deck (New&Boxed)	499	299
Nakamichi DR10 Cassette deck Ex-Demo	699	399
Teac T/BX10 Tuner S/H	399	179

Midland Audio X-change are looking for Audio Research, Krell, Mark Levinson, Naim Audio, Theta, Wadia, cash paid call John Roberts on 01562 822236 now!

- Suppliers and installers of High Quality Audio Systems :
- 47 Laboratory : Graff
 - Accuphase : Gryphon
 - Audio Note : Lavardin
 - Audio Research : Mark Levinson
 - Avid : Martin Logan
 - Basis : Michell
 - Cabasse : Nagra
 - Cardas : Primare
 - Clearaudio : ProAc
 - Conrad Johnston : Rega
 - Copland : Resolution Audio
 - Dcs : Sonus Faber
 - DNM / Reson : Spectral
 - Einstein : SPM
 - Electrocompaniet : Sugden
 - Final : UKD
 - Finite Elemente :

www.midlandaudiox-change.co.uk

call John Roberts Tel / Fax 01562 822236

181 Franche Rd • Kidderminster • Worcs • DY11 5AD

e-mail sales@midlandaudiox-change.co.uk

Mobile 07721 605966

WILLIAMS HART ELECTRONICS

HART ELECTRONIC KITS TRAD D FOR OVER 30 YEARS



NEW LAYOUT

80Watt Mosfet Stereo Power Amp Kit
110Watt Mosfet Monoblock Power Amp Kits

ONE OF THE BEST AMPLIFIERS YOU WILL HEAR! Regardless of price
ON DEMO @ Wigan, Southend, Peterborough and Burnley



Single Ended Class A Valve Sound
15Watt Power Amp modules
FOR THOSE WHO WANT THAT VALVE
MIDBAND BUT BASS AND TREBLE TO MATCH



ACTIVE RC control SUBWOOFER MODULE £175.00

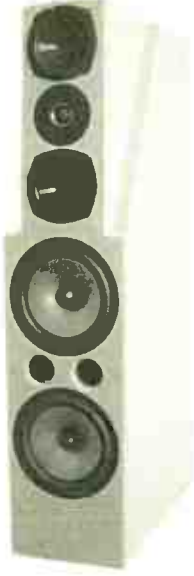

Range of speaker Kits
Passive and Active

Advertise your Hi-Fi on my website (FREE)

Also Award Winning Phono Stage Kit, Active Crossover Modules, Speaker Drive Units,
M Cap Capacitors, Caddick Restorers, Remote Control Volume and much more!

WEB SITE www.williamshart.com

e-mail: williamshart@classifm.net

or Tel/Fax for catalogue 01942 25364

PERSONAL VISITORS SHOULD PHONE FIRST TO AVOID DISAPPOINTMENT

Run by former Technical Director of Wilmslow Audio



X electrical

We buy, sell & part exchange quality Hi-fi

AMPLIFIERS / RECEIVERS

Tandberg Haldra 8 valve	£195
Magnum MF160 pre amp (chrome)	£225
Technics SEA 808/ST808 pre power	£95
Audiolab 8000A	£245
Denon PMA 1500R	£250
Sony TA9000ES 6ch receiver	£545
Musical Fidelity 3A pre amp	£130
Cyrus 3 + PSD	£475
Nad 319	£375
Nad 3130	£95
Linn LK1/2 pre power	£425
Arcam Alpha 10 integrated amp	£445
Arcam Alpha 5	£125
Creek 4040	£60
Marantz PM66SE	£125
Cyrus One	£120
Quantum Pre Power a	£180
Rogers cadet 3	£145
Alchemist Nexus	£375
Yamaha MX 830 power amp	£295
QED A240	£90
Marantz 1550L revr	£125
Pioneer DS080 revr	£145
Sony TAPE 330R	£95
Pye Mozart dual valve monoblocks	£345
Technics SUA700 #2	£120

CD PLAYERS & MINI DISCS

Audio Alchemy DDS11	£245
Sony MDSJA30ES	£325
Audiolab 8000CD	£525
Thorens TDA2000DAC	£325
Arcam Alpha BSE	£325
Arcam Alpha 5+	£195
Arcam Delta 70	£115
Sony CDP228ES	£95
Philips CDRT70	£140
Many portable mini discs in stock	
Arcam Alpha 7	£145
Arcam Delta 80	£95
Sony STS8920	£125
Nad 4130	£80
Denon TU260L	£70
Musical Fidelity TI	£115
Marantz 450L	£50
Systemdek 1	£175
Technics SL1200 as new	£320
Thorens TD 3001	£295

SPEAKERS

Castle Chesters	£275
Mission 752s	£260
B&O RL140	£245
Audi Physics 'the step'	£525
Bose 901/VI	£645
JBL XPL 90	£400
Heybrook Haystacks	£225
Monitor Audio R353	£95
Celestion DL8s	£75
Rogers LS55	£275
Canon S75	£395
Bose 305	£275
CASSETTES	
Teac V3000	£145
Yamaha KXS80S	£110
Wakamichi CR2E	£160
Wakamichi S80M	£165
Wakamichi BX1	£150
Pioneer CT91A	£175
EQ3	
ADC Soundshaper 2	£225
Technics SHGE90	£170

Please call us if you have any equipment to sell or are looking for anything in particular. New stock daily
All equipment is fully tested and guaranteed

Also: Music CDs, Games, Musical Equipment, Computers, TV, VCR& Photographic

Web page: www.xelectrical.com

email: x@xelectrical.com

125 King Street Hammersmith
4 Station Bldgs Fife Road Kingston
Games & CDs upstairs at Kingston
43 Church Street Croydon

020 - 8563 7383
020 - 8546 1233
020 - 8546 4442
020 - 8680 0007

MUSICAL IMAGES

PRODUCT	HOUNSLOW	LIST	NOW
ACOUSTIC ENERGY AE 120SE Speakers	EX/DEMO	£600	£375
ACOUSTIC ENERGY AE 509 Speakers	EX/DEMO	£850	£425
DENON AVC-A1D Gold AV Amp	EX/DEMO	£2,000	£1,300
QED ARIAS Silver Speakers	EX/DEMO	£200	£100
SONY CDPXB930E QS CD Player	EX/DEMO	£300	£250
SONY MDSJB940 Black or Silver Mini-Disc Player	EX/DEMO	£330	£250
SONY STS3000ES Gold ES Tuner	EX/DEMO	£250	£150
YAMAHA CDX-496 CD Player	EX/DEMO	£180	£130

PRODUCT	EDGWARE	LIST	NOW
DENON DVD3300 Black or Gold DVD Player	EX/DEMO	£650	£550
DENON DVD5000 Gold DVD Player	EX/DEMO	£1,600	£600
JAMO CONCERT 11 American Cherry Speakers	EX/DEMO	£2,300	£1,200
KEF TDM45 Subwoofer	S/H	£800	£550
MARANTZ DR6000 CD Recorder	EX/DEMO	£400	£300
MARANTZ PM17 Gold Amp	EX/DEMO	£1,000	£600
SONY DVPS435 Silver DVD Player	EX/DEMO	£300	£175
SONY MDSJB940 Black or Silver Mini-Disc Player	EX/DEMO	£330	£250

PRODUCT	COVENT GARDEN	LIST	NOW
DENON AVR3300 AV Receiver	EX/DEMO	£800	£475
DENON DVD3300 Black DVD Player	EX/DEMO	£650	£550
MUSICAL FIDELITY XDACHDCD DAC	EX/DEMO	£300	£150
MUSICAL FIDELITY XP100 Pre AMP	EX/DEMO	£800	£640
PRO-AC RESPONSE 3.8 Cherry Speakers	EX/DEMO	£3,990	£2,800
ROKSAN CASPIAN DSP DSP Processor	EX/DEMO	£1,295	£100
SONY SCD-XB940 Silver Super Audio CD Player	EX/DEMO	£550	£325
THORENS TD166 MK6 Turntable, Arm & Cartridge	S/H	£500	£350

PRODUCT	BECKENHAM	LIST	NOW
CHORD DSC1100 Silver DAC inc Trigger	EX/DEMO	£2,815	£2,300
DENON DVD3300 Black or Gold DVD Player	EX/DEMO	£650	£550
MUSICAL FIDELITY XA-1 Amp	EX/DEMO	£480	£350
PIONEER DV 530 DVD Player	EX/DEMO	£230	£150
SONY DVPS9000ES DVD Player	EX/DEMO	£1,300	£1,000
SONY MDSJB940 Black or Silver Mini-Disc Player	EX/DEMO	£330	£250
YAMAHA DSP-AX1 Black AV Amp	EX/DEMO	£2,000	£900

ALL BRANCHES KEF REFERENCE SPEAKERS SPECIAL OFFER

MODEL 1-2 Black/Cherry/Rosenut/Rosetta Burr	NEW	£1,350	£1,000
MODEL 2-2 Black	NEW	£1,750	£1,400
MODEL 3-2 Black/Albina Burr/Classic Rosewood	NEW	£2,750	£2,000
MODEL 4-2 Black/Cherry/Rosetta Burr	NEW	£3,650	£2,800

PLEASE VISIT OUR SHOWROOMS
OR CALL OUR HOTLINE
NUMBER FOR DETAILS. HURRY, MANY ARE
ONE-OFF ITEMS!!

SEE IT! HEAR IT! BUY IT!

Beckenham
126 High Street
Beckenham, Kent
BR3 1EB
Tel: 020 8663 3777
Fax: 020 8663 3555

Covent Garden
18 Monmouth Street
Covent Garden
London, WC2H 9HB
Tel: 020 7497 1346
Fax: 020 7497 9205

Edgware
173 Station Road
Edgware, Middlesex
HA8 7JX
Tel: 020 8952 5535
Fax: 020 8951 5864

Houslow
45 High Street
Houslow, Middlesex
TW3 1RH
Tel: 020 8569 5802
Fax: 020 8569 6353

E-Mail: sales@musical-images.co.uk

NOT VALID WITH ANY OTHER OFFERS OR PROMOTIONS E.A.O.F

HICAM

**CHERISHED PRE-OWNED HI-FI EQUIPMENT SOLD, PURCHASED, P/X. CASH WAITING FOR THE FOLLOWING BRANDS
NAIM, MERIDIAN, AUDIOLAB, KRELL, WADIA, SONUS FABER,
MARTIN LOGAN MARK LEVINSON, COPLAND, QUAD**

	WAS	NOW	PRECIOUS METALS GAMMA 1 METRE INTERCONNECT NEW	60	50
ALCHEMIST NEXUS APO32A 24 BIT			PRECIOUS METALS SILVER SIGNAL 202B		
CD PLAYER NEW	599	325	BALANCED NEW	500	425
AUDIOLAB 8000 DAX 24BIT DAC	1100	525	PRECIOUS METALS SILVER SIGNAL 204 INTERCONNECT 1		
ALPHASON AKROS 2 SPEAKER STANDS BOXED	60	30	METRE	490	425
ATACAMA SE 24 SPEAKER STANDS NEW	75	65	NAIM INTRQ LOUDSPEAKERS BLACK BOXED	695	425
AUDIONOTE OTO INT AMP LINE LEVEL AS NEW	999	850	AUDIONOTE AN CD 2 1X INT CD PLAYER AS NEW	999	895
LYRA HELIKON SL MC CARTRIDGE NEW	1249		LINN CLASSIK DVD/TUNER/AMP BLACK AS NEW 1995	1895	
EAR HEADPHONE AMP HP4 AS NEW	1695	1500	PSB ALPHA 6 ACTIVE SUBWOOFER AS NEW	500	325
AV1 S2000 MM MONOBLOCKS NEW	1225		ELAC CL 330 JET INC STANDS NEW	2499	
AV1 S2000MT11 AM/FM REFERENCE TUNER NEW	899	800	RUARK CL10 CHERRY FINISH (NEW)		
AVI PRO NINE SPK NEW	699	625	SLIGHT MARK	900	625
AVI S2000MC REFERENCE 24/96 CD			AUDIONOTE ANTT THREE SUPER TURN TABLE	2450	2250
PLAYER 2 WEEKS OLD	999	895	RUARK PROLOGUE CHERRY (NEW) SLIGHT MARK	995	625
AUDIOQUEST INDIGO 1X2 METRE PAIR	90	45	PASS LABS LS3 POWER AMP CLASS A	2600	1600
AUDUSA EUPEN POWER CABLES FULL RANGE	POA		STAX SRS 4040 SYSTEM SIGNATURE 2 NEW	1195	
AUDIOLAB 8000 DAX 24 BIT DAC/BOXED	1100	525	SOMETEER BYRON CD PAYER AS NEW	795	525
EARV 20 INTERGRATED CLASS A NEW	2798	POA	SOMETEER CAMPION INT AMP AS NEW	599	425
RUARK 100 VITA ACTIVE SUB BOXED/AS NEW	550	425	AUDIONOTE ANS1 CARTRIDGE TRANSFORMER	400	195
AUDIONOTE OTO PHONO INT AMP 1 MONTH OLD	1300	1100	SME 300/312 ARM/BOXED MINT	1000	575
AUDIONOTE DAC 2 1X 24/96 AS NEW	1149	975	TRICHORD DINO PSU NEW	225	
EAR 861 POWER AMP CLASS A 1 MONTH OLD	3599	2995	SONICLINK AST200 BIWIRE SPK CABLE NEW	10	8
OALI ROYAL MENUET MK2 CHERRY FINISH NEW	400	250	SONICLINK THE BASE 1 METRE PAIR		
EAR BL6 INTERGRATED/PRE/MAIN AMP NEW	2298	POA	INTERCONNECT NEW	25	18
EAR 834P CHROME DELUXE MM/MC PHONO			SONICLINK THE REBEL SPK CABLE NEW	7.56 PER METRE	
AS NEW	778	695	SONICLINK 8 WAY DISTRIBUTION BLOCK 2 METRE CABLE		
EAR 834P MM/MC PHONO STAGE	549	475	NEW	299	250
EAR MC3 MC TRANSFORMER 1 MONTH OLD	658	595	SONICLINK SIMPLICITY 1 METRE PAIR		
EAR 834 INT AMP NEW	2198	POA	INTERCONNECT NEW	35	27
HEYBROOK QUARTET ROSEWOOD FINISH	595	225	SONICLINK VIOLET 1 METRE PAIR		
AUDIONOTE A2 TWO LOUDSPEAKERS S3 DB MINT	599	500	INTERCONNECT NEW	85	40
LAT SS800 SPEAKER CABLE 5MTR NEW	206	175	SONICLINK VIOLET INTERCONNECT (OFF THE REEL)		
LAT 8 WAY DISTRIBUTION BLOCK 3 FT NEW	226	195		15 PER METRE	
LAT AC2 6 WAY DISTRIBUTION BLOCK 3 FT NEW	195	160	STAX SRS 2020 MK2 EARSPEAKERS MINT	449	375
LAT AC2 POWER CABLE 3 FT NEW	68	63	AUDIONOTE MS LINE LEVEL PRE AMP		
LAT IC100 MK2 1 METRE BOXED NEW	105	90	MINT NEW	4650	POA
SONICLINK 8 DISTRIBUTION BLOCK NEW	399	250	QUAD 306 POWER AMP X2	325	EACH
AUDIONOTE ZERO TRANSPORT/DAC	1048	925	SUMIKO PEARL MM CARTRIDGE NEW	79	
MERIDIAN DSP 5500 24/96 SPEAKERS	7000	4200	SUMIKO BLUE POINT SPECIAL MC NEW	279	249
MERIDIAN D500 CONVERTED TO M60 ACTIVE	2000	995	AUDIONOTE ANXK 1 METRE PAIR NEVER USED	574	495
MERIDIAN 565 AV PROCESSOR DTS.7 1 ETC	2800	1495	TALK ELECTRONIC THUNDER 1 CO PLAYER		
EXSPOSURE XV11 AMP BOXED MM PHONO STAGE 1000 550			TARGET MX100 SPEAKER STANDS PIANO BLACK		
LYRA LYDIAN BETA MC CARTRIDGE NOT USED	599	525	TRICHORD PSU FOR DINO PHONO STAGE NEW	225	
MUSIC FIDELITY X AI INTERGRATED AMP	490	295	TOM EVANS MICROGROOVE MM PHONO STAGE	400	225
MERIDIAN DSP 5000C 24/96 CENTRE SPEAKER	1995	1095	TRICHORD RESEARCH 500 POWERBLOCK	299	275
MICHELL LARGE PSU NEW	399	399	TRICHORD RESEARCH DINO M/M/MC PHONO STAGE NEW	299	
MICHELL ALECTO MONOBLOCKS AS NEW	1989	1800	QED FULL RANGE	POA	
MICHELL GYRO SE/RB300 ARM	1017	POA	VDH INTERGRATION 1 METRE PAIR BOXED	300	250
MICHELL ORBE SEALED BOX	2095	1895	SOUND ORGANISATION FULL RANGE	POA	
MICHELL ORCA PRE AMP	1251	1095	VDH MC 10 MC CARTRIDGE NEVER USED	700	600
MYRYAD MT 100 FM TUNER NEW	599	95	MYRYAD MD 600 CD PLAYER NEW	1299	
MICHELL GYRODECK /RB 300 ARM AS NEW	1190	1095	AUDIONOTE ANCO 3 1X CD PLAYER NEW	1499	
NAIM 62/90 OLD STYLE AMPS	250		VDH FIRST ULTIMATE 0.6 METRE NEW	220	190
STAX OMEGA REFERENCE SR 007/SRM 717			VDH THE SOURCE HB 0.8 METRE NEW	65	57.5
TUBE ENERGISER	2795				

AGENTS FOR, EAR, TRICHORD, AUDIONOTE, MICHELL, MYRYAD, AVI, STAX, LAT, VDH, ELAC, RUARK, SME, BLACK RHODIUM, LYRA, SUMIKO, QED

**OPEN MON-SUN 10AM-6PM
FOR FURTHER DETAILS: TEL 01726 74474 / FAX 01726 70387
MOBILE: 07973 233 380
E-MAIL HICAM1@FREENETNAME.CO.UK
OR VISIT OUR WEBPAGE HICAM.CO.UK**



THE AUDIO ROOM EX-DEMONSTRATION AND USED ITEMS

Compact Disc Players	Was £	Now £
Linn Sondek CD12	12,000	9,999
Linn Genki (Silver)	1,030	830
Rega Jupiter (Black)	998	850
Sugden Masterclass now in stock		
Sugden CD Master now in stock		

Amplifiers

Audiolab 8000A	s/h	275
Cyrus IIII	s/h	295
Linn LK85 (Silver)	530	430
Linn Kolektor (Silver)	530	430
Linn AV5125 (Silver)	1,785	1,500
Rega Brio (Black)	298	248
Rega Cursa (Black)	498	398
Rega Maia (Black)	498	398
Sugden Masterclass (Intergrated) now in stock		

Speakers

B&W CDM 9 NT (Cherry)	1,800	1,000
B&W CDM C NT (Black)	400	240
B&W CDM S NT (Cherry)	750	450
B&W CM 4 (Maple)	895	695
B&W CM C (Maple) and (Rosewood)	350	250
Meridian M60 Active (Rosewood)	s/h	695
PMC FB 1 (Oak)	1,410	1,200
Rega Jura (Light Oak)	498	398

Other items

B&W ASW 2500 Subwoofer (Black)	895	695
Linn Pekin Tuner (Silver)	530	400
Rega Radio (Black)	374	300

**2 George Street, Hedon, Hull, HU12 8JH T: 01482 891375
E:hifi@audiroom.karoo.co.uk F: 01482 896804**

Advanced high speed, ultra-low noise discrete regulators.

Replaces standard voltage regulators in CD/DVD and SACD players providing improved low level information, sound stage and musicality.

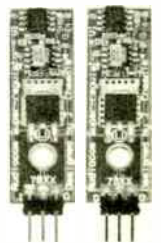

Super regulator



audiocom-uk.com
01646 685601

AD825 Op-Amp Module

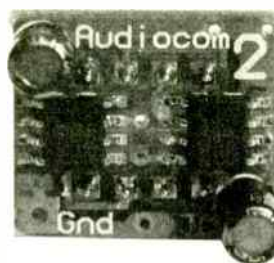

Op-amps used in CD players are generally of poor quality, corrupting the analogue signal. AD825 is a high performance drop-in replacement board providing a more natural and musical sound, with greater dynamics, detail and transparency.

We are best known for our single-ended 300B power amplifiers and power supply upgrades for valve amplifiers, but did you know that we supply complete systems, new and used equipment, and components? We also provide support and servicing for Audio Innovations valve products. For full information visit www.borderpatrol.net or ring 01273 276716.

passion, grace & fire

www.borderpatrol.net

Selected products from:

BorderPatrol • Living Voice • SME • Audio Note • Cartridge Man • Goldring
Western Electric • Electrofluidics

BorderPatrol Brighton UK
Tel/Fax +44 (0)1273 276716
e-mail: bp@borderpatrol.net
www.borderpatrol.net



BorderPatrol



MUSONIC STYLI

**SPECIALIST MANUFACTURER &
SUPPLIER FOR MORE THAN 40 YEARS**

REPLACEMENTS & ORIGINALS

MANY OBSOLETE/78 VERSIONS

PICK-UP CARTRIDGES

RECORD/TAPE/CD ACCESSORIES

**WHY NOT TRY US AND HEAR THE
DIFFERENCE !!**

NAGAOKA CARTRIDGES NOW IN STOCK

For further information tel/fax/e-mail to:-

MUSONIC (UK) LIMITED
Unit 13 Wenta Business Centre Colne Way
Watford Hertfordshire WD24 7ND

Tel: 01923 213344 Fax: 01923 213355
E-mail: sales@musonic.co.uk

VISIT OUR NEW WEBSITE
www.musonic.co.uk

Trade and Export enquiries welcome



PROGRESSIVE AUDIO



2 Maryland Court, Rainham, Kent, ME8 8QY
Telephone / Fax No. 01634 389004

WEBSITE: www.progressiveaudio.co.uk E-MAIL: dave@progressiveaudio.co.uk

We have the following ex demonstration and part exchange items for sale:

- DNM Series 3 Start pre amp. £550. S/H.
- MUSICAL FIDELITY X-Ray CD Player. As new. £525. S/H.
- LINN Tukan loudspeakers. black. Mint. £325. S/H.
- TSUNAMI TS300 active subwoofer. Rosewood. Mint. £150. S/H.
- MICHELL Gyro SE/RB300/Denon DL304/QC power supply. Mint. £1150. S/H.
- SUMIKO Celebration Pearwood Signature m/c cartridge. 10 hours dem use only. £800.
- IMPULSE H2 horn loudspeakers. Mahogany. Slightly tatty cloth. £950. S/H.
- SILTECH SL 2.60 speaker cabel. 2.75m single wire set. £550. S/H.
- AUDIOMECA Mephisto CD transport. Mint. Boxed. £1050. S/H.
- SUGDEN AU51 DAC. Mint. Boxed. £695. S/H.
- ILLUMINATI D-60 Digital interconnect cable. 0.5m. £120. S/H.
- ANTHEM (by Sonic Frontiers) amp 2 (silver) Mint £1200 S/H.
- DNM series 3 pre amp with twin power supply £750 S/H
- PROJECT perspective turntable £650 Ex Dem
- PROAC Response 1 SC loudspeakers. Black. With Target R stands.
Mint. Boxed. £1050. S/H.
- THETA D5 pro progeny DAC. Mint £850 S/H
- LFD LS1 Line stage. £525. S/H
- REGA Jupiter /lo CD Transport and DAC with digital interconnect. £795. S/H.
- VERITAS H3 Horns. Piano black. As new. £4600. X/D.
- VERITAS 20'S. Piano Black. With stands. As new. £1250. X/D.
- BLACK Rhodium interconnect. 1.5m. Boxed as new. £795. S/H.
- ALON Petite loudspeakers. Walnut. As new. Boxed. £850. X/D.
- ALON 1 loudspeakers. Walnut. Excellent condition. Boxed. £795. X/D.
- PRIMARE D30.2 CD player. £995. S/H
- MICHELL Argo HR Line pre amp. With Hera P/S. £650. X/D.
- MICHELL Iso HR phono stage. With Hera P/S. Excellent condition. £495. S/H.
- ACOUSTIC SOLUTIONS "Eight" loudspeakers. Oak. As new. With stands. £1200. X/D.
- LINN Kaber loudspeakers with stone stands. £825. S/H.
- JEFF ROWLAND Model 2 power amp with BPS 2 battery power supply plus SYNERGY 11 pre amp. £6000. S/H.
- AUDIONOTE AN-KSp speakers (Oak) with matching Audionote stands. £725. S/H.
- CASTLE Harlech speakers (Natural Oak) Mint. Boxed. £525. S/H.
- QUAD 989 loudspeakers. Ex Dem. little use. £4000.
- MERIDIAN 500 transport/563 DAC £1500. S/H

**NOW ON PERMANENT DEMONSTRATION THE SUGDEN
MASTERCLASS INTEGRATED AMP AND CD PLAYER,
RED ROSE ROSETTA AND ROSEBUDS, MOON
ELECTRONICS, VELODYNE SUBWOOFERS, WADIA CD
PLAYERS, AUDIO ANALOGUE MAESTRO CD PLAYER
AND AMP MUSICAL FIDELITY 3D CD PLAYER, LIVING
VOICE AND AUDIO PHYSICS LOUDSPEAKERS, AVID
TURNTABLES AND CHAPTER AUDIO POWER AMP**

Oxford Audio Consultants Ltd.

OUR SUPERB SERVICE IS THE SAME REGARDLESS OF PRICE



Now Demonstrating



Ex-Demonstration & Previously Owned Equipment

SALE LIST - February 2002

VERITAS P400 POWER AMPLIFIER EX DEM	£2500	XD
CASTLE SEVERN 2 MAHOAGANY	£395	SH
KRELL AVS-FULLY LOADED	£3495	SH
KRELL FPB200C POWER AMPLIFIER EX DEM	£7995	XD
KRELL FPB300C POWER AMPLIFIER - OUR DEM MODEL	£9995	XD
SME 309 ARM AS NEW	£625	SH
SONUS FABER MUSICA AMPLIFIER EX DEM	£1495	XD
SONUS FABER CONCERTINOS HOME AS NEW WALNUT	£529	SH
NAIM 02 TUNER	£750	SH
NAIM 102 PREAMP	£695	SH
NAIM 180 POWER AMP	£695	SH
NAIM AUDIO 140	£395	SH
NAIM SBL SPEAKERS ACTIVE upgraded bass drivers with NAXO	£795	SH
NAIM 90.3 POWER AMP	£350	SH
MARANTZ CD17 KI SIGNATURE	£795	SH
NORDOST QUATROFIL 0.6M BAL PR INTERCONNECTS	£895	SH
NORDOST SOLAR WIND INTERCONNECTS	£50	PR
TRANSPARENT MUSIC LINK BAL IM	£195	SH
TRANSPARENT PDL IM DIGITAL	£150	SH
CHORD CPA3200 PREAMPLIFIER	£2695	SH
CHORD SPM1200C POWER AMPLIFIER	£2795	SH
COPLAND CSA 8 AMPLIFIER	£699	XD
COPLAND CSA28 DEMO MODEL	£1095	XD
DYNAUDIO CONTOUR 3.0 ROSEWOOD AS NEW	£1995	SH
AUDIO ANALOGUE BELLINI PREAMP SILVER	£325	SH
LINN LP12/LVX	£295	SH
KRELL KPS30i	£2350	SH
KRELL KAV300CD AS NEW	£2795	SH
KRELL 250P PREAMPLIFIER	£1795	XD
KRELL 300CD	£2295	SH
KRELL KAV300CD CD PLAYER	£1995	SH
KRELL 300i AMPLIFIER	£1795	SH
AUDIO RESEARCH LS9 PREAMPLIFIER	£995	SH
AUDIO RESEARCH D130 POWER AMPLIFIER EX DEM	£1295	XD
AUDIO RESEARCH D100.2	£2995	XD
THE TA PROGENY	£595	SH
LOEWE PLANUS 32" WITH CABINET ARCTIC EX DEM	£1295	XD
PATHOS ACOUSTICS TWIN TOWERS AMPLIFIER	£2295	SH

SH - Second Hand XD - EX Demonstration

0% interest free credit

Licensed Credit Broker

REFER TO OUR WEBSITE FOR THE LATEST UPDATED SALE LIST.

Agencies include Acoustic Energy, Alphason, Alpacana, Audio Analogues, Audio Research, Beyer, BOSE, Castle, Chord Company, Copland, Crestion, Denon, Diapason, Dwin Electronics, Eireann, Fujitsu, GM Audio, Goldring, Graaf, Integra Systems, IXOS, Jadia, Jamo, Kel, Koelsch, Krell, Levinson, Loewe, TV Video, Linn, Classic, Lyra, Marantz, Martin Logan, Michell, MRS, Multiroom Systems, Musical Fidelity, NAD, Naim, NEC, Gas Plasma Screens, Nakamichi, Nordost, Onkyo, Opera, Ortofon, Parasound, Pioneer, ProAc, Project, Turntables, QED Multiroom, Quad, Quadraspire, REL Subwoofers, Rotel, Sennheiser, Sharp, LCD TVs, SME, Sonus Faber, Sonus Systems, SoundStyle, Standeesign, Stands Unique, Stax, Stewart Screens, Tag McLaren, Tannoy, Teac, Theta, Transparent Systems, Van den Hul, Vibe Acoustics subwoofers, VideoLogic, Vienna Acoustics, Wilson, Yamaha

TAX-FREE EXPORT SERVICE
MAIL-ORDER AVAILABLE ON MANY ITEMS

Cantay House Park End Street
Oxford OX1 1JD

Telephone: Oxford (01865) 790879

Facsimile: Oxford (01865) 791665

E-MAIL: Oxford.Audio@btinternet.com

WEBSITE: www.oxfordaudio.co.uk



V.A.T. No.
729580013



QUALITY USED
EQUIPMENT,
BOUGHT, SOLD,
PART EXCHANGE

TEL/FAX
0121 747 4246



URGENTLY REQUIRED
LINN, NAIM,
MERIDIAN, QUAD,
CASH WAITING

	RRP	NOW £
ACCUPHASE DP70V DIGITAL VOLUME	5500	1995
ATR AUDIO QUINTET VALVE POWER	1800	695
AUDIO INNOVATIONS 2ND AUDIO'S SERIES 11	4000	1395
AUDIO LAB 8000C	N/A	150
AVI S2000 PRE	900	395
BALANCED AUDIO TECHNOLOGIES VK20 PHONO REMOTE	4000	1095
BALANCED AUDIO TECHNOLOGIES VK30SE REMOTE	4000	2495
BALANCED AUDIO TECHNOLOGIES VK60 POWER	4600	2750
BASIS 1400 REGA RB300	1300	695
BRYSTON 4B ST 6 MTHS OLD 20 YEAR WTEE	2050	1395
BOW TECHNOLOGIES WAZOO XL INTEGRATED AMP	2500	1395
CAL DX-2 CD EX DEM	650	250
CAL ICON MK 11 CD EX DEM	1100	395
CAL ALPHA 20 BIT DAC VALVE EX DEM	1495	595
CAL SIGMA DAC VALVE EX DEM	1100	395
CARY SLP-50 VALVE PRE	1400	450
CHARIO SYNTAR 100 TOWER BLACK	450	250
COPLAND CTA 505 POWER AMP	1900	895
COUTERPOINT BIJOU-MYSTIC-ORPHEUM 5 SPEAKER SYSTEM	1500	295
DENSEN DP DRIVE PHONO STAGE	350	195
DYNAUDIO 1.3 MK11 CHERRY + MASTER STANDS 6 MTHS OLD	1300	795
EAR 834L PRE	550	295
GOLDEN TUBE AUDIO SEP-1 VALVE PRE BALANCED PHONO	1500	795
JM LABS MINI UTOPIA + STANDS	5250	3295
KRELL DSP CD MK11	5000	1795
LINN TROIKA NEEDS REBUILD	N/A	150
LINN LP 12 ITTOK LINGO BLACK	N/A	695
LINN LINTO	850	495
MAGNUM DYNALAB MD10 VIRTUAL DECODER EX DEM	700	295
MAGNUM DYNALAB SIGNAL SLEUTH EX DEM	350	195
MARANTZ CD7	3500	2795
MARANTZ ST 17 TUNER	600	395
MARTIN LOGAN QUESTS OAK	5500	1795
MARTIN LOGAN AEON NEW	3300	2295
MICHELL ORBE SME 309 ORTOFON MC20 SUPER	3100	1795
MICHELL ORBE SME V LYRA CLAVIS VERY LOW HOURS	4500	2195
MICHELL ARGO + HERA	N/A	395
MONITOR AUDIO STUDIO 5 BLACK ASH	700	350
MUSE MODEL 8/296 DVD/CD TRANS & 24/96 KHZ DAC	7000	2995
NAIM NBL CHERRY	7165	4500
NAIM SBL BLACK	2400	750
NAIM 82 + PHONO	2400	1595
NAIM CDI MK2	2000	895
NAIM 62	450	150
NAIM 52+SCAP	6245	3995
NAIM 140 NEW STYLE	850	395
NAIM 135'S 12 MONTHS OLD	3710	2395
NAIM HEADLINE	225	150
NAIM 92	520	250
NAIM 90/3 X2	550	250
NAKAMICHI 700 TRI TRACER REMOTE & SERVICE MANUAL	N/A	395
NHT 1.3A SPEAKERS PIANO BLACK EX DEM	500	295
NHT 1.1 SPEAKERS PIANO BLACK EX DEM	400	195
PROCEED AMP 2 (2 channel) THX	2000	995
PROCEED AMP 3 (3 channel) THX	3000	1495
QUAD FM4 TUNER BRONZE DIN	N/A	175
QUAD 66 PRE + SYSTEM REMOTE	N/A	450
QUAD 606 MK11	N/A	450
REL STENTOR MK1 OAK	1800	695
REVEL ULTIMA GEM PIANO BLACK + stands	8000	3500
SAT CDFIX 24/96 KHZ WITH UPSAMPLER NEW SEALED BOX	1500	995
SIM AUDIO CELESTE 4000 INTEGRATED	1000	295
SONIC FRONTIERS ANTHEM INTEGRATED AMP 2	2000	995
SOUND STYLE 4 TIER MAROON	350	95
TANNOY LANCASTER 15 INCH MONITOR GOLDS	N/A	1295
VAN DEN HUL THE SECOND DIGITAL XLR	150	75
VAN DEN HUL REVELATION HB 2X 1.5 PAIR	800	395
WILSON BENESCH CIRCLE + 0.5 ARM VAN DEN HUL MM2	2000	995
XLO 4.1 SIGNATURE DIGITAL CABLE RCA	325	175

OPEN MON-SUN 10.00 TO 8.00
Website: www.centralaudio.co.uk
E-mail: tony@centralaudio.co.uk



HEATHERDALE AUDIO LTD.



202 FINDON ROAD, WORTHING, WEST SUSSEX. BN14 0EJ
TEL. 01903-872288 OR (AFTER HOURS) 07860 660001 FAX. 01903-872234
e-mail: heatherdale@hifi-stereo.com //www.hifi-stereo.com

BRAND NEW TONEARMS
Eminent Technology Air Bearing Tonearm
Normal Price £2500 Our Price (standard) £1495

HEATHERDALE PRE-OWNED GUARANTEED EQUIPMENT EXPORT FACILITIES AVAILABLE

SPEAKERS

Dynaudio Audience 40 Speakers (rosewood) £250
Mission 753 Freedoms Floorstanding Speakers £450
Orchid PLL1 Speakers with stands (ex demo) £4495
Quad ESL63 Speakers with Stands £1395
Audio Note AN E/SP Walnut Finish Speakers £995
John Bowers Active Speakers £250
Mission 782 Loud Speakers (Stand mount model)
Selection of Thiel ex Demo Speakers. All with 10 year guarantee
MAIN DEALER FOR ORCHID SPEAKERS

PRE-AMPS

Adcom GTP 450 Tuner/Pre Amp £350
Sony TAE 900 Esprit Pre Amp (mint, boxed, rare) £695
Dakley High-end Valve Pre Amp (similar to Conrad Johnson) £1195
EAR 864 Pre Amp £2750
Perreaux SM6P Pre-amp 350P Power Amplifier £150
Naim NAC 42.5 Pre-Amp £495
Musical Fidelity MVT Pre Amplifier with Phonostage + PSU £175
Musical Fidelity 'The Pre-amp'

ALL USED CARTRIDGES ARE CHECKED UNDER A MICROSCOPE BEFORE BEING OFFERED FOR SALE.

Classe Audio DR6 Pre-Amp with PSU & Phono Stage (cost new £3900) £1995

AMPLIFIERS

Jeff Rowland Model 5 Power Amp £1995
Lunteck Integrated Amp £425
Adcom GA 5000 Power Amp £149
AVI 2000MI Integrated Amp (ex demo) £350
Mark Levinson ML5 Power Amp £750
Audio Note Neiro Power Amp £1995
Perreaux SM6P Pre-Amp 350P Power Amplifier £5495
Naim 120 Power Amplifier £2750
Rogers E40a Integrated Amplifier with phono-stage (NEW) £995
Exposure 11/12 Super 8 £995

CD PLAYERS & TRANSPORT

Micromega T Drive CD Transport £595
Marantz CD 94 Transport, COA 94 DAC £895
Teac VRDS T1 CD Transport £295
Teac VRDS 9 CD Player (mint) £650

DACS

Sonic Frontiers SF01 Digital Processor £895
DCS Egar & Purcell DAC & Upsampler with Cables (2 years warranty) £7500
Theta Chroma HOCO DAC (ex demo) £775
Mark Levinson ML30.6 Reference DAC (ex demo) £90A

MISCELLANEOUS

Sonic Frontiers Ultra Jitterbug £195
Accuphase T11 Tuner £895
Luxman K351 Cassette Deck £271
Luxman K31 W Cassette Deck £150
Beyer 811 Headphones £110
Audio Note AN57 MC Transformer with Phono-Phono Stage £8495
Selections of MIT cables available at discounted prices

TURNTABLES, CARTRIDGES & TONEARMS

Micro Seiki DDX 1000 Turntable £1250
VPI HW 16.5 Record cleaning machine (new) £425
Project Oebut Glass Black Turntable £99
Koetsu Urushi Cartridge (unused) £1895
Koetsu Itogawa Diamond Cartridge (unused) £4495
Helius Silver wired tonearm £995

BRAND NEW BOW WAZOO
INTEGRATED AMPLIFIER NORMAL PRICE £2500 OUR PRICE £1995

NOW DEMONSTRATING THE MARK LEVINSON 383 INTEGRATED AMP

WE NOW OFFER 0% FINANCE (subject to status)

PLEASE PHONE TO ARRANGE AN AUDITION

MAIN DEALERS FOR MARK LEVINSON, THIEL, AND ABSOLUTE SOUNDS

VISA - SWITCH - MASTER CARD - AMEX - DINERS CLUB WELCOME
WE TAKE PART EXCHANGE ON NEW & USED STOCK AND BUY IN FOR CASH



Soundcraft HiFi.com

At 40 High Street, Ashford, Kent. TN24 8TE

SPECIAL CLEARANCE SALE April 2002

Hi-Fi Separates (! = Ex - demonstration)

B&W 601 S2 speakers	£199!	Linn Mimik CD	£499
B&W 802 Nautilus (red cherry)	£4995	Linn Axis Turntable	£250
Castle Richmond ant/oak	£199!	Linn LP-12 Basic/Val	£799
Castle Severn 2's (Birch)	£499	Linn 5105 Power Amp	£899!
Castle Harlechs ant/oak	£850!	Marantz DV-7000 DVD	£349!
Castle Harlech (cherry)	£700!	M/F A3 Amplifier	£599
Chario Syntar 100 speakers	£149!	M/F X-A1 Amp	£399!
KEF Q-35 (apple) I	£299	Micell Prisma Turntable	£1000
KEF Concerto 2	£399!	Naim Nait 2	£299
KEF Concerto 1	£299!	Naim NAC-62/ NAP 90/3	£499
Linn Index II's + Stands	£199	Nakamichi MB-10 CD	£399!
Linn Karik CD	£599	Quad 44 pre/303 pwr amps	£399
Linn CD-12 I	£7995	Rega Planar 25 Table & Cart	£550

Our exciting range includes: Arcam, DiVA & FMJ, Chord Electronics, Linn, Lexicon, MC-12, Naim, Rega, Musical Fidelity, Denon, Yamaha, Rotel, B&W Nautilus, PMC, Ruark, Kef, Loewe TV, Hitachi & Pioneer Plasma, Sim 2 DPL!
Hotline: 01233 624441 Fax: 01233 640333.

AV Separates (! = demonstration)

Arcam AVR 100 Receiver	£599	Pioneer PDP-502 Plasma	£8995
Arcam FMJ A-22 DAVE Amp	£1499!	Pioneer VSX-859 THX Rcr	£599!
Denon DVD 5000 DVD player	£499!	Rotel RSX-972 AV Amp/Rcr	£799!
Naim AV-1 Processor	£650	Sony DVPS 335	£199
Nakamichi 10-S DVD player	£449!	Sony DVP S-7700 DVD player	£599!
Pioneer DV-535 DVD zone free	£199!	Yamaha AX-1 Amplifier	£999!
Pioneer NS-DV1 DVD System	£999!	Yamaha DVD-S510 zone free	£199!
Pioneer XV-DV55 + S-59 spkrs	£649!	Yamaha DSP E 800 processor	£249!

Check our web site: soundcraft.hifi.com

Sound Investment

If you have invested expertise and money in building up a sound system to your own unique specifications, then why compromise with indifferent housing units?

Fi-Rax offers a new dimension in audio visual racking - from a range of standard designs to the flexibility to custom create a unit to suit your particular sound system and lifestyle.

- *High quality aluminium construction.
- *Finishes available to your choice.
- *Fully adjustable 6mm glass shelving.
- *Sound isolation on shelving/feet.
- *Custom created to suit your system.
- *Free delivery throughout the UK.

Fi-Rax - a sound investment for those who want the best from their equipment.

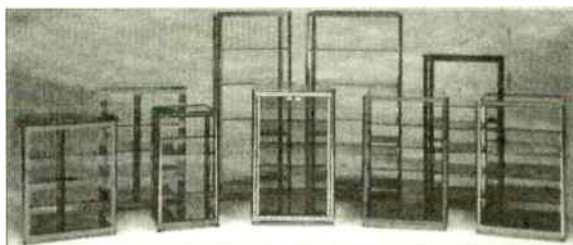

Audio Visual Furniture

For further information or a free brochure contact: JEM Distribution, Springfield Mills, Spa Street, Ossett Wokefield WF5 0HW.
Tel: 01924 277626 Fax: 01924 270759

Are you making the right connections?

Send for Britain's biggest catalogue of specialist cable and connections.

All available by mail order.
Phone 020-8942 9124 or clip the coupon for your Free copy
www.custom-cable.co.uk

CUSTOM CABLE SERVICE

PO Box 4007, London SW17 8XG

Please send me your FREE Custom Cable Catalogue

Name _____

Address _____

Postcode _____

NO FURTHER INFORMATION REQUIRED

Send to: Custom Cable Service
PO Box 4007
London SW17 8XG

HFV 04/02



True Colours Industries

Put Some Life In Your System



HI-FI INTERCONNECTS
CUSTOM VIDEO LEADS
MAINS POWER LEADS
SPEAKER CABLES

New Catalogue Available Now

AVAILABLE MAIL ORDER

Anglia Audio
Tel. 01359 270212
Audiocraft
Tel. 018 9525 3340
Doug Brady Hi-Fi
Tel. 01925 828009
Eastern Audio
Tel. 014 7921 7217
Kronos Hi-Fi
Tel. 028 8775 3606
Hi-Fi Studios
Tel. 013 0272 5550
Hi-Fi City
Tel. 019 2322 6169
Lyric Hi-Fi
Tel. 028 9038 1296
The Listening Rooms
Tel. 020 7244 7759
Sevenoaks Hi-Fi (Preston)
Tel. 017 7282 5777
Walrus Systems
Tel. 020 7724 7224
Hi-Fi Corner (Dublin)
Tel. 00353 1671 4343
Sherwoods (Waterford)
Tel. 00353 5187 2622

True Colours Industries

Unit 263
Lisburn Enterprise Centre
Ballinderry Road
Lisburn
BT28 2SA
Tel 077 1019 6949
Fax 087 0120 5923
Email support@true-colours.com

See us at the
**Sound & Vision
Show
2002**

Full dealer list available at

<http://www.true-colours.com>

Sound Music

- Arcam A65 Integrated Amplifier(XD) - £250
- Arcam CD92 CD Player(XD) - £700
- Arcam AT51 Diva Tuner(Silver)(New) - £200
- ATC CA2 Preamplifier (SH) - £450
- ATC SCM 10-2 Active Speakers (SH) - £750
- Beard P500&P50 Pre&Power(Valve)(SH) - £875
- Castle Bastion Centre (Oak)(XD) - £250
- Castle Harlech (Cherry) (XD) - £750
- Castle Richmond (Rosewood)(XD) - £200
- Castle Severn Speakers(Maple)(XD) - £500
- Cyrus Discmaster/Dacmaster(SH) - £750
- Cyrus Pre-Amplifier (SH) - £400
- Energy Encore AV Sub & Sats (XD) - £850
- Jamo Home Cinema Speaker System(XD) - £300
- John Shearne Phase 2 Amplifier(SH) - £350
- Linn Classik CD/Tuner/Amplifier Unit (XD) - £750
- Linn Keilidh Speakers (Black) (SH) - £450
- Linn Majik I Amp & Sneaky Line Driver(XD)-£600
- Linn LK140 Power Amps (3 Available)(SH)-£550
- Linn Tukan Speakers (Black) (SH) - £300
- Meridian DSP 5000 Active Speakers(XD) - £3000
- Musical Fidelity A3 Integrated Amplifier(XD)-£700
- Musical Fidelity A300CR Power Amp(XD) - £1750
- Myrad MT100 Tuner (XD) - £300
- Myrad MC100 CD Player (XD)- £350
- NAD 216 THX Power Amplifier(XD) - £200
- Opera Super Pavarotti Speakers(XD) - £700
- Proac Studio 150 Speakers(Mahogany/XD)-£650
- Project Perspective Turntable & Arm (New) - £500
- Quad 44 Pre & 405 Power Amplifiers(SH) - £400
- Sanyo PLV30 Projector (XD) - £1800

**Sound Of Music, 93-95 Nantwich Rd.
Crewe, Cheshire. CW2 6AW
Tel.:01270 214143**

For : Linn, Arcam, Musical Fidelity, Castle, Roksan, Onkyo, Monitor Audio, Quad, NAD, Wharfedale, Loewe, Project, Meridian, S.M.E., & Many Others.

Audio Classics are back!

Item	Price	Condition	Description
Radford STA25/III	£800	4.9	Classic 25WPC EL34
Leak TL12+ CHROME	£600	5.0	Rebuilt, perfect pair
Leak TL12+ Bronze	£450	3.1	Rebuilt, perfect pair
Decca Kelly DK30	£250	4.9	Pair ribbon tweeters
Leak Troughline III	£100	4.9	Mono FM tuner, perfect
Garrard 301	ASK	4.5	Perfect Garrard TT
Garrard 401	ASK	4.9	Perfect Garrard TT
Tannoy IHLZ Monitor Gold	£500	3.9	No badges, nice pair
Lowther TP1	£1200	3.9	No grills, original PM3A
B&W P2II	£1200	4.8	Fully working IONICs
RCA Cinema Monoblocks	£500	3.1	Fully working pair
Gaumont Kalee "Duosonic"	£600	2.9	HUGE monoblocks, pair
B&O Beogram 4000	£400	4.3	Jacobsen classic, new cart
Technics SP-10	£250	1.9	EX-Studio turntable
Technics SL-D1	£80	4.0	Direct Drive parallel track
Nottingham Analog Mentor	£500	3.9	Heavy turntable, no arm
Nottingham Analogue Hyper Space*			Vinyl perfection
And Space Arm	£2300*		Amazing 1970s arm
Micro Seiki MA77	£350	5.0	My fave arm
Alphason HR100MCS	£350	4.5	
EAR MC-3	£600*		High-End MC step up
EAR 834P (MC/V)	£500*		MM/MC phono stage,
EAR CL-EAR	£350*		MM phono & control
Full EAR range available*			(great for Leaks)
Croft Vitale	£360*		Budget BARGAIN!
Full Croft range available*			
B&O Beomaster 8000	£500	4.7	Remote Receiver
Leeson API / CPI	£650	3.9	Design classics
Yamaha T2	£400	5.0	AMAZING FM tuner
EAR V20	£2800*		Simply AMAZING!
KLIPPSCHORN	£2000	3.0	Painted white?
KEF LS3/Sa L.E.	£1000	5.0	Raymond Cook, pair # 20
JBL L100	£350	3.0	Damage to grill on one
Audio Classics Model "C"	£1500*		

Key * = New item 1 = Poor 2 = Presentable 3 = Average 4 = Good 5 = Mint, like new.
Part Exchange Welcomed! FREE delivery on all new items, everything else, please enquire.
Callers welcome by special appointment. New dealers for EAR, Croft, Nottingham Analogue.

Tel:01942 257525 www.audioclassics.co.uk



AUDIOVECTOR

Call us to arrange a demo or visit our website at:
www.audiovector.co.uk

- * New Improved M Series
- * New AV3C centre channel, including new Signature version
- * New Avantgarde versions of all M Series speakers
- * New MSub active subwoofer
- * New S6 model (replaces 6X)

See and hear our new products, April 6-7 2002
The London Hi-Fi Show,
Renaissance Hotel, Heathrow

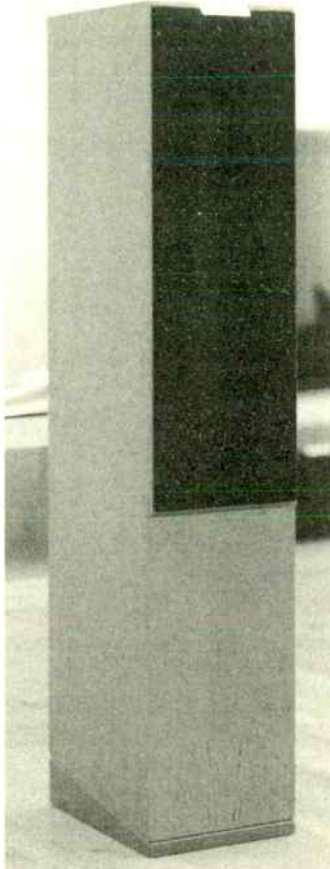

Post to: Audiovector UK, Unit 7, Wren Industrial Estate, Coldred Road, Maidstone, ME15 9YT Tel: 01622 201983
Web: www.audiovector.co.uk
Please send me info on Audiovector

Name:.....
.....
Address:.....
.....
.....
.....
Post code:.....HFW0204

www.Supradirect.co.uk

The **ONE-STOP** secure website for SUPRA cables to improve your Hi-Fi and/or Home Cinema system.

Hi-Fi Nuts

Upgrade your existing cheap cables and enjoy better sound quality with Award-winning Supra speaker and interlink cables!

Home Cinema Users

Choose from Supra's range of composite, s-video, or RGB/Component video cables to improve your picture quality. Or use Supra co-ax digital or fibre optic cables from DVD to AV amp/receiver.

DIY'ers

Fit Supra Boxcon 4mm terminals to your kit amplifier or loudspeakers.

Quick and simple instructions for obtaining better cables:

- 1 - VISIT:
www.supradirect.co.uk
- 2 - VIEW the range on/offline (download the PDF catalogue)
- 3 - SELECT from the wide range
- 4 - SAVE money when you make your purchase
- 5 - ENJOY

Products now available:

EFF-ISL "25th Anniversary" the updated version of the Hi-Fi Choice "Best Buy" EFF-ISL cable.

Classic 4T New tin-plated version of What Video "Best Buy" speaker cable.

Ply 3.4 Low inductance, square section, tin-plated OFC speaker cable. As "Recommended" by Hi-Fi Choice

Ply 3.4/S shielded version of Ply 3.4 - Also a Hi-Fi Choice "Recommended" award winner

NEW PRODUCTS:

Trico Co-ax digital cable

ZAC Fibre Optics

Lo-Rad shielded mains cable

AV2 s-video cable

AV3 RGB/component video cable

AV6 multi-core AV cable



We belong to the Which? Webtrader Code of Practice

Bocchino Audio Connectors

Australia's finest range of high-end phono connectors

Upgrade your phono cable connectors from the **low-conductivity, gold-plated brass types** to the **Bocchino Brenda phono plugs**.

Each plug is fabricated from one-piece of pure high-conductivity copper, luxuriously silver-plated and finished with hard-gold-plating.



- Brenda™ B7 (single bay, short) - £99/pair**
- Brenda™ B7 (dual bay) - £109/pair (top left picture)**
- Brenda™ B9 (dual bay) - £149/pair (top right picture)**

Common features: Each plug machined from a solid billet of 99.94% pure High Conductivity Oxygen Free Copper, then plated with 15+ micron silver and 1.0+ micron hard gold.
Signal tips plated with 3.0+ micron hard gold.

Now available from specialist accessory dealers.
Or visit our website at: www.bocchino-audio.co.uk

Trade/OEM enquiries welcome

- please contact sole UK distributor -

Bocchino Audio UK, PO Box 364, Maidstone, ME15 9FE

Email: sales@bocchino-audio.co.uk

Tel: 01622 201983

Fax: 01622 761560

SONIC DESIGN® DAMPING FEET

www.sonicdesign.co.uk

Virtues of using Sonic Design Damping Feet

These feet will give a substantial decrease in loudspeaker cabinet movements. This is apparent when you put one finger softly against the top of the front baffle, as it vibrates much less after damping. The transmission of vibrations from the cabinet into the floor will also be reduced. The music will be cleaner, with a less coloured sound quality.

For Loudspeakers:

Audiophile Damping Feet provide the best possible isolation and damping but it is important that the feet are optimised to the weight of your loudspeakers. Both the stiffness and size of the feet are selected to achieve this. Speakers within the range 5 to 200 kg can be optimised. Let us know the mass of your loudspeakers and we can advise you the correct set to purchase.

The Standard Loudspeaker Damping Feet have a large overload margin, and are lower priced than the Audiophile version. The resonance frequency is a few Hertz higher. The colour is nut brown, except for the stiffest feet which are grey. The standard feet are produced in four different weight classes and do not need to be fine tuned to specific loudspeaker models.

For CD/DVD Players:

The CD Damping Feet are made from the same material as the Standard Damping Feet. If the sound of your CD/DVD player is sensitive to vibrations, the CD Feet will be the way to go. The sensitivity to shock and the accompanying mistracking will be reduced with the use of the CD feet. They can also be used with any other audio product that you would like to isolate from vibrations. The set contains four small and one large foot. The large foot is used if the centre of gravity is off-centre or for those CD/DVD players that have five feet.

BEFORE >>
(top) 125 Hz sine signal to the speaker, (lower) floor movement, using spikes



<< AFTER:
(top) 125Hz Sine signal to the speaker, (lower) floor movement, using soft feet (note floor signal magnified x2)

Damping Feet for CD players (pack of 5) - £9.99

Available in three sizes: 2-5kg, 5-10kg, 10-25kg

Damping Feet for Loudspeakers (pack of 8) - £19.99

Available in four sizes: upto 12kg, 12-28kg, 28-50kg, 50-100kg

Audiophile Damping Feet for Loudspeakers - £44.99

Available for most high-end loudspeakers from 5 kg upto 200 kg

Available from all good specialist hi-fi/accessory dealers (trade enquiries welcome - email sales@sonicdesign.co.uk or fax 01622 761560)

Or, in case of difficulty, on the internet at: www.sonicdesign.co.uk

MATRIX HI-FI

VALVE AMP REPAIRS

VALVE CD PLAYERS FROM £330.00 ON DEMO - PLEASE PHONE FOR DETAILS.

APOGEE MINI GRAND WITH SUB WOOFERS & ACTIVE XOVER PR	3,999.00
AUDIO NOTE ANJ/SPE INCLUDING STANDS BLK	750.00
BASIS DABU GOLD DECK WITH AIRTANGENT UPGRADED 2B TONE ARM. SPARE TUBE, 2nd ARM - GRAHAM 1.5LT WITH KEITSU GOLD CARTRIDGE ON SPARE ARM BOARD.	7,300.00
BEARD P35 CHROME - MINT	450.00
CELESTION A1 SPEAKERS BLACK - NEW	499.00
CONRAD JONSON PV6 PRE-AMP	799.00
EMINENT TECHNOLOGY TONE ARM 2 WITH AIR PUMP.	300.00
FERRAGRAPH LOGIC 7 REEL TAPE WITH TAPES ETC.	299.00
HI-FI WORLD KAT-88 VASULTY UPGRADED	550.00
HEART/MARANTZ VALVE OUTPUT CD PLAYER - IMPROVED	650.00
KREIL KSA 50 (TWO OFF VGC) - EACH	1,250.00
LEAK STEREO 20 VGC	399.00
LEAK TL12+ PAIR VGC	350.00
LEAK TL25 PLUS PR RARE	699.00
LINN CLASSIC VARIOUS COLOURS	995.00
LINN KEOSA FLOOR STANDERS - BLACK/MAPLE/CHERRY	350.00
LUXMAN MQ3600 POWER AMP KT88	700.00
MARANTZ CD-63	90.00
MARANTZ PM-6010 AMPLIFIER KI- SIGNATURE - BLK	240.00

NAKAMICHI LX2 CASSETTE DECK	200.00
PHILIPS 420P10/00 42" PLASMA SCREEN - SPECIAL	4,299.00
PIONEER ER-420 VALVE RECEIVER	195.00
PRECIOUS METALS COPPERTECH DELTA	59.00
PRECIOUS METALS SILVER S5200 SIGNAL	187.00
PRECIOUS METALS SILVER COPPERTECH 102 SIGNAL	110.00
PRECIOUS METALS SILVERTECH 52 SIGNAL	81.00
PROJECT 2.9 RECORD DECK WITH ORTOFON CART. CHERRY	399.00
PS AUDIO 5.6 PRE-AMP WITH MM/MC PHONO	550.00
QED PASSIVE CD PRE AMP ALPS POT.	65.00
QUAD II PAIR. MINT	650.00
QUAD II PAIR. BIT TATTY.	500.00
QUAD AM TUNER VGC	50.00
QUAD FM 1 TUNER	50.00
RAIDFORD MA50 MONOBLOCS - MINT	1,499.00
ROGERS JUNIOR 4 PRE AMP - RARE	350.00
ROTHWELL INDUS PASSIVE PRE AMP STEPPED CONT.	399.00
ROTHWELL RUBICON POWER VALVE AMP	799.00
SONY MDS-JE320 MINI DISK PLAYER- NO REMOTE	120.00
SOUND ORGANISATION RACK - SILVER 4 SHELVES 40% OFF	120.00
SOUND STYLE XS RACK - ICE BLUE GLASS - 5 SHELVES	299.00
TRIPLETONE STEREO INTERGRATED	95.00
VAL 20WATT INTERGRATED VALVE STEREO EL34	399.00
VERDIK QUALITY 10 VALVE MONOBLOCS	350.00
YAMAHA CT710 TUNER	100.00



● HI-FI/THEATRE DEM ROOM NOW AVAILABLE ● VINTAGE HI-FI FOR SALE & WANTED

MICHELL - ALCHEMIST. CELESTION, QED, AUDIOQUEST, MARANTZ - ETC...
NEW AND VINTAGE VALVES - INTERCONNECTS & SPEAKER - OFC & SILVER
WEALTH OF KNOWLEDGE SPANNING OVER 30 YEARS, FOR ENQUIRIES OR
A CONTROVERSIAL CHAT, ASK FOR DAVE OR LEE.

PHONE : (01322) 292391

FAX : (01322) 229908

E-MAIL: INFO@MATRIXHI-FI.CO.UK

WEB: WWW.MATRIXHI-FI.CO.UK

SHOWROOM

65 DARENTH ROAD

DARTFORD

FREE EASY PARKING

KENT DA1 1LU



01376 521132
07802 483698

CHELMSFORD, ESSEX

E-MAIL: soundstage@netlineuk.net

BY APPOINTMENT ONLY

PRE-OWNED EQUIPMENT

AUDIO INNOVATIONS SERIES 1000 MIKI MONO'S WITH 11 VALVE PRE AMP	£1195
AUDIOLAB 8000CD	£595
AUDIOLAB 8000DAC	£399
AUDIOLAB 8000S INTEGRATED R/C AMP	£529
AUDION SILVER KNIGHTS 300B MONOBLOCS NEW VALVES 3 YRS OLD	£395
BEARD CA35/P35 II VALVE PRE-POWER (£2500 APPROX. N/W)	£1195
DENON AVC-A1 GOLD BOXED AND IMMACULATE (£2000 NEW)	£795
DENON AVP-A1 GOLD BOXED AND IMMACULATE (£3000 NEW)	£995
DENON DVD-5000 GOLD WITH MULTI REGION CHIP FIFTH-D-SUPERB MACHINE	£995
DENON AVR 3300 DOLBY DIGITAL DTS BLACK BOXED IMMACULATE	£449
EPOS ES14 WALNUT SUPERB CONDITION	£349
EPOS ES11 LOUDSPEAKERS BLACK ASH WITH HARD COVERS	£199
LINN AW5103 ACARF LASER DISC INPUT DD PRE-AMP IMMAC (£4750 NEW)	£1795
LINN ISOBARKS DMS WALNUT LOVELY CONDITION BUYER COLLECTS	£595
MAGNEPLANAR MQ2 7SE QR OAK 3 YRS OLD BOXED AND IMMACULATE	£1795
MERIDIAN 506 24 BOXED AND IMMACULATE	£695
MERIDIAN 500/566-20 BIT TRANSPORT/DAC BOXED AND IMMACULATE	£1195
MERIDIAN 602/606 TRANS/DAC-BRAND NEW LASER BOXED/IMMACULATE	£1195
MERIDIAN 501.2 PRE-AMP BOXED AND IMMACULATE	£495
MICROMEGA STAGE 6 IMMACULATE AND BOXED	£495
MICROMEGA DRIVE 3/DAC BOXED AND IMMACULATE	£995
MONITOR AUDIO MA1000REF GOLD TRAK	£595
MUSIC MODEL 3 PRE-AMP REMOTE BLACK BOXED AND IMMACULATE	£995
MUSICAL FIDELITY T1 FM ONLY TUNER BOXED AND IMMACULATE	£199
NAIM NAC 32/SNAPS/NAP250 OLD STYLE SUPERB CONDITION	£995
NAIM NAC 77 PRE-AMP BOXED AND IMMACULATE (£790 NEW)	£449
NAIM NAC 92 PRE-AMP BOXED AND IMMACULATE	£279
NAIM NAI9/PRE-OUT MODIFICATION BOXED AND IMMACULATE (1999 MODEL)	£399
NAIM IXC 2-WAY ACTIVE X-OVER WITH VARIABLE FREQUENCY	£349
NAIM NAP140 OLD STYLE SUPERB CONDITION	£399
NAIM NAP903 BOXED AND IMMACULATE	£329
NAKAMICHI CR2 CASSETTE DECK	£149
NAKAMICHI CASSETTE DECK 2	£179
PIONEER CD95 LITE LASER DISC PLAYER (£2000 NEW)	£495
PRO AC TABLETT 50 MAHOGANY QR CHERRY-IMMACULATE	£395
PROCEED PCD SERIES 3 CD PLAYER (£3500 NEW)	£1695
QUAD ESL61-LITE MODEL APPROX 1992-93 BLACK WITH STANDS SUPERB	£1295
REGA PLANET CD PLAYER BOXED AND IMMACULATE	£299
REVON B760 TUNER-SUPERB CONDITION	£449
RUARK CL30 CHERRY WOOD (N/W £2500) WITH SILTECH AND XLO INTERNAL HARD WIRE UPGRADES AND WB1 BINDING POSTS SAVE OVER £500	£1895

PROFESSIONAL RECORD CLEANING SERVICE - KEITH MONKS MACHINE - PLEASE RING FOR FURTHER DETAILS AND PRICES.

THREE MONTH WARRANTY ON ALL ITEMS

www.sound-stage.co.uk

STOWSOUNDS

Stone Farm Borough Lane, Great Finborough, Stowmarket, Suffolk, IP14 3AS
Special prices on the following new and used products:

ENGINES	
Creek Cd 53	999
Michell Gyrodek bronze with SME V arm	1100
Nakamichi BX 2	125
Musical Fidelity X Ray	675
DPA Renaissance CD	450
Trichord Revelation CD	450
YBA CD 3	1400
Alchemist Nexus	295
GEARBOX	
Creek 5350SE	700
Linn LK 100	300
Exposure 25 integrated	800
Musical Fidelity XA 100R	350
Sonneteer Campion integrated	425
YBA 3 Pre Power	1600
EXHAUST	
Neat Petite	675
Castle Seven 2	385
JM Lab Tantal 515	325
Linn Keosa Maple	349
JM Lab Cobalt 810	525
JM Lab Electra 905	795
Living Voice Auditorium	1350
Rogers LS4a	140
FURRY DICE	
Quad FM 4	175
Tripod Rack with LP storage	75
Sound Organisation Z545	100
Soundstyle X105	160
Linn Classic	800
Rotel RT 950BX	75
Beyerdynamic DT911	140
Beyerdynamic DT531	80
Grado SR60	65
Atacama SE24	50
SonicLink - all stock 40% off	poa
Van den Hul - all stock 40% off	poa
Soundstyle X midi width racks 320mm	90

Various interconnects, supports, cables at reduced prices.

Phone for details
Sale of CDs. Phone for latest list.

TEL: 01449 675060

X electrical

We buy, sell & part exchange quality Hi-fi

AMPLIFIERS / RECEIVERS	CD PLAYERS & MINI DISCS	SPEAKERS
Tandberg Hukara B valve £195	Audio Alchemy DDS11 £245	Castle Chesters £275
Magnum MF160 pre amp (chrome) £225	Sony MDSJA30ES £325	Mission 752s £260
Technics SEA 808/STR808 pre power £95	Audiolab 8000CD £525	B&O RL140 £245
Audiolab 8000A £245	Thorens TDA2000DAC £325	Audio Physics 'the step' £525
Denon PMA 1500R £250	Arcam Alpha BSE £325	Bose 901/791 £645
Sony TA9000ES 6ch receiver £545	Arcam Alpha S+ £195	JBL XPL 90 £400
Musical Fidelity 3A pre amp £130	Arcam Delta 70 £115	Heybrook Haystacks £225
Cyrus 3 + PSX £475	Sony CDP228ES £95	Monitor Audio R353 £95
Nad 319 £375	Philips CDR170 £140	Celestion DL8s £75
Nad 3130 £95	Many portable mini discs in stock	Rogers LS55 £275
Linn LK1/2 pre power £425		Canon S75 £395
Arcam Alpha 10 integrated amp £445	TUNERS	Bose 305 £275
Arcam Alpha 5 £125		
Creek 4040 £60	Arcam Alpha 7 £145	CASSETTES
Marantz PM66SE £125	Arcam Delta 80 £95	
Cyrus One £120	Sony STS8920 £85	Teac X3000 £145
Quantum Pre Power 2 £180	Nad 4130 £80	Yamaha KS500S £110
Rogers cadet 3 £145	Denon TD260L £70	Nakamichi CR2E £160
Alchemest Nexus £375	Musical Fidelity T1 £115	Nakamichi S80M £165
Yamaha MX 830 power amp £295	Marantz 450L £50	Nakamichi BK1 £150
QED A240 £90		Pioneer CT91A £175
Marantz 1550L rcr £125	TURNABLES	
Pioneer DS500 rcr £145		EQS
Sony TAFE 330R £95	Systemdek 1 £175	
Pye Mozart dual valve monoblocks £345	Technics SL1200 as new £320	ADC Soundshaper 2 £225
Technics SUA700 #2 £120	Thorens TD 3001 £295	Technics SHGE90 £170

Please call us if you have any equipment to sell or are looking for anything in particular. New stock daily
All equipment is fully tested and guaranteed
Also: Music CDs, Games, Musical Equipment, Computers, TV, VCR & Photographic
Web page www.xelectrical.com email x@xelectrical.com
125 King Street Hammersmith 020 - 8563 7383
4 Station Bldgs Fife Road Kingston 020 - 8546 1233
Games & CDs upstairs at Kingston 020 - 8546 4442
43 Church Street Croydon 020 - 8680 0007

CLASSIQUE SOUNDS (LEICESTER) INC ONE THING. VINTAGE HI-FI & VALVE SPECIALIST

FOR SALE PREP. W. RAMPIT T. R.

Sugden Symetra monoblocks pure class-A amplifiers 50Watts/channel Silver front. Gorgeous lush sound. £895 pr	£249	Linn LK2 power amplifier. Good condition. £299
Linn LK1 pre-amp and remote. Good condition. £799	£299	Copland CTA501 power amplifier. Valve. £1800
Kenwood KA6600 integrated amplifier. Black. £60	£349	Myriad M120 int amplifier. Mint/boxed/remote. £499
Musical Fidelity A300 int amplifier. Dual mono. £749	£495	Richard Allen pure class A integrated amplifier. £175
Quad 77 pre-amplifier with large 1 CD remote. £299	£299	Hantson Kardon integrated valve amp. 110V. A rare. £599
Single ended stereo valve power amp. 7.5W. Super. £400	£650	Pair Leak TL12+ valve amps. Rebuilt by us. As new. £299
Quad 606 mk1. Excellent condition. Rare. £150	£299	Audiolab 8000C pre-amplifier. Boxed/instructions. £169
Obelisk 2 integrated amplifier. Good condition. £299	£175	Mission Cyrus2 amplifier. Mk1. Ex condition. £175
DPA Renaissance integrated amplifier. Mint. Boxed. £125	£599	Arcam 290 integrated amp & remote. Small dent. £699
Quad 303 power amplifiers from. £125	£175	Alchemest Forsen pre-amp. Mint. Boxed. £599
Sugden A48 integrated amplifier. Ex condition. £375	£175	Nakamichi PAS 100W/CH power amp. Cost £1300. £650
Nakamichi CA5 pre-amplifier. Ex cond. Cost £750. £799	£295	NVA A60 stereo power amplifier. Good condition. £295
Leak TL101 single valve mono. Mint-original. £175	£395	Linn LK100 power amplifier. Excellent condition. £395
NVA A80 mono power amplifiers X 2. Good cond. £150	£160	Arcam Alpha 3 amplifier. Mint. Boxed/instructions. £160
Leak TL101 single valve mono. Mint-original. £150	£225	Creek 4040 integrated amplifier. 5 pin din version. £225
NVA A60 stereo power amplifier. Good condition. £199	£80	Quad 34 pre-amplifier. 5 pin din. Boxed. Ex cond. £80
Linn LK100 power amplifier. Excellent condition. £99	£120	Technics SHGE 70 Graphic Equaliser. 12 presets. £120
Musical Fidelity Pre-8 pre-amplifier. Mint. Boxed. £450	£75	Mission Cyrus 1 amplifier. Good condition. £75
Naim Nac 42.5 pre-amplifier with MC heads. £100	£399	Arcam Zeta 1 Pro logic Cinema amp. Cost £999.00. £399
Single Heathkit MM12 mono valve amplifier. £199	£249	Quad 33 pre-amplifiers. From £249
Musical Fidelity The Pre-amplifier with MM/MC. £99	£89	Leak Stereo 20 valve power amplifiers from. £89
Scott 410A integrated transistor amplifier. £99	£89	Arcam Alpha 2 amplifier. Mint. Boxed/instr. £89
Arcam Zeta 1 Pro logic Cinema amp. Cost £999.00. £450		
Leak Stereo 20 valve power amplifiers from. £95		
Arcam Alpha 2 amplifier. Mint. Boxed/instr. £95		

TURNABLES

Revolver turntable and Linn LKX basic arm. 3/4/5. £150	£125	Garrard 301 & 401 motor units all serviced from. £125
Linn Sondek with Valfalla and basic + tone arm. £499	£499	NVA phono 2 MC pre-amp + 2 X PSL. Awesome. £499
Revolver Rebel 4w. Revolver arm & AT Technica. £125	£90	Thorens TD125 Chassis only. £90
Dual S504 record deck. Good condition/instr. £100	£55	Tro K13550. Direct drive turntable. £55
Thorens TD166BC Deck only Cut out for SME Bvd. £150	£89	Thorens TD166 MK2 with thorns arm. £89
Arnstor RD50 turntable. Boxed. Good condition. £99	£89	Dual C90S-2 turntable. Mint condition. Boxed. £89

SPEAKERS

Mirage OM6 loudspeakers. Built in active subwoofer. Goes down to 18Hz. Cost new £2800. Bargain for only. £1299	£199	Quad ESL57 speakers. All fully serviced with full 3 months warranty. Hear what ESL57s should sound like. From. £199
Par Quad ESL57 spks. Fully rebuilt. 1e-4 Recom buss & 2 recon treble units. All new electronics. 12m warranty. £120	£399	Mission 77A floor standers. Mint/boxed. Half price. £399
Kef C20 Bookshelf monitor speakers in black. £60	£195	Magnephaner MG 1.4. Boxed with £400 rack stands. £195
Heybrook Heylous. Black. Boxed. Ex condition. £199	£125	Richard Allen monitor spks. 3 way. High efficiency. £125
Kef concertos in super condition. Teak cabinets. £169	£95	Par Linn Keithall in black with Kusone stands. Absolutely mint. 6 months old 4 yrs warranty. Left. (L398) Bvd. £95
Par Linn Keithall in black with Kusone stands. Absolutely mint. 6 months old 4 yrs warranty. Left. (L398) Bvd. £450	£70	Naim Intro speakers in black ash. Mint. Boxed. £70
Naim Intro speakers in black ash. Mint. Boxed. £249	£80	Dynalab 2.8 ref speakers. Cost \$1200 were £450. £80
BKW DM220 slight cabinet marks. Boxed. £79	£169	Celestion Ditton 44. £169
Mordant Short MS20 Pearl Black finish. New. £449	£175	Tannoy Chassworths C/W. 12 inch monitor. golds. £175
Roksan Qjan 3 speakers. Good condition. £175		Tannoy Lanxasters cabinets 15 inch/monitor. golds. £175

OTHER ITEMS

Audio note CDT Zero CD Transport. Ex Condition. £350	£400	Audio note DAC 1 Valve CD DAC. Good condition. £400
Linn Klassik CD tuner/amp. Few months old. Silver. £750	£275	Quad IM4 Tuner. Very late model. Grey. Mint Bvd. £275
Quad FM2 valve tuner. Fully serviced. Incredible. £250	£70	Musical Fidelity X100 the missing link. Valve. Bvd. £70
Tim De Pavancini MC transducer. The Head. Mint. £49	£75	Technics SL-PC440A Mash CD player/remote. £75
Marantz SD275 twin cassette deck. Dolby B/C. £75	£150	Cogan Hall loudspeaker cable. 1.5 metre pair. £150
Audionote silver interconnects. Stunning. £35	£250	Nakamichi CDP 2F CD player. Ex condition. £250
Nad 4020 tuner. Scratch on top hence. £79	£49	Chord Chameleon interconnect. For naim caps. Bvd. £49
Marantz CD50 CD player. Ex condition. £99	£79	Rotel 950 CD player. Ex cond. Boxed. £79
Linn Basik plus tone-arm. Good condition. £249	£109	Sugden SD11 & SD11 Transport & Dac/remote. £109
Audio Alchemy Dac in the box with separate psu. £89	£55	Technics SL PS620A CD player/remote. £55
Linn Basik plus tone-arm. Good condition. £150	£90	Spare armature for SME series 3. New. Unused. Boxed. £90
Mitchell Iso Phono pre-amp and PSU. Ex condition. £195	£99	Teac TR450 tuner. AM/FM synthesised/RDS. Boxed. £99
Rotel RQ970 MM/MC phono pre-amplifier. £249	£125	Quad 1M13 tuner in excellent condition. £125
Rotel 965 BX CD player. Excellent condition. £195	£100	Marantz CD83 top loader cd player. Collectable. £100
Leak Troughline 3 stereo valve tuner. Fully serviced. £149	£100	Avantec Beam Echo valve tuner. BM611. AM/FM. £100
Linn Tuner. Mint. Boxed. Very unusual. Cost £549. £149	£75	ADC AL11 tone-arm. Mint. Boxed. Unused. £75
Arcam Alpha S cd player. Mint. Boxed/remote. £149	£125	Tro K13501 synthesiser tuner. AM/FM. Black. £125
Avantec Beam Echo valve tuner. BM611. AM/FM. £149	£125	SME S-93. £125

QUAD ESL57 & ELS63 PANELS/SERVICING ETC
Reconditioned Quad ESL57 speakers from only £750.00 pr. Why spend £4000+?
Have your ESL57s refurbished for only £349.00/Pair. Ring for full details.
Exchange/ recon ESL57 bass panel £120. Treble £100. ESL63 panels £100 Refurbished.
ELS63/ESL57 speaker stands, available in black or woodgrain @ £150.00 a pair.
New socks for ELS63s £38 pr. Many other spare parts available. Please ring.
"Classique Sounds servicing restores the Quads to a position where they can hold their head high". Jon Marks. HI-FI WORLD. April 1999. Full servicing facilities available.
Troughline tuner service & realignment £95.00. (excludes valves. Rarely needed). Subject to tuner being in a serviceable condition, with no modifications. One thing stereo decoder (back in stock) £175.00 Ex review Hifi world

TRANSLUCENT. (somewhat of a bargain) Hifi World. Jan 1999
PURE SILVER INTERCONNECT CABLE
99.99% pure silver conductors. Quality gold plated RCA phono plugs.
Half Metre terminated £60.00 One metre terminated £80.00
7 day money back guarantee if not better than existing cable. Regardless of price or quality.

NEW. Translucent pure silver mains cable. 3 amp. Intro offer. £99.00
One Thing Mains cables. Class 1 RFI suppressed. Silver plated conductors. Voltage spike protection. only...£55.00. 6 way mains block & lead only £99.00

NEW EAR YOSHINO EQUIPMENT
Ear 834P MM/MC phono stage with/without volume. Brand new. Boxed at only £529
Ear 834P MM phono stage. No volume control. Brand new. Boxed at only £379
Ear 834L Line only valve pre-amplifier. Amazing. Brand new. Boxed at only £479

NEW... Classique sounds 6 way heavy duty 13A mains blocks. Only £99.00
WANTED Vintage and modern hifi eqpt. Part exchange welcome.

Tel 0116 38 582 or 07802 213740 Mobile! Callers by appt only.
Open 10.00am - 6.00pm Mon-Fri 10.00am - 2.00pm Saturday.
61 Aylestone drive, Aylestone, Leicester, LE2 8QE. Email classique_sounds@yahoo.co.uk

RESERVE YOUR COPY TODAY!

Complete this form and hand to your local newsagent

Please reserve/deliver* (delete as appropriate) Hi-Fi & Computer Audio World on a regular basis, commencing with the next issue, until further notice.

Name _____

Address _____

Signed _____ Date _____



Distributed to the newstrade by

COMAG
MAGAZINE MARKETING



listening
rooms

PHONE FOR LATEST LIST

NEW, EX-DEM AND CLEARANCE ITEMS

	RRP	SALE	
Acoustic Energy AE1 MKII	£995.00	£695.00	D
Arcam Alpha 10	£799.00	£549.00	D
Arcam Alpha 8R Amp.	£350.00	£259.00	N+D
Arcam Alpha 7R Amp.	£280.00	£229.00	N+D
Arcam Alpha 9P Pre. Amp.	£400.00	£300.00	N+D
Audio Research VT50	£3,499.00	£2,279.00	D
Copeland CDA266	£1,399.00	£1,195.00	D
Copeland CDA289	£1,985.00	£1,295.00	D
Cyrus SL Amp	£400.00	£250.00	D
Cyrus AV Master Processor	—	£200.00	D
Krell KAV 500i Int. Amp.	£5,498.00	£3,895.00	D
Linn Kaber	£1,995.00	£695.00	D
Linn Keosa	£499.00	£369.00	D
Meridian 500 Transport (mint)	£1,350.00	£849.00	D
Meridian M33 Active speakers	£1495.00	£995.00	N+D
Mission 701 speakers	£160.00	£119.00	N
Mission X space speakers	£199.00	£95.00	N+D
Musical Fidelity XA200R	£699.00	£559.00	D
Musical Fidelity XA50 mono amps (1 pair)	—	£299.00	D
Neate Mystique	£735.00	£499.00	D
ProAc 3.8	£3,990.00	£2,990.00	D
Rotel RX96SRDS A/V receiver	£950.00	£695.00	D

D = EX DEMONSTRATION, N = NEW, S/H = SECOND HAND

Hi-Fi Multiroom and home cinema

ACOUSTIC ENERGY ARCAM ASH DESIGN AUDIO
RESEARCH CELESTION COPELAND CYRUS
DENON KEF KRELL LINN TAG MCLAREN MARTIN
LOGAN MERIDIAN MICHELL MISSION MONITOR
AUDIO MUSICAL FIDELITY NEAT ACOUSTICS
PIONEER PROAC QED QUADRASPIRE REL SONUS
FABER SME STANDS UNIQUE STAX THETA
WILSON AUDIO ETC...

THE LISTENING ROOMS LTD

161 OLD BROMPTON ROAD LONDON SW5 0LJ

TEL: 020- 7244 7750/59 FAX: 020 - 7370 0192

www.listeningrooms.com E-mail: clr@dial.pipex.com

Mon-Sat 10-6pm

diverse vinyl

10 charles st newport south wales np20 1ju
01633 259661/256261 sales@diversevinyl.com

Forthcoming Releases

ALISON KRAUSS & UNION STATION - NEW FAVORITE
The first release on DIVERSE RECORDS - due end February

Aim	Hinterland	£TBC
Chimera	Chimera (Tenth Planet)	£15.90
Gomez	In Our Gun	£TBC
Gong	Camembert Electrique	£10.90
Hives	Your New Favourite Band	£10.90
Led Zeppelin	Coda / In Through The Out Door	£26.90
Madonna	GHV2 - Greatest Hits 2	£TBC
Miles Davis	Young Man With A Horn (Classic)	£26.90
Patto	Patto/Hold Your Fire (Akarma)	£14.90
Pete Townsend with	Ronnie Lane - Rough Mix	£TBC
Pink Floyd	Echoes - The Best Of - 4LPset	£33.00
Sergio Mendes &	Brasil 66 Equinox(SpeakersCorner)	£TBC
Tom Waits	Alice/Red Drum -new on Epitaph	£TBC

NEW ALBUM OF THE MONTH

The Electric Soft Parade - Holes In The Wall (45 rpm) £14.90

CLASSIC REISSUE OF THE MONTH

John Coltrane - A Love Supreme (Speakers Corner)£19.90

New Stock And Recent Releases

B.R.M.C.	Black Rebel Motorcycle Club	£12.90
BB King	Live At The Regal	£19.90
Byrds	Preflyte Sessions	£17.90
Chemical Brothers	Come With Us	£18.90
Cornelius	Point (Matador)	£13.90
Count Basie	Atomic/Chairman Of The Board	£26.90
Dido	No Angel - Very Ltd pressing	£11.90
Ella & Basie	Sunny Side Of The Street	£19.90
Erik Truffaz	Mantis (Blue Note France)	£19.90
Eva Cassidy	Songbird	£18.90
Haven	Between The Senses	£12.90
Jim O'Rourke	Insignificance (Domino)	£12.90
Koop	Waltz For Koop	£11.90
Lambchop	Is A Woman 2LP (City Slang)	£13.90
Muddy Waters	Folk Singer (Classic Records)	£26.90
No Doubt	Rock Steady (Interscope)	£12.90
Paul McCartney	Driving Rain	£18.90
Roxy Music	Concerto (live 1979) 2LP	£14.90
Sarah Vaughan	You're Mine You	£26.90
Sparklehorse	It's A Wonderful Life	£14.90
Sun Ra	Angels & Demons/Nubians Of	£15.90
The Who	Quadrophenia 2LP	£19.90
Various	Almost Famous (OST)	£41.90

DISCO ANTI STAT LP CLEANER

Probably the most economical LP
cleaning device on the market

Only £41.95

Call for details

Call for a catalogue of over 3500 brand new LPs, or visit



www.diversevinyl.com

RETRO Reproduction

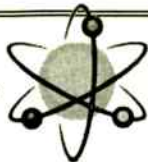

When Tim de Paravicini does a job, he does it properly, whether it is a custom studio installation or an affordable phono pre-amplifier like the EAR 834P. With years of experience in design and manufacturing, nobody can come close to the unique point of view and life experience he puts into all of his designs.

When first launched, the 834P was the only valve phono stage you could buy with facilities for both good quality moving coil (MC) and moving magnet (MM) cartridges. In addition, the unit could be purchased with a volume control, allowing direct connection to a power amplifier. Now in its seventh year of production it still sets the standard with fantastic soundstaging that all transistor phono stages can just dream off, coupled to low background noise and enviable reliability.

There are now four models in the EAR lineup:

The classic 834P uses the same circuit architecture as its more expensive brothers, and shares the same high quality sound through MM type cartridges, it is enclosed in a tough, rigid metal case and is fully "CE" type approved. price £380.00

The signature builds on the Classic 834P specification by adding a superb moving coil (MC) input stage, as well as the no-extra-price option of a high quality volume control, price £530.00

Top of the range, the Deluxe 834P comes in stunning chrome and gold cabinet, and has extra attention and quality control. With different moving coil input options, this unit will fit the most demanding of audiophile systems. For the true vinyl enthusiast, price £800.00

MC3 - The ultimate stage for MC matching with 3 fixed transformer taps to cover all types of moving coil cartridges, and separate left/right grounding. MC3 in used in the new £10,000 312 pre. price £650.00

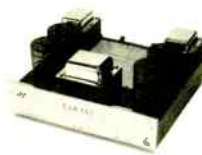

PS

New Showroom & Dem rooms now open

28a Haddington Place Edinburgh EH7 4AF Phone/Fax 0131 558 9989

Open 11.00am - 5.30pm - closed Monday & Sunday

STOP PRESS - NOW DEMONSTRATING

THE NEW EAR KT90 70W PER CHANNEL BALANCED BRIDGEABLE POWER AMPLIFIER PHONE FOR DETAILS

Ear 869 single ended triode integrated amplifier

Improved version of the classic 859 with revised output transformers modified input stage with the addition of a extra signal valve which has allowed an increase to 15watt of single ended power, also the 869 can be used as a power amp. Don't be fooled by its modest power output this amp drives real world speakers. price £2100.99

Ear 8L6 Integrated/Pre-main amplifier

Using 8 EL34 power valves to produce 50watt per channel in push pull class A with in-house designed output transformers. The 8L6 has been designed to meet a wide variety of needs from the most demanding of audio files to the professional seeking high quality monitoring equipment in the studio field. Valve life is long and replacement cost are modest. There is also a balanced power amp version with monoblocking capabilities to produce 100watt per channel. Price £2199.00

LIMITED PERIOD

Part Exchange your existing equipment against any Ear product and it will be valued at private prices not usual dealer rates.

"HARMONIC TECHNOLOGY SINGLE CRYSTAL CABLE" NOW IN STOCK - AT LAST I HAVE A CABLE TO DO ALL THE THINGS THE MANUFACTURE CLAIMS AND AT A RIDICULOUS LOW PRICE - PHONE FOR MORE DETAILS

NOW DEMONSTRATING ATC CLASS A ACTIVE 10 SPEAKERS WITH SA2 REMOTE PRE AMP AT A VERY ATTRACTIVE PRICE

Used Equipment For Sale

Quad 606 MKII power amp £295
 Quad 66 Tuner with remote £295
 Quad pre amp with remote £295
 Quad 66 CD player £325
 Audiolab 8002B black finish £485
 Audiolab 8000S pre £1195
 Audio Innovations 2nd audio mono blocks superb sounding £1250
 Horning one spk lowdist drive units, Birch ply cabinet wonderful with low power valve amps £795
 Linn LP12 with Lingo 2 Cirkus bearing recent service £795
 Ortono Rotemas cartridge low hours £695
 Top McLaren 120 Tuner £150
 Musical Fidelity 100A int amp £95
 Troughline Tuner 3 £995
 Tube Technology prophet 2 box pre with rare MC stage new £2700
 Quad 44 pre old style £195
 Mission 753 rosewood speakers boxed £2350
 Teac VRD57 CD player £350
 Audio Innovations series 800 valve power amp £95
 Sugden A48 £235
 Leak Troughline stereo Tuner GT upgrade £85
 Cyrus I integrated amp £75
 NAD 4020A Tuner £75
 Copeland CS48 integrated amp as new £825
 Theta chroma DAC £575
 Theta progeny DAC £1750
 Graaf DTL power amp 3 months old £1795
 Primare 120 FM Tuner £395
 Marantz KI Signature 83 CD player MKII £250
 Fons CD30 with Mission tonearm 78rpm facility £250
 Revox A78 Tuner & A78 int amp £295
 Haybrook Serfati £450
 Magnephaner 3.3R outboard crossovers awesome new £3500
 Quad 77 int amp grey/blue finish £275
 Sony 321 ES2 10kg monster & very fine player new £800
 JBL T12k boxed un-opened new £1600

Marantz CD85 "Martin Colloms rave review" rosewood end stops 16 bit superb sounding player £295
 Naim SBL speakers black finish £695
 Lumley 120 mono block 120 watt per channel £1600
 Kenwood heavy weighted transport £195
 Primare A20 MKII integrated amp new £700 £395
 System Deck IIX turntable UPGRADE YOUR REGA from Art Audio valve pre amp with superb headphone facility without board PSU new £300 £195
 Arcam SR integrated amp as new £1250
 NAD 312 integrated amp boxed mint £795
 Epas M15 floorstanding speakers cherry new model £795
 Musical Fidelity E10 integrated amp £395
 Rogers LS33 with ABS3 £295
 Quad ESL63 black mint with stands £150
 Solstice Advanced Acoustic Design open baffle design speakers outboard crossover with stands new £1000's? £695
 SME V tonearm boxed £350
 ProAc response 25 loudspeakers burr oak finish new £2300 with Target R stands £250
 Rogers LS5 speakers £350
 QLN signature speakers with crossover and stands £95
 Musical Fidelity F25 remote pre £235
 Cyrus III I integrated amp £250
 Tube Technology Genesis 100watts monoblocks re-valved £75
 Kef Reference 1.2 rosenut finish new mint £825
 Pink Triangle Ordinal DAC with filter £250
 Sueden 148 stereo tuner £1750
 Pioneer PD5703 CD player £195
 Pioneer precision CD player £250
 Sonus Fiber Signum boxed new £995
 Audion golden knights 3000 mono blocks new valves £1250
 Revox G36 open reel mint £395
 Conrad Johnson PH10 pre amplifier as new £495
 Audio Research SP14 valve pre amp £1250
 Audio Research CDII cd player £2250
 EAR V20 integrated amp bargain price £1795

EAR 834P £235
 Trilogy valve MC head amp £295
 Michelle DC power supply £185
 EAR 834 L valve line stage £250
 Revox A77 Open Reel £275
 Counterpoint SA 5000 Pre - the ultimate Valve Pre Amp (very rare) £1495
 rosewood end stops new £1500 £495
 QED T-237 tuner £75
 Audiolab 8000A int amp various from £195
 Celestion Diffon 10 bookshelf spk's £95
 KEF K2 bookshelf spk's £95
 Leak Sandwich 250 spk's £95
 Marantz 105 tuner £85
 Nitech power amp £125
 Meridian 206 CD player £350
 Audio Innovations LZ valve line stage £925

Due in

Haim Aro Tone arm £1195
 Pve Pamphonic KT88 power amps £125
 KT88 power amps, PA4 power amp £995
 Mark Levinson 26 229 £795
 Audio Research V7100 MKII power amp £1350
 Audio Research remote integrated amp £995
 Quad II monoblocks consecutive serial numbers £295
 various centre speakers £50
 Sonab omni directional speakers £165
 Gale 401 chrome ended speakers with matching stands £250
 Garrard 301 £995
 Linn LA100 power amp £1250

Various hi-end interconnects and speaker cables PRICES TO CLEAR

Selected products from: ATC, Audio physic speakers, Ear Yoshino, Nottingham Analogue, Creek, Triangle, Sugden, Dynavector

ERGO ago-go

Mail order service for quality Swiss headphones
 Free next day delivery hotline 01924 406016

ERGO MODEL ONE	£109.00	=====
ERGO MODEL TWO	£149.00	=====
ERGO MODEL AMT	£599.00	=====

ERGOPHONES are designed for fatigue free listening and can be used for many pleasure filled hours without discomfort. Acting as a true earspeaker, they have a wide bandwidth capability coupled with low distortion figures of less than 0.30%.

All music types are replayed beautifully, offering a remarkable near-field listening experience. We guarantee superb sound quality at sensible price points.

More info available at www.precide.ch and info@audiosynergy.co.uk

Distributed in the UK by Audio Synergy Limited

SUGDEN HEIL AMT PRECIDE MDM ACE ERGO JECKLIN FLOAT

Private Ads

Dealers must not advertise in the Private Classified section. Monthly consecutive insertions will be considered Trade advertising. The Publisher reserves the right to judge submissions.

THIEL CS 3.6 speakers high end US audio, regarded as one of the worlds finest dynamic systems. Boxed in mint condition £2800 ovno. (5K new). Tel: 01903 507489 or 07881 550627 (May/I)

LEAK FM Troughline 3 mono tuner, Radford FMT2 stereo tuner, Meridian pre/amp also Sansui Sony A&R Cambridge Mission 771 amplifiers, chokes available for vintage amps EMI BTR2 ex BBC offers. Misc speaker cones - offers. Tel: 0131 332 7536 (Apr/I)

LATEST dcS DELIUS DAC, less than one year old and perfect with Meridian 500 transport. State-Of-The-Art CD playback was £7,000 new - now a rare bargain for £4,700 ono for both. Tel: 020 7643 3948 or 07974 353 885 (Apr/I)

MERIDIAN 518 digital preamp/resolution enhancer with Meridian system remote £500 (£1300). Audio Synthesis DAX, balanced and unbalanced outputs, £750 (£3000). Audio Research VT100 MkII £3200. Offers. Tel: 0131 225 9002 or Email: S.Hussain@ed.sac.ac.uk (Apr/I)

WADIA 3200 transport DPA PDM2 DAC (Deltrans modification) (£4200) £1595. B & VV 801F (£4000) £995. Tel: 01277 211685 or 07966 267404 (Apr/I)

ONE PAIR KLS 10 high tech mini monitor, gold dome, mahogany veneer plus KLS10 sub woofer plus Target stands £460. Tel: 0115 975 4070 (Nottingham) (Apr/I)

ROKSAN CASPIAN amp £395. Exposure 21 Pre: £495 and 2 Super 18 Powers: £450 each; £1300 all three. All mint.(swaps). 2x3 mtrs QED Genesis £95. All ovno. Tel: 01622-746425 or Email: cheri@offcampus.net (Apr/I)

MANA SOUND bases £100, Rega Planer 3 RB250 £150. Lexicon CPI processor £200, Deltec Little Bit £80, Sony CDP 101 CD player £50 Leak FM tuner £40, Rotel RCD 965BX CD player £80 Electrostatic headphones wanted. Tel: 07967 182 599 (Apr/I)

ATC 50 Active SL. Rosewood finish. Boxed, paperwork. List £7900. Sell £3400. Meridian 200 transport with £400 worth of Trichord modifications. Sell £350. Illuminati D60 available. Offers. Tel: 0131 225 9002 or Email S.Hussain@ed.sac.ac.uk (Apr/I)

AUDIO NOTE Zero transport, Audiocom clocked + Q Power. Dac 1.1x as new £850. Will split. Audio Note Dac 3.1x Sig, military spec valves + silver foil caps as extras, latest, 3 months old £1850. Loricraft PSU 80 same as PS. mains con. £850 excellent. Lynwood Mega Pure Power conditioner 1000VA £190. PHY/HP phono-phono 1.2 metre £100. ES Lab DX S4 Class T power amp, as new, black, latest case work £2000. Tel: 07900 918 882 (Apr/I)

TACT MILLENIUM Mark 2 amplifier, as new, was £7,500 retail. Only £1500. Call 07774 703030. Tannoy Kingdom, top of range speakers. £25,000 new, approx 1.5 years old, £7,000. Tel: 07774 703 030 (May/I)

NAD C350 amp, only weeks old £200 (£300). Marantz CD6000 OSE £175 (£300). Yamaha NS200 speakers £200 (£300). All light use, mint, boxed, manuals. Tel: Anthony 0115 912 9855 (Nottingham) (Apr/I)

LEAK TL12+ monoblocs, refurbished £250. Two Leak pre-amps £30. One pair Leak Sandwich speakers £35. Thorens TL166 turntable £60. Tel: 01744 755 434 (Apr/I)

NAD 3020A £60. Rega drive belt £1. MP10 Boron cartridge £12. MP10 Boron cartridge £12. Tel: 01656 657 484 (Apr/I)

MANA ACOUSTICS 5 tier hi-fi rack system in as new condition. Original box and packing available £425. Tel: 01952 691 190 or Email: micksandra@btopenworld.com (Apr/I)

MISSION 782 colour beech excellent sound, excellent condition, Hi-Fi World reference speaker, highly reviewed. Also packaging and instructions. 8 months old. Upgrade forces sale. Offers around £450. Tel: 0151 334 8721 (Apr/I)

ARCAM FMJ 23 CD player. Boxed, one year old £800. Wilson Benesch 'Orator' speakers in red cherry. Two years old in perfect condition £1400. Tel: 01303 863 424 (Apr/I)

LINN ISOBARIK speakers, early DMS with internal crossovers £395 ono. May swap or P/Ex for Naim NAPI80 Hi-Cap Nat02. Tel: 01932 820 825 (Apr/I)

ATC SCM 20 'SL' rosewood with 21" slate stands, mint condition, boxed, can demo, new £2500, now £1200 ono. Tel: 02380 470107 (Southampton) (May/I)

IMPULSE H2 Horn loudspeakers (light cherry stained ash), high sensitivity with big clean, relaxed and dramatic sound £1250 - very reluctant sale from original owner (Essex/M25 area) Tel: 01992 813956 home 0207 242 5532 work, Email: mike_hannibal@lineone.net (Apr/I)

COPLAND CSA28 integrated amplifier £599 ono. Tel: R. Burton 0774 8457422 (West Sussex) (Apr/I)

PAIR IMF TLS 50 Mk2 transmission line floor-standing speaker with stands. Real light oak veneer, excellent condition, genuine reason for sale. Best offer secures. Buyer collects. Tel: 01787 269 559 (Sudbury, Suffolk) (Apr/I)

LINN SONDEX LP12 with Basik LVX arm £400. Quad 44 pre-amp & 405 amplifier £400. Quad FM4 receiver £150. All 1983 with boxes. Nakamichi BX2 cassette £100. Pair IMF Electronics monitor speakers with stands (£110). Pair Mission 751 speakers (2 years old) £150. All in excellent condition. Tel: 01488 648 954 (Hungerford, Berks) (Apr/I)

LINN LP12 Trampolin Lingo Ekos K9 excellent condition £1200. Ittok LULL mint £250. Linn Sara 9 speakers and stands, mint £350. Naim 32.5 £150. Hicap £395. Nap250 £595. Nat101 tuner £495. Tel: 0121 422 4371 (Apr/I)

CONRAD JOHNSON PV Twelve valve pre-amplifier. All triode, zero feedback, includes excellent phono stage just revealed boxed with manuals £950 (£2600). Quad 303 serviced £90. Tel: 01424 755375 (East Sussex) (Apr/I)

NAIM CD3 £450. Hicap £400. NAP 140 £400. 42.5 pre-amp £110. All excellent condition. Boxed. Will consider offers. Tel: Dave 01744 894787 Email: daveb@billwig.freereserve.co.uk (Apr/I)

NAIM NAC 102 pre-amp with NAPSC power supply £750. NAPI40 power amp £395. CDI CD player £695. Buyer collects. Reasonable offers considered. Tel: 023 925 96162 South Hampshire (Apr/I)

MERIDIAN CD 588 mint boxed manuals £1400. Tel: 01628 626085 (Apr/I)

Classified Ads

Classified Ads

HEATHCOTE AUDIO

TEL: 01992 653999 MOBILE: 07860 511111 E-MAIL ADDRESS: HeathcoteAudio@aol.com

VALVE AMPS

JADIS J480 CLASS A MONOBLOCS (WERE £10 000) RE-VALVED SUPERB
NESTAROVICH LABS 150 WATT MONOBLOCS (VERY RARE)RE-VALVED ETC
AUDIO RESEARCH LS7 PRE-AMP
WILSON RESEARCH SIMPLY FIDUR INTEGRATED
COUNTERPOINT SA-20 VALVE HYBRID 2 X 200+ WATTS (BRIDGEABLE) X 2
AUDIOVALVE PPP-45 MONOBLOCS (VERY PRETTY)
AUDIO INNOVATIONS SECOND AUDIO TRIODE MONO'S (2A3 VALVES) REVALVED
CONRAD JOHNSON PV10-AL PRE AMP
AUDIO INNOVATIONS 300 INTEGRATED MMMC PHONO (CREAM EXPORT CASE)
AUDIO INNOVATIONS 300 INTEGRATED (BLACK CASE)
AUDIONOTE M-1 PRE AMP (WITH PHONO STAGE) EX DEM
AUDIONOTE P-2 POWER AMP EX DEM
LUMLEY REFERENCE 120 MONOBLOCS TRIODE SWITCHABLE
MONRO ASTY VALVE PRE (VERY PRETTY) NEW
CARY AE - ONE P LINE PRE AMP (EXPOSED VALVES) REVALVED
ROTEL MICH RHC10 PASSIVE PRE
AUDIO SYNTHESIS PASSION PRE (BLACK MARBLE CASE)
MICHAELSON & AUSTIN/MENTMORE TVA-1 KT88 POWER AMP CHROME CHASSIS

MINT £3750
MINT £2495
MINT £795
MINT/BOXED £995
VGC (EACH) £1250
MINT £895
MINT/BOXED £1395
MINT/BOXED £650
MINT £375
MINT/BOXED £295
AS NEW/BOXED £550
AS NEW/BOXED £650
MINT/BOXED £1650
NEW/BOXED £395
MINT £495
MINT/BOXED £375
MINT £350
EXCLT £795

SOLID STATE

ELECTROCOMPANET EC-1 REMOTE INTEGRATED (WITH PRE-OUT) EX DIS/DEM
ELECTROCOMPANET AW-60 POWER AMP (60 WATTS CLASS A) EX DIS/DEM
SUGDEN AU-51P CLASS A POWER AMP (HIGH BIAS) NEW EX DIS
SUGDEN P-41 PRE/ALU-41 POWER AMPS
AUDIOLAB 8000-MONOBLOCS
AUDIOLAB 8000-C PRE AMP
AUDIOLAB 8000-C PRE-AMP
LINX STRATOS PRE AMP & 2X 120 WATT MONOBLOCS MM/MC ETC (VERY RARE/GOOD)
MISSION 776/777 BATTERY PRE & MATCHING POWER (VERY RARE INC MANUALS)
MAGNUM REFERENCE MP 125 PRE & 2 X MF125 MONOBLOCS(140WATTS)
LINN LK-1/LK-2 PRE/POWER & REMOTE
NAIM NAC-62/NAP-90 PRE/POWER
MUSICAL FIDELITY THE PRE-AMP & 2 TYPHOON BRIDGEABLE POWER AMPS(BALANCED)
MUSICAL FIDELITY 3B PRE/P-140 POWER
MUSICAL FIDELITY MVT 2 BOX PRE AMP
MUSICAL FIDELITY 2 X P-180 POWER AMPS & CRPS PSU
MUSICAL FIDELITY P-180 POWER AMP
TAG MACLAREN 60-I INTEGRATED FEW HOURS USE ONLY
EZO ARIA REMOTE INTEGRATED (VERY PRETTY) AS NEW- FEW HOURS USE
ARCAM DELTA 290 REMOTE INTEGRATED
ECA VISTA PRE AMP(SUPERB)
MUSICAL FIDELITY 3A PRE AMP
DENON 2500 DIGITAL PRE AMP (HAS ONBOARD DAC)
THRESHOLD FET-2 PRE AMP
DPA ENLIGHTENMENT REMOTE PRE AMP (LIGHT DEM USE ONLY SUPERB)
LINN PRETEK PRE AMP
ION SP1 PRE-AMP & X-PACK-2 SEPERATE POWER SUPPLY
MUSICAL FIDELITY P180
AUDIOGRAM P-1 W02 ITALIAN POWER AMP (2X 45 WATTS) BRAND
HARMAN KARDON 2100 POWER AMPS X 2 (BRIDGEABLE MONO'S)

AS NEW/BOXED £750
AS NEW/BOXED £750
MINT/BOXED £795
MINT/BOXED £795
MINT £895
MINT/BOXED £325
MINT/BOXED £295
MINT £895
MINT £895
VGC £695
VGC £350
MINT £450
MINT £550
EXCLT £350
MINT/BOXED £450
MINT/BOXED £895
EXCLT/BOXED £395
AS NEW BOXED £425
MINT/BOXED £350
MINT/BOXED £225
AS NEW/BOXED £550
MINT/BOXED £195
GC £175
GC £325
MINT/BOXED £495
MINT/BOXED £195
MINT £195
VGC/BOXED £395
NEW/BOXED £250
EACH/BOXED £200

CD

TECHNICS SLP-2000 REFERENCE CD PLAYER (BALANCED & PHONO OUT)
ARCAM 8 CD PLAYER
ARCAM DELTA 70.2 CD PLAYER DIGITAL/VOLUME OUT
MYRIAD T-10 CD PLAYER
AUDIONOTE CDT ZERO TRANSPORT EX DEM (£549 NEW)
AUDIONOTE DAC ONE 1-X 18 BIT/96kHz EX DEM (£749 NEW)
ROTEL RDD/980 TRANSPORT (1 MONTHS USE)
ROTEL RDP/980 DIGITAL PROCESSOR (1 MONTHS USE)
ROKSAN DP1 5 TOP LOADING TRANSPORT
ARCAM DELTA 170 TRANSPORT
ARCAM BLACK BOX -500
ARCAM BLACK BOX-50 DAC
ARCAM BLACK BOX 3 DAC
DPA ENLIGHTENMENT DAC
AUDIOLAB 8000 DAC
AUDIONOTE DAC-1 (BLACK/GOLD) EX DIS
THETA CHROMA 396 DAC HDCC
TEAC D-TI DAC
MERIDIAN 203 DAC
ORELLE DA-188 DAC
WOODSIDE DAC 1
MUSICAL FIDELITY X-10D THE MISSING LINK

MINT £595
VGC £250
MINT/BOXED £195
MINT £275
MINT/BOXED £375
MINT/BOXED £475
MINT/BOXED £295
MINT/BOXED £295
MINT/BOXED £575
V G C £225
MINT/BOXED £425
MINT/BOXED £225
V G C £125
MINT/BOXED £475
MINT/BOXED £425
AS NEW/BOXED £495
MINT/BOXED £575
BRAND NEW BOXED £250
MINT £175
MINT/BOXED £300
MINT/BOXED £165
MINT £85

VINYL

PINK TRIANGLE PT TOO & PSU (WALNUT/BLACK LID)
DAIS TURNTABLE (GOLD STUNNING LOOKS VERY RARE)
PROJECT 6 TURNTABLE & ARM/NEW GOLDRING 1022 CARTRIDGE
STD 305M TURNTABLE & MAYWARE ARM
TECHNICS SL-110 CLASSIC TURNTABLE
BURMEISTER B38 LEGENDRY PHONO STAGE & PSU BALANCED/PHONO OUT (CHROME)
DPA DSP 200S-D MMMC PHONO STAGE (VERY RARE)
PS AUDIO IIB MM PHONO STAGE
NAD PP-1 PHONO STAGE
COUNTERPOINT SA2 VALVE STEP UP SEPERATE PSU(WAS £1700 NEW)
ORTOFON T-10 STEP UP
AUDIO INNOVATIONS T-2 MOVING COIL TRANSFORMER

BOXED £395
BOXED £395
V G C £375
VGC £175
VGC £175
MINT £650
MINT/BOXED £295
GWO £175
MINT/BOXED £30
VGC £575
VGC £75
MINT TBA

AUDIO INNOVATIONS 1000 IMPEDANCE MATCHING TRANSFORMER
MARANTZ SK-72 DIGITAL SCRATCH SUPPRESSOR
HELIOS ORION 10 INCH TONE ARM

MINT TBA
MINT £275
MINT/BOXED £325

LOUDSPEAKERS

B K S 107 MK 2 RIBBON HYBRID FLOORSTANDERS (HIGHLY REVIEWED)
AUDIONOTE ANE-SP SILVER WIRED BLACK ASH
AUDIONOTE ANE-SP AMERICAN OAK FINISH EX DISPLAY (NEW £3000)
SNELL TYPE E MK3 VERY RARE
TANNQY ARDEN'S 15"
TANNQY ARUNDEL 15" DRIVERS 92/95 DB SENSITIVE VERY RARE
TANNQY PAIR 12"HPD DRIVERS + CROSSOVERS
SD ACOUSTICS SD-OBS (SMALLER BROTHER TO SD-1 TRI-WIREABLE)
CELESTION 7000'S 4FT HIGH RIBBON TWEETER VERY RARE (WERE EXPENSIVE)
MISSION 753 FREEDOMS
PROAC-3 STUDIO MONITORS (ATC DRIVERS) WALNUT
PROAC-2 MONITORS (ONE OWNER)
PROAC SUPER TABLETTS
CASTLE SEVERN MARK 2
CASTLE EDENS
INFINITY REFERENCE STANDARD KAPPA 5 EMIT RIBBON TWEETER SANTOS ROSEWOOD
MIRAGE FXR-3 STANDMOUNT FEW HOURS USE ONLY
WILMSLOW AUDIO VORTEX VOLT DRIVERS PIANO BLACK EXT X OVER
ROYD EDENS
SPENDOR BC-1 CLASSIC BBC BASED SPEAKER
MORDANT SHORT MS20 PEARL (LIGHT FINISH)
IMF PROFESSIONAL MONITOR VII (NEW/UNUSED) PLEASE PHONE FOR DETAILS
IMF TLS 80'S CLASSIC TRANSMISSION LINE (ONE OWNER)
SEQUENCE 400 WALL MOUNT/FLOORSTANDING SPEAKERS

MINT/BOXED £1250
MINT £1095
AS NEW/BOXED £1750
MINT/BOXED £995
MINT £895
MINT £1095
EXCLT £225
MINT/BOXED £675
MINT/BOXED £675
MINT/BOXED £475
MINT £795
MINT £350
VGC £225
MINT £450
MINT/BOXED £395
MINT/BOXED £475
AS NEW/BOXED £195
£475
VGC £275
GC £175
MINT £95
MINT £450
NEW/BOXED £250

TUNERS /TAPE

LINX AUDIO THETA TUNER FULL WIDTH (WAS EXPENSIVE) VERY HIGH QUALITY
SONY 730ES DIRECT COMPARTOR TUNER
SONY ST-SE 300 TUNER AS NEW
HITACHI FT-5500 TUNER

MINT £275
MINT £185
MINT/BOXED £70
MINT/BOXED £95

RACKS/STANDS

SOUNDSTYLE XS 105 NEW STYLE (CURVED GLASS) 5 SHELF BLACK OR SILVER EX DIS
SOUNDSTYLE X100 SILVER/BLACK
SOUNDSTYLE AV/TABLE SILVER
SOUND ORG Z545 NEW BLACK FINISH 500MM WIDE
SOUND ORG Z540 NEW BLACK FINISH MIDI SIZE
SOUND ORG Z545 GLOSS BLACK 440MM WIDE
KUDOS S507 18 INCH SPEAKER STANDS SAND FILLED
SOUNDSTYLE SELECT 4 PILLAR 22 INCH SPEAKER STANDS BLACK
TARGET R4 24 INCH LOUDSPEAKER STANDS VERY HEAVY
ATTACAMA R724/ATTABITE (FEW WEEKS OLD WAS £250)

NEW/BOXED £195
EX DIS £140
EX DIS/NEW £185
EX DIS £110
EX DIS £100
EX DIS £110
GC £50
NEW/BOXED £75
MINT £195
MINT £175

SPECIAL OFFERS

SOUNDSTYLE SPEAKER STANDS * 18 OR 24" NEW/BOXED LAST FEW £50.00 !!!

CABLES

LOUDSPEAKER CABLE

CARDAS HEXLINK 2 METRE PAIR
GOERTZ M1-3 DIVINITY 2.5 METRE PAIR AS NEW/BOXED
AUDIOQUEST CRYSTAL HYPERLITZ 2 X 7 METRE PAIRS (EACH PAIR)
LINN LK-400 2.5 METRE PAIR
DPA IS19 4.5 METRE PAIR
ROKSAN HDC B15 2.9 METRE PAIR X 2 NEW
ROKSAN HDC B15 2 METRE PAIR NEW
SILVER SONIC T-14 (AMERICAN) 2.4 METRE LENGTH

£325
£395
£200
£75
£195
£35
£25
£50

INTERCONNECT

DPA BLACK SLINK 1/2 METRE £80/95
LINDSAY AUDIOPHILE SATIN GRAY (AMERICAN NEW/PACKED WAS £480) £200
OED QUNEX SILVER SPIRAL 0.5 METRE PAIR (PACKAGED AS NEW) £50
AUDIOQUEST RUBY 1 METRE £50
VAN DEN HUL MCD 102 MK111 SPECIAL 1 METRE £60
YFERA 1.5 METRE PAIR £50
SHARKWIRE BRAND NEW 1 X 3FT 1 X 2FT 2 X 1/2 METRE ALL NEUTRI
XLR BALANCED TERMINATIONS £200 THE LOT
BEYER MICROPHONE CABLE 2 X 1 METRE PHONO PLUGS £30 EACH

DIGITAL

VAN DEN HUL AES/EBU £40
AUDIOQUEST AES/EBU PRO £60
AUDIOQUEST OPTILINK X TOSLINK £40
AUDIOQUEST AES/EBU PRO BALANCED 14 INCHS £75
BELDEN-M DATATWISTER AES/EBU 1 METRE £65
AUDIOQUEST VIDEO LINK 0.8 METRE £25
OED QUNEX P-75 (1 METRE) £25
DPA COAX DIGITAL CABLE £25

MOST EQUIPMENT STOCKED IS ONE OWNER MINT/BOXED, SIMILAR QUALITY VINTAGE AND MODERN EQUIP-
MENT REQUIRED FOR IMMEDIATE CASH PURCHASE.THIS IS A SELECTION OF STOCK FOR A FULL CURRENT
LIST PLEASE PHONE/E-MAIL GEORGE. MAIL ORDER A SPECIALITY

www.soundsexpensive.com

Hi-Fi & Audio Consultants, Sales and Service

Buy What Hi Fi's Award
winners at the cheapest prices!

QUAD ESL 63 speakers, serviced by Quad, with Quad speaker cables £1100. 66 pre-amp and control panel £350. 606 power amp £350. All immaculate. Tel: 01993 883523 (Apr/I)

TUBE TECHNOLOGY Fusion CD player valve excellent condition, Audiocom S. Clock upgrade, over £350 worth, including Black Gates £800. Tannoy Ardens/ Sinch cones excellent condition £650 ovno. 01634 723 223 (Apr/I)

MARTIN LOGAN Scenario speakers mint £1100 (£1900). Unison Research Simply Two integrated amp mint bargain £395 (£995). Russ Andrews The Silencer x 4 £20 each (£40). Tel: David 01491 572684 days (Apr/I)

NAIM NAC 112 pre-amp. NAP 150 power amp CD5 CD player all brand new, unopened, genuine reason for sale, cost £2500 sell £1875. May consider split. Tel: 01634 268071 (Kent) (Apr/I)

AUDIO ALCHEMY DTI 2.0 with Power Station Four £250. DDE 3.0 and DTI Pro 32 with Power Station Three's £450 and £500 respectively. Audio-Pro BI-45 subwoofer £100. Tel: 01642 559078 (Stockton) (Apr/I)

CROFT CARISMA Elite pre-amp modified £400. Thorens TD124 MkII Mentor arm NoI cartridge £600. Leak Stereo 20s monoblocs modified £600. Decca Blue cartridge new £350. Shure V15 cartridge new £150. Records all sorts £5 each. Tel: 02476 327948 (Apr/I)

AUDIO SYNTHESIS DAX Decade DAC. Legendary detail resolution/bass control. 24/96 upgradable. Remote volume control, crystal display. Mint, boxed. Bargain £1395 (£3000). Sugden AU51 DAC Crown Chipset. Stunning, bargain £349 (£1250) Tel: 01865 862745 Leave message (Apr/I)

MICROMEGA TEMPO P pre-amp. Tempo 'amp' power amp, 'detailed and musical', said What Hi-Fi?, circa '97 mint boxed (£2500) £750. Genuine reason for sale. Tel: 0121 246 048607946 340588 (Apr/I)

ACOUSTIC SERIES 3311 studio monitors. Brand new boxed £400. Tel: 0208 343 1576 / 07946 340588 (Apr I)

COMPLETE SYSTEM Marantz CD-63 MkII Sig. Marantz PM-66SE Sig amp KEF Q35 speakers £400. Or £150 each plus Tannoy 631 SE speakers £75. Musical Fidelity X10-D missing link £80. Tel: 01438 221477 (Apr/I)

AUDIONOTE 300B Kit amplifier professionally built using Blackgates, paper in oil capacitors 12 watts superb £325. Mission 775S turntable. Mission arm Grado MM mint £300. Atacama Europa 5 tier stand £125. Tel: 01923 224404/07930 524246 (Apr/I)

GYRODECK BLACK bronze RB300 mint £775. Sumo Athena pre-amp £275. KEF 104/3 walnut £325. Ion Nexus system including MA50 100 watt amps £300. JVC Monster amp. 150 w.p.c. £225. Tel: 01362 687615 (Apr/I)

LINN KEILIDH speakers, walnut plus bases excellent condition £250, 2 x 5m biwired NAC A5 £25. Ringmat £20. Tel: Martin 01986 895631 (Apr/I)

NAIM CD5 and Hicap £750/£490 less than one year old vgc. Royd Abbots black £250. Tel: 01633 669797 South Wales. Email: antonyclark@tinyworld.co.uk (Apr/I)

LS3/5a KEF Reference Series model piano black limited edition 35th anniversary 500 pairs produced mint boxed £790 also LS 3/5a Rogers teak mint bi-wire £400 (15 ohms) LP12 Ittok LV II mint £500 Tel: 01707 392063 (Apr I)

PURIFIER BLOCK/KORD £400. 8TC speaker cable 4.5m pr £300. KCAG 0.5m pr £100. Linn silver interconnect 1.5m pr £100. LK400 5m pr £50. Russ Andrews Torlyte speaker platforms 275mm x 200mm x 32mm £120. Tel: 0790 552 1340 or 0208 926 6916 (Apr)

MARANTZ CD63SE CD player. Sounds great, very good condition £125. Tel: 01494 580640 (please leave message) (Apr/I)

ROKSAN XERXES, Artemiz arm, Shiraz cartridge £700. Siemel MC20 phono, stage £300. Yamaha surround sound processor DSP-800, £150. Pioneer DVD player DV717, £150. Tel: 01454 418997 South Gloucs. (Apr/I)

CHORD 3200 pre-amp. £2200 Chord I200c power amp £2200 Chord phono. £800 Trichord power supply £150. Tel : 01706 223820 (Apr)

TEAC P-700 CD transport, excellent, unmarked condition, five stars 'What Hi-Fi 1994 (£900+), superb sound with good DAC/digital recorder/amplifier £425 ono. Tel: 07941 923881 or 01273 698793 (eves/weekends) (Apr/I)

LIVING VOICE Auditorium Avatar OBX-R speakers, cherry, mint condition, hardly used, boxed, £4000 new, accept £2800 ono. AVI Biggatron speakers, cherry finish, excellent condition, £275 ono. Tel: 0208 566 0424 or 07780 553828 (Apr/I)

DENSEN B-400 CD player 15 hours use immaculate £715 (RRP £1275). Tag McLaren 60i RV integrated amplifier unused immaculate £455 (RRP £999). Koetsu Red unused immaculate offers. Tel: 01531 670525 (Apr/I)

LOUDSPEAKERS WANTED - LS3/5a Harbeth or Rogers. Excellent condition essential. Tel: 01394 388399 (Apr I)

MICROMEGA DRIVEZ/DAC with XLO Reference interconnect: £750; Audiolab 8000A (91): £250 MA monitor fourteen gold (deflex + mass-loaded): £250 boxed/manuals: £1000 inclusive. Tel: 07778 591188. Email: howard.sherwood@btinternet.com (Apr/I)

QUAD 34 pre-amp, grey £195. Quad 306 power amplifier, grey £195. Tel: 0208 554 1431 (London) (Apr/I)

RESTEK "VECTRA" pre-amp and Z (two) monoblocs £900. Heybrook Sextet speakers £350. Celestion 700 speakers £350. Quad FM4 £130. Tel: 0207 357 9350 Email: j.kelt@lse.ac.uk (Apr/I)

CERWIN- VEGA AT-100 15" 3-way 400w £500 ono. Rogers Studio IA £400 ono. Dual 1209 £50. Garrard SP25 offers record decks, with plinths, Philips VLP700 laserdisc player with some discs £100. Tel: 01467 624565 (Apr/I)

FOR SALE. AVI S2000 monoblock amps, mint, boxed £650. Trichord Dino MM/MC phono amp as new £180. Audio Technica AT24 cartridge re-tipped, low mileage and boxed £30. Tel: 01903 247779 Sussex (Apr/I)

MERLIN MUSIC V.S.M. loudspeakers. Stereophile class A exceptional Dynaudio Esotar 330 tweeter. Cardas wired. Read the outstanding reviews. Email: www.merlinmusic.com. \$7100, asking £3800. Tel: 01296 437314 (Aylesbury, Bucks) (Apr/I)

2 X CREEK 52SE mono power amps £650. Creek passive pre R80 DNM Reason interconnects £30. Marantz CD-63 MkII KI-S £150. Creek MC SE head amp £80. Tel: daytime 01582 693178 evenings 01727 850904 (Apr/I)

PROAC RESPONSE 2 speakers unmarked £750. Target R2 stands £130. Dynaco Stereo 70 £350. Garrard 401 in Aphellion plinth £295. Hadcock 242 SE arm, 6 months old £360. Atacama Europa 5 tier stand (£299) £125. Tel: 01923 224404 or 0208 908 4633 (Apr I)

NAIM 102 NAPSC 180 523 phono boards with Russ Andrews KCAG 4 pin din .5m interconnect. Oak cones and 2 x high current power chords £1600. Tel: Dave 01639 894247 (Apr/I)

HARBETH HL-K6 standmount speaker walnut bi-wire superb (£980) £599 Mission 754 Freedom-Fives oak mint boxed (£1400) £649. Sony TA-50ES amplifier black remote 10 months old boxed (£849) £449 Tel: 0115 960 3934 (Apr/I)

upgrade your turntable

"It's value is nothing short of tremendous"
LISTENER MAGAZINE

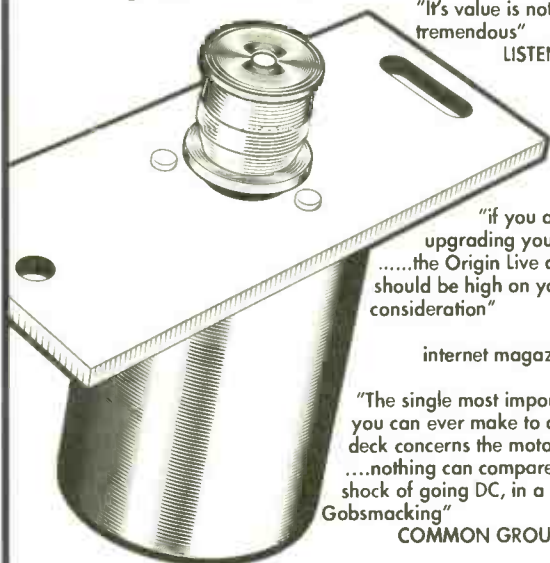

"if you are thinking of upgrading your system,the Origin Live dc-motor kit should be high on your list for consideration"

TNT AUDIO internet magazine April 2000.

"The single most important upgrade you can ever make to any record deck concerns the motor drivenothing can compare you for the shock of going DC, in a word Gobsmackin'"
COMMON GROUND MAGAZINE

Whether you own a Linn Lingo or a Rega, the results of upgrading to the Origin Live dc motor and power supply are simply astounding. This high grade motor kit is designed as a drop in replacement for almost all turntable motors. Decks benefiting from this ultimate of upgrades include Linn, Roksan, Ariston, Miche, Oracle, Systemdeck, Rock, Rega, Thorens, Well tempered etc. With a 12 Volt power supply it is safe and easy to fit. Guidance instructions are provided. At £262 with fully soldered and tested regulator board and money back guarantee this is a bargain out of all proportion to it's value in terms of performance. A larger purpose made transformer is also available as optional extra at £175.

origin live turntable kit

Now you can save money and build your own high performance deck. The standard parts kit is offered at £282 and is complete apart from a plinth.

The kit comes with a full set of drawings and guidance instructions. It allows for your creativity or there are optional parts that will enable you to assemble a tried and tested design within 1 - 4 hours. The optional parts include items for suspended and non-suspended designs along with sub-chassis etc. The optional parts upgrade the standard kit of parts to high end performance levels and is probably the easiest kit you will ever make.

exceptionally easy to build and professional in both sound quality and appearance .

HI FI NEWS

"this vinyl front-end had my jaw heading towards the floor with the solidity and transparency of the music it was making." "the standard came up with crystal clear images set in a broad sound stage" "with all these goodies in place the Standard would give turntables at the £ 1200 - £ 1400 GBP mark a hard time."
HI FI WORLD

★★★★★

WHAT HI FI

group comparison test of 8 leading turntables.

new breakthrough design laminar flow ultra

Laminar flow cable is a groundbreaking new design of cable. The "Ultra" version outperforms other interconnects at 4 times it's price and the "Reference" is a cable that reviewers use to judge other cables due to it's incredible transparency and musicality.

With a money back guarantee if not satisfied you have nothing to lose. Why not order a pair or see your local Origin Live dealer?

Advanced interconnect:	£45 per stereo pair
Laminar flow Ultra Interconnect:	£85 per stereo pair
Laminar flow Reference Interconnect:	£159 per stereo pair



"A high end sound with a sensible look and price tag"
HI-FI WORLD July 2001
"The Ultra's are a deeply satisfying musical product and a supreme bargain"

STEREO TIMES Aug 2001

turbocharging your rega arm



"Nothing less than total dynamite"

HI-FI WORLD

If you are the proud owner of any Rega arm why not utterly transform it into the league of super arms with the Origin live structural modification:- £75. This modification will enable your Rega to perform at a level exceeding that of arms costing over £1200. Rewiring with high grade litz cable is also offered at an additional £70 and external rewiring is £70.

"I have to say the Rega modifications turn this humble arm into a real Giant killer. Gone is the rather grey, sterile sound of the cooking Rega. Instead, tonal colour is fresh, dynamics have great speed and impact, and the sound stage is huge."

HI FI WORLD SUPPLEMENT NOV 97
(structural modification to an RB250)

★★★★★

WHAT HI-FI MAGAZINE

For arm modifications we normally return your arm in 2 - 3 days

for full information see web site or contact

Origin live, Unit 5, 362b Spring Road, Sholing, Southampton SO19 2PB

Tel: 023 80578877 Fax: 023 80398905

E MAIL: originlive@originlive.com WEB SITE: <http://www.originlive.com>

SMART 300B's single ended Triode's mono-blocs 25 x 25 watts, new/ boxed new 4.5K, sell 2.5K N-T-W. Nikito FM tuner Gamma 40. T/Locked black good condition £40. Tel: 01562 827710, Email: tgd121569@cablenet.co.uk (Apr/I)

PROAC RESPONSE 2 speakers £795. Target R2 stands £140. Dynaco Stereo 70 serviced by GT Audio £375. Garrard 401/ Aphellion plinth £275. Hadcock 242 SE 6 months old £360. 2 x 4.5 mts. Nordost Flatline Gold £80. Tel: 0208 908 4633 (office) Mobile: 07930 524246 (Apr/I)

CELESTION SL6S speakers. Perfect condition. First class. £150. JVC KD25 cassette deck old but perfect condition and excellent quality £50. Call Barry, 07801 619613 or 01635 869668 (Apr I)

AUDIOMECA KREATURA transport mint £700 ono. P/Triangle Ordinal DAC £250. Mission 735 floorstanders £280. B & W ASW1000 sub-woofer £150. B&W CC6 centre speaker £70. All mint vgc. Tel: Sean 01296 334476 evenings. (Apr/I)

COUNTERPOINT SA3000 pre-amp valve hybrid twin plates PSU, boxed, mint, trounces bat's £795. Tel: 01277 211685 (Apr/I)

SME IV arm £695. Klyne MC transformer SKI £295, Thorens TD 125 £195. Sumiko Blue Point cart MC £39. Leak Troughline III tuner A9 needs service. Tel: 01279 452222 work or 07778 181326 (Apr/I)

TUBE TECHNOLOGY UNISIS, pristine condition, boxed, cost £2600, £850 ono. Wilson Benesch Actor speakers, 2 years old, cherry, mint condition £2000, cost £4300. Audio Note ANVZ interconnects 1m The Real One cost £1500, £575 ono. Tel: 01206 298836 (Apr I)

CROFT SUPER Micro pre amp £200. Croft Series 'V' power amp £250. Original styling (1991) from days when Glen Croft built units personally. Tel: 01483 275389 (Malcolm) (Apr/I)

NAIM NAC pre-amp 102 with MC boards. Hi-Cap power supply with NAP 250 power amplifier. Excellent condition £2095 with all leads Tel: 01708 760571 (Apr I)

MUSICAL FIDELITY E624 CD player £250. Musical Fidelity Tubalog valve DAC. Very rare £275. Acoustic Energy AE120 floor standing speakers, black finish £175. Tel: Malcolm 01483 275389 (Apr/I)

TAG MCLAREN AV32R Pro Logic 2 £1700. 5XR £2200. Recent software immaculate condition in black Audiolab CDM T2L upgradable £595, boxed with manuals. Email: mj.007@talk21.com (Apr/I)

MOBILE FIDELITY and other audiophile LPs for sale either sealed, upplayed or mint. Phone or Fax 01623 423389 for list (Apr/I)

V.P.I. HW19/4 turntable, Rega, Dynavector, black, stand alone motor, immaculate £725 ono. May consider p/ex. Audionote MI phono pre-amp £550. May p/ex. Wanted LP12 Vallhala P.S.U. Tel: 0191 422 3415. (Apr/I)

NAIM NAT 03 £210. Quad stereo tuner £100. Slate Audio/Garrard 401 with Slate Audio arm (unused since reconditioned by Peter Soper) £350 (£1250). Mono Decca London cartridge. Tel: Tony 01497 831439. Email: jean@kc3.co.uk (Apr/I)

MAGNUM IAI70 good condition. £100 Leak Troughline 3 tuners good condition. 2 off £50 each. Sherwood ES4060R processor mint £50. Tel: 01706 844835 after 7pm Mobile: 07770 862722 (Apr/I)

ROKSAN ZERZES in rosewood with RB300 arm and AT032 £450. Also Linn Sara speakers with stands in black £250. Tel: 01926 493732 or 07773 223104. Email: andrew.buckley@btinternet.com (Apr/I)

ARCAM ALPHA 9 amplifier (integrated) £300 ono, remote, original box and manual. Tel: Dom 0113 264 5454 evenings or 0113 289 7296 daytime (Apr/I)

WANTED MUSICAL Fidelity MVT Mk1 and power supply (silvercase) sell Audiolab 800C pre-amp £200 ono. Tel: Laurence 01273 605310 (Apr/I)

PASS LABS Aleph 5 power amp. 60W per channel class A perfect condition upgrading £1200 ono. Tel: 0207 469 3450 (Kent) (Apr/I)

CHRIS ROGERS home built PRO9TL floor standing speakers 24 years regular use fair condition £100. Tel: 0116 266 6319 evenings (Apr/I)

SONY X77ES CDP mint £125 (£1000 new). Original packaging manual. Naim 250 power amp traditional case, excellent condition £795 serviced. Naim Audio original packaging manual. Tel: 0208 643 4260 (Sutton) (Apr/I)

WANTED ROTEL RB 850 power amplifier. Must be in excellent condition. Will consider more than one amp/or matching pre-amp. Tel: Neil 07990 562579 (Apr/I)

HOME CINEMA projector, Sharp XV-380H LCD, 60 hours domestic use only, composite and S-video inputs, power focus and zoom, remote, 7 foot screen, 9 metre cable, £750. Tel: 01780 763714 (Stamford, Lincs) (Apr/I)

RADFORD LDMSI low distortion measuring set. Measures down to 0.003% distortion with a +/- 6dB auto-null invaluable tool excellent condition with instructions £350. Tel: Mike 01758 741026, Email: m.davis@virgin.net (Apr/I)

NAIM HI-CAP and Armageddon latest style each £375. Sony Walkman Pro little used £100. Tel: 07860 513729 leave message (Apr/I)

KRK PROFESSIONAL Active near field V8 studio reference monitor speaker £400 (£999). KEF KMS2002 speaker system new £250. VRR EL34 monoblocks amplifier £300. Wilmslow Audio Vogue speakers £350. Tel: 0208 531 5979 (May/I)

COPLAND CSA 14 integrated amp phono 70 wpc new valves £450. Tel: 01827 261082 (Tamworth) (Apr/I)

TAG MCLAREN audio system: CDT20R transport, DAC20 DAC. PA20R pre amp, 125m x 2 monoblocks, selling £3400 ono (£6800), may split mint, boxed with manuals. Tel: Michael 07720 718933. Email: michael.muir-browne@virgin.net (Apr/I)

RARE MATCHED Quad II Complete & Fully Original in VGC condition. Pair of Quad II Power Amps & Gec's and Osram valves. 22 Pre amp with Mullard's & both cans. Quad FM3 Valve tuner. Gold matched ELS57 electrostatic's by consecutive serial no's. Full service by Quad 5 years ago. All original Boxes, Instructions owners manuals, Full service history. Sounds sublime. £1800. Tel: Paul 01322 224269 (Apr/I)

KENWOOD DP-X9010 'Clock 2' transport vgc £200. Systemdek IIX900, RB300, Arcam P77, mint £250. Audio Alchemy Vac-In-The Box, Power Station IV, mint £250. Trichord, Pioneer transport, mint £375. Orelle DA-180 w/balanced output, mint £250. Tel: 07957 344541 or 0118 9671909 (Apr/I)

B+W P4 Floorstanders, rosenut on plinths, rewired crossovers with Chord Odyssey, perfect condition £300 ono. Plus Nordost Super Flatline bi-wire 4m pair 2-4 boxed £150 or £400 if both bought. Tel: 07960 249 566 (Apr/I)

ALPHASON SYMPHONY turntable superior to Sonata £595. Linn Ekos 2 £395. Boxes, manuals. Ekos marked. Horning One Lowther based 3-way light wood £1250. Wanted: Alphason HR-100S with accessories. Tel: 01273 727 476 (Apr/I)

FOR SALE: 4 x Aktiv Klout amplifiers, Pair Keltik Aktiv loudspeakers (black) + cables. Owner upgrading Linn system. £5,500. Tel 0161 766 1021 (Apr/I)



SIEA 3D-LABS CDP, DAC, TRANSPORT AND DVD's 24/192 with SRC sampling rate and bit converter translates 16,18 and 20 bit inputs to 24 bits format. All 32, 44.1 and 48kHz frequency is re-sampled to 192kHz. This is known as upsampling. The SRC is comparable with that used by DCS in the Purcell unit. Prices start from £1110 for a CDP with SRC.



DVD with SRC and CV2 - Video system for unmatched picture quality - best with projection systems . DVD with SRC and CV2 start from £1470. DVD with CV2 £1210.

AUDUSA EUPEN CSA 2.5 MAINS CABLE - HI FI CHOICE SEPT 2001 BEST BUY AWARD



AUDUSA-Eupen CSA 2.5

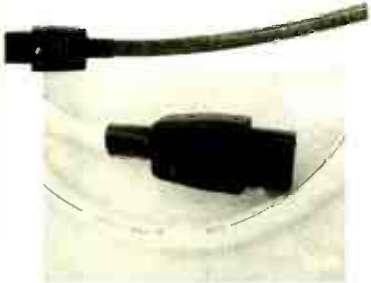

AUDUSA EUPEN GNLM 5.0 mains cable

CSA and GNLM Cable with FERRITE TECHNOLOGY - A polymer material mixed with a considerable quantity of homogeneously fine high quality ferrite powder. This compound is called EMC/COM and it can be extruded around copper conductors. The ferrite itself is a non-conducting material, but it has a very interesting magnetic behaviour. As a ferromagnetic material, it will go through hysteresis loops whenever it is under influence of an alternating magnetic field. Consecutively magnetizing and demagnetizing the material will cause considerable losses of high frequency energy. This energy is absorbed in the ferrite grains and converted into heat. This effect is more or less proportional to the field frequency. By coating conductors with a thin layer of ferrite compound, high frequencies will be strongly attenuated, because their energy will be absorbed by the ferrite powder. This applies to high frequency disturbances that are propagating on the conductor and which we don't want to disturb the environment, as well as to surrounding interferences, which we want to prevent from disturbing the signals on our cable. The CSA cable which in addition to the above described ferrite technology is further protected with a foil shield and a drain wire and specifically manufactured for High End audio use.

£48 for 1.0m
£58 for 1.5m
£68 for 2.0m
off the reel £30
for 1st meter, £20
per m thereafter.

Fitted with IEC (Martin Kaiser) and MK Tough Plug. Figure of eight, 16 amp IEC, Bulgin etc also available as well as USA, European Schuko, and other mains plugs. Cable can be supplied fitted to our all steel 4, 6 and 8 way distribution blocks. We can rewire the distribution blocks with Eupen cable as an extra cost option. Refer to our web site for details.

L A T INTERNATIONAL NJ USA - all cables now with SILVERFUSE conductors

LAT AC-2 HI-FI CHOICE - SEPT 2001 - RECOMENDED MAINS CABLE

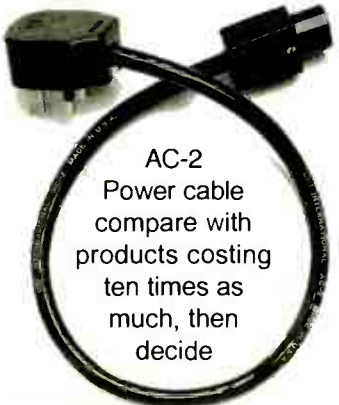

AC-2
Power cable
compare with
products costing
ten times as
much, then
decide



LAT AC-2 Power cable. We have developed a cabling (weaving) pattern along with an unusual shielding/filtering system that gets rid of the garbage that contaminates your components. The difference you hear with our cord is astounding. Our power cord takes advantage of silver in its design through use of our proprietary Silverfuse conductors. The conductors are 10 gauge and insulated with Teflon; the best insulation available. Fitted as standard with an IEC and MK Toughplug. Other connectors are available incl Schuko, 16 amp IEC, Figure of eight etc. 2ft £56, 3ft £68, 4ft £78, 6ft £99. other lengths available and off the reel at £39 per meter. SE version available with GP Tough plug and IEC, outer black braid all for an extra £12 irrespective of length **4,6 and 8 way all steel mains distribution blocks** fitted with UK, Schuko or USA type sockets. CE tested and approved mains distribution units manufactured out of heavy gauge steel, finished in black and fitted with high quality Wadsworth 13amp sockets. It has no filters, circuit breakers, surge protection, transformers, resistors, capacitors, LED's, on/off switches, chokes, regulators, just fitted with 3ft of LAT AC-2 mains cable. From £161 for 4 way, £194 for 6 way, £226 for 8 way.

NEW GOLD MK Tough plug with gold plated pins (£14)
Otto Heil IEC with gold plated contacts (£10).

SILVERFUSE is a near alloy of silver and copper. IT IS NOT SILVER PLATED OR SILVER CLAD. Plating (or clad, which is the same thing as plating) causes a dioding effect when signal is passed through resulting in brightness and distortion. The Silverfuse process starts with seven nines OFHC copper wire with a diameter that is slightly larger than the required size. It is then pulled through a trough of molten silver. The wire with a silver deposit, is then forced through a compacting die where it is subject to tremendous pressure. The silver and the high purity copper are fused together into a near alloy. The compacting fusion also reduces the wire diameter to the desired size. No dioding subsequently occurs with this process. The result provides for the benefits of silver; which are excellent definition and clarity, with the high purity copper benefits of warmth and mellowness.

LAT AC-2 mains cable available with 16 amp IEC (MF, KRELL etc), Figure of eight, Bulgin, USA mains and European Schuko plugs. Check our web site for available variants.

LAT INTERNATIONAL - Analogue, Digital and Video interconnects and Speaker cable. Refer to www.audusa.com for further details or ask for reviews etc

SUNFIRE CORPORATION



New Sunfire True Sub Woofer MKIV 11 inch cube 220v. Signature True Sub Woofer 13 inch cube 220v. Junior Sub Woofer 9 inch cube -all with two drivers, 16-25hz, 1200 -2700 watt patented amp technology. Classic Tube Pre-amp, Solid state power amps 2 channel (300 x 2 or 600 x 2) and 5 channel (220 x 5 or 430 x 5) patented amp technology and Theatre Grand processor pre-amp.



Trade Ads

Dealers must not advertise in the Private Classified section. Monthly consecutive insertions will be considered Trade advertising. The Publisher reserves the right to judge submissions.

VINTAGE WIRELESS
 COMPANY LONDON
 Website: www.vintagewirelesslondon.co.uk
 Buy-Sell-Exchange. Vintage wireless and classical audio. Repairs, spares, restoration, modification to all valve equipment. Quad II, Leaks etc, shipped worldwide, best prices, call us at 17 Bell Street, London, NW1 5BY. Tel: 020 7258 3448
 Fax 020 7258 3449 Email: vwirelesslondon@aol.com (Oct02(I))

WANTED - EARLY HI-FI LOUDSPEAKERS
 Tannoy, Lowther, Parmeko, Voigt, Vitavox, RCA WE etc
TURNTABLES
 Garrard, BBC301, EMT SME, Ortofon, Decca, etc.
VALVE AMPLIFIERS
 AEI, EMI, Leak, Rogers, PYE-Quad, WE etc
AUDIO VALVES
 DA30, KT66, KT88, PX4, PX25, PP3/350, WE300
CLEAR CRYSTAL SYSTEMS
 John Petrie-Baker
 Tel: 020 7328 9275

AMAZING INTERCONNECTS! Hand built pure silver cables with world class connectors. Fantastic performance, money back guarantee. £105 per metre pair, £5 p&p. Other lengths available. Details: 0115 982 5772 after 7pm, Email: Bob@skydivers.co.uk (Apr(I))

DX4/EX4 LOWTHERS Half Price, ex-demo. Less than 100 hours. 1 pair of each. Surplus to our requirements. Tel: 01483 268 814 or email: info@hornutopialoudspeakers.co.uk (Apr(I))

MOTIONAL FEEDBACK sub-woofer -3db at 12Hz! No muddiness. Sharp uncoloured bass from a shoebox. Easily interfaced with your system. Small footprint, volume only 29 Litres assembled £599. Kit £499. Details 01243 532464 (Apr(I))

BRUCE MOORE Hi End Dual Mono pre-amp, immaculate (£8000) £3200. Leider Spoor, pure silver speaker cable, 2.01 mtr (£1200) £650. Audio Technica OC9 cartridge brand new exchange £270. Please telephone Jules on 01792 280061, E-mail: info@sounddrjuleshifi.co.uk
 Web: www.sounddrjuleshifi.com (Apr(I))

AUDIO RESEARCH SPI4, pre-amp, black, boxed, manual, and in mint condition, £1350 ono. Linn Sondek, early 1980's £300. Myriad T20 CD player, as new £250. Transparent Music Link Super 25ft, interconnect RCA £600. Transparent Music Wave Plus Bi Wire Speaker cable 8ft £300. Please telephone Jules on 01792 280061, E-mail: sales@sounddrjuleshifi.co.uk
 Web: www.sounddrjuleshifi.com (Apr(I))

AUDIOLAB 8000A Mk II, black, excellent condition £260. Krell CD 10 Signature Transport. Approx 5 yrs old, mint, sexy heavy Perspex hydraulic lid (£10,000) £4000. Krell KRC-2 pre-amp, as new £1900. Michell ISO / Hera £330 ono. Please telephone Jules on 01792 280061, E-mail: sales@sounddrjuleshifi.co.uk
 Web: www.sounddrjuleshifi.com (Apr(I))

SONY CDP R1 Reference. Transport Das R1 Dac as new. (£6000) £2600 excellent condition. UKD Opera Callas Gold speakers as new £690, Audio Research SP7 Pre, D60 Power, excellent condition, Inc heavy duty transformer, pair price (\$3200) £1200 Please telephone Jules on 01792 280061, E-mail: sales@sounddrjuleshifi.co.uk
 Web: www.sounddrjuleshifi.com (Apr(I))

B & W 603 S3, Sorrento 3 months old £495. B&W CDM ISE, Cherry, £350. Manley Stingray Valve Integrated 50W X. Dem £1450. Exposure 17,18, Pre/Power. £695. Musical Fidelity A3 CD £550, Silver. Musical Fidelity A3 Amp. Int. Silver £649. Musical Fidelity XA1 Amp Int. £265. Rega Planet CD £415. Sugden A21a Amp. Latest model £750. Just a small selection of what is available. Over 80 Bargains Available on line at www.apexacoustics.co.uk
 Contact Steve. 01527 450500, Mobile 07773198336. E-mail Apexnm@aol.com (Apr(I))

CARY 300B Signature valve monoblocks, boxed £2595. Restek Tensor stereo amplifier, mint £1495. Krell KSP-7B pre-amplifier, PSU, boxed, upgraded £1395. Audio Physics Virgos MkII loudspeakers, boxed £1650. Tel: 0207 349 9675 or 07958 607 613. Website: www.geocities.com/olddaysaudio (Apr(I))

NAKAMICHI 1000ZXL Limited Edition (gold/rosewood) cassette deck, only 100 made worldwide, boxed £2995. Nakamich Dragon cassette deck, mint £995. Nakamichi RX-505 £595. Nakamichi RX-202 £395. Audio Alchemy CD X units £1200. Tel: 0207 349 9675 or 07958 607 613. Website: www.geocities.com/olddaysaudio (Apr(I))

WOODSIDE ELECTRONICS service and repair. Woodside, Radford and Quad valve products. Replacement transformers are available to original specifications (Quad transformers are approved by Quad). Tel: 01758 741026, Email: m.davis@virgin.net
 Website: http://freespace.virgin.net/m.davis (Jun (I))

www.audioatmosphere for exclusive cables from Gutwire, Pierre Gabriel and Power Snakes, Online catalogue featuring top brands, accessories and spares. Also services including Black Gate upgrades Contact stuart@audioatmosphere.com telephone 01785 711 232 (Apr(I))

HORSHAM HI-FI Offer: Wadia 21 CD player £1995. Jeff Rowland Model One power amplifier £1195. Sirius (Gamut) D-200 power amplifier £1995. Magnaplanar MG-1 (improved) speakers £395. Musical Fidelity Elektra E100 integrated amplifier £395. Tel: 01403 272 931 Fax: 01403 251 587 (Apr(I))

WYCHWOOD DESIGN. Specialist Hi-Fi furniture for audio equipment. Hand crafted in solid English oak with carved panels, finely laid Italian 23 carat gold leaf. Speaker stands. For details telephone: 01935 825220 or 078 12345 169 (May(I))

MARTIN LOGAN owners SL3 etc. Bass problems. Booming overbearing no control, muddy midrange. Wanted Marantz CD941 and CDA94 for project perfect working condition and reasonably priced. Tel: 01226 764272 (Apr(I))

REPAIR, RESTORATION, modification, custom design and construction of audio equipment. Theo Argiriadis BSc Hons. Phone 020 8881 1623 Mon-Fri 9.30am to 5.30am. Website: www.tube-electronics.com (Apr(I))

DX4/EX4 LOWTHERS Half Price, ex-demo. Less than 100 hours. 1 pair of each. Surplus to our requirements. Tel: 01483 268 814 or email: info@hornutopialoudspeakers.co.uk (Apr(I))

Classified Ads



Faithful to your music



Music as it was meant to be heard • Systems start from £3000

For your nearest stockist call +44 (0)1722 332266. Or visit www.naim-audio.com

World Radio History



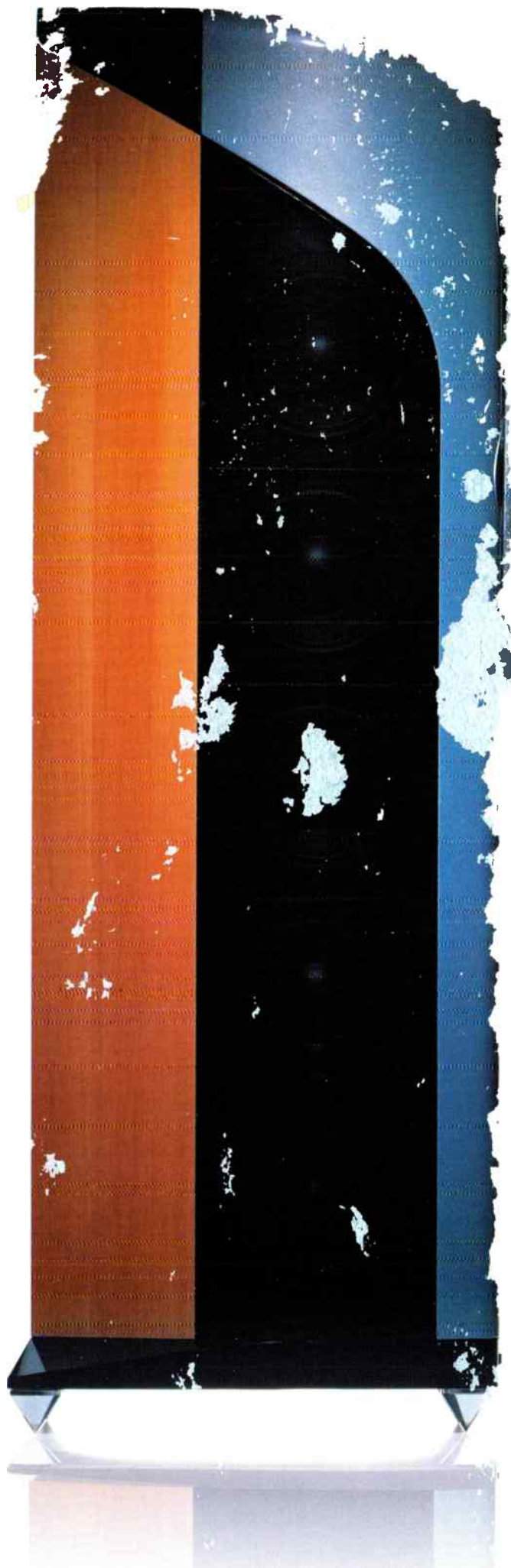

pilastro

By

MISSION

the simplicity of sound perfection

www.mission.co.uk