

ONLY £2.50

www.hi-fiworld.com

hi-fi

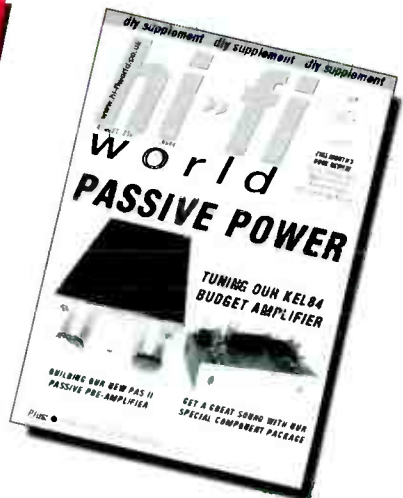

AUGUST 2001 £2.50

WORLD

DIY SUPPLEMENT
No. 59 INSIDE
THIS ISSUE!

& computer audio

A TUNER DAY

TOP BRITISH ANALOGUE TUNERS FROM
LINN, MUSICAL FIDELITY, NAIM & ROKSAN



SPIN DOCTOR
The sexy new
RPMfour, budget
turntable from
Project

plus

- Vienna Acoustics Bach speakers
- Myryad MI240 integrated amplifier
- Mission m72 speakers
- LFD DAC3
- Recordable DVD feature
- Tannoy Super Tweeters
- Arcam CD92 CD player
- Audio Note Zero amplifier
- Rega RB600 tonearm
- **Computer Audio World**
 - HanGo Personal Jukebox PJB-100
 - Sony CRX10-U CD portable burner
 - Iomega HipZip MP3 portable
 - LaCie 16x10x40 CD-RW
 - In-Ear headphones roundup

COMPETITION
win a superb
Unison Research S6
valve amplifier worth
£1600

AUGUST 2001



World Radio History
+ 100s of classified ads full of secondhand bargains!!!

CYRUS

Advanced Audio and Video Systems

Cyrus is dedicated to the development of superb hi-fi systems. Our team is based near Cambridge, England from where we have been designing and manufacturing superior audio equipment for 20 years, for distribution across the world.

Our unique, understated aesthetic design and intelligent digital control systems combine with proven audio expertise to shape a range of components that encompasses everything from easy to operate systems through to advanced hi-fi, A/V and multiroom installations.



Based on the latest NXT flat-panel technology, the revolutionary new Icon loudspeakers represent the state-of-the-art.

Contact us to find your nearest showroom, or to request our new range brochure.



As you can probably judge from the picture below, I'm not one of the world's foremost advocates of physical exercise. If I therefore reveal to you that I've recently reacquainted myself with the delights of surfing you'd be right to raise an eyebrow. However, this kind of surfing doesn't involve me being shark-bait on a six foot breaker off the coast of Hawaii - it involves riding the airwaves. Many moons ago when I should have been revising for school exams I would lock myself in my bedroom with just my homework and John Peel on the radio for company. Needless to say as Peel would indulge himself and his listeners in progressively more fascinating music as the night wore on, so my concentration would drift from the Peasant's Revolt to, say, The Frank Chickens or The Fall - two of Peel's favourite selections from his wildly eclectic taste. Every night I was transfixed by the diverse range of music he'd play - I thought there was no other radio programme like it or would never be again. Until recently, that is.

Reviewing a quartet of tuners recently had me listening to more radio than I usually do and at different times to usual. Having matured slightly (musically, anyway) since my mid-eighties 'Peel sessions' I now prefer the more traditional pipe and slippers tastes of Radio 3 for my relaxation. Then listening late one night to the station I came across 'Late Junction' presented by Verity Sharp and Fiona Talkington (Monday-Thursday from 10.15pm). Pipe and slippers my foot! This is perhaps the most exciting music programme to be found on the airwaves at present, and I'm hooked.

Ms. Sharp and Talkington's selection is meditative, hypnotic and refreshingly varied - but most of all, it's on Radio 3, a primary broadcaster of 'elitist' classical music! Those tuning in for the first time can expect to experience a melting pot of perhaps Kraftwerk, Massive Attack, Tibetan chanting and Indian ragas with a bit of Chick Corea, Lebanese folk song and Spanish Renaissance choral music chucked in for good measure!

Admittedly, on paper this sounds like the worst sort of politically correct cultural event ever conceived but in reality it's essential listening. Instead of just smugly demonstrating a vast knowledge of everything musical the music is chosen with a remarkably 'good ear' and to quote Hot Chocolate, "everyone's a winner". It's also great stuff to nod off to! Plus, many recommendations for pieces come from the notice board via Radio 3's website (bbc.co.uk/radio3/world/latejunction), making it a truly interactive music sharing experience (although not quite in the Napster league).

As long as these kind of programmes are commissioned the music and hi-fi lover will continue to use a tuner, be it analogue or digital. Often thought of as the 'scrag end' of hi-fi, a good tuner and aerial can be a bottomless pit of musical and audiophile enjoyment, an education for a fraction of the price a decent CD player and matching software library would set you back. And you never get bored of listening to the same old music - as long as you steer clear of daytime Radio 1! It's heartening to see the licence payer contributing to keeping British radio alive and our brains working, as opposed to increasing our international status as couch potatoes. So, good on the Beeb and Radio 3 for having the courage of their convictions. Don't chuck out that tuner just yet - turn on, tune in and nod off! ■



Simon Pope

how we test the products

- Hi-Fi World has its own advanced test laboratory and acoustically treated listening room.
- Hi-Fi World has a dedicated in-house team of experienced listeners. We review thoroughly by extensive auditioning, rather than by quick-fire group listening tests.
- Hi-Fi World's engineering team designs a wide range of products in-house. No other hi-fi magazine is so expert and dedicated.

- £ ——— NICE PRICE - Represents excellent value for money.
- EXCELLENT - Superb sound, among the best available.
- ——— VERY GOOD - Well worth a listen.
- ——— ADEQUATE - Room for improvement.
- ——— PDDR - Seriously flawed. Forget it!
- ——— Half globes are added for those products that we feel are between categories

HI-FI WORLD

SUITE G4, IMEX HOUSE
KILBURN PARK ROAD
LONDON, NW6 5LF

www.hi-fiworld.co.uk

Contact Numbers

Mon-Fri 9am - 5pm

General Editor

Simon Pope
tel/fax: +44 (020) 8786 8141
e-mail: editorial@hi-fiworld.co.uk

Computer Audio World Editor

David Price
email: editorial@computeraudio.co.uk

Graphic/Advertising Designer

Faiza Chunara
tel: +44 (020) 7625 3129
fax: +44 (020) 7328 1844
e-mail: adproduction@hi-fiworld.co.uk

Production/Photography Editor

David Noble
tel: +44 (020) 7625 3134
fax: +44 (020) 7328 1844
e-mail: classifieds@hi-fiworld.co.uk

Advertising & Marketing Manager

Amanda Sweeney
tel/fax: +44 (020) 8864 4760
e-mail: advertising@hi-fiworld.co.uk

Accounts

Michael Ogazi
tel: +44 (020) 7625 8032
fax: +44 (020) 7328 1844

Credit Control

Louise Palfrey
tel: +44 (0) 1923 270833
fax: +44 (0) 1923 260588
e-mail: subscriptions@hi-fiworld.co.uk

WORLD AUDIO DESIGN

Technical Manager - Nick Lucas

www.worldaudiodesign.co.uk

tel/fax: +44 (0) 1908 218 836
e-mail: nick@worldaudiodesign.co.uk

Publisher

Noel Keywood
e-mail: publisher@hi-fiworld.co.uk

Private & Trade Classified Ads

tel: +44 (020) 7625 3134
fax: +44 (020) 7328 1844
e-mail: classifieds@hi-fiworld.co.uk

Subscriptions & Back Issues

9:30am - 12:00 noon
tel: +44 (0) 1923 270833
fax: +44 (0) 1923 260 588
e-mail: subscriptions@hi-fiworld.co.uk

Distributed by
Comag Magazine Marketing,
Tavisstock Road, West Drayton,
Middlesex UB7 7QE
Tel: +44 (0) 1895 444 055

Printed by
Southern Print, Dorset
Tel: +44 (0) 1202 622 226

All unsolicited submissions and goods are at the owner's risk. We accept no responsibility for such submissions, nor do we undertake to return them.

No material may be reproduced from this magazine without the publisher's written permission.
© Audio Publishing Ltd



contents

reviews

tuners

ANALOGUE TUNER
GROUP TEST 10



There's plenty of life left in FM. Noel Keywood and Simon Pope test out four British tuners from specialist hi-fi companies and guide you through the technology involved.

digital sources

ARCAM CD92 60



The CD92 is the replacement for the excellent Alpha 9 CD player. Will it reach the audiophile heights of its predecessor?

LFD DAC3 DIGITAL TO
ANALOGUE
CONVERTOR 21



Is the external DAC dead? Not so, thinks David Price with the likes of this £3,000 number cruncher around.

loudspeakers

VIENNA ACOUSTICS
BACH 18



From Austria comes this £1,000 pair of compact floorstanders. Will they be whipped cream or schmalz, wonders Simon Pope?

TANNOY
SUPER TWEETER 55



These are the latest development in high frequency reproduction from the historic 'speaker company.

MISSION m72 58



Following on from last month's glowing review of the m73 floorstanders, we now tackle the larger standmounts in the range. Dominic Todd does the honours.

amplifiers

MUSICAL FIDELITY A3 24



Yes, the model number may be familiar to eagle eyed readers but this modern classic has had an extensive makeover. Simon Pope reveals all.

AUDIO NOTE ZERO
PRE/POWER 26



This stylish little combination is from the Zero entry-level range from the high-end valve company. David Price discovers whether size matters when it comes to glass bottles.

MYRYAD MI240
INTEGRATED 42



This is the latest high-end integrated to hit the stores featuring high wattage and top technology.

vinyl

PROJECT RPM FOUR
TURNTABLE 39

This is the sexy new budget turntable from the Czech Republic. Will it offer as good value as the cheaper Debut?

AUDIO TECHNICA AT440-
ML CARTRIDGE 51

Noel Keywood gets into the groove with this budget MM cartridge from Audio Technica.

REGA RB600
TONEARM 57

This top of the range arm from the vinyl specialists is the latest voyage of vinyl discovery for David Price.

features

RECORDABLE DVD
FEATURE 36

Noel Keywood looks at the fight for the Recordable DVD market.

AUDIO NOTE
INTERVIEW 34

David Price visits the Audio Note UK HQ to interview one of the industry's most flamboyant characters, Peter Qvortrop.

regulars

WORLD NEWS 6

NEXT ISSUE 9

READERS LETTERS 44

Hi-Fi World's team reply to your letters and e-mails.

SUBSCRIPTIONS 56



Hi-Fi World is second to none for news and reviews. Subscribe today!

COMPETITION 70

In this month's competition we have a superb Unison Research S6 valve amplifier worth £1,600 up for grabs.

CLASSIC CUTS 74

In a new feature industry guru Andy Giles shares with us his enthusiasm for classic recordings. It promises to be a monthly highlight!

HI-FI WORLD KITS 64

Check out all the latest kits.

HI-FI WORLD LIBRARY 68

A comprehensive selection of titles covering audio, valve amplifiers, loudspeakers, solid state electronics and more.

COLUMNS 71,73,75

HFV's team of experts share their thoughts everything audio.

OLDE WORLDE 83

This month David Price gives you the low down on the Inca Tech Claymore integrated amplifier.

SPECIALIST HI-FI
DEALERS 84

Got a problem? - see a specialist.

DIAL-A-DEALER 86

Who sells what, and where to find them.

MEET YOUR MAKER 90

Who makes what, and how to get in touch.

WORLD FAVOURITES 91

Components which we know to be truly worthy of audition.

WORLD CLASSICS 96

Our list of products that have stood the test of time.

MARKETPLACE 123

DIY SUPPLEMENT
NO. 59 P99-P122

READERS
CLASSIFIEDS 137

The definitive place to find classic audio components.

ADVERTISERS' INDEX 146

computer audio world

CONTENTS & NEWS 77

HANGO PERSONAL
JUKEBOX PJB-100 78, 79

IOMEGA HIPZIP 80

LACIE CD-RW 81

SONY DIGITAL RELAY 82

IN-EAR HEADPHONES
ROUNDUP 83

world news

▶▶ LINN DEMONSTRATION

Many thanks to everyone who attended our demonstration of Vinyl-versus-CD, hosted by Linn Products in the plush surroundings of the Grosvenor House Hotel on Saturday 9th June. Attendance was well beyond our expectations with well over three hundred people turning up to hear the fascinating demonstrations given every half an hour, some hosted by Linn supremo Ivor Tiefenbrun (pictured). Once again, thanks for making it a very successful and enjoyable day, a full report will be in next month's issue. **SP**



▶▶ CHIPS WITH EVERYTHING!

Progress at last seems to have been made towards a true universal optical disc player. Until now companies such as Sony, Technics and Pioneer have chosen between SACD or DVD-A as the high resolution audio format to combine with their DVD-V players. What many consumers are hanging on for, though, is a true universal player - one that both fully supports DVD-Audio and SACD. Many don't see the point of shelling out for one or the other format at present when they see, quite rightly, an affordable machine that will play everything they require in the not too distant future.

The industry is now one step closer to this goal thanks to ESS Technology, who have recently introduced their third generation ES 4438 DVD chip. This little beauty can apparently cope with DVD-Audio, SACD, CD, MP3, CD-DA, VCD, SVCD, DVD, Dolby Digital, Dolby ProLogic, DTS decoding,

progressive scan output as well as Internet functions, opening the door for a true universal machine to be introduced as soon as one company or another finally bites the bullet.

And there's more. Apparently it will also handle Karaoke functions, 3-D sound effects and voice recording! In a press release, William Wong of ESS said the reduced system costs resulting from one-chip solutions will help drive the consumer market. "We believe that the ES4438 DVD single-chip solution will lead the industry in fulfilling the demand in the digital audio/video market." Production of the chip starts in the second half of this year. Manufacturers take note!

www.esstech.com

▶▶ SOUND IN MOTION

Things are looking up in the world of DVD-A software. Soon to be released are a handful of new titles from AIX Recordings, a subsidiary of the AIX Media Group, California. These discs are very different to the existing titles available at present, due to the fact that they use DVD-Video footage of the performance as part of the package. The complex discs are all dual sided and one of the sides will also have dual layers. The single layer side contains DVD-A information - 5.1 channel 24-bit/96kHz audio using Meridian Lossless Packing. The other DVD-Video side has Stereo PCM, Dolby Digital 5.1 and DTS 5.1 versions on the discs that offer a different sonic view of the music and another (second) Dolby Digital 5.1 version offers the sound from the performers (stage) perspective. In addition to all this the dual-layer sided audio tracks have full motion video with three different camera angles to boot, as well as photos from the sessions, pictures of Johannes Brahms and even a recording of the composers own voice!

The brains behind the discs is one Mark Waldrep, California university lecturer in musical composition and AIX Media Group president. On enquiring whether the company are to release two channel 24/192 recordings, he told us "because we're not recording at 192kHz yet (equipment limitations), there are no immediate plans to embrace even higher resolutions than 96 kHz. Our approach is unique in that I think surround and high resolution together make the most compelling discs...with or without video according to preference."

The first discs to be released are a recording of the Brahms Piano Quintet and will be available from the company website for £24.98.

www.aixrecords.com

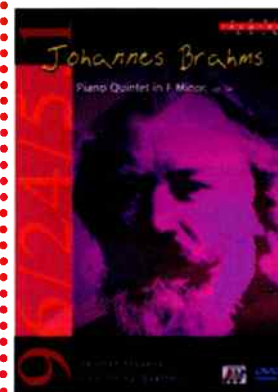

▶▶ **HARMAN RIDE AGAIN**



A recently re-emerged Harman Consumer UK have announced the launch of a new DVD player from Harman Kardon. The DVD 10 includes features such as 10-bit video processing, RGB and S-Video output and Dolby Digital and DTS compatibility, although

no onboard decoding. It uses a Burr-Brown PCM1716 DAC and includes both coaxial and digital outputs and 2-channel down mix analogue outputs. It offers a host of picture search and scanning options such as 4-speed smooth scan (x2 - x16) as well as 4-speed

slow motion (x1/2 - x1/16). It comes with a full infrared remote control and retails for £319.

Harman Consumer UK
Tel. 020 8731 4670
www.harman.com

▶▶ **HEAVENS ABOVE!**

As every dedicated Wagnerian will know, Valhalla was the home of the Gods. Being an ethereal habitat for these deities, it's obvious that any real estate agent would charge a premium for such an address and it's with this notion in mind, perhaps, that high end cable kings, Nordost, have named their new exorbitantly expensive audio cable. The new Valhalla interconnect and 'speaker cable both use the company's Micro Monofilament air tube technology and are both a flat design just 0.95mm thick. A Teflon microfilament is wound around the conductor supporting an extruded Teflon air tube which reduces the dielectric contact by 85%. The conductors are 22 AWG gauge Oxygen Free Copper extruded in 78 microns of solid silver, of which the interconnect uses ten and the 'speaker cable forty. The 'speaker cable comes terminated with Nordost's own low mass 4mm Z plug and is available in both bi-wire and "shot-gun" (single wire) versions. The interconnect is terminated with gold plated RCA phono plugs and balanced XLR connectors are available. Each cable is "hand-built" and serial numbered.

Now for the bad news. A metre pair of the interconnect will £2,195, whilst the 'speaker cable is a wallet crippling £4,200 for a two metre, bi-wire pair. Ouch!

Nordost UK Ltd.
First Floor, Unit 7
Aber Park Industrial Estate
Aber Road
Flintshire CH6 5EX
01352 730251
www.nordost.com



▶▶ **ONKYO'S NEW BOX OF TRICKS**



ONKYO'S NEW TX-DS696 is an "audiophile friendly" A/V receiver featuring the latest technology, such as Dolby Pro Logic II. The receiver also features WRAT technology which offers a frequency response up to 100kHz for use with multichannel SACD and DVD-Audio information. The TX-DS696 offers 5x130W of power into 6ohms, has five S-Video inputs as well as an RDS FM/AM radio with 40 presets. It comes in black or silver complete with backlit learning remote with macro function for a price of £850.

Jamo UK Ltd.
Oakfield Park
Bilton Road
Rugby
Warwickshire
CV22 7AL
Tel: 01788 556777
www.onkyo.net



Get inside the music.
Sony Super Audio CD.

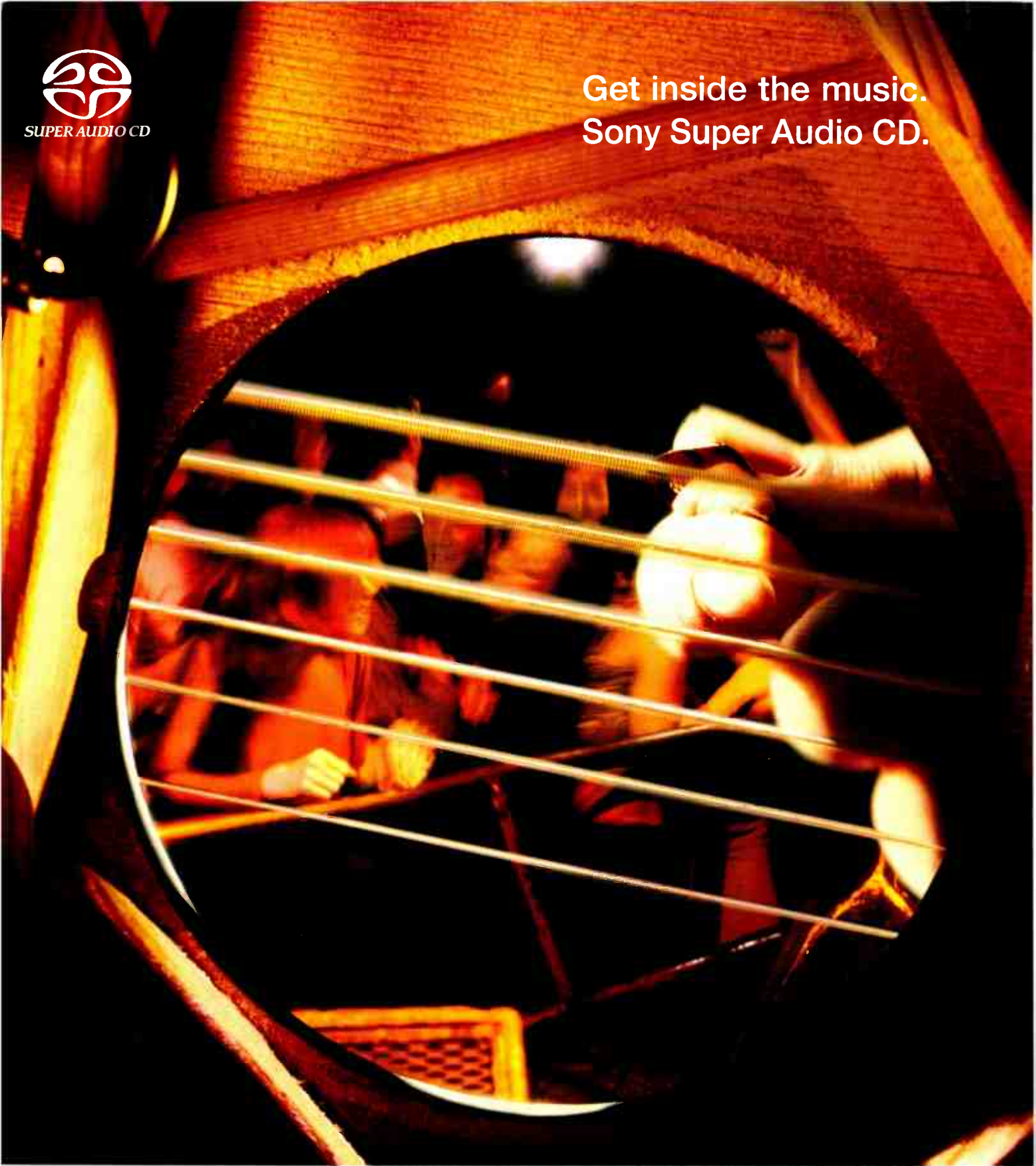

No other music system gets you closer. The Sony Super Audio CD provides you with unrivalled sound reproduction thanks to Direct Stream Digital (DSD). A clever little 1-bit recording system that samples audio signals at a rate 64 times higher than conventional Compact Disc. Giving you a dynamic range of over 120db and an unprecedented bandwidth of over 100kHz. With its multichannel capabilities, the new Sony SCD-XB770 immerses you in sound. So you do more than just hear the music, you are part of it. And because all Sony SACD players are compatible with conventional CDs, there's no need to replace your CD collection. To see the Sony SCD-XB770 visit your closest Sony retailer. To hear one, why not try your nearest concert venue.

www.sony.co.uk

Customer information number 08705 111 999 Sony, Direct Stream Digital and Sony Super Audio CD are registered trademarks of Sony Corporation, Japan.

World Radio History

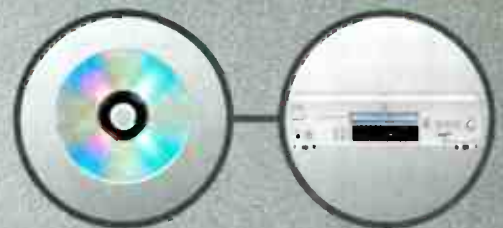

go create

SONY

▶▶ **IT'S ALL IN THE NAIM**



The new Naim Allae is the latest loudspeaker from Naim Audio and the first for quite some time. Looking similar to the company's Credo 'speaker the Allae houses each driver in its own enclosure in an effort to reduce mechanical interference and to create a "predictable acoustic performance not possible in conventionally configured loudspeakers."

Naim's precision interface pins (PIPs) separate the individual cabinets. The lower cabinet acoustically loads the bass-mid driver, whilst the PIPs "define the air gap" between the two enclosures, where a controlled distribution reflex port is located. Drivers consist of a 200mm mid-bass driver with the company's familiar split-mass aluminium

phase plug and a 19mm wide-dispersion Scan tweeter which is spring mounted. Thermally stable aluminium mass dampers are located on the internal cabinet walls and the drive units to control resonance. The Allae comes with an aluminium stand with leaf springs and spikes for floor coupling and the curved and non-parallel design of the 'speaker reduces internal standing waves. Prices for the Allae are £1,950 for the active configuration and £2,130 for passive.

Naim Audio Ltd.
Southampton Road
Salisbury
England
SP1 2LN
Tel: 01722 332266
www.naim-audio.com

▶▶ **ARC ANGELS**

ARC Acoustics are a new name to us here at the magazine but they've just released a new product that grabbed our attention. The Sonare 5.1 home cinema loudspeaker system is the latest of a line of products to utilise NXT flat panel technology. The five panels are each 16cm across and can be used free standing or wall mounted, with connections from the crossover straight to the panels and the subwoofer. The package is priced at £230 for five panels and the subwoofer, plus cables and mounting brackets.

ARC Acoustics Ltd.
PO Box 4,
Fordham
Cambridge
CB7 5GX
Tel: 01638 721237



next issue

here's a little taster of what we hope to bring you in September's issue

AUDIO ANALOGUE MAESTRO

Hi-Fi World get first crack at this new monster integrated from the Italian electronics company. See what we think of it next month.

TURNTABLE GROUP TEST

We gather in four classic updated British turntables to see which reigns supreme. Find our results in four weeks time.

MYRYAD MCD600 CD PLAYER

This is the new high-end CD player from Hampshire based hi-fi specialists. Will it compete with the best in the class?

TURN ON, TUNE IN, SPEAK OUT!



It's the dawn of the digital radio age but there are still plenty of analogue options available for the audiophile. Simon Pope and Noel Keywood highlight four mid-priced British contenders battling for the rule of the airwaves.

Sales of analogue tuners are fairly low but steady. The truth is that for many, radio isn't an essential requirement in the home so much as in the car. Compare the attraction of either digital (or analogue) radio to the lure and lightning speed growth of DVD - there's simply no competition. Within this limited market then, there's a format storm brewing, except it's more like a weak breeze. Digital radio availability, whilst expanding, is still limited in the U.K. and whilst many more people can receive an FM analogue signal the market's still there for these tuners - as the manufacturers know. If you live in an area with a weak FM signal and can receive DAB broadcasts, though, it could be worth looking into buying a digital tuner, or a hybrid DAB/FM unit such as those made by Technics or Sony.

Let's presume you want a new, high quality analogue tuner, though. What are the things you should look for? Firstly, for maximum quality FM you should seek out a high quality

aerial for installation (see page 13). Once this is done the rest basically depends on which facilities and features tickle your fancy. For the audiophile, most listening is of course done on the stereo FM band, although many tuners also offer the added bonus of mono MW and LW bands.

Again for the best sound quality from AM broadcasts you'll also need a different type of aerial, although this is less important for mono broadcasts.

Many tuners, including the ones featured here, offer a selection of presets in which you can store favourite stations to cut out the annoyance of re-tuning. These can vary from six to a hundred.

Next, there's autotuning which allows the user to scan the waveband and stops at those broadcasts with a strong enough signal. This simply, but effectively, saves on wrist work. RDS is another feature that can be useful. Radio Data System is an inaudible signal carried only on FM which

supplies a host of handy features especially for in-car use. These include showing the tuned station name and finding that same station at another frequency should anything move. Another RDS feature is EON (Extended Other Stations) which when in operation will interrupt the current transmission for news or traffic reports and also allows you to choose a particular programme genre, such as 'classical' for which the tuner will scan the airwaves for relevant stations.

Aerial apart, not all of these features are necessary for great FM sound. The excellent Naim NAT01, for example, has no presets, RDS or even remote control but commands a £1,800 price tag and probably the best FM sound you'll come across.

The four we have here in this test are all slightly lowlier in price than the NAT01 but carry on the great British tradition in radio. Along with world-class broadcasting this country makes some of the finest audiophile tuners in the world. . .



LINN PEKIN



MUSICAL FIDELITY X-PLORA

LINN PEKIN £545

A strange name, this. We don't know whether it's named after the Chinese city or the beak action of a chicken. The Pekin shares the same simple box shape and design as the latest range of electronics from the Glasgow company. Unlike the others in the test, many functions can be executed by using the front panel controls as opposed to the remote, even though it's a very comprehensive 'system remote' type. The Pekin features MW reception as well as FM, there's no RDS but you do get 80 presets for logging in your favourite stations. There's scan and manual tuning which can also be customised. Chassis build is good but the overall weight of the Pekin is frighteningly light - it's not advised to place it near an open window!

When it comes to sound quality, it's almost as quirky as the name. With local commercial stations such as Capital or Kiss FM the Pekin showed up all the worst traits of these processed monstrosities. Vocals were sibilant and thin and the bass overblown. Listening to these stations revealed something about the Pekin that was discovered with more refined stations: it handles vocals very well indeed. Voices were very clear and well presented being nicely centrally placed, too. This was confirmed by tuning in to a Radio 3 lunchtime song recital, where the soprano sounded pure and detailed, with excellent focus.

However, there are down sides to the Pekin. Our measurements showed it to be fairly insensitive and this was apparent for the fairly high amount of hiss present when compared to the other auditionees and a cheaper but very good Hitachi product. This also results in a lack of body to much of the sound. There's plenty of features and facilities here but the sound was overall a little disappointing.

Linn Products Ltd.
Floors Rd.
Eaglesham
Glasgow G76 0EP
www.linn.co.uk

MUSICAL FIDELITY X-PLORA £600

From the ever increasing range of the Wembley-based manufacturer comes this stylish and well equipped customer. It has the X-Series trademark 'squashed' cylindrical look and a nice clear display window joined by a minimum of fascia controls located on the thick aluminium front plate. As far as features go, the X-Plora has virtually everything you could wish for. There's autotuning, RDS and a dedicated remote control, plus a selection of presets, albeit only 20 (but how many do you actually need?) and FM only coverage. The signal strength meter is a numerical type (0-10). The build quality, like the

rest of the range, is superlative with a good feel to the controls.

This is a very good sounding tuner. It's the brightest of the four in the sound stakes and perhaps the most 'CD' sounding (and less tuner like) but this also means that detail, especially low level, is very good. Tuning in to capital FM found the X-Plora showing up everything that's bad about these stations, fuzzy upper treble and sibilant vocals, but it also showed mix details that other tuners couldn't pick up on, such as acoustic guitar tracks and ride cymbals.

Moving to the dance station, Kiss, saw the X-Plora demonstrate a full and tight bass response and a firm grip with rhythms. Vocals were also clean and precise, if a tad too sibilant. With the high quality transmission of Radio 3 the X-Plora showed where its priorities lie. The sound was nicely 'flat' and a good sense of the Wigmore Hall's ambience was created in the lunchtime recital. The piano had a full resonance and natural decay and the soprano voice was very natural, including the natural 'edginess' that often comes with the register. This is a very natural and open sounding tuner with a high level of detail.

Musical Fidelity Ltd.
15/16 Olympic Trading Estate
Wembley
Middlesex
HA9 0TF
Tel: 020 8900 2866



World Verdict



LINN PEKIN
Good when it comes to facilities and features. The Pekin suffers from insensitivity and a slightly thin sound, although vocals are clear and detailed.

World Verdict



MUSICAL FIDELITY X-PLORA
Natural and open, the X-Plora is at home with the likes of Radio 3 and 4 with it's detailed sound.



NAIM NAT05

ROKSAN CASPIAN

NAIM NAT05 £725

Naim have made something of a, er, name for themselves when it comes to tuners. Although they're more famous for their amplifiers, they've consistently knocked out some of the finest radios money can buy. And you'll need a lot of money for the just-short-of-two-grand NAT01 but it's probably the finest tuner available. The more humble Nat05, however, still carries on the Naim tuner traditions, such as minimal features.

Whilst the NAT02 and 03 have the barest of functions you do get a selection of 99 presets with the 05. Alas, though, not the easiest to set up via the remote control only. Although it's limited to just FM and there's no RDS - there is autotuning.

The finish of the 05 Series chassis and its build are excellent. It's a very attractive looking customer when in full-lit mode!

For sheer sound quality it's hard to better the NAT05 at the price. It has inherited a few sonic traits from its more expensive cousins and delivers a full, rounded and warm sound with any station you care to chuck at it. It even does a good job with the likes of Capital FM, with its bells and whistles studio processing, giving a good 'hi-fi' sound - a rarity. Voices are well focussed and life like and the separation is superb. In the Naim mould, there's a focus on rhythms and attack and the bass is fast and tight.

With a Radio 3 recital the sound was again warm and forward but with a good sense of space in the recording location. The piano had a full and rich sound that was yet high on detail and the voice was free from

chestiness. The NAT05 impressed with its warm and generous sound.

Naim Audio
Southampton Rd.
Salisbury
Wilts
SP1 2LN
Tel: 01722 332266

ROKSAN CASPIAN £695

The Caspian range has been around since 1997 but the latest range of Caspian products haven't. Whilst other companies simply make units obsolete and replace them with an uncannily similar product, Roksan make the changes but keep the name. The changes are purely internal and every product in the range keeps the same attractive chassis and Sherman tank build as it's always had. This incarnation of the Caspian tuner still retains the fairly steep price tag, but there complete changes in the PCB layout were made to optimise sound quality, after eighteen months' existence of the Mk1 model.

The tuner still has an arsenal of fifty presets, along with autotuning, but no RDS facility. Remote control, if you should so wish for it, is via the Caspian system remote unit, with its slightly garish but striking iMac transparent blue appearance. The remote isn't a necessity here, as all the functions can be triggered from the thick machined front panel which features two solid rotary knobs, as well as the usual Caspian metallic push buttons. The display window is in 'Caspian green' and it has a good, comprehensive red signal strength meter.

We found the sound of the Caspian both smooth and clean. This

is a good sounding tuner that hones in well on weakish signals to create a full and open sound with commercial stations and a detailed sound with the 'flat' stations such as Radio 3 and 4.

Tuning in to Capital and Kiss FM, with studio compression in all its glory, didn't turn out to be as traumatic a listening experience as it can sometimes be. Whilst still not exactly audiophile standard, the Caspian managed to create a full and rich sound with these stations and due to the nicely smooth upper end the horrendous sibilance that they have was kept to a minimum. Bass was good and firm and the sound had an impressive command with rhythms.

Moving onto the less choppy waters of Radio 3, the Caspian gave an impressively 'flat' relay of a live lunchtime piano/voice recital from the Wigmore Hall. The piano had good presence and fullness whilst the baritone voice was very clear and realistic. The excellent hall acoustics were audible, along with the dropped programs and badly timed coughs that characterise any such recital.

The Caspian is a nice sounding and looking tuner that will last well into the digital age, and perhaps until the FM transmitters are switched off! It's not cheap but has a well balanced sound and good sensitivity that's indicative of a quality radio. Highly recommended if RDS isn't a priority.

Roksan Audio Ltd.
Unit 6 Northfield Industrial Estate
Bereford Avenue
Alperton,
Middlesex
HA10 1NW
T: 020 8900 6801/6802
www.roksan.co.uk



World Verdict



NAIM NAT05

A very fine tuner indeed, the NAT05 easily makes up for in sound what it lacks in facilities.

World Verdict



ROKSAN CASPIAN

A well built and good sounding tuner that should give many years happy listening.

CONCLUSION

Whatever your requirements for a tuner, sound quality should always take preference. It doesn't really matter if it can tell you the time, make your morning tea and run your bath, if it doesn't cut the sonic mustard, forget it. Many people are under the impression that one tuner is the same as another but this assumption is wrong, as both measurement and listening tests prove.

For the best overall sound quality with all types of broadcasts, the Naim NAT05 has to be the pick of this crop. It has a warm and full sound with a deep soundstage and excellent stereo separation. As well as having good control of rhythms and fast bass it's also sensitive to classical broadcasts, due to its smooth and detailed presentation. Facilities are few but this is largely irrelevant when the sound is considered.

For out and out detail with Radio 3 and 4 the X-Plora showed its mettle. It also has a fine array of features, such as RDS (the only one in our test). Build quality and looks are also very good.

The Caspian is well built, looks good and has fine all round sound quality but lacks the last piece of detail to bring it up to the standard of the MF or Naim.

Lastly, the Linn was a bit of a disappointment. Whilst good with vocals and voices, the sound was a little thin and there was recognisable hiss at fairly low volume with Radio 3 which really shouldn't be the case, especially at this price, although its features are good.

AERIALS

VHF/FM radio can provide superb sound quality, but it's a strength and a weakness of the system that it is so flexible in its signal requirements. Whilst the hi-fi tuners tested here can typically pick up a few millionths of a volt from an aerial and make sense of it, they actually need one thousand times as much (1mV) to give best results. Specifically, this means lowest hiss. With 1mV or more – and there's little variation between models – a hi-fi tuner reaches 'full quieting' where hiss becomes inaudible (-73dB or



Ron Smith Aerials

less). Clarity and detailing, as well as a sense of atmosphere become much more apparent from broadcasts, especially live studio discussions.

In most areas of the UK, 1mV or more means using an outside aerial. Up to 10 miles from a transmitter a single dipole will usually do, at 20-30 miles a three element dipole will be the minimum. Anything above this distance is long distance working, requiring quite a large multi-element array. Britain is well covered by transmitters, so the nearest is generally within 50 miles, or it is very powerful, like London's distant Wrotham. A list of vhf/fm transmitters, with power and grid reference, is available at www.bbc.co.uk/reception/rpb/index.shtml.

Loft aerials can be effective with a transmitter 10 miles or so away. The simple wire dipoles that come supplied with tuners rarely get enough signal though. They are only provided to get you up and running and compromise the quality available from a good tuner.

Having an aerial installed will cost around £60 and the aerial itself



Antiference Aerials

around £35, so £100 will usually be sufficient, but it does depend upon the length of time taken. It is worth it: vhf/fm gives fabulous sound quality when set up properly.

If you are wondering about DAB, aerials are smaller and more suited to flats, where roof access is impossible. However, not all of Britain is covered (see www.bbc.co.uk and www.ukdigitalradio.com), and even in DAB areas there are dead zones in concrete buildings, basements etc.

VHF/FM aerials are available from Maxview (www.maxview.ltd.uk), Antiference (www.applegate.co.uk), Blake Aerials (www.blake-aerials.co.uk), and Ron Smith Aerials (Tel: 01582 736 561). Think of the aerial as part of the tuner - it is crucial if you want results that can, with good broadcasts, be better than any other source. **NK** ■ ▲

MEASURED PERFORMANCE

LINN PEKIN

The Pekin gave a comparatively poor measured performance. Linn say it is 'sensitive' in the handbook but sensitivity was poor. No less than 630µV was need for -50dB hiss on stereo and 6mV needed for full quieting - roughly ten times more signal than usual. Even when in full quieting the noise floor was a high -64dB, 10dB noisier than usual and audible with Radio 3 silences.

In keeping with this frequency response rolls down early to minimise noise and also pilot tone at 19kHz, because the Pekin has no mpX filter. It will have an obviously warm, likely dull sound as a result. There's bass roll down too, so bass output will be a bit lighter than usual.

Channel separation was adequate at 36dB in the midband and 23dB at

10kHz, a little better than a pickup cartridge - and they manage good stereo.

The signal strength indicator indicated maximum at 500µV where the tuner produces obvious hiss (-49dB).

I tested two samples and both were the same. The Pekin has an unimpressive performance. **NK**

Frequency response	37Hz-7kHz
Stereo separation	36dB
Distortion (50% mod.)	0.5%
Hiss (IEC A)	-65dB
Signal for minimum hiss	6mV
Selectivity (at 0.4MHz)	62dB
Sensitivity	
mono	30µV
stereo	630µV
signal strength meter:	3-500µV

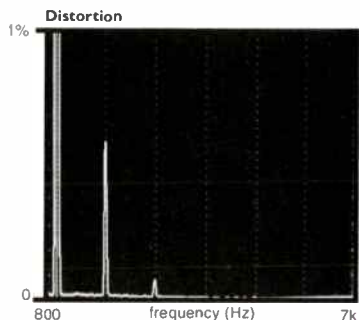
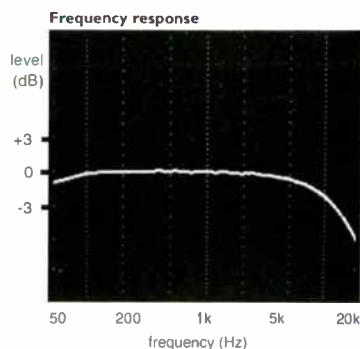

MEASURED PERFORMANCE

MUSICAL FIDELITY X-PLORA

Our frequency response analysis shows a small amount of high frequency plateau lift in the X-Plora's response, enough to give its sound a sheen and a little perceived lightness of balance perhaps. It will also enhance detail a little, but the X-Plora is unlikely to sound warm or fulsome as a result of this. I'd expect a bright, light forward sound.

An upper response limit (-1dB) of 16.5kHz is high, so the tuner has a well designed and tuned mpX filter. It provided an adequate -50dB suppression to pilot tone at 19kHz and completely eliminated (-98dB) sub-carrier at 38kHz, so the tuner doesn't output unwanted high frequencies to the amplifier. Talking of which, the tuner produces 400mV, on the low side nowadays.

Distortion wasn't so low (0.4%) on the mono or difference channels, but it was second harmonic only, as our analysis shows, so it will not affect sound quality.

Hiss measured a normal enough -73dB (IEC A), providing the tuner

was fed 1.25mV or more to put it into full quieting. Local or DX making no difference. This is a little more than usual and not unexpectedly sensitivity was on the low side at 40µV (DX only), but neither value is too consequential providing a proper aerial is used. The tuner will not receive stations below 20µV in DX mode or 100µV in Local mode because of noise muting, so selectivity is not an issue, since weak stations are simply unavailable (and I was unable to measure selectivity too).

A signal strength meters reads from 0 to 9, the upper limit being a useful 1.6mV in Local, a figure only good aerials will reach.

The X-Plora is much like earlier Musical Fidelity tuners, offering a basically well engineered, tidy performance. **NK**

Frequency response	6Hz-16.5kHz
Stereo separation	43dB
Distortion (50% mod.)	0.4%
Hiss (IEC A)	-73dB

Signal for minimum hiss	1.25mV
Selectivity (at 0.4MHz)	N.A.
Sensitivity	
mono	mute
stereo	40µV
signal strength meter:	none

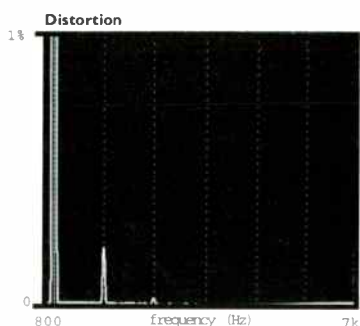
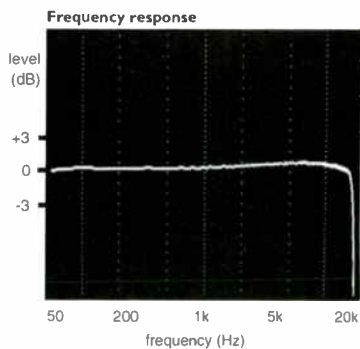

KEF Q series
home theatre.
Clearly
outstanding.



Perfect 3D clarity is what brings home theatre to life - you want to hear where the pin drops, as well as when.

The less that speaker tone varies, the crisper the soundscape becomes. No wonder the award winning Q Series sounds so real: with identical Uni-Q drivers for each speaker, the system's tonal match is perfect. And by mounting an advanced tweeter at the acoustic centre of each midrange cone, KEF's Uni-Q technology creates what all speaker manufacturers aspire to: a sonic point source. Compared to the row of drivers you get in conventional centre speakers, this makes on-screen voices sound incredibly natural.

That's why nothing else at the price even comes close for delivering the full richness of today's digital soundtracks for everyone in the room. Loud and clear.



Q
SERIES
POINT - TWO



The experience
of sound

MODELS SHOWN ARE THE Q SERIES 2 COMPRISING MAIN PICTURE MODELS Q65.2 AND Q95c. GROUP PICTURE Q85a, Q15.2, Q35.2, Q55.2, Q65.2, Q95c. KEF AND UNI-Q IS PROTECTED UNDER GB PATENT 2 236929. US PATENT NO. 5,548,657. WORLDWIDE PATENTS PENDING. FOR DETAILS ON KEF Q SERIES 2 PLEASE CONTACT: KEF AUDIO (UK), DEPT. HF001, FREEPOST, MA1332, ECCLESTON ROAD, TOVIL, MAIDSTONE, KENT ME15 8BR. FREE PHONE 0800 7315620 www.kef.com

MEASURED PERFORMANCE NAIM NAT 05

I was not surprised to see Naim roll off the top end response of the NAT 05 gently, giving it a low upper response limit of 12kHz. It doesn't have less treble than other tuners, so much as a gentler mpx filter roll off. This will give it the softer, smoother sound Naim tuners are known for. It makes for an easy sound that is unchallenging and Naim tuners have become well liked for it.

Properly tuned, the NAT 05 gives 50dB channel separation and low-ish distortion. Unfortunately the tune frequency display lacks a last digit, doubtless for cost, resolving to 0.1MHz when in fact the tuner tunes in 0.05MHz steps, so there are two tune steps to every last digit - bizarre. The answer is to use auto-tune.

Hiss was low at -74dB and sensitivity very high, the tuner needing just 0.8mV to achieve this result. It was commensurately quieter than usual at lower signal levels, but

switches to mono at 50µV, so a conventional stereo sensitivity figure cannot be quoted. However, at 50µV the NAT 05 was producing -55dB hiss and in mono it would resolve 1µV or so, so it will work from wet string, even if an aerial will give better results.

Selectivity was very high and audio output also healthy at 700mV.

The NAT 05 measures well and will give a smooth sound, continuing the Naim tradition with tuners. It's a very good design. **NK**

Frequency response	10Hz-12kHz
Stereo separation	50dB
Distortion (50% mod.)	0.4%
Hiss (IEC A)	-74dB
Signal for minimum hiss	0.8mV
Selectivity (at 0.4MHz)	84dB
Sensitivity	
mono	2µV
stereo	50µV
signal strength meter:	none

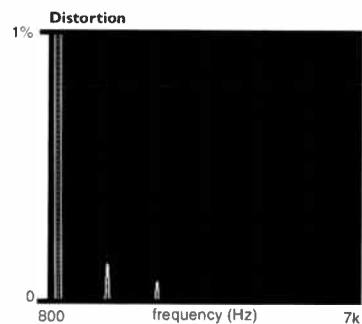
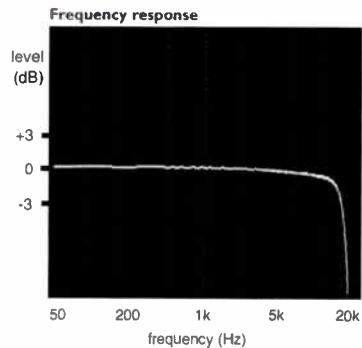

MEASURED PERFORMANCE ROKSAN CASPIAN

The Caspian has a good, flat frequency response that reaches 13kHz (-1dB) before rolling down to the usual mpx notch at 19kHz. It should give a very even sound with no sign of brightness. Channel separation was unusually high at 60dB in the midband and around 55dB at 10kHz. At around 0.3% distortion was a little higher than the best but this was innocuous second harmonic.

Given enough signal, 1.25mV or more, the Caspian produces -74dB hiss, quite a low level. Sensitivity figures were good on stereo and mono so the tuner will pick up weak stations effectively. It has good, if not exceptional selectivity at 74dB for the alternate channel (400kHz spacing). It may struggle in some congested urban situations if you are after pirates.

The signal strength and tune accuracy indicator was better calibrated and more helpful than most. When all five leds light the tuner is getting 0.8mV or more, ideal for best results, so the Caspian will give a good idea of how effective the aerial is.

The Caspian gives a balanced set of figures that ensure it will deliver good sound quality. **NK**

Frequency response	8Hz-13kHz
Stereo separation	60dB
Distortion (50% mod.)	0.3%
Hiss (IEC A)	-74dB
Signal for minimum hiss	1.2mV
Selectivity (at 0.4MHz)	74dB
Sensitivity	
mono	3µV
stereo	32µV
signal strength meter:	30-800µV

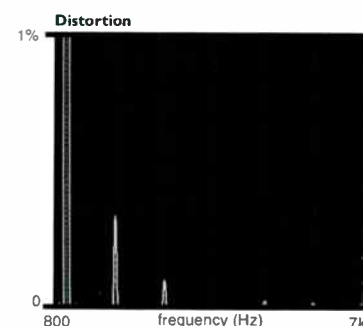
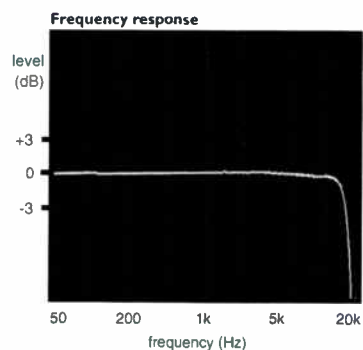

A lot of changes - and still rather a lot of money.



Speakers as universally revered as our Reference Series are a tough act to follow. After all, what can you do to improve on excellence?

Rather a lot, as it happens. Take the high order crossovers, for example. They've been completely redesigned, using advanced polypropylene capacitors for even greater lucidity. And every crossover is further fine-tuned to match the parameters of each individual drive unit. We even found ways of making the drivers themselves with greater precision to iron out the slightest sonic imbalance.

Having perfected the acoustics, we turned to aesthetics. Hence the choice of five stunning contemporary finishes - exquisitely book-matched veneers, now including Cherry and the highly figured pale Albina Burr, with corners carefully radiused to eliminate residual edge diffractions. In all, literally hundreds of painstaking improvements were made.

So many small improvements can make a big difference to sound quality - and these do. You'll find the Reference Series~Two vastly more accomplished than its illustrious predecessors. Sweeter. Purer. Even more lavishly detailed.

Like all the best things in life, they still don't come cheap - but to anyone who really appreciates sound, they're better value than ever.



REFERENCE SERIES



Ah, Vienna!

Simon Pope samples a slice of rich Sacher Torte in the shape of Vienna Acoustics's Bach floorstanders.

The Austrian capital of Vienna is synonymous with music. At one time or another Mozart, Schubert, Brahms, Bruckner, Mahler and, of course, Johann Strauss, among countless others, lived and worked there.

At £1,000 the Bach is the smallest floorstander in its range. They are of compact stature (190x855x250mm, WxHxD) and weigh a fairly light 68lbs for the pair, resulting in a build that one doesn't usually associate with a 'grand' price tag. The drivers are both produced by the Norwegian company SEAS (as used by Opera, among others) and comprise of a 180mm advanced stiffened paper cone mid/bass which is triple coated and a rear coated 28mm 'silk' dome tweeter. The bass reflex system features a rear located port. Crossover components are of high quality and use "hand picked" capacitors (I didn't realise they grew on trees) and film resistors of less than 1% tolerance.

Due to the small stature of the Bach's it's essential that the 'speaker has the right dispersion characteristics, otherwise you'd end up on bended knee to locate the hot-spot. The company's attempt at lifting the dispersion succeeds well and the sound is lifted up into the room and well out of the box. Indeed this is indicative of the sound overall. It has an easy going and very fluid nature. Not that the Bach's can't handle rhythm well but others, such as Mission's lower sensitivity 783s have more impact and control when it comes to grooving. I found the sound of the Bachs is similar to rivals such as Opera's Super Pavarotti and Chario's Constellation Lynx 'speakers, both similarly priced and both Italian. And both also prefer classical music to

rock, just like the Bachs - it must have something to do with the relevant countries musical history. When was the last time you heard a decent Italian or Austrian pop song ('Rock Me, Amadeus' included)?

I ploughed my way through a variety of recordings and genres. Firstly I tried the Bachs out with some (surprise, surprise) Bach in the shape of Karajan's beefy St. Matthew Passion and Yo-Yo Ma's reading of the 'cello suites. Both fared well. The big sound of the St., Matthew suited the big, warm sound of the Bach 'speakers. I found that 'speaker placement needed attention, as when too close to the back wall the hefty bass players of the Berlin Philharmonic became a little too eager.

The smooth sound of the Bachs meant that the treble was kept under control, if detail a little fuzzy, and the performance had a good feel to it - it was very musical in the lyrical stakes. Voices were again fluid and warm and lyrical instruments such as the woodwind cast their musical spell with success. The 'cello suites were also communicative, with a forward sound that, whilst warm and generous, wasn't the most neutral I've heard, due to a certain amount of cabinet coloration. Nevertheless the 'cello was appropriately 'woody' and rich and there was a generous amount of detail to be heard.

Whilst the Bachs didn't succeed as well with pop and rock as they had done with classical, they still were free from harshness, so for example, cymbals were shimmery and light and guitars full sounding as opposed to rough. Paul Weller's 'Stanley Road' CD demonstrated this well as the guitars panned gracefully from left to right with a rounded and deep sound,

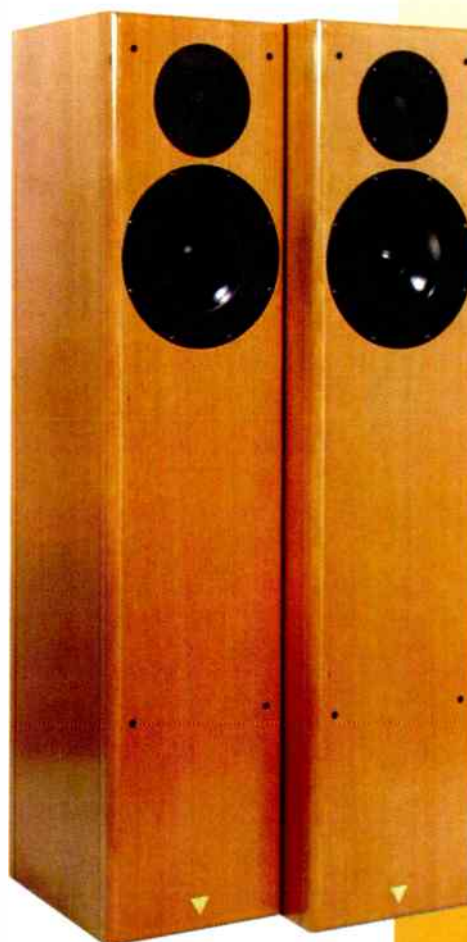

the vocals being forward and fruity.

Whilst not the best around the imaging was good, with a wide open sound stage. These 'speakers aren't the best around with Rock bass and drums, though, and the fluid nature resulted in a sound which I felt lagged slightly behind the beat.

With the laid back jazz of Miles Davis's 'Sketches Of Spain' the Bachs once again fitted in well with the overall 'laziness' of the rhythmic patterns. I heard good timbre in the instruments but again it wasn't the most natural sounding of performances, although still enjoyable.

The Bachs won't suit those who adhere to the Linn/Naim school of 'rhythm rules' school of listening. The sound is full and fruity and commendably big for the cabinet size and is therefore much for those who like their music (especially classical)

rich and open, as opposed to tight and insightful. I like a bit more kick to the sound.

They are colourful in the good sense of the word and will give an enjoyable and musical performance, but one also has to consider the very strong competition around at the price, too. ■ ▲

Vienna Acoustics Bach £1,000

Henley Designs
Unit 10 Moorbrook
Southmead Industrial Park, Didcot
Oxfordshire OX11 7HR
Tel: 01235 511166

MEASURED PERFORMANCE

The Bach had a surprisingly large response dip in its crossover region, centred at 3kHz. Our analysis clearly shows this. Since little changed as the measuring microphone was moved vertically, it is an amplitude dip. It means the Bach will sound, soft, a little warm and possibly low in detail. Whilst not accurate, some listeners may just prefer the softer delivery this gives, especially with CD.

The rest of this loudspeaker's response curve was a bit lumpy, due to the properties of the plastic cone used. It is not an expensive drive unit. Bass extends strongly down to 40Hz with some slight peaking. The port reaches down a little further, to 25Hz. I suspect the Bach will have strong bass, possibly with some looseness to it.

Sensitivity was average at 86dB SPL from one watt of input. Impedance measured 5.6ohms overall and the impedance curve shows that like most two-ways nowadays the Bach has an 8ohm tweeter and a 4ohm woofer in an attempt to raise its voltage sensitivity.

The Bach will have a soft sound, with fulsome bass, which may suit some tastes. **NK**

Frequency response

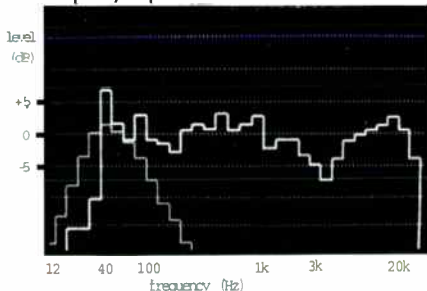

Impedance

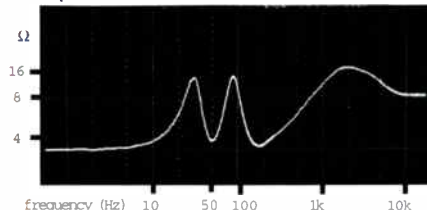

World Verdict



A rich and full sound that's fluid and musical. Not the tightest bass or the most neutral sound, though, and the competition is extremely tough.

Beauhorn
naked music



the **Virtuosos**
fully horn loaded speakers

-that's all you'll hear

"...simply manage to make music of all kinds more interesting and involving" Paul Messenger, Hi-Fi+
"...made each listening experience satisfying, even revelatory" Chis Beeching, Listener
"...approach the status of true genius" Ketan Bahradia, What Hi-Fi?

learn more, contact us now:

Thomas Transducers
Songlines, Fourteen Acre Lane, Three Oaks,
Hastings, TN35 4NB, United Kingdom
Tel: 01424 813888 Fax: 01424 812755
eMail: infol@beauhorn.com
website: www.beauhorn.com



MUSIC MATTERS

THE FINEST HI-FI AND HOME CINEMA

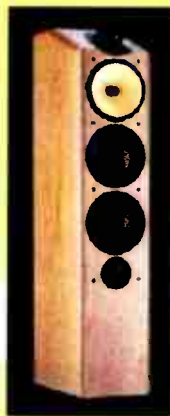

PLEASE CONTACT ONE OF OUR BRANCHES TO ARRANGE A DEMONSTRATION OF B&W CDM NT LOUDSPEAKERS AND ARCAM DIVA ELECTRONICS, INCLUDING THE STUNNING DV88 DVD PLAYER, TO EXPERIENCE A COMBINATION OF EXCELLENT SOUND AND PICTURE QUALITY WITH SUPERB AESTHETICS!



Music Matters stock one of the widest ranges of hi-fi and home cinema products including Chord, Copland, Cyrus, Denon, Dynaudio, KEF, Krell, Marantz, Meridian, Mission, Musical Fidelity, Pioneer, REL, Ruark, Sonus Faber, Tag McLaren, TEAC and Yamaha. All of our branches offer excellent demonstration facilities and we pride ourselves in providing friendly and un-biased advice. We are members of BADA and CEDIA to give the best support to our customers, accept all major credit cards and can arrange finance including interest-free on selected items (Written details on request. Licenced credit broker. APR 0%.)



363, HAGLEY ROAD, EDGBASTON, BIRMINGHAM, B17 8DL. TEL: 0121 420 2811
93-95, HOBS MOAT ROAD, SOLIHULL, WEST MIDLANDS, B92 8JL. TEL: 0121 742 0254
9, MARKET STREET, STOURBRIDGE, WEST MIDLANDS, DY8 1AB. TEL: 01384 444184
10, BOLDMERE ROAD, SUTTON COLDFIELD, B73 5TD. TEL: 0121 354 2311
344, UXBRIDGE ROAD, HATCH END, MIDDLESEX, HA5 4HR. TEL: 020 8420 1925

Open Tuesday to Saturday 10.00 - 5.30. Late night Thursday until 6.30 (except Stourbridge).

THE NEW AFFORDABLE PHONO AMPLIFIER FROM TRICHORD RESEARCH

DINO



Moving Coil
Moving Magnet
Switchable Gain
Switchable Loading
Super Regulators
Discrete Output Stage
Upgradeable Power Supply

Tel: +44 (0)1684 573524
Fax: +44 (0)1684 577380

WWW.TRICHORDRESEARCH.COM

Nothing Like this

Dr Richard Bews and Professor Malcolm Omar Hawksford are the not inconsiderable brains behind this unusual high end digital-to-analogue converter. David Price listens in.



By anybody's reckoning, three grand is a lot of money to spend on a DAC. By the look of LFD's DAC3, all the money has gone into the circuit design and build rather than any external frivolities. The DAC3's Spartan aesthetics are a function of the company's design philosophy, which sees meticulous attention paid to signal routing, earthing and component quality. LFD generally keeps feedback to a minimum, even at the expense of higher total harmonic distortion. Its printed circuit boards are topologically laid out so that signal runs (on PCBs) are as short as possible - it's claimed to be typically 5 times shorter in length than average because LFD believes high quality audio cables exhibit less degradation. Indeed, single and multi strand cables are mixed for optimum sound. Star earthing is applied rigorously, and passive components have been selected meticulously.

The DAC3 uses a custom made Ultra Analog 20-bit converter, with five separate power supplies using two high-isolation transformers for the digital section and four separate supplies fed by a large 325 VA transformer for the analogue section. To prevent ground loop contamination from the CD transport to the DAC, a wide bandwidth digital isolation transformer is used. This is followed by an ultra fast comparator to optimally condition the data sent to the interface receiver. An advanced output buffer is claimed to have a very low output impedance and is completely discrete, feedback-free and does not use DC correction.

In the publicity blurb, LFD asks potential purchasers to, "please compare the DAC3 to the very best digital to analogue converters and we are sure you will not be disappointed with its performance". A Linn CD12CD player was duly pressed

into service!

The LFD is an exceptionally fine sounding digital converter, that when partnered with a decent transport (I used the CD12 for this too, so no worries on that score) really sings.

I started with Van Morrison's 'Have I Told You Lately', a sumptuous sounding affair with beautifully recorded strings and piano which proved meat and drink to the DAC3. Whereas the CD12 did the classic Linn thing and went straight for the rhythmic jugular - picking out, for example, the occasional guitar licks with incredible speed - the LFD concentrated more on recreating the studio's recorded acoustic. To wit, it gave an even more airy, expansive soundstage than the Linn (which is no mean feat) with greater breadth and depth.

The other obvious difference was its tonal balance. The Linn is by no means mid-forward but the LFD

Ortofon



Pro-Ject

The year is 2001, the age of .com, poor service and fast turnover.

At Henley Designs we feel that things should be done differently. Customers should be treated with respect by staff who not only care, but who possess a knowledge and interest in the products they sell.

Our aim is to have a nationwide team of elite dealers who are able to offer advice, demonstrate and set up Pro-ject and Ortofon equipment. As a customer you should feel valued and comfortable during your purchase. As an owner, the value should continue through your pleasure in the music and its reproduction.

A limited number of dealers have been selected for their exceptional standards in customer service. Their staff have been trained by ourselves to ensure the highest level of expertise and at least one member of staff from each store is fluent in all aspects of our products.

We are proud to recommend the following dealers who have demonstrated their commitment and deserve the title:

Centres of EXCELLENCE

Town	Dealer	Telephone	Store Expert
Aldridge (West Mids)	Sound Cinergy	01922 457926	Clive
Ashby De La Zouch	Zouch Audio	01530 414128	Mick
Bedford	Richards A/V	01234 365165	Dave
Birmingham (Edgebaston)	Music Matters	0121 434 3298	Mike
Brentwood	Audio T	01277 264730	Paul
Bristol	Radford HiFi	01179 422860	Glen
Bristol	Audio Excellence	0117 9264975	Jason
Cambridge	The Audiofile	01223 368305	Malcolm
Cardiff	Sevenoaks S&V	0292 047 2899	Chris
Chester	Audio Excellence	01244 345576	Tyler
Colchester	Grayston S&V	01206 577682	Nat
Coventry	Frank Harvey	0247 6525200	David
Doncaster	The Hi-Fi Studios	01302 727274	Jeff
East Grinstead	Audio Designs**	01342 314569	Niel
Edinburgh	Russ Andrews*	0131 5571672	Drew
Exeter	Sevenoaks S&V**	01392 218895	Mark
Helston, Cornwall	Sounds Perfection	01326 221372	Nigel
Ipswich	Sevenoaks S&V	01473 286977	Chris
Kidderminster	Midland Audio Ex*	01562822236	John
Leeds	Sevenoaks S&V**	0113 245 2775	Chris
Lincoln	Sevenoaks S&V	01522 527397	David
London (Euston)	Kamla	0207 3232747	Moss
London (Holburn)	Sevenoaks S&V	0207 837 7540	Matt
Manchester	Sevenoaks S&V**	0161 831 7969	Sam
Manchester	Practical Hi-Fi	0161 839 8869	Dave
New Malden, Surrey	Unilet	0208 942 9567	Vernon
Newbury	B&B Hi-Fi**	01635 32474	John
Newcastle (Gateshead)	Lintone Audio	0191 477 4167	Mark
Norwich	Sevenoaks S&V	01603 767605	Justin
Nottingham	Notts Hi-Fi Centre	0115 9248320	Andy
Rainham (Kent)	Progressive Audio	01634 389004	Dave
Reading	B&B Hi-Fi**	0118 9583730	Dave
Reading	Audio T*	0118 9585463	Tom
Salisbury	Salisbury Hi-Fi**	01722 322169	Paul
Sheffield	Moorgate Acoustics	0114 275 6048	Paul
Southampton	Phase Three**	0238 0228434	Dave
Swansea	Sevenoaks S&V	01792 465777	Craig
Tuxford (Notts)	Chantry Audio*	01777 870372	Nigel
Warrington	Doug Brady*	01925 828009	Dean
Worthing	Phase Three	01903 245577	James
Yeovil	Mike Manning Audio*	01935 479361	Mike

* Ortofon only
** Pro-ject only

For a full dealer list and more information contact:
Henley Designs Ltd, Unit 10 Moorbrook, Southmead Industrial Park, Didcot, Oxon, OX11 7HR
Tel: 01235 511166, Fax: 01235 511266, E-mail henley.designs@virgin.net, WWW.henleydesigns.co.uk

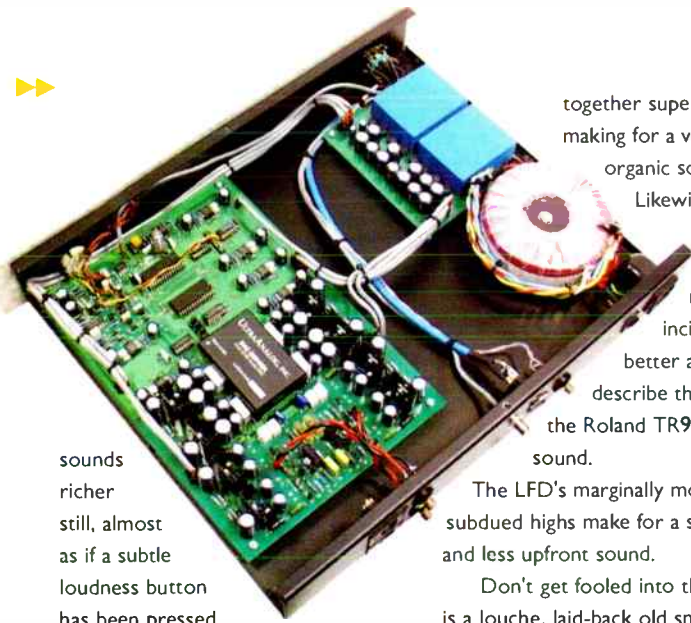

sounds richer still, almost as if a subtle loudness button has been pressed.

Van Morrison's voice sounded both beautifully smooth yet highly tangible, the DAC3 communicating grain and patina in all its glory.

Upper bass is richer, fruitier and - true to LFD tradition in my experience - very subtly overhung. If it wasn't for the DAC3's superb grip, this would slow the sound down. I cued up K-Klass's 'Rhythm is a Mystery' and the CD12's sub-bass was tighter and more grippy, but still the LFD tied the component parts

together superbly, making for a very fluid, organic sound.

Likewise the CD12's treble is more incisive, better able to describe the sheen of the Roland TR909 hi-hat sound.

The LFD's marginally more subdued highs make for a smoother and less upfront sound.

Don't get fooled into thinking this is a louche, laid-back old smoothie though. Nirvana's 'Come As You Are' saw the DAC3 turning in a remarkable performance, with a slightly more bass-heavy sound than the Linn but nearly all of its excellent dynamics and much of its lightning rhythm. Tremendously accomplished at starting and stopping, snare drums sounded beautifully tight and tuneful, giving the song a wonderfully engaging rhythmic flow. The DAC3 is an out and out music maker, and offers a rare combination of tonal warmth

and rhythmic punch. The way it combines a vice-like grip on the music's rhythmic inflections with an ability to knit everything together into an organic whole is very special indeed.

It is to the LFD's eternal credit that it ran the CD12's DAC section so close. Ultimately it's more euphonic than the tighter, tauter Linn, but the overall effect is remarkably liquid, engaging and musical. While it can't absolutely match the £12,000 Glaswegian, this slice of 'budget super-fi' from Essex makes a remarkably convincing case for itself. Whereas most other sub-£5,000 rivals sound variously aggressive or unengaging, the DAC3 is a brilliantly judged compromise. ■ ▲

LFD DAC3 £2,999

LFD Audio,
7 Lancaster Gardens West,
Clacton-on-Sea,
Essex
CO15 6QG
Tel: 01255-422533

MEASURED PERFORMANCE

The LFD has a smoothly falling high frequency response, our analysis shows. The upper response limit still measured a normal enough 21.1kHz though, so the rate of fall is not too steep, likely just enough to ensure the convertor does not have a bright sound.

The distortion results were unusually poor for a modern design, being more reminiscent of designs of yore. One channel produced a reasonable 0.036% distortion at -30dB but the other a high 0.116%, with an extended harmonic structure. Our distortion analysis clearly shows this as an array of spikes reaching right up to 20kHz, not a good sign in terms of sound quality. There will likely be a little greyness, or roughness or coarseness as a result. The LFD is unlikely to sound as smooth as the best, but then its designers almost certainly know about all this and have chosen parts for qualities other than low distortion. The only good sign was that a -90dB signal was not only resolved but at normal distortion levels, whereas in the past when a

convertor went non-linear it invariably got worse as level decreased.

Output was a massive 3.4V, no less than +5dB up on the usual 2V standard, so this convertor will sound much louder than others.

Separation and noise figures were normal enough. Although the convertor was in mute during conventional noise measurement the noise floor in our distortion analysis is lower than usual.

The LFD is unusual and doubtless characterful. It doesn't measure well but I can't help feeling LFD know this and have made a conscious decision to focus on other properties. **NK**

Frequency response 4Hz- 21.125kHz

	left	right
Distortion		
-6dB	0.007	0.008
-30dB	0.036	0.116
-60dB	0.48	0.52
-90	29	30

Separation	left	right
1kHz	108	118
20kHz	84	93

Noise	-108dB
with emphasis	-108dB

Dynamic range	107dB
Output	3.4V

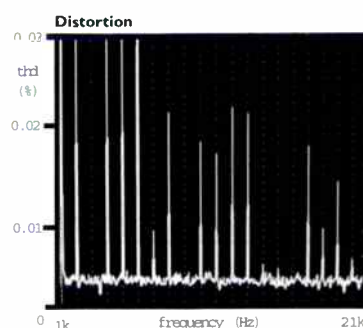
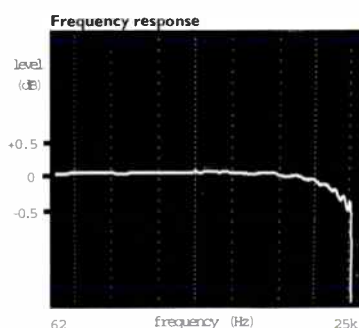

World Verdict

Three grand is a lot to spend, but few other digital convertors come close. Brilliantly warm, musical and engaging sound makes the most of any music.

Second



Once more Musical Fidelity have upgraded a best selling amplifier to improve sound quality. This time it's the turn of the A3 and Simon Pope is suitably impressed.

Is there no end to the Musical Fidelity story? This company more than any other I can think of has such a vast proliferation of equipment available that one day, just one day you think they may blow it. Needless to say it never happens. Buying a Musical Fidelity product is like having your hair cut at Toni and Guy or having dinner at Pizza Express - not that there's anything High St. about them.

This is a specialist company, without doubt. It's just that they all offer consistently exceptional quality at a more than sensible price. You end up with a product that will often cost twice as much in the hands of others. This isn't all good, as it often induces a smugness towards those that have paid twice as much and have often ended up with less!

The latest annoyingly good product from Musical Fidelity is a revamp of their first A Series product, the very fine A3 integrated amplifier. "If it ain't broken, don't fix it" I hear you cry, but this is Musical Fidelity remember, where the fixing often reaps rewards. Since the original A3 was launched, the company have worked on many fine high end products such as the Nu-Vista 300 power amp, the awesome Nu-Vista A3 integrated and the A3 CR pre and power amps. MD Antony Michaelson

felt that each of these was an improvement in design and concept on its predecessor and wished for the momentum to continue with the A3 integrated. The design objectives for improvement were for an increased speed and attack with more "apparent" power, greater tonal refinement and improved imaging. Not that there was a failing with any of these points with the original A3 but the A3 CR pairing showed how much could be done with the resources, they had perhaps, a little more kick and headroom than the A3.

The new A3 power supply has been updated by 50%. The wire gauge of the transformer has been increased and is of higher quality than previously. There have also been minor changes in the power supply de-coupling resistor and capacitor values. This, say MF mimics the effect of choke regulation' (used in MF's more expensive amplifiers). As for the exterior, much remains the same, expect for the gold trim becoming a more tasteful (in my humble opinion, anyway) silver to match the rest of the faceplate. Still present is a switchable MM/MC phono stage and the same number of line inputs.

Kicking off with Bach's sublime 'cello suites played by Yo-Yo Ma I

found the Musical Fidelity had the trademark detail and transparency that we've come to expect from the brand. There was space around the instrument and a fine sense of realism as the bow dug deep into the strings to produce a full and rugged sound. Not the smoothest I've heard but then neither is the recording - the A3 was just doing its job! This same transparency and magnified detail was also in a recording of Mahler's 7th symphony played by the Vienna Philharmonic under Boulez on a DG '4D' recording. The orchestra was nicely spaced and the spiky orchestration of the third movement was relayed with speed and agility. I can't think of any other manufacturer at this price who can provide such a natural sound of an orchestra the way MF can (maybe it's to do with the fact that Antony is a mean clarinettist and a regular recorder and performer), it's quite bright and hard going at climaxes but anyone who's sat in the first five rows of the Royal Festival Hall will know that an orchestra is too - it's part of the excitement. Percussive detail was spot on - triangles clean and shimmery, timpani sharp and fast and the percussive 'thwack of the double bass strings against the finger board awesomely startling.

time around



To test the company's attempt for faster attack and imaging, I found myself spinning Nirvana's "Nevermind" on vinyl with an Ortofon MC30 Supreme feeding the phono stage. Sure enough, the A3 delivered well. The opening onslaught of "Smells Like Teen Spirit" had guts and drive, with the thick sound of the chorus failing to trip up the A3. There was strong and fast bass in bucket loads and the kick drum pounded through my Quad 988s with precision speed. The wall of sound climaxes could be a tad bright and hard at times but were still involving and highly communicative. Imaging was very good, with Mad Kurt's voice pin

point in the centre and the rest of the mix exactly as the

producer intended, I'm sure. So it seems (I'm sure much to the chagrin of many in the industry) that MF have done it again with an amplifier. Offering quality of transparency, brilliance and detail, as well as clout, rarely found at the price. It doesn't have the ultimate slam and control of the more expensive MF products but why should it? For a company that started with valve amps they've made the transistor transition well. How they keep doing it I don't quite know, it's

becoming a habit and my job becomes increasingly difficult - writing praise filled reviews is hard work. Musical Fidelity take note! 📊 📈

Musical Fidelity A3 £850

Musical Fidelity
15-17 Olympic Trading Estate
Fulton Road
Wembley
Middlesex
HA9 0TF
Tel: 020 8900 2866

MEASURED PERFORMANCE

The A3 is reasonably compact but heavy and powerful too. It delivers 84W into 8ohms and 132W into 4ohms, more than enough to generate high volume in most homes. Musical Fidelity are of the opinion that very high powers are needed to reproduce the potential dynamic range of a musical performance, not a new argument and one that supposes very high sound pressure levels can be generated in the home. This is as much a test of loudspeaker ability as anything else. Whatever, the A3 has plenty of punch.

Our distortion analysis shows there's little sign of unwanted harmonics above a 1W 10kHz test signal. It is at high frequencies that amplifiers can look weak in this area, but the A3 was linear at all power levels, producing just 0.02% second harmonic distortion at full output, a low figure. Low distortion figures are a good indicator of smoothness and cleanliness of an amplifier's sound, if a weak guide to its overall character.

Sensitivity on all inputs was high at 220mV, enough to be able to cope with all sources, including older design tuners and cassette decks. Musical Fidelity make the A3 freindly to other 'legacy' sources (i.e. old kit you might still be using) by including a

phono stage that handles Moving Magnets or Moving Coils at the push of a rear panel switch. It's common for such a switch to increase gain by x10 and do little else, but not the A3. It offers x6 increase, being sensitive with MMs but not-so-sensitive with MCs. It isn't really intended for ultra high quality MCs with miniscule outputs, like Linns and Lyras. Ortfons are more like it, although not the most expensive (think Supremes). Bass response was a little curtailed when switched to MC, to help flatten the bass peaking that occurs due to arm/cartridge resonance I imagine, due to lower compliance of an MC. It isn't wise to extend MM response either though, due to the possibility of severe cone flap from cartridges like the AT-440ML I review this month, so there's quite a lot to consider here. All the same the A3 does a good job of putting in a good set of performance figures with both types of cartridges.

The A3 is a powerful amplifier that is flexible in its accommodation of sources. In all areas it measures well. **NK**

Power 84watts
CD/tuner/aux.
Frequency response 5Hz-41kHz

Separation	80dB
Noise	-96dB
Distortion	0.004%
Sensitivity	220mV
dc offset	1/2mV
Disc MM	
Frequency response	14Hz-30kHz
Separation	54dB
Noise	-80dB
Distortion	0.004%
Sensitivity	2.3mV
Overload	53mV
Disc MC	
Frequency response	57Hz-22kHz
Separation	52dB
Noise	-72dB
Distortion	0.006%
Sensitivity	0.4mV
Overload	7.7mV

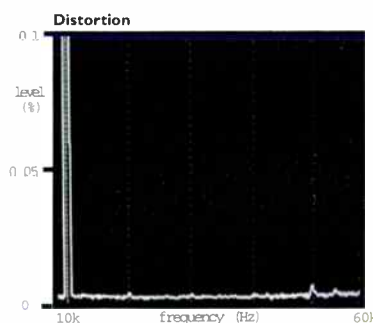

World Verdict
£★★★★

A level of detail and transparency rare at the price (and higher). The A3 is a class leader in solid state design.

Zero Sum



The ZERO series is the cheapest way to get a taste of the famed Audio Note magic. David Price plays with the M1R preamplifier and P ZERO monoblocks.

Think of the ZEROs as a kind of 'Audio Note Lite'. For a surprisingly modest outlay you can kit yourself out with the CDT ZERO CD transport (£549) and ZERO tube DAC (£749), plus the M1-R tube preamplifier (£749) and P ZERO monoblock tube power amps (£699 per pair) tested here. By any standards - let alone those of a company that sells Gaku-On power amps for £49,500 per pair - this is cheap for an all-valve system.

The good news is that despite the beer budget price tags, this pre-power combination is impressively well screwed together. Petite, shoebox-sized extruded aluminium cases double as heatsinks, while brushed aluminium fronts complete a fine looking package. You even get a choice of black or silver finishes. Standard gold plated RCA phono sockets are used throughout, along with dual-purpose spade/4mm banana speaker terminals.

The M-One R preamplifier is a neat little unit, offering a front panel

volume and balance control along with warning lights denoting which of the four inputs are selected. In addition to these, round the back you'll find two pairs of preamp outputs for biwiring, plus one tape out. Inside lurks a single 6111WA tube in the M ZERO's line stage. The R version tested here offers a wireless remote control with volume, balance and source selection, but also boasts upgraded components inside, including Black Gate Graphite electrolytic capacitors and Audio Note paper-in-oil signal caps.

The P ZEROs are slightly deeper than the M preamplifier, but otherwise the same size. Inside is the fairly unusual sight of two ECL82 triode-pentodes (more commonly known as the 6BM8 in The States) giving a claimed power output of 8W. In the P ZERO they're run in Class AB2 mode, meaning they'll last a long time (between five to seven years), use relatively little power and not produce too much heat. To wit, the manufacturer suggests they can be left on all the time for optimum sound,

where they'll still last around three years!

I used Audio Note's AN-Vx cable between M and P amplifiers, and AN-L to hook up my Yamaha NS1000M and Mission 782 loudspeakers. For the purposes of this review, I used a Michell Orbe/Linn Ekos/ Linn Arkiv turntable with Michell Delphini phonostage and Linn CD12 CD player.

SOUND QUALITY

This combo has - to put it politely - a distinctive sound. They're a riot. About as zesty, bubbly and bouncy as tube amps get (without spending silly sums), they have musicality and sheer joie de vivre - call it what you will - that few other equivalently priced products, valve or transistor possess. Oh, and they're also horrendously coloured and about the least transparent amps I've heard of late. Neutral, open, even-handed? Not on your life!

I kicked off the listening in a circumspect mood, rather worried that the P Zeros wouldn't be able to

Game

drive my NS1000Ms (91dB sensitivity but a tricky load). I needn't have worried - from the second the stylus hit the groove of Be Bop Deluxe's 'Modern Music' I was treated to vast amounts of volume without the slightest hint of anything wanting to let go. The next thing I realised was how fast and fizzy these babies are.

Essentially this combo is a tad mid-forward, but that's not to say you'll have to handle with care, as there's none of the hardness you get with similarly upfront transistor amps. Rather, the music assumes a crisp, brightly lit character that chimes out at you.

Equally obvious is the bass, which isn't the deepest or most generous around but it is incredibly bouncy. I don't know quite how or why, but you'll never hear workmanlike basslines through this combo. Rather, the lows come barrelling out at you with tunefulness and speed.

Cueing up Seal's 'Crazy' was a fine test of the Audio Note combo's mettle. The Zeros dived straight in, filling the room with a powerful and punchy 'soundscape' through which a number of different instruments shone through. Synth tracks and drum

machines sparkled and vocals were carried with impressive clarity. Large scale dynamic peaks were flattened somewhat, but the music's smaller, more subtle rhythmic inflections were carried superbly. Cymbals were a touch too crunchy for my liking, and while left-to-right soundstaging was incredibly expansive the depth perspective was relatively mediocre.

Suzanne Vega's 'Luka' is an extremely clean, clear eighties recording but you wouldn't know it listening to the Zeros. The song's intro with its chiming DX7 keyboards quickly showed how the Audio Notes were adding a layer of grain to the sound. Make no mistake, this wasn't the nasty, sandpapery variety you hear on lesser solid-state stuff, but a kind of veiled hash that got in the way of Vega's rich voice.

Cue up some acoustic jazz in the shape of Lonnie Smith's 'Think' (on Blue Note LP) and you soon realise how far from the truth the Zeros are. Like many lesser valve amplifiers (especially push-pullers) this combo is tonally rather disappointing. Of course you get that initial valve bloom, but everything gets it regardless of whether it's there in the first place.

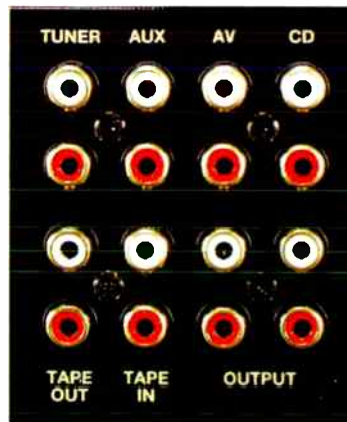

The result is that it's harder to get closer to the real music.

A very coloured combo then, but the Audio Note Zero duo has a single redeeming feature that makes you want to forgive it its sins - fun. Despite its fuzzy, mushy soundstage and lack of subtlety and low level detail, it's a right old riot to listen to (or should that be 'with!') If you're looking for an easy and stylish way into valves then you could do far worse than these. Otherwise, if it's a more sensible, even-handed tube sound at the price you seek then look to Unison Research. ■ ▲

Audio Note MIR pre-amp £749
Audio Note P ZERO £699/pair

Audio Note UK Ltd.,
Unit C Peacock Industrial Estate
Lyon Close, Hove,
East Sussex, BN3 1SG
T: 01273 220 511
info@audionote.co.uk
www.audionote.co.uk

MEASURED PERFORMANCE

The Audio Note monoblocks produce 7W into 8ohms, as specified in the handbook. However, at low frequencies where transformer iron is important, this fell to just 3W. The power bandwidth of these amplifiers is limited.

Frequency response rolled off below 35Hz. Although deep bass fundamentals stop at 40Hz with string instruments there's still plenty more energy lower down and a 35Hz roll off (-1dB) will subjectively lighten bass a little. The high frequency limit was 28kHz, free from resonant peaks - a good sign.

The preamp and amp in combination had a lot of gain, input sensitivity measuring 80mV. This gave a slightly worse than usual noise

figure of -80dB (IEC A weighted).

This was satisfactory all the same.

Valve amplifiers always produce more distortion than solid-state designs. The Audio Note units were no exception here, but at 1V it was mainly innocuous second harmonic. Unfortunately, at 3V, 40Hz the monoblocks were producing 1% with extended harmonics and this will start to add muddiness and confusion into the sound if volume is pushed up.

The Audio Notes measured satisfactorily. In use it is limited power that will most influence sound quality; they must be used with sensitive loudspeakers to run within normal operating parameters. **NK**

Power	7watts
CD/tuner/aux.	
Frequency response	35Hz-28kHz
Separation	60dB
Noise	-80dB
Distortion	0.3%
Sensitivity	80mV

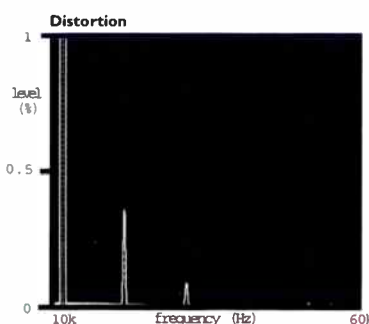

World Verdict

Tremendous life, zip and brio make for an eminently musical listen, but try before you buy as it may not be to everyone's taste.



J A Michell Gyro SE Turntable **£974.95**

Founded in Borehamwood by mechanical engineer John Michell. For over thirty years, Michell Engineering have been at the forefront of quality audio, with world-wide appreciated products like the GyroDec and Orbe Turntables.

In the early eighties, the revolutionary GyroDec Turntable, with its elegant and effective suspension system, was introduced. The **Gyro SE** is a smaller and cheaper package that retains the classy sound of the GyroDec and can be upgraded to the full GyroDec specification by adding a plinth and dustcover. **Price includes Rega RB300 Tone Arm**



Super Audio CD or SACD is a new initiative from Philips and Sony, the original inventors of Compact Disc. It is a superior performance format which takes advantage of the technological improvements which have evolved over the past twenty years, while at the same time maintaining retro-compatibility with existing CD software.

SACD uses 24 bit word lengths and a 96kHz sampling frequency compared with 16 bit, 44.1kHz of conventional CD. Many audiophiles consider the performance of SACD, even in its early stages, readily bettered the performance of any CD player.



MISSION



782 bases its performance on a 165mm Nomex bass unit fitted to a reflex enclosure that extends low frequency output to reach the lowest fundamental of bass guitar - an astonishing performance for such a graceful and compact cabinet.

783 houses a larger 200mm bass unit with massive motor system, capable of floor shaking, yet tightly controlled low frequency extension. Both use Keraform midrange drivers for outstanding clarity and midrange detail coupled to superb dynamic range together with the smooth and finely detailed Mission silk dome tweeter.

780 and **781** are the pinnacle of Mission's research into creating a three dimensional soundstage, extensive bandwidth and dynamic range from the smallest possible cabinet dimensions. The **780** is diminutive in form but massive in its sonic capabilities. Its 130mm Keraform bass unit is carefully matched to a novel reflex enclosure for full bodied bass extension, the qualities of Keraform produce a dynamic and ultra detailed midrange. In the **781** a 165mm Keraform driver takes advantage of a larger, stand mount cabinet to extend bass performance and increase efficiency whilst maintaining that superb midband transparency and finely detailed treble.

SACD Selection

Sony SCD-XB940	£299.95
Sony SCD-XB770	£399.95
Sony SCD-XA333	£999.95
Sony SCD-555ES	£999.95
Sony SCD-777ES	£1699.95
Sony SCD-1	£3699.95
Philips SACD1000	£1299.95

Mission 780 Series

783	£999.95
782	£699.95
781	£499.95
780	£299.95

Please Note: Some products may not be available at all outlets. Advertisement valid until at least 1st August 2001, E&OE.



more entertaining

World Radio History



ARCAM

DiVA Series

CD72 CD Player	£399.95
DV88 DVD Player	£999.95
A65 Integrated Amplifier	£379.95
A75 Integrated Amplifier	£449.95
P75 Power Amplifier	£299.95
P85 Power Amplifier	£499.95
T51 Tuner	£279.95
AVR100 AV Receiver	£799.95



| DiVA CD92 CD Player £849.95
| DiVA A85 Integrated Amplifier £749.95

Arcam's quest for higher performance, has led to the development of the new **DiVA** series, the most complete range of high performance home entertainment equipment ever launched by a specialist audio manufacturer. Innovative design and production techniques have enabled Arcam to build on established values of excellent sound quality and value.

The DiVA series comprises, two CD Players, three Integrated Amplifiers, two Power Amplifiers, an AM/FM Tuner, a high performance DVD Player and Arcam's first Home Cinema Receiver. All models are available in either silver or black.

| AE1 Series II £699.95



In 1988 the original AE1 was launched. Designed to satisfy the needs of the professional audio sector of the market, by offering great accuracy, precise stereo imaging, dynamics, and transparency coupled with high power handling and linearity. The AE1 quickly acquired a global reputation with musicians, recording artists and studio engineers.

Subsequently the AE1 won the British Hi-Fi Award for Best Speaker in 1991 and 1992, and acclaim within the hi-fi press grew world-wide.

Unrivalled in its class the AE1 is renowned for superb bass, speed and dynamics.

The **AE1 Series II** retains these qualities and provides greater clarity, transparency and harmonic timbre, coupled with a larger stereo sound stage and increased sensitivity.

Critical matching of the voice coil and metal-cone have improved the mid-range, allowing for a much simpler, short path crossover network achieving gentle first order acoustic slopes and a seamless blend between the drivers.

The crossover features upgrades to the internal wiring and Industrial grade encapsulation is also applied to the total crossover assembly eliminating resonance, microphony and increasing power handling.



Arcam's approach to hi-fi has always been to provide the best combination of performance and price in the hi-fi separates market. The **FMJ** series not only continues this tradition but also evolves and extends it.

It quickly became apparent to Arcam's design team that the significant performance improvements gained from using more advanced chassis and casing materials and a solid metal front panel, could be taken further by revisiting the mechanical design of the units.

All FMJ products have finely textured, 8mm thick, aluminium machined front panels. These panels are then "sealed" by baking them in industrial ovens to ensure the durability of their high quality finish. Even the control knob on the A22 Amplifier is turned from solid aluminium before being given the same finishing treatment.



World Radio History



Please Note: Price Excludes STAE1 Stands.

| CD23 £1099.95

The **CD23** benefits from a second power supply transformer. This, like the power supply transformers used in nearly all Arcam amplifiers, is a toroidal transformer. Whilst being expensive compared to the alternatives, toroids are known to dramatically improve the audio performance of many hi-fi products. In this product, both transformers are custom made for Arcam and are used to supply the analogue and digital circuits separately.



CDM™NT Series

The CDM™NT series from B&W combines the unbeatable sound purity of their highly acclaimed Nautilus 800 Series and the classic looks of their predecessors, the CDM SE. Complete in both looks and sound quality, this is one of B&W's finest loudspeaker ranges to date. The CDM™NT Series is available in a choice of beautifully finished real wood veneers.

CDM™NT Selection

CDM™1NT	£749.95
CDM™7NT	£1249.95
CDM™9NT	£1799.95
CDM™CNT Centre	£399.95
CDM™SNT Surround	£749.95

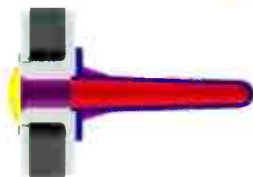

Nautilus Tapered Tubes
The most effective way of absorbing unwanted sound from the back of the drive unit.



Kevlar™ Cones The same properties that make Kevlar the right material for bulletproof vests also benefit the design of wide bandwidth drivers.



Flowport™ Technology
Golf ball aerodynamics theory points the way to lower distortion reflex ports.



LINN
the only sound

Founded in 1972, independent precision-engineering company, Linn Products Limited, specialise in top performance sound reproduction.

Linn's first product was the revolutionary Linn Sondek LP12 Turntable. 25 years later it is still, for many, the reference Turntable. Today, Linn's hi-fi range includes over 50 products including CD Players, Tuners, Amplifiers and Loudspeakers.

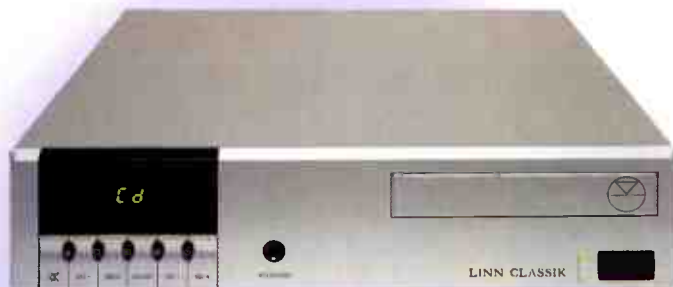

Classik K CD Receiver £999.95

The **Classik** is an alternative to the sound and looks of mass market compact systems. Designed to be useful throughout the home, the Classik is simple and stylish with all the advanced features needed to satisfy the most demanding hi-fi enthusiast or discriminating music lover.

The **Classik** combines an extensive and flexible control system, high quality CD, Tuner, and powerful Amplifier, capable of driving any Loudspeakers, in a single, compact package and is available in a choice of colours.



Genki CD Player £994.95

The **Genki** is a versatile, high performance CD Player combining value and multi-zone flexibility. With both fixed and variable outputs, the Genki can be connected to a Pre Amplifier in the conventional way or, using its local volume control, connected directly to a Power Amplifier. **Features include:** HDCD playback capability, Delta-Sigma digital-analogue conversion, carefully implemented low-noise circuitry to deliver pitch accurate sound, surface mount electronics for optimum signal routing and Linn proprietary Brilliant silent power supply technology.

Pekin AM/FM Tuner £544.95

Integrating the knowledge gained from developing other Linn Tuners such as the Kremlin, the Kudos and most recently the Classik, the **Pekin** AM/FM Tuner takes it one step further, to produce a powerful and truly musical performance to the unique standards that you expect from Linn.

Features include: 80 memory pre-sets, upgradeable software, fully screened low-noise circuitry, high overload margin and high sensitivity, low noise switchmode power supply and two audio outputs.



Linn Selection

Ikemi CD Player	£1949.95
Majik Integrated Amplifier	£694.95
LK85 Power Amplifier	£494.95
LK140 Power Amplifier	£749.95
Katan Speakers	£634.95
Ninka Speakers	£894.95
Kolektor Pre Amplifier	£494.95
Wakonda Pre Amplifier	£794.95



more entertaining

World Radio History

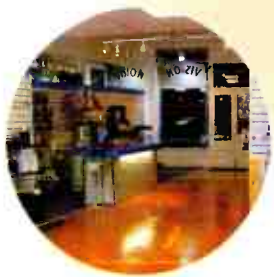

MUSICAL FIDELITY

Musical Fidelity's A-Series is a ground-breaking range of CD Players, Pre-Power and Integrated Amplifiers. The whole series has received enormous acclaim and has won many hi-fi awards worldwide.

X-Ray CD Player	£799.95
X-A2 Integrated Amplifier	£499.95
A3 Pre Amplifier	£999.95
A3 Power Amplifier	£999.95
A300 Integrated Amplifier	£1399.95
A300 Power Amplifier	£2199.95
NuVista M3 Integrated Valve Amplifier	£2974.95



A3 CD Player **£799.95**
 Integrated Amplifier **£849.95**

A3 CD Player "OK, so not everyone will be drawn to the styling, but when it comes to turning on the sonic fireworks, few players come even close at this price... A class act and a worthy winner." *What Hi-Fi?* Awards 2000

A3 Amplifier "The A3 does a wonderful trick of conveying a great romantic sweep of music while at the same time delivering as much internal detail as anyone could possibly want... This is an amplifier capable of performing well beyond its price. We guarantee you won't be disappointed." *What Hi-Fi?* Awards 2000



MONITOR AUDIO
Gold Reference Series

Gold Reference 20 £1499.95

"Monitor Audio has made an immensely accomplished pair of speakers in the *Gold Reference 20*. In sonic and physical terms there is little to criticise; even the price is highly competitive. We have no choice but to recommend them highly." ★★★★★ *What Hi-Fi?* March 2001

ROKSAN

Caspian CD Player **£894.95**
Caspian Integrated Amplifier **£794.95**

Founded in 1985, Roksan's objective has always been to bring high-end specialist hi-fi to every home. Today with the *Caspian* range, that goal has been fully achieved. The sound and build quality of true British engineering has been made available to the most discerning of music listeners.



Caspian CD Player

"If you can stretch to it, though, Roksan's Caspian the player to go for. Yeas, it's the most expensive here, but no rival can touch it when it comes to bringing music to life - regardless of genre. And that's what hi-fi is all about." ★★★★★ *What Hi-Fi?* May 2001

Caspian Integrated Amplifier

"The Caspian has been around for a few years, but Roksan has developed it to a point where it now leads the class in all-round terms. In specific areas other amps equal it, but overall none can beat its combination of clarity, timing and dynamics. The Caspian is a worthy winner." ★★★★★ *What Hi-Fi?* February 2001

Please Note: Some products may not be available at all outlets. Advertisement valid until at least 1st August 2001, E&OE.



who are **sevenoaks?**

Founded as Sevenoaks Hi-Fi in the summer of 1972, the original shop, in the market town of Sevenoaks, Kent, quickly gained a reputation for offering a wide range of products at competitive prices, and providing excellent service.

Exciting new technologies like compact disc, meant that throughout the 1980's there was considerable interest in hi-fi and Sevenoaks were able to grow. By 1990, the company was established as one of the leading independent hi-fi specialists in the country.

More stores were opened and a number of the original shops were relocated. In 1995 the important decision was made to change the name to Sevenoaks Sound & Vision, reflecting the wide appeal of new audio visual products.

After twenty-nine years of trading, the company has more than forty outlets nationwide, and is for many of the UK's leading manufacturers of electronics and loudspeakers, their largest and most successful retailer.

solutions

solutions

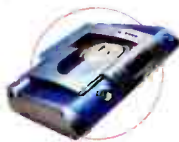

sevenoaks sound & vision



DVD Video is a great way of enjoying movies at home

The people at Sevenoaks appreciate that customers have a choice. This appreciation has meant that over the years Sevenoaks have had to adapt.

As new products and technologies have arrived, the staff have been trained to ensure that they can explain the issues, simply and informatively.

This orientation to customer service remains, and the implementation of a company charter is one example of this commitment.

By staying true to the original ideals of offering a wide range of the latest products, at competitive prices, and providing superb service in pleasant surroundings, Sevenoaks are able to listen, recommend, demonstrate and supply the products that best suit the needs of their many customers.

As the world becomes a more complex place and people search for entertainment and relaxation, Sevenoaks Sound & Vision believe that whatever the requirement, they have the solution.

brochure

available in all outlets

more entertaining

World Radio History





scotland and north

- Aberdeen** 491 Union Street **01224 587070**
- Edinburgh** 5 The Grassmarket **0131 229 7267**
- Glasgow*** 88 Great Western Road **0141 332 9655**
- Hull** 1 Savile Row, Savile Street **01482 587171**
- Leeds*** 112 Vicar Lane **0113 245 2775**
- Liverpool** 16 Lord Street **0151 707 8417**
- Manchester** 69 High Street, City Centre **0161 831 7969**
- Newcastle** 19 Newgate Street **0191 221 2320**
- Preston*** 40-41 Lune Street **01772 825777**
- Sheffield*** 635 Queens Road, Heeley **0114 255 5861**

midlands and east

- Bedford** 29-31 St Peters Street **01234 272779**
- Cambridge** 17 Burleigh Street **01223 304770**
- Ipswich** 12-14 Dogs Head Street **01473 286977**
- Leicester** 10 Loseby Lane **0116 253 6567**
- Lincoln** 20-22 Corporation Street **01522 527397**
- Norwich** 29/29a St Giles Street **01603 767605**
- Nottingham** 597-599 Mansfield Road **0115 911 2121**
- Oxford** 41 St Clements Street **01865 241773**
- Peterborough** 36-38 Park Road **01733 897697**

midlands and west

- Birmingham** 12 Queensway Arches, Livery Street **0121 233 2977**
- Bristol** 92b White Ladies Road, Clifton **0117 974 3727**
- Cardiff** 104-106 Albany Road **029 2047 2899**
- Cheltenham** 14 Pitville Street **01242 241171**
- Exeter** 28 Cowick Street **01392 218895**
- Plymouth** 107 Cornwall Street **01752 226011**
- Swansea** 24 Mansel Street **01792 465777**

london and south east

- Brighton** 57 Western Road, Hove **01273 733338**
- Bromley** 39a East Street **020 8290 1988**
- Chelsea** 403 Kings Road **020 7352 9466**
- Crawley** 32 The Boulevard **01293 510777**
- Croydon*** 369-373 London Road **020 8665 1203**
- Epsom*** 12 Upper High Street **01372 720720**
- Guildford** 73b North Street **01483 536666**
- Holborn** 144-148 Grays Inn Road **020 7837 7540**
- Kingston** 43 Fife Road **020 8547 0717**
- Maidstone** 96 Week Street **01622 686366**
- Reading** 3-4 Kings Walk Shopping Centre **0118 959 7768**
- Sevenoaks** 109-113 London Road **01732 459555**
- Southampton** 33 London Road **023 8033 7770**
- Southgate** 79-81 Chase Side **020 8886 2777**
- Swiss Cottage*** 21 Northways Parade, Finchley Road **020 7722 9777**
- Tunbridge Wells** 28-30 St Johns Road **01892 531543**
- Watford*** 478 St Albans Road **01923 213533**
- Witham** 1 The Grove Centre **01376 501733**

*Open Sunday Please call to verify hours of business.

installation centres

With the pace of life and demands of work increasingly prying into our leisure time, being able to relax while enjoying music at home is a priority for many people.

By using a number of techniques, the hi-fi system, once confined to a single room, can be liberated to give musical pleasure all around the house. Hence the term 'multi room'. The degree of liberation can extend to every room in the house or even outside into the garden, although simple solutions, providing music in two or three of the most frequently inhabited rooms, are readily available.

Areas can be activated or deactivated when required, and the source being replayed can vary, along with the volume, in each of the different rooms. The possibilities with 'multi room' are endless.

The outlets in Bristol, Edinburgh, Manchester and Sevenoaks have been appointed as Installation Centres, because of their level of expertise in multi room solutions, system integration and remote programming.

Each Installation Centre is able to provide a complete service, including the manufacture and supply of 'bespoke' furniture, designed to house all of the components, whilst complementing the decor of the room into which it is placed.



meridian audio

Launched in 1977, Meridian have an enviable reputation for designing and developing 'class-leading' products. Indeed, with the release of the MCD in 1983, they were the first British company to embrace Compact Disc.



This appreciation of digital technology has kept their products in the spotlight, like their digitally driven loudspeakers, and helped them to write Meridian Lossless Packing (MLP), the mandatory data reduction algorithm for DVD Audio.

The latest addition to the Meridian Range is the 588 CD Player. Evolved from the 508 and 800, sound quality is clear, open and authoritative.

Meridian Audio products can be found in the Sevenoaks outlets in Bristol, Exeter, Guildford, Reading, Swiss Cottage and Watford.

dvd audio

As DVD Audio is expressly intended to offer sound quality significantly superior to standard Compact Disc, whilst retaining compatibility with DVD Video films, conventional CDs and the various recordable CD formats, it has the potential to be the most flexible and comprehensive solution to the future of sound and vision reproduction.

The availability of DVD Audio software has been an issue as numerous delays have resulted from encryption and security watermarking problems.

The first DVD Audio software titles are now available, courtesy of Warner Music. These titles - released in the USA in November of 2000 - can be found on demonstration, along with a selection of the latest DVD Audio players in all Sevenoaks outlets.



► This guy is absolutely and unremotely passionate about what he says. Acerbic yet charming, outspoken yet funny, Peter Holme Qvortrup was born July 4 1950 in Copenhagen. As a child he inherited his father's love of music, listening on his Philips mono valve system. His first student loan in 1968 went on a pair of Lowther PM6 full range drivers, an old Quad 22/II combination and an ERA turntable, SME arm and Stanton cartridge. When he got his first "real" job in 1972 as an apprentice at a large shipping company, he immediately went deep into debt buying a Quad 33/303 combination and a Fidelity Research FR3 MkII MC cartridge. He was "never that happy" with the transistorised Quad set up, which he felt inferior to the valves. He says that, "like most other

when he and Mr. Kondo went their separate ways. Current turnover is £2 million a year. "We could easily do more," he says, "but I prefer to have a company that my wife Lesley and I can oversee personally".

When he entered the hi-fi world professionally back in the late seventies, he says it was very different. "What we have now is so coldly commercial and aggressive that it is almost unbearable. Products now are so sonically homogenised that it is difficult for customers to find any real choice, which partially explains why most reviews are the way they are and why most dealers stock the same products. People lose interest because there is little to be interested in, and it definitely is a contributing factor in the market contraction the industry is currently experiencing."



Tube-Way

AudioNote UK's Peter Qvortrup is possibly the thermionic valve's most aggressive proponent. He tells David Price exactly why.

people I thought it was me that was not able to appreciate the quality of the more modern technology". Told that the Lowthers weren't up to the job, he changed to stacked Quad 57s and a Pioneer ribbon super tweeter. Still unhappy, he sold them all and bought a pair of Lowther TP1s and a McIntosh C19 with an MC40 power amplifier. "Now that was more like it", he says!

At the 1975 hi-fi show in London, he realised, "that the way hi-fi was being made and sold really lacked any consistent vision", prompting him to quit his job as a marine broker to import Leak, Quad, Audio Master, Lowther, Decca, Sugden and other brands into Denmark. He started a shop called Audio Consult on 42, H.C. Oerstedstvej, Copenhagen in March 1979 which he owns to this day. Peter then moved to England and started Audio Note UK Ltd in 1989, as a vehicle for closer collaboration with Mr. Kondo in Japan. In 1990 they agreed to share the name for production of UK designed products. The company grew quickly until the economic crisis in South East Asia,

In the great scheme of things, Peter sees AudioNote UK as standing in opposition to mass produced, homogenised hi-fi. He says that, "music is very personal, and if well performed or reproduced is an uplifting, enlightening and sometimes intimate experience. This does not integrate well with the aggressive marketing led approach of most audio companies. I deliberately want to be different from all that."

He feels strongly that technological "progress" isn't necessarily to the benefit of audiophiles. Rather, much of it is there to help manufacturers with the mass production process. "Working as I do with 1920's technologies, and expressing a preference for early audio technologies and materials, automatically pigeonholes you as nostalgic and backwards. However, the fact is that not all development happens because of quality improvements. Rather, most is related to cost reduction which then either leaves the marketing department with more money to beat the promotional drum with, or hands the greedy shareholders more profit."

For Peter this explains the inexorable rise of solid-state hi-fi. "Many of the best audio technologies have been abandoned for the wrong reasons. Single-ended triodes and transformer coupling are two of the most prominent, but in many areas of materials technology this quest for cheaper has left numerous casualties. The audio industry has a one-dimensional formula for judging quality - it is done on the oscilloscope. If on crude simplistic frequency tests, a cheap circuit can be seen to have lower distortion and better bandwidth than a transformer, hey-ho, you have a cost saving of 95%." The result of this "prevailing belief system" is that "it is not far removed from commercial suicide not to support it."

Where then does this leave AudioNote? "First and foremost, it's a way for me to get the best hi-fi money can buy, in order to play my own records, of which I have 20,000 plus. Secondly, I see the company as a vehicle for protecting something I care a great deal about, our recorded musical heritage. Most modern



equipment manufacturers regard music as a servant and an inconvenience. Thirdly, I think this is a fun hobby. I like pitting my ears and common logic against those of the rest of the industry. It is full of very clever people, but inhabited by extraordinarily few wise ones."

Qvortrup's philosophy is all-

replaced after ten years on the throne, when they hear its replacement it becomes obvious why".

So what would he say to those who believe valves are less transparent than solid-state? And isn't

discrepancies in their logic:

Why

do two amplifiers that measure the same rarely sound the same? This poses a serious problem for the consistency of "if it measures better, it sounds better" supporters.

Peter

says that it's always fascinated him how convenient most of the arguments against valves are. "These same arguments have always been used against the older technology when the new technology arrived.

So where does he see hi-fi going in the future? "I see two channel audio going back to what it was in the 1950s, primarily an elitist pursuit with the market evenly split between the knowledgeable DIY hobbyists and the music loving customer buying high quality reproduction equipment. The boys toys brigade seeking male jewelry are already leaving

It's hard not to admire this guy's sheer bloody-minded disregard for conventional hi-fi wisdom. As all the big companies - British, American and Japanese, plus all the magazines and dealers rush to embrace multi-channel because that's where the business is, this guy doesn't give a stuff. "I still do not see why we need more than two channels to reproduce good stereo. What we need are better and more consistently interesting recordings. Furthermore, I see little in the multi channel market that I identify with and even less that I think creates a future for what I believe in. People will be less interested in music if it does not stimulate or challenge their emotions and intellect, and I do not see how multi channel music reproduction is going to succeed with more of the same technology that failed in two channel, why should it?"

After a whirlwind afternoon with Peter Qvortrup, you realise that he's wrong about at least one thing - there are still some charismatic hi-fi companies left. ■ ▲

Army

pervasive. Check out his website and you'll be treated to great tracts of the man's thoughts on the tension between hi-fi and accuracy. There are two commonly accepted 'positions' on the question of what constitutes 'good hi-fi'. Some believe that "accuracy" is all-important - as Quad's Peter Walker famously put it, an amplifier should be "a piece of wire with gain". Others think it a false god - followers of the Linn/Naim sound think the notion of accuracy to be a white elephant, and what's really important is a system's ability to involve and entertain you. Peter thinks that while absolute accuracy is unattainable, one should always strive for "more accuracy". So how do AudioNote products fit into this equation?

"They have good degree. More accuracy comes with higher prices, any product that gets into the product line must pass my test of 'comparison by contrast'. It must prove itself to be "more" accurate than the cheaper siblings. I view the adherence to these principles as paramount. Most of my customers understand this. While they may not initially understand why their cherished ONGAKU is suddenly

their coloration a good thing, especially given the appalling quality of many music recordings? "Lumping valves into one category is the first and most serious mistake people make. A zero feedback low power single-ended directly heated triode amplifier is a very different animal from a high power push-pull parallel 6550 amplifier with 16 paralleled output valves. Tarring them both with the same brush demonstrates more about how little the people who do this know, than it does about the real issues of valve amplification. Most detractors just go by what they have heard elsewhere, but as Goebbels used to say, "if you repeat a lie often enough it becomes the truth".

"Many detractors have an agenda that precludes them looking at the subject objectively, hardly a credible position to throw stones from either! The largest camp of people who maintain that transistors are more transparent are tech heads who do so on the basis of measurements. Wider static bandwidth, lower static distortion, higher static damping factor, lower static output impedance all feature as central parts of that argument. But what they fail to explain are the following serious

RECORDA

We look at the coming battle for the recordable DVD market between DVD-RAM, DVD-RW and DVD+RW. Which is likely to be the winner?



Philips DVDR1000 video recorder, due soon. It will be one of the first to provide DVD+RW video recording.

In our last issue we took a look at upcoming storage formats for audio. Most of them try and pack useful playing time into a small package, with portability in mind. At the other end of the spectrum lie a family of rival DVD recording formats where sheer storage capacity is the main issue. They're not dedicated audio carriers but can carry it all the same, with the promise of either vast playing time or the ability to store high resolution 24bit/96kHz recordings. Here's what's coming soon.

The three systems on offer are DVD-RAM from Panasonic, DVD-R from Pioneer and DVD+RW from Philips, Sony and Hewlett Packard (to name a few). DVD-RAM was first to arrive and has offered massive recording capacity for some time now, 5.2GB being available from a double-sided disc used in the LF-D101 back in 1999. Although DVD-RAM drives can read normal DVD ROMs, such as DVD videodiscs, the disc in a caddy approach raises cost and bulk. With the simplest single sided 2.6GB disc priced costing £15 and a 5.2GB £22 DVD-RAM has

priced itself out of the market. DVD-RAM was agreed as a computer storage format but now Panasonic offer it as a home A/V recording format too, to try and extend its popularity. It looks like price and incompatibility have prevented DVD-RAM catching on.

Pioneer of Japan announced their own recordable DVD disc, the DVD-RW, at the end of 1999 and the expensive DVD-R1000 domestic video recorder at that time too. This DVD disc has no caddy and DVD-RW discs are available on the shelves now at around £10. Originally DVD-R was for professional use only, but now DVD-R for general use has been agreed as a standard, paving the way for write-once (DVD-R) or Re-Write (DVD-RW) recorders to be made available. DVD-RW was meant to be a home video format and it too has been slow to take off. Pioneer replaced the DVR-1000 with the DVR-2000 domestic recorder at the end of 2000 which records in either original DVD video format or new, more flexible Video Recording (VR) Format, being switchable between the

two. This partially solves a compatibility issue where the new VR format recordings would not play on legacy video players.

It is computer use that drives a format these days, however, and until recently Pioneer's DVD-R system wasn't available for computers, a situation that has held it back. The situation changed at the end of 2000 when Pioneer DVD-R recorder mechanisms were shipped for the first time, appearing in Apple G4s, as well as Compaq and Sony Viao machines. Pioneer told us that their first stand-alone DVD-R/RW computer drives were shipping June 2001 and should start to appear in UK stores soon, priced at around £699, with discs likely priced at £10 for a 4.7GB DVD-R and £18 for a similarly sized DVD-RW. Although of

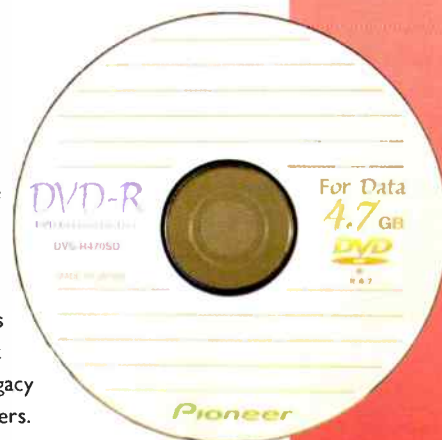

BLE DVD

The Pioneer DVR-2000 provides 3 recording modes: Video Mode, Standard Mode and Manual Mode - to suit the application or type of disc being used.

Video Mode allows playback on many existing DVD players. It is a recording method based on the 'DVD-Video Format'. DVD-R (for General Ver. 2.0) and DVD-RW (Ver. 1.1) discs that have been recorded in Video Mode can be played back not only in Pioneer-made DVD players but also on many existing DVD players from other manufacturers, as well as on personal computers outfitted with drives and software supporting DVD-Video.

Standard Mode and Manual Mode supports both version 1.0 and 1.1 DVD-RW discs and uses the 'Video Recording Format'. This format applies MPEG compression technology and realizes real-time recording of high-quality images, while also providing a wealth of editing functions.

course computer discs are not strictly speaking for audio use, one DVD-R would store eight music CDs (600MB) or eighty mp3 compressed (10:1). Whether people will feel a need for 80 hours of music on one disc we have yet to see. Pioneer told us their format is approved by the DVD standards body and "it is a done deal" in this area. They are unhappy at a long shadow cast across the industry by the third, last and potentially strongest rider of the apocalypse: DVD+RW.

Conceived by Philips, Sony, Yamaha and Hewlett Packard to be more compatible than DVD-R it relies upon high precision "lossless linking" to ensure backwards compatibility with all legacy DVD ROMs and DVD



video drives, Philips claim. No mention is made in Philips White Paper of the Video Recording Format however, that gives DVD-RW editing flexibility. Instead, Philips have considered the whole video editing process carefully, to arrive at their own solution which offers real-time DVD Video compatible editing and formatting. Pioneer's VR editing is not backwards compatible by way of contrast. However, Philips system is their own and although it offers simplified editing and PC compatibility it sets its own standard, which is different to Pioneer's standard and, Pioneer claim, not agreed by the DVD consortium.

Such matters apart DVD+RW offers 4.7GB on a single sided disc and 9.4GB on a double sided.

There is only one recording layer; it is not a dual-layer disc. The disc is bare; there is no caddy. Surprisingly, where CD and its successors were all Constant Linear Velocity (think of this as constant groove speed) DVD+RW can be run Constant Angular Velocity (i.e.. constant rpm, but not 33rpm!). This, Philips say, makes for faster disc access and editing, because the disc

does not have to change speed. Write speeds of x1 or x2.4 are quoted at present. Since DVD+RW drives produce DVD Video compatible discs and can read such discs they should also be able to read DVD-A high resolution audio discs.

DVD+RW will be rolled out this



The new Pioneer DVR-A03 DVD-R computer drive. It comes bundled with two software packages: VOB for data writing and Sonic Solutions' "My DVD" for making DVD Video discs - a budget version of a Sonic package called DVDiT.

autumn we are told by Philips. Until then a lot of manufacturers are holding fire on the issue of recordable DVD to see which system is likely to predominate. You can be certain Philips will fight on the basis of price, so it looks as if the market will see a lot of action this coming winter on the recordable DVD front. ■ ▲

Question: Is this the best amplifier ever built?

Answer: oui, si, ya, nai,
ja, igen, yes,
haan, ken, evet,
chai khan, ano,
da, hai, ia.....

In any language the answer is the same



The Veritas P400 Digital Power Amplifier.

400 watts of pure power.

Made in England without compromise.

V E R I T A S

Veritas Horn Systems Ltd

Manor Farm Barns
Glandford, Holt
Norfolk NR25 7JP
Tel: 01263 741417 Fax: 01263 740937
e-mail: p400@veritashifi.co.uk
web: www.veritashifi.co.uk

*" the most musically complete
power amplifier I have used"*

Ivor Humphreys, HiFi News

Czech for a Fiver!

Simon Pope encounters the latest affordable stylish vinyl spinner from Project, the RPMfour.



▶ **S**ales of vinyl LPs started to grow in the final quarter of last year and the trend is apparently continuing. It seems that more and more people of the thirty-something generation are blowing the dust from record collections once consigned to the attic.

The problem was that whilst the record collection was in the attic, the turntable was often in the skip. Enter Project from the Czech Republic, or more to the point the company's Debut turntable, a budget wonder that you simply take out of the box, plug in and play for the inconsiderable sum of just £110. It's a fair assumption to say that Project's contribution to the hardware market could well be a major contributing factor in the latest rush for vinyl, because Henley Designs are apparently currently selling a whopping two thousand of these little beauties a month and they

can barely keep up with demand - whoever said that vinyl's dead? Add to this the amount of Rega Planars that are sold each month, along with Michell Gyrodecs and Linn LPI2s and you have yourself a not inconsiderable total, and I've not included products for the DJ market!

The Debut is the cheapest product in the Project range that includes other bargains such as the Classic, Project 2 and the top of the range Perspective at £1,000 (with an Ortofon MC30).

What each of these products offer is fantastic value, with the price of the supplied arm and cartridge often just short of, or even equalling the price of the whole turntable package! Throughout the range, the quality of the product is very good, making the turntable no longer the pursuit of the flushed audiophile but a product for all.

This latest spinner from Project has injected a bit of funky styling into the equation. Whilst the previous products such as the Classic Cherry or the Perspective have had a more traditional but still appealing design, the new RPMfour is a real head turner, taking on the likes of Michell's Gyrodec or (even more so) Wilson Benesch's Full Circle in the style stakes.

And here's the good news: It's still very affordable. A total of £300 buys you the turntable, Project 9 tonearm and an Ortofon 510 moving magnet cartridge. Considering the RRP of the arm is £250 and the cartridge £45, you get the actual turntable itself for £5!

STYLE AND SUBSTANCE

The RPMfour is a very fine looking customer. We have the nice, ergonomic rounded edges, and the

PHONE FOR LATEST LIST
NEW, ED-DEM AND CLEARANCE ITEMS

	RRP	SALE	
Arcam Alpha 8R Amp.	£350.00	£259.00	N+D
Arcam Alpha 7R Amp.	£280.00	£229.00	N+D
Arcam Alpha 9P Pre. Amp.	£400.00	£300.00	N+D
Acoustic Energy A109	£350.00	£195.00	D
Copeland CDA266	£1399.00	£1,195.00	D
Musical Fidelity XA1	£480.00	£295.00	N+D
Krell KAV 500i Int. Amp.	£5,498.00	£3,995.00	D
Mission 701 speakers	£160.00	£119.00	N
Linn Kaber	£1,995.00	£695.00	D
Mission X space speakers	£199.00	£95.00	N+D
ProAc 3.8	£3,990.00	£2,990.00	D
Neate Mystique	£735.00	£499.00	D
Cyrus SL Amp	£400.00	£250.00	D
Cyrus AV Master Processor		£200.00	D
KAV 300i	£2,790.00	£1,895.00	D
KAV 250A Power Amp.	£3,698.00	£2,495.00	D
KAV 250P Pre-amp	£2,398.00	£1,595.00	D
Meridian 508	£2,000.00	£1,295.00	D
Rogers Studio 1A Speakers		£195.00	S/H
Audio Research VT50	£3,499.00	£2,279.00	D
Audiolab 8000PX		£400.00	S/H
Rotel RX965RDS A/V receiver	£950.00	£695.00	D
Sonus Faber grand piano (original)	£1,799.00	£1,095.00	D
Tannoy Revolution R3 speakers	—	£295.00	S/H
Denon DVD5000	£1,500.00	£695.00	D
Trichord Genesis CD player	£500.00	£249.00	D

D = EX DEMONSTRATION, N = NEW, S/H = SECOND HAND

Hi-Fi Multiroom and home cinema

ACOUSTIC ENERGY ARCAM ASH DESIGN AUDIO
RESEARCH CELESTION COPELAND CYRUS
DENON KEF KRELL LINN TAG MCLAREN MARTIN
LOGAN MERIDIAN MICHELL MISSION MONITOR
AUDIO MUSICAL FIDELITY NEAT ACOUSTICS
PIONEER PROAC QED QUADRASPIRE REL SONUS
FABER SME STANDS UNIQUE STAX THETA
WILSON AUDIO ETC...

THE LISTENING ROOMS LTD

161 OLD BROMPTON ROAD LONDON SW5 0LJ
TEL: 020- 7244 7750/59 FAX: 020 - 7370 0192
www.listeningrooms.com E-mail: tlr@dial.pipex.com
Mon-Sat 10-6pm

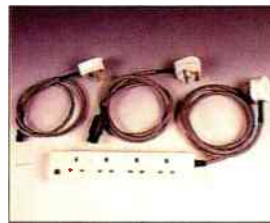

campaign audio design
“Love Hertz”

Getting a better, more involving sound often means spending a lot of hard earned money. It's such a waste, because every system can benefit from our cables and accessories, at a fraction of the cost of some new "black box". Here are some of the ways we can help.

We have Linear Crystal Oxygen Free Copper interconnects (£12.48) up to High Purity Silver balanced cables (£99.00) and high definition

loudspeaker cables in Silver Plated Copper or Pure Silver. Our mains cables add weight, power and scale, and with non-inductive RF filtering (£10.00) and over-voltage protection (£3.00) enhance performance still further. Gold plated AV cables, both RF (£19.95) and OFC Scart with PTFE insulation (£19.21), help bring picture quality in line with NICAM sound resolution.

We also have a cure for your noisy fridge or central heating motor (£3.50), enabling you to throw away your big mains noise suppressor, which has been giving you that "sat upon sound" for years. There's lots we can do to bring you closer to the emotion and energy of the performance. So confident are we, that we offer a 21 day money back guarantee.

Ring or write for details:-

CAMPAIGN AUDIO DESIGN
Llandudno Road (HW)
Cardiff CF3 3PG
Tel:- 02920 779401

Website: <http://business.virgin.net/cad.cables/>



Trade and International Enquiries Welcome.

ORANGES
& LEMONS

Juicy fruit from
London's freshest
hi-fi / home cinema retailer.
Free home installation + credit cards,
0% credit finance available
(subject to status).

ARCAM, B&W, CABLETALK,
CASTLE, CHORD CO, DENON,
EPOS, KEF, LINN, MARANTZ,
NAD, NAIM, NEAT, QUAD, REGA,
ROKSAN, ROTEL, ROYD, RUARK,
SOUNDSTYLE, STANDS UNIQUE,
YAMAHA

Our Sixth succulent year

THE INNOVATIVE
AUDIO RETAILER

0171-924 2040

61/63 WEBBS ROAD, CLAPHAM, SW11

www.orangesandlemonshifi.com



through Chopin's Nocturnes on a DG disc proved enjoyable listening. There was good tonal quality and focus of the instrument but my only small gripe was that perhaps a little more depth and overall ease could have been present, as there was with my reference Michell Gyrodec SE/RB300 set up - at admittedly almost three times the price! Similarly deft sounding performances were achieved by the Vienna Philharmonic ensemble playing Schubert's string quintet and a Hyperion recording of Spohr's double quartets played by the Academy of St. Martin's.

The RPMfour is a very fine entrance into the world of the specialist turntable. It has more sex appeal and a more controlled sound than the popular Debut and with a good MC and an upgrade of interconnect will deliver a very fine sound indeed. Not that the £300 package has anything to worry about. Whereas a Planar 3 may have slightly more poise and control (mainly due to the RB250), the RPMfour is stable and fluid, especially with rock and jazz, and a classy looker to boot. And for £5, something of a bargain - yet again! ■ ▲

monochrome film noir appeal as well as a very fine sounding machine. Under the low resonance MDF platter there's the usual Project type bearing and belt drive mechanism, with a suspended motor for resonance reduction. A 45/33 speed change is manual, by moving the belt on the drive pulley. The power switch is located under the base of the turntable.

A record clamp is provided to appeal to high enders as well as control warped discs and gold plated interconnects are also supplied. On the base of the RPMfour there are adjustable 'Flexfeet' for stability and level placement.

Set up couldn't be easier. You simply get it out of the box, fit the counter weight and put a record on the platter. It's as simple as that, as the cartridge is already factory set. As well as looking neat, the RPMfour also sounds the business. The Project 9 tonearm is a fine sounding design, with good bearings to boot (although not quite up there with the RB250 for my money) and the RPMfour has decent stability and pitch control. Talvin Singh's Mercury Prize-winning 'OK' was first on the platter and the results were impressive, the opening track 'Traveller' had weight and depth in the introductory synthesizer chords, with only a hint of background noise in the silences, and speed and attack when the electronic

percussion eventually kicked in. Although fast and immediate (a trait of the 510) the sound was also smooth and controlled - as was also confirmed by switching over to a £400 Ortofon Kontrapunkt B moving coil design. Rock music in the shape of Paul Weller's 'Greatest Hits' had agility and smoothness with the percussion and drums tight and the bass solid, if not quite the tautest I've encountered. Vocals, though were clean and well focussed and the mix had a nice cohesion to it, giving an overall connected feel to the sound.

Next came the turn of solo piano music, always a tough test for pitch stability (along with organ music). Daniel Barenboim tinkling his way

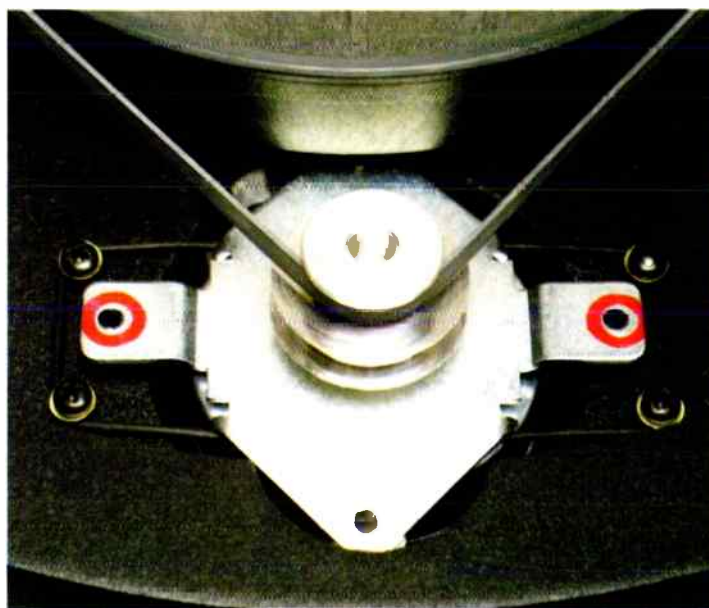

Project RPMfour
(including Project 9 arm & Ortofon
510 MM cartridge) £300

Henley Designs
Unit 10, Moorbrook
Southmead Industrial park
Didcot,
Oxfordshire
OX11 7HR
Tel: 01235 511166

World Verdict
£★★★★

Easy to set up and great looking, with a stable and smooth sound. The RPMfour is an audiophile bargain.

Master



Hot from the manufacturer comes a new super amp from Myryad. Simon Pope integrates well with the MI 240.

Myryad are one of the dark horses of British audio. Whilst never quite the first name mentioned when it comes to benchmark companies, they nonetheless turn out products of high quality, solid build and pleasing aesthetics. Everything is made in the UK and their prices don't demand a price tag that many feel the privilege of such audio pedigree deserves. In other words, Myryad offer a quality, affordable package that pleases died-in-the-wool audiophiles just as much as the high disposable income buyer.

The MI 240 is part of the company's 'high end' M Series of products - the MI120's bigger brother - and adheres to the party line when it comes to appearance. The trademark gigantic (but attractive) rotary knob is present and the other front panel controls are kept to a pleasing minimum - this is a 'remote based' product, as the comprehensive handset testifies.

Unlike the MI120 the 240 combines separate purpose built pre and power sections into the one chassis, as opposed to being merely a

high gain power amplifier with inputs and a volume control. There's actually quite a lot of electronics going on here, with a digitally controlled preamplifier section similar to the top integrated/preamps amps from, say, Arcam, Linn or Cyrus. This user friendly technology allowed me to execute a variety of functions, including fine tuning the sensitivity of the inputs, to make switching between components less of a nerve jangling experience and you can also personalise the input names (e.g. "Meridian 206" for the CD). There's also a comprehensive balance control and the input menu could be altered and adjusted to suit my particular set up. Miles way from the 'piece of wire with gain' school of preamp design but far less hassle and much more fun.

WELL DRIVEN

Power is quoted by the manufacturer to be 120W/channel into 8ohms, so the 240 is a real John Surtees of an amp - able to drive virtually anything - the power amplifier section is based closely on the company's MA240

dedicated power amp. Good quality audiophile grade components are used throughout the MI240, such as Vishay precision 'bulk foil' main feedback resistors and 0.1% precision resistors in other feedback locations.

There are a total of eight line inputs, which Myryad say are high bandwidth, to handle DVD-A and SACD information. An additional 'aux' input is located with a phono ground and an MM or MC board can be installed for an extra £80 and £100 respectively.

Also round the back I found a bi-amp output which can be linked to an MA240 power amp (the MI240 only has one pair of 'speaker outputs) and a 'line direct' input which is a high quality, short signal path input. If this input is used you cannot use the amp's tape outputs to record from it.

Last, but not least, the MI240 is the first Myryad product to take advantage of 'smart Mylink', a system designed to improve communications between separate Myryad components.

Like other heavyweight integrations, when it comes to sound

Blaster

▶ quality it's best to think of the 240 as a separate pre/power amp combination in one chassis, for those who have limited shelf space or a wire phobia.

Using a Meridian 506.24 CD player along with Quad ESL988s and Mission's 782 floortstanders, I found that music was produced with more than ample power and dynamics with an overall transparent and deep sound. It's not in the sterile school of audio engineering however, as transparency is balanced out by a smoothness of upper frequencies and a warm but fast bass. Bjork's well produced 'Homogenic' CD was first into the drawer and the opening track 'Hunter' opened up through the Missions. Percussive detail was very good and the vocals clean and centrally placed back in the deep sound stage. The track has some seriously low bass which was picked up clearly by the 240, creating a taut and controlled foundation to the sonic picture, which I found very well focussed.

ROCK STEADY

Rock music was again well controlled in the nether regions, in true high-end transistor integrated style. The bass guitar and kick drum in Soundgarden's 'Drown Me' held tight in a powerful groove as the rest of the layers piled

atop. Whilst the 240 did well to recover all the information laid down in the mix, when the going got tough (i.e. complex) a certain hardness appeared in the sound that other amps (although admittedly not many) avoid. This heavy layered guitar sound is a tough test for equipment and at climaxes the 240 picked up a little too much of the compression in the recording, resulting in a 'postbox effect' in the midrange information (comparable recordings such as Radiohead's 'OK Computer' gleaned similar results).

This apart though, the 240 showed plenty of power and control and gave an clear and extended sound that was undeniably impressive.

Moving onto classical music with Belioz's manic 'March To The Scaffold' from the 'Symphonie Fantastique' and Shostakovich's third string quartet played by the Emerson foursome, there was some exciting and enlightening listening. The Berlioz had drive and speed, with a good accentuation on the rhythm that's so essential in this movement. The 240 made the music dance in a light way that also had grip and control - it never became stodgy or muddy, as can sometimes happen. The only let down here was that a certain lyrical quality in this music was lost. Woodwind instruments lacked a

'breathy' quality that the best Musical Fidelity amps, for example, could muster. A quick change to an MF X-A200R confirmed this, but it also lacked the rhythmic bounce of the Myryad.

The 240 is well worth a listen for anyone on the hunt for a big time integrated. The competition in the market is strong but the Myryad demands a listen. It has insight and detail with good bass and a sweetish treble. The midrange with acoustic recordings is very good and open but suffers slightly with heavily treated studio rock, where it could sound a bit 'squashed' at times. With classical though, it's insightful and detailed with a strong hold on line and pulse to make it a worthy all rounder. Mix these sonic traits with the advanced electronic user facilities that are actually useful as well as easy to use and you have a package that can be highly recommended. Perhaps not quite the best at the price but not far off. ■ ▲

Myryad MI240 £1,500

Myryad Systems Ltd.
2 Pipers Wood
Waterberry Drive
Waterlooville
Hants, PO7 7XU
Tel: 02392 265508
www.myryad.co.uk

MEASURED PERFORMANCE

Power output measured a massive 153W into 8ohms and 256W into 4ohms. There's enough here to handle any loudspeaker in any size of room, except a hall.

When tested for distortion the MI240's output looked clean enough, with levels of 0.018% at 10kHz, comprising a little odd-order 3rd and 5th. Although components like this are not the best the level was low enough not to worry about. At high powers distortion was lower at 0.009%, showing the design to deliver current well.

Input sensitivity was low at

500mV on CD (but it's adjustable) and low gain also gave a good noise figure of -108dB. There was minimal d.c. offset at the loudspeaker terminals. Frequency response extended out to 90kHz, meaning the amp will SACD and DVD-A faithfully.

The MI240 is a powerful beast with a hi-tech interface. It delivers a tidy set of performance figures that suggest it will provide a clean, powerful sound. **NK**

Power	153watts
CD/tuner/aux.	
Frequency response	5Hz-90kHz

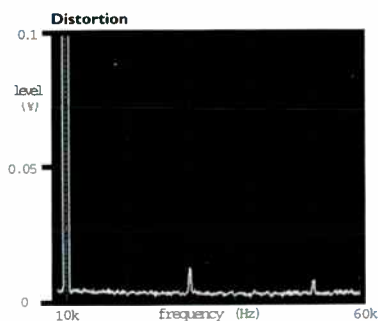

Separation	68dB
Noise	-108dB
Distortion	0.005%
Sensitivity	500mV
dc offset	0.6/0.6mV

World Verdict



A powerful and detailed sound thats easy to live with, plus great flexibility and features.

letters & e-mails

Visit our website at www.hi-fiworld.co.uk or send your e-mails to letters@hi-fiworld.co.uk

Every letter we print wins a superb prize including Precious Metals interconnects and a **FREE** subscription to **Hi-Fi World** for the best letter of the month!!

LETTER
OF THE
MONTH

QUAD SQUAD

I have a Quad 34 Control Unit, Quad 306 Power Amplifier, and Quad FM4 Tuner.

The speakers are a pair of Spendor SPIs. For many years I used also a Garrard 301 Transcription Motor with an SME Series IIIIS arm with a Shure MV30HE cartridge, all of which I still have. All the equipment was bought from new many years ago. None of it has given any trouble over the years and none has needed servicing apart from minor replacements of stylus etc.

When CDs were introduced, none of those I heard - including the Quad CD player then available - sounded satisfactory compared to the LPs I was accustomed to, so I resisted the suggestion of switching to CDs. About three years ago, however, a friend was disposing of her Cambridge Audio CD6 before going abroad, and I bought it from her. I found it more satisfactory than I had expected, and because of that and the ease of use and reliability of CDs I have played few LPs during the past two years or so. However, the CD player has recently become less reliable and I am looking for

a replacement. I approached Quad first, but they told me that their current model is not compatible with my equipment, but suggested that I could buy second-hand, which I am reluctant to do. The current Quad system of CD player, amplifiers and tuner would cost about £2650, though I gather that this cost might be slightly offset by either the trade-in or second-hand value of my present equipment. One dealer suggested that I might find it more satisfactory to buy a different CD player to work with my present amplifiers etc. He suggested a Linn Genki at about £1000, considerably more expensive than the Quad.

I should like some advice as to my best course of action. I am not unwilling to spend the sums suggested, but I seem to be faced with a choice of three courses of action: to buy a CD player to work with my current equipment, to buy the Quad system, or to buy some other system or set of separates to approximately the same cost. My present speakers seem quite satisfactory so I see no point in changing them, but I would need to be sure that whatever I bought would play well through them.

Ken Cocks

As far as the compatibility of the Quad CD player with your existing equipment is concerned, the current Quad 99 CD player has no mains transformer and therefore has to be powered by a 99 series preamp. At the time Quad apparently presumed that people would buy a complete Quad system. So a 99 CD player is out of the question unless you also purchase the matching preamplifier to power it! However, the CD player is priced at £650 and the preamp at £750 and this is all you need, so paying £2650 for the complete Quad system is not necessary.

Connections to all the Quad 99 range is via 'bog standard' phono inputs and outputs. If you were told by the dealer that you'd have to buy the Quad full monty, then he was wrong. Also, the 99 preamp offers a big step up in sound quality and technology from the 34 so this is worth considering when thinking of the overall sound of your system and it could be the best option.

If, as you say, you're willing to shell out for a non-Quad new, the CD market between £600-£1,000 is

ARCAM

Visit www.arcam.co.uk

for Arcam news, product information, technical support and advice on how to get the best from your system

Arcam, Pembroke Avenue, Waterbeach, Cambridge, CB5 9PB, England
Tel: +44 (0) 1223 203203 Fax: +44 (0) 1223 863384
support@arcam.co.uk www.arcam.co.uk

very competitive, with plenty of fine options to choose from. You could start by listening to the Cyrus CD7 at £800. This is a very smooth and sophisticated sounding customer which not only has a fine lyrical quality but also a beguiling way with rhythm, having plenty of attack and slam to boot. The Musical Fidelity X-Ray at the same price, although fairly old in the current whirlwind scheme of things, is also an obvious auditionee. It has a lively and insightful sound with wonderful transparency and speed and is a very natural sounding player free from the mechanical edge of many.

Moving up the price ladder to £995, as your dealer chap said, you could do a lot worse than the Linn Genki. It's a full and open sounding player with plenty of bass and immediacy free from harshness. Yes, it's not the cheapest option for you but it holds its own amid the stiff competition - you also get HDCD compatibility. Alternatively another £100 or so on top of this gets you the latest Meridian 506 24bit player, which is a fine machine indeed, with an extremely fluid and detailed character and you'll be safe in the knowledge that some of digital audio's finest brains are behind it! **SP**

budgets of say up to £250, and up to £500 would be wonderful.

Phil Tosh
Warrington

Frankly I'm surprised that your vinyl front end isn't up to the Mimik - as Simon and I found on our visit to Linn earlier this year, the fully specced LP12 was still quite a way ahead of Linn's best CD12 silver disc spinner. If your Sondek has been Cirkus'd - which is probably the most significant mod the LP12 has had, and better even than the Valhalla and Lingo upgrades in my humble opinion - then it must be your tonearm letting the side down. The Basik Plus (LVX+) was never a classic Linn product, and was essentially designed to get people 'on the road' with an LP12 at a bargain price. It is miles behind the Rega arm and not on the same planet as an Origin Live modded RB250. To wit, I'd strongly urge you to upgrade to the latter, but you (or your Linn dealer) may have to carefully file a niche into the right rear plinth brace to stop the Rega's arm base fouling it. This sounds more dramatic than it is - as soon as you unscrew the LP12 armboard out you'll see exactly what I mean. This course of action is easily the best way to part with £250. The good news is that when this small

isn't as good as Linn's Ekos/Arkiv (which is the cost no object option), but it's far, far closer than your existing arm/cartridge combo. You could say it's three fifths as good for one fifth of the cost. Finally, when you've got everything fitted and set-up, clean the rim of your LP12's inner platter, motor hub and belt with isopropyl alcohol, plus all your plug contacts, and hear your CD player fall into disuse! **DP**

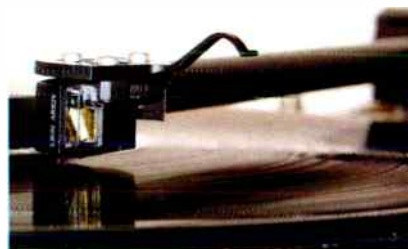

Arkiving with an Ekos is the vinyl word for Phil Tosh!

DIGITAL DILEMMA

I am looking to invest in a replacement CD player, and as a regular reader of your magazine have turned to you for help. I currently have a Yamaha CDX 710 that was donated by a friend in the hope of converting me to CD! Unfortunately it's dropping information and seems to be on its last legs. I was never a great fan of silver discs, having always preferred vinyl. However, I now seem to have gathered a CD collection and would appreciate listening to it on something that at least equals the quality of my turntable. I have listened to an Arcam CD 72 and Rega Planet 2000, and liked the involving and musical nature of the Rega along with the way it did not highlight noise. I would appreciate a recommendation that will work well with the rest of my system (which comprises a Rega Planar 3/AT 450E, Naim Nait 2 and KEF Q55) within a budget of £500. Taste in music range from R&B, jazz and rock to classical. As my wife is a violinist we get a great deal of pleasure from the emotion conveyed by that instrument.

Tom Hyde
Via email

Well, I think you've answered your own question. The Rega is a star, and far, far more capable than its price suggests. The Arcam CD72 you identify, along with the Marantz CD6000 KIS which would be your other logical choice, are both less



THE LINN GENKI - A fine source of musical enjoyment

GO YOUR OWN WAY?

Are you able to offer me any sense of direction with my LP12/Valhalla, Cirkus, Basic Plus, K9? No matter how hard I try, I find vinyl doesn't equal CD via my Linn Mimik. So having many more LPs than CDs I am looking for a modest upgrade to the Sondek. Going 'the Linn way' would probably mean big money, whilst another - Origin Live, Dynavector, Rega arm, etc - might if shown to work okay, be more cost effective. The rest of the system is Linn Majik, Royd Doublet, Linn interconnects and bi-wiring. The LP12 sits on a spiked MDF shelf and steel wall brackets. Suggestions based on

matter is attended to you'll find the Rega works superbly in the Linn - the former's slightly dry sound compliments the latter's warmth beautifully.

With your next £250, kill that K9. These were warmly recommended by certain eighties hi-fi mags but really are miles off the pace these days. Depending on how much you want to spend, I'd go for the Dynavector DV10x4 II (£199) or the DV20X-H (£299). I'd strongly urge you to go for the latter, which is an extremely musical and punchy sounding moving coil with the benefit of working directly into your Majik preamp's existing MM input. As I found out recently, an OL RB250/Dynavector

enhance your listening pleasure

Buy van den Hul cables from AV Zone

Storm II HB Interconnect

 RRP £29.99 (0.8m)

PB5 HB Interconnect

 RRP £49.99 (0.8m)

Orange Source HB Interconnect

 RRP £64.99 (0.8m)

D102III HB Interconnect

 RRP £79.99 (0.8m)

Optocoupler Optical Link

 RRP £49.99 (1.0m)

First Ultimate Interconnect

 RRP £219.99 (0.6m)

CS122 HB

 RRP £13.49/m

Teatrack HB
 Bi-wire version of CS-122HB
 RRP £23.99/m

Next Day Delivery*
Massive Discounts
Excellent Service

We carry an extensive range of van den Hul cables in stock

We also supply the following brands:

(AE) **Atacama** **Nakamichi** **NÖRDOST**

VDP
 van den Hul

THE LINK BETWEEN
 TECHNOLOGY & IMAGINATION
www.vandenhul.com

Save ££££. Prices shown are RRP. Call for our BEST PRICE

Tel: (020) 8991 9200

www.avzone.co.uk



definitive audio

Living Voice · Lowther · Vitavox · Electrofluidics · Art Audio · Border Patrol
 Canary · DNM · MF · Sugden · Wavac · Western Electric · Resolution Audio
 Wadia · Michell · Nott'm Analogue · SME · Ortofon · Van den Hul



...land of opportunity and adventure...

Sale of part exchanged and ex-dem items

	Sale	New
Michell Orbe turntable.	£1400	£2000
Ortofon Rohman cartridge. (6 months)	£500	£1000
Hadcock tonearm. New	£400	£800
SJS Electroacoustics Model1 pre-amp. Immaculate - rare.	£700	£1000
Audio Innovations P2 phono stage, with full Border Patrol conversion, inc. Hovland film & foil capacitors and choke power supply. Very rare and very special.	£1100	--
Audio Innovations Series 1000 monos. Serviced and re-valved.	£850	--
Art Audio VP-Special pre-amp with phono stage. Full conversion with Hovland film and foil caps and Panasonic potentiometer.	£850	£1450
Art Audio VP-S pre-amp. Standard.	£600	£1150
Art Audio Diavolo. Special chrome finish. Hovland film and foil caps throughout. Border Patrol MB pau (£1000). Great opportunity.	£3500	£5500
Art Audio Quintet monos. Chrome.	£1800	£2400
Living Voice Avatar. Rosewood - refurbished - French polish.	£2100	£2500
Living Voice Auditorium. Walnut - second.	£900	£1500
Hellos Model 2 CD player.	£900	£1200
Gloucester Old Spot. 25 head - soiled - virus free.	each - £10	£873
B+W 620i loudspeakers	£200	£400
B+W CDM1 SE loudspeakers	£390	£600
Snell Type J loudspeakers. Oak	£390	--
Snell Type J loudspeakers. Walnut - French polished	£390	--
MAF stands and Pirate stands for above	£70/£150	--
Lowther Bicare 2000 speakers	£500	--
Nottingham Analogue 12" carbon fibre tonearm	£700	£1000

AMEX VISA MASTERCARD

Tel 0115 973 3222 Fax 0115 973 3666

internet: www.definitiveaudio.co.uk email: shout@definitiveaudio.co.uk

DVC-1

Low Jitter Master Clock

High performance low jitter master clock for CD/DVD players

Features 5ppm clock accuracy, fast, 2ns rise time, and our proprietary ultra-low noise

discrete regulators. DVC-1 improves the resolution, sound stage and musicality of your CD/DVD player whilst removing digital irritations such as tonal glare and hardness.

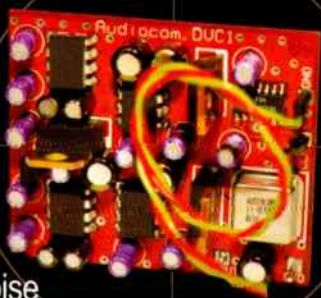

Audiocom
 01646 685601
audiocom-uk.com



pear audio

presents

Shahinian DYNAVECTOR Well Tempered

Stockists and Information from
Pear Audio Ltd. 7 Prospect Place,
Alnmouth, Northumberland, NE66 2RL
Tel: 01665 830862 Fax: 01665 830051

focused products with a more 'Radio 2' presentation. Both of these players have a tonally warmer but less grippy nature which is a perfect palliative for budget systems, whereas the Planet 2000 is more of a budget super-fi product that's destined for more rigorous systems such as yours. I also found it unusually capable at reproducing strings, with real talents at recreating the rich harmonics of acoustic instruments. Despite its leaner tonal balance, in no way is it a coarse sounding machine and so should integrate well into your Nait 2-based line up. You may even find it sounds rich compared to your vinyl front end, thanks to your Audio Technica cartridge which is an extremely 'toppy' sounding pick-up. If you wanted the two sources to match better tonally, a Goldring G1042 MM wouldn't go amiss. **DP** ■

Planar no less(!), which has a superbly transparent sound. On the second-hand market, a neat all-in-one solution would be the long lost Dual CS5000, a late eighties deck with a warm sound that goes for around £60 these days. However, some of your 78s may not be recorded at exactly 78RPM, which is where a turntable with widely variable pitch comes in handy. To wit, think about buying a Garrard 301/401 which has a usefully versatile pitch control. A classic partner for this deck would be an SME 3009S2 Improved on an old SME plinth, but it would work far better in a Loricraft plinth with a Rega RB250 tonearm.

The next question is, what cartridge and stylus to use? There are 78RPM styli available for cartridges like Shure's M44 and V15 and Stanton's 500, but as the discs

LIFE & STYLE

Hi,
I have a pair of Celestion SL600 speakers that I have had for some time, hooked up to a Sumo Polaris power amp, and a Meridian 207 CD/preamp. Recently, I replaced my tuner with a Technics STGT1000 DAB tuner. I still like the sound my Celestions produce on a wide variety of music (Classical, Jazz, Rock etc), and I love the new tuner. However, I recently moved house, and I'm having a real problem placing them in my new lounge. They need more space than I have!

I've been thinking of buying smaller lifestyle speakers like the Bose Acoustimass 5 but retain the Sumo amp and the rest of the system. They sound okay in the shop, but I'm having trouble convincing myself, that I'll be happy with the sound long term, and will end up regretting pensioning off the Celestions! What are your thoughts on these 'small' speaker systems, and is there something other than the Bose speakers that you would recommend I try?

I'd appreciate any advice you can give me.

Regards,
Vic Morris

I'm not going to 'Bose bash' here, because they've got it right for their sector of the market as the phenomenal sales figures show. The Bose 'speaker packages are popular for anyone wishing to maximize space; they're a stylish and easy way to solve an age old problem. However, the sound, whilst not garbage, doesn't match up to a fully fledged 'hi-fi' option when it comes to midrange detail, bass speed and characteristics such as imaging and sound staging. You'd find them a very different sound to the one you're used to with the Celestions. It's obvious you have doubts, so you ought to try listening to a few alternatives available.

There are a few options that



The CD72 - for all Terry Wogan fans!

SEVENTY EIGHT SPECIALIST?

While rummaging around in my mother's attic I came across a tea chest full of old 78s, some dating back to around 1912 and I would really like to be able to get them onto CD. The problem is that I cannot find a turntable that will play 78s and that can be connected to my hi-fi and computer. Does this mean that I will have to go to a specialist? If so can you or your readers recommend anyone?

Tim Boyden
Via email

For an in-depth feature on transcribing vinyl to CD using your computer, may I point readers to www.computeraudio.co.uk. There's a full review of Steinberg's Clean - now in its 2.0 incarnation - which will be just the job for you. As far as turntables go, there's actually a lot of choice out there. The simplest answer is to buy a Rega Planar 78, which is a 78 RPM only version of the

themselves vary enormously, you'll have to experiment with the size and shape of stylus used. With a 'one size fits all' approach, generally those from major manufacturers don't trace the groove very well. In truth, several different sizes are needed for the majority of records, but some shellac anoraks use over thirty! What you need is a truncated stylus, flattened off at the bottom, which can track the relatively unworn upper part of the groove. (The groove bottom is invariably badly damaged by the steel needles originally used on gramophones). The problem is that Stanton, Shure, et al., don't make them - so you need to contact a specialist such as Wyndham Hodgson at Expert Stylus (01372 276604, w.hodgson@btclick.com) for more information. **DP** ■

The oldies are sometimes the best!



maybe don't have the overtly slick look of the Bose system but will better it in the sound stakes and not take much more real estate.

Firstly give a listen to Mission's fs2 NXT satellite and subwoofer system. Available in both surround (£800) and stereo (£500) packages, this is a real chameleon of a speaker system. The small flat panels can be placed unobtrusively up in the corners of the room - even the supplied cable blends in as much as possible. With the equally sensible sized sub - easily chucked behind a sofa - you have sound that's open and strong that fills the whole room with the fine NXT dispersion characteristics.

Also available in sub/sat form, with perhaps more audiophile status and a fine detailed sound are the tiny Entry S bookshelf 'speakers (£179) with the matching new sub (£400 - system reviewed next month) from ALR/Jordan. This is a very fine sound with more of a traditional hi-fi edge than either the Bose or the Missions. They also look smart, with tiny but well built boxes and a serious subwoofer that delivers a seamless sound with good bass extension and

audiophile detail. Whatever, both the Missions and the ALR/Jordan will leave the Bose standing when it comes to the finer aspects of sound quality.

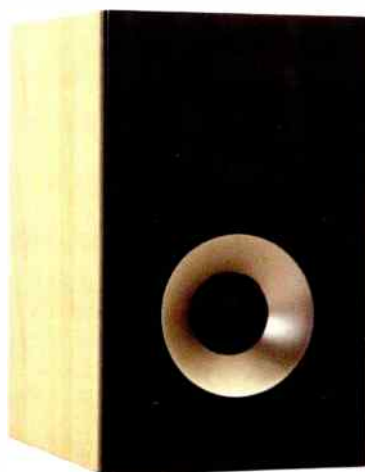

With a matching sub, the Entry S is a real Bose beater

▶ GETTING LESS SENSITIVE

I am getting confused with the apparent lowering of amplifier input sensitivity. I note that Naim have changed from 75mV to approx. 400mV. I assume this is to allow better operation with modern

high output CDs with 2V or higher as a norm. So what is better, as I am sure Naim owners with old amps may possibly be asking?

Can you please explain the relationship between source component output and amplifier input sensitivity. Is there a reasonably easy way to calculate the potential overload ceiling with a known input sensitivity?

Is the CD output linear increasing from 0 to full output? With amp input sensitivity of 75mV what does this point relate to in volume terms when the source output is 75mV?

Does the amplifier perform OK all the way up to up to overload, or is it a progressive change?

And when it does overload, what are the symptoms?

And the final question. If there is a problem, is there a fix without buying a new amp?

Mike_Borr@thermoking.com

Amplifier manufacturers are lowering input sensitivity these days, to better match high output sources. Cassette decks, tuners and what have you once commonly produced around 300mV maximum output, but the figure is

SUPRA®

Supra cables are manufactured to exceptional standards of quality in our very own factory near Gothenberg in Sweden - in tune with nature & in tune with your needs.

Interconnects

EFF-ISL "Hi-Fi Choice Best Buy", fitted with locking gold-plated phono's (0.75m) **£84.95/pr**

EFF-IX - same cable as EFF-ISL, but fitted with non-locking phono's (0.75m) **£69.95/pr**

EFF-IXLR - same cable as EFF-ISL, but fitted with XLR connectors (0.75m) **£89.95/pr**

Digital Cables (1m)

DAC-XLR 110ohm AES/EBU cable **£44.95ea**

EFF-ID co-ax digital cable **£44.95ea**

Fibre optic cables(1m)

ZAC (Available in 3 versions: TosLink>TosLink, 3.5mm>TosLink, or 3.5mm>3.5mm) **£29.95ea**

X-ZAC (Hi-End TosLink>TosLink) **£59.95ea**

Most interlinks cables are available in other lengths. New range of scart + s-video cables now in stock. See website or catalogue for details.

Supra Retailer websites: www.custom-cable.co.uk
www.supradirect.co.uk

Classic Series Tin-plated speaker cables (unterminated)

Classic 2.5mm £2.69/m

Classic 4mm £3.95/m

Classic 6mm £5.49/m

Quattro 4x4mm biwire cable £8.95/m

(All Classic cables are multi-stranded OFC - Classic 4mm is a "What Video Best Buy")

Ply Series low inductance OFC speaker cable

Ply 2.0 £4.95/m

Ply 3.4 £7.49/m

Ply 3.4/S £8.95/m

(Both Ply 3.4 are "Hi-Fi Choice - Recommended" cables)

LINC Series Installation Speaker Cable (shielded)

LINC 4.0 £4.95/m

For a catalogue, complete the coupon and post to our address. E. & O.E.

Post to: Glaive Limited, Unit 7, Wren Industrial Estate, Coldred Road, Maidstone, ME15 9YT Tel/Fax: 01622 664070 Web: www.supracables.co.uk
Please send me info on: Supra hi-fi and home cinema cables

Name:

Address:

.....

.....

Post code:HFW0108



AUDIOVECTOR

The new improved range of Audiovector M Series speakers are now available...

Call us to arrange a demo or visit our website at:

www.audiovector.co.uk and consider the full range of Audiovector speakers from just **£329** (per pr) to over **£2,000**

Example prices (for Black Ash):

Bookshelf/stand mounts

M1 (bi-wire/bi-amp) £649.95/pr

M1 Signature £1,179.95/pr

Floorstanding speakers

M2 (as "Recommended" by

Hi-Fi Choice) £999.95/pr

M3 (tri-wire/tri-amp) £1,199.95/pr

M3 Super £1,699.95/pr

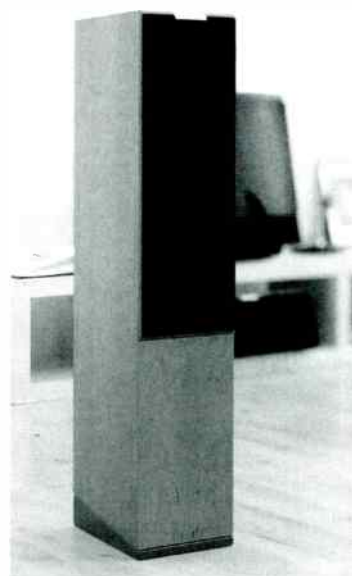

Post to: Audiovector UK, Unit 7, Wren Industrial Estate, Coldred Road, Maidstone, ME15 9YT Tel/Fax: 01622 664070 Web: www.audiovector.co.uk
Please send me info on Audiovector speakers

Name:

Address:

.....

.....

Post code:HFW0108

rising to typically 500-800mV. The need to better match CD players is the main reason.

When Philips introduced the CD in 1983 they wanted to keep the lowest level signals produced by it just above the noise level of an amplifier, meaning full output had to be set high at 2V to get the full 90dB dynamic range. CD usually sounds louder than other sources as a result. As the output of other sources has risen to match there's ever less need for high sensitivity. And technically, excess gain wasted by turning down volume increases noise unnecessarily.

There's no hard and fast relationship between source output level and amplifier input sensitivity. However, generally the amplifier's sensitivity should be two or three times higher than the source output. So if a tuner produces, say 600mV then an amplifier with around 300mV sensitivity should match.

If an amplifier is overly sensitive, as a Naim at 75mV is for CD at 2000mV (1:26), volume will have to be cranked right back.

If an amplifier is insensitive with, say, sensitivity matching source output, then the volume control will have to be cranked to maximum to get full volume from the amplifier.

After input selection most amplifiers feed the input signal direct to the volume control. This avoids overload completely, so it is not a problem.

Some amps, including Naims, have buffered inputs, in which case input overload needs to be greater than 3V. Internal supply voltages and circuit design set this, so it cannot be calculated. I am not sure buffering offers any advantages these days. It might have done when sources had high impedance and/or reactive outputs, but now they usually have a sturdy output stage capable of driving a line.

Feedback amplifiers work properly right up to full output then crack up badly if overloaded. Reducing feedback subjectively softens the sound of overload, but also slightly raises distortion before overload sets in.

I have never found a serious overload problem in any amplifier; it is too easy to avoid. Reducing sensitivity is more a matter avoiding a sudden change in volume when switching between sources. **NK** ■

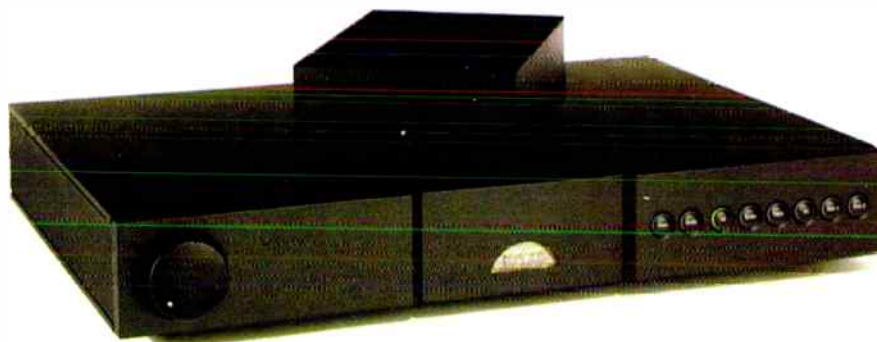

A sensitive soul?

▶▶ PLAYING IN THE SAND

Last year for my 40th my wife bought me (under advice from one of your regular readers) a Rotel CD player. I didn't get it out of the box until a few weeks ago when my brother in law (your reader who has not turned off his Gyrodek for years) came round to stay. The Rotel was great and we put my Wharfedales on some boxes to improve the sound. "You should get some new speakers," he said. "What sort?" "Missions are quite good. Have a look at their website." I discovered a shop in Melksham, PR Sounds, which sold them and with my 6year old, went round there. They did sound good, so I bought a pair of m73s for about £170. At home they sounded good too.

Just this last weekend, the bank holiday, the Hi-Fi World buff in the family came round with a copy of your article about filling loudspeakers up with sand. "What's all this about?" I asked, thinking him insane. Well, under instruction from my audiophile relative, I baked 17kg of sand in the oven and stuck it in. To be fair there was some help provided with positioning etc. but the effect from the speakers was amazing. Janis Joplin sighing, pleading, whispering on 'Ball and Chain' sounded in touching distance. Ben Watts complex mixing on Everything but the Girl's 'Temperamental' opened my ears to a new aspect to life. Mahler's 2nd Symphony was literally a Resurrection - of childlike wonder in the power of music. Sheryl Crow shook the crockery in the kitchen. Thomas Tallis's Spem in Allium sounded as if it was coming from heaven. The bass on the Cardigan's 'Erase/Rewind' was like a kick somewhere low.

In brief, three cheers for Mission plus silver sand. What fantastic value and what a delight. What other crazy suggestions have you got?

Patrick Ingram

It is a bit of a surprise isn't it? Mission have put some fine drive units into a budget box. Adding sand damps the cabinet and stabilises it, giving you big-speaker sound. Since the m73 is accurate and revealing, but perfectly representative of an 'average' loudspeaker I am using them as reviewing tools. **NK** ■

PS. The editor approves of your taste in music! **SP** ■



Sandy sure? The Mission's benefit from a few baked grains!

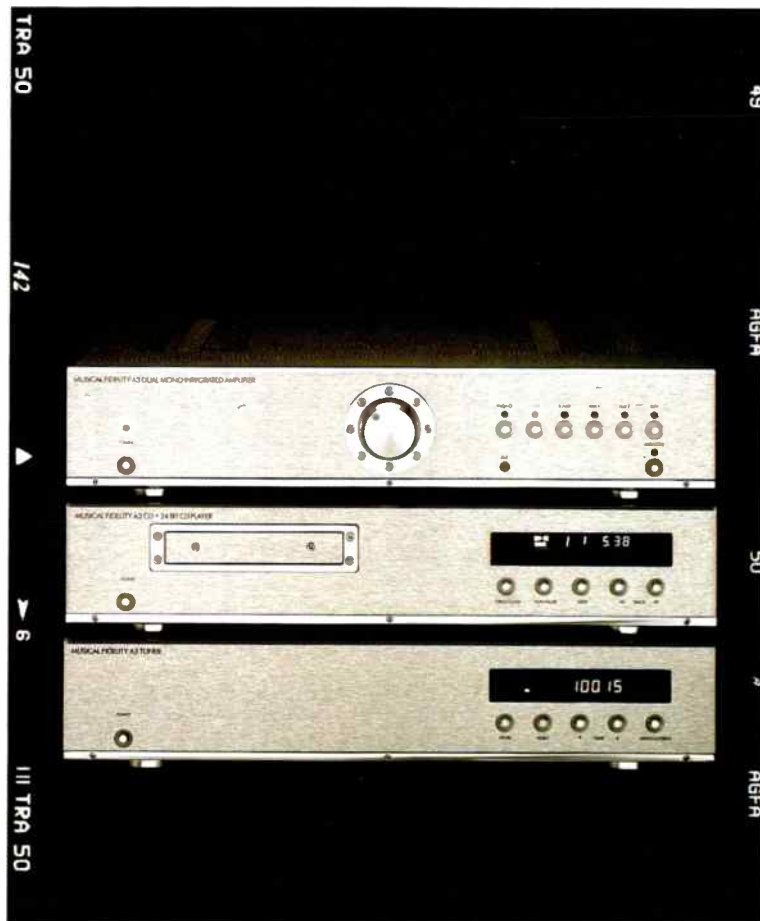

A3 RANGE.

MACHINED, MIL-SPEC ALUMINIUM
FRONT PANEL.

TWENTY-FOUR CARAT GOLD
PLATED FITTINGS.

REMOTE CONTROLLED.

PHONO STAGE.

POWERFUL, ROBUST, BUILT.

MUSICAL FIDELITY

Toppy Tip

Audio Technica's AT440ML has a Micro-Linear stylus that gives top performance - in many ways Noel Keywood found.

There are budget cartridges – and there are super cartridges. Both have problems. Go for a budget jobbie and it won't cost you, but it won't reveal just how good vinyl can be, nor will it necessarily track your finest drum an' bass cuts, damaging the groove in the process. Super cartridges are fine, but bounce one at home and you'll be shelling out £100 or more for a new stylus - enough to make anyone blanche. Somewhere in between these extremes lie the mid-price designs, including Audio Technica's AT-440ML reviewed here, price £89.95.

This cartridge category should appeal to audiophiles because it's where quality and price reach a sensible compromise. For reasons I don't understand though, it rarely works out like that. Most mid-price cartridges seem to lose the plot a little. Can Audio Technica, with their precision Japanese engineering, make an impression here with the AT-440ML?

The cartridge looks good on paper. It uses Audio Technica's V magnet arrangement, where twin miniature tubular magnets are bonded to the top of the stylus cantilever. I have to point out that although this appears to separate the stereo channels, it does not necessarily. Separation depends upon the alignment of the magnets relative to the groove axes; if they are misaligned channel separation will suffer all the same. The stylus assembly is easily removed for when the cartridge is fitted.

Audio Technica make much of the Micro Linear stylus used. They claim it is "practically identical to the cutter head" and offers "clear and non-

distorted playback over the entire frequency range even for the inner part of the record groove".

Weighing a normal 6.5gms the AT-440ML fits all arms easily and they will balance out properly before down pressure is applied. There are a few unusual points though. Running an eye down the specs I was surprised to find it tracks best at a mere 1.25gms - flyweight by today's standards, where 1.8gms is the norm. Good arm bearings are needed for such a low downforce, so the '440 is not an upgrade option for budget turntables. Think Rega or SME.

The cartridge is very compliant, so there'll be cone flap with warped records, even in a low mass arm. In my 12in SME arm resonance was at 6Hz - right down in the warp region and cone flap on Eddie Grant's 45rpm Electric Avenue caused my Cyrus 7 amp to cut out when volume was raised.

With its stylus assembly removed the AT was easy enough to fix, but I had to push the stylus carrier hard to make it seat properly in the body, scary when you've just parted with lots of cash!

I know Audio Technicas well and like them - but my, how little has changed. The AT440ML has the same bright, 'fast' sound as of yore. A good quality balanced cut like Jackie Leven's excellent Stranger on the Square had supple and powerful bass but transients were hard edged and the sound generally brittle, if clear. End-of-side track The Crazy Song remained clean and clear too, still with a bright balance. The stylus certainly tracks inner grooves, just as AT claim.

Muddy recordings like Gabrielle's Rise were given a useful boost in

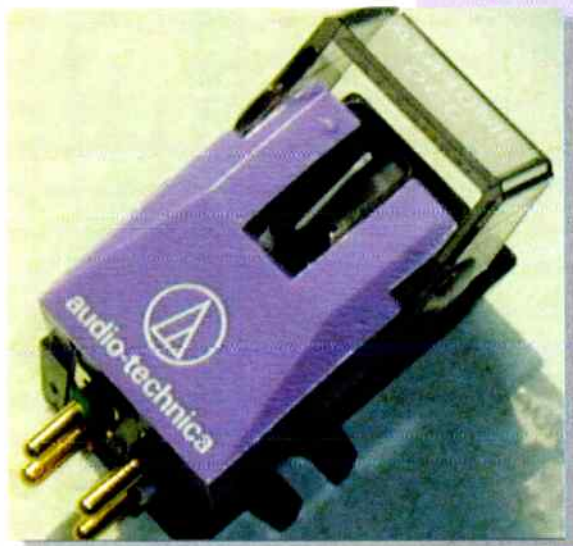

clarity and zing; the 440ML lifted it nicely. Tina Turner's Steamy Windows, with its driving bass line was thunderous, but again generally hard edged and Turner's voice often sibilant.

I fancied Eddy Grant's Electric Avenue wasn't quite as solid in its bottom end drive as my normally resident Goldring 1042 would have it, the 440ML showing just a touch of softness in its fulsome bass. And Grace Jones superb The Hunter Gets Captured by the Game, which is a little 'enhanced', was spitty-bright and thin - almost unbearable.

This cartridge will only suit some systems. My Garrard 401 helped it produce solid bass but the Mission 743 loudspeakers I used accurately portrayed the AT's bright nature. Nowadays, its rivals are tonally more even handed so the 440ML, in spite of all its good points, such as fine clarity and excellent detail retrieval, was too bright to be easily recommended. If you have a dull system and want it speeded up, then the 440ML will suit. It's still a mystery to me why

WHERE TO FIND US

BASINGSTOKE 01256 324311

2 Feathers Lane
E-mail: basingstoke@audio-t.co.uk

BRENTWOOD 01277 264730

30 Crown Street
E-mail: brentwood@audio-t.co.uk

BRISTOL 0117 926 4975

65 Park Street
E-mail: bristol@audio-excellence.co.uk

CAMBERLEY 01276 685597

173-175 London Road
E-mail: camberley@audio-t.co.uk

CARDIFF 029 2022 8565

134/136 Crwys Road
E-mail: cardiff@audio-excellence.co.uk

CHELTENHAM 01242 583960

38 Winchcombe Street
E-mail: cheltenham@audio-t.co.uk

CHESTER 01244 345576

88/90 Boughton
E-mail: chester@audio-excellence.co.uk

ENFIELD 020 8367 3132

159a Chase Side
E-mail: enfield@audio-t.co.uk

EPSOM 01372 748888

15 Upper High Street
E-mail: epsom@audio-t.co.uk

EXETER 01392 491194

156 Sidwell Street
E-mail: exeter@audio-excellence.co.uk

GLOUCESTER 01452 300046

58 Bristol Road
E-mail: gloucester@audio-excellence.co.uk

HIGH WYCOMBE

01494 558585
30-32 Castle Street
E-mail: wycombe@audio-t.co.uk

LONDON: W. HAMPSTEAD

020 7794 7848
190 West End Lane
E-mail: hampstead@audio-t.co.uk

OXFORD 01865 765961

19 Old High Street, Headington
E-mail: oxford@audio-t.co.uk

READING 0118 958 5463

4 Queens Walk, Broad Street Mall
E-mail: reading@audio-t.co.uk

SOUTHAMPTON 023 8025 2827

10-12 Hursley Road
Chandlers Ford
E-mail: southampton@audio-t.co.uk

SWANSEA 01792 474608

9 High Street
E-mail: swansea@audio-excellence.co.uk

SWINDON 01793 538222

60 Fleet Street
E-mail: swindon@audio-t.co.uk

TUNBRIDGE WELLS

01892 525666
6 High Street
E-mail: tunbridge@audio-t.co.uk

WORCESTER 01905 619059

Independence House
The Trinity
E-mail: worcester@audio-excellence.co.uk

All shops are closed on Mondays



For the very latest information
please check our web sites:

www.audio-t.co.uk

www.audio-excellence.co.uk

[www.audio-t.co.uk]
[www.audio-excellence.co.uk]

audio
E X C E L L E N C E

audio T

THE BEST OF BOTH WORLDS

Audio Excellence and Audio T have joined forces to bring you the benefits and security of buying from a larger dealer, yet each of our stores is run as an individual specialist shop. Our staff are enthusiastic and friendly, with the knowledge and experience to satisfy your expectations. Plus, we haven't forgotten that buying hi-fi should be as much fun as listening to it!

CUSTOM INSTALLATION

If you want your Hi-Fi equipment neatly and attractively integrated into your home we can plan out the system to be installed, the choice of the equipment to be used, where it will be installed in your home and how it will be connected. Call us for advice on how you can enjoy music all round your home.

- 55 YEARS JOINT EXPERIENCE
- 3 YEAR GUARANTEE ON HI-FI SEPARATES
- FULL DEMONSTRATION FACILITIES
- PRICE PROMISE
- 10 DAY EXCHANGES
- 30 DAY NO COST PENALTY UPGRADES
- PART EXCHANGES
- INTEREST FREE OPTION ON SALES OVER £250*
- HOME LOANS AND HOME DEMONSTRATIONS
- EVENING DEMONSTRATIONS BY APPOINTMENT

Products we sell include:

- ACOUSTIC ENERGY
- ALB/JORDAN
- ARCAM
- AVI
- B&W
- BOW
- BRYSTON
- CASTLE
- CELESTION
- CHORD
- ELECTRONICS
- CURA
- CYRUS
- DAVIS
- DENON
- DENSEN
- DYNAUDIO
- DYNAVECTOR
- ELAC
- KEF
- LINN
- LOEWE
- MARANTZ
- MERIDIAN
- METZ
- MICHELL
- MILLER
- S & KREISEL
- MISSION
- NAD
- NAIM
- NAKAMICHI
- ONKYO
- PANASONIC
- PIONEER
- PMC
- PRIMARE
- PROAC
- PRO-JECT
- QUAD
- REGA
- REL
- ROKSAN
- ROTEL
- RUARK
- SENNHEISER
- SHAHINIAN
- SONANCE
- SONY
- SYSTEMLINE
- TAG McLaren
- TALK
- ELECTRONICS
- TANNOY
- TEAC
- WILSON
- BENESCH
- YAMAHA

Not all products are stocked by every shop so please check with your local branch before travelling

*Subject to status. Written details on request

For your FREE copy of **MUSIC AT HOME**,
The Ultimate Guide 2001
FREEPHONE 0500 101501 (quote ref HFW2)

or visit our web site at www.music-at-home.co.uk



2001 EDITION

cartridges in this price bracket so commonly seem a little oddball. ■▲

AT440ML £89.95

Audio Technica Limited
Royal London Industrial Estate
Old Lane, Leeds LS11 8AG
Tel: 0113 2771441
www.audio-technica.co.uk

MEASURED PERFORMANCE

Our response analysis shows the AT440ML has quite a strong rise in treble output above 5kHz. It peaks by +3dB at 10kHz. This will be clearly audible as brightness in the sound. Increasing capacitive loading made matters worse.

Tracing loss on inner grooves was low, giving little reduction in treble. This means the 440ML has an excellent stylus but it will sound bright on inner grooves - very unusual.

Tracking performance was superb at low frequencies and in the midband. This is a cartridge for high level vocals. Good tracking gives a steady, assured sound. It also minimises groove wear.

Audio Technica have engineered a vertical tracking angle of exactly 22 degrees, right on standard. As a result distortion values were reasonably low all round.

Output was normal at 5.4mV at 5cms/sec rms, so hiss will not be a problem. The generator mod. axes were a little off; I had to tilt the cartridge to get balanced channel separation figures and then the V magnet generator could only manage 24dB - adequate but not great.

The AT440ML is well engineered but its sound will be dominated by strong treble. **NK**

Tracking force	0.8-1.6
optimum	1.25
Weight	6.5gms
Vertical tracking angle	20degrees
Frequency response	20-20k
Channel separation	25dB
Tracking ability (300Hz)	
lateral	90µm
vertical	45µm
lateral (1kHz)	25cms/sec.
Distortion (45µm)	
lateral	1.4%
vertical	3.5%
Output (5cms/sec rms)	5.4mV

Frequency response

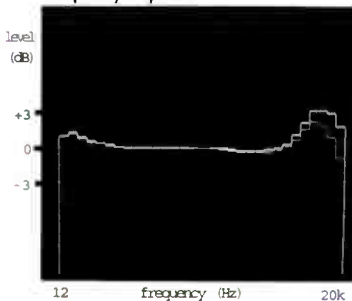

World Verdict



Bright, fast sounding and detailed, with fulsome bass. The AT440ML can be spitty at times.

The way out of today's digital quagmire will soon be much clearer for many people, as dCS start to roll out some radical new products – all future-proof as usual.

Digital solutions

World-famous for their Elgar and Delius DACs and the revolutionary Purcell upsampler, dCS will soon introduce an **SACD TRANSPORT** and an industry first – the Grieg upsampler with **ANALOGUE INPUTS**.

Now you can connect tuner, tape or even **PHONO** (MM or MC) without a separate preamp. Then upsample and pass the signal to the Elgar or Delius d/a converter to drive the power amp direct, via its digital volume control and high power output stage.

The cost of entry is higher than with some other brands, although you can start with just a Delius connected to your present player as a transport. But consider: today's dCS products – with low-cost **SOFTWARE UPGRADES** installed from your own transport in the meantime – will still be defining the state-of-the-art in 10 years' time.

Then the cost of ownership becomes attractive, especially when:

- you think of the enjoyment
- you realise how many times you would have changed lesser items.

The key to all this digital wizardry is that dCS have developed their own core software, not relying on off-the-shelf standard chips. Their converters are used in the **RECORDING** and **AEROSPACE** industries.

Not many home audio companies can claim that level of high-tech heritage.

Customers say we make some of the **BEST SOUNDS** they have ever heard, so you know we can do the same in your home. Our advice will take account of your best components and guide you where change is needed, in stages you can afford.

You **AVOID EXPENSIVE MISTAKES**, enjoy music along the way and save money in the long run.

JUST LISTEN AND YOU'LL KNOW

CD: ACCUPHASE, ADVANTAGE, AUDIO SYNTHESIS, BAT, dCS ELGAR, DELIUS AND PURCELL, MERACUS, PASS, SAT, SUGDEN, WADIA. **VINYL:** BASIS, CLEARAUDIO, CROWN JEWEL, DNM, GRAHAM, THE GROOVE, LEHMANN, MICHELL, SUMIKO BLUE POINT SPECIAL, TRANSMUTATION. **AMPLIFIERS:** ACCUPHASE, ADVANTAGE, BALANCED AUDIO TECHNOLOGY, CAT, DNM, GAMUT, NAGRA, PASS, SAT, SONNETEER, SPECTRAL, SUGDEN. **LOUDSPEAKERS:** AUDIO PHYSIC, BKS, ETHOS, LUMLEY, NEAT, TOTEM, VERITY AUDIO. **TUNERS:** ACCUPHASE, MAGNUM DYNALAB. **CABLES:** ARGENTO, CHORD CO., DNM, HOVLAND, NORDOST, SILTECH, SPECTRAL, YAMAMURA CHURCHILL ETC. **SUPPORTS:** STANDS UNIQUE, VIBRAPLANE ETC.

The Right Note

Music in the home



BATH

01225 874728

Sonic((link

WHISPER - VERSATILITY



- Interconnect 0.5 and 1m stereo Pairs for audio
- Can be used in video and digital audio (CD-DAC)
- Available in 5m single lengths for SubWoofer Applications

32 Derwent Business Centre, Clarke Street, DE1 2BU
soniclink@audiocables.co.uk www.audiocables.co.uk
Tel: 01332 361390 Fax: 01332 200698

campaign audio design "Love Hertz"



Getting a better, more involving sound often means spending a lot of hard earned money. It's such a waste, because every system can benefit from our cables and accessories, at a fraction of the cost of some new "black box". Here are some of the ways we can help.

We have Linear Crystal Oxygen Free Copper interconnects (£12.48) up to High Purity Silver balanced cables (£99.00) and high definition

loudspeaker cables in Silver Plated Copper or Pure Silver. Our mains cables add weight, power and scale, and with non-inductive RF filtering (£10.00) and over-voltage protection (£3.00) enhance performance still further. Gold plated AV cables, both RF (£19.95) and OFC Scart with PTFE insulation (£19.21), help bring picture quality in line with NICAM sound resolution.

We also have a cure for your noisy fridge or central heating motor (£3.50), enabling you to throw away your big mains noise suppressor, which has been giving you that "sat upon sound" for years. There's lots we can do to bring you closer to the emotion and energy of the performance. So confident are we, that we offer a 21 day money back guarantee.

Ring or write for details:-

CAMPAIGN AUDIO DESIGN
Llandudno Road (HW)
Cardiff CF3 3PG
Tel:- 02920 779401

Website: <http://business.virgin.net/cad.cables/>



Trade and International Enquiries Welcome.



MICHELL GYRODEC SE

A SYMBOL OF PRECISION



WHAT HI-FI?
June 1999

Michell Engineering Ltd, 2 Theobald St, Borehamwood, Herts, WD6 4SE
Tel: 0208 953 0771 Web: www.michell-engineering

Super Sonic!

David Price has hours of fun knocking bats out of the sky with Tannoy's ST-100 SuperTweeter.

▶▶ **W**hat's the point of a super tweeter? After all, most of us over twenty five years of age can't really hear much above 15kHz - if that - and the tweeters that come with our speakers can easily stretch that far, can't they? Well, having heard Tannoy's super tweeters in the factory dem room, and now in my own home, I can report that they really do work. The difference is audible from the moment you switch them in, and it's clear as night and day.

Most surprising is that it isn't the treble that they improve most of all - there's definitely a benefit here, but the most obvious beneficiary of the SuperTweeter was the mid-band!

Hewn from black ash wood, they're about 150mm in diameter and weigh a not inconsiderable 6.5kg per side. The 25mm tweeter domes are made from high stiffness titanium, finished with 24 carat vapour deposited gold with copper clad aluminium voice coils on aluminium formers.

Powerful neodymium magnets are said to minimise eddy current losses in the voice coils.

The ST-100s are suitable for use with amplifiers of up to 250 Watts with a continuous power handling of 135W RMS. Sensitivity is quoted as 95dB (2.83Volts @ 1 metre) with a nominal impedance of 8 ohms. Tannoy says they have a usable output all the way up to 100kHz. Atop the SuperTweeters you'll find an adjustment panel, into which adjustment screws are inserted to give a sensitivity of 89dB, 90.5dB, 92dB, 93.5dB or 95dB, and crossover frequencies of 14kHz, 16kHz or 18kHz.

My listening kicked off with a great acoustic test track, 'Alligator Bogaloo', which features beautifully recorded (well, it was 1967!) cymbals

recorded on a dual opposed pair of microphones. Putting the Tannoys into the circuit (crossing over at 19kHz, sensitivity matched my Yamahas' 91dB figure) added a subtle airiness to what was already a beautiful hi-hat sound. Amazingly though, this wasn't half as obvious as what had happened in the upper midband - suddenly Lou Donaldson's alto saxophone and Melvin Lastie's cornet sounded dramatically smoother and better defined. I was gobsmacked - why on earth would something that kicked up above 19kHz do this to instruments way, way below on the frequency scale?

Mine was not to reason why, so I moved onto Rose Royce's 'Wishing on a Star', complete with its sublime female vocals. Again, the ST-100s did their stuff, introducing a sense of air and space to the recorded acoustic, smoothing and sweetening vocals and giving strings a more natural shimmering, quality. Indeed, I may have been imagining things but I seriously thought I heard a cleaner, more rhythmic bass too. In hindsight I reckon this was because the Tannoys gave the whole acoustic a more natural, unstrained feel, with more space for all parts of the frequency spectrum to breathe - including the bass.

Moving to Sugar's 'Changes' - a more cranked up piece of heavy guitar rock you will not hear - and they did their stuff once again. The whole soundstage was appreciably less cluttered, sounding far more natural, transparent and musical. The nature of the change they make is fascinating - inasmuch as the sound softens and sweetens AND gets faster and more punchy - usually it's one OR the other. Again the upper mid was the most obviously improved. Any DAT user who switches from 44.1kHz to 48kHz sampling frequency when recording will instantly know what I mean - although you can't hear any extra treble information, the midrange smoothes out and tightens up.

No, I'm not going to attempt an explanation. Suffice to say that they really work. They're expensive at £1,100, but if you're running a high end system you'll find they're a surprisingly cost-effective upgrade. You won't want to go back to life without them - now bat's what I call music!

Tannoy ST-100 SuperTweeter £1,100



World Verdict



High enders will love them - they really work. The only downside is the price - Tannoy, can't we have a cheaper version for us mere mortals?

Time A Half

Eighteen years after its original 'budget super arm' swept the board, Rega has finally upgraded it. At last, David Price auditions the new RB600...

In August 1983 Rega's new RB300 was an innovative piece of design. It used a tapered, one piece aluminium cast arm tube with integrated headshell to eliminate mechanical joints, lessen mass and optimise stiff-



ness. Its bearing gimbal was a substantial casting employing a threaded stem and locknut. The counterweight was machined from dense tungsten alloy for the smallest possible diameter, and hence the lowest moment of inertia.

The result was a remarkably clean and detailed sounding tonearm, which ran the best superarms frighteningly close in some respects. Most surprising of all though was the price Rega elected to charge for it - a paltry £90. This makes it one of the most amazing hi-fi bargains of all time.

The RB300 did have some weak points. An industry grew up around tweaking it and various mods appeared claiming to pull its performance up to the top drawer. By far the most popular was rewiring.

Until recently Rega somewhat contrarily resisted the temptation to mod the RB300 at all. However, with the advent of the £358 RB600, the company has succumbed. Sporting a natty silver paint finish, higher quality cabling and expensive Neutrik phono plugs, it's a sensibly priced step up

from the flawed gem that is the RB300. Otherwise, it's pretty much identical to the arm on which it's based.

So how does it sound? Excellent is the answer. Mounted atop my Michell GyroDec (always a synergistic match for Rega arms) with a Linn Arkiv moving coil cartridge installed and a standard RB300 to hand for comparison, I kicked off the listening with The Crusaders' 'Street Life'. Most obvious was the treble quality, which was sweeter, cleaner and more airy with

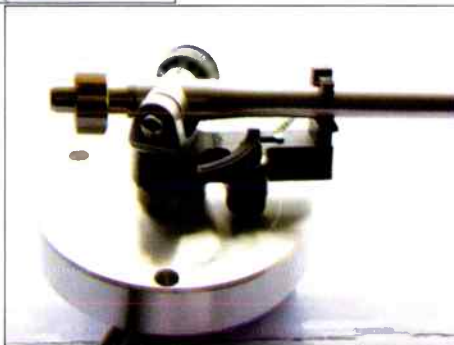

the new arm. Hi-hats glistened and shimmered with the six, whereas the three made them sound a touch too digital for my liking. With an expensive MC like the Linn this was an important plus, but I doubt if the differences would have been so clearly signposted with a more humble £100 MM.

The lower frequency extreme was subtly improved too. Bass guitars sounded fluid and tuneful, giving a more cohesive sound than the RB300 which by contrast seemed a rather disjointed and uneven.

A Chandos pressing of Elgar's Enigma Variations (Sir Alexander Gibson, Scottish National Orchestra)

showed the new arm to be noticeably better at soundstaging. The size of the recorded acoustic grew, projecting further out of the loudspeakers. Depth perspective improved too - it was as if a layer of mush had been removed at the back - and image location firmed up.

Impressive stuff, but only when I cued up some techno music in the shape of Jam & Spoon's remix of 'Age of Love' by Age of Love, did the RB600's talents become most obvious. As well as sounding tidier and better controlled, with a sweeter more natural tonality, the new arm really pulled away from the RB300 in the rhythmic stakes and its dynamics are an improvement too.

The new Rega RB600 is a definite improvement on the cooking RB300 then, and well worth buying instead, despite the extra cost. Whether it's worth upgrading to from your existing RB300 is another matter though. Personally I'd suggest not, unless you're already using an

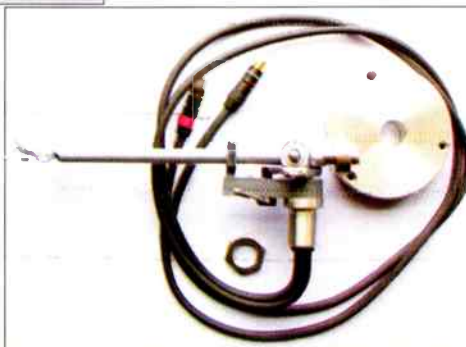

excellent turntable and cartridge - and in this case Rega's more radically reworked RB900 would probably be the one to go for. Overall, this is a truly excellent product, but should have come along years ago! ■ ▲

Rega RB600 £358

Tel: 01702 333071

World Verdict



Sweeter and more musical sound with greater transparency and better soundstaging makes this a superb step up from the RB300.

M for Music

The latest Mission products have been impressive. Dominic Todd pits Mission's m72 budget bookshelf against the competition. How does it fare?



really don't envy Mission. After having great critical and sales success with their 701 and, prior to that, 732, any new model has a tough act to follow. This time around it falls to Mission's new, budget, large stand-mounter, the m72. I say large, yet it's actually a good deal smaller than the previous models, but still bigger than the tiny m71s.

Construction is similar to that of the m73 (reviewed June 2001). No bad thing, as the cabinets are solid, cross-overs bi-wired, and drive units of decent quality. The bonded, woven glass composite woofer cone is particularly impressive for a 'speaker of this price. What's more the price

hasn't risen from the excellent value 701s, at £160. A price at which there are no shortage of rivals including sonic stars such as Mordaunt Short's 902 (£150), KEF's Cresta 2 (£150) and Tannoy's MX2 (£150). Other details are that the m-Range is magnetically shielded for A/V use, and now rear ported. The 701s had the port at the front.

This last point is of some relevance I found, when finding the ideal listening position. Mission quote from between 10-30cm from a rear wall. In practice I found 30cm to be the absolute minimum, with a distance of more like 40cm ideal. Set up in such a manner, and with the

minimum of toe-in, the Missions got off to an excellent start with Eva Cassidy's powerful rendition of 'Wayfaring Stranger'. Vocal projection was startlingly good - almost a match for Epos's acclaimed M12 that is a good three times more expensive. Otherwise the balance came straight from the Mission textbook. Dynamic, punchy, yet with a trace of hardening at higher levels. Just as with the previous 701s it was hard not to be involved with such an exciting presentation. Pleasingly, although the m72s may not be the most refined, they weren't overly bright or excessively sibilant either, meaning long term listening wouldn't become

a chore. The only real disappointment came from the bass response. It was certainly deep enough, but with too much bloom and softness to really convince.

This particular trait was emphasised with bass heavy material such as the reggae style of Mission Control's, "The Last Trumpet". Whilst the bass response was probably deeper than just about any rival, like its m73 sibling it was rather under damped. Also like the m73 it is possible to cure it, although not quite as successfully in this case. With the m73s one simply fills the cabinet with dry sand; here one inserts foam bungs into the rear ports. This certainly had the desired effect of tightening up the bass, but to the slight detriment of the weight and dynamics. Bearing in mind the likely market for these 'speakers, I'd guess that Mission thought the typical customer would appreciate the extra bass weight, rather than ultimate control.

Classical music fared rather better. Although the violin reproduction from Finzi's 'Love's Labour Lost' was only average, the decay and timbre shown with the brass section was commendable. It didn't quite bring goose pimples to my neck, and a rival such as the Mordaunt Short 902 would be rather more analytical here. However, the

smooth balance and broad sound stage still allowed for a highly enjoyable interpretation of the music.

Traditionally, though, budget Mission 'speakers tend to be bought by younger listeners for rock, dance or rap music. Bearing this in mind it seemed appropriate to try Eminem's 'The Real Slim Shady'. It was here where the m72s excelled. Powerful and upbeat sounding, with an expansive sound stage, particularly impressive in terms of height. Although the level of instrumental layering and detail proved the

Mission's to be much more than simple boom boxes.

While the m72s stay true to the sonic balance that made the 701s so endearing, they both surprise and disappoint in other ways. The over all balance is still full-bodied, exciting and yet surprisingly refined (just as the 701s). Yet the bass response seems to have taken a step backwards. It's a bit too flabby for its own good, unless used with stands that would be well out of a comparative price range. Vocals have literally taken a step forward though. It's hard to think of another rival that can quite place the vocalist 'in the room' as well as the Missions. Hence I would still recommend these 'speakers just so long as the partnering equipment erred towards the lean side of neutral - as most budget amps do. Mission has little to worry about. Despite increased competition, the M72s should convincingly carry on from where the 701s left off.



Mission m72 £160

Symphonix Ltd.
Stonehill
Huntingdon
Cambs.
PE29 6EY
Tel: 01480 451777



MEASURED PERFORMANCE

Good drive units give a flat frequency response. It is the random resonant systems in a poorly controlled or inconsistent cone assembly that produce random peaks and troughs. Each is a colouration and together they add up to produce the tonal colour of a drive unit, often related to the cone material, like the quack of a heavy plastic cone. Conversely a flat, smooth frequency response like that of Mission's woven glass fibre cones used in their budget 'm' Series, repeated in the m72, suggests there will be little colouration.

The m72 also has no crossover suckout over a reasonably wide forward range, meaning it will sound bright but detailed. Happily, it does not peak up, so there'll be no sit in the treble, except where there's strong treble energy, like sibilance, in the recording. I know the m73 well

and these drivers do throw it out at you. They resolve tonal texture better than usual too.

Mission have mated a 4ohm woofer to an 8ohm tweeter to come up with the usual '6ohm' nominal impedance (5.5ohms measured) that dips down to 3.4ohms at minima. Consequently the m72 will draw current. It is also reactive over most of its frequency range, if not heavily so. As a load, therefore, the m72 is not the easiest going, demanding current from an amplifier, but it goes reasonably loud at any particular volume control setting, with a healthy voltage sensitivity of 86.6dB SPL from one nominal watt of input.

As budget loudspeakers go

the m72 measures very well. It's about the best currently possible. **NK**

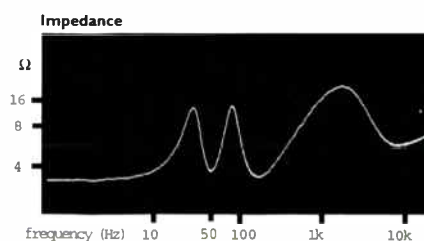
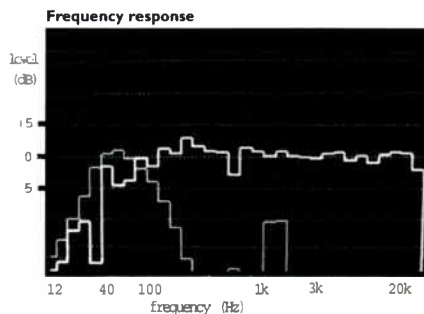

World Verdict



Fine imaging and vocal presence that kicks dirt in the faces of rivals. Good, out of the box sound but the bass may need some home tweaking to control it.

CLASS OF

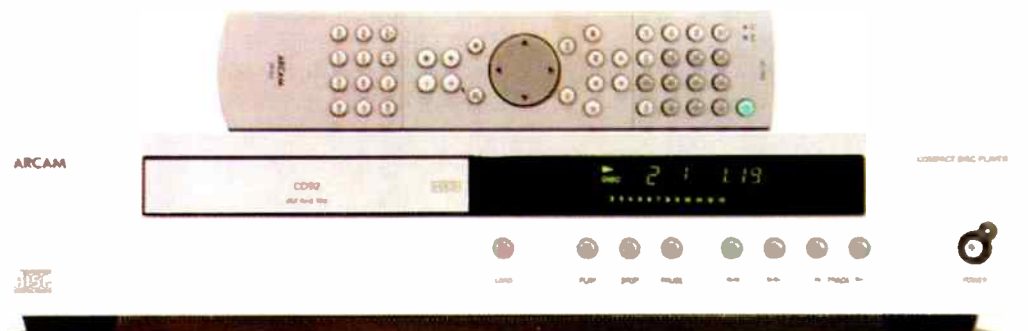

Arcam's CD92 CD player replaces the company's much-vaunted Alpha 9 as flagship of its budget range. David Price puts the new top DiVA through its paces.

▶ **T**he CD92 you see before you sells for £849.95, making it a direct replacement for the excellent Alpha 9. Like its predecessor, the new DiVA's most distinguishing mark is its Ring DAC. This is a response to many people's criticisms of Bitstream digital-to-analogue conversion. Many still believe that multibit done properly leaves it for dead in terms of musicality, even if it lacks the former's refinement and couthness. The trouble is that multibit converters are critically dependent both on the tolerances of their resistor networks and on glitch-free electronic switching. Time and temperature drift play havoc, causing high distortion and poor noise modulation performance. Bitstream overcomes this, but gives a terrible signal to noise ratio that's only overcome by heavy oversampling and noise shaping. Problems here cause unpleasant in-band idle tones and timing errors, making for a muddled sound.

Arcam's Ring DAC is claimed avoid these pitfalls by using technology refined by dCS (Data Conversion Systems) based on research done in the UK in the 1980s on military aircraft radar. Combining multibit and Delta Sigma technology, it works by continuously varying the number and positions of the selected

current sources from sample to sample, as though around a circle. This ensures the inevitable slight variations in the values of the current sources are randomly distributed throughout the quantising range, effectively turning them into random white noise rather than distortion. The result is said to be high linearity plus very low noise and distortion, making for a cleaner and more natural sound.

The new top DiVA attempts to further refine the Arcam budget line. To wit, its designers have paid closer attention to clock accuracy and jitter, power supplies, digital filters and audio output stages. Digital filtering is provided by the latest Pacific Microsonics PMD100 24bit digital signal processor, which also decodes HDCD recordings. The Ring DAC module has extra power regulation and uses a four layer circuit board to optimise grounding and shorten signal paths. The new steel chassis uses 'Sontech' sound damping material (which looks like our old friend Sorbothane to me) a la FMJ CD23, and there's a beefy power transformer with six separately regulated power supplies. It's a nicely screwed together bit of kit alright, but wins no prizes for dramatic design statements or Herculean build.

Encased in a lightweight 430x 290x 85mm metal box, it's a tidy looking audio separate that gets on with the job in a fuss-free way.

SOUND QUALITY

Like the Alpha 9 before it - and indeed the FMJ CD23 - the CD92 has a distinctive sound. Most notable is the way it combines a warm, rich tonality with outstanding timing. Often in hi-fi it's one or the other - many CD players get their fast, involving sound from a rising treble (giving a sharper, more incisive character) or by adding too much distortion (adding a zing) - but the CD92 does neither.

First on was Supergrass's 'Moving', and from the first few bars I could tell the Arcam was impressively even handed. Vocals were smooth but sounded alive with texture and grain, while guitars were crisp with fast attack and plenty of body. Then the chorus kicked in and it fast became clear that the CD92 was no slouch in the bass department either. If anything, it's a touch over full, with a touch too much overhang compared to the (marginally more expensive) Linn CD12 reference. Despite this, bass guitar notes started very swiftly indeed, making the bass player's finger movements extremely easy to hear -

92

Indeed the CD92 sounded amazingly engaging for a player of its price. While I don't rate its dynamics as particularly special, it has a kind of 'cloying' rhythmic quality that just pulls you in and keeps you.

Next on was a spot of classic techno in the shape of New Order's 'Vanishing Point', from their 1989 album Technique. Once again, as the lead in started, I was impressed by the way the Arcam sewed together a success of sequenced bass notes into a tune. Although it lacks the razor-blade transients of Naim's (pricier) CD5 and, to a lesser extent, Cyrus's CD7/PSX-R, the timing was still spot on. The leading edges of notes may not cut you like a knife, but they still reach you very quickly indeed. As the main part of the song kicked in, the CD92 showed off its expressive and open midband, even if it isn't as transparent as the Cyrus. Once again I loved the way the hi-hats bounced around, the Arcam conveying perfectly the way they'd been programmed to float on and off the beat.

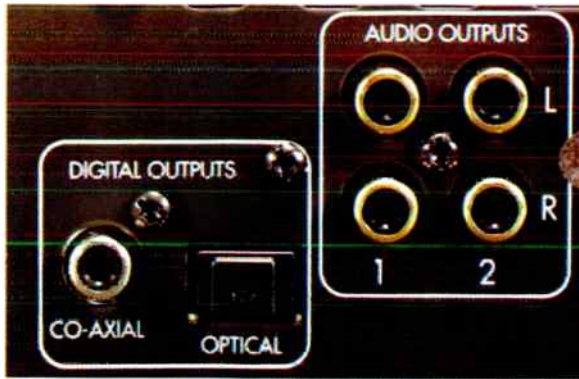

Swapping to Nirvana's 'Come As You Are' was another ear opener. Voices were deliciously full and grainy, in marked contrast to the CD5's rather perfunctory attention to detail in this respect. The snares kicked in with surprising power, and together with the thudding bass drums and crashing cymbals, the Arcam proved itself able to 'rock out' with the best of them. (SP will have to try his Soundgarden CD on this). Again, bass sounded fruity and full but extremely fluid and tuneful. The overall effect was far more than I'd expect from a 'budget CD player on steroids', which is what the CD92 is, if we're honest.

Don't get me wrong - this machine isn't perfect. Its midband is a little veiled and woolly, image location lacks the hewn-from-granite feel of the Cyrus, its bass is a tad overblown and the treble isn't the most airy or spacious I've heard. Despite these

quibbles, however, the Arcam CD92 is a famously good all rounder with few glaring weak points and a wonderfully supple and warm sound to recommend it. The biggest cloud on its horizon is the company's own FMJ CD23 at only a few hundred pounds more, which offers an altogether more grippy and detailed sound. To use the Spinal Tap analogy, the FMJ is like turning the CD92 up to eleven. Still, at this price, ten out of ten isn't bad. ■ ▲

Arcam CD92 £849.95

A & R Cambridge Ltd.
Pembroke Avenue
Denny Ind. Centre
Cambridge CB5 9PB
Tel: 01223 203200
www.arcam.co.uk

MEASURED PERFORMANCE

This player gives a flatter response than most Arcams, although there is a little filter ringing at the top end. It is more common to see some roll down, a characteristic I feel is preferable, but Arcam seem to have changed their approach a little here.

Distortion was low enough at high signal levels but rose somewhat further down the range, measuring 0.55% against a best possible result of 0.3%. This is no great difference though and at -90dB the usual 31% figure (or thereabouts) was recorded during measurement, showing that the CD92 manages to resolve low levels quite effectively.

With good channel separation and low noise the CD92 measured well enough. Output was high at 2.4V.

I'd expect the CD92 to sound a little lighter and brighter than other

CD players from the company. It's performance figures look good and it should perform well **NK**

Frequency response 4Hz - 21.25kHz
 left right

Distortion			
-6dB	0.006	0.006	
-30dB	0.02	0.022	
-60dB	0.55	0.6	
-90	31	32	

Separation left right
 1kHz 99 99
 20kHz 85 93

Noise with emphasis -97dB -97dB

Dynamic range 106dB
 Output 2.4V

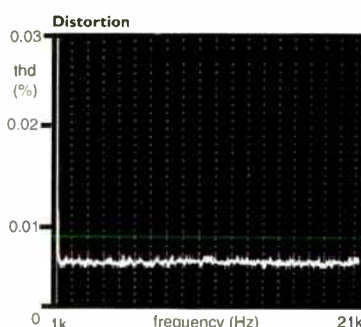
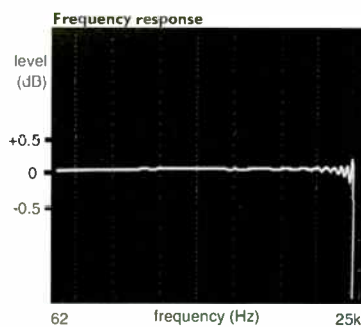

World Verdict

Full bodied and musical, it's an extremely impressive performer at the price.



CYRUS

CD7 CD Player £799.95
7 Integrated Amplifier £699.95

The new **CD7** combines the latest transport developments with 24-bit DAC technology. The CD player can be easily upgraded by adding the external PSX R power supply.

"This player is just as convincing with thundering orchestral strings and brass, making a great job of Bernstein's recording of *Mahler's Symphony No 5* and it has the definition to unravel the instrumental strands in the Kronos Quartet's disc of *Phillip Glass string quartets*... It's that that makes it special - and this is a very special player indeed."

★★★★★ What Hi-Fi? | November 1999

The 60 Watt **Cyrus 7** is a powerful integrated amplifier and system controller that can be upgraded in many directions. This flexible unit will form the cornerstone of your system and provide access into Cyrus' Audio Visual and Multiroom systems.

"This is a fabulous amplifier. It's fast, punchy and has bags of power on tap but crucially delivers huge sackfuls of subtlety when the music requires. Some of the other amplifiers in this group may be better with particular genres of music but as an all-rounder it takes some beating." ★★★★★ What Hi-Fi? | November 1999

CLS70 Speakers £799.95

"The **CLS70s** have a strong sonic flavour. Tonally, they sound rich with a full bass end and refined high frequencies. However it's the midrange performance that is really special. These speakers have a lovely three-dimensional presentation that give vocalists and instruments an almost physical presence in the listening room... Pleasingly, there's fine level resolution too, even down to the lowest frequencies - an area where many rivals start to struggle. Add expressive dynamics to the list and these Cyrus speakers emerge as entertainers of the highest order. Move onto *Carmina Burana* and the CLS70s show themselves to be masters of imaging with a tightly focused sound stage and well-developed depth. Integration between the drive units is immaculate, so the speakers produce one of the most seamless and cohesive sounds to be heard for under £1000." ★★★★★ What Hi-Fi? | December 2000

Quattro CD/Pre Amplifier £649.95
SmartPower Power Amplifier £549.95

"Looking at first glance like the CD7 CD player, this elegant box has a lot more going on under the bonnet. As well as a CD transport, it contains a preamp and can accept an optional FM RDS tuner... Add to all that the fact that the **Quattro** also has outputs for an optional multiroom facility, and what we have here is a claim for the tag of a serious hi-fi style system with great flexibility.

You need to partner it with a power amp, of course, and for this purpose we're using Cyrus's new SmartPower. Put them together, and it's not hard to see that style and ease of use are a big factor in the Quattro's design.

And it performs impressively. Space, detail and lightning quick transients make for a precise punchy sound... The depth and realism of acoustic instruments also make this a great listen, whether with Neil Young's acoustic guitar or Steve Reich's ensemble of woodwind, strings and pianos." ★★★★★ What Hi-Fi? | January 2001



Price excludes optional Tripod Speaker Stands



Please Note: Some products may not be available at all outlets. Advertisement valid until at least 1st August 2001, E.O.F.

more entertaining

World Radio History



scotland and north

Leeds 112 Vicar Lane (Open Sunday)

0113 245 2775

Liverpool 16 Lord Street

0151 707 8417

Manchester 69 High Street, City Centre

0161 831 7969

Newcastle 19 Newgate Street

0191 221 2320

Preston 40-41 Lune Street (Open Sunday)

01772 825777

midlands and east

Cambridge 17 Burleigh Street

01223 304770

Lincoln 20-22 Corporation Street

01522 527397

midlands and west

Birmingham 12 Queensway Arches, Livery Street

0121 233 2977

Bristol 92b White Ladies Road, Clifton

0117 974 3727

Cheltenham 14 Pitville Street

01242 241171

london and south east

Bromley 39a East Street

020 8290 1988

Chelsea 403 Kings Road

020 7352 9466

Croydon 369-373 London Road (Open Sunday)

020 8665 1203

Holborn 144-148 Grays Inn Road

020 7837 7540

Kingston 43 Fife Road

020 8547 0717

Maidstone 96 Week Street

01622 686366

Reading 3-4 Kings Walk Shopping Centre

0118 959 7768

Sevenoaks 109-113 London Road

01732 459555

Southampton 33 London Road

023 8033 7770

Tunbridge Wells 28-30 St Johns Road

01892 531543

Watford 478 St Albans Road (Open Sunday)

01923 213533

who are sevenoaks?

Founded as Sevenoaks Hi-Fi in the summer of 1972, the original shop, in the market town of Sevenoaks, Kent, quickly gained a reputation for offering a wide range of products at competitive prices, and providing excellent service.

As the business grew the number of outlets increased, and by 1981 there were also branches in Beckenham, Brighton, Chatham, Tunbridge Wells and Woolwich.

Exciting new technologies like compact disc, meant that throughout the 1980's there was considerable interest in hi-fi and Sevenoaks were able to grow steadily, both in size and stature. By 1990, the company was established as one of the leading independent hi-fi specialists in the country.

More stores were opened and a number of the original shops were relocated. In 1995 the important decision was made to change the name to Sevenoaks Sound & Vision, reflecting the wide appeal of new audio visual products.

After twenty-nine years of trading, the company has more than forty outlets nationwide, and is for many of the UK's leading manufacturers of electronics and loudspeakers, their largest and most successful retailer.

solutions



DVD Video is a great way of enjoying movies at home

solutions brochure available in all outlets

The people at Sevenoaks appreciate that customers have a choice. This appreciation has meant that over the years Sevenoaks have had to adapt.

As new products and technologies have arrived, the staff have been trained to ensure that they can explain the issues, simply and informatively.

This orientation to customer service remains, and the implementation of a company charter is one example of this commitment.

By staying true to the original ideals of offering a wide range of the latest products, at competitive prices, and providing superb service in pleasant surroundings, Sevenoaks are able to listen, recommend, demonstrate and supply the products that best suit the needs of their many customers.

As the world becomes a more complex place and people search for entertainment and relaxation, Sevenoaks Sound & Vision believe that whatever the requirement, they have the solution.

PROBABLY THE BEST

NEW DEMONSTRATION ROOM NOW OPEN AT 12A SPRING GARDENS, NEWPORT PAGNELL,

Kel84 VALVE INTEGRATED AMPLIFIER KIT

This is our brand new, low cost, beginner level amplifier kit. It features a pair of EL84 valves per channel in push-pull configuration. They give 15 watts into an 8 ohm load - plenty for medium sensitivity loudspeakers. The output transformers are Ultra Linear, keeping distortion down to a minimum. Up front the ECF80 input/phase splitter valve has an extremely smooth sound.

The Kel84 has very low hum, to solid-state standards. For simplicity the kit is built on a printed circuit board. A strong steel chassis is fronted by a 3mm anodised front panel and attractive chromed custom made knobs. There are five line level inputs, plus one monitor input, with a tape output included, all controlled from the front panel. The phono input sockets and 4mm banana socket speaker terminals are gold plated.

At rear is a mains switch, an IEC power input and an earth post. This kit is aimed at beginners. The instructions include pictures as well as diagrams, making them very easy to follow. At a UK price of £278.00 all inclusive you cannot ignore Kel84. Simon Pope says, "The quality that can be gleaned from this amp is a fine introduction to the joys of the valve sound. The Kel84 will highlight all the intricacies and



£278

depth of detail in your favourite recordings whilst retaining a warmth and fullness that is almost exclusive to pure valve amps and is rare at this price point."

Kel84 weighs 10kg. External dimensions with valves are 300mm(w) x 270mm(d) x 150mm(h).

KIT88 VALVE INTEGRATED AMPLIFIER KIT & KAT88 VALVE POWER AMPLIFIER KIT

Here is the amazing KIT88. The circuit is similar to that of our popular KEL34 with a few changes to incorporate the Tesla, JJ branded KT88 power tetrode. This is a pure Class A push-pull design providing 36 watts into an 8ohm load. Andy Grove has come up with a gem of an output transformer (E/I). With the KT88 it offers a virtually unmatched result for a valve amplifier. Frequency response measures 11Hz to 75kHz, separation 71dB, noise 98dB, sensitivity 400mV and distortion 0.03%. "As valve amplifiers go, the KIT88 is one of the best measured performances I have ever come across", said Noel Keywood. Jon Marks said, "The KIT88 pulled a series of surprisingly fast, meaty basslines out of its trickbag when dealing with Suzanne Vega's Nine Objects Of Desire album. As if this wasn't enough, the mid and treble

were nice too - cymbals had a deliciously natural, golden shimmer without sounding soft, and vocals were extremely transparent and crisply defined. KIT88 didn't hang around when it came to exploiting the virtues of its four output valves on numbers such as 'Leaves' and 'Suspect Sustain' from Cirrus' Land's End Jazz CD. Saxophone had a wonderfully smooth, realistic character, and acoustic guitar mixed speed with harmonic richness to very impressive effect. Asian Dub Foundation and Moloko showed no sign at all of the sluggish, woolly bottom-end and poorly-delineated bass beats that most valve amps are to blame for. Which makes the KIT88 an all-round, high-end bargain." Weight 16kg, external dimensions with valves are 330mm(w) x 300mm(d) x 190mm (h).



KaT88 upgrade kit now available £140

£468

← **KaT88 VALVE POWER AMPLIFIER KIT**



← **KIT88 VALVE INTEGRATED AMPLIFIER KIT**

£484

KIT88 upgrade kit now available £150

ALL NEW SERIES II MODULAR PRE-AMP KIT

The PRE-II is a valve pre-amplifier with six inputs, tape monitor and two sets of output sockets. It utilises a high quality line driver transformer and x5 gain. The PHONO-II is a dedicated valve phono stage that incorporates a step-up transformer for MC users. Finally, PSU-II is a power supply unit that feeds both the PRE-II and PHONO-II.

Power Supply Unit (PSU-II)	£195.00
Pre-amplifier (PRE-II)	£195.00
Phono Stage (PHONO-II)	£110.00
Moving coil step-up transformer	£77.00
Passive pre-amplifier (PAS-II)	£215.00

NEW!



DIY KITS IN THE WORLD

MILTON KEYNES, BUCKS MK16 0EE - CALL FOR DETAILS ON 01908 218836

KAT34 VALVE POWER AMPLIFIER KIT & KIT34 VALVE INTEGRATED AMPLIFIER KIT

£480

NEW KITS

£495



KiT34 is a 32 watt stereo valve integrated amplifier, featuring a pair of EL34s, in push-pull mode, per channel, plus an ECF80 pentode/triode as input/phase splitter. The power supply is valve rectified (2 x 5U4), using a heavy duty choke to achieve exceptional smoothing. The output transformers are 14% Ultra Linear tapped to keep distortion down to its lowest level and the kit is totally hard wired utilising three tag boards. It has five line level inputs, plus a tape-in and tape out, all controllable from the front.

Simon Pope says, "This integrated bring together the best sonic virtues of our KiT88, kel34 and top of the range 300B PSE in an affordable package. The highlights of the sound are a deep and taut bass response, together with an open and highly detailed mid and high frequency response that only the best valve designs can achieve... a true valve classic" Weight 22kg, External dimensions with valves fitted - 390mm(w) x 360mm(d) x 210mm(h)

300B PSE MONOBLOC KIT

Our Parallel Single Ended amplifiers offer ultimate sound quality Each monobloc has two of the beautifully linear 300B directly heated triode in its output stage, producing 20 watts into an 8 ohm load. At the front we have a 6AU6 pentode and an ECC82 as the driver valve. This design utilises a 5U4 rectifier valve in the power supply, in combination with a 10H choke, giving an extremely quiet supply. Both mains and output transformers we E/I pattern.

For purists, feedback is switchable and the kit is totally hard-wired. For those that require valves we provide the superb Tesla 300Bs, Russian 5U4s and European 6AU6s & ECC82. Simon Pope says, "Not to put too fine a point on it, the sound these monoblocs create is among the finest that

can be encountered in hi-fi." Our 300B PSE kit bears an affordable price of £875.00 (UK price) excluding valves.

Each monobloc weighs 23kgs., external dimensions with valves: 25cm(w) x 38cm(h) x 22cm(d) per monobloc.

300B PSU upgrade kit now available £150

£875
A pair



KEL80 MONOBLOC AMPLIFIER KIT

Following the success of our budget KEL34 40watt kit amplifier, we have come up with a 'big brother' design. The output stage uses two pairs of TESLA EL34 pentodes in parallel-push-pull mode, allowing KEL80 to turn out 80 watts into an 8ohm load. Heading up the input stage we have the wonderfully linear Russian 6AU6 working into an American 5687 phase-splitter. KEL80's output transformers are 4ohm and 8ohm tapped. With an input sensitivity at around 380mV for full output, it will happily partner both passive and active pre-amplifiers. It is easy to assemble. Simon Pope says, "The proof of the pudding is in the eating and the KEL80 is a feast for the ears, with solid bass attack, lightning fast reactions,

that emphasises musicality as well as power. At £649.00 a pair, a definite valve winner. Each monobloc weighs 12kgs., external dimensions with valves: 14cm(w) x 8cm(h) x 43.5cm(d).

£649
A pair



HD83 VALVE HEADPHONE AMPLIFIER KIT

The HD83 headphone amplifier is a beautifully simple design using Mullard ECL83 valves, a triode and power pentode housed in the same envelope. It works directly from any source, be it CD, tape, tuner etc., or from an amplifier's tape out or pre-amp out sockets. The circuit uses high specification E/I output transformers that will drive any headphone load from 16 ohms to over 300 ohms depending on how the secondaries are wired up. The HD83 is a single-ended design with the power pentode wired up in triode configuration for added sonic purity, and it is as quiet as a mouse. For sound quality Jon Marks says, "The bass is punchy and controlled

without becoming artificial, while treble has the crispness of the best solid-state, with the tonal purity, delicacy and speed associated with valves." External dimensions 18cm(w) x 30cm(l) x 8cm(h) weight 4kg.

£195



World Audio design

PROBABLY THE BEST DIY KITS IN THE WORLD

NEW DEMONSTRATION ROOM NOW OPEN AT 12A SPRING GARDENS, NEWPORT PAGNELL, MILTON KEYNES, BUCKS MK16 0EE- CALL FOR DETAILS ON 01908 218836

KLS10 HIGH TECHNOLOGY COMPACT MONITOR

Our mini-marvel uses an Audax carbon fibre bass/midrange unit, married to the world's most advanced tweeter, the piezo-electric gold dome HD3P from Audax. KLS10 offers high performance from a small package. The main 'speakers are designed to work alone, or with a dedicated subwoofer to extend their bass. Alone, they are suited to near-wall mounting and can be tuned by port adjustment to suit personal taste and location. They are easy to drive and need just 30-60watts. KLS10 is unique. Technically advanced, yet compact and relatively inexpensive, there is little to match it. Sensitivity 89dB 1W/1m, 15mm MDF, internal volume 9Ltrs, external dimensions 19cm(w) x 31cm(h) x 23cm(d).

Drive Unit & Crossover kit **£433.00**
Drive Unit only **£394.00**



£433

KLS10 GOLD SUBWOOFER

Designed to complement KLS10 Gold stand mounters by providing deep and open bass. The subwoofer is inexpensive, easy to build, comprising a simple crossover network with a high quality 8 inch Aerogel dual voice coil unit. A must for all KLS10 Gold customers. Sens. 89dB, volume 25 litres, external dimensions 28cm(w) x 43cm(h) x 34cm(d).

Drive Unit & Crossover kit **£164.00**
Drive Unit only **£78.00**



£164

KLS3 GOLD MK II ADVANCED TECHNOLOGY 3 WAY LOUDSPEAKER

KLS3 Gold uses the latest version of Audax's innovative oval gold dome piezo electric tweeter, giving it the sweetest and most extended treble. Married to a 4in. carbon fibre cone midrange driver for neutral and clear reproduction, and a powerful 8in. bass driver for superb depth, this is our top-of-the-line reference 'speaker. Sensitivity 90dB at 1W/1m, 25mm MDF, internal volume 60Ltrs, external dimensions 26cm(w) x 100cm(h) x 35cm(d).

Drive Unit & Crossover kit **£633.00**
Drive Unit Pack **£495.00**



£633

Upgrade your KLS3s to Gold status. Includes latest oval gold dome piezo tweeter and all components.

for

£363

Mains transformers & Chokes

KEL84 mains transformer
1.5 inch stack, 90mm(h)x 80mm(w)x 95mm(d) drop through fitting with zinc cap. Secondaries: 0V-240V 300mA, 3.15V-0V-3.15V, 5.5A, suitable for 120/240V operation

KIT88/KAT88 mains toroidal transformer
120mm dia. x 60mm(h). Secondaries: 195V-0V-95V, 450mA/0V-27V, 100mA/3.15V-0V-3.15V, 9A, suitable for 120/240V operation

300B PSE mains E/I transformer
130mm(h) x 95mm(w) x 115mm(d), drop through fitting with zinc cap.
Secondaries: 380V-0V-380V, 180mA/150-0V-150V, 25mA/0V-5V, 1.2A/0V-5V, 1.2A/0V-5V, 3A/3.15V-0V-3.15V, 0.4A suitable for 120/240V operation

KEL80 mains toroidal transformer (encapsulated)
130mm dia. x 65mm(h). Secondaries: 195V-0V-195V, 390mA/0V-27V, 100mA/3.15V-0V-3.15V, 7.5A, suitable for 120/240V operation

HD83 mains toroidal transformer
80mm dia. x 35mm(h). Secondaries: 0V-165V, 75mA/3.15V-0V-3.15V, 1A, suitable for 120/240V operation

PSU-II mains toroidal transformer
80mm dia. x 35mm(h). Secondaries: 0V-270V, 60mA/0V-10V, 2A, suitable for 120/240V operation

TRANS1 mains toroidal transformer
95mm dia. x 50mm(h). Secondaries: 0V-370V, 150mA/0V-6.3V, 3.5A 300B E/I choke 65mm(h) x 70mm(d) x 80mm(w) open frame fitting, 10H, 180mA.

KEL84 E/I choke
0.5 inch stack, 40mm(h)x 35mm(d)x 70mm(w) clamp fitting, 1H, 250mA

PSU-II E/I
40mm(h) x 35mm(d) x 70mm (w) clamp fitting, 15H, 20mA

KIT34/KAT34 mains transformer
2.5 inch stack, 120mm(h)x115mm(w)x95mm(d), drop through fitting with zinc cap. Secondaries 365V - 0V - 365V, 300mA/0V - 5V, 6A/3.15V - 0V - 3.15V, 7.5A. Suitable for 120/240V operation.

KIT34/KAT34 choke
1.25 inch stack, 65mm(h)x105mm(w) with fitting holes x 60mm(d), clamp fitting, 2.5 H, 350mA

Output transformers

KEL84 E/I Ultra Linear push-pull output transformer
1.25 inch stack, 76mm(h)x 65mm(w)x 76mm(d)
Primary - secondary, 8K with 12.5% UL tap - 8ohms, max o/p-15watts, max current 150mA valves EL84 etc

KIT88/KAT88 E/I push-pull output transformer
80mm(w)x95mm(l)x100mm(h).
Primary-secondary 10K - 8ohms, max o/p-40watts, max current-160mA valves-KT88, 6550, EL34

KIT34/KAT34 E/I 14% tapped Ultra Linear push-pull output transformer
2 inch stack, 80mm(w)x95mm(l)x100mm(h), drop through fitting with zinc cap.
Primary-secondary 6.4K, 14% UL taps, Secondary 8ohm, max output 34watts, max current 150mA, valves EL34, 6L6, 6CA7

KEL80 E/I parallel-push-pull output transformer
95mm(w)x115mm(l)x133mm(h).
Primary-secondary 4.6K - 8 & 4ohms, max o/p-80watts, max current-250mA valves-EL34, 5881, 6L6

HD83 E/I single ended output transformer
40mm(w)x50mm(l) x55mm(h).
Primary-secondary 4K - 4 x 64ohms windings, max o/p-1watts, max current-25mA valves-ECL83 etc

Pre-II E/I driver transformer
80mm(w)x60mm(l) x65mm(h). 6:1 step down transformer, max current-10mA valves-6922 etc pre-amp stage

300B PSE E/I parallel single ended output transformer
130mm(h) x 95mm(w) x 115mm(d).
drop through fitting with zinc cap.
Primary 1K5 Secondary 8R, output .

Printed circuit boards

Kel84 Printed Circuit Board 280mm(w) x 135mm(l) x 1.6mm(d)

KIT88/KAT88 Printed Circuit Board 140mm(w) x 310mm(l) x 2.4mm(d)

Kel34 Printed Circuit Board 140mm(w) x 310mm(l) x 2.4mm(d)

Kel80 Printed Circuit Board (a pair) 120mm(w) x 215mm(l) x 2.4mm(d)

HD83 Printed Circuit Board 140mm(w) x 160mm(l) x 1.6mm(d)

PSU-II Printed Circuit Board 105mm(w) x 130mm(l) x 1.6mm(d)

PRE-II Printed Circuit Board 105mm(w) x 130mm(l) x 1.6mm(d)

PHONO-II Printed Circuit Board 105mm(w) x 130mm(l) x 1.6mm(d)

TAG board 2 x 16 connections (hard wiring) 40mm(w) x 140mm(l) x 3mm(d)

special offers

Kel34 chassis

330mm(d)x 190mm (h). ideal for the constructor who requires a compact chasis to incorporate 4 octals, 2 B9A & B7G bases mounted on kel35 PCB - £12.00 2x 78 lam holes, and fixing for a 115mm dia toroidal mains. rear has 5 phoho pair holes & 2 XLR holes.

KIT88/Kat88 chassis

330mm(w)x 300mm (d)x 78mm(h). ideal for the constructor who requires a compact chasis to incorporate 4 octals, 2 B9A & B7G bases mounted on kel35 PCB - £12.00 2x 78 lam holes, and fixing for a 115mm dia toroidal mains. rear has 5 phoho pair holes & 2 pairs of 4mm socket. Includes 6mm front plate plus chrome knobs - £100.00 (uk prices)



World Audio Library

WE HAVE OVER 40

AUDIO ELECTRONIC THEORY BOOKS



Electronics made Simple
by Ian Sinclair
This book covers the basic theory and principles of electronics. A good read for the beginner.
Code No 1420
£12.99 + £2.00 P&P (UK)

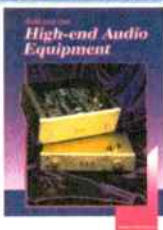

Build your own High-End Audio Equipment
by Elektor
Build your own High-End Audio equipment contains construction projects for solid state preamplifiers and power amplifiers, active cross-over filters, an active subwoofer, a mono/stereo compressor and a headphone amplifier.
Code No. 1390
£14.95 + £2.25 P&P (UK)



Practical Electronic Fault-Finding and Troubleshooting
by Robin Pain
This book explains the basic techniques needed to be a troubleshooter, using only basic equipment: a digital multimeter and an oscilloscope. Simple circuit examples are used to illustrate principles and concepts fundamental to the process of fault finding.
240pp 235mm x 156mm Paperback
Code No. 1430
£19.95 + £2.25 P&P (UK)



Build your own Electronic Test Instruments
by Elektor
This book contains designs for 17 measuring instruments, seven generators and analysers, ten miscellaneous instruments and a number of test ancillaries and auxiliaries. The designs range from a simple multicore cable designs contain a special printed circuit, drawing of which are given in an appendix.
Code No. 1400
£15.95 + £3.25 P&P (UK)



The LP is back
by Audio Amatures
Your complete guide to LP care and maintenance designed to offer you everything useful for those who love and enjoy this older music medium. This covers the theory and care of LPs and the electronics and mechanics of its players.
154pp Paperback
Code No. 1620
£8.00 + £1.50 P&P (UK)

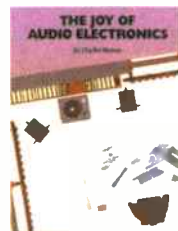

The Joy of Audio Electronics
by Charles Hansen
This is a fail-safe guide to the pleasures of hands-on electronic construction. This book covers test and measurement projects, how to build simple kits, safety issues, the workplace, theory and resources. A must for the beginner who plans to build more advanced electronic projects in the future.
124pp Paperback
Code No. 1650
£10.50 + £2.25 P&P (UK)

VALVE BOOKS

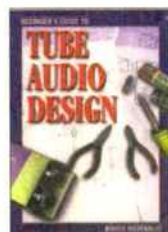

The Beginner's Guide to Tube Design
by Bruce Rozenblitz
This book takes a comprehensive look at tube audio design. It explains how vacuum tubes work and how to design with them. Rozenblitz covers stabilisation and testing, a description of 13 famous and classic amps and preamps and how to work effectively as a designer. A hands-on guide to construction techniques, tools and choosing components and tubes is provided. 1997. 132pp., 8 1/2" x 11"
Paper back
Code No. 1340
£15.50 + £2.25 P&P (UK)

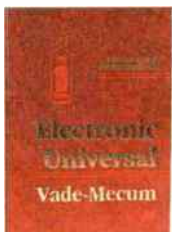

Electronic Universal Vade-Mecum
by Piotr Milekajczyk & Bohdan Paszkowski.
This Data book comprises 5693 valves divided into 442 groups. A comprehensive book which contains connection details, operating parameters, load lines and example circuits.
Hard back
Code 1060
£49.95 + £ 8.50 P&P (UK)



Mullard Tube Circuits for Audio Amplifiers
Includes full designs for eleven power and control amps, including 5-20, using valves. Begins with a four chapter tutorial on getting the best sound from valve amplifiers.
142pp 8" x 10" Paperback
Code No. 1030
£13.95 + £1.50 P&P (UK)

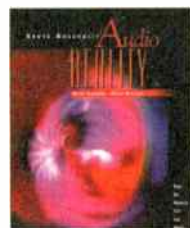

Audio Reality
by Bruce Rozenblitz
A fine read that investigates conductors, skin effect, impedance, interconnects, speaker cables, balanced lines, transmission lines, power cords, isolation transformers, damping systems, tubes, acoustics and much more. Also, includes 6 excellent detailed valve design projects, 80watt OTL, 25watt OTL, grounded grid pre-amp, 150watt amp., 6550 SE amp. and a grounded grid cascode phono preamp.
Paperback 128pp
Code No. 1640
Price 21.50 + 2.25 P&P (UK)



An Approach to Audio Electronic Valves in Audio Frequency Amplifiers
by E. Rodenhuis
Originally published in 1954 by Philips, this book encourages amp. builders to experiment with design elements. Discussing the use of valve data, the function of different amplifier stages and includes detailed descriptions of eight designs. A wealth of practical data, measurements and interesting features will be found. A very good read.
Paperback 147pp
Code No. 1520
Price £12.95 + £2.00 P&P (UK)

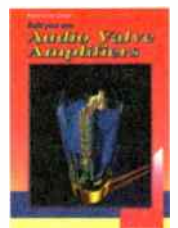

Build your own Audio Valve Amplifiers
by Rainer Zur Linde
This book covers construction projects for preamplifiers, power amplifiers and two amplifiers for musical instruments aimed at the practical audio/hifi enthusiast, it offers much information on the operation of electron tubes, while the first chapter gives a short history of the thermionic valve.
paperback, 251pp, 235mm x 133mm
Code No. 1320 £14.95 + 2.25 P&P (UK)



Radio Designer's Handbook 4th Edition
by Fritz Langford-Smith
This is a classic reference handbook for all who are interested in the design and application of audio amplifiers and radio receivers, and deals with basic principles and the practical design of all types of classic audio amplifiers, radio receivers and record-producing equipment up to the invention of the transistor, covering valves, valve testing, general theory and components; audio and radio frequencies; power supplies, design of complete AM and FM receivers, and reference information.
1498pp 216mm x 138mm Hard back
Code No. 1600
£35.00 + £6.00 P&P (UK)

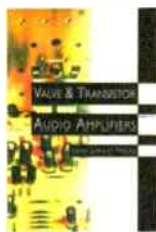

Valve & Transistor Audio Amplifiers
by J L Hood
This is J L Hood's greatest work yet, describing the milestones that have marked the development of audio amplifiers, from the earliest valve amps to the latest solid state design. It is the complete world guide to audio amp design. Other contents: active & passive components, amplifiers, pre-amplifiers and power supplies.
250pp., 156mm x 232mm Paperback
Code No. 1530
£19.99 + £3.50 P&P (UK)

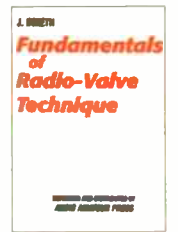

Fundamentals of Radio-Valve Technique
J. DeKeth
This is part of the Philips technical series written in 1947 it was one of the most authoritative and comprehensive treatments of the nature and function of the vacuum tube.
534pp 6' x 9" Paper back
Code No. 1630
£21.50 + £2.50 P&P (UK)



The Williamson Amplifier
by D.T.N. Williamson.
Offers practical advice on how to build and set up the amplifier for best results.
40pp 8 1/2" x 11" Paper back
Code No. 1040
£9.95 + £1.50 P&P (UK)



Valve Amplifiers (second edition)
by Morgan Jones, Audio Engineer
This book allows those with a limited knowledge of the field to understand both the theory and the practice of valve audio amplifier design, such that they can analyse and modify circuits, and rebuild an amplifier. Constructional techniques are also provided so readers can build from scratch designs that actually work.
488pp 6" x 9 1/4" Paper back
Code No. 1330
£25.00 + 3.50 P&P (UK)



The Best of Audion editorial projects
by Luciano Marci
This book contains six excellent audio projects - a high sensitivity speaker, a superb tube pre-amp, a 2A3 amplifier design, a project using the Russian 6C33CB and two projects using 300Bs as output valves. Overall the book is a fabulous read.
62pp, paper back
book code 1750
£12.00 + £2.00 UK p+p

ORDER 4 BOOKS & OVER & PAY ONLY £7.00 P&P (UK ONLY)

World Audio Library

TITLES ON OFFER!!!

NEW TITLE



Manuale HI-FI a valvole Schemario 2*
An Italian publication with all circuit diagrams in standard conformation, therefore, all circuits are easy to follow. This book is dedicated to self makers and to Hi-Fi tube engineers. With a wealth of circuit diagrams from some of the best valve amplifiers, pre-amplifiers and phono equipment producers in the world. Including, Audio Research, Altec, Conrad Johnson, Art Audio, Luxman, Carver, Dynaco, Electrovoice, Leak, McIntosh, Marantz, Quad, Radford, Quick Silver, numerous OTL designs, Verdier, VTL and Western Electric. Well worth the money.
208pp. 210mm x 300mm Paperback
Code No. 1720
£44.00 + £4.00 P&P (UK)

NEW TITLE



Getting the most out of Vacuum Tubes
by Robert B. Tomar
From the cover, "Types and causes of tube failures, what to expect from tubes, testing methods and all about tube maintenance programs." This book is intended to offer explanations of why tubes fail and what to do about it. Discussions of catastrophic and degenerative failures; selecting tubes and tube types and testing and predicting tube performance.
160pp 140mm x 216mm
Paperback,
Code No. 1710
£13.95 + £2.00 P&P (UK)

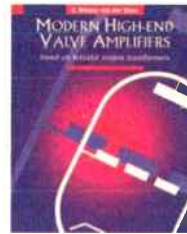

Modern High-End Valve Amplifiers Based on Toroidal Output Transformers
by Menno van der Veen
Explains the whys and wherefores of toroidal output transformers at various technical levels. Discussed extensively within this book are designs for amplifiers from 10 to 100 watts. Finally, the author gives some attention to a number of special valve amplifiers, and to the theory and practice of negative feedback.
250pp 170mm x 240mm
Hard back
Code No. 1670
£24.95 + £2.50 P+P (UK)

NEW TITLE



First in High Fidelity
The Products and History of H. J. Leak & Co. Ltd.
by Steven Spicer
This book is the unique and comprehensive story about one of the world's best high-fidelity audio companies. Contained are 300 pictures, 30 circuit diagrams for classic designs of the day. There are also numerous anecdotes and contributions from ex-employees. A wonderful historical read.
270pp 195mm x 264mm Paperback
Code no. 1740
£19.95 + £3.25 p+p UK

NEW TITLE



Basic Theory and Application of Electron Tubes
A US Army & Navy Publication
This book is an excellent introduction into valves. It does just about everything its title suggests. Written in 1957 it was used by the US military as a text book in their electronics department. Superbly written it contains all you need to know.
215pp
200mm x 260mm Paperback
book code 1760
£17.95 + £3.25 P&P (UK)

NEW TITLE



Sylvania Technical Manual
by Sylvania Electric Products Inc.
This 13th edition contains data on more than 3300 electron tubes and semiconductor devices. Reprinted here without the TV picture tube section, this manual contains detailed information on Sylvania's devices including charts and diagrams. A master index is found in the front of the book for reference.
516pp 140mm x 216mm Paper back
Code No. 1700
£16.95 + £3.50 UK p+p

LOUDSPEAKER BOOKS



Testing Loudspeakers*
by Joe D'Appolito
Joe D'Appolito, loudspeaker designer and consultant, has written the definitive text on testing loudspeakers. Dr. D'Appolito brings his expertise to the subject and provides you with a hands-on discussion of testing drivers and systems. He brings you the theory and physics behind loudspeaker testing in this volume.
Paperback
Code No. 1580
£24.95 + £2.50 P&P (UK)

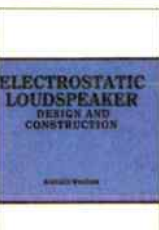

Electrostatic Loudspeaker Design and Construction
by Ronald Wagner
Step by step guide to the design and construction of a full range electrostatic loudspeaker, including basic operating principles. Strongly recommended for those wanting to either build, repair and/or restore, or who are just interested in electrostatics.
243pp 7" x 9 5/8" Paperback
Code No. 1080
£16.95 + £3.25 P&P (UK)



The Loudspeaker Design Cookbook, 6th edition (new) - by Vance Dickason
This best seller offers up-to-date design information for the home constructor. It uses modern Thiele-Small theory and parameters.
288pp 8 1/2" x 11 1/2" Paperback
Code No. 1090
£29.50 + £4.00 P&P (UK)



Bullock On Boxes
by Robert M. Bullock III.
Using Thiele-Small parameters clearly, it offers lots of helpful tables and graphs to get to grips with the sizing of the box and port of a reflex loudspeaker.
72pp 8 1/2" x 11" Paperback
Code No. 1100
£12.95 + £2.00 P&P (UK)

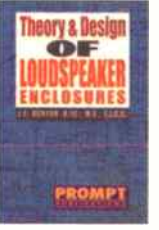

Theory and Design of Loudspeaker Enclosures
by J. E. Benson
Covers infinite baffle, reflex, passive radiator etc. in great detail with a highly mathematical approach, making it unsuitable for beginners but highly authoritative for experienced designers.
244pp 6" x 9" Paperback
Code: 1140
£23.95 + £2.50 P&P (UK)

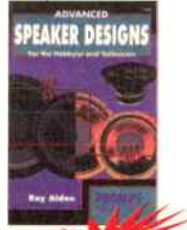

Advanced Speaker Designs
by Ray Alden
One for the mathematical minded with all the equations one would need for speaker design. Driver parameters are discussed. Sealed & Vented Enclosures have a chapter to themselves. Crossover design is covered as well as measuring speakers. At the rear there are seven projects that rely upon American sourced drivers (Radio Shack). The book offers concise technical explanations of how speakers work.
128 pp 230mm x 150mm Paperback
Code No. 1680
£14.99 + 2.00 P&P (UK)



Audio Amateur Loudspeaker Projects
A collection of the 25 best speaker articles published in the Audio Amateur throughout the 1970s, this popular book is proof that great designs are never out of date. This volume is a rich source of theory, practice and design.
135pp 8 1/2" x 11" Paperback
Code No. 1550
£16.95 + £2.50 P&P (UK)

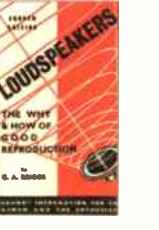

Loudspeakers: The Why and How of Good Reproduction
by G.A. Briggs
An easy to understand book on building loudspeakers, using empirical techniques that pre-date computer analysis. Strongly recommended for beginners.
88pp 5 1/2" x 8 1/2" Paperback
Code: 1070
£10.95 + £1.50 P&P (UK)



Horn Loudspeaker Design
by Mr. J. Dinsdale
A collection of papers by Mr J. Dinsdale, that discuss the design and theory of this wonderful breed of loudspeaker. The book contains detailed drawings of numerous designs, including some Lowther classics. Also, included with the book is a 3.5inch floppy disc with straight forward software to assist in the design process. A serious reference for those with an interest in horn speakers.
112pp paper back & 3.5 floppy disc
210mm x 300mm
Code: 1730
£29.50 + £2.50 P&P (UK)

ORDER FORM

Please send (Code No.) _____ (enter codes clearly)
Pay: World Audio Publishing Ltd. £ _____ or debit my Mastercard/Visa/Switch/Solo (Card No) _____
Expiry date: _____ (Switch/Solo only) Valid Date: _____ Issue No. _____ Name: _____ Signed: _____
Delivery Address: _____
Tel: (Day) _____ Please return to: W.A.P. Ltd. 12A Spring Gardens, Newport Pagnell, Milton Keynes, MK16
09E. ENGLAND TEL/FAX: 01908 218836 **ORDER ON LINE** Website: www.worldaudiodesign.co.uk E-Mail: nick@worldaudiodesign.co.uk
Please contact us for overseas P&P charges. Allow 28 days for delivery. All orders subject to availability. If further space is required please attach separate sheet.
 TICK BOX IF YOU HAVE ORDERED BEFORE

ORDER 4 BOOKS & OVER & PAY ONLY £7.00 P&P (UK ONLY)

HI-FI WORLD'S GREAT COMPETITION GIVEAWAY

WIN A UNISON RESEARCH S6 INTEGRATED VALVE AMPLIFIER WORTH £1,600 IN THIS MONTH'S SUPERB COMPETITION

Unison Research was founded in 1986 in Vicenza, northern Italy, and quickly grew to become one of the most respected valve amplifier manufacturers in the world. One of the first apostles of the Single-Ended school of tube amplifier design, in the days when the transistor reigned unchallenged, Unison has over the years produced some hugely successful valve amplifiers, (like the Simply Two of which 10,000 were made and sold during its 5 year production life!) and also some seriously esoteric equipment. Who can forget for example the awesome 845 Absolute or the fabulous Dream, products of pure audiophile fantasy to set the mind a-boggling? Unison Research has always striven to combine the old-fashioned values of craftsmanship with the most up to date in electronics and every model in the range is a reflection of the character of its perfectionist designer, Prof. Giovanni Sacchetti. For example the transformers are made in-house, the wood parts are handmade and hand lacquered, electronic components and tubes are individually selected, and the fit and finish of Unison Research products is regarded as a benchmark in the industry.

The current range consists of both the 'classic' models using single-ended pure class-A circuit topology, like the S6 recently given a glowing 4-globe review by David Price in this very magazine and a new range of amps and preamps using mixed tube and solid-state topology with some very advanced features. A CD-player will also be added to the Unison Research range soon.

Unison Research is distributed in the UK by the specialist Italian hi-fi importer, UKD. The company was founded in 1979 in Rome by Nick Green, who incidentally shares the same surname as the Italian composer Verdi (green being verdi in Italian!) It was originally formed to distribute

British hi-fi equipment into the Italian market. According to the man himself, Nick used to visit his customers wearing only a Union Jack, bowler hat and rolled-up broly. This technique was so successful that the company grew during the 1980s to become one of the most successful and respected quality-audio distributors operating in Italy. But in order to satisfy the ever increasing demands by Italian audiophiles for style and quality (no ugly black boxes please!) UKD diversified into manufacturing by founding Opera Loudspeakers, which since 1989 has grown to become one of Italy's best known brands of quality audio. Opera has in fact just completed an impressive expansion programme by moving into a purpose-built 2200 sq. metre factory near Venice. UKD is today a fully fledged Anglo-Italian operation, with the British base established in January 1993 to distribute the finest quality Italian audio equipment here in the UK. As well as Opera and Unison Research, UKD also distributes top names like Audio Analogue, GRAAF, Diapason, Pathos Acoustics, BCD Engineering and Monrio. And also some non-Italian brands: Final Electrostatics and KE-Power equipment from Holland, and Triangle from France. Nick Green no longer wears a bowler hat and broly, he has

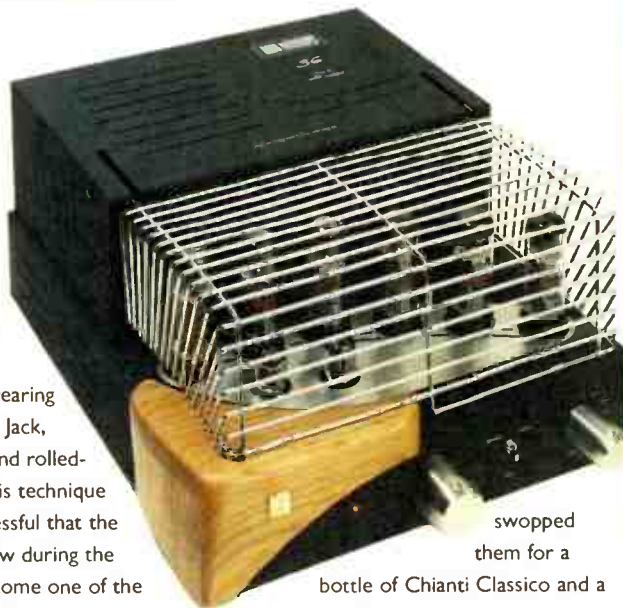

swopped them for a bottle of Chianti Classico and a wedge of Parmesan cheese.

To get your hands on this fabulous prize, simply answer the questions below on a postcard and send it to the address below by July 31st. The first correct answer picked out of our hat will be the lucky winner and have a glowing valve amp to keep them warm during the long winter months! ■ ▲

Hi-Fi & Computer Audio World Competition rules and conditions of entry

1. Only one entry per house hold.
2. Multiple entries will be automatically disqualified.
3. Purchase of the magazine is not a pre-condition of entry.
4. No correspondence will be entered into.
5. The Editor's decision is final.
6. No employees of Audio Publishing Limited, or of any companies associated with the production or distribution of the prizes may enter.

Competition Questions

[1] In which Italian city are Unison Research based?

- [a] Venice
- [b] Bologna
- [c] Rome
- [d] Vicenza

[2] In which year was Unison research founded?

- [a] 1996
- [b] 1986
- [c] 1956
- [d] 1886

[3] Who is the "perfectionist designer" of Unison Research products?

- [a] Prof. Giovanni Sacchetti
- [b] Prof. Gianfranco Zola
- [c] Prof. Luciano Pavarotti
- [d] The Mad Professor

[4] In Italian, Nick Green of UKD shares the same surname as which famous Italian composer?

- [a] Puccini
- [b] Berio
- [c] Verdi
- [d] Mantovani

Please send all entries to:

August Competition
Hi-Fi World
Freepost LON3478
LONDON
NW6 6YR

CONGRATULATIONS!

to the 10 winners of our June competition. Well done!!!

Jan Danhof, The Netherlands. - Phil Gates, Sholing, Southampton. - P. Kyle, Barrow-in-Furness. - Mrs. S. Palmer, Basildon. - Richard Hare, Bradford on Avon. - Michael Higgins, London SW11. Hassni Malik, Epsom Downs. - A. Hillard, Martlock, Somerset. - Lyn Casling. Nr. Pontypriidd. - D. Brook, Hebdon Bridge, West Yorkshire. Each winner will receive a pair of Wharfedale Diamond 8.1 'speakers.

should be an SACD supporter, or perhaps a DVD addict. The promise of better sound quality should appeal to me, of all people. My whole life, you might think, revolves around the pursuit of greater enjoyment of music through better sound quality.

Well, yes – but there are limits. I also live in the real world and have real world concerns and interests like so many others. You know, simple things like not having to climb over the rear channel loudspeakers to get to the settee, not having wires slung up over the door like an extension of the national grid, and having space in the lounge to lounge, rather than having my head stuck in a woofer and my toes in a reflex port.

DVD-A and SACD may promise better sound quality, but at what cost? They're big ticket items in every sense of the word and I think the consumer electronics industry is losing touch with reality here. They see DVD-A and SACD essentially as surround-sound systems, rather than a hi-tech successor to CD. The expectation is that people around the world will progressively abandon traditional two channel audio in favour of five-channel, comprising two rear speakers, two fronts, a centre speaker for speech and a subwoofer for realistic explosions. Were this to happen the CE business would be in for a bonanza. They'd be selling six loudspeakers instead of two, so sales would triple.

Surround-sound amplifiers are humungous devices with six channels of amplification, mains transformers stout enough to act as mooring posts for the QE2, and so many inputs and outputs their role is beyond normal comprehension. I've ferreted around with this sort of kit, perusing acres of arcane instructions about Dolby surround-decoding, dts, pseudo-surround sound and heaven knows what else. Then you have to balance the channels, which brings you to the sudden realisation that all this clobber in the lounge, all this technology and expense serves just one person properly, the person in the hot seat. For everyone else it is out of balance.

Then it gets worse. Instruments start coming at you from behind, the sides and heaven knows where else.

Where to place instruments and how to construct a sound stage, or even what form it should take, has always been a big problem for surround sound. I know better than most because I actively participated in all this nonsense back in the late seventies when we were offered surround-sound in the form of SQ, QS and CD-4. I still have the LPs of whale sounds and choo-choos in my racks and the CD-4 decoder in the loft.



We can expect the music business to crank up disc prices unmercifully.

Been there, done that – and won't be going back.

For a short time back then there was an intelligent debate about how to encode a sound field, which led to the Calrec ambisonic sound field mic. This device brought home to me the theoretical problems of trying to construct a three-dimensional sound field where everything was in its proper position. If you don't do this, or simply cannot, then you end up with aural anarchy, instruments and sounds flying from anywhere and everywhere, which I know from experience is a bizarre listening experience.

The difficulties faced in recording and mixing for surround-sound are all but insurmountable. An orchestra requires distant mics and fill-in mics. Their outputs should be integrated so that the instruments take up their usual established positions in front of a listener – but this is stereo. The temptation is to put instruments all around, to take advantage of the technology, producing an unrealistic listening experience that I find unsettling.

Rock bands should be easier you might think, but not necessarily so. There's often no natural acoustic, just a little studio reverb that will be captured by the vocal mics alone. The question is: how do you mix this? As a frontal image, which

can just as easily be provided by stereo, or as instruments all-round to highlight the abilities of surround-sound. The temptation is to go for the latter.

Even if you like guitars and violins coming from behind is it really worth all the expense and intrusion of a surround-sound system to set up such an illusion? I think not. After the novelty wears off the experience wears thin. As part of a home cinema system perhaps, but surround-sound has little to offer music-only reproduction.

DVD-A and SACD will also give us better sound quality - more open, airy and smoother too. But the differences won't be dramatic and may often be quite small, depending upon the quality of the recording. Trouble is, whilst sound quality differences won't, to most people be great, the price difference will be. We can expect the music business to crank up disc prices unmercifully. I'd guess SACDs and DVD-As will be priced at £20-£25 apiece. I'll think twice before paying this for a disc and, quite frankly, most people have higher priorities in their daily budget. Like a comfortable settee they can get to. ●



Noel Keywood



A selection of our ever changing offers for sale
(all fully guaranteed)

Equivalent Sale
New Price Price

A selection of our ever changing offers for sale
(all fully guaranteed)

Equivalent Sale
New Price Price

AMPLIFIERS	
Art Audio Quint-tet Valve Power-Amp. (2 x 15 Watts Triode / 2 x 25 Watts Ultra-Linear) (Variable Negative Feedback) MINT / Boxed / Manuals	2137.00
Linn Majik-1 Remote Int. / M.M. Phono-Stage MINT / As New / Manual	800.00
Michell Argo Pre-Amp./Power-Supply (Panasonic Pot Upgrade) MINT	800.00
John Shearman Phase Two Int. (2 x 50 Watts) MINT / Boxed / Manual	690.00
Exposure XX Int. VGC / Boxed	700.00
Alchemist Kraken Anniversary / Phono-Stage / P.S.U. MINT	650.00
Arcam Alpha 8 Int. Mint / As New / Boxed/7 Manual	380.00
Rotel RB-981 (2 x 120 Watts Power-Amp.) GC	450.00
Rotel RB-991 THX (Balanced-In) (2 x 200 Watts Power-Amp.) MINT	700.00
Moth Series 30 Active Pre. / Power-Amp. (2 x 30 Watts) MINT / Boxed (Black Ash Version) (Reduced)	600.00
Meridian 605 Mono-Block (2 x 150 Watts) MINT/As New/Boxed/Manuals	2000.00
Meridian 101B(M.M. Boards)(Black) MINT (Rare Black Version) N / A	
Marantz PM-66 Kl Signature (Remote Int.) MINT / Boxed Etc:	400.00
Marantz PM-6010 Remote Int. MINT / As New / Boxed Etc:	230.00
Quad 34 Pre. (Grey / Late Version) MINT / As New / Boxed Etc:	414.00
Quad 606 L Power-Amp. (2 x 120 Watts) MINT / As New / Boxed Etc:	718.00
Musical Fidelity A-1001 Remote Int. (2 x 200 Watts Class A) (See "STAR PRODUCT") VGC	2500.00
Musical Fidelity "The PreAmp" (Balanced-Out Etc.) MINT / Manual	280.00
Denon PMA-500V Int. (2 x 80 Watts / M.M. / M.C. Phono-Stage) VGC / Manual	400.00
NAD 3020i (2 x 25 Watts Int. / Phono-Stage) MINT / Boxed	180.00
Mission Cyrus One (Original) VGC	N/A
Mission Cyrus One (Original) Fair Condition	N/A
Pioneer A-30L X Int. MINT / As New (Reduced)	230.00
Cambridge Audio A-1 Int. 2 x 30 Watts VGC	95.00
Cambridge Audio A-1 Int. 2 x 30 Watts (Another One) VGC	95.00
(Buy Them Both And Bi-Amp. For £100.00)	

VINYL	
Heybrook TT-2 / Rega RB-250 / Goldring 1006 M.M. Cartridge (Oak) VGC / Box / Manuals	700.00
Linn Axis / Akito MINT / Boxed / Manuals	700.00
Dunlop Systemdek II XE / Alphason Xenon / Grado Prestige Black VGC	600.00
Garrard 401 (Motor-Unit) VGC	N/A
ADC I600 Direct-Drive / Ortofon VMS-20E Cartridge VGC	300.00
E.A.R. 834P M.M. Valve Phono-Stage MINT / Boxed	79.95
Monacor SPR (M.M. Phono-Stage) NEW / Excellent Value	380.00
Bruce Springsteen 5-Album Vinyl Boxed-Set (Digitally Remastered / Booklet) MINT / Unplayed	29.95
N/A	25.00

Lots of Vinyl in Stock and always WANTED.
Record-Cleaning Service Available. Your Records Cleaned to Perfection on Moth Machine For £1.00 Each Including New Inner-Sleeve. (Maximum 10 at a time please)
Turntables / Tonearms / Cartridges (M.M. / M.C.) "Urgently" Required. Also any "interesting" Vinyl Accessories. Clamps, Protractors, Stylus Scales, Cleaning Devices etc:

PRODUCT OF THE MONTH
Musical Fidelity A-1001. 2 x 200 Watts 8 Ohms / 2 x 400 Watts 4 Ohms Class A Integrated Amplifier with Remote Control. In VGC Condition With Manuals.
Last Retail Price £2500.00 - affordable-audio price £1295.00

LOUDSPEAKERS	
Rega EL 8 Floorstanders VGC	300.00
Meridian M-200 Active (Black Ash) (Complete With Pirate Heavy Stands / Cones) MINT	N/A
B&W CD-7 (Cherry) MINT	495.00
Chario Syntar 100 / Stands MINT / Boxed	1000.00
B&W DM-603 Floorstanders VGC / Manuals	579.95
Spendor BC-1 BBC Monitors G/C / Original Trolley Stands N / A	500.00
Rel Q-100E 100 Watts Active-Sub. MINT / Manuals	550.00
Kef Q-55 Floorstanders MINT / Boxed	169.95
Audiovector Model 5 (92 dB / 200 Watts / Tri-Wire) (Piano-Black) VGC / Boxed	500.00
Arcadyis ASC Stand-Mount MINT	2500.00
Castle Chester 1/4-Wave Horns (Light Oak) MINT	400.00
TDL RTL-1 Mini-Monitors (Rosewood) VGC	700.00
Tannoy M-2 Mercury VGC	140.00
Royd Minstral / Bases (Rosewood) MINT	300.00
Acoustic Solutions Image One Floorstanders (Rosewood) VGC	129.95
Cannon S-25 Satellites MINT	259.00
Linn Tukan (Bi-Wirable) (Black) MINT / Boxed / Manuals	150.00
Linn Keilidh / Ku-Stones (Latest Spec.) (Black) MINT / Boxed	550.00
Mission 780 Minis (Bi-Wire) Cabinet Marks	269.95
Heybrook Heylios (Rosewood) MINT / Boxed / Manuals	800.00
Acoustic Research 208V Minis MINT / Boxed	270.00
Lots of Loudspeaker Cables in Stock, both New & Used.	149.95
	69.95

TUNERS	
Cyrus FM-7 FM. Tuner Mint / As New / Boxed Etc:	400.00
Sony ST-SA3ES RDS FM. Tuner MINT / As New / Boxed Etc:	250.00
Sugden DT-48 FM (Digital Display / Pre-Sets) Fair Condition	N/A
Sugden R-21 FM VGC(Cash Sale)	N/A
A&R T-21 FM Tuner VGC	N/A
Denon TU-1 RDS Tuner MINT	150.00
Rotel RT-820L 3-Band Tuner VGC	N/A
Pioneer F-504 Precision RDS MINT / As New / Boxed Etc:	300.00
Q.E.D. T-231 VGC	N/A

MISCELLANEOUS

Sony DVP-S725D Remote DVD Player (Region Two) MINT/Boxed / Manuals Etc:	500.00
Yamaha DVD-S700 Remote DVD Player (Region Two) MINT / Boxed / Manual	600.00
Pioneer DVD-525 Remote DVD-Player (Region Two) (DVD's In Stock And Always Wanted) MINT / Boxed / Manuals	350.00
Cambridge Audio V-500 Dolby-Digital Processor With Remote VGC	200.00
Jamo Center 100 Shielded Centre Speaker VGC	125.00
Jamo Omega One Surround L.S. MINT / Boxed Etc:	50.00
A.K.G. K-105 VHF Cordless Headphones MINT / As New / Boxed Etc:	60.00
Target VR-4 Gloss Silver Stand (Glass Shelves) NEW Slight Second	230.00
Target B-4 Gloss Silver Stand (Glass Shelves) NEW Slight Second	243.80
Target HS-60 Piano-Black Spiked L.S. Stands NEW	105.80
Target SP-60 Spiked Stands MINT	60.00
Target 24" Spiked Stands (Electric Orange) MINT	90.00
Stands For LS-35a, Kans or Pro-Ac Tablettes Etc. (Homemade) GC	N/A
Monacor SPS-35 Spike Kit (Gold or Anodised Black Finish) speaker Spikes (Per 4) NEW	9.95
Monacor SPS-45 Spike Kit (Small) Loudspeaker Spikes (Per 4)	NEW
Monacor SPS-65 Spike Kit (Large) Loudspeaker Spikes (Per 4)	NEW
Roni LSS 2 (2-Way Speaker Switch-Box)	NEW
Vivanco PHC (Optical to Co-Axial Converter) MINT / As New	30.00
Roni 4 m.m Banana Plugs (Gold Plated) (Screw-Type, No Soldering) Per 4	NEW
Roni Optical Linc Cables (C.D/Minidisc to D.A.C. Etc.)	NEW
Scart to Scart 21-Pin / Gold-Plated High-Grade Scart Cables Screened OFC / 1.5 Metres	NEW
LFD Tri-Link Incon (0.8M) MINT	150.00
Cable Talk Advanced 3 Incon (1.0M) (New / Just In)	NEW
Puresonic 7770A Incon (0.8M) MINT / Boxed	NEW
Puresonic 9010A Incon (1.0M) MINT / Boxed	80.00
XLO/VDC Digital Incon. 4 Metres / MINT / Boxed	70.00
Monacor 75 Ohm. Digital Incon. NEW	N/A
Nexera Gold 5-Pin DIN To 4 Phono NEW	N/A
Monacor SPS-20 Anodised Adjustable Polished Cone Equipment Supports NEW (Superb Spike System at a very good price)	Set of 4
(Black Anodised Or Gold Finish)	19.95
XLR Cannon Linc-Sockets (Gold-Plated) High-Grade XLR	NEW
discwasher CD Radial Cleaner VGC / Boxed	N/A
Parastatic Disc Preener VGC	N/A
Monacor Power Concept Incons (0.8M. / 1.5M / 5.0M) Excellent Value Interconnects	NEW
NEW Only 7.95 0.8M. 10.95 1.5M. or 13.95 5.0M. (Blue And Black)	
DNM Solid L.S. Cable (2 x 3.5 Metres Terminated)	MINT
affordable-audio Bi-Wire L.S. Cable (In Brown or White) NEW Only	3.50
79-Strand L.S. Cable (Black-Round-Section or White-Flat-Section) NEW Only	1.25
Monacor DC-100 Carbon-Fibre Brush (Essential)	NEW
Various Plugs (RCA / DIN / Cannon Etc) Various NEW / S/H P.O.A.	6.95

RECORDING EQUIPMENT	
Sony TC-KA6 ES (3-Head / Dolby S Etc.) MINT / As New / Boxed Etc:	600.00
Sony TC-K51 IS (3-Head / Dolby S Etc.) MINT	129.95
Pioneer PD-R04 CDR Recordable / Remote MINT / Boxed / Manuals	700.00
Denon DR-M34 HR (3-Head) (Hi-X-Pro / Variable Bias Etc.) VGC	300.00
Tascam 32-2B (Teac X-10) Reel to Reel (NAB / 1/2-Track / High-Speed) G/C	N/A
Nakamichi RX-202E (Auto-Reverse Mechanism Etc.) VGC	329.95
Nakamichi DR-3 (2-Heads / Vari. Bias Etc.) GC.	450.00
Aiwa ADF-800 3-Head / Vari-Bias Etc: VGC	300.00
Sharp MDMS-200 (Portable Mini-Disc Recorder / Headphones / Power Supply) MINT / Manuals	300.00

DIGITAL	
Micromega Solo P Remote (Top-Loader) MINT	1600.00
Naim CD-3 Remote MINT / Boxed / Manuals	950.00
Teac P-500 / D-500 (Transport & DAC) VGC	1200.00
Meridian 208 C.D. / Pre-Amp c/w 209 Remote Control Station MINT / Boxed / Manuals	1800.00
Quad 77 Carbon / Remote (Mains Version) MINT / As New / Boxed Etc:	900.00
Rotel RCC-955 (5-Disc Multi-Player / HDCD) MINT / Boxed	525.00
Rotel RDD-980 Transport (Optical / Co-Axial Inputs) VGC	219.95
Arcam Black-Box 5 D.A.C. VGC	400.00
Entech Number Cruncher 203.3 (20-Bit DAC) MINT / As New/Boxed/Manuals	400.00
Cambridge Dacmagic D.A.C. VGC	200.00
AMC CD-9 (Remote) MINT / Manuals / Digital Out	250.00
Pioneer PDR-04 Recordable / Remote MINT / Boxed / Manuals	700.00
Pioneer PD-S505 Precision MINT / Manuals	460.00
Technics SL-1000 Remote Etc: MINT / Boxed / Manuals	800.00
Sony X-222 ES (Optical-Out) VGC / No Remote	200.00
NAD Monitor 5000 (Digital Out) VGC	310.00

Hundreds Of Compact Discs In Stock And Always WANTED...
...(Complete Collections Purchased, JAZZ in particular

affordable-audio will happily "build" Systems for your individual requirements, and if you purchase three or more components, i.e. (C.D. Player, Amplifier, & Loudspeakers), we will give you a 15% Discount on the total price! Please enquire for further details.

PLEASE VISIT OUR WEB-SITE (UPDATED DAILY)
E-MAIL: Sales@affordable-audio.CO.UK
WWW.affordable-audio.CO.UK

***** GOOD HI-FI SEPARATES WANTED *****
Phone anytime with your wants, stock changing daily. All equipment is sold with warranties.
Don't forget we can offer mail order.
All major credit cards accepted.
We welcome part-exchange on any of the above.
Affordable Audio is always keen to buy, (or part-exchange) Good quality HI-FI separates in good condition, Especially top British manufacturers products!



We can also sell your equipment for you on a commission basis.
(Lowest rates/best return)
(Please phone Paul for details!)

For many years - up to the seventies in fact - it was taken as read that the goal of hi-fi was that it should show 'high fidelity' to the original recording (to wit, Quad's famous, "the closest approach to the original sound"). Presumably then, poor recordings - made on early microphones and mastered to shellac or steam-age tape recorders - should sound 'authentically bad'. Next came the revisionism of Linn and Naim, which argued that listening to music was not about accuracy or transparency - which were false gods anyway - but fun. To wit, the 'foot-tapping' factor has (arguably) informed the design of products of these two companies (and some others) for many years.

Peter Qvortrop's take on the subject - and I'm sure he'd make no special claim to have 'invented' it (even if he is one of its loudest proponents) is that hi-fi is about 'capturing the magic' of the original recording. Rather than describing it in all its (sometimes unlovely) glory, or investing it with a feel that it (possibly) didn't originally have, this third way focuses on communicating music's 'certain something' (these are my words).

To pad out this idea it's interesting to glance back to the works of two twentieth century philosophers interested in what made art (music, poetry, literature, film, painting etc.) special. Walter Benjamin, in *The Work of Art in the Age of Mechanical Reproduction*, talked about art's 'aura'; its capacity to communicate directly (emotionally and intellectually) with the listener. To my mind at least, this is what PQ is alluding to.

Several decades later, Marshall McLuhan spoke about "the electronic age" as being the ultimate "age of mankind" where media - such as TV and audio (and, by implication, hi-fi) become the "most spectacular" extension of our human central nervous system. He sees television as a 'cool' medium, thanks to the inadequately small amount of information it carries (thanks to a small screen and poor sound). Audio (and print and film) are by contrast 'hot'

media because of their ability to feed very focused, high definition 'data' directly into listeners and viewers.

Being a keen student of hi-fi, meeting Audio Note's Peter Qvortrop was a memorable experience. To be sure, audio has some 'characters' and this guy is surely one of them. On a personal level, he exudes self-belief - and the willingness to share it with others. He's outspoken, sometimes brash, but never short of incisive - and often cutting - comments on the nature of hi-fi, the industry, and its key players.

”

Being a keen student of hi-fi, meeting Audio Note's Peter Qvortrop was a memorable experience.

Just in case you hadn't noticed, this guy is passionate about music. This might be stating the bleedin' obvious, but you'd be surprised by how many people in the industry are preoccupied by either abstract theoretical matters of hi-fi design, or the logistics of selling it for profit.

To meet someone with such a forensic and encyclopaedic knowledge of the art that necessitates hi-fi is hardly a regular occurrence. His gob-smacking collection of rare and historically significant recordings only serves to underline this passion.

Peter told me, "I want people to experience what I experience when I listen to great music well performed," and added, "even if it is a bad recording". This is a compelling caveat, because what many audiophiles fear most - and indeed often avoid - is a poorly recorded, mastered and/or pressed 'software' that fails to flatter their prized hi-fis.

When I met him at his home in Hove, PQ most certainly did not have a stack of pristine audiophile discs at the ready. Rather, we dipped in and out of a host of LPs, some of which (thanks to their antiquity) were tragically badly recorded. What impressed me was the 'hear through' nature of the sound. Rather than

drawing attention to itself as 'dynamic', 'rhythmic', 'transparent', 'open' or 'uncoloured', the system simply let the music's flavour flood out. It was a mightily expensive bit of kit but didn't sound like one - instead it didn't really sound like anything at all.

Peter said that he listens to a lot of historical piano recordings which are, "pretty terrible from a recording point of view". Hi-fi to him is about, "the fact that we can listen to people that have long since passed away, but left their performances and art for us to cherish as long as the media we use to store their art does not destroy their greatness". This is an interesting departure for hi-fi thinking, and something of a philosophical third way.

I really think there's something in this. Hi-fi should be about tapping into the emotion inside every worthy piece of music, about getting inside the senses of the performer(s). This is something that can't be described by empirical measurements (although they can be a useful clue to its absence), only done by listening. Because 'two channel' hi-fi lacks the distractions of video and surround sound mixing, if done properly it can be a truly transfixing medium. As someone once said so concisely, "sound affects". ●



David Price

Classic Cuts

In the first of a new series of personal record-reflections, audio PR guru and music aficionado Andy Giles tells how he discovered the Miles Davis classic 'Kind of Blue'.

In 1960, when I was an 18-year-old first-year student, my politics tutor tried to seduce me after getting me drunk on cider in the Feathers at Ludlow. It was a forlorn task on his part. He had lured me back to his flat - a classic 60s affair of a home - replete with tacky icons of that new age, including a carry-out type orange-mock leather clad record player, nestling next to which was an LP with a sombre cover, showing a black man blowing a trumpet.

I became aware of an approach in my direction. To distract my hapless predator (who was now becoming uncomfortably aware that all my gushing talk of having a girlfriend was no hoax) I grabbed the album cover, ripped the record from its sleeve and gingerly placed it on to the turntable platter. I raised the arm and set the thing in motion. The usual crackle and warm sound of the stylus entering the groove followed - and then the music. It was Miles Davis's 'Kind of Blue' and I was utterly overwhelmed by it. And the seduction attempt was over.

The next day I took the train to Birmingham and, having borrowed the required fifteen bob (75p), bought the album and played nothing else for weeks. I still have the original copy, now with the seam completely split (you always got that with vinyl LPs due to pushing the record back in its sleeve too firmly when pissed) and covered with scorch marks from many a rested joint. It stands supreme in my collection as a genuine example of a record that changed my musical direction. Its effect on me - and seemingly countless others - was simply profound.

It is that opening track, 'So What' that gets to you. Notice the lack of a question mark. It's a statement made by the instruments. It hits the spot and sets the trend for the rest of the album - sheer cool. The liner notes (by Bill Evans, classics in their own

right) tell you that 'So What' "is a simple figure based on 16 measures of one scale, 8 of another and 8 more of the first, following a piano and bass introduction in free rhythmic style." Well, erm, bless you, Bill, but that hardly sounds "simple" to me. But, of course, he's right. It is sublime simplicity that carries this track - and the subsequent four, 'Freddie Freeloader', 'Blue in Green', 'All Blues' and 'Flamenco Sketches' - into musical nirvana.

To analyse this album in a musically scientific manner is to bestow little justice upon it. It's only music, for God's sake! Jazz confounds many people, who claim they just "can't get into it". To make matters worse, hard-core jazz fans refuse to admit entrance to their club with any alacrity. They snub innocent attempts by music lovers to enjoy jazz by putting as many obstacles in place as possible - and by making the whole format inaccessible, complicated and downright cliquish.

'Kind of Blue', for me at least, changed a lot of that and, I feel, to the annoyance of the elitist duffle-coat jazz fan of the late nineteen-fifties, brought jazz into the public domain to be enjoyed by all. It is certainly the one jazz album which seems to have made its way into everyone's collection. Boasting a line up which included John Coltrane, "Cannonball" Adderley, Bill Evans, Wynton Kelly, Paul Chambers and Jimmy Cobb, it appears, now, that it could hardly fail. But, back in 1959, when released, none of these great performers was internationally acclaimed by anyone other than those within the jazz cognoscenti. What placed it where it has become is its total commitment to both its art and its artistic values. Steadfastly refusing to reject their roots, nor compromising origin for popularity, the performers went into the studio to create a joyful message

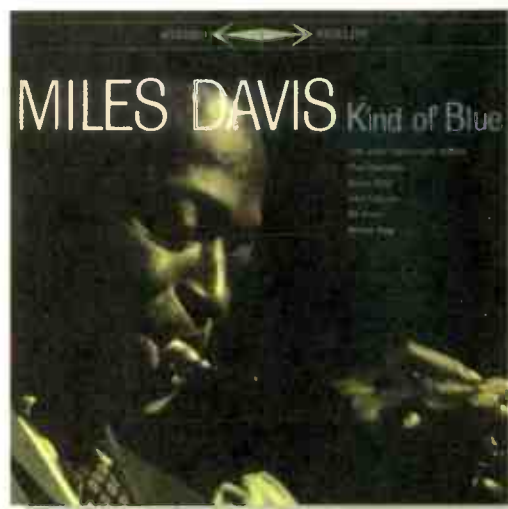

which lends funk to inner repose. Each track is beautifully crafted and is chronologically positioned in the grooves of the album to give the listener an outstanding short but complete exercise in how jazz should be relayed to Everyman.

Jazz purists still tell me that I should listen to this by Miles Davis or that by John Coltrane. Well, I have. All fine and dandy, but I come back to 'Kind of Blue' because of its immense and all embracing appeal. Don't misunderstand my point. I don't want to downgrade this album as an attempt to popularise jazz as an art form. That was never its intention. 'Kind of Blue' just gets on and does what it does naturally, without aim or ambition.

I'm desperately trying not to employ too many clichés in this piece. But I fail here, so forgive me, when I say that 'Kind of Blue' is a seminal album. Not just for Miles Davis or John Coltrane but also for jazz - no, I go further, for music. It's a stunning record to this day and I play it (now on CD, my precious original 1960 vinyl album is completely unplayable) with regularity. It never fails me. Just think. Had I been gay, I might never have heard it. ■ ▲

*** A Special Millennium Edition CD of 'Kind of Blue' is available from Sony on its Columbia label: MILLEN101 4952242000.**

Great design is great design forever". So goes the headline for a certain car advertisement.

The feature for the advert is not actually a car, but a Dualit toaster circa 1946. Needless to say, the toaster looks exactly the same today as it did back then. Of course it's not just toasters that have become lasting design icons. Thousands of man made creations from the Bic pen to Durham cathedral can claim a similar aesthetic and functional endurance. Within the microcosm we call hi-fi there are many such examples too, which broadly fall into two categories: design classics that have long since ended their production life but are still sought after, and those that received critical acclaim at their launch and are still being produced today.

As with any good design the aesthetics are far from being the 'be all and end all' of the matter.

Functionality, or more to the point with hi-fi, sound quality, is what really matters. If it looks good too, then that's simply an added bonus. The term 'hi-fi classics' could be made for the now sadly defunct Leak Troughline tuners, Garrard 301/401 turntables, Marantz ST-8 and Quad's 22/II and ESL57 amp and electrostatic 'speaker combo. Deceased they may be yet, like others, they are presently enjoying serious revival within a second-hand market that has seen prices rising sharply over the past year or so.

With the best vintage and classic hi-fi now becoming so coveted it's hardly surprising to find both Quad and Marantz keen to recapture the iconic status of previous works. One only needs to see Quad's latest QC II-Forty valve pre and power amps and their electrostatic ESL-988 and 989 loudspeakers to see more than a nod of acknowledgement to past glories.

The new ESLs still use a high voltage electrostatic system to create the near seamless balance that past Quads have always boasted. Visually they still possess all the subtlety of a barn door too!

Likewise, the new Quad amps have all the visual cues from before, with just

a slight tweak in the colour.

Interestingly, although they may look much like the old 22/II, there's barely any resemblance in the exact technical spec. No doubt marketers will begin talking of company design signatures, and visual cues that insight brand awareness! Whatever next? How about a range of Sony products with garish, colourful legends and Corbusieresque brutal styling to evoke the golden age of the companies first CD players!

I digress. Like the Dualit, a few hi-fi icons have remained in production to this day. stalwarts that have been in



With the best vintage and classic hi-fi now becoming so coveted

it's hardly surprising to find both Quad and Marantz keen to recapture the iconic status of previous works.

production for at least fifteen years are few and far between. Yet, to this day few could argue with the innate design integrity of the Dual CS-505, Michell Gyrodec, Rega Planar 3, Linn LP 12, Technics SL1200 turntables, SME Series V tonearm or Acoustic Energy AE1 loudspeakers. No doubt I've left a few other heroes out, yet the above represent exactly what was needed in their particular class at a particular time. Qualities that are just as relevant today. Note that there are no digital products here, perhaps indicating the technology is still within formative years!

Of course, few products of functional use stay exactly the same with the passing of time. No doubt the most recognisable toaster of all time has faced a whole host of electrical changes to keep pace with legislation. Likewise Durham cathedral no doubt is equipped with electrical light and power these days, whilst even the Bic has a hole in the top to prevent choking for when pen top chewing becomes a little too aggressive! Even these modern classics have had the odd tweak or two along the years. In SME's case, it has to be said, remarkably little has happened, yet then again it is the

baby of this sextet. If one was to look at their other classic, the 309, it's had rather more development over the years; years it has to be said that number rather a lot!

The Linn LP12, on the other hand, is the hi-fi equivalent of Lincoln's axe - the one that over time has had three new handles and four heads! Likewise, I'd struggle to identify an area of the Linn that hasn't been tweaked. The plinth, platter, power supply, suspension and even lid have all been upgraded over the years. Yet it is still recognisably a Linn LP12, both visually and sonically. It says much for the evolutionary approach that, in most unbiased eyes, the deck still outperforms the company's far more expensive CD12 CD player.

With technology changing at such a pace it's difficult to say whether these icons will still be available in another fifteen years. Given that CD was supposed to be the death of vinyl fifteen years ago, and the transistor the death of the valve fifteen years before that - and neither have died - I suspect not. There will always be a demand for the highest quality music reproduction just as there is for decent toast (as both a Quad and Dualit user I couldn't agree more - ed.)! ●



Dominic Todd

A kick up the Eighties

David Price looks at one of that decade's punchiest integrated amplifiers, the Inca Tech Claymore.

▶ **O**h the eighties - remember them well! The Cold War, Maggie Thatcher, Golf GTIs, red braces, the 'tell Sid' campaign. In hi-fi they were turbulent times too. The record companies launched CD

gold lettering ("nice"), and this is no exception.

Round the back you get RCA sockets for phono, CD, Aux and Tape sources - paltry by today's standards but to see a CD input on 1985 amps

and big-hearted sound with real skin-of-the-teeth transient ability, it actually sounds remarkably modern and can comfortably see off many of today's sub £1,000 integrations. Along with power aplenty, the Claymore can

go loud (and quiet) very quickly, making it great at conveying rhythms. You can use it with truly transparent loudspeakers without having to reach for the Paracetamol. It's a remarkably refined and modern sounding design, but it still does the business in terms of musicality and dynamics. And the icing on the cake



with a 'scorched earth' marketing strategy. Valves were about as fashionable as beige Morris Minors, and the only kind of speaker to have needed half a kilowatt of power to raise a squeak.

Stimulated by the success of Naim's Nait it was also a time for British muscle amps. The NAIT's nemesis came from Essex's Canvey Island, in the unlovely shape of Inca Tech's Claymore. From a little known company, this £345 amp relied entirely on its superb sonics to gain a foothold in the fast-growing 'super integrated' market.

By 2001 standards, fit and finish are poor. The chassis and casing are roughly pressed aluminium with a crackle black finish (what else!) on the top and front panel. Two large black knobs take care of volume and input selection, while a couple of rough feeling push buttons offer tape monitoring and mute functions (pure luxury!). A clunky front panel on-off switch and headphone complete the package. Just as blue LEDs are currently de rigeur, in the eighties every black box had to sport tasteful

was a revelation. In classic cottage industry fashion, many Claymores came with an empty headphone socket blank on the back panel, covered with nothing more than a piece of Sellotape! Best of all though was the amplifier's underside, which sported both an MM-MC phono gain selector and a vestigial balance control pot (thankfully devoid of a knob). Mad.

If all this is 'nightmare on amplifier street', then the inside provides welcome relief. The Claymore wins back cool points with a high quality ALPS volume pot, beefy ELNA power supply smoothing capacitors and a muscular toroidal transformer. Circuit layout is clean and relatively simple. You can tell a lot of effort has gone into this aspect of the Claymore's design. Particularly impressive are the super-chunky wires running from the output transistors to the rear panel loudspeaker terminals.

Plug it in and you get almost all the Naim NAIT's grip and speed with stacks more grunt and finesse. Blending a genuinely sweet, smooth



is its truly superb phono stage that works with both moving magnets and moving coils.

The good news is that you can pick Claymores up second-hand for anything from £75 to £125, making them far better value than any other 'super integrated'. Later on in life, the finish got a bit better and Inca Tech even did a gold plated version. If sound per pound is utmost, there are few classic amplifiers that can touch it. ■▲

computer

audio world

advertising@computeraudio.co.uk

editorial@computeraudio.co.uk

newsletter@computeraudio.co.uk

www.computeraudio.co.uk

contents

HanGo Personal Jukebox PJB-100 78-79

Here's a detailed look at one of the most interesting computer audio products around right now, Hango's 'personal jukebox'.

Iomega HipZip 80

An MP3 portable with a twist - instead of flash memory, this one uses Iomega's Click! discs.

LaCie CD-RW 81

A furiously fast silver disc burner using the trendy FireWire connection system

Sony Digital Relay 82

Trust Sony to do a combined CD Discman and portable CD writer!

In-Ear Headphones roundup 83

David Price tries out a host of possible upgrades.

Part II of Build Your Own Audio server will be published next month

STEREO SONICS

Here's an interesting development - the first ever digital music portable preloaded with an album and finished in the band's own logo! Rio, manufacturer of the first MP3 portable, has broken the mould again in a joint venture with Welsh indie-rockers Stereophonics to offer the band's new album, 'Just Enough Education to Perform' on a limited edition Rio 600, complete with custom faceplate and exclusive bonus track 'Maritime Bellview in Kiel'. The package also includes the original, 'hard copy' of the CD, and the compressed format is Microsoft's latest Windows Media 8.0. Stereophonics lead singer Kelly Jones said, "Digital music is the future and it's great to be involved with a company that's helping to change the industry. Digital audio players are one of the hottest devices around and this package helps us to bring our music to fans and new listeners in an exciting way." [Click on www.stereophonics.com](http://www.stereophonics.com)



PHONEY WAR

'Digital music' is marching ever forward onto a host of new devices, as the launch of a new mobile phone accessory, the Nokia Music Player HDR-1, proves. Users can listen to FM stereo radio and downloadable music files, as well as use it as a handsfree kit for their phone. You can download AAC and MP3 music files via the Nokia Audio Manager PC software, and play up to 1 hour of music on the integral 32MB memory card. As it requires only one AAA battery, it can also be used as a stand-alone device too. The player supports AAC (Advanced Audio Coding), secured with InterTrust digital rights management technology, and MP3. It works with Nokia 3310, 3330, 8210 and 8850 phones and will be available during the third quarter of 2001 - click on www.nokia.com for more details. Sony also has a new mobile phone, the CMD-MZ5 with a built in digital audio player using its proprietary ATRAC3 format. Watch this space for more!

HIDING IN THE LIGHT

Being the size and weight of a matchbox, Hyper Hyde is arguably the world's smallest MP3 portable. Although this dinky device is more diminutive than even Sony's latest digital music portable, it sacrifices nothing in features. A single 32MB MultiMedia Card is supplied but you can easily buy another to double its playing time to two hours, and there's even a handy voice recorder too. Downsides include its old-fashioned parallel port PC connection system, baffling Japanese software and the fact that it's so darned easy to lose.

[Click on www.hyperhid.com](http://www.hyperhid.com)

SATELLITES OF LOVE

KEF says its new α199 HTS2001 multimedia speaker system is, "a genuine marriage of absolute high fidelity and stunning appearance". They're certainly beautifully built, with cast aluminium enclosures and a new 100mm KEF Uni-Q, driver featuring new 'alu-skin' aluminium faced polypropylene cones and a die-cast chassis. They have a 70W rated power handling and are magnetically shielded for near VDU use. Partnered with the matching PSW 2000 Sub-Woofer, they make up the three-piece KMS 2002 hi-fi system (α499) and the six-piece surround sound KHT 2005 home-cinema system (α799). Watch out for a review soon. [Click on www.kef.com](http://www.kef.com) for more details.

DIGITAL MUSIC DEVELOPS

The story so far: Vivendi Universal has just acquired the famous MP3.com music portal for \$372 million. Home to labels including Interscope, MCA, Mercury, A&M, Motown, Island, and Def Jam, ironically it's the only major not to have settled in court with the famous online music site. This development follows news of Bertelsmann buying Napster, AOL Time Warner acquiring RealNetworks, and Bertelsmann and EMI Group launching MusicNet. In another important move, Vivendi Universal, Sony and Yahoo are launching Duet. The new company is based in San Francisco, with a plan to eventually license 50 percent of the world's music, offering both subscription and pay-per-listen services. Compared to even a few years ago, the world's music industry is 'another country'. The formerly web-shy majors have swiftly co-opted online music as a key distribution strategy, effectively taking control of what had been a true populist alternative distributing a vast amount of non-mainstream music.

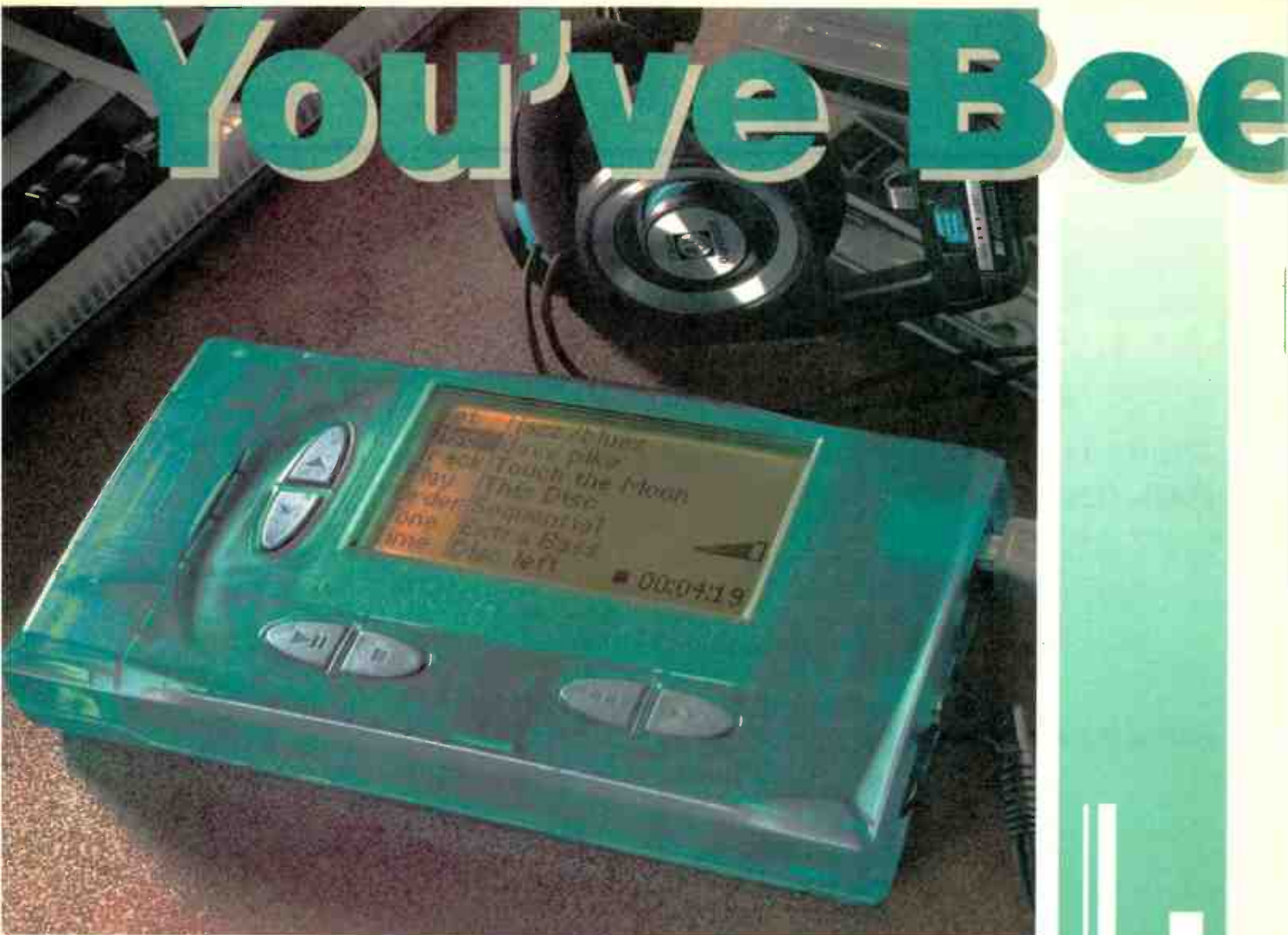

David Price reviews a sparkling product from a hitherto unknown Korean company, the HanGo Personal Jukebox PJB-100.

No, I hadn't heard of HanGo Electronics either, but judging by this little slice of high technology, the Korean company isn't completely new to the MP3 game. Its new PJ Box is essentially a hard disk-based MP3 music centre, originally designed and developed by Compaq's Corporate Research Laboratories. The idea of it is that you rip all your MP3s to it rather than storing them on your computer's invariably overcrowded hard drive.

There's a choice of three different models, from the basic 6GB PJB-100 without backlight at £389, the backlit version at £429 and the 20GB backlit version at £529. The latter is by far the most capacious 'MP3 jukebox' around - remember that the Creative Labs' DAP Jukebox has less than one third its storage capacity. The result is that you can store up to 5000 CD

tracks, or the equivalent of 320 hours playing time!

If this doesn't impress, one look at the size of thing will put it all in perspective. Essentially it carries a room full of CDs in something the size of a late-nineties mobile phone. To me at least, this is staggering but I'm sure in a couple of years' time it will seem as cumbersome as a common or garden house brick! In any case, measuring 150x 80x 260mm and weighing just 280g it's lighter and considerably less bulky than Creative's DAP Jukebox. In the year since the latter's arrival, things have obviously moved on apace.

Its styling could have come straight out of the late eighties. In a way it reminds me of Sony's Walkman Professional. This means clean angular lines, a sparse, no-nonsense control set consisting of six top-mounted

buttons and lots of satin black plastic (although translucent blue and titanium and also available).

There's a large (70x40mm) seven line alphanumeric display (backlit or not depending on whether you're prepared to pay). It shows 'Set', 'Disc', 'Track', 'Play', 'Order', 'Tone' and 'Time'. The idea is that when you rip your MP3s from your PC's CD-ROM drive to the HanGo, you specify a 'Set' which is rather like the title of a section of your music collection. Within this, you file the 'Disc' (the name of the CD itself), the 'Track' (song), 'Play' (choose between 'this disc', 'this set' or 'everything'), 'Order' (sequential, repeat, shuffle), Tone ('normal', 'extra bass' and 'super bass') and Time ('track', 'track left', 'disc' and 'disc left'). If this sounds complex, then in practice it's considerably simpler. It's actually a very intuitive

n Hango'd!

SYSTEM REQUIREMENTS

Microsoft Windows 98, Windows 2000 or
Mac OS operating systems; 200 MHz min.
64 MB RAM; 50 MB space on PC or Laptop
hard drive; CD-ROM Drive; USB port

system which means that any six permutations of the above determine what you hear, and how. There's also a volume display and a quality indicator (showing the bitrate you've selected). Round the side, there's an output volume control, 3.5mm headphone socket, USB socket, hold control and 5v DC in socket.

The box comes full of bits, including a car connection kit (with a cigarette lighter charger



and cassette

adapter), AC adapter, case, USB cable, a set of Koss PortaPro headphones and a rechargeable lithium ion battery giving over ten hours playing time.

There's also a CD-ROM containing HanGo's software, which is far better than it first appears. It lets you rip CD songs to the PJ Box directly via its USB connection. This is easy and quick to do - taking just 15 seconds per track you can rip an entire CD in approximately 10 minutes.

In practice, the PJ Box is better to use than the DAP Jukebox, whose ergonomics and navigation feel fussy by comparison. Together the review sample's v2.1.6 operating system and the 12MB onboard memory make for very quick track access, whereas the DAP Jukebox gives the impression of having to think about things first.

Although my DAP is a pre-production sample, it's also considerably more noisy (with that whirring hard disk drive easily audible inside) than the HanGo. The PJ Box's only obvious failing is the software - it works perfectly well, it's just that the Creative's code seems to offer so much more.

SOUND QUALITY

Look underneath the PJ100 and you see a reassuring sign - no, not the 'Made in Korea' legend (not that this is anything to worry about, of course), but the words 'Fraunhofer Institut Integrierte Schaltungen'. This denotes the presence of the famed Fraunhofer codec, which - as Computer Audio World was the first to reveal - is the only decent sounding way to play MP3s. The presence of this inside the PJBox's firmware means the HanGo at least has a decent start in life.

The review sample of the PJBox thoughtfully had a welter of music pre-installed - ranging from the good (Catatonia) to the not so good (Aqua) - but I also ripped some of my own music to the HanGo too. Hooked up to my World Audio K5881 and Yamaha NS1000M loudspeakers, the sound was really quite superb. Obviously, it's extremely dependent on the bitrate you encode the music at, but give it the full 320kbps and you'll hear soon discover how clean, powerful and musical the PJ Box can be.

Nirvana's 'Smells Like Teen Spirit' proved a revelation - bass was full and firm, midband extremely clean, dynamic and detailed and treble was smooth and surprisingly airy. Frankly I've heard a lot worse from certain conventional CD players! Most impressive was the extra mile the

HanGo went to reconstruct the song's recorded acoustic, bringing hitherto unheard levels

of depth and breadth to my MP3 files. Likewise, Catatonia's 'Road Rage' saw the HanGo punching out vast tracts of bass - indeed it almost sounded overblown. Singer Cerys's acerbic vocals were surprisingly smooth and free from grain and there was a fine sense of air and space around the guitars.

Dynamically the HanGo is in another league to most MP3 devices - it really is able to contrast the 'light and shade' of a piece of music, meaning there's subtlety and power there in equal measures. It's no less accomplished rhythmically too - you get the sense of real musicians playing together rather than just a metronomic procession of digital beats. Thumbs up for its sonics then - HanGo (or Compaq) has obviously done its homework and specified a decent DAC and analogue output stage to go with that codec.

Downsides? Well, I'd have liked a dedicated Line Out jack in addition to the 3.5mm headphone jack - the DAP Jukebox has two, after all!

Overall, this is a very interesting product. I'd be tempted to go for the £529 20GB version (which sold for £749 until recently), which is a reasonable price for near infinite amounts of hi-fi quality music on the move. If you're a student, traveller or businessman roaming from Travelodge to Travelodge, it's a tempting proposition. The beauty of it is that when you get back home you can just plug it into you amp's AUX input and carry on listening. ■ ▲



HanGo PJ Box 100 £389
www.pjbox.co.uk

World Verdict



Real hi-fi sound plus a stratospheric storage capacity and easy operation make this a fantastic way to enjoy music on the move.

Hip or Square?

David Price reviews Iomega's chunky new HipZip MP3 portable.

Computer traspotters will have heard of Iomega. The company makes a popular range of computer data storage 'solutions' based around its famous 'Zip' drive, which stores large amounts of data on a disk only slightly bigger than a conventional floppy disk. The new HipZip is an MP3 walkie with a difference. As well as the usual digital audio portable gubbins inside that you'd find in, say, the SONICblue Rio 600, it boasts its own miniature Iomega Zip drive inside.

Why so? Many mp3 players only have 32MB, which gives only around half an hour of high quality MP3 playback. The HipZip circumvents this by using small 40MB discs which you can simply load and unload like MiniDiscs. As the MP3s they store are variable bitrate, you can hold anything from half an hour to an hour's worth of music on each disc. With a handful of discs stuffed in your top pocket, you can carry a serious amount of music around.

Of course, the MMC flash memory cards (MultiMediaCards) that conventional MP3 walkies use can also be plugged and unplugged, but they cost around ten times as much per megabyte. Approximately one-quarter of the size of CDs and almost half as small again as MDs, the discs are encased in a metal shell for durability and are a breeze to use. Another bonus is that as well as storing music, the HipZip also acts as a storage device for transporting images, spreadsheets, digital-media presentations, etc from computer to computer. Some will find this very handy indeed.

The player itself is a behemoth compared to the latest and greatest from SONICblue and Philips. Iomega does not publish its vital statistics, but

suffice to say it's slightly bigger than most first generation MP3 walkies and about the equal of the ridiculously lardy Thomson Lyra. It's very well made though, and has the feeling of something you could bash around without having to subsequently throw away. The large LCD display is sadly not backlit, but given that you're using it in daylight is very easy to read. The package comprises power supply/charger, USB connection lead, PocketZip disc, Quick Start guide, case, headphones and installation disc. The HipZip itself contains its own lithium-ion rechargeable battery giving around 12 hours playing time.

It's easy to set up. Being USB you just connect the HipZip to your computer with the supplied connecting cable, insert the 'Iomegaware' CD-ROM in your computer drive and the rest takes care of itself. Once you've rebooted your PC you can access the HipZip using Windows Explorer (as you would your hard drive), or the supplied Windows Media Player 7 software - which regular readers will know is excellent. The player is compatible with MP3 and WMA, and is software upgradeable to new formats like Audible and Dolby AAC. Windows Media Player 7 is included for Windows users and MusicMatch Jukebox software for Mac users.

The Iomega's sound quality came as a complete surprise to me. I have to say I hadn't expected something with its roots in data storage to possess such fine sonics. I squirted my usual 256kbps drum and bass test track, 4 Hero's 'Golden Age of Life' over to the HipZip and plugged it into my Cyrus 7 amp and 782 loudspeakers. I was greeted with an exceptionally clean and powerful

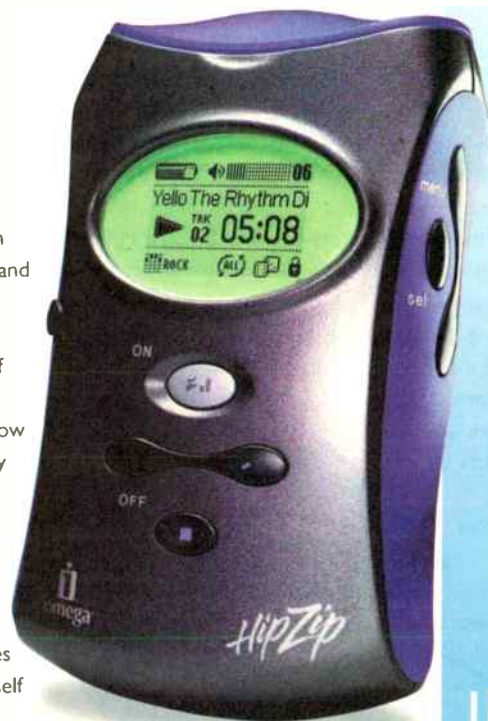

sound - easily as good as the class-leading Philips Rush. There's real sophistication here, with tremendous stage depth and smoothness right across the frequency spectrum. Treble is sparkling, midband alive with air and space and bass is full and tuneful. On high quality MP3s you'd easily think you were listening to good CDs.

This is an interesting product. It's about as portable as the latest MD players but just a bit lighter. The discs it uses are noticeably smaller than MDs but give noticeably shorter playing times. Sound quality is superb and the drive works faultlessly in every way, from the USB interface to disc loading. It has a fair smattering of facilities and doesn't feel anywhere near as flimsy as many conventional MP3 walkies. It's even codec agnostic, so you can download software to play AAC files too. It's a pricey device alright, but if sound quality is paramount or the PocketZip disc facility is useful to you, this is an essential purchase. ■ ▲

World Verdict



Expensive, but the sound is sublime and the interchangeable disc facility is handy too.

Iomega HipZip £289.99

LaCie's on fire!

FireWire is the word on everyone's lips right now, and the major manufacturers are falling over themselves to get suitably specified products out. Davi Price put LaCie's new 16x10x40 CD-RW through its paces.



LaCie isn't a name that springs to mind quite as easily as 'Sony' or 'Pioneer'. It's a French company, founded in 1989 and listed on the Paris stock exchange, with offices in France and Oregon in the USA, plus a network of fifteen offices around the world. Essentially it's a cross-platform specialist, focusing on storage solutions that work on both Macs and PCs using the best available ways of hooking them up.

Three years ago, most external CD burners were using the fast but inconvenient SCSI connectors (which needed a separate SCSI card to make them work with most PCs) or the slow and fussy IDE system. LaCie, however, made an external drive that linked to your computer via a USB (Universal Serial Bus) connector, which was both faster than IDE and far easier to use than SCSI. When we reviewed it back in the summer of 1999, we were suitably impressed, even if its 2x Philips mechanism made it a bit of a slow burner.

How time flies! Now, three years on, we're looking at this slick 16x item complete with both USB and FireWire connections. FireWire, lest we forget, has been around since 1986 when Apple Computer came up with a new standard in digital connections. The Institute of Electrical and Electronics Engineers (IEEE) subsequently approved it and classified it as IEEE 1394. It's a super fast, high-performance serial bus that's ideal for digital video capture and editing, not to mention audio. Like USB it's 'hot-pluggable', meaning you can add and remove devices

without powering your system down, and can be used with Windows and Mac machines. It's only recently however that FireWire has migrated off Macs onto PCs - which is why many manufacturers haven't bothered to support it until now ("shame!")

The uses for a drive like this are numerous - it's far more flexible than buying a dedicated hi-fi CD recorder (like Pioneer's fine PDR-609, for example). You can use the LaCie for digitally extracting music CDs to your computer hard drive for editing, creating multimedia files. It can burn your MP3 song files to CD for playing on the latest generation of CD portables, in-car CD tuners and even the new Meridian 588 high end CD player! It can also archive important computer files. The CD-Rs produced by the drive can be read on ordinary CD-ROM drives, CD-Audio player, CDR drives, DVD-ROM and DVD-RAM drives.

True to LaCie form, this drive sports "U&I" technology, meaning that it contains both USB and FireWire interfaces on the same drive. This makes a very flexible friend. Using FireWire, its 16x CD-R speed means it will copy an entire audio CD onto a data CD in less than five minutes - a tad faster than the latest hi-fi CD recorders, then. Via the USB connection, the speeds fall to 4x4x6. There's an 8MB buffer, which sounds a lot (first generation burners made

do with 1MB) but remember that the faster the drive is, the more memory it needs to ensure fault-free operation. The smooth operating transport also incorporates Yamaha's Pure Phase Laser System which tunes the laser power to the disc's reflectivity.

It's a nicely put together piece of kit, with a characteristically stylish case measuring a compact 148x194x42mm and weighing a sturdy 1.1kg. Each drive comes with cables, a 16x/80mn CD-R blank, a rewritable 10x/74mn CD-RW blank and LaCie's Recording Utilities suite of software. This includes (an old version of) Roxio's (previously called 'Adaptec') Easy CD Creator and DirectCD for Windows 98SE/2000/ME - plus Toast for MacOS. Usefully the drive comes fitted with an international power supply.

With both FireWire and USB it worked perfectly - I used it for an intensive session of vinyl archiving - and it made fine sounding copies of my .WAV files stored on my PC's hard drive onto TDK blank CD-Rs. One thing to note however - and this isn't the fault of the LaCie - is that at very high speeds the sound can degrade a little. I put this down to Red Book CD's middling error correction. With all high speed burners, if you want the very best possible sound, stick to high quality blanks at under 8x. A fine product then - it's pricey but all external drives are, and you do get a lot for your money. ■ ▲

LaCie 16x10x40 CD-RW £315
www.lacie.co.uk

World Verdict



Excellent build, superb connectivity, impressive specs and faultless operation make it highly recommended.

Relay Runner

Sony's new CRX10-U portable CD burner is the first in a series of mobile multimedia peripherals going by the name of 'Digital Relay'. David Price runs with it.



No doubt about it, Sony's new Digital Relay CD-RW is a great idea - a silver disc burner that connects easily to either Macs or PCs, works off rechargeable batteries and offers equally powerful functionality. Enter Sony's brand new CRX10U-RP.

It boasts a plug-and-play USB interface for easy connection to both Windows and Macintosh systems (and comes with separate set-up discs for both). The package features an impressive software bundle including Roxio's WinOnCD and DirectCD (CD authoring) and Steinberg's WaveLab (audio recording/editing) for Windows, plus Adaptec's Toast and SonicWorx for MacOS.

There's also a host of non audio-related stuff including PhotoBase, VideoImpression, PhotoStudio, DataKeeper and Retrospect Express. The box also comes with multilingual electronic hardware and software manuals, a quickstart installation poster, CD-R media, a rechargeable Sony InfoLithium battery, AC adapter, power cable, USB interface cable and a CD marker pen.

For the admittedly steep £410 typical selling price (which will doubtless be heavily discounted by the time this review goes to print), the specs of the drive itself aren't terribly impressive. Essentially it's a 4x4x6 speeder, which is pretty much where full size drives were about eighteen months ago. The 8MB data buffer is more encouraging - it's very generous considering the low speeds this unit will be burning at. The CD text facility is welcome, as is the facility to playback MP3 CDs and display their ID3 tags.

Sony has thoughtfully designed the CRX10U-RP to be used as an audio CD portable too. There's full 'ESP' shock protection and in playback mode the CRX10U-RP is controlled by a wired remote that features standard playback and volume controls, a battery life indicator and a LC display for viewing music title information of CD TEXT and ID3 tag MP3 CDs if encoded on the disc. You even get a middling set of in-ear headphones, although to Sony's credit the remote's designed in such a way that you can substitute them for a decent set at a later date. The supplied InfoLithium battery gives up to two hours of CD recording or two and a half hours playback. The unit itself is impressively compact at 132x25x189.5mm and pretty light at 435g including battery.

So how does it work in practice? After the surprise and delight of the concept itself, not to mention the elaborate packaging and lavish software bundle, the Digital Relay itself proved disappointing. Basically, it's an extremely flimsy and lightweight bit of kit that frankly doesn't inspire confidence to use or carry around. It feels so fragile that I began to wonder whether it would last the duration of the review, let alone the lifetime of my notebook. Unlike Sony's first cassette walkman,

DATman or Discman, this is no hardly built product.

The software installed faultlessly, and my wobbly old Windows OS even found the USB drivers without so much as a crash. Burning was another matter though - the first time I tried it the Sony crashed, with Windows reporting: "Error 00000200: 73400c08 writing block 00005994 in Disc 01 Copy 01, Track 01". Hardly off to a good start! When I did get it to go, the Digital Relay always felt rather precariously balanced, and far less sturdy than, say, an Iomega Jazz Zip drive. The CD-Rs it burned sounded excellent, but whichever way you look at it, fragile portable devices should be a contradiction in terms. The concept has legs alright, but the reality is less likely to last the distance. ■ ▲

SONY CRX10U-RP SPECS

- USB 1.1 Interface
- analogue stereo output (headphone jack)
- 4x write speed CD-R/RW, 6x read speed
- 8MB buffer memory-average access time: 250 ms (Random)
- Formats supported: CD Digital Audio, CD Extra, CD Text, CD-ROM, CD-ROM XA, CD-I, CD-I Ready, Video CD, Photo CD (single and multi session)
- Write methods supported: Disc at once, session at once, track at once, fixed/variable-packet recording, multi session
- MacOS 8.6/9, Windows 98, Windows 2000, Windows Me supported

Sony CRX10U-RP £410

Sony CTNCE
The Heights, Brooklands,
Weybridge,
Surrey
KT13 0XW
www.sony.eu.com

World Verdict



Fantastic idea let down by poor execution. Premium price doesn't reflect low specs and flimsy build.

Phoney Wars

Summer's here and your MP3 portable is really earning its keep. But what of those nasty bundled in-ear phones? David Price tries out a host of possible upgrades.

▶ AIIWA HP-VJ20 SWOOPS £10.99

They've got a silly name and equally strange styling, but these budget Aiwas are perfect for active sports thanks to their almost unbreakable, water-resistant design. They stay on your head even during energetic exercise, thanks to the unusual 'headband' which sits on the back of your neck and 'Air Fit' rubber earpads. Sound is okay for the low selling price, and they're certainly toughly made, but if performance is paramount then look elsewhere.

SONY MDR-228LP £17.50

These feature Sony's 'Groove' contoured earpieces, which are claimed to give an extended treble response, plus its 'Acoustic Twin Turbo' system to take care of low frequencies. The result is a fine sounding set of in-ear phones with full, if slightly boomy, lows and crisp, sweet, airy highs. Together with good looks and top class build quality, these phones' high sound per pound ratio makes them excellent value.

SENNHEISER MX500 £19.99

Claimed to be the definitive upgrade to the cheap in-ear phones that come with all cassette, CD, MP3 and MiniDisc portables, these promise much but don't completely deliver. Nicely put together with Sennheiser's trademark toughness, they also come with a neat 'wind up' carry case.

Usefully, the headphone lead features a small volume control but it's a shame that no foam earpads come as standard. Sound is taut and tight with decent midband clarity, although treble's rough. Good, but not a great improvement on bundled phones.

AIIWA HP-X225 £19.99

Finished in trendy silver and ice blue, these full size folding headphones look bang up to date. They fold up really small for storage and then unfold easily again. With soft cloth earpads they're comfortable, and also light enough to wear out and about, while the 2m cord makes use with home hi-fi's perfectly easily. Sound is surprisingly good for the low price, and quite a lot better than all but the top in-ear designs. Bass is strong, treble crisp and they image well too. The only downside is that they take a bit of driving, so low powered MP3 walkies won't be up to the job. Decent value.

TECHNICS RPF200 £19.99

The biggest of the group, these closed-back phones are also suitable for DJ use because they keep out most external, ambient noise. Another benefit of this kind of design is a tight, powerful bass which these Technics cans have in spades. Further up the frequency range however, things aren't quite so good - coarse and unrefined, extended listening is hard work. People after a big bang for their buck might approve, but if you want more music then look elsewhere.



SONY MDR-G52LP £19.50

More than just a headphone, Sony's 'Horizontal Headphones' are something of a street style statement right now. Rather like the Aiwa 'Scoops', the headband goes round the bank of the head instead of on top, faithfully preserving your hairstyle and clamping the cans to your ears. The result is a fine sound with a taut and tuneful bass and usefully clear and open treble. They're surprisingly comfortable to wear too, so long listening periods are perfectly possible. Excellent value overall with little to criticise at the price.

PHILIPS SBCHP160 £19.99

Big and bulbous, these full size closed back cans give you lots of plastic for your cash but aren't ideally suited to mobile music. With big 'bass vents' to boost the low frequencies and high quality Neodymium drivers, they have Philips' characteristically clean and tidy sound with plenty of punch in reserve. This, allied to oodles of atmosphere and space makes them the best sounding design of the group. The only drawback is that clumsy 'double headband', which isn't the most comfortable thing to wear on your head for long periods. Nevertheless, top value product if size isn't a consideration.

LONDON



INSTANT 0% FINANCE AVAILABLE SERVING LONDON FROM BATTERSEA

ORANGES & LEMONS

Juicy fruit from London's newest, freshest hi-fi/home cinema retailer. Telephone demonstrations or just pop in. All the usual, i.e. friendly and efficient service, free home installation + credit cards.

THE INNOVATIVE AUDIO/VISUAL HI-FI RETAILER. ARCAM, CABLETALK, CHORD CO, DENON, EPOS, MARANTZ, NAD, NAIM, REGA, ROKSAN, ROTEL, ROYD, RUARK, SOUNDSTYLE, STANDS UNIQUE, YAMAHA.

NOW IN OUR SIXTH FLAMBOYANT YEAR.
020-7924 2040

61/63 WEBBS ROAD, SW11
Visit www.orangesandlemonshifi.com



27 BOND STREET, EALING
LONDON W5 5AS
TEL: 020 8567 8703

Audio Analogue, Art Glass, Ash Designs, Avik, B&O, B&W, Cabletalk, Chord Company, Creek, Denon, Epos, Harman Kardon, Infinity, KEF, Lat, Marantz, Musical Fidelity, NAD, Nakamichi, Nordost, Orelle, Onkyo, Primare, Quad, Roksan, Rotel, Ruark, Sennheiser, SonicLink, Sound Style, Stands Unique, Straightwire, Supra, Tag McLaren, Target, Teac, Thorens, van den Hul.

10 - 8 pm Mon., Tues., Friday, & Sat.
Late night Thur., closed Wed.

Two demonstration rooms.
Free local delivery and installation.
Repairs and Services



ARCAM • ANTHEM • AUDIOGRAM • AUDIO RESEARCH • AUDIO TECHNICA • BEYER • CABLETALK • CHORO • CREEK • DENON • DENISEN • JADIS • JECKLIN • MICHELL • MUSICAL FIDELITY • NAD • NAIM • OPERA • PRECIOUS METALS • QEO • REGA • ROGERS • ROYD • SENNHEISER • SILTECH CABLES • SME • SONNETEER • SONUS FABER • TEAC • THORENS • TRANSPARENT CABLES • UNISON RESEARCH • WILSON



Clearance / Second Hand / Ex Dem Equipment - Details on request

0% Instant Finance Available
(Written details on request)

New Demonstration Room • Free car parking • Major Credit Cards
Personal Export • Mail Order • Installation Service • Repair facilities
5 mins walk Raynes Park BR • 20 mins Waterloo
5 mins from A3 (Raynes Park B282exit) • 25 mins M25 Junc 10

60 Durham Rd, West Wimbledon, London SW20 0TW
Est. 1966
Tel: 020 8946 1528 Fax: 020 8946 0331

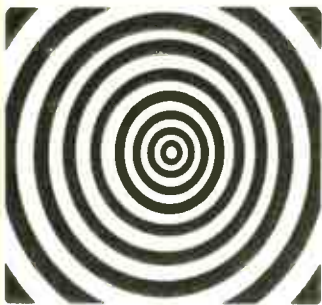

020 7384 3030

think audio think...

Auditorium

THE HI-FI SHOP 112 NEW BINGE ROAD LONDON SW16

LONDON



Best place in town for Hi Fi and Home Cinema

- * Six demonstration rooms
- * All leading brands
- * Interest Free Credit
- * Free Parking
- * Open 10-4 every Sunday

UNILET SOUND & VISION
38 HIGH STREET, NEW MALDEN,
SURREY, KT3 4BY

Tel: 020 8942 9567 Fax: 020 8336 0820

We aim to provide a well chosen selection of quality hi-fi and accessories including FMJ, ARCAM, B&W, NAUTILUS, DYNAVECTOR, LINN, LOEWE, MERIDIAN, M&K, NAIM, PIONEER, PROCEED, NEAT, REGA, ROTEL, SHAHINIAN, YAMAHA + more

Infidelity
INDECENTLY GOOD HI-FI

9 High Street, Hampton Wick,
Kingston upon Thames, Surrey KT1 4DA

Open:
Tues-Fri
10 30am-7pm,
Saturday
10am-6pm



SOUTH

SPALDINGS

THE SOUTH EAST'S LEADING HI-FI COMPANY

3 DEM ROOMS A.V.
HOME DEMS., 0% CREDIT
FREE INSTALLATION

LINN • NAIM • MISSION • KEF
DENON • TAG MCLAREN
MARANTZ • MUSICAL FIDELITY
CASTLE

MON TO SAT 9.00 to 6.00. TUE 9.00 to 8.00

Closed WEDNESDAYS
SERVICE DEPT

325-354 Lower Addiscombe Road, Croydon,
Surrey CRO 7AF

Telephone: 020 8654 1231/2040 Facsimile: 020 8655 3922

WORTHING AUDIO

20 Treville Gate, W.Sussex BN11 1UA
(01903) 212133

The friendly shop with the best sound system in the South.
Talk Electronics - Friendly Advice - 3 Year Guarantee
Easy Parking - Open Mon-Sat. 10am-6pm
Late Night Wed 7.30pm.

Agencies include: Dynaudio, Ruark, Gradient, Plikon, Naim, Orelle, Sonneteer, Kora, Cymbal, Talk Electronics and many more.....

SOUTH WEST

SOUTH WEST ANALOGUE

SME - MICHELL - NOTTINGHAM ANALOGUE - LORICRAFT GARRARD - PROJECT - ORTOFON - TUBE TECHNOLOGY 64bit Valve CD Player, Remote Control Hybrid Integrated Valve Amplifier VOODOO Isolation platforms/Loudspeakers, Equipment Stands and T/Turntable lift off Perspex Covers. Record cleaning service - Secondhand equipment

01643 851 351
graham@southwestanalogue.fsnet.co.uk

WEST

audio excellence

WHERE THE MUSIC MATTERS

Bristol 65 Park Street Bristol BS1 5PB (01179) 264975	Cardiff 134/6 Crwys Road Cardiff CF2 4NR (01222) 228565
Gloucester 58 Bristol Road Gloucester GL1 5SD (01452) 300046	Swansea 9 High Street Swansea SA1 1LE (01792) 474608

Exeter
156 Sidwell Street, Exeter, EX4 6RT
(01392) 491194

TUESDAY - SATURDAY 9.00 - 5.30
CLOSED MONDAY

NORTH

Basically Sound

NORWICH • NORFOLK

Audio Analogue, Bryston, Chord Co, Denon, Epos, Harman Kardon, Infinity, KEF, Lat, Marantz, Musical Fidelity, NAD, Nakamichi, Nordost, Orelle, Onkyo, Primare, Quad, Roksan, Rotel, Ruark, Sennheiser, SonicLink, Sound Style, Stands Unique, Straightwire, Supra, Tag McLaren, Target, Teac, Thorens, van den Hul.

The Old School
School Road, Bracon Ash
Nr Norwich, Norfolk NR14 8HG
Tel (01508) 570829

audio excellence

WHERE THE MUSIC MATTERS

CHESTER 86-90 Boughton, Chester CH3 5AQ (01244) 345576	PRESTON 131 Friargate Preston, PR1 2EE (01772) 253057
--	---

TUESDAY - SATURDAY 9.00 - 5.30
CLOSED MONDAY



Unison Research 845

ZENAUDIO

Stockists of
Naim, Densen, Dynaudio, Ruark, J.Mlab,
Proac, Craft, Sugden, SME, Michell,
Unison Research, Nad, Teac, and many more.

35 George Street Hull. tel 01482 587397

TO ADVERTISE IN
SPECIALIST HI-FI DEALER PLEASE
CALL ANDREW MAYNES ON
020 7604 4890

SPECIALIST HI-FI DEALERS * SPECIALIST HI-FI DEALERS

EAST



BG Audio Visual

9 Hatter Street
Bury St Edmunds
Suffolk
01284 765 227

Bang & Olufsen, Sony,
Technics, Denon,
Yamaha, Rotel, Linn,
Mission, KEF, Jamo,
JBL, Harman, Boston

**GRAYSTON
sound&vision**

Alchemist Arcam B&W Boston Acoustics
Castle Acoustics Denon Harman Kardon
KEF Reference Linn Loewe Meridian Musical Fidelity
Philips Pioneer Pro-ject Rotel Sennheiser Thomson

33 Sir Isaac's Walk Colchester
Tel: 01206 577682

Lend us your ears and we'll
blow your mind . . .

Arcam, A.T.C., B & W, Celestion, Denon,
Kenwood, Kef, Marantz, Michell,
Mission, Meridian, NAD, Panasonic,
Phillips, Pioneer, Quad, REL, Rotel, Ruark, Sony,
TAG McLaren, Tannoy, Technics, Yamaha and more.
Audition the very best at Lincolnshire's
premier Hi-Fi dealer . . .



2-4 EDWARD STREET (Off Pasture St.)
GRIMSBY. TEL: (01472) 351391

STOWSOUNDS
audio consultants

Quality Equipment Available From:

- | | |
|--------------------|----------------|
| Acoustic Solutions | J.M. Labs |
| Alchemist | Neat Acoustics |
| Atacama | Nordost |
| Audioquest | QED |
| Beyer | Sonic Link |
| Cable Talk | Sonnenteer |
| DPA | Soundstyle |
| Electrocompaniet | Stands Unique |
| Exposure | Van den Hul |

For A Demonstration & Expert Advice Call
Stowmarket (01449) 675060
Stone Farm, Borough Lane, Gt. Finborough, Stowmarket



Johns
Audio & Visual
Specialists

Technics Yamaha Sony
Panasonic Kenwood Aiwa
Toshiba Pioneer Mission

Low, low prices
all year round!!!
(Established 1959)

142 High St
Scunthorpe, Nth Lincs
01724 843800

SERVICES & CONSULTANTS

Front End Problem?
contact
The Cartridge Man

It doesn't have to cost an arm and a
leg to get the best - listen to my
Koetsu - and Decca -eater.

Also agents for Croft, Haddock.
E.A.R. Michell &
Moth.

plus cartridge re-tipping service
020 8688 6565

Website: www.thecartridgeman.com

STUDER REVOX

SALES, SERVICE, SPARES
SERVICE & REPAIR OF
A77, B77, A700, PR99 &
36 SERIES

HI-FI SPARES TO ORDER
SERVICED MACHINES IN
STOCK

APPROVED CONVERSIONS
E.M.A.S

TEL: 01246-275479
FAX: 01246 550421

atv

- Service & Repairs
- Valve & transistor amplifiers
- Vintage valve Radios
- Hi-Fi VCR's
- Valves Tested

ATV SERVICES
LEATHERHEAD
01372 456921

VINYL

THE DIRECT DISC
VINYL VINYL VINYL

Thousands of records always in stock.
+ a full range of sought after compact discs.
Extensive search service for wanted albums.
Comprehensive 96 page full catalogue
available at £1.50
Telephone / Fax 01992 447764
Or visit our web site on
www.directdisc.demon.co.uk

VINYL CLEANERS

**CHERISHED
RECORD CO**

UK SUPPLIERS OF
VPI TURNTABLES,
RECORD CLEANING
MACHINES AND ACCs.
HUGE SELECTION OF
NEW & USED LPS & CDS
www.cherished-record-company.co.uk
01579 363 603

MAIL ORDER



**Russ Andrews
Accessories Ltd**

Hi-Fi & Home Theatre
Cables & Accessories

- Mains Cables
- Interconnects
- Speaker Cables
- Equipment Supports
- Expert Advice

UK FREEPHONE
0800 373467
and quote AH71
for a free catalogue

Russ Andrews Accessories Ltd.,
FREEPOST NW881A, KENDAL LA8 9ZA
Tel: +44 (0)1539 825500 Fax: +44 (0)1539 825540
E-mail: AH71@russandrews.com
www.russandrews.com

VALVES & TUBES



Buy CVC PREMIUM HI - FI valves direct from us.
All valves processed for improved performance.
We also have stock of MAJOR BRAND types Inc.
MULLARD, GEC, BRIMAR, RCA, GE, PHILIPS, etc.

The Stables, Baddow Park, Great Baddow
Chelmsford, Essex, CM1 7SY
Tel: 01245 241301 Fax: 01245 241309
Email: sales@chelmervalve.com



£600

Mr. Andrew Everard in Gramophone Magazine
"delivers a sound that's both smooth and refined
... allied to a good degree of clarity and finesse"
Hi-Fi Choice "it's a 'classic valve sound'... warm and
cuddly...vocals are generally lifelike and involving"
FREE colour literature. £600 with free delivery
Phone 01634 373410 anytime. 1 month home trial
www.affordablevalvecompany.com

REPAIR & DIY

TECHNICAL & GENERAL
THE ORIGINAL TURNTABLE SPECIALIST

for the Great Classical Turntable, Arms, Cartridges, Styli
CONNOISSEUR • GARRARD • GOLDRING •
LENCO • ORTOFON • SHURE • S.M.E •
THORENS • WATTS
All available Genuine spares and our own
re-manufacture of obsolete parts
NO ILLUSORY 'IMPROVEMENT' NO DUBIOUS
OR HARMFUL 'MODIFICATIONS'
Cartridges and stylis, correct radius diamonds, for early
recordings - 78s & LPS
TECHNICAL & GENERAL
P.O.Box 53 Crowborough, East Sussex TN6 2BY
Tel: 01892 65 45 34

DIAL-A-DEALER

This is a comprehensive directory of Hi-Fi Dealers throughout the UK and Ireland.

BEDFORDSHIRE

RICHARD'S AUDIO VISUAL 4 Greyfriars Bedford. Tel: 01234 365165. Stockists of: Arcam, Audioquest, Beyer, B&W, Bose, Cable Talk, Celestion, Cyrus Denon, Heybrook, Marantz, Mission, Moth, Nakamichi, Ortofon, Pioneer, Pro-Ject, Quad, REL, Rotel, Royd, Ruark, Sennheiser, Sound Style, Systemdek, Target, Teac, Thorens, van den Hul & more! Expert friendly service: Listening room, Pioneer Reference Point, Visa / Access.

BRISTOL & BATH

THE RIGHT NOTE Tel: (01225) 874728. Just think: most audiophiles listen for most of the time to systems that are 'not quite right'. Are you happy with yours? Forget the reviews and trying to put together a system like a patchwork quilt with the 'best' bits around. It's our job to do the assessing, you judge our results. We'll help you to plan a system for the future, even if you spread the purchases. Leave the 'up-grade-itis' behind, save money and enjoy music all the time. Just listen, and you'll know. CD: Acuras, Audio Synthesis, Classe, DCS, Enlightened Audio Design, Meracus, Oreille, Wadia, XTC. Vinyl: Basis, Crown, Jewel, Graham, Michell, Sumiko, Transfiguration. Amps: Acuras, Audio Sculpture & more. Speakers: Audio Artistry, Audio Physics & more. Tuners: Fanfare, Magnum Dynalab & many more. Cables: Chord, DNM, Silver Sounds & more. (Credit Cards Accepted).

VAUDIO HiFi Consultants: 36 Druid Hill, Stoke Bishop, Bristol. BS9 1EJ. Tel: 0117 968 6005. ATC, AVI, Alon, Audio Analogue, Audiomeca, Cadence Valve, Chord Amps, Electrocompaniet, Harman Kardon, Heybrook, Jamo, LFD, Lyr, Opera, Ortofon, Pink Triangle, Ruark, Mark Levinson, Michell, REL, SME, Shearman, Sonic Link, Sugden, Townshend, Triangle, Unison Research Valve Amps. Home Cinema demonstrated including, A/V Amps, DVD Players, Video Projectors and Screens. Demos by appointment only. Home trial facilities. Free installations. We are not a shop.

BUCKINGHAMSHIRE

TECHNO SOUND/ AUDIO INSIGHT 7 Granville Square, Willen, Milton Keynes, MK15 9JL. Tel: (01908) 604949. Audiophile Hi-Fi and Home Cinema Specialists. All major brands stocked from Arcam to Yamaha. Meridian Digital Home Theatre dealer. Custom home cinema and multi room installation. 4 dem rooms and expert advice. Audiophile CDs, LPs and LaserDiscs to buy. Open late on Fridays.

NORTHWOOD AUDIO 98 Cambridge St, Aylesbury, Bucks HP20 1BA. Tel: 01296 428790. Selected sounds from Acoustic Energy, Alchemist, Audio Meca, Audio Note, Boston, B & W, Cabletalk, Castle, Celestion, Chord, The Chord Company, CR Developments, DNM Virtual Reality, Denon, DPA, Epos, Exposure, Gyrodek, Harman Kardon, Heybrook, Kef, Klipsch, Marantz, Micromega, Monitor Audio, Moth, Musical Technology, NAD, Nakamichi, Pioneer, PMC, Proac, Rega, Rel, Rose, Rotel, Ruark, Stax, Tannoy, Teac, Talk Electronics, Thorens, Triangle, Tube Technology and a range of quality pre-used equipment. Export orders welcome. - The ultimate Hi-Fi Specialist experience... a mere phone call away.

CAMBRIDGESHIRE

THE AUDIO FILE 41 Victoria Road, Cambridge. Tel: 01223 368305. 'For the best in British Hi-Fi and Home cinema entertainment'. Visit or call to arrange a dem with products from: Arcam, Linn, Naim, Rega, Cyrus, Absolute Sounds, Kef, Sony, Yamaha, Rel, Ruark, Denon.

CHESHIRE

ACOUSTICA 17 Hoole Rd, Chester CH2 3NH. www.acoustica.co.uk. Tel: 01244 344227. All that's best in HiFi & Home Cinema from quality manufacturers including Naim, Rega, Arcam, Musical Fidelity, Rotel, Selecio Projectors, Kef, Ruark, Densen, Primare, Teac, JM Lab, Nakamichi, Quadraspire, Celestion & Crimson. We offer friendly, helpful advice, interest free credit &

trade-in facilities, and deliver & install systems throughout Cheshire, Merseyside & North Wales. Opening hours are Tuesday to Saturday 10.00 until 5.30, evenings by arrangement

ACTON GATE AUDIO 4 Ruabon Road, Wrexham, North Wales. Tel: 01978 364500. Audio Visual Specialists. Arcam, Audio Analogue, Bose, B&W, Celestion, Castle, Denon, Harmon Kardon, Jamo, Marantz, Michell, Mission, Onkyo, Pro-Ject, Musical Fidelity, NAD, Micromega, Myrad, QUAD, Radford, Rotel, Ruark, Tannoy, TDL, Teac, Thorens, UKD, Unison Research, Yamaha, DSP Club Member, Demo Room, installation service. Easy Parking and Motorway access. All major credit cards accepted. 9.30 - 5.30 daily. Closed Sunday & Monday.

DOUG BRADY HI-FI Kingsway Studios, Kingsway North, Warrington, WA1 3NU Tel: 01925 828009 Fax 01925 825773. Visa, Mastercard, Lombard Tricity. 2 dem rooms, home trial; Agencies include: Arcam, Tag McLaren, AVI, B&W, Castle, Caspian, Chord Electronics, Exposure, Harbeth, Heybrook, Krell, LFD, Michell, Meridian, Musical Fidelity, Monitor Audio, Naim, Nautilus 800 series, Pink Triangle, ProAc, Roksan, SME, Wilson Benesch, XTC and many more.

PRACTICAL HI-FI 88 Bridge Street, Warrington, WA1 2RF. Tel: 01925 632179. See our main entry under Preston, Lancs.

REPLAY AUDIO CONSULTANTS Tel/Fax 0161 202 9922. Cheshire's alternative hi-fi specialists. Honest advice and personal service. We can demonstrate Alchemist, AVI, Henly, Heybrook, LFD, Michell, Moth, Musical Fidelity, NAD, Neat, Origin Live, Ortofon, Pink Triangle, Royd, Sonneteer, Totem, Trichord. Demonstrations by appointment in Chester or in your own home. Delivery & installation available. Mastercard, Visa, Switch, Delta

SWIFT HI-FI St. Annes Parade, Wilmslow, 01625 526213. Aura, B&W, Denon, Kenwood, Marantz, Nad, Pioneer, Rotel, Systemdek, Tannoy, Revolver, J.P.W., M. Short, Mission, Celestion, Technics, Audiolab, Castle. Open 9.30-6. Dem room. No pressure. BADA member.

CORNWALL

SOUNDS PERFECTION 'Cornwall's most exclusive Audio retailer'. Agencies include: Alchemist, Audio Analogue, Audio Note, Audio Spectrum, Border Patrol, Boston, Electrocompaniet, Elemental Audio, Henly, JM Labs, Michell, Monitor Audio, Musical Fidelity, Ortofon, Parasound, Sonic Frontiers, Primare, Project, Nordost, Philosophy, REL, Tsunami, S.M.E., Sugden, Stands Unique, Teac, Vienna Acoustics, Triangle, Trichord's, Tara Labs, Sonic Link. Home Demonstrations by Appointment. Tel/Fax: 01326 221372 Mobile 0468 754353. E-mail. soundsperfection@mailcity.com

CUMBRIA

PRACTICAL HI-FI 106 English Street, Carlisle, CA3 8ND Tel: 01228 44792 See our main entry under Lancaster.

DORSET

MOVEMENT AUDIO 588 Ashley Road, Poole, Parkstone, Dorset BH14 0AQ. Tel: (01202) 730865. Arcam, Audiolab, B&W, Castle, Cyrus, Denon, Kef, Marantz, Meridian, Michell, Micromega, Pioneer, Ruark, Shearman Audio. 2 Dem Rooms. Listen to the available choice and decide at your leisure - no pressure, no obligation. Our staff enjoy music, with our choice of products, you can too! Service Department. Free installation, Home trial facilities. Access, Visa, Amex, Diners Card. Credit facilities available. Open Mon-Fri 10-6, Sat 9-6

MOVEMENT AUDIO 336 Wimborne Road, Winton, Bournemouth, Dorset. BH9 2HH. Tel: (01202) 529988/520066 Arcam, B&W, Denon, Kef, Marantz, Meridian, Mission, Pioneer, Sony, Yamaha. Full dem facilities available, also home dem. Friendly expert advice. Service Department. Free installation. Home trial facilities. Access, Visa, Amex. Open Mon-Fri 9-5.30

DAWSONS OF WESTBOURNE Home Cinema Specialists. Main agents for Bang & Olufsen, Harman Kardon, JBL, REL, Mordaunt Short, Sony, Technics and TDL. Demonstration facilities include our unique Dolby pro-logic system comparator for the ultimate way to choose the perfect system. Also on demonstration large screen televisions from Thomson, Sony and Ferguson with video projectors from Sharp and Selecio. Dawsons, 23 Seamoore Road, Westbourne, Bournemouth 01202 764965

SUTTONS HI-FI 18 Westover Road, Bournemouth, Dorset. Tel: 01202 555512. You will find the very latest in superb Hi-Fi facilities with stocks to include: Arcam, Cabletalk, Celestion, Denon, DTS, KEF, Linn, Marantz, Meridian, NAD, Pioneer, QED, Rotel, Sennheiser, Sony, Sound Organisation, Tag McLaren, Target, Teac, Technics, Yamaha, and many more. If you're serious about Hi-Fi you've probably heard of all these brands and probably heard of Suttons too! We've been around for over 45 years. Please call for expert knowledge and friendly advice.

WEYMOUTH HI-FI 33-35 Maiden Street, Weymouth, Dorset DT4 8BA. Tel (01305) 785729. Arcam, Aura, B&W, Denon, Kenwood, Marantz, Micromega, Musical Fidelity, Panasonic, Quad, Sony, Technica, Yamaha. Dem room. Friendly professional advice. Only quality hi-fi dealer in Weymouth area. Service Department. Free installation. Home trial facilities. Access, Visa, Amex, Switch, Delta Mastercard. Interest free credit. Instant credit. Open Mon-Fri 9.30-5.30 Sat - 9.30-5.30

ESSEX

GRAYSTON SOUND & VISION 33 Sir Isaac's Walk, Colchester. (01206) 577682. Alchemist, Arcam, B&W, Boston Acoustics, Castle, Denon, Harman Kardon, KEF, Linn, Loewe Opta, Meridian, Michell, Musical Fidelity, Philips, Pioneer, Project, Rotel, Sennheiser. Superb demo rooms, free regional delivery and installation. Regular musical and surround evenings, home demonstrations. Excellent credit facilities.

GLOUCESTERSHIRE

THE RIGHT NOTE - Bath. For specialist advice and home demonstrations. See BRISTOL & BATH.

HAMPSHIRE

AUDIO T. 2-12 Hursley Road, Chandlers Ford, Hants, SO53 2FJ. Tel Southampton (02380) 252827/265232. Three Hi-Fi and two Home Cinema/Dolby Surround Sound Demonstration Rooms, one with Projection TV and an 8' wide screen. Brands stocked include ARCAM (incl. Xeta), Audiolab, Audioquest, Celestion, Cyrus, Denon, Gradient, Infinity, KEF, Marantz, Meridian, Mission, Polk, Quad, Rotel, Selecio, Sennheiser, Soundstyle, Tannoy, Target Audio, Thorens, & Yamaha. Established 1969, we offer a 2-year Guarantee covered by our own well-equipped Service Dept. We have a large FREE car parking facility and we are located within 3 miles from Junction 14 (M3/M27 Interchange) and Junctions 13 (M3) and 5 (M27). Closed Mondays, except in December. Late Night: Thurs to 8pm. BADA Founder Member. All deposits fully covered by BADA Bonding.

NOW THATS HI-FI 32 Arundel Street, Portsmouth Tel: (01705) 811230. Pioneer, Yamaha, Marantz, Kenwood, Mission, TDL, REL, Attacama and much more. Laserdisc and AC3 specialists. Accessory center at 24 Arundel Way, Portsmouth. Tel: (01705) 811618

HEREFORDSHIRE

ENGLISH AUDIO 37 Whitecross Road, Hereford, HR4 0DE. (01432) 355081. Arcam, A.T.C., B&W, Castle, Cura, Cyrus Centre, Denon, Dynaudio, JM Lab, KEF, Marantz, Mission, Musical Fidelity, MVL, Naim, ProAc, Pink Triangle, Pioneer, Project, REL, Rotel, Ruark, John Shearman, Stax, System Audio, Tag McLaren, Teac, Vienna Acoustics, Wadia, and Yamaha. Single speaker dem room, home trial facilities, free installation, service dept, Access/Visa, Credit arranged. Open Mon-Sat, 9.30-5.30pm. BADA members.

HERTFORDSHIRE

ACOUSTIC ARTS LTD 101 St. Albans Road, Watford, Herts. Tel: (01923) 245250. Fax: (01923) 230798. Audio Research, B&W, Boston, Castle, Celestion, Chord, Copland, Denon, Densen, DPA, Jalis, KEF, Krell, Marantz, Martin Logan, Michell, Micromega, Rel, Roksan, Ruark, SME, Sonus, Faber, Theta, Thorens, Wilson. 4 demonstration rooms. Purpose built AV studio. Credit available. 100 yards from Watford Junction station. Open Tues-Sat 10-5.30 (Thursday open by appointment until 8pm).

AUDIO FILE (THE)

27 Hockerill Street, Bishops Cleeve, Herts. Tel: (01279) 506576.

AUDIO FILE OBJECTIVE 37 Tower Centre, Hoddesdon, Hertfordshire, EN10 8JD. Tel: 01992 478666 Fax 01992 440431. Selected British and special-interest brands. New, Ex-dem, and S/H. Mail order Hi-Fi. Purchased. Free Parking.

DARBY'S OF ST. ALBANS, 6 Market Place, St Albans, Herts. Tel: (01727) 851596. Hertfordshire's premier Hi-Fi/Audio Visual specialists established 1946. Full Home Cinema demonstration suite. Whether your needs are large or small, we stock it all; Arcam, Yamaha, Quad, Denon, Sony, Bang & Olufsen, Pioneer, REL, KEF, Mission, Ruark, Celestion, Polk, and many more. Free planning service. Free Delivery and basic installation. Full workshop facilities. Open 9-6 Mon-Sat.

KENT

ASHFORD SOUNDCRAFT HI-FI 40 High Street, Ashford. Seeking music lovers, male or female, any age, to share common interest in musical Pro-aktiv Hi-Fi Systems, Multi Room of Home Cinema. Attractive unusual equipment in unusual setting, your place or ours, we guarantee lasting pleasure. Open Mon-Sat. Appointment Service or just pop in. Tel (01233) 624441

DOVER HI-FI 43 High Street, Dover. Tel: 01304 207562. Suppliers of quality hi-fi equipment including: Arcam, Akai, B&W, Denon, Jamo, Mordaunt Short, NAD, Panasonic, ProAc, Quad, Rotel, Ruark, TDL, Technics, Tannoy. Part exchange, Listening room. Service and repairs. Credit facilities. Access/Visa. Open 6 days 9.5-3.0.

KIMBERLEY HI-FI 193 Broadway, Bexleyheath, Kent. Tel. 020 8304 3272. Sep dem rooms, Denon, Technics, Kenwood, Aiwa, NAD, Dual, Wharfedale, Mission, Marantz, Tannoy, Castle, Monitor Audio, Heco, Jamo, Cerwin Vega and many more.

MATRIX HI-FI SHOWROOM - 65 Darenth Road, Dartford, Kent DA1 1LU. Tel: 01322 292391. Fax: (01322) 229908. Email: Matrixcomputers@compuserve.com. Hi-end, Home Dem, By appointment, over 30 years experience, for enquiries or a chat, give us a ring.

LANCASHIRE

ADVENTURES IN HI-FI S, Bishopgate, off Hallgate, Wigan, WN1 1NL. Tel 01942 234202. For the best hi-fi and home cinema products from quality manufacturers including Naim, Rega, Cyrus, NAD, KEF, Denon, Dynavector, Rotel, Shahinian, JM Lab, PMC, Project, Quadraspire, Seleco and Sanyo projectors. We offer friendly advice, excellent demonstration facilities, 0% finance, free delivery and installation throughout the North West. Opening hours 10.00 - 5.30pm Tuesday to Saturday evenings by appointment.

CLEARTONE 235 Blackburn Road (1/2 mile from city center on the A 666 Blackburn Road) Bolton, Lancs BL1 8HB Tel: (01204) 531423. Bolton's biggest Hi-Fi superstore. Every top brand & all the best buys at guaranteed unbeatable prices. Aiwa, Akai, Arcam, Audiolab, B&W, Bose, Castle, Celestion, Denon, Hitachi, Infinity, JBL, JVC, KEF, Kenwood, Marantz, Meridian, Mission, Mordaunt Short, NAD, Panasonic, Pioneer, Rotel, Sony, Tannoy, TDL, Technics, Toshiba, Yamaha. 2 dedicated Hi-Fi Demo rooms and 2 A/V Demo rooms, no appointments necessary. Service department, free installation, home trial facilities, free parking, Access, Visa, Amex, Diners, Interac free credit. Open Mon-Wed 10.00-6.00, Thurs-Fri 10.00-7.00, Sat 9.00-6.00, Sun 11.00-5.00

MARTON MUSIC 5 Masterson Ave. Read, Burnley, BB12 7PL. for addition of the best stereo and surround sound equipment from BRYSTON (20 yr guar), MYRYAD, PMC, RUARK, YAMAHA, and the latest WILMSLOW-HART electronics, in a comfortable

demonstration room through commercial and custom-built speakers including Transmission Line, Open Baffle and Reflex designs. Home demos encouraged for complete satisfaction. Also main agent for Liberty Audiosuite loudspeaker/audio measurement system, ETF4.0 room measurement system and LspCAD room/box design/crossover package. Call Tony Seaford anytime for an appointment, a chat or free advice on 01282 773198 (fax 776413), or e-mail 106505.251 @compuserve.com.

PRACTICAL HI-FI 43 Friargate, Preston. Tel:- 01772 883958. The audio visual specialist, expert advice, instant demonstrations, best prices, instant free credit, part exchange welcome. Extended warranty. Stockists of Yamaha, Castle, Teac, NAD, Lexicon, Arcam, Kenwood, Denon, Sony, Technics, Onkyo, Marantz, Pioneer, Mission, Kef, Celestion, B&W.

PRACTICAL HI-FI 84 Penny Street, Lancaster, LA1 1XN Tel:- 01524 39657 - See our main entry under LANCASHIRE

PRACTICAL HI-FI 33/35 Knowsley Street, Bolton, Lancs Tel:- 01204 395789 - See our main entry under LANCASHIRE

PRACTICAL HI-FI 81 Whitegate Drive, Blackpool, FY3 9DA Tel:- 01253 300599. See our main entry under LANCASHIRE

ROMERS HI-FI, 94-96 High Street, Rishton, BB1 4LQ. Suppliers of quality hi-fi equipment including: Linn, Arcam, Cyrus, Quad, Yamaha, Mission, Ruark, Sony, Monitor Audio, NAD, Onky, Bose, Castle, Nordost, Straightwire, Panasonic, Pioneer, Loewe, TDL, JVC, Target, Stands Unique. Specialists in multiroom installations. Access/Visa/Amex. Credit facilities. Open 9.00-5.30 Mon-Sat (5.00pm Wed & Sat). Tel: 01254 887799 Fax: 01254 876866

LEICESTERSHIRE

CYMBIOSIS 6 Hotel Street, Leicester, LE1 5AW. Tel: (0116) 2623754. Email: shop@cymbiosis.com. Arcam, Acoustic Energy, Cable Talk, Castle, Chario, Chord Company, Cura, Denon, Linn Hi-Fi, Linn Knekt, Loewe Televisions, Lutron Lighting, Musical Technology, Naim, Nordost, Projekt Furniture, Rega, Revox, Rotel, System Audio, Tag McLaren, and Wadia. Multi room design & Installation Service. 4 listening lounges, Installation Service, Finance Available. Open 10-5.30 Monday to Saturday.

LEICESTER HI-FI 6 Silver Walk, St Martins Square, Leicester LE1 5EW. Tel: (0116) 2539753. info@leicesterhifi.co.uk www.leicesterhifi.co.uk Arcam, B&W, Chord Electronics, Copland, Cyrus, Denon, Greig Loudspeakers, KEF, Marantz, Michell, Miller & Kreisel, Musical Fidelity, NAD, Nakamichi, Nautilus, Mission, Project, Rotel, Sanyo Projection, Talk Electronics, Teac, Technics, Yamaha, and many more. 4 Listening areas over 3 floors. We can demonstrate, deliver and install, including A.V. and Multiroom. Credit Facilities. All cards taken, open 6 days 9.30-5.30.

STEREO SHACK 1-3 Guildhall Lane, Leicester. Tel: (0116) 2530330. Fax: (0116) 2626097. Yamaha, Kenwood, NAD, Mission, Teac, Aiwa, Cerwin Vega, Pioneer, TDL, Thorens, JBL, Rotel, Celestion, Jamo & many more. We are A.V. specialists. 2 dem rooms. We can demonstrate, deliver and install. Credit facilities and all cards taken. Open 6 days 9.30-5.30

LONDON

BABBER ELECTRONICS SERVICE CENTRE 158 Uxbridge Road, West Ealing, London, W13 8SB Tel. 020 8579 6315. Akai, Aiwa, A&R, Celestion, Dual, Goodmans, Harman Kardon, JBL, JVC, Kenwood, Marantz, Panasonic, Sennheiser, Sony, ES range, Tannoy, Technics, Wharfedale, Yamaha and many more. Auth. Service Dept. Credit facilities. Open 10.30 - 5.30 Mon-Sat.

BILLY VEE SOUND SYSTEM 248 Lee High Road, Lewisham, London SE13 SPL. Tel: 020 8318 5755/020 8852 1321. Arcam, Denon, Marantz, Linn, Mission, Naim, Tag McLaren, Pioneer-DVD, Rega, etc. 2 domestic style listening lounges. Appts required. service dept, home trial facilities. Interest free credit, Access, Visa, Amex cards accepted. Opened Mon-Sat 10-6.30. Closed Thursday.

CHOICE HI-FI Tel. 020 8392 1959. Specialist dealers in high end quality second-hand equipment. All main brands in stock including Krell, Audio Research, Wadia, Mark Levinson, Sonus Faber, Linn, Naim, SME & many

more. Generous price given on trade-in. Part exchange welcome. Also dealers for Trichord, SME, Gamma, Trilogy, Lumley, Boulder & many more.

INFIDELITY 9 High Street, Hampton Wick, Kingston-upon-Thames. Tel: (020) 8943 3530. for full details see entry under SURREY

HIFI EXPERIENCE 227 Tottenham Court Road, London W1 020 7580 3535. Arcam, Cyrus, Denon Gold, Quad, Kef, Meridian, Yamaha, Marantz, McCormack, Mirage, Nakamichi, Musical Fidelity, PAFF and many more. Open 10.00-7.00 Mon-Fri, 9-6 on Sat. Service dept. Credit facilities, delivery and free installation.

K J WEST ONE 26 New Cavendish St, London W1M 7LH. 020 7486 8262/63. Fax 020 7487 3452. Two hi-fi & two home cinema dem studios. Appts pref. Home trial. Installation by arrangement. Service dept, Major credit cards. Interest free credit on selected items. Major brands stocked: Arcam, Audio Alchemy, Audion, Audiolab, Audio Research, B&W Castle, Chord, Copeland, DPA, Epos, Graaf, Harbeth, KEF, Klipsch, Krell, Lexicon, Marantz, Martin Logan, Meridian, Michell, Micromega, Mission, Musical Fidelity, Nitty Gritty, Pink, ProAc, Quad, Ref, Rotel, Orelle, Sonus Faber, Stax, Tannoy, Theta, Unison Research, Wilson Benesch. Open 6 days.

THE LISTENING ROOMS 161 Old Brompton Road, London SW5 0LJ, (020) 7244 7750/59. Fax (020) 7370 0192. Linn, Quad, Meridian, Nakamichi, Arcam, Audiolab, Acoustic Energy, SME, Audio Research, Krell, Wadia, Theta, Apogee, Martin Logan, Pioneer, Tannoy, Systemdek, Stax, Pink Triangle, Michell, Monitor Audio, Yamaha, Marantz, KEF, Bose, Celestion, Epos, Mission, Denon, Neat Petite Mon-Sat 10-6pm

ORANGES AND LEMONS 61-63 Webbs Road, Battersea, SW11 1. Tel: 020 7924 2040. Visit www.orangesandlemons.com Juicy fruit from London's freshest Hi-Fi / Home Cinema retailer, our sixth succulent year. Telephone demonstrations, or just pop in. All the usual, i.e. friendly and efficient service, free home installation, credit cards, 0% credit finance available (subject to status), plus...all the very best from Arcam, Cable Talk, Castle Acoustics, The Chord Co., Denon, Epos, Kef, Linn, Marantz, NAD, Naim Audio, Neat, Quad, Rega, Roksan, Rotel, Royd, Ruark, Soundstyle, Stands Unique, Yamaha and more.

THOMAS HEINITZ LTD 35 Moscow Road, Bayswater, London, W2 4AH. Tel: 020 7229 2077. Fax: 020 7277 9348. Email: info@thomasheinitz.com. Web site: www.thomasheinitz.com. Established in 1952, Thomas Heinitz has a long history of providing the best music and AV systems available. We continue to offer the highest standard of service in the most relaxed atmosphere. Whatever your needs, from multiroom and home cinema to a high quality stereo system, we offer consultation, design specification, architect liaison and installation in order to ensure your system is tailored to your exact requirements. For quotes contact our manager Johnny Drum.

GREATER MANCHESTER

ADVENTURES IN HI-FI S, Bishopgate, off Hallgate, Wigan, WN1 1NL. Tel 01942 234202. See our main entry under LANCASHIRE

PRACTICAL HI-FI 65 Bridge Street, Manchester M3 3BQ Tel:- 0161 839 8869 See our main entry under LANCASHIRE

SWIFT OF WILMSLOW, 4-8 St. Annes Parade Wilmslow. Tel (01625) 526213. Aura, B&W, Denon, Kenwood, Marantz, NAD, Pioneer, Rotel, Tannoy, Revolver, JPW. Open 9.30-6.00pm. 2 dem. rooms. No pressure!

MERSEYSIDE

ACOUSTICA 17 Hoole Rd, Chester CH2 3NH. Tel 01244 344227. See our main entry under "Cheshire".

MIDDLESEX

MUSICAL IMAGES 45 High Street, Hounslow, Middlesex. Tel.(020) 8569 5802. Fax: (020) 8569 6353.

MUSICAL IMAGES 173 Station Road, Edgeware, Middlesex. Tel. (020) 8952 5535 . Fax. (020) 8952 5535. Most brands available - see full page advert. Interest free credit, ask for details. Demo rooms. Repairs & Service. Sunday opening - Open all week. A Home Cinema Specialist. Mail order. Part exchange.

DIAL-A-DEALER

OPAL DESIGNS LTD. Rockware Business Centre, 5 Rockware Avenue, Greenford, Middlesex, UB6 0AA. Tel: (020) 8930 7972. Fax: (020) 8930 7976. Email: jas@opal.co.uk. Home Page: www.opal.co.uk. High-end Audio & Home Theatre Consultants. Authorised dealers: Mark Levinson, Proceed, Linn Hi-Fi, Linn Knekt, Runco Projectors, Faroudja, Stewart Film Screen, Revel Loudspeakers, Stax, Wilson Audio, Martin Logan, Sonus Faber, MIT, Transparent, B & W. Mail order welcome. Credit cards accepted. Phone for latest brochure.

RIVERSIDE HI-FI 422 Richmond Road, East Twickenham, Middlesex, TW1 2EB. Tel: 020 8892 7613 Fax: 020 8892 7749. www.riversidehifi.co.uk Arcam, Bose, B&O, Castle, Copland, Denon, Krell, Marantz, Martin Logan, Mitchell, Monitor Audio, Musical Fidelity, NAD, Pioneer, Project, Rel, Sonus Faber, Sony, Tag McLaren Audio, Tannoy, Teac, Theta, Wilson, Finance available. Subject to status. Written details available on request. Export orders welcome. UK mail order available. 3 demonstration rooms. All major credit cards. Open 10am-5.30pm Mon-Sat.

NORFOLK

BASICAL SOUND The Old School, School Road, Bracon Ash (Nir Norwich), Norfolk, NR14 8HG. Tel: (01508) 570 829. Stockists of the following leading Hi-Fi: Arcam, Audio Analogue, Beyer, Denon, Dynavector, Epos, Grado, Naim, ProAc, Rega, Royd, Sennheiser, Talk Electronics, Teac and more. Bada members, 2 comprehensive demo rooms.

NORTHAMPTON

CLASSIC HI-FI At Classic Hi-Fi we cover the best in quality sounds. Be it a question of taste, a question of balance or a question of price, we're the ones to help. We stock: Marantz, Nad, Pioneer, Roksan, Yamaha, Heybrook, LFD, Sugden, Rotel, Kenwood, B & W, Kef, Rogers, Monitor Audio, Musical Fidelity, Tannoy, Shearpe Audio, Royd, Audio Alchemy, Teac and many more. For more details call: 01536 310855

LISTEN INN 32 Gold Street, Northampton, NN1 1RS. Tel: 01604 637 871. The World's Finest Hi-Fi from Arcam, Audio Analogue, Chord Company, Copland, Denon, FMJ, Fujitsu, KEF, Krell, Linn, Loewe, Martin Logan, Meridian, Miller & Kreisell, Mission, NAD, Naim, Proac, Rega, Rotel, Sennheiser, Sonus Faber, Wilson Benesch, Yamaha. Dedicated Viewing & Listening Rooms, Friendly Staff, Fresh Coffee, 2 Full Years Warranty, Part Exchange Welcome, Free Car Parking, Interest Free Credit, Members of BADA. Open 10am-5.30pm (Closed Thursday).

NOTTINGHAMSHIRE

CASTLE SOUND & VISION 48-50 Maid Marian Way, Nottingham, NG1 6GF. Tel: 0115 958 4404. Nottingham's leading hi-fi, multi room and home cinema store, serving the whole of the East Midlands. Brands stocked include: Alchemist, Audio Valve, Bose, Boston Acoustics, Castle Acoustics, Chord Electronics, DMP, Denon, Jolida, KEF, Klyne, Linn, Linn Knekt, Lexicon, Loewe, Monarchy, Musical Fidelity, Naim, Nordost, Pink Triangle, Pioneer, Project Turntables, Precious Metals, REL, Rega, Revox, Selec Projectors, Sheffield Lab, Solidsteel, Sony, Stand Unique, Stereophile, Talk Electronics, TEAC, Wavac, Wilson Benesch and XLO. Large showroom including purpose built home cinema room as well as three demonstration rooms. Home demonstrations and a full installation service available, including multiroom systems. Open 10.00 am - 6.00 pm Tuesday, Thursday, Friday and Saturday; 11.30am - 7.30pm Wednesday. Appointments out of normal shop opening hours can also be arranged.

NOTTINGHAM HI-FI CENTRE 120-122 Alfreton Road, Nottingham. Tel: 0115 9786919. Multi-room specialists. Hi-Fi, Home cinema. All leading brands stocked. Three superb demonstration areas. Two year parts and labour guarantee. Home trials. On site service facility. Full delivery and installation service. Easy free parking. BADA Dealer. Established 1968. Mon-Sat 9.00-5.30

OXFORDSHIRE

OVERTURE HI-FI 3 Church Lane, Banbury, Oxon OX16 8LR. Tel (01295) 272158. Email sales@overture.co.uk Website: www.overture.co.uk Arcam, Bose, Cura, Denon, KEF, Linn Products, Miller and Kriesel, Mission, NAD, Naim Audio, Yamaha. For sensible unbiased advice, call Oxfordshire's audio experts. Superb demo facilities. No appts. necessary. Home Cinema, Plasma

TV, Projectors, Lutron Lighting, MultiRoom and Commercial installations. Access/Visa, instant credit. Mon-Fri 10-6, Sat 9.30-5.30.

SHROPSHIRE

ADAMS & JARRETT Hi-Fi and Home Cinema Specialist. Phone or visit us at 6-18, Norman Road, St. Leonards-on-Sea, E.Sussex. (01424) 437165/432398. Stockist of quality equipment including: Audio Innovations, Meridian, KEF, Ruark, Marantz, NAD, JBL, Royd, Dalí, Jamo, Onkyo, Rel, Traget, Cable Talk, Technics, TDC, Yamaha, Kenwood. Air conditioned listening rooms, on site service and repair facilities

SHROPSHIRE HI-FI St Michael Street, Shrewsbury, Shrops. SY1 2ES. Tel. 01743 232065. Stockists of Musical Fidelity, Mordaunt Short, Sony, Kenwood, Pioneer, Rotel, Denon, B&W, Proac. Audio Visual. Products available. Open 9.30 - 5.30pm Mon-Sat.

STAFFORDSHIRE

ACOUSTICA 114 Wolverhampton Rd, Stafford ST17 4AH. www.acoustica.co.uk. Tel 01785 258216. All that's best in HiFi & Home Cinema from quality manufacturers including Naim, B&W, Musical Fidelity, Rotel, Selec Projectors, Kef, Ruark, Teac, JM Lab, Rega, NAD, Yamaha, REL, Sanyo projectors, Fujitsu. We offer friendly, helpful advice, interest free credit & trade-in facilities, and deliver & install systems throughout Staffordshire & the Midlands. Opening hours are Tuesday to Friday 10.30 until 6.00, Saturday 10.30 until 5.00.

SOUND OF MUSIC

The alternative Hi-Fi shop. 01270 214143, A.K.G., A.V.I., Alchemist, B.C.D., Blueprint, Castle, Chord Co., Deva, Dynaudio, Dynavector, Electrocompaniet, John Shearn, Kef, Lexicon, Linn, Loewe, Mitchell, Myrrad, Nordost, Ortofon, Project, Projekt Stands, Q.L.N., Restek, Roksan, Stands Unique, Teac.

SUFFOLK

AANVIL AUDIO, Tel/Fax 01359 240687 Mobile 0467 404874 Music from the Sound Foundry! Suppliers of: [Audio Physic]: loudspeakers, Adyton: amplifiers, Meracus: CD transports, players, DAC's pre and power amplifiers, Yamamura Churchill: cables and accessories. ART: Accessories Mail Order Accessories/CD's Cable/Amp Stock Clearance: Phone or fax for further details and ex-demo hardware offers. Most major credit cards accepted.

ANGLIA AUDIO The Street, Hessel, Bury St Edmonds, Suffolk, IP30 9AZ. Tel. 01359 270212. "Hi-Fi and speaker centre dedicated to quality hi-fi since 1971. Open 10-6. Closed Weds and Sundays. Evening and Sunday Demos by appointment.

AUDIO IMAGES 128 London Road North, Lowestoft, Suffolk, NR32 1HB. Tel: 01502 582853. Arcam, Acurus, Castle, Rotel, Moth, Triangle, QTA, Sugden, Denon, Yamaha, Mirage, M & K, Definitive, Musical Fidelity, plus the incredible Rothwell range. Refreshingly different selection. Dem Room, Professional AV installer's from budget to high end. Full credit facilities. 9.30 to 5.30 Mon & Sat - 9.30 to 6.00 Tues to Fri.

EASTERN AUDIO 41 Bramford Road, Ipswich, Tel. 01473 217 217. Fax 01473 215705. Quad, Arcam, Audiolab, Meridian, Mission, Denon, Rotel, Marantz, NAD, Sony, Rogers, Nakamichi, Systemdek, Technics, Celestion, B&W, Tannoy, Morel Thorens and Top Tape. Also stock a wide range of accessories. usual credit facilities. A BADA dealer.

SURREY

INFIDELITY 9 High Street, Hampton Wick, Kingston upon Thames, Surrey, KT1 4DA. Tel. 020 943 3530. Email: infidelity@compuserve.com - Web Address: infidelity.co.uk Stockists of: Linn, Naim, Arcam, Meridian, Rega, B&W Nautilus, Neat, Proceed, Royd, M&K, Rotel, Stax, Shahnian, Dynavector. Open 10.30 - 7.00 Tues - Fri, 10.00 - 6 Sat.

SPALDINGS HI-FI 352-4 Lower Addiscombe Rd., Croydon, Surrey, CR0 7AT. 0181 654 1231/2040. 3 dem rooms and home dem. Free installation/credit. Meridian, Linn, Naim, Quad, Arcam, Audiolab, Mission, Denon, Tannoy, Marantz, Ruark. Mon-Sat 9-6, Tues 9-8. Service dept. (3 Dem rooms incl. A.V. 0% credit).

SUSSEX (EAST)

ADAMS & JARRETT For the best Audio Visual Specialist with friendly helpful staff phone or visit us at 6-18 Norman Road St. Leonards-On-Sea, East Sussex. Tel. 01424 437165/432398. Copland, Castle, Denon, Densen, Dynaudio, Jamo, Kef, Kenwood, Marantz, Meridian, Musical Fidelity, NAD, Onkyo, Primare, Rel, Rotel, Ruark, Tannoy, Technics, Yamaha. Interest free credit available subject to status. Visa, Mastercard.

WEST MIDLANDS

ACOUSTICA, 114 Wolverhampton Rd, Stafford ST17 4AH. See our main entry under "STAFFORDSHIRE".

MUSIC MATTERS

Birmingham - 363, Hagley Road, Edgbaston, B17 8DL. Tel. 0121 429 2811.

Solihull - 93-95, Hobs Moat Road, B92 8JL. Tel. 0121 342 0254.

Stourbridge - 9, Market Street D48 IAB. Tel. 01384 444184.

Sutton Coldfield - 10, Boldmere Road, B73 5TD. Tel. 0121 354 2311.

Arcam, Alchemist, Apollo, Audioquest, Audio Research, B&W, Cable Talk, Castle, Celestion, Chord, Copland, Cyrus, Denon, DPA, JBL, Kef, Krell, Marantz, Martin Logan, Meridian, Musical Fidelity, Panasonic, Pioneer, REL, Rotel, Ruark, SME, Sennheiser, Sonus Faber, Tag McLaren, Teac, Theta, Yamaha etc. Classical CD's available at Birmingham only. Demonstration rooms, service and installation. BADA member. VISA / MASTERCARD / AMEX / SWITCH. Open: 10-5.30 Tuesday to Saturday. Late night Thursday till 7.00 (not Stourbridge).

SOUND ACADEMY

For the Midlands. The Parade, Sutton Coldfield, Tel. 0121 321 2445 & High Street, Bloxwich, Nr Walsall, (sharing the ASDA shopping centre) Tel 01922 493499. Hosts 4 private studios plus a Home Theatre Cinema with Tube & LCD Projectors. The best in hi-fi from Naim, Arcam, Audiolab, Chord, Meridian, Monitor Audio and many more. So... if you've taken time to read this, please let us make you welcome. Phone 0121 321 2445 for Sutton or 01922 493499 for Walsall. Call in and to browse our exciting display of hi-fi and home cinema equipment. Mail order available. interest free credit S.T. Status. Open 6 days, 9am to 5.30pm. Please call for late night. Expert Advice, Cable Dressing and Installation.

WILTSHIRE

SALISBURY HI-FI LTD. 15 Catherine Street, Salisbury, Wiltshire SP1 2DF. Tel (01722) 322169. Arcam, B&W, Celestion, Denon, KEF, Kenwood, Marantz, Meridian, Micromega, NAD, Ruark, Sony, Yamaha, 2 Dem rooms. Friendly, relaxed atmosphere. Professional advice. Home dem available. Service department, Free installation. Home trial facilities. Access, Visa, Amex. Interest free credit. Instant credit. Open Mon-Sat 9-5.30.

THE RIGHT NOTE - See under **BATH & BRISTOL** heading.

YORKSHIRE (NORTH)

SOUND ORGANISATION YORK, 2 Gillygate, York YO31 7EQ. Tel (01904) 627108. Carefully chosen Hi-Fi and AV equipment includes Arcam, B&W, Nautilus, Denon, Linn, Naim, Rega, Rotel, Stax etc 3 dem rooms incl. Home Cinema and Linn connect. Service Department. Home installations, instant Credit and major credit cards. Closed Mondays. Phone for chat and more details. www.soundorg.co.uk

YORKSHIRE (EAST)

ZEN AUDIO 35 George Street, Hull Tel. 01482 587397. "Comfortable listening rooms; Home dems; Personal, friendly service; Free installations. Agencies include: Arcam, Audiolab, Atacama, Audio Innovations, Audio Note, Audion, Alchemist, B&W, Cable Talk, Chord CO, DPA, Densen, Denon, DNM, EAR, Exposure, Fi-Rax, Harbeth, Heybrook, Impulse, KAR, KEF, Michell, Micromega, Monitor Audio, Musical Technology, Myrrad, NAD, NAIM, Pioneer, REL, Rehdeko, Rotel, Royd, Ruark, Shearpe Audio, Stands Unique, Sugden, Spendor, Sonic Link, TEAC, TDL, Tube Technology, Vivanco and many others.

YORKSHIRE (SOUTH)

THE HI-FI STUDIOS - The Long Barn, Wakefield Road, Hampole, Doncaster, DN6 7EU.

Tel: (01302) 727274/725550.

E-mail: info@shehifistudios.freemove.co.uk

HIFI, HOME CINEMA AND MULTI-ROOM EXPERTS Musical Fidelity, Electrocompaniet, ProAc, PMC, Ruark, Castle, TEAC, Unison Research, Monitor Audio, Impulse Horns, Primare, Harbeth, NAD, Michell Turntables, Nottingham Analogue Studios, Audio Analogue, Living Voice, Densen, Exposure, Celestion (A Series only), Opera, Trichord Research, Nordost, Stands Unique, Ortofon, Project, Goldring, REL Subwoofers, Denon, TAG McLaren, Rotel, Yamaha, Proceed Home Cinema Products. Plus many others. **(Viewing and demonstration by appointment).** Home trials and installation. Card facilities and interest free credit available. Phone for more information. Tuesday-Friday 10-6.30, Saturday 10-5, closed Sunday/Monday. Later appointments by arrangement welcome. B.A.D.A - C.E.D.I.A.

MOORGATE ACOUSTICS 8 Westgate Chambers, Rotherham Tel: 01709 370666. 184 Fitzwilliam Street, Sheffield Tel: 01142 756048 - Audio Alchemy, Atacama, Arcam, Audio Lab, Audio Quest, Beyer, Bose, Canon, Castle, Cyrus, Celestion, Denon, Jamo, John Shearn (Amplifiers), Linn, Marantz, Mission, REL (Sub Woofers), Rogers (Speakers & Amplifiers), Royd, Sennheiser, Sponder, Tannoy "D", T.D.L., Technics, Yamaha. Demo rooms (6), Home Cinema, Access, Visa. Switch, interest free credit (details available upon request), up to 5 years guarantee.

YORKSHIRE (WEST)

HUDDERSFIELD HI-FI CENTRE 4 Cross Church St, Huddersfield, (01484) 544668. B&W, Cyrus, Kenwood, Denon, Rotel, Arcam, Musical Fidelity, Quad, Audio Lab, Marantz, Mission, etc. Dem facilities - appointment reqd. Mon-Sat 9-5.30, Thurs 9-8. Closed Wed. Free installation, credit facilities. Access, Visa

HUDDERSFIELD HI-FI CENTRE HALIFAX 3-5 King Cross St, Halifax. 01422 366832. Audio Analogue, Arcam, B&W, Castle, Cyrus, KEF, MF, Mission, NAD, PRO-AC, Sugden, Quad. 2 Dem rooms Mon - Sat 9-5.30 closed Thursday. Credit facilities.

PREMIER AUDIO Wakefield (01924) 255045. A brand new company offering a range of exciting Audiophile products carefully selected and professionally demonstrated. Equipment includes Audio Synthesis, Chord Company, Classe, cable Talk, DPA, EAD, Exposure, Harbeth, Korá, Mirage, Myryad, Orelle, Trichord and many others. demonstration facilities. Home demonstrations & Free installation. Part Exchange & used equipment Available. telephone for details and opening offers.

SCOTLAND

CENTRAL

COLIN MACKENZIE'S HIFI CORNER 52 Gordon Street Glasgow 0141 248 2840. Rose St Edinburgh 0131 220 1535, 1 Haddington Place, Edinburgh 0131 556 7901 and 44 Cow Wynd, Falkirk 01324 629011. Audiolab, Cyrus, Sound-Bytes, Meridian, etc. Most major Brands stocked. Free five year guarantee on all loudspeakers, keen prices.

JAMES KERR & CO. 145 Bath St, Glasgow 0141 226 5711. Glasgow's oldest established hifi specialist, now at new larger premises.

LOTHIAN

COLIN MACKENZIE'S HIFI CORNER 52 Gordon Street Glasgow 0141 248 2840. Rose St Edinburgh 0131 220 1535, 1 Haddington Place, Edinburgh 0131 556 7901 and 44 Cow Wynd, Falkirk 01324 629011. Audiolab, Cyrus, Sound-Bytes, Meridian, etc. Most major Brands stocked. Free five year guarantee on all loudspeakers, keen prices.

JAMES KERR & CO. 145 Bath St, Glasgow 0141 226 5711. Glasgow's oldest established hifi specialist, now at new larger premises

MUSIC MILL 72 Newhaven Road, Edinburg EH6 5QG. Tel: 0131 555 3963 Fax: 0131 555 3964. Audio Research, Copland, Naim Audio, Krell, Roksan, Rotel, DNM, Marantz, AVI, Martin Logan, Pro-Ac, Wilson Audio, Wilson Benesch Theta Digital, Transparent Audio, Alchemist, Quadraspire, Stands Unique, Listening Rooms, Free Parking, Full Workshop, Delivery and Installation. Open Mon-Sat 10-6.00 pm. Please phone for a map or contact Raoul, John, Mark, or Mike.

GRAMPIAN

HOLBURN HI-FI 441 Holburn Street, Aberdeen. Tel: 01224 585713. Arcam, Audiolab, B&W, Celestion, Denon, Dtal, Epos, Heybrook, ION, Kenwood, Creek, Marantz, Meridian, Mission, Cyrus, M.S., NAD, Nakamichi, Pioneer, QED, Quad, Revox, Rotel, Ruark, Tannoy, Technics, Wharfedale, Yamaha. 9.30-5.30 Mon-Sat

STRATHCLYDE

COLIN MACKENZIE'S HIFI CORNER 52 Gordon Street Glasgow 0141 248 2840. Rose St Edinburgh 0131 220 1535, 1 Haddington Place, Edinburgh 0131 556 7901 and 44 Cow Wynd, Falkirk 01324 629011. Audiolab, Cyrus, Sound-Bytes, Meridian, etc. Most major Brands stocked. Free five year guarantee on all loudspeakers, keen prices.

KEVIN GALLOWAY AUDIO., Audio Physic, Accuphase, Audion, Basis, DCS, JM Lab, Pink Triangle, Electrocompaniet, Sugden, Nagra, Tara Labs. Nationwide delivery and installation. Demonstration by appointment. Tel: 01563 574185. Fax: 01563 573207

JAMES KERR & CO. 145 Bath St, Glasgow 0141 226 5711. Glasgow's oldest established hifi specialist, now at new larger premises

LOUD & CLEAR 520 St Vincent Street, Finnieston, Glasgow G3 8XZ. Tel: (0141) 221 0221 or visit us at www.loud-clear.co.uk. Glasgow's finest and friendliest Hi-Fi store, combining knowledgeable advice with specially selected products and the best of service. Three comfortable demonstration rooms, full service and installation facilities, interest free credit on selected products. Product lines include Naim Audio, Exposure, Alchemist, Rega, Tag McLaren, Musical Fidelity, Marantz, Denon, Rotel, Acoustic Energy, KEF, KEF Reference, Monitor Audio, Tannoy, ProAc, VdH, Chord Co., DNM, Ash Design, Stands Unique. Open Tues-Sat 10am-6pm, Thurs till 7pm. Complimentary parking at PC World, Finnieston Street.

STEREO STEREO 278 St Vincent Street, Glasgow, Tel: 0141 248 4079
Email: stereo@cix.compulink.co.uk
We will supply the most musical sound for your budget and if you take the time to visit us we will take the time to return the compliment with free installation of your chosen equipment. Open 10-6.00pm closed Sunday, Tuesday Installation Nation-wide Interest free credit available.

WALES

NORTH WALES

ACOUSTICA 17 Hoole Rd, Chester CH2 3NH. Tel 01244 344227. See our main entry under "Cheshire".

ACTON GATE AUDIO 4 Ruabon Road, Wrexham, North Wales, Tel. 01978 364500. See our main ad under Cheshire.

GLAMORGAN (SOUTH)

SOUND DR. JULES SWANSEA, 01792280 061. Call now for price list, UK or overseas. Hi end new and pre-owned hi-fi at an affordable price. Home trial prior to purchase. Reliable courier service and repair service. Friendly and enthusiastic advice, day or evening seven days a week. A service to suit you.

IRELAND

AUDIO AUDIO HIFI SPECIALISTS 15 Mansfield Heights, Portlengone, Co. Antrim, N. Ireland BT44 8JR. Telephone 01266 822128/ Fax 01266 822128. Products include Totem, Sugden, Denon, Ortofon, Project, Alchemist, QED, Chord Co., Arcam, Quadraspire, Audioquest, Rega, Soundstyle, Apollo, Grado, Ixos, Sonace, Optimum, Acoustic Energy, Tangent, Mighty Mighty, Sound Organisation, Jamo, Free installation. Please ask about our FREE customer care package

CLONEY AUDIO 55 Main Street, Blackrock, Dublin, Tel. 2889449/2888477 Fax 2834887. Products include: Arcam, Classe, Philips, B&W, Naim Audio, Meridian and others. Open Tues/Sat 10am-6pm. Thurs/Fri till 9pm. Closed Mondays.

DUBLINN HI-FI 38 Augier Street, Dublin 2. Tel: (00 353) 1 4785205. Fax: (00 353) 14785219. We all have two ears and one mouth - use them accordingly. We only stock the best products, based on performance and reliability - not reviews or sales patter. Call Mark or drop in for a listen. Three single speaker demo rooms.

Free delivery and installation. Full service department. Open Mon-Fri 10-7, Sat 10-6

NORTHERN IRELAND

KRONOS HI-FI 7 Scotch Street Centre, Dungannon, BT70 1AR. Tel: (01868) 753606. Fax: 753006. Email: David@KronosHi-Fi.demon.co.uk. website <http://www.KronosHi-Fi.demon.co.uk> We have one of the largest ranges of quality Hi-Fi in Ireland. Our agencies include Absolute Sounds, Apogee, Audion, Audiomeca, Blueprint, BOW Technology, Cadence, Copeland, Denson, Frameworks, Harman Kardon, Helios, JBL, Kelly, Kimber, Klipsch, Living Voice, Lyra, LFD, Marantz, Michell, MIT, Musical Fidelity, Nottingham Analogue, Oracle, Orelle, QLN, Rogers, Roksan, Rotel, Ruark, Silver Sounds, SME, Triangle, Trichord, Unison, UKD, Wilson Benesch, YBA and much more. Demo rooms for Hi-Fi and A.V. Free installation, home demos and home trial. Access and Visa. Credit including instant and interest free. Multi-Room specialists. Open Mon-Fri 9.30-5.30. Closed Wed. Sat 10-5. We are also open any evening by appointment.

VINYL/RECORD MAIL ORDER

DIVERSE VINYL 10 Charles Street, Newport, NP20 1JU. Tel/Fax: 01633 259661/256261
Email: sales@diverse-music.co.uk Probably the most varied and impressive selection of brand new LPs you'll find anywhere: international new releases, reissues and audiophile products. Also UK distributor of the Disco Anti Stat LP Cleaning Device. Call for a free catalogue, or visit www.diverse-music.co.uk

SILVERNOTE PO Box 158, Cheshunt, Herts, EN7 6UH Always wanted: Vintage and Modern Equipment. Records & CD's. Tel/fax Steve on 01992 620905.

VIVANTE - Unit 4, 60 High Street, Hampton Wick, Surrey KT1 4DB. Tel: 0181 977 6600, Fax: 0181 977 4445. One of the UK's largest importer and distributor of audiophile and conventional vinyl is now operating a mail order service specialising in jazz and classical reissues. Labels include Decca, London, Deutsche Gramophon, Archiv, EMI, Telefunken, Testament, Verve, MPS, Milestone, Fantasy, Pablo and more. Extensive catalogue available. Access/Visa accepted.

VINTAGE

AUDIO CLASSICS, 18/20 Chapel Green Road, Hindley, Wigan, WN2 3LL. Tel: 01942 257525. Fax 01942 207089. Mobile: 0585 476574. Hi-Fi bought, sold, repaired and renovated. Mail order and vintage specialists. Please see our main ad (look under the ad index to find) for further information

PRE-OWNED MAIL ORDER

AFFORDABLE AUDIO. (NORTHAMPTON) Pre-Owned Hi-Fi Specialists. 168 Wellingborough Road, Northampton, NN1 4DU. Tel/Fax: 01604 231261 or Tel 01933 273281 Mobile: (0370) 877893. Email: sales@affordable-audio.co.uk Website: www.affordable-audio.co.uk Urgently required: compact disc collections, hi-fi separates, especially Linn products, Naim Audio, Cyrus Electronics, Musical Fidelity, Quad Electronics, almost anything British/American. Cash waiting, part exchange welcome. We also stock lots of audio accessories, compact discs, vinyl, DAT players. All equipment is sold with warranties. All Credit Cards accepted. Please phone anytime for stock update.

EX DEMONSTRATION

AUDIO CLASSICS, 18/20 Chapel Green Road, Hindley, Wigan, WN2 3LL. Tel: 01942 257525. Fax: 01942 207089. Mobile: 0585 476574. Hi-Fi bought, sold, repaired and renovated. Mail order and vintage specialists. Please see our main ad (look under the ad index to find) for further information.

CHOICE HI-FI/HI-FI EXCHANGE Open 10am-8pm, 7 days by appt. Tel: 0181 392 1959/1963. Fax: 0181 392 1994. Agents for Acoustic Energy, Alon, ATC, Boulder, Bryston, Chord, Forsell, Gamma, Van den Hul, Lumley, Rockport, SME, Soundstyle, Straight Wire, Targel, Trichord, Trilogy VPI XLO and many more. We offer: generous part exchange, your equipment purchased, show room/dem room, single speaker dem room, trade in policy, credit card facilities, mail order, export service, finance available.

To advertise in Dial a Dealer please call 020 7604 4890

meet your maker

A reference guide to Britain's manufacturers and distributors

AFFORDABLE VALVE COMPANY £600 Valve amplifier. Powerful 40 watts. Powerful bass. See colour photograph in Specialist Hi-Fi Dealers' section Mr Andrew Everard in Gramophone Magazine "delivers a sound that's both smooth and refined... allied to a good degree of clarity and finesse". Free colour literature. Telephone 01634 373 410 any time. Website: www.affordablevalve.com

ALCHEMIST PRODUCTS Call us and allow us to transform your life with products from an acclaimed range of Amplifiers, CDs and Pre/Power combinations including such models as 'Kraken' and 'Forestry' right through to our award winning 'The Alchemists' range (Winners 1996 C.O.T.V. Japan) Unit 1, Furzewood House, Cranbourne Ind Est, Potters Bar, Herts. EN6 3JN. Tel: 01707 664607 (for enquiries) Tel: 01753 889949 (for UK Sales) Fax: 01707 664207 (for enquiries) Fax: 01753 889636 (for UK Sales).

ALEMA LTD 103 South Street, Lancing, BN15 8AS. Tel: 01903 75055/6. "AUDION" "EDISON" "DAC" "AMP" Europe's Leading Brands. Gold Medal Winners "A" Rated in Stereophile, Best of Year (Taiwan). Buy the Best Full Remote Valve And New Transistor Range. Tube Amps £599 - £1500. Kits From £399. Check the Latest at www.hi-fidelity.co.uk.

APPOLLO The UK based designers and manufacturers of high quality speaker stands and equipment racks have now added to their comprehensive range a modular system ideal for housing audio visual products and CD storage. Please send for our free brochure to Zenith Crown Ltd, Tipson Rd, Dudley, West Midlands, DY14 1EL. 0121 520 5070. Fax: 0121 522 2055. All export trade enquiries welcome.

AUDIOPHILE FURNITURE LTD The Square, Forest Row, East Sussex RH18 5ES. Tel: 01342 826262. Fax: 01342 824845. Manufacturers of the patented BASE Vibration Control Platforms and the Modular Audio Support System. These Products are endorsed by Hi-Fi World. Also newly introduced are the Resonance Controlled Hi-Fi Cabinets which are multi level modular design and available in various sizes and wood finishes. Please telephone for more details and a product portfolio.

AUDIO SYNTHESIS Manufacturers of the outstanding DAX digital to analogue converter, comes DAX-2, a new Hi-End reference converter able to dig deeper into the digital source than ever before! A new addition to the superb PASSION series of all Vishay controllers has just been introduced in the form of PASSION 8, a fully remote controlled uniquely transparent passive preamplifier, the perfect match for DESIRE. By word of mouth our DESIRE power amplifier is rapidly convincing listeners, whether passive or active! New for 1997 is TRANSCEND a state of art CD transport with AES, coaxial, AT&T glass and Toslink outputs. Audio Synthesis, PO BOX 50, Nottingham, NG9 1DZ. Tel: (+44) (0)115 922 4138. Fax: (+44) (0)115 922 9701.

BORDER PATROL 63 Bernside Avenue Hove BN3 4JD. Tel/Fax 01273 276716. Manufacturers of Power Supply Units for valve amplifiers, Single-Ended Power Amplifiers and high quality Transformers. The Border Patrol PSU, valve-rectified choke input filter power supply units which dramatically improves the sound of valve amplifiers: models available to suit Audionote, Audio Innovations, Audion, Art Audio, Cary, Union Research, World Audio Designs. The Border Patrol 300B SE single-ended valve amplifier featuring interstage driver transformers and valve rectified choke input filter power supplies. Border Patrol transformers: high quality output (PP and SE), interstage and pre-amp output transformers and high-value inductors.

CAMPAIGN AUDIO DESIGN Llandudno Road, Cardiff CF3 8PG. Tel: 01222 779 401. Supplies / manufacturers/malord; high purity silver interconnects, loudspeaker cables, internal wires and bespoke mains cables. Generous two week trial period.

CANFORD AUDIO PLC Crowther Road, Washington, Tyne & Wear, NE38 0BW. UK Sales: 0191 415 0205. Fax: 0191-416-0392. E-Mail: mbc@canford.co.uk Internet: www.canford.co.uk The UK's leading manufacturer and distributor of professional audio equipment, specialists in cabling & connectors. Canford invite interested parties to call for one of their FREE 850 page bi-annual catalogues which details over 12,000 products. Canford have offices and distributors world-wide.

CHORD ELECTRONICS LIMITED 3 Bower Mount Road, Maidstone, Kent ME16 8AX. Telephone: 01622-764874. Fax: 01622-688480. We have recently complemented our highly acclaimed SP1 range of power amplifiers with 2 superb pre-amps - the CPA 2800 + CPA 4000s as well as the BBC qualified L5512A loudspeaker & LFS12 bass extension system. Call us for copies of reviews that will leave you wanting details of your nearest retailer.

CREEK AUDIO LTD 2 Bellevue Road, Friern Barnet, London N11 3ER. Tel: 020 8361 4133. Fax: 020 8361 4136. E-mail: info@creekaudio.co.uk Internet: www.creekaudio.co.uk Creek Audio build stylish Hi-Fi products in the UK, combining state of the art electronic design, with full bodied, accurate and musically rewarding sound. Our standard size products come in two award-winning ranges, the entry level 43 series and higher priced 53 series. These include: CD43 MK2 - CD player with 24 bit resolution DAC, T43 AM/FM Tuner, Integrated Amps - S350, S350SE and 4330 MK2 (described by Stereophile Magazine as the best amp under \$1000). Our A43 MK2 and A53 Power Amps range from 50 to 250 Watts and both P43 and P53 Pre-Amps offer passive and active operation with remote control. In addition we have an award winning OBH range of small products: OBH-88SE MM and OBH-9 MC Phono Pre-Amplifiers, OBH-11 and 11 SE Headphone Amplifiers, OBH-10 and 12 Remote Control Passive Pre-Amps and OBH-14 - 24 bit DAC. See our home page for further details or call us for leaflets

DBS AUDIO/PO Box 91 Bury St Edmunds, Suffolk, IP28 6RY. Phone: 01284 723 933. Fax: 01284 811791. E-mail: DBSAudio@AOL.COM Superior sound with our self-build loudspeakers, featuring quality components and novel technologies. True high end on a budget - £269 floor-standing DBS7 would cost over £1600 retail. Save £££s with stand-mount DBS8, DBS5, DBS4/3 and DBS6/2. CUJO Lite electronic measuring system with mic, only £455. Also Netelec, Boxcalc and Boxdraw speaker CAD software.

EMINENT AUDIO Distributor of Croft Valve Amplification Tel: 01902 656517. Fax: 0121 681 8772. Mobile 0956 921740. UK Stockists are: Claxtone Sounds (Leicester) The Audio (London NW9) Nottingham Analogue, Purist Audio, The Cartridge Man (Len Greeny - Crofton), call for overseas distributors.

EPoS ACUSTICS 2 Bellevue Road, Friern Barnet, London N11 3ER. Tel: 020 8631 8864. Fax: 020 83614136. E-mail: info@epos-acoustics.com Website: www.epos-acoustics.com Innovative design and superior sound distinguish EPoS speakers from

other brands in a similar price category. Adhering to the EPoS tradition of musicality and communication, the new M12 follows closely the style of the successful ES12, and was awarded five gold stars in the March 2001 edition of What Hi-Fi?. For more information about the M12 or the new M15 please see our home page or call us for leaflets.

FALCON ACOUSTICS LTD Tabor House, Norwich Road, Mulbarton, Norwich, Norfolk, NR14 8JT. Tel: (01508) 578272. UK distributors of FOCAL drive units and SOLEIL (Chateauroux) polypropylene capacitors and the largest inductor manufacturer in the UK. Comprehensive range of DIY Speaker Parts and Kits, Sub-Bass and Electronic Filters. "Everything but the wood" Enquiries should be accompanied by a 44p stamped addressed envelope.

IAN EDWARDS The Old Chapel, 282 Skipton Road, Harrogate, Yorks. Tel: 01423 500442. Somebody Somewhere must make better storage units for CDs, Music, LPs, Hi-Fi, Books, etc. than Ian Edwards. BUT until he appears, why not send for the brochure showing a selection of HAND MADE units. To do this please send 3 x 2nd class stamps.

JAMO UK LTD Jamo House, 5 Faraday Close, Drayton Fields, Daventry, Northants, Tel: 01327 301300.

JEM DISTRIBUTION (FI RAX) Springfield Mills, Spa Street, Orsett, Wakefield WF5 0HW. Tel: 01924 277626. Fax: 01924 270759. Fi-Rax offers a new dimension in audio visual racking. High quality aluminium construction. Finishes available to your choice. Fully adjustable 6mm glass shelving sound insulation on shelves. Custom created to suit your system. Free delivery throughout the UK. For further information or a free brochure contact JEM Distribution.

JORDAN WATTS ACOUSTICS LTD Cnra Plca, 201 Mare Street, Hackney, London E8 3QE. Tel: 020 8 985 1646. Jordan Watts Acoustics for Sight AND Sound.

KESWICK AUDIO RESEARCH Coach Road, Outwood, Wakefield, W Yorks. WF1 3EX. Tel/Fax 01924 870606. "I'd say that the Figaro is the best miniature speaker I have heard" Audiophile March 1993. Write in or call for details on our full product range and your nearest stockist.

KRONOS DISTRIBUTION 7 Scotch Street Centre, Dungannon BT70 1AR. Tel: 01868 753606. Fax: 01868 753606. Kronos is the UK distributor of some of the finest Hi-Fi products in Europe. These include Audiomeca digital products and turntables; Lieder silver speaker and interconnect cables; Pro-Ject turntables and amplifiers; Triangle speakers and electronics; and YBA amplifiers. We also handle Frameworks equipment: Aron valve amplifiers and mains filters and Essex Audio digital products from the UK. Please telephone or write for product details and dealer lists.

LANGREX SUPPLIES LTD 1 Mayo Road, Croydon, Surrey, CR0 2QP. Tel: 020 8684 1166. Fax: 020 8684 3056. One of the largest distributors of electronic valves, tubes and semi-conductors in the UK and USA manufacturers stock. We specialise in obsolete types including original UK and USA made audio valves. Telephone or fax for an immediate quotation.

MICROMEGA distributed by Surrey Sounds, 32-33 Enterprise House, Terrace Road, Walton On Thames, Middlesex, KT11 2SD. Tel: 01932 254297. Fax: 01932 230174. For dealer and product info on the fantastic Minium complete system, up to the Solo and Data and Dialog. Also the new 24bit audio and video DVD player and the outstanding new premium range of CD players: All Micromega CD players play CDs like Vinyl!

MORGAN AUDIO SYSTEMS LTD range of equipment hand built in the UK, consisting of a CD player / DA converter / integrated & pre/power amplifiers. The integrated amplifiers are designed 125/250/600. Priced at £249/£399/£999. Pre-power versions of the 250/600 are priced at £799/£899. The CD player @ £579 & DAC @ £899 offer astounding performance and complete the 250 range. For further info please call: 0151 236 7667.

NORTON TECHNOLOGIES LTD Manufacturers of the acclaimed AirPower LP12 Power Supply, 14 Rothsey Avenue, Chelmsford CM2 9BU. (01245) 283125

NOTTINGHAM ANALOGUE STUDIO Tel: 01773 762947. Design and manufacture of quality analogue audio. We're in the business because we realise how important music is. Our turntable arms and cartridges sell the world over a commitment to providing all our customers with the best of analogue. We love music.

OPUS PENTACONE Natural Acoustical Music recorded on CD & LP. Three Dimensional, Dynamic and Live System Harmonising A service to extract the full potential of your Hi-Fi equipment by careful and innovative methods of Energy Tuning. VEEWERE AT THE RECORDING SESSION!! Because we record live music we know what it sounds like. 4. Cross Bank Road, Batley, W Yorks. WF17 8PL. Tel/Fax: 01924 445039. E-Mail: opuspentacone@hotmail.com WWW: <http://dSPACE.dalpix.com/vlm>

PLATFORM 7 High density marble ISOLATION PLATFORMS for all makes of equipment RACKS/STANDS An elegant way to UPGRADE improve clarity, better BASS control 3 Abbots Drive, North Wembley, Middlesex HA9 3SB. Tel: 020 8904 2646. Also NEALGAR DISTRIBUTION Tel/Fax 01296 24756.

PMC/BRYSTON Emmy award winning manufacturers of the highest quality loudspeakers and amplification. Industry standard in Mastering, Film Scoring, Broadcast and Post Productions (5.1 & Stereo) PMC Products: Compacts, Floorstanders and Large passive & active monitors. Prices range from £500 to £32,000. Finished in a large selection of exquisite real wood veneers, all PMC loudspeakers are available in horizontal mirrored pairs, centre channels and complementary subs for 5.1 surround systems. Bryston's balanced range of products include R/C Preamps, Integrated Amp modules for all the PMC range, Mono Stereo ISOW to 300W per ch, 2 Ch, 4 ch and 5 channel THX amplifiers, Surround processors, all with distortion figures and build quality to die for. Every product is available in silver or black backed by a 20 year warranty. PMC Ltd 43-45 Crawley Green Road Luton LU2 0AA. Tel: 08704 441044 Fax: 08704 441045 Email: sales@promonitor.co.uk web: www.pmc-speakers.com

PREMIER MARBLE LTD Uncover the true sound quality and potential of your system. Use the natural benefits of granite and marble. These natural materials offer better bass definition, clarity, and natural sound staging capabilities. CD/Turn-table platforms, custom made stands, shelves or anything you desire cut and polished to any shape or size required. Tel: 01603 721995

REL ACOUSTICS North Road, Bngend Ind Est, Bngend, Mid Glamorgan, CF31 3TP. UK Tel: 01656 768 777, international +44 656 768 777. Fax: 01656 766 093, international +44 656 766 093. Email: contact@rel.net Web: <http://rel.net> The UK's only specialist sub-bass

speaker manufacturer. "The only one that works!" Get your dealer to give you a home demo and find out what the fuss is all about.

RDE TANDBERG HI-FI SERVICES Hely Tree House, The Green, Full Sutton, YORK YO4 1HW. Tel: 01759 372795. The service, overhaul and reconditioning of all Tandberg hi-fi products regardless of age.

SHARANE AUDIO P O BOX 22, Steevenage, Haverfordshire SG2 8HF. England Tel: 01438 740953. Following the highly acclaimed Phase 2 integrated by adding the Phase 3 power amplifier and bi-amping, Sharane Audio are continuing the design philosophy of an upgradable system through the range. Introducing the Phase 6, a superbly musical, specialised pre-amplifier allowing owners of the Phase 2 or 3 or both to upgrade their systems to highly specialised levels, also the introduction of the Phase 5, 100 watt Monoblock, these along with the phase 6 pre-amplifier can be used via Phono inputs or balanced mode giving even greater versatility.

SONIC LINK The Derwent Business Centre, Clarke Street, Derby DE1 2BU. Tel: 01332 361390. Fax: 01332 200698. "Makes the World's Finest Hi-Fi Cable From the Highest Quality Materials". SonicLink Black Rhodium interconnect uses Rhodium plated wire. Vermilion uses pure Titanium wire. S-Goldmans cable improves the picture quality in TVs, computer monitors and home cinema as well as sound in hi-fi systems. Best selling products include Red, Silver Pink and Violet interconnects, AS75x2, AS730x2 and S130x2 Biwire loudspeakers and Green digital 75 ohm interconnect.

SOUND BYTES 72 Novar Drive, Hyndland, Glasgow, G12 9TZ. Tel: 0141 339 7595. Fax: 0141 339 7592. e-mail: bytes@colloquium.co.uk. We specialise only in mass loading material. After hours, exhaustively testing SOUND BYTES with various types of speakers, we know it works and so do you - we have never had a single complaint. Call us for advice on how much to add to your equipment for the best performance and the location of your nearest dealer.

SOUND IMAGE UK LTD 52 Milton Road, London SW14 8JR. Tel: 020 - 8255-6868. Importers and distributors of the finest audio equipment, featuring the stunning Boulder 2,000 series and the complete range from Norwegian manufacturer Electrocompaniet.

JJ SUGDEN & CO LTD Valley Works, Station Lane, Heckmondwike, West Yorkshire, WF16 1NF. Tel: 01724 404088. Email: jjsugden@compuserve.com. Super amplifiers and compact disc players from the original class A Company. Our unique wide-bandwidth, laserclass series sets new standards in sound reproduction and can be upgraded to 180 Watt balanced monoblocks. Prices start from £549.00 for the incredible Audition-T and £649 for the legendary A21a. Contact us now for Brochures, reviews and purchase details. British owned - British built.

TALIC ELECTRONICS Unit 12, Farnborough Business Centre, Eimoor Road, Farnborough, Hampshire, GU14 7XA. Tel: 01252 378383. Please ring for details.

TAG McCLAREN AUDIO - The Summit, 11 Latham Road, Huntingdon, Cambs. PE18 6ZU. Tel: +44 (0) 1480 415600. Fax: +44 (0) 1480 52159. Combining science and technology with distinct style, TAG McLaren Audio's complete range of audio and audio-visual products are designed to bring maximum pleasure to the discerning listener. To find out more visit our website at www.tagclarenaudio.com, email us on HelpDesk@tagclarenaudio.com or contact our helpdesk on freephone 0800 763 8007.

TARGET AUDIO PRODUCTS PLC Britannia House, Leagrave Road, Luton, LU3 1RJ. The Audio equipment, rack and speaker stand specialist. For information on our products please telephone or write.

TECH-LINK distributes some of the best performing hi-fi and av accessories currently available in the UK. These include: Pursonic, best known for its range of high performance interconnects and connectors, and cable adapters for a wide variety of hi-fi and av applications in its range. Tech-Link's own brand Switch Boxes are the perfect solution to multiple applications - for example, its highly acclaimed TAS-1 is a very practical and inexpensive way of switching your speakers between hi-fi and home cinema systems; and Shark - a range of very exclusive high quality cables, interconnects and connectors. For more information, contact Tech-link at Units 1/2, 76a Farley Road, London, SE25 6NX. Tel: 020 8771 8388. Fax: 020 8771 1840.

TEAC'S Marlin House, The Croxley Centre, Watford WD1 8YA. Tel: 01923 819630. Fax: 01923 236290. Teac has already established a virtual world dominance in the manufacture of precision recording equipment and data storage products and the company is now turning its attention to its core hi-fi and audio related products. The Tokyo Electro-Acoustic Company (hence TEAC) was formed in 1936. Over the years TEAC has produced some of the world's most outstanding recording equipment, including many excellent affordable home cassette decks for which the name TEAC became almost synonymous; and by the time of the dawn of the digital age at the beginning of the 1980's it was internationally acknowledged as a world leader in audio technology with a string of high fidelity firsts to its name. 1997 saw a significant turning point for TEAC with the launch of a superb new mini-system, a newly developed VRDS mini CD player and a British designed CD player.

TRINCHORD RESEARCH LTD Following on from the highly acclaimed CD clock oscillator modifications the Pulsar Series One digital to analogue converter. This unique design is part multi-bit and part bitstream to give absolute linearity over an extremely wide dynamic range. Switchable between 18 or 20 bit resolution this converter will become the standard for CD replay. For details telephone 01684 573524.

VADIS AMPLIFIERS Kirkland, 32 Head Street, Beth, Ayrshire KA15 2PU. Tel: 01505 504128. A new manufacturer in Scotland producing a very different valve power amplifier. The DIRECT OUTPUT (Patent applied for) design, after two years of development, has resulted in a power amplifier which dispenses with the output transformer, yet has an output impedance of only 0.2 ohm! Distortion is low at about 0.05%, and because there is no output transformer the bandwidth is very wide with no loss of power or increase in distortion. The result is astonishingly clear and natural sound. Two versions had made to order the S15 giving 15W per channel stereo, the M50, 50W mono. Black or colour finish.

SERVICES & CONSULTANTS

RJF AUDIO VISUAL Tel: 01209 612260/710777. Fax: 01209 711939. A.K.G. Atacama, Audioquest, Audio Technica, Beyer, Chario, Denon, Goldring, Harmon Kardon, Henley Designs, JBL, Klipsch, Magnat, Micromega, Musical Technology, NAD, Neat Acoustics, Onkyo, Ortofon, Primere, Project, QED, Quad, Revov, Rowland, SME, Sonic Link, Soundstyle, TDL, TEAC, Thorens, Trinchord Research. Service and repair to most high end Hi-Fi and studio products, including open reel and multitracks, modifications including CD re-clocking and laser disc AC3, Valve, transistor, analogue and digital specialists, PA and studio equipment supplied (new & used).

welcome to

world favourites

Here's a list of products that are a good buy. We've tried to cater for a range of tastes, identifying strong products in every area. We're agnostic so you'll find a wide range of products, from valve pre-amps through to MiniDisc players. Products marked * are recently out of production but make a good second-hand buy.

Prices shown are those at the time of the review



Roksan Caspian CD player
Solid as a ROK

COMPACT DISC

ARCAM FMJ CD23 £1100
This British-built player is extremely versatile. Controlled and detailed with a musical insight that few match. (Jul 2000)

CAMBRIDGE CD4SE* £200
A touch soft in the treble but outstanding in every other respect. (Feb 98)

KENWOOD DP-3080/11* £180
Has great clarity and presence for the price. Not as naturally expressive as the CD4SE though. (Feb 98)

LINN KARIK III* £1775
Under rated and overlooked, the final Karik was a gem. Superb transport gives a brilliantly tight, grippy dynamic sound, albeit tonally rather dry.

MARANTZ CD-17 KI-S £1100
The Marantz excels in all areas. Without doubt this is one of the most involving CD players on the planet. Build quality is also exemplary. (Sep 97)

MARANTZ CD-63 MKII KI-S* £400
Similar to the CD-63SE but more powerful bass and an all-round smoother sound. The famous KI tweaks pay off again. Whether or not it is still pre-eminent against the vastly improved competition is a matter of opinion.

MERIDIAN 506 20-BIT* £1100
Very detailed and revealing player. More cerebral than visceral sounding, however. (May 95)

MUSICAL FIDELITY X-RAY £800
Commonsense sturdy CD player of exceptional ability. Clear and detailed with high quality internal processing system. The X-Ray is inclined to show up poor recordings, but it's only doing its job! (Feb 99)

NAD S500 £1000
This dynamic top of the range Silverline spinner delights with any type of music. Exciting, sophisticated sounding and highly recommended. (Jun 2000)

ROKSAN CASPIAN £895
The Caspian has a smooth, slightly bright sound with some of the clearest treble in the business. Very engaging, dynamic character. (Aug 97)

ROTEL RCD 951 £300
HDCD capability at a midrange price. Plain Jane looks but solid construction. There is some higher than average measured distortion which may take the edge off this otherwise tempting product. (Aug 99)

COMPACT DISC TRANSPORTS

SONIC FRONTIERS TRANSPORT £6999
Cutting-edge design and technology combine to make this one very desirable product. The only problem is the fantasy hi-fi price. (Sep 98)

TEAC P-30 £2500
Cheap it isn't, but then it sounds like a million digital dollars. Nothing short of superb. (Jun 97)

TEAC VRDS-T1 £600
Excellent mid-price silver disc spinner with a powerful, expansive and warm sound. Easily beats most sub-£1000 designs. A good choice for the budget conscious who want the best. (Feb 95)

DACS

CAMBRIDGE AUDIO DACMAGIC 3* £99
Superb value for money with extensive facilities and solid, detailed sonics. Upgrades any sub-£300 player.

DCS ELGAR £8500
Future-proof convertor which will handle 24/96 and 24/192. Extremely open and natural performer. (Nov 97)

DPA LITTLE BIT 3* £299
A taste of the high end on a budget. Rich, clean, punchy sound transforms budget CD players.

MIDIMAN FLYING COW £299
Excellent as a DAC and doubles as an ADC for archiving to CDR. (Jun 98) Great value, as is junior version Flying Calf at £109. (Feb 99)

MUSICAL FIDELITY X-DAC* £300
A bargain for normal CDs and even better with HDCDs. (Nov 97)

SONIC FRONTIERS PROCESSOR 3 £6999
Quality never comes cheap! This DAC oozes class and when matched with the Transport 3 is certainly up with the best. (Sep 98)

TURNTABLES

LINN SONDEK LP12 BASIK £1100
Off the pace these days in many respects but still an extremely sweet and engaging listen with a quintessentially analogue sound.

MICHELL GYRODEC SE £775
Exquisitely built, infinitely upgradeable deck that gives true high end sound at mid-fi prices.

MICHELL ORBE £2000
Fantastically capable all rounder with commanding, powerful, detailed sound that gets the best from almost any arm and cartridge. Supreme build, brilliant value. (Apr 95)

ORIGIN LIVE STANDARD (KIT) £145
Good in standard form with AC motor; frighteningly good with a DC motor and battery PSU.

PINK TRIANGLE TARANTELLA £680
Not only does the Tarantella have more style than a catwalk full of models, it also combines PT's usual clarity with real authority. (Oct 97)

PRO-JECT DEBUT £110
Straight out of the box and onto the shelf! Nothing short of a bargain. Vinyl's never had it so good, so cheaply!

REGA PLANAR 2 £214
Brilliant starter deck with extremely polished manner. Better built £274 Planar 3 is a great all-in-one package that eats mid-price CD players for breakfast.

ROKSAN XERXES X £1295
DSU or XPS 3.5 power supply £150/170 extra. Excellent pitch stability from a new Swiss motor and outboard power supply. Very tight bass, fine dynamics and revealing clarity. (Jan 97)

SYSTEMDEK IIX900*/RB250 £330
A fine all-rounder and easy to upgrade too. More depth and breadth than Rega Planar 3. (Sep 94)

VESTAX BDT-2000 £225
A stylish looking deck with infinitely variable speed 16-90 rpm, DC belt drive and built-in MM phono stage. Good value, with plenty of chassis room for alternative arms, if required. (Sep 99)

TONERMS

HADCOCK 242 SE £649
Latest of a long line of unipivot arms. Added mass makes the 242 suitable for both low compliance MCs and straw-in-the-wind high compliance types. Revised geometry and chromium plating completes a first-class job. (Jun 2000)

NAIM ARO* £975
Truly endearing and charismatic performer - wonderfully engaging mid-band makes up for softened frequency extremes

REGA RB300 £180
Some may prefer the simpler RB250 at £130. Detailed, tight, rhythmic sound but tonally rather grey and cold-sounding. Still excellent value, though.

Prices shown are those at the time of the review



Musical Fidelity X-Cans2
Warm, sumptuous, sweet sound

SME 3009SII £309
Once state of the art, but no longer. Weak at frequency extremes and detail, but its legendary serviceability makes it a cult in Japan. Can be picked up for peanuts second-hand. (Jan 93)

SME 309 £689
A down-market version of the IV and V with aluminium armtube and detachable headshell. Tight, neutral sound with good tonality, but lacks the IV's pace and precision. Like the older SME 3009 series, this arm is also available in 10" and 12" versions. (Jan 93)

CARTRIDGES

AUDIO TECHNICA AT-110E £30
Great starter cartridge that's refined, detailed and musical beyond its price. Best value MM under £50

GOLDRING 1012GX £74
An accomplished MM with a solid bass, slightly forward midband and clean transients. Very reasonable price for such an able performer. (Jul 93)

DNM MICA £185
Better than Goldring's 1042 and costs only £135 on trade-in. An assured and transparent MM. (Feb 98)

DYNAVECTOR DV20X-H £299
The best modern budget MC combines deliciously sweet sound with fantastic get-up-and-go. High output version works a treat with valve phono stages too.

MUSIC MAKER £575
When mated with a good quality arm, this hand finished high-output pick-up gives an ear-boggling account of itself. Very high compliance ensures maximum information retrieval. An absolute (grain orientated) gem. (Feb 99)

ORTOFON MC 7500 £2000
Conclusive proof that there's hope for the world. It's a long time ago now but this high-priced favourite still earns its niche - CD lovers would die if they heard it. (May 94)

ORTOFON MC 15 SUPER II £140
Not quite as good as the dearer Supremes but the Super II is a splendid introduction to the joys of moving-coil cartridges.

GOLDRING 1042 £130
One of the best Moving Magnet cartridges going, with beautiful treble and muscular bass. New low price makes it a bargain.

ORTOFON ROHMANN £1000
In a way it's MC 2000 meets MC 7500 with great tonal strengths and a dynamo sound. (Apr 96)

INTEGRATED AMPLIFIERS

AUDIO ANALOGUE PUCCINI SE £595
This superbly-built Italian integrated has a lucidity and control which leaves others nowhere. Sound stage a wow. (Dec 97)

AUDIOLAB 8000a * £495
Well rounded integrated with smooth and detailed sound plus a huge feature count. Great build makes later versions a top used buy.

DENON PMA-250SE £160
It might not have bags of grunt but the Denon can sound exceedingly natural and open. (Feb 97)

McINTOSH MA6800* £3735
The MA6800 not so much plays music as takes control of it, with effortless bass drive. (Sep 95)

MISSION CYRUS 2 * £299
Classic eighties minimalism combines arresting styling with clean, open, lively sound. Further upgradable with PSX power supply.

MUSICAL FIDELITY X-CANS2 £160
Warm, sumptuous, sweet sound h/phone amp. gives startling results with a decent set of headphones.

NAIM NAIT 3 * £575
Superb rhythms and dynamics make for great music making, but tonally monochromatic. Super optional phono stage makes it ideal for vinyl junkies.

ROKSAN CASPIAN £695
Smooth, warm integrated with remote control that works happily into most 'speakers. (Dec 97)

SONNETEER ALABASTER £995
Builds on the strengths of the Campion with ample control, colour and drive. (Oct 97)

PHONO STAGES

CREEK OBH-8 SE £180
Punchy, rhythmic character with oodles of detail makes this a great budget audiophile product.

LFD MISTRAL PHONO STAGE * £300
The Mistral has a warmth and involvement that make many pricier stages sound overpriced.

MICHELL DELPHINI MONOBLOCS £1995
Analogue tour-de-force gives supremely clean, detailed and finely resolved sound with breathtaking dynamics. Great value, even at this price.

MUSICAL FIDELITY X-LP £125
One of the famous MF X series. Full marks throughout for clarity and detail. Switchable between MM and MC. Indestructible build! (May 99)

PRO-JECT PHONO BOX £39
Not the last word in many respects but a thoroughly honest piece of work. Inexpensive introduction to all that vinyl has to offer. MM and MC provision plus choice of two impedances.

ROKSAN ARTAXERXES X £950
With the Accessa PSU the Artaxerxes X MM/MC stage still shines. Great stage depth, neutrality and tonal colour. (Oct 97)

Billy Vee
SOUND SYSTEMS

248 Lee High Rd, London SE13 5PL (Mon - Sat 10am to 6.30pm Closed Thurs & Sun)

SAME NAIM, BUT A WHOLE NEW GAME

Call 020 8318 5755 to find out more...

Sometimes it just happens, a new range appears to replace existing products that have already carved and enviable reputation for affordable excellence and you think, Oh no - how can it be better? And it is! The new 5 Series is right here, right now. Call Paul or Patrick for more info, a leaflet or more importantly an audition, you won't be disappointed - promise!

- Local delivery and installation included in purchase price
- 3 year warranty for all 5 Series products - part exchange available
- Deferred and Interest Free Credit available at 0% APR - Call for details.
- Complete Naim range available for audition inc NAP500 & NBL



Featured - CD5 Player (Top) £1125 & Nait 5 (Bottom) £799

world favourites |

SONNETEER SEDLEY £399
Combines transparency and fine dynamics with excellent rhythmic ability. (May 98)

PRE-AMPLIFIERS

AMC 1100 £150
Suffers from un-defeatable tone controls but an extremely good value piece of kit. Partners the similarly budget level AMC 2200 power amplifier, also at £150. Comfortable beginners' choice. (Mar 99)

AUDIO ANALOGUE BELLINI £475
Showcases AA's characteristic mix of clarity and musicality and blasts the competition. (Apr 98)

CHORD CPA1800 £1800
Clarity, insight and control are second to none - an addictive mixture. (Mar 98)

CROFT VITALE £350
A modestly priced valve pre-amp with exceptionally transparent performance. MM phono stage plus three line stages are standard. Volume controls are separate for each channel, thus giving balance adjustment. A remarkable item in all respects. (Feb 2000)

XTC PRE-1 * £1000
Almost valve-like in its smoothness, the line-level Pre-1 is warm and seductively clear. (Nov 96)

POWER AMPLIFIERS

ARCAM 9 * £400
With 70W on tap, the 9P will drive most loudspeakers with a spacious and detailed sound. Good bass welly too. (Dec 96)

CHORD SPM400 £1400
There's a sense of effortless power to the Chord that gives music real scale and presence. (Mar 98)

MARANTZ MODEL 9 * £8000
Authentic reproduction monoblocs still more than cut the sonic mustard. Highly expensive and highly sought after. (Mar 97)

MICHELL ALECTO £1989
Crisp, clean and beautifully controlled with gorgeous styling. Partnered with the £1650 Orca this is a superb winning combo. (Oct 98)

MUSICAL FIDELITY X-A200 £1000/pair
200W of high-end monobloc power in a grooved tube. (Aug 98)

NAIM NAPI80 £1060
Partnered with a NAC82, this has classic Naim control, and a superbly rhythmic presentation.

TUNERS

CAMBRIDGE T500 £180
An extremely engaging tuner with a performance at odds with its low price. Not exactly a Troughline, but you may not notice... (Feb 99)

CREEK T43 £399
Excellent detail, separation and dynamics. A great little tuner and unbeatable at this price. (May 98)

MARANTZ ST17 £600
A positive dreadnought of a tuner. Sweet and refined but with a heavy punch when needed. A tuner of this quality demands a decent aerial. (Jul 99)

MISSION CYRUS FM7* £300
Clear and lucid sound puts it up with the best. Superb build too. (Apr 94)

NAIM NAT03 £595
The NAT03's warm, atmospheric sound is further proof of Naim's proficiency with tuners. (Sep 93)

SONY ST-SA3ES* £250
Beguiling RDS tuner for the sonically discerning. Good ergonomics and sensitive too. (Apr 97)

CASSETTE DECKS

AIWA AD-S750* £200
Sonically a very decent machine at the price. Comes fitted with Dolby B, C and the dead handy Dolby S. (Apr 96)

AIWA AD-S950* £300
A stable transport, superb head and Dolby S make the AD-S950 an excellent all-rounder. (Feb 95)

KENWOOD KX-3080* £160
A simple deck, but excellent-quality head and transport give top quality sound. (Oct 96)

PIONEER CT-S740S £430
A great piece of engineering from Pioneer, with first-rate sound. (Jun 96)

YAMAHA KX-580SE* £250
The 'SE' tag is more than a marketing gimmick. Sound is solid and clear with Dolby S. (Sep 97)

LOUDSPEAKERS

CASTLE EDEN £469
Impressively vice-free 'speakers that offer great transparency and involvement. One of a select band that simply makes music regardless. (Mar 97)

EPOS ES12 * £495
Strong, punchy bass is allied to finely detailed, articulate midrange and sparkling treble. (Oct 96)



Kef Cresta I loudspeakers
A very musical sound

KEF CRESTA I £100
Delightfully sophisticated presentation for the price. Won't blow the roof off, but will deliver a very musical sound. (April 2000)

KLIPSCH HERESY II £1100
An outstanding high sensitivity loudspeaker with midrange and treble horns coupled with infinite baffle 12" bass driver. Effortless, fast and accurate. (May 99)

MISSION 752 * £495
Cracking mid-price mini towers combined HDA drive units and metal dome tweeters with surprisingly warm results. Benign load characteristics makes them great for valves.

MISSION 771 £170
Characteristically fast, punchy Mission sound from the Aerogel mid/bass and silk-dome tweeter. (Jul 98)

Billy Vee
SOUND SYSTEMS

248 Lee High Rd, London SE13 5PL (Mon - Sat 10am to 6.30pm Closed Thurs & Sun)

Your chance to own the best for less!

Call (020) 8318 5755 or 8852 1321 now

Genuine bargains are few and far between!

We are delighted to offer two top quality Linn units with a substantial saving on the normal retail price. Both are ex demonstration units in mint condition, have recently been serviced by Linn & carry a full two year warranty. Don't delay, book an audition today. Interest free credit is available over 9 or 12 months (call for details) & installation with system overhaul is included.



Linn CD12 CD Player £7995



Linn AV 5103 DTS Preamp (RF Demod) £3395

Linn CD12 CD Player normal price £12000
Linn AV 5103 Preamp normal price £5100

QUAD ESL 63 * £1450
A reference against which all other loudspeakers are judged, the '63s have superb imaging and genuine transparency.

TANNOY AMS8 * £2700
Bold sounding pro active monitor with solid bass, clear midrange and delicious treble. (Aug 96)

TANNOY MERCURY m2 * £140
A true audiophile bargain which embarrasses many more expensive boxes. Never mind the price, let your ears decide. (May 97)

MINIDISC PLAYERS

KENWOOD DM-9090 £500
One of the best MD players yet. ATRAC 4.5 gives clean and very musical recordings from this Kenwood. (Jan 98)

SONY MDS-JB930Q £250
Great mid-price machine that adds better build and facilities to the '530's already excellent sonics.

SONY MDS-JA50ES * £1300
This Sony can put the wind up Nakamichi cassette decks when used with better blank MDs. (Apr 98)

SONY MDS-JE55ES £520
MiniDisc recorder
The best sounding MD deck made so far, thanks to awesome build and heroic ATRAC-DSP Type R coding.



Alesis Masterdisk
A glimpse of the future

SONY MDS-JE510 £300
An impressive sound and unmatched convenience make this MiniDisc player an excellent buy.

DIGITAL RECORDERS

ALESIS MASTERDISK £1400
A groundbreaking hard disc recorder with a built-in CD drive. An amazing bit of kit, and a glimpse of the future. (July 2000)

KENWOOD DMF-9020 £500
An excellent tool for home recording, combines convenience, superb sound and a fair price. (Aug 99)

MARANTZ DR-17 £1100
Probably the best sounding CD recoder on the market. Built like a brick out house with a true audiophile sound. HDCD compatible. (July 2000)

PHILIPS CDR-765 £360
One of the first twin deck recorders/players that boasts high speed dub facility. Playback could be warmer, but still a bargain. (Oct 99)

PIONEER PDR-555RW £480
Excellent mid-priced CD recorder that both plays and records with equal panache. (Oct 99)

SONY TCD-8 DATMAN * £599
Super clean and detailed sound makes this an amazing portable. Not as robust as it should be though.

DVD PLAYERS

DENON DVD-5000 £1600
Monster build, as you'd expect at this price. Facilities and gadgets galore and drop-dead high end looks. A very smooth and sophisticated sound, although not as good as similarly-priced CD players. (Mar 99)

PIONEER DV-717 £700
Well built and a solid performer, with a 'true' 24/96 digital output. Facilities in abundance and a controlled, exciting way with CD replay. Shame it lacks a Dolby Digital decoder! (Sep 99)

SONY DVP-S725 £490
One of the best buys in the DVD market. Available in a dodgy white case, but the facilities and performance more than make up for this. Excellent with both music and visuals, and a whole host of up to the minute facilities to keep you occupied. (Mar 2000)

HEADPHONES

JECKLIN FLOAT MODEL TWO £99
Wonderful panel-like and open sound from these esoteric-looking headclamps. Do not wear in public unless you like being made a fool of!

SENNHEISER HD-490 £50
Good value cans with an exciting and bassy sound. Everything one should look for in headphones at a sensible price.



Nordost Blue Heaven
A simple and effective upgrade

INTERCONNECTS

CHORD COMPANY CHAMELEON 2 £90/m
One of our favourite favourites, the Chameleons are musical performers with a smooth yet open sound.

DNM RESON £40/m
Neutral and transparent, and a steal at forty quid!

NORDOST BLUE HEAVEN £150/m
Some of the fastest and most transparent cable around. A simple and effective upgrade.

VAN DEN HUL ULTIMATE THE FIRST £260/0.6m
Carbon interconnects that help you forget the electronics and concentrate on the music. Miraculous transparency.

LOUDSPEAKER CABLE

CHORD COMPANY RUMOUR £9.95/m
The Rumour is our reference at the price. Tight and tuneful bass mixed with air and space results in a cracking cable for the money.

DNM RESON £6.95/m
This cable has a transparency of sound that's rarely heard at the price. Excellent value for money.

NORDOST BLUE HEAVEN £375/3m pair
This isn't cheap, but it sounds absolutely fab. An open and spacious sound that simply carries music.

Billy Vee
SOUND SYSTEMS

SAVE £££'S ON OUR DISPLAY CLEARANCE

SOME AS NEW WITH 1 YR WARRANTY. 24HR DEL ONLY £5. CHECK AVAILABILITY BEFORE ORDERING

CALL SALES: (020) 8318 5755 or 8852 1321 - 248 Lee High Road, London, SE13 5PL

0% APR is available on purchases of more than £660. Please call for details. * Prices Correct at 12/06/01 £&OE

Arcam AV50 Amplifier(699.00)	£429.00	Naim Nait 3 Amplifier S/H (1Yr G/tee)(680.00)	£399.00
Arcam Alpha 10 DAB Tuner(799.00)	£549.00	Naim NAT 02 Tuner (2Yr G/tee)(1240.00)	£849.00
KEF Concerto 1 Spkrs (5Yr G/tee)(599.00)	£329.00	Naim AV1 Surround Procs E/D (2Yr G/tee) .(1835.00)	£699.00
KEF Concerto 2 Spkrs (5Yr G/tee)(799.00)	£469.00	Naim SBL Passive Speakers S/H (1Yr G/tee)(2475.00)	£1495.00
Linn Kremlin Tuner (1Yr G/tee)(2600.00)	£995.00	Naim 52 Preamp Head Unit S/H (1Yr G/tee)(3685.00)	£2095.00
Linn Kairn Pre Amplifier (2 Yr G/tee)(1700.00)	£799.00	Naim Credo Speakers (2Yr G/tee)(1285.00)	£895.00
Linn AV5103 RF Demod DTS Preamp(2Yr) .(5100.00)	£3395.00	Naim NAP 250 Power amp (1Yr G/tee) . .(1855.00)	£1390.00
Linn CD12 CD Player E/D (2Yr G/tee) . . .(12000.00)	£9500.00	Naim Hi Cap Power Supply S/H (1Yr G/tee) .(780.00)	£495.00
Linn Keilidh Spkrs Black inc Stands(885.00)	£695.00	ProAc Response 2 Spkrs S/H (1Yr G/tee) .(1995.00)	£1190.00
Marantz CD 6000 Ki CD Player (2Yr G/tee) .(499.00)	£329.00	Pro-Ac Tablette 50 Speakers (2Yr G/tee) . .(599.00)	£349.00
Marantz PM 6010 Ki Amplifier (2Yr G/tee) .(499.00)	£319.00	PMC TB2 Spkrs S/H - Cherry (1Yr G/tee) . . .(700.00)	£549.00
Nakamichi DVD10a Reg2 DVD (2Yr G/tee) .(799.00)	£299.00	PMC LB1 Speakers (2Yr G/tee)(1150.00)	£825.00
Naim CD2 CD Player S/H (1Yr G/tee)(1995.00)	£1299.00	Rega Jura Speakers (2Yr G/tee)(498.00)	£329.00

World Classics

CASSETTE

NAKAMICHI DR-2

A great machine with Nakamichi's legendary heads. The lowest cost 'true' Nakamichi at the time, retailing for £600.

NAKAMICHI CR-7

The last of the great ones, and definitely the best Nakamichi ever (yes, better than a Dragon)

YAMAHA TC-800G

Early classic in serious cassette. Its ski-slope looks got it a cult following once it had ceased to be simply ugly.

CD PLAYERS

MERIDIAN 207

Beautifully-built two-box with pre-amp stage. Very musical although not as refined as modern Bitstream gear. No digital output.

PIONEER PD-91

Built-to-last player with easy upgrade routes for modifiers. Not knockout as it stands but get one cheap and have a go!

CAMBRIDGE CD1

The first two box player with weighted mechanics and even an optional Dropout/error counter. Radical and effective at the time - a classic.

AMPLIFIERS

LEAK POINT ONE, TL12 & TL10

Ancestors of hi-fi, consequently expensive nowadays. As with all vintage valve stuff, overhauling is de rigueur before use, using original parts if possible.

LEAK PRE-AMPS

Line of 'good for their time' pre-amps. Use of EF86 pentode valve for high gain rules out ultra performance. Not the highest-fi.



Garrard 401
A legendary turntable.

LEAK STEREO 20

Excellent workaday classic valve amp. In good order the 20 will not disgrace itself. Various upgrades are available from specialist repairers.

LEAK TL12+

Plentiful monobloc equivalent of Stereo 20. Reasonably inexpensive and a tweekers' dream. Genuine valve hi-fi on a budget.

NAD 3020

You can't argue with success! NAD's budget transistor integrated gave thousands their first taste of hi-fi and remains great value.

QUAD 33/303 PRE/POWER

Great style and construction, also bullet proof. Warm and wooly sound, but easy going. A good introduction to early transistor audio classics.

QUAD 22/II PRE/POWER

One of the all-time classic valve amplifiers. Unusual circuit but it works beautifully. 22 pre-amp not up to today's standards.

SUGDEN A21

Seventies transistor integrated has an eminently likeable smoothness and musicality. Limited inputs via DIN sockets.

TECHNICS SE-A5 Mk2

Nice transformer and electronics, shame about the casework. With tweaking, this 150watter can sound sweet.

LOUDSPEAKERS

KLIPSCHORN

Not exactly plentiful or cheap but a splendid beast. For efficiency they have seldom been equalled. Space hungry!

LEAK SANDWICH

Rather warm sounding big infinite baffle but cheap with it. With a reasonably powerful amp can sound quite satisfying.

LOWTHER PM6A

High quality full-range driver; still manufactured. High sensitivity, as fitted to many classic horn designs.

MAGNEPLANAR SMGa

Touch dry in the bass but a technological loudspeaker with genuinely musical abilities.

MISSION 770

Father of the 77 range which continues to this day. Well mannered with a warm sound and a kind load to amplifiers.

QUAD ESL57

Unrivalled. Properly serviced there is nothing like them. Their natural presentation may make them caviar to the general.

YAMAHA NS1000M

Hi-tech favourites of the Japanese and Americans. Viewed more warily in the UK but can give excellent results.

TANNOY GRF & AUTOGRAPH

Folded horn monsters which certainly sound good if you have the space. For Tannoy vintage see HFV November 1998.

WHARFEDALE SUPER 8 RS DD

Ideal experimenters' driver. High sensitivity ~14,000 Gauss magnet and extended frequency range. Inexpensive too!

TANNOY YORK, LANCASTER

Many similar models of infinite baffle or reflex design. Not the last word in tautness but the drivers work well in modern cabinets.

VINYL

ACOS LUSTRE

Very honest piece of kit, well made and easily adjusted. Vinyl beginners could do very much worse.

ALPHASON HRI00S

First class arm, up to present-day standards. Buy carefully, though, as there's no service available now.

ARISTON RD11

A one-time king of turntables very similar to the Linn LP12. Now deposited but worth a look at the right price.

LINN AXIS

Uncomplicated, lower-price version of the famous Sondek. Less expensive than some of its stablemates.

GARRARD 301 & 401

Legendary turntables, once fairly plentiful. Excellent back-up available; many different custom plinths available. High quality.

GOLDRING Lenco 88 & 99

Great deck for the kitchen table enthusiast. Garrard fans won't look at 'em but cheap and capable. Servicing available.

HADCOCK 228

Recently out-classed by Hadcock's updated 228 Special Edition but a proper hi-fi arm for all that. Makers still service.

MICHELL FOCUS ONE

20 years and still going strong. Early runner in the 'modern' turntable cycle with a first class arm. Factory servicing available.

SHURE M75

Recent line-contact improvements have left the M75 behind but the wide range of needles make it a handy tool.

SME 3009 IIS

Everlasting classic tone-arm. Spares permanently available from SME. No longer the last word but peanuts second-hand.

THORENS TD124

Best classic deck ever? Judging by the prices they fetch it's possible - 78rpm too!

THORENS TD150

Mid-price deck with a keen following. No real difficulty with servicing - novices may find the suspension system unnerving.

TRIO L-07D

Knockout heavyweight from 1980 with stainless bearing and 11lb platter! Not a give-away and beware! - spares scarce.

TUNERS

LEAK TROUGHLINE (ORIGINAL)

Interesting ornament but no longer hi-fi. Limited coverage of 88MHz to 100MHz only.

LEAK TROUGHLINE II & III MONO

Arguably the best-sounding tuners ever. Adaptation for stereo easy via phono multiplex socket.

LEAK TROUGHLINE III STEREO

Excellent tuner with indifferent stereo decoding circuit. Best when adapted to use modern outboard decoder.

MARANTZ ST-8

Possibly the ultimate Tardis console, including an oscilloscope for checking the strength of signal. Expensive even now.



In fidelity

9 High Street, Hampton Wick, Kingston Upon Thames, Surrey, KT1 4DA
Tel: 020 8943 3530 Fax: 020 8943 4509
www.infidelity.co.uk

Sale List 2001

AMPLIFIERS

			NEW PRICE	SALE PRICE
Rega Elex	integrated amp	s/hand	N/A	£225
Rega Brio	integrated amp	new	£298	£265
Densen Beat B100	integrated amp	s/hand	£700	£450
Linn LK100	power amp	s/hand	N/A	£350
Linn Majik	integrated amp	s/hand	£695	£450
Linn LK140	power amp X5	s/hand	£750	£550*
Linn 5103	processor/preamp	s/hand	£4500	£2900*
Linn 5103	processor/preamp	ex-dem	£4500	£3250
Naim NAB2	preamp	s/hand	£2435	£1760
Naim NAP135s	mono power amps	s/hand(each)	£1855	£1350
Arcam Alpha 9	integrated amp	s/hand	£500	£300

TURNTABLES

Drtofon Jubilee	moving coil cartridge	new	£1250	£850
Naim Armageddon	LP12 power supply	new	£665	£565
Linn LP12/Ittok/Valhalla	turntable	s/hand	N/A	£450

CD & DVD Players

Densen B400	integrated player	ex-dem	£1280	£900
Naim CD2	integrated player	s/hand	N/A	£1350
Naim Cdr (new mech)	integrated player	s/hand	N/A	£1250
Naim CD3	integrated player	s/hand	N/A	£595
Linn Karik slimline	integrated player	s/hand	N/A	£850
Arcam Alpha 9	integrated player	ex-dem	£800	£550
Rotel RDV 985	DVD player	ex-dem	£600	£395
Nakamichi DVD 10s	DVD player silver	ex-dem	£600	£495
Pioneer DV717	DVD player	s/hand	£600	£395

Loudspeakers

Musical Technology Harner	floor-standing oak	ex-dem	£635	£485
B&W CDM9 NT	floor-standing cherry	ex-dem	£1800	£1350
Linn S120	centre speaker cherry	ex-dem	£685	£450
Naim SBL	floor-standing walnut	s/hand	£2465	£1595
Naim SBL	floor-standing black	s/hand	£2465	£1695
Naim SBL	floor-standing beech	ex-dem	£2465	£1795
Naim Uredo	floor-standing beech	ex-dem	£1285	£895
Epos ES11 with stands	stand mount black	s/hand	N/A	£250

Stands & Headphones Etc.

Sennheiser HD580/Lucas Dolby surround + h/ph	new	N/A	£225
Harmon Kardon TC1000 LCD learning remote	s/hand	N/A	£95*

*Items being sold by us on the owner's behalf
ALL THE ABOVE ITEMS ARE SUBJECT TO AVAILABILITY



Choice hi-fi you choose
 Choice hi-fi make it easy for you to fulfill your sonic dreams. Quality hi-fi is not just about expensive brandnames. It's about aspiring to the very best sound, about choosing your ideal system from the widest selection in the country, in a unique no-pressure environment.

your choice

- Acoustic Energy
- Advantage
- Alon
- ATC
- Audible Illusions
- Audio Physics
- B.A.T
- Boulder
- Bryston
- Cary
- C.A.T.
- Chord
- Clear Audio
- Denon
- DNM
- Dynavector
- Egglaston Works
- Electrograph Delphi
- Genelec
- Gryphon
- Graham
- Helios
- J M Lab
- John Shearn
- Krell
- Lexicon
- Loewe
- Mark Levinson
- Michell Eng.
- Musical Fidelity
- NEC
- Nordost
• Oracle
- Plinius
- P.M.C.
- Primare
- Quadraspire
- Seleco
- REL
- Rockport
- Roksan
- Ruark
- Shahinian
- SME
- Straight Wire
- Sugden
- Tara Labs
- Teac
- Thule
- Totem
- Trifurcation
- Trichord
- Trilogy
- Van den Hul
- VPI
- Wilson Audio
- Wilson Research
- YBA

New this month

POWER AMPLIFIER

	Our Price	Original Retail Price
Krell FPB 600	£7,500.00	£12,000.00
Audio Research Classic 150 Monoblocks	£3,750.00	£12,000.00
Copland CTA 402	£1,395.00	£1,700.00
Denon POA6600 Monos	£795.00	£ -
DPA Renaissance	£395.00	£700.00

PRE AMPLIFIER

Conrad Johnson PV10 AL	£895.00	£1,200.00
Boulder 1012 (pre amp/ 24.96 dac/ Phono)	£ On Dem	£13,000.00
Krell KRC3	£1,995.00	£3,250.00

SPEAKERS

JM Lab Utopia (Ex Dem)	£13,495.00	£16,999.00
Vienna Acoustics Mozart	£1,095.00	£1,500.00

CD PLAYERS & DACS

Acuphase 90/91	£6,999.00	£16,000.00
Marantz CD7	£2,695.00	£3,500.00
Meridian 508.24	£1,695.00	£2,500.00
Audio Research CDI	£1,495.00	£3,400.00

TURNTABLES, ANALOGUE, VARIOUS

Meridian 504 Tuner	£395.00	£795.00
Goldmund Studio + T3F arm	£2,995.00	£ -
Musical Surroundings Phenomena phono stage	£495.00	£ -
Pink Triangle PT too 5A/RB300 5/W	£795.00	£ -

Pre amplifiers

Trilogy 901 Pre	£549.00	£995.00
Krell KSL + Phono	£1,295.00	£ -
Naim Hi Cap	£350.00	£ -
Cary SLP 50	£795.00	£1,195.00
YBA Pre I Alpha & psu mm/mc	£ On Dem	£4,900.00
YBA Passion Pre + mc	£ On Dem	£5,595.00
Boulder 2010 Pre	£p.o.a.	£30,000.00
Plinius 16L	£ On Dem	£3,200.00
Audible Illusions LI	£1,595.00	£2,000.00
C.A.T. ultimate reference Pre Amp Inc/ Phono X-Demo	£4,895.00	£5,750.00
Tube Tech Seer Pre Amp	£595.00	£935.00
Audible Illusions P3A Pre MM/MC	On demo	£3,140.00
Electrocompaniet EC 4.5 (new)	£895.00	£1,195.00
Jeff Rowland Constate + phono (3box)	£2995.00 *	£8,000.00
Mark Levinson No 28	£1,495.00	£4,000.00
Naim 42.5	£195.00	£450.00

Quality speakers

Audio Physics Avanti	£ On Dem	£7,500.00
Sonus Faber Concerto + Iron Wood Stands	£895.00	£1,400.00
Rogers ABI Sub	£450.00	£550.00
Kef 104.2	£695.00	£1,200.00
Audio Physics Steps and Stands	£899.00	£1,300.00
Audio Plan Contrast 3	£1,795.00	£3,200.00
Proac Response 3.5 Cherry	£2,250.00	£4,250.00
Proac Studio 3 Rosewood	£995.00	£ -
Avalon Ascents	£6,995.00	£12,000.00
JM Lab Micro Utopia	£ On dem	£3,899.00
JM Lab Mini Utopia	£ On dem	£4,500.00
JM Lab Mezzo Utopia	£ On dem	£7,300.00
JM Lab Electra 915.1	£ Ex Dem	£1,895.00
Audio Physics Tempo III	£ On Dem	£2,000.00
Naim SBL's	£1,695.00	£2,225.00
BC Acoustics Tibre	£795.00	£1,100.00
ClaraVox Magnifica	£8500.00*	£14,500.00
BC Acoustics Araxe	£895.00	£1,195.00
Ensemble Speakers PAI	£995.00	£2,000.00
Alon Adriana (new)	Special	£10,000.00
Alon V MK III	Special	£5,500.00
Audio Physics Caldera	On demo	£10,000.00
Audio Physics Libra	X-demo	£4,799.00
Audio Physics Rhea Sub	£2,350.00	£3,099.00
Audio Physics Spark	On demo	£1,749.00
Audio Physics Steps	On demo	£999.00
Audio Physics Virgo	£2,395.00	£3,295.00
Rogers LS55 (new)	£330.00	£430.00
Wilson System 5.1	£8,500.00	£18,000.00

Power amplifiers

Krell 250 A/3 3 Chanel amp	£2,995.00	£4,698.00
Jadis JA30 Monoblocks	£2,495.00	£6,000.00
Audio Note P2 SE	£795.00	£850.00
Graff GM200	£4,750.00	£8,000.00
ML 436 Mono Power Amps	£10,500.00	£12,000.00
Cello Duetto 350	£4,995.00	£10,000.00
Cary SLA 70 mk II/70	£1,450.00	£2,250.00
Audio Refinement Complete Amp	£695.00	£895.00
Audio Research VT200 mk II	£7,795.00	£9,998.00
Audio Research Ref 600 mk II	£29,995.00	£ -
YBA Passion Monoblocks	£ On Dem	£8,995.00
YBA Passion Stereo	£ On Dem	£5,995.00
Krell FPB 300c	£8,500.00	£9,998.00
Krell FPB 200c	£7,500.00	£8,450.00
Sunfire 300 Power Amp	£1,395.00	£1,495.00
Plinius 50s	£ On Dem	£3,000.00
Krell FPB 250M Monoblocks	£7,990.00	£10,796.00

Plinius 250 mk IV	£ Dem	£6,000.00
Audio Note Kasi	£12,495.00*	£30,000.00
Cary 805 C Monoblocks	On Demo	£8,250.00
Audio Note Neiro (as new)	£7,995.00	£16,500.00
Audio Note Ongaku (new)	p.o.a.	£45,000.00
Cary 300 se LX20 Monoblocks	£3,750.00	£5,250.00
Cary 572 se Monoblocks	£1,750.00	£2,350.00
Counterpoint SA12	£795.00	£1,400.00
Jadis Dely 7 MK III	£2,000.00	£4,790.00
John Shearn Reference Phase 3 Power Amp	£550.00	£749.00
Krell FPB 300	£6,500.00	£9,990.00
Krell FPB 600 c	£9,995.00	£14,994.00
Meracur Intrare 6 (int) X-demo	£1,795.00	£2,000.00
Sugden AU51	£995.00	£1,500.00
YBA 3x Pre/PWR	£1,295.00	£2,400.00

CDplayers & DACS

YBA CD1 Alpha	£3,495.00	£5,000.00
YBA CD Speciale	£495.00	£675.00
Theta Data III/ Progen III Bal	£2,750.00	£8,500.00
Thule Spirit CD 150B	£ On Dem	£899.95
Audio Refinement CD Complete	£650.00	£875.00
Boulder 2020 dac	£p.o.a.	£24,000.00
California Audio Lab Sigma II dac	£1,495.00	£2,400.00
/California Audio Lab Delta Trans		
Forsell Air Ref Transport MK II	£4,995.00	£8,000.00
Krell KP5 25sc	£18,995.00	£23,498.00
Marantz CD14	£1,295.00	£1,600.00
Mark Levinson 30.5/31	£11,500.00	£24,000.00
Micromega CD 3.1	£1,095.00	£1,995.00
Oracle CD 2000 Transport	P.O.A.	£7,299.00
Pink Triangle Da Capo	£795.00	£1,595.00
Theta Data II Transport AT + link	£1,995.00	£4,000.00
YBA CD Integre	On Demo	£1,195.00

AV components

AV Components		
Krell HTS (AV Processor)	£4,495.00	£6,498.00
Thule PR250B DTS/ Dolby	£ On Dem	£1,549.95
Thule PA250B 5 Channel Amp	£ On Dem	£1,549.95

TELEVISIONS & DVD PLAYERS BY LOEWE

Loewe DVD	On Demo	£495.00
Loewe Aconda	-	POA
Loewe Planus + Std	£995.00	POA
Loewe Xelos + Std	£750.00	POA
Loewe L2A Active Speakers	-	POA

PLASMAS

From NEC	-	POA
From Electrograph Delphi	-	POA

Turtables & analogue

TURNTABLES/ ANALOGUE/ VARIOUS		
Pink Triangle PT Toof RB300 Silver Wired	£495.00	£ -
Tandberg 3001 Tuner	£795.00	£ -
Meridian 504 Tuner	£395.00	£695.00
Linn LP12/ Cirkus/ Ittok LVII	£695.00	£ -
Rockport Capella/ Air Tangent 2B/ Clear Audio Insider	£11,995.00	£17,000.00
Roksan Shiraz (New)	£550.00	£1,000.00
Ortofon MC 3000 mk II	£695.00	£1,000.00
Voyd Reference/ IO Limited/psu/ reference psu/ step up	£12,999.00	£25,000.00
Plinius 14 Phono	£1,995.00	£2,750.00
Transparent Audio Music Wave Ultra XL Bi-Wire	£2,100.00	£4,000.00
Cary PH301 MM/MC	£995.00	£1,695.00
Koetsu Red K Sig.	£1,295.00	£2,000.00
Michell Orbe	£1,495.00	£2,000.00
SME V Gold (Silver Wired)	£1,595.00	£2,500.00
Nackamichi DR 3	£225.00	£400.00
Nakamichi 202E	£295.00	£600.00
Tom Evans - The Groove	£ On Dem	£1,500.00
Clear Audio Reference Mc phono stage X-demo	£1,695.00	£2,065.00
Rega Planer 3 + Hi Fi News Out Board Power Supply	£320.00	£423.00
Clear Audio Symphono phono stage X-demo MM/MC	£640.00	£740.00
Lavardin Reference Phono	£	£2,500.00
Musical Fidelity XLP2	£395.00	£495.00
Oracle MK V Turntable	P.O.A.	£4,199.00

Quarterly Sale items

Burmester 850 Monoblocks	£995.00	£3,000.00
Trilogy 948 Stereo	£995.00	£2,000.00
Exposure IX Power supply	£595.00	£1,500.00
Exposure VIII	£325.00	£700.00
Kenwood L1000C pre/ L1000M Power Amp	£795.00	£2,500.00
Pioneer A300 Int	£90.00	£180.00
Exposure VII	£195.00	£600.00
Exposure XI pre XII psu	£595.00	£1,500.00
Acoustic Energy AE120	£295.00	£500.00
Orelle Swings	£495.00	£1,200.00
Cyrus Dac Master &	£350.00	£899.00
Cyrus Disc Master	£395.00	£899.00
Teac P500	£295.00	£600.00
Harmon Kardon AVPI	£175.00	£ -
Pioneer CLD 2850 Laserdisc	£175.00	£ -

* Reduced this month

tel: 020 8392 1959 & 020 8392 1963
 fax: 020 8392 1994 info@choice-hifi.com

Open from 10am to 6pm Mon-Sat and other times by appointment.
 Buy, sell, exchange quality hi-fi equipment.
 We accept all major credit cards. Finance available subject to status
 World Radio History

www.hi-fiworld.co.uk
hi-fi
AUGUST 2001 No59
World

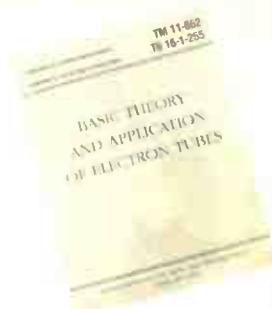

**THIS MONTH'S
BOOK REVIEW:**
*Basic Theory and
Application of
Electron Tubes*
U.S. Services Manual

PASSIVE POWER



**BUILDING OUR NEW PAS II
PASSIVE PRE-AMPLIFIER**

**TUNING OUR KEL84
BUDGET AMPLIFIER**



**GET A GREAT SOUND WITH OUR
SPECIAL COMPONENT PACKAGE**

Plus: ● news, letters, books and more

LANGREX SUPPLIES LTD

DISTRIBUTORS OF ELECTRONIC VALVES, TUBES AND SEMI-CONDUCTORS AND I.C.S.

1 MAYO ROAD • CROYDON • SURREY CR0 2QP

24 HOURS EXPRESS MAIL ORDER SERVICE ON STOCK ITEMS

PHONE

020 8684 1166

E-MAIL: LANGREX@AOL.COM

FAX

020 8684 3056

A selection of our stocks of **New Original Valves / Tubes.**
Many other brands available.

STANDARD TYPES			SPECIAL QUALITY TYPES					OTHER TYPES	
ECC83	E.I	3.00	A2900/CV6091	GEC	17.50	12BY7A	GE	7.00	
ECC85	RFT	5.00	E88CC/CV2492	BRIMAR	10.00	5687WB	ECCG	6.00	
ECC88	BRIMAR	6.00	ECC81/CV4024	MULLARD	6.00	6072A	GE	6.00	
ECC88	MULLARD	10.00	ECC81/M8162	MULLARD	7.50	6146B	GE	15.00	
ECH81	MULLARD	3.00	ECC81/6201	MULLARD	8.50	6336A	RCA	35.00	
ECL82	MULLARD	5.00	ECC82/CV4003	MULLARD	7.50	6550A	JAN GE	25.00	
ECL86	PHILIPS	7.50	ECC82/M8136	MULLARD	10.00	7027A	GE	25.00	
EL36	MULLARD	5.00	ECC83/CV4004	MULLARD	20.00	7581A	SYL	15.00	
EZ81	MULLARD	7.50							
EZ80	MULLARD	5.00							
GZ33/37	MULLARD	15.00							
5Z4G	BRIMAR	5.00	5R4GY	RCA	7.50	ECC81	RFT	3.00	
6V6GT	BRIMAR	6.00	5U4GB	SYLVANIA	10.00	ECC82	RFT	5.00	
12E1	STC	10.00	5Y3 WGT	SYLVANIA	3.50	ECC83	RFT	6.00	
13E1	STC	85.00	6BX7GT	GE	7.50	EF86	USSR	5.00	
807	HYTRON	7.50	6B4G	SYLVANIA	22.00	EL84	USSR	3.00	
811A	RCA	25.00	6FQ7	SYLVANIA	7.50	EL34G	SOVTEK	5.00	
6080	MULLARD	10.00	6L6GC	GE/SYL	17.50	EL34	E.I	5.00	
			6L6WGB	SYL	10.00	6SL7GT	USA	5.00	
			12AX7WA	SYLVANIA	6.00	6SN7GT	USA	7.50	

THESE ARE A SELECTION FROM OUR STOCK OF OVER 6000 TYPES. PLEASE CALL OR FAX FOR AN IMMEDIATE QUOTATION ON ANY TYPES NOT LISTED. WE ARE ONE OF THE LARGEST DISTRIBUTORS OF VALVES IN THE UK.

SAME DAY DESPATCH VISA/ACCESS ACCEPTABLE. OBSOLETE TYPES A SPECIALITY.

CREDIT CARD MIN ORDER £10.00.

OPEN TO CALLERS MON.-FRI. 9AM - 4PM. CLOSED SATURDAY

U.K. P&P 1-3 VALVES £2.00, 4-6 VALVES £3.00 ADD 17.5% VAT TO TOTAL INC P+P. O'SEAS P & P PLEASE ENQUIRE



Watford Valves

7 DAYS A WEEK 9AM - 9PM The Audiophiles Choice
All output valves multi-tested and digitally matched
Full no quibble guarantee. Expert advice on all valve amps

ECC81	Philips	6.00	GZ34	Mullard	50.00
ECC82	Philips.	6.00	GZ37	Mullard	25.00
ECC83	Philips	7.00	KT66	Harma	25.00
ECC83	R.F.T	10.00	KT66	GEC	80.00
ECC83	Tungram	15.00	KT88	Sovtek	20.00
ECC803S	Tesla.	20.00	KT88	JJ/Tesla	25.00
E83CC	Siemens	25.00	2A3	Sovtek	18.00
ECC85	R.F.T.	8.00	5687WB	Philips	6.00
E88CC/6922	Harma	12.00	5842WA	Raytheon	10.00
ECL82	Telefunken	20.00	5881WXT	Sovtek	6.00
ECL83	Amprex	6.00	6550C	Svetlana	22.00
EF86	Svetlana	8.00	6550EH	Sovtek	22.00
EF86	Mullard	20.00	6550WE	Sovtek	18.00
EL34EH	Sovtek	8.50	6AU6WC	Philips	4.00
EL34	Svetlana	10.85	6CG7	GE	15.00
EL34L	JJ/Tesla	8.50	6L6EH	Sovtek	9.00
EL84	EI	8.00	6SL7GT	Philips	8.00
E84M	Harma	6.00	6SN7GT	Philips	20.00
EL519	EI	12.00	7199	Philips.	20.00
PL519	Mullard	15.00	7591AEH	Sovtek	16.00
EZ81	Tesla	8.00	7868	GE	40.00
GZ32	Harma	9.00	12AX7LPS	Sovtek	8.00
GZ34	Sovtek	8.00	12AX7EH	Sovtek	8.00
			12BH7A	Sylvania	20.00

KIT66 QUAD II SPECIAL OFFER

Improved detail, a bigger soundstage and a smooth rich midrange has prompted the comments that the performance is equal to the G.E.C. KT66.

"I took out the inferior substitutes and breathed new life into my Quad" was one remark.

Each valve undergoes a high plate volt test and comes digitally matched on plate current and transconductance to ensure perfect matching. At only £25 each the Harma KT66, like the Vintage Quad II are an audio bargain, leaving you to simply enjoy the music, with nothing added and nothing taken away!

WATFORD VALVES 3 Ryall Close,
Bricket Wood, St Albans, Herts AL2 3TS

Fast mail order/next day delivery/World Wide shipping
1000's more valves stocked. Prices exclude VAT and carriage.



01923 893270

Fax: 01923 679207

www.watfordvalves.com



hi-fi
world

HI-FI WORLD
IMEX HOUSE,
THE PARK BUSINESS CENTRE,
KILBURN PARK ROAD,
LONDON, NW6 5LF

Web Sites
www.hi-fiworld.co.uk
www.worldaudiodesign.co.uk

NEWS & LETTERS e-mail
diynews@hi-fiworld.co.uk
diyletters@hi-fiworld.co.uk

Subscriptions & Back Issues
9.30am - 2.30pm
+44 (0)1923 270833

Private & Trade Classified Ads
020 7625 3134
Fax: 020 7328 1844

Contact Numbers
9am - 5pm Mon - Fri

Editor
Nick Lucas
+44 (0) 1908 218836
nick@worldaudiodesign.co.uk

Technical Editor
Noel Keywood
publisher@hi-fiworld.co.uk

Design & Production
Faiza Chunara
020 7625 3129
Fax: 020 7328 1844

Photography
David Noble
020 7625 3134

Sales and Marketing Manager
Andrew Maynes
020 7604 4890
Fax: 020 7328 1844

Accounts
Michael Ogazi
020 7625 8032
Fax: 020 7328 1844

Credit Control
Louise Palfrey
+44 (0)1923 270833
Fax: +44 (0)1923 270833

Publisher
Noel Keywood

WORLD AUDIO DESIGN
Technical Manager
Nick Lucas
Tel/Fax: +44 (0)1908 218836
nick@worldaudiodesign.co.uk

Distributed by
Comag Magazine Marketing,
Tavistock Road, West Drayton,
Middlesex UB7 7QE
Tel: +44 (0)1895 444 055

Printed by
Southernprint, Dorset.
Tel: +44 (0)1202 622 226

All unsolicited submissions are made at the owner's risk. We accept no responsibility for such submissions, nor do we undertake to return them.

No material may be reproduced from this magazine without the publisher's written permission.
© Audio Publishing Ltd

ALL RIGHTS to the designs are reserved by World Audio Publishing Ltd. They are published for single use by private individuals. They are not to be used for commercial gain without prior permission from World Audio Publishing Ltd.

World Audio Publishing Ltd accept no responsibility for accident or injury arising from the construction or use of any of the designs published. All of the projects in this supplement have gone through rigorous listening and test procedures. The performance and specification of these projects can only be guaranteed on kits bought directly from World Audio Publishing Ltd.

diy supplement/contents

No59



DIY NEWS	102
PAS II WAD PASSIVE PRE AMP KIT	104
<i>An active preamp isn't always necessary. But there's more to a passive than meets the eye, says Nick Lucas</i>	
KEL84 UPGRADE	110
<i>Nick Lucas guides us through tweaking the sound of our popular budget valve amplifier</i>	
GAINING CONTROL	113
<i>Controlling the volume of an amplifier isn't so simple when sound quality is an issue. Designer Andy Grove looks at the issues and options.</i>	
BOOK REVIEW	119
<i>Basic Theory and Application of Electron Tubes, reviewed by Andy Grove.</i>	
LETTERS	120
ADVERTISERS' INDEX	146

e-mail us with news at - diynews@hi-fiworld.co.uk

KIT & COMPONENT NEWS

►► *Duncan's Amp Pages*

<http://www.duncanamps.com/whatsnew.html>

Avid tube designers can find useful help at Duncan's amp pages (www.duncanamps.com) where new power supply design software has been made available on site. Anyone who has visited this rich mine of Internet tube (valve) info will know how comprehensive it is. The new PSU II designer does, however, cater for solid-state and tube design criteria.

As well as listing no fewer than twenty one rectifier tubes catered for there are half wave, full wave, bridge and voltage doubler configurations. Filter calculations take account of a simple capacitor, C+R, pi filter type C/L/C and even choke input (swinging choke) L/C types.

Like most engineering packages this one runs on PCs only, not Macs, requiring Windows 95/98/2000 or NT.

IMPROVING CLARITY

Industrial Capacitors (Wrexham), or ICW for short, believe that one of the main reasons for

improved sonic performance of a component is related to its internal resistance. The resistance can be reduced in a number of ways, the most significant being a drastic change to the aspect ratio (diameter x width), they say.

Trials involved winding components from the narrowest possible film, which increases the wound diameter significantly. The photo shows the component resembles a discuss. To make fixing easier ICW can offer the component with copper bushes or studs, with an epoxy resin fill, which allows contact to the component to be easily achieved whilst also offering a means of fixing it securely.

However the component is terminated the sound quality is better than anything we have achieved before and are informed is the best currently available on the market.

Industrial Capacitors (Wrexham) Ltd
Miners Road

Llay Industrial Estate,
Wrexham
LL12 0PJ

Tel: 01978 853805
Email Sales@icw ltd.co.uk
<http://www.claritycap.co.uk>

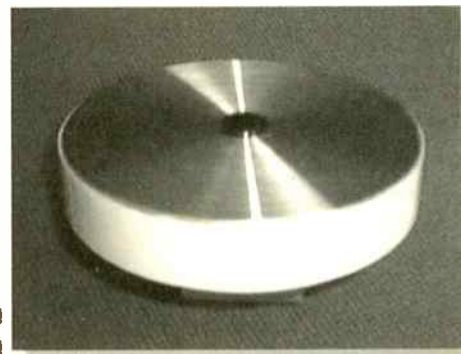

Intro

PSU Designer II is designed to help you with the design of simple linear (unregulated) mains power supplies, as often found in tube amplifiers.

Key features

- **Rectifier types:** Solid state, Vacuum tube types 5AR4, 5R4-G/GY/GYA/GYB, 5U4-G/GA/GB, 5V3-A, 5V4-G/GA, 5Y3-Q/GA/GT, 5Z3, 6AU4-GT, 6AX4-GT/GTA/GTB, 6CA4, 6D22S, 6DE4, 6X4, 6X5/GT, 6W4-GT, 83, EZ80, EZ81, GZ33, GZ34, GZ37.
- **Rectifier configurations:** Half-wave, Full-wave, Full-wave bridge, Voltage Doubler.
- **Filter configurations:** Simple C filter, C/R/C, C/L/C and LC (swinging choke). ESR in capacitors can be catered for, as can winding resistance in chokes. Chain as many filters together as you like.
- **Outputs:** Graphic representation of voltages and currents present in the power supply.
- **Tools/Utilities:** Transformer off-load voltage calculator, transformer source impedance calculator.
- **Other features:** Online context sensitive help. Ability to add extra rectifier types.

System requirements

- **Operating system:** Windows 95, Windows 98, Windows 2000 or Windows NT.
- **Display:** 640 x 480 or greater, with 256 colour capability, or greater.
- **Memory:** As per minimum requirement for operating system.

Download the Software

To download the PSU Designer version 2.0.1, [click here](#).

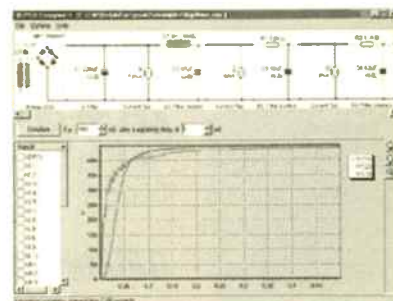

Above shows actual screen from the software



Caters for popular vacuum tube rectifiers in addition to solid-state

All trademarks acknowledged. Duncan Amplification reserve the right to vary the software specification from that published here.

Back Home Up Next

SOVTEK PRODUCE TOP KT88

One of the last audio power valves to be designed before transistors took over was GEC's KT88, a kinkless tetrode (i.e. low distortion) with high anode dissipation. It's a great sounding valve - fast and with lots of real punch when used in a good amplifier. This is a tube for Naim lovers!

Sovtek have produced an advanced design, they say, that "offers the highest output power and the most reliable, linear performance available in a KT88. The unique tri-alloy plate structure of the Sovtek KT88 yields higher minimum plate current and higher transconductance while improving heat dissipation and reducing tube warm-up time. Its triple-carbonate Oxide Cathode allows the Sovtek KT88 to operate at full power for extended time periods without failure. These improved characteristics offer increased power output, higher amplification factors, and more precise tube matching with minimal drift while still maintaining tonal clarity.

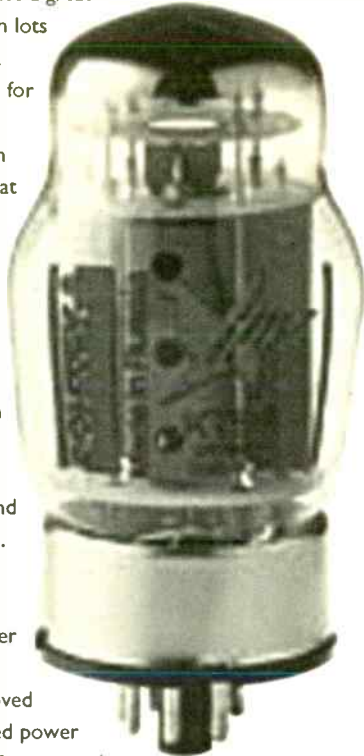

www.sovtek.com

ELECTRO-HARMONIX 6550

Electro-harmonix have recently added the 6550EH power tube to their EH range of premium quality tubes. The 6550EH delivers the highest power of any 6550, they say. It has 42W of plate (anode) dissipation in tetrode operation and 44W in triode

operation. Other features are a ruggedised screen construction, phosphor bronze side rods and screen, Tung Sol style Coke bottle shape and most importantly, heavier plate material giving more surface area for increased cooling. There's a new cathode coating too.

Electro-Harmonix claim a pair of factory matched 6550s are the best sounding tubes of their type today, offering a "sweet tone" for vintage McIntosh, Harman Kardon, or Dynaco classics, as well as ruggedness for "today's groundbreaking designs from companies like Audio Research, Conrad Johnson and Jadis". They also say the 6550EH can replace the KT88 in any application.

www.ehx.com



FALCON Acoustics Ltd

Falcon Electronics, Basically Sound

http://www.falcon-acoustics.co.uk

Full Price List and Focal details on Web Site

DRIVE UNITS: by FOCAL & Seas, and a pick of the best from other manufacturers. Coming:- **ETON HEXACONE Range of units**

100+ CROSSOVER NETWORKS: - Active & Passive, Components, Accessories, COMPONENTS

SOLENE Polypropylene capacitors, 0.1mFd. to 100mFd.

Polyester and Polycarbonate Film Capacitors, 0.1mFd. to 10mFd.

ALCAP Reversible Electrolytic Capacitors (Non-Polar); 50v, 100v & Low Loss, 2mfd. to 600mFd.

FALCON Custom-wound Inductors.

FERRITE:- Standard, High Power, Super Power, Super Super Power +

AIRCORED 0.56 - 1.25mm wire: IRON DUST, 1mm wire

TAPPED INDUCTORS:- 0-10mH in 1mH steps & 0-1mH in 0.1mH steps

AUDIO AMATEUR PUBLICATIONS

NEW- Valves for Audio Frequency Amplifiers from Philips Technical Library plus lots in P/L.

Back year sets of Speaker Builder, Audio Amateur & Glass Audio, plus the Audio Anthology Set.

Altogether 50+ books and 50+ Audio Amateur's magazine year sets. 2000 sets available

FOCAL 'State of the Art' Units & Kit Designs

Units in PolyKevlar, PolyGlass, NeoGlass, Paper and Neoflex. Tweeters in Tioxid & Kevlar using Focal's inverted dome design.

FOCAL SUMMER SALE

All FOCAL UNITS -15%

on all orders received before the end July 2001.

Extra special:- Audiom 15VX -20%

First come first served, from stock.

Unit Spec Booklet available 30p. OR FREE on Web Site

Please send A4 SAE with 44p stamp

(66p with PL) +30p extra stamps.

SUPPLIERS TO THE TRADE SINCE 1972

Send for our FREE price list PL30: Just send a large S.A.E. (44p stamp) or US\$2 bill overseas.

Europe US\$1 bill or 3 International Reply Coupons (IRC) to:-(Dept HFV) Tabor House,

Norwich Road, MULBARTON, Norwich, Norfolk. NR14 8JT Tel (0)1508 578272

PRICE VALIDITY TO END APRIL 2001 - ASK ABOUT ANY TYPES NOT ON THIS LIST

CVC CHELMER VALVE COMPANY

for High Quality Audio Tubes

Everybody in the tube business knows that the justly famous Brand names of yesteryear like BRIMAR,

GEC, MULLARD, RCA & TELEFUNKEN Etc. Etc. are scarce and often very expensive.

Although we supply all major brands when available (and have many in stock) our policy is to offer a

range of tubes, mostly of current manufacture, the best we can find from factories around the world,

which we process specially to suit audio applications. The result - CVC PREMIUM BRAND.

Our special processing includes selection for LOW NOISE, HUM & MICROPHONY and controlled

BURN-IN on all power tubes to improve STABILITY and select out tubes with weaknesses Etc.

A selection of CVC PREMIUM Audio Tubes

PRE-AMP TUBES £	POWER TUBES £	POWER TUBES £	SOCKETS ETC. £
ECC81 5.70	EL34G 8.20	(continued)	B9A (Chassis or PCB) 1.60
ECC82 5.70	EL34 (Tesla) 8.30	6336A 46.00	B9A (Ch or PCB) G/Plated 3.00
ECC83 5.70	EL34/CA7 (Large Dia) 10.80	6550A 11.00	Octal (Ch. or PCB) 1.80
ECC85 6.50	EL84/6BQ5 5.20	6550WA or WB 14.50	Octal (Ch. or PCB) G/Plated 4.20
ECC88 5.50	EL509/519 13.00	7581A 11.50	4 Pin (For 2A3, 300B etc.) 3.30
ECCF2 5.50	E84L/7189A 7.00	811A 11.00	4 Pin (For 2A3, 300B etc.) 5.00
ECL82 5.90	K165 10.00	812A 34.00	4 Pin (For 2A3, 300B etc.) 5.00
ECL86 5.90	KT66F 22.50	845 New Design 33.00	4 Pin Jumbo (For 211 etc.) 10.00
EF86 6.20	KT77 12.90		4 Pin Jumbo (For 211 etc.) 10.00
E80F Gold Pin 11.00	KT88 (Standard) 13.00		Gold Plated 13.00
E81CC Gold Pin 7.50	KT88 (Special) 17.00		5 Pin (For 807) 3.00
E82CC Gold Pin 8.80	KT88 (GL Type) 30.00	EZ80 4.90	7 Pin (For 6C33C-B) 4.50
E83CC Gold Pin 8.00	KT88 (JJ) 17.00	EZ81 5.20	9 Pin (For EL, PL509, Ch. or PCB) 5.00
E88CC Gold Pin 8.60	PL509/519 9.60	GZ32 15.00	Screening Can 2.00
6EU7 6.70	2A3 (4 or 8 pin) 15.50	GZ33 7.00	(For ECC83 etc.)
6SL7GT 8.50	211 22.00	GZ34 7.00	Anode Connector 1.50
6SN7GT 5.00	300B 48.00	GZ37 8.70	(For 807 etc.)
6922 6.00	6C33C-B 27.00	5U4G 6.00	Anode Connector 1.50
7025 7.00	6L6GC 7.00	5V4GT 4.70	(For EL509 etc.) 1.50
	6L6WGC/5881 8.70	5Y3GT 4.20	Retainer (For 6L6WGC etc.) 2.00
	6V6GT 5.50	3Z4* 3.20	
	6148B 11.50		

and a few "Other Brands" (inc. Scarce types).

SR4GY FIVRE 8.00	6B4G / SYLVANIA 27.00	6SN7GT BRIMAR 12.00	13E1 STC 100.00
SR4WGY CHATHAM USA 10.00	6B6B BRIMAR 5.00	12AT7WA MULLARD 6.00	805 CETRON 50.00
5U4GB RCA or GE 12.00	6BX7 GE 8.50	12AY7 GE-SYLVANIA 7.75	5842A GEC 15.00
5Y3WGT SYLVANIA 5.00	6CG7/6FQ7/SYLVANIA 10.70	12AZ7 GE 7.50	6080W TUNGSTOL 12.50
6AS7G RCA or SIEMENS 12.00	6CL8 RCA or GE 8.00	12BH7A GE or RCA 13.00	6550A GE 24.00
6AU6W SYLVANIA 1.50	6CW4 RCA 12.00	12BY7A GE 9.00	6148B GE 18.00
	6EL8T GTC 4.00	17E1 STC 12.50	

Please note carriage charge extra - VAT (EEC Only) - When ordering state if matching required (add £1.00 per tube).

Payment by CREDIT CARD (ACCESS, VISA, MASTERCARD) or BANKERS DRAFT, TRANSFER or CHEQUE (UK ONLY).

FAX or POST your ORDER - We shall send PROFORMA INVOICE if necessary.

MILLIONS OF OTHER TUBES IN STOCK

Valve Amplifiers sound better still fitted with CVC PREMIUM Valves!

Chelmer Valve Company, The Stables Baddow Park, Great Baddow,

Chelmsford, Essex, CM2 7SU, England.

email: sales@chelmervalue.com / 44 (0)1245 241301 Fax: 44 (0)1245 241309 www.chelmervalue.com

Passive Preamp

An active preamp isn't always necessary. But there's more to a passive than meets the eye, says Nick Lucas.

Intro by Nick Lucas
Sound quality by Andy Grove
Designed by Andy Grove

▶ If you look at the passive pre-amplifiers on the market today you will see that they follow a similar design formula, namely, a small box with one to three pairs of phono socket inputs, usually gold plated, at the rear. These are wired directly onto a printed circuit board based stepped attenuator, furnished with good quality metal film resistors, which connect to two pairs of phono socket outputs.

Wouldn't it be nice to build a unit that can deal with more than a couple of inputs and have a tape in and tape out too?

The argument for minimalist designs is plain. As there is no active line driving device within a passive pre-amplifier it is best to keep the length of signal cables to a minimum - hence a small box. But when you have a 1 metre interconnect coming in from your source, and the same again going to your amplifier, the addition of 40cm of cabling to the internal signal path in order to use a larger chassis is not going to make a lot of difference. You could even build up your own interconnects to exact length keep the signal path distances to a minimum.

Also, having an input-attenuator-output system, as the single input variety have, does not allow the use of additional switches, such as an input selector and tape/source switch, that could degrade the sound. However, there are many good quality switches on the market at reasonable prices and the bonus of being able to control your sound from one unit, in my opinion outweigh a switchless box.

Andy Grove and I and devised the PAS II. This is basically the same basic chassis as our Series II pre-amplifier, the PRE II, but with all the vents and unused holes covered to make a

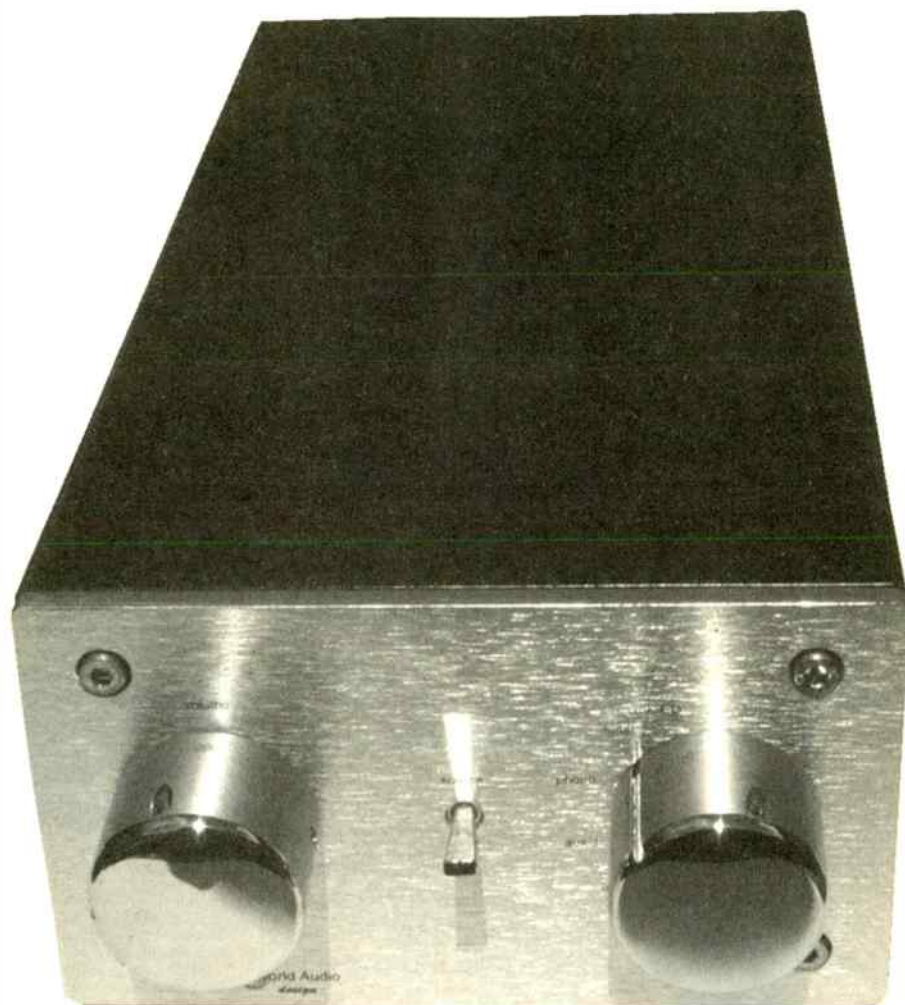

sealed unit. This prevents dust entering and contaminating the connections and switch mechanisms. The PAS II has 5/6 line level inputs, tape in and out and two pairs of outputs, all controllable from the front panel. We say 5/6 inputs as we have given the option to wire the Aux 3 input directly to the input of the attenuator, effectively bypassing the selector and tape/source switch. In this configuration you cannot have a source plugged into Aux 3 if you intend on using one of the other inputs as it affects the input impedance the attenuator sees. The volume control is a two wafer attenuator. Please note that for a closer technical look, Andy Grove has written an article within this issue, that fills any gaps you may feel exist in this article.

COMPONENT SELECTION.

As there is little circuitry within a passive pre-amplifier, we paid close attention to component selection, using gold plated, insulated phono sockets throughout. We have used them many times before without fault, so they were a confident choice.

The signal cable was a trickier problem. It had to be single screened, as this type provides better protection from RF pickup and crosstalk than twin screened wire. A passive of this quality would be weakened if we had stuck grey standard RS wire in, but where do you draw the line? You can spend a great deal of money on top, audio grade, screened wire, up to hundreds of pounds per metre and as 8 metres is required we were not going to take that route.

My mind was drawn back to an article that Jon Marks had written a few years back, about DIY cables. I sat in on the listening test and was amazed by the sound and the price tag of an interconnect constructed of Shark wire from Song Electek Corp. My interest was further reinforced when Andy said he uses it for all his specialist builds. Shark wire features high purity oxygen free copper, is extremely well insulated throughout with high density polyethylene, reducing greatly any chance of oxidation and, thus, sound degradation. It measures 5mm diameter and is quite rigid. To strip it down and solder it in place is slightly laborious; I found it took me around 3 minutes to wire one end to a phono socket.

The most important component in a passive is the attenuator. For my attenuator I decided to contact a company that Neville Roberts had talked highly of in a DIY letter published a few months ago. Blore Edwards Ltd is a company based in South Wales and specializes in potentiometers, multi-position rotary switches and spring load terminals. All components are manufactured on site - always a good sign. I ordered a make-before-break, type PZ, 23 way rotary, two-wafer and a week later it arrived. It was very well made, bigger than I expected at 49.2 x 41.3 x 50mm, heavy duty and needing plenty of torque on the shaft. I actually had to fit a knob to get the thing turning. The contacts are brass with



Diagram shows schematic diagram of PAS II - Series II passive pre-amplifier module

note that R1/R24 refers to an open circuit and R23/R46 refers to a short

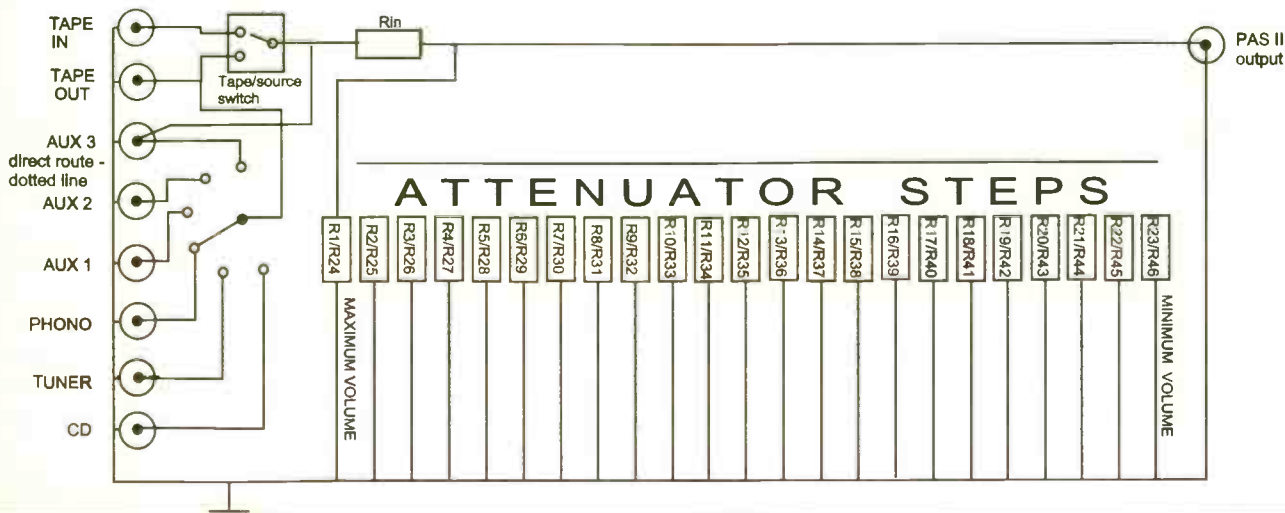
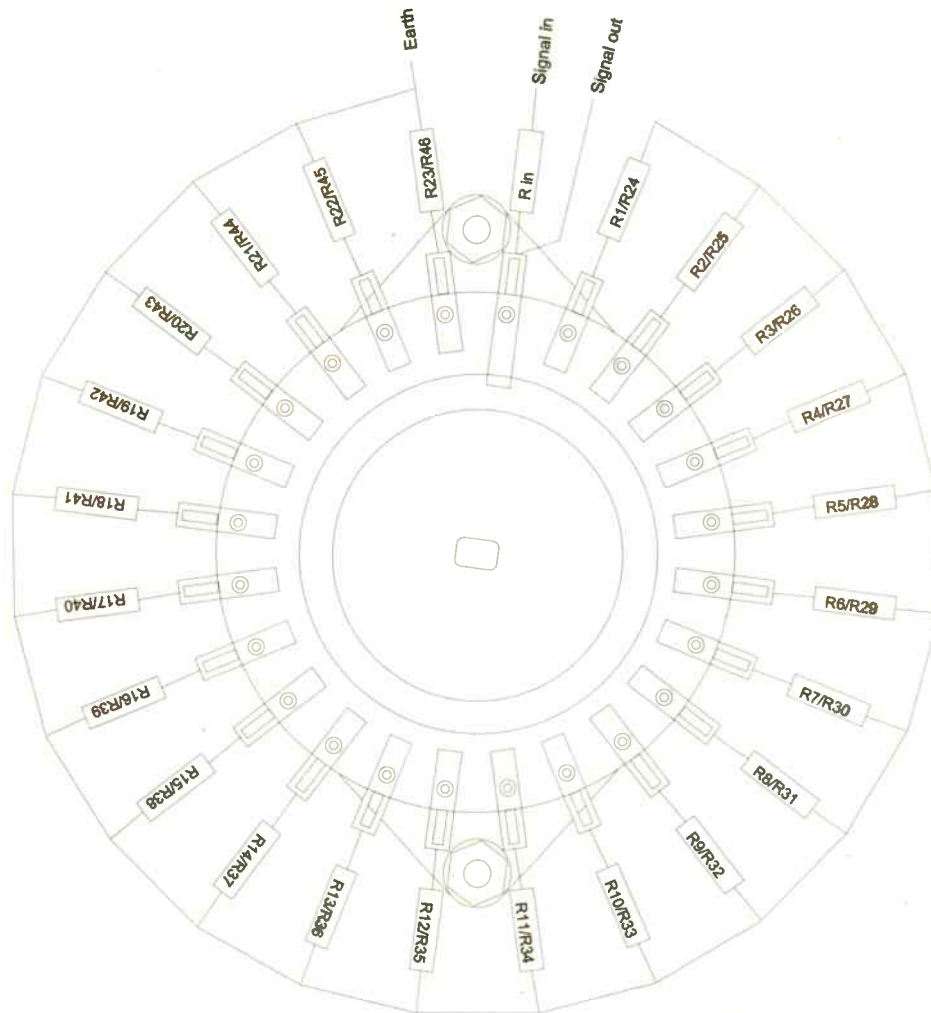

Diagram shows connections of attenuator
note that R1/R24 refers to an open circuit and
R23/R46 refers to a short. Only one wafer shown here



silver plating. We could have gone for a gold plate but that would have raised the price somewhat. Each contact was suitably drilled to accommodate a resistor lead. I was very impressed.

The input selector we chose was a 2 pole, 6 way rotary switch made by C&K, a company based in America. It is a single wafer switch and can be adjusted to a variety of switch configurations. All contacts are gold plated. The tape/source switch we choose was a long, flat lever DPDT on-on 'professional' toggle switch, also with gold contacts.

Last but not least, which resistors did we use and how did we determine the values? These questions lead me to two stories that occurred while trying to resolve the answers. Not soon after the PAS II's conception, Andy Grove went off on one of his trips. Ordinarily I would have waited for his return, but, fuelled by a desire to hear the PAS II I set about resistor selection and reached for the RS catalogue. Knowing that most attenuators use metal films, I wondered why carbon films were not used, being a lover of carbon films. I preferred their sound in our valve amps to that of metals, a decision arrived at by a head to head between two differently furnished K5881 power amps. So carbon films it was, a choice I would soon regret. To assess component values I attached a couple a crocodile clipped wires to the signal out and signal in of the 100K volume pot of a KiT88. Although

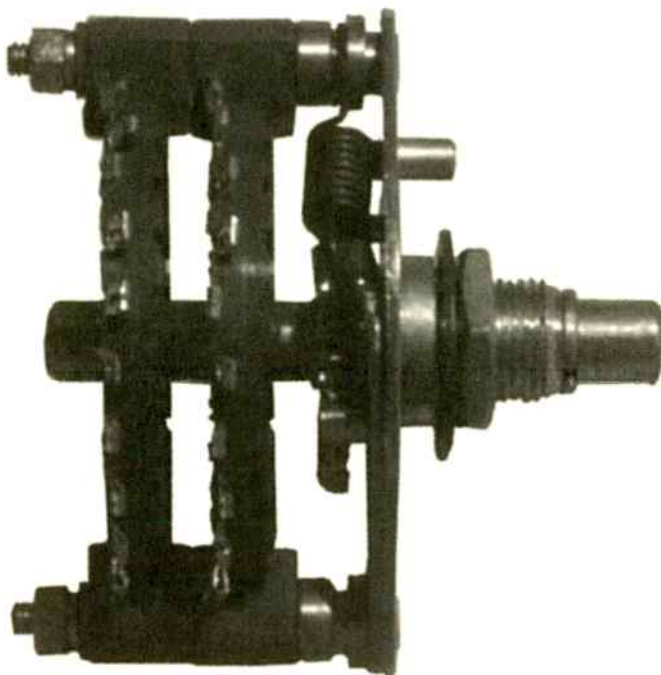

CAPTIONS

Left: The twenty-three way switch has two wafers and a strong spring detent that gives it a positive action.

Top right: Each wafer has as many contacts as it is possible to fit on - which makes for a lot of contacts.

Bottom right: Resistors must be neatly soldered direct to each contact terminal and the other ends commoned. The two resistors below are the series inputs.

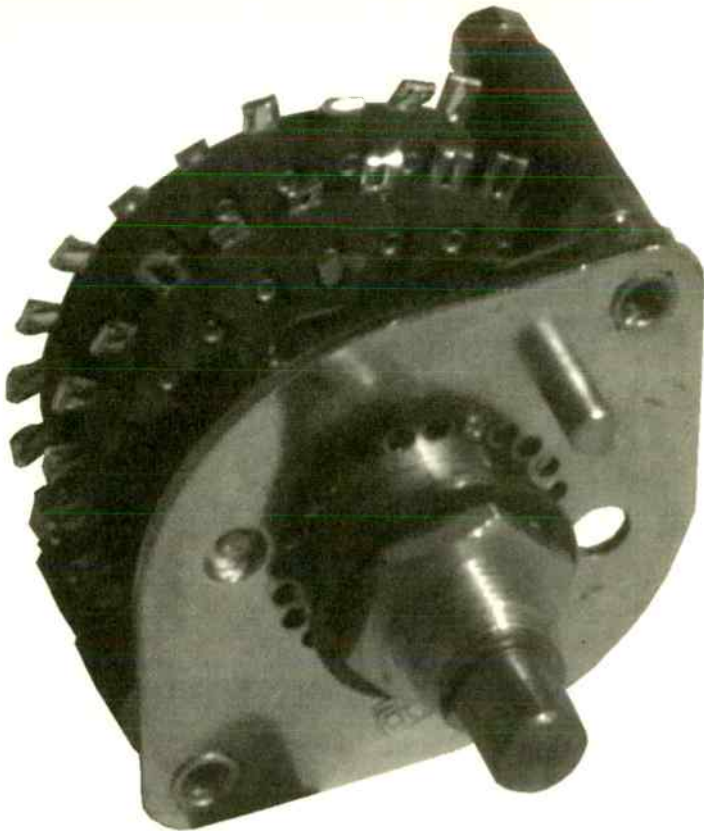

article in this issue. Refer to the diagrams as to how the attenuator is put together. He also derived Table 1 that shows the values to use. The first seven steps, starting at full volume, are 3db steps and the remaining ones are 2db.

We are offering two different overall resistances for the attenuator, 10kohm, for those who do not use a valve phono stage and 50kohm for those that do. As some people may be interested in putting attenuators directly in their integrated amplifiers to replace their potentiometers we are offering attenuator+resistor packs as well.

ABOUT THE KIT

The kit comes with all the parts listed and is relatively straightforward to construct. However, patience is required as there's a lot of wire stripping and careful soldering to be done. A steady hand is a must, not to be attempted on the morning after a heavy night out. A useful tool for stripping the Shark wire is a Stanley knife, just ring-cut the outer sheath and carefully pull away. It took me six hours from start to finish.

SOUND QUALITY by Andy Grove

One thing you notice immediately is the fact that the PAS II has some physical weight about it, unlike some smaller box passives I have used that tend to move if you are a bit heavy handed. Also, a very useful feature is the amount of gold on the back panel. Enough inputs to keep any source junky happy. The two pre-amp output pairs prove useful for all those subwoofer users.

For the listening test I used the 300B PSE monoblocs, the KLS9 two way speakers and a NAD Silverline as a source. This proved to be a superb combination. The attenuation steps were spot on, offering very good control over the listenable range.

I have always found it difficult to speak of sound quality with passive preamplifiers because in the past I have found them to be somewhat flat and uninspiring, also generally lacking 'air'. But I was pleasantly surprised in this case. Essentially the PAS II is very neutral in character, but without seeming either bland or mathematically analytical. I was surprised at how dynamic this passive was. Listening to Theme From Shaft the brass instruments had a fantastically clean and sweet quality, and were easily differentiated from within this complex mix. This track should get the feet tapping with it's rhythm and here the new passive also excelled. Percussion and bass were clean and fast, allowing that funky sound to penetrate the soul. The PAS II has brilliant drive; nothing sluggish about this one, very impressive.

my maths is good, I am a practical man with little time to spare. I turned the volume up gradually and measured the resistance at each step to suit my ear.

In hindsight, I chose the worst possible method of constructing an S type attenuator, where a chain of 23 resistors add up to 100k, each join on the chain leads to a tag of the attenuator, the first attached to signal in and

the last to earth. I sat down for a good old listen and after 10 minutes put my attenuator to one side. The word that best described it was slushy.

I decided to wait for Andy to return. He promptly told me carbon films work superbly in an active situation, but when there is no juice behind them they flag dreadfully and that my attenuator method stank as the input

signal, no matter what setting the attenuator was at, would pass through 23 resistors and will be affected by noise and all sorts. Well you live and learn, that is what DIY is about.

THE CORRECT WAY

Andy pointed me to Philips 0.6W 1% resistors as the best for the job at a reasonable price. He also came up with a way of setting the attenuator up so that only 2 resistors are in the signal path on any step - surprised? I was, take a look at his

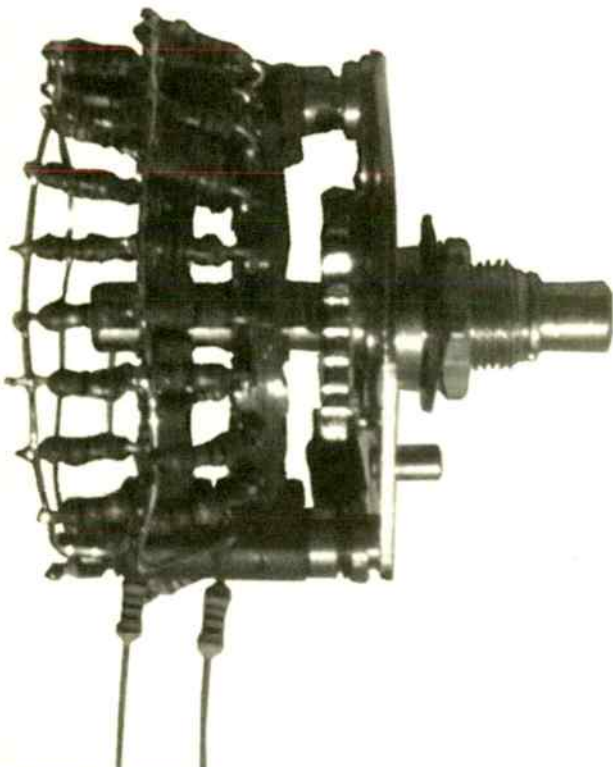

Falcon Acoustics Ltd

Falcon Electronics, Basically Sound

<http://www.falcon-acoustics.co.uk>

Full Price List and Focal details on Web Site

DRIVE UNITS: by FOCAL & Seas, and a pick of the best from other manufacturers. Coming:- **ETON HEXACONE** Range of units
100+ CROSSOVER NETWORKS: - Active & Passive. Components, Accessories. **COMPONENTS**
SOLENE Polypropylene capacitors. 0.1mFd. to 100mFd.
 Polyester and Polycarbonate Film Capacitors. 0.1mFd. to 10mFd.
ALCAP Reversible Electrolytic Capacitors (Non-Polar); 50s, 100s & Low Loss, 2mFd. to 600mFd.
FALCON Custom-wound Inductors.
FERRITE:- Standard, High Power, Super Power, Super Super Power + **AIRCORED** 0.56 - 1.25mm wire; **IRON DUST**, 1mm wire
TAPPED INDUCTORS:- 0-10mH in 1mH steps & 0-1mH in 0.1mH steps
AUDIO AMATEUR PUBLICATIONS
 NEW: Valves for Audio Frequency Amplifiers from Philips Technical Library plus lots in P/L. Back year sets of Speaker Builder, Audio Amateur & Glass Audio, plus the Audio Anthology Set. **Altogether 50+ books and 50+ Audio Amateur's magazine year sets, 2000 sets available**

FOCAL 'State of the Art' Units & Kit Designs

Units in PolyKevlar, PolyGlass, NeoGlass, Paper and Neoflex. Tweeters in Tioxid & Kevlar using Focal's inverted dome design.

FOCAL SUMMER SALE

All FOCAL UNITS -15%
 on all orders received before the end July 2001.
 Extra special:- **Audiom 15VX -20%**
 First come first served, from stock.
 Unit Spec Booklet available 30p. OR FREE on Web Site
 Please send A4 SAE with 44p stamp
 (66p with PL) +30p extra stamps.

SUPPLIERS TO THE TRADE SINCE 1972

Send for our FREE price list PL30. Just send a large S.A.E. (44p stamp) or US\$2 bill overseas. Europe US\$1 bill or 3 International Reply Coupons (IRC) to:- (Dept HFV) Tabor House, Norwich Road, MULBARTON, Norwich, Norfolk, NR14 8JT Tel (01)508 578272

PRICE VALIDITY TO END APRIL 2001 - ASK ABOUT ANY TYPES NOT ON THIS LIST



CHELMER
 VALVE
 COMPANY

for High Quality Audio Tubes

Everybody in the tube business knows that the justly famous Brand names of yesteryear like BRIMAR, GEC, MULLARD, RCA & TELEFUNKEN Etc. Etc. are scarce and often very expensive. Although we supply all major brands when available (and have many in stock) our policy is to offer a range of tubes, mostly of current manufacture, the best we can find from factories around the world, which we process specially to suit audio applications. The result - CVC PREMIUM BRAND. Our special processing includes selection for LOW NOISE, HUM & MICROPHONY and controlled BURN-IN on all power tubes to improve STABILITY and select out tubes with weaknesses Etc.

A selection of CVC PREMIUM Audio Tubes

PRE-AMP TUBES £	POWER TUBES	POWER TUBES	SOCKETS ETC.	£
ECC81 5.70	EL34G 8.20	(continued)	B9A (Chassis or PCB)	1.60
ECC82 5.70	EL34 (Tesla) 8.30	6336A 46.00	B9A (Ch or PCB) G/Plated	3.00
ECC83 5.70	EL34/6CA7 (Large Dia) 10.80	6550A 11.00	Octal (Ch. or PCB)	1.80
ECC85 6.50	EL84/ 6BQ5 5.20	6650WA or WB 14.50	Octal (Ch. or PCB) G/Plated	4.20
ECC88 5.50	EL509/519 13.00	7581A 11.50	4 Pin (For 2A3, 300B etc.)	3.30
ECC82 5.50	EL509/519 13.00	807 10.00	4 Pin (For 2A3, 300B etc.)	4.20
ECL82 5.90	E84L/ 7189A 7.00	811A 11.00	G/Plated	5.00
ECL86 5.90	KT66 10.00	812A 34.00	4 Pin Jumbo (For 211 etc.)	10.00
EF86 5.90	KT66R 22.50	845 New Design 33.00	4 Pin Jumbo (For 211 etc.)	10.00
EF86 6.20	KT77 12.90		Gold Plated	13.00
EF86 6.20	KT88 (Standard) 13.00		5 Pin (For 807)	3.50
EF86 Gold Pin 11.00	KT88 (Special) 17.00		7 Pin (For 6C33C-B)	4.00
E81CC Gold Pin 7.50	KT88 (GL Type) 30.00	E280 4.90	9 Pin (For EL, PL509, Ch. or PCB)	5.00
E82CC Gold Pin 8.80	KT88 (J) 17.00	E281 5.20	Screening Can	2.00
E83CC Gold Pin 8.00	PL509/519 9.60	E282 15.00	(For ECC83 etc.)	1.50
E88CC Gold Pin 8.60	2A3 (4 or 8 pin) 15.50	E283 15.00	Anode Connector	1.50
6E17 6.70	211 22.00	GZ33 7.00	Anode Connector	1.50
6SL7GT 8.50	300B 48.00	GZ37 8.70	Retainer (For 6LWGC etc.)	2.00
6SN7GT 5.00	6C33C-B 27.00	5U4G 6.00		
6922 6.00	6L6GC 7.00	5V4GT 4.70		
7025 7.00	6L6WGC/ 5881 8.70	5Y3GT 4.20		
	6V6GT 5.50	5Z4GT 5.20		
	6080W 11.50			
	6146B 11.50			

and a few "Other Brands" (inc. Scarce types).

5R4GY 5VIRE 8.00	6EN6 / SYLVANIA 27.00	65N7GT 5R1MAAF 12.00	13E1 STC 100.00
5R4WG CHATHAM USA 10.00	6B9B BRIMAR 5.00	12A77WA MULLARD 6.00	805 CETRON 50.00
5U4GB RCA or GE 12.00	6BX7 GT GE 8.50	12AY7 GE-SYLVANIA 7.75	5842A GEC 15.00
5Y3MGT SYLVANIA 5.00	6CG7 8FQ7 SYLVANIA 10.70	12AZ7 GE 7.50	6090W TUNGSTOL 12.50
6A8T RCA or SIEMENS 12.00	6CL6 RCA or GE 8.00	12B7A GE or RCA 13.00	6550A GE 24.00
6AU6C SYLVANIA 4.50	6CW4 RCA 12.00	12BY7A GE 9.00	6146B GE 18.00
	6SL7GT STC 9.50	12E1 STC 12.50	

ALL PRICES IN U.K. POUNDS £
 Please note carriage charge extra + VAT (EEC Only) - When ordering state if matching required (add £1.00 per tube).
 Payment by CREDIT CARD (ACCESS, VISA, MASTERCARD) or BANKERS DRAFT, TRANSFER or CHEQUE (UK ONLY).
 FAX or POST your ORDER - We shall send PROFORMA INVOICE if necessary.

MILLIONS OF OTHER TUBES IN STOCK

Valve Amplifiers sound better still fitted with CVC PREMIUM Valves!

Chelmer Valve Company, The Stables Baddow Park, Great Baddow, Chelmsford, Essex, CM2 7SU, England.

email: sales@chelmervalue.com £ 44 (0)1245 241301 Fax: 44 (0)1245 241309 www.chelmervalue.com

TECHNICAL & GENERAL

SOME NECESSITIES - FROM THE ORIGINAL CLASSIC TURNTABLE SPECIALISTS

CONNOISSEUR

		£11.60	£1.90
BD1/2 Drive Belt			
BD1/2 Motor Suspension kit		£14.50	£2.50
SAU.2 Headshell		£17.50	£2.90
SAU.2 Connecting Lead		£16.50	£3.20

GARRARD Standard Models

		from	£14.50	£2.90
Wired arm tubes				
Cartridge carriers (sliders)		£12.50		£1.90

301/401 Transcription models

Original Thrust pad assembly		£12.50	£2.50
Original Idler tension spring		£3.25	£1.90
Original Brake pad		£2.40	£1.90
Xeroxcopy Owners Manual 301 incl. full size mounting template		£9.30	£1.90
		£7.20	£1.90

Replacement 301 control knobs On-Off/Speed select	pair	£21.50	£2.90
Replacement 301 suppressor unit		£6.20	£2.50
Replacement 301 motor pulley (-2%), (-1%), (Std), (+1%)	each	£16.20	£2.50
Replacement 301 Chrome plated mounting bolts	set	£7.20	£2.50
Recommended Lubrication set - early 301 or 301/401	(specify)	£6.20	£1.90

GOLDRING/LENCO

Idler wheel (lock-nut or clip fixing)		£21.20	£2.90
Tension spring		£3.25	£1.90
Arm pivot bearings - with fitting instructions		£9.25	£1.90
Spindle/Main bearing assembly complete	GL.69/72	£21.00	£3.90
	GL.75/7B	£25.00	£3.90
Chassis suspension springs (set of 4)	set	£19.50	£3.90
Headshells	from	£22.25	£2.80
Instruction books	from	£4.50	£1.90

THORENS

TD.124 series

Idler wheel original		£28.50	£2.90
Idler wheel our redesigned replacement		£16.50	£2.90
Drive belt		£19.50	£1.90
Suspension rubbers ('mushrooms')		£16.50	£2.90

TD.150/160

Drive Belt		£17.90	£1.90
Suspension springs (-1%), (Std), (+1%) (set of 3) set		£13.50	£2.90
Suspension - main bushes (set of 3) set		£13.50	£2.90
Armboards TD.150 blank		£12.50	£2.50
TD.160		£10.20	£2.90

CECIL WATTS Dustbugs & spares - incl. Preener wicks

Cartridges and styli for 7Bs and Mono LPs in addition to current Stereo LPs

TECHNICAL & GENERAL

PO BOX 53, CROWBOROUGH, EAST SUSSEX, TN6 2BY
 TELEPHONE: 01892 654 534

Advanced high speed, ultra-low noise discrete regulators.

Replaces standard voltage regulators in CD/DVD and SACD players providing improved low level information, sound stage and musicality.

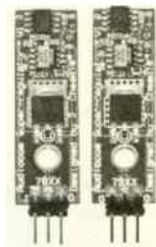

Super regulator



audiocom-uk.com

01646 685601

AD825 Op-Amp Module



Op-amps used in CD players are generally of poor quality, corrupting the analogue signal. AD825 is a high performance drop-in replacement board providing a more natural and musical sound, with greater dynamics, detail and transparency.

PARTS LIST

Attenuator	1
Resistor pack	1
Low noise 0.6W Philips metal film resistor pack	1
Gold contact 2/6 rotary selector switch	1
Gold contact tape/source switch	1
Gold plated black phono insulated sockets	10
Gold plated red phono insulated sockets	10
Self adhesive rubber feet	4
OFC single screened wire	8 metres
Silver plated copper wire	0.5 metres
Grub screw	2
M3 x 6 screw	4
M4 x 12 hex screw	4
Chrome knob	2
Chassis (base and Lid)	1
Front panel	1
PAS II chassis (2 parts)	1
PAS II anodised front plate	1
Instruction manual	1

TABLE I : RESISTOR LIST FOR ATTENUATOR

resistor values	10k attenuator	50k attenuator
R1/R24	open circuit	open circuit
R2/R25	24K	120k
R3/R26	10K	51k
R4/R27	5.6K	27k
R5/R28	3.3K	16k
R6/R29	2.2K	11k
R7/R30	1.5K	7.5k
R8/R31	1.2K	6.2k
R9/R32	820R	4.3k
R10/R33	680R	3.3k
R11/R34	510R	2.4k
R12/R35	430R	2.2k
R13/R36	330R	1.6k
R14/R37	270R	1.3k
R15/R38	200R	1k
R16/R39	160R	820R
R17/R40	130R	620R
R18/R41	100R	510R
R19/R42	82R	430R
R20/R43	68R	330R
R21/R44	51R	240R
R22/R45	39R	200R
R23/R46	short circuit	short circuit

THE PAS II PASSIVE PREAMP IS AVAILABLE AS A KIT

The PAS II kit and Attenuator + Resistors are available from World Audio Publishing Ltd

UK (inc. vat & p&p)

Overseas (exc. vat & p&p)

PAS II passive pre-amp module	£215.00	£185.00
including attenuator + resistor pack - please specify resistance required	10k / 50k	

The attenuators with their relevant resistor pack can be purchased separately.

attenuator – 50k	£75.00	£65.00
attenuator – 10k	£75.00	£65.00

**Call or fax Nick Lucas on: +44 (0) 1908 218836
(9am-5pm, Monday-Friday)**

e-mail: nick@worldaudiodesign.co.uk

**For overseas freight charges, please call, fax or e-mail.
order online - www.worldaudiodesign.co.uk**

Upgrading KEL84

Nick Lucas guides us through tweaking the sound of our popular budget valve amplifier

Intro by Nick Lucas

Sound quality by Simon Pope

Designed by Andy Grove

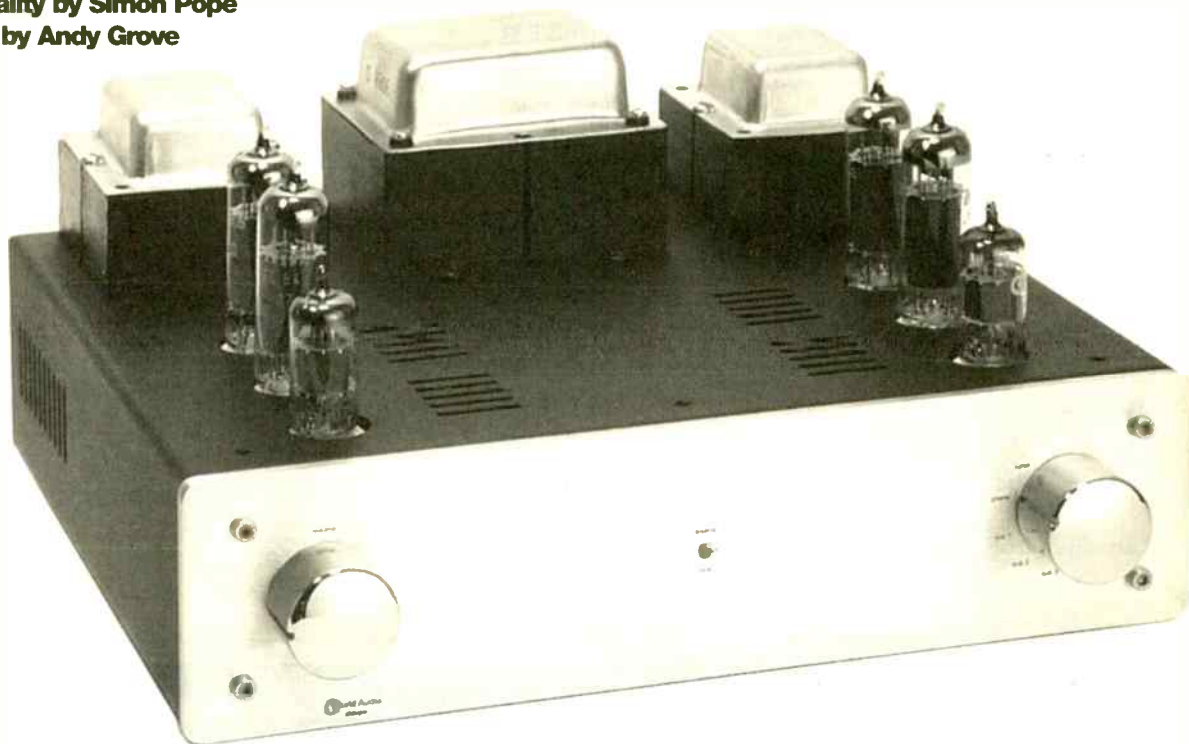

The KEL84 kit is a 15watt stereo integrated budget amplifier featuring a pair of EL84s in push-pull configuration in the output stage. It is a sweet sounding little amplifier that has won the hearts of a good number of budding DIYers, because it not only has a lovely tone but is detailed and engaging too. All the same, there are ways to improve things still further.

For this amplifier we followed a similar formula to our previous upgrade kits, namely use of wonderful Black Gate, high performance, graphite foil electrolytic capacitors in the position of the EL84's cathode by-pass capacitors, C12, C13, C14 and C15. Black Gates were also used as the low frequency component feedback capacitors C6/C7. Rubycon PLC (Japan), the manufacturers of Black Gate capacitors, have increased worldwide availability and they are now less expensive as a result. Being electrolytic these capacitors are polarised. They have positive and negative leadouts that are clearly marked. In KEL84 they have the same orientation as the original capacitors, so substitution is straightforward.

The signal capacitors that block anode volts from the grids of the EL84 output valves - C8/C9, C10/C11, significantly affect the sound. Consequently, we have gone for a change here, using Jensen's paper-in-oil capacitors. Jensen make a range of paper-in-oils. The capacitors we chose are their aluminium foil type, hermetically sealed in an aluminium tube. The terminal leads of tinned copper are solder-sealed to eyelets in the end-discs. The capacitor element is insulated from the tube. The terminal in contact with the outer foil (the foil that is the closest to the can) is always marked with a vertical line on the body of the capacitor. To ensure best performance, this terminal must be connected to the grid stoppers, R20/R21, R22/R23 (6.8kohm resistor that feeds the input grid of the EL84 valves.) The aluminium foil type was chosen to keep cost down. The copper foil, silver leadout type costs a fifth of the price of the amplifier!

The volume potentiometer, effectively the front line of the KEL84, is an obvious target

for a change. The original carbon track part pot. has a good sound, but a 100k Alps is so much better. This high-grade potentiometer offers comfortable operation and possesses high precision characteristics, ideal for audio applications. I have heard some say it gives the high-end Panasonic pot a good run for its money - and for a third of the price you can see why we stick with it.

DIFFICULT TO UPGRADE?

If you built the kit, then you will have no trouble with the upgrade. The Alps 100k potentiometer has a small location lug that needs to be removed so the part fits flush; this can be easily done with a pair of cutters. The bush of the potentiometer fits the hole for the old unit, and even though it is tight there is no need to open up the hole further with a drill bit or reamer.

Both sides of the PCB need to be accessed, so the PCB fixing screws must be undone. You will have to desolder the signal-input links so you can get to the valve base (track side) easily.

A word of warning: when putting the PCB

back in place on completion of the upgrade, make sure all external connections are still good, as moving the PCB can break joints, especially if they were weak in the first place.

With the use of a desoldering pump, remove all components to be upgraded, leaving the pin holes solder free. With the use of a 1mm drill bit, drill all the exposed holes. This is needed because the upgrade component leadouts measure 1mm in diameter and the original drill file varies from 0.6mm to 0.8mm diameter. I would recommend using a hand drill for this job; power types can be a little difficult to control and can easily destroy component cases.

You will find the pitch (the distance between component leads) of the Black Gates to be larger than the original components, so when fitting these components ensure the leads do not touch when bending them into place, as this may short the EL84 cathode bypass caps, causing the valve's anodes – the visible outer electrode – to glow red. It will damage the valve. Like the original components, the Black Gates must be correctly orientated (i.e. negative to ground).

The Jensens are much larger than the original Philips 486 orange capacitors. Even though there is a lot of available space for fitting you need to be able to get the iron in to solder the component side without burning the capacitor body. Plan it before fitting. The

capacitor's outer foil end, signified by a line on the component body, needs to be soldered to the join that relates to the 6.8k grid stopper that feeds the grid of the EL84 to ensure best performance. Their long leads need to be isolated with rubber sleeving to avoid unwanted contact with other parts of the circuits.

Simon Pope on sound quality.

KEL84 in original form

Our KEL84 provides both a sense of presence and depth to recordings. This is matched by its smooth and rounded overall sound that defies the kit's humble price tag. It has good, controlled bass weight and an exceptionally sweet delivery of upper frequencies. It is a great introduction for the uninitiated to the valve sound, as well as a subtle and sophisticated performer for those who crave more presence from a valve amp.

With an excellent SACD/CD hybrid disc of Faure, Debussy and Ravel's piano trios on the Hyperion label, the KEL84 demonstrated its deft and graceful handling of the music. The imaging and depth in this recording is near perfect and the KEL84 made the most of the simple but effective mix. Balance between the piano and strings was perfect, the piano placed, with the right amount of sonic weight, slightly to the back right, whilst the string soloists bowed with dexterity in front.

The amplifier handled the dexterous playing deftly and gracefully, bringing a high-

end sound to the performance. The same went for a CD of Nick Cave's greatest hits. Good detail and sweetness was the hallmark of the sound, along with good, taut bass and a natural, open midrange.

KEL 84 WITH ALPS POT

Replacing the standard potentiometer with an ALPS version gave a much crisper presentation to the sound, with every instrument having a stronger sense of purpose and focus. The string trios disc benefited from a more forward presentation, as the strings sounded more detailed and the accompanying piano had more body. The sound stage was extended to both the side and the rear, opening up the space around the instruments to great effect.

The studio sound of the Nick Cave album was more detailed and precise. I could better follow all the lines of each instrument in the mix and the bass had been tightened up to create a trim and muscular foundation. Midrange information such as keyboards and vocals were fuller and warmer and the treble still remained sweet, yet there was slightly more air in the sound.

KEL 84 WITH ALPS POT AND BLACK GATE CAPACITORS

Adding the Japanese Black Gate capacitors to the equation brought along a finer sense of focus and an improved presence to many

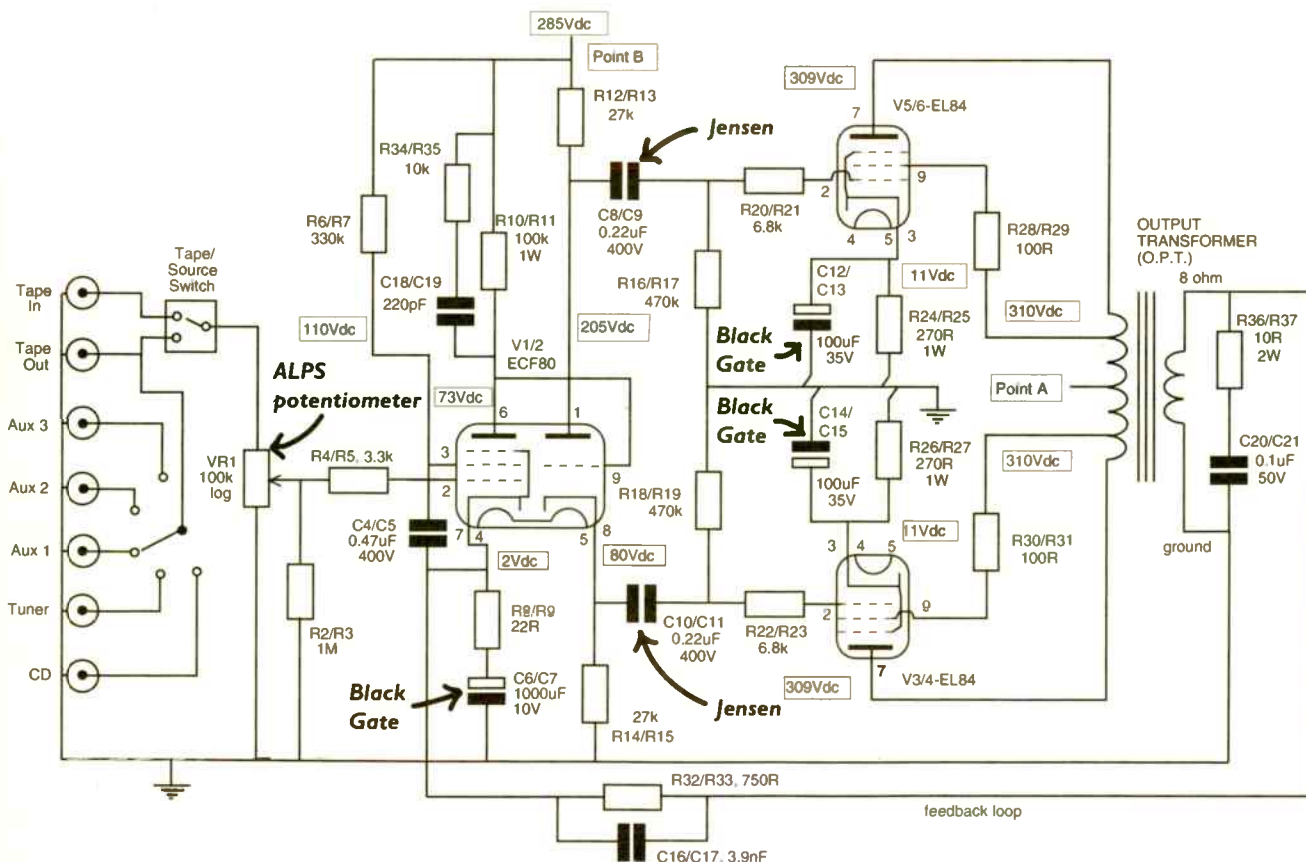

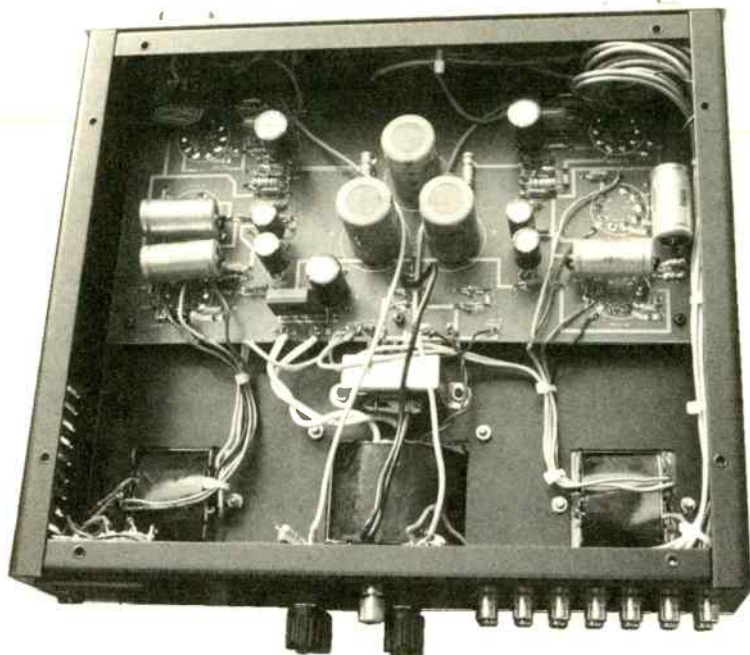

having an eerie life-like quality. Bass became tighter and more solid and a greater sense of ambience was created in the treble and midrange.

FURTHER UPGRADES

There is no limit as to how far you can take an upgrade. If you decide that you wish to take things further here are a few pointers.

- a) We have heard many good comments about Tantalum Resistors, so swap all grid stoppers - R4, R5, R20, R21, R22 and R23 and possibly the feedback resistors R32 and R33. A word of warning: it is never a good idea to swap all resistors, especially if you go to the high-end metal film type, as they can sound a touch too bright, diminishing bass output.
- b) Swap D1 - D4 for type STTA512D Turbofast diodes. Make sure you know your cathode from your anode as these are in a different package and are labeled K and A. The line on a standard diode denotes the cathode K

c) Invest in some Aerovox or Cerafine electrolytics to replace C1, C2 and C3. Watch out on physical headroom as the original components sit on the printed circuit board, so the replacements can only be 55mm high, unless you mount them elsewhere.

d) C16/C17, the capacitors in the feedback network, are key components. Try swapping to Scan-Ex polystyrenes. These are available from Audio-Links, 01724 870432.

Happy upgrading. ■ ▲

▶ aspects of the recordings. In the French Piano Trios, the strings of the ensemble had a more sinuous sound, with stronger detailing as the bow moved across the string. The piano was brought forward slightly in the mix and had more rhythmic attack.

With Nick Cave's well-recorded CD, the instruments possessed more detail and an overall faster and more responsive sound was evident. The vocals had weight and more 'spit' to them and the drums and percussion greater immediacy, resulting in life-like speed and presentation.

KEL 84 WITH ALPS POT BLACK GATE AND JENSEN CAPACITORS

The further addition of Jensen's paper-in-oils added a touch more weight and smoothness to the sound, to accompany the rhythm and presence of the Black Gates. The French Trios

disc had more breadth and fullness and both the strings and piano displayed greater natural timbre, the strings woody and rich, whilst the piano was rounded and percussive, with an excellent natural sense of and decay.

Nick Cave's 'Best Of' CD had superb detail and weight. The mix sounded very clean and precise, yet lyrical and warm. Sound staging was deep and wide and vocals remarkably clear, with the close mic'd track

KEL84 PARTS LIST

Part No.	Description	Quantity
VR1	Alps 100k dual log potentiometer	1
C6/7	Black Gate 1000uF 16V	2
C8/9/10/11	Jensen paper in oil 0.22uF 400V	4
C12/13/14/15	Black Gate 100uF, 50V	4
	rubber sleeving	20cm
	1mm drill bit	1

KEL84 UPGRADE IS AVAILABLE AS A KIT

The KEL84 upgrade kit is available from World Audio Publishing Ltd

	UK (inc. vat & p&p)	Overseas (exc. vat & p&p)
Kel84 upgrade kit-	£100.00	£86.00
	or	
100k Alps Pot.	£14.00	£12.00
Jensen 0.22uF, 400V	£12.00	£10.20
Black Gate 1000uF, 16V	£8.00	£6.80
Black Gate 100uF, 50V	£6.00	£5.20

Call or fax Nick Lucas on: +44 (0) 1908 218836 (9am-5pm, Monday-Friday)

e-mail: nick@worldaudiodesign.co.uk

For overseas freight charges, please call, fax or e-mail.

order online - www.worldaudiodesign.co.uk

Gaining Control

Controlling the volume of an amplifier isn't so simple when sound quality is an issue. Designer Andy Grove looks at the issues and options.

The common volume control used in audio equipment is often seen as a weak link and various attempts have been made to either improve or eliminate it. The simple rotary potentiometer normally used has a sliding 'wiper' on a resistive track – usually carbon. It is easy to implement and gives smooth, infinitely variable control of volume level. Various problems can crop up with this approach.

Firstly with a two-channel stereo amplifier two 'ganged' potentiometers are needed and both channels must be attenuated by equal amounts across the range of the dial's travel. If this is not the case, channel imbalance will occur which will skew the stereo image. Cheap potentiometers suffer this at low volume settings. It isn't all that important in budget midi systems but it is not acceptable in true hi fi equipment, where the two tracks of the potentiometer must be accurately matched to avoid this problem.

Another bug common with audio potentiometers is that of a scratching noise when volume is adjusted. This is caused by small, random resistance changes occurring while the wiper contact traverses the track. To overcome this an audio grade pot usually

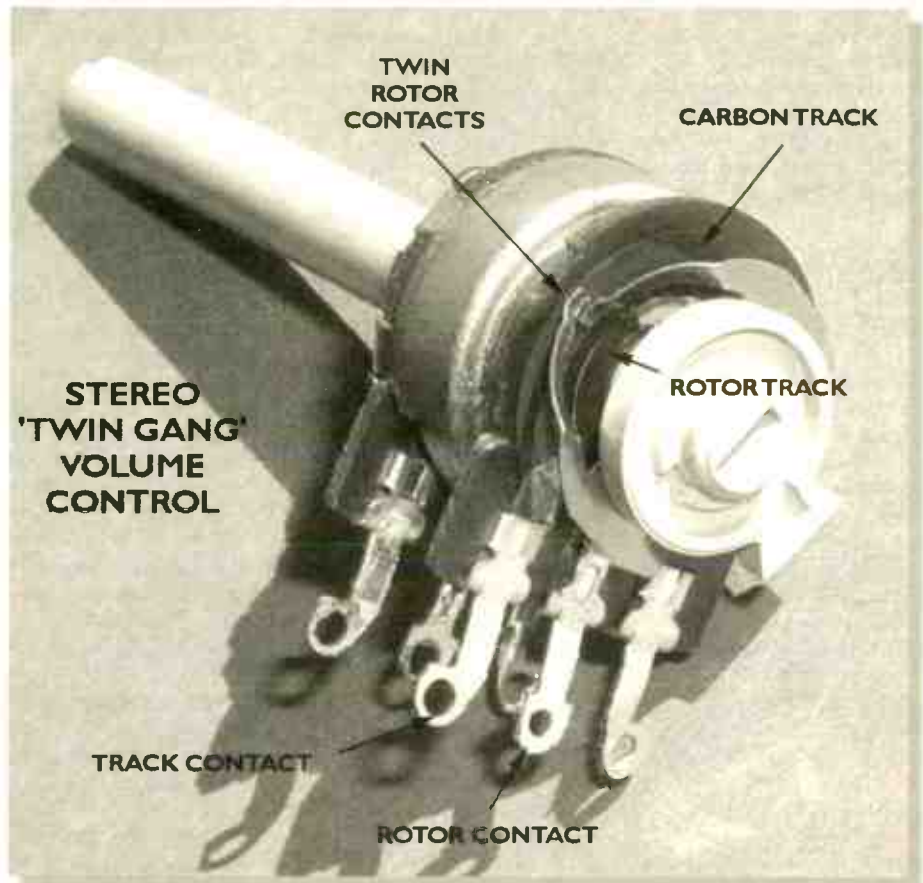

A standard stereo volume control (potentiometer) with the cover of the rear unit removed. The twin contacts of the rotor can be seen on the carbon track. There's a rotor track too, which doubles the number of contacts.

FIG 1 A CONVENTIONAL VOLUME CONTROL

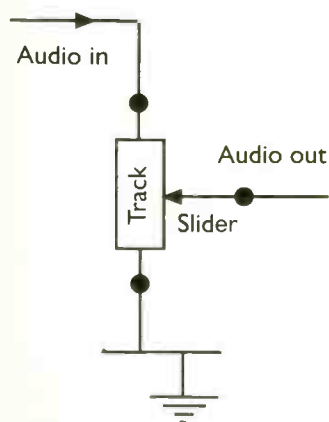

has a multi-contact or forked wiper contact to smooth out the bumps. Still, after time the track wears and dirt and dust contaminate its surface, causing noise problems. Also, if any DC leakage is present across the pot this will exacerbate any noise problems.

The track material used in a conventional audio volume control is usually carbon or conductive plastic, sometimes a Cermet film. There is debate as to which sounds best, but the combination of a sprayed on film and a wiper contact are unlikely to be good for sound quality unless both are of extremely high quality – meaning very expensive.

To my mind the finest audio pot on the planet is the top of the range Alps model, only available as a special order because it is hand made. It's huge, machined brass case, and



An Alps 'Blue' high quality stereo volume control, appropriate for hi-fi use.

KIT & COMPONENT SUPPLIERS

CLASSIC TURNTABLES

Technical & General
P.O. Box 53, Crowborough,
East Sussex TN6 2BY.
Tel: 01892 65 45 34.

The original specialist source of spares, replacements and expertise for the classic turntables. Years of actual experience and comprehensive range of parts (originals and re-manufactures), manuals, ancillaries, No dubious 'improvements' - no harmful 'modifications'. Our specialities: Connoisseur; Garrard; Goldring; Lenco; S.M.E.; Thorens; Watts; Ortofon; Shure: Cartridges and styli for 78s, Mono LPs, Stereo LPs.

COMPONENT SUPPLIERS

AudioCom (UK),
Unit 14 Pier Road
Pembroke Dock
Pembrokeshire, SA72 6TR
Tel: 01646 685601
Fax: 01646 685602
Website: www.audiocom-uk.com
E-Mail:

enquiries@audiocom-uk.com
Massive range of audio components and accessories available including Black Gate electrolytics, Elna SILMIC (Silk Fibre) electrolytics, Audyn-Cap film and foil capacitors, OFC air core and copper foil inductors, high power resistors, loudspeaker-crossovers, high-end cable, Vishay & Holco resistors, 99.9999% pure Silver wire, DACT CT1 & CT2 attenuators, audio connectors, spikes & damping materials, plus over 50 loudspeaker kits. Active products include the SUPERCLOCK master clock plus super-low noise PSU, & Q-power super-low noise discrete regulators. A new, 365 page 2001 handbook is available for £3.50 (UK) and £5.00 (overseas).

White Noise
11, Station Road, Bearsden
Glasgow G61 4AW
Tel: 0141 942 2460
Fax: 0141 587 7377
Email:
david.white38@ntlworld.com
Supplier of the widest range of standard and audiophile kits for solid state preamplifiers, power amplifiers, headphone amplifiers, power supplies, MM/MC phono stages, active crossovers, balanced i/o modules, and stepped attenuators; more kits in the pipeline. All kits use the highest quality, glass fibre, solder masked, silkscreened, PCBs. We also supply a wide range of active (esp. Japanese transistors and Exicon mosfets) and

passive components, gold plated connectors, and silver plated wires. Write, phone or email for a free catalogue. Mail order only.

Audio-Links
7 Fairmont Crescent, Scunthorpe,
North Lincolnshire DN16 1EL
Tel: 01724 870432
Fax: 01724 875340
Email: audiolinks@europe.com
Extensive stock of specialist audiophile components for valve and solid state enthusiasts. Supplier of the largest range of high-end audio volume controls in Europe. 30 Page Catalogue - Free via e-mail or £3.00 posted.

LOUDSPEAKER KIT SUPPLIERS

Audio Note (UK Ltd)
Unit C, Peacock Ind. Est.
125-127 Davigdor Road
Hove, East Sussex BN13 1SG
Tel: 01273 220511
Fax: 01273 731298
Suppliers of a large amount of components for the Audiophile Kit builder. Valve amplification data and vintage circuits also available. See the double page spread in the back section of the main issue for extra & more detailed information.

Falcon DIY Speakers
Falcon Acoustics Ltd,
Tabor House,
Norwich Road, Mulbarton,
Norfolk NR14 8JT.
Tel: 01508 578272
UK distributors of FOCAL drive units & kits, and ETON loudspeakers, plus SOLEN (SCR-Chateauroux) polypropylene capacitors. We are the largest specialist Audio inductor manufacturer in the UK. We also stock Audio Amateur Publications and Audio Computer Software and a comprehensive range of D.I.Y speaker kits, parts, accessories and books. Please send large SAE (44p) for free price list. "Everything but the wood".

IPL Acoustics, Chelsea Villa, Torrs Park, Ilfracombe, North Devon, EX34 8AY
Tel/Fax: 01271 867 439
Website: www.iplacoustics.co.uk
IPL Acoustics supply a range of 7 transmission line, 3 conventional, speaker kits, and kits for centre speakers and active subwoofers. We also supply a full range of drive units from Audax, SEAS, Morel and Legend Acoustics (Ribbon Tweeters) as well as custom built metal coned drivers. Also included is a range of

capacitors, inductors and quality cabinet accessories as well as Silver Plated PTFE insulated cables.

SPECIALIST UPGRADE SERVICES

AudioCom (UK),
Unit 14 Pier Road
Pembroke Dock
Pembrokeshire, SA72 6TR
Tel: 01646 685601
Fax: 01646 685602
Website: www.audiocom-uk.com
E-Mail:
enquiries@audiocom-uk.com
Release the full potential of your digital source with CD/DVD upgrades from audiocom. Available is the highly acclaimed SUPERCLOCK master clock oscillator. (Dave Berriman fits the S-Clock to the Teac VRDS-10SE and comments..."there was not one area of music reproduction which didn't improve".) SUPERCLOCK super low noise power supply, & Q-power ultra-low noise discrete regulators. Why not contact us to see how this service can be adapted to suit your requirements?

Rush Communications, 10 Chesnut Avenue, Clacton on Sea, Essex, CO15 2BQ
Tel: 01255 224 041
Fax: 07092 260 243
E-Mail: rcom@lineone.net
Website:
www.rcom.connectingbusiness.com
VALVES VALVES VALVES
Audio Engineer with 35 years experience can repair, modify or upgrade any valve amplifier or pre-amplifier

VALVE AND OUPUT TRANSFORMER SUPPLIERS

Wilson Valves, 28 Banks Avenue, Golcar, Huddersfield, West Yorks HD7 4LZ.
Tel: 01484 654650
Fax: 01484 655699
E-mail:
wilsonvalves@surfink.co.uk
We stock over 2,500 different types of valves, N.O.S. and New. Please send a S.A.E. for full list. No charge for matching. Most major credit cards accepted.

Billington Export Ltd.
1E Gillmans Trading Estate,
Billingshurst,
West Sussex RH14 9EZ
Tel: 01403 784961
Fax: 01403 783519
Billington Export Ltd. holds large stocks of audio valves including many obsolete brands such as Mullard, GEC, Brimar etc. as well as Sovtek,

Thermionic Gold Brand and the recently introduced Billington Gold range. Also Cathode Ray Tubes (eg. used in Marantz tuner 10B). 50 page catalogue available, tel or fax for a quotation. Minimum order £50.00 UK, £100 export
Website: www.bel-tubes.co.uk

Watford Valves
3 Ryall Close, Bricket Wood,
St. Albans, Herts AL2 3TS
Tel: 01923 893270
Fax: 01923 679207
Specialist in new old stock and current production valves. Sole UK distributor of the Harma Diamond range selected for their superior performance. Huge range held, stockists of Mullard, GE, Philips, National, Brimar, Sylvania, Telefunken, RCA, MOV and many more. All valves are new boxed and guaranteed. For free price list and specialist advice call or fax Derek Rocco, Watford Valves.

Chelmer Valve Company Ltd
The Stables, Baddow Park
Great Baddow, Chelmsford, Essex CM2 7SY
Tel: 01245 241301
Fax: 01245 241309.
Email: sales@chelmervalue.com
Web Site: www.chelmervalue.com
Supplier of premium range of audio valves, other valves and components also available. (Please see our main advertisement in this supplement).

Langrex Supplies Ltd
1 Mayo Road, Croydon,
Surrey CRO 2QP
Tel: 020 86841166
Fax: 020 86843056
One of the largest distributors of electronic valves, tubes and semi-conductors in the UK by original UK and USA manufacturers. Obsolete types are a speciality. Telephone or fax for an immediate quotation.

**TO ADVERTISE IN THE
KIT & COMPONENT
SUPPLIERS PAGE
PLEASE CALL
020 7604 4890
Email:
[diyadvertising@
hi-fiworld.co.uk](mailto:diyadvertising@hi-fiworld.co.uk)**

50形金属軸高音質ボリューム

50mm Size Metal Shaft High-quality-audio-potentiometers

高音質、高特性、高品位で最高級オーディオ機器に対応。

Better tone, better characteristics and high definition and suitable for high-grade audio equipment.



詳細は、P11とP12
を参照願います。

■ 特長

- 新開発の低歪率カーボンインクを採用し、忠実な音質再現性を実現。
- 金メッキ多接点ワイヤブラシを採用し、歪みの少ない音質を実現。
- 新開発の低抵抗インクを採用し、連動誤差-100~0dBにて、±1dB(実力値)を実現。
- 黄銅の削り出しケースの採用により、高チャンネルセパレーションが可能。
- 新開発の鏡面抵抗体により、低しゅう動ノイズを実現。
- 新構造のトルク出し機構の採用により、良好なオーディオフィーリングを実現。

■ Features

- A newly developed low-distortion carbon ink realizes high fidelity sound reproduction.
- Gold plated multi contact point wire brushes reduce distortion in sound reproduction.
- A newly developed low resistance ink realizes a gang error of within ±1dB at between -100 and 0dB.
- A solid brass lathe-carved case improves channel separation performance.
- Newly-developed mirror surface treated resistor materials reduce sliding noise.
- A newly designed torque mechanism adds a good operation feel.

Alps of Japan (www.alps.co.jp) specialise in volume controls - and this is their best. Note the "solid brass lathed case". Cost is around £500.

FIG 2 A RESISTOR STRING ATTENUATOR

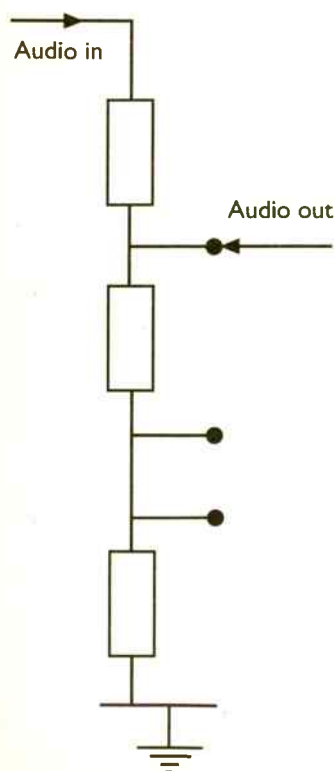

fastidious design and craftsmanship, make it The Mother Of All Potentiometers. It weighs more than the mains transformer in some power amplifiers! I bought one for a special preamp project. Price? Try nigh on £500 apiece! This shows what it takes to do the job properly, suggesting the 50p volume pot. is pretty flawed. There are alternatives.

The common potentiometer volume control can be replaced by a string of resistors and a multi-position switch to produce a 'switched attenuator'. Now we have far better metal-to-metal contact courtesy of the switch, and the resistors can be as accurately matched as you like, all for a relatively low price.

How many positions should the switch have? That's open to debate but if you actually watch yourself in how you use the volume control on your stereo you'll see that you generally make quite coarse adjustments. I think that twenty odd steps are fine. After all, I don't seem to remember wishing to increase

FIG 3 A SHUNT ATTENUATOR

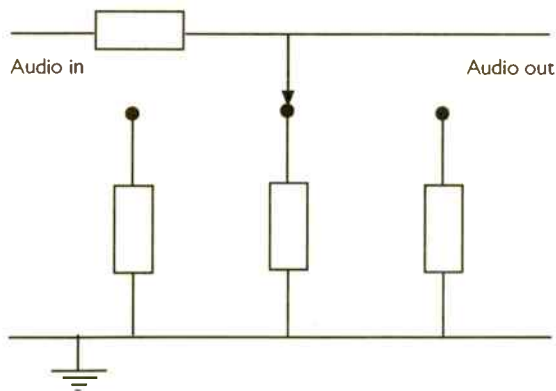

the volume by 0.5dB. A little bit louder usually means an increase of 3dB or more. A switch with more than 23 or 24 positions is going to hurt the wallet badly anyway.

The resistor string type stepped attenuator has similar electrical properties to the standard potentiometer in that it presents a more or less constant load to the preceding stage and has a variable output impedance. The latter is not usually a problem as we are talking about AF not RF so VSWR (or

audioXpress... It Just Sounds Better

Your Favorite Audio - One New Magazine!

- PROJECTS
- REVIEWS
- THE NEWEST TECHNOLOGIES
- AUDIO CLASSROOM
- and Much More!



Subscribe To This Great Monthly Publication Today!

Only \$59.95 US for 12 Issues!

audioXpress • PO Box 876 • Peterborough, NH 03458-0876 USA • Phone: 603-924-9464

Fax: 603-924-9467 • E-mail: custserv@audioXpress.com

ORDER ONLINE AT: www.audioXpress.com



500 WATT SUB BASS Loudspeaker Amplifier Panel
 50W, 100W, 200W and 300W R.M.S versions are also available. For full specs and prices view our website at WWW.BKELEC.COM

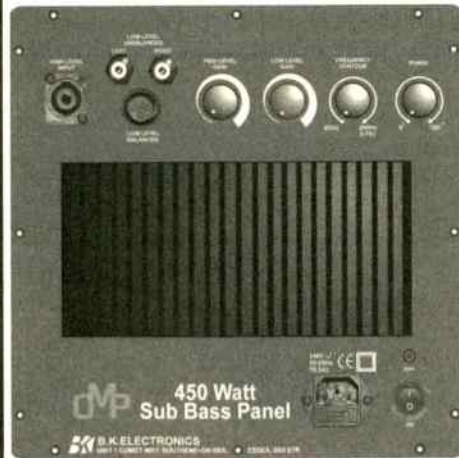

Ideal for building Audiophile and Home Theatre subwoofer loudspeaker Projects

Customised OEM Versions Available

Features:- *500W R.M.S. into 4 Ohm *Continuously Variable Phase control * Toroidal Transformer *Short Circuit protection *Low Level, High Level & Balanced Inputs *Frequency Roll Off, Lower 3Hz Upper 40Hz to 120Hz (Fully Adjustable) *AC3 Compatible, Filter can be by passed for 5-1 formats *Airtight construction *Tens of thousands of our panels already in use *Complete with leads,

SPECIFICATION: *Power 500W RMS @ 4 Ohms *F.Resp 3Hz 15KHz -3dB *Damping Factor >300 *Distortion 0.01% *S/N A Weighted >100dB *Supply 230V. A.C. *Weight 7kg *Size H259 W259 D140mm

The above item may be ordered by post, fax, email or phone and payment is welcome by cheque or credit card. Price: £219.50 +£6.00 P&P Incl VAT

B.K.ELECTRONICS
 UNIT 1 COMET WAY
 SOUTHEND-ON-SEA
 ESSEX SS2 6TR

Web:-<http://www.bkelec.com>
 E-mail:- Sales@bkelec.com
 TEL: 01702-527572
 FAX: 01702-420243



Vacuum Tubes for Audio Are Back!

Glass Audio brings together yesterday's tube with today's improved components, voltage control, and the exciting new Soviet tubes, to make smooth sound in your livingroom possible again!

YES!

Please send my first issue of *Glass Audio*. I'll pay just \$45.00 for six issues (1 year); \$80.00 for 12 issues (2 years) of the best information on tubes to be found anywhere. I understand that my satisfaction is guaranteed!

Name _____

Street & Number _____

City _____ Postal Code _____

Country _____

REMIT IN US \$ DRAWN ON A US BANK ONLY. PRICE GOOD THROUGH DECEMBER 31, 1995.

We Accept MC/VISA.

Glass Audio

PO Box 176, Dept. HFWS, Peterborough, NH 03458-0176 USA
 Phone: (603) 924-9464 or FAX 24 hours a day (603) 924-9467

FIG 4 A SWITCHED LADDER ATTENUATOR

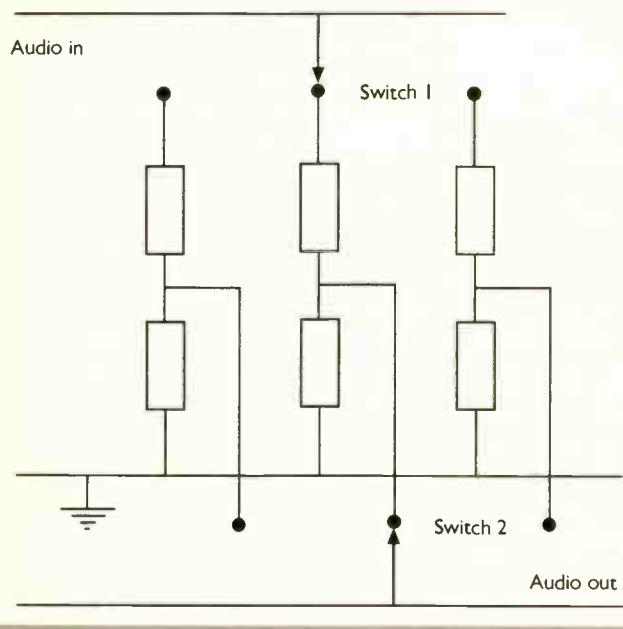

however, as maximum volume is never used. It could be a problem where a high impedance attenuator is required, as necessarily the resistor will also be of a high value.

An elegant development of the shunt attenuator is the ladder attenuator. Here we have pairs of resistors with values calculated to give varying degrees of attenuation and these are switched in step by step. This

quality audio silicon I usually turn to either Analog Devices or Burr Brown (now part of TI). Analog Devices have developed the concept of the multiplying DAC to produce a super attenuator chip. Basically, a regular D-to-A converter generates a signal by setting internal resistor strings to output a current or voltage referenced to a fixed internal reference. If the reference were allowed to vary this would result in an output that is the product of the input digital code and the varying reference voltage. Now if the reference was our audio signal and the digital code was our desired attenuation setting we have a volume control. Of course the control range would be linear which is incorrect for audio, as we need a logarithmic control. The Analog Devices AD7112 LOGDAC uses internal logic to obtain the desired log steps.

Other ways of making an electronically controlled volume control include using a JFET as a voltage controlled variable resistor, using a variable mu valve or an LDR (light dependant resistor):

A JFET has two distinct portions to it's

impedance mismatch) is not an issue and the following stage usually has a high input impedance.

If we want to become purist, then cutting down upon the amount of resistors the signal has to travel through is an advantage. The minimum is of course one, as we need one series and one shunt component in order to attenuate. Enter the shunt attenuator. Here we have a fixed series resistor and the switch switches in an array of shunt resistances of varying value. Now the signal only has to pass through one high quality resistor, maximising sound quality. This device acts a little differently in the circuit as it's input impedance changes as the dial is moved, as well as output impedance. This again is not usually an issue because we expect the output impedance of the preceding stage to be considerably lower than the minimum input impedance of the attenuator.

Another (non?) issue is the fact that there is always a resistance in series with the output no matter where the control is set. This is usually the case with all audio attenuators,

is probably the best attenuator for audio use. The problem with it is complexity. Two channels require a four-gang switch and that of



Some Alps motorised volume controls, needed for remote control operation.

course greatly increases price. We could connect together all of the tops of the resistor pairs but that can cause loading problems.

Modern semiconductor developments have brought us solid-state volume controls from manufacturers such as Dallas and National Semiconductor. These cheap little chips are widely used in TV sets and so on.

Unfortunately they have also been used in some hi-fi equipment as well.

These things generally sound absolutely awful. They were meant to be used inside consumer equipment such as TVs and cheap midi systems so the IC manufacturer cannot be blamed by misuse in hi-fi. It is an unfortunate case of the "application note engineering" mentality of some modern equipment designers. Select an array of chips which have reasonable specifications, and then tag them all together. Works for tellies, but not for high quality audio.

When it comes to super high

characteristic. Above the knee the device enters its saturation region where it operates as a transconductance device. Below the knee the device operates in its linear region where it has an impedance that is related to the gate voltage. This effect could be used on it's own but the word "linear" is misleading as quite a sizeable amount of distortion would result from the characteristic curvature. Instead these devices are usually incorporated into an op-amp's feedback path to reduce the voltage swing and hence distortion. Then we have what is called a VCA, a voltage controlled amplifier.

FIG 8 A SIMPLE VCA

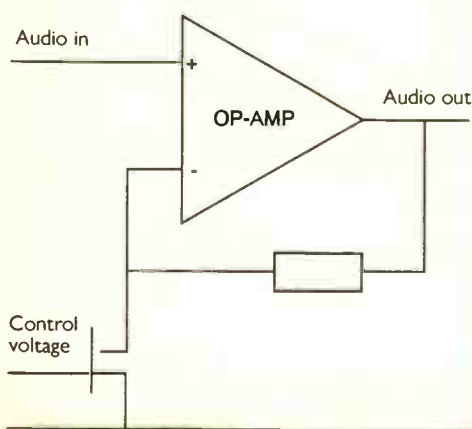

FIG 8 A MULTIPLYING DAC

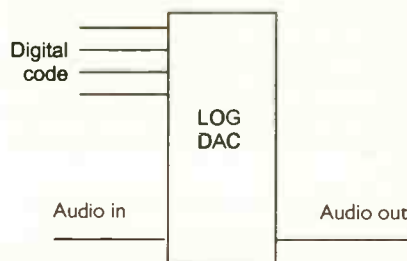
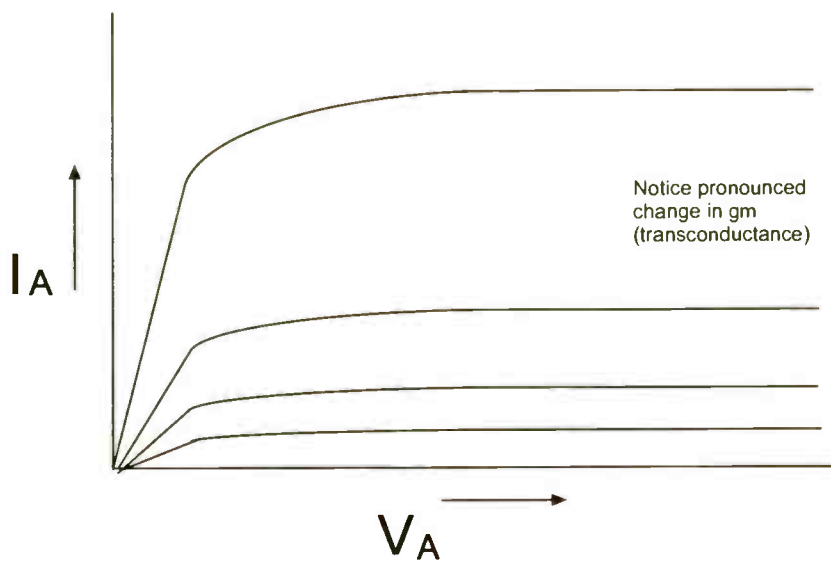

FIG 9 THE CHARACTERISTICS OF A VARIABLE MU PENTODE



and the rest are 2dB apart from the last step which is mute. Past a certain position of the control a coarser adjustment is OK as this part is rarely used, except maybe at parties. For normal listening the 2dB steps are fine.

The first version of the passive preamp has a nominal 10k impedance that is suitable for connecting to the output of a CD player, as that will have a low output impedance. However most valve devices like to see 50k plus, so we will release a high impedance version. The problem with passive preamps is the fact that they can present quite high output impedance to the cable, which reduces treble response. Hence our initial choice of 10k, which is fine for all but very long runs of cable. If of course the attenuator is placed within the amplifier (an integrated) a 50k impedance would be fine, as the cable run is only a few inches. ■ ▲

►► The variable mu (variable amplifying factor) valve was used in radio sets to perform the AGC function. This valve has what is called a remote cut-off characteristic. The valve has a pronounced change of transconductance from low to high currents. Therefore if the DC current through the valve is altered by changing the grid bias voltage, the amplification of that stage will also vary. This was the first type of VCA. In a radio set the signal level is only likely to vary slowly. But if the gain of the amplifier is altered quickly a surge is produced on the output due to the anode voltage changing. Therefore, for use in compressors and expanders the variable mu valve is usually used in a pair to balance out the DC signal while preserving the AC audio. This device also suffers from severe distortion if the signal level is high.

In a similar vein one can use a bipolar transistor as a VCA as its transconductance is a function of its collector current. This is usually the method used in IC VCAs.

The LDR is a resistor made from cadmium sulphide, a compound that has the property of varying electrical resistance with light intensity. This is very handy as we can use a separate and isolated light source (controlled by circuitry) such as a bulb or LED to alter the resistance of the LDR. Once again though, if the signal level is high then distortion results. So it is quite common for the LDR to be incorporated into an AGC circuit similar to that used for the JFET. Both VCAs and volume control potentiometers have the property of being infinitely variable. Stepped attenuators and multiplying DACs have discrete attenuation steps. However, the steps in the attenuation of the AD7112 are very small (0.375dB). When designing a stepped attenuator one has to bear in mind their discrete nature and the ergonomics in use.

With the World Audio PAS II shunt attenuator feature in this issue we used a twenty three position switch where the first six attenuation steps are 3dB

FIG 9 CURVE OF A TYPICAL JFET

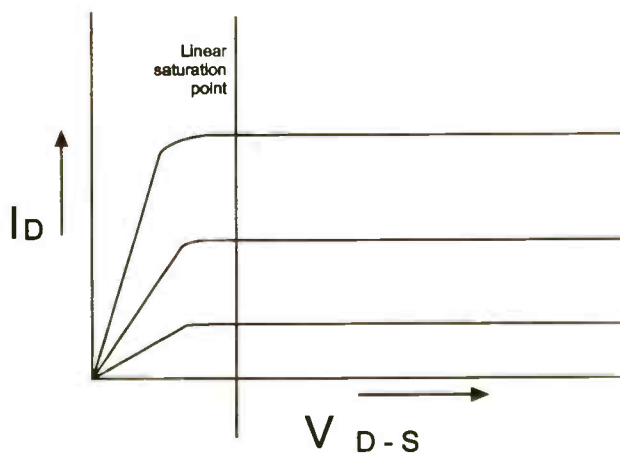
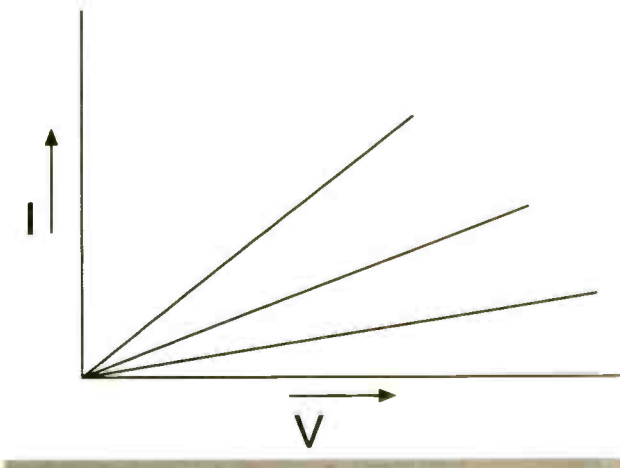

Fig 7. Shows the blown up view of the linear portion



Book Review

Basic Theory And Application Of Electron Tubes, reviewed by Andy Grove

This is an Audio Amateur reprint of an American Army and Air Force training manual, dated 1952. These books are uniquely matter of fact and succinct in their presentation, which is to be expected, bearing in mind military efficiency.

The book is divided into twelve chapters, beginning with a short chapter on the very first developments in electron tubes and the basic conceptual uses of each, such as the principle of amplification. The next chapter introduces the principles of electronic emission. Thermionic emission, the basic principle used in most valves, secondary emission and photoelectric emission of electrons are covered briefly but enough information is given for the student to understand how conceptually a valve functions.

Chapter Three is entitled Diodes and is the first chapter in which actual electronic elements are introduced. Firstly the internal construction of the diode is described, then how the electrons within the valve are affected by the applied potentials, and the resultant internal electrostatic fields. There is a good description of how the space charge is formed by cathode emission, with some neat diagrams illustrating the electrostatic fields. These are the basics of all vacuum tube operation. The student is introduced to the characteristic curves of a diode, drawn up by applying a range of external potentials.

Logically the triode is the next valve on the list. This chapter builds upon the lessons learnt about the diode's operation. The characteristic curves of a real life valve (type 6J5) are used as an example, the data is presented in its various forms, grid curves, plate curves etc. The concept of transconductance is also introduced and a method of graphically determining gm from the curves is described. We move on to the load line and operating point. This section is an absolute gem. The use of graphical diagrams is really excellent.

Chapter five is entitled Multielectrode Tubes and covers tetrodes to octodes. This chapter is short because the tetrode was made obsolete by the pentode, which is the subject of the next section. There is a nice

piece on beam power tubes (beam tetrodes). At the time they were the latest development in valve technology and were seen as an improvement over the traditional pentode. There are internal diagrams illustrating the action of the beam plates.

The final section briefly describes those valves used as mixers in radio sets, namely the heptode and octode, and valves with more than one element within the envelope, double triode etc.

Chapter Six moves on to amplification. Classes of operation are described with their relative efficiencies and distortions. Amplification is graphically shown by projecting a waveform onto the valve's dynamic characteristic, illustrating the magnifying effect. This graphical approach is also used to illustrate the various classes of operation, showing where the valve cuts off. This shows how distortion is produced by nonlinearities caused by the dynamic characteristic, and by the crossover region between the two valves in a class B amplifier. Various methods of biasing a valve are shown, fixed, cathode and combinations of both. Also described is contact potential bias, where the small grid current present is used to generate a negative voltage at the grid.

Chapter Seven covers the various forms of interstage coupling used. First is the most commonly used RC coupling method. Then RCL coupling and transformer coupling are introduced to the student.

Chapter Eight takes us into the realm of rectifiers and diodes. Beginning with power rectification, briefly discussing full wave and half wave rectifier circuits and the waveforms present at the output of the circuit. We move to the principle of diode signal detection or rectification. Most of the common types of detectors using diodes and triodes are briefly covered with an outline of their relative advantages and disadvantages.

Chapter Nine is entitled Oscillators and here we move more firmly into communications territory which may not be of such great interest to the audiophile.

Now we get a look at the heavy metal, Transmitting Tubes, chapter Ten. This chapter is comprehensive and takes the student from

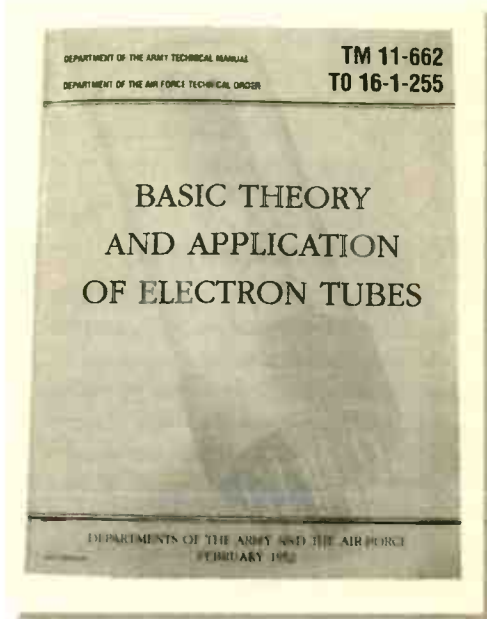

the filament to the antenna. There are excellent sections on the plate and cathode materials which must be used at the extreme power levels encountered within a transmitter valve. All of the information that the student has been presented earlier in the book is now brought into cohesion. The various circuits described are brought together to form a transmitter. The microphone amplifier, voltage amplifier, oscillator, power amplifier and so on. Plate and grid modulators are described with circuits used to illustrate the principles involved. The penultimate chapter Other Tubes gives a quick overview of the other types of valves the radio engineer is likely to encounter, such as the gas filled valve, the phototube, the magnetron and the CRT. The final chapter gives a short overview of the different types of valve bases, valve nomenclature and so on.

This book presents information clearly and is easy to understand. It is logically organised and a great deal of work must have gone into writing it. It is also interesting from a historical standpoint, as it gives a glimpse into the American Military at that point in time, when the Cold War was beginning. ■ ▲

This title is available from World Library see page 68 and 69 of this issue
Book code is 1760
book cost is £17.95 + £3.25 UK postage

D.I.Y. LETTERS

This month we own up to a miracle that really was a mistake; discuss the pros and cons of Distributed Loading, reveal the secrets of the Loyez phase splitter in intimate detail and talk about tuning our KLS9 loudspeaker. So don your thinking caps and get reading!

► CORE OF THE MATTER

Hi, I am developing a push pull valve amplifier product in Australia incorporating a concept that tie's the two halves together so tightly that symmetry is as close to the symmetry that occurs naturally in a single ended circuit. What appears to me to be the final limitation without going to an OTL design, is the output transformer. My question to you is, have you ever considered using an R-core as an output transformer ? Particularly as it has totally balanced physical and winding symmetry, very low losses ,ect. I am not trying to sell the concept, just looking for others experience with the idea before I put the effort in myself. If you are , or you are considering trying this I would appreciate your feedback on the subject or perhaps if you already are making some please let me know.

Leonard Cue

I believe that the R-Core is basically a C-Core with a round cross section which makes winding easier, especially with heavy gauges, and that increases efficiency due to better usage of the winding area.

Regarding symmetry within a transformer there are various things to consider. There is the DC winding resistance, the distributed capacitance and the distributed leakage inductance. When using a conventional EI core one has to compromise one or more of these parameters in order to arrive at a working solution. This is less problematic with a core type like C-Core as we can have a good winding on each limb of the core and that results in better symmetry at high frequencies.

The use of a unity coupled output stage developed by Macintosh is the best method of coupling the valves together, whether on an EI core or a C-Core.

Another approach is the use of a toroidal core where the two ends of the solenoid are joined which results in a lower overall leakage

inductance. Of course a toroid can also be used together with unity coupling. Generally C-Cores and Toroids are manufactured from better grade steel such as M4 or Hi-B.

You could well investigate R-Cores and C-Cores. Also, try to get hold of the articles by Norman Crowhurst on C-Core output transformers.

AG ■

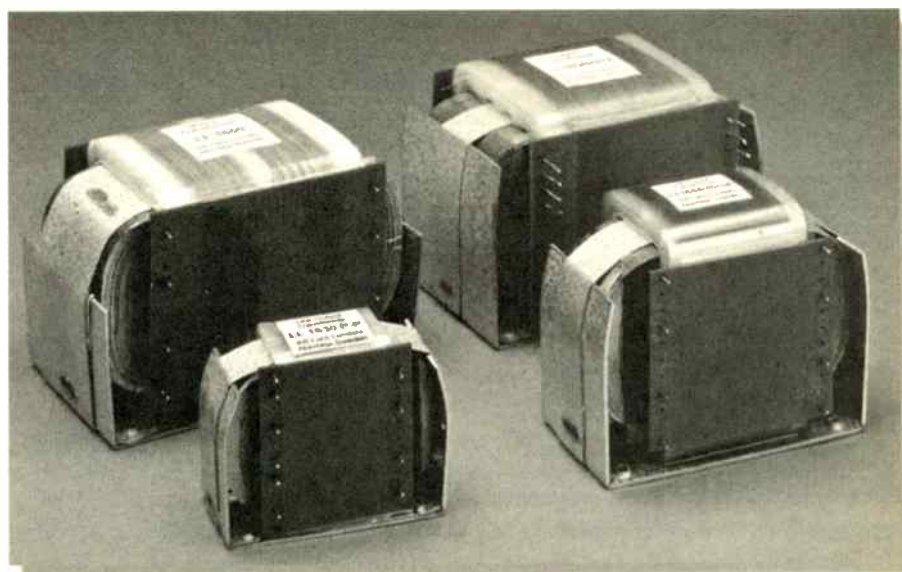

C-Core transformers with a square cross section core. The looped core is cut in half to form two C, but the gap between them is very fine to maintain efficiency.

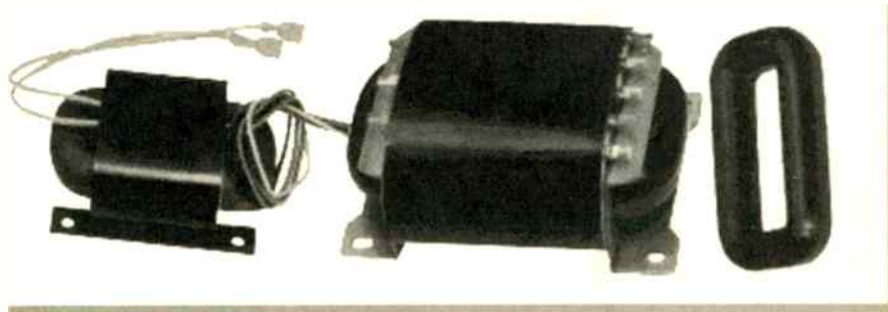

R-Core transformers have a closed loop core, which is more efficient, but also more prone to saturate with clipped mains. They are wound on a special machine.

►►KLS3 GOLDS OR KLS10S?

I am in the process of building a parallel 845 SET amplifier of my own design which will produce close to 60 watts. I am looking for a top quality pair of loudspeakers to partner it. I want something close to state of the art with a kind impedance curve and about 89db or more sensitivity. Deep bass is important to me and good dynamics most important. I play many types of music including loud electronic Jazz and Rock. So they must go loud with low distortion.

Things like human voice and violin string tone are also critical, as is ability to handle complex large orchestral works. So you see I want it all. This is reflected in my choice of amplifier which is choke and transformer coupled and has a separate power supply for each tube (6J5, 6V6, 300B, 2 x 845). I found my old back-issues and both your KLS3 Gold Mk II and KLS10 Gold plus Subwoofer.

Space is important to me and I like the imaging and ease of placement often found in smaller designs. However my first criteria is always absolute sound quality. Which of these two designs offers the superior overall sound quality?

My room is typically furnished and about 17ft by 12ft with high ceilings. I am previously a "big speaker" person, also owning a pair of IMF RSPM MkIV Improved. I have found with most other full range designs the bottom starts to roll off in the 40Hz region and so I feel the need for a sub in any case. Then their extended response becomes a problem rather than a virtue as the combination running the mains full-range creates a hump in the bass.

If you recommend the KLS10s, will the raised response around 90Hz present a problem with a sub? I would probably use them about 2-3 ft from the rear wall and about 4ft in from the side walls. All walls are double brick.

I seem to remember the sub is only an 8". Will this be adequate for low distortion at high volumes or is there an advantage in using two of these?

Is there any loss in coherence from having the sub(s) in slightly different position(s) to the mains? I would be prepared to go to a bigger sub or an active one if this would provide better sound. I kinda like to use the big 845 amps full-range for their superior bass though rather than a dry SS sound!

Above all I want very natural sound, NOT "Hi-Fi" sound, with a very dynamic nature and no trace of bass boom, sub over-emphasis or cabinet colourations. I have built many speakers and I'm only interested in the "best". Would it help to make the cabinets thicker or line with lead? I have had great results with lead lining in the past.

I have lost some back copies and need the second part of the KLS10 design and the sub design issues (if this is your suggestion else I

need the KLS3 issues - I have the KLS3 port tuning issue).

Please let me know the cost for these to be air mailed to Sydney.

Thanks for your time.

Bart Shepherd

Your room's lowest (length) mode is 32Hz, whilst the height mode is 45Hz. You don't give width but it is likely somewhere in the 45-32Hz region. There is therefore 'room gain' at these frequencies which, being in the audible bass region, means your room should support bass fundamentals well. I don't know why you believe "the bottom starts to roll off in the 40Hz region". If this is down to the loudspeaker then it isn't a very good design; my loudspeaker tests clearly show modern loudspeakers reach down to 40Hz easily and large cabinets should get down to 30Hz or so, the port going even lower, often to 20Hz.

Running a subwoofer in parallel with a full range design will result in excessive bass. REL subwoofers, and our own, have high pass filters for the main loudspeakers to prevent this.

An 8in driver will give good, clean bass up to reasonably high volumes. The Audax

HM210Z2 dual-coil drive unit (see DIY Supplement October 1998, No39) handles plenty of power but cone area is everything so two of them would certainly give even better results. You would need to use to HM210Z0 drivers, one driver/cab per channel.

Satellite and subwoofer combinations never sound quite as cohesive as large stereo cabinets, but you never get something for nothing. Their benefit is, obviously, smaller size. Most commercial subwoofers are cheaply made and boom badly. Sturdy cabinets and lead lining would improve results, but again it is up to you how far you want to go relative to cost and inconvenience. If you have already been impressed by lead lining then you will know better than most what to expect.

KLS3 Gold (DIY Supplement No32/33, Nov/Dec 1997) is the more complex design of the two and the most sophisticated in its sound. Its big advantage is the HMI30CO carbon fibre midrange unit. Three-way loudspeakers are difficult to get right but can be mightily impressive when they are so, and KLS3 Gold has some unique features, not the least being the HD3P piezo-electric gold dome tweeter. **NK** ■



The Cyrus aPA7 monoblocs would be a good choice for replacing your current power amplifier.



II► HUMMING ALONG

Since I remember reading Noel Keywood's experiments with Quad ESL 63s and sub-woofers and since your magazine encourages real involvement in this hobby rather than simply buying boxes, I am hoping you can help me with an irritating problem.

I have just returned from Canada to the UK and have achieved a long term ambition by replacing my TDL Monitors with (second hand) Quad ESL 63s/Gradient SW63 s. My system is summarised below and I am very happy with the sound it produces, although you may not be familiar with some of the components. However, since I have added the Gradient sub-woofers I have had to bring back into operation a Forte model 4 amp (made by Threshold) to drive them.

The problem is that the toroidal mains transformer in this amp is very noisy - clearly audible from the listening position 15+ feet away (albeit in an otherwise quiet environment) - as it was before I left the UK. All of the North American equipment exhibits some transformer noise, but the Forte is by far the worst offender. The level of noise varies substantially over time but, with one exception, I have been unable to correlate anything in the system or the rest of the house with this variation. The one exception is if dimmer switches are used on Halogen lamps- this causes a substantial buzz in the UK and also did so in Canada.

Since this amp was silent in operation when running on 60Hz mains in Canada (dimmer switches banned!), I suspect that the transformers are not really designed for 50Hz (although it is marked as being for 50/60Hz).

Here in the UK the system is running on a dedicated ring-main, although in Canada it shared its supply with various household electronics. Running the amp through a power conditioner does not seem to have any benefit, nor did trying to isolate any of the other pieces of equipment in the same way.

Can you suggest anyway of eliminating or ameliorating the noise from the transformer? , Is there anything I could have done to the mains supply or the amp, for example? Since Threshold has disappeared, I am not too worried about having the amp modified. Do you think that replacing the transformer with one sourced from the UK would give a better result? Failing that would it be possible to shroud the transformer (with what?) to absorb the noise? Obviously the upper cost limit for fixing this problem is the cost of acquiring another suitable amp to drive the sub-woofers

I use a Quad 67 as transport MSB Link DAC III with Nelson upgrade, 96 kHz up-sampling option and P1000 Power Base power supply. Passive pre based on twin Shallco 32 step ladder attenuator switch with (I think) Holco resistors Single series 33nF polypropylene capacitor to Sim Audio W5 power amp driving Quad ESL 63s Gradient low pass filter to Forte Model 4 power amp driving Gradient SW3 subwoofers.

All the critical interconnect cables are Cardas (lightning 15 for digital interconnect and neutral reference for analogue interconnects) although the sub-woofer leg currently has different interconnects. Speaker cables are generic multi-strand, oxygen-free copper.

I would be grateful for anything you could suggest to help and for any

Suggestions for suitable speaker cables. with thanks

Don Fleet

I presume you have re-set the primary winding configuration for 240V. A switch is usually available for this. If you haven't then here is the problem. It is conceivable that the amp would work like this without going up in a puff of smoke!

Andy Grove, who as you might know designs transformers, pointed out that the flux density in the transformer core goes up as frequency goes down, so it is a little more stressed in the UK. However, the difference is hardly great and we both would have expected any decent transformer to shrug this off. In our experience if you don't design a mains tranny to have plenty of leeway in its parameters then whenever it is stressed it will squeal, one way or another!

The only thing you can do is ensure the core is firmly clamped and secured to the chassis effectively. Beyond this it is most cost effective to replace the amp with a budget power amp from NAD, or perhaps Musical Fidelity, according to your budget.

If your mains supply is impure then I can't help but feel you haven't got a very good supply line back to the nearest supply transformer. This will make the interference of dimmers more obvious. Again, there is little you can do about this beyond what you have already done. **NK ■**

www.hi-fiworld.co.uk

hi-fi

WORLD

& computer audio

WELCOME TO OUR MARKET PLACE

Here are a wide variety of specialist hi-fi products and services.
Keep an eye open for regular advertisers, who know the market and serve their customers in a friendly and reliable manner.

Cable Talk

Interconnects & Speaker Cables

1994



Best Speaker Cable

1995



Best Interconnect & Highly Recommended Speaker Cable

1996



Best Interconnect & Best Speaker Cable

1997



Best Speaker Cable & Highly Recommended Interconnect

Interconnects Speaker Cables

Doesn't Your System Deserve The Best?

FOR FURTHER INFORMATION

Please telephone, fax or write to

Cable Talk,

Unit J, Albany Park, Camberley, Surrey, GU15 2PL

Tel (UK ONLY): FREEPHONE 0808 - 100 - 6868

TEL: (+44) (0) 1276 686717. FAX: (+44) (0) 1276 686353

(CT HFW 0801)

WANTED

HI-FI & accessories

any make, any age

BUY • SELL • TRADE

OPEN 7 DAYS 10am - 8pm

Please bring official ID with address & signature when selling or exchanging

MUSIC & VIDEO EXCHANGE

56 Notting Hill Gate, London W11

☎ 020 7792 3474

480 Fulham Rd (Broadway), London SW6

☎ 020 7385 5350

95 Berwick St, Soho, London W1

☎ 020 7434 2939

www.buy-sell-trade.co.uk

LARGE SELECTION ON SALE

ALSO BUY, SELL, TRADE MUSICAL & PHOTOGRAPHIC EQUIPMENT

Oxford Audio Consultants Ltd.

OUR SUPERB SERVICE IS THE SAME REGARDLESS OF PRICE



Now Demonstrating



Ex-Demonstration & Previously Owned Equipment

SALE LIST - May 2001

AUDIOLAB 8000A AMPLIFIER	£ 295	SH
AUDIOLAB 8000S AMPLIFIER	£ 395	SH
MARTIN LOGAN AERIUS I SPEAKERS EX DEM	£1695	SH
MARANTZ CD63SE CD PLAYER	£ 140	SH
KRELL 300CD	£2495	SH
AUDIO RESEARCH VT50 POWER AMP AS NEW	£2295	SH
AUDIO RESEARCH D130 POWER AMPLIFIER EX DEM	£1495	XD
AUDIO RESEARCH LS8 EX DEM	£995	SH
KRELL KAV300i AMPLIFIER	£1995	SH
REGA PLANAR 3	£195	SH
QUAD ESL63 LOUDSPEAKERS	£1195	SH
VAN DEN HUL REVELATION 3m SPEAKER CABLE	£ 350	SH
WILSON SYSTEM 5 EX DEM	£7995	XD
VAN DEN HUL THE SECOND XLR 1m	£ 125	SH
AUDIO ANALOGUE PAGANINI CD PLAYER EX DEM	£ 595	XD
AUDIO ANALOGUE MAESTRO CD PLAYER EX DEM	£ 850	XD
NAIM SBL BLACK EX DEM PASSIVE	£1495	XD
NAIM 180 POWER AMP	£795	SH
NAIM 90.3 POWER AMP	£ 450	SH
NAIM 72 PREAMP	£ 495	XD
THETA CASANOVA SILVER DTS/VSCAS NEW	£3995	SH
THETA PROGENY	£795	SH
THETA MILES	£1695	SH
PATHOS ACOUSTICS TWIN TOWERS AMPLIFIER	£2495	SH
OPERA CALLAS GOLD SPEAKERS MAHOGANY	£695	SH
KRELL DT10 CD TRANSPORT	£3495	SH
KRELL KRC PREAMPLIFIER	£2495	SH
KRELL KAV300CD AS NEW	£2995	SH
KRELL 250A POWER AMPLIFIER	£2995	XD
UNISON RESEARCH SMART 845 - our demonstrators	£1795	XD
JADIS ORCHESTRA CD PLAYER	£795	XD
JADIS ORCHESTRA AMPLIFIER	£ 795	XD
WILSON BENESCH ACT ONE	£2795	SH

0% INTEREST FREE CREDIT

Licensed Credit Broker

REFER TO OUR WEBSITE FOR THE LATEST UPDATED SALE LIST.

Agencies include: Audio Analogue, Audio Research, Audio Technica, BOSE, B&W Cable Talk, Castle, Copland, Denon, Graaf, Goldring, Jamo, Jadis, KEF, Koetsu, Krell, Lexicon, Loewe TV & Video, Lyr, Marantz, Martin Logan, Michell, Musical Fidelity, MRS, NAD, Naim, NEC Gas Plasma Screens, Nordost Cables, Onkyo, Opera, Orfon, Pioneer, Proac, Pro-ject, QED, REL Subwoofers, Rotel, Sharp LCD Screens, Speakercraft, Sennheiser, SME, Sonus Faber, Sonance, Stands Unique, Stax, Target, TAG McLAREN, TEAC, Theta, Thorens, Transparent Cables, Unison Research, van den Hul, Vidikron, Wilson, Yamaha

TAX FREE EXPORT SERVICE
MAIL ORDER AVAILABLE ON MANY ITEMS

Cantay House, Park End Street
Oxford OX1 1JD

Telephone: Oxford (01865) 790879

Facsimile: Oxford (01865) 791665

E-MAIL: Oxford.Audio@btinternet.com

WEBSITE: www.oxfordaudio.co.uk



V.A.T. No.
729580013



QUALITY USED
EQUIPMENT,
BOUGHT, SOLD, PART
EXCHANGE

TEL/FAX
0121 747 4246



URGENTLY REQUIRED
LINN, NAIM,
MERIDIAN, QUAD,
CASH WAITING

	RRP	NOW £
ACCUPHASE E306V INTEGRATED 1 MTH OLD	3300	1995
ART AUDIO DIAVLO 300B SE CHROME & GOLD POWER AMP	4500	1995
ATC SCM 10 BLACK	1000	495
AUDIO SYNTHESIS TRANSCEND TRANSPORT	1200	295
AUDIO RESEARCH PH3 PHONO STAGE	2000	1095
AUDIO RESEARCH D130 POWER	2200	1195
BOW TECHNOLOGIES WAZOO XL INTEGRATED AMP	2500	1695
BOW TECHNOLOGIES WIZARD CD + WAND REMOTE	3500	2195
CARDAS CROSS 2 X 2.5 MTRS SPEAKER CABLE	720	395
COPLAND CTA 401 INTEGRATED AMP	1700	895
COPLAND CTA 505 POWER AMP	1900	995
DIAPASON ADAMANTES 11 + STANDS	2250	1195
DNM PRE 3A START PRE AMP	1300	695
DNM PA1 POWER AMP	1300	695
DNM AMP STAND	600	195
ELECTROCOMPANET EMC1 CD EX DEM	2500	1895
EQUATION 2 SPEAKERS PIANO BLACK	3500	695
JEFF ROWLAND MODEL 1 POWER AMP	3000	1195
KEF 20B SUBWOOFER	350	195
KEF 103/4 WALNUT	1000	450
KEF LS35A RAYMOND COOKE SE PIANO BLACK LTD ED 110HM	1750	795
KRELL KAV 250P PRE	2400	1595
KRELL FPB 600C	15000	9500
LINN KARIK 111 LATEST SPEC	1850	895
LINN NUMERIK LATEST SPEC	1500	695
LINN KABER AKTIV WALNUT + CROSSOVER	2640	695
LINN KABER AKTIV MODULES FOR LINN AMPS	800	295
LINN KABER AKTIV + OVR	N/A	295
LINN LP12 ITTOK LV11 TRAK VALHALLA AFROMOSIA	N/A	450
LINN TUKANS BLACK	650	295
MAGNUM DYNALAB MD208 GOLD RECEIVER	2700	1695
MAGNUM DYNALAB MD10 VIRTUAL DECODER	N/A	POA
MAGNUM DYNALAB ETUDE BLACK TUNER	1250	795
MAGNUM DYNALAB SIGNAL SLEUTH	350	195
MARTIN LOGAN QUESTS	5500	1795
MARK LEVINSON NO 36 DAC	4000	1995
MERIDIAN 502 PRE	1400	850
MERIDIAN 505 MONOBLOCKS	1700	1095
MERIDIAN 201 PRE + MSR	700	295
MERIDIAN 204 TUNER	700	295
MERIDIAN 206 CD	1000	195
MERIDIAN 205 MONOBLOCKS	1600	395
MIT 330 PLUS INTERCONNECTS I MTR	300	150
MUSICAL FIDELITY A3 CD	800	550
MUSICAL FIDELITY MVX 2 PRE	2500	695
MONARCHY DIP DIGITAL INTERFACE	400	195
MONITOR AUDIO STUDIO 20 SE	1800	695
NAD T760 DOLBY DIGITAL DTS ETC	650	350
NAIM 62 OLD STYLE PREAMP	N/A	150
NAIM 92	520	295
NAIM 42 PRE AMP	N/A	50
NAIM 90/3 X2	550	295
NAKAMICHI CASSETTE DECK 2	N/A	250
NAKAMICHI TUNER 2	N/A	150
NEAT MYSTIQUE CHERRY	750	295
NORDOST SOLAR WIND INTERCONNECT IM	85	50
PATHOS TWIN TOWERS	3250	1995
PROAC TABLETE 50 WALNUT + TARGET STANDS	1000	495
PRIMARE T20 TUNER	550	395
PROCEED CDD TRANSPORT	2400	1495
PROCEED AMP 2 (2 channel)	2000	1295
PROCEED AMP 3 (3 channel)	3000	1995
QUAD 34 PRE	N/A	195
REL STRATA 111 CHERRY	700	395
SAMUEL JOHNSON PTS100 CD EX DEM	1000	595
SAMUEL JOHNSON PDC100 DAC EX DEM	1100	695
SAMUEL JOHNSON PCA100 PRE EX DEM	1800	995
SAMUEL JOHNSON PPA100 POWER EX DEM	2300	1195
SME 10 A	3350	2695
SONIC FRONTIERS ANTHEM INTEGRATED AMP 2	2000	1195
TAG McLAREN PA10 PRE	850	550
TAG McLAREN 125M MONO'S	2400	1595
TAG McLAREN CD 20R	1250	850
TAG McLAREN DAC 20 (hdcd)	1250	850
TANNOY ARDEN'S MK11 15 INCH DUAL CONCENTRIC (reconed)	N/A	895
TECHNICS SLP6440A CD	300	75
VAN DEN HUL THE SECOND DIGITAL XLR	150	95
WADIA 860X 24/96khz LTD EDITION SILVER CD	7500	4995
WILSON AUDIO WITT PIANO BLACK	9000	3995
XLO LTD EDITION DIGITAL CABLE	1100	495

OPEN MON-SUN 10.00 TO 8.00
Website: www.centralaudio.co.uk
E-mail: tony@centralaudio.co.uk



HEATHERDALE AUDIO LTD.



202 FINDON ROAD, WORTHING, WEST SUSSEX. BN14 0EJ
TEL. 01903-872288 OR (AFTER HOURS) 07860 660001 FAX. 01903-872234
e-mail: heatherdale@hifi-stereo.com //www.hifi-stereo.com

HEATHERDALE PRE-OWNED GUARANTEED EQUIPMENT EXPORT FACILITIES AVAILABLE

SPEAKERS

Linn Isobanks with stands £595
Mendian A500 Speakers £595
KLH Speakers £195
Heybrook Prima Speakers £125
Kef 10172 speakers £475
Mission 782 Loud Speakers (Stand mount model) £250
Selection of Thiel ex Demo Speakers. All with 10 year guarantee
MAIN DEALER FOR ORCHID SPEAKERS
Klipsch La Scala Speakers £1295
Thiel 1.5 Speakers £1495

PREAMPS

Pierreux 5M6P Pre-amp 350P Power Amplifier £3695
Naim NAC 42.5 Pre-Amp £150
Musical Fidelity MVT Pre Amplifier with Phonostage + PSU £495
Musical Fidelity "The Pre-amp" £175
Michell Argo line level pre-amp £450
Lumley passive pre-amp £275
Burmester 785 with phono-stage £895
Audio Research phono 1 phono stage MM &MC £735
Exposure 21 Pre-amp NEW with remote £890
Mark Levinson ML 26 Balanced Pre-Amp £1995
Mark Levinson ML 26 Pre-Amp with Phono-Stage £2395

AMPLIFIERS

Pierreux 5M6P Pre-amp 350P Power Amplifier £3695
Naim 120 Power Amplifier £175
Meridian 605 Mono-Blocs £195
Sudgen AUS1p amplifier £575
Rogers E40a Integrated Amplifier with phono-stage (NEW) £995
Exposure 11/12 Super 8 £995
Celo Performance 11 Mono amplifiers £3995
Audionote P4 Monoblocks £3395
Parasound HCA 2200 Power Amp £1395

CD PLAYERS & TRANSPORT

Micromega Leader CD Player £150
Teac X1 Balanced CD Player £1095
Classe CD P5 HDCC Balanced CD Player £995
Pioneer PD-S505 Precision CD Player £195
Cec. TL Zero Mk2 CD Transport £5500
(cost new £12300) 2 months old (Stereophile Class A1 recommended)
Teac VRDS 9 CD Player (mint) £650
Teac P700 CD Transport £495

DACS

Mark Levinson ML360S DAC £4995
PS Audio Ultralink Digital Processor £995
Cello Reference DAC £2995
LFD DAC 3 £1395

MISCELLANEOUS

Pioneer CT 91A Reference Cassette Deck Mint/Boxed £450
Teac A-33405 Tape recorder £595
Selections of MIT cables available at discounted prices

TURNTABLES, CARTRIDGES & TONEARMS

Koetsu Urishi Cartridge (unused) £4495
Koetsu Itoigawa Diamond Cartridge (unused) £1995
Revolver Turntable with linn basic arm £195
Luxman PD 282 Turntable £75
Helius Silver wired tonearm £995
VPI TNT Mk3 Turntable £2695
Thorens TD125 Turntable £295

SAVE ONE THOUSAND SIX HUNDRED POUNDS.
BRAND NEW BOW WIZARD CD PLAYER WITH WAND
(Normal Price £3495) OUR PRICE £2495
To Include FREE 24/96 UPGRADE Worth £600.

NOW DEMONSTRATING THE MARK LEVINSON 383 INTEGRATED AMP

WE NOW OFFER 0% FINANCE (subject to status)
PLEASE PHONE TO ARRANGE AN AUDITION
MAIN DEALERS FOR MARK LEVINSON, THIEL, AND ABSOLUTE SOUNDS

VISA - SWITCH - MASTER CARD - AMEX - DINERS CLUB WELCOME.
WE TAKE PART EXCHANGE ON NEW & USED STOCK AND BUY IN FOR CASH!

ALL USED CARTRIDGES ARE CHECKED UNDER A MICROSCOPE
BEFORE BEING OFFERED FOR SALE.



Soundcraft HiFi

At 40 High Street, Ashford, Kent. TN24 8TE

Clearance! Ex-dem & Re-sale stock August Sale 2001

Hi-Fi Separates

Arcam Xeta II amp	£199!	Musical Tech, Hawk speakers	£850!
Arcam Alpha 7R amp	£199	Marantz Ki Sig 6010 Amp Gold	£350!
Arcam Alpha 5 + CD Player	£150	Marantz Ki Sig 6000 CD Gold	£450!
Audiolab 8000A Amp	£299	Marantz DR4050 CD recorder	£299!
Castle Harlech spks (cherry)	£700!	Marantz CD-50 CD Player	£199
Linn Karik CD	£799	Marantz CD-67 MKII CD Player	£150
Linn Kairn Phono Pre-amp	£999!	Meridian CD-206 CD Player	£399
Linn Mimik CD	£599	Music Technology Harrier walnut	£299
Linn Majik amp	£450!	Naim NAC-72	£600
Linn Axis turntable	£250	Naim CD-3	£650
Linn Keilidh Speakers	£500	Rega Planar 25 Turntable & cart	£550!
Mission Cyrus Two amp & PSX	£349	Rotel RCD-971 CD Player	£299
Musical Fidelity T1 tuner	£99	Rotel RC-970BX/RSP960-AX	£299
Musical Fidelity X-A1 amp	£399!	Spendor SP1 spks walnut	£399
Musical Fidelity X-Plora	£499!	Tannoy 611 Loudspeakers	£199

Our exciting range includes: Arcam, DiVA & FMJ, Chord Electronics, Linn (CD12), Naim (NAP 500 & NBL), Rega, Musical Fidelity, Denon, Yamaha, Rotel, B&W Nautilus, PMC, Ruark, Castle, Kef, Loewe TV, Pioneer Plasma!
HOTLINE: 01233 624441 Fax: 01233 640333.

AV Separates

Denon AVR-2700RD amp	£399!	Pioneer NS-DV1AV System	£999!
Denon DV-2500 DVD player	£399!	Selecto SVT-195CRT Projector	£1499
H/K AVR-65 DTS/AC-3 Amp	£499!	Yamaha A5 AV Amp	£299
H/K AVR-45 Receiver	£399!	Yamaha RXV-795 receiver	£499!
Naim AV-1 Processor	£799	Yamaha RXV-395 receiver	£199!
Marantz DV-4100 zone free	£299!	Yamaha DSP-492 processor	£149!
Pioneer DV-626 DVD zone free	£299!	Yamaha RXV 496 receiver	£249
Pioneer DV-535 DVD zone free	£199!		

Check our web site: www.soundcraftkent.ltd.uk

Sound Investment

If you have invested expertise and money in building up a sound system to your own unique specifications, then why compromise with indifferent housing units?

Fi-Rax offers a new dimension in audio visual racking - from a range of standard designs to the flexibility to custom create a unit to suit your particular sound system and lifestyle.

- *High quality aluminium construction.
- *Finishes available to your choice.
- *Fully adjustable 6mm glass shelving.
- *Sound isolation on shelving/feet.
- *Custom created to suit your system.
- *Free delivery throughout the UK.

Fi-Rax - a sound investment for those who want the best from their equipment.

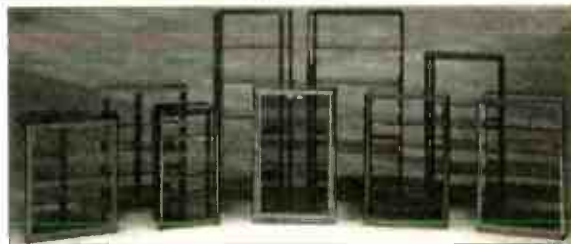

Audio Visual Furniture

For further information or a free brochure contact: JEM Distribution,
Springfield Mills, Spa Street, Ossett Wakefield WF5 0HW.
Tel: 01924 277626 Fax: 01924 270759

Are you making the right connections?

Send for Britain's biggest catalogue of specialist cable and connections.

All available by mail order.

Phone 020-8942 9124 or clip the coupon for your Free copy

CUSTOM CABLE SERVICE

PO Box 4007, London SW17 8XG

Please send me your FREE Custom Cable Catalogue

Name _____

Address _____

Postcode _____

NO FURTHER INFORMATION REQUIRED

Send to: Custom Cable Service
PO Box 4007
London SW17 8XG

HFV 08/01



S/hand and ex-demo clearance items - August '01

	Was	Now
CD Players & DAC'S		
Accuphase DG28 Digital Equaliser S/H	5690	3750
Einstein Valve CD Player Ex-demo	2999	1799
Mark Levinson 31.5 Transport S/H	9500	5999
Micromega Data/Dialog 2 Box CD Player S/H	3000	1599
Quad 77CD+77 integrated I-bus system S/H	1200	599
Roksan DA2 DAC S/H	599	299
Roksan DP2T Transport S/H	1295	599
Theta Carmen CD/DVD Transport S/H	3800	2999
Theta Pro Basic II DAC S/H	2290	1099

Turntables Tonearms & Cartridges

Basis 1400/RB250 (New & Boxed)	1200	899
Basis 2000/RB300 (New & Boxed)	2000	1599
Benz Micro Silver MC High Output Ex-Demo	169	99
Kuzma Stogi/Stabi S Turntable (New & Boxed)	1299	1099
Garrard 401/Aphelion/RB300 Ex-Demo	N/A	599
Rega Planar 3 Green Turntable S/H	298	175
Roksan Corus Black MM S/H	170	69
Roksan Radius 3 Turntable (98) Ex-Demo	470	250
Roksan Xerxes Piano Lacquer XPS 1 (SME Cut) S/H	1295	399
Sumiko Blue Point MC S/H	99	49
Vdh MC10 MC Cartridge S/H	995	299

Preamplifiers

Alchemist Forsetti Signature Preamplifier S/H	1500	749
Audio Synthesis Passion Kit in Box S/H	N/A	179
Densen DM20 Preamplifier Ex-Demo	1380	899
Graaf WFB 2 Hybrid Preamplifier Ex-demo	1395	950
Naim Audio NAC72/N Preamplifier S/H	870	399

Amplifiers

Conrad Johnson MV55 Power Amplifier Ex-demo	1999	1399
Conrad Johnson Premier 11 Power Amplifier (New&Boxed)	3695	2799
DNM PA3S Stereo Power Amplifier 6 months old S/H	2999	2495
Electrocompaniet ECI-1 Integrated 80 Amps S/H	3295	1599
Graaf GM100 Power Amplifier (New&Boxed)	4450	3299
Graaf GM20 OTL Power Amplifier Ex-Demo	2995	2195
Graaf 5050 Power Amplifier (New & Boxed)	2195	1695
Graaf Venticinque 25 Watt Integrated S/H	1795	995
Michell Engineering Alecto Stereo Ex-Demo	1150	899
Naim Audio NAP140 Power Amplifier S/H	N/A	379
Naim Audio NAP250 Power Amplifier S/H	1805	1099
Naim Audio Hi-Cap Power Supply S/H	780	549
Pass Labs Aleph 4 100W Class A Stereo S/H	5100	249

Loudspeakers

Audio Note AN-K/SP Light Ash Loudspeakers Ex-Demo	1070	629
Boston Acoustics VR 10 Centre Channel (New&Boxed)	250	175
Diapason Adamantes III inc Stands Ex-Demo	2450	1895
Infinity Outrigger jr Outdoor Speakers (New&Boxed)	249	129
JM Lab Colbalt 815 Dark Cherry Floor standers Ex-Demo	950	749
Martin Logan SL3 Hybrid Electrostatics S/H	3400	2199
Opera Callas Gold Mahogany Speakers Ex Demo	1095	699

Opera Duetto Mahogany Speakers Ex-Demo	395	289
VelodyneTX810MK2 Subwoofer S/H	695	379

Cables & Accessories

Audio Sculpture 2m RCA Interconnect Ex-Demo	380	149
Black Diamond Racing "Round Things" (New&Boxed)	230	149
Black Diamond Racing "The Pits" (New&Boxed)	180	99
Bow Technologies Wand Remote S/H	349	199
Deskadel 1M Interconnects WBT/RCA S/H	300	150
Einstein Octopus 8 Way Mains Block (Ex-Demo)	199	149
Golden Sounds Ceramic Cones (New & Boxed)	85	49
G- Flex isolators (New & Boxed)	199	75
Madrigal HPC 2m Balanced Interconnect Ex-Demo	310	149
MIT MH330 MkII RCA-RCA 1M Interconnects S/H	300	150
Rega 6 Tier Modular Stand Ex Demo	375	175
Roksan HA01 1M Interconnect S/H	99	49
Shakti On Lines (New&Boxed)	85	45
Sound Org Record Racks Double with CD Inserts S/H	199	75
Tara Labs 2x2m Bi-Wired Nexa Terminated S/H	150	75

Tuners & Tape Decks

Nakamichi DR8 2 Head Cassette Deck (New& Boxed)	599	449
Naim 101/Snaps Analogue Tuner S/H	N/A	499
Roksan Caspian Tuner AM/FM (Ex-Demo)	699	359
Studer A807 2 Track _ Reel to Reel S/H	6298	1499

Clearance Items Under £100

Sony Playstation With 2 controllers S/H	N/A	59
Trio K500 SME Cut S/H	N/A	99

Midland Audio X-change are looking for Audio Research, Krell, Mark Levinson, Naim Audio, Theta, cash paid call John Roberts on 01562 822236 now!



- Suppliers and installers of High Quality Audio Systems:
- 47 Laboratory
 - Accuphase
 - Audio Note
 - Audio Research
 - Avid
 - Basis
 - Cabasse
 - Cardas
 - Clearaudio
 - Conrad Johnson
 - Copland
 - Dcs
 - DNM / Reson
 - Einstein
 - Electrocompaniet
 - Final
 - Finite Elements
 - Graaf
 - Gryphon
 - Lavardin
 - Mark Levinson
 - Martin Logan
 - Michell
 - Nagra
 - Primare
 - ProAc
 - Rega
 - Resolution Audio
 - Sonus Faber
 - Spectral
 - SPM
 - Sugden
 - UKD

www.midlandaudiox-change.co.uk

Midland Audio X-change is looking for Krell, Mark Levinson, Naim Audio, Theta, cash paid call John Roberts on 01562 822236

www.midlandaudiox-change.co.uk

call John Roberts Tel / Fax 01562 822236

181 Franche Rd • Kidderminster • Worcs • DY11 5AD

e-mail sales@midlandaudiox-change.co.uk

Mobile 07721 605966

cartridges

derron
dmm
goldring
lyra
ortofon
pumiko

cables

audioquest
cable talk
chord company
dnn
heybrook
ixos
kontak
lfd
nordost flatline
ortofon
qed
sonic link
trichord
van den hul
xlo

headphones

beyer
ergo
grado
jecklin
sennheiser
stax

stands

alphason
frameworks
sound org'n
something solid
soundstyle
stands unique
target

accessories

audioquest
creek
densen demagic
dishwasher
earmax
goldring
ixos
kontak
michell
milty
monarchy
moth
musical fidelity
nordost
pixall
qed
rms
shure
trichord
zerostat

hardware

atc
audio physic
audio synthesis
bow technology
densen
harbeth
michell
nva
nordost
primare
qln
royd
sequence
sugden
teac
thorens
totem
trichord

audio, cables and accessories available by post

(post haste)

phone, fax or write

for latest price list

/ newsletter

Second hand & ex dem deals

ATC SCM20 Pro Active loudspeakers. Perfect, ex demo, complete with "flight case" pods. (£3050). Full 6 year warranty. **£2350**

KEF RDM 2 loudspeakers in cherry. About 4 years old, in perfect condition but with no boxes. Fitted to Atacama SE24 stands which have been finished in matching slightly metallic charcoal. Original price, over £800 (inc stands). **£375**

Musical Fidelity MC2 loudspeakers in black ash vinyl wrap. Chunky stand - mount loudspeakers in good condition (the foam grilles are OK too!) in original boxes. **£100**

EAR V20 line level integrated valve amplifier. S/H, boxed in perfect condition, just over one year old, supplied new by Signals. **£2700**



Summer special

For a limited period, the stunning, much loved and highly reviewed Harbeth compact Seven loudspeakers are being offered with FREE Something Solid stands.

These stands normally retail for £175 / pair and at that price represent excellent value.

Eucalyptus or Cherry veneer **£1295**

Rosewood or Birds Eye Maple **£1495**



hi-fi for grown-ups



ipswich (01473) 655171

fax (01473) 655172

email: enq@signals.uk.com

www.signals.uk.com

Bucklesham Ipswich IP10 0DY



MUSONIC STYLUS

SPECIALIST MANUFACTURER & SUPPLIER FOR MORE THAN 40 YEARS

REPLACEMENTS & ORIGINALS

MANY OBSOLETE/78 VERSIONS

PICK-UP CARTRIDGES

RECORD/TAPE/CD ACCESSORIES

WHY NOT TRY US AND HEAR THE DIFFERENCE !!

For further information tel/fax/e-mail to:-

MUSONIC (UK) LIMITED
Unit 13 Wenta Business Centre Colne Way
Watford Hertfordshire WD24 7ND

Tel: 01923 213344 Fax: 01923 213355

E-mail:sales@musonic.co.uk

VISIT OUR NEW WEBSITE

www.musonic.co.uk



Trade and Export enquiries welcome



English Analogue

Supplier of quality second-hand classical records
Reasonable prices for truly collectable original vinyl from
the 1950s to the 1970s. Labels include:

DECCA - SXL, SDD, SET, RCS, SPA, PFS

HMV - ALP, ASD, SAN, SLS

COLUMBIA - 33CX, SAX

RCA - SB - 2000/6000, VICS, SER

DEUTSCHE GRAMMOPHON, PHILIPS
etc, also available

If you are unfamiliar with classical music, recommendations are available of great recordings to enhance the enjoyment of your Hi-Fi and enter you into the vast world of Classical Music. Just as there are good recordings or Rock, Pop or Jazz, the same applies to Classical.

To increase your satisfaction, all the records sold are cleaned and audibly checked before being sold, free of charge, as well as a guarantee. The records are also supplied with a new innersleeve, as well as the old, to ensure a high standard. In addition, if you have any classical LPs or CDs you wish to sell or want a free catalogue, please write, phone or fax to:

3 Naseby Rise, Newbury, Berks, RG14 2SF, England
Tel: 44 (0) 1635 40242. Fax: 44 (0) 1635 524239

www.multiplex.co.uk/Records

WILLIAMS HART ELECTRONICS

HART ELECTRONIC KITS TRADED FOR OVER 30 YEARS



NEW LAYOUT

80Watt Mosfet Stereo Power Amp Kit
110Watt Mosfet Monoblock Power Amp Kits
ONE OF THE BEST AMPLIFIERS YOU WILL HEAR! Regardless of price
ON DEMO @ Wigan, Southend, Peterborough and Burnley



Single Ended Class A Valve Sound
15Watt Power Amp modules
FOR THOSE WHO WANT THAT VALVE
MIDBAND BUT BASS AND TREBLE TO MATCH



ACTIVE R/Control SUBWOOFER MODULE £177.30



Range of speaker Kits
Passive and Active

Advertise your Hi-Fi on my website (£2.50 admin charge)
Also: Award Winning Phono Stage Kit, Active Crossover Modules, Speaker Drive Units,
M Cap Capacitors, Caddock Resistors, Remote Control Volume and much more

WEB SITE www.williamshart.com

e-mail: williamshart@classicfm.net

or Tel/Fax for catalogue 01942 253647 121 Long Lane, Hindley Green, Wigan, WN2 4XD

PERSONAL VISITORS SHOULD PHONE FIRST TO AVOID DISAPPOINTMENT

Run by former Technical Director of Wilmslow Audio



Connoisseur Audio

Now on demo the AMAZING 50w
Integrated from Manley Labs

SCOTLAND'S ONLY MANLEY DEALER



NEW EQUIPMENT/EX DEMO MODELS

Manley Labs	£NEW	£
Stingray Integrated Valve amplifier 50w/chan	2195	1995
Manley Labs Purist Pre amp	1650	1495
Manley Labs 50w valve monoblocks	2250	2050
Unison Research		
S2 Ex Demo	975	775
SR1 Ex Demo	1250	995
S6 Ex Demo	1600	1395
S8 Ex Demo	2950	2495
Simply Phono NEW	510	490
PSU for Simply Phono NEW	400	390
Smart 845 monoblocks pair NEW	3450	2990
Feather One ex-demo	795	695
Mystery One ex-dem	1750	1450
Power 35 NEW	1500	1295

Pathos	£NEW	£
Twin Towers Hybrid ex-dem	3250	2495
Graaf		
GM100 NEW	4450	3900
GM20 NEW	2950	2500
VT5.35.5 (5 channel power amp)	2500	1995
Venticinque ex-dem	1790	1490
Venticinque Power ex-dem	1395	1195

Monri	£NEW	£
MP-5 (5 x 120w power amp) NEW	1395	1195

Audio Analogue	£NEW	£
Maestra CD player NEW	1500	1295
Maestra 150w integrated NEW	2500	1990

Craft	£NEW	£
Vitale SC NEW	750	690
Series VC 8x EL84 NEW	1250	1050

Opera Speakers	£NEW	£
Platea NEW	795	695
Pavarotti NEW	695	595
Super Pavarotti NEW	995	895
Callas Gold NEW	1095	895

Final Electrostatics	£NEW	£
0.3 Ex-dem	1495	1295
0.4 NEW	2500	2195

Diapason	£NEW	£
Adamantes LTD & Stands NEW	3995	3495
Adamantes III NEW	1975	1775
NUX NEW	1495	1295

Loth-X	£NEW	£
Othello Precision Turntable ON-Dem		
Ion BS-1 Speakers, 94db Great HiFi news review NEW	400	375
Stamm Polaris Horns 104 db 90kg each!! NEW	5990	POA

Accessories	£NEW	£
Kemp Elektroniks		
KE-Power Source, 8-way, 3.8kw NEW	795	
KE-Mains noise detector NEW	95	
KE-SNS Noise suppressor plug NEW	75	
KE-LO Power mains cord (1m) NEW	36	
KE-HI power mains cord (1m) NEW	50	

USED Equipment

Turntables / Cartridges / Phono Stages	£
Boxed NEW Michell Gyrodec SE with Acrylic Cover and record clamp. RB300	(£1175) 795
Nottingham Analogue spacedeck with Carbon Tonearm, Benz Micro glider.	(£2295) 1295
Michell Gyrodec Bronze/Black, Zeta one piece, MC20 supreme.	(£2500) 1295
Linn LP12, Valhalla, LVX, Black plymth - boxed	450
Linn LP12, Valhalla, Black plymth - boxed	350
Linn LP12, Valhalla, LVX, K18 - Boxed	395
Michell Hydraulic Reference Transcript - As new	650
Gorrad 20.1 30 years old - BOXED as NEW manual	195
Michell ISO MC - as new	290
Orifon Jubilee - £1250 new, boxed unused	750
SME 309 - BOXED NEW	692
SME IV - Boxed NEW	890

Amplifiers	£
Quad 405-2 - recent service	240
Quad 405-2 - recent service - matched to above	240
Quad 405 Boxed manual as new	250
Moan i5 Black Boxed NEW (£2600)	2100
Jadis Orchestra Reference BOXED NEW (£2495)	1795
Sunfire Cinema Grand 5 x 200w BOXED warranty (£2695)	1295
Pathos Twin Towers Hybrid as new	1995

Pre-Amplifiers	£
DNM 3C Twin with various interconnects, Chord, DNM etc (£1600)	790
Quad 34 - BOXED unused VERY RARE	275
Quad 44	150
Quad 34 Boxed Manuals	175
Bryston Sp-1 in silver THX Ultra, DTS, DD (£3800)	1900

Speakers	£
Martin Logan Aeries I Electrostatic Hybrids - BOXED as new (£2700)	1595
Quad ESL 57 electrostatics, black panels, manual amazing condition	675
Living Voice Avatar OBX - boxed, warranty, as new (£4000)	2900
CD Players	
Pink Triangle Litaural HDCD - Boxed (£2295)	£1195

VERY GENEROUS PART EXCHANGE AVAILABLE.

Dealers for: Manley Labs, Craft, Loth-x, Unison research, Opera, Audio Analogue, Final, Pathos, Graaf, LAT, Monri, Audio Analogue, Diapason.

Personal Consultation, demonstrations by appointment.

Telephone: 01592 630652

Open Mon - Sat 9.30 - 5.30

PLEASE NOTE WE WILL BE CLOSED 14th-28th July for refurbishment.

E-Mail: audioconnoisseur@btinternet.com

01592 630652

Web site www.connoisseuraudio.co.uk

Valves & Vinyl
are our vocation

Connoisseur Audio

replay

64 FLIXTON ROAD
URMSTON
MANCHESTER
M41 5AB
0161 202 9922

SECOND HAND AND EX DEM ITEMS FOR SALE

RRP SALE PRICE

CD PLAYERS

Creek CD 43 mkII (as new)	£599	£499
LFD Mistral mk II (silver)	£1000	£599
Myryad T10	£400	£299
NAD S500 Silver Series	£1000	£850

AMPLIFIERS

Audio Analogue Bellini pre amp (black)	£495	£300
Audio Analogue Donizetti power amp (silver)	£595	£399
Crimson 610 preamp with MM/MC phono stage	£450	£249
LFD Mistral integrated	£550	£399
LFD Mistral pre amp	£450	£350
LFD PAO power amp	£650	£349
Musical Fidelity E100 integrated	£700	£300
NAD C300 integrated	£150	£119
NAD C370 integrated (new)	£450	£405
NAD S300 integrated	£1500	£1099
Woodside M100 valve monoblocks	£3000	£1250

LOUDSPEAKERS

Acoustic Energy Aego 2 (NEW)	£300	£250
ART ST One	£2000	£1500
Audio Physic Step	£1299	£599
AVI Biggatron Red Spot	£600	£525
Blueroom Minipod blue	£289	£239
Epos M12	£429	£375
Heybrook HB3 beech	£349	£299
Monitor Audio Silver 3i	£279	£225
Monitor Audio Silver 5i (rosemah)	£450	£350
Monitor Audio Gold Reference 20	£1500	£1200
Naim SBL walnut	N/A	£750
Neat Critique II (black)	£495	£249
Neat Mystique II (cherry)	£735	£500
Neat Petite III (cherry)	£795	£549
PMC TB2 (oak)	£700	£599
Royd Merlin (black)	£299	£175
Spendor SP2/2 (black)	£749	£300
Totem Model One	£1249	£650

MISCELLANEOUS

Linn Klassik T silver	£1029	£850
NAD 533 turntable	£219	£175
NAD T550 DVD player	£500	£400
Onkyo 525 DVD player (multiregion)	£550	£350
Project RPM Four turntable	£300	£250
Soundstyle five shelf silver/glass	£299	£199
Teac DV3000 DVD player (new)	£229	£199

check out our website for up-to-date list : www.replay.dial.pipex.com

We are best known for our single-ended 300B power amplifiers and power supply upgrades for valve amplifiers, but did you know that we supply complete systems, new and used equipment, and components? We also provide support and servicing for Audio Innovations valve products. For full information visit www.borderpatrol.net or ring 01273 276716.

passion, grace & fire

www.borderpatrol.net

Selected products from:

BorderPatrol • Living Voice • SME • Audio Note • Cartridge Man • Goldring
Western Electric • Electrofluidics

BorderPatrol Brighton UK
Tel/Fax +44 (0)1273 276716
e-mail: bp@borderpatrol.net
www.borderpatrol.net



BorderPatrol

AUDIO MATTERS

NEW EX-DEM & PART EXCHANGE
EQUIPMENT FOR SALE
020 8255 0572/0973 436135

	LIST	SALE
Alchemist Kraken Anniversary MkII	£599	£POA
Alchemist Product 8 pre & pwr (on dem)	£2047	-
Alchemist Product 8 dac & drive (on dem)*	£1898	-
Alchemist The Statement pre amp ex/dem	£4999	£2295
Alchemist The Statement Stereo pwr ex/dem	£3999	£1995
Audion Black Shadows 845 valve monoblocks	£4000	£POA
Audion Silvernight 300B monoblocks	£2250	£POA
Audion Golden Nights	£4000	£2200
Bow Technology Wazoo (ex/d)	£2195	£1595
Bryston BP ST4 pwr	£2100	£1195
Chario Academy 1 solid walnut (ex/d)	£1299	£800
Classe DR 6L pre	£3400	£1295
DPA Renaissance CD player ex/d	£995	£595
Krell 250 CD Player	£2592	£1795
Krell Kav 3001	£2495	£POA
Linn Tukan spks. - Rosewood	£650	£295
Linn Karin pre	£1400	£595
Linn LK 100 pwr	£650	£325
Mark Levinson 331 pwr	£4500	£2695
Mark Levinson 23.5 pwr	£7500	£3195
Naim 72 pre	£800	£395
Naim 90 pwr	£487	£250
Perreux AC 3 pre ex.d	£1700	£1195
Perreux 6 ch. pwr amp	£2500	£1695
Roksan Caspian (AC3 DTS) pre & 5 ch. pwr amp (on/dem)	£2290	-
Ruark Prologue re 1 spks.	£999	£595
Monitor Audio 20SE	£2200	£950

A NEW RANGE OF VIENNA ACOUSTICS SPKS. NOW ON DEM

*New Product 8 from Alchemist Dac & Drive with 192 sampler in-built ON-DEM

Also On-Dem: Alchemist. Anthem. A.R.T. spks., Audiomeca, Audion Valve Amps, Cadence Spks., Chario, D.P.A., Goertz cables, Lavardin, Monarchy, Ortofon, Pink Triangle, Project T-T, Roksan., Sonic Frontiers, Triangle Spks., Van den Hul., Rogue Audio Valve Amps., Amphion Spks.

VISA/MASTERCARD ACCEPTED



PROGRESSIVE AUDIO



2 Maryland Court, Rainham, Kent, ME8 8QY
Telephone / Fax No. 01634 389004

WEBSITE: www.progressiveaudio.co.uk E-MAIL: dave@progressiveaudio.co.uk

We have the following ex demonstration and part exchange items for sale :

- CHORD 3200E pre amp. Silver. with 4 Integra legs. Absolutely mint condition. Little use. £4580 new. £3500. X/D
- CHORD 1200C power amp. Silver. With 4 Integra legs. Absolutely mint condition. Little use. £4750 new. £3600. X/D.
- CHORD DSC 1500E DAC. Silver. With 4 Integra legs. Absolutely mint condition. Little use. ££5635 new. £4500. X/D.
- CHORD system remote. New. £150.
- YBA CD2. As new. Silver. £2250. X/D.
- PRIMARE 30.1 Integrated amp. Mint condition. £995. S/H.
- AUDIO SYNTHESIS Desire Decade power amp. Mint. £1750. S/H.
- AUDIO SYNTHESIS DAX Decade. Mint. £1950. S/H.
- LAVARDIN PO phono stage. Mint. £1500. S/H.
- LINN Klassik. Amp, tuner and CD in one box. New. £800.
- RUARK Equinox speakers with stands. Excellent condition. £800. S/H.
- LINN Tukan loudspeakers. £295. S/H
- AUDIO SYNTHESIS Desire (Not Decade) power amp. £750. S/H
- LFD LS1 Line stage. £525. S/H
- LFD MCI phono stage. £525. S/H
- REGA Jupiter /o CD Transport and DAC with digital interconnect. £795. S/H.
- GRAAF GM 20 OTL valve power amp. £2250. S/H.
- VERITAS H3 Horns. Piano black. As new. £4600. X/D.
- VERITAS 7's. Piano Cherry. With stands. As new. £995. X/D.
- VERITAS 20'S. Piano Black. With stands. As new. £1250. X/D.
- UNISON RESEARCH simply Four valve amp with Simply phono stage. Mint £1425 X/D
- BLACK Rhodium interconnect. 1.5m. Boxed as new. £795. S/H.
- ALON Petite loudspeakers. Walnut. As new. Boxed. £850. X/D.
- ALON 1 loudspeakers. Walnut. Excellent condition. Boxed. £795. X/D.
- ELEMENTAL Audio monolith. (£499) £300. X/D.
- ELEMENTAL Audio speaker stands (the best ever ?) £1500 new. £850. X/D.
- ANALYSIS Epsilon ribbon loudspeakers. Good condition. Boxed. £3495 new. £1250. S/H.
- TRIANGLE Alcante loudspeakers. Excellent match for valve amps. Black. Mint. Boxed. £650. S/H.
- MICHELL Argo HR Line pre amp. With Hera P/S. £650. X/D.
- MICHELL Iso HR. phono stage. With Hera P/S. Excellent condition. £495. S/H.
- ORIGIN LIVE Sovereign loudspeakers. Cherry. Good condition. £650. X/D.
- ACOUSTIC SOLUTIONS "Eight" loudspeakers. Oak. As new. With stands. £1200. X/D.
- LINN Kaber loudspeakers with stone stands. £825. S/H.
- MUSE Model eighteen subwoofer. £1500. S/H.
- ROTEL 965 CD player. £125. S/H.
- ARCAM CD9 CD Player (just serviced by Arcam) Mint. £525. S/H
- UNISON RESEARCH 845 Mono blocks. Mint. Boxed. £1695. S/H.

**NOW ON PERMANENT DEMONSTRATION THE
TOTALLY AMAZING SUGDEN MASTERCLASS CD
PLAYER. AT £2500 THIS IS AN ABSOLUTE SNIP!
PHONE NOW TO BOOK YOUR DEM.**

5 MINS FROM M25

MATRIX HI-FI

VALVE AMP
REPAIRS

CURRENT HI-FI STOCK

ONE ONLY - LEAK TROUGHLINE 3 TUNER - NEW SEALED/BOXED WITH ORIG. WARRANTY AND MANUAL. HIGHEST OFFER SECURES. VALVE CD PLAYERS FROM £299.00 - PLEASE PHONE FOR DETAILS.

Acoustic Research Floor Standing Spkrs. with external crossover	200.00	Mtl Pre-Amp With Phono Stage	85.00
Alchemist Kraken Amp with PSU	289.00	Pr. Leak T112+ With Border Patrol PSU.	650.00
Audiolab 8000a - mint	289.00	Precious Metals Coppertech Delta	59.00
Audion Premier Valve Pre-Amp with Valve Phono	799.00	Precious Metals Silver 33200 Signal	187.00
Castle Howard S2 Pair - Silver Wired	625.00	Precious Metals Silvercoppertech 102 Signal	110.00
Celestion A1 Speakers Black	499.00	Precious Metals Silverttech 52 Signal	81.00
Celestion A2 Speakers Cherry	999.00	Project 2.9 Record Deck With Ortofon Cart. Cherry	449.00
DPA 'Little Bit 3' DAC	165.00	QED Passive Cd Pre Amp Alps Pot.	60.00
Goldring Lenco '88' Record Deck with		Quad Est-63 Black Inc. Stands	1,350.00
SME 3009 ADC Cartridge.	150.00	Rogers Cadet III VGC	160.00
KEF 104/2 Speakers Black Ash	625.00	Rothwell Indus Passive Pre Amp Stepped Cont.	449.00
Leak T112+ Mint - one only	200.00	Rothwell Rubicon Power Valve Amp	849.00
Leak Trough Line 3 Stereo VGC	95.00	Sansui Au-70 Valve Amp	150.00
Linn Classic various colours	995.00	Sansui Valve Tuner to match above	100.00
Linn Keosa Floor Standers	499.00	Sony Mds-Je320 Mini Disk Player	120.00
Marantz CD52SE	120.00	Teac A3300-12 Reel Tape Deck	160.00
Marantz Pm-6010ki- Signature - blk 4 months old	240.00	Tripletone Mono Blocs PR	100.00
Musical Fidelity X-Tone	80.00	Tripletone Stereo Intergrated	95.00
Michell Gyro Deck RB300 Arm Bronze	1,199.00	Warldale 415 Bookshelf Speakers	85.00
Michell Orca Pre Amp with large power supply	1,399.00		



NEW HI-END HI-FI VINTAGE HI-FI FOR SALE & WANTED

MICHELL - ALCHEMIST, CELESTION, QED. AUDIOQUEST, MARANTZ - ETC...
NEW AND VINTAGE VALVES - INTERCONNECTS & SPEAKER - OFC & SILVER
WEALTH OF KNOWLEDGE SPANNING OVER 30 YEARS, FOR ENQUIRIES OR
A CONTROVERSIAL CHAT, ASK FOR DAVE OR LEE.

PHONE : (01322) 292391

FAX : (01322) 229908

E-MAIL: MATRIXHIFI@HOTMAIL.COM

WEB: WWW.MATRIX-CS.CO.UK

SHOWROOM

65 DARENTH ROAD

DARTFORD

KENT DA1 1LU

FREE EASY PARKING

Audio Direct (UK)

- All prices include vat and free UK delivery -

Goertz Cables

Available at genuine US Domestic prices up to 50% cheaper than the copies!
Audio Direct are the approved UK agents for all Goertz cables and Alpha-Core inductors
***Goertz cables are quiet, dynamic and natural, with incredible imaging and detail and need less than a 30 minute burn-in!

Speaker Cables

MI 1 Centre Stage - £11.95/m MI 2 Veracity - £23.95/m MI 3 Divinity (Big Boy) - £49.95/m
New Python MI 2 - 29.95/m New Boa MI 3 - £79.95/m New Python MI 2 Hybrid £109.95/m

These new cables offer leading performance in all areas and are housed in a conventional round polymer sheath
Termination extra at £34.95/cable pair in Rhodium Bananas/spades, £49.95 Bi-wire set, Silver spades £44.95/cable pair

Pure Silver Interconnects

Micro Purl Ag RCA - £99.95/1m pr Triode Quartz 2 RCA - £149.95/1m pr. Sapphire Solid Silver RCA - £299.95/1m pr.
(All standard Goertz Cables offered on 21 day trial basis subject to normal conditions exc. MI 3 and Silver range)

****Note that we have some new but soiled MI 1 and MI 2 cables available at a 25% discount - (£8.99/m and £17.95/m)****

Chassis and Hook-up wires

astounding improvements in all electronics, speaker and signal applications

Cardas 15 Sawg Teflon insulated litz const. 6N copper £7.95/m. 20.5 awg version £6.95/m Twin 21.5 awg shielded version £14.95/m
XLO Teflon insulated 6N copper wires. 23 awg solid core £4.95/m. 21 awg spiral wound multicore version £12.95/m
Nordost Silver Note chassis wire- multi purpose 22 awg parallel pair made of ultra pure copper and silver - Teflon dielectric £7.95/m

PowerLinx Power Cords

Manufactured for audio using the best materials and construction techniques.

Prices from £69.95 - £199.95 These cords are quiet, natural and dynamic and outperform anything at similar cost.

Selected Valves

Super quality premium valves (no rubbish!) - offered at the best available prices

Super quality premium valves (no rubbish!) - offered at the best available prices

ECC82 JJ £5.95	300B JJ £67.95	6L6GC JJ £ 9.95	6B4G new Sovtek single-plate £22.95
ECC83 JJ £5.95	EL84 JJ £ 5.95	KT88 JJ £22.95	2A3 new Sovtek single-plate £19.95
E88CC JJ £5.95	6SN7/6SL7 £ 4.95	EL34L JJ £ 7.95	6AU6WC Jan Philips nos £ 3.50
6922 Sov £7.95	6AS7G Sov. £ 3.95	12AX7LPS £ 7.95	5814a (ECC82) Jan Philips nos. £ 5.95
300B EH £54.95	6550 EH £ 16.95	EF86 Sov £ 5.95	SAR4 Sovtek (Mullard copy) £ 6.95

Factory selected pairs and quads also available at 80p extra per valve

Special Offer

Valve mains and output transformers - High Quality 6K P/P outputs @ £29.95, 3K P/P @ £34.95

Range of Mains transformers from only £39.95 Custom 'C' core mains transformers from £69.95 - superb

JJ Capacitors

Superb new range of capacitors for valve amp power supplies etc. - quiet, transparent & dynamic

Values available now include 32+32 uF, 50+50uF, 100+100uF, 22uF, 47uF, 68uF, 100uF, 200uF, 250uF and 500uF - all at 500V
Prices range from £4.95 to £11.95 according to value and capacitor physical size. Tag and snap-in connections available

Panasonic pots Dual log 100k stereo pot now @ £29.95

Wonder Solder £2.00/m

InfiniCap SETI (Range 0.01uF through to 10 uF)

Kiwame carbon resistors 2 watt / £1.50

The very best - superb! e.g. 0.47uF x 450V @ £11.95

Superb for crossovers and valves! 5 watt / £2.95

Many other components available incl. platforms, distribution blocks, JJ valve amps, AudioLinx cables etc

All major credit cards accepted. Carriage free - UK only - Overseas please inquire, Non EC, please deduct 14.5%

Audio
Direct (UK)

2 Craigs Road, Carlisle Park, Ballynahinch, Co. Down BT24 8PQ, UK.
Tel: 02897 561348 Fax: 02897 564063 Email: audiodirect@btinternet.com

Sound Music

Now Demonstrating Arcam Diva Components
Also The Latest Quad Valve Amplification.

Philips(36PW9525)36"TV&Stand(XD) - £1350
Onkyo 575 Dolby Digital/DTS Amplifier (XD) - £300
Myryad Cameo System (Tuner/CD/Amp)(XD) - £1000

Loewe System Tuner/Amplifier & CD Player & Stand/CD Rack(XD) - £1200

S Myryad MC100 CD Player (XD) - £550
A Nakamichi CMS 5 System (XD) - £300
L Nakamichi Soundspace 5 (XD) - £375
E Nakamichi Soundspace 8 (XD) - £700
E Nakamichi DR3 Cassette Deck(SH) - £200
Musical Fidelity Explorer (XD) - £450
Musical Fidelity XAS 100 (XD) - £650
Musical Fidelity A3 CD Player (XD) - £650
Audio Analogue Paganini (XD) - £550
Audio Analogue Puccini SE (XD) - £500
Opera Super Pavarotti (XD) - £700
Roksan Kandy Tuner(XD) - £200
Roksan Kandy CDPlayer(XD) - £350

Roksan Kandy Integrated Amplifier(XD) - £350

Arcam AT51 Diva Tuner (New) - £200
Energy Encore A.V. Sub&Sat Speaker Set (XD) - £850
Loewe Planus + Base 32" Wide Screen 100 Hz - £1200
Musical Technology Kestrel Speakers (XD) - £350
Linn Kairn Pre-amplifier (Phono) (SH) - £600
Linn LK140 Power Amps (3 Available)(SH) - £550
Linn Majik (Phono) Integrated Amplifier (SH) - £400

***£100 Worth Of Accessories Free With Every Arcam Diva CD Player And *
*** Amplifier Bought Together *****

Jamo E800 Speakers(XD) - £125
Jamo Home Cinema Speaker System(XD) - £300
Quad 44 Pre & 405 Power Amplifiers (SH) - £500
Quad ESL63 Electrostatic Speakers (SH) - £2000
Stand Design Saturn 5 Stand (XD) - £200
Cyrus Discmaster/Dacmaster (SH) - £750
Cyrus Pre-amplifier (SH) - £400
Cyrus Power Amps (2 Available)(SH) - £250 Each
Naim CDS & Power Supply(SH) - £2500
RoksanXerxes/Artimez/OC9/XPS3/DSU(SH)-£1200

**Sound Of Music, 93-95 Nantwich Rd.
Crewe, Cheshire. CW2 6AW
Tel.:01270 214143**

For : Linn, Arcam, Musical Fidelity, Castle, Roksan, Onkyo, Monitor Audio, Quad, NAD, Wharfedale, Loewe, Project, Audio Analogue, & Many Others.

IAN HARRISON HI-FI

HI-FI AT DISCOUNT PRICES. FREE NATIONWIDE DELIVERY

TEL: 01283 702875

9am- 9pm

INCLUDING SUNDAYS

TRADE IN YOUR OLD MOVING COIL CARTRIDGE & SAVE UP TO 45% OFF THE RRP.

CARTRIDGES & STYL	HIFI FURNITURE	MINI DISCS	TUNERS
DENON SHURE AUDIO TECHNICA GOLDRING SUMIKO TRANSFIGURA-TION LONDON (DECCA) GRADO ROKSAN VAN DEN HUL ORTOFON AUDIO NOTE RESON CLEAR AUDIO KOETSU	APOLLO SOUND STYLE SOUND ORGANISATION ALPHASON CABLES SONIC LINK AUDIOQUEST VAN DEN HUL QED ORTOFON NORDOST ARGENTO AUDIO	SONY DENON HEADPHONES SENNHEISER SONY AKG GRADO AUDIO-TECHNICA DAT TASCAM SONY PANASONIC	SONY DENON DVD SONY DENON AMPLIFIERS DENON AUDIO NOTE PHONO STAGE MICHELL CREEK NAD AUDIO NOTE EAR ROKSAN LOUDSPEAKERS HARBETH
TONEARMS	TURNTABLES	CASSETTE DECKS	
ROKSAN SOUTHER GRAHAM MOTH CLEAR AUDIO	ROKSAN MICHELL CLEAR AUDIO AUDIO NOTE	PIONEER TEAC SONY DENON	
ACCESSORIES			
Hifi News Cartridge Alignment Gauge £5	Alignment Gauge £15	Digital Tracking Force Gauge £199	Micell Record Clamp £20
Hifi News Test Record & Shure SFG/2 Tracking Force Gauge £25	Milky Zerostat 3 £30	Black head step up transformer £72.50	Moth Record cleaning machines £POA
Audio Technica Stylus Cleaning Fluid £5	Clearaudio Carbon Fibre Record Cleaning Brush £14	Clear Audio OFC cartridge tags £35	Maxell AA Alkaline batteries 20pk £6
		TDK Duracell £POA	

PLEASE PHONE TO CONFIRM PRICE & AVAILABILITY PRIOR TO ORDERING.
ALL GOODS ARE BRAND NEW & BOXED WITH FULL U.K. GUARANTEES.
NO EX. DEM OR EX DISPLAY GOODS. NO GREY IMPORTS. GOODS ARE NOT SUPPLIED ON APPROVAL. SORRY, NO GENERAL CATALOGUES. PLEASE PHONE OR WRITE FOR SPECIFIC REVIEWS, BROCHURES OR PRICES.

MAIL ORDER ONLY FROM: IAN HARRISON, 7 MILL HILL, REPTON, DERBY, DE65 6GQ. TEL: 01283 702875. 9am - 9pm INCLUDING SUNDAYS.



Hi-Fi & Audio Components
Sales and Service

	Was	Now
ARCAM ALPHA 1 AMPLIFIER	N	£230.00 £190.00
ARCAM ALPHA 9 P POWER AMPLIFIER	X	£400.00 £275.00
ARCAM ALPHA 10 P / 3		
POWER AMPLIFIER - 3 CHANNEL	X	£850.00 £575.00
ARCAM ALPHA 8 CD PLAYER	S	£450.00 £275.00
ARCAM ALPHA 10 DAB DIGITAL TUNER	X	£800.00 £675.00
B & W DM 603 S2 LOUDSPEAKERS	X	£550.00 £400.00
BOSE 501 MK5 LOUDSPEAKERS	N	£600.00 £350.00
CASTLE INVERSION 15 LOUDSPEAKERS	N	£425.00 £275.00
DENON AVR 3300 AV RECEIVER	X	£800.00 £585.00
DENON AVP-1, POA-T3, POA-T2 AV AMPS	S	£4,950.00 £1,400.00
JAMO CONCERT 11 LOUDSPEAKERS	X	£2,300.00 £1,595.00
JAMO CONCERT 8 LOUDSPEAKERS	X	£1,400.00 £995.00
KEF Q 95 C CENTRE SPEAKER	X	£200.00 £140.00
MERIDIAN M 2500 SUBWOOFER	S	£1,750.00 £750.00
MERIDIAN M 33 C CENTRE SPEAKER	S	£795.00 £495.00
MUSICAL FIDELITY PREAMP 8 PRE		
AMPLIFIER - CHROME	S	- £150.00
NAD C 540 CD PLAYER	X	£330.00 £225.00
NAD C 520 CD PLAYER	X	£170.00 £130.00
QUAD 405 ? 2 (MONOBLOCKS) POWER AMPLIFIER	S	- £400.00
REL STRATA III SUBWOOFER - CHERRY	S	£750.00 £500.00
ROTEL RC 972 & RB 971 PRE & POWER AMP	X	£550.00 £350.00
TANNOY R 3 LOUDSPEAKERS	X	£550.00 £350.00
YAMAHA MDX 595 MD RECORDER	X	£230.00 £170.00

12 Regent Street, Rugby, Warwickshire, CV22 5LP
Tel: 01788 540772 Fax 01788 542170
www.soundexpensive.co.uk

RETRO REPRODUCTION



The Outstanding V20 Integrated Amp

*****EXCLUSIVE SCOTTISH DESIGNER*****
E.A.R./Yoshino, Croft Cary Nottingham Analogue Creek Triangle, B.C. Acoustique

Now in Stock AUDIO PHYSIC SPEAKERS



Small but perfectly formed MC3

RETRO REPRODUCTION
Is now offering a restoration service for Quad & Leak valve amps at very reasonable prices phone for more details

V20
Introducing Tim De Paravicini's latest masterpiece, the outstanding V20. Using no less than 20 ECC93 triodes operating in Class A with no overall feedback, the result is the most natural and uncoloured sound available today.
HI-FI NEWS: Ken Kessler: 'What I think we're witnessing here is Tim De Paravicini's finest moment and that's scary, when you consider that even his disasters are better than most designer's triumphs!'
WHAT HI-FI: Verdict *****
Leading French magazine Diapason voted the V20 Amplifier of the year. To hear what all the fuss is about phone now for a personal home demonstration

Used Equipment For Sale

- Pink Triangle ordinal dual DAC 7 P/A converter £375
- Sugden A48 amplifier £95
- Sugden T48 MKII tuner £75
- Beard P35 MKII 35watt class-A power amp £450
- Rotel RB850 power amplifier £175
- Arcam Alpha 8 integrated amp £225
- Naim NAP120 with 12S pre amp £295
- Quad 33 wooden sleeve boxed as new £75
- MicroMega stage 6 CD player -495
- Tube Technology Genesis 100watts monoblocks re-valved £1495
- Musical Fidelity P270 MKII power amp with MX pre £950
- Kef Reference 2.2 finish cherry new boxed £1395
- Kef Reference 1.2 resnetat finish new mint £1095
- Luxman Line matching transformers £175
- Cynus straight line amplifier £275
- DPA little bit DAC £95
- Audio Innovations series 1000 CD line matching transformer £55

- Sugden T48 stereo tuner £50
- Naim NATM3 tuner £395
- Premier PDS702 CD player £165
- 2A3 integrated valve amp with large transformers £450
- Concordant excelior valve pre amp with superb phono stage and outboard PSU £595
- Marlin Logan Aerius 1 speakers still under warranty £1695
- Sonus Faber Signum boxed new £995
- NVA monoblocks with two boxed pre £275
- Audion golden knights 300b mono blocs new £4000 £1500
- Naim Nat integrated amp £165
- Revox G36 open reel mint £395
- Musical Fidelity X3 £95
- Conrad Johnson MV55 power amplifier £1250
- Conrad Johnson PV10 pre amplifier £750
- Ion Nexus mono blocs MA40 £350
- Audio Research SP14 valve pre £1395
- Audio Research C CDIII £2250
- Audiomote speakers with stands £750
- Naim G2.5 Pre mint £150
- Kef Concerto speakers £175
- Quad 405 MKII excellent condition £225
- Cary 572 SE monoblocks boxed £1495
- SME 309 tonearm £395
- Gamma Rhythm integrated amplifier £795
- Audio Research SL7 preamp, as new £795
- EAR V20 integrated amp bargain price £1795
- Arcam Alpha 7 Tuner £175
- EAR R34P £175
- Quad 77 integrated amp with Remote carbon finish £295
- Trilogy valve MC head amp £195
- Tube Technology Prophet 2 box and pre with phono stage mint boxed £695
- ATC SCM 20 spks walnut £795
- ATC SCM10 spks rosewood boxed mint £595
- Heybrook Setai Ribbon tweeter rosewood £295
- Michelle QC power supply £295
- EAR 834 L valve line stage £275
- Leak stereo 60 mint & professionally rebuilt £595
- Leak Stereo 70 amp mint £50
- Quad II pair various £350

CROFT PRODUCTS
Croft's new Vitali Valve Pre with Phono Stage an ideal partner for Vintage Amps or a upgrade from solid state £350.00

MC3
Producing the very best from vinyl has long been a black art and it's no wonder with so many permutations involved. Most people agree that Moving Coil cartridge design is technically superior than the Moving magnet but demands much more from it's ancillaries, especially the phono stage.

E.A.R./Yoshino have just launched the MC3 Cartridge Transformer with a band width of 3Hz-100kHz, facilities for a wide range of quality cartridge outputs and twin isolated earth terminals for maximum noise reduction.
The MC3 captures all the subtleties from the most complex recording without resorting to thrusting or spitting it out. Its extreme clarity and grainless presentation makes for a superb vinyl experience.
ART DUDLEY: Leading American hi-fidelity critic.
"I'm impressed with the MC3, and from a musical point of view, I think it's worth every penny of the price. Those of you who have tube-based systems & can afford it should pester your local dealer until he lets you take one home and try out Value/Quality *****"

- Leak TL12+ pair £350
- Revox A77 Open Reel £350
- Sugden A21 INT Amp £125
- Sugden R21 Tuner £195
- Sugden CS1, P51, R51 £295
- T21 Tuner £95
- Ameron DC-300A Power Amp £350
- Linn Wakonda with tuner & MM & MC phono stage £595
- Audio Golden Knight 300B Monoblocks NEW £4000.00 £1395
- Cary SLP-94 Pre-Amp with superb PhonoStage +outboard PSU (mint) NEW £3000.00 SELL FOR £1195
- Counterpoint SA 3000 Pre - the ultimate Valve Pre Amp (very rare) £1495
- Audio Research SP-9 II Pre Amp £695
- Audio Research D-115 MK II Valve Power £1195

NOV. 2011 REMAINING
LAST BERT GORDON'S ALLY ZING MOVING IRON
CARTON OF CARBON SPICE ARM

New Showroom now open
28a Haddington Place Edinburgh EH7 4AF
Phone/Fax 0131 558 9999 Open 11.00am - 5.30pm - closed Monday & Sunday

HARVING TECHNOLOGY SINGLE CRYSTAL CABLE
NOW AVAILABLE AT LAST! THE ONLY CABLE TO DO ALL THE THINGS THE MANUFACTURERS CLAIMS AND AT A RIDICULOUSLY LOW PRICE. PHONE FOR MORE DETAILS



2nd User Hi-Fi & audio

PRE-OWNED EQUIPMENT

- NAIM CD2 BOXED AND IMMACULATE (£2200 NEW) £1195
- NAIM CD3 BOXED AND IMMACULATE (£1000 NEW) £495
- NAIM HI-CAP OLD STYLE VGC INC INTERCONNECT £399
- MONITOR AUDIO MA1800REF GOLD TEAK £595
- NAIM NAC 72 PRE AMP BOXED AND IMMACULATE (£790 NEW) £449
- NAIM NAC 92 PRE AMP BOXED AND IMMACULATE £279
- NAIM NAT3/PRE OUT MODIFICATION BOXED AND IMMACULATE (1999 MODEL) £399
- NAIM NAP 135'S BOXED AND IMMACULATE (GREEN CASES) £1995
- NAIM NAP 140 OLD STYLE SUPERB CONDITION £399
- NAIM NAP 160 OLD STYLE 1982 BUT ALMOST MINT CONDITION £449
- NAIM NAP 250 ONE YEAR OLD AS NEW AND UNUSED £1395
- NAIM NAP90/3 BOXED AND IMMACULATE £329
- NAIM NAPSA ARMAGEDDON BOXED WITH INSTRUCTIONS £475
- PIONEER CLD95 BITE LASER DISC PLAYER (£2000 NEW) £795
- BEARD CA35/P35 II VALVE PRE/POWER (£2500 APPROX NEW) £1295
- DENON AVC-A1 GOLD BOXED AND IMMACULATE (£2000 NEW) £495
- DENON AVP-A1 GOLD BOXED AND IMMACULATE (£3000 NEW) £995
- DENON DVD-5000 GOLD WITH MULTI REGION CHIP FITTED-SUPERB MACHINE £995
- EPOS ES12 DARK CHERRY BOXED WITH INSTRUCTIONS £349
- EPOS ES14 WALNUT SUPERB CONDITION £349
- LINN AY5103 AC3 REF LASER DISC INPUT DD PRE AMP IMMAC (£4750 NEW) £1995
- LINN KANS BLACK BOXED AND IMMACULATE £249
- NAIM III-CAP NEW STYLE GREEN CASE SUPERB CONDITION-BOXED £479
- LOEWE PLANUS 32" WIDESCREEN ARCTIS BOXED AND IMMACULATE £895
- MERIDIAN 500/566-20 BIT TRANSPORT/DAC BOXED AND IMMACULATE £1495
- MERIDIAN 602/606 TRANS/DAC-BRAND NEW LASER BOXED/IMMACULATE £1495
- MICROMEGA DRIVE 3/DAC BOXED AND IMMACULATE £995
- TDL RTL 2 BLACK ASH LOUDSPEAKERS £189
- NAKAMICHI CR2 CASSETTE DECK £175
- QUAD ESL63-LATE MODEL APPROX 1992/93 BLACK WITH STANDS SUPERB £1395
- REGA CURSA MM/MALA PRE/POWER IMMACULATE WITH SOLAR REMOTE £595
- ROKSAN CASPIAN CD PLAYER-SILVER OR BLACK AVAILABLE £495
- ROKSAN XERXES BLACK ASH/TABRIZ ZICORUS BLACK £595
- ROTEL RB985THX 5 CHANNEL POWER AMP BOXED WITH INSTRUCTIONS £395
- RURK CRU/SADER II SPECIAL ORDER YEW VENEER-BOXED & IMMACULATE £1295
- TEAC VRDS 25 CD PLAYER BOXED AND IMMACULATE (£1400 NEW) £695
- YAMAHA DSP-A1 BLACK (£1800 APPROX NEW) BOXED AND IMMACULATE £595
- LINN EKOS MKII TONEARM BOXED LINN SERVICE/NEW BEARINGS 4/01 £895
- LINN ARKIV MC CARTRIDGE (£1200 NEW) £695
- QUAD 34/306/FM4 £595
- DPA LITTLE BIT 3 DAC £249

PROFESSIONAL RECORD CLEANING SERVICE - KEITH MONKS MACHINE - PLEASE RING FOR FURTHER DETAILS AND PRICES.

THREE MONTH WARRANTY ON ALL ITEMS

www.sound-stage.co.uk

STOWSOUNDS

Stowfarm Borough Lane, Great Finborough, Stowmarket, Suffolk, IP14 3AS
We have the following equipment to clear:

	WAS £	NOW £
Alchemist Nexus CD	599	480
Atacama Audio Rack 6 shelf	200	140
Atacama Speaker Stands		from 40
Creek 4330 integrated	279	235
DPA Enlightenment Pre amp	795	550
DPA Enlightenment DAC	825	600
DPA Renaissance CD	995	700
Exposure 21 Pre amp	1100	900
Exposure 18 Power amp	1000	800
Exposure 25 integrated	1100	950
JM Lab Tantal 515	499	375
JM Lab Cobalt 810	799	600
JM Lab Electra 905	1199	999
Linn Numerik DAC	1500	950
Linn LK100 Power amp	750	500
Linn Wakonda Pre amp	650	400
Magnat Needle floorstander	479	300
Magnat Vector 55 floorstander	399	225
Magnat S1 sub and satellite	249	195
Micromega Sage 4 CD	600	400
Mordant Short MS 30i	350	200
NAD 310 integrated	110	80
Neat Petite cherry	795	575
Rogers LS4a	-	150
Sonneteer Byron CD	795	600
Sonneteer Alabaster integrated	900	700
Sonneteer Campion integrated	600	500
TDL RTL 3	-	200
Trichord Revelation CD	800	575
Yamaha DSP E492 Processor	-	175

Various interconnects, supports, cables at reduced prices.
Phone for details

Sale of CDs. Phone for latest list.

TEL: 01449 675060

UPGRADE YOUR TURNTABLE

"If you are thinking of upgrading your system...the Origin Live dc-motor kit should be high on your list for consideration" TNT AUDIO internet magazine April 2000.

"The single most important upgrade you can ever make to any record deck concerns the motor drivenothing can compare you for the shock of going DC. in a word Gobsmacking" COMMON GROUND MAGAZINE

"Its value is nothing short of tremendous" LISTENER MAGAZINE

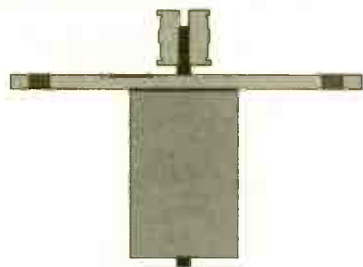

Whether you own a Linn Valhalla/Lingo, Rega or any other deck, the results of upgrading to the Origin Live dc motor and power supply are simply astounding. This high grade motor kit is designed as a drop in replacement for almost all turntable motors. Decks benefiting so far from this ultimate of upgrades include Linn, Roksan, Michell, Systemdeck, Rock, Rega etc. With a 12 Volt power supply it is safe and easy to fit. Guidance instructions are provided. At £262 with fully soldered and tested regulator board plus money back guarantee, this is a bargain out of all proportion to it's value in terms of performance. A larger purpose made transformer is also available as an optional extra at £175.

AURIOS ISOLATION MOUNTS



"highly recommended" March 2001

HI-FI WORLD

With the Aurius, I am now (finally) consistently hearing what I've always wanted out of audio"

STEREO TIMES

"unbelievable until you've heard the difference"

SOUNDSTAGE

Placed under Turntables, CD Players, Amplifiers, Loudspeakers etc these amazing devices dramatically upgrade the sound of your Hi-Fi. Reviewers who try them won't be without them. The investment made in the Aurius will last a lifetime. They reflect excellent value in terms of outstanding performance which is only possible through expensive production techniques and the finest engineering available.

The Aurius (MIB) mounts are £197.50 GBP for a set of 3 mounts (carriage is an additional £5.50 within the UK and will be quoted for outside). One set of 3 mounts normally supports one item of equipment.

Make cheques payable to Origin Live and send to address shown We can take credit card orders if you wish. Remember there is a no risk money back guarantee if not entirely satisfied.

ORIGIN LIVE TURNTABLE KIT

Now you can save money and build your own high performance deck. The standard parts kit is offered at £195 and is complete apart from a plinth. The kit comes with a full set of drawings and guidance instructions. It allows for your creativity or there are optional parts that will enable you to assemble a tried and tested design within 1 - 4 hours. The optional parts include the ultra platter (£84), plinths for suspended and non-suspended designs along with sub-chassis etc. The optional parts upgrade the standard kit to high end performance levels and is probably the easiest kit you will ever make.

"this Vinyl front end had my jaw heading towards the floor with the solidity and transparency of the music it was making"...
"the standard came up with crystal clear images set in a broad sound stage"... "With all these goodies in place, the standard would give turntables at the £1200-£1400 mark a hard time."

HI-FI WORLD SUPPLEMENT

"is exceptionally easy to build and professional in both sound quality and appearance"

HI-FI NEWS SUPPLEMENT

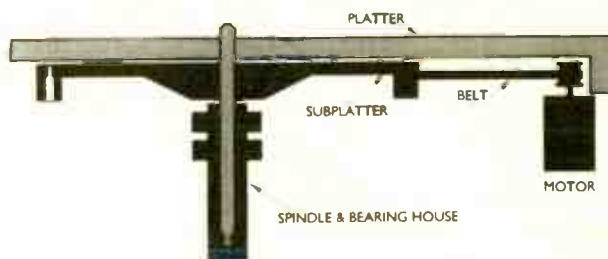

TURBOCHARGING YOUR REGA ARM

"Nothing less than total dynamite" HI-FI WORLD

If you are the proud owner of any Rega arm, why not utterly transform it into the league of super arms with the Origin live structural modification:- £75. This modification will enable your Rega to perform at a level exceeding that of arms costing over £1200.

Rewiring with high grade litz cable is also offered at an additional £70, and external rewiring is £70.

"I have to say the Rega modifications turn this humble arm into a real Giant killer. Gone is the rather grey, sterile sound of the cooking Rega. Instead, tonal colour is fresh, dynamics have great speed and impact, and the sound stage is huge." HI-FI WORLD SUPPLEMENT NOV 97 (structural modification to a RB250) WHAT HI-FI gave this modification a 5 star rating.

For arm modifications we normally return your arm in 2 - 3 days

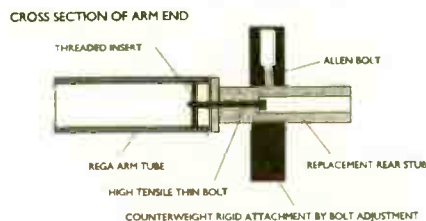

For further information contact
Origin Live, 87 Chessel Crescent, Bitterne,
Southampton, SO19 4BT
Tel: 02380 442183 / 578877 - Fax: 02380 398905

EMAIL: origin.live@virgin.net

WEBSITE: <http://www.originlive.com>

The Original blue 'n white

audioSource

We lead; the others follow! In 1995 AudioSource launched the first high-end interconnect at mid-fi prices. Those who heard, believed, and spread the word. Now we have so many Scottish copies, we are flattered. Unfortunately, they rely on the same expensive dealer network. They also lack the expertise and enthusiasm of our design team of three. Six years of painstaking professional (but unpaid) development work on three Petros interconnects have culminated in the latest Stratos Series III.



The result is to experience sonic quality delivered from your existing components - the justification for highly priced cables, but in our case the reason for a relatively *inexpensive* interconnect. From 1997 we provocatively advertised: "Try an £800 interconnect in your system and keep it for only £125" for that is the price of our one metre flagship model. Today we still invite comparisons with the most expensive and acclaimed cables. There are good reasons detailed in our literature and the forthcoming website because AudioSource is now selling internationally, exclusively distributed by The Audio Salon, direct to the user. The provocative valuation of our audio interconnect at more than five times our price point, incidentally, was suggested and subsequently supported by our customers.

All Quiet on the Mains Power Front



For several years we said little about our audio power products, because there weren't any. The design we now proudly launch was achieved by examining neutrality, ie. mains purification without degrading and compressing sonics, then testing filter circuits that audibly and universally boosted the performance of all tested Hi-Fi brands, right up to reference level, and we use our 6-way AudioSource Power Port with Mark Levinson reference components. To find out why, send for the free literature and put us to the test. By selling direct, the Model E4 six-way audio power port, our most popular configuration, sells for just £299 and has saved many people from expensive equipment or format changes.

Our "Double Helix" British Braided Cord (bbc) offers for only £45 an excellent 1.5 metre a/c mains cord with high current near-instantaneous wave, filtered against RFI and EMI to an unrivalled 64% ISM for its price.

AudioSource products are sold direct, exclusively by The Audio Salon. Go for the Originals. All else are copies.

The Audio Salon, 5 Crown Terrace, Hyndland, Glasgow G12 9HA
Tel: 0141 357 5700. Fax 0141 339 9762. E-mail: info@audiosource.co.uk

Acton Gate Audio Ltd. The HiFi Centre

4 Ruabon Road, Wrexham, LL13 7PB
Tel: 01978 364500

email: sales@acton-gate.com
website: www.acton-gate.com

Spring sale of ex.display and customers' equipment

Micromega Stage 1 CD	£175
Quad 34/306/FM4	£750
Rotel RC980/RB980/RB980	£650
Quad 34/FM4/405 II	£625
Audio Analogue Donizetti Power	£475
Audio Analogue Bellini Pre-amp	£395
Quad 99 Pre & CD	£1125
Rotel 951 CD Ex.Disp.	£275
Quad 50e (pair)	£350
Harman/Kardon HK630 amp/KD720 CD	£320
Marantz CD63 II SE	£100
Yamaha KX580 SE	£120
Linn Classik (silver.ex-dem)	£800
Linn Sondek	£400

Stock constantly changing - many other offers

THE AUDIO SALON

SCOTLAND'S FIRST AND FOREMOST DEALER

Established 1979 as The Music Room. Four demo rooms. By appointment please.

Scotland's Authorised Dealers in Mark Levinson/Reference, Suggden/MasterClass and Bow. Valve equipment by ANJ, ART, EAR, and Western Electric. Turntables by Michell, SME and Simon Yorke. Speakers by ATC, ART, ProAc, and Revel. Zingali domestic and Home Monitor horn loudspeakers.

Specialists in audio cables, mains cords and conditioning.

ATC SCA2 bal pre-amp, lphono/remote <i>Back on market as owner kept deciding to keep it!</i>	£4,150	£1,995
ATC SCM-20A SL Tower Speakers <i>One pair boxed, unused, cancelled order</i>	£4,968	£2,995
Audio Note TT1 with AN ARM-2 <i>Black Ash. Factory sealed, unused.</i>	£749	£475
Audio Note K/D Speakers with own stands <i>Ideal match and performance for valves</i>	£809	£450
Audio Note Japan, Kegon <i>One of only seven made, this is the real Kegon Revalved inc. 2 matched pairs Western Electric 300B</i>	£84k	£22,000
Audio Note Quests with Border Patrol PSU <i>Solid 300B monoblock amps supplied by us. One careful user, buying Diavolo. Priced for quick sale.</i>	£3,750	£1,750
Conrad-johnson Premier 14 Pre-amp	£4,495	£1,995
Conrad-johnson Premier 15 PhonoStage	£3,995	£2,195
Mark Levinson No 380 pre-amp <i>Mint, six months old, sold by us new</i>	£3,995	£2,600
Mark Levinson No 39 CD Processor <i>As new. Owner upgrading to 31.5 + 360S</i>	£4,995	£3,650
Mark Levinson 360S 24/192 DAC <i>As new. Owner upgrading to No 30.6 DAC</i>	£6,895	£5,250
Mark Levinson 30.6 DAC+PLS-330 PSU <i>The world reference. Has the new Upsampling readout Software which is further upgradeable in future</i>	£16,495	£9,495
SJS Arcadia 26 wpc SET <i>British built "Kegon" using 2x 6P, 1V32B Copper chassis, silver wired, superbe</i>	hand-built	£3,295
Sonus Faber Extremas <i>With dedicated amazing pedestals</i>	£6,890	£3,295

5 Crown Terrace, Hyndland, Glasgow G12 9HA
Tel: 0141 357 5700. Fax 0141 339 9762. E-mail jack@Hi-Fi.eu.com

Private Ads

Special Internet offer
 see page 130 for details

Orders must not advertise in the Private Classified section.
 Heavy commercial enquiries will be considered under
 advertising. The Publisher reserves the right to judge submissions.

LOWTHER ACOUSTAS - originals - Finnish Birch throughout. Professionally renovated, dark oak with dud PM6s. Renovation cost=£1200 For Sale @£495. Tel: 01483 268 814 or Email: info@hornutopialoudspeakers.co.uk (Sep/1)

LINN LP12 Valhalla Basik plus Goldring 1006 cartridge £350! KRK V8 monitor active speakers £500! Wilmslow Audio elegance speakers £100! Tel: 020 8531 5979 (Aug/1)

NAIM NAP 250 power amplifier (new style). Mint and boxed as new. £900 ono. Naim Credo loudspeakers, cherry veneer. Mint and boxed as new. £650 ono. Linn Lingo LP12 power supply. Mint condition. £350 ono. Helios Model I CD player. Mint and boxed as new. £800 ono. Yamaha KX 580 Dolby S cassette deck. Boxed, as new £65 ono. ADC Program electronic stylus pressure gauge. Boxed, £10. Dark Rock isolation platforms x 2 £60 each. Absolute Sounds Sicomin isolation platform £60. Tel: 023 8073 5988. (Aug/1)

MUSICAL FIDELITY A3-CR Power Amplifiers x 2, as new, boxed, instructions etc, £675.00 each - can deliver. Ruark Prologues Ref 1, Cherry Veneer, brand new boxed, £750 o.n.o. Tel: home 01622 721 011 / mobile 07973 899 651) (Oct/1)

LEAK FM Troughline 3 mono tuner, Radford FM7 stereo tuner, Quad FM3 stereo tuner, Quad 33 Meridian p/amp also Sansui Sony A&R Cambridge Mission 771 amplifiers chokes available for vintage amps EMI BTR2 ex BBC offers. Tel: 0131 332 7536 (Aug/1)

PRE-AMPS Parasound PLD 2000 Class A dual mono John Curl design 6 inputs £695 (£1495). Cyrus pre fitted phono stage £295 (£650) both full remote controlled balanced in/out. Tel: 01273 325 901 (Aug/1)

NAIM CD3.5 with remote £800, NAC102 with remote £900, NAPSC £150, 2 Flat Caps £180 each, NAPI40 £400, Cherry Credos £600. All boxed and as new. Tel: Jon 07801 442 693 (Aug/1)

EPOS ES14 speakers black ash £300. Project 6.1 turntable £250. All boxed and excellent condition. Tel: 01243 379 022 (Hampshire/West Sussex border). (Aug/1)

TANNOY AMS 8 active speakers. Rare model, mint £1399. Tel: 0141 956 1440 (Aug/1)

NAIM SYSTEM CD3 CD player £675. NAC72 pre-amp £295. NAPI10 power amp £295. FlatCap power supply £150. SBL speakers, black £800. Tel: 07768 061 020 anytime (Sheffield, Yorkshire) (Aug/1)

AUDIO SYNTHESIS Dax Decade £1,500, Teac P10 CD Transport with upgraded clock/power supply £650, Concordant Exquisite Doug Dunlop original all-valve pre-amp £800, Audioquest Midnight Blue speaker cable 4 x 8ft £100. Tel: 020 7281 0821 or Email: denis.baker@virgin.net (Aug/1)

AUDIOLAB 8000 CD, mint condition, 4 years old, boxed, manuals £425 ono. Audiolab 8000s, mint condition, boxed, manual £275 ono. Tel: 02380 550 489, (Mobile) 07799 686 477 (Southampton) (Aug/1)

MUSICAL FIDELITY
 XA100R integrated amplifier and XLP phono stage. Both in perfect condition. £500. Tel: 020 8440 1402 (North London) (Aug/1)

AUDIO RESEARCH LS7 pre-amp, mint £750. Ear 834P MM/MC phonostage, excellent condition £295. Quicksilver valve preamp £375 mint. Atacama 'Europa' 4 tier table, new £160. Atacama R724 stands £65. Heybrook HBZ £85. Tel: 020 8952 2044 (Aug/1)

HI-FI CLEAROUT: Hi-Fi publications, accessories etc. Email: lesperkins@lineone.net for my list. Sunfire true sub-woofer £750. Audio Synthesis Dax Coax Tosh £700. Magnum Etude, Sleuth, ST-2 £900. Rotel 965BX CD £100. Tel: 020 8502 3017 (Aug/1)

EPOS ES25 (black), boxed, as new £850. Plinius 8151 amp (£1850), boxed, as new £1100. Marantz PM17K1 Signature amp and matching SM17 poweramp, as new £900. Tel: 01952 502 097 (Telford) (Aug/1)

MERIDIAN 602/606, mint, boxed £695. Naim 32.5 MM/MC (72 spec), mint £90. Ariston RD115 Grace 747 Ortofon OM10 £145 (see Hi-Fi World Classics) Tel: Lou 01932 260 069 (Aug/1)

MICHELL ISO Hera phono £210. Linn Sondek, Valhalla £275. Thorens TD150 £60. Brenell Reel to Reel Stereo £200. Rotel Monster receiver, scary, £300. IMF TLS 50's £80. Wanted: Rotel Michi power amp. Tel: 0161 303 8819 (Aug/1)

THETA DATA Basic CD transport, boxed, as new £950 ono. Tel: 01636 830 944 or 07979 536 753 (Aug/1)

MUSICAL FIDELITY F Series amplifiers, F 2 preamp, two Fx 2 power amps, switchable, stereo monoblocks awesome build, sound, mint, boxed, new £2000, sell £750. Absolute bargain. Tel: 0161 688 0152 (Aug/1)

ONKYO GRAND Integra CD £600 (£1700). Sony amp FA30ES R/C £190. Sony SA3ES tuner £125. B&W DM4's £45. Wanted: Audiolab 8000 CDM & DAC, Spondor BCI's. Tel: 0121 246 0486 (Aug/1)



SOUNDS PERFECTION



AUDIONOTE AN-S7 MK II MOVINGCOIL TRANSFORMER £2995
 SUGDEN MASTERCLASS POWER AMP BOXED MINT £1995
 AUDIONOTE QUEST MONOBLOCKS EX-DEM £1895
 PARASOUND AVC 2500 JUST RUN IN SUPERB PROCESSOR £1795
 REL ACOUSTICS STENTOR III WALNUT NEW JUST RUN IN £1795
 QUAD 63 ELECTROSTATICS PLUS GRADIENT SUB/UPGRADED £1695
 ALCHEMIST FORSETI SS POWER AMP MINT BOXED £1195
 VIENNA ACOUSTIC MOZART SPKS ROSENUIT BOXED £1095
 PRIMARE D 30.2 CD PLAYER ALMOST NEW BOXED £1095
 REL ACOUSTICS STADIUM III CHERRY MINT BOXED £1049
 BOSTON ACOUSTIC 10X SATS SET OF 4 MINT BOXED £995
 ELECTROCOMPANIE 4.6 PRE-AMP BOXED ONLY £995
 ALCHEMIST FORSETI PRE/POWER COMBO £995
 AUDIONOTE CD 3 PLAYER £995

AUDIONOTE M2 PHONO EX-DEM NEW £1699 NOW ONLY £895
 MUSICAL FIDELITY A-300 INTEGRATED AMP MINT £895
 TRIANGLE ZAYS SPEAKERS JUST RUN IN £795
 PARASOUND AVC 1800 BOXED HARDLY USED ONLY £695
 AUDIONOTE P2 SE POWER AMP BOXED £649
 AUDIONOTE MODEL 3 SPEAKERS ROSENUIT ONLY £549
 VIENNA ACOUSTICS HADYNS BOXED MINT £475
 PRIMARE A 20 AMP BOXED MINT £449
 AUDIONOTE MODEL 2 SPEAKERS BLACK £375
 X-WING 4 TIER STAND MARBLE SHELVES £325
 REGA PLANER 3 / RB 300 ARM BOXED ONLY £195
 STANDS UNIQUE CD 300 RACK ASH FINISH ONLY £159
 MUSICAL FIDELITY OFFER X-200R NEW ONLY £625

**SPECIALIST IN HOME ENTERTAINMENT
 WE STOCK**

BOSTON*J.M.LABS*LEXICON PARASOUND*
 PRIMARE*TRIANGLE*REL
 SUBWOOFERS*M.F.*NAD*QED*NAKAMICHI*
 VIENNA ACOUSTICS STANDS UNIQUE* ATC*
 ACOUSTIC RESEARCH*GENELEC NORDOST*
 ROTEL * SONIC LINK SPEAKER*CRAFT*
 STRAIGHT WIRE*TEAC

FOR FRIENDLY SERVICE CALL NIGEL

01326 221372

MOBILE:- 07798 554357

Email :- nigel@soundsprecision.co.uk

kathryn@soundsprecision.co.uk

Web :- www.soundsprecision.co.uk

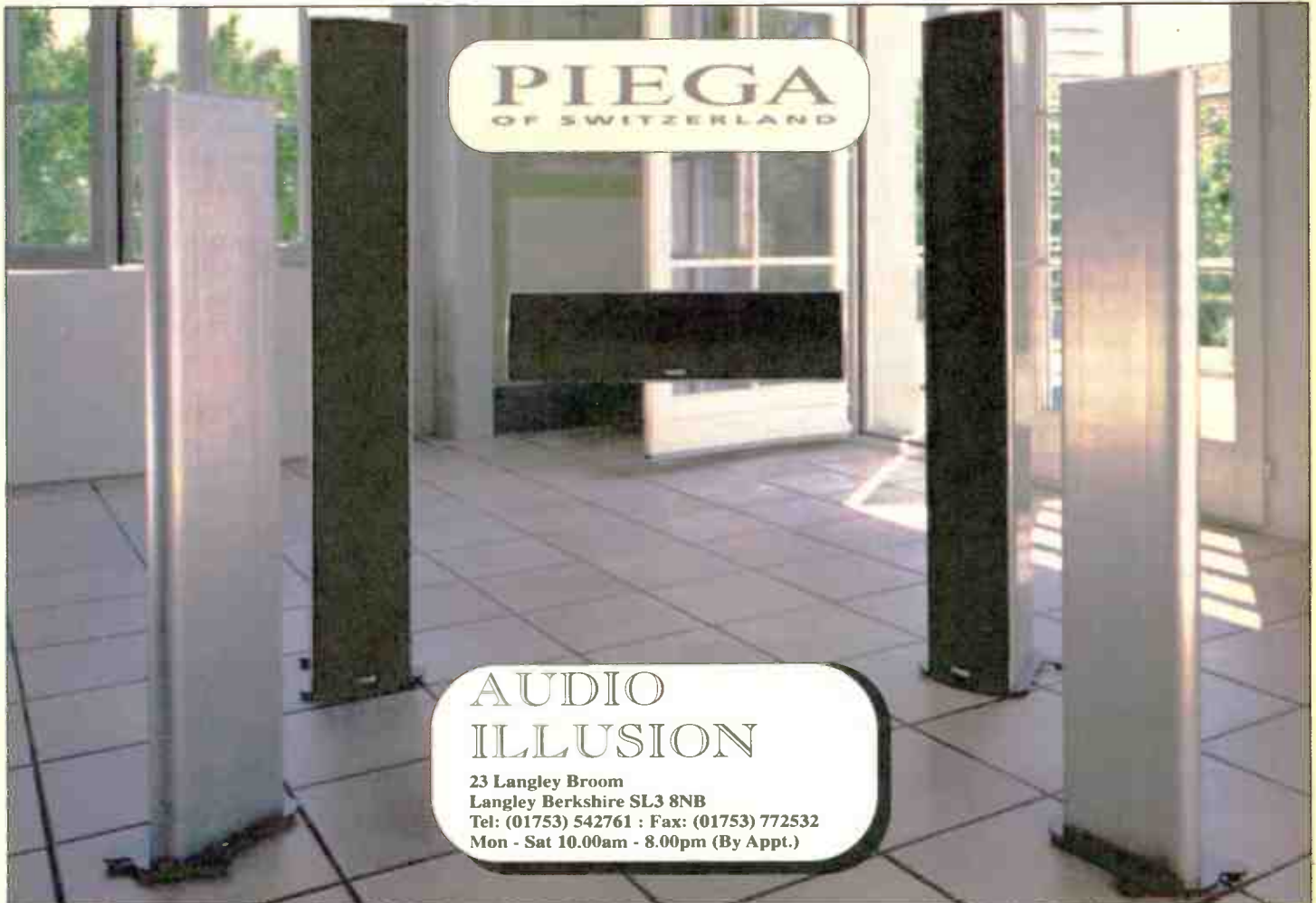

AUDIO ILLUSION

23 Langley Broom
 Langley Berkshire SL3 8NB
 Tel: (01753) 542761 : Fax: (01753) 772532
 Mon - Sat 10.00am - 8.00pm (By Appt.)

Special Internet offer
see page 130 for details

NAIM NAC72 preamp, boxed, manuals, new shape, excellent condition £425 ono. (may swap for Hi-Cap) Dunlop system deck turntable Grace arm suede effect plinth £100 ono. Tel: 01444 455 593 (Sussex) (Aug(I))

EXPOSURE XXIRC remote control preamp, nearly new £395 (£1100 new). YBA2 pre/power combo, as new £2200 (£4000 new) VDH D102 Mk3 interconnects, nearly new £50. Helius Orion I, Audio-Note silver wired £290. Tel: 01423 712 351 or Email: maddoganderson@aol.com (Aug(I))

HI-FI CHOICE & Stereophile Best Buy - Rega Planar 25 turntable, RB600 tonearm, Elys cartridge, maple finish. Superb quality deck, as new, boxed, cost £708, accept £395. Tel: 01429 290 213 (Hartlepool) (Aug(I))

NAIM CDX CD player £1700. Naim 102, 180 and NAPSC pre-power amplifier with p/supply £1800. Naim 72 140 pre-power amplifier £950. Epos ES22 floor-standers, light cherry £650. Linn LP12 black Ekos Troika (refurbished) Lingo £1250. Mana 4 tier table, Sound Stage, mini table, Sound Base and Spirit Level £650. Cyrus DAD3Q CD player £500. All products in good condition. Tel: Andy 01367 240 309 after 7.30pm (Aug(I))

UNISON SMART Mono-B 300-B. New-B. Plus-warr, £2500 (£4250). Simply 845-int., £1750. No offers. Rotel EQ-12E-860 £50. Nikko FM-tuner £60. Sony tuner ST-3950 £50. Sony cass-deck TC-229 £70. KT88 valves. Tel: 01562 827 710 N.T.W. (Aug(I))

NAIM SBLs cherry, fourteen months old with £150 marble plinths as new, boxed £1200. Tel: Chris 07718 267 988 or 020 8592 9797 (Aug(I))

LOWTHER's PM.6, £200. KEF, Celeste's £60. Mission's, 700's, £40. J.P.W.s, £30. Mordant Short bass drivers £20. Leak 2030's £30. Leak 150's £20. KEF kits £50. Akai 4000 DS £75. PL12 t/table £45. Armstrong 626 £60. Armstrong 521 £30. Pioneer SA 500 £30. Goldring GL72 £10. Hacker, valve record player £30. Sugden A48 £50. Conneseur t/table, parts £20. Soundstyle rack £45. Tel: 07980 195 292 (London) (Aug)

MARK LEVINSON No. 37 transport, Mark Levinson No. 36 DAC both mint, boxed, manuals £4750 ovno. Krell KSL pre amp mint £995. Also Klipsh La Scala boxed. Sensible offers. Tel: 01403 713 783 (Sep(I))

MERIDIAN PAIR of M30 Active loudspeakers, Meridian M207 two box CD with M209 remote, plus M204 tuner £950. Includes manuals. Individual offers considered. Tel: 01582 591 714 (Aug)

MERIDIAN 555 power amplifier, boxed, excellent condition £300. Tel: 02380 556 035 (Aug)

ROTEL RB 971 power amps X2 £100 each. Rotel RC972 pre amp £120. As a unit £300. Linn Kollector £325. Mission 752F speakers £300. DPA Little Bit DAC £80. Target 5 tier equipment rack £70. All items fully serviceable. Tel: 01526 320 513 (Aug(I))

TANNOY ARDEN's 15" golds, ideal valve companion 91 dB sensitivity v.g.c. £750. World Audio Kit Kel 34 amp 40 watts various tubes to sort your tastes. All torodial output model alps pot £250. Tel: 01634 723 223 (Aug(I))

LINN KEILIDH speakers, black with stands, boxed, unused vgc, two years old £350, Naim Audio NAC 92 pre amp, boxed, unused, two years old £200. Tel: 01189 810 097 (Basingstoke) (Aug(I))

ATC SCM 20 SL rosewood with 21" slate stands, boxed, can demonstrate £2500 new, now £1300. Mint condition. Tel: 02380 470 107 (Southampton) (Aug)

LEAK TL12+ £280. Single ESL57 gold mint £210. Troughline II £60. Quad FM1 new P.S.U. decoder £75. All working order. Lowther Acousta twin cabinets £55. Tel: 01840 212 387 or Mobile: 07714 587 212 (Aug)

WORLD AUDIO Design 300B push pull amplifier. Built by WAD £500. Ear 834P MM/MC valve phono stage £300. Phone Shaun 01472 883 722 after 5pm (Grimsby, Lincs) (Aug (I))

CYRUS STRAIGHTLINE amplifier £200. Musical Fidelity "X" cans £65. Henley moving coil amplifier £80. Stax electret headphones £70. First three items only 30 months old. Tel: 01241 872 131 anytime, ask for Les. (Aug)

MAGNEPLANAR SMGA panel loudspeakers, black grills, wooden sides, immaculate condition £450 o.v.n.o. Tel: 07961 822 895 (Aug (I))

WANTED AUDIOLAB 8000PX or late 8000P power amplifier, must be good condition. Tel: 01377 267 413 (E.Yorks) (Aug(I))

KEF CONCORD speakers original 1970s vintage. Teak enclosure. Floor standing 24m high. Excellent condition £55 pair or offer 01491 837 269 (Wallingford, Oxon) (Aug(I))

REL STORM Active sub-woofer, excellent condition £495. Tel: 01495 350 677 (Ebbw Vale) (Aug(I))

AUDIO RESEARCH D90B circuit board (working), new valves with mains transformer £195. Micromega Duo CD3. Transport £595. T-Dac £295. Custom valve DAC (TDA1451) £495. Wanted: Goodmans Axiom 80/120/201/301 speakers. Tel/Fax: 01642 649 702. Email: goodstuff57@hotmail.com (Aug(I))

OIL-FILLED valve pre-amp transformers, with circuit diagrams for valve and silicon rectifiers, and regulators, NOS boxed £35 each. GEC KT66 good £40 each. Quad mains & OPTX £50 each. Preamps £25 each. Tel/Fax: 01642 649 702. Email: goodstuff57@hotmail.com (Aug(I))

REGA PLANAR III deck mint condition, very little use £160. Naim 32.5 preamp, good condition £125. Tel: 01777 700 066 (N.Notts) (Aug(I))

NAIM NAC 62 / NAP 90 pre / power M/C boards £330. Naim CD3 recently serviced by Naim £500. Tel: 01276 503 994 evenings (Aug(I))

SUPRA[®]

Supra cables are manufactured to exceptional standards of quality in our very own factory near Gothenberg in Sweden - in tune with nature & in tune with your needs.

Interconnects

EFF-ISL "Hi-Fi Choice Best Buy",

fitted with locking gold-plated phono's (0.75m)

£84.95/pr

EFF-IX - same cable as EFF-ISL, but fitted with

non-locking phono's (0.75m)

£69.95/pr

EFF-IXLR - same cable as EFF-ISL, but fitted

with XLR connectors (0.75m)

£89.95/pr

Digital Cables (1m)

DAC-XLR 110ohm AES/EBU cable £44.95ea

EFF-ID co-ax digital cable £44.95ea

Fibre optic cables(1m)

ZAC (Available in 3 versions: TosLink>TosLink,

3.5mm>TosLink, or 3.5mm>3.5mm) £29.95ea

X-ZAC (Hi-End TosLink>TosLink) £59.95ea

Most interlinks cables are available in other lengths. New range of scart + s-video cables now in stock. See website or catalogue for details.

Supra Retailer websites:

www.custom-cable.co.uk

www.supradirect.co.uk

Classic Series Tin-plated speaker cables (unterminated)

Classic 2.5mm £2.69/m

Classic 4mm £3.95/m

Classsic 6mm £5.49/m

Quattro 4x4mm biwire cable £8.95/m

(All Classic cables are multi-stranded OFC - Classic 4mm is a "What Video Best Buy")

Ply Series low inductance OFC speaker cable

Ply 2.0 £4.95/m

Ply 3.4 £7.49/m

Ply 3.4/S £8.95/m

(Both Ply 3.4 are "Hi-Fi Choice - Recommended" cables)

LINC Series Installation Speaker Cable (shielded)

LINC 4.0 £4.95/m

For a catalogue, complete the coupon and post to our address. E. & O.E.



AUDIOVECTOR

The new improved range of Audiovector M Series speakers are now available...

Call us to arrange a demo or visit our website at:

www.audiovector.co.uk and consider the full range of Audiovector speakers from just £329 (per pr) to over £2,000

Example prices (for Black Ash):

Bookshelf/stand mounts

M1 (bi-wire/bi-amp) £649.95/pr

M1 Signature £1,179.95/pr

Floorstanding speakers

M2 (as "Recommended" by

Hi-Fi Choice) £999.95/pr

M3 (tri-wire/tri-amp) £1,199.95/pr

M3 Super £1,699.95/pr

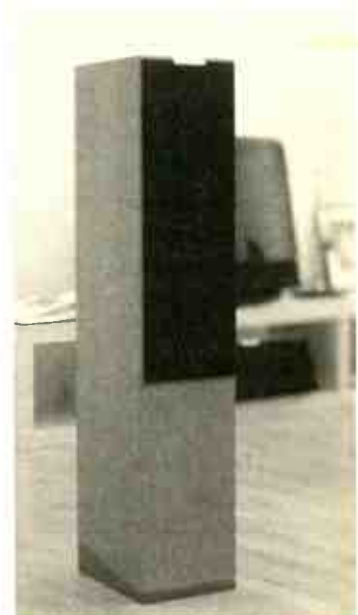

Post to: Glave Limited, Unit 7, Wren Industrial Estate, Coldred Road, Maidstone, ME15 9YT Tel/Fax: 01622 664070 Web: www.supracables.co.uk
Please send me info on: Supra hi-fi and home cinema cables

Name:

Address:

Post code:HFW0108

Post to: Audiovector UK, Unit 7, Wren Industrial Estate, Coldred Road, Maidstone, ME15 9YT Tel/Fax: 01622 664070 Web: www.audiovector.co.uk
Please send me info on Audiovector speakers

Name:

Address:

Post code:HFW0108



Vacuum Tubes for Audio Are Back!

Glass Audio brings together yesterday's tube with today's improved components, voltage control, and the exciting new Soviet tubes, to make smooth sound in your livingroom possible again!

YES!

Please send my first issue of *Glass Audio*. I'll pay just \$45.00 for six issues (1 year); \$80.00 for 12 issues (2 years) of the best information on tubes to be found anywhere. I understand that my satisfaction is guaranteed!

Name _____

Street & Number _____

City _____ Postal Code _____

Country _____

REMIT IN US \$ DRAWN ON A US BANK ONLY. PRICE GOOD THROUGH DECEMBER 31, 1995.

We Accept MC/VISA.

Glass Audio

PO Box 176, Dept. HFWS, Peterborough, NH 03458-0176 USA
Phone: (603) 924-9464 or FAX 24 hours a day (603) 924-9467

Special internet offer
see page 130 for details

CELESTION A1 speakers, black ash, boxed £899 new, sell £499. QED Silver Anniversary B/W speaker cable 2 x 4 metres £90 new, sell £50. Tel: 020 7432 2128 (Aug/1)

AUDIOLAB 8000A amplifier; Systemdex 11A turntable; Yamaha CD player; Monitor 352MD speakers; Target stands; Denon 500 cassette; Leads. £500 or sensible offers. Will not split, excellent condition. Tel: 01708 728 605 (Romford) (Aug/1)

ROKSAN OJAN 3 speakers, rosewood finish floor-standers £350. Pink Triangle Ordinal DAC, 20 bit filter £300. Yamaha DSP-A5 home cinema amplifier, 7 months old, £200. All mint. Tel: 01702 306 498 (Essex) (Aug/1)

GOLDMUND MIMESIS 3 amplifier excellent condition £1495 (£1510 new). Spondor 3/1 speakers, cherry wood, unused £295. Tel: 01531 670 525 (Aug)

NAIM AUDIO NAPI40 NAC32/5 complete with M.C., M.M., boards and NA328 variable sensitivity boards for CD. Also 2 x 5m Naim speaker cables. Top condition £400. Demonstration collect only. Retired so phone anytime. Tel: 01328 711 795 (North Norfolk) (Aug/1)

LINN KLIMAX power amplifiers £7250. Linn 5103 pre amp/processor £2995. Linn Keltiks latest spec £POA. Linn Sizmik subwoofer £695. All as new and boxed with warranty. Tel: 01582 456 137 (Aug/1)

ARCAM DELTA 170 C/D transport with Arcam black Box 2 £340. Musical Fidelity E10 amplifier £120. Nakamichi BX2 cassette deck £150. Yamaha tuner £50. Linn Index speakers plus stands £150 vgc. Tel: 020 8681 1054 (Croydon) (Aug/1)

LINN AKTIV System Karik, Numerik, Kairn Pro, LK100 (2) Kelidh (Walnut) stand cables £1500. Tel: 01628 47364. Email: David.Norris@compaq.com (Aug/1)

TEAC CD transport VRDS TI Teac multi D/A converter D-TI both boxed, very good condition £400 ono the pair, will split. Tel: 0121 744 1528 (Aug/1)

WORLD AUDIO KEL80 monoblocs with polished black granite plinths and Wilmslow Audio passive volume pre 12 months old, excellent £450. Tel: 0116 284 9087 (Leicester) (Aug/1)

MERIDIAN 566.20 DAC £450. 200 transport £200. 203 DAC £100, all in mint condition. Linn Axis turntable with Akito arm mint £200. Tel: 01296 770 903 (daytime) (Aug/1)

IMF TLS 50's £175. Pair Quad II Quad 22 £250. Quad II pair for rebuild £100. Pioneer A400 GT £180. Tel: 01829 751 743 (Aug/1)

VALVE AMP Kit 88. Bits for sale. Output and input transformers, PCB board built up, chassis, Noble volume pot. Plus many more upgraded capacitors and resistors. £200 ono. Tel: 01785 213 686 (Aug/1)

KLIPSCH LASCALA's superb horned beasts 104 d B/W fantastic condition, black, uses same drivers as Klipschorn (£2500) £875. ATC SCM 20 loudspeakers mint condition boxed (£1400) £500. Tel: 07720 392 792 (Aug/1)

TARGET FIVE tier equipment table £50. Ear 834P with volume control as new £190. Music Maker cartridge as new £250. Tel: 01132 565 915 (Aug/1)

LINN LP12 turntable, Cirkus upgrade and Trampolin. Ittok LV II arm. Audio Technica OC9 cartridge. Black. Very little used £900. Tel: 01628 781 253 or Mobile: 07881 782 662 (Aug/1)

QUAD SYSTEM. Rare opportunity. ESL 57's (black), 44 control unit, 405 power amplifier, FM 3 tuner. All unused, in mint condition, in tailor made export cartons. £1500. Will split. Tel: 01934 418 124 (Aug/1)

VINTAGE CLEAROUT Radford STA 25 £500. Leak ST 20 £250. Tannoy horns 26" x 3 £150. Avantic SPA 11 + tuner £100. Lowther mono cabinet £50, other equipment, big caps + valves. Tel: evenings 01903 236 246 (West Sussex) (Aug/1)

REGA ELICIT amp mint condition, excellent phono stage boxed with manual £375. Tel: 01782 810 295 (Aug/1)

QUAD 405 Mk II, overhaul and converted DIN to RCA, Quad Nov 2000. £225. Denon DF10 system, amp, tuner, CD, cassette manual, boxed. Unmarked. £450. Cable Talk interconnects available £50. Tel: 07949 682 425 (Bournemouth) (Aug/1)

SNELL TYPE C II speakers £1250. Magnum MPI20 2 x MF120 pre power amplifiers £700. Audio Alchemy V.2.O & V.3.O Jitterbox converter £675. Grace 707 brand new £300. Pro-Ac tablette 2000 £400. Thorens TDI66 Mk VI RB250 £285. Sony CDP 715-E £175. Tel: 01179 556 555 (Aug/1)

ATACAMA R724 stands £70. Heybrook HB2 speakers £95. Musical Fidelity A1 £100. Linn Kan stands perfect for Heybrooks £40. STD turntable Mayware arm MC cartridge mint £150. Soniclink cable 2 x 5 mtrs (£200) £90. Tel: 020 8952 2044 (Aug/1)

NAIM CD 3.5 £650. Roksan Caspian CD £500. NVA P60 A40 pre/power £150. Nakamichi DR2 £350. Owner moving house. Tel: Chris 01732 882 024 (Sevenoaks) (Aug/1)

WANTED: CD or Aux module for Meridian MCA pre-amplifier. For sale or exchange: moving coil module, mint and boxed (excellent - I have two!). Please telephone 0131 447 9308 (Edinburgh) (Aug/1)

NUVISTA M3 valve amplifier, 3 mths old, 275w/ch. (I'm gutted, house move forces sale) £2400 ono. Monitor Audio Silver 5i speakers £270. Sony MDS-QB940 minidisc £170, all as new. Tel: Anthony 07974 269 044 (Sep/1)

STD TURNTABLE Mayware arm MC cartridge ex con £150. Musical Fidelity A1 £95 vgc. Meridian 201 pre/ remote ex-con £250. Heybrook HB2's £95 vgc. Tel: 020 8952 2044 (Aug/1)

Classified Ads

Classified Ads

MUSICAL IMAGES

PRODUCT		LIST	NOW
ACOUSTIC ENERGY AE 509 Speakers	EX/DEMO	£850	£425
ACOUSTIC ENERGY AE520 Speakers	EX/DEMO	£1,000	£500
ARCAM ALPHA 1 Amp	EX/DEMO	£230	£100
ARCAM ALPHA 8 Power Amp	EX/DEMO	£250	£175
ARCAM ALPHA 9CD CD Player	EX/DEMO	£800	£475
ATACAMA SE1000S Speaker Stands	S/H	£80	£50
CHORD DSC1100 Silver DAC inc Trigger	EX/DEMO	£2,815	£2,300
CYRUS AVMASTER+ Processor	EX/DEMO	£800	£400
DENON AVC A1D AV Amp	S/H	£2,000	£1,250
DENON AVC 2800 AV Amp	S/H		£250
EAD THEATRE AV Amp	S/H		£1,000
HARMAN KARDON AVR80 & APD303 AV COMBO	S/H		£700
JAMO ATMOS Black Speakers	EX/DEMO	£480	£150
KEF TDM45 Subwoofer	S/H	£800	£550
MARANTZ MM500 Power Amp	S/H	£350	£100
MERIDIAN 519 Demodulator	S/H	£480	£250
MERIDIAN 565 Surround Processor	S/H	£2,850	£1,000
MICROMEGA STAGE 6CD CD Player	EX/DEMO	£950	£450
MISSION 774 Black Speakers	S/H	£500	£350
MISSION 77C Cherry Center Speaker	S/H	£200	£120
MUSICAL FIDELITY A3CR Pre Amp	S/H	£1,000	£700
MUSICAL FIDELITY A3CR Power Amp	S/H	£1,000	£700
MUSICAL FIDELITY XA-1 Amp	EX/DEMO	£480	£400
MUSICAL FIDELITY XACT DAC	S/H		£150
MUSICAL FIDELITY XRAY CD Player	S/H	£800	£500
NAD 533 Turntable	S/H		£150
NAD 917 AV Tuner/PRE Amp	EX/DEMO	£550	£300
NAIM CD 3.5 CD Player	EX/DEMO	£1,112	£750
NAIM FLATCAP Power Supply	EX/DEMO	£370	£250
NAIM NAC 3 Amp	S/H	£600	£425
NAIM NAC 5 Amp	S/H		£500
NHT VS1.2 Black Surround Speakers	S/H	£400	£200
NHT VS1.2 White Centre Speaker	S/H	£200	£100
PIONEER DV515 DVD Player	EX/DEMO	£250	£175
PIONEER DV525 DVD Player	EX/DEMO	£250	£175
PIONEER DV626 DVD Player	EX/DEMO	£450	£300
PRIMARE A20 Amp	S/H	£700	£480
PRIMARE A30.1 Amp	S/H	£1,500	£950
QED P3600 Power Amp	S/H		£70
ROKSAN CASPIAN DSP Processor	S/H	£1,000	£400
ROKSAN RADIUS Turntable + PSU	S/H		£200
SONY SDPEP9ES AC3 Processor	EX/DEMO	£600	£275
TARGET LR5 Silver Rack	S/H	£190	£150
THORNS TD166 MK6 Turntable, Arm & Cartridge	S/H	£500	£350
TUBE TECHNOLOGY UNISIS Stereo Power Amp	S/H	£3,000	£1,500
UNISON RESEARCH TWO Amp	S/H	£1,900	£600

Special KEF Reference Old Range Demo Offer

KEF MODEL 1 Rosetta Speakers	NEW	£1,550	£775
KEF MODEL 1 Classic Rosewood Speakers	NEW	£1,450	£725
KEF MODEL 2 Rosetta Speakers	NEW	£2,150	£1,425

PLEASE VISIT OUR SHOWROOMS OR CALL OUR HOTLINE NUMBER FOR DETAILS. HURRY, THESE ARE ONE-OFF ITEMS!!

SEE IT! HEAR IT! BUY IT!

HOTLINE NUMBER:
020 7497 1346

14-18 Monmouth Street, Covent Garden, London WC2H 9HB
E-Mail: sales@musical-images.co.uk

Beckenham

Edgware

Hounslow

0208 663 3777

0208 952 5535

0208 569 5802

NOT VALID WITH ANY OTHER OFFERS OR PROMOTIONS E&OE

diverse vinyl

01633 256261 / 259661
10 Charles Street Newport South Wales NP20 1JU.
sales@diverse-music.co.uk

Forthcoming Releases

Beta Band	Hotshots Part 2 16/7	£15.90
Eva Cassidy	Songbird (Out In Sept)	£TBC
Jesus And Mary Chain	Complete John Peel Sessions	£16.90
Love	Forever Changes (Sundazed)	£15.90
Matt Deighton	The Common Good29/5	£TBC
MC5	Kick Out The Jams (Sdazed)	£15.90
Muse	Origin Of Symmetry - Very Ltd	£12.90
Nitin Sawhney	Prophecy	£15.90
White Stripes	White Blood Cells7/7	£9.90

ALBUM OF THE MONTH

TRAVIS "Invisible Band" - £12.90

New Stock And Recent Releases

Air	10,000 Hz Legend 2LP	£18.90
Aretha Franklin	I Never Loved A Man 180gm	£15.90
Black Sabbath	Never Say Die/Technical each	£15.90
Bob Dylan	Desire/Planet/Mercy SV each	£18.90
Bob Dylan	Highway 61(Sundazed Mono)	£16.90
Box Tops	Soul Deep (Best Of) SV	£18.90
Byrds	Sanctuary Vol 3	£15.90
Destiny's Child	Survivor	£14.90
Elbow	Asleep In The Back	£14.90
Fleetwood Mac	Showbiz Blues(1968-70) 2LP	£14.90
Genesis	Live/Selling England (Classic)	£25.90
Giles Giles And Frapp	Metaphormosis	£15.90
Grand Drive	True Love/Road Music3LP	£17.90
Incredible Bongo Band	Bongo Rock/Story Of 2LP	£12.90
Joni Mitchell	Blue (Reprise)180gm	£22.90
Joni Mitchell	Ladies Of (Reprise) 180gm	22.90
Led Zeppelin	1/2/3/4 All In Stock On Classic	£25.90
Led Zeppelin	Houses Of The Holy Next	£25.90
Metallica	Various Titles(Ring For List)	
Mott The Hoople	Mott (Absolute Analogue)	£29.90
Neu	Neu/2/75 Each	15.90
Plaid	Double Figure(Warp)	£13.90
Radiohead	Amnesiac 2LP	£18.90
Stereo Mc's	Deep Down And Dirty 3LP	£19.90
Tindersticks	Can Our Love - Very Ltd	£13.90
Various	Studio One Soul (Soul Jazz)	£14.90
White Stripes	White Stripes/De Stijl Each	£8.90

UK P & P £1.50 1st LP; 50p each Additional LPs (up to 5 LPs)
Visit Our New Look Web Site. Secure Shopping Now Available.
www.diversevinyl.com

TEL: 01428-651554

P.G. Hi-Fi

FAX: 01428-654592

Buying & Selling Vintage HiFi, Valves,
Classical LP Records & Spare Parts.

Quad	Valve Alert
All spares available for Quad II and Quad 22	Mullard ECC81 Genuine N.O.S. Blue Box, Made In England each £8
Quad 405 Power Amp £200	Valves N.O.S.
Quad QC1 Pre-amp (Early Model) £120	ECC84 Mullard £6
Quad QC Pre-amp £40	ECC84 Birmar £6
Quad FM1 Tuner £40	EF80 Mullard £5
Quad II Mains Transformer £100	ECC81/CV455 Mullard £8
Quad II Output Transformer £100	ECC81/CV4024 Haltron £5
Quad II Output Transformer (100v Line) £50	ECC81/CV4024 White Box? £5
Quad II Choke £30	Photocopies Of Circuit Diagrams + Vintage Hi-Fi Literature
Quad II Fuse Holder £7	Spare Parts For Quad + Leak + Transformers Etc.Garrard 301 Spares
Quad II Chassis + Wiring Loom £35	Teac C-2 Cassette Deck. High quality deck in excellent condition, very little use, working, but requires minor mechanical service (running slow in 'fast forward'. Can be serviced at Natural Sound Services, Ealing, London. £100
Please Phone For Details Of Other Quad/Leak/Garrard Spares	

Leak

Leak TL12.1 (Pair)	£1500
Leak Stereo 20	£250
Leak Stereo 60	£550
Leak Stereo 30	£30

Most Models Of Leak Mono + Stereo Pre-Amps In Stock.

Nakamichi 610 Pre-Amp/620 Power-Amp/630 FM Tuner	£500
Tannoy HPD15" gold crossover (Single)	£50
Ortofon SMG 212 arm with "Expert" cartridge	£250

Valves (G.E.C. Mullard etc.)

KT66 ECC81/84 EF80	
Many Others, Please Phone For Details	

Quad ESL57 Electrostatic Loudspeakers

2 pairs, both in excellent condition and sounding superb. £600 (pair)
Pair 1. Bronze, Serial No's. 35882 + 35906
Pair 2. Black. Serial No's. 11031 + 7143
Packing available in tailor-made export quality cartons £50 (pair)

WANTED
LARGE COLLECTIONS OF CLASSICAL LP'S

Special Internet offer
see page 130 for details

MERIDIAN 200 £325. 203 £150. 201 £275. 209 £50. Sony MDS-JE510 £50. MDS-JB920E £75. All boxed. 6-off DPA "The Power" £50 each. Tel: Mike 0032 2 512 0952 (Belgium, but equipment in North London) (Aug/I)

MISSION 753 speakers, satin black, finish, uprated bases, excellent condition. Can be demo'd £350 ono. Tel: 01384 820 321 or 07855 364 434 (Aug/I)

LINN KAIRN preamp phono £495. Kabers black passive £445. Karik numeric £895 including cables. Tel: 01277 211 685. Mobile: 07966 267 404 (Essex) (Aug/I)

NOT YET Run in Living Voice Auditoriums, Border Patrol power supply, Audio Innovations Series 300 export version and Hitachi Special Edition loudspeaker cable £1600. Wanted: CD In America by Defunkt, mint or new. Tel: eves 01444 456 772 or day 020 7488 4533 (Aug/I)

ACOUSTIC ENERGY AEI speakers with Sound Organisation stands, all in white. Superb imaging and transparency. Addiction to WAD kits requires sale at £400 to help finance KLS3 Golds. Tel: Guy 01202 392 635 (Aug/I)

NAIM SUPERCAP new case. Naim 102.5 plus PSU pre amp new case. Naim 250 power, trad case. Naim serviced, mint, boxed. Naim interconnects speaker cables £2750. Will demonstrate. Tel: 01202 481 386 (Dorset) (Aug/I)

TANNOY AMS 8 active speakers. Rare model, mint £1399. Tel: 0141 956 1440 (Aug/I)

TOWNSEND ROCK, just serviced, new bearing, new belt. Origin Live fully modified RB250 with Denon DL304, excellent condition £425. Castle Howard 3 latest model, maple, 100% mint (£1300) £925. Tel: 020 8952 2044 (Aug/I)

LEHMANN BLACK Cube phono stage £270. Manticore Magician tonearm silver wired £180. Ortofon MC20 Supreme £170. Linx tuner £190. DPA IS19 speaker cable, 4.5m pair £100. All ono. Tel: 01296 623 573 (Aug/I)

WADIA 8 TRANSPORT, 12 DAC, good condition, boxed, £1800, buyer collects. Tel: 07973 405 916 or email: adamstanhope@compaqnet.co.uk (Aug/I)

THULE PA200 monoblocks, Thule PR200 pre-amp, powerful sound, £599. Acoustic Energy AEI Mk2 speakers, classic tight, open sound £299. Systemdeck 2x2 turntable with Rega RB250, Origin Live modified, forget CD, £299. Excellent. Tel: 01484 327 739 (Aug/I)

KEF MODEL 107 Reference Series flagship model in mahogany with original manufacturers data. Pristine condition, can demonstrate, £1500 ono. Tel: 01925 762 228 (evenings), 07703 193 791 (day) (Aug/I)

ARISTON Q DECK, Ortofon OMB10 Proton 1100 Pre., Wharfedale 3XP's/XP2's, Hitachi DA-6000, Wye 525 amplifier, Reslo 15 watt valve P.A., Scopex 4D10B oscilloscope. Offers, all must go. Tel/Fax: 01323 500 174 (Aug/I)

CASTLE HOWARD S3 speakers, latest model, maple, 100% mint (£1300) - £925. Quicksilver valve pre-amp, mint (£800) £375. Heybrook HB2's £85. Mordaunt Short Festivals £50. Atacama R724 stands £70. Tel: 020 9852 2044 (Aug/I)

NAIM NAC A5 5m pair £45. Chord Rumour cable, 3m pair £50. Impex motor, rebuilt £40. Avondale taps turntable power supply £50. Tel: 01296 623 573 (Aug/I)

LOWTHER ACOUSTAS - originals - Finnish Birch throughout. Professionally renovated, dark oak with dud PM6s. Renovation cost=£1200 For Sale @£495. Tel: 01483 268 814 or Email: info@hornutopialoudspeakers.co.uk (Sep/I)

LINN LP12 Valhalla Basik plus Goldring 1006 cartridge £350! KRK V8 monitor active speakers £500! Wilmslow Audio elegance speakers £100! Tel: 020 8531 5979 (Aug/I)

NAIM NAP 250 power amplifier (new style). Mint and boxed as new. £900 ono. Naim Credo loudspeakers, cherry veneer. Mint and boxed as new. £650 ono. Linn Lingo LP12 power supply. Mint condition. £350 ono. Helios Model I CD player. Mint and boxed as new. £800 ono. Yamaha KX 580 Dolby S cassette deck. Boxed, as new £65 ono. ADC Program electronic stylus pressure gauge. Boxed, £10. Dark Rock isolation platforms x 2 £60 each. Absolute Sounds Sicomin isolation platform £60. Tel: 023 8073 5988. (Aug/I)

GUIDELINES FOR BUYING AND SELLING SECOND-HAND EQUIPMENT

FOR THE BUYER

1. Not everyone is honest - Buyer Beware!
2. **Don't send cash!**
3. Accept no verbal guarantees.
4. Have you heard the item or something similar? If not, why do you want it?
5. Don't pretend to have knowledge - it's your fingers that will get burnt!
6. Is it working? If not, why not?
7. Has it been modified and, if so, have notes been kept?
8. Was it any good in the first place?
9. **Don't send cash!**
10. If you are in the slightest doubt, arrange an audition (see point 5). If it's too far, wait for another time.
11. Either buy it or don't: vendors are excusably impatient with 'consultation' exercises.
12. **Don't send cash!**

FOR THE SELLER

1. Not everyone is honest - Seller Beware!
2. Make no verbal guarantees.
3. Even 'nearly new' is still second-hand. If the manufacturer's guarantee is no longer in force, your price should reflect this.
4. There is very little intrinsic value in second-hand hi-fi; it's only worth what some one will pay for it.
5. The best guide to pricing is last month's Classifieds: that a 'classic' was worth £xxx a year or two ago is no guide. Values fall as well as rise.
6. Amateur second-hand dealing is not a big money game: you win some, you lose some.
7. Be prompt with despatch. If in doubt about buyer's bona-fides, either wash out the deal or send C.O.D.
8. There will always be time-wasters; be tolerant within reason!

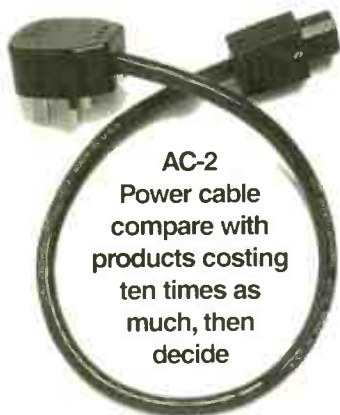

AC-2
Power cable
compare with
products costing
ten times as
much, then
decide



LAT AC-2 Power cable We have developed a cabling (weaving) pattern along with an unusual shielding/filtering system that gets rid of the garbage that contaminates your components. The difference you hear with our cord is astounding. Our power cord takes advantage of silver in its design through use of our proprietary Silverfuse conductors. The conductors are 10 gauge and insulated with Teflon; the best insulation available. Fitted as standard with an IEC and MK Toughplug. Other connectors are available incl Schuko, 16 amp IEC, Figure of eight etc. 2ft £56, 3ft £68, 4ft £78, 6ft £99. other lengths available and off the reel. **4,6 and 8 way all steel mains distribution blocks** fitted with UK, Schuko or USA type sockets. CE tested and approved mains distribution units manufactured out of heavy gauge steel, finished in black and fitted with high quality Wadsworth 13amp sockets. It has no filters, circuit breakers, surge protection, transformers, resistors, capacitors, LED's, on/off switches, chokes, regulators, just fitted with 3ft of LAT AC-2 mains cable. From £161 for 4 way, £194 for 6 way, £226 for 8 way. All solder connections with Wonder solder. Gold plated surfaces treated with **ProGold Gp5**. Other surfaces treated with **DeoxIT DP5**

NEW GOLD MK Tough plug with gold plated pins (£14)
Otto Heil IEC with gold plated contacts (£10)

SILVERFUSE is a near alloy of silver and copper. IT IS NOT SILVER PLATED OR SILVER CLAD. Plating (or clad, which is the same thing as plating) causes a dioding effect when signal is passed through resulting in brightness and distortion. The Silverfuse process starts with seven nines OFHC copper wire with a diameter that is slightly larger than the required size. It is then pulled through a trough of molten silver. The wire with a silver deposit, is then forced through a compacting die where it is subject to tremendous pressure. The silver and the high purity copper are fused together into a near alloy. The compacting fusion also reduces the wire diameter to the desired size. No dioding subsequently occurs with this process. The result provides for the benefits of silver; which are excellent definition and clarity, with the high purity copper benefits of warmth and mellowness.

ANALOG INTERCONNECTS

- IC-200-MKII £159 RCA/XLR - Silverfuse, solid, quad, braided screen, Teflon
- IC-100 - MKII £105 RCA/XLR - Silverfuse, solid, twin, braided screen, Teflon
- IC-80 MKII £60 RCA - Silverfuse, solid, twin, Teflon - 5 Star What Hi Fi
- IC-50 MKII £42 RCA - Copper, Coaxial - 5 Star What Hi Fi, Home Cinema etc

DIGITAL INTERCONNECT

- DI-20 MKII £85 RCA/XLR - Silverfuse, solid, quad, braided screen, Teflon

What Hi Fi - IC 200 - most listening with IC-200, CD17 MF X-A1 & MA SE20Se.
IC-100 - Excellent buy, bass sub woofers love, atmospheric and detailed treble, big powerful dynamic sound for good CDs and amplifiers

VIDEO INTERCONNECT

- VI-6 MKII £61 RCA/BNC/SCART - 2m - Silverfuse, solid, coaxial
- VI-6 MKII £114.00 RCA/BNC - 2m. 3 VI-6 conductors in a single sheath that contains metal particles for maximum rejection of external RF and EMI

Component Video

- SPEAKER CABLE**
- SS800 £17/m 12 gauge Silverfuse, Teflon insulated
- SS800 BIWIRE £25/m 12 gauge Silverfuse, Teflon insulated
- SS1000 £39/m 10 gauge Silverfuse, Teflon insulated, floating ground
- SS1000 BIWIRE £55/m 12 gauge Silverfuse, Teflon insulated, floating ground

SUNFIRE CORPORATION

SNOHOMISH USA. PATENTED DOWNTRACKING TECHNOLOGY - no heat sinks, runs cool. Sub -woofers with two drivers



Classic Tube pre amplifier
Optional all tube phono stage, reverse RIAA and line input for CDP



Cinema Grand Signature
430 watts per channel x 5 into 8 ohms. Also Cinema Grand 200 w/pc x 5

Signature True Sub Woofer - 13 inch cube -
two drivers, 2700 watt amplifier, 16 hz, 116 db spl, 360 cu ins air movement



Sunfire Stereo Signature
600 watts per channel into 8 ohms. Also Stereo power amplifier 300 w/pc



Threatre Grand processor pre-amplifier. DTS, Dolby Digital, auto sensing, tuner etc



True Sub Woofer MKII - 11 inch cube -
two drivers, 2700 watt amplifier, 18 hz, 110 db spl, 235 cu ins air movement.



Junior True Sub Woofer - 9 inch cube - two drivers, 1200 watt amplifier, 25 hz, 105 db spl, 120 cu ins air movement



AUREX CD/DVD MAT From Ohio USA, a polymeric mat with a uniform multilayer of a specially formulated mixture of organic compounds. Clarity and depth in music from CD's, sharper pictures and brilliant colours from DVD. £26.50 - 14 day money back warranty.



COMING SOON

REPAIR SERVICE - SUMO AND CARVER CORPORATION PRODUCTS. REFER TO WEBB SITE FOR DETAILS



3D-LABS CDP, DAC, TRANSPORT AND DVD's



SRC sampling rate converter translates 16,18 and 20 bit inputs to 24 bits format. All 32, 44.1 and 48kHz frequency is re-sampled to 96kHz. **DVD with SRC and CV2** - Video system for unmatched picture quality - best with projection systems and large Flat TV's TFTS' LCD's.

Trade Ads

Special internet offer
 see page 130 for details

Readers must not advertise in the Private Classified section.
 Monthly commercial insertions will be considered Trade
 advertising. The Publisher reserves the right to judge submissions.

SUMO ATHENA 9 + Power amp, Pre amp. excellent condition. (£1,700) £690. Audio Technica OC9 cartridge, brand new, unused. exchange price: £230. Audio Research SPI4, boxed inc. Manual. Totally mint £1250. Audio Research PH1 Phono Stage, totally Mint condition. Boxed as new (£1500) £750 ono. Crimson 610 & 620 pre & power inc DNM lead £390. DPA Enlightenment transport. £350.00. Deltec Black Slink 0.75 mtr interconnect £90. Deltec Black sixteen 1.5 mtr pair £90. Heybrook HBI 2000, dem'd once, immaculate £120. Linn Sondek LP12, Afro, good condition early 1980's £490 ono. Myriad T20 CD player, boxed as new £285. Target TT5 5 Tier rack £90. Transparent Link 100 interconnect, boxed £90. Transparent The Wave 12ft speaker cable, Spades, boxed £170. Transparent Music Link Super. 25ft, High quality interconnect with RF boxes. £700. Yamaha AX550 amp. £70. Please telephone Jules on 01792 280061
 E-mail: sales@sounddrjuleshifi.co.uk
 Web: www.sounddrjuleshifi.com

APOGEE RIBBONS! Replace damaged ones with new stock, direct 'Graz' replacements, original materials - computerised manufacture. Mail Order! Fitkit included. Also custom designed ribbons made to order. Email (preferred): graz@graz.com.au
 Phone Australia 0061 412 804 804. Check out www.apogeeribbons.totalserve.co.uk (unrelated)! Aug(I)

WANTED - EARLY HI-FI LOUDSPEAKERS
 Tannoy, Lowther, Parmeko, Voigt, Vitavox, RCA WE etc
TURNTABLES
 Garrard, BBC301, EMT SME, Ortofon, Decca, etc.
VALVE AMPLIFIERS
 AEI, EMI, Leak, Rogers, PYE- Quad, WE etc
AUDIO VALVES
 DA30, KT66, KT88, PX4, PX25, PP3/350, WE300
CLEAR CRYSTAL SYSTEMS
 John Petrie-Baker
 Tel: 020 7328 9275

VINTAGE WIRELESS COMPANY LONDON
 Website: www.vintagewirelesslondon.co.uk
 Buy-Sell-Exchange. Vintage wireless and classical audio. Repairs, spares, restoration, modification to all valve equipment. Quad II, Leaks etc, shipped worldwide, best prices, call us at. 17 Bell Street, London, NW1 5BY. Tel: 020 7258 3448
 Fax 020 7258 3449 Email: vwirelesslondon@aol.com (Aug(I))

VALVES WANTED For cash. ECC32/33; ECC83; EL34/84; KT66/88; AC044; DA25/30; PX4; PP3/250; PP5/400; PX25; GZ32/34; U52. Vintage Hi-Fi wanted: Tannoy, Leak, Radford, Quad, Armstrong, AVO Valve Tester. Tel: 020 8343 0533 or 07901 976 441 or Email: altofidelity@infinito.it www.altofidelity.com (Aug(I))

MERIDIAN 606\602 transport\dac boxed, mint £850. Musical Fidelity X-Ray C. D player mint, boxed £495. Arcam 8SE C.D. player boxed, new £350. Cyrus 3i amp, boxed £275 ono. Cyrus power, boxed £245 ono. Cyrus 2 & PSX boxed £335 ono. Musical Fidelity XA1 boxed £275. Conrad Johnson PV10A/MV55 Pre/Power boxed, mint, final reduction £1400. Roksan RokL2.5 Pre Rok S1.5 Power DS1.5 PSU Silver, boxed, bargain £1400 ono. Musical Fidelity X-Plora tuner 5 months old £400 ono. Cable clearout vdH The 1st. Ultimate 1m. ex.dem £270. vdH 1ST. 0.8M ex.dem.£160. vdH Source 0.8m new £45. vdH Royal Jade 3m pair factory terminated ex. dem. £60. vdH The Wind 3m pair factory terminated ex. dem £225. vdH Teatrack 3m bi-wire 2x4 ex dem.£140. Ecosse Reference 3m pairs ex dem & 2nd hand from £115. Ecosse Reference CA1 I/C IM new £40. Einstein mains blocks to clear black & chrome from £135. Monitor Audio Studio 12's no boxes to clear buyer collects £250. Loads more bargains available For details call Steve 01527 450 500 or 07773 198 336, fax 01527 450 320, E-Mail: Apexnm@aol.com (Aug(I))
 MARTIN LOGAN owners SL3 Seque II etc. Bass problems? Overbearing bass? Using cut to no good effect! For the solution and total transformation please telephone 01226 764 272 (Aug(I))

TRANSCRIPTORS SPARES REPAIRS SERVICING
 Tel: +44 (0) 163 558 568
 E: uk-sales@transcriptors.co.uk
 W: www.transcriptors.co.uk (Aug(I))

VALVE PREAMPS! Best selection of sensibly priced valve amplifiers in England. New valve preamps from £250. New class 'A' valve powers from £350. Stockists of Croft, EAR, Audio Classics. Tel: 01942 257 525. Email: audioclassics@hotmail.com (Aug(I))

WORLD'S MOST powerful production valve amplifier. See details at www.bigvalveamplifiers.co.uk BVA type I, 1500w RMS monoblock with separate PSU, both housed in 19 inch racks. Not yet released for sale. Tel: 01603 662 438 (Aug(I))

VINTAGE WIRELESS COMPANY LONDON
 Website: www.vintagewirelesslondon.co.uk
 Buy-Sell-Exchange. Vintage wireless and classical audio. Repairs, spares, restoration, modification to all valve equipment. Quad II, Leaks etc, shipped worldwide, best prices, call us at. 17 Bell Street, London, NW1 5BY. Tel: 020 7258 3448
 Fax 020 7258 3449 Email: vwirelesslondon@aol.com (Aug(I))

Classified Ads

Classified Ads



classified ads order form

Dealers must not advertise in the Private Classified section. Monthly consecutive insertions will be considered Trade advertising. The Publisher reserves the right to judge submissions

SPECIAL OFFER
Book a private or trade classified advert, and get one months FREE internet advert

In a rush to get your advert published? Why not use our Instant Internet Advert to get on our website immediately. Only £15 per week (7 days)

RATES:

Maximum length per advert is 30 words, each additional word is 50p extra. Telephone numbers and E-mail addresses are treated as one word. Model numbers are treated as one word i.e. Quad 303 = two words. Please tick the box for the advert required

**Free internet adverts are published three weeks AFTER the magazine has been published*

Instant Internet Only Advert Private or Trade published immediately	£15 per week
Private magazine advert plus *FREE internet advert	£10 per month
Private magazine advert display black box plus *FREE internet advert	£15 per month
Trade magazine advert plus *FREE internet advert	£10 per month
Trade magazine advert display black box plus *FREE internet advert	£15 per month
Please tick here if you DO NOT WANT your FREE internet advert <input type="checkbox"/>	

Please write or type your advertisement copy in block capitals with one word per box.
Please continue on a separate sheet if necessary.
WE WILL ACCEPT PHOTOCOPIES OF THIS FORM

1	2
3	4
5	6
7	8
9	10
11	12
13	14
15	16
17	18
19	20
21	22
23	24
25	26
27	28
29	30

Name _____
 Address _____
 Post Code _____
 Daytime Tel: _____

Please debit my VISA/MASTER/SWITCH Card No. (Switch card issue No _____)
 Expiry Date: _____ Cardholder Signature: _____

I enclose a cheque/postal order for £ _____ Made payable to: Audio Publishing Ltd.
 Send in your private classified ads with our NEW Freepost service. No need for a stamp!
 Send this form together with your payment in an envelope marked:
Hi-Fi World, FREEPOST LON3478, LONDON NW6 6YR

ADVERTISERS INDEX

Absolute Analogue	92
Acton Gate Audio	136
Affordable Audio	72
Arcam	44
Audio Direct	131
Audio Express	116
Audio Matters	129
Audio Salon	136
Audio Source	136
Audio T	52
Audusa	144
Audiocom	46, 108
Audion Illusion	138
Audiophile Candy	92
Billy Vee	93, 94, 95
BK Electronics	116
Cable Talk	123
Campaign Audio Design	54
Central Audio	124
Chelmer Valve	108
Choice Hi-Fi	98
Classique Sounds	132
Connoisseur Audio	128
Custom Cable	125
Cyrus	IFC
Definitive Audio (Notts)	46
Definitive Audio (Brighton)	129
Diverse Vinyl	142
Emporium (The)	130
English Analogue	127
Falcon Acoustics	108
Glaive	48
Heathcote Audio	132
Heatherdale Audio	125
Ian Harrison	133
Infidelity	97
Jem Distribution	125
Kef	15, 17
Langrex	100
Listening Rooms	40
Mantra Audio	92
Matrix	131
Michell Engineering	54
Midland Audio Exchange	126
Mission	BC
Music Matters	20
Music Video Exchange	123
Musical Images	142
Musonic Styli	127
Old days Vintage Audio	40
Oranges and Lemons	40
Origin Live	135
Ortofon	22
Oxford Audio Consultants	124
Pear Audio	46
P.G. Hi-Fi	142
Progressive Audio	129
Replay	128
Retro Reproduction	134
Sevenoaks 28, 29, 30, 31, 32, 33,	
Sevenoaks	62, 63
Signals	127
Sonic Link	54
Sony	8
Soundcraft	125
Sound Stage	134
Sounds Expensive	133
Sounds of Music (Crewe)	133
Sounds Perfection	138
Stowsounds	134
Technical & General	108
The Right Note	53
Thomas Transducers	19
Trichord Research	20
UKD	IBC
Van den Hul	46
Veritas	38
Watford Valves	100
Williams Hart	128

Advertisers Index Classified Ads Order Form

DEADLINE FOR SEPTEMBER 2001 ISSUE IS FRIDAY 6TH JULY 2001
DEADLINE FOR OCTOBER 2001 ISSUE IS FRIDAY 3RD AUGUST 2001

UNISON RESEARCH

For a lifetime of musical enjoyment



S6

Single-ended pure Class-A integrated amplifier. This is how Hi-Fi World (April 2001) described it:”Strong, confident power delivery, wide tonal palette, with sweetness, warmth, rhythmic alacrity and a deliciously clean, open sound.....
“At the price, It’s easily the best tube amplifier I’ve heard...Superb value for money”.

S2K

Pure Class-A all-tube amplifier using the legendary KT-88 power valve in single-ended mode for maximum transparency and detail. The sound it gives is delightful, unforced and natural. S2K is truly a machine for making beautiful music.



SR1

Combines the virtues of valve and solid-state in a thoroughly modern, fuss-free design. With 80 watts per channel dynamic Class-A power, plus the grace and delicacy you would expect from triode valves. The SR1 really gives you the best of both worlds.

For more information on the range of Unison Research Products please contact:



23 Richings Way, Iver, Bucks, SL0 9DA, England
Tel: 01753 652 669 Tel: 07000 853 443 Fax: 01753 654 531
www.ukd.co.uk email: post@ukd.co.uk

*models illustrated: S6, £1600. S2K, £1295. SR1, £1250. All complete with radiowave remote control.

MISSION

FS2 SERIES

Imagine...

...a discreet loudspeaker system that adapts to any living space, with a room filling sound for both movies and music.

Imagine no longer... **FS2**



"LOUDSPEAKER SYSTEM OF THE YEAR..."



AV Speaker Packages Best Buy £500-£900

Home Entertainment AWARDS 2000 WINNER

"PRODUCT INNOVATION..."



"HI-FI COMPONENT OF THE YEAR..."

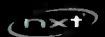

NX1 is a registered trademark of New Transducers Limited

Tel: +44 (0) 1480 423 700 Fax: +44 (0) 1480 423 701
email: info@mission.co.uk web: www.mission.co.uk

World Radio History