

Hi-Fi  
WORLD

Hi-Fi

Hi-Fi

WORLD

APRIL 1999 £2.50

*For the love of music*



**IL MAESTRO**  
Paganini CD  
player from  
Audio Analogue

**SUPPLEMENT No44**  
(Overseas inside)  
free with this issue

**TOTALLY  
GYRO-SCOPIC**  
Michell's new  
GyroDec SE  
turntable

**SWEET LAVARDIN**  
Valve amp sound from  
French solid-state integrated

**£1400** WIN A STYLISH CLEARAUDIO  
TURNTABLE AND A  
VPI RECORD CLEANER

**SIX PAGES OF CLASSIFIED AD BARGAINS**

ISSN 0961-7663



9 770961 766079

*From dream...*

*...to reality*



The Nautilus™ is an acoustic engineer's dream. Its radical cabinet technology and full-mesh spiral have reshaped the audio landscape. Literally. For the B&W Nautilus™ loudspeaker sounds like no other. Its performance can only be coloured by cables or external source equipment. It is hailed the best loudspeaker money can buy.

B&W's Nautilus™ 801 fuses the innovative Nautilus™ tube technology with a series of industry firsts: Fixed Suspension Transducer™, Kevlar® drive units, Matrix™ cabinet bracing and Flowport™ technology. The result is an unprecedented purity of sound. The reason EMI's Abbey Road studios, along with best in the recording industry, are now upgrading to the Nautilus™ 801. Listen and you'll see – at your nearest authorised Nautilus™ 800 Series dealer. For more info contact B&W: 01903 750 750 or visit our website <http://www.bwspeakers.com>

**B&W**

L I S T E N   A N D   Y O U ' L L   S E E

World Radio History

**T**his month we have a true star cast heading up *Hi-Fi World's* reviews list. One for fans of vinyl is Michell's brand new turntable, the £700 GyroDec SE. A cut-down version of the original Gyro without its expensive perspex base-plate, the SE has an outboard motor attached to a solid aluminium cylinder to minimise the amount of noise reaching the sub-chassis. This last remains a gorgeous aluminium casting supporting an inverted bearing and brass-weighted platter in the sort of stylish design audiophiles have come to expect from this respected company.

Flying the flag for digital reproduction is Audio Analogue's £600 Paganini CD player. The superb Puccini SE integrated amplifier from Italy would be a difficult act for anyone to follow but Tim Liu reckons AA have come up with the goods. Separate transformers for analogue and digital sections as well as plenty of audiophile components are typical of this manufacturer's attention to detail.

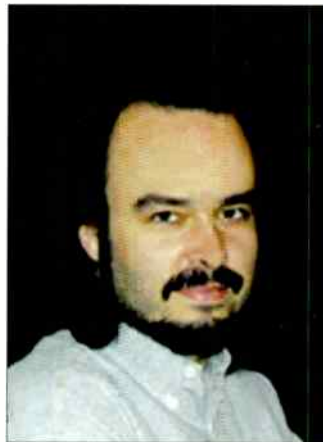

**JON MARKS**

Third in the front-line is Lavardin's Reference IT integrated amplifier. This flagship one-box relies on special circuitry to eliminate Memory Distortion which, Lavardin say, gives transistor amps their characteristic hard, mechanical sound. Trannies that mimic the natural smoothness of valves have been a holy grail almost as long as solid-state has existed, but no designer has yet succeeded in assembling an amp that really cuts the mustard. The IT could be the one that finally reaches this goal.

Two more components are also sure to make waves - Canary's 601

Mk2 valve pre-amplifier and Pink Triangle's latest revision of the Da Capo Digital-to-Analogue Converter.

American outfit Canary have chosen the minimalist route in the 601 Mk2 - the slim metal case of this line-level device isn't exactly bulging with parts. The advantage here is that some of the best bits and pieces could be included: TKD's excellent stepped attenuator serves as the volume control, while Sprague and MIT supply many of the capacitors. The results have a clarity and control beyond the capabilities of the majority of valve equipment.

The same could be said of Pink Triangle's 24-20 digital filter for their Da Capo DAC. This small metal box is a plug-and-play affair which transforms the performance of this long-lived convertor, bringing it bang up to date. Partnered with an able transport and an amp like the Lavardin IT, affordable digital doesn't get much better.

## HOW WE TEST THE PRODUCTS

- *Hi-Fi World* has its own advanced test laboratory and acoustically treated listening room. No other hi-fi magazine has the benefit of such facilities.
- *Hi-Fi World* has a dedicated in-house team of experienced listeners, and uses selected freelance professionals. We review thoroughly by extensive auditioning, rather than by quick-fire group listening tests.
- *Hi-Fi World's* engineering team designs a wide range of products in-house. No other hi-fi magazine is so expert and dedicated.



## WORLD VERDICT



**OUTSTANDING** - Superb sound, something we'd use ourselves.



**GOOD** - Has strong merit. Well worth an audition.



**ADEQUATE** - Mediocre in several areas. May be worth auditioning.



**POOR** - Seriously flawed. Not worth considering.

# Contents

## 13... MICHELL GYRODEC SE TURNTABLE



## 16... LAVARDIN IT AMPLIFIER

## 59... CHARIO LYNX LOUDSPEAKERS



## 78... REFURBISHING QUAD'S ELS 57 LOUDSPEAKERS



## Reviews

### Amplifiers

#### 16... LAVARDIN IT

This innovative French integrated aims to combine the virtues of valve and silicon.

#### 39... NAD C320

Is the C320 a worthy successor to NAD's 3020, the amp which launched a thousand systems?

#### 41... CANARY 601 MkII

This valve pre-amp from America boasts a stepped attenuator and audio-grade parts.

#### 53... EDMUND ESI 10 INTEGRATED

From a new name on the block comes a sleek mid-price integrated.

### Loudspeakers

#### 31... MISSION 772

With the memory of the small 771s still fresh in his mind, Jon Marks spends time with the 772s.

#### 59... CHARIO LYNX

Italian outfit Chario continues to win friends with stylish stand mounters like the Lynx.

### Compact Disc

#### 15... AUDIO ANALOGUE PAGANINI

After a long wait, AA's Paganini player finally arrives in Britain. Tim Liu was there to meet it.

#### 57... THULE CD100

It's digitalia from Denmark as we check out Thule's £600 one-box machine.

### Vinyl

#### 13... MICHELL GYRODEC SE TURNTABLE

Based on the classic GyroDec, Michell's skeletal SE has a bright future ahead of it.

#### 37... CLEARAUDIO ALPHA MM

Going up against DNM's superb Mica is this £130 MM from German outfit Clearaudio.

### Headphones

#### 28... JECKLIN FLOAT 2 VS ERGO MODEL 2

Simon Pope dons his cans in a show-down which includes Creek's OBH-11SE headphone amplifier.

## Features

### 20... FOR THE RECORD

We find out how CD-R and MD are faring against that old-timer, Compact Cassette.

### 23... UP AND ABOUT IN LAS VEGAS

Tony Hamza reports from the Consumer Electronics Show in Las Vegas.

### 33... LOUDSPEAKER LINK

Simon Pope gets hooked with a wiry twosome from The Chord Company and Nordost.

### 65... RUNNING RINGS

In the quest for better sound from LP, Richard White auditions the complete Ringmat cycle.

### 71... DIGITAL IN THE PINK

Pink Triangle's Da Capo convertor gets a fresh lease of life with a new 24-bit filter.

### 78... NOTHING BUT 'STATIC

If the only loudspeaker which sets your pulse racing is Quad's ELS 57 electrostatic, discover how to resuscitate a tired pair with Jon Marks.

### 80... ESL ODDITIES

We probe the past of electrostatic loudspeakers and uncover some of the stranger designs.

### 81... VECTOR ENHANCEMENT

Richard White profiles a major step forward in cable technology from Vector Developments.

## Regulars

### 7... NEWS

The HFW newshounds scour the globe for all the latest audio happenings.

### 11... NEXT MONTH

Look no further for a taster of the top hi-fi contained in next issue's pages.

### 34... COMPETITION

Two winners could take home a VPI record cleaner and Clearaudio Solution turntable.

### 42... READERS' LETTERS

Delve with us into a post-bag bulging with missives covering every hi-fi topic.

### 50... HI-FI WORLD LIBRARY

Before you reach for the soldering iron, seek guidance from the World Library.

### 55, 61, 67, 93... COLUMNS

See hi-fi from a different perspective with the help of our columnists.

### 62... SPECIALIST HI-FI DEALERS

After the sleepless nights and head-scratching, move in this direction for component fulfilment.

### 66... MEET YOUR MAKER

These are the names behind the boxes.

### 74... HI-FI WORLD KITS

If you prefer to 'roll your own', these are the pages you should turn to.

### 89... DIAL-A-DEALER

Save your soles and let your fingers do all the hard work.

### 111... MEASURED PERFORMANCE

After the test of the ears, this month's components undergo the ordeal of the measurement suite.

### 119... WORLD FAVOURITES GUIDE

Herein lies all the equipment which has made it to the HFW hall of fame.

### 125... OLDE WORLDE

This month's past master is Golding's G88.

### 127... READERS' CLASSIFIEDS

Bargains abound in our second-hand section.

### 138... ADVERTISERS' INDEX

## Music Reviews

### 82... ROCK AND POP

RECORD OF THE MONTH: Cassius, 1999

### 84... DANCE/AMBIENT

RECORD OF THE MONTH: Various, Kosmonauts

### 87... JAZZ

### 95... CLASSICAL

RECORD OF THE MONTH: Johannes Brahms, Choral Music

# Hi-Fi WORLD

### HI-FI WORLD

IMEX HOUSE,  
THE PARK BUSINESS CENTRE,  
KILBURN PARK ROAD,  
LONDON, NW6 5LF

### WEB SITE

www.hi-fiworld.co.uk

### MAIL ORDER

Tel: 0171-266 0461  
(24 hour answerphone)

### SUBSCRIPTIONS

See page 97 or our web site.

### CONTACT NUMBERS

10am - 6pm

Editor

**Jon Marks**

0171 625 8074

Email: edit@hi-fiworld.co.uk

Editorial Assistants

**Richard White**

**Simon Pope**

0171 328 8627

Fax: 0171 328 1844

Individual queries cannot be answered by telephone.

Contributors

**David Price**

**Dominic Todd**

**Haden Boardman**

**Timothy Liu**

Music Reviewers

**Peter Herring**

**Simon Hopkins**

**Jon Clarke**

**Sara Davis**

**Stuart Lenz**

**Ian Nicolson**

Design & Production

Editor

**Fredrick Dittlau**

Advertising Designer

**Lorraine Cezair-Phillip**

0171-625 8033

Fax 0171 328 1844

Photography

**David Noble**

Sales and Marketing

Manager

**Annanda Sweeney**

0171-328 2213

Advertising Sales

Executive

**Sarah Wrenn**

0171 328 4892

Technical Manager

**Nick Lucas**

Tel/Fax: 0171-625 8032

wad@hi-fiworld.co.uk

Accounts

**Michael Ogazi**

0171 289 3533

Fax: 0171 289 5620

Credit Control Manager

**Louise Palfrey**

0171 289 3533

Publisher

**Noel Keywood**

Distributed by:

Marketforce Ltd, 245

Tottenham Court Road,

London, W1P 0AU

Tel: 0171 261 5555

Printed by:

Southernprint, Dorset.

Tel: 01202 622226

All unsolicited submissions are made at the owner's risk. We accept no responsibility for such submissions, nor do we undertake to return them.

No material may be reproduced from this magazine without the publisher's written permission.

© Audio Publishing Ltd

ABC  
CONSUMER PRESS

# The new wave in sound.



All digital recording media sound the same, right? Not with TDK's new MD-RXG PRO MiniDisc they don't. Better definition, more precise control, an even more 'real' sound. All thanks to TDK's leading edge digital technology. But don't take our word for it. Believe the audio experts from across Europe who raved that the MD-RXG PRO was the most realistic MiniDisc they'd ever heard. So, if you really care what you listen to, there is only one MiniDisc. TDK's amazing MD-RXG PRO.

**TDK**

*at the heart of it*

<http://www.tdk-europe.com>

World Radio History

## NAD DRAW THE SILVERLINE

NAD have decided to break with tradition in their new SilverLine range of electronics. Gone is the hallmark grey, replaced by matt silver; the usual budget price tag has been supplanted by figures that start at £750 (\$400 tuner) and rise to £1900 (\$300 integrated).

Heading the roster is the £800 S100 pre-amp. The four line inputs (one of which is balanced) and two tape loops feed class A circuitry powered by a low-noise toroidal transformer and 20000uF of reservoir capacitance. Vinyl fans can sate their lust for the black disc with the optional phono module. Output to the power amp comes in a choice of RCA and XLR.

The £1600 S200 is that matching power amp. With 200watts per side drawn from a pair of Holmgren transformers, NAD claim the S200 is "stable and musical into even unreasonable low-impedance loads."

Putting out a more humble 100watts is the S300 dual-mono integrated with its mirror-image PCBs. All signal switching is effected by relays with gold-plated contacts, which are controlled by a logic system operating from its own dedicated PSU.

Eitherphiles are catered for in the S400 FM/RDS tuner. Two fully-independent antenna inputs permit reception via cable as well as aerial, with Wide/Narrow IF filtering to get the most from stations far and near. 30 presets store not only the fre-



quency but also the selected antenna, IF mode and mono/stereo status. Keeping noise down are the separate supplies for analogue audio, RF and logic sections.

In the £1100 S500 CD player a 24-bit DAC from Crystal Semiconductors joins a five-pole analogue filter and all-discrete, class A output stage. Easing upgrade worries is the convertor's modular construction, which allows dealers to fit next-generation DACs at minimal cost. Interfacing with the outside world is accomplished digitally with BNC and AES/EBU sockets; RCA phono and XLR balanced handle analogue signals.

**NAD**  
**15 Faraday Road,**  
**Aylesbury,**  
**Bucks. HP19 3RY**  
**Tel: 01296 482017**



## SONY'S TOP DOG

Sony have announced the launch of their new flagship DVD player, the DVP-S7700. Compatible with Dolby Digital AC3 and MPEG Audio formats, the player also has a digital output for DTS.

The designers of the '7700 concentrated on points such as "wider sound field and excellent rendering of vibrations in the low frequency range". Price is yet to be confirmed, but the Sony is available from dealers now.

**Sony**  
**The Heights,**  
**Brooklands,**  
**Weybridge,**  
**Surrey KT13 0XW**  
**Tel: 01932 816000**

## KEF GO FOUR IT

If you happen to be a wealthy audiophile with a craving for bass, KEF's new flagship, the £12000 Maidstone 109, might be of interest. No less than four drivers per side are knit together by a computer-designed crossover which operates at 100Hz, 400Hz and 2.8kHz.

Underpinning the Maidstone is a 15in. reflex-loaded woofer with a doped-paper cone, cast-aluminium chassis and a low-distortion, short-coil/long-gap motor system. The same technologies feature in the 10in. mid/bass which sits higher up the cabinet (which is tilted backward to enable correct time-alignment of the drive units).

Topping off the 109 is a fifth-generation Uni-Q point-source driver consisting of a 6in. polypropylene midrange and 1in. fabric-dome tweeter.

All of the above are housed in their own enclosures of braced 25m MDF, which adds up to a not inconsiderable 87kgs per cabinet. Impedance is quoted as 4ohms and sensitivity as 91dB.

**KEF**  
**Ecclestone Road,**  
**Kent ME15 6QP**  
**Tel: 01622 672261**



*these people produce one of the world's most powerful, advanced pieces of electronic equipment. they also build our racing cars.*

Much of TAG McLaren's experience in developing specialist electronics for the cramped and electrically noisy environment of a Formula 1 racing car is directly applicable to the development of hi-fi equipment. Just as our racing division strives to build world beating racing cars, TAG McLaren Audio aims to make the best audio and audio visual equipment money can buy.

The **F3 series**, the first fruit of our merger with Audiolab, one of Britain's most respected audio companies, is a range of audio components which represents unparalleled levels of technology and engineering. Throughout the range, from the definitive entry-level integrated amplifier or single-chassis cd player, to preamplifier and monoblocs coupled with separate cd transport, da converter and tuner, the **F3 series** delivers controlled power and superior sonic reproduction. In short, hi-performance hi-fidelity.

Call 0800 7838007 to arrange a test drive.



email: [helpdesk@tagmclarenaudio.com](mailto:helpdesk@tagmclarenaudio.com)

products featured: cd player CD20R, tuner T20, preamplifier PA10, amplifier 100P

**TAG McLaren**  
audio

*hi-performance hi-fidelity*



## GOING TO GREAT LENGTHS

LAT International of New Jersey, manufacturers of the AC-2 mains lead, have had a change of heart. Until recently, said cable has only been available in a 6ft. length at £89. Now, however, you can buy this Teflon-dielectric, shielded wire in 2ft. (£49), 3ft. (£59), and 4ft. (£69) runs, all topped off with IEC plugs. Other terminations to order and subject to the practicalities imposed by the 10awg conductors.

**Audusa & Co**  
**4 Arundel Road,**  
**Kingston-upon-Thames,**  
**Surrey KT1 3RZ**  
**Tel: 0181 942 6241**

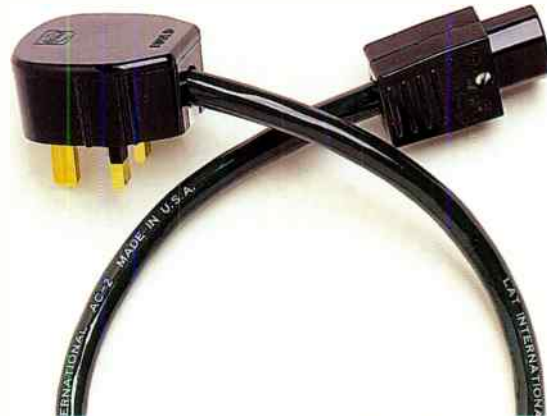

## PICTURE THE SOUND?

The Japanese electronics firm NEC have produced small, flat-panel loudspeakers that double as photo frames. The technology has been licensed from the British company NXT Ltd. Available only at present in Japan, these have built-in amplification with plastic frames. A special adhesive allows photos to be removed and replaced on the panels numerous times.

The 'speakers are intended to be used in conjunction with portable CD and MD players or PCs. With two AA batteries the output is 0.5watts, with an AC adaptor a thunderous 1.5watts. The photo frames currently cost about £295 in Japan; a world-wide launch date has yet to be finalised.

## DIGITAL CABLE-FEST

QED have added to their catalogue two digital cables which are designed to achieve an impedance of exactly 75ohms, which QED describe as being crucial for the optimum transmission of digital signals.

This impedance is guaranteed by QED in their new cables, the Qnect D and DS. The cheaper of the two is the £25 D which uses 99.999% Oxygen-Free Copper conductors. A PVC outer jacket absorbs vibration, leaving the triple-screen aluminium/mylar foil and copper braid to prevent magnetic and static interference. The phono plugs are QED's own, hewn from zinc alloy with gold-plated pins.

The £50 DS employs silver-plated OFC conductors and braids to improve on conductivity and noise exclusion. QED's Reference plugs, which have a split centre-pin and locking mechanism, finish off the package.

**QED**  
**Ridgeway House,**  
**Ridgeway Close,**  
**Lightwater,**  
**Surrey GU18 5XU**  
**Tel: 01276 452211**

## CHIPS WITH EVERYTHING!

News comes from electronics firm Mediamatics of an integrated "DVD-on-a-chip" solution for DVD players. Most of these require a large number of different ICs to perform functions like data-stream processing, CSS decoding and MPEG video decoding. The Pantera-DVD brings together these 'back-end' functions on a single chip.

This technology has been developed in close co-operation with manufacturers, so the first consumer players incorporating the chip should be on the market in March. With the reduced production costs the Pantera brings, future DVD equipment in the region of £150-£200 could rival the sound of existing £500 players.

**National Semiconductor GmbH**  
**Livry-Gargan-Strasse 10,**  
**D-82256 Fürstfeldbruck,**  
**Germany.**  
**Tel: +49 (0) 180 532 7832 (English)**



# It was 20 years ago today....



In November '77, the design team of Bob Stuart and Allen Boothroyd launched their first Meridian product, an active loudspeaker of course!

Since then, Meridian Audio has continued to pioneer advanced audio design in products such as the first high end CD player, the first CD transport, the first DSP domestic loudspeaker, the first digital home theatre and now, high end DVD.

Safeguard your investment, trust Meridian - the real leaders in audio and video

BOOTHROYD STUART  
**MERIDIAN**

**Meridian Audio Limited**

Stonehill, Stukeley Meadows, Huntingdon, PE18 6ED

Tel (0) 1480 434334 Fax (0) 1480 432948

<http://www.meridian-audio.com>

## CANARY'S SONG

Audio Connoisseurs are pleased to announce the arrival of Canary Audio's first integrated valve amplifier, the CA608. Offering 35watts of class A power per channel from four 6CA7 (EL34) valves, it's positively bulging with audiophile parts. These include an Alps volume control, Teflon-coated silver wire, Mallory capacitors, oversized transformers and gold-plated binding posts. All these goodies bring the CA608's price up to £1295.

**Audio Connoisseurs**  
Unit 7,  
Claremont Buildings,

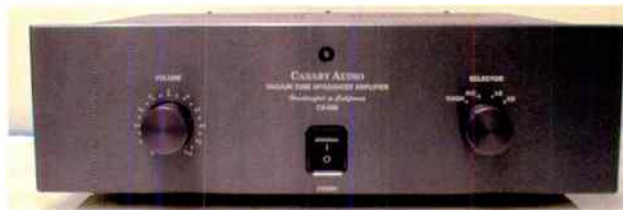

Old Clatterbridge Road,  
Bebbington,  
Merseyside L63 4JB  
Tel: 0151 343 0007

## ROTHWELL AMP REVAMP

Rothwell Electronics of Bolton have readied their Indus pre and Rubicon triode power amplifiers for the Millennium with a spot of restyling and under-bonnet tidying. As a result, both now have hand-finished solid-hardwood fascias and shorter signal paths. The Indus retains its stepped attenuator for volume control, while the Rubicon gains an internal bridging switch.

**Rothwell Electronics**  
60 Pennington Road,  
Great Lever,  
Bolton BL3 3BR  
Tel: 01204 654614

## VERILY VERITAS

John Hullah, one of Veritas Horn Systems' co-founders, has spent the last 20 years producing quality acoustic guitars, so squeezing sound from wooden boxes is not exactly alien territory.

The core of Veritas' new transducers is an enclosure whose inner 18mm MDF shell is encased in 10mm bookmatched hardwood. The hand-assembled crossovers are made with high-quality capacitors and hardwired to gold-plated bi-wire terminals. Veritas say the loudspeakers' fortes are spacial imagery and bass. Prices are £1000 for the 7s, £1400 for the 20s and £1900 for the 40s. External crossovers are available for £400 extra, which includes stands for the 7s and 20s.

**Veritas Horn Systems**  
2 Manor Farm Barns,  
Glandford,  
Norfolk NR25 7JP  
Tel: 01263 741417

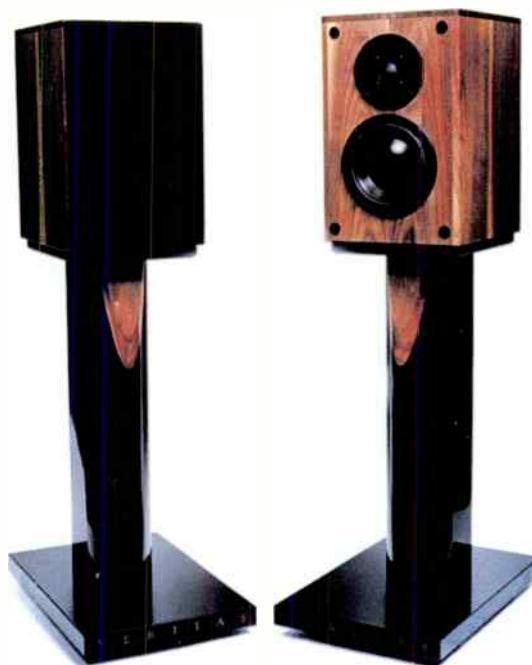

## NEXT MONTH'S ISSUE

In four weeks' time the following will be on show in a Hi-Fi World near you:

### LOUDSPEAKER GROUP TEST

We rustle up five £1100-£1500 'speakers that are a little different from the norm, including the Magneplanar 1.2s, B&W 805s and the Carlsson 50.4s to name but three.

### NAD S400 SILVERLINE TUNER

The new high-end SilverLine range from NAD includes this sleek £750 tuner. Will it sound as good as it looks though?

### YAMAHA MSP5 ACTIVES

The new MSP5s are the latest active

studio monitors from Yamaha. At £400 they could be a bit of a bargain.

### BASIS 2000 TURNTABLE

Does the new breed of turntables warrant their prices? Our vinyl contribution continues with this £2000 perspex design from the US of A.



# As close as you'll get to the original sound

For more than 60 years the Quad philosophy has been to create the closest approach to the original sound. Our engineering integrity, care in manufacture and inspired design work has ensured that the new 99 Series hi-fi system and electrostatic loudspeakers bring that philosophy to a new level of reality in your home.

  
**QUAD**

Sovereign Court, Ermine Business Park,  
Huntingdon, Cambs, PE18 6WA, England  
Tel: +44 (0)1480 433777 / 447700 Fax: +44 (0)1480 431767

Member of the International Audio Group

**99**  
SERIES



World Radio History

# WEBBED WONDER

David Price listens to Michell's latest evolution of the popular GyroDec turntable, the Spider Edition.

It isn't every day that Britain's longest-lived turntable manufacturer brings out a new disc spinner. The Orbe was the last, back in 1994, while Michell's original GyroDec appeared 13 years prior to that. So, all things considered, the launch of the Gyro Spider Edition is a bit special.

Designer John Michell says his new baby came about for several reasons. First is the huge sound quality gain from physically detaching a turntable's motor from its base. To wit, the new Spider gets an Orbe-style separate motor unit. Second is the current fashion for stripped-down decks that Clearaudio and Pink Triangle have so astutely identified. Thanks to their minimalist design they offer a high sound-per-pound ratio, but John was unimpressed by the former's lack of in-built isolation and believed he could do better. Third, all those acres of beautiful Danish acrylic that the standard Gyro uses in its base and cover cost a packet. By offering a naked version, he found he could knock £200 off the purchase price. And so the £775 Spider Edition was born.

For those unfamiliar with the original Gyro, it has a cast-aluminium chassis holding an inverted bearing. On this sits an acrylic platter, from which gold-plated brass weights hang to add mass. This is driven via a long rubber belt by a Papst motor housed in a large billet of aluminium.

The chassis rests on three height-adjustable springs attached to the base. In the 'classic' version of the GyroDec, which is still available for £975, this is a full-size affair with a dustcover and comes in a variety of finishes. The Spider Edition does away with all this, using a simple acrylic 'spider' (similar to the base of



Clearaudio's Solution) to hold the deck's feet and suspension mounting points instead.

Finally, all Gyros come with aluminium armboards, each tailored to suit the user's choice of tone-arm. These are designed so that, together with the arm, the total mass is a constant one kilogram. To counterbalance this armboard and arm mass, the underside of the Gyro chassis carries lead weights, meaning the sub-chassis is correctly levelled even when arms and boards are swapped.

Off-board motor aside, the Gyro SE brings two further tweaks. First is a 40VA power transformer, which is a considerable improvement on the previous 10VA wall-plug affair. This is just as well, because before its introduction there was a yawning chasm between the standard PSU and the £399 Gyropower QC. (The latter uses a 100VA toroid and

extensively-regulated, quartz-synthesised circuitry for a clean power feed).

The second change is the new spring assembly, which offers considerably better isolation and easier adjustment. This upgrade is also retrofittable for around £40.

## SPINNING THE WEB

Setting up the Spider is a breeze if you've dealt with a GyroDec in the past. If you haven't, the diagramless instructions can take some fathoming. Basically, you screw the three feet to the Spider's underside and fit the three spring assemblies above. Then fix your arm to its mounting plate and bolt the two to the chassis. The bearing assembly screws in from underneath the chassis before the whole caboodle slips over the motor onto whatever platform the deck will be sitting on. All that's left is to lower the platter

onto the bearing, level it using the spring adjusters, plug the motor into its power supply, fit the belt and you're away!

There's rather more than this to getting the best from the Spider, however. A decent support like Audiophile Furniture's Base or a Townshend Seismic Sink is essential. The turntable must also be dead level - you can see how the Gyro's springs float better when it's sat perfectly true. By the way, the spring adjusters not only set the chassis height but also its alignment relative to the motor. This is critical and should be set for the most fluid bounce possible. Lastly, as the Spider Edition has no P-clip you have to improvise a way to get the arm cable hanging freely, touching nothing on its way from deck to pre-amp.

## THE LISTENING

Fitted with an Origin Live Rega RB250 tone-arm and Ortofon MC30 Supreme cartridge, first impressions were very positive. The Gyro SE has an extremely clean, open and even sound with remarkably few vices. Bass is fast, firm and extended yet totally lacking in coloration or lumpiness. The midband is a treat, with cinematic stereo imaging, huge levels of low-level detail, neutral tonality and strong, if not peerless, dynamics. Treble is clear and detailed and possesses excellent extension. By any standards, let alone those of sub-£800 turntables, the Michell produces winning results.

The smooth Soul of 4Hero's 'Universal Love' saw the Gyro SE set up a wide open acoustic, laying the instruments out in front of me clear as day. Double-basses had great power, while the cello and violins had a wonderfully rich, resonant quality that only high-end vinyl does properly.

Rock was no less fun, as REM's 'The One I Love' proved. Here, the Gyro SE really homed in on the song's huge, Eighties-style production. Those crashing power chords were absolutely thunderous, yet had a master tape-like composure.

This was the Spider on top form -



Bits and pieces - there's rather more self-assembly to the GyroDec SE than your average turntable. In this picture you can clearly see the three-legged acrylic 'spider' which supports the sub-chassis.

given a modern hi-fi recording it is dynamite. But when you move to subtler, less audiophile climes, things start to change a bit. You see, the Gyro SE is essentially an analytical device. With older recordings, such as Art Blakey and The Jazz Messengers' 'Gypsy Folk Tales', it made a nice enough noise but was too cerebral and deconstructed. Individual instruments were conveyed well enough, yet their players sounded dispassionate and uninvolved. I got the sense that these great musicians were technically gifted but not really into the rhythm.

Curious as to the difference the Gyropower QC would make, I plugged it in and cued up 'Gypsy Folk Tales' again. Whoah there! Now this was special - all the deck's fine qualities remained in abundance but things really began to swing.



On the underside of the Gyropower QC is a spike to ground the transformer's vibration.

Suddenly the music was so much better syncopated and more emotively performed. Rather than just giving the big picture, the Spider at last got into the groove and communicated on a human level.

From a late Karajan recording of Beethoven's Fifth to the pounding Drum 'n' Bass of LTJ Bukem, the QC Gyro SE was consistently light years ahead of its cheaper, conventionally-powered stablemate. Indeed, it moved embarrassingly close to Michell's top Orbe. Ultimately there was a gentle flattening of depth perspective and a slightly mechanical feel to rhythms, but it still wasn't so far off.

## CONCLUSION

The standard Michell GyroDec SE is a super performer which excels at conveying the scale and power present on modern vinyl LPs. But give it clean mains from a Gyropower QC and it really grows in stature. High-end turntables are an emotive subject, but even the most ardent devotees of rival marques would have to admit the Spider is a gem. By any standards it's a powerful package but at £775 it's nigh-on unbeatable. Add the £399 QC power supply, a top arm and a decent cartridge and the stratosphere's the limit. It may have been a long time coming, but the Spider was well worth the wait ●

Michell Gyrodec SE  
£775

Michell Engineering  
2 Theobald Street,  
Borehamwood,  
Herts. WD6 4SE  
Tel: 0181 953 0771

### WORLD VERDICT



Great sound, superb build and excellent upgradability make the Spider corking at the price.

# ITALIAN STALLION

Named after an Italian composer, can Audio Analogue's Paganini CD player live up to its illustrious name? Timothy Liu investigates.

The world of hi-fi sometimes operates in strange ways. In a manner reminiscent of the quantum leaps made in LP's reproduction as CD started to take over, with DVD-Audio and Super Audio CD apparently months rather than years off, the mind boggles at how the boffins continue to devise new means of squeezing ever higher performance from CD.

The Dons at Audio Analogue, doubtless still beaming from the success of their Puccini SE integrated amplifier reviewed in September 1997, have just released their first CD player, the Paganini.

The Paganini shares the 10mm aluminium fascia and heavy-gauge, folded steel casework which houses the Puccini. The round display and circular button cluster resemble the chamber on a Smith and Wesson revolver. Perhaps the inspiration came from those classic Sixties Spaghetti Westerns. . .

A peek at the rear-panel socketry shows the Paganini is a no-frills affair. Two gold-plated RCA phonos deal with the analogue output; a single co-axial digital out enables the Paganini to double up as a transport.

As is typical of all Audio Analogue products, construction inside and out is first rate. Lifting the lid revealed a beefed-up Sony transport bolted through the PCB to the base-plate. Behind this sit two Talema toroids feeding separate digital and analogue supplies.

The number crunching is handled by Crystal Semiconductors' flagship 24-bit, dual-differential chip. The analogue output circuitry, however, is Audio Analogue's own and relies on quality discrete components such as metal-film resistors and polypropylene capacitors.

After the recommended 100-hour burn-in, it was time for some sibling

rivalry. The Paganini was duly slipped into a system with a Puccini SE and a pair of Sonus Faber Electa Amator 2s.

First disc to hit the drawer was Led Zeppelin's Houses Of The Holy. The Paganini captured intact the acoustic guitar opening the track 'Over The Hills And Far Away', showing off the speed and intensity of Jimmy Page's strumming. Treble was sweet and free from grain or smear but not rolled off, as a real sense of air and space confirmed. When things really kicked off, the Paganini's deep, tuneful bass lifted this track into overdrive.

What struck me about CDs played on the Paganini was their effortless, wholly musical delivery; music flowed with an ease that allows you to sit back, relax and take in the performance, whatever the type of music or recording.

With XTC's Nonsuch album, the Paganini left me in no doubt as to its ability to scavenge for subtleties and detail on tracks like 'Wrapped In Grey'. The Beach Boys-style vocal harmonies on this number were individually-layered and separated but musically homogeneous. Set behind them was a scintillating string section well to the rear of a broad, deep soundstage. Although not from the clinical or analytical schools, the Paganini repeated this enviable trick on countless discs; details like triangles and percussion on CDs I know well were not heard for the first time but in a different light, with added freshness and immediacy.



The real acid test for the Paganini came in the form of Kate Bush's 'Rocket's Tail' (from her Sensual World album). The haunting vocals of Trio Bulgarka competed with Dave Gilmour's guitar to bring on the goosebumps. The sibilance and brightness in this song's production can have you leaping for the volume control but the Paganini remained controlled and neutral, revealing the cool tonal balance of the track without sapping its musicality.

The Dons at Audio Analogue haven't let success go to their head - they have produced another class-leader in the Paganini. Saving the best till last, this piece of delectable digitalia sits the right side of a grand at £750. In terms of sheer musicality the Paganini leaves competitors this side of the Atlantic looking worried, and is bound to bring a wide grin to many a face, especially those looking for a CD player to take them into the next millennium.

**Audio Analogue Paganini**  
£749

UKD  
23 Richings Way,  
Ivor,  
Bucks,  
SLO 9DA  
Tel: 01753 652669

## WORLD VERDICT



The Paganini does for CD replay what the outstanding Puccini SE does for amplification.

Measured Performance  
see p111

# SUPERIOR SILICON

**Jon Marks discovers transistors that sound like valves in Lavardin Technologies' IT Reference integrated amplifier.**

One of the oldest questions to puzzle hi-fi designers is why valves and transistors sound so different. Glass bottles have a tonal sweetness and lack of artificiality which, at its best, is a revelatory experience. Unfortunately, the circumstances for this revelatory experience tend to include silver-wound output transformers the weight of a canon ball and horns the size of a potting shed. Speakers on a smaller scale which provide some of the speed and impact of such horns often don't fulfil their promise unless driven by a huge black box with enough heatsinking to cool the Gobi desert and a power output approaching the requirements of a small city. In the world of amps, it seems, you can have natural and sweet or grunt and control but not a combination of the two.

Despite the efforts of a legion of hi-fi designers, this riddle has remained unsolved. Until now, that is, if you believe the claims that Lavardin Technologies make for their IT Reference integrated amplifier. Naming a component "IT" is possibly not the brightest start in life from a nomenclature point of view, but this French company are rather confident of their large box. A brief rifle through the literature explains: "The elegant flagship of the Lavardin Technologies range, the IT is of minimalist design utilizing a highly accurate, high-performance Memory-free design. . . This is the secret of "tube sound". We are proud, at Lavardin Technologies, to have full control on that which remains "the mystery of tube musicality" for previous audio designers (sic)."

Lavardin believe that "Memory Distortion" is what gives transistors their characteristic hard, mechanical edge. Like many others, LT suspected



that the vacuum inside a valve's glass envelope, which allows electrons free passage, was at the root of the more fluid, relaxed presentation of thermionic amplification. In contrast, an audio signal has to battle its way through silicon, leaving behind an impression of its passage which affects the electrons which come after it.

The goal of eliminating Memory Distortion set LT on the path to 12 years' research which revolved around developing a measurement system which would permit them to quantify MD and thereby come up with a circuit topology to eradicate it. The result is the S and Reference series, each of which includes an integrated, pre, stereo power and monobloc amplifiers.

## ACTIVELY SEEKING AMNESIA

Look inside the IT and it's obvious there's something a little out of the ordinary going on here electronically. For a start, many of the transistors and some of the ICs have had their numbers filed off to protect their identities. Then there are the parts potted inside the four mystery black

boxes, each about 1.5in. square, a pair of which sits in each channel. The cables carrying the input and output signals are also unencumbered by PVC or Teflon jackets - they appear simply to have been given a coat of urethane.

More familiar are the Alps Blue potentiometer and four-way selector switch (for the line-level, unbalanced inputs) shaft-driven from the thick front panel. The mains transformer is hidden away under an alloy cover mounted on large grommets to reduce vibration.

The IT's internals have a look of purposeful high-quality akin to what you might find inside the pricier products from smaller Japanese companies where the character of every single part is examined before its use is contemplated.

## AMP ANONYMITY

To determine if Lavardin were either guilty of Gallic hyperbole or discoverers of a major step forward in transistor sound, I lined the IT up against a modified, battery-powered DPA 50S (which is on a par with pres at around £2000). Power amplification was provided by



Musical Fidelity's X-A200 monoblocs. Loudspeakers were Magneplanar SMGas, refurbished Quad ESL 57s and Kelly KT3 floorstanders. Sources came from Trio (L-07D turntable with SME V arm) and Pioneer (tweaked DV-505 DVD player).

## ANTI-POLLUTION SQUAD

Powering up the IT for the first time, I was greeted by a clean but not particularly earth-shattering rendition of Tori Amos' Boys For Pele CD. However, within 10 minutes the IT was beginning to unveil its true capabilities as the sound became ever clearer and more natural. After about half an hour it had evidently warmed through, judging from the outstanding clarity and purity of the music emerging from the Quads.

The ESL 57s are renowned for their pollution-free midrange and treble, which makes them a great yardstick of what an amplifier is doing to vocals especially. The answer with the Lavardin was very, very little indeed. When you compare what 'normal' transistor amps do to the signal next to the impact of the IT, Lavardin's assertion that they've succeeded in eliminating transistor nastiness has a ring of truth to it.

Running from its four lead/acid batteries, the DPA 50S and the X-A200s are smooth, detailed performers by the standards of most transistor amps, but the IT made them sound coarse, grainy and very

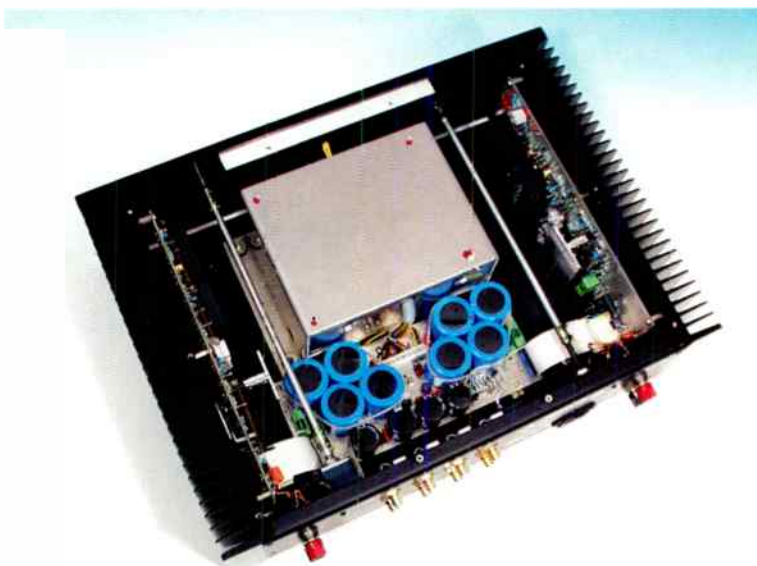

The main PCBs are bolted to the heatsinks over the single pair of output devices per channel.

coloured. These aberrations stood out like sore thumbs on vocals, harpsichord and cymbals, which all had a tonal naturalness through the Lavardin which made sitting back and listening to the music an addictive activity. On the other hand, switching back to the DPA and MFs in the wake of the French challenger was hard work, a husky nasality on vocals and a bright, spiky 'break-up' on percussion (neither obvious before listening to the IT) making it difficult to relax.

Other areas where this skilled integrated pulled well ahead of the pack were imaging and soundstaging. Where the DPA and MFs can produce an image of a vocalist which would cover about three pages of A4, the IT's focus was roughly twice as precise, as Tori

Amos' head and shoulders hung lifesize between the Quads.

The same was true of orchestral pieces, the IT yielding a much more coherent and convincing overall picture. Strings and woodwind had a smoothness and harmonic richness close to those valves are capable of, but I suspect the best of thermionic would still leave the Lavardin with some catching up to do. The tables would turn when it came to coloration, though, the IT sounding fabulously neutral without ever being clinical or mechanical.

Heavyweight Dance albums like Johnny Magnetic's L, Asian Dub Foundation's Rafi's Revenge and Axiom Dub's Mysteries Of Creation benefited from what the IT had to offer as much as more acoustic recordings. The purity of hi-hats and synths had me reappraising the production quality of some of these discs, as did the crisp bass and effortless control of the IT.

Lavardin Technologies have made some bold claims for their IT amp, but on the basis of what flows from the 4mm binding posts on the rear panel, they're putting their Francs firmly where their mouth is. This is certainly one of the most self-effacing, natural amplifiers I've heard, almost regardless of price. But beware, once you've heard it, returning to run-of-the-mill solid-state which has a memory is a difficult task●

Lavardin Technologies IT  
£3200

Absolute Analogue  
PO Box 1532,  
Fordingbridge,  
Hants. SP6 1SB  
Tel: 01425 654488



To the left of the PCB are the two black boxes which play a part in eliminating Memory Distortion. Shaft drive of the selector switch helps keep signal paths short.

### WORLD VERDICT



The IT has clarity in spades and an extremely rare tonal purity. Outclasses transistor alternatives at the same price easily.

Measured Performance  
see p111

# Outlets Nationwide



At Sevenoaks Hi Fi you will find a wide range of products on show with the emphasis on quality combined with unbeatable value for money.

Everything in stock is on display and available for audition in our dedicated Hi Fi and Home Cinema demonstration rooms.

Our friendly and experienced staff will be happy to assist you through every step of your purchase and will, when appropriate, deliver and install your equipment to ensure total listening satisfaction.

**Sevenoaks Hi Fi - there is no better place to buy.**

**UK  
TOP TEN  
CD Albums  
only £9.99 each**

Participating outlets only.  
Offer subject to availability.  
Personal callers only. E&OE.



## SEVENOAKS HI FI OUTLETS NATIONWIDE

- SEVENOAKS  
01732 459555  
109-113 London Road
- ABERDEEN  
(LATE NIGHT THURSDAY)  
01224 587070  
491 Union Street
- BEDFORD  
01234 272779  
29-31 St Peters Street
- BIRMINGHAM  
0121 233 2977  
12 Queensway Arches,  
Livery Street
- BRIGHTON  
01273 733338  
57 Western Road, Hove
- BRISTOL  
0117 974 3727  
92b White Ladies Road,  
Clifton
- BROMLEY  
0181 290 1988  
39a East Street
- CAMBRIDGE  
Apologies - Opening Delayed
- CARDIFF  
01222 472899  
104-106 Albany Road
- CARLISLE  
01228 590775  
3 Earls Lane  
(Next to Bus Station)
- CHELSEA  
0171 352 9466  
403 Kings Road, SW10
- CHELTENHAM  
01242 241171  
14 Pittville Street
- CRAWLEY  
Apologies - Opening Delayed
- CROYDON  
(LATE NIGHT THURSDAY)  
0181 665 1203  
373 London Road
- EDINBURGH  
Apologies - Opening Delayed
- ESSEX  
01376 501733  
1 The Grove Centre,  
Witham
- EXETER  
01392 218895  
28 Cowick Street
- GUILDFORD  
01483 536666  
73b North Street
- HOLBORN  
(OPEN UNTIL 7PM EXCEPT SAT)  
0171 837 7540  
144-148 Grays Inn Rd
- HULL  
(OPEN SUNDAYS)  
01482 587171  
1 Savile Row, Savile Street



- IPSWICH  
01473 286977  
12-14 Dogs Head Street
- KINGSTON  
(LATE NIGHT THURSDAY)  
0181 547 0717  
43 Fife Road
- LEEDS  
0113 245 2775  
112 Vicar Lane
- MAIDSTONE  
01622 686366  
96 Week Street
- NEWCASTLE  
0191 221 2320  
19 Newgate Street
- NORWICH  
01603 767605  
29/29a St Giles Street
- OXFORD  
01865 241773  
41 St Clements
- PETERBOROUGH  
(LATE NIGHT THURSDAY)  
01733 897697  
36 Park Road
- PLYMOUTH  
01752 226011  
107 Cornwall Street
- PRESTON  
01772 825777  
40-41 Lune Street
- READING  
0118 959 7768  
3 & 4 Kingswalk
- SHEFFIELD  
(OPEN SUNDAYS)  
0114 255 5861  
635 Queens Rd, Heeley
- SOUTHAMPTON  
01703 337770  
33 London Road
- SOUTHGATE  
0181 886 2777  
79-81 Chase Side, N14
- **new** SWANSEA  
01792 465777  
24 Mansel Street
- **new** SWISS COTTAGE  
(OPEN SUNDAYS)  
0171 722 9777  
21 North Ways Parade
- TUNBRIDGE WELLS  
01892 531543  
28-30 St Johns Road
- WATFORD  
(OPEN SUNDAYS)  
01923 213533  
478 St Albans Road
- WORCESTER  
01905 612929  
2 Reindeer Court

Mail Order 01732 458985

## ★ NEW SEVENOAKS HI FI OUTLETS ★

EXETER 01392 218895 28 Cowick Street

PLYMOUTH 01752 226011 107 Cornwall Street

HOLBORN 0171 837 7540 144-148 Grays Inn Rd

SWANSEA 01792 465777 24 Mansel Street

IPSWICH 01473 286977 12-14 Dogs Head Street

SWISS COTTAGE 0171 722 9777 21 North Ways Parade

# Sensational Selection at



PLEASE NOTE NOT ALL PRODUCTS ARE STOCKED AT ALL OUTLETS. PLEASE TELEPHONE TO VERIFY PRICE AND AVAILABILITY BEFORE TRAVELLING.

## CD PLAYERS

Arcam Alpha 7 CD	£ CALL
Arcam Alpha 8 CD	£ CALL
Arcam Alpha 8SE CD	£ CALL
Arcam Alpha 9 CD	£ CALL
Cyrus DAD1	£ CALL
Cyrus DAD3	£ CALL
Cyrus DAD3Q	£ CALL
Denon DCD435	£ CALL
Denon DCD635	£ CALL
Denon DCD835	£ CALL
Denon DCD1550 AR	£ CALL
Exposure CD	£ CALL
Marantz CD46	£ CALL
Marantz CD67II	£ CALL
Marantz CD67IIIOSE	£ CALL
Marantz CD63IIK1 Signature	£ CALL
Marantz CD17K1 Signature	£ CALL
Meridian 506 20 Bit	£ CALL
Meridian 508 24 Bit	£ CALL
Musical Fidelity E624	£ CALL
Musical Fidelity X-Ray	£ CALL
Myrrad T10	£ CALL
Myrrad T20	£ CALL
Myrrad MC100	£ CALL
Myrrad MCD500	£ CALL
Naim Audio	£ CALL
Pioneer PDSS05 Precision	£ CALL
Roksan Caspian	£ CALL
Rotel RCD951	£ CALL
Rotel RCD971	£ CALL
Sony CDPXE310	£ CALL
Sony CDPXE520	£ CALL
Sony CDPXB920	£ CALL
TAG McLaren CD20R	£ CALL
Yamaha CDX493	£ CALL
<b>CD MULTIPLAYERS</b>	
Arcam Alpha MCD	£ CALL
Yamaha CDCS65	£ CALL
<b>CD TRANSPORTS</b>	
Meridian 500	£ CALL
TAG McLaren CDT20R	£ CALL
<b>DACS</b>	
Meridian 566 24 Bit	£ CALL
TAG McLaren DAC20	£ CALL
<b>MINI DISC/CD RECORDERS</b>	
Denon DMD1000	£ CALL
Kenwood DM3090	£ CALL
Marantz DR700	£ CALL
Philips CDR760	CD Recorder £ CALL
Philips CDR765	CD Recorder £ CALL
Pioneer PDR555RW	CD Recorder £ CALL
Sharp MDMS702	MD Portable £ CALL
Sharp MDMS722	MD Portable £ CALL
Sony MZR35	MD Portable £ CALL
Sony MZR50	MD Portable £ CALL
Sony MDSJE520	£ CALL
Sony MDSJB920	£ CALL
Sony MDSJA20ES	£ CALL
Yamaha MDX793	£ CALL
<b>CASSETTE DECKS</b>	
Denon DRM550	£ CALL
Denon DRW585 Twin	£ CALL
Pioneer CTS550 Precision	£ CALL
Yamaha KX393	£ CALL
Yamaha KXS80SE	£ CALL
<b>TURNTABLES</b>	
Micell Gyrodec	inc RB300 £ CALL
Project 0.5	£ CALL
Project 1	£ CALL
Technics SL1210	£ CALL
Thorens TD280/IV	inc AT95E £ CALL
Thorens TD166/VI	inc RB250 £ CALL
<b>TUNERS</b>	
Arcam Alpha T7	£ CALL
Arcam Alpha T8	£ CALL

Creek T43	£ CALL
Cyrus FM7	£ CALL
Denon TU260L	£ CALL
Denon TU21SRDS	£ CALL
Denon TU1S00RD	£ CALL
Marantz ST48	£ CALL
Marantz ST17	£ CALL
Meridian 504	£ CALL
Myrrad T30	£ CALL
Myrrad MT100	£ CALL
Pioneer F504 Precision	£ CALL
Roksan Caspian	£ CALL
Sony STSE500	£ CALL
Sony STSB920	£ CALL
TAG McLaren T20	£ CALL
Yamaha TX492RDS	£ CALL
<b>AMPLIFIERS</b>	
Arcam Alpha One	£ CALL
Arcam Alpha 7R	£ CALL
Arcam Alpha 8R	£ CALL
Arcam Alpha 9	£ CALL
Arcam Alpha 10	£ CALL
Cyrus SL	£ CALL
Cyrus MR3	Multiroom £ CALL
Cyrus III i	£ CALL
Denon PMA250SE	£ CALL
Denon PMA350SE	£ CALL
Denon PMA1300R	£ CALL
Exposure Super 10	£ CALL
Exposure Super 20	£ CALL
Exposure Super 15	£ CALL
Exposure 25	£ CALL
John Shearme	£ CALL
Marantz PMS7	£ CALL
Marantz PM66SE	£ CALL
Marantz PM66KI Signature	£ CALL
Marantz PM17K1 Signature	£ CALL
Meridian 551	£ CALL
Musical Fidelity X-A1	£ CALL
Myrrad T40	£ CALL
Myrrad Mi 120	£ CALL
Naim Audio	£ CALL
Pioneer A300R Precision	£ CALL
Roksan Caspian	£ CALL
Rotel RA921	£ CALL
Rotel RA931	£ CALL
Rotel RA971	£ CALL
Sony TAF248E	£ CALL
Sony TAFB920R	£ CALL
TAG McLaren 60I	£ CALL
TAG McLaren 60IRv	£ CALL
<b>PRE AMPLIFIERS</b>	
Arcam Alpha 9C	£ CALL
Cyrus AEQ7	Phono £ CALL
Cyrus ACA7	£ CALL
Exposure 13	Phono £ CALL
Exposure 19	£ CALL
Exposure 17	£ CALL
Exposure 21	£ CALL
Meridian 501.2	£ CALL
Meridian 502	£ CALL
Myrrad MP100	£ CALL
Musical Fidelity X-Pre	£ CALL
Naim Audio	£ CALL
Rotel RC971	£ CALL
TAG McLaren PA10	£ CALL
TAG McLaren PA20R	£ CALL
TAG McLaren PPA20 Phono	£ CALL
<b>POWER AMPLIFIERS</b>	
Arcam Alpha 8P	£ CALL
Arcam Alpha 9P	£ CALL
Arcam Alpha 10P	£ CALL
Cyrus XPA	£ CALL
Cyrus PSXR	Power Supply £ CALL
Cyrus Power	£ CALL
Cyrus APA7 Mono (each)	£ CALL

Exposure Super18	£ CALL
Exposure Super18 Mono (pair)	£ CALL
Meridian 556	£ CALL
Meridian 557	£ CALL
Myrrad T60	£ CALL
Myrrad MA120	£ CALL
Musical Fidelity X-A50 Mono (pair)	£ CALL
Naim Audio	£ CALL
Roksan Caspian	£ CALL
Rotel RB971	£ CALL
Rotel RB981	£ CALL
TAG McLaren 60P	£ CALL
TAG McLaren 100P	£ CALL
TAG McLaren 125M Mono (each)	£ CALL
<b>LOUDSPEAKERS (Pair)</b>	
Acoustic Energy Aegis One	£ CALL
Acoustic Energy AE1001	£ CALL
Acoustic Energy AE109	£ CALL
AVI NuNeutron	£ CALL
B&W DM601	£ CALL
B&W DM602	£ CALL
B&W DM603	£ CALL
B&W CDM1SE	£ CALL
B&W CDM2SE	£ CALL
B&W CDM7SE	£ CALL
Castle Isis	(Deluxe Extra) £ CALL
Castle Isis	(Deluxe Extra) £ CALL
Castle Isis	(Deluxe Extra) £ CALL
Castle Kendall	(Deluxe Extra) £ CALL
Castle Severn 2	(Deluxe Extra) £ CALL
Castle Avon	(Deluxe Extra) £ CALL
Castle Harlech	(Deluxe Extra) £ CALL
Epos ES12	£ CALL
Epos ES15	£ CALL
Epos ES22	£ CALL
Epos ES30	£ CALL
Kef Q15	£ CALL
Kef Q35	£ CALL
Kef Q55	£ CALL
Kef Reference	£ CALL
Mission 700	£ CALL
Mission 701	£ CALL
Mission 771	£ CALL
Mission 772	£ CALL
Mission 773	£ CALL
Mission 774	£ CALL
Mission 750LE	£ CALL
Monitor Audio Silver S3	£ CALL
Monitor Audio Silver S5	£ CALL
Monitor Audio Silver S7	£ CALL
Monitor Audio Silver S9	£ CALL
Mordaunt Short MS814	£ CALL
Mordaunt Short MS814	£ CALL
Mordaunt Short MS815	£ CALL
Ruark Epilogue	(Deluxe Extra) £ CALL
Ruark Icon	(Deluxe Extra) £ CALL
Ruark Templar II	(Deluxe Extra) £ CALL
Ruark Sceptre	(Deluxe Extra) £ CALL
Ruark Talisman II	(Deluxe Extra) £ CALL
Ruark Prologue One	(Deluxe Extra) £ CALL
Tannoy Mercury M1	£ CALL
Tannoy Mercury M2.5	£ CALL
Tannoy Revolution R1	£ CALL
Tannoy Mercury M3	£ CALL
<b>SYSTEMS</b>	
Denon DM3 ex tape	ex spks £ CALL
Denon DM5 ex tape	ex spks £ CALL
Denon DM7 ex tape	ex spks £ CALL
Denon DF88	ex spks £ CALL
Denon System 6.5	ex spks £ CALL
Pioneer NS5 ex tape	inc spks £ CALL
Pioneer NS7 ex tape	inc spks £ CALL
Sony CMTED1	inc spks £ CALL
Sony CMTMD1	inc spks £ CALL
Teac Ref 300	ex spks £ CALL
Teac Ref 500	ex spks £ CALL
Technics SCHD51	inc spks £ CALL

Technics SCHD55	inc spks £ CALL
Technics SCHD81	inc spks £ CALL
Yamaha AV57	inc spks £ CALL
Yamaha AV1	inc spks £ CALL
<b>DVD &amp; LASER DISC PLAYERS</b>	
Denon DVD3000	£ CALL
Panasonic DVDA150	£ CALL
Panasonic DVDA350	£ CALL
Pioneer DV505	£ CALL
Pioneer DV717	£ CALL
Pioneer DVL909	£ CALL
Samsung DVD907	£ CALL
Sony DVPS315	£ CALL
Sony DVPS715	£ CALL
Yamaha DVDS700	£ CALL
<b>SURROUND AMPLIFIERS</b>	
Arcam AV50	£ CALL
Yamaha DSPA592	£ CALL
Yamaha DSPA2	£ CALL
Yamaha DSPA1	£ CALL
Yamaha DSPA1 Gold	£ CALL
<b>SURROUND RECEIVERS</b>	
Denon AVR1100RD	£ CALL
Denon AVR2700	£ CALL
Sony STRDB925	£ CALL
Yamaha RXV393	£ CALL
Yamaha RXV592	£ CALL
Yamaha RXV795	£ CALL
<b>SURROUND PROCESSORS</b>	
Meridian	£ CALL
Yamaha APD1	Demodulator £ CALL
Yamaha DSPE492	£ CALL
Yamaha DDP2 AC3	Decoder £ CALL
<b>CENTRE SPEAKERS</b>	
Acoustic Energy AE107C	£ CALL
B&W CC6	£ CALL
B&W CDMCSE	£ CALL
Kef 80C	£ CALL
Kef Q95C	£ CALL
Mission 70c1	£ CALL
Mission 70c2	£ CALL
Mission 77C	£ CALL
Monitor Audio Silver Centre	£ CALL
Mordaunt Short T1000	£ CALL
Ruark Dialogue One	£ CALL
Tannoy MC	£ CALL
Yamaha NSC60	£ CALL
Yamaha NSC105	£ CALL
Yamaha NSC150	£ CALL
<b>SURROUND SPEAKERS (Pair)</b>	
Acoustic Energy AE101	£ CALL
Boston	£ CALL
Mission 70	£ CALL
Yamaha NSE60	£ CALL
Yamaha NSE105	£ CALL
<b>SUB WOOFERS</b>	
Acoustic Energy AE1085	£ CALL
Rei Q50	£ CALL
Rei Q100E	£ CALL
Rei Strata II	£ CALL
Rei Storm	£ CALL
Rei Stadium II	(Blk) £ CALL
Rei Stentor II	(Blk) £ CALL
Yamaha YSTSW40	£ CALL
Yamaha YSTSW80	£ CALL
<b>SPEAKER PACKAGES</b>	
Boston Micro 90t	£ CALL
Mission Cinema I	£ CALL

Advertisement valid until at least 15th March, 1999 E&OE

# SENSATIONAL SAVINGS IN-STORE

# THREE RING CIRCUS

Choice for the home recordist as never before, but which format? Ringmaster Richard White puts CD-R, MiniDisc and Cassette through the hoop.

To a certain degree, audiophiles are spoilt rotten when it comes to recording media nowadays. Compared with the not-so-good old days of tape, tape or tape, there is an immense and potentially confusing array of systems which sail close to the copyright laws. Of course the day when genuinely high-fidelity solid-state recording is available cheaply to the average enthusiast is still a way off. Similarly, the demand for direct-lacquer cutting has fallen off a bit recently. Which leaves, as always, the middle ground to be filled.

Ignoring the weeping, wailing and gnashing of teeth of all Digital Compact Cassette owners, there are now arguably three main contenders in the domestic recording picture: MiniDisc, CD-Recordable and, fighting a brave rearguard, Compact Cassette.

Since the above are sold primarily as domestic recording machines, we decided that an informal group test was in order. As regular readers of these pages will be aware, we feel that levelling the analogue/digital playing field can be something of a tricky task. For instance, if a tape recorder hisses can it be excused on the grounds of being "lovely analogue technology"? Likewise, with digital formats, can car-crusher compression be counted as "the price you pay for convenience"?

To give the three competitors as fair a chance as possible, we made the primary comparisons chiefly on sound quality whilst also weighing up some of the other pros and cons that go with each.

Let's meet our lovely contestants (thank-you, Anthea). First is Philips' CDR 870 recordable CD machine, coming to you at about £500 (applause). Next, looking as though it's got everything taped, is Pioneer's CT-S550S Precision cassette machine at £339.95 (applause). Finally, bringing up the rear, in the end, eventually, last but by no means least (laughter), is Kenwood's fine DM-5090



Philips' CDR 870 can record onto both CD-Recordable as well as CD-ReWritable discs.

MiniDisc recorder wearing a fetching £329.95 price-tag (applause).

## THE RULES

Each recorder was tested with the following source materials: Diana Krall (Jazz vocalist) with acoustic instrumental trio on an Impulse CD; Radio 4 via Leak Troughline; a commercial Rock station; the third movement of Elgar's first Symphony on vinyl; DGG Archiv LP, Concert Music Of The Baroque Court.

The reason for most of these choices is fairly obvious, but Miss Krall was chosen for the somewhat aggressively digital sound of the disc, Radio 4 for the spoken word, the Elgar for a touch of complex orchestral thunder and the Baroque Court record because it has some of the most piercing recorded harpsichord in the catalogue and is thus a good provider in the 15kHz+ region.

## CD-RECORDABLE

The Philips CDR 870 was the front-runner in the field of affordable, domestic CD-R/CD-RW machines. Studio bugs had been working with the format for a few years beforehand so that by the time things went domestic, a nicely ironed-out component was ready for sale.

First in to bat was Diana Krall, whose

husky, slightly sibilant delivery I hoped would inform me of the CDR 870's transient signature. This recording has a lot of space round it and the initial effect of the CD-R copy was close to the original. Listening hard revealed that the full extent of the recorded sound was captured with practically nothing added (apart from a tiny amount of hiss) and even less taken away.

Radio 4's non-stop talk proved to be an easy task for the Philips - vocal colours were realistically reproduced with apparently 'full' spectrum warmth.

On commercial broadcasts there can be so much distortion in the first place it's often a fruitless task listening out for subtleties, but they have their uses nonetheless. This indeed was the only source which regularly pushed the CDR 870 anywhere near over-recording. As a whole, the machine took everything in its stride, recorded level setting being fairly non-critical.

Now to the difficult bit, full-bandwidth vinyl. Actually, the results were surprisingly good considering the battery of tonal colours the late-Romantic orchestra is capable of firing off. Frequency extremes, both on the Elgar and the Baroque record, failed to trip the Philips.



Pioneer's CT-S550S Precision shows what some audiophile tweaking by Tom Evans can do for cassette.

Criticisms which could be levelled at the '870 when recording vinyl (if not other sources) were a slight 'papery' quality and loss of life.

### COMPACT CASSETTE

When we reviewed the Pioneer a month or two ago, it gained top marks for its sound quality. Add to this the late-burgeoning convenience of track finding arrangements and we felt the CT-S550S Precision to be fighting fit.

One of the interesting features of this test was the confirmation that analogue and digital recorders do actually have complementary vices and virtues. The heavy guns of the Elgar artillery offered no problem to the Pioneer and a Maxell Metal tape as long as a close eye was kept on the level indicator. A sense of almost 'unlimited' bandwidth pervaded the recording, bass and treble stretching off into the distance rather than being stuffed into a cramped package.

Recording from CD was a marginally different story with some hiss apparent on quiet passages; as ever, an eagle eye on the recording level can pay dividends here. There was in any case very little discernible amplitude distortion over the frequency range, so the sound remained as natural as the studio had managed to leave it.

Radio 4 gave the CT-S550S a little more to think about. With the prevalence of speech and silence on this station, tape hiss could become a real issue. As we noted in our review, the Pioneer is a very strong performer in this field, but there is still hiss. Of course using Dolby would help here but the overall sound quality suffers; in an extreme case, noise reduction can produce sonic symptoms similar to those of the MiniDisc compression noted below.

### MINIDISC

Playing pre-recordeds seemed to be the great strength of the Kenwood DM-5090 when it was reviewed in our February issue. Now it was about to meet its peers in a rather different battle.

Given that MiniDisc is an unashamedly data-reduced medium, we slung it in at the deep end with the Elgar on vinyl. Again, as we had found with CD-R, level setting was not a matter of life and death: obviously it makes sense to put in as loud a signal as possible, but the display seems to suggest that the working bracket is many decibels better than can be tolerated with tape.

To be honest, quality was not over-special working from vinyl. Without a doubt, recording of this standard would have seemed near-miraculous from a domestic cassette machine not so very long ago, but time moves on. There was a noticeable lack of 'air' which suggested that numbers were being squeezed to crunch point. The recording remained 'clean' inasmuch as there was no appreciable noise (aside from surface noise) but the performance remained unconvincing. Bandwidth was good, with little obvious compression at the extremes of treble and bass, and it handled the

small-scale orchestral work of the Baroque Court quite adequately compared with the Elgarian cannon-fire.

Feeding the Kenwood from a CD source was a different and happier story. Maybe because the CD had been digitally processed from birth, Miss Krall's Love Songs took much more kindly to the inevitable compression. The true drive of the double-bass was passed on without a murmur and the vocal sibilance, albeit slightly emphasized, was easily accommodated within the context of the music.

What MD lost in sound quality it made up for in trumps with convenience. The sheer ease with which the blocks of our test recordings could be shuffled or deleted made an all but unanswerable case for the medium as a quick fix for fiddle-fingers and level-forgetters everywhere. As the sound quality continues to rise, this format is unquestionably one to keep an ear on.

### GRAND FINALE

In an overview of this sort, it is a surprise to find the three formats with such complementary merits. Better still, none has insuperable demerits. Cassette remains cheap, popular and capable of exceedingly good work with quality tape and careful setting. CD-R combines almost indistinguishable sound quality when copying from digital recordings with universal playback compatibility. MiniDisc, the somewhat poorer relation for sound quality, has nonetheless a degree of programmable convenience which makes splicing blocks look mediæval.

All this is to the benefit of the enthusiast; the world is his oyster as never before, except that it currently contains at least three pearls.



Kenwood's DM-5090 MiniDisc recorder demonstrates just what a convenient format MD is.

*Classé*



*... you  
cannot  
buy  
better  
electronics.*

**CAP-151  
INTEGRATED  
AMPLIFIER**



**AUDIO  
ILLUSION**

23 Langley Broom  
Langley  
Berkshire SL3 8NB  
TEL: 01753 542761 FAX: 01753 772532

The CAP-151 has the typical beautiful Classe contoured, slimline chassis with special faceplates in either Soft Shadow Silver or Anodised Black.

Remote controls include: Power On/Off, Volume, Mute, all Input Selections. Tape and Display Brightness. Front panel controls include: INPUT SELECTION, VOLUME, TAPE MUTE and POWER.

The CAP-151 is a very substantial integrated amplifier, quite capable of driving speakers well above its price range.

FOR THAT TOUCH OF CLASSE - CONTACT - AUDIO ILLUSION - 01753 542761

Don't read the  
Gramophone - listen to it



**PROJECT**  
AUDIO SYSTEMS

01491 834700

DISTRIBUTED BY HENLEY DESIGNS LIMITED

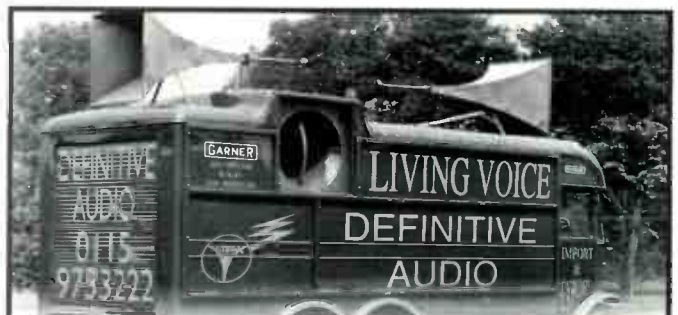

**DEFINITIVE AUDIO**

You may be a newcomer to Hi-Fi, bewildered by choice. You may be a seasoned audiophile, tired of hype and marketing. Perhaps you should give us a call.

Our range of equipment moves from modest to exotic, from mainstream to unusual. All of it serious. We have a system based approach that achieves results far greater than the sum of the parts. Our starter system, featured in 'Hi-Fi Choice' last year was praised as "One of the best systems I have heard. At any price."

If you share our passion for music and have the urge to hear something a little bit different, ring for an information pack or make an appointment to visit our new listening rooms. We are situated in a fabulous Victorian mill just off junction 25 M1., 10 minutes from East Midlands Airport.

**Part exchanged items for sale:**

	Sale	New
Audio Innovations S.500 Int. Excellent	£ 550	(£1200)
Audio Innovations L2 Line Pre	£ 500	(£ 750)
Audio Innovations S100 Pre	£ 500	(£1350)
Audio Innovations S200 Pre	£ 150	(£ 350)
Audio Innovations 2 <sup>nd</sup> Audio Monos 6B4G	£ 900	(£3000)
Ariston RD 80 Turntable (no arm)	£ 100	
AudioNote DAC3 Sig.	£1850	(£ 2850)
AudioNote ANV 1/2 2 metres	£ 250	(£ 500)
Alchemist Forsetti power amp	£ 699	(£1350)
Border Patrol 300B SE 'Blue'	£1500	(£2500)
Denon Transport and DAC	£7000	(£15000)
Pass Labs X600 Monos	£15000	(£23000)
Border Patrol PSU	£ 495	(£ 595)
Orchid Precision PLL 1 loudspeakers	£3900	(£7900)
Kelly KT3 loudspeaker (new)	£1200	(£1850)
Dali 104 MS (94dB)	£ 450	(£ 650)
Impulse H2 loudspeakers Mahogany	£1500	(£2500)
Impulse Ta'us	£1900	(£3100)
Linn LP12, Avendale PSU, Helios Aurius	£ 450	
Naim CDS	£2250	(£3940)
Naim 72 pre-amp	£ 400	(£ 745)
Naim 250 power-amp	£ 800	(£1705)
Naim CD2	£1200	(£2000)
Naim 82 pre-amp	£1500	(£2225)
Naim NAP 250 power	£1200	(£1705)
Naim Hi-Cap	£ 450	
Naim A5 Speaker cable 5 & 7 metre sets	£ 50 & 60	

**AMEX - VISA - MASTERCARD**

**Tel 0115 973 3222 Fax 0115 973 3666**

• Living Voice • Border Patrol • Art Audio • SJS Electroacoustics • Wadia • Vitavox • Lowther • Helios • MF • Kelly • Nott'm Analogue • Mvstic Mat • SME • WB Ortofon •

# ALL CHANGE AT LAS VEGAS 1999?

Tony Hamza ponders the future of hi-fi at the Las Vegas Consumer Electronics Show.

As I walked down Las Vegas Boulevard, locally called the Strip, I became aware of the huge transformation that's taking place in America's playground city. All around me new hotels were emerging from the desert sands. Every creation is designed to outdo last year's sensation. Behind me was the Luxor Hotel (a huge black pyramid with the Sphinx guarding its entrance) and across the way was New York, New York (with a quarter-scale model of that city's familiar skyline). These will soon lose their appeal as the Paris Hotel is finished (complete with the Eiffel Tower, Arc de Triomphe and Louvre) and the Venetian Hotel opens (with a full-scale rendering of St Mark's Square, water-filled canals and floating gondolas).

Amongst all the new glitter were the faded palaces of former glory. The Dunes, the Sahara and the Stardust are all hotels well past their best and I wondered how they'd survive with so much new glamour around.

As I began to explore the Consumer Electronics Show the next day, I couldn't help feeling that another great transformation was taking place. Of course audio has always been a small part of the CES, but this year I could feel the pull of new technologies seducing the consumer away from good, old two-channel audio. There's high-definition digital television, MP3, movies on DVD, computer games and the Internet.

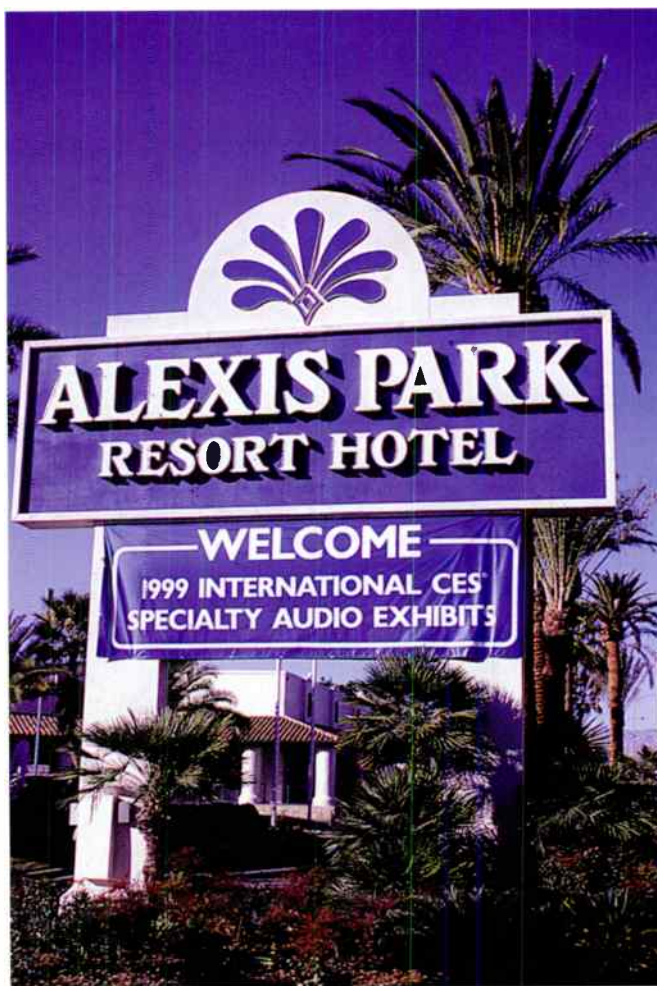

The Alexis Park welcome in palm-decked Las Vegas.

These are also taking away the money that, 10 years ago, would have been spent on audio.

Finding real hi-fi in the main Exhibition Halls was almost impossible. The Panasonic display was at least 100metres long but only a few of those were devoted to pure audio products. There was a closed demonstration for

DVD-Audio (with up to six channels at 24 bits and up to 192kHz sampling), the proposed high-resolution replacement for CD. Panasonic promised its launch within a year. The format is incompatible with existing DVD-Video players and current CD players. The first machines will be devoted to DVD-Audio only. "Universal" players, capable of working with both DVD-Video and DVD-Audio standards, will follow shortly afterwards.

On the Philips stand I found a static display of a Super Audio CD player that will use dual-layer discs to store DSD data as well as conventional CD data. Again, the promise was that the format would be launched towards the end of 1999.

Sony's exhibit focused on the future of digital technology in the home and included a proposed 8Megabyte "Memory Stick" to transfer data between cameras, audio devices and computers. Sony also featured Super Audio CD and tried to explain, to a con-

fusioned audience, how the format would make CDs sound even better.

Before leaving the main Exhibition Hall I headed for an interesting flat 'speaker being produced by Infinity. The FPS-1000 is only 38mm deep and uses conventional moving-coil technology. Sound quality (with an additional sub-woofer) was actually quite decent.

RELEASE *the* **FULL POTENTIAL** of YOUR SYSTEM



**WHAT HI-FI?**

★★★★★

"What's more, a mains block of this quality is for life."

Dec '98

**STEP 1: YOUR MAINS**

Start at the beginning! The truth is that poor mains quality ruins the sound of even the best equipment. The better the equipment, the bigger the difference.

Kimber PowerKords and Distribution PowerBlocks remove mains pollution so effectively that they can more than double the performance of your system.

Call NOW for your free brochure.

"They've now taken up permanent residence in our system!"



Hi-Fi World Dec '97

Russ  
Andrews

**MAIL ORDER** *direct* **0800 373467** (UK ONLY)

Russ Andrews Accessories Ltd., Edge Bank House, Skelsmergh, Kendal, Cumbria LA8 9AS

Tel: +44 (0)1539 823247

Fax: +44 (0)1539 823317

E-mail: info@russandrews.com

Website: www.russandrews.com

FR11/HW04/99

Are you getting the  
Maximum from your  
System

**D102II Hybrid Interconnect cable**

£89.99/0.8m pair

**Best Interconnect Cable** - What Hi-Fi?  
Award Winner 1998

Review: "...a wiry wonder" What Hi-Fi? May '98

★★★★★ "...this is pretty much as good as cable gets"

**Best Buy Hi-Fi Choice** March '98

**CS122 Hybrid Loudspeaker Cable**

£11.99/m

**Highly Recommended** - What Hi-Fi? Awards 1998

★★★★★ "Buy with confidence" What Hi-Fi? Oct '98

**The Teatrack Hybrid Bi-Wire** (£21.99/m)

Insist on Cables by

**van den Hul**

The Link Between Technique and Emotion

For details of our extensive range of cables and cartridges please contact

van den Hul UK, Imex House, 6 Wadsworth Road, Greenford, Msex, UB6 7LJ. Tel: 0181 997 4280

**DANGER!**  
**Diamond Mine**

ortofon  
Rohmann

**ortofon** 01491 834700

DISTRIBUTED BY HENLEY DESIGNS LIMITED





Alex Garner of Tannoy transported to Saturn.



The KEF heavies including the 109 Maidstone.

Wharfedale were demonstrating their "Loudpanel" using NXT technology. These hang-on-the-wall picture/loudspeakers were only 27mm deep but a subwoofer, set too high, spoiled the sound.

My next destination was the Las Vegas Hilton where I found many of the larger, true hi-fi companies. Tannoy was unveiling the Saturns, a new range of five dual-concentric loudspeakers. The Saturn 6lcr (£199 each) and Saturn 8lcr (£249 each) are bookshelf models whilst the Saturn 6 (£499 a pair), Saturn 8 (£699 a pair) and Saturn 10 (£899 a pair) are floor standing. Judging from the demonstration, all the models are capable of very high SPLs.

The company's Prestige models have been re-engineered using stiffer suspensions and now include earthing terminals. Earthing terminals on loudspeakers? Alex Garner (Tannoy's Technical Director) explained: "It's all the rage with Japanese audiophiles. We've done our own research and found that the improved sound quality comes from cutting down RF pick-up in the voice-coil. By using shielded cable connected to the earthed 'speaker-chassis, there's a 6dB to 25dB reduction. This means that the amplifier doesn't have RF entering the loudspeaker cables and messing up the sound."

Meridian had a very impressive stand demonstrating MLP (Meridian Lossless Packing), which compression system has been adopted as a standard for DVD-Audio.

Krell Industries were showing the

Master Reference Amplifier, a monster monobloc capable of putting 16000watts into a half-ohm load. It stood on a massive pedestal looking like a giant sculpture. At \$120000, a pair of Henry Moores might be cheaper.

My next stop was the Alexis Park Hotel to see what's called the "Specialty Audio Exhibits". This hotel is one of the few in Las Vegas that doesn't have a casi-



Inversion from Castle Acoustics.

no, and its cabana-style layout means that it was possible to enjoy a breath of fresh air between demonstration rooms. Here I found some very familiar names. Creek Audio was launching a neat £199 D-to-A convertor called the OBH-14. Housed in a small box is a Crystal 24-bit chip that accepts sampling rates up to 48kHz. It made some nice sounds using the optical output from a portable CD player.

At the other end of the scale dCS

showed the Purcell sampling-rate convertor that steps standard 16-bit 44.1kHz up to 24-bit 192kHz. If you then use a dCS Elgar DAC (working at 24/192) the results are said to greatly increase the sound quality of a standard CD. The Purcell will be available in February at £3500.

Continuing with out-board convertors, Chord Electronics were showing the DCS1500E Digital pre-amplifier with its six inputs and three outputs. On board are two DAC chips, one from Analogue Devices and the other from AKM. As each has a slightly different sonic characteristic, the user can remotely switch between them for optimal results with different digital sources.

Castle Acoustics launched the complete Inversion range of loudspeakers that represent a bold design statement. The Inversion 100 floor standing loudspeakers (at £1975 a pair) will be followed by the smaller Inversion 50 (in April, at £900 a pair) plus a supporting cast of rear, centre and subwoofer models. The 'speakers on display looked stunning in Maple.

KEF launched their new loudspeaker, the 109 Maidstone. This is a four-way system using a 15in. woofer, 10in. lower-mid and 6in. Uni-Q mid/high-frequency unit. The loudspeaker was capable of very high SPLs whilst remaining totally in control. It is expected to cost £12000.

Cambridge Audio launched a new range of electronics that included two

# Jamo loudspeakers are No. 1 in Europe



**- and here is a couple in love**

**Jamo**

**30<sup>th</sup> ANNIVERSARY**



**Jamo 7 series**

The bass forms the foundations of most music. It pulses out into the air, so the body reacts, feeling the music rushing down to the feet. If it turns into sweet music, it is time to dance.

At Jamo, we have always had a particular love for the bass. In the new 7 series, this love has been allowed to blossom.

The development of new high performance bass units was given top priority. But that was not all. We also wanted to design a cabinet which gave the bass the best possible conditions to develop and grow. This led to a design in which the bass unit is mounted face down in the bottom of the cabinet. In this way, the floor itself acts as an acoustic surface, adding even more weight to the low frequencies.

Even at low volume, the bass can now live out its intended role – supplying the backing to the music. With the new design, the bass is an active ingredient, with every tone ringing out loud and clear. No wonder, then, that the 7 Series has quickly made new friends at the “deep end” of the orchestra.

Millions of people around the world have chosen Jamo products. To find out why you should be choosing Jamo, call free on 0321 300316 for a free information pack. Lines are open 24 hours a day every day of the week. All callers will be entered for our free draw to win one of ten exclusive leather CD wallets every month. Don't forget to mention Hi-Fi World and the month of the magazine.

**Call Free 0321 300316 and WIN**

<http://www.jamo.co.uk>



How did Acoustic Design get the SERIES-1 in the door?

power amplifiers (the A300 at £149 and the A500 at £199) and two CD players (the D300 at £149 and the D500 at £199). All share the same remote control and sounded very good playing through a pair of Mordaunt-Short 815 loudspeakers. This choice came as no surprise as Audio Partnership (who own Cambridge Audio) announced, just before the show began, that they'd bought Mordaunt-Short.

Arcam are doing very well in the USA having had rave reviews for the Alpha 9 CD player which uses the dCS-patented Ring DAC. However they're very aware of the importance of Home Theatre and Multi-Room for the future and have extended the facilities of the Arcam 10 amplifier to include the DAVE card for decoding Dolby Digital signals. Asked about Arcam's plans for a DVD player John Dawson (Managing Director) points out, in the Arcam Newsletter, that they will not release any products until a "Universal" DVD player is possible.

German loudspeakers are hardly common in the UK but that may be changing soon. Steve Harris (formerly with Mordaunt-Short and Epos) announced the distribution of ALR Jordan in the UK. Of special interest was the NOTE 3, a two-

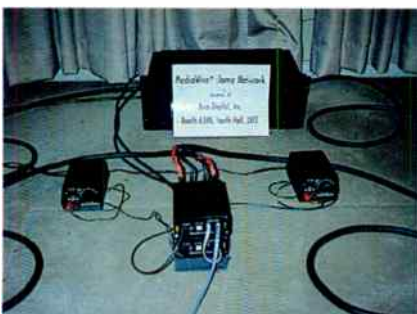

The scary phone-line interconnect and digital amps.

way stand mounter with metal basses and tweeters which incorporates an elliptical ABR on the rear. Steve explained: "There are weights you can add to the ABR that allow you to optimise the bass response to your room and musical tastes. The two extremes are: the heaviest weight for maximum bass extension, perhaps for Classical music in a large room, and the lightest weight for a snappier bass with Rock and Jazz in a smaller room."

There were a few products that I'm sure will never make it across the Atlantic. One was the TLG Acoustic Design SERIES-1 'speaker. This all-in-one horn-loaded stereo loudspeaker took up a whole wall in one of the hotel rooms. It must be very efficient but I'd like to know how they managed to squeeze it through the door.

Something that will make it across the Atlantic in a big way will be the new breed of digital amplifiers. These achieve high efficiencies (95% compared to 50% for an average amplifier) so there's no need for large heat-sinks, exotic casing or massive power supplies.

Linn showed a prototype digital amplifier called the Klimax and Apogee



Russian Trawler 6C33s on the CR Developments Artemis.

Technology were showing a 25watt module about the size of a matchbox. They directed me to the Huff Loudspeaker room to listen to a pair of omni-directional Huff System Three loudspeakers driven by the tiny tots. When I got there, I found that the digital signal from the source flowed to the amplifiers down a piece of cheap telephone cable (using a technology called MediaWire Home Network). The results were impressive - incredibly transparent and completely free of glare and grain.

MediaWire claim that their system can



New York, New York on the Strip.

distribute many channels of DVD-Video and DVD-Audio around a house via the cheapest cable or an existing phone network. It's perhaps unfair to judge a system on just one demo, but if I were a cable manufacturer or a builder of monster amplifiers, I'd be very worried indeed.

In the Ballroom of the Alexis Park there were lots of stalls selling tubes (valves) from many exotic locations, 180gm vinyl discs, audiophile CDs and 24/96 audio discs.

Next door in the St Tropez Hotel was a breakaway show running in parallel with the CES. There I found Chris Lanham showing CR Electronics' impressive Artemis power amplifiers (£6000 a pair). These beautifully-finished units come with huge Russian 6C33 valves that were originally designed for "Russian trawlers!" They were producing very liquid sounds with loudspeakers from Jean-Marie Reynaud. These French works of art have drivers with double-voice coils, each of which is fed with different frequencies.

Utterly exhausted at the end of the show, I found myself back on the Strip. There's no doubt that Las Vegas is about to change but what about audio? The show indicated that several technologies were waiting in the wings to revolutionise the industry over the next few years. Manufacturers will really have to keep their eyes on the ball if they want to survive.

For myself, I find the prospect of multi-channel, high-resolution audio both exciting and a little scary. Would I have to buy my CD collection all over again in a new format? I don't think so. However, the prospect of the computer industry taking over audio is much more worrying; after all, they have yet to demonstrate any great understanding of sound quality ●

# CANNED LAUGHTER

Simon Pope seeks headphone solace in Ergo's Model 2 and Jecklin's Float 2. Joining the fray is Creek's OBH-11SE headphone amplifier.

There are certain members of society who, when taking a personal stereo out of its box for the first time, file the supplied headphones under 'Emergency Use Only'. If these low-budget, in-the-ear boom 'n' tizzers are supplanted by Ergo's Model 2 or Jecklin's Float 2, suffice to say their, erm, non-conformist appearance would probably be greeted with much merriment from fellow commuters.

Both Ergo and Jecklin are Swiss designs which incorporate little or no (depending on cranial dimensions) contact between the ear and the 'speakers. They stay put thanks to a foam strip that sits behind each ear, resulting in an air flow between the ear and the 'speakers which reduces discomfort and listening fatigue. The sort of presentation that both of these open-back headphones aim to create through this arrangement is supposed to be close to that of an electrostatic design.

## ERGO MODEL 2

Of the two, the £140 Ergo 2 actually looks slightly less daft, to be blunt. The drivers possess neodymium magnets, very thin membranes and aperiodic damping to reduce distortion. Frequency response is quoted as 20Hz to 20kHz and Total Harmonic Distortion at less than 0.3%.

The Ergo's bass and soundstaging are very different from those of closed-back headphones, where both can sound flat and processed. This talent for revealing meant these 'phones could be unforgiving of poor source material. Conversely, well-produced recordings sounded very good indeed. Talvin Singh's Anokha album impressed with its wide soundscapes and deep, precise Drum 'n' Bass tracks. Every nuance across the frequency range was



The Ergo 2s.

cleanly executed, with close-mic'd vocals atmospheric and high frequencies smooth and airy.

Where this open sound really makes its presence felt is on acoustic music. Bach's meditative sonatas for solo cello, played by Yo-Yo Ma, were beautifully lucid and uncoloured. In addition to the notes themselves, the sound of the bow digging into the strings gave an

almost frighteningly realistic performance.

## JECKLIN FLOAT 2

The £100 Jecklin Float 2 builds on the shape of the Ergo and takes it to a full-blown helmet design (if you wish to complete the look, simply do your listening in a suit of chain-mail). The claimed response is slightly reduced next to that of the Ergo at 30Hz-20kHz, and the distortion higher at around 0.8%. Not as sturdy as the Model 2 but still comfortable, the Float 2's 400gms of weight are very evenly spread out. The only problem with the loose fit is that it can wobble about if you nod your head to the beat!

The Jecklin has a cooler, thinner tonal balance than the Ergo. Talvin Singh's CD had plenty of space and colour but there was a lack of deep bass compared to the Ergo. Despite



Inside the OBH-11SE, all circuitry is discrete.

this, what there was remained enjoyably fast and controlled.

With Yo-Yo Ma's inspired Bach interpretations, the Float brought out the delicacy in the music, endowing this complex piece with an effortless elegance. Overall, the Float turned out to be truly transparent with the caveat that, with bad recordings, the mid and treble is weaker than the Ergo's.

Whatever their shortcomings, the music emerging from the Jecklin is infinitely preferable to what a lot of closed-back designs manage. It's a bit like comparing panel 'speakers to boxes; the panels take the honours when it comes to airy acoustic reproduction (especially Classical), but if you want more punch and bass, artificial though they may often be, then your best bet is a box.

### CONCLUSION

Looks apart, these sci-fi headphones have an awful lot to offer the music lover with the amount of detail they dig from recordings and the uncoloured way in which they present it.

Although they are of extremely similar design (and share the same country of origin - Switzerland - and distributor), the Ergo and Jecklin do have different sonic characteristics. The Model 2 has an extra refinement reflected in its price; the bass goes lower and the tonal balance is more even as well. Both, however, have a kid-glove touch which more traditional 'phones at the same price have a hard time getting near. And as for the fatigue factor, you can actually listen to either for hours without your ears getting sweaty, itchy or bored.

### IN THE DRIVING SEAT

The lack of a headphone output on a lot of mid-price and high-end equipment has given amplifier manufacturers like Creek a chance to plug the hole with some dedicated headphone stages. One benefit for the audiophile is that the latter tend to be sonically leaps and bounds ahead of the former. In fact, if you're an avid headphone listener, a

stand-alone box is an essential accessory.

Of the relatively few headphone amps available at present, two are made by Creek, the £129 OBH-11 and the one reviewed here, the £199 OBH-11SE. One major difference between the two is that the SE possesses a pair of 0.25in. jacks, so your musical edification can be shared with a loved one. Another is that it works in class A with zero feedback, powered by Creek's own high-quality OBH-2 DC power supply in a bid to deliver optimum sound quality. Also featuring on the front panel is an Alps Blue volume potentiometer.

Like the standard OBH-11, the SE is compatible with any line-level source, so components can be connected directly to it. There are two pairs of phono sockets at the back, one the input and the other an output for linking the OBH-11 to another component, such as an amplifier or recorder, for monitoring. I duly warmed up the amp for the recommended 24 hours and set to work with two pairs of headphones, the Sennheiser HD565 Ovation and Ergo Model 2.

Kicking off with Bjork's Post spinning inside Thule's CD100, I was greeted by a full sound with crystal-clear imaging, vocals centred just above the horizontal. Tonally the Creek was neutral without veering towards the clinical due to its treble and midrange smoothness.

With Rameau's Suites from Plâtée And Dardanus the OBH-11SE responded with a splendid rendition. Detailing and transparency were top-notch, the liveliness of the tambourines and tambour drums



Two headphone sockets enable shared listening.



Jecklin's Float 2s.

lending the performance a rhythmic 'lilt' that made for engrossing listening. The demanding sound of the period violins was tamed by the natural warmth of the acoustic and unexaggerated by the Creek so that none of my fillings fell out. This contrasted strongly with the brittle, sour version of these instruments which a lot of solid-state gear stoops to.

The bass of acoustic string instruments is never going to be as pronounced as a studio bass guitar or kick-drum, but it was neatly balanced by the Creek against the rest of the orchestra to give it just the right amount of weight.

U2's new Best Of compilation proved a sterner test for the Creek. The early singles with their metallic, bass-light Eighties production style sounded unremittingly hard, with a very prominent midrange. All this was down to the engineers rather than the Creek, but then this little black box doesn't take any prisoners.

The OBH-11SE is a very lucid, natural headphone amplifier which scores just as highly on acoustic and Classical music as it does on competently-produced Pop and Rock. The only time it might not suit is if your collection contains a lot of poorly-engineered discs whose faults it won't hesitate to show up.

- Ergo Model 2 £140
- Jecklin Float 2 £99
- Creek OBH-11SE £199

May Audio Marketing  
Aireside Mills,  
Cononley,  
Keighley,  
West Yorks. BD20 8LW  
Tel: 01535 632700

Creek Audio  
2 Bellevue Road,  
Friern Barnet,  
London N11 3ER  
Tel: 0181 361 4133

# CLEARAUDIO

## TURNTABLES & CARTRIDGES



*Sound of Mind  
Clear of Thought...*

**@A**  
Absolute  
Analogue

TEL +44 (0)1425 654488  
FAX +44 (0)1425 654400

Please phone for your nearest stockist  
Dealer enquiries welcome

# THULE

## AUDIO



Introducing the Thule Audio range of remote control products:

Amplifier	Pre/Power amps	CD Players	FM RDS Tuner
Spirit IA60 (2x60W) £449	Spirit PR100 £399	CD100 £599	TU100 £499
Spirit IA100 (2x100W) £599	Spirit PA100 (2x100W) £599	CD150B £699	
Spirit IA60B (2x60W) £699	Spirit PR150B £699	Digit £439*	
Spirit IA150B (2x150W) £999	Spirit PA150B (2x150W) £999	(*upgrade for CD150B)	
Space IA250B (2x250W) £1799	Space PR250B	Avail Spring 99	

\*B' suffix products have Fully Balanced inputs and/or outputs.

Thule Audio products are guaranteed for TWO years from date of purchase.

# AUDIOVECTOR



### Loudspeakers for 1999

Entry level C Series  
C1 bookshelf (£399/pr)  
C2 floorstander (£799/pr)  
(finishes: Beechwood, Black Ash, Cherry and Rosewood)

### And the UPGRADEABLE M Series

M1 (from £759/pr - "Worth consideration" - Hi-Fi World, Aug '98)  
M2 (from £1399/pr - "Recommended" - Hi-Fi Choice, Jul/Aug '98)  
M3 Signature £2499+ and the NEW M3 Signature Active (£3999+)  
(veneers: Beechwood, Birds-eye Maple, Black Ash, Cherry & Rosewood)

5 year transferable guarantee on all Audiovector speakers

# SUPRA

### Interconnects

DAC-X analogue (phono/phono)  
EFF-ISL analogue (phono/phono) "Best Buy: Hi-Fi Choice"  
EFF-IXLR balanced (XLR/XLR)  
EFF-ID digital co-ax (phono/phono)  
DAC-XLR AES/EBU digital (XLR/XLR)  
ZAC fibre optic - New for 1999  
EFF-IV video (phono/phono)

### Speaker Cables

Classic Series: 2.5mm, 4mm, Quattro 4 (bi-wire),  
Ply Series: 2.0 & 3.4 (low inductance)  
LINC Series 2.5mm and 4mm (shielded)



Hi-Fi cables - analogue  
Focus 1.2 OFC hi bargain at £30\* - Hi-Fi World  
IC100 Mk 11 Class 1 LC OFC interconnects  
Status 3.4 LC oxygen free silver

Hi-Fi cables - digital audio  
Dateline 500 OFC digital co-ax cable  
Dateline 700 silver plated digital co-ax cable

Home Cinema Cables  
Image 5.1 silver plated OFC analogue/digital  
"Highly commended" - Home Cinema  
Choice 1998 Awards (pictured)  
Optic 2.1 fibre optic (for Dolby Digital)  
Dateline 700 composite video  
Dateline 750 s-video (for DVD Laser Disc)  
Scart 1.2 fully wired scart cables



Analogue, Digital,  
Video and Optical  
cables for  
hi-fi and home  
cinema applications.



For all your present and future needs  
... look no further

Please rush me the low-down on:

Thule Audio  Supra  Audiovector  Insert Audio

Name: .....

Address: .....

.....

.....

Post code: .....HFV9904

For catalogues, prices and dealer lists, please contact:  
(or post/fax the coupon)

Glaive Limited  
Unit 7, Wren Industrial Estate  
Coldred Road, Maidstone  
Kent ME15 9YT

Tel/Fax: 01622 664070  
Email: sales@glaive.co.uk  
Web: www.glaive.co.uk

# THE MAGNIFICENT 7?

Do Mission have another loudspeaker success story on their hands with the new 772, asks Jon Marks.

It takes a certain degree of corporate muscle-flexing to produce a budget 'speaker that looks like more than just a biscuit box with delusions of vinyl-wrapped grandeur. However, Mission have managed this tough trick where many others have failed; the name on the enclosures trundling off the conveyor belts is the 77 series.

Proving that these attractive transducers are more than merely pretty packaging are the drivers bolted to the MDF front baffle. Below a 25mm silk-dome tweeter with leaf-spring suspension moulded into its face-plate is a 130mm mid/bass unit with Aerogel cone and phase plug. This is loaded by the reflex-ported, 11 litre enclosure.

It comes as no surprise sonically that the 772 is a very close cousin to the 771 reviewed back in the July 1998 issue. Though the cabinet may be more coffin-like this time around, there was that same precision imaging and soundstaging which, on Eric Bibb's Good Stuff, breathed life into the acoustic and the band members.

Another welcome trait was the tonal evenness that comes from an able silk tweeter and Aerogel mid/bass unit linked by an unobtrusive crossover. It was in this area that the 771s had pulled ahead of the all-conquering Tannoy Mercury m1s, whose treble is a touch bland and fizzy by comparison. Returning to EB and co, the Missions' clarity and tonal richness were undeniably impressive as they set cleanly-outlined and three-dimensional images within a deep acoustic, and this went for heavyweight numbers as well as voice-and-guitar tracks.

The 771s' sole flaw (although that's possibly too strong a term) was



bass extension, or rather the lack of it. If Classical is your favourite genre and you have a penchant for orchestral pyrotechnics, the way in which the 771s' mid/bass drivers could crack against their end-stops would be a disappointment. While their bigger brothers employ a cone of the same diameter, the greater box volume allows them to delve deeper without running out of steam. Large-scale orchestral works like Stravinsky's Firebird Suite and some truly heavyweight Dance and Dub CDs went to show that the 772s don't suffer the same limitations, although cranking the volume too high will eventually have the drivers protesting.

The enclosure volume of 11 litres may allow lower bass frequencies to be explored than was the case with the 771s' 6.5 litres, but it does

involve a small penalty. Larger boxes mean larger panels mean more cabinet honk, with the 772s becoming occasionally overenthusiastic in the upper bass. Mission have kept this type of coloration to fairly innocuous levels in the 772s, and part of the reason it sticks out here is because of the lack of cone and dome anomalies adding to the sonic pollution.

Bi-wired with quality cable and happily resident on heavy stands like Atacama SE20s or SE24s, the 772s repay investment in a source of real budget calibre. Partner them with amplification at least as good as Denon's classic PMA-250SE and either a Pro-ject 1.2 turntable or Cambridge CD-4SE CD player, and you won't feel that your wallet's been emptied in vain.

**Mission 772** £229.90  
**Mission,**  
**Stonehill,**  
**Huntingdon,**  
**Cambs. PE18 6ED**  
**Tel: 01480 451777**

## WORLD VERDICT



Civilised standmounters which lack nothing in control, finesse or transparency.

Measured Performance see page 111

# HIGH END OPEN WEEK

VINYL AND CD : NO HOME CINEMA : JUST PURE HI-FI

Mon 5th April	Tue 6th April	Wed 7th April	Thu 8th April	Fri 9th April	Sat 10th April
DNM amplifiers	ATC amplifiers and/or	EAR YOSHINO and FINAL amplifiers	TRILOGY amplifiers	PASS LABS amplifiers	CAT preamplifier
REHDEKO loudspeakers	ATC active loudspeakers	AVANTGARDE loudspeakers	AUDIO PHYSIC loudspeakers	HALES and JM LAB loudspeakers	PASS LABS power amplifier
					EGGLESTON loudspeakers

The following source components will be available for all days: **AUDIO SYNTHESIS (DAX DECADE) BAT MORCH PASS LABS HELIOS (STARGATE) (cd), VERDIER MORCH CLEARAUDIO GRAHAM TRANSFIGURATION AMAZON (vinyl).**

You are welcome to turn up whenever you like (between 11am and 7pm), no booking necessary, with your favourite cds and records, to just enjoy yourself. Whenever possible, there will be a manufacturer's or distributor's representative on hand to give you detailed information, as well as the usual help from Les and Pete.

ARS Acoustica ATC Audio Physic Audio Synthesis Avantgarde Balanced Audio Technology Clearaudio DNM EAR Yoshino Eggleston Works Electrocompaniet Final Graaf Hales Helios JM Lab Living Voice Morch Musical Fidelity Nordost Pass Labs Rega Rehdeko Stax Sugden Trilogy Unison Research Van den Hul Yamamura Churchill



## Walrus Systems

11 New Quebec Street London W1 0171 724 7224

fax 0171 724 4347  
e-mail: mail@walrus.co.uk  
web: www.walrus.co.uk

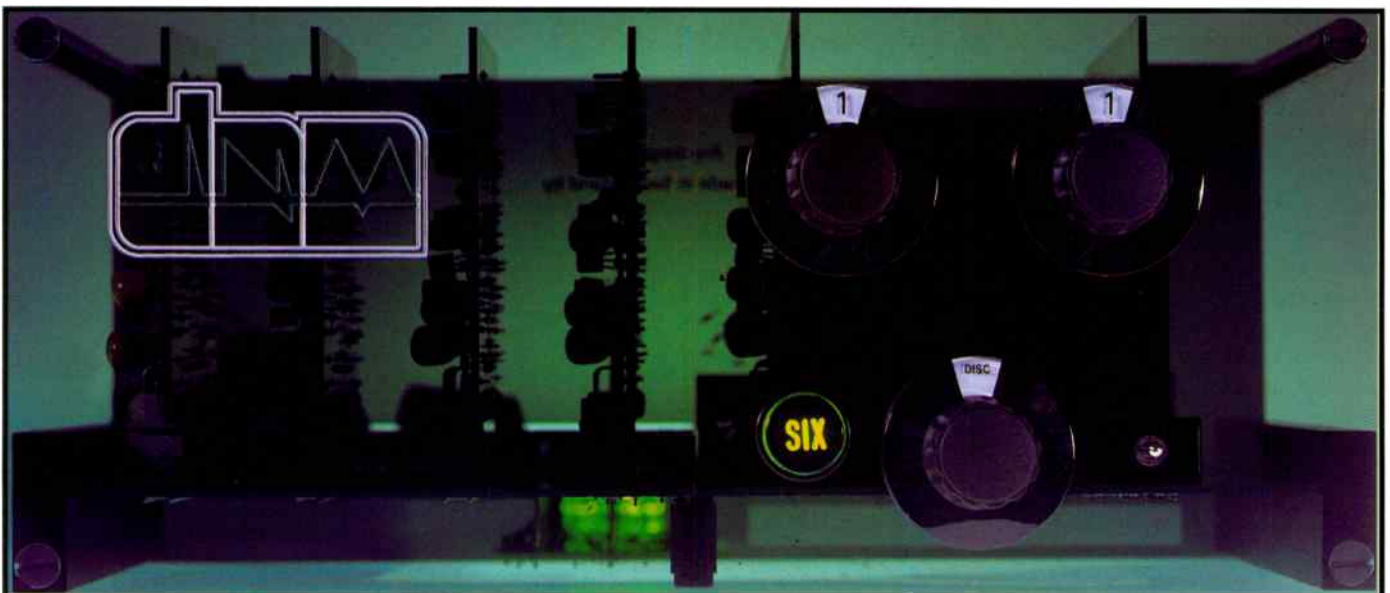

# Thinking different...



Audio Scene  
Chesterfield  
01246 204005

Hazlemere Audio  
High Wycombe  
01494 437892

The Right Note  
Bristol  
01225 874728

LMD Audio  
Margate  
01843 220092

The Music Mill  
Edinburgh  
0131 555 3963

Walrus Systems  
London  
0171 724 7224

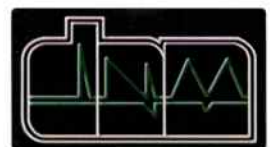

high-tech for music  
British amplifiers handmade in Switzerland



# FLAT RESPONSE

Simon Pope tests a pair of 'speaker cables that won't make your living room look like a hosepipe shop.

## NORDOST SUPER FLATLINE £17.95/m.

The Super Flatline was specifically developed as a bi-wire cable with its 16 solid-core, Oxygen-Free Copper rectangular conductors. Bass frequencies are isolated on a separate cable to reduce inter-frequency interference.

This cable's most obvious trait is its exquisite openness, Classical music benefiting greatly. Carrying a well-recorded CD of Messiaen's orchestral music as performed by the Cleveland Orchestra under Pierre Boulez, the Super Flatline showed off a class-leading clarity and detail.

Shimmering percussion, airy woodwind and rasping brass all contributed to some highly enjoyable listening. Timpani strokes were fast and clean, and the treble percussion sweet and smooth without sounding veiled. The root of this clarity was the Super Flatline's ability to create real space between orchestral instruments.

With a Dance album (Second Toughest In The Infants by Underworld) the Flatline displayed an adept handling of bass. Isolating the lower frequencies on a separate cable really seems to work, as the drum machine had a new-found depth and precision which added pace to the music.

The Yank Rock of the Screaming Trees was next in line, and yet again

instrumental separation was excellent - bass and drums proved tight and powerful, vocals crystal clear. The acoustic guitars of some tracks were eerily atmospheric, leaving the electric guitars to Rock like crazy.

This cable manages to combine both delicacy and clout with clarity and is highly recommended.

## CHORD COMPANY MYTH £14.95/m.

The Chord Company Myth is constructed from two sets of seven strands each for the bass (which requires relatively large amounts of current) and two sets of four strands each for the treble. The Chord Company say the conductors are spaced to provide optimal capacitance and inductance values; polyethylene is used in the jacket because of its low dielectric constant.

Returning to the Messiaen CD, I discovered the Myth had a brighter

top-end than that of the Nordost. The rasp of the brass was slightly too harsh for my tastes and percussion such as triangles and cymbals had an artificial metallic edge to it. This aside, the rest of the tonal spectrum and detailing were very good - bass drum, timpani and bass clarinets had deep, realistic resonance and I could easily make out the frenetic fingerwork of the woodwind players.

Underworld's album got along fine with the Myth, its crisp treble bringing out the best in what is a 'dark' recording and lifting it out of the doldrums it can fall into with poor equipment. The classic track, 'Pearl's Girl', stomped out of the Heybrooks, small details which are usually difficult to pin down clearly defined among the musical melée.

The Myth's treble emphasis raised its head once more when I plied it with the Screaming Trees. Although everything else was present and correct, the guitars and vocals often had a steely edge to them which, although in keeping with this sort of guitar-based Rock, could become fatiguing.

The Chord Company's Myth has its fortes in detail and imaging. If you like your treble hard and crisp too, it could be right up your street●

**Nordost**  
1st floor, Unit 7,  
Aber Park Ind. Estate,  
Aber Road,  
Flint,  
Clwyd CH6 5EX  
Tel: 01352 730251

**The Chord Company**  
30a Sarum Business Park,  
Portway,  
Salisbury,  
Wilts. SP4 6EA  
Tel: 01722 331674



# WIN A STYLISH TURNTABLE AND A RECORD CLEANER WORTH £1300

**This month's competition is definitely for lovers of vinyl with a Clearaudio Solution turntable and VPI HW16.5 record cleaner.**

**J**on Marks auditioned the Clearaudio Solution turntable back in February 1999 when all at World Towers were taken by its skeletal looks. What endows the Solution with such eye-catching aesthetics is a low-mass perspex base and a matching platter standing on three brass cones. The inverted bearing on which the platter rotates is also machined from brass and bolted through the chassis.

Upholding a tradition reinforced by Japanese decks in the Seventies, three tone-arms can be bolted to the Clearaudio. In a



bid to minimise noise from the motor, the AC synchronous unit is bolted to a free-standing brass cylinder. This makes swapping between 45rpm and 33rpm easier than on many decks where you have to go in for a spot of dismantling just to get at the belt.

Sonically, the Solution scored for its powerful presentation which manifested itself in a very musical way; with a little attention to set-up, it began to produce fine results. Going under an RB300 (supplied along with Clearaudio's Alpha MM with the Solution in this competition) and Clearaudio's own Sigma MC, Heaven 17's *The Luxury Gap* produced "an airy, open sound and meaty bass". Lou Reed's *Transformer* was equally impressive, Jon Marks noting that the clarity of the vocals and detailing were "unpolluted by their passage from groove to loudspeaker. Tracks like 'Vicious' and 'Walk On The Wild Side' had a weight and imaging precision that made for some very convincing replay".

With Classical recordings the Clearaudio managed to turn in similar results. The neutral tonality of perspex suited Britten's *Young Person's Guide To The Orchestra*; "Strings and brass were both incisive and crisp, set within a soundstage of commendable size". To top it all off, the Solution homed in on rhythms and beefy basslines to bring out the excitement in performances.

This month's second competition prize is the HW16.5 from American manufacturer VPI. While it might bear more than a passing resemblance to an old gramophone unit minus the horn, this device makes cleaning records a painless process.

Cleaning fluid is evenly applied with a small brush to an LP clamped to the platter. As the platter revolves, a flick of a switch gets the vacuum motor going. This draws the arm with its velvet pad down onto the record and sucks the used fluid from the groove and into a dedicated container. The one thing to remember is that the VPI has to be used in conjunction with the supplied fluid - it's not a 'dry' cleaner.

Richard White found that most records needed only one sweep to regain their former pristine condition. Once finished, he adjudged the VPI to have done "a splendid job". Surface noise was reduced considerably, the added bonus being extended stylus life due to the diamond not having to plough through so much grunge in the groove.

To qualify for the opportunity of winning one of the above, all you have to do is answer the questions below correctly and follow this by completing our Miltonesque tie-breaker in no more than 30 words. Stick the form (or a photocopy) onto a postcard or sealed envelope (not inside it!) and send it to the following address to arrive by April 5th:

**Clearaudio/VPI Competition**  
**Hi-Fi World Magazine,**  
**Suite F29, Imex House,**  
**Kilburn Park Road,**  
**London NW6 5LF**

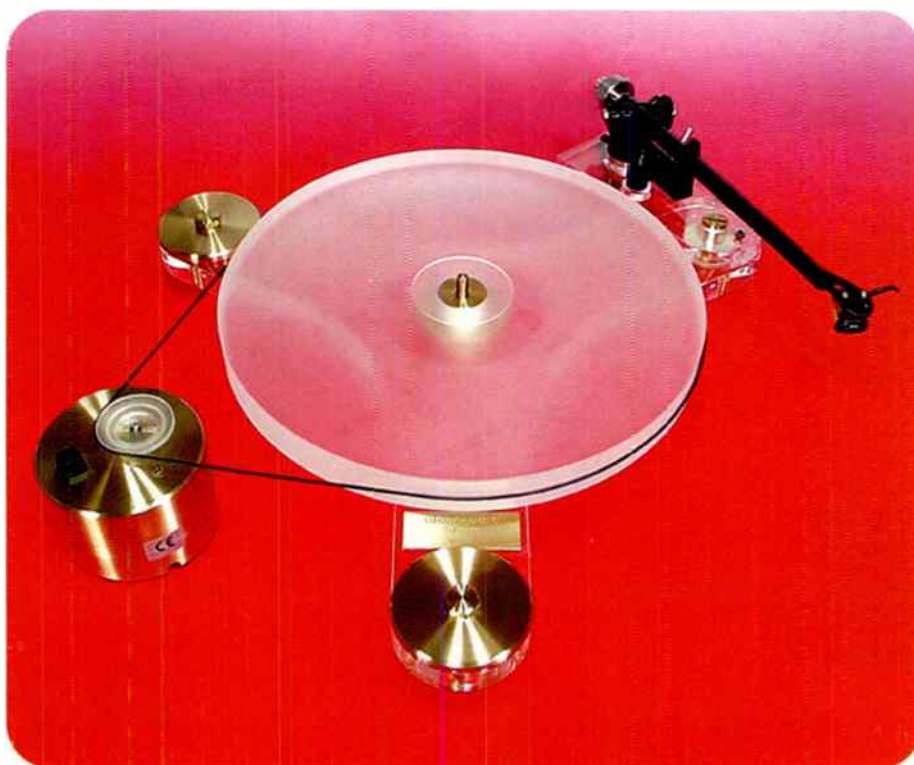

## COMPETITION ENTRY QUESTIONS

1) From what substance is the base of the Solution made?

- A. Perspex                      C. Gravy  
 B. Solid hardwood          D. Polystyrene

2) What type of outboard motor does the Solution use?

- A. AC synchronous          C. Induction  
 B. DC                              D. Perpetual motion

3) How many tone-arms can be mounted on the Solution?

- A. 1                                C. 3  
 B. 2                                D. 5

4) How does the VPI remove rubbish from the groove?

- A. Vacuum suction          C. Sand blasting  
 B. Magnetism                D. Eviction notice

5) What is the VPI record cleaner called?

- A. TV21                         C. HW16.5  
 B. Rambo-4x4                D. The groover

## COMPETITION VERSE (obligatory)

Complete the following in fewer than 30 words

*This month, we've a couple of spinners*

*So pause now, and reflect - if*

*You're amongst the lucky winners,*

*Will you keep things in perspective. . ?*

## COMPETITION WINNERS

February's prizes have been snapped up thus: Victor Story of Middlesborough nets the Musical Fidelity X-Ray CD player; Mick Page of Birmingham takes home the Black Box loudspeaker stands; Mr R. Heyward of Herts. is the new owner of a Sonneteer Sedley phono stage; Andrew Chapman of Surrey collects the Midiman Flying Calf DAC. **Congratulations!**

# reson

## reson mica

MM Cartridge £185.00

Trade-in price \*£135.00



## reson etile

MC Cartridge £455.00

Trade-in price \*£345.00



## reson aciore

MC Cartridge £299.00

Trade-in price \*£215.00



## reson lexe

MC Cartridge £1300.00

Trade-in price \*£975.00



## reson reca

MM Cartridge £250.00



Virtual Reality Audio Systems Ltd.

P.O. Box 383, Borehamwood, Essex, CM14 4GB

Tel: 01377 237355 Fax: 01377 224103

E-mail: info@vreality.demon.co.uk



## ORANGES & LEMONS

Juicy fruit from  
London's freshest  
hi-fi / home cinema retailer.  
Free home installation + credit cards,  
0% credit finance available  
(subject to status).

ARCAM, B&W, CABLETALK, CAS-  
TLE, CHORD CO, DENON, EPOS,  
KEF, MARANTZ, MICROMEGA,  
NAD, NAIM, NEAT, QUAD, REGA,  
ROKSAN, ROTEL, ROYD, RUARK,  
SOUNDSTYLE, STANDS UNIQUE,  
YAMAHA

Now in our fifth flamboyant year

**THE INNOVATIVE  
AUDIO RETAILER**

0171-924 2040

61/63 WEBBS ROAD, CLAPHAM, SW11

# PASSLABS

CALL FOR  
OUTSTANDING  
WORLDWIDE  
REVIEWS

STEREOPHILE  
AMPLIFIER OF  
THE YEAR



**Aleph 3**  
30W Single Ended Stereo



**X 1,000**  
1,000 W Class A Mono Block



**DAC D1**  
Fully Balanced/Volume Control Output

## 'IN A CLASS OF THEIR OWN'

Call for more details to our specially selected  
dealers below

WALRUS SYSTEMS	LONDON	0171 734 7224
ZOUCH AUDIO	ASHBY DE LA ZOUCH, Lincs	01530 414 128
LINTONE AUDIO	GATESHEAD, TYNE & WEAR	0191 477 4167
THE RIGHT NOTE	BATH, AVON	01225 874728
THE AUDIO NOTE SALON	GLASGOW	0141 357 5700
SOUNDS OF MUSIC	TUNBRIDGE WELLS, Kent	01892 547 003
MIDLANDS AUDIO EXCHANGE	HIDDERMINSTER, WORCS	01562 822 238
HAZELHIRE AUDIO	HIGH WYCOMBE	01494 437892
AUDIO EDGE	WOKING, Surrey	0800 052 1944

## ZENTEK MUSIC LTD

Manufacturers of fine music products

PASSLABS • FOGLESTON WORKS • HALES • COPPELLAR

SYNERGISTIC RESEARCH • BALANCED AUDIO TECHNOLOGY • REFERENCE SA

T: 01892 539595 F: 01892 547004

# MAGNETIC PERSONALITY?

The competition is stiff, so how does the Alpha, Clearaudio's entry-level MM, shape up? Simon Pope rides the groove.

The current World team may unfortunately be of the last generation to grow up taking vinyl for granted. In our search for current products to keep the black stuff spinning, we came across the Alpha MM cartridge from Clearaudio, whose stylish perspex Solution turntable we reviewed in our February issue. Once you've struggled through the chic plastic pyramid of a box, you can appreciate the hefty construction (10gms!) - for a change the metal body is real and not a tin-foil casing.

For its first spin, the Alpha was screwed to a Linn Akito arm on an Axis turntable. No colour-coding on the output pins, unfortunately, so it took a few more minutes than usual to set up. Ready to Rock, I put on my new reference Dance LP, Talvin Singh's OK with its esoteric mixture of Indian Classical music and Drum 'n' Bass.

This is a superbly-engineered album with high levels cut into its grooves. The Alpha immediately picked up the detail in the production, the acoustic contribution from the Madras Philharmonic Orchestra tidily presented alongside clear strings and precise mechanical syncopation. In the bass the Clearaudio didn't dig as deep as the Goldring 1042 or the DNM Mica, but it remained musical.

Moving on to Paul Weller's greatest hits produced a rather different outcome. This poorly-mastered record has eight tracks per side. The result? Lower levels due to tighter groove spacing, which meant

the Alpha had a hard time teasing subtleties from the vinyl. While vocals and guitars were detailed the rest of the musical canvas was a bit of a blur. Rhythm lost out too, with the kick-drum late in delivering its thud and cymbals a little too splashy for comfort.

Kleiber's Vienna Philharmonic recording of Brahms' Fourth Symphony on DG is an acid test for pick-ups, and it found the Alpha floundering a little on rhythmic grounds. This pressing contains some of the best playing and musicianship ever committed to disc, although admittedly its engineering is not the most polished. The woodwind and rich Vienna strings were fine, but the overall performance lacked essential drive, the strings attack and timpani that spark of precision.

A session with the slightly more sympathetic combination of an LP12/SME 3009 showed a marked improvement. However, a failing which had been a mere background feature before now became more prominent. The upper registers of violins picked up a steely edge that stood in stark contrast to the triangle, which was bright, open and natural. Bass was again light, but massive extension is not a prerequisite with this music anyway.

Crystallising the Alpha's way with Classical LPs was the Borodin Quartet performing Borodin's Second String Quartet. The tonal balance was on the cool, light side and lacked the warmth to highlight

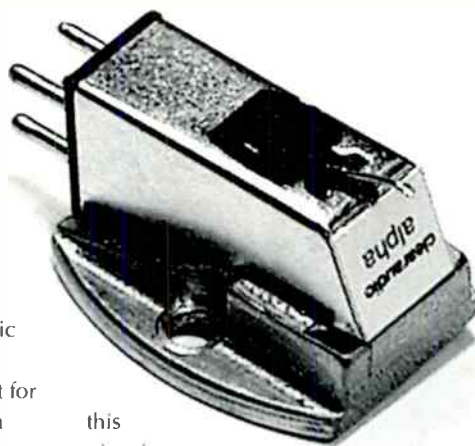

this piece's brooding melancholy. This isn't an obstacle with the academic precision of the likes of Webern, but it doesn't cut the mustard on Brahms or Borodin.

Picking up some Pop with the Depeche Mode singles compilation I encountered a less flabby bass response. The tight electronic rhythms pounded out with verve but the vocals, although prominent, were sibilant in places. This became slightly annoying after a while, but at least my feet were still tapping away.

The Alpha is by no means a bad cartridge, it just isn't too fond of poor recordings. The imaging and soundstaging have decent focus and openness, and there's a certain amount of finesse with more delicate recordings. However the Clearaudio's occasionally clinical sound can fail to communicate musically, especially with Classical fare. In the face of competition from Goldring's 1042 at £120 and Reson's Mica at £135, the Alpha comes close but no cigar●

Clearaudio Alpha  
£130

Absolute Analogue  
PO Box 1532,  
Fordingbridge,  
Hants. SP6 1SB  
Tel: 01425 654488

## WORLD VERDICT



Tends to sound quite hard at the top, but imaging and detail are good. Best in a warm system.

Measured Performance  
see page 111

# HIGH END OPEN WEEK

VINYL AND CD : NO HOME CINEMA : JUST PURE HI-FI

Mon 5th April	Tue 6th April	Wed 7th April	Thu 8th April	Fri 9th April	Sat 10th April
DNM amplifiers	ATC amplifiers and/or	EAR YOSHINO and FINAL amplifiers	TRILOGY amplifiers	PASS LABS amplifiers	CAT preamplifier
REHDEKO loudspeakers	ATC active loudspeakers	AVANTGARDE loudspeakers	AUDIO PHYSIC loudspeakers	HALES and JM LAB loudspeakers	PASS LABS power amplifier
					EGGLESTON loudspeakers

The following source components will be available for all days: **AUDIO SYNTHESIS (DAX DECADE)**  
**BAT MORCH PASS LABS HELIOS (STARGATE) (cd)**, **VERDIER MORCH CLEARAUDIO GRAHAM**  
**TRANSFIGURATION AMAZON (vinyl)**.

You are welcome to turn up whenever you like (between 11am and 7pm), no booking necessary, with your favourite cds and records, to just enjoy yourself. Whenever possible, there will be a manufacturer's or distributor's representative on hand to give you detailed information, as well as the usual help from Les and Pete.

ARS Acoustica ATC Audio Physic Audio Synthesis Avantgarde Balanced Audio Technology  
 Clearaudio DNM EAR Yoshino Eggleston Works Electrocompaniet Final Graaf Hales  
 Helios JM Lab Living Voice Morch Musical Fidelity Nordost Pass Labs Rega Rehdeko  
 Stax Sugden Trilogy Unison Research Van den Hul Yamamura Churchill



## Walrus Systems

11 New Quebec Street London W1 0171 724 7224

fax 0171 724 4347  
 e-mail: mail@walrus.co.uk  
 web: www.walrus.co.uk

It's signed, sealed and it delivers.  
 It could be yours.



01491-834700

THE FORSETI SIGNATURE SERIES PRE/POWER AMPLIFIERS:  
 DESIGNED BY TIM DE PARAVICINI AND ALCHEMIST  
 DISTRIBUTED IN THE UK BY HENLEY DESIGNS

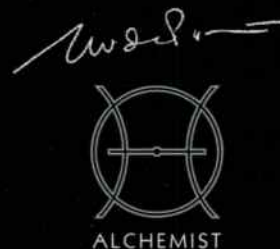

# 320 NAD OUT

Can history repeat itself with a new NAD budget amp to frighten costlier rivals?  
Richard White is our man on the scene.

When it first appeared in 1978 the NAD 3020 quickly gained an enviable reputation as an inexpensive integrated with a difference; in short, it was a fine product at a decent price. With its handy seperable pre and power sections, tone and balance controls as well as an output power indicator, the 3020 quickly won itself friends in all quarters.

As the years have rolled by, NAD has found that imitation may be flattering, but elbow room is becoming a little less easy to find. Although the 3020 has been steadily updated, it is fair to say that the splash of glory kicked up by the original has quietened to a ripple of approval.

To give this situation a prod in the right direction, NAD have produced the C320, an integrated amplifier which, according to the press release, bears the mantle of "the 3020 of the Millenium". The updated layout springs few surprises - the grey fascia has weathered too many changes of fashion to be lightly abandoned. There is input provision for CD, Tuner, two Tape inputs (one monitored), Video, the inevitable Aux and Disc. For one glorious moment I took the last to be a phono stage, but remembering NAD's PPI equaliser, I realized this was another line input.

Treble and bass controls are still provided in addition to the Pre Out and Power In links. The manufacturers claim 40watts per channel driving an 8ohm load so, although not bursting with power, the C320 should provide a comfortable reserve of power when coupled to moderately sensitive loudspeakers (>88dB/1m).

Although not exactly the zenith of recordings, the Naxos CD of Haydn's



Prussian Quartets was given a very fair hearing by the C320. When not among friends, this disc can sound painfully brash, and since string music is a hanging judge for the midrange, I was pleased to find the NAD laying down the foundations solidly, without painful accentuations in the treble.

Diana Krall was set to woo with the aid of some old, Jazzy dinner music favourites. This Impulse CD has some odd equalization in places but the double-bass is recorded with a clarity the NAD capitalised on - there were no booming 'car stereo' effects or one-note phenomena. Although the rhythm guitar remained well back in the mix, the amp made no bones about bringing out its essential (and intentional) blandness. The icing on the cake was the smouldering huskiness of Ms Krall's voice, the NAD's controlled top-end never pushing it towards dry roughness.

As my acquaintance with the C320 deepened, there was evidence of real refinement in places. The only stumbling block here is that it could lead you to forget the NAD's modest price and instead unfairly find it a bit lacking compared to

more expensive machinery.

Our old friend Eric Bibb on Opus 3 obliged with 'Walking Up To Heaven'. While I've heard weightier double-bass, the midrange and lower treble proved once again that the NAD remained an engagingly musical performer when handling pizzicato mandolin and mouth organ obligati.

With my earplugs in place, I travelled around the volume control to way beyond normal listening levels but found that there was plenty of power to spare. Adding some bass boost lent a touch more chunkiness without spoiling the balance of the recording. This could be beneficial if you're listening late at night and don't want the neighbours banging on your door.

NAD's C320 is an unflappable all-rounder at a very tempting price. Even dedicated high-end fans might fare worse if they're after a second system. As for the not so comfortably off, this amplifier has many virtues and no major vices. Whether it will have the impact of its illustrious predecessor remains to be seen: making a budget amplifier worth its sonic salt is a good trick if you can do it at all, let alone twice.

NAD C320 £199.90

NAD Marketing Ltd  
Unit 15, Faraday Road,  
Aylesbury,  
Bucks. HP19 3RY  
Tel: 01296 482017

## WORLD VERDICT



The C320 fills the boots of the famous 3020 in fine style thanks to its balanced, natural character.

Measured Performance  
see p111

## Jecklin float and Ergo headphones ... a revolution in sound

Sonically quite exceptional, for my money these are the best headphones in the review. (Hi-Fi choice, England)\*\*\*

Distinguishing the Ergo AMT from my reference AKG 1000 (costing twice as much) was an extremely difficult task. (Audio USA) \*\*\*

Ergonomic headphone without any pressure, ideal for long term listening. Exceptional clean and transparent sound. (Sound Switzerland) \*\*\*



The Ergo AMT can be viewed like the best combination between a dynamic headphone and electrostatic, with a total absence of distortion and a complete balance in its timbre. (Audio Review Italy). \*\*

Hours of listening pleasure for everyone without the typical headphone fatigue. (New HiFi Sound, Australia) \*\*\*

The balanced advantages and excellent sound image make the J Float 2, without question, the headphone I would like for myself. (Audio Ideas, Canada) \*\*

Their lightweight comfort and effortless sound make the Float 2 a joy to use (What Hi-Fi, England).

Ergo and Float headphones present a natural soundfield to the ear, the unique construction ensuring no direct contact with the ear, unlike conventional headphones that can deprive the human of its natural function by pressing on and distorting the outer ear.

Outstanding performance and comfort at affordable prices. From £79.00

### May Audio

Box 27, Skipton  
North Yorkshire, BD23 1YE  
Tel: 01756 793777 Fax: 01756 793999

## BRAND NEW Rogers loudspeakers at bargain prices!

**DB-101** high tech compact design, unique styling and great sound ! Choice of finishes: electric blue, gold and opal.  
**only £ 148.00 pair.**

### Also available:

Classic **LS3/5a** famous BBC compact monitors, available in black ash, walnut and a very special piano black finish.  
**only £ 424.00 pair.**

Superb **AB-1** sub bass loudspeaker system, dramatically improves the performance of your LS3/5A / Studio 3 / LS 1 models. Choice of black ash, rosewood, ebony and special piano black finish.  
**only £322.00 pair.**

**Limited stocks - so please hurry!**

**All units are brand new, boxed and sold with full 1 year warranty.**

Call: **01256 851001**

**Stirling Broadcast** Charter Alley, Basingstoke, Hants. RG26 5PX



# THE CAGED BIRD SINGS

Jon Marks steps out with Canary Audio's new 601 Mk2 valve pre-amplifier.

While I'm a fully-paid-up member of the valve appreciation society, there are times when I find myself wishing for the crisp insight and incision of well-engineered solid-state to counterbalance the likeable but oft-overdone sweetness so frequently a part of valve pre and power amplifiers. Some companies throw a little odd-order distortion into the recipe to sharpen the taste, others reach their goal by carefully selecting components with a bright signature. In most cases, the latter boils down to capacitors and resistors; for Canary, the volume control, like the Sprague and MultiCap caps, is also fair game. What the lucid, self-effacing TKD stepped attenuator fitted to the 601 Mk2 allows it to do is produce a sound akin to the best of both thermionic and silicon worlds.

The Canary teamed up with sources from Pioneer (a modified DV-505 DVD player) and Trio (L-07D direct-drive turntable, SME V tone-arm and DNM Lexe MC). Ahead of the Magneplanar SMGa panel loudspeakers were Musical Fidelity's X-A200 monoblocs working through 6in. runs of QED Profile Silver 12 loudspeaker cable.

One sure musical grilling most valve pres fail is Dance music followed by Dub Reggae. The treble may shimmer and the midrange may be pure, but the bass which underpins both normally lacks punch, drive and extension. The result is tunes which sound as though they're trying to run through treacle. Not so with the Canary, which can hammer out basslines with speed and power. Axiom Dub's *Mysteries Of Creation* album along with Asian Dub Foundation's *Rafi's Revenge* and System 7's *Golden Section* all made it through the 601 sounding taut, crisp but very smooth. Even Soundgarden's

thrashier Metal moments were controlled and taut, the Canary demonstrating a knack for peering deep into the individual strands of a recording yet still presenting this wealth of detail as a cohesive whole.

A very prime example of this was Sheryl Crow's *Tuesday Night Music Club* album. Most pre-amps at this price homogenise the tracks on this CD. The 601 made it very obvious who had been doing what at the controls and how the band had been mic'd up - some numbers were flat as beer mats in soundstaging and imaging where others had a much more life-like ambience.

The Canary's musicality was just as convincing with the Palladian Ensemble's *Trios For Four* on Linn Records, as it captured the harmonic signatures and tonal characters of the recorder, violin, viola da Gamba and archlute with ease. Its dynamic speed matched with a freedom from hardness or spit were the main qualities contributing to an enjoyable and highly expressive performance.

It was orchestral recordings such as Elgar's violin concerto (L.P.O. under Vernon Handley with Nigel Kennedy) where the scale this pre-amp is capable of portraying came to light. The whole orchestra lay spread out between and behind the SMGas, the 601 Mk2 giving competitors a run for their money in the way it relayed the feeling of open space in the venue. Elgar said of this work, "It's good! Awfully emotional, too emotional, but I love it." These words are put into context by the Canary's natural, fluid presentation.

The 601 Mk2 owes a great deal of its transparency and control to the TKD stepped attenuator and its valve complement (two Sovtek 6922s and an RCA 6CG7). Unfortunately, therein lay a problem with our sample.



The designers of the amp have chosen a high-gain line stage for its sonic prowess. With high output sources like CD players, and power amps of average sensitivities (0.7V-1V), there's little room for manoeuvre on the volume front. With the DV-505, I rarely went past step three on Rock and step 5 on Classical. The situation wasn't quite so bad with phono stages and tuners, whose outputs are often in the 0.3V to 0.5V area. However, if you were driving Lowther 'speakers with Leak monoblocs, you could forget about the Canary - the first position on the TKD would see the cones forcibly ejected from their baskets. After a couple of phone calls to Audio Connoisseurs, it now transpires that the manufacturers will be adding input attenuation to all of the 601s destined for the UK's shores.

At £1600 the Canary is a serious contender for adding to your shopping list. Cheap it isn't, but the internal construction is the best I've seen at the price and the TKD is a storming device. If you're searching for a pre-amp which mixes valve sweetness with grip and control, put the 601 on your list ●

Canary 601 Mk2 £1600

Audio Connoisseurs  
Unit 7, Claremont  
Buildings,  
Old Clatterbridge Road,  
Bebington,  
Wirral,  
Merseyside L63 4JB  
Tel: 0151 343 0007

## WORLD VERDICT



Very musical and very revealing, the 601 Mk2 makes a strong case for itself.

Measured Performance  
see p111

# Letter of the Month

The writer of the 'Letter of the Month' wins a free subscription to Hi-Fi World.

## MILLENNIUM MAN

I read with interest NK's article on the MPMAN portable MP3 device. Along with the new APS camera system, my 20th-century time capsule will include this device. My two great passions are hi-fi and computers, in that order. I can therefore view the MPMAN debate from both sides of the fence.

The main claim of the record companies is that the MPMAN is a recording device and thus will affect corporate profitability. However, cassettes, DAT, DCC and MiniDisc have furnished us with this ability for years. They also say the Internet supplies

material for download over which no control exists in distribution.

To counter this, three points come to mind; (a) The Internet is slow, thus downloads can be costly, even with compression. It would be more cost-effective to buy the required disc.

(b) I have viewed the MP3 sites and sampled the music available. In short, they are unlikely to tempt the readership of hi-fi magazines.

(c) The Win/Win/Win situation. New recording artists need exposure; without distribution this cannot happen. Groups see the Internet as a low-cost distribution network for material. With much-needed exposure, this encourages an interest first from the buying public and subsequently from the record companies. These then arrange recording contracts, sign the bands up and promote their music to the general public. The groups get a wider audience, the public receives more music and the record companies make more money. They discover groups with little effort.

The upshot of MP3 technology is this; people surf the Net, people record music, but people also covet. As a result, LPs and CDs will continue to be bought. The benefits are that MP3 technology is portable, solid-state, non-skip and easy on the batteries. Yes, the situation in the



It remains to be seen exactly what effect on the music business portable MP3 devices will have.

music industry will change, but not on the time-scales that are mentioned in some quarters. I want to listen to music on the move, not destroy the livelihoods of Sony et al. Suffice to say I shall purchase an MPMAN before they are banned.

Terry Vassell  
London.

## WRITE & WIN WITH HI-FI WORLD!

Every letter we print wins a superb prize! On offer are the Chord Co. interconnects, Audio Electronics books, Ringmat Statmats, DNM Licon contact enhancer, DNM Reson 'speaker cable, Vivante LPs, Nimbus Records CD box-sets and a FREE subscription to Hi-Fi World for the best letter of the month! Every other month we are also giving away a DNM Mica cartridge worth £185 or a Musical Fidelity X-ACT DAC worth £130. Please write, fax or E-mail to Hi-Fi World Mail, Suite F29, Imex House, Kilburn Park Road, London NW6 5LF, Fax: 0171 328 1844 E-mail: edit@hi-fiworld.co.uk

**Hi-Fi WORLD**  
W O R L D

**DYNAMITE DVD**  
Battleship DVD-5000  
from Denon

**TWIN SET**  
Top pre/power  
amps under  
£600 tested!

**BABY BOOM**  
Wharfedale's  
Live Diamonds

**1800** WIN TAG MCLAREN PRE AND POWER AMPLIFIERS WITH INTERCONNECTS

**STATMAT**

**BETHOVEN**

## FINALLY BATTERED

I enjoyed your review of the Final Music-5 and Music-6 in the February issue very much, but you didn't mention how long the dry cells last. This I think is important. However it is very clear that a simple amplifier can work very well indeed and I was wondering what could be achieved with your chip amp in Supplement 27 with high-quality components and battery power.

With the proposal to connect homes to the Internet via the already noisy mains, it may well be worth investigating battery power for sources and becoming totally independent.

Perhaps with turntables we could go back to clockwork and save the expense of batteries, but a quiet drive unit may well be too difficult and expensive to produce economically. Nevertheless such a unit could be mounted outboard and belt driven in the usual way. A special version could even be made for Garrards and Thorens with their idler drives.

**Aaron Proctor**  
Scunthorpe.

*Apologies for the omission as to battery life, but then any figures will vary widely depending on loudspeaker impedance, efficiency and volume levels. If the Finals are driving loudspeakers like Thomas Transducers' Virtuoso Gold horns, because these are so sensitive battery life could well hit 60 hours. Into a 4ohm load of only 85dB-87dB you're more likely to get around 20 hours.*

## SHORT-SITED

This query doesn't concern an upgrade as such but relates to equipment siting.

I have just moved house and the room in which the hi-fi is to be located has a sprung timber floor, under which there are no timber joists, only 2in. block polystyrene. The floor actually floats on the polystyrene and isn't fixed at any point. The result is that the floor is 'live' and footfalls are magnified many times - quite alarming amounts of movement can be detected.

Obviously this situation will have to be improved before I install my equipment. Unfortunately the building regulations won't allow a traditional floor



Guinea power is one possible answer to the problem of keeping that platter turning. . .

*The Finals prove that non-rechargeable batteries can sound extremely good, but they're not a practical proposition for higher-power amplifiers. The chip amp we built in Supplement 27 can be made to sound superb seeing as the parts count is very low, which means it can be Vishay'd and Black Gated without taking out a mortgage. Connect two pairs of car batteries to form +/-24V rails as the PSU and the results are sure to surprise. Just beware of completely discharging the car batteries as they're not intended to be deep-cycled. Instead, they should be topped up after use each day.*

*Batteries are equally effective with sources, as I've found out with DC-motor turntables and CD players.*

*Clockwork, hmmm; best*

*reserved for children's toys, methinks. Mechanical speed control would be a headache, and there would be plenty of noise too. By far the best way to optimise the performance of a deck with an AC motor is to plug it into either a huge mains transformer or an AC synthesiser. Slate in their Powerhouse offer one of these. Slightly more comprehensive designs with distortion meters and an output guaranteed to +/-1V are produced by Accuphase, but the 500VA version costs a not inconsiderable £3500. Still, when you consider you could probably run all your sources and a pre-amp or small integrated from it, it doesn't look so expensive. JM*

**Keep the grunge from your connections with a free bottle of DNM's Licon contact enhancer.**

to be installed, so the situation may have to remain.

The walls are constructed in a similar way with brickwork on the outer skin, then a cavity, then plasterboard. How will these methods of construction influence the overall sound in my listening room?

My first thought is to use a wall shelf for my turntable to lift it clear of the floor. As I work in the building trade I won't have any difficulty fixing into the brickwork behind the plasterboard, but I am concerned that the plasterboard may well resonate and influence the turntable.

I had in mind to try to de-couple the

shelf from the wall by using perhaps a squash-ball cut in half, and locate this around the point of fixing. If a squash ball is not ideal, perhaps you could suggest an alternative.

Would it be necessary to locate all my equipment in this way, bearing in mind that the CD player, amps, etc aren't as susceptible to this problem as the turntable?

To be honest the movement around the periphery of the room isn't as bad as it is at the centre. Perhaps locating the equipment tables on paving slabs or the like with cones or spikes might do this trick (except of course for the turntable).

# PURITY of form

# PURITY of function



## ARIA S2

by Unison Research

Combining styling of classic elegance with a sound both pure and natural, ARIA S2 has an unbeatable pedigree. Electronic design to reference standard is by Giovanni Sacchetti, and includes pure silver circuitry throughout. Appearance design is by Italy's top audio stylist Claudio Chiarello. Made for the serious music-lover, the S2 gives you the enchanting sound of a fine single-ended valve amplifier in a sensibly-powered and sensibly-priced package. Check it out soon at your nearest UKD stockist. You'll be enthralled.

### *Thoroughbred Audio Products*

from  
**UKD**

23 Richings Way, Iver, SL0 9DA, Bucks, England

Tel: 07000-853443 (UKD HIFI) Tel: 01753-652669: Fax: 01753-654531  
or visit our website: [www.ukd.co.uk](http://www.ukd.co.uk)

All my gear usually rests on specialist tables - Target and Mana. At my previous address I was fortunate enough to have a concrete floor so none of these problems has arisen before.

J. Watson  
Address Not Provided.

*Given the nature of the problems, I tend to agree that wall fixing is your best route for components. Brick is a superb material for non-resonance but has a much lower absorption co-efficient than plasterboard so, to get the best of both worlds, I should anchor the structure to the brick but spread the load onto the plasterboard.*

*Anyone for squash? Not particularly! Let's examine the required function of any game-type ball. The necessary feature, whether it's for soccer, squash or, for that matter billiards, is to store energy and release it quickly. This is the last thing you want for a*

*decoupling medium. To be of any use, an absorbent needs to waste as much energy as possible. This is why a plastic bag filled with dry sand is such an excellent economy measure: each grain has to be set in motion individually and, since each will impinge upon other grains, the damping works as a chain reaction in reverse. Lightweight it isn't, but if you're keener on results than on weight saving, give it a go!*

*If you don't fancy such Scroogesque measures, there's quite a lot of wonder plastics which are specifically designed to absorb kinetic energy. Sorbothane is perhaps the best known, but Astrosorb is another. The uncanny thing about these materials is that a ball made from them, dropped onto a concrete floor, hardly bounces at all.*

*The paving-slab idea is probably your best bet for loudspeakers. Some of the colours*



If all else fails, it might be worth taking a leaf out of the Building Research Station's book!

*available are quite decor-friendly and unobjectionable if discreetly placed. It is necessary to use enough weight compared with the 'speaker to avoid setting up what could be a second resonant system between your floor and the loudspeaker. RMW*

One more step in the right direction - a pair of Siren interconnects from The Chord Company.

## BOTTLE BANKING

I have an Oracle Alexandria MkIII turntable, Rega RB300 arm and Shure V-ST V which feed an Audio Innovations 500 integrated valve amplifier and Diamond Acoustics loudspeakers. Could you please help me with the following questions:

- 1) The cartridge and replacement stylus are no longer available. Should I replace them with a DNM Mica?
- 2) Would it be worthwhile having the arm modified by Origin Live?
- 3) The valves in the amplifier will need replacing soon. Can I obtain better sound by paying a little more for valves?
- 4) You will note that although my system was only purchased seven years ago, most of it is no longer available. What kind of time span do I have before replacement parts are unobtainable?

Allan Keates  
East Sussex.

*If you're happy with the Shure, you might like to try one of the stylus specialists who advertise in our pages before you give up on it. They may very well have some new/old*

*stock. Failing that, the Mica should quite happily partner your Rega.*

*The Origin Live modifications can offer considerable sonic benefits. An upgrade arrangement I have taken a shine to is the Black Plastic (tel: 01902 751861) replacement counterweight which is*



Fresh valves in place of faded can often add much needed sparkle to the sound of an amp.

*designed to bring down the centre of gravity of the arm. This involves no structural modifications other than unscrewing the old stub and screwing in the new one. The Black Plastic arrangement sells for £40.*

*Valves and their contribution to*

*the sound are a subject of some controversy. In the old days it was recommended you change valves about once a year. In my experience there is still something to be said for this approach: the freshness a new set can impart to an amplifier still surprises me.*

*Premium valves have a good many sonic merits but they do make you hesitate before discarding them. Horrible to relate, but I use valves as they come to hand. If a cheap-and-cheerful example sounds rough, especially in the input stages, I change it for a better one.*

*I do not think we need worry about vinyl for the foreseeable future - 78rpm records mainly ceased production over 30 years ago but, to date, I can't think of many serious difficulties you would encounter if you wanted to listen to them. Granted it's a specialist market, but there are people falling over themselves to sell replacement motor springs, needles, etc. RMW*

For more on thermionic amplification, have a browse through John Linsley Hood's Audio Electronics.

# e-mail

Visit our website at  
<http://www.hi-fiworld.co.uk>  
 or send your e-mails to  
[edit@hi-fiworld.co.uk](mailto:edit@hi-fiworld.co.uk)

## ALL CHANGE, PLEASE

I was fortunate to inherit an audiophile's legacy and thus build up a system. All the equipment was bought in the mid-Seventies and spent around 15 years idle while the previous owner lived abroad. The equipment consists of the following: Quad 33 pre and tuner; Quad 405 power amp; Linn LP12 with Grace arm and Stanton cartridge; IMF transmission line Reference monitors (MkIII).

I have had several years' use out of the equipment as it stands but am considering updating it. In particular I am interested in replacing the IMFs, which really cannot be accommodated in my small London flat (given their fabulous bass extension). I'm not necessarily looking for small 'speakers - floor or stand mounted would be fine - it's just that the IMFs are extremely large. I also want to replace the pre-amp with something that is more appropriate for digital sources (I have DAT and CD) bearing in mind that I have no intention of parting from the Sondek.

What could I expect to raise by



Castle's Edens sound every bit as good as they look.

selling the IMFs second-hand (they are in near-mint condition) and could this amount fund a switch to another pair of 'speakers and a decent pre-amp.

Jim Copperthwaite  
[jim@adsoft.com](mailto:jim@adsoft.com)

*I believe there's actually a number*

*of changes which would boost your system's sound. It's hard to put a price on the IMFs as a second-hand buy, but let's assume you can rustle up roughly £500 for them.*

*On the loudspeaker front there are Castle's Eden stand mounts (£450). This doesn't give you much leeway on the pre-amp front. To be perfectly frank, I'd stick with the 33 and go for a Rotel RQ-970BX phono stage. If you're short of inputs, an external switchbox would be the answer.*

*When further funds permit, have the 405 serviced by Quad and swap the Grace for either an Origin Live-modified Rega RB250 or a second-hand Ittok. Replacing your cartridge's stylus would probably be a wise move too. JM*

Partner a new phono stage with these free Siren interconnects from The Chord Company.

## WHITHER WALLET?

Please could you give some of your valuable advice. My current set-up comprises a Pioneer PD-S703 CD player, Quad 34 and 306 amps and Music Technology Harrier 'speakers. My 'speaker cable is QED Qudos and interconnects are Ixos 104. I also have a Rega Planar 3 and a Nakamichi BX-300E, which I am more than happy with.

I am thinking of upgrading my CD player or loudspeakers but I'm not really sure where the weak spot in the system is. I find that the 'speakers don't really like being played at moderate volumes. The music I favour is mainly Rock and Indie but everything else does get played.

Is it worth changing the 306 to a pair of Quad IIs? My gut feeling is that the Harriers may need some extra grunt behind them. I would also consider



A pair of 306 power amps (one seen here below the 34 pre and FM4 tuner) would be fine for bi-amping.

bi-wiring. I have a budget of £500-£1000 and am quite happy to buy second-hand.

David Walford  
[DJWalford@aol.com](mailto:DJWalford@aol.com)

*To be honest, the last thing you*

*should do is go for a pair of Quad II valve amps if you're after more grunt - these venerable monoblocs only put out about 15watts (the 306 manages 50watts into 8ohms).*

*You could buy another 306 for bi-amping new loudspeakers such as KEF's Q35 floorstanders. In this arrangement, you can maximise sound quality by having one 306 for each channel rather than splitting them across the mid/bass and tweeter units. This will also allow you to keep loudspeaker cabling very short.*

*As for the CD player, Marantz's £400 CD-63 KI-S is still the one to beat. JM*

Amplify your knowledge of hi-fi with a free copy of John Linsley Hood's Audio Electronics.

If you do not want your e-mail address published, please let us know.

**MORE FROM MARANTZ**

I currently have a Marantz CD-94 CD player and a Pioneer A-400 amplifier driving Spondor Prelude 2/2 'speakers on Atacama SE24 stands. The interconnect and 'speaker cables are from The Chord Company and the 'speakers are bi-wired.

The system is quite musical and sounds fine on simple pieces but lacks detail and cohesion when more complicated music is played. The treble also lacks control. I want to make changes that will bring the music into sharper focus and produce more life-like performances.

I suspect that the weaknesses in the system are the amplifier and the internal DAC in the CD-94, so I was considering different amplification and an external DAC (you've previously suggested that the CD-94 works well as a transport). I'd also like to be able to purchase a vinyl source later and have a simple upgrade path.

I mainly listen to Rock and female vocals but also play Jazz and Classical

music. My budget is £1000 which I hope will be sufficient to make a significant improvement, especially if I consider second-hand equipment.

**Geoff Pownall**  
pownalls@mcmail.com



It may be an oldie but it's still a goldie - Marantz's heavyweight CD-94 CD player.

*As you say, if you're prepared to go second-hand, you could radically improve your set-up. A pair of Musical Fidelity P170 power amps (around £250 each) bi-amping the Spondors would produce a much tighter grip on music than a single A-400.*

*Seeing as you only have one CD source, Danish Audio Connect's CT1 stepped attenuator (£106 from AudioCom, tel:) would make a superbly transparent passive pre-amp. Should you prefer active instead, a second-hand DPA 50S (approx £350) would mark another massive upgrade over the Pioneer.*

*With the money you have left over, get your Marantz 'clocked'. We hope to be doing a group test of after-market CD player master clocks in a forthcoming Supplement, but if you can't wait, Trichord (tel: 01684 573524), AudioCom and Acoustic Precision (tel: 01443 833570) are the ones to speak to. It may be a crude tweak, but bolting a lead sheet to the CD-94's base-plate is apparently highly effective. JM*

Discover more of your Marantz's hidden promise with a Ringmat Statmat.

**GETTING THE NEEDLE**

I own a turntable which is based around a Thorens motor unit of unknown origin built into a home-made plinth cut out of solid 60mm plywood. The arm is a Linn Basik LVX and the cartridge A&R Cambridge's P77.

I was, until recently, looking for a replacement stylus but I now suspect that I could do better than retain this cartridge. Do you have any advice on what replacement I might try? I listen mainly to Fusion, Funk, Jazz and occasionally Rock.

**Shaun Onverwacht**  
sonverwacht@ziton.com

*One way of starting cheap without cutting off your cartridge upgrade path is Goldring's 10 series. The most basic model, the 1012, costs £85 but can be boosted to the level of the assured*

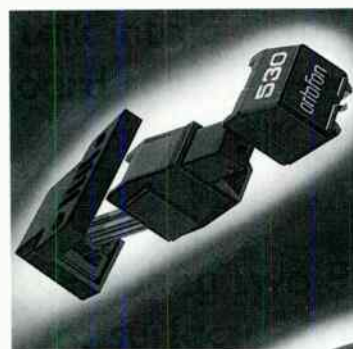

Ortofon's 500 range of MMs contains some competent budget performers.

*1042 with a better stylus.*

*If your budget can't quite stretch to the 1012, then Ortofon's 500 series begins with the 510 at £40 and ends on the 540 at £140. JM*

Keep your contacts in shape with a dose of DNM's Licon enhancer.

**BASS ON A DIET**

My current system is a Linn LP12/Valhalla with Cirkus bearing, Ittok LVII arm and Klyde MC. My Linn Majik amplifier and Tukan 'speakers are wall-mounted with Linn Brakits. Other sources are an Arcam Alpha Plus CD player and Creek CAS3040 tuner.

The Klyde was a recent purchase and replaced an Ortofon MC 25FL. However, I am unhappy with the sound of the Klyde which, whilst more full-bodied than the Ortofon, sounds a lot slower and tonally dull. My local dealer has recommended changing to a van den Hul MC10. I can't afford to make any more expensive

mistakes but desperately need to make the system more listenable.

Is it really necessary to spend over £800 simply to get a tonally-balanced sound? Would I be better off trying something like a DNM Mica?

**Steve White**  
steve.white7@virgin.net

*Cartridges which have an even*

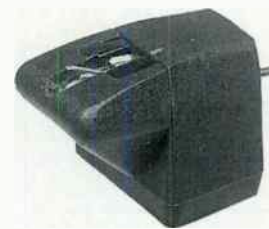

One MM which can show cheap MMs a thing or two is DNM's Mica.

*tonal balance can indeed be had for as little as the DNM Mica's £135. Their £180 Rica is better still. It might also be worth investigating some of Dynavector's mid-price MCs with their solid-diamond cantilevers before you think about splashing out £800. JM*

One area where this free bottle of DNM Licon contact enhancer will work particularly well is cartridge pins and tags.



**VIBRATION CONTROL  
PLATFORMS AND THE  
MODULAR AUDIO  
SUPPORT SYSTEM**

*UNIQUE PATENTED  
PLATFORM DESIGN !!*

The **NEW** Resonance Control  
Hi Fi Cabinet Range

It's refreshing to find a complete isolation system that values aesthetics as highly as it does sonic benefits -  
Mr P M Rodwell, Cornwall.

Thanks!! The improvement is astonishing and after hearing and trying other audio stands, the performance of BASE is second to none -  
Mr M Slattery, Sussex.

*"The hi fi cabinet is harmonious to the eye as well as to the ear. It improves the sound reproduced by the system with greater clarity, depth and control of all kinds of music".* -  
Mr C V Lawick, Herts.



**WORLD VERDICT**

OUTSTANDING - Superb Sound, something we'd use ourselves.

**WORLD VERDICT**

Great Build and finish, and it sounds great too.

**\*0% FINANCE NOW AVAILABLE ON ALL HI FI CABINETS**

\*Subject to Status

Audiophile  
Furniture Ltd  
The Square  
Forest Row  
East Sussex  
RH18 5SE.



For more details  
and a product  
portfolio please  
contact:

Tel: 01342 826262  
Fax: 01342 824845

**Trichord Research Limited**  
**CD UPGRADE**

**CLOCK 3**

**CD PLAYER UPGRADE FROM £132**

From the designer of the original Clock 2 upgrade  
A new generation of Master Clock

"Significantly better than anything else I've experienced to date."

- Jimmy Hughes.

"Superior Clarity & Imaging - Irrestibly foot-tapping."

- Clive Meakins - Hi-Fi News - June '98

- \* High accuracy (5ppm) low jitter performance master clock.
  - \* Up to five times reduction in date related jitter
  - \* Increased transparency, resolution and sound staging
  - \* Greater dynamics and sheer listening pleasure
  - \* Can be fitted to most players or transports regardless of price
- The level of improvement is just as significant with expensive transports as it is with inexpensive players.

These modifications can be carried out by Trichord Research Ltd, or by your local Trichord dealer. Also available in kit form with instructions for the technically competent.

**Pulsewire Digital + Analogue Cable**  
**Major Credit Cards Accepted**

Tel: (01684) 573524 Fax: (01684) 577380  
**6 Woodlands Close, Malvern Wells, Worcs,  
WR14 4JD**

**pear audio**

presents

**Shahinian**  
**DYNAVECTOR**  
**Well Tempered**

Stockists and Information from  
**Pear Audio Ltd. 7 Prospect Place,  
Alnmouth, Northumberland, NE66 2RL**  
Tel: 01665 830862 Fax: 01665 830051

**FEELING  
GRAVITY'S  
PULL**

**Elemental  
Audio**

**Precision Support Systems**  
**+44 (0)1840 211045**



## DELIVERING DYNAMICS

I have had my current system for over 10 years with the exception of the CD player. The line-up consists of an A&R A60, Heybrook HB1 Mk1, Roksan Xerxes and a Micromega Stage 1.

I have resisted upgrading until my finances changed and significantly better but affordable products appeared. I want to start by upgrading my amplifier and 'speakers. I am, however, constrained by my living room which is not large. I have a budget of £1500 to £2000.

I listen to a broad range of music, but I want a system which is dynamic and detailed. I was thinking of amplifiers such as the Anthem 1, John Shearpe Phase 2 Reference, Exposure XV Super or the Sonneteer Alabaster. As for 'speakers I am interested in the Kelly KT3, Castle Harlech, Triangle Zephyr and the Audiovector M1. Should I go for a pre/power or a good integrated? I also need a phono stage for my Xerxes.

**Jonathan Smith**

[Johnathan\\_Smith@novell.com](mailto:Johnathan_Smith@novell.com)

*Of the amps you mention, the Anthem 1 and Alabaster would both be reliable choices. I'd forget about the Kellys as their bass can be overpowering in small rooms. Instead, consider Epos' ES22s at £1200 and Roksan's Ojans at*

## SPEAKING THE LINGO

I am considering a new set of 'speakers for my system (Linn LP12, Ekos, Arkiv, Lingo, Linto, Naim 82, 250, a pair of Hi-caps and a CDi). My current 'speakers are Epos ES14s which I adore for their speed and attack. Although I would like to gain greater bass depth, I don't want to lose this dynamism.

I have considered bigger Epos, Naim and even Linn 'speakers but need a guide as to what else is out there. I am also concerned with the present situation with Epos closing.

**Pete Brackley**

[brackley@cwcom.net](mailto:brackley@cwcom.net)

*Epos' closure is a shame as they made some fine loudspeakers, including the ES22s which would probably suit your system down to*



Musical Fidelity's twin-can Nu-Vista pre-amp is one of the best of the breed.

*£1000. These two have deep but controlled bass. I suspect the Alabaster and ES22s would be the better combination.*

*An excellent alternative would be Harbeth's active DPM-1 Xpression! 'speakers fronted by a Musical Fidelity Nu-Vista pre-amp with its on-board phono*

*stage. This would offer the most transparent, dynamic sound.*

*King of HFW's current sub-£500 phono-stage list is the £400 Lehmann Audio Black Cube. JM*

You can stop worrying about interconnects with these Sirens from The Chord Company.

*the ground. You could try to buy a pair from a dealer who still has some for sale, but then servicing might be problematic. Having said that, 'speakers rarely need fixing and Epos is a respected company likely to find another owner soon.*

*Naim's Credos and Intros (from what we've measured and heard) will please some within the context of a Naim system but they're not the best transducers around.*

*Since you love the ES14s, why not consider a subwoofer. When set-up properly, a good one sounds surprisingly fast. REL (tel: 01656 768777) offer a range which runs from around £300 up to £4000. JM*

Squeeze the most from the digits read by your CDi with a Statmat from Ringmat.



Whatever the future of Epos, the ES22s remain enjoyable and accomplished floorstanders.

# WORLD LIBRARY

## OVER 40 TITLES ON OFFER!!!

### LOUDSPEAKERS

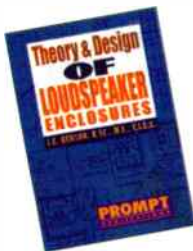

#### Theory and Design of Loudspeaker Enclosures

**J. E. Benson**  
Covers infinite baffle, reflex, passive radiator etc. in great detail with a highly mathematical approach making it unsuitable for beginners but highly authoritative to experienced designers.  
**244pp 6" x 9"**  
Paperback Code: 1140  
£23.95 + £2.50 P&P (UK)

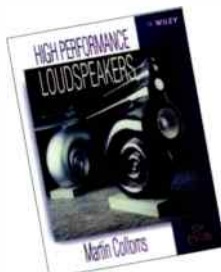

#### High Performance Loudspeakers 5th Edition

**by Martin Colloms**  
An up to date high performance reference book. Ideal for professionals and students. Covering reviews of CAD packages, digital loudspeaker design, new results in loudspeaker distortion, new developments in short path, low order crossover network design, bending wave panel speaker technology, hybrid loudspeakers and more.  
**478pp 7 1/8" x 9 1/2"**  
Paperback Code No 1350  
£27.50 + £3.50 P&P (UK)



#### The Loudspeaker Design Cookbook, 5th edition - Vance Dickason

This best seller offers up-to-date design information for the home constructor. It uses modern Thiele-Small theory and parameters.  
**185pp 8 1/2" x 11 1/2"**  
Paperback  
Code No. 1090  
£22.95 + £3.25 P&P



#### Electrostatic Loudspeaker Design and Construction

**Ronald Wagner**  
Step by step guide to the design and construction of a full range electrostatic loudspeaker, including basic operating principles. Strongly recommended for those wanting to either build, repair and/or restore or who are just interested in electrostatics.  
**243pp 7" x 9 5/8"**  
Paperback Code No. 1080  
£16.95 + £3.25 P&P (UK)

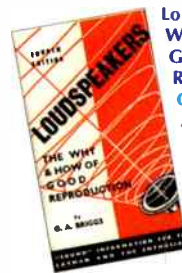

#### Loudspeakers: The Why and How of Good Reproduction

**G.A. Briggs**  
An easy to understand book on building loudspeakers, using empirical techniques that pre-date computer analysis. Strong recommendation for beginners.

**88pp 5 1/2" x 8 1/2"**  
Paperback Code: 1070  
£10.95 + £1.50 P&P (UK)

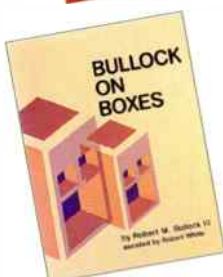

#### Bullock On Boxes

**Robert M. Bullock III.**  
Using Thiele-Small parameters clearly, it offers lots of helpful tables and graphs to get to grips with the sizing of the box and port of a reflex loudspeaker.  
**72pp 8 1/2" x 11"**  
Paperback Code No. 1100  
£12.95 + £2.00 P&P (UK)

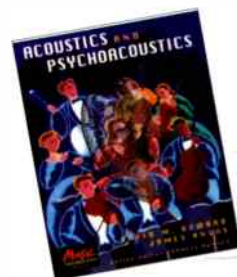

#### Acoustics & Psychoacoustics

**by David M. Howard & James Angus**  
This book provides an introduction to acoustics, including the principles of human perception of sound, notes and harmony, musical dynamics, timbre of musical instruments, acoustic model for musical instruments, hearing music in different environments, deceiving the ear and processing sound electronically  
**224pp 244 x 189mm**  
Paperback Code No. 1370  
£25.00 + £3.25 P&P (UK)



#### Testing Loudspeakers+

**by Joe D'Appolito**  
The authoritative book on the subject of loudspeaker testing! Joe D'Appolito, loudspeaker designer and consultants, has written the definitive text on testing loudspeakers. Dr. D'Appolito

brings his expertise to the subject and provides you with a hands-on discussion of testing drivers and systems. He brings you the theory and physics behind loudspeaker testing in this volume.  
Paperback Code No. 1580  
£24.95 + £2.50 P&P (UK)

#### Loudspeaker and Headphone Handbook

**Second Edition**  
**by John Borwich**

This book brings together in a single volume every aspect and practice in sufficient depth to equip students and professionals alike with a solid working knowledge of the subject.  
**592pp 234 x 156mm Paperback** Code No. 1360  
£50.00 + £4.25 P&P (UK)

### AUDIO ELECTRONIC THEORY BOOKS



#### Scroggie's Foundation of Wireless and Electronics

**Roger Amos B.Sc. B.D., M.I.T.S.C. & S.W. Amos**  
Scroggie's Foundations is a classic text for anyone working with electronics, who needs to know the art and craft of the subject. Based on experience since the dawn of the electronic age, and updated in regular editions over 60 years, it covers both the theory and practical aspects of a huge range of topics from valve and tube technology, and the application of cathode ray tubes to radar, to digital tape systems and optical recording techniques.  
**400pp 234 x 156mm Paperback**  
Code No. 1590 £19.99 + £3.00 P&P (UK)

#### Electronics made Simple

**by Ian Sinclair**  
This books covers the basic theory and principles of electronics. A good read for the beginner.  
Code No 1420 £12.99 + £2.00 P&P (UK)

#### Build your own High-end Audio Equipment

**by Elektor**  
Build your own High-end equipment contains construction projects for solid state and valve preamplifiers and power amplifiers, active cross-over filters, and active subwoofer, a mono/stereo compressor and a headphone amplifier.  
Code No. 1390 £14.95 + £2.25 P&P (UK)



#### High Performance Audio Power Amplifiers

**by Ben Duncan**  
Power Amplifiers and their performance lie at the heart of audio engineering. This handbook is the distillation of the state of the art. Linking analog electronics, acoustics, heat and music technology; high-end hi-fi and professional PA and recording studio use; theory, modelling and real-world practice; design and repair; the old and the new, the mainstream and the specialised.  
**288pp, 234x156mm,**  
Hardback Code No.1460  
£40.00 + £3.25 P&P (UK)

#### Build your own Electronic Test Instruments

**by Elektor**  
This book contains designs for 17 measuring instruments, seven generators and analysers; ten miscellaneous instruments and a number of test ancillaries and auxiliaries. The designs range from a simple multicore cable designs contain a special printed circuit, drawing of which are given in an appendix.  
Code No. 1400  
£15.95 + £3.25 P&P (UK)

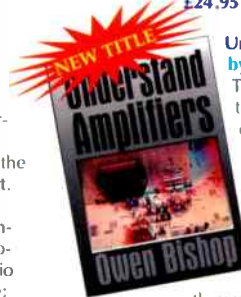

#### Understand Amplifiers

**by Owen Bishop**  
This is a readable introduction for those with little previous knowledge of the subject. The theme of amplification is central to many branches of electronics. Consequently there is a large and confusing array of amplifier types intended for a wide range of applications. This book describes amplifier types, how they work, their properties, advantages and disadvantages, and applications. Amplifiers are treated with the minimum of mathematics and lots of illustrations.  
Paperback Code No. 1560  
£16.99 + £2.50 P&P (UK)

#### Practical Electronic fault-Finding and Troubleshooting

**by Robin Pain**  
This book explains the basic techniques needed to be a troubleshooter, using only the basic equipment: a digital multimeter and an oscilloscope. Simple circuit examples are used to illustrate principles and concepts fundamental to the process of fault finding.  
**240pp 2 1/4" x 156mm**  
Paperback Code No. 1430  
£19.95 + £2.25 P&P (UK)

## VALVE BOOKS



### The Beginner's Guide to Tube Design

by Bruce Rozenblit

The best beginner's guide on vacuum tube audio is now available. This book takes a comprehensive look at tube audio design. For the beginner, the author starts by explaining how vacuum tubes work and how to design with them. For the more experienced constructor,

Rozenblit has provided chapters on subjects including stabilisation and testing, a description of 13 famous and classic amps and preamps and how to work effectively as a designer. A hands-on guide to construction techniques, tools and choosing components and tubes is provided. 1997, 132pp., 8 1/2" x 11" Paper back Code No. 1340 £15.50 + £2.25 P&P (UK)



### Mullard Tube Circuits for Audio Amplifiers

Includes full designs for eleven power and control amps, including 5-20, using valves. Begins with a four chapter tutorial on getting the best sound from valve amplifiers.

142pp 8" x 10" Paperback Code 1030 £13.95 + £1.50 P&P (UK)

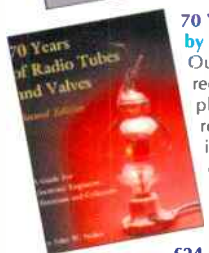

### 70 Years of Radio Tubes and Valves

by John W. Stokes.

Outlines the evolution of radio receiving tubes and the part they played in the domestic radio receiver. A reference for those interested in the history and development, and collectors alike.

256pp "8 1/2" x 11" Paper back Code: 1050 £24.95 + £3.50 P&P (UK)

### An Approach to Audio Frequency Amplifier Design

Seventeen circuits from 5 to 1100watts - General Electric Co. High quality amp. designs using KT66s, KT88s, DA100s etc. Includes two valve pre-amps complete with phono stages. 126pp 6" x 9" Paper back Code No. 1020 £19.95 + £1.75 P&P (UK)

## RADIO DESIGNER'S HANDBOOK

### 4th Edition

Fritz Langford-Smith

This is a classic, comprehensive reference handbook for all who are interested in the design and application of audio amplifiers and radio receivers, and deals with basic principles and the practical design of all types of classic audio amplifiers, radio receivers and record-producing equipment up to the invention of the transistor.

This reprint of the classic fourth edition, first published by Iliffe in 1953 and revised in this edition in 1967, provides information that is not available from any other source. It will therefore be invaluable to anyone working with valves, and provides a definitive guide to the valve and other components, audio and radio frequency technology, rectification, regulation, filtering, hum, complete receivers and sundry data.

This book is the work of 10 authors and 23 collaborating engineers, under the editorship of F Langford-Smith. The enormous amount of data included in the book has been made readily accessible by means of a fully detailed list of contents and a very complete index. The main subjects are: valves, valve testing, general theory and components; audio and radio frequencies; power supplies, design of complete AM and FM receivers, and reference information.

1498pp 216mm x 138mm Hard back Code No. 1600 £35.00 + £6.00 P&P (UK)



**Saga of the Vacuum Tube**  
by Gerald E.J. Tyne  
Paperback 494pp, 5 1/2" x 8" Code No. 1540 £16.95 + £2.50 P&P (UK)

### Saga of the Vacuum Tube

by Gerald E.J. Tyne

This book covers the history of the evolution of the thermionic vacuum tube, tracing its complex genealogy, and presenting essential facts to assist in the identification of such tubes made prior to 1930. Bell Labs News, March 29, 1974, "Today Tyne probably knows more about the history of tubes than any-

one else in the world". As reviewed in

August Supplement 1998

Paperback 494pp, 5 1/2" x 8" Code No. 1540 £16.95 + £2.50 P&P (UK)

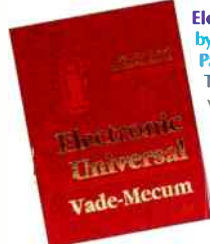

### Electronic Universal Vade-Mecum

by Piotr Mikolajczyk & Bohdan Paszkowski.  
This Data book comprises 5693 valves divided into 442 groups. A comprehensive book which contains connection details, operating parameters, load lines and example circuits.

Hard back Code 1060 £49.95 + £ 8.50 P&P (UK)

### Build your own Audio Valve Amplifiers

by Rainer Zur Linde

This book is intended for a broad cross-section of the public: apart from construction projects for preamplifiers, power amplifiers and two amplifiers for musical instruments aimed at the practical audio/hi-fi enthusiast, it offers much information on the operation of electron tubes, while the first chapter gives a short history of the thermionic valve.

Code No.1320 £14.95 + 2.25 P&P (UK)

### Valve Amplifiers

Morgan Jones, Audio Engineer

This book allows those with a limited knowledge of the field to understand both the theory and the practice of valve audio amplifier design, such that they can analyse and modify circuits, and rebuild an amplifier. Constructional techniques are also provided so readers can build from scratch designs that actually work.

374pp 6" x 9 1/4" Paperback Code No. 1330 £25.00 + 2.75 P&P (UK)

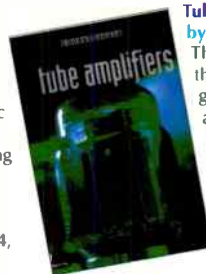

### Tube Amplifiers

by Kavsek & Kavsek

The most beautiful tube amp book in the world. No specs. no test. just 215 gorgeous four colour photos of 65+ amps with a short description of each. Including a 12 page explanation of the history of tubes and tubeamps. Appendix with addresses with tech. data.

167pp 9 1/2" x 12 1/8" Hard back Code No. 1310 £47.95 + £5.50 P7P (UK)

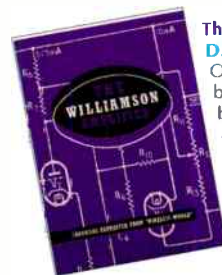

### The Williamson Amplifier

D.T.N. Williamson.

Offers practical advice on how to build and set up the amplifier for best results.

40pp 8 1/2" x 11" Paper back Code No. 1040 £9.95 + £1.50 P&P (UK)

### Electronic Valves in Audio Frequency Amplifiers

by E. Rodenhuis

Originally published in 1954 by Philips, this book encourages amp. builders to experiment with design elements. Discussing the use of valve data, the function of different amplifier stages and includes detailed descriptions of eight designs. A wealth of practical data, measurements and interesting features will be found. A very good read.

Paperback 147pp Code No. 1520 Price £12.95 + £2.00 P&P (UK)

### Audio Amateur Power Amp Projects

by the editors of Audio Amateur

This profusely illustrated handbook features 26 of the best articles on power amps published in Audio Amateur from 1970-89. Authors from six countries offer an array of designs to provide almost any level of high-quality audio power needed by the resourceful amateur who prefers the pleasure of building his or her own equipment.

205pp., 8 1/2" x 11" Paper back Code No. 1300 £14.95 + £2.25 P&P (UK)

### Principles of Electron Tubes

Herbert J. Reich.

A textbook for beginners starting with the basics of how a vacuum tube actually works. Shows how a simple circuit is designed including amplifiers, transformers and power supplies. A must for both enthusiasts and hobby-

ists. 398 pp 6" x 9" Paperback Code No. 1010 £27.95 + £3.00 P&P (UK)

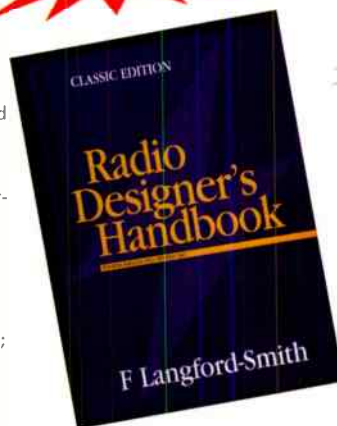

### Valve & Transistor Audio Amplifiers

by J L Hood

This is J L Hood's greatest work yet, describing the milestones that have marked the development of audio amplifiers, from the earliest valve amps to the latest solid state design. This book is the complete world guide to audio amp design. Other contents: active & passive components, amplifiers, pre-amplifiers and power supplies.

As reviewed in June 98 Supplement Paperback 250pp., 156mm x 232mm Code No. 1530 £19.99 + £2.50 P&P (UK)

## ORDER FORM

Please send (Code No.) \_\_\_\_\_ (enter codes clearly)

Pay: World Audio Publishing Ltd. £ \_\_\_\_\_ or debit my Mastercard/Visa card (Card No): \_\_\_\_\_

Expiry date: \_\_\_\_\_ Name: \_\_\_\_\_ Signed: \_\_\_\_\_

Delivery Address: \_\_\_\_\_

Tel: (Day) \_\_\_\_\_ Please return to: W.A.P.Ltd, Suite G4, Imex House, The Park Business Centre, Kilburn Park Road,

London NW6 5LF, ENGLAND TEL/FAX: 0171 625 8032 OR 24 HOUR ANSWERING MACHINE: 0171 226 0461 E-Mail: wad@hi-fworld.co.uk  Tick if you do not want to be added to our mailing list

Please contact us for overseas P&P charges. Allow 28 days for delivery. All orders subject to availability. If further space is required please attach separate sheet.

## NEW PRODUCTS

from the designers of RINGMAT and **STATMAT**

### The RINGMAT SUPPORT SYSTEM

*a complete, modular system to help you  
achieve the perfect sound from your LPs*

The RINGMAT SUPPORT SYSTEM comprises four components, including the long awaited RINGMAT Spacers, the LP version of **STATMAT**, RINGCAP and a RINGMAT for those who do not already have one.

#### Prices:

Full System with RINGMAT MkII XLR £160.00

Full System without RINGMAT (for existing users) £115.00

P&P £4.50 within UK; £10.00 outside UK

Prices are available for modules of the complete System, platter inserts for Roksan Xerxes & Garrard 401 turntables and other products

### A MkII version of STATMAT

*for an even better sound from your CDs*

#### Prices:

STATMAT MkII £19.95

MkII replacements, exchanges & upgrades £12.50

P&P £1.95 within UK; £5.05 outside UK

Replacements, etc., post free within UK; £3.00 outside UK

RINGMAT and **STATMAT** have been extensively reviewed around the world. Extracts and copies of the reviews are available on request, as well as brochures and price lists.

Information on our products and other services can be found on our website:

[www.ringmat.com](http://www.ringmat.com)

*Our products can be obtained through good hi-fi retailers.  
Also available on mail order with moneyback guarantee.*

*For further information, or to place an order, contact:*

RINGMAT DEVELOPMENTS

PO BOX 200 BRENTWOOD ESSEX CM15 9FB GB

T: +44 (0)1277 200 210 F: +44 (0)1277 201 225

## SONIC LINK

Make The World's Finest HiFi Cables  
From The Highest Quality Materials



Good design improves your hi-fi  
Good interconnect improves your music  
Good music improves your life.

Derwent Business Centre, Clarke Steet Derby DE1 2BU

Sales Office Hot Line 07000 SONIC LINK

Tel: + 44 (0) 1332 361 390

Fax: + 44 (0) 1332 298 836

**Crimson**  
AMPLIFIERS WITH ATTITUDE

Virtual Reality

P.O. Box 383 Brentwood Essex CM14 4GB  
Tel. 01277 227355 Fax: 01277 224103 email: info@virtual.demon.co.uk

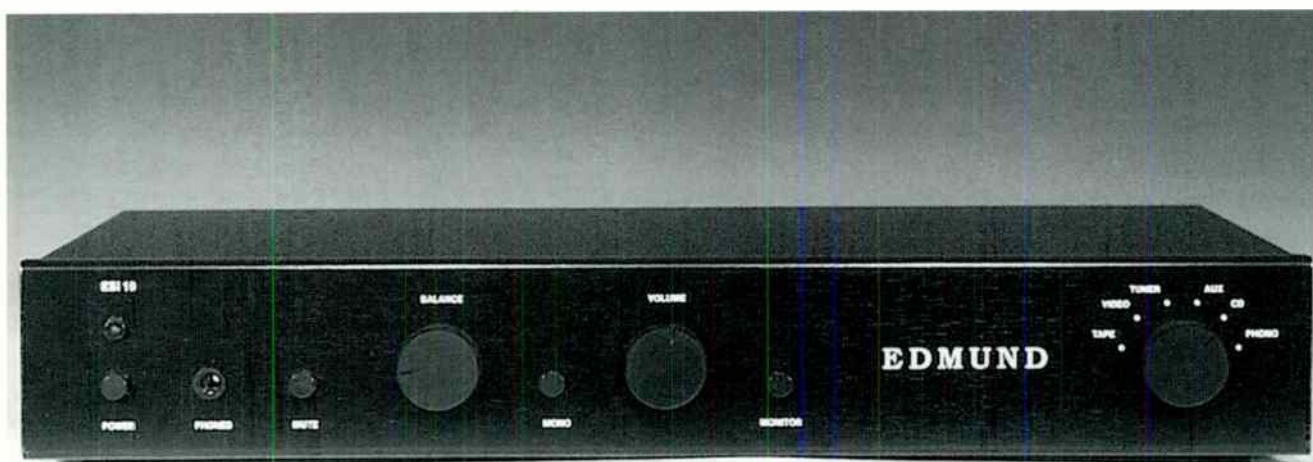

# GLORIA EDMUNDI

Simon Pope samples the ESI 10 integrated amp from Edmund Audio, a new company under the REL umbrella.

**E**dmond is an unusual choice of name for an amplifier.

Aside from the villain in King Lear and a certain Mr. Blackadder on television, I can't call to mind that many examples. I don't even think that Edmund is a particularly Welsh name, though the amplifier hails from the headquarters of REL, famous for their subwoofers, down in Bridgend.

Unpacking the ESI 10 brings you face to face with a plain blue-black box (it's also available in chrome) of reasonably hefty build. There aren't that many £400 amplifiers that require genuine effort to lift them up, but this is one of them.

"Edmund" is emblazoned on the front in large capitals (lest you forget) where you'll find the three solid knobs for input selection, balance and volume. Along with these main controls come a mono button, tape monitor, mute switch and headphone socket. A little touch which separates the ESI 10 from the crowd is the inclusion of one of the ever-growing population of blue LEDs.

Another bonus which accrues for vinylphiles is the fact that, although normally a line-level device, the Edmund can be ordered with an MM/MC input at no extra cost, this replacing an auxiliary input.

Under the bonnet of this class

AB design nestle a pair of Darlington transistors in each channel's output stage. Star earthing is employed throughout and two of the controls, the volume and input selector, are from Alps. This hardware was put through its paces in a system where the loudspeakers were Heybrook Optimas and the sources a Roksan Caspian CD player and Linn LP12 with SME 3009 and DNM Mica.

Soundgarden's Superunknown album can be a tough cookie for some equipment, but the Edmund responded well to its tight, compressed production. The opening onslaught of 'Drown Me' had the taut cohesion necessary to keep it pounding along undiminished. All this blood and guts didn't obscure detail in quiet passages, however - I could make out the buzz from one of the cranked-up guitar amps easily.

The ESI 10 was at its most impressive handling the drum kit, where every complex pattern was crisp and unconfused. The amp never deteriorated into an unrecognisable mess; listening fatigue was noticeable by its absence.

Tchaikovsky's Fourth Symphony (played by the Oslo Philharmonic on Chandos Records) sounded rich in texture and emotion, especially

as the amplifier gradually burned in. The intricate and precise playing could possibly have been better highlighted, but the first movement retained just the right amount of melodrama. Bass was especially deep and well-pronounced despite the slightly coloured, heavy sound the Edmund can produce in the nether regions.

When it came to trying out the phono stage, an Audioweb LP demonstrated good stereo separation and imaging. The deep, Dub-style bass guitar was well-rounded and clear, but when joined by the rest of the instruments some of the detail was lost. This also applied to the vocals, which shrank back into the mix. In complete contrast, a 1964 recording of Schubert's String Trio played by the Vienna Philharmonic String Trio on the black disc was beautifully delicate, the violin tone untainted by any papery break-up.

The Edmund's bias towards bass and the meaty sound this leads to are better suited to Rock; Classical music can lose some of its spaciousness when travelling the same route. Then there's a small loss of detail on heavily-layered, complex music to consider as well. Nonetheless, all in all the Edmund is a welcome addition to the mid-price amp ranks.

Edmund Audio ESI 10  
£399.95

Edmund Audio  
North Road,  
Bridgend Industrial  
Estate,  
Bridgend,  
Mid-Glamorgan  
CF31 3TP  
Tel: 01656 768777

## WORLD VERDICT



Solid build and a big sound make the ESI 10 worthy of audition. Not the most transparent at the price.

Measured Performance  
see p111

**T+A**  
elektroakustik



## Elite sports, made even more so

What subliminal advertising messages are contained in this apparently innocent sporting picture? T+A reveals all. Firstly the Audio Triax double-shielded coaxial cable has 330 silver OFC wire strands, unique to T+A. Secondly the CD 1220 is the first CD player in the world with a two-way converter. Thirdly 'Audio' magazine puts it in the five-figure price bracket, although it barely costs a third as much. Fourthly listen to both, that's the hammer!

**Visit an 'elite' dealer in hi-fi systems:**

**HIRSCHMANN**

Rheinmetall Elektronik

Richard Hirschmann Electronics U.K. Limited

St. Martins Way

St. Martins Business Centre

Bedford MK42 0LF

Telephone: 01234 345999

Telefax: 01234 352222

Email: [Richard.Hirschmann@compuserve.com](mailto:Richard.Hirschmann@compuserve.com)



Noel Keywood

I was intrigued by literature for Lavardin's IT Reference integrated transistor amplifier reviewed this month. Their engineers claim to have discovered the reason why valve amplifiers sound "musical" and are commonly rated above solid-state amplifiers in high-quality audio systems. I have my own theories on all of this and at heart they differ little from Lavardin's.

If we can hear the sound of the material used in resistors, capacitors and cables, then there is no reason we should not be able to hear the difference between a valve and a transistor, especially since they differ so much. As designer Andy Grove points out, current density through a valve is but a fraction of that through a transistor since high powers can be supported without high currents.

A valve has no dielectric, nor any real insulation. It passes a current through a deep vacuum by the strangest method imaginable - charged particles are kept in order primarily by electric potentials. The glass of a valve is there to support the vacuum and the electrodes. That's vastly different from the high currents that flow through the minute junctions of a transistor. If a material is excited by the amount of current flowing through it - and current is electricity - then we should expect a valve to have less coloration than a transistor.

We know from loudspeaker research that colorations are to be found as minute signals in the time domain. When a loudspeaker cabinet panel resonates, it stores energy that is returned

later and heard as a 'wooden' signature. Such signals are very hard to measure, even though the ear hears them quite easily. They exist whilst the music is playing, where they are all but impossible to detect, but also reveal themselves for a short period just after the music stops as a small 'tail'. Capturing these tails by measurement reveals a complex pattern of resonant frequencies that go to make up that woody coloration.

I believe conductors behave in a similar manner, albeit on a much smaller scale. This applies to both valves and transistors. I am even haunted by a most peculiar effect that I cannot pin down conclusively. After using a valve amplifier I am sure I hear, for a brief moment, a sort of noisy, grainy swishing sound from a transistor amplifier when music plays through it. This noise can be heard for the briefest moment when music stops. Trouble is, it is so elusive that I hear it

other. I am reminded of cabinet coloration: although very obvious, it is difficult to measure. So what is it that Lavardin say?

"Memory distortion is the property that is the dominant factor in causing solid-state amplifiers to sound shrill and mechanical. Tube technology allows electrons to travel through a vacuum which causes no storage or memory effect, but solid-state amplifiers use silicon components which keep the trace of electrons flux that have gone through. Memory distortion occurs each time that the dynamic behaviour of a system is different to its static behaviour."

What Lavardin are saying is that an amplifier behaves differently when handling time-varying signals like music instead of non-varying test signals. This is not new nor widely disputed. I am glad to see someone trying to nail this phenomenon, though, using such a

*"If we can hear the sound of the material used in resistors, capacitors and cables, then there is no reason we should not be able to hear the difference between a valve and a transistor."*

only once. Then my hearing seems to adjust so I'm unable to hear it again. Until I change back to the valve amplifier that is, whereupon I notice deep, dark silences and a complete absence of grain to the music. If I listen to a valve amplifier against a transistor amplifier in a structured fashion then they do not seem to sound very different; it is at a subliminal level that their sound quality diverges.

A great problem in all this is that nothing can be measured. Harmonic distortions are not the cause - they do not enhance sound in the way some people think, and low-distortion valve amps do not sound more like transistor amps. But as Lavardin say, we only measure using steady tones, not music-like signals that vary all the time - and one is not the

theory, because my experience and love of valve amplifiers suggests other explanations are wide of the mark.

I am disappointed that Lavardin, after a lot of grand claims such as "we are glad at Lavardin Technologies to have full control on that which remains the mystery of tube musicality for previous audio designers" say nothing specific about how they tackle the time-domain problems they claim to identify, nor how they may be either measured or somehow gauged. But the IT Reference does offer something different and better in sound quality, and it measures unusually too. I hope in time we can get more substantial information from Lavardin on all this. The mystery of the valve sound is a mystery I would love to see solved ●



# WIRE & INSULATION

introduce **DESKADEL** Products

731/733 Ormskirk Road • Pemberton  
Wigan • Lancashire • England • WN5 8AT  
TEL/FAX: 44 - 1 - 942 887171

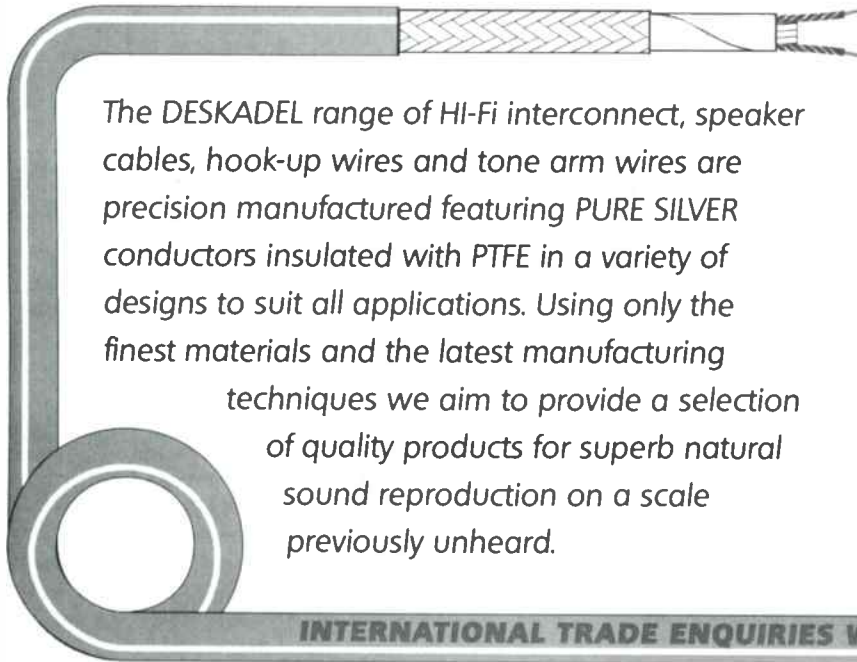

The DESKADEL range of HI-Fi interconnect, speaker cables, hook-up wires and tone arm wires are precision manufactured featuring PURE SILVER conductors insulated with PTFE in a variety of designs to suit all applications. Using only the finest materials and the latest manufacturing techniques we aim to provide a selection of quality products for superb natural sound reproduction on a scale previously unheard.

**INTERNATIONAL TRADE ENQUIRIES WELCOME**

## DISTRIBUTORS:

Switzerland  
**ARBELOS**

Tel/Fax: 41-613616466

UK

**AUDIO SYNTHESIS**  
Tel: 44-1-159224138  
Fax: 44-1-159229701

Holland  
**ANALOGUE AUDIO PRODUCTS**  
Tel/Fax: 31-30-6044342

Belgium  
**DESKADEL INT BVBA**  
Tel: 32-3-8892231  
Fax: 32-38609181



*"NOW THERE'S ANOTHER NAME"*

**"THE BEAST OF BRITISH HI-FI"**  
UNIQUE DESIGN  
BALANCED SINGLE ENDED  
NO ACTIVE GAIN STAGES  
NO LOOP FEEDBACK  
AFFORDABLE  
19" 2u  
BRITISH  
HAND WIRED

**ALEMA LTD +44 01903 750755/6**  
[www.hi-fidelity.co.uk](http://www.hi-fidelity.co.uk)

*"NOT EVERYTHING IN LIFE IS  
BLACK AND WHITE"*



## FLUX SYSTEM 2



*"FILL YOUR LIFE WITH THE  
COLOR OF MUSIC"*

**ADVANCED MAGNETIC POWER**  
"FOR THE LIFE IN MUSIC"





# THULE THE FLAMES

Is Danish digitalia on a par with their tasty bacon? Simon Pope tucks in to Thule's CD100 CD player.

**T**hule was founded in 1989 by Danish electronic engineer Anders Thule. In the decade since its inception, the company's output has grown to the 12 components that now form the Spirit series. These include two CD players which fit snugly into the all-important (and very crowded) £600-£800 market, the CD100 at £600 and the CD150 with its balanced outputs and twin DACs at a £100 premium.

Internally there may be differences but both machines share the same sleek, black lines as the rest of the Spirits. Disconcertingly, all that adorns the metal fascia is a drawer, a red LED display and a lone button. Naturally a remote is included, but lose it and you could be limited in your control options. The single button opens and closes the drawer, sets the disc playing and jumps forward to the next track and, er, that's about it. All of the other commands are located on the remote.

With no power switch on its case, the CD100 automatically switches into standby mode after five minutes of inactivity. A touch of either the fascia or remote buttons will swing it back into action.

Turning digits into analogue with-in is a Philips CDM12.4 transport and CD7 digital servo; the circuit and software are Thule's own. A Burr-Brown PCM 1710 converter with multi-level Delta/Sigma completes the package.

Opening the Thule's trial by disc was the 'Hardbag' House of Sasha and John Digweed. The Dane furnished a smooth and sophisticated overall sound, maintaining a certain foot-tappability in place of the all-out, rave-in-your-front-room presentation this album normally evinces from more adrenal players. This wasn't altogether to the bad as the CD100 allowed me to actually lis-



ten to the music rather than being bludgeoned by it, and what it lacked in out-and-out impact it made up for in refinement. My only gripe was that after 30 minutes or so my attention was drifting as the Thule's unfussed calm failed to gel with club-style compositions.

More guitar-based material in the shape of New Order's Movement album found the Spirit responding with abundant detail and a commendably uncoloured interpretation. This better suited NO's rather clinical production as the CD100 brought warmth to what is deliberately cold and calculated music.

Starting a Classical session with the first act of Wagner's Die Walkure played by the Vienna Philharmonic, the Spirit leapt straight into the exciting opening string writing with gusto. The reproduction of the aggressive, accentuated double-basses at the start didn't make it to the top rank rhythmically, but the string tone was superb, with not a hint of hardness. Vocals were clear and well-focused but not too forward of the 'speakers, as often happens with this CD.

Seeking a recording with more treble energy, I tried the Overture to Verdi's Nabucco. As well as ironing out the harshness of the orchestration, the player picked out details I had not noticed previously, such as the podium straining under Maestro Giuseppe Sinopoli's efforts in the quieter passages. With its manically fast rhythms and cymbal crashes, this overture can all too frequently sound like a hand grenade going off in a percussion shop, but the Spirit kept a commendably sustained and sensible grip on things.

Thule's CD100 has a lot going for it: it never gives the impression it's merely going through the motions as some mechanical-sounding players do. It displays plenty of insight too, even heavily-compressed music revealing detailing that's usually hidden away. The treble won't offend either, the strings of Classical works relayed with a pleasing weight and body. At the price, the Thule has a sound that you parents would definitely approve of, although headbangers and ravers may find themselves looking elsewhere.

**Thule Spirit CD100**  
£599.95

**Glaive**  
Unit 7, Wren Ind. Estate,  
Coldred Road,  
Maidstone,  
Kent ME15 9XN  
Tel: 01622 664070

## WORLD VERDICT



A very smooth and refined player with the added bonus of good detailing. Can lack rhythmic bite with loosely-recorded material.

Measured Performance  
see page 111

**VIVANTE LONDON**

Unit 4, 60 High Street, Hampton Wick, Surrey, KT1 4DB  
 Tel: 0181 977 6600 Fax: 0181 977 4445  
 E-Mail: vivantelondon@compuserve.com

## OL' BLUE EYES IS BACK!

In what must be one of the musical coups of the decade, LA-based audiophile specialists DCC have just announced an historic agreement with Artanis (the company started by the Sinatra family to handle the late crooner's musical catalogue) to issue previously unreleased archive material. The world-wide deal has given DCC access to over 60 hours of tapes which will result in a series of 180g vinyl and 24 carat gold CD releases, all to be remastered by engineering maestro Steve Hoffman using DCC's renowned vintage vacuum

playback system, resulting in what we all hope will be the best-sounding Sinatra releases ever. The first title is *The Summit*, a 1962 "Rat Pack" recording featuring Ol' Blue

Eyes and accomplices Sammy Davis Jnr and Dean Martin (see page 7 for details), and this will be followed by a solo Sinatra live recording, '57 Concert, and many more releases will follow. Given not just the musical but also historical importance of the project, we all fervently hope that at last the audiophobes in the non-hifi media will give the project the exposure it deserves.

Available on Deluxe: **Double Play Gold CD** £23.95  
**Double 180gm LP** £31.95



### On The Record

The UK's leading bi-monthly audiophile news letter is free to Hi-Fi World readers, simply give us a call and we'll be glad to forward our latest issue to you.

### Visit VIVANTE

At the Manchester Hi-Fi Show at the Britannia Hotel 20-21st March 1999



**EUROPE'S PREMIER AUDIOPHILE MAIL ORDER COMPANY**

**NORDOST** FLATLINE CABLE  
*Making the connection...*

...between technology and music

For further details contact:  
**Nordost (UK) Ltd**  
 1st Floor, Unit 7, Aber Park Industrial Estate,  
 Aber Road, Flint, Flintshire CH6 5EX  
 Telephone: +44 (0)1352 730251 Facsimile: +44 (0)1352 731273

## The Cartridge Man

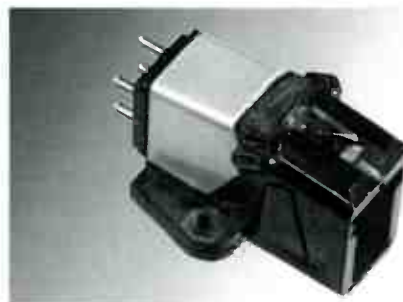

You've read about it - so if you're seriously considering a cartridge change, why not change for the better? Change to the Music Maker by the cartridge Man. Also available are our stylus gauge and Test record.

**0181 688 6565 'phone & fax**

Also agents for;  
**Croft, E.A.R. Hadcock, Moth, and others**

**PLUS CARTRIDGE RETIPPING SERVICE**

# MISSING LYNX

Richard White points his ears in the direction of Chario's latest Lynx loudspeakers.

**C**hario loudspeakers come in a variety of guises but there is a family resemblance shared by them all. In the first place, the cabinet is as well built as it finished - solid hardwood cheeks form a substantial part of the construction and add a distinctive touch of class to what can be a rather drab 'black box' world.

Another common theme is the fondness of Chario's designers for downward-firing reflex ports. This arrangement has been moving in and out of favour for almost as long as the bass-reflex itself. Granted there is a triumphant neatness to the arrangement which also distributes the port's radiation evenly, but it means the loudspeaker becomes reliant for bass augmentation on the stands chosen. In this case, flat-topped versions are mandatory, so our usual Elemental Audio open-frame types were out.

Set in a compact cabinet around 14in. by 8in. by 10in. (hwd), the Lynx's main driver is a 5in. mid/bass with a paper cone and concave dustcap. A generous rubber-roll surround gives long-throw capability, a handy consideration when you require a small unit to move a good deal of air. The tweeter is of the fabric-dome type an inch and a half across, its front-plate profiled to prevent 'corners' interfering with the sound. As mentioned before, the port is cut into the bottom of the cabinet and kept clear of the 'speaker stands by four pointed rubber feet.

Having plugged the Lynxes into a Meridian pre/power system fronted by the Teac transport and an Alchemist TS-D-1 DAC, I commenced my Pop picking with Linn's sampler of their various Jazz/Easy Listenin' albums.

Claire Martin's voice was given a healthy push by the Charios, with



her slightly sibilant delivery and huskiness-to-order well in evidence. Imaging was well defined too, and the soundstage quite broad for such small cabinets.

For the genuine audiophile article, I invited Joe Beard to call with Ronnie Earl's Broadcasters. One thing which became clear with this disc was that, for loudspeakers of their diminutive size, the Lynxes have a phenomenal output in the upper bass.

Unfortunately, on the wrong disc this could easily overstep the bounds of decency and tramp into the realms of one-note bass. In addition, as a result of what seemed to be forward reproduction in the extreme treble, Mr Beard's voice sounded rather recessed in the soundstage. Piano tone in the upper midrange had genuine appeal, however, and showed that outside their suspected 'boom and tizz zone' there was quite an engaging performance to be had from the Charios.

Feeling that I might perhaps be feeding these standmounters the wrong musical diet (much like

British Railways and snow), I brought to bear Rimsky-Korsachov's Scherezade. This piece gave the Lynxes a fairer crack of the whip, the opening flute notes reproduced with a natural delicacy. And thanks again to their bass-spreading port, the illusion of a broad orchestral sweep was well sustained.

All classical music is not delicacy and subtlety: when the going got tough about five minutes in, the recessed midrange was back at its old tricks again. Although the climaxes had considerable floor-shaking power, the overall effect had a touch of the Underground about it, with low-frequency rumblings and rather echoey tutti.

Given the excellence of Chario's cheaper Hiper 1000 (reviewed February 1999), the Lynxes are rather disappointing. Their over-enthusiastic bass and treble make their presences felt on most recordings and distract attention from the music. Given the drab styling of your average box, it's a shame these 'speakers don't sound as good as they look●

Chario Lynx £549

Musical Design  
Company  
PO Box 4146,  
Epping,  
Essex CM16 6HJ  
Tel: 01992 573030

## WORLD VERDICT



The Lynxes are superbly built but their rising bass and treble suit home cinema more than hi-fi.

Measured Performance  
see page 111

You want to improve your CD source... is it worth just adding a DAC to your player? What about the new 24/96kHz – should you wait?

## Are all bits equal? ...

In digital audio all bits are definitely not equal, despite theory. We hear differences between components, even interconnects, and all players are affected by vibration.

A good but older player can benefit from a new DAC, especially one that is 24/96kHz-ready or upgradeable. **BUT BEWARE.** It's a very complex subject and there are **BIG** traps. Speak to us for guidance.

We like to drive the power amp direct (no preamp) from good DACs with **DIGITAL VOLUME** control for ideal clarity and fine detail, eg DAX Decade (can now have 3 analogue inputs), dCS Elgar or Pass DI.

But don't wait **YEARS** for a full catalogue of DVD or DSD (which will win?). Enjoy most of that sound from today's CDs with the **dCS UPSAMPLER**.

Customers say we make some of the best sounds they have ever heard, so you know we can do the same in your home.

Our advice will take account of your best components and guide you where change is needed, in stages you can afford.

You **AVOID EXPENSIVE MISTAKES**, enjoy music along the way and save money in the long run.

**JUST LISTEN AND YOU'LL KNOW**

The  
Right  
Note  
*Music in the home*

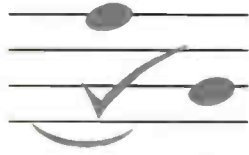

BATH

01225 874728

**CD:** ACCUPHASE, ADVANTAGE, AUDIO SYNTHESIS, BALANCED AUDIO TECHNOLOGY, dCS ELGAR, MERACUS, PASS, WADIA, XTC. **VINYL:** BASIS, CROWN JEWEL, DNM, GRAHAM, LEHMANN, MICHELL, STRATOSPHERE, SUMIKO BLUE POINT SPECIAL, TRANSGURATION. **AMPLIFIERS:** ACCUPHASE, ADVANTAGE, BALANCED AUDIO TECHNOLOGY, CAT, DNM, LUMLEY, NAGRA, PASS, SIEMEL, SIRIUS, SONNETEER, XTC. **LOUDSPEAKERS:** AUDIO PHYSIC, BKS, ETHOS, HALES, HARBETH, LUMLEY, MAGNEPLANAR, MIRAGE, NEAT, TOTEM. **TUNERS:** ACCUPHASE, FANFARE, MAGNUM DYNALAB. **CABLES:** ARGENTO, CHORD Co., DNM, NORDOST, YAMAMURA CHURCHILL ETC. **SUPPORTS:** DH CONES, STANDS UNIQUE ETC.



# 100% value

A supremely elegant, neat and complete, CD music system combining power, performance and style.

a classik by Linn®



**LINN**  
*the only sound®*

Linn is available from the very best hi-fi retailers and Linn at Harrods. For further information simply see our website on [www.linn.co.uk](http://www.linn.co.uk) or call 0500 888909



## David Price

One of the best songs ever written about my greatest passion is by a certain Mr Elvis Costello and is called, predictably, 'High Fidelity'. That aside, I can count the number of Pop's odes to audiophilia on the fingers of one small hand.

There were, of course, a couple from the late, great Steely Dan, who in Walter Becker and Donald Fagen had two big-time hi-fi freaks. 'FM' was a classic, while the cover to *The Nightfly* still seems about as cool as you can get for an album released in the Eighties.

At this time it's probably best to end this train of thought before someone goes and spoils it by recalling probably the best-selling hi-fi singalong ever, Cliff Richard's hymn to the Walkman, 'Wired For Sound'. Still, you've got to hand it to the man, "Walking along with a head full of music/Cassette in my pocket and I'm going to use it," is as unforgettable as any Beatles lyric I've heard, albeit for slightly different reasons!

No, strange as it may seem, hi-fi has played a tragically small part in Pop cul-



ture through the years. Unsurprising, perhaps, given the recording and mastering quality of most of its releases, but that's another story. For today I want to talk about a band called Stereolab, who to me are the absolute gvnors.

It all started several summers ago, when walking past a certain Soho record shop I noticed a copy of the old Hi-Fi Sound HFS75 test record. Unfortunately this is further proof, as if anyone needed it, that I am in fact the sort of sad addict who'd twig such an obscure thing in the first place. But what the hell! As any analogue addict will tell you, the HFS75 was once a vital tool for setting up turntables properly, so of course you'd recognise it, wouldn't you?

As the temporary elation finally subsided, I suddenly realised that it wasn't in fact the aforementioned mid-Seventies hi-fi set-up sensation, but a new LP from Stereolab called *Transient Random Noise Bursts With Announcements*. "Oh dear," I said to myself (or words to that effect). Still, I bought it anyway, and gave it a right old blast on the GyroDec for good measure.

I was hooked, and suffice to say, I now own all their vinyl output. The music is oddball, eclectic in its influences and quite unlike anything else I've heard. If pressed, I'd have to say it resembles Astrud Gilberto meets the Beach Boys ('Pet Sounds'/'Surf's Up' era), meets Sonic Youth meets My Bloody Valentine meets Neu!, Can and Faust. Phew!

If you've heard any Stereolab it won't come as a total surprise to learn that they're an international combo staffed by musicians with impressive pasts before joining the band. English guitarist Tim Gane and French vocalist Laetitia Sadier are both ex-McCarthy, a respected Eighties Indie band, while early singles included Martin Kean, previously of *The Chills* (once one of New Zealand's most

promising bands) and Joe Dilworth, of *Th' Faith Healers* and a *Melody Maker* photographer!

NME scribe Gina Morris was also there singing in the early days, while the second singer, Mary Hansen, is an Aussie, Morgane Lhote is French and drummer Andy Ramsay is English. But perhaps the brightest star is Sean O'Hagan of *Microdisney* and *High Llamas* fame, whose superb brass, string and keyboard arrangements are having ever more affect on the band's musical direction.

*Low-Fi*, the band's first release in September 1992, came only on 10in. vinyl. Cleverly, its name reflected its production values, so Stereolab starters might do well to look to later stuff like the



aforementioned *Transient Random Noise Bursts* from 1993, 1996's *Emperor Tomato Ketchup*, or better still 1997's *Dots And Loops*. Undoubtedly their most accessible LP to date, it's a beautiful confection of Sixties French Pop, James Bond soundscapes and warm, mellow, orchestral Jazz. Beautifully sung, played and recorded, it's a must for those seeking Pop with a difference.

And there's more. Buy the vinyl and you're into instant collector's territory. Stereolab treat their analogue releases as treasurable artifacts, meaning limited pressing runs and coloured vinyl à go-go. *Dots* is an exquisite slice of white plastic, while *Emperor* comes in a corblimey shade of sparkling gold glitter. By far the best band ever to love hi-fi, and only disciples of the great Sir Cliff could argue otherwise●

# LONDON



think audio think...  
**Auditorium**

**0171 384 3030**

THE HI-FI SHOP 112 NEW KINGS ROAD LONDON SW6



INSTANT 0%  
FINANCE  
AVAILABLE  
SERVING LONDON  
FROM BATTERSEA

**ORANGES  
& LEMONS**

Juicy fruit from London's newest, freshest hi-fi/home cinema retailer. Telephone demonstrations or just pop in. All the usual, i.e. friendly and efficient service, free home installation + credit cards.

THE INNOVATIVE AUDIO/VISUAL HI-FI RETAILER. ARCAM, CABLETALK, CHORD CO, DENON, EPOS, MARANTZ, NAD, NAIM, REGA, ROKSAN, ROTEL, ROYD, RUARK, SOUNDSTYLE, STANDS UNIQUE, YAMAHA

**NOW IN OUR THIRD  
TANGY YEAR.**

**0171- 924 2040**

61/63 WEBBS ROAD, SW11

**O'Brien Hi-Fi**



MARLIN LOGAN      GLOPAND

Clearance • Second Hand • Ex-Dock Equipment • Details on request

**0% Instant Finance Available**  
Without a credit check

Free Demonstration Room • Free car parking • 30 Day Credit Card  
Personal Express • 1 Day Order • Installation Service • Repair facilities  
5 mins from A3 (Raynes Park BR) • 20 mins Waterloo  
5 mins from A3 (Raynes Park B2/Bwest) • 25 mins M25 Junc 10

60 Durham Rd, West Wimbledon, London SW20 0TW  
Est 1966  
Tel: (0181) 946-1528 Fax (0181) 946 0331

**AUDIO CONCEPTS**

27 BOND STREET, EALING  
LONDON W5 5AS  
TEL. 081 - 567 8703

AMC, Acoustic Energy, Aura, Audiolab, Audio Innovations, B&O, B&W, Cannon, Castle, Cyrus, Denon, Dual, Evolution, JPW, KEF, Marantz, Micromega, Mission, Monitor audio, Musical Fidelity, NAD, Nakamichi, Onix, Onkyo, Quad, REL, Rogers, Rotel, Systemdek, Target, Teac, Thorens, Van den Hul

10 - 6 pm Mon., Tues., Friday, & Sat.  
Late night Thur., closed Wed.

Two demonstration rooms  
Free local delivery and installation.  
Repairs and Services

**BADA**  
the symbol of security

Oxford  
01865 765961  
Enfield  
0181-367 3132  
Swindon  
01793 538222  
Hampstead  
0171-794 7848  
Cheltenham  
01242 583960

Advice & demonstrations,  
Home Cinema  
& Multi-Room, Part X  
e.mail:  
hfi@audio-t.co.uk

**audio-T**

**PRICE PROMISE**

- We know you won't find better service
- We know you won't find better sound
- But if you find a better deal, let us know and as long as we can verify it we'll be happy to match it.

Gants Hill  
0181-518 0915  
Basingstoke  
01256 324311  
Reading  
0118-958 5463  
Camberley  
01276 685597  
Brentwood  
01277 264730

Interest Free Credit,  
3 year guarantee on  
all hi-fi separates  
see us at:  
www.audio-t.co.uk

*Great Value Sound & Vision*

# SOUTH

**SPALDINGS**  
THE SOUTH EAST'S LEADING HI-FI COMPANY

3 DEM ROOMS A.V.  
HOME DEMS., 0% CREDIT  
FREE INSTALLATION

**LINN . NAIM . MISSION . KEF  
DENON . TAG MCLAREN  
MARANTZ . MUSICAL FIDELITY  
CASTLE**

MON TO SAT 9.00 to 6.00, TUE 9.00 to 8.00 Closed  
WEDNESDAYS

**SEVICE DEPT**

325-354 Lower Addiscombe Road, Croydon, Surrey CRO  
7AF  
Telephone: 0181 654 1231/2040 Facsimile: 0181 655 3922

**Front End Problem?**  
*contact*  
**The Cartridge Man**

It doesn't have to cost an arm and a leg to get the best - listen to my Koetsu - and Decca - eater.

Also agents for Croft, Hadecock, Real Music Co, Michell & Moth.

**plus cartridge re-tipping service**

**0181 - 688 6565**

# SOUTH EAST

**UNILET**  
Sound & Vision

*Best place in town for Hi Fi and Home Cinema*

- \* Three demonstration rooms
- \* All leading brands
- \* Interest Free Credit
- \* Good parking facilities

**UNILET SOUND & VISION**  
24-26 UNION STREET, MAIDSTONE ME14 1ED  
Tel: 01622 676703 Fax: 01622 676723

Stocks of: ARCAM • CREEK • EPOS • LINN • MERIDIAN • NAIM AUDIO • NAUTILUS 800 • NEAT • REGA • ROTEL • ROYD • SHAHINIAN • STAX • YAMAHA

**Infidelity**  
indecently good hi-fi

9 High Street, Hampton Wick, Kingston upon Thames, Surrey KT1 4DA. Tel. 081-943 3530  
Open Tues - Sat 10.30am - 7.00pm.

# NORTH WEST

**UNILET**  
Sound & Vision

*Best place in town for Hi Fi and Home Cinema*

- \* Six demonstration rooms
- \* All leading brands
- \* Interest Free Credit
- \* Free Parking
- \* Open 10-4 every Sunday

**UNILET SOUND & VISION**  
35 HIGH STREET, NEW MALDEN,  
SURREY, KT3 4BY  
Tel: 0181 942 9567 Fax: 0181 336 0820

**WORTHING AUDIO**

20 Treville Gate, W.Sussex BN11 1UA  
(01903) 212133

The friendly shop with the best sound system in the South.  
Talk Electronics - Friendly Advice - 3 Year Guarantees  
Easy Parking - Open Mon-Sat. 10am-6pm.  
Late Night Wed 7.30pm.

Agencies include: Arcam, Exposure, Kinshaw, Naim, Audio, Marantz, Ruark, Audio Technica, Target, Tripod, JPW, TDL, Orelle, and many more.....

**audio excellence** 

**WHERE THE MUSIC MATTERS**

CHESTER      PRESTON  
86-90 Boughton,      131 Friargate  
Chester CH3 5AQ      Preston, PR1 2EE  
(01244) 345576      (01772) 253057

**TUESDAY - SATURDAY 9.00 - 5.30  
CLOSED MONDAY**

specialist hi-fi dealers

# NORTH

## THE hi-fi ROOM

50 BRIDGE STREET, MANCHESTER M3 3BN. TELEPHONE: 0161-832 0888/0161-835 1366

*An Oasis of Sound*

EXCLUSIVE HI-FI AND AUDI VISUAL SYSTEMS

GLASGOW  
0141 248 2857

EDINBURGH  
0131 220 0909

NEWCASTLE  
0191 230 3600

LEEDS  
0113 242 7777

### SERIOUS KIT

The finest range of Hi-Fi in the north. Stockists of Audionote, Sugden, Impulse, Pro-Ac, Harbeth, Stemsfort, Target, Neat, Trichord, Systemdek, Lyra, Proceed, SME, Michell, Heart, Keswick etc etc  
Open 10-6pm Mon-Fri  
10-5pm Sat  
10-2pm Sun

Phone: 0161 793 6742  
Fax: 0161 727 7042



### Soundcraft

INSTALLATIONS

VISIT THE LEADING HI-FI DEALER  
IN THE SOUTH EAST  
"SEE & HEAR THE DIFFERENCE  
REAL HI-FI MAKES"

LINN NAIM ARCAM REGA  
HELPLINE: 01233 624441



### Basically Sound

NORWICH • NORFOLK

Arcam, Audio Analogue, Cabletalk, Chario, Chord Co., Denon, Epos, Naim Audio, ProAc, Rega, Royd, stax, Talk Electronics, Teac, UKD Opera, Audio Note and many others

The Old School  
School road, Braken Ash  
Nr Norwich, Norfolk, NR14 8HG  
Tel (01508) 570829

# NORTH WEST

Demonstrating some of the worlds finest HI-FI  
Home Demonstrations a speciality  
(see Dial-A-Dealer for complete product range)

Tel/Fax 0161 304 7494 Mobile: 0402 268490  
Evening calls welcome

INPUT For The Pleasure of Music

# MIDLANDS

## MUSIC MATTERS



### LATEST ARRIVALS

CHORD SPA3200 & SPM1200B PRE-POWER, MERIDIAN DSP6000 SPEAKER SYSTEM, S65AC-3 SURROUND PROCESSOR, 557 POWER AMP, 518 DIGITAL PROCESSOR AND 566 20-BIT DAC.

ALCHEMIST MAXIM, NEMESIS AND FORSETI AMPLIFIERS, DYNAUDIO RANGE OF SPEAKERS, EPOS ES22, SPENDOR AND PRO-AC SPEAKERS, ROYD SQUIRE & DOUBLET SPEAKERS, QUAD 77 RANGE....

### CLEARANCE & SECOND HAND SALE

OUR VERY SUCCESSFUL SALE NOW MEANS WE HAVE A NEW LIST. PLEASE SEND A N.S.A.E. FOR AN UPDATE OF THE NEW BARGAINS AVAILABLE.

PLEASE NOTE OUR NEW OPENING TIMES  
TUESDAY TO SATURDAY 10am TILL 5.30pm.  
LATE NIGHT THURSDAY TILL 7pm.

Branches at:

■ Birmingham : 363 Hagley Road, Edgbaston, Tel: 0121 429 2811

■ Solihull : 93-95 Hobs Moat Road, Tel: 0121 742 0254

■ Stourbridge : 9 Market Street, Tel 01384 444184

~Demonstrations By Appointment~

## FRANK HARVEY Hi-Fi EXCELLENCE

163 Spun Street, Coventry, CV1 3BB Tel : 0203 525200  
Mon to Sat 9.30 till 5.30. Closed Thursday

MUCH MORE THAN HI-FI

WE ARE A  
BADA DEALER

Audiolab - Audio Alchemy - Arcam - Alphason - Bose - Bang & Olufsen - Celestion - Cyrus - Denon - Dual - Foundation - Kel - Marantz - Monitor Audio - Mission - Musical Fidelity - Nakamichi - Nad - Quad - Rega - Rogers - Rotel - Target - Tripod - Tannoy - Thorens - Van Den Hul - Yamaha

MAILORDER - EXPORT - HOME TRIALS

3 Floors, 3 Dem rooms, 3000 sq feet in the pursuit of Hi-Fi Excellence



### Audio & Visual Solutions



Arcam - Audiolab - Castle - Chario - Denon - Epos - Kel - Linn - Linn Kuzma - Loewe - Mir ramegi - Mission - Short - Musical Technology - Tannoy - Primare - Rega - Rotel - 4 listening rooms - Multi-room design & installation

Hotel Street, Leicester, LE1 5AW  
Telephone 0116 262 3754  
Pleased to be a BADA member

Cymbiosis  
Audio & Visual Solutions

### THE LEAMINGTON HI-FI COMPANY THE LEADING HI-FI SPECIALIST

ARCAM AUDIOLAB QUAD MERIDIAN MARANTZ DENON PIONEER YAMAHA NAD MICROMEGA MISSION KEF CELESTION ATACAMA TECHNICS TRICHORD TDL REL DCS SINGLE SPEAKER DEM ROOM WHO DO NOT USE ANY COMPARETORS WE ALSO HAVE FULL DEMONSTRATION OF PROJECTION TV WITH LASERDISC AND FULL PRO LOGIC SYSTEMS PART EXCHANGE WELCOME PLEASE PHONE OR E-MAIL FOR PRICES WE HAVE IN STOCK OVER 200 LASERDISCS CALL FOR OUR LATEST CATALOGUE THE LEAMINGTON HI-FI COMPANY 23a Regent Street, Leamington Spa, Warwickshire CV32 5EJ Phone: 01926 876644 Fax: 01926 887488 E-mail: k.brown@bbccbs.org.uk

## CREATIVE AUDIO

9 DOGPOLE, SHREWSBURY, SHROPSHIRE  
Tel: (01743) 241924  
Closed Mondays

- Comfortable listening rooms
- Home demonstrations available
- Part exchange welcome
- Free home installation
- Interest free credit

Authorised retailer for:

A&R ARCAM, AUDIOLAB, CELESTION, CYRUS, DENON, DUAL, MERIDIAN, MISSION, MONITOR AUDIO, QUAD, REVOLVER, ROKSAN, ROTEL, YAMAHA, EPOS, NAIM, KEF, NAD

# WEST & WALES

## audio excellence

### WHERE THE MUSIC MATTERS

**Bristol**  
65 Park Street  
Bristol BS1 5PB  
(01179) 264975

**Cardiff**  
134/6 Crwys Road  
Cardiff CF2 4NR  
(01222) 228565

**Gloucester**  
58 Bristol Road  
Gloucester GL1 5SD  
(01452) 300046

**Swansea**  
9 High Street  
Swansea SA1 1LE  
(01792) 474608

**Exeter**  
156 Sidwell Street, Exeter, EX4 6RT  
(01392) 491194

TUESDAY - SATURDAY 9.00 - 5.30  
CLOSED MONDAY

## EIRE

Hearing is Believing

**CLONEY**  
*Audio*  
30 years of Excellence

55 Main Street,  
Blackrock,  
Dublin.

Tel: (01) 2889449/2888477  
Open: Tues - Sat 10 am to 6 pm.  
Thur - Fri 10 am to 6 pm.

**Arcam  
B&W  
Audiolab  
Castle  
Meridian  
Classé  
Rega  
Marantz  
Epos  
Naim Audio  
Sony  
REL**

## REPAIR & DIY

### TECHNICAL & GENERAL

THE ORIGINAL TURNTABLE SPECIALIST

for the Great Classical Turntable, Arms, Cartridges, Styli

CONNOISSEUR • GARRARD • GOLDRING •  
LENCO • ORTOFON • SHURE • S.M.E. •  
THORENS • WATTS

All available Genuine spares and our own  
re-manufacture of obsolete parts

NO ILLUSORY 'IMPROVEMENT' NO  
DUBIOUS OR HARMFUL 'MODIFICATIONS'

Cartridges and styli, correct radius diamonds, for early  
recordings - 78s & Lps

**TECHNICAL & GENERAL**

P.O.Box 53 Crowborough, East Sussex TN6 2BY  
Tel: 01892 65 45 34

## VALVES & TUBES

**CVC** CHELMER VALVE COMPANY  
for  
High Quality Audio Valves

Buy CVC PREMIUM Hi-Fi valves direct from us.  
All valves processed for improved performance.  
We also have Stock of MAJOR BRAND types  
including :MULLARD, GEC, BRIMAR, RCA, GE, etc  
130, New London Road, Chelmsford, Essex, CM2 0RG  
Tel: 01245 265865 Fax: 01245 490064

## VINYL

**MUSONIC STYLII**  
SPECIALIST MANUFACTURER &  
SUPPLIER FOR MORE THAN 40 YEARS  
REPLACEMENTS & ORIGINALS  
MANY OBSOLETE/78 VERSIONS  
PICK-UP CARTRIDGES  
& RECORD ACCESSORIES  
For prices telephone mail to

**MUSONIC (UK) LIMITED**  
Unit 13 The Wenta Business Centre Colne Way  
Watford Hertfordshire WD2 4ND  
e-mail: musonic@compuserve.com  
Tel: 01923 213444 Fax: 01923 213355



## SERVICES & CONSULTANTS

### REVOX SERVICE

Fully Guaranteed Service and Repair  
Insured Carriage arranged  
Free Estimation

Also: Tape Supplies  
Second User Reconditioned Machines  
Spare Parts orders welcome  
Free Advice

**Ram Tek**

Tel: (0181) 207 6159  
Fax: (0181) 953 1118

Kinetic Centre, Theobald Street,  
Borehamwood, Herts. WD6 4SE

### STUDER REVOX

SALES, SERVICE, SPARES  
SERVICE & REPAIR OF  
A77, B77, A700, PR99 &  
36 SERIES  
HI-FI SPARES TO ORDER  
SERVICED MACHINES IN  
STOCK

APPROVED CONVERSIONS

**E.M.A.S.**

TEL: 01246-275479  
FAX: 01246 550421

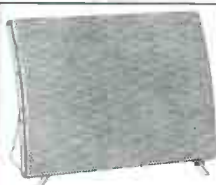

Got a burnt-out QUAD ESL?

We have the spare parts for every  
QUAD electrostatic speaker.  
Ask for free catalogue and price list.

**QUAD Musikwiedergabe GmbH**

Rheinstrasse 24 · 56068 Koblenz (Germany)

Tel: x 49-261-38824 · Fax: x 49-261-38172 · e-mail: quad.ger@t-online.de

## MAIL ORDER

YOUR



**MAIN**  
*problem*

COULD BE YOUR

**MAINS**  
*problem!*

Call now for the Russ Andrews  
essential guide  
to upgrading your mains.

**0800 373467** UK ONLY

Russ Andrews Accessories Ltd., Kendal, Cumbria, LA8 9AS  
Tel: +44 (0)1539 823247 www.russandrew.com

ref: 0493H/WB

TO ADVERTISE IN  
SPECIALIST HI-FI DEALERS  
PLEASE CALL  
AMANDA or SARAH ON 0171  
328 2213/0171 328 4892

**atv**

- Service & Repairs
- Valve & transistor amplifiers
- Vintage valve Radios
- Hi-Fi VCR's
- Valves Tested

ATV SERVICES  
LEATHERHEAD  
01372 456921

specialist hi-fi dealers



# MATS A-PLENTY

Will the rainbow hues of the new Ringmat record supports do Richard White a good turn?

Turntable mats have always offered the experimenter a free field; until you've tried it, it can't be wrong! In view of the interesting concepts I have foisted on my turntable over the years, before I began this test I re-instated the turntable's original mat and had a re-acclimatizing earful of rubber-supported software.

Remembering that the job in hand was to test the new Ringmat package, not ruin records, I reached for the Ringmat instruction booklet and was soon comforted by the directions in Step One: "Remove any felt, rubber or other mat" - good, done that! - "and place the non-slip spacer mat on the platter."

This base mat is a thin 'rubber' disc with a couple of circles stamped out of it and a foam triangle stuck on the edge. The purpose of this last is to engage with the spacer mats placed over it, to prevent slippage.

Now to the spacer mats themselves. These are colour-coded by thickness: depending on which set you have bought, you get a greater or lesser assortment of discs distinctly reminiscent of stage-lighting 'gels'. Each of these, and the base mat as well for that matter, has five wedges cut out of the centre, making a sort of spoke pattern on a two-inch radius. In addition the two circular holes are again stamped out opposite the notch where the base mat 'stud' engages.

Following the directions once more, when I had placed the correct sequence of spacers on the turntable, it was time to adjust the arm height. This procedure is second only to the humble sweater sleeve as an executioner of pick-ups, so due care and attention is recommended.

The trick with the Ringmat outfit is to level the tone-arm with x number of spacers plus a 'dead'

record. Then, when y number of spacers are used for the proper record playing, the optimum vertical tracking angle should automatically have been set, all this without resort to protractors, try-squares and the like.

Having removed the setting-up spacers, placed the Statmat and the main Ringmat on the spindle and checked the tracking weight, it was high time to listen to the gramophone.

With Haydn's F major concerto for violin and harpsichord ready for action, and with all the proper scepticism of a seasoned reviewer, I lowered the needle.

Surprise number one was the immediate beneficial effect on the bass. With the best will in the world, a chamber orchestra seldom exhibits much punch in the lower octaves. I had really chosen this record to show more the mid and upper ranges - a harpsichord pushes out harmonics in excess of 20kc/s, which gives a useful index for top-end response. Bass improvements were thus a very welcome bonus; both the sound level and the accuracy were considerably improved. Bowed double-basses sound like the worst loudspeaker in the world - honks, booms and rattles all being par for the course. It's when a bass sounds smooth and 'cello-like that you're not getting the full story!

Moving onwards and upwards, solo fiddle floated through the 'speakers with enchanting sweetness. On some of the climactic moments, where I knew the record to be worn, the Ringmat managed to keep audible distortion well under control; the static-y clicks had disappeared. As I ploughed on through my collection it was plain that, although my cartridge had been carefully set up prior to trying the mats, it was by no means



unhappy in its new horizontal alignment. Records which generally track indifferently can be fine-tuned by use of additional spacers; this can make quite a difference, since cutting angles have resisted standardisation despite all endeavours.

To avoid trusting my ears alone I tried out a couple of test records. Tracking and biasing arrangements were proved to be very well optimized and the general behaviour of the needle was as good as it's ever been. Where the inherently low-mass Ringmat cannot help much is with mechanical rumble, but this is rather like expecting a petrol additive to inflate the tyres as well!

As is usual with modular products, not everybody will need all the bits. The full system may look a little expensive but it is easily possible to trim costs by selective exclusion, although the sheer convenience of the precision spacers for setting up stylus rake should not be overlooked. Certainly if you've never been able to face the rigours of vertical alignment or your turntable is still struggling with the mat 'as supplied', the Ringmat Support System could be money well spent ●

Ringmat Support System  
£160

Ringmat Developments  
PO Box 200,  
Brentwood,  
Essex,  
CM15 8QG  
Tel: 01277 200210

## WORLD VERDICT



The system is very effective if a touch expensive. Not everyone will need all the individual parts.

**ALCHEMIST PRODUCTS** Call us and allow us to transform your life with products from an acclaimed range of Amplifiers, CD's and Pre/Power combinations including such models as 'Kraken' and 'Forsetti' right through to our 'The Alchemist' range. The Alchemist range (Winners 1996 C.O.T.Y. Japan) Unit 1, Furzedown House, Cranbourne Ind Est, Puttens Bar, Herts. EN6 3JN. Tel: 01707 664607 (for enquiries). Tel: 01753 889949 (for UK Sales). Fax: 01707 664207 (for enquiries). Fax: 01753 889636 (for UK Sales).

**ALEMA UK LTD** 25 Montford Road, Hove, BN1 1RD. Tel: 01273 202637. Audion® Edition® Andersson® (Trade enquiries welcome for our newly extended range).

**APOLLO** The UK based designers and manufacturers of high quality speaker stands and equipment racks have now added to their comprehensive range a modular system ideal for housing audio visual products and CD storage. Please send for our free brochure to Zenith Crown Ltd, Tipton Rd, Dudley, West Midlands, DY14 Tel: 0121 520 5070. Fax: 0121 522 2055. All export trade enquiries welcome.

**ARCAM** Pembroke Ave, Denny Industrial Centre, Waterbeach, Cambridge, CB5 9PB. Tel: 01223 440964 or Fax: 01223 863394. Manufacturers of the Delta 290 Amplifier and the Delta 280 Digital FM Tuner. The two together produce a sound that has been described as "subtle and intriguing" and that provide "real clout" - discover this for yourself. For information on not only these products but also the Arcam CD Players, Speakers, Cassette Decks etc., Phone or write in to request a brochure - The pleasure is all yours!

**AUDIOPHILE FURNITURE LTD** The Square, Forest Row, East Sussex RH18 5ES Tel: 01342 826262. Fax: 01342 824845. Manufacturers of the patented **BASSE VIBRATION CONTROL PLATFORMS AND THE MODULAIR AUDIO SUPPORT SYSTEM.** All our Products are endorsed by Hi-Fi World. Also newly introduced are the **RESONANCE CONTROLLED HI-FI CABINETS** which are multi level modular design and available in various sizes and wood finishes. Please telephone for more details and a product portfolio.

**AUDIOLAB** Cambridge Systems Technology Ltd, Spire Close, Ermine Park, Huntingdon, Cambs, PE18 6XY. Tel +44 (0)1480 415600. Fax +44 (0) 1480 52159. The Audiolab amplifiers, CD players and tuners are internationally acknowledged for their sophisticated, modern design, combined with outstanding sound quality and flexibility. There are now 10 Audiolab models which range from the famous 8000A Integrated Amplifier through to the new 8000CD Integrated CD Player. For full information and details of your Audiolab dealer, please phone or write.

**AUDIO SYNTHESIS** Manufacturers of the outstanding DAX digital to analogue converter, comes DAX-2, a new Hi-end reference converter able to dig deeper into the digital source than ever before! A new addition to the superb PASSION series of hi-fidelity controllers has just been introduced in the form of PASSION 8, a fully remote controlled uniquely transparent passive preamplifier, the perfect match for DESIRE. By word of mouth our DESIRE power amplifier is rapidly convincing listeners, whether passive or active! New for 1997 is TRANSCEND a state of art CD transport with AES support, A/D converters and Toslink outputs. Audio Synthesis, PO BOX 50, Nottingham, NG9 1DZ. Tel: (+44) (0)115 922 4138. Fax: (+44) (0)115 922 9701.

**BORDER PATROL** 63 Berriedale Avenue Hove BN1 4JD. Tel/Fax: 01273 276711. Manufacturers of **Power Supply Units** for valve amplifiers, **Single-Ended Power Amplifiers** and high quality **Transformers.** The **Border Patrol PSU:** valve-rectified choke input filter power supply units which dramatically improves the sound of valve amplifiers: models available: **Audio Autocore, Audio Innovations, Audio Art, Cary, Unison Research, World Audio Designs.** The **Border Patrol 300B SE** single-ended valve amplifier featuring interstage driver transformers and valve rectified choke input filter power supplies. **Border Patrol transformers:** high quality output (PP and SE) interstage and pre-amp output transformers and high value inductors.

**CABLE TALK** Unit 12, Farnborough Business Centre, Eelmoor Road, Farnborough, Hampshire, GU14 7XA. Tel: (+44) (0)1252 37424. Fax: (+44) (0)1252 371818. Designers and manufacturers of British made high quality, value for money, interconnect and speaker cables. Phone or fax for a free full colour brochure on our What Hi-Fi? 5 star rated products.

**CAMPAIGN AUDIO DESIGN** Lindlundo Road, Cardiff CF3 8PG. Tel: 01222 779 401. Supplies / manufactures mailorder, high purity silver interconnects, loudspeaker cables, internal wires and bespoke mains cables. Generous two week trial period.

**CANFORD AUDIO PLC** Cromlow Road, Washington, Tyne & Wear, NE38 0BW. UK Sales 0191 415 0205. Fax: 0191 416 0392. E-Mail: mbc@canford.co.uk. Internet: www.canford.co.uk The UK's leading manufacturer and distributor of professional audio equipment, specialists in cabling & connectors. Canford invite interested parties to call for one of their FREE 850 page bi-annual catalogues which details over 12,000 products. Canford have offices and distributors world-wide.

**CHORD ELECTRONICS LIMITED** 3 Bower Mount Road, Maidstone, Kent ME16 4JX. Telephone: 01622 764874. Fax: 01622 688480. We have recently complemented our highly acclaimed SPM range of power amplifiers with 2 superb pre-amps: the CPA 2800 + CPA 4000s as well as the BBC qualified L55/12A loudspeaker & L55/12 bass extension system. Call us for copies of reviews that will leave you wanting details of your nearest retailer.

**CREEK AUDIO LTD** 2 Bellevue Road, Friern Barnet, London N11 3ER. Tel: 0181 361 4133. Fax: 0181 361 4136. E-mail: mcreek@ibm.net. Internet: www.creekaudio.co.uk. Creek Audio build stylish Hi-Fi products in the UK combining state of the art electronic design, with full bodied, accurate and musically rewarding sound. Our standard size products come in two award-winning ranges, the entry level 43 series and higher priced 52 series. These include: CD43 - CD player with 24 bit resolution, DAC, T43 AM/FM Tuner, integrated Amps, 5250, 5205SE and 4330 (described by Stereophile Magazine as the best amp under \$1000). Our A43, A52 and A25SE Power Amps range from 50 to 250 Watts and both P43 and P52 Pre-Amps offer passive and active operation with remote control. In addition we have an award winning OBH range of mini products: OBH-805E, HM and OBH-9 MC. Phone Pre-Amplifiers, OBH-11 and 11SE Headphone Amplifiers, OBH-10 and 12 Remote Control Passive Pre-Amps and OBH-14 - 24 bit DAC. See our home page for further details or call us for leaflets.

**DBS AUDIO P.O.** Box 91, Bury St Edmunds, Suffolk, IP30 0NF. Tel: 01284 828 926 Fax: 01284 828 026. DBS Audio supply quality loudspeaker kits designed by Dave Berriman. The DBS 6, features a custom-built 6-inch cast-chassis woofer with high-power voice coil, a metal high-power tweeter, and gold-plated crossover with van den Hul cable ICW 630V polypropylene capacitors and bi-wired with gold-plated terminals. By popular demand DBS4II is now upgraded to MkIII (upgrade kit available). New designs are planned. Also a distributor for the C.I.U professional quality (but easy to use) PC-based audio measuring system, Mastercard / Visa accepted.

**ECA DISTRIBUTION** Resulting from our own research and development, The ECA Design Team, has pioneered the award winning Vector Lectern 5 Pre Power combo (Best Buy: Hi-Fi Choice) and the Vista HD/Lectern HD Pre-Power combo (Gramophone Audio Choice 1996 Award). Closely followed by our ECA A.2 True Ribbon Speakers and Prisma Phono Amp for "the naturally neutral chain". The barest minimum of wiring in the amps: super symmetry in the circuits and vacuum impregnator coating custom made for the speakers. P.O.Box 3023 London NW2 7RW. Tel/Fax: 0181 998 1086.

**ENHMENT AUDIO** Distributor of Croft Valve Amplification. Tel: 01902 656517. Fax: 0121 681 8772. Mobile 0956 921740 U.K. Stocks are: Classique Sounds (Leicester) GT Audio (London NW) Nottingham Analogue, Purist Audio, The Cartridge Man (Len Gregory - Croydun), call for overseas distributors.

**FALCON ACOUSTICS LTD** Tabor House, Norwich Road, Mulbarton, Norwich, Norfolk, NR14 8JT. Tel: (01508) 578272. U.K. distributors of FOCAL drive units and SOLEN (chateauroux) polypropylene capacitors and the largest industrial manufacturer in the UK. Comprehensive range of DIY Speaker Parts and Loudspeaker Systems. Everything but the wood! Enquiries should be accompanied by a 38p stamped addressed envelope.

**FULLERS AUDIO** 20 Tunbridge Road, Southend on Sea, Essex SS2 6LT. Tel: 01702 612116. Fullers's products produce a range of innovative products. Amplification - all single ended class A semiconductor power amplifier - £1200, b70 a mosfet power amplifier of high standard - £599, pre and pre + matching pre-amplifiers - £599/£649, gen phono stage for mm and mc cartridges £239. Loudspeakers - Pharaoh system, upgradeable from 1 pair of cabinets to 3 pairs for truly extended bass, passive/active options £649-£2499. Sphinx a 3 way floor standing unit £849. Sultan Hifi, 98dB sensitivity £439, matching Sub Woofer £559. Sultan, 91.5dB sensitivity £309.

**IAN EDWARDS** The Old Chapel, 282 Skipton Road, Harratage, Yorks. Tel: 01423 500442. Somebody Somewhere must make better storage units for CDs, Music, LPs, HiFi, Books, etc. than Ian Edwards. BUT until it appears, why not send for the brochure showing a selection of HAND MADE units. To do this please send 3 x 2nd class stamps.

**IPL ACOUSTICS** are a long established supplier of high quality speaker kits, components and PTFE Silver cables. Our kit range includes 6 Transmission Lines and 6 Hi-Fi kits, available with or without flat-pack cabinets (Plain or veneered). Our latest Transmission Line has a spun aluminium bass unit and a superb new ribbon tweeter. For details send large 30p S.A.E. - IPL Acoustics, 2 Laverton Road, Westbury, Wiltshire, BA13 3RS. Tel: 01737 823333.

**JAMO UK LTD** Jamo House, 5 Faraday Close, Drayton Fields, Daventry, Northants, Tel: 01327 301300.

**JEM DISTRIBUTION (FI RAX)** Springfield Mills, Spa Street, Ossett, Wakefield, WFS OHW. Tel: 01924 277626. Fax: 01924 270759. Fi-Rax offers a new dimension in audio visual ranging. High quality aluminium construction. Finishes available to your choice. Fully adjustable 6mm glass shelving, sound insulation on shelves. Custom created to suit your system. Free delivery throughout the UK. For further information or a free brochure contact JEM Distribution.

**JORDAN WATTS ACOUSTICS LTD** Cyntra Place, 1 Mare Street, Hackney, London E8 3QE. Tel: 0181 985 1646. Jordan Watts Acoustics for Sight AND Sound.

**KESWICK AUDIO RESEARCH** 54 Coach Road, Outwood, Wakefield, W Yorks, WF1 3EX. Tel/Fax: 01924 870606. "I'd say that the figure is the best miniature speaker I have heard." Audiophile March 1993. Write in or call for details on our full product range and your nearest distributor.

**KRONOS DISTRIBUTION** 7 Scotch Street, Dungannon, BT70 1JA. Tel: 01868 753606. Tel: 01868 753006. Kronos is the UK distributor of some of the finest Hi-Fi products in Europe. These include Audiomeca digital products and turntables; Lieder silver speaker and interconnect cables; Project turn-tables and amplifiers; Triangle speakers and electronics; and YBA amplifiers. We also handle Frameworks equipment tables; Arion valve amplifiers and mains filters and Essex Audio digital products from the UK. Please telephone or write for product details and dealer lists.

**LANGREX SUPPLIES LTD** 1 Mayo Road, Croydon, Surrey, CR0 2QP. Tel: 0181 684 1166. Fax: 0181 684 3056. One of the largest distributors of electronic valves, tubes and semi-conductors in the UK and USA manufacturers. stock. We specialise in obsolete types including original UK and USA made audio valves. Telephone or fax for an immediate quotation.

**LORICRAFT AUDIO** "Vintage D.I.Y." 4 Big Lane, Goose Green, Lambour, Berks. RG17 8XQ. Tel: 01488 72767. Specialist restoration of Garrard 301's and 401's using genuine spares and re-manufactured parts to original British standards in our newly built work shops designed primarily for these purposes. *Worked, Goldring GL75.*

**MARSTON AUDIO** 17, Queens Avenue, King's Lynn, Norfolk, PE30 5LR. Tel: 01553 728785. Fax: 01553 728788. marston@planetnetweb.co.uk, website: www.planetnetweb.co.uk/marston. Manufacturers of the Silhouette and Silhouette Elite Digital to Analogue Converters and the new "Marston Silhouette" CD Player, engineered to produce stunning dynamics, unprecedent timing and a better than CD sound. Telephone for stocks and future developments.

**MAY AUDIO MARKETING U.K. LTD** Areside Mills, Cononley, Keighley, West Yorkshire, BD20 8LW. Tel: 01535 632700. Fax: 01535 632887. Distributors of High Quality audio products from LFD amplifiers, Topend Loudspeakers, Reference Recordings, Jocklin Flex Headphones, Sequence Loudspeakers, Sonnetee Amplifiers and quality recordings from Proprius. IF ITS MUSIC YOU LOVE, TELEPHONE OR WRITE FOR LITERATURE.

**MICROMEGA** distributed by Surrey Sounds, 32-33 Enterprise House, Terrace Road, Walton on Thames, Middlesex, KT12 2SD. Tel: 01932 254297. Fax: 01932 230174. For dealer and product info on the fantastic Micro mega complete system, up to the Solo and Data and Dialog. Also the new 24bit audio and video DVD player and the outstanding new premium range of CD players. All Micromega CD players play CDs like Vinyl!

**MORGAN AUDIO SYSTEMS LTD** A range of equipment hand built in the UK, consisting of a CD player / D.A. converter / integrated & pre/power amplifiers. The integrated amplifiers are designated 125/250/600. Priced at £2499/£3999. Pre-power versions of the 250/600 are priced at £799/£899. The CD player @ £579 + DAC @ £399 offer astounding performance and complete the 250 range. For further info, please call: 0151 236 7667.

**NORTON TECHNOLOGIES LTD** Manufacturers of the acclaimed AirPower LP12 Power Supply, 14 Rothsay Avenue, Chelmsford CM2 9BU. (01245) 283125.

**NOTTINGHAM ANALOGUE STUDIO** Tel: 01773 762947. Design and manufacture of quality analogue audio. We're in the business because we realise how important music is. Our turntable arms and cartridges sell the world over a commitment to providing all our customer's with the best of analogue. We love music.

**OPTIMUM INTERNATIONAL 2000** "A beautiful and stunning range of support systems for both hi-fi and audio visual equipment. Manufactured in the UK for the new millennium. Comprising stylish rugged safety glass and stainless steel support racks, these products provide both visual and sound performance. The new Premier range is totally modular and therefore totally flexible, suiting the needs of all customers. All models are fully spiked and flat packed for ease of transportation. Please call for further details. Tel/Fax: +44 (0)1274 583249.

**OPUS/PENTACONE** Natural Acoustical Music recorded on CD & LP. Three Dimensional, Dynamic and LIVE. SYSTEM HARMONISING: A service to extract the full potential of your hi-fi equipment by careful and innovative methods of Synergy Tuning. WE WERE AT THE RECORDING SESSION! Because we record live music we know what it sounds like. 4, Cross Bank Road, Batley, W. Yorks. WF11 8PJ. Tel/Fax: 01924 445039. E-Mail: pentacone@hotmail.com WWW: http://dspace.dial.pipex.com/nlm

**PLATFORM 7** High density marble ISOLATION PLATFORMS for all makes of equipment RACKS/STANDS. An elegant way to UPGRADE. Improves clarity; better BASS control. 3 Abbots Drive, North Wembley, Middlesex HA0 3SB. Tel: 0181 904 2646. Also to NEALGAR DISTRIBUTION Tel/Fax: 01296 24756.

**P.M. COMPONENTS LTD** Are the specialist component company for high end audio enthusiasts. Also carbon tubes/audio valves. Major stocks for Golden Dragon, Mullard, REC & Tecnix valves plus a vast archive of vintage tubes.

**PRISM ACOUSTICS LTD** Prism House, Duncan Street, Banff, Aberdeenshire, AB45 1EQ. Tel: 01261 818444. Fax: 01261 818555. <http://www.primsaudio.com> E-mail: [enquiries@primsaudio.com](mailto:enquiries@primsaudio.com) Prism Acoustics Ltd. Has pioneered the use of Reflective Wave Technology (RWT) in the design of all our loudspeakers. Contact to find out more!

**PREMIER MARBLE LTD** Uncover the true sound quality and potential of your system. Use the natural benefits of granite and marble. These natural materials offer better base definition, clarity, and natural sound staging capabilities. CD/Turn-table platforms, custom made stands, shelves or anything you desire, cut and polished to any shape or size required. Tel: 01603 721995

**REL ACOUSTICS** North Road, Bridgend Ind Est, Bridgend, Mid Glamorgan, CF31 3TP UK. Tel: 01656 768 777. international +44 656 768 777. Fax: 01656 766 092. Internationally +44 656 766 092. Email: [customers@rel.ac](mailto:customers@rel.ac) Web: <http://rel.ac> The UK's only specialist sub-bass speaker manufacturer. "The only one that works". Get your dealer to give you a home demo and find out what the fuss is all about.

**RDE TANDBERG HI-FI SERVICES** Helly Tree House, The Green, Full Sutton, YORK YO4 1JH. Tel: 01759 372795. The service, overhaul and reconditioning of all Tandberg hi-fi products regardless of age.

**RINGMAT DEVELOPMENTS** Ringmat Developments, PO Box 200, Brentwood, Essex CM15 9FB. Tel: 01277 200 210. Ringmat Developments provide unique solutions to the problems of mechanical and electrical vibration at the front end of the signal chain. There are no comparative products. NEW! 1998/99 - RINGMAT SUPPORT SYSTEM. A complete, modular system of components providing all you need on your platter to extract the best sound from your turntable. The support system includes a RINGMAT, RINGMAT Spacers, LP STATMAT and RINGCAP. The improvements in LP sound reproduction vastly exceed anything otherwise achievable from turntables. In addition, there are platter inserts for Roksan and Garrard turntables. STATMAT for CD Players just gets better and better, bringing the greatest advance in CD sound reproduction since compact discs were introduced in 1983. MKII version now available. More products to follow in 1998/99.

**SHEARNE AUDIO P O BOX 22**, Stevenage, Hertfordshire SG2 8HF, England. Tel: 01438 740953. Following the highly acclaimed Phase 2 integrated, by adding the Phase 3 power amplifier and bi-amping. Shearne Audio are continuing the design philosophy of an upgradable system through the range. Introducing the Phase 6, a superbly musical, specialised pre-amplifier allowing owners of the Phase 2 or 3 or both to upgrade their systems to highly specialised levels, also the introduction of the Phase 5, 100 watt mono block also with the Phase 6 pre-amplifier can be used via Phono inputs or balanced mode giving even greater versatility.

**SONIC LINK** The Derwent Business Centre, Clarke Street, Derby, DE1 2BT. Tel: 01332 361390. Fax: 01332 298826. "Makes the World's Finest Hi-Fi Cable From the Highest Quality Materials" SonicLink BLACK RHODIUM interconnect uses Rhodium plated wire, VERMILION uses pure Titanium wire. 23-GOLD mains cable improves the picture quality in TVs, computer monitors and home cinema as well as sound in hi-fi systems. Best selling products include RED, SILVER PINK AND VIOLET interconnects, AST752, AST7002 and S130x2 BiWire loudspeakers cables and GREEN digital 75 ohm interconnect.

**SOUND BYTES** 72 Novar Drive, Hyndland, Glasgow, G12 9TZ. Tel: 0141 339 7595. Fax: 0141 339 7592. E-mail: [bytes@colloquium.co.uk](mailto:bytes@colloquium.co.uk). We specialise only in mass loading material. After hours exhaustively testing SOUND BYTES with various types of speakers, we know it works and so do you - we have never had a single complaint. Call us for advice on how much to add to your equipment for the best performance and the location of your nearest dealer.

**SOUND IMAGE UK LTD**, 52 Milton Road, London SW14 8JR. Tel: 0181 255 6868. Importers and distributors of the finest audio equipment, featuring the stunning Boulder 2,000 series and the complete range from Norwegian manufacturer Electrocompam.

**J E SUGDEN & CO LTD** Valley Works, Station Lane, Heckmondwike, West Yorkshire, WF16 0NF. Tel: 01924 404088. Manufacturers of hand crafted audio products. "A world of Music". Call or write in for information on our SDA-1 Digital to Analogue Converter, SDT-1 CD Player, A21a Class "A" Amplifier, A25B Integrated Reference Amplifier, AuSiC Pre Amplifier, AuSiP Power Amplifier and more interconnects and connectors.

**TALK ELECTRONICS** Unit 12, Farnborough Business Centre, Eelmoor Road, Farnborough, Hampshire, GU14 7XA. Tel: 01252 378833. Please ring for details.

**TARGET AUDIO PRODUCTS PLC** Britannia House, Leagrave Road, Luton, LU3 1JR. The Audio equipment, rack and speaker stand specialist. For information on our products please telephone or write.

**TECH-LINK** distributes some of the best performing hi-fi and av accessories currently available in the UK. These include: Puresonic, best known for its range of high performance interconnects and connectors, and cable adapters for a wide variety of hi-fi and av applications; the 1990's was formed by its own brand Switch Boxes are the perfect solution to multiple applications - for example, its highly acclaimed TASI-1 is a very practical and inexpensive way of switching your speakers between hi-fi and home cinema systems; and Shark - a range of very exclusive high quality cables, interconnects and connectors. For more information, contact: Tech-Link at Units 1/2, 76a Farnley Road, London, SE25 6NX. Tel: 0181 771 8388. Fax: 0181 771 1840

**TEAC S Marlin House, The Crowley Centre, Watford WD17 8BY. Tel: 01924 819630. Fax: 01923 232930.** Teac has already established a virtual world-dominance in the manufacture of precision recording equipment and data storage products and the company is now turning its attention to its core hi-fi and audio related products. The Tokyo Electro-Acoustic Company (known as TEAC) was formed in 1956. Over the years TEAC has produced some of the world's most outstanding recording equipment, including many excellent affordable home cassette decks (for which the name TEAC became almost synonymous) and by the time of the dawn of the digital age at the beginning of the 1980's it was internationally acknowledged as a world leader in audio technology with a string of high fidelity firsts to its name. 1997 saw a significant turning point for TEAC with the launch of a superb new mini-system, a newly developed VRDS mini CD player and a British designed CD player.

**TRICHORD RESEARCH LTD** Following on from the highly acclaimed CD clock oscillator modifications the Pulsar Series One digital to analogue converter. This unique design is part multibit and part bitstream to give absolute linearity over an extremely wide dynamic range. It switches between 18 or 20 bit resolution this converter will become the standard for CD replay. For details telephone 01684 373524.

**VADIS AMPLIFIERS** Kirkland, 37 Head Street, Beith, Ayrshire KA21 2EU. Tel: 01505 504128. A new manufacturer in Switzerland producing a very different valve power amplifier. The DIRECT OUTPUT (Patent applied for) design, after two years of development, has resulted in a power amplifier which dispenses with the output transformer, yet has an output impedance of only 0.2 ohm! Distortion is low at about 0.05%, and because there is no output transformer the bandwidth is very wide with no loss of power or increase in distortion. The result is astonishingly clear and natural sound. Two versions hand made to order, the S15 giving 15w per channel stereo, the MS0, 50w mono. Black or colour finish.

**WILMSLOW AUDIO** 50 Main Street, Broughton Aston, Leicester LE9 6RO. Tel: (01455) 286603. Fax: (01455) 286605. "Extensive range of Drive Units and over 30 different designs of self-assembly kit. Drive units include those from KEF, Dynaudio, Audax, Seas. Fearless, Scanspeak and Morel. Everything required for the loudspeaker Builder, and facilities to listen to the kits in built up form"

## SERVICES & CONSULTANTS

**RIF AUDIO VISUAL** tel: 01209 612260/710777 Fax: 01209 711939. A.K.G., Atacama, Audiocoust, Audio Technica, Beyser, Chario, Denon, Goldring, Harmon Kardom, Henley Designs, JBL, Klipsch, Magnat, Micromega, Musical Technology, NAD, Neat Acoustics, Onkyo, Ortofon, Primere, Project, QED, Quad, Revox, Rowland, SME, Sonor, Union, Soundstyle, DL, TEAC, Thorens, Trichord Research. Service and repair to most high end Hi-Fi and studio products, including open reel and multitracks, modifications including CD re-clocking and laser disc AC3. Valve transistor, analogue and digital specialists, PA and studio equipment supplied (new & used).

## STYL

**MUSONIC UK LTD** Specialist manufacturer & supplier of replacement & original styl for more than 40 years. Over 600 types stocked with many obsolete - 78 versions available. Also pick-up cartridges, record, tape, CD accessories. Why not try us & hear the difference!! Trade-Export enquiries welcome. Tel/Fax: e-mail your requirements to: - Unit 13, Hents Business Centre, Colne Way, Watford, Herts, WD0 4JL. Tel: 01923 211923. Fax: 01923 213355. E-mail: [musonic@compuserve.com](mailto:musonic@compuserve.com)

To advertise in Meet Your Maker call Amanda or Sarah on 0171 328 2213/0171 328 4892

# VINTAGE VIRTUES

By Haden Boardman

**T**he Quad Electrostatic - it's either the most fantastic loudspeaker ever produced or the most over-rated piece of Fifties kitsch, a 'speaker so odd it makes you wonder just what on earth all the fuss is about.

Peter Walker's original ELS 57 electrostatic was not based on anything radically new, and in some ways can be directly linked to the work of an American, F.J. Hunt. What it was, and what it remains, is one of the world's audiophile bargains, a commercial product that broke moulds, set standards and will still be impressing people well into the 21st century.

So, now you know my view, but what about the detractors? Well, the Quad ELS does have its flaws. I have never met the perfect 'speaker, and I know I never will, but ultimately you have to decide if this loudspeaker's shortcomings are something you can live with or not.

Its main drawback to me is its acoustic power output - the '57 is just not capable of playing at ear-splitting levels.

Electrostatic technology is a nightmare to work with; the bigger the panel, the louder it will play, but the higher the polarising voltages (danger!) and input it will require (causing lower sensitivity). This also makes the design harder to manufacture (larger panel gaps, greater electrical insulation), never mind 'putting up' with the things in your home.

Mr Walker realised this problem, and I think the resultant size is more than acceptable for the results the '57 gives. If you're still not happy with volume levels below 11 out of 10 on the dial, then the ELS is not for you. In an average room, just over 100dB is about the maximum SPL a single pair can realistically generate.

Another foible is the fact that electrostatics are also pretty directional - you have to sit on-axis to enjoy the very best



sound. With a stereo pair, this can get quite selfish in your average British semi! Some people don't like this and do not even try to hunt out the 'sweet spot' - they have their head too high and the 'speakers too low.

As I have said before in these pages, good stereo transducers should be directional - all dome tweeters should be binned and decent cones developed instead! The (original) electrostatics behave as a true line source. As such, the acoustic output does not drop off with distance as much as you might expect compared to a normal two-way box 'speaker. The ELS 57s do benefit from a room of reasonable size, as Quad used to recommend. However, one of the best sets I ever heard was in the tiniest room, no more than six foot by eight foot, and with a low ceiling!

In the average room, positioning can be tricky; in an ideal world, there would

be just as much space behind the 'speaker as in front of it. Never put a '57 flat against a wall - it will sound appalling. Position them at least one metre from a side wall as well. Bear this in mind if you are considering buying a pair - these 'speakers are far from 'plug 'n' play'.

## BASICALLY SPEAKING

The worst accusation levelled against the '57s is that they lack bass. Frankly, this is balderdash. The ELS design has the cleanest, crispest bass I have heard, even if its extension won't do justice to Bob Marley or any Drum 'n' Bass.

The real obstacle here is people's idea of what bass should sound like. The majority of commercial loudspeakers these days are brewed from Theile and Small parameters. I am not knocking the research of either Theile or Small, just the products which result from mediocre designers taking the easy route of blindly

# EGGLESTON WORKS



## THE ANDRA 'Stereophile' loudspeaker of the year 1997

An astonishing range of speakers,  
models from 3-80K  
crafted in Granite and wood.

WARRIS SYSTEMS	LONDON	0171 724 7224
ZOUCH AUDIO	ASHBY DE LA ZOUCH, LEICS	01530 414 128
LINTONE AUDIO	GATESHEAD, TYNE & WEAR	0191 477 4167
THE RIGHT NOTE	BATH, AVON	01225 874728
THE AUDIO NOTE SAISON	GLASGOW	0141 357 5700
SOUNDS OF MUSIC	TUNBRIDGE WELLS, KENT	01892 547 003
MIDLANDS AUDIO EXCHANGE	KIDDERMINSTER, WORCS	01562 822 226
HAZERMERE AUDIO	HIGH WYCOMBE	01494 437892
AUDIO EDGE	WORKING, SURREY	0800 052 1966

## ZENTEK MUSIC LTD

ENTHUSIASTS OF THE PHILIP BRUNTON

PASSIANS • EGGLESTON WORKS • HALES • COPULARE

SYNERGISTIC RESEARCH • BALANCED AUDIO TECHNOLOGY • REFERENCE 1A

T. 01892 519545 F. 01892 347004

# REPLAY

## audio consultants

AUDIO ANALOGUE

AUDIO PHYSIC

AVI

CREEK

CRIMSON

DNM

HEYBROOK

JAMO

LFD

MUSICAL FIDELITY

NEAT

ORIGIN LIVE

PINK TRIANGLE

PROJECT

ROKSAN

ROYD

SONNETEER

TEAC

TRICHORD

TRILOGY

UKD

CURRENT SALE ITEMS INCLUDE

DPA 20005 phono amp £299

Naim NAC/2/HiCap/NAP180 £1250

Roaie RV23 valve preamp £199

EMAIL [replay@total.pipex.com](mailto:replay@total.pipex.com)

WEB SITE <http://dspix.uktotal.pipex.com/replay>

TEL 01244 401290

contact us for a copy of our product guide, newsletter or a list of our clearance items.

Panton Road, Hoole, Chester, CH2 3HX

## campaign audio design



Getting a better, more involving sound often means spending a lot of hard earned money. It's such a waste, because every system can benefit from our cables and accessories, at a fraction of the cost of some new "black box". Here are some of the ways we can help.

We have Linear Crystal Oxygen Free Copper interconnects (£12.48) up to High Purity Silver cables (£89.00) and high definition loudspeaker cables in Silver Plated Copper or Pure Silver.

Our mains cables add weight, power and scale, and with non-inductive RF filtering (£10.00) and over-voltage protection (£3.00) enhance performance still further. Gold plated AV cables, both RF (£17.95) and OFC Scart (£19.21), help bring picture quality in line with NICAM sound resolution.

Valves, capacitors and transistors are all microphonic. They cannot perform optimally if vibrated. Our set of three brass isolation cones (£5.00) are worth their weight in gold - revealing low level resolution and dynamics hitherto hidden beneath electronic noise. We also have a cure for your noisy fridge or central heating motor (£3.50), enabling you to throw away your big mains noise suppressor, which has been giving you that "sat upon sound" for years. There's lots we can do to bring you closer to the emotion and energy of the performance. So confident are we, that we offer a 14 day money back guarantee.

Ring or write for details:-

**CAMPAIGN AUDIO DESIGN**

Llandudno Road (HW)

Cardiff CF3 8PG

Tel:- 01222 779401



**VISA**

Trade and International Enquiries Welcome.

plugging numbers into equations without bothering to do any homework. This has led to an almost total stagnation of ideas in the 'speaker market.

The sad fact is that most of us have grown up with ported boxes that suffer exaggerated bottom-ends and badly-coloured bass. This artificial box-speaker 'slam' can make the Quad sound as if it lacks weight - it doesn't, it happens to be very accurate down to 45Hz. Still, some people may miss the bass bloom they've become accustomed to. Subwoofers are not my cup of tea but it is true that one of decent quality can 'lighten the load' on the '57s and allow them to play a little louder. By introducing a box in the bass, you also gain a little coloration where most people want it!

The Quads' midrange is the best bit. Voices are amazing - no alternative can get close to the level of transparency offered by these units. The seamless integration across the whole midrange means Aled Jones or Louis Armstrong communicate clearly. The treble is similarly open, with no 'spit', 'sizzle' or metallic 'ting'. Some have complained in the past that the high frequencies are not especially extended, but to be honest, like the coloration in the bass, it's mainly the artificial additives they are missing. Mind you, there is some merit to adding a high-quality ribbon tweeter like a Decca-Kelly to the set-up as it adds a little more 'air' to the soundstage.

**LOADING UP**

One thing you have to be very careful of is matching the '57s to an amplifier. A medium-power, push-pull valve amp is about right - valves don't mind the nasty



"Well I must say, darling, that new radiator sounds absolutely wonderful!"

capacitive load and don't tend to get too upset by the downright vicious impedance curve (would you believe it swings from as low as 1.8ohms to over 60ohms?) Calling the Quads nominal 16ohm loads is a bit of a joke! Most well-engineered solid-state amps are equally suitable. For safety's sake, though, check with the manufacturer before you risk melting your poor amp.

Power-wise, you only really need 25watts to drive these electrostats. With that 16ohm load, no harm will occur if there's a little more power on tap. If your '57s have been serviced by Quad, they will have fitted a 'clamp' circuit, which helps prevent over-driving and the terminal damage which results. These devices are a necessary evil when using big transistor amps, but personally I believe they spoil the sound, and if I know the 'speak-

ers are going to be used with a moderately-powered valve amplifier, I usually remove them.

Now the worst part: servicing. Until recently, all parts were available direct from Quad. Sadly, some chemical or other going out of production meant that Quad could no longer offer spare panels for the older ELS. I'm still puzzled by how they managed to find something to build the ESL 63s and the new electrostats with, though. It would be easy to get the impression that they didn't want to keep all their old 'speakers up and running. Anyway, the good news is that the panels are now available from several sources, with Quad GmbH in Germany having acquired the original jig.

One more word of warning; everything can and will go wrong with an ELS. With age all of the panels fade and die. EHT

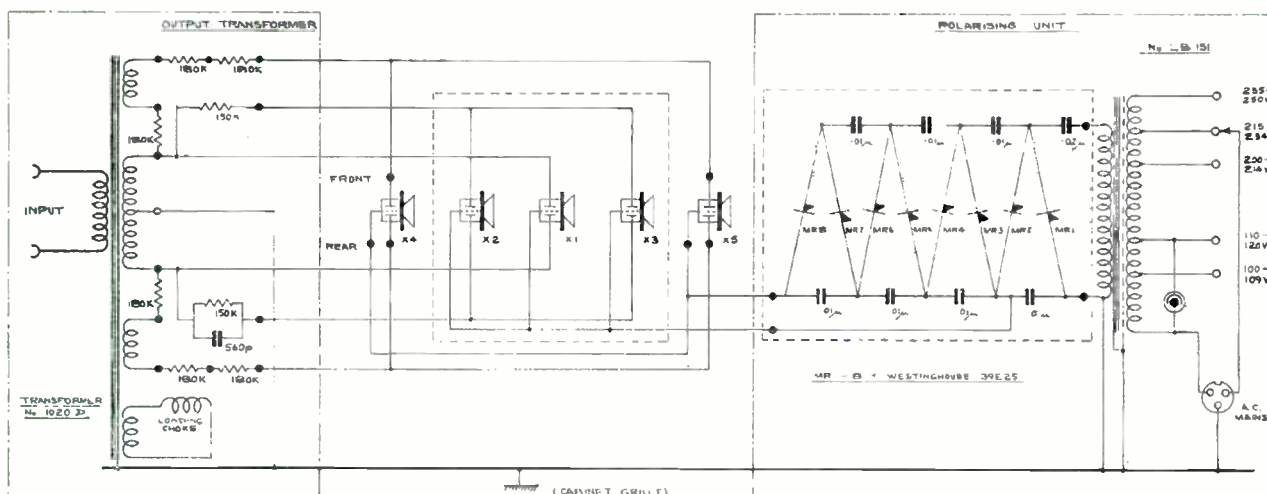

The circuit diagram for the ELS 57.

(Extra-High Tension) units, which generate the panels' polarising voltage, fail. Even the capacitors and resistors on the base of the audio transformer eventually give up the ghost.

Unless you can prove potential purchases have been fully serviced, you can budget on at least £500 to sort them out. Make sure you consider this if buying a set blind or with no documentation since even a '57 on its way out can sound impressive.

As a matter of course you should replace all passive components with the best your budget can afford. Original EHT units should be swapped for some of the newer types too - this alone can transform a tired-sounding pair. In addition, Russ Andrews recommends fitting separate EHT units to all of the panels for a worthwhile improvement.

The panels themselves can be somewhat trickier. The most delicate is the treble panel, which is swiftly barbecued by solid-state amps run too loud. A dull overall sound and crackles indicate duff treble panels. The bass units can suffer as well, losing efficiency and going pop! It is a good idea to remove the grilles and check the 'clingfilm' dust covers for tiny rips and tears. **WARNING: BEFORE YOU REMOVE A SINGLE SCREW, UNPLUG THE SPEAKER FROM BOTH THE MAINS AND YOUR AMPLIFIER AND LEAVE WELL ALONE FOR AT LEAST ONE HOUR.** The voltages within the Quad '57 can kill.

Dust and moisture are the enemies of all high-voltage devices, especially ones that rely on this kind of technology to move air. Without doubt, the expanded metal grilles make a real mess of the

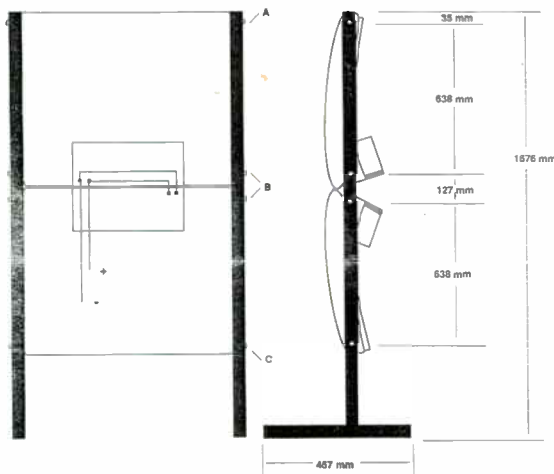

If you want to stack two pairs of '57s, this is the sort of frame you'll need. Adding a Decca-Kelly or

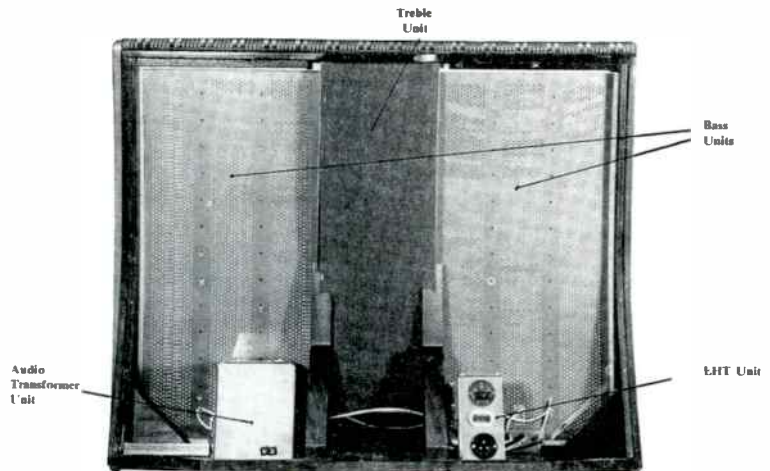

Seen from behind, the ELS 57's most important parts - the panels, EHT unit and input transformer.

sound, and total recluses who live on their own with no cats, dogs or rug rats would be advised to remove them completely (see warning text above). For those of us without such an option, just give the entire 'speaker a good clean out with one of those canisters of compressed air.

### ONE STEP BEYOND

There are so many modifications which can be applied to the Quads. However, in addition to what has been suggested already, here are a few more tweaks to consider:

- 1) Use a decent, rigid 18in.-24in. stand. You can perhaps use even two under each 'speaker.
- 2) Located inside the back of the ELS panels is a covering of what looks like sack-cloth. This does nought for the sound, and the tweeter panel has an even thicker chunk of felt; remove them!
- 3) Stacking. If you are going to have a pair of crazy old 'speakers, why not be really perverse and have two pairs in a stack! Extra efficiency, higher SPLs and better bass are the rewards. This requires a properly rigid frame. Most people build one which screws into the sides of the '57s in place of the wooden end cheeks.
- 4) New frame. The original wooden carcass is not of the most solid build. Major gains can be had by building a stiffer frame.
- 5) Ribbon tweeter.

an ATD ribbon can bring with it slightly more spaciousness. Wire in a single 6dB/octave filter - most people prefer a 2uF cap, although there's invariably room for experiment.

In terms of value, it's quite difficult to put a figure on the '57s. It can and will cost hundreds of pounds to get a pair back into pristine condition. At junk shops and car boots Quads have been known to go for pin money. Privately, people tend to want a bit much for tired examples, so be careful.

Later black-grille versions with IEC mains sockets command the highest prices, and it's not unrealistic to expect to pay around £1000 for a well-serviced pair. If buying 'as is' with no demo, pay as little as possible, say £50 single or £120 a pair.

The ELS 57 is still an awesome 'speaker. It may be nearly 45 years since 'Walker's Wonder' was first demonstrated but it remains a show-stopper to this day. If, for a fantasy moment, the ELS was still being made, you would be looking at about £2500 in new money, and I feel it would be worth every penny.

I am not alone in preferring the older ELS to the newer ESL 63, in spite of the fact that it is much better built. I'm not taken by the audio delay circuit on the latter. Sonically, there are areas where the older model beats the newer hands down, especially in the upper-mid and treble. Maybe it's that wonderfully Fifties style that draws me to the older 'speaker. Maybe it's because it's such a bargain, and very underrated in this country. The Quad ELS 57 is tweakable, fun and offers high-end sound at a low-end price. Call me the number-one fan!

# HEAD OF THE CLASS?

**Pink Triangle have revitalised their long-lived Da Capo DAC with the new 24-20 filter. Jon Marks plugs in to more bits.**

Compared to analogue components, the lifespan of many digital products is similar to what's meted out to some members of the insect world - they emerge from their eggs to enjoy a season or so of life before becoming worm fodder. One exception is Pink Triangle's Da Capo convertor.

Originally launched in 1990, its various digital filter upgrades maintained it as a viable piece of equipment for almost a decade. Now it looks set to break into the third millennium with its next filter, the £400 24-20. This small metal box (which plugs into Da Capos of any vintage) processes data with 25-bit precision. In addition, the latest triangular dithering apparently improves low-level resolution, as does strictly-controlled jitter.

I gauged the 24-20 against its predecessor, the HDCD filter, in a system of Teac's P-30 transport, Meridian's 501 pre-amp, Musical Fidelity's X-A200 monoblocs and Jamo's Concert 8 loudspeakers.

Having allowed the Da Capo and 24-bit filter an hour or so to warm up and hit their stride I reached for an old reviewing favourite, Dave Brubeck's Time Out. This SBM gold disc from Mastersound purred away within Teac's P-30 as I headed for the sofa.

After the warm but rather woolly presentation of the filters which had

preceded it, the 24-bit had a speed and crispness which startled my ears. Where the penultimate Da Capo incarnation had a relaxed, mellifluous view of music which clicked with Jazz and Classical but didn't get on so well with Rock and Dance, its heir demonstrated it was a more neutral performer. The drums of 'Take Five' had a far more realistic leathery thwack, their decay sustained for longer within the acoustic. The 24-bit filter didn't view cymbals through such rose-tinted specs either; it wasn't that they had lost any smoothness or shimmer, rather that they had greater power and sparkle without becoming bright or fizzy.

Transparency is the hallmark of this filter. 'Strange Meadow Lark' and 'Kathy's Waltz' were again portrayed in larger and more convincing soundstages than had been the case with earlier DACs, which had a habit of veiling low-level subtleties. Both tracks also gained in impact, for where a lot of digital gives the superficial impression of slam and smack, very few components actually deliver the real thing.

Images of instruments like double-basses which put out predominantly lower frequencies tend to be spread far and wide by most gear, analogue or digital. The PT was closer to actually producing a recognisable outline here, with commendable focus.

A second reviewing favourite, Eric Bibb and Good Stuff, demonstrated that the Pink Triangle didn't seek to please by dropping off at the top-end faster than a brick thrown off a cliff. It didn't shy away from reproducing the brightly-lit cymbals of this track, keeping its composure. Spicing up the mix with 'Nothing Like You Used To Do', I was happy to hear the Da Capo and

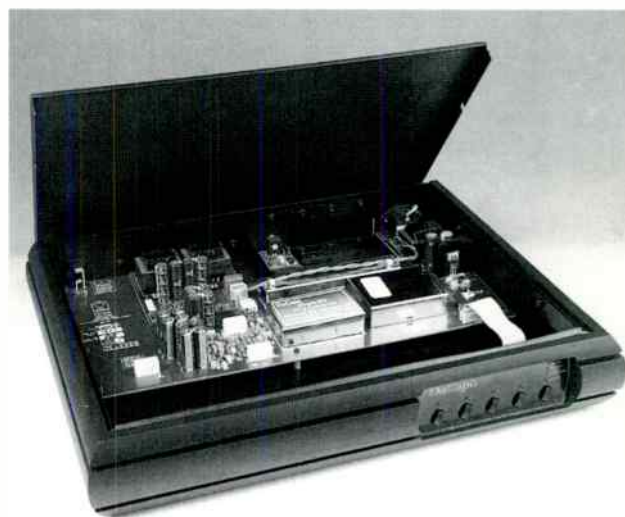

24-bit filter didn't wilt in the face of brisker bpm's, although they didn't fully cash in on this song's bump-and-grind drive.

Dancier material like The Chemical Brothers' Dig Your Own Hole, or Heaven 17's Penthouse And Pavement, might not be the Da Capo's strongest suit but Classical works such as Sibelius' symphony No2 in D major were a better bet. Rich but not syrupy woodwind tone partnered strings which were incisive but not metallic or caustic. With its ability to dig out detail, the 24-bit PT did a fine job of scale too, climaxes building and then exploding to powerful effect. And whenever the going got tough, the Da Capo kept its grip on soundstaging and imaging, refusing to blend orchestral sections together into an amorphous blob of sound.

If you're a long-time Da Capo owner who's feeling the first niggings of upgraditis, the best cure would be the 24-20. This digital filter provides a significant lift in performance for its £400, elevating the PT to the ranks of contemporary convertors around the £1500-£2000 mark.

**Pink Triangle 24/20  
£400**

**The Pink Triangle  
Partnership  
The Basement,  
Camberwell Bus. Centre,  
Lomond Grove,  
Camberwell,  
London SE5 7HN  
Tel: 0171 703 5498**



This is the box of tricks which turns the Da Capo into a leading DAC once more.

# Time Waits For Saga of the Audio Note

**W**hile we all wait for the brave new world of DVD, with its many proposed (imagined??!) benefits to sound quality, Audio Note is introducing a highly innovative and unusual addition to existing digital converter technology.

*The question is, will the one times oversampled D to A converter with no digital filter make a further contribution to 96kHz/24Bit technology or extend the life of the existing 16Bit system??*

A brief technical discussion follows below.

Digital Audio recording consists of measuring (sampling) the amplitude of the audio waveform at regular intervals and storing the measurement results in the form of binary data.

A digital to analogue converter generates an output which bears a direct relation to the digital data it is presented with, and hopefully if all goes well we retrieve the original analogue signal.

The sampling rate is the rate at which measurements are made and the resolution is the accuracy of these measurements. The greater the sampling rate, and the greater the resolution (number of "Bits") the closer we theoretically get to the original, and infinite amounts of each would result in a perfect recording, this has been the limiting factor so far, because more resolution and higher sampling rate means more information which in turn requires greater storage space and thus greater cost.

The engineers who originally specified CD decided upon 44.1kHz sampling rate and 16 Bits (65536 discrete levels) of resolution were aiming at good recording time on the disc combined with acceptable cost within the technology available at the time (1982/83). This just about gets us to the generally accepted 20kHz upper hearing limit and gives acceptable dynamic range and distortion, but only just.

Due to the limited sampling rate of 44.1kHz the actual bandwidth of the system is limited to a theoretical maximum of 22.05kHz (half the sampling rate). If a digitally recorded signal is played back above the high frequency limit there is a lot of signal related noise which is generally considered to be undesirable. In fact, if you observe a 16Bit 44.1kHz encoded signal which has been directly converted by a D to A converter without filtering it looks a real mess. The current wisdom is to use a digital filter which interpolates the 16Bit/44.1kHz signal to a higher sampling rate and to a seemingly higher resolution. Commonly the interpolation is 8 times oversampling (to 352.8 kHz) and to 18 or 20 Bits of resolution, no information is added, the filter mathematically joins the "dots". Then after the interpolated signal has been converted to analogue an analogue filter is used to put the final polish on the signal.

As the theoretical maximum frequency limit is 22.05kHz and the required bandwidth is 20kHz the digital filter has to cut off very very quickly. In fact the popularity of the digital filter today is entirely due to the impossibility of designing an analogue filter which can roll off so fast, and without phase distortion and time related problems. The digital filter uses a mathematical function called a sinc function which gives the required "brickwall" roll-off and with no theoretical phase distortion. The sinc function is an impulse which starts at time Zero and ripples off infinitely into the future, and the past!! Of course this is impossible in reality and the filter uses a part of the function and feeds the data into one end. Even though the filter only uses a small part of the sinc function it must still be large enough to be effective at filtering and this means that it is usually several milliseconds long, regardless of the duration of the signal itself.

At Audio Note we have long pondered the question of how much damage the signal suffers at the hands of this filter function and the unavoidable time smearing it introduces. To give you an example, if an impulse lasting only one sample is fed into a digital filter, it gets smeared out into a ringing signal several milliseconds long, hardly supporting claims of accurate reproduction, or as we say here at Audio Note; time waits for no-one, not even the "perfect" digital medium. Time displacement is the greatest cause of audible anomalies in audio reproduction and always has been.

Whilst we are not alone in questioning the effects of the sinc function and the digital filtering universally used in all CD-players and D to A converters, we are the only manufacturer unconventional enough to have grasped the nettle properly and removed the digital filter altogether, in an attempt to answer the central question; "how else do you establish with any accuracy exactly what the digital filter actually

does to the signal and is there an alternative method of filtering that would preserve the signal better??"

After much trial and error we found a way of removing the digital filter and incorporating a carefully designed analogue filter after the D to A conversion. Needless to say, this goes so completely against the grain of all current opinion because a lot of the spurious signals above 20kHz are still present in the output of the converter after the analogue filtering. The filter is a 3rd order design with a silver wired inductor and silver capacitors and is so designed to slowly attenuate the higher harmonics in a natural way, preserving as much of the musical waveform as possible, each filter is dynamically matched to within 0.5dB of its partner in the other channel across the full frequency spectrum, to achieve best possible channel balance.

Rather than use an off the shelf voltage regulator chip for the low voltage digital and analogue power supplies for the DAC we designed a unique discrete shunt regulator circuit, and use only the finest components throughout. In fact the DAC 5 power supplies take up more than 2/3rds of the substantial chassis. After the signal leaves the filter it is passed to a valve output stage, similar to that used in the M5 pre-amplifier, and is transformer coupled to the output, allowing both balanced and single-ended operation.

So how does the Direct Line DAC 5 converter with no digital filter and one-times oversampled D to A converter sound??

Let me first give you some background to what I believe matters in music reproduction and how I have arrived at the evaluation criteria we use at Audio Note.

It is no great secret that ever since Digital Audio was introduced in 1983, I have seriously questioned the validity of the claims that the technology would deliver the "Perfect Sound Forever" that launched the technology, I, and many others with me, found analog reproduction far more "real", satisfying and authentic, not to mention less fatiguing.

The main criterion I have always used when evaluating any hifi system or component is that when playing different pieces of software (whether LP or CD) the better system or component is the one that individualises the sound from each record the most, or in other words makes you sense each recording as a different and individual musical "event".

This evaluation system is based on a fundamental analysis of recording in all its forms that concludes that all we really know about recordings, is that they must sound different from each other, the conclusion is based on the indisputable fact that each piece of software was done at a different time in a different location, with different microphones, cables, mixers, tape recorders and they were recorded by different people to any other recording, furthermore the software was manufactured by different cutting and pressing machinery at different plants and as a result must have an individual character or "signature" uniquely its own.

I call this method of differentiation "Comparison by Contrast" and with this tool in hand (or should I say ear??) I have spent many years searching out the "better", more accurate (you will notice that the term used is more accurate, not accurate in its absolute sense, because total accuracy does not exist in recording or music reproduction, it is an unachievable goal, that will never be a reality, no matter how much the marketing men of the hifi industry would like you to believe it is) audio components and technologies in a largely selfish quest to improve the reproduction of my own record collection.

I made this pursuit my livelihood in 1977, when I left my career as a broker with a large multinational shipping company.

Back to the main subject, by the criteria outlined above, CD fails miserably compared against even quite cheap analog component hifi, and I have always thought that this failing was inherent in the medium itself, i.e. the fact that the musical signal is broken down into little "bits", with poor resolution at low levels, which is after all the entropy of the musical signal (it is often forgotten that music starts from silence, not from somewhere up the amplitude scale, the assumption is often made that what we hear at the beginning of a note is what was recorded and the words "I hear more detail" assumes that we somehow know what is supposed to be there, which we certainly do not, what the reviewer should perhaps say is I hear more contrast!) it never seems to occur to anyone that the starting parts of the musical note might be missing.

The quiet background of the digital medium should therefore allow the best possible low level detail, but it does not, low level acoustic information like hall ambience is almost completely lost on most digital recordings (it is a little better on good analog recordings transferred to CD, indicating that the digital recording process is at least



# No One or the DAC 5 D/A Converter.

partly to blame), modern recording techniques do not help, as multi miking, digital mixing and other technical gadgets used in the studio, "help" the recording engineers do their job speedily and within budget, a far cry from the simplicity, dedication and time that went into every recording made from the early acoustically recorded 78's to the earliest LP's) and this real acoustic information is replaced by a varying degree of hard and bright electronic echo, which makes most CD listening fatiguing, unless of course the system used tailors the high frequencies to suit, creating a "listenability" that comes at the price of severe loss of information at high frequencies, which may be preferable, but does nothing for the idea of a wide band system or signal, nor does it improve the listener's ability to distinguish between the great and the merely good performance or interpretation.

While I owned Audio Innovations (sold out 1991) I spent years in denial and despite all the arguments in favour of the commercial considerations of what my company required I heard nothing from CD that encouraged much enthusiasm and since I prize my longterm credibility more than just making money and as long as my favourite music was available on LP either new or second hand, I had no need for CD until the early 1990's when a lot of interesting material (mainly historical piano recordings previously unavailable) suddenly appeared on CD-only releases.

I had already spent a lot of time looking at the subject of digital to analog conversion, without achieving any really substantial sonic improvements against the better converters already available, my approach was to conformist, as it turned out, as it accepted too much of the existing dogma and therefore too closely followed the already beaten track.

In 1990 I decided to test the use of an interface transformer between the converter chip and the analog filter, primarily in the belief that a better interface between the D-A converter chips output should yield sonic improvements but also because I felt that separating the digital and analog circuits ground planes ought to yield some improvements.

Early experiments showed promise, but the matching impedance and associated analogue filter configuration were more critical than first assumed, after two years later we finally got it right and Audio Note launched it's first digital product, the DAC3 D-to-A converter with patents awarded in the UK, the USA, Germany, Australia and elsewhere.

Since then we have progressed with greatly refined components quality (DAC3 Signature), even more high quality components plus a power supply with a valve rectifier (the DAC4), and finally the best output stage and ultimate component quality (the DAC4 Signature), and whilst all of these measures achieved even better sound quality than the original DAC3 offered, the improved versions did nothing to dent the original product's price/quality relationship to competing converters, after 6 years on the market it is no mean achievement for a digital product to stay at the top of the performance spectrum in its price range in a market where model life generally is measured in months rather than years. The more I studied the fundamental equations that all digital theory is based on, the more convinced I became that the sinc functions used in the digital filtering must have a far more damaging effect on the signal, than is generally accepted (or even considered).

The basis for my idea is that there has to be a price to pay in all attempts to improve, "correct" or manipulate the signal, regardless whether it is done in the digital or the analog domain, and I have always thought that the digital filters with their oversampling, reclocking, noise shaping, jitter reduction and whatever else are no different in their fundamental properties to the corrective feedback systems employed in the analog domain, in that they also try to "stop" or reverse time, so their deteriorating effect on the sound must be similar.

In early 1995 work started on the no digital filter - 1 x oversampling D to A converter and when Andy Grove joined me in 1996, his contribution to the idea was a first prototype within weeks of joining, a great credit to his talent and ability.

Although the first version had a fair bit of the sampling frequency breaking through, even with this interference it was obvious to everyone that the sound had something fundamentally "right", it was freer, had more presence, immediacy, delicacy and contrast than any digital product I had ever heard, there was obviously more good information in the digital data stream than previously thought, and it was clear that this converter had very serious sonic potential, so we persevered getting the interface transformer and filtering right, and here we are, nearly three years later introducing the finished product, the DAC5 Direct Line D/A Processor with 1 x oversampling and no digital filtering, reclocking, noise shaping, jitter reduction or other such signal correction or manipulation.

Having listened to the final version of the DAC5 with its no-oversampling D to A conversion for nearly a year, I can say for the first time since my earliest experience with digital audio in late 1983 that digital has more to offer than I had ever imagined, because for the first time there is genuine contrasting quality between recordings, with the DAC5, a fact which combined with an incredible sense of hall ambience, where instruments have greater presence, solidity and texture and a far more defined spatial position (provided this is what how it was recorded). An orchestra now has an organic quality where the musicians appear more like real people actually playing in real space, rather than as cardboard images in a sound deadened studio, the reproduction of stringed instruments has the sound and feel of real wood rather than the usual artificial and plasticky presentation of digital.

It may sound absurd, but the greatest beneficiaries of this vast improvement in the sound of my CD's are my big collection of historical recordings of piano music, the distinct differences in style, touch, tempo, tone and sound of each of the great pianists from Sergei Rachmaninov to Joseph Lhevinne, and from Simon Barere to David Saperton is a true revelation, which has greatly contributed to my appreciation of the interpretative skill, dedication and pure musicianship of these great artists.

When all is said and done, however and despite the DAC 5's great and almost analog qualities I still find my AN-TT Three Reference turntable with AN-1s/AN-Vz arm and 10Gold cartridge excels with the best recordings, but at least now it is a contest between the two formats rather than a race between a Ferrari and a man wearing a pair of worn shoes!

The DAC 5 uses the Analog Devices AD1862NJ chip with as little in the signal path between it and the input chip as possible, the analog filtering has been done in such a way that the carrier frequency is inaudible, although it will show up on the oscilloscope in abundance (another example of the hard to grasp reality of measuring and its correlation to sonic reality)! We have experimented extensively with different filter configurations to find the one that passes an amount of breakthrough that does not disturb the ear without affecting the quality of sound more than necessary.

The DAC 5 has facility for 96KHz DVD technology, as well as the conventional 44.1 and 48KHz, it has high B C-core output transformers, with a 600Ohm balanced output using a professional Lemo connector (we can provide the silver cables with the Lemo plug for this) as well as a standard unbalanced RCA output.

There will be no patent applications or copy rights filed on this revolutionary idea, because that would limit its wider use by other manufacturers, to the detriment of the reproduction of music, instead we are offering a small technical paper on the technology to anyone who wants to test the idea, and this includes any of our competitors, all we ask is that you remember who thought of it first.

The DAC 5 is not cheap at £ 18,500.00, its component, power supply and transformer quality is far too expensive and elaborate for that, but go and give it a listen anyway, even if it is out of your price range, because the improvement it represents is nothing short of a digital revolution and you can rest assured that we shall move this advance in technology down in price as quickly as possible, so after 6 years most of our DAC-range (from the DAC3 upwards) will be upgraded to 1 x oversampling and 96KHz technology, to take us through at least another 6 years, which is in line with our stated aim to do our homework thoroughly and properly and only release products that have longevity built in.

Peter Qvortrup  
01.09.1998.



Audio Note

*Music's Finest Conductor*

Audio Note (UK) Ltd, Unit C, Peacock Industrial Estate,  
Lyon Close, 125-127 Davigdor Road, Hove East Sussex BN3 1SG

Tel: + 44 (0) 1273 220511

Fax: + 44 (0) 1273 731498

Web: [www.audionote.co.uk](http://www.audionote.co.uk)

# KITS HAVE NEVER

**NEW!**



**£175**

## HD83 VALVE HEADPHONE AMPLIFIER KIT

The HD83 is our new headphone amplifier, a beautifully simplistic design using Mullard ECL83 valves, a triode and power pentode housed in the same envelope. It works directly from any source be it a CD, tape, tuner etc., or from an amplifier's tape out or pre-amp sockets. The circuit utilises high specification output E and I output transformers that will drive any headphone load from 16 ohms to over 300 ohms depending on how the secondaries are wired up. The HD83 is a single ended design with the power pentode wired up in triode configuration for that added purity and is as quiet as a mouse. For sound quality Jon Marks says, "The bass is punchy and controlled without becoming artificial, while treble has the crispness of the best solid-state, with the tonal purity, delicacy and speed associated with valves. External dimensions 18cm(w) x 30cm(l) x 8cm(h) weight 4kg.

Please note that we are selling the full range of sennheiser headphones at discounted prices when purchased in combination with our HD83. Please ring 0171 221 0691 for further details.

## KEL34 VALVE INTEGRATED AMPLIFIER KIT

The KEL34 is our all-new budget stereo integrated valve amplifier, providing a massive 40 watts of pure valve sound, with 4 line level inputs and one tape output, fully controllable from the front panel. The KEL34's simple and elegant circuit design utilises a 6AU6 pentode input valve, an ECC82 double-triode phase splitter and a push-pull pair of Ei 6CA7s (a turbo-charged EL34). The result is a typically sweet, open valve sound with atypical bass control and power. And with 40watts output, KEL34 will work its magic into 'speakers of average sensitivity too. "When I first heard the KEL34 under test I was astonished at the strong, punchy bass which, good as it was, did not compromise the smooth clarity and true detailing in the treble. What I most appreciated about this amp was the sumptuous valve midrange; the feeling that the sounds were being painted from a broad and secure palette." At the price, this kit is second to none and will open up the benefits of valve amplification to a whole new class of audio nuts! Weight 10kg. External dimensions with valves: 33cm(w) x 27.5cm(d) x 18cm(h).

**NEW!**



**£295**

## K5881 MkII VALVE AMPLIFIER KIT

MkII with SRPP input stage!



**£395**

A 20watt, Class A power amplifier that uses reliable Russian 5881 output valves, a military version of the American 6L6, designed for low distortion audio work. Now with a super shunt regulated push-pull (SRPP) input stage K5881 offers amazing sound quality. It can be used with a simple passive pre-amp or one of our own pre-amplifiers, and it matches modern loudspeakers well. Weight 15kg external dimensions with valves 40cm(w) x 32.5cm(d) x 17cm(h).

**£850**



## 300B VALVE AMPLIFIER KIT

This is a specialised 28watt amplifier based on the highly linear 300B triode valve. Our 300B runs in Class A, giving one of the most sweet, open and neutral sounds possible today. Matched with good loudspeakers, it is unsurpassed. All parts are included in the kit, except valves since different 300B makes are available. Weight 26kg, external dimensions with valves 44cm(w) x 35cm(d) x 20cm(h).

## K5881 MkII Upgrade kit

Upgrade your pre November 1996 K5881 amplifier to MkII status. The kit converts your amplifier to the new 7025 double triode input stage in place of the original EF86 pentode input.

**£35**

## KLPP1 VALVE PHONO PREAMPLIFIER

KLPP1 has five line inputs, a tape input with monitor and a unique low noise valve MM/MC phono stage. There is a switchable subsonic filter to prevent output transformers of valve amplifiers saturating. The line stage has gain, so it will drive any power amplifier. Audio grade components are used and many parts are custom made for highest quality. KLPP1 has a super clear sound, sweet and detailed through line and phono inputs. Weight 6.5kg external dimensions 28.5cm(w) x 23cm(d) x 8cm(h).

**£495**

KLPP1 & KLP1 use the same chassis

**£345**



## KLP1 VALVE LINE PREAMP

The KLP1 line level preamp uses one elegant cathode follower line drive circuit to give a sound of remarkable clarity and detail. The components are all high quality and include Alps volume control, Sovtek valves, silver plated wire etc. With a gain off x1, it matches our sensitive power amplifiers. Beautifully built, with solid machined alloy fascia and gold anodised knobs, it looks compact and elegant in the home. Weight 5kg external dimensions 28.5cm(w) x 23cm(d) x 8cm(h).

## K5881PSE VALVE AMPLIFIER KIT

**£650**

An audiophile parallel-single-ended valve amplifier at an affordable price. K5881PSE uses the reliable Russian 5881 output valve. Its 17watts is enough to drive most loudspeakers, making high-end sound quality and design available to everyone. Can be easily monoblocked to give 32watts. Weight 17kg external dimensions with valves 40cm(w) x 32.5cm(d) x 17cm(h).



# BEEN SO GOOD!

**NEW!**



**£394**

## KLS10 HIGH TECHNOLOGY COMPACT MONITOR

Want high technology loudspeakers without a high cabinet high price? You couldn't do better than build KLS10, our latest mini-marvel. Using an Audax carbon fibre bass/midrange unit, married to the world's most advanced tweeter, the piezo-electric gold dome HD3P from Audax, KLS10 offers high performance from a small package. The main speakers are designed to work alone, or with a dedicated subwoofer to extend their bass. Alone, they are suited to near-wall mounting and can be tuned by port adjustment to suit personal taste and location. They are easy to drive and need just 30-60watts. Those who want the bass of a big loudspeaker can build our inexpensive dedicated subwoofer at a little extra cost or intrusion into the room, this custom designed addition offers big loudspeaker performance. KLS10 is unique. Technically advanced, yet compact and relatively inexpensive. There is little to match it. Sensitivity 89dB 1W/1m, 15mm MDF, internal volume 9Ltrs, external dimensions 19cm(w) x 31cm(h) x 23cm(d).

**DRIVE UNITS & CROSSOVER KIT £394.00**  
**DRIVE UNITS ONLY £358.00**

## KLS10 GOLD SUBWOOFER

Our new KLS10 Gold subwoofer was designed to compliment KLS10 Gold stand mounters by providing a deep and open bass. The subwoofer is inexpensive, easy to build, comprising a simple crossover network to a high quality 8 inch Aerogel, dual voice coil bass unit. A must for all KLS10 Gold customers. Sensitivity 89dB, volume 25 litres, external dimensions 28cm(w) x 43cm(h) x 34cm(d).

**Drive unit and crossover £149.95 GBP**  
**Drive unit only £71.00GBP**

**NEW!**



**£149.95**

## KLS9 TWO WAY FLOOR-STANDER

Here's a storm for you - KLS9, with its BB4 alignment bass cabinet and Audax High Definition Aerogel 8in bass/midrange unit. Designed by Noel Keywood to possess optimal bass damping and a clean step response. Aided by a teensy bit of bass lift, KLS9 really thunders; it will rearrange your furniture. But it does not waffle, falling silent when there's no bass in the music. Aided by a high power 1in fabric dome tweeter, KLS9 is detailed, evenly balanced and images superbly. It is an easy 12ohm load and is 88dB sensitive. For amps up to 60W. Easy to build and great for beginners. Internal volume 70Ltrs, 18mm MDF external dimensions 25cm(w) x 93cm(h) x 40cm(d).

**DRIVE UNITS & CROSSOVER KIT £230.00**  
**DRIVE UNIT PACK £160.00**

**£230**



## KLS3 Gold Mk II ADVANCED TECHNOLOGY THREE WAY LOUDSPEAKER

KLS3 Gold uses the latest version of Audax's innovative oval gold dome piezo electric tweeter, giving it the sweetest and most extended treble.

Married to a 4in. carbon fibre cone midrange driver for neutral and clear reproduction, and a powerful 8in. bass driver for superb depth, this is our top-of-the-line reference speaker. Sensitivity 90dB at 1W/1m, 25mm MDF, internal volume 60Ltrs, external dimensions 26cm(w) x 100cm(h) x 35cm(d).

**DRIVE UNIT & CROSSOVER KIT £575.00**  
**DRIVE UNIT PACK £450.00**

**£575**



## KLS3 THREE WAY CARBON-FIBRE DRIVER LOUDSPEAKER

KLS3 uses extremely light and stiff carbon fibre cone drive units for a fast, accurate sound. A dedicated 4inch carbon-fibre midrange drive unit provides the clean, smooth and detailed midrange characterised by superb projection. Its high 90dB sensitivity and near flat 8ohm impedance make it one of the easiest loudspeakers to drive. An ideal loudspeaker for high-end valve amplifiers. 25mm MDF, internal volume 60Ltrs, external dimensions 26cm(w) x 100cm(h) x 35cm(d).

**DRIVE UNIT & CROSSOVER KIT £350.00**  
**DRIVE UNIT PACK £230.00**

**£350**



**£260**



## KLS8 TWO WAY HIGH SENSITIVITY

With a sensitivity of 94dB, KLS8 needs very little power. Its 10in. professional bass driver and horn loaded tweeter give it a BIG sound. Ideal for low power amplifiers. Provides high level listening without fatigue! Internal volume 50.5Ltrs, 18mm MDF, external dimensions 29cm(w) x 65cm(h) x 36cm(d).

**DRIVE UNIT & CROSSOVER KIT £260.00**  
**DRIVE UNIT PACK £175.00**

## KLS4 TWO WAY CARBON-FIBRE DRIVER LOUDSPEAKER

A two way standmounter using stagger-tuned reflex loading for good bass, plus light and fast carbon-fibre drivers. Sensitivity 86dB at 1W/1m, 18mm MDF, internal volume 15.3 Ltrs, external dimensions 21.6cm(w) x 42cm(h) x 25.8cm(d).

**DRIVE UNIT & CROSSOVER KIT £230.00** **DRIVE UNIT PACK £120.00**

**Audax HD-3P Gold dome piezo-electric tweeter**

**£130**

## KLS7 TWO WAY CARBON-FIBRE DRIVER FLOORSTANDER

Compact and affordable two way reflex loudspeaker. KLS7's slim dimensions make it easy to accommodate, but it uses top quality carbon-fibre drivers, so performance isn't compromised. An audiophile bargain. Sensitivity 86dB at 1W/1m 12mm MDF, internal volume 18Ltrs, external dimensions 15cm(w) x 80cm(h) x 22cm(d).

**DRIVE UNIT & CROSSOVER KIT £195.00**  
**DRIVE UNIT PACK £110.00**

**Upgrade your KLS3s to Gold status. Includes latest oval gold dome piezo tweeter and all components.**

**£330**



*Sounds of Music*

# The hills really are alive in Tunbridge Wells

For those of you who have already visited us, you will know that our service and advice is second to none. We have now expanded into 7 studios, set up as closely as possible to your own domestic environment where you can audition an amazing selection of all the very best in hi-fi currently available.

We have systems on demonstration from £1k to £100k covering all that's best across all formats. Couple all this to our well known policy of a one months trial exchange system and our extensive range indicated below and choosing us as your Number 1 hi-fi dealer must surely be your obvious choice.

**If you are really serious about music, call us for an appointment today.**

## FREE DELIVERY & INSTALLATION

### Agencies include:

Avantgarde, Argento, Audio Synthesis, Advantage, Audio Physics, Apollo, Audion, Audio Note, Audio Research, Audio Analogue, Anthem, Altis, AVI, ATC, Alon, Acoustic Energy, Atacama, Artemis, BCD, Base, Balanced Audio Technology, B&W, Bow, Bose, Convergent Audio Technology, Chord, Copland, Cadence, Cable-Talk, Churchili, Copulare, Dunlavy, DAC, Eggleston-Works, Electrocompanient, Eikos, F M Acoustics, Genesis, Graham, Graff, Goertz, Goldring, Gershman, Hales, Harbeth, Helios, Jamo, J M Labs, Koetsu, Krell, KEF, Klipsch, Kimber, Lumley, Lyra, L.A.T, Lavardin, Musical Technology, MIT, Magnum, Magnum Dynalab, Micromega, Marantz, Mordant Short, Martin Logan, Michell, Neat, Nordost, Nottingham Analogue, Opera, Optimum, Ortofon, Orelle, Osborn, Promenade, PAD, Passlabs, Pro-ac, Pink Triangle, Primare, QED, Quad, Reference 3A, Ruark, Rel, Roland, SME, Shure, Sequerra, Sennheiser, Sonic Link, Soundstyle, Sonic Frontiers, Spondor, Sonus-Faber, Stands Unique, Synergistic Research, Target, Trilogy, Tannoy, Totem, Talk, Transparent, Transfiguration, Triangle, Unison Research, VAC, Woodside, Wilson, Wilson Benesch, Wadia, XTC, XLO, YBA, Zingali.

**OPEN SUNDAYS BY APPOINTMENT ONLY**

**10-12 Chapel Place, Tunbridge Wells, Kent TN1 1YQ**

**Tel: 01892 547003 Fax: 01892 547004**

**Web Site [HTTP://www.sounds-of-music.co.uk](http://www.sounds-of-music.co.uk)**

World Radio History

P  
A  
R  
T  
E  
X

O  
%  
F  
I  
N  
A  
N  
C  
E

# WARNING

THESE ARE EXPERT KITS, NOT FOR THE INEXPERIENCED. YOU MUST BE ABLE TO SOLDER AND READ A CIRCUIT DIAGRAM. THE VALVE KITS CONTAIN LETHAL VOLTAGES. WE CANNOT BE HELD RESPONSIBLE FOR ANY ERRORS ARISING FROM THE CONSTRUCTION OF THESE KITS.

## ORDER FORM

Please send your completed order form to: **WORLD AUDIO PUBLISHING LTD, Suite G4, Imex House, The Park Business Centre, Kilburn Park Road, London, NW6 5LF Tel/Fax: 0171 625 8032 e-mail: wad@hi-fiworld.co.uk**

240/120 option - delete the voltage NOT required. Valves included except where otherwise stated.

IF YOU WOULD LIKE A DATA SHEET ON ANY OF THE KITS, PLEASE WRITE A 'D' IN THE QTY BOX

**WARNING** - World Audio Publishing Ltd accept no responsibility for kits, parts or modifications made or supplied by third parties.

DESCRIPTION	ORDER No.	QTY	UK (inc VAT & carriage)	OVERSEAS (exc. VAT)
<b>AMPLIFIER KITS</b>				
HD83 Valve headphone amplifier kit.....	HD83-K240/120	<input type="checkbox"/>	£175	£150
HD83 Transformer set.....	HD83-K240/120(T.set)	<input type="checkbox"/>	£105	90
HD83 Printed Circuit Board.....	HD83-K240/120(PCB)	<input type="checkbox"/>	£35	£29
KEL34 40W push-pull integrated amplifier.....	KEL34-K240/120(withvalves)	<input type="checkbox"/>	£295	£260
KEL34 (without valves).....	KEL34-K240/120(No valves)	<input type="checkbox"/>	£250	£220
KEL34 Transformer set (1 main & 2 outputs).....	KEL34-K240/120(T. set)	<input type="checkbox"/>	£110	£97
KEL34 Printed Circuit Board.....	KEL34-K240/120(PCB)	<input type="checkbox"/>	£65	£57
K5881 MkII 20W push-pull valve amplifier.....	K5881-K240/120	<input type="checkbox"/>	£395	£350
K5881 MkII Built.....	K5881-B240/120	<input type="checkbox"/>	£595	£550
K5881PSE 17W single-ended amplifier.....	K5881PSE-K240/120	<input type="checkbox"/>	£650	£555
K5881PSE Built.....	K5881PSE-B240/120	<input type="checkbox"/>	£850	£725
300B 28W valve power amplifier (Not inc. Valves).....	300B-K240/120	<input type="checkbox"/>	£850	£725
300B Built (Not inc. Valves).....	300B-B240/120	<input type="checkbox"/>	£1150	£950
KLP1 line level pre-amplifier.....	KLP1-K240/120	<input type="checkbox"/>	£345	£295
KLP1 Built.....	KLP1-B240/120	<input type="checkbox"/>	£545	£465
KLPP1 valve phono pre-amplifier.....	KLPP1-K240/120	<input type="checkbox"/>	£495	£425
KLPP1 Built.....	KLPP1-B240/120	<input type="checkbox"/>	£695	£595

## LOUDSPEAKER KITS

KLS10 2-way carbon-fibre standmounter loudspeaker with piezo gold tweeter				
Drive Units + Crossover kit etc.....	KLS10-C	<input type="checkbox"/>	£394	£343
Drive Units.....	KLS10-D	<input type="checkbox"/>	£358	£311
KLS10 SUBWOOFER Drive Unit + Crossover Kit etc.....	KLS10-SubC	<input type="checkbox"/>	£149.95	£130
KLS10 SUBWOOFER Drive Unit.....	KLS10-SubD (1 x HM210Z2)	<input type="checkbox"/>	£71	£61
KLS3 3-way carbon-fibre driver floorstanding loudspeaker				
Drive Units + Crossover kit etc.....	KLS3-C	<input type="checkbox"/>	£350	£300
Drive Units.....	KLS3-D	<input type="checkbox"/>	£230	£200
KLS3 Gold 3-way carbon-fibre driver floorstanding loudspeaker with piezo tweeter				
Drive Units + Crossover kit etc.....	KLS3-C	<input type="checkbox"/>	£575	£500
Drive Units.....	KLS3-D	<input type="checkbox"/>	£450	£392
KLS4 2-way carbon fibre driver standmounting loudspeaker				
Drive Units + Crossover kit etc.....	KLS4-C	<input type="checkbox"/>	£230	£200
Drive Units.....	KLS4-D	<input type="checkbox"/>	£120	£105
KLS7 2-way carbon fibre driver floorstanding loudspeaker				
Drive Units + Crossover kit etc.....	KLS7-C	<input type="checkbox"/>	£195	£170
Drive Units.....	KLS7-D	<input type="checkbox"/>	£110	£95
KLS8 2-way high sensitivity standmounting loudspeaker				
Drive Units + Crossover kit etc.....	KLS8-C	<input type="checkbox"/>	£260	£225
Drive Units.....	KLS8-D	<input type="checkbox"/>	£175	£150
KLS9 2-way HDA driver floorstanding loudspeaker				
Drive Units + Crossover kit etc.....	KLS9-C	<input type="checkbox"/>	£230	£200
Drive Units.....	KLS9-D	<input type="checkbox"/>	£160	£140

## AUDAX DRIVE UNITS

Carriage and packaging please add £6.00 for one unit or a tweeter pair, otherwise add £15.00 for 2-6 units \* Not applicable to overseas prices

### High Definition Aerogel Drivers

3inch midrange, 93dB.....	HM100Z0	<input type="checkbox"/>	£35	£30
4inch midrange, 92dB.....	HM130Z0	<input type="checkbox"/>	£47	£40
6.5inch bass/mid, 91dB.....	HM170Z0	<input type="checkbox"/>	£53	£45
8inch bass, 91dB.....	HM210Z0	<input type="checkbox"/>	£64	£55
10inch bass, 90dB.....	PR240Z0	<input type="checkbox"/>	£76	£65

### Carbon Fibre Drivers

4inch midrange, 90dB.....	HM130C0	<input type="checkbox"/>	£41	£35
6.5inch bass/mid, 90dB.....	HM170C0	<input type="checkbox"/>	£47	£40
8inch bass, 90dB.....	HM210C0	<input type="checkbox"/>	£58	£50



### Paper Cone Drivers

10inch paper cone bass, 95dB.....	PR240M0	<input type="checkbox"/>	£67	£55
13inch paper cone bass, 97dB.....	PR330M0	<input type="checkbox"/>	£147	£125

### Fabric Dome Tweeters

25mm 92dB for 2 way systems.....	TW025M0	<input type="checkbox"/>	£15	£13
25mm 92dB for 3 way systems.....	TW025M1	<input type="checkbox"/>	£16	£14
25mm horn loaded 97dB.....	PR125T1	<input type="checkbox"/>	£25	£21
34mm 93dB - powerful sound.....	TW034X0	<input type="checkbox"/>	£26	£22
Oval Gold Piezo electric dome tweeter, 89dB.....	HD-3P	<input type="checkbox"/>	£130	£110

(Please telephone for further details regarding other Audax Drive Units).

NAME: _____	<b>CREDIT CARD ORDERS TEL: 0171 266 0461 (24 hours)</b>	<b>OVERSEAS PRICES &amp; DETAILS</b> Please allow for your own local import taxes (customs duties) and for carriage charges, which must be added to the net price. Telephone or Fax for a quote. <b>METHODS OF PAYMENT</b> International money order in Sterling, Mastercard or Visa.
ADDRESS: _____	I enclose cheque/postal order for £_____ made payable	
_____	to World Audio Publishing Ltd. I wish to pay by Mastercard / Visa.	
_____	Please debit my account no: _____	
POST CODE: _____	<input type="checkbox"/> <input type="checkbox"/> <input type="checkbox"/> <input type="checkbox"/> <input type="checkbox"/> <input type="checkbox"/> <input type="checkbox"/> <input type="checkbox"/> <input type="checkbox"/> <input type="checkbox"/> <input type="checkbox"/> <input type="checkbox"/> <input type="checkbox"/> <input type="checkbox"/> <input type="checkbox"/> <input type="checkbox"/>	
COUNTRY: _____	Expiry Date: _____	
TEL. (DAY): _____	Signature: _____	 

# A RETURN TO FORM

**Do you lust after Quad's ESL 57 electrostatics but worry about the lack of servicing? Jon Marks seeks restorative help from Classique Sounds and One Thing.**

**A**h, serial numbers 12599 and 12273, you have indeed seen better days. The miserly sum of £100 made you both mine, but I have to say you possess all the sparkle, life and speed of a wet blanket. Connected to my favourite CD player, turntable and amplification, you had me wondering at the fuss surrounding ESL 57s.

If this rings bells with you, you've obviously been through the same anti-climax of purchasing a pair of Quad's vintage super-speakers in less than mint condition. As Haden Boardman comments in *Vintage Virtues* this month, even when they're only pale shadows of their former selves, ESL 57s can still sound better than a lot of other loudspeakers. The problem is, with Quad no longer servicing these electrostatics, where can you have a poorly pair spruced up?

We decided to get a test set of ESL 57s fully refurbished by Classique Sounds (tel: 0116 283 5821). 12599 and 12273 were duly handed over for diagnosis.

As the list of woes said, the 'speakers were "working but sounding tired". This was a bit of an understatement as there seemed to be precious little treble above 4kHz or 5kHz, all the crispness and pizzazz of a month-old lettuce and bass that was murky and indistinct.

On the bench some typical ailments showed up. The blocks which supply the panels with their Extra-High Tension voltages (6kV for the bass and 1.5kV for the treble) were down on one 'speaker and up on the other. This meant new blocks with modern rectifiers (£80 per pair).



A new patient prepares to undergo examination.

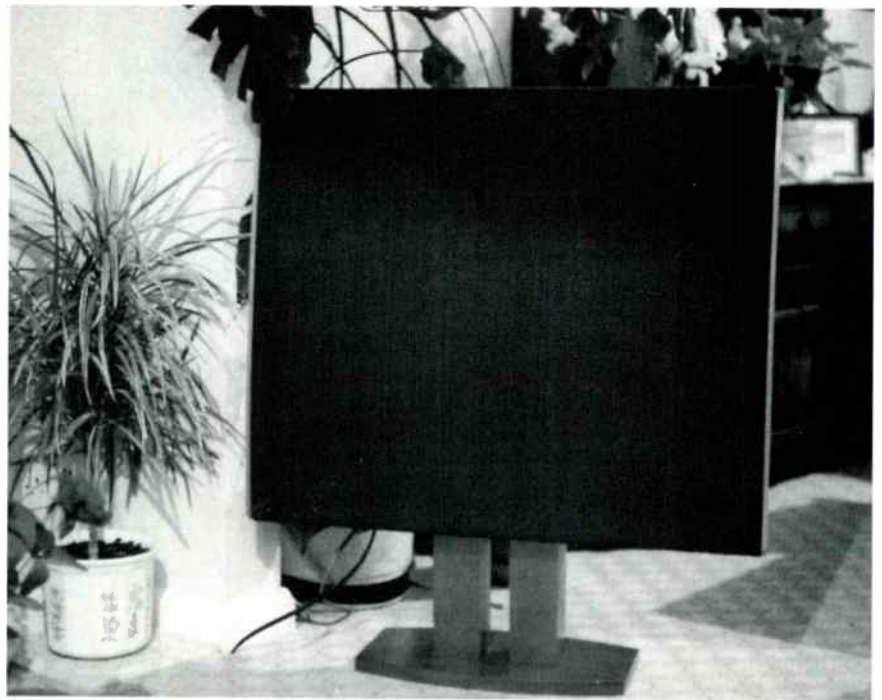

The three short legs fitted by Quad to the ESL 57 do a fair job but the loudspeakers sound a lot happier when they're higher off the floor on solid stands.

None of the panels were torn or burned, but the bass stators were well past their prime. Their three separate sections are connected by conductive bridges which often go open-circuit. While the loss of a section won't stop a panel functioning, it means it will take longer to charge and will produce muddier bass. The cure is to clean away the detritus and replace the bridges. Rebuilding and soak-testing bass and treble panels costs £120 each for the former and £100 each for the latter, although not all of them invariably require treatment - nine times out of 10, it's the tweeters that have given up the ghost.

As far as the 'speaker diaphragms themselves go, their conductive coatings need to be checked to make sure they're not too high in resistance (which will cause arcing) or too low (which reduces efficiency).

## HAPPY TO BE CLAMPED

One sure-fire way of sending '57s to their

graves is by over-driving them. Later samples were protected by factory-fitted 'clamp' boards, which prevent input voltages exceeding the 33volts which Quad quote as a maximum. Our examples lacked clamp boards but had escaped damage. Seeing as they were going to be

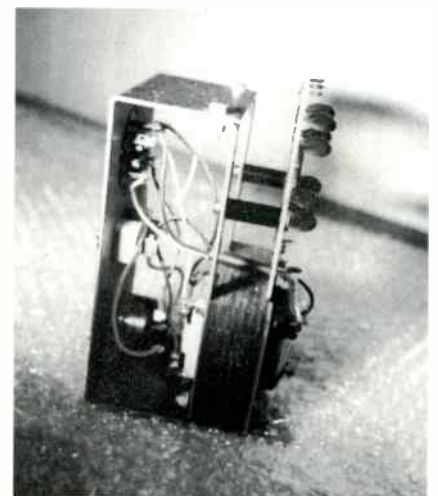

Classique Sounds offer rebuilt EHT blocks as well as brand new replacements.



Soak testing of rebuilt panels is carried out on the test jig pictured above.

used on the end of a pair of Musical Fidelity X-A200 monoblocs (over 300watts into 8ohms), ours were duly fitted with CLP1 clamps (£45 per pair).

**WIRED FOR ACTION**

Once the major surgery on the moving parts was complete, the wiring loom came in for some attention. Most of the old wire was removed and fresh EHT cable soldered in place. The final stage of servicing involved fitting new 'speaker sockets and testing the input transformers along with their associated crossover resistors and caps. After a thorough valet (£20 per ESL, including relacquering the feet and the side strips, touching up the grille and frame), the Quads were ready for a last listening session before they returned to World Towers.

**ELECTRO-ECSTATIC?**

After the disappointment of their initial sound, I was hoping for something more promising this time, especially considering



Some panels, like the bass one to the right, have had a very hard life. On the left is a rebuilt treble panel.

our ESL 57s had been given the full treatment, bringing their total cost including purchase up to around £1000.

Having hooked up the Quads to the X-A200s, a battery-powered DPA 50S pre and a Trio L-07D turntable, I gingerly fired them up and allowed them an hour to settle down. The first LP under the DNM Lexe/SME V was Joan Armatrading's Back To The Night.

**FILM STARS**

What emerged from those featherweight diaphragms was superbly crisp and clean across the whole of the frequency range. Cymbals had a speed, clarity and freedom from distortion which only the rarest of esoteric dome tweeters can get close to. Vocals were also untainted by the normal cone and box colorations, the result a nat-



Checking the three bass stator sections to ensure continuity across them.

ural transparency which really opened up recordings.

Swapping to a modified Pioneer DV-505 DVD player and Talvin Singh's Anokha compilation of Dance music, I homed in on the bass. Positional foibles aside (hunting out the right spot in a room for '57s can be a very time-consuming business), the bottom-end was taut and very nimble. The long-lived myth of the Quads being bassless was also banished, this album's heavier tracks benefitting from a satisfying (if not furniture re-arranging) extension.

As Haden notes in Vintage Virtues, it's the low-frequency 'sludge' which most box loudspeakers pump out that plays a large role in lending their presentation extra weight. Even compared to relatively inexpensive panels like the Magneplanar SMGas (which aren't electrostatics and have higher diaphragm masses) most boxes sound slow, blurred and boomy.



A rejuvenated '57, unclothed to show the central treble and two bass panels. The input transformer is sitting on the bench.

Tori Amos' Boys For Pele with its spiky harpsichord and vocals (which are more shrieked than sung) failed to provoke any nasties in the Quads. In fact, whatever was played through them had a dynamic freedom which made even the sprightly SMGas sound dull and sluggish.

**BUY, BUY BABY?**

If you're thinking of buying a pair of '57s and having them overhauled, it would probably be more sensible to opt for a cheap, tired set and have the necessary work done (usually just EHT units and treble panels) rather than spending £400 on a good but not perfect pair.

Considering our totally revamped ESL 57s cost around £1000, the results more than justify their price tag. Contemporary electrostatics aren't particularly cheap but Classique Sounds' servicing restores the Quads to a position where they can hold their head high in some exalted (for which read expensive) company●

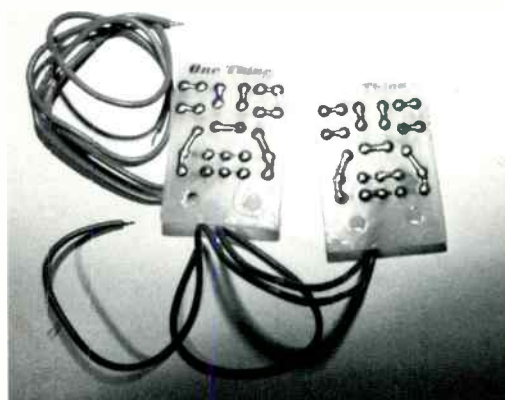

If you're going to be driving your '57s with a large solid-state amp, clamp boards are a wise precaution.

# ELECTRO-STATISTICS

As this is electrostatic loudspeaker month at Hi-Fi World, we thought we'd catalogue some of the alternatives to the Quad ELS 57 which have surfaced over the years.

Half lost in the mists of antiquity are the pioneering efforts of Voigt in the late-Twenties and McLachlan's 'Stretched-Membrane Electrostatic Loudspeaker' of 1933. As happens so often in audio, it seems that the theory has to tread water for donkey's years waiting for technology to catch it up. Considering the primitive state of plastics chemistry in those days, these fellows did well to get anything going for long enough to write up their notes! Indeed, one experimental model, the Oscilloplane, used a stretched metal diaphragm instead. In audio, which is Applied Physics when all's said and done, you don't get anything for nothing; the Oscilloplane boasted an improved bass response but suffered poor treble, a classic indication that the diaphragm had too much mass.

Before he perfected the familiar Quad panel version, Peter Walker himself toyed with a variety of designs for electrostatics. Earlier versions included a five-foot-tall, full-range panel and a rather fetching omni-directional column with two bands of narrow panels. Both of these emerged from the Walker workshop around 1955.

In the end, the pressures of domiciliary considerations gave rise to the more compact dimensions we now know so well. On the opposition benches, throughout 1956 H.J. Leak and Co. advertisements were full of their forthcoming electrostatic unit, and members of the public were freely invited to send for Messrs Leak and Sarkar's paper on their research findings

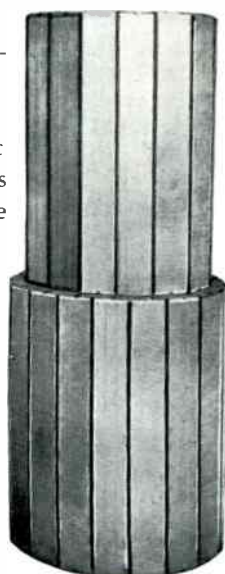

Peter Walker's elegant multi-cell column of c.1955

reprinted from The Gramophone.

Where the Leak scheme differed from the 'usual' push-pull electrostatics was in the arrangement whereby the polarizing charge was applied to a fixed perforated electrode placed between twin external diaphragms.

Among the advantages stated for this arrangement were the accessibility of the diaphragms and the lower resistances required in the circuit. The experimentors claimed that, since the coated film had considerable resistance in itself, the need to even out the polarizing voltage by a vast number of

megohms was avoided. In addition, it was hoped that the layer of air trapped between the diaphragms would have applications in controlling resonance and bass extension.

The device even had a name - FREL for Full Range Electrostatic Loudspeaker - and was confidently advertised to be 'available to the public in 1957'. As far as I am aware, only the treble unit was ever shown in public and, over 40 years later, the world is still waiting for the rest to follow! Naturally Leak themselves gave no reason for FREL's non-appearance but the introduction of the famous (and eminently reliable) Sandwich loudspeaker in 1962 must have counted as the final nail in its coffin.

Although few firms were prepared to endure the blood, sweat and tears of a full-range electrostat, by the late Fifties there were a number of treble units on the market.

Decca Special Products manufactured an interesting curved treble panel under

the name Audistic. Very much a period piece, it dates from a time when 'adding a tweeter' implied that you already owned a loudspeaker which catered for up to, say, 8kc/s and wanted to take advantage of the new, extended-frequency records. With this in mind, the Decca job has a built-in crossover and a variable level setting for the bass output. Having tried out one of these units, I guess this last feature was to bring the midrange level down to the rather feeble level of the tweeter - full-range reproduction at last, but at a whisper!

Janszen, the famous American firm, marketed a tweeter comprising four small cells arranged in a 'W' formation. It seems likely that this arrangement was intended to give some directional reinforcement of the sound and additionally some welcome reduction of the doublet cancellation effect around the edges of the baffle.

Of course, if you had the money, you could have things built to order. Mr Ewing Nunn, supremo of the legendary

Audiophile records (microgroove at 78rpm!) was able to persuade

Janszen to make some full-range panels for his listening room.

Photographs show six panels, each roughly five feet high by 18in. broad, grouped in two sets of three (for stereo) either side of his fireplace. What

Mr Nunn shelled out for these is not recorded but perhaps I ought to start doing the lottery!

Despite their manifest virtues, electrostatics have been around for a long time without significantly altering the market and, perhaps more tellingly, without becoming comparatively less expensive. To quote Peter Walker: "... (electrostatic 'speakers are) capable of a theoretically predictable solution. However, available materials and practicable limitations make its realization extremely difficult. The work is both fascinating, absorbing and rewarding."●

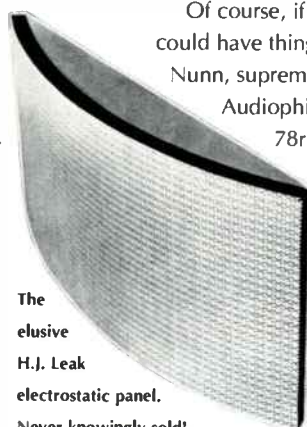

The elusive H.J. Leak electrostatic panel. Never knowingly sold!

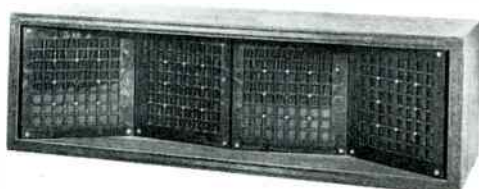

The Janszen company's four-cell tweeter.



# WHY OH WIRE?

Richard White turns the spotlight on a radical advance in cable technology from Vector Developments.

The World offices are dead centre in the sights of interconnect companies - scarcely a day passes when we don't have to fight our way through yet another pile of specimen cables. As regular readers will know, we frequently do group tests on the latest offerings, so when an extraordinarily hi-tech interconnect was described to us by Vector Developments, we decided to investigate further.

Most interconnects we review have something special in the conductor and dielectric departments; Vector have taken these materials to logical conclusions and developed an interconnect in which the dielectric is provided by as near perfect a vacuum as possible.

At first sight, this is an idea which is so obvious, it is staggering that no-one has thought of it before. On the other hand, like so many simple ideas, this could be one that has just been waiting for technology to catch it up.

At first, the development team at Vector tried out pure elemental metals for the outer casing: copper, silver, even tin was tried in the search. Since the technology for drawing tubes in all grades of wall thickness is readily available, all seemed set for success until it occurred to one of the designers that it might be possible to attain a degree of super-conductivity by progressive cooling of the casing to draw heat away from the inner conductor. This would, however, rule out the use of the metals already tried, since none could be made strong enough and thin enough to support the outside atmospheric pressure when the vacuum was applied.

Since combatting the mechanical stresses caused by acute pressure differences is all part and parcel of the technology for space exploration, the team tried the European Space Research Bureau but found themselves unexpectedly stymied:

"We found that all of the 'outer space' designs were naturally enough concerned with the containment of inner pressure - the completely opposite problem to the one we faced. . . We obviously had to think again."

The reconsideration process occupied the team for the next 18 months. In the end, a double-walled, honey-comb pattern was found to offer the greatest strength per unit of material. Taking no chances with all the vagaries of domestic atmospherics, the unusual but ultimately logical teardrop pattern was developed.

"With the degree of vacuum we were hoping to achieve being so high, it made sense to compensate for the altitude difference between the upper and lower surfaces of the tube; maybe it's a perfectionist sort of madness but it didn't seem worth leaving it to chance."

The altitude pressure compensation naturally means that the interconnect is orientation sensitive, a potential problem which the team faced from the outset. Various options were mooted to ensure that, in use, the finished product would remain 'upright', including stands, feet and a novel system of slings. In the end, the best solution was also the most obvious:

"With the great improvements made in recent years with miniature, battery-driven gyroscopes, it became a simple matter to arrange that the 'cable' (as we had long ceased to think of it as) would stay in the same position, even if the building fell down about its ears. With power already on hand for operating the vacuum maintenance system, there didn't seem any point in persevering with other potentially more complex solutions."

With the design of the outer conductor more or less fixed, the team turned to the important inner conductor. Since Vector had decided to take nothing for granted, the same extensive research was put in motion in the search for the perfect cable. Nothing quite met the desiderata:

"With all the metals we tried, the residual gases (air or oxides of the metal)

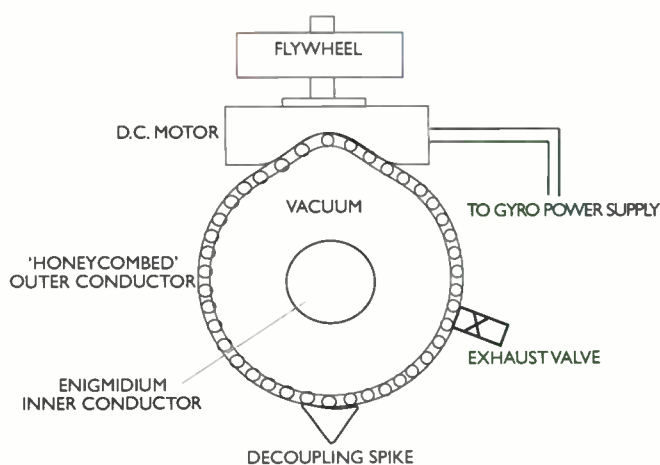

trapped between the molecules ruined our attempt to achieve adequate vacuum. We tried heating in liquid nitrogen but soon discover that metal assimilates gas as quickly as you try to burn it out!

"In the end, we developed a patented alloy which we have dubbed 'Enigmidium' after the famous code-crackers at Bletchley during the war. Enigmidium has the peculiarity that the atomic activity of its constituents generates tiny ionizing currents which get rid of gas - rather like the 'getter' in a thermionic valve."

With the basic prototypes all set up, Vector were ready to try the ultimate test; trying for full vacuum and full self-acting super-cooling under simulated 'domestic conditions'. As most people know, when a current is passed along a wire, the electron flow causes the wire to heat. Since this would ruin the super-conductivity conditions, the designers opted for a clever delay-and-anti-phase circuit in the pre-amplifier which senses the signal current, holds it in memory while the anti-phase signal is synthesized and then joins the two by a matrix arrangement. By this means, a complete cessation of noise is achieved, regardless of the quality of source components - a welcome bonus.

The Vector Enigmidium cable should be available about the beginning of April and Vector are confident that initial demand will be high●

## ROCK & POP

by Jon Clarke & Stuart Lenz



### OASIS THE MASTERPLAN

OK, so it's been in the shops for a few months, but we couldn't possibly let an Oasis album slip by unnoticed.

The Masterplan was indeed a clever ruse: bring out an album of B-sides and various out-takes, live and otherwise, make a bit of money in the process and let everyone know that you haven't gone away. Already a big seller, released as it was just prior to Christmas, this album still smells like a con-job, except (and this is a big exception) that its 14 tracks actually knock the socks off their previous studio effort, *Be Here Now*.

Of course, if you're a big fan and you've been there from the beginning, you'll know that on each of the group's brilliant singles, 'Supersonic', 'Live Forever', 'Cigarettes And Alcohol', 'Some Might Say', etc, there was a trio of extra tracks. This is rare in this day of high consumer living, when a B-side most often means the Dance mix, extended mix, radio edit mix and the cat, dog and ferret mix. But the Gallagher boys, creativity gushing from their every pore,

were producing so much material that the singles were a useful secondary outlet to the public.

Gelling remarkably well considering they span four years, at least a couple of these tracks are as good as the singles that they were released on. Take 'Listen Up', a wonderfully angry ballad. It was easily as good as 'Cigarettes And Alcohol'. Then there's 'Acquiesce', on 'Some Might Say', which has even been included in Top 100 polls. Anthemic, punchy and downright dirty, there can be no better way to start an album than this number; featuring the lyrics "We need each other, we believe in one another", it was perhaps the first sign of the secret brotherly bond between Noel and Liam. Great live, it is the classic Oasis track, sadly missing in spades on *Be Here Now*.

Skipping the decidedly dodgy 'Underneath The Sky' - one of only two stinkers on *The Masterplan*, the other being the irritating 'I Am The Walrus', the Beatles track that they seem so obsessed with playing live at the drop of a hat - we chug on to the moving 'Talk Tonight' and the again Beatlesque 'Going Nowhere', which, while slightly off-key, is nonetheless catchy. Then it's on to the Punky two-chord, Buzzcocks-style 'Fade Away' from 1994's 'Cigarettes And Alcohol', power Pop at its very best.

The second side keeps up the pressure with the excellent Grunge number 'Listen Up' and 'Rockin' Chair', a

melodic, Paul Wellersque chant from 'Roll With It'. Continuing in the same gentle vein is the brilliantly moody 'Half The World Away. . .'. This is Noel at his reflective best, singing as well. Ending with the superb 'Masterplan', the album leaves a very up-beat aftertaste, one that will hopefully carry Oasis in good spirits towards the Millennium and beyond.

With Noel declaring recently that he has packed in the drugs (charlie to be exact) we can only hope that he will channel his creativity into producing some more of this stuff.

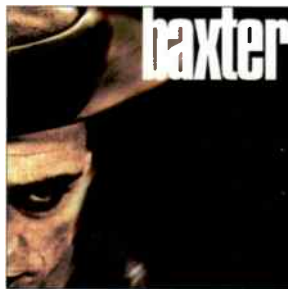

### BAXTER INSIDE

Forget Gay Dad and all the other hyped bands for 1999, one group to keep a real look out for is Baxter. Consisting of the musical talents of the Baxter brothers and friends Tim and Henry, this band is the best thing to come out of East Anglia since Alan Partridge and Lenny Beige.

Southwold, or Islington-on-sea as it is often known in the media, has spawned little more than a cracking cream tea over the years. Now it has produced something a little

different. On *Inside*, a five-track mini album, Tom and Charlie Baxter, a musical student of some stature, show just the sort of instrumental nous needed to make an impact in the cut-throat world of Pop. With a wonderful assortment of sounds and instruments (violins and horns included), Baxter conjure up a part-mystical, Oriental earthy feel, driven along by a series of brisk Ska/Reggae basslines.

From the up-beat White Reggae sound of 'Only Joking' (a floating, moving composition which builds slowly up to a catchy, spiralling Dance number) to the assured, moody and sad cries of 'Inside', this is a debut of some promise.

As was the case with Gomez last year, it's hard to pigeon-hole this lot. A dose of Reggae, a pinch of Ska, a sprinkling of Punk, a trip to the theatre and a visit to the Orient. Whatever, Baxter might spring a few surprises this year.



### BECK MUTATIONS

This is supposedly the record Beck has been wanting to make for the last five years, and for an audience weaned

ROCK & POP

RECORD OF THE MONTH

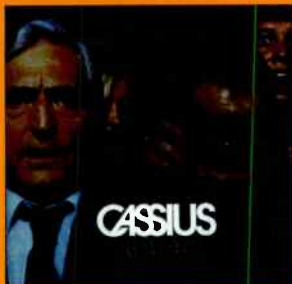

CASSIUS  
1999

Oh la la - the French making hip music? Unheard of. Well, in the wake of Air's brilliant debut last year, amazingly they seem to be doing just

that. In the shape and form of Phillipe and Hubert, two 31-year-old Parisian Disco nuts, Cassius have produced a belter of an album.

It's not as if the two gentlemen concerned lack the musical pedigree, having spent the last 10 years working behind the scenes for French luminaries such as MC Solaar as well as remixing for the likes of Neneh Cherry, Björk and Air themselves. They have even been known to cross the pond to DJ in a series of trendy London clubs, including Basement Jaxx and

Scaramangas.

With 1999 they have drawn on their 12 years of experience to create the classic new-Disco sound. Big on bass, the 16 tracks are hewn from a steamy mix of Funk, Disco, House and Garage.

The downright sleazy 'Foxy', the impossibly funky 'Hey Babe' and the title track, already a big hit on the dancefloors, might be the pick of the bunch on first listen, but there's a lot more besides.

Second track 'Feeling For

You' slides in aggressively on a Tuff-Jam-style tape loop, to metamorphose into a banging House masterpiece. 'Mister Eveready' is Cassius' nod to Rap with its street-style Break Beat; the James Brown-like 'Nulife is a riot'; 'Interlude' is a slow moody affair and 'Somebody'... Well, it gives the Chemical Brothers a ride for their money.

It may be more suited to the dancefloor than your flat, but 1999 is bound to get you in the right mood for a big night out. For the French, ce n'est pas mal!

on Mellow Gold and Odelay, Mutations is anything but a sprawling, cut-and-paste follow-up.

Intended originally as a low-key personal affair, experimental in content and never considered as a full release, Mutations was set for a quiet life on a minor label. His record label Geffen, however, had entirely different plans. Realising there was a rich vein to be mined here, and having heard the early demos which were surprisingly good, the chiefs at Geffen fought to reclaim Mutations as one of theirs.

Labelling it as a series of 'transitional' pieces for the big Beck fan, they knew this album would sell like hotcakes. Hence, while Mutations still contains Beck's special blend of Folk, Rock and Pop, the style has evolved in a subtle new direction. In short, the block-rockin' beats have been replaced by a quiet magic.

Comprising 11 beautifully-crafted tracks, Mutations could easily be (and could be yet) a soundtrack to a low-budget Western with its loose, melancholy, late-night feel. The songwriting may be tainted by Folk, Cabaret and Space Pop, but its heart lies unashamedly in Ragtime and Sixties Country Rock.

A collection of ramblin' tumbleweeds, Rawhide it ain't. And with no complex Japanese hardware to taint the proceedings, Beck simply let his strummed guitar take charge of the two weeks during which the album was recorded.

'Cold Brains', a surreal piece influenced as much by vintage Psychedelia as up-to-date Country, sets the pattern magnificently. And the harmonica solo is simply sublime.

Sixties Folk Pop is never far away, though, as you'll discover from the spellbinding

selection which follows. From 'Nobody's Fault But My Own' - beginning with a Doorsish 'The End' and framed by a droning sitar and Indian violin - to 'We Live Again', a Donovan-type 'Mellow Yellow' number swimming in dreamy, rolling harpsichord figures, we are in for a series of treats.

'Cancelled Check', which sounds like the Rolling Stones at the peak of their love affair with honky-tonk Americana, takes up the reins thereafter and is swiftly followed by Beck's cheeky 'Sing It Again', which by any other name is 'Norwegian Wood'.

For every Sixties rake-over there is a Country standard built along the lines of 'O Maria' or 'Sing It Again', which serves as a reminder to all that Beck, with his fluffy sideburns, really would not be out of place at the Grand Ole Opry.

Only once does Beck live

up to his perverse image when, out of the blue, he does a breezy Bossa Nova song, 'Tropicalia', modelled on the Brazilian protest music of the same name which was popular in the Sixties and Seventies. Alongside the movement's figurehead, Caetano Veloso, to whom the song is a tribute, Beck shares an unusually sophisticated sense of rhythm. The result is a sort of quirky 'Girl From Ipanema', if you like.

In Mutations Beck doesn't really go anywhere he hasn't been before - it could easily be a companion to 1994's One Foot In The Grave, though it's not perhaps as raw. Thanks to his wry invention and humour Mutations is always a refreshing stroll down memory lane and holds the fort safely until the arrival of the 'official' follow-up to Odelay which should hit the planet some time next year.

DANCE & AMBIENT

by Sara Davis

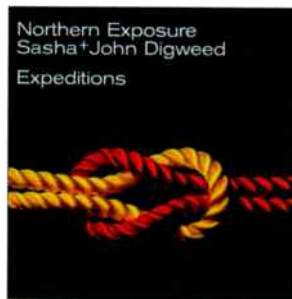

SASHA AND DIGWEED  
**NORTHERN EXPOSURE**  
SONY EXPOCD1-1

The observant will notice that this third instalment of the Northern Exposure collection comes via Sony rather than Ministry Recordings; clearly the Sasha/Digweed phenomenon has changed hands (probably for lots of money). The new label InCredible appears to have been set up in order to continue the Northern Exposure tradition which was built on the touring club night of the same name some years ago.

The new label signifies a change of affairs that comes at a strange point for the halves of the Sasha/Digweed partnership. Both are going through unsettled times, be it with fresh residency contracts or musical diversifications. Sasha especially has evolved his sound quite radically since the early Northern Exposure days, so it's hard to imagine how this album will sit next to earlier releases. His recent Global Underground CD, classy and sophisticated, consolidated his Ambient and experimental House tastes. This was hardly the Sasha House vibe that, in the old

days, would have had you reaching for your handbag.

As for Digweed, so far he's stuck with churning out the characteristic dreamy House that he has always played, and getting abuse for it in some quarters. Despite the fact that his formula pleases crowds, he's falling victim to the stagnant syndrome and probably needs to take his sets one notch lower on the underground scale. Which is a strange co-incidence, because that's exactly what Sasha's done to great effect.

Hence the appeal of this double-CD, Sasha's new, dark House vibe tempered by Digweed's love of quality hard House. Expect sleek, groovy House, a whole array of layers held together by a tight, slowly accelerating beat. The mix is extremely consistent, Sasha's underground vibe dominating Digweed's tendency towards peaks and troughs. The partnership has probably never been greater, and certainly never as complementary.



PAUL OAKENFOLD  
**BEST OF CREAM  
COURTYARD, CD2**  
CREAM/VIRGIN VTDCD237

The first DJ to have his name

shortened, is it because Oaky's success is so great everybody wants to be on casual terms with him? Or perhaps it's because people feel they know Mr Oakenfold? Any witness will vouch for the fact that his sets are extremely infectious - it's as if he can sense the collective feeling and play to it. Such is the sign of the world's biggest DJ, the first to be credited in the Guinness Book Of Records and one of the most respected men in the business.

So just what is the secret of his success? It has to be down to Oaky's selfless approach to music, the way he concentrates on the tracks the crowd want to hear rather than the one's he's pushed to promote. Then there's his seamless mixing plus a broad-minded approach to his sets which he builds track by track to create waves of sonic atmosphere rather than a line-up which hops blandly from tune to tune.

Thankfully, all these elements are recreated on this double-album, right down to the cheering Cream crowd egging Oaky on as he works in those haunting break-downs. And the tracks? An excellent choice of tunes that can be slotted into that category of songs you know and love but don't yet own. In other words, they belong to that respectable class common to the dancefloor but not yet being power-played to the masses; melodic and catchy enough to make the Top 40 but still to be plucked from the realms of the

underground.

It's sophisticated House music like the intro, Taste Experience's 'Summersault', and Mansun's 'Wide Open Space', that gets under your skin in an un-cheesy way. Cream regulars, especially those with the first episode of Courtyard, will find that this album adds more of the same epic, dreamy House to their collection and serves as a good souvenir of the legendary Cream nights. The Tilt version of 'Children' is particularly reminiscent of the Cream years, representing for some the highlight of the emotive House-club days.

Those who have yet to visit Oaky's Courtyard Of Dreams will never get the chance to hear Paul's resident set at Liverpool's finest club night and will have to comfort themselves with this CD series, coupled with the new Radio 1 residency that he's just accepted.

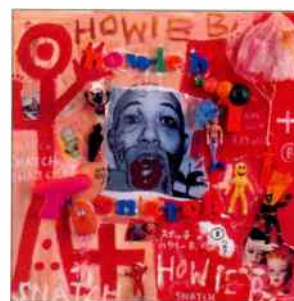

HOWIE B  
**SNATCH**  
PUSSYFOOT CDLP011

After two critically-acclaimed solo albums, Music For Babies and Turn The Dark Off, one of the most innovative producers around creates an album on

DANCE & AMBIENT

RECORD OF THE MONTH

VARIOUS

KOSMONAUTS

KOSMO RECORDS LC 3252

Kosmo Records is always quick off the German mark to react to market changes. This time it's up there amongst several other German record labels who have found it necessary to diversify away from the traditional hard-edged Techno and Euro-Trance of yesteryear and concentrate on the awkward Big Beat and glammy Disco-House elements that continue to prevail in the UK scene at present.

More than a fast-buck mix CD that strikes the right chord, Kosmonauts signifies a sea change within the structure of Kosmo Records as they prepare to launch a UK wing under Logic. Just how successful this mission will be remains to be seen.

Some might see traditional German Techno producers adopting the very British breakbeat and funky handclaps as a disaster waiting to happen since the two strands of Dance music are light



years apart in terms of musicality and culture. But anyone familiar with Kosmo will know that it has regularly been the feeding ground for highly reputable labels such as FFRR and Hooj Choons, who have returned time and again to license artists like Da Hool and Eniac, both of whom are featured here.

Despite what the politics and theory behind this album might imply, there is still a strong, melodic Techno vibe to this release. The double-edged Funk does exist but mainly in the form of a

typical Big-Beat intro featuring yet another Fifties-style recording on the subject of the definition of music (you know, choc-full of dialogue samples, this time a square music teacher who's trying to cut it with the kids).

The rolling, funky tip also manifests itself subtly within the tracks, artists such as Mo Funk providing a particularly jammin' remix of 'Whoosh' building into Dani Konig's 'Disco 3000', a fine example of hip-grinding House riding a mean, Trancy riff.

On the whole, Kosmonauts orbits lighter musical influences in a sturdy Techno rocket, even Novy vs Eniac's groovy House tune 'Someday, Somehow' losing its defined vocals to a pounding bassline and psychedelic break-downs. The rule of thumb is that the rhythmic Funk fades out whilst the chirpy House co-exists nicely with gorgeous, melodic Techno. It's great to hear Kosmo's new UK breed of Euro-Trance utilising the label's traditional Techno talents in a refreshing and exciting format.

Pussyfoot. It's been a long time coming, but considering that he's been DJing for U2 on their Popmart tour, remixing Steve Reich and producing Sly and Robbie's latest LP, it is fair to say that he's been a busy man. He even had a transportable studio custom-built so he could continue making his own music as he circumnavigated the world.

Leap-frogging from tea-boy to tape operator to fledgling engineer, Mr B. cut his teeth as an assistant to soundtrack composer Stanley Myers. He has since worked with Björk, Tricky, Skylab and Bryan Eno amongst many others, a reflection of his diverse tastes

and open-minded outlook.

Howie is famed for his ability to explore the furthest realms of the sonic spectrum through ethereal soundscapes, quirky sounds and addictive loops from bizarre sources. So is this digital Jazz or bodge-it-all pizazz? Could any insane person with a mobile studio and the power of a gut-busting effects desk at their finger tips do better?

Snatch is one of those experimental beat-fests that requires multiple listening before it can even begin to hook itself into the subconscious. As there aren't any volunteers around willing to store it in their CD players

for the foreseeable future, it's true calibre may remain ungauged.

After average amounts of play there are definitely some tunes which feel good - track three, 'Cook For You', maintains more order than most, mixing a big Bristol bassline with a jazzy flute sample and a spiritual melody. 'To Kiss You' also appeals instantly, its head-nodding groove built around an oddball piano and guitar loop that perfectly illustrates Howie's penchant for combining the surreal with the sublime.

'I Can Sing But I Don't Want To' has an equal capacity to infect, although it's

on a melancholic and laid-back tip. You can imagine this tune as the closing music to a British realist film from the Sixties - it evokes images of a lonely heroine who has just experienced not very much, walking slowly into a factory-lined metropolis as the credits roll.

You're left with a similar kind of sensation after trying Snatch. In its raw, down-to-earth feel it's entertaining enough. There's some true creativity to be found within the fabric of the medium too. Interesting and fun to listen to, Snatch the album ultimately leaves you somewhat empty afterwards.

# MICHELL GYRODEC AND QC POWER SUPPLY

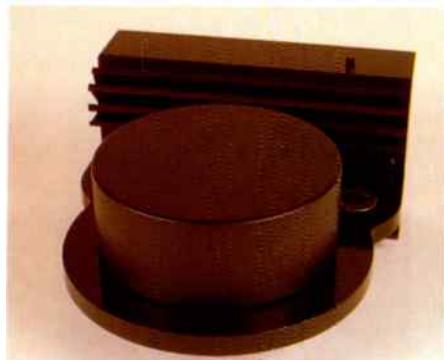

A SYMBOL OF PRECISION



**"THE MOST DESIRABLE DECK BELOW £1500"**

Ken Kessler - Hi-Fi News & Record Review

**Michell Engineering, 2 Theobald Street, Borehamwood, Herts WD6 4SE**  
**Tel: 0181 953 0771**

## **MORE CLASSIC REISSUES ON VINYL**

**MASTERED FROM THE ORIGINAL TAPES AND PRESSED  
ON 180G VIRGIN VINYL - ONLY £21.95 EACH PLUS P&P  
RECORDS SO GOOD YOU WON'T BELIEVE YOUR EARS**



Miles Davis  
Sketches of Spain



Bruce Springsteen  
Born To Run



Billie Holiday  
Lady In Satin

### **OTHER RECENT AUDIOPHILE VINYL REISSUES:**

J J Cale: Naturally - £19.95

Original Soundtrack: Glory - £21.95

Roy Gaines: T-Bone Blues - £19.95

Hank Mobley: Roll Call - £21.95

Cliff Jordan: Cliff Craft - £21.95

Jethro Tull: Original Masters - £21.95

Linda Ronstadt: Greatest Hits Vol.2 - £21.95

Ben Webster: Soulville - £19.95

Charlie Byrd: Bossa Nova Pelos Passaros - £19.95

Doug Macleod: You Can't Take My Blues - £15.95

TO PLACE AN ORDER OR TO RECEIVE A FREE AUDIOPHILE VINYL OR CD CATALOGUE,  
PLEASE CONTACT:

## **VIVANTE LONDON**

UNIT 4, 60 HIGH STREET, HAMPTON WICK, SURREY KT1 4DB

TEL: 0181 977 6600 FAX: 0181 977 4445

**EUROPE'S PREMIER AUDIOPHILE MAIL ORDER COMPANY**

JAZZ

by Ian Nicolson

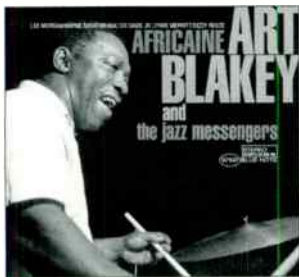

ART BLAKEY AND THE JAZZ MESSENGERS  
**AFRICAINE**  
BLUE NOTE 7234 97507

Many fans with tuned-in ears rate Blakey and Blue Note as the ultimate in Jazz talent-spotting, and his Jazz Messengers were their Academy of Excellence. Lee Morgan, Cedar Walton, Wayne Shorter, Freddie Hubbard, Hank Mobley, Curtis Fuller, Horace Silver and Bobby Timmons all became Messengers, in front of one of the presiding geniuses of Hard Bop.

Blakey ruled the drum stool from the inception of the band in the mid-Fifties to the end of the line in the late Eighties.

The sessions for *Africaine* (recorded in 1959 but not released until 1979) saw innovative young tenorist Shorter linked with the equally forward-looking trumpet of Lee Morgan for the first time on record. These two were set against the efforts of producer Alfred Lion to shape another commercial hit to match Blakey's breakthrough with 'Moanin''. What he got instead was a showcase for two hot young horn players and composers burning ideas and talent over the uniquely wide-screen Blakey percussion style, all

anchored by Walter Davis's low-key, self-effacing and supportive Blues piano.

This first CD release for *Africaine* as part of Blue Note's 60th anniversary programme does what Blakey always wanted for his music and his Messengers - it captures a transitory creative coalition at a peak moment and keeps the fruit of their imaginations and skill as something timeless, elegant and brave. Essential.



VARIOUS ARTISTS  
**ALL NIGHT JAZZ**  
LINN AKD 087

You can buy Linn Products' hi-fi from Glasgow to Bombay to Tokyo, and a lot of people do. I wonder how many realise that the same company has a kid-sister operation called Linn Records that believes in the same grails: quality, precision and musicality.

Periodically, the label issues samplers from their roster of predominantly Folk and Jazz acts. Hi-fi shops are often the easiest place to find them because the recording, mastering and musical quality makes them ideal audiophile testers.

Don't expect a mid-Atlantic nerd intoning: "15000Hertz, left channel", or the sound of a cabbage

being sawn in half while performing backflips off the wall behind the sofa. Do expect immaculate, hallmark performances from vocalists Carol Kidd, Ray Gelato and Claire Martin; lyrical, sophisticated, smooth Jazz keyboards from Tommy Smith and the under-rated Gerard Presencer; delicately inflammatory acoustic guitar inspired by Martin Taylor's passion for Django; and a glimpse of the Kane brothers (aka Hue And Cry) in plangent ballad mode.

Not all the tracks are the latest recordings by the acts, and only a few of them have ruffled the airwaves or battled for racking in HMV, but there's a coherent A&R, production and recording philosophy at work here that deserves more favour. Try one and see.



THE NEW TESTAMENT OF FUNK  
**VOLUME 1**  
ACID JAZZ LP106

After too long - around two years - since the last album to be released by the indispensable London-based Acid Jazz label, 1999 is off to a flying start with this hour's worth of classics that have wired up UK dancefloors to the latest mash-up of breaks, beats and improvisation.

Volume 1 (what a promising title. . .) kicks off with Xavier Fisher's latest enclave, the seriously souled-out Sookie All Stars funkng up Richie Haven's monster 'Freedom', all dripping Curtis M. guitar and fruity clavinet. Then it slips seamlessly into stripped-down Gallic Disco with NLE, pumps up the bass bumps and triangle accents for German new signing Erobique (aka Casten Meyer), and comes over all hard-boiled Breakbeats with The New Testament slamming the theme to The Professionals up against the Granada just one more time.

Next is a slyly addictive taste of Bhangra Jazz from new signing Pathaan, then a lyrical, spaced-monkey, James Lavelle stretch mix as the Man From Unkle tries on the 'Emperor's New Clothes', which dissolves into Aussie Martin Sheen getting anthemic over a psychoactive sitar and handclaps backbeat.

If you're not tired of jiggng about yet, Chekhov's mesmeric 'Aha' and T-Boy's traffic-jammed baritone saxes in 'Jetsonville' or Melbourne-based remixer OSS's latest incarnation (where the Models meet Devo in Daft Punk's backyard) should all trigger your slow-twitch fibres nicely. Which only leaves Paul Murphy collaborating with Canadian producers High Fidelity and German DJs Unique on a madhouse Breakbeat pastiche of Sixties ads, Seventies Soul and several sampled kitchen sinks. Face it, if you can't find your cup of tea in here then you're either not thirsty or in the wrong town altogether...

## JAZZ



VARIOUS ARTISTS  
**BRASIL 2MIL**  
ZIRIGUIBOOM ZIR 02



BELEZA  
**TROPICAL 2**  
LUAKA BOP 46275

After one too many Sunday mornings lugging half the contents of Tesco around bits of south London dampened by profoundly unconvincing snowflakes, I reach for something tropical. So perhaps it's no coincidence that both Luaka Bop and the Austrian Jazz-to-Pop Ziriguiboom labels fancy their chances with compilations of new Brazilian Jazz at this time of year.

Jazz musicians have eagerly embraced Latin influences - and vice versa - since at least the end of WW2. There was even a period in the mid-Sixties when trying to get a gig without a couple of Bossa Nova tunes in the book was like spitting into the wind. If it was good enough for Stan

Getz or Dizzy Gillespie, and if Herbie Mann and Sergio Mendes could get rich quick off Samba and Bossa, why not?

Now Astor Piazzolla's tangos and octogenarian Cuban lounge acts fill the Albert Hall, while Jobim or Gal Costa truly sit comfortably next to Marley and The Chieftains in thousands of European living rooms. Latin music informs everything from The Mavericks to Baaba Maal. But the Sixties Bossa boom eventually transformed a vigorous, fertile fusion of African, native and European musics into something a lot closer to tinned soup: ingredients the same as the real thing, but what happened to the taste? It's just too easy to bolt some Samba or Lambada onto traditional Pop changes and, hey, look, the Spice Girls singing 'All Around The World'.

But Brazil is every bit as influential and volatile a music-making culture as the US, and these outstanding new collections illustrate that breadth. Ex-Talking Head David Byrne A&Rs Luaka Bop, and Tropical 2 is a follow-up to his first Brazilian compilation (released in 1989) which keeps the faith that breakthrough set inspired: giants like Gilberto Gil, Tom Zé and Caetano Veloso updating Tropicalia, Marisa Monte and Carlos Careca's seductive Nineties Bossa sounds, the strident African drums of the Bloco Afro underpinning new star Daniela Mercury's patois-Pop and original internationalist Sergio Mendes mixing it over

and under Jazz-Rap lyrics that wouldn't be out of place on a Bootsy Collins set. . .

Brasil 2mil compiles many of the best of Brasil's young Bossa and Axé dance-based acts who have absorbed House and Trance - and, through Brazilian producer Béco Dranoff, breathe new life into Bossa. If you've already heard Smoke City and Arto Lindsay (both represented here), you'll know how the melancholy of memory - the quintessentially Brazilian synthesis known as "saudades" that is traditionally alleviated by music - can be wrapped in a parcel of Jazz-Funk that defies categorisation. They call it Bass-o-Nova on the sleeve - an appalling pun but a lovely record.



CLAIRE MARTIN  
**TAKE MY HEART**  
LINN AKD 093

Sensational young London-born Jazz/Folk singer Martin has built an enviable international reputation with her five Linn albums to date. Every date or session has revealed her catholic taste in songwriters, her unwillingness to be categorised, and an exceptional ability to breathe personality into both

unexpected and familiar tunes, all underpinned by the wit and technique to keep lyric, melody and swing in easy harness.

Whether her growing following will take easily to her latest depends on one simple test: are we far enough down Rock's river to let Jazz embrace these songs by writers like Nick Drake, David Sylvian, Elvis Costello and Lennon/McCartney?

Then again, every one of the originals was full of doors being opened by mould-breaking singers itself. And why shouldn't a 30-something singer steeped in British Pop and Rock history pick the eye-teeth out of that canon, rather than that of the Thirties or Fifties legends? Which is probably part of why ace magpie Noel Gallagher worked on Martin's version of 'Help', while her producer and guitarist, Paul Stacey, is helping to incubate the next batch of Oasis' tunes.

There are real reminders of the K.D. Lang approach to making records on Take My Heart, a kind of absolute focus on the performances and a burnished, succinct, economically-arranged classicism that never shouts "look at me!" - especially in the tricky bits - or parades in front of the mirror. Meanwhile, Martin's leisurely, smoky voice never dodges a syllable or blurs a meaning as it sends slow, lingering chills up the back of the neck.

I've never really been confident that I knew what "plangent" means, but I'm pretty sure that this is it.



**BEDFORDSHIRE**

**RICHARD'S AUDIO VISUAL** 4 Greyfriars Bedford. Tel: 01234 365165. Stockists of: Arcam, Audioquest, Beyer, B&W, Bose, Cable Talk, Celestion, Cyrus Denon, Heybrook, Marantz, Mission, Moth, Nakamichi, Ortofon, Pioneer, Pro-Ject, Quad, REL, Rotel, Royd, Ruark, Sennheiser, Sound Style, Systemdek, Target, Teac, Thorens, van den Hul & more! Expert friendly service: Listening room. Pioneer Reference Point. Visa / Access.

**BERKSHIRE**

**SEVENOAKS HI-FI** 3 & 4 Kingswalk Shopping Centre, 19-23 King Street, Reading, Berks. RG1 2HG. Tel. 0118 9597768. A specialist Hi-Fi store with two demonstration rooms. The audio visual room is complete with Meridian Digital Surround Sound. Major brands stocked are: Arcam, Audioblab, Cyrus, Denon, Marantz, Meridian, Rotel, Yamaha, Acoustic Energy, Castle, B&W, Kef Reference, Monitor Audio & Ruark.

**BRISTOL & BATH**

**THE RIGHT NOTE** Tel: Tel.No. (01225) 874728. Just think: most audiophiles listen for most of the time to systems that are 'not quite right'. Are you happy with yours? Forget the reviews and trying to put together a system like a patchwork quilt with the 'best' bits around. It's our job to do the assessing, you judge our results. We'll help you to plan a system for the future, even if you spread the purchases. Leave the 'up-grade-it's' behind, save money and enjoy music all the time. Just listen, and you'll know. CD: Acuras, Audio Synthesis, Classe, DCS, Enlightened Audio Design, Meracus, Orelle, Wadia, XTC. Vinyl: Basis, Crown, Jewel, Graham, Michell, Sumiko, Transfiguration. Amps: Acurus, Audio Sculpture & more. Speakers: Audio Artistry, Audio Physics & more. Tuners: Fanfare, Magnum Dynalab & many more. Cables: Chord, DNM, Silver Sounds & more. (Credit Cards Accepted).

**BUCKINGHAMSHIRE**

**HAZLEMERE AUDIO CONSULTANTS** To hear how realistic music can sound please call for an appointment (day or evening). Objective advice, comfortable listening, home demonstrations, free installation, part exchange, repairs and superb service. Acoustic Precision, Air tangent, ATC, Audiomeca, Basis, Classe, EAD, Fanfare, Henley, Magnaplanar, Mirage, Monrio, Muse, Nottingham Analogue, Opera, Ortofon, SD, Sirius, Straightwire, Tice, Triangle, Trilogy, VPI. Based in High Wycombe. Please call: 01494 437892.

**TECHNO SOUND/ AUDIO INSIGHT** 7 Granville Square, Willen, Milton Keynes, MK15 9JL. Tel. (01908) 604949. Audiophile Hi-Fi and Home Cinema Specialists. All major brands stocked from Arcam to Yamaha. Meridian Digital Home Theatre dealer. Custom home cinema and multi room installation. 4 dem rooms and expert advice. Audiophile CDs, LPs and LaserDiscs to buy. Open late on Fridays.

**NORTHWOOD AUDIO** 98 Cambridge St, Aylesbury, Bucks HP20 1BA. Tel. 01296 428790. Selected sounds from Acoustic Energy, Alchemist, Arion, Audio Meca, Audio Note, Boston, B & W, Cabledtalk, Castle, Celestion, Chord Co, DNM Virtual Reality, Denon, DPA, Epos, Exposure, Gyrodek, Harman Kardon, Heybrook, Kef, Klipsch, Marantz, Micromega, Monitor Audio, Moth, Musical Technology, Myryad, NAD, Nakamichi, Neat, Pioneer, Proac, Rega, Rel, Rose, Rotel, Ruark, Stax, Tannoy, Teac, Talc Electronics, Thorens, TDL, Triangle, Tube Technology and a range of quality pre-used equipment. Export orders welcome. 2 Dem rooms. Credit facilities available.

**CAMBRIDGESHIRE**

**THE AUDIO FILE** 41 Victoria Road, Cambridge. Tel: 01223 368305. 'For the best in British Hi-Fi and Home cinema entertainment'. Visit or call to arrange a dem with products from: Audioblab Arcam, Mission, Linn, Naim, Rega, Cyrus, Absolute Sounds, Kef, Sony, Yamaha, Rel, Quad, Ruark, Denon.

**THE HI-FI COMPANY PETERBOROUGH**

The region's largest range of enthusiast hi-fi. Arcam, Audioblab, B&W, Cyrus, Denon, Kef, Kenwood, Krell, Marantz, Martin Logan, M&K, Meridian, Mission, NAD, NAIM, Pioneer, Quad, REL, Rotel, Yamaha and many more. Excellent hi-fi and A/V demonstration facilities. Part exchange welcome. Huge selection of top quality, carefully used equipment. telephone for mailing list. 35-42 COWGATE, Peterborough. Phone: (01733) 341755 Fax: (01733) 358141.

**CHESHIRE**

**ACOUSTICA** 17 Hoole Rd., Chester CH2 3NH Tel: 01244 344227. All that's best in hi-fi from Epos, Kef, Teac, Royd, Linn, Rega, Naim, Arcam, Audioblab, Ruark, Rotel and many more. Multi room systems from Linn Knekt. Superb demonstration facilities, home demonstrations and installation a pleasure. We offer the best products, the best service and the best sounds. Open Tuesday to Saturday, evenings by appointment.

**THE AUDIO COUNSEL** 14 Stockport Road, Cheadle, Cheshire. Tel (0161) 428 7887 and 12 Shaw Road, Oldham, Manchester OL1 3JQ Tel (0161) 633 2602. Linn, Arcam, Naim, Audio Research, Martin Logan, Yamaha, Creek, Nakamichi, denon, J'W, Marantz, Royd, Lexicon. 3 dem rooms, free install, VISA/ACCESS Full multi-room and A.V. installation 10:00 - 5:30pm Mon-Sat, till 8:00 Thursday.

**ACTON GATE AUDIO** 4 Ruabon Road, Wrexham, North Wales. Tel. 01978 364500. Audio Visual Specialists. Arcam, Audio Analogue, Bose, B&W, Celestion, Castle, Denon, Harmon Kardon, Jamo, Marantz, Michell, Mission, Onkyo, Pro-Ject, Musical Fidelity, NAD, Micromega, Myrad, QUAD, Radford, Rotel, Ruark, Tannoy, TDL, Teac, Thorens, UKD, Unison Research, Yamaha, DSP Club Member, Demo Room, installation service. Easy Parking and Motorway access. All major credit cards accepted. 9.30 - 5.30 daily. Closed Weds pm.

**INPUT AUDIO** Dukinfield, Cheshire, Tel/Fax: 0161 304 7494. Mobile: 0402 268490. We have the time, we have the patience, we have the desire, and we have the products to help you reach your musical goals. featuring: Adyton, Altis, Art, Audiogram, Audio Analogue Puccini, Audiomeca, Audio Physic, Audio Vector, Base, B.C.D., Chord, Diapason, Graaf, Insert Audio Immedia, Meracus Monrio, Neat, P.A.D., Siemel Silver Sounds, Stands Unique, System Audio, Triangle UKD Opera, Unison Research, Yamamura-Churchill, YBA. And much more arriving soon, specialising in home demo's. Please phone for more information or friendly chat. All usual facilities. Input for the pleasure of music

**DOUG BRADY HI-FI** Kingsway Studios, Kingsway North, Warrington, WAI 3NU Tel: 01925 828009 Fax 01925 825773. Visa, Mastercard, Lombard Tricity. 2 dem rooms, home trial; agencies include: Arcam, Tag McLaren, AVI, B&W, Castle, Caspian, Chord Electronics, Exposure, Harbeth, Heybrook, Krell, LFD, Michell, Meridian, Musical Fidelity, Monitor Audio, Naim, Nautilus 800 series, Pink Triangle, ProAc, Roksan, SME, Wilson Benesch, XTC and many more.

**PRACTICAL HI-FI** 88 Bridge Street, Warrington, WAI 2RF. Tel: 01925 632179. See our main entry under Preston, Lancs.

**REPLAY AUDIO CONSULTANTS** Tel/Fax Chester (01244) 401290. Cheshire's alternative hi-fi specialists. Honest advice and personal service. We can demonstrate Alchemist, AVI, Henly, Heybrook, LFD, Michell, Moth, Musical Fidelity, NAD, Neat, Origin Live, Ortofon, Pink Triangle, Royd, Sonneteer, Totem, Trichord. Demonstrations by appointment in Chester or in your own home. Delivery & installation available. Mastercard, Visa, Switch, Delta

**SWIFT HI-FI** St. Annes Parade, Wilmslow. 01625 526213. Aura, B&W, Denon, Kenwood, Marantz, Nad, Pioneer, Rotel, Systemdek, Tannoy, Revolver, J.P.W., M. Short, Mission, Celestion, Technics, Audioblab, Castle. Open 9.30-6. Dem room. No pressure. BADA member.

**CORNWALL**

**SOUNDS PERFECTION** 'Cornwall's most exclusive Audio retailer'. Agencies include: Audiomecca, Analysis, Audio Spectrum, Audionote, Cadence, Harmon Kardon, Impulse, Konnekt Cables, Michell, Ortofon, Parasound, Project, Phylosophy Cables, Rel and SME. Home Demonstrations by Appointment. Tel/Fax: 01326 221372 Mobile 0468 754353

**CUMBRIA**

**MISONS SOUND & VISION** Viaduct House, Victoria Viaduct, Carlisle, CA3 8AN. Tel (01228) 22620. Exposure, Heybrook, Aura, Bang & Olufson, B & W, Castle, NAD, Quad, Rotel, Sony, Sugden, Yamaha, Demo Suite. No apps net. Home trial facilities. Free installation. Service Department Mon - Sat. 9 - 5.30

**PRACTICAL HI-FI** 106 English Street, Carlisle, CA3 8ND Tel: 01228 44792 See our main entry under Lancaster.

**DORSET**

**MOVEMENT AUDIO** 588 Ashley Road, Poole, Parkstone, Dorset BH14 0AQ. Tel: (01202) 730865. Arcam, Audioblab, B&W, Castle, Cyrus, Denon, Kef, Marantz, Meridian, Michell, Micromega, Pioneer, Ruark, Shearpe Audio, 2 Dem rooms. Listen to the available choice and decide at your leisure - no pressure, no obligation. Our staff enjoy music, with our choice of products, you can too! Service Department. Free installation. Home trial facilities. Access, Visa, Amex, Diners Card. Credit facilities available. Open Mon-Fri 10-6. Sat 9-6

**MOVEMENT AUDIO** 336 Wimborne Road, Winton, Bournemouth, Dorset. BH9 2HH. Tel: (01202) 529988/520066 Arcam, B&W, Denon, Kef, Marantz, Meridian, Mission, Pioneer, Sony, Yamaha. Full dem facilities available, also home dem. Friendly expert advice. Service Department. Free installation. Home trial facilities. Access, Visa, Amex. Open Mon-Fri 9-5.30

**DAWSONS OF WESTBOURNE** Home Cinema Specialists. Main agents for Bang & Olufsen, Harman Kardon, JBL, REL, Mordaunt Short, Sony, Technics and TDL. Demonstration facilities include our unique Dolby pro-logic system comparator for the ultimate way to choose the perfect system. Also on demonstration large screen televisions from Thomson, sony and Ferguson with video projectors from Sharp and Seleo. Dawson's, 23 Seamoore Road, Westbourne, Bournemouth 01202 764965

**SUTTONS HI-FI** 18 Westover Road, Bournemouth, Dorset. Tel: 01202 555512. You will find the very latest in superb Hi-Fi facilities with stocks to include: Arcam, Cabledtalk, Celestion, Denon, DTS, Kef, Linn, Marantz, Meridian, NAD, Pioneer, QED, Rotel, Sennheiser, Sony, Sound Organisation, Tag McLaren, Target, Teac, Technics, Yamaha, and many more. If you're serious about Hi-Fi you've probably heard of all these brands and probably heard of Suttons too! We've been around for over 45 years. Please call for expert knowledge and friendly advice.

**WEYMOUTH HI-FI** 33-35 Maiden Street, Weymouth, Dorset DT4 8BA. Tel (01305) 785729. Arcam, Aura, B&W, Denon, Kenwood, Marantz, Micromega, Musical Fidelity, Panasonic, Quad, Sony, Technica, Yamaha. Dem room. Friendly professional advice. Only quality hi-fi dealer in Weymouth area. Service Department. Free installation. Home trial facilities. Access, Visa, Amex, Switch, Delta Mastercard. Interest free credit. Instant credit. Open Mon-Fri 9.30-5.30 Sat - 9.30-5.30

**ESSEX**

**GRAYSTON SOUND & VISION** 33 Sir Isaac's Walk, Colchester. (01206) 577682. Akai, Arcam, B&W, Boston Acoustics, Denon, Grundig, Infinity, Kef, Linn, Loewe Opta, Meridian, Nokia, Philips, Pioneer, Quad, Rotel, Ruark, Sennheiser, Spondor, Thorens. Superb demo rooms, free regional delivery and installation. Regular musical and surround evenings, home demonstrations. Excellent credit facilities.

**GLOUCESTERSHIRE**

**THE RIGHT NOTE - BATH** For specialist advice and home demonstrations. See Bristol & Bath.

**HAMPSHIRE**

**HAMPSHIRE AUDIO LTD.** 2-12 Hursley Road, Chandlers Ford, Hants, SO53 2FU. Tel Southampton (01703) 252827/265232. 3 Hi-Fi and 2 Home Cinema/Dolby Surround Sound Demonstration Rooms, one with Projection TV and an 8' wide screen. Brands stocked include ARCAM (incl. Xeta), Audioblab, Audioquest, Celestion, Cyrus, Denon, Gradient, Infinity, Kef, Marantz, Meridian, Mission, Polk, Quad, Rotel, Seleo, Sennheiser, Soundstyle, Tannoy, Target Audio, Thorens, & Yamaha. Established 1969, we offer a 2-year Guarantee covered by our own well-equipped Service Dept. We have a large FREE car parking facility and we are located within 3 miles from Junction 14 (M3/M27 Interchange) and Junctions 13 (M3) and 5 (M27). Closed Mondays, except in December. Late Night: Thurs to 8pm. BADA Founder Member. All deposits fully covered by BADA Bonding.

**NOW THATS HI-FI** 32 Arundel Street, Portsmouth Tel: (01705) 811230. Pioneer, Yamaha, Marantz, Kenwood, Mission, TDL, REL, Attacama and much more. Laserdisc and AC3 specialists. Accessory center at 24 Arundel Way, Portsmouth. Tel: (01705) 811618

**SOUTH COAST SPEAKERS Ltd** 326 Portsmouth Road, Southampton, Hampshire. Tel: 01703 559312. Hand made Loudspeaker Systems! Tailored to your individual tastes. Many real wood veneers. Any colour finish available. U.K. suppliers of Driver Units for: SEAS, VOLT, MOREL, VISATION, RCL, SCAN-SPEAK & MORE. Home builder kits always on demo. High quality accessories/components, comfortable listening area, ample free parking, friendly advice.

**HEREFORDSHIRE**

**ENGLISH AUDIO** 37 Whitecross Road, Hereford, HR4 0DG. (01432) 355081. Arcaydis, Harman, A.T.C., B&W, Castle, Cyrus Centre, Denon, Dynaudio, Heybrook, Kef, Marantz, Mission, Musical Fidelity, Naim, ProAc, Pink Triangle, Pioneer, Quad, REL, Rotel, Ruark, John Shearpe, Stax, Tag McLaren, Tannoy, Teac, Yamaha. Single speaker dem room, home trial facilities, free installation, service dept, Access/Visa, Credit arranged. Open Mon-Sat, 9.30-5.30pm. BADA members.

**HERTFORDSHIRE**

**ACOUSTIC ARTS LTD** 101 St. Albans Road, Watford, Herts. Tel: (01923) 245250. Fax: (01923) 230798. Audio Research, B&W, Boston, Castle, Celestion, Chord, Copland, Denon, Densen, DPA, Jadis, Kef, Krell, Marantz, Martin Logan, Michell, Micromega, Rel, Roksan, Ruark, SME, Sonus, Faber, Theta, Thorens, Wilson. 4 demonstration rooms. Purpose built AV studio. Credit available. 100 yards from Watford Junction station. Open Tues-Sat 10-5.30 (Thursday open by appointment until 8pm).

**AUDIO FILE (THE)** 27 Hockerill Street, Bishops Cleeve, Herts. Tel. (01279) 506576. Please see main ad under Cambridgeshire.

**AUDIO FILE OBJECTIVE** 37 Tower Centre, Hoddesdon, Hertfordshire, EN10 8UD. Tel: 01992 478666 Fax 01992 440431. Selected British and specialist brands. New, Ex-dem, and S/H. Mail order Hi-Fi Purchased. Free Parking.

**DARBY'S OF ST. ALBANS.** 6 Market Place, St Albans, Herts. Tel: (01727) 851596. Hertfordshire's premier Hi-Fi/Audio Visual specialists established 1946. Full Home Cinema demonstration suite. Whether your needs are large or small, we stock it all; Arcam, Yamaha, Quad, Denon, Sony, Bang & Olufsen, Pioneer, REL, Kef, Mission, Ruark, Celestion, Polk, and many more. Free planning service. Free Delivery and basic installation. Full workshop facilities. Open 9-6 Mon-Sat.

**dial-a-dealer**

**KENT**

**ASHFORD SOUNDCRAFT HI-FI 40** High Street, Ashford. Seeking music lovers, male or female, any age, to share common interest in musical Pro-aktiv Hi-Fi Systems, Multi Room of Home Cinema. Attractive unusual equipment in unusual setting, your place or ours, we guarantee lasting pleasure. Open Mon-Sat. Appointment Service or just pop in. Tel (01233) 624441

**DOVER HI-FI 43** High Street, Dover. Tel: 01304 207562. Suppliers of quality hi-fi equipment including; Arcam, Akai, B&W, Denon, Jamo, Mordaunt Short, NAD, Panasonic, ProAc, Quad, Rotel, Ruarc, TDL, Technics, Tannoy. Part exchange. Listening room. Service and repairs. Credit facilities. Access/Visa. Open 6 days 9-5.30.

**THE LINN STUDIO** Sondek LP12\* knekt\* Karik\* Kairn\* Klout\* Kremlin\* Keltik\* Kaber\* Kelledh\* Numerik\* Tukan\* Wakonda\* Majik\* Mimik\* LK100\* Ekos\* Kudos\* Arkiv\* Brilliant\* Lingo\* Valhalla\* Sekrit\* Aktiv\*...Dream systems for everyone from £2,000 to £30,000+. A new dealership from a specialist family business, established in 1948. Outstanding service and facilities. Multi-room specialist. 123 Snargate Street, Dover, Kent. CT17 9AP. Tel: 01304 201525, Fax: 01304 240135.

**KIMBERLEY HI-FI 193** Broadway, Bexleyheath, Kent. Tel. 0181 304 3272. Sep dem rooms, Denon, Technics, Kenwood, AiW, NAD, Dual, Wharfedale, Mission, Marantz, Tannoy, Castle, Monitor Audio, Heco, Jamo, Cerwin Vega and many more.

**PROGRESSIVE AUDIO 2**, Maryland Ct, Rainham, Kent, ME8 8QY. Tel. 01634 389004. Agencies include: Audio Innovations, Audion, Audionote, Audio Mecca, Audio Systems, Audio Static, Audio Technica, Chord Amps, Cogan Hall, Conrad Johnson, Convergent, Denson, Goldring, Impulse, Koetsu, Levinson, LFD, Lyra, Moth, Nordost, Origin Line, Pink Triangle, Proac, SD Acoustics, Silversounds, SME, Sugden, Sumiko, Systemdek, Snell, Target, TDL, Transfiguration, Townshend, Tube Technology, Unison Research, UKD., Voyd, VPI, etc. Dens by appointment.

**UNILET SOUND & VISION 24-26** Union Street, Maidstone, Kent. Tel. (01622) 676703. Fax (01622) 676723. The best place in town for Hi-Fi and Home Cinema. \* Three superb dem rooms \* Interest Free Credit \* All leading brands \* Also Open Sundays 10 - 4.00pm.

**LANCASHIRE**

**CLEARTONE 235** Blackburn Road (1/2 mile from city center on the A 666 Blackburn Road) Bolton, Lancs BL1 8HB Tel: (01204) 531423. Bolton's biggest Hi-Fi superstore. Every top brand & all the best buys at guaranteed unbeatable prices. Aiwa, Akai, Arcam, Audioblab, B&W, Bose, Castle, Celestion, Denon, Hitachi, Infinity, JBL, JVC, KEF, Kenwood, Marantz, Meridian, Mission, Mordaunt Short, NAD, Panasonic, Pioneer, Rotel, Sony, Tannoy, TDL, Technics, Toshiba, Yamaha. 2 dedicated Hi-Fi Demo rooms and 2 A/V Demo rooms, no appointments necessary. Service department, free installation, home trial facilities, free parking, Access, Visa, Amex, Diners. Interest free credit. Open Mon-Wed 10.00-6.00. Thurs-Fri 10.00-7.00. Sat 9.00-6.00. Sun 11.00-5.00

**MARTON MUSIC 5** Masterson Ave. Read, Burnley, BB12 7PL for audition of the best stereo and surround sound equipment from BRYSTON (20 yr guar.), MYRYAD, PMC, RUARK, YAMAHA, and the latest WILMSLOW-HART electronics, in a comfortable demonstration room through commercial and custom-built speakers including Transmission Line, Open Baffle and Reflex designs. Home demos encouraged for complete satisfaction. Also main agent for Liberty Audiosuite loudspeaker/audio measurement system, ETF4.0 room measurement system and LspCAD room/box design/crossover package. Call Tony Seaford anytime for an appointment, a chat or free advice on 01282 773198 (fax 776413), or e-mail 106505.251@compuserve.com.

**ORPHEUS AUDIO** Tel: 01257 473175 See our main entry under Greater Manchester.

**PRACTICAL HI-FI 43** Friargate, Preston. Tel:- 01772 883958. The audio visual specialist, expert advice, instant demonstrations, best prices, instant free credit, part exchange welcome. Extended warranty. Stockists of Yamaha, Castle, Teac, NAD, Lexicon, Arcam, Kenwood, Denon, Sony, Technics, Onkyo, Marantz, Pioneer, Mission, Kef, Celestion, B&W.

**PRACTICAL HI-FI 84** Penny Street, Lancaster, LA1 1XN Tel:- 01524 39657 - See our main entry under Lancaster.

**PRACTICAL HI-FI 33/35** Knowsley Street, Bolton, Lancs Tel:- 01204 395789 - See our main entry under Lancaster.

**PRACTICAL HI-FI 81** Whitegate Drive, Blackpool, FY3 9DA Tel:- 01253 300599. See our main entry under Lancaster.

**ROMERS HI-FI, 94-96** High Street, Rishton, BBL 4LQ. Suppliers of quality hi-fi equipment including: Linn, Arcam, Cyrus, Quad, Yamaha, Mission, Ruark, Sony, Monitor Audio, NAD, Onky, Bose, Castle, Nordost, Straightwire, Panasonic, Pioneer, Loewe, TDL, JVC, Target, Stands Unique. Specialists in multiroom installations. Access/Visa/Switch. Credit facilities. Open 9.00 - 5.30 Mon-Sat (5.00pm Wed & Sat). Tel: 01254 887799 Fax: 01254 878666

**LEICESTERSHIRE**

**ZOUCH AUDIO** Suppliers of quality Hi-Fi, Apollo, Audio Analogue, AVI, Bow Technologies, C.A.T., Celestion, Chord Electronics, Creek, D.C.S., Dyalab, Graham, John Shearn, L.A.T., Lumley, M.I.T., Magnum, Munrio, Musical Fidelity, Musical Technology, Neat, Opera, Orchid, Orelle, Sirius, Stands Unique, Sumiko, Teac, Tice, Townshend, Transfiguration, Unison Research, Wilson Benesch, X.T.C. Open 10.00-5.30. Closed Monday. Zouch Audio, The Old Coach House, off South Street, Ashby De La Zouch, LE65 1AN. For further information call Michael on 01530 414128 or 0976 571875

**CYMBIOSIS 6** Hotel Street, Leicester, LE1 5AW. Tel: (0116) 2623754. Email: sales@cymbiosis.com. Arcam, Acoustic Energy, Cable Talk, Castle, Chario, Chord Company, Denon, Linn Hi-Fi, Linn Knekt, Loewe Televisions, Lutron Lighting, Musical Technology, Naim, Nordost, Projekt Furniture, Rega, Revox, Rotel, System Audio, Tag McLaren, and Wadia. Multi room design & Installation Service. 4 listening lounges, Installation Service, Finance Available. Open 10-5.30 Monday to Saturday.

**LEICESTER HI-FI 6** Silver Walk, St Martins Square, Leicester LE1 5EW. Tel: (0116) 2539753. Fax: (0116) 2626097. Arcam, B&W Nautilus, Mission, Cyrus, Marantz, Pioneer, Quad, Tannoy, Copland, Pink Projects, Michell, Technics, Rotel, Rogers, Yamaha, Acoustic Energy, Chord Electronics, Teac, Miller & Kreisel, DPA, Talk Electronics, Greig Loudspeakers, E.T.C. 4 Listening areas over 3 floors. We can demonstrate, deliver and install. Including A.V. and Multiroom. Credit Facilities. All cards taken, open 6 days 9.30-5.30.

**STEREO SHACK 1-3** Guildhall Lane, Leicester. Tel: (0116) 2530330. Fax: (0116) 2626097. Yamaha, Kenwood, NAD, Mission, Teac, Aiwa, Cerwin Vega, Pioneer, TDL, Thorens, JBL, Rotel, Celestion, Jamo & many more. We are A.V. specialists, 2 dem rooms. We can demonstrate, deliver and install. Credit facilities and all cards taken. Open 6 days 9.30-5.30

**LONDON**

**AUDIO CONCEPT 27** Bond Street, Ealing, W5 5AS. Tel: (0181) 567 8703. Audioblab, Audio Analogue, Aura, B&O, B&W, Boston Acoustics, Cable Talk, Denon, Epos, Infinity, Ixos, KEF, Marantz, Mission, Musical Fidelity, NAD, Nordost, Quad, Rotel, Ruark, Roksan, Straight Wire, Sonic Link, Target, Teac, Thorens, Van den Hul. Two dem rooms. Interest free credit, free local delivery & installation, service department. 'Hi-Fi Specialists without the attitude'. Visa, Mastercard, Switch.

**BABBER ELECTRONICS SERVICE CENTRE** 158 Uxbridge Road, West Ealing, London, W13 8SB Tel. 0181 579 6315 Akai, Aiwa, A&R, Celestion, Dual, Goodmans, Harman Kardon, JBL, JVC, Kenwood, Marantz, Panasonic, Sennheiser, Sony, ES range, Tannoy, Technics, Wharfedale, Yamaha and many more. Auth. Service Dept. Credit Facilities, Open 10.30 - 5.30 Mon-Sat.

**BILLY VEE SOUND SYSTEM 248** Lee High Road, Lewisham, London SE13 5PL. Tel: 0181 318 5755/0181 852 1321. Arcam, Denon, Marantz, Linn, Mission, Naim, Tag McLaren, Pioneer-DVD, Rega, etc. 2 domestic style listening lounges. Appts required, service dept, home trial facilities. Interest free credit. Access, Visa, Amex cards accepted. Opened Mon-Sat 10-6.30, Closed Thursdays.

**CHOICE HI-FI** Tel. 0181 392 1959. Specialist dealers in high end quality second-hand equipment. All main brands in stock including Krell, Audio Research, Wadia, Mark Levinson, Sonus Faber, Linn, Naim, SME & many more. Generous price given on trade-in. Part exchange welcome. Also dealers for Trichord, SME, Gamma, Trilogy, Lumley, Boulder & many more.

**INFIDELITY 9** High Street, Hampton Wick, Kingston-upon-Thames. Tel: (0181) 943 3530. for full details see entry under SURREY

**HIFI EXPERIENCE 227** Tottenham Court Road, London W1. 0171 580 3535. Arcam, Audioblab, Mission, Cyrus, Quad, Celestion, Kef, Meridian, Rogers, Tannoy, Yamaha, TDL, Thorens, Marantz, Nakamichi, Musical Fidelity and many more. Open 10.00-7.00 Mon-Fri. 9-6 on Sat. Service dept, Credit facilities, delivery and free installation.

**K J WEST ONE 26** New Cavendish St., London W1M 7LH. 0171 486 8262/63. Fax 0171 487 3452. Two hi-fi & two home cinema dem studios. Appts pref. Home trial. Installation by arrangement. Service dept. Major credit cards. Interest free credit on selected items. Major brands stocked: Arcam, Audio Alchemy, Audion, Audioblab, Audio Research, B&W Castle, Chord, Copeland, DPA, Epos, Graaf, Harbeth, KEF, Klipsch, Krell, Lexicon, Marantz, Martin Logan, Meridian, Michell, Micromega, Mission, Musical Fidelity, Nitty Gritty, Pink, ProAc, Quad, Rel, Rotel, Orelle, Sonus Faber, Stax, Tannoy, Theta, Unison Research, Wilson Benesch. Open 6 days.

**THE LISTENING ROOMS 161** Old Brompton Road, London SW5 0LJ. (0171) 244 7750/59. Fax (0171) 370 0192. Linn, Quad, Meridian, Nakamichi, Arcam, Audioblab, Acoustic Energy, SME, Audio Research, Krell, Wadia, Theta, Apogee, Martin Logan, Pioneer, Tannoy, Systemdek, Stax, Pink Triangle, Michell, Monitor Audio, Yamaha, Marantz, KEF, Bose, Celestion, Epos, Mission, Denon, Neat Petite. Mon-Sat 10-6pm.

**ORANGES AND LEMONS 61-63** Webbs Road, Battersea, SW11. Tel: 0171 924 2040. Juicy fruit from London's freshest Hi-Fi / Home Cinema retailer, now in our second year. Telephone demonstrations, or just pop in. All the usual, i.e. friendly and efficient service, free home installation, credit cards, 0% credit finance available (subject to status), plus...all the very best from Arcam, Cable Talk, Castle Acoustics, The Chord Co., Denon, Epos, Kef, Marantz, Micromega, NAD, Naim Audio, Neat, Quad, Rega, Roksan, Rotel, Royd, Ruark, Soundstyle, Stands Unique, Yamaha and more.

**THOMAS HEINITZ LTD 35** Moscow Road, Bayswater, London, W2 4AH. Tel: 0171 229 2077. Fax: 0171 727 9348. Nearest tube stations are Queensway and Bayswater. Plenty of parking meters available. Demonstration room available by appointment. Stockists of B&O, NAIM, REGA, Micromega, Cyrus, Denon and Epos. Payment Via, Access, Visa, Cheques, Cash and interest free credit facilities (details on request.) Open 10.30am-6.00pm, Tue-Sat.

**TIME & TUNE** For T.V, video, Hi-Fi, and in-Car Hi-Fi. We are dealers of: Aiwa, Bose, Hitachi, Jamo, Kenwood, Marantz, Mitsubishi, Nad, Panasonic, Pioneer, Sony, Technics. For these and more come and see us at Time & Tune, 218-220 Whitechapel Rd, London, E1 1BJ. Or call 0171 377 2000.

**UNIQUE AUDIO** Tel: 0181 4507384. Specialists in our field of high end, high Fidelity Audio Products incl: Audiosynthesis, LFD, VPI, Audiophysics, Yamayuru, Pink Triangle, QLN, Townsend, Credo, XLO, Rockport, Mell, Impulse to name just a few! We are also valve and vinyl experts and can offer ex-dem and 2nd hand equipment too. 9.00am-7.00pm Mon-Sat.

**GREATER MANCHESTER**

**AUDIO COUNSEL, 14** Shaw Road, Oldham, OL1 3LQ. Tel (0161) 633 2602 Fax (0161) 633 2502 Linn, Naim, Rega, Arcam, Rotel, Royd, Mission, Micromega, Marantz, Shahinian, Celestion, Nakamichi, Dynavector. Free installation. Record Club. Major credit cards and credit facilities. Open Tuesday-Saturday 10.00- 5.30, 8pm on Thurs

**ORPHEUS AUDIO...Passion for Total Fidelity... Authorised Dealer for Acoustic Precision, Art Audio, Audio Analogue, Audiomeca, Audio Physic, Audio Synthesis, Boulder, Burmester, Cabasse, Conrad Johnson, Croft, DPA, E.A.R., Electrocompanion, Forsell, Gamma Acoustics, Golden Tube, Graaf, Klipsch, Living Voice, Lowther Voigt, Magnum, Meracus, OCM, Oracle, Orelle, Ortofon, Papworth, Project, Pentachord, Pink Triangle, Purist, QED, Sequence, Stax, Teac, Triangle, Trichord Research, Totem, Unison Research, VPI, Yamamura Churchill, YBA and others. Free delivery/installation. Call for list of part ex. bargains. Demonstrations by arrangement in Standish (J27 of the M6), or in your own home without obligation. Tel: 01257 473175 (evening calls welcome).**

**PRACTICAL HI-FI 65** Bridge Street, Manchester M3 3BQ Tel:- 0161 839 8869 See our main entry under Lancaster

**SWIFE OF WILMSLOW, 4-8** St. Annes Parade Wilmslow, Tel (01625) 526213. Aura, B&W, Denon, Kenwood, Marantz, NAD, Pioneer, Rotel, Tannoy, Revolver, JPW, Open 9.30-6.00pm. 2 dem. rooms. No pressure!

**MERSEYSIDE**

**ACOUSTICA 17** Hoole Rd., Chester CH2 3NH Tel: 01244 344227. See our main ad under Cheshire.

**MIDDLESEX**

**MUSICAL IMAGES 45** High Street, Hounslow, Middlesex. Tel.(0181) 569 5802. Fax. (0181) 569 6353.

**MUSICAL IMAGES 173** Station Road, Edgware, Middlesex. Tel. (0181) 952 5535. Fax. (0181) 952 5535. Most brands available - see full page advert. Interest free credit, ask for details. Demo rooms. Repairs & Service. Sunday opening - Open all week. A Home Cinema Specialist. Mail order. Part exchange.

**OPAL DESIGNS LTD.** Rockware Business Centre, 5 Rockware Avenue, Greenford, Middlesex, UB6 0AA. Tel: (0181) 930 7972. Fax: (0181) 930 7976. Email: jas@opal.co.uk. Home Page: www.opal.co.uk. High-end Audio & Home Theatre Consultants. Authorised dealers: Mark Levinson, Proceed, Linn Hi-Fi, Linn Knekt, Runco Projectors, Faroudga, Stewart Film Screen, Revel Loudspeakers, Stax, Wilson Audio, Martin Logan, Sonus Faber, MIT, Transparent, B & W. Mail order welcome. Credit cards accepted. Phone for latest brochure.

**RIVERSIDE HI-FI 422** Richmond Road, East Twickenham, Middlesex, TW1 2EB. Tel: 0181 892 7613 Fax: 0181 892 7749. www.riversidehifi.co.uk Arcam, Bose, B&O, Castle, Copland, Denon, Krell, Marantz, Martin Logan, Michell, Monitor Audio, Musical Fidelity, NAD, Pioneer, Project, Rel, Sonus Faber, Sony, Tag McLaren Audio, Tannoy, Teac, Theta, Wilson. Finance available. Subject to status. Written details available on request. Export orders welcome. UK mail order available. 3 demonstration rooms. All major credit cards. Open 10am-5.30pm Mon-Sat.

## NORFOLK

**BASICALLY SOUND** The Old School, School Road, Bracon Ash (Nr Norwich), Norfolk, NR14 8HG. Tel: (01508) 570 829. Stockists of the following leading Hi-Fi: Arcam, Audio Analogue, Beyer, Denon, Dynavector, Epos, Grado, Naim, ProAc, Rega, Royd, Sennheiser, Talk Electronics, Teac and more. Bada members, 2 comprehensive demo rooms.

## NORTHAMPTON

**CLASSIC HI-FI** At Classic Hi-Fi we cover the best in quality sounds. Be it a question of taste, a question of balance or a question of price, we're the ones to help. We stock: Marantz, Nad, Pioneer, Roksan, Yamaha, Heybrook, LFD, Sugden, Rotel, Kenwood, B & W, Kef, Rogers, Monitor Audio, Musical Fidelity, Tannoy, Shearman Audio, Royd, Audio Alchemy, Teac and many more. For more details call: 01536 310855

**LISTEN INN** 32 Gold Street, Northampton, NN1 1RS. Tel: (01604) 637871 Making Music with help from Linn, Naim, Rega, Myryad, Arcam, Denon, Rotel, Yamaha, Marantz, Castle, Shahinian, Epos, KEF, Mission, Tannoy, Chord Company, Cable Talk, Dynavector, Sumiko and others. 2 listening rooms, Open 10am-5.30pm (closed Thursday).

## NOTTINGHAMSHIRE

**CASTLE SOUND & VISION** 48-50 Maid Marian Way, Nottingham, NG1 6GF. Tel: 0115 958 4404. Nottingham's leading hi-fi, multi room and home cinema store, serving the whole of the East Midlands. Brands stocked include: Alchemist, Audio Valve, Bose, Boston Acoustics, Castle Acoustics, Chord Electronics, DMP, Denon, Jolida, KEF, Klyne, Linn, Linn Knekt, Lexicon, Loewe, Monarchy, Musical Fidelity, Naim, Nordost, Pink Triangle, Pioneer, Project Turntables, Precious Metals, REL, Rega, Revox, Selec Projectors, Sheffield Lab, Solidsteel, Sony, Stand Uniq, Stereophile, Talk Electronics, TEAC, Wavac, Wilson Benesch and XLO. Large showroom including purpose built home cinema room as well as three demonstration rooms. Home demonstrations and a full installation service available, including multiroom systems. Open 10.00 am - 6.00 pm Tuesday, Thursday, Friday and Saturday; 11.30am - 7.30pm Wednesday. Appointments out of normal shop opening hours can also be arranged.

**NOTTINGHAM HI-FI CENTRE** 120-122 Alfreton Road, Nottingham. Tel: 0115 9786919. Multi-room specialists. Hi-Fi, Home cinema. All leading brands stocked. Three superb demonstration areas. Two year parts and labour guarantee. Home trials. On site service facility. Full delivery and installation service. Easy free parking. BADA Dealer. Established 1968. Mon-Sat 9.00-5.30

## OXFORDSHIRE

**HI-CAM** Buy/Sell Part Exchange. Good Quality Audio Products. Equipment includes: Naim, Linn, Audiolab, Kef, Mission, Krell, Meridian, Rel, Epos, Also Prologic Equipment. Open Mon-Sun 10.00am - 8.00pm. For genuine & friendly service Tel. Fax 01844 260182 Mobile 0973 233380.

**OVERTURE HI-FI**, 3 Church Lane, Banbury, OX16 8LR. Tel: (01295) 272158. Email sales@overturehifi.demon.co.uk. Arcam, Bose, B&W Solid, Denon, KEF, Linn Products, Miller and Kreisel, Mission, NAD, Naim Audio, Yamaha. For sensible unbiased advice, call Oxfordshire's audio experts. Superb demo facilities. No appts. necessary, service dept. free install, home trial. Access/Visa, instant credit. Mon-Fri 10-6, Sat 9.30-5.30.

## SHROPSHIRE

**ADAMS & JARRETT** Hi-Fi and Home Cinema Specialist. Phone or visit us at 6-18, Norman Road, St. Leonards-on-Sea, E.Sussex. (01424) 437165/432398. Stockist of quality equipment including: Audio Innovations, Meridian, KEF, Ruark, Marantz, NAD, JBL, Royd, Dali, Jamo, Onkyo, Rel, Traget, Cable Talk, Technics, TDC, Yamaha, Kenwood. Air

conditioned listening rooms, on site service and repair facilities

**SHROPSHIRE HI-FI** St Michael Street, Shrewsbury, Shrops. SY1 2ES. Tel. 01743 232065. Stockists of Musical Fidelity, Mordaunt Short, Sony, Kenwood, Pioneer, Rotel, Denon, B&W, Proac. Audio Visual. Products available. Open 9.30 - 5.30pm Mon-Sat.

## SOMERSET

**SOUTH WEST ANALOGUE** Quality British and European Hi-Fi. SME specialist, Mk 2 turntable on demonstration. Michell, Garrard, Project, Ortofon, Tube Technology, Tesserac, Castle, Ensemble Cables. 01643 851351 anytime.

## STAFFORDSHIRE

**SOUND OF MUSIC** The alternative Hi-Fi shop. 01270 214143. A.K.G., A.V.I., Alchemist, B.C.D., Blueprint, Castle, Chord Co., Deva, Dynaudio, Dynavector, Electrocompaniet, John Shearn, Kef, Lexicon, Linn, Loewe, Michell, Myryad, Nordost, Ortofon, Project, Projekt Stands, Q.L.N., Restek, Roksan, Stands Unique, Teac.

## SUFFOLK

**AANVIL AUDIO**, Tel/Fax 01359 240687 Mobile 0467 404874 Music from the Sound Foundry! Suppliers of: [Audio Physic]: loudspeakers, Adyton: amplifiers, Meracur: CD transports, players, DAC's pre and power amplifiers, Yamamura Churchill: cables and accessories, ART: Accessories Mail Order Accessories/CD's Cable/Amp Stock Clearance: Phone or fax for further details and ex-demo hardware offers. Most major credit cards accepted

**ANGLIA AUDIO** The Street, Hesseset, Bury St Edmonds, Suffolk, IP30 9AZ. Tel. 01359 270212. "Hi-Fi and speaker centre dedicated to quality hi-fi since 1971. Open 10-6. Closed Weds and Sundays. Evening and Sunday Demos by appointment.

**AUDIO IMAGES** 128 London Road North, Lowestoft, Suffolk, NR32 1HB. Tel: 01502 582853. Arcam, Accurus, Castle, Rotel, Moth, Triangle, QTA, Sugden, Denon, Yamaha, Mirage, M & K, Definitive, Musical Fidelity, plus the incredible Rothwell range. Refreshingly different selection. Dem Room, Professional AV installer's from budget to high end. Full credit facilities. 9.30 to 5.30 Mon & Sat - 9.30 to 6.00 Tues to Fri.

**EASTERN AUDIO** 41 Bramford Road, Ipswich, Tel. 01473 217 217. Fax 01473 215705. Quad, Arcam, Audiolab, Meridian, Mission, Denon, Rotel, Marantz, NAD, Sony, Rogers, Nakamichi, Systemdek, Technics, Celestion, B&W, Tannoy, Morel Thorens and Top Tape. Also stock a wide range of accessories. usual credit facilities. A BADA dealer.

**STOWSOUNDS** audio consultants, Stone Farm, Borough Lane, Great Finborough, Stowmarket. Tel: 01449 675060. We offer genuine impartial advice and demonstrations of quality audio equipment, racks and accessories. Demonstration by appointment here or in your own home. Some ex-demo and second-hand equipment. Phone for a consultation, demonstration, or price lists and product information.

## SURREY

**INFIDELITY** 9 High Street, Hampton Wick, Kingston upon Thames, Surrey. KT1 4DA. Tel. 0181 943 3530. Stockists of: Arcam, Creek, Epos, Linn, Meridian, Naim Audio, Nautilus 800, Neat, Rega, Rotel, Royd, Shahinian, Stax, Yamaha. Open Tues - Saturday, 10.30am - 7.00pm.

**SPALDINGS HI-FI** 352-4 Lower Addiscombe Rd., Croydon, Surrey, CR0 7AT. 0181 654 1231/2040. 3 dem rooms and home demo. Free installation/credit. Meridian, Linn, Naim, Quad, Arcam, Audiolab, Mission, Denon, Tannoy, Marantz, Ruark. Mon-Sat 9-6, Tues 9-8. Service dept. (3 Dem rooms incl. A.V. 0% credit).

**UNILET SOUND & VISION** 35 High Street, New Malden, Surrey. Tel (0181) 942 9567 or Fax. (0181) 336 0820. Six superb dem rooms, Interest free credit on all leading brands \* Also Open Sundays 10 - 4.00pm.

## SUSSEX (EAST)

**ADAMS & JARRETT** For the best Audio Visual Specialist with friendly helpful staff phone or visit us at 6-18 Norman Road St. Leonards-on-sea, East Sussex. Tel. 01424 437165/432398. Meridian, Kef, Ruark, JBL, Marantz, NAD, Dali, Jamo, Onkyo, Rel, Target, Technics, Yamaha, Kenwood, Musical Fidelity, Dynaudio, Denon, Tannoy, B&W, Rotel, Thorens. Interest free credit available subject to status. Visa, Mastercard.

**THE POWERPLANT** "Brighton's Leading HiFi Shop", 66 Upper North Street, Brighton, Tel. 01273 775978. Fax. 01273 748419. Email@powerplant.co.uk. Open 10am-6pm Tues-Sat. Comfortable listening rooms. Experienced and friendly staff. ATC, Arcam, B&W, Cyrus, Rega, Linn, Pro-Ac, Tag McLaren, and much more.

## SUSSEX (WEST)

**AUDIO DESIGNS** 26 High Street, East Grinstead, West Sussex RH19 3AS. Tel/Fax (01342) 314569. Hi-Fi, Home cinema + multi room specialists. Authorised specialists of: Arcam, Audiolab, Castle, Cyrus, Epos, KEF, Linn (inc AV51), Marantz, Mission, Naim, Pioneer (inc LaserDisc), Quad, Rel, Rotel, Sony, Soundstyle, Stands Unique, Target, Thorens, Yamaha & more. 3 dedicated demonstration rooms - Hi-Fi & Home cinema. Service dept 0% finance available 9.30-6.00 Mon-Sat. Late by appointment.

## WARWICKSHIRE

**THE LEAMINGTON HI-FI CO** 23a Regent Street, Leamington Spa, Warwks CV32 5EJ. Tel: 01926 888644. Fax: 01926 887486. E-mail: k.browne@bbcncs.org.uk. Arcam, Audiolab, Quad, Meridian, Marantz, Denon, Pioneer, Yamaha, NAD, Micromega, Mission, Kef, Celestion, Atacama, Technics, Trichord, TDL, Rel, Ixos. Single speaker dem room. We do not use any comparators. We also have full demonstration of Projection T.V. with Laserdisc and full Pro Logic systems. Part exchange welcome. Please phone or E-mail for prices. We have in stock over 200 Laserdiscs. Call for our latest catalogue.

**SOUNDS EXPENSIVE** 12 Regent St, Rugby, Warwks CV21 2QF. Tel: 01788 540772. Agents for: Arcam, Audiolab, B&O, Castle, Celestion, Denon, Dual, Kef, Mission, Marantz, Meridian, Pioneer, Quad, Rotel, Sony, Tannoy, Yamaha & many more. 2 year warranty on all hi-fi separates. 2 year demonstration rooms, Home Trials, All Major Credit Cards Accepted, Mail Order Welcome. Ring Now For Keenest Prices. Open Monday - Saturday 9-5.30. Closed Wednesday. If We Haven't Got It It's Probably Not Worth Having.

**STRATFORD HI-FI** 10a Chapel Street, Stratford upon Avon, Warwickshire. Tel: (01789) 414533. Arcam, B&W, Bose, Cyrus, Denon, KEF, Marantz, Micromega, Mission, Monitor, Audio, NAD, Panasonic, Onkyo, Pioneer, Rotel, Sony, Technics, Yamaha. Demonstration room. Service facilities. Mail order, Interest free credit. Open 9.30-5.30 Monday to Saturday. all major credit cards.

## WEST MIDLANDS

**MUSIC MATTERS** Birmingham - 363, Hagley Road, Edgbaston, B17 8DL. Tel. 0121 429 2811. Solihull - 93-95, Hobs Moat Road, B92 8JL. Tel. 0121 342 0254. Stourbridge - 9, Market Street D48 1AB. Tel. 01384 444184. Sutton Coldfield - 10, Boldmere Road, B73 5TD. Tel. 0121 354 2311. Arcam, Alchemist, Apollo, Audioquest, Audio Research, B&W, Cable Talk, Castle, Celestion, Chord, Copland, Cyrus, Denon, DPA, JBL, Kef, Krell, Marantz, Martin Logan, Meridian, Musical Fidelity, Panasonic, Pioneer, REL, Rotel, Ruark, S.M.E., Sennheiser, Sonus

Faber, Tag McLaren, Teac, Theta, Yamaha etc. Classical CD's available at Birmingham only. Demonstration rooms, service and installation. BADA member. VISA / MASTERCARD / AMEX / SWITCH. Open: 10-5.30 Tuesday to Saturday. Late night Thursday till 7.00 (not Stourbridge).

## FRANK HARVEY HI FI EXCELLENCE

163 Spon Street Coventry. Tel: 01203 525200 Fax: 01203 631403 Audiolab - Audio Alchemy-Atacama Aura - Arcam - Audio Quest - Alphonson - Apollo - Bang & Olufson - Bose - Castle - Canon - Cable Talk - Celestion - Chord - Cyrus - Denon - Dual Foundation - Heybrook - IXOS - Kef Reference - JBL - JPW - Jamo - Kenwood - Laser Disc Marantz - Meridian - Monitor Audio - Micromega - Mission - Michell Gyrodek Monster - Mordaunt Short - Musical Fidelity - Nakamichi - NAD - Ortofon - Onkyo - Panasonic - Pioneer - Polk Audio - Quad - QED - REL - Rega - Revolver - Rogers - Rotel - Royd - Sennheiser - Systemdek - Target - Teac - Technics - Tannoy - Thorens - TDL - Van Den Hul - Wessex - Yamaha Much Much More In Store on 3 Floors 4000 SQ Feet with 3 Dedicated Hi Fi Demo Rooms of the very Best Hi Fi Plus 2 A/V Demo Rooms. Nice staff Nice coffee. Appts Nec. Service Dept. Free Install & Home Trial. All Credit Facilities. Plus Interest Free Credit. Open 9.30am to 5.30pm Monday to Saturday.

**GRIFFIN AUDIO** 94 Bristol St., Birmingham, B5 7AH. Tel. 0121 622 2230 Fax 0121 666 6795. Tues-Sat 10 a.m.-6 p.m. Enjoy music at home with a system from Griffin Audio. We demonstrate and install the very best hi-fi, with systems from £500 to £25 000. Ask for Bob, Tim or Alex. Stockists of Arcam, Denon, Linn, Musical Technology, Naim, Quad, Rega, Shahinian, Stax.

**SOUND ACADEMY** For the Midlands. The Parade, Sutton Coldfield, Tel. 0121 321 2445 & High Street, Bloxwich, Nr Walsall, (sharing the ASDA shopping centre) Tel 01922 493499. Hosts 4 private studios plus a Home Theatre Cinema with Tube & LCD Projectors. The best in hi-fi from Naim, Arcam, Audiolab, Chord, Meridian, Monitor Audio and many more. So... if you've taken time to read this, please let us make you welcome. Phone 0121 321 2445 for Sutton or 01922 493499 for Walsall. Call in and to browse our exciting display of hi-fi and home cinema equipment. Mail order available, interest free credit S.T. Status. Open 6 days, 9am to 5.30pm. Please call for late night. Expert Advice, Cable Dressing and Installation.

## WILTSHIRE

**SALISBURY HI-FI LTD**, 15 Catherine Street, Salisbury, Wiltshire SP1 2DF. Tel (01722) 322169. Arcam, B&W, Celestion, Denon, KEF, Kenwood, Marantz, Meridian, Micromega, NAD, Ruark, Sony, Yamaha, 2 Dem rooms. Friendly, relaxed atmosphere. Professional advice. Home dem available. Service department, Free installation. Home trial facilities. Access, Visa, Amex. Interest free credit. Instant credit. Open Mon-Sat 9-5.30.

**THE RIGHT NOTE** - See under BATH & BRISTOL heading.

## WORCESTERSHIRE

**MAX - MIDLAND AUDIO X-CHANGE** 181 Franche Road, Kidderminster, Worcs. DY11 5AD. Phone: 01562 822236 • Mobile: 0421 605966 • e-mail: john.roberts20@virgin.com Analogue Hi-end specialist • Open Monday to Saturday 9.30 to 6.00 • Part exchange always welcome • Evening demos arranged by appointment • Service facilities • Free delivery. Suppliers and installers of high quality audio systems, including: Audio Note • Basis • BAT • Densen • Dpa • Electrocompaniet • Mark Levinson • Michell • Nagra • Pass • Primare • ProAc • Rega • Revel • Roksan • SPM • Sugden • UKD • Unison Research • Wadia. Access, MasterCard, Visa and Switch.

**YORKSHIRE (EAST)**

**ZEN AUDIO** 35 George Street, Hull Tel. 01482 587397. "Comfortable listening rooms; Home dems; Personal, friendly service; Free installations. Agencies include: Arcam, Audiolab, Atacama, Audio Innovations, Audio Note, Audion, Alchemist, B&W, Cable Talk, Chord CO, DPA, Densen, Denon, DNM, EAR, Exposure, Fi-Rax, Harbeth, Heybrook, Impulse, KAR, KEF, Michell, Micromega, Monitor Audio, Musical Technology, Myryad, NAD, NAIM, Pioneer, REL, Rehdeko, Rotel, Royd, Ruark, Shearpe Audio, Stands Unique, Sugden, Spondor, Sonic Link, TEAC, TDL, Tube Technology, Vivanco and many others.

**YORKSHIRE (SOUTH)**

**HIFI STUDIOS DONCASTER** Hi-Fi Studios. Sunnyfields, Doncaster, DN5 8SA. Tel: (01302) 781387, Fax: (01302) 391193. Alchemist, Audio Analogue, Audio Physic, AudioQuest, Blueprint, Castle, Celestion (A Series only), Densen, Electrocompaniet, Exposure, Harbeth, Impulse Horns, John Shearpe Amplifiers, Living Voice, Michell Turntables, Monitor Audio, Musical Fidelity, Nottingham Analogue Studios, Opera, ProAc, Reel Acoustics Subwoofers, Ruark, Tag McLaren, TEAC, T&A, Unison Research. Home Cinema and multi-room experts. Demonstrations available. Audio Technica, Nordost, Ortofon, Stands Unique, Stax Electrostatics, Goldring, Listening Rooms. Home Trial, Free delivery, and installation. 2 years Guarantee. Access & Visa. 10-8pm Tues - Fri, 10-6pm Sat, Closed Monday. Phone for further information and FREE fact-pack.

**MOORGATE ACOUSTICS** 8 Westgate Chambers, Rotherham Tel: 01709 370666, 184 Fitzwilliam Street, Sheffield Tel: 01142 756048 - Audio Alchemy, Atacama, Arcam, Audio Lab, Audio Quest, Beyer, Bose, Canon, Castle, Cyrus, Celestion, Denon, Jamo, John Shearn (Amplifiers), Linn, Marantz, Mission, REL (Sub Woofers), Rogers (Speakers & Amplifiers), Royd, Sennheiser, Spondor, Tannoy "D", T.D.L., Technics, Yamaha. Demo rooms (6), Home Cinema, Access, Visa, Switch, Interest free credit (details available upon request), up to 5 years guarantee.

**SOUNDWAVE AUDIO** 22 Lord Mayor's Walk, York, YO3 7HA. Tel. 01904 646309. Hi-Fi sales incl. NAD, Onkyo, Dali, Cerwin Vega, Teac, Kenwood, Ortofon, Alchemist, Jamo and many others. In-house workshops for repairs and svcg. on all makes. Dem-room incl. Home Cinema. No pushy sales staff!! Just good equipment and a friendly atmosphere.

**SOUND ORGANISATION YORK**, 2b Gillygate, York YO3 7EQ. Tel (01904) 627108. Carefully chosen Hi-Fi and AV equipment includes Arcam, B&W, Denon, Linn, M&K subwoofers, Naim, Rega, Rotel, Royd, etc 3 dem rooms incl. Home Cinema and Multi-room facilities. Service Department. Home installations. Instant Credit and major credit cards. Closed Mondays. Phone for chat and more details.

**YORKSHIRE (WEST)**

**HUDDERSFIELD HI-FI CENTRE** 4 Cross Church St, Huddersfield. (01484) 544668. B&W, Cyrus, Kenwood, Denon, Rotel, Arcam, Musical Fidelity, Quad, Audio Lab, Marantz, Mission, etc. Dem facilities - appointment reqd. Mon-Sat 9-5.30, Thurs 9-8. Closed Wed. Free installation, credit facilities. Access, Visa

**PREMIER AUDIO** Wakefield (01924) 255045. A brand new company offering a range of exciting Audiophile products carefully selected and professionally demonstrated. Equipment includes Audio Synthesis, Chord Company, Classe, cable Talk, DPA, EAD, Exposure, Harbeth, Kora, Mirage, Myryad, Orelle, Trichord and many others. demonstration facilities, Home demonstrations & Free installation. Part Exchange & used equipment Available. telephone for details and opening offers.

**SCOTLAND**

**CENTRAL**

**COLIN MACKENZIE'S HIFI CORNER** 52 Gordon Street Glasgow 0141 248 2840. Rose St Edinburgh 0131 220 1535, 1 Haddington Place, Edinburgh 0131 556 7901 and 44 Cow Wynd, Falkirk 01324 629011. Audiolab, Cyrus, Sound-Bytes, Meridian, etc. Most major Brands stocked. Free five year guarantee on all loudspeakers, keen prices. JAMES KERR & Co., 145 Bath St, Glasgow 0141 226 5711. Glasgow's oldest established hifi specialist, now at new larger premises.

**LOTHIAN**

**COLIN MACKENZIE'S HIFI CORNER** 52 Gordon Street Glasgow 0141 248 2840. Rose St Edinburgh 0131 220 1535, 1 Haddington Place, Edinburgh 0131 556 7901 and 44 Cow Wynd, Falkirk 01324 629011. Audiolab, Cyrus, Sound-Bytes, Meridian, etc. Most major Brands stocked. Free five year guarantee on all loudspeakers, keen prices. JAMES KERR & Co., 145 Bath St, Glasgow 0141 226 5711. Glasgow's oldest established hifi specialist, now at new larger premises

**MUSIC MILL** 72 Newhaven Road, Edinburgh EH6 5QG. Tel: 0131 555 3963 Fax: 0131 555 3964. Audio Research, Copland, Naim Audio, Krell, Roksan, Rotel, DNM, Marantz, AVI, Martin Logan, Pro-Ac, Wilson Audio, Wilson Benesch Theta Digital, Transparent Audio, Alchemist, Quadraspire, Stands Unique. Listening Rooms, Free Parking, Full Workshop, Delivery and Installation. Open Mon-Sat 10-6.00 pm. Please phone for a map or contact Raoul, John, Mark, or Mike.

**GRAMPIAN**

**HOLBURN HI-FI** 441 Holburn Street, Aberdeen. Tel: 01224 585713. Arcam, Audiolab, B&W, Celestion, Denon, Dual, Epos, Heybrook, ION, Kenwood, Creek, Marantz, Meridian, Mission, Cyrus, M.S., NAD, Nakamichi, Pioneer, QED, Quad, Revox, Rotel, Ruark, Tannoy, Technics, Wharfedale, Yamaha. 9.30-5.30 Mon-Sat.

**STRATHCLYDE**

**COLIN MACKENZIE'S HIFI CORNER** 52 Gordon Street Glasgow 0141 248 2840. Rose St Edinburgh 0131 220 1535, 1 Haddington Place, Edinburgh 0131 556 7901 and 44 Cow Wynd, Falkirk 01324 629011. Audiolab, Cyrus, Sound-Bytes, Meridian, etc. Most major Brands stocked. Free five year guarantee on all loudspeakers, keen prices.

**KEVIN GALLOWAY AUDIO**, Audio Physic, Accuphase, Audion, Basis, DCS, JM Lab, Pink Triangle, Electrocompaniet, Sugden, Nagra, Tara Labs. Nationwide delivery and installation. Demonstration by appointment. Tel: 01563 574185. Fax: 01563 573207.

**JAMES KERR & Co.**, 145 Bath St, Glasgow 0141 226 5711. Glasgow's oldest established hifi specialist, now at new larger premises

**LOUD & CLEAR** 520 St Vincent Street, Finnieston, Glasgow G3 8XZ. Tel: (0141) 221 0221 or visit us at [www.loud-clear.co.uk](http://www.loud-clear.co.uk). Glasgow's finest and friendliest Hi-Fi store, combining knowledgeable advice with specially selected products and the best of service. Three comfortable demonstration rooms, full service and installation facilities, interest free credit on selected products. Product lines include Naim Audio, Exposure, Alchemist, Rega, Tag McLaren, Musical Fidelity, Marantz, Denon, Rotel, Acoustic Energy, KEF, KEF Reference, Monitor Audio, Tannoy, ProAc, VdH, Chord Co., DNM, Ash Design, Stands Unique. Open Mon-Sat 10am-6pm, Thurs till 7pm. Complimentary parking at PC World, Finnieston Street.

**STEREO STEREO** 278 St Vincent Street, Glasgow, Tel: 0141 248 4079 E mail Stereo @ cix. compulink.co.uk We will supply the most musical sound for your budget and if you take the time to visit us we will take the time to return the compliment with free installation of your chosen equipment. Open 10-6.00pm closed Sunday, Tuesday Installation Nationwide Interest free credit available

**WALES**

**NORTH WALES**

**ACOUSTICA** 17 Hoole Rd., Chester CH2 3NH Tel: 01244 344227. See our main ad under Cheshire.

**ACTON GATE AUDIO** 4 Ruabon Road, Wrexham, North Wales, Tel. 01978 364500. See our main ad under Cheshire.

**GLAMORGAN (SOUTH)**

**SOUND DR. JULES SWANSEA**, 01792280 061. Call now for price list, UK or overseas. Hi end new and pre-owned hi-fi at an affordable price. Home trial prior to purchase. Reliable courier service and repair service. Friendly and enthusiastic advice, day or evening seven days a week. A service to suit you.

**IRELAND**

**CLONEY AUDIO** 55 Main Street, Blackrock, Dublin, Tel.2889449/2888477 Fax. 2834887. Products include: Arcam, Classe, Philips, B&W, Naim Audio, Meridian and others. Open Tues/Sat 10am-6pm. Thurs/Fri 'till 9pm Closed Mondays.

**DUBLINN HI-FI** 38 Augier Street, Dublin 2. Tel: (00 353) 1 4785205. Fax: (00 353) 14785219. We all have two ears and one mouth - use them accordingly. We only stock the best products, based on performance and reliability - not reviews or sales patter. Call Mark or drop in for a listen. Three single speaker demo rooms. Free delivery and installation. Full service department. Open Mon-Fri 10-7, Sat 10-6

**VINYL / RECORD MAIL ORDER**

**AUDIOPHILE UK LTD** 214 Station Road, Addlestone, Surrey, KT15 2PH. Specialists in high quality, new and used vinyl & CD. Telephone order: 01932 701248 Fax order: 01932 701162. E-mail order: [sales@audiophile.co.uk](mailto:sales@audiophile.co.uk). Order your copy of our free monthly flyer and get the most up to date information on new releases plus the thousands of mint used LPs we hold in stock. As well as this we stock interconnects, record cleaning materials, isolation feet and many more accessories. Callers welcome by appointment. Hours Mon - Fri 9.30am 5.30pm and occasional Saturdays.

**ABERGAVENNY MUSIC** 23 Cross Street, Abergavenny, S. Wales. NP7 5EW Tel: 01873 853394. 9am - 5pm Monday-Saturday. E-mail: [abermusic@compuserve.com](mailto:abermusic@compuserve.com). All major credit cards accepted. Abergavenny Music is a specialist classical music shop carrying a wide stock of CDs & Tapes. We regret we do not stock vinyl. Please phone for prompt personal service. Any item in stock can usually be posted on same day. First class free p&p. We welcome any enquiry or order.

**DIVERSE MUSIC** 12 Upper Dock Street, Newport, Gwent. NP9 1DF. 9am-5.30pm Mon-Sat. Internet site <http://www.diversemusic.co.uk>. Phone/fax 01633 259661 / 256261. E-mail: [sales@diversemusic.clx.co.uk](mailto:sales@diversemusic.clx.co.uk). Catalogues available. Mastercard, Visa, Amex, Switch, JCB. New and forthcoming releases: Blue Note 180gm LPs - re-issued on 14th April (very limited) also large current and back catalogue stock selection. P&P £1.00 1st LP, additional LPs 50p each (max £3.50) Please contact us for more details and catalogues.

**SILVERNOTE** PO Box 158, Cheshunt, Herts, EN7 6UH Always wanted: Vintage and Modern Equipment, Records & CD's. Tele/fax Steve on 01992 620905.

**VINYL DEMAND** Stockists of VPI record cleaning machines and the widest range of

audiophile vinyl in the UK - at the best prices. Living Stereo, Verve, Mobile fidelity, Decca, Absolute Analogue, Testament, MCA, DCC. Also a vast range of analogue accessories. Phone 01425-654545 or Fax 01425-654400 for orders or catalogues.

**VIVANTE** - Unit 4, 60 High Street, Hampton Wick, Surrey KT1 4DB. Tel: 0181 977 6600. Fax: 0181 977 4445 One of the UK's largest importer and distributor of audiophile and conventional vinyl is now operating a mail order service specialising in jazz and classical reissues. Labels include Decca, London, Deutsche Gramophon, Archiv, EMI, Telefunken, Testament, Verve, MPS, Milestone, Fantasy, Pablo and more. Extensive catalogue available. Access/Visa accepted.

**CHRISTMAS TREAT** - From the region's largest vinyl stockist: Spend £30.00 or more in store, cash or cheque, during December and get a whopping 15% discount. **WOODSTOCK RECORDS**, 22 Heritage Close, St. Albans, Herts AL3 4EB Tel/Fax 01727 846 907. Shop opening Mon 9.30-1.00 \*Tues-Sat 9.30-5.30.

**VINTAGE**

**AUDIO CLASSICS**. Audio Classics / Mellotone Acoustics Co. P.O. Box 67, Wigan, Greater Manchester, WN2 3AG. Tel: 01942 257525. Fax: 01942 525861. Mobile: 0585 476574. E-mail: [mell@tone-u-net.com](mailto:mell@tone-u-net.com). Hi-Fi bought, sold, repaired and renovated. Mail order and vintage specialists. Please see our main ad (look under the ad index to find) for further information.

**EX DEMONSTRATION**

**AFFORDABLE AUDIO** (Northampton) Pre-Owned Hi-Fi Specialists. 168 Wellingtonborough Road, Northampton, NN1 4DU. Tel: ( 01604) 231261/845138. Mobile: (0370) 877893 Urgently required: compact disc collections, hi-fi separates, especially Linn products, Naim Audio, Cyrus Electronics, Musical Fidelity, Quad Electronics, almost anything British/American. Cash waiting, part exchange welcome. We also stock lots of audio accessories, compact discs, vinyl, Naim video recorders, DAT players. Single speaker dem room. All equipment is sold with warranties. All Credit Cards accepted. Please phone anytime for stock update.

**AUDIO CLASSICS**. Audio Classics / Mellotone Acoustics Co. P.O. Box 67, Wigan, Greater Manchester, WN2 3AG. Tel: 01942 257525. Fax: 01942 525861. Mobile: 0585 476574. E-mail: [mell@tone-u-net.com](mailto:mell@tone-u-net.com). Hi-Fi bought, sold, repaired and renovated. Mail order and vintage specialists. Please see our main ad (look under the ad index to find) for further information.

**CHOICE HI-FI/Hi-Fi Exchange** Open 10am-8pm, 7 days by appt. Tel: 0181 392 1959/1963. Fax: 0181 392 1994. Agents for Acoustic Energy, Alon, ATC, Boulder, Bryston, Chord, Forsell, Gamma, Van der Hul, Lumley, Rockport, SME, Soundstyle, Straight Wire, Target, Trichord, Trilog, VPI, XLO and many more. We offer: generous part exchange, your equipment purchased, show room/dem room, single speaker dem room, trade in policy, credit card facilities, mail order, export service, finance available.

**HAZELMERE AUDIO**. To hear how realistic music can sound, please call for an appointment. (day or evening). Objective advice, comfortable listening, home-demonstration, free installations, part exchange, repairs and superb service. Acoustic Precision, Air Tagent, ATL, Audiomeca, Basis Classe, EAD, Fanfaere, Henley, Magnephanar, Mirage, Monrio, Muse, Notts, Analogue, Opera, Ortofon, SD, Sirius, Straightwire, Tice, Triangle, Trilog, VPI. High Wycombe (01494) 437892.

**TO ADVERTISE IN  
DIAL A DEALER CALL  
AMANDA SWEENEY ON 0171 328 1711  
SARAH WRENN ON 0171 328 4892**



## Dominic Todd

The question of hi-fi design has been chewed over many times before within this publication. Yet with the onset of the millennium (sorry to mention the "M" word again) the world of good hi-fi has been, or at least is about to be, brought to a wider audience. As part of the bedomed millennial experience, visitors are to see products that reflect the best of British hi-fi design which, in this case, relates as much to aesthetics as function and sound quality. Any opportunity to present decent gear to the great British public sounds like a fine idea to me, especially when it's shown that it doesn't have to come encased in boring black boxes.

So the question is, what are the fabled products selected to represent the UK's esteemed audio manufacturers? Well, it came as little surprise to find B&W's Nautilus loudspeakers are one of the chosen. After all, they already have a spot within the Science Museum, and prove that even when form follows function a product can still be visually arresting. On the other hand, priced at about the same level as a Midlands terraced house, they perhaps don't offer the best example of affordable hi-fi.

More realistic yet also somewhat baffling is the inclusion of the Arcam Alpha 10 amplifier. Don't get me wrong, this is a well-implemented, competitive amplifier. It's hardly what could be called a 'looker' though. Nor does it redefine sound quality at the £800 price level. It's included because of its modular construction which renders it

future-proof, and forward-looking is just the sort of thing I could see the millennium judges going for in a big way. Fair enough, but I still can't help thinking something from Cyrus would have been of more aesthetic interest.

That's the pinnacle of hi-fi design then, so where does it leave the rest of the industry as we race towards Y2K? The really exciting news is that Pioneer have produced a new badge. It's the same colour as the old one (gold) and it sits on the same sort of equipment (shiny, black boxes) but it's a little more 'organic' than before.

Call me cynical but it's hard to find anything affordable that challenges the status quo these days. Of course there are a few exceptions - Musical Fidelity's X range seems to be growing by the day and has had favourable reactions from press and public alike. Tracking down components from the larger Japanese multi-nationals which get the juices

the Altos failed because, despite standing out visually, they fell down in terms of function. For the price they didn't sound good enough (see Hi-Fi World April '94 for our review on the amp). Later price reductions weren't enough to save them, even though at the end the Alto range had something of a cult following.

More recently I've been reacquainting myself with the Rogers DB101 loudspeakers. Rather like the Alto, this was a futuristic product from a traditional company. Also like the Alto, it was over-pricing that led to its downfall; that a company could even dream of charging £400 for a 'speaker with spring-clip terminals, a basic hard-dome tweeter and a plastic cabinet is hard to believe. The only sign of the sort of quality I'd expect for the money was in the bass driver whose cast chassis and fixed phase plug offered some hope for decent sound quality.

*"In the recent past there have been products that have dared to be different and only succeeded in bankrupting the whole company."*

flowing can be a fruitless task. Many have an esoteric range, usually not available in this country, that looks as if it has been hewn from a solid billet of titanium, but exciting, attainable stuff is hard to come by. Sony's cute CDP-X3000ES is one product that begs to differ from the norm, but it's the only one that springs to mind.

It's not hard to imagine why many companies choose to tread such a conservative path. When Audio Innovations launched the Alto amplifier and CD player, it was fair to say that both raised eyebrows amongst the industry and public.

Producing hi-fi that resembled miniature flying saucers was one thing, but coming from a company that had specialised in solid, workman-like valve amps was quite another. Seen by some as gimmicky but others as stimulating,

This hope proved to be misguided as listening to them reminded me of why most 'speakers use wood and not plastic for their cabinets. Despite a taught bass response, the overall presentation was so coloured as to make me reach for the nearest budget mini monitor as a source of refuge.

In the Rogers' defence I think the retro toaster styling looks great, but I guess that form has to support function, not the other way around. And therein lies the rub. There is a demand for hi-fi that looks as good as it sounds - Michell, Cyrus and Musical Fidelity can all testify to that - but when form becomes the overriding concern, manufacturers are beginning to lose the plot. As fascinated by design as I am, I would rather have my hi-fi ugly than make sacrifices in terms of sound quality. If that means more black boxes, then so be it!●

# TIGER WOODS



**NOTHING ROARS LIKE THE NEW TANNOY R1. REAL WOOD. UNDER £200.**

The beauty of the Tannoy R1 is more than just skin-deep. Beneath the real wood exterior you'll see updated drivers built to closer tolerances, redesigned higher-spec crossovers, tunable bass ports and bi-wiring. The result is a startling sound quality unheard of at this price. Call 01753 680868, or visit your local hi-fi specialist to judge the new Tannoy R1 for yourself.

**TANNOY®**

CLASSICAL

by Peter Herring

We're in unknown territory this month, though it's surprising to discover works by Brahms that qualify as 'neglected'. More esoteric still is the enigmatic 17th-century Italian Michele Mascitti and Dmitri Shostakovich with his 15th symphony.

RECORD OF THE MONTH

JOHANNES BRAHMS

**Choral music: Two Motets, Op29/Two Motets, Op74/Three Motets, Op110/ Fest- und Gedenksprüche, Op109 et al Alain Planès, piano; Stefan Jezierski, Manfred Klier, horns; Marie-Pierre Langlanet, harp RIAS-Kammerchor; director, Marcus Creed**

**HARMONIA MUNDI FRANCE 2901 591.93 (3-CD SET) (DDD/186.56)**

The music of Brahms is so familiar that it is hard to believe that a large measure of his output - and in an area in which he excelled - could justifiably be described as neglected. Yet, in comparison with the symphonies, concertos, chamber and piano music, Brahms' choral compositions are lamentably underexplored. There is one monumental exception to this observation, the German Requiem. If you followed up the recommendation in the February issue and - like me - revelled in the reissue of Otto Klemperer's classic account, this handsome boxed set of Brahms' lesser-known choral music, sacred

and secular, will reward investigation.

Brahms wrote choral music throughout his creative life. One motivation for this was that his principal conducting appointments were with choirs. He was only 14 when he directed a choral society for the first time and, in 1857, aged 24, he secured the post of chorus master at the court of Detmold. Two years later Brahms formed a choral group of his own, the all-female Hamburg Frauenchor, in his home city. His work with this ensemble was one of the happiest periods of his life, a contrast to the discord that clouded his time as chorus master of the Wiener Singakademie in Vienna.

It was for the Hamburg Frauenchor that Brahms wrote his Vier Gesänge, Op17, with the unusual but effective accompaniment of two horns and harp. As elsewhere in this Harmonia Mundi collection, the recording of these songs is a model of clarity and definition, with

the choir perfectly 'placed' within an ideally resonant acoustic (disappointingly, the

venue is not disclosed).

The sound of the 35-strong RIAS Chamber Choir under its British-born director, Marcus Creed, is characterised by a wide range of tone colour, finely-judged vibrato, commendable accuracy of pitch and stylish phrasing. They project the music to thrilling effect.

The choir was founded in 1948 and this set supplies a splendid celebration of its 50th anniversary last year. RIAS, incidentally, stands for Radio In The American Sector, the radio station set up during the Allied occupation of West Berlin. Its 'Cold War' choir made contributions to many classic recordings, principally for Deutsche Grammophon.

Tradition mattered to Brahms too, and - like Mendelssohn and Bruckner - he found inspiration in the polyphonic choral music of the past. But everything sung here has its own distinctive

stamp, with harmonies that could only belong to Brahms. The motet settings are richly varied, ranging from a simple chorale style to substantial double-choir compositions with multi-layered contrapuntal textures. The Vocal Quartets with piano accompaniment - here an 1870 Riedel instrument played by Alain Planès - are similarly inventive, although the invention is often cleverly masked by an engaging lightness and charm.

The composition of the quartets spanned 27 years (1864-1891), and Brahms set texts - mostly on romantic themes - by Goethe, Schiller and several lesser literary lights. They refute the old chestnut about Brahms' supposed heavy-handed technique and drab colouring.

The two sets of gypsy songs (Zigeunerlieder) supply a sparkling coda to this immaculately-produced set (texts and translations are included, along with some lucid insights into the music). Throughout, this is Brahms at his most fluent and idiomatic, unfettered and unburdened by the weight of expectation and self-imposed sense of destiny which haunted his career as a symphonist.



## CLASSICAL

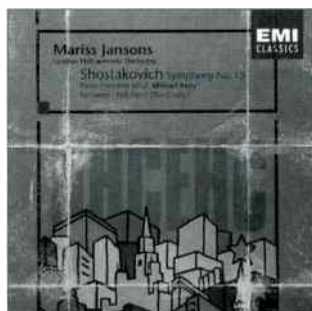

*DMITRI SHOSTAKOVICH*  
**Symphony No15 in A major, Op141/Piano Concerto No2 in F major, Op102\*/Suite: The Gadfly, Op97a**  
**Mikhail Rudy, piano\***  
**London Philharmonic Orchestra; conductor, Mariss Jansons**  
**EMI CLASSICS 5 56591 2**  
**(DDD/74.56)**

After the 'programmatic' 11th and 12th symphonies and the 'song cycle' symphonies, Nos 13 and 14, Shostakovich returned to the orthodox four-movement, purely instrumental format for his 15th and - as it was to prove - last symphony. But if the structure was unremarkable, the content was far from straightforward.

Quotations from his own works perhaps suggest a summation on the part of the composer, whose health was failing. But why include three motifs from Wagner, including the first three notes of *Tristan und Isolde*? And why the undisguised references to the main theme from Rossini's *William Tell* overture? The composer's son, Maxim, who conducted the first performance of the symphony in 1972, relates that his father described the burlesque-like first movement as a 'toyshop'.

If Shostakovich was preoccupied with his own mortality,

then he expressed it with chilling, heart-rending eloquence in the symphony's mighty slow movement, with its sepulchral brass intonations. And if the clues to understanding this puzzling, elusive yet hypnotic music are buried within the score, then Mariss Jansons' broad and considered reading ought to reveal them. Attentive to both detail and line, and with marvellous phrasing, Jansons simply allows the symphony to unfold and the result commands attention.

That he is able to sustain this hold owes much to some outstanding playing from the London Philharmonic; the brass and woodwind sections are in top form, and the percussion make the most of the many opportunities to shine which Shostakovich presents them with.

There are no riddles surrounding the Second Piano Concerto which Shostakovich wrote as a 19th birthday gift for his son and which Maxim, then studying piano at the Moscow Conservatoire, gave its premiere there in May 1957. Two scintillating outer movements enclose an andante of melting beauty. It contains one of Shostakovich's most lyrical themes, one which the soloist here - Mikhail Rudy - mercifully refuses to sentimentalise. The approach adopted by both Rudy and Jansons reveals a depth to this concerto which many other versions completely overlook. The virtuosity here serves a purpose.

Jansons concludes with the engaging suite assembled from the music Shostakovich wrote for a 1955 film, *The Gadfly*. It

supplies a rousing encore to the programme, and the LPO sound as if they thoroughly enjoyed recording it. Mike Hatch's finely-judged sound balance, one of the best I've encountered recently from Abbey Road's Studio No1, does full justice to the performers' achievement.



*MICHELE MASCITTI*  
**Sonate Da Camera, Op1**  
**Fabrizio Cipriani, violin; Antonio Fantinuoli, cello**  
**CANTUS C9610 (DDD/60.55)**

No, I hadn't heard of Michele Mascitti either, but then the list of itinerant Italian virtuosos of the 17th and 18th centuries is well-nigh endless. Does Mascitti warrant more than a one-line entry in the musical dictionaries? On the evidence of these exquisitely-played and beautifully-recorded violin and cello duos, he is clearly a more substantial figure than the many other followers of the great Arcangelo Corelli.

Mascitti, who was born in 1664, almost certainly studied with Corelli in Rome before migrating to Germany, the Netherlands and finally France. He settled in Paris in 1704 and it was there, in 1738, that he published all his collections of instrumental music.

It cannot have been easy for Mascitti to succeed in France, a country whose musical and aesthetic tastes were the antithesis of those of his homeland. In France, instrumental music was regarded as the poor relation of vocal compositions; in Italy, composers such as Corelli had constructed an instrumental language which reflected the expressive structures of vocal music and become immensely successful on the strength of it.

Mascitti took this with him and, judging by these refined and captivating chamber sonatas of 1706, was able to resist any Gallic dilution of his rich and colourful Italian musical 'recipes'. The final movements, usually jigs, have a bright, Mediterranean feel and the discourses between the two instruments are full of expressive freedom. The effect is of an intimate conversation between two members of a family; sometimes they're in sunny harmony, on other occasions in fiery conflict. It makes for enticing listening.

The two soloists on this recording from the Spanish Cantus label make a persuasive case for Mascitti's music. Violinist Fabrizio Cipriani plays a Venetian instrument from 1788 while cellist Antonio Fantinuoli uses a copy of an 18th-century Stradivarius-Piatti. They combine to make a lovely sound, one whose vibrant colours are well caught by the lively, airy acoustic of the Church of San Bartolomeo in Cravasco, Genoa. Michele Mascitti may only be a detail in the tapestry of music history, but it is one sewn with the brightest of threads.



# UK SUBSCRIPTION £27 ONLY !!!

GET THOSE CLASSIFIED ADS EARLY AND GRAB A BARGAIN !!!  
SUBSCRIBE TO HI-FI WORLD !!!

**INTERNET**  
Visit our site  
[www.hi-fiworld.co.uk](http://www.hi-fiworld.co.uk)



News; DIY; valve amps/pre-amps; speaker kits; reviews  
+ lots more information  
not published in the magazine.  
[www.hi-fiworld.co.uk](http://www.hi-fiworld.co.uk)

## OVERSEAS SUBS RATES

Surface Mail	£40
Airmail Europe	£50
Airmail Middle East & South-East Asia	£60
Airmail USA, Canada, Australia, Japan, Korea and China	£70

- Airmail  
 Surface mail

1 year's subscription only £27 (£2.25 per issue!), and we mail it to you free.  
Get to our amazing classified ads first and grab a bargain.  
Run by dedicated hi-fi engineers and enthusiasts, Hi-Fi World has become famous for its informative reviews and radical kit designs.

### MISSED AN ISSUE?

Back issues also available at a cost of £3.00 only (includes P&P), payment by cheque only - overseas please contact for details.

By telephone: Contact Lorraine Cezair-Phillip  
Credit card hotline 9.30AM - 12.00AM: (44) 0171 625 8033  
Fax: (44) 0171 328 1844 (Please fax form below)

By post: Make cheque or postal order payable to Audio Publishing Ltd, sent in an envelope marked Hi-Fi World, FREEPOST LON3478, LONDON, W9 1BR

## HI-FI WORLD SUBSCRIPTION CARD

**PLEASE REGISTER ONE YEAR'S SUBSCRIPTION FOR HI-FI WORLD**

I WOULD LIKE TO PAY BY CHEQUE MADE PAYABLE TO AUDIO PUBLISHING LTD  CREDIT CARD

DEBIT MY MASTERCARD/ACCESS/VISA ACCOUNT NO:

EXPIRY DATE:    SIGNATURE \_\_\_\_\_ DELIVERY ADDRESS IF DIFFERENT \_\_\_\_\_

NAME \_\_\_\_\_

ADDRESS \_\_\_\_\_  
\_\_\_\_\_  
\_\_\_\_\_

DAYTIME TEL NO \_\_\_\_\_

HI-FI WORLD

# marantz®



Sunglasses by Ray-Ban,  
suit by Cerruti,  
watch by Cartier,  
Hi-Fi by Marantz.



Telephone: 01753 680868 Internet: [www.marantz.com](http://www.marantz.com)

because music matters

# Electra Etc

sounds to believe in!

## EX DEMONSTRATION & PART EXCHANGE BARGAINS

			WAS	NOW	
ARCAM ALPHA 6	AMPLIFIER	PX		£159	EP
ARCAM ALPHA 7	AMPLIFIER	XD	£260	£199	EN
ARCAM ALPHA 8P	POWER AMPLIFIER	XD	£260	£199	ALL
ARCAM ALPHA 6	CD PLAYER	PX	£600	£249	EP
ARCAM ALPHA 8	CD PLAYER	XD	£450	£359	ALL
ARCAM ALPHA 8SE	CD PLAYER	XD	£600	£479	ALL
ARCAM ALPHA T7	TUNER	XD	£230	£189	ALL
ARCAJA ALPHA T8	TUNER	XD	£280	£225	ALL
ARCAM ALPHA 9	AMPLIFIER	XD	£500	£399	EP
ARCAM ALPHA 9	CD PLAYER	XD	£800	£639	EP
ARCAM ALPHA 9P	POWER AMPLIFIER	XD	£400	£329	ALL
AUDIOLAB 8000LX	AMPLIFIER	XD	£470	£299	EP
AUDIOLAB 8000C	PRE AMPLIFIER	PX	£500	£299	EP
AUDIOLAB 8000CDM	CD TRANSPORT	XD	£1400	£899	EP
AURA V8100/II	AMPLIFIER	PX	£350	£179	EN
AVI POSITRON	SPEAKERS	XD	£900	£650	LE
CREEK CD43	CD PLAYER	XD	£600	£449	ALL
CYRUS DAD3	CD PLAYER	PX	£598	£399	EP
CYRUS FM7	TUNER	PX	£398	£249	EP
DENON DCDB25	CD PLAYER	XD	£240	£169	ALL
DENON DCD1500R	CD PLAYER	XD	£350	£279	ALL
DEMON DRM740	CASSETTE DECK	XD	£260	£179	LE
EXPOSURE 18	POWER AMPLIFIER	PX	£850	£449	EP
HEYBROOK OPTIMA	SPEAKERS	XD	£259	£179	EN
JAMO CONCERT 8	SPEAKERS	XD	£1365	£999	ALL
JAMO CONCERT II	SPEAKERS	XD	£2250	£1680	EP
KENWOOD DP4090	CD PLAYER	NEW	£240	£119	ALL
MARANTZ CD17KI SIGNATURE	CD PLAYER	XD	£1100	£849	EP
MARANTZ PM66KI SIGNATURE	AMPLIFIER	XD	£400	£319	ALL
MARANTZ CD63KI SIGNATURE	CD PLAYER	XD	£400	£319	ALL
MERIDIAN 203	DAC	PX		£179	EN
MERIDIAN 263	DAC	PX		£229	EN
MERIDIAN A500	SPEAKERS	XD	£795	£549	EN
MERIDIAN 541	AV PROCESSOR	PX	£1095	£699	EP
MERIDIAN 551	AMPLIFIER	PX	£845	£499	EP
MERIDIAN 566 20-BIT	DAC	PX	£1095	£699	EP
MERIDIAN 502	PRE AMPLIFIER	PX	£1385	£899	EP
MERIDIAN 506 20-BIT	CD PLAYER	PX	£1195	£799	EP
MICROMEGA STAGE 5	CD PLAYER	XD	£750	£499	ALL
MICROMEGA STAGE 6	CD PLAYER	XD	£950	£650	EN
MICROMEGA DRIVE I	CD TRANSPORT	XD	£750	£450	EN
MICROMEGA MINIMUM	AMPLIFIER	XD	£300	£189	EP
MICROMEGA MINIMUM	TUNER	XD	£300	£189	EP
MONITOR AUDIO MA303	SPEAKERS	XD	£500	£299	EN
MUSICAL FIDELITY X-PRE	PRE AMPLIFIER	XD	£200	£129	EP
MUSICAL FIDELITY X-10D	CD ENHANCER	XD	£120	£79	EP
NAKAMICHI DR3	CASSETTE DECK	PX	£500	£199	EN
PROJECT 7	AMPLIFIER	PX	£260	£100	EP
PINK TRIANGLE VENTRICAL	SPEAKERS	XD	£1000	£599	EN
PINK TRIANGLE NUMERAL	CD PLAYER	XD	£1000	£649	EN
QUAD 77 MAINS	CD PLAYER	NEW	£900	£599	ALL
QUAD 77	AMPLIFIER	XD	£850	£569	ALL
REL 050	SUB WOOFER	XD	£375	£299	EP
REL STRATA II	SUB WOOFER	XD	£575	£459	ALL
REL STORM	SUB WOOFER	XD	£695	£549	ALL
ROGERS LS3/5A	SPEAKERS	PX	£699	£349	EP
SONNETEER CAMPION	AMPLIFIER	XD	£600	£450	EP
SONY TC6600S	CASSETTE DECK	XD	£300	£169	EP
TALK ELECTRONICS HURRICANE 3	PRE AMPLIFIER	XD	£900	£629	ALL
TALK ELECTRONICS STORM 1	AMPLIFIER	XD	£500	£349	ALL
TALK ELECTRONICS STORM 2	AMPLIFIER	XD	£650	£450	ALL
TALK ELECTRONICS STORM 2	POWER AMPLIFIER	XD	£600	£419	ALL
TEAC ABX10	AMPLIFIER	XD	£999	£649	LE
TEAC DT1	DAC	XD	£500	£349	EN
TSUNAMI TS200	SUB WOOFER	NEW	£300	£199	ALL
YAMAHA KX580SE	CASSETTE DECK	NEW	£250	£158	ALL

XD = EX DEMONSTRATION - PX = PART EXCHANGE  
 LOCATIONS - EP = EPSOM - EN = ENFIELD - LE = LEICESTER - ALL = AT ALL 3 STORES  
 PLEASE CONFIRM AVAILABILITY BEFORE TRAVELLING - FOR MAIL ORDER PLEASE TELEPHONE THE APPROPRIATE BRANCH

## NOW DEMONSTRATING

ANTHEM INTEGRATED 2	"A True Valve Monster Amplifier"
ANTHEM CD1	"High End CD Convenience"
ALR-JORDAN	"German Loudspeakers"
AVI POSITRON	"Revealing, Dynamic & Breathtaking"
AVI NU NEUTRON	"Miniature Heaven"
ARCAM ALPHA 9 CD	"HDCD At An Incredible Price"
CREEK A52SE & P43R	"Unbeatable Pre/Power Combination"
CREEK CD43	"A Refreshing Alternative"
CREEK T43	"FM Tuner Heaven"
JAMO CONCERT 8	"Monitor Heaven"
JAMO CONCERT 11	"Truly Awesome"
LUMLEY PROMENADE SPEAKERS	"Miss At Your Peril"
MUSICAL FIDELITY X-A1 AMP & X-RAY CD	"Competent & Smooth"
MUSICAL FIDELITY X-A100R	"Big Brother To X-A1"
MARANTZ CD PLAYERS	"Incredibly Detailed"
MICROMEGA CD	"Premium 18 & 20"
MYRYAD 'T' SERIES	"Unrivalled British Sound"
PIONEER PRECISION	"UK Tuned Japanese Value For Money"
PROJECT TURNTABLES	"Lay Your CD Player To Rest"
RESTEK CHALLENGER II	"German Battleship Hi Fi"
RESTEK FANTASY	"A Smoother Challenger II"
RESTEK CONCRET II CD	"All Hail To The Ultimate"
SONY MINIDISC	"Try It"
SONNETEER SEDLEY	"Phono Stage Perfection"
SONNETEER BYRON CD	"Beautiful Sounding"
SONNETEER CAMPION	"The Old Faithful"
SONNETEER ALABASTER	"So Open"

Please Note -  
 Not all products are on demonstration at all branches, please telephone before visiting.  
 Valid until at least the end of March 1999, £60E

FOR FIRST CLASS WORLDWIDE MAIL ORDER ☎ + 44(0)1372 720720 OR FAX 01372 745883

AGENCIES - ANTHEM, ALR-JORDAN, ARCAM, AVI, BEYER, CABLETALK, CELESTION, CREEK, CYMBAL, DENON, HARMAN KARDON, HEYBROOK, JAMO, JBL, JM LAB, JTL, KENWOOD, LUMLEY, MARANTZ, MICHELL, MICROMEGA, MISSION, MONARCHY, MORDAUNT SHORT, MYRYAD, NAD, PINK TRIANGLE, PIONEER, PRECIOUS METALS, PROJECT, QED, REL, RESTEK, ROTEL, SENNHEISER, SONICLINK, SONNETEER, SONY, TANNOY, TDL, TEAC, TECHNICS, THORENS, TRICHORD, TOTEM, TUBE TECHNOLOGY, VAN DEN HUL, YAMAHA

### Leicester

94 Granby Street, Leicester, LE1 1DJ  
**0116 255 7518**  
 Fax 0116 255 7541  
 Open 9.30-5.30 Monday-Saturday

### Epsom

12 Upper High Street, Epsom, KT17 4QJ  
**01372 720 720**  
 Fax 01372 745883  
 Open 9.30-5.30 Monday-Saturday  
 Open Sunday 11.00-5.00

### Enfield

7 Genotin Road, Enfield, EN1 2AA  
**0181 342 2333**  
 Fax 0181 367 6866  
 Open 9.30-5.30 Monday-Saturday - Closed Wednesday

5 Rocks Lane Barnes  
London SW13 0DB  
Tel: 0181 876 3355  
Fax: 0181 876 3399



**Hi-End**

# Top of The Roks !



**Roksan Rok One**  
Awesome performance  
at a giftwrapped price  
~~£600~~ **£279** Limited Stock

Crowd pulling attention to detail  
from

Sonneteer  
Campion Amp  
Alabaster Amp  
Byron CD  
Sedley Phono



AVI, ALCHEMIST, ANTHEM, BEYER, BOSE, BOULDER, CABLETALK, CASTLE, CHARIO,  
CITATION, ELECTROCOMPANIET, EXPOSURE, FINAL, GAMMA ACOUSTICS, GENESIS,  
HEYBROOK, JAMO, KEF, LINN, LUMLEY, MAGNUM DYNALAB, MARANTZ, MARSTON,  
MCINTOSH, MERIDIAN, MICHELL, MICROMEGA, MONARCHY, MYRYAD,

**MAIL ORDER HOTLINE 0181 878 0066**

# 0%

- ▾ Interest Free Credit
- ▾ On Selected items
- ▾ Subject to status
- ▾ UK only



# Hi-End

We specialise in:

- Audio visual interior design.
- Multi-room installations.
- 'Life-style' systems.
- Systems from £300 to over £30,000.

For your convenience:

- All Major Credit Cards Accepted.
- Finance Arranged.
- 2 Demonstration Rooms.
- Open 9.00 to 6.00 Mon to Sat.  
10.00 to 5.00 Sundays

## CLEARANCE BARGAINS

Hotline: 0181 878 0066

	<u>Was</u>	<u>NOW</u>
Electrocompaniet EC1-1	£2195	£1749
Electrocompaniet EC1-2	£1195	£849
Electrocompaniet EC4R	£1495	£1195
Linn Classic (CD/amp)	£995	£849
Micromega Stage 4	£600	£519
Monarchy Audio D18B	£595	£399
Teac CDP3450SE	£200	£139
Thorens TD180	£199	£145

<u>STANDS</u>	<u>Was</u>	<u>NOW</u>
Apollo Aria Glass (3 shelf)	£253	£199

<u>SPEAKERS</u>	<u>Was</u>	<u>NOW</u>
AVI Nu-Neutron	£499	£449
Castle Eden	£470	£419
Castle Severn	£580	£519
Castle Tay	£350	£299
Jamo Concert 8	£1300	£1149
Linn Keilidh & stands	£950	£699
Ruark Broadsword	£900	£599

PRECIOUS METALS, PRIMARE, PROJECT, ORTOFON, QED, QUAD, RESTEK, REVOX, ROKSAN, RUARK, SEQUENCE, SOUNDSTYLE, SONNETEER, SONICLINK, SENNHEISER, SONIC FRONTIERS, SME, STAX, TDL, TEAC, TOTEM, TRICHORD, TANNOY, TARGET, XANTEK.

## **WORLDWIDE MAIL ORDER + 44 181 878 0066**

# SONNETEER

A · U · D · I · O · P · H · I · L · E

Campion  
Byron Dryden  
Sedley  
Alabaster

It's time for a change...

p.o.box 163c, esher, surrey, kt10 0yh, england.

tel: +44 (0) 1372 468676

fax: +44 (0) 1372 470053

[www.sonneteer.co.uk](http://www.sonneteer.co.uk)

- amplifiers - CD player - phono stage - dac -



Hi-Fi & Audio Components  
Est. 1977 and 1978

CODE KEY:- N = NEW X = EX DEM S = SECOND HAND

Make	Model	Description	Code	Stock	R.R.P.	Now
ARCAM	ALPHA	AMPLIFIER	S	1	-	£30.00
BANG & OLUFSEN	AV-5	TELEVISION - CD & RADIO	X	1	£4650.00	£3000.00
BANG & OLUFSEN	BEOCENTRE 9300	CD/RADIO AND CASSETTE	X	1	£1650.00	£1200.00
BANG & OLUFSEN	BEOCLAB 2000	ACTIVE LOUDSPEAKER	X	1	£550.00	£400.00
BANG & OLUFSEN	BEOCLAB 3500	HORIZONTAL ACTIVE LOUDSPEAKER	X	1	£900.00	£650.00
CAMBRIDGE AUDIO	C70	PRE AMPLIFIER	S	1	-	£70.00
CASTLE	AVON	LOUDSPEAKERS - BIRCH & MAPLE	N	1	£730.00	£550.00
CASTLE	HOWARD	LOUDSPEAKERS - CHERRY	N	1	£1,200.00	£850.00
CASTLE	ISIS	LOUDSPEAKERS - MAHOGANY	N	1	£250.00	£190.00
CASTLE	TAV	LOUDSPEAKERS - WALNUT	N	1	£350.00	£250.00
CELESTION	100	LOUDSPEAKER - MAHOGANY	N	1	£540.00	£350.00
CELESTION	300	LOUDSPEAKER - WALNUT	N	2	£1,100.00	£500.00
CELESTION	251	LOUDSPEAKER - BLACK	N	3	£400.00	£250.00
CELESTION	CSW	SUBWOOFER	N	3	£300.00	£150.00
DENON	DRW 580	TWIN CASSETTE DECK	X	1	£200.00	£150.00
KEF	1042	LOUDSPEAKERS	S	1	£2,300.00	£850.00
KENWOOD	CS 6	CENTRE SPEAKER	S	1	-	£70.00
MERIDIAN	518	DIGITAL AUDIO PROCESSOR	S	1	£985.00	£585.00
MERIDIAN	500 + 566 DAC	CD TRANSPORT + 20 BIT DAC	S	1	£2,425	£1,400.00
MERIDIAN	502	PRE AMPLIFIER	X	1	£1,385.00	£1,000.00
MERIDIAN	565 7.1 AC-3	AC-3 DOLBY DIGITAL PROCESSOR	S	1	£2,850.00	£1,900.00
MERIDIAN	A500	LOUDSPEAKERS	S	1	£750.00	£400.00
NAD	910	PROCESSOR	S	1	-	£100.00
PINK TRIANGLE	LITURAL	CD PLAYER	X	1	£2,200.00	£1,500.00
QUAD	10L	LOUDSPEAKERS	N	2	£600.00	£325.00
QUAD	77 AMP	AMPLIFIER - NEXTEL	N	3	£700.00	£300.00
QUAD	77 AMP	AMPLIFIER - CARBON	X	1	£700.00	£300.00
QUAD	ESL 63s	ELECTROSTATIC LOUDSPEAKERS	S	1	£3,500.00	£1,500.00
ROTEL	RA 921	AMPLIFIER	X	2	£125.00	£100.00
ROTE	RCD 970 BX	CD PLAYER	S	1	£300.00	£125.00
SPENDOR	2040	FLOOR STANDING LOUDSPEAKERS	S	1	£900.00	£500.00
TANINOY	611	FLOOR STANDING LOUDSPEAKERS	S	1	£450.00	£200.00
YAMAHA	AV 1	PROLOGIC SYSTEM	N	2	£650.00	£500.00
YAMAHA	CC-75	MINI SYSTEM	X	1	£800.00	£400.00
YAMAHA	DSPA 3090	AV AMPLIFIER	S	2	£1,600.00	£750.00
YAMAHA	DSPA 492	AV AMPLIFIER	N	3	£250.00	£140.00
YAMAHA	DSPA 592	AV AMPLIFIER	N	3	£330.00	£290.00
YAMAHA	DSPA 1000	AV AMPLIFIER	S	1	£1,000.00	£250.00
YAMAHA	KX 493	CASSETTE DECK	N	2	£180.00	£150.00
YAMAHA	KX 580 SE	CASSETTE DECK	X	2	£250.00	£200.00

Wanted Items:-

Audiolab  
B & O  
Meridian  
QUAD

8000 PX or SX  
Overture  
500 Series  
77 T & 707

Power-Amplifiers  
& any B & O active loudspeakers  
Any Meridian 500 series  
77 Tuner and 707 Power amplifier

**ALL HI-FI WANTED  
PLEASE RING FOR CASH PRICES**

12 Regent Street, Rugby, Warwickshire, CV22 5LP  
Tel: 01788 540772 Fax 01788 542170

"NOW THERE'S ANOTHER NAME"

"THE BEAST OF BRITISH HI-FI"  
UNIQUE DESIGN  
BALANCED SINGLE ENDED  
NO ACTIVE GAIN STAGES  
NO LOOP FEEDBACK  
AFFORDABLE  
19" 2u  
BRITISH  
HAND WIRED

ALEMA LTD +44 01903 750755/6  
[www.hi-fidelity.co.uk](http://www.hi-fidelity.co.uk)

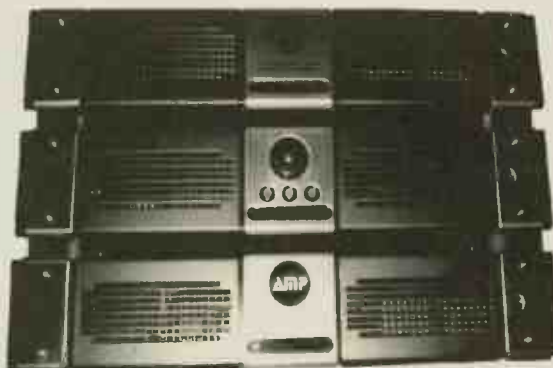

"NOT EVERYTHING IN LIFE IS  
BLACK AND WHITE"

**FLUX SYSTEM 2**

"FILL YOUR LIFE WITH THE  
COLOR OF MUSIC"

**ADVANCED MAGNETIC POWER**  
"FOR THE LIFE IN MUSIC"



You want to improve your CD source... is it worth just adding a DAC to your player? What about the new 24/96kHz - should you wait?

## Are all bits equal? ...

In digital audio all bits are definitely not equal, despite theory. We hear differences between components, even interconnects, and all players are affected by vibration.

A good but older player can benefit from a new DAC, especially one that is 24/96kHz-ready or upgradeable. **BUT BEWARE.** It's a very complex subject and there are **BIG** traps. Speak to us for guidance.

We like to drive the power amp direct (no preamp) from good DACs with **DIGITAL VOLUME** control for ideal clarity and fine detail, eg DAX Decade (can now have 3 analogue inputs), dCS Elgar or Pass DI.

But don't wait **YEARS** for a full catalogue of DVD or DSD (which will win?). Enjoy most of that sound from today's CDs with the **dCS UPSAMPLER.**

Customers say we make some of the best sounds they have ever heard, so you know we can do the same in your home.

Our advice will take account of your best components and guide you where change is needed, in stages you can afford.

You **AVOID EXPENSIVE MISTAKES**, enjoy music along the way and save money in the long run.

**JUST LISTEN AND YOU'LL KNOW**

The  
Right  
Note  
*Music in the home*



**BATH**

**01225 874728**

**CD:** ACCUPHASE, ADVANTAGE, AUDIO SYNTHESIS, BALANCED AUDIO TECHNOLOGY, dCS ELGAR, MERACUS, PASS, WADIA, XTC. **VINYLS:** BASIS, CROWN JEWEL, DNM, GRAHAM, LEHMAN, MICHELL, STRATOSPHERE, SUMIKO BLUE POINT SPECIAL, TRANSGURATION. **AMPLIFIERS:** ACCUPHASE, ADVANTAGE, BALANCED AUDIO TECHNOLOGY, CAT, DNM, LUMLEY, NAGRA, PASS, SIEMEL, SIRIUS, SONNETEER, XTC. **LOUDSPEAKERS:** AUDIO PHYSIC, BKS, ETHOS, HALES, HARBETH, LUMLEY, MAGNEPLANAR, MIRAGE, NEAT TOTEM. **TUNERS:** ACCUPHASE, FANFARE, MAGNUM DYNALAB. **CABLES:** ARGENTO, CHORD Co., DNM, NORDOST, YAMAMURA CHURCHILL ETC. **SUPPORTS:** DH CONES, STANDS UNIQUE ETC.

# Oxford Audio Consultants HI-FI SPECIALISTS

WE VE MOVED RIGHT NEXT DOOR TO  
MUCH BIGGER PREMISES WITH SUPERB  
PURPOSE BUILT DEM ROOMS



## NOW DEMONSTRATING

**SONUS FABER AMATI HOMAGE** - a sensational world-beating product from our favourite Italian company - a full scale floor standing **GUARNERI** that we've prayed for for ages.

**KRELL KPS25 CD PLAYER - THE NEW REFERENCE** - we become more and more impressed as each day goes past; it is just outrageously good!

**B&W NAUTILUS 800 SERIES - WE ARE VERY PROUD TO BE A PREMIER RETAILER OF THIS MOULD-BREAKING RANGE FROM £1400 TO £8500**

**NAIM AUDIO CDS MK 2** - a sensationally good CD PLAYER for the money - audition an absolute must!

**KRELL 250 CD PLAYER & 150 POWER AMPLIFIER - JUST OUT & 'HOT'**  
**VIDIKRON HELIOS PROJECTOR - PINAFARINNA LOOKS & PICTURE**  
**WILSON AUDIO SYSTEM 5** - still our reference speaker; ours sound even better now!!  
**SONUS FABER SIGNUM** - a replacement for the wonderful **MINIMA AMATOR** at **£1249**  
**MUSICAL FIDELITY X RAY CD, X-A1 AMP & ALL OTHER X SERIES**

- superb value for money

**AUDIO ANALOGUE PAGANINI CD PLAYER** - staggering build quality and unrivalled sound; on dem at last after a long wait

**THE TA DAVID DVD PLAYER** - superb results

**YAMAHA DSP A1** - a stunningly good home theatre package

**MARANTZ CD17/PM17/ST17 TUNER K.I. SIGNATURE SERIES** - hear how good it is.

**KRELL 250P PREAMP & 250A POWER AMP** - incredible value for money

- just ask for a dem

**CABLES & ACCESSORIES FROM TRANSPARENT, SILTECH, CABLE TALK, GM AUDIO, SOUNDSTYLE, TARGET, KONTAK etc.**

**GM AUDIO EQUIPMENT TABLES - THE ELITE** - now even better looking and superb value

\*\*\*\*\*MAIL ORDER INTEREST FREE CREDIT NOW AVAILABLE\*\*\*\*\*

**COPLAND CD266/271/288 CD PLAYERS** - all superb value for money from this very impressive company; now joined by the **CSA28** amplifier

## EX DEM & P/EX BARGAINS

ARCAM BLACK BOX 3	£ 100	SH
AUDIO RESEARCH CLASSIC 60 BAL INPUT	£1295	SH
AUDIO RESEARCH VTM120 SE PRIVATE SALE	£ 3750	
AUDIO SYNTHESIS PASSION PRIVATE SALE	£ 850	
CASTLE HOWARD SPEAKERS LIGHT OAK EX DEM	£ 795	XD
EPOS ES14 SPEAKERS	£ 295	SH
HEYBROOK SEXTETS	£ 495	SH
KRELL KPS201 CD PLAYER	£5995	SH
KRELL KRC HR PREAMPLIFIER	£4500	SH
KRELL MD10/ REFERENCE 64	P.O.A.	
LINN LPI2/BASIK ARM	£495	SH
MARTIN LOGAN AERIUS LOUDSPEAKERS	£1295	SH
MARTIN LOGAN QUESTS	P.O.A.	
MICHELL ISO	£ 295	SH
NAKAMICHI CR1 CASSETTE DECK	£ 195	SH
NAIM 90.3 POWER AMP	£ 375	SH
NAIM 92R PREAMPLIFIER	£495	SH
NAIM 22 PRE AMPLIFIER	£ 95	SH
ORELLE XTC PRE AMPLIFIER	£ 595	SH
PROAC RESPONSE 3.5 LIGHT OAK	£2500	XD
TEAC VRDS 10SE EX DEM	£ 595	XD
YAMAHA DSPA590	£ 195	SH

## 0% INTEREST FREE CREDIT

Licensed Credit Broker

Agencies include: Audio Analogue, Elir Tangent, Audigham, Audio Research, Audio Technica, B&W, Cable Talk, Castle, Copland, Denon, Goldring, Harmonik, Heybrook, Jadis, Koetsu, Krell, Lyr, Marantz, Martin Logan, Michell, Musical Fidelity, NAD, Naim, Onkyo, Ortolon, Opera, Pink Triangle, Pioneer, Proac, Proceed, Projekt, QED, QUAD, REL Subwoofers, Rotel, Sennheiser, SME, Sonus Faber, Stax, Target, T.D.L., TEAC, Theta, Thorens, Transparent Cables, Unison Research, van den Hul, Vidikron, Wilson, Yamaha

TAX-FREE EXPORT SERVICE  
MAIL-ORDER AVAILABLE ON MANY ITEMS

Open Mon-Sat 10am-6pm

# Oxford Audio Consultants

Oxford Audio Consultants, Cantay House, Park End Street Oxford OX1 1JD  
Telephone: Oxford (01865) 790879 Facsimile: Oxford (01865) 791665  
E-MAIL: Oxford.Audio@btinternet.com

# DENYS TRICKETT'S HI-FI CURIOSITY SHOP

## WE BUY & SELL VALVES!

For all valve amp repairs;  
overhauls, rebuilds.

The best workmanship at  
the fairest prices

**Buy: Sell: Exchange:**  
Tannoys: Garrard 301/401  
Thorens 124/224: Quad: Leak:  
Radford: Williamson W.H.Y.

**We ship abroad:-**  
Tel/Fax for a quote, No destination too far

**0171 723 8545**

Visit us at:  
23 Bell Street, London, NW1 5BY.  
(Edgware Road Tube 50 yds)



DANISH AUDIO CONNECT

Made in Denmark



### CTI Audio Attenuator / Volume Control

Improve the sound quality of your amplifiers by changing to the CTI volume control.

CTI offers you a more effortless sound, more details, better dynamics, lower distortion and improved bandwidth. CTI has the ability to "disappear" and not influence the enjoyment of the music. The tracking between stereo channels and the attenuation is within the range of professional equipment. Besides, CTI is very compact for easy build-in.

<p>How do we solve this?</p> <ul style="list-style-type: none"> <li>• 24 dB gain control</li> <li>• 0 dB output</li> <li>• reduction in grid current</li> <li>• no RF for harmonic distortion, overtones, 500 Hz noise</li> <li>• no need for extra grid plate for conventional design</li> </ul>	<p>Key CTI specifications</p> <p>Gain: 24 dB</p> <p>Attenuation range: 0 dB to 24 dB</p> <p>Tracking between channels: ±0.05%</p> <p>THD: &lt; 0.001%</p> <p>THD at 200 Hz: 0.001%</p> <p>THD at 10 kHz: 0.001%</p>	<p>CTI features</p> <p>Standard impedance: 10, 20, 30, 100 and 250 Ohm</p> <p>Available with:</p> <ul style="list-style-type: none"> <li>• 1 extra stage (used in most)</li> <li>• 2 extra stages (used in most)</li> <li>• 4 extra stages (used in most)</li> </ul>
---	---	--

Danish Audio Connect (Thailand) Ltd. 110/111 Sukwitong Rd. P.O. Box 110/111, Bangkok 10110, Thailand. Tel: 02-254 2424 Fax: 02-254 2424

UK distributor: AudioCom (UK) Ltd. 100, 101, 102, 103, 104, 105, 106, 107, 108, 109, 110, 111, 112, 113, 114, 115, 116, 117, 118, 119, 120, 121, 122, 123, 124, 125, 126, 127, 128, 129, 130, 131, 132, 133, 134, 135, 136, 137, 138, 139, 140, 141, 142, 143, 144, 145, 146, 147, 148, 149, 150, 151, 152, 153, 154, 155, 156, 157, 158, 159, 160, 161, 162, 163, 164, 165, 166, 167, 168, 169, 170, 171, 172, 173, 174, 175, 176, 177, 178, 179, 180, 181, 182, 183, 184, 185, 186, 187, 188, 189, 190, 191, 192, 193, 194, 195, 196, 197, 198, 199, 200, 201, 202, 203, 204, 205, 206, 207, 208, 209, 210, 211, 212, 213, 214, 215, 216, 217, 218, 219, 220, 221, 222, 223, 224, 225, 226, 227, 228, 229, 230, 231, 232, 233, 234, 235, 236, 237, 238, 239, 240, 241, 242, 243, 244, 245, 246, 247, 248, 249, 250, 251, 252, 253, 254, 255, 256, 257, 258, 259, 260, 261, 262, 263, 264, 265, 266, 267, 268, 269, 270, 271, 272, 273, 274, 275, 276, 277, 278, 279, 280, 281, 282, 283, 284, 285, 286, 287, 288, 289, 290, 291, 292, 293, 294, 295, 296, 297, 298, 299, 300, 301, 302, 303, 304, 305, 306, 307, 308, 309, 310, 311, 312, 313, 314, 315, 316, 317, 318, 319, 320, 321, 322, 323, 324, 325, 326, 327, 328, 329, 330, 331, 332, 333, 334, 335, 336, 337, 338, 339, 340, 341, 342, 343, 344, 345, 346, 347, 348, 349, 350, 351, 352, 353, 354, 355, 356, 357, 358, 359, 360, 361, 362, 363, 364, 365, 366, 367, 368, 369, 370, 371, 372, 373, 374, 375, 376, 377, 378, 379, 380, 381, 382, 383, 384, 385, 386, 387, 388, 389, 390, 391, 392, 393, 394, 395, 396, 397, 398, 399, 400, 401, 402, 403, 404, 405, 406, 407, 408, 409, 410, 411, 412, 413, 414, 415, 416, 417, 418, 419, 420, 421, 422, 423, 424, 425, 426, 427, 428, 429, 430, 431, 432, 433, 434, 435, 436, 437, 438, 439, 440, 441, 442, 443, 444, 445, 446, 447, 448, 449, 450, 451, 452, 453, 454, 455, 456, 457, 458, 459, 460, 461, 462, 463, 464, 465, 466, 467, 468, 469, 470, 471, 472, 473, 474, 475, 476, 477, 478, 479, 480, 481, 482, 483, 484, 485, 486, 487, 488, 489, 490, 491, 492, 493, 494, 495, 496, 497, 498, 499, 500, 501, 502, 503, 504, 505, 506, 507, 508, 509, 510, 511, 512, 513, 514, 515, 516, 517, 518, 519, 520, 521, 522, 523, 524, 525, 526, 527, 528, 529, 530, 531, 532, 533, 534, 535, 536, 537, 538, 539, 540, 541, 542, 543, 544, 545, 546, 547, 548, 549, 550, 551, 552, 553, 554, 555, 556, 557, 558, 559, 560, 561, 562, 563, 564, 565, 566, 567, 568, 569, 570, 571, 572, 573, 574, 575, 576, 577, 578, 579, 580, 581, 582, 583, 584, 585, 586, 587, 588, 589, 590, 591, 592, 593, 594, 595, 596, 597, 598, 599, 600, 601, 602, 603, 604, 605, 606, 607, 608, 609, 610, 611, 612, 613, 614, 615, 616, 617, 618, 619, 620, 621, 622, 623, 624, 625, 626, 627, 628, 629, 630, 631, 632, 633, 634, 635, 636, 637, 638, 639, 640, 641, 642, 643, 644, 645, 646, 647, 648, 649, 650, 651, 652, 653, 654, 655, 656, 657, 658, 659, 660, 661, 662, 663, 664, 665, 666, 667, 668, 669, 670, 671, 672, 673, 674, 675, 676, 677, 678, 679, 680, 681, 682, 683, 684, 685, 686, 687, 688, 689, 690, 691, 692, 693, 694, 695, 696, 697, 698, 699, 700, 701, 702, 703, 704, 705, 706, 707, 708, 709, 710, 711, 712, 713, 714, 715, 716, 717, 718, 719, 720, 721, 722, 723, 724, 725, 726, 727, 728, 729, 730, 731, 732, 733, 734, 735, 736, 737, 738, 739, 740, 741, 742, 743, 744, 745, 746, 747, 748, 749, 750, 751, 752, 753, 754, 755, 756, 757, 758, 759, 760, 761, 762, 763, 764, 765, 766, 767, 768, 769, 770, 771, 772, 773, 774, 775, 776, 777, 778, 779, 780, 781, 782, 783, 784, 785, 786, 787, 788, 789, 790, 791, 792, 793, 794, 795, 796, 797, 798, 799, 800, 801, 802, 803, 804, 805, 806, 807, 808, 809, 810, 811, 812, 813, 814, 815, 816, 817, 818, 819, 820, 821, 822, 823, 824, 825, 826, 827, 828, 829, 830, 831, 832, 833, 834, 835, 836, 837, 838, 839, 840, 841, 842, 843, 844, 845, 846, 847, 848, 849, 850, 851, 852, 853, 854, 855, 856, 857, 858, 859, 860, 861, 862, 863, 864, 865, 866, 867, 868, 869, 870, 871, 872, 873, 874, 875, 876, 877, 878, 879, 880, 881, 882, 883, 884, 885, 886, 887, 888, 889, 890, 891, 892, 893, 894, 895, 896, 897, 898, 899, 900, 901, 902, 903, 904, 905, 906, 907, 908, 909, 910, 911, 912, 913, 914, 915, 916, 917, 918, 919, 920, 921, 922, 923, 924, 925, 926, 927, 928, 929, 930, 931, 932, 933, 934, 935, 936, 937, 938, 939, 940, 941, 942, 943, 944, 945, 946, 947, 948, 949, 950, 951, 952, 953, 954, 955, 956, 957, 958, 959, 960, 961, 962, 963, 964, 965, 966, 967, 968, 969, 970, 971, 972, 973, 974, 975, 976, 977, 978, 979, 980, 981, 982, 983, 984, 985, 986, 987, 988, 989, 990, 991, 992, 993, 994, 995, 996, 997, 998, 999, 1000

# SUPERCLOCK....a new concept in digital master clock design

## Simply the *Ultimate CD upgrade*

The latest in CD master clock development, using a completely new unique design resulting in a much greater accuracy in data retrieval and conversion processes. Features comprehensive circuit topology using push-pull techniques and series mode oscillation, and the sine-square converter utilises a very high speed IC to provide a precision square wave clock signal.

- ⇨ Greatly improved resolution and detail
- ⇨ Extended accurate bass with real weight, control and presence
- ⇨ High frequencies have less glare and hardness at all listening levels
- ⇨ Greater dynamics, and detail at all frequencies
- ⇨ Spacious 3-D presentation of vocals and instruments.

The SUPERCLOCK is available *exclusively* from AudioCom (UK) and can be fitted to any CD players/transporters using the following frequencies: 11.2896MHz, 16.934MHz & 22.5792MHz. Modifications are carried out at AudioCom (UK). A kit is also available with instructions for the technically competent.

## Specialist Upgrade Service

Professional modifications using leading edge components. Modifications are carried out by engineer with 30 years experience in the field of analogue and digital electronics. Upgrades available to all types of audio equipment.

- CD Players/Transporters & D-A converters  
Analogue stage, digital stage, master clock, power supplies
- Pre & Power amplifiers,  
Power supplies, signal decoupling, volume control

For further information on SUPERCLOCK and other products request a copy of our FREE catalogue. (Overseas: £3.50)

Tel 01834 842803 Tel/Fax 01834 842804 E-Mail: [audiocom@compnet.co.uk](mailto:audiocom@compnet.co.uk)



# DBF ACOUSTICS

## Superior Quality Audio/Visual Products

Our massive range of high performance audio and video products now include digital & analogue interconnects, 4 & 5-pin DIN cables, audio/video cables including 3-Video plus loudspeaker cables and a unique loudspeaker kit. Many more also available custom made to order. All available exclusively by mail order direct from the manufacturer, cutting out the middle men to give you maximum performance for minimum cost.

"The cable is very accurate across the bandwidth... From the highest treble to the deepest bass it has no hidden nasties. All the accuracy with an openness and earthy sense of dynamics and you have a cable that is well worth checking out, sold exclusively through mail order, with a 14-day money back guarantee. By 3, it's unlikely that you'd send it back."

(see review in *Stereo* 1997 Home Entertainment magazine)



Credit card facilities  
available for fast delivery



Web site: <http://www.dbf.u-net.com>  
Or e-mail: [sales@dbf.u-net.com](mailto:sales@dbf.u-net.com)

24 hour Telephone/FAX: 01920 823 208



EXAMPLES	Algorhythm phono-phono 1m digital interconnect	£ 34.99
	Black Velvet gold plated phono-phono 1m	£ 29.99
	Black Velvet 4 x phono - 5 pin DIN 1m	£ 39.99
	Black Velvet SCART-2 x phono 1m	£ 29.99
	Azure gold plated phono-phono 1m	£ 49.99
	Azure 2 x phono - 5pin DIN 1m	£ 49.99
	Azure SE gold plated phono-phono 1m	£ 69.99
	Tornado spkr cable - £4/m eg 3m pair + gold 4mm	£ 54.00
	Typhoon spkr cable - £9/m eg 3m pair + gold 4mm	£ 84.00

(When ordering DBF cables please give the required pin configuration, and also specify for stereo or mono)

DBF-Acoustics 11 Fishers Wood, Puckeridge WA 1E, Herts. SG11 1SP, UK

Call now for your FREE 25 page catalogue





# SOUND CONNECTIONS

TEL / FAX : 0151 348 1988  
E-mail : sound.connections@dial.pipex.com

MAIL ORDER SUPPLIERS OF QUALITY HI-FI ACCESSORIES

## EX-DEMONSTRATION SALE

SALE		RETAIL	SALE		RETAIL
<b>Electronics etc</b>					
Wilson Beresch turntable (RC)	2,175	4,350			
complete with Act Two tonearm					
Stage One MM/MC phono stage					
& Sennoko Blue Point Special					
H-C MIC Cartridge					
Roksan Caspian CD player	750	1,000			
Roksan Caspian int amplifier	600	800			
Roksan Caspian power amplifier	450	600			
Roksan Caspian FM tuner	450	600			
Yamaha DSP 1092 AC 3 amp	625	850			
AVI Positron speakers	595	900			
Rel Q1000 subwoofer	370	495			
Sennheiser HD580 Jubilee phones	175	230			
<b>Interconnects</b>					
Nordost Red Dawn 1m	225	300			
Nordost Blue Heaven 1m	115	150			
Nordost Solar Wind 1m	65	85			
Chord chorus 1m	150	200			
Chord Solid 2 1m	90	120			
Chord Chameleon 2 1m	65	80			
Chord Calina 2 1m	40	55			
Chord Chrysalis 1m	30	40			
DNM Reson 1m (5din - 5 din)	45	74			
DNM Reson 1m (2 din - 5 din)	40	57			
Soniclink Maroon 1m	85	125			
Soniclink Silver Pink 1m	25	35			
QED Orchest 2 mtr	25	30			
van den Hul The 2nd 1m (MRI)	215	275			
van den Hul The First 1m	180	240			
van den Hul D102 MK	60	80			
<b>Digital Interconnects</b>					
Nordost Moonlight 1m (AES - EBU)	150	200			
Nordost Moonlight 1m (RC - RCA)	115	155			
Audio Quest Digital Pre 0.5m	50	70			
Audio Quest Video Two 0.5m	37	50			
Chord Prelude 1m	35	65			
van den Hul The First 0.6m	70	95			
<b>Speaker Cables</b>					
Nordost Red Dawn 3m pair	575	750			
Nordost Blue Heaven 3m pair	325	435			
Nordost Solar Wind 5m pair (Bi)	300	375			
Nordost Super Flat 5m pair (Bi)	180	240			
Nordost 2 Flat 5m pair	45	60			
Chord Rummur 5m pair (Bi)	180	250			
Chord Odyssey 5m pair	150	200			
Chord Rummur 5m pair	105	140			
DNM Reson 5m pair (Bi)	150	200			
DNM Reson 5m pair	85	110			
Soniclink A/T 200 5m pair (Bi)	110	144			
Soniclink A/T 150 5m pair	35	70			
van den Hul The Wind 3m pair	235	315			
van den Hul CS 122 (HBI) 5m pair	135	185			
van den Hul CS 122 (HBI) 1.5m pair	70	90			
<b>Accessories</b>					
Target B5 200 Equip Table (new)	155	215			
Soniclink S-Cable 4AV mains block	85	120			
Audio Prism Iso Barrier 3.3 (x3)	50	85			
Audio Technica 637 stylus cleaner	35	N/A			
DNM L100 30w 100 ohm books	23	30			

Please telephone for a full sale list

52 Green Lane ♦ Great Sutton ♦ South Wirral ♦ Cheshire ♦ L66 4LE

## UNIVERSITY AUDIO SALE

1&2 PEAS HILL CAMBRIDGE

01223 354 237

	WAS	NOW
AVI S2000 DAC	449	299.00
AVI S2000MP Pre/Phono	1,199	599.00
Arcam Xeta 1	499	299.00
Arcam Xeta 2	499	299.00
Boston CRX Dipole Spkrs	199	99.00
Boston Micro 90 Center	179	99.00
Boston VRS Pros	299	149.00
Cyrus AV Master	698	299.00
Cyrus Discmaster/Dacmaster	1,790	950.00
Cyrus FM7	398	199.00
Cyrus Pre/Power	1,198	499.00
Cyrus PSXR	328	149.00
Cyrus XPA	298	149.00
Linn AV 5103	5,499	2999.00
Linn Kaber Active	3,000	999.00
Linn Kairn Phono	1,700	999.00
Linn Kairn Pre Line	1,400	799.00
Linn Majik I Phono	800	499.00
Meridian 508 3 Beam	1,650	995.00
Meridian DSP 5000 rose	3,650	1995.00
Mission 73 Active Sub	499	249.00
Mission 735 B	649	399.00
Monitor Active SW	449	299.00
Monitor CC900 Blk	499	249.00
Myryad Pre/Power MA120/MP100	1,079	599.00
Pioneer A 300R Precision	400	199.00
Pioneer A 400X Amplifier	299	149.00
Pioneer CLD 515 Laser Disc	899	299.00
Pioneer PDS505P CD Player	460	299.00
Polk SW3000 MK2 Sat/Sub	499	299.00
Rotel Michi Pre Amp	795	399.00
Rotel RDP980 DAC	450	299.00
Yamaha DSP-A2070 A/V Amp	1,499	699.00
Yamaha DSP-E1000 Process	699	399.00

ALL ITEMS ARE EX-DEMONSTRATION  
MAIL ORDER ADD £10.00

### cartridges

denon  
dnm  
goldring  
lyra  
ortofon  
sumiko

### cables

audioquest  
cable talk  
chord company  
dnm  
heybrook  
ixos  
kantak  
lfd  
nordost flatline  
ortofon  
qed  
sonic link  
trichord  
van den hul  
xlc

### headphones

beyer  
ergo  
grado  
jecklin  
sennheiser  
stax

### stands

alphason  
frameworks  
sound org'n  
something solid  
soundstyle  
stands unique  
target

### accessories

audioquest  
creek  
densen demagic  
discwasher  
earmax  
goldring  
ixos  
kantak  
michei  
milfy  
monarchy  
motn  
musical fidelity  
nordost  
pixall  
qed  
rms  
shure  
trichord  
zerostat

### hardware

alc  
audiomeca  
audio physic  
audio synthes  
densen  
harbeth  
jm labs  
michell  
nva  
nordost  
q'n  
royd  
sequence  
sugden  
teac  
thoreas  
totem  
trichord

# audio, cables and accessories available by post

## (post haste)

phone, fax or

write for latest

price list / newsletter

## Second hand & ex dem deals

Audio Research LS7 preamplifier, mint, boxed s/h (£1700) ... £895

Audiomeca Tallisman CD transport with Trichord DOB 3 + modified (external) power supplies. Absolutely stunning performance and pretty too. BNC, phono & AES/EBU digital outputs. x/d, boxed, warranted (£2200) ... £1450

Musical Fidelity Elektra E100 r/control amplifier, S/H excellent, boxed (£600) ... £325

Musical Fidelity X-ray CD player ex display, full warranty (£799) ... £640

Naim Headline headphone amplifier with Flatcap PSU s/h perfect boxed (£555) ... £325

Nordost superflat gold (bi-wire) loudspeaker cable 5m pair s/h (customer needed a longer set) current cost £217 ... £120

Pink Triangle DeCapo DAC, 1307 chip S/H boxed, perfect ... £650

Pink Triangle Cardinal CD transport, S/H perfect. No handset ... £350

Quad II Power amplifiers. Excellent, original condition (but IEC mains and phono sockets) s/h ... £450

Quad 77-10L loudspeakers. Yew wood, boxed, excellent s/h ... £340

Quantum Minstrel hybrid amplifier, S/H Boxed, (£999) ... £349

Royd Minstrel SE loudspeakers. Cherry veneer with optional steel bases. x/d (£454) ... £250

Sony CDP XE 320 CD player x/d (£140) ... £70

Teac Reference 500 mini system. Amp / CD / Tuner / Cassette x/d (£800) ... £600



hi-fi for grown-ups



ipswich(01473)622866  
signals martlesham heath  
ipswich suffolk IP5 3UA  
fax (01473) 631588  
email: enq@signals.uk.com  
www.signals.uk.com

AE  
Atacama  
Audiolab  
B&W  
Cable Talk  
Copland  
Cyrus  
Epos  
Harman-Kardon  
JBL  
KEF  
Kenwood  
Krell  
Marantz  
Martin-Logan  
Meridian  
Michell  
Mission  
Monitor Audio  
Musical-Fidelity  
Pickering  
Pink Triangle  
Pioneer  
Quad  
REL  
Rogers  
SME  
Sonus-Faber  
Spendor  
Tannoy  
TDL  
Thorens  
Yamaha  
& lots more...

# York... a great place for...

- Widest choice in the area
- Independent advice
- Qualified staff
- Comfortable dem rooms
- Superb showrooms
- Main road location
- Major car parks nearby
- Insurance estimates
- Over 30yrs experience
- Service Dept.
- Delivery & installation
- Part Exchange
- Open 10.30-5.30 6 days

**Up to 3 yrs.  
Interest Free  
Credit**

deposit only 20% of  
£500+ for 12 months  
£1500+ for 24 months  
£3000+ for 36 months  
subject to status

PS: if you're making a special trip  
it's best to book, weekdays



**24 Gillygate, York**  
**Tel. 01904 629659**  
**High Fidelity Specialists est. 1967**

Cyrus

Audiolab

*The very best  
in Hi-Fi and  
Home Cinema...*

Martin-  
Logan

Krell

Monitor-  
Audio

## X Dem. Sale...

	Was	Now
Acoustic Energy AE1 II r/w	£995	£745
AE2 II r/wood inc stands	£2090	£1400
Audiolab 8000C	£580	£475
8000LX	£470	£395
8000CDM+DAC	£2300	£1725
8000DAC	£900	£650
8000MX pair	£1800	£1495
B&W CDM2 r/wood	£400	£320
Copland CDA288	£1999	£1599
Cyrus 111i	£598	£475
Commander remote	£100	£50
PSX-R	£328	£275
Power	£498	£395
SL integrated amp	£398	£325
JBL Aquarius S119 LSs	£1250	£625
KEF LS3/5a piano bk LE	£1800	£895
Krell 250 Pre+power	£5195	£4650
KAV300 cd	£3550	£3195
Marantz CD17 bk.	£800	£650
PM17 gold	£900	£695
Meridian A500 r/wood	£875	£650
M60 r/wood	£2500	£1875
566.20	£1095	£750
500 CDT +566.20 DAC	£2420	£1795
Michell Argo pre.+Hera	£885	£595
ISO phono stage	£420	£320
Mission 753f oak	£898	£750
754f oak	£1498	£1125
Monitor Audio Studio 50SE		
r/wood piano laq.	£5000	£2995
Studio 12 r/wood	£1100	£825
Pink Triangle Litaural CD	£2099	£1675
Tarantella+RB+XLZ	£1054	£750
Pioneer CLD-D925	£800	£595
A300 Precision	£400	£300
PDS505 Precision	£460	£350
Quad 77 Power amp	£600	£450
77 Pre-Amp	£700	£525
77 Remote	£300	£150
77 CD bus (all carbon)	£700	£595
REL Q100E bk.	£495	£395
Yamaha DSP-A3090	£1500	£1125

## Classic second-hand...

Acoustic Energy AE1 r/w	£495
Audiolab 8000C pre-amp	£375
8000A integrated amp	£350
Audio Innovations Series 1000	
monobox (were £1799)	£750
2nd Audio (was £3000)	£1000
Gale 401 chrome/black	£250
HK Citation 11/12 pre/power	
& 15 tuner the very first models,	
in walnut cases	£300
KEF 104/2 r/w (£2000)	£850
Marantz CD63 II K1-S	£275
CD85 (built like a tank)	£250
Mission 776/777 batt pre amp	
&	
2 x 100w power amp	£950
Argonaut bk., big, twin bass	£325
Quad 22 pre & powers	£600
ESL57 pair bk latest spec.	£750
34 pre-amp	£150
44 pre (din)	£185
405 power amp	£200
FM4 tuner (din)	£150
Revox G36 1/2 track 10"	£195
B77 reel-reel 1/4 track, 7.5ips	
pro-nabs, op cover	£850
Rogers LS6 teak	£175
Ruark Sabre bk	£250
SME original 3012	£175
3009 mk1 original box	£75
Tandberg TD20A	
1/4 track 7.5ips 10" reel	£650
Tannoy Cheviot 10"	
Dual Concentrics, walnut	£350
609 marble effect inc. stands	£195
Thorens TD124 mk2 +3012	£150
TD125 mk2 +3009	£200
TD150+3012 in SME plinth	£300
Vortexion Series 4 recorder	£100

Wide  
range of  
popular, classic,  
vintage, rare  
Electron Tubes  
from STOCK.

# E.T.O.L.S

Electronic Tube On Line Shopping

Division of HALFIN  
50 years of experience.  
We ship worldwide.

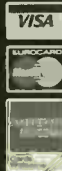

Web site

[www.halfin.com/shop](http://www.halfin.com/shop)

Free membership  
gives access to the gateway  
of the world.

37/39  
Quai aux  
Pierres de Taille  
B-1000 Brussels  
BELGIUM

Phone: +32.2.218 10 11 Fax: +32.2.218 69 98  
E-Mail: etols@halfin.com

## HEATHERDALE AUDIO LTD.

HEATHERDALE PRE-OWNED GUARANTEED EQUIPMENT  
EXPORT FACILITIES AVAILABLE

NAKAMICHI 1000 ZXI Gold 1st edition! MINT/BOXED/MANUALS	£3995
SONY CD9 22x60 Cd Player	£125
TECHNICS SU-V85A Stereo Integrated amp	£95
THIEL 7 2 Speakers B&W wire frame! EX DEM	£16995
SOLISTICE AAD Speakers w/ Stereo	£495
ALDIS CDT III Cd Transport (5000 new)	£3500
ACCPHASE 8000L CD Player	£2995
AERIAL Acoustics Speakers (Piano Black)	£3995
AUDIOTE Neo Night Monitor ex combobox	£1100
AUDIOTE P2SE Piano Area Speaker	£895
AUDIOTE P4 Monitor	£3395
AUDIOTE Neo amp MINT/BOXED (new £15400)	£5495
AUDIOTE 10 Inverted Cartridge & Pre	£2750
AUDIOTE Ongallo	£34995
AUDIOTE ANE S & L Speakers (rosewood) F veneer	£3995
MONITOR AUDIO Studio 10 Speakers (Piano Black)	£3495
B & W DM20's (Teak)	£150
MIRAGE M15 Speakers (Piano black) Mint/boxed	£3995
MADRIGAL C2 Gel 1+1r (Blackwood)	£419.95
DRELE CD101 TRANSPORT & DA188 Dac ex combobox	£395
SNELL K's Speakers (Black Ash)	£295
EXPOSURE 25 Pre-amp with remote NEW	£850
EXPOSURE 21 Pre-amp with remote NEW	£890

EXPOSURE 18 Stereo Power amp NEW	£720
JVC 7050 Power Amp Power amp	£695
LUXMAN M1200 KT88 Stereo Power amp	£1295
LUXMAN 5T10 Tuner	£450
MARTIN LOGAN CLS IIz boxed manual	£2995
ARAGON AURIUM pre-amp boxed manual	£895
ARAGON PALLADIUM monoblocks boxed manual (€3000 new)	£1895
KINERGETIC SUBWOOFERS with X-over individual manuals	£2195
LUXMAN M2000 amp	£495
AUDIO INNOVATIONS 500 Integrated amp	£550
HAIM NAC 32.5 pre-Nap 140 Pwr & Smpls PSU	£695
NEAT Mystique Speakers (Walnut)	£350
MARK LEVINSON 332 Power amp	£4995
MARK LEVINSON 35 Dac EX OEM	£5795
MARK LEVINSON 28 Pre-amp	£1995
MARK LEVINSON 38 Pre-amp	£3995
MARK LEVINSON 30 S 31.5 Cd transport & dac	£12995
MILLER & KREISAL MX100 Subwoofer EX CON	£795
MISSION 782 Loudspeakers with stands	£250
BURWESTER 877 pre-amp	£1995
VPI119 MK3 (dark oak) AT Tangent Koetsu Black	£1800
PRIMAIRE 201 Pre-amp with 202 monoblocks	£995
FORSELL Cartridge	£795
FINESTRA Pre-amp (with spj)	£595
JADIS JPL Pre-amp	£1995
VPI T1000 with hopper cart SPJ arm	£4995
MERIDIAN 203 DAC	£195

RUARK Talisman II Speakers (Mahogany) 4yrs old	£395
QUAD 77 Integrative Amp MINT	£395
JADIS J80 Monoblocks	£3995
AUDIO RESEARCH SP15 Pre-amp	£2495
KEF 104 Loudspeakers	£450
KOETSU Gold Tone black cartridge (new)	£995
KRELL KSA - 50s Power amp	£2295
KRELL NRC PRE-AMP & PSU	£2000
KRELL Studio Dac	£2000
KRELL CD-DSP MKII Cd Player	£1995
REVOX 877 (hs) Tape Recorder Excellent condition	£595
REVOX PR99 MK2 Tape Recorder (Trolley mounted)	£1750
REVOX A77 Tape Reel/Reel	£150
VOYD Tube SME V & Cartradio Delta Cart	£2495
VOYD Tube upgraded psu & mtr) Helius orion	£1495
VOYD Standard Turrtab MINT	£1495
AVALON ASCENT Speaker light wood MINT/CRATED (€16000)	£7000
MIT W6 2 MTR Interconnect	£200
HELIUS Silver Wired tonearm	£995

WE NOW OFFER 0% FINANCE \* PLEASE PHONE FOR DETAILS  
(\*Subject to status)

MAIN UK DEALERS FOR THEIL SPEAKERS  
MARK LEVINSON, ABSOLUTE SOUNDS, & MUCH MORE

EX-DEM EXPOSURE EQUIPMENT AVAILABLE PHONE FOR LIST  
FOR AN UP-TO-THE-MINUTE LIST VISIT OUR WEB SITE:  
<http://www.hifi-stereo.com>

VISA - SWITCH - MASTER CARD - AMEX - DINERS CLUB WELCOME.  
WE TAKE PART EXCHANGE ON NEW & USED STOCK AND BUY IN FOR CASH

# Cable Talk

— Interconnects & Speaker Cables —

- 1994  Best Speaker Cable
- 1995   Best Interconnect & Highly Recommended Speaker Cable
- 1996   Best Interconnect & Best Speaker Cable
- 1997   Best Speaker Cable & Highly Recommended Interconnect
- Interconnects Speaker Cables

## Doesn't Your System Deserve The Best?

### FOR FURTHER INFORMATION

Please telephone, fax or write to

### Cable Talk,

Unit J, Albany Park, Camberley, Surrey, GU15 2PL

Tel (UK ONLY): FREEPHONE 0808 - 100 - 6868

TEL: (+44) (0) 1276 686717. FAX: (+44) (0) 1276 686353

Please quote HFW 04/99



## BorderPatrol

Valve Amplifier Power Supply Upgrade £595.00

Off board valve rectified, choke input filter power supply for Valve Amplifiers. This upgrade reduces distortion, increases resolution and strengthens bass performance and dynamics. If you like the sound of your valve amplifier but would like to tighten the bass and strengthen the overall dynamics this is what you need. Versions available to suit everything from vintage Leaks to modern Audio Innovations, Audio Note and Art Audio designs. If you are unsure about the suitability for your amp please telephone us.

'In every instance the Border Patrol effect was nothing short of a transformation. Bass solidified, imaging became significantly more three-dimensional and substantial, and the power supplied amp made the regular version sound, quite literally, a mess.'

'With the Border Patrol back on the music regained its composure: instruments not only sounded more natural and realistic, but seemed much more musically coherent. In many respects it was like taking the good things about transistor amps and adding them to the natural strengths of valves - a remarkable blend.'

...Jason Kennedy Hi-Fi Choice April 97

**Call us for A/B with/without demonstrations of the BorderPatrol effect**

BorderPatrol Tel/Fax Brighton 01273 276716

## Sound Investment

If you have invested expertise and money in building up a sound system to your own unique specifications, then why compromise with indifferent housing units?

Fi-Rax offers a new dimension in audio visual racking - from a range of standard designs to the flexibility to custom create a unit to suit your particular sound system and lifestyle.

- \*High quality aluminium construction.
- \*Finishes available to your choice.
- \*Fully adjustable 6mm glass shelving.
- \*Sound isolation on shelving/feet.
- \*Custom created to suit your system.
- \*Free delivery throughout the UK.

Fi-Rax - a sound investment for those who want the best from their equipment.

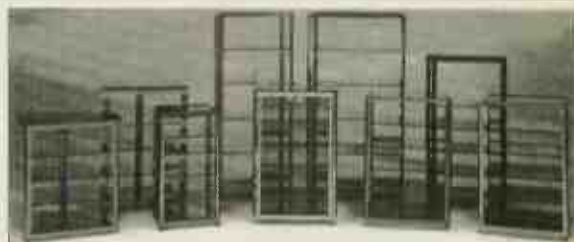

Audio Visual Furniture

For further information or a free brochure contact JEM Distribution, Springfield Mills, Spa Street, Ossett Wakefield WF5 0HW. Tel: 01924 277626 Fax: 01924 270759

## Are you making the right connections?

Send for Britain's biggest catalogue of specialist cable and connections.

All available by mail order.

Phone 0181-942 9124 or clip the coupon for your Free copy

**CUSTOM CABLE**  
SERVICE

PO Box 4007, London SW17 8XG

Please send me your FREE Custom Cable Catalogue

Name \_\_\_\_\_

Address \_\_\_\_\_

Postcode \_\_\_\_\_

NO FURTHER INFORMATION REQUIRED

Send to: Custom Cable Service  
PO Box 4007  
London SW17 8XG

HFW 02/99



# RETRO REPRODUCTION



The Outstanding V20 Integrated Amp

**V20**  
Introducing Tim De Paravacini's latest masterpiece, the outstanding V20. Using no less than 20 ECC83 triodes operating in Class A with no overall feedback, the result is the most natural and uncoloured sound available today.

**HIFI NEWS:** Ken Kessler: "What I think we're witnessing here is Tim De Paravacini's finest moment and that's scary when you consider that even his disasters are better than most designers' triumphs!"

**WHAT HIFI:** Verdict \*\*\*\*\*

Leading French magazine Diapason voted the V20 Amplifier of the year.

To hear what all the fuss is about phone now for a personal home demonstration

## Used Equipment For Sale

Fisher x 100 Integrated valve amp	£195.00
Rodgers Cadet III valve amp mint	£145.00
Marantz 5 x 72 Vinyl noise suppressor	£175.00
Quad II with Pre, AM, F, & multiplex decoder all original boxed	£495.00
Leak stereo 20 with Pre very good condition	£225.00
Michel ISO with Hera P.S.U.	£295.00
RB 300 tone arm	£89.00
Rodgers LS 35A BBC Monitors 15 ohm Walnut Boxed	£350.00
DNM Floor Stand For Turntables /Pre Amps /	£75.00
Denon DP 60 D/Drive Turntable Built Like A Tank	£295.00
Pioneer PL 12 D/Drive Turntable	£75.00
Garnard 401 Turntable	£95.00
Linn Axis with Akito & KS Mint Condition	£195.00
Cambridge C70 pre Amp	£125.00

**\*\*SPECIAL OFFER\*\***  
E.A.R. Clear Kit comprising of MM stage 5 passive line stages housed in the E.A.R. 834 case work. Simply stunning. £299.00

Linx Vega Pre Amp	£175.00
Audio Innovations S200 Valve Pre with MC	£229.00
B & O Beolab 5000 Amp	£95.00
Revox A78 Amp MK II	£95.00
STD Integrated Single Ended Valve Amp Art Deco Style mint condition	£195.00
Michaelson Odeysseus Valve Amp 8 x EL34 45 Watt Class A stunning sound & condition	£595.00
Michel Hera ISO HR with Hera power supply boxed	£475.00
JR 149 speakers mint	£125.00
Musical Fidelity X LP Pre as new	£90.00
CR Development & Kalypso integrated valve amp	

**Exclusive Scottish distributor for E.A.R./Yoshino Equipment and Nottingham Analogue Turntables V20 & MC3 and spacedeck now in stock.**

with valve cover as new was £600	£295.00
Meridian 500 Transport	£625.00
Cambridge P60 amplifier	£45.00
Cambridge A60	£45.00
Marantz 105B Analogue Tuner	£60.00
Ariston RD11 Turntable with 3009 tonearm	£95.00
Sumiko Tone Arm	£125.00
Quad II pair various	£300.00
Leak TL12+ pair	£300.00
EAR 834P	£235.00
Kef 102/2 Mahogany Speakers	£195.00

**\*\*SPECIAL OFFER\*\***  
£100 WORTH OF DNM ACCESSORIES OF YOUR CHOICE WHEN PURCHASING THE MC3 LIMITED PERIOD ONLY



Small but perfectly formed MC3

**MC3**  
Producing the very best from vinyl has long been a black art and it's no wonder with so many permutations involved. Most people agree that Moving Coil cartridge design is technically superior than the Moving magnet but demands much more from it's ancillaries, especially the phono stage

E.A.R./Yoshino have just launched the MC3 Cartridge Transformer with a band width of 3Hz-100kHz, facilities for a wide range of quality cartridge outputs and twin isolated earth terminals for maximum noise reduction.

The MC3 captures all the subtleties from the most complex recording without resorting to thrusting or spitting it out. Its extreme clarity and grainless presentation makes for a superb vinyl experience.

**ART DUDLEY:** Leading American hi-fidelity critic.

"I'm impressed with the MC3, and from a musical point of view, I think it's worth every penny of the price. Those of you who have tube-based systems & can afford it should listen to it before you make up your mind. Value/Quality \*\*\*\*\*"

Meridian 206 Delta Sigma CD	£295.00
Michel Argo pre with Hera	£295.00
Audio Innovations L1 Pre	£195.00
Revox B77 Open Reel mint	£495.00
Stax head phones and energisers various models	(phone)
Audio Innovations S800 Anniversary valve power amp as new	£695.00
Magnaplanner SMGA panel speakers	£195.00
Sugden A48 Class A amplifier	£175.00
Due in:	
PX 25, KT 61, KT88 (valves new boxed) Leak 12.1, Decca Decola amplifier, Quad boxed ESL57 mint, Thorens 124, Leak TL50 + mono blocks and various leaks new spares, Garnard 301, Revox G36, Radford STA15, SME 12" Tonearms (various models)	

NEW SHOWROOM NOW OPEN

Phone / Fax 0131 553 4126 or 07801/288686



## Vacuum Tubes for Audio Are Back!

*Glass Audio* brings together yesterday's tube with today's improved components, voltage control, and the exciting new Soviet tubes, to make smooth sound in your livingroom possible again!

**YES!**

Please send my first issue of *Glass Audio*. I'll pay just \$45.00 for six issues (1 year); \$80.00 for 12 issues (2 years) of the best information on tubes to be found anywhere. I understand that my satisfaction is guaranteed!

Name \_\_\_\_\_

Street & Number \_\_\_\_\_

City \_\_\_\_\_ Postal Code \_\_\_\_\_

Country \_\_\_\_\_ REMIT IN US \$ DRAWN ON A US BANK ONLY. PRICE GOOD THROUGH DECEMBER 31, 1995.

We Accept MC/VISA.

**Glass Audio**

PO Box 176, Dept. HFWS, Peterborough, NH 03458-0176 USA  
Phone: (603) 924-9464 or FAX 24 hours a day (603) 924-9467

# THE EMPORIUM

28 St Nicholas Street, Diss,  
Norfolk IP22 3LB  
Tel/Fax: 01379 650744  
emporium@dircon.co.uk

## CD & DAC's

	Cost	Price	
ALTI5 CD transport + DAC	NEW5500	1750	ELECTROCOMPANIEI ELCTRO 25 watt class A power amp 400
ARCAM 9	800	500	EXPOSURE XV integrated 800 400
ARCAM Alpha 5	450	200	EXPOSURE XV111 Super Poweramp 850 500
MARANTZ CD80 enormously heavy	300	400	10N OBELISK 3X & XPAK-1 Amp 300
MERIDIAN 207	1000	400	LFD PA1 power amp 900 450
MICROMEGA T-DRIVE transport & T-DAC with AES-EBU lead	2150	900	LFD MISTRAL integrated 500 300
MICROMEGA DUO 3.1 transport & DUO B5 DAC	2100	900	LUXMAN Avance Z501 power amp 150
PINK TRIANGLE ORDINAL DAC	500	500	McINTOSH C28 PRE / MC250 power amp
PS AUDIO LAMBDA CD Transport	2700	1000	Enormous beauties with wooden sleeves and they light up in blue! 900
ROKSAN CASPIAN 3 months old	900	670	McINTOSH MC250 classic early transistor power amp with output transformers 400

## VALVE AMPS

AUDIO INNOVATION5 series 500 integrated with phono	500		MUSICAL FIDELITY pre 3A/MA50 monoblocks 1350 600
AUDIO RESEARCH 5P6	750		NAIM AUDIO ECLAT P5U 200
AUDION 2 Box Pre with Phono	1500	800	NAIM NAIT 3 400
AUDION SILVER NIGHTS 300B 17 watts monoblocks	2250	1250	NAIM 62 pre old style with mm or mc boards 200
BEARD BBA100 line integrated	1500	600	NAIM hicap old style 350
BEARD P500A valve pre with phono	400		NVA 50 watt stereo power amp old style 200
CONCORDANT EXCELCIOR Phono Pre amp with offboard PSU	650		NVA A80 monoblocks 3 years old boxed 1600 800
CONRAD JOHNSON PV10AL/MV55 pre/power	3000	1800	NVA P50 pre with mc input and two PSU old style 250
COPLAND pre/Power	3400	1700	PIONEER spec 174 Pre/Power 150 Watts 400
CR development KALYPSO	300		P5 AUDIO PLUS C power amps pair bridgable for 150 watts per channel pair 560
CROFT SERIES V power amp	650	300	QUAD 33/FM2/303 250
EAR859 line integrated	1999	850	ROKSAN CASPIAN remote integrated amp 3 months old 700 490
GAMMA AEON monoblocks orig version and £100s spent	5000+	250	ROKSAN CASPIAN power amp 3 months old 500 350
stereo power amp	2000	900	ROTEL MICH1 RHC10 800 400
GAMMA SPACE REFERENCE 300B single ended line integrated	4000	1500	ROTEL RB970BX each 125
GAMMA ERA pre, phono and line	2500	1000	ROTHWELL INDUS, top of the range passive pre 450 250
HEATHKIT MA 12 valve monoblocks 12 watts pair	250		SUGDEN AUS1C Line Pre 1000 500
MORE FIDELITY German 300B amp	2000	900	SUGDEN OPTIMA 140 remote line integrated 550 350
ORANGE pre mm/line very smooth sound	300		SUGDEN OPTIMA 200 amp 1000 600
QUAD II Poweramps rebuilt & repainted pair	Guineas	350	TOWNSHEND ELITE pre, mm,mmc and line 125
TRILOGY PRE/POWER	3000	1500	

## LOUDSPEAKERS

APOGEE SCINTILLA 4ohm	5000	1000
CADENCE ES hybrid electrostatic	3500	1500
BOSE 901 poor condition	200	
IMPULSE H2 horn loaded	2500	1250
JR 149 round version of Is375a	175	
LOWTHER ACOUSTAS - beautiful pair	400	
MAGNEPLANAR 2.5R large panel speaker	2500	900
PROACTABLETTE 50 3 months old	600	400
REL Q-100E Subwoofer 3 months old	500	350
ROGERS STUDIO 1	275	
ROYD MINSTREL pair	120	
RUARK EQUINOX	2500	1200
SONUS FABER MINIMA AMATOR	1000	
SONUS FABER MINIMA boxed	700	
SPENDOR 5100	1650	750
STAX LAMBDA signature and SRM-T1 valve energiser	700	
TANNOY little gold monitor	700	

## CASSETTE DECKS & TUNERS

DYNACO FM3 valve stereo FM Tuner	120	
LEAK STEREO FETIC FM Tuner	40	
LEAK STEREO TROUGHLINE WITH STUDIO 12 DECODER	120	140
LUXMAN T2 tuner	70	
McIntosh MAC1700 Hybrid valve/solid state receiver	500	
MERIDIAN 104 FM tuner	120	
NAKAMICHI 480Z cassette deck	200	
QUAD FM 2 stereo valve tuner	100	
REVOX A77 MK4 2 TRACK SUPERB PERFORMANCE	250	
SONY ST88 little upright tuner	25	

## SOLID STATE AMPS

ARCAM Delta 60 amp	300	160
ARCAM Delta 290P Power Amp	275	
ALCHEMIST FREYA/ODIN pre/power original budget high end designs	2100	1100
BURMESTER 838 phonostage	250	
DNM 3 pre with twin psu	500	

## TURNTABLES/ARMS/CARTRIDGES

ARISTON RD115	150
DENON DL304	200 100
GARRARD 301 in granite plinth with sme refurbished 3009 II beautiful	700
GARRARD 401 in slate plinth	300
LINN LP12 EARLY MODEL no arm 250	
LINN LP12 with avondale psu	350
MICHEL FOCUS, no arm crack in lid 90	
ORACLE DELPHI MK11 WITH WELL TEMPERED ARM & ONIX psu	1000
ORTOFON MC3000 light use since rebuild	1000 350
ORTOFON TX3000 matching step up transformer	900 350
OXFORD ACOUSTICS CRYSTELLE turntable (floorstanding model)	1100
ROKSAN XERXES with XP5 II (SME cutout)	895 400
SYSTEMDEK IIX900 with RB250	200

## VINTAGE

JORDAN WATTS 4" Full range speaker modules pair	75
LOWTHER PM4A with new silver voice coils pair	800
PYE MOZART Pre/Power	400
RADFORD 5TA25	600
RADFORD 5TA100	1100
TANNOY CORNER YORKS with 15" red POA	
TANNOY HPD3 15 12" Dual Concentrics refurbished pair	275
WESTREX 2080 15" Bass units & 2090 Pressure units (pairs)	1500

## CLASSICAL LPS

ask for our list some of our prices are 75% less than our competitors!

## WANTED

ANY QUAD 34, 44, 306, 405 FM4, 66 SERIES

# WANTED

## HI-FI & accessories any make, any age

**BUY · SELL · TRADE**

**NOTHING LEGAL REFUSED!**

Please bring official ID with address & signature when selling or exchanging

## MUSIC & VIDEO EXCHANGE

**64 Notting Hill Gate, London W11**  
☎ 0171 792 3474

**480 Fulham Rd (Broadway), London SW6**  
☎ 0171 385 5350

**95 Berwick St, Soho, London W1**  
☎ 0171 434 2939

**MVE, Manchester Arndale Centre (near High St entrance)** ☎ 0161 839 0677

**OPEN 7 DAYS**

## LARGE SELECTION ON SALE

Hi-fi/camera expert wanted ☎ 0171 727 3538

## EX - DEMONSTRATION EQUIPMENT

	NEW	SALE
BANG & OLUFSEN MX6000 28" TELEVISION (BLUE)	£1550	£1095
CYRUS PRE PRE AMPLIFIER	£648	£475
CYRUS MC1 MM/MC BOARD FOR CYRUS PRE	£100	£50
EPOS ES22 SPEAKERS CHERRY FINISH (MARKED)	£1185	£785
LINN LK100 POWER AMPLIFIER	£650	£450
MARANTZ PM66KI INTEGRATED AMPLIFIER	£400	£350
MISSION 731 PRO BLACK FINISH	£140	£99
PROJECT 6 TURNTABLE (INC. ORTOFON MC 10 CARTRIDGE)	£600	£395
REGA KYTE BLAC K FINISH	£198	£125
ROTEL RCD-950 COMPACT DISC PLAYER	£250	£180
REL STORM 100W ACTIVE SUBWOOFER	£695	£550
YAMAHA DSP-E1000 7 CHANNEL PRO LOGIC PROCESSOR	£700	£350

## QUALITY USED EQUIPMENT

AUDIO ALCHEMY DDE/PS3 DAC INC POWER STATION 3	£1000	£376
AUDIOLAB 8000Q PRE AMPLIFIER	£1250	£795
AUDIOLAB 8000M MONO POWER AMPLIFIERS	£1400	£795
AUDIOLAB 8000P STEREO POWER AMPLIFIER	£650	£495
B&W 6001FS CENTRE LOUDSPEAKER	£200	£65
CYRUS PRE PRE-AMPLIFIER	£648	£396
CYRUS POWER POWER AMPLIFIER	£498	£350
ROKSAN DP11 COMPACT DISC TRANSPORT	£1100	£425
ROKSAN DA1 DIGITAL TO ANALOGUE CONVERTER	£450	£75
STAX SRM-T15 VALVE ENERGISER	£1195	£650
YAMAHA NSE105 EFFECT LOUDSPEAKERS	£110	£69
TRICHORD GENESIS COMPACT DISC PLAYER	£570	£ 375

## SPECIAL PURCHASE NEW BOXED EQUIPMENT

YAMAHA KX-690 3 HEAD CASSETTE DECK	£400	£249
------------------------------------	------	------

Now playing at The Powerplant

The Totem Model One Loudspeakers

The Rega Planar 25 Record Player inc. RB600 Tonearm

The New Linn Kolektor Pre Amplifier

## THE power plant

66/67 Upper North Street Brighton BN1 3FL

Tele: 01273 775978 Fax: 01273 748419

Email: [email@powerplant.co.uk](mailto:email@powerplant.co.uk)

ATC, Audiolab, Arcam, B&O, B&W, Cines, Exposure, Kef, Linn, Mission, Marantz, Mission, Mark Levinson, Pro Ac, Procell, Rega, Roksan, Stax and other quality equipment.

Mail order and Worldwide Export service available



# MEASURED PERFORMANCE

## AMPLIFIERS

### EDMUND ESI 10

The Edmund produces 78watts into 8ohms, rising to 110watts into 4ohms. It has reasonably good power supply regulation and should have some bass slam as a result.

Although the amplifier is powerful it exhibits a Class B distortion characteristic where, as signal level decreases, distortion increases. Our standard figures showed a maximum of 0.2% distortion at 1watt, 10kHz. However, further measurement showed that at very low levels as much as 2% distortion existed (100mW output at 10kHz), with odd-order harmonics extending up to ninth order and beyond. This sort of distortion is invariably heard as coarseness in the sound and

is not commonly met in amplifiers nowadays.

Frequency response measured flat from 10Hz up to 30kHz through the CD input. Via the phono stage there was +1dB treble lift at 20kHz and some shelving off of bass output. This would produce a bright or slightly light sound from LP. Input noise was very low and gain quite high, giving a sensitivity of 2.5mV on both channels.

The Edmund has some weaknesses that need attention before it is a match for good, modern designs. **NK**

Power 78watts

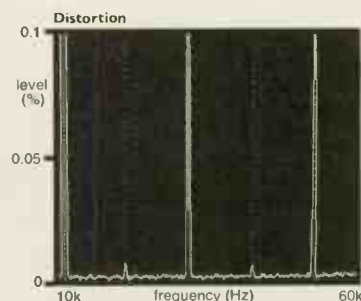

CD/tuner/aux.	
Frequency response	10Hz-30kHz
Separation	65dB
Noise	-95dB
Distortion	0.037%
Sensitivity	220mV
DC off-set	-21mV/-6mV

### LAVARDIN IT

The Lavardin produces 50watts into 8ohms, rising to 72watts into 4ohms. It's not enormous, but it is enough power with reasonably sensitive loudspeakers to get very high volumes. Power supply regulation was fair so there will be reasonable bass control too.

The interesting and unusual feature of this amplifier is its distortion characteristic. It is common for distortion to be low up to a few kHz with a rise thereafter. With this amplifier high-frequency distortion was lower than that in the midband. So I moved down to 40Hz and found distortion there very high, measuring no less than 1.7% third harmonic.

Luckily, the sole distortion harmonic was well correlated with the signal, much like that of a valve amplifier, so although there might be a little 'sharpening' of the bass, possibly adding emphasis to leading edges, I would not expect this distortion to be perceived as the coarseness or roughness of classic 'distortion'.

With good overall distortion figures

from 0.02% at 1kHz (all powers) to 0.005% at 10kHz (all powers), I have no problem with the Lavardin's distortion performance. Our 300B valve amplifier produces more, but it is not audible.

In all other ways the Lavardin measured well, although it is not very sensitive. Old tuners and cassette decks, producing around 300mV output will not drive it sufficiently to produce full power.

The Lavardin has an interesting measured performance. It works well. Feedback seems to increase with frequency, decreasing distortion progressively. **NK**

Power 50watts

CD/tuner/aux.	
Frequency response	28Hz-18kHz
Separation	85dB
Noise	-96dB
Distortion	0.037%
Sensitivity	400mV
DC off-set	-3mV/-14mV

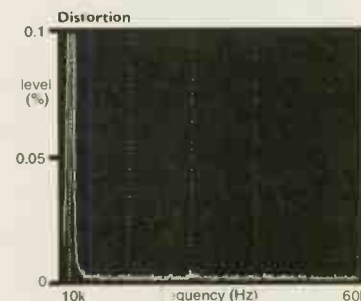
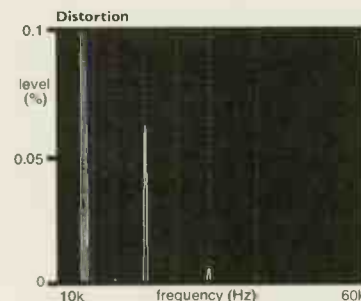

# DOUG BRADY HIFI

Kingsway Studio Kingsway North, Warrington, Cheshire, WA1 3NY

Tel: 01925 828009 Fax: 01925 825773

**A SELECTION OF USED OR EX DISPLAY EQUIPMENT FROM OUR STOCK. ALL EQUIPMENT CAN BE HEARD BEFORE PURCHASE EITHER IN-STORE OR IN YOUR HOME, AND IS GUARANTEED.**

CD TRANSPORTS	WAS	NOW	POWER AMPLIFIERS				
Audiolab 8000 CDM	1400	1190	Dawson DP50 valve	1199	699	Linn Kaber Passive black	1100 699
XTC-1 LE	1250	1095	JDI Monoblock pair	900	695	Harbeth HLK6/ stands	1200 749
Teac P30 transport	2499	1899	Linn Kairn	1600	1099	Magnaplanar M.G. 1.4	1200 799
Teac VRDS T1	550NEW	450	Naim NAP 250	1700	1290	SD Acoustics SD1 Black	1600 995
			Musical Fidelity MA50 pair	900EXDEM	650	Gradient sub for Quad ELS 63	1600 1199
			Musical Fidelity the Pre Amp	199	99	Mission 753 Rose	800 550
			Musical Fidelity Rainbow Pre Amp	249	149	Heybrook Octet	2000 995
<b>CD DACS</b>							
XTC DAC 1	1000	799				Also available:- Pink Triangle, Michell	
LFD DAC 2	1990	1299				Wilson Benesch, Oracle, Basis,	
			<b>TAPE DECKS</b>			Thorens, A.R., Systemdek, Project,	
			Teac 8030 - SUPER BUILD QUALITY -			Ariston.	
			Champagne gold finish			A selection of used or ex display	
			new boxed	650NEW	499	equipment from our stock. All	
<b>CD PLAYERS</b>						equipment can be heard before	
Marantz CD 17 KI Sig	1100	799				purchase either in store or in your	
TEAC VRDS 10SE	850	650				home, and is guaranteed.	
			<b>LOUDSPEAKERS</b>				
<b>PRE AMPLIFIERS</b>			B&W P4	675	495		
Naim NAC 52&PS	5000	3495	DCM Time Frame FI.Floorst	350	199		
Naim Supercap	2200	1499	Triangle Comet	400	249		
JDI Pre & P.supply	1600	999	Heybrook Quartet & ST	649	399		
Meridian 601 digital	3000	1495	Celestion 5000 walnut	850	399		
Michell Argo / Hera P.sup	823	599	Naim Intro	680	499		
			Spendor SP2/2	919	499		

Canary Audio CA-601 PRE AMPLIFIER - reviewed in this issue -  
**NOW ON DEMONSTRATION**

Private parking 2.3 miles J21 - M6 detailed map on request

Established 1960



## PROGRESSIVE AUDIO

2 Maryland Court, Rainham, Kent, ME8 8QY  
Telephone / Fax No. 01634 389004

We now have on permanent demonstration the following new products; PROAC Response 3.8 loudspeakers, the whole range of AUDIO SYNTHESIS products, the GRAAF GM 20 amplifier, the MUSIC FIDELITY NU-VISTA pre amp, the CADENCEARCA and latest CADENCE ES loudspeakers, DIAPASON loudspeakers, GOERTZ cables and TICE power conditioners and enhancers, the amazing INNERSOUND hybrids and of course all our usual equipment. For any more information please call.

- Nottingham Analogue Mentor turntable complete with Mentor arm and Fidelity Research MC201 cartridge. Turntable has carbon fibre platter upgrade. In first class condition. £1,495.
- Proac Studio 150 Loudspeakers. Yew. Boxed. Mint. £1,025.
- Proac Response 2 Loudspeakers (Black) with Target R2 stands. Boxed. Mint. £995.
- Audionote SN 3 (Silver) MC transformer. Mint. £1,100.
- Conrad Johnson PV10a (Phono) with special edition upgrade. Boxed. Mint. £1,250.
- Mirage M3SI Loudspeakers. Boxed. Mint. £1,950.
- Pioneer Exclusive M6 300 Watt Class A mono blocks. Very rare. Boxed. Mint. Cost £8000 nine years ago. The pair £2,995.
- Tube Technology Prophet Pre amp and Genesis 100 Watt mono blocks. Boxed. Mint. £2,750.
- Audiolab 8000CDM Transport (CDM 9 Pro mechanism) Boxed. £895.
- Genesis Digital Lens. Mint. £995.
- Monarchy 22 B DAC. 20 Bit Burr Brown. Mint. £475.
- Music Fidelity P180 power amp. £440.
- Chord 1200 Power amp. Boxed. Mint. £1,595.
- SD Acoustics SD 1E Loudspeakers £1,995.
- Unison Research Mystery One Pre amp. Boxed. Mint. £1,350.
- Proac Response 3 Loudspeakers. (Mahogany) Boxed. Mint. £1,550.
- Proac Response 3.5 Loudspeakers. (Burnt Oak) Boxed. Mint. £2,850.
- Jamo Concert II Loudspeakers (Mahogany) Boxed. Mint. £1,395.
- Voyd Vald Turntable (Ash). RB300 Tonearm. Genz Micro Glider Cartridge. Absolutely Mint. £850.
- Audionote CD 2 CD Player (One Year Old). £725.
- KEF Reference 4 Loudspeakers (Rosewood). Boxed. Mint. £650.
- Audio Innovations Series 1000 M/C Transformer. £185.
- Audiolab 8000 CD Player. Boxed. Mint. £650.
- Audionote Level 5 E's. Ebony. Cost new £9,600. £2,995.
- Densen DM10 Int. Amp. Boxed. mint. £750.
- Audio Synthesis Desire Power Amp. Boxed. Mint. £1,295.
- Audio Synthesis Passion Pre Amp. £385.
- Audion Golden Knights 9W 300B. Boxed. Mint. £2,495.
- Tube Technology Synergy 150W Integrated Amp (New) £5,250.
- Harbeth HLP3ES (ExDem). Boxed. Mint. (Teak) £550.
- Harbeth K6 (ExDem). Boxed. Mint. (Walnut) £725.
- Suggden AU51 Pro CD Transport + AO SI DAC. The Combo. £1,995.
- Acoustic Solutions "Eight" Loudspeakers (ExDem) Boxed. Mint. £795.

## the HI-FI store

70 STAFFORD STREET, HANLEY,  
STOKE-ON-TRENT.

TEL: 01782 21 95 95

e-mail: hifistore@aol.com

Quality new and used Hi-fi at bargain prices.

**SALE NOW ON!**

**PART EXCHANGE WELCOME.**

**DVD NOW IN STOCK.**

HI-FI	R.R.P	SALE
ELECTROCOMPANIE ECI-2. CLASS A. 50 WATTS, LINE LEVEL. MINT. (S)	£1000	£650
AUDIO SYNTHESIS PASSION. PASSIVE PRE. TOP SPEC. ALL SILVER WIRE, WBT PLUGS. (S)	£700	£385
YAMAHA MX2 POWER AMP. 150 WATTS. (S)	£750	£400
MARANTZ CD-17KI SIG. AMAZING MACHINE		
GOLD FINISH. ABSOLUTELY MINT. BOXED. (XD)	£1100	£875
REL STADIUM II. BLACK FINISH. MINT. (XD)	£995	£775
YAMAHA DSPA 2. AV AMP. DTS. DOLBY DIGITAL 6 CHANNEL INPUT. MINT. BOXED. (XD)	£1000	£750
ROTEL RC/RB971 PRE/POWER 70 WRMS (XD)	£375	£300
TANNOY P40 FLOOR STANDER. REAL CHERRY VENEER. BRAND NEW. (N)	£800	£400
MARANTZ CD63 KI SIG. MINT. BOXED. (XD)	£400	£325
YAMAHA RXV 592. AV AMP. 6 CHANNEL INPUT MINT. BOXED. (XD)	£400	£300
YAMAHA DSPA592. AWARD WINNER. (XD)	£330	£250

NEW MICHELL GYODEC SE NOW IN STOCK. WITH UPGRADED SUSPENSION AND A FREE STANDING MOTOR, AT £775 EX ARM THIS IS SURELY THE BEST SUB £1000 DECK AVAILABLE. CALL FOR INFO.

**QUALITY HI-FI FROM MOST MAJOR MANUFACTURERS AVAILABLE TO ORDER. CALL FOR MORE INFO!**

YAMAHA, MARANTZ, TANNOY, KEF, ROTEL, REL, MICHELL, JBL, SENNHEISER AND MORE!



## NAD C320

The C320 produces a lot of power into a standard 8ohm load - no less than 90watts. This is plenty enough to get very high volumes in the home. The only unusual feature of this NAD compared to previous models is relatively poor power supply regulation, due to the use of a small-ish mains transformer. Output into 4ohms hardly rose at all, unusual for a solid-state "constant-voltage source" amplifier. This commonly softens out bass in terms of attack and slam.

Frequency response proved wide and again the C320 was different from earlier models in this respect. NAD have tended to limit high-frequency extension in the past to get a soft, warm, yet clean sound.

The C320 may well sound brighter and clearer than NADs of yore as a result. NAD have not compromised on low distortion, however, with figures of 0.003% at low power in the midband, up to a reasonable 0.037% at full output at 10kHz - a very arduous test. I would expect the C320 to sound smooth and free from the coarseness caused by distortion.

The NAD measured well in most areas but its power supply is not especially sturdy, which may well soften bass impact. NK

Power	90watts
CD/tuner/aux.	
Frequency response	8Hz-106kHz

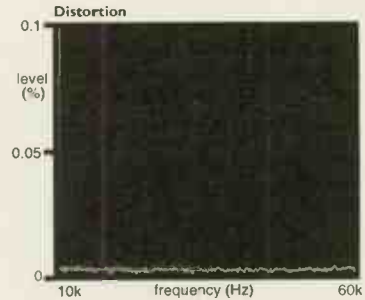

Separation	77dB
Noise	-95dB
Distortion	0.003%
Sensitivity	320mV
DC off-set	-2mV/-6mV

# CARTRIDGE

## CLEARAUDIO ALPHA MM

The Alpha has a very long cantilever that projects forward from the cartridge body, making cueing easy and accurate.

However, this is also a method of getting correct vertical tracking angle, so it was no surprise that VTA measured a theoretically correct 22degrees. This in turn minimises vertical distortion which, on the Alpha, measured an unusually low 1.3%, comprising mainly second harmonic.

Trouble is, few designers in the world choose such a design route, viewing a short, stiff, low tip-mass cantilever as preferable to the long, flexy, higher tip-mass that correct VTA demands. Low measured distortion is not overly important when the distortion concerned is correlated second harmonic.

One channel was 2dB down on the other. Frequency response was reasonably flat; the Alpha displays less midrange generator droop than old designs, although it is no better than modern Goldring's, for example. Tip mass resonance puts a peak into the response at a low 12kHz, which

will add a little brightness. This low-ish frequency comes about as a direct result of the long cantilever. All the same, tracking performance was respectable, if not exceptional, at all frequencies.

The Alpha has been engineered to give a good measured performance. The decisions made have compromised it in other areas though. NK

Tracking force	1.6gms
Weight	10gms
Vertical tracking angle	22degrees
Frequency response	20Hz-20kHz
Channel separation	30dB
Tracking ability (300Hz)	
lateral	63um
vertical	45um
lateral (1kHz)	20cms/sec.
Distortion	(45um)
lateral	1.5%
vertical	1.3%
Output (5cms/sec rms)	4.2mV

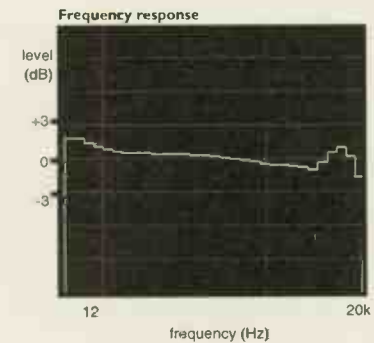

## ORIGIN LIVE TURNTABLE KITS Standard & Ultra

Now you can save money and build your own high performance deck. The standard kit version is offered at £145, and the ultra version at £279. Both decks come with a full set of drawings and guidance instructions. The kit allows for your creativity or there are optional parts that will enable you to assemble a tried and tested design within 1-4 hours. This is probably the easiest kit you will ever make.

*"this Vinyl font end had my jaw heading towards the floor with the solidity and transparency of the music it was making"...*  
*" the standard came up with crystal clear images set in a broad sound stage"...* *"With all these goodies in place, the standard would give turntables at the £1200-£1400 mark a hard time."*  
HI-FI WORLD SUPPLEMENT NOV 97

*"is exceptionally easy to build and professional in both sound quality and appearance"*  
HI FI NEWS SUPPLEMENT NOV 97

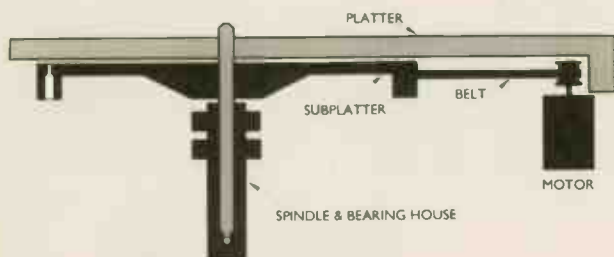

## TURBOCHARGING YOUR REGA ARM

*"Nothing less than total dynamite!"*

HI-FI WORLD, FEB 1999

If you are the proud owner of any Rega arm, why not utterly transform it into the league of super arms with the Origin live structural modification:- £75 inc post & packing. This modification will enable your Rega to perform at a level exceeding that of arms costing over £1200. Internal rewiring with high grade litz cable is also offered at an additional £70.

*"I have to say the Rega modifications turn this humble arm into a real Giant killer. Gone is the rather grey, sterile sound of the cooking Rega. Instead, tonal colour is fresh, dynamics have great speed and impact, and the sound stage is huge."* HI FI WORLD SUPPLEMENT NOV 97 (structural modification only to a RB250) WHAT HI-FI Sept 98 gave this modification a 5 star rating.

For arm modifications we normally return your arm in 2-3 days

CROSS SECTION OF ARM END

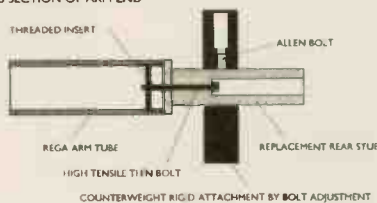

For further information contact:-

Origin Live, 87 Chessel Crescent, Bitterne,  
Southampton, SO19 4BT

Tel: 01703 578877 / 442183 Fax: 01703 398905

Email: [origin.live@virgin.net](mailto:origin.live@virgin.net)

web site: <http://www.originlive.com>

# R.J.F.

## AUDIO VISUAL

**HIGH END  
AUDIO FOR  
DISPOSAL AT  
GIVE-AWAY  
PRICES!**

84 PENDARVES STREET, TUCKINGMILL, CAMBORNE CORNWALL  
TR14 8NJ 01209 710777

### NEW ITEMS

Denon AVD-2000, best buy for home cinema	£380.00
Denon DVD-3000, best buy for home cinema	£650.00
Denon - full range available	£POA
Neat Acoustics - full range available	£POA
Ortofon cartridges - full range available	£POA
Seleco SVP 350, AWARD WINNING CRT PROJECTOR	£3,500.00
Sharp XV-C20E LCD projector	£1,350.00
SME 20/2 precision turntable	£POA
SME 20/2A as above with series V arm	£POA
SME series II model 3009 pick-up arm	£POA
SME series 300 model 309 pick-up arm	£POA
SME series IV pick-up arm	£POA
SME series V pick-up arm	£POA
TDL Loudspeakers - full range available	£POA

We are Dealers for a good number of audio brands including PA and studio equipment. Please conduct us with your requirements.

#### DVD, LASER DISC AND PROJECTION SYSTEMS NOW AVAILABLE

Consult us for your high (or low) end repairs/mods, CD re-clocking, LASER DISC AC3 UPGRADES - PIONEER, SONY, PHILIPS, DENON. We are valve and transistor specialists. Specialist cables supplied and made to order.

**DUE TO THE ADVENT OF TRICHORD CLOCK III WE NOW HAVE A NUMBER OF CLOCK II UNITS FOR DISPOSAL. WE CAN OFFER THESE FITTED TO YOUR CD PLAYER OR TRANSPORT AT £110.00 INCLUDING RETURN CARRIAGE.**



# bass?

Audion Audio Note Art Audio  
Audio Innovations Cary  
Unison Research Leak  
World Audio Designs

Famous names and impressive amplifiers but  
you will not experience their full capability until you  
fit a BorderPatrol power supply



**BorderPatrol**  
Take control

Tel/Fax +44 (0) 1273 276716

# CD PLAYERS

## AUDIO ANALOGUE PAGANINI

The Paganini would not replay a pulse test used for frequency response measurement, which is unusual. The only other players to behave unusually with a pulse are those with special processing from Pioneer and Denon, but both display curtailed frequency response rather than no response. However, the Paganini replayed white and pink noise correctly, as well as fixed tones, displaying flat frequency response to 21kHz. Our third-octave analysis, with fine 0.5dB/division scaling, shows the Paganini was very flat. In use, inability to reproduce a short pulse may well make the player sound a little warm and easy-going.

Distortion levels were much the same as most good players. Our analysis clearly shows absence of quantisation products at -30dB and there was little distortion at lower levels too, so this player will sound clean and free from coarseness.

With a normal output of 2V and wide channel separation, the Paganini measured well. NK

Frequency response	4Hz-21kHz	
	left	right
Distortion (%)		
-6dB	0.005	0.004
-30dB	0.01	0.009
-60dB	0.56	0.57
-90dB	30	31
Separation (dB)	left	right
1kHz	120	117
20kHz	103	107
Noise		-109dB
with emphasis		-109dB
Dynamic range		107dB
Output		2V

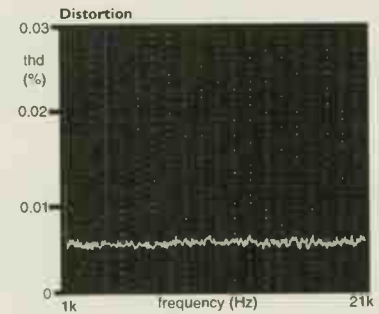
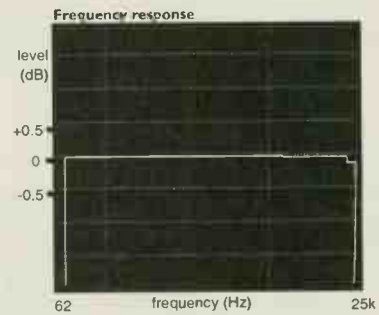

## THULE CD100

The Thule gave a conventional CD measured performance. It has a flat frequency response with slight top-end loss, just enough to avoid a bright, spitty sound, as our frequency response analysis shows.

Distortion was low at all signal levels, comprising mostly quantisation noise at -30dB, the level shown in our distortion analysis. At lower levels distortion from the Thule rose a little higher than usual, a figure of 0.8% being double that of a good, modern design. This compromised the EIA dynamic-range figure, putting it at 107dB.

Channel separation was satisfactory, noise low and output normal. The Thule uses a pretty standard chip set which offers conventional results. NK

Frequency response	4Hz-21kHz	
	left	right
Distortion (%)		
-6dB	0.005	0.004
-30dB	0.02B	0.028
-60dB	0.7	0.8
-90dB	37	36
Separation (dB)	left	right
1kHz	80	80
20kHz	68	68
Noise		-105dB
with emphasis		-105dB
Dynamic range		107dB
Output		1.975V

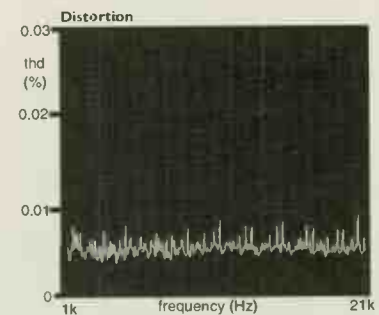
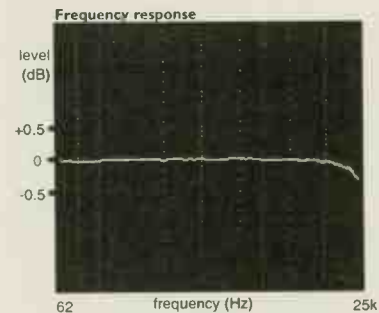

# THE MANCHESTER HI-FI SHOW 1999

**BRITANNIA HOTEL MANCHESTER UK  
20-21 MARCH 1999  
SHOW ADMISSION £2.50  
CHILDREN UNDER 16 FREE WHEN ACCOMPANIED BY AN ADULT**

**THE MANCHESTER HI-FI SHOW  
HAS NO CONNECTION  
WITH THE NORTHERN HI-FI SHOW**

**FOR FURTHER DETAILS TEL LEADING EDGE PROMOTIONS  
ON +44 (0) 1425 652595 OR FAX +44 (0) 1425 654400**



## listening rooms

	RRP	SALE	
<b>AMPS/PRE-AMPS/A.V.CONTROLLERS</b>			
ARCAM ALPHA7	249.00	199.00	D
AUDIO RESEARCH LS 3 PRE AMP	1895.00	995.00	D+N
AUDIOLAB 8000LX	469.90	359.90	D
AUDIOLAB 8000A	499.90	379.90	D
AUDIOLAB 8000Q	1,249.90	849.90	D
CROFT SMA 4 preamp		199.00	S/H
HARMAN KARDON AVR 80	1,200.00	550.00	D
HARMAN KARDON AVP 1A THX PROC	1,499.00	349.00	S/H
KRELL KRC3	2,998.00	2,299.00	D
KRELL KSA 200S		3,599.00	S/H
LINN LK100	650.00	455.00	D
LINN KLOUT POWER AMP		895.00	D
LINN 5105 POWER	1,200.00	840.00	D
LINN 5103 AV Controller	4,850.00	3,199.00	D
MERIDIAN 555 POWER	695.00	449.00	D
MERIDIAN 501 PRE	695.00	489.00	D
MICHELL, J.A. ALECTO stereo	1,150.00	849.00	D
MICROMEGA TEMPO2 int	899.90	599.00	D
QUAD 77 int	650.00	449.00	D+N
<b>CD PLAYERSTRANSPTS/DACS</b>			
ARCAM DELTA 270	800.00	399.00	S/H
AUDIOLAB 8000CDM	1,399.00	899.00	D
AUDIOLAB 8000CD	999.90	699.00	D
AUDIOLAB DAC	899.90	579.00	D
MARANTZ CD67	269.90	189.00	D
MARANTZ CD67 SE	349.90	269.00	D
MICROMEGA DAC 1	699.90	399.00	D
MICROMEGA STAGE 2	549.00	369.00	D
MICROMEGA STAGE 1	499.00	349.00	D
QUAD MODEL 77	595.00	416.00	D+N
TRICHORD RESEARCH PULSAR	1,400.00	699.00	S/H
<b>SPEAKERS</b>			
EPOS ES22	1,145.00	749.00	D
EPOS ES12	500.00	350.00	D
KEF CODA	189.00	119.00	D
MERIDIAN M1500 SUB	895.00	679.00	D

D = EX DEMONSTRATION. N = NEW, S/H = SECOND HAND

**THE LISTENING ROOMS LTD**  
161 OLD BROMPTON ROAD LONDON SW5 0LJ  
TEL: 0171 - 244 7750/59 FAX: 0171 - 370 0192  
Mon-Sat 10-6pm

## MANTRA AUDIO

CARTRIDGE SELECTION	STYLUS	REPLACEMENT STYLUS	
Audio Technica		Swiss Copy Diamond Styli	
AT 95 E	£22 £14	ADC XLM Mk III	£14.00
AT 110 E	£27 £14	Akal AN 5, AN 60	£10.00
AT OC 9	£280 £210 EX	AN2, AN 70	£12.00
Denon		Dual DN 145 E, DN 165 E	£14.00
DL 110	£70 £55 EX	Goldring G800 Super E	£14.00
DL 304	£190 £160 EX	JVC DT 55, DT 60	£10.00
Goldring		National EPS 24 CS, P 30 D, P 33 D	£10.00
1012 GX	£76 £50	Ortofon FF 15 E II, VMS 20 E II, DM 20	£14.00
1022 GX	£94 £62	Pioneer PN 210, PN 220, PN 240	£10.00
1042	£115 £76	Shure N 75 C, SC 35 C	£10.00
Eroica (LX or H)	£102 £78 EX	N 75 ED T2, N 75 EJ T2	£12.00
Elite	£200 £153 EX	N 95 ED, N 95 EJ, N 75 3 (78)	£14.00
Excel VX	£446 £342 EX	VN 35 E	£16.50
Grado		N 95 HE, N 97 HE, VN 35 HE	£22
Prestige Black	£44 £24	ND 142 G, ND 150 G, ND 155 G	£10.00
Prestige Gold	£134 £74	CN234	£12.00
Ortofon		*** DVER 500 STYLI TYPES STOCKED ***	
510	£34 £22	ORTOFON DJ PACKS (CARTRIDGE + 2 STYLI)	
MC 15 Super II	£120 £102 EX	Concorde Pro SSS Pack	£67 Stylus £15
MC 25 FL	£210 £178 EX	Concorde Nightclub SSS Pack	£106 Stylus £27
MC 10 Supreme	£263 £224 EX	Concorde Nightclub EEE Pack	£82 Stylus £33
MC 20 Supreme	£330 £280 EX	Concorde DJ SSS Pack	£82 Stylus £21
MC 30 Supreme	£392 £333 EX		
Rohmann	£725 £645 EX		
Jubilee	POA POA EX		
Shure		HEADPHONE SELECTION	
V 15 V XMR	£265 £178	GRADO Prestige Series	
SC 35 X	£32 £24	SR-40	£45
		SR-60	£75
		SR-80	£90
		SR-125	£135
		SR-225	£180
		SR-325	£270
		Reference Series	
		RS-1	£590
		RS-2 (new)	£425
		RECORD/DISC CLEANER	
		Milly Permaclean Record Cleaner	£12.00 £8.00
		Permatat Anti-static Spray	£12.00 £9.00
		Dishwasher CD Cleaner	£14.00 £5.50

EX - Exchange price any MC cartridge  
Order direct from the full selection as shown on our Website  
<http://www.mantra-audio.co.uk>

MAIL ORDER (1 TO 10 DAYS) PRICES (INC P&P) ARE BEST WE CAN OFFER THROUGH COMPETITIVE SOURCING UK & MAINLAND EUROPE - ALL ITEMS CARRY FULL MANUFACTURERS GUARANTEE - OVERSEAS CUSTOMERS PLEASE ADD £5.00 TO ORDERS OVER £50 IN VALUE TO COVER INSURANCE  
Tel/Fax (01757) 288652 e-mail: [enquiry@mantra-audio.co.uk](mailto:enquiry@mantra-audio.co.uk)  
MANTRA AUDIO (HFV), 22 GARTH AVENUE, NORTH DUFFIELD, SELBY, NORTH YORKS YO8 5RP

**DESIGNS ENGINEERED FOR EXCELLENCE WITH:-**

- POLYPROP CAPS
- AIR CORED COILS
- HI-TEC DRIVERS
- TOP GRADE COMPONENTS

**CABINETS INCLUDED WITH OPTIONS ON FINISH**

- NOTES AND SPECIFICATIONS
- COMPREHENSIVE INSTRUCTIONS
- AVAILABLE AS COMPLETED UNITS WITH STANDARD OR EXOTIC VENEERS
- DISCRETE COMPONENTS
- CUSTOM MACHINING SMALL PANELS, JOINTS & CUT-OUTS

**FOR FURTHER DETAILS:-**

# Q.T.A. Systems

2 Wheatsheaf Way  
Linton - Cambs CB1 6XB  
Tel: 01223 891091

# LOUDSPEAKERS

## CHARIO CONSTELLATION LYNX

The Lynx has been engineered to have pronounced bass and treble lifts, like many European loudspeakers. It may sound lively in a showroom but it makes no attempt at accuracy and may well prove tiring in the home after a while. Output from the tweeter peaks up +4dB at 16kHz, enough to sound sharp on CDs with a lot of treble. Bass rises by +5dB at 160Hz, which will add speed but possibly boom at this level.

The impedance curve is more bizarre than the frequency response. From 20kHz down to 1kHz it is a high 12ohms, doubtless attributable to the dome tweeter.

Below this, impedance plunges to a very low 3ohms at 200Hz, broken only by the twin peaks of reflex loading.

There is a lot of reactance in the load, plus heavy current draw at bass frequencies, not a good mix at all. This is one of the most awkward looking loads I have ever seen and could well upset some amplifiers. Sensitivity was a normal 86dB sound pressure level from 2.83V input, a nominal watt.

The Lynxes need to be auditioned carefully, with the amplifier they are to be paired with. I was unimpressed with every aspect of their engineering. **NK**

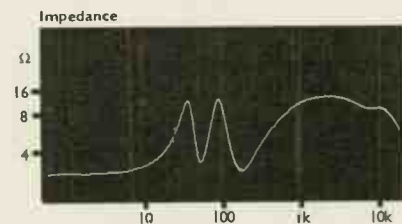
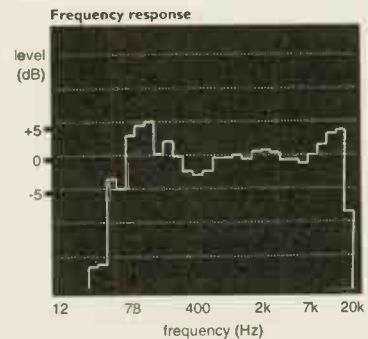

## MISSION 772

The Mission 772s have a smooth forward frequency response, as our analysis shows. There is a small dip between the mid/bass unit and the tweeter but it is an amplitude dip that holds constant over a wide forward angle, so the loudspeakers' sound will remain stable with listening position. Phase integration between drivers was very tight, a good sign. This gives solid, clear treble, especially with transients like struck cymbals.

There is a small but steady rise in bass to a peak at around 150Hz, which will add bass speed and slap to hand drums. Below this bass continues down to 60Hz, after which the port takes over, delivering its contribution at 50Hz, as the impedance curve shows. Mission place port resonance right on bass unit resonance for the tightest bass damping. The 772s should be used within a few feet of a rear

wall to lift low bass a little.

The impedance curve is unusually flat, meaning the 772s are essentially a resistive load that will not return energy to the amplifier, thereby affecting the feedback signal, except at low frequencies. This minimises differences between amplifiers and makes the most of them. Also, as the Missions measured out at a high overall impedance of 12ohms, amplifiers will not have to deliver much current to them, again making them a light load as far as an amplifier is concerned. With reasonable sensitivity (as small loudspeakers go) of 86dB, they deliver good volume from low powers and should need no more than 60watts to go loud.

The 772s are very well engineered in every area, better so than all rivals. Impressive. **NK**

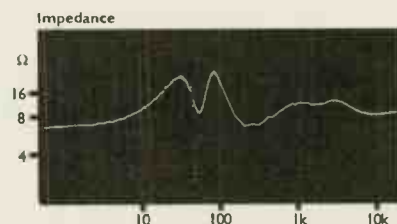
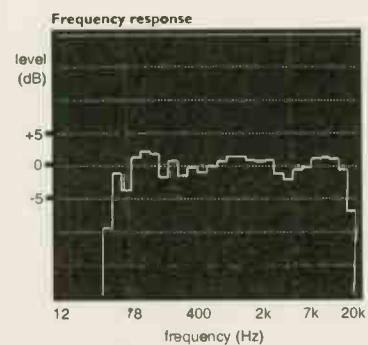

# Previously Cherished Items, Or something new from Choice

## Clearance Items

	Choice Price	Original Retail Price
Audio Research D240 mk II	£ 1395.00	£ 3500.00
Chameleon Ruby Power amp (200W)	£ 395.00	£ 1200.00
Alchemist Kraken x 2 Stereo & Pre-amp	£ 595.00	£ 1400.00
Exposure V Active x over	£ 295.00	£ 995.00
EAD 7000 Transport	£ 395.00	£ 2495.00
Tesseract Tala pre-amp	£ 695.00	£ 1495.00
Magnum P200 pre-amp	£ 895.00	£ 1895.00
Alon IV mk II	£ 1500.00	£ 3500.00
Royd Priors	£ 395.00	£ 950.00
Sonus Faber Gravis Sub woofer + X-over + power amp	£ 1250.00	£ 3200.00
Kenwood 9010 CD Transport	£ 195.00	£ 500.00
Alon Adriana	£ 3500.00	£ 10000.00
Alon PW1 Subwoofer (Passive)	£ 295.00	£ 750.00
Gale 401	£ 250.00	-
Linn Kan	£ 250.00	£ 500.00

## New in This Month

POWER AMPLIFIERS		
2 x Copland CSA 14 Integrated (black/Silver)	£ 795.00	£ 1195.00
Restek Extract Monoblocks (180 watt)	£ 2495.00	£ 3500.00
Mark Levinson 331	£ 2750.00	£ 5000.00
Krell KSA 100 mk 2	£ 1495.00	-
Audiolab 8000P	£ 575.00	£ 800.00
PRE AMPLIFIERS		
Marantz Model 7 (Limited Edition)	£ 2995.00	£ 4000.00
Jeff Rowland Consumate + Phono	£ 3995.00	£ 8000.00
Audiolab 8000S	£ 450.00	£ 700.00
SPEAKERS		
Aliate Spazio	£ 350.00	£ 550.00
Rogers LS3/5A Black	£ 550.00	£ 699.00
Kef Reference Model 4 (Rosetta Burr)	£ 3300.00	£ 4000.00
Impulse Taus	£ 1800.00	£ 3100.00
TURNTABLES/ANALOGUE/VARIOUS		
Voyd Reference/Reference Power supply/ Helios Cyalene/Audio Note 10 limited + P/S	£ 11500.00	£ 22000.00
Roksan Xerses/Linn Akito/PSII/DSU	£ 650.00	£ 1200.00
Musical Fidelity T1 FM Tuner	£ 150.00	£ 300.00
Ortofon MC30	£ 450.00	£ 650.00
Linn LP12/ Lingo/Cirkus	£ 750.00	£ 1400.00
SME V (Gold Print)	£ 850.00	£ 1600.00
C.D PLAYERS & DACS		
Krell MD-10 CD Turntable	£ 3495.00	£ 7990.00
Krell Studio Dac	£ 1995.00	£ 4450.00
Theta Data Basic 2	£ 1295.00	£ 2400.00
Theta Pro Basic III (Balanced)	£ 1695.00	£ 2990.00
Cambridge Dac Magic	£ 150.00	-
Mark Levinson No36 Dac + 37 Transport	£ 3995.00	£ 8000.00
Audiolab 8000 CD	£ 650.00	£ 1000.00

## Power Amplifiers

Krell KAS 2 Monoblock	£ 9195.00	£ 18490.00
Michell Alecto Stereo	£ 995.00	£ 1500.00
Exposure XV	£ 450.00	£ 795.00
Jadis JA500	£ 7995.00	£ 21000.00
Boulder 102 AE	£ 2650.00	£ 3400.00
Boulder 500 AE	£ 3795.00	£ 5000.00
LFD PA1/LS1	£ 895.00	£ 1998.00
Audio Note P1 SE	£ 500.00	£ 950.00
Jadis JA 80 Monoblocks	£ 4995.00	£ 10000.00
Audion Golden Knights	£ 2200.00	£ 4000.00
Audion Silver Knights (Gold)	£ 1200.00	£ 2250.00
Jadis Defy 7 mk III	£ 3250.00	£ 4790.00
Audio Research VT150 SE	£ 11995.00	£ 17000.00
Micromega Tempo 2 Integrated	£ 595.00	£ 900.00
Krell FPB 600	£ 8995.00	£ 12900.00
Krell KSA 250	£ 2750.00	£ 6700.00
Audio Note Ankoru Monoblocks	£ 8500.00	£ 14500.00
VTL Monoblocks	£ 1795.00	£ 4000.00
Micromega amp	£ 750.00	£ 1295.00
Audio Research CA50 Integrated	£ 2495.00	£ 3400.00
Audio Research VT50	£ 2095.00	£ 2895.00
Copland CTA 505	£ 1295.00	£ 1899.00
Micromega Tempo P	£ 750.00	£ 1250.00

Audiolab 8000A	£ 250.00	£ 600.00
Air Tight AT1	£ 2600.00	£ 4200.00

## Pre Amplifiers

Michell Argo & Hera PSU	£ 495.00	£ 900.00
Krell KRC2 + KPE Phono Stage	£ 2500.00	£ 4300.00
Conrad Johnson PV12 (mm/mc)	£ 1995.00	£ 2590.00
McCormack Micro Line Drive	£ 350.00	£ 595.00
Audio Research LS3	£ 1095.00	£ 1900.00
Audio Research LS5 mk II	£ 2695.00	£ 5700.00
Meridian 541 Dolby Surround	£ 695.00	£ 1095.00
Burmester 785	£ 395.00	£ 900.00
Angstrom 200 (Home cinema controller)	£ 1800.00	£ 3495.00
Audio Research LS7	£ 1095.00	£ 1620.00
Audio Research LS15	£ 2400.00	£ 3200.00
Copland CTA 301 Mk II (mm)	£ 795.00	£ 1249.00
Electrocompaniet EC4.5	£ 695.00	£ 1195.00
Audio Note M2	£ 650.00	£ 950.00

## Quality Speakers

Audio Note AN-E/B	£ 795.00	£ 1520.00
Acoustic Energy AE1	£ 550.00	£ 795.00
Ensemble PA1	£ 995.00	£ 2000.00
Alon V mk II Bk	£ 2500.00	£ 5000.00
Wilson 3/2 (Black)	£ 5995.00	£ 15000.00
Alon Lotus SE	£ 2500.00	-
Sonus Faber Extrema + Stands	£ 4250.00	£ 7000.00
Wilson 5.1 (Piano White)	£ 11500.00	£ 19000.00
Thiel CS1.5	£ 1595.00	£ 2700.00
Mini Grand	£ 2995.00	£ 7600.00
Acoustic Energy AEGIS 1/ Stands	£ 295.00	£ 590.00
Martin Logan SL3	£ 2795.00	£ 3499.00
B & W 801 Series 2 (Black Ash)	£ 2200.00	£ 4000.00
Apogee Stage	£ 995.00	£ 3000.00
Sonus Faber Electa Amator	£ 1495.00	£ 2992.00
Kef Reference 4	£ 2200.00	£ 3600.00
Martin Logan Aeries I	£ 1650.00	£ 2200.00

## CD Players & DACS

Mark Levinson No 39	£ 4250.00	£ 5000.00
Micromega T-Drive/T-DAC	£ 895.00	£ 2100.00
Wadia 6	£ 1995.00	£ 4300.00
EAD DSP 1000	£ 695.00	£ 1495.00
Audio Alchemy DDE V1.0 + psu 1	£ 150.00	£ 300.00
P.S. Audio Ultralink	£ 795.00	£ 2390.00
McCormack DAC-1	£ 450.00	£ 995.00
Acuphase DP90/91	£ 9950.00	£ 20000.00
Forsell Air Ref Transport mk II	£ 4995.00	£ 8000.00
Forsell Air Ref dac	£ 2995.00	£ 5800.00
Mark Levinson 30.5/31	£ 11500.00	£ 24000.00
Meracus Transport	£ 1500.00	£ 3995.00
Meridian 566 DAC (20 Bit)	£ 895.00	£ 1095.00
DPA PDM 1 mk III	£ 550.00	£ 1000.00
Marantz CD94/94A	£ 595.00	£ 1600.00
Audio Research CD 2	£ 2495.00	£ 3500.00
Micromega Duo CD 2 Transport	£ 895.00	£ 2000.00
Audio Alchemy DDS II Transport	£ 395.00	£ 900.00

## Turntables & Analogue

Well Tempered Turntable and arm	£ 895.00	£ 1500.00
Linn LP12, Lingo Cirkus, Ittok III, Troika Trampolin	£ 1795.00	£ 3200.00
Piere Lurne J1/SL5	£ 1500.00	£ 4500.00
Piere Lurne J1/Sowther mk III	£ 1800.00	£ 4500.00
Forsell Air Force One	£ 11995.00	£ 25000.00
Quad FM3 Tuner	£ 195.00	-
Clear Audio Sigma	£ 450.00	£ 600.00
Linn Klyde	£ 450.00	£ 600.00
Pink Triangle PT Too Ref Bearing, platter, clamp	£ 850.00	-
Stax Lambda Nova Signature/ SRM-TIS	£ 995.00	£ 1195.00
Transparent Musiclink	-	-
Reference (RCA-RCA)	£ 1000.00	£ 2200.00
Transparent Musicwave	-	-
Ultra Bi-Wire 3.6mtr	£ 1600.00	£ 3300.00
Lyra Parnasus (VdH tip)	£ 950.00	£ 1895.00

## STOCKIST OF:

- Acoustic Energy, Rockport, Alon, SME, ATC, Soundstyle, Boulder, Tara Labs, Bryston, Target, C.A.T., Totem, Chord, Trichord, ClearAudio, Trilogy, Elemental Audio, van den Hul, Graham, VPI, Helios, XLO, Lavardin, DVD Players now available from Sony, Panasonic and Pioneer, Michell, Musical Fidelity, Oracle analogue and digital, and many more.

- ⊗ In-depth experience on high end new and used equipment
- ⊗ Best prices paid for top quality equipment
- ⊗ Generous part exchange
- ⊗ Show room/dem room
- ⊗ Long term trade in policy, to allow continual upgrading
- ⊗ All credit cards inc. Amex
- ⊗ Mail order
- ⊗ Export service
- ⊗ Finance arranged subject to status
- ⊗ Widest range available
- ⊗ Unbiased advice
- ⊗ Unique 'Hi-Fi Exchange' - a computerised database of sales and wants - will put you in touch

Choice hi-fi make it easy for you to fulfil your sonic dreams. Quality hi-fi is not just about expensive brandnames, it's about aspiring to the very best sound, about choosing your ideal system from the widest selection in the country, in a unique no-pressure environment. It's about taking advantage of our unrivalled knowledge and being given the freedom to choose and upgrade the audio equipment you want, when you want. Others may sell you hi-fi, Choice hi-fi will sell you solutions.



tel **0181 392 1959 & 0181 392 1963**

fax 0181 392 1994 e-mail choice\_hifi@man.com open from 10am to 8pm by appointment  
All previously cherished items in mint, second hand or as new condition - guaranteed

## COMPACT DISC PLAYERS

**QUAD 67** SECOND-HAND

One of Quad's best products for a long time, the '67 is warmer and smoother than most, yet is highly musical and revealing. (May 93)

**KENWOOD DP-3080/II** £180

Has great clarity and presence for the price. Not as naturally expressive as the CD4SE though. (Feb 98)

**CAMBRIDGE CD4SE** £200

A touch soft in the treble but outstanding in every other respect. (Feb 98)

**ARCAM ALPHA 7** £330

This British-built player is extremely good value. Up-front, punchy. Suits Techno and Rock. (Mar 97)

**MARANTZ CD-63MKII KI-S** £400

Similar to the CD-63SE but more powerful bass and an all-round smoother sound. The famous KI tweaks pay off again.

**PHILIPS CDR 870 RECORDER** £500

Replay quality is on a par with £250 machines but analogue and digital recordings on CD-R and CD-RW are outstanding. (Jan 98)

**DENON DVD-3000** £699.99

The Denon is a fine performer with CD and better still with 24/96. It's sonically strong with a crisp, clean and involving sound.

**ROKSAN CASPIAN** £895

The Caspian has a smooth, slightly bright sound with some of the clearest treble in the business. Very engaging, dynamic character. (Aug 97)

**PANASONIC DVD-L10** £999.95

This mini-marvel with its built-in screen isn't cheap but it's an outstanding portable and a more-than-capable domestic device. (Nov 98)

**MERIDIAN 506 20-BIT** £1100

Very detailed and revealing player. More cerebral than visceral sounding, however. (May 95)

**MARANTZ CD-17 KI-S** £1100

The Marantz excels in all areas. Without doubt this is one of the most involving CD players on the planet. Build quality is also exemplary. (Sep 97)

**DENON DCD-S10** £1300

A warm, atmospheric and smooth performer that never fails to involve. Silken musicality par excellence. (Jul 97)

**MCINTOSH CDM7009** £2635

A thoroughly inspiring machine. One of the most musical CD players around; sweet, open and detailed. (Dec 95)

## COMPACT DISC TRANSPORTS

**TEAC VDRS-T1** £550

Not as substantially built as its chunky looks suggest, the T1 is nevertheless a good entry-level transport with a warm, expansive sound. (Feb 95)

**TEAC P-30** £2500

Cheap it isn't, but then it sounds like a million digital dollars. Nothing short of superb. (Jun 97)

**SONIC FRONTIERS TRANSPORT** £6999

Cutting edge design and technology combine to make this one very desirable product. The only problem is the fantasy hi-fi price. (Sep 98)

## CD CONVERTORS

**MIDIMAN FLYING COW** £299.99

Excellent as a DAC and doubles as an ADC for archiving to CDR. (Jun 98) Great value, as is junior version Flying Calf at £109. (Feb 99)

**MUSICAL FIDELITY X-DAC** £300

A bargain for normal CDs and even better with HDCDs. (Nov 97)

**ASSEMBLAGE DAC-2** £400 (KIT)

Takes little building to produce a clean, clear sound. HDCD filter included.

**MARSTON SILHOUETTE** £795

With Crystal Semiconductors' 18-bit DAC the Marston produces clean-cut images and a transparent sound stage. Very rhythmic too. (Aug 97)

**DPA 1024** £6000

Proof positive that today's CDs needn't sound CD-like! Uses an in-house discrete convertor, and DPA haven't skimped on the build either! (Jul 94)

**DCS ELGAR** £8500

Future-proof convertor which will handle 24/96 and 24/192. Extremely open and natural performer. (Nov 97)

**SONIC FRONTIERS PROCESSOR 3** £6999

Quality never comes cheap! This DAC oozes class and when matched with the Transport 3 is certainly up with the best. (Sep 98)

## TURNTABLES

**GARRARD 301/401** second-hand

In a decent plinth with an arm of SME 309 calibre, the 301 & 401 have a highly authoritative sound with solid, expressive bass. Very musical, but treble isn't up to modern standards.

**THORENS TD124** second-hand

One of Thorens' best turntables. Needs a modern plinth to give its best. Duly installed, it's good enough to face off the Garrards, swapping some of its bass power for a more delicate, incisive treble.

**ORIGIN LIVE STANDARD** £145 (KIT)

Fine in standard form with AC motor, frighteningly good with a DC motor and battery PSU.

**SYSTEMDEK IIX900/RB250** £330

A fine all-rounder and easy to upgrade too. More depth and breadth than Rega Planar 3. (Sep 94)

**PINK TRIANGLE TARANTELLA** £680

Not only does the Tarantella have more style than a catwalk full of models, it also combines PT's usual clarity with real authority. (Oct 97)

**VPI HW19 JUNIOR/RB300** £599

With its control and grip on music the Junior never fails to engage. Set-up is a piece of cake and there's a range of upgrades on offer too. (Oct 97)

**MICHELL GYRODEC** £875

Stunning looks, build and fine sound. Standard PSU has detailed, architectural, if undynamic sound. With QC PSU, scale and insight excel.

**PRO-JECT 6.1SA** £999

The Pro-ject places the listener in the best seat in the control room. Comes with Sumiko arm and Ortofon MC 30 Supreme. (Dec 94)

**ROKSAN XERXES X** £1295

DSU or XPS 3.5 power supply £150/170 extra. Excellent pitch stability from a new Swiss motor and outboard power supply. Very tight bass, fine dynamics and revealing clarity. (Jan 97)

**MICHELL ORBE** £1995

The Darth Vader of analogue, the Orbe builds on the strengths of the Gyrodec. An ultra-tuneful, expansive sound. (Apr 95)

**SME MODEL 20** £3400

Including the excellent SME V tone-arm, the Model 20 is one of the last great turntables, unless you've got £11000 for the Model 30, that is. (Oct 92)

## TONE-ARMS

**LINN ITTOK** second-hand

This early heavyweight arm benefits from fine engineering. Good dynamics and grip.

**REGA RB300** £180

Supremely capable at the price, but not quite humankind's salvation. Some may prefer the simpler RB250 at £130. Detailed, tight, rhythmic sound but tonally rather grey and cold-sounding.

**SME 3009SII** £309

This Paleolithic device is no longer state-of-the-art with frequency extremes or detail, but its legendary serviceability makes it a cult in Japan. Can be picked up for peanuts second-hand. (Jan 93)

# World favourites guide

**HADCOCK GH 228 SE** £595  
Venerable unipivot design re-engineered for bang up-to-date performance. Bucks current tone-arm fashions but the sweet sound tells why. (Dec 98)

**SME 309** £689  
A down-market version of the IV and V with aluminium armtube and detachable headshell. Tight, neutral sound with good tonality, but lacks the IV's pace and precision. (Jan 93)

## CARTRIDGES

**GOLDRING 1012GX** £74  
An accomplished MM with a solid bass, slightly forward midband and clean transients. (Jul 93)

**ORTOPHON MC 15 SUPER II** £140  
Not quite as good as the dearer Supremes but the Super II is a splendid introduction to the joys of moving-coil cartridges.

**DNM MICA** £185  
Bettors Goldring's 1042 and costs only £135 on trade-in. An assured and transparent MM. (Feb 98)

**GREGORY MUSIC MAKER** £575  
When mated with a good quality arm, this hand finished high-output pick-up gives an ear-boggling account of itself. An absolute gem. (Feb 99)

**ORTOFON MC 2000** £799  
We came across this in an SME IV on a Garrard 401; it gave one of the best results we've heard.

**ORTOFON ROHMANN** £1000  
In a way it's MC 2000 meets MC 7500 with great tonal strengths and a dynamo sound. (Apr 96)

**LYRA LYDIAN** £649  
A truly musical, sophisticated device that makes most other MCs sound frigid. (Jun 95)

**VAN DEN HUL MC-10** £840  
Fluid bass, finely-etched treble and highly tuneful. The MC-10 is a honey, pure and simple. (Jun 95)

**ORTOFON MC 7500** £2000  
Conclusive proof that there's hope for the world. CD lovers would die if they heard it. (May 94)

## INTEGRATED AMPLIFIERS

**MISSION CYRUS I/II** S/H  
Both versions give a detailed, articulate and dynamic sound. Worth keeping an eye out for second-hand.

**DENON PMA-250SE** £160  
It might not have bags of grunt but the Denon can sound exceedingly natural and open. (Feb 97)

**ROTEL RA-970BX** £250  
With its smooth and powerful sound; sings a seductive song with all types of music. (Oct 96)

**PIONEER A-300R PRECISION** £399  
This is the A-300 tweaked. Rhythm and detail are first-class; the phono stage is not far behind. (Apr 95)

**AUDIO ANALOGUE PUCCINI SE** £595  
This superbly-built Italian integrated has a lucidity and control which leaves others nowhere. Sound stage a wow. (Dec 97)

**ROKSAN CASPIAN** £695  
Smooth, warm integrated with remote control that works happily into most 'speakers. (Dec 97)

**SONNETEER ALABASTER** £995  
Builds on the strengths of the Campion with ample control, colour and drive. (Oct 97)

**UNISON SIMPLY 2** £995  
This single-ended valve amplifier is smooth, sweet & open. An extremely musical performer. (Oct 95)

**UNISON SIMPLY 4** £1495  
Sonically similar to the Simply 2, but with more power and control. (Oct 95)

**MCINTOSH MA6800** £3735  
The MA6800 not so much plays music as takes control of it, with effortless bass drive. (Sep 95)

## PHONO STAGES

**QED DISCSAVER** £35  
A true bargain that offers a cohesive, musical sound but avoid using it in thin sounding systems.

**NAD PP1** £39.99  
An unassuming little box that nevertheless gets on with it. Comes complete with wall-plug power supply. No provision for battery power.

**ROTEL RQ-970BX** £130  
Superb-value entry-level phono stage with audiophile quality components and clear sound.

**LFD MISTRAL PHONO STAGE** £300  
The Mistral has a warmth and involvement that make many pricier stages sound overpriced.

**LEHMANN AUDIO BLACK CUBE** £395  
Capable of involvement, neutrality and insight normally the preserve of phono stages three to four times the price. (Oct 98)

**SONNETEER SEDLEY** £399  
Combines transparency and fine dynamics with excellent rhythmic ability. (May 98)

**ROKSAN ARTAXERXES X** £950  
With the Atessa PSU the Artaxerxes X MM/MC stage still shines. Great stage depth, neutrality and tonal colour. (Oct 97)

## PRE-AMPLIFIERS

**AUDIO ANALOGUE BELLINI** £475  
Showcases AA's characteristic mix of clarity and musicality and blasts the competition. (Apr 98)

**XTC PRE-1** £1000  
Almost valve-like in its smoothness, the line-level Pre-1 is warm and seductively clear. (Nov 96)

**CHORD CPA1800** £1800  
Clarity, insight and control are second to none - an addictive mixture. (Mar 98)

**MARANTZ MODEL 7** £3500  
A Sixties reissue, the Marantz pre-amp still sounds superb. Great phono stage. (Mar 97)

## POWER AMPLIFIERS

**QUAD II** second-hand  
Classic valve monobloc with many thousands still in use. Archetypal warm, smooth valve sound.

**LEAK STEREO 20** second-hand  
The Stereo 20 can sound impressively up-to-date, although power and detail are ultimately limited. The TL10, TL12 and TL12+ monoblocs are also very worthy contenders.

**ARCAM 9** £400  
With 70watts on tap, the 9P will drive most loudspeakers with a spacious and detailed sound. Good bass welly too. (Dec 96)

**MISSION CYRUS POWER** £450  
This power amplifier is a real honey. Rich and smooth, but with a firm grip.

**SUGDEN AU41P** £530  
Extremely competitive at the price with 100W of unusually smooth, full-bodied sound.

**MUSICAL FIDELITY X-A200** £1000/PAIR  
200watts of high-end monobloc power in a grooved tube. (Aug 98)

**NAIM NAP180** £1060  
Partnered with a NAC82, this has classic Naim control, and a superbly rhythmic presentation.

**MICHELL ALECTO** £1989  
Crisp, clean and beautifully controlled. Partnered with the £1650 Orca a winning combo. (Oct 98)

**CHORD SPM400** £1400  
There's a sense of effortless power to the Chord that gives music real scale and presence. (Mar 98)



**CHORD SPM1200** £2995  
Like the SPM400 but loads more power on tap. Will drive just about anything. (Mar 93)

**XTC POW-1** £2000  
As smooth and composed as the Pre-1, the POW-1 has bags of power and refinement. (Nov 96)

**MARANTZ MODEL 9** £8000  
Authentic reproduction monoblocs still more than cut the sonic mustard. (Mar 97)

## TUNERS

**LEAK TROUGHLINE** second-hand  
Our favourite way of listening to the wireless. A deliciously mellifluous sound will have you junking your transistor radio in seconds.

**NAD 412** £190  
The 412 is remarkably musical and natural sounding. Rich sound and full bass. (June 96)

**SONY ST-SA3ES** £250  
Beguiling RDS tuner for the sonically discerning. Good ergonomics and sensitive too. (Apr 97)

**MISSION CYRUS FM7** £300  
Clear and lucid sound puts it up with the best. Superb build too. (Apr 94)

**CREEK T43** £399  
Excellent detail, separation and dynamics. A great little tuner and unbeatable at this price. (May 98)

**ROTEL RT-990BX** £500  
High-quality Michi-based tuner with a sophisticated, forward sound with great imaging. (Apr 95)

**NAIM NAT03** £595  
The NAT03's warm, atmospheric sound is further proof of Naim's proficiency with tuners. (Sep 93)

**FANFARE FT-1** £1295  
In its native US the FT-1 is no mere tuner but a 'broadcast monitor'. Clear and powerful. (Mar 93)

**NAIM NAT01** £1380  
Perhaps the best solid-state tuner available. For better radio, go and live in the studio. (Sep 93)

## CASSETTE DECKS

**KENWOOD KX-3080** £160  
A simple deck, but excellent-quality head and transport give top quality sound. (Oct 96)

**AIWA AD-S750** £200  
Sonically a very decent machine at the price. Comes fitted with Dolby B, C and the dead handy Dolby S. (Apr 96)

**YAMAHA KX-580SE** £250  
The 'SE' tag is more than a marketing gimmick. Sound is solid and clear with Dolby S. (Sep 97)

**AIWA AD-S950** £300  
A stable transport, superb head and Dolby S make the AD-S950 an excellent all-rounder. (Feb 95)

**PIONEER CT-S740S** £430  
A great piece of engineering from Pioneer, with first-rate sound. (Jun 96)

**NAKAMICHI CR-7** second-hand  
Kills all other tape deck and stamps on the graves. Like all Naka decks, sadly discontinued. (Aug 93)

## LOUDSPEAKERS

**TANNOY MERCURY M2** £140  
A true audiophile bargain which embarrasses many more expensive boxes. Never mind the price, let your ears decide. (May 97)

**KEF Q15** £199  
These stand mounters offer impressive bass and excellent clarity but need a powerful amplifier to perform at their considerable best. (Feb 97)

**MISSION 771** £170  
Characteristically fast, punchy Mission sound from the Aerogel mid/bass and silk-dome tweeter. (Jul 98)

**B&W DM 602** £300  
Deep, strong bass, pure, projected and uncoloured midrange. Treble quality is a little metallic, imaging is precise. A lively, enjoyable sound. (Nov 96)

**REL Q-BASS** £350  
Few subwoofers match the Q-Bass at the price. The tuning controls can be a bit of a fiddle, but once set up the rest is pleasure. (May 96)

**CASTLE EDEN** £469  
Impressively vice-free 'speakers that offer great transparency and involvement. One of a select band that simply makes music regardless. (Mar 97)

**EPOS ES12** £495  
Strong, punchy bass is allied to finely detailed, articulate midrange and sparkling treble. (Oct 96)

**REL STRATA** £500  
The Strata subwoofer is not a toy. It offers superb, true hi-fi bass depth and power, and opens up the sound stage depth in particular. (Mar 94)

**HARBETH HL-P3ES** £799  
A fine example of good loudspeaker engineering. The top of the mini-monitor league. (Feb 96)

**KEF REFERENCE SERIES ONE** £995  
Combine pin-point imagery and detail with a smooth, polite balance. Good, agile bass. (May 95)

**HARBETH HL-K6** £1049  
Clean, musical and classy - Harbeth have done themselves proud again. (Dec 96)

**JAMO CONCERT 8** £1365  
With their inch-thick cabinets and fabulous drive units, the Concert 8s are the most transparent stand mounters around. (Jun 97)

**BKS D107 HYBRID MK II** £1500  
Unusual design with reflex loaded bass/mid driver and a ribbon tweeter. Granite side panels and a perspex/MDF sandwich for front and back. Can be a demanding load for an amp but natural sound of great clarity. (Dec 98)

**EPOS ES25** £1505  
Epos' best. Combines near-uncoloured tonality with characteristic fireworks in the rhythm department. Superb by any other name. (May 95)

**TANNOY AMS8** £2700  
Bold sounding pro active monitor with solid bass, clear midrange and delicious treble. (Aug 96)

**QUAD ESL 63** £3450  
A reference against which all other loudspeakers are judged, the '63s have superb imaging and genuine transparency.

**KEF REFERENCE SERIES FOUR** £3299  
Superb bass and near-electrostatic sound staging make these involving loudspeakers a reference for others. Need a strong amplifier though. (Oct 96)

**JBL S2600** £3500  
Smooth, detailed and spacious with great dynamics and fine imaging. Capable of producing a superb performance when used in a big room. (Jul 96)

**TANNOY WESTMINSTER ROYAL** £14920  
An incredibly dynamic, detailed full-range horn design with a rich sound.

## MINIDISC PLAYERS

**SONY MDS-JE510** £300  
An impressive sound and unmatched convenience make this MiniDisc player an excellent buy.

**KENWOOD DM-9090** £500  
One of the best MD players yet. ATRAC 4.5 gives clean and very musical recordings from this Kenwood. (Jan 98)

**SONY MDS-JA50ES** £1300  
The Sony can put the wind up Nakamichi cassette decks when used with better blank MDs. (Apr 98)

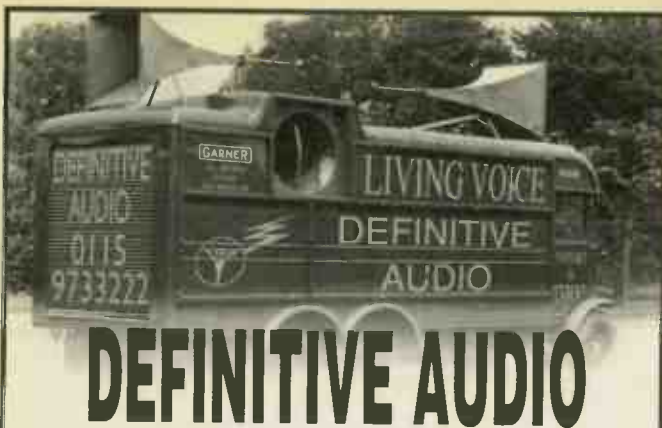

# DEFINITIVE AUDIO

You may be a newcomer to Hi-Fi, bewildered by choice. You may be a seasoned audiophile, tired of hype and marketing. Perhaps you should give us a call.

Our range of equipment moves from modest to exotic, from mainstream to unusual. All of it serious. We have a system based approach that achieves results far greater than the sum of the parts. Our starter system, featured in 'Hi-Fi Choice' last year was praised as "One of the best systems I have heard. At any price."

If you share our passion for music and have the urge to hear something a little bit different, ring for an information pack or make an appointment to visit our new listening rooms. We are situated in a fabulous Victorian mill just off junction 25 M1., 10 minutes from East Midlands Airport.

## Part exchanged items for sale:

	Sale	New
Audio Innovations S.500 Int. Excellent	£ 550	(£1200)
Audio Innovations L2 Line Pre	£ 500	(£ 750)
Audio Innovations S100 Pre	£ 500	(£1350)
Audio Innovations S200 Pre	£ 150	(£ 350)
Audio Innovations 2" Audio Monos 6B4G	£ 900	(£3000)
Ariston RD 80 Turntable (no arm)	£ 100	
AudioNote DAC3 Sig.	£1850	(£ 2850)
AudioNote ANV 1/2c 2 metres	£ 250	(£ 500)
Alchemist Forsetti power amp	£ 699	(£1350)
Border Patrol 300B SE 'Blue'	£1500	(£2500)
Denon Transport and DAC	£7000	(£15000)
Pass Labs X600 Monos	£15000	(£23000)
Border Patrol PSU	£ 495	(£ 595)
Orchid Precision PLL 1 loudspeakers	£3900	(£7900)
Kelly KT3 loudspeaker (new)	£1200	(£1850)
Dall 104 MS (94dB)	£ 450	(£ 650)
Impulse H2 loudspeakers Mahogany	£1500	(£2500)
Impulse Ta'us	£1900	(£3100)
Linn LP12, Avendale PSU, Helios Aurilus	£ 450	
Naim CDS	£2250	(£3940)
Naim 72 pre-amp	£ 400	(£ 745)
Naim 250 power-amp	£ 800	(£1705)
Naim CD2	£1200	(£2000)
Naim 82 pre-amp	£1500	(£2225)
Naim NAP 250 power	£1200	(£1705)
Naim Hi-Cap	£ 450	
Naim A5 Speaker cable 5 & 7 metre sets	£ 50 & 60	

AMEX - VISA - MASTERCARD

Tel 0115 973 3222 Fax 0115 973 3666

• Living Voice • Border Patrol • Art Audio • SJS Electroacoustics • Wadia • Vitavox • Lowther • Helios • MF • Kelly • Nott'm Analogue • Mystic Mat • SME • WB Ortofon •

# pear audio

presents

# Shahinian DYNAVECTOR Well Tempered

Stockists and Information from  
**Pear Audio Ltd. 7 Prospect Place,  
 Alnmouth, Northumberland, NE66 2RL**  
 Tel: 01665 830862 Fax: 01665 830051

## NEW PRODUCTS

from the designers of RINGMAT and STATMAT

## The RINGMAT SUPPORT SYSTEM

*a complete, modular system to help you achieve the perfect sound from your LPs*

*The RINGMAT SUPPORT SYSTEM comprises four components, including the long awaited RINGMAT Spacers, the LP version of STATMAT, RINGCAP and a RINGMAT for those who do not already have one.*

### Prices:

Full System with RINGMAT MkII XLR £160.00

Full System without RINGMAT (for existing users) £115.00

P&P £4.50 within UK; £10.00 outside UK

Prices are available for modules of the complete System, platter inserts for Roksan Xerxes & Garrard 401 turntables and other products

A MkII version of

# STATMAT

*for an even better sound from your CDs*

### Prices:

STATMAT MkII £19.95

MkII replacements, exchanges & upgrades £12.50

P&P £1.95 within UK; £5.05 outside UK

Replacements, etc., post free within UK; £3.00 outside UK

RINGMAT and STATMAT have been extensively reviewed around the world. Extracts and copies of the reviews are available on request, as well as brochures and price lists.

Information on our products and other services can be found on our website:

[www.ringmat.com](http://www.ringmat.com)

*Our products can be obtained through good hi-fi retailers. Also available on mail order with moneyback guarantee.*

For further information, or to place an order, contact:  
 RINGMAT DEVELOPMENTS  
 PO BOX 200 BRENTWOOD ESSEX CM15 9FB GB  
 T: +44 (0)1277 200 210 F: +44 (0)1277 201 225

# SLATE AUDIO



*Linking The Past, Present & Future*

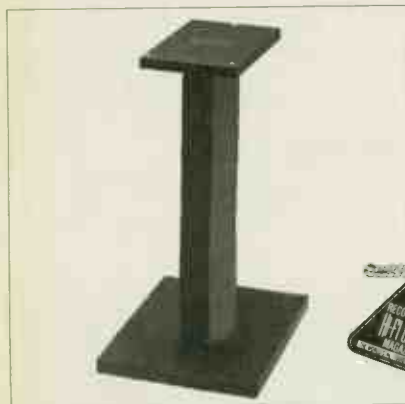

## **THE SPEAKERSTAND®**

**The best speaker supports in the world.**

State of the art in performance and design, custom made to suit any loudspeaker. Solid slate, supremely rigid and totally neutral" (\*One specific Slate was chosen after extensive testing on all other stones)

**SPEAKER PLATFORMS ISOLATION PLATFORMS TURNTABLE PLATFORMS SHELVING SYSTEMS**

"Immaculately finished, sublimely rigid, on a par with the best stands I've used." Ken Kessler, Hi-Fi News R/R. "An astonishing degree of instrumental separation, stable and holographic, with great precision and remarkable poise. The ultimate in high fidelity supports." David Praker, Hi-Fi Answers. "Superbly finished, the sound quality was considered to be first rate." Martin Colloms, Hi-Fi News R/R. "The sound quality when using the Slate Audio stands proved to be a revelation, something special." Paul Messenger, Hi-Fi Choice. "The finish is excellent, the sound quality magnificent and breathtaking." Tom Bryant, The Telegraph. "The Slate stand is unusual and expensive, but if you are after an exceedingly neutral stand it's the leading contender. This stand offers an exceptionally neutral platform for speakers; highly transparent sound leads to musical performances with real insight." SOUND QUALITY: ■■■■■ Malcolm Steward Hi-Fi Choice.

## **SLATE AUDIO GARRARD 301 and 401**

**The best & most musical record players in the world.**

Our researched Solid Marble Plinth System® brings the Garrards into the 21st century. All wooden Plinths produce unacceptably levels of coloration and feedback. No other Plinth system can claim to improve the performance of these superb players.

### **THE REVIEWERS**

"The Slate deck defines what real instrument solidity should be, it's in a class of its own." Alan Sircom, Hi-Fi Choice. "The build and performance of the Slate Audio 401 are the audio equivalent of the E type Jaguar." Audiophile. "I have never used a system like this one, it gets everything right. Peter Soper insists Garrards are best mounted on Marble or stone, and from my experience with this plinth I wouldn't disagree." Noel Keywood, Hi-Fi World. "The Garrards main problems are dealt with most effectively by three cures; correct set up, heavy plinth and appropriate mat. Peter Soper has mastered them all, the results are close to miraculous." Ken Kessler, Hi-Fi News R/R. "I have been using the fantastic Slate plinthed Garrard, the sound was nothing short of breathtaking. The basic Garrard without the Slate plinth is well engineered and pleasant sounding, but they only give exceptional results with the right kind of treatment." Dominic Baker, Hi-Fi World.

**OUR CLIENTS** "I have tested your 301, the sound quality as you know is excellent!" G. Pyne. "The results I get are really unbelievable and I have tried some of the best turntable around, (Linn LP12 Roksan Xerxes). "Thanks again for a marvellous piece of art." Mr Teilinger. "I am delighted with my Slate Audio Garrard 301, it sounds fantastic. Well worth all the detailed work that went into the design." R. Newham. "When I first put up the Slate Audio 301 I must admit to having quite a shock, forever converted." K. Van Green, Electric Eel Studios. "I'm over the moon, the plinth looks and sounds superb, stunningly beautiful!! I would very highly recommend any of your customers to seriously consider this great combination." J. Marsh.



*Nothing sings like a diamond*

## **THE GLASSMAT®**

**The finest platter mat in the world.**

The Glassmat® was developed to improve the performance of the Garrard 301 and 401 record players. However it also gives astonishing results when used on other turntables. So effective is its performance, we have now made it available as a universal replacement mat. In all cases other mats introduce colorations of their own, robbing the music of large amounts of detail and ambience. In order to achieve maximum information retrieval with optimum damping, a hard and unyielding material is required. Glass is ideal in every respect, damping is complete, the playing surface being quite simply sublime. In terms of detail resolution and sheer three dimensional ability, no other mat comes close. But then you still have to consider the absolute clarity, precision and solidity of the presentation. This is the ultimate platter mat.

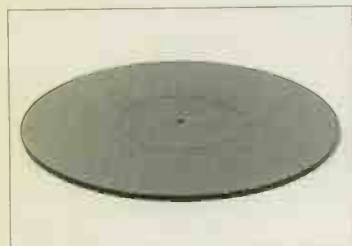

**THE POWERHOUSE OUR QUARTZ REFERENCED GARRARD 301/401 TD124 AND UNIVERSAL POWER SUPPLY. "KILLER" K.K.**  
**THE TABLESTROBE QUARTZ REFERENCED STROBE GUN DESIGNED SPECIFICALLY FOR THE GARRARD 301 AND 401.**  
**THE HANDSTROBE QUARTZ REFERENCED HAND HELD STROBE SUITABLE FOR ANY TURNTABLE WITH SPEED ADJUSTMENT.**  
**STORMFORCE SOLID MARBLE ENCLOSURES® FOR ALL TANOY DUAL CONCENTRICS. BEWARE... STRUCTURAL DAMAGE MAY OCCUR!**  
**HUMDINGER ELEVATE YOUR EARLY SME 3009S2 TO 1997 STATUS. BREATHES NEW LIFE INTO A GREAT CLASSIC.**  
**BACKLASH SUPERB SME 3009 & 3012 GOLD PHONO SOCKET CONVERSION, INCLUDING OFC LEADS: BRILLIANT? YES.**  
**BRAZEN UPGRADE YOUR V15III WITH OUR ALLOY RE-BODY AND MICRO RIDGE STYLUS: INSANE? NO.**  
**SOLID MARBLE PLINTH SYSTEMS® ALSO FOR EMT AND THORENS TD124.**

SLATE AUDIO GARRARD 301 AND 401 ARE AVAILABLE COMPLETE OR MARBLE PLINTH SYSTEM® ONLY.  
SME CELEBRATION ARMS WITH SPECIAL GRAPHICS "SLATE AUDIO 301 OR 401 CELEBRATION" AND "SLATE AUDIO TD124 CELEBRATION" 309 • 312 • IV • V.  
THE TONEARM OUR SPECIAL VERSION OF THE FAMOUS REGA RB300, FITTED WITH GOLD PHONOS.  
SME 3009S2 (1997 VERSION) A PERFECT MATCH FOR OUR V15III BRAZEN AND THE NEW SHURE V15V x MR. "STILL CRAZY AFTER ALL THESE YEARS".  
THE SPIKEKIT SPECIALLY DEVELOPED TO FIT DIRECTLY TO FLOOR STANDING LOUDSPEAKERS OR ANY WOODEN SUPPORT ADJUSTABLE AND VERY SIMPLE TO FIT.

**"COMPETITION IS HEALTHY, IT ENSURES WE STAY AHEAD"**

SHURE STYLUS PRESSURE GAUGE • GARRARD 301 SWITCH SUPPRESSOR • TURNTABLE SERVICING • GARRARD 301 LEVER SET • GARRARD 301 FIXING BOLT SET  
STROBE DISC • GARRARD 401 CONTROL PANEL SET • GARRARD 301 MOTOR PULLEY • FULL RESTORATION OF GARRARDS TO ORIGINAL CONDITION  
ALWAYS WANTED, GARRARD 401, GARRARD 301 AND THORENS TD124 RECORD PLAYERS, PLEASE PHONE

**47 GEMINI CLOSE, LEIGHTON BUZZARD, BEDS, LU7 8UD.**

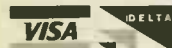

**TEL/FAX: 01525 384174 MOBILE: 0956 471601**



Another silly

# SALE

AMPLIFIERS:	Was:	SALE	SPEAKERS:	Was:	SALE
Arcam Alpha 8	£370.00	£P.O.A.	Mission 752	£649.00	£449.00
Talk Storm 1 Phono	£550.00	£419.95	Heybrook Quartet & Stands	£750.00	£399.00
Talk Storm 2 Line	£650.00	£499.95	Rega Ela	£508.00	£379.00
Talk Hurricane 1	£500.00	£399.95	Epos ES 11 & Stands (S/H)	£599.00	£349.00
Talk Tornado 1	£450.00	£359.95	Tannoy M3	£230.00	£169.00
Arcam AV50	£699.00	£P.O.A.	Definitive BP2002	£2400.00	£1599.00
			Plus several other big savers		
CD PLAYERS:			A. V. AMPLIFIERS etc		
EIKOS	£1800.00	£1199.00	Yamaha DSPA 492	£250.00	£159.00
Roksan Caspian	£749.00	£P.O.A.	Pioneer 505	£300.00	£179.00
DAC CONVERTERS:			Pioneer AC3 Decoder	£799.00	£469.00
ARCAM Delta B/Box 50	£350.00	£189.95	QUAD:		
"DAC IN A BOX"	£229.00	£159.95	77 integrated Amplifier	£749.00	£429.00
Deltec Little Bit (S/h)	£450.00	£99.95	67 CD Player (S/Hand)	£849.00	£349.00

10% OFF ALL OTHER DEMO STOCK FOR MARCH ONLY

## mike manning

*the hi-fi specialists* audio

YEOVIL  
110, Middle Street  
Yeovil  
Somerset  
01935-479361

TAUNTON  
54, Bridge Street  
Taunton  
Somerset  
01823-326688

Most sale items are either new or ex demonstration models and are covered by our full one year guarantees. Please phone either branch for further details. Mail Order plus £7 per single item. Access, Visa, Switch



## MUSONIC STYLI

SPECIALIST MANUFACTURER &  
SUPPLIER FOR MORE THAN 40 YEARS

REPLACEMENTS & ORIGINALS

MANY OBSOLETE/78 VERSIONS

PICK-UP CARTRIDGES

RECORD/TAPE/CD ACCESSORIES

WHY NOT TRY US AND HEAR THE  
DIFFERENCE !!

For prices tel/fax/e-mail to:-

MUSONIC (UK) LIMITED

Unit 13 Wenta Business Centre Colne Way

Watford Hertfordshire WD2 4ND

Tel: 01923 213344 Fax: 01923 213355

e-mail: musonic@compuserve.com

Trade and Export enquiries welcome

VISA



## LOUDSPEAKER and ROOM MEASUREMENT PACKAGES

**LIBERTY AUDIOSUITE v 3** visit <http://www.libinst.com>

Loudspeaker (and Electronic) Measurement System with

- \* **HIGHEST CAPABILITY**  
Now with Multitone distortion measurements (IMD) using up to 4 simultaneous test stimulus frequencies, plus many new added functions
- \* **STRAIGHTFORWARD OPERATION**  
With built-in, expanded, EASY SCRIPTS
- \* **DOWN TO EARTH PRICE** **£696.00 plus VAT**  
Plus £15 next day delivery

**ETF4** (WINDOWS95/NT) visit <http://www.etfacoustic.com>

Room Measurement and Analysis System

- \* **ROOM ACOUSTIC MEASUREMENTS**  
presented in simple graphical form, easy to understand
- \* **DESIGN ROUTINES for HELMHOLTZ RESONATORS and QRD DIFFUSERS** for you to correct room acoustic problems
- \* uses your existing soundcard, and an omni mic **£ 80.00 plus VAT**

**LspCADv3** visit <http://hem1.passagen.se/tjdata>

Combined Room / Loudspeaker Box / Crossover program

- \* imports data from LAUD, LEAP and MLLSA **£68.00 plus VAT**

Tony Seaford at MARTON MUSIC  
Phone 01282-773198 or Fax 01282-776413  
e-mail 106505.251@compuserve.com

# CLICKETY CLICK 88

**Goldring-Lenco's answer to the Garrard 301 was the G88 motor unit.  
Gold-digger Richard White travels down memory lane.**

To tell the truth, the names Goldring and Lenco are not at the top of everyone's vintage hi-fi wants list. These days Goldring make excellent cartridges to suit all pockets and Lenco is just a badge found on television sets and the like in continental hotel rooms.

Of the vast number of GL75 turntables still floating about, most are suffering the well-known droop in the rubber tone-arm bearing and, if you're really unlucky, the unit will have been left with its idler drive in the On position for a few of its years in the attic and the idler wheel will consequently have a well-developed flat on one side. Possibly because of these common problems, the general opinion of Goldring-Lenco decks is very low and, as audio jumbler will tell you, even inducements like "Lenco deck free with every purchase over £5. . ." fail to shift 'em.

To me this is roughly equivalent to pronouncing, say, the Quad II amplifier to be 'rubbish' because the valves and smoothing caps are worn out. No piece of kit is at its best after years of neglect and turntables are commonly in very poor fettle indeed by the time they get on to the second-hand market.

Since we have often dealt with the Garrard transcription units in these pages, we decided to have a look at Goldring-Lenco's equivalent offerings, the G88 and the updated model, G99. Since these decks are the same in all essential details, unless otherwise noted, for G88 read also G99.

The G88 was conceived to fill a gap in the market. Although there were some excellent transcription decks about at the time for the enthusiast, public perception was more or less Garrard 301 or nothing; after all, that was what the BBC used. Audiophiles might compare the merits of Collaro and Connoisseur but it needed another volume manufacturer to break the 301 monopoly.

At first glance the G88 is not dissimilar to the Garrard, with its un-square shape, controls at the front, the cream and black paint and the 12in. platter. Where the

G88 had the potential to score was with its rather more up-to-date appearance and, even more important, its very competitive price: £17.14s compared with over £22 for the 301, £21.16s for the three-speed Connoisseur and a whacking £38.8s for the (admittedly 'armed') Thorens TD124.

One of the reasons why Goldring could undercut so convincingly in this way was due to the cunning use of readily-available bits from other decks in the GL range. Thus the well-designed motor, idler wheel, idler arm, the excellent main bearing and platter had all been developed and road-tested 'in-house'. The geometry for the famous infinitely-variable transmission had withstood many years of practical use. What remained was to design a stylish chassis to incorporate all these known factors in the most compact way possible.

On its appearance around the beginning of 1963, the G88 won mostly plaudits from the reviewers. The then lack of choice in transcription turntables was commented upon, and most welcomed a new face on the scene. Caveats were voiced on the subject of wear - when the idler and motor bearing are worn, would vertical-component rumble wash out the unit for stereo? On the other hand, it was reasoned that the 8lb platter of itself ought to stand guarantor for damping moderate motor noise.

When compared with, say, the Garrard, the G88 protrudes little either below (less than 3in.) or above plinth level. With the platter surface less than an inch above the plinth there could be difficulty in getting a tall arm pillar to telescope sufficiently, but since transcription arms in those days were somewhat simpler than today's, this difficulty did not arise.

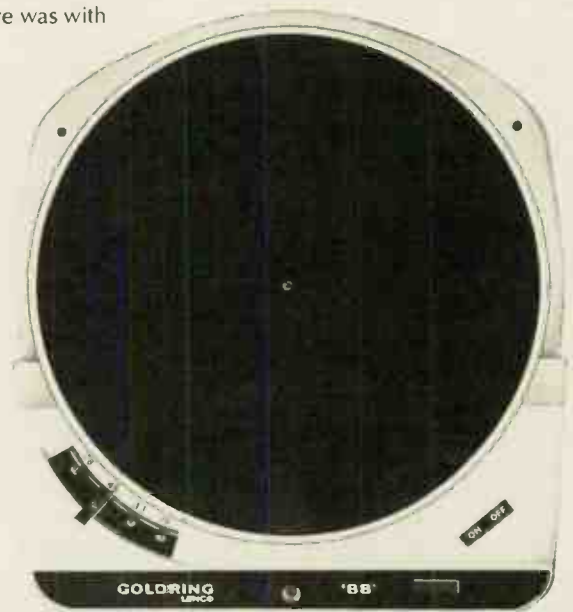

Wow and flutter were quoted as 0.2%; this seems high to me but as the reviewers seemed to think it 'inaudible' perhaps measuring techniques have changed. For instance, the 1968 GL75 deck quoted .06%, although mechanically it is substantially the same as the G88.

The Goldring 88 and 99 series still offer serious sonic possibilities today. For a start, they are unloved and consequently cheap. Most essential replacement parts are available from Technical And General (tel: 01892 654534); a chic plinth is also made for them by Aphelion (tel: 01237 422772). What's more, the decks can be stripped down to the last nut and bolt on the kitchen table. The G99 offers an integral stroboscope à la Thorens TD124 but this feature seems to me to be 'something and nothing'. Although the speed control knob on the G99 is more elegant than the lever on the G88, in use there is precious little to choose between them.

When next you spot a G88 or G99 at an audio jumble or whatever, don't dismiss it out of hand. Although they never quite overcame their 'poor man's Garrard' reputation, there is unquestionably gold in these old Goldrings - you just have to dig it out!

# Midland Audio X-change

Suppliers and installers of High Quality Audio Systems

Audio Note • Basis • BAT • Densen • Dpa • Electrocompaniet • Mark Levinson • Michell • Nagra  
Pass • Primare • ProAc • Rega • Revel • Roksan • SPM • Sugden • UKD • Unison Research • Wadia

Sfhand and ex-demo clearance items - March '99

## CD players and Digital converters

	Was	Now
Audio Alchemy DDE 1.0V	349	175
Cambridge Audio DAC Magic II	149	89
Meridian 203 DAC	499	179
Micromega CD3/ Duo Pro DAC	3000	1299
Orelle DAC 180 DAC	599	195
Pink Triangle Cardinal/DeCapo 1307/HDCD	2500	1295
Radford/Woodside WS2 CD Player	1200	399
Restek Concret II CD Player	2500	1795
Roksan Atessa DP2P CD Player	1595	699
Roksan Atessa DP3T Transport	1295	699
Roksan Caspian CD Player	895	650
Roksan DA2 DAC	595	449
Roksan DP1 Transport	995	495
Roksan DS 5 Power Supply	549	429
Sony X3000 ES CD Player	500	349
Sugden SDT-1 Special Edition CD Player	1499	895
Sony X3000 ES CD Player	500	349
Sugden SDT-1 Special Edition CD Player	1499	895

## Turntables Tonearms & Cartridges

	Was	Now
AR EB101 Turntable	279	129
Audio Note IO II Cartridge Kondo (re-tip)	1800	850
Audio Note TTL/RB250/IQ1	750	495
Goldbug Brier Cartridge Boxed 400 Hrs	N/A	250
Koetsu Black Re-tip (low hours)	N/A	350
Linn LP12 Valhalla Black/Basik Plus/Linn k9	N/A	450
Rega Planar 3 Turntable	274	175
Roksan Shiraz 350hrs use	1000	375
Roksan Xerxes/Tabrizi/MC25FL	1295	695

## Preamplifiers & Poweramplifiers & Integrated Amplifiers

	Was	Now
Audio Innovations 1000 Passive Controller	199	100
Audio Innovations 800 Series III Valve	1000	499
Audio Research LS 7 Line Preamp	1599	950
Audio Research LS1 line Preamplifier	1295	650
Audion Golden Knights 300B Mono Blocks	3995	1799
Conrad Johnson PV10 AL SE	1299	825
Electrocompaniet ECI-2 Class A Amplifier	995	599
Krell KRC HR Remote Preamp	6950	4750
Michaelson Audio Chronos 2 Box Valve Preamplifier	4700	1250
Naim Audio NAC 32mm/MC Preamplifier	N/A	149
Orelle SA 100 Amplifier	449	359
PS Audio 4.5 Preamplifier	499	225
Rega HAL Pre Amp MM/MC Remote	998	649
Roksan L1.5 Preamplifier	2250	1495
Rotel RA 931 Integrated	149	99
Rotel RC 970 BX Pre Amp (new)	175	99
Unison Research Smart 845 Mono's	3250	2199

## Loudspeakers

	Was	Now
Celestion SL600 Loudspeakers	679	279
Epos ES 11 Loudspeakers Black	479	249
Harbeth HL-K6 Cherry	1049	599
Impulse Lali Cherry Loudspeaker	1750	1295
Impulse Maya Loudspeaker	695	459
Mission 754 Freedoms Primavera	1499	799
Mordaunt Short MS25 I Black	349	119
Rega ELA Cherry Latest Spec	535	425
Rogers Studio 5 Rosewood	799	399
Roksan ROK-1	650	279
Ruark Epilogue Walnut	269	85
Ruark Talisman II Dark Oak	750	599
Tannoy Series 10 DTMI studio monitors	1200	575

## Cables & Miscellaneous

	Was	Now
Cogan Hall Intermezzo REF 0.5M	375	95
Musical Fidelity T1 Tuner	N/A	145
Transparent Music Link Plus 1.5m	219	129
Transparent Reference Balanced Music Link 1.5m	2895	1495
VDH CD 102 Mk2 3.0M WBT	N/A	115

Midland Audio X-change is looking for good used British & American Hi-fi, cash paid call John Roberts on 01562 822236

New products now on demonstration

**Aria** - S2 a single ended triode valve amplifier, the sweetest little thing you ever saw with a superb sound quality to match. From the unison research factory in Italy this EL34 10 watt per channel has stunned everyone who has heard it, it's level of build quality is second to none stainless steel and mated walnut meet in a heavenly combination and all for the princely sum of - £1050.00

**Densen** - Beat 200 remote controlled preamplifier is now here at last. Priced at £1,000 this beautifully styled Dane incorporates full remote control switching and volume has a rear port for audio access in a multi-room situation. In conjunction with an AV processor you have a nerve centre for a home movie theatre system with all the convenience of an all in one amplifier. Then at a flick of a switch it can now be your high end pre-amplifier for the purest of audiophiles. The Densen CD player will also emerge as a formidable £1,000 machine within the next few weeks. Ring for more details concerning any part of the Densen range

**Rega** - RB600 Tonearm is now available by itself and is a worthy upgrade upon the trusty RB300. At £350, you will find it very difficult to find a better sounding Tonearm at this price. Worthy of many fine cartridges, the RB600 incorporates RB900 bearings, has a metallic paint finish and is wired with Klotz high definition audio cable. So rather than upgrade your RB300. Why not invest in a new RB600, the difference is well worth every penny

**Totem Acoustics** - We are pleased to announce that we are now the Midlands authorised dealer for these amazing speakers from Canada. The Arrow is a very small and slim floorstander with incredible staging and depth of image. They work extremely well with valve amplifiers and class A solid state. The price £950. The Totem Model one is no newcomer to MAX. Hailed as one of the worlds best small monitors in Stereophile magazine it has the ability to give a very three-dimensional sound and amazing bass extension for its size. The price £1249. The Totem Tabu is a two way medium sized monitor loudspeaker and is capable of earth shattering levels of audio pleasure. Priced at £2,299 it is a must for any discerning listener. The Mani 2 is an Isobarik loaded two way monitor which when first heard made us stand to attention. It's capabilities far outreach any other speaker of its size. My word of warning is listen at your own peril. Priced at £3,100 the Mani 2 is not for the faint hearted

**Michell Engineering** - Well looky here... the guys in Borehamwood have done it again. The Gyro SE takes the bull by the horns at the sub £800 turntable market. Basically they have taken the Gyro off it's Perspex plinth and given it a stand alone motor, (this can be upgraded to a full Gyro at a later stage) the price without Tonearm and with a standard power supply - £775.00

## Rega

Alya Loudspeaker has a 3/4" soft dome tweeter and a 5" Rega bass driver available in Cherry, Light Oak, Black Ash - £350.00

The Planar 25 exceeds all expectations with truly exceptional performance and build quality akin to the Planar 9. Also, a new Tonearm RB600 will be available with it. Early indication of price, around £600. Available end of November

New CD Transport 'Jupiter' will be available in conjunction with a new DAC the 'Io'. The price is around £950 'the pair'

## Mark Levinson

A new leading edge digital to Analogue Converter incorporating full 96 kHz/24 capability and 44.1 sampling rates. It made big waves at this year's Renaissance Show in conjunction with Pioneer DVD players which have a 96 kHz output on the rear. Price - £3999.00

## Opera Loudspeakers

A new mini monitor on the books. The Prima is a 2 way; solid wood loudspeaker which sounds very well balanced like the others in the range. Price - £495

## Graff

The new GM20 OTL valve amplifier. Yes the one Ken Kessler raves about and guess what, he's right, a truly magnificent piece of Italian Design and Build Quality. Rated at 2 x 60 watts and at a very attractive price - £2750.00

## Audiogram

Audiogram Elle 1 Full range Electrostatics. Italian Design at its most elegant. These really sound as good as they look, and with a reasonable price to match - £2500.00

## Wadia

830/850/860 Compact Disc players of the finest quality. The 830 being the new arrival, full 24 bit D/A system, DVD/96K Chip fitable, fully balanced outputs with digital volume control, a truly ground breaking price - £2999.99

181 Franche Road • KIDDERMINSTER • Worcs • DY11 5AD  
Ring John Roberts • Tel/Fax 01562 822236 • Mobile 0421 605966

# HI-FI WORLD PRIVATE CLASSIFIED ADS

Dealers must not advertise in the Private Classified section. Monthly consecutive insertions will be considered Trade advertising. The Publisher reserves the right to judge submissions.

SPECIAL  
INTERNET  
OFFER SEE  
PAGE 138 FOR  
DETAILS

KEF REFERENCE 4 speakers, 6 months old, mint £2395. Pioneer CTS 8305 cassette deck. 6 months old £295. Aiwa XK009 cassette deck £95. Tel: 01869 278 249 (May/1)

**ROKSAN DPI CD transport/Woodside DA1 DAC. Both items £475. Bryston 12B preamp/4B power amp with calibration certificate £975. Roksan speakers. Ojan 3 matt black £375. Rega Planer 3 £110. All items boxed and in excellent condition. Tel: Rob 01600 772 020 (Daytime) (May/1)**

NAIM NAC72 inc MC board (£450), NAPI40 (£425), HiCap (£450) - All new style, Epos ES11 biwire walnut with stands and 10m NAC5 cable (£275), Meridian 566 (20 bit) DAC (£495) Arcam Delta 270 CD player (£275), Soundstyle 4 glass shelved black triangular table (£120). All boxed and in excellent condition. also Heybrook HBS1 speaker stands (£20). Tel: 0411 407 135 or 01844 353 741 (S.Oxen - 2 miles JN6 M40) (Apr)

AUDIO SYNTHESIS DAX. Ultra analog converters. Balanced outputs, Coax, Toslink, AT&T AES inputs £650. Orelle Orator speakers, rosewood, including Partington A7-50 stands, sand and lead filled £500. Tel: 01372 450 620 evenings (Apr/1)

MONITOR AUDIO MA703 PMC loudspeakers (light oak finish, plinths and spikes) £400 ono. Rotel RCD-965BX CD player £60 ono. Audiolab 8000A 50w amplifier £250. Tel: Richard 01582 414 915 (Apr/1)

AUDIO RESEARCH D 240 mint, boxed, as new, balanced op/RCA £1100. Audio Research SP9 MkII, boxed, mint £900. Audio Research SP11 inc p/s, mint £1400. Electrocompaniet EC4R £900 ono, under 2 yrs as new, boxed manual etc. Electrocompaniet 100 AW-DMB power amp (£2095) £1350 ono. Epos ES14 walnut as new, boxed, superb condition inc. stands £350. Marston Silhouette CD. 6 months old £500. Denon TU 425 RD tuner £120. Naim NAP 250 new style £1150. Tel: Jules 01792 280 061 (Apr/1)

TRICHORD PULSAR DAC rrp £1500+, vgc £650. Leak Troughline 3 tuner incl. Teak sleeve superb cond. £100. Tel: 0181 539 8262 (Apr/1)

LINN SONDEK LP12, Ittock LV2 arm, Audio Technica OC9 Moving Coil cartridge, Cirkus Kit and recently fully serviced, Ringmat. Mint condition. £650 ono. Tel: Mr. Brown 0181 461 3798 (Apr/1)

SIRIUS D 200 power amp. 6 months old (£2995) £2000. Sirius passive controller silver wired with Elna pot, balanced output (£995) £600. Acoustic Eergy AE2 Signature Piano black wth AE stands, 2 years old, mint (£3400) £2000. Various hi-end leads - Transparent, Tice etc. Tel: 01202 303 693 (Bournemouth) (Apr/1)

QUAD ELECTROSTATIC loudspeakers (ESL 57) bronze. Genuine reason for sale. £350 the pair. Tel: 0116 289 2420 (Leicester) (Apr/1)

NAIM 90/92 pre/power amps, moving coil board, mint £650. Linn LP12, Valhalla, Ittock, Denon DL304 (new) Studio 99 service history £595. Castle Edens Yew, mint £325 (new) Target R2 stands £195. Unique sound tower, natural ash, 6 glass shelves, new £125. Sonic Link AST 200, 10 metres £60. Tel: Brian 0181 952 2044 (Apr/1)

KEF 105/11 rosewood, excellent condition £595. Bang & Olufsen Beocord 9000 - offers. Tel: 0385 237 583 or 01438 833 691 (Herts) (Apr/1)

DRIVE UNITS. Morel MDT 33 tweeters. Kef B110 & B139 & Wilmslow crossover units. One pair of each £150. Tel: 01225 757 646 (Apr/1)

ENTHUSIASTS EQUIPMENT. Musical Fidelity A370.2. professionally, expensively modified £1350. F19/25. New boxed unused £2200/£850. Celestion Studio 66 monitors £650 ono Horn speakers, singular design, superb £1500. Tel: 01226 764 272 (Apr/1)

QUAD POWER amplifiers. 707 £520, 77 £390. AVI NuNeutron speakers £490. Ruark Templars £275. Harbeth HL Extenders (bass speakers for LS3/5a and similar) £195. Technics SL120 D/D turntable unit £100. Tel: 01892 536 919 (W. Kent) (Apr/1)

REVOX F36 reel to reel £70 or exchange for Troughline Naim 602 speakers circa 1978 - unmarked £90. Buyer collects. Tel: 013873 75852 (Scottish Borders) (Apr/1)

MARANTZ D63 KI Signature, excellent condition, boxed and instructions £220. Alchemist Kraken pre and power 70wpc Class A amplifier, instruction books, (£1100) £475. Tel: 01508 499 586 (Apr/1)

AUDIO RESEARCH LS7 valve line preamplifier. Superb clear sound. Excellent condition. Boxed with manual £825 for quick sale. Tel: 0961 316 947 (anytime) or 01622 736 283 (eves) (Apr/1)

AUDIOLAB 8000CDM transport and 8000DAC hardly used, boxed with instructions, excellent condition. Reluctant seller moving abroad. Cost £2000 new will accept £1300. Tel: Brian 0181 210 5050 (01372 844 595 eves) (Surrey) (Apr/1)

MICROMEGA STAGE I with Trichord output board, Clock II, twin PSU's. Duo BS2 DAC balanced interconnect, boxed, good cond. £400 ono. System 935 speakers, black, £135. Tel: 0181 508 8100 (Apr/1)

CYRUS DAD7 CD player Creek OBH-12 pre, NAD 218THX power, Mission 734i speakers, £1300. Free black Slink cables etc. Pioneer A-400X amp, CT-S640S tape, £300. Offers considered. Tel: Rob 0114 266 5400 (Apr/1)

TEAC T1 transport £250 and D-T1 DAC £250 (£450 pair) mint. Audio Research SP-6 preamp £400 and Yves Cochet AL2 valve power amp £400 (£700 pair). Tel: Dominic 0161 773 0113 (Apr/1)

A selection of our ever changing offers for sale (all fully guaranteed)

Equivalent New Price Sale Price

A selection of our ever changing offers for sale (all fully guaranteed)

Equivalent New Price Sale Price

A selection of our ever changing offers for sale (all fully guaranteed)

Equivalent New Price Sale Price

**AMPLIFIERS**

Audiolab 8000S 2 x 60 Watts Remote int (NGC) s/h	750.00	429.95
Audion Silver Nights (200B) Class A monobloc power amps (mint/as new) s/h	2250.00	1395.00
Chameleon Ruby power amp (2x200 watts) (vgc) s/h	1200.00	449.95
Creek DBH11 Headphone Amplifier (Mint) s/h	1200.00	89.95
Exposure XP int c/w MC/PM	750.00	399.95
Kinshaw Overture int (mint/as new) s/h	435.00	199.95
Leak Stereo 30 int (vgc) s/h	1200.00	45.00
Lumley YTP 1000 valve line pre-amp (vgc) s/h	1000.00	399.95
Marantz PM40 S.E. (int.) (vgc) s/h	250.00	139.95
Meridian MCA int. amp (moss module) (vgc) s/h	199.95	199.95
Michel Rega Pre/ Hera PSU (NGC) s/h	730.00	349.00
Mission Cyrus Two / PSX (grey steel version) (vgc) s/h	550.00	299.95
Musical Fidelity X-Pre valve pre-amp (new)	200.00	200.00
Musical Fidelity A100 2 x 50 Watts Class A Integrated (NGC) s/h	500.00	249.99
Naim NAC 62 (Lboards) / NAP90 pre/power late style (mint) s/h	1000.00+	(cash sale)
Papworth M100 100 watt valve monobloc power amps (mint/as new) s/h	3800.00	2000.00
QED C300/P300 pre/power amps (f.c.) s/h	700.00	299.95
Quad 34 pre-amp (borom) (vgc) s/h	388.00	199.95
Quad 33 pre-controller (vgc) s/h	450.00	89.95
Rega Mira 2 x 60 Watts / Remote integrated (Mint) s/h	450.00	299.99
Rega Mira 2x60 watts / Remote int. (mint) s/h	250.00	139.95
Rega Brio 2 x 30 watts int. (vgc) s/h	149.95	149.95
Roeliff RB 9608X (2x60watts) power-amp (vgc)	loads	169.95
SAE Mark IV CH 2x100watts American power amp (g.c.) s/h	loads	89.95
Sugden CSI pre-amp (vgc) s/h	450.00	249.95
Technics SUAR90 Mk II 2 x 70 Watts integrated (NGC) s/h	1150.00	795.00
Union Research Simply Two Valve Integrated (Mint) s/h		

**TUNABLES/ARMS/CARTRIDGES PHONO-STAGE ETC**

Anson RD80/Linn Bask LVM/Oroton VMS30 (VGC) s/h	500.00	189.95
Decca International uniprot tonearm (g.c) s/h	150.00	49.90
Dual 503 1 (vgc) s/h	500.00+	79.95
Linn Asa/Alcora (Mint) s/h	500.00+	329.95
Linn LP12 (altro) / Alphonson delta/ K18 II (vgc) s/h	1700.00	545.00
Linn LP12 (mainline) Black arm/ K9 (vgc) s/h	1500.00	445.00
Mission 775 SH774 arm/VMS 20E (vgc) s/h	loads	399.95
Monacor SPL6 MM Phono Stage/PSU (Brilliant Value) New	226.95	
Musical Fidelity X LP (The One At This Price) MM/MC NEW	130.00	
NAD PPI MM Phono Stage/PSU (Mint) s/h	40.00	30.00
Q.E.D. R232 arm/NADA RP20 (g.c)	200.00+	109.95
Revoher Nebel c/w arm/AT cart (mint) s/h	149.95	149.95
Sarou SR222 IV/Nagasaki MP 11 (GC) s/h	loads	79.95
STD 305M c/w Mayware Uniprot/Golding Ebn cart (vgc) s/h	loads	199.95
Surmo Blue Point High Output MC Cartridge (Mint Based 30 hours) s/h	120.00	80.00
Syrinx PMS Ippasina Silver Wired Tone Arm (mint/boxed etc) s/h	loads	229.95

**LOUDSPEAKERS**

Apogee Caliper (piano black) with bases (Restoration project/need finishing) (g.c) s/h	3500.00	500.00
Canon 5.35 inc. stands (vgc) s/h	300.00	169.95

**PRODUCT OF THE MONTH**  
AUDIOLAB 8000CD  
FULL REMOTE CONTROL COMPACT DISC PLAYER  
in mint (as new condition with box) manuals  
**RRP-1000.00 AA PRICE 629.95**

Cyrus 782 (black) (vgc) s/h	350.00	149.95
Denon SC E 313 (Rosewood) (mint) s/h	160.00	99.95
Epos ES12 (Light Ash) (Mint) s/h	550.00	375.00
Epos ES14H Bi-wire (Black) inc. stands (Mint) s/h	675.00	429.95
Foundation Heavy 18" stands (vgc) s/h	80.00	59.95
Gale 301 (black) (vgc) s/h	300.00	169.95
Heybrook Point 5 Bi-wire (black) (vgc) s/h	179.00	89.95
IPW Monitors c/w stands (black) (vgc) s/h	250.00	139.95
Kef 103/4 Uuo-0 Floorstanders (Black) (vgc) s/h	1300.00	599.95
Kef Coda 7 (mint) s/h	130.00	89.95
Kef Coda 7 (unused) (mint) s/h	130.00	89.95
Linn Helix LS 150 (vgc) inc. stands (black) s/h	280.00	179.95
Linn Helix II/Ku-Stone stands (black) (vgc) s/h	350.00	199.95
Lumley LM 3 (Natural Pine) (Mint) s/h	1000.00	499.95
Monitor Audio R300 MD (black) (vgc) s/h	300.00	159.95
Monitor Audio R852 MD (gold) (vgc) s/h	450.00	189.95
Rega EL-8 Floorstanders (Black) (Mint) s/h	300.00	199.95
Revoher Purdy Floorstanders (VGC) s/h	200.00	119.95
Ruark Paladin (Dark Walnut)/Soundbytes (VGC)	1100.00	599.95
Spendor SP2 (walnut) (vgc) s/h	450.00	229.95
Tannoy 603 inc. stands (mint) s/h	200.00	139.95
Tannoy 625 ALF 100 watt active sub (vgc) s/h	600.00	299.95
Tannoy T185 Dual Concentric (Walnut) (VGC) s/h	loads	249.95
Tannoy 605 Bi-wire (VGC) s/h	170.00	109.95
Tannoy DC-200 Dual Concentric (Black Vinyl) (VGC) s/h	loads	199.95
Lots of LS. stands in stock including Target/Alphonson etc.		

**TAPE DECKS/TUNERS ETC.**

Arcam Delta 100 Dolby S Cassette Deck (VGC) s/h	loads	499.95
Denon DNH-S10 HL Pro etc. (GC) s/h	150.00	89.95
Denon DRM 6505 Dolby S etc (Mint) s/h	230.00	149.95
Denon DRM10.HX cassette deck / 3 motor / HK Pro etc (vgc) s/h	loads	119.95
Rega Radio FM Tuner (Mint/As New) s/h	250.00	189.95
Teac A.3340S high speed 2.4 track / 4. channel reel to reel with simul-sync (vgc)	loads	399.95
Technics ST.GT350 FM Digital Tuner (New)	150.00	119.95

**COMPACT DISC PLAYERS/TRANSPORTS/D.A.C.S.**

Arcam Alpha One CD Player (GC) s/h	350.00	249.95
Arcam Delta 250 transport/Black Box 50 DAC (mint) s/h	1250.00	795.00

Audiolab 8000 CD Full Remote (mint/As New) s/h	1000.00	629.95
Cambridge Discmagic I/ Dacmagic 1 (vgc) s/h	500.00	269.95
Denon DVD-2000 (region 1 conversion)		
Full remote DVD player (mint)	600.00	429.95
DPA little bit 3 D.A.C. (vgc) s/h	350.00	199.95
Marantz CD-42 (f.c.) s/h	1500.00	795.00
Micro Mega CD3 top loader transport (Acrylic) (vgc) s/h	1500.00	795.00
Musical Fidelity X-Ray 24/96 player (superb player) (new)	799.00	
Musical Fidelity X-24k DAC (new)		300.00
Musical Fidelity X-Act Dac (new)		130.00
Musical Fidelity X-100 missing Link Line Buffer (Mint) s/h	120.00	90.00
Philips CD1 240 (interactive) (mint) s/h	400.00	109.95
Pioneer PD-102 Basic CD Player (GC) s/h	150.00	89.95
Pioneer PDS 703 (stable platter) remote (vgc) s/h	450.00	179.95
Rotel RCD.9708X Remote CD Player (Mint/As New) s/h	350.00	249.95
Technics SL PS 770D remote (mint/as new) s/h	250.00	189.95
Technics SL P550 remote (vgc) s/h		129.95
Teac VRDS.7 (mint) s/h	600.00	379.95

**OTHER ITEMS OF INTEREST**

Alphonson Glass 4 shelf mini stand (ideal for X Series) (mint) s/h	1000.00	69.95
Horizont Short Decoder One (Dolby Pro Logic Processor) (inexpensive route to home cinema) (mint) s/h	400.00	149.95
Shun Acoustics Jpsun/Phymer LS stands (20") (g.c) s/h	150.00	79.95
Yamaha DSP A492 remote Pro Logic amp (mint) s/h	250.00	169.95
Yamaha DSP-E1000 remote pro-logic processor/amp (mint) s/h	700.00	249.95
Nordost Flatline 4 Bi-wire Cable 2 x 2m (VGC) s/h	£120.00	£59.95
Atacama SE24 (Filled) Stands (VGC)	£75.00	£49.95
Sennheiser HD 455 Cans (Mint) s/h	£60.00	£35.00
Audioquest Crystal Hyperlatz Bi-wire 2 x 3m (Mint) s/h	£100.00+	£59.00
Target B.3W Equipment Stand (Blue) (Mint) s/h	£178.00	£149.00
Puresonic 9010A Psoc Interconnects (New)	£100	£79.95
Rega IS Cable s/h	loads	phone
Hamm NAC AA Cable s/h	loads	loads

**\*\*\* GOOD HI-FI SEPARATES WANTED \*\*\***

Don't forget we can offer mail order. All major credit cards accepted.

Phone anytime with your wants, stock changing daily. All equipment is sold with warranties. We welcome part-exchange on any of the above.

Affordable Audio is always keen to buy, (or part-exchange) Good quality Hi-Fi separates in good condition. Especially top British manufacturers products!

We can also sell your equipment for you on a commission basis. (Lowest rates/best return) (Please phone Paul for details!)

**Art Audio**

THE **QUINTET** IS NOW AVAILABLE IN **300B KIT** FORM @ £935  
ASSEMBLED KIT £1135

As recommended by Hi-Fi Choice

**R.R.P WAS £1550**

**300B KIT @ £1232**

ASSEMBLED KIT £1432

**R.R.P WAS £2499**

ALL PRICES INCLUDE VALVES & VAT

REVIEWS AVAILABLE

Art Audio (UK) Ltd  
62 Vaughan Avenue  
Hucknall  
Nottingham NG15 8BT  
Tel/Fax 0115 963 7795

HTTP://WWW.AUDIO.NDIRECT.CO.UK/ART/

**AUDIO MATTERS**  
**NEW EX-DEM & PART EXCHANGE**  
**EQUIPMENT FOR SALE**

**0181 255 0572 / 0973 436135**

	LIST PRICE	SALE PRICE
Alchemist Forsetti pre + power	£2398	P.O.A.
Alchemist Kraken Anniversary MK.II	£579	P.O.A.
Alchemist - The Stereo Poweramp 200 watt (ex/d)	£3995	£2195
Anthem CD player (5 star What Hi-Fi) (ex/d)	£1699	£1250
Apogees ribbon monitors (new & ex/d)	£999	£699
Audiomeca Mephisto CD transport	£2400	£1250
Audion Black Shadows 845 valve monoblocks	£4000	P.O.A.
Audion Silvernight 300B monoblocks	£2250	P.O.A.
Chario Academy 1 solid walnut (ex/d)	£1299	£800
Chario Academy 2 solid walnut (ex/d)	£1649	£1100
Chario Academy 3J (ex/d) floor standing, solid walnut speakers	£5999	£2699
Genesis Gen 500 spks In Built Active Bass(ex/d)	£11000	£6499
<b>SUPERB</b>		
Krell Kav 3001	£2495	P.O.A.
Meridian 208 CD & pre & remote	£1650	£500
Micromega T Drive & T Dac & XLO cable	£2150	£999
Musical Fidelity P140 pwr. Amp x		£300
Nakamichi 1.5 cass.		£200
Nakamichi LX5 cass.		£350
Restek 6ch. pwr. Amp	£900	£595
Revox H1 cass.	£1150	£650
Revox H6 RDS Tuner	£1000	£495
Triangle Antials spkrs (ex/d)	£739	£499
Genesis APM1 SPK (ex/d)	£9000	£4999
Genesis Sub Woofer R/C (ex/d)	£1900	£999
Proceed AVF AC3 DTS		
AMP 5 SCH Pwr Amp }	£10000	£6500

A NEW RANGE OF AUDION AMPS ON DEM - THE BLACK SHADOWS 845 TO THE GOLDEN DREAMS - WITH CADENCE ES MK II's - LISTEN & BE PERSUADED.

WA200 INTEGRATED AMP FROM BOW TECHNOLOGIES NOW ON DEM

On Dem - Alchemist, Anthem, Audiomeca, Audion Valve Amps, Cadence Spks., Chano, D.P.A., Monarchy, Ortofon, Pink Triangle, Project T-T, Sonic Frontiers, Triangle Spks., Trilogly Valve Amps, Van der Hul.

**VISA/MASTERCARD ACCEPTED**



# CLASSIFIED ADS

## 6 PAGES OF BARGAIN HI-FI

SPECIAL  
INTERNET  
OFFER SEE  
PAGE 138 FOR  
DETAILS

QUAD 33/303 plus FM3 tuner, pair Spondor BC3 speakers. best offer secures the lot. Tel: 0181 788 7073 (Putney) after 7pm or weekends (Apr/I)

SINGLE LEAK TL12 Point One with matching preamp and rare Lowther tuner, slightly tatty condition but all in working order with original valves and components, offers. Tel: 0131 556 6707 (Apr/I)

LINN KARMA cartridge virtually unused £180. Linn Troika cartridge used £120. Sony 700-ES tape deck £180. Philips 104 CD player classic £100 also other hi-fi, video for sale. Tel: 01273 306 519 (Apr/I)

SONY CDP-101 CD boxed as new and stored, reviewed February £110. Decca Deram speakers £18. Sony TV tuner TT3000UB £25. Wanted - Technics SA-210L circuit diagram. Tel: 01323 500174 (Eastbourne) (Apr/I)

CELESTION DITTON 44 loudspeakers good condition £130. Various mono Leak preamps Varislope III x2, Point One plus Varislope II Point One £20 each. Tel: 01277 364 833 (Ongar, Essex) (Apr/I)

ATC 10's black boxed vgc £600. Meridian 506 CD player £450. Lumley PU1 valve preamp with Tom Evans designed solid state MC phono section. Line stage upgraded with Howland Music-Caps by the Audio Consultants, boxed, vgc £650 Tel: 01844 347 729 (Apr/I)

LINN LINTO phono stage less than one year old. Mint condition. Happy to demonstrate. £600. Tel: John 01222 453 230 (Apr/I)

GARRARD 401, SME 3009/II original veneered plinth and cover £130 ono. Osram KT66 valve, offers. 4 Michell screw thread/banana plugs £10. Bulgin plug for Quad II £5. Audioquest video-Z interconnect £40. Tel: 01793 526 796 (Apr/I)

KEF 103/4 Ref (boxed) £350. Tel: 0113 294 4937 daytime 01274 411 013 eves. (W. Yorkshire) (Apr/I)

B&W P5 loudspeakers excellent condition rosenut finish £500. Exposure XV integrated amplifier. Mint condition £300. 2x4.5 metre length Chord Legend bi-wire speaker cable £75. Tel: 01902 835 459 (Wolverhampton) (Apr)

NAIM NAC102 remote control preamp plus NAPSC power supply mint condition £775. Tel: 01273 556 458 or 07971 131 324 (Sussex)(Apr/I)

TUBE TECHNOLOGY Unisis integrated valve amplifier Audiophile valves cost £2300 accept £1150 or exchange for Naim pre/power. Rega Planar 9, 6 months old cost £1600 accept £1000. No offers Tel: 01803 297 691 (Apr/I)

TECHNICS SL150 turntable with SME 3009 tone arm. EE1-500 cartridge. Very little used from new. £190. Tel 01484 606 241 (Huddersfield) (Apr/I)

GARRARD 401 with SME 3009II arm, in SME 2000 plinth, immaculate, £300 ono. Musical Fidelity 3A pre amp with Acurus A150 power amp (powerful) £500 together or £170 & £385. Tel: 0181 574 5510 (Apr)

LINN KEILIDH speakers and bases plus 4x4 metres Naim NAC 5 cable £425. Tel: 01444 248 424 (Apr/I)

TRICHORD REVELATION CD player, boxed and remote, excellent condition £385. Wanted: Meridian 502 preamp. Tel: 01634 668 822 (Apr/I)

RUARK EQUINOX speakers. Rosewood finish. Boxed. £2000 new, now £900. Tel: 01772 315 723 (Apr/I)

AUDIO NOTE phono stage. M1 RIAA Special. MC, MM, line. mint. 10 hours use. £700 ono. Impulse H2s. Horn loaded, awesome £1175 ono. Tel: 01765 677 639 (May/I)

MERIDIAN 500 transport £675. Celestion SL600s £300. Arcam Delta 290 (MM/MC) £250. Rega RB300 £70. Meridian component moving coil preamp £50. Skyline turntable platform £20. Single Celestion Ditton 10 speaker £15. Tel: 01621 772 884 (Apr/I)

FOR SALE: Source record deck (£1500 new) with Zeta balancing arm, Audio Technica AT-F3 cartridge. Also The Preamp (Musical Fidelity). Tel: Evans 01269 832 204 (Apr/I)

REVOX B77 10" reel to reel 4 track, 3-7.5 ips. perspex cover. hardly used last 8 years. £500. Tel: 01422 843 866 eves 01422 845 143 work (Halifax) (Apr/I)

SONY MD MZ R50 plus 20 mini discs £190. 0.5 metre stereo balanced Cardas Hexilink £80. 0.8 metre stereo balanced van den Hul Second £85. Tel: 0181 670 6411 (Apr/I)

C 37 VALVE Studer tape machine for sale. A fine machine in excellent condition £1200. Leak TL12.1 two amps with GEC KT66s. £800. Tel: (Dublin) 353 1 497 7643 evenings (May/I)

MANA SUPPORTS: Sound stage x 4, £150 each. Sound Table x 2, £165 each, Power Supply Table x 2, £95 each, Mini Table £95. QED Profile Silver 12 Bi-Wire, 2m x 2 £30 pair. Tel: 01952 660 207 (Telford) (Apr/I)

FOR SALE: English and American valve amps 1 valve power amp, many valves. Tel: 0113 240 3496 (Apr/I)

MERIDIAN 500 transport and 566 24-bit DAC, absolutely mint and boxed, all accessories £1600. VDH DI02/III XLR interconnect £60. Chord Cobra 2 XLR-to-DIN £50. Tel: 01793 526 796 (Apr/I)

WILSON WATT 5/Puppy 2, gloss black, paws, tails, new unused grilles, mint, shipping crates, £6995 (£17000 new) possible p/x Watt 5 for 3 - enjoy System 5 virtues cost effectively! Tel: 0860 850 786 (May/I)

AUDIO TECHNICA OC9 cartridge, brand new, unopened £200, NAD 1000S pre-amp MC/MM 3 outputs including balanced, THX approved, boxed, instructions £135. Wanted: Assemblage DAC2, Rega RB250/300 any condition. Tel: 01642 594 645 (May/I)

QUAD II x 2, QCII mono x 2, AM valve, FM valve, FM2, 33 x 2 (one intermittent fault), 303 x 2 £400 ono. Thorens I66/P77 £70. Tel: 01942 826 250 (Apr/I)

SNELL TYPE E II speakers + Pirate stands £575. Helios Orion Silver wired tone arm £290. Marantz CD17 CD player £450. Tel: Derek 01297 489 877 (Apr/I)

TEAC VRDS105E CD player, excellent condition, boxed £475, Quad FM3 tuner £30 ono. Tel: 01582 758 049 (Luton) (Apr/I)

71 HIGH STREET,  
NEW MALDEN,  
SURREY, KT3 4BT.  
ENGLAND.  
TEL: 0181 336 0012  
FAX: 0181 336 2703



**0% CREDIT**  
(SUBJECT TO STATUS)

2 DEMONSTRATION ROOMS  
FREE PARKING  
WIDE RANGE OF PRODUCTS  
OPEN 9.00-6.00 MON -SAT

**CLEARANCE BARGAINS**



USA ESOTERIA



UNISON RESEARCH

	WAS	NOW
AVI S2000 Amp	£ 999	£ 699
ATC 20TSL R/W	£ 3055	£ 2199
Jamo Concert 8	£ 1365	£ 999
EPOS ES22	£ 1350	£ 949
Mark Levinson No. 332	£ 6500	£ 4999
McIntosh MC7100 Power	£ 1575	£ 999
Musical Fidelity E20 & E30	£ 900	£ 699
Musical Fidelity E50	£ 300	£ 229
Musical Fidelity X-ACT	£ 130	£ 99
Musical Fidelity X-PRE	£ 200	£ 149
Musical Fidelity X-P100 & X-AS100	£ 1600	£ 1249
Musical Fidelity X-A100R	£ 1000	£ 789
Proceed CDP	£ 3400	£ 2699
Teac VRDST/DTI	£ 1050	£ 699



CHORD

U.K. ESOTERIA

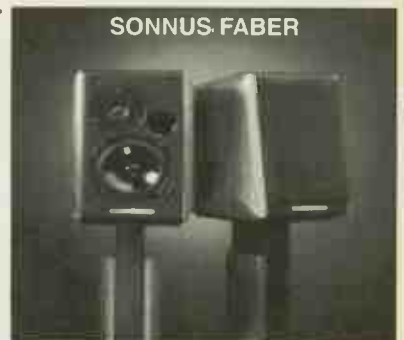

SONNUS FABER

**EXCLUSIVE AREA DEALERSHIP FOR...**  
 ● ACOUSTIC ENERGY ● AUDIO ANALOGUE ● ATC ●  
 ● AVI ● CASTLE ● CHORD ● COPLAND ● DIAPASON ●  
 ● EPOS ● GRAAF ● JAMO CONCERT ● LINN ●  
 ● MARK LEVINSON ● MUSICAL FIDELITY ● PROCEED  
 ● RESTEK ● SONUS FABER ● TEAC  
 ● UNISON RESEARCH ● PLUS:

APOLLO, CABLE TALK, DPA, HARBETH, JBL, MARANTZ,  
MICHELL, MCINTOSH, NAD, NORDOST, PROJECT,  
REL, ROTEL, SENNHEISER, SONIC LINK, STANDS UNIQUE,  
TANNOY, TDL, AND MANY MORE

"MAIL ORDER WELCOME"

**NEW ARRIVALS AUDIO ANALOGUE ● COPLAND ● ROTEL ● SONUS FABER**

**IAN HARRISON HI-FI**

TEL: 01283 702875

9am - 9pm

INCLUDING SUNDAYS

HIFI AT DISCOUNT PRICES. FREE NATIONWIDE DELIVERY

TRADE IN YOUR OLD MOVING COIL CARTRIDGE & SAVE UP TO 45% OFF THE RRP.

CARTRIDGES & STYLUS    TONEARMS    CASSETTE DECKS    COMPACT DISC

DENON SHURE AUDIO TECHNICA GOLDRING AUDIOQUEST TRANSFIGURATION LONDON (DECCA) ARCAM GRADO ROKSAN VAN DEN HUL ORTOFON & OTHERS AUDIO NOTE DNM	ROKSAN SME MOTH  <b>TURNTABLES</b>  SME TECHNICS MICHELL  <b>HIFI FURNITURE</b>  APOLLO SOUND STYLE PROJEKT SOUND ORGANISATION  <b>CABLES</b>  SONIC LINK AUDIOQUEST AUDIO-TECHNICA VAN DEN HUL GOLDRING QED	PIONEER TEAC SONY DENON YAMAHA MARANTZ TASCAM  <b>DAT</b>  PIONEER TEAC TASCAM SONY FOSTEX  <b>MINI DISC</b>  SONY DENON  <b>CD</b>  PIONEER  <b>REEL-REEL</b>  STUDER TASCAM	PIONEER TEAC SONY DENON YAMAHA MARANTZ PHILIPS CREEK  <b>TUNERS</b>  SONY DENON PIONEER YAMAHA MARANTZ PHILIPS  <b>AMPLIFIERS</b>  DENON MARANTZ PIONEER YAMAHA MARANTZ PHILIPS & OTHERS
HARBETH ATC SONY ROYD			
<b>HEADPHONES</b>  SENNHEISER BEYER SONY AKG GRADO AUDIO-TECHNICA			
<b>TEST CASSETTES</b> TEST CD'S TEST RECORD DEMO CD'S  *PHONE OR WRITE FOR DETAILS	<b>BLANK TAPES / DISCS</b> TDK SONY MAXWELL BASF 353	<b>ACCESSORIES</b> DISCWASHER MILTY QED GOLDRING TDK	MAXWELL SONY ANTIFERRENC MAXWELL PIVOTELU

\*ALL GOODS ARE BRAND NEW & BOXED  
WITH FULL U.K. GUARANTEES. NO  
EX/DEM OR EX DISPLAY GOODS. NO  
GREY IMPORTS.

PLEASE PHONE TO CONFIRM PRICE & AVAILABILITY PRIOR TO ORDERING. GOODS  
ARE NOT SUPPLIED ON APPROVAL. SORRY, NO GENERAL CATALOGUES. PLEASE  
PHONE OR WRITE FOR SPECIFIC REVIEWS, BROCHURES OR PRICES.

MAIL ORDER ONLY FROM: IAN HARRISON, 7 MILL HILL, REPTON,  
DERBY, DE65 6GQ. TEL: 01283 702875. 9am - 9pm INCLUDING SUNDAYS.

**HICAM**

GOOD QUALITY PRE OWNED HI-FI EQUIPMENT PLUS  
PHOTOGRAPHIC EQUIPMENT - NIKON, CANNON A.F.  
BOUGHT SOLD PX  
(SOLD ON COMMISSION)

Audiolab 8000A	£275
Audio Alchemy decoding engine + power station 3	£450
Audionote ANB 2x2 metre	£30
Cable Talk Concert 4 2x5 metres	£80
Cable Talk Improved 2 1 metre pair	£20
Cable Talk Reference 2 1/2metre pair	£35
Castle Howard Antique Oak	£600
Castle Chester Mahogany marked, hence	£350
Exposure XV Phono	£395
Linn Kabers Black	£650
Linn Kairn Line Level (slps)	£750
Linn Kairn L/L	£600
Linn Karik (slps)	£1200
Linn LP12 Vahala basic plus K9	£495
Linn Numerik (slps)	£950
Linn Wakonda Phono	£500
LK400 2x4 metres	£30
Mark Levinson 28/29 + PSU	£2750
Meridian 563 uprated to 566	£550
Meridian 200 transport	£300
MF 3A Pre/Phono	£150
Mission 753 black	£395
Naim 72 new style	£425
Naim 140 new style	£425
Naim 180	£695
Naim Hicap new style	£450
Naim NAC5 2x4 metres	£15
Naim SBL Black	£850
Neat Petite MK3 Cherry	£495
Quad 66 Pre + Remote	£350
Revolver T/T	£80
Rogers Cadet 3	£50
Roksan Roki Transport	£325
Sonic Link Violet 1 metre pair	£45
Sonus Faber Concerto Walnut	£695
Sound Organisation 4 shelf rack, Blue	£150
Sugden SDR1 CD mint	£600
Technics SU900 MK2	£195
Transparent 'The Wave' 2x3 metre	£80

\*\*\* DVD PLAYERS ALSO WANTED \*\*\*

5 miles from either J6/8A M40

Mon-Sun 10am - 8pm VISA Switch - Mastercard  
For further details Phone/FAX 01844 260182  
Mobile: 0973 233380 E-mail: HICAM@GLOBALNET.CO.UK

# CLASSIFIED ADS

## 6 PAGES OF BARGAIN HI-FI

SPECIAL  
INTERNET  
OFFER SEE  
PAGE 138 FOR  
DETAILS

ROKSAN XERXES RB300 1990 boxed, vgc £300 ono. Choice of cartridges. Micromega Duo BSII DAC 1992 boxed, vgc £200 ono. Tel: Nik 01905 280 33 weekends, 01628 667 765 eves. E-mail: nik@liverfluke.demon.co.uk (Apr/I)

MUSICAL FIDELITY P170 power amp £250 ono blk. Good condition. Tel: 01256 844 218 (Apr)

UNISON RESEARCH Simply Two, new, boxed: 700. Concordant Excelsior (Good condition) £500. Tel: 0043 664 431 56 25 daytime (Apr/I)

AUDIO RESEARCH LS8 all valve linestage. Latest model. New January '99. lovely unit but not needed. As new £950 (£1500). Clearaudio Gamma cartridge, latest version. Barely used. £400 (£750). Tel: 0181 325 2585 (Apr/I)

THORENS TD150, Mayware Mk4, custom plinth £90. AR legend, Basik. totally as new £225. Walker CJ55, RB300 £170. Goldring Lenco £30. Tel: 0113 216 9896 (Leeds/Notts) (Apr/I)

DECCA INTERNATIONAL arm and London Gold cartridge. Both boxed and in excellent condition £150. Tel: Lee 01824 705 629 (N.Wales) (Apr/I)

AUDIO RESEARCH LS2 preamp £950. Teac A-BX10 amplifier 9 months old £700. Both mint boxed with manuals. Offers. Tel: 01639 886 297 (Apr/I)

CABLETALK INTERCONNECTS: Just run in. One careful owner. Only used for Chopin. 1 metre Broadcast 2; 1 metre Rference 2. Cost £99 & £149. Accept £50 & £75. Tel: 01483 281 234 (Surrey) (Apr)

WANTED: AUDIO Innovations pre-amp L2. EAR 834L, Rogers Studio 5, VDH Teatrack. For sale: Musical Fidelity X-Pre £120, Rogers Studio 3 £285, Kudos S100 speaker stands £170. Tel: 01865 553 428 or 278 200 (day) (Oxford)(Apr/I)

NAIM INTRO black ash speakers £440. Naim Naixo active crossover £460. M&K V75MkII black ash subwoofer £430. All with boxes and manuals, little used. Cash only, must collect. Tel: 01233 626 163 eves (Apr/I)

RADFORD ZD22/ZD100 (solid) amps, IMF Mk4 Ref Pro Monitor Transmission Line speakers, Naim CD3, Logic DM101/Helios/Decca London, Denon DR-M30HX cassette, best offer(s) secure. Tel: 0117 985 6480 (Bristol) (Apr/I)

COUNTERPOINT SA7 valve preamplifier GT Audio PSU upgrade £300. Gamma Space 300B amplifier, upgraded Space Reference III PSU (£3500) £700. Tannoy Mayfair floorstanding speakers 10" Dual Concentric & 10" ABR units £175. Tel: 0181 672 4319 (Apr/I)

CABASSE (FARELLA 400 97) 93dB floorstander £450. Danish AC (CTI 100K) £60. Audio Innovations (Second Audios) modified PWO £925 ono. Scanspeak Natural Tower mahogany floorstander 28 inch carbon & revelator. Similar Proac Response 3.4 £1500 ono. Tel: 01662 548 623 (Apr/I)

CD MERIDIAN TRANSPORT 200 with full Trichord upgrade Pink Triangle Da Capo DAC with battery power supply. Great sounding combination so won't split £1930 ono. Tel: 0131 661 6040 (May/I)

PROAC TABLETTE 50. Black ash. Dedicated Target R4 stands. One month old. Cost £900. Any reasonable offer considered. Tel: Richard 01455 631 396 (Apr)

LINN LP12 Afro, Ittock LVII, Asak, £140 spent, new motor, reset, serviced, mint (£1700) £480. Musical Fidelity T1 digital tuner, rave reviews (£300) £140. Pink Triangle LPT RB300 (£600) £250. Tel: 0161 762 9884 (Apr)

ARCAM ALPHA 10 amp, 10P power amp, 8SE CD player. Van den Hul interconnects. Soundstyle stand. Tannoy D700 Definition speakers. Everything boxed, only 6 months old. Sale due to emigration. Cost new £5200 +. Offers around £4000. Tel: 0973 199 523 24 hrs 01703 582 160. (Apr/I)

EPOS ES22 speakers (unused) £950. Naim Credo speakers £750. Audio Research LS3 pre-amp £750. Audiolab 8000Q pre-amp. Unused from new £850. Audio Note CD2 £750. Quad 77 pre/power & remote £850. Tel: 01952 502 097 (Telford)(Apr/I)

WANTED: PAIR of Epos ES11 loudspeakers. Any condition or single's considered, Wanted: Pioneer A400 amp. Non-working considered. Tel: Dan 01484 516 494 (Huddersfield)(Apr/I)

MAHOGANY VENEERED KLS10 speaker cabinets (Hi-Fi World) £100 per pair. Also another pair with Audax HMI70C0 drive units, terminal boxes & ports - just need tweeters and crossovers - £195. Wanted: SME plinth for Garrad 301 (SME 3012 arm). Genuine enquiries only please ring 0115 975 4070 (after 5pm) (Apr/I)

HARBETH COMPACT 7s. Walnut boxed excon £450. Acowstat Spectra IIs Electrostatic hybrids, boxed £450. Rega ELAs boxed, excon £250. Musical Fidelity A1 original £100. Meridian 203 DAC £100. Edison 12 stereo valve preamplifier £150. Stax Gamma headphones with energiser £100. Leak Troughline (stereo) £100. Tel: 01423 565 661 (Apr/I)

LINN AXIS, Akito, K18, mint £255. NAD 533/Rega 2 turntable as new £125. Meridian 206 ΔΣ 1993 last of the 206 models, mint £325. Pioneer A300R Precision as new £225. Nakamichi BX 100E £125. Tel: Glasgow 01505 359 572 or 07801 587 407 (Apr/I)

KELLY KT34 speakers vgc RRP £1200. now £450. Ferrograph S1 twin transmission line monitors very open sound £250. Technics SP-10 MkII motor unit, £225. Technics ST-3500 tuner £20. Tel: Jon 0181 904 8023 (Apr/I)

RUARK EQUINOX loudspeakers, light oak finish, bi-wired, crossovers mounted in stands, beautiful condition £995 (£1850). Hi-Fi World favourite Sugden AU41 amplifier pre/power 100w £650. Micromega bitstream DAC £175. Tel: 01869 322 007 (Apr/I)

KEF CODA 9 Speakers £90. Sennheiser IS550 cordless headphones £65. QED headphone amplifier £25. Cabletalk Monitor 2 interconnect 0.5m £20. Cabletalk 4.1 Biwire 2x5.5m £40. Cabletalk 3 2x4m £10. QED Qudos 2x6m £16, 2x3m £8. Pioneer PD-M700 CD £55. Tel: 01489 570 990 (Apr/I)

# AUDIO ILLUSION

23 Langley Broom

Langley

Berks SL3 8NB

TEL: (01753) 542761 FAX: (01753) 772532

OPENING HOURS:

10am - 8pm Monday - Saturday (By appointment)



\*Mail Order Service \* Export Facilities: \* All Major Credit Cards Accepted

## PRICES NEVER TO BE REPEATED



MASSIVE CLEARANCE



ALL PRICES REDUCED

			NEW SALE
<b>ACURUS</b> DIA 100 Integrated Amplifier	Mint Ex. Demo	£1100	£699
<b>ALCHEMIST</b> Monoblocks Pure Class A - 2 Pairs available	Mint S/Hand	£9000	ppOffers
<b>AUDIO RESEARCH</b> LS3B Linestage Preamplifier	Mint S/Hand	£2250	£1395
<b>CLASSE</b> CP 50 including Phono, Fully Balanced Remote Preamplifier (Black)	Mint Ex. Demo	£3190	£1995
<b>CLASSE</b> CA-200 200w/500w Balanced Stereo/Mono Switchable Power Amplifier (Black)	Mint Ex. Demo	£3000	£2195
<b>CLASSE</b> CDP 1 20 BIT HDCD Balanced CD Player (Black)	Mint Ex. Demo	£3495	£2250
<b>COUNTERPOINT</b> SA 20 220w Valve Hybrid Power Amplifier	Mint. S/Hand	£3000+	£995
<b>EAD</b> TheaterVision Ultimate NTSC Laserdisc Player, AC-3 Output Finished in 24ct Gold. *No 1 of only 5 ever Made in Gold Unique*	Mint Ex. Demo	£6100	£2800
<b>KORA</b> D30 30w Pure Class A Integrated Line Tube Amplifier	Mint Ex. Demo	£1850	£1295
<b>KORA</b> D50 50w Pure Class A Integrated Line Tube Amplifier	Mint Ex. Demo	£2700	£1950
<b>KORA</b> 100SB Pure Triode Monoblocks + Bal & S/E Inputs & Resonance Tuned Chassis	Min Ex. Demo	£5350	£3950
<b>MARK LEVINSON</b> no. 27.5 Power Amplifier - Still under warranty - As new -	Mint S/Hand	£5400	£2650
<b>MIRAGE:-</b>			
M-290 2-Way Audiophile Compact Monitors	Mint Ex. Demo	£400	£235
M-390s 2 Way Tuned Vent Floorstander (Black Ash)	Mint Ex. Demo	£550	£295
M-490s 2 Way Tuned Vent Magnetically Shielded Floorstander (Piano Black)	Mint Ex. Demo	£650	£395
BPSS-210 250w Active Servo Subwoofer	Mint S/Hand	£1800	£1195
LPX-3 Active 3-Channel Crossover *Clear Lexon Top*	Mint Ex. Demo	£800	£449
<b>MUSICAL FIDELITY</b> F18 200 wpc Power Amplifier	Mint S/Hand	£4000	£1995
<b>PROAC</b> 3.5 Loudspeakers finished in Rosewood	Mint S/Hand	£5000	£2750
<b>TEAC</b> VRDS 10 CD Player	Mint S/Hand	£770	£425

HOME CINEMA	
<b>RCE</b> 3001 CRT Projector	Mint Ex. Demo £4000 £2650
<b>LASERDISCS</b> Various available - call for titles and prices	Mostly new sealed

Information available on the following:-

**acurus**

*Classe Audio: Enlightened Audio Designs*

EUPHONIA ISOLATION DEVICES

RENAISSANCE AUDIO

KORA

MIRAGE

For your nearest stockist contact AUDIO ILLUSION

## CLASSIQUE SOUNDS (LEICESTER)

### VINTAGE HI-FI & VALVE SPECIALIST

Now appointed agents for Sugden for the East Mids

Sugden A21A pure class A integrated £799

Sugden Audition CD player £649

### FOR SALE. PRE/POWER AMPLIFIERS

Luxman M03B power amplifier. Black. Ex condition	£450	Sound Design S02 pre-amplifier. Valve. Amazing	£495
Croft Mten S11 Valve pre-amplifier. Ex condition.	£225	Leak stereo 20. Refurbished. 12 months warranty	£350
Quad 303 power amplifier. Good condition.	£125	Croft integrated valve amplifier. Ex condition.	£375
Pair Very heavy mono Valve/Modet (hybrid) power amplifiers	£60W pure class A. Incredible sound for only		£295
Pye HF50s integrated valve amplifier. As new. Mono	£195	Sonndales AZ3 mono valve amp. Sell or buy yours. Ex	£249
Armsstrong A10 mono valve power and pre-amp	£195	Crimson Elektrik 530 mono blocks. No outer casing.	£85
Audio Innovations L1 Valve pre-amplifier. Mint.	£195	Quad 4051 power amplifier. Good condition.	£175
Audio innovations Allo integrated amplifier. Mint.	£180	Beard BB100 integrated valve amp. Mint	£600
Sugden A48 integrated amplifier. Good condition	£100	Gamma Era Standard valve pre-amp with phono.	£450
Creek 4040 MK1 amplifier. Excellent condition	£75	Denon PMA350 amplifier.	£75
Naim Nac 42.5K. pre-amplifier with MC board.	£195	Naim 22 pre-amplifier & 110 power amplifier	£249
Concordant modified Quad22 pre-amplifier.	£75	O.A.C. Mistral int. val. amp. 50W. Cost £1800. 695	£199
Harman Kardon HK610 integrated amplifier	£99	O.A.C. Mistral int. val. amp. 55W. Cost £450	£199
Fisher X100A integrated valve amplifier. GC	£250	Rogers Cadet 2 prepower amplifier. Ex condition.	£195
Rogers HC98 MK2 integrated valve amplifier.	£99	Comman Sugden stereo prepower amp. Very rare.	£150
Musical Fidelity E200 pre-amp with remote	£299	Dynaco CA35 integrated valve amplifier. Ex cond.	£199
Quad 115 various conditions. from £350 pair	£350+	Richard Allen class A integrated amplifier	£150
Quad 33 pre-amplifiers. Various from	£75	Rogers cadet mono valve amplifiers. Pair. Reduced	£100
Leak Stereo 20 power amps. Various condition from	£200	Leak TL25 mono valve power amplifiers. From.	£180
Quad 44 pre-amplifier. Mint. Boxed	£250	Sugden CS1 pre-amplifier.	£95

### TURNTABLES

Garrard 301 & 401 motor units. All Serviced. From.	£125	Thorens 124 motor units. Serviced. From.	£200
Thorens 125 with plinth. No arm cut-out for SME.	£95	Thorens TD150 chassis only. Good condition.	£80
Roxel RP 900 turntable. Ex condition	£75	Anston R340 with Mission tone-arm. Ex condition.	£160
Thorens TD160 and Thorens arm. No lid.	£65	Thorens TD160 and Thorens arm. Good condition.	£145

### SPEAKERS

TDL RTL2 speakers. Mint. Boxed	£160	Gale 301 speakers in black. Mint. Boxed	£150
Snell J3 with custom built heavy stands. Mint. Boxed.	£500	Cyrus 781 speakers & stands. Mint.	£150
Pair Lowther A80s speakers. Good condition.	£250	Kel 1022 speakers. Ex condition. Cost £780. Boxed	£295
Gradient subwoofer for EL503 BXD. Cost £1700	£750	Richard Allan Monitor 80 speakers. Ex condition.	£175
Magneplexer SMGB loudspeakers. Mint. Boxed.	£550	SD Acoustics S02 speakers and stands. Good cond.	£199
Single Lowther acousta using PMA. Early style cab	£190	Mordant Short MS940 with Decca Kelly Ribbons	£195
Celestion SL600 & Celestion stands. Ex cond. Boxed	£350	Quad Electrostatic speakers. From £400 pair	£400+

### OTHER ITEMS

Shure V15A cartridge. Excellent condition	£50	Linn Asak cartridge. VDH1 mipped. Ex cond.	£180
Dynavector Ruby. Karat MC cartridge. Ex condition	£85	Anam Alpha 5 CD player. Mint. Boxed	£250
Narantz CD80. Mint. Boxed. A real heavy weight	£249	Cambridge Audio Dacman. Gold & silver means lead	£100
Revox A77 track 3.75K 7.5 good condition	£225	Revox A77 wooden case. As new	£50
Denon HA 900 MC step up. Mains. As new. Boxed.	£95	Quad LW1M/SW. tuner	£40
VDH The First Digital Interconnect. Cost £125	£65	Acis i. usre tone arm. Ex Condition	£40
Narantz C678E cd player. Mint. Boxed	£150	Quad FM3 tuner. Good condition	£75
Arcam Alpha CD player. Boxed with remote.	£150	Phillips CD960 CD player. Cost £700. Make oil trans.	£199
Quad FM1 Mono tuner	£20	Audio Alchemy Dac in the box. Cost £230	£75
Leak Triangler 2 & 3 Mono Stereo. From	£75	Narantz CD52 MK2. No remote	£69
SME 3009 tone arms. Various. From	£60	Sony CDP 5011 CD player	£99
Yamaha KX580 SE Cassette deck. Mint. Boxed	£150	QUAD Digital (stereo) power supply	£75
Audio Technica AT1000 mono. (Boxed) (no. 341)	£35	A.P. 100 HR 100S MCS. (4 arm) Silver shell	£275

### QUAD ESL57 PANELS/SERVICING ETC

Rebuilt & soak tested treble panels. Fitted new dustcovers. Exchange	£100
Rebuilt and soak tested bass panels. Fitted new dustcovers. Exchange	£120
New high spec rectifier boards. Excellent quality and long lasting	£40
High spec rectifier block (rebuild wax unit). Exchange. Price each	£30
Clamp boards. (price per pair).	£45
New dust covers bass or treble panels. Fitted	£25
Treble protection boards (before S/N 16800) price each	£15
Refurbish Grille with fabric overcover. Black or brown. Each	£30

Full servicing facilities available. 12 months warranty on all panels/parts

(somewhat of a bargain Hifi World, Jan 1999)

### TRANSLUCENT PURE SILVER INTERCONNECT CABLE

99.99% pure silver conductors. Quality gold plated RCA phono plugs.  
Half Metre terminated £60.00 One metre terminated £80.00  
NEW..... Translucent Minor 99.99% pure silver conductors. Single screen. White finish.  
Half Metre terminated £40.00 One Metre terminated £55.00  
Translucent Digital. 1M £40.00 Half metre. £30.00  
Please add £200 per additional Half metre. £1500 Minor & £1000 per half metre (digital)  
7 day money back guarantee if not better than existing cable. Regardless of price or quality. Ex Minor.  
99.99% pure silver wire .5mm (unsleeved) Only £4.95M

### NEW EAR/YOSHINO EQUIPMENT

Ear 834P MM/MC phono stage with/without volume	Brand new. Boxed at only £499
Ear 834P MM phono stage. No volume control	Brand new. Boxed at only £350
Ear 834L. Line only valve pre-amplifier. Amazing	Brand new. Boxed at only £450

### 301/401/124 PLINTHS AND POWER SUPPLIES

Power supplies for above as well as any i/table/CD etc. Eg TD125/150/160 etc. Amazing value at only £125.00 each.  
Plinths @ only £199 unfinished or £299 finished (veneered)  
Awarded 4 Globes October 98 (HIFI WORLD)

### WANTED EQPT BY:-

Leak, Quad, Radford, Rogers, Sme, Lowther, Tannoy, Croft, Garrard, Ear, Lumley, Audionote, Thorens, Musical Fidelity and other quality eqpt.

Tel/Fax 0116 2835821 or 0802 213740 (Mobile). Callers by appt only.  
Opening times 10.00am-6.00pm Mon-Friday. 10.00am-2.00pm Saturday.

Classique House, 61 Aylestone Drive, Aylestone, Leicester, LE2 8QE

# CLASSIFIED ADS

## 6 PAGES OF BARGAIN HI-FI

SPECIAL  
INTERNET  
OFFER SEE  
PAGE 138 FOR  
DETAILS

REVOX G36 quarter track stereo 7.5 & 3.75 recorder £200, Tandberg 62 valve half track £75. Quad 33/303/FM3 £150. Yamaha Wedge TC 800GL cassette £150. Crimson 510/520 pre/power £150. Tel: 01704 530 928 eves/ weekends (Apr/I)

AUDIO INNOVATIONS 200 valve pre/power amplifier £350. Quad II pre/power amplifier, original KT66 valves £400. Rappaport I preamp, suits Quad IIs £200. Tannoy 3LZ 10" dual concentric loudspeakers £200. Tel: 01704 530 928 eves/weekends (Apr/I)

GALE 401 chrome loudspeakers with stands £300. Musical Fidelity A1 (late model) amplifier £90. Nytech 302 35 watt integrated amplifier £90. Lux PD300 vacuum turntable £200. Tel: 01704 530 928 eves/weekends (Apr/I)

KRELL KAV500 5 channel power amplifier £2990. Lexicon DC1 with DTS/DTS/AC3 upgrades fitted. Both mint condition. Both 8 months old. Tel: 0113 236 111 or 0113 240 2043. E-mail: [tompledge@msn.com](mailto:tompledge@msn.com) (Apr/I)

EARLY ACOUSTAS (birch-ply) professionally renovated in matt walnut and fitted with Lowther's latest neodymium cored DX3s. Redesigned front panels. Style-2000 compliant. £1450. Tel: 01483 268 804 or E-mail: [ano@zsizsi.demon.co.uk](mailto:ano@zsizsi.demon.co.uk) (Jun/I)

AUDIONOTE AN-J speakers (rosewood) with MAF stands, superb £835. Naim NAT 0.1 tuner £650. Tel: 01903 756 582 (Apr/I)

REVOX B77 MkII R/C centre channel, dust covers, loads of new 10.5" tape, virtually unused £950. Private sale but credit card accepted. Tel: 01908 543 210 (Apr/I)

QUAD 33/303/F3 preamp & power & tuner £350. Garrard 401 £125, SME 3009 MkI with Shure V15E cartridge £75. Mordant Short Pageants MkII £150. Private sale but credit card accepted. Tel: 01908 543 210 (Apr/I)

AUDIO RESEARCH Classic 30 amp £850; Robertson 4010 amp (IAR rated class 1a! review available) £395; Z-Man audio signal enhancer (for CDs) £80; California Audio Lab Sigma II tube DAC (120 volts, transformer available) £300. 0.75m Kimber Select 1020 £295; 1.5m Audioquest Lapiz £195; 1m Straightwire Virtuoso Gold £225; 5m Audioquest Crystal+ £195. All excellent condition, ovno. WTB or p/ex: Symo speaker cables (4-5m). Tel: 01865 558 075 or E-mail: [cyril888@aol.com](mailto:cyril888@aol.com) (May/I)

CONRAD JOHNSON MV55 power amp £1995 new, £1200 ono. Copland CTA401 integrated £1695 new £1300 ono. One must go. Both excellent condition. Pioneer A400 good condition £80 ono. Tel: 0171 257 1134 daytime 01932 841 361 eves (Apr/I)

QUAD 33/303 Classic pre + power amp combination. Boxed, immaculate with manuals £175. DPA Little Bit DAC, boxed, good condition £110. Will demonstrate. Tel: 01746 710 356 (Shropshire) (Apr/I)

LINN SARA loudspeakers, original type with stands. Very good condition £200. Tel: 0181 994 2030 after 6 p.m. (Apr)

PIONEER A400X amplifier, mint, boxed £130. STD 3055 T/T with SME armboard £60. Sony TCD-D100 DATman, mint, 10 hours only £395. Sony SS86e bookshelf speakers, boxed £35. Wanted: Mission 752, Michell Gyropower PSU, old hi-fi mags. Tel: 07899 816 120 (Apr/I)

DENON DMD1000, Minidisc recorder, new, boxed, guarantee, impeccable recordings, can demonstrate £259. Tel: 01306 883 557 (Dorking) (Apr/I)

MUSICAL FIDELITY NuVista Class A tube preamplifier, remote controlled, highly acclaimed, 6 months, mint, boxed/manuals, spare nuvistors. 18 months warranty + purchase option for upcoming limited edition nu-vistor poweramp transferable. £900 or highest bid!. Tel: 01865 842 055, office hours: 01865 852 803 (Apr/I)

MUSICAL FIDELITY X-A200 Monoblocks 200Watt, MF's large 'aluminium tube' design, 6 months, mint, boxed/manuals. Very good match to the NuVista! £700 for the pair. Offers welcome. Tel: 01865 842 055, office hours 01865 852 803 (Apr/I)

AUDIO INNOVATIONS Series 200 (Mk II) pre/power, new Sowter transformers and valves - work carried out by Haden Boardman. Boxed, mint, free XLO i/c £580 ovno. Michell Gyrodeck (MkI), Helius Orion, MC3 Turbo £380. SME 3009 Mk II S2, boxed, mint £50. Tel: Matt 0161 225 7496 Manchester (Apr/I)

AUDIOLAB 8000 DAC £400. Micromega CD 3.1 transport (£1500) £500. QLN Ref HD2 floorstanding speakers in cherry veneer (£2500) £1200. All in excellent condition. Little use. Sale due to divorce. Tel: 0161 724 9109 (Apr/I)

MODIFIED RB300. 1998 arm structurally modified and rewired with silver Litz by Origin Live. (See Hi-Fi World article Feb 99) Palpable improvements. Mods alone cost £145. Sell complete £175. Tel: 01483 281 234 (Surrey) (Apr)

TEAC TI TRANSPORT (£550) £330, DPA Little Bit III, DAC (£325) £160, Teac V5000 cassette deck (£320) £160. All mint and boxed. Sound Systems Tower (mahogany) (£270) £160. Tel: 0114 288 7326 (Sheffield) (Apr/I)

GARRARD 301, SME 3009II, Linn K18. Linn interconnect, strobe platter, heavy and large MDF plinth, original mat (£500) £225. Ixos 604 bi-wire 2x7m (£75) £35. Tel: 0114 288 7326 (Sheffield) (Apr/I)

YAMAHA KX380 cassette (5 star) £100. Hitachi FTMD5500 tuner (5 star) £70. 2x1.5m lengths Exposure speaker cable, terminated 4mm banana plugs £20. Pair of Castle Avon speakers, as new, mint £550. All new, never used. Tel: Tony 01424 431 536 (Sussex) (Apr/I)

LINN LP12 Cirkus/Lingo/Ekos 2/Archiv. Top spec (£4450) £1700, serviced and upgraded from new by Grahams. Naim 82/180 (£3375) £2200. Naim NAT 02 (£1130) £700. Nakamichi Dragon (£1890) possibly the last one bought in UK! £1400. Rega Ela's £295. Tel: Lawrence 0181 941 9196 or 07050 053 153 (May/I)

# L A T INTERNATIONAL

World Class Cables Made in U.S.A

AC-2 Power cable - Silver clad, Teflon insulated at 10awg; this is the largest gauge of power cord we know of. The design of our shielding system effectively eliminates interferences from RF and EMI sources. 2ft £49, 3ft £59, 4ft £69, 6ft £89, 4, 6 and 8 way all steel distribution boxes also available. Analogue Interconnects, IC-50, IC-80, IC 100, IC, 200. Speaker cables - SS800, BIWIRE, SS1000



## Gershman Acoustics

Avante Garde RX20 - a mere 36" tall and 12" x 12" at the base - Absolute Sound review - " a true torture test with a bass line that's big, super fast and continuous - the Gershman's handled it beautifully, servo driven Infinity RS1 towers have more power but are way too slow. The Magnepan MG3.5/R's, can't match the low bass impact of the Avant Gardes, only the Thiel 3.6 can handle this track with aplomb and even they don't sound quite as fast. Unquestionably, the Avant Gardes are a tremendously musical loudspeakers".

X-1, Specter, Enigma 500-X, GAP-520X



## Sunfire Corporation

from the mind & soul of Bob Carver

TUBE PRE AMP, POWER AMPS 300 & 600  
wpc. FIVE CHANNEL AMP 200 wpc. TRUE  
SUB-WOOFER 11 INCH CUBE 18 HZ

**Taperwire**  
flat speaker cable

418 Biwire \*\*\*\*\*What Hi Fi,  
also 420, 212, 215, 218, 222

**AUDUSA & Co**

## Vampire Wire

Analogue, Digital & Video Interconnects,  
Speaker Cable continuous cast copper, OFS, OFC

4 Arundel Road Kingston Upon Thames  
Surrey KT1 3RZ  
Tel: 44 (0) 181 241 9826  
Mobile: 0956 230056  
Fax: 44 (0) 181 241 0999  
E-Mail: cweere @mcaim.com

# diverse vinyl

12 Upper Dock Street Newport Gwent NP9 1DF 9am-5.30pm Mon - Sat.  
Internet site <http://www.diverse-music.co.uk>  
phone/fax 01633 259661 / 256261 E Mail - sales@diverse-music.co.uk  
-Mastercard -Visa- Catalogues available -Amex-Switch-JCB-

## CLASSIC RECORDS RELEASE BOB DYLAN'S "ROYAL ALBERT HALL"

After all the hassle that we had with Sony over the LP of this release, those fine people at Classic Records are to do us proud by releasing an audiophile double LP of this defining moment in rock history. The release date is for early march (watch this space) Expected price of Bootleg Series 4/5 is £32.90

### EMI Millennium Vinyl (Follow up to Centenary Vinyl) - 22 March

David Bowie	Aladdin Sane	£13.90
Deep Purple	Book Of Taliesyn	£13.90
Frank Sinatra	In The Wee Small Hours	£13.90
Jethro Tull	This Was	£13.90
John Lennon	Walls And Bridges	£13.90
Queen	Day At The Races	£13.90
REM	Document	£13.90
Specials	Specials	£13.90
Talking Heads	Stop Making Sense	£13.90
The Band	Music From Big Pink	£13.90

### New And Forthcoming Releases

Sebadoh	The Sebadoh	£9.90
Mogwai	Come On Die Young	£12.90
Stereolab	Switched On	£9.90
Jimi Tenor	Organism	£11.90
Ananda Shankar	Ananda Shankar	£6.90
XTC	Apple Venus Volume One	£11.90
Jimi Hendrix	Live At The Fillmore East 3LP	£22.90
Kula Shaker	Peasants Pigs & Astronauts	£TBC
Stereophonics	Performance And Cocktails	£TBC
Blur	13 - 2LP 15/3	£TBC
Tom Waits	Mule Variations 19/4	£TBC
Curtis Mayfield	Curtis - 180gm	£16.50
Curtis Mayfield	Roots - 180gm	£16.50
Curtis Mayfield	Superfly - 180gm	£16.50
Wings/Paul McCartney	Band on the Run - 25th Anniv	£TBC
Metallica	Garage Inc - 3LP	£21.50
Beck	Mutations (LP + 7")	£12.90

### Nagaoka Anti Static Sleeves (Pack Of 50) - £12.50

### New Audiophile Titles

Bruce Springsteen	Born to Run(Classic Records)	£21.90
Michael Hedges	Aerial Boundaries (Alto)	£19.90
James McMurtry	It Had To Happen (Alto)	£19.90
Lorna Hunt	All In One Day (Alto) - Double	£32.90

### ALL PRICES SUBJECT TO CHANGE

P and P £1.00 1st LP additional LP's 50p each (max £4.00)

## THE MIDLANDS BEST USED EQUIP- MENT SPECIALIST

TEL/FAX 0121 783 8227



QUALITY USED  
EQUIPMENT,  
BOUGHT, SOLD, PART  
EXCHANGE

URGENTLY REQUIRED  
LINN, NAIM,  
MERIDIAN, QUAD,  
CASH WAITING

	RRPE	NOWE
Audio Alchemy DDS 3 s/h	700	395
Audio Research LS7 s/h	1700	995
Audiotech LP12 Table s/h	n/a	35
DPA PDM 1.3 s/h	1200	350
Epos ES14 & Stands s/h	850	295
Exposure 7 Pre s/h	450	95
Linn Kan MK1 & MKII Stands s/h	n/a	150
Linn Karik Transport s/h	1850	595
Linn LP12 Cirkus Trampolin Lingo Aro Arkiv s/h	4020	1795
Linn LP12 Ittok Valhala s/h	2000	495
Linn LP12 Lingo Ittok K18 s/h	2500	895
Linn LP12 Valhala Basic Plus s/h	1400	395
Linn Numerik s/h	1500	595
Linn Sara & Stands s/h	900	250
Lumley ST70 Triode switchable x/d	2300	895
Martin Logan Sequel 2 s/h	3500	1795
Meridian 566 20 bit s/h	1095	595
Meridian 601 s/h	2750	1295
Meridian 602 s/h	1750	695
Mission DAC5 DAC s/h	300	50
Naim 101 Tuner + Snaps s/h	n/a	450
Naim 102 Phono + PSC s/h	1337	895
Naim 110 s/h	n/a	250
Naim 140 s/h	770	450
Naim 160 s/h	n/a	450
Naim 180 s/h	1090	695
Naim 250 s/h	1705	1195
Naim 32.5 s/h	450	250
Naim 42.5 s/h	n/a	175
Naim 62 New Style MM/MC s/h	450	250
Naim 82 s/h	222.5	149.5
Naim 90 s/h	460	295
Naim 92 Phono s/h	567	350
Naim Hi-Cap s/h	720	495
Naim MM/MC Boards s/h	82	30
Naim Nail 3 Phono s/h	657	450
Naim Naxo 3/6 New Style s/h	650	295
Pink Triangle Export Rega RB300 s/h	1070	450
Pioneer PD95 s/h	2000	795
Proac Response 2 & Stands s/h	2000	750
Quad 44 s/h	n/a	250
Roksan Xerves Artemiz Piano Black s/h	2500	895
Roksan Xerves Table s/h	n/a	25
Siltoch HF6 1/2 metre s/h	100	50
Sound Organisation LP12 Table s/h	n/a	10
Stax Lambda Nova Basic s/h	450	295
Syrinx PU3 s/h	n/a	195

OPEN MON-SUN 10.00 TO 8.00 RING FOR FURTHER DETAILS TEL/FAX 0121 783 8227

## English Analogue

Supplier of quality second hand classical records  
Reasonable prices for truly collectable original vinyl from  
the 1950s to the 1970s. Labels include:

**DECCA -SXL, SDD, SET, RCS, SPA, PFS**  
**HMV - ALP, ASD, SAN, SLS**  
**COLUMBIA - 33CX, SAX**  
**RCA - SB - 2000/6000, VICS, SER**  
**DEUTSCHE GRAMMOPHON, PHILIPS**  
etc, also available

If you are unfamiliar with classical music,  
recommendations are available of great recordings to  
enhance the enjoyment of your Hi-Fi and enter you into  
the vast world of Classical Music. Just as there are good  
recordings or Rock, Pop or Jazz, the same applies to  
Classical.

To increase your satisfaction, all the records sold are  
cleaned and audibly checked before being sold, free of  
charge, as well as a guarantee. The records are also  
supplied with a new innersleeve, as well as the old. to  
insure a high standard. In addition, if you have any  
Classical LPs or CDs you wish to sell or want a free  
catalogue, please write, phone or fax to:

3 Naseby Rise, Newbury, Berks, RG14 2SF, England  
Tel: 44 - (0) 1635 40242 Fax: 44 (0) 1635 524239  
[www.multiplex.co.uk/Records](http://www.multiplex.co.uk/Records)

# CLASSIFIED ADS

## 6 PAGES OF BARGAIN HI-FI

SPECIAL  
INTERNET  
OFFER SEE  
PAGE 138 FOR  
DETAILS

ROGERS E40 valve amp £1000 (as new). ABI Subwoofers £250. Avanti 625 loudspeakers £250. LS3/5A loudspeakers (walnut) £350. All items mint. Tel: 01344 872568 (Apr/I)

ROKSAN XERXES (Walnut) turntable. Rega RB300 arm, Audio Technics OC5 cartridge, plus XPS3 & DSU power supply. Excellent condition with box £375. Tel: 01299 271266 (eves) W. Midlands (Apr/I)

TANNOY 609 Mk II plus dedicated Tannoy stands, good condition £180 ono. Target 3 tier equipment stand £50 ono. Tel: 01332 835 823 after 6 p.m. (Derby) (Apr/I)

WANTED SONY tuner ST SA3ES. Goodmans receiver 110/120. Rotel receiver RX 850 AL. Tel: David 01524 823 904 (Apr/I)

EAR 519 amplifiers £1600. Sony CD player and DAC (CDP552ES + DAS702ES) £650. All kit in excellent condition. Tel: 01959 524 258 eves/weekends (Apr/I)

MICROMEGA SOLO CD player boxed with receipt as new £595. Goodman Magnum loudspeakers £80. QED Connect 2 interconnect new £20. Sony Elcaset Mediatech transport working but no sound. Offers. Tel: 01705 376 247 (Hants)(Apr/I)

VOYD VALDI turntable, white ash plinth, Helius Aureus tone arm, Goldring Electro II cartridge £835. Audio Innovations 1000 pre-amp and First Audio power amp £1235. Snell Type 'J' speakers, white ash, with stands £795. Tel: Richard 0181 255 9194 (Twickenham)(Apr/I)

ATC SCM 50ASL LOUDSPEAKERS rosewood £3800. Chord CPA 3200. enhanced pre-amplifier, silver £2300. Both items 4 months old, boxed as new. Tel: 01355 264 586 (Apr/I)

PROAC RESPONSE 3s £1500. Orelle CD10 Transport £350. Sugden SDA-1 DAC £350. Denson amp DM-10 £800. Aiwa ADF850 £80. Interconnects, van den Hul £180, Red Dawn £180, Kimber £60. Tel: 01634 826 324 (Apr)

**THETA CHROMA 396 DAC.**  
Beautifully detailed smooth sound £430 for quick sale.  
Tel: 0171 435 4365 or 0973 278216 (Apr/I)

QUAD ELS57 speakers, excellent (black) £400. Quad II valve power amps, phono inputs £250. Audionote OTO amp (phono) unique version, revalved £750. Tel: 0141 571 2045 (Apr/I)

CYRUS dAD 3 CD (£600 new) £350, Cyrus III amp (£550) £300, Mission 751 rosewood speakers (£330) £150, van den Hul cables & interconnects (£130) £55 or offers for whole system boxed and complete. Tel: 0181 440 9524

PINK TRIANGLE Cardinal & DaCapo 1307 filter & relocking card £350 & £600 respectively or £900 pair with 22 bit filter & pair i/cs also. Tel: 0181 879 0364 (SW London) (Apr/I)

MERIDIAN 200/203 DAC7 Transport and DAC Trichord Clock 2 and power supply fitted. Superb condition, all leads, manuals, boxes £495 ono. Sony STS370LBRDS tuner, excellent. boxed £50 ono. Tel: 01803 315 391 (Apr/I)

RADFORD STA-15 amp. SC 22 control unit. FMT 1 tuner. Original technical instructions £850. Also Leak 2200 amp, 2300 tuner, 2060 speakers. Original owners handbooks and sales brochure £450. Tel: 01592 758 753 (Fife) (Apr/I)

LINN KABERS, excellent condition, black ash, boxed as new, only £500. Tel: 01865 246 405 (home) or 077 88888 059 (mobile) or Email: charlie.osmond@worc.ox.ac.uk (Apr/I)

FALCON C800 Three way loudspeaker kit. Amazing performance. Electrics alone cost £700. Cabinets included. Needs completing. £300 ono. Tel: 01202 690 339 (Apr/I)

PRIMARE D30.2 CD player £1000 (£1500) brand new in factory sealed container. Current What Hi-Fi 5 star winners. Tel: 0171 724 9945 (Apr/I)

**CELESTION 7000 speakers (£395), QEDA240PA integrated (£150), QEDP300 power (£125) amps (both £250), Linn LK1 preamp w/o remote (£135), Sony DTCP7 DAT recorder and tapes (£250). Tel: David 0113 266 2723 anytime (Leeds) (Apr/I)**

QUALITY SWEDISH Sonab hi-fi, little used and carefully stored for years; comprises tuner, turntable, cassette deck and specially made attractive Kef speakers, manuals and connecting cables. £250. No offers. Tel: 0181 467 1441 (Apr/I)

PIONEER D-05 DAT recorder £550. Sony 555ES CD player £300. Sony MDS JE510 MD £110. Akai 4000DS open reel deck £80. Tel: 01707 267 379 (Apr)

EXPOSURE XX integrated amplifier. Recent purchase, boxed, unmarked and as new. Cost £800, will accept £500. Delivery considered. Tel: 01423 780 687 (especially evenings) (Apr/I)

**NAIM HEADLINE**  
Headphone amp & NAPSC PSU £225, boxed. Sennheiser HD565 Ovation headphones £100 boxed, mint. 4x7m terminated runs of NAC A5 cable £50/pair ono. Tel: Chris 0121 453 9950 (Apr/I)

FERROGRAPH S1 monitors with stands. Twin transmission line design, very transparent £300 ono. Technics SP10 Mk2 BBC version, upgraded with copper screening, superb sound, slightly scruffy £225. Technics ST-3500 tuner £40. B&W Active I loudspeakers, very clean open sound with fast deep bass, mint condition £400. Tel: Jon 0181 904 8023 evenings (Apr/I)

ROTEL RCD-965BX CD player, mint, boxed, complete with interconnects, manual, remote etc. £130. Tel: 01689 820 112 (Chislehurst, Kent)(Apr/I)

VAN DEN HUL Cables. D10211 interconnect 0.8m boxed £40. 2m bi-wire pair Teatrack silver hardwired insert audio phonos £50. Tel: 01293 786 453 (Apr/I)

**LINN KLOUT power amps, two, £1195 each. LK100 power amp £325. Linn Isobarik Aktive electronic crossover (bingoed) with Dirac power supply £595. Tel: Kevin 01932 761 000 (day) 01932 781 614 (eves), Email: kevin@macrotech.co.uk (Apr/I)**

SD OBS SPEAKERS & 3 metre pair of Chord Flatline Tri-wire cable £350. Pair of 3 metre Audionote ANB speaker cable £25. Tel: 01636 683 830 after 5pm (Apr/I)

# MUSICAL IMAGES

PRODUCT	LIST	NOW
AVI S2000 MC/20 REF CD PLAYER	EX/DEMO	£1400 £1000
ANTHEM INTEGRATED AMP 1	EX/DEMO	£1300 £1100
ANTHEM CD 1	EX/DEMO	£1700 £1355
B & W-MATRIX 801 walnut speakers	EX/DEMO	£4000 £2800
APOGEE-Centaurus Ribbon Monitor black spkrs	S/H	£1000 £400
CABASSE FARELLA 400 beech speakers	EX/DEMO	£1000 £700
DENON-PMA Q5 10II amp	EX/DEMO	£1800 £1200
DPA - ENLIGHTENMENT pre amp	EX/DEMO	£695 £350
DPA - ENLIGHTENMENT power amp	EX/DEMO	£995 £495
EXPOSURE-17 pre amp	S/H	£850 £450
KELLY KT2 speakers	S/H	£700 £500
LINN-KARIK III cd player	S/H	£1850 £1100
LINN-KEILIH walnut speakers	EX/DEMO	£850 £650
LUMLEY-VTP1000 pre amp	S/H	£1000 £500
MARANTZ MM 500 amp	S/H	£500 £250
MERIDIAN-DSPA 5000 black digital speakers	NEW	£3495 £2500
MERIDIAN-501V AV pre amp	S/H	£875 £400
MICHELL GYRODEC bronze turntable+RB300ar	EX/DEMO	£1106 £880
MISSION 753 - black speakers	S/H	£700 £300
MISSION 754 -r/wood speakers	EX/DEMO	£1500 £900
MONITOR AUDIO STUDIO20SE r/wood speaker	EX/DEMO	£2400 £1900
MONITOR AUDIO STUDIO50 r/wood speakers	EX/DEMO	£3300 £2600
MUSICAL FIDELITY-P270 power amp	S/H	£1250 £500
MUSICAL FIDELITY -3B pre amp	S/H	£380 £150
OPERA TERZA - mahogany speakers	S/H	£1000 £600
PINK TRIANGLE-NUMERAL cd player	EX/DEMO	£1050 £850
PINK TRIANGLE-LITAUURAL cd player	EX/DEMO	£2100 £1575
PROAC-RESPONSE 2.5 yew speakers	EX/DEMO	£3000 £2400
PROAC-STUDIO150 cherry/walnut speakers	EX/DEMO	£1400 £950
ROGERS-AB33 black speakers	EX/DEMO	£400 £200
ROGERS-LS33 black speakers	EX/DEMO	£280 £140
ROGERS-GS5 black speakers	EX/DEMO	£380 £190
ROGERS-GS6 black speakers	EX/DEMO	£430 £215
ROGERS-E20A valve amp	EX/DEMO	£1230 £700
ROKSAN-RADIUS turntable (MINT)	S/H	£620 £500
ROKSAN-S1.5 silver power amp	EX/DEMO	£1495 £1150
ROKSAN-XPS V CONTROL UNIT	EX/DEMO	£320 £240
ROKSAN-DS 1.5 POWER SUPPLY	EX/DEMO	£695 £525
SONY - MDSJA30ES mini disc player	EX/DEMO	£700 £550
SOUNDLAB-PRISTINE electrostatics speakers	S/H	£8000 £2000
TDL - T LINE 2 speakers	S/H	£550 £350
TUBE TECHNOLOGY - PROPHET pre amp	EX/DEMO	£1970 £1379
TUBE TECHNOLOGY - GENESIS mono power amp	EX/DEMO	£4700 £3290
TUBE TECHNOLOGY - SEER PHONO pre amp	EX/DEMO	£1000 £700
TUBE TECHNOLOGY - UNISIS power amp	EX/DEMO	£1900 £1330

PLEASE VISIT OUR SHOWROOMS OR  
CALL OUR HOTLINE NUMBER FOR DETAILS.  
HURRY, THESE ARE ONE-OFF ITEMS!!

**SEE IT! HEAR IT! BUY IT!**

**HOTLINE NUMBER:  
0171 497 1346**

18 Monmouth Street, Covent Garden, London WC2H 9HB  
E-Mail: sales@musical-images.co.uk

Beckenham                      Edgware                      Hounslow  
0181 663 3777                  0181 952 5535                  0181 569 5802

NOT VALID WITH ANY OTHER OFFERS OR PROMOTIONS E&OE

## Rothwell



### Valve Amps of Distinction

This pre/power combo has been winning admiration and praise from satisfied customers throughout Britain and abroad for over five years. Many are so impressed with the performance that they have invested in a second Rubicon, running the two amps as monoblocks. To find out for yourself why these music lovers are so dedicated to Rothwell, contact your nearest dealer for a dem.

**The Rubicon** is a stereo valve power amp using triode configured EL84s to give a remarkably delicate sound, guaranteed to captivate. Bridgeable for monoblock operation. **£949**

**The Indus** is the ultimate passive pre-amp, based on Rothwell's unique stepped attenuator. This precision device has fine and coarse volume controls to give 132 volume settings and unbeatable sonic accuracy. **£499**

Audio Images	Lowestoft, Suffolk	01502 582853
Kronos Hi-Fi	Dungannon, N.Ireland	01868 753606
Serious Kit	Prestwich, Manchester	0161 798 9649
Sounds Perfection	Helston, Cornwall	01326 221372
Shadwell Hi-Fi Studios	Leeds, Yorkshire	0113 237 1019
Input Audio	Dukinfield, Cheshire	0161 3047494
Kevin Galloway Audio	Killmarnock, Ayrshire	01563 574185
Romers Hi-Fi	Rishton, Lancashire	01254 887799
Hazlemere Audio Consultants	High Wycombe, Bucks	01494 437892
Audio Illusion	Langley, Berkshire	01753 542761

Rothwell Electronics 60 Pennington Road, Great Lever, Bolton BL3 3BR  
Tel/Fax 01204 654614

TEL: 01428-651554

**P.G. Hi-Fi**

FAX: 01428-654592

**Buying & Selling Vintage HiFi, Valves,  
Classical LP Records & Spare Parts.**

#### Quad

QA12P Amplifiers (Pair) £Offers  
QCII Pre-Amp £25

#### Leak

TL12+ (Pair) £300  
Stereo 20 £250  
TL12.1 (Pair) £1300  
TL25+ (single) Black £150  
Garrard 301/Goldring Arm  
+ Plinth and cover £300  
Armstrong 227 valve receiver with  
ceramic pick-up input £25

#### Valves (G.E.C. Mullard etc.)

KT66 ECC81/84 EF80  
Many Others.  
Please Phone For Details.

#### Most Models Of Leak Mono + Stereo Pre-Amps In Stock.

Williamson design stereo amp using  
4x807 + 4x6SN7 & separate power  
supply, also  
Mullard design stereo amp using  
4xEL84, also pre-amp + 6 boxed  
transformers + documentation  
The lot £130

#### Servicing for Quad II + Leak Amplifiers

Spare Parts For Quad +  
Leak - Transformers etc.  
Garrard 301 spares

Quad II mains transformer £80  
Quad II output transformer £80  
Quad II choke £25  
Please phone for details of other  
Quad/Leak/Garrard spares

#### Speakers

Quad Electrostatic ESL63 Speakers  
Bargain £850  
Goodmans Axiom 150 MKII 12" bass  
units (pair) £50  
Lowther TP1 corner speaker, mahogany  
finish with PM3/Alnico in excellent original  
condition (Cabrille legs) £750  
Tannoy 3LZ (cabinets only) very good  
condition £50  
Tannoy Lancasters with 15" monitor  
golfs £900  
Tannoy speakers + drive units  
for sale please phone for details

#### Wanted

**Tannoy Speakers - Lancaster,  
York, G.R.F. and Autograph.**



# HI-FI WORLD TRADE CLASSIFIED ADS

Dealers must not advertise in the Private Classified section. Monthly consecutive insertions will be considered Trade advertising. The Publisher reserves the right to judge submissions.

SPECIAL  
INTERNET  
OFFER SEE  
PAGE 138 FOR  
DETAILS

OFFICIAL SUGDEN Service, repairs, and upgrades. Sales of new and reconditioned SUGDEN audio products. Prices from £150 including carriage for recons with guarantee. Full details available. Tel: Audio Synergy 01924 406 016 (Jul99(I))

**WANTED - EARLY HI-FI LOUDSPEAKERS**  
Tannoy, Lowther, Parmeko, Voigt, Vitavox, RCA WE etc  
**TURNTABLES**  
Garrard, BBC301, EMT, SME, Ortofon, Decca, etc.  
**VALVE AMPLIFIERS**  
AEI, EMI, Leak, Rogers, PYE- Quad, WE etc  
**AUDIO VALVES**  
DA30, KT66, KT88, PX4, PX25, PP3/350, WE300  
**CLEAR CRYSTAL SYSTEMS**  
John Petrie-Baker  
Tel: 0171 328 9275

**ELECTROSTATIC RESEARCH** Model II Vista hybrid speakers Black RRP £4480. Sell £2200 with warranty. SUMO repairs and service. Other agencies Sunfire, Gershman Acoustics, LAT International, Tapewire, Vampire Wire. Contact Audusa & Co. Tel: 0181 241 9826, Fax: 0181 241 0999 (Apr(I))

**BUY-SELL-EXCHANGE.** Vintage wireless and classical audio. Repairs, spares, restoration, modification to all valve equipment. Quad II, Leaks etc. Regonda and Vega T.V. and Radio parts in stock. 17 Bell Street, NW1 5BY. Tel: 0171 258 3448 Fax 0171 258 3449 (Apr)

**NEW PRODUCT**  
**MOVING COIL CARTRIDGE**  
**VALVE HEAD AMPLIFIER**  
THERE IS NO SUBSTITUTE  
FOR VALVES HERE  
CALL FOR DETAILS  
PAUL HYNES  
PHASE DESIGN  
Tel/Fax: 01931 712822 (Apr(I))

**STUDIO 12 Stereo Decoder** for Troughline tuner. Assembled and aligned PCB with instructions £18.50. Boxed, mains powered outboard unit ready to use £56.50. Tel: 01736 798 393 (Apr(I))

**CASTLE LOUDSPEAKERS**  
New. Discounts available. Deliver Anywhere UK. Please telephone for details. Five Ways Hi-Fidelity Ltd (Est 1972), 12 Islington Row, Edgbaston, Birmingham B15 1LD Tel: 0121 455 0667. Tues-Sat 10.30-6.00 (Apr(I))

**FREE REPORT** on passive preamp plus catalogue of other reports available. Build your own top quality equipment. Send SAE to R. E. Robertson, 21 Barons Court Road, West Kensington, London W14 9DY (Apr(I))

**MIRAGE LOUDSPEAKERS** M55i/1090i/MBS2/MC2/BPS 150. Also MIT MH 750 2s bi-wire/MIT 350. Proline balanced lead 20. All at bargain prices never to be repeated. Phone Audio Visual Concepts on 01628 440 873 now. (Apr(I))

**OLD DAYS**  
**VINTAGE/AUDIO**  
"WANTED" Tannoy - Lowther - Quad - Telefunken -- Siemens - Radford - W/Electric - Garrard 301 - Thoren 124/135 - SME 12" - Ortofon. VALVES: DA30 - DA60 - DA100 - PX25. AUDIO NEW/USED: Krells - Mark Levinsons, latest specs, Nakamichi Dragon. Tel/Fax: 0171 349 9675 or 0958 607 613 (Apr(I))

**ROGERS SPEAKERS** (new and ex-demo) still for sale, massive discounts. Studio 9 £550, Studio 7 £350, Studio 5 £250. BBC, Gold and LS ranges available. E40A valve amps £1000. Spares and servicing. Mitcham Loudspeakers Tel: 0181 648 0743 or 01344 872 568 (Apr(I))

**EX-DEMONSTRATION** stock. Range of quality valve amps/pre-amps available. Also Musical Fidelity, Heybrook, Parasound, Quad and Celestion audio equipment for sale. Phone for more details and prices. Tel: 0151 343 0007 (Apr(I))

2 x QUAD QCII valve mono preamps £330, Quad 22 £200, Quad 405 £150. Naim 42 £75. Marantz CD67SE new boxed £249, TDL rosewood T. Lines £399 (£600) DPA DAC £139. Stax SR34 £85. P/X. Tel: Jim 01206 510 392 (Apr(I))

**JT HORN LOUDSPEAKERS** gives music simply astonishing clarity and dynamics with stunning imaging and depth. Exciting without fatigue, just wonderful music. cabinets made from Birch-ply. Probably the most affordable horns around. For information on our horns write or telephone: JT Horn Loudspeakers, 4 Datchet Close, Littleover, Derby DE23 7SQ. Tel: 01332 512 510 (Apr(I))

EMT 948 £500, EMT 950 £750, Technics SP10 £280, Studer A710 £550, Studer A807 £1200, Studer AB12 £2000, Revox G36 £600, Nagra III £500, Revox PR99 £950, Uher 4200 RM £280. Tel: 01246 235 024 (Apr(I))

**PROFESSIONAL VENEERING** Service for speakers, plinths etc, large choice of veneers, exotic burrs speciality for LS3/5a size. (You Can Post). Also custom Hi-Fi cabinets designed and made. Tel: P&J Design 01424 715 692 (Apr(I))

**ACTIVE CROSSOVERS** designed specifically for your loudspeakers. Complete service from testing/measuring room acoustics to final installation. Prices start at £400. Passive crossover repair and upgrading service. Passive and active pre amps and control units built to your exact specification. Contact IMMORTAL COILS on 01480 391 744 Fax: 0870 0560 033 (Apr(I))





# "MAGIC SHOW"

Fi Magazine



InnerSound Eros is a bi-amplified Hybrid Electrostatic loudspeaker system including 400 watt base amplification and active crossovers.

"This is the first speaker system to succeed at sonically marrying a dynamic woofer with an electrostatic for mid and upper frequencies, and it is the first electrostatic system of any kind (either full-range or hybrid) to furnish truly excellent quality bass." – Peter Moncrieff, *International Audio Review*

"The first reflected highs you hear arrive about a week later than the direct sound. The result is that the Eros sounds so clear you almost can't believe it." – Dr Robert Greene, *Fi Magazine July 98*

"...this is a warm, most romantic sounding speaker ... warmer and more romantic than you'd expect an electrostatic design to be, and with considerable dynamic 'snap' and gradation. All of which would be as nothing if things didn't sound so alive."

– Harry Pearson, *The Absolute Sound, May/June 98, Issue 112*

"Truly stunning." – Chris Beeching, *Audio Quarterly*

InnerSound Inc., 1700 Hwy 16, Whitesburg, GA 30185 USA Tel (770) 838 1400 Fax (770) 838 0111

Innersound (UK), International House, Horsecroft Road, Harlow, Essex CM19 5SX [www.InnerSound.net](http://www.InnerSound.net) 44 1279 442701

**INNER SOUND**  
www.InnerSound.net

**B**ehind beauty...



...lies technological elegance.



**Real wood veneers:-**  
From sustainable european forests



**Sculptured 35mm Medite baffle:-**  
Maximum rigidity without reflective surfaces



**Spring loaded tweeter:-**  
Ensuring clarity through isolation.



**Aerogel:-**  
Lightness with carbon fibre rigidity.

